

iWay

iWay Transaction Adapter for CICS (XML) User's Guide
Version 5 Release 5

Updated for J2EE CA 1.5

EDA, EDA/SQL, FIDEL, FOCCALC, FOCUS, FOCUS Fusion, FOCUS Vision, Hospital-Trac, Information Builders, the Information Builders logo, Parlay, PC/FOCUS, SmartMart, SmartMode, SNAPPack, TableTalk, WALDO, Web390, WebFOCUS and WorldMART are registered trademarks, and iWay and iWay Software are trademarks of Information Builders, Inc.

Sun and Java are trademarks or registered trademarks of Sun Microsystems, Inc. in the U.S. and other countries.

Due to the nature of this material, this document refers to numerous hardware and software products by their trademarks. In most, if not all cases, these designations are claimed as trademarks or registered trademarks by their respective companies. It is not this publisher's intent to use any of these names generically. The reader is therefore cautioned to investigate all claimed trademark rights before using any of these names other than to refer to the product described.

Copyright © 2005, by Information Builders, Inc and iWay Software. All rights reserved. Patent Pending. This manual, or parts thereof, may not be reproduced in any form without the written permission of Information Builders, Inc.

Preface

This documentation describes how to configure and use the iWay Transaction Adapter for CICS (XML).

How This Manual Is Organized

The following table lists the numbers and titles of the chapters and appendices for this manual with a brief description of the contents of each chapter and appendix.

Chapter/Appendix		Contents
1	Introducing the iWay Transaction Adapter for CICS (XML)	Introduces the adapter environment.
2	Configuring the Adapter	Describes how to configure a connection to the adapter.
3	Designing the Adapter	Describes how to create transactions and events for the adapter. It also provides information on how to use the generated schemas to listen for events in CICS and create iWay Business Services, which expose functionality as Web services.
4	Using Web Services Policy-Based Security	Describes how to configure Web services policy-based security.
5	Management and Monitoring	Describes how you can use managing and monitoring tools provided by iBSE and JCA to gauge the performance of your run-time environment.
A	Configuring VTAM for AnyNet	Provides examples of the major VTAM nodes for AnyNet operation and connection and session definitions required for the adapter to connect to CICS.
B	Running the Adapter Using LU6.2 Communication	Contains technical information that you can use as a guide to ensure LU6.2 communication to the CICS region.
C	Running the Adapter Using TCP/IP Communication	Contains technical information that you can use as a guide to ensure TCP/IP communication to the CICS region.

Chapter/Appendix		Contents
D	Executing Adabas/ Natural Using the Adapter	Describes the requirements for executing Adabas/Natural using the adapter.
E	Installing the Sample IWAYIVP and IWAYSAMP Programs in CICS	Describes how to verify correct installation of the adapter.
F	Sample Requests, Schemas, and Cobol File Descriptions	Provides documents and schemas for the sample programs and the Cobol descriptions used as input for the sample CICS transactions.
G	Sample Programs	Includes the source code for the sample programs.
H	Debugging and Troubleshooting	Includes tips and techniques for debugging the adapter.

Documentation Conventions

The following table lists and describes the conventions that apply in this manual.

Convention	Description
THIS TYPEFACE or <i>this typeface</i>	Denotes syntax that you must enter exactly as shown.
<i>this typeface</i>	Represents a placeholder (or variable) in syntax for a value that you or the system must supply.
<u>underscore</u>	Indicates a default setting.
<i>this typeface</i>	Represents a placeholder (or variable) in a text paragraph, a cross-reference, or an important term.
this typeface	Highlights a file name or command in a text paragraph that must be lowercase.
<i>this typeface</i>	Indicates a button, menu item, or dialog box option you can click or select.
Key + Key	Indicates keys that you must press simultaneously.
{ }	Indicates two or three choices; type one of them, not the braces.
	Separates mutually exclusive choices in syntax. Type one of them, not the symbol.
...	Indicates that you can enter a parameter multiple times. Type only the parameter, not the ellipsis points (...).
.	Indicates that there are (or could be) intervening or additional commands.

Related Publications

To view a current listing of our publications and to place an order, visit our World Wide Web site, <http://www.iwaysoftware.com>. You can also contact the Publications Order Department at (800) 969-4636.

Customer Support

Do you have questions about the iWay Transaction Adapter for CICS (XML)?

If you bought the product from a vendor other than iWay Software, contact your distributor.

If you bought the product directly from iWay Software, call Information Builders Customer Support Service (CSS) at (800) 736-6130 or (212) 736-6130. Customer Support Consultants are available Monday through Friday between 8:00 a.m. and 8:00 p.m. EST to address all your iWay Transaction Adapter for CICS (XML) questions. Information Builders consultants can also give you general guidance regarding product capabilities and documentation. Please be ready to provide your six-digit site code number (xxxx.xx) when you call.

You can also access support services electronically, 24 hours a day, with InfoResponse Online. InfoResponse Online is accessible through our World Wide Web site, <http://www.informationbuilders.com>. It connects you to the tracking system and known-problem database at the Information Builders support center. Registered users can open, update, and view the status of cases in the tracking system and read descriptions of reported software issues. New users can register immediately for this service. The technical support section of www.informationbuilders.com also provides usage techniques, diagnostic tips, and answers to frequently asked questions.

To learn about the full range of available support services, ask your Information Builders representative about InfoResponse Online, or call (800) 969-INFO.

Help Us to Serve You Better

To help our consultants answer your questions effectively, please be prepared to provide specifications and sample files and to answer questions about errors and problems.

The following tables list the specifications our consultants require.

Specifications	Comments
Platform	
Operating System	
OS Version	
Product List	
Adapters	
Adapter Deployment	For example, JCA, Business Services Engine
Container Version	

The following table lists components. Specify the version in the column provided.

Component	Version
iWay Adapter	
EIS (DBMS/APP)	
HOTFIX / Service Pack	

The following table lists the types of Application Explorer. Specify the version (and platform, if different than listed previously) in the columns provided.

Application Explorer Type	Version	Platform
Swing		
Servlet		
ASP		

In the following table, specify the JVM version and vendor in the columns provided.

Version	Vendor

The following table lists additional questions to help us serve you better.

Request/Question	Error/Problem Details or Information
Provide usage scenarios or summarize the application that produces the problem.	
Did this happen previously?	
Can you reproduce this problem consistently?	
Any change in the application environment: software configuration, EIS/ database configuration, application, and so forth?	

Request/Question	Error/Problem Details or Information
Under what circumstance does the problem <i>not</i> occur?	
Describe the steps to reproduce the problem.	
Describe the problem .	
Specify the error message(s).	

The following table lists error/problem files that might be applicable.

Error/Problems	Description
XML schema	
XML instances	
Other input documents (transformation)	
Error screen shots	
Error output files	
Trace and log files	
Log transaction	

User Feedback

In an effort to produce effective documentation, the Documentation Services staff welcomes your opinions regarding this manual. Please use the Reader Comments form at the end of this manual to communicate suggestions for improving this publication or to alert us to corrections. You also can go to our Web site, <http://www.iwaysoftware.com> and use the Documentation Feedback form.

Thank you, in advance, for your comments.

iWay Software Training and Professional Services

Interested in training? Our Education Department offers a wide variety of training courses for iWay Software and other Information Builders products.

For information on course descriptions, locations, and dates, or to register for classes, visit our World Wide Web site, <http://www.iwaysoftware.com> or call (800) 969-INFO to speak to an Education Representative.

Interested in technical assistance for your implementation? Our Professional Services department provides expert design, systems architecture, implementation, and project management services for all your business integration projects. For information, visit our World Wide Web site, <http://www.iwaysoftware.com>.

Contents

1. Introducing the iWay Transaction Adapter for CICS (XML)	1-1
Overview of the Adapter	1-2
The iWay Transaction Adapter for CICS (XML)	1-3
CICS Programs	1-4
Software Requirements for the Adapter	1-4
Deployment Information for the Adapter	1-5
Deployment Information Roadmap	1-5
The iWay Business Services Engine	1-6
The iWay Enterprise Connector for J2EE Connector Architecture	1-6
2. Configuring the Adapter	2-1
Starting Servlet Application Explorer	2-2
Configuring a Connection to CICS	2-3
Managing a Connection to CICS	2-14
3. Designing the Adapter	3-1
Creating an Adapter Transaction	3-2
Sample Program IWAYSAMP	3-3
Cobol Descriptions for Input and Output Communications	3-8
Creating Schemas for an Adapter Transaction	3-8
Understanding iWay Business Services	3-10
Creating a Web Service	3-10
Testing the Web Service	3-13
Generating WSDL From a Web Service	3-14
Identity Propagation	3-16
Creating an Event	3-16
Creating, Editing, and Deleting an Event Port	3-17
Creating an Event Port From the iWay Events Tab	3-17
Editing and Deleting an Event Port	3-33
Creating, Editing, and Deleting an Event Channel	3-34
Editing and Deleting a Channel	3-41
4. Using Web Services Policy-Based Security	4-1
iWay Business Services Policy-Based Security	4-2
Configuring iWay Business Services Policy-Based Security	4-3
5. Management and Monitoring	5-1
Managing and Monitoring Services and Events Using iBSE	5-2
Managing and Monitoring Services and Events Using the JCA Test Tool	5-17
Setting Engine Log Levels	5-22

Contents

Migrating Repositories	5-23
File Repositories	5-23
iBSE Repositories	5-23
JCA Repositories	5-28
Migrating Event Handling Configurations	5-28
Exporting or Importing Targets	5-32
Retrieving or Updating Web Service Method Connection Information	5-37
Starting or Stopping a Channel Programmatically	5-40
A. Configuring VTAM for AnyNet	A-1
VTAM and AnyNet Configuration Requirements	A-2
TCP6.2 AnyNet Setup Samples for the VTAM Administrator	A-2
TCP6.2 AnyNet Setup Samples for the CICS Administrator	A-3
Post-Configuration Steps	A-6
Verifying That the AnyNet Port is Listening	A-6
Verifying That the CICS Program is Accessible and Enabled in the CICS Region	A-7
Error Conditions	A-8
VTAM BIND Failures	A-8
Connect Failures Module BPX1AI0	A-8
B. Running the Adapter Using LU6.2 Communication	B-1
MVS OS/390 APPC Communication	B-2
LU6.2 Setup on MVS	B-2
LU6.2 Setup on CICS	B-3
Microsoft SNA Server Communication	B-4
LU6.2 Setup on a Windows SNA Server	B-4
Application Run Time Requirements	B-6
C. Running the Adapter Using TCP/IP Communication	C-1
MVS OS/390 TCP/IP Communication	C-2
TCP/IP Requirements	C-2
D. Executing Adabas/Natural Using the Adapter	D-1
Natural Program Execution Overview	D-2
Adabas/Natural Proxy Programs	D-3
E. Installing the Sample IWAYIVP and IWAYSAMP Programs in CICS	E-1
Installing and Configuring the Sample CICS Program IWAYIVP	E-2
Installing and Configuring the Sample CICS Program IWAYSAMP	E-5

F. Sample Requests, Schemas, and Cobol File Descriptions	F-1
Request Document for the Generic Transaction IWAYIVP	F-2
Request Schema for the Generic Transaction IWAYIVP	F-3
Response Schema for the Generic Transaction IWAYIVP	F-4
Request Documents for the Program IWAYSAMP	F-5
Request Schema for the Program IWAYSAMP	F-6
Response Schema for the Program IWAYSAMP	F-7
Request Document for the Program AASNATN	F-8
Request Schema for the Program AASNATN	F-8
Response Schema for the Program AASNATN	F-9
Sample Cobol File Descriptions	F-10
G. Sample Programs	G-1
IWAYIVP Program	G-2
IWAYSAMP Program	G-3
CICS TCP/IP Sockets Program for Mainframe	G-4
CICS TCP/IP Sockets Program for TX	G-9
H. Debugging and Troubleshooting	H-1
Troubleshooting	H-2
Data Type Conversions	H-4

Contents

CHAPTER 1

Introducing the iWay Transaction Adapter for CICS (XML)

Topics:

- Overview of the Adapter
- The iWay Transaction Adapter for CICS (XML)
- Deployment Information for the Adapter

This section describes the iWay Transaction Adapter for CICS (XML). The adapter supports automatic transaction invocation, message transformation, and error recovery. The adapter enables applications to call CICS programs and to work with the native features and syntax of CICS.

Overview of the Adapter

The adapter enables you to execute CICS programs. The advantages of the adapter include the following:

- No modification required to existing CICS programs.
- No installation of new code required on CICS.
- Adapter processing performed off of the mainframe.
- Configuration by metadata—no coding required.
- Support for older versions of CICS.
- Support for CICS COMMAREA programs.

The following diagram illustrates the framework for executing CICS programs with the iWay Application Explorer and the iWay Transaction Adapter for CICS.

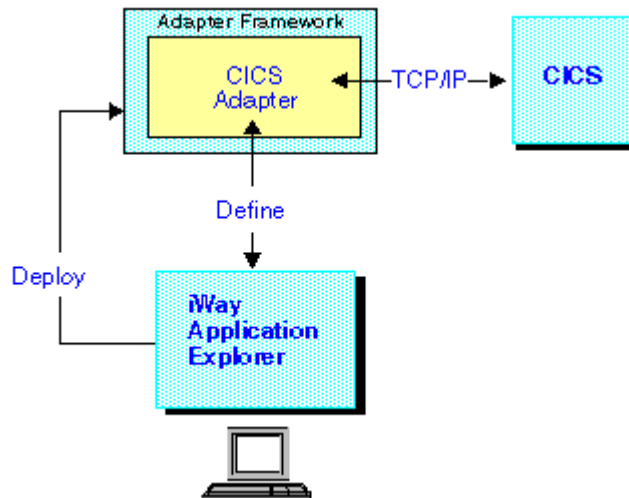

The following bidirectional scenarios are supported by the adapter:

- CICS services
- CICS events

The iWay Transaction Adapter for CICS (XML)

The following diagram illustrates the use of AnyNet to connect to the CICS region. For CICS Transaction Server Version 2 Release 2 or higher, you have the option to use straight TCP/IP.

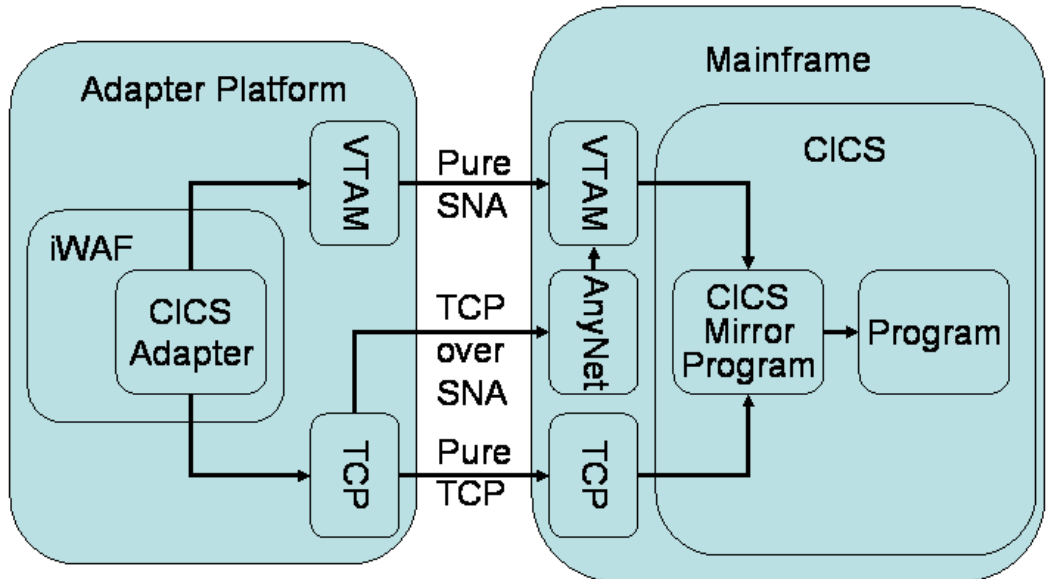

The adapter is the component that connects to CICS. It is hosted in a container that supports events. The adapter enables the following functions:

- Connecting to CICS.
- Executing COMMAREA programs.
- Mapping XML messages to and from CICS data structures.
- Listening for events triggered in CICS.

The adapter enables you to invoke a CICS program by sending a request and retrieving the response.

The adapter sends the request to execute a transaction over the Multi-Platform Transport Network (MPTN, also known as AnyNet). This enables the adapter to use TCP/IP to send the request although CICS is expecting LU6.2 (also known as APPC).

The adapter attaches the CICS Mirror transaction, CPMI, which is the standard External Communication Interface (ECI) transaction for ASCII clients.

At design time, you describe the request and response messages by mapping them to Cobol descriptions.

Note:

- Because distributed transactions are not supported, the synchronization level is CONFIRM.
- An extended call (executing several program calls in one unit of work) currently is not supported.

CICS Programs

The two main types of CICS programs are:

- COMMAREA programs that are designed to be called by other CICS programs.
- 3270 programs that read and write terminal screen maps using Basic Mapping Support (BMS).

Because the adapter can execute only COMMAREA programs, this distinction is important.

To execute 3270 programs, you require a screen scraper such as the iWay Adapter for 3270. For many years CICS applications were structured so that the business processing, as opposed to the screen dialogue, was in COMMAREA programs. Therefore, in many cases, executing a COMMAREA program is recommended for application integration.

Software Requirements for the Adapter

The following are the software requirements for the adapter:

- OS/390 v2.6 or higher or z/OS.
- TCP/IP communication available to the adapter.
- VTAM AnyNet option (for CICS Transaction Server Version 2 Release 1 or earlier).
- One of the following releases of CICS:
 - CICS Transaction Server for z/OS, Version 2 Release 2.
 - CICS Transaction Server for OS/390, Version 1 Release 2 or higher.
 - IBM CICS/ESA, Version 4 Release 1.
 - CICS Transaction Server for VSE/ESA, Version 1.1.0 or higher.
 - CICS for VSE/ESA, Version 2.3.
 - CICS for IBM OS/400, Version 4.4.
 - TXSeries, Version 4.2 (HP-UX); TXSeries, Version 4.3 with PTF 4 (Windows NT, AIX, SunSM SolarisTM operating environment); or TXSeries, Version 5.0 (AIX and Windows).
- For Adabas/Natural execution, Adabas and Natural must be installed and configured within the CICS region.

Deployment Information for the Adapter

The iWay Transaction Adapter for CICS (XML) works in conjunction with iWay Application Explorer with either of the following components:

- iWay Business Services Engine (iBSE)
- iWay Enterprise Connector for J2EE™ Connector Architecture (JCA)

Application Explorer is used to configure database connections and create Web services and events. It can be configured to work in a Web services environment in conjunction with the iWay Business Services Engine or with the iWay Enterprise Connector for J2EE Connector Architecture (JCA). When working in a JCA environment, the connector uses the Common Client Interface (CCI) to provide fast integration services using iWay Adapters instead of Web services.

Both iBSE and the iWay connector for JCA are deployed to an application server such as Java Sun Application Server with iWay Application Explorer and the adapters.

Deployment Information Roadmap

The following table lists the location of deployment information for the adapter and Application Explorer. A description of the iWay Business Services Engine (iBSE) and the iWay Enterprise Connector for J2EE Connector Architecture (JCA) follow the table.

Deployed Component	For more information, see
iWay Application Explorer	Chapters 2 and 3 of this guide <i>iWay Installation and Configuration</i> <i>iWay Servlet Application Explorer User's Guide</i>
iWay Business Services Engine (iBSE)	<i>iWay Installation and Configuration</i>
iWay Enterprise Connector for J2EE Connector Architecture (JCA)	<i>iWay Connector for J2EE Connector Architecture User's Guide</i> <i>iWay Installation and Configuration</i>

The iWay Business Services Engine

The iWay Business Services Engine (iBSE) exposes—as Web services—enterprise assets that are accessible from adapters regardless of the programming language or the particular operating system.

iBSE simplifies the creation and execution of Web services when running:

- Custom and legacy applications
- Database queries and stored procedures
- Packaged applications
- Terminal emulation and screen-based systems
- Transactional systems

Web services is a distributed programming architecture that overcomes hurdles with Enterprise Application Integration (EAI) that other programming models cannot. It enables programs to communicate with one another using a text-based but platform- and language-independent message format called XML.

Coupled with a platform- and language-independent messaging protocol called SOAP (Simple Object Access Protocol), XML enables application development and integration by assembling previously built components from multiple Web services.

The iWay Enterprise Connector for J2EE Connector Architecture

The iWay Enterprise Connector for J2EE Connector Architecture (JCA) enables developers of JCA-compliant applications to deploy iWay adapters as JCA resources. The connector is supported on the Sun Java System Application Server.

The iWay Connector for JCA is distributed as a standard Resource Adapter Archive (RAR) for deployment to the application server. Thus, the connector can be used in systems that are non-compliant, although services such as pooled connections are not available.

Two connectors are distributed in the iWay installation package. One conforms to the JCA 1.0 specification, with extensions that allow for the consumption of events. The other conforms to the JCA 1.5 specification. The JCA 1.0 connector provides for event functionality through the configuration of ports and channels. When using the adapter in conjunction with a JCA 1.5 connector, there is no need to create event ports to dispose of event data. However, you must create a channel to enable event listening capabilities. For more information on event capabilities of the iWay JCA connectors, see Chapter 3, *Designing the Adapter*. For more information on installing and deploying both connectors see *iWay Installation and Configuration*.

CHAPTER 2

Configuring the Adapter

Topics:

- Starting Servlet Application Explorer
- Configuring a Connection to CICS
- Managing a Connection to CICS

At design time, you use Application Explorer to create the configuration and metadata the adapter requires at run time. This section describes how to configure a connection to CICS.

Starting Servlet Application Explorer

The server must be started where Servlet Application Explorer is running.

Procedure: How to Start Application Explorer

1. Ensure the server is started where Application Explorer is running.
2. Type the following URL in your browser window

`http://hostname:port/iwae/index.html`

where:

`hostname`

Is the machine where Application Explorer is installed.

`port`

Is the port number for iBSE. The default port is 80.

Application Explorer opens.

The Available Hosts drop-down list appears in the upper-right corner. Three tabs appear near the top of the Application Explorer screen. From left to right they are:

- iWay Adapters, where you create and manage connections to CICS.
- iWay Events, where you configure CICS event listening.
- iWay Business Services, where you create and view business services.

The left pane of the window contains an expandable list of adapter nodes (based on the adapters installed), events, or business services, depending on the tab that is selected. The right pane provides the details of the selected adapter, event, or service, and is the work area where you will define and modify adapter functions and services.

The Available Hosts drop-down list specifies to which Servlet iBSE instance or JCA instance you connect.

For more information on accessing different instances of a JCA installation or a Servlet iBSE, see the *iWay Installation and Configuration* documentation.

You are now ready to define a new target to CICS.

Configuring a Connection to CICS

To access an adapter, you must configure a connection to that adapter. After the connection is created, it automatically is saved. You must establish a connection to the system every time you start Application Explorer or after disconnecting.

Procedure: How to Configure a Connection to CICS

1. Expand the *iWay Adapters* node in Application Explorer.
2. Click the *CICS* node.
3. In the right pane, move your pointer over *Operations* and select *Define a new target*.

The Add a new CICS target dialog box opens in the right pane, as shown in the following image, where you enter the Target Name and Description, and select the Target Type from a drop-down list.

Add a new CICS target

Targets represent configured connections to instances of backend systems. Choose a name and description for the new target that you wish to create.

Target Name:

Description:

Target Type:

Help < Back Next > Cancel

4. Type a name for the new target (for example, CICS_Connection).
5. Type a description (optional).
6. From the Target Type drop-down list, select the type of target (for example, CICS via AnyNet).
7. Click *Next*.
 - If you selected CICS via AnyNet as the type of target, proceed to Step 8.
 - If you selected CICS via SNA as the type of target, proceed to Step .
 - If you selected CICS via TCP/IP as the type of target, proceed to Step .

8. If you selected CICS via AnyNet, the Set connection info dialog box opens containing Connection, Region, and Advanced tabs. The Connection tab window displays by default.

The following image shows the Set connection info dialog box that opens to the Connection tab window containing three text fields for entry and three action (Back, Finish, and Cancel) buttons.

The screenshot shows a dialog box titled "Set connection info" with three tabs: "Connection", "Region", and "Advanced". The "Region" tab is selected and highlighted in yellow. Below the tabs are three text input fields: "Host:" (empty), "AnyNet Port:" (containing "397"), and "VTAM Network Qualifier:" (empty). At the bottom of the dialog are four buttons: "Help" (disabled), "< Back", "Finish", and "Cancel".

Note: The CICS connection parameters are consistent with those found in your CICS system. For more information on parameter values that are specific to your CICS configuration, consult your CICS system administrator. This information should be the same for all transactions and messages in a single CICS system.

You enter the parameters to create a new connection to CICS.

For information on the relationship of these parameters to the CICS VTAM definitions using AnyNet, see Appendix A, *Configuring VTAM for AnyNet*.

- a. In the Connection tab, type values for the connection parameters as defined in the following table:

Parameter	Description
Host	Host name, or IP address, for the computer where CICS is running.
AnyNet Port	<p>The AnyNet option always communicates back to the calling environment on a specific AnyNet port (usually, 397). Therefore, the server platform must not use any other product that also requires the services of the AnyNet port.</p> <p>On certain platforms such as UNIX, port numbers between 0 and 1023 are privileged, meaning that these ports are used to connect to services that require system-level privileges, such as Telnet, FTP, and SMTP daemons. Port numbers above 1023 are generally associated with processes that do not need special privileges. In these cases, assign an AnyNet port of 1024.</p>
VTAM Network Qualifier	Network qualifier for VTAM.

- b. Click the *Region* tab.

The following image shows the Set connection info dialog box which opens to the Region tab window containing seven fields for entry and three action (Back, Finish, and Cancel) buttons.

The image shows a dialog box titled "Set connection info" with three tabs: "Connection", "Region", and "Advanced". The "Region" tab is currently selected. The dialog contains the following fields and controls:

- User ID: [Text input field]
- Password: [Text input field]
- CICS LU: [Text input field]
- Local LU: [Text input field]
- LogMode: [Text input field]
- Trusted:
- Codepage: [Dropdown menu showing "Cp500"]
- Number of Sessions: [Text input field containing "2"]

At the bottom of the dialog, there are four buttons: "Help", "Back", "Finish", and "Cancel".

- c. Type values for the region parameters as defined in the following table:

Parameter	Description
User ID	Valid user ID for CICS. If you specify the user ID and the password, then the CICS connection definition for this LU must be specified with ATTACHSEC(VERIFY). If you specify the user ID only (with no password), then the CICS connection definition for this LU must be specified with ATTACHSEC(IDENTIFY). If you specify neither the user ID nor the password, then the CICS connection definition for this LU must be specified with ATTACHSEC(LOCAL).
Password	Valid password associated with the CICS user ID. For additional information, see the User ID parameter above.
CICS LU	VTAM applid to connect to the CICS system.
Local LU	LU of the SNA access point to which you have access (for example, SNA server).
LogMode	Log mode for the connection to CICS (for example, PARALLEL).
Codepage	Select the codepage from the drop-down menu. Cp500 is the default value.
Number of Sessions	Number of sessions for the AnyNet connection. 2 is the default value.

- d. Proceed to Step 11.

If you selected CICS via SNA, the Set connection info dialog box opens, as shown in the following image containing six fields for entry and three action (Back, Finish, and Cancel) buttons.

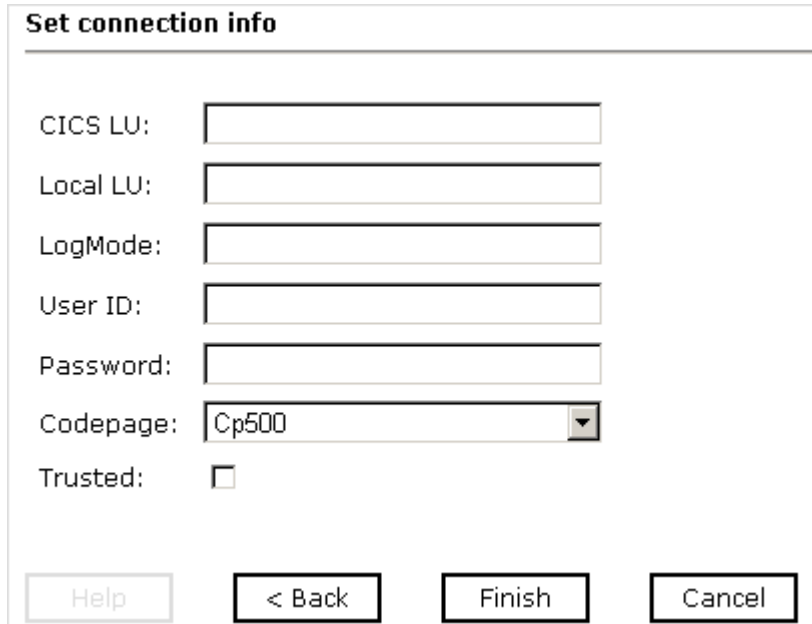

The image shows a dialog box titled "Set connection info". It contains six input fields and three buttons. The fields are: CICS LU: (text box), Local LU: (text box), LogMode: (text box), User ID: (text box), Password: (text box), and Codepage: (dropdown menu showing "Cp500"). The "Trusted:" field has an unchecked checkbox. The buttons at the bottom are "Help", "< Back", "Finish", and "Cancel".

Note: The CICS connection parameters are consistent with those found in your CICS system. For more information on parameter values that are specific to your CICS configuration, consult your CICS system administrator. This information should be the same for all transactions and messages in a single CICS system.

For more information, see Appendix B, *Running the Adapter Using LU6.2 Communication*.

- a. Enter values for the SNA parameters to create a new connection to CICS as defined in the following table:

Parameter	Description
CICS LU	VTAM applid to connect to the CICS system.
Local LU	LU of the SNA access point to which you have access (for example, SNA server).
LogMode	Log mode for the connection to CICS (for example, PARALLEL).
User ID	<p>Valid user ID for CICS.</p> <p>If you specify the user ID and the password, then the CICS connection definition for this LU must be specified with ATTACHSEC(VERIFY).</p> <p>If you specify the user ID only (with no password), then the CICS connection definition for this LU must be specified with ATTACHSEC(IDENTIFY).</p> <p>If you specify neither the user ID nor the password, then the CICS connection definition for this LU must be specified with ATTACHSEC(LOCAL).</p>
Password	Valid password associated with the CICS user ID. For additional information, see the User ID parameter above.
Codepage	Select the codepage from the drop-down menu. Cp500 is the default value.

- b. Proceed to Step 11.

If you selected CICS via TCP/IP, the Set connection info dialog box opens, as shown in the following image containing five fields for entry.

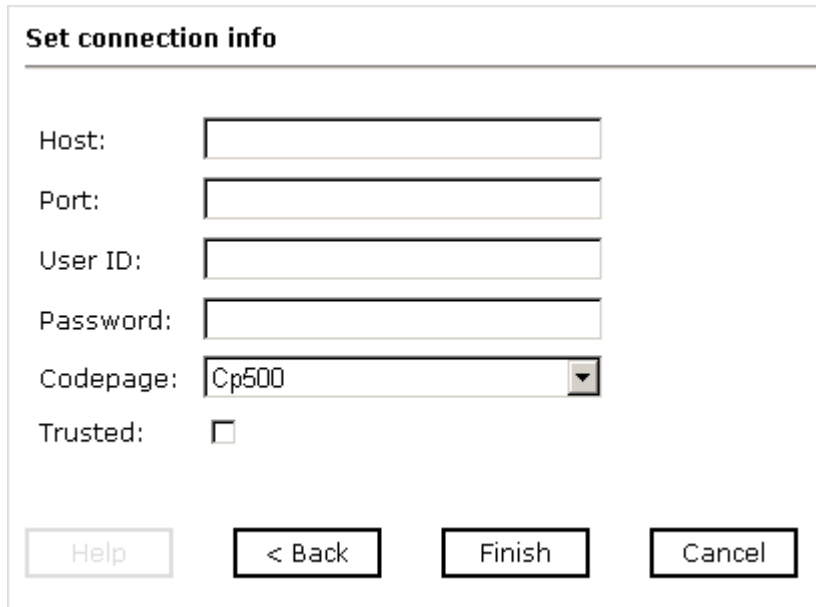

The image shows a dialog box titled "Set connection info". It contains five input fields: "Host:", "Port:", "User ID:", "Password:", and "Codepage:". The "Codepage:" field is a dropdown menu with "Cp500" selected. Below the fields is a "Trusted:" checkbox, which is unchecked. At the bottom of the dialog are four buttons: "Help", "< Back", "Finish", and "Cancel".

Note: The CICS connection parameters are consistent with those found in your CICS system. For more information on parameter values that are specific to your CICS configuration, consult your CICS system administrator. This information should be the same for all transactions and messages in a single CICS system.

For more information, see Appendix C, *Running the Adapter Using TCP/IP Communication*.

- a. Enter values for the TCP/IP parameters to create a new connection to CICS as defined in the following table:

Parameter	Description
Host	Host name, or IP address, for the computer where CICS is running.
Port	TCP port that CICS is listening on for ECI or DPL connections.
User ID	Valid user ID for CICS. If you specify the user ID and the password, then the CICS connection definition for this LU must be specified with ATTACHSEC(VERIFY). If you specify the user ID only (with no password), then the CICS connection definition for this LU must be specified with ATTACHSEC(IDENTIFY). If you specify neither the user ID nor the password, then the CICS connection definition for this LU must be specified with ATTACHSEC(LOCAL).
Password	Valid password associated with the CICS user ID. For additional information, see the User ID parameter above.
Codepage	Select the codepage from the drop-down menu. Cp500 is the default value.
Trusted	Not applicable. This parameter is obsolete.

- b. Proceed to Step 11.

9. If you are executing Adabas/Natural programs, click the *Advanced* tab. Otherwise, proceed to Step 11.

The following image shows the Set connection info dialog box for a CICS via AnyNet connection. When the Advanced tab window opens it contains five text fields for entry and three action (Back, Finish, and Cancel) buttons.

Set connection info

Connection Region **Advanced**

Natural Nucleus:

Proxy Program:

Natural Logon Parameters:

Help < Back Finish Cancel

The CICS/Natural Bridge enables Natural programs to be invoked by the adapter through CICS using Software AG's Natural CICS Interface.

10. Enter values for the Advanced parameters as defined in the following table:

Parameter	Description
Connection Time Limit (ms)	Specify a timeout interval (in milliseconds).
Natural Nucleus	Name of the Natural subsystem on which the Natural program you wish to invoke resides. For example, for Natural Version 3.14, the nucleus is N314re.
Proxy Program	CICS program that calls the Natural CICS Interface. The name of the proxy provided by iWay Software is AASNATC.
Natural Logon Parameters	String that represents the default logon parameters. It can be modified depending on installation requirements. Note: Software AG's Natural CICS Interface requires a programmatic "logon" to the Natural System.
CICS Mirror	Mirror program used for AnyNet connections. Use the default unless the mirror program is different than DFHMIRS.

11. Click *Finish*.

The newly created connection, CICS_Connection, appears as a node under the CICS service adapter. The configuration information is stored in the repository for the configuration you defined at installation time.

Procedure: How to Connect to a Defined CICS Target

1. Expand the *iWay Adapters* node.
2. Expand the *CICS* node.
3. Click the target name (for example, CICS_Connection) under the CICS node.
4. Move your pointer over *Operations* and select *Connect*.

The Connect to CICS_Connection dialog box opens, populated with values you entered for the connection parameters.

5. Verify your connection parameters. If required, provide the password and then click *OK*.
The x icon disappears, indicating that the node is connected, as shown in the following image.



Managing a Connection to CICS

To manage CICS connections, you can:

- Disconnect from a connection that is not currently in use.

Although you can maintain multiple open connections to different transaction processing systems, it is recommended to disconnect from connections not in use.

- Edit a connection to change its properties.
- Delete a connection that is no longer required.

Procedure: How to Disconnect From a Connection to CICS

1. Expand the *iWay Adapters* node.
2. Expand the *CICS* node.
3. Click the connection, for example, *CICS_Connection*, move your pointer over *Operations*, and select *Disconnect*.

Disconnecting from CICS drops the connection with CICS, but the node remains.

The x icon appears, indicating that the node is disconnected, as shown in the following image.



Procedure: How to Edit a Connection to CICS

1. In the left pane of Application Explorer, expand the *iWay Adapters* node.
2. Expand the *CICS* node and select the defined target (for example, *CICS_Connection*) you want to edit.
3. In the right pane, move the pointer over *Operations* and select *Edit*.

The following image shows the Edit dialog box that opens in the right pane containing three fields (Target Name, Description, and Target Type) and two action buttons (Next and Cancel).

Edit CICS target CICS_Connection

Targets represent configured connections to instances of backend systems. Choose a name and description for the new target that you wish to create.

Target Name:

Description:

Target Type:

4. Modify the target information as needed and then click *Next*.

The Set connection info dialog box opens in the right pane containing the Connection, Region, and Advanced tabs.

5. Modify the information as needed and then click *Finish*.

Procedure: How to Delete a Connection to CICS

1. Expand the *iWay Adapters* node.
2. Expand the *CICS* node.
3. Click the connection, for example, *CICS_Connection*, move your pointer over *Operations*, and select *Delete*.

A message appears, prompting you to confirm the deletion of the node.

4. Click *OK*.

The node disappears from the list of available connections.

CHAPTER 3

Designing the Adapter

Topics:

- Creating an Adapter Transaction
- Creating Schemas for an Adapter Transaction
- Understanding iWay Business Services
- Creating an Event
- Creating, Editing, and Deleting an Event Port
- Creating, Editing, and Deleting an Event Channel

Application Explorer is a Web application running within a servlet container and is accessible through a browser. It enables the adapter to explore metadata and create XML schemas.

The following topics describe how to use Application Explorer to create CICS transactions and generate request and response XML schemas for new or existing transactions. These schemas are used to represent a transaction for integration with external systems.

In addition, this section provides information on how to use the generated schemas to listen for events in CICS and create iWay Business Services, which expose functionality as Web services.

Creating an Adapter Transaction

After you create a connection to CICS, you can add adapter transactions using Application Explorer. A single CICS connection may be associated with multiple transactions. Each transaction represents one service offered by CICS and consists of a program and its metadata.

A generic transaction is automatically added and represents CICS services whose data will not be mapped to XML. You can use a generic transaction for programs that accept no input and for programs that return no output or when it is acceptable to return a non-formatted answer set.

For example, the supplied program IWAYIVP connects to CICS and returns "Congratulations" on successful adapter installation and configuration. Because IWAYIVP requires no input or output, you do not require Cobol descriptions for the input or output. One request and response schema is applicable for this program. The request schema for the generic transaction is in Appendix F, *Sample Requests, Schemas, and Cobol File Descriptions*.

Using the generic transaction, the XML request document that is received must include the name of the program to be called in the <Transaction> element. The payload to be sent as the COMMAREA must be in the <CommArea> tag, which can be a maximum of 32,500 bytes.

The generic response schema is constructed from the data received from CICS. If the <CommArea> element has more than 80 bytes, the received COMMAREA is split into 80-byte messages. Illegal XML characters ('<', '/', and '&') are converted to XML entities.

For programs that require input and output and a formatted response, which is usually the case, (IWAYIVP is an exception), you must add your own adapter transactions, as described in *How to Create an Adapter Transaction* on page 3-3. XML request messages must specify the transaction to use in the location attribute of the <Transaction> tag. For example, if you create a CICS transaction called IWAYSAMP, the location is "CICS/Transactions/IWAYSAMP".

To view a sample generic request or response schema or for information about specifying a transaction to use in the location attribute of the <Transaction> tag, see Appendix F, *Sample Requests, Schemas, and Cobol File Descriptions*.

Sample Program IWAYSAMP

iWay Software supplies the IWAYSAMP and IWAYIVP programs with the adapter. This document uses the IWAYSAMP program for illustration purposes and as a reference for the adapter. Based on what is passed to the IWAYSAMP program, an answer set is returned from the program with two possible layouts.

- If the value for the field STAT is 'P', the program returns 40 bytes of data.
- If the value for the field STAT is 'F', the program returns 60 bytes of data.

The IWAYSAMP program is an example of a program that returns multiple answer sets. Two different answer sets are returned based on what is passed in the request. The adapter enables you to create a response schema that contains different possible return messages.

Sample request documents are in Appendix F, *Sample Requests, Schemas, and Cobol File Descriptions*, with a sample response schema for the IWAYSAMP program. You specify the output as explained in *Creating an Adapter Transaction* on page 3-2. You must know the field in the Cobol description that can be used as a record type and the value of that field. You specify the value of the field to create the appropriate response schema. This is also true for events to determine what layout is returned from CICS when you configure a CICS event.

Procedure: How to Create an Adapter Transaction

1. Expand the *iWay Events* tab.
The iWay Events window opens.
2. Expand the *CICS* node and connect to a CICS target (for example, *CICS_Connection*).
3. Expand the node to which you connected.
The Transaction node appears under the connected node.
4. Click *Transactions*, move your pointer over *Operations*, and select *Add Service*.

The following image shows the Add Service dialog box which opens in the right pane, containing parameters that will enable you to map the Cobol descriptions for the CICS transaction.

Add Service

Node Name :

Program Name :

Input COBOL Data Description :

Size of COMMAREA :

Natural Library :

Use data structure information from COBOL :

Output COBOL Data Description

COBOL Data Description	Field	Value
<input type="text" value="Ds\IWAYSAMP_out_F.cbl"/>	<input type="text" value="STAT"/>	<input type="text" value="F"/>
<input type="text" value="FDs\IWAYSAMP_in_F.cbl"/>	<input type="text" value="STAT"/>	<input type="text" value="P"/>
<input type="text"/>	<input type="text"/>	<input type="text"/>
<input type="text"/>	<input type="text"/>	<input type="text"/>

5. To map the Cobol descriptions for the CICS transaction, type values for the parameters as defined in the following table.

Field	Description
Node Name	Name of the adapter transaction you are creating (for example, CICS_Transaction). Use this name in the <Transaction location="..."> attribute.
Program Name	Name of the program to be called in CICS (for example, IWAYSAMP). The IWAYSAMP program appears in Appendix G, <i>Sample Programs</i> .
Input COBOL Data Description:	Location of the Cobol description that describes the COMMAREA of the CICS program to execute. Converted by the adapter to an XML schema that the adapter uses to map from XML to the format required by CICS at run time.
Size of COMMAREA	Size of the COMMAREA (in bytes) for programs that expect a specific size. By default, the adapter passes 32,500 to the program. For best performance, specify a number that can accommodate the larger of the input COMMAREA or output COMMAREA. For example, to run IWAYSAMP, specify 60.
Natural Library	Run-time location of the Natural program to execute. Use only if the adapter is to execute Adabas/Natural programs.

Field	Description
Use data structure information from Cobol	<p>Check this parameter when Cobol descriptions contain OCCURS or REDEFINES statements.</p> <p>When this parameter is checked, the adapter creates request and response schemas that reflect Cobol group levels (for example, 05, 10, 20, and so on). The Cobol grouping will be reflected in the XML request and response schemas.</p> <p>You must check this parameter when Cobol input or output descriptions contain the Cobol OCCURS statement.</p> <p>When this parameter is checked and there is an OCCURS Cobol statement, you cannot test run an adapter transaction. Application Explorer returns an "OCCURS in COBOL Data Description" error message.</p> <p>When this parameter is checked and the program COMMAREA contains an OCCURS statement, the output Cobol definition must also contain an OCCURS statement. Do not "flatten out" the Cobol output description, since the adapter relies on the number of OCCURS when formulating the program's output.</p>

Field	Description						
<p>Output COBOL Data Description - contains the following columns:</p> <ul style="list-style-type: none"> • COBOL Data Description • Field • Value 	<p>Path that corresponds to the message you want returned from the CICS program.</p> <p>If the program can return multiple types of messages, for each output Cobol description, enter the Cobol description field and value to determine the schema to use for a particular message.</p> <p>Application Explorer creates the schema to use for a particular message based on the contents of a field that is returned. For example, a program called IWAYSAMP_IN populates the COMMAREA field called STAT. Depending on program logic, Application Explorer creates the correct response schema.</p> <table border="0" style="width: 100%;"> <tr> <td style="width: 50%;">Value in STAT Field:</td> <td style="width: 50%;">Cobol Description:</td> </tr> <tr> <td>IWAYSAMP_OUT_P</td> <td>'P'</td> </tr> <tr> <td>IWAYSAMP_OUT_F</td> <td>'F'</td> </tr> </table> <p>The IWAYSAMP_OUT_P and IWAYSAMP_OUT_F Cobol descriptions appear in Appendix F, <i>Sample Requests, Schemas, and Cobol File Descriptions</i>.</p>	Value in STAT Field:	Cobol Description:	IWAYSAMP_OUT_P	'P'	IWAYSAMP_OUT_F	'F'
Value in STAT Field:	Cobol Description:						
IWAYSAMP_OUT_P	'P'						
IWAYSAMP_OUT_F	'F'						

Important: When connecting to a remote server, the location path of the Cobol description must match the operating system path of the machine on which the CICS adapter has been installed. For example, d:\iWay55\Cobol\ is a Windows path, whereas /iWay55/Cobol/ is a UNIX path.

6. Click *Add*.

The new CICS transaction is added, for example, CICS_Transaction under the Transactions node for the current connection.

Cobol Descriptions for Input and Output Communications

The following are considerations for Cobol descriptions for input and output communications.

You must use the following syntax for binary, packed, and float fields for the Cobol descriptions for the adapter transaction input and output formats.

For a binary field:

```
05 BINARY-FIELD          PIC S9(n) COMP.
```

For a packed-decimal field:

```
05 PACKED-FIELD         PIC S9(n) COMP-3.
```

For a single-float field:

```
05 FLOAT-SINGLE         COMP-1.
```

For a double-float field:

```
05 FLOAT-DOUBLE        COMP-2.
```

Note: Underscores are not supported in Cobol descriptions.

Creating Schemas for an Adapter Transaction

When deployed to the Sun Java System Application Server and used in conjunction with an iBSE configuration, Application Explorer stores the schemas it creates in subdirectories under the Sun directory structure on the machine where the Sun Java System Application Server is installed. When used in conjunction with an iWay JCA configuration, Application Explorer stores schemas in a subdirectory of the iWay home directory.

When the adapter is used with an iBSE configuration, Application Explorer stores the schemas under a `\schemas` subdirectory in the Sun Java System Application Server installation directory, for example,

```
C:\SUN\AppServer\domains\domain1\applications\j2ee-apps\ibse\ibse_war\wsd1\schemas\service\CICS\CICS_Connection
```

where:

```
CICS_Connection
```

Is the name of the connection to the `as` as defined in Application Explorer. Under this directory, Application Explorer creates subdirectories containing schemas.

When the adapter is used with a JCA configuration, Application Explorer stores the schemas under a \schemas subdirectory of the iWay home directory, for example,

`C:\Program Files\iWay55\config\base\schemas\CICS\CICS_Connection`

where:

`CICS_Connection`

Is the name of the connection to the CICS system as defined in Application Explorer. Application Explorer stores the schemas in this directory.

Procedure: How to Create Schemas for an Adapter Transaction

1. In the left pane, select the transaction for which you want to generate schemas.
2. In the right pane, move the pointer over Operations and select *Generate Schema*.

The adapter generates the schemas for the selected Cobol descriptions and associates them with the transaction. The schemas generated for the sample Cobol descriptions appear in Appendix F, *Sample Requests, Schemas, and Cobol File Descriptions*.

The Schemas table appears in the right pane. The following image shows the Schemas window which is a table of four rows and three columns, Part, Root Tag and Schema. Only the first two rows are applicable, Request and Response under the Part column that have CICS as the value located under the Root Tag column and clickable ellipsis under the Schema column.

Schemas		
Part	Root Tag	Schema
Request	CICS	...
Response	CICS	...
Event	N/A	N/A
EventReply	N/A	N/A

Help OK Cancel

- a. To view the request schema, click the ellipsis symbol that is located in the third column of the Request row.
 - b. To view the response schema, click the ellipsis symbol that is located in the third column of the Response row.
3. Click *OK* to exit the Schemas window.

Understanding iWay Business Services

Application Explorer provides Web developers with a simple, consistent mechanism for extending the capabilities of the adapter. The iWay Business Services Engine exposes functionality as Web services. It serves as a gateway to heterogeneous back-end applications and databases.

A Web service is a self-contained, modularized function that can be published and accessed across a network using open standards. It is the implementation of an interface by a component and is an executable entity. For the caller or sender, a Web service can be considered as a “black box” that may require input and delivers a result. A Web service integrates within an enterprise as well as across enterprises on any communication technology stack, whether asynchronous or synchronous, in any format.

Note: In a J2EE Connector Architecture (JCA) implementation of iWay adapters, Web services are not available. When the adapters are deployed to use the iWay Connector for JCA, the Common Client Interface provides integration services using the iWay adapters. For more information, see the *iWay Installation and Configuration* documentation and the *iWay Connector for J2EE Connector Architecture User's Guide*.

Creating a Web Service

After you connect to your application system and create an XML schema for a transaction, you can create a Web service. The following procedure describes how to create a Web service using Application Explorer.

Procedure: How to Create a Web Service

1. Click the *iWay Adapters* tab.
The iWay Adapters window opens.
2. In the left pane, expand the *CICS* node.
3. Connect to a CICS target (for example, *CICS_Connection*).
4. Expand the node to which you connected.
The Transaction node appears under the connected node.
5. Click *Transactions* and then select the transaction for which you want to create a Web service.

6. In the right pane, move your cursor over *Operations* and select *Create iWay Business Services*.

The Create Web Service dialog box opens in the right pane. The following image shows the Create Web Service for Generic_Transaction dialog box which contains three fields for entry.

Create Web Service for Generic_Transaction

Service Name:

Description:

License:

- production
- test

Help < Back Next > Cancel

7. Enter information that is specific to the Web service you are defining.
 - a. In the Service Name field, type a descriptive name for the Web service.
 - b. In the Description field, type a brief description for the Web service (optional).
 - c. In the License field, select one or more license codes to assign to the Web Service. To select more than one, hold down the *Ctrl* key and click the licenses.

8. Click *Next*.

Another dialog box with the Method Name and Description fields opens. The following image shows another Create Web Service for Generic_Transaction dialog box that has two fields for entry.

Create Web Service for Generic_Transaction

Method Name:

Description:

9. Enter information that is specific to the method you are defining.

- a.** In the Method Name field, type a descriptive name for the method.
- b.** In the Description field, type a brief description for the method.

10. Click *Finish*.

The iWay Business Services Engine tab opens. The Web service is created and published to the iWay Business Services Engine. Application Explorer displays the newly created Web Service under the iWay Business Services folder.

Testing the Web Service

After a business service is created, test it to ensure that it functions properly. iWay provides a test tool for testing the business service.

Procedure: How to Test the Web Service

1. If you are not on the iWay Business Services tab of Application Explorer, click the tab to access business services.
2. If it is not expanded, expand the list of business services under iWay Business Services.
3. Expand the *Services* node.
4. Select the name of the business service you want to test.

The business service name appears as a link in the right pane.

5. In the right pane, click the named business services link.

The test option appears in the right pane.

6. In the input xml field, either type a sample XML document that queries the service, for example,

```
<?xml version="1.0" encoding="UTF-8" ?>
<CICS>
  <Transaction location="/CICS/Transaction/IWAYSAMP">
    <CommArea>
      <WS-AREA>P will pass down 40 bytes</WS-AREA>
    </CommArea>
  </Transaction>
</CICS>

<?xml version="1.0" encoding="UTF-8" ?>
<CICS>
  <Transaction location="/CICS/Transaction/IWAYSAMP">
    <CommArea>
      <WS-AREA>F will pass down 60 bytes</WS-AREA>
    </CommArea>
  </Transaction>
</CICS>
```

or browse to the location of an XML instance and click *Upload*.

7. Click *Invoke*.

The result appears in the right pane.

Generating WSDL From a Web Service

Generating Web Services Description Language (WSDL) from a Web service enables you to make the Web service available to other services within a host server such as Sun Java System Application Server.

Procedure: How to Generate WSDL From a Web Service

1. If you are not already in the iWay Business Services tab, click the tab to access business services.
2. In the left pane, expand the list of services to display the Web service for which you want to generate WSDL.
3. Click the Web service.
The link for the service appears in the right pane.
4. Right-click the *Service Description* link and choose *Save Target As*.
5. Choose a location for the file and specify *.wsdl* for the extension.
Note: The file extension must be *.wsdl*.
6. Click *Save*.

Example: Viewing WSDL Generated from a Web Service

After generating a WSDL file from the IWAYSAMP.ibs serialized object, the IWAYSAMP.wsdl file looks similar to the following image which is a sample XML file.

```

- <definitions xmlns:tns="urn:schemas-iwaysoftware-
  com:iwse" targetNamespace="urn:schemas-
  iwaysoftware-com:iwse"
  xmlns:soapenc="http://schemas.xmlsoap.org/soap/enc"
  xmlns:mime="http://schemas.xmlsoap.org/wsdl/mime/"
  xmlns:m11="urn:iwaysoftware:ibse:jul2003:IWAYSAMP:r
  xmlns:tm="http://microsoft.com/wsdl/mime/textMatch
  xmlns="http://schemas.xmlsoap.org/wsdl/"
  xmlns:xs="http://www.w3.org/2001/XMLSchema"
  xmlns:m1="urn:iwaysoftware:ibse:jul2003:IWAYSAMP"
  xmlns:soap="http://schemas.xmlsoap.org/wsdl/soap/"
- <types>
- <xs:schema targetNamespace="urn:schemas-
  iwaysoftware-com:iwse"
  elementFormDefault="qualified">
- <xs:element name="ibsinfo">
- <xs:complexType>
- <xs:sequence>
  <xs:element type="xs:string"
    name="service" />
  <xs:element type="xs:string"
    name="method" />
  <xs:element type="xs:string"
    name="license" />
  <xs:element type="xs:string"
    minOccurs="0"
    name="disposition" />

```

Identity Propagation

If you test or execute a Web service using a third party XML editor, for example XMLSPY, the Username and Password values that you specify in the SOAP header must be valid and are used to connect to CICS. The user name and password values that you provided for CICS during target creation using Application Explorer are overwritten for this Web service request. The following is a sample SOAP header that is included in the WSDL file for a Web service:

```
<SOAP-ENV:Header>
  <m:ibsinfo xmlns:m="urn:schemas-iwaysoftware-com:iwse">
    <m:service>String</m:service>
    <m:method>String</m:method>
    <m:license>String</m:license>
    <m:disposition>String</m:disposition>
    <m:Username>String</m:Username>
    <m>Password>String</m>Password>
    <m:language>String</m:language>
  </m:ibsinfo>
</SOAP-ENV:Header>
```

Note: You can remove the following tags from the SOAP header, since they are not required:

```
<m:disposition>String</m:disposition>
<m:language>String</m:language>
```

Creating an Event

Events are generated by the CICS transaction processing system as a result of activity on that system. You can use events to trigger an action in your application. For example, the CICS application program can generate an event when customer information is updated. If your application must perform when this happens, you must provide a mechanism to publish that event to the outside world.

The adapter has the capability of capturing events using protocols such as TCP/IP or a File directory. For other protocols, such as HTTP, contact Customer Support Services.

The following steps describe creating an event and processing it by the adapter:

- Creating the CICS application program.
For example, a program can be triggered by certain criteria and publish information to the specific protocol, such as TCP/IP. The application program that is written for the event passes data to a TCP/IP port.
- Configuring the connection using Application Explorer to create the event schema from a Cobol File Description.

The Cobol File Description describes the format and layout of the data that is passed by the TCP/IP program to the TCP/IP port.

- Configuring an iWay port and channel using Application Explorer.

After the event schema is created, you can configure an iWay port and channel using Application Explorer. The port you specify is the same port to which the CICS application event program is writing the event data.

For information on creating an iWay event port, see *Creating, Editing, and Deleting an Event Port* on page 3-17. For information on creating a channel, see *Creating, Editing, and Deleting an Event Channel* on page 3-34.

Important: When using the adapter in conjunction with the iWay connector for JCA 1.5, there is no need to create event ports to dispose of event data. However, you must create a channel to enable event listening capabilities.

Creating, Editing, and Deleting an Event Port

Application Explorer enables you to create event ports from the iWay Adapters tab or from the iWay Events tab. You also can modify or delete an existing port.

Important: When using the adapter in conjunction with the iWay connector for JCA 1.5, there is no need to create event ports to dispose of event data. However, you must create a channel to enable event listening capabilities.

Creating an Event Port From the iWay Events Tab

The following procedures describe how to create an event port from the iWay Events window for various dispositions using Application Explorer. You can switch between an iBSE and a JCA deployment by choosing one or the other from the drop-down menu in the upper right of Application Explorer.

The following dispositions are available when using Application Explorer in conjunction with an iBSE deployment.

- File
- iBSE
- MSMQ
- JMSQ
- SOAP
- HTTP
- MQ Series

Note: The MAIL disposition option will be supported in a future release.

The following dispositions are available when using Application Explorer in conjunction with a JCA connector deployment.

- File
- JMSQ
- HTTP
- MQ Series

Important: When using the adapter in conjunction with the iWay connector for JCA 1.5, there is no need to create event ports to dispose of event data. However, you must create a channel to enable event listening capabilities.

Procedure: How to Create an Event Port for File

1. Click the *iWay Events* tab.

The iWay Events window opens.

2. In the left pane, expand the *CICS* node.

3. Select the *ports* node.

4. In the right pane, move the pointer over *Operations* and select *Add a new port*.

The following image shows the ports node highlighted in the left pane and the Operations menu listing Add a new port and Refresh options in the right pane.



The Create New Port dialog box opens in the right pane containing fields to enter a name, description, disposition protocol, and disposition, as shown in the following image.

Create New Port

Choose parameters of the port that you wish to create.

Port Name:

Description:

Disposition Protocol:

Disposition:

- a. Type a name and a brief description for the event port.
- b. From the Disposition Protocol drop-down list, select *FILE*.
- c. In the Disposition field, specify a destination file to which the event data is written.

When pointing Application Explorer to an **IBSE** deployment, specify the destination file using the following format:

```
ifile:/// [location]; errorTo= [pre-defined port name or another disposition url]
```

When pointing Application Explorer to a **JCA** deployment, provide the full path to the directory.

Important: When using the adapter in conjunction with the iWay Connector for JCA 1.5, there is no need to create event ports to dispose of event data. However, you must create a channel to enable event listening capabilities.

The following table lists and defines the parameters for the File disposition:

Parameter	Description
Location	Destination and file name of the document where event data is written. For example, D:\in\x.txt
ErrorTo	Location to which error logs are sent. Optional. A predefined port name or another disposition URL. The URL must be complete, including the protocol.

5. Click *OK*.

The port appears under the ports node in the left pane. In the right pane, a table appears that summarizes the information associated with the event port you created.

You are ready to associate the event port with a channel. For more information, see *Creating, Editing, and Deleting an Event Channel* on page 3-34.

Procedure: How to Create an Event Port for iBSE

1. Click the *iWay Events* tab.
The *iWay Events* window opens.
2. In the left pane, expand the *CICS* node.
3. Select the *ports* node.
4. Move the pointer over *Operations* and select *Add a new port*.

The Create New Port dialog box opens in the right pane containing fields to enter a name, description, disposition protocol, and disposition, as shown in the following image.

- a. Type a name and a brief description for the event port.
- b. From the Disposition Protocol drop-down list, select *IBSE*.
- c. In the Disposition field, enter an iBSE destination in the following format:

`ibse:[svcName].[mthName];responseTo=[pre-defined port name or another disposition url];errorTo=[pre-defined port name or another disposition url]`

The following table lists and defines the parameters for the iBSE disposition:

Parameter	Description
svcName	Name of the service created with iBSE.
mthName	Name of the method created for the Web service.
responseTo	Location to which responses are posted. Optional. A predefined port name or another disposition URL. The URL must be complete, including the protocol.

Parameter	Description
errorTo	Location to which error logs are sent. Optional. A predefined port name or another disposition URL. The URL must be complete, including the protocol.

5. Click *OK*.

The port appears under the ports node in the left pane. In the right pane, a table appears that summarizes the information associated with the event port you created.

You are ready to associate the event port with a channel. For more information, see *Creating, Editing, and Deleting an Event Channel* on page 3-34.

Procedure: How to Create an Event Port for MSMQ

1. Click the *iWay Events* tab.

The *iWay Events* window opens.

2. In the left pane, expand the *CICS* node.

3. Select the *ports* node.

4. Move the pointer over *Operations* and select *Add a new port*.

The *Create New Port* dialog box opens in the right pane containing fields to enter a name, description, disposition protocol, and disposition, as shown in the following image.

Create New Port

Choose parameters of the port that you wish to create.

Port Name:

Description:

Disposition Protocol:

Disposition:

- a. Type a name and a brief description for the event port.
- b. From the Disposition Protocol drop-down list, select *MSMQ*.
- c. In the Disposition field, enter an MSMQ destination in the following format:

`msmq:/[machineName]/private$/qName;errorTo=[pre-defined port name or another disposition url]`

Note: This syntax is for a private queue. Private queues are queues that are not published in Active Directory. They appear only on the local computer that contains them. Private queues are accessible only by Message Queuing applications that recognize the full path name or format name of the queue.

The following table lists and defines the parameters for the MSMQ disposition:

Parameter	Description
machineName	Machine name where the Microsoft Queuing system is running.
qName	Name of the private queue where messages are placed.
errorTo	Location to which error logs are sent. Optional. A predefined port name or another disposition URL. The URL must be complete, including the protocol.

5. Click *OK*.

The port appears under the ports node in the left pane. In the right pane, a table appears that summarizes the information associated with the event port you created.

You are now ready to associate the event port with a channel. For more information, see *Creating, Editing, and Deleting an Event Channel* on page 3-34.

Procedure: How to Create an Event Port for JMSQ

1. Click the *iWay Events* tab.
The iWay Events window opens.
2. In the left pane, expand the *CICS* node.
3. Select the *ports* node.
4. Move the pointer over *Operations* and select *Add a new port*.

The Create New Port dialog box opens in the right pane containing fields to enter a name, description, disposition protocol, and disposition, as shown in the following image.

Create New Port

Choose parameters of the port that you wish to create.

Port Name:

Description:

Disposition Protocol:

Disposition:

- a. Type a name and a brief description for the event port.
- b. From the Disposition Protocol drop-down list, select *JMSQ*.
- c. In the Disposition field, enter a JMS destination.

When pointing Application Explorer to an **ibSE** deployment, use the following format:

```
jmsq: [myQueueName]@[myQueueFac] ; jndiurl= [myurl] ;  
jndifactory= [myfactory] ; user= [user] ; password= [xxx] ;  
errorTo= [pre-defined port name or another disposition url]
```

When pointing Application Explorer to a **JCA** deployment, use the following format:

```
jms: jmsqueue@jmsfactory; jndiurl=; jndifactory=;
```

Important: When using the adapter in conjunction with the iWay Connector for JCA 1.5, there is no need to create event ports to dispose of event data. However, you must create a channel to enable event listening capabilities.

The following table lists and defines the parameters for the JMSQ disposition.

Parameter	Description
myQueueName or jmsqueue	JNDI name of a queue to which events are emitted.
myQueueFac or jmsfactory	Resource that contains information about the JMS Server. You must create the connection factory; for example, sampleQCF.
jndiurl	URL to use to contact the JNDI provider. The syntax of this URL depends on the JNDI provider being used. This value corresponds to the standard JNDI property, <code>java.naming.provider.url</code> . The URL of the Sun Java System Application Server is <code>iiop://localhost:3700</code> where: <code>3700</code> Is a default port.
jndifactory	Is JNDI context.INITIAL_CONTEXT_FACTORY and is provided by the JNDI service provider. For Sun Java System Application Server, this is <code>iscom.sun.jndi.cosnaming.CNCTXFactory</code>
user	Valid user name required to access a JMS server.
password	Valid password required to access a JMS server.
errorTo	Location to which error logs are sent. Optional. A predefined port name or another disposition URL. The URL must be complete, including the protocol.

5. Click OK.

The port appears under the ports node in the left pane. In the right pane, a table appears that summarizes the information associated with the event port you created.

You are now ready to associate the event port with a channel. For more information, see *Creating, Editing, and Deleting an Event Channel* on page 3-34.

Procedure: How to Create a Port for SOAP

1. Click the *iWay Events* tab.

The *iWay Events* window opens.

2. In the left pane, expand the *CICS* node.
3. Select the *ports* node.
4. Move the pointer over *Operations* and select *Add a new port*.

The Create New Port dialog box opens in the right pane containing fields to enter a name, description, disposition protocol, and disposition, as shown in the following image.

Create New Port

Choose parameters of the port that you wish to create.

Port Name:

Description:

Disposition Protocol:

Disposition:

- a. Type a name and a brief description for the event port.
- b. From the Disposition Protocol drop-down list, select *SOAP*.
- c. In the Disposition field, enter a SOAP destination in the following format:

```
soap: [wsdl-url] ; soapaction= [myaction] ; method= [web service  
method] ; namespace= [namespace] ; responseTo= [pre-defined port name or  
another disposition URL] ; errorTo= [pre-defined port name or another  
disposition url]
```

The following table lists and defines the parameters for the SOAP disposition:

Parameter	Description
wsdl-url	<p>URL to the WSDL file that is required to create the SOAP message. For example:</p> <pre>http://localhost:7001/ibse/IBSEServlet/test/webservice.ibs?wsdl</pre> <p>where:</p> <p><i>webservice</i></p> <p>Is the name of the Web service you created using Application Explorer.</p> <p>This value can be found by navigating to the iWay Business Services tab and opening the <i>Service Description</i> link in a new window. The WSDL URL appears in the Address field.</p> <p>You can also open the WSDL file in a third party XML editor (for example, XMLSPY) and view the SOAP request settings to find this value.</p>
soapaction	<p>Method that will be called by the SOAP disposition. For example</p> <pre>webservice.method@test@@</pre> <p>where:</p> <p><i>webservice</i></p> <p>Is the name of the Web service you created using Application Explorer.</p> <p><i>method</i></p> <p>Is the method being used.</p> <p><i>test</i></p> <p>Is the license that is being used by the Web service.</p> <p>This value can be found by navigating to the iWay Business Services tab and opening the <i>Service Description</i> link in a new window. Perform a search for <i>soapAction</i>.</p> <p>You can also open the WSDL file in a third party XML editor (for example, XMLSPY) and view the SOAP request settings to find this value.</p>

Parameter	Description
method	Web service method you are using. This value can be found in the WSDL file.
namespace	XML namespace you are using. This value can be found in the WSDL file.
responseTo	Location to which responses are posted. Optional. A predefined port name or another disposition URL. The URL must be complete, including the protocol.
errorTo	Location to which error logs are sent. Optional. A predefined port name or another disposition URL. The URL must be complete, including the protocol.

5. Click *OK*.

The port appears under the ports node in the left pane. In the right pane, a table appears that summarizes the information associated with the port you created.

You are now ready to associate the event port with a channel. For more information, see *Creating, Editing, and Deleting an Event Channel* on page 3-34.

Procedure: How to Create an Event Port for HTTP

1. Click the *iWay Events* tab.
The *iWay Events* window opens.
2. In the left pane, expand the *CICS* node.
3. Select the *ports* node.
4. Move the pointer over *Operations* and select *Add a new port*.

The Create New Port dialog box opens in the right pane containing fields to enter a name, description, disposition protocol, and disposition, as shown in the following image.

Create New Port

Choose parameters of the port that you wish to create.

Port Name:

Description:

Disposition Protocol:

Disposition:

- a. Type a name and a brief description for the event port.
- b. From the Disposition Protocol drop-down list, select *HTTP*.
- c. In the Disposition field, enter an HTTP destination.

When pointing Application Explorer to an **ibSE** deployment, use the following format:

```
http://[myurl];responseTo=[pre-defined port name or another disposition url];
```

When pointing Application Explorer to a **JCA** deployment, use the following format:

```
http://host:port/uri
```

Important: When using the adapter in conjunction with the iWay Connector for JCA 1.5, there is no need to create event ports to dispose of event data. However, you must create a channel to enable event listening capabilities.

The following table lists and defines the parameters for the HTTP disposition when using an **iBSE** deployment:

Parameter	Description
myurl	URL target for the post operation, for example, http://myhost:1234/docroot
responseTo	Location to which responses are posted. Optional. A predefined port name or another disposition URL. The URL must be complete, including the protocol.

The following table lists and defines the parameters for the HTTP disposition when using a **JCA** deployment:

Parameter	Description
host:port	Combination of the name of the host on which the Web server resides and the port on which the server is listening for the post operation.
uri	Universal resource identifier that completes the URL specification.

5. Click *OK*.

The port appears under the ports node in the left pane. In the right pane, a table appears that summarizes the information associated with the event port you created.

You are now ready to associate the event port with a channel. For more information, see *Creating, Editing, and Deleting an Event Channel* on page 3-34.

Procedure: How to Create an Event Port for MQ Series

1. Click the *iWay Events* tab.
The *iWay Events* window opens.
2. In the left pane, expand the *CICS* node.
3. Select the *ports* node.
4. Move the pointer over *Operations* and select *Add a new port*.

The Create New Port dialog box opens in the right pane containing fields to enter a name, description, disposition protocol, and disposition, as shown in the following image.

Create New Port

Choose parameters of the port that you wish to create.

Port Name:

Description:

Disposition Protocol:

Disposition:

- a. Type a name and a brief description for the event port.
- b. From the Disposition Protocol drop-down list, select *MQ Series*.
- c. In the Disposition field, enter an MQ Series destination.

When pointing Application Explorer to an **ibSE** deployment, use the following format:

```
mqseries:/[qManager]/[qName];host=[hostname];port=[port];
channel=[channelname];errorTo=[pre-defined port name or another
disposition url]
```

When pointing Application Explorer to a **JCA** deployment, use the following format:

```
mq:qmanager@respqueue;host=;port=;channel=
```

Important: When using the adapter in conjunction with the iWay Connector for JCA 1.5, there is no need to create event ports to dispose of event data. However, you must create a channel to enable event listening capabilities.

The following table lists and defines the parameters for the MQ Series disposition:

Parameter	Description
qManager	Name of the queue manager to which the server must connect.
qName or respqueue	Name of the queue where messages are placed.
host	Host on which the MQ server is located (for the MQ Client only).
port	Number to connect to an MQ server queue manager (for the MQ client only).
channel	Case-sensitive name of the channel that connects with the remote MQ server queue manager (for the MQ client only). SYSTEM.DEF.SVRCONN is the default channel name for MQSeries.
errorTo	Location to which error logs are sent. Optional. A predefined port name or another disposition URL. The URL must be complete, including the protocol.

5. Click *OK*.

The port appears under the ports node in the left pane. In the right pane, a table appears that summarizes the information associated with the event port you created.

You are now ready to associate the event port with a channel. For more information, see *Creating, Editing, and Deleting an Event Channel* on page 3-34.

Editing and Deleting an Event Port

The following procedures provide information on how to edit and delete an event port using Application Explorer.

Procedure: How to Edit an Event Port

1. Click the *iWay Events* tab.
The iWay Events window opens.
2. In the left pane, expand the *CICS* node.
3. Select the *ports* node.
4. Select the event port you want to edit.
5. In the right pane, move the pointer over *Operations* and select *Edit*.
The Edit Port dialog box opens.
6. Make the necessary changes and click *OK*.

Procedure: How to Delete an Event Port

1. Click the *iWay Events* tab.
The iWay Events window opens.
2. In the left pane, expand the *CICS* node.
3. Select the *ports* node.
4. Select the event port you want to delete.
5. In the right pane, move the pointer over *Operations* and select *Delete*.
A confirmation dialog box opens.
6. To delete the event port you selected, click *OK*.
The event port disappears from the list in the left pane.

Creating, Editing, and Deleting an Event Channel

You create a channel to associate an event with an iWay port and also potentially to process the event document. The event that is passed through the channel is processed by parsers or premitters defined in the channel. A premitter is created automatically by assigning a Cobol description to it that describes the layout of the data being passed by CICS to the channel.

The following procedure describes how to create a channel for your event using Application Explorer. All defined event ports must be associated with a channel.

Procedure: How to Create a Channel

To create a channel:

1. Click the *iWay Events* tab.
The iWay Events window opens.
2. In the left pane, expand the *CICS* node.
3. Select the *channels* node.
4. In the right pane, move your cursor over *Operations* and select *Add a new channel*.

The following image shows the channels node highlighted in the left pane and the Operations menu listing Add a new channel and Refresh options in the right pane.



The Add a new CICS channel dialog box opens in the right pane containing fields to enter a name, description, and channel type, as shown in the following image.

Add a new CICS channel

Choose a name and description for the new channel that you wish to create.

Channel Name:

Description:

Channel Type:

Help < Back Next > Cancel

5. Specify information for the channel you are creating:
 - a. In the Channel Name field, type a descriptive name for the channel (for example, CICSChannel).
 - b. In the Description field, type a brief description for the channel (for example, CICS Event Channel).
 - c. In the Channel Type field, select a channel type from the drop-down list (for example, TCP Listener).
6. Click *Next*.

The following image shows the Edit channels dialog box which opens in the right pane containing parameters where you can specify values for the protocol you are using with the channel.

Edit channels

Port Number:	<input type="text"/>
Host/IP Binding:	<input type="text"/>
Synchronization Type:	REQUEST_RESPONSE ▾
Is Length Prefix:	<input type="checkbox"/>
Is XML:	<input checked="" type="checkbox"/>
Is Keep Alive:	<input type="checkbox"/>
Location of COBOL Data Description:	<input type="text"/>
Use data structure information from COBOL:	<input type="checkbox"/>
Remote Codepage:	Cp500 ▾

<input type="button" value="Help"/>	<input type="button" value=" < Back"/>	<input type="button" value=" Next >"/>	<input type="button" value="Cancel"/>
-------------------------------------	---	---	---------------------------------------

7. Specify the values for the protocol you are using with the channel.

The following table lists and describes each property.

Property	Description
Port Number	For TCP/IP, specify port number.
Host/IP binding	Host name or IP address of the application server.

Property	Description
Synchronization Type	Choose one of the following: <ul style="list-style-type: none"> • Select REQUEST_RESPONSE if the event application expects a reply sent back to it. Specify a premitter. • Select REQUEST_ACK when a TCP/IP acknowledgement (ACK) is sent back to the event application. • Select REQUEST if the event application does not expect a return.
Is Length Prefix	For CICS events that send data back that is not in XML format. The TCP/IP event application must prefix the data with a 4-byte binary length field when writing the data to the TCP/IP port.
Is XML	For CICS events that send data back in XML format. No parser is required.
Is Keep Alive	Maintains continuous communication between the event transaction and the channel.
Location of COBOL Data Description	<p>Path that corresponds to the message you want returned from CICS, based on an event.</p> <p>If the program can return multiple types of messages, for each output Cobol description, enter the Cobol description field and value to determine the schema used for a particular message.</p> <p>Application Explorer creates the schema to use for a particular message based on the contents of a particular field that is returned. For example, a program called IWAYSAMP populates the COMMAREA field called STAT. Depending on program logic, a value of P in the STAT field indicates the IWAYSAMP_OUT_P Cobol description, a value of F in the STAT field, indicates the IWAYSAMP_OUT_F Cobol description.</p> <p>The IWAYSAMP_OUT_F and IWAYSAMP_OUT_P Cobol descriptions appear in Appendix F, <i>Sample Requests, Schemas, and Cobol File Descriptions</i>.</p>

Property	Description
<p>Use data structure information from Cobol</p>	<p>Check this parameter when Cobol descriptions contain OCCURS or REDEFINES statements.</p> <p>When this parameter is checked, the adapter creates request and response schemas that reflect Cobol group levels (for example, 05, 10, 20, and so on). The Cobol grouping will be reflected in the XML request and response schemas.</p> <p>You must check this parameter when Cobol input or output descriptions contain the Cobol OCCURS statement.</p> <p>When this parameter is checked and there is an OCCURS Cobol statement, you cannot test run an adapter transaction. Application Explorer returns an "OCCURS in COBOL Data Description" error message.</p> <p>When this parameter is checked and the program COMMAREA contains an OCCURS statement, the output Cobol definition must also contain an OCCURS statement. Do not "flatten out" the Cobol output description, since the adapter relies on the number of OCCURS when formulating the program's output.</p>
<p>Remote Codepage</p>	<p>Select the codepage from the drop-down menu. Cp500 is the default value.</p>

8. Click Next.

The following image shows the Select Ports dialog box which opens in the right pane containing lists for available and current ports and buttons to enable you to move ports from one list to the other.

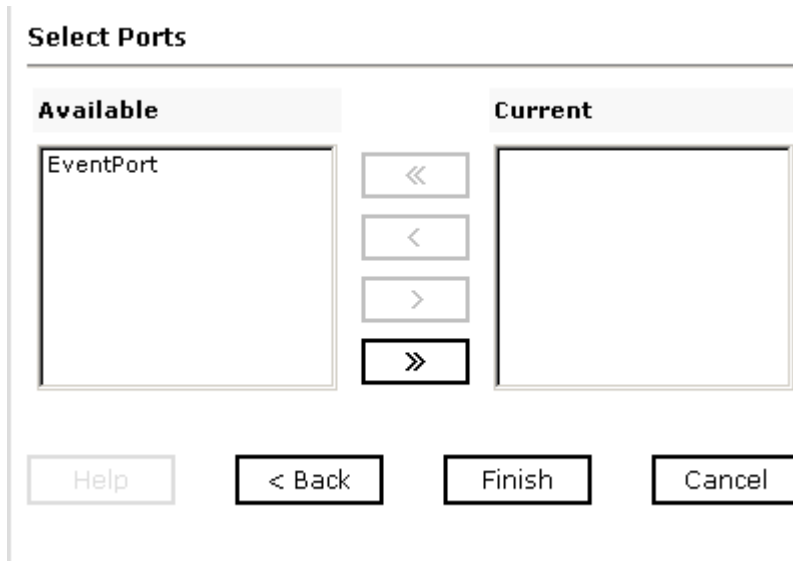

- a. Select an event port from the list of available ports. To select more than one, hold down the *Ctrl* key and click the ports.
- b. Click the single right arrow button to transfer the selected port(s) to the list of current ports. To transfer all event ports, click the double right arrow button.

After you select and move the event port or ports, the port(s) appear(s) in the list of current ports. The following image shows EventPort listed in the Current column of the Select Ports dialog box.

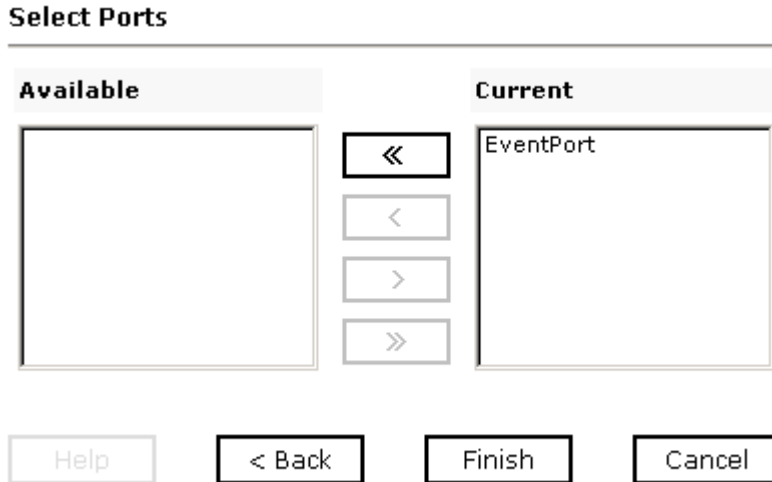

9. Click *Finish*.

The summary appears in the right pane. The summary provides the channel description, channel status, and available ports. All the information is associated with the channel you created.

The following image shows the newly created CICSChannel under the channels node in the left pane. An X over the icon indicates that the channel is currently disconnected. You must start the channel to activate your event configuration.



Procedure: How to Start or Stop a Channel

To start or stop a channel:

1. Click the *iWay Events* tab.
The iWay Events window opens.
2. In the left pane, expand the *CICS* node.
3. Select the *channels* node.
4. Select the channel you want to start or stop.
5. In the right pane, move your cursor over *Operations*.
 - a. If you want to start the channel, select *Start the channel*.
The channel becomes active and the X over the icon disappears.
 - b. If you want to stop the channel, select *Stop the channel*.
The channel becomes inactive and the X appears over the icon.

Editing and Deleting a Channel

The following procedures describe how to edit and delete a channel.

Procedure: How to Edit a Channel

To edit a channel:

1. Click the *iWay Events* tab.
The iWay Events window opens.
2. In the left pane, expand the *CICS* node.
3. Select the *channels* node.
4. Select the channel you want to edit.
5. In the right pane, move your cursor over *Operations* and select *Edit*.
The Edit Channel dialog box opens.
6. Make any required changes to the channel configuration and click *OK*.

Procedure: How to Delete a Channel

To delete a channel:

1. Click the *iWay Events* tab.
The iWay Events window opens.
2. In the left pane, expand the *CICS* node.
3. Select the *channels* node.
4. Select the channel you want to delete.
5. In the right pane, move your cursor over *Operations* and select *Delete*.
A confirmation dialog box opens.
6. To delete the channel you selected, click *OK*.
The channel disappears from the list in the left pane.

CHAPTER 4

Using Web Services Policy-Based Security

Topics:

- iWay Business Services Policy-Based Security
- Configuring iWay Business Services Policy-Based Security

Servlet Application Explorer provides a security feature called iWay Business Services policy-based security. The following topics describe how this feature works and how to configure it.

iWay Business Services Policy-Based Security

iWay Business Services provide a layer of abstraction between the back-end business logic they invoke and the user or application running the business service. This enables easy application integration but raises the issue of controlling the use and execution of critical and sensitive business logic that is run as a business service.

Servlet Application Explorer controls the use of business services that use adapters with a feature called policy-based security. This feature enables an administrator to apply *policies* to iWay Business Services (iBS) to deny or permit their execution.

A *policy* is a set of privileges associated with the execution of a business service that can be applied to an existing or new iBS. When you assign specific rights or privileges inside a policy, you need not recreate privileges for every iBS that has security issues in common with other iWay Business Services. Instead, you can use one policy for many iWay Business Services.

The goal is to secure requests at both the transport and the SOAP request level that is transmitted on the wire. Some policies do not deal with security issues directly but affect the run-time behavior of the business services to which they are applied.

The iBSE administrator creates an instance of a policy type, names it, associates individual users and/or groups (a collection of users), and then applies the policy to one or more business services.

You can assign a policy to an iBS or to a method within an iBS. If a policy is applied only to a method, other methods in that iBS are not governed by it. However, if a policy is applied to the iBS, all methods are governed by it. At run time, the user ID and password that are sent to iBSE in the SOAP request message are checked against the list of users for all policies applied to the specific iBS. The Resource Execution policy type is supported and dictates who can or cannot execute the iBS.

When a policy is not applied, the default value for an iBS is to “grant all.” For example, anyone can execute the iBS until the Resource Execution policy is associated to the iBS. At that time, only users granted execution permission, or those who do not belong to a group that was denied execution permissions, have access to the iBS.

Configuring iWay Business Services Policy-Based Security

Before you create instances of policies, you must have a minimum of one user or one group to associate to an instance. You can create users and groups using Servlet Application Explorer. For more information, see *How to Create a User to Associate With a Policy* on page 4-3 or *How to Create a Group to Associate With a Policy* on page 4-5.

An execution policy governs who can execute the business service to which the policy is applied. For more information, see *How to Create an Execution Policy* on page 4-8.

You configure the IP and Domain Restriction policy type slightly differently from other policy types. The IP and Domain Restriction policy type controls connection access to iBSE and therefore, need not be applied to an individual business service. You need not create a policy, however, you must enable the Security Policy option in Servlet Application Explorer. For more information, see *How to Configure IP and Domain Restrictions* on page 4-12.

Procedure: How to Create a User to Associate With a Policy

To create a user to associate with a policy:

1. Open *Servlet Application Explorer*.

The following image shows the window that opens and includes three tabs corresponding to iWay Adapters, iWay Events, and iWay Business Services. The iWay Business Services tab is active and displays a Welcome screen on the right. The image shows the iWay Business Services node expanded in the left pane.

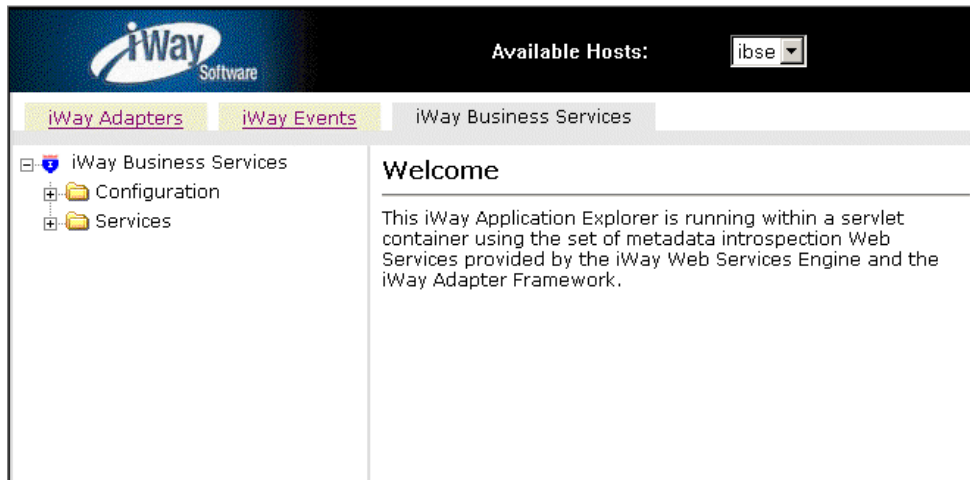

- a. Click the *iWay Business Services* tab.
- b. Expand the *Configuration* node.

- c. Expand the *Security* node.
 - d. Expand the *Users and Groups* node.
 - e. Select *Users*.
2. In the right pane, move the pointer over *Operations* and select *Add*.

The following image shows the Add a new user pane that opens and includes fields where you enter a user name, a password, and a description of the user. The pane includes a Help button, an OK button to instruct the system to accept inputs, and a Cancel button to escape from the pane.

Add a new user

Name:

Password:

Description:

- a. In the Name field, type a user ID.
 - b. In the Password field, type the password associated with the user ID.
 - c. In the Description field, type a description of the user (optional).
3. Click *OK*.

The following image opens and shows a new user added to the configuration. It includes a definition of a user and a user ID and description.

Operations ▶



Users

A user is an object that can be granted or denied permissions to run iWay Business Services. A user can belong to one or more groups. Policies that specify particular rights can be associated with user.

User Id	Description
<input type="checkbox"/> bse1	

Procedure: How to Create a Group to Associate With a Policy

To create a group to associate with a policy:

1. Open *Servlet Application Explorer*.
 - a. Click the *iWay Business Servicestab*.
 - b. Expand the *Configuration* node.
 - c. Expand the *Security* node.
 - d. Expand the *Users and Groups* node.
 - e. Select *Groups*.
2. In the right pane, move the pointer over *Operations* and click *Add*.

The following image shows the Add new group pane that opens with fields where you enter a name and a description for the group. To continue after typing inputs, click the Next button. The pane also includes a Help button, a Back button to return to the previous screen, and a Cancel button to escape from the pane.

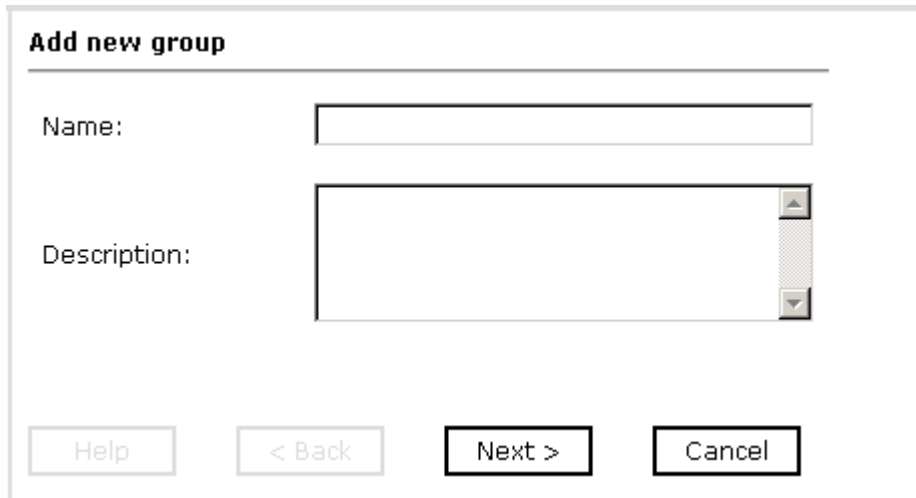

The image shows a dialog box titled "Add new group". It contains two input fields: "Name:" with a single-line text box and "Description:" with a multi-line text area. At the bottom, there are four buttons: "Help", "< Back", "Next >", and "Cancel". The "Next >" button is highlighted with a black border.

- a. In the Name field, type a name for the group.
 - b. In the Description field, type a description for the group (optional).
3. Click Next.

The following image shows the Modify Group Membership pane where you can move users to or from a group using the arrow keys to move them between the Current and Available lists and then clicking the Finish button. The pane includes a Help button, a Back button to return to the previous screen, and a Cancel button to escape from the pane.

Modify Group Membership

You can either highlight a single user in the list of available users and add it to the current list by clicking the left arrow, or you can click the double left arrow to add all users in the list of available users to the group.

4. After you select a minimum of one user, click *Finish*.

The new group is added.

The following image shows a pane with a new group added to the configuration. It includes a definition of a group and the group name and description.

Operations ▶



Groups

A group is an object that can be granted or denied permissions to run iWay Business Services. A group is used as a container for one or more users. Policies that specify particular rights can be associated with a group.

Group name	Description
<input type="checkbox"/> newgroup	

Procedure: How to Create an Execution Policy

To create an execution policy:

1. Open *Servlet Application Explorer*.
 - a. Click the *iWay Business Servicestab*.
 - b. Expand the *Configuration* node.
 - c. Select *Policies*.

The following image shows the Policies pane on the right where you apply a policy. The Operations menu becomes available with three options, Build/Rebuild, Add, and Refresh.

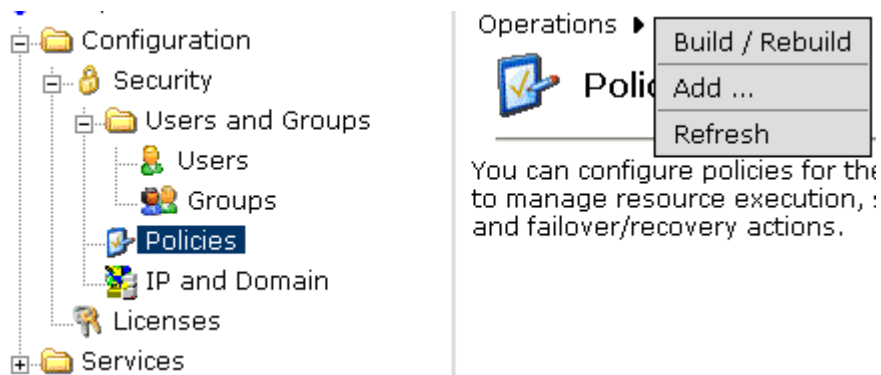

2. Move the pointer over *Operations* and click *Add*.

The following image shows the Add a new policy pane that opens with fields for entering the name, type, and description of the policy. To continue, click the Next button. The pane includes a Help button, a Back button to return to the previous screen, and a Cancel button to escape from the pane.

Add a new policy

Name:

Type:

Description:

- a. In the Name field, type a name for the policy.
 - b. From the Type drop-down list, select *Execution*.
 - c. In the Description field, type a description for the policy (optional).
3. Click *Next*.

The following image shows the Modify policy targets pane that opens and includes a list of current and available targets and arrow buttons to move targets from one list to the other. The pane also includes a Help button, a Back button to return to the previous screen, a Next button to continue to the next screen, and a Cancel button to escape from the pane.

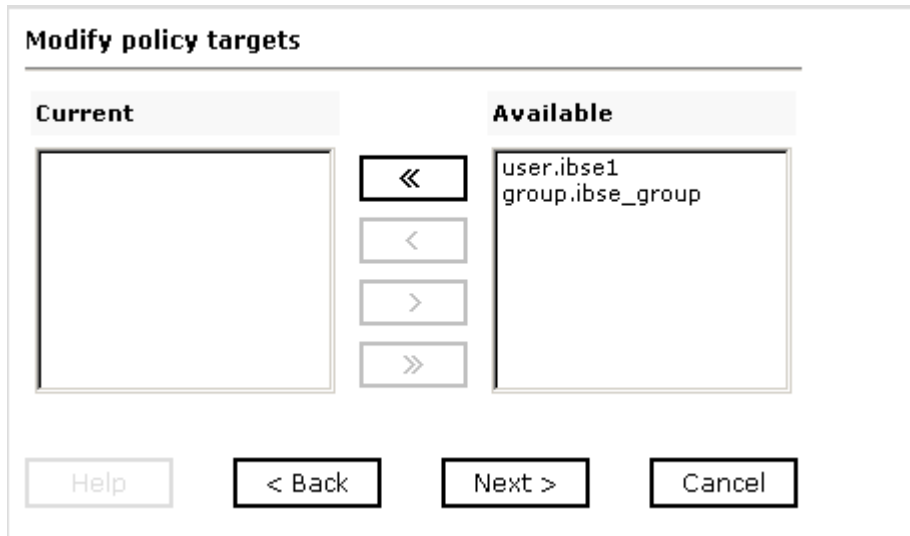

4. Select a minimum of one user or group from the Available pane.

Note: This user ID is checked against the value in the user ID element of the SOAP header sent to iBSE in a SOAP request.

5. Click *Next*.

The following image shows the Modify policy permissions pane that opens and includes drop-down lists where you can select to grant or deny permission to members and then click a button to finish. The pane also includes a Help button, a Back button to return to the previous screen, and a Cancel button to escape from the pane.

Member Id	Permission
user.ibse1	Deny
group.ibse_group	Deny

Buttons: Help, < Back, Finish, Cancel

6. To assign whether users or groups may execute the iBSE, select *Grant* to permit execution or *Deny* to restrict execution from a Permission drop-down list.
7. Click *Finish*.

The following image shows the pane that summarizes your configuration. It includes a definition of policies and the name, type, and description of the policies.

Operations ▶

 **Policies**

You can configure policies for the iWay Business Services Engine to manage resource execution, service routing, data restrictions and failover/recovery actions.

Name	Type	Description
<input type="checkbox"/> ibse_policy	Execution	

Procedure: How to Configure IP and Domain Restrictions

To configure IP and domain restrictions:

1. Open *Servlet Application Explorer*.
 - a. Select the *iWay Business Services* tab.
 - b. Expand the *Configuration* node.
 - c. Expand the *Security* node.
 - d. Select *IP and Domain*.
2. In the right pane, move the pointer over *Operations* and click *Add*.

The following image shows the Add a new IP/Domain pane that opens where you enter information for the IP/Domain in four fields. You must select a type of restriction from a drop-down list before you can enter information in the IP(Mask)/Domain field. The pane also includes a Help button, an OK button to instruct the system to accept inputs, and a Cancel button to escape from the pane.

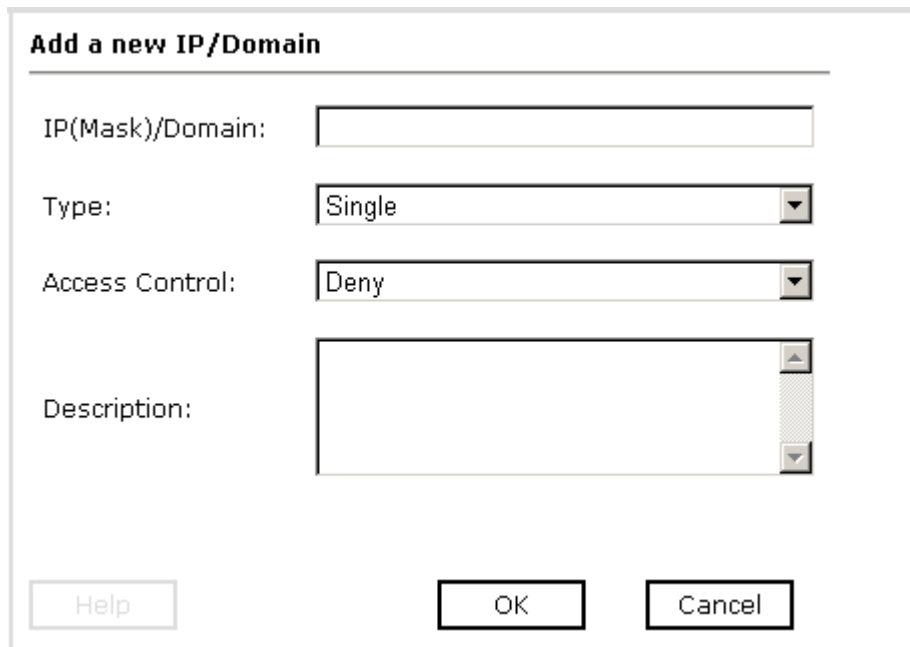

Add a new IP/Domain

IP(Mask)/Domain:

Type:

Access Control:

Description:

- a. From the Type drop-down list, select the type of restriction.

- b.** In the IP(Mask)/Domain field, type the IP or domain name using the following guidelines.

If you select Single (Computer) from the Type drop-down list, you must provide the IP address for that computer. If you only know the DNS name for the computer, click *DNS Lookup* to obtain the IP Address based on the DNS name.

If you select Group (of Computers), you must provide the IP address and subnet mask for the computer group.

If you select Domain, you must provide the domain name, for example, yahoo.com.

- 3.** From the Access Control drop-down list, select *Grant* to permit access or *Deny* to restrict access for the IP addresses and domain names you are adding.
- 4.** Click *OK*.

The following image shows the pane that opens and summarizes your configuration including the domain name, whether access is granted or denied, and a description (optional).

Operations ▶



IP and Domain

You can configure the iWay Business Services Engine to use policies that control access from a single IP address, a group of IP addresses, or all addresses within a particular domain.

IP(Mask) / Domain	Access	Description
<input type="checkbox"/> test	Deny	

CHAPTER 5

Management and Monitoring

Topics:

- Managing and Monitoring Services and Events Using iBSE
- Managing and Monitoring Services and Events Using the JCA Test Tool
- Setting Engine Log Levels
- Migrating Repositories
- Exporting or Importing Targets
- Retrieving or Updating Web Service Method Connection Information
- Starting or Stopping a Channel Programmatically

After you create services and events using Servlet Application Explorer, you can use managing and monitoring tools provided by the iWay Business Services Engine (iBSE) and the iWay Connector for JCA to measure the performance of your run-time environment. This section describes how to configure and use these features.

Managing and Monitoring Services and Events Using iBSE

iWay Business Services Engine (iBSE) provides a console to manage and monitor services and events currently in use and to display resource usage and invocation statistics. These indicators can help you adjust your environment for optimum efficiency.

The following monitoring levels are available for services:

- System
- Service
- Method

The following monitoring levels are available for events:

- System
- Channel
- Port

Procedure: How to Configure Monitoring Settings

To configure monitoring settings:

1. Ensure that your application server is started.
2. To access the monitoring console, type the following URL in your Web browser:

`http://localhost:port/ibse/IBSEConfig`

where:

`localhost`

Is the machine where the application server is running.

`port`

Is the HTTP port for the application server.

The following image shows the iBSE Settings window that opens. It lists property names and includes fields where you can enter values for each property. To configure system settings, the System pane contains drop-down lists for selecting language, encoding, the debug level, and the number of asynchronous processors. It also contains a field where you can enter a path to the adapters lib directory.

To configure security settings, the Security pane contains fields for typing the Admin User name and the associated password and a check box for specifying policy.

To configure repository settings, the Repository pane contains a drop-down list for selecting the repository type, fields to type information for the repository URL, driver, user, and password, and a check box where you can enable repository pooling. In the upper and lower right of the window is a Save button. In the lower left of the window is an option to click to access more configuration settings.

iBSE Settings:		Save
Property Name	Property Value	
System		
Language	English ▾	
Adapter Lib Directory	C:\Program Files\iWay55\lib	
Encoding	UTF-8 ▾	
Debug Level	NONE ▾	
Number of Async. Processors	0 ▾	
Security		
Admin User	iway	
Admin Password	****	
Policy	<input type="checkbox"/>	
Repository		
Repository Type	File System ▾	
Repository Url	file://C:\Program Files\iWay55\bea\ibe	
Repository Driver		
Repository User		
Repository Password		
Repository Pooling	<input type="checkbox"/>	
More configuration...		
		Save

3. Click *More configuration*.

Tip: To access the monitoring console directly, type the following URL in your Web browser

<http://localhost:port/ibse/IBSEStatus>

where:

[localhost](#)

Is the machine where the application server is running.

[port](#)

Is the HTTP port for the application server.

The following image shows the iBSE Monitoring Settings window that opens. It lists property names and includes a corresponding field where you can enter values for each property. The Monitoring pane contains a drop-down list for selecting the repository type, fields to type information for the repository URL, driver, user, and password, and a check box where you can enable repository pooling. The Auditing pane contains an option button to click to specify whether to store a message and a drop-down list where you can select the maximum messages to store. At the bottom of the window is a row of buttons that you can click to save your configuration, view events, or view services. The Save History button is inactive. After you enter properties and choose whether to save or view, you can click the Start Monitoring button.

iBSE Monitoring Settings:

Property Name	Property Value
Monitoring	
Repository Type	File System
Repository Url	file://C:\Program Files\iWay55\bea
Repository Driver	
Repository User	
Repository Password	
Repository Pooling	<input type="checkbox"/>
Auditing	
Store Message	<input type="radio"/> yes <input checked="" type="radio"/> no
Max Message Stored	10,000
<input type="button" value="Save Configuration"/> <input type="button" value="Save History"/> <input type="button" value="View Events"/> <input type="button" value="View Services"/>	
<input type="button" value="Start Monitoring"/>	

- a. In the Monitoring pane, from the Repository Type drop-down list, select the type of repository you are using.
- b. To connect to the database in the Repository Url field, type a JDBC URL.
- c. To connect to the database in the Repository Driver field, type a JDBC Class.
- d. To access the monitoring repository database, type a user ID and password.
- e. To enable pooling, click the *Repository Pooling* check box.
- f. In the Auditing pane, select *yes* if you want to store messages.
This option is disabled by default.
Note: You must start and then, stop monitoring to enable this option.
- g. Select the maximum number of messages you want to store.

By default, 10,000 is selected.

Note: Depending on your environment and the number of messages that are exchanged, storing a large number of messages may affect system performance. If you need more information about your system resources, consult your system administrator.

- h.** Click *Save Configuration*.
- 4.** Click *Start Monitoring*.
iBSE begins to monitor all services and events currently in use. If you selected the option to store messages, iBSE stores messages.
- 5.** To stop monitoring, click *Stop Monitoring*.

Procedure: How to Monitor Services

To monitor services:

- 1.** Ensure that your application server is started.
- 2.** From the iBSE Monitoring Settings window, click *Start Monitoring*.
- 3.** Click *View Services*.

The following image shows the System Level Summary (Service Statistics) window that opens. The Web Service Methods pane contains a drop-down list where you select a service. On the right, space is reserved for a drop-down list of methods that will appear. The Statistics pane contains a table with a summary of service statistics and two drop-down lists where you can select a successful or failed invocation to view more information about that service. At the bottom of the window is a home button to click to return to the iBSE Monitoring Settings window.

Service Statistics

Web Service Methods

Service	Method
<input style="width: 90%;" type="text" value="all"/>	

Statistics

Total Time	55 min
Total Request Count	1
Total Success Count	1
Total Error Count	0
Average Request Size	409.0 bytes
Average Response Size	665.0 bytes
Average Execution Time	656 ms
Last Execution Time	828 ms
Average Back End Time	530 ms
Last Back End Time	765 ms
Successful Invocations	<input style="width: 90%;" type="text" value="select a correlation id"/>
Failed Invocations	<input style="width: 90%;" type="text" value="select a correlation id"/>

The system level summary provides services statistics at a system level.

The following table consists of two columns, one that lists the name of each statistic and the other that describes the corresponding service statistic.

Statistic	Description
Total Time	Total amount of time iBSE monitors services. The time starts after you click Start Monitoring in the iBSE Monitoring Settings window.
Total Request Count	Total number of services requests that were made during the monitoring session.
Total Success Count	Total number of successful service executions.
Total Error Count	Total number of errors that were encountered.
Average Request Size	Average size of an available service request.
Average Response Size	Average size of an available service response size.
Average Execution Time	Average execution time for a service.
Last Execution Time	Last execution time for a service.
Average Back End Time	Average back end time for a service.
Last Back End Time	Last back end time for a service.
Successful Invocations	A list of successful services arranged by correlation ID. To retrieve more information for a service, you can select the service from the drop-down list.
Failed Invocations	A list of failed services arranged by correlation ID. To retrieve more information for a service, you can select the service from the drop-down list.

4. Select a service from the drop-down list.

The following image shows the System Level Summary (Service Statistics) window that opens. The Web Service Methods pane contains a drop-down list on the left where you select a service and a drop-down list on the right where you select a service method. The Statistics pane contains a table with a summary of service statistics and two drop-down lists. To view more information about that service, you can select it from the Successful Invocations or Failed Invocations drop-down list. To suspend or resume a service, you can click a button in the lower right. To return to the iBSE Monitoring Settings window, you click the home button (also located in the lower right).

Service Statistics

Web Service Methods

Service	Method
<input type="text" value="E0100033"/>	<input type="text" value="all methods"/>

Statistics

Total Time	1 hrs
Total Request Count	1
Total Success Count	1
Total Error Count	0
Average Request Size	409.0 bytes
Average Response Size	665.0 bytes
Average Execution Time	656 ms
Last Execution Time	656 ms
Average Back End Time	530 ms
Last Back End Time	530 ms
Successful Invocations	<input type="text" value="select a correlation id"/>
Failed Invocations	<input type="text" value="select a correlation id"/>

- a. To stop a service at any time, click *Suspend Service*.
- b. To restart the service, click *Resume Service*.

- 5. Select a method for the service from the Method drop-down list.

The following image shows the Method Level Summary (Service Statistics) window that opens. The Web Service Methods pane contains a drop-down list on the left where you select a service and a drop-down list on the right where you select a service method. The Statistics pane contains a table with a summary of service statistics and two drop-down lists. To view more information about that service, you can select it from the Successful Invocations or Failed Invocations drop-down list. To suspend or resume a service, you can click a button in the lower right. To return to the iBSE Monitoring Settings window, you click the home button (also located in the lower right).

The screenshot shows a window titled "Service Statistics". It is divided into two main sections: "Web Service Methods" and "Statistics".

Web Service Methods

Service: [B0100033] Method: [GetEffectiveAddress]

Statistics

Total Time	1 hrs
Total Request Count	1
Total Success Count	1
Total Error Count	0
Average Request Size	409.0 bytes
Average Response Size	665.0 bytes
Average Execution Time	656 ms
Last Execution Time	656 ms
Average Back End Time	530 ms
Last Back End Time	530 ms
Successful Invocations	[select a correlation id]
Failed Invocations	[select a correlation id]

Buttons: [Suspend Service] and [< home]

- For additional information about a successful service and its method, select a service based on its correlation ID from the Successful Invocation drop-down list.

The following image shows the Invocation Level Statistics window that opens. The Message Information pane contains a table of information about the message. The Client Information pane contains a table of information about the client. The Detail pane contains a table that shows the size of the request and response messages, with options to click to view the respective XML documents. In the lower right of the window is a home button to click to return to the iBSE Monitoring Settings window.

Invocation Statistics

Message Information

Received	2004-09-14 12:04:16.312
Sent to adapter	2004-09-14 12:04:16.406
Received from adapter	2004-09-14 12:04:16.936
Responded	2004-09-14 12:04:16.968
Status	SUCCESS

Client Information

Client IP	127.0.0.1
Client Host Name	127.0.0.1
User Name	

Detail

Message	Size
Request Message	409 bytes
Response Message	665 bytes

[< home](#)

- To view the XML request document in your Web browser, click *Request Message*.
You can also view the XML response document for the service.
- To return to the iBSE Monitoring Settings window, click *home*.

Procedure: How to Monitor Events

To monitor events:

- Ensure that your application server is started.
- In the iBSE Monitoring Settings window, click *Start Monitoring*.

3. Click *View Events*.

The following image shows the System Level Summary (Channel Statistics) window that opens. The Channels pane contains a drop-down list on the left where you select a channel. On the right, space is reserved for a drop-down list of ports that will appear. The Statistics pane contains a table with a summary of event statistics and two drop-down lists where you can select a successful or failed event to view more information about that event. In the lower right of the window is a home button to click to return to the iBSE Monitoring Settings window.

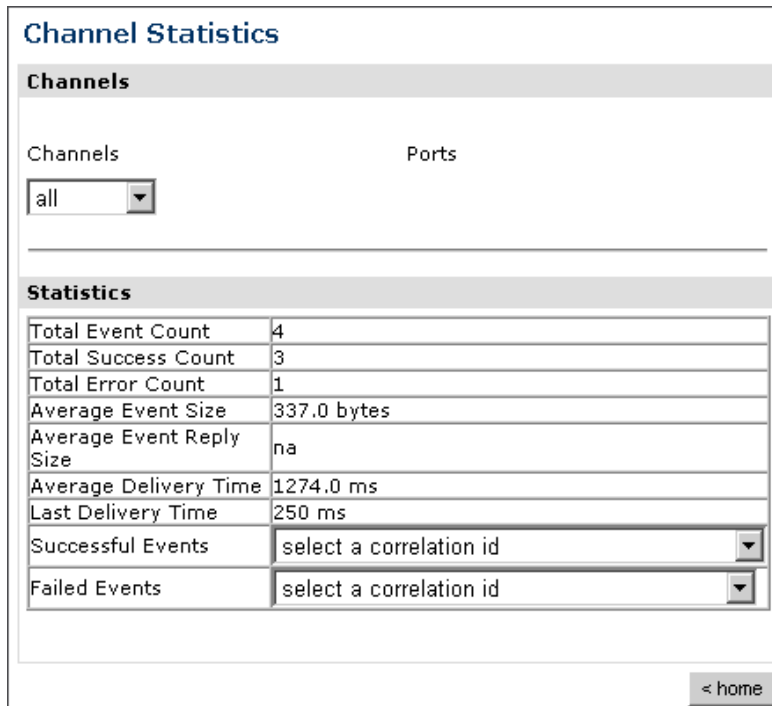

The system level summary provides event statistics at a system level.

The following table consists of two columns, one that lists the name of each statistic and the other that describes the corresponding event statistic.

Statistic	Description
Total Event Count	Total number of events.
Total Success Count	Total number of successful event executions.
Total Error Count	Total number of errors that were encountered.
Average Event Size	Average size of an available event request.
Average Event Reply Size	Average size of an available event response.
Average Delivery Time	Average delivery time for an event.
Last Delivery Time	Last delivery time for an event.
Successful Events	List of successful events arranged by correlation ID. To retrieve more information for an event, select the event from the drop-down list.
Failed Events	List of failed events arranged by correlation ID. To retrieve more information for an event, select the event from the drop-down list.

4. Select a channel from the drop-down list.

The following image shows the Channel Level Event Summary (Channel Statistics) window that opens. The Channels pane contains a drop-down list on the left where you select a channel and a drop-down list on the right where you select a port. The Statistics pane contains a table with a summary of event statistics and two drop-down lists where you can select a successful or failed event to view more information about that event. In the lower right of the window is a button to click to suspend or resume a channel and a home button to click to return to the iBSE Monitoring Settings window.

The screenshot shows a window titled "Channel Statistics". It is divided into two main sections: "Channels" and "Statistics".

Channels Section: Contains two drop-down menus. The "Channels" menu is set to "TestChan" and the "Ports" menu is set to "all".

Statistics Section: Contains a table with the following data:

Total Event Count	3
Total Success Count	2
Total Error Count	1
Average Event Size	401.0 bytes
Average Event Reply Size	na
Average Delivery Time	1542.0 ms
Last Delivery Time	250 ms
Successful Events	select a correlation id
Failed Events	select a correlation id

At the bottom of the window, there are three buttons: "Suspend Channel", "Start Channel", and "< home".

- a. To stop a channel at any time, click *Suspend Channel*.
 - b. To start the channel, click *Start Channel*.
5. From the Ports drop-down list, select a port for the channel.

The following image shows the Port Level Event Summary (Channel Statistics) window that opens. The Channels pane contains a drop-down list on the left where you select a channel and a drop-down list on the right where you select a port. The Statistics pane contains a table with a summary of event statistics and two drop-down lists where you can select a successful or failed event to view more information about that event. In the lower right of the window is a button to click to suspend or resume a channel and a home button to click to return to the iBSE Monitoring Settings window.

Channel Statistics

Channels

Channels: TestChan ▾ Ports: TestPort ▾

Statistics

Total Event Count	2
Total Success Count	2
Total Error Count	0
Average Event Size	446.0 bytes
Average Event Reply Size	na
Average Delivery Time	2189.0 ms
Last Delivery Time	na
Successful Events	select a correlation id ▾
Failed Events	select a correlation id ▾

- For more information about a successful event and its port, select an event based on its correlation ID from the Successful Events drop-down list.

The following image shows the Event Level Statistics (Message Statistics) window that opens. The Message Information pane contains a table of information pertaining to the event message. The Messages pane contains a table that shows the size of the event and reply messages, with an option to view an XML document of the event message. In the lower right of the window is a home button to click to return to the iBSE Monitoring Settings window.

The screenshot displays a window titled "Message Statistics". It is divided into two main sections: "Message Information" and "Messages".

Message Information

Received At	2004-09-14 12:18:20.842
Disposed At	● TestPort
Delivered At	2004-09-14 12:18:23.562

Messages

Detail	size
Event Message	446 bytes
Reply Message	na

In the bottom right corner of the window, there is a button labeled "< home".

- a. To view the XML event document in your Web browser, click *Event Message*.
- b. To return to the iBSE Monitoring Settings window, click *home*.

Managing and Monitoring Services and Events Using the JCA Test Tool

The JCA Test Tool, which is also known as the JCA Installation Verification Program (IVP), provides a console to manage and monitor services and events currently in use and to display resource usage and invocation statistics. These indicators can help you adjust your environment for optimum efficiency.

Procedure: How to Manage and Monitor Services Using the JCA Test Tool

To manage and monitor services using the JCA Test Tool:

1. Open a Web browser to

<http://localhost:port/iwjcaivp>

where:

[localhost](#)

Is the name of the machine where your application server is running.

[port](#)

Is the HTTP port for the application server, for example:

<http://localhost:7001/iwjcaivp>

The following image shows the JCA Test Tool page that opens. The page contains a description of the function of the tool and configuration information, including options to change your connection settings. It also provides options for viewing service or event adapters.

This JSP application is used to test the functionality of the J2EE-CA connector. There are several types of adapters available thru this J2EE-CA connector.

Configuration

- Running in MANAGED mode.
- `iwjca.jndi :eis/IWAFConnectionFactory:`
- [Refresh Connection Factory after redeployment](#) - [Destroy Connection Factory for redeployment](#)

Adapters

- [Service adapters](#)
- [Event adapters](#)

The JCA Test Tool runs in managed mode by default.

2. Perform the following steps to monitor the latest service adapter configuration.

Note: You must perform these steps for every new adapter target that is created using a JCA implementation of Application Explorer. In addition, you also must perform these steps for every new JCA configuration that is created using Application Explorer.

- a. Click *Destroy Connection Factory for redeployment*.
 - b. Redeploy the JCA connector.
 - c. In the JCA Test Tool, click *Refresh Connection Factory after redeployment*.
3. Click *Service adapters*.

The following image shows the Service Adapters page that opens. The page provides a live list of available service adapters and a list of targets configured for a specific adapter. In the lower right is a Back button to click to return to the previous page.

Service Adapters

Select an adapter from the following list to review its available targets (configurations)

- [CICS](#)
- [Clarify\(CBO\)](#)
- [EMAIL](#)
- [IMS](#)
- [JDEdwards](#)
- [JMS](#)
- [Lotus](#)
- [MQ](#)
- [MSMQ](#)
- [Oracle Applications](#)
- [PeopleSoft](#)
- [RDBMS](#)
- [SAP](#)
- [Siebel](#)
- [Telnet](#)
- [Tibco](#)

Targets for CICS

No targets configured for this adapter.

<< Back

4. Select a service adapter to monitor.

The following image shows the page that opens. The left side provides a live list of available service adapters and a list of any targets configured for a specific adapter. The upper right side shows statistics for a selected target. The middle right has a User field and a Password field. The lower right contains a box where you type or paste an input document. Below the input box is a Send button to click to send a request for a test service and a Reset button to click to reset the fields. In the lower right is a Back button to click to return to the previous page.

<p>Service Adapters Select an adapter from the following list to review its available targets (configurations)</p> <ul style="list-style-type: none"> • CICS • Clarify(CBO) • EMAIL • IMS • JMS • Lotus • MQ • MSMQ • Oracle Applications • RDBMS • Telnet • Tibco • Tuxedo 	<p>Statistics for CICS target TestService</p> <p>TotalRequestCount : 0 TotalSuccessCount : 0 TotalErrorCount : 0 AverageExecutionTime : 0 msec. LastExecutionTime : 0 msec.</p>
<p>Targets for CICS</p> <ul style="list-style-type: none"> • TestService 	<p>Request for CICS target TestService Enter the data for this interaction. The configured user/password will be used if the User name is not provided.</p> <p>User: <input type="text"/></p> <p>Password: <input type="password"/></p> <p>Input Doc:</p> <div style="border: 1px solid gray; height: 100px; width: 100%;"></div> <p style="text-align: center;"> <input type="button" value="Send"/> <input type="button" value="Reset"/> </p> <p style="text-align: right;"><input type="button" value=" << Back"/></p>

- a. Click the desired target for your service adapter.
 - b. In the Request area, type a user name and password.
 - c. In the Input Doc area, type a request document that was created from the request schema for your service.
5. Click *Send*.

The following image shows the updated statistics that appear for your service if the request is successful. The statistics include the total number of requests, successes, and errors and the average and last execution time in milliseconds.

TotalRequestCount	: 0
TotalSuccessCount	: 0
TotalErrorCount	: 0
AverageExcectionTime	: 0 msec.
LastExcectionTime	: 0 msec.

Procedure: How to Manage and Monitor Events Using the JCA Test Tool

To manage and monitor events using the JCA Test Tool:

1. Open a Web browser to

<http://localhost:port/iwjcaivp>

where:

localhost

Is the name of the machine where your application server is running.

port

Is the HTTP port for the application server, for example:

<http://localhost:7001/iwjcaivp>

The following image shows the JCA Test Tool page that opens. The page contains a description of the function of the tool and configuration information, including options to change your connection settings. It also provides options for viewing service or event adapters.

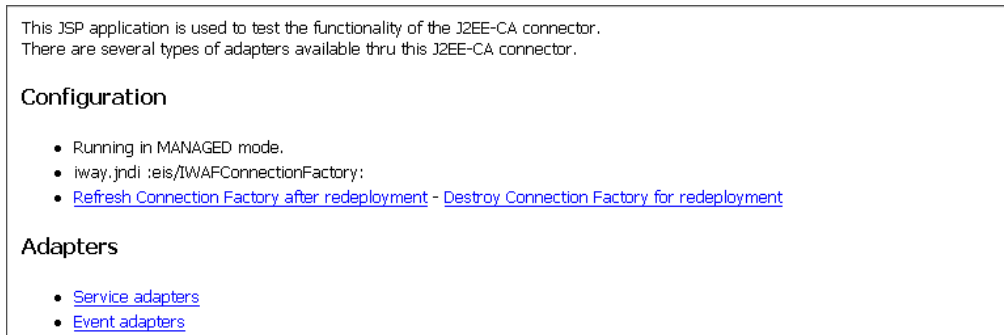

The JCA Test Tool runs in managed mode by default.

2. Perform the following steps to monitor the latest event adapter configuration.

Note: You must perform these steps for every new adapter target that is created using a JCA implementation of Application Explorer. In addition, you must also perform these steps for every new JCA configuration that is created using Application Explorer.

- a. Click *Destroy Connection Factory for redeployment*.
 - b. Redeploy the JCA connector.
 - c. In the JCA Test Tool, click *Refresh Connection Factory after redeployment*.
3. Click *Event adapters*.
The Event Adapters page opens.
 4. Select the event adapter to monitor.
 5. Click the desired channel for your event adapter.
 6. Click *start*.

The following image shows the updated statistics for your channel and the port. The statistics include the total number of requests, successes, and errors and the average and last execution time in milliseconds. There are options to click in the upper right of the page to start or refresh the channel.

Current channel Statistics	
Commands: start refresh	
Active: false	
TotalRequestCount	: 0
TotalSuccessCount	: 0
TotalErrorCount	: 0
AverageExcecutionTime	: 0 msec.
LastExcecutionTime	: 0 msec.
Statistics for port 'fileIN'	
TotalRequestCount	: 0
TotalSuccessCount	: 0
TotalErrorCount	: 0
AverageExcecutionTime	: 0 msec.
LastExcecutionTime	: 0 msec.

Setting Engine Log Levels

The following section describes how to set engine log levels for Servlet iBSE and JCA. For more information, see the documentation.

Procedure: How to Enable Tracing for Servlet iBSE

To enable tracing for Servlet iBSE:

1. Open the Servlet iBSE configuration page at

`http://localhost:port/ibse/IBSEConfig`

where:

`localhost`

Is the name of the machine where your application server is running.

`port`

Is the HTTP port for the application server, for example:

`http://localhost:7001/ibse/IBSEConfig`

2. In the System pane, from the Debug drop-down list, select the level of tracing.
3. Click *Save*.

Tracing information is written to the `ibselogs` directory where your application server accesses or has expanded Servlet iBSE.

Procedure: How to Enable Tracing for JCA

To enable tracing for JCA:

1. Open the extracted `ra.xml` file in a text editor.
2. Locate and change the following setting:

LogLevel. This setting can be set to `DEBUG`, `INFO`, or `ERROR`.

```
<context-param>
<config-property>
  <config-property-name>LogLevel</config-property-name>
  <config-property-type>java.lang.String</config-property-type>
  <config-property-value></config-property-value>
</config-property>
```

For example:

```
<config-property-value>DEBUG</config-property-value>
```

A directory in the configuration directory contains the logs.

- a. Review the logs generated by your application server.
 - b. Leave the remainder of the previous file unchanged.
3. Save the file and exit the editor.
 4. Redeploy the connector.

Migrating Repositories

During design time, a repository is used to store metadata created when using Application Explorer to configure adapter connections, browse EIS objects, configure services, and configure listeners to listen for EIS events. For more information on configuring repositories, see the *iWay 5.5 Installation and Configuration* documentation.

The information in the repository also is referenced at run time. For management purposes, you can migrate iBSE and JCA repositories to new destinations without affecting your existing configuration. For example, you may want to migrate a repository from a development environment to a production environment.

File Repositories

If you want to migrate a File repository to another destination, copy the `ibserepo.xml` file from the following path

```
drive:\Program Files\iWay55\ibse\ibserepo.xml
```

where:

```
drive
```

Is the location of your iWay 5.5 installation.

You can place the `ibserepo.xml` file in a new location that is a root directory of the iBSE Web application, for example:

```
drive:\ProductionConfig\ibse\ibserepo.xml
```

iBSE Repositories

The following topic describes how to migrate an iBSE repository that is configured for Oracle. You can follow the same procedure if you want to migrate an iBSE repository that is configured for Microsoft SQL Server 2000, Sybase, or DB2. However, when you are configuring a new environment, you must execute the script that creates the repository tables for your database. In addition, verify that all required files and drivers for your database are in the class path. For more information on configuring repositories, see the *iWay 5.5 Installation and Configuration* documentation.

Note: The following procedure allows you to migrate only Web services. If migrating event handling information is one of your requirements, you must migrate at the database level. For more information, see *Migrating Event Handling Configurations* on page 5-28.

Procedure: How to Migrate an iBSE Repository Configured for Oracle

To migrate an iBSE repository that is configured for Oracle:

1. Copy the iBSE configuration service URL, for example:

<http://localhost:7777/ibse/IBSEServlet/admin/iwconfig.ibs?wsdl>

2. Open a third party XML editor, for example, XMLSPY.

The following image shows the XMLSPY window. The upper left has a Project pane that contains a tree of sample files, and the lower left has a blank Info pane. The middle pane is blank. The right side is divided into three blank panes.

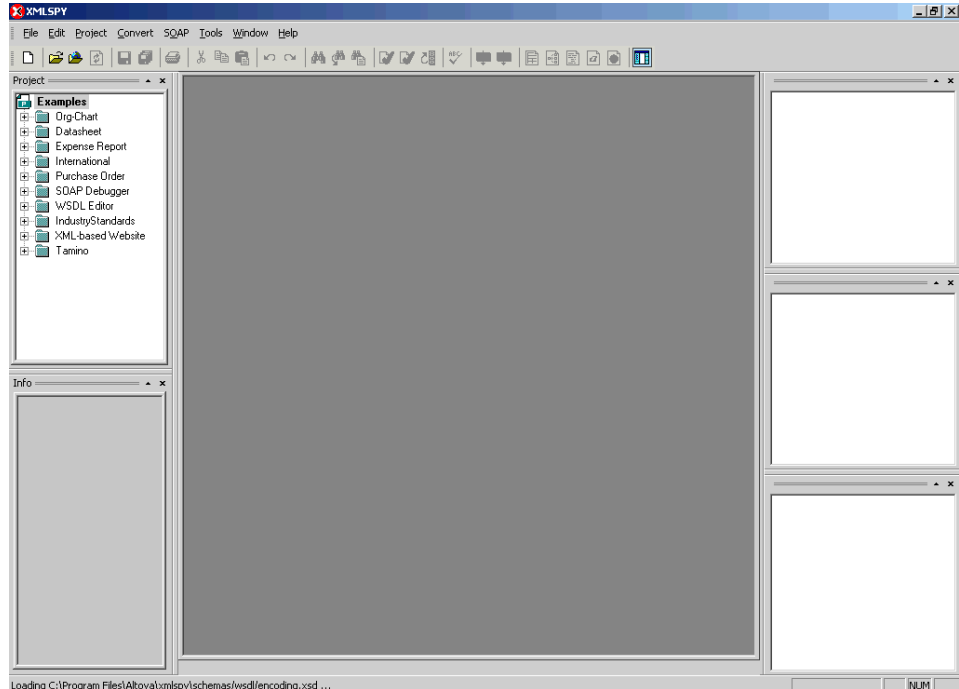

3. From the SOAP menu, select *Create new SOAP request*.

The following image shows the WSDL file location dialog box that opens, where you enter a local path or URL. The dialog includes Browse, Window, OK, and Cancel buttons.

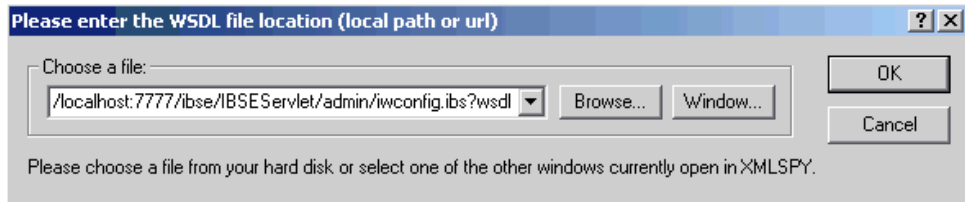

4. In the Choose a file field, paste the iBSE configuration service URL.
5. Click *OK*.

The following image shows the soap operation name dialog box that opens with a list of available control methods. You can select from the list and click *OK* or to escape from the dialog box, you can click *Cancel*.

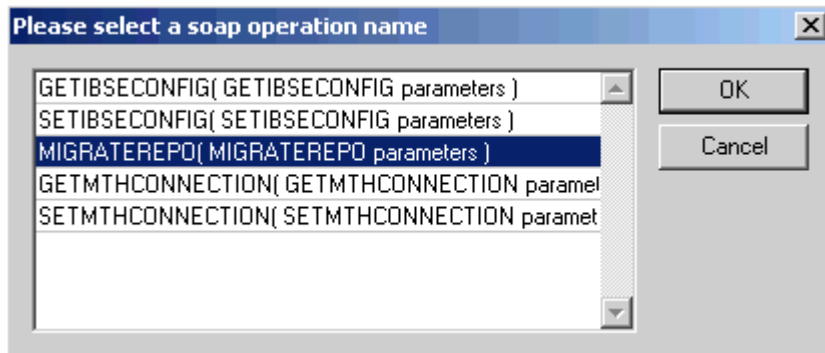

6. Select the *MIGRATEREPO(MIGRATEREPO parameters)* control method and click *OK*.

The following image shows a portion of the window that opens with the structure of the SOAP envelope. It includes information about location and schemas.

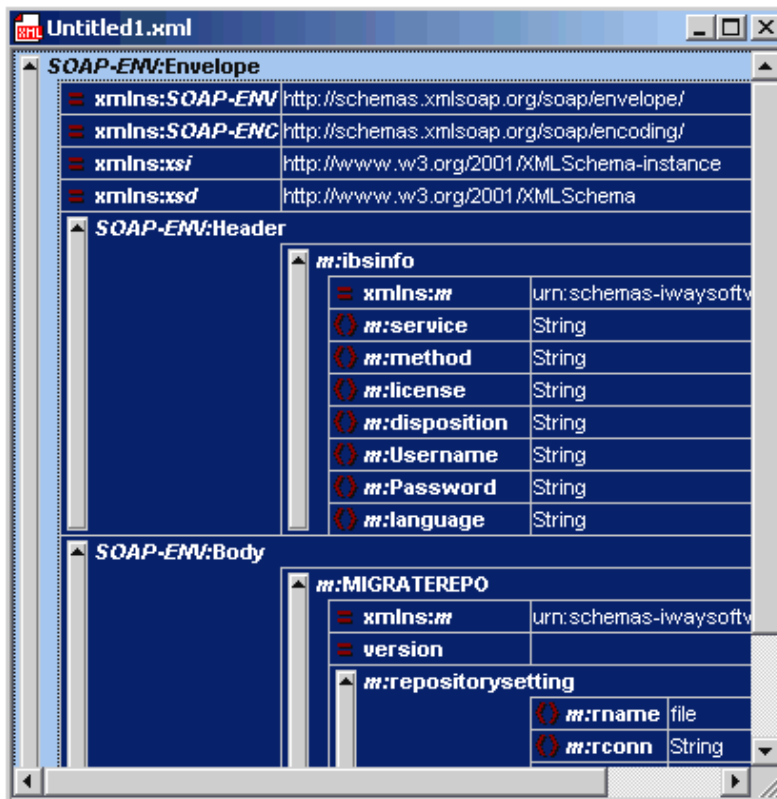

7. Locate the *Text view* icon in the tool bar.

In the following image, the pointer points to the *Text view* icon.



8. To display the structure of the SOAP envelope as text, click the *Text view* icon.
The <SOAP-ENV:Header> tag is not required and can be deleted from the SOAP envelope.

9. Locate the following section:

```
<m:MIGRATEREPO
xmlns:m="urn:schemas-iwaysoftware-com:jul2003:ibse:config" version="">
<m:repositorysetting>
<m:rname>oracle</m:rname>
<m:rconn>String</m:rconn>
<m:rdriver>String</m:rdriver>
<m:ruser>String</m:ruser>
<m:rpwd>String</m:rpwd>
</m:repositorysetting>
<m:servicename>String</m:servicename>
</m:MIGRATEREPO>
```

- a. For the `<m:rconn>` tag, replace the String placeholder with the repository URL where you want to migrate your existing iBSE repository.

For example, the Oracle repository URL has the following format:

```
jdbc:oracle:thin:@[host]:[port]:[sid]
```

- b. For the `<m:rdriver>` tag, replace the String placeholder with the location of your Oracle driver.

Note: This is an optional tag. If you do not specify a value, the default Oracle JDBC driver is used.

- c. For the `<m:ruser>` tag, replace the String placeholder with a valid user name to access the Oracle repository.
- d. For the `<m:rpwd>` tag, replace the String placeholder with a valid password to access the Oracle repository.

10. Perform one of the following migration options.

If you want to migrate a **single** Web service from the current iBSE repository, type the Web service name in the `<m:servicename>` tag, for example:

```
<m:servicename>Service1</m:servicename>
```

If you want to migrate **multiple** Web services from the current iBSE repository, duplicate the `<m:servicename>` tag for each Web service, for example:

```
<m:servicename>Service1</m:servicename>
<m:servicename>Service2</m:servicename>
```

If you want to migrate **all** Web services from the current iBSE repository, remove the `<m:servicename>` tag.

11. From the SOAP menu, select *Send request to server*.

Your iBSE repository and the Web services you specified migrate to the new Oracle repository URL that you specified.

JCA Repositories

The following procedure describes how to migrate a JCA repository. For more information on configuring JCA repositories, see the documentation.

Procedure: How to Migrate a JCA Repository

To migrate a JCA repository:

1. Navigate to the location of your JCA configuration directory where the repository schemas and other information is stored, for example:

```
C:\Program Files\iway55\config\base
```

2. Locate and copy the *repository.xml* file.
3. Place this file in a new JCA configuration directory to migrate the existing repository.

Your JCA repository migrates to the new JCA configuration directory.

Migrating Event Handling Configurations

This topic describes how to migrate your iBSE repositories at a database level for Microsoft SQL Server 2000, Oracle, Sybase, or DB2. You can use this information to migrate event handling information, for example, port or channel configurations.

Procedure How to Migrate a Microsoft SQL Server 2000 Repository

To migrate a Microsoft SQL Server 2000 repository:

1. Open a command prompt and navigate to the iWay setup directory. The default location on Windows is:

```
C:\Program Files\iWay55\etc\setup
```

This directory contains SQL to create the repository tables in the following file:

```
iwse.sql
```

You can use `iwse.sql` to create the database tables that are used by iBSE. For example, the following image shows the tree in the left pane and tables in the right pane. The tables are listed by name in one column with corresponding columns for information about owner, type, and the date the table was created.

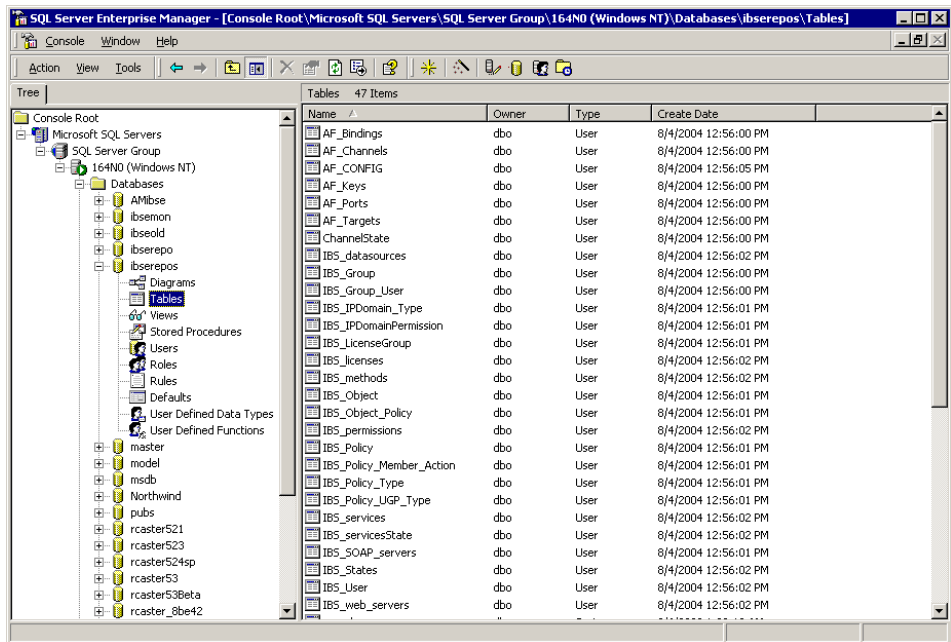

For more information on configuring the Microsoft SQL Server 2000 repository, see the documentation.

2. To migrate the tables that were created by the `iwse.sql` script for iBSE, use your Microsoft SQL Server 2000 database tool set. For more information, consult your database administrator.

Procedure How to Migrate an Oracle Repository

To migrate an Oracle repository:

1. Open a command prompt and navigate to the iWay setup directory. The default location on Windows is:

```
C:\Program Files\iWay55\etc\setup
```

This directory contains SQL to create the repository tables in the following files:

For Oracle 8:

```
iwse.ora
```

For Oracle 9:

```
iwse.ora9
```

2. To create the Oracle database tables that are used by iBSE, use the SQL script as shown in the example in the following image that shows a list of tables.

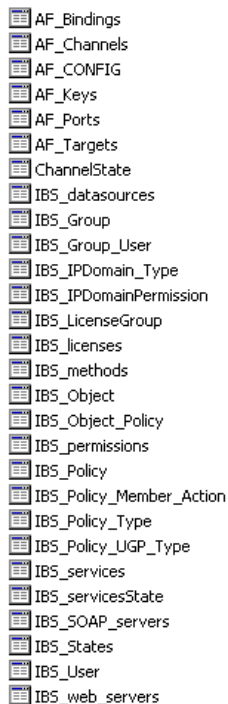
A screenshot of a database table list, likely from an Oracle Enterprise Manager interface. The list contains 30 table names, each preceded by a small icon representing a table. The tables are: AF_Bindings, AF_Channels, AF_CONFIG, AF_Keys, AF_Ports, AF_Targets, ChannelState, IB5_datasources, IB5_Group, IB5_Group_User, IB5_IPDomain_Type, IB5_IPDomainPermission, IB5_LicenseGroup, IB5_licenses, IB5_methods, IB5_Object, IB5_Object_Policy, IB5_permissions, IB5_Policy, IB5_Policy_Member_Action, IB5_Policy_Type, IB5_Policy_UGP_Type, IB5_services, IB5_servicesState, IB5_SOAP_servers, IB5_States, IB5_User, and IB5_web_servers.

AF_Bindings
AF_Channels
AF_CONFIG
AF_Keys
AF_Ports
AF_Targets
ChannelState
IB5_datasources
IB5_Group
IB5_Group_User
IB5_IPDomain_Type
IB5_IPDomainPermission
IB5_LicenseGroup
IB5_licenses
IB5_methods
IB5_Object
IB5_Object_Policy
IB5_permissions
IB5_Policy
IB5_Policy_Member_Action
IB5_Policy_Type
IB5_Policy_UGP_Type
IB5_services
IB5_servicesState
IB5_SOAP_servers
IB5_States
IB5_User
IB5_web_servers

For more information on configuring the Oracle repository, see the documentation.

3. To migrate the tables that were created by the SQL script for iBSE, use your Oracle database tool set. For more information, consult your database administrator.

Procedure How to Migrate a Sybase Repository

To migrate a Sybase repository:

1. Open a command prompt and navigate to the iWay setup directory. The default location on Windows is:

```
C:\Program Files\iWay55\etc\setup
```

This directory contains SQL to create the repository tables in the following file:

```
sybase-iwse.sql
```

2. To create the Sybase database tables that are used by iBSE, use the SQL script as shown in the example in the following image that shows a list of tables.

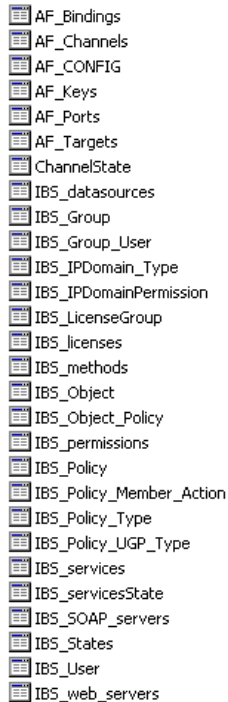

A screenshot showing a list of database tables. Each table name is preceded by a small icon representing a table. The list includes:

- AF_Bindings
- AF_Channels
- AF_CONFIG
- AF_Keys
- AF_Ports
- AF_Targets
- ChannelState
- IB5_datasources
- IB5_Group
- IB5_Group_User
- IB5_IPDomain_Type
- IB5_IPDomainPermission
- IB5_LicenseGroup
- IB5_licenses
- IB5_methods
- IB5_Object
- IB5_Object_Policy
- IB5_permissions
- IB5_Policy
- IB5_Policy_Member_Action
- IB5_Policy_Type
- IB5_Policy_UGP_Type
- IB5_services
- IB5_servicesState
- IB5_SOAP_servers
- IB5_States
- IB5_User
- IB5_web_servers

For more information on configuring the Sybase repository, see the documentation.

3. To migrate the tables that were created by the SQL script for iBSE, use your Sybase database tool set. For more information, consult your database administrator.

Procedure How to Migrate a DB2 Repository

To migrate a DB2 repository:

1. Open a command prompt and navigate to the iWay setup directory. The default location on Windows is:

```
C:\Program Files\iWay55\etc\setup
```

This directory contains SQL to create the repository tables in the following file:

```
db2-iwse.sql
```

2. To create the DB2 database tables that are used by iBSE, use the SQL script as shown in the example in the following image that shows a list of tables.

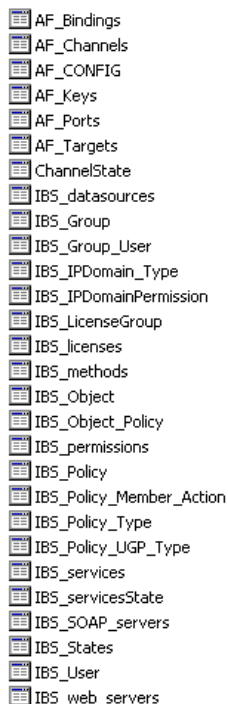

A screenshot of a list of database tables, each preceded by a small icon. The list includes:

- AF_Bindings
- AF_Channels
- AF_CONFIG
- AF_Keys
- AF_Ports
- AF_Targets
- ChannelState
- IB5_datasources
- IB5_Group
- IB5_Group_User
- IB5_IPDomain_Type
- IB5_IPDomainPermission
- IB5_LicenseGroup
- IB5_licenses
- IB5_methods
- IB5_Object
- IB5_Object_Policy
- IB5_permissions
- IB5_Policy
- IB5_Policy_Member_Action
- IB5_Policy_Type
- IB5_Policy_UGP_Type
- IB5_services
- IB5_servicesState
- IB5_SOAP_servers
- IB5_States
- IB5_User
- IB5_web_servers

For more information on configuring the DB2 repository, see the documentation.

You can migrate the tables that were created by the SQL script for iBSE using your DB2 database toolset. For more information, consult your database administrator.

Exporting or Importing Targets

After you migrate your repository, you can export or import targets with their connection information and persistent data between repositories.

Procedure: How to Export a Target

To export a target:

1. Copy the iBSE administrative services for Application Explorer URL, for example:
<http://localhost:7777/ibse/IBSEServlet/admin/iwae.ibs?wsdl>
2. Open a third party XML editor, for example, XMLSPY.

The following image shows the XMLSPY window. The upper left has a Project pane that contains a tree of sample files, and the lower left has a blank Info pane. The middle pane is blank. The right side is divided into three blank panes.

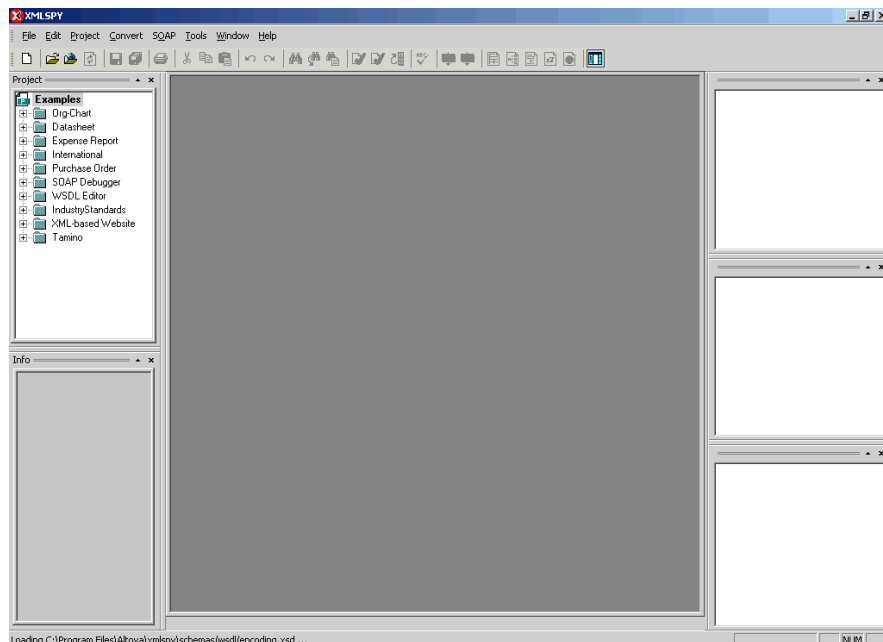

3. From the SOAP menu, select *Create new SOAP request*.
 The WSDL file location dialog box opens.
4. In the Choose a file field, paste the iBSE administrative services for Application Explorer URL.
5. Click *OK*.
 The soap operation name dialog box opens and lists the available control methods.
6. Select the *EXPORTTARGET(EXPORTTARGET parameters)* control method and click *OK*.
 A window opens that shows the structure of the SOAP envelope.

7. Locate the *Text view* icon in the tool bar.

In the following image, the pointer points to the Text view icon.



8. To display the structure of the SOAP envelope as text, click the *Text view* icon.

The <SOAP-ENV:Header> tag is not required and can be deleted from the SOAP envelope.

9. Locate the following section:

```
<m:EXPORTTARGET  
xmlns:m="urn:schemas-iwaysoftware-com:dec2002:iwse:af">  
<m:target>String</m:target>  
<m:name>String</m:name>  
</m:EXPORTTARGET>
```

- a. For the <m:target> tag, replace the String placeholder with the EIS target system name as it appears in Application Explorer and verify whether this value is case sensitive.
 - b. For the <m:name> tag, replace the String placeholder with the name of the target you want to export.
10. From the SOAP menu, select *Send request to server*.

A response is returned that contains the <m: exporttime> and <m: contents> elements. You must use these elements when importing your target.

Procedure: How to Import a Target

To import a target:

1. Copy the iBSE administrative services for Application Explorer URL, for example:

<http://localhost:7777/ibse/IBSEServlet/admin/iwae.ibs?wsdl>

2. Open a third party XML editor, for example, XMLSPY.

The following image shows the XMLSPY window. The upper left has a Project pane that contains a tree of sample files, and the lower left has a blank Info pane. The middle pane is blank. The right side is divided into three blank panes.

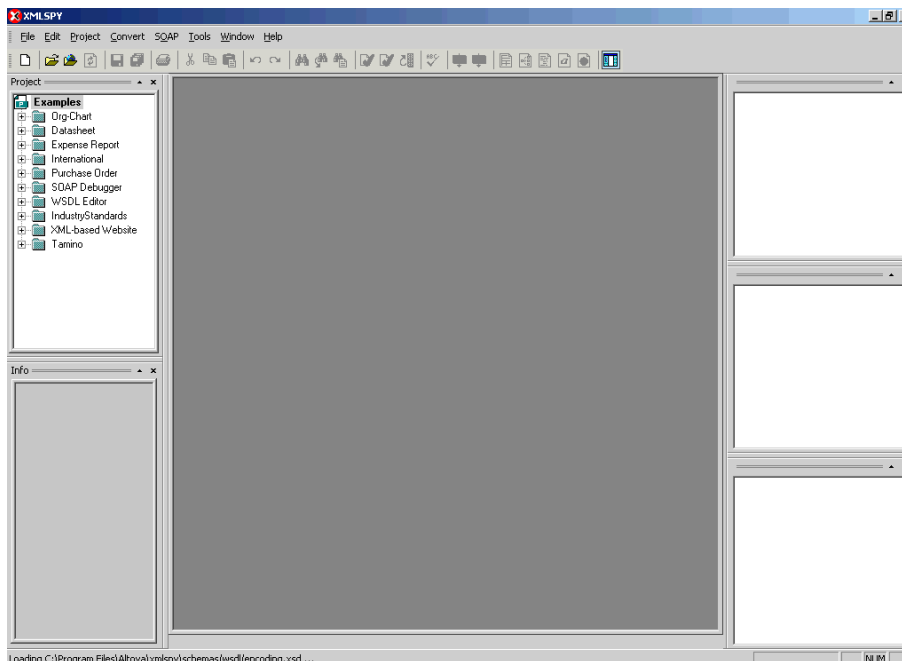

3. From the SOAP menu, select *Create new SOAP request*.

The WSDL file location dialog box opens.

4. In the Choose a file field, paste the iBSE administrative services for Application Explorer URL and click *OK*.

The soap operation name dialog box opens and lists the available control methods.

5. Select the *IMPORTTARGET(IMPORTTARGET parameters)* control method and click *OK*.

A window opens, which shows the structure of the SOAP envelope.

6. Locate the *Text view* icon in the toolbar.

In the following image, the pointer points to the Text view icon.



7. To display the structure of the SOAP envelope as text, click the *Text view* icon.

The <SOAP-ENV:Header> tag is not required and can be deleted from the SOAP envelope.

8. Locate the following section:

```
<m: IMPORTTTARGET
xmlns:m="urn:schemas-iwaysoftware-com:dec2002:iwse:af">
<m:targetinstance>
<m:target>String</m:target>
<m:name>String</m:name>
<m:description>String</m:description>
<m:repositoryid>String</m:repositoryid>
<m:exporttime>2001-12-17T09:30:47-05:00</m:exporttime>
<m:contents>R0lGODlhcgGSALMAAAQCAEMmCZtuMFQxDS8b</m:contents>
</m:targetinstance>
</m: IMPORTTTARGET>
```

- a. For the <m:target> tag, replace the String placeholder with the EIS target system name.
 - b. For the <m:name> tag, replace the String placeholder with the new name of the target you want to import.
 - c. For the <m:description> tag, replace the String placeholder with a description of the target.
 - d. For the <m:repositoryid> tag, copy and paste the contents of the <m:repositoryid> tag that was returned when you exported your target.
 - e. For the <m: exporttime> tag, copy and paste the contents of the <m: exporttime> tag that was returned when you exported your target.
 - f. For the <m: contents> tag, copy and paste the contents of the <m: contents> tag that was returned when you exported your target.
9. From the SOAP menu, select *Send request to server*.

Retrieving or Updating Web Service Method Connection Information

After you migrate your repository, you can retrieve or update connection information for your Web service methods.

Procedure: How to Retrieve Web Service Method Connection Information

To retrieve Web service method connection information:

1. Copy the iBSE configuration service URL, for example:

<http://localhost:7777/ibse/IBSEServlet/admin/iwconfig.ibs?wsdl>

2. Open a third party XML editor, for example, XMLSPY.

The following image shows the XMLSPY window. The upper left has a Project pane that contains a tree of sample files, and the lower left has a blank Info pane. The middle pane is blank. The right side is divided into three blank panes.

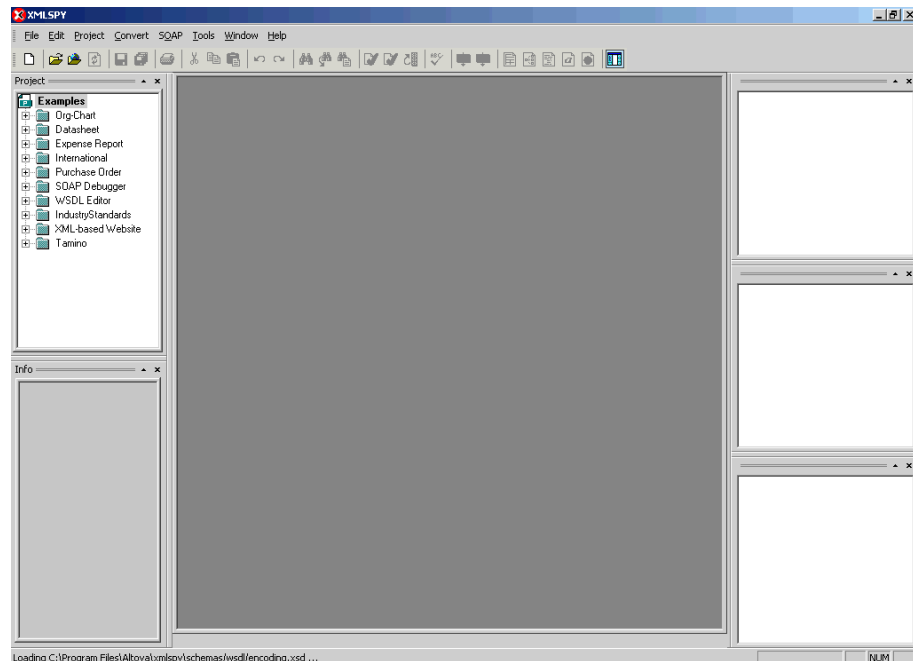

3. From the SOAP menu, select *Create new SOAP request*.

The WSDL file location dialog box opens.

4. In the Choose a file field, paste the iBSE configuration service URL, and click *OK*.

The soap operation name dialog box opens and lists the available control methods.

5. Select the *GETMTHCONNECTION*(*GETMTHCONNECTION parameters*) control method and click *OK*.

A window opens, which shows the structure of the SOAP envelope.

6. Locate the *Text view* icon in the toolbar.

In the following image, the pointer points to the *Text view* icon.



7. To display the structure of the SOAP envelope as text, click the *Text view* icon.

The `<SOAP-ENV:Header>` tag is not required and can be deleted from the SOAP envelope.

8. Locate the following section:

```
<m:GETMTHCONNECTION
xmlns:m="urn:schemas-iwaysoftware-com:jul2003:ibse:config">
<m:servicename>String</m:servicename>
<m:methodname>String</m:methodname>
</m:GETMTHCONNECTION>
```

- a. For the `<m:servicename>` tag, replace the `String` placeholder with the name of the Web service.
 - b. For the `<m:methodname>` tag, replace the `String` placeholder with name of the Web service method.
9. From the SOAP menu, select *Send request to server*.

A response is returned that contains the `<m:descriptor>` element. You must use this element when updating your Web service method.

Procedure: How to Update Web Service Method Connection Information

To update Web service method connection information:

1. Copy the iBSE configuration service URL, for example:

```
http://localhost:7777/ibse/IBSEServlet/admin/iwconfig.ibs?wsdl
```

2. Open a third party XML editor, for example, XMLSPY.

The following image shows the XMLSPY window. The upper left has a Project pane that contains a tree of sample files, and the lower left has a blank Info pane. The middle pane is blank. The right side is divided into three blank panes.

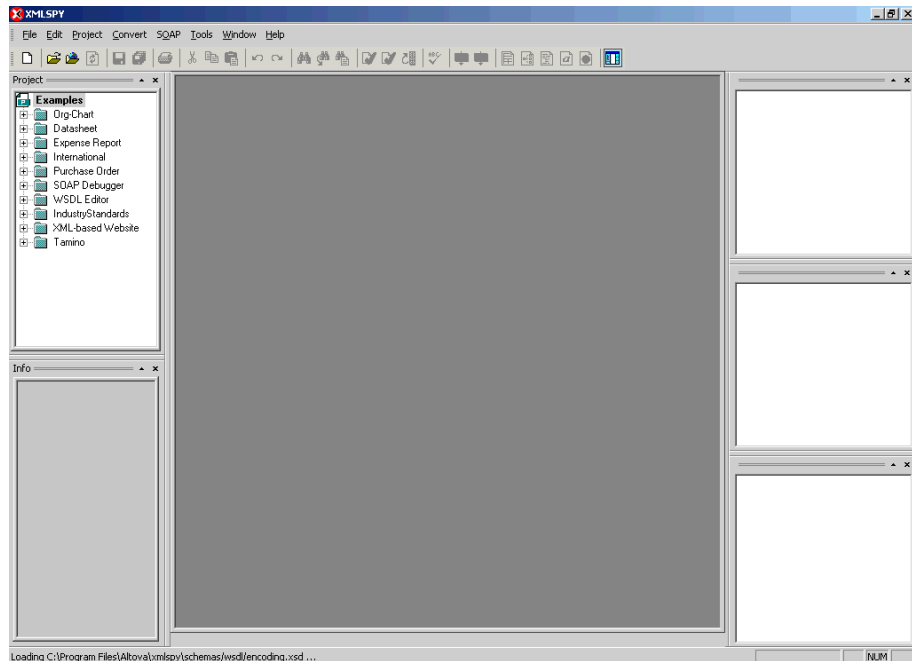

3. From the SOAP menu, select *Create new SOAP request*.
The WSDL file location dialog box opens.
4. In the Choose a file field, paste the iBSE configuration service URL, and click *OK*.
The soap operation name dialog box opens and lists the available control methods.
5. Select the *SETMTHCONNECTION(SETMTHCONNECTION parameters)* control method and click *OK*.
A window opens that shows the structure of the SOAP envelope.
6. Locate the *Text view* icon in the toolbar.
In the following image, the pointer points to the Text view icon.



7. To display the structure of the SOAP envelope as text, click the *Text view* icon.

The <SOAP-ENV:Header> tag is not required and can be deleted from the SOAP envelope.

8. Locate the following section:

```
<m:SETMTHCONNECTION
xmlns:m="urn:schemas-iwaysoftware-com:jul2003:ibse:config">
<m:servicename>String</m:servicename>
<m:methodname>String</m:methodname>
<m:descriptor format="" channel="">
  <m:option title="">
    <m:group title="">
      <m:param/>
    </m:group>
  </m:option>
</m:descriptor>
</m:SETMTHCONNECTION>
```

- a. For the <m:servicename> tag, replace the String placeholder with the name of the Web service.
 - b. For the <m:methodname> tag, replace the String placeholder with the name of the Web service method.
 - c. For the <m: descriptor> tag, copy and paste the contents of the <m: descriptor> tag that was returned when you retrieved Web Service method connection information.
9. Modify the contents of the <m: descriptor> tag to change the existing Web Service method connection information.
 10. From the SOAP menu, select *Send request to server*.

Starting or Stopping a Channel Programmatically

The following topic describes how to start or stop a channel programmatically.

Procedure: How to Start a Channel Programmatically

To start a channel programmatically:

1. Copy the iBSE control event URL, for example:
<http://localhost:7777/ibse/IBSEServlet/admin/iwevent.ibs?wsdl>
2. Open a third party XML editor, for example, XMLSPY.

The following image shows the XMLSPY window. The upper left has a Project pane that contains a tree of sample files, and the lower left has a blank Info pane. The middle pane is blank. The right side is divided into three blank panes.

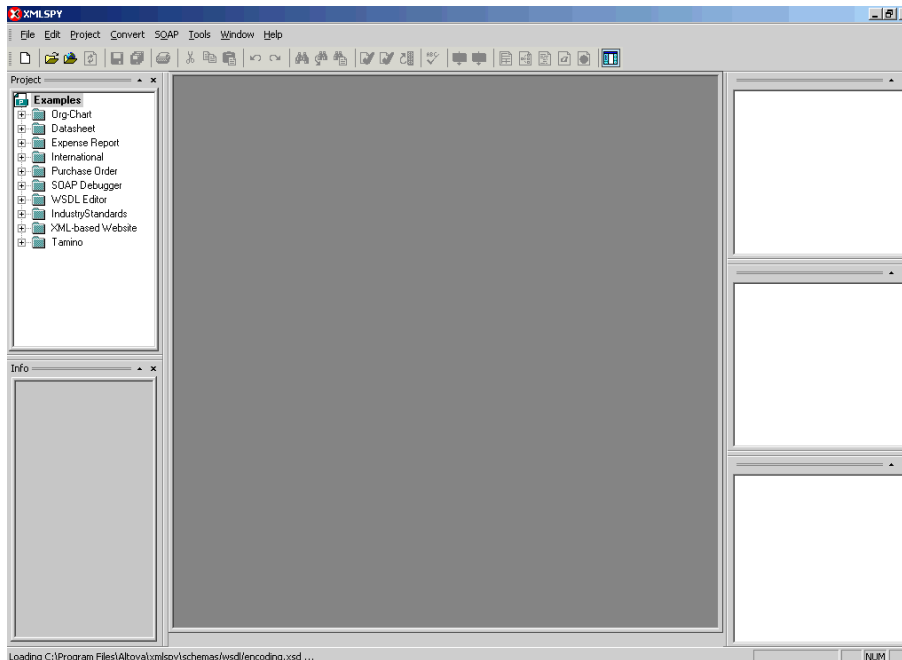

3. From the SOAP menu, select *Create new SOAP request*.
The WSDL file location dialog box opens.
4. In the Choose a file field, paste the iBSE control event URL, and click *OK*.

The following image shows the soap operation name dialog box that opens with a list of available control methods. You can select one and click OK or to escape from the dialog box, you can click Cancel.

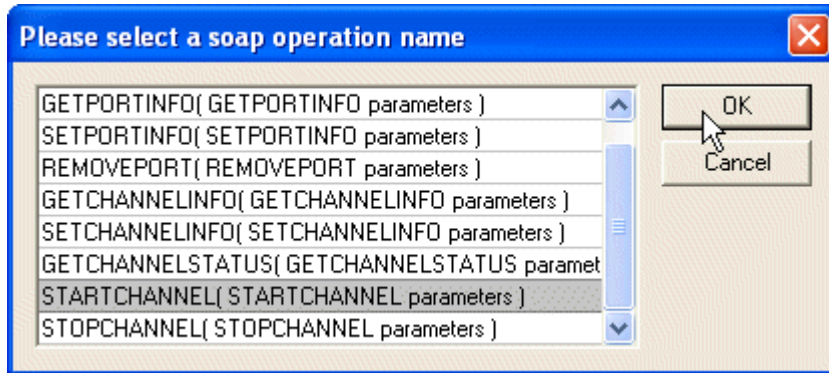

5. Select the *STARTCHANNEL(STARTCHANNEL parameters)* control method and click *OK*.

A window opens, which shows the structure of the SOAP envelope.

6. Locate the *Text view* icon in the toolbar.

In the following image, the pointer points to the *Text view* icon.



7. To display the structure of the SOAP envelope as text, click the *Text view* icon.

The `<SOAP-ENV:Header>` tag is not required and can be deleted from the SOAP envelope.

8. Locate the following section:

```
<SOAP-ENV:Body>
  <m:STARTCHANNEL
    xmlns:m="urn:schemas-iwaysoftware-com:dec2002:iwse:event">
    <m:channel>String</m:channel>
  </m:STARTCHANNEL>
</SOAP-ENV:Body>
```

9. For the `<m:channel>` tag, replace the String placeholder with the name of the Channel you want to start.

10. From the SOAP menu, select *Send request to server*.

Procedure: How to Stop a Channel Programmatically

To stop a channel programmatically:

1. Copy the iBSE control event URL, for example:

<http://localhost:7777/ibse/IBSEServlet/admin/iwevent.ibs?wsdl>

2. Open a third party XML editor, for example, XMLSPY.

The following image shows the XMLSPY window. The upper left has a Project pane that contains a tree of sample files, and the lower left has a blank Info pane. The middle pane is blank. The right side is divided into three blank panes.

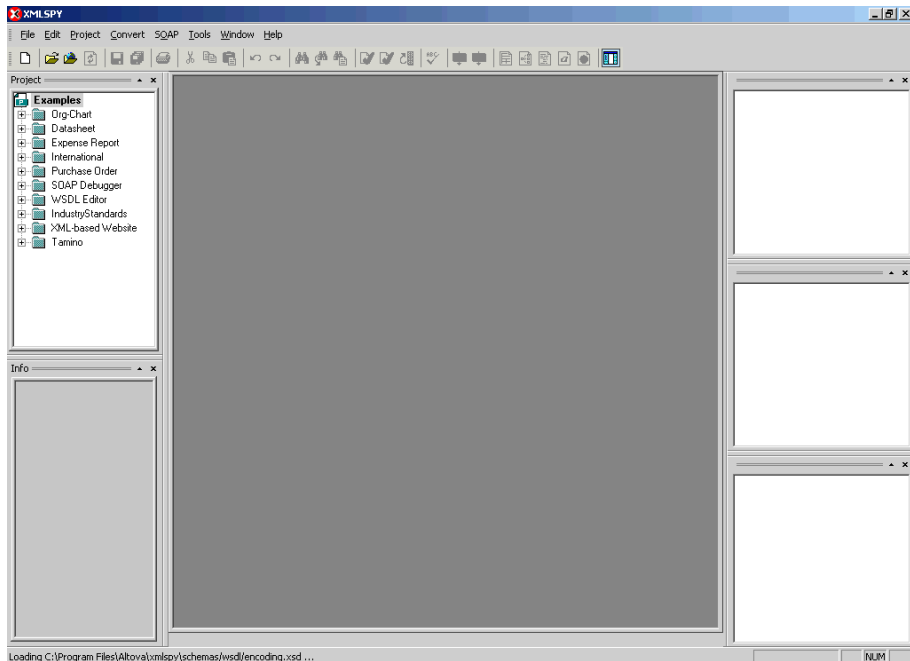

3. From the SOAP menu, select *Create new SOAP request*.

The WSDL file location dialog box opens.

4. In the Choose a file field, paste the iBSE control event URL, and click *OK*.

The following image shows the soap operation name dialog box that opens with a list of available control methods. You can select one and click OK or to escape from the dialog box, you can click Cancel.

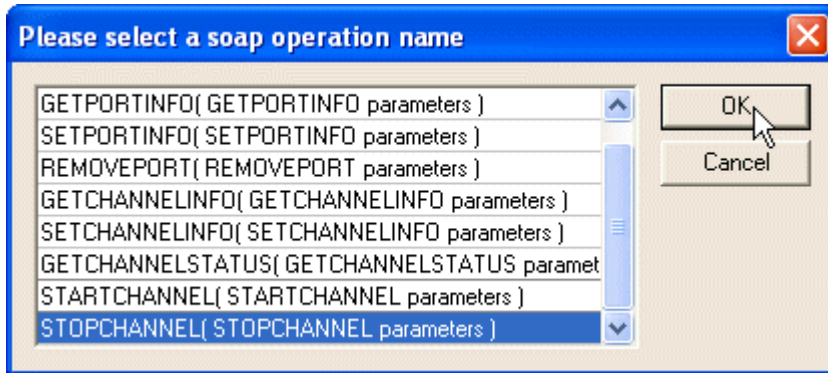

5. Select the *STOPCHANNEL(STOPCHANNEL parameters)* control method and click *OK*.

A window opens, which shows the structure of the SOAP envelope.

6. Locate the *Text view* icon in the toolbar.

In the following image, the pointer points to the *Text view* icon.



7. To display the structure of the SOAP envelope as text, click the *Text view* icon.

The `<SOAP-ENV:Header>` tag is not required and can be deleted from the SOAP envelope.

8. Locate the following section:

```
<SOAP-ENV:Body>
  <m:STOPCHANNEL
    xmlns:m="urn:schemas-iwaysoftware-com:dec2002:iwse:event">
    <m:channel>String</m:channel>
  </m:STOPCHANNEL>
</SOAP-ENV:Body>
```

9. For the `<m:channel>` tag, replace the String placeholder with the name of the Channel you want to stop.

10. From the SOAP menu, select *Send request to server*.

APPENDIX A

Configuring VTAM for AnyNet

Topics:

- VTAM and AnyNet Configuration Requirements
- TCP6.2 AnyNet Setup Samples for the VTAM Administrator
- TCP6.2 AnyNet Setup Samples for the CICS Administrator
- Post-Configuration Steps
- Error Conditions

Although the adapter requires no code to be installed on the mainframe, VTAM using AnyNet and CICS must be configured correctly. This appendix provides the configuration and communications information the adapter requires to communicate with CICS.

VTAM and AnyNet Configuration Requirements

The CICS adapter requires MVS AnyNet configuration on the mainframe. AnyNet must be installed and working properly before you can access CICS. A VTAM/CICS Administrator must be made aware of this requirement.

For its operation, AnyNet requires the following VTAM nodes:

- Major Node for the AnyNet Listener
- Standard VTAM LU Definitions for APPC
- Major Node for Cross Domain Resources

Note: It is vital that the VTAM/CICS Administrator becomes familiar with the IBM documentation before attempting to use the adapter. Use the following steps for guidance.

TCP6.2 AnyNet Setup Samples for the VTAM Administrator

The following are sample major nodes and LU definitions for the VTAM Administrator.

VTAM Major Node for the AnyNet Listener:

```
AN01 VBUILD TYPE=TCP,DNSUFFIX=NETLOGAN.INT,PORT=397
AN01G GROUP ISTATUS=ACTIVE
AN01L LINE ISTATUS=ACTIVE
AN01P PU ISTATUS=ACTIVE,NETID=USLAI101
```

VTAM LU Definitions for APPC:

```
AN01SW VBUILD TYPE=SWNET
AN01SWPU PU ADDR=01,IDBLK=05D,IDNUM=10101, X
MAXPATH=3, X
PUTYPE=2, X
MODETAB=ISTINCLM, X
DLOGMOD=D4C32XX3, X
ISTATUS=ACTIVE
ANMISP01 LU LOCADDR=2
ANMIST01 LU LOCADDR=3
```

VTAM Major Node For Cross Domain Resources:

```
AN01CDRS VBUILD TYPE=CDRSC
AN01CDNW NETWORK NETID=USLAI101
AN01CDG GROUP
ANMISP01 CDRSC ALSLIST=AN01P
ANMIST01 CDRSC ALSLIST=AN01P
```

Sample logmode:

```
PARALLEL MODEENT LOGMODE=PARALLEL,FMProf=X'13',TSProf=X'07',
PRIProt=X'B0',SECProt=X'B0',COMProt=X'50B1',TYPE=X'00',
RUSIZES=X'8787',PSERVIC=X'06020000000000000002F00'
```

This supports parallel sessions and LU62 headers. **The LU must support parallel sessions.** MODIFY or cycle of VTAM is required for any changes to take effect.

TCP6.2 AnyNet Setup Samples for the CICS Administrator

Verify you have the proper CICS connections and sessions for AnyNet. The following are sample CICS connection and session parameters for the CICS region.

Sample Connection:

```
I CONN(PB01)
STATUS: RESULTS - OVERTYPE TO MODIFY
Con(PB01) Net(T29DPB01)      Ins Rel Vta Appc      CEDA EX GROUP(*)
CONNECTION(PB01)
EX GROUP(*) CONN(PB01)
ENTER COMMANDS
NAME          TYPE          GROUP
PB01         CONNECTION  SPGCICS
OBJECT CHARACTERISTICS
CEDA View Connection( PB01 )
Connection    : PB01
Group         : SPGCICS
Description   :
CONNECTION IDENTIFIERS
Netname       : T29DPB01
INDsys       :
REMOTE ATTRIBUTES
REMOTESYSTEM :
REMOTENAME   :
REMOTESYSNet :
CONNECTION PROPERTIES
Accessmethod : Vtam          Vtam | IRc | INdirect | Xm
Protocol     : Appc          Appc | Lu61 | Exci
Conntype     :              Generic | Specific
Singlesess   : No           No | Yes
DATAstream   : User         User | 3270 | SCs | STRfield | Lms
RECORDformat : U            U | Vb
+ REMOTENAME :
REMOTESYSNet :
CONNECTION PROPERTIES
Accessmethod : Vtam          Vtam | IRc | INdirect | Xm
Protocol     : Appc          Appc | Lu61 | Exci
Conntype     :              Generic | Specific
```

TCP6.2 AnyNet Setup Samples for the CICS Administrator

```

SIngleless      : No           No | Yes
DATastream     : User         User | 3270 | SCs | STRfield | Lms
RECOrdformat   : U           U | Vb
Queuelimit     : No           No | 0-9999
Maxqtime       : No           No | 0-9999
OPERATIONAL PROPERTIES
AUtoconnect    : All         No | Yes | All
INService      : Yes         Yes | No
SECURITY
SEcurityname   :
+ ATTachsec    : Verify      Local | Identify | Verify | Persistent
+ Queuelimit   : No           No | 0-9999
  Maxqtime     : No           No | 0-9999
OPERATIONAL PROPERTIES
AUtoconnect    : All         No | Yes | All
INService      : Yes         Yes | No
SECURITY
SEcurityname   :
ATTachsec     : Verify      Local | Identify | Verify | Persistent
                | Mixidpe
BINDPasswOrd  :             PASSWORD NOT SPECIFIED
BINDSecurity   : No           No | Yes
Usedfltuser    : No           No | Yes
RECOVERY
PSrecovery     : Sysdefault Sysdefault | None
Xlnaction      : Keep         Keep | Force
+                | Mixidpe
BINDPasswOrd  :             PASSWORD NOT SPECIFIED
BINDSecurity   : No           No | Yes
Usedfltuser    : No           No | Yes
RECOVERY
PSrecovery     : Sysdefault Sysdefault | None
Xlnaction      : Keep         Keep | Force

```

Sample Session:

```

EX GROUP(*) SESSION(T29DPB01)
ENTER COMMANDS
  NAME      TYPE          GROUP
  T29DPB01  SESSIONS      SPGCICS
OBJECT CHARACTERISTICS                                CIC
CEDA View Sessions( T29DPB01 )
  Sessions      : T29DPB01
  Group         : SPGCICS
  Description    :
SESSION IDENTIFIERS
  Connection    : PB01
  SESSName      :
  NETnameq     :
  MODename     : PARALLEL
SESSION PROPERTIES
  Protocol      : Appc                Appc | Lu61 | Exci
  MAXimum      : 008 , 000            0-999
  RECEIVEPfx   :
  RECEIVECount :                      1-999
  SENDPfx      :
  SENDCount    :                      1-999
  SENDSize     : 04096                1-30720
  RECEIVESize  : 04096                1-30720
SESSION PROPERTIES
  Protocol      : Appc                Appc | Lu61 | Exci
  MAXimum      : 008 , 000            0-999
  RECEIVEPfx   :
  RECEIVECount :                      1-999
  SENDPfx      :
  SENDCount    :                      1-999
  SENDSize     : 04096                1-30720
  RECEIVESize  : 04096                1-30720
  SESSPriority  : 000                  0-255
  Transaction   :
OPERATOR DEFAULTS
  OPERId       :
  OPERPriority  : 000                  0-255
  OPERRsl      : 0                    0-24,...
  OPERSecurity : 1                    1-64,...
PRESET SECURITY
  SESSPriority  : 000                  0-255
  Transaction   :
OPERATOR DEFAULTS
  OPERId       :
  OPERPriority  : 000                  0-255
  OPERRsl      : 0                    0-24,...
  OPERSecurity : 1                    1-64,...

```

Post-Configuration Steps

```
PRESET SECURITY
  USERId      :
OPERATIONAL PROPERTIES
  Autoconnect : All           No | Yes | All
  INservice   :               No | Yes
  Buildchain  : Yes           Yes | No
  USERArealen : 000          0-255
  IOarealen   : 00000 , 00000 0-32767
  RELreq      : No            No | Yes
  DIScreq     : No            No | Yes
  USERId      :
OPERATIONAL PROPERTIES
  Autoconnect : All           No | Yes | All
  INservice   :               No | Yes
  Buildchain  : Yes           Yes | No
  USERArealen : 000          0-255
  IOarealen   : 00000 , 00000 0-32767
  RELreq      : No            No | Yes
  DIScreq     : No            No | Yes
  NEPclass    : 000          0-255
RECOVERY
  RECOVOption : Sysdefault    Sysdefault | Clearconv | Releasesess
                | Uncondrel | None
  RECOVNotify : None          None | Message |
```

Post-Configuration Steps

Once AnyNet is configured, the following steps should be taken:

- Verify that the AnyNet port is listening.
- Verify that the CICS program is accessible and enabled in the CICS region.

Verifying That the AnyNet Port is Listening

After both VTAM and TCP/IP are up and running, type the following command to verify that AnyNet is up and running.

```
TSO NETSTAT (PORT 397)
```

The following should display if AnyNet is up and running:

```
EZZ2350I MVS TCP/IP NETSTAT CS V2R10 TCPIP NAME: TCPIP 18:37:36
EZZ2585I User Id Conn Local Socket Foreign Socket State
EZZ2586I -----
EZZ2587I VTAM 0000008E 0.0.0.0..397 *.* UDP
EZZ2587I VTAM 0000008F 0.0.0.0..397 0.0.0.0..0 Listen
```

If a blank screen appears instead, this means that AnyNet is not up and running. To start AnyNet, see *Starting AnyNet* on page A-7.

Alternatively, you can type the following command:

```
/ D TCPIP,TCPIP,N,CONN,PORT=397
```

The following should display if AnyNet is up and running:

```
EZZ2500I NETSTAT CS V1R4 TCPIP 782
USER ID CONN LOCAL SOCKET FOREIGN SOCKET STATE
VTAM 000226A8 0.0.0.0..1397 0.0.0.0..0 LISTEN
VTAM 000226A7 0.0.0.0..1397 *.* UDP
2 OF 2 RECORDS DISPLAYED
```

If the following appears instead, AnyNet is not up and running and you must start AnyNet.

```
EZZ2500I NETSTAT CS V1R4 TCPIP 197
USER ID CONN LOCAL SOCKET FOREIGN SOCKET STATE
0 OF 0 RECORDS DISPLAYED
```

Example: Starting AnyNet

To start AnyNet, type the following commands:

```
/v net,id=tcp62cdr,inact,f
/v net,id=tcp62,inact,f
/v net,id=tcp62,act
/v net,id=tcp62cdr,act
```

Verifying That the CICS Program is Accessible and Enabled in the CICS Region

Assume that the program you want to execute using the adapter is called PING0001. Verify that the program, for example, PING0001, is enabled in the CICS region:

```
CEMT I PROGRAM(PING0001)
STATUS: RESULTS - OVERTYPE TO MODIFY
Prog(PING0001 ) Len(0000000000) Cob Pro Ena Pri Ced
Res(000) Use(0000000001) Any Uex Ful Qua
```

Error Conditions

The following sections describe VTAM BIND failures and connection failures.

VTAM BIND Failures

If there are VTAM BIND errors indicated in the CICS and VTAM logs, or you receive messages from the adapter such as "No available sockets", the problem may be that the LU is not dynamically registered with the MVS host file (DNS).

When AnyNet opens the TCP session on port 397 to the adapter (after the SNASVCMG session is established), it uses the domain name *lu.vtamid.DNSSuffix* to contact the adapter. For example, if the LU is T29DPB01, the vtamid is USIBINET, and the DNS Suffix is ibi.com, the DNS name is T29DPB01.USIBINET.ibi.com.

You must update the TCP hosts file on the mainframe host. Modify the TCPIP.HOSTSLOCAL file on MVS with the IP address of the adapter platform. Run the MAKESITE utility, HLQ=TCPIP, for example.

Verify that the Mainframe host can communicate with the adapter by issuing the following command:

```
TSO PING T29DPB01.USIBINET.ibi.com
```

Connect Failures Module BPX1A10

Verify in the TCPIP Hosts file that the AnyNet port you are using is not restricted to a particular job name. The following specification in the TCP hosts file restricts port 397 to the job MYNET. This will cause connection failures. Either remove this specification or change the port number and cycle TCPIP.

```
397 TCP MYNET;VTAM AnyNet xxxxx 10/20
```

APPENDIX B

Running the Adapter Using LU6.2 Communication

Topics:

- MVS OS/390 APPC Communication
- Microsoft SNA Server Communication
- Application Run Time Requirements

This appendix contains technical information that you can use as a guide to ensure LU6.2 communication to the CICS region.

MVS OS/390 APPC Communication

The following topics contain technical information that you can use as a guide to ensure LU6.2 APPC communication to the CICS region.

Use the following information for conversation with VTAM and CICS administrators.

LU6.2 Setup on MVS

To correctly set the APPC/MVS LU definition, use the following VTAM APPC settings as a guide.

VTAM LU Definitions:

```

T39HPAPU PU      PUTYPE=2,                                +
                  ADDR=01,                                +
                  DISCNT=NO,                              +
                  IDBLK=05D,                              +
                  IDNUM=54435,                            +
                  MAXPATH=2,                              +
                  MAXOUT=7,                               +
                  MODETAB=IBILM,                          +
                  DLOGMOD=SNA3270,                       +
                  USSTAB=USSIBSNA,                       +
                  ISTATUS=ACTIVE                          +

T39HPAI0 LU      LOCADDR=0, MODETAB=MTOS2EE, DLOGMOD=PARALLEL
T39HPAI1 LU      LOCADDR=0, MODETAB=MTOS2EE, DLOGMOD=PARALLEL
T39HPAI2 LU      LOCADDR=0, MODETAB=MTOS2EE, DLOGMOD=PARALLEL
T39HPAI3 LU      LOCADDR=0, MODETAB=MTOS2EE, DLOGMOD=PARALLEL
T39HPAT1 LU      LOCADDR=2
T39HPAT2 LU      LOCADDR=3
T39HPAT3 LU      LOCADDR=4, DLOGMOD=LU62
T39HPAT4 LU      LOCADDR=5, DLOGMOD=LU62
    
```

Sample LogMode Definition:

```

PARALLEL MODEENT LOGMODE=PARALLEL, FMPROF=X'13', TSPROF=X'07',
PRIPROT=X'B0', SECPROT=X'B0', COMPROT=X'50B1', TYPE=X'00',
RUSIZES=X'8787', PSERVIC=X'060200000000000000002F00'
    
```

In Application Explorer, based on the above definitions, the LogMode entered is Parallel and the Local LU entered is T39HPAI1.

Note: An SNA Stack must be configured with Local LU T39HPAI1 on the adapter platform.

LU6.2 Setup on CICS

The following image shows a sample Object Characteristics screen for a CICS connection.

```

OBJECT CHARACTERISTICS                                CICS RELEASE = 0530
CEDA View Connection( HP64 )
  Connection      : HP64
  Group          : KUPYN
  Description     : HP64 CONNECTION
CONNECTION IDENTIFIERS
  Netname        : T39HPAI1
  INdsys         :
REMOTE ATTRIBUTES
  REMOTESYSTEM   :
  REMOTENAME     :
  REMOTESYSNET   :
CONNECTION PROPERTIES
  ACcessmethod   : Vtam          Vtam | IRc | INdirect | Xm
  PRotocol       : Appc          Appc | Lu61 | Exci
  Conntype       :               Generic | Specific
  SInglesess     : No           No | Yes
  DAtastream     : User         User | 3270 | SCs | STRfield | Lms
  RECORDformat   : U           U | Vb
                                                    SYSID=CICS APPLID=IWAYDEMO

```

The following image shows a sample Object Characteristics screen for a CICS session.

```

OBJECT CHARACTERISTICS                                CICS RELEASE = 0530
CEDA View Sessions( T39HPAI1 )
  Sessions       : T39HPAI1
  Group         : KUPYN
  Description    : HP64 LU
SESSION IDENTIFIERS
  Connection     : HP64
  SESSName       :
  NETnameq      :
  M0dename      : PARALLEL
SESSION PROPERTIES
  Protocol       : Appc          Appc | Lu61 | Exci
  MAximum        : 004 , 002     0-999
  RECEIvEpfX    :
  RECEIvECounT  :               1-999
  SENDPfx       :
  SENDCounT     :               1-999
  SENDSize      : 04096         1-30720
  RECEIvESize   : 04096         1-30720
                                                    SYSID=CICS APPLID=IWAYDEMO

```

Microsoft SNA Server Communication

The following topics contain technical information that you can use as a guide to ensure Microsoft SNA Server communication to the CICS region.

LU6.2 Setup on a Windows SNA Server

Verify that the SNA Service is active. You must create one or more remote LUs on the SNA Server with equivalent names for the remote LUs for the CICS region(s).

The following image displays the CICS LU, CICSAPPC, and the SNA Manager properties for the Remote LU.

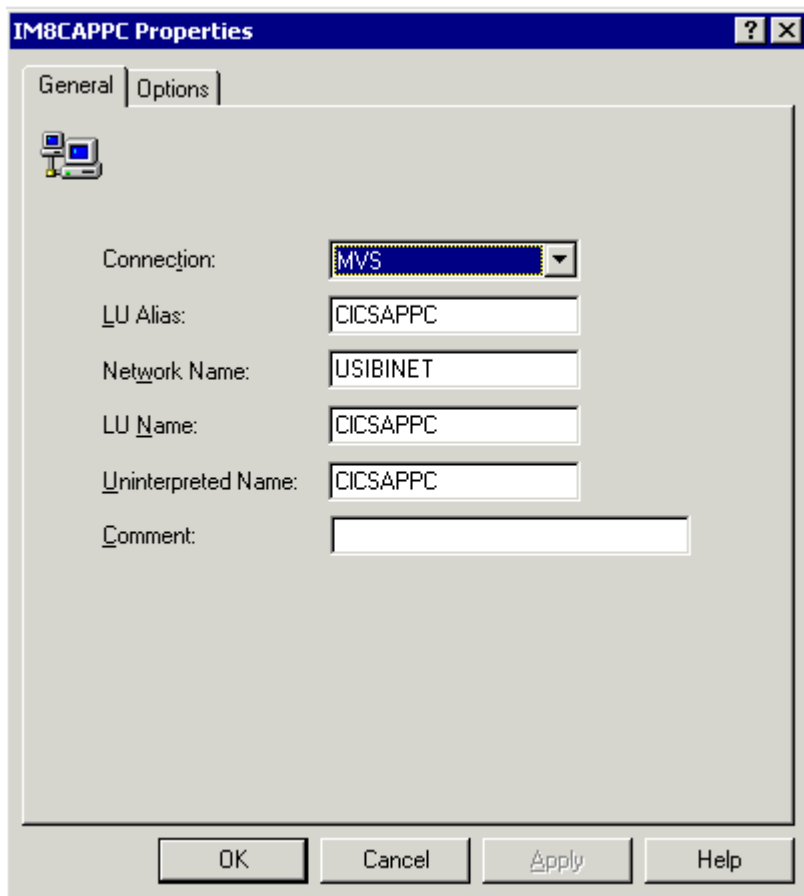

The following image displays SNA Manager on a Windows NT platform with remote LUs and an active SNA Service. A remote LU for the CICS region has been created (CICSAPPC). The SNA Server Local LU is T26ZCAI1.

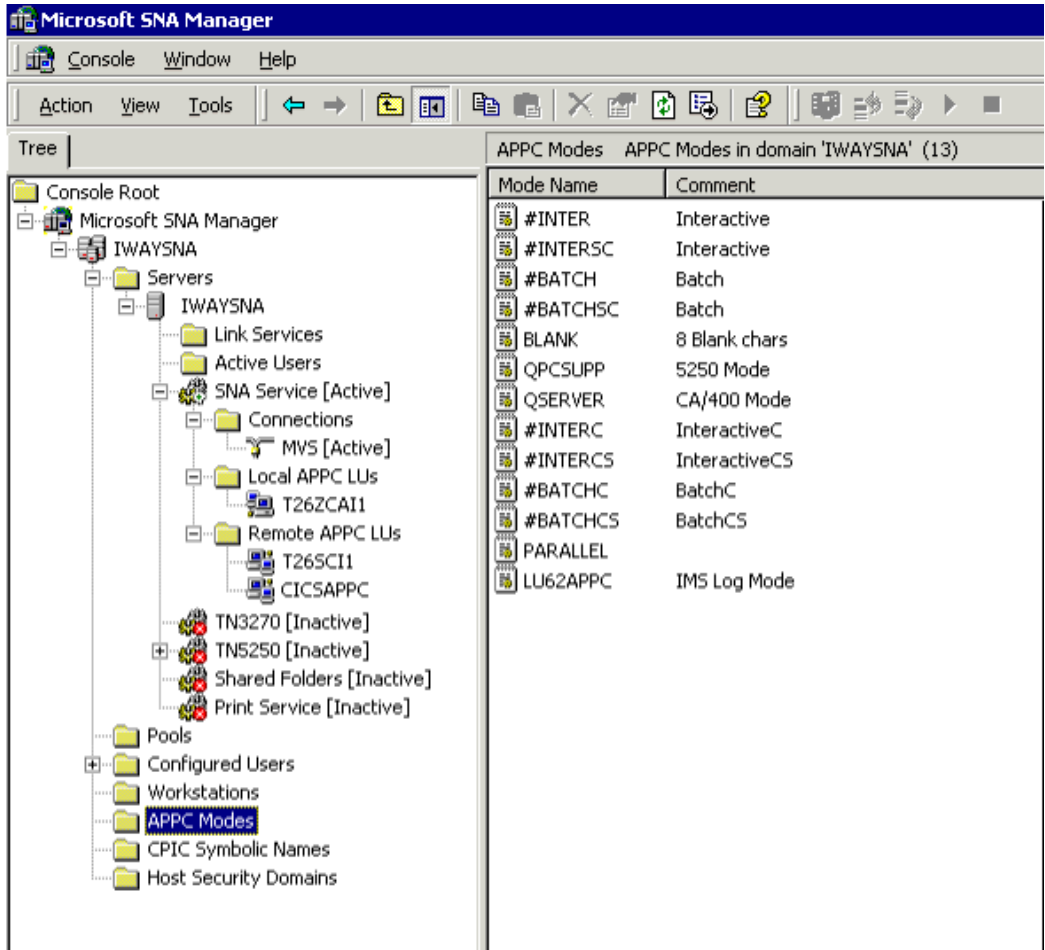

Application Run Time Requirements

The following are run time requirements for applications that invoke the CICS adapter using SNA Services. The adapter engine, iBSE, or any application server must include the required SNA dlls.

The following image displays the Set connection info dialog box using Application Explorer. Note that the remote LU is the CICS LU (IWAYDEMO) which matches the Remote LU on the SNA server.

The Local LU (T26ZCAI1) matches the SNA server local LU.

PARALLEL logmode is used for the connection. Make sure that you specify a valid logmode for the CICS region (VTAM mode table entry for APPC sessions).

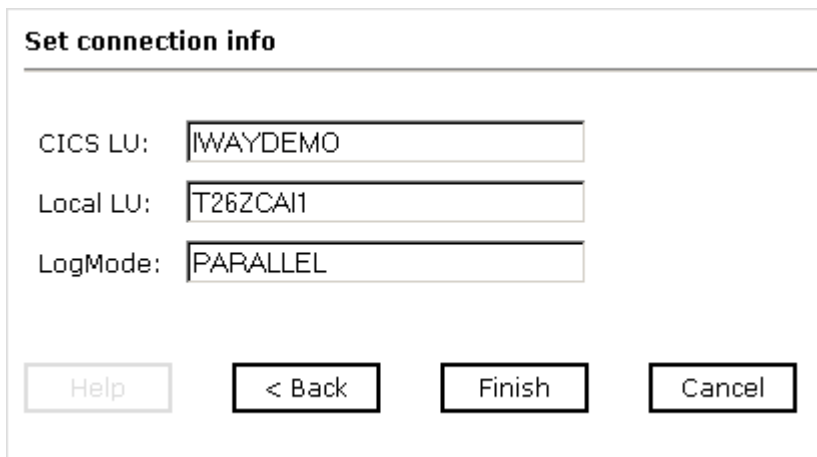

The image shows a dialog box titled "Set connection info". It contains three text input fields: "CICS LU:" with the value "IWAYDEMO", "Local LU:" with the value "T26ZCAI1", and "LogMode:" with the value "PARALLEL". At the bottom of the dialog, there are four buttons: "Help", "< Back", "Finish", and "Cancel".

APPENDIX C

Running the Adapter Using TCP/IP Communication

Topic:

- MVS OS/390 TCP/IP Communication

This appendix contains technical information that you can use as a guide to ensure TCP/IP communication to the CICS region.

MVS OS/390 TCP/IP Communication

The following topic contains technical information that you can use as a guide to ensure TCP/IP communication to the CICS region.

Use the following information for conversation with VTAM and CICS administrators.

TCP/IP Requirements

The following are requirements for TCP/IP communication to the CICS region:

- TCP must be installed on z/OS.
- The CICS system initialization must specify TCPIP=YES (the default is NO). Note that the TCP parameter is not related to the TCP/IP protocol.
- You must define a TCPIPSERVICE for the CICS region. This can be accomplished using CEDA. You must specify PROTOCOL(ECI) and ATTACHSEC(LOCAL).

Note: The default transaction is CIEP. This can be changed if you want. You may want to set STATUS(OPEN) so that it is started when installed. The default port is 1435. This can be changed using the PORT parameter.

For this to run, the TCPIPSERVICE must be installed and started. This can be accomplished automatically (by ensuring that the TCPIPSERVICE is defined in a group that is in a CICS start up list) or manually from CEDA.

APPENDIX D

Executing Adabas/Natural Using the Adapter

Topics:

- Natural Program Execution Overview
- Adabas/Natural Proxy Programs

This appendix describes the requirements for executing Adabas/Natural Proxy Programs using the adapter.

Natural Program Execution Overview

The following image illustrates the Natural Program execution process.

When a client application makes a request to the adapter, the adapter receives an XML message and uses its metadata (an XSD) to map the message to a CICS COMMAREA program. The adapter wraps this with the configured information for the Natural gateway (AASNATC) and sends an SNA over the TCP External Communication Interface (ECI) message to AnyNet. AnyNet uses the embedded attach header to set up an SNA session to CICS. The CICS mirror is attached. This is a transaction called IWAY, not the CPMI default transaction, because the Natural gateway needs a TWA of 128 bytes. The IWAY transaction runs the program DFHMIRS (the CICS Mirror program supplied by CICS) which links to the AASNATC program. AASNATC invokes the Natural program, passing it the name and library of the program to run. It also puts the COMMAREA passed where AASSUBC can find it. The Natural program makes calls to AASSUBC to get the input COMMAREA. The Natural program performs its function, writes its return information to the COMMAREA using AASSUBC, and returns. AASNATC returns and DFHMIRS passes back the COMMAREA. The adapter inspects the COMMAREA and maps it into an XML message using more metadata. The return XML message is passed back to the client.

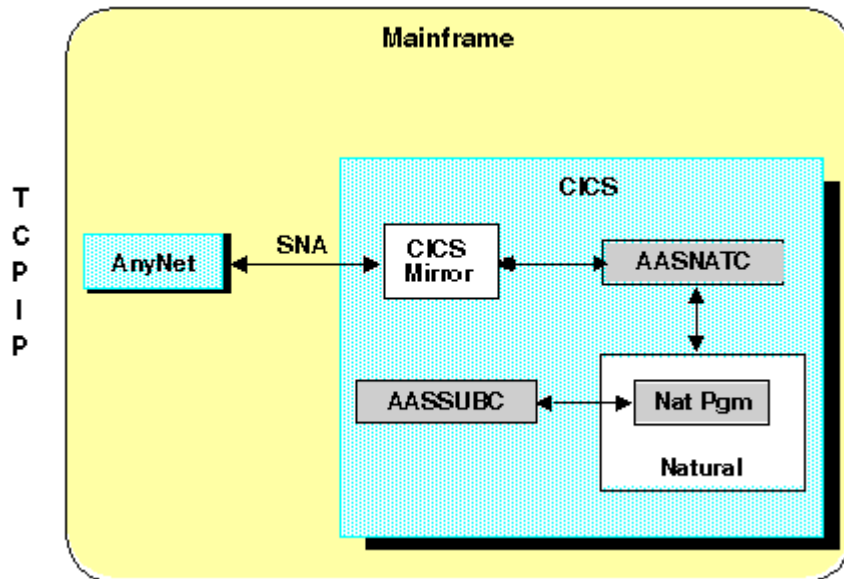

Adabas/Natural Proxy Programs

The adapter Adabas/Natural proxy programs are required to execute Adabas/Natural programs via the adapter. You must define the two load modules AASNATC and AASSUBC to the CICS region by including these members in a PDS Load library allocated to the DFHRPL DD of the CICS region.

Procedure: How to execute Adabas/Natural programs using the adapter

1. The following FTP procedure is used to retrieve the adapter load modules from the iWay Software FTP site.

Issue these commands from an MVS READY prompt:

```
FTP
IWAYDEMOS.IWAYSFTWARE.COM
CD /ADAPTERS/CICS/NATURAL
BINARY
LOCSITE PRI=50 SEC=100 RETPD=0 LRECL=80 BLKSIZE=3120 RECFM=FB CYL
GET AASNATC AASNATC.BIN
GET AASSUBC AASSUBC.BIN
QUIT
>>READY
RECEIVE INDATASET(AASNATC.BIN) DATASET(AASNATC.LOAD)
RECEIVE INDATASET(AASSUBC.BIN) DATASET(AASSUBC.LOAD)
```

After successful completion of the download, there will be two new load libraries created on the MVS system. It is up to the CICS administrator to copy or move these members to the appropriate library allocated to CICS.

2. Define the CICS transaction IWAY equivalent to the CICS CPMI transaction, but specify that TWAsize=00128.
3. To enable your Natural program, use the sample Natural program AASNATN in Appendix G, *Sample Programs* as a guide.

Note: All screen logic or terminal input/output is replaced by calls to the iWay input/output program AASSUBC.

APPENDIX E

Installing the Sample IWAYIVP and IWAYSAMP Programs in CICS

Topics:

- Installing and Configuring the Sample CICS Program IWAYIVP
- Installing and Configuring the Sample CICS Program IWAYSAMP

This section describes how to verify that you have correctly installed the adapter.

Installing and Configuring the Sample CICS Program IWAYIVP

The following procedure demonstrates how to install and configure the sample CICS program, IWAYIVP. Sample source code for the Cobol program IWAYIVP is provided in Appendix G, *Sample Programs*. For specific information for your site, see your CICS Systems Administrator.

Procedure: How to Install and Configure the Sample CICS Program IWAYIVP

To install and configure the sample CICS program, IWAYIVP:

1. Use the source code provided in Appendix G, *Sample Programs*, compile the program, and make it available to CICS.
2. Define the Cobol program to the CICS region.
 - a. Log onto the CICS region.
 - b. Issue the following command:

```
CEDA DEF PROG(IWAYIVP) GROUP(IWAY)
```

The following image shows the Define Program (IWAYIVP) mainframe screen that appears after you issue the command.

```

Session A - [24 x 80]
File Edit Transfer Appearance Communication Assigt Window Help
PrtScr Copy Paste Send Recv Display Color Map Record Stop Play Quit Clipbrd Index

DEF PROG(IWAYIVP) GROUP(IWAY)
OVERTYPE TO MODIFY                                CICS RELEASE = 0530
CEDA DEFine PROGRAM( IWAYIVP )
PROGRAM      : IWAYIVP
Group       : IWAY
DEscription ==> -
Language    ==> CObol | Assembler | Le370 | C | Pli
RELoad     ==> No      | Yes
RESident   ==> No      | Yes
USAge      ==> Normal | Transient
USElpacopy ==> No      | Yes
Status     ==> Enabled | Disabled
RSl        : 00      | Public
CEdf       ==> Yes    | No
DAtalocation ==> Below | Any
EXECKey    ==> User  | Cics
CONcurrency ==> Quasirent | Threadsafe
REMOTE ATTRIBUTES
DYnamic    ==> No      | Yes
+ REMOTESystem ==>
I New group IWAY created.

SYSID=CICS APPLID=EDBGH010
DEFINE SUCCESSFUL                                TIME: 12.58.17 DATE: 03.220
PF 1 HELP 2 COM 3 END                            6 CRSR 7 SBH 8 SFH 9 MSG 10 SB 11 SF 12 CNCL
MA a                                             06/022
    
```

3. Install the program in the CICS region.

a. Issue the following command:

```
CEDA INST PROG(IWAYIVP) GROUP(IWAY)
```

The following image displays a sample installation mainframe screen.

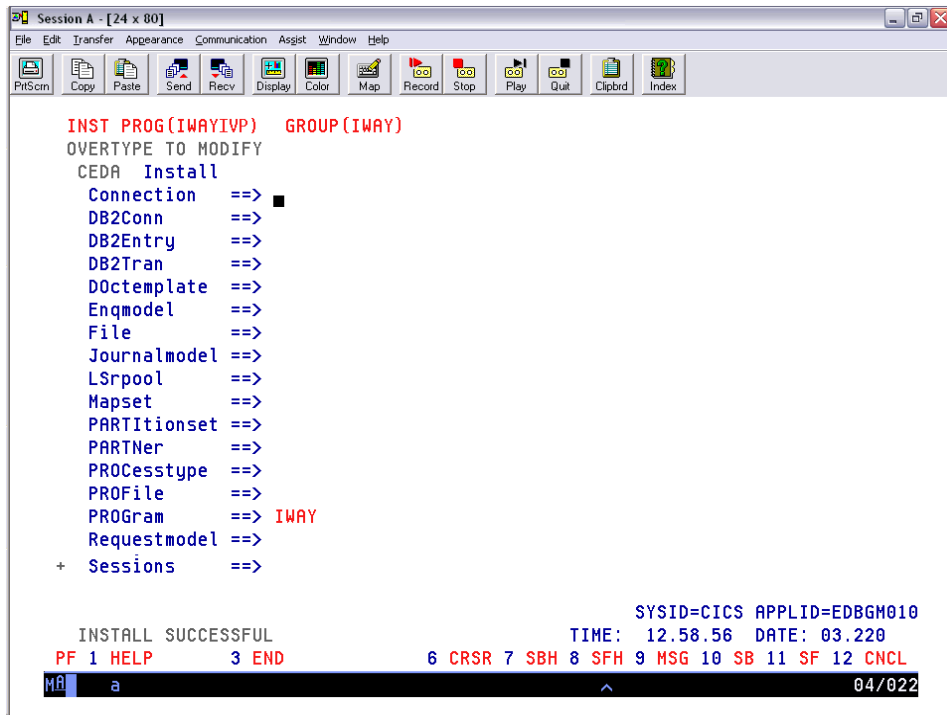

b. Display the program by typing the following command:

```
CEMT I PROG(IWAYIVP)
```

The following image shows a sample results mainframe screen.

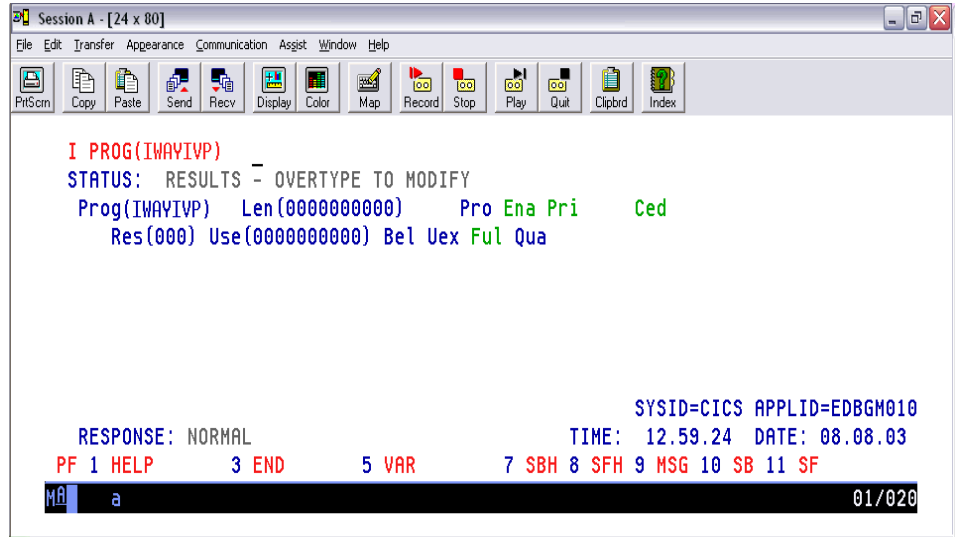

Installing and Configuring the Sample CICS Program IWAYSAMP

The following procedure demonstrates how to install and configure the sample CICS program, IWAYSAMP. Sample source code for the Cobol program IWAYSAMP is provided in Appendix G, *Sample Programs*. For specific information for your site, see your CICS Systems Administrator.

Procedure: How to Install and Configure the Sample CICS Program IWAYSAMP

To install and configure the sample CICS program, IWAYSAMP:

1. Use the source code provided in Appendix G, *Sample Programs*, compile the program, and make it available to CICS.
2. Define the Cobol program to the CICS region.
 - a. Log onto the CICS region.
 - b. Issue the following command:

```
CEDA DEF PROG(IWAYSAMP) GROUP(IWAY)
```

The following image shows the Define Program (IWAYSAMP) screen appears after you issue the command.

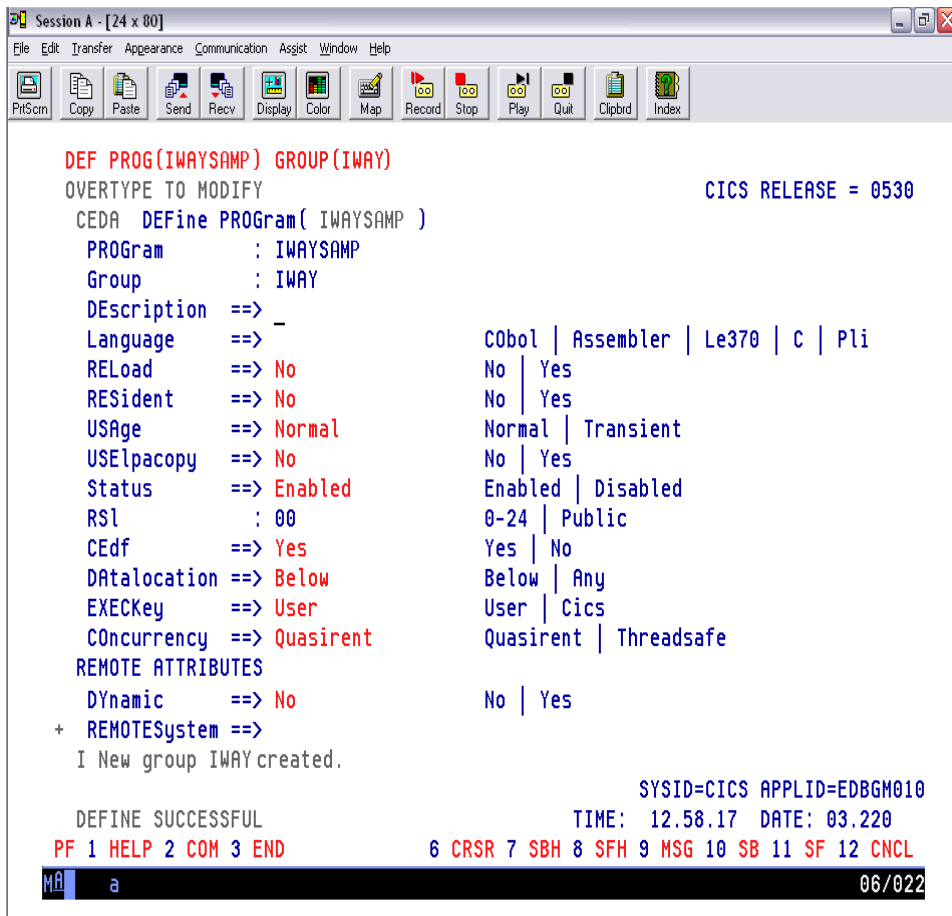

3. Install the program in the CICS region.
 - a. Issue the following command:

```
CEDA INST PROG(IWAYSAMP) GROUP(IWAY)
```

The following image shows a sample installation screen for IWAYSAMP.

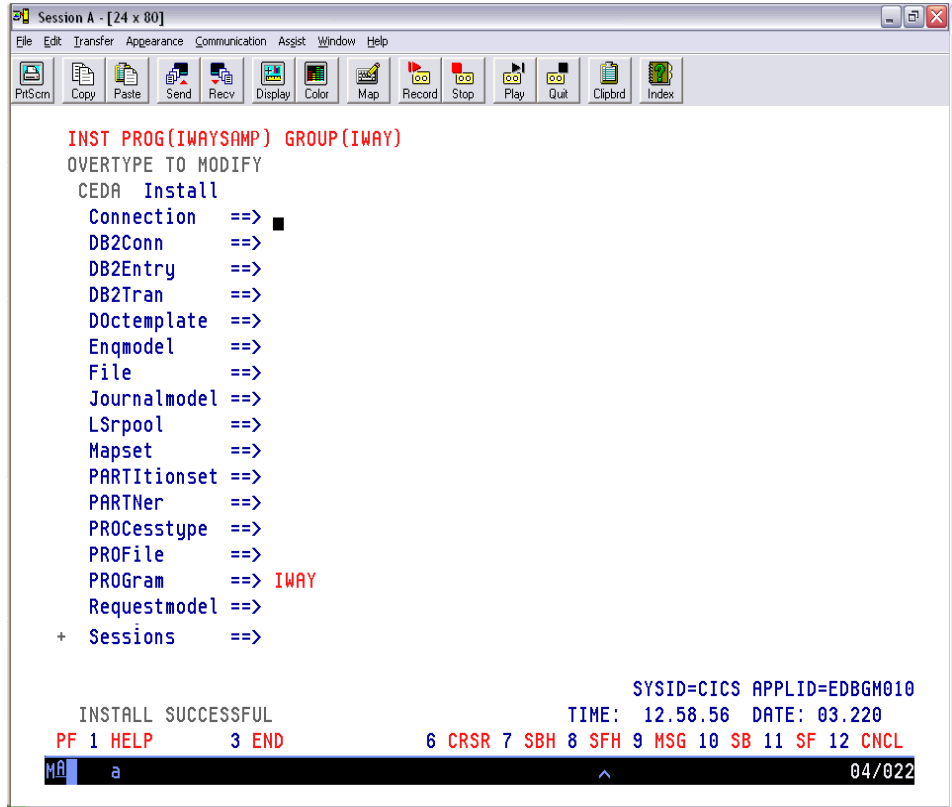

b. Display the program by typing the following command:

```
CEMT I PROG(IWAYSAMP)
```

The following image shows a sample of the IWAYSAMP results screen.

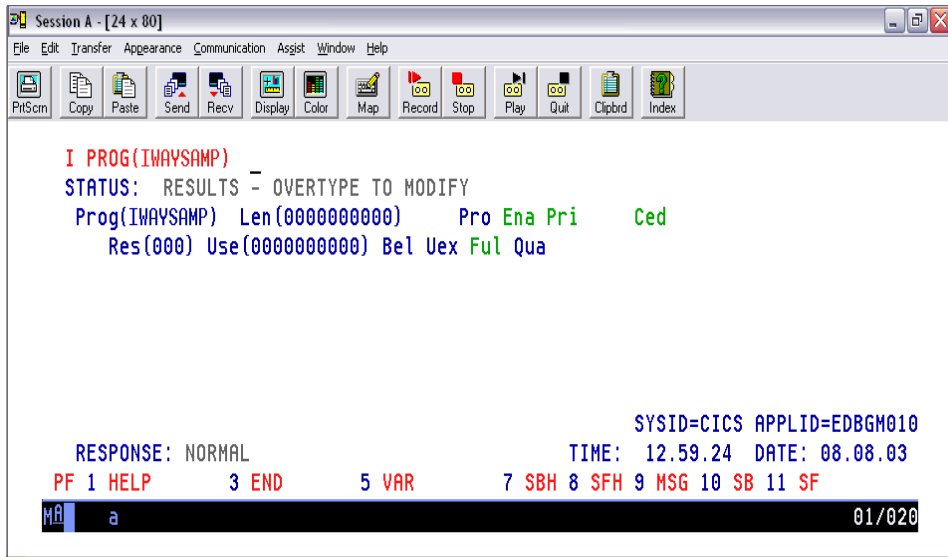

APPENDIX F

Sample Requests, Schemas, and Cobol File Descriptions

Topics:

- Request Document for the Generic Transaction IWAYIVP
- Request Schema for the Generic Transaction IWAYIVP
- Response Schema for the Generic Transaction IWAYIVP
- Request Documents for the Program IWAYSAMP
- Request Schema for the Program IWAYSAMP
- Response Schema for the Program IWAYSAMP
- Request Document for the Program AASNATN
- Request Schema for the Program AASNATN
- Response Schema for the Program AASNATN
- Sample Cobol File Descriptions

After you create a connection to CICS, you can add CICS transactions using Application Explorer. The generic transaction is always added automatically and represents CICS services whose data will not be mapped to XML.

The documents and schemas for the sample programs are shown in the following topics. Also, the Cobol descriptions that were used as input for the sample CICS transactions are shown.

Request Document for the Generic Transaction IWAYIVP

The following is a sample XML request document to run the IWAYIVP program:

```
<?xml version="1.0" encoding="UTF-8" ?>
<CICS>
  <Transaction location="CICS/Transactions/IWAYIVP">
    <CommArea>
      <WS-AREA>anything you want</WS-AREA>
    </CommArea>
  </Transaction>
</CICS>
```

Request Schema for the Generic Transaction IWAYIVP

```

<?xml version="1.0" encoding="UTF-8" ?>
<!-- Generated by the iBSE 2004-11-04T16:19:05Z -->
<xsd:schema xml:lang="en" xmlns:xsd="http://www.w3.org/2001/XMLSchema"
targetNamespace="urn:iwaysoftware:CICS/Transactions/IWAYIVP_Request"
attributeFormDefault="unqualified" elementFormDefault="qualified">
  <xsd:element name="CICS">
    <xsd:complexType>
      <xsd:all>
        <xsd:element name="Transaction">
          <xsd:complexType>
            <xsd:all>
              <xsd:element name="CommArea">
                <xsd:complexType>
                  <xsd:sequence>
                    <xsd:element minOccurs="1"
name="DFHCOMMAREA" maxOccurs="1">
                      <xsd:simpleType>
                        <xsd:restriction base="xsd:string">
                          <xsd:length value="1"/>
                        </xsd:restriction>
                      </xsd:simpleType>
                    </xsd:element>
                  </xsd:sequence>
                </xsd:complexType>
              </xsd:element>
            </xsd:all>
            <xsd:attribute type="xsd:string" use="required"
fixed="CICS/Transactions/IWAYIVP" name="location"/>
          </xsd:complexType>
        </xsd:element>
      </xsd:all>
    </xsd:complexType>
  </xsd:element>
</xsd:schema>

```

Although the message element is restricted to 80 bytes in the schema, this is not enforced at run time. The message can be up to 32,500 bytes long and is sent as the COMMAREA.

Response Schema for the Generic Transaction IWAYIVP

```
<?xml version="1.0" encoding="UTF-8" ?>
<!-- Generated by the iBSE 2004-11-04T16:19:05Z -->
<xsd:schema xml:lang="en" xmlns:xsd="http://www.w3.org/2001/XMLSchema"
targetNamespace="urn:iwaysoftware:CICS/Transactions/IWAYIVP_Response"
attributeFormDefault="unqualified" elementFormDefault="qualified">
  <xsd:element name="CICS">
    <xsd:complexType>
      <xsd:all>
        <xsd:element name="Transaction">
          <xsd:complexType>
            <xsd:sequence>
              <xsd:element name="CommArea" maxOccurs="unbounded">
                <xsd:complexType>
                  <xsd:sequence>
                    <xsd:element minOccurs="1"
name="DFHCOMMAREA" maxOccurs="1">
                      <xsd:simpleType>
                        <xsd:restriction base="xsd:string">
                          <xsd:length value="1"/>
                        </xsd:restriction>
                      </xsd:simpleType>
                    </xsd:element>
                  </xsd:sequence>
                </xsd:complexType>
              </xsd:element>
            </xsd:sequence>
          </xsd:complexType>
        </xsd:element>
      </xsd:all>
    </xsd:complexType>
  </xsd:element>
</xsd:schema>
```

The returned data is split into 80 byte parts, each encoded in <message> tags. If there are illegal XML characters in the data returned from CICS ('<', '/', or '&'), they are turned into XML entities as part of the encoding.

Request Documents for the Program IWAYSAMP

The following are sample XML request documents to run the IWAYSAMP program:

```
<?xml version="1.0" encoding="UTF-8" ?>
<CICS>
  <Transaction location="/CICS/Transaction/IWAYSAMP">
    <CommArea>
      <WS-AREA>P will pass down 40 bytes</WS-AREA>
    </CommArea>
  </Transaction>
</CICS>
```

```
<?xml version="1.0" encoding="UTF-8" ?>
<CICS>
  <Transaction location="/CICS/Transaction/IWAYSAMP">
    <CommArea>
      <WS-AREA>F will pass down 60 bytes</WS-AREA>
    </CommArea>
  </Transaction>
</CICS>
```

Request Schema for the Program IWAYSAMP

```
<?xml version="1.0" encoding="UTF-8" ?>
<!-- Generated by the iBSE 2004-11-04T16:20:49Z -->
<xsd:schema xml:lang="en" xmlns:xsd="http://www.w3.org/2001/XMLSchema"
targetNamespace="urn:iwaysoftware:CICS/Transactions/IWAYSAMP_Request"
attributeFormDefault="unqualified" elementFormDefault="qualified">
  <xsd:element name="CICS">
    <xsd:complexType>
      <xsd:all>
        <xsd:element name="Transaction">
          <xsd:complexType>
            <xsd:all>
              <xsd:element name="CommArea">
                <xsd:complexType>
                  <xsd:sequence>
                    <xsd:element minOccurs="1"
name="DFHCOMMAREA" maxOccurs="1">
                      <xsd:simpleType>
                        <xsd:restriction base="xsd:string">
                          <xsd:length value="1"/>
                        </xsd:restriction>
                      </xsd:simpleType>
                    </xsd:element>
                  </xsd:sequence>
                </xsd:complexType>
              </xsd:element>
            </xsd:all>
            <xsd:attribute type="xsd:string" use="required"
fixed="CICS/Transactions/IWAYSAMP" name="location"/>
          </xsd:complexType>
        </xsd:element>
      </xsd:all>
    </xsd:complexType>
  </xsd:element>
</xsd:schema>
```

Response Schema for the Program IWAYSAMP

```

<?xml version="1.0" encoding="UTF-8" ?>
<!-- Generated by the iBSE 2004-11-04T16:20:49Z -->
<xsd:schema xml:lang="en" xmlns:xsd="http://www.w3.org/2001/XMLSchema"
targetNamespace="urn:iwaysoftware:CICS/Transactions/IWAYSAMP_Response"
attributeFormDefault="unqualified" elementFormDefault="qualified">
  <xsd:element name="CICS">
    <xsd:complexType>
      <xsd:all>
        <xsd:element name="Transaction">
          <xsd:complexType>
            <xsd:choice>
              <xsd:element name="message1">
                <xsd:complexType>
                  <xsd:sequence>
                    <xsd:element minOccurs="1" name="STAT"
maxOccurs="1">
                      <xsd:simpleType>
                        <xsd:restriction base="xsd:string">
                          <xsd:length value="1"/>
                        </xsd:restriction>
                      </xsd:simpleType>
                    </xsd:element>
                  </xsd:sequence>
                </xsd:complexType>
              </xsd:element>
              <xsd:element name="message2">
                <xsd:complexType>
                  <xsd:sequence>
                    <xsd:element minOccurs="1" name="STAT"
maxOccurs="1">
                      <xsd:simpleType>
                        <xsd:restriction base="xsd:string">
                          <xsd:length value="1"/>
                        </xsd:restriction>
                      </xsd:simpleType>
                    </xsd:element>
                  </xsd:sequence>
                </xsd:complexType>
              </xsd:element>
            </xsd:choice>
          </xsd:complexType>
        </xsd:element>
      </xsd:all>
    </xsd:complexType>
  </xsd:element>
</xsd:schema>

```

The returned data is split into 80 byte parts, each encoded in <message> tags. If there are illegal XML characters in the data returned from CICS ('<', '/', or '&'), they are turned into XML entities as part of the encoding.

Request Document for the Program AASNATN

The following is a sample XML request document to run the AASNATN program:

```
<?xml version="1.0" encoding="UTF-8"?>
<CICS>
  <Transaction location="CICS/Transactions/CICSNAT">
    <message>
      <STARTEMP>Text</STARTEMP>
      <ENDEMP>Text</ENDEMP>
    </message>
  </Transaction>
</CICS>
```

Request Schema for the Program AASNATN

```
<?xml version="1.0" encoding="UTF-8" ?>
<xs:schema xml:lang="en" attributeFormDefault="unqualified"
xmlns:xs="http://www.w3.org/2001/XMLSchema" elementFormDefault="qualified">
  <xs:element name="CICS">
    <xs:complexType>
      <xs:all>
        <xs:element name="Transaction">
          <xs:complexType>
            <xs:all>
              <xs:element name="message">
                <xs:complexType>
                  <xs:sequence>
                    <xs:element minOccurs="1" name="STARTEMP" maxOccurs="1"/>
                    <xs:element minOccurs="1" name="ENDEMP" maxOccurs="1"/>
                  </xs:sequence>
                </xs:complexType>
              </xs:element>
            </xs:all>
            <xs:attribute type="xs:string" use="required"
              fixed="CICS/Transactions/CICSNAT" name="location"/>
          </xs:complexType>
        </xs:element>
      </xs:all>
    </xs:complexType>
  </xs:element>
</xs:schema>
```

Response Schema for the Program AASNATN

```

<?xml version="1.0" encoding="UTF-8" ?>
<xs:schema xml:lang="en" attributeFormDefault="unqualified"
xmlns:xs="http://www.w3.org/2001/XMLSchema" elementFormDefault="qualified">
  <xs:element name="CICS">
    <xs:complexType>
      <xs:all>
        <xs:element name="Transaction">
          <xs:complexType>
            <xs:sequence>
              <xs:element name="message" maxOccurs="unbounded">
                <xs:complexType>
                  <xs:sequence>
                    <xs:element minOccurs="1" name="EMPNUM" maxOccurs="1" />
                    <xs:element minOccurs="1" name="FIRSTNAME" maxOccurs="1" />
                    <xs:element minOccurs="1" name="LASTNAME" maxOccurs="1" />
                    <xs:element minOccurs="1" name="MARITALSTATUS" maxOccurs="1" />
                    <xs:element minOccurs="1" name="SEX" maxOccurs="1" />
                    <xs:element minOccurs="1" name="BIRTH" maxOccurs="1" />
                    <xs:element minOccurs="1" name="DEPARTMENT" maxOccurs="1" />
                    <xs:element minOccurs="1" name="JOBTITLE" maxOccurs="1" />
                    <xs:element minOccurs="1" name="CCODE1" maxOccurs="1" />
                    <xs:element minOccurs="1" name="CCODE2" maxOccurs="1" />
                    <xs:element minOccurs="1" name="CCODE3" maxOccurs="1" />
                    <xs:element minOccurs="1" name="CCODE4" maxOccurs="1" />
                    <xs:element minOccurs="1" name="CCODE5" maxOccurs="1" />
                    <xs:element minOccurs="1" name="SALARY1" maxOccurs="1" />
                    <xs:element minOccurs="1" name="SALARY1" maxOccurs="1" />
                    <xs:element minOccurs="1" name="SALARY1" maxOccurs="1" />
                    <xs:element minOccurs="1" name="SALARY1" maxOccurs="1" />
                    <xs:element minOccurs="1" name="SALARY1" maxOccurs="1" />
                    <xs:element minOccurs="1" name="SALARY1" maxOccurs="1" />
                    <xs:element minOccurs="1" name="FILLER" maxOccurs="1" />
                  </xs:sequence>
                </xs:complexType>
              </xs:element>
            </xs:sequence>
          </xs:complexType>
        </xs:all>
      </xs:element>
    </xs:schema>

```

Sample Cobol File Descriptions

The following sample Cobol File Descriptions are used as input for the CICS transactions in Chapter 3, *Designing the Adapter*.

IWAYSAMP_in.cbl

```
01 DFHCOMMAREA.  
   05 WS-AREA          PIC X(100).
```

IWAYSAMP_out_P.cbl

```
01 DFHCOMMAREA.  
   05 STAT             PIC X(1).  
   05 FILLER           PIC X(39)
```

IWAYSAMP_out_F.cbl

```
01 DFHCOMMAREA.  
   05 STAT             PIC X(1).  
   05 FILLER           PIC X(59).
```

AASNATN_in.txt

```
***** 08800000  
*      INPUT to NATURAL PROGRAM AASNATN  
***** 23100000  
   02 NATREC.                24000000  
   03 START-EMP             PIC X(8).  32000000  
   03 END-EMP               PIC X(8).  32000000
```

AASNATN_out.txt

```

***** 08800000
*      OUTPUT FROM NATURAL PROGRAM AASNATN
***** 23100000
02  NATREC .                                24000000
03  EMP-NUM          PIC X(8) .             32000000
03  FIRSTNAME       PIC X(20) .            40000000
03  LASTNAME        PIC X(20) .            40000000
03  MARITAL-STATUS  PIC X(1) .             40000000
03  SEX             PIC X(1) .             40000000
03  BIRTH           PIC X(4) .             40000000
03  DEPARTMENT      PIC X(6) .             40000000
03  JOB-TITLE       PIC X(25) .            40000000
03  CCODE1          PIC X(3) .             40000000
03  CCODE2          PIC X(3) .             40000000
03  CCODE3          PIC X(3) .             40000000
03  CCODE4          PIC X(3) .             40000000
03  CCODE5          PIC X(3) .             40000000
03  SALARY1         PIC X(9) .             40000000
03  SALARY1         PIC X(9) .             40000000
03  SALARY1         PIC X(9) .             40000000
03  SALARY1         PIC X(9) .             40000000
03  SALARY1         PIC X(9) .             40000000
03  FILLER          PIC X(2) .             40000000

```

APPENDIX G

Sample Programs

Topics:

- IWAYIVP Program
- IWAYSAMP Program
- CICS TCP/IP Sockets Program for Mainframe
- CICS TCP/IP Sockets Program for TX

This appendix includes the source code for the sample programs.

IWAYIVP Program

The following sample program called IWAYIVP tests the adapter installation. This program takes no input and returns a fixed string as output. Therefore, the generic transaction is suitable.

```
*-----+-----*
* IWAYIVP      |
*-----
* IWAY SOFTWARE INSTALLATION VERIFICATION PROGRAM (IVP)
*
* THIS PROGRAM WILL RETURN CONGRATULATIONS SIGNIFYING
* SUCCESSFUL CONNECTION AND EXECUTION.
*
*-----*
* TAILORING:                                     *
*-----+-----+-----*
IDENTIFICATION DIVISION.
PROGRAM-ID. IWAYIVP.
ENVIRONMENT DIVISION.
DATA DIVISION.

WORKING-STORAGE SECTION.

01 WS-AREA          PIC X(50) VALUE
   'CONGRATULATIONS!!!'.

LINKAGE SECTION.
01 DFHCOMMAREA          PIC X(50) .

PROCEDURE DIVISION.
   EXEC CICS HANDLE ABEND
       LABEL (030-ABEND)
   END-EXEC.

   MOVE WS-AREA TO DFHCOMMAREA.

   EXEC CICS RETURN
   END-EXEC.
   GOBACK.
030-ABEND.

   MOVE 'PROGRAM ERROR HAS OCCURRED!' TO WS-AREA.
   MOVE WS-AREA TO DFHCOMMAREA.

   EXEC CICS RETURN
   END-EXEC.
   GOBACK.
```

IWAYSAMP Program

The following sample program called IWAYSAMP processes multiple record type outputs.

```

*-----+-----*
* IWAYSAMP
*-----
* 100 BYTE COMMAREA
*      'P' IN FIRST POSITION RETURNS 40 BYTES
*      'F' IN FIRST POSITION RETURNS 60 BYTES
*      ELSE
*          RETURN ERROR MESSAGE UNFORMATTED STRING
*
*-----+-----*
* TAILORING:
*-----+-----+-----*
IDENTIFICATION DIVISION.
PROGRAM-ID. IWAYSAMP.
ENVIRONMENT DIVISION.
DATA DIVISION.
WORKING-STORAGE SECTION.

01 WS-DATA-OUT-P          PIC X(40) .
01 WS-DATA-OUT-F          PIC X(60) .

LINKAGE SECTION.

01 DFHCOMMAREA.
   05 CA-DATA.
      10 CA-FIRST-1          PIC X(1) .
      10 FILLER              PIC X(99) .

PROCEDURE DIVISION.
   EXEC CICS HANDLE ABEND
      LABEL (030-ABEND)
   END-EXEC

   IF EIBCALEN = 0
      MOVE ' EIBCALEN IS = ZERO ' TO CA-DATA
      PERFORM 020-RETURN
   END-IF.

   IF CA-FIRST-1 = 'P'
      MOVE 'VALUE OF P IN FIRST BYTE OF COMMAREA'
          TO WS-DATA-OUT-P
      MOVE WS-DATA-OUT-P TO CA-DATA
      GO TO 020-RETURN
   END-IF.

```

CICS TCP/IP Sockets Program for Mainframe

```
IF CA-FIRST-1 = 'F'
  MOVE 'VALUE OF F IN FIRST BYTE OF COMMAREA'
    TO WS-DATA-OUT-F
  MOVE WS-DATA-OUT-F TO CA-DATA
  GO TO 020-RETURN
END-IF.

MOVE 'SUPPLY P OR F IN FIRST BYTE OF INPUT...PLEASE'
  TO CA-DATA.

020-RETURN.

EXEC CICS RETURN
END-EXEC.
GOBACK.

030-ABEND.
GO TO 020-RETURN.
```

CICS TCP/IP Sockets Program for Mainframe

This program uses the MVS sockets interface EZASOKET. For other platforms, use the socket interface appropriate for that platform.

```
000100 CBL TRUNC(BIN)
000200 ID DIVISION.
000300 PROGRAM-ID. TCPIPOC.
000400*****
000500* CICS TCP/IP SOCKET INTERFACE PROGRAM--SEND TO SOUND-LISTENER
000600*****
000700 ENVIRONMENT DIVISION.
000800 DATA DIVISION.
000900 WORKING-STORAGE SECTION.
001000 01 SOCKET-GROUP.
001100     05 SOC-FUNCTION          PIC X(16) VALUE SPACES.
001200     05 ERRNO                PIC 9(8) BINARY VALUE ZEROES.
001300     05 RETCODE              PIC S9(8) BINARY VALUE ZEROES.
001400     05 AF                    PIC 9(8) BINARY VALUE 2.
001500     05 SOCTYPE              PIC 9(8) BINARY VALUE 1.
001600     05 PROTO                 PIC 9(8) BINARY VALUE 0.
001700     05 NAMELEN              PIC 9(8) BINARY.
001800     05 HOSTNAME             PIC X(255).
001900     05 HOSTENT              PIC 9(8) BINARY.
002000     05 NAME.
002100         10 FAMILY            PIC 9(4) BINARY VALUE 2.
002200         10 PORT              PIC 9(4) BINARY VALUE 4772.
002300         10 IP-ADDRESS        PIC 9(8) BINARY.
002400         10 IP-ADDRESS-ALPHA REDEFINES IP-ADDRESS PIC X(4).
002500         10 RESERVED         PIC X(8) VALUE LOW-VALUES.
```

```

002600      05  FLAGS                      PIC 9(8) BINARY VALUE 0.
002700      05  SOCKET                     PIC 9(4) BINARY.
002800      05  NBYTE                       PIC 9(8) BINARY.
002900      05  CMD                         PIC 9(8) BINARY.
003000      05  REQARG                     PIC 9(8) BINARY.
003100
003200 01  WORKAREA.
003300      05  RESP                         PIC S9(9) BINARY VALUE 0.
003400      05  DATAPTR                     POINTER VALUE NULL.
003500      05  DATAPTR-L REDEFINES DATAPTR PIC 9(9) BINARY.
003600      05  DATAKEY                    PIC S9(9) BINARY VALUE 0.
003700      05  DATALEN                    PIC S9(4) BINARY VALUE 0.
003800      05  STARTTIME                   PIC S9(15) PACKED-DECIMAL.
003900      05  ENDTIME                     PIC S9(15) PACKED-DECIMAL.
004000      05  DURATION                    PIC 99999.
004100      05  LLEN                        PIC 9(8) BINARY VALUE 4.
004200      05  TMSG                      PIC X(25)
004300      VALUE 'ELASPED TIME = '.
004400      05  ERRMSG                     PIC X(41)
004500      VALUE 'ERROR ENCOUNTERED DURING '.
004600      05  TRCMSG                     PIC X(41)
004700      VALUE 'RC = 9999999999 FOR '.
004800
004900 LINKAGE SECTION.
005000 PROCEDURE DIVISION.
005100 MAINLINE.
005200      PERFORM GETSOCK
005300*     PERFORM GETHOSTBYNAME
005400      PERFORM SETBLOCK
005500      PERFORM CONNECTTOHOST
005600      PERFORM SENDDATA
005700      PERFORM CLOSESOCK
005800      EXEC CICS RETURN END-EXEC
005900      GOBACK
006000      .
006100
006200006300 GETSOCK.
006400      MOVE 'SOCKET' TO SOC-FUNCTION
006500      CALL 'EZASOKET' USING SOC-FUNCTION,
006600          AF,
006700          SOCTYPE,
006800          PROTO,
006900          ERRNO,
007000          RETCODE
007100
007200      MOVE RETCODE TO SOCKET
007300      IF RETCODE < 0
007400          PERFORM WRITERR-EXIT

```

CICS TCP/IP Sockets Program for Mainframe

```
007500     END-IF
007600     .
007700
007800 SETBLOCK.
007900     MOVE 'FCNTL           ' TO SOC-FUNCTION
008000     MOVE 4 TO CMD
008100     MOVE 0 TO REQARG
008200     CALL 'EZASOKET' USING SOC-FUNCTION, SOCKET, CMD, REQARG,
008300             ERRNO, RETCODE
008400     .
008500
008600 CONNECTTOHOST.
008700     MOVE X'AC1EA611' TO IP-ADDRESS-ALPHA
008800     MOVE 'CONNECT           ' TO SOC-FUNCTION
008900     CALL 'EZASOKET' USING SOC-FUNCTION,
009000         SOCKET,
009100         NAME,
009200         ERRNO,
009300         RETCODE,
009400     IF RETCODE = 0
009500         CONTINUE
009600     ELSE
009700         PERFORM WRITERR-EXIT
009800     END-IF
009900     .
010000
010100 SENDDATA.
010200     MOVE 'SEND           ' TO SOC-FUNCTION
010300     EXEC CICS STARTBR FILE('TESTFILE') RIDFLD(DATAKEY) RBA
010400         RESP(RESP)
010500     END-EXEC
010600
010700     EXEC CICS ASKTIME ABSTIME(STARTTIME) END-EXEC
010800
010900     PERFORM 300 TIMES
010910*     PERFORM UNTIL RESP > 0
011000         EXEC CICS READNEXT FILE('TESTFILE')
011100             RIDFLD(DATAKEY)
011200             RBA
011300             LENGTH(DATALEN)
011400             RESP(RESP)
011500             SET(DATAPTR)
011600     END-EXEC
011700     IF RESP = 0
011710         MOVE DATALEN TO NBYTE
011800*         ADD 0 TO DATALEN GIVING NBYTE
011900         MOVE 4 TO LLEN
012000         MOVE 0 TO RETCODE
```

```

012100*          PERFORM UNTIL RETCODE = NBYTE
012200*              OR RETCODE < 0
012300
012400              CALL 'EZASOKET' USING SOC-FUNCTION,
012500                  SOCKET,
012600                  FLAGS,
012700                  LLEN,
012800                  NBYTE,
012900                  ERRNO,
013000                  RETCODE
013100
013200          IF RETCODE = -1
013300              MOVE 1 TO RESP
013400              PERFORM WRITERR-EXIT
013500          END-IF
013600*          MOVE RETCODE TO TRCMSG(6:10)
013700*          MOVE NBYTE TO TRCMSG(22:10)
013800*          EXEC CICS WRITEQ TD QUEUE('CSSL')
013900*              FROM(TRCMSG) LENGTH(41)
014000*          END-EXEC
014100
014200          MOVE DATALEN TO NBYTE
014300
014400          CALL 'EZASOKET' USING SOC-FUNCTION,
014500              SOCKET,
014600              FLAGS,
014700              NBYTE,
014800              BY VALUE DATAPTR,
014900              BY REFERENCE ERRNO,
015000              RETCODE
015100
015200**          MOVE RETCODE TO TRCMSG(6:10)
015300**          MOVE NBYTE TO TRCMSG(22:10)
015400**          EXEC CICS WRITEQ TD QUEUE('CSSL')
015500**              FROM(TRCMSG) LENGTH(41)
015600*          END-EXEC
015700*          IF RETCODE NOT = NBYTE
015800*              SUBTRACT RETCODE FROM NBYTE
015900*              ADD RETCODE TO DATAPTR-L
016000*          END-IF
016100*          END-PERFORM
016200          IF RETCODE = -1
016300              MOVE 1 TO RESP
016400              PERFORM WRITERR-EXIT
016500          END-IF
016600          END-IF
016700          END-PERFORM
016800

```

CICS TCP/IP Sockets Program for Mainframe

```
016900     IF RESP = 1
017000         PERFORM WRITERR-EXIT
017100     END-IF
017200
017300     EXEC CICS ASKTIME ABSTIME(ENDTIME) END-EXEC
017400
017500     SUBTRACT STARTTIME FROM ENDTIME GIVING DURATION
017600
017700     MOVE DURATION TO TMSG(17:8)
017800
017900     EXEC CICS SEND TEXT FROM(TMSG)
018000         LENGTH(LENGTH OF TMSG)
018100     END-EXEC
018200
018300     .
018400
018500     CLOSESOCK.
018600     MOVE ZEROES TO RETCODE ERRNO
018700     MOVE 'CLOSE          ' TO SOC-FUNCTION
018800     CALL 'EZASOKET' USING SOC-FUNCTION
018900         SOCKET
019000         ERRNO
019100         RETCODE
019200     IF RETCODE < 0
019300         PERFORM WRITERR-EXIT
019400     END-IF
019500     .019600 GETHOSTBYNAME.
019700     MOVE 'GETHOSTBYNAME  ' TO SOC-FUNCTION
019800     CALL 'EZASOKET' USING SOC-FUNCTION NAMELEN NAME
019900         HOSTENT RETCODE
020000     .
020100
020200     WRITERR-EXIT.
020300     MOVE SOC-FUNCTION TO ERRMSG(26:15)
020400     EXEC CICS SEND TEXT FROM(ERRMSG)
020500         LENGTH(LENGTH OF ERRMSG)
020600     END-EXEC
020700
020800     EXEC CICS RETURN END-EXEC.
```

CICS TCP/IP Sockets Program for TX

The following sample C program uses a TX sockets interface.

```

#include <cics_api.h>
#include <cics_eib.h>

/*****
/* C Sample Program
/*
/* This is a sample program for a cics client to the iWay adapter.
/*
/*
/* Author John Schlesinger
/* Version 1.0
*****/

/*****
/* #includes
*****/

#include <cicstype.h>
#include <string.h>
#include <stdlib.h>
#include <stdio.h>

#include <ctype.h>
#include <errno.h>
/* Include the right sockets headers */
#ifdef _MSC_VER
#include <winsock2.h>
#else
#include <arpa/inet.h>
#include <sys/socket.h>
#endif

/*****
/* #defines
*****/

#define InsertCursor          '\x13'      /* 3270 Insert cursor  */
#define ebcdic_ProtectAttribute '\xe4'   /* 3270 Protected Attr */
#define ascii_ProtectAttribute '\x55'   /* 3270 Protected Attr */

#define MSG_SIZE  32500                /*

/*****
/* Procedure Declarations
*****/

```

CICS TCP/IP Sockets Program for TX

```
void Output_Text (char*);
void Log_Text (char*);
void cics_time (cics_char_t []);
void Process_Startup_Parameters (void);
void return_to_cics (void);

void SendData(char *, short);
int  writen(int, const void *, size_t);
int  readn(int, void *, size_t);

/*****
/* Structures
*****/

struct screen_struct
{
    cics_char_t sf;
    cics_char_t attr;
    cics_char_t display [160];
};

struct log_struct
{
    cics_char_t program [8];
    cics_char_t filler0;
    cics_char_t applid [8];
    cics_char_t filler1;
    cics_char_t msg [80];
};

/*****
/* Global Variables
*****/
cics_char_t Term_Code [2] = "00"; /* Terminal Code
cics_char_t sba [4]; /* 3270 set buffer address
cics_char_t ProtectAttribute ; /* 3270 Protect Attribute
cics_sshort_t scrnwd = 80; /* Width of the screen
struct screen_struct output_screen = {'\x1d', '\ ', ""};
struct log_struct CSMT_log = {"CICSDEXI", '\ ', "", '\ ', ""};

/*****
/* Procedure : Main
/* Function : To call all sub-procedures
/* Input : None
/* Returns : Nothing
*****/

void main( void )
{ \
```

```

int cics_api_temp_var = cics_api_edf_init_c_extended(0, &CicsArgs);

Process_Startup_Parameters();

Output_Text("Starting the test");

SendData("168.135.180.16", 4773);
// SendData("168.135.63.14", 4773);

Output_Text("Test completed");

return_to_cics();

} /* End of main */

/*****
/* Procedure      : Process_Startup_Parameters
/* Function       : To Determine how the transaction was initiated
/*                and process any parameters supplied
/* Input          : None
/* Returns        : Nothing
*****/

void Process_Startup_Parameters()
{
    cics_sshort_t len_out;
    cics_char_t  ascii_sba [4] = {'\x11', '\x20', '\x41', '\x13'};
    cics_char_t  ebcdic_sba [4] = {'\x11', '\x40', '\xC1', '\x13'};
    cics_char_t  Start_Code [2] = "00"; /* Start Code */
    cics_sshort_t Text_Length = 80;
    cics_char_t  Text_Buffer [80];
    cics_ubyte_t This_OPSPYS = '\0'; /* local OPSPYS */
    cics_char_t  This_RELEASE [5] = ""; /* local cics release */
    char * pch;

    /* initialise storage */
    memset(Text_Buffer, '\0', 79);
    Text_Buffer [79] = '\0';
    /* EXEC CICS ADDRESS EIB(dfheiptr); */ \

    { \
    CicsArgs.ArgCode[0] = 77; \
    CicsArgs.ArgData[0].PointerRef = &dfheiptr; \
    CicsArgs.ArgMask = 0x20000000; \
    CicsArgs.ArgCount = 1; \
    CicsArgs.FnCode = 2; \
    CicsArgs.DebugLine = -1; \
    cics_api_exec_c_extended(&CicsArgs); \

```

```

dfheiptr = (dfheiptr); \
}

/* EXEC CICS INQUIRE SYSTEM
   OPSYS(&This_OPSYS)
   RELEASE(This_RELEASE); */ \
{ \
CicsArgs.ArgCode[0] = 325; \
CicsArgs.ArgData[0].StringArea = This_RELEASE; \
CicsArgs.ArgCode[1] = 252; \
CicsArgs.ArgData[1].ByteArea = &This_OPSYS; \
CicsArgs.ArgMask = 0x20000000; \
CicsArgs.ArgCount = 2; \
CicsArgs.FnCode = 42; \
CicsArgs.DebugLine = -1; \
cics_api_exec_c_extended(&CicsArgs); \
}

/* if ASCII opsys use ASCII 3270 cursor positioning*/
if ((This_OPSYS == 'P') || (This_OPSYS == 'A') ||
    (This_OPSYS == 'H') || (This_OPSYS == 'O') ||
    (This_OPSYS == 'S') || (This_OPSYS == 'L') ||
    (This_OPSYS == 'N'))
{
    strncpy(sba, ascii_sba, 4);
    output_screen.attr = '\x48';
    ProtectAttribute = ascii_ProtectAttribute;
}
else
{
    strncpy(sba, ebcdic_sba, 4);
    output_screen.attr = '\xc8';
    ProtectAttribute = ebcdic_ProtectAttribute;
}

/* EXEC CICS ASSIGN
   APPLID(CSMT_log.applid)
   SCRNRD(scrnrd)
   STARTCODE(Start_Code)
   TERMCODE(Term_Code); */ \
{ \
CicsArgs.ArgCode[0] = 18; \
CicsArgs.ArgData[0].StringArea = CSMT_log.applid; \
CicsArgs.ArgCode[1] = 351; \
CicsArgs.ArgData[1].ShortArea = &scrnrd; \
CicsArgs.ArgCode[2] = 373; \
CicsArgs.ArgData[2].StringArea = Start_Code; \
CicsArgs.ArgCode[3] = 397; \
}

```

```

CicsArgs.ArgData[3].StringArea = Term_Code; \
CicsArgs.ArgMask = 0x20000000; \
CicsArgs.ArgCount = 4; \
CicsArgs.FnCode = 5; \
CicsArgs.DebugLine = -1; \
cics_api_exec_c_extended(&CicsArgs); \
}
/* Handle input from terminal or from a START */
if (Start_Code [0] == 'S')
{
/* EXEC CICS RETRIEVE INTO(Text_Buffer) LENGTH(Text_Length); */ \
{ \
CicsArgs.ArgData[8].DataArea = Text_Buffer; \
CicsArgs.ArgData[2].ShortArea = &Text_Length; \
CicsArgs.ArgMask = 0x20000104; \
CicsArgs.FnCode = 71; \
CicsArgs.DebugLine = -1; \
cics_api_exec_c_extended(&CicsArgs); \
}
}
else
{
/* EXEC CICS RECEIVE INTO(Text_Buffer) LENGTH(Text_Length); */ \
{ \
CicsArgs.ArgData[8].DataArea = Text_Buffer; \
CicsArgs.ArgData[2].ShortArea = &Text_Length; \
CicsArgs.ArgMask = 0x20000104; \
CicsArgs.FnCode = 67; \
CicsArgs.DebugLine = -1; \
cics_api_exec_c_extended(&CicsArgs); \
}
}

/* Check if screen input is new or modified */
/* If modified need to jump 3 bytes to skip sba */

if (!(memcmp(Text_Buffer, sba, 3)))
{
memcpy(Text_Buffer, Text_Buffer+3, (size_t)Text_Length);
}

/* if a 3270 terminal resend hostid back to the screen */
/* and position InsertCursor for new line */

if ((Term_Code [0] > '\x90') &&
(Term_Code [0] < '\xa0'))
{
strncpy(output_screen.display, Text_Buffer, (size_t)Text_Length);
}

```

```

        len_out = (cics_sshort_t) (scrnwd + 3);

        output_screen.display [scrnwd - 2] = InsertCursor;
        /* EXEC CICS SEND FROM(&output_screen) LENGTH(len_out) ERASE; */ \
    { \
    CicsArgs.ArgData[4].DataArea = &output_screen; \
    CicsArgs.ArgData[2].ShortValue = len_out; \
    CicsArgs.ArgMask = 0x20000414; \
    CicsArgs.FnCode = 74; \
    CicsArgs.DebugLine = -1; \
    cics_api_exec_c_extended(&CicsArgs); \
    }
    }

    } /* End of Process_Startup_Parameters */

/*****
/* Procedure      : Output_Text                               */
/* Function       : To Display text to Termianl (if appropriate) */
/* Input         : Text to be displayed                       */
/* Returns       : Nothing                                    */
*****/

void Output_Text(char* Text)
{
    cics_sshort_t len_out;
    char Temp_Text [92];           /* text buffer          */
    cics_char_t time_msg [9];

    cics_time(time_msg);
    sprintf (Temp_Text, "%s %s",time_msg,Text);
    len_out = (cics_sshort_t) (scrnwd + 3);

    if ((Term_Code [0] > '\x90') &&
        (Term_Code [0] < '\xa0'))
    {
        strncpy(output_screen.display, Temp_Text, 92);
        memset(output_screen.display+92, ' ',
            sizeof(output_screen.display)-92);
        output_screen.display [scrnwd - 1] = InsertCursor;
        output_screen.attr = ProtectAttribute;

        /* EXEC CICS SEND FROM(&output_screen) LENGTH(len_out) WAIT; */ \
    { \
    CicsArgs.ArgData[4].DataArea = &output_screen; \
    CicsArgs.ArgData[2].ShortValue = len_out; \
    CicsArgs.ArgMask = 0x20800014; \
    CicsArgs.FnCode = 74; \
    CicsArgs.DebugLine = -1; \

```

```

cics_api_exec_c_extended(&CicsArgs); \
}
}

/* clear screen structure */

memset(output_screen.display, '\0', 159);
output_screen.display [159]='\0';

} /* End of Output_Text */

/*****
/* Procedure      : Log_Text                               */
/* Function       : To send text to CICS CSMT log         */
/* Input          : Text to be displayed                */
/* Returns        : Nothing                               */
*****/
void Log_Text(char* Text)
{
    cics_sshort_t Text_Length = 105;
    cics_char_t time_msg [9];

    cics_time(time_msg);
    sprintf (CSMT_log.msg, "%s %s",time_msg,Text);

    /* EXEC CICS WRITEQ TD QUEUE("CSMT") FROM(&CSMT_log)
       LENGTH(Text_Length); */ \
    { \
    cics_api_strncpy(CicsArgs.ArgData[9].StringValue, "CSMT", (short)4); \
    CicsArgs.ArgData[4].DataArea = &CSMT_log; \
    CicsArgs.ArgData[2].ShortValue = Text_Length; \
    CicsArgs.ArgMask = 0x20000214; \
    CicsArgs.FnCode = 106; \
    CicsArgs.DebugLine = -1; \
    cics_api_exec_c_extended(&CicsArgs); \
    }

    /* clear log structures */
    memset(CSMT_log.msg, '\0', 79);
    CSMT_log.msg [79]='\0';

} /* End of Output_Text */

/*****
* Function name: return_to_cics                               *
* Description:   Return to CICS and exit program             *
* Parameters:    None                                        *
* Returns:       None                                        *
*****/

```

```

void return_to_cics(void)
{
    cics_char_t blank_log [80] = "" ;

    /* write blank line to log */
    /* EXEC CICS WRITEQ TD QUEUE("CSMT") FROM(blank_log) LENGTH(80); */ \
    { \
    cics_api_strncpy(CicsArgs.ArgData[9].StringValue, "CSMT", (short)4); \
    CicsArgs.ArgData[4].DataArea = blank_log; \
    CicsArgs.ArgData[2].ShortValue = 80; \
    CicsArgs.ArgMask = 0x20000214; \
    CicsArgs.FnCode = 106; \
    CicsArgs.DebugLine = -1; \
    cics_api_exec_c_extended(&CicsArgs); \
    }

    /* reposition 3270 cursor
    if ((Term_Code [0] > '\x90') &&
        (Term_Code [0] < '\xa0'))
    {
        EXEC CICS SEND FROM(sba) LENGTH(4);
    } */

    /* EXEC CICS RETURN; */ \
    { \
    CicsArgs.ArgMask = 0x20000000; \
    CicsArgs.FnCode = 72; \
    CicsArgs.DebugLine = -1; \
    cics_api_exec_c_extended(&CicsArgs); \
    }
}

/*****
* Function name: SendData
* Description:   Sends the data to the host and port
* Inputs:       Host id and port number
* Returns:      None
*****/

void SendData(char * Host_Id, short Port_Num)
{
    char * pch;
    static char Temp_Text [80];           /* text buffer */
    int connfd, crc, i, BytesRead;
    struct sockaddr_in servaddr;
    char RcvBuf[MSG_SIZE+1];
    char MsgBuf[] = \
    "<?xml version='1.0' encoding='UTF-8'?> \

```



```

<ZPBT_IN> \
  <in> \
    <ORDER_NUM/> \
    <ITEM_NUM>00000</ITEM_NUM> \
    <BANK_CODE/> \
    <BANK_ACCT/> \
  </in> \
  <in> \
    <ORDER_NUM>2015689292</ORDER_NUM> \
    <ITEM_NUM>00001</ITEM_NUM> \
    <BANK_CODE>123456789</BANK_CODE> \
    <BANK_ACCT>9753124680</BANK_ACCT> \
  </in> \
  <in> \
    <ORDER_NUM>2025689393</ORDER_NUM> \
    <ITEM_NUM>00001</ITEM_NUM> \
    <BANK_CODE/> \
    <BANK_ACCT>1345678920</BANK_ACCT> \
  </in> \
  <in> \
    <ORDER_NUM>2025689393</ORDER_NUM> \
    <ITEM_NUM>00006</ITEM_NUM> \
    <BANK_CODE/> \
    <BANK_ACCT/> \
  </in> \
  <in> \
    <ORDER_NUM>2025689393</ORDER_NUM> \
    <ITEM_NUM>00000</ITEM_NUM> \
    <BANK_CODE/> \
    <BANK_ACCT/> \
  </in> \
</ZPBT_IN>";

connfd = socket(AF_INET, SOCK_STREAM, 0);

if (connfd < 0) {
  Output_Text("Error creating socket");
  return_to_cics();
}

sprintf (Temp_Text, "Trying to connect to host %s and port %d",
  Host_Id, Port_Num);
Output_Text(Temp_Text);
servaddr.sin_family = AF_INET;
servaddr.sin_port = htons(Port_Num);
servaddr.sin_addr.s_addr = inet_addr(Host_Id); /* Use quad 4 notation
*/
if ((crc = connect(connfd, (struct sockaddr *) &servaddr,
sizeof(servaddr))) < 0) {

```

```

        Output_Text("Connect Error");
        return_to_cics();
    }
    sprintf (Temp_Text, "Number of bytes to send is %d bytes",
strlen(MsgBuf));
    Output_Text(Temp_Text);

    writen(connfd, MsgBuf, strlen(MsgBuf));

    BytesRead = readn(connfd, RcvBuf, sizeof(RcvBuf));

    sprintf (Temp_Text, "Number of bytes read is %d bytes", BytesRead);
    Output_Text(Temp_Text);
    Output_Text("First ten lines of payload are:");
    for (i=519;i<1220;i+=70) {
        strncpy(Temp_Text, &RcvBuf[i], 70);
        Output_Text(Temp_Text);
    }
    for (i=0;i<BytesRead;i+=78) {
        pch = RcvBuf + i;
        strncpy(Temp_Text, pch, 78);
        Log_Text(Temp_Text);
    }

#ifdef _MSC_VER
    closesocket(connfd);
#else
    close(connfd);
#endif

    return;
}
/* End send data */

/*****
 * Function name: cics_time
 * Description: gets the time
 * Returns: time_msg as 8 cics_char_t string
 *****/

void cics_time (cics_char_t time_msg[])
{
    cics_char_t abstime [8];

    /* EXEC CICS ASKTIME ABSTIME(abstime); */ \
    { \
    CicsArgs.ArgData[0].DataArea = abstime; \
    CicsArgs.ArgMask = 0x20000001; \
    CicsArgs.FnCode = 4; \
    CicsArgs.DebugLine = -1; \

```

```

cics_api_exec_c_extended(&CicsArgs); \
}
/* EXEC CICS FORMATTIME ABSTIME(abstime) TIME(time_msg) TIMESEP; */
\
{ \
CicsArgs.ArgData[0].DataArea = abstime; \
CicsArgs.ArgData[15].StringArea = time_msg; \
CicsArgs.ArgMask = 0x20018001; \
CicsArgs.FnCode = 22; \
CicsArgs.DebugLine = -1; \
cics_api_exec_c_extended(&CicsArgs); \
}
time_msg [8]='\0';
}

/*****
* Function name: readn
* Description: Utility function to read a socket
* Inputs: fd - socket number,
* vptr - buffer to read into
* n - length of the data read
* Returns: int number of bytes read
*****/

int readn(int fd, void *vptr, size_t n)
{
size_t nleft;
size_t nread;
char *ptr;

ptr = vptr;
nleft = n;
while (nleft > 0)
{
if ( (nread = recv(fd, ptr, nleft, 0)) < 0)
{
if (errno == EINTR)
nread = 0;
else
return (-1);
}
else if (nread == 0)
break;

nleft -= nread;
ptr += nread;
}
return (n - nleft);
}

```

```

/*****
 * Function name: writen
 * Description: Utility function to write a socket
 * Inputs:      fd - socket number,
 *             vptr - buffer to write from
 *             n - length of the data to write
 * Returns:     int number of bytes not written
 *****/

```

```

int writen(int fd, const void *vptr, size_t n)
{
    size_t nleft;
    size_t nwritten;
    const char *ptr;

    ptr = vptr;
    nleft = n;
    while (nleft > 0)
    {
        if ( (nwritten = send(fd, ptr, nleft, 0)) <= 0)
        {
            if (errno == EINTR)
                nwritten = 0;
            else
                return (-1);
        }
        nleft -= nwritten;
        ptr += nwritten;
    }
    return (nleft);
}

```

Natural Source Code for Program AASNATN

```

/*****
/* SAMPLE NATURAL PROGRAM.  AASEMPNO
/*
/* THIS PROGRAM MUST BE CALLED BY AASNATC OR AASNATCB WHICH ARE*/
/* THE 'C' AND COBOL DRIVER PROGRAMS.  ALL INTERACTION BETWEEN*/
/* THIS CODE AND THAT RESIDING OUTSIDE OF NATURAL IS HANDLED BY*/
/* THE DATA MOVER PROGRAMS AASSUBC(C) AND AASSUBCB(COBOL).
/*
/* COMMUNICATION WITH THE DATA MOVER PROGRAMS REQUIRE THE
/* CONTROL BLOCK:
/*     1 #REQUEST-PARMS
/*     2 #FUNCTION      (A2)  GT,PT,LC,LI
/*     2 #OFFSET        (I2)  DATA OFFSET OF INPUT/OUTPUT
/*     2 #LENGTH        (I2)  LENGTH OF DATA TO GET OR PUT

```

```

/*          2 #RESPONSE-CODE (I4)          */
/*          2 #ERR-MESSAGE  (A72)         */
/*                                          */
/* THE IMPLEMENTED FUNCTIONS ARE:          */
/* GT - GET INPUT BY OFFSET.              */
/*     THE OFFSET MUST BE SET TO 0 FOR THE FIRST CALL ONLY!! */
/*     THE OFFSET IS INCREMENTED FOLLOWING EACH CALL BY THE */
/*     DATA MOVER PROGRAM                 */
/*     THE LENGTH OF THE REQUESTED DATA MUST BE PROVIDED FOR */
/*     EACH CALL. IT SHOULD MATCH THE LENGTH OF THE AREA */
/*     PROVIDED TO RECEIVE THE INPUT DATA */
/*     IE: MOVE #FUNC-GT TO #FUNCTION      */
/*           MOVE 8 TO #LENGTH             */
/*           MOVE 0 TO OFFSET - FIRST CALL ONLY */
/*           CALL 'AASSUBC' #FUNCTION #EMP-NUM1 */
/*                                          */
/*           WHERE #EMP-NUM1 IS AN EIGHT BYTE FIELD */
/*                                          */
/* PT - PUT OUTPUT BY OFFSET              */
/*     THE OFFSET MUST BE SET TO 0 FOR THE FIRST CALL ONLY!! */
/*     THE OFFSET IS INCREMENTED FOLLOWING EACH CALL BY THE */
/*     DATA MOVER PROGRAM                 */
/*     THE LENGTH OF THE REQUESTED DATA MUST BE PROVIDED FOR */
/*     EACH CALL. IT SHOULD MATCH THE LENGTH OF THE AREA */
/*     PROVIDED CONTAINING THE OUTPUT DATA */
/*     IE: MOVE #FUNC-PT TO #FUNCTION      */
/*           MOVE 8 TO #LENGTH             */
/*           MOVE 0 TO OFFSET - FIRST CALL ONLY */
/*           CALL 'AASSUBC' #FUNCTION #EMP-NUM1 */
/*                                          */
/*           WHERE #EMP-NUM1 IS AN EIGHT BYTE FIELD */
/*                                          */
/* LI - GET LENGTH OF INPUT DATA          */
/*     UPDATES THE #LENGTH FIELD WITH THE TOTAL LENGTH OF ALL */
/*     INPUT PARMS. NO OTHER PARMS ARE NEEDED */
/*     IE: MOVE #FUNC-LI TO #FUNCTION      */
/*           CALL 'AASSUBC' #FUNCTION      */
/*                                          */
/* LC - GET LENGTH OF COMMAREA USED TO SEND DATA. */
/*     UPDATES THE #LENGTH FIELD WITH THE COMMAREA LENGTH. */
/*     NO OTHER PARMS ARE NEEDED          */
/*     IE: MOVE #FUNC-LC TO #FUNCTION      */
/*           CALL 'AASSUBC' #FUNCTION      */
/*                                          */
/* IMPLEMENTED RESPONSE-CODES:            */
/* 0 - OPERATION COMPLETED SUCCESSFULLY  */
/* 4 - ENDDATA - OFFSET EXCEEDS END OF INPUT DATA. */
/*     INDICATES NO FURTHER INPUT IS AVAILABLE */

```

CICS TCP/IP Sockets Program for TX

```
/*      8 - ENDBUFF - OFFSET + LENGTH IS GREATER THEN COMMAREA      */
/*                                                                    */
/* NOTE:                                                                */
/*      ALWAYS USE THE FIRST FIELD OF A GROUP WHEN CALLING          */
/*      DATA MOVER PROGRAMS.  NOTICE ALL CALLS ARE MADE WITH      */
/*      #FUNCTION NOT #REQUEST-PARMS.                                */
/*                                                                    */
/*      ALL INPUT PARMS MUST BE PROCESSED BEFORE OUTPUT.            */
/*-----*/

DEFINE DATA LOCAL
1 #FUNC-TYPE
  2 #FUNC-GT (A2) INIT<'GT'>
  2 #FUNC-PT (A2) INIT<'PT'>
  2 #FUNC-LC (A2) INIT<'LC'>
  2 #FUNC-LI (A2) INIT<'LI'>

1 #REQUEST-PARMS
  2 #FUNCTION      (A2) /*GT,PT,LC,LI
  2 #OFFSET        (I2) /*DATA OFFSET OF INPUT/OUTPUT
  2 #LENGTH        (I2) /*LENGTH OF DATA TO GET OR PUT
  2 #RESPONSE-CODE (I4)
  2 #ERR-MESSAGE   (A72)

1 #PARMS
  2 #EMP-NUM1      (A8)
  2 #EMP-NUM2      (A8)

1 EMPLOY-VIEW VIEW OF EMPLOYEES1
  2 PERSONNEL-ID
  2 FIRST-NAME
  2 NAME
  2 MAR-STAT
  2 SEX
  2 BIRTH
  2 DEPT
  2 JOB-TITLE
  2 CURR-CODE(1:5)
  2 SALARY(N9/1:5)

1 #ERROR-PARMS
  2 #NATPROG (A8)
  2 #NATMSG  (A65)
  2 #NATERR  (A7)
END-DEFINE

/* USE LI FUNCTION TO THE GET LENGTH OF INPUT PARAMETERS */
MOVE #FUNC-LI TO #FUNCTION
CALL 'AASSUBC' #REQUEST-PARMS
```

```

IF #LENGTH LT 16 /*REQUIRED FOR THIS PROGRAM*/
THEN TERMINATE
END-IF

/* USE GET FUNCTION TO RETRIEVE DATA PARMS */
MOVE 8 TO #LENGTH
MOVE 0 TO #OFFSET
MOVE #FUNC-GT TO #FUNCTION
CALL 'AASSUBC' #FUNCTION #EMP-NUM1
CALL 'AASSUBC' #FUNCTION #EMP-NUM2
MOVE 0 TO #OFFSET
MOVE 147 TO #LENGTH
MOVE #FUNC-PT TO #FUNCTION
FIND ALL EMPLOY-VIEW WITH PERSONNEL-ID = #EMP-NUM1 THRU #EMP-NUM2
  IF NO RECORDS FOUND
    MOVE *PROGRAM TO #NATPROG
    MOVE ' REQUESTED EMPLOYEE NUMBERS NOT IN THE DATABASE' TO #NATMSG
    MOVE 80 TO #LENGTH
    MOVE #FUNC-PT TO #FUNCTION
    CALL 'AASSUBC' #FUNCTION #NATPROG
    TERMINATE
  END-NOREC
  CALL 'AASSUBC' #FUNCTION PERSONNEL-ID
END-FIND

ON ERROR
  MOVE *PROGRAM TO #NATPROG
  DECIDE FOR FIRST CONDITION
    WHEN *ERROR-NR = 1106
      MOVE ' EMPLOYEE NUMBER IS TOO LARGE. 8 BYTES IS '
      TO #NATMSG
      MOVE 'THE MAX' TO #NATERR
    WHEN *ERROR-NR = 3061
      MOVE ' INVALID EMPLOYEE NUMBER RANGE SPECIFIED '
      TO #NATMSG
      MOVE ' ' TO #NATERR
    WHEN NONE
      MOVE ' HAS DETECTED THE FOLLOWING ERROR NUMBER: '
      TO #NATMSG
      MOVE *ERROR-NR TO #NATERR
  END-DECIDE
  MOVE 80 TO #LENGTH
  CALL 'AASSUBC' #FUNCTION #NATPROG
  TERMINATE
END-ERROR
END

```

APPENDIX H

Debugging and Troubleshooting

Topics:

- Troubleshooting
- Data Type Conversions

This section includes tips and techniques for debugging the adapter.

Troubleshooting

Certain situations may cause the adapter to return error messages. This topic describes error messages, possible causes, and solutions.

Error message

An Error has occurred running {program name}: CICS has returned no CommArea

Accompanied by:

```
at com.ibi.tcpappc.DirectTCPConnection.execute(DirectTCPConnection.java:nnn)
at com.ibi.cics.CICSIPServer.execute(CICSIPServer.java:nmm)
at com.ibi.cics.CICSConnection.execute(CICSConnection.java:nmm)
at com.ibi.cics.CICSAdapter.process(CICSAdapter.java:nnn)
at com.iwaysoftware.ibse.iwse.Adapter2Runner.process(Adapter2Runner.java:nnn)
at com.iwaysoftware.ibse.iwse.Adapter2Runner.<init>(Adapter2Runner.java:nmm)
at com.iwaysoftware.ibse.iwse.XDSOAPRouter.handleAdapter(XDSOAPRouter.java:nnn)
at com.iwaysoftware.ibse.iwse.XDSOAPRouter.process(XDSOAPRouter.java:nnn)
at com.iwaysoftware.ibse.iwse.IBSEServlet.doPost(IBSEServlet.java:nnn)
```

where:

nnn

Is the line number in the Java program.

Possible Cause: Occurs when a program abends.

Solution: Verify that the input request document accurately describes the input needed for the program, and that the Cobol description matches what the program is using.

Error message

Unable to execute Transaction {program name}

Accompanied by:

{applid of region} While performing an attach for node {nodename} a security violation was detected.

Possible Cause: Occurs when the password sent to CICS is lowercase.

Solution: Change the password from lowercase to uppercase.

Error message

Unable to execute Transaction {program name}

Accompanied by:

VTAM and CICS error message:

```
VTAM RETURN CODE 1001 SENSE CODE 8004 0000
```

Possible Cause: Network DNS problem: old connection lingering in DNS.

Solution: Flush DNS.

At the command prompt:

1. Ping the host address for the machine where the adapter is running (for example, PMSNJC) to obtain the IP address that you require for the following step.
2. Use the IP address (for example, 172.30.166.90) and type the following command:

```
nbtstat -A 172.30.166.90
```

The following image shows the DOS screen listing the host addresses when the nbtstat command is executed.

```
H:\>
H:\>ping pmsnjc

Pinging pmsnjc.ibi.com [172.30.166.90] with 32 bytes of data:

Reply from 172.30.166.90: bytes=32 time<10ms TTL=127
Reply from 172.30.166.90: bytes=32 time<10ms TTL=127
Reply from 172.30.166.90: bytes=32 time<10ms TTL=127
Reply from 172.30.166.90: bytes=32 time<10ms TTL=127

Ping statistics for 172.30.166.90:
    Packets: Sent = 4, Received = 4, Lost = 0 (0% loss),
    Approximate round trip times in milli-seconds:
        Minimum = 0ms, Maximum = 0ms, Average = 0ms

H:\>nbtstat -A 172.30.166.90

Local Area Connection:
Node IpAddress: [172.30.242.94] Scope Id: []

          NetBIOS Remote Machine Name Table

   Name                  Type                  Status
   ----                  -
PGMMGY                   <00>  UNIQUE              Registered
EDA                      <00>  GROUP               Registered
PGMMGY                   <20>  UNIQUE              Registered
EDA                      <1E>  GROUP               Registered
PGMMGY                   <03>  UNIQUE              Registered

   MAC Address = 00-50-DA-BA-15-9E

H:\>
```

3. If the host address (PGMMGY) as shown in the previous screen is not the same as in the previous command (PMSNJC), issue the command:

```
ipconfig /flushdns
```

Note: If the problem is still not resolved, contact your Network Administrator.

Data Type Conversions

When the adapter parses the Cobol structure, it creates the following values as its view of the types in the byte array it either creates or receives. These are visible in the log, for example, the CANTV log:

```
<outputFields>
  <fldData>
    <recfd="C:\Operaciones_ADMSAP\IWAY_ADAPTERS_FILES\OLRCOMU_OUT.FD">
      <field fdtype="6" type="string" length="3" name="CODIGOTRANSACCION"/>
      <field fdtype="6" type="string" length="8" name="LUGARTRANSACCION"/>
      <field fdtype="6" type="string" length="4" name="CODIGOAREA"/>
      <field fdtype="6" type="string" length="7" name="TELEFONO"/>
      <field fdtype="6" type="string" length="6" name="FECHAULTIMAFACTURACION"/>
      <field fdtype="5" type="string" length="13" name="DEUDAMES"/>
      <field fdtype="6" type="string" length="6" name="FECHAINDETERMINADA"/>
      <field fdtype="5" type="string" length="13" name="SALDOVENCIDO"/>
      <field fdtype="6" type="string" length="76" name="FILLER1"/>
      <field fdtype="5" type="string" length="13" name="DEUDATOTAL"/>
      <field fdtype="6" type="string" length="30" name="NOMBRECLIENTE"/>
      <field fdtype="6" type="string" length="1" name="TIPOCLIENTE"/>
      <field fdtype="6" type="string" length="2" name="CODIGORETORNO"/>
      <field fdtype="6" type="string" length="1" name="TIPOSERVICIO"/>
      <field fdtype="6" type="string" length="8" name="FECHAVENCIMIENTOFACTURA"/>
      <field fdtype="6" type="string" length="4" name="FILLER2"/>
      <field fdtype="6" type="string" length="1" name="TIPOTELEFONO"/>
      <field fdtype="6" type="string" length="44" name="FILLER3"/>
    </recfd>
  </fldData>
</outputFields>
```

Reader Comments

In an ongoing effort to produce effective documentation, the Documentation Services staff at Information Builders welcomes any opinion you can offer regarding this manual.

Please use this form to relay suggestions for improving this publication or to alert us to corrections. Identify specific pages where applicable. You can contact us through the following methods:

Mail: Documentation Services - Customer Support
Information Builders, Inc.
Two Penn Plaza
New York, NY 10121-2898

Fax: (212) 967-0460

E-mail: books_info@ibi.com

Web form: <http://www.informationbuilders.com/bookstore/derf.html>

Name: _____

Company: _____

Address: _____

Telephone: _____ Date: _____

E-mail: _____

Comments:

Reader Comments