



---

# SunVTS™ 2.1.2 Test Reference

## **Solaris™ 2.6 Hardware: 3/98**

---

Sun Microsystems, Inc.  
901 San Antonio Road  
Palo Alto, CA 94303  
U.S.A. 650-960-1300

Part No. 805-3519-10  
March 1998, Revision A

Send comments about this document to: [smcc-docs@sun.com](mailto:smcc-docs@sun.com)



Copyright 1997 Sun Microsystems, Inc., 901 San Antonio Road, Palo Alto, California 94303 U.S.A. All rights reserved.

This product or document is protected by copyright and distributed under licenses restricting its use, copying, distribution, and decompilation. No part of this product or document may be reproduced in any form by any means without prior written authorization of Sun and its licensors, if any. Third-party software, including font technology, is copyrighted and licensed from Sun suppliers.

Parts of the product may be derived from Berkeley BSD systems, licensed from the University of California. UNIX is a registered trademark in the U.S. and other countries, exclusively licensed through X/Open Company, Ltd.

Sun, Sun Microsystems, the Sun logo, SunSoft, SunDocs, SunExpress, and Solaris are trademarks, registered trademarks, or service marks of Sun Microsystems, Inc. in the U.S. and other countries. All SPARC trademarks are used under license and are trademarks or registered trademarks of SPARC International, Inc. in the U.S. and other countries. Products bearing SPARC trademarks are based upon an architecture developed by Sun Microsystems, Inc.

The OPEN LOOK and Sun™ Graphical User Interface was developed by Sun Microsystems, Inc. for its users and licensees. Sun acknowledges the pioneering efforts of Xerox in researching and developing the concept of visual or graphical user interfaces for the computer industry. Sun holds a non-exclusive license from Xerox to the Xerox Graphical User Interface, which license also covers Sun's licensees who implement OPEN LOOK GUIs and otherwise comply with Sun's written license agreements.

**RESTRICTED RIGHTS:** Use, duplication, or disclosure by the U.S. Government is subject to restrictions of FAR 52.227-14(g)(2)(6/87) and FAR 52.227-19(6/87), or DFAR 252.227-7015(b)(6/95) and DFAR 227.7202-3(a).

DOCUMENTATION IS PROVIDED "AS IS" AND ALL EXPRESS OR IMPLIED CONDITIONS, REPRESENTATIONS AND WARRANTIES, INCLUDING ANY IMPLIED WARRANTY OF MERCHANTABILITY, FITNESS FOR A PARTICULAR PURPOSE OR NON-INFRINGEMENT, ARE DISCLAIMED, EXCEPT TO THE EXTENT THAT SUCH DISCLAIMERS ARE HELD TO BE LEGALLY INVALID.



Please  
Recycle



Adobe PostScript

Copyright 1997 Sun Microsystems, Inc., 901 San Antonio Road, Palo Alto, Californie 94303 Etats-Unis. Tous droits réservés.

Ce produit ou document est protégé par un copyright et distribué avec des licences qui en restreignent l'utilisation, la copie, la distribution, et la décompilation. Aucune partie de ce produit ou document ne peut être reproduite sous aucune forme, par quelque moyen que ce soit, sans l'autorisation préalable et écrite de Sun et de ses bailleurs de licence, s'il y en a. Le logiciel détenu par des tiers, et qui comprend la technologie relative aux polices de caractères, est protégé par un copyright et licencié par des fournisseurs de Sun.

Des parties de ce produit pourront être dérivées des systèmes Berkeley BSD licenciés par l'Université de Californie. UNIX est une marque déposée aux Etats-Unis et dans d'autres pays et licenciée exclusivement par X/Open Company, Ltd.

Sun, Sun Microsystems, le logo Sun, SunSoft, SunDocs, SunExpress, et Solaris sont des marques de fabrique ou des marques déposées, ou marques de service, de Sun Microsystems, Inc. aux Etats-Unis et dans d'autres pays. Toutes les marques SPARC sont utilisées sous licence et sont des marques de fabrique ou des marques déposées de SPARC International, Inc. aux Etats-Unis et dans d'autres pays. Les produits portant les marques SPARC sont basés sur une architecture développée par Sun Microsystems, Inc.

L'interface d'utilisation graphique OPEN LOOK et Sun™ a été développée par Sun Microsystems, Inc. pour ses utilisateurs et licenciés. Sun reconnaît les efforts de pionniers de Xerox pour la recherche et le développement du concept des interfaces d'utilisation visuelle ou graphique pour l'industrie de l'informatique. Sun détient une licence non exclusive de Xerox sur l'interface d'utilisation graphique Xerox, cette licence couvrant également les licenciés de Sun qui mettent en place l'interface d'utilisation graphique OPEN LOOK et qui en outre se conforment aux licences écrites de Sun.

CETTE PUBLICATION EST FOURNIE "EN L'ETAT" ET AUCUNE GARANTIE, EXPRESSE OU IMPLICITE, N'EST ACCORDEE, Y COMPRIS DES GARANTIES CONCERNANT LA VALEUR MARCHANDE, L'APTITUDE DE LA PUBLICATION A REpondre A UNE UTILISATION PARTICULIERE, OU LE FAIT QU'ELLE NE SOIT PAS CONTREFAISANTE DE PRODUIT DE TIERS. CE DENI DE GARANTIE NE S'APPLIQUERAIT PAS, DANS LA MESURE OU IL SERAIT TENU JURIDIQUEMENT NUL ET NON AVENU.

# Contents

---

<b>Preface</b>	<b>xxix</b>
<b>1. Introduction</b>	<b>1</b>
Hardware and Software Requirements	1
Software Requirements	2
General Package Requirement	2
SunVTS with CDE	2
SunVTS with OPEN LOOK	2
How to Access SunVTS	4
Standard Command Line Arguments	4
Test-Specific Arguments	6
Test Modes	6
Hardware Verification	6
How to Test Multiple Frame Buffers	7
Remote Testing of Frame Buffers	7
<b>2. Advanced Frame Buffer Test (afbtest)</b>	<b>9</b>
afbtest Options	10
afbtest Test Modes	16
afbtest Command Line Syntax	17

afbtest Error Messages	18
<b>3. SunATM Adapter Test(atmtest)</b>	<b>27</b>
atmtest Options	28
atmtest Test Modes	29
atmtest Command Line Syntax	30
atmtest Error Messages	30
<b>4. Audio Test (audio)</b>	<b>33</b>
audio Subtests	34
audio Options	35
audio Test Modes	41
audio Command Line Syntax	42
audio Error Messages	43
<b>5. Bidirectional Parallel Port Printer Test (bpptest)</b>	<b>47</b>
Printer Test Hardware and Software Requirements	47
bpptest Options	48
bpptest Test Modes	49
bpptest Command Line Syntax	50
bpptest Error Messages	50
<b>6. Compact Disc Test (cdtest)</b>	<b>53</b>
Volume Management and Compact Discs	53
cdtest Options	54
cdtest Test Modes	56
cdtest Command Line Syntax	57
cdtest Error Messages	58
<b>7. Color Graphics Frame Buffer Test (cg14test)</b>	<b>61</b>

cg14test Groups	62
cg14test Options	69
cg14test Command Line Syntax	70
cg14test Test Modes	70
cg14test Error Messages	71
<b>8. Frame Buffer, GX, GX+ and TGX Options Test (cg6)</b>	<b>73</b>
cg6 Subtests	74
cg6 Options	75
cg6 Test Modes	76
cg6 Command Line Syntax	76
cg6 Error Messages	77
<b>9. Disk and Floppy Drives Test (disktest)</b>	<b>81</b>
disktest Test Options	83
disktest Test Modes	85
disktest Command Line Syntax	87
disktest Error Messages	88
<b>10. ECP 1284 Parallel Port Printer Test (ecpptest)</b>	<b>95</b>
Printer Test Hardware and Software Requirements	95
ecpptest Subtests	96
ecpptest Options	97
ecpptest Test Modes	98
ecpptest Command Line Syntax	98
ecpptest Error Messages	99
<b>11. Sun Enterprise Network Array Test(enatest)</b>	<b>103</b>
enatest Options	106
Fault Isolation Capability	108
enatest Test Modes	109

enatest	Command Line Syntax	110
enatest	Error Messages	110
<b>12.</b>	<b>StorEdge 1000 Enclosure Test (enctest)</b>	<b>115</b>
enctest	Options	117
enctest	Test Modes	118
enctest	Command Line Syntax	119
enctest	Error Messages	119
<b>13.</b>	<b>Environmental Test (envtest)</b>	<b>121</b>
envtest	Options	122
envtest	Test Modes	124
envtest	Command Line Syntax	124
envtest	Error Messages	125
<b>14.</b>	<b>Environmental Test (env2test)</b>	<b>129</b>
env2test	Options	130
env2test	Test Modes	132
env2test	Command Line Syntax	132
env2test	Error Messages	133
<b>15.</b>	<b>Frame Buffer Test (fbtest)</b>	<b>137</b>
fbtest	Options	137
fbtest	Command Line Syntax	138
fbtest	Test Modes	138
fbtest	Error Messages	139
<b>16.</b>	<b>Fast Frame Buffer Test(ffbtest)</b>	<b>141</b>
ffbtest	Options	142
ffbtest	Test Modes	148
ffbtest	Command Line Syntax	148



	ffbttest Error Messages	150
<b>17.</b>	<b>Floating Point Unit Test (fputest)</b>	<b>159</b>
	fputest Options	160
	fputest Test Modes	161
	fputest Command Line Syntax	161
	fputest Error Messages	161
<b>18.</b>	<b>Intelligent Fibre Channel Processor Test (ifptest)</b>	<b>185</b>
	ifptest Options	187
	ifptest Command Line Syntax	188
	ifptest Test Modes	189
	ifptest Error Messages	189
<b>19.</b>	<b>Dual Basic Rate ISDN (DBRI) Chip (isdntest)</b>	<b>193</b>
	isdntest Options	196
	isdntest Test Modes	197
	isdntest Command Line Syntax	197
	isdntest Error Messages	198
<b>20.</b>	<b>ZX and TZX Graphics Accelerator Test (leotest)</b>	<b>201</b>
	leotest Options	202
	leotest Subtests	203
	leotest Test Modes	206
	leotest Command Line Syntax	207
	leotest Command Line Examples	208
	leotest Error Messages	209
<b>21.</b>	<b>SPARCprinter Port Test (lpvittest)</b>	<b>217</b>
	Printer Test Hardware and Software Requirements	217
	lpvittest Options	218

lpvittest Test Mode 219  
lpvittest Command Line Syntax 220  
lpvittest Error Messages 221

**22. M64 Video Board Test (m64test) 225**

m64test Options 226  
m64test Test Modes 228  
m64test Command Line Syntax 228  
m64test Error Messages 229

**23. Multiprocessor Test (mptest) 235**

mptest Options 236  
mptest Test Modes 238  
mptest Command Line Syntax 238  
mptest Error Messages 239

**24. Network Hardware Test (nettest) 241**

nettest Options 242  
nettest Test Modes 244  
nettest Command Line Syntax 245  
nettest Error Messages 246

**25. NVRAM Card Test (nvtest) 249**

nvtest Options 250  
nvtest Test Modes 250  
nvtest Command Line Syntax 250  
nvtest Error Messages 251

**26. PCMCIA Modem Card Test (pcsertest) 255**

pcsertest Options 255  
pcsertest Test Mode 256

	pcsertest Command Line Syntax	256
	pcsertest Error Messages	257
<b>27.</b>	<b>SPARCstorage Array Controller Test (plntest)</b>	<b>259</b>
	plntest Controller Test	260
	plntest Options	260
	plntest Test Modes	261
	plntest Command Line Syntax	261
	Probing for SSA Controller Devices	262
	plntest Error Messages	263
<b>28.</b>	<b>Physical Memory Test (pmem)</b>	<b>265</b>
	pmem Options	265
	pmem Test Modes	267
	pmem Command Line Syntax	267
	pmem Error Messages	268
<b>29.</b>	<b>Prestoserve Test (pstest)</b>	<b>271</b>
	pstest Options	272
	pstest Test Modes	273
	pstest Command Line Syntax	273
	pstest Error Messages	274
<b>30.</b>	<b>SunVideo Test (rtvctest)</b>	<b>277</b>
	rtvctest Subtests	277
	rtvctest Options	280
	Source Format	280
	Ports	281
	rtvctest Command Line Syntax	281
	rtvctest Error Messages	282

- 31. Serial Asynchronous Interface (PCI) Test (saiptest) 285**
  - saiptest Hardware Requirements 285
  - saiptest Options 286
  - saiptest Test Modes 288
  - saiptest Command Line Syntax 289
  - saiptest Error Messages 290
  
- 32. Sun Enterprise Cluster 2.0 Network Hardware Test (scitest) 293**
  - scitest Options 294
  - scitest Test Modes 295
  - scitest Command Line Syntax 295
  - scitest Error Messages 297
  
- 33. Environmental Sensing Card Test (sentest) 299**
  - sentest Options 300
  - sentest Test Modes 301
  - sentest Command Line Syntax 302
  - sentest Error Messages 302
  
- 34. Soc+ Host Adapter Card Test (socaltest) 305**
  - socaltest Options 305
  - socaltest Options 306
  - socaltest Test Modes 307
  - socaltest Command Line Syntax 307
  - socaltest Error Messages 308
  
- 35. NeWSprinter Test (spdtest) 311**
  - spdtest Options 311
  - spdtest Test Mode 312
  - spdtest Command Line Syntax 313

spptest Error Messages	314
<b>36. Serial Parallel Controller Test (spif)</b>	<b>317</b>
spif Hardware Requirements	317
spif Options	318
spif Test Modes	320
spif Command Line Syntax	321
spif Error Messages	322
<b>37. Serial Ports Test (sptest)</b>	<b>325</b>
Synchronous Testing Software Requirements	327
sptest Options	328
sptest Test Modes	331
sptest Command Line Syntax	332
sptest Error Messages	334
<b>38. SunButtons Test (sunbuttons)</b>	<b>341</b>
Running the sunbuttons Tests	341
Starting SunVTS	342
sunbuttons Command Line Syntax	344
sunbuttons Test Modes	344
sunbuttons Error Messages	344
<b>39. SunDials Test (sundials)</b>	<b>345</b>
Running the sundials Test	345
sundials Test Modes	346
sundials Command Line Syntax	347
sundials Error Messages	347
<b>40. HSI/S Board Test (sunlink)</b>	<b>349</b>
sunlink Options	350

sunlink Command Line Syntax	351
sunlink Test Modes	352
sunlink Loopback Connectors	352
sunlink Error Messages	352
<b>41. Pixel Processor Test (sxttest)</b>	<b>355</b>
sxttest Options	356
sxttest Test Parameters	358
sxttest Module Descriptions	359
sxttest Test Modes	366
sxttest Command Line Syntax	367
sxttest Error Messages	368
<b>42. System Test (systest)</b>	<b>371</b>
systest Options	371
systest Test Modes	372
systest Command Line Syntax	372
systest Error Messages	372
<b>43. Tape Drive Test (tapetest)</b>	<b>375</b>
tapetest Options	375
tapetest Test Modes	378
tapetest Command Line Syntax	379
tapetest Error Messages	380
<b>44. S24 Frame Buffer Test (tcxtest)</b>	<b>383</b>
Test Groups	383
tcxtest Subtests	384
tcxtest Options	386
tcxtest Test Modes	386
tcxtest Command Line Syntax	387

tcxtest Error Messages	388
<b>45. Virtual Memory Test (vmem)</b>	<b>395</b>
Handling Swap Space	395
vmem Options	396
vmem Test Modes	398
vmem Command Line Syntax	398
vmem Error Messages	399
<b>46. SBus Expansion Subsystem Test (xbtest)</b>	<b>401</b>
xbtest Modes	402
xbtest Options	403
xbtest Test Modes	404
xbtest Command Line Syntax	404
xbtest Error Messages	405





# Figures

---

- FIGURE 1-1 `afbtest` Option Menu 11
- FIGURE 2-1 `atmtest` Option Menu 28
- FIGURE 3-1 `audio` Test Option Menu for `audioamd(7)` 35
- FIGURE 3-2 `audio` Test Option Menu for Speakerbox `dbri(7) audio` 36
- FIGURE 3-3 `audio` Test Option Menu for SPARCstation LX `dbri(7)` without a Speakerbox attached 37
- FIGURE 3-4 `audio` Test Option Menu for on-board `dbri(7)` for SPARCstation 20 and S240 38
- FIGURE 3-5 `audio` Test Option Menu for `audiocs(7)` 39
- FIGURE 3-6 `audio` Test Option Menu for `audiocs(7)` with Internal Loopbacks 40
- FIGURE 4-1 `bpptest` Option Menu 48
- FIGURE 5-1 `cdtest` Option Menu 54
- FIGURE 6-1 `cg14test` Option Menu 69
- FIGURE 7-1 `cg6` Options Menu 75
- FIGURE 8-1 `disktest` Configuration and Options Menu 83
- FIGURE 9-1 `ecpptest` Option Menu 97
- FIGURE 10-1 `enatest` Options 106
- FIGURE 11-1 `enctest` Options 117
- FIGURE 12-1 `envtest` Options Menu 122
- FIGURE 13-1 `env2test` Options Menu 130

FIGURE 14-1	<code>fbtest</code> Option Menu	137
FIGURE 15-1	<code>ffbtest</code> Option Menu	142
FIGURE 16-1	<code>fputest</code> Option Menu	160
FIGURE 18-1	<code>isdntest</code> Local Loopback Subtest	194
FIGURE 18-2	<code>isdntest</code> Remote Loopback Subtest	195
FIGURE 18-3	<code>isdntest</code> Read/Write Subtest	195
FIGURE 18-4	<code>isdntest</code> Data Path Subtest	196
FIGURE 18-5	<code>isdntest</code> Options Menu	196
FIGURE 19-1	<code>leotest</code> Option Menu	202
FIGURE 20-1	<code>lpvittest</code> Option Menu	218
FIGURE 21-1	<code>m64test</code> Option Menu	226
FIGURE 22-1	<code>mpctest</code> Option Menu	236
FIGURE 23-1	<code>nettest</code> Option Menu	242
FIGURE 25-1	<code>pcsertest</code> Option Menu	255
FIGURE 26-1	<code>plntest</code> Option Menu	260
FIGURE 27-1	<code>pmem</code> Option Menu	265
FIGURE 27-2	<code>pmem</code> UltraSPARC Server Option Menu	266
FIGURE 28-1	<code>pstest</code> Option Menu	272
FIGURE 29-1	<code>rtvctest</code> Option Window	280
FIGURE 30-1	<code>saiptest</code> Options Menu	286
FIGURE 31-1	<code>scitest</code> Option Menu	294
FIGURE 32-1	<code>sentest</code> Options Menu	300
FIGURE 33-1	<code>socaltest</code> Options Menu	305
FIGURE 34-1	<code>spdtest</code> (NeWSprinter) Option Menu	311
FIGURE 35-1	<code>spif</code> Option Menu	318
FIGURE 36-1	<code>sptest</code> Option Menu	328
FIGURE 37-1	<code>sunbuttons</code> Test Menu	343
FIGURE 38-1	<code>sundials</code> Test Menu	346

- FIGURE 39-1 sunlink Options menu 350
- FIGURE 40-1 sxttest Option Menu (CMEM:0MB, none, cg14 board) 356
- FIGURE 40-2 sxttest Option Menu (CMEM:4MB, cg14:4MB) 357
- FIGURE 41-1 systest Option Menu 371
- FIGURE 42-1 tapetest Option Menu (4-mm tape drives) 376
- FIGURE 43-1 tcxtest Option Menu 386
- FIGURE 44-1 vmem Option Menu 396
- FIGURE 45-1 xbtest Option Menu 403



# Tables

---

TABLE P-1	Typographic Conventions	xxxi
TABLE P-2	Shell Prompts	xxxi
TABLE P-3	Related Documentation	xxxii
TABLE P-4	SunExpress Contact Information	xxxii
TABLE 1-1	SunVTS System Interfaces	4
TABLE 1-2	Standard SunVTS Command Line Arguments	5
TABLE 1-3	SunVTS Test-Specific Arguments	6
TABLE 1-4	<code>afptest</code> Options	11
TABLE 1-5	<code>afptest</code> Command Line Syntax	17
TABLE 1-6	<code>afptest</code> Error Messages	18
TABLE 2-1	<code>atmtest</code> Options	29
TABLE 2-2	<code>atmtest</code> Command Line Syntax	30
TABLE 2-3	<code>atmtest</code> Error Messages	30
TABLE 3-1	<code>audio</code> Subtests	34
TABLE 3-2	<code>audio</code> Options	40
TABLE 3-3	<code>audio</code> Test Modes	41
TABLE 3-4	<code>audio</code> Command Line Syntax	42
TABLE 3-5	<code>audio</code> Error Messages	43
TABLE 4-1	<code>bpptest</code> Options	49
TABLE 4-2	<code>bpptest</code> Test Modes	49

TABLE 4-3	bpptest Command Line Syntax	50
TABLE 4-4	bpptest Error Messages	50
TABLE 5-1	cdtest Options	55
TABLE 5-2	cdtest Test Modes	56
TABLE 5-3	cdtest Command Line Syntax	57
TABLE 5-4	cdtest Error Messages	58
TABLE 6-1	cg14 Test Groups	62
TABLE 6-2	cg14test NTA Testing Patterns	67
TABLE 6-3	cg14test Options	69
TABLE 6-4	cg14test Command Line Syntax	70
TABLE 6-5	cg14test Error Messages	71
TABLE 7-1	cg6 Subtests	74
TABLE 7-2	cg6 Command Line Syntax	76
TABLE 7-3	cg6 Error Messages	77
TABLE 8-1	disktest Subtests	82
TABLE 8-2	disktest Configurations and Options	84
TABLE 8-3	disktest Test Modes	86
TABLE 8-4	disktest Command Line Syntax	87
TABLE 8-5	disktest Error Messages	88
TABLE 9-1	ecpptest Subtests	96
TABLE 9-2	ecpptest Options	97
TABLE 9-3	ecpptest Test Modes	98
TABLE 9-4	ecpptest Command Line Syntax	98
TABLE 9-5	disktest Error Messages	99
TABLE 10-1	enatest Coverage	104
TABLE 10-2	Element Enclosure Status	105
TABLE 10-3	enatest Options	107
TABLE 10-4	enatest Fault Isolation Configurations	108

TABLE 10-5	enatest Test Modes	109
TABLE 10-6	enatest Command Line Syntax	110
TABLE 10-7	enatest Error Messages	110
TABLE 11-1	enctest Status LEDs	115
TABLE 11-2	enctest Enclosure Status Report	116
TABLE 11-3	enctest Options	117
TABLE 11-4	enctest Test Modes	118
TABLE 11-5	enctest Command Line Syntax	119
TABLE 11-6	enctest Error Messages	119
TABLE 12-1		125
TABLE 13-1	env2test Error Messages	133
TABLE 14-1	fbtest Command Line Syntax	138
TABLE 14-2	fbtest Error Messages	139
TABLE 15-1	ffbtest Options	143
TABLE 15-2	ffbtest Test Modes	148
TABLE 15-3	ffbtest Command Line Syntax	148
TABLE 15-4	ffbtest Error Messages	150
TABLE 16-1	fputest Test Modes	161
TABLE 16-2	fputest Error Messages	161
TABLE 17-1	ifptest Command Line Syntax	188
TABLE 17-2	ifptest Test Modes	189
TABLE 17-3	ifptest Error Messages	189
TABLE 18-1	isdntest Subtests	193
TABLE 18-2	isdntest Options	197
TABLE 18-3	isdntest Command Line Syntax	197
TABLE 18-4	isdntest Error Messages	198
TABLE 19-1	leotest Subtests	204
TABLE 19-2	leotest Command Line Syntax	207

TABLE 19-3	leotest Error Messages	209
TABLE 20-1	lpvittest Options	219
TABLE 20-2	lpvittest Command Line Syntax	220
TABLE 20-3	lpvittest Error Messages	221
TABLE 21-1	m64test Options	226
TABLE 21-2	m64test Test Mode	228
TABLE 21-3	m64test Command Line Syntax	228
TABLE 21-4	m64test Error Messages	229
TABLE 22-1	mpptest Options	237
TABLE 22-2	mpptest Test Modes	238
TABLE 22-3	mpptest Command Line Syntax	238
TABLE 22-4	mpptest Error Messages	239
TABLE 23-1	nettest Options	243
TABLE 23-2	nettest Test Modes	244
TABLE 23-3	nettest Command Line Syntax	245
TABLE 23-4	nettest Error Messages	246
TABLE 24-1	nvtest Command Line Syntax	250
TABLE 24-2	nvtest Error Messages	251
TABLE 25-1	pcsertest Command Line Syntax	256
TABLE 25-2	pcsertest Error Messages	257
TABLE 26-1	plntest Test Modes	261
TABLE 26-2	plntest Command Line Syntax	261
TABLE 26-3	plntest Error Messages	263
TABLE 27-1	pmem Test Modes	267
TABLE 27-2	pmem Command Line Syntax	267
TABLE 27-3	pmem Error Messages	268
TABLE 28-1	pstest Test Modes	273
TABLE 28-2	pstest Command Line Syntax	273



TABLE 28-3	<code>pstest</code> Error Messages	274
TABLE 29-1	<code>rtvctest</code> Verification Modules	278
TABLE 29-2	<code>rtvctest</code> Source Format Options	280
TABLE 29-3	<code>rtvctest</code> Port Options	281
TABLE 29-4	<code>rtvctest</code> Command Line Syntax	281
TABLE 29-5	<code>rtvctest</code> Error Messages	282
TABLE 30-1	<code>saiptest</code> Asynchronous Serial Ports	286
TABLE 30-2	<code>saiptest</code> Options	287
TABLE 30-3	<code>saiptest</code> Command Line Syntax	289
TABLE 30-4	<code>saiptest</code> Error Messages	290
TABLE 31-1	<code>scitest</code> Options	294
TABLE 31-2	<code>scitest</code> Test Modes	295
TABLE 31-3	<code>scitest</code> Command Line Syntax	295
TABLE 31-4	<code>scitest</code> Error Messages	297
TABLE 32-1	<code>sentest</code> Options	301
TABLE 32-2	<code>sentest</code> Test Modes	301
TABLE 32-3	<code>sentest</code> Command Line Syntax	302
TABLE 32-4	<code>sentest</code> Error Messages	302
TABLE 33-1	<code>socaltest</code> Options	306
TABLE 33-2	<code>socaltest</code> Command Line Syntax	307
TABLE 33-3	<code>socaltest</code> Error Messages	308
TABLE 34-1	<code>spdtest</code> Options	312
TABLE 34-2	<code>spdtest</code> Command Line Syntax	313
TABLE 34-3	<code>spdtest</code> Error Messages	314
TABLE 35-1	<code>spif</code> Serial Ports for the SPC/S Board	319
TABLE 35-2	<code>spif</code> Options	319
TABLE 35-3	<code>spif</code> Command Line Syntax	321
TABLE 35-4	<code>spif</code> Error Messages	322

TABLE 36-1	Serial Port Tests	325
TABLE 36-2	sptest Serial Devices	329
TABLE 36-3	sptest Options	329
TABLE 36-4	sptest Test Modes	331
TABLE 36-5	sptest Command Line Syntax	332
TABLE 36-6	sptest Error Messages	334
TABLE 37-1	sunbuttons Error Messages	344
TABLE 38-1	sundials Error Messages	347
TABLE 39-1	sunlink Options	351
TABLE 39-2	sunlink Command Line Syntax	351
TABLE 39-3	sunlink Error Messages	352
TABLE 40-1	sxtest Test Parameter Options	358
TABLE 40-2	sxtest Modules	359
TABLE 40-3	sxtest Command Line Syntax	367
TABLE 40-4	sxtest Error Messages	368
TABLE 41-1	sytest Error Messages	372
TABLE 42-1	tapetest Options	377
TABLE 42-2	tapetest Test Modes	378
TABLE 42-3	tapetest Command Line Syntax	379
TABLE 42-4	tapetest Error Messages	380
TABLE 43-1	tcxtest Subtests	384
TABLE 43-2	tcxtest Command Line Syntax	387
TABLE 43-3	tcxtest Error Messages	388
TABLE 44-1	vmem Options	397
TABLE 44-2	vmem Command Line Syntax	398
TABLE 44-3	vmem Error Messages	399
TABLE 45-1	xbtest Modes	402
TABLE 45-2	xbtest Options	404

TABLE 45-3	xbtest Command Line Syntax	404
TABLE 45-4	xbtest Error Messages	405



# Preface

---

The Sun Validation and Test Suite (SunVTS™) product is a diagnostic tool that verifies the configuration, functionality, and reliability of hardware controllers and devices. SunVTS is primarily used from a graphical user interface (GUI), which may be either OPEN LOOK or Common Desktop Environment™ (CDE). This book describes SunVTS tests that run on machines with SPARC™ architectures. The descriptions include specific test options, procedures, and error messages.

This book is primarily written for hardware testing and verification purposes. Developers or experienced users who want to run SunVTS diagnostic applications in a test environment will also find it useful.

---

## Before You Read This Book

In order to make full use of the information in this document, you may need access to the following documents:

- *SunVTS 2.1 User's Guide*
- *SunVTS 2.1 Quick Reference Card*

---

# How This Book Is Organized

This book is organized as follows:

**Chapter 1 “Introduction”** describes SunVTS Hardware and Software Requirements, How to Access SunVTS, SunVTS System Interfaces, Standard Command Line Arguments, Test Modes, and How to Test Multiple Frame Buffers.

**Chapters 2 through 41**, describe the individual SunVTS tests, their options, command line syntax, other applicable test modes, and error messages.

**Appendix A “Loopback Connectors”** provides information about the serial and parallel port loopback connectors that are required by some of the SunVTS tests.

---

# Using UNIX Commands

This document may not contain information on basic UNIX<sup>®</sup> commands and procedures such as shutting down the system, booting the system, and configuring devices.

See one or more of the following for this information:

- *Solaris 2.x Handbook for SMCC Peripherals*
- AnswerBook<sup>™</sup> online documentation for the Solaris<sup>™</sup> 2.x software environment
- Other software documentation that you received with your system

---

# Typographic Conventions

TABLE P-1 Typographic Conventions

Typeface or Symbol	Meaning	Examples
AaBbCc123	The names of commands, files, and directories; on-screen computer output.	Edit your <code>.login</code> file. Use <code>ls -a</code> to list all files. % You have mail.
<b>AaBbCc123</b>	What you type, when contrasted with on-screen computer output.	% <b>su</b> Password:
<i>AaBbCc123</i>	Book titles, new words or terms, words to be emphasized. Command-line variable; replace with a real name or value.	Read Chapter 6 in the <i>User's Guide</i> . These are called <i>class</i> options. You <i>must</i> be <code>root</code> to do this. To delete a file, type <code>rm filename</code> .

---

# Shell Prompts

TABLE P-2 Shell Prompts

Shell	Prompt
C shell	<i>machine_name</i> %
C shell superuser	<i>machine_name</i> #
Bourne shell and Korn shell	\$
Bourne shell and Korn shell superuser	#

---

## Related Documentation

**TABLE P-3** Related Documentation

Application	Title	Part Number
Installation	<i>ABC Release Notes</i>	801-xxxx
Service	<i>ABC System Service Manual</i>	801-xxxx
Options	<i>DEF SBus Card Manual</i>	800-xxxx

---

**Note** – This manual covers SunVTS revision 2.1.2 tests. It serves as an updated reference companion to the SunVTS 2.1 manuals listed above.

---

---

## Ordering Sun Documents

SunDocs<sup>SM</sup> is a distribution program for Sun Microsystems technical documentation. Contact SunExpress for easy ordering and quick delivery. You can find a listing of available Sun documentation on the World Wide Web.

**TABLE P-4** SunExpress Contact Information

Country	Telephone	Fax
Belgium	02-720-09-09	02-725-88-50
Canada	1-800-873-7869	1-800-944-0661
France	0800-90-61-57	0800-90-61-58
Germany	01-30-81-61-91	01-30-81-61-92
Holland	06-022-34-45	06-022-34-46
Japan	0120-33-9096	0120-33-9097
Luxembourg	32-2-720-09-09	32-2-725-88-50
Sweden	020-79-57-26	020-79-57-27
Switzerland	0800-55-19-26	0800-55-19-27



**TABLE P-4** SunExpress Contact Information

---

United Kingdom	0800-89-88-88	0800-89-88-87
United States	1-800-873-7869	1-800-944-0661

---

**World Wide Web:** <http://www.sun.com/sunexpress/>

---

---

## Sun Documentation on the Web

The `docs.sun.com` web site enables you to access Sun technical documentation on the World Wide Web. You can browse the `docs.sun.com` archive or search for a specific book title or subject at <http://docs.sun.com>.

---

## Sun Welcomes Your Comments

We are interested in improving our documentation and welcome your comments and suggestions. You can email your comments to us at [smcc-docs@sun.com](mailto:smcc-docs@sun.com). Please include the part number of your document in the subject line of your email.



# Introduction

---

The Sun Validation and Test Suite (SunVTS) software runs multiple diagnostic hardware tests from a single user interface. SunVTS verifies the configuration, functionality, and reliability of most hardware controllers and devices.

SunVTS works from either the Common Desktop Environment (CDE) or the OPEN LOOK (OL) graphical user interface (GUI). The GUI lets you set test parameters quickly and easily while running the diagnostic tests. The sample screens and menus in this manual show SunVTS using the CDE user interface.

This manual describes SunVTS Version 2.1.2, which is on the *SMCC Supplement CD*. The default installation directory for SunVTS is `/opt/SUNWvts`. When you are installing SunVTS, you can specify a different directory to install the software.

This chapter describes hardware and software requirements, how to access the tests, how tests are grouped, and standard command line arguments.

---

## Hardware and Software Requirements

The SunVTS Version 2.1.2 software runs on any system with the Solaris 2.5, 2.5.1, or 2.6 operating environment installed. The operating system kernel must be configured to support all peripherals that are to be tested.

Some SunVTS tests have additional requirements such as the connection of loopback connectors or the availability of disk space. For additional requirements see the specific test chapter in this book.

# Software Requirements

## General Package Requirement

To run SunVTS the SUNWvts package must be loaded on your system. To see if this package is loaded type the following:

```
% pkginfo SUNWvts
```

If your system responds with, “system SUNWvts Online Validation Test Suite” the package is present

## SunVTS with CDE

SunVTS is designed to run in the Common Desktop Environment (CDE). To run the CDE GUI you must have the CDE end-user software installed on your system, or at least the SUNWdtbas package from it. Perform this command to see if this package is installed on your system:

```
% pkginfo SUNWdtbas
```

If your system responds with, “system SUNWdtbas CDE application basic runtime environment” the package is present. If necessary, see your system administrator for assistance with installing the CDE software.

## SunVTS with OPEN LOOK

You must meet the following requirements to run SunVTS with the OPEN LOOK GUI:

- Run Solaris operating system (Version 2.5 through 2.6)
- Run OPEN LOOK, Version 3.3

- **Set the correct openwin path:** Set the `OPENWINHOME` environment variable to point to the location where OPEN LOOK is installed on your system. You can ignore this requirement if you use the default location, `/usr/openwin`. Otherwise, use the following command and substitute the *pathname* variable for the actual path where OPEN LOOK is installed.

```
% setenv OPENWINHOME pathname
```

Check the existing `OPENWINHOME` by typing `env`.

- **Set the correct library path:** Set the `LD_LIBRARY_PATH` environment variable to point to the location of the Windows library directory on your system. If you use the default location, `/usr/openwin/lib`, you can ignore this requirement. Otherwise, use the following command and substitute the *pathname* variable for the actual path where OPEN LOOK library is installed.

```
% setenv LD_LIBRARY_PATH pathname
```

Check the existing `LD_LIBRARY_PATH` by typing `env`.

---

# How to Access SunVTS

You can run SunVTS tests from various interfaces: The CDE and OL graphical user interfaces, or the TTY interface. SunVTS tests can also be run individually from a shell command line, using the command line syntax for each test. Table 1-1 describes the various SunVTS system interfaces.

**TABLE 1-1** SunVTS System Interfaces

<b>SunVTS System Interfaces</b>	<b>Description</b>
Graphical User Interfaces (GUIs)	Users can select tests and test options by pointing and clicking with a mouse button in the CDE or OL interface.
TTY Interface	Users can run SunVTS from a terminal or modem attached to a serial port. This feature requires that you use the keyboard instead of the mouse, and it displays one screen of information at a time. However, it emulates the window system whenever possible.
Command Line Interface	Lets users run each of the SunVTS tests individually from a shell command line using the command line syntax. Each test description contains the corresponding command line syntax. For more information about running individual tests from the command line, refer to the specific test description in this manual.
Online Interface	Provides access to SunVTS testing through the SyMON monitoring tool.

---

## Standard Command Line Arguments

Different types of command line arguments can be applied to a test: generic command arguments (common to all tests) and test-specific command arguments. Because the code for each test defines test-specific arguments, this section only addresses generic command parameters.

The standard syntax for all SunVTS tests is:

```
testname [-scruidtelnf] [-p number] [-i number] [-w number]
          [-o test specific arguments]
```

The following table defines the standard SunVTS command line arguments:

**TABLE 1-2** Standard SunVTS Command Line Arguments

Argument	Definition
-s	Runs a test in SunVTS mode.
-c	Enables a core dump; the test creates a core file if a system crash occurs.
-r	Run-on-Error mode; if an error occurs, the test continues the next test sequence instead of exiting.
-u	Displays the Usage statement.
-v	Runs the test in Verbose mode; the test displays VERBOSE messages that tell more about the testing process.
-d	Runs the test in Debug mode; the test displays DEBUG messages to help programmers debug their test code.
-t	Runs the test in Trace mode; the test displays TRACE messages that track down function calls and sequences currently being used by the test code.
-e	Runs in Stress mode; the test runs under increased system load.
-l	Runs in Online mode.
-n	Runs in Connection test mode.
-f	Runs in Functional test mode.
-i <i>number</i>	Defines the number of instances for scalable tests.
-p <i>number</i>	Defines the number of passes.
-w <i>number</i>	For scalable tests, defines to which instance the test is assigned.

---

# Test-Specific Arguments

There are test-specific arguments, as described in TABLE 1-3 Test-specific arguments should follow the format specified in the `getsubopt(3C)` man page. For information about test-specific arguments refer to the specific test chapter in this book.

TABLE 1-3 SunVTS Test-Specific Arguments

Argument	Definition
-o	Separate each test-specific argument by commas, with no space after the each comma. For example: <code>#./sample -v -o dev=/dev/audio,volume=78</code>  The test option format is specified by the man page <code>getsubopt(3C)</code> .

---

# Test Modes

SunVTS has three test modes:

- Connection test mode—a low stress, quick testing of the availability and connectivity of the tested device.
- Functional test mode—a more robust testing capability that uses whatever system resources are required to do thorough testing, and assumes that there are no other applications running.
- Online test mode—executed from SyMON. This mode invokes non-intrusive tests which do not significantly affect other applications.

---

# Hardware Verification

The SunVTS kernel automatically probes the system kernel for installed hardware devices on your system or a remote system. Those devices are then displayed on the SunVTS control panel with the appropriate tests and test options. This provides a quick check of your hardware setup.



---

# How to Test Multiple Frame Buffers

The following rules apply when you test multiple frame buffers (displays) simultaneously:

- You can test multiple frame buffers on a system at the same time, but only one frame buffer can run the window environment.
- To avoid incorrect test failures, for those frame buffer tests that have a window locking option, the frame buffer that runs the window environment, such as CDE or OPEN LOOK software, must have window locking enabled. Any other frame buffers must have window locking disabled.



---

**Caution** – If window locking is disabled (unlocked) on frame buffers that are running, the SunVTS tests can return false error messages if you move the mouse during testing. Even a slight mouse movement can cause a test to fail.

---

- By default, SunVTS enables window locking on the console monitor (frame buffers that are the `/dev/fb` named device).
- If you are running a frame buffer test from a command line, you can disable Window Locking by specifying a command line argument (see the test command line descriptions in this manual). For example, when running the generic frame buffer test (`fbtest`), use the `lock=e/d` option to enable or disable Window Locking. The example below shows the command that enables Window locking (frame buffer locking):

```
#./fbtest -o dev=cgthree0,lock=e
```

## Remote Testing of Frame Buffers

The frame buffer locking option does not work when you start `sunvts` or `vtsk` remotely. In this case, disable the window locking option to `d`. Do not run any graphic programs (including `vtsui`) on that frame buffer during graphic testing.



## Advanced Frame Buffer Test ( `afbtest` )

---

`afbtest` verifies the functionality of the Advanced Frame Buffer.

`afbtest` can detect and adapt to the various video modes of the advanced frame buffer (AFB). Instead of only running in one standard graphics mode, all tests can run in any mode. In stereo mode, all tests write into the right and left eyes unless you specify otherwise.

You can interrupt `afbtest` using Control-C. Turn off all other keyboard input if OPEN LOOK is running on the unit being tested.

Test accuracy is checked using a checksum algorithm. Possible locations of failing pixels are colored chartreuse to help visually identify their position.



---

**Caution** – Do not run any other application or screen saver program that uses the AFB accelerator port while running `afbtest`. This combination causes SunVTS to return incorrect errors.

---

---

**Note** – Disable all screen savers before testing any graphics device. Type `xset s off` at a UNIX prompt to disable the Solaris screen saver.

---

---

**Note** – DO NOT run Open Windows across multiple monitor while running `afbtest`, otherwise the test will return errors.

---

---

**Note** – `afbtest` requires approximately 29 Mbytes of disk space in the `/tmp` directory to extract its working files. If this space is not available, the diagnostic will fail and report warning and error messages, indicating a lack of disk space.

---

---

# afbtest Options

By default, all afbtest options are enabled.



**FIGURE 1-1** `afbtest` Option Menu

**TABLE 1-4** `afbtest` Options

<code>afbtest</code> Options	Description
3DRAM Test	<p>The 3DRAM test thoroughly tests the video memory in the AFB using 512-bit reads and writes. 3DRAM makes a full screen pass, consisting of a write and a read to each pixel location, for each access mode on the list below. The data used can be either random or specified by the user. A second pass is made with the one's complement of the data used in the first pass so that each memory location is tested with both a zero and a one.</p> <p>Errors in this subtest are attributes to the 3DRAM. A failing chip is indicated by (x, y) locations and device-specific "U" numbers.</p> <ul style="list-style-type: none"><li>• DFB8R, DFB8G, DFB8B, DFB8X - Buffer A</li><li>• DFB24 - Buffer A</li><li>• DFB32 - Buffer A</li><li>• SFB8R, SFB8G, SFB8B, SFB8X - Buffer A</li><li>• SFB8R, SFB8G, SFB8B, SFB8X - Buffer B</li><li>• SFB32 - Buffer A</li><li>• SFB32 - Buffer B</li><li>• SFB32 - Buffer C</li><li>• SFB64 - Buffers A and C</li><li>• SFB64 - Buffers B and C</li></ul>

**TABLE 1-4** afbtest Options

afbtest Options	Description
3DRAM Logic Test	<p>The 3DRAM Logic test provides logical functionality to the AFB. The following services are tested:</p> <ul style="list-style-type: none"><li>• Compare Controls - Match AB</li><li>• Compare Controls - Magnitude AB</li><li>• Compare Controls - Match C</li><li>• Compare Controls - Magnitude C</li><li>• Match Mask - AB</li><li>• Magnitude Mask - AB</li><li>• Match Mask - C</li><li>• Magnitude Mask - C</li><li>• Raster Operations - RGB</li><li>• Raster Operations - X</li><li>• Raster Operations - YZ</li><li>• Plane Mask - RGB</li><li>• Plane Mask - X</li><li>• Plane Mask - Y</li><li>• Plane Mask - Z</li><li>• Group Enable - R, G, B, X</li><li>• Group Enable - Y, Z</li></ul> <p>Each function is tested separately with a series of SFB64 writes. A total of 16 writes are made for each different test case with Y coordinate values varying from 0 to 30 in increments of 2 pixels. This dotted column organization provides page thrashing and block flashing in all screen resolutions. For each operation all possible combinations are tested. For example, in <code>ROP RGB new==old</code> there are three possible values: <i>new &lt; old</i>, <i>new == old</i>, and <i>new &gt; old</i>. Each of these cases are tested.</p> <p>Five passes of the functions are made. Each pass writes into a different AFB address space: SFB32-A, SFB32-B, SFB32-C, SFB64-AC, and SFB64-BC. Note that the passes that write into the SFB32 address spaces are writing two pixels at a time because the tests use SFB64 writes.</p> <p>Care is taken to ensure that all 3DRAM chips are tested. Errors in this subtest are attributed to the 3DRAM.</p>

**TABLE 1-4** `afbtest` Options

<code>afbtest</code> Options	Description
RAMDAC Test	<p>RAMDAC registers are tested using simple read/write patterns to determine if there are any bad bits. This includes all LUTs (4 CLUTs, PWLUT and OWLUT). <code>afbtest</code> ensures that data is actually being read from the RAMDAC and not being supplied by the driver.</p> <p>RAMDAC on AFB can be in SEP8 or Combined mode. RAMDAC test detects the RAMDAC mode and tests the RAMDAC output for that mode. The RAMDAC Signature Register captures the pixels going to the screen. This test determines that all of the different data paths within the RAMDAC are functioning properly.</p> <p>The data pattern is designed so all the data paths are tested. i.e., All CLUTs, PWLUTs and OWLUTS. A cursor is also displayed on the screen.</p> <p>Errors in this test are attributed to the RAMDAC.</p>
Microcode Test	<p>Micro code test generates the checksum for the microcode of the each enabled float and compares all the check sums for equality.</p> <p>Errors in this test are attributed to the Microcode PROMS &amp; SRAMS.</p>
Rendering Pipeline Test	<p>Rendering Pipeline uses the rendering pipeline tests developed for the FFB stand-alone diagnostics. Each FFB primitive is tested thoroughly with a variety of sources and configurations.</p> <ul style="list-style-type: none"> <li>• Dots</li> <li>• Anti-aliased dots</li> <li>• Lines using all four line drawing primitives</li> <li>• Triangles</li> <li>• Polygons</li> <li>• Rectangles</li> <li>• Fonts</li> </ul> <p>Errors in this test are attributed to the Draw Chips.</p>
Fast Fill/Vertical Scroll Test	<p>Fast Fill/Vertical Scroll primitives are separated from the Rendering Pipeline tests because of their dependence on screen type. There are three different tests, one for each screen type. Each test uses both block and page mode <code>fast_fills</code>.</p> <p>Errors in this test are attributed to the Draw Chips.</p>

**TABLE 1-4** afbtest Options

afbtest Options	Description
Pixel Process Test	<p>The Pixel Processor test, a subtest, exercises the options selected by the AFB's Pixel Processor Control (PPC) register.</p> <ul style="list-style-type: none"><li>• Auxiliary clipping (additive and subtractive)</li><li>• Depth cueing</li><li>• Alpha blend</li><li>• Viewport clip (2D and 3D)</li><li>• Area pattern (transparent and opaque)</li></ul> <p>Errors in this test are attributed to the Draw Chips.</p>
AFB Dots Test	<p>This test uses the AFB primitive tests developed for the AFB stand-alone diagnostics. AFB Dots are tested thoroughly with a variety of sources and configurations.</p> <ul style="list-style-type: none"><li>• Dots</li><li>• Anti-aliased dots</li><li>• Big dots</li></ul> <p>Errors in this test are attributed to the Command &amp; Draw Chips.</p>
AFB Lines Test	<p>This test uses the AFB primitive tests developed for the AFB stand alone diagnostics. AFB Lines are tested thoroughly with a variety of sources and configurations.</p> <ul style="list-style-type: none"><li>• Jaggy lines</li><li>• Anti-aliased lines</li><li>• Lines with patterns</li><li>• Bresenham Lines</li><li>• Wide Lines drawn as lines and Triangles</li></ul> <p>Errors in this test are attributed to the Command &amp; Draw Chips.</p>
AFB Triangles Test	<p>This test uses the AFB primitive tests developed for the AFB stand alone diagnostics. AFB Triangles are tested thoroughly with a variety of sources and configurations.</p> <ul style="list-style-type: none"><li>• Triangles drawn clock wise &amp; counter clockwise</li><li>• Triangles drawn as stripes</li><li>• Independent Triangles</li><li>• Triangles drawn as stars</li><li>• Triangles with facet normals</li></ul> <p>Errors in this test are attributed to the Command &amp; Draw Chips.</p>
Lighting Test	<p>The Lighting test exercises AFB float and lighting microcode. This test lights an object with maximum number of lights (32) that AFB can handle in hardware. A check sum is generated for the rendered image and compared with the check sum generated for the same image on a known good system.</p> <p>Errors in this test are attributed to the Float &amp; Microcode SRAMS.</p>



**TABLE 1-4** `afbtest` Options

<code>afbtest</code> Options	Description
Texture Processor Test	<p>The Texture Processor test exercises the different options of the AFB's Texture Pixel Processor Control (TPPC) register.</p> <ul style="list-style-type: none"><li>• Texture Minification</li><li>• Texture Magnification</li><li>• Blend</li><li>• Decal</li><li>• Modulation</li></ul> <p>Errors in this test are attributed to the Draw Chips.</p>
AFB Mix Test	<p>The AFB Mix test draws different primitives with variety combinations of sources and configurations, exercising all the Draw, Float, Microcode and 3DRAM chips on AFB. This test is to stress the AFB.</p> <p>Errors in this test are attributed to Draw, Float, Microcode and/or 3DRAM Chips.</p>
Picking Test	<p>The Picking test exercises the pick detect login of the 3DRAM. We define a pick detect window and make sure that writes to the window are picked, and writes outside the window are not picked. The test is repeated once for each 3DRAM.</p> <p>Errors in this test are attributed to the 3DRAM.</p>
Arbitration Test	<p>The Arbitration test, a subtest, continuously renders an object into the accelerator port while doing reads and writes through the direct port. A picture is rendered into all 32 planes of the B buffer while the other process does 32-bit DFB reads and writes in the A plane. This subtest simulates conditions in the real world, where rendering processes and windows operations run concurrently.</p> <p>Errors in this test are attributed to the Context switching between DFB and SFB.</p>

**TABLE 1-4** afbtest Options

afbtest Options	Description
Stereo Test	Stereo displays an object in stereo mode with different images for the right and left eye. The user can verify proper operation by looking at the screen with stereo glasses and following the instructions being displayed. If the monitor type is not 1280x1024 @ 76MHz, this test prints a warning message and does not execute. To prevent this message from being displayed or written to the SunVTS information log, disable the stereo test in the test option menu. Only Sony P4 and N2 monitors support stereo resolutions. This test temporarily switches the monitor into stereo mode, renders a stereo image, performs a signature analysis on the stereo image (using the RAMDAC signature capture register), and after displaying the image for five seconds, restores the monitor to its previous resolution.  Errors in this test are attributed to the RAMDAC.

---

## afbtest Test Modes

Due to the nature of graphic tests, reading data from, or writing data to the frame buffer during graphic tests will disturb user operation. For this reason, afbtest is only available in Functional mode.

---

# afbtest Command Line Syntax

`/opt/SUNWvts/bin/afbtest standard_arguments -o dev=device_name, S=subtest_number, F=#_of_subtest_loops, B=#_of_test_loops, P=test_pattern`

TABLE 1-5 afbtest Command Line Syntax

Argument	Explanation
<code>dev=device_name</code>	<code>device_name</code> is the relative path name of the device being tested with respect to <code>/dev/fbs</code> ; The default is <code>afb0</code> .
<code>S=subtest_number</code>	<code>subtest_number</code> is the test number of the subtest to be run. Select from the subtests below. You can run multiple subtests by adding the subtest numbers together. For example, <code>n=0x3</code> runs both test 1 and test 2; <code>n=0x180</code> runs both test <code>0x080</code> and test <code>0x0100</code> . You do not need the leading zeros. <code>n - 0x00001 3DRAM</code> <code>n - 0x00002 3DRAM Logic</code> <code>n - 0x00004 RAMDAC</code> <code>n - 0x00008 Micro code</code> <code>n - 0x00010 Rendering Pipeline</code> <code>n - 0x00020 FastFill/Vertical Scroll</code> <code>n - 0x00040 Pixel Processor</code> <code>n - 0x00080 AFB Dots</code> <code>n - 0x00100 AFB Lines</code> <code>n - 0x00200 AFB Triangles</code> <code>n - 0x00400 Lighting</code> <code>n - 0x00800 Texture Processor</code> <code>n - 0x02000 AFB Mix Test</code> <code>n - 0x04000 Picking</code> <code>n - 0x08000 Arbitration</code> <code>n - 0x10000 Stereo</code>
<code>F=#_of_subtest_loops</code>	The number of times to repeat each subtest; the default is 1.
<code>B=#_of_test_loops</code>	The number of times to repeat a test loop before passing; the default is 1.
<code>P=test_pattern</code>	The test pattern number. The default is <code>r</code> , for random patterns. You may also choose 0 for <code>0x0000000</code> , 3 for <code>0x33333333</code> , 5 for <code>0x55555555</code> , or 9 for <code>0x99999999</code> .

# afbtest Error Messages

Errors returned by `afbtest` are nonspecific: It is not possible to determine which component caused a failure. In all error conditions, the field replaceable unit (FRU) is the entire AFB.

TABLE 1-6 `afbtest` Error Messages

Error Message	Probable Cause(s)	Recommended Action
6000 <i>string</i> error: 3DRAM Memory error <i>string</i> Plane at ( <i>data,data</i> ) Expected = 0x%02x, actual = 0x%02x, xor = 0x%02x	Faulty frame buffer.	If the problem persists, contact your authorized Sun service provider.
6002 <i>string</i> error: 3DRAM Memory error <i>string</i> Plane at ( <i>data,data</i> ) Expected = 0x%06x, actual = 0x%06x, xor = 0x%06x		
6004 <i>string</i> error: 3DRAM Memory error <i>string</i> Plane at ( <i>data,data</i> ) Expected = 0x%08x, actual = 0x%08x, xor = 0x%08x		
6006 <i>string</i> error: 3DRAM Memory error <i>string</i> Mode, Plane A at ( <i>data,data</i> ) Expected = 0x%08x, actual = 0x%08x, xor = 0x%08x	Faulty frame buffer.	If the problem persists, contact your authorized Sun service provider.
6008 <i>string</i> error: 3DRAM Memory error <i>string</i> Mode, Plane B at ( <i>data,data</i> ) Expected = 0x%08x, actual = 0x%08x, xor = 0x%08x	Faulty frame buffer.	If the problem persists, contact your authorized Sun service provider.
6010 <i>string</i> error: 3DRAM Memory error <i>string</i> Mode, Plane C at ( <i>data,data</i> ) Expected = 0x%08x, actual = 0x%08x, xor = 0x%08x		

**TABLE 1-6** afbtest Error Messages (Continued)

Error Message	Probable Cause(s)	Recommended Action
6012 Misaligned raster	Software error.	Reinstall software or contact your system administrator.
6013 File Not Found Could not open file <i>string</i>		
6014 Could not open file <i>string: string</i>		
6015 Keyword not Found, line <i>data</i>		
6016 Miscompares, starting at <i>string</i>	Faulty frame buffer.	Contact your authorized Sun service representative.
6017 Picking test error. Got a pick hit with picking disabled		
6018 Picking test error. Got a pick hit outside the picking area		
6019 Picking test error. Should have detected a pick hit		
6020 Out of memory	Software System Error.	Contact your system administrator.
6021 <i>string</i> failed	Software error.	Reinstall software or contact your system administrator. Check for existence and/or permissions on <i>string</i> . Also check for available space in /tmp.
6022 <i>string</i> failed	Software error.	Reinstall software or contact your system administrator. Check for existence and/or permissions on <i>string</i> .
6023 fork1(2) failed	Software error.	Reinstall software or contact your system administrator.
6024 execl(2) failed		
6025 Unable to open <i>string</i>	Software error.	Reinstall software or contact your system administrator. Check device for existence and/or permissions on <i>string</i> .

**TABLE 1-6** afbtest Error Messages (Continued)

Error Message	Probable Cause(s)	Recommended Action
6026 ioctl(2) failed trying to read CLUT.	Possible hardware failure, more likely a software driver error.	Reinstall software first, if failure continues, see a System Administrator or your Sun Service provider.
6027 ioctl(2) failed trying to turn on AFB video.	Possible hardware failure, more likely a software driver error.	Reinstall software first, if failure continues, see a System Administrator or your authorized Sun service provider.
6028 ioctl(2) failed trying to post CLUT.		
6029 Miscompare found in Green channel of CLUT entry <i>data</i> . Expected = 0x%02x, Observed = 0x%02x, XOR = 0x%02x.	Faulty frame buffer.	<b>If the problem persists, contact your authorized Sun service provider.</b>
6030 Miscompare found in Green channel of CLUT entry <i>data</i> . Expected = 0x%02x, Observed = 0x%02x, XOR = 0x%02x.		
6031 Miscompare found in Blue channel of CLUT entry <i>data</i> . Expected = 0x%02x, Observed = 0x%02x, XOR = 0x%02x.		
6032 ioctl(2) failed trying to read WID LUT.	Possible hardware failure, more likely a software driver error.	Reinstall software first, if failure continues, see a System Administrator or your authorized Sun service provider.
6033 ioctl(2) failed trying to post WID LUT.		
6034 ioctl(2) failed trying to get RAMDAC signature analysis.		
6035 Miscompare found in WID LUT entry <i>data</i> . Expected = 0x%06x, Observed = 0x%06x, XOR = 0x%06x.	Faulty frame buffer.	<b>If the problem persists, contact your authorized Sun service provider.</b>
6036 RAMDAC test failed. The on-screen image is incorrect.		

**TABLE 1-6** afbtest Error Messages (Continued)

Error Message	Probable Cause(s)	Recommended Action
6037 sysinfo(2) failed getting hostname.	Software error.	Must be superuser
6038 can't acquire console semaphore	Software error.	Reinstall software or contact your system administrator.
6039 Cannot gain control of mouse: <i>string</i>		
6040 Cannot gain control of keyboard: <i>string</i>		
6046 ioctl(2) failed trying to get current video mode.	Possible hardware failure, more likely a software driver error.	Reinstall software first, if failure continues, see a System Administrator or your authorized Sun service provider.
6047 ioctl(2) failed trying to set current video mode.		
6048 ioctl(2) failed trying to get AFB system info.		
6049 ioctl(2) failed trying to go into Diagnostic mode.		
6050 mmap(2) failed: <i>string</i> .	Software system error.	Reinstall software or contact your system administrator.
6051 munmap(2) failed: <i>string</i> .		
6052 close(2) failed: <i>string</i> .		
6053 DGA error grabbing window on screen <i>data</i> .		
6054 DGA error getting window from token on screen <i>data</i> .		
6055 ioctl(2) failed trying to read Transparent Overlay registers.	Possible hardware failure, more likely a software driver error.	Reinstall software first, if failure continues, see a System Administrator or your authorized Sun service provider.
6056 ioctl(2) failed trying to post Transparent Overlay registers.		
6057 ioctl(2) failed trying to post cursor.		
6058 ioctl(2) failed trying to read cursor.		
6059 No AFB device found on display 0.	The environmental variable DISPLAY is set wrong or the display being used is not using an AFB.	Set the variable to a display that has the AFB plugged into it.

**TABLE 1-6** afbtest Error Messages (Continued)

Error Message	Probable Cause(s)	Recommended Action
6060 There is an inconsistency with the version of the X Window System.	Software error.	Contact your system administrator.
6061 stat(2) failed trying to get info about Device Under Test.	Software error.	Reinstall software or contact your system administrator.
6062 stat(2) failed trying to get info about screen 0: <i>data</i> .		
6063 Can't access XWindows.	Software error.	Try running xhost(1) or contact your system administrator.
6064 wait(2) failed: <i>string</i>	Software error.	Reinstall software or contact your system administrator.
6065 signal(2) failed: <i>string</i>		
6066 thr_kill(2) failed		
6067 thr_join(2) failed: <i>string</i>		
6071 To get signatures, run afbtest from the command line.		
6072 Stereo image incorrect	Faulty frame buffer.	If the problem persists, contact your Sun Service provider.
6075 System LWP limit exceeded.	Software error.	Reinstall software or contact your system administrator.
6076 Error <i>data</i> creating thread.		
6104 Error in getting the length of the file. <i>string</i>		
6105 Stencil test failed <i>string</i>	Faulty 3DRAM.	If the problem persists, contact your Sun Service provider.
6106 Passin test failed <i>string</i>		
6107		



**TABLE 1-6** afbtest Error Messages (Continued)

Error Message	Probable Cause(s)	Recommended Action
6115 <i>string</i> error: GCopy error <i>string</i> at ( <i>data</i> , <i>data</i> ) Expected = 0x%02x, actual = 0x%02x, xor = 0x%02x.	Faulty frame buffer.	If the problem persists, contact your Sun Service provider.
6116 <i>string</i> error: GCopy AFB to Memory error <i>string</i> at ( <i>data</i> , <i>data</i> ) Expected = 0x%02x, actual = 0x%02x, xor = 0x%02x.		
6117 <i>string</i> error: GCopy Memory to AFB error <i>string</i> at ( <i>data</i> , <i>data</i> ) Expected = 0x%02x, actual = 0x%02x, xor = 0x%02x.		
6208 ioctl(2) failed trying to post Overlay WID LUT.	Possible hardware failure, more likely a software driver error.	Reinstall software first, if failure continues, see a System Administrator or your authorized Sun service provider.
6209 ioctl(2) failed trying to post Primary WID LUT.		
6210 Mismatch found in Overlay WID LUT entry <i>data</i> . Expected = 0x%06x, Observed = 0x%06x, XOR = 0x%06x.	Faulty frame buffer.	If the problem persists, contact your Sun Service provider.
6211 Mismatch found in Primary WID LUT entry <i>data</i> .		
6212 ioctl(2) failed trying to read CLUT # <i>data</i> .	Possible hardware failure, more likely a software driver error.	Reinstall software first, if failure continues, see a System Administrator or your authorized Sun service provider.
6213 ioctl(2) failed trying to post CLUT # <i>data</i> .		

**TABLE 1-6** afbtest Error Messages (Continued)

Error Message	Probable Cause(s)	Recommended Action
6214 Miscompare found in Red channel of CLUT # <i>data</i> in entry <i>data</i> . Expected = 0x%02x, Observed = 0x%02x, XOR = 0x%02x.	Faulty frame buffer.	If the problem persists, contact your Sun Service provider.
6215 Miscompare found in Green channel of CLUT # <i>data</i> in entry <i>data</i> . Expected = 0x%02x, Observed = 0x%02x, XOR = 0x%02x.		
6216 Miscompare found in Blue channel of CLUT # <i>data</i> in entry <i>data</i> . Expected = 0x%02x, Observed = 0x%02x, XOR = 0x%02x.	Faulty frame buffer.	If the problem persists, contact your Sun Service provider.
6217 RAMDAC test failed. The on-screen image in sep 4 mode is incorrect.		
6218 RAMDAC test failed. The on-screen image in sep 8 mode is incorrect.		
6219 RAMDAC test failed. The on-screen image in combined mode is incorrect.		
6220 ioctl(2) failed trying to read Overlay WID LUT.	Possible hardware failure, more likely a software driver error.	Reinstall software first, if failure continues, see a System Administrator or your authorized Sun service provider.
6221 ioctl(2) failed trying to read Primary WID LUT.		

**TABLE 1-6** afbtest Error Messages (Continued)

	Error Message	Probable Cause(s)	Recommended Action
6230	L-core checksum mismatch, L-core Checksum of Float #data = 0xvalue	Possible hardware failure.	If the problem persists, contact your Sun Service provider
6231	S-core checksum mismatch, S-core Checksum of Float #data = 0xvalue		
6232	F-core checksum mismatch, F-core Checksum of Float #data = 0xvalue		
6233	F-core SRAM error in Float #data, Failing address = 0xvalue, expected data = 0xvalue, actual data = 0xvalue, XOR of expected and actual data = 0xvalue, F-core checksum = 0xvalue		
6234	L-core SRAM error in Float #data, Failing address = 0xvalue, expected data = 0xvalue, actual data = 0xvalue, XOR of expected and actual data = 0xvalue, L-core checksum = 0xvalue		
6235	S-core SRAM error in Float #data, Failing address = 0xvalue expected data = 0xvalue, actual data = 0xvalue, XOR of expected and actual data = 0xvalue, S-core checksum = 0xvalue		



## SunATM Adapter Test(`atmtest`)

---

`atmtest` checks the functionality of the SunATM-155 and SunATM-622 SBus and PCI bus adapters.

It runs only in loopback (external or internal) mode. The Asynchronous Transfer Mode (ATM) adapter, and ATM device driver must be present. To run the `atmtest` in external loopback mode, a loopback connector must be attached to the ATM adapter. The internal loopback mode does not require a loopback connector.

`atmtest` uses DLPI RAW mode to talk to the device driver. It establishes a virtual circuit (VC) to send a message, receive a message, and compare messages. If the message does not match, or the message is out of sequence, it displays an error message.

Using a random number generator, `atmtest` sends data into a data buffer and then sends each message from a different starting point. This assures that no two consecutive messages are the same.

`atmtest` can test more than one virtual circuit. The more virtual circuits used increases the stress level of the test. `atmtest` automatically selects the virtual circuit number which is unique to the test. `atmtest` is nonscalable as it provides for more than one virtual circuit to be tested for each instance, which is adequate for the purpose of a stress test.

`atmtest` can only be selected when the Intervention mode is enabled since it requires a loopback connector for external loopback testing. While Intervention mode is enabled, `atmtest` and `nettest` are both available as default selections, however, you must deselect `nettest` when testing the ATM device.

---

**Note** – Do not run `nettest` while running `atmtest`.

---

---

**Note** – Bring the ATM interface down to make sure that the interface is in offline mode before running `atmtest`.

---

# atmtest Options

**ba0(atmtest) Test Parameter Options**

**Configuration:**  
Host\_Name: ss5-4-net191  
Host Address: 172.18.191.34  
Host ID: 80720852  
Domain Name: nettest.eng.sun.com

**Options:**

Total\_packets: ▲ ▼ [10000]

Number\_of\_VC: ▲ ▼ [2]

MAX\_PKT\_LEN: ▲ ▼ [9140]

Outstanding\_Pkts: ▲ ▼ [4]

First\_VC\_no: ▲ ▼ [30]

Bandwidth: ▲ ▼ [14]

Loopback:  External  Internal

Print\_Warning:  Enable  Disable

Instance: ▲ ▼ [1]

Apply    Reset    Cancel

FIGURE 2-1 atmtest Option Menu

**TABLE 2-1** atmttest Options

Options	Description
Configuration	The Post Address, Host ID, and Domain Name of the system being tested.
Total Packets	The total number of packets sent. The default number of packets sent is 10000.
Number of VC	The number of virtual circuits to be set up by one instance. The default number of virtual circuits is 2for each instance. The atmttest uses these two virtual circuits to send out messages simultaneously. The message is received in sending order.
Loopback	Enables the user to select either the external loopback field or internal loopback field. The default selection is the external loopback field. A loopback connector is only needed for external loopback testing.
MAX_PKG_LEN	The maximum packet length to be used by the test to send out the data. The default number is 9140.
Outstanding_pkts	Describes the maximum number of outstanding packets. atmttest stops sending messages when the outstanding packet count is more than the number of packets this field specifies.
First_VC_no	Enables the user to set up the starting virtual circuit number to be used for each atmttest instance. atmttest can automatically avoid virtual circuit numbers that have already been used.
Bandwidth	Enables the user to select different bandwidths to test. The default number is 14.

---

## atmttest Test Modes

atmttest can only be run in Functional test mode.

---

# atmtest Command Line Syntax

`/opt/SUNWvts/bin/atmtest standard_arguments -o dev=device,tpkts=n,nv=n,ml=n,bw=n,opkts=n,ld,sd,sl,nc,ns,vcf`

**TABLE 2-2** atmtest Command Line Syntax

Argument	Explanation
<code>dev=device</code>	Specifies the device name to be tested, such as <code>ba0</code> .
<code>tpkts=n</code>	Specifies the number of packets to loopback [1.2147483647].
<code>nv=num_vc</code>	Specifies the number of simultaneous virtual circuits to be tested.
<code>ml=max_len</code>	Specifies the maximum length of the random packet.
<code>bw=bandwidth</code>	Specifies the bandwidth in MBits/s of a virtual circuit.
<code>opkts=n</code>	Specifies the number of packets for each virtual circuit that can be transmitted without receiving a corresponding packet.
<code>lb</code>	The internal loopback mode is selected.
<code>sd</code>	Changes the payload data to static instead of random.
<code>sl</code>	Changes all packets to their maximum length.
<code>nc</code>	Instructs the test not to check the receive payload (Improves throughput).
<code>ns</code>	Instructs the test not to exit on a packet reception failure.
<code>vcf=n</code>	Specifies the first virtual circuit number used.

---

# atmtest Error Messages

The atmtest error messages are listed below with explanations or probable causes:

**TABLE 2-3** atmtest Error Messages

Error Message	Probable Cause(s)	Recommended Action
6000 putmsg failed, errmsg= <i>data</i>		
6001 getmsg failed, errmsg= <i>data</i>		



**TABLE 2-3** atmtest Error Messages (Continued)

	Error Message	Probable Cause(s)	Recommended Action
6002	wrong vc: exp: <i>number</i> , obs: <i>number</i>		
6003	VC <i>number</i> bogus pkt, seq: exp= <i>number</i> , obs= <i>number</i> ; len: exp= <i>number</i> , obs= <i>number</i>		
6004	VC <i>number</i> bad pkt len, EXP: <i>number</i> , OBS: <i>number</i> , seq= <i>number</i>		
6005	VC number memcmp error		
6006	VC number failed to rcv a packet		
6007	Complete Usage: <i>string</i> u		
6008	<i>string</i> : alarm		
6009	<i>string</i> : getmsg		
6010	receive <i>string</i> for <i>string</i> with <i>string</i> error		
6011	DL_OK_ACK was not M_PCPROTO		
6012	short response ctl.len: <i>number</i>		
6013	ctl.len sizeof (dl_ok_ack_t): <i>number</i>		
6014	receive <i>string</i> for string with <i>string</i> error		
6015	DL_BIND_ACK was not M_PCPROTO		
6016	ioctl DLIOCRAW failed, errmsg <i>string</i>		
6017	ioctl DL_IOC_HDR_INFO failed, errmsg <i>string</i>		
6018	len= <i>number</i> hdrmax= <i>number</i>		
6019	ioctl ADDVC failed, errmsg <i>string</i>		
6020	ioctl ALLOCBW failed, errmsg <i>string</i>		
8000	open device failed, errmsg= <i>string</i>		

**TABLE 2-3** atmttest Error Messages (Continued)

Error Message	Probable Cause(s)	Recommended Action
8001 sa_add_vpci failed, errmsg= <i>string</i>		
8002 sa_allocatebw failed, errmsg= <i>string</i>		
8003 atm_attach failed, errmsg= <i>string</i>		

## Audio Test (audio)

---

The `audio` test verifies the hardware and software components of the `audio` subsystem. This test supports all Sun `audio` implementations.

The `audio` device is an *exclusive use device*. Only one process or application can interface with it at a time. This test is not scalable.

The availability of the following subtests depends on the particular `audio` implementation being tested.

---

# audio Subtests

**TABLE 3-1** audio Subtests

Subtest	Description
Record/Play Test	This test plays and records one second of data. It does not check data. This test is run on all audio implementations.
Crystal Test	The crystal test measures the accuracy of the crystal that generates the sample rate clock. It does this by playing a one-second signal and then measuring the actual time required to play the signal. This measurement is performed for each of the eight standard sample rates. This test is available for <code>dbri(7)</code> and <code>audiocs(7)</code> audio implementations
Loopback Tests	This test verifies the functionality and signal quality of the audio ports. The test simultaneously plays and records a known signal. The recorded signal is analyzed for loop gain and signal-to-noise ratio plus distortion. This is repeated at various sample rates, encodings, precisions and channels. The audio ports that are supported depend on the audio implementation under test. The <code>audiocs(7)</code> implementation supports loopbacks from/to headphone, line-out, microphone, and line-in ports. The <code>dbri(7)/speakerbox</code> implementation supports fewer ports. The <code>audioamd(7)</code> implementation does not support loopback tests. Most tests require a stereo loopback cable. NOTE: The microphone loopback tests require special hardware and are used by manufacturing centers and special test facilities. Do not invoke the microphone loopback tests unless you have the required hardware.
Controls Test	This test verifies the three control buttons on the Sun Speakerbox. The Controls test plays music while the user is prompted to press the Volume Down, Volume Up, and Mute buttons in a specific order. If no button is pressed, the music plays for about 30 seconds, then stops, and returns an error. This test is only supported on the <code>dbri(7)/speakerbox</code> implementation.
Audio Test	This test plays a 30-second music file out of the speaker or headphone. The user must decide if the test passes or fails. Badly distorted audio, or no audible music indicates a problem. This test is supported on all audio implementations.

---

## audio Options

Upon start-up, the SunVTS probe utility determines which audio implementation is present and adjusts the `audio` option menu appropriately. The possible option menus are as follows:

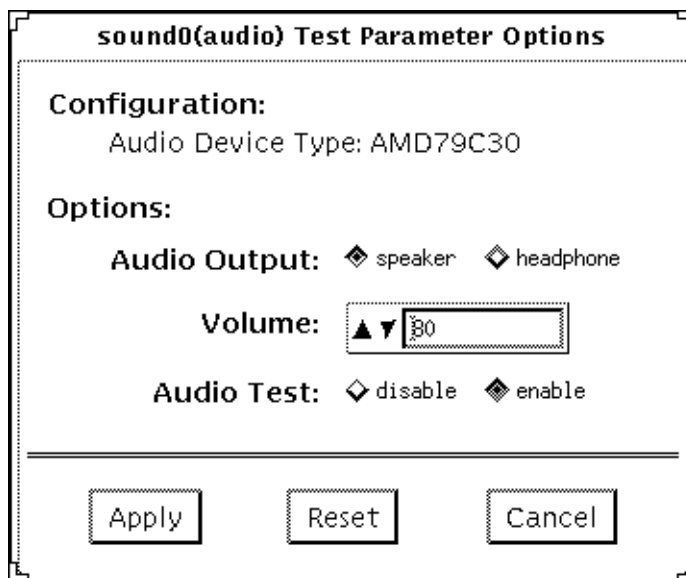

**FIGURE 3-1** audio Test Option Menu for `audioamd(7)`

The `audioamd(7)` is an 8-bit mono, telephone-quality, audio device.

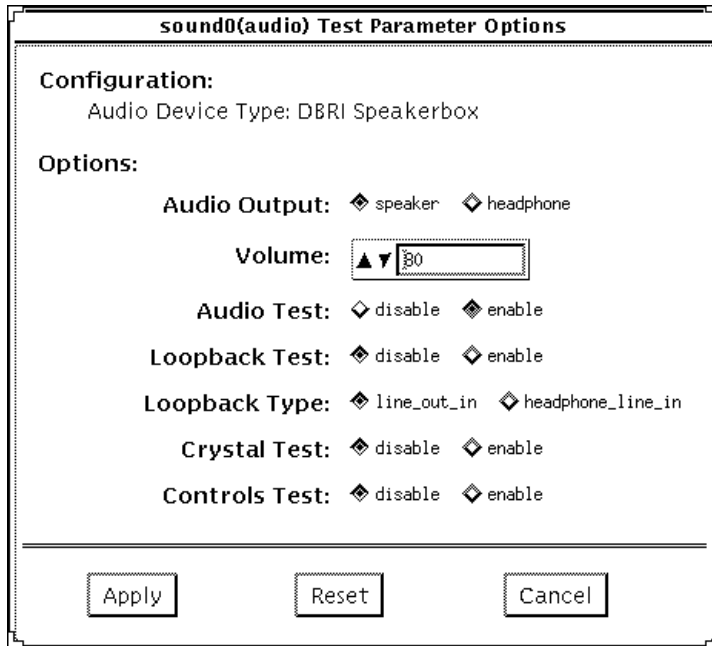

**FIGURE 3-2** audio Test Option Menu for Speakerbox dbri(7) audio

The speakerbox dbri is a high-quality 16-bit stereo multimedia (coder/decoder (codec)).

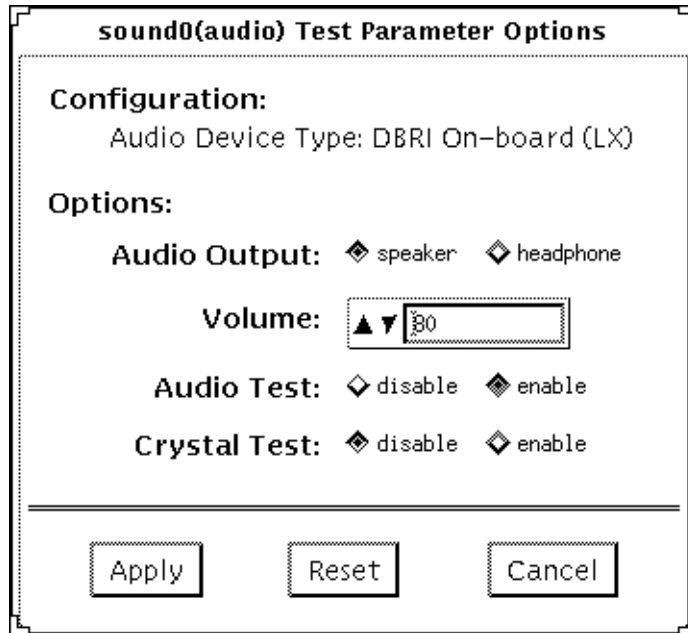

**FIGURE 3-3** audio Test Option Menu for SPARCstation LX dbri(7) without a Speakerbox attached

The on-board DBRI interface is a high-quality, 16-bit stereo multimedia codec.

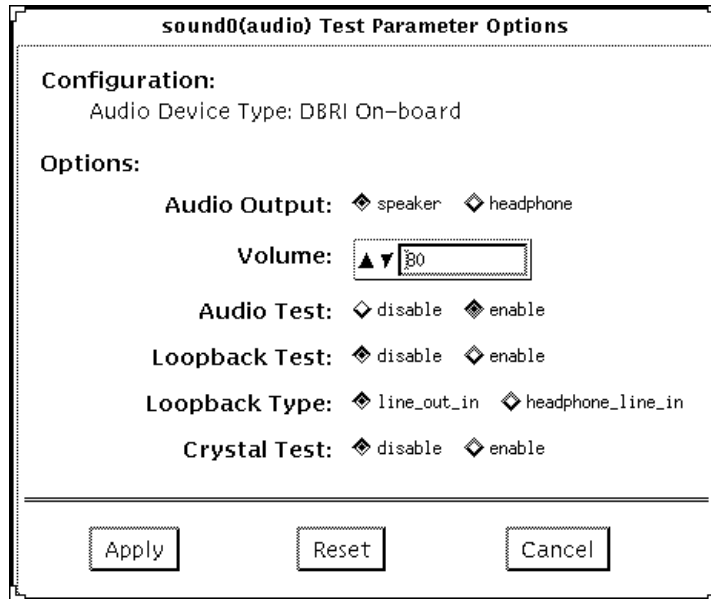

**FIGURE 3-4** audio Test Option Menu for on-board dbri(7) for SPARCstation 20 and S240

The SPARCstation 20 On-board dbri is a high-quality 16-bit stereo multimedia codec.



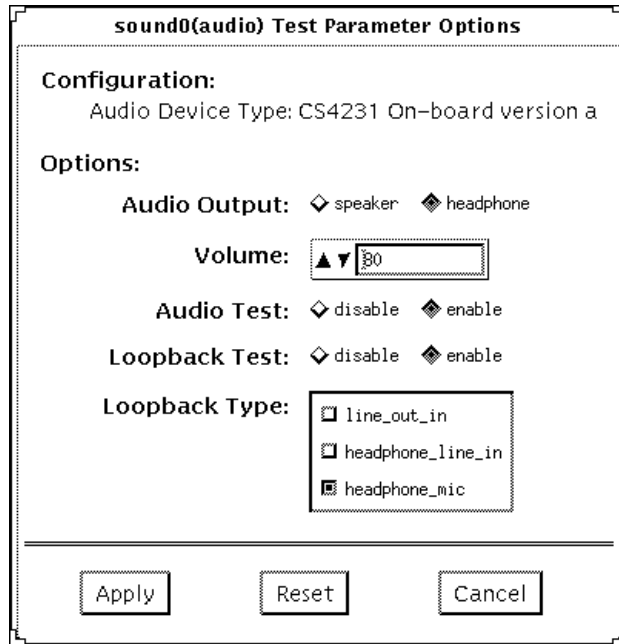

**FIGURE 3-5** audio Test Option Menu for audiocs(7)

The audiocs(7) is an on-board, high-quality 16-bit stereo multimedia codec.

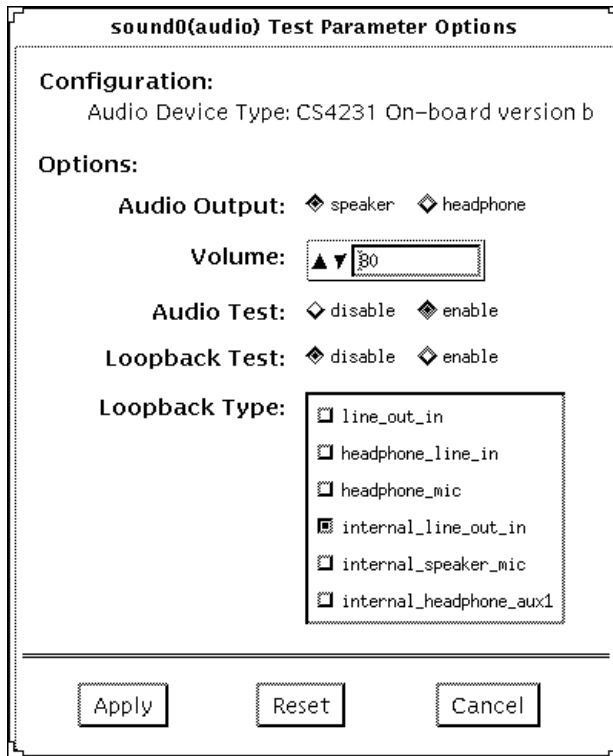

**FIGURE 3-6** audio Test Option Menu for audiocs(7) with Internal Loopbacks

The `audiocs(7)` is an on-board, high-quality 16-bit stereo multimedia codec.

---

**Note** – The internal loopbacks are only active if the audio jacks are unused (nothing connected).

---

Some options can only be selected through the command line. See the command line option descriptions in “audio Command Line Syntax” on page 42.

**TABLE 3-2** audio Options

Option	Description
Audio Test	Enables or disables the music play test. This test is enabled by default.
Audio Output	Selects the output port for the music play test.
Volume	Sets the volume for the music play test.

**TABLE 3-2** audio Options (*Continued*)

Option	Description
Loopback Test	Enables or disables the loopback test. A loopback cable must be installed between the selected ports to run this test. This test is disabled by default.
Loopback type	Selects the type of loopback test to run.
Crystal Test	Enables or disables the crystal test. This test is disabled by default.
Controls Test	Enables or disables the speakerbox Controls test. This is an interactive test and the user is prompted to press the control buttons on the speakerbox. This test is disabled by default.

---

**Note** – Do not run the crystal test while running other SunVTS tests. The crystal test is timing-dependent. If the system is too busy, it fails due to time-out errors.

---

## audio Test Modes

**TABLE 3-3** audio Test Modes

Test Mode	Description
Connection Test	A simple open and close is performed. No data is transferred. The test returns a pass if the device can be opened and closed successfully. If the device cannot be opened because it is busy, then it is assumed that the device is successfully connected to another process and the test passes.
Functional Test	The record/play test is run and you can choose to run any of the tests described earlier. In this mode, the test will fail if the device is busy.  If you invoke SunVTS through SyMON, the following Functional Test description applies: The record/play test is run. If the device cannot be opened because it is busy, then it is assumed that the device is successfully connected to another process and the test passes.

# audio Command Line Syntax

```
/opt/SUNWvts/bin/audio standard_arguments -o dev=/dev/sound/  
unit_no,I=/dev ioctl_device, M, L, Q, S,  
T=loopback_test_type,X,E,LE,CD,CDD=CD_device_name,  
CDT=track_number,CDG=play_gain,CDL=play_time,W,  
MF=filename,TF=filename
```

TABLE 3-4 audio Command Line Syntax

Argument	Explanation
dev=/dev/ audio_device	Specifies the audio device to be tested. The default is dev=/dev/audio
I=/dev/ioctl_device	Specifies the audio ioctl device to be tested; the default is /dev/audiocntl.
M	Enables the music play test.
L	Enables the loopback test.
Q	Enables the quality test. This option does the same thing as L option except that it prints an extra status message upon completion.
S	Enables the speakerbox controls test.
T=loopback_test_type	Specifies the type of loopback test. The default is 1; the choices are listed below. 0 Speaker/Microphone 1 Line-in/Line-out 2 Headphone/Line-in 3 Headphone/Microphone 4 Speaker/CD-input I1 Internal Line-in/Line-out I2 Internal Spk/Mic I3 Internal Headphone/Aux1  Note: Test types 0, 3, and 4 require special hardware, and are used by manufacturing centers and special test facilities. Do not invoke these tests unless you have the required hardware.
X	Enables the Audio Crystal test.
E	Continues testing if an error occurs.
LE	Loops on Error. This plays the signal data in a continuous loop.

**TABLE 3-4** audio Command Line Syntax (*Continued*)

Argument	Explanation ( <i>Continued</i> )
CD	Enables the cdtest. This is for systems with an internal CD-ROM drive. A CD disc with music tracks must be loaded prior to running this test.
CDD=CD_device_name	Specifies the raw device name for the CD-ROM drive. The default is CDD=/dev/rdisk/c0t6d0s0.
CDT=number	Specifies the track number of CD-ROM to play. The default is to play the first track on the disc.
CDG=play_gain	Specifies the play gain of the CD Play test (0 to 255). The default is 120.
CDL=play_time	Specifies the number of seconds to run the CD Play test. The default is 30 seconds.
W	Shows warning messages during the loopback test.
MF=filename	Selects an optional music file.
TF=filename	Specifies an optional tolerance file. Note: The tolerance file is used by manufacturing centers and special test facilities. Do not use this option unless you are familiar with the tolerance file format.

## audio Error Messages

**TABLE 3-5** audio Error Messages

	Error Message	Probable Cause(s)	Suggested Action (if applicable)
6000	Signal To Noise ratio too low ( <i>name</i> ) on <i>name</i> , SNR = <i>number</i> db, Min SNR = <i>number</i> db ( <i>text</i> )	Loopback cable is missing or faulty. Audio hardware (usually consistent failures). System software problem (usually intermittent failures).	
6001	Channel Separation too low ( <i>name</i> ), SEP = <i>number</i> db, Min SEP = <i>number</i> db ( <i>text</i> )	Loopback cable is faulty. Audio hardware is faulty (usually consistent failures). System software problem (usually intermittent failures).	

**TABLE 3-5** audio Error Messages (*Continued*)

	<b>Error Message</b>	<b>Probable Cause(s)</b>	<b>Suggested Action (if applicable)</b>
6002	Loop gain is out of range ( <i>name</i> ), <i>name</i> GAIN = <i>number</i> db, Min = <i>number</i> Max = <i>number</i> db ( <i>text</i> )	Loopback cable is missing or faulty. Audio hardware is faulty (usually consistent failures). System software problem (usually intermittent failures).	
8000	Must be super user ( <i>root</i> ) to execute	The user does not have root privileges.	
8012	Invalid audio device ( <i>device_name</i> ) for Crystal test	The crystal test is not supported on the system audio device.	
8013	Invalid audio device ( <i>device_name</i> ) for Controls test	The system audio device does not support a speakerbox.	
8014	Invalid audio device ( <i>device_name</i> ) for Loopback Quality test	No loopback tests are supported on the system audio device.	
8015	Invalid audio device ( <i>device_name</i> ) for Loopback Quality test (T= <i>number</i> )	The specified loopback test is not supported on the system audio device. The specified loopback type is not supported on this audio device.	
8020	Incomplete button press sequence	The required button presses were not detected in the time allowed.	
8023	Underrun/Overrun error failure	The audio driver detected underrun or overrun errors while transferring data to the audio device. These errors usually happen when the loopback test is run while during heavy system activity.	
8027	<i>name</i> : `name( <i>name=number</i> , <i>name=number</i> , <i>name=number</i> )` system call timeout. No response after <i>number</i> seconds. Device = <i>device_name</i>	The system call is hanging. Audio hardware (usually consistent failures). System software problem (usually intermittent failures).	

**TABLE 3-5** audio Error Messages (*Continued*)

	<b>Error Message</b>	<b>Probable Cause(s)</b>	<b>Suggested Action (if applicable)</b>
8028	Audio crystal test did not complete in the expected time, rate = <i>number</i> Hz, time = <i>number</i> usecs, min = <i>number</i> , max = <i>number</i>	Excessive loading on the system.	Disable all other tests and try again.
8029	Speaker is an invalid output port for device	The system does not have an on-board speaker.	
8032	Failed ioctl name ( <i>error_message</i> )	The ioctl() system call failed.	See the appended error message.
8033	Failed mmap ( <i>error_message</i> )	The mmap() system call failed.	See the appended error message.
8034	Failed fstat ( <i>error_message</i> )	The fstat() system call failed.	See the appended error message.
8035	Failed ftruncate ( <i>error_message</i> )	The ftruncate() system call failed.	See the appended error message.
8036	Write to audio device returned error condition ( <i>error_message</i> )	The write() system call failed.	See the appended error message.
8037	Read from audio device returned error condition ( <i>error_message</i> )	The read() system call failed.	See the appended error message.
8038	Failed to allocate number bytes of memory ( <i>error_message</i> )	The memory allocation system call failed, most likely due to a lack of system memory resource.	See the appended error message.
8051	Unknown audio device ( <i>name=device_name</i> , <i>config=name</i> )		
8052	Unable to get platform name		
8053	Unknown architecture/audio = <i>name</i> / <i>device_name</i>		
8055	Could not open <i>device_name</i> : <i>error_message</i>	The open() system call failed Examine system message files (/var/adm/messages) for other information. Device does not respond. No mmcodec device found. Unable to communicate with speakerbox.	

**TABLE 3-5** audio Error Messages (Continued)

	<b>Error Message</b>	<b>Probable Cause(s)</b>	<b>Suggested Action (if applicable)</b>
8075	Invalid audio file format	Specified audio file is not in expected format.	
8077	Invalid audio encoding	An unknown audio encoding type was specified.	
8090	Only one <i>name</i> loopback can be selected at a time	The user specified more than one loopback test on the same port.	
8091	Cannot enable loopback testing without selecting a loopback type	The user enabled loopback testing but did not specify a loopback type.	



## Bidirectional Parallel Port Printer Test (`bpptest`)

---

`bpptest` verifies the functionality of the bidirectional parallel port. SBus printer cards have two printer ports: one for SPARCprinters™, and one for a parallel port printer. Use the `lpvittest` to verify SPARCprinter functionality.

The `bpptest` verifies that your SBus card and its parallel port are working properly by attempting to transfer a data pattern from the SBus card to the printer.

Two indications show that the card and printer are functioning properly: First, you can see from the SunVTS Status window that `bpptest` made a successful pass, and second, that the pattern transmitted to the printer printed correctly.

If the `bpptest` passes successfully, you know that the SBus DMA circuitry, the printer, and the device driver are functioning properly.

---

**Note** – Large Postscript files or raster files may require that the printer has 2 Mbytes or more of memory. Otherwise, the printout may appear on two different sheets of paper.

---

---

## Printer Test Hardware and Software Requirements

The SBus printer card and device drivers must be installed to run `lpvittest` or `bpptest`. A printer must be connected to the SPARCprinter or bidirectional parallel port, and be powered-up. If both a SPARCprinter and a parallel port printer are connected to the SBus card, you can test both devices at the same time.

---

**Note** – For a SPARCstation 10, SPARCstation LX, or SPARCclassic system, you can connect a printer directly to the onboard parallel port to run `bpptest`.

---

If you are testing the SPARCprinter port, be sure the magnets on the SPARCprinter paper tray are set to the correct paper size. For more information, see the *SPARCprinter Installation and User's Guide* and the label on the paper tray.

---

## bpptest Options

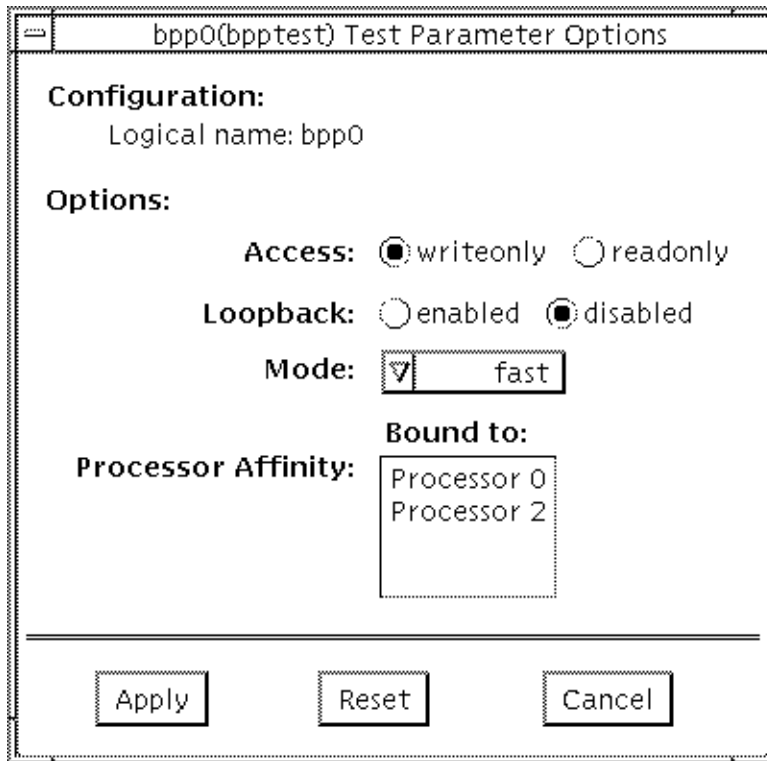

**FIGURE 4-1** bpptest Option Menu

**TABLE 4-1** `bpptest` Options

Options	Description
Access	Determines the direction of data transfer; this field is informational only. Writeonly is the only option currently available. Data is transferred only from the SBus printer card to the printer.
Mode	Sets the print intervals. This option lets you select the intervals at which the test image is printed. The default setting is Fast. In the online and Functional tests this option is set to medium. In the Functional test, the choices are: Fast: Prints an image every 10 seconds. Medium: Prints an image every 12 minutes. Extended: Prints an image every 30 minutes.

---

## `bpptest` Test Modes

This test supports Connection and Functional test modes.

**TABLE 4-2** `bpptest` Test Modes

Test Mode	Description
Connection Test	In this mode, <code>bpptest</code> verifies that a bidirectional parallel port is configured on the system. The success of the <code>bpptest</code> in this mode indicates that the system has the bidirectional parallel port hardware and the software driver is installed.
Functional Test	The testing done in this mode is the same as in the online mode, except that the test registers a failure if the port is found busy. This is because SunVTS tests make the assumption that all the resources will be available for testing in the Functional test and therefore the unavailability of the device is interpreted as an indication of a fault condition.  If you invoke SunVTS through SyMON, the following Functional test description applies: the test attempts to verify the functionality of the parallel port and the path between the parallel port and the host memory. An internal loopback test is performed and if a printer is attached to the port, a data pattern is transferred to the printer.

---

# bpptest Command Line Syntax

```
/opt/SUNWvts/bin/bpptest standard_arguments -o  
dev=device_name,access=writeonly | readonly,mode=mode,loop=disable | enable
```

TABLE 4-3 bpptest Command Line Syntax

Argument	Explanation
dev= <i>device_name</i>	Specifies the name of the device. This should be of the form /dev/bpp#, where # is the minor number of the device.
access= <i>writeonly</i> / <i>readonly</i>	Determines test mode: <i>writeonly</i> or <i>readonly</i> . Note: This flag is mandatory.
mode= <i>mode</i>	Sets the test image print rate. The test image is a continuous printout of the ASCII character set. Possible rates are: Fast: Prints the test image at 10-second intervals. Medium: Prints the test image at 12-minute intervals. Extended: Prints the test image at 30-minute intervals.

---

# bpptest Error Messages

TABLE 4-4 bpptest Error Messages

Error Message	Probable Cause(s)	Suggested Action (if applicable)
6000 Read compare failed, expected: <i>value</i> , observed: <i>value</i>	Suspect DMA circuitry or FIFO associated with bpp.	
6001 Error occurred while accessing <i>device_name</i> ; Time out Error: <i>value</i> ; Bus Error: <i>value</i> ; Pin Status: <i>value</i>	System error message.	
8000 could not open <i>device_name</i>	System error message. Device does not exist. Device not configured correctly.	

**TABLE 4-4** bpptest Error Messages (Continued)

	Error Message	Probable Cause(s)	Suggested Action (if applicable)
8001	Encountered error while writing to <i>device_name</i> ; Requested bytes to write: <i>value</i> ; Bytes successfully written: <i>value</i>	Device not configured correctly or does not exist. Too many print requests queued up. Printer out of paper.	
8002	Failed to obtain memory from malloc() system call	System heavily loaded.	
8003	Error occurred while attempting to fork a child process	System error message.	
8004	ioctl fail on <i>device_name</i>	System error message.	
8005	error= <i>number</i>	System error message.	
8006	Device <i>device_name</i> unavailable for testing	Device is busy.	Retry later.



## Compact Disc Test (`cdtest`)

---

`cdtest` checks the CD-ROM unit by reading the CD. `cdtest` is not a scalable test. Each track is classified as follows:

- Mode 1 uses error detection/correction code (288 bytes).
- Mode 2 uses that space for auxiliary data, or as an audio track.

---

**Note** – Load a compact disc into the drive before starting the test. See the explanation for CD Type in TABLE 5-2 in the chart in “`cdtest` Test Modes,” later in this chapter.

---

---

## Volume Management and Compact Discs

`cdtest` tests the CD-ROM drive(s) even if the Volume Manager is not running. If the Volume Manager is running and no media is installed in the CD-ROM drive(s), SunVTS prompts you to install media in the drive before selecting the test.

The test fails if you try to run it without a CD in the drive.

# cdtest Options

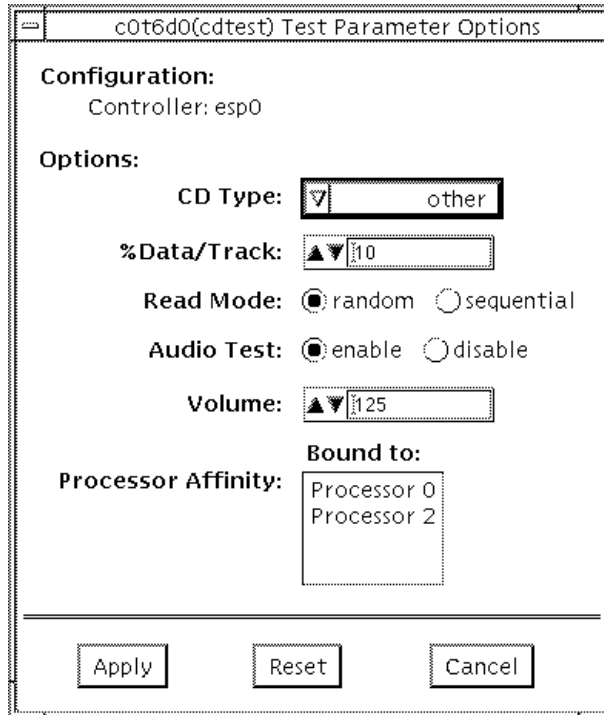

FIGURE 5-1 cdtest Option Menu



**TABLE 5-1** `cdtest` Options

Options	Description
CD Type	The types of compact discs that can be tested are listed in the CD Type menu. The choices are: <code>pdo</code> , <code>multi-session</code> , or <code>other</code> (the default CD type is <code>other</code> ). In the Connection test, this option has a default value of <code>other</code> . NOTE: Your choice must correspond with the disc used for testing.
% Data/Track	Tests a percentage of data on each track; type a value between 0 and 100 in this field to indicate the percentage. In the online and connection tests this option has a canned value of 2%.
Read Mode	<code>cdtest</code> reads the CD either in Random or Sequential mode. In Random mode, data blocks are read from random track positions; in Sequential mode, data blocks are read in sequence. For both modes, the total number of blocks read is determined by the <code>%_of_data</code> option. In the online and Connection tests this option has a canned value of <code>random</code> .
Audio Test	Enables or disables the audio test. You must connect headphones or a speaker to the audio jack on the CD player to hear audio output. In the Connection test, this option has a default value of <code>disable</code> .
Volume	Adjusts the volume; type a value between 0 and 255 in this field. In the online and connection tests this option has a default value of 125.

---

# cdtest Test Modes

This test supports Connection and Functional tests.

**TABLE 5-2** cdtest Test Modes

Test Mode	Description
Connection Test	In this mode, <code>cdtest</code> verifies that a CD-ROM drive is connected to and configured in the system.
Functional Test	<p>This mode is similar to Online mode except that the test registers a failure if the device is found to be busy. This is because SunVTS tests make the assumption that all the resources will be available for testing in the Functional test and the unavailability of a device is interpreted as an indication of a fault condition.</p> <p>If you invoke SunVTS through SyMON, the following Functional Test description applies: This mode attempts to verify the functionality of the drive by accessing and reading the media in the drive. If the media contains audio and the audio test is enabled, <code>cdtest</code> tries to play it. Only a small percentage of the media is read, as this is sufficient to verify the functionality of the drive and keeps the test runtime from being unnecessarily extended.</p> <p>If the device is found to be busy at the time of testing, the test exits after printing a message indicating that the device is unavailable for testing. The pass and error counts are unaffected.</p>

---

# cdtest Command Line Syntax

`/opt/SUNWvts/bin/cdtest standard_arguments -o dev=raw_device_name, mode=mode, read=random|sequential, data=%_of_data, vol=volume, audio=enable|disable, type=CD_type`

**TABLE 5-3** cdtest Command Line Syntax

Argument	Explanation
<code>dev=raw_device_name</code>	Specifies the name of the raw device to be tested.
<code>read=random sequential</code>	Indicates random or sequential read access.
<code>data=%_of_data</code>	Sets the percentage of data to be tested; you can specify 0 to 100 percent.
<code>vol=volume</code>	Controls the audio volume; you can specify 0 through 255; the default is 255.
<code>audio=enable disable</code>	Enables or disables the audio test; you must connect headphones or a speaker to the audio jack on the CD player to hear audio output.
<code>type=CD_type</code>	Specifies the type of CD used for the test; the choices are: <code>pdo</code> , <code>multi-session</code> , <code>sunos</code> and <code>other</code> ; the default is <code>other</code> .

# cdtest Error Messages

TABLE 5-4 cdtest Error Messages

Error Message	Probable Cause(s)	Suggested Action (if applicable)
6000 Fail to seek at block <i>value</i>	System error message. Bad media.	Retry with a different CD-ROM.
6001 Fail to read <i>number</i> bytes at block <i>number</i>	System error message. Bad media Incorrect CD-ROM type passed to cdtest.	
6002 Data mode <i>value</i> not supported	Datamode has a value other than CD_DATAMODE1 or CD_DATAMODE2 (see <code>cdio(7)</code> ).	
6003 Error occurred while playing audio track <i>number</i>		
6004 Failed to obtain memory from <code>malloc()</code> system call	Audio stop before complete at track <i>number</i> .	
6005 Unexpected audio status <i>value</i> received at track <i>number</i>	System error message	
6006 Fail in reading offset of the multi-session, offset = <i>value</i>	An incorrect value for <code>cdtype</code> has been passed to the <code>cdtest</code> . Bad media.	
6007 This is not a CD ROM Multi-Session disc!	An incorrect value for <code>cdtype</code> was passed to the <code>cdtest</code> .	
8000 Fail to open device <i>device_name</i>	System error message.	
8001 Fail <code>ioctl</code> <i>name</i>	System error message.	
8002 Fail <code>ioctl</code> <i>name</i>	System error message. No partitions on the disc	
8003 Fail to allocate <i>number</i> bytes of memory		

**TABLE 5-4** *cdtest* Error Messages (Continued)

	<b>Error Message</b>	<b>Probable Cause(s)</b>	<b>Suggested Action (if applicable)</b>
8004	Error occurred while reading TOC header	Track numbers out of range; First track: <i>value</i> , Last track: <i>value</i> .	
8005	Data miscompare while reading number bytes starting from block <i>number</i>	An incorrect value for <i>cdtype</i> has been passed to <i>cdtest</i> . Bad media.	
8006	ioctl CDROMSTART failure (number of retries: <i>value</i> )		



## Color Graphics Frame Buffer Test (`cg14test`)

---

`cg14test` checks the `cg14` frame buffer card. `cg14test` is specific to the VSIMM (Video SIMM) devices in the SPARCstation 10 SX and the SPARCstation 20 SX.



---

**Caution** – Due to possible conflicts between SunVTS `cg14` frame buffer tests and OPEN LOOK applications that use the `cg14` frame buffer, the following restrictions apply when running `cg14test`:

Do not run graphic applications other than OPEN LOOK while SunVTS is running frame buffer tests.

Do not run OPEN LOOK programs that generate video updates outside or on top of the SunVTS window.

Do not close the SunVTS window to an icon while it is running frame buffer tests.

Ensure that the frame buffer locking option is enabled from the Options window (see the section about testing frame buffers in *SunVTS 2.1 User's Guide* for details).

---

---

# cg14test Groups

There are nine test groups in `cg14test`:

1. MDI and VBC Chip Control Registers
2. Memory Chips
3. MDI Chip Cursor Registers
4. MDI Chip CLUT Registers
5. DAC Chip Registers
6. MDI Chip XLU Registers
7. CG14 Display (visual only)
8. MDI Chip Testmode Readback in 8-bit mode
9. Driver IOCTLs

**TABLE 6-1** `cg14` Test Groups

Test Groups	Description
Hardware (Groups 1-6)	These test groups are tested by opening <code>/dev/fbs/cgfourteenX</code> , mapping the MDI Control Address Space, modifying the target test location (using direct writes to the mapped address space), reading from the mmapped address space for verification, and closing the device.
Visual Pattern (Group 7)	This subtest loads a visual pattern of 256 colors, then rotates the pattern around. You verify this test by seeing it display.
Data Propagation (Group 8)	This test group is tested by loading the frame buffer (FB) memory with four neutral data patterns, then setting a target FB pixel with data that triggers the test mode readback latch. The result is read from the readback register after vertical blanking occurs. Two different trigger patterns are used at each FB pixel. All four MDI pixel paths (A - D) are used, and the pixel locations for each trigger are designed to detect gross MDI input data opens or short, VRAM SAM addressing, and VRAM-to-SAM transfer addressing. The screen shows four horizontal bars, which are either greyscale or colored. These bars change each time the trigger data is inverted, and as it completes the testing of a raster pattern.  <b>NOTE</b> — If the resolution and VRAM size permits, 8-bits per pixel mode are tested.



**TABLE 6-1** cg14 Test Groups (Continued)

Test Groups	Description
Driver (Group 9)	<p>Test all IOCTL calls that have not yet been used to verify proper driver communication to the hardware. Call the driver to perform a hardware update, and then confirm that the update was successful by using the complementary driver read, or reading the mmap'ed address space and comparing it against the stimulus.</p> <p>cg14test performs the appropriate steps before and after each test (if possible) to maintain context and prevent visual confusion by saving the register data before it is overwritten, disabling video (if possible), performing the specific test, and restoring the saved register data information.</p> <p>The data used for register testing is optimized to include all 0's, all 1's, and walking a 1 through each bit being tested.</p>
MDI and VBC Chip Control Registers (Group 1)	<p>Master Control Register bits 7-0 write/read verify            Packed Pixel Register bits 3-0 write/read verify            Master Status Register bits 7-4 read-only verify 0x00 and 0x30 occur            Horizontal Blank Start Register bits 9-0 write/read verify            Horizontal Blank Clear Register bits 9-0 write/read verify            Horizontal Sync Set Register bits 9-0 write/read verify            Horizontal Sync Clear Register bits 9-0 write/read verify            Composite Sync Clear Register bits 9-0 write/read verify            Vertical Blank Start Register bits 11-0 write/read verify            Vertical Blank Clear Register bits 11-0 write/read verify            Vertical Sync Set Register bits 11-0 write/read verify            Vertical Sync Clear Register bits 11-0 write/read verify            Transfer Cycle Set Register bits 9-0 write/read verify (MDI revision 0 only)            Transfer Cycle Clear Register bits 9-0 write/read verify (MDI revision 0 only)            Fault Status Address Register bits 15-0 write/read verify            Auto-increment Address Space Register bits 7-0 write/read verify            Video Base Register bits 23-12 write/read verify</p>
Memory Chips (Group 2)	<p>The Memory Chips test group includes VRAM Testing, Memory Retention, and Test Write Recovery.</p> <p><i>VRAM Testing</i>            The Data Bus Test uses 18 NTA patterns (Nair, Thatte, and Abraham's testing procedure for RAM) to check for data and address faults. This test is performed in MDI_CHUNKY_XBGR_MAP access mode only. See <b>Table 7-2</b>.</p>

**TABLE 6-1** cg14 Test Groups (Continued)

Test Groups	Description
Memory Chips (Group 2) Continued	<p data-bbox="518 241 782 263"><i>VRAM Testing (Continued)</i></p> <p data-bbox="518 269 1200 378">The test ascends through the Frame buffer memory, clearing it to 0's. The NTA pattern test number <i>x</i> reads a location to make sure test data <i>y</i> is present. It then writes new data <i>z</i> to that location. The location ascends through the FB sequentially. See Table 7-2.</p> <p data-bbox="518 413 696 435"><i>Memory Retention</i></p> <p data-bbox="518 440 1193 520">VRAM Data Retention checks for gross problems with the VRAM refresh. Since refresh is active during this test, no retention problems should occur unless the refresh is defective.</p> <p data-bbox="518 553 1198 663">This test turns off the video, writes 0's to all the VRAM, waits the specified <code>memory_hold</code> time (the default is five seconds), then reads and compares all VRAM data. This process is repeated with data of f's, then the video is restored and the test is complete.</p> <p data-bbox="518 696 1186 829">There are two new command line parameters related to this test: <code>R=number</code> and <code>H=number</code>. <code>R=</code> lets the user specify the refresh interval from 128-1023. The time between refresh cycles and the system default is 123. <code>H=</code> lets the user specify the retention test hold time in seconds.</p> <p data-bbox="518 862 711 885"><i>Test Write Recovery</i></p> <p data-bbox="518 890 1200 1083">A write recovery test is used in all the EMC mapping modes to write data to 0's followed by immediately reading that data location to see if the VRAM can recover from a write correctly. This is done to all sequential ascending locations. Next, a second independent pass of memory is made with the complementary data of 0xffffffff written to descending locations of the FB memory buffer.</p> <p data-bbox="518 1116 901 1138">The EMC mapping access modes are:</p> <p data-bbox="518 1144 772 1359"> <code>MDI_CHUNKY_XGBR_MAP</code>  <code>MDI_CHUNKY_BGR_MAP</code>  <code>MDI_PLANAR_X16_MAP</code>  <code>MDI_PLANAR_C16_MAP</code>  <code>MDI_PLANAR_X32_MAP</code>  <code>MDI_PLANAR_B32_MAP</code>  <code>MDI_PLANAR_G32_MAP</code>  <code>MDI_PLANAR_R32_MAP</code> </p>

**TABLE 6-1** cg14 Test Groups (Continued)

Test Groups	Description
MDI Chip Cursor Registers (Group 3)	<p>The MDI Chip Cursor Registers are:</p> <ul style="list-style-type: none"> <li>Cursor Plane 0 Register bits 31-0 write/read verify</li> <li>Cursor Plane 1 Register bits 31-0 write/read verify</li> <li>Cursor Plane 0 Register bits 31-0 write/read verify (with auto increment)</li> <li>Cursor Plane 1 Register bits 31-0 write/read verify (with auto increment)</li> <li>Cursor Control Register bits 2-0 write/read verify</li> <li>Cursor Color Register 1 bits 28-0 write/read verify</li> <li>Cursor Color Register 2 bits 28-0 write/read verify</li> <li>X-Cursor Location Register bits 11-0 write/read verify</li> <li>Y-Cursor Location Register bits 11-0 write/read verify</li> <li>Cursor Plane 0 Non-Auto Registers test</li> <li>Cursor Plane 0 Auto Registers test</li> <li>Cursor Plane 1 Non-Auto Registers test</li> <li>Cursor Plane 1 Auto Registers test</li> <li>Cursor Planes Retry A test</li> <li>Cursor Planes Retry B test</li> </ul>
MDI Chip CLUT Registers (Group 4)	<p>The MDI Chip CLUT Registers are:</p> <ul style="list-style-type: none"> <li>LUT1 Registers 0-255 bits 31-27 &amp; 23-0 write/read verify</li> <li>LUT1 Registers 0-255 bits 31-27 &amp; 23-0 write/read verify (with auto increment)</li> <li>LUT1D Registers 0-255 bits 31-27 &amp; 23-0 write/read verify</li> <li>LUT1D Registers 0-255 bits 31-27 &amp; 23-0 write/read verify (with auto increment)</li> <li>LUT2 Registers 0-255 bits 31-27 &amp; 23-0 write/read verify</li> <li>LUT2 Registers 0-255 bits 31-27 &amp; 23-0 write/read verify (with auto increment)</li> <li>LUT2D Registers 0-255 bits 31-27 &amp; 23-0 write/read verify</li> <li>LUT2D Registers 0-255 bits 31-27 &amp; 23-0 write/read verify (with auto increment)</li> <li>LUT3 Registers 0-255 bits 31-27 &amp; 23-0 write/read verify</li> <li>LUT3 Registers 0-255 bits 31-27 &amp; 23-0 write/read verify (with auto increment)</li> <li>LUT3D Registers 0-255 bits 31-27 &amp; 23-0 write/read verify</li> <li>LUT3D Registers 0-255 bits 31-27 &amp; 23-0 write/read verify (with auto increment)</li> </ul>

**TABLE 6-1** cg14 Test Groups (Continued)

Test Groups	Description
DAC Chip Registers (Group 5)	<p>The DAC Chip Registers test group includes the RAMDAC registers and control registers.</p> <p><i>RAMDAC Registers</i>  Address Register bits 7-0 (0x7 maximum) write/read verify  Mode Register bits 7-0 (skip bit 5) bits write/read verify</p> <p><i>Control Registers</i>  ID Register bits 7-0 r/o verify data is 0x8C  Pixel-Mask Register bits 7-0 write/read verify (skipped if dac rev = 2)  Command2 Register bits 7-0 write/read verify (skipped if dac rev = 2)  Command3 Register bits 7-0 write/read verify (skipped if dac rev = 2)</p>
MDI Chip XLUT Registers (Group 6)	<p>The MDI Chip XLUT Registers are:</p> <p>XLUT Registers 0-255 bits 7-0 write/read verify  XLUT Registers 0-255 bits 7-0 write/read verify (with auto increment)  XLUTD Registers 0-255 bits 7-0 write/read verify  XLUTD Registers 0-255 bits 7-0 write/read verify (with auto increment)</p>
CG14 Display (visual only) Group 7)	<p>This test visually displays 256 boxes on the screen (each in a different color), and then shifts the CLUT1 entries giving the visual impression of the pattern mirroring itself from left to right horizontally. The pattern then rotates up, down, followed by mirroring itself horizontally left to right.</p>
MDI Chip Test Mode Readback Register (Group 8)	<p>This Test Mode reads back register bits 23-0 in read-only and verify modes.</p>

**TABLE 6-1** cg14 Test Groups (Continued)

Test Groups	Description
Driver IOCTLs (Group 9)	<p>MDI_GET_CFGINFO check # of CLUT's, pixel height, pixel width, and pixel mode against hardware</p> <p>FBIOGATTR check real_type, fb_height, fb_width, fb_depth, fb_cmsize, and fb_size against cfginfo values</p> <p>FBIOGTYPE check fb_type, fb_height, fb_width, fb_depth,fb_size, and fb_cmsize against driver defines or cfginfo values</p> <p>FBIOGVIDEO check status returned against hardware</p> <p>FBIOSVIDEO set off, off, on, on, off verifying against hardware</p> <p>FBIOVERTICAL (imbedded in FBIOSVIDEO)</p> <p>MDI_VRT_CNTL turn off, off, on, on, off the video interrupt enable and verify the hardware agreesMDI_SET_PIXELMODE set different modes and verify against the hardware</p> <p>MDI_SET_PPR set the different modes and verify against the hardware</p> <p>MDI_SET_COUNTERS set HSS, HSC, XCC, HBC, XCS, HBS, CSC, VSS, VSC, VBC, VBS, HCT, and VCT then verify against hardware</p> <p>MDI_SET_XLUT set xlut and verify against hardware</p> <p>MDI_GET_XLUT get xlut and verify against hardware</p> <p>MDI_SET_CLUT set clut (1-3 as applicable) and verify against hardware</p> <p>MDI_GET_CLUT get clut (1-3 as applicable) and verify against hardware</p> <p>FBIOPUTCMAP set and verify clut1 matches</p> <p>FBIOGETCMAP verify clut1 matches get</p> <p>FBIOSATTR set emu_type to FBTYPE_MDICOLOR and verify FBIOGATTR check</p> <p>FBIOGCURMAX verify x and y size match driver defines</p> <p>FBIOSCUSOR verify set at 3 locations matches hardware</p> <p>FBIOGCURSOR verify driver knows what set(s) just did</p> <p>FBIOSCUSOR verify set at three locations matches hardware</p> <p>FBIOGCURPOS verify driver knows what set(s) just did</p> <p>MDI_SET_CURSOR set then check CCR, XCU, and YCU cursor hardware registers</p>

**TABLE 6-2** cg14test NTA Testing Patterns

NTA Test Pattern Number = x	Test Data = y	New Data = z
1.0	0x00000000	0x01010101
1.5	0x01010101	0xffffffff
2.1	0xffffffff	0xf1f1f1f1
2.2	0xf1f1f1f1	0x33333333
3.1	0x33333333	0xf0f0f0f0

**TABLE 6-2** `cg14test` NTA Testing Patterns (Continued)

<b>NTA Test Pattern Number = x</b>	<b>Test Data = y</b>	<b>New Data = z</b>
3.2	0xf0f0f0f0	0x0f0f0f0f
4.1	0x0f0f0f0f	0x55555555
4.2	0x55555555	0xaaaaaaaa
5.1	0xaaaaaaaa	0x05050505 (1x) 0x88888888 (2x)
5.2	0x88888888	0xf5f5f5f5
6.1	0xf5f5f5f5	0x00000000 (1x) 0x5f5f5f5f (2x)
6.2	0x5f5f5f5f	0x11111111
7.1	0x11111111	0x00000000 (1x) 0xcccccccc (2x)
7.2	0xcccccccc	0xdbdbdbdb
8.1	0xdbdbdbdb	0x6d6d6d6d
8.2	0x6d6d6d6d	0x6b6b6b6b
9.1	0x6b6b6b6b	0x00000000
9.2	0x00000000	-

# cg14test Options

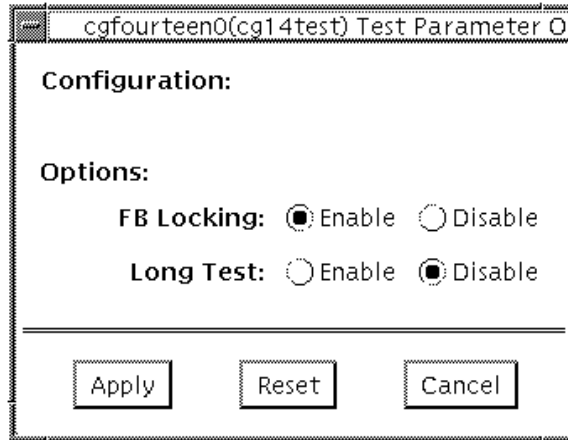

**FIGURE 6-1** cg14test Option Menu

**TABLE 6-3** cg14test Options

Options	Description
FB Locking	See the section about Testing Multiple Frame Buffers in the <i>SunVTS 2.1 User's Guide</i> for details.
Long Test	When enabled, the color bar screen(s) in the MDI Testmode Readback test checks all SAM transfers in clock=0 mode and clock=1 mode. If Long test is disabled, clock=1 runs checks on the first eight addresses and the first SAM transfer only.
Processor Affinity	For multiprocessor systems, indicates the processor to be tested.

---

# cg14test Command Line Syntax

```
/opt/SUNWvts/bin/cg14test standard_arguments -o dev=device_name,  
lock=E(nable)/D(isable), L, I
```

**TABLE 6-4** cg14test Command Line Syntax

Argument	Explanation
dev=device_name	Specifies the path of the cg14 device file to be tested; for example: /dev/fbs/device_name.
lock=E(nable)/D(isable)	Enables and disables the window system locking option. See the Testing Multiple Frame Buffers sections in the <i>SunVTS 2.1 User's Guide</i> for details. Do not use when your device is the window system display.
L	Enables the long TMRB test.
I	Enables optional driver ioctl tests for cursor. Note- Do not move the mouse during the cg14test when you run this option.

---

## cg14test Test Modes

Due to the nature of graphic tests, reading from or writing to the frame buffer during graphic tests will disturb user operation. This test is only available in Functional test mode.

The Functional test uses all subtests to test the cg14 frame buffer. The user can select the long mode for TRMB subtest.



# cg14test Error Messages

TABLE 6-5 cg14test Error Messages

Error Message	Probable Cause(s)	Suggested Action (if applicable)
6002 MDI <i>name</i> register = <i>number</i>	CG14 video board	
6004 MDI Cursor planes retry test maximum retry limit exceeded	CG14 video board	
6006 <i>name</i> error message	CG14 video board	
6008 Failed open of file <i>name</i> , errno= <i>number</i>	Disk CPU board	
6010 Failed write to file <i>name</i> , errno= <i>number</i>	CG14 video board CPU board Disk	
6012 Failed close of file <i>name</i> , errno= <i>number</i>	Disk CPU board	
6014 MDI chip TestMode Readback, <i>number</i> -bit <i>name</i> mode, offset= <i>number</i> pixelpipe= <i>name</i> clock= <i>number</i> exp= <i>number</i> obs= <i>number</i>		
6016 MEM ( <i>name</i> ), Data Retention offset= <i>number</i> exp= <i>number</i> obs= <i>number</i>	CG14 video board CPU board	
6018 MEM ( <i>name</i> ), NTA <i>name</i> offset= <i>number</i> exp= <i>number</i> obs= <i>number</i>	CG14 video board CPU board	
6020 MEM ( <i>name</i> ), WRRD <i>name</i> offset= <i>number</i> exp= <i>number</i> obs= <i>number</i>	CG14 video board CPU board	
6022 failed, mapping <i>name</i> space, errno = <i>number</i>	CG14 device file SunOS CG14 video board CPU board	

**TABLE 6-5** cg14test Error Messages (Continued)

Error Message	Probable Cause(s)	Suggested Action (if applicable)
6024 MEM ( <i>name</i> ), WRD <i>name</i> offset= <i>number</i> exp= <i>number</i> obs= <i>number</i>	SunOS CG14 video board CPU board	
6026 VBC Control Register exp= <i>number</i> obs= <i>number</i>	CG14 video board CPU board	
8002 <i>name</i> is an invalid parameter for <i>name</i> !	Operator error	
8004 unable to close device <i>name</i>	CG14 device file SunOS CG14 video board	
8006 invalid CG14 device type from <i>name</i>	CG14 device file SunOS CG14 video board	
8008 IOCTL Error: <i>name</i>	CPU board CG14 video board	
8008 IOCTL( <i>name</i> ) <i>name</i>	CPU board CG14 video board	
8010 unable to unlock OL windows	SunOS Operator error	
8012 IOCTL( <i>name</i> , CLUT <i>number</i> ) <i>name</i>	CG14 device file SunOS CG14 video board	
8014 unable to open CG14 device <i>name</i>	Incorrect device name No existing device CG14 video board	

## Frame Buffer, GX, GX+ and TGX Options Test (`cg6`)

---

The `cg6` test verifies the `cgsix` frame buffer and the graphics options offered with most SPARC based workstations and servers. This test stresses the frame buffer with the subtests described below.

---

**Note** – Disable all screen savers before testing any graphics device. Type `xset s off` at the prompt to disable the Solaris screen saver.

To start SunVTS with `vtsui`, but without `vtsk`, add the host name to `xhost` as:  
`xhost + hostname`.

---

---

# cg6 Subtests

TABLE 7-1 cg6 Subtests

Subtests	Description
Cursor Test	cg6 visually checks the overlay registers of the RAMDAC. A pointer is drawn on the screen and moved to predetermined locations. There is a problem if the pointer disappears. This visual test ensures that the overlay is working properly
Fast Copy in Double Buffer Test Mode	Creates two full-size screen raster images in double buffer mode, writing different patterns to each. The hidden buffer is copied to the visible buffer, and the data is compared. An error message is returned if there are inconsistencies. Then the buffer is flipped and the process is repeated. Note: This test only applies to Sun Microsystems GX+ graphic accelerators with double-buffering capacity.
TEC Test	Verifies that the Transformation Engine and Cursor control logic are accessible to confirm that further TEC access is performed correctly.
FBC Test	Verifies that the Frame Buffer Controller logic is accessible to confirm that further FBC access is performed correctly.
Frame Buffer Test	Verifies that the frame buffer memory is working. A “walking ones” pattern is written to memory, with a specific color signifying one of eight bits. The screen is divided into eight equally wide vertical stripes. A “walking one” is written to each stripe, causing eight iterations of these stripes. The value written is read back and checked. If the values do not match, an error is reported.
Screen Test Using Blits	Draws blocks of color and performs <code>blit</code> transfers to other portions of the screen. First, the entire screen is drawn with cyan, then a black block is placed in the upper-left corner. This subtest <code>blits</code> this block on the upper-right, lower-right, and lower-left corners, then “or’s” the whole image.
Blit Test	Draws a block of data and <code>blit</code> into a location at the bottom-right rectangle.

TABLE 7-1 cg6 Subtests

Subtests	Description
Line Test	Draws lines on the screen in different colors with different data values. The data is read back and compared with the expected values. An error is returned in the case of a mismatch.
Polygon Test	Draws hourglass-shaped polygons on the screen, using the four vertices. After all the polygons are rendered in the video memory, they are read back and the data compared with expected values. If there is a mismatch, an error is displayed.
Colormap Test	Loads all 256 locations in the color map with a greyscale, both backward and forward. This means decreasing values are loaded to all R, G, and B values. Note: If the system being tested has a monochrome or greyscale monitor, visual color problems are undetectable.

---

## cg6 Options

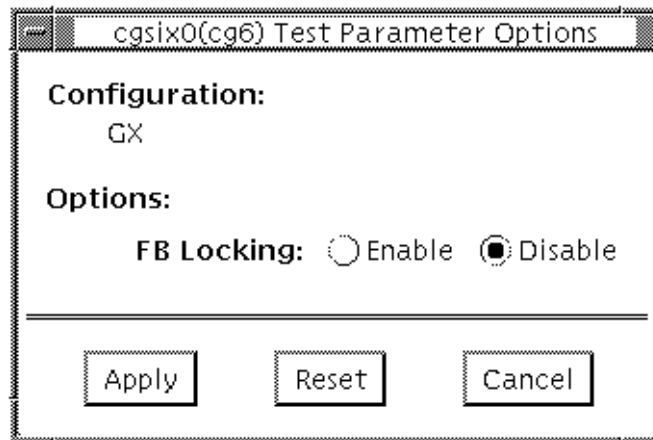

FIGURE 7-1 cg6 Options Menu

### *FB Locking*

See the section about Testing Frame Buffers in the *SunVTS 2.1 User's Guide* for details about frame buffer locking.

---

## cg6 Test Modes

Due to the nature of graphic tests, reading from or writing to the frame buffer during graphic tests will disturb user operation. This test is only available in Functional test.

---

## cg6 Command Line Syntax

```
/opt/SUNWvts/bin/cg14test standard_arguments -o dev=device_name,  
lock=E(nable)/D(isable), L, Passes=number, I
```

TABLE 7-2 cg6 Command Line Syntax

Argument	Explanation
dev=device_name	Specifies the path of the cg14 device file to be tested; for example: /dev/fbs/device_name.
lock=E(nable)/D(isable)	Enables/disables the window system locking option. See the section about Testing Multiple Frame Buffers in the <i>SunVTS 2.1 User's Guide</i> for details. Do not use when device is the window system display.
L	Enables the long TMRB test.
Passes=number	The number of passes to run; the default is 1.
I	Enables optional driver ioctl tests for cursor. Note: Do not move the mouse during the cg14test when you run this option.

---

**Note** – Extra swap space of 5 MBytes is required.

---

# cg6 Error Messages

TABLE 7-3 cg6 Error Messages

Error Message	Probable Cause(s)	Recommended Action(s)
6000 Resolution not supported for double buffering	Unsupported resolution.	Change to other resolutions.
6002 data error: x_pos: <i>number</i> , y_pos: <i>number</i> . *mobs: <i>number</i> , *mexp: <i>number</i>	Faulty frame buffer.	If the problem persists, call your authorized Sun service provider.
6004 FB Screen Test data error: xpos= <i>number</i> , ypos= <i>number</i> , exp( <i>number</i> ), obs( <i>number</i> )	Faulty frame buffer.	If the problem persists, call your authorized Sun service provider.
6006 Data Error: Screen location x: <i>number</i> , y: <i>number</i> , Obs: <i>number</i> , Exp: <i>number</i>	Faulty frame buffer.	If the problem persists, call your authorized Sun service provider.
6007 Multibuffering extension does not exists	Faulty frame buffer.	If the problem persists, call your authorized Sun service provider.
6008 Cannot create CMAP	System error. Faulty frame buffer.	If the problem persists, call your authorized Sun service provider.
6009 name off( <i>number</i> )exp( <i>number</i> ), obs( <i>number</i> ), xor( <i>number</i> )	Faulty frame buffer.	If the problem persists, call your authorized Sun service provider.
6010 Could not get color	System error. Faulty frame buffer.	If the problem persists, call your authorized Sun service provider.
6011 <i>name</i> off( <i>number</i> )exp( <i>number</i> ), obs( <i>number</i> ), xor( <i>number</i> ) <i>name</i>	Faulty frame buffer.	If the problem persists, call your authorized Sun service provider.
6012 Checksum test failed for PROM. Observed: <i>number</i> , Expected: <i>number</i>	Faulty frame buffer.	If the problem persists, call your authorized Sun service provider.
6014 Unable to lock frame buffer	FB lock was enabled while window system was not running.	Disable the FB lock.
6016 Found error in sine test	Faulty frame buffer.	If the problem persists, call your authorized Sun service provider.

**TABLE 7-3** cg6 Error Messages (Continued)

	<b>Error Message</b>	<b>Probable Cause(s)</b>	<b>Recommended Action(s)</b>
6018	Found error in cursor test	Faulty frame buffer.	If the problem persists, call your authorized Sun service provider.
6020	Found error in fb test	Faulty frame buffer.	If the problem persists, call your authorized Sun service provider.
6022	Found error in polygon test	Faulty frame buffer.	If the problem persists, call your authorized Sun service provider.
6024	Found error in cmap test	Faulty frame buffer.	If the problem persists, call your authorized Sun service provider.
6026	Found error in db test	Faulty frame buffer.	If the problem persists, call your authorized Sun service provider.
6028	Found error in line test	Faulty frame buffer.	If the problem persists, call your authorized Sun service provider.
6030	Found error in dac test	Faulty frame buffer.	If the problem persists, call your authorized Sun service provider.
8000	<i>name</i> not mapped	System error.	If the problem persists, call your authorized Sun service provider.
8002	can't acquire console semaphore	System error.	If the problem persists, call your authorized Sun service provider.
8004	XCreateSimpleWindow failed	System error.	If the problem persists, call your authorized Sun service provider.
8008	Couldn't create enough buffers	Not enough memory available. System error.	Reduce the system load. If the problem persists, call your authorized Sun service provider.
8010	grab of pointer unsuccessful	Not enough memory available. System error.	Reduce the system load. If the problem persists, call your authorized Sun service provider.



**TABLE 7-3** cg6 Error Messages (Continued)

Error Message	Probable Cause(s)	Recommended Action(s)
8012 cmap mapping failed	Not enough memory available.	Reduce the system load.
	System error.	If the problem persists, call your authorized Sun service provider.
8014 Blit status. Could not launch draw	Faulty frame buffer.	If the problem persists, call your authorized Sun service provider.
8016 Draw Wait FBC_DRAW status= <i>number</i>	Faulty frame buffer.	If the problem persists, call your authorized Sun service provider.
8018 Could not get cmap	Faulty frame buffer.	If the problem persists, call your authorized Sun service provider.
8020 Could not get color	Faulty frame buffer.	If the problem persists, call your authorized Sun service provider.
8022 Could not create child raster	Incorrect device name.	Re-enter the correct name.
	Not enough memory available.	Reduce the system load.
8024 Failed to get malloc	Not enough memory available.	Reduce the system load.
	System error.	
8026 Cannot create CMAP	System error.	If the problem persists, call your authorized Sun service provider.
	Faulty frame buffer.	
8028 Couldn't get hostname of machine under test	System error.	If the problem persists, call your authorized Sun service provider.
8030 Failed in opening device <i>name</i>	Incorrect device name.	Re-enter the correct name.
	Faulty frame buffer.	If the problem persists, call your authorized Sun service provider.
8032 Failed to create raster	Incorrect device name.	Re-enter the correct name.
	Not enough memory available.	Reduce the system load.

**TABLE 7-3** cg6 Error Messages (Continued)

Error Message	Probable Cause(s)	Recommended Action(s)
8034 Failed to create context	Not enough memory available.	Reduce the system load.
	System error.	If the problem persists, call your authorized Sun service provider.
8036 fbs/cgsix0 FATAL: "mmap() failed	Overloaded system.	Reduce the system load.
	System error.	Check OS release number.

## Disk and Floppy Drives Test (disktest)

---

`disktest` verifies the functionality of hard disk drives and floppy drives using three subtests (see TABLE 8-1): Media, File System, and Asynchronous I/O. `disktest` performs a random seek check followed by a read test or a read-after-write test on the disk. Most disk drives, such as SCSI disks, native or SCSI floppy disks, IPI, and so on, are supported. The type of drive being tested is displayed at the top of the option menu.

Initially, `disktest` probes the disks under `/dev/rdisk`. It checks all of the partitions of each disk in the Functional test mode. If any partition has a file system that is not yet mounted, `disktest` pre-mounts these partitions for the File System subtest. The pre-mount point bears the name of the disk partition appended with a system-wide unique number. For example, if the disk name is `/dev/dsk/c0t3d0`, `disktest` mounts it as superuser under the name `/disktest_c0t3d0`. The `disktest` option menu shows all partitions (except the `swap` partition) that are available for testing. The File System subtest can only be run if the selected partition is mounted. The Write option of the Media subtest is allowed only if a selected partition is *not* mounted.

`disktest` tests the floppy drive regardless of whether the Volume Management software is running.

- If the Volume Management software is running, `disktest` tests the disk drive with the mount point name in the `/etc/mnttab` file.



**Caution** – If a power failure occurs while the Media subtest is being run in write mode, disk data will be destroyed.

---

- If the Volume Management software is *not* running, `disktest` tests the disk drive with the device name `dev=/dev/diskette`. Do not edit the `/etc/vold.conf` file to change the floppy drives. Currently, the SunVTS software is hard-coded to use these path names as the default logic name.

Table 2-1 describes the `disktest` subtests.

**TABLE 8-1** `disktest` Subtests

Subtest	Description
Media Subtest	<p>Verifies disk media by writing data to and reading data from the disk. The Media subtest treats a disk as one large chunk of contiguous data.</p> <p>This is a scalable test that can run multiple copies in read/write mode on the same disk partition. To avoid data corruption, all simultaneous instances of <code>disktest</code> communicate through a shared memory service. This ensures that different copies of the media subtest do not overlay the same disk block at the same time.</p>
File System Subtest	<p>Verifies the disk system's integrity. The file system subtest exercises the partition being tested to determine if it is mounted. If the partition is not already mounted or pre-mounted, then the test is blocked. The test opens two temporary files (of the size specified on <code>File System File Size</code>) and performs a Read/Write test.</p>
Asynchronous I/O Subtest	<p>Uses the asynchronous read/write feature of the Solaris disk driver to exercise the disk. In read-only mode, the test sends a maximum of four asynchronous read packets, each with a random size and a random offset into the selected partition. The test then waits for all outstanding I/O activity to complete before issuing another round of packets. This process continues until the whole area is tested. In read-write mode, one write packet is issued in every four read packets as a spot check of the write operation. Before data is written to a particular location, data is backed up, write-verified, and restored to its original state.</p>

# disktest Test Options

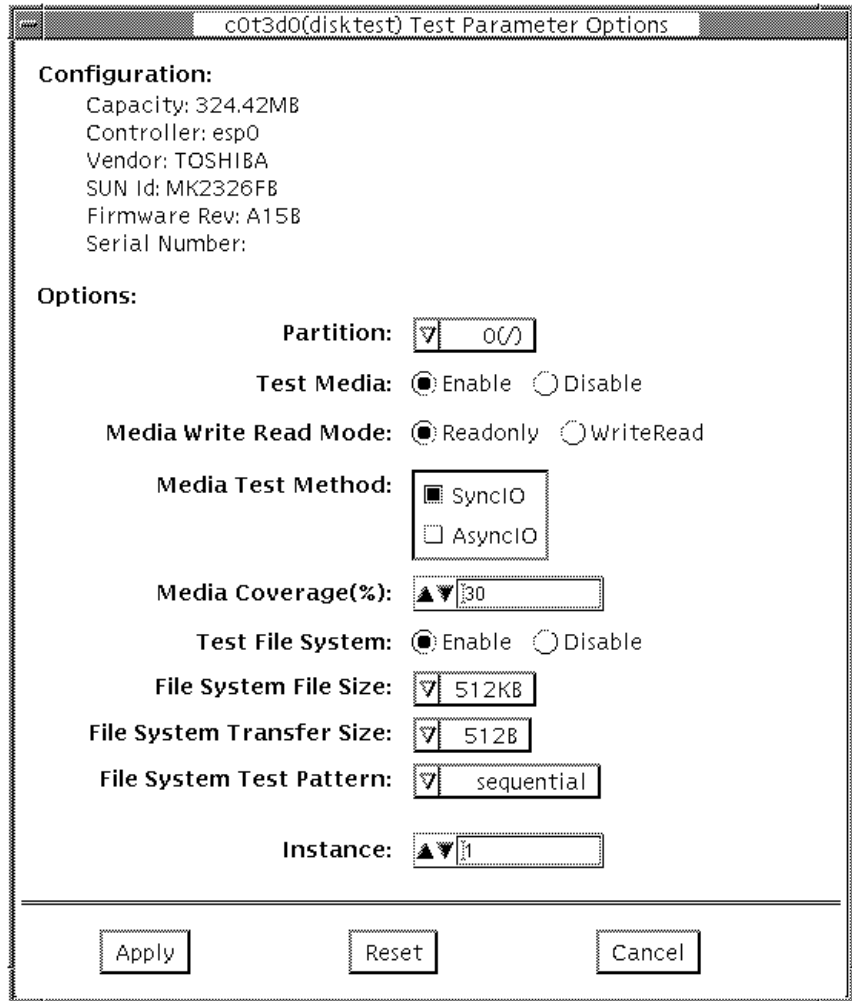

**FIGURE 8-1** disktest Configuration and Options Menu

The disktest test (see FIGURE 8-1 and TABLE 8-2) has different option menus for different test modes.

**TABLE 8-2** disktest Configurations and Options

<b>disktest Options</b>	<b>Description</b>
Partition	Displays the partition for the Media subtest. If a partition is mounted, its mount point is appended after the partition number, such as 1(/usr), where 1 is the partition number, and /usr is the mount point.
Test Media	Enables or disables the Media subtest.
Media Write Read Mode	Enables Read-Only or Read mode after write, with or without backup.
Media Coverage (%)	Enables users to test all or part of a partition (in percentages).
Test File System	Enables or disables the File System subtest; File System File Size: creates a file system file size twice the size as what is specified.
File System Transfer Size	Displays the transfer size of the File System subtest. File System Test Pattern: Test pattern of File System subtest.
Connection Test for Hard Disk	Option Menu for hard disk partition: 0 - 7 [default] Test Media: [Enable~](fixed to Enable) Test Mode: [Read Only~](fixed to Read Only) Media Coverage(%): [1](default - can be changed) Media Transfer Size: [2KB] Test File System: [Disable~](fixed to Disable)

**TABLE 8-2** `disktest` Configurations and Options (*Continued*)

<code>disktest</code> Options	Description
Online Mode for Hard Disk	Online Mode for hard disk partition: 0 - 7 [default] Test Media: [Enable]- [Disable] Test Mode: [Read-only~](fixed to Read-only) Media Coverage(%): [10] Media Transfer Size: [2KB] [10KB] [20KB] - [40KB] [60KB] Test File System: [Disable~](fixed to Disable)
Functional Test for Hard Disk	(under SCSI-devices group): partition: 0 - 7 [default] Test Media: [Enable]- [Disable] Mode: [Read-only]- [BackupWriteRead] [NoBackupWriteRead] Media Coverage(%): [30] Media Transfer Size: [2KB] [10KB] [20KB] - [40KB] [60KB] Test File System: [Enable] [Disable] - File System File Size:[512KB]-[2MB][8MB][20MB] [100MB] [200MB] File System Transfer Size:[512B]- [1024B][10KB][40KB] [100KB] File System Test Pattern:[sequential] [0x00000000] [0xffffffff] [0x5aa55aa5] [0xdb6db6db] [random]
Functional Test for Floppy Disk	(under Other-Devices group): partition: 0 - 7 [default] Test Media: [Enable]- [Disable] Mode: [Read-only]- [BackupWriteRead] [NoBackupWriteRead] Media Coverage(%): [30] Media Transfer Size: [2KB]- [10KB] [20KB] Test File System: [Enable] [Disable] - File System File Size:[512KB]- [2MB] [8MB] [20MB] [100MB] [200MB] File System Transfer Size:[512B]- [1024B] [10KB] File System Test Pattern:[sequential] [0x00000000] [0xffffffff] [0x5aa55aa5] [0xdb6db6db] [random] <b>NOTE:</b> The floppy <code>disktest</code> can only be run in Functional test mode.

## disktest Test Modes

`disktest` supports all three test modes. It performs different test schemes on the network device according to the mode you select.

**TABLE 8-3** `disktest` Test Modes

Test Mode	Description
Connection Test	<p>This mode is only available for the hard disk test. There is no Connection test for the floppy driver test. Only one instance of <code>disktest</code> (which monitors UNIX error messages) is allowed for each disk device. <code>disktest</code> displays messages and reports errors. The test also opens the hard disk, checks the disk configuration, reads a few blocks, and then closes the hard disk. No File System subtest is run. No Write option is available in Connection test.</p>
Functional Test	<p>This mode does not allow <code>disktest</code> to monitor UNIX error messages. More than one instance of <code>disktest</code> is allowed for one disk device. Both the File System and Media subtests can be run in Functional test. The floppy test can also be run in Functional test mode.</p> <p>If you invoke SunVTS through SyMON, the following Functional Test description applies:</p> <p>This mode is only available for the hard disk test. There is no Online mode for the floppy driver test. Only one instance of <code>disktest</code> is allowed for each disk device, which monitors UNIX error messages. <code>disktest</code> displays messages and reports errors.</p> <p>In this mode, <code>disktest</code> also opens the hard disk, checks the disk configuration, and executes the Media subtest. Next, <code>disktest</code> performs random seek checks. Only Read Only mode is allowed. The default coverage is 30percent. No File System subtest is run. When the test finishes, <code>disktest</code> closes the disk device being tested. No Write option is available in Online mode.</p>



# disktest Command Line Syntax

```
/opt/SUNWvts/bin/disktest standard_arguments -o p=n,-i=n,  
-w=n,dev=device_name,partition=0-7,rawsub=E/D,rawrw=,  
rawcover=,rawiosize=,fssub=,fssize=,fsiosize=,fspattern=
```

TABLE 8-4 disktest Command Line Syntax

Argument	Explanation
p=number	Sets the number of passes for the test to run; default is 1.
i=number	Sets the number of total instances for the test; default is 1.
w=number	Determines which instance this test is assigned; default is 0.
dev=device_name	Specifies the name of the disk to be tested, such as c0t3d0.
partition=0-7	Specifies the partition number to test as partition=6(/export/s6) if mounted on partition 6.
rawsub=Enable/Disable	Enables or disables the media subtest.
rawrw= Readonly BackupWriteRead NoBackupWriteRead	Specifies the Media subtest Read and Write mode: -Read Only -Write, read then backup -Write, read without backup
rawcover=	Specifies media coverage from 0-100% of the partition, such as 70526f.
rawiosize=2KB,10KB 20KB,40KB,60KB	Specifies the media size to transfer.
fssub=Enable/Disable	Enables or disables the file system subtest.
fspattern=data pattern	Specifies the file system data pattern as sequential or random. {seq(uequential)/0x0(0000000)/0xf(ffffff)/0xa(5a5a5a5)/ 0x5(a5a5a5a)/ran(dom)/0xd(b6db6db)}
fssize=file system size	Indicates the file system subtest size in kilobytes or megabytes: K/k/KB/kb:kilobytes, M/m/MB/mb: megabytes.
fsiosize=file system I/O transfer size	Indicates the size of the file system subtest I/O transfer in bytes or kilobytes: {512B/1024B/10KB/40KB/100KB}

# disktest Error Messages

TABLE 8-5 disktest Error Messages

Error Message	Probable Cause(s)	Recommended Action
6000 Re-reading and re-comparing block <i>number</i> on name	Media error. Faulty cable, disk, or controller.	If the problem persists, call your authorized Sun service provider.
6002 Error on re-comparing block <i>number</i> on <i>name</i>	Media error. Faulty cable, disk, or controller.	If the problem persists, call your authorized Sun service provider.
6004 <i>name</i> failed on <i>name</i> , blk <i>number</i> : <i>error_message</i>	Faulty cable, disk, or controller.	If the problem persists, call your authorized Sun service provider.
6006 Compare error on <i>name</i> , block <i>number</i> , offset <i>number</i>	Faulty cable, disk, or controller.	If the problem persists, call your authorized Sun service provider.
6008 Compare error: Block <i>number</i> on <i>name</i> was written with a repeating hex pattern of <i>number</i>	Media error. Faulty cable, disk, or controller.	If the problem persists, call your authorized Sun service provider.
6010 TIME OUT!	System too busy. Faulty cable, disk, or controller.	Reduce the system load. If the problem persists, call your authorized Sun service provider.
6012 Couldn't close <i>name</i>	System error.	
6014 <i>name</i> read failed on disk, in-between blocks <i>number</i> and <i>number</i> : <i>name</i>	Media error. Faulty cable, disk, or controller.	If the problem persists, call your authorized Sun service provider.
6016 <i>name</i> read failed due to unexpected end of media		
6018 <i>name</i> write failed on disk, in-between blocks <i>number</i> and <i>number</i> : <i>name</i>	Media error. Faulty disk or controller.	If the problem persists, call your authorized Sun service provider.
6020 <i>name</i> write failed due to unexpected end of media:		

**TABLE 8-5** disktest Error Messages (Continued)

Error Message	Probable Cause(s)	Recommended Action
6022 <i>name</i> compare failed on <i>name</i> , block <i>number</i> , offset <i>number</i>	Media error. Faulty disk or controller.	If the problem persists, call your authorized Sun service provider.
6024 Couldn't close name	Faulty disk or controller. System error.	If the problem persists, call your authorized Sun service provider.
6026 failed automount <i>name</i> onto <i>name: error_message</i>	Un-supported file system. System error.	Disable the file system subtest. Disable the file system subtest. If the problem persists, call your authorized Sun service provider.
6028 <i>error_message</i>		
8000 File system subtest only allow to run on off-line mode	Parameter error.	Re-enter the command line correctly.
8002 malloc() failed	System load too heavy. System error.	
8006 File operation error: Couldn't <i>name</i> file <i>name</i> on <i>name: error_message</i>	Lack of system resource. Permission error. System error.	Reduce the system load. Check directory or file permission. If the problem persists, call your authorized Sun service provider.
8008 Not enough free blocks on <i>name</i> (partition <i>number</i> )		Try another partition or delete files.
8010 No writable partition on <i>name</i>		Try another partition.
8012 No file system on device: <i>name</i>		Use <code>newfs</code> to create the file system. Disable the file system subtest.

**TABLE 8-5** disktest Error Messages (Continued)

Error Message	Probable Cause(s)	Recommended Action
8014 Couldn't run fstest on any partition of device: <i>name</i> (except 2)	File system not supported.	Disable the file system subtest.
	System error.	If the problem persists, call your authorized Sun service provider.
8016 Cannot open device: <i>name</i>	Parameter error.	Enter the correct name of disk as dev=c0t3d0.
	System error.	If the problem persists, call your authorized Sun service provider.
8018 Couldn't mount /dev/dsk/ <i>name</i>	Parameter error.	Enter the correct name of disk as dev=c0t3d0.
	System error.	If the problem persists, call your authorized Sun service provider.
8020 Couldn't remove temporary dir <i>name</i> : <i>error_message</i>	System error.	If the problem persists, call your authorized Sun service provider.
8022 fail get semaphore: <i>error_message</i>	Lack of system resource.	Reduce the system load.
	System error.	If the problem persists, call your authorized Sun service provider.
8024 failed lock mtab semaphore: "semop" system call failure, errmsg <i>error_message</i>	disktest instances exceed system semaphore operation limitation (default system limit for seminfo_semmnu=30)system software error.	Add the line "set semsys: seminfo_semmnu=0x100" to your /etc/system file and reboot the machine. If the problem persists, call your authorized Sun service provider.
8026 fail unlock mtab semaphore: <i>error_message</i>	System error.	If the problem persists, call your authorized Sun service provider.
8028 failed get_volmgr_name()		
8030 Couldn't open <i>name</i> : <i>error_message</i>	Cable loose or disconnected.	Check the cable.
	Device off line or missing.	Check the device on line.
	Device not configured.	Configure the device.
8032 Get file state <i>name</i> failed: <i>error_message</i>	System error.	If the problem persists, call your authorized Sun service provider.

**TABLE 8-5** disktest Error Messages (Continued)

<b>Error Message</b>	<b>Probable Cause(s)</b>	<b>Recommended Action</b>
8034    Couldn't open <i>name</i>	Permission error. System error.	Check the permissions. If the problem persists, call your authorized Sun service provider.
8036    failed putmntent(): <i>error_message</i>	System error.	If the problem persists, call your authorized Sun service provider.
8038    fail rename file	Permission error. System error.	Check permission. If the problem persists, call your authorized Sun service provider.
8040    Couldn't get mount table entry for <i>name</i>		
8042    Invalid device name in <i>name</i>	Parameter error.	Enter the correct name of disk as dev=c0t3d0.
8044    Message table overflow on device <i>name</i>	Parameter error. System error. Program error.	Enter the correct name of disk as dev=c0t3d0. If the problem persists, call your authorized Sun service provider.
8046    Invalid controller id <i>name</i> for <i>name</i>	Parameter error.	Re-enter the command line correctly.
8048 <i>name</i> , disk DKIOCINFO ioctl: <i>name</i>	Controller is not supported. System error.	Disable the file system subtest. If the problem persists, call your authorized Sun service provider.
8050    failed getting shared memory for monitor <i>number</i> : <i>error_message</i> :	Lack of system resource. System error.	Reduce the system load. If the problem persists, call your authorized Sun service provider.
8052    failed attaching monitor shared memory: <i>error_message</i>	Lack of system resource. System error.	Reduce the system load. If the problem persists, call your authorized Sun service provider.

**TABLE 8-5** disktest Error Messages (Continued)

Error Message	Probable Cause(s)	Recommended Action
8053 failed create monitor shared memory <i>number</i> :	Lack of system resource. System error.	Reduce the system load. If the problem persists, call your authorized Sun service provider.
8054 Shm remove error: <i>error_message</i>	System error.	If the problem persists, call your authorized Sun service provider.
8056 New error messages in system log. Extracted below: <i>error_message</i>	Faulty cable/disk/controller.	See /var/adm/messages for more information. If the problem persists, consult your authorized Sun service provider.
8060 fails to open any partition of <i>name</i>	File system not mounted.	Mount the file system then run the test. Disable the file system subtest. If the problem persists, call your authorized Sun service provider.
8060 failed getting semaphore: <i>error_message</i>	System error.	If the problem persists, call your authorized Sun service provider.
8062 failed getting shared memory: <i>error_message</i>	System error.	If the problem persists, call your authorized Sun service provider.
8064 failed attaching shared memory: <i>error_message</i>	System error.	If the problem persists, call your authorized Sun service provider.
8068 failed unlocking semaphore: <i>error_message</i>	System error.	If the problem persists, call your authorized Sun service provider.
8070 fail open floppy disk	No floppy disk in drive.	Check the floppy disk.
8072 failed FDIOGCHAR on floppy ioctl	System error.	If the problem persists, call your authorized Sun service provider.
8074 ioctl DKIOCGGEM failed	File system not supported. System error.	If the problem persists, call your authorized Sun service provider.

**TABLE 8-5** disktest Error Messages (Continued)

Error Message	Probable Cause(s)	Recommended Action
8074 ioctl DKIOCGAPART failed	System error.	If the problem persists, call your authorized Sun service provider.
8076 fail initialize shared memory	System error.	If the problem persists, call your authorized Sun service provider.
8078 Illegal parameters on Online Mode	Parameter error.	Enter the correct option.
8080 Illegal parameters on Conn. Mode	Parameter error.	Enter the correct option.
8082 failed get_volmgr_name()	No floppy disk in drive.	Check the floppy disk.
8084 Mounted file system on device!	Not enough disk space.	Reduce the system load.
	Permission error.	Check directory or file permissions.
	System error.	If the problem persists, call your authorized Sun service provider.
8086 Invalid controller id <i>number</i> from <i>name</i>	Parameter error.	Enter the correct name of disk as dev=c0t3d0.
8088 Couldn't get file system information on <i>name</i> errno= <i>number</i>	System error.	If the problem persists, call your authorized Sun service provider.
8090 ioctl() failed on <i>name: name</i>	System error.	If the problem persists, call your authorized Sun service provider.
8092 Fail to get disk information	No supported disk.	No UNIX message monitor feature in this disk(2).
	System load is too heavy.	Reduce the system load
8094 Failed to create a message base for controller <i>number</i>	No disk under this controller.	Connect the disk driver then run the test again.
8096 fail to make directory <i>name</i>	Lack of system resource.	Reduce the system load.
	Permission error.	Check directory or file permissions.
	System error.	If the problem persists, call your authorized Sun service provider.
8098 Failed to mount partition	Does this disk only have partition 2.	Partition 2 must be manually mounted.

**TABLE 8-5** disktest Error Messages (Continued)

Error Message	Probable Cause(s)	Recommended Action
8010 r/w is on /dev/rname	System error.	If the problem persists, call your authorized Sun service provider.
8102 write/read count error	Out of disk space.	Try another partition or delete some files.
8104 failed to create buffer	Not enough memory.	Reduce the system load. If the problem persists, call your authorized Sun service provider.
8106 failed aioread() : <i>offset error number error string</i>	Faulty cable, disk, or controller.	If the problem persists, call your authorized Sun service provider.
8108 failed aiowrite() : <i>offset error number error string</i>	Faulty cable, disk, or controller.	If the problem persists, call your authorized Sun service provider.
8110 failed aiooperation() : <i>number text</i>	Faulty cable, disk, or controller.	If the problem persists, call your authorized Sun service provider.



## ECP 1284 Parallel Port Printer Test (ecpptest)

---

The `ecpptest` verifies the functionality of the `ecpp(7)` IEEE 1284 parallel printer port device.

The `ecpp(7)` device is an *exclusive use device*. Only one application can interface with it at a time. This test is not scalable.

---

## Printer Test Hardware and Software Requirements

The `ecpp(7)` driver is installed with the OS if the system being tested supports the `ecpp(7)` device. To run the optional printer subtest, a Centronics or ECP-mode printer must be attached to the printer port. To run the optional external loopback test, a passive loopback connector must be installed on the printer port.

---

**Note** – The external loopback test is intended for Sun internal manufacturing use only. It requires a custom loopback connector not available to an external customer.

---

---

# ecpptest Subtests

**TABLE 9-1** ecpptest Subtests

Subtest	Description
Internal Test FIFO Loopback	Verifies DMA and PIO accesses to the ecpp device. It uses an internal test fifo on the ecpp device. There are no printer or loopback connectors required. This test is always executed.
External Passive Loopback	This verifies the parallel port I/O connections to the back panel connector. This test requires a passive loopback connector (Sun part no. 270-2965-01). This test is disabled by default and must be manually enabled by the user. Note: The external loopback test is intended for Sun internal manufacturing use only. It requires a custom loopback connector that is not available to an external customer.
Printer Test	This verifies the parallel port printer operation. It will output a half page of ASCII character data. The output mode (for example, ECP and Centronics) is determined by whatever mode the printer and ecpp driver automatically negotiate. It will not change the current mode. The user must verify that data printed properly. This test is disabled by default and must be manually enabled by the user. If this test passes successfully, you know that the SBus DMA circuitry, the printer, and the device driver are functioning properly.

# ecpptest Options

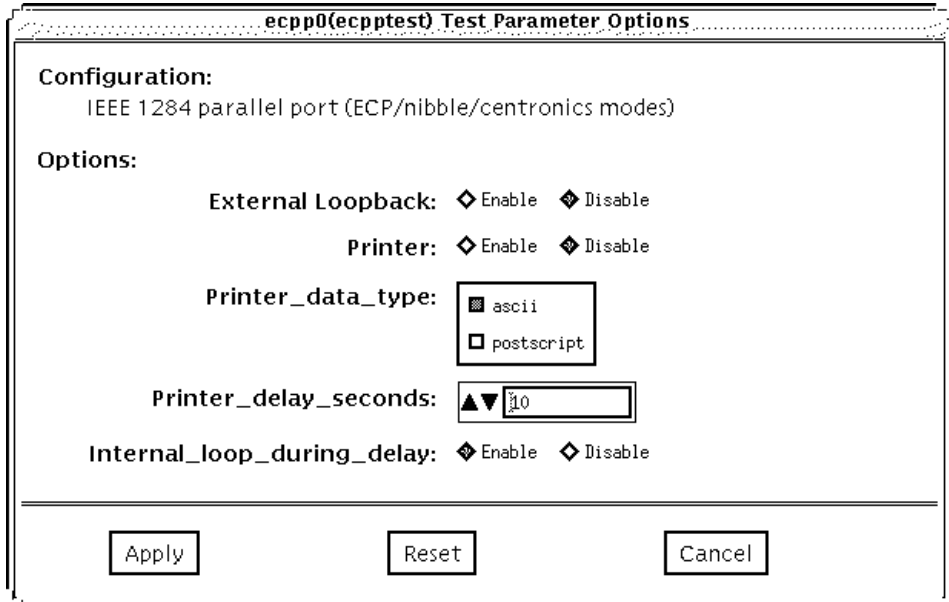

FIGURE 9-1 ecpptest Option Menu

TABLE 9-2 ecpptest Options

ecpptest Options	Description
External Loopback	Enables or disables the external loopback test. This test requires a special loopback plug
Printer	Enables or disables the printer test; this test requires a printer to be attached to the parallel port

---

# ecpptest Test Modes

TABLE 9-3 ecpptest Test Modes

Test Mode	Description
Connection Test	Opens and closes the <code>ecpp(7)</code> device. No data is transferred. The test passes if the device can be open and closed successfully. The test also passes if the device cannot be opened because the device is busy with another process
Functional Test	Runs the internal loopback test and the user can optionally run the External loopback test and Printer test. The test will fail if the device is busy  If you invoke SunVTS through SyMON, the following Functional Test description applies: Runs the internal loopback test. If the device cannot be opened because it is busy, then it is assumed that the device is successfully connected to another process

---

# ecpptest Command Line Syntax

```
/opt/SUNWvts/bin/ecpptest standard_arguments -o [dev=device_name]  
[ext_loop=Enable/Disable] [printer=Enable/Disable]
```

TABLE 9-4 ecpptest Command Line Syntax

Argument	Explanation
<code>dev=device_name</code>	Specifies the name of the device. This should be of the form <code>/dev/ecpp#</code> , where <code>#</code> is the minor number of the device. The default device is <code>/dev/ecpp0</code> .
<code>ext_loop=enable/disable</code>	If enabled, the external loopback test is run. The External loopback plug must be attached to the printer port.
<code>printer=enable/disable</code>	If enabled, the printer test is run. A Centronics or ECP mode parallel port printer must be attached

# ecpptest Error Messages

TABLE 9-5 disktest Error Messages

Error Message	Probable Cause(s)	Recommended Action
8000 External loop test and printer test cannot be enabled at the same time	Operator error.	Examine system message files (/var/adm/messages) for other information.
8001 <i>device_name</i> : Device does not exist or is otherwise inaccessible	Correct ecpp driver not installed.  Faulty ecpp device or motherboard hardware.  System software problem.	Examine system message files (/var/adm/messages) for other information.
8002 Must be super user ( <i>root</i> ) to execute	Operator error.	Examine system message files (/var/adm/messages) for other information.
8003 Failed to open <i>device_name</i> ( <i>error_message</i> )	Correct ecpp driver not installed.  Faulty ecpp device or motherboard hardware.  System software problem.	Examine system message files (/var/adm/messages) for other information.
8004 Failed ioctl <i>name</i> , device = <i>device_name</i> , error = <i>error_message</i>	Correct ecpp driver is not installed.  Faulty ecpp device or motherboard hardware.  System software problem.	Examine system message files (/var/adm/messages) for other information.
8005 Device not in correct mode, device = <i>device_name</i> , expected mode = <i>number</i> , observed mode = <i>number</i>	Correct ecpp driver is not installed.  Faulty ecpp device or motherboard hardware.  System software problem.	Examine system message files (/var/adm/messages) for other information.

**TABLE 9-5** disktest Error Messages (Continued)

Error Message	Probable Cause(s)	Recommended Action
8006 <i>device_name</i> : Status line mismatch, expected = <i>number</i> , observed = <i>number</i> , xor = <i>number</i>	<p>Faulty or missing external loopback connector.</p> <hr/> <p>Correct ecpp driver is not installed.</p> <hr/> <p>Faulty ecpp device or motherboard hardware.</p> <hr/> <p>System software problem.</p>	Examine system message files (/var/adm/messages) for other information.
8007 ECPP_nACK in wrong state, expected = <i>number</i> , observed = <i>number</i> , xor = <i>number</i>	<p>Faulty or missing external loopback connector.</p> <hr/> <p>Correct ecpp driver not installed.</p> <hr/> <p>Faulty ecpp device or motherboard hardware.</p> <hr/> <p>System software problem.</p>	Examine system message files (/var/adm/messages) for other information.
8008 <i>subtest_name</i> : Data mismatch, expected = <i>number</i> , observed = <i>number</i> , xor = <i>number</i>	<p>Faulty or missing external loopback connector.</p> <hr/> <p>Correct ecpp driver not installed.</p> <hr/> <p>Faulty ecpp device or motherboard hardware.</p> <hr/> <p>System software problem.</p>	Examine system message files (/var/adm/messages) for other information.
8009 Could not set correct port type, expected = <i>number</i> ( <i>device_name</i> ), observed = <i>number</i> , device = <i>device_name</i>	<p>Correct ecpp driver not installed.</p> <hr/> <p>System software problem.</p> <hr/> <p>Faulty ecpp device or motherboard hardware.</p>	Examine system message files (/var/adm/messages) for other information.

**TABLE 9-5** disktest Error Messages (Continued)

Error Message	Probable Cause(s)	Recommended Action
8010 <i>subtest_name</i> : Failed to allocate <i>number</i> bytes of memory, error = <i>error_message</i>	<p>System resources temporarily not available, try again.</p> <hr/> <p>Correct ecpp driver not installed.</p> <hr/> <p>Faulty ecpp device or motherboard hardware.</p> <hr/> <p>System software problem.</p>	Examine system message files (/var/adm/messages) for other information.
8011 <i>subtest_name</i> : Write() failed, device = <i>device_name</i> , error = <i>error_message</i>	<p>Correct ecpp driver not installed.</p> <hr/> <p>Faulty ecpp device or motherboard hardware.</p> <hr/> <p>System software problem.</p>	Examine system message files (/var/adm/messages) for other information.
8012 <i>subtest_name</i> : Write count is wrong, expected = <i>number</i> , observed = <i>number</i>	<p>Correct ecpp driver is not installed.</p> <hr/> <p>Faulty ecpp device or motherboard hardware.</p> <hr/> <p>System software problem.</p>	Examine system message files (/var/adm/messages) for other information.
8013 <i>subtest_name</i> : Data miscompare, expected = <i>number</i> , observed = <i>number</i> , xor = <i>number</i> , offset = <i>number</i>	<p>Correct ecpp driver not installed</p> <hr/> <p>Faulty ecpp device or motherboard hardware.</p> <hr/> <p>System software problem.</p>	Examine system message files (/var/adm/messages) for other information.
8014 <i>device_name</i> : Device busy	<p>Another process is using the device.</p> <hr/> <p>Someone is printing with the device.</p> <hr/> <p>Faulty ecpp device or motherboard hardware.</p> <hr/> <p>System software problem.</p>	<p>Make sure no other process is using the device.</p> <hr/> <p>Make sure no one is printing to the device.</p> <hr/> <p>Examine system message files (/var/adm/messages) for other information.</p>
8015 Bad state for device <i>name</i> , expected mode = <i>number</i> , observed mode = <i>number</i>		

**TABLE 9-5** disktest Error Messages (Continued)

<b>Error Message</b>	<b>Probable Cause(s)</b>	<b>Recommended Action</b>
8016 ecpp device busy: device <i>name</i> , expected mode = <i>number</i> , observed mode = <i>number</i>		
8017 Paper out: device <i>name</i> , expected mode = <i>number</i> , observed mode = <i>number</i>		
8018 Printer offline: device <i>name</i> , expected mode = <i>number</i> , observed mode = <i>number</i>		
8019 Printer error: device <i>name</i> , expected mode = number, observed mode = <i>number</i>		
8020 Printer unplugged: device <i>name</i> , expected mode = <i>number</i> , observed mode = <i>number</i>		
8021 Unrecognized printer error: device <i>name</i> , expected mode = <i>number</i> , observed mode = <i>number</i>		



## Sun Enterprise Network Array Test(enatest)

---

`enatest` is used to provide configuration verification, fault isolation, and repair validation of the Sun Enterprise Network Array.

The Sun Enterprise Network Array is a high availability mass storage subsystem consisting of:

- SCSI fibre channel protocol host adapters with dual 100-Megabyte FC-AL ports.
- A disk enclosure.
- A Front panel display for configuration information.
- Up to two interface boards in the enclosure, which provide FC-AL connections to the enclosure and also provide status information and control of the conditions within the enclosure.
- Other field-replaceable units (FRUs) within the enclosure include power supply units, fan trays and backplane.

`enatest` can be used for validation, configuration verification, repair verification and fault isolation.

enatest detects all Sun Enterprise Network Array enclosures connected to the host and collects relevant configuration information. FIGURE 10-1 shows the Options menu which contains a sample configuration listing and test parameters. TABLE 10-1 describes the extent of the test coverage and provides samples of the configuration information that is displayed.

**TABLE 10-1** enatest Coverage

Test Coverage	Description
Host Connections	<p>enatest searches for all the active and inactive connections between the host and the enclosure and reports the number of existing active connections. If the VERBOSE mode is enabled, the social port on the host side and the GBIC port on the enclosure side is reported for each active connection. The test also diagnoses any inactive connection(s) and reports the possible causes for the failure. The test will fail if there are one or more inactive connections. See the section on "Fault Isolation Capability" on page 108" for more information.</p>
Sample Output:	<pre> SUNWvts.enatest.1010 06/05/97 13:48:53 enatest ses0 VERBOSE: "MYBOX: Lower-Right GBIC connected to host via /devices/sbus@1f,0/ SUNW,socal@0,0:1" SUNWvts.enatest.1006 06/05/97 13:48:53 enatest ses0 VERBOSE: "MYBOX: Interface Board (Bottom one in the enclosure) detected to be installed and OK" SUNWvts.enatest.6023 06/05/97 13:48:53 enatest ses0 ERROR: "MYBOX: Cannot communicate with the enclosure via /devices/sbus@1f,0/SUNW,socal@0,0:0; possibly connected to Lower-Left GBIC in the enclosure" Probable_Cause(s):   (1)Signal too low at the GBIC module in the enclosure   (2)Faulty cable or cable disconnected   (3)Faulty GBIC module on the host side Recommended_Action(s):   (1)Ensure the cables are properly connected   (2)Please contact your service representative  SUNWvts.enatest.2006 06/05/97 13:48:53 enatest ses0 INFO: "MYBOX: Number of connections to the host: 1" </pre>
Disk Access	<p>During the testing, each disk is accessed through each active connection leading to that disk. The enatest opens partition 2 on the disk and reads 512 bytes of raw data. If there are any failures, the test tries to isolate the fault to either an enclosure element, the cable, the host adapter card or the OE module on the host adapter. See the section on "Fault Isolation Capability" on page 108" for more information.</p>

**TABLE 10-1** enatest Coverage

Test Coverage	Description
Enclosure Status	The status of the enclosure is obtained by querying the SCSI Enclosure Services (SES) device in the enclosure. Detailed information regarding the status of the elements within the enclosure is reported. The test fails if a critical condition is detected in the enclosure. TABLE 10-2 shows how the status information is reported.

**TABLE 10-2** Element Enclosure Status

Enclosure Element	Information
Disk	Fault Sensed: Yes/No Status of ports A and B: Connected or Bypassed
Power Supply	Status: ON/OFF Temperature: OK/Critical Overtemp/Abnormal AC Input: OK/Not OK DC Output: OK/Not OK
Fan	Status: On/Off Speed: High/Low/Stopped
Backplane	Status: OK/Failed Status of ports A and B: Connected/Bypassed
Interface Board	Temperature: OK/Critical Overtemp Loop A status: OK/Failed Loop B status: OK/Failed
GBIC	Status: Disabled/Enabled Signal Level: OK/Too low Transmitter: OK/Failed

# enatest Options

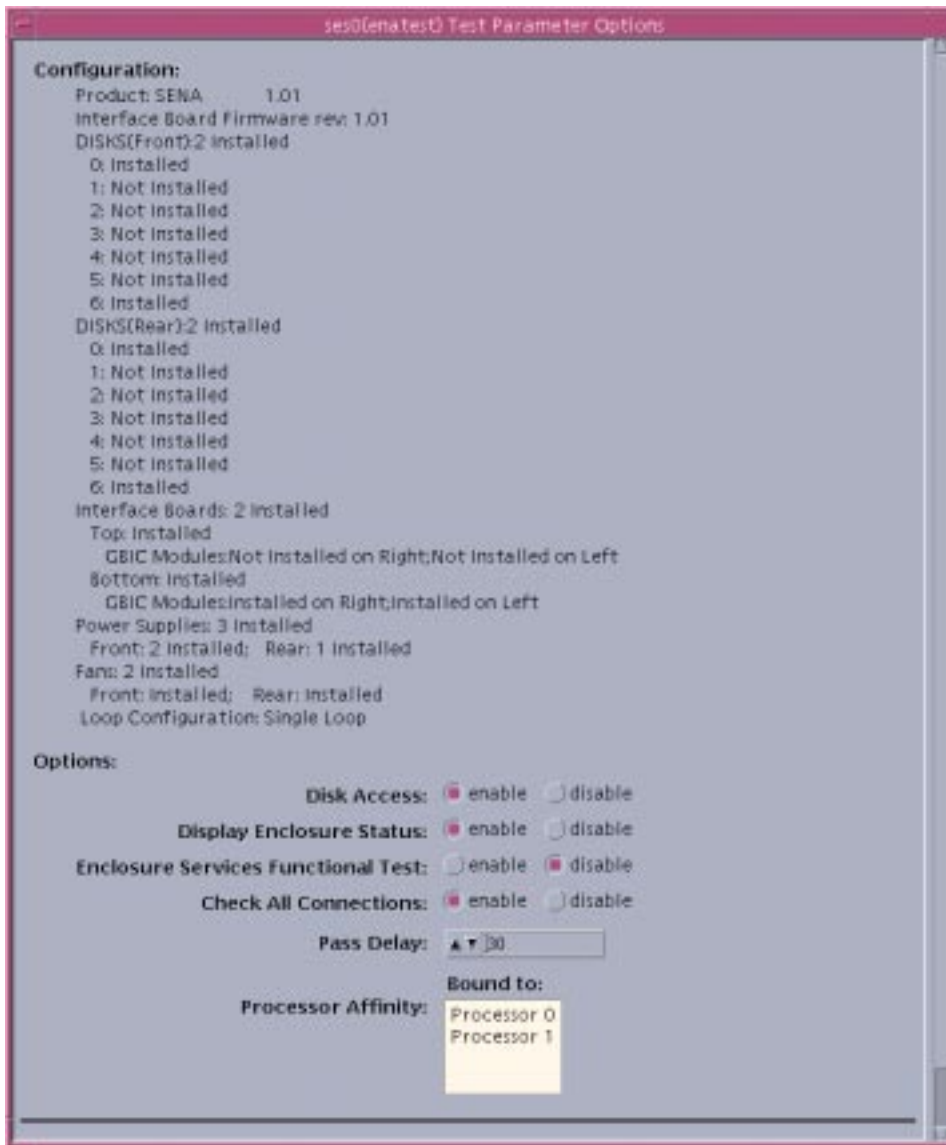

FIGURE 10-1 enatest Options

**TABLE 10-3** enatest Options

enatest Options	Description
Enclosure Services Functional Test (General Description)	<p>Certain control operations are performed on devices in the enclosure through the SES device and verified that the operation was performed successful. This functional test involves the following steps:</p> <ul style="list-style-type: none"><li>(a) Perform control operation.</li><li>(b) Verify control operation was successful.</li><li>(c) Restore state to what it was before (a).</li><li>(d) Verify restore operation was successful.</li></ul> <p>The test will fail if any one of the above steps fails.</p> <p>This test targets the Disks and the Fans in the enclosure.</p>
Enclosure Services Functional Test (Detailed disk test description)	<ul style="list-style-type: none"><li>(a) Control Operation: Each port of the disk is toggled from its original state: a port that was originally connected will be bypassed and vice-versa.</li><li>(b) Verify Control Operation: This is done in two ways. First, the new status of the disk ports is verified by reading the status through the SES device. The test will fail if the status read back does not reflect the change. Next, disk access is attempted through the port that was originally connected but has now been bypassed. The test will fail if the access attempt is successful.</li><li>(c) Restore State: The port states are restored to what they were before the Control Operation.</li><li>(d) Verify Restore Operation: This is done in two ways. First the status of the disk ports is verified by reading the status through the SES device. The test will fail if the status read back does not reflect the change. Next, disk access is attempted through the port that have been reconnected. The test will fail if the access attempt is unsuccessful.</li></ul>

**TABLE 10-3** `enatest` Options

<code>enatest</code> Options	Description
Enclosure Services Functional Test (Detailed Fan test description)	<p>(a) Control Operation: The speed of each fan is toggled. Possible speeds are HIGH and LOW.</p> <p>(b) Verify Control Operation: The status is read back through the SES device and the speeds are compared. Failure to vary the speed in this case will result in an INFO message indicating that the fan speed could not be changed but does not result in a test failure. This is because SES can ignore fan speed change requests if required because of existing ambient temperature conditions.</p> <p>(c) Restore State: Restore the fan speed to the original speed.</p> <p>(d) Verify Restore Operation: This is similar to the Verify Control Operation step above.</p>

## Fault Isolation Capability

In the case of a failure, the test aids in fault isolation by reporting the possible cause(s) of failure. The fault isolation capability varies depending on the nature of the fault and the system configuration. `enatest` can detect and isolate hard faults. The following table shows the fault isolation capability for different configurations. A `Yes` indicates that fault isolation capability is available for that component in that configuration and a `No` indicates lack of fault isolation capability for that component in that configuration.

**TABLE 10-4** `enatest` Fault Isolation Configurations

Connections to Enclosure	System Architecture	SOC+ Host Adapter	Host Side GBIC or Cable	Enclosure Elements			
				Disk	Backplane	IB	GBIC
Multiple	sun4u	Yes	Yes	Yes	Yes	Yes	Yes
Multiple	sun4d	Yes	No	Yes	Yes	No	No
Single	sun4u	Yes	No	No	No	No	No
Single	sun4d	Yes	No	No	No	No	No

---

# enatest Test Modes

**TABLE 10-5** enatest Test Modes

Test Mode	Description
Connection Test	In this mode, the host connections and the status of the enclosure are checked. The test fails if there are any broken connections or if a critical enclosure condition is detected. Non-critical conditions result in a warning. A sample of the output follows.  Connection test starting....  ses0 Status: Connected Enclosure: Product Anemones Enterprise Network Array, Enclosure Name=MYBOX, Host Connections: Number of Active Connections=2, Enclosure State: Critical Conditions=None, Non-Critical Conditions=None  Connection test complete
Functional	When invoked through SyMON, The Enclosure Services Functional Test is not allowed and the Disk Access option is disabled by default. When the test is invoked through regular SunVTS GUI, all the options are allowed in this mode.

---

# enatest Command Line Syntax

`/opt/SUNWvts/bin/enatest standard_arguments -o dev=device_name,  
disk_access=enable|disable, disks=disk1:disk2:disk3:...:diskn disp=enable|disable,  
esfunc=enable|disable`

TABLE 10-6 enatest Command Line Syntax

Argument	Explanation
dev	The name of a ses device in the enclosure.
disk	The disks will be accessed only if this option is enabled.
disks	This argument consists of a “:” separated list of disks contained within this enclosure, that the test will attempt to access if the disks_access option is enabled. If this option is absent the test will access all the disks that it can find in the enclosure.
disp	Detailed status information regarding the enclosure elements will be displayed only if this option is enabled.
esfunc	The Enclosure Services Functional Test will be performed only if this option is enabled.

---

# enatest Error Messages

TABLE 10-7 describes the enatest error messages, probable causes, and recommended actions.

TABLE 10-7 enatest Error Messages

Error Message	Probable Cause(s)	Recommended Action
6000 <i>enclosure_name</i> : Unable to access disk <i>diskname</i> ( <i>enclosure name</i> , <i>Front/Rear</i> , <i>Slot</i> )	Bad disk.	Contact your authorized Sun service representative.
6001 Unable to access any disk through host adapter: <i>host adapter device</i>	Bad host adapter.	Run SunVTS <code>socaltest</code> on the host adapter.



**TABLE 10-7** enatest Error Messages (Continued)

	Error Message	Probable Cause(s)	Recommended Action
6003	<i>enclosure_name</i> : Unable to access disk <i>diskname</i> ( <i>enclosure_name</i> , <i>Front</i> / <i>Rear</i> , Slot) through <i>Host adapter device name</i> . This disk is still accessible through other path(s)	Port A or B of the disk is faulty.	Contact your authorized Sun service representative.
6004	<i>enclosure_name</i> : Failed to determine the location of disk <i>diskname</i>	Invalid device name.	Contact your authorized Sun service representative.
6005	<i>enclosure_name</i> : Could not access <i>diskname</i> ( <i>enclosure_name</i> , <i>Front</i> / <i>Rear</i> , Slot) through <i>Host adapter device name</i>	Host adapter is faulty.	Contact your authorized Sun service representative.
6006	<i>enclosure_name</i> : Disk <i>diskname</i> cannot be accessed through <i>Host adapter device name</i>	Critical failure in the Interface Board (in the enclosure) through which this disk is accessed.	Contact your authorized Sun service representative.
6007	<i>enclosure_name</i> : Disk <i>diskname</i> cannot be accessed through <i>Host adapter device name</i>	Interface Board (in the enclosure) through which this disk is accessed is not installed.	
6008	<i>enclosure_name</i> : Disk <i>diskname</i> cannot be accessed through <i>Host adapter device name</i>	Critical failure (transmitter fault) in the GBIC module (in the enclosure) through which this disk is accessed.	Contact your authorized Sun service representative.
6009	<i>enclosure_name</i> : Disk <i>diskname</i> cannot be accessed through <i>Host adapter device name</i>	Loss of light at the GBIC module (in the enclosure) through which this disk is accessed.	Contact your authorized Sun service representative.
		Faulty cable.	
		Faulty GBIC module on the host side.	
6013	<i>enclosure_name</i> : Could not access <i>diskname</i> ( <i>enclosure name</i> , <i>Front</i> / <i>Rear</i> , Slot) through <i>Host adapter device name</i>	Faulty GBIC module on host side.	
		Bad cable connection.	
6014	<i>enclosure_name</i> : Could not access <i>diskname</i> ( <i>enclosure name</i> , <i>Front</i> / <i>Rear</i> , Slot) through <i>Host adapter device name</i>	Faulty Host Adapter.	
		Faulty GBIC on host side.	
		Faulty cable.	

**TABLE 10-7** enatest Error Messages (Continued)

Error Message	Probable Cause(s)	Recommended Action
6015 <i>enclosure_name</i> : Could not access <i>diskname</i> through <i>Host adapter device name</i>	Disk is not installed.	
6016 <i>enclosure_name</i> : Could not access <i>diskname</i> through <i>Host adapter device name</i>	Disk detected to be installed, but may be bypassed or powered off.	
6017 <i>enclosure_name</i> : Disk <i>diskname</i> cannot be accessed through <i>Host adapter device name</i>	Critical failure in the enclosure backplane through which this disk is accessed.	Contact your authorized Sun service representative.
6018 <i>enclosure_name</i> : Disk <i>diskname</i> cannot be accessed through <i>Host adapter device name</i>	Enclosure backplane through which this disk is accessed is not installed.	
6019 <i>enclosure_name</i> : Disk <i>diskname</i> cannot be accessed through <i>Host adapter device name</i>	GBIC module (in the enclosure) through which this disk is accessed is not installed.	
6020 <i>enclosure_name</i> : Cannot communicate with the enclosure via <i>Host adapter device name</i>	Critical failure in the Interface Board (top/bottom one in enclosure).	Contact your authorized Sun service representative.
6021 <i>enclosure_name</i> : Cannot communicate with the enclosure via <i>Host adapter device name</i>	Interface board (top or bottom) is not installed in the enclosure.	
6022 <i>enclosure_name</i> : Cannot communicate with the enclosure via <i>Host adapter device name</i> ; possibly connected to <i>location</i> GBIC in the enclosure	Critical failure (transmitter fault in the GBIC module in the enclosure).	Contact your authorized Sun service representative.
6023 <i>enclosure_name</i> : Cannot communicate with the enclosure via <i>Host adapter device name</i> ; possibly connected to <i>location</i> GBIC in the enclosure	Signal level too low at the GBIC module in the enclosure. Faulty cable or cable disconnected. Faulty GBIC module on the host side.	Ensure the cables are properly connected. Contact your authorized Sun service representative.
6024 <i>enclosure_name</i> : Cannot communicate with the enclosure via <i>Host adapter device name</i>	GBIC module ( <i>location</i> ) is not installed in the enclosure.	

**TABLE 10-7** enatest Error Messages (Continued)

	<b>Error Message</b>	<b>Probable Cause(s)</b>	<b>Recommended Action</b>
6026	<i>enclosure_name</i> : Failed to <i>Restore/ Toggle</i> disk ( <i>Front/Rear</i> , slot <i>slot_number</i> ) state. Expected: Port A: <i>Bypassed/ Connected</i> ; Port B: <i>Bypassed/ Connected</i> ; Observed: Port A: <i>Bypassed/ Connected</i> ; Port B: <i>Bypassed/ Connected</i>	Error in Enclosure Services or Enclosure Element.	Contact your authorized Sun service representative.
6027	<i>enclosure_name</i> : Unable to access disk <i>diskname</i> ( <i>Front/Rear</i> slot <i>slot_number</i> ) through port A/B even after bringing the port online	Error in Enclosure Services or Enclosure Element.	Contact your authorized Sun service representative.
6028	<i>enclosure_name</i> : Disk access succeeded for <i>diskname</i> ( <i>Front/Rear</i> slot <i>slot_number</i> ) through port A/B even after requesting that the port be bypassed	Error in Enclosure Services or Enclosure Element.	Contact your authorized Sun service representative.
6035	<i>enclosure_name</i> : Cannot access enclosure through <i>Host adapter device name</i>	Critical GBIC failure in the enclosure; location GBIC: disabled   enabled Signal: <i>signal_level</i> ; Transmitter: <i>Failed/ OK</i> ; location GBIC: <i>disabled/ enabled</i> Signal: <i>signal_level</i> ; Transmitter: <i>Failed/ OK</i>	Contact your authorized Sun service representative.
6036	<i>enclosure_name</i> : Critical condition detected in enclosure!		Run this test in 'Functional' mode for more information. Contact your authorized Sun service representative.
8001	Could'nt determine the host adapter through which <i>diskname</i> being accessed	Software error.	Contact your authorized Sun service representative.
8003	Internal error	Software error in test. system error message.	Contact your authorized Sun service representative

**TABLE 10-7** enatest Error Messages (Continued)

Error Message	Probable Cause(s)	Recommended Action
8004 <i>enclosure_name</i> : Could not communicate with enclosure via <i>Host adapter device name</i>	Bad connection.	Ensure the cables are properly connected. Contact your authorized Sun service representative.
8005 Could not communicate with the enclosure	Faulty connection.	Ensure the cables are properly connected. Run SunVTS <code>socaltest</code> to verify the host adapter. Contact your authorized Sun service representative.

## StorEdge 1000 Enclosure Test (enctest)

`enctest` tests the StorEdge 1000 enclosures. The enclosure can support either 12 1" 4GB drives or 8 1.6" 9GB drives and have redundant power and cooling. Two enclosure models are available:

- StorEdge A1000 – Disk Tray with the hardware RAID controller
- StorEdge D1000 – Disk Tray without the hardware RAID controller.

`enctest` can be used for validation, configuration verification, repair verification, and fault isolation of both models.

The `enctest` probe detects all the connected StorEdge enclosures and displays the status of the various elements in the enclosure.

`enctest` sets the StorEdge D1000 LEDs as follows:

**TABLE 11-1** `enctest` Status LEDs

LED State	Indicated Condition
On	Unrecoverable or critical condition
Blinking	Non-critical condition
Off	Informational or no condition to report

**Note** – NOTE: The `ses` driver must be present on the system with the StorEdge enclosure(s). If the `ses` driver is not present, SunVTS will not detect the StorEdge hardware. Use the following command to see if the `ses` driver is present:

```
pkginfo SUNWses
```

Install the package if necessary.

enctest reports the status of the various elements in the enclosure. An error is registered if an unrecoverable or critical condition is detected. Non-critical conditions are reported through warning messages. TABLE 11-2 describes the information that is reported for each enclosure element.

**TABLE 11-2** `enctest` Enclosure Status Report

Enclosure Element	Information reported (per device slot)
Disk	Present/Not Present Failed/OK
Power supply	Present/Not Present Failed/OK
Fan	Present/Not Present Failed/OK
Temperature	OK/Over temperature
RPA cache Battery (StorEdge A1000 only)	OK/Low Charge

# enctest Options

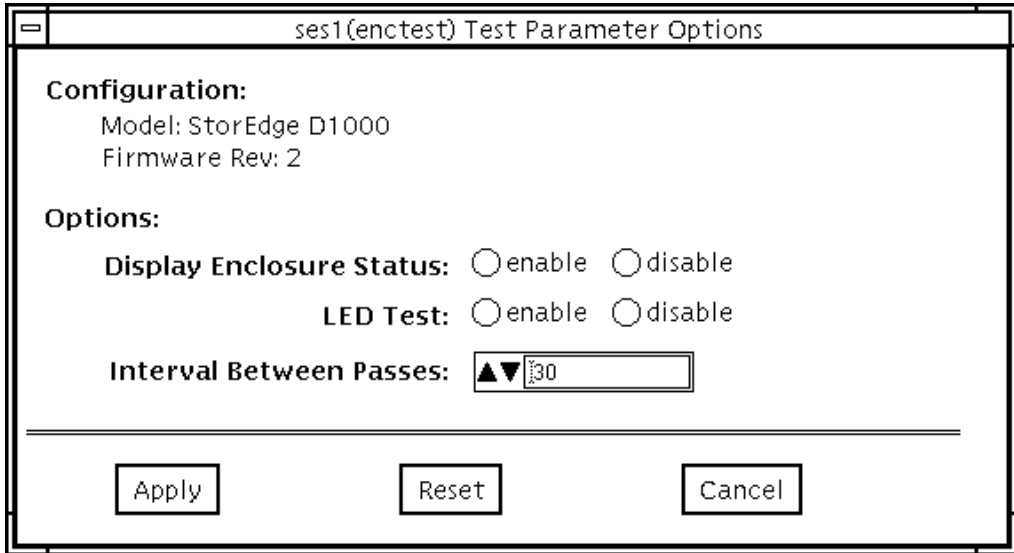

FIGURE 11-1 enctest Options

TABLE 11-3 enctest Options

enctest Options	Description
Display Enclosure Status	When enabled, the status of the enclosure elements are displayed as messages in the SunVTS console. These messages are also logged in the SunVTS info log file.
LED Test	When enabled, the LEDs associated with the disks are flashed for a short period of time.
Interval Between Passes	Sets the minimum delay between successive invocations of the test.

---

# enctest Test Modes

**TABLE 11-4** enctest Test Modes

<b>Test Mode</b>	<b>Description</b>
Connectivity Mode	The enclosure status summary bits are read. Detailed information is reported only if an unrecoverable or critical condition is detected.
Functional Mode	When started through Symon, the LED test is not allowed and the “Display Enclosure Status” option is disabled by default. When started through the regular SunVTS GUI, all options are allowed.



---

# enctest Command Line Syntax

`/opt/SUNWvts/bin/enctest standard_arguments -o dev=device_name, disp=enable|disable, led=enable|disable, delay=delay_in_seconds`

**TABLE 11-5** `enctest` Command Line Syntax

Argument	Explanation
<code>dev</code>	This is the name of a ses device in the enclosure.
<code>disp</code>	Detailed status information regarding the enclosure elements will be displayed if enabled
<code>led</code>	Option to enable or disable the LED test.
<code>delay</code>	Minimum delay between successive invocations of the test.

---

# enctest Error Messages

TABLE 11-2 describes the `enctest` error messages, probable causes, and recommended actions.

**TABLE 11-6** `enctest` Error Messages

Error Message	Probable Cause(s)	Recommended Action
8000 Failed to open device.	System error. Cable loose or disconnected or device not configured.	Verify the cable is properly connected and the device configured. Contact your authorized Sun service representative.
8001 Failed to communicate with the enclosure	System error. Cable loose or disconnected or device not configured.	Verify the cable is properly connected and the device configured. Contact your authorized Sun service representative.
8002 Cannot proceed further due to lack of memory	Heavy system load.	Please try later.
8003 <i>unrecoverable critical non-critical</i> informational condition detected in the enclosure		

**TABLE 11-6** `enctest` Error Messages (Continued)

<b>Error Message</b>	<b>Probable Cause(s)</b>	<b>Recommended Action</b>
8004 Failed to obtain list of enclosure elements	System error	Contact your authorized Sun service representative.
8005 Failed to obtain status of an enclosure element	System error	Contact your authorized Sun service representative.
8006 Failed to set the status of an enclosure element	System error	Contact your authorized Sun service representative.

## Environmental Test (`envtest`)

---

`envtest` exercises the I2C bus on the Sun Enterprise 450 product line. `envtest` contains five subtests to test and report on the power supply status, system temperature status, fan speed, disk LEDs, and front panel and keyswitch. `envtest` is not scalable.

# envtest Options

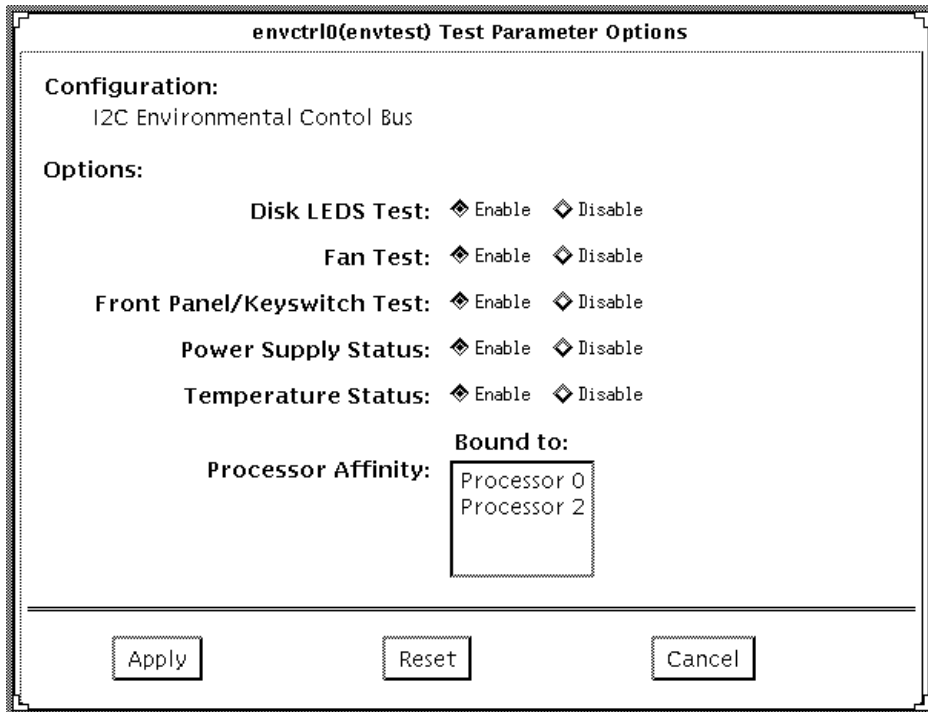

FIGURE 12-1 envtest Options Menu

Table 0-1

<code>envtest</code> Options	Description
Disk LEDs Test	Illuminates each LED on the disk backplane(s) to green, then amber, and then back to its original state. The test then illuminates <i>all</i> disk LEDs to green, then amber, and then back to their original state. This test is only enabled in Functional test mode.
Fan Test	Cycles each fanbank speed to low, medium, and high, then verifies the correct speed. Next, each fanbank is stopped, one at a time. The test then verifies that a fan fault has occurred. Next, the watchdog timer is invoked to simulate a catastrophic failure. The test verifies that the system set all fanbanks to high and then resets the fan speed to normal. This test is only enabled in Functional test.
Front Panel and Keyswitch Test	Flashes each individual LED on the front panel to ON (green or amber), then OFF, and then back to its original state. The test then illuminates all front panel LEDs then sets them back to their original state. The power on LED is Read Only and will not be cycled. The test then displays the current keyswitch position. This test is only enabled in Functional test mode.
Power Supply Status	Identifies the number of power supplies that are in the system, and the state of each power supply, and verifies that the power supply temperatures are within normal operating parameters. This test is enabled in all modes.
Temperature Status	Identifies the current temperature of each CPU in the system, and the ambient temperature of the system, and <code>envtest</code> verifies that all temperatures are within normal operating parameters. This test is enabled in all modes.

---

# envtest Test Modes

envtest supports Connection and Functional tests.

Table 0-2

Test Mode	Description
Connection Test	Reports the status of the power supplies, the temperature sensors within the system, and verifies normal operating parameters.
Functional Test	Tests the disk back panel, front panel LEDs, and fan control circuitry. Also uses the same functionality as Online mode and connection test  If you invoke SunVTS through SyMON, the following Functional Test description applies: envtest runs in Connection Test mode (see description above).

---

# envtest Command Line Syntax

```
/opt/SUNWvts/bin/envtest [standard arguments] [-o  
dev=device name, diskleds=E/D, fans=E/D, fpanel=E/D,  
psupply=E/D, temp=E/D
```

Table 0-3

Argument	Explanation
dev=raw_device_name	Specifies the name of the raw device to test.
diskleds=enable disable	Enables or disables the diskleds test.
fans=enable disable	Enables or disables the fans test.
fpanel=enable disable	Enables or disables the front panel test.
psupply=enable disable	Enables or disables the power supply test
temp=enable disable	Enables or disables the temperature test.

# envtest Error Messages

Table 12-1

Error Message	Probable Cause(s)	Recommended Action
8000 Unable to open driver <i>driver_name: sys error msg</i>	Device name is wrong or driver is not loaded.  Device busy.	Check the device name (if entered) or load driver.  Kill all other processes accessing driver.
8001 kstat_open failed	No kernel resource available.  System software error	Consult <code>/var/adm/messages</code> file for more information.
8002 kstat_lookup failed for envtest <i>structure</i> in <i>kstat module</i>	envtest module not found.  No kernel resource available.  System software error.	Check revision and reload <code>envctrl</code> driver.  Consult <code>/var/adm/messages</code> file for more information.
8003 kstat_read failed envtest <i>structure</i> in <i>kstat module</i>	envtest module not found.  No kernel resource available.  System software error.	Check revision /reload <code>envctrl</code> driver.  Consult the <code>/var/adm/messages</code> file for more information.
8004 Unable to close kstat	No kernel resource available.  System software error	Consult the <code>/var/adm/messages</code> file for more information.
8005 Unable to set mode to DIAG using <code>ioctl.</code> : <i>sys error msg</i>	System software error	Consult the <code>/var/adm/messages</code> file for more information.
8006 Unable to set disk LEDs: <i>sys error msg</i>	System software error	Consult the <code>/var/adm/messages</code> file for more information.
8007 Unable to get disk LEDs: <i>sys error msg</i>	System software error.	Consult the <code>/var/adm/messages</code> file for more information.
8008 Unable to set <i>fan type</i> fan speed to <i>speed</i> : <i>sys error msg</i>	Fan hardware failure.  System software error.	Manually check the fan speed and replace the fan.  Consult the <code>/var/adm/messages</code> file for more information.
8009 Unable to get <i>fan type</i> fan speed: <i>sys error msg</i>	System software error.	Consult the <code>/var/adm/messages</code> file for more information.

Table 12-1

<b>Error Message</b>	<b>Probable Cause(s)</b>	<b>Recommended Action</b>
8010 <i>fan type</i> fan speed: <i>speed</i> out of range	Fan hardware failure. System software error.	Manually check the fan speed and replace the fan. Consult the /var/adm/messages file for more information.
8011 Forced fan fault did not occur for <i>fan type</i> fanbank	Hardware failure. System software error.	Replace the hardware. Consult the /var/adm/messages file for more information.
8012 Forced fan fault did not clear for <i>fan type</i> fanbank	Hardware failure. System over temperature. System software error.	Replace the hardware. Consult the /var/adm/messages file for more information.
8013 Unable to set watchdog timer	Hardware failure. System software error.	Replace the hardware. Consult the /var/adm/messages file for more information.
8014 Unable to set temperature to <i>temperature</i>	System software error.	Consult the /var/adm/messages file for more information.
8015 Power Supply <i>supply</i> has failed: Limit <i>0=PASS/1=FAIL</i> Current Share <i>0=PASS/1=FAIL</i> Temperature <i>temperature</i>	Power supply hardware failure.	Replace the power supply.
8016 Unable to allocate memory using malloc. : <i>sys error msg</i>	System software error.	Consult the /var/adm/messages file for more information.
8017 Unable to set mode to NORMAL using ioctl. : <i>sys error msg</i>	System software error.	Consult the /var/adm/messages file for more information.
8018 Error encountered during call to <i>function</i> <i>name</i>		
8019 Unable to set front panel LEDs using ioctl.: <i>sys error msg</i>	System software error.	Consult the /var/adm/messages file for more information.
8020 Unable to reset front panel LEDs to original state	System software error.	Consult the /var/adm/messages file for more information.



Table 12-1

<b>Error Message</b>	<b>Probable Cause(s)</b>	<b>Recommended Action</b>
8021 Unable to set front panel LEDs to <i>led mask</i>	System software error	Consult the <code>/var/adm/messages</code> file for more information.
8022 Ambient temperature: <i>temperature</i> Celsius out of range	envctrl hardware error.	
8023 CPU CPU # temperature: <i>temperature</i> Celsius out of range	envctrl hardware error.	
8024 Data Miscompare: ioctl diskled mask = <i>diskled mask</i> kstat diskled mask = <i>diskled mask</i>	envctrl hardware error System software error.	Consult the <code>/var/adm/messages</code> file for more information.
8025 Illegal options passed to envttest <i>option</i>	User error.	Check usage by typing <code>envttest -u</code> .
8026 Unable to retrieve power supply information.	I2C hardware failure I2C bus wedged	Replace power supply. Check for other I2C devices that may be corrupting the I2C bus.
8027 Power Supply Over Temperature: PS Slot <i>slot</i> PS Temperature <i>temperature</i> .	Bad Power Supply.	Replace Power Supply.



## Environmental Test ( `env2test` )

---

`env2test` exercises and validates the I2C bus on systems that support the `envctrltwo` driver.

Five subtests are in `env2test` to test and report the status of the power supply, system temperature, fan speed, disk LEDs, front panel, and keyswitch.

`env2test` is not scalable.

---

# env2test Options

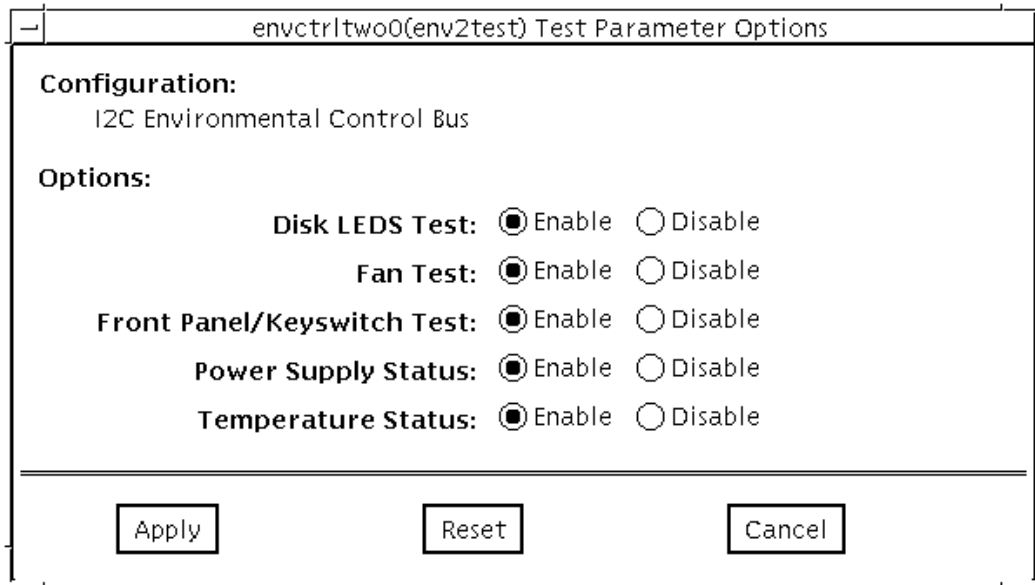

FIGURE 13-1 env2test Options Menu

Table 0-4

<code>env2test</code> Options	Description
Disk LEDs Test	Determines the number of disks that are present and the state of each disk. Illuminates each LED on the disk backplane to amber, and then back to its original state. The test then illuminates <i>all</i> disk LEDs to amber, and then back to their original state. This test is only enabled in Functional test.
Fan Test	Sets the fanbank speed to halfway between the current speed and max speed, then verifies the correct speed. Next, the fanbank speed is set to max speed, and the speed is verified. The fanbank speeds are then returned to normal, and then verified. This test is only enabled in Functional test.
Front Panel and Keyswitch Test	Flashes each individual LED on the front panel to ON (green or amber), then OFF, and then back to its original state. The test then illuminates all front panel LEDs then sets them back to their original state. The power on LED is read-only and will not be cycled. The test then displays the current keyswitch position. This test is only enabled in Functional test.
Power Supply Status	Identifies the number of power supplies that are in the system and the state of each power supply. This test is enabled in all modes.
Temperature Status	Identifies the current temperature of each CPU in the system, the ambient temperatures of the system, the temperature on the SCSI and power distribution boards, and verifies that all temperatures are within normal operating parameters. This test is enabled in all modes.

---

# env2test Test Modes

env2test supports Connection and Functional tests.

Table 0-5

Test Mode	Description
Connection Test	Reports the status of the power supplies, the temperature sensors within the system, and verifies normal operating parameters
Functional Test	Tests the disk back panel, front panel LEDs, and fan control circuitry. Also uses the same functionality as Online mode and connection test  If you invoke SunVTS through SyMON, the following Functional Test description applies: Uses the same functionality as connection test (above)

---

# env2test Command Line Syntax

```
/opt/SUNWvts/bin/env2test [standard arguments] [-o  
dev=device=name, diskleds=E/D, env_mon=poll_interval, fans=E/D, fpanel=E/D,  
psupply=E/D, temp=E/D
```

Table 0-6

Argument	Explanation
dev=raw_device_name	Specifies the name of the raw device to test
diskleds=enable disable	Enables or disables diskleds test
env_mon=poll_interval	Displays all system environmental statics every "poll_interval" seconds. (Display ONLY, Does not test.)
fans=enable disable	Enables or disables fans test
fpanel=enable disable	Enables or disables front panel test
psupply=enable disable	Enables or disables power supply test
temp=enable disable	Enables or disables temperature test

# env2test Error Messages

Table 13-1 env2test Error Messages

Error Message	Probable Cause(s)	Recommended Action
8000 Unable to open driver <i>driver name: sys error msg</i>	Device name is wrong or driver is not loaded.	Check the device name (if entered) or load driver.
	Device busy.	Kill all other processes accessing driver.
8001 kstat_open failed	No kernel resource available.	Consult <code>/var/adm/messages</code> file for more information.
	System software error	
8002 kstat_lookup failed for env2test structure in <i>kstat module</i>	env2test module not found.	Check revision and reload <code>envctrl</code> driver.
	No kernel resource available System software error.	Consult <code>/var/adm/messages</code> file for more information.
8003 kstat_read failed env2test structure in <i>kstat module</i>	env2test module not found.	Check revision /reload <code>envctrl</code> driver.
	No kernel resource available. System software error.	Consult the <code>/var/adm/messages</code> file for more information.
8004 Unable to close kstat	No kernel resource available.	Consult the <code>/var/adm/messages</code> file for more information.
	System software error.	
8005 Unable to set mode to DIAG using ioctl.: <i>sys error msg</i>	System software error	Consult the <code>/var/adm/messages</code> file for more information.
8006 Unable to set disk LEDs: <i>sys error msg</i>	System software error	Consult the <code>/var/adm/messages</code> file for more information.
8007 Unable to get disk LEDs: <i>sys error msg</i>	System software error.	Consult the <code>/var/adm/messages</code> file for more information.
8008 Unable to set fan speed to <i>speed:</i> <i>sys error msg</i>	Fan hardware failure	Manually check the fan speed and replace the fan.
	System software error.	Consult the <code>/var/adm/messages</code> file for more information.
8009 Unable to get fan speed: <i>sys error msg</i>	System software error	Consult the <code>/var/adm/messages</code> file for more information.

Table 13-1 env2test Error Messages

Error Message	Probable Cause(s)	Recommended Action
8010 Fan speed <i>speed</i> out of range: MIN <i>speed</i> MAX <i>speed</i>	Fan hardware failure. System software error.	Manually check the fan speed and replace the fan. Consult the /var/adm/messages file for more information.
8011 Forced fan fault did not occur for <i>fan type</i> fanbank	Hardware failure. System software error.	Replace the hardware. Consult the /var/adm/messages file for more information.
8015 Power Supply <i>supply</i> has failed: State <i>state</i>	Power supply hardware failure.	Replace the power supply.
8016 Unable to allocate memory using malloc. : <i>sys error msg</i>	System software error.	Consult the /var/adm/messages file for more information.
8017 Unable to set mode to NORMAL using ioctl. : <i>sys error msg</i>	System software error.	Consult the /var/adm/messages file for more information.
8018 Error encountered during call to <i>function name</i>		
8019 Unable to set front panel LEDs using ioctl.: <i>sys error msg</i>	System software error.	Consult the /var/adm/messages file for more information.
8020 Unable to reset front panel LEDs to original state	System software error.	Consult the /var/adm/messages file for more information.
8021 Unable to get front panel LEDs.	System software error.	Consult the /var/adm/messages file for more information.
8022 Ambient temperature <i>temperature</i> Celsius out of range	envctrl hardware error.	
8023 CPU CPU # temperature <i>temperature</i> Celsius out of range	envctrl hardware error.	



**Table 13-1** env2test Error Messages

<b>Error Message</b>	<b>Probable Cause(s)</b>	<b>Recommended Action</b>
8024 Data Mismatch: ioctl diskled mask = <i>diskled mask</i> kstat diskled mask = <i>diskled mask</i>	hardware error System software error.	Consult the /var/adm/messages file for more information.
8025 Illegal options passed to env2test <i>option</i>	User error.	Check usage by typing <b>env2test -u.</b>
8026 Unable to retrieve power supply information.	I2C hardware failure. I2C bus wedged.	Replace power supply. Check for other I2C devices that may be corrupting the I2C bus.
8033 Temperature <i>temperature</i> celsius out of range.	Hardware error.	Check all thermistors.



## Frame Buffer Test (fbtest)

`fbtest` is a generic test for all dumb frame buffers used with the Solaris 2.x software.

The `fbtest` checks the frame buffer by sequentially writing, reading, and verifying small blocks of random patterns across the entire video RAM. The block size is 64 x 64 pixels. If a miscompare occurs, the test stops with an error message that indicates the location of the error.

If a generic frame buffer device name (`dvc/fb`) is specified, `fbtest` automatically detects the depth of the frame buffer, and adjusts testing to the frame buffer size.

### fbtest Options

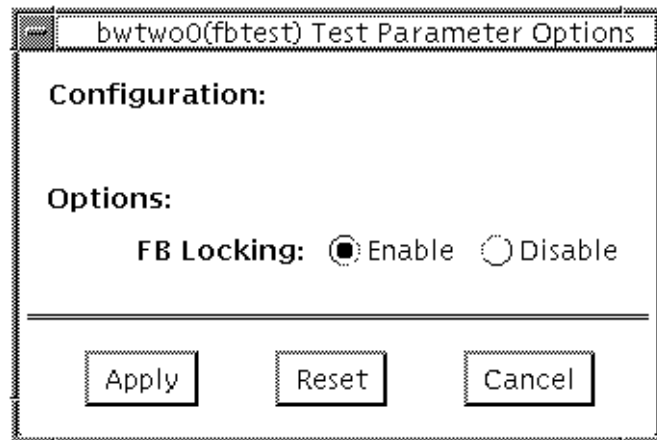

FIGURE 14-1 `fbtest` Option Menu

---

**Note** – To start SunVTS with `vtstui`, but without `vtstk`, you must add the host name to `xhost` as: `xhost + hostname`.

---

---

## fbtest Command Line Syntax

```
/opt/SUNWvts/bin/fbtest standard_arguments -o dev=device_name  
lock=E(nable)/D(isable)
```

**TABLE 14-1** fbtest Command Line Syntax

Argument	Explanation
<code>dev=device_name</code>	Specifies which frame buffer to be test.
<code>lock=E(nable)/ D(isable)</code>	Enables or disables the window system locking option. See the section about Testing Multiple Frame Buffers in the <i>SunVTS 2.1 User's Guide</i> for details. Frame buffer locking is enabled by default on the window server running the Open Windows software.

---

## fbtest Test Modes

Due to the nature of graphic tests, reading from or writing to the frame buffer during graphic tests disturbs user operation. This test is only available in Functional test.

---

# fbtest Error Messages

TABLE 14-2 fbtest Error Messages

Error Message	Probable Cause(s)	Recommended Action	
6000	Data compare error	FB lock is disabled. Bad frame buffer.	Enable FB lock. If the problem persists, call your authorized Sun service provider.
6001	Video memory error at <i>address</i> , expected: <i>number</i> , observed: <i>number</i>	FB lock is disabled. Bad frame buffer.	Enable FB lock. If the problem persists, call your authorized Sun service provider.
6002	Unable to lock frame buffer	FB lock was enabled while the window system was not running.	
8000	can't acquire console semaphore	System load is too heavy. System error.	Reduce the system load. If the problem persists, contact your Sun service provider.
8001	Parameter error - Improper test parameters supplied	fbtest can only run in Functional test.	
8002	Device name missing!	Parameter error.	Must provide device name
8003	Create_Raster() failed for <i>name</i>	Parameter error. No such device.	
8004	Create_Raster() failed for type RAS_CHILD	Operator error. Software error.	Check test options, mode and retry, if appropriate. Contact your Sun service provider.
8005	Malloc failed	System load too heavy. System error	Reduce the system load If the problem persists, call your authorized Sun service provider.



## Fast Frame Buffer Test(`ffbttest`)

---

`ffbttest` verifies the functionality of the Fast Frame Buffer.

`ffbttest` can detect and adapt to the video modes of single- and double-buffer versions of the fast frame buffer (FFB). All `ffbttest` tests can run in several screen resolutions such as standard, stereo, and high resolution. In stereo mode, all tests write into the right and left eyes unless you specify otherwise. This test also supports FFB, FFB2, and FFB2+ fast frame buffer configurations. Use the `ffbconfig -prconf` command to display the configuration of the frame buffer you want to test.

You can interrupt `ffbttest` using Control-C. Turn off all other keyboard input if OPEN LOOK is running on the unit being tested.

Test accuracy is checked using a checksum algorithm. Possible locations of failing pixels are identified, as well as the likely failing FRU.



---

**Caution** – DO NOT run any other application or screen saver program that uses the FFB accelerator port while running `ffbttest`. Do not run power management software. These programs causes SunVTS to return incorrect errors.

---

---

**Note** – Disable all screen savers before testing any graphics device. Type `xset s off` at a UNIX prompt to disable the Solaris screen saver. Disable power management software if it is running.

---

---

**Note** – DO NOT run Open Windows across multiple monitors.

---

---

**Note** – `ffbttest` requires approximately 7 Mbytes of disk space in the `/tmp` directory to extract its working files. If this space is not available, the diagnostic will fail and report warning and error messages, indicating a lack of disk space.

---

---

**Note** – To start SunVTS with `vtstui`, but without `vtstsk`, you must add the host name to `xhost` as: `xhost + <hostname>`.

---

## fbttest Options

By default, all tests are enabled except the stereo test.

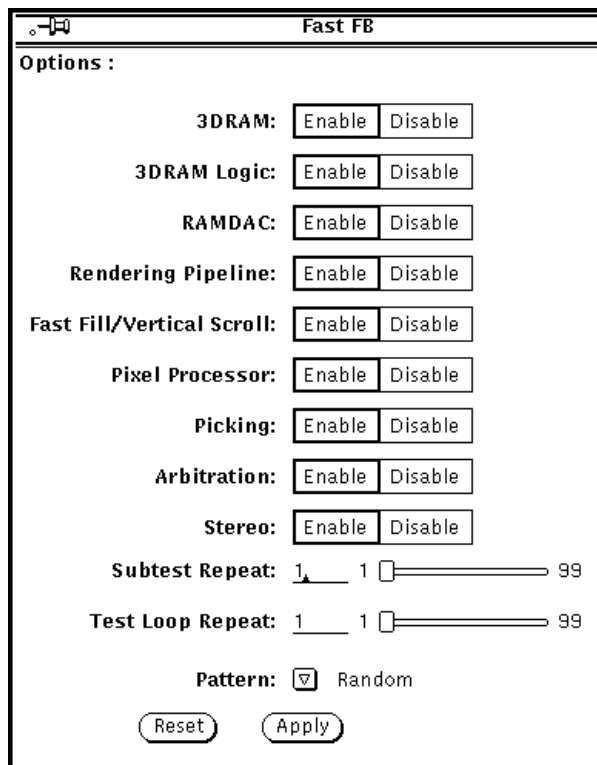

FIGURE 15-1 fbttest Option Menu



**TABLE 15-1** `fbttest` Options

<code>fbttest</code> Options	Description
3DRAM Test	<p>The 3DRAM Test thoroughly tests the video memory in the FFB using 512-bit reads and writes. 3DRAM makes a full screen pass, consisting of a write and a read to each pixel location, for each access mode on the list below. You can use either random data or specify data at the command line. A second pass is made with the one's complement of the data used in the first pass so that each memory location is tested with both a zero and a one. Notice that some passes are skipped on the single-buffered FFB.</p> <p>Errors in this subtest are attributes to the 3DRAM. A failing chip is indicated by (x, y) locations and device-specific "U" numbers.</p> <p>DFB8R, DFB8G, DFB8B, DFB8X - Buffer A            DFB24 - Buffer A            DFB32 - Buffer A            SFB8R, SFB8G, SFB8B, SFB8X - Buffer A            SFB8R, SFB8G, SFB8B, SFB8X - Buffer B (double buffer only)            SFB32 - Buffer A            SFB32 - Buffer B (double buffer only)            SFB32 - Buffer C (double buffer only)            SFB64 - Buffers A and C (double buffer only)            SFB64 - Buffers B and C (double buffer only)</p>
3DRAM Logic Test	<p>3DRAM Logic provides logical functionality to the FFB. The following services are tested:</p> <p>Compare Controls - Match AB            Compare Controls - Magnitude AB            Compare Controls - Match C (double buffer only)            Compare Controls - Magnitude C (double buffer only)            Match Mask - AB            Magnitude Mask - AB            Match Mask - C (double buffer only)            Magnitude Mask - C (double buffer only)            Raster Operations - RGB            Raster Operations - X            Raster Operations - YZ (double buffer only)            Plane Mask - RGB            Plane Mask - X            Plane Mask - Y            Plane Mask - Z            Group Enable - R, G, B, X            Group Enable - Y, Z (double buffer only)</p>

**TABLE 15-1** `fbttest` Options (Continued)

<code>fbttest</code> Options	Description
3DRAM Logic Test (Continued)	<p><code>fbttest</code> tests each function separately with a series of SFB64 writes. A total of 16 writes are made for each different test case with Y coordinate values varying from 0 to 30 in increments of 2 pixels. This dotted column organization provides page thrashing and block flashing in all screen resolutions. For each operation, all possible combinations are tested. For example, <code>ROP RGB new==old</code> has three possible values are: <code>new &lt; old</code>, <code>new == old</code>, and <code>new &gt; old</code>. <code>fbttest</code> tests each of these cases.</p> <p>Five passes of the functions are made. Each pass writes into a different FFB address space: SFB32-A, SFB32-B, SFB32-C, SFB64-AC, and SFB64-BC. Note that the passes that write into the SFB32 address spaces are writing two pixels at a time because the tests use SFB64 writes.</p> <p>For FFB2+ boards, additional testing is performed on the new stencil and <code>passin</code> capabilities if the board is DBZ.</p> <p>Care is taken to ensure that all 3DRAM chips are tested. Errors in this subtest are attributed to the 3DRAM.</p>
RAMDAC Test	<p>RAMDAC registers are tested using simple read/write patterns to determine if there are any bad bits. This includes all LUTs. <code>fbttest</code> ensures that data is actually being read from the RAMDAC and not being supplied by the driver. Next, the RAMDAC Signature Register captures the pixels going to the screen. This test determines that all of the different data paths within the RAMDAC are functioning properly.</p> <p>The following modes are tested:</p> <ul style="list-style-type: none"> <li>24-bit true color from A</li> <li>24-bit true linear color from A</li> <li>24-bit direct color from A</li> <li>24-bit true color from B (double buffer only)</li> <li>24-bit true linear color from B</li> <li>24-bit direct color from B (double buffer only)</li> <li>8-bit pseudo color (from each plane in RGB) from A</li> <li>8-bit pseudo color (from each plane in RGB) from B (double buffer only)</li> <li>8-bit non-linear grayscale (from each plane in RGB) from A</li> <li>8-bit non-linear grayscale (from each plane in RGB) from B (double buffer only)</li> <li>8-bit linear grayscale (from each plane in XRGB) from A</li> <li>8-bit linear grayscale (from each plane in XRGB) from B (double buffer only)</li> <li>8-bit overlay pseudo color (from buffer A, X plane)</li> </ul>

**TABLE 15-1** `ffbtest` Options (Continued)

<code>ffbtest</code> Options	Description
RAMDAC Test (Continued)	<p>This test displays a total of 11 different types of windows on the screen for the single-buffered configuration; 22 for double-buffered. A cursor is also displayed on the screen.</p> <p>RAMDAC on FFB2+ board supports three modes (SEP8, SEP4 and Combined). This test detects the RAMDAC type and tests the original and additional features like increased number of CLUTs, increased WLUT size, additional overlay WLUT.</p> <p>Errors in this test are attributed to the RAMDAC.</p>
Rendering Pipeline Test	<p>Rendering Pipeline uses the rendering pipeline tests developed for the FFB stand-alone diagnostics.</p> <p>Each primitive is tested thoroughly with the following sources and configurations:</p> <ul style="list-style-type: none"><li>• Dots</li><li>• Anti-aliased dots</li><li>• Lines using all four line drawing primitives</li><li>• Triangles</li><li>• Polygons</li><li>• Rectangles</li><li>• Fonts</li></ul> <p>Errors in this test are attributed to the FBC.</p>
Fast Fill/Vertical Scroll Test	<p>The Fast Fill/Vertical Scroll primitives are separated from the Rendering Pipeline tests because of their dependence on screen type. There are three different tests, one for each screen type. Each test uses both block and page mode fistfuls.</p> <p>Errors in this test are attributed to the FBC.</p>
Pixel Process Test	<p>Pixel Processor, a subtest, exercises the following options selected by the FFB's Pixel Processor Control (PPC) register.</p> <ul style="list-style-type: none"><li>• Auxiliary clipping (additive and subtractive)</li><li>• Depth cueing</li><li>• Alpha blend</li><li>• Viewport clip (2D and 3D)</li><li>• Area pattern (transparent and opaque)</li></ul> <p>Errors in this test are attributed to the FBC.</p>

**TABLE 15-1** `ffbttest` Options (Continued)

<code>ffbttest</code> Options	Description
Picking Test	<p>The Picking test exercises the pick detect login of the 3DRAM. <code>ffbttest</code> defines a pick detect window and checks that writes to the window are picked, and writes outside the window are not picked. The test is repeated once for each 3DRAM.</p> <p>Errors in this test are attributed to the 3DRAM.</p>
Arbitration Test	<p>Arbitration, a subtest, continuously renders an object into the accelerator port while performing reads and writes through the direct port. For single-buffered configuration, a picture is rendered into the RGB planes while another process does DFB reads and writes in the X plane. For doubled buffered configuration, a picture is rendered into all 32 planes of the B buffer while the other does 32-bit DFB reads and writes in the A plane. This subtest simulates conditions in the read world, where rendering processes and windows operations run concurrently.</p> <p>Errors in this test are attributed to the FBC.</p>

**TABLE 15-1** `ffbttest` Options (Continued)

<code>ffbttest</code> Options	Description
Stereo Test	<p>The Stereo test displays an object in stereo mode with different images for the right and left eye. The user can verify proper operation by looking at the screen with stereo glasses and following the displayed instructions. If the monitor type is not 1280x1024 @ 76MHz, this test prints a warning message and does not run. To prevent this message from being displayed or written to the SunVTS information log, disable the stereo test in the test option menu. Only Sony P4 and N2 monitors support stereo resolutions. This test temporarily switches the monitor into stereo mode, renders a stereo image, performs a signature analysis on the stereo image (using the RAMDAC signature capture register), and after displaying the image for five seconds, restores the monitor to its previous resolution.</p> <p>Errors in this test are attributed to the RAMDAC.</p> <p><b>NOTE</b> — If vertical lines are displayed on the console when running SunVTS, this could be caused by the <code>ffbttest</code> stereo test. There is a time-critical period in the FFB hardware when trying to change the screen resolution from standard to stereo and back to standard. When the system is heavily loaded or running all of the SunVTS tests, the FFB device driver may get interrupted while changing screen resolution. If this occurs, FB ASIC and RAMDAC get out of synchronization, resulting in an unusual display on the FFB screen. This problem could also cause a system hang condition.</p> <p>This test is disabled by default because it is only needed when a stereo monitor and stereo glasses are present.</p> <p>To avoid this type of display problem, disable the <code>ffbttest</code> stereo test when other SunVTS tests are enabled.</p>

---

## ffbttest Test Modes

Due to the nature of graphic tests, reading from or writing to the frame buffer during graphic tests will disturb user operation. This test is only available in Functional Test and Stress Mode.

TABLE 15-2 ffbttest Test Modes

Test Mode	Description
Functional Test	The ffbttest verifies both the single- (SFB) and double-buffered (DBZ) fast frame buffer boards.
Stress Mode	Stress mode exercises the frame buffer as much as possible. The Random Test generator, constructed as part of the verification effort, is used. Starting from a known seed, random primitives with random attributes are generated. The primitives are checked to ensure that they were rendered in the same way as on a known good system. The test is repeated ten times, with each random picture overlaying the previous one. Stress mode is not available on FFB2+ boards.

---

## ffbttest Command Line Syntax

`/opt/SUNWvts/bin/ffbttest standard_arguments -o dev=device_name, s=subtest_number,F=#_of_subtest_loops,B=#_of_test_loops,P=test_pattern`

TABLE 15-3 ffbttest Command Line Syntax

Argument	Explanation
<code>dev=device_name</code>	<code>device_name</code> is the relative path name of the device being tested with respect to <code>/dev/fbs</code> ; The default is <code>ffb0</code> .

**TABLE 15-3** `fbttest` Command Line Syntax

Argument	Explanation ( <i>Continued</i> )
<code>S=subtest_number</code>	<p><code>subtest_number</code> is the test number of the subtest to be run. Select from the subtests below. You can run multiple subtests by adding the subtest numbers. For example, <code>n=0x3</code> runs both test 1 and test 2; <code>n=0x180</code> runs both test 0x080 and test 0x0100. Note that you do not need the leading zeros.</p> <ul style="list-style-type: none"><li><code>n - 0x00001</code> 3DRAM</li><li><code>n - 0x00002</code> 3DRAM Logic</li><li><code>n - 0x00004</code> RAMDAC</li><li><code>n - 0x00008</code> Rendering Pipeline</li><li><code>n - 0x00010</code> FastFill/Vertical Scroll</li><li><code>n - 0x00020</code> Pixel Processor</li><li><code>n - 0x00040</code> Picking</li><li><code>n - 0x00080</code> Arbitration</li><li><code>n - 0x00100</code> Stereo</li></ul> <p>More than one test can be selected by ORing subtest numbers. For example: <code>n = 0x00009</code> selects 3DRAM and Rendering Pipeline tests. A hex number must be preceded by <code>0x</code>, decimal numbers are also acceptable.</p>
<code>F=#_of_subtest_loops</code>	Specifies the number of times to repeat each subtest; the default is 1.
<code>B=#_of_test_loops</code>	Specifies the number of times to repeat a test loop before passing; the default is 1.
<code>P=test_pattern</code>	Specifies the test pattern number. The default is <code>r</code> , for random patterns. You may also choose <code>0</code> for <code>0x0000000</code> , <code>3</code> for <code>0x33333333</code> , <code>5</code> for <code>0x55555555</code> , or <code>9</code> for <code>0x99999999</code> .

---

# ffbttest Error Messages

Errors returned by `ffbttest` are nonspecific. It is not possible to determine which component caused a failure. In all error conditions, the field replaceable unit (FRU) is the entire FFB.

TABLE 15-4 `ffbttest` Error Messages

Error Message	Probable Cause(s)	Recommended Action
6000 3DRAM Memory error in <i>string</i> Plane	Faulty 3DRAM, or possibly host memory error during <code>gcopy</code> operation.	If the problem persists, contact your authorized Sun service provider.
6002 3DRAM Memory error in <i>string</i> Plane	Faulty 3DRAM, or possibly host memory error during <code>gcopy</code> operation.	If the problem persists, contact your authorized Sun service provider.
6004 3DRAM Memory error in <i>string</i> Plane	Faulty 3DRAM, or possibly host memory error during <code>gcopy</code> operation.	If the problem persists, contact your authorized Sun service provider.
6006 3DRAM Memory error in Buffer A	Faulty 3DRAM, or possibly host memory error during <code>gcopy</code> operation.	If the problem persists, contact your authorized Sun service provider.
6008 3DRAM Memory error in Buffer B	Faulty 3DRAM, or possibly host memory error during <code>gcopy</code> operation.	If the problem persists, contact your authorized Sun service provider.
6010 3DRAM Memory error in Buffer C	3DRAM Memory error in Buffer C.	If the problem persists, contact your authorized Sun service provider.
6012 Misaligned raster.	Software error.	Reinstall software. If the problem persists, contact your authorized Sun service provider.
6013 File Not Found. Could not open file <i>string</i> .	Software error	Reinstall software. If the problem persists, contact your authorized Sun service provider.
6014 Could not open file <i>string</i> : <i>string</i> .	Software error.	Reinstall software. If the problem persists, contact your authorized Sun service provider.



**TABLE 15-4** `ffbtest` Error Messages (Continued)

	<b>Error Message</b>	<b>Probable Cause(s)</b>	<b>Recommended Action</b>
6015	Keyword not Found, line <i>data</i>	Software error, Suspect data file corruption.	Reinstall software. If the problem persists, contact your authorized Sun service provider.
6016	<i>string</i> error. Miscompares, starting at <i>string</i> .	Faulty frame buffer.	If the problem persists, contact your authorized Sun service provider.
6017	Picking test error. Got a pick hit with picking disabled.	Faulty frame buffer.	If the problem persists, contact your authorized Sun service provider.
6018	Picking test error. Got a pick hit outside the picking area.	Faulty frame buffer.	If the problem persists, contact your authorized Sun service provider.
6019	Picking test error. Should have detected a pick hit.	Faulty frame buffer.	If the problem persists, contact your authorized Sun service provider.
6020	Out of memory	Software System Error.	Contact system administrator
6021	<i>string</i> failed	Software error.	Check for existence and/or permissions on <i>string</i> . Also check for available space in tmp. Reinstall software or contact your system administrator.
6022	<i>string</i> failed	Software error.	Check for existence and/or permissions on <i>string</i> .
6023	fork1(2) failed	Software error.	Reinstall software or contact your system administrator.
6024	execl(2) failed	Software error.	Reinstall software or contact your system administrator.
6025	Unable to open <i>string</i> .	Software error.	Check device for existence and/or permissions on <i>string</i> . Reinstall software or contact your system administrator.
6026	ioctl(2) failed trying to read CLUT.	hardware failure or software driver error.	Reinstall software first, if failure continues, see a system administrator or your authorized Sun service provider.

**TABLE 15-4** ffbtest Error Messages (Continued)

Error Message	Probable Cause(s)	Recommended Action
6027 ioctl(2) failed trying to turn on FFB video.	hardware failure or software driver error.	Reinstall software first, if failure continues, see a system administrator or your authorized Sun service provider.
6028 failed trying to post CLUT.	hardware failure or software driver error.	Reinstall software first, if failure continues, see a system administrator or your authorized Sun service provider.
6029 Miscompare found in Red channel of CLUT entry <i>data</i> .	Faulty frame buffer.	If the problem persists, contact your authorized Sun service provider.
6030 Miscompare found in Green channel of CLUT entry <i>data</i>	Faulty frame buffer.	If the problem persists, contact your authorized Sun service provider.
6031 Miscompare found in Blue channel of CLUT entry <i>data</i>	Faulty frame buffer.	If the problem persists, contact your authorized Sun service provider.
6032 ioctl(2) failed trying to read WID LUT.	hardware failure or software driver error.	Reinstall software first, if failure continues, see a system administrator or your authorized Sun service provider.
6033 ioctl(2) failed trying to post WID LUT	hardware failure or software driver error.	Reinstall software first, if failure continues, see a system administrator or your authorized Sun service provider.
6034 failed trying to get RAMDAC signature analysis.	hardware failure or software driver error.	Reinstall software first, if failure continues, see a system administrator or your authorized Sun service provider.
6035 Miscompare found in WID LUT entry <i>data</i>	Faulty frame buffer	If the problem persists, contact your authorized Sun service provider.
6036 RAMDAC test failed. The on-screen image is incorrect	Faulty frame buffer.	If the problem persists, contact your authorized Sun service provider.
6037 sysinfo(2) failed getting hostname	Software error.	Make sure you are superuser.

**TABLE 15-4** ffbtest Error Messages (Continued)

	<b>Error Message</b>	<b>Probable Cause(s)</b>	<b>Recommended Action</b>
6038	can't acquire console semaphore	Software error.	Reinstall software or contact your system administrator.
6039	Cannot gain control of mouse: <i>string</i>	Software error.	Reinstall software or contact your system administrator.
6040	Cannot gain control of keyboard: <i>string</i>	Software error	Reinstall software or contact your system administrator.
6046	ioctl(2) failed trying to get current video mode.	Possibly hardware failure, likely software driver error.	Reinstall software first, if failure continues, see a system administrator or your authorized Sun service provider.
6047	ioctl(2) failed trying to set current video mode	Possibly hardware failure, likely software driver error.	Reinstall software first, if failure continues, see a system administrator or your authorized Sun service provider.
6048	ioctl(2) failed trying to get FFB system info	Possibly hardware failure, likely software driver error.	Reinstall software first, if failure continues, see a system administrator or your authorized Sun service provider.
6049	ioctl(2) failed trying to go into Diagnostic mode	Possibly hardware failure, likely software driver error.	Reinstall software first, if failure continues, see a system administrator or your authorized Sun service provider.
6050	mmap(2) failed: <i>string</i>	Software system error.	Reinstall software or contact your system administrator.
6051	munmap(2) failed: <i>string</i>	Software system error.	Reinstall software or contact your system administrator.
6052	close(2) failed: <i>string</i>	Software system error.	Reinstall software or contact your system administrator.
6053	DGA error grabbing window on screen <i>data</i>	Software error.	Reinstall software or contact your system administrator.
6054	DGA error getting window from token on screen <i>data</i>	Software error.	Reinstall software or contact your system administrator.
6055	failed trying to read Transparent Overlay registers	Possibly hardware failure, likely software driver error.	Reinstall software first, if failure continues, see a system administrator or your authorized Sun service provider.

**TABLE 15-4** ffbtest Error Messages (Continued)

Error Message	Probable Cause(s)	Recommended Action
6056 ioctl(2) failed trying to post Transparent Overlay registers	Possibly hardware failure, likely software driver error.	Reinstall software first, if failure continues, see a system administrator or your authorized Sun service provider.
6057 failed trying to post cursor	Possibly hardware failure, likely software driver error.	Reinstall software first, if failure continues, see a system administrator or your authorized Sun service provider.
6058 ioctl(2) failed trying to read cursor	Possibly hardware failure, likely software driver error.	Reinstall software first, if failure continues, see a system administrator or your authorized Sun service provider.
6059 No FFB device found on display 0	The environmental variable DISPLAY is set wrong or the display being used is not using an FFB.	Set the variable to a display that has the FFB plugged into it.
6060 There is an inconsistency with the version of the X Window System	Software error.	Contact your system administrator
6061 stat(2) failed trying to get info about Device Under Test	Software error.	Reinstall software or contact your system administrator.
6062 stat(2) failed trying to get info about screen 0: data	Software error.	Reinstall software or contact your system administrator.
6063 Can not access X Windows	Software error.	Try running xhost(1) or contact your system administrator.
6064 wait(2) failed: <i>string</i>	Software error.	Reinstall software or contact your system administrator.
6065 signal(2) failed: <i>string</i>	Reinstall software or contact your system administrator.	Reinstall software or contact your system administrator.
6066 thr_kill(2) failed	Software error.	Reinstall software or contact your system administrator.
6067 thr_join(2) failed: <i>string</i>	Software error.	Reinstall software or contact your system administrator.

**TABLE 15-4** *ffbtest* Error Messages (Continued)

Error Message	Probable Cause(s)	Recommended Action
6071 get signatures	operator error.	To get signatures, run <i>ffbtest</i> from the command line
6072 Stereo image incorrect	Stereo image incorrect.	If the problem persists, contact your authorized Sun service provider.
6075 System LWP limit exceeded	Software error.	Reinstall software or contact your system administrator.
6076 Error <i>data</i> creating thread	Software error.	Reinstall software or contact your system administrator.
6104 Error in getting the length of the file. <i>string</i>	Software error.	If the problem persists, contact your authorized Sun service provider.
6105 Stencil test failed <i>string</i>	Faulty 3DRAM.	If the problem persists, contact your authorized Sun service provider.
6106 Passin test failed <i>string</i>	Faulty 3DRAM.	If the problem persists, contact your authorized Sun service provider.
6107 Blend2 test failed <i>string</i>	Faulty 3DRAM.	If the problem persists, contact your authorized Sun service provider.
6115 3DRAM Memory error testing <i>string</i>	Faulty 3DRAM, or possibly GCopy error.	If the problem persists, contact your authorized Sun service provider.
6116 <i>string</i> error: 3DRAM Memory error testing <i>string</i>	Faulty 3DRAM, or possibly GCopy FFB to Memory error.	If the problem persists, contact your authorized Sun service provider.
6117 <i>string</i> error: 3DRAM Memory error testing <i>string</i>	Faulty 3DRAM, or possibly GCopy Memory to FFB error.	If the problem persists, contact your authorized Sun service provider.
6208 ioctl(2) failed trying to post Overlay WID LUT.	Possibly hardware failure, likely software driver error.	Reinstall software first, if failure continues, see a system administrator or your authorized Sun service provider.
6209 ioctl(2) failed trying to post Primary WID LUT	Possibly hardware failure, likely software driver error.	Reinstall software first, if failure continues, see a system administrator or your authorized Sun service provider.

**TABLE 15-4** ffbtest Error Messages (Continued)

Error Message	Probable Cause(s)	Recommended Action
6210 Miscompare found in Overlay WID LUT entry <i>data</i>	Faulty frame buffer.	If the problem persists, contact your authorized Sun service provider.
6211 Miscompare found in Primary WID LUT entry <i>data</i>	Faulty frame buffer.	If the problem persists, contact your authorized Sun service provider.
6212 ioctl(2) failed trying to read CLUT # <i>data</i>	Possibly hardware failure, likely software driver error.	Reinstall software first, if failure continues, see a system administrator or your authorized Sun service provider.
6213 ioctl(2) failed trying to post CLUT # <i>data</i>	Possibly hardware failure, likely software driver error.	Reinstall software first, if failure continues, see a system administrator or your authorized Sun service provider.
6214 Miscompare found in Red channel of CLUT # <i>data</i> in entry <i>data</i>	Faulty frame buffer.	If the problem persists, contact your authorized Sun service provider.
6215 Miscompare found in Green channel of CLUT # <i>data</i> in entry <i>data</i>	Faulty frame buffer.	If the problem persists, contact your authorized Sun service provider.
6216 Miscompare found in Blue channel of CLUT # <i>data</i> in entry <i>data</i>	Faulty frame buffer.	If the problem persists, contact your authorized Sun service provider.
6217 RAMDAC test failed. The on-screen image in sep 4 mode is incorrect.	Faulty frame buffer.	If the problem persists, contact your authorized Sun service provider.
6218 RAMDAC test failed. The on-screen image in sep 8 mode is incorrect.	Faulty frame buffer.	If the problem persists, contact your authorized Sun service provider.
6219 RAMDAC test failed. The on-screen image in combined mode is incorrect.	Faulty frame buffer.	If the problem persists, contact your authorized Sun service provider.
6220 ioctl(2) failed trying to read Overlay WID LUT	Possibly hardware failure, likely software driver error.	Reinstall software first, if failure continues, see a system administrator or your authorized Sun service provider.

**TABLE 15-4** *ffbtest* Error Messages (Continued)

Error Message	Probable Cause(s)	Recommended Action
6221 ioctl(2) failed trying to read Primary WID LUT	Possibly hardware failure, likely software driver error.	Reinstall software first, if failure continues, see a system administrator or your authorized Sun service provider.





## Floating Point Unit Test (`fputest`)

---

`fputest` checks the floating point unit on machines with the SPARC-based architecture. `fputest` performs the following subtests:

Instruction tests:

- FSR Register test
- Registers test
- NACK test
- Move Registers test
- Positive to Negative test
- Negative to Positive test
- Absolute test
- Single-Precision Integer to Floating Point test
- Double-Precision Integer to Floating Point test
- Single-Precision Floating Point to Integer test
- Double-Precision Floating Point to Integer test
- Single-Precision Round Toward Zero test
- Double-Precision Round Toward Zero test
- Single to Double-Precision Format Conversion test
- Double to Single-Precision Format Conversion test
- Single and Double-Precision Addition, Subtraction, Multiplication, Square-root, Division, and Compare tests
- Single and Double-Precision Compare and Exception if Unordered tests
- Branching and no Branching on Condition Instructions tests
- Single and Double-Precision Chaining tests
- Weitek Status tests
- Lock test
- Single and Double-Precision Datapath tests
- Timing (load) test

Benchmark tests:

- Linpack test
- Cparanoia test
- Cora test
- Kcsqrt test
- Kcdiv test
- Clorenz test
- Cvector test

---

## fputest Options

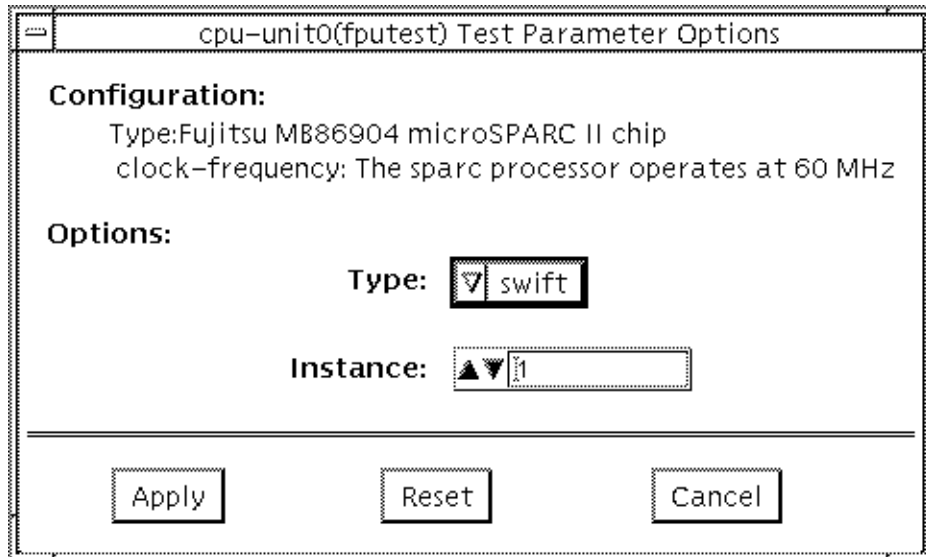

FIGURE 16-1 fputest Option Menu

---

# fputest Test Modes

**TABLE 16-1** fputest Test Modes

Test Mode	Description
Connection Test Mode	In this mode, <code>fputest</code> includes all the instruction tests.
Functional Test Mode	Functional test includes all the Instruction Tests and all the benchmark tests.
Online Mode	Provides a means to run <code>fputest</code> through SyMON. In Online mode, the following Functional Test description applies: <code>fputest</code> includes Linpack test and all the instruction tests.
Stress Mode	When stress mode is selected, several <code>fpu</code> benchmark tests are run.

---

# fputest Command Line Syntax

`/opt/SUNWvts/bin/fputest standard_arguments`

---

# fputest Error Messages

**TABLE 16-2** fputest Error Messages

	Error Message	Probable Cause(s)	Recommended Action
6012	Precision worse than 5 decimal figures	Faulty CPU module.	Retry test. If the problem persists, contact your Sun service provider.
6013	Radix is too big: roundoff problems	Faulty CPU module.	Retry test. If the problem persists, contact your Sun service provider.
6014	Radix is not as good as 2 or 10	Faulty CPU module.	Retry test. If the problem persists, contact your Sun service provider.
6015	(1-U1)-1/2 < 1/2 is FALSE, prog. fails?	Faulty CPU module.	Retry test. If the problem persists, contact your Sun service provider.

**TABLE 16-2** fputest Error Messages (Continued)

	<b>Error Message</b>	<b>Probable Cause(s)</b>	<b>Recommended Action</b>
6016	X=1 but X-1/2-1/2!= 0	Faulty CPU module.	Retry test. If the problem persists, contact your Sun service provider.
6017	Subtraction is not normalized X=Y,X+Z != Y+Z!	Faulty CPU module.	Retry test. If the problem persists, contact your Sun service provider.
6018	Multiplication lacks a Guard Digit, so 1*X != X	Faulty CPU module.	Retry test. If the problem persists, contact your Sun service provider.
6019	Multiplication gets too many final digits wrong	Faulty CPU module.	Retry test. If the problem persists, contact your Sun service provider.
6020	Division lacks a Guard Digit	Faulty CPU module.	Retry test. If the problem persists, contact your Sun service provider.
6021	Division lacks a Guard Digit, so X/1 != X	Faulty CPU module.	Retry test. If the problem persists, contact your Sun service provider.
6022	Computed value of 1/1.000.1 >= 1	Faulty CPU module.	Retry test. If the problem persists, contact your Sun service provider.
6023	Multiplication and/or Division gets too many last digits wrong	Faulty CPU module.	Retry test. If the problem persists, contact your Sun service provider.
6024	Subtraction lacks Guard Digit, so cancellation is obscured	Faulty CPU module.	Retry test. If the problem persists, contact your Sun service provider.
6025	X * (1/X) differs from 1	Faulty CPU module.	Retry test. If the problem persists, contact your Sun service provider.
6026	Radix * ( 1 / Radix ) differs from 1	Faulty CPU module.	Retry test. If the problem persists, contact your Sun service provider.
6027	Incomplete carry-propagation in Addition	Faulty CPU module.	Retry test. If the problem persists, contact your Sun service provider.
6028	Square root of 0.0, -0.0 or 1.0 wrong	Faulty CPU module.	Retry test. If the problem persists, contact your Sun service provider.
6029	sqrt gets too many last digits wrong	Faulty CPU module.	Retry test. If the problem persists, contact your Sun service provider.
6030	Square root is neither chopped nor correctly rounded	Faulty CPU module.	Retry test. If the problem persists, contact your Sun service provider.
6031	PseudoZero prints out as: <i>value</i>	Faulty CPU module.	Retry test. If the problem persists, contact your Sun service provider.
6032	PseudoZero prints out as: <i>value</i>	Faulty CPU module.	Retry test. If the problem persists, contact your Sun service provider.

**TABLE 16-2** *fputest* Error Messages (Continued)

	<b>Error Message</b>	<b>Probable Cause(s)</b>	<b>Recommended Action</b>
6033	Underflow prints out as: <i>value</i>	Faulty CPU module.	Retry test. If the problem persists, contact your Sun service provider.
6034	Accuracy deteriorates as numbers approach a threshold = <i>value</i>	Faulty CPU module.	Retry test. If the problem persists, contact your Sun service provider.
6035	Underflow confuses Comparison	Faulty CPU module.	Retry test. If the problem persists, contact your Sun service provider.
6036	X = <i>value</i> is not equal to Z = <i>value</i> yet X - Z yields <i>value</i>	Faulty CPU module.	Retry test. If the problem persists, contact your Sun service provider.
6037	X = <i>value</i> is not equal to Z = <i>value</i> yet X - Z yields <i>value</i>	Faulty CPU module.	Retry test. If the problem persists, contact your Sun service provider.
6038	Calculation yields: <i>value</i> :This is not between 0 and underflow threshold = <i>value</i>	Faulty CPU module.	Retry test. If the problem persists, contact your Sun service provider.
6039	Calculation yields: <i>value</i> :This is not between 0 and underflow threshold = <i>value</i>	Faulty CPU module.	Retry test. If the problem persists, contact your Sun service provider.
6040	Calculated <i>value</i> for (1 + ( <i>value</i> ) ^ ( <i>value</i> )); differs from correct value by <i>value</i>	Faulty CPU module.	Retry test. If the problem persists, contact your Sun service provider.
6041	Calculated <i>value</i> for (1 + ( <i>value</i> ) ^ ( <i>value</i> )); differs from correct value by <i>value</i>	Faulty CPU module.	Retry test. If the problem persists, contact your Sun service provider.
6042	Overflow(`Z = -Y') test on Y = <i>value</i> finds that -(-Y) differs from Y	Faulty CPU module.	Retry test. If the problem persists, contact your Sun service provider.
6043	Overflow(`Z = -Y') test on Y = <i>value</i> finds that -(-Y) differs from Y	Faulty CPU module.	Retry test. If the problem persists, contact your Sun service provider.
6044	Overflow past <i>value</i> shrinks to <i>value</i>	Faulty CPU module.	Retry test. If the problem persists, contact your Sun service provider.
6045	Overflow past <i>value</i> shrinks to <i>value</i>	Faulty CPU module.	Retry test. If the problem persists, contact your Sun service provider.
6046	Comparisons involving +- <i>value</i> , +- <i>value</i> and +- <i>value</i> are confused by Overflow	Faulty CPU module.	Retry test. If the problem persists, contact your Sun service provider.
6047	Comparisons involving +- <i>value</i> , +- <i>value</i> and +- <i>value</i> are confused by Overflow	Faulty CPU module.	Retry test. If the problem persists, contact your Sun service provider.

**TABLE 16-2** fputest Error Messages (Continued)

Error Message	Probable Cause(s)	Recommended Action
6048 A total of <i>value</i> floating point exceptions were registered	Faulty CPU module.	Retry test. If the problem persists, contact your Sun service provider.
6049 ( <i>value</i> ) ^ ( <i>value</i> ) yielded <i>value</i> ; which compared unequal to correct <i>value</i> ; they differ by <i>value</i>	Faulty CPU module.	Retry test. If the problem persists, contact your Sun service provider.
6050 ( <i>value</i> ) ^ ( <i>value</i> ) yielded <i>value</i> ; which compared unequal to correct <i>value</i> ; they differ by <i>value</i>	Faulty CPU module.	Retry test. If the problem persists, contact your Sun service provider.
6051 What prints as Z = <i>value</i> compares different from Z * 1 = <i>value</i>	Faulty CPU module.	Retry test. If the problem persists, contact your Sun service provider.
6052 What prints as Z = <i>value</i> compares different from 1 * Z == <i>value</i>	Faulty CPU module.	Retry test. If the problem persists, contact your Sun service provider.
6053 What prints as Z = <i>value</i> compares different from Z / 1 = <i>value</i>	Faulty CPU module.	Retry test. If the problem persists, contact your Sun service provider.
6054 What prints as Z = <i>value</i> compares different from Z * 1 = <i>value</i>	Faulty CPU module.	Retry test. If the problem persists, contact your Sun service provider.
6055 What prints as Z = <i>value</i> compares different from 1 * Z == <i>value</i>	Faulty CPU module.	Retry test. If the problem persists, contact your Sun service provider.
6056 What prints as Z = <i>value</i> compares different from Z / 1 = <i>value</i>	Faulty CPU module.	Retry test. If the problem persists, contact your Sun service provider.
6057 Multiplication does not commute:Comparison alleges that 1 * Z = <i>value</i> differs from Z * 1 = <i>value</i>	Faulty CPU module.	Retry test. If the problem persists, contact your Sun service provider.
6058 Multiplication does not commute:Comparison alleges that 1 * Z = <i>value</i> differs from Z * 1 = <i>value</i>	Faulty CPU module.	Retry test. If the problem persists, contact your Sun service provider.
6059 <i>subtest_name</i> test appears to be inconsistent.	Faulty CPU module.	Retry test. If the problem persists, contact your Sun service provider.
6060 Comparison alleges that - 0.0 is Non-zero!	Faulty CPU module.	Retry test. If the problem persists, contact your Sun service provider.

**TABLE 16-2** *fputest* Error Messages (Continued)

	<b>Error Message</b>	<b>Probable Cause(s)</b>	<b>Recommended Action</b>
6061	Disagreements among the values X1, Y1, Z1 respectively <i>value value value</i>	Faulty CPU module.	Retry test. If the problem persists, contact your Sun service provider.
6062	Disagreements among the values X1, Y1, Z1 respectively <i>value, value, value</i>	Faulty CPU module.	Retry test. If the problem persists, contact your Sun service provider.
6063	Comparison alleges $(1-U1) < 1$ although subtraction yields $(1-U1) - 1 = 0$	Faulty CPU module.	Retry test. If the problem persists, contact your Sun service provider.
6064	Multiplication appears to chop	Faulty CPU module.	Retry test. If the problem persists, contact your Sun service provider.
6065	Multiplication is neither chopped nor correctly rounded	Faulty CPU module.	Retry test. If the problem persists, contact your Sun service provider.
6066	Division appears to chop	Faulty CPU module.	Retry test. If the problem persists, contact your Sun service provider.
6067	Division is neither chopped nor correctly rounded	Faulty CPU module.	Retry test. If the problem persists, contact your Sun service provider.
6068	Addition/Subtraction appears to be chopped	Faulty CPU module.	Retry test. If the problem persists, contact your Sun service provider.
6069	Addition/Subtraction neither rounds nor chops	Faulty CPU module.	Retry test. If the problem persists, contact your Sun service provider.
6070	$(X - Y) + (Y - X)$ is non zero	Faulty CPU module.	Retry test. If the problem persists, contact your Sun service provider.
6071	Sticky bit used incorrectly or not at all	Faulty CPU module.	Retry test. If the problem persists, contact your Sun service provider.
6072	$X * Y == Y * X$ trial fails	Faulty CPU module.	Retry test. If the problem persists, contact your Sun service provider.
6073	Sqrt(X) is non-monotonic for X near <i>value</i>	Faulty CPU module.	Retry test. If the problem persists, contact your Sun service provider.
6074	Sqrt(X) is non-monotonic for X near <i>value</i>	Faulty CPU module.	Retry test. If the problem persists, contact your Sun service provider.
6075	Anomalous arithmetic with Integer Radix-Precision = <i>value</i> fails test whether sqrt rounds or chops	Faulty CPU module.	Retry test. If the problem persists, contact your Sun service provider.

**TABLE 16-2** fputest Error Messages (Continued)

	<b>Error Message</b>	<b>Probable Cause(s)</b>	<b>Recommended Action</b>
6076	Anomalous arithmetic with Integer Radix-Precision = <i>value</i> fails test whether sqrt rounds or chops	Faulty CPU module.	Retry test. If the problem persists, contact your Sun service provider.
6077	Square root appears to be chopped	Faulty CPU module.	Retry test. If the problem persists, contact your Sun service provider.
6078	Comparison alleges that $Z = \text{sqrt}(Z)^2$ <i>value</i> is too far from	Faulty CPU module.	Retry test. If the problem persists, contact your Sun service provider.
6079	Comparison alleges that $Z = \text{sqrt}(Z)^2$ <i>value</i> is too far from	Faulty CPU module.	Retry test. If the problem persists, contact your Sun service provider.
6080	Unbalanced range; $UfThold * V = \text{value}$ is too far from 1	Faulty CPU module.	Retry test. If the problem persists, contact your Sun service provider.
6081	Unbalanced range; $UfThold * V = \text{value}$ is too far from 1	Faulty CPU module.	Retry test. If the problem persists, contact your Sun service provider.
6082	$\text{sqrt}(\text{value}) - \text{value} = \text{value}$ instead of correct value 0	Faulty CPU module.	Retry test. If the problem persists, contact your Sun service provider.
6083	$\text{sqrt}(\text{value}) - \text{value} = \text{value}$ instead of correct value 0	Faulty CPU module.	Retry test. If the problem persists, contact your Sun service provider.
6084	Similar discrepancies have occurred <i>value</i> times	Faulty CPU module.	Retry test. If the problem persists, contact your Sun service provider.
6085	$X / X$ traps when $X = \text{value}$	Faulty CPU module.	Retry test. If the problem persists, contact your Sun service provider.
6086	$X / X$ traps when $X = \text{value}$	Faulty CPU module.	Retry test. If the problem persists, contact your Sun service provider.
6087	$X / X$ differs from 1 when $X = \text{value}$ instead, $X / X - 1/2 - 1/2 = \text{value}$	Faulty CPU module.	Retry test. If the problem persists, contact your Sun service provider.
6088	$X / X$ differs from 1 when $X = \text{value}$ instead, $X / X - 1/2 - 1/2 = \text{value}$	Faulty CPU module.	Retry test. If the problem persists, contact your Sun service provider.
6089	Computed: <i>character</i> Expected: <i>character</i>	Faulty CPU module.	Retry test. If the problem persists, contact your Sun service provider.
6090	Failed Vector test	Faulty CPU module.	Retry test. If the problem persists, contact your Sun service provider.
6091	Error: Invalid operator ( <i>character</i> )	Faulty CPU module.	Retry test. If the problem persists, contact your Sun service provider.



**TABLE 16-2** *fputest* Error Messages (Continued)

	<b>Error Message</b>	<b>Probable Cause(s)</b>	<b>Recommended Action</b>
6092	Error: Invalid version ( <i>character</i> )	Faulty CPU module.	Retry test. If the problem persists, contact your Sun service provider.
6093	Error: Invalid precision ( <i>character</i> )	Faulty CPU module.	Retry test. If the problem persists, contact your Sun service provider.
6094	Error: Illegal input ( <i>character</i> )	Faulty CPU module.	Retry test. If the problem persists, contact your Sun service provider.
6095	Failed Vector <i>subtest_name</i> sub-test[ <i>text</i> ], Operand 1 <i>text value value</i> , Operand 2 <i>text value value</i> , <i>charactercharactercharacter</i> Correct <i>text value value (text)</i> , Computed <i>text value value (text)</i>	Faulty CPU module.	Retry test. If the problem persists, contact your Sun service provider.
6096	Failed Vector <i>subtest_name</i> sub-test[ <i>text</i> ], Operand 1 <i>text value value</i> , Operand 2 <i>text value value</i> <i>value</i> , <i>charactercharactercharacter</i> Correct <i>text value value value (text)</i> , Computed <i>text value value value (text)</i>	Faulty CPU module.	Retry test. If the problem persists, contact your Sun service provider.
6097	Failed Vector <i>subtest_name</i> sub-test[ <i>text</i> ], Operand 1 <i>text value value value</i> <i>value</i> , Operand 2 <i>text value value value</i> <i>value</i> , <i>charactercharactercharacter</i> Correct <i>text value value value</i> <i>value (text)</i> , Computed <i>text value value value</i> <i>value (text)</i>	Faulty CPU module.	Retry test. If the problem persists, contact your Sun service provider.
6098	Failed Vector <i>subtest_name</i> sub-test[ <i>text</i> ] Operand 1 <i>text value value</i> Operand 2 <i>text value value</i> <i>value</i> <i>charactercharactercharacter</i> Correct <i>text value value value (text)</i> Computed <i>text value value value</i> ( <i>text</i> )	Faulty CPU module.	Retry test. If the problem persists, contact your Sun service provider.

**TABLE 16-2** fputest Error Messages (Continued)

	Error Message	Probable Cause(s)	Recommended Action
6099	<i>charactercharactercharacter value</i> ( <i>text</i> ) <i>character value</i> ( <i>text</i> ) <computed <i>character</i> >	Faulty CPU module.	Retry test. If the problem persists, contact your Sun service provider.
6100	<i>charactercharactercharacter Op1</i> ( <i>text</i> ) <i>character Op2</i> ( <i>text</i> ) <computed <i>character</i> >	Faulty CPU module.	Retry test. If the problem persists, contact your Sun service provider.
6101	Flags: Correct ( <i>text</i> ) Computed ( <i>text</i> )	Faulty CPU module.	Retry test. If the problem persists, contact your Sun service provider.
6102	FPU initialization failure	Faulty CPU module.	Retry test. If the problem persists, contact your Sun service provider.
6103	Multiplication failed, result was ( <i>value</i> ), expected ( <i>value</i> )	Faulty CPU module.	Retry test. If the problem persists, contact your Sun service provider.
6104	Failed Single-Precision FPA math test	Faulty CPU module.	Retry test. If the problem persists, contact your Sun service provider.
6105	Failed Double-Precision FPA math test	Faulty CPU module.	Retry test. If the problem persists, contact your Sun service provider.
6106	Failed linpack test	Faulty CPU module.	Retry test. If the problem persists, contact your Sun service provider.
6107	Failed cparanoia test	Faulty CPU module.	Retry test. If the problem persists, contact your Sun service provider.
6108	Failed cora test	Faulty CPU module.	Retry test. If the problem persists, contact your Sun service provider.
6109	Failed clorenz test	Faulty CPU module.	Retry test. If the problem persists, contact your Sun service provider.
6110	Failed kcsqrt test	Faulty CPU module.	Retry test. If the problem persists, contact your Sun service provider.
6111	Failed kcdiv test	Faulty CPU module.	Retry test. If the problem persists, contact your Sun service provider.
6112	Error: a + b, Expected: 2.2221000 Actual: <i>value</i>	Faulty CPU module.	Retry test. If the problem persists, contact your Sun service provider.
6113	Error a - b,, Expected: 0.2469000 Actual: <i>value</i>	Faulty CPU module.	Retry test. If the problem persists, contact your Sun service provider.
6114	Error a * b, Expected: 1.2191922 Actual: <i>value</i>	Faulty CPU module.	Retry test. If the problem persists, contact your Sun service provider.
6115	Error a / b, Expected: 1.2500000 Actual: <i>value</i>	Faulty CPU module.	Retry test. If the problem persists, contact your Sun service provider.

**TABLE 16-2** `fputest` Error Messages (Continued)

	<b>Error Message</b>	<b>Probable Cause(s)</b>	<b>Recommended Action</b>
6116	Error: $a + (a + b)$ , Expected: 1.4814000 Actual: <i>value</i>	Faulty CPU module.	Retry test. If the problem persists, contact your Sun service provider.
6117	Error: $a - (a + b)$ , Expected: -0.9876000 Actual: <i>value</i>	Faulty CPU module.	Retry test. If the problem persists, contact your Sun service provider.
6118	Error: $a + (a * b)$ , Expected: 2.4536924 Actual: <i>value</i>	Faulty CPU module.	Retry test. If the problem persists, contact your Sun service provider.
6119	Error: $a - (a * b)$ , Expected: 0.0153078 Actual: <i>value</i>	Faulty CPU module.	Retry test. If the problem persists, contact your Sun service provider.
6120	$a + (a / b)$ , Expected: 2.4845002 Actual: <i>value</i>	Faulty CPU module.	Retry test. If the problem persists, contact your Sun service provider.
6121	Error: $a - (a / b)$ , Expected: -0.0155000 Actual: <i>value</i>	Faulty CPU module.	Retry test. If the problem persists, contact your Sun service provider.
6122	Error: $a * (a + b)$ , Expected: 2.7431825 Actual: <i>value</i>	Faulty CPU module.	Retry test. If the problem persists, contact your Sun service provider.
6123	Error: $a * (a - b)$ , Expected: 0.3047980 Actual: <i>value</i>	Faulty CPU module.	Retry test. If the problem persists, contact your Sun service provider.
6124	Error: $a / (a - b)$ , Expected: 0.5555550 Actual: <i>value</i>	Faulty CPU module.	Retry test. If the problem persists, contact your Sun service provider.
6125	Error: $a / (a - b)$ , Expected: 5.0000000 Actual: <i>value</i>	Faulty CPU module.	Retry test. If the problem persists, contact your Sun service provider.
6126	Error: $a * (a / b)$ , Expected: 1.5431250 Actual: <i>value</i> )	Faulty CPU module.	Retry test. If the problem persists, contact your Sun service provider.
6127	Error: $a / (a * b)$ , Expected: 1.0125557 Actual: <i>value</i> )	Faulty CPU module.	Retry test. If the problem persists, contact your Sun service provider.
6128	Error: $a + b$ , Expected: 2.222100000000000 Actual: <i>value</i>	Faulty CPU module.	Retry test. If the problem persists, contact your Sun service provider.

**TABLE 16-2** fputest Error Messages (Continued)

	<b>Error Message</b>	<b>Probable Cause(s)</b>	<b>Recommended Action</b>
6129	Error: $a - b$ , Expected: 0.246899999999999 Actual: <i>value</i>	Faulty CPU module.	Retry test. If the problem persists, contact your Sun service provider.
6130	Error: $a * b$ , Expected: 1.219192199999999 Actual: <i>value</i>	Faulty CPU module.	Retry test. If the problem persists, contact your Sun service provider.
6131	Error: $a / b$ , Expected: 1.249999999999999 Actual: <i>value</i>	Faulty CPU module.	Retry test. If the problem persists, contact your Sun service provider.
6132	Error: $a + (a - b)$ , Expected: 1.481399999999999 Actual: <i>value</i>	Faulty CPU module.	Retry test. If the problem persists, contact your Sun service provider.
6133	Error: $a - (a + b)$ , Expected: - 0.987600000000000 Actual: <i>value</i>	Faulty CPU module.	Retry test. If the problem persists, contact your Sun service provider.
6134	Error: $a + (a * b)$ , Expected: 2.453692200000000 Actual: <i>value</i>	Faulty CPU module.	Retry test. If the problem persists, contact your Sun service provider.
6135	Error: $a - (a * b)$ , Expected: 0.015307800000000 Actual: <i>value</i>	Faulty CPU module.	Retry test. If the problem persists, contact your Sun service provider.
6136	Error: $a + (a / b)$ , Expected: 2.484500000000000 Actual: <i>value</i>	Faulty CPU module.	Retry test. If the problem persists, contact your Sun service provider.
6137	Error: $a - (a / b)$ , Expected: - 0.015499999999999 Actual: <i>value</i>	Faulty CPU module.	Retry test. If the problem persists, contact your Sun service provider.
6138	Error: $a * (a + b)$ , Expected: 2.743182449999999 Actual: <i>value</i>	Faulty CPU module.	Retry test. If the problem persists, contact your Sun service provider.
6139	Error: $a * (a - b)$ , Expected: 0.304798049999999 Actual: <i>value</i>	Faulty CPU module.	Retry test. If the problem persists, contact your Sun service provider.
6140	Error: $a / (a + b)$ , Expected: 0.555555555555555 Actual: <i>value</i>	Faulty CPU module.	Retry test. If the problem persists, contact your Sun service provider.
6141	Error: $a / (a - b)$ , Expected: 5.000000000000002 Actual: <i>value</i>	Faulty CPU module.	Retry test. If the problem persists, contact your Sun service provider.

**TABLE 16-2** *fputest* Error Messages (Continued)

	<b>Error Message</b>	<b>Probable Cause(s)</b>	<b>Recommended Action</b>
6142	Error: $a * (a / b)$ , Expected: 1.5431249999999999 Actual: <i>value</i>	Faulty CPU module.	Retry test. If the problem persists, contact your Sun service provider.
6143	Error: $a / (a * b)$ , Expected: 1.0125555690562980 Actual: <i>value</i>	Faulty CPU module.	Retry test. If the problem persists, contact your Sun service provider.
6144	Error: $\sin(-2\pi)$ , Expected: -0.000000000820413 Actual: <i>value</i>	Faulty CPU module.	Retry test. If the problem persists, contact your Sun service provider.
6145	Error: $\sin(-3\pi^2)$ , Expected: 1.0000000000000000 Actual: <i>value</i>	Faulty CPU module.	Retry test. If the problem persists, contact your Sun service provider.
6146	Error: $\sin(-3\pi/2)$ , Expected: 1.0000000000000000 Actual: <i>value</i>	Faulty CPU module.	Retry test. If the problem persists, contact your Sun service provider.
6147	Error: $\sin(-\pi)$ , Expected: 0.000000000410206 Actual: <i>value</i>	Faulty CPU module.	Retry test. If the problem persists, contact your Sun service provider.
6148	Error: $\sin(-\pi/2)$ , Expected: -1.0000000000000000 Actual: <i>value</i>	Faulty CPU module.	Retry test. If the problem persists, contact your Sun service provider.
6149	Error: $\sin(0)$ , Expected: 0.0000000000000000 Actual: <i>value</i>	Faulty CPU module.	Retry test. If the problem persists, contact your Sun service provider.
6150	Error: $\sin(\pi/2)$ , Expected: 1.0000000000000000 Actual: <i>value</i>	Faulty CPU module.	Retry test. If the problem persists, contact your Sun service provider.
6151	Error: $\sin(\pi)$ , Expected: - 0.000000000410206 Actual: <i>value</i>	Faulty CPU module.	Retry test. If the problem persists, contact your Sun service provider.
6152	Error: $\sin(3\pi/2)$ , Expected: - 1.0000000000000000 Actual: <i>value</i>	Faulty CPU module.	Retry test. If the problem persists, contact your Sun service provider.
6153	Error: $\sin(2\pi)$ , Expected: 0.000000000820143 Actual: <i>value</i>	Faulty CPU module.	Retry test. If the problem persists, contact your Sun service provider.

**TABLE 16-2** fputest Error Messages (Continued)

	<b>Error Message</b>	<b>Probable Cause(s)</b>	<b>Recommended Action</b>
6154	Error: $\cos(-2\pi)$ , Expected: 1.0000000000000000 Actual: <i>value</i>	Faulty CPU module.	Retry test. If the problem persists, contact your Sun service provider.
6155	Error: $\cos(-3\pi/2)$ , Expected: 0.000000000615310 Actual: <i>value</i>	Faulty CPU module.	Retry test. If the problem persists, contact your Sun service provider.
6156	Error: $\cos(-\pi)$ , Expected: -1.0000000000000000 Actual: <i>value</i>	Faulty CPU module.	Retry test. If the problem persists, contact your Sun service provider.
6157	Error: $\cos(-\pi/2)$ , Expected: - 0.000000000205103 Actual: <i>value</i>	Faulty CPU module.	Retry test. If the problem persists, contact your Sun service provider.
6158	Error: $\cos(0)$ , Expected: 1.0000000000000000 Actual: <i>value</i>	Faulty CPU module.	Retry test. If the problem persists, contact your Sun service provider.
6159	Error: $\cos(\pi/2)$ , Expected: -0.000000000205103 Actual: <i>value</i>	Faulty CPU module.	Retry test. If the problem persists, contact your Sun service provider.
6160	Error: $\cos(\pi)$ , Expected: - 1.0000000000000000 Actual: <i>value</i>	Faulty CPU module.	Retry test. If the problem persists, contact your Sun service provider.
6161	Error: $\cos(3\pi/2)$ , Expected: 0.000000000615310 Actual: <i>value</i>	Faulty CPU module.	Retry test. If the problem persists, contact your Sun service provider.
6162	Error: $\cos(\pi/2)$ , Expected: 1.0000000000000000 Actual: <i>value</i>	Faulty CPU module.	Retry test. If the problem persists, contact your Sun service provider.
6163	Error: $\sin(\pi/4)$ , Expected: 0.707106781259062 Actual: <i>value</i>	Faulty CPU module.	Retry test. If the problem persists, contact your Sun service provider.
6164	Error: $\sin(3\pi/4)$ , Expected: 0.707106780969002 Actual: <i>value</i>	Faulty CPU module.	Retry test. If the problem persists, contact your Sun service provider.
6165	Error: $\sin(5\pi/4)$ , Expected: - 0.707106781549122 Actual: <i>value</i>	Faulty CPU module.	Retry test. If the problem persists, contact your Sun service provider.

**TABLE 16-2** *fputest* Error Messages (Continued)

	<b>Error Message</b>	<b>Probable Cause(s)</b>	<b>Recommended Action</b>
6166	Error: $\sin(7\pi/4)$ , Expected: - 0.707106780678942 Actual: <i>value</i>	Faulty CPU module.	Retry test. If the problem persists, contact your Sun service provider.
6167	Error: $\cos(\pi/4)$ , Expected: 0.707106781114032 Actual: <i>value</i>	Faulty CPU module.	Retry test. If the problem persists, contact your Sun service provider.
6168	Error: $\cos(3\pi/4)$ , Expected: - 0.707106781404092 Actual: <i>value</i>	Faulty CPU module.	Retry test. If the problem persists, contact your Sun service provider.
6169	Error: $\cos(5\pi/4)$ , Expected: - 0.707106780823972 Actual: <i>value</i>	Faulty CPU module.	Retry test. If the problem persists, contact your Sun service provider.
6170	Error: $\cos(7\pi/4)$ , Expected: 0.707106781694152 Actual: <i>value</i>	Faulty CPU module.	Retry test. If the problem persists, contact your Sun service provider.
6171	Error: $\exp(0)$ , Expected: 1.0000000000000000 Actual: <i>value</i>	Faulty CPU module.	Retry test. If the problem persists, contact your Sun service provider.
6172	Error: $\exp(1)$ , Expected: 2.718281828459045 Actual: <i>value</i>	Faulty CPU module.	Retry test. If the problem persists, contact your Sun service provider.
6173	Error: $\exp(2)$ , Expected: 7.389056098930650 Actual: <i>value</i>	Faulty CPU module.	Retry test. If the problem persists, contact your Sun service provider.
6174	Error: $\exp(5)$ , Expected: 148.413159102576600 Actual: <i>value</i>	Faulty CPU module.	Retry test. If the problem persists, contact your Sun service provider.
6175	Error: $\exp(10)$ , Expected: 22026.465794806718000 Actual: <i>value</i>	Faulty CPU module.	Retry test. If the problem persists, contact your Sun service provider.
6176	Error: $\exp(-1)$ , Expected: 0.367879441171442 Actual: <i>value</i>	Faulty CPU module.	Retry test. If the problem persists, contact your Sun service provider.
6177	Error: $\exp(-2)$ , Expected: 0.135335283236612 Actual: <i>value</i>	Faulty CPU module.	Retry test. If the problem persists, contact your Sun service provider.

**TABLE 16-2** *fpptest Error Messages (Continued)*

	<b>Error Message</b>	<b>Probable Cause(s)</b>	<b>Recommended Action</b>
6178	Error: $\exp(-5)$ , Expected: 0.006737946999085 Actual: <i>value</i>	Faulty CPU module.	Retry test. If the problem persists, contact your Sun service provider.
6179	Error: $\exp(-10)$ , Expected: 0.000045399929762 Actual: <i>value</i>	Faulty CPU module.	Retry test. If the problem persists, contact your Sun service provider.
6180	Error: $\exp(\log(1))$ , Expected: 1.0000000000000000 Actual: <i>value</i>	Faulty CPU module.	Retry test. If the problem persists, contact your Sun service provider.
6181	Error: $\exp(\log(10))$ , Expected 10.000000000000002 Actual: <i>value</i>	Faulty CPU module.	Retry test. If the problem persists, contact your Sun service provider.
6182	Error: $\log(1)$ , Expected: 0.0000000000000000 Actual: <i>value</i>	Faulty CPU module.	Retry test. If the problem persists, contact your Sun service provider.
6183	Error: $\log(2)$ , Expected: 0.693147180559945 Actual: <i>value</i>	Faulty CPU module.	Retry test. If the problem persists, contact your Sun service provider.
6184	Error: $\log(10)$ , Expected: 2.302585092994045 Actual: <i>value</i>	Faulty CPU module.	Retry test. If the problem persists, contact your Sun service provider.
6185	Error: $\log(100)$ , Expected: 4.605170185988091 Actual: <i>value</i>	Faulty CPU module.	Retry test. If the problem persists, contact your Sun service provider.
6186	Error: $\log(\exp(0))$ , Expected: 0.0000000000000000 Actual: <i>value</i>	Faulty CPU module.	Retry test. If the problem persists, contact your Sun service provider.
6187	Error: $\log(\exp(1))$ , Expected: 1.0000000000000000 Actual: <i>value</i>	Faulty CPU module.	Retry test. If the problem persists, contact your Sun service provider.
6188	Error: $\log(\exp(10))$ , Expected: 10.0000000000000000 Actual: <i>value</i>	Faulty CPU module.	Retry test. If the problem persists, contact your Sun service provider.
6189	Error: $\tan(-2\pi)$ , Expected: -0.000000000820414 Actual: <i>value</i>	Faulty CPU module.	Retry test. If the problem persists, contact your Sun service provider.



**TABLE 16-2** *fputest* Error Messages (Continued)

	<b>Error Message</b>	<b>Probable Cause(s)</b>	<b>Recommended Action</b>
6190	Error: $\tan(-7\pi/4)$ , Expected: 0.99999998564275 Actual: <i>value</i>	Faulty CPU module.	Retry test. If the problem persists, contact your Sun service provider.
6191	Error: $\tan(-5\pi/4)$ , Expected: - 1.000000001025517 Actual: <i>value</i>	Faulty CPU module.	Retry test. If the problem persists, contact your Sun service provider.
6192	Error: $\tan(-\pi)$ , Expected: 0.00000000410207 Actual: <i>value</i>	Faulty CPU module.	Retry test. If the problem persists, contact your Sun service provider.
6193	Error: $\tan(-3\pi/4)$ , Expected: 0.99999999384690 Actual: <i>value</i>	Faulty CPU module.	Retry test. If the problem persists, contact your Sun service provider.
6194	Error: $\tan(-\pi/4)$ , Expected: - 1.00000000205103 Actual: <i>value</i>	Faulty CPU module.	Retry test. If the problem persists, contact your Sun service provider.
6195	Error: $\tan(0.0)$ , Expected: 0.000000000000000 Actual: <i>value</i>	Faulty CPU module.	Retry test. If the problem persists, contact your Sun service provider.
6196	Error: $\tan(\pi / 4)$ , Expected: 1.00000000205103 Actual: <i>value</i>	Faulty CPU module.	Retry test. If the problem persists, contact your Sun service provider.
6197	Error: $\tan(3\pi/4)$ , Expected: - 0.99999999384690 Actual: <i>value</i>	Faulty CPU module.	Retry test. If the problem persists, contact your Sun service provider.
6198	Error: $\tan(\pi)$ , Expected: 0.00000000410207 Actual: <i>value</i>	Faulty CPU module.	Retry test. If the problem persists, contact your Sun service provider.
6199	Error: $\tan(5\pi/4)$ , Expected: 1.000000001025517 Actual: <i>value</i>	Faulty CPU module.	Retry test. If the problem persists, contact your Sun service provider.
6200	Error: $\tan(7\pi/4)$ , Expected: - 0.99999998564275 Actual: <i>value</i>	Faulty CPU module.	Retry test. If the problem persists, contact your Sun service provider.
6201	Error: $\tan(2\pi)$ , Expected: 0.00000000820414 Actual: <i>value</i>	Faulty CPU module.	Retry test. If the problem persists, contact your Sun service provider.

**TABLE 16-2** fputest Error Messages (Continued)

	<b>Error Message</b>	<b>Probable Cause(s)</b>	<b>Recommended Action</b>
6202	Error: sqrt(0), Expected: 0.0000000000000000 Actual: <i>value</i>	Faulty CPU module.	Retry test. If the problem persists, contact your Sun service provider.
6203	Error: sqrt(1), Expected: 1.0000000000000000 Actual: <i>value</i>	Faulty CPU module.	Retry test. If the problem persists, contact your Sun service provider.
6204	Error: sqrt(4), Expected: 2.0000000000000000 Actual: <i>value</i>	Faulty CPU module.	Retry test. If the problem persists, contact your Sun service provider.
6205	Error: sqrt(9), Expected: 3.0000000000000000 Actual: <i>value</i>	Faulty CPU module.	Retry test. If the problem persists, contact your Sun service provider.
6206	Error: sqrt(16), Expected: 4.0000000000000000 Actual: <i>value</i>	Faulty CPU module.	Retry test. If the problem persists, contact your Sun service provider.
6207	Error: sqrt(25), Expected: 5.0000000000000000 Actual: <i>value</i>	Faulty CPU module.	Retry test. If the problem persists, contact your Sun service provider.
6208	Error: sqrt(36), Expected: 6.0000000000000000 Actual: <i>value</i>	Faulty CPU module.	Retry test. If the problem persists, contact your Sun service provider.
6209	Error: sqrt(49), Expected: 7.0000000000000000 Actual: <i>value</i>	Faulty CPU module.	Retry test. If the problem persists, contact your Sun service provider.
6210	Error: sqrt(64), Expected: 8.0000000000000000 Actual: <i>value</i>	Faulty CPU module.	Retry test. If the problem persists, contact your Sun service provider.
6211	Error: sqrt(81), Expected: 9.0000000000000000 Actual: <i>value</i>	Faulty CPU module.	Retry test. If the problem persists, contact your Sun service provider.
6212	Error: sqrt(100), Expected: 10.0000000000000000 Actual: <i>value</i>	Faulty CPU module.	Retry test. If the problem persists, contact your Sun service provider.
6213	log-test failed: int = <i>value</i> , expected / observed = <i>value</i> / <i>value</i>	Faulty CPU module.	Retry test. If the problem persists, contact your Sun service provider.
6214	kvm_read(mem,nl[0].n_value, ..) failed	Faulty CPU module.	Retry test. If the problem persists, contact your Sun service provider.
6215	kvm_open() failed:<error_message>	Faulty CPU module.	Retry test. If the problem persists, contact your Sun service provider.

**TABLE 16-2** fputest Error Messages (Continued)

	<b>Error Message</b>	<b>Probable Cause(s)</b>	<b>Recommended Action</b>
6216	kvm_nlist() failed:<error_message>	Faulty CPU module.	Retry test. If the problem persists, contact your Sun service provider.
6217	Add SP failed: expected / read = <i>value</i> / <i>value</i>	Faulty CPU module.	Retry test. If the problem persists, contact your Sun service provider.
6218	Multiply SP failed:expected / read = <i>value</i> / <i>value</i>	Faulty CPU module.	Retry test. If the problem persists, contact your Sun service provider.
6219	Add DP failed: msw : expected / read = <i>value</i> / <i>value</i> ,                                lsw : expected / read = <i>value</i> / <i>value</i>	Faulty CPU module.	Retry test. If the problem persists, contact your Sun service provider.
6220	Multiply DP failed: msw : expected / read = <i>value</i> / <i>value</i> , lsw : expected / read = <i>value</i> / <i>value</i>	Faulty CPU module.	Retry test. If the problem persists, contact your Sun service provider.
6221	Single-Precision: add, expected / observed = 0x41200000 / 0x <i>value</i>	Faulty CPU module.	Retry test. If the problem persists, contact your Sun service provider.
6222	Single-Precision: Multiply, expected / observed = 0x43470000 / 0x <i>value</i>	Faulty CPU module.	Retry test. If the problem persists, contact your Sun service provider.
6223	Double-Precision: Add, MSW : expected / observed = 0x40240000 / 0x <i>value</i> , LSW : expected / observed = 0x0 / 0x <i>value</i>	Faulty CPU module.	Retry test. If the problem persists, contact your Sun service provider.
6224	Double-Precision: Multiply, MSW : expected / observed = 0x4034000 / 0x <i>value</i> , LSW : expected / observed = 0x0 / 0x <i>value</i>	Faulty CPU module.	Retry test. If the problem persists, contact your Sun service provider.
6225	Error: expected / observed = <i>value</i> / 0x <i>value</i>	Faulty CPU module.	Retry test. If the problem persists, contact your Sun service provider.
6226	Error: expected / observed = <i>value</i> / 0x <i>value</i>	Faulty CPU module.	Retry test. If the problem persists, contact your Sun service provider.
6227	fitos failed: int = <i>value</i> , expected / observed = <i>value</i> / <i>value</i>	Faulty CPU module.	Retry test. If the problem persists, contact your Sun service provider.
6228	fitod failed: int = <i>value</i> , expected / observed = <i>value</i> / <i>value</i>	Faulty CPU module.	Retry test. If the problem persists, contact your Sun service provider.

**TABLE 16-2** fputest Error Messages (Continued)

	<b>Error Message</b>	<b>Probable Cause(s)</b>	<b>Recommended Action</b>
6229	fstoi failed: int = <i>value</i> , expected / observed = <i>value</i> / <i>value</i>	Faulty CPU module.	Retry test. If the problem persists, contact your Sun service provider.
6230	fdtoi failed: int = <i>value</i> , expected / observed = <i>value</i> / <i>value</i>	Faulty CPU module.	Retry test. If the problem persists, contact your Sun service provider.
6231	fstod failed: int = <i>value</i> , expected / observed = <i>value</i> / <i>value</i>	Faulty CPU module.	Retry test. If the problem persists, contact your Sun service provider.
6232	fdtos failed: int = <i>value</i> , expected / observed = <i>value</i> / <i>value</i>	Faulty CPU module.	Retry test. If the problem persists, contact your Sun service provider.
6233	fmovs failed : written <i>value</i> to f0, read from f31 = <i>value</i>	Faulty CPU module.	Retry test. If the problem persists, contact your Sun service provider.
6234	fnegs failed(from pos to neg): int = <i>value</i> , expected / observed = <i>value</i> / <i>value</i>	Faulty CPU module.	Retry test. If the problem persists, contact your Sun service provider.
6235	fnegs failed (from neg. to pos): int = <i>value</i> , expected / observed = <i>value</i> / <i>value</i>	Faulty CPU module.	Retry test. If the problem persists, contact your Sun service provider.
6236	fabs failed: int = <i>value</i> , expected / observed = <i>value</i> / <i>value</i>	Faulty CPU module.	Retry test. If the problem persists, contact your Sun service provider.
6237	fadds failed: int = <i>value</i> , f0 = <i>value</i> , f2 = <i>value</i> , f0+f2 = f4 = <i>value</i>	Faulty CPU module.	Retry test. If the problem persists, contact your Sun service provider.
6238	faddd failed: int = <i>value</i> , f0 = <i>value</i> , f2 = <i>value</i> , f0+f2 = f4 = <i>value</i>	Faulty CPU module.	Retry test. If the problem persists, contact your Sun service provider.
6239	fsubs failed:int = <i>value</i> , f0 = <i>value</i> , f2 = <i>value</i> , f0-f2 = f4 = <i>value</i>	Faulty CPU module.	Retry test. If the problem persists, contact your Sun service provider.
6240	fsubd failed: int = <i>value</i> , f0 = <i>value</i> , f2 = <i>value</i> , f0-f2 = f4 = <i>value</i>	Faulty CPU module.	Retry test. If the problem persists, contact your Sun service provider.
6241	fsqrt(single) failed: written / read = <i>value</i> / <i>value</i>	Faulty CPU module.	Retry test. If the problem persists, contact your Sun service provider.
6242	fsqrt(double) failed: written / read = <i>value</i> / <i>value</i>	Faulty CPU module.	Retry test. If the problem persists, contact your Sun service provider.

**TABLE 16-2** *fputest* Error Messages (Continued)

	<b>Error Message</b>	<b>Probable Cause(s)</b>	<b>Recommended Action</b>
6243	<i>fdivs</i> failed: int = <i>value</i> , f0 = <i>value</i> , f2 = <i>value</i> , f0 / f2 = f4 = <i>value</i>	Faulty CPU module.	Retry test. If the problem persists, contact your Sun service provider.
6244	<i>fdivd</i> failed: int = <i>value</i> , f0 = <i>value</i> , f2 = <i>value</i> , f0 / f2 = f4 = <i>value</i>	Faulty CPU module.	Retry test. If the problem persists, contact your Sun service provider.
6245	<i>fmuls</i> failed: int = <i>value</i> , f0 = <i>value</i> , f2 = <i>value</i> , f0 / f2 = f4 = <i>value</i>	Faulty CPU module.	Retry test. If the problem persists, contact your Sun service provider.
6246	<i>fmuld</i> failed: int = <i>value</i> , f0 = <i>value</i> , f2 = <i>value</i> , f0 / f2 = f4 = <i>value</i>	Faulty CPU module.	Retry test. If the problem persists, contact your Sun service provider.
6247	<i>fcmps</i> failed: f0 = <i>value</i> , f2 = <i>value</i> : expected / observed = 0 / <i>value</i>	Faulty CPU module.	Retry test. If the problem persists, contact your Sun service provider.
6248	<i>fcmps</i> failed: f0 = <i>value</i> , f2 = <i>value</i> : expected / observed = 1 / <i>value</i>	Faulty CPU module.	Retry test. If the problem persists, contact your Sun service provider.
6249	<i>fcmps</i> failed: f0 = <i>value</i> , f2 = <i>value</i> : expected / observed = 2 / <i>value</i>	Faulty CPU module.	Retry test. If the problem persists, contact your Sun service provider.
6250	<i>fcmps</i> failed: f0 = <i>value</i> , f2 = NaN : expected / observed = 3 / <i>value</i>	Faulty CPU module.	Retry test. If the problem persists, contact your Sun service provider.
6251	<i>fcmpd</i> failed: f0 = <i>value</i> , f2 = <i>value</i> : expected / observed = 0 / <i>value</i>	Faulty CPU module.	Retry test. If the problem persists, contact your Sun service provider.
6252	<i>fcmpd</i> failed: f0 = <i>value</i> , f2 = <i>value</i> : expected / observed = 1 / <i>value</i>	Faulty CPU module.	Retry test. If the problem persists, contact your Sun service provider.
6253	<i>fcmpd</i> failed: f0 = <i>value</i> , f2 = <i>value</i> : expected / observed = 2 / <i>value</i>	Faulty CPU module.	Retry test. If the problem persists, contact your Sun service provider.
6254	<i>fcmpd</i> failed: f0 = <i>value</i> , f2 = NaN : expected / observed = 3 / <i>value</i>	Faulty CPU module.	Retry test. If the problem persists, contact your Sun service provider.
6255	FBU failed. result = <i>value</i>	Faulty CPU module.	Retry test. If the problem persists, contact your Sun service provider.
6256	FBG failed: f0 = <i>value</i> , f2 = <i>value</i>	Faulty CPU module.	Retry test. If the problem persists, contact your Sun service provider.

**TABLE 16-2** fputest Error Messages (Continued)

	<b>Error Message</b>	<b>Probable Cause(s)</b>	<b>Recommended Action</b>
6257	FBUG (unordered) failed	Faulty CPU module.	Retry test. If the problem persists, contact your Sun service provider.
6258	FBUG (greater) failed: f0 = <i>value</i> , f2 = <i>value</i>	Faulty CPU module.	Retry test. If the problem persists, contact your Sun service provider.
6259	FBL failed: f0 = <i>value</i> , f2 = <i>value</i>	Faulty CPU module.	Retry test. If the problem persists, contact your Sun service provider.
6260	FBUL (unordered) failed	Faulty CPU module.	Retry test. If the problem persists, contact your Sun service provider.
6261	FBUL (Less) failed: f0 = <i>value</i> , f2 = <i>value</i>	Faulty CPU module.	Retry test. If the problem persists, contact your Sun service provider.
6262	FBLG (Less) failed: f0 = <i>value</i> , f2 = <i>value</i>	Faulty CPU module.	Retry test. If the problem persists, contact your Sun service provider.
6263	FBLG (Greater) failed: f0 = <i>value</i> , f2 = <i>value</i>	Faulty CPU module.	Retry test. If the problem persists, contact your Sun service provider.
6264	FBNE failed: f0 = <i>value</i> , f2 = <i>value</i>	Faulty CPU module.	Retry test. If the problem persists, contact your Sun service provider.
6265	FBE failed : f0 = <i>value</i> , f2 = <i>value</i>	Faulty CPU module.	Retry test. If the problem persists, contact your Sun service provider.
6266	FBUE (unordered) failed	Faulty CPU module.	Retry test. If the problem persists, contact your Sun service provider.
6267	FBUE (equal) failed : f0 = <i>value</i> , f2 = <i>value</i>	Faulty CPU module.	Retry test. If the problem persists, contact your Sun service provider.
6268	FBGE (equal) failed : f0 = <i>value</i> , f2 = <i>value</i>	Faulty CPU module.	Retry test. If the problem persists, contact your Sun service provider.
6269	FBGE (greater) failed: f0 = <i>value</i> , f2 = <i>value</i>	Faulty CPU module.	Retry test. If the problem persists, contact your Sun service provider.
6270	FBUGE (unordered) failed	Faulty CPU module.	Retry test. If the problem persists, contact your Sun service provider.
6271	FBUGE (equal) failed : f0 = <i>value</i> , f2 = <i>value</i>	Faulty CPU module.	Retry test. If the problem persists, contact your Sun service provider.
6272	FBUGE (greater) failed: f0 = <i>value</i> , f2 = <i>value</i>	Faulty CPU module.	Retry test. If the problem persists, contact your Sun service provider.
6273	FBLE (Less) failed: f0 = <i>value</i> , f2 = <i>value</i>	Faulty CPU module.	Retry test. If the problem persists, contact your Sun service provider.
6274	FBLE (equal) failed : f0 = <i>value</i> , f2 = <i>value</i>	Faulty CPU module.	Retry test. If the problem persists, contact your Sun service provider.

**TABLE 16-2** *fputest* Error Messages (Continued)

	<b>Error Message</b>	<b>Probable Cause(s)</b>	<b>Recommended Action</b>
6275	FBULE (unordered) failed	Faulty CPU module.	Retry test. If the problem persists, contact your Sun service provider.
6276	FBULE (Less) failed: f0 = <i>value</i> , f2 = <i>value</i>	Faulty CPU module.	Retry test. If the problem persists, contact your Sun service provider.
6277	FBULE (equal) failed : f0 = <i>value</i> , f2 = <i>value</i>	Faulty CPU module.	Retry test. If the problem persists, contact your Sun service provider.
6278	FBO failed: f0 = <i>value</i> , f2 = <i>value</i>	Faulty CPU module.	Retry test. If the problem persists, contact your Sun service provider.
6279	FBA failed: f0 = <i>value</i> , f2 = <i>value</i>	Faulty CPU module.	Retry test. If the problem persists, contact your Sun service provider.
6280	FBN failed: f0 = <i>value</i> , f2 = <i>value</i>	Faulty CPU module.	Retry test. If the problem persists, contact your Sun service provider.
6281	FBU failed	Faulty CPU module.	Retry test. If the problem persists, contact your Sun service provider.
6282	FBG failed: f0 = <i>value</i> , f2 = <i>value</i>	Faulty CPU module.	Retry test. If the problem persists, contact your Sun service provider.
6283	FBUG failed: f0 = <i>value</i> , f2 = <i>value</i>	Faulty CPU module.	Retry test. If the problem persists, contact your Sun service provider.
6284	FBLfailed: f0 = <i>value</i> , f2 = <i>value</i>	Faulty CPU module.	Retry test. If the problem persists, contact your Sun service provider.
6285	FBUL failed: f0 = <i>value</i> , f2 = <i>value</i>	Faulty CPU module.	Retry test. If the problem persists, contact your Sun service provider.
6286	FBLG failed: f0 = <i>value</i> , f2 = <i>value</i>	Faulty CPU module.	Retry test. If the problem persists, contact your Sun service provider.
6287	FBNE failed: f0 = <i>value</i> , f2 = <i>value</i>	Faulty CPU module.	Retry test. If the problem persists, contact your Sun service provider.
6288	FBE failed: f0 = <i>value</i> , f2 = <i>value</i>	Faulty CPU module.	Retry test. If the problem persists, contact your Sun service provider.
6289	FBUE failed: f0 = <i>value</i> , f2 = <i>value</i>	Faulty CPU module.	Retry test. If the problem persists, contact your Sun service provider.
6290	FBGE failed: f0 = <i>value</i> , f2 = <i>value</i>	Faulty CPU module.	Retry test. If the problem persists, contact your Sun service provider.
6291	FBUGE failed: f0 = <i>value</i> , f2 = <i>value</i>	Faulty CPU module.	Retry test. If the problem persists, contact your Sun service provider.
6292	FBLE failed: f0 = <i>value</i> , f2 = <i>value</i>	Faulty CPU module.	Retry test. If the problem persists, contact your Sun service provider.

**TABLE 16-2** fputest Error Messages (Continued)

	<b>Error Message</b>	<b>Probable Cause(s)</b>	<b>Recommended Action</b>
6293	FBULE failed: f0 = <i>value</i> , f2 = <i>value</i>	Faulty CPU module.	Retry test. If the problem persists, contact your Sun service provider.
6294	FBO failed	Faulty CPU module.	Retry test. If the problem persists, contact your Sun service provider.
6295	fcmpxs failed: Exception did not occur. fsr = <i>value</i>	Faulty CPU module.	Retry test. If the problem persists, contact your Sun service provider.
6296	fcmpxd failed: Exception did not occur. fsr = <i>value</i>	Faulty CPU module.	Retry test. If the problem persists, contact your Sun service provider.
6297	Error: Bus error occurred. ftt = <i>value</i>	Faulty CPU module.	Retry test. If the problem persists, contact your Sun service provider.
6298	Error: Bus error did not occur(IEEE exception). ftt = <i>value</i>	Faulty CPU module.	Retry test. If the problem persists, contact your Sun service provider.
6299	Error: Bus error did not occur(Unfinished exception). ftt = <i>value</i>	Faulty CPU module.	Retry test. If the problem persists, contact your Sun service provider.
6300	register read/write failed : reg = <i>value</i> , expected / observed = <i>value</i> / <i>value</i>	Faulty CPU module.	Retry test. If the problem persists, contact your Sun service provider.
6301	register test-2 read/write failed : reg = <i>value</i> , expected / observed = <i>value</i> / <i>value</i>	Faulty CPU module.	Retry test. If the problem persists, contact your Sun service provider.
6302	register read/write failed : reg = <i>value</i> , expected / observed = <i>value</i> / <i>value</i>	Faulty CPU module.	Retry test. If the problem persists, contact your Sun service provider.
6303	FSR Error: expected / observed = <i>value</i> / <i>value</i>	Faulty CPU module.	Retry test. If the problem persists, contact your Sun service provider.
6304	Wrong code is given	Faulty CPU module.	Retry test. If the problem persists, contact your Sun service provider.
6305	FPU Trap did not occur , i = <i>value</i>	Faulty CPU module.	Retry test. If the problem persists, contact your Sun service provider.
6306	FPU Trap Should not occur but occurred	Faulty CPU module.	Retry test. If the problem persists, contact your Sun service provider.
6307	Bus Error did not occur	Faulty CPU module.	Retry test. If the problem persists, contact your Sun service provider.



**TABLE 16-2** fputest Error Messages (Continued)

	<b>Error Message</b>	<b>Probable Cause(s)</b>	<b>Recommended Action</b>
6308	Did not create correct IEEE exception (Inexact): expected = 1, observed = <i>value</i>	Faulty CPU module.	Retry test. If the problem persists, contact your Sun service provider.
6309	Did not create correct IEEE exception (Divide By zero): expected = 2, observed = <i>value</i>	Faulty CPU module.	Retry test. If the problem persists, contact your Sun service provider.
6310	Did not create correct IEEE exception (Overflow): expected = 8, observed = <i>value</i>	Faulty CPU module.	Retry test. If the problem persists, contact your Sun service provider.
6311	Did not create correct IEEE exception (Invalid): expected = 10, observed = <i>value</i>	Faulty CPU module.	Retry test. If the problem persists, contact your Sun service provider.
6312	Sun FPU Reliability Test Failed due to segment violation error	Faulty CPU module.	Retry test. If the problem persists, contact your Sun service provider.
6313	Sun FPU Reliability Test Failed due to fpu bus error	Faulty CPU module.	Retry test. If the problem persists, contact your Sun service provider.
6314	Number of failures (out of <i>value</i> cases) = <i>value</i>	Faulty CPU module.	Retry test. If the problem persists, contact your Sun service provider.
6315	malloc(0x <i>value</i> ) failed :<error_message>	Faulty CPU module.	Retry test. If the problem persists, contact your Sun service provider.
6316	Failed <i>value</i> precision linpack test	Faulty CPU module.	Retry test. If the problem persists, contact your Sun service provider.
6317	DIVTEST <i>value</i> : Number of failures (out of <i>value</i> cases) = <i>value</i>	Faulty CPU module.	Retry test. If the problem persists, contact your Sun service provider.
6318	, expected t <i>value</i> , observed <i>value</i> , expected x <i>value</i> ,observed <i>value</i> , expected y <i>value</i> , observed <i>value</i> , expected z <i>value</i> , observed <i>value</i>	Faulty CPU module.	Retry test. If the problem persists, contact your Sun service provider.

**TABLE 16-2** fputest Error Messages (Continued)

Error Message	Probable Cause(s)	Recommended Action
6319 , expected t <i>value</i> , observed <i>value</i> /n expected x <i>value</i> , observed <i>value</i> , expected y <i>value</i> , observed <i>value</i> , expected z <i>value</i> , observed <i>value</i>	Faulty CPU module.	Retry test. If the problem persists, contact your Sun service provider.
6320 Failed <i>value</i> precision Cora test:Check Sum = <i>value</i> Expected <i>value</i>	Faulty CPU module.	Retry test. If the problem persists, contact your Sun service provider.
6321 <i>value</i>	Faulty CPU module.	Retry test. If the problem persists, contact your Sun service provider.
6322 Sun FPU Reliability Test Failed due to floating point exception error	Faulty CPU module.	Retry test. If the problem persists, contact your Sun service provider.
6323 Sun FPU Reliability Test Failed due to illegal instruction error	Faulty CPU module.	Retry test. If the problem persists, contact your Sun service provider.
8000 Failed systest for FPU		
8001 Floating point exception interrupt		

## Intelligent Fibre Channel Processor Test (`ifptest`)

---

`ifptest` tests the functionality of the PCI FC\_AL card when there are no devices attached to the loop. The driver checks for devices on the fibre loop. If devices are detected it blocks any diagnostic commands.

---

**Note** – When devices are attached to the loop, do not run `ifptest`. Instead, run tests against the individual devices. This will test the whole subsystem including the FC\_AL controller.

---

---

**Note** – The driver checks for devices on the fibre loop, and will block any diagnostic command if it finds attached devices.

---

`ifptest` uses the “mailbox” interface to the card. This interface allows certain firmware operations to be performed that normally would not be available to the application layer.

There are four subtests that are run in online and functional modes:

- Mailbox loopback Test

Loads a series of registers into the input mailboxes on the card and then reads the output mailboxes and compares results. This verifies that the system side of the card is operating correctly, and that the internal data paths are ok.

- Firmware revision check

Reads the firmware revision from the firmware and compares it against a revision loaded by the driver.

- Checksum firmware test

Runs an internal checksum test on the installed firmware. This verifies that the risc ram on the card is fully functional and that the installed firmware is still intact. This test also serves as a quick ram check of the risc ram.

- Dump revision levels

Extracts the hardware and firmware revision levels of different sub modules on the card.

# ifptest Options

IFP FC\_AL Controller

**Configuration :**

IFP controller at /devices/pci@1f;2000/pci1077;2100@2

**Options :**

**Mailbox Loopback Test:**

**Firmware Revision Check:**

**Firmware Checksum Test:**

**Check Module Revisions:**

ifptest Option Menu

**Table 0-7** ifptest Options

ifptest Options	Description
Mailbox Loopback Test	Enable   Disable the mailbox loopback command. This test writes data patterns into the mailboxes and then reads them back from the output mailboxes and verifies the data is correct.
Firmware Revision Check	Enable   Disable the firmware revision check command. This test extracts the firmware revision from the RISC firmware code and verifies against expected values.
Firmware Checksum Test	Enable   Disable the firmware checksum command. This command instructs the interface's risc processor to calculate the checksum on the current microcode and then compare it against the checksum that was loaded in with the microcode.
Check Module Revisions	Enable   Disable the firmware checksum command. This command returns the revision level of several sub-modules on the interface card. Although this test is executed when enabled, the module revision levels are only printed out in VERBOSE mode.

---

# ifptest Command Line Syntax

```
/opt/SUNWvts/bin/ifptest standard_arguments [-p n] [-i n] [-w n]
-o [dev=device name] [mbox=Enable|Disable] [fwrevcheck=Enable|Disable]
[checksum=Enable|Disable] [modrevcheck=Enable|Disable]
```

TABLE 17-1 ifptest Command Line Syntax

Argument	Explanation
dev	The name of the device to test.
mbox	<i>Enable Disable</i> the mailbox loopback command. This test writes data patterns into the mailboxes and then reads them back from the output mailboxes and verifies the data is correct.
fwrevcheck	<i>Enable Disable</i> the firmware revision check command. This test extracts the firmware revision from the RISC firmware code and verifies against expected values.
checksum	<i>Enable Disable</i> the firmware checksum command. This command instructs the interface's risc processor to calculate the checksum on the current microcode and then compare it against the checksum that was loaded in with the microcode.
modrevcheck	<i>Enable Disable</i> the firmware checksum command. This command returns the revision level of several sub-modules on the interface card. Although this test is executed when enabled, the module revision levels are only printed out in VERBOSE mode.

---

# ifptest Test Modes

ifptest runs in three modes.

**TABLE 17-2** ifptest Test Modes

Test Mode	Description
Functional mode	ifptest runs the full set of mailbox tests
Online mode	ifptest runs the full set of mailbox tests
Connectivity	ifptest only performs an open/close

---

**Note** – Connectivity mode will only open the controller to verify that the path is still viable.

---

---

# ifptest Error Messages

**TABLE 17-3** ifptest Error Messages

Error Message	Probable Cause(s)	Recommended Action
6000 Mailbox loopback failed	FC_AL board, System software.	Replace FC_AL board. If the problem persists, contact your authorized Sun service provider.
6001 Error: No device specified to test.		
6002 Can not associate device with <i>string</i> .	New hardware added since VTS probe or system software.	Stop all testing and re-probe. If the problem persists, contact your authorized Sun service provider.
6003 FW Stop command returned <i>data</i> , expected 0.	IFP Firmware or a system software.	Reload IFP firmware. If the problem persists, contact your authorized Sun service provider.
6004 Command # <i>data</i> (cmd=value) did not successfully complete, status: Obs 0x <i>value</i> , Exp 0x <i>value</i>	IFP Firmware or a system software.	Reload IFP firmware. If the problem persists, contact your authorized Sun service provider.

**TABLE 17-3** ifptest Error Messages (Continued)

	<b>Error Message</b>	<b>Probable Cause(s)</b>	<b>Recommended Action</b>
6005	Chained command number <i>data</i> failed to complete.	IFP Firmware or a system software.	Reload IFP firmware. If the problem persists, contact your authorized Sun service provider.
6006	<i>data</i> errors were observed during this cycle.		
6007	Command chain aborted: <i>data</i> commands queued, <i>data</i> commands run		
6008	Command Issued: mbox[0]=0x <i>value</i> , mbox[1]=0x <i>value</i> , mbox[2]=0x <i>value</i> , mbox[3]=0x <i>value</i> , mbox[4]=0x <i>value</i> , mbox[5]=0x <i>value</i> , mbox[6]=0x <i>value</i> , mbox[7]=0x <i>value</i>		
6009	Result Mboxes: mbox[0]=0x <i>value</i> , mbox[1]=0x <i>value</i> , mbox[2]=0x <i>value</i> , mbox[3]=0x <i>value</i> , mbox[4]=0x <i>value</i> , mbox[5]=0x <i>value</i> , mbox[6]=0x <i>value</i> , mbox[7]=0x <i>value</i>		
6010	HCCR=0x <i>value</i> , BUS_SEMA=0x <i>value</i> , ISR=0x <i>value</i> , ICR=0x <i>value</i> , CDMA_COUNT=0x <i>value</i> , CDMA_ADDR=0x <i>value</i>		
6011	CDMA_STATUS=0x <i>value</i> , CDMA_CONTROL=0x <i>value</i> , RDMA_COUNT=0x <i>value</i> , RDMA_ADDR=0x <i>value</i> , RDMA_STATUS=0x <i>value</i> , RDMA_CONTROL=0x <i>value</i>		
6012	TDMA_COUNT=0x <i>value</i> , TDMA_ADDR=0x <i>value</i> , TDMA_STATUS=0x <i>value</i> , TDMA_CONTROL=0x <i>value</i> , RISC_PSR=0x <i>value</i> , RISC_IVR=0x <i>value</i>		



**TABLE 17-3** ifptest Error Messages (Continued)

	<b>Error Message</b>	<b>Probable Cause(s)</b>	<b>Recommended Action</b>
6013	RISC_REGS: RR0=0xvalue, RR1=0xvalue, RR2=0xvalue, RR3=0xvalue, RR4=0xvalue, RR5=0xvalue, RR6=0xvalue, RR7=0xvalue		
6014	RISC_REGS: RR8=0xvalue, RR9=0xvalue, RR10=0xvalue, RR11=0xvalue, RR12=0xvalue, RR13=0xvalue, RR14=0xvalue, RR15=0xvalue		
6015	RISC_PCR=0xvalue, RISC_RAR0=0xvalue, RISC_RAR1=0xvalue, RISC_LCR=0xvalue, RISC_PC=0xvalue, RISC_SP=0xvalue		
6016	REQUEST_IN=0xvalue, REQUEST_OUT=0xvalue, RESPONSE_IN=0xvalue, RESPONSE_OUT=0xvalue		
6017	CURRENT_REQ_PTR=0xvalue, BASE_REQ_PTR=0xvalue, CURRENT_RESP_PTR=0xvalue, BASE_RESP_PTR=0xvalue		
8000	<i>string</i> : invalid file descriptor <i>data</i> passed in.	Programming error or system software.	If the problem persists, contact your authorized Sun service provider.
8001	<i>string</i> : IOCTL call failed: <i>string</i> .	wrong/missing IFP driver.	Contact your system administrator to load correct driver. If the problem persists, contact your authorized Sun service provider.
8002	<i>string</i> : Firmware checksum failed, Rec: <i>value</i> , Exp: 0x0	Unsupported or bad firmware loaded or bad ifp controller.	Load the correct ifp driver. If the problem persists, contact your authorized Sun service provider.
8003	<i>string</i> : Get Revision command failed, return code 0xvalue.	Incorrect ifp firmware loaded or a system software problem.	Load the correct ifp driver. If the problem persists, contact your authorized Sun service provider.
8004	<i>string</i> : Phase 1 Revision check failed, Act: 0xvalue, Exp: 0xvalue	System software problem.	Contact your system administrator. If the problem persists, contact your authorized Sun service provider.
8005	<i>string</i> : Firmware restart failed, Counter: 0xvalue, Status: 0xvalue	System software problem. Possible defective IFP card.	Contact your system administrator. If the problem persists, contact your authorized Sun service provider.

**TABLE 17-3** ifptest Error Messages (Continued)

	<b>Error Message</b>	<b>Probable Cause(s)</b>	<b>Recommended Action</b>
8006	Unknown option passed in: <i>string</i>	Program error or system software problem.	Contact your system administrator. If the problem persists, contact your authorized Sun service provider.
8007	Bad option string passed to test: <i>string</i>	Program error or system software problem.	Contact your system administrator. If the problem persists, contact your authorized Sun service provider.
8008	Open of IFP device failed; <i>string</i>	System software problem.	Contact your system administrator. If the problem persists, contact your authorized Sun service provider.

## Dual Basic Rate ISDN (DBRI) Chip (isdntest)

`isdntest` verifies the functionality of the ISDN portion of the Dual Basic Rate ISDN (DBRI) chip.

`isdntest` is actually a set of several subtests. Three main channels exist within an ISDN: D, B1 and B2. In each of the following subtests, unless otherwise indicated, the D channels are in Basic Rate HDLC data mode, the B1 channels are in 56 kbps HDLC data mode, and the B2 channels are in 64-kbps HDLC data mode. The D channel packet size is 256 bytes, and the B channel packet size is 1024 bytes. The packet count is 10 packets. Each channel runs as an independent thread.

**TABLE 18-1** `isdntest` Subtests

<code>isdntest</code> Subtests	Description
Local Loopback Test	The local loopback test checks the initial activation state of the Network Termination (NT) and Terminal Equipment (TE) interfaces to make sure they are deactivated. Then it activates each interface using the “force activation” capability of DBRI. Each interface is put into local loopback mode (See FIGURE 18-1). Data residing in host memory is written to each interface, which loops the data back to itself. The data is then read back into host memory and verified. Each channel, D, B1 and B2 is tested (with the exception of the TE D channel, which cannot be tested in local loopback mode). The local loopback test runs internal to the DBRI chip and does <i>not</i> require an NT-to-TE external loopback connector.
Activation/ Deactivation Test	The activation/deactivation test runs through the activation/deactivation sequence for the NT and then the activation sequence for the TE. The T101 and T103 timers are set to five seconds. This subtest requires an NT-to-TE external loopback connector.

**TABLE 18-1** isdntest Subtests (Continued)

isdntest Subtests	Description
Remote Loopback Test	The remote loopback capability is tested next. The TE interface is put into remote loopback mode, and the NT transmits data to the TE on all three channels, D, B1 and B2 (See FIGURE 18-2). The TE loops all data back to the NT and reads a copy of it. Data is then verified. Next, the whole process is repeated with the TE transmitting to the NT, which is placed in remote loopback mode. This subtest requires an NT-to-TE external loopback connector.
Read/Write Test	Next, a read/write test is performed on all six ISDN channels: TE D, TE B1, TE B2, NT D, NT B1 and NT B2. The external loopback connector connects each channel on the TE interface to its corresponding channel on the NT (See FIGURE 18-3). A unique data pattern is used for each path. Packets read are compared against packets written. The test is repeated with the B1 channels placed in 64-kbps HDLC data mode and the B2 channels in 56-kbps HDLC data mode. This subtest requires an NT-to-TE external loopback connector.
Packet Size Test	The next subtest is a packet size test. A read/write test, similar to the previous one, is performed with a packet count of 100. Each packet transmitted and received is a unique size, computed randomly. This subtest requires an NT-to-TE external loopback connector.
Data Path Test	The last subtest is a data path test. Using the ISDN_SET_CHANNEL ioctl, data is routed through a series of short pipe interconnects within DBRI (See FIGURE 18-4). This subtest requires an NT-to-TE external loopback connector.

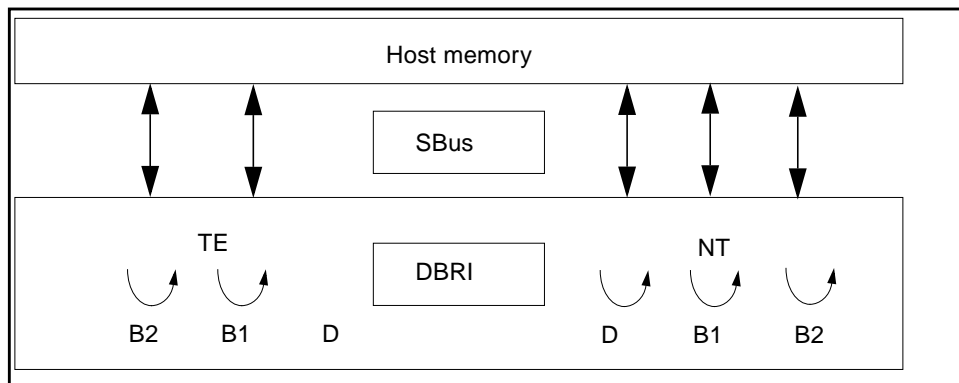

**FIGURE 18-1** isdntest Local Loopback Subtest

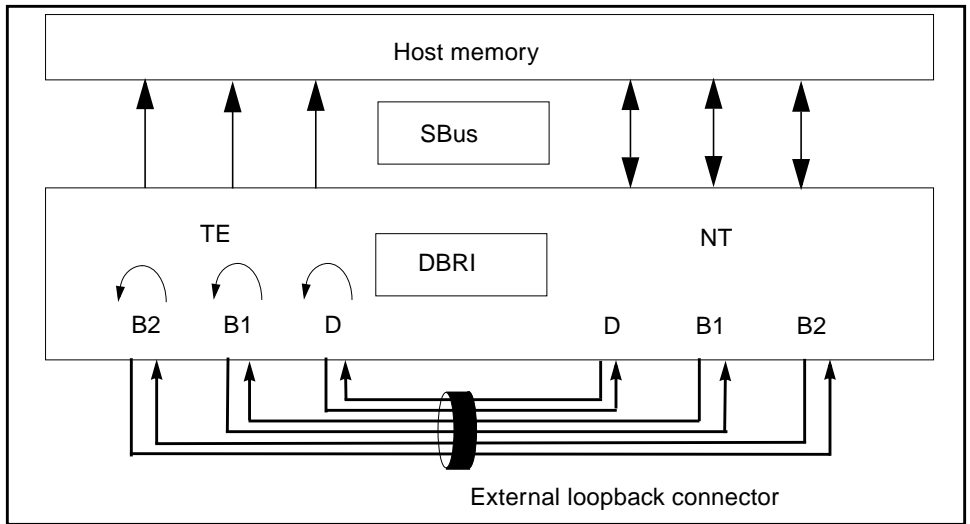

FIGURE 18-2 *isdntest* Remote Loopback Subtest

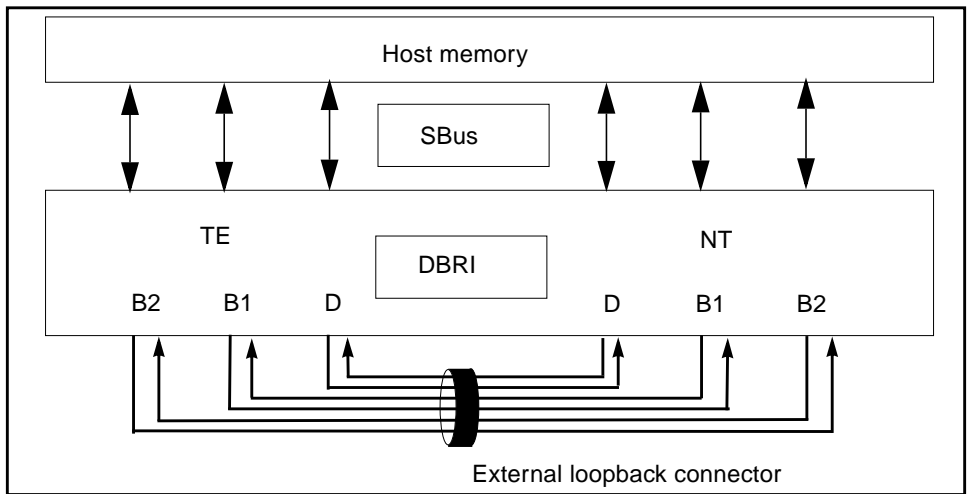

FIGURE 18-3 *isdntest* Read/Write Subtest

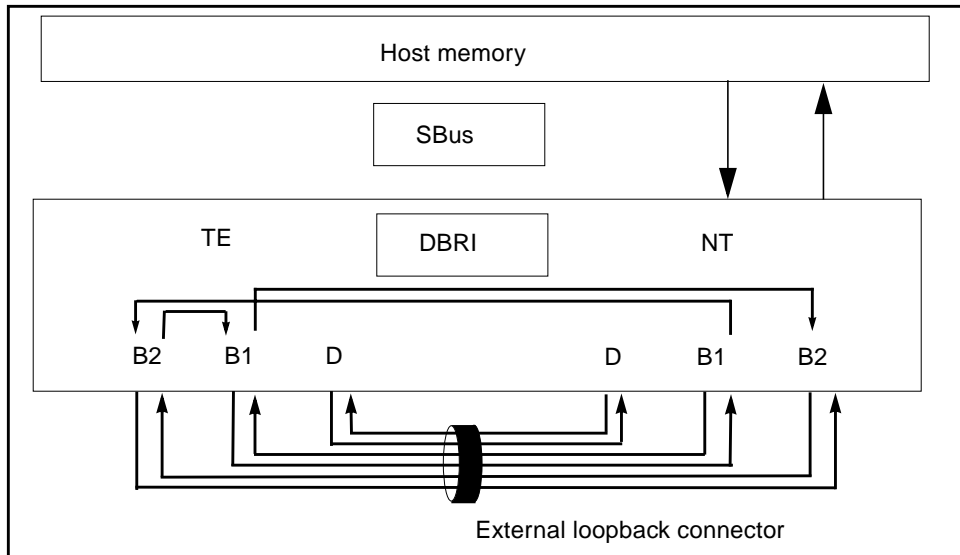

FIGURE 18-4 isdntest Data Path Subtest

## isdntest Options

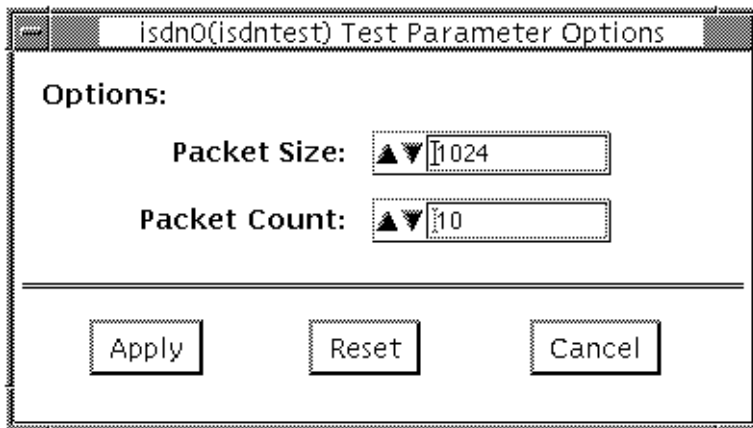

FIGURE 18-5 isdntest Options Menu

**TABLE 18-2** `isdntest` Options

<code>isdntest</code> Options	Description
Packet Size	The byte size of the B channel packets. The default size is 1024 bytes for the B channels and 256 for the D channels. The maximum packet size is 8186 bytes for the B channels, and the minimum packet size is 1 byte. The D channel packet size is set to 256, except during the packet size test, when it is set to random values between 1 and 256
Packet Count	How many packets are to be transmitted and received for all channels. The default packet count is 10 packets. The maximum packet count is 100 packets

---

## `isdntest` Test Modes

This test only supports Functional Test mode.

---

## `isdntest` Command Line Syntax

```
/opt/SUNWvts/bin/isdntest standard_arguments -o size=packet_size,  
count=packet_count
```

**TABLE 18-3** `isdntest` Command Line Syntax

Argument	Explanation
<code>size=packet_size</code>	The byte size of the B channel packets. The B channel default size is 1024 bytes. The D channel default size is 256 bytes. The B channel maximum packet size is 8186 packets. The B channel minimum packet size is 1 packet. The D channel packet size is 256 (except during the packet size test, when it is set to random values between 1 and 256).
<code>count=packet_count</code>	How many packets are to be transmitted and received for all channels The default count is 10 packets. The Maximum packet count is 100 packets.

# isdntest Error Messages

TABLE 18-4 isdntest Error Messages

Error Message	Probable Cause(s)	Recommended Action
6000	ISDN_PARAM_SET ioctl failed for <i>device_name</i> . ( <i>error_message</i> )	
6001	ISDN_SET_LOOPBACK ioctl failed for <i>device_name</i> . ( <i>error_message</i> )	
6002	ISDN_RESET_LOOPBACK ioctl failed for <i>device_name</i> . ( <i>error_message</i> )	
6003	ISDN_SET_CHANNEL ioctl() failed for <i>device_name</i> . ( <i>error_message</i> )	
6004	Unable to open <i>device_name</i> . ( <i>error_message</i> )	
6005	poll() failed. ( <i>error_message</i> )	
6006	Invalid packet size: S= <i>number</i> . Max is <i>number</i>	
6007	Invalid packet count: C= <i>number</i> . Max is <i>number</i>	
6008	ISDN_SET_FORMAT, ioctl() failed for ISDN_CHAN_TE_D during <i>device_name</i> . ( <i>error_message</i> )	
6009	ISDN_SET_FORMAT, ioctl() failed for ISDN_CHAN_NT_D during <i>device_name</i> . ( <i>error_message</i> )	
6010	ISDN_SET_FORMAT, ioctl() failed for ISDN_CHAN_TE_B1 during <i>device_name</i> . ( <i>error_message</i> )	
6011	ISDN_SET_FORMAT, ioctl() failed for ISDN_CHAN_NT_B1 during <i>device_name</i> . ( <i>error_message</i> )	



**TABLE 18-4** isdntest Error Messages (Continued)

	Error Message	Probable Cause(s)	Recommended Action
6012	Mode is unknown: <i>number</i>		
6013	ISDN_SET_FORMAT, ioctl() failed for ISDN_CHAN_TE_B2 during <i>device_name</i> . ( <i>error_message</i> )		
6014	ISDN_SET_FORMAT, ioctl() failed for ISDN_CHAN_NT_B2 during <i>device_name</i> . ( <i>error_message</i> )		
6015	Unable to open <i>device_name</i> during <i>device_state</i> . ( <i>error_message</i> )		
6016	Unable to close <i>device_name</i> during <i>device_state</i> . File descriptor = <i>number</i> ( <i>error_message</i> )		
6017	Initial state of <i>string</i> is ISDN_ACTIVATED		
6018	Initial state of <i>string</i> is unknown: <i>number</i>		
6019	ISDN_PARAM_SET ioctl() <i>parameter</i> failed for <i>device_name</i> . ( <i>error_message</i> )		
6020	ISDN_ACTIVATION_STATUS ioctl() failed for <i>device_name</i> . ( <i>error_message</i> )		
6021	getmsg() failed. ( <i>error_message</i> )		
6022	Invalid message returned from getmsg()		
6023	<i>string</i> ioctl() failed for <i>device_name</i> . ( <i>error_message</i> )		
6024	\n <i>device_name</i> .\nTE state = <i>string</i> \tNT state = <i>string</i>		
6025	shmget() failed. ( <i>error_message</i> )		
6026	Initial state unknown: <i>number</i>		
6027	<i>string</i>		



## ZX and TZX Graphics Accelerator Test (`leotest`)

---

`leotest` verifies the Sun Microsystems ZX and TZX graphics accelerators with a sequence of subtests. All tests are nondestructive and maintain the system integrity during and after the tests are run.



---

**Caution** – Do not run any other application that uses the ZX or TZX accelerator port while running `leotest`. This combination causes SunVTS to return incorrect errors.

---

---

**Note** – Disable all screen savers before testing any graphics device. Type `xset s off` at a UNIX prompt to disable the Solaris screen saver.

To start SunVTS with `vtsui`, but without `vtsk`, you must add the host name to `xhost` as: `xhost + hostname`

`leotest` requires approximately 2 Mbytes of disk space in the `/tmp` directory to extract its working files. If this space is not available, the diagnostic will fail and report warning and error messages, indicating a lack of disk space.

This test cannot be run on UltraSPARC systems.

---

# leotest Options

By default, SunVTS runs all of the available tests described in the next section, “leotest Subtests” on page 203, except the Stereo test. To avoid excessive test cycle times when testing the ZX or TZX Graphics Accelerators, follow these instructions to ensure that leotest runs once, reports the status as each test routine, and then exits:

1. Select Single Pass in the SunVTS Options menu.
2. Select Verbose in the SunVTS Options menu.
3. Do not select any other diagnostic tests.

---

**Note** – Disable all screen savers before testing any graphics device. Type `xset s off` at a UNIX prompt to disable the Solaris screen saver.

---

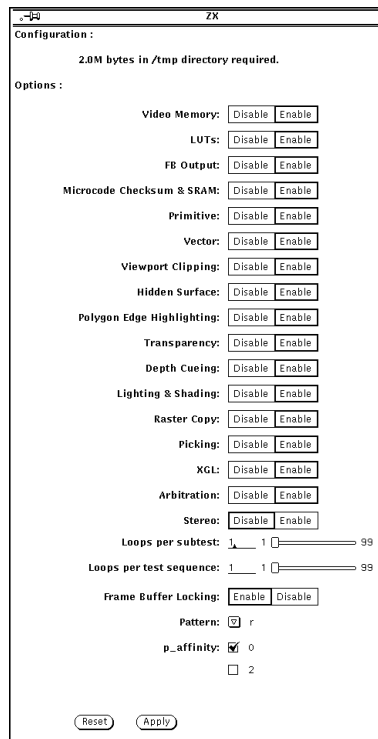

FIGURE 19-1 leotest Option Menu

---

# leotest Subtests

leotest is divided into two subtest categories:

- **Direct Port tests**

The direct port tests check the non-accelerated portion of the ZX using various subtests (refer to TABLE 19-1).

- **Accelerator Port tests**

The accelerator port test consists of a sequence of subtests that are designed to ensure the ZX Graphics Accelerator integrity at the system level (refer to TABLE 19-1). They take accelerator port transaction files as input. These files contain graphic data that is passed to the ZX Accelerator port in groups of 32-bit words called packets. These packets contain dots, vectors, triangles, and pass-through commands, and are generated in either immediate (programmed I/O) or DMA mode. The ZX SunVTS queries the system software for DMA capability, and if applicable, renders objects in DMA mode for some subtests. For more information on ZX hardware, refer to the *Leo Hardware Reference Manual*.

For verification, after the image is rendered to the frame buffer, each subtest reads the RGB image data from the frame buffer and compares the data against known good images. To save disk space, the good image data is stored in a reduced size (64 times smaller than the normal size), and is stored in the Sun raster file format. The files are stored in the `leotest.data` file in the `/opt/SUNWvts/bin` directory.

---

**Note** – The leotest subtests verify a frame buffer region of 1152 by 900 pixels, regardless of monitor size.

---

**TABLE 19-1** leotest Subtests

leotest Subtests	Description
<b>Direct Port Tests</b>	
Video Memory	The video memory array subtest selects and tests 64 x 64 pixel regions covering all video memory planes, including the 24-bit double-buffered image plane, 8-bit overlay plane, 24-bit depth (Z buffer) plane, and 10-bit window identification (WID) plane. If the subtest detects an error, SunVTS reports the defective plane and location.
LUTs	This subtest performs a nondestructive read-write test on the frame buffer color look-up tables and the WID look-up tables. After the test is complete, the table contents are restored. If this subtest detects a failure, SunVTS reports the location of the failure. At the beginning of this subtest, red, green, and blue stripes are displayed for visual verification of the digital-to-analog converters (DACs).
Frame Buffer Output	The Frame Buffer Output subtest creates various windows in the Window ID plane, then sets up the look-up tables (LUTs) associated with these windows. This subtest then writes random values to the video memory of these windows. Next, the test verifies the RGB image data of each pixel by triggering the trap registers, reading and generating RGB checksums from these values, and comparing these checksums with known values. This is also a visual cursor test as the cursor is being displayed for each pixel that is being tested. Note: Moving the mouse cursor during the test can prolong the test and cause failures. For best results, remove the mouse from the mouse pad during this test.
<b>Accelerator Port Tests</b>	
Microcode SRAM Checksum and Read/Write Selftest	This subtest sends a diagnostic package to the microcode of the floating point transform engine with instructions to reset the accelerator port, run the SRAM selftest, and restart the engine. Then the test verifies each SRAM of all four Leo float chips in the floating point transform engine to make sure they have the same checksum. If not, the test reports an error, based on the information it receives from the microcode. Nondestructive read/write tests are also performed on each SRAM.
Primitive	This subtest renders primitives such as dots and lines, as well as triangle, with different color and shading at each vertex.
Vector	This subtest renders fairly large vector objects with aliased and anti-aliased vectors. This subtest is rendered in DMA mode, when applicable.

**TABLE 19-1** leotest Subtests (*Continued*)

leotest Subtests	Description
Viewpoint Clipping	This subtest renders and clips an object around and in front of the screen.
Hidden Surface	This subtest renders objects with the Z-buffer-compare attribute turned on.
Polygon edge Highlighting	This subtest renders an object with the polygon edge attribute turned on. This subtest is rendered in DMA mode, when applicable.
Transparency	This subtest renders a scene with two transparency modes (standalone and alpha blend) in various degrees. This results in a two-pass transparency of the objects in the scene. This subtest is rendered in DMA mode, when applicable.
Depth-Cueing	This subtest renders an object with the depth-cueing attribute turned on.
Lighting and Shading	This subtest renders an object with multiple light sources and Gouraud shading for front and back surfaces. This subtest is rendered in DMA mode, when applicable.
Raster Copy	This subtest renders 32-bit image and various subregions of it, and zooms in on a subregion, using the microcode raster data copy command.
Picking	This subtest has two parts: a Pick Detect test and a Pick Echo test.
XGL	The transaction file for this subtest was generated from an XGL program to ensure that the XGL registers are exercised.
Arbitration	This subtest continually renders an object into the accelerator port while a second process performs a read/write test to the WID planes from the direct port on the frame buffer. This subtest simulates conditions where rendering processes and windows operation run concurrently. This subtest is rendered in DMA mode, when applicable.
Stereo (Interactive)	This subtest displays text information in stereo mode. The user verifies proper operation by looking at the screen with stereo glasses and following the instructions displayed.
Loops per subtest	Type the number of times each test should be run before going on to the next test. The default is one loop.

**TABLE 19-1** leotest Subtests (Continued)

leotest Subtests	Description
Loops per test sequence	Type the number of times the entire test sequence should be run. Each sequence pass registers one in the SunVTS Pass Count window. The default is one loop.
FB Locking	See the section “Testing Multiple Frame Buffers” in Chapter 3 of the <i>SunVTS 2.1 User’s Guide</i> for details.
Pattern	Press MENU to select a data pattern for the direct port tests. The default is r for random patterns. You may select a pattern of 0s, 3s, 5s, or 9s. For example, if you choose a pattern of 3s, the value 0x33333333 is written to and read from the frame buffer.

---

## leotest Test Modes

Due to the nature of graphic tests, reading from or writing to the frame buffer during graphic tests will disturb user operation. This test is only available in Functional test.

In Functional test, leotest verifies the ZX and TZX graphics accelerators by running direct port tests and accelerator port tests.



# leotest Command Line Syntax

`/opt/SUNWvts/bin/leotest standard_arguments -o dev=device_name, S=subtest_number, F=#_of_subtest_loops, B=#_of_test_loops, lock=E(nable)/D(isable), P=pattern`

**TABLE 19-2** leotest Command Line Syntax

Argument	Explanation
<code>dev=device_name</code>	<code>device_name</code> is the full path name of the device being tested; the default is <code>/dev/fbs/le00</code> .
<code>S=subtest_number</code>	<p><code>subtest_number</code> is the test number of the subtest to be run. Select from the subtests below. You can run multiple subtests by adding the subtest numbers. For example, <code>n=0x3</code> runs both test 1 and test 2; <code>n=0x180</code> runs both test 0x080 and test 0x0100. Note that you do not need the leading zeros. To run all tests, enter <code>n=0xFFFF</code>.</p> <p>0x 000 001 Direct port—video memory            0x 000 002 Direct port—CLUTs and WID LUTs            0x 000 004 Direct port—Frame buffer output section            0x 000 008 Direct port—SRAM checksum and read/write            0x 000 010 Accelerator port—primitives            0x 000 020 Accelerator port—vectors            0x 000 040 Accelerator port—clipping            0x 000 080 Accelerator port—z-buffer            0x 000 100 Accelerator port—polygon edge            0x 000 200 Accelerator port—transparency            0x 000 400 Accelerator port—depth cueing            0x 000 800 Accelerator port—lighting &amp; shading            0x 001 000 Accelerator port—raster copy            0x 002 000 Accelerator port—picking            0x 004 000 Accelerator port—XGL            0x 008 000 Accelerator port—arbitration            0x 010 000 Accelerator port—stereo (interactive)</p>
<code>F=#_of_subtest_loops</code>	<code>#_of_subtest_loops</code> is the number of loops for each subtest; the default is 1.

**TABLE 19-2** leotest Command Line Syntax (Continued)

Argument	Explanation (Continued)
B=#_of_test_loops	#_of_test_loops is the number of loops of each test sequence. The default is 1.
lock=E(nable)/D(isable)	Enables or disables frame buffer locking. See the section “Testing Multiple Frame Buffers” in Chapter 3 of the <i>SunVTS 2.1 User’s Guide</i> for details.
P=pattern_number	Selects a pattern number to be used with the direct ports tests; the default is r, for random patterns. You may also choose 0, 3, 5, or 9.

## leotest Command Line Examples

The following three examples illustrate how to run `leotest` from a command line. Make sure to change the directory to `/opt/SUNWvts/bin` before running `leotest` from the command line. `leotest` is hard-wired to look for its data file, `leotest.data` in `/opt/SUNWvts/bin`.

- To test the simple accelerator port with a primitive single pass:

```
machine# cd /opt/SUNWvts/bin
machine# leotest -o S=0x10
```

- To test all direct port with five loops of sequence:

```
machine# cd /opt/SUNWvts/bin
machine# leotest -o S=0x7,B=0x5
```

- To test all subtests (except the interactive tests) with two loops of each subtest and four loops of each test sequence:

```
machine# cd /opt/SUNWvts/bin
machine# leotest -o S=0xFFFF,F=2,B=4
```

# leotest Error Messages

In all error conditions, the field replaceable unit (FRU) is the entire FFB.

TABLE 19-3 leotest Error Messages

	Error Message	Probable Cause(s)	Recommended Action
1	Arbitration test failed	The arbitration test fails, and the cause is given in the message that follows.	
2	Background process wouldn't die. System error	A software error.	Reboot the SPARCstation.
3	Busy wait exceeded <i>number</i> loops. Error in the Floating Point Transform section. Rerun Leoconfig	A timeout error.	There is a possible problem with the floating point transform section. Execute the leoconfig software (located in /etc/opt/SUNWleo/bin/leoconfig) again. Check the leoconfig man pages for more details.
4	[Plane group name] Byte Access Mode error at x= <i>number</i> y= <i>number</i> , bank= <i>number</i> , expected= <i>number</i> , observed= <i>number</i> , XOR= <i>number</i>	The direct port video memory test found an error at pixel (x,y) in the named plane group. The bank # refers to the corresponding VRAM bank number. Byte/Stencil Access Mode applies to all plane groups that access 8 bits of the frame buffer memory (in other words, the 8-bit image and overlay planes). The test expected to find exp but observed obs, yielding xor when the two values are exclusive or'd with each other.	
5	Cannot read Window ID look up table from device <i>device_name</i>	Software error.	Check device for existence or permissions.
6	Cannot write Window ID look up table to device <i>device_name</i>	Software error.	Check device for existence or permissions.
7	Cannot post Color LUTs to device <i>device_name</i>	Software error	Check device for existence or permissions.

**TABLE 19-3** leotest Error Messages (Continued)

	<b>Error Message</b>	<b>Probable Cause(s)</b>	<b>Recommended Action</b>
8	Cannot get monitor mode from device <i>device_name</i>	Software error.	Check device for existence or permissions.
9	Cannot set diagnostic mode from device <i>device_name</i>		Check device for existence or permissions.
10	Cannot set monitor mode from device <i>device_name</i>		Check device for existence or permissions.
11	Cannot create raster for device <i>device_name</i>		Check device for existence or permissions.
12	Cannot create color map for device <i>device_name</i>		Check device for existence or permissions.
13	Cannot create context for device <i>device_name</i>		Check device for existence or permissions.
14	Cannot create color translation object for device <i>device_name</i>		Check device for existence or permissions.
15	Cannot create path object for device <i>device_name</i>		Check device for existence or permissions.
16	Cannot create child raster for device <i>device_name</i>		Check device for existence or permissions.
17	Cannot create multiple plane group information for device <i>device_name</i>	Software error. The device that you specified (the default is /dev/fbs/leo0) may not be available to the test, therefore the above operation cannot be performed on this device.	Check device for existence or permissions. Make sure that you are executing the test on a machine with a ZX, and that you have permission to access it, and that the device is not being used by another application.
18	Cannot start another process. Software error	Software error. The process table may be full.	Reboot.

**TABLE 19-3** leotest Error Messages (Continued)

	Error Message	Probable Cause(s)	Recommended Action
19	Cannot grab mouse or keyboard because <i>message</i>	Software error. When the FB locking option is selected, <i>leotest</i> tries to lock the mouse and keyboard but was not successful. The reason can be one of the following, according the window system software: <ul style="list-style-type: none"> <li>• Mouse/keyboard is frozen</li> <li>• Grab window is not viewable</li> <li>• Grabbed at an invalid time</li> <li>• Another client grabbed it</li> </ul>	Bring down other graphic software that is currently running the same window server.
20	CLUT <i>number</i> , index <i>number</i> , color <i>name</i> , expected <i>number</i> , observed <i>number</i> , XOR= <i>number</i>	An error was found in one of the three color look-up tables tested by SunVTS. The error was found in the <i>n</i> th CLUT. The index is out of 256 entries in each CLUT. Each CLUT has an 8-bit value for RED, GREEN, and BLUE. The color indicates the 8-bit set in which the error was found. The test expected to find <i>expected</i> but received <i>observed</i> , yielding XOR when the two values are exclusive or 'd with each other	
21	Data file <i>file_name</i> missing in the current test directory	Software error. ZX SunVTS can't find the data file ( <i>leotest.data</i> ) in the current /opt/SUNWvts/bin directory	Reinstall the SUNWvts package in the specified directory.
22	Error in <i>subtest_name</i> test	The subtest fails and the cause is given in the message that follows.	
23	Error in verifying the <i>red/green/blue</i> plane at <i>x=number</i> , <i>y=number</i> , <i>bank=number</i> , <i>expected=number</i> , <i>observed=number</i> , XOR= <i>number</i>	Failed accelerator port test. The error is in either the RED, GREEN, or BLUE image plane. The x-y coordinate of the pixel should contain the <i>expected</i> value but instead received the <i>observed</i> value. This yields XOR value, or the bits in error, when the two values are exclusive or 'd with each other.	

**TABLE 19-3** leotest Error Messages (Continued)

Error Message	Probable Cause(s)	Recommended Action
24 Failed to open data file <i>file_name</i> . Suspect incomplete or incorrect hardware installation. Files may also have been corrupted	Software initialization problem. <i>file_name</i> is the data file that SunVTS can't open.	
25 Failed to read data file <i>file_name</i> . Suspect incomplete or incorrect hardware installation. Files may also have been corrupted	Indicates a software initialization problem where <i>file_name</i> is the data file that SunVTS can't read.	
26 Illegal SBus DVMA code = <i>number</i> addr = 0x%x data= <i>number</i>	Data file may be corrupt.	
27 Illegal SBus packet, code = <i>number</i> addr = <i>number</i> data = <i>number</i> . Maybe data file is corrupted	This error occurs while the subtest is reading the transaction file. It is likely that the data file is corrupt.	The SUNWvts package may need to be reinstalled.
28 Out of Memory	No memory available.	Increase swap space or kill other processes.
29 Pick Detect misses: <i>number</i> lines and/or triangles inside the pickbox and/or <i>number</i> lines and triangles outside the pickbox	Failed the Picking accelerator port test. Only the failing component <i>Red</i> , <i>Green</i> , or <i>Blue</i> appears in the message.	
30 Pick Echo failed: *** Error(s) found in <i>Red</i> , <i>Green</i> , or <i>Blue</i> components	Failed the Picking accelerator port test. Only the failing component <i>Red</i> , <i>Green</i> , or <i>Blue</i> appears in the message.	
31 Picking: *** Error(s) found in <i>Red</i> , <i>Green</i> , or <i>Blue</i> components	Failed the picking accelerator port test. Only the failing component <i>Red</i> , <i>Green</i> , or <i>Blue</i> appears in the message.	

TABLE 19-3 leotest Error Messages (Continued)

	Error Message	Probable Cause(s)	Recommended Action
32	<p><i>Plane group name</i> Pixel Access Mode error at <i>x=number y=number, bank=number, expected=number, observed=number, XOR=number</i></p>	<p>The direct port video memory test found an error at pixel (<i>x, y</i>) in the named plane group. Pixel Access Mode applies to all plane groups that access the frame buffer memory 4-bytes at a time. (In other words, all planes except 8-bit planes). The memory for the pixel resides in the given VRAM bank. The test expected to find <i>expected</i> but found <i>observed</i>, yielding <i>XOR</i> when the two values are exclusive or'd with each other.</p>	
33	<p>SRAM checksum mismatch. Float #1 = <i>number</i>, Float #2 = <i>number</i>, Float #3 = <i>number</i>, Float #4 = <i>number</i></p>	<p>All four checksums of the SRAMs in the floating point transform section are not identical. The subtest displays the mismatched checksum from each SRAM of each LeoFloat chip.</p>	
34	<p>SRAM of the LeoFloat [0/1/2/3], number of failures = <i>number</i>, first SRAM location = <i>number</i>, expected = <i>number</i>, observed = <i>number</i>, XOR = <i>number</i></p>	<p>An error is found in the SRAM test of the LeoFloat chip number 0, 1, 2, or 3. If the number of failures is more than one, the subtest displays the first SRAM location that fails, the expected and observed values in this location, and the bits in error (values of expected and observed are xor'd together).</p>	
35	<p>tar never finished. System software problem</p>	<p>Software error.</p>	<p>Make sure that the tar program is installed correctly on your system. Also, use <code>df</code> to see if you have enough disk space left in your <code>/tmp</code> directory.</p>
36	<p>tar error</p>	<p>Software error. The tar program cannot unpack data file to the <code>/tmp</code> directory due to limited disk space. A space of approximately 2MB in <code>/tmp</code> is required for the test to run correctly.</p>	<p>Make sure that the tar program is installed correctly on your system. Also, use <code>df</code> to see if you have enough disk space left in your <code>/tmp</code> directory.</p>

**TABLE 19-3** leotest Error Messages (Continued)

Error Message	Probable Cause(s)	Recommended Action
37 The checksums for <i>red/green/blue</i> image data of all pixels don't match, expected = <i>number</i> , observed = <i>number</i> , XOR = <i>number</i>	The FB output section subtest prints this message when the checksums of either RED, GREEN, or BLUE image data <i>observed</i> from the trap registers in the Video Output test are not the same as the <i>expected</i> values. It also prints the error messages below if the upper four bits in the trap registers are not set or reset as expected.	
38 The Even Field bit expected to be 0, observed 1		
39 The Composite Sync bit expected to be 1, observed 0		
40 The Composite Blank field expected to be 1, observed 0		
41 The Stereo bit expected to be 1, observed 0		
42 The Stereo bit expected to be 1, observed 0	These bits are either not set correctly, or the read is from the wrong location, which indicates there is an error in the Video Output section.	
43 Unable to map <i>device_name</i> . Not enough memory	Software error. There is not enough memory to map the addresses for the ZX device; the default is /dev/fbs/leo0.	You may have to increase swap space or add more memory.
44 Unable to open device <i>device_name</i> . Check device for existence and/or permission	Software error. SunVTS is unable to open the ZX device.	Make sure that /dev/fbs/leo0 exists and that the permissions are correct. There may be a software installation problem in which the ZX software packages need to be reinstalled.



**TABLE 19-3** leotest Error Messages (Continued)

	Error Message	Probable Cause(s)	Recommended Action
45	Uncompression of data file failed. Note: A space of approximately 2MB in /tmp is required for the test to run correctly	Software error. There is not enough disk space in /tmp; about 2 Mbytes is required to uncompress the data file.	You may have to remove unneeded files or link /tmp to a larger disk partition.
46	Unknown data file magic number = <i>number</i>	Software error. The data file was generated by an older version of software tools.	Report this error by filing a bug report or contacting your Sun Service representative.
47	Unsupported 24-bit data length. Maybe data file is corrupted	This error occurs while the substest is reading the transaction file. Data may be corrupt.	Reinstall the SUNWvts package.
48	Unable to open display. Window server not running	Warning message only. This message is displayed when the ZX SunVTS is executed from the command line remotely or if SunVTS is run in TTY mode.	
49	vfork: <i>error</i>	Software error. An error occurred while trying to fork a child process.	Increase swap space, or close other processes.
50	[PWID/QWID] WLUT: Look up table error at index <i>number</i> , expected <i>number</i> , observed <i>number</i> , XOR <i>number</i>	An error was found in either the PWID (Hardware Window ID) or the QWID (Software Window ID) look-up tables. The error was found in the <i>n</i> th WLUT. The index is out of 64 entries for PWID or 15 for QWID. The test expected to find <i>expected</i> but received <i>observed</i> , yielding <i>XOR</i> when the two values are exclusive or'd with each other, which indicates the bits in error. This error message indicates there is an error in the Video Output section.	



## SPARCprinter Port Test (lpvittest)

---

`lpvittest` verifies the functionality of SPARCprinter ports, and `bpptest` verifies the functionality of bidirectional parallel ports. SBus printer cards have two printer ports: one for SPARCprinters, and one for any parallel port printer.

---

### Printer Test Hardware and Software Requirements

The SBus printer card and device drivers must be installed to run `lpvittest` or `bpptest`. A printer must be connected to the SPARCprinter or bidirectional parallel port, and powered-up. If both a SPARCprinter and a parallel port printer connected to the SBus card, you can test both ports simultaneously.

If you are testing the SPARCprinter port, be sure the magnets on the SPARCprinter paper tray are set to the correct paper size. For more information, see the *SPARCprinter Installation and User's Guide* and the label on the printer tray.

The `lpvittest` verifies that your SBus card and SPARCprinter are working properly by attempting to transfer a data pattern from the SBus card to the SPARCprinter and printing the pattern.

If the SBus card and printer are functioning properly, you can see in the SunVTS Status window that `lpvittest` made a successful pass, and the pattern transmitted to the printer printed correctly.

If this test passes successfully, the SBus DMA circuitry, the SPARCprinter, and the device driver are functioning properly.

---

# lpvittest Options

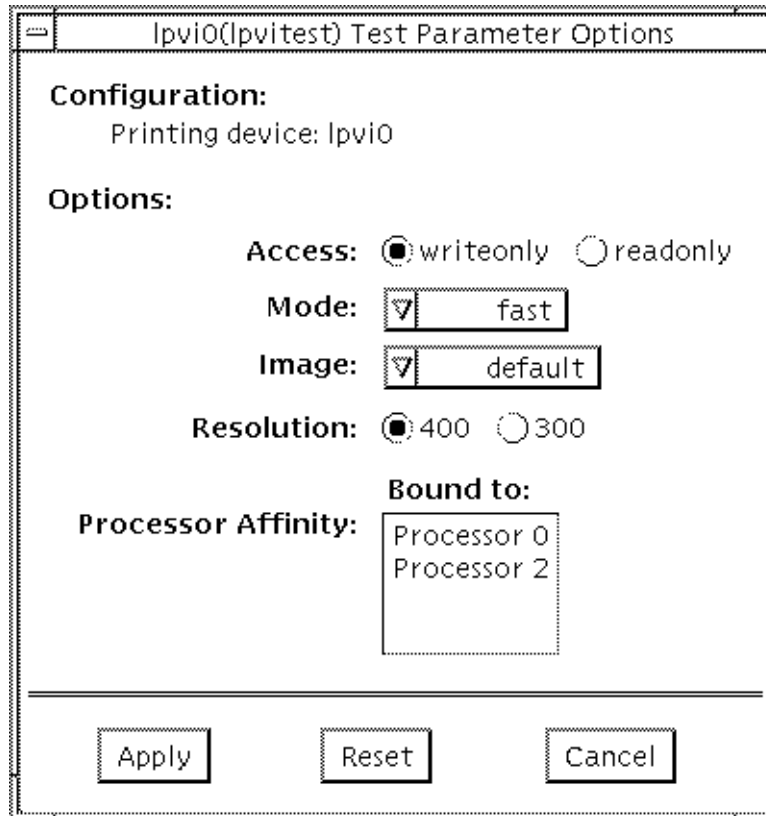

FIGURE 20-1 lpvittest Option Menu

**TABLE 20-1** `lpvittest` Options

<code>lpvittest</code> Options	Description
Access	This field is informational only. <code>Writeonly</code> is the only option currently available. This indicates that the only data being transferred is going from the SBus printer card to the SPARCprinter.
Mode	Use this option to select how often to print the test image. The default setting is <code>Fast</code> ; the available settings are: <code>Fast</code> : Prints an image every 1 minute. <code>Medium</code> : Prints an image every 12 minutes. <code>Extended</code> : Prints an image every 30 minutes.
Image	This option lets you choose which test image to print. The settings are: <code>Default</code> : A pattern of vertical lines on one page and a checkerboard pattern on another. <code>57fonts</code> : An image of the 57 different fonts that the printer supports. <code>User defined</code> : You can use any raster file as a test image. Just place the file in the <code>/opt/SUNWvts/bin</code> directory and save it as the file name <code>u_image</code> .
Resolution	This setting defines the printer resolution of the printed test pattern. The choices are 300 or 400 dots per inch. <b>Note:</b> Patterns such as the default test pattern are printed at different sizes and at different dpi resolutions. The text in the 57 fonts pattern prints in the same size, using the two different resolutions.

---

## `lpvittest` Test Mode

This test only supports the Functional test.

---

# lpvittest Command Line Syntax

```
/opt/SUNWvts/bin/lpvittest standard_arguments -o  
dev=device_name,access=writeonly|readonly,image=filename,reso=resolution,  
mode=mode
```

TABLE 20-2 lpvittest Command Line Syntax

Argument	Explanation
dev= <i>device_name</i>	Specifies the name of the device. This should be of the form /dev/lpvi#, where # is the number of the device.
access=	Choices are write-only or read-only, but write-only is the only option supported at this time. See the <i>Access</i> description in TABLE 20-1 on page 219.
image= <i>filename</i>	The name of the file containing the test image. Possible values are:  <i>imagefile</i> : Any file containing user-defined images. Before running SunVTS, copy the raster image file to the /opt/SUNWvts/bin directory and save it with the filename <i>u_image</i> . The size of the image is adjusted based on the resolution  <i>57fonts</i> : Contains an image of 57 fonts. The size of the image is adjusted, based on the resolution  <i>default</i> : The default images print on two pages, one image is a pattern of vertical lines and the other is a checkerboard
reso= <i>resolution</i>	<i>resolution</i> is the resolution of the output in dots per inch (DPI). Possible values are 300 and 400.
mode= <i>mode</i>	<i>mode</i> is the print speed mode. This is the rate at which the test image is printed. Possible values are:  <i>fast</i> : Prints the test image at 1-minute intervals.  <i>medium</i> : Prints the test image at 12-minute intervals.  <i>extended</i> : Prints the test image at 30-minute intervals.

---

# lpvittest Error Messages

TABLE 20-3 lpvittest Error Messages

Error Message	Probable Cause(s)	Recommended Action
6000	Error occurred while attempting to obtain paper size	System error message. No tray installed. Printer out of paper.
6001	Error occurred while attempting to fork a child process	System error message.
6002	image in <i>name</i> raster file too big	
6003	error= <i>number</i>	System error message.
8000	couldn't open <i>device_name</i>	Device does not exist. Device not configured correctly.
8001	ioctl fail on <i>device_name</i>	System error message.
8002	Failed to obtain memory from malloc() system call	System is heavily loaded.
8003	Couldn't open <i>file_name</i>	
8004	Error occurred while reading raster file header <i>value</i> for <i>device_name</i>	Specified image raster file does not have the proper format.
8005	Error occurred while loading image file <i>value</i> for <i>device_name</i>	Specified image raster file does not have the proper format.
8006	Error occurred while writing to printer device	System error message.
8007	Error encountered while accessing printer device <i>device_name</i> ; Paper size: <i>value</i> , Counters: <i>value</i> , Print Engine: <i>value</i>	

**TABLE 20-3** lpvittest Error Messages (Continued)

	<b>Error Message</b>	<b>Probable Cause(s)</b>	<b>Recommended Action</b>
8008	Error encountered while accessing printer device <i>device_name</i> ; Error code: <i>value</i>	Error in main motor.	
8009	Error encountered while accessing printer device <i>device_name</i> ; Error code: <i>value</i>	ROS out of order.	
8010	Error encountered while accessing printer device <i>device_name</i> ; Error code: <i>value</i>	FUSER out of order.	
8011	Error encountered while accessing printer device <i>device_name</i> ; Error code: <i>value</i>	XERO failure.	
8012	Error encountered while accessing printer device <i>device_name</i> ; Error code: <i>value</i>	Interlock open	
8013	Error encountered while accessing printer device <i>device_name</i> ; Error code: <i>value</i>	No tray installed.	
8014	Error encountered while accessing printer device <i>device_name</i> ; Error code: <i>value</i>	No paper exists in selected tray	
8015	Error encountered while accessing printer device <i>device_name</i> ; Error code: <i>value</i>	Exit JAM.	
8016	Error encountered while accessing printer device <i>device_name</i> ; Error code: <i>value</i>	Misfeed JAM.	
8017	Error encountered while accessing printer device <i>device_name</i> ; Error code: <i>value</i>	Drum cartridge is nearly exhausted.	



**TABLE 20-3** lpvitest Error Messages (Continued)

	Error Message	Probable Cause(s)	Recommended Action
8018	Error encountered while accessing printer device <i>device_name</i> ; Error code: <i>value</i>	Deve module is nearly exhausted.	
8019	Error encountered while accessing printer device <i>device_name</i> ; Error code: <i>value</i>	No drum cartridge.	
8020	Error encountered while accessing printer device <i>device_name</i> ; Error code: <i>value</i>	No deve cartridge.	
8021	Error encountered while accessing printer device <i>device_name</i> ; Error code: <i>value</i>	Drum cartridge exhausted.	
8022	Error encountered while accessing printer device <i>device_name</i> ; Error code: <i>value</i>	Deve cartridge exhausted.	
8023	Timed out while accessing printer device <i>device_name</i>		
8024	EIO error		



## M64 Video Board Test (`m64test`)

---

`m64test` tests the PCI-based M64 video board by performing the following subtests:

- Video Memory test
- RAMDAC test
- Accelerator Port test



---

**Caution** – DO NOT run any other application or screen saver program that uses the Pineapple accelerator port while running `m64test`. Do not run power management software. These programs cause SunVTS to return incorrect errors.

---

---

**Note** – Disable all screen savers before testing any graphics device. Type `xset s off` at a UNIX prompt to disable the Solaris screen saver. Disable power management software if it is running.

---

---

**Note** – DO NOT run Open Windows across multiple monitors.

---

---

**Note** – To start SunVTS with `vtsui`, but without `vtsk`, you must add the host name to `xhost` as: `xhost + hostname`.

---

# m64test Options

By default, all options are enabled except frame buffer locking.

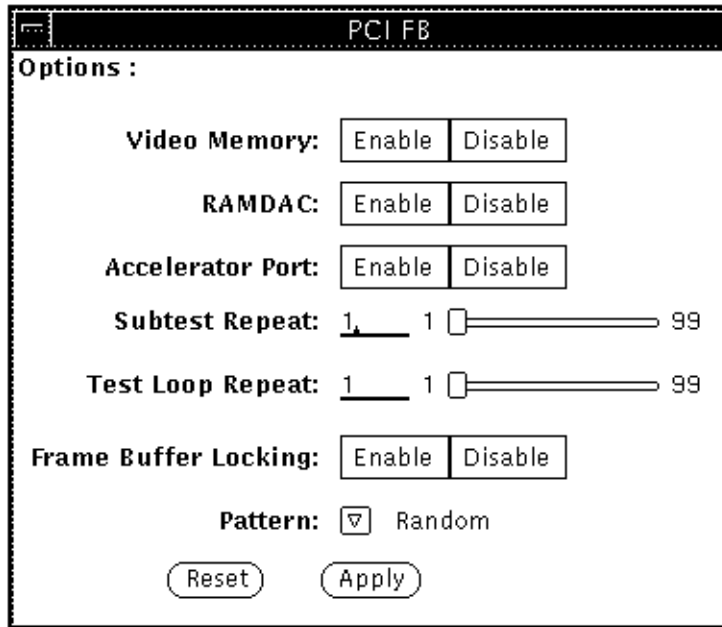

FIGURE 21-1 m64test Option Menu

TABLE 21-1 m64test Options

m64test Options	Description
Video Memory Test	Thoroughly tests the on-screen video memory (the memory part that is mapped on to the monitor) of the M64 video board in 8-bit, 16-bit, 32-bit, 64-bit, and 64 byte (block) modes. Entire on screen video memory is tested by testing 512 bit blocks at a time (8x8 pixel block). Each block is tested in two passes. Each pass consists of a data write and read. In the first pass user specified data or random data is used and in the second pass one's complement of the data used in the first pass is used so that each on-screen video memory location (bit) is tested with a zero (electrical low state) and one (electrical high state).

**TABLE 21-1** m64test Options

m64test Options	Description
RAMDAC Test	<p>Tests the RAMDAC in three phases. In the first phase the RAMDAC CLUT (Color LookUp Table) is tested using simple write/read patterns to determine if there are any bad bits in CLUT.</p> <p>The data patterns used are:</p> <ul style="list-style-type: none"><li>• Random data</li><li>• Complement of the random data (used as first data pattern)</li><li>• The data pattern 0101</li><li>• The data pattern 10101</li></ul> <p>In the second phase four different patterns are drawn on the screen. Each pattern stays on the screen for approximately three seconds. The four patterns that are drawn are listed below. For each pattern signature is captured and compared with the signature obtained for the same pattern on a known good board. This test verifies that all the different data paths within the RAMDAC are functioning properly.</p> <p>Patterns drawn on screen:</p> <ul style="list-style-type: none"><li>• Red ramp with cursor at top-left corner of the screen</li><li>• Blue ramp with cursor at top-right corner of the screen</li><li>• Green ramp with cursor at bottom-left of the screen</li><li>• Grey ramp with cursor at bottom-right of the screen</li></ul> <p>In the last (third) phase of the RAMDAC test the Vertical Retrace Interrupt is tested for 300 interrupts.</p>
Accelerator Port Test	<p>Tests all the data paths (sources: fixed color, host data, blit, fixed pattern), arithmetic and logic unit (ALU), color comparator, primitives (destinations: line, rectangle), and mono to color expansion logic. Primitives are drawn using a combination of different data paths (allowed), ALU functions, and color comparator functions. A checksum is generated for each data combination and is compared with the checksum generated for the same data combination on a known good board.</p>
Frame Buffer Locking	<p>This option is set to <i>disable</i> if the M64 is not the console device. When Sunvts GUI is brought up FB Locking is enabled by default if M64 is console device. If M64 is not console device, FB Locking is disabled by default.</p>

---

## m64test Test Modes

Due to the nature of graphic tests, reading from or writing to the frame buffer during graphic tests will disturb user operation. This test is only available in the Functional Test mode.

TABLE 21-2 m64test Test Mode

Test Mode	Description
Functional Test	The m64test verifies the M64 video board.

---

## m64test Command Line Syntax

```
/opt/SUNWvts/bin/m64test standard_arguments -o dev=device_name,  
S=subtest_number,F=#_of_subtest_loops,B=#_of_test_loops,L=disable,P=test_pattern
```

TABLE 21-3 m64test Command Line Syntax

Argument	Explanation
dev=device_name	device_name is the relative path name of the device being tested with respect to /dev/fbs; The default is m640.
S=subtest_number	subtest_number is the test number of the subtest to be run. Select from the subtests below. You can run multiple subtests by adding the subtest numbers. For example, n=0x00003 runs both test 00001 and test 00002; n=0x00005 runs both test 0x00001 and test 0x00004. Note that you do not need the leading zeros. n - 0x00001 VRAM n - 0x00002 RAMDAC n - 0x00004 Accelerator port test (Rendering Pipeline) More than one test can be selected by ORing subtest numbers. For example: n = 0x00005 means VRAM and Rendering Pipeline tests. A hex number must be preceded by 0x, decimal numbers are also acceptable.
F=#_of_subtest_loops	Specifies the number of times to repeat each subtest; the default is 1.

**TABLE 21-3** m64test Command Line Syntax

Argument	Explanation ( <i>Continued</i> )
B=#_of_test_loops	Specifies the number of times to repeat a test loop before passing; default is 1.
L=disable	<i>Disables the frame buffer lock.</i> Disable the lock when the m64 is not the console or when the server is not running on the m64 under test.
P=test_pattern	Specifies the test pattern number. The default is r, for random patterns. You may also choose 0 for 0x0000000, 3 for 0x33333333, 5 for 0x55555555, or 9 for 0x99999999.

## m64test Error Messages

Errors returned by m64test are nonspecific. It is not possible to determine which component caused a failure. In all error conditions, the field replaceable unit (FRU) is the entire M64 video board. The errors messages are listed below, along with probable causes and recommended actions.

**TABLE 21-4** m64test Error Messages

Error Message	Probable Cause(s)	Recommended Action
6000 Out of memory	System error.	If problem persists, call your authorized Sun service provider.
6002 <i>string</i> error: Misaligned raster.	Software error.	If problem persists, call your authorized Sun service provider.
6003 Unable to open <i>string</i> .	Device not present.	Check for device presence.
	Device failure.	Replace device.
	Permission restrictions.	Check device permissions.
6004 ioctl(2) Error in loading the Frame Buffer structure fbtype.	IOCTL call to driver failure.	Try replacing device.
	Device failure.	Call your authorized Sun service provider.
6005 ioctl(2) Error in loading the Original Color Map Values.	IOCTL call to driver failure.	Try replacing device.
	Device failure.	Call your authorized Sun service provider.

**TABLE 21-4** m64test Error Messages (Continued)

Error Message	Probable Cause(s)	Recommended Action
6006 ioctl(2) Error in Setting the Cursor Values.	IOCTL call to driver failure. Device failure.	Try replacing device. Call your authorized Sun service provider.
6007 ioctl(2) Error in loading the GXInfo Structure fbtype.	IOCTL call to driver failure. Device failure.	Try replacing device. Call your authorized Sun service provider.
6008 <i>string</i> (1-byte access) error: x/y ( <i>data</i> ) Expected 0x%02x, Actual 0x%0 2x, Xor 0x%02x.	Device failure.	Replace device. Call your authorized Sun service provider.
6009 <i>string</i> (2-byte access) error: x/y ( <i>data, data</i> ) Expected 0x%04x, Actual 0x%0 4x, Xor 0x%04x.	Device failure.	Replace device. Call your authorized Sun service provider
6010 <i>string</i> (4-byte access) error: x/y ( <i>data, data</i> ) Expected 0x%08x, Actual 0x%0 8x, Xor 0x%08x.	Device failure	Replace device. Call your authorized Sun service provider.
6011 <i>string</i> (8-byte access) error: x/y ( <i>data, data</i> ) Expected 0x%08x, Actual 0x%0 8x, Xor 0x%08x.	Device failure	Replace device. Call your authorized Sun service provider.
6012 <i>string</i> (64-byte access) error: x/y ( <i>data, data</i> ) Expected 0x%08x, Actual 0x% 08x, Xor 0x%08x.	Device failure.	Replace device. Call your authorized Sun service provider.
6013 Error in Allocating Memory mmap call Failure.	System error.	If problem persists, call your authorized Sun service provider.
6014 Error in DeAllocating Memory unmap call Failure.	System error.	If problem persists, call your authorized Sun service provider.



**TABLE 21-4** m64test Error Messages (Continued)

	Error Message	Probable Cause(s)	Recommended Action
6015	ioctl(2) failed trying to turn on M64 video.	IOCTL call to driver failure. Device failure.	Replace device. Call your authorized Sun service provider.
6016	ioctl(2) failed trying to post CLUT.	IOCTL call to driver failure. Device failure.	Replace device. Call your authorized Sun service provider.
6017	ioctl(2) failed trying to read CLUT.	IOCTL call to driver failure. Device failure.	Replace device. Call your authorized Sun service provider.
6018	Miscompare found in Red channel of CLUT entry <i>data</i> . Expected 0x%02x, Observed 0x%02x, XOR 0x%02x.	RAMDAC failure. Device failure.	Replace device. Call your authorized Sun service provider.
6019	Miscompare found in Green channel of CLUT entry <i>data</i> . Expected 0x%02x, Observed 0x%02x, XOR 0x%02x.	RAMDAC failure Device failure	Replace device. Call your authorized Sun service provider.
6020	Miscompare found in Blue channel of CLUT entry <i>data</i> . Expected 0x%02x, Observed 0x%02x, XOR 0x%02x.	RAMDAC failure. Device failure	Replace device. Call your authorized Sun service provider.
6021	RAMDAC test screen CRC signature error message. Monitor type <i>data</i> , Cursor Position <i>data</i> , Expected Signature 0x <i>value</i> , Actual Signature 0x <i>value</i>	Device failure.	Call your authorized Sun service provider.
6022	sysinfo(2) failed getting hostname.	No system permissions.	Become superuser. If problem persists, call your authorized Sun service provider.
6023	Can't acquire console semaphore	System error.	If problem persists, call your authorized Sun service provider.

**TABLE 21-4** m64test Error Messages (Continued)

Error Message	Probable Cause(s)	Recommended Action
6024 Cannot gain control of mouse: <i>string</i>	System error.	If problem persists, call your authorized Sun service provider.
6025 Cannot gain control of keyboard: <i>string</i>	System error.	If problem persists, call your authorized Sun service provider.
6026 Already grabbed by another client		Try stopping other similar actions. If problem persists, call your authorized Sun service provider.
6027 grabbed at invalid time	System error.	If problem persists, call your authorized Sun service provider.
6028 grab window is not viewable		If problem persists, call your authorized Sun service provider.
6029 pointer/keyboard is frozen		If problem persists, call your authorized Sun service provider.
6030 Unknown cause		If problem persists, all your authorized Sun service provider.
6031 ioctl(2) failed trying to get current video mode.	IOCTL call to driver failure Device failure.	Replace device. Call your authorized Sun service provider.
6032 ioctl(2) failed trying to set current video mode.	IOCTL call to driver failure. Device failure.	Replace device. Call your authorized Sun service provider.
6033 ioctl(2) failed trying to get M64 system info.	IOCTL call to driver failure. Device failure.	Replace device. Call your authorized Sun service provider.
6034 mmap(2) failed: <i>string</i> .	System error.	If problem persists, all your authorized Sun service provider.
6035 munmap(2) failed: <i>string</i> .	System error	If problem persists, all your authorized Sun service provider.

**TABLE 21-4** m64test Error Messages (Continued)

	Error Message	Probable Cause(s)	Recommended Action
6036	close(2) failed: <i>string</i> .	System error.	If problem persists, all your authorized Sun service provider.
6045	Can't access X Windows	Permission denial from Host. System error. X Server is not running.	Run <i>xhost(1)</i> . If X server is not running, run X server. If problem persists, all your authorized Sun service provider.
6046	wait(2) failed: <i>string</i>	System error.	If problem persists, all your authorized Sun service provider.
6047	signal(2) failed: <i>string</i>	System error.	If problem persists, all your authorized Sun service provider.
6048	ioctl(2) Error in vertical retrace test.	IOCTL call to driver failure. Device failure.	Replace device. Call your authorized Sun service provider.
6049	Can't open display	Permission denial from Host. System error. X Server is not running.	Run <i>xhost(1)</i> . If X server is not running, run X server. If problem persists, call your authorized Sun service provider.
6050	m64 open file failed Could not open the signature file <i>string: string</i>	No file permission or file does not exist.	Check the file permissions. If problem persists, call your authorized Sun service provider.
6051	m64 FTRUNCATE failed in checker. Accelerator could not extend or truncate the signature file.	Insufficient disk space.	Create more space by deleting unnecessary files. If problem persists, call your authorized Sun service provider.

**TABLE 21-4** m64test Error Messages (Continued)

	<b>Error Message</b>	<b>Probable Cause(s)</b>	<b>Recommended Action</b>
6052	m64 close failed in checker. Accelerator could not close signature file.	System error.	If problem persists, call your authorized Sun service provider.
6053	m64 check error in checker	Device failure.	Replace device.  If problem persists, call your authorized Sun service provider.
6054	m64 ROP test failed	Device failure.	Replace device.  If problem persists, call your authorized Sun service provider.
6055	m64 IOCTL fails FBIOPUTCMAP Error while putting color map.	Device failure.	Check software installation.  Replace device.  If problem persists, call your authorized Sun service provider.
6056	m64 IOCTL fail FBIOGETCMAP. Error while getting color map. IOCTL call to deriver failure	Device failure.	Check software installation.  Replace device.  If problem persists, call your authorized Sun service provider.
6057	Internal error Mon XLATOR Internal error occurred while translating monitor type to index into signature file	Monitor types are modified.	If problem persists, call your authorized Sun service provider.

## Multiprocessor Test ( `mptest` )

---

`mptest` verifies the functionality of multiprocessing hardware. This test allocates a page of virtual memory for the test, declaring the page shared, locks the page against swapping, and creates threads to each of the processors being tested. Up to 64 processors can be tested by `mptest` in a CPU.

The processor mask argument can be sent to `mptest` during test probing. The `mptest` verifies that the current processor mask matches the argument you entered in the command line or from the GUI/TTYUI.

# mpctest Options

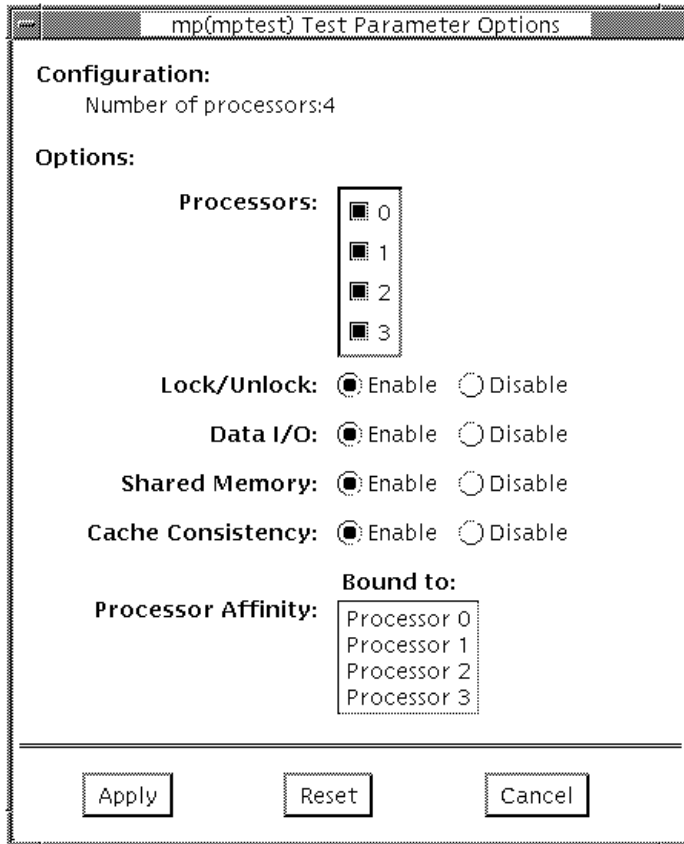

FIGURE 22-1 mpctest Option Menu

The processors that can be tested are listed in the Configuration area of the menu. The multiprocessing test can be enabled or disabled for individual processors on this menu.

The options listed in Table 17-1 can be run alone or concurrently with other options.

**TABLE 22-1** `mptest` Options

<b>mptest Options</b>	<b>Description</b>
Processors	You can test specific processors by clicking SELECT on the check boxes to enable or disable each processor. A check mark means the processor is enabled for testing; the default setting is all processors enabled. Note that <code>mptest</code> requires at least two enabled processors to test multiprocessing systems.
Lock/Unlock	<p>Tests the lock/unlock mechanism that guarantees exclusive access to a physical page to one processor. A thread is created at each of the processors. Each processor uses the SPARC atomic instruction <code>ldstub</code> to write to the same shared physical memory page. While one processor is attempting the write, the other processors should be free spinning for their turn. As each processor acquires the lock, it writes an ordinal number to a shared trace buffer using a shared write pointer. After the test cycle is complete, the trace buffer is dumped for analysis.</p> <p>This test fails and returns an error message if the trace buffer does not contain an equal number of ordinal numbers for each processor. For example, if the specified loop count is 5, the trace buffer should contain five 0s, five negative 1s, five 2s, and so on.</p>
Data I/O	Requires two or more threads, each of which locks onto one of the processors. Each processor, in turn, writes data to a temporary file that has been mapped to the physical address. The modified data is immediately read by other processors being tested. This test hangs and fails if the processors do not recognize the expected data.
Shared Memory	<p>A shared memory buffer is divided into a number of contiguous chunks, one for each of the CPUs participating in the test. Each CPU is assigned a unique chunk based upon its ID (1-N). This subtest has two parts.</p> <p>First, each CPU locks and writes data to its data chunk. Identical data is written for each CPU. Then each CPU reads and compares the information on its data chunk with that of another CPU. If two CPUs do not confirm consistent data, the test fails and returns an error message. If that happens, testing stops and this test is run again in verbose mode to return more detailed information.</p>
Cache Consistency	<p>Requires two or more processors to access and write to the same physical address. This test verifies that a change in physical address by one processor is confirmed by another.</p> <p>If two processors do not confirm consistent data, the test continues to run, but the Pass Count in the SunVTS status window stops incrementing. If this happens, stop testing and run the test again in verbose mode for a more detailed picture of the problem.</p>

---

# mptest Test Modes

**TABLE 22-2** mptest Test Modes

Test Mode	Description
Connection Test	The Connection test checks the current processors on the system with the original processor mask. An error is reported if they do not match. The original processor mask is set during probing, which shows the processors on system during the probe. The status of each selected processor is checked by <code>procsesor_bind</code> .
Functional Test	This test mode verifies that the current processor mask is the same as that from the command line, or the same as that from the GUI/TTYUI
Online Mode	Provides a means to run <code>mptest</code> through SyMON. In Online mode, the following Functional Test description applies: This test mode verifies that the current processor mask is the same as that from the command line, or the same as that from the GUI/TTYUI

---

# mptest Command Line Syntax

```
/opt/SUNWvts/bin/mptest standard_arguments -o M=0+1+2+3... ,NL,ND,NS,NC
```

**TABLE 22-3** mptest Command Line Syntax

Arguments	Explanation
NL	Disable the Lock/Unlock subtest.
ND	Disable the Data I/O subtest.
NS	Disable the Shared Memory subtest.
NC	Disable Cache Consistency subtest
M= <i>processors to be enabled</i>	Where 0, 1, 2 are processors.
<i>omask=original mask of processors</i> >	



# mptest Error Messages

**TABLE 22-4** mptest Error Messages

	<b>Error Message</b>	<b>Probable Cause(s)</b>	<b>Recommended Action</b>
6000	mp lock failed	Faulty processor.	If the problem persists, call your authorized Sun service provider.
6001	All subtests are disabled	Parameter error.	Enable at least one subtest.
6002	thr_setconcurrency error	System load is too heavy. System error.	Reduce the system load. If the problem persists, call your authorized Sun service provider.
6003	Error in creating threads: <i>name</i>	System load is too heavy. System error.	Reduce the system load. If the problem persists, call your authorized Sun service provider.
6004	thr_join() thread <i>number</i> error status: <i>number</i>	System load is too heavy. System error	Reduce the system load. If the problem persists, call your authorized Sun service provider.
6005	Processor Mask Error: Expect <i>number</i> Was <i>number</i>	Some processors are disappeared from processor mask.	If the problem persists, call your authorized Sun service provider.
6006	Failed in system call uadmin, errno = <i>number</i> , sys_errlist = <i>name</i>	System load is too heavy. System error.	Reduce the system load. If the problem persists, call your authorized Sun service provider.
6007	Failed in function getnextbitmsk!	System error.	If the problem persists, call your authorized Sun service provider.
6008	Processor Mask Error: check mask <i>number</i> cpu mask <i>number</i>	Some processors disappeared from the processor mask.	If the problem persists, call your authorized Sun service provider.
6009	Failed to get shared memory, err = <i>name</i>	System load is too heavy. System error.	Reduce the system load. If the problem persists, call your authorized Sun service provider.
6010	Failed to create shared memory, err = <i>name</i>	System load is too heavy. System error	Reduce the system load. If the problem persists, call your authorized Sun service provider.

**TABLE 22-4** mptest Error Messages (Continued)

Error Message	Probable Cause(s)	Recommended Action
6011 Shared Memory Subtest: Process <i>number</i> , Processor <i>number</i> , *curr_add <i>number</i> curr_addr <i>number</i> , cpu_mask <i>number</i> failed	System load too heavy. System error.	Reduce the system load. If the problem persists, call your authorized Sun service provider.
6014 Failed on read & compare: Processor <i>number</i> , read= <i>number</i> , exp= <i>number</i>		
6016 Not a MP system!	Faulty Processor. Do not run mptest on this system.	
8000 Failed to open <i>name</i>	Not enough disk space. Permission error. System error.	Allocate disk space. Check directory/file permissions. If the problem persists, call your authorized Sun service provider.
8001 Failed to create a page	System load too heavy. System error.	Reduce the system load. If the problem persists, call your authorized Sun service provider.
8002 mmap address space to device	System load too heavy. System error.	Reduce the system load. If the problem persists, call your authorized Sun service provider.
8003 mlock error. <i>name</i>	Processor error.	Isolate the bad processor.
8005 All subtests are disabled	Parameter error: None subtest is selected.	Re-enter command line correctly; Select at least one subtest.
8006 Can not run mptest! You need to enable at least two processors	Parameter error You have selected less than two processors for testing.	Re-enter command line correctly; Select at least two processors.

## Network Hardware Test (`nettest`)

---

`nettest` checks all the networking hardware on the system CPU board and separate networking controllers (for example, a second SBus Ethernet controller). For this test to be meaningful, the machine under test must be attached to a network with at least one other system on the network.

---

**Note** – This version of `nettest` is used for *all* networking devices, including Ethernet (`ie` and `le`), token ring (`tr`, `trp`), quad Ethernet (QED), fiber optic (`fddi`, `nf`, `bf`, `pf`), SPARCcluster™ 1 System (`em`), ATM (`sa`, `ba`), and 100-Mbits per second Ethernet (`be`, `hme`) devices.

---

The `nettest` mainly uses the Internet Control Message Protocol (ICMP), and requires at least two machines on a network—the machine under test and another machine reliable enough to be a test target. Both machines must support the transport control protocol/interface program (TCP/IP) (ICMP is part of TCP/IP). The target machine must either be configured to respond to ICMP broadcast or to RPC broadcast.

First `nettest` determines the target machine(s) to test against. If no targets are specified, it sends an ICMP broadcast to find them. If it fails to find all necessary targets, it tries RPC broadcast to the RPC port mapper daemon. If you specify the targets, `nettest` uses the specified target(s) instead.

After finding the necessary targets, `nettest` performs the following tests:

- **Random test** sends out 256 packets with random data length and random data.
- **Incremental test** sends out packets with length from minimum to maximum packet size using incremental data. (Minimum and maximum values differ for each device.)

- **Pattern test** sends 256 packets of maximum length, where each packet contains one test pattern, and all byte patterns (0 to 0xFF hex) are used. That is, the first packet contains pattern 0, the second packet contains pattern 1, and so on, until the last packet pattern of 0xFF.

---

**Note** – `nettest` is a scalable test. However, the maximum number of networked devices allowed on a system is 255, and the number of instances for each device is limited to 200. So, if you start the SunVTS exerciser using the `-i` option to specify a default number of instances for all tests, `nettest` cannot assign more than 200 instances per each networked device.

---

## nettest Options

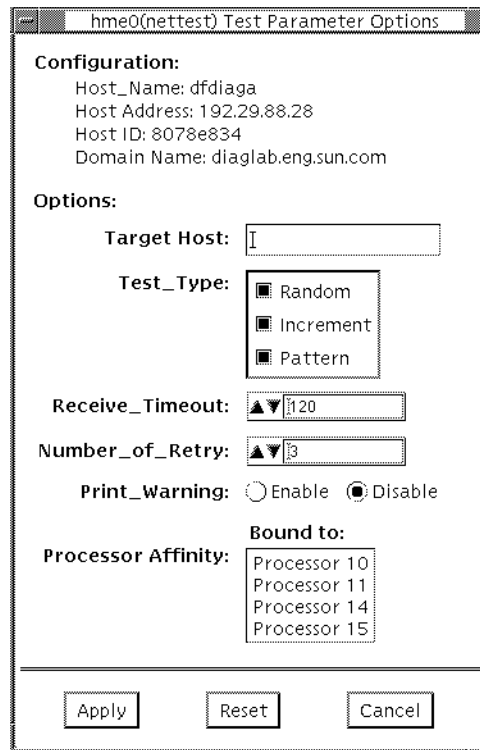

FIGURE 23-1 nettest Option Menu

The Configuration section specifies the host name, host ID, host address, and domain name of the system being tested.

**TABLE 23-1** nettest Options

<code>nettest</code> Options	Description
Target Host	Specifies one or more targets to be tested against. Target host entries can be either a host name or an Internet address. When no target host is specified, the test finds necessary targets through broadcasting. The default setting leaves this field empty.
Receive Timeout field	The default is 120 seconds, but can be changed. Use a range between 0 - 600 seconds.
Number of Retries field	The default number of retries before flagging an error is three, but can be changed. Use a range between 0 to 128 retries.
Print Warning	Disabled by default. Click Enable to see warning errors, such as retry on timeout.

---

# nettest Test Modes

All three modes are supported by `nettest`. Different test schemes are performed on the network device based on the mode selected.

**TABLE 23-2** `nettest` Test Modes

Test Mode	Description
Connection Test	Checks whether the device is connected. It searches through all the network interfaces for a specified device name. If <code>nettest</code> does not find the device connected the test fails, otherwise it returns: device is connected.
Functional Test	Performs all three tests (Random test, Incremental test, and Pattern test) sequentially. It allows you to specify options that will perform heavy stress testing. If you invoke SunVTS through SyMON, the following Functional Test description applies: Online mode, <code>nettest</code> is aware that the user's application may be running, it tries to minimize the influence on the application while it is testing. So the <code>nettest</code> uses only random test in online mode. Since the network device can be shared and the system resource is available, applications shall be affected fairly small
Online Mode	Provides a means to run <code>nettest</code> through SyMON. The following Online Functional Test description applies: <code>nettest</code> is aware that the user's application may be running, it tries to minimize the influence on the application while it is testing. So <code>nettest</code> uses only random test in Online mode. Since the network device is shared and system resources are available, applications are minimally affected.

---

# nettest Command Line Syntax

```
/opt/SUNWvts/bin/nettest standard_arguments -o target=h1+h2+... ,  
dev=interface ,test=type ,packets=n ,pattern=hex ,delay=seconds ,  
timeout=seconds ,retry=n ,warn
```

**TABLE 23-3** nettest Command Line Syntax

Argument	Explanation
target=h1+h2+...	A list of test targets by host name or Internet address.
dev=interface	Network interface name. The default value is <code>le0</code> for Ethernet networks.
test=type	The test type. Type <b>Random</b> , <b>Increment</b> , or <b>Pattern</b> for the desired test. The default value is <code>Random+Increment+Pattern</code> where all tests run.
packets=n	Number of random/pattern packets. The default is 256.
pattern=hexn	Specifies a data pattern, in hexadecimal form. The default is all patterns from 0 to 0xff.
delay=seconds	Indicates the time between subtests in seconds; the default is 30 seconds.
timeout=seconds	Indicates the number of seconds to wait before a timeout; the default is 20 seconds.
retry=n	Indicates the number of test timeout retries; the default is three retries.
warn	When enabled, prints warning messages.

# nettest Error Messages

TABLE 23-4 nettest Error Messages

Error Message	Probable Cause(s)	Recommended Action
6000 RPC broadcast failure <i>error_message</i>		
6001 Unable to resolve <i>host_name</i> Ethernet address		
6002 No ICMP echo reply from <i>host_name</i>	System load too heavy.	Reduce system load or increase timeout time.
	No cable connection.	Check cable connection!
	Target machine too busy.	Reduce target machine load.
6003 ICMP echo reply incorrect length from <i>host_name</i> , exp <i>data</i> obs <i>data</i>		
6004 ICMP echo reply length <i>number</i> from <i>host_name</i> , data mismatch at byte <i>number</i> , exp <i>value</i> obs <i>value</i>		
6005 Unable to find any test target		
6006 Unable to find necessary test targets for the ethernet switch		
8000 Unable to open <i>device_name</i> <i>error_message</i>		
8001 Bad ioctl <i>name error_message</i>		
8002 Unable to allocate <i>number</i> bytes of memory <i>error_message</i>		
8003 System call <i>name</i> returned <i>value error_message</i>		
8004 Unable to map network entry for <i>host_name</i>		
8005 ATM device <i>device_name</i> requires target specification		



**TABLE 23-4** nettest Error Messages (Continued)

Error Message	Probable Cause(s)	Recommended Action
8006 Failed to allocate <i>number</i> bytes of swap space for configuration		
8007 dl_primitive response = <i>value</i>		
8008 dl_ok_ack: short response		
8009 dl_phys_addr_ack: short response		
8010 Invalid Argument string		
8011 Interface <i>device_name</i> not configured in system		



## NVRAM Card Test (`nvttest`)

---

`nvttest` tests the SBus NVRAM card. During the probe phase, it attempts to open all `/dev/nvramX` devices. If successful, it makes an `ioctl` (`NVRAMIOCGETINFO`) call to determine that the card size is non-zero and makes an entry under “Other devices” for that instance of the card.

`nvttest` performs the following actions:

1. Opens the device
2. Uses the `ioctl` (`NVRAMIOCGETINFO`) call to determine the size of the available memory to be tested.
3. Uses the `ioctl` (`NVRAMIOCGETREGS`) call to determine whether all the batteries are connected and not low on voltage. This call also verifies that the board is not in a “dirty” state. The test aborts if the dirty state is true or if a battery problem is detected.
4. Starts the memory test which consists of:
  - mapping the memory board to the user address space.
  - checking the functionality of the EDC (error detection & correction unit) In this phase, the board is put in the checkbit injection mode and the checkbits are written corresponding to an error in bit 0 through 63. The data is read back to verify that the bits in error were corrected. The syndrome bits are also checked to make sure they were generated correctly. In addition to the 64 bits of data, the error correction for the 8 checkbits are also verified.
  - performing write-read-compare tests once the board is set to normal mode with parity checking enabled. The write-read-compare is done in byte, short, long, long and 64 bit burst modes. The number selected to test burst mode is a sequential number, and patterns `0xaa` and `0x55` are used to test the long burst mode.
  - examining the diagnostic register for single-bit and multi-bit errors while the board is set to diagnostic output mode.

- clearing the diagnostic registers, returning the board to normal mode with parity checking enabled, setting all the memory to zero using the NVRAMIOCZAP ioctl call, and unmapping the memory board.

---

**Note** – In normal mode the error checking and correction is enabled.

---

---

## nvtest Options

nvtest does not have options.

---

## nvtest Test Modes

nvtest only supports offline mode since the test is intrusive. It is a non-scalable test because simultaneously writing to the same memory will cause the test to fail.

---

## nvtest Command Line Syntax

```
/opt/SUNWvts/bin/nvtest standard_arguments -o dev=device
```

**TABLE 24-1** nvtest Command Line Syntax

Argument	Explanation
dev= <i>device</i>	<i>device</i> is the name of the device being tested such as nvram0

---

# nvtest Error Messages

TABLE 24-2 nvtest Error Messages

Error Message	Probable Cause(s)	Recommended Action
6000 <i>string</i>		
6001 Nvmem ioctl failed: <i>command</i>		
6002 Nvmem ECC multibit error		
6003 Nvmem ECC single-bit error		
6004 byte compare: location = <i>number</i> , observed = <i>number</i> , expected = <i>number</i>	On-board memory error.	Contact your authorized Sun Service provider.
6005 word compare: location = <i>number</i> , observed = <i>number</i> , expected = <i>number</i>	On-board memory error.	Contact your authorized Sun Service provider.
6006 long compare: location = <i>number</i> , observed = <i>number</i> , expected d = <i>number</i>	On-board memory error.	Contact your authorized Sun Service provider.
6007 lseek() failed: error <i>message</i>		
6008 NVRAM write failed: <i>error</i> <i>message</i>		
6009 NVRAM read failed: <i>error</i> <i>message</i>		
6010 Failed to mmap nvmem: <i>error</i> <i>message</i>		
6011 Failed to munmap nvmem: <i>error message</i>		
6012 Failed to mmap nvmem: <i>error</i> <i>message</i>		
6013 Failed to munmap nvmem: <i>error message</i>		

**TABLE 24-2** nvtest Error Messages (Continued)

Error Message	Probable Cause(s)	Recommended Action
6014 Nvmem ECC error count is non-zero		
6016 Data compare failed.		
6018 Nvmem test is applicable in Offline mode only		
6019 NVMEM battery 1 voltage is low	Battery.	Contact your authorized Sun service provider.
6020 NVMEM battery 1 is disabled	Battery may not be jumpered correctly.	Please refer to the hardware manual for instructions for connecting the battery jumper. If the problem persists, contact your authorized Sun service provider.
6021 Nvmem battery 2 voltage is low	Battery.	Contact your authorized Sun Service provider.
6022 Nvmem battery 2 is disabled	Battery may not be jumpered correctly.	Please refer to the hardware manual for instructions for connecting the battery jumper. If the problem persists, contact your authorized Sun service provider.
6023 Nvmem battery 3 voltage is low	Battery.	Contact your authorized Sun Service provider.
6024 Nvmem battery 3 is disabled	Battery may not be jumpered correctly.	Please refer to the hardware manual for instructions for connecting the battery jumper. If the problem persists, contact your authorized Sun service provider.
6025 Nvmem battery 4 voltage is lo	Battery.	Contact your authorized Sun Service provider.
6026 Nvmem battery 4 is disabled	Battery may not be jumpered correctly.	Please refer to the hardware manual for instructions for connecting the battery jumper. If the problem persists, contact your authorized Sun service provider.
6027 Nvmem ECC multibit error	On-board memory error.	Contact your authorized Sun service provider.

**TABLE 24-2** nvtest Error Messages (Continued)

Error Message	Probable Cause(s)	Recommended Action
6028 Nvmmem ECC single-bit error	On-board memory error.	Contact your authorized Sun service provider.
6029 Nvmmem ECC error count is non-zero!	On-board memory error.	Contact your authorized Sun service provider.
6030 vmmem ECC Diagnostic Registers num of errors = <i>number</i> error type = <i>number</i> Last ckbit = <i>number</i> Last syndrome = <i>number</i> First ckbit = <i>number</i> First syndrome = <i>number</i>	On-board memory error.	Contact your authorized Sun service provider.
6031 Nvmmem: valloc failed, skipping burst mode test		
6032 Nvmmem: EDC test failed in bitno <i>number</i> corrected data sbe: <i>number</i> data is: <i>number</i>	On-board memory error.	Contact your authorized Sun service provider.
6033 Nvmmem: EDC test failed in bitno: <i>number</i> syndrome sbe: <i>number</i> is: <i>number</i> checkbits sbe: <i>number</i> is: <i>number</i>	On-board memory error.	Contact your authorized Sun service provider.
8000 <i>string</i>		
8001 Failed to open nvmmem board: <i>device</i>		
8003 Battery Error		
8004 memory_check ( <i>pass number</i> ) failed		
8005 The board is dirty, exit memory test		
8008 Open directory failed: <i>error</i> Please enter test file directory		





## PCMCIA Modem Card Test (pcsertest)

`pcsertest` verifies the functionality of the PCMCIA modem card. The `pcsertest` issues a series of commands to the modem that instructs the modem's firmware to run an internal analog loopback diagnostic test. Upon completion, the firmware sends back a three-digit status message indicating whether the test passed or failed.

As an option, the `pcsertest` tests socket I/O cards. This test writes an 8-Kbyte incrementing data pattern to the I/O card, which is then looped back, read, and verified.

**Note** – When testing socket I/O cards, a 9-pin loopback connector is required. However, no loopback connector is required when testing the default modem card. See Appendix A for loopback connector wiring instructions.

### pcsertest Options

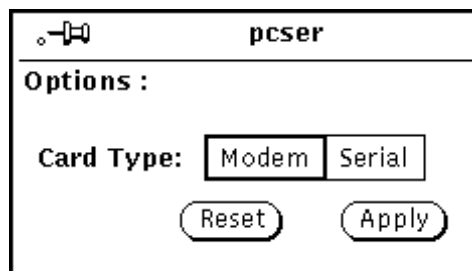

```

┌───┐
│ ◦-[]  pcser                               │
├───┤
│ Options :                                  │
│                                             │
│ Card Type:  Modem  Serial                 │
│                                             │
│ (Reset)    (Apply)                       │
└───┘

```

FIGURE 25-1 `pcsertest` Option Menu

The default card type for each PCMCIA slot is a modem card. If only one modem card is plugged in, the empty slot is ignored.

From the `pcsertest` Option window, you can choose to test socket I/O cards. To test a socket card, choose Socket on the Card Type switch. If you choose to test a socket I/O card in an empty slot, the test fails.

Any combination of modem and socket I/O cards can be placed in the PCMCIA slots. However, you must select the correct type of card in the Option window. If you select an incorrect card type, the test fails.

---

## pcsertest Test Mode

This test only supports Functional Test mode.

---

## pcsertest Command Line Syntax

```
/opt/SUNWvts/bin/pcsertest standard_arguments -o dev=device_name,  
type=card_type
```

**TABLE 25-1** `pcsertest` Command Line Syntax

Argument	Explanation
<code>dev=device_name</code>	The device name (for example, <code>dev=pc0</code> and <code>pc1</code> )
<code>type=card_type</code>	The card type for the previously specified device name (for example, <code>type=serial</code> ). You do not need to specify the type if the device is a modem, since modem is the default card type.

---

# pcsertest Error Messages

TABLE 25-2 pcsertest Error Messages

Error Message	Probable Cause(s)	Recommended Action
6000	tcgetattr failed for modem card <i>number</i> <i>error message</i>	
6001	tcsetattr failed for modem card <i>number</i> <i>error message</i>	
6002	Write failed while setting modem card <i>number</i> <i>error message</i>	
6003	ioctl TIOCSSOFTCAR failed for serial card <i>number</i> <i>error message</i>	
6004	tcsetattr failed for serial card <i>number</i> <i>error message</i>	
6005	tcsetattr failed for serial card <i>number</i> <i>error message</i>	
6006	Card in slot <i>number</i> is not a serial card	
6007	Data miscompare error	
6008	Modem card <i>number</i> returned unknown status	
6009	ioctl TIOCMSET failed for serial card <i>number</i> <i>error message</i>	
6010	ioctl TIOCMBIS failed for serial card <i>number</i> <i>error message</i>	
6011	Write to serial card <i>number</i> failed. <i>error message</i>	
6012	Timeout waiting for data from serial card <i>number</i>	

**TABLE 25-2** pcsertest Error Messages (Continued)

<b>Error Message</b>	<b>Probable Cause(s)</b>	<b>Recommended Action</b>
6013	Read from serial card <i>number</i> failed. <i>error message</i>	
6014	Status timeout from modem card <i>number</i>	
6015	Read from modem card <i>number</i> failed. <i>error message</i>	
6016	Card in slot %d is not a modem card	
8000	can't open <device> <i>error message</i>	
8001	Serial card <i>number</i> loopback defective	
8002	Write to modem card <i>number</i> failed. <i>error message</i>	

## SPARCstorage Array Controller Test (`plntest`)

---

`plntest` checks the functionality of the controller board on the SPARCstorage™ Array. The SPARCstorage Array (SSA) is a large disk storage I/O subsystem capable of housing up to 30 SCSI hard drives. The SSA communicates with a host system over a fiber-optic link provided by an SBus-based host adapter card in the host system and the corresponding SSA controller board hardware.

The SSA controller card is an intelligent, CPU-based board with its own memory and ROM-resident software. In addition to providing a communications link to the disk drives, it also buffers data between the host system and disk drives in its nonvolatile RAM (NVRAM). For data to go from the host to a particular disk, it must first be successfully transferred to this NVRAM space.

The host machine, SBus host adapter card, fiber-channel connection, and the SSA controller board must be working properly to perform this data transfer operation. By verifying and stressing this operation, `plntest` can isolate failures on the SSA disk drives from failures on the SSA controller board.

---

**Note** – `disktest` transfers data on the SSA disk drives over the same path mentioned above. However, `disktest` does not transfer data as quickly as `plntest`.

---

---

# plntest Controller Test

The `plntest` exercises the hardware and software by invoking SCSI read buffer commands of various sizes to the NVRAM. These operations exercise the host fiber channel hardware, the SSA fiber channel hardware, the SSA resident management software, and the hardware component interaction on the SSA controller card (all components except the SCSI devices). In addition, the `plntest` reports failure of the fan module and the NVRAM battery module of the SPARC storage array.

---

## plntest Options

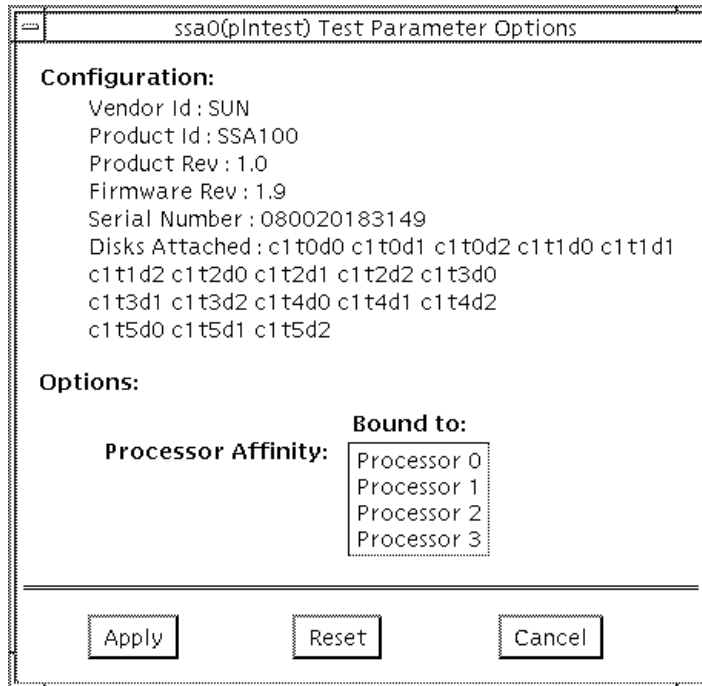

FIGURE 26-1 `plntest` Option Menu

Configuration lists the names of all the logical disk drives (both single and grouped) that are attached to the SPARCstorage Array controller board. `plntest` is not a scalable test.

---

**Note** – If no disks are present, `none` is displayed under the Attached Disks heading.

---

---

## plntest Test Modes

**TABLE 26-1** `plntest` Test Modes

Test Mode	Description
Connection Test	In this mode, <code>plntest</code> checks the state of the battery module and the fan module of the SPARCstorage array.
Functional Test	Performs the same type of tests as Online mode.
Online Mode	Provides a means to run <code>plntest</code> through SyMON. In Online mode, the following Functional Test description applies: <code>plntest</code> checks the state of the battery module and the fan module of the SPARCstorage array. The <code>plntest</code> issues a SCSI command, <code>READBUFFER</code> , causing the entire NVRAM to be read. This test uses different transfer buffer sizes

---

## plntest Command Line Syntax

`/opt/SUNWvts/bin/plntest standard_arguments -o ?,dev=device_name, x,`

**TABLE 26-2** `plntest` Command Line Syntax

Argument	Explanation
<code>?</code>	Probes the system for valid SSA controller devices and prints them to screen (see “Probing for SSA Controller Devices.”)
<code>dev=device_name</code>	Specifies the physical path name of the SSA controller card to be tested. This argument <i>must</i> be included when running <code>plntest</code> from the command line, unless the <code>?</code> argument is used.

**TABLE 26-2** `plntest` Command Line Syntax

Argument	(Continued)Explanation
x	Probes the specified SSA controller card for the single and grouped disks attached to the controller card, and prints their logical names to the screen. Note: The <code>dev=device_name</code> must be specified for this option to work.

---

## Probing for SSA Controller Devices

Unlike most other hardware devices, the SSA controller card does not have a logical device name (one you would find in the `/dev` directory). Therefore, the SSA controller card is identified by its longer, physical device name.

---

**Note** – The physical device name of the SSA controller card cannot be used to run `plntest`.

---

When running `plntest` from the command line, the physical device name of the SSA controller card cannot be used, so a logical name must be specified. ANSI standards require commas as delimiters between items. Since the physical name of the SSA controller contains embedded commas, if you use a physical name that contains commas as a command line option, `plntest` misinterprets the option.

There are two ways that you can create a logical name:

- Run the SunVTS kernel (`vtsk`), which automatically creates a logical name entry for the SSA controller under the `/dev` directory, such as:

# `/dev/ssaXX`, where `XX` represents the decimal number of the controller

Use this name as the parameter for the `dev=` option of `plntest`.

- Manually make a soft link from the actual physical device name to a logical name of your choice (under `/dev`). Use this name as the parameter for the `dev=` option of `plntest`, as shown in the following example:



```

machine# ./plntest "?"

1: /devices/io-unit@f,e3200000/sbi@0,0/SUNW,soc@1,0/
SUNW,pln@0c0d,0e0f0102:ctlr
2: /devices/io-unit@f,e0200000/sbi@0,0/SUNW,soc@3,0/
SUNW,pln@0c0d,0e0f0102:ctlr

machine# ln -s \ /devices/io-unit@f,e3200000/sbi@0,0/SUNW,soc@1,0/
SUNW,pln@0c0d,0e0f0102:ctlr \
/dev/ssa1
machine# /opt/SUNWvts/bin/plntest dev=/dev/ssa1

```

## plntest Error Messages

TABLE 26-3 plntest Error Messages

Error Message	Probable Cause(s)	Recommended Action
6010 <i>device_name text1</i> during <i>text2</i> . <i>text1</i> indicates SCSI sense information for the SCSI command <i>text2</i>		
6011 <i>device_name</i> SCSI status returned is <i>text</i> , Command issued was <i>text</i>		
6012 <i>device_name</i> : NVRAM Battery is low or has failed	Suspect battery module.	Fast writes will be disabled. Consult your authorized Sun service provider.
8000 <i>device_name</i> Failed to open() ( <i>error_message</i> )	Suspect fiber optic cable. Suspect SSA controller board. Suspect SOC host adapter.	Consult your authorized Sun service provider.

**TABLE 26-3** plntest Error Messages (Continued)

Error Message	Probable Cause(s)	Recommended Action
8010 <i>device_name text1</i> during <i>text2</i> . <i>text1</i> indicates SCSI sense information for the SCSI command <i>text2</i>		
8011 <i>device_name</i> SCSI status returned is <i>text</i> , Command issued was <i>text</i>		
8012 <i>device_name</i> Fans have failed	Fan failure.	Consult your authorized Sun service provider.

## Physical Memory Test ( pmem )

The pmem test checks the physical memory of the system. The pmem test locates parity errors, hard and soft error correction code (ECC) errors, memory read errors, and addressing problems. The pseudo driver mem(7) is used to read the physical memory.

### pmem Options

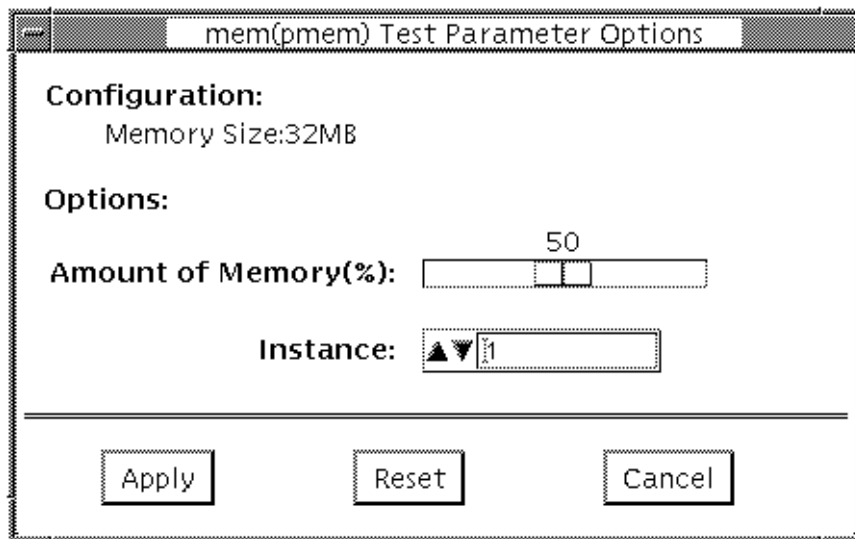
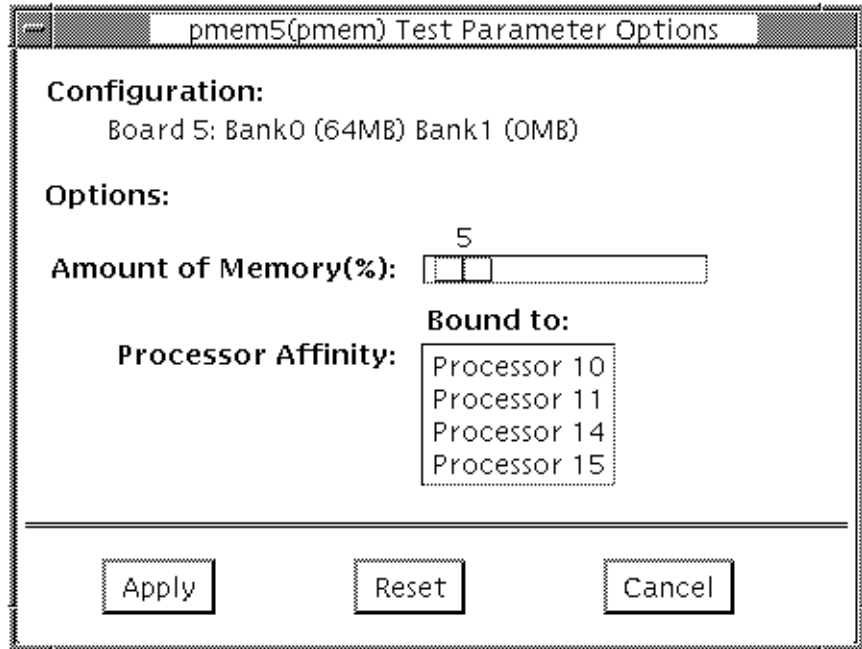

FIGURE 27-1 pmem Option Menu

The amount of memory shown in the Configuration field is the total physical memory probed by the SunVTS kernel. It reflects the amount of physical memory found, rounded up to the nearest megabyte. The test options enable you to choose the amount of memory to be read.



**FIGURE 27-2** pmem UltraSPARC Server Option Menu

In the case of UltraSPARC servers, the configuration field lists the banks of memory on each cpu or memory board separately. When physical mapping is used pmem test is registered for each cpu or memory board separately.

---

# pmem Test Modes

TABLE 27-1 pmem Test Modes

Test Mode	Description
Connection Test	In this mode, 1 percent of the memory is read; pmem also informs the user of how much physical memory is available. For sun4m, sun4u, and UltraSPARC servers, the test reports the ECC errors that have occurred since it was last invoked. The test reports ECC errors for a particular CPU or memory board when physical mapping is selected, otherwise it provides the SIMM number of the ECC memory error.
Functional Test	In Functional test, the amount of memory to be read can vary; the default is 100 percent. For UltraSPARC servers, this test mode reports all ECC errors that have occurred since the system was brought online
Online Mode	Provides a means to run pmem through SyMON. In Online mode, the following Functional Test description applies: A variable amount of memory is read in Online mode; the default is 100 percent. For UltraSPARC servers, the ECC error reporting is the same as for the Connection test.

---

# pmem Command Line Syntax

```
/opt/SUNWvts/bin/pmem standard_arguments [-p=n] [-i=n] [-w=n] [size=n] [binfo=n]
```

TABLE 27-2 pmem Command Line Syntax

Argument	Explanation
size= <i>number</i>	Specifies the percentage of memory to be read.
binfo= <i>number</i>	For UltraSPARC servers, indicates board number information. For example, if board 0 and board 5 have memory and you want the test to read the memory on these two boards, then binfo=33 (2*5 + 2*0).

# pmem Error Messages

TABLE 27-3 pmem Error Messages

Error Message	Probable Cause(s)	Recommended Action
6003 <i>number</i> intermittent errors on <i>text</i> . <i>text</i> would indicate the SIMM locations		
6004 Symbol <i>text</i> not found in kernel image. <i>text</i> will indicate the name of the symbol not found in the kernel image		
6005 <i>number</i> persistent errors on <i>text</i> SIMM(s). <i>text</i> would indicate the SIMM locations	SIMM(s), check the SIMM location	Call your Sun service representative.
8000 <code>kvm_open()</code> failed: <i>error_message</i>		
8001 <code>sysinfo(SI_PLATFORM)</code> failed: <i>error_message</i>		
8002 Symbol <i>text</i> not found in kernel image. <i>text</i> will indicate the name of the symbol not found in the kernel image		
8003 Couldn't open file <code>/dev/mem</code> : <i>error_message</i>		
8004 Unable to read pointer to memlist structure		
8005 Unable to read "size" and "address" in memlist		
8006 <code>llseek()</code> to address <i>address</i> failed ( <i>error_message</i> )		
8007 <code>read()</code> at address <i>address</i> failed ( <i>error_message</i> )		
8008 <code>sysconf(_SC_NPROCESSORS_ONLN)</code> failed: <i>error_message</i>		

**TABLE 27-3** pmem Error Messages (Continued)

	Error Message	Probable Cause(s)	Recommended Action
8009	llseek to address <i>address</i> failed ( <i>error_message</i> )		
8010	llseek to address <i>address</i> [ <i>text</i> ] failed ( <i>error_message</i> )	This message is seen on UltraSPARC servers only. The <i>text</i> indicates to which board and bank the physical address <i>address</i> maps.	
8011	read() at address <i>address</i> [ <i>text</i> ] failed ( <i>error_message</i> )	This message is seen on UltraSPARC servers only. The <i>text</i> indicates to which board and bank the physical address <i>address</i> maps.	





## Prestoserve Test (`pstest`)

---

Prestoserve™ is an NFS accelerator. It reduces the frequency of disk I/O access by caching the written data blocks in nonvolatile memory. Prestoserve then flushes the cached data to disk asynchronously, as necessary.

`pstest` verifies the Prestoserve accelerator's functionality with the following three checks:

- Board Battery Check

To ensure proper battery power level, the test runs this check before running the other two checks. If it finds a bad battery, it exits `pstest` immediately with a fatal error message.

- Board Memory Check

This check maps the entire board memory to a process address space and locks the board to prevent multiple accesses. The test then travels through the mapped address spaces sequentially, doing a character, short, and long comparison on each space. The `pstest` runs this check twice.

- Board Performance and File I/O Access Check

This check exercises only synchronous read/write access. `pstest` writes data equal to the amount of on-board memory to the memory cache and reads the data back for comparison. The time taken to write that data is measured twice: the first time with the Prestoserve accelerator disabled, the second time with Prestoserve enabled. The first value is divided by the second to get the performance ratio. If the ration is less than 1.5 on three passes of the test, the Prestoserve board may or may not have a problem.

Since the Prestoserve accelerator speeds up the `/opt` partition during testing and this partition may be mounted remotely, there may or may not be a problem with the Prestoserve board itself, a network performance problem could be the problem. In either case, a warning message is displayed if the performance ratio is less than 1:5.



---

**Caution** – To ensure consistent results, run as many concurrent tests as possible when a Prestoserve product has been installed. Tests are selected from the Option menu. The default is 2; the maximum is 10. However, do not run `pstest` and `kmem` tests at the same time. Running these tests together causes SunVTS to report erroneous errors.

---

## pstest Options

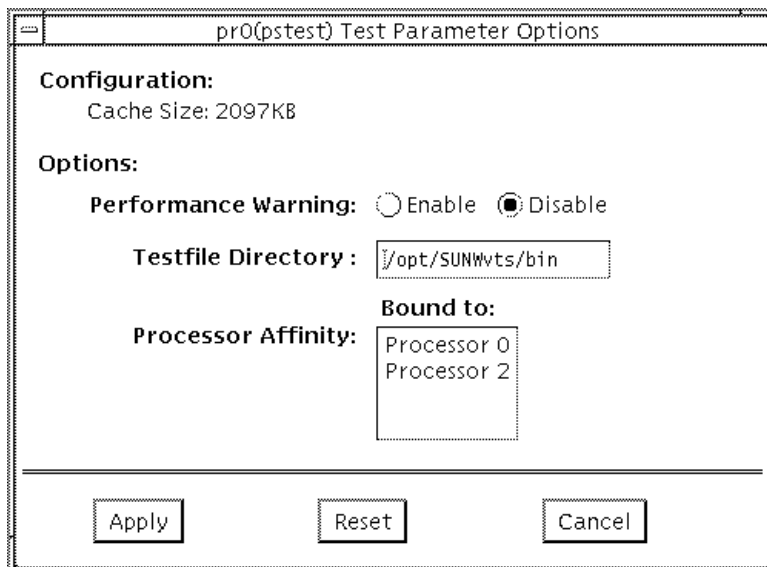

FIGURE 28-1 `pstest` Option Menu

---

# pstest Test Modes

**TABLE 28-1** pstest Test Modes

Test Mode	Description
Functional Test	The test runs the Board Battery Check subtest, Board Memory Check subtest, and Board Performance and File I/O Access Check subtest.

---

# pstest Command Line Syntax

`/opt/SUNWvts/bin/pstest standard_argument -o e,1,f=testfile_directory`

**TABLE 28-2** pstest Command Line Syntax

Argument	Explanation
e	Enables performance warning, which displays a warning message if the performance ratio is less than 1:5.
1	Enables the long memory test.
f=testfile_directory	Specifies the directory of a test file.

---

# pstest Error Messages

TABLE 28-3 pstest Error Messages

Error Message	Probable Cause(s)	Recommended Action
6001	Checking prstatus failed:	
6002	Failed to turn prestoserve DOWN:	
6003	File I/O test failed with low performance ratio: <i>number</i>	Check that Prestoserve is configured for /tmp.
6004	byte compare: location = <i>address</i> , observed = <i>number</i> , expected = <i>number</i>	
6005	word compare: location = <i>address</i> , observed = <i>number</i> , expected = <i>number</i>	
6006	(data type) long compare: location = <i>address</i> , observed = <i>number</i> , expected = <i>number</i>	
6007	lseek() failed:	
6008	NVRAM write failed:	
6009	NVRAM read failed:	
6010	Failed to get status of Prestoserve failed:	
6011	Failed to reinitialize Prestoserve:	
6012	Failed to turn prestoserve UP:	
6013	Failed to munmap prestoserve:	
6014	File write failed:	
6015	File read failed:	
6016	Data compare failed	
6017	Failed to restore prestoserve state: %s	

**TABLE 28-3** pctest Error Messages (Continued)

Error Message	Probable Cause(s)	Recommended Action
6018 Prestoserve test is applicable in Functional test only		
8001 Failed to open prestoserve board:	Prestoserve hardware not installed. <hr/> NVSIMM/NVRAM SBus board not seated correctly. <hr/> Prestoserve software not installed. <hr/> Not in superuser mode.	
8002 Prestoserve is in the ERROR state	Errors occurred on a disk drive.	
8003 Some batteries are not good or not enabled		
8004 memory_check (pass <i>pass_id</i> ) failed		
8005 fileio_check (pass <i>pass_id</i> ) failed		
8006 File I/O test failed (Prestoserve down)		
8007 File I/O test failed (Prestoserve up)		
8008 Open %s also failed: %s. Please enter test file directory		
8009 PRESTOSERVE TESTS FAILED!		



## SunVideo Test (`rtvctest`)

---

`rtvctest` verifies the functionality of the SunVideo™ SBus card. SunVideo technology captures and compresses video input in realtime, making it possible to have realtime video conferencing over standard Ethernet networks.

`rtvctest` is available as a `customtest`. To display the test on the SunVTS user interface, you must:

1. Edit the `.customtest_OtherDevices` file in the SunVTS bin directory.
2. Uncomment the line starting with the label `SunVideo`.

The `rtvctest` was originally written for `Sundiag™` and the messages from the test are displayed on the SunVTS console within a SunVTS INFO message wrapper.

The `rtvctest` is available under the `OtherDevices` group, and is only available in the Functional Test mode.

---

### `rtvctest` Subtests

`rtvctest` is divided into four subtests: `PROMCheck`, `Memory`, `Jalapeno`, and `CL4000`. The `PROMCheck` subtest verifies the SunVideo card's programmable read-only memory. The `memory` test verifies all of the memory on the card, including the 2 Mbytes of memory on the CL4000 compression engine and the memory on the Jalapeno application-specific integrated circuit (ASIC). The `Jalapeno` subtest verifies the interface logic between the SBus, A/D conversion chips, and the CL4000 compression engine. The `CL400` subtest verifies that the compression engine ASIC is able to compress digitized video data from the A/D chips and send this data to the SBus through the Jalapeno ASIC.

The `rtvctest` is composed of 49 verification test modules. TABLE 29-1 lists these modules and their associated test sequence numbers.

**TABLE 29-1** `rtvctest` Verification Modules

SunVideo Verification Module Name	Test Sequence Number
RTVC SUNDIAG Start	0
RTVC Checksum	1
RTVC Jalapeno SMEM	2
RTVC CL4000 DMEM	3
RTVC Jalapeno SBus Interrupt Mask	4
RTVC CL4000 Interrupt Mask	5
RTVC DVMA Control Register	6
RTVC DVMA Transfer Size Counter	7
RTVC DVMA Memory Address Counter	8
RTVC DVMA Virtual Memory Address Counter	9
RTVC DVMA Slave SBus Rerun Register	10
RTVC IIC Control Register	11
RTVC IIC Data Register	12
RTVC Video DMA Control Register	13
RTVC Video DMA Transfer Size Counter	14
RTVC Video DMA Memory Address Counter	15
RTVC User Interrupt 0	16
RTVC User Interrupt 1	17
RTVC User Interrupt 2	18
RTVC User Interrupt 3	19
RTVC Video Control and Status Register	20
RTVC Video Control Field Line Interrupt 1	21
RTVC Video Control Field Line Interrupt 2	22
RTVC Video Scan Line Mask Registers	23
RTVC Video Input Format Type	25
RTVC Video Horizontal Lock	26
RTVC Video Even Odd Field	27
RTVC CL4000 Host Control	28



**TABLE 29-1** `rtvctest` Verification Modules (Continued)

SunVideo Verification Module Name	Test Sequence Number
RTVC CL4000 Host Lock	29
RTVC CL4000 Video Port A Control	30
RTVC CL4000 Video Port B Control	31
RTVC CL4000 Video Port A FIFO	32
RTVC CL4000 Video Port B FIFO	33
RTVC CL4000 Address Memory Registers	34
RTVC CL4000 Instruction Memory Access Registers	35
RTVC Time Stamp Register	36
RTVC CL4000 Register Memory	37
RTVC CL4000 Scratch Memory	38
RTVC CL4000 DMA Mode	39
RTVC CL4000 Motion Estimation Registers	40
RTVC CL4000 PSW	41
RTVC CL4000 Variable Length Coder Registers	42
RTVC CL4000 Channel Memory Registers	43
RTVC CL4000 CPU Control	44
RTVC CL4000 Multiply Control	45
RTVC CL4000 DMA Interrupt Control	46
RTVC CL4000 Block Transfer Mode	47
RTVC CL4000 Accumulator MSB	48
RTVC CL4000 JPC Field	49
RTVC SUNDIAG Finish	50

# rtvctest Options

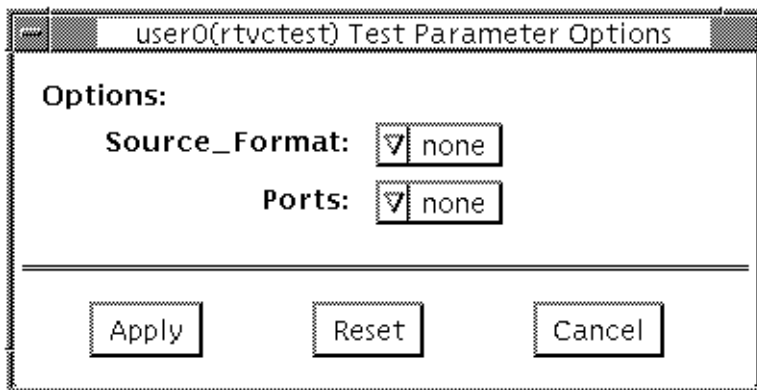

FIGURE 29-1 rtvctest Option Window

You may test the SunVideo card without any video device (camera, video disc player, or VCR) connected to an input port. However, if you connect a video device to the card, then you must state the format of the video source and the input port to which the device is connected.

---

**Note** – If you do not state both the video source and the input port, the `rtvctest` prints an error and terminates testing.

---

## Source Format

Select the format of the video source used for testing. You may select from the sources shown in TABLE 29-2.:

TABLE 29-2 rtvctest Source Format Options

Video Source	Definition
None	No video source.
NTSC	National Television System Committee (NTSC) video source, which is the video standard in the United States and Japan.
PAL	Phase alternate line video source, which is the video standard in Europe.

# Ports

If you have selected a video source for testing, then you must state which input port you have used to connect the source to the SunVideo card. You may select from the ports shown in TABLE 29-3:

TABLE 29-3 `rtvctest` Port Options

Input Port	Definition
None	No input port used.
CV1	Composite video input Port 1 (RCA type input).
CV2	Composite video input Port 2 (RCA type input).
SVHS	Super VHS input port.

---

## `rtvctest` Command Line Syntax

```
/opt/SUNWvts/bin/rtvctest [fmt=none|ntsc|pal]
[port=none|cv1|cv2|svhs] dev=rtvc_device
```

TABLE 29-4 `rtvctest` Command Line Syntax

Arguments	Description
<code>fmt</code>	Select the format of the video source used for testing. Select either <code>ntsc</code> (video standard in the United States and Japan) or <code>pal</code> (video standard in Europe).
<code>port</code>	If you have selected a video source for testing, then you must state which input port you have used to connect the source to the SunVideo card. You may select from the following ports: <ul style="list-style-type: none"><li>• <code>cv1</code> Composite video input port 1 (RCA type)</li><li>• <code>cv2</code> Composite video input port 2 (RCA type)</li><li>• <code>svhs</code> Super VHS port</li></ul>
<code>dev</code>	You are required to state the SunVideo device when running the <code>rtvctest</code> from the command line. Replace <code>rtvc_device</code> with <code>rtvcn</code> , where <code>n</code> is the device number (from 0 to 31) of the SunVideo card being tested.

---

# rtvctest Error Messages

**TABLE 29-5** rtvctest Error Messages

Error Message	Description
SunVideo 10	<i>message</i> Where: <i>message</i> is one of the following: Missing REQUIRED argument D=rtvc[0..31]
SunVideo 20	<i>message</i> Error # <i>number</i> Where: <i>message</i> is one of the following: ioctl RTVC_CMD_RESET fault ioctl RTVC_CMD_SET_VIDEO fault ioctl RTVC_CMD_GET_VIDEO fault open /dev/rtvc fault close /dev/rtvc fault open /dev/rtvcctl fault close /dev/rtvcctl fault Unknown Jalapeno Version <i>number</i> is one of the following: ioctl error module version
SunVideo 30	<i>message name</i> Error # <i>number</i> Where: <i>message</i> is one of the following: memory map fault for memory unmap fault for selected /dev/rtvc and /dev/rtvcctl not available. <i>name</i> is one of the following: prom sram buses reset dmem rtvc <i>number</i> is the error number

**TABLE 29-5** rtvctest Error Messages (Continued)

Error Message	Description
SunVideo 40	<p>RTVC Fault Detected via module <i>name</i>            Physical Address <i>value</i> Expected Value <i>value</i> Actual Value <i>value</i>            RTVC Sundiag Module number <i>number</i>            Location <i>location</i>            Message: <i>message(s)</i>            Where:  <i>name</i> is the name of the module under test  <i>value</i> are the values associated with physical address, expected value, actual value  <i>number</i> is the Sundiag Module under test.  <i>location</i> is the U location of the faulty component.  <i>message(s)</i> are any additional messages.</p>
SunVideo 41	<p>RTVC Fault Detected via module <i>name</i>            Where:  <i>name</i> is the name of the module under test.</p>
SunVideo 42	<p><i>message value1</i> Actual <i>value2</i>            Where:  <i>message</i> is one of the following:            Video Format Expected            Video Port Expected  <i>value1</i> is the expected value.  <i>value2</i> is the actual value.</p>
SunVideo 50	<p><i>message number</i>            Where:  <i>message</i> is one of the following:            Unknown RTVC CL4000 test module            Unknown RTVC Jalapeno test module            Unknown RTVC test module            Unknown RTVC memory test module            Unknown Start Bit  <i>number</i> is the module number or start bit location.</p>



## *Serial Asynchronous Interface (PCI) Test (saiptest)*

---

`saiptest` checks the functionality of the Serial Asynchronous Interface card through its device driver.

---

### `saiptest` Hardware Requirements

Before running the SunVTS diagnostics software, make sure you install the device driver and the cards to be tested. Also, you should reboot your system with the `boot -r` command to reconfigure the system and allow the SunVTS kernel to recognize the new driver.

---

**Note** – You must run the `saiptest` in intervention mode.

---

The following minimum hardware configuration is required to successfully run the Internal test:

- PCI-based SPARC desktop system with a PCI slot
- Serial Asynchronous Interface card, installed in one of the PCI slots

The following hardware is also required to run other SunVTS Serial Asynchronous Interface tests:

- Serial Asynchronous Interface Patch Panel (Part No. 7600-0027)
- 25-pin serial loopback plugs (Part No. 540-1558)
- RS-232 serial cables (Part No. 530-1685)
- TTY terminal

# saiptest Options

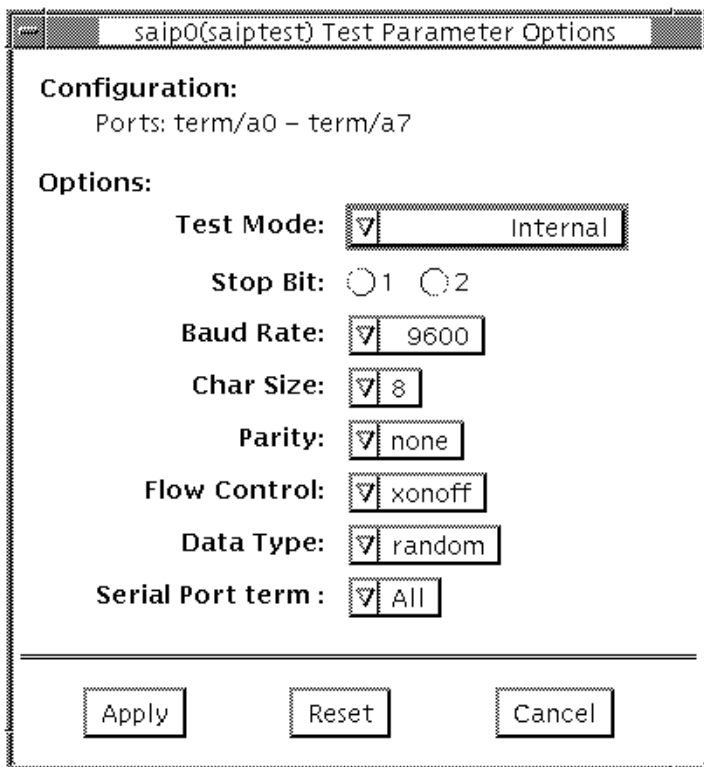

Figure 30-1 saiptest Options Menu

The Configuration section of the option menu displays the asynchronous serial ports available for the Serial Asynchronous Interface board. Table 4-1 shows the available ports.

Table 30-1 saiptest Asynchronous Serial Ports

Board Number	Board Device	Serial Ports
0	saip0	term/a000-a007
1	saip1	term/b000-b007
2	saip2	term/c000-c007
3	saip3	term/d000-d007



**Table 30-1** saiptest Asynchronous Serial Ports (Continued)

Board Number	Board Device	Serial Ports
4	saip4	term/e000-e007
5	saip5	term/f000-f007
6	saip6	term/g000-g007
7	saip7	term/h000-h007
8	saip8	term/i000-i007
9	saip9	term/j000-j007
10	saip10	term/k000-k007
11	saip11	term/l000-l007

**Table 30-2** saiptest Options

saiptest Option	Description
Internal Test	Performs internal loopback testing on the Serial Asynchronous Interface card(s) installed in PCI slots. You do not need to attach anything to the card(s) to perform this test.
25-pin Loopback	Provides full-duplex transmission and full-modem loopback testing of the serial port selected in the Serial Port section of the option menu. You must attach the 25-pin loopback plug to the serial port on the Serial Asynchronous Interface Patch Panel that is being tested. This test cannot be run concurrently with the Echo-TTY option enabled.
Echo-TTY	Checks the proper operation of the serial port selected in the Serial Port selection of the option menu by echoing characters typed on a TTY terminal keyboard to the TTY terminal screen. The characters you type on your TTY keyboard display on the TTY screen. <b>NOTE:</b> A TTY connection to the Serial Asynchronous Interface serial port requires corresponding character size set up. For example, if a TTY attachment is running with 8-bit character size, then the Char Size saiptest option should be set to 8-bits. If you do not type any characters within two minutes, this test times-out.

**Table 30-2** saiptest Options (*Continued*)

<code>saiptest</code> Option	Description
Baud Rate	Specifies the baud rate; choose 110, 300, 600, 1200, 2400, 4800, 9600, 19200, or 38400 baud. <b>NOTE:</b> The baud rate of 38400 can only be used if the Internal Test is disabled and you are testing one port at a time.
Char Size	Specifies the character length; choose 5, 6, 7, or 8 characters.
Stop Bit	Specifies the number of stop bits; choose 1 or 2 bits.
Parity	Specifies the selectable parity; choose none, odd, or even.
Flow Control	Specifies the selectable flow control; choose XOnOff, rtscts, or both.
Data Type	Specifies the selectable data type pattern; choose 0x55555555 (0x55), 0xaaaaaaaa (0xaa), or random.
Serial Port	Specifies the serial port to be tested. The available ports are listed in the Configurations section at the top of the <code>saiptest</code> options menu.

---

## saiptest Test Modes

`saiptest` is only available in the Functional Test mode.

# saiptest Command Line Syntax

```
/opt/SUNWvts/bin/saiptest standard_arguments -o dev=device_name,  
M=test_mode,B=baud_rate,Size=character_size,Stop=#of_stop_bits,  
Parity=parity,F=flow_control,Data=test_pattern,sp=serial_port
```

**Table 30-3** saiptest Command Line Syntax

Argument	Explanation
dev=device_name	Specifies the asynchronous serial ports of the PCI card slots tested. Since there is no default, you must type a device name—either a board(saip0-12) or an individual port (term/x000-term/x007, where x is a-l): <ul style="list-style-type: none"><li>•saip0 = the 8 asynchronous serial ports in the first card</li><li>•saip1 = the 8 asynchronous serial ports in the second card</li><li>•saip2 = the 8 asynchronous serial ports in the third card</li><li>•saip3 = the 8 asynchronous serial ports in the fourth card</li><li>•saip4 = the 8 asynchronous serial ports in the fifth card</li><li>•saip5 = the 8 asynchronous serial ports in the sixth card</li><li>•saip6 = the 8 asynchronous serial ports in the seventh card</li><li>•saip7 = the 8 asynchronous serial ports in the eighth card</li><li>•saip8 = the 8 asynchronous serial ports in the ninth card</li><li>•saip9 = the 8 asynchronous serial ports in the tenth card</li><li>•saip10 = the 8 asynchronous serial ports in the eleventh card</li><li>•saip11 = the 8 asynchronous serial ports in the twelfth card</li></ul> or /dev/term/x00m Where x is a-l and m is 0 to 7 (any of the asynchronous serial ports in PCI card slots).
M=test_mode	Specifies Internal, 25_pin_loopback, or Echo_TTY test mode.
B=baud_rate	Sets the baud rate to 110, 300, 600, 1200, 2400, 4800, 9600, 19200, 38400; the default is 9600.
Stop=#of_stop_bits	Toggles the number of stop bits between 1 or 2; the default is 1.
Size=character_size	Sets the character size as an integer between 5 and 8.
Parity=parity	Specifies the parity as none, odd, or even; the default is none.
F=flow_control	Specifies flow control as xonoff, rtscts, or both.
Data=test_pattern	Specifies test pattern as 0x55555555, 0xAAAAAAAA, or random.
sp=serial_port	Specifies the terminal and asynchronous serial port number, such as term/a003.

---

## saiptest Error Messages

The saiptest error messages are generated when the SunVTS Serial Asynchronous Interface discovers errors. The error descriptions in Table 30-4 identify probable causes for the card or test failure, and identify the Field Replaceable Unit (FRU) and recommended action, if possible. The three FRUs under test are: the Serial Asynchronous Interface card, the 78-pin shielded cable, and the Patch panel.

**Table 30-4** saiptest Error Messages

Error Message	Probable Cause(s)	Recommended Action
6000	<i>error_message</i>	
6001	Expected = <i>value</i> , observed = <i>value</i>	
6002	Expected <i>value</i> :	
6003	Observed <i>value</i> :	
6004	Modem Loopback test failed on <i>device_name</i>	
6005	Off-line error on device <i>device_name</i>	
6007	Busy error on device <i>device_name</i>	
6008	Error on device <i>device_name</i>	
6009	Retry <i>number</i> exceeds limit <i>number</i> rc =s <i>value</i>	
6010	Expected <i>number</i> bytes, observed <i>number</i> bytes	
6011	Internal test failed on <i>device_name</i>	
6012	Data Loopback test failed on <i>device_name</i>	
6013	Ioctl TIOCSSOFTCAR error on <i>device_name</i>	
8000	Must provide device name!	
8001	No SAI/P card found or device driver not installed	

**Table 30-4** saiptest Error Messages (Continued)

<b>Error Message</b>	<b>Probable Cause(s)</b>	<b>Recommended Action</b>
8002 Ioctl TCSETS failed on <i>device_name</i>		
8003 Open error on <i>device_name</i> - device driver may not be installed properly		
8004 Device <i>device_name</i> is already opened		
8005 Ioctl SAIP_ENLOOP error in <i>device_name</i>		
8006 Ioctl SAIP_DISLOOP error in <i>device_name</i>		
8011 Ioctl TIOCMGET failed on <i>device_name</i>		
8012 <i>device_name</i> : Expected DSR set, observed clear		
8013 <i>device_name</i> : Expected DSR clear, observed set		
8014 Ioctl TIOCMSET failed on <i>device_name</i>		
8015 Ioctl TIOCMBIC failed on <i>device_name</i>		
8016 Read error on <i>device_name</i>		
8017 Write error on <i>device_name</i>		
8020 Timeout error on <i>device_name</i>	No loopback plug.	Check the loopback plug.
8021 Timeout error on <i>device_name</i>	TTY terminal not connected.	Check the TTY terminal connected to the device.
8022 Timeout error on <i>device_name</i>		



## Sun Enterprise Cluster 2.0 Network Hardware Test (`scitest`)

---

`scitest` verifies the functionality of the Sun Enterprise Cluster 2.0 by checking the networking hardware. For this test to be meaningful, the cluster must already be configured before the test is run. For details on how to configure the cluster, refer to *Sun Enterprise Cluster 2.0 Hardware Site Preparation, Planning, and Installation Guide*.

`scitest` reads the `/etc/sma.ip` file to determine the target nodes in the cluster. `scitest` mainly uses the Internet Control Message Protocol (ICMP) to test the connections between cluster nodes.

After finding the cluster nodes (targets), `scitest` performs the following tests:

- **Random test** sends out 256 packets with random data length and random data.
- **Incremental test** sends out packets with length from minimum to maximum packet size using incremental data.
- **Pattern test** sends 256 packets of maximum length, where each packet contains one test pattern and all byte patterns (0 to 0xFF) are used.

---

**Note** – `scitest` is a scalable test. The maximum number of instances is two per SCI card.

---

# scitest Options

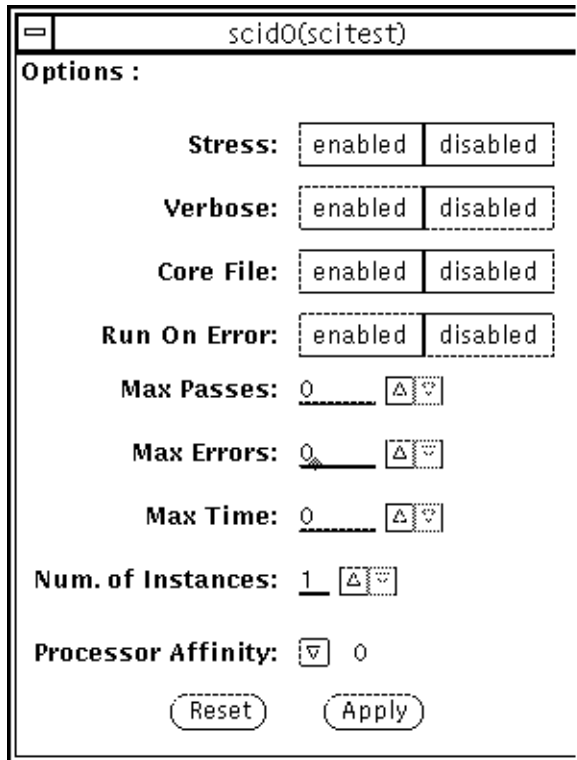

FIGURE 31-1 scitest Option Menu

TABLE 31-1 scitest Options

scitest Options	Description
Target Host	Not used.
Receive Timeout field	Specify a number between 0–600 seconds. The default is 120 seconds.
Number of Retries field	The number of retries before an error is flagged. Specify a number between 0–128.
Print Warning	Disabled by default. Choose Enable to see warning errors, such as retry on timeout errors.



---

# scitest Test Modes

Connection, Functional and Online modes are supported by `scitest`. Different test schemes are performed on the network device based on the mode selected.

**TABLE 31-2** `scitest` Test Modes

Test Mode	Description
Connection Test	<code>scitest</code> checks if the device is connected. It searches through all the network interfaces for the specified device name. <code>scitest</code> finds the device not connected the test fails, otherwise, it returns device is connected.
Functional Test	<code>scitest</code> performs all three tests (Random test, Incremental test, and Pattern test) sequentially. It allows you to specify an option in such a way that <code>scitest</code> performs a very stressful test.
Online Mode	Running <code>scitest</code> through SyMON. In Online mode, the following Functional Test description applies: <code>scitest</code> is aware that the user's application may be running, it tries to minimize the influence on the application while it is testing by only running the random test. Since the network device is shared and system resources are available, applications will not be heavily impacted.

---

# scitest Command Line Syntax

```
/opt/SUNWvts/bin/scitest standard_arguments -o  
dev=interface,test=type,packets=n,pattern=hex,delay=seconds,  
timeout=seconds,retry=n,warn
```

**TABLE 31-3** `scitest` Command Line Syntax

Argument	Explanation
<code>dev=interface</code>	Network interface name. The default value is <code>1e0</code> for Ethernet networks.
<code>test=type</code>	The test type. Specify <code>random</code> , <code>increment</code> , or <code>pattern</code> . The default value is <code>random+increment+pattern</code> to run.
<code>packets=n</code>	Number of random/pattern packets. The default is 256.

**TABLE 31-3** `scitest` Command Line Syntax

<b>Argument</b>	<b>Explanation (<i>Continued</i>)</b>
<code>pattern=hex</code>	Specifies a data pattern in hexadecimal form. The default is all patterns from 0 to 0xff.
<code>delay=seconds</code>	Indicates the time between subtests in seconds. The default is 30 seconds.
<code>timeout=seconds</code>	Indicates the number of seconds to wait before a timeout. The default is 20 seconds.
<code>retry=n</code>	Indicates the number of test timeout retries. The default is three retries.
<code>warn</code>	When enabled, prints warning messages.

---

# scitest Error Messages

**TABLE 31-4** scitest Error Messages

Error Message	Probable Cause(s)	Recommended Action
4001 Unable to communicate from <i>string</i>	SCI adapter failure or no cable connected.	Check cable connections. Replace the SCI adaptor.
4002 Can not access /etc/sma.ip file. "I WILL STOP TESTING SCI INTERFACES"	/etc/sma.ip is missing, or the cluster is not configured, or this is an old cluster version.	Use sm_config to configure the cluster. Restore the files from a backup tape. Specify the cluster machines in the target host of test options before running the test.
6000 RPC broadcast failure <i>error_message</i>		
6001 Unable to resolve <i>host_name</i> ethernet address		
6002 No ICMP echo reply from <i>string</i>	SCI adaptor failure or no cable connected.	Check cable connections. Replace the SCI adaptor.
6003 ICMP echo reply incorrect length from <i>host_name</i> , exp <i>data</i> obs <i>data</i>		
6004 ICMP echo reply length <i>number</i> from <i>host_name</i> , data mismatch at byte <i>number</i> , exp <i>value</i> obs <i>value</i>		
6005 Unable to find any test target		
8000 Unable to open <i>device_name</i> <i>error_message</i>		
8001 Bad ioctl <i>name</i> <i>error_message</i>		
8002 Unable to allocate <i>number</i> bytes of memory <i>error_message</i>		
8003 System call <i>name</i> returned <i>value</i> <i>error_message</i>		
8004 Unable to map network entry for <i>host_name</i>		

**TABLE 31-4** scitest Error Messages (Continued)

Error Message	Probable Cause(s)	Recommended Action
8006	Failed to allocate <i>number</i> bytes of swap space for configuration	
8007	dl_primitive response = <i>value</i>	
8008	dl_ok_ack: short response	
8009	dl_phys_addr_ack: short response	
8010	Invalid Argument <i>string</i>	
8011	Interface <i>device_name</i> not configured in system	
8012	SCITEST can not open/read /etc/sma.ip	

## Environmental Sensing Card Test ( `sentest` )

---

`sentest` checks the SCSI Environmental Sensing card (SEN) installed in the SPARCstorage RSM to monitor the enclosure environment. The SEN card monitors the enclosure's over-temperature condition, fan-failures, power-supply failures, and drive activity.

`sentest` verifies the SEN card by first setting each control function to a predetermined value, and then reading it back to verify if the value is correct.

`sentest` verifies the following control functions in the enclosure:

- **Alarm** (enable/disable)-`sentest` toggles the alarm to the disable state, then to the enable state.
- **Alarm time** (0-0xff seconds)-`sentest` sets the time (from 0 to 4095), then reads it back to verify the time setting.
- **Drive fault LED** (DL0-DL6)-`sentest` toggles each LED to its OFF and ON states.

`sentest` is a nonscalable test. It cannot verify the control function settings correctly if another instance is changing the setting.

---

# sentest Options

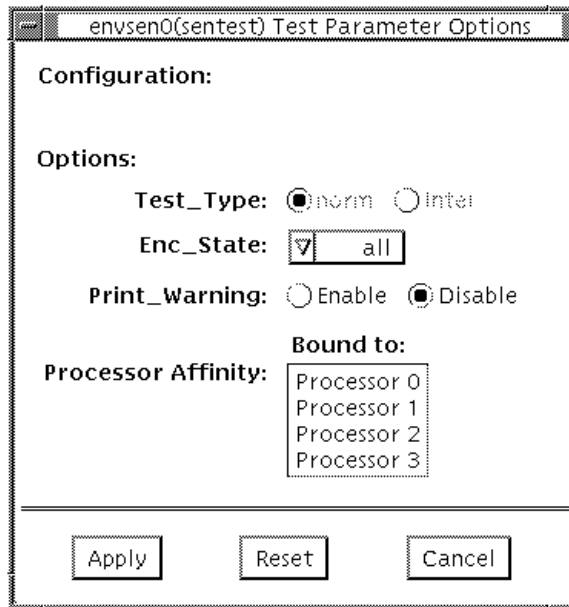

**FIGURE 32-1** sentest Options Menu

**TABLE 32-1** `sentest` Options

<code>sentest</code> Option	Description
Test Type	Specifies the test to be performed. <code>NORM</code> test type performs normal testing as alarm enable/disable, alarm time setting, and drive LED on/off testing; Interactive test type reports the current enclosure status.
Enc_state	Specifies which subsystem's status in the enclosure is reported. Default is <code>ALL</code> . This test is only used with the <code>inter</code> test type and in Functional test. The test options are: <ul style="list-style-type: none"> <li>• Alarm enable/disable status</li> <li>• Drive present status</li> <li>• Drive LED status</li> <li>• Power modules status</li> <li>• Fan modules status</li> <li>• Over temperature, <code>abs</code> (abnormal, no immediate attention needed), <code>chk</code> (abnormal, immediate attention needed) status</li> <li>• All of the above</li> </ul>

## `sentest` Test Modes

`sentest` supports all three test modes. Each mode performs a different test scheme on the SEN card.

**TABLE 32-2** `sentest` Test Modes

Test Mode	Description
Connection Test	Checks the device connection by opening the device. If the device does not open, the device is not connected.
Functional Test	Checks three components within the enclosure. It checks alarm enable/disable, alarm time setting, and the drive LEDs. It does not test the power on/off function (only functions whose values can be changed are tested).
Online Mode	Provides a means to run <code>sentest</code> through SyMON. In Online mode, the following Functional Test description applies: <code>sentest</code> opens the device and reports the current enclosure status.

---

# sentest Command Line Syntax

`/opt/SUNWvts/bin/sentest standard arguments`

`-o dev=interface, test=type, enc=component`

**TABLE 32-3** sentest Command Line Syntax

Argument	Explanation
<code>dev=interface</code>	SEN card device name; the default value is <code>ses0</code> .
<code>test=type</code>	Specifies the test type; select <code>Norm</code> for normal testing or <code>Inter</code> for interactive testing; the default value is <code>Norm</code> . Possible values are: <code>norm</code> and <code>inter</code> .
<code>enc=component</code>	Indicates which part of the enclosure status is reported; the default value is <code>ALL</code> . Possible values are: <code>enalm</code> , <code>dp</code> , <code>dl</code> , <code>pm</code> , <code>fan</code> , <code>ovt</code> , and <code>ALL</code> .

---

# sentest Error Messages

**TABLE 32-4** sentest Error Messages

Error Message	Probable Cause(s)	Recommended Action
6000 Check alenb failed, exp= <i>value</i> , obs= <i>value</i>		
6001 Check alenb failed, exp= <i>value</i> , obs= <i>value</i>		
6002 Check alenb failed, exp= <i>value</i> , obs= <i>value</i>		
6003 Check altime failed, exp time= <i>value</i> , obs= <i>value</i>		
6004 Fan failed		
6005 Dual fan failed		
6006 Enclosure over temperature		
6007 Device failed, need immediate attention		



**TABLE 32-4** sentest Error Messages (Continued)

Error Message	Probable Cause(s)	Recommended Action
6008	Power module A failed	
6009	power module B failed	
8000	power module B failed	
8001	ioctl get state failed, errmsg= <i>message</i>	
8002	ioctl get state failed, errmsg= <i>message</i>	



## Soc+ Host Adapter Card Test(socaltest)

socaltest aids the validation and fault isolation of the SOC+ host adapter card. In the case of a faulty card, the test tries to isolate the fault to the card, the GBIC module, or the DMA between the host adapter card and the host memory.

### socaltest Options

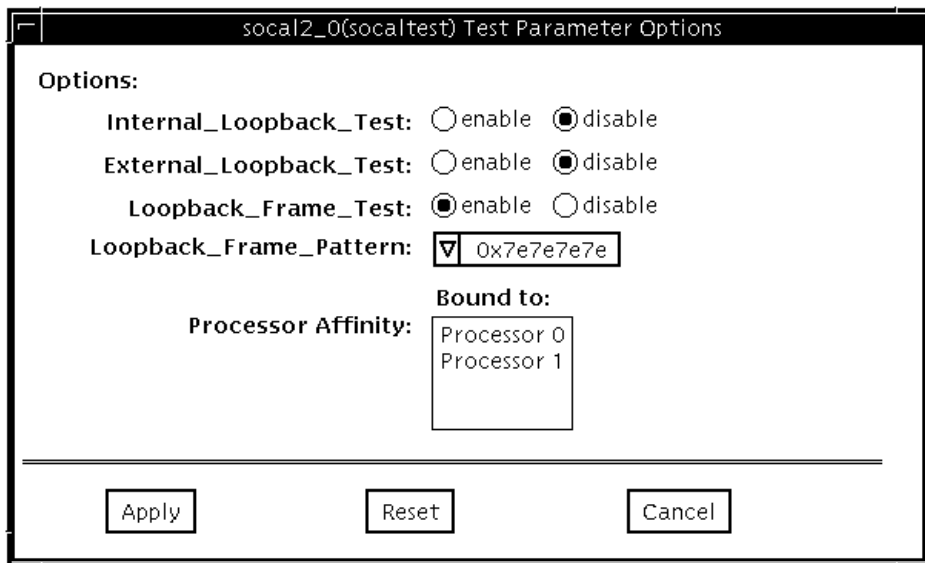

FIGURE 33-1 socaltest Options Menu

---

# socaltest Options

**TABLE 33-1** socaltest Options

socaltest Options	Description
Internal Loopback Test	<p>Checks the host adapter card and the direct memory access (DMA) with the host system. This is accomplished as follows:</p> <ul style="list-style-type: none"><li>• A frame is created in the host adapter local memory, sent out through the SOC+ transmitter and internally looped back to the SOC+ receiver. The received data is compared with the original data.</li><li>• A frame is created in the host adapter local memory, sent out through the SOC+ transmitter and looped back through the SERDES (serialiser-deserialiser) chip on the host adapter card. The received data is compared with the original data.</li><li>• A frame is created in the host main memory, transferred through the DMA to the host adapter transmitter, looped back within the SOC+ chip, and transferred from the receiver to the host main memory through the DMA. The received frame is compared with the original transmitted frame, which tests the host memory to the host adapter DMA path.</li></ul>
External Loopback Test	<p>The External Loopback Test verifies the proper functioning of the GBIC module. A frame is created in the host adapter local memory, sent out and looped back through the external loopback connector attached to the port. If the external loopback test is run together with the internal loopback test, the DMA path is also tested by creating a frame in host main memory, transferring it to the host adapter through the DMA, looping it back through the external loopback connector and transferring the received frame back to the host main memory by DMA.</p>
Loopback Frame Test	<p>Sends out a buffer initialized with the selected pattern and compares it with the looped back frame. It passes if the two compare and fails if they do not.</p>
Loopback Frame Pattern	<p>List of selectable patterns for the Loopback Frame Test.</p>

---

**Note** – In addition to the tests described above, `socaltest` also tests the basic functions of the SOC+ chip, the on-board XRAM, and the host control buffer by invoking the appropriate tests implemented in firmware.

---

---

## socaltest Test Modes

socaltest can only be run in the Functional Test modes.

---

**Note** – You cannot run the internal and external loopback tests if the port is connected to a disk array.

---

---

## socaltest Command Line Syntax

`/opt/SUNWvts/bin/socaltest` *standard arguments*

`-o dev=device`

*name, elb=enabled | disabled, ilb=enabled | disabled, lbf=enable | disable, ptn=pattern*

**TABLE 33-2** socaltest Command Line Syntax

Argument	Explanation
<code>dev=device name</code>	The name of the socal port to be tested.
<code>elb=enabled   disabled</code>	Enables or disables the external loopback test.
<code>ilb=enabled   disabled</code>	Enables or disables the internal loopback test.
<code>lbf=enable   disable</code>	Enables or disables the loopback frame test.
<code>ptn=pattern</code>	Specify the pattern in hexadecimal, for example: <code>ptn=0x7e7e7e7e</code>

# socaltest Error Messages

**TABLE 33-3** socaltest Error Messages

Error Message	Probable Cause(s)	Recommended Action
8000    Couldn't open <i>device_name</i>	SOC+ card not installed.	Verify that the target SOC+ card is installed properly.
8002    {SOC+ host adapter}-- {host memory} loopback test failed!	Fault in DMA between host and SOC+ host adapter.	Contact your authorized Sun service provider.
8006    SOC+ host adapter external loopback test failed!	Loopback cable not connected.	Connect loopback cable.
	OEC module faulty or not installed properly.	Replace OEC module and retry.  Contact your authorized Sun service provider.
8009    SOC+ host adapter internal loopback test failed!	SOC+ host adapter is faulty or is not properly installed.	Verify that the SOC+ host adapter is installed properly.
		Replace the host adapter and retry.  Contact your authorized Sun service provider.
8010    Failed ioctl <i>ioctl_name</i>	System error.	Contact your authorized Sun service provider.
8011    Host control buffer test failed	SOC+ host adapter is faulty.	Replace the host adapter and retry.
		Contact your authorized Sun service provider.
8012    SOC+ selftest fails	SOC+ host adapter is faulty.	Replace the host adapter and retry.
		Contact your authorized Sun service provider.

**TABLE 33-3** socaltest Error Messages (Continued)

Error Message	Probable Cause(s)	Recommended Action
8013 XRAM test fails	SOC+ host adapter is faulty.	Replace the host adapter and retry. Contact your authorized Sun service provider.
8015 Loopback frame test failed Mismatch in looped back frame Expected: <i>value</i> Observed: <i>value</i>		





## NeWSprinter Test (spdttest)

spdttest is a two-part test that checks the printer support hardware. The first part is a register test that checks the NeWSprinter™ 20 SBus printer card's internal functions. The second part is a printing test that checks the interaction between the printer and the print server, as well as the printer's capabilities.

### spdttest Options

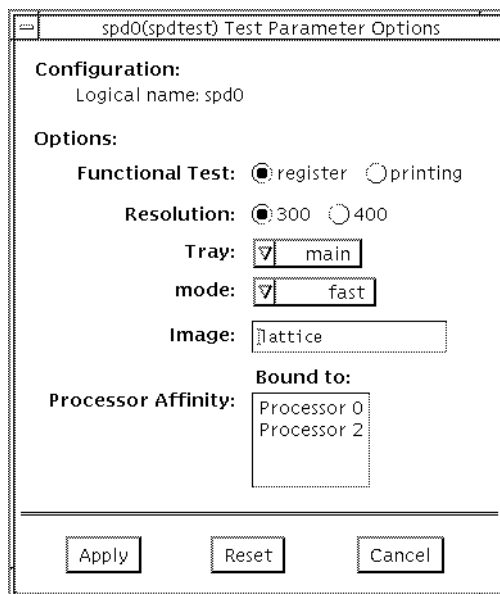

FIGURE 34-1 spdttest (NeWSprinter) Option Menu

**TABLE 34-1** spdtest Options

spdtest Options	Description
Functional Test	This test is composed of two subtests: <ul style="list-style-type: none"><li>•The <code>Register</code> subtest checks the NeWSprinter 20 SBus printer card.</li><li>•The <code>Printing</code> subtest tests the printer's capabilities. The default setting is <code>Register</code>.</li></ul>
Resolution	This exclusive setting defines the printer resolution of the printer test pattern. You can choose either 300 or 400 dots per inch (dpi). The default setting is 300 dpi.
Tray	From the Tray menu, you can choose from five types of paper cassettes: <ul style="list-style-type: none"><li>•Main Tray (or Tray 1) is the top cassette that feeds paper to the printer.</li><li>•Tray 2 is the bottom cassette that feeds paper to the printer.</li><li>•Tray 3 is an optional tray.</li><li>•Manual Tray is a manual feed tray connected to the rear of the printer. This tray is used to hand-feed print media that cannot be accommodated by the paper cassettes.</li><li>•Auxiliary Feeder is optionally installed in place of the manual feed tray. The Feeder stores and automatically feeds print media that would otherwise require the manual feed.</li></ul> The default setting is the Main tray.
Mode	From the Mode menu, you can set the interval at which images are printed. The choices are: <ul style="list-style-type: none"><li>•<code>Fast</code>: prints an image every 10 seconds.</li><li>•<code>Medium</code>: prints an image every 12 minutes.</li><li>•<code>Extended</code>: prints an image every 30 minutes.</li></ul> The default setting is <code>Fast</code> .
Image	Use this option to enter the file name of the test image to print.

---

## spdtest Test Mode

This test only supports the Functional Test mode.

---

# spdtest Command Line Syntax

`/opt/SUNWvts/bin/spdtest standard_arguments -o dev=device_name, func=function, reso=resolution, tray=tray, mode=mode, image=image`

**TABLE 34-2** `spdtest` Command Line Syntax

Argument	Explanation
<code>dev=device_name</code>	Specifies the full path name of the device.
<code>func=function</code>	Represents one of the following functional tests: register = Register test printing = Printing test
<code>reso=resolution</code>	Specifies a number that indicates print resolution: 300 = 300 dpi 400 = 400 dpi
<code>tray=tray</code>	Specifies a number that represents the printer cassette type: main = Main tray (Tray 1) tray2 = Tray 2 tray3 = Tray 3 (optional) manual = Manual Tray aux = Auxiliary feeder (optional)
<code>mode=mode</code>	Specifies a number that represents how often to print the test image: fast = Fast (Prints an image every 10 seconds) medium = Medium (Prints an image every 12 minutes) extended = Extended (Prints an image every 30 minutes)
<code>image=image</code>	Specifies a raster file name.

# spptest Error Messages

TABLE 34-3 spptest Error Messages

Error Message	Probable Cause(s)	Recommended Action
6000 Test function is not selected		Select from register and printing for the Functional Test (func) parameter.
6001 Error occurred while driver was running self diagnostics on spd device	Initialization Error.	Retry. If failure persists, contact your authorized Sun service provider.
6002 Error occurred while driver was running self diagnostics on spd device	Read/Write Error.	Retry. If failure persists, contact your authorized Sun service provider.
6003 Error occurred while driver was running self diagnostics on spd device	Loopback Error.	Retry. If failure persists, contact your authorized Sun service provider.
6004 Error occurred while printing raster image	Printer RAM failure.	Retry. If failure persists, contact your authorized Sun service provider.
6005 Error occurred while printing raster image	Printer motor failure.	Retry. If failure persists, contact your authorized Sun service provider.
6006 Error occurred while printing raster image	Printer ROS failure.	Retry. If failure persists, contact your authorized Sun service provider.
6007 Error occurred while printing raster image	Printer fuser failure.	Replace the fuser unit.
6008 Error occurred while printing raster image	Printer XERO failure.	Properly install or replace toner kit.
6009 Error occurred while printing raster image	No toner kit.	Install a new toner kit.
6010 Error occurred while printing raster image	Toner end of life.	Replace toner kit.
6011 Error occurred while printing raster image	Printer cover open.	Close the printer cover.
6012 Error occurred while printing raster image	Paper jam.	Clear the paper jam.
6013 Error occurred while printing raster image	No cassette in the selected tray.	

**TABLE 34-3** spdtest Error Messages (Continued)

	<b>Error Message</b>	<b>Probable Cause(s)</b>	<b>Recommended Action</b>
6014	Error occurred while printing raster image	No paper in the selected tray.	
6015	Error occurred while printing raster image	No paper in the manual tray.	
6023	Error occurred while printing raster image	Late error.	Retry. If failure persists, contact your authorized Sun service provider.
6024	Error occurred while printing raster image	Serial buffer overrun.	Retry. If failure persists, contact your authorized Sun service provider.
6025	Error occurred while printing raster image	Serial error.	Retry. If failure persists, contact your authorized Sun service provider.
6026	Error occurred while printing raster image, in setting tray or resolution		
6027	Error in setting tray or resolution		
6028	Error occurred while printing raster image	Specified file is not a raster file.	
6029	Error occurred while printing raster image	Specified file is not a raster file. Not enough memory.	
6030	Error occurred while printing raster image	File error: raster width does not fall on 32-bit boundary.	
6031	Failure to write raster header to file		
6032	Failure to write raster image to file		
8000	<i>device_name</i> not found	Device does not exist on system under test.	
8001	<i>device_name</i> could not be opened	The device is not configured correctly.	
8002	Image file could not be opened	The specified image file does not exist.	
8003	Invalid parameter(s)		Please refer to “spdtest Command Line Syntax” on page 313

**TABLE 34-3** spdtest Error Messages (Continued)

Error Message	Probable Cause(s)	Recommended Action
8004 Can not create raster file		Check the directory permission and user status.
8005 Error occurred while printing raster image	Printer power off.	
8006 Cannot get memory		

## Serial Parallel Controller Test ( `spif` )

---

The `spif` test accesses card components such as the `cd-180` and `ppc2` chips, and the serial and parallel ports through the serial parallel controller device driver.

---

### `spif` Hardware Requirements

Before running the SunVTS system exerciser, make sure you install the cards to be tested and the device driver. You should also reboot your system with the `boot -r` command to reconfigure the system and allow the SunVTS kernel to recognize the new driver.

---

**Note** – The `spif` test must be run in Intervention mode.

---

The following minimum hardware configuration is required to successfully run the Internal test:

- SBus-based SPARC desktop system with an SBus slot
- Serial parallel controller card, installed in one of the SBus slots

The following hardware is also required to run the other SunVTS serial parallel controller tests:

- Serial parallel controller patch panel (part number 540-2007)
- 96-pin loopback plugs (part number 370-1366)
- 25-pin serial loopback plugs (part number 540-1558)
- RS-232 serial cables (part number 530-1685)
- TTY terminal

# spif Options

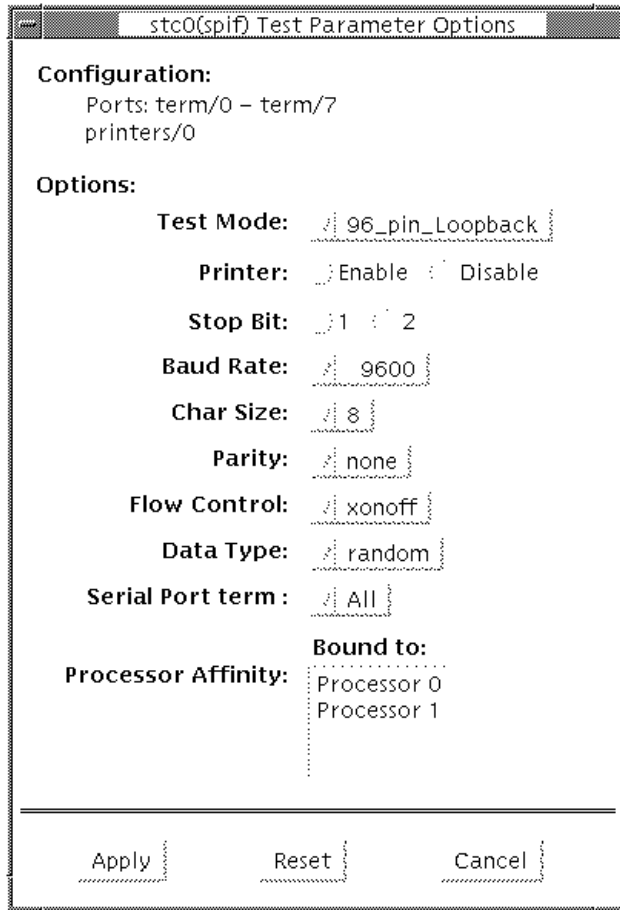

FIGURE 35-1 spif Option Menu



The Configuration section of the Option menu displays the serial ports available for the SPC/S board. The available ports are listed in TABLE 35-1.

**TABLE 35-1** `spif` Serial Ports for the SPC/S Board

Board Number	Board Device	Serial Ports	Parallel Ports
0	stc0	term/0-7	printers/0
1	stc1	term/8-15	printers/1
2	stc2	term/16-23	printers/2
3	stc3	term/24-31	printers/3
4	stc4	term/32-39	printers/4
5	stc5	term/40-47	printers/5
6	stc6	term/48-55	printers/6
7	stc7	term/56-63	printers/7

The `spif` test options are described in TABLE 35-2.

**TABLE 35-2** `spif` Options

<code>spif</code> Option	Description
96-pin Loopback (LB)	Provides data transmission, full-modem loopback, and parallel port loopback testing. You <i>must</i> attach a 96-pin loopback connector (part number 370-1366) to the card before running this test (see Appendix A, “96-Pin Female Loopback Connector”).
Internal Test	Performs a quick internal check of the serial parallel controller card(s) installed in SBus slots. You do not need to attach anything to the card(s) to perform this test.
25-pin Loopback (LB)	Provides full-duplex transmission and full-modem loopback testing of the serial port selected in the Serial Port selection of this menu. You <i>must</i> attach the 25-pin Loopback plug to the serial port on the Serial Parallel Controller Patch Panel that is being tested (See Appendix A). This test cannot be run concurrently with the Echo-TTY option enabled.

**TABLE 35-2** `spif` Options

<b>spif Option</b>	<b>Description</b>
Echo-TTY	Checks the proper operation of the serial port selected in the Serial Port section of this menu by echoing characters typed on a TTY terminal keyboard to the TTY terminal screen. The characters you type should be displayed on the TTY screen. Note: TTY connection to the <code>spif</code> serial port requires corresponding character size setup. For example, if a TTY attachment is running with 8-bit character size, then the <code>spif</code> test option 'Char Size' should also be set to 8 bits. If you do not type within two minutes, this test will time-out. Terminate testing by pressing Control-C. After a short delay, the Status window updates the Pass Count. This test cannot be run concurrently with the 25-pin Loopback subtest.
Printer	Sends the entire ASCII character set to a parallel printer. You must attach a parallel printer to the parallel port on the Serial Parallel Controller patch panel. Observe the printer output to validate the test.
Baud Rate	Specifies the baud rate; choose 110, 300, 600, 1200, 2400, 4800, 9600, 19200, or 38400 baud. Note: The baud rate of 38400 can only be used if one port is tested at a time and the Internal Test is disabled.
Char Size	Indicates character length; choose 5, 6, 7, or 8 characters.
Stop Bit	Specifies the number of stop bits; choose 1 or 2 bits.
Parity	Specifies the selectable parity; choose none, odd or even.
Flow Control	Specifies the selectable flow control; choices are XOnOff, rtscts, or both.
Data Type	Specifies the selectable data type pattern; it can be 0x55555555 (0x55), 0xaaaaaaaa (0xaa), or random.
Serial Port	Specifies the serial port to be tested. The available ports are listed in the Configurations section at the top of the <code>spif</code> Options menu.

You can also change the test options by modifying the `/opt/SUNWvts/bin/.customtest` file. See "Adding Your Own Tests" in `.customtest` in the *SunVTS 2.1 User's Guide*.

---

## `spif` Test Modes

The `spif` test supports only the Functional test mode.

# spif Command Line Syntax

`/opt/SUNWvts/bin/spif standard_arguments -o dev=device_name, M=test_mode, Ptr=enable/disable, B=baud_rate, Size=character_size, S=#of_stop_bits, Parity=parity, F=flow_control, Data=test_pattern, sp=serial_port`

TABLE 35-3 spif Command Line Syntax

Argument	Explanation
<code>dev=device_name</code>	<p>Specifies the serial ports in SBus card slots (0-63) being tested. Since there is no default, you must type a device name—either a board (stc0-7) or an individual port (term/0 - term/63):</p> <p>stc0 = the 8 serial ports in the first card stc1 = the 8 serial ports in the second card stc2 = the 8 serial ports in the third card stc3 = the 8 serial ports in the fourth card stc4 = the 8 serial ports in the fifth card stc5 = the 8 serial ports in the sixth card stc6 = the 8 serial ports in the seventh card stc7 = the 8 serial ports in the eighth card</p> <p>or</p> <p>/dev/term/mm</p> <p>Where <i>mm</i> is 0 to 63 (any of the serial ports in SBus card slots)</p>
<code>M=test_mode</code>	<p>Specifies <code>Internal</code>, <code>96_pin_loopback</code>, <code>25_pin_loopback</code>, or <code>Echo_TTY</code> test mode.</p>
<code>Ptr=printer_test</code>	<p>Enables or disables the Printer subtest.</p>
<code>B=baud_rate</code>	<p>Sets the baud rate to 110, 300, 600, 1200, 2400, 4800, 9600, 19200, or 38400; the default is 9600. To use the 38400 rate, only one port at a time can be tested, and the <code>Internal</code> test must be disabled.</p>
<code>Stop=#of_stop_bits</code>	<p>Toggles the number of stop bits between 1 or 2; the default is 1.</p>
<code>Size=character_size</code>	<p>Sets character size as a number between 5 and 8.</p>
<code>P=parity</code>	<p>Specifies the parity as none, odd, or even; the default is none.</p>
<code>F=flow_control</code>	<p>Specifies flow control as <code>xonxoff</code>, <code>rtscts</code>, or <code>both</code>.</p>
<code>Data=test_pattern</code>	<p>Specifies test pattern as <code>0x55555555</code>, <code>0xAAAAAAAA</code>, or <code>random</code>.</p>
<code>sp=serial_port</code>	<p>Specifies the terminal and serial port number, such as <code>term/3</code>.</p>

---

## spif Error Messages

These error messages are generated when the SunVTS serial parallel controller discovers any errors. The error descriptions below identify probable causes for the card or test failure, and identify the Field Replaceable Unit (FRU), if possible. The three FRUs affected are: the serial parallel controller card, the 96-pin shielded cable, and the patch panel.

TABLE 35-4 spif Error Messages

Error Message	Probable Cause(s)	Recommended Action
6000	<i>error_message</i>	
6001	Expected = <i>value</i> , observed = <i>value</i>	
6002	Expected <i>value</i> :	
6003	Observed <i>value</i> :	
6004	Modem Loopback test failed on <i>device_name</i>	
6005	Off-line error on device <i>device_name</i>	
6006	Paper out error on device <i>device_name</i>	
6007	Busy error on device <i>device_name</i>	
6008	Error on device <i>device_name</i>	
6009	retry <i>number</i> exceeds limit <i>number</i> rc =s <i>value</i>	
6010	Expected <i>number</i> bytes, observed <i>number</i> bytes	
6011	Internal test failed on <i>device_name</i>	
6012	Data Loopback test failed on <i>device_name</i>	
6013	ioctl TIOCSSOFTCAR error on <i>device_name</i>	
8000	Must provide device name!	

**TABLE 35-4** spif Error Messages (*Continued*)

	<b>Error Message</b>	<b>Probable Cause(s)</b>	<b>Recommended Action</b>
8001	No SPC/S card found or device driver not installed		
8002	ioctl TCSETS failed on <i>device_name</i>		
8003	Open error on <i>device_name</i> - device driver may not be installed properly		
8004	Device <i>device_name</i> is already opened		
8005	ioctl STC_SREGS(STC_IOREG-COR2) error in <i>device_name</i>		
8006	ioctl STC_GREGS(STC_IOREG-CCR) error in <i>device_name</i>		
8007	ioctl STC_S1REGS(STC_IOREG-CCR) error in <i>device_name</i>		
8008	ioctl STC_SREGS(STC_PPCREG-PDATA) error in <i>device_name</i>		
8009	ioctl STC_GREGS(STC_PPCREG-PDATA) error in <i>device_name</i>		
8011	ioctl TIOCMGET failed on <i>device_name</i>		
8012	<i>device_name</i> : Expected DSR set, observed clear		
8013	<i>device_name</i> : Expected DSR clear, observed set		
8014	ioctl TIOCMSET failed on <i>device_name</i>		
8015	ioctl TIOCMBIC failed on <i>device_name</i>		
8016	Read error on <i>device_name</i>		
8017	Write error on <i>device_name</i>		
8018	ioctl STC_GPPC error on device <i>device_name</i>		
8019	Can't kill all processes		

**TABLE 35-4** spif Error Messages (*Continued*)

<b>Error Message</b>	<b>Probable Cause(s)</b>	<b>Recommended Action</b>
8020 Timeout error on <i>device_name</i> .	There is no loopback plug	Check the loopback plug.
8021 Timeout error on <i>device_name</i>	TTY terminal not connected	Check the TTY terminal connection.
8022 Timeout error on <i>device_name</i>		

## Serial Ports Test ( `sptest` )

`sptest` checks the system's on-board serial ports (`zs[0,1]`, `zsh[0,1]`, `se[0,1]`, `se_hdlc[0,1]`), as well as any multi-terminal interface (ALM2) boards (`mcp[0-3]`). Data is written and read in asynchronous and synchronous modes utilizing various loopback paths.

Intervention mode must be enabled to run this test. This test is non-scalable.

**TABLE 36-1** Serial Port Tests

Mode	Description
Asynchronous Testing	<p>This mode uses the asynchronous communication protocol as described in the <code>zs(7D)</code> and <code>se(7D)</code> man pages. The <code>termio(7I)</code> interface is used for configuring port characteristics.</p> <p>The user can select the loopback paths to use, the amount of data to transfer, and the baud rate to use.</p> <p>The test writes and reads data through the loopback path and compares the data to the original data. The test first sends a single character. If no errors or timeouts are detected, the rest of the data is simultaneously written and read, then compared.</p>

**TABLE 36-1** Serial Port Tests (*Continued*)

Mode	Description
Synchronous Testing	<p data-bbox="515 241 1190 321">This mode uses the synchronous hdlc-framing interface as described in the <code>zsh(7D)</code> and <code>se_hdlc(7D)</code> man pages. Data is written and read in checksum-protected packets.</p> <p data-bbox="515 352 1179 378">The user can select the loopback paths to use and the clock rate.</p> <p data-bbox="515 409 958 435">The synchronous test runs in three phases:</p> <ul data-bbox="515 466 1200 933" style="list-style-type: none"><li data-bbox="515 466 1200 546">• The first phase looks for activity on the port. If no activity is detected for at least four seconds, the test proceeds to the next phase. If activity is detected <code>sptest</code> exits with an error.</li><li data-bbox="515 548 1200 687">• The second phase attempts to send and receive one packet. If no packets are detected after five attempts, the test exits with an error. If a packet is returned, the result is compared to the original. If the length and content of the packets do not match exactly, the test exits with an error.</li><li data-bbox="515 689 1200 933">• The third phase attempts to send many packets through the loop. Some packet drops are to be expected especially on a heavily loaded system. The test allows a percentage of the packets to be dropped. The user can set the drop tolerance between 0 percent and 99 percent. The default is 20 percent. If the system is extremely busy then the drop tolerance should be increased. Each packet is compared with its original for length and content. If a mismatch is detected, the test exits with an error.</li></ul>



---

# Synchronous Testing Software Requirements

If you have `zs(7D)` serial ports on your machine, the synchronous devices may not exist. Look in the `/dev` directory for `zsh` (where `h=0` and/or `1`). If they do not exist, you can create them. Verify that the following two lines are in the `/etc/devlink.tab` file. If they are not there, add them.

```
type=ddi_pseudo;name=zsh zsh\M0
type=ddi_pseudo;name=clone;minor=zsh zsh
```



---

**Caution** – The white spaces in the lines above *must* be a single tab character before and after the `zsh` variables; using spaces will not work.

---

When these lines have been added to the `/etc/devlink.tab` file:

- **Change directories to `/kernel/drv`, and run the `add_drv zsh` command.**

If this command does not work:

- **run the `rem_drv zsh` command and then run the `add_drv zsh` command again.**

# sptest Options

**se0(sptest) Test Parameter Options**

**Configuration:**  
port a = se0 = /dev/term/a = /devices/...se...a  
port b = se1 = /dev/term/b = /devices/...se...b

**Options:**

Test\_Type:

Loopback\_Type:

Test\_Mode:

Data\_Type:

Async\_Baud\_Rate:

Async\_Block\_Size:

Async\_Data\_Size:

Async\_Parity:

Async\_Flow\_Control:

Sync\_Baud\_Rate:

Sync\_Packet\_drop\_tolerance(%):

Sync\_Poll\_Wait(seconds):

FIGURE 36-1 sptest Option Menu

There are a variety of loopback paths available. The internal loopback paths do not require an external connector. Their availability depends on the device. The `zs(7D)` device has an internal path for synchronous mode and the `se(7D)` device has an internal path for asynchronous mode. The external loopback connectors are described in Appendix A. The exact type of loopback connector required depends on the system I/O panel.

Legend: In the following table, *a* represents port a of the CPU board (motherboard), *b* represents port b of the CPU board, and the device names of the ports for each CPU board are listed.

**TABLE 36-2** *sptest* Serial Devices

CPU	Port	Async Device	Sync Device
0	a	zs0 or se0	zsh0 or se_hdlc0
	b	zs1 or se1	zsh1 or se_hdlc1
1	a	zs2	zsh2 *
	b	zs3	zsh3 *
2	a	zs4	zsh4 *
	b	zs5	zsh5 *

\* Currently, only zsh0 and zsh1 are supported by device drivers.

**TABLE 36-3** *sptest* Options

<i>sptest</i> Options	Description
Test Type	Selects how the test will run. Test options include: <ul style="list-style-type: none"> <li>• a= runs the test on port a</li> <li>• b= runs the test on port b</li> <li>• a_b= runs the test on ports a and b sequentially</li> <li>• a_b_concurrent= runs the test on port a and port b concurrently.</li> </ul>
Test Mode	Selects the mode to put the serial device into before running the test. The modes available are Asynchronous, Synchronous or Both. When Both is selected, the test runs in Asynchronous mode then Synchronous mode.
Loopback Type	Selects the loopback test. Options include: <ul style="list-style-type: none"> <li>• Internal is an internal path for a, b, a_b, and a_b_concurrent test types.</li> <li>• Plug_a_to_a_b_to_b is an external loopback plug for a, b, a_b, and a_b_concurrent test types.</li> <li>• no_modem_a_to_b is an external loopback cable for a_to_b and a_to_b_concurrent test types.</li> <li>• Modem_a_to_b is an external loopback cable with a modem attached to generate synchronous Transmit and Receive clocks. This type is only available in synchronous test mode.</li> </ul>

**TABLE 36-3** sptest Options

sptest Options	Description
Data Type	Selects the data pattern to transfer. The user can select: <ul style="list-style-type: none"><li>•Random</li><li>•Sequential</li><li>•Alphanumeric</li><li>•0x00-0xff</li></ul>
Async Baud Rate	Selects the baud rate for Asynchronous mode testing. The valid rates are: 110, 300, 600, 1200, 4800, 9600, 19200, 38400, 57600, 76800, 115200, 153600, 230400, 307200, 460800, and ALL. The default rate is 9600 baud. Some platforms can only support up to 38400 or 76800. The test will return an error if you try to use a higher baud rate than is supported. For baud rates greater than 153600 the serial line drivers must be set for RS-423 mode and not RS-232 mode. The RS-423 and RS-232 modes are usually selected by a hardware jumper on the motherboard. Consult your hardware installation manual for more information.
Async Block Size	Selects the size (in bytes) of each write. This can range from 1 to 10000. The default is 100. If it is larger than the async size it will be truncated to the async size.
Async Data Size	Selects the total number of bytes to transfer in Asynchronous mode. This can range from 1 to 10000.
Async Parity	Selects the parity to use in asynchronous mode. The user can select even, odd, or none. The default is none.
Async Flow Control	Selects the type of flow control to use in asynchronous mode testing. The user can select <code>Hardware (RTS/CTS)</code> , <code>Software (XON/XOFF)</code> or <code>None</code> . The default depends on the loopback type. Software flow control is not allowed on a, b, a_b, or a_b_concurrent loopback types.
Sync Baud Rate	Selects the device generated clock rate for synchronous mode testing. The valid rates are from 110 to 230400. The rate does not have to be a specific value as required for async mode baud rates. The default rate is 9600. Some platforms can only support up to 38400 or 76800. The test will return an error if you try to use a higher rate than is supported. For rates greater than 100000 the serial line drivers must be set for RS-423 mode and not RS-232 mode. The RS-423 and RS-232 modes are usually selected by a hardware jumper on the motherboard. Consult your hardware installation manual for more information.
Sync Packet Drop Tolerance	Selects the tolerance level of Synchronous mode dropped packets during the many_packets subtest. The default is 20 percent. The valid range is from 0 percent to 99 percent. Some packet drops are expected especially at higher clock rates and on a heavily loaded system.

**TABLE 36-3** `sptest` Options

<b>sptest Options</b>	<b>Description</b>
Sync Poll Count	Selects the number of seconds in additional time to wait for a Synchronous mode packet to be sent. Additional time may be needed when there is heavy system activity and time-outs are being detected. In general, the user can decrease the value to 0 when the system load is light or increase the value when there is a heavy system load.

---

## sptest Test Modes

`sptest` supports all three SunVTS test modes.

**TABLE 36-4** `sptest` Test Modes

<b>Test Mode</b>	<b>Description</b>
Connection Test	In this mode, the <code>sptest</code> tries to open the port to determine if the device is connected. If it fails and the port is not busy, the test exits with an error. If it is successful or fails with a busy or exclusive use error, then the port is considered connected, and the test passes.
Functional Test	In Functional test, <code>sptest</code> performs the selected loopback test.
Online Mode	Provides a means to run <code>sptest</code> through SyMON. In Online mode, the following Functional Test description applies: <code>sptest</code> tries to minimize the impact on the applications that are running. The Online test runs in synchronous and asynchronous modes. If the device supports an internal loopback then the functional test is run utilizing the internal loopback. The <code>zs(7D)</code> device supports an internal synchronous loopback and the <code>se(7d)</code> device supports an internal asynchronous loopback.

# sptest Command Line Syntax

```
/opt/SUNWvts/bin/sptest standard_arguments -o  
dev=device_name,porta=first_port_name,T=port,L=loopback_type,M=mode,D=data_pa  
ttern,AB=async_baudrate,BS=async_write_size,S=async_total_size,PAR=parity,F=flow_  
control,B=sync_speed,DP=sync_drop_tolreance,P=sync_timeout
```

TABLE 36-5 sptest Command Line Syntax

Argument	Explanation
dev=device_name	Identifies the serial port(s) to test. There is no default value; you must specify a device name such as: se0, zs0, zs1 zs2, zs3 ..., ...
porta=port_name	The name of the first device of a serial device pair. The default is a.
M=mode	The default test mode is asynchronous. Specify one of the following modes: <ul style="list-style-type: none"><li>• asynch</li><li>• synch</li><li>• both</li></ul>
T=test_type	Specifies the type of test to run: <ul style="list-style-type: none"><li>• a= runs the test on port a.</li><li>• b= runs the test on port b.</li><li>• a_b= runs the test on ports a and b sequentially.</li><li>• a_b_concurrent= runs the test on port a and port b concurrently.</li><li>• a_to_b= runs the test from port a to port b.</li></ul>
L=test_loopback	The type of loopback connector attached to ports: <ul style="list-style-type: none"><li>• No_modem_a_to_b</li><li>• Internal_a_to_a_b_to_b</li><li>• Plug_a_to_a_b_to_b</li><li>• Modem_a_to_b</li></ul>
D=data_pattern	Selects the data pattern to transfer. The user can select: <ul style="list-style-type: none"><li>• Random</li><li>• Sequential</li><li>• Alphanumeric</li><li>• 0x00-0xFF</li></ul>
AB=baud_rate	Asynchronous baud rate (default = 9600). The valid values are between 110 - 460800. Note: Some platforms can only support asynchronous baud rates up to 38400 or 76800. For baud rates greater than 153600 the serial line drivers must be set for RS-423 mode and not RS-232 mode.

**TABLE 36-5** `sptest` Command Line Syntax (*Continued*)

<b>Argument</b>	<b>Explanation (<i>Continued</i>)</b>
<code>BS=write_size</code>	Asynchronous mode write size; from 1 to 10000 bytes.
<code>S=size</code>	Asynchronous mode total number of bytes to write. 1 to 10000 bytes.
<code>PAR=parity</code>	Asynchronous mode parity type: <ul style="list-style-type: none"><li>• None</li><li>• Even</li><li>• Odd</li></ul>
<code>F=flow_control and default</code>	Asynchronous mode flow control <ul style="list-style-type: none"><li>• Hardware (RTS/CTS)</li><li>• Software (xon/xoff)</li><li>• None</li></ul>
<code>B=baud_rate</code>	Synchronous baud rate (default = 9600). The valid rates are between 110 - 256000. Note: Some platforms can only support synchronous rates up to 38400 or 76800. For rates greater than 100000 the serial line drivers must be set for RS-423 mode and not RS-232 mode.
<code>DP=drop_tolerance</code>	Synchronous mode drop packet tolerance (default=20 percent)
<code>P=poll_seconds</code>	Synchronous mode additional wait time during poll (in seconds).

# sptest Error Messages

TABLE 36-6 sptest Error Messages

Error Message	Probable Cause(s)	Recommended Action
6003 data miscompare, cnt = <i>number</i> , exp = <i>value</i> , obs = <i>value</i> , receive device = <i>name</i> , source device = <i>name</i> , baud rate = <i>value</i>	System load too heavy for selected baud rate.	Reduce the system load.
	Loopback connection defective.	Lower the baud rate.
	Bad serial port hardware.	Check loopback connection.
	System software error.	If the problem persists, contact your authorized Sun service provider.
6011 <i>name</i> : packet read failed, error = <i>error_message</i> , speed = <i>number</i>	System load too heavy.	Reduce the system load.
	Loopback connection missing or defective.	Check loopback connection.
	Bad serial port hardware.	If the problem persists, contact your authorized Sun service provider.
6012 <i>name</i> : packet write failed, error = <i>error_message</i> , speed = <i>number</i>	System load too heavy.	Reduce the system load.
	Bad serial port hardware.	If the problem persists, contact your authorized Sun service provider.
	System software error	
6013 Device ' <i>device_name</i> ' not responding. No data detected after <i>number</i> seconds. Received <i>number</i> bytes out of <i>number</i> sent. Baud rate = <i>number</i>	System load too heavy for selected baud rate.	Reduce the system load.
	Loopback connection missing or defective.	Lower the baud rate.
	Bad serial port hardware.	Check the loopback connection.
	System software error.	If the problem persists, contact your authorized Sun service provider.
6014 <i>name</i> : expected <i>text</i> got <i>text</i>		



TABLE 36-6 sptest Error Messages (Continued)

	Error Message	Probable Cause(s)	Recommended Action
6015	Incomplete write on Port <i>name</i> , len <i>number</i> should be <i>number</i> , speed = <i>number</i>	System load too heavy.	Reduce the system load.
		Loopback connection missing or defective.	Check loopback connection.
		Bad serial port hardware.	If the problem persists, contact your authorized Sun service provider.
		System software error.	
6016	Incomplete read on Port <i>name</i> , len <i>number</i> should be <i>number</i> , speed = <i>number</i>	System load too heavy.	Reduce the system load.
		Loopback connection missing or defective.	Check loopback connection.
		Bad serial port hardware	If the problem persists, contact your authorized Sun service provider.
		System software error.	
6018	<i>name</i> : port not ready for writing after <i>number</i> seconds, speed = <i>number</i>	System load too heavy	Reduce the system load.
		Loopback connection missing or defective.	Check loopback connection.
		Bad serial port hardware.	If the problem persists, contact your authorized Sun service provider.
		System software error.	
6020	packet data miscompare, cnt = <i>number</i> exp = <i>value</i> , obs = <i>value</i> , device = <i>name</i> , speed = <i>number</i>	System load too heavy	Reduce the system load.
		Loopback connection defective.	Check loopback connection.
		Bad serial port hardware.	If the problem persists, contact your authorized Sun service provider.
		System software error.	
6021	<i>name</i> : port not ready for reading after <i>number</i> seconds, no data available, speed = <i>number</i>	System load too heavy.	Reduce the system load.
		Loopback connection missing or defective.	Check loopback connection.
		Bad serial port hardware.	If the problem persists, contact your authorized Sun service provider.
		System software error.	
6022	<i>name</i> : port not ready for writing after <i>number</i> seconds, wrote <i>number</i> bytes out of <i>number</i> . Baud rate = <i>number</i>	System load too heavy.	Reduce the system load.
		Loopback connection missing or defective.	Check loopback connection.
		Bad serial port hardware.	If the problem persists, contact your authorized Sun service provider.
		System software error	

**TABLE 36-6** sptest Error Messages (Continued)

Error Message	Probable Cause(s)	Recommended Action
8001 Test Type <code>a_to_b</code> is not allowed on Quick Test!		
8002 <i>name</i> : <code>open()</code> failed, error = <i>error_message</i>		
8003 Invalid Data Type: I= <i>text</i>		
8004 <i>name</i> : <code>poll()</code> error, ( <code>revents &amp; (POLLERR   POLLHUP   POLLNVAL)</code> ) = <i>value</i>		
8005 Siemens serial device ( <i>se</i> ) does not support synchronous internal loopback test		
8006 Invalid port parameter: <i>name</i>		
8007 Invalid device name ' <i>name</i> ', must specify either <code>zsX</code> or <code>seX</code> , where X is the first instance number of a device pair (ex., <code>zs0</code> )		
8009 Failed <code>ioctl</code> <i>name</i> , device = <i>name</i> , error = <i>error_message</i>		
8010 <i>name</i> : Not able to push Tty compatibility STREAMS module		
8011 Invalid Test Type: T= <i>name</i>		
8012 Invalid Mode: M= <i>name</i>		
8013 <i>name</i> device does not exist		
8014 Invalid baud_rate: <i>number</i>		
8015 <code>write()</code> to <i>name</i> failed: <i>error_message</i> , baud rate = <i>number</i>		
8016 <code>read()</code> to <i>name</i> failed: <i>error_message</i> , baud rate = <i>number</i>		

**TABLE 36-6** sptest Error Messages (Continued)

Error Message	Probable Cause(s)	Recommended Action
8017 Invalid size, requested = <i>number</i> bytes, min = <i>number</i> , max <i>number</i>		
8018 Could not open <i>name</i> after waiting <i>number</i> seconds	Another process is using the port Port is hung Bad serial port hardware System software error	Stop other process using the port. If the problem persists, contact your authorized Sun service provider.
8021 <i>name</i> : No valid packets returned after <i>number</i> attempts, last error = <i>error_message</i> , wrote <i>number</i> packets, read <i>number</i> packets, device accounting shows <i>number</i> packets sent and <i>number</i> packets received	System load too heavy Timeout too short Loopback connection missing or defective Bad serial port hardware System software error	Reduce the system load. Increase Sync_Poll_Count from pop menu. Check the loopback connection. If the problem persists, contact your authorized Sun service provider.
8022 printdlprim: unsupported primitive type <i>value</i>		
8023 stringtoaddr: invalid input string: <i>text</i>		
8025 dlinfoack: response ctl.len too short: <i>number</i>		
8026 dlinfoack: DL_INFO_ACK was not M_PCPROTO		
8027 dlokack: response ctl.len too short: <i>number</i>		
8028 dlokack: DL_OK_ACK was not M_PCPROTO		
8029 dlerrorack: response ctl.len too short: <i>number</i>		
8030 dlerrorack: DL_OK_ACK was not M_PCPROTO		
8031 dlbindack: response ctl.len too short: <i>number</i>		
8032 dlbindack: DL_OK_ACK was not M_PCPROTO		
8033 sigalrm: TIMEOUT		

**TABLE 36-6** sptest Error Messages (Continued)

Error Message	Probable Cause(s)	Recommended Action	
8037	invalid packet length: <i>number</i>		
8038	<i>name</i> : poll() failed, error = <i>error_message</i>	System load too heavy	Reduce the system load.
		Bad serial port hardware	If the problem persists, contact your authorized Sun service provider.
		System software error	
8039	Failed I_STR ioctl, cmd = <i>name</i> , device = <i>name</i> , error = <i>error_message</i>		
8040	<i>name</i> : No packets sent, last error = <i>error_message</i> , wrote <i>number</i> packets, read <i>number</i> packets, device accounting shows <i>number</i> packets sent and <i>number</i> packets received	No transmit clock present	Reduce the system load.
		System load too heavy	Increase Sync_Poll_Count from the pop menu.
		Timeout too short	Check the loopback connection.
		Loopback connection missing or defective	If the problem persists, contact your authorized Sun service provider.
		Bad serial port hardware	
System software error			
8041	Sporadic packets detected on <i>name</i> . The port must be quiescent before running test	Another process is generating activity on the port	Stop other process using the port.
		Bad serial port hardware	Stop other process using the port.
		System software error	
8042	syncinit: <i>name</i> missing minor device number		
8046	Test requires local or remote modem loopback (external data loop, external clocking)		
8047	<i>name</i> loopback type not allowed on Connection test		
8048	<i>name</i> loopback type not allowed on online mode		
8049	Invalid baud rate for device <i>name</i> , select between <i>number</i> and <i>number</i>		

**TABLE 36-6** sptest Error Messages (Continued)

	Error Message	Probable Cause(s)	Recommended Action
8050	<i>name</i> internal loopback test not allowed on <i>name</i> device		
8051	Thread creation failed, <i>error_message</i>		
8054	<i>name</i> : At least <i>number</i> packets dropped (tolerance = <i>number</i> ), last error = <i>error_message</i> . Wrote <i>number</i> packets, read <i>number</i> packets. Device statistics shows <i>number</i> packets sent and <i>number</i> packets received. <i>number</i> packets dropped in outbound queueing, <i>number</i> packets dropped in inbound queueing	System load too heavy Loopback connection missing or defective Bad serial port hardware System software error	Reduce the system load. Increase the drop tolerance option. Check the loopback connection. If the problem persists, contact your authorized Sun service provider.
8055	<i>name</i> : <i>number</i> bad packets received, last error = <i>error_message</i> , wrote <i>number</i> packets, read <i>number</i> packets, device accounting shows <i>number</i> packets sent and <i>number</i> packets received	System load too heavy Loopback connection missing or defective Bad serial port hardware System software error	Reduce the system load. Check the loopback connection. If the problem persists, contact your authorized Sun service provider.



## SunButtons Test ( sunbuttons )

---

The `sunbuttons` test verifies that the SunButtons graphics manipulation device is working correctly.

---

**Note** – Install SunVTS2.1 making sure that the following packages are installed: `SUNWdial` and `SUNWdialh`.

---

---

## Running the sunbuttons Tests

The following tests verify the functionality of SunButtons:

▼ **Create a `.customtest` file in `/opt/SUNWvts/bin`**

Create a `.customtest` file to verify that each button functions; each button lights up in a round-robin fashion.

Edit the `.customtest` file to include the following lines:

```
sunbuttons;sunbuttons; Mode<CYCLE|diag|diag|mode>
sundials;sundials; Mode<CYCLE|diag|diag|mode>
(For diag mode you may have to execute the xhost + command)
```

▼ **Configure the Port Using the `bdconfig` Command**

To configure the port, perform the following steps:

1. **Run the `/usr/sbin/bdconfig` command to configure the `/dev/term/a` or `/dev/term/b` port and enable it. The following example shows how to check a configured serial port b:**

```
# ls -l /dev/bd*
lrwxrwxrwx 1 root  other    11 Nov 12 15:39 /dev/bd -> /dev/term/b
#
```

2. **Connect the `sunbuttons/sundials` device to your configured serial port (a or b).**

## Starting SunVTS

After starting SunVTS, you should see Customtest as one of the available options with `sundials` and `sunbuttons` available for selection.

1. **Change to the Functional test mode and enable intervention.**
2. **Enable the `sunbuttons` and `sundials` tests.**
3. **Start testing.**

In Diag mode, a pop-up window is displayed.

4. **Select the Diagnostics button.**  
Let the test run its course (the Diagnostics button will be selectable again).
5. **Close the pop-up window.**

The test should register a single pass.

## ▼ Running the `sunbuttons` Test From a Shell Command Line

This is an interactive test. The test displays a screen representation of the buttonbox (see FIGURE 37-1) where you can press each of the buttons and see the corresponding button's display change.

To run the diagnostic test, select the Diagnostics Button on the top of the menu representation. The buttonbox buttons on the screen do not change while the diagnostics test is running.

Be sure that the buttonbox is connected to one of the serial ports, and that the buttonbox has a power transformer.

There is no option menu for this test.



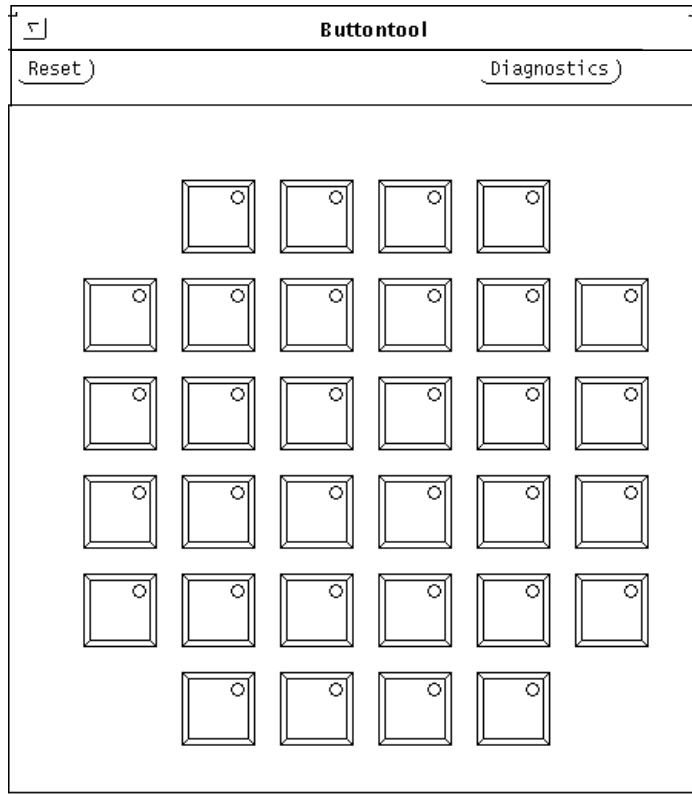

FIGURE 37-1 sunbuttons Test Menu

---

# sunbuttons Command Line Syntax

`/opt/SUNWvts/bin/sunbuttons diag standard_arguments`

---

## sunbuttons Test Modes

Available only in the Functional test mode. In the Functional test mode, the `sunbuttons` test verifies the functionality of each button, and that each button lights up in sequence.

---

## sunbuttons Error Messages

TABLE 37-1 sunbuttons Error Messages

Error Message	Probable Cause(s)	Recommended Action
6000	Cannot open device	
6001	<code>ioctl(VUIDSFORMAT, VUID_NATIVE)</code>	
6002	Writing <code>diag</code> command failed	
6003	No response from Buttonbox	
6004	Selftest failed	
6005	Weird unknown kind of error	
6006	Can not open device <code>/dev/db</code>	
6007	<code>ioctl(VUIDSFORMAT, VUID_NATIVE) -- you may need to run <code>bdconfig</code></code>	

## SunDials Test ( sundials )

---

The `sundials` test verifies that the SunDials graphics manipulation device controls are working properly. `sundials` also verifies the connection between the dialbox and serial port.

---

### Running the `sundials` Test

The following tests verify SunDial functionality.

#### ▼ From a `.customtest` File

Create a `.customtest` file to test the SunDials.

Here is an example of a `.customtest` entry for `sundials`:

```
sundials;sundials;text<TEXT|20|-s|>
```

#### ▼ From a Command Line

Running the `sundials` test from a command line starts an interactive test that displays a screen representation of the dialbox (see FIGURE 38-1). You can move each of the dials and see the corresponding dial's display change. To run the interactive test, select the Diagnostics button on the top of the window representation. The dialbox dials on the screen will not move while the diagnostics test is running

Be certain that the dialbox is connected to one of the serial ports, and that the dialbox has a power transformer.

There is no option menu for this test.

The sundials Test menu is shown in FIGURE 38-1.

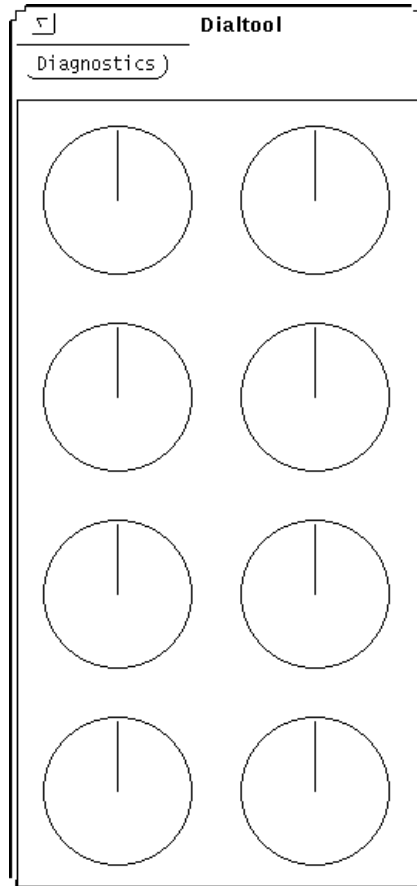

FIGURE 38-1 sundials Test Menu

---

## sundials Test Modes

This test is available only in the Functional test mode. The sundials test verifies the connection between the dialbox and serial port. The test also verifies all manipulation device controls.

---

# sundials Command Line Syntax

`/opt/SUNWvts/bin/sundials diag standard_arguments`

---

## sundials Error Messages

**TABLE 38-1** sundials Error Messages

Error Message	Probable Cause(s)	Recommended Action
6000	Open failed for /dev/bd	
6001	ioctl(VUIDSFORMAT, VUID_NATIVE) error	
6002	ioctl(VUIDSFORMAT, VUID_EVENT) error	
6003	Could not talk to Dialbox	
6004	Cannot open device	
6005	Writing Diag Command failed	
6006	No response from Dialbox	
6007	Selftest failed	
6008	Weird unknown kind of error	
6009	ioctl(VUIDSFORMAT, VUID_NATIVE) -- you may need to run bdconfig	



## HSI/S Board Test ( `sunlink` )

---

The `sunlink` test verifies the functionality of the SBus HSI boards. `sunlink` tests the HDLC and SDLC protocol of SBus HSI boards and PCI bus HSI boards. `sunlink` downloads the DCP microcode, initializes the selected channel, and configures the selected channel to the protocol being tested.

Next, `sunlink` opens a datagram socket and tries to modify the socket to accept `ioctl` communications with the driver, and receive Synchronous mode information from it.

`sunlink` then opens the ports, linking the upper and lower layers with `ioctl` calls. After initialization, this test checks for activity before attempting to send or receive data. An error message is returned if activity is detected; otherwise the transmit buffer is filled with random data. Random data is used by default; other patterns may be specified. The data is then transmitted. If the transmission succeeds, `sunlink` then receives the returned data and verifies that it is identical to what was sent. Finally, statistics about the send and receive are gathered from the socket.

A full `sunlink` test takes approximately eight minutes per port and makes a brief check of the board ports before the actual test begins. If the port is bad, the test immediately aborts and returns an error message.

---

**Note** – This test will not pass unless you install the correct loopback connectors or port to port cables on the ports you are testing. The ports specified for test in the option menu must have loopback connectors attached. See Appendix A for loopback connector part numbers and wiring instructions.

---

---

# sunlink Options

The Configuration field displays the available ports. (See FIGURE 39-1.)

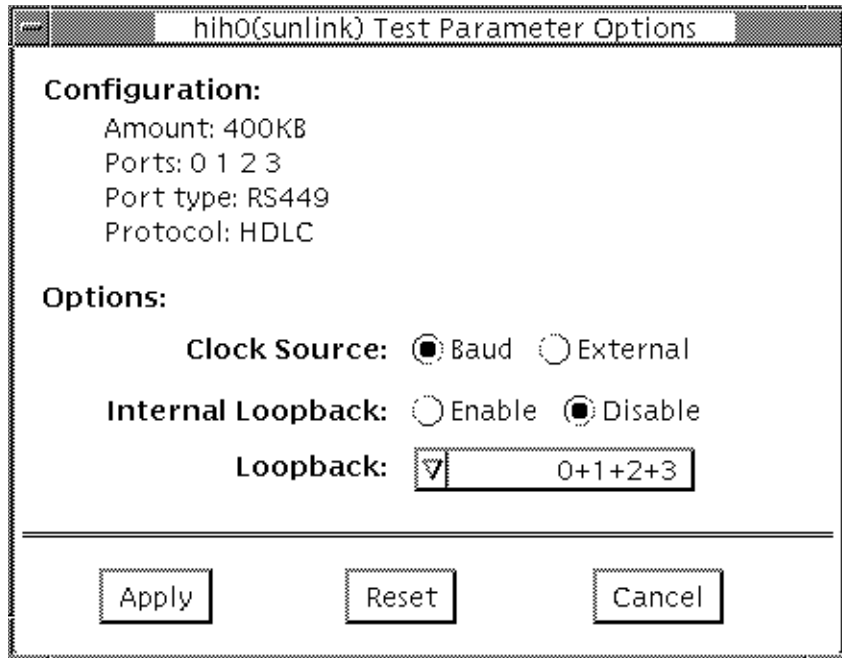

FIGURE 39-1 sunlink Options menu



**TABLE 39-1** sunlink Options

sunlink Options	Description
Clock source	Select either the on-board clock or an external clock for use when using sunlink. To use the external clock option, the transmit, receive, and clock data lines must be physically loopbacked.
Internal Loopback	Enables or disables internal loopback tests. Internal Loopback is only needed when the Loopback setting is not port-to-port, and the clock source is on-board.
Loopback	Specifies the loopback type: simple single external port loopback, multiple external port loopback, and port-to-port external loopback.

## sunlink Command Line Syntax

```
/opt/SUNWvts/bin/sunlink standard_arguments -o
dev=device_name,P=port#, p=data_pattern,I,C=B/E
```

**TABLE 39-2** sunlink Command Line Syntax

Argument	Explanation
<i>dev=device_name</i>	Specifies the device to be tested. hih0 HDLC and SDLC protocols
<i>P=ports</i>	Specifies the port number to be tested.
<i>p=data_pattern</i>	Specifies the <i>data_pattern</i> as one of the following: c: Character (0x55) i: Incrementing d: Decrementing r: Random (default)
<b>I</b>	Enables internal loopback for HSI/S (external).
<i>c=clocksource</i>	Specifies the clock source value as one of the following: B: On-board clock source E: External clock source

The following is a typical command line syntax for testing an HSI/S Sbus card:

```
# /opt/SUNWvts/bin/sunlink -o dev=hih0,P=0_to_1+2_to_3
```

Typing this at the command line tests the internal loopback for port 0.

---

## sunlink Test Modes

The sunlink test only supports the Functional test mode.

---

## sunlink Loopback Connectors

Refer to Appendix A of this manual, and the High Speed Serial Interface hardware manuals for information on loopback connectors.

---

## sunlink Error Messages

**TABLE 39-3** sunlink Error Messages

Error Message	Probable Cause(s)	Recommended Action
6000	Device name must be provided!	
6001	Invalid port specification	
6002	Invalid port number	
6003	BSC protocol is not implemented for <i>device_name</i>	
6004	ASYNC protocol is not implemented for <i>device_name</i>	
6005	Illegal protocol specified for ' <i>device_name</i> '	
6006	Could not open file: <i>file_name</i>	

**TABLE 39-3** sunlink Error Messages (Continued)

	<b>Error Message</b>	<b>Probable Cause(s)</b>	<b>Recommended Action</b>
6007	Could not open file devname <i>device_name</i>		
6008	Could not open file (clonename) <i>file_name</i>		
6009	Can't get sync mode info for <i>device_name</i>		
6010	Can't set sync mode info for <i>device_name</i>		
6011	Couldn't successfully execute `/usr/sunlink/dcp/dcp <i>file_name</i>		
6012	Packet received but none sent! Activity on-line. Quiesce other end before starting		
6013	Transmit failed on ' <i>device_name</i> '		
6014	Receive failed on ' <i>device_name</i> '		
6015	Data compare error on ' <i>device_name</i> ', exp = <i>value</i> , actual = <i>value</i> , offset = <i>number</i>		
6016	<i>device_name</i> does not respond	No loopback plug. System load is too heavy.	Check the loopback plug. Reduce the system load.
6017	sigalrm: TIMEOUT	No loopback plug. System load is too heavy.	Check the loopback plug. Reduce the system load.
8000	Unsupported primitive type <i>value</i>		
8001	<i>text</i> ( <i>error_message</i> )		
8002	Response ctl.len too short: <i>value</i>		
8003	DL_INFO_ACK was not M_PCPROTO		
8004	DL_OK_ACK was not M_PCPROTO		



## Pixel Processor Test ( `sxtest` )

---

`sxtest` checks models of SPARCstation 10 and SPARCstation 20 machines equipped with an onboard Pixel Processor module. `sxtest` is specific to the VSIMM (Video SIMM)/SX Memory Controller) devices in the SPARCstation 10 SX and SPARCstation 20 SX.

---

**Note** – Because of possible conflicts between `cg14` SunVTS frame buffer tests and OpenWindows applications that use the `cg14` frame buffer, the following restrictions apply when running the `sxtest` SunVTS test:

Do not run any graphic applications other than OpenWindows while running SunVTS frame buffer tests.

To start SunVTS with `vtsui`, but without `vtstk`, you must add the host name to `xhost` as: `xhost + hostname`.

Do not run any OpenWindows programs that generate video updates outside or on top of the SunVTS window.

Do not close the SunVTS window to an icon while it is running frame buffer tests.

Enable the frame buffer locking option from the Options window for the system console `cg14` device (see “The `sxtest` test parameter options are described in TABLE 40-1.” on page 358).

If you run `sxtest` with VRAM enabled, then frame buffer locking *must* be enabled.

---

`sxtest` locates load error, store error, ALU error, logic error, and so on, of the pixel processor by reading and verifying data from the control registers of the pixel processor, virtual memories, or video memories.

This test also verifies the integration function of the `cg14` frame buffer and its device driver, video memories, and data memories. `sxtest` also writes a test pattern to the frame buffer for visual verification. The accuracy of this test is dependant on other hardware, such as the CPU, memory card(s), and `cg14` graphics card. Run the `cg14test` and other tests before running `sxtest`. `sxtest` is a series of 13 modules, described FIGURE 40-1.

## sxtest Options

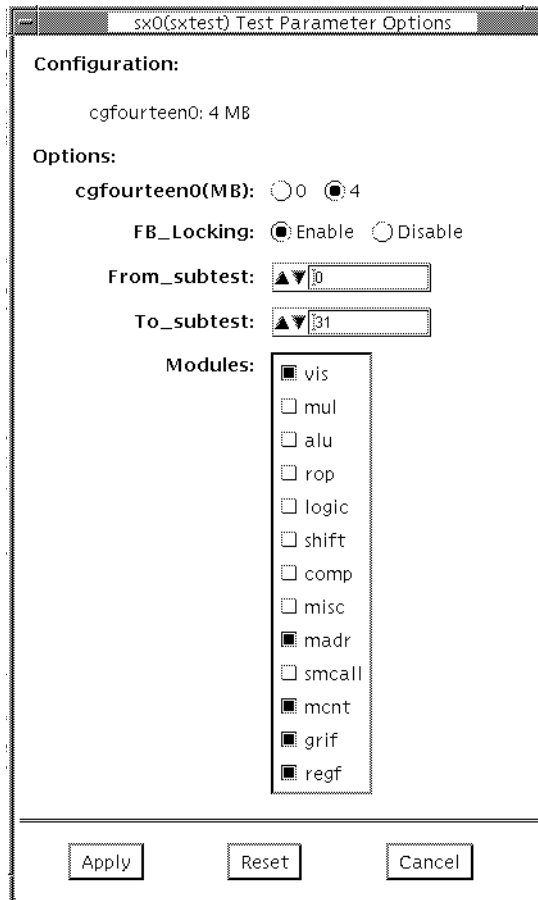
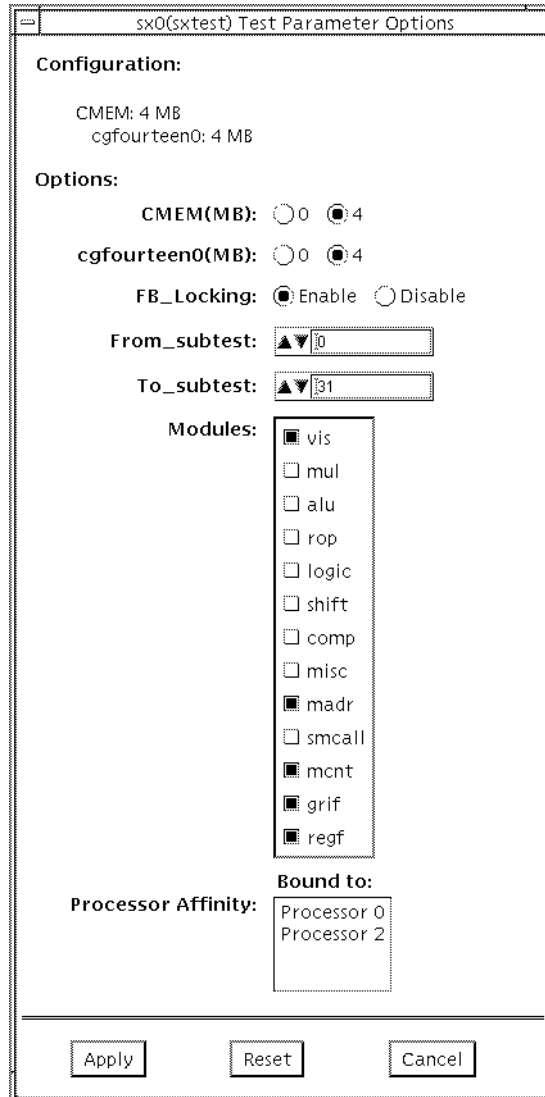

FIGURE 40-1 `sxtest` Option Menu (CMEM:0MB, none, `cg14` board)

---

**Note** – The `sxtest` option menu is customized, based on the configuration of the test system.

---



**FIGURE 40-2** `sxtest` Option Menu (CMEM:4MB, cg14:4MB)

---

# sxtest Test Parameters

The `sxtest` test parameter options are described in TABLE 40-1.

**TABLE 40-1** `sxtest` Test Parameter Options

Option	Description
FB Locking	Frame buffer locking is enabled by default on the window server running the OpenWindows software.  See the section about testing multiple frame buffers in the <i>SunVTS 2.1 User's Guide</i> for details.
CMEM (Contiguous Memory)	Choose either 0 or 4 if your system has 4 Mbytes (or more) of contiguous memory available.  To set CMEM on a SPARCstation 10, enter the following: <pre>cd /usr/platform/SUNW,SPARCstation10,SX/sbin</pre> The system must have 32 Mbytes of memory or more to set CMEM. For example: <pre>% sxconfig -s 4 -l 28 -f</pre>
VRAM (Video Random Access Memory)	Choose either 0 4 8 video random access memory. <b>CAUTION:</b> If <code>sxtest</code> is run with its VRAM enabled, then frame buffer locking must be enabled or SunVTS results in errors.



---

# sxtest Module Descriptions

The 13 `sxtest` modules are described in TABLE 40-2.

**TABLE 40-2** `sxtest` Modules

Module	Description
Display (module0)	<p>Click Enable to display visual patterns.</p> <p>Three subtests call the SPAM library and display pictures to verify the integrity of a subset of the kernel and the SPAM libraries through the SPARCstation 10 SX video system. These routines are ported from the SPAM demonstration programs. All subtests in this module are skipped if the <code>cg14</code> frame buffer does not exist, or if the VRAM is disabled.</p> <p>One of the following subtests displays screens between other subtests. This helps you determine whether the system is hung or if <code>sxtest</code> is running.</p> <p><code>rect_test</code>: The screen is filled with random rectangles. The rectangles are drawn in <code>CHUNKY_XBGR</code> mode if 32-bit mode OpenWindows is running. If not, they are drawn in <code>CHUNKY_C8</code> mode with the SPAM library routine <code>sl_rect_fill_32</code>.</p> <p><code>shaa</code>: A picture of shaded lines is drawn in <code>CHUNKY_BGR</code> mode with the SPAM library routines <code>sl_line_shaa_32</code>, <code>sl_span_load_8</code>, and <code>sl_rect_fill_8</code>. <b>NOTE:</b> The <code>shaa</code> test is skipped if the test is running on an 8-bit window.</p> <p><code>lines</code> — The screen is filled with lines of various colors. These lines are drawn in <code>CHUNKY_XBGR</code> mode if 32-bit mode OpenWindows is running; if not, they are drawn in <code>CHUNKY_C8</code> mode with SPAM library routine <code>sl_line_fill_8</code>.</p>

**TABLE 40-2** sxtest Modules (Continued)

Module	Description
MUL (module1)	<p>Click Enable to test the multiplier operations.</p> <p>Eight subtests are called, each having 2500 randomly generated MUL SPAM macros.</p> <pre> sp_mul0 sp_mul1 sp_mul2 sp_mul3 sp_mul4 sp_mul5 sp_mul6 sp_mul7 </pre> <p>Each subtest tests SPAM MUL instruction sets by running random SPAM MUL macro patterns, for example:</p> <pre> spam_dot(S_0,R42,R45,R31,5) spam_mulr(L_16,R44,R29,R52,1) spam_mul(S_15,R115,R114,R58,4) spam_mul(L_16,R89,R110,R81,8) spam_mulr(S_8,R21,R76,R53,1) spam_saxpr(S_8,R54,R46,R98,2) spam_dotr(L_16,R75,R40,R20,5) spam_dot(L_16,R44,R45,R84,4) spam_saxp(L_0,R93,R96,R44,8) spam_mulr(L_0,R86,R56,R56,5) spam_dotr(L_0,R14,R62,R40,2) spam_saxpr(S_15,R112,R85,R95,7) </pre>
ALU (Module2)	<p>Click Enable to test ALU operations.</p> <p>Five subtests are called, each having 2500 randomly generated ALU SPAM macros.</p> <pre> sp_alu0 sp_alu1 sp_alu2 sp_alu3 sp_alu4 </pre> <p>Each subtest tests SPAM ALU instruction sets by running random SPAM ALU macro patterns, for example:</p> <pre> spam_subv(R101,R31,R42,1) spam_subs(R90,R44,R90,14) spam_subv(R44,R70,R29,14) spam_sum(R58,R95,R114,9) spam_adds(R54,R46,R98,10) spam_addi(R9,51,R68,9) spam_abs(R76,R28,7) spam_addv(R80,R59,R93,11) </pre>

**TABLE 40-2** `sxtest` Modules (Continued)

Module	Description
ROP (Module3)	<p>Click Enable to test the ROP operations.</p> <p>Five subtests are called, each having 2500 randomly generated ROP SPAM macros.</p> <pre>sp_rop0 sp_rop1 sp_rop2 sp_rop3 sp_rop4</pre> <p>Each subtest tests SPAM ROP instruction sets by running random SPAM ROP macro patterns, for example:</p> <pre>spam_selb(R101,R31,R42,1) spam_rop1(R90,R27,R44,14) spam_sels(R19,R16,R112,15) spam_ropm(R47,R29,R96,16) spam_selb(R52,R43,R29,5) spam_ropb(R115,R114,R58,7) spam_selv(R57,R75,R16,2) spam_ropm(R110,R93,R83,13)</pre>
LOGIC (Module4)	<p>Click Enable to test the logical operations.</p> <p>Five subtests are called, each having 2500 randomly generated LOGIC SPAM macros.</p> <pre>sp_logic0 sp_logic1 sp_logic2 sp_logic3 sp_logic4</pre> <p>Each subtest tests SPAM LOGIC instruction sets by running random SPAM LOGIC macro patterns, for example:</p> <pre>spam_xors(R101,R31,R42,1) spam_xori(R90,101,R90,14) spam_xorv(R30,R19,R95,13) spam_andv(R115,R114,R58,7) spam_ors(R46,R89,R8,16) spam_orv(R57,R75,R16,2) spam_andi(R9,51,R68,9)</pre>

**TABLE 40-2** `sxtest` Modules (Continued)

Module	Description
SHIFT (Module5)	<p data-bbox="515 239 929 262">Click Enable to test the shift operations.</p> <p data-bbox="515 296 1162 348">Five subtests are called, each having 2500 randomly generated SHIFT SPAM macros.</p> <pre data-bbox="515 354 639 487"> sp_shift0 sp_shift1 sp_shift2 sp_shift3 sp_shift4 </pre> <p data-bbox="515 522 1150 574">Each subtest checks SPAM SHIFT instruction sets by running random SPAM SHIFT macro patterns, for example:</p> <pre data-bbox="515 579 853 826"> spam_sllv(R101,R31,R42,1) spam_slli(R90,5,R90,14) spam_srai(R30,19,R95,13) spam_srli(R108,16,R125,1) spam_sllv(R52,R43,R29,5) spam_sffi(R46,25,R8,16) spam_slfs(R57,R75,R16,2) spam_srav(R54,R44,R93,8) spam_srlv(R58,R60,R96,16) </pre>
COMP (Module6)	<p data-bbox="515 847 972 869">Click Enable to test the compare operations.</p> <p data-bbox="515 904 1162 956">Five subtests are called, each having 2500 randomly generated COMP SPAM macros.</p> <pre data-bbox="515 961 625 1095"> sp_comp0 sp_comp1 sp_comp2 sp_comp3 sp_comp4 </pre> <p data-bbox="515 1130 1150 1182">Each subtest checks SPAM COMP instruction sets by running random SPAM COMP macro patterns. For example:</p> <pre data-bbox="515 1187 908 1520"> spam_cmpv_gt(R101,R31,R42,1) spam_cmps_lt(R90,R44,R90,14) spam_cmps_eq(R95,R112,R19,12) spam_cmpv_gt(R44,R43,R29,14) spam_cmpv_lt(R115,R114,R58,7) spam_cmps_gt(R46,R89,R8,16) spam_cmps_eq(R57,R75,R16,2) spam_cmpv_le(R54,R46,R98,10) spam_cmpv_eq(R9,R51,R68,9) spam_cmps_gt(R76,R103,R28,7) spam_cmpv_eq(R52,R37,R50,8) spam_cmpv_ge(R61,R86,R16,12) </pre>

**TABLE 40-2** *sxtest* Modules (Continued)

Module	Description
MISC (Module7)	<p data-bbox="596 239 1108 262">Click Enable to test the miscellaneous operations.</p> <p data-bbox="596 296 1243 348">Five subtests are called, each having 2500 randomly generated MISC SPAM macros.</p> <pre data-bbox="596 357 705 487">sp_misc0 sp_misc1 sp_misc2 sp_misc3 sp_misc4</pre> <p data-bbox="596 522 1222 574">Each subtest checks SPAM MISC instruction sets by running random SPAM MISC macro patterns, for example:</p> <pre data-bbox="596 583 933 795">spam_scat(R45,-1,R29,1) spam_gath(R95,-6,R114,9) spam_delt(R89,R9,R16,16) spam_plot(R54,R46,R98,10) spam_plot(R53,R20,R75,16) spam_scat(R91,-2,R70,9) spam_gath(R120,-2,R51,15) spam_delt(R59,R95,R120,1)</pre>
MADR (Module8)	<p data-bbox="596 817 1043 840">Click Enable to test the address lines of <i>sx</i>.</p> <p data-bbox="596 874 1282 979">Eight subtests are called; each subtest verifies the 0x100000 SPAM address with <code>spam_stld</code> and <code>spam_ldld</code> instructions. All address bits and data bits of 4 Mbytes of VRAM and 4 Mbytes of DRAM are tested after running through the eight subtests.</p> <pre data-bbox="596 987 911 1208">0x00000000-0x000fffff 0x00100000-0x001fffff 0x00200000-0x002fffff 0x00300000-0x003fffff 0xfc000000-0xfc0fffff * 0xfc100000-0xfc1fffff * 0xfc200000-0xfc2fffff * 0xfc300000-0xfc3fffff *</pre> <p data-bbox="596 1242 1225 1263">* These subtests are skipped if the CMEM option is disabled.</p>

**TABLE 40-2** `sxtest` Modules (Continued)

Module	Description
SMCALL (Module9)	<p>Click Enable for a brief test of <code>sxtest</code> functionality.</p> <p>Eleven subtests are called from <code>spam.smcalls</code> to verify the general function of the SMC chip. All subtests have a <code>cg14</code> version and a non-<code>cg14</code> version. These subtests repeat four times, each time with the <code>IQ_FIFO</code> programmed to a different number of entries (8, 16, 32, or 64).</p> <pre> shift_ldst instr_mix * arith_ldst cmp_ldst select_ldst interlock_all * logic_ldst mult_ldst rop scat_ldst delt_ldst </pre> <p>* These subtests are skipped if the <code>VRAM</code> option is set to <code>disable</code>.</p>
MCNT (Module10)	<p>Click Enable to test the load and store functions with different repeat counts.</p> <p>Twelve subtests are called; they test the SPAM store functions by varying address offset and item count.</p> <pre> spsd_stba_cnt spsd_stbd_cnt spsd_stbds_cnt spsd_stcd_cnt spsd_stla_cnt spsd_stld_cnt spsd_stlds_cnt spsd_stpd_cnt spsd_stqd_cnt spsd_stsa_cnt spsd_stsd_cnt spsd_stsds_cnt </pre>

**TABLE 40-2** `sxtest` Modules (Continued)

Module	Description
GRIF (Module11)	Click Enable to test the graphic interface logic.
	Thirty-six subtests are called; they test the SPAM graphic interface login with load/store instructions. All subtests are skipped if <code>cg14</code> does not exist.
	<code>spsd_stbd_dram</code>
	<code>spsd_stbd_xbgr</code>
	<code>spsd_stbd_bgr</code>
	<code>spsd_stbd_8x</code>
	<code>spsd_stbd_8c</code>
	<code>spsd_stbd_x32</code>
	<code>spsd_stbd_b32</code>
	<code>spsd_stbd_g32</code>
	<code>spsd_stbd_r32</code>
	<code>spsd_stsd_dram</code>
	<code>spsd_stsd_xbgr</code>
	<code>spsd_stsd_bgr</code>
	<code>spsd_stsd_8x</code>
	<code>spsd_stsd_8c</code>
	<code>spsd_stsd_x32</code>
	<code>spsd_stsd_b32</code>
	<code>spsd_stsd_g32</code>
	<code>spsd_stsd_r32</code>
	<code>spsd_ldbd_dram</code>
	<code>spsd_ldbd_xbgr</code>
	<code>spsd_ldbd_bgr</code>
	<code>spsd_ldbd_8x</code>
	<code>spsd_ldbd_8c</code>
	<code>spsd_ldbd_x32</code>
	<code>spsd_ldbd_b32</code>
	<code>spsd_ldbd_g32</code>
	<code>spsd_ldbd_r32</code>
	<code>spsd_ldsd_dram</code>
	<code>spsd_ldsd_xbgr</code>
	<code>spsd_ldsd_bgr</code>
	<code>spsd_ldsd_8x</code>
	<code>spsd_ldsd_8c</code>
	<code>spsd_ldsd_x32</code>
	<code>spsd_ldsd_b32</code>
	<code>spsd_ldsd_g32</code>
	<code>spsd_ldsd_r32</code>

TABLE 40-2 `sxtest` Modules (Continued)

Module	Description
REGF (Module12)	<p>Click Enable to test the register file pointer logic.</p> <p>Twenty-two subtests are called from <code>spam.regfile</code> to verify the register file's logic with assorted SPAM instructions.</p> <p><code>readpointer1 *</code> <code>readpointer2 *</code> <code>readpointer3 *</code> <code>readpointer4 *</code> <code>writepointer1 *</code> <code>writepointer2 *</code> <code>writepointer3 *</code> <code>writepointer4 *</code> <code>readpointer5 *</code> <code>writepointer5 *</code> <code>rdptr0 †</code> <code>wrptr0 †</code> <code>rdptr1 †</code> <code>wrptr1 †</code> <code>rdptr2 †</code> <code>wrptr2 †</code> <code>rdptr3 †</code> <code>wrptr3 †</code> <code>rdptr4 †</code> <code>wrptr4 †</code> <code>rdptr5 †</code> <code>wrptr5 †</code></p> <p>* These subtests are skipped if the VRAM option is disabled. † These subtests are skipped if the CMEM option is disabled.</p>

## `sxtest` Test Modes

Due to the nature of graphic tests, reading from or writing to the frame buffer during testing will disturb user production. `sxtest` is available only in the Functional test mode.

In Functional test, `sxtest` runs the visual subtest, memory address subtest, memory count subtest, graphic interface subtest, and register file subtest by default. The user can select or de-select other subtests as needed.



---

# sxtest Command Line Syntax

```
/opt/SUNWvts/bin/sxtest standard_arguments -o dev=device_name,  
lock=E(nable)/D(isable),tm=to_module#,cmem=n,vram=n, md=XXX
```

**TABLE 40-3** sxtest Command Line Syntax

Argument	Explanation
dev=device_name	Specifies the device_name to be tested.
lock=E(nable)/ D(isable)	Enables/disables frame buffer locking. See “Testing Multiple Frame Buffers” in Chapter 3 of the <i>SunVTS 2.1 User’s Guide</i> for details. Frame buffer locking is enabled by default on the window server running the OpenWindows software.
tm=to_module#	Specifies an ending module number; use these last four arguments to narrow sxtest to a specific test scope.
cmem=0/4	Enables or disables the contiguous memory; choose either 1 to enable or 0 to disable. Note: You must choose disable (0) if your system is equipped with less than 4 Mbytes of contiguous memory.
cgfourteen0=0/4 /8	Enables or disables the video random access memory; choose 1 to enable or 0 to disable.
md=vis+alu+...	Selects which modules are tested in a pass.

# sxtest Error Messages

TABLE 40-4 sxtest Error Messages

Error Message	Probable Cause(s)	Recommended Action
6002	Unable to lock frame buffer	FB lock was enabled while Window System was not running.
6004	Can't get sem <i>number</i>	
6006	Failed lock sem:dev <i>number</i> , type <i>number</i>	
6008	Failed unlock sem	
6010	Failed GETVAL sem=	
6012	Failed sem_val	
6014	console_p() failed:	
6016	Failed sem_setall	
6017	Failed sem_rmid	
6018	Failed get sem	
6020	ioctl command <i>name</i> failed	
6022	<i>error_message</i>	
6024	Failed to malloc for <i>name</i>	
6026	mem ccitt[ <i>name+number</i> , <i>name+number</i> ]: o: <i>number</i> e: <i>number</i> o^e: <i>number</i>	
6028	mem crc16[ <i>name+number</i> , <i>name+number</i> ]: o: <i>number</i> e: <i>number</i> o^e: <i>number</i>	
6030	reg ccitt: o: <i>number</i> e: <i>number</i> o^e: <i>number</i>	
6032	reg crc16: o: <i>number</i> e: <i>number</i> o^e: <i>number</i>	
6034	Failed to open <i>name</i> device	
6035	First Open of sx device	
6036	Modules selected improperly!!!	

**TABLE 40-4** sctest Error Messages (Continued)

	Error Message	Probable Cause(s)	Recommended Action
6038	<i>name</i> , i_module = <i>name</i>		
6040	FB unlock request failed		
8000	Can't acquire console semaphore	System load too heavy. System error.	Reduce the system load. If the problem persists, call your authorized Sun service provider.
8002	Can't get sem <i>number</i>		
8004	Unable to set page bounds		
8006	mmap: unable to map MDI control register space		
8008	Failed to mmap <i>name</i>		
8010	sctest is only running in Functional test		
8012	Failed to open <i>name</i>		



# System Test (systest)

systest checks the CPU board by exercising the I/O, memory, and CPU channels simultaneously as threads. There is no quick test option for systest; it is a CPU stress test.

## systest Options

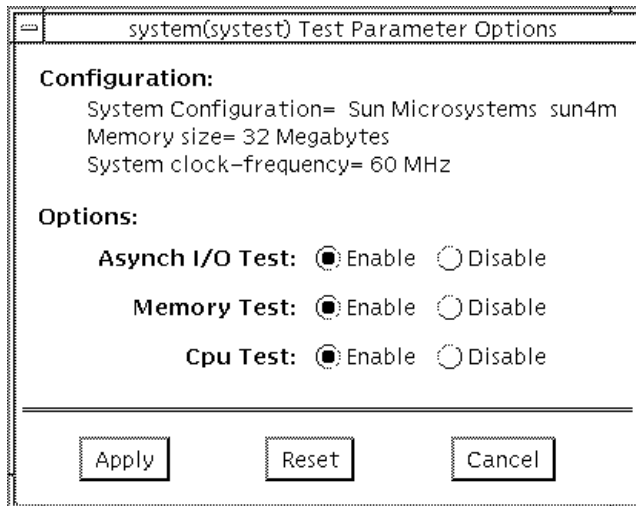

FIGURE 41-1 systest Option Menu

---

# systemst Test Modes

The Functional test is the only test mode available for systemst.

---

# systemst Command Line Syntax

`/opt/SUNWvts/bin/systemst standard_arguments`

---

# systemst Error Messages

TABLE 41-1 systemst Error Messages

Error Message	Probable Cause(s)	Recommended Action
6005 ( <i>thread_id</i> )Couldn't open file / dev/mem: <i>error_message</i>		
6006 ( <i>thread_id</i> )'valloc' results incorrect: <i>error_message</i>		
6007 ( <i>thread_id</i> )Bad 'mmap' results: <i>error_message</i> , page = <i>value/value</i> , addr = <i>address</i>		
6008 ( <i>thread_id</i> )kvm_open() failed: <i>error_message</i>		
6009 ( <i>thread_id</i> )kvm_nlist() failed: <i>error_message</i>		
6010 ( <i>thread_id</i> )Defective namelist in '/vmunix'		
6011 ( <i>thread_id</i> )Couldn't read physical memory list: <i>error_message</i>		
6012 ( <i>thread_id</i> )Couldn't read physical memory address		

**TABLE 41-1** `systest` Error Messages (Continued)

<b>Error Message</b>	<b>Probable Cause(s)</b>	<b>Recommended Action</b>
6013 <code>(thread_id)Couldn't read physical memory size: error_message</code>		
6014 Cannot open <code>device_name</code>		
6015 Test Failed due to segment violation error	Lack of sufficient memory resources.	Retry the test after increasing available memory.
6016 Test Failed due to fpu bus error	Lack of sufficient memory resources.	Retry test after increasing available memory.
6017 Test Failed due to fpu exception error	Lack of sufficient memory resources.	Retry test after increasing available memory.
6018 Test Failed due to illegal instruction	Lack of sufficient memory resources.	Retry test after increasing available memory.
8000 Failed system test (FPU, VMEM, I/O)		





## Tape Drive Test (tapetest)

---

The `tapetest` synchronous I/O test writes a pattern to a specified number of blocks (or, for a SCSI tape, writes to the end of the tape). The `tapetest` then rewinds the tape and reads and compares the data just written. The `tapetest` asynchronous I/O test sends a series of up to five asynchronous read/write requests to the tape drive, writing to the tape and then reading and comparing the data. The `tapetest` file test writes four files to the tape and then reads them back, comparing the data. For tape library testing, the pass count is incremented only after all tapes in the library have been tested.

---

**Note** – If you have a tape drive in your system, load a blank writable tape (scratch tape) before you start SunVTS. If you fail to do this, the `tapetest` option displays `drive type:unknown` on the option menu for the `tapetest`.

---

---

### tapetest Options

`tapetest` supports 4-mm, 8-mm, DLT, 1/4-inch cartridge, and 1/2-inch front-load tape drive testing. The options available for each of the tape devices differ slightly. An example of the option pop-up menu for a device is shown in FIGURE 42-1.

The Async I/O subtest uses the asynchronous read and write feature of the Solaris tape driver to exercise tape drives. In read-only mode the test sends a maximum of four asynchronous read packets, each with a random size and a random offset, to the tape drive. The test then waits for all outstanding I/O activity to complete before issuing another round of packets. This process continues until the whole area being tested has been covered. In read-write mode, one write packet is issued for every four read packets to ensure a spot check of the write operation. The area of the tape to be tested is written to first in order for the test to work correctly. This test is only supported under Solaris 2.6 and later releases.

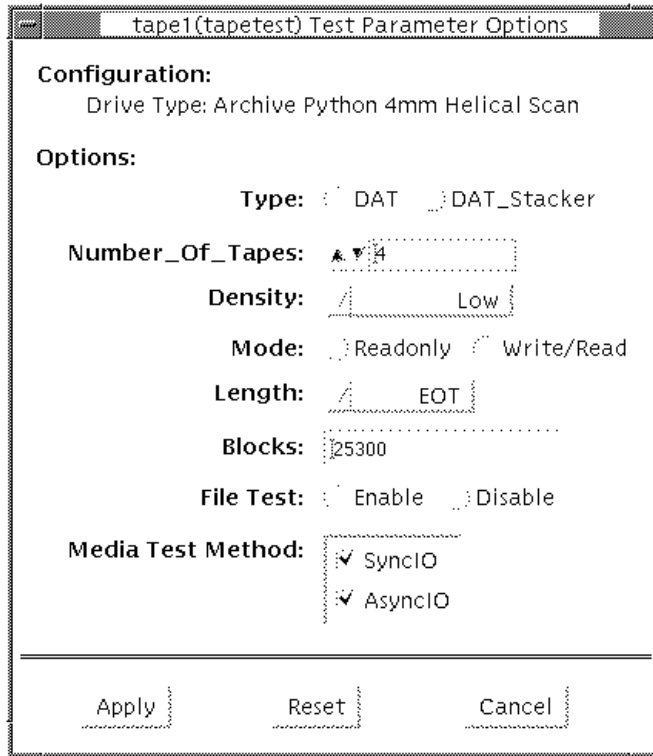

**FIGURE 42-1** tapetest Option Menu (4-mm tape drives)

---

**Note** – This test does not immediately stop after being disabled.

---

FIGURE 42-1 shows an example of the options menu for a 4-mm tape drive.

---

**Note** – The option menus for the 1/4-inch, 1/2-inch, DLT, and 8-mm tape drives differ slightly from FIGURE 42-1.

---

**TABLE 42-1** tapetest Options

tapetest Options	Description
Type	Normal tape drive or tape library (stacker).
# of Tapes	The number of tapes in the tape library. tapetest registers a single tape library pass only after all tapes in the library pass.
Format	QIC-11 and QIC-24 are quarter-inch tape formats that this test uses when it writes to the scratch tape you inserted. QIC-11 uses a 1-byte block ID; QIC-24 uses a 4-byte block ID, so each block on a QIC-24 tape is uniquely identifiable. Use a standard scratch tape for this test. QIC-11 format is the default testing format; however, you can choose QIC-24 only, or both of QIC-11 and QIC-24 formats. If you choose both, the test first writes one pass to the tape in QIC-11 format, and then writes a second pass over it in QIC-24 format.
Density	The following settings are available for 8-mm tape drives: -EXB8200: Writes 2.3 Gbytes of data to the tape -EXB8500: Increases the density and writes 5 Gbytes of data to the tape -Both: Writes both 2.3 Gbytes, and 5 Gbytes of data to the tape. For half-inch tape drives the available settings are 800, 1600, and 6250 BPIs.
Mode	If you enable Write/Read mode, the test first writes to the tape and then reads it back to compare. If you enable Read_Only mode, the test assumes the tape has been properly written and merely reads and compares. This mode is useful to check proper head alignment.
Length	The amount of the tape to be tested. The choices are: -EOT: The default; tests to the entire tape. -Long: The SCSI tape tests 70,000 blocks of the tape. -Short: Only the first 1000 blocks are tested. -Specified: You must type the number of blocks to be tested in the # of blocks field.
# of Blocks	If you select Specified under the Length option, you must type the number of blocks you want to test.

**TABLE 42-1** tapetest Options

tapetest Options	Description
File Test	<p>The <i>tape file</i> test sequence is as follows:</p> <ul style="list-style-type: none"> <li>-Writes three files</li> <li>-Rewinds</li> <li>-Reads part of the first file</li> <li>-Forward spaces to the start of the second file</li> <li>-Reads the second file</li> <li>-Forward spaces to the start of the third file</li> <li>-Tries to read to the end of that file for SCSI tapes only, the tape file test tries to backspace to the start of the second file and read it</li> </ul>
Retension	When enable is selected, the program retensions the tape.
Media Test Method	<p>Sync I/O: tapetest reads and or writes the number of blocks selected in Length.</p> <p>Async I/O: tapetest makes four asynchronous read requests to the tape drive. If read and write testing is selected, one asynchronous write request is also sent. The test continues after completing the requests.</p>

## tapetest Test Modes

The tapetest supports all three modes. It performs different test schemes on the network device, according to the mode you select.

**TABLE 42-2** tapetest Test Modes

Test Mode	Description
Connection Test	In this mode, tapetest verifies that the drive can be opened and that the drive type can be determined. If both checks are successful, or if the drive is currently busy, then the test passes. The tapetest fails if the open operation is unsuccessful for any reason other than the drive is busy.
Functional Test	tapetest checks the status, rewinds the tape, erases and retensions it. If the device is a cartridge tape, tapetest writes a pattern to nblks or eot (default), rewinds the tape, and then reads and compares of the pattern.
Online Mode	Provides a means to run tapetest through SyMON. In Online mode, the following Functional Test description applies: tapetest opens the device and reads several blocks from it. If the read operation is successful, the test has passed. On the other hand, if the device is busy or if no tape cartridge can be found in the drive, the test cannot be run and fails.

---

# tapetest Command Line Syntax

`/opt/SUNWvts/bin/tapetest standard_arguments -o dev=device_name, s=block_count,d=density,m=mode,l=length,method=method,ft=enables/disables,ret=enables/disables, dat=dat_type,8mm=8mm_type num=magazine_size`

**TABLE 42-3** tapetest Command Line Syntax

Argument	Explanation
<code>dev=device_name</code>	Specifies the <i>device_name</i> of the tape drive (required).
<code>s=block_count</code>	Specifies the number of blocks to be tested.
<code>d=density</code>	Specifies the density of the tape to open.
<code>m=mode</code>	Enables either the Write_Read or Read_Only tests.
<code>l=length</code>	Specifies the length of the test (EOT, Specified, Long, or Short).
<code>method=method</code>	Specifies the media test method (SyncI/O and or AsyncI/O) used.
<code>ft=enables/disables</code>	Enables or disables the file test.
<code>ret=enables/disables</code>	Enable or disables tape retention.
<code>dat=dat_type</code>	If you are testing a digital audio tape drive, specify whether it is a regular DAT drive or a DAT stacker. The choices are DAT and DAT_Stacker.
<code>8mm=8mm_type</code>	If you are testing an 8-mm tape drive, specify whether it is a regular 8-mm tape drive or a tape library. The command line choices are 8mm and 8mm_Library.
<code>num=magazine_size</code>	If you are testing a tape library, specify the magazine size.

# tapetest Error Messages

TABLE 42-4 tapetest Error Messages

Error Message	Probable Cause(s)	Recommended Action
6000 Missing device name	No device name is specified.	Retry test with correct device name specification.
6001 failed ioctl on unload and load next tape: err_code = <i>number</i> !	This stacker/library unit may lack the Automatic Cycle option.	Run the test with Single Pass Option enabled.
6002 Cannot open <i>device_name</i> : <i>error_message</i>	No tape media in drive.	Load tape media and retry test.
6005 Cannot close <i>device_name</i> : <i>error_message</i>	Bad drive.	Retry test; if problem persists, check or replace the drive.
6006 <i>text</i> write failed on <i>error_message</i> , block <i>number</i> : EOF reached	EOF reached prematurely.	Retry test with reduced blocksize specification or until EOF.
6007 <i>text</i> write failed on <i>device_name</i> , block <i>number</i> : <i>error_message</i> , sense key(0xvalue) = <i>text</i>	Drive needs attention.	Perform action to reset sense key and retry the test.
6008 <i>text</i> read failed on <i>device_name</i> , block <i>number</i> : EOF reached	EOF reached prematurely.	Retry test with reduced blocksize specification or until EOF.
6009 <i>text</i> read failed on <i>device_name</i> , block <i>number</i> : <i>error_message</i> , sense key(0xvalue) = <i>text</i>	Drive needs attention.	Perform action to reset sense key and retry test.
6010 <i>text</i> compare failed on <i>device_name</i> , block <i>number</i> , offset <i>number</i> , pattern 0xvalue, data= 0xvalue	Bad drive.	Retry test; if problem persists, check or replace the drive.
6011 <i>device_name</i> tape MTIOCGETDRIVETYPE ioctl: <i>number</i>	Bad drive.	Retry test; if problem persists, check or replace the drive.
6012 <i>text</i> failed on <i>device_name</i> : <i>error_message</i>	Bad drive.	Retry test; if problem persists, check or replace the drive.
6013 Failed Connection test on <i>device_name</i> : <i>error_message</i>	Broken cable. Bad drive.	Check or replace the cable. Check or replace the drive.

**TABLE 42-4** tapetest Error Messages (Continued)

	<b>Error Message</b>	<b>Probable Cause(s)</b>	<b>Recommended Action</b>
6014	Failed Online test: <i>device_name</i>	Device may be in use.	Retry later.
6015	Failed Online test: <i>device_name: error_message</i>	No tape media in drive.	Load tape media and retry test.
6016	Online test was unsuccessful: <i>device_name</i>	No tape media in drive.	Load tape media and retry test.
6017	Failed Online read test: <i>device_name</i>	Bad drive.	Retry test; if problem persists, check or replace the drive.
6018	Open Failed on <i>device_name: error_message</i>	Broken cable.	Check or replace the cable.
		Bad drive.	Check or replace the drive.
6018	recon: No Corresponding SCSI disk device		
6019	Needs both SCSI disk and SCSI tape to run the test		
6020	Couldn't retention ' <i>device_name</i> '		
6021	Couldn't read file ' <i>device_name</i> '		
6022	SCSI disconnect/ reconnect failed		
6023	Spurious signal received from child		





## S24 Frame Buffer Test ( `tcxtest` )

---

Through a series of protocol, memory, acceleration, and colormap tests, `tcxtest` checks the functionality of the S24 Frame Buffer SBus card used on the SPARCstation5 and checks the FSV (fast SBus video) ASIC on the SPARCstation4 motherboard.

---

**Note** – Disable all screen savers before testing any graphics device. Type `xset s off` at a UNIX prompt to disable the Solaris screen saver.

---

---

### Test Groups

`tcxtest` has four distinct test groups:

- AFX Protocol tests (in 8/16/32/64-bit mode)
  - WRC
- Frame Buffer Memory tests (in 8/16/32/64-bit14 mode)
  - address
  - constant
  - random
- Acceleration tests (both User and Raw modes)
  - blit
  - stip
- Colormap and Cursor tests
  - cursor (does not apply to SPARCstation4)
  - colormap

# tcxtest Subtests

TABLE 43-1 tcxtest Subtests

tcxtest Subtests	Description
WRC	By performing multiple writes and reads, and then verifying the results, the WRC test exercises the FIFO inside the S24 chip. The WRC test is composed of these three subtests: <code>test_afx_alt_wr</code> , <code>test_memafx</code> , and <code>test_afx_random</code> . If these tests fail, they print an error message showing the expected and observed data.
Test_afx_alt_wr	This test performs 16 writes to alternative pages (for example: WR (Page1), WR (Page2), WR (Page1+off), WR (Page2+off), etc.). It then reads back the data and compares it with the expected results. This test also writes to the frame buffer space 16 times, followed by a write to a different page in the frame buffer space. The test then reads this data back and verifies it with the expected results.
Test_memafx	The CPU in the SWIFT chip has closely coupled interfaces for the DRAM and the AFX bus. This test checks the arbitration between the two accesses. This test performs a number of alternating writes to the AFX and the CPU memory. After writing to different locations, the test reads and verifies the data. By performing an access across the page boundaries, the test covers both the cached and non-cached accesses.
Test_afx_random	After writing to one page in the DRAM memory, the test performs a few random writes/reads to random locations in the AFX space. The test then writes to a different page in the DRAM space, where it performs random accesses. This test does not perform any data verification, it just checks to see if any of these random accesses caused a time out.
Constant	This test writes a data pattern to the whole memory. This pattern is read back and compared with the expected data. Once the memory fill operation is completed, the test reads the memory back and verifies that the value read is correct.
Address	This test writes a data pattern (which is same as the value of the address) to the whole memory. This pattern is then read back to verify that it is the correct value.
Random	This test writes a random data pattern to the whole memory. This pattern is read back and compared with the expected data. After the memory fill operation is completed, the test reads the memory and verifies the values read are correct.

**TABLE 43-1** `tcxtest` Subtests

<b>tcxtest Subtests</b>	<b>Description</b>
Blit	<p>This test has two parts; the raw <code>blit</code> test and the user <code>blit</code> test. The raw <code>blit</code> test draws a 64x64x24 pixel image at the top-left corner of screen. Next it <code>blits</code> the image to the screen. The destination images are read back and compared with the original image to verify the raw <code>blit</code> operation has run correctly. The user <code>blit</code> test draws a 64x64x24 pixel image at the top left corner of screen. It then <code>blits</code> the image to the screen. The destination images are read back and compared with the original image. The user <code>blit</code> test is the same as the raw <code>blit</code> test, except the user <code>blit</code> test uses the user data space for the <code>blit</code> command.</p>
Stip	<p>This test performs numerous corner cases for stipple. The test writes to the destination with different data values using a stipple operation. The destination data is read back and verified. For the fast SBus video (SV), the following is checked:</p> <ul style="list-style-type: none"> <li>• Walks 1 through pixel mask</li> <li>• Walks 1 through ROP bits</li> <li>• Walks 1 through destination byte</li> <li>• Walks 1 through IDX byte</li> </ul>
Cursor (does not apply to SPARCstation 4)	<p>This test performs a data register regression test. It writes a walking 1 pattern to the cursor data registers. The data is then read back and verified with the expected results. The test is repeated using a walking 0 as the data pattern</p>
Colormap	<p>Loads all locations in the colormap with varying values of RGB. Note: If the system being tested has a monochrome or greyscale monitor, visual color problems are undetectable.</p>

---

## tcxtest Options

FB Locking is the only test parameter options for this test. See the section about testing multiple frame buffers in the *SunVTS 2.1 User's Guide* for details.

- Click enable or disable to configure Frame Buffer locking.

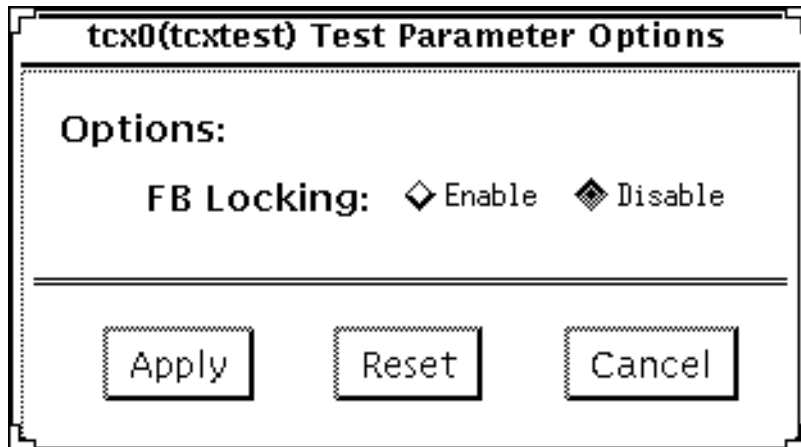

FIGURE 43-1 tcxtest Option Menu

---

## tcxtest Test Modes

Available only in the Functional test mode. Functional test is the default for tcxtest. tcxtest runs the appropriate subtests for the hardware platform being tested.

---

# tcxtest Command Line Syntax

```
/opt/SUNWvts/bin/tcxtest standard_arguments -o  
dev=device_name,lock=E(nable)/D(isable), X=bit_mode,T=test,S=[dfb8, dfb24,  
dfb32]
```

TABLE 43-2 tcxtest Command Line Syntax

Argument	Explanation
dev=device_name	Specifies the filename of the device to be tested, for example: dev=tcx0.
lock=E(nable)/ D(isable)	Enables or disables the window system locking option. See the section about Testing Frame Buffers in <i>SunVTS 2.1 User's Guide</i> for details. Do not use when device is the window system display.
X=bit_mode	Specifies the data transfer size; supported values are: 8byte 16short 32long 64double word
T=test	Specifies a particular test; to specify an individual test, replace <i>test</i> with: a=Address c=Constant r=Random b=Blit s=Stipple h=Cursor w=WRC Note: When you select either the <i>Blit</i> or <i>Stipple</i> test, both the <i>User</i> and <i>Raw</i> mode tests are run.
S=[dfb8, dfb24, dfb32]	Specifies which frame buffer memory space to use. -dfb8Dumb frame buffer 8-bit space. Memory is accessed only by bytes. -dfb24Dumb frame buffer 24-bit space. Memory is accessed only by 24-bit reads and writes. -dfb32Dumb frame buffer 8-bit space. Memory is accessed by 8-bit reads and writes.

# tcxtest Error Messages

**TABLE 43-3** tcxtest Error Messages

Error Message	Probable Cause(s)	Recommended Action
6000 F BIOGATTR failed in is_24bit subroutine	Driver not installed.  OS driver problem.  AFX bus error.	Examine system message files (/var/adm/messages) for other information.
6010 Colormap failure, Address: <i>address</i> , red, Expected: <i>value</i> Observed: <i>value</i>	Bad RAMDAC.  Bad a24 board.  AFX bus error.	Replace the frame buffer card.  Examine system message files (/var/adm/messages) for other information.
6011 Colormap failure, Address: <i>address</i> , green, Expected: <i>value</i> Observed: <i>value</i>	Bad RAMDAC.  Bad a24 board.  AFX bus error	Replace the frame buffer card.  Examine system message files (/var/adm/messages) for other information.
6012 Colormap failure, Address: <i>address</i> , blue, Expected: <i>value</i> Observed: <i>value</i>	Bad RAMDAC.  Bad a24 board.  AFX bus error.	Replace the frame buffer card.  Examine system message files (/var/adm/messages) for other information.
6013 THC Cursor Regression failed Address: <i>address</i> , Expected: <i>value</i> , Observed: <i>value</i>	Bad a24 board.  AFX bus error.	Replace the frame buffer card.  Examine system message files (/var/adm/messages) for other information.
6014 Can't clear frame buffer, dst_start: <i>address</i> , src_start: <i>address</i> , Address: <i>value</i> , Observed: <i>value</i> Expected: <i>value</i>	Bad a24 board.  AFX bus error.	Replace the frame buffer card.  Examine system message files (/var/adm/messages) for other information.

**TABLE 43-3** tcxtest Error Messages (Continued)

Error Message	Probable Cause(s)	Recommended Action
6015 Frame buffer pattern test failed, dst_space: <i>address</i> , src_space: <i>address</i> , check_x = <i>value</i> , check_y = <i>value</i> , Address: <i>value</i> , Observed: <i>value</i> Expected: <i>value</i>	Bad a24 board. AFX bus error.	Replace frame buffer card Examine system message files (/var/adm/messages) for other information.
6016 Can't clear frame buffer pattern, dst_space: <i>address</i> , src_space: <i>address</i> , check_x: <i>value</i> , check_y: <i>value</i> , Address: <i>value</i> Observed: <i>value</i> Expected: <i>value</i>	Bad a24 board. AFX bus error.	Replace the frame buffer card. Examine system message files (/var/adm/messages) for other information.
6017 Can't clear frame buffer after write, Address: <i>value</i> , Expected: <i>value</i> Observed: <i>value</i>	Bad a24 board. AFX bus error.	Replace the frame buffer card. Examine system message files (/var/adm/messages) for other information.
6018 Raw Blit test failed, Offset: <i>address</i> , Expected: <i>value</i> Observed: <i>value</i>	Bad a24 board. AFX bus error.	Replace the frame buffer card. Examine system message files (/var/adm/messages) for other information.
6019 Blit test failed CHECKING, Offset: <i>address</i> , Expected: <i>value</i> Observed: <i>value</i>	Bad a24 board. AFX bus error.	Replace the frame buffer card. Examine system message files (/var/adm/messages) for other information.
6020 Blit test failed, Offset: <i>value</i> , Expected: <i>value</i> Observed: <i>value</i>	Bad a24 board. AFX bus error.	Replace the frame buffer card. Examine system message files (/var/adm/messages) for other information.
6021 Blit accel test failed. Offset: <i>value</i> , Expected: <i>value</i> Observed: <i>value</i>	Bad a24 board. AFX bus error.	Replace the frame buffer card. Examine system message files (/var/adm/messages) for other information.
6022 Stipple test failed. Offset: <i>address</i> , Expected: <i>value</i> Observed: <i>value</i>	Bad a24 board. AFX bus error.	Replace the frame buffer card. Examine system message files (/var/adm/messages) for other information.

**TABLE 43-3** tcxtest Error Messages (Continued)

	Error Message	Probable Cause(s)	Recommended Action
6025	Raw Stipple test failed. Offset: <i>address</i> , Expected: <i>value</i> Observed: <i>value</i>	Bad a24 board. AFX bus error.	Replace the frame buffer card. Examine system message files (/var/adm/messages) for other information.
6027	Frame buffer pattern test miscompare, y: <i>value</i> x: <i>value</i> Observed: <i>value</i> Expected: <i>value</i> Address: <i>value</i>	Bad RAMDAC. Bad a24 board. AFX bus error.	Replace the frame buffer card. Examine system message files (/var/adm/messages) for other information.
6029	Afx protocol test <i>message</i> Expected: <i>value</i>	AFX bus error. Bad a24 board. Bad CPU board.	Examine system message files (/var/adm/messages) for other information.
6030	Null allocation to membase	AFX bus error. Bad a24 board. Bad CPU board.	Examine system message files (/var/adm/messages) for other information.
6031	Afx_mem test failure, Address: <i>address</i> , Expected: <i>value</i>	AFX bus error. Bad a24 board. Bad CPU board.	Examine system message files (/var/adm/messages) for other information.
6032	Afx_mem Mem test failure, Address+0x4000 Value: <i>value</i> , Exp 0x5555aaaa	AFX bus error. Bad a24 board. Bad CPU board.	Examine system message files (/var/adm/messages) for other information.
6033	Pattern test failed in Byte mode for DFB <i>value</i> . Offset: <i>address</i> , Expected: <i>value</i> OBServed: <i>value</i> xor( <i>value</i> )	AFX bus error. Bad a24 board. Bad CPU board.	Examine system message files (/var/adm/messages) for other information.



**TABLE 43-3** tcxtest Error Messages (Continued)

Error Message	Probable Cause(s)	Recommended Action
6034 Pattern test failed in Short mode for DFBvalue. Offset: value, Expected: value Observed: value xor(value)	AFX bus error. Bad a24 board. Bad CPU board.	Examine system message files (/var/adm/messages) for other information.
6035 Pattern test failed in Long mode for DFBvalue. Offset: value, Expected: value Observed: value xor(value)	AFX bus error. Bad a24 board. Bad CPU board.	Examine system message files (/var/adm/messages) for other information.
6036 Pattern test failed in Long mode for DFBvalue Offset: value, Expected: value Observed: value	AFX bus error. Bad a24 board. Bad CPU board.	Examine system message files (/var/adm/messages) for other information.  Examine system message files (/var/adm/messages) for other information.
6039 Random test failed in Byte mode for DFvalue, Offset: value, Expected: value Observed: value xor: value	AFX bus error. Bad a24 board. Bad CPU board.	
6040 Random test failed in Short mode for DFBvalue, Offset: value, Expected: value Observed: value xor: value	AFX bus error. Bad a24 board. Bad CPU board.	Examine system message files (/var/adm/messages) for other information.
6041 Random test failed in Long mode for DFBvalue, Offset: value, Expected: value Observed: value xor: value	AFX bus error. Bad a24 board. Bad CPU board.	Examine system message files (/var/adm/messages) for other information.
6042 Pattern test failed in Dblword mode for DFBvalue, Offset: value, Expected: value Observed: value, xor: value	AFX bus error. Bad a24 board. Bad CPU board.	Examine system message files (/var/adm/messages) for other information.

**TABLE 43-3** tcxtest Error Messages (Continued)

Error Message	Probable Cause(s)	Recommended Action
6043 Address test failed in Char mode for DFBvalue. Offset: value, Expected: value Observed: value xor: value	AFX bus error. Bad a24 board. Bad CPU board.	Examine system message files (/var/adm/messages) for other information.
6044 Address test failed in Short mode for DFBvalue, Offset: value, Expected: value Observed: value xor: value	AFX bus error. Bad a24 board. Bad CPU board.	Examine system message files (/var/adm/messages) for other information.
6045 Address test failed in Long mode for DFBvalue, Offset: value, Expected: value Observed: value xor: value	AFX bus error. Bad a24 board. Bad CPU board.	Examine system message files (/var/adm/messages) for other information.
6046 Address test failed in Dblword mode for DFBvalue, Offset: value, Expected: value Observed: value xor: value>	AFX bus error. Bad a24 board. Bad CPU board.	Examine system message files (/var/adm/messages) for other information.
6047 Verifying Double:word writes	AFX bus error. Bad a24 board. Bad CPU board.	Examine system message files (/var/adm/messages) for other information.
8000 Open failure for device device name	Driver not installed. OS driver problem. AFX bus error.	Examine system message files (/var/adm/messages) for other information.
8001 Pattern test failed in Long mode, Offset: value, Expected: value Observed: value	Driver not installed. AFX bus error. Bad CPU board.	Examine system message files (/var/adm/messages) for other information.

**TABLE 43-3** tcxtest Error Messages (Continued)

	<b>Error Message</b>	<b>Probable Cause(s)</b>	<b>Recommended Action</b>
8002	can't acquire console semaphore	Not enough memory.	Examine system message files (/var/adm/messages) for other information.
		Not enough swap space.	
8003	XCreateSimpleWindow failed	Not enough memory.	Examine system message files (/var/adm/messages) for other information.
		Not enough swap space.	
8004	Multibuffering extension does not exists	Not enough memory.	Examine system message files (/var/adm/messages) for other information.
		Not enough swap space.	
8005	Couldn't create enough buffers	Not enough memory.	Examine system message files (/var/adm/messages) for other information.
		Not enough swap space.	



## Virtual Memory Test ( `vmem` )

---

The `vmem` test checks virtual memory; that is, it tests the combination of physical memory and the swap partitions of the disk(s).

---

**Note** – This test may not stop immediately after being disabled.

---

This test uses the Solaris `valloc` (page aligned) system call to allocate, write, read, and compare virtual memory. These operations normally cause heavy paging activity on the system and simulates a stressful environment for the operating system. This test also detects ECC parity errors, memory read errors, addressing problems, and displays the corresponding virtual memory addresses on failure.

---

## Handling Swap Space

Running this test places a significant burden on the operating system, since it uses the majority of swap space available for testing. You should use the `swap space reserve` option to `vmem` when non-SunVTS test processes are started after SunVTS testing has started. See “*Swap Space Requirements*” in the *SunVTS User’s Guide* for a complete discussion of swap space requirements.

# vmem Options

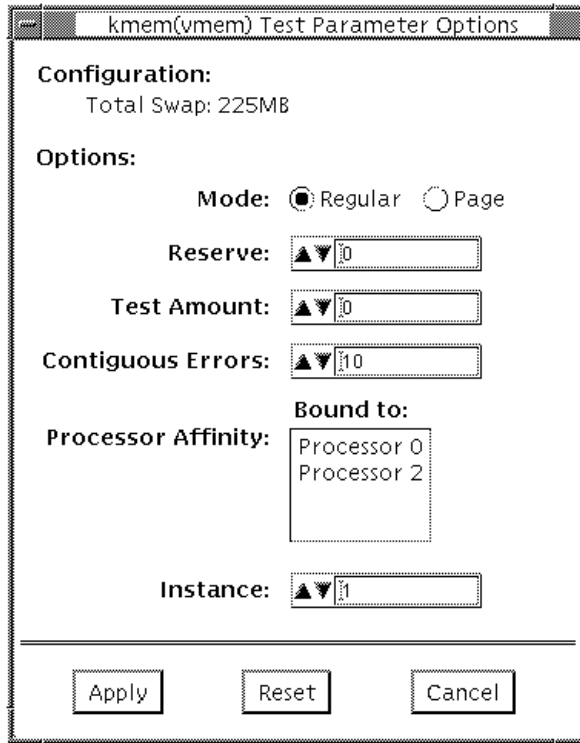

FIGURE 44-1 vmem Option Menu

**TABLE 44-1** `vmem` Options

<b>vmem Options</b>	<b>Description</b>
<code>vmem Configuration</code>	The amount of memory listed in the configuration field is equivalent to the sum of the used and available swap space amounts returned by the <code>swap -s</code> command. It indicates the amount of virtual memory found, rounded up to the nearest Kbyte.
Test Amount	An amount can be specified to test the virtual memory, instead of the default. Specifying a number greater than the available memory, can cause <code>vmem</code> or other running tests to fail.
Mode	Two modes are available: <ul style="list-style-type: none"><li>• Regular mode tests the amount of memory and is limited by the amount of physical memory available to the system under test.</li><li>• Page mode tests assign virtual memory one page at a time. Each page is mapped to the temporary file <code>/tmp/vmem.page</code> and is then paged out to storage once test data is written. Next, the temporary page is paged back into memory for a read and compare.</li></ul> <p>When the stress test execution option is selected, the <code>vmem</code> test allocates the entire assigned system memory (through <code>valloc</code>), writing from beginning to end. The memory is then read back and compared with the original pattern, one long word at a time.</p>
Reserve	The Reserve option specifies the amount of memory to reserve from being tested by <code>vmem</code> . The reserved space is used for other processes running concurrently with the or SunVTS tests. The Reserve option can be used to reserve memory in addition to the default. This option applies only to a specific instance. Trying to reserve more memory than what is assigned to be tested by this instance will cause the test to fail.

---

## vmem Test Modes

This test is only available in the Functional test mode. In this mode the, `vmem` test writes a pattern to an amount of virtual memory specified by the user. Then the data is read back and compared. If there is a miscompare, the data is read again and compared. Whenever there is a miscompare, the virtual address is reported. When there is a miscompare on recomparison, an attempt is made to convert the virtual address to the physical address if the SunVTS diagnostic driver is installed.

---

## vmem Command Line Syntax

```
/opt/SUNWvts/bin/vmem standard_arguments -o mode=type, reserve=number,  
amount=number, bdfinfo=number, cerr=number
```

TABLE 44-2 vmem Command Line Syntax

Argument	Explanation
<code>mode=type</code>	Specifies which mode of the <code>vmem</code> test you want to run; you can choose between <code>page</code> mode, which tells the write/read memory test to proceed one system memory page at a time, and <code>regular</code> , which <code>valloc</code> 's the entire assigned memory which is read and compared, one long word at a time.
<code>reserve=number</code>	Specifies the amount of Mbytes of virtual memory to reserve in addition to the default amount.
<code>amount=number</code>	Specifies the number of Mbytes of memory to be tested instead of the default amount.
<code>bdfinfo=number</code>	Provides the board number information for all the CPU/memory boards in the system. For example, if board 0 and board 5 have memory, then the <code>bdfinfo=33</code> ( $2^{**}5+2^{**}0$ ).
<code>cerr=number</code>	Specifies the maximum number of contiguous errors to be dumped when a memory error occurs.



# vmem Error Messages

TABLE 44-3 vmem Error Messages

Error Message	Probable Cause(s)	Recommended Action
6001 setrlimit(RLIMIT_DATA) failed to set to RLIM_INFINITY: <i>error_message</i>	Failed to increase the size of test process's heap to 2GB (fatal error).	
6002 Test terminated after finding maximum number ( <i>number</i> ) of noncontiguous errors	Fatal error.	
6003 msync() failed: <i>error_message</i>	Failed to synchronize memory with physical storage (fatal error).	
6004 Test terminated after finding miscompared data	Test failed (fatal error).	
8001 Test completed. Found <i>data</i> noncontiguous miscompare errors	Suspect swap partition(s) (fatal error). Suspect SCSI controller. Faulty system software.	Consult your authorized Sun service provider.
8002 Increase swap space to allocate at least <i>number</i> MB from the process' heap	Failed to increase mem process' heap storage.	
8003 Attempt to reserve more than what's been assigned	Fatal error.	Reduce the "reserve" amount.
8004 valloc( <i>address</i> ) failed: <i>error_message</i>	Fatal error.	Increase swap space or reduce the reserve amount.
8005 Open( <i>file_name</i> ) failed: <i>error_message</i>	Failed to open the file <i>file_name</i> used in the "page" mode (fatal error).	
8006 mmap() virtual address <i>address</i> to <i>file_name</i> failed: <i>error_message</i>	Failed to map a region at the virtual address of the file <i>file_name</i> used in the "page" mode (fatal error).	

**TABLE 44-3** vmem Error Messages (Continued)

	<b>Error Message</b>	<b>Probable Cause(s)</b>	<b>Recommended Action</b>
8007	<code>munmap(<i>address</i>) failed: <i>error_message</i></code>	Failed to unmap a region at the virtual address of the file <i>file_name</i> used in the “page” mode (fatal error).	
8008	<code>close() failed on <i>file_name</i>: <i>error_message</i></code>	Fatal error.	
8009	Not enough space to store miscompare information	Failed to allocate space to store miscompare data (fatal error).	Increase swap space or reduce the load on the system.
8010	<code>swapctl() failed: <i>error_message</i></code>	Failed to obtain the amount of swap space configured in the system (fatal error)	

## SBus Expansion Subsystem Test ( `xctest` )

---

`xctest` verifies the functionality of the Sun SBus expansion subsystem (XBox) hardware and its peripherals. The SBus expansion subsystem can be used in two mutually exclusive modes: Transparent and Nontransparent. In Transparent mode, `xctest` checks SBus expansion subsystem peripherals, such as SBus cards and disk drives. In Nontransparent mode `xctest` checks the actual expansion subsystem itself.

---

**Note** – Do not select the Nontransparent mode if SBus cards are installed in the SBus expansion slots. Do not select Transparent mode if the SBus expansion slots are empty.

---

# xbtest Modes

The `xbtest` modes are described in the following table:

TABLE 45-1 `xbtest` Modes

Mode	Description
Transparent Mode	<p>In Transparent mode, the <code>wait_for_error</code> test is used. When <code>xbtest</code> is started, a child process is created. The parent process waits for the child process to terminate and then it exits. The child process issues a <code>WAIT_FOR_ERROR_PAK ioctl</code> call and then enters sleep mode.</p> <p>When the device driver receives an error, it wakes up and passes an error packet to the child process. The child process dumps the contents of the error packet, and also exits.</p> <p>If the child process does not receive an error message before the end of the test period specified by the <code>time</code> option, it exits. The parent process then exits. The default value for the <code>time</code> option is one minute. If you do not specify another value for the <code>Time</code> option, the default value is used in both regular and stress test modes.</p>
Nontransparent Mode	<p>In Nontransparent mode, <code>self_diagnostic</code> test is used. If you do not have an XBox SBus card in any slot of your system, you must add the following line to the <code>/etc/system</code> file:</p> <pre>set xbox:xbox_no_cards_in_slot0=1</pre> <p>After adding this line to <code>/etc/system</code>, reboot the machine using the <code>-r</code> option. You can now run the Nontransparent mode test of <code>xbtest</code>.</p> <p>This test checks the expansion subsystem hardware; the subtests are described below. The subtests, part of the diagnostic test, are repeated three times in both Regular and Stress test modes. Time-out checks are included to avoid indefinite hangs. If any test should fail, it does not result in a system panic; however, full recovery is not guaranteed.</p>

## ▼ To Perform a Self-Diagnostic Test

1. **Reset your system using the `<L1-A>` or `<Stop-A>` keyboard commands.**
2. **Check for the expected value from the XAC register.**

3. Run a DVMA XAC Interrupt test:
  - a. Create a DVMA transfer by asserting DVTE + INTT in control register 1 of XAC.
  - b. Wait for the interrupt.
  - c. Compare the error status packet with the expected values.
4. Run a DVMA XBC Interrupt test:
  - a. Create a DVMA transfer by asserting DVTE + INTT in control register 1 of XBC.
  - b. Wait for the interrupt.
  - c. Compare the error status packet with the expected values.

---

## xbtest Options

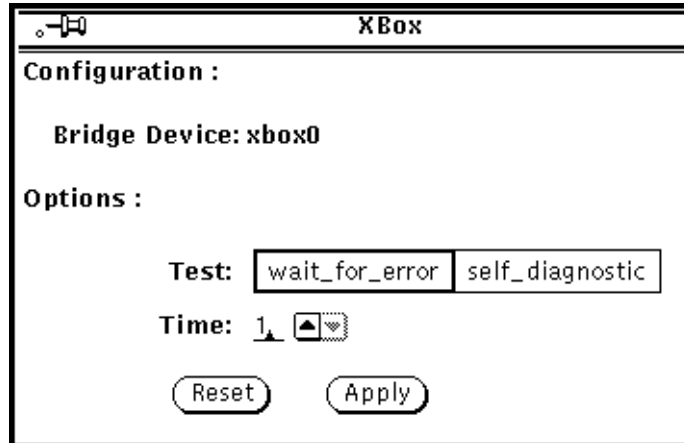

FIGURE 45-1 xbttest Option Menu

The top section of the `xbtest` Options menu displays the device name of the SBus Expansion Subsystem card being tested.

TABLE 45-2 `xbtest` Options

<code>xbtest</code> Options	Description
Test	Specifies <code>self_diagnostic</code> or <code>wait_for_error</code> test. See “Nontransparent Mode” on page 402 before running the <code>self_diagnostic</code> test.
Time	The number of minutes <code>xbtest</code> waits for an error to be returned. You can change the <code>xbtest</code> time setting by selecting the text field and typing the number of minutes you want the test to run (minimum 1 minute; maximum 20 minutes).

## `xbtest` Test Modes

This test is only available in the Functional test mode. A wait time of 10 seconds is used with the `wait_for_error` test if the XBox is in Transparent mode. If the XBox is in nontransparent mode, the subtests that are part of the self-diagnostic test are repeated three times.

## `xbtest` Command Line Syntax

```
/opt/SUNWvts/bin/xbtest -o dev=xbox#,test=we|sd,time=test_time
```

TABLE 45-3 `xbtest` Command Line Syntax

Argument	Explanation
<code>dev=xbox#</code>	Specifies the physical path name of the subsystem unit to be tested ( <code>.xbox#</code> ), where # is the instance number defined in <code>path_to_inst(4)</code> . You need to search the <code>/devices</code> tree to find the physical pathname of the subsystem. Note: You must include the <code>device_name</code> path when running <code>xbtest</code> from the command line.

**TABLE 45-3** `xbtest` Command Line Syntax

Argument	Explanation
<code>time=test_time</code>	The number of minutes this test waits for an error to be returned. Used only with the <code>we</code> option. Substitute <code>test_time</code> with the number of minutes you want <code>xbtest</code> to wait. The default is one minute.
<code>test=we sd</code>	<code>we</code> = specifies <code>wait_for_error</code> test. This option directs <code>xbtest</code> to run in Transparent mode. This option runs <code>xbtest</code> continually until an error is returned, or until the time interval specified with the <code>T=test_time</code> option has ended.  <code>sd</code> = specifies <code>self_diagnostic</code> test. This option is used in Nontransparent mode. See TABLE 45-1 on page 402, before running Nontransparent mode.

For example, to run `xbtest`, type:

```
# /opt/SUNWvts/bin/xbtest -o dev=xbox0,test=we,time=2
```

## xbtest Error Messages

**TABLE 45-4** `xbtest` Error Messages

Error Message	Probable Cause(s)	Recommended Action
6002 Incorrect options	Failed to increase the size of test process's heap to 2GB (fatal error).	
6003 XAC_WAIT_FOR_ERROR ioctl command fail ( <i>error_message</i> )		
6004 XAC_CLEAR_WAIT_FOR_ERROR ioctl command fail ( <i>error_message</i> )		
6005 XAC_WRITE0 ioctl command fail ( <i>error_message</i> )		
6006 Failed to open /etc/path_to_inst file ( <i>error_message</i> )		
6007 <i>device_name</i> invalid device name		

**TABLE 45-4** xbttest Error Messages (Continued)

Error Message	Probable Cause(s)	Recommended Action
6008 <i>device_name</i> 's instance number() not in /etc/path_to_inst file		
6009 error status dirty bit <i>number</i>	This bit is set to 0 when the XBox detects an error.	
6010 error status indicator <i>number</i>	This bit is set to 0 when the XBox detects an error.	
6011 expansion sbus slave selects 0x%x		
6012 parent master request <i>data</i>		
6013 packet type		
6014 physical address info		
6015 sbus size <i>data</i>		
6016 cable resend limit timeout error (dpr1)	This error is detected by the XBox controller.	
6017 cable parity error (dpr1)	This error is detected by the XBox controller.	
6018 expansion sbus read error (err ack)	The signal err ack is asserted on the expansion SBus by XBox slave while being read by an XBox master.	
6019 expansion sbus read error (rsvd ack)	The signal rsvd ack is asserted on the expansion SBus by XBox slave while being read by an XBox master.	
6020 expansion sbus read error (late error)	The signal rsvd ack is asserted on the expansion SBus by XBox slave while being read by an XBox master.	
6021 expansion sbus timeout error	XBox controller detects a timeout on the expansion SBus during a read or write to an XBox slave.	
6022 write 0 error		
6023 buffer write error (err ack)	The signal err ack is asserted on the expansion or host SBus while the XBox controller / XAdapter was performing a DVMA write.	



**TABLE 45-4** xbttest Error Messages (Continued)

	<b>Error Message</b>	<b>Probable Cause(s)</b>	<b>Recommended Action</b>
6024	buffer write error (rsvd ack)	The signal rsvd ack is asserted on the expansion or host SBus while the XBox controller / XAdapter was performing a DVMA write.	
6025	buffer write error (late error)	The signal late error is asserted on the expansion or host SBus while the XBox controller / XAdapter was performing a DVMA write.	
6026	cable resend timeout error (dpr0)	This error is detected by the XAdapter controller.	
6027	cable ack timeout error	This error occurs when XAdapter does not detect cable acknowledgment.	
6028	cable parity error (dpr0)	This error is detected by the XAdapter controller.	
6029	cable serial interrupt parity error	This error is detected by the XAdapter controller.	
6030	child not ready error	This error indicates that the XBox controller can no longer communicate with the XAdapter.	
6031	XAC_GET_REG_VALUES ioctl command fail ( <i>error_message</i> )		
6032	XAC_GET_ERROR_PKT ioctl command fail ( <i>error_message</i> )		
6033	XAC_TRANSPARENT ioctl command fail ( <i>error_message</i> )		
6034	XAC_NON_TRANSPARENT ioctl command fail ( <i>error_message</i> )		
8003	XAC_NON_TRANSPARENT ioctl command fail ( <i>error_message</i> )		
8004	XAC_REG_CHECK ioctl command fail ( <i>error_message</i> )		



## Loopback Connectors

Loopback connectors are designed for the testing of communication ports. They take the form of either a single plug or a port-to-port cable with some communication connections shorted (looped-back).

**Note** – Loopback connectors must be wired properly and connected firmly for the Serial Port tests to work correctly. Miswired, poorly soldered, or missing loopback connectors can cause erroneous diagnostic error messages.

TABLE A-1 depicts the pin assignments for most loopback plugs and cables that may be used when testing a system.

**TABLE A-1** Pin Connections for Loopback Plugs

Signal Description	EIA	CCITT #	RS-449 "A" "B"		DIN 8 8-pin round	DB9 9-pin	DB25 25-pin	Direction	Alpha ID
Chassis/Frame Ground	AA	101	1	NC*	NC*	NC*	1	none	AA
Transmit Data (TxDa)	BA	103	4	22	3	3	2	output	BA
Receive Data (RxDa)	BB	104	6	24	5	2	3	input	BB
Request To Send (RTSa)	CA	105	7	25	6	7	4	output	CA
Clear To Send (CTSa)	CB	106	9	27	2	8	5	input	CB
Data Set Ready (DSRa)	CC	107	11	29	NC*	6	6	input/ output	CC

**TABLE A-1 Pin Connections for Loopback Plugs (Continued)**

Signal Description	EIA	CCITT #	RS-449 "A" "B"		DIN 8 8-pin round	DB9 9-pin	DB25 25-pin	Direction	Alpha ID
Signal Ground (SG)	AB	102	19	NC*	4	5	7	none	AB
Data Carrier Detect (DCDa)	CF	109	13	31	7	1	8	input	CF
Transmit Clock In (TRxCa)	DB	114	5	23	NC*	NC*	15	input	DB
Receive Clock in (RTxCa)	DD	115	8	26	8	NC*	17	input	DD
Data Terminal Ready (DTRa)	CD	108	12	30	1	4	20	output	CD
External Clock Out (TRxCa)	DA	113	17	35	NC*	NC*	24	output	DA
Secondary Data Carrier Detect (DCDb)	SCF	122	NC*	NC*	NC*	NC*	12	input	SCF
Secondary Clear to Send (CTSb)	SCB	121	NC*	NC*	NC*	NC*	13	input	SCB
Secondary Transmit Data (TxDb)	SBA	118	NC*	NC*	NC*	NC*	14	output	SBA
Secondary Receive Data (RxDb)	SBB	119	NC*	NC*	NC*	NC*	16	input	SBB
Secondary Request to Send (RTSb)	SCA	120	NC*	NC*	NC*	NC*	19	output	SCA

NC = No connection

---

# 25-Pin RS-232 Loopback Plug

The RS-232 and RS-423 single-port loopback plug is a specially wired male DB-25 connector. It is plugged in to a serial port in the back of the system under test. The wiring is shown in FIGURE A-1.

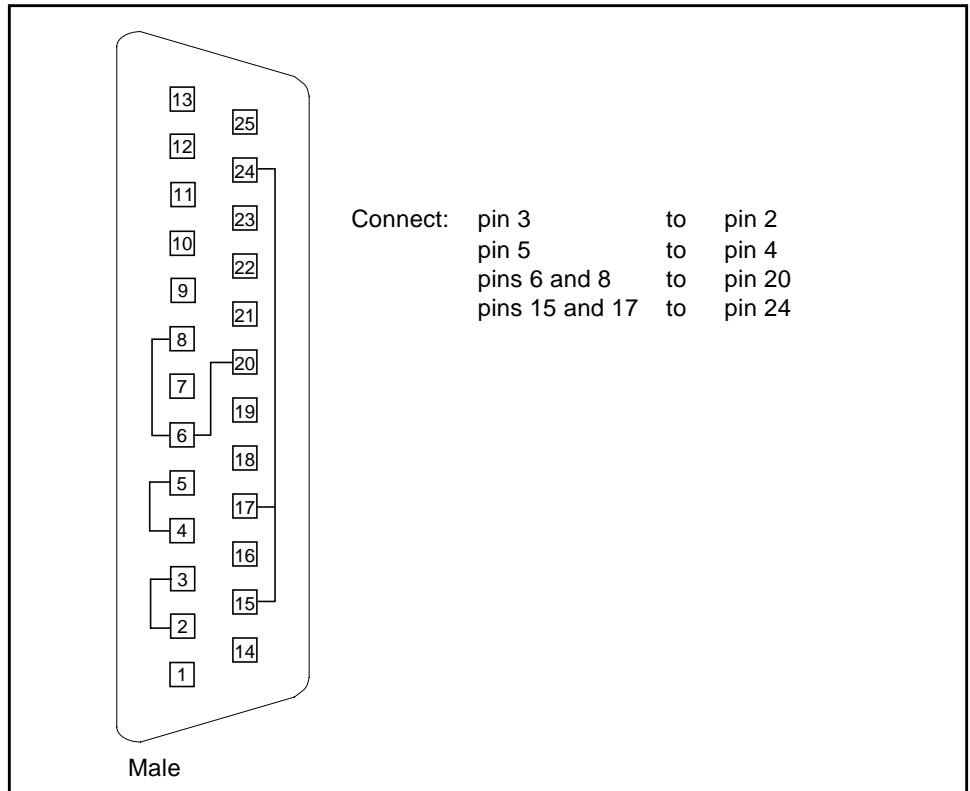

FIGURE A-1 25-pin RS-232 Loopback Plug

# 25-pin RS-232 Port-to-Port Loopback Cable

Use these wiring instructions for 25-pin RS-232 and RS-423 port to 25-pin RS 232 and RS 423 port loopback cables (two DB-25 connections). It is plugged into a pair of serial ports in the back of the system under test. Both connectors are male. The wiring is shown in FIGURE A-2.

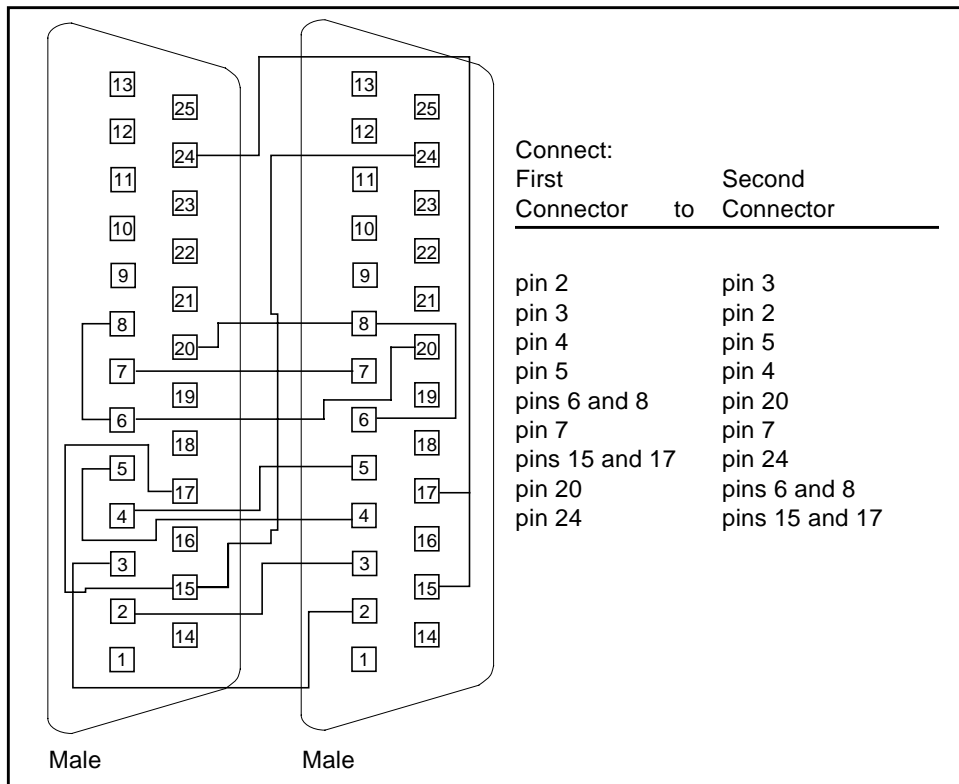
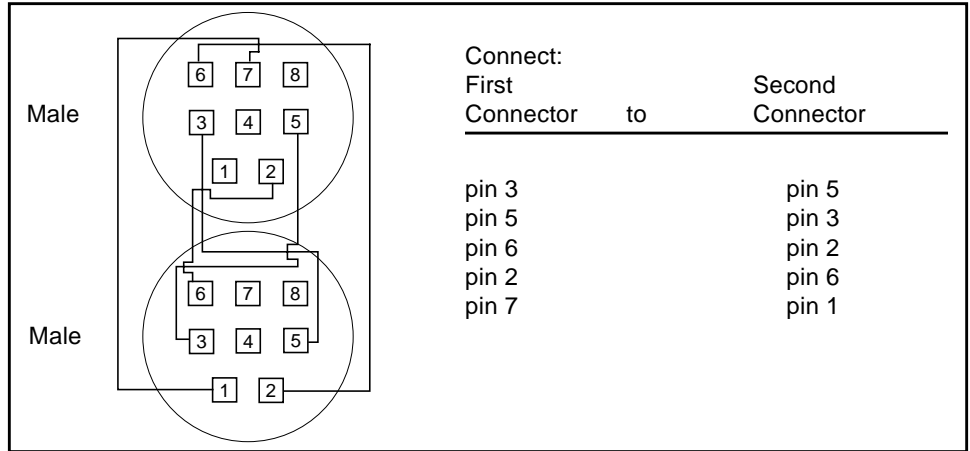

FIGURE A-2 25-pin RS-232 Port-to-Port Loopback Cable

# 8-Pin to 8-Pin Loopback Cable

Use these wiring directions for 8-pin round DIN RS-232 port to RS-423 to 8-pin round-DIN RS-232 and RS-423 port loopback cable (see FIGURE A-3). Both connectors are male.



**FIGURE A-3** 8-Pin to 8-Pin Loopback Cable

Pin 8, Receive clock In (DD), remains unconnected.

---

# 8-Pin Loopback Plug

Use these wiring directions for male 8-pin round-DIN RS-232 and RS-423 Single port loopback plugs (see FIGURE A-4).

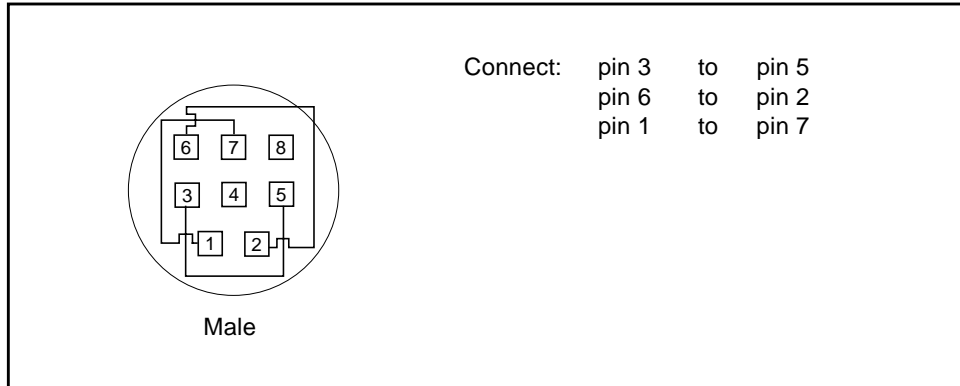

**FIGURE A-4** 8-Pin Loopback Plug

Pin 8, Receive Clock In (DD), remains unconnected.



---

# 25-pin Port A-to-Port B Loopback Plug

Use these wiring directions for a 25-pin Port A to Port B loopback plug for most systems (see FIGURE A-5).

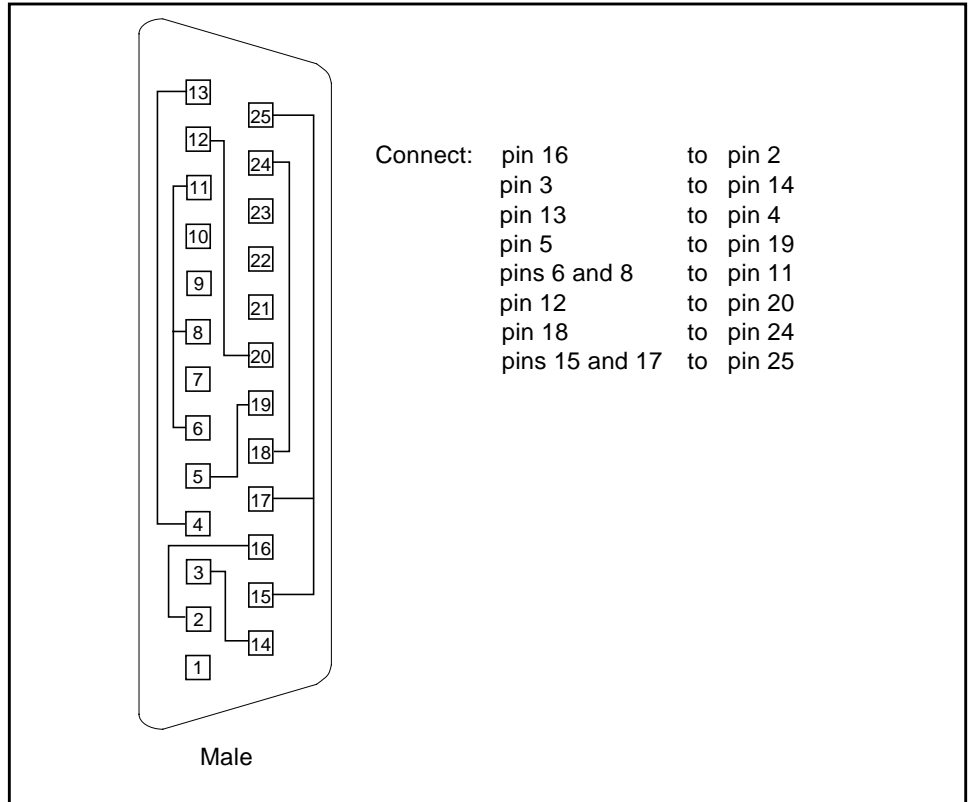
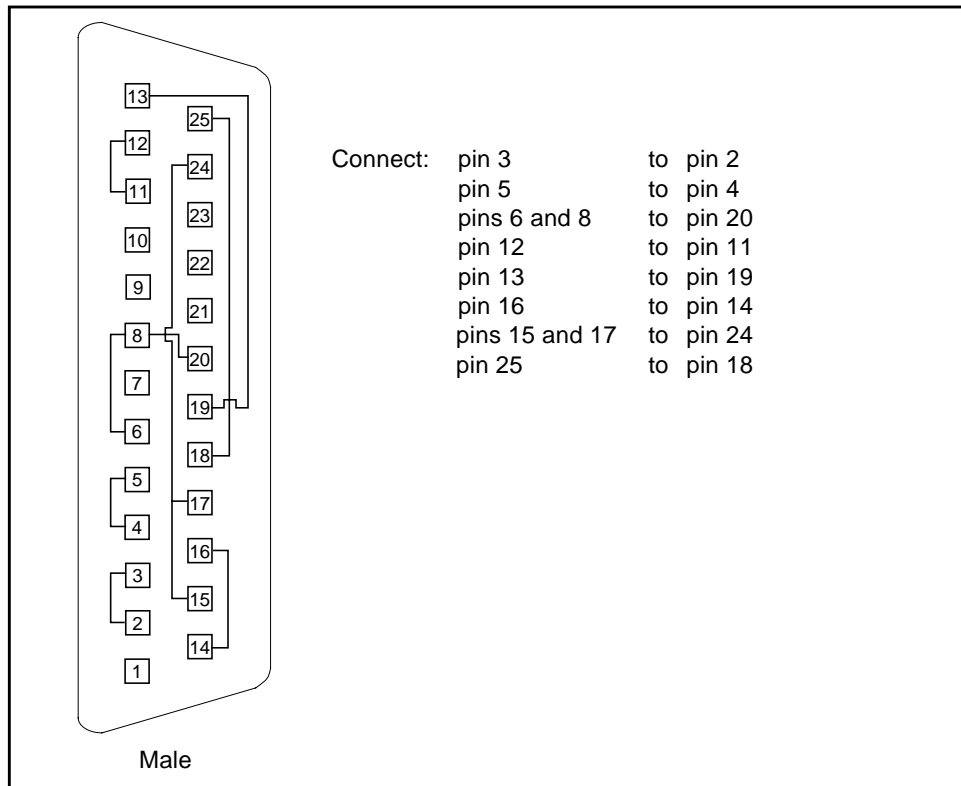

**FIGURE A-5** Port A-to-Port B Loopback Plug

---

## 25-pin Port A-to-A Port B-to-B Loopback Plug

If your system has a single communication port to connect it to peripherals, use these wiring instructions for making a male 25-pin loopback plug for that communication port (see FIGURE A-6):



**FIGURE A-6** Port A-to-A, Port B-to-B Loopback Plug

# 96-Pin Female Loopback Connector

This 96-pin connector (see FIGURE A-7) can be ordered from Sun Microsystems (Part Number 370-1366).

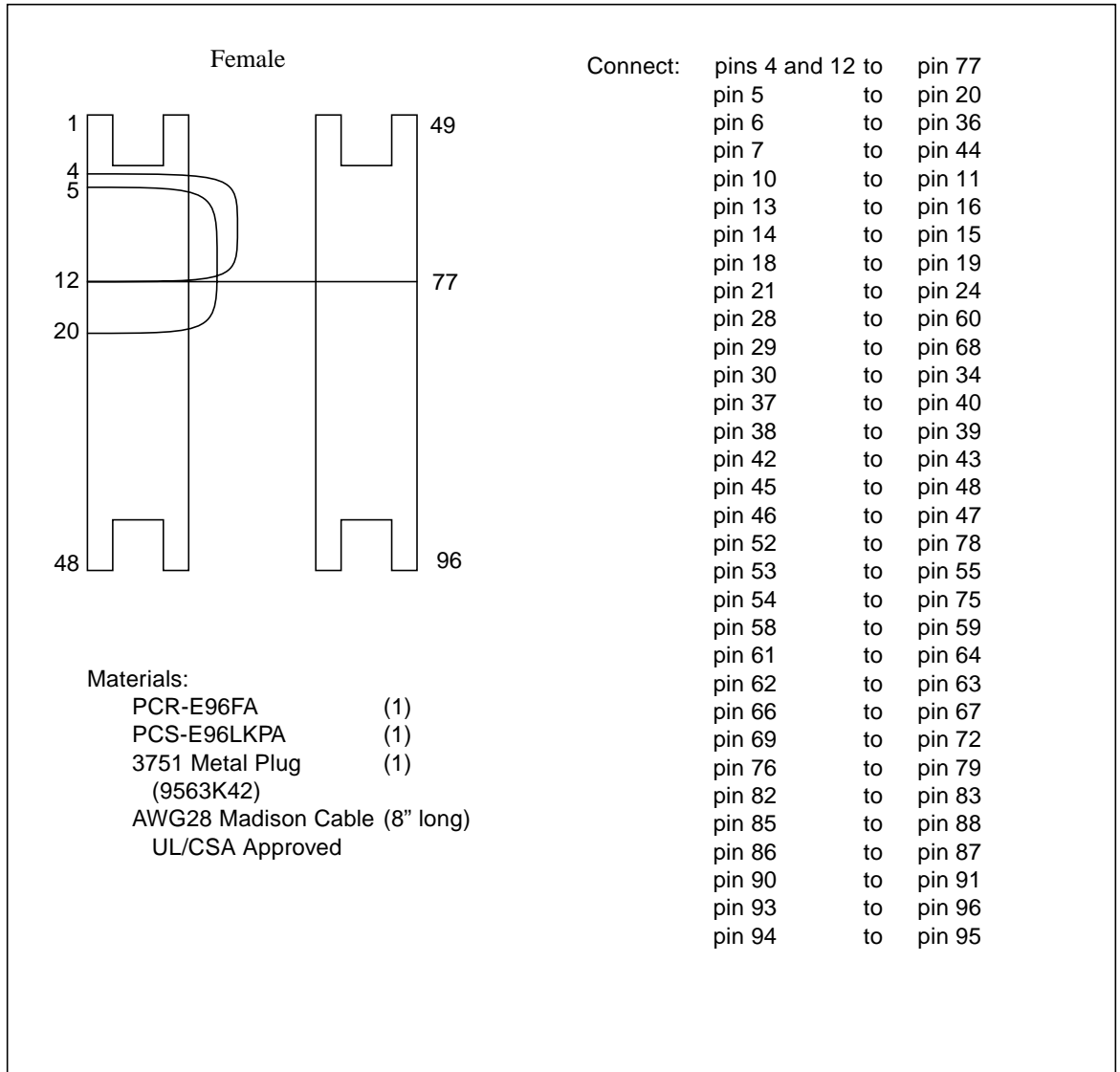

FIGURE A-7 96-Pin Female Loopback Connector

# 96-Pin Female Special Loopback Connector

This 96-pin connector (see FIGURE A-8) can be ordered from Sun Microsystems (Part Number 370-1381).

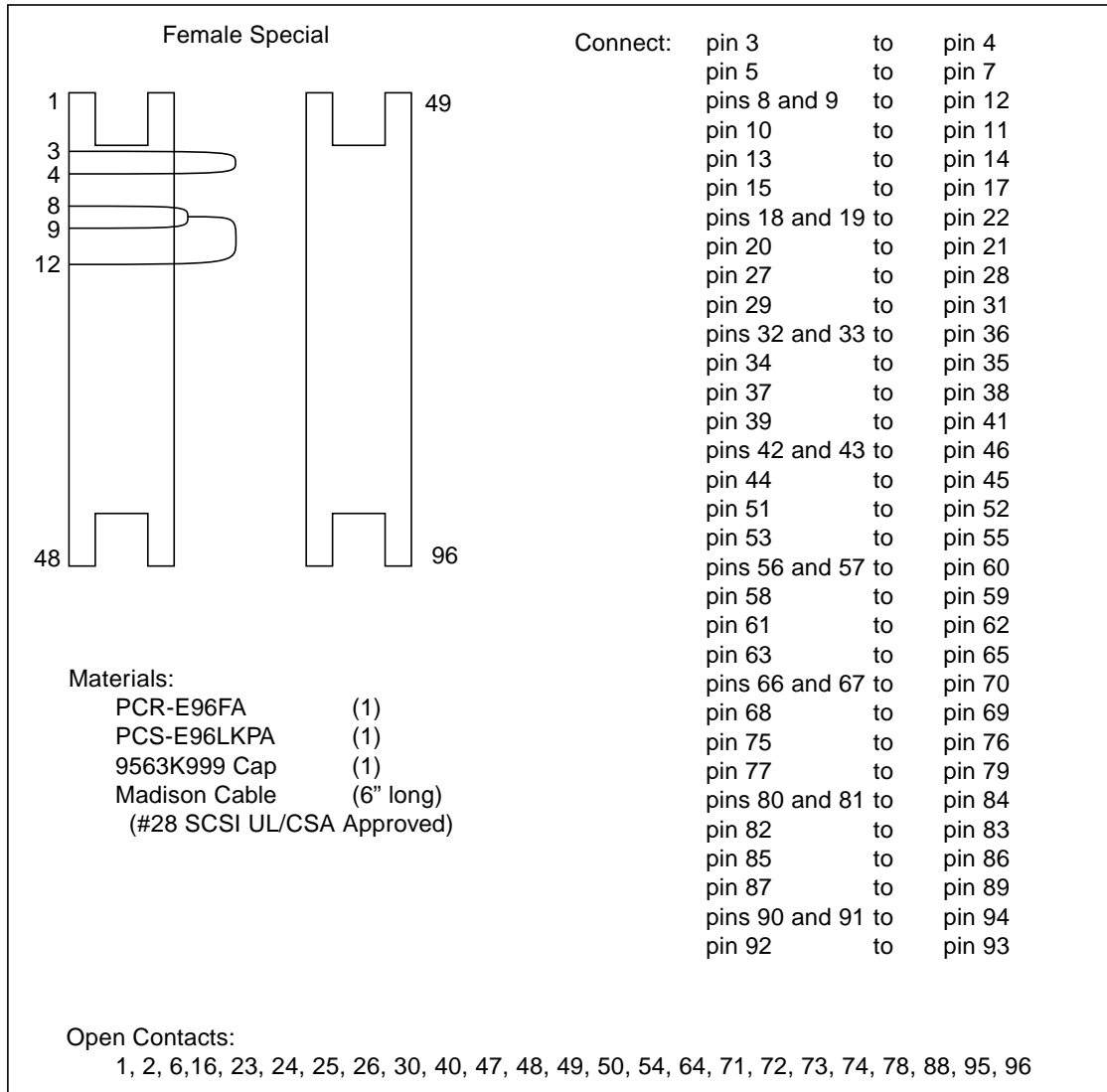
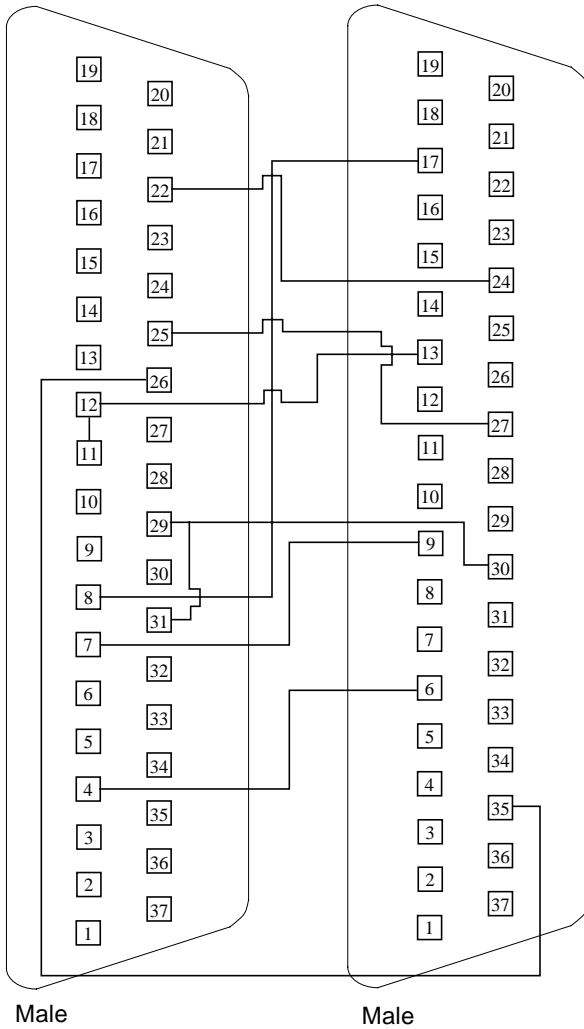

FIGURE A-8 96-Pin Female Special Loopback Connector

---

# 37-Pin RS-449 Loopback Cable

Use these wiring instructions for a loopback cable for two 37-pin RS-449 synchronous ports (see FIGURE A-9).



Connect:

- pin 4 to pin 6
- pin 7 to pin 9
- pin 8 to pin 17
- pins 11 and 12 to pin 13
- pin 22 to pin 24
- pin 25 to pin 27
- pin 26 to pin 35
- pins 29 and 31 to pin 30

**FIGURE A-9** 37-Pin RS-449 Loopback Cable

---

# 37-Pin RS-449 Loopback Plug

Use these wiring instructions for making a male 37-pin RS-449 loopback plug (see FIGURE A-10). This connector is also available from Sun (Part Number 530-1430).

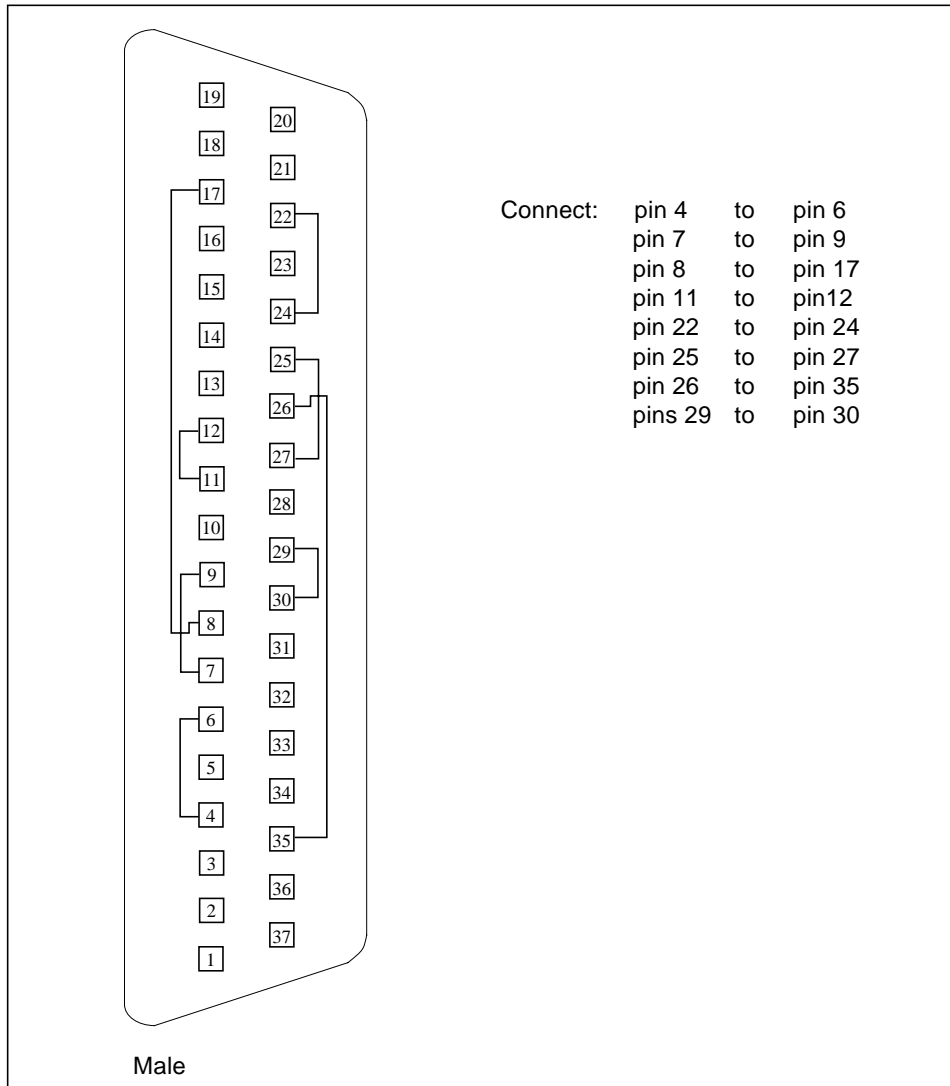

FIGURE A-10 37-Pin RS-449 Loopback Plug

---

# 9-pin Male Single-port Loopback Plug

Use these wiring instructions for male 9-pin RS-232 and RS-423 single-port loopback plugs (see FIGURE A-11):

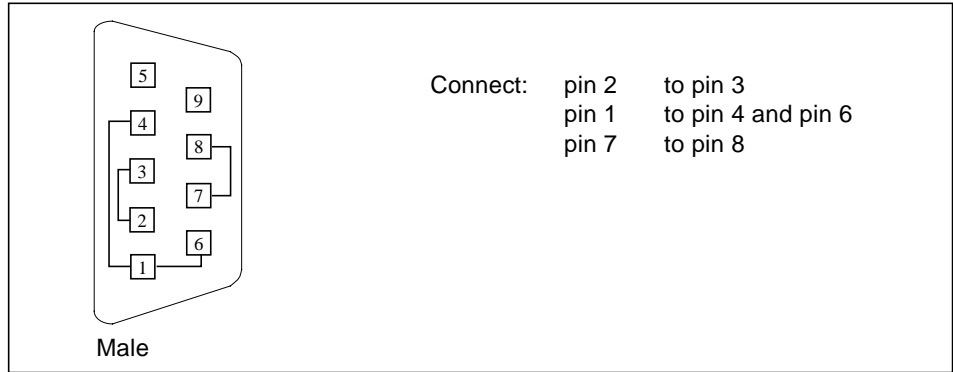

FIGURE A-11 9-Pin Male Single-port Loopback Plug

---

# 9-pin Female Single-port Loopback Plug

Use these wiring directions for female 9-pin RS-232 and RS-423 single-port loopback plugs (see FIGURE A-12):

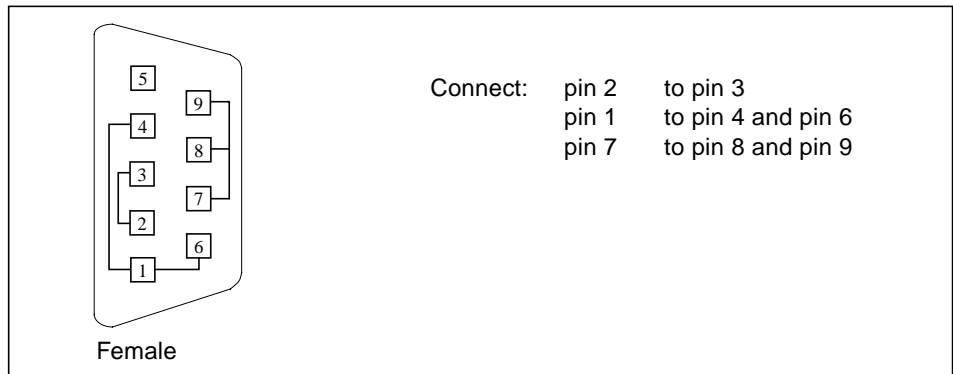
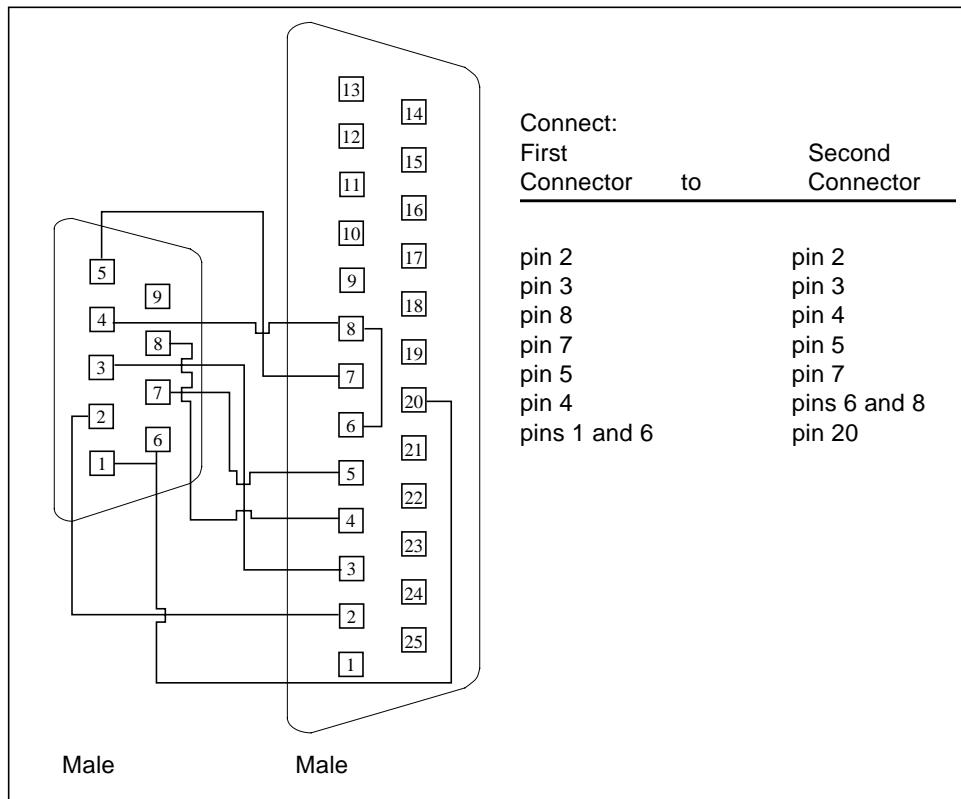

FIGURE A-12 9-Pin Female Single-port Loopback Plug

**Note** – Use this loopback plug with the `pcmciaetest`.

## 9-Pin to 25-Pin Port-to-Port Loopback Cable

Use these wiring instructions for a 9-pin RS-232 and RS-423 port to 25-pin RS-232 and RS 423 port loopback cables (see FIGURE A-13). Both connectors are male.



**FIGURE A-13** 9-Pin to 25-Pin Port-to-Port Loopback Cable



# 9-Pin to 9-Pin Port-to-Port Loopback Cable

Use these wiring instructions for 9-pin RS-232 and RS 423 port to 9-pin RS-232 and RS-423 port loopback cables (see FIGURE A-14). Both connectors are male.

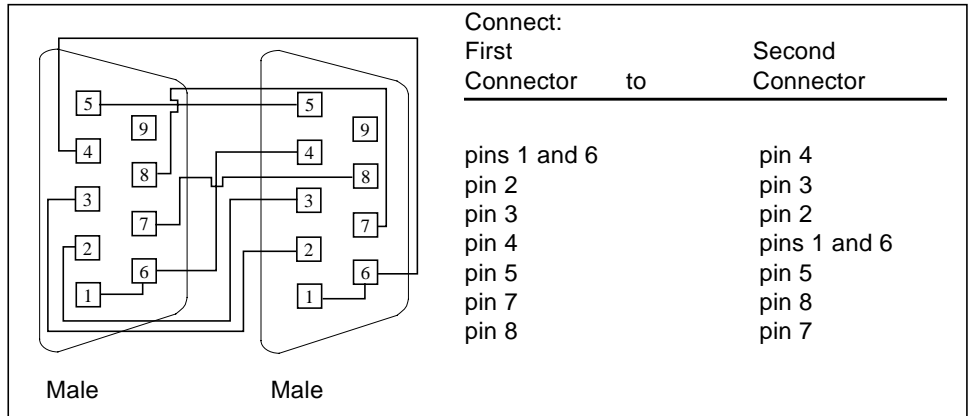

FIGURE A-14 9-Pin to 9-Pin Port-to-Port Loopback Cable

Please note that this cable has no Sun part number assigned to it.

# NT to TE Loopback Cable

Using two standard RJ45 connectors, and connect pin1 to pin1, pin 2 to pin 2, and so on, for all pins. This loopback is a “straight-through” connection.



# Index

---

## NUMERICS

- 25-pin port A-to-A port B-to-B loopback plug, 416
- 25-pin port A-to-port B loopback plug, 415
- 25-pin RS-232 loopback plug, 411
- 25-pin RS-232 port-to-port loopback cable, 412
- 8-pin loopback plug, 414
- 8-pin to 8-pin loopback cable, 413

## A

- Acceleration tests of `tcxtest`, 383
- accessing SunVTS, 4
- Advanced Frame Buffer test, `afbtest`, 9
- `afbtest`, Advanced Frame Buffer test, 9
  - command line syntax, 17
  - error messages, 18
  - options, 10
  - test modes, 16
- AFX Protocol tests of `tcxtest`, 383
- Alm test, See `sptest`, 325
- arguments
  - generic, 4
  - standard, 5
  - test-specific, 4
- `atmtest`, SunATM adapter test, 27
  - command line syntax, 30
  - error messages, 30
  - options, 28
  - test modes, 29
- audio subsystem test, `audio`, 33
- `audio`, audio subsystem test, 33
  - command line syntax, 42
  - error messages, 43

- options, 35
- subtests, 34
- test modes, 41

## B

- Bidirectional parallel port test, `bpptest`, 47
- `bpptest`, Bidirectional parallel port test, 47
  - command line syntax, 50
  - error messages, 50
  - options, 48
  - requirements, 47
  - test modes, 49

## C

- CDE (Common Desktop Environment), 1
- CDE, (Common Desktop Environment), xxix
- CD-ROM test, `cdtest`, 53
- `cdtest`, Compact Disc test, 53
  - and Volume Management, 53
  - command line syntax, 57
  - error messages, 58
  - options, 54
  - test modes, 56
- `cg14` frame buffer card test, `cg14test`, 61
- `cg14test`, CG14 test, 61
  - cautions, 61
  - command line syntax, 70
  - error messages, 71
  - options, 69
  - test groups, 62

- test modes, 70
- cg6 test, `cg6`, 73
- cg6, CG6 frame buffer test, 73
  - and swap requirements, 76
  - command line syntax, 76
  - error messages, 77
  - Frame buffer locking, 75
  - options, 75
  - subtests, 74
  - test modes, 76
- CL4000, `rtvctest`, 277
- Colormap and Cursor tests of `tcxtest`, 383
- command line options, 5
- Common Desktop Environment (CDE), `xxix`
- Common Desktop Environment, (CDE), 1
- Compact Disc (CD) test, `cdtest`, 53
- Connection mode, 6
- Connection test mode option, 5
- core dump option, the, 5
- CPU stress test, `systest`, 371
- CPU tests
  - `fptest`, 159
  - `mpctest`, 235
  - multiprocessor test `mpctest`, 235
  - `systest`, 371

## D

- debug mode option, the, 5
- Defining the number of instances, 5
- Defining the number of passes, 5
- disk drive and floppy test, `disktest`, 81
- `disktest`, disk and floppy test, 81
  - command line syntax, 87
  - options, 83
  - subtests, 82
  - test modes, 85
- Dual Basic Rate ISDN test, `isdntest`, 193

## E

- ECC memory errors, locating with `pmem`, 265
- `ecpp(7)` IEEE 1284 parallel printer port device test, 95
- `ecpptest`, Parallel port printer test, 95
  - command line syntax, 98
  - error messages, 99

- options, 97
- requirements, 95
- subtests, 96
- test modes, 98
- `enatest`, Sun Enterprise Array test, 103
  - command line syntax, 110
  - error messages, 110
  - fault isolation, 108
  - options, 106
  - status, 105
  - test modes, 109
- `enctest`, StorEdge 1000 test, 115
  - command line syntax, 119
  - error messages, 119
  - options, 117
  - test modes, 118
- Enterprise Network Array test, `enatest`, 103
- `env2tes`, I2C bus test, 129
- `env2test`, I2C bus test
  - command line syntax, 132
  - error messages, 133
  - options, 130
  - test modes, 132
- environment
  - OPEN LOOK, 1
- Environmental hardware tests
  - `envtest`, 121
- Environmental Sensing card test, `sentest`, 299
- `envtest`, I2C bus test, 121
  - command line syntax, 124
  - error messages, 125
  - options, 122
  - test modes, 124
- error messages, 88
- Ethernet hardware test, `nettest`, 241
- exercising SSA fiber channel with `plntest`, 260

## F

- Fast Frame Buffer test, `ffbtest`, 141
- `fbtest` frame buffer test, 137
  - command line syntax, 138
  - error messages, 139
  - options, 137
  - test modes, 138
- `ffbtest`, Fast frame buffer test, 141
  - cautions and notes, 141
  - command line syntax, 148

- error messages, 150
- options, 142
- test modes, 148
- fiber optic test, `nettest`, 241
- floating point unit test, `fputest`, 159
- floppy drive and disk test, `disktest`, 81
- `fputest`, floating Point Unit test, 159
  - command line syntax, 161
  - error messages, 161
  - options, 160
  - test modes, 161
- frame buffer
  - multiple, 7
  - testing, 7
- Frame Buffer Memory tests `tcxtest`, 383
- frame buffer test, generic, `fbtest`, 137
- Frame buffer tests
  - `cg14test`, 61
  - `cg6`, 73
- Functional test mode, 6
- Functional test mode option, 5

## G

- graphical user interface (GUI), xxix
- GUI (graphical user interface), xxix
- GX & GX+ test, `cg6`, 73

## H

- hardware
  - setup, 6
  - verification, 6
- HDLC and SDLC test (for the HSI), `sunlink`, 349
- HSI board test, `sunlink`, 349

## I

- I2C bus test, `env2test`, 129
- I2C bus test, `envtest`, 121
- `ifptest`, PCI FC\_AL card test, 185
  - command line syntax, 188
  - error messages, 189
  - options, 187
  - test modes, 189
- Internet control message protocol (ICMP) and

- `nettest`, 241
- IPI tests
  - `disktest`, 81
- ISDN test, `isdntest`, 193
- `isdntest`, ISDN test, 193
  - command line syntax, 197
  - error messages, 198
  - options, 196
  - subtests, 193
  - test mode, 197

## J

- Jalapeno, `rtvctest`, 277

## L

- `leotest`, ZX and TZX test, 201
  - command examples, 208
  - command line syntax, 207
  - error messages, 209
  - notes, 201
  - options, 202
  - subtests, 203
  - test modes, 206
- listing banks of memory with `pmem`, 266
- loopback connectors
  - 25-pin port A-to-A port B-to-B plug, 416
  - 25-pin RS-232 plug, 411
  - 25-pin RS-232 port-to-port cable, 412
  - 8-pin plug, 414
  - 8-pin to 8-pin cable, 413
  - pin connections, 409
  - port A-to-port B plug, 415
  - See Appendix A
- `lpvittest`, SPARCprinter port test, 217
  - command line syntax, 220
  - error messages, 221
  - options, 218
  - requirements, 217
  - test mode, 219

## M

- M64 video board test, `m64test`, 225
- `m64test`, M64 Video test, 225

- cautions and notes, 225
- command line syntax, 228
- error messages, 229
- options, 226
- subtests, 225
- test modes, 228

Media tests

- cdtest, 53
- disktest, 81
- tapetest, 375

Memory errors detected by vmem, 395

Memory tests

- pmem, 265
- vmem, 395

modem card (PCMCIA) test, pcsertest, 255

mouse

- movement, can cause test failure, 7

mpctest multiprocessor test, 235

- command line syntax, 238
- error messages, 239
- options, 236
- test modes, 238

multiprocessor test, mpctest, 235

## N

nettest network hardware test, 241

- command line syntax, 245
- error messages, 246
- options, 242
- test modes, 244

Network tests

- isdntest, 193
- nettest, 241
- scitest, 293

NeWSprinter test, spdtest, 311

NFS accelerator, 271

nvtest , SBus NVRAM card test, 249

- command line syntax, 250
- error messages, 251
- test modes, 250

## O

- Online mode option, 5
- Online test mode, 6
- OPEN LOOK, xxix

- environment, 1
- user interface, 1

## P

parallel port test, bpptest, 47

parallel printer port test ecptest, 95

parallel/serial port test, spif, 317

parity errors, locating with pmem, 265

PCI FC\_AL card test, ifptest, 185

PCI test, saiptest, 285

PCI tests

- atmtest, 27

PCMCIA modem card test, pcsertest, 255

pcmciatest PCMCIA modem card test, 255

- command line syntax, 256
- error messages, 257
- loopback requirement, 255
- options, 255
- test mode, 256

performance of Prestoserve, 271

Peripheral tests

- cdtest, 53
- disktest, 81
- tapetest, 375

physical memory test, pmem, 265

pin connections for loopback plugs, 409

Pixel Processor test, sxttest, 355

plntest SPARCstorage Array controller test, 259

- command line syntax, 261
- error messages, 263
- important note, 262
- options, 260
- test modes, 261

pmem, memory test, 265

- command line syntax, 267
- error messages, 268
- options, 265
- test modes, 267

Prestoserve

- battery check by pptest, 271
- cache check, 271
- I/O access check, 271
- performance check, 271

Printer tests

- bpptest, 47
- ecptest, 95
- lpvittest, 217

pstest, Prestoserve test, 271  
cautions, 272  
command line syntax, 273  
error messages, 274  
options, 272  
test modes, 273

## Q

quad ethernet test, *nettest*, 241

## R

register testing with *fputest*, 159  
remote  
  testing, 7  
*rtvctest*, SunVideo Sbus card test, 277  
  command line syntax, 281  
  error messages, 282  
  options, 280  
  ports, 281  
  source format options, 280  
  subtests, 277  
  verification test modules, 278  
Run-on-Error option, 5

## S

*saiptest*, PCI test, 285  
  available ports, 286  
  command line syntax, 289  
  error messages, 290  
  hardware requirements, 285  
  options, 286  
  test modes, 288  
SBus DMA circuitry, test with *bpptest*, 47  
SBus expansion subsystem (XBox) test,  
*xbtest*, 401  
SBus NVRAM card test, *nvtest*, 249  
SBus printer card test, *bpptest*, 47  
SBus tests  
  *atmtest*, 27  
  *bpptest*, 47  
*scitest*, Cluster networking hardware test, 293  
  command line syntax, 295  
  error messages, 297

  options, 294  
  test modes, 295  
SCSI Environmental Sensing card test,  
*sentest*, 299  
SCSI tests  
  *cdtest*, 53  
  *disktest*, 81  
SDLC and HDLC test (HSI board), *sunlink*, 349  
*sentest*, SEN card test, 299  
  command line syntax, 302  
  error messages, 302  
  options, 300  
  test modes, 301  
  verification, 299  
Serial Asynchronous Interface card test,  
*saiptest*, 285  
serial port test, *sptest*, 325  
serial/parallel port test, *spif*, 317  
SOC+ host adapter card test, *socaltest*, 305  
*socaltest*, Soc+ card test, 305  
  command line syntax, 307  
  error messages, 308  
  options, 305  
  test modes, 307  
SPARCprinter port test, *lpvittest*, 217  
SPARCstation 5 S24 frame buffer test,  
*tcxtest*, 383  
SPARCstation SX VSIMM test, *sxtest*, 355  
SPARCstation tests  
  audio, 33  
SPARCstation VSIMM test, *cgl4test*, 61  
SPARCstation4 TCX frame buffer test, *tcxtest*, 383  
SPARCstorage Array controller test, *plntest*, 259  
SPARCstorage RSM environmental sensing card  
test, *sentest*, 299  
*spdtest*, NeWSprinter test, 311  
  command line syntax, 313  
  error messages, 314  
  options, 311  
*spif*, serial/parallel port test, 317  
  available ports, 319  
  command line syntax, 321  
  error message, 322  
  hardware requirements, 317  
  options, 318  
  test modes, 320  
*sptest*, serial port test, 325  
  command line syntax, 332  
  error messages, 334

- options, 328
- requirements, 327
- test modes, 331
- tests, 325
- SSA
  - exercising fiber channel with `plntest`, 260
  - probing for controller devices, 262
- SSA controller test, `plntest`, 259
- SSA fault isolation with `plntest`, 259
- standard
  - command line arguments, 5
  - usage, 5
- standard\_arguments, 5
- Storage subsystem tests
  - `enatest`, 103
- StorEdge 1000 enclosure test, `enctest`, 115
- Stress mode option, 5
- Sun Enterprise 450 bus test, `envtest`, 121
- Sun Enterprise Cluster networking hardware test, `scitest`, 293
- Sun Enterprise Network Array test, 103
- SunATM adapter test, `atmtest`, 27
- SunButton controls test, `sunbuttons`, 341
- `sunbuttons`, SunButton controls test, 341
  - `.custometest` file, and the, 344
  - command line syntax, 344
  - error messages, 344
  - interactive test, 342
  - test modes, 344
- SunDial controls test, `sundials`, 345
- `sundials`, SunDial controls test, 345
  - command line syntax, 347
  - error messages, 347
  - running the, 345
  - test modes, 346
- `sunlink`, HSI/S board test, 349
  - command line syntax, 351
  - error messages, 352
  - loopback connectors, 352
  - options, 350
  - requirements, 349
  - test modes, 352
- SunVideo Sbus card test, `rtvctest`, 277
- SunVTS
  - accessing, 4
  - interfaces
    - CDE, 4
    - OPEN LOOK, 4
    - TTY, 4

- SunVTS basic command line, 5
- SX Memory Controller test, `sxtest`, 355
- `sxtest`, Pixel Processor Test, 355
  - command line syntax, 367
  - error messages, 368
  - module descriptions, 359
  - options, 356
  - restrictions, 355
  - test modes, 366
  - test parameters, 358
- `systemtest`, CPU stress test, 371
  - command line syntax, 372
  - error messages, 372
  - options, 371
  - test modes, 372

## T

- `tapetest`, tape drive test, 375
  - command line syntax, 379
  - error messages, 380
  - options, 375
  - test modes, 378
- `tcxtest`, Fast SBus Video card test, 383
- `tcxtest`, S24 Frame Butter SBus card test, 383
  - command line syntax, 387
  - error messages, 388
  - options, 386
  - subtests, 384
  - test groups, 383
  - test modes, 386
- test options, 5
- testing
  - remotely, 7
- Test-specific arguments, 6
- TGX test, `cg6`, 73
- token ring test, `nettest`, 241
- Trace mode option, 5
- TZX and ZX frame buffer test, `leotest`, 201

## V

- verbose mode option, the, 5
- Video SIMM (VSIMM) test, `sxtest`, 355
- Video test
  - `cg6`, 73
- Video tests



- cg14test, 61
- fbtest, 137
- ffbtest, 141
- leotest, 201
- m64test, 225
- virtual memory test, vmem, 395
- vmem, virtual memory test, 395
  - command line syntax, 398
  - error messages, 399
  - options, 396
  - swap space, and, 395
  - test modes, 398
- Volume Management and disktest, 81
- VSIMM test, cg14test, 61

## **W**

- window
  - locking default, 7
  - locking disabled, 7
  - locking enabled, 7

## **X**

- XBox test, xbtest, 401
- xbtest, SBus expansion subsystem (Xbox) test, 401
  - command line syntax, 404
  - error messages, 405
  - modes (subtests), 402
  - options, 403
  - self-diagnostics, 402
  - test modes, 404

## **Z**

- zs test, sptest, 325
- ZX and TZX graphics accelerator test, leotest, 201

