



Sun Cluster Concepts Guide for Solaris OS

Beta



Sun Microsystems, Inc.
4150 Network Circle
Santa Clara, CA 95054
U.S.A.

Part No: 821-0259-05
October 2009, Revision 50

Copyright 2009 Sun Microsystems, Inc. 4150 Network Circle, Santa Clara, CA 95054 U.S.A. All rights reserved.

Sun Microsystems, Inc. has intellectual property rights relating to technology embodied in the product that is described in this document. In particular, and without limitation, these intellectual property rights may include one or more U.S. patents or pending patent applications in the U.S. and in other countries.

U.S. Government Rights – Commercial software. Government users are subject to the Sun Microsystems, Inc. standard license agreement and applicable provisions of the FAR and its supplements.

This distribution may include materials developed by third parties.

Parts of the product may be derived from Berkeley BSD systems, licensed from the University of California. UNIX is a registered trademark in the U.S. and other countries, exclusively licensed through X/Open Company, Ltd.

Sun, Sun Microsystems, the Sun logo, the Solaris logo, the Java Coffee Cup logo, docs.sun.com, OpenBoot, Solaris Volume Manager, StorEdge, Sun Fire, Java, and Solaris are trademarks or registered trademarks of Sun Microsystems, Inc. or its subsidiaries in the U.S. and other countries. All SPARC trademarks are used under license and are trademarks or registered trademarks of SPARC International, Inc. in the U.S. and other countries. Products bearing SPARC trademarks are based upon an architecture developed by Sun Microsystems, Inc.

The OPEN LOOK and Sun™ Graphical User Interface was developed by Sun Microsystems, Inc. for its users and licensees. Sun acknowledges the pioneering efforts of Xerox in researching and developing the concept of visual or graphical user interfaces for the computer industry. Sun holds a non-exclusive license from Xerox to the Xerox Graphical User Interface, which license also covers Sun's licensees who implement OPEN LOOK GUIs and otherwise comply with Sun's written license agreements.

Products covered by and information contained in this publication are controlled by U.S. Export Control laws and may be subject to the export or import laws in other countries. Nuclear, missile, chemical or biological weapons or nuclear maritime end uses or end users, whether direct or indirect, are strictly prohibited. Export or reexport to countries subject to U.S. embargo or to entities identified on U.S. export exclusion lists, including, but not limited to, the denied persons and specially designated nationals lists is strictly prohibited.

DOCUMENTATION IS PROVIDED "AS IS" AND ALL EXPRESS OR IMPLIED CONDITIONS, REPRESENTATIONS AND WARRANTIES, INCLUDING ANY IMPLIED WARRANTY OF MERCHANTABILITY, FITNESS FOR A PARTICULAR PURPOSE OR NON-INFRINGEMENT, ARE DISCLAIMED, EXCEPT TO THE EXTENT THAT SUCH DISCLAIMERS ARE HELD TO BE LEGALLY INVALID.

Copyright 2009 Sun Microsystems, Inc. 4150 Network Circle, Santa Clara, CA 95054 U.S.A. Tous droits réservés.

Sun Microsystems, Inc. détient les droits de propriété intellectuelle relatifs à la technologie incorporée dans le produit qui est décrit dans ce document. En particulier, et ce sans limitation, ces droits de propriété intellectuelle peuvent inclure un ou plusieurs brevets américains ou des applications de brevet en attente aux Etats-Unis et dans d'autres pays.

Cette distribution peut comprendre des composants développés par des tierces personnes.

Certains composants de ce produit peuvent être dérivés du logiciel Berkeley BSD, licenciés par l'Université de Californie. UNIX est une marque déposée aux Etats-Unis et dans d'autres pays; elle est licenciée exclusivement par X/Open Company, Ltd.

Sun, Sun Microsystems, le logo Sun, le logo Solaris, le logo Java Coffee Cup, docs.sun.com, OpenBoot, Solaris Volume Manager, StorEdge, Sun Fire, Java et Solaris sont des marques de fabrique ou des marques déposées de Sun Microsystems, Inc., ou ses filiales, aux Etats-Unis et dans d'autres pays. Toutes les marques SPARC sont utilisées sous licence et sont des marques de fabrique ou des marques déposées de SPARC International, Inc. aux Etats-Unis et dans d'autres pays. Les produits portant les marques SPARC sont basés sur une architecture développée par Sun Microsystems, Inc.

L'interface d'utilisation graphique OPEN LOOK et Sun a été développée par Sun Microsystems, Inc. pour ses utilisateurs et licenciés. Sun reconnaît les efforts de pionniers de Xerox pour la recherche et le développement du concept des interfaces d'utilisation visuelle ou graphique pour l'industrie de l'informatique. Sun détient une licence non exclusive de Xerox sur l'interface d'utilisation graphique Xerox, cette licence couvrant également les licenciés de Sun qui mettent en place l'interface d'utilisation graphique OPEN LOOK et qui, en outre, se conforment aux licences écrites de Sun.

Les produits qui font l'objet de cette publication et les informations qu'il contient sont régis par la législation américaine en matière de contrôle des exportations et peuvent être soumis au droit d'autres pays dans le domaine des exportations et importations. Les utilisations finales, ou utilisateurs finaux, pour des armes nucléaires, des missiles, des armes chimiques ou biologiques ou pour le nucléaire maritime, directement ou indirectement, sont strictement interdites. Les exportations ou réexportations vers des pays sous embargo des Etats-Unis, ou vers des entités figurant sur les listes d'exclusion d'exportation américaines, y compris, mais de manière non exclusive, la liste de personnes qui font objet d'un ordre de ne pas participer, d'une façon directe ou indirecte, aux exportations des produits ou des services qui sont régis par la législation américaine en matière de contrôle des exportations et la liste de ressortissants spécifiquement désignés, sont rigoureusement interdites.

LA DOCUMENTATION EST FOURNIE "EN L'ETAT" ET TOUTES AUTRES CONDITIONS, DECLARATIONS ET GARANTIES EXPRESSES OU TACITES SONT FORMELLEMENT EXCLUES, DANS LA MESURE AUTORISEE PAR LA LOI APPLICABLE, Y COMPRIS NOTAMMENT TOUTE GARANTIE IMPLICITE RELATIVE A LA QUALITE MARCHANDE, A L'APTITUDE A UNE UTILISATION PARTICULIERE OU A L'ABSENCE DE CONTREFACON.

Contents

Preface	7
1 Introduction and Overview	13
Introduction to the Sun Cluster Environment	14
Three Views of the Sun Cluster Software	15
Hardware Installation and Service View	15
System Administrator View	16
Application Developer View	18
Sun Cluster Software Tasks	18
2 Key Concepts for Hardware Service Providers	21
Sun Cluster System Hardware and Software Components	21
Cluster Nodes	22
Software Components for Cluster Hardware Members	23
Multihost Devices	24
Multi-Initiator SCSI	25
Local Disks	25
Removable Media	26
Cluster Interconnect	26
Public Network Interfaces	27
Client Systems	27
Console Access Devices	28
Administrative Console	28
SPARC: Sun Cluster Topologies	29
SPARC: Clustered Pair Topology	30
SPARC: Pair+N Topology	31
SPARC: N+1 (Star) Topology	31

SPARC: N*N (Scalable) Topology	32
SPARC: LDom Guest Domains: Cluster in a Box Topology	33
SPARC: LDom Guest Domains: Single Cluster Spans Two Different Hosts Topology	34
SPARC: LDom Guest Domains: Clusters Span Two Different Hosts Topology	35
SPARC: LDom Guest Domains: Redundant I/O Domains	37
x86: Sun Cluster Topologies	38
x86: Clustered Pair Topology	39
x86: N+1 (Star) Topology	39
3 Key Concepts for System Administrators and Application Developers	41
Administrative Interfaces	42
Cluster Time	42
High-Availability Framework	43
Zone Membership	44
Cluster Membership Monitor	44
Failfast Mechanism	44
Cluster Configuration Repository (CCR)	45
Global Devices	46
Device IDs and DID Pseudo Driver	46
Device Groups	47
Device Group Failover	47
Multiported Device Groups	48
Global Namespace	49
Local and Global Namespaces Example	50
Cluster File Systems	51
Using Cluster File Systems	51
HASStoragePlus Resource Type	52
syncdir Mount Option	53
Disk Path Monitoring	53
DPM Overview	54
Monitoring Disk Paths	55
Quorum and Quorum Devices	56
About Quorum Vote Counts	58
About Quorum Configurations	58
Adhering to Quorum Device Requirements	59

Adhering to Quorum Device Best Practices	60
Recommended Quorum Configurations	61
Atypical Quorum Configurations	62
Bad Quorum Configurations	63
Data Services	64
Data Service Methods	67
Failover Data Services	67
Scalable Data Services	68
Load-Balancing Policies	69
Failback Settings	71
Data Services Fault Monitors	71
Developing New Data Services	71
Characteristics of Scalable Services	72
Data Service API and Data Service Development Library API	73
Using the Cluster Interconnect for Data Service Traffic	73
Resources, Resource Groups, and Resource Types	74
Resource Group Manager (RGM)	75
Resource and Resource Group States and Settings	75
Resource and Resource Group Properties	77
Support for Solaris Zones	77
Support for Global-Cluster Non-Voting Nodes (Solaris Zones) Directly Through the RGM	78
Support for Solaris Zones on Sun Cluster Nodes Through Sun Cluster HA for Solaris Containers	79
Service Management Facility	80
System Resource Usage	81
System Resource Monitoring	82
Control of CPU	82
Viewing System Resource Usage	83
Data Service Project Configuration	83
Determining Requirements for Project Configuration	85
Setting Per-Process Virtual Memory Limits	86
Failover Scenarios	87
Public Network Adapters and IP Network Multipathing	92
SPARC: Dynamic Reconfiguration Support	94
SPARC: Dynamic Reconfiguration General Description	94

SPARC: DR Clustering Considerations for CPU Devices	95
SPARC: DR Clustering Considerations for Memory	95
SPARC: DR Clustering Considerations for Disk and Tape Drives	95
SPARC: DR Clustering Considerations for Quorum Devices	96
SPARC: DR Clustering Considerations for Cluster Interconnect Interfaces	96
SPARC: DR Clustering Considerations for Public Network Interfaces	96
4 Frequently Asked Questions	99
High Availability FAQs	99
File Systems FAQs	100
Volume Management FAQs	101
Data Services FAQs	101
Public Network FAQs	102
Cluster Member FAQs	103
Cluster Storage FAQs	104
Cluster Interconnect FAQs	104
Client Systems FAQs	105
Administrative Console FAQs	105
Terminal Concentrator and System Service Processor FAQs	106
Index	109

Preface

The *Sun Cluster Concepts Guide for Solaris OS* contains conceptual and reference information about the Sun™ Cluster product on both SPARC® and x86 based systems.

Note – This Sun Cluster release supports systems that use the SPARC and x86 families of processor architectures: UltraSPARC, SPARC64, AMD64, and Intel 64. In this document, x86 refers to the larger family of 64-bit x86 compatible products. Information in this document pertains to all platforms unless otherwise specified.

Who Should Use This Book

This document is intended for the following audiences:

- Service providers who install and service cluster hardware
- System administrators who install, configure, and administer Sun Cluster software
- Application developers who develop failover and scalable services for applications that are not currently included with the Sun Cluster product

To understand the concepts that are described in this book, you need to be familiar with the Solaris Operating System and also have expertise with the volume manager software that you can use with the Sun Cluster product.

Before reading this document, you need to have already determined your system requirements and purchased the equipment and software that you need. The *Sun Cluster Data Services Planning and Administration Guide for Solaris OS* contains information about how to plan, install, set up, and use the Sun Cluster software.

How This Book Is Organized

The *Sun Cluster Concepts Guide for Solaris OS* contains the following chapters:

Chapter 1, “Introduction and Overview,” provides an overview of the overall concepts that you need to know about Sun Cluster.

Chapter 2, “Key Concepts for Hardware Service Providers,” describes the concepts with which hardware service providers need to be familiar. These concepts can help service providers understand the relationships between hardware components. These concepts can also help service providers and cluster administrators better understand how to install, configure, and administer cluster software and hardware.

Chapter 3, “Key Concepts for System Administrators and Application Developers,” describes the concepts with which system administrators and developers who intend to use the Sun Cluster application programming interface (API) need to know. Developers can use this API to turn a standard user application, such as a web browser or database into a highly available data service that can run in the Sun Cluster environment.

Chapter 4, “Frequently Asked Questions,” provides answers to frequently asked questions about the Sun Cluster product.

Related Documentation

Information about related Sun Cluster topics is available in the documentation that is listed in the following table. All Sun Cluster documentation is available at <http://docs.sun.com>.

Topic	Documentation
Overview	<i>Sun Cluster Overview for Solaris OS</i> <i>Sun Cluster 3.2 11/09 Documentation Center</i>
Concepts	<i>Sun Cluster Concepts Guide for Solaris OS</i>
Hardware installation and administration	<i>Sun Cluster 3.1 - 3.2 Hardware Administration Manual for Solaris OS</i> Individual hardware administration guides
Software installation	<i>Sun Cluster Software Installation Guide for Solaris OS</i> <i>Sun Cluster Quick Start Guide for Solaris OS</i>
Data service installation and administration	<i>Sun Cluster Data Services Planning and Administration Guide for Solaris OS</i> Individual data service guides

Topic	Documentation
Data service development	<i>Sun Cluster Data Services Developer's Guide for Solaris OS</i>
System administration	<i>Sun Cluster System Administration Guide for Solaris OS</i> <i>Sun Cluster Quick Reference</i>
Software upgrade	<i>Sun Cluster Upgrade Guide for Solaris OS</i>
Error messages	<i>Sun Cluster Error Messages Guide for Solaris OS</i>
Command and function references	<i>Sun Cluster Reference Manual for Solaris OS</i> <i>Sun Cluster Data Services Reference Manual for Solaris OS</i> <i>Sun Cluster Quorum Server Reference Manual for Solaris OS</i>

For a complete list of Sun Cluster documentation, see the release notes for your release of Sun Cluster software at <http://wikis.sun.com/display/SunCluster/Home/>.

Getting Help

If you have problems installing or using the Sun Cluster software, contact your service provider and provide the following information:

- Your name and email address (if available)
- Your company name, address, and phone number
- The model and serial numbers of your systems
- The release number of the operating system (for example, the Solaris 10 OS)
- The release number of Sun Cluster software (for example, 3.2 1/09)

Use the following commands to gather information about your systems for your service provider.

Command	Function
<code>prtconf -v</code>	Displays the size of the system memory and reports information about peripheral devices
<code>psrinfo -v</code>	Displays information about processors
<code>showrev -p</code>	Reports which patches are installed
<code>SPARC: prtdiag -v</code>	Displays system diagnostic information
<code>/usr/cluster/bin/clnode show-rev</code>	Displays Sun Cluster release and package version information

Also have available the contents of the `/var/adm/messages` file.

Documentation, Support, and Training

The Sun web site provides information about the following additional resources:

- [Documentation](http://www.sun.com/documentation/) (<http://www.sun.com/documentation/>)
- [Support](http://www.sun.com/support/) (<http://www.sun.com/support/>)
- [Training](http://www.sun.com/training/) (<http://www.sun.com/training/>)

Sun Welcomes Your Comments

Sun is interested in improving its documentation and welcomes your comments and suggestions. To share your comments, go to <http://docs.sun.com> and click Feedback.

Typographic Conventions

The following table describes the typographic conventions that are used in this book.

TABLE P-1 Typographic Conventions

Typeface	Meaning	Example
AaBbCc123	The names of commands, files, and directories, and onscreen computer output	Edit your <code>.login</code> file. Use <code>ls -a</code> to list all files. <code>machine_name%</code> you have mail.
AaBbCc123	What you type, contrasted with onscreen computer output	<code>machine_name%</code> su Password:
<i>aabbcc123</i>	Placeholder: replace with a real name or value	The command to remove a file is <i>rm filename</i> .
<i>AaBbCc123</i>	Book titles, new terms, and terms to be emphasized	Read Chapter 6 in the <i>User's Guide</i> . A <i>cache</i> is a copy that is stored locally. Do <i>not</i> save the file. Note: Some emphasized items appear bold online.

Shell Prompts in Command Examples

The following table shows the default UNIX® system prompt and superuser prompt for the C shell, Bourne shell, and Korn shell.

TABLE P-2 Shell Prompts

Shell	Prompt
C shell	machine_name%
C shell for superuser	machine_name#
Bourne shell and Korn shell	\$
Bourne shell and Korn shell for superuser	#

Introduction and Overview

The Sun Cluster product is an integrated hardware and software solution that you use to create highly available and scalable services. Sun Cluster Concepts Guide for Solaris OS provides the conceptual information that you need to gain a more complete picture of the Sun Cluster product. Use this book with the entire Sun Cluster documentation set to provide a complete view of the Sun Cluster software.

This chapter provides an overview of the general concepts that underlie the Sun Cluster product.

This chapter does the following:

- Provides an introduction and high-level overview of the Sun Cluster software
- Describes the several views of the Sun Cluster audience
- Identifies key concepts that you need to understand before you use the Sun Cluster software
- Maps key concepts to the Sun Cluster documentation that includes procedures and related information
- Maps cluster-related tasks to the documentation that contains procedures that you use to complete those tasks

This chapter contains the following sections:

- [“Introduction to the Sun Cluster Environment” on page 14](#)
- [“Three Views of the Sun Cluster Software” on page 15](#)
- [“Sun Cluster Software Tasks” on page 18](#)

Introduction to the Sun Cluster Environment

The Sun Cluster environment extends the Solaris Operating System into a cluster operating system. A cluster is a collection of one or more nodes that belong exclusively to that collection. In a cluster that runs on the Solaris 10 OS, a *global cluster* and a *zone cluster* are types of clusters.

In a cluster that runs on any version of the Solaris OS that was released before the Solaris 10 OS, a node is a *physical machine* that contributes to cluster membership and is not a quorum device. In a cluster that runs on the Solaris 10 OS, the concept of a node changes. In this environment, a node is a Solaris *zone* that is associated with a cluster. In this environment, a *Solaris host*, or simply *host*, is one of the following hardware or software configurations that runs the Solaris OS and its own processes:

- A “bare metal” physical machine that is not configured with a virtual machine or as a hardware domain
- A Sun Logical Domains (LDom) guest domain
- A Sun Logical Domains (LDom) I/O domain
- A hardware domain

These processes communicate with one another to form what looks like (to a network client) a single system that cooperatively provides applications, system resources, and data to users.

In a Solaris 10 environment, a global cluster is a type of cluster that is composed only of one or more global-cluster voting nodes and optionally, zero or more global-cluster non-voting nodes.

Note – A global cluster can optionally also include `solaris8`, `solaris9`, `lx` (Linux), or `native` brand, non-global zones that are not nodes, but high availability containers (as resources).

A global-cluster voting node is a `native` brand, global zone in a global cluster that contributes votes to the total number of quorum votes, that is, membership votes in the cluster. This total determines whether the cluster has sufficient votes to continue operating. A global-cluster non-voting node is a `native` brand, non-global zone in a global cluster that does *not* contribute votes to the total number of quorum votes, that is, membership votes in the cluster.

In a Solaris 10 environment, a zone cluster is a type of cluster that is composed only of one or more `cluster` brand, voting nodes. A zone cluster depends on, and therefore requires, a global cluster. A global cluster does not contain a zone cluster. You cannot configure a zone cluster without a global cluster. A zone cluster has, at most, one zone cluster node on a machine.

Note – A zone-cluster node continues to operate only as long as the global-cluster voting node on the same machine continues to operate. If a global-cluster voting node on a machine fails, all zone-cluster nodes on that machine fail as well.

A cluster offers several advantages over traditional single-server systems. These advantages include support for failover and scalable services, capacity for modular growth, and low entry price compared to traditional hardware fault-tolerant systems.

The goals of the Sun Cluster software are:

- Reduce or eliminate system downtime because of software or hardware failure
- Ensure availability of data and applications to end users, regardless of the kind of failure that would normally take down a single-server system
- Increase application throughput by enabling services to scale to additional processors by adding nodes to the cluster
- Provide enhanced availability of the system by enabling you to perform maintenance without shutting down the entire cluster

For more information about fault tolerance and high availability, see [“Making Applications Highly Available With Sun Cluster”](#) in *Sun Cluster Overview for Solaris OS*.

Refer to [“High Availability FAQs”](#) on page 99 for questions and answers on high availability.

Three Views of the Sun Cluster Software

This section describes three different views of the Sun Cluster software and the key concepts and documentation relevant to each view.

These views are typical for the following professionals:

- Hardware installation and service personnel
- System administrators
- Application developers

Hardware Installation and Service View

To hardware service professionals, the Sun Cluster software looks like a collection of off-the-shelf hardware that includes servers, networks, and storage. These components are all cabled together so that every component has a backup and no single point of failure exists.

Key Concepts – Hardware

Hardware service professionals need to understand the following cluster concepts.

- Cluster hardware configurations and cabling
- Installing and servicing (adding, removing, replacing):
 - Network interface components (adapters, junctions, cables)
 - Disk interface cards
 - Disk arrays
 - Disk drives
 - The administrative console and the console access device
- Setting up the administrative console and console access device

More Hardware Conceptual Information

The following sections contain material relevant to the preceding key concepts:

- “Cluster Nodes” on page 22
- “Multihost Devices” on page 24
- “Local Disks” on page 25
- “Cluster Interconnect” on page 26
- “Public Network Interfaces” on page 27
- “Client Systems” on page 27
- “Administrative Console” on page 28
- “Console Access Devices” on page 28
- “SPARC: Clustered Pair Topology” on page 30
- “SPARC: N+1 (Star) Topology” on page 31

Sun Cluster Documentation for Hardware Professionals

The *Sun Cluster 3.1 - 3.2 Hardware Administration Manual for Solaris OS* includes procedures and information that are associated with hardware service concepts.

System Administrator View

To the system administrator, the Sun Cluster product is a set of Solaris hosts that share storage devices.

The system administrator sees software that performs specific tasks:

- Specialized cluster software that is integrated with Solaris software to monitor the connectivity between Solaris hosts in the cluster
- Specialized software that monitors the health of user application programs that are running on the cluster nodes
- Volume management software that sets up and administers disks

- Specialized cluster software that enables all Solaris hosts to access all storage devices, even those Solaris hosts that are not directly connected to disks
- Specialized cluster software that enables files to appear on every Solaris host as though they were locally attached to that Solaris host

Key Concepts – System Administration

System administrators need to understand the following concepts and processes:

- The interaction between the hardware and software components
- The general flow of how to install and configure the cluster including:
 - Installing the Solaris Operating System
 - Installing and configuring Sun Cluster software
 - Installing and configuring a volume manager
 - Installing and configuring application software to be cluster ready
 - Installing and configuring Sun Cluster data service software
- Cluster administrative procedures for adding, removing, replacing, and servicing cluster hardware and software components
- Configuration modifications to improve performance

More System Administrator Conceptual Information

The following sections contain material relevant to the preceding key concepts:

- “Administrative Interfaces” on page 42
- “Cluster Time” on page 42
- “High-Availability Framework” on page 43
- “Global Devices” on page 46
- “Device Groups” on page 47
- “Global Namespace” on page 49
- “Cluster File Systems” on page 51
- “Disk Path Monitoring” on page 53
- “Data Services” on page 64

Sun Cluster Documentation for System Administrators

The following Sun Cluster documents include procedures and information associated with the system administration concepts:

- *Sun Cluster Software Installation Guide for Solaris OS*
- *Sun Cluster System Administration Guide for Solaris OS*
- *Sun Cluster Error Messages Guide for Solaris OS*
- Sun Cluster Release Notes for Solaris OS

Application Developer View

The Sun Cluster software provides *data services* for such applications as Oracle, NFS, DNS, Sun Java System Web Server, Apache Web Server (on SPARC based systems), and Sun Java System Directory Server. Data services are created by configuring off-the-shelf applications to run under control of the Sun Cluster software. The Sun Cluster software provides configuration files and management methods that start, stop, and monitor the applications. If you need to create a new failover or scalable service, you can use the Sun Cluster Application Programming Interface (API) and the Data Service Enabling Technologies API (DSET API) to develop the necessary configuration files and management methods that enable its application to run as a data service on the cluster.

Key Concepts – Application Development

Application developers need to understand the following:

- The characteristics of their application to determine whether it can be made to run as a failover or scalable data service.
- The Sun Cluster API, DSET API, and the “generic” data service. Developers need to determine which tool is most suitable for them to use to write programs or scripts to configure their application for the cluster environment.

More Application Developer Conceptual Information

The following sections contain material relevant to the preceding key concepts:

- “Data Services” on page 64
- “Resources, Resource Groups, and Resource Types” on page 74
- Chapter 4, “Frequently Asked Questions”

Sun Cluster Documentation for Application Developers

The following Sun Cluster documents include procedures and information associated with the application developer concepts:

- *Sun Cluster Data Services Developer’s Guide for Solaris OS*
- *Sun Cluster Data Services Planning and Administration Guide for Solaris OS*

Sun Cluster Software Tasks

All Sun Cluster software tasks require some conceptual background. The following table provides a high-level view of the tasks and the documentation that describes task steps. The concepts sections in this book describe how the concepts map to these tasks.

TABLE 1-1 Task Map: Mapping User Tasks to Documentation

Task	Instructions
Install cluster hardware	<i>Sun Cluster 3.1 - 3.2 Hardware Administration Manual for Solaris OS</i>
Install Solaris software on the cluster	<i>Sun Cluster Software Installation Guide for Solaris OS</i>
SPARC: Install Sun™ Management Center software	<i>Sun Cluster Software Installation Guide for Solaris OS</i>
Install and configure Sun Cluster software	<i>Sun Cluster Software Installation Guide for Solaris OS</i>
Install and configure volume management software	<i>Sun Cluster Software Installation Guide for Solaris OS</i> Your volume management documentation
Install and configure Sun Cluster data services	<i>Sun Cluster Data Services Planning and Administration Guide for Solaris OS</i>
Service cluster hardware	<i>Sun Cluster 3.1 - 3.2 Hardware Administration Manual for Solaris OS</i>
Administer Sun Cluster software	<i>Sun Cluster System Administration Guide for Solaris OS</i>
Administer volume management software	<i>Sun Cluster System Administration Guide for Solaris OS</i> and your volume management documentation
Administer application software	Your application documentation
Problem identification and suggested user actions	<i>Sun Cluster Error Messages Guide for Solaris OS</i>
Create a new data service	<i>Sun Cluster Data Services Developer's Guide for Solaris OS</i>

Key Concepts for Hardware Service Providers

This chapter describes the key concepts that are related to the hardware components of a Sun Cluster configuration.

This chapter covers the following topics:

- [“Sun Cluster System Hardware and Software Components” on page 21](#)
- [“SPARC: Sun Cluster Topologies” on page 29](#)
- [“x86: Sun Cluster Topologies” on page 38](#)

Sun Cluster System Hardware and Software Components

This information is directed primarily to hardware service providers. These concepts can help service providers understand the relationships between the hardware components before they install, configure, or service cluster hardware. Cluster system administrators might also find this information useful as background to installing, configuring, and administering cluster software.

A cluster is composed of several hardware components, including the following:

- Solaris hosts with local disks (unshared)
- Multihost storage (disks are shared between Solaris hosts)
- Removable media (tapes and CD-ROMs)
- Cluster interconnect
- Public network interfaces
- Client systems
- Administrative console
- Console access devices

The Sun Cluster software enables you to combine these components into a variety of configurations. The following sections describe these configurations.

- [“SPARC: Sun Cluster Topologies” on page 29](#)

- [“x86: Sun Cluster Topologies” on page 38](#)

For an illustration of a sample two-host cluster configuration, see [“Sun Cluster Hardware Environment” in *Sun Cluster Overview for Solaris OS*](#).

Cluster Nodes

In a cluster that runs on any version of the Solaris OS that was released before the Solaris 10 OS, a node is a *physical machine* that contributes to cluster membership and is not a quorum device. In a cluster that runs on the Solaris 10 OS, the concept of a node changes. In this environment, a node is a Solaris *zone* that is associated with a cluster. In this environment, a *Solaris host*, or simply *host*, is one of the following hardware or software configurations that runs the Solaris OS and its own processes:

- A “bare metal” physical machine that is not configured with a virtual machine or as a hardware domain
- A Sun Logical Domains (LDom)s guest domain
- A Sun Logical Domains (LDom)s I/O domain
- A hardware domain

Depending on your platform, Sun Cluster software supports the following configurations:

- SPARC: Sun Cluster software supports from one to sixteen Solaris hosts in a cluster. Different hardware configurations impose additional limits on the maximum number of hosts that you can configure in a cluster composed of SPARC based systems. See [“SPARC: Sun Cluster Topologies” on page 29](#) for the supported configurations.
- x86: Sun Cluster software supports from one to eight Solaris hosts in a cluster. Different hardware configurations impose additional limits on the maximum number of hosts that you can configure in a cluster composed of x86 based systems. See [“x86: Sun Cluster Topologies” on page 38](#) for the supported configurations.

Solaris hosts are generally attached to one or more multihost devices. Hosts that are not attached to multihost devices use the cluster file system to access the multihost devices. For example, one scalable services configuration enables hosts to service requests without being directly attached to multihost devices.

In addition, hosts in parallel database configurations share concurrent access to all the disks.

- See [“Multihost Devices” on page 24](#) for information about concurrent access to disks.
- See [“SPARC: Clustered Pair Topology” on page 30](#) and [“x86: Clustered Pair Topology” on page 39](#) for more information about parallel database configurations.

All nodes in the cluster are grouped under a common name (the cluster name), which is used for accessing and managing the cluster.

Public network adapters attach hosts to the public networks, providing client access to the cluster.

Cluster members communicate with the other hosts in the cluster through one or more physically independent networks. This set of physically independent networks is referred to as the *cluster interconnect*.

Every node in the cluster is aware when another node joins or leaves the cluster. Additionally, every node in the cluster is aware of the resources that are running locally as well as the resources that are running on the other cluster nodes.

Hosts in the same cluster should have similar processing, memory, and I/O capability to enable failover to occur without significant degradation in performance. Because of the possibility of failover, every host must have enough excess capacity to support the workload of all hosts for which they are a backup or secondary.

Each host boots its own individual root (/) file system.

Software Components for Cluster Hardware Members

To function as a cluster member, a Solaris host must have the following software installed:

- Solaris Operating System
- Sun Cluster software
- Data service application
- Volume management (Solaris Volume Manager™ or Veritas Volume Manager)

An exception is a configuration that uses hardware redundant array of independent disks (RAID). This configuration might not require a software volume manager such as Solaris Volume Manager or Veritas Volume Manager.

- See the *Sun Cluster Software Installation Guide for Solaris OS* for information about how to install the Solaris Operating System, Sun Cluster, and volume management software.
- See the *Sun Cluster Data Services Planning and Administration Guide for Solaris OS* for information about how to install and configure data services.
- See [Chapter 3, “Key Concepts for System Administrators and Application Developers,”](#) for conceptual information about the preceding software components.

The following figure provides a high-level view of the software components that work together to create the Sun Cluster environment.

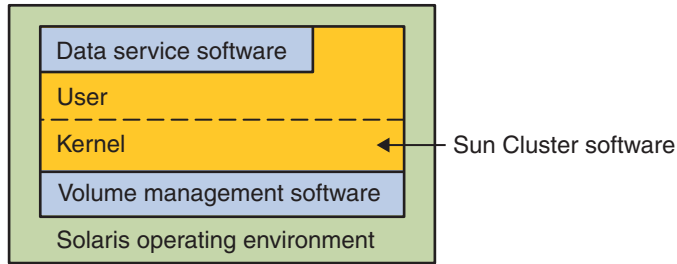

FIGURE 2-1 High-Level Relationship of Sun Cluster Software Components

See [Chapter 4, “Frequently Asked Questions,”](#) for questions and answers about cluster members.

Multihost Devices

Disks that can be connected to more than one Solaris host at a time are multihost devices. In the Sun Cluster environment, multihost storage makes disks highly available. Sun Cluster software requires multihost storage for two-host clusters to establish quorum. Greater than two-host clusters do not require quorum devices. For more information about quorum, see [“Quorum and Quorum Devices” on page 56.](#)

Multihost devices have the following characteristics.

- Tolerance of single-host failures.
- Ability to store application data, application binaries, and configuration files.
- Protection against host failures. If clients request the data through one host and the host fails, the requests are switched over to use another host with a direct connection to the same disks.
- Global access through a primary host that “masters” the disks, or direct concurrent access through local paths. The only application that uses direct concurrent access currently is Oracle Real Application Clusters Guard.

A volume manager provides for mirrored or RAID-5 configurations for data redundancy of the multihost devices. Currently, Sun Cluster supports Solaris Volume Manager and Veritas Volume Manager as volume managers, and the RDAC RAID-5 hardware controller on several hardware RAID platforms.

Combining multihost devices with disk mirroring and disk striping protects against both host failure and individual disk failure.

See [Chapter 4, “Frequently Asked Questions,”](#) for questions and answers about multihost storage.

Multi-Initiator SCSI

This section applies only to SCSI storage devices and not to Fibre Channel storage that is used for the multihost devices.

In a standalone (that is, non-clustered) host, the host controls the SCSI bus activities by way of the SCSI host adapter circuit that connects this host to a particular SCSI bus. This SCSI host adapter circuit is referred to as the *SCSI initiator*. This circuit initiates all bus activities for this SCSI bus. The default SCSI address of SCSI host adapters in Sun systems is 7.

Cluster configurations share storage between multiple hosts, using multihost devices. When the cluster storage consists of single-ended or differential SCSI devices, the configuration is referred to as multi-initiator SCSI. As this terminology implies, more than one SCSI initiator exists on the SCSI bus.

The SCSI specification requires each device on a SCSI bus to have a unique SCSI address. (The host adapter is also a device on the SCSI bus.) The default hardware configuration in a multi-initiator environment results in a conflict because all SCSI host adapters default to 7.

To resolve this conflict, on each SCSI bus, leave one of the SCSI host adapters with the SCSI address of 7, and set the other host adapters to unused SCSI addresses. Proper planning dictates that these “unused” SCSI addresses include both currently and eventually unused addresses. An example of addresses unused in the future is the addition of storage by installing new drives into empty drive slots.

In most configurations, the available SCSI address for a second host adapter is 6.

You can change the selected SCSI addresses for these host adapters by using one of the following tools to set the `scsi-initiator-id` property:

- `eeeprom(1M)`
- The OpenBoot™ PROM on a SPARC based system
- The SCSI utility that you optionally run after the BIOS boots on an x86 based system

You can set this property globally for a host or on a per-host-adapter basis. Instructions for setting a unique `scsi-initiator-id` for each SCSI host adapter are included in [Sun Cluster 3.1 - 3.2 With SCSI JBOD Storage Device Manual for Solaris OS](#).

Local Disks

Local disks are the disks that are only connected to a single Solaris host. Local disks are, therefore, not protected against host failure (they are not highly available). However, all disks, including local disks, are included in the global namespace and are configured as *global devices*. Therefore, the disks themselves are visible from all cluster hosts.

You can make the file systems on local disks available to other hosts by placing them under a global mount point. If the host that currently has one of these global file systems mounted fails, all hosts lose access to that file system. Using a volume manager lets you mirror these disks so that a failure cannot cause these file systems to become inaccessible, but volume managers do not protect against host failure.

See the section “[Global Devices](#)” on page 46 for more information about global devices.

Removable Media

Removable media such as tape drives and CD-ROM drives are supported in a cluster. In general, you install, configure, and service these devices in the same way as in a nonclustered environment. These devices are configured as global devices in Sun Cluster, so each device can be accessed from any node in the cluster. Refer to *Sun Cluster 3.1 - 3.2 Hardware Administration Manual for Solaris OS* for information about installing and configuring removable media.

See the section “[Global Devices](#)” on page 46 for more information about global devices.

Cluster Interconnect

The *cluster interconnect* is the physical configuration of devices that is used to transfer cluster-private communications and data service communications between Solaris hosts in the cluster. Because the interconnect is used extensively for cluster-private communications, it can limit performance.

Only hosts in the cluster can be connected to the cluster interconnect. The Sun Cluster security model assumes that only cluster hosts have physical access to the cluster interconnect.

You can set up from one to six cluster interconnects in a cluster. While a single cluster interconnect reduces the number of adapter ports that are used for the private interconnect, it provides no redundancy and less availability. If a single interconnect fails, moreover, the cluster is at a higher risk of having to perform automatic recovery. Whenever possible, install two or more cluster interconnects to provide redundancy and scalability, and therefore higher availability, by avoiding a single point of failure.

The cluster interconnect consists of three hardware components: adapters, junctions, and cables. The following list describes each of these hardware components.

- **Adapters** – The network interface cards that are located in each cluster host. Their names are constructed from a device name immediately followed by a physical-unit number, for example, qfe2. Some adapters have only one physical network connection, but others, like the qfe card, have multiple physical connections. Some adapters also contain both network interfaces and storage interfaces.

A network adapter with multiple interfaces could become a single point of failure if the entire adapter fails. For maximum availability, plan your cluster so that the only path between two hosts does not depend on a single network adapter.

- Junctions – The switches that are located outside of the cluster hosts. Junctions perform pass-through and switching functions to enable you to connect more than two hosts. In a two-host cluster, you do not need junctions because the hosts can be directly connected to each other through redundant physical cables connected to redundant adapters on each host. Greater than two-host configurations generally require junctions.
- Cables – The physical connections that you install either between two network adapters or between an adapter and a junction.

See [Chapter 4, “Frequently Asked Questions,”](#) for questions and answers about the cluster interconnect.

Public Network Interfaces

Clients connect to the cluster through the public network interfaces. Each network adapter card can connect to one or more public networks, depending on whether the card has multiple hardware interfaces.

You can set up Solaris hosts in the cluster to include multiple public network interface cards that perform the following functions:

- Are configured so that multiple cards are active.
- Serve as failover backups for one another.

If one of the adapters fails, IP network multipathing software is called to fail over the defective interface to another adapter in the group.

No special hardware considerations relate to clustering for the public network interfaces.

See [Chapter 4, “Frequently Asked Questions,”](#) for questions and answers about public networks.

Client Systems

Client systems include machines or other hosts that access the cluster over the public network. Client-side programs use data or other services that are provided by server-side applications running on the cluster.

Client systems are not highly available. Data and applications on the cluster are highly available.

See [Chapter 4, “Frequently Asked Questions,”](#) for questions and answers about client systems.

Console Access Devices

You must have console access to all Solaris hosts in the cluster.

To gain console access, use one of the following devices:

- The terminal concentrator that you purchased with your cluster hardware
- The System Service Processor (SSP) on Sun Enterprise E10000 servers (for SPARC based clusters)
- The system controller on Sun Fire™ servers (also for SPARC based clusters)
- Another device that can access `ttya` on each host

Only one supported terminal concentrator is available from Sun and use of the supported Sun terminal concentrator is optional. The terminal concentrator enables access to `/dev/console` on each host by using a TCP/IP network. The result is console-level access for each host from a remote machine anywhere on the network.

The System Service Processor (SSP) provides console access for Sun Enterprise E1000 servers. The SSP is a processor card in a machine on an Ethernet network that is configured to support the Sun Enterprise E1000 server. The SSP is the administrative console for the Sun Enterprise E1000 server. Using the Sun Enterprise E10000 Network Console feature, any machine in the network can open a host console session.

Other console access methods include other terminal concentrators, `tip` serial port access from another host, and dumb terminals.



Caution – You can attach a keyboard or monitor to a cluster host provided that the keyboard and monitor are supported by the base server platform. However, you cannot use that keyboard or monitor as a console device. You must redirect the console to a serial port, or depending on your machine, to the System Service Processor (SSP) and Remote System Control (RSC) by setting the appropriate OpenBoot PROM parameter.

Administrative Console

You can use a dedicated machine, known as the *administrative console*, to administer the active cluster. Usually, you install and run administrative tool software, such as the Cluster Control Panel (CCP) and the Sun Cluster module for the Sun Management Center product (for use with SPARC based clusters only), on the administrative console. Using `cconsole` under the CCP enables you to connect to more than one host console at a time. For more information about to use the CCP, see the [Chapter 1, “Introduction to Administering Sun Cluster,”](#) in *Sun Cluster System Administration Guide for Solaris OS*.

The administrative console is not a cluster host. You use the administrative console for remote access to the cluster hosts, either over the public network, or optionally through a network-based terminal concentrator.

If your cluster consists of the Sun Enterprise E10000 platform, you must do the following:

- Log in from the administrative console to the SSP.
- Connect by using the `net con` command.

Typically, you configure hosts without monitors. Then, you access the host's console through a `telnet` session from the administrative console. The administration console is connected to a terminal concentrator, and from the terminal concentrator to the host's serial port. In the case of a Sun Enterprise E1000 server, you connect from the System Service Processor. See [“Console Access Devices” on page 28](#) for more information.

Sun Cluster does not require a dedicated administrative console, but using one provides these benefits:

- Enables centralized cluster management by grouping console and management tools on the same machine
- Provides potentially quicker problem resolution by your hardware service provider

See [Chapter 4, “Frequently Asked Questions,”](#) for questions and answers about the administrative console.

SPARC: Sun Cluster Topologies

A topology is the connection scheme that connects the Solaris hosts in the cluster to the storage platforms that are used in a Sun Cluster environment. Sun Cluster software supports any topology that adheres to the following guidelines.

- A Sun Cluster environment that is composed of SPARC based systems supports from one to sixteen Solaris hosts in a cluster. Different hardware configurations impose additional limits on the maximum number of hosts that you can configure in a cluster composed of SPARC based systems.
- A shared storage device can connect to as many hosts as the storage device supports.
- Shared storage devices do not need to connect to all hosts of the cluster. However, these storage devices must connect to at least two hosts.

You can configure logical domains (LDDoms) guest domains and LDDoms I/O domains as virtual Solaris hosts. In other words, you can create a clustered pair, pair+N, N+1, and N*N cluster that consists of any combination of physical machines, LDDoms I/O domains, and LDDoms guest domains. You can also create clusters that consist of only LDDoms guest domains, LDDoms I/O domains, or any combination of the two.

Sun Cluster software does not require you to configure a cluster by using specific topologies. The following topologies are described to provide the vocabulary to discuss a cluster's connection scheme. These topologies are typical connection schemes.

- Clustered pair
- Pair+N
- N+1 (star)
- N*N (scalable)
- LDoms Guest Domains: Cluster in a Box
- LDoms Guest Domains: Single Cluster Spans Two Different Hosts
- LDoms Guest Domains: Clusters Span Two Different Hosts
- LDoms Guest Domains: Redundant I/O Domains

The following sections include sample diagrams of each topology.

SPARC: Clustered Pair Topology

A clustered pair topology is two or more pairs of Solaris hosts that operate under a single cluster administrative framework. In this configuration, failover occurs only between a pair. However, all hosts are connected by the cluster interconnect and operate under Sun Cluster software control. You might use this topology to run a parallel database application on one pair and a failover or scalable application on another pair.

Using the cluster file system, you could also have a two-pair configuration. More than two hosts can run a scalable service or parallel database, even though all the hosts are not directly connected to the disks that store the application data.

The following figure illustrates a clustered pair configuration.

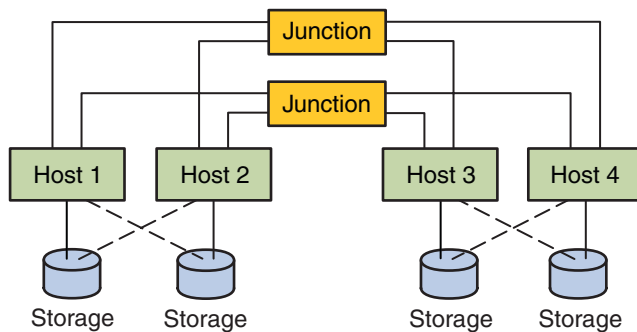

FIGURE 2-2 SPARC: Clustered Pair Topology

SPARC: Pair+N Topology

The pair+N topology includes a pair of Solaris hosts that are directly connected to the following:

- Shared storage.
- An additional set of hosts that use the cluster interconnect to access shared storage (they have no direct connection themselves).

The following figure illustrates a pair+N topology where two of the four hosts (Host 3 and Host 4) use the cluster interconnect to access the storage. This configuration can be expanded to include additional hosts that do not have direct access to the shared storage.

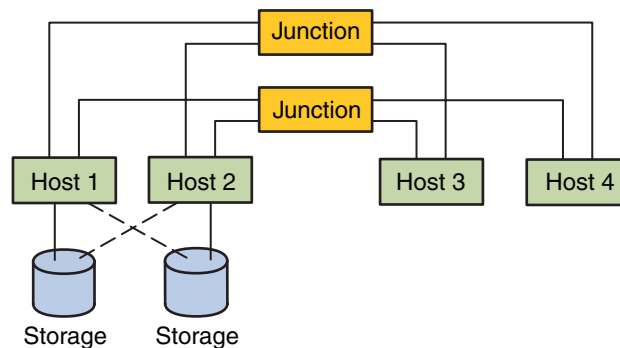

FIGURE 2-3 Pair+N Topology

SPARC: N+1 (Star) Topology

An N+1 topology includes some number of primary Solaris hosts and one secondary host. You do not have to configure the primary hosts and secondary host identically. The primary hosts actively provide application services. The secondary host need not be idle while waiting for a primary host to fail.

The secondary host is the only host in the configuration that is physically connected to all the multihost storage.

If a failure occurs on a primary host, Sun Cluster fails over the resources to the secondary host. The secondary host is where the resources function until they are switched back (either automatically or manually) to the primary host.

The secondary host must always have enough excess CPU capacity to handle the load if one of the primary hosts fails.

The following figure illustrates an N+1 configuration.

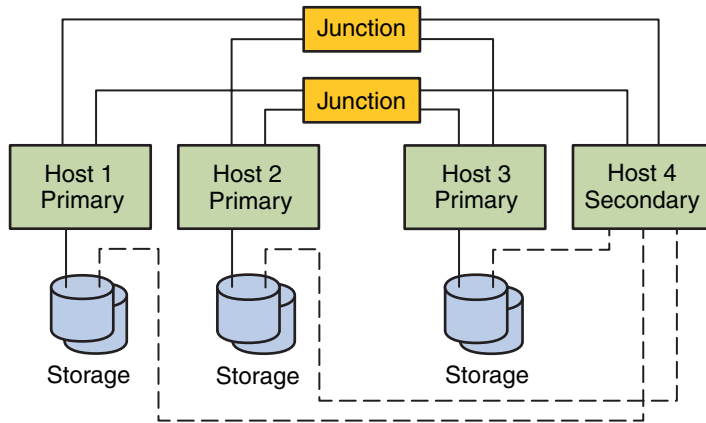

FIGURE 2-4 SPARC: N+1 Topology

SPARC: N*N (Scalable) Topology

An N*N topology enables every shared storage device in the cluster to connect to every Solaris host in the cluster. This topology enables highly available applications to fail over from one host to another without service degradation. When failover occurs, the new host can access the storage device by using a local path instead of the private interconnect.

The following figure illustrates an N*N configuration.

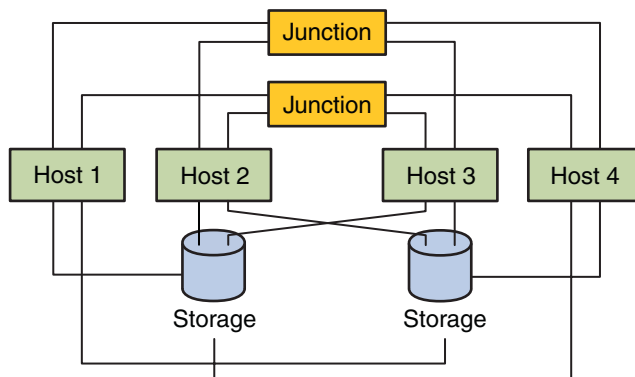

FIGURE 2-5 SPARC: N*N Topology

SPARC: LDoms Guest Domains: Cluster in a Box Topology

In this logical domains (LDoms) guest domain topology, a cluster and every node within that cluster are located on the same Solaris host. Each LDoms guest domain node acts the same as a Solaris host in a cluster. To preclude your having to include a quorum device, this configuration includes three nodes rather than only two.

In this topology, you do not need to connect each virtual switch (vsw) for the private network to a physical network because they need only communicate with each other. In this topology, cluster nodes can also share the same storage device, as all cluster nodes are located on the same host. To learn more about guidelines for using and installing LDoms guest domains or LDoms I/O domains in a cluster, see [“How to Install Sun Logical Domains Software and Create Domains”](#) in *Sun Cluster Software Installation Guide for Solaris OS*.

This topology does not provide high availability, as all nodes in the cluster are located on the same host. However, developers and administrators might find this topology useful for testing and other non-production tasks. This topology is also called a “cluster in a box”.

The following figure illustrates a cluster in a box configuration.

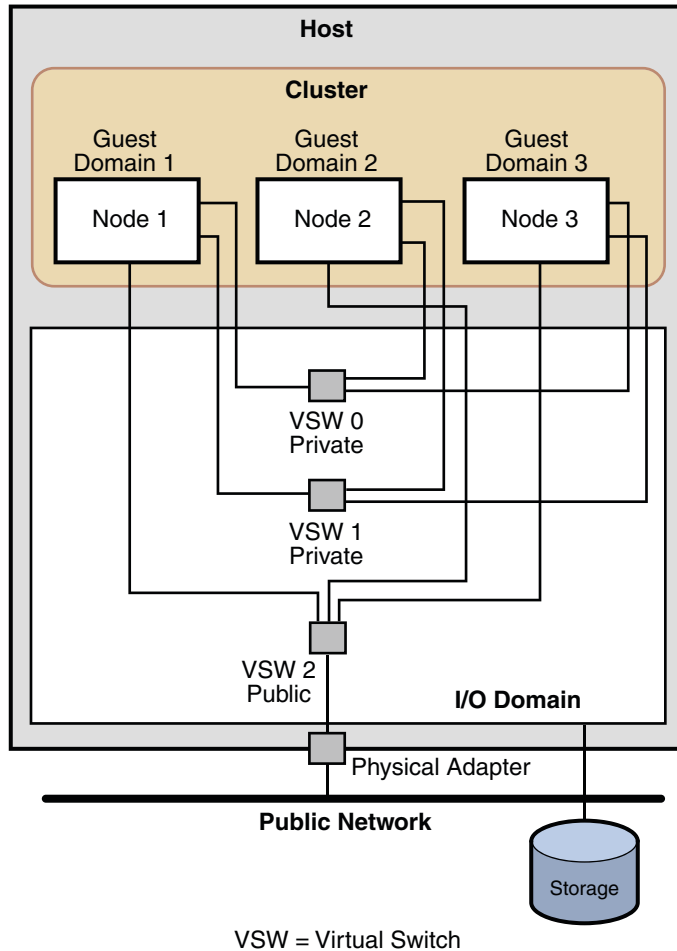

FIGURE 2-6 SPARC: Cluster in a Box Topology

SPARC: LDom Guest Domains: Single Cluster Spans Two Different Hosts Topology

In this logical domains (LDoms) guest domain topology, a single cluster spans two different Solaris hosts and each cluster comprises one node on each host. Each LDom guest domain node acts the same as a Solaris host in a cluster. To learn more about guidelines for using and installing LDoms guest domains or LDoms I/O domains in a cluster, see [“How to Install Sun Logical Domains Software and Create Domains”](#) in *Sun Cluster Software Installation Guide for Solaris OS*.

The following figure illustrates a configuration in which a single cluster spans two different hosts.

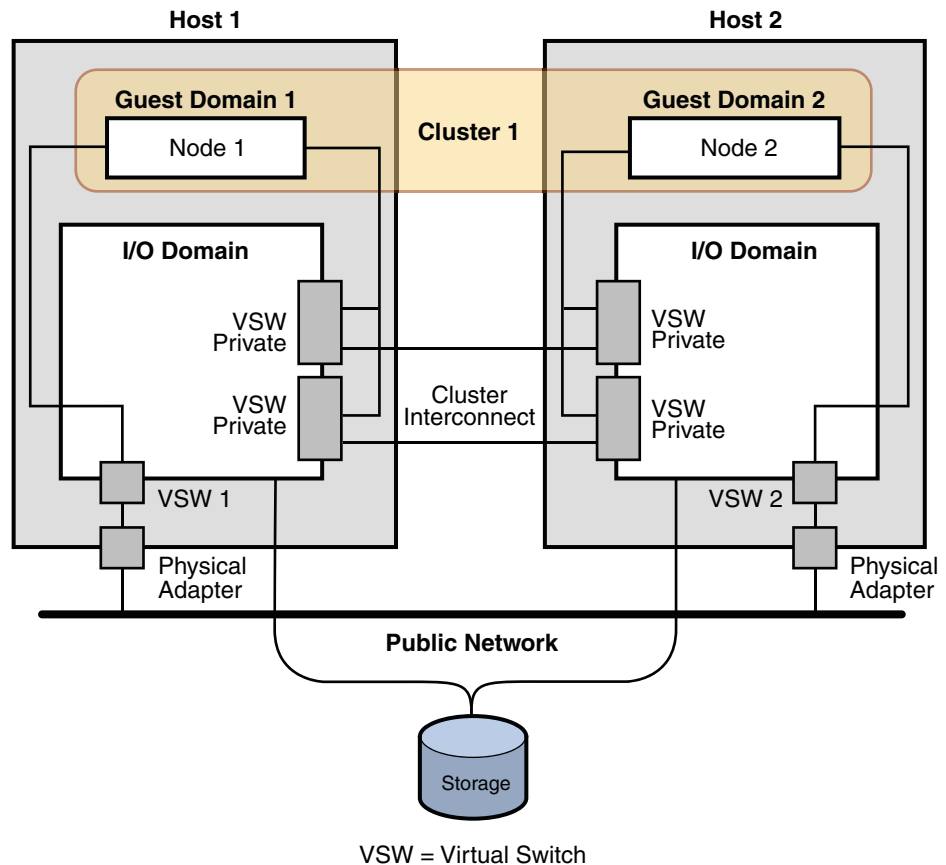

FIGURE 2-7 SPARC: Single Cluster Spans Two Different Hosts

SPARC: LDom's Guest Domains: Clusters Span Two Different Hosts Topology

In this logical domains (LDoms) guest domain topology, each cluster spans two different Solaris hosts and each cluster comprises one node on each host. Each LDom's guest domain node acts the same as a Solaris host in a cluster. In this configuration, because both clusters share the same interconnect switch, you must specify a different private network address on each cluster. Otherwise, if you specify the same private network address on clusters that share an interconnect switch, the configuration fails.

To learn more about guidelines for using and installing LDom guest domains or LDom I/O domains in a cluster, see [“How to Install Sun Logical Domains Software and Create Domains” in Sun Cluster Software Installation Guide for Solaris OS.](#)

The following figure illustrates a configuration in which more than a single cluster spans two different hosts.

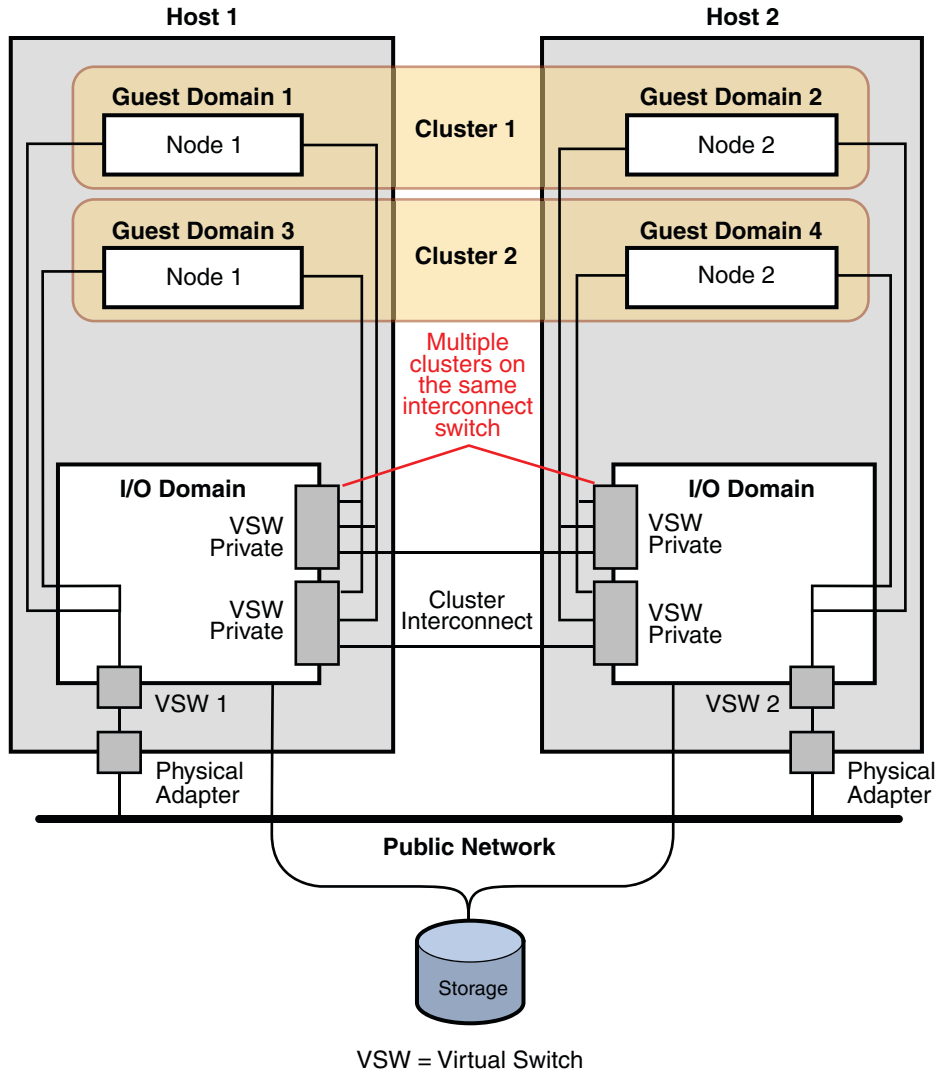

FIGURE 2-8 SPARC: Clusters Span Two Different Hosts

SPARC: LDoms Guest Domains: Redundant I/O Domains

In this logical domains (LDoms) guest domain topology, multiple I/O domains ensure that guest domains, or nodes within the cluster, continue to operate if an I/O domain fails. Each LDoms guest domain node acts the same as a Solaris host in a cluster.

In this topology, the guest domain runs IP network multipathing (IPMP) across two public networks, one through each I/O domain. Guest domains also mirror storage devices across different I/O domains. To learn more about guidelines for using and installing LDoms guest domains or LDoms I/O domains in a cluster, see [“How to Install Sun Logical Domains Software and Create Domains”](#) in *Sun Cluster Software Installation Guide for Solaris OS*.

The following figure illustrates a configuration in which redundant I/O domains ensure that nodes within the cluster continue to operate if an I/O domain fails.

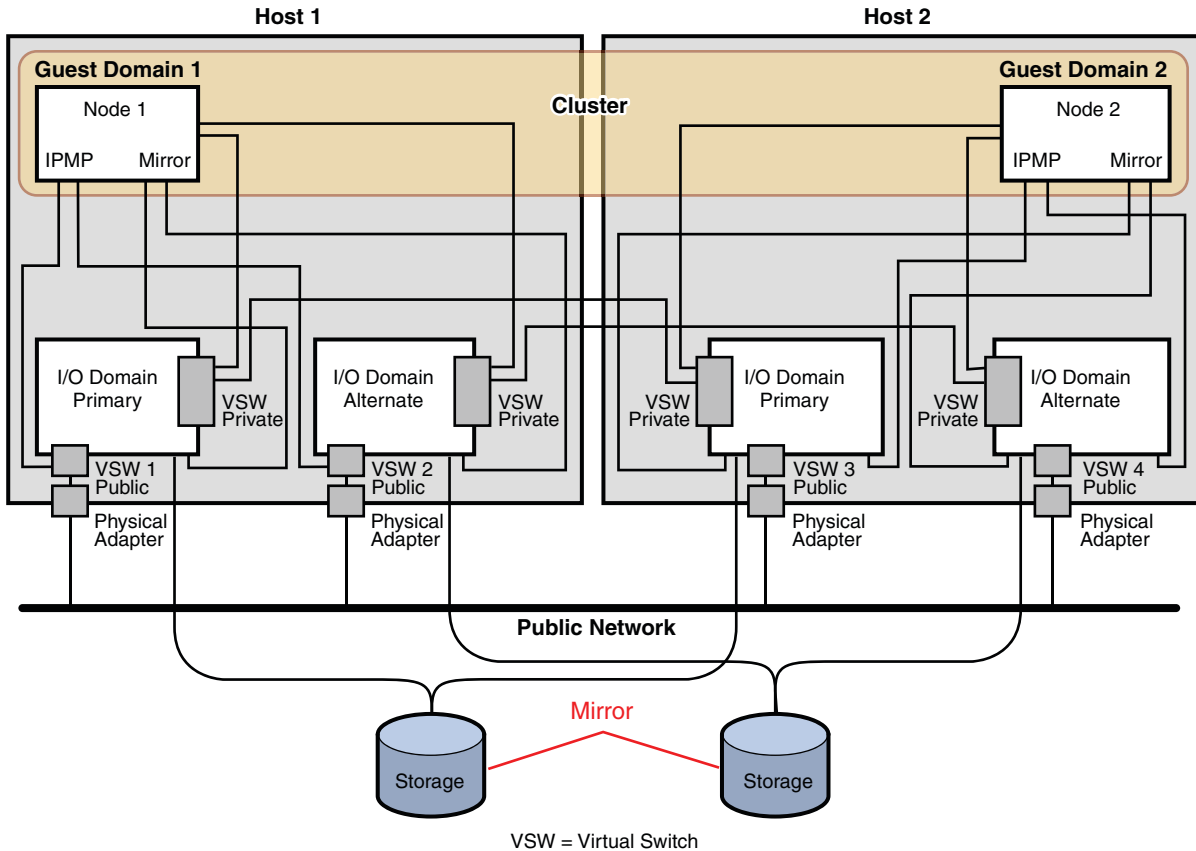

FIGURE 2-9 SPARC: Redundant I/O Domains

x86: Sun Cluster Topologies

A topology is the connection scheme that connects the cluster nodes to the storage platforms that are used in the cluster. Sun Cluster supports any topology that adheres to the following guidelines.

- Sun Cluster software supports from one to eight Solaris hosts in a cluster. Different hardware configurations impose additional limits on the maximum number of hosts that you can configure in a cluster composed of x86 based systems. See “[x86: Sun Cluster Topologies](#)” on page 38 for the supported host configurations.
- Shared storage devices must connect to hosts.

Sun Cluster does not require you to configure a cluster by using specific topologies. The following clustered pair topology, which is a topology for clusters that are composed of x86 based hosts, is described to provide the vocabulary to discuss a cluster's connection scheme. This topology is a typical connection scheme.

The following section includes a sample diagram of the topology.

x86: Clustered Pair Topology

A clustered pair topology is two Solaris hosts that operate under a single cluster administrative framework. In this configuration, failover occurs only between a pair. However, all hosts are connected by the cluster interconnect and operate under Sun Cluster software control. You might use this topology to run a parallel database or a failover or scalable application on the pair.

The following figure illustrates a clustered pair configuration.

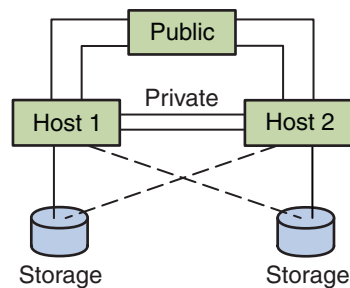

FIGURE 2-10 x86: Clustered Pair Topology

x86: N+1 (Star) Topology

An N+1 topology includes some number of primary Solaris hosts and one secondary host. You do not have to configure the primary hosts and secondary host identically. The primary hosts actively provide application services. The secondary host need not be idle while waiting for a primary host to fail.

The secondary host is the only host in the configuration that is physically connected to all the multihost storage.

If a failure occurs on a primary host, Sun Cluster fails over the resources to the secondary host. The secondary host is where the resources function until they are switched back (either automatically or manually) to the primary host.

The secondary host must always have enough excess CPU capacity to handle the load if one of the primary hosts fails.

The following figure illustrates an N+1 configuration.

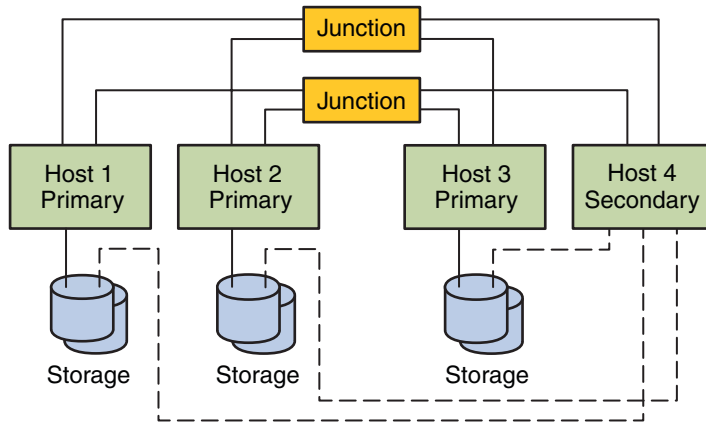

FIGURE 2-11 x86: N+1 Topology

Key Concepts for System Administrators and Application Developers

This chapter describes the key concepts that are related to the software components of the Sun Cluster environment. The information in this chapter is directed primarily to system administrators and application developers who use the Sun Cluster API and SDK. Cluster administrators can use this information in preparation for installing, configuring, and administering cluster software. Application developers can use the information to understand the cluster environment in which they work.

This chapter covers the following topics:

- “Administrative Interfaces” on page 42
- “Cluster Time” on page 42
- “High-Availability Framework” on page 43
- “Global Devices” on page 46
- “Device Groups” on page 47
- “Global Namespace” on page 49
- “Cluster File Systems” on page 51
- “Disk Path Monitoring” on page 53
- “Quorum and Quorum Devices” on page 56
- “Data Services” on page 64
- “Developing New Data Services” on page 71
- “Using the Cluster Interconnect for Data Service Traffic” on page 73
- “Resources, Resource Groups, and Resource Types” on page 74
- “Support for Solaris Zones” on page 77
- “Service Management Facility” on page 80
- “System Resource Usage” on page 81
- “Data Service Project Configuration” on page 83
- “Public Network Adapters and IP Network Multipathing” on page 92
- “SPARC: Dynamic Reconfiguration Support” on page 94

Administrative Interfaces

You can choose how you install, configure, and administer the Sun Cluster software from several user interfaces. You can accomplish system administration tasks either through the Sun Cluster Manager graphical user interface (GUI) or through the command-line interface. On top of the command-line interface are some utilities, such as `scinstall` and `clsetup`, to simplify selected installation and configuration tasks. The Sun Cluster software also has a module that runs as part of Sun Management Center that provides a GUI to particular cluster tasks. This module is available for use in only SPARC based clusters. Refer to [“Administration Tools” in *Sun Cluster System Administration Guide for Solaris OS*](#) for complete descriptions of the administrative interfaces.

Cluster Time

Time between all Solaris hosts in a cluster must be synchronized. Whether you synchronize the cluster hosts with any outside time source is not important to cluster operation. The Sun Cluster software employs the Network Time Protocol (NTP) to synchronize the clocks between hosts.

In general, a change in the system clock of a fraction of a second causes no problems. However, if you run `date`, `rdate`, or `xntpdate` (interactively, or within `cron` scripts) on an active cluster, you can force a time change much larger than a fraction of a second to synchronize the system clock to the time source. This forced change might cause problems with file modification timestamps or confuse the NTP service.

When you install the Solaris Operating System on each cluster host, you have an opportunity to change the default time and date setting for the host. In general, you can accept the factory default.

When you install Sun Cluster software by using the `scinstall` command, one step in the process is to configure NTP for the cluster. Sun Cluster software supplies a template file, `ntp.cluster` (see `/etc/inet/ntp.cluster` on an installed cluster host), that establishes a peer relationship between all cluster hosts. One host is designated the “preferred” host. Hosts are identified by their private host names and time synchronization occurs across the cluster interconnect. For instructions about how to configure the cluster for NTP, see [Chapter 2, “Installing Software on Global-Cluster Nodes,” in *Sun Cluster Software Installation Guide for Solaris OS*](#).

Alternately, you can set up one or more NTP servers outside the cluster and change the `ntp.conf` file to reflect that configuration.

In normal operation, you should never need to adjust the time on the cluster. However, if the time was set incorrectly when you installed the Solaris Operating System and you want to change it, the procedure for doing so is included in [Chapter 9, “Administering the Cluster,” in *Sun Cluster System Administration Guide for Solaris OS*](#).

High-Availability Framework

The Sun Cluster software makes all components on the “path” between users and data highly available, including network interfaces, the applications themselves, the file system, and the multihost devices. In general, a cluster component is highly available if it survives any single (software or hardware) failure in the system.

The following table shows the kinds of Sun Cluster component failures (both hardware and software) and the kinds of recovery that are built into the high-availability framework.

TABLE 3-1 Levels of Sun Cluster Failure Detection and Recovery

Failed Cluster Component	Software Recovery	Hardware Recovery
Data service	HA API, HA framework	Not applicable
Public network adapter	IP network multipathing	Multiple public network adapter cards
Cluster file system	Primary and secondary replicas	Multihost devices
Mirrored multihost device	Volume management (Solaris Volume Manager and Veritas Volume Manager)	Hardware RAID-5 (for example, Sun StorEdge™ A3x00)
Global device	Primary and secondary replicas	Multiple paths to the device, cluster transport junctions
Private network	HA transport software	Multiple private hardware-independent networks
Host	CMM, failfast driver	Multiple hosts
Zone	HA API, HA framework	Not applicable

Sun Cluster software's high-availability framework detects a node failure quickly and creates a new equivalent server for the framework resources on a remaining node in the cluster. At no time are all framework resources unavailable. Framework resources that are unaffected by a failed node are fully available during recovery. Furthermore, framework resources of the failed node become available as soon as they are recovered. A recovered framework resource does not have to wait for all other framework resources to complete their recovery.

Most highly available framework resources are recovered transparently to the applications (data services) that are using the resource. The semantics of framework resource access are fully preserved across node failure. The applications cannot detect that the framework resource server has been moved to another node. Failure of a single node is completely transparent to programs on remaining nodes by using the files, devices, and disk volumes that are available to this node. This transparency exists if an alternative hardware path exists to the disks from another host. An example is the use of multihost devices that have ports to multiple hosts.

Zone Membership

Sun Cluster software also tracks zone membership by detecting when a zone boots up or halts. These changes also trigger a reconfiguration. A reconfiguration can redistribute cluster resources among the nodes in the cluster.

Cluster Membership Monitor

To ensure that data is kept safe from corruption, all nodes must reach a consistent agreement on the cluster membership. When necessary, the CMM coordinates a cluster reconfiguration of cluster services (applications) in response to a failure.

The CMM receives information about connectivity to other nodes from the cluster transport layer. The CMM uses the cluster interconnect to exchange state information during a reconfiguration.

After detecting a change in cluster membership, the CMM performs a synchronized configuration of the cluster. In a synchronized configuration, cluster resources might be redistributed, based on the new membership of the cluster.

Failfast Mechanism

The *failfast* mechanism detects a critical problem on either a global-cluster voting node or global-cluster non-voting node. The action that Sun Cluster takes when failfast detects a problem depends on whether the problem occurs in a voting node or a non-voting node.

If the critical problem is located in a voting node, Sun Cluster forcibly shuts down the node. Sun Cluster then removes the node from cluster membership.

If the critical problem is located in a non-voting node, Sun Cluster reboots that non-voting node.

If a node loses connectivity with other nodes, the node attempts to form a cluster with the nodes with which communication is possible. If that set of nodes does not form a quorum, Sun Cluster software halts the node and “fences” the node from the shared disks, that is, prevents the node from accessing the shared disks.

You can turn off fencing for selected disks or for all disks.



Caution – If you turn off fencing under the wrong circumstances, your data can be vulnerable to corruption during application failover. Examine this data corruption possibility carefully when you are considering turning off fencing. If your shared storage device does not support the SCSI protocol, such as a Serial Advanced Technology Attachment (SATA) disk, or if you want to allow access to the cluster's storage from hosts outside the cluster, turn off fencing.

If one or more cluster-specific daemons die, Sun Cluster software declares that a critical problem has occurred. Sun Cluster software runs cluster-specific daemons on both voting nodes and non-voting nodes. If a critical problem occurs, Sun Cluster either shuts down and removes the node or reboots the non-voting node where the problem occurred.

When a cluster-specific daemon that runs on a non-voting node fails, a message similar to the following is displayed on the console.

```
cl_runtime: NOTICE: Failfast: Aborting because "pmfd" died in zone "zone4" (zone id 3)
35 seconds ago.
```

When a cluster-specific daemon that runs on a voting node fails and the node panics, a message similar to the following is displayed on the console.

```
panic[cpu1]/thread=2a10007fcc0: Failfast: Aborting because "pmfd" died in zone "global" (zone id 0)
35 seconds ago.
409b8 cl_runtime: __0FZsc_syslog_msg_log_no_argsPviTCPCcTB+48 (70f900, 30, 70df54, 407acc, 0)
%l0-7: 1006c80 000000a 000000a 10093bc 406d3c80 7110340 0000000 4001 bfb0
```

After the panic, the Solaris host might reboot and the node might attempt to rejoin the cluster. Alternatively, if the cluster is composed of SPARC based systems, the host might remain at the OpenBoot PROM (OBP) prompt. The next action of the host is determined by the setting of the `auto-boot?` parameter. You can set `auto-boot?` with the `eeprom` command, at the OpenBoot PROM `ok` prompt. See the [eeprom\(1M\)](#) man page.

Cluster Configuration Repository (CCR)

The CCR uses a two-phase commit algorithm for updates: An update must be successfully completed on all cluster members or the update is rolled back. The CCR uses the cluster interconnect to apply the distributed updates.



Caution – Although the CCR consists of text files, never edit the CCR files yourself. Each file contains a checksum record to ensure consistency between nodes. Updating CCR files yourself can cause a node or the entire cluster to stop working.

The CCR relies on the CMM to guarantee that a cluster is running only when quorum is established. The CCR is responsible for verifying data consistency across the cluster, performing recovery as necessary, and facilitating updates to the data.

Global Devices

The Sun Cluster software uses *global devices* to provide cluster-wide, highly available access to any device in a cluster, from any node, without regard to where the device is physically attached. In general, if a node fails while providing access to a global device, the Sun Cluster software automatically discovers another path to the device. The Sun Cluster software then redirects the access to that path. Sun Cluster global devices include disks, CD-ROMs, and tapes. However, the only multiported global devices that Sun Cluster software supports are disks. Consequently, CD-ROM and tape devices are not currently highly available devices. The local disks on each server are also not multiported, and thus are not highly available devices.

The cluster automatically assigns unique IDs to each disk, CD-ROM, and tape device in the cluster. This assignment enables consistent access to each device from any node in the cluster. The global device namespace is held in the `/dev/global` directory. See [“Global Namespace” on page 49](#) for more information.

Multiported global devices provide more than one path to a device. Because multihost disks are part of a device group that is hosted by more than one Solaris host, the multihost disks are made highly available.

Device IDs and DID Pseudo Driver

The Sun Cluster software manages shared devices through a construct known as the DID pseudo driver. This driver is used to automatically assign unique IDs to every device in the cluster, including multihost disks, tape drives, and CD-ROMs.

The DID pseudo driver is an integral part of the shared device access feature of the cluster. The DID driver probes all nodes of the cluster and builds a list of unique devices, assigns each device a unique major and a minor number that are consistent on all nodes of the cluster. Access to shared devices is performed by using the normalized DID logical name, instead of the traditional Solaris logical name, such as `c0t0d0` for a disk.

This approach ensures that any application that accesses disks (such as a volume manager or applications that use raw devices) uses a consistent path across the cluster. This consistency is especially important for multihost disks, because the local major and minor numbers for each device can vary from Solaris host to Solaris host, thus changing the Solaris device naming conventions as well. For example, `Host1` might identify a multihost disk as `c1t2d0`, and `Host2` might identify the same disk completely differently, as `c3t2d0`. The DID framework assigns a common (normalized) logical name, such as `d10`, that the hosts use instead, giving each host a consistent mapping to the multihost disk.

You update and administer device IDs with the `cldevice` command. See the [cldevice\(1CL\)](#) man page.

Device Groups

In the Sun Cluster software, all multihost devices must be under control of the Sun Cluster software. You first create volume manager disk groups, either Solaris Volume Manager disk sets or Veritas Volume Manager disk groups, on the multihost disks. Then, you register the volume manager disk groups as *device groups*. A device group is a type of global device. In addition, the Sun Cluster software automatically creates a raw device group for each disk and tape device in the cluster. However, these cluster device groups remain in an offline state until you access them as global devices.

Registration provides the Sun Cluster software information about which Solaris hosts have a path to specific volume manager disk groups. At this point, the volume manager disk groups become globally accessible within the cluster. If more than one host can write to (master) a device group, the data stored in that device group becomes highly available. The highly available device group can be used to contain cluster file systems.

Note – Device groups are independent of resource groups. One node can master a resource group (representing a group of data service processes). Another node can master the disk groups that are being accessed by the data services. However, the best practice is to keep on the same node the device group that stores a particular application's data and the resource group that contains the application's resources (the application daemon). Refer to “[Relationship Between Resource Groups and Device Groups](#)” in *Sun Cluster Data Services Planning and Administration Guide for Solaris OS* for more information about the association between device groups and resource groups.

When a node uses a device group, the volume manager disk group becomes “global” because it provides multipath support to the underlying disks. Each cluster host that is physically attached to the multihost disks provides a path to the device group.

Device Group Failover

Because a disk enclosure is connected to more than one Solaris host, all device groups in that enclosure are accessible through an alternate path if the host currently mastering the device group fails. The failure of the host that is mastering the device group does not affect access to the device group except for the time it takes to perform the recovery and consistency checks. During this time, all requests are blocked (transparently to the application) until the system makes the device group available.

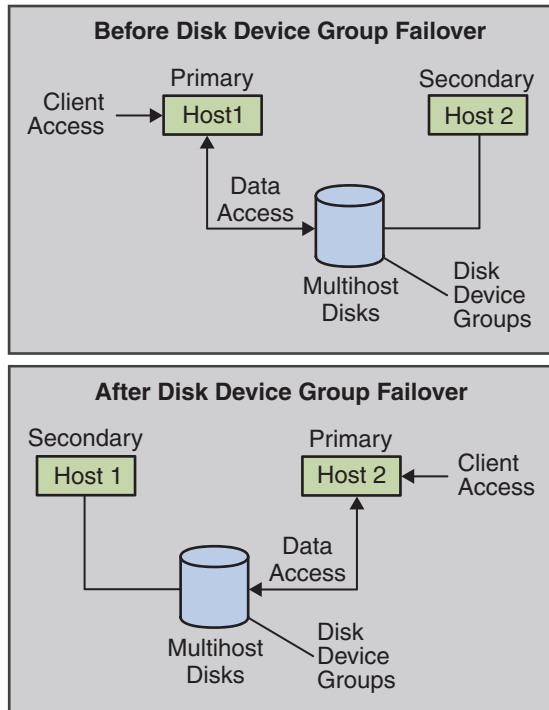

FIGURE 3-1 Device Group Before and After Failover

Multiported Device Groups

This section describes device group properties that enable you to balance performance and availability in a multiported disk configuration. Sun Cluster software provides two properties that configure a multiported disk configuration: `preferred` and `numsecondaries`. You can control the order in which nodes attempt to assume control if a failover occurs by using the `preferred` property. Use the `numsecondaries` property to set the number of secondary nodes for a device group that you want.

A highly available service is considered down when the primary node fails and when no eligible secondary nodes can be promoted to primary nodes. If service failover occurs and the `preferred` property is `true`, then the nodes follow the order in the node list to select a secondary node. The node list defines the order in which nodes attempt to assume primary control or transition from spare to secondary. You can dynamically change the preference of a device service by using the `clsetup` command. The preference that is associated with dependent service providers, for example a global file system, is identical to the preference of the device service.

Secondary nodes are check-pointed by the primary node during normal operation. In a multiported disk configuration, checkpointing each secondary node causes cluster

performance degradation and memory overhead. Spare node support was implemented to minimize the performance degradation and memory overhead that checkpointing caused. By default, your device group has one primary and one secondary. The remaining available provider nodes become spares. If failover occurs, the secondary becomes primary and the node or highest in priority on the node list becomes secondary.

You can set the number of secondary nodes that you want to any integer between one and the number of operational nonprimary provider nodes in the device group.

Note – If you are using Solaris Volume Manager, you must create the device group before you can set the `numsecondaries` property to a number other than the default.

The default number of secondaries for device services is 1. The actual number of secondary providers that is maintained by the replica framework is the number that you want, unless the number of operational nonprimary providers is less than the number that you want. You must alter the `numsecondaries` property and double-check the node list if you are adding or removing nodes from your configuration. Maintaining the node list and number of secondaries prevents conflict between the configured number of secondaries and the actual number that is allowed by the framework.

- (Solaris Volume Manager) Use the `metaset` command for Solaris Volume Manager device groups, in conjunction with the `preferenced` and `numsecondaries` property settings, to manage the addition of nodes to and the removal of nodes from your configuration.
- (Veritas Volume Manager) Use the `cldevicegroup` command for VxVM device groups, in conjunction with the `preferenced` and `numsecondaries` property settings, to manage the addition of nodes to and the removal of nodes from your configuration.
- Refer to “[Overview of Administering Cluster File Systems](#)” in *Sun Cluster System Administration Guide for Solaris OS* for procedural information about changing device group properties.

Global Namespace

The Sun Cluster software mechanism that enables global devices is the *global namespace*. The global namespace includes the `/dev/global/` hierarchy as well as the volume manager namespaces. The global namespace reflects both multihost disks and local disks (and any other cluster device, such as CD-ROMs and tapes), and provides multiple failover paths to the multihost disks. Each Solaris host that is physically connected to multihost disks provides a path to the storage for any node in the cluster.

Normally, for Solaris Volume Manager, the volume manager namespaces are located in the `/dev/md/diskset/dsk` (and `rdsk`) directories. For Veritas VxVM, the volume manager namespaces are located in the `/dev/vx/dsk/disk-group` and `/dev/vx/rdsk/disk-group`

directories. These namespaces consist of directories for each Solaris Volume Manager disk set and each VxVM disk group imported throughout the cluster, respectively. Each of these directories contains a device host for each metadevice or volume in that disk set or disk group.

In the Sun Cluster software, each device host in the local volume manager namespace is replaced by a symbolic link to a device host in the `/global/.devices/node@nodeID` file system. `nodeID` is an integer that represents the nodes in the cluster. Sun Cluster software continues to present the volume manager devices, as symbolic links, in their standard locations as well. Both the global namespace and standard volume manager namespace are available from any cluster node.

The advantages of the global namespace include the following:

- Each host remains fairly independent, with little change in the device administration model.
- Devices can be selectively made global.
- Third-party link generators continue to work.
- Given a local device name, an easy mapping is provided to obtain its global name.

Local and Global Namespaces Example

The following table shows the mappings between the local and global namespaces for a multihost disk, `c0t0d0s0`.

TABLE 3-2 Local and Global Namespace Mappings

Component or Path	Local Host Namespace	Global Namespace
Solaris logical name	<code>/dev/dsk/c0t0d0s0</code>	<code>/global/.devices/node@nodeID/dev/dsk/c0t0d0s0</code>
DID name	<code>/dev/did/dsk/d0s0</code>	<code>/global/.devices/node@nodeID/dev/did/dsk/d0s0</code>
Solaris Volume Manager	<code>/dev/md/diskset/dsk/d0</code>	<code>/global/.devices/node@nodeID/dev/md/diskset/dsk/d0</code>
Veritas Volume Manager	<code>/dev/vx/dsk/disk-group/v0</code>	<code>/global/.devices/node@nodeID/dev/vx/dsk/disk-group/v0</code>

The global namespace is automatically generated on installation and updated with every reconfiguration reboot. You can also generate the global namespace by using the `cldevice` command. See the [cldevice\(1CL\)](#) man page.

Cluster File Systems

The cluster file system has the following features:

- File access locations are transparent. A process can open a file that is located anywhere in the system. Processes on all Solaris hosts can use the same path name to locate a file.

Note – When the cluster file system reads files, it does not update the access time on those files.

- Coherency protocols are used to preserve the UNIX file access semantics even if the file is accessed concurrently from multiple nodes.
- Extensive caching is used along with zero-copy bulk I/O movement to move file data efficiently.
- The cluster file system provides highly available, advisory file-locking functionality by using the `fcntl` command interfaces. Applications that run on multiple cluster nodes can synchronize access to data by using advisory file locking on a cluster file system. File locks are recovered immediately from nodes that leave the cluster, and from applications that fail while holding locks.
- Continuous access to data is ensured, even when failures occur. Applications are not affected by failures if a path to disks is still operational. This guarantee is maintained for raw disk access and all file system operations.
- Cluster file systems are independent from the underlying file system and volume management software. Cluster file systems make any supported on-disk file system global.

You can mount a file system on a global device globally with `mount -g` or locally with `mount`.

Programs can access a file in a cluster file system from any node in the cluster through the same file name (for example, `/global/foo`).

A cluster file system is mounted on all cluster members. You cannot mount a cluster file system on a subset of cluster members.

A cluster file system is not a distinct file system type. Clients verify the underlying file system (for example, UFS).

Using Cluster File Systems

In the Sun Cluster software, all multihost disks are placed into device groups, which can be Solaris Volume Manager disk sets, VxVM disk groups, raw-disk groups, or individual disks that are not under control of a software-based volume manager.

For a cluster file system to be highly available, the underlying disk storage must be connected to more than one Solaris host. Therefore, a local file system (a file system that is stored on a host's local disk) that is made into a cluster file system is not highly available.

You can mount cluster file systems as you would mount file systems:

- **Manually.** Use the mount command and the `-g` or `-o global` mount options to mount the cluster file system from the command line, for example:

```
SPARC: # mount -g /dev/global/dsk/d0s0 /global/oracle/data
```

- **Automatically.** Create an entry in the `/etc/vfstab` file with a global mount option to mount the cluster file system at boot. You then create a mount point under the `/global` directory on all hosts. The directory `/global` is a recommended location, not a requirement. Here's a sample line for a cluster file system from an `/etc/vfstab` file:

```
SPARC: /dev/md/oracle/dsk/d1 /dev/md/oracle/rdisk/d1 /global/oracle/data ufs 2 yes global,logging
```

Note – While Sun Cluster software does not impose a naming policy for cluster file systems, you can ease administration by creating a mount point for all cluster file systems under the same directory, such as `/global/disk-group`. See *Sun Cluster 3.1 9/04 Software Collection for Solaris OS (SPARC Platform Edition)* and *Sun Cluster System Administration Guide for Solaris OS* for more information.

HASStoragePlus Resource Type

The HASStoragePlus resource type is designed to make local and global file system configurations highly available. You can use the HASStoragePlus resource type to integrate your local or global file system into the Sun Cluster environment and make the file system highly available.

You can use the HASStoragePlus resource type to make a file system available to a global-cluster non-voting node. To enable the HASStoragePlus resource type to do this, you must create a mount point on the global-cluster voting node and in the global-cluster non-voting node. The HASStoragePlus resource type makes the file system available to the global-cluster non-voting node by mounting the file system in the global-cluster voting node. The resource type then performs a loopback mount in the global-cluster node.

Sun Cluster systems support the following cluster file systems:

- UNIX® File System (UFS) – Uses Sun Cluster Proxy System (PxFS)
- SPARC: Veritas File System (VxFS) – Uses PxFS

Sun Cluster software supports the following as highly available failover local file systems:

- UFS
- Solaris ZFS™

- Sun QFS
- VxFS

The HAS`storagePlus` resource type provides additional file system capabilities such as checks, mounts, and forced unmounts. These capabilities enable Sun Cluster to fail over local file systems. In order to fail over, the local file system must reside on global disk groups with affinity switchovers enabled.

See “[Enabling Highly Available Local File Systems](#)” in *Sun Cluster Data Services Planning and Administration Guide for Solaris OS* for information about how to use the HAS`storagePlus` resource type.

You can also use the HAS`storagePlus` resource type to synchronize the startup of resources and device groups on which the resources depend. For more information, see “[Resources, Resource Groups, and Resource Types](#)” on page 74.

syncdir Mount Option

You can use the `syncdir` mount option for cluster file systems that use UFS as the underlying file system. However, performance significantly improves if you do not specify `syncdir`. If you specify `syncdir`, the writes are guaranteed to be POSIX compliant. If you do not specify `syncdir`, you experience the same behavior as in NFS file systems. For example, without `syncdir`, you might not discover an out of space condition until you close a file. With `syncdir` (and POSIX behavior), the out-of-space condition would have been discovered during the write operation. The cases in which you might have problems if you do not specify `syncdir` are rare.

If you are using a SPARC based cluster, VxFS does not have a mount option that is equivalent to the `syncdir` mount option for UFS. VxFS behavior is the same as UFS when the `syncdir` mount option is not specified.

See “[File Systems FAQs](#)” on page 100 for frequently asked questions about global devices and cluster file systems.

Disk Path Monitoring

The current release of Sun Cluster software supports disk path monitoring (DPM). This section provides conceptual information about DPM, the DPM daemon, and administration tools that you use to monitor disk paths. Refer to *Sun Cluster System Administration Guide for Solaris OS* for procedural information about how to monitor, unmonitor, and check the status of disk paths.

DPM Overview

DPM improves the overall reliability of failover and switchover by monitoring secondary disk path availability. Use the `cldevice` command to verify the availability of the disk path that is used by a resource before the resource is switched. Options that are provided with the `cldevice` command enable you to monitor disk paths to a single Solaris host or to all Solaris hosts in the cluster. See the [cldevice\(1CL\)](#) man page for more information about command-line options.

The following table describes the default location for installation of DPM components.

Location	Component
Daemon	<code>/usr/cluster/lib/sc/scdpmd</code>
Command-line interface	<code>/usr/cluster/bin/cldevice</code>
Daemon status file (created at runtime)	<code>/var/run/cluster/scdpm.status</code>

A multithreaded DPM daemon runs on each host. The DPM daemon (`scdpmd`) is started by an `rc.d` script when a host boots. If a problem occurs, the daemon is managed by `pmfd` and restarts automatically. The following list describes how the `scdpmd` works on initial startup.

Note – At startup, the status for each disk path is initialized to UNKNOWN.

1. The DPM daemon gathers disk path and node name information from the previous status file or from the CCR database. See [“Cluster Configuration Repository \(CCR\)” on page 45](#) for more information about the CCR. After a DPM daemon is started, you can force the daemon to read the list of monitored disks from a specified file name.
2. The DPM daemon initializes the communication interface to respond to requests from components that are external to the daemon, such as the command-line interface.
3. The DPM daemon pings each disk path in the monitored list every 10 minutes by using `scsi_inquiry` commands. Each entry is locked to prevent the communication interface access to the content of an entry that is being modified.
4. The DPM daemon notifies the Sun Cluster Event Framework and logs the new status of the path through the UNIX `syslogd` command. See the [syslogd\(1M\)](#) man page.

Note – All errors that are related to the daemon are reported by `pmfd`. All the functions from the API return 0 on success and -1 for any failure.

The DPM daemon monitors the availability of the logical path that is visible through multipath drivers such as Solaris I/O multipathing (MPxIO), which was formerly named Sun StorEdge Traffic Manager, Sun StorEdge 9900 Dynamic Link Manager, and EMC PowerPath. The

individual physical paths that are managed by these drivers are not monitored because the multipath driver masks individual failures from the DPM daemon.

Monitoring Disk Paths

This section describes two methods for monitoring disk paths in your cluster. The first method is provided by the `cldevice` command. Use this command to monitor, unmonitor, or display the status of disk paths in your cluster. You can also use this command to print a list of faulted disks and to monitor disk paths from a file. See the `cldevice(1CL)` man page.

The second method for monitoring disk paths in your cluster is provided by the Sun Cluster Manager graphical user interface (GUI). Sun Cluster Manager provides a topological view of the monitored disk paths in your cluster. The view is updated every 10 minutes to provide information about the number of failed pings. Use the information that is provided by the Sun Cluster Manager GUI in conjunction with the `cldevice` command to administer disk paths. See [Chapter 13, “Administering Sun Cluster With the Graphical User Interfaces,”](#) in *Sun Cluster System Administration Guide for Solaris OS* for information about Sun Cluster Manager.

Using the `cldevice` Command to Monitor and Administer Disk Paths

The `cldevice` command enables you to perform the following tasks:

- Monitor a new disk path
- Unmonitor a disk path
- Reread the configuration data from the CCR database
- Read the disks to monitor or unmonitor from a specified file
- Report the status of a disk path or all disk paths in the cluster
- Print all the disk paths that are accessible from a node

Issue the `cldevice` command with the disk path argument from any active node to perform DPM administration tasks on the cluster. The disk path argument consists of a node name and a disk name. The node name is not required. If you do not specify a node name, all nodes are affected by default. The following table describes naming conventions for the disk path.

Note – Always specify a global disk path name rather than a UNIX disk path name because a global disk path name is consistent throughout a cluster. A UNIX disk path name is not. For example, the disk path name can be `c1t0d0` on one node and `c2t0d0` on another node. To determine a global disk path name for a device that is connected to a node, use the `cldevice list` command before issuing DPM commands. See the `cldevice(1CL)` man page.

TABLE 3-3 Sample Disk Path Names

Name Type	Sample Disk Path Name	Description
Global disk path	<code>schost-1:/dev/did/dsk/d1</code>	Disk path <code>d1</code> on the <code>schost-1</code> node
	<code>all:d1</code>	Disk path <code>d1</code> on all nodes in the cluster
UNIX disk path	<code>schost-1:/dev/rdisk/c0t0d0s0</code>	Disk path <code>c0t0d0s0</code> on the <code>schost-1</code> node
	<code>schost-1:all</code>	All disk paths on the <code>schost-1</code> node
All disk paths	<code>all:all</code>	All disk paths on all nodes of the cluster

Using Sun Cluster Manager to Monitor Disk Paths

Sun Cluster Manager enables you to perform the following basic DPM administration tasks:

- Monitor a disk path
- Unmonitor a disk path
- View the status of all monitored disk paths in the cluster
- Enable or disable the automatic rebooting of a Solaris host when all monitored shared-disk paths fail

The Sun Cluster Manager online help provides procedural information about how to administer disk paths

Using the `clnode set` Command to Manage Disk Path Failure

You use the `clnode set` command to enable and disable the automatic rebooting of a node when all monitored shared-disk paths fail. When you enable the `reboot_on_path_failure` property, the states of local-disk paths are not considered when determining if a node reboot is necessary. Only monitored shared disks are affected. You can also use Sun Cluster Manager to perform these tasks.

Quorum and Quorum Devices

This section contains the following topics:

- “About Quorum Vote Counts” on page 58
- “About Quorum Configurations” on page 58
- “Adhering to Quorum Device Requirements” on page 59

- “Adhering to Quorum Device Best Practices” on page 60
- “Recommended Quorum Configurations” on page 61
- “Atypical Quorum Configurations” on page 62
- “Bad Quorum Configurations” on page 63

Note – For a list of the specific devices that Sun Cluster software supports as quorum devices, contact your Sun service provider.

Because cluster nodes share data and resources, a cluster must never split into separate partitions that are active at the same time because multiple active partitions might cause data corruption. The Cluster Membership Monitor (CMM) and quorum algorithm guarantee that, at most, one instance of the same cluster is operational at any time, even if the cluster interconnect is partitioned.

For an introduction to quorum and CMM, see “[Cluster Membership](#)” in *Sun Cluster Overview for Solaris OS*.

Two types of problems arise from cluster partitions:

- Split brain
- Amnesia

Split brain occurs when the cluster interconnect between nodes is lost and the cluster becomes partitioned into subclusters. Each partition “believes” that it is the only partition because the nodes in one partition cannot communicate with the node or nodes in the other partition.

Amnesia occurs when the cluster restarts after a shutdown with cluster configuration data that is older than the data was at the time of the shutdown. This problem can occur when you start the cluster on a node that was not in the last functioning cluster partition.

Sun Cluster software avoids split brain and amnesia by:

- Assigning each node one vote
- Mandating a majority of votes for an operational cluster

A partition with the majority of votes gains *quorum* and is allowed to operate. This majority vote mechanism prevents split brain and amnesia when more than two nodes are configured in a cluster. However, counting node votes alone is not sufficient when more than two nodes are configured in a cluster. In a two-host cluster, a majority is two. If such a two-host cluster becomes partitioned, an external vote is needed for either partition to gain quorum. This external vote is provided by a *quorum device*.

About Quorum Vote Counts

Use the `clquorum show` command to determine the following information:

- Total configured votes
- Current present votes
- Votes required for quorum

See the `cluster(1CL)` man page.

Both nodes and quorum devices contribute votes to the cluster to form quorum.

A node contributes votes depending on the node's state:

- A node has a vote count of *one* when it boots and becomes a cluster member.
- A node has a vote count of *zero* when the node is being installed.
- A node has a vote count of *zero* when a system administrator places the node into maintenance state.

Quorum devices contribute votes that are based on the number of votes that are connected to the device. When you configure a quorum device, Sun Cluster software assigns the quorum device a vote count of $N-1$ where N is the number of connected votes to the quorum device. For example, a quorum device that is connected to two nodes with nonzero vote counts has a quorum count of one (two minus one).

A quorum device contributes votes if *one* of the following two conditions are true:

- At least one of the nodes to which the quorum device is currently attached is a cluster member.
- At least one of the hosts to which the quorum device is currently attached is booting, and that host was a member of the last cluster partition to own the quorum device.

You configure quorum devices during the cluster installation, or afterwards, by using the procedures that are described in [Chapter 6, “Administering Quorum,”](#) in *Sun Cluster System Administration Guide for Solaris OS*.

About Quorum Configurations

The following list contains facts about quorum configurations:

- Quorum devices can contain user data.
- In an $N+1$ configuration where N quorum devices are each connected to one of the 1 through N Solaris hosts and the $N+1$ Solaris host, the cluster survives the death of either all 1 through N Solaris hosts or any of the $N/2$ Solaris hosts. This availability assumes that the quorum device is functioning correctly.

- In an N -host configuration where a single quorum device connects to all hosts, the cluster can survive the death of any of the $N-1$ hosts. This availability assumes that the quorum device is functioning correctly.
- In an N -host configuration where a single quorum device connects to all hosts, the cluster can survive the failure of the quorum device if all cluster hosts are available.

For examples of quorum configurations to avoid, see “[Bad Quorum Configurations](#)” on [page 63](#). For examples of recommended quorum configurations, see “[Recommended Quorum Configurations](#)” on [page 61](#).

Adhering to Quorum Device Requirements

Ensure that Sun Cluster software supports your specific device as a quorum device. If you ignore this requirement, you might compromise your cluster's availability.

Note – For a list of the specific devices that Sun Cluster software supports as quorum devices, contact your Sun service provider.

Sun Cluster software supports the following types of quorum devices:

- Multihosted shared disks that support SCSI-3 PGR reservations.
- Dual-hosted shared disks that support SCSI-2 reservations.
- A Network-Attached Storage (NAS) device from Sun Microsystems, Incorporated or from Network Appliance, Incorporated.
- A quorum server process that runs on the quorum server machine.
- Any shared disk, provided that you have turned off fencing for this disk, and are therefore using software quorum. Software quorum is a protocol developed by Sun Microsystems that emulates a form of SCSI Persistent Group Reservations (PGR).



Caution – If you are using disks that do not support SCSI, such as Serial Advanced Technology Attachment (SATA) disks, turn off fencing.

Note – You cannot use a replicated device as a quorum device.

In a two-host configuration, you must configure at least one quorum device to ensure that a single host can continue if the other host fails. See [Figure 3-2](#).

For examples of quorum configurations to avoid, see [“Bad Quorum Configurations” on page 63](#). For examples of recommended quorum configurations, see [“Recommended Quorum Configurations” on page 61](#).

Adhering to Quorum Device Best Practices

Use the following information to evaluate the best quorum configuration for your topology:

- Do you have a device that is capable of being connected to all Solaris hosts of the cluster?
 - If yes, configure that device as your one quorum device. You do *not* need to configure another quorum device because your configuration is the most optimal configuration.



Caution – If you ignore this requirement and add another quorum device, the additional quorum device reduces your cluster's availability.

- If no, configure your dual-ported device or devices.
- Ensure that the total number of votes contributed by quorum devices is strictly less than the total number of votes contributed by nodes. Otherwise, your nodes cannot form a cluster if all disks are unavailable, even if all nodes are functioning.

Note – In particular environments, you might want to reduce overall cluster availability to meet your needs. In these situations, you can ignore this best practice. However, not adhering to this best practice decreases overall availability. For example, in the configuration that is outlined in [“Atypical Quorum Configurations” on page 62](#) the cluster is less available: the quorum votes exceed the node votes. In a cluster, if access to the shared storage between Host A and Host B is lost, the entire cluster fails.

See [“Atypical Quorum Configurations” on page 62](#) for the exception to this best practice.

- Specify a quorum device between every pair of hosts that shares access to a storage device. This quorum configuration speeds the fencing process. See [“Quorum in Greater Than Two-Host Configurations” on page 61](#).
- In general, if the addition of a quorum device makes the total cluster vote even, the total cluster availability decreases.
- Quorum devices slightly slow reconfigurations after a node joins or a node dies. Therefore, do not add more quorum devices than are necessary.

For examples of quorum configurations to avoid, see [“Bad Quorum Configurations” on page 63](#). For examples of recommended quorum configurations, see [“Recommended Quorum Configurations” on page 61](#).

Recommended Quorum Configurations

This section shows examples of quorum configurations that are recommended. For examples of quorum configurations you should avoid, see [“Bad Quorum Configurations”](#) on page 63.

Quorum in Two-Host Configurations

Two quorum votes are required for a two-host cluster to form. These two votes can derive from the two cluster hosts, or from just one host and a quorum device.

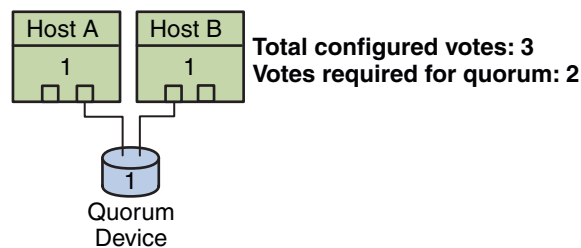
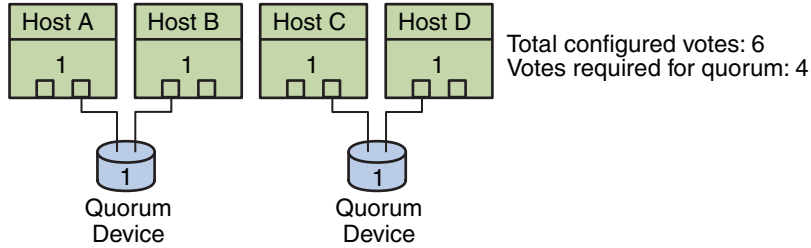

FIGURE 3-2 Two-Host Configuration

Quorum in Greater Than Two-Host Configurations

Quorum devices are not required when a cluster includes more than two hosts, as the cluster survives failures of a single host without a quorum device. However, under these conditions, you cannot start the cluster without a majority of hosts in the cluster.

You can add a quorum device to a cluster that includes more than two hosts. A partition can survive as a cluster when that partition has a majority of quorum votes, including the votes of the hosts and the quorum devices. Consequently, when adding a quorum device, consider the possible host and quorum device failures when choosing whether and where to configure quorum devices.



In this configuration, each pair must be available for either pair to survive.

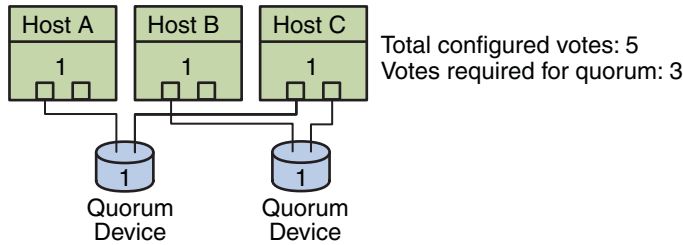

In this configuration, usually applications are configured to run on Host A and Host B and use Host C as a hot spare.

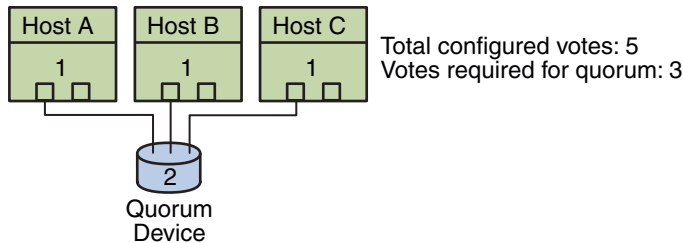

In this configuration, the combination of any one or more hosts and the quorum device can be from a cluster.

Atypical Quorum Configurations

Figure 3–3 assumes you are running mission-critical applications (Oracle database, for example) on Host A and Host B. If Host A and Host B are unavailable and cannot access shared data, you might want the entire cluster to be down. Otherwise, this configuration is suboptimal because it does not provide high availability.

For information about the best practice to which this exception relates, see [“Adhering to Quorum Device Best Practices”](#) on page 60.

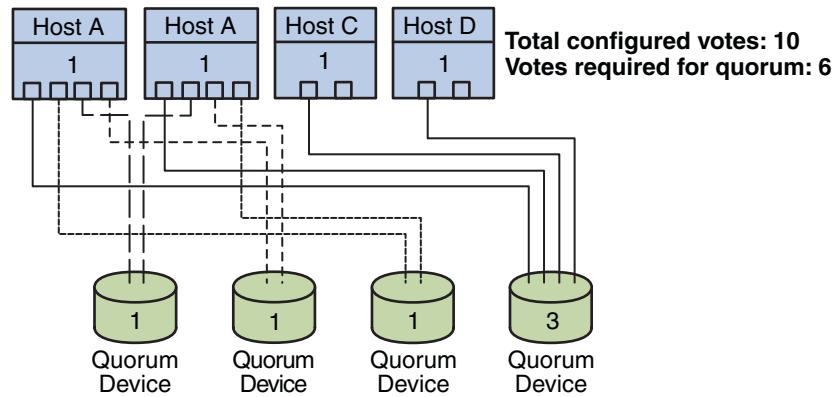
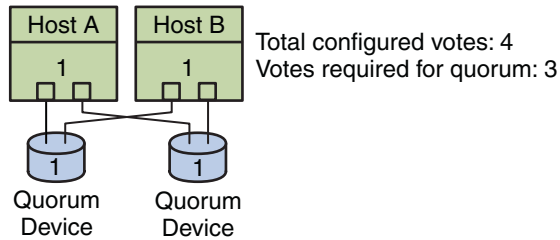

FIGURE 3-3 Atypical Configuration

Bad Quorum Configurations

This section shows examples of quorum configurations you should avoid. For examples of recommended quorum configurations, see [“Recommended Quorum Configurations”](#) on page 61.



This configuration violates the best practice that quorum device votes should be strictly less than votes of hosts.

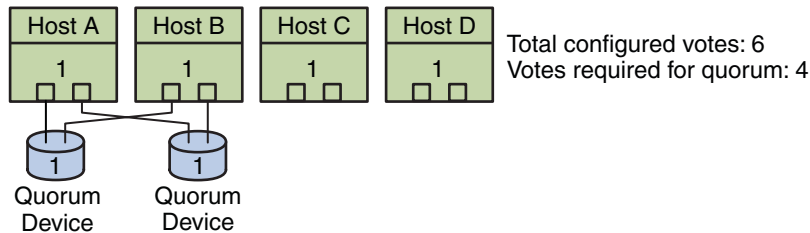

This configuration violates the best practice that you should not add quorum devices to make total votes even. This configuration does not add availability.

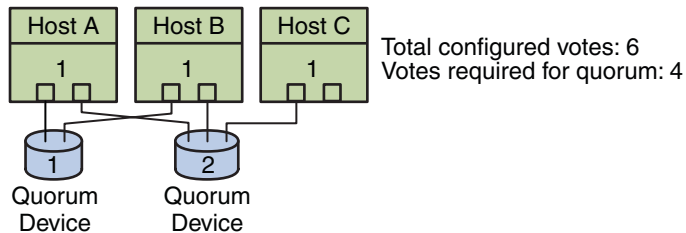

This configuration violates the best practice that quorum device votes should be strictly less than votes of hosts.

Data Services

The term *data service* describes an application, such as Sun Java System Web Server or Oracle, that has been configured to run on a cluster rather than on a single server. A data service consists of an application, specialized Sun Cluster configuration files, and Sun Cluster management methods that control the following actions of the application.

- Start
- Stop
- Monitor and take corrective measures

For information about data service types, see “Data Services” in *Sun Cluster Overview for Solaris OS*.

Figure 3–4 compares an application that runs on a single application server (the single-server model) to the same application running on a cluster (the clustered-server model). The only difference between the two configurations is that the clustered application might run faster and is more highly available.

Standard Client-Server Application

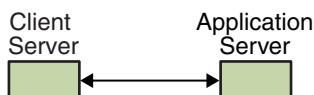

Clustered Client-Server Application

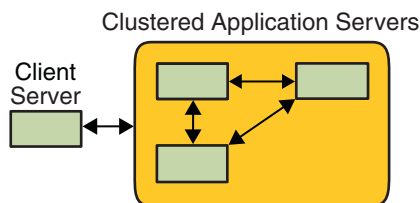

FIGURE 3–4 Standard Compared to Clustered Client-Server Configuration

In the single-server model, you configure the application to access the server through a particular public network interface (a host name). The host name is associated with that physical server.

In the clustered-server model, the public network interface is a *logical host name* or a *shared address*. The term *network resources* is used to refer to both logical host names and shared addresses.

Some data services require you to specify either logical host names or shared addresses as the network interfaces. Logical host names and shared addresses are not always interchangeable. Other data services allow you to specify either logical host names or shared addresses. Refer to the installation and configuration for each data service for details about the type of interface you must specify.

A network resource is not associated with a specific physical server. A network resource can migrate between physical servers.

A network resource is initially associated with one node, the *primary*. If the primary fails, the network resource and the application resource fail over to a different cluster node (a secondary). When the network resource fails over, after a short delay, the application resource continues to run on the secondary.

Figure 3–5 compares the single-server model with the clustered-server model. Note that in the clustered-server model, a network resource (logical host name, in this example) can move between two or more of the cluster nodes. The application is configured to use this logical host name in place of a host name that is associated with a particular server.

Standard Client-Server Application

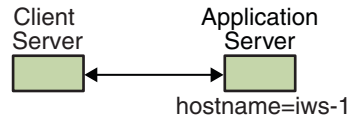

Failover Clustered Client-Server Application

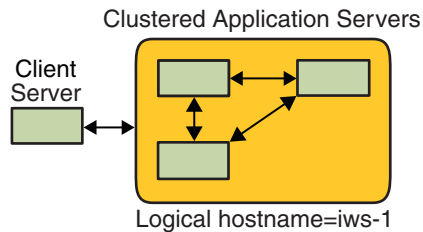

FIGURE 3–5 Fixed Host Name Compared to Logical Host Name

A shared address is also initially associated with one node. This node is called the global interface node. A shared address (known as the *global interface*) is used as the single network interface to the cluster.

The difference between the logical host name model and the scalable service model is that in the latter, each node also has the shared address actively configured on its loopback interface. This configuration enables multiple instances of a data service to be active on several nodes simultaneously. The term “scalable service” means that you can add more CPU power to the application by adding additional cluster nodes and the performance scales.

If the global interface node fails, the shared address can be started on another node that is also running an instance of the application (thereby making this other node the new global interface node). Or, the shared address can fail over to another cluster node that was not previously running the application.

Figure 3–6 compares the single-server configuration with the clustered scalable service configuration. Note that in the scalable service configuration, the shared address is present on all nodes. The application is configured to use this shared address in place of a host name that is associated with a particular server. This scheme is similar to how a logical host name is used for a failover data service.

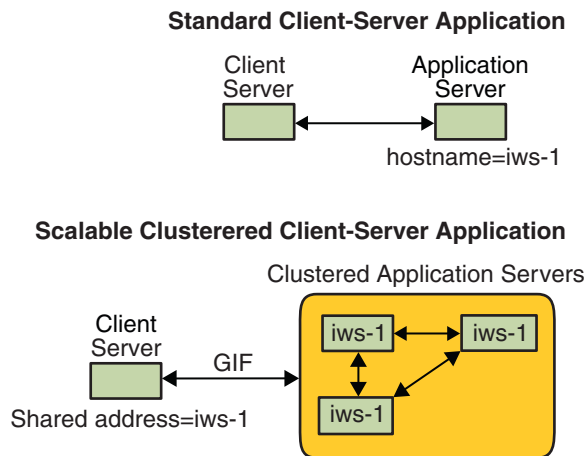

FIGURE 3-6 Fixed Host Name Compared to Shared Address

Data Service Methods

The Sun Cluster software supplies a set of service management methods. These methods run under the control of the Resource Group Manager (RGM), which uses them to start, stop, and monitor the application on the cluster nodes. These methods, along with the cluster framework software and multihost devices, enable applications to become failover or scalable data services.

The RGM also manages resources in the cluster, including instances of an application and network resources (logical host names and shared addresses).

In addition to Sun Cluster software-supplied methods, the Sun Cluster software also supplies an API and several data service development tools. These tools enable application developers to develop the data service methods that are required to make other applications run as highly available data services with the Sun Cluster software.

Failover Data Services

If the node on which the data service is running (the primary node) fails, the service is migrated to another working node without user intervention. Failover services use a *failover resource group*, which is a container for application instance resources and network resources (*logical host names*). Logical host names are IP addresses that can be configured on one node, and at a later time, automatically configured down on the original node and configured on another node.

For failover data services, application instances run only on a single node. If the fault monitor detects an error, it either attempts to restart the instance on the same node, or to start the instance on another node (failover). The outcome depends on how you have configured the data service.

Scalable Data Services

The scalable data service has the potential for active instances on multiple nodes.

Scalable services use the following two resource groups:

- A *scalable resource group* contains the application resources.
- A failover resource group, which contains the network resources (*shared addresses*) on which the scalable service depends. A shared address is a network address. This network address can be bound by all scalable services that are running on nodes within the cluster. This shared address enables these scalable services to scale on those nodes. A cluster can have multiple shared addresses, and a service can be bound to multiple shared addresses.

A scalable resource group can be online on multiple nodes simultaneously. As a result, multiple instances of the service can be running at once. All scalable resource groups use load balancing. All nodes that host a scalable service use the same shared address to host the service. The failover resource group that hosts the shared address is online on only one node at a time.

Service requests enter the cluster through a single network interface (the global interface). These requests are distributed to the nodes, based on one of several predefined algorithms that are set by the *load-balancing policy*. The cluster can use the load-balancing policy to balance the service load between several nodes. Multiple global interfaces can exist on different nodes that host other shared addresses.

For scalable services, application instances run on several nodes simultaneously. If the node that hosts the global interface fails, the global interface fails over to another node. If an application instance that is running fails, the instance attempts to restart on the same node.

If an application instance cannot be restarted on the same node, and another unused node is configured to run the service, the service fails over to the unused node. Otherwise, the service continues to run on the remaining nodes, possibly causing a degradation of service throughput.

Note – TCP state for each application instance is kept on the node with the instance, not on the global interface node. Therefore, failure of the global interface node does not affect the connection.

[Figure 3–7](#) shows an example of failover and a scalable resource group and the dependencies that exist between them for scalable services. This example shows three resource groups. The failover resource group contains application resources for highly available DNS, and network

resources used by both highly available DNS and highly available Apache Web Server (used in SPARC-based clusters only). The scalable resource groups contain only application instances of the Apache Web Server. Note that resource group dependencies exist between the scalable and failover resource groups (solid lines). Additionally, all the Apache application resources depend on the network resource `schost-2`, which is a shared address (dashed lines).

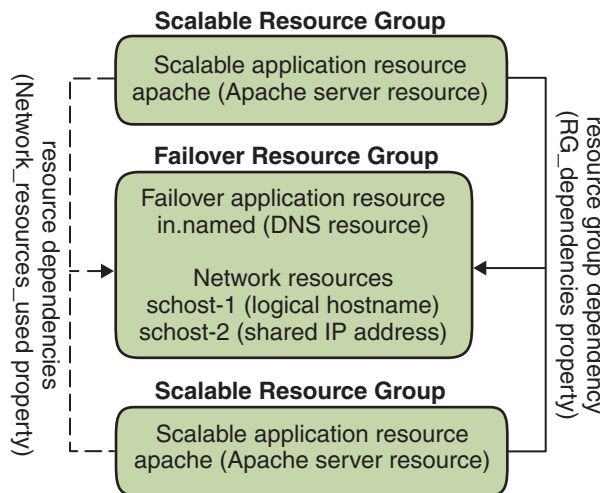

FIGURE 3-7 SPARC: Failover and Scalable Resource Group Example

Load-Balancing Policies

Load balancing improves performance of the scalable service, both in response time and in throughput. There are two classes of scalable data services.

- Pure
- Sticky

A *pure* service is capable of having any of its instances respond to client requests. A *sticky* service is capable of having a client send requests to the same instance. Those requests are not redirected to other instances.

A pure service uses a weighted load-balancing policy. Under this load-balancing policy, client requests are by default uniformly distributed over the server instances in the cluster. The load is distributed among various nodes according to specified weight values. For example, in a three-node cluster, suppose that each node has the weight of 1. Each node services one third of the requests from any client on behalf of that service. The cluster administrator can change weights at any time with an administrative command or with Sun Cluster Manager.

The weighted load-balancing policy is set by using the `LB_WEIGHTED` value for the `Load_balancing_weights` property. If a weight for a node is not explicitly set, the weight for that node is set to 1 by default.

The weighted policy redirects a certain percentage of the traffic from clients to a particular node. Given X =weight and A =the total weights of all active nodes, an active node can expect approximately X/A of the total new connections to be directed to the active node. However, the total number of connections must be large enough. This policy does not address individual requests.

Note that the weighted policy is not round robin. A round-robin policy would always cause each request from a client to go to a different node. For example, the first request would go to node 1, the second request would go to node 2, and so on.

A sticky service has two flavors, *ordinary sticky* and *wildcard sticky*.

Sticky services enable concurrent application-level sessions over multiple TCP connections to share in-state memory (application session state).

Ordinary sticky services enable a client to share the state between multiple concurrent TCP connections. The client is said to be “sticky” toward that server instance that is listening on a single port.

The client is guaranteed that all requests go to the same server instance, provided that the following conditions are met:

- The instance remains up and accessible.
- The load-balancing policy is not changed while the service is online.

For example, a web browser on the client connects to a shared IP address on port 80 using three different TCP connections. However, the connections exchange cached session information between them at the service.

A generalization of a sticky policy extends to multiple scalable services that exchange session information in the background and at the same instance. When these services exchange session information in the background and at the same instance, the client is said to be “sticky” toward multiple server instances on the same node that is listening on different ports.

For example, a customer on an e-commerce web site fills a shopping cart with items by using HTTP on port 80. The customer then switches to SSL on port 443 to send secure data to pay by credit card for the items in the cart.

In the ordinary sticky policy, the set of ports is known at the time the application resources are configured. This policy is set by using the `LB_STICKY` value for the `Load_balancing_policy` resource property.

Wildcard sticky services use dynamically assigned port numbers, but still expect client requests to go to the same node. The client is “sticky wildcard” over ports that have the same IP address.

A good example of this policy is passive mode FTP. For example, a client connects to an FTP server on port 21. The server then instructs the client to connect back to a listener port server in the dynamic port range. All requests for this IP address are forwarded to the same node that the server informed the client through the control information.

The sticky-wildcard policy is a superset of the ordinary sticky policy. For a scalable service that is identified by the IP address, ports are assigned by the server (and are not known in advance). The ports might change. This policy is set by using the `LB_STICKY_WILD` value for the `Load_balancing_policy` resource property.

For each one of these sticky policies, the weighted load-balancing policy is in effect by default. Therefore, a client's initial request is directed to the instance that the load balancer dictates. After the client establishes an affinity for the node where the instance is running, future requests are conditionally directed to that instance. The node must be accessible and the load-balancing policy must not have changed.

Failback Settings

Resource groups fail over from one node to another. When this failover occurs, the original secondary becomes the new primary. The failback settings specify the actions that occur when the original primary comes back online. The options are to have the original primary become the primary again (failback) or to allow the current primary to remain. You specify the option you want by using the `Failback` resource group property setting.

If the original node that hosts the resource group fails and reboots repeatedly, setting failback might result in reduced availability for the resource group.

Data Services Fault Monitors

Each Sun Cluster data service supplies a fault monitor that periodically probes the data service to determine its health. A fault monitor verifies that the application daemon or daemons are running and that clients are being served. Based on the information that probes return, predefined actions such as restarting daemons or causing a failover can be initiated.

Developing New Data Services

Sun supplies configuration files and management methods templates that enable you to make various applications operate as failover or scalable services within a cluster. If Sun does not offer the application that you want to run as a failover or scalable service, you have an alternative. Use a Sun Cluster API or the DSET API to configure the application to run as a failover or scalable service. However, not all applications can become a scalable service.

Characteristics of Scalable Services

A set of criteria determines whether an application can become a scalable service. To determine if your application can become a scalable service, see “[Analyzing the Application for Suitability](#)” in *Sun Cluster Data Services Developer’s Guide for Solaris OS*.

This set of criteria is summarized as follows:

- First, such a service is composed of one or more server *instances*. Each instance runs on a different node. Two or more instances of the same service cannot run on the same node.
- Second, if the service provides an external logical data store, you must exercise caution. Concurrent access to this store from multiple server instances must be synchronized to avoid losing updates or reading data as it’s being changed. Note the use of “external” to distinguish the store from in-memory state. The term “logical” indicates that the store appears as a single entity, although it might itself be replicated. Furthermore, in this data store, when any server instance updates the data store, this update is immediately “seen” by other instances.

The Sun Cluster software provides such an external storage through its cluster file system and its global raw partitions. As an example, suppose a service writes new data to an external log file or modifies existing data in place. When multiple instances of this service run, each instance has access to this external log, and each might simultaneously access this log. Each instance must synchronize its access to this log, or else the instances interfere with each other. The service could use ordinary Solaris file locking through `fcntl` and `lockf` to achieve the synchronization that you want.

Another example of this type of store is a back-end database, such as highly available Oracle Real Application Clusters Guard for SPARC based clusters or Oracle. This type of back-end database server provides built-in synchronization by using database query or update transactions. Therefore, multiple server instances do not need to implement their own synchronization.

The Sun IMAP server is an example of a service that is not a scalable service. The service updates a store, but that store is private and when multiple IMAP instances write to this store, they overwrite each other because the updates are not synchronized. The IMAP server must be rewritten to synchronize concurrent access.

- Finally, note that instances can have private data that is disjoint from the data of other instances. In such a case, the service does not need synchronized concurrent access because the data is private, and only that instance can manipulate it. In this case, you must be careful not to store this private data under the cluster file system because this data can become globally accessible.

Data Service API and Data Service Development Library API

The Sun Cluster software provides the following to make applications highly available:

- Data services that are supplied as part of the Sun Cluster software
- A data service API
- A development library API for data services
- A “generic” data service

The *Sun Cluster Data Services Planning and Administration Guide for Solaris OS* describes how to install and configure the data services that are supplied with the Sun Cluster software. The *Sun Cluster 3.1 9/04 Software Collection for Solaris OS (SPARC Platform Edition)* describes how to instrument other applications to be highly available under the Sun Cluster framework.

The Sun Cluster APIs enable application developers to develop fault monitors and scripts that start and stop data service instances. With these tools, an application can be implemented as a failover or a scalable data service. The Sun Cluster software provides a “generic” data service. Use this generic data service to quickly generate an application's required start and stop methods and to implement the data service as a failover or scalable service.

Using the Cluster Interconnect for Data Service Traffic

A cluster must usually have multiple network connections between Solaris hosts, forming the cluster interconnect.

Sun Cluster software uses multiple interconnects to achieve the following goals:

- Ensure high availability
- Improve performance

For both internal and external traffic such as file system data or scalable services data, messages are striped across all available interconnects. The cluster interconnect is also available to applications, for highly available communication between hosts. For example, a distributed application might have components that are running on different hosts that need to communicate. By using the cluster interconnect rather than the public transport, these connections can withstand the failure of an individual link.

To use the cluster interconnect for communication between hosts, an application must use the private host names that you configured during the Sun Cluster installation. For example, if the private host name for `host1` is `clusternode1-priv`, use this name to communicate with `host1` over the cluster interconnect. TCP sockets that are opened by using this name are routed over the cluster interconnect and can be transparently rerouted if a private network adapter fails. Application communication between any two hosts is striped over all interconnects. The traffic

for a given TCP connection flows on one interconnect at any point. Different TCP connections are striped across all interconnects. Additionally, UDP traffic is always striped across all interconnects.

An application can optionally use a zone's private host name to communicate over the cluster interconnect between zones. However, you must first set each zone's private host name before the application can begin communicating. Each zone must have its own private host name to communicate. An application that is running in one zone must use the private host name in the same zone to communicate with private host names in other zones. An application in one zone cannot communicate through the private host name in another zone.

Because you can configure the private host names during your Sun Cluster installation, the cluster interconnect uses any name that you choose at that time. To determine the actual name, use the `scha_cluster_get` command with the `scha_privatelink_hostname_node` argument. See the [scha_cluster_get\(1HA\)](#) man page.

Each host is also assigned a fixed per-host address. This per-host address is plumbed on the `clprivnet` driver. The IP address maps to the private host name for the host: `clusternode1-priv`. See the [clprivnet\(7\)](#) man page.

If your application requires consistent IP addresses at all points, configure the application to bind to the per-host address on both the client and the server. All connections appear then to originate from and return to the per-host address.

Resources, Resource Groups, and Resource Types

Data services use several types of *resources*: applications such as Sun Java System Web Server or Apache Web Server use network addresses (logical host names and shared addresses) on which the applications depend. Application and network resources form a basic unit that is managed by the RGM.

Data services are resource types. For example, Sun Cluster HA for Oracle is the resource type `SUNW.oracle-server` and Sun Cluster HA for Apache is the resource type `SUNW.apache`.

A resource is an instantiation of a *resource type* that is defined cluster wide. Several resource types are defined.

Network resources are either `SUNW.LogicalHostname` or `SUNW.SharedAddress` resource types. These two resource types are preregistered by the Sun Cluster software.

The `HASStoragePlus` resource type is used to synchronize the startup of resources and device groups on which the resources depend. This resource type ensures that before a data service starts, the paths to a cluster file system's mount points, global devices, and device group names are available. For more information, see [“Synchronizing the Startups Between Resource Groups and Device Groups”](#) in *Sun Cluster Data Services Planning and Administration Guide for Solaris OS*. The `HASStoragePlus` resource type also enables local file systems to be highly available. For more information about this feature, see [“HASStoragePlus Resource Type”](#) on page 52.

RGM-managed resources are placed into groups, called *resource groups*, so that they can be managed as a unit. A resource group is migrated as a unit if a failover or switchover is initiated on the resource group.

Note – When you bring a resource group that contains application resources online, the application is started. The data service start method waits until the application is running before exiting successfully. The determination of when the application is up and running is accomplished the same way the data service fault monitor determines that a data service is serving clients. Refer to the [Sun Cluster Data Services Planning and Administration Guide for Solaris OS](#) for more information about this process.

Resource Group Manager (RGM)

The RGM controls data services (applications) as resources, which are managed by *resource type* implementations. These implementations are either supplied by Sun or created by a developer with a generic data service template, the Data Service Development Library API (DSDL API), or the Resource Management API (RMAPI). The cluster administrator creates and manages resources in containers called *resource groups*. The RGM stops and starts resource groups on selected nodes in response to cluster membership changes.

The RGM acts on *resources* and *resource groups*. RGM actions cause resources and resource groups to move between online and offline states. A complete description of the states and settings that can be applied to resources and resource groups is located in [“Resource and Resource Group States and Settings”](#) on page 75.

Refer to [“Data Service Project Configuration”](#) on page 83 for information about how to launch Solaris projects under RGM control.

Resource and Resource Group States and Settings

A system administrator applies static settings to resources and resource groups. You can change these settings only by administrative action. The RGM moves resource groups between dynamic “states.”

These settings and states are as follows:

- **Managed or unmanaged settings.** These cluster-wide settings apply only to resource groups. The RGM manages resource groups. You can use the `cl resourcegroup` command to request that the RGM manage or unmanage a resource group. These resource group settings do not change when you reconfigure a cluster.

When a resource group is first created, it is unmanaged. A resource group must be managed before any resources placed in the group can become active.

In some data services, for example, a scalable web server, work must be done prior to starting network resources and after they are stopped. This work is done by initialization (INIT) and finish (FINI) data service methods. The INIT methods only run if the resource group in which the resources are located is in the managed state.

When a resource group is moved from unmanaged to managed, any registered INIT methods for the group are run on the resources in the group.

When a resource group is moved from managed to unmanaged, any registered FINI methods are called to perform cleanup.

The most common use of the INIT and FINI methods are for network resources for scalable services. However, a data service developer can use these methods for any initialization or cleanup work that is not performed by the application.

- **Enabled or disabled settings.** These settings apply to resources on one or more nodes. A system administrator can use the `cl resource` command to enable or disable a resource on one or more nodes. These settings do not change when the cluster administrator reconfigures a cluster.

The normal setting for a resource is that it is enabled and actively running in the system.

If you want to make the resource unavailable on all cluster nodes, disable the resource on all cluster nodes. A disabled resource is not available for general use on the cluster nodes that you specify.

- **Online or offline states.** These dynamic states apply to both resources and resource groups.

Online and offline states change as the cluster transitions through cluster reconfiguration steps during switchover or failover. You can also change the online or offline state of a resource or a resource group by using the `cl resource` and `cl resourcegroup` commands.

A failover resource or resource group can only be online on one node at any time. A scalable resource or resource group can be online on some nodes and offline on others. During a switchover or failover, resource groups and the resources within them are taken offline on one node and then brought online on another node.

If a resource group is offline, all of its resources are offline. If a resource group is online, all of its enabled resources are online.

You can temporarily suspend the automatic recovery actions of a resource group. You might need to suspend the automatic recovery of a resource group to investigate and fix a problem in the cluster. Or, you might need to perform maintenance on resource group services.

A suspended resource group is *not* automatically restarted or failed over until you explicitly issue the command that resumes automatic recovery. Whether online or offline, suspended data services remain in their current state. You can still manually switch the resource group to a different state on specified nodes. You can also still enable or disable individual resources in the resource group.

Resource groups can contain several resources, with dependencies between resources. These dependencies require that the resources be brought online and offline in a particular order. The methods that are used to bring resources online and offline might take different amounts of time for each resource. Because of resource dependencies and start and stop time differences, resources within a single resource group can have different online and offline states during a cluster reconfiguration.

Resource and Resource Group Properties

You can configure property values for resources and resource groups for your Sun Cluster data services. Standard properties are common to all data services. Extension properties are specific to each data service. Some standard and extension properties are configured with default settings so that you do not have to modify them. Others need to be set as part of the process of creating and configuring resources. The documentation for each data service specifies which resource properties can be set and how to set them.

The standard properties are used to configure resource and resource group properties that are usually independent of any particular data service. For the set of standard properties, see [Appendix B, “Standard Properties,”](#) in *Sun Cluster Data Services Planning and Administration Guide for Solaris OS*.

The RGM extension properties provide information such as the location of application binaries and configuration files. You modify extension properties as you configure your data services. The set of extension properties is described in the individual guide for the data service.

Support for Solaris Zones

Solaris zones provide a means of creating virtualized operating system environments within an instance of the Solaris 10 OS. Solaris zones enable one or more applications to run in isolation from other activity on your system. The Solaris zones facility is described in [Part II, “Zones,”](#) in *System Administration Guide: Solaris Containers-Resource Management and Solaris Zones*.

When you run Sun Cluster software on the Solaris 10 OS, you can create any number of global-cluster non-voting nodes.

You can use Sun Cluster software to manage the availability and scalability of applications that are running on global-cluster non-voting nodes.

Support for Global-Cluster Non-Voting Nodes (Solaris Zones) Directly Through the RGM

On a cluster where the Solaris 10 OS is running, you can configure a resource group to run on a global-cluster voting node or a global-cluster non-voting node. The RGM manages each global-cluster non-voting node as a switchover target. If a global-cluster non-voting node is specified in the node list of a resource group, the RGM brings the resource group online in the specified node.

Figure 3–8 illustrates the failover of resource groups between nodes in a two-host cluster. In this example, identical nodes are configured to simplify the administration of the cluster.

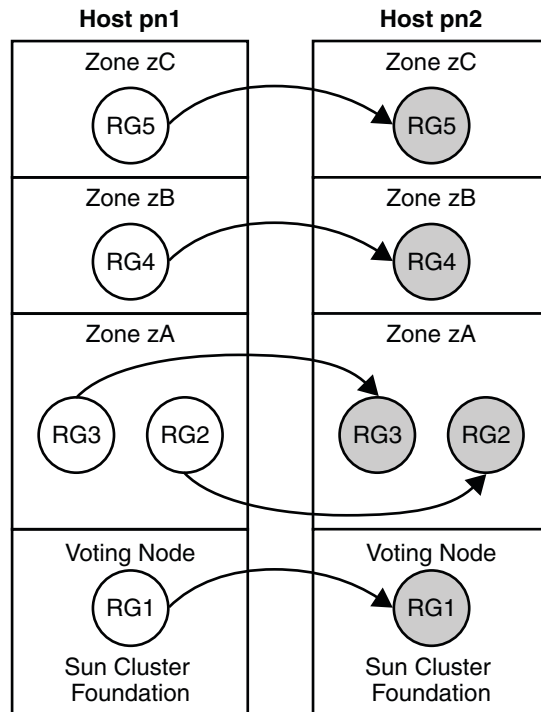

FIGURE 3–8 Failover of Resource Groups Between Nodes

You can configure a scalable resource group (which uses network load balancing) to run in a cluster non-voting node as well.

In Sun Cluster commands, you specify a zone by appending the name of the zone to the name of the host, and separating them with a colon, for example:

phys-schost-1:zoneA

Criteria for Using Support for Solaris Zones Directly Through the RGM

Use support for Solaris zones directly through the RGM if any of following criteria is met:

- Your application cannot tolerate the additional failover time that is required to boot a zone.
- You require minimum downtime during maintenance.
- You require dual-partition software upgrade.
- You are configuring a data service that uses a shared address resource for network load balancing.

Requirements for Using Support for Solaris Zones Directly Through the RGM

If you plan to use support for Solaris zones directly through the RGM for an application, ensure that the following requirements are met:

- The application is supported to run in non-global zones.
- The data service for the application is supported to run on a global-cluster non-voting node.

If you use support for Solaris zones directly through the RGM, ensure that resource groups that are related by an affinity are configured to run on the same Solaris host.

Additional Information About Support for Solaris Zones Directly Through the RGM

For information about how to configure support for Solaris zones directly through the RGM, see the following documentation:

- “Guidelines for Non-Global Zones in a Global Cluster” in *Sun Cluster Software Installation Guide for Solaris OS*
- “Zone Names” in *Sun Cluster Software Installation Guide for Solaris OS*
- “Configuring a Non-Global Zone on a Global-Cluster Node” in *Sun Cluster Software Installation Guide for Solaris OS*
- *Sun Cluster Data Services Planning and Administration Guide for Solaris OS*
- Individual data service guides

Support for Solaris Zones on Sun Cluster Nodes Through Sun Cluster HA for Solaris Containers

The Sun Cluster HA for Solaris Containers data service manages each zone as a resource that is controlled by the RGM.

Criteria for Using Sun Cluster HA for Solaris Containers

Use the Sun Cluster HA for Solaris Containers data service if any of following criteria is met:

- You require delegated root access.
- The application is not supported in a cluster.
- You require affinities between resource groups that are to run in different zones on the same node.

Requirements for Using Sun Cluster HA for Solaris Containers

If you plan to use the Sun Cluster HA for Solaris Containers data service for an application, ensure that the following requirements are met:

- The application is supported to run on global-cluster non-voting nodes.
- The application is integrated with the Solaris OS through a script, a run-level script, or a Solaris Service Management Facility (SMF) manifest.
- The additional failover time that is required to boot a zone is acceptable.
- Some downtime during maintenance is acceptable.

Additional Information About Sun Cluster HA for Solaris Containers

For information about how to use the Sun Cluster HA for Solaris Containers data service, see [Sun Cluster Data Service for Solaris Containers Guide for Solaris OS](#).

Service Management Facility

The Solaris Service Management Facility (SMF) enables you to run and administer applications as highly available and scalable resources. Like the Resource Group Manager (RGM), the SMF provides high availability and scalability, but for the Solaris Operating System.

Sun Cluster provides three proxy resource types that you can use to enable SMF services in a cluster. These resource types, `SUNW.Proxy_SMF_failover`, `SUNW.Proxy_SMF_loadbalanced`, and `SUNW.Proxy_SMF_multimaster`, enable you to run SMF services in a failover, scalable, and multi-master configuration, respectively. The SMF manages the availability of SMF services on a single Solaris host. The SMF uses the callback method execution model to run services.

The SMF also provides a set of administrative interfaces for monitoring and controlling services. These interfaces enable you to integrate your own SMF-controlled services into Sun Cluster. This capability eliminates the need to create new callback methods, rewrite existing callback methods, or update the SMF service manifest. You can include multiple SMF resources in a resource group and you can configure dependencies and affinities between them.

The SMF is responsible for starting, stopping, and restarting these services and managing their dependencies. Sun Cluster is responsible for managing the service in the cluster and for determining the hosts on which these services are to be started.

The SMF runs as a daemon, `svc.startd`, on each cluster host. The SMF daemon automatically starts and stops resources on selected hosts according to pre-configured policies.

The services that are specified for an SMF proxy resource can be located on global cluster voting node or global cluster non-voting node. However, all the services that are specified for the same SMF proxy resource must be located on the same node. SMF proxy resources work on any node.

System Resource Usage

System resources include aspects of CPU usage, memory usage, swap usage, and disk and network throughput. Sun Cluster enables you to monitor how much of a specific system resource is being used by an *object type*. An object type includes a host, node, zone, disk, network interface, or resource group. Sun Cluster also enables you to control the CPU that is available to a resource group.

Monitoring and controlling system resource usage can be part of your resource management policy. The cost and complexity of managing numerous machines encourages the consolidation of several applications on larger hosts. Instead of running each workload on separate systems, with full access to each system's resources, you use resource management to segregate workloads within the system. Resource management enables you to lower overall total cost of ownership by running and controlling several applications on a single Solaris system.

Resource management ensures that your applications have the required response times. Resource management can also increase resource use. By categorizing and prioritizing usage, you can effectively use reserve capacity during off-peak periods, often eliminating the need for additional processing power. You can also ensure that resources are not wasted because of load variability.

To use the data that Sun Cluster collects about system resource usage, you must do the following:

- Analyze the data to determine what it means for your system.
- Make a decision about the action that is required to optimize your usage of hardware and software resources.
- Take action to implement your decision.

By default, system resource monitoring and control are not configured when you install Sun Cluster. For information about configuring these services, see [Chapter 10, “Configuring Control of CPU Usage,”](#) in *Sun Cluster System Administration Guide for Solaris OS*.

System Resource Monitoring

By monitoring system resource usage, you can do the following:

- Collect data that reflects how a service that is using specific system resources is performing.
- Discover resource bottlenecks or overload and so preempt problems.
- More efficiently manage workloads.

Data about system resource usage can help you determine the hardware resources that are underused and the applications that use many resources. Based on this data, you can assign applications to nodes that have the necessary resources and choose the node to which to failover. This consolidation can help you optimize the way that you use your hardware and software resources.

Monitoring all system resources at the same time might be costly in terms of CPU. Choose the system resources that you want to monitor by prioritizing the resources that are most critical for your system.

When you enable monitoring, you choose the *telemetry attribute* that you want to monitor. A telemetry attribute is an aspect of system resources. Examples of telemetry attributes include the amount of free CPU or the percentage of blocks that are used on a device. If you monitor a telemetry attribute on an object type, Sun Cluster monitors this telemetry attribute on all objects of that type in the cluster. Sun Cluster stores a history of the system resource data that is collected for seven days.

If you consider a particular data value to be critical for a system resource, you can set a *threshold* for this value. When setting a threshold, you also choose how critical this threshold is by assigning it a severity level. If the threshold is crossed, Sun Cluster changes the severity level of the threshold to the severity level that you choose.

Control of CPU

Each application and service that is running on a cluster has specific CPU needs. [Table 3–4](#) lists the CPU control activities that are available on different versions of the Solaris OS.

TABLE 3–4 CPU Control

Solaris Version	Zone	Control
Solaris 9 OS	Not available	Assign CPU shares
Solaris 10 OS	Global-cluster voting node	Assign CPU shares

TABLE 3-4 CPU Control (Continued)

Solaris Version	Zone	Control
Solaris 10 OS	Global-cluster non-voting node	Assign CPU shares Assign number of CPU Create dedicated processor sets

Note – If you want to apply CPU shares, you must specify the Fair Share Scheduler (FFS) as the default scheduler in the cluster.

Controlling the CPU that is assigned to a resource group in a dedicated processor set in a global-cluster non-voting node offers the strictest level of control. If you reserve CPU for a resource group, this CPU is not available to other resource groups.

Viewing System Resource Usage

You can view system resource data and CPU assignments by using the command line or through Sun Cluster Manager. The system resources that you choose to monitor determine the tables and graphs that you can view.

By viewing the output of system resource usage and CPU control, you can do the following:

- Anticipate failures due to the exhaustion of system resources.
- Detect unbalanced usage of system resources.
- Validate server consolidation.
- Obtain information that enables you to improve the performance of applications.

Sun Cluster does not provide advice about the actions to take, nor does it take action for you based on the data that it collects. You must determine whether the data that you view meets your expectations for a service. You must then take action to remedy any observed performance.

Data Service Project Configuration

Data services can be configured to launch under a Solaris project name when brought online by using the RGM. The configuration associates a resource or resource group managed by the RGM with a Solaris project ID. The mapping from your resource or resource group to a project ID gives you the ability to use sophisticated controls that are available in the Solaris OS to manage workloads and consumption within your cluster.

Note – You can perform this configuration if you are using Sun Cluster on the Solaris 9 OS or on the Solaris 10 OS.

Using the Solaris management functionality in a Sun Cluster environment enables you to ensure that your most important applications are given priority when sharing a node with other applications. Applications might share a node if you have consolidated services or because applications have failed over. Use of the management functionality described herein might improve availability of a critical application by preventing lower-priority applications from overconsuming system supplies such as CPU time.

Note – The Solaris documentation for this feature describes CPU time, processes, tasks and similar components as “resources”. Meanwhile, Sun Cluster documentation uses the term “resources” to describe entities that are under the control of the RGM. The following section uses the term “resource” to refer to Sun Cluster entities that are under the control of the RGM. The section uses the term “supplies” to refer to CPU time, processes, and tasks.

This section provides a conceptual description of configuring data services to launch processes on a specified Solaris OS UNIX [project\(4\)](#). This section also describes several failover scenarios and suggestions for planning to use the management functionality provided by the Solaris Operating System.

For detailed conceptual and procedural documentation about the management feature, refer to [Chapter 1, “Network Service \(Overview\)”](#), in *System Administration Guide: Network Services*.

When configuring resources and resource groups to use Solaris management functionality in a cluster, use the following high-level process:

1. Configuring applications as part of the resource.
2. Configuring resources as part of a resource group.
3. Enabling resources in the resource group.
4. Making the resource group managed.
5. Creating a Solaris project for your resource group.
6. Configuring standard properties to associate the resource group name with the project you created in step 5.
7. Bringing the resource group online.

To configure the standard `Resource_project_name` or `RG_project_name` properties to associate the Solaris project ID with the resource or resource group, use the `-p` option with the `clresource` set and the `clresourcegroup` set command. Set the property values to the resource or to the resource group. See [Appendix B, “Standard Properties,”](#) in *Sun Cluster Data*

Services Planning and Administration Guide for Solaris OS for property definitions. See the `r_properties(5)` and `rg_properties(5)` man pages for descriptions of properties.

The specified project name must exist in the projects database (`/etc/project`) and the root user must be configured as a member of the named project. Refer to [Chapter 2, “Projects and Tasks \(Overview\)”](#), in *System Administration Guide: Solaris Containers-Resource Management and Solaris Zones* for conceptual information about the project name database. Refer to `project(4)` for a description of project file syntax.

When the RGM brings resources or resource groups online, it launches the related processes under the project name.

Note – Users can associate the resource or resource group with a project at any time. However, the new project name is not effective until the resource or resource group is taken offline and brought back online by using the RGM.

Launching resources and resource groups under the project name enables you to configure the following features to manage system supplies across your cluster.

- **Extended Accounting** – Provides a flexible way to record consumption on a task or process basis. Extended accounting enables you to examine historical usage and make assessments of capacity requirements for future workloads.
- **Controls** – Provide a mechanism for constraint on system supplies. Processes, tasks, and projects can be prevented from consuming large amounts of specified system supplies.
- **Fair Share Scheduling (FSS)** – Provides the ability to control the allocation of available CPU time among workloads, based on their importance. Workload importance is expressed by the number of shares of CPU time that you assign to each workload. Refer to the following man pages for more information.
 - `dispadmin(1M)`
 - `priocntl(1)`
 - `ps(1)`
 - `FSS(7)`
- **Pools** – Provide the ability to use partitions for interactive applications according to the application's requirements. Pools can be used to partition a host that supports a number of different software applications. The use of pools results in a more predictable response for each application.

Determining Requirements for Project Configuration

Before you configure data services to use the controls provided by Solaris in a Sun Cluster environment, you must decide how to control and track resources across switchovers or failovers. Identify dependencies within your cluster before configuring a new project. For example, resources and resource groups depend on device groups.

Use the `nodelist`, `failback`, `maximum primaries` and `desired primaries` resource group properties that you configure with the `clresourcegroup set` command to identify node list priorities for your resource group.

- For a brief discussion of the node list dependencies between resource groups and device groups, refer to “[Relationship Between Resource Groups and Device Groups](#)” in *Sun Cluster Data Services Planning and Administration Guide for Solaris OS*.
- For detailed property descriptions, refer to `rg_properties(5)`.

Use the `preferred` property and `failback` property that you configure with the `cldevicegroup` and `clsetup` commands to determine device group node list priorities. See the `clresourcegroup(1CL)`, `cldevicegroup(1CL)`, and `clsetup(1CL)` man pages.

- For conceptual information about the `preferred` property, see “[Multiported Device Groups](#)” on page 48.
- For procedural information, see “[How To Change Disk Device Properties](#)” in “[Administering Device Groups](#)” in *Sun Cluster System Administration Guide for Solaris OS*.
- For conceptual information about node configuration and the behavior of failover and scalable data services, see “[Sun Cluster System Hardware and Software Components](#)” on page 21.

If you configure all cluster nodes identically, usage limits are enforced identically on primary and secondary nodes. The configuration parameters of projects do not need to be identical for all applications in the configuration files on all nodes. All projects that are associated with the application must at least be accessible by the project database on all potential masters of that application. Suppose that Application 1 is mastered by *phys-schost-1* but could potentially be switched over or failed over to *phys-schost-2* or *phys-schost-3*. The project that is associated with Application 1 must be accessible on all three nodes (*phys-schost-1*, *phys-schost-2*, and *phys-schost-3*).

Note – Project database information can be a local `/etc/project` database file or can be stored in the NIS map or the LDAP directory service.

The Solaris Operating System enables for flexible configuration of usage parameters, and few restrictions are imposed by Sun Cluster. Configuration choices depend on the needs of the site. Consider the general guidelines in the following sections before configuring your systems.

Setting Per-Process Virtual Memory Limits

Set the `process.max-address-space` control to limit virtual memory on a per-process basis. See the `rctladm(1M)` man page for information about setting the `process.max-address-space` value.

When you use management controls with Sun Cluster software, configure memory limits appropriately to prevent unnecessary failover of applications and a “ping-pong” effect of applications. In general, observe the following guidelines.

- Do not set memory limits too low.
When an application reaches its memory limit, it might fail over. This guideline is especially important for database applications, when reaching a virtual memory limit can have unexpected consequences.
- Do not set memory limits identically on primary and secondary nodes.
Identical limits can cause a ping-pong effect when an application reaches its memory limit and fails over to a secondary node with an identical memory limit. Set the memory limit slightly higher on the secondary node. The difference in memory limits helps prevent the ping-pong scenario and gives the system administrator a period of time in which to adjust the parameters as necessary.
- Do use the resource management memory limits for load balancing.
For example, you can use memory limits to prevent an errant application from consuming excessive swap space.

Failover Scenarios

You can configure management parameters so that the allocation in the project configuration (/etc/project) works in normal cluster operation and in switchover or failover situations.

The following sections are example scenarios.

- The first two sections, “[Two-Host Cluster With Two Applications](#)” on page 88 and “[Two-Host Cluster With Three Applications](#)” on page 89, show failover scenarios for entire hosts.
- The section “[Failover of Resource Group Only](#)” on page 91 illustrates failover operation for an application only.

In a Sun Cluster environment, you configure an application as part of a resource. You then configure a resource as part of a resource group (RG). When a failure occurs, the resource group, along with its associated applications, fails over to another node. In the following examples the resources are not shown explicitly. Assume that each resource has only one application.

Note – Failover occurs in the order in which nodes are specified in the node list and set in the RGM.

The following examples have these constraints:

- Application 1 (App-1) is configured in resource group RG-1.
- Application 2 (App-2) is configured in resource group RG-2.
- Application 3 (App-3) is configured in resource group RG-3.

Although the numbers of assigned shares remain the same, the percentage of CPU time that is allocated to each application changes after failover. This percentage depends on the number of applications that are running on the node and the number of shares that are assigned to each active application.

In these scenarios, assume the following configurations.

- All applications are configured under a common project.
- Each resource has only one application.
- The applications are the only active processes on the nodes.
- The projects databases are configured the same on each node of the cluster.

Two-Host Cluster With Two Applications

You can configure two applications on a two-host cluster to ensure that each physical host (*phys-schost-1*, *phys-schost-2*) acts as the default master for one application. Each physical host acts as the secondary node for the other physical host. All projects that are associated with Application 1 and Application 2 must be represented in the projects database files on both nodes. When the cluster is running normally, each application is running on its default master, where it is allocated all CPU time by the management facility.

After a failover or switchover occurs, both applications run on a single node where they are allocated shares as specified in the configuration file. For example, this entry in the `/etc/project` file specifies that Application 1 is allocated 4 shares and Application 2 is allocated 1 share.

```
Prj_1:100:project for App-1:root::project.cpu-shares=(privileged,4,none)
Prj_2:101:project for App-2:root::project.cpu-shares=(privileged,1,none)
```

The following diagram illustrates the normal and failover operations of this configuration. The number of shares that are assigned does not change. However, the percentage of CPU time available to each application can change. The percentage depends on the number of shares that are assigned to each process that demands CPU time.

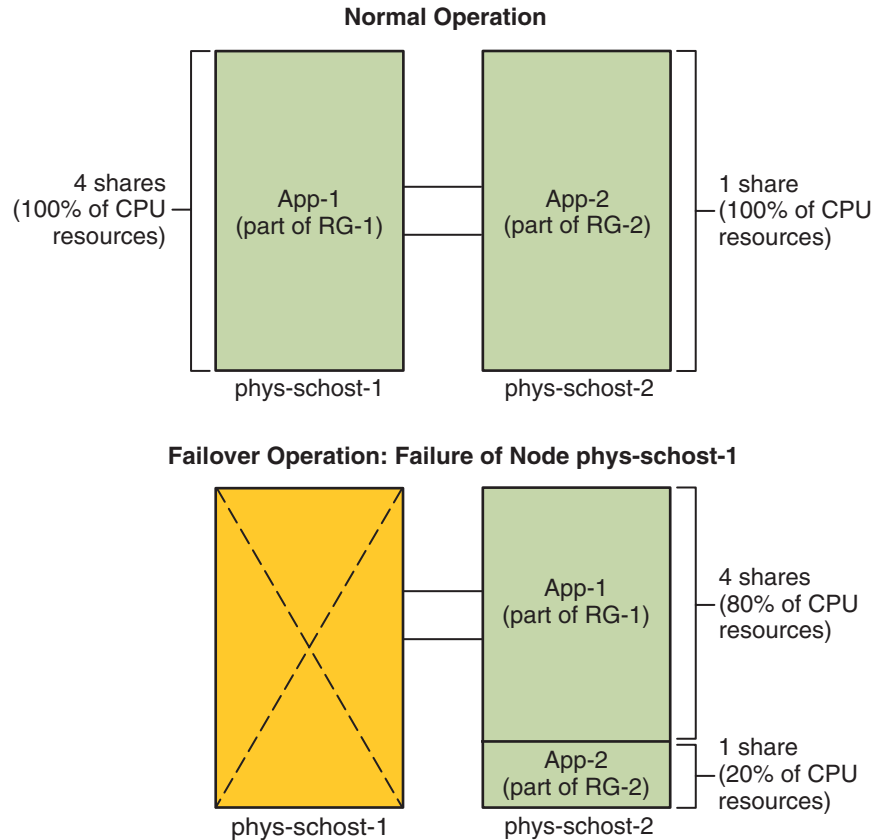

Two-Host Cluster With Three Applications

On a two-host cluster with three applications, you can configure one host (*phys-schost-1*) as the default master of one application. You can configure the second physical host (*phys-schost-2*) as the default master for the remaining two applications. Assume the following example projects database file is located on every host. The projects database file does not change when a failover or switchover occurs.

```
Prj_1:103:project for App_1:root::project.cpu-shares=(privileged,5,none)
Prj_2:104:project for App_2:root::project.cpu-shares=(privileged,3,none)
Prj_3:105:project for App_3:root::project.cpu-shares=(privileged,2,none)
```

When the cluster is running normally, Application 1 is allocated 5 shares on its default master, *phys-schost-1*. This number is equivalent to 100 percent of CPU time because it is the only application that demands CPU time on that host. Applications 2 and 3 are allocated 3 and 2 shares, respectively, on their default master, *phys-schost-2*. Application 2 would receive 60 percent of CPU time and Application 3 would receive 40 percent of CPU time during normal operation.

If a failover or switchover occurs and Application 1 is switched over to *phys-schost-2*, the shares for all three applications remain the same. However, the percentages of CPU resources are reallocated according to the projects database file.

- Application 1, with 5 shares, receives 50 percent of CPU.
- Application 2, with 3 shares, receives 30 percent of CPU.
- Application 3, with 2 shares, receives 20 percent of CPU.

The following diagram illustrates the normal operations and failover operations of this configuration.

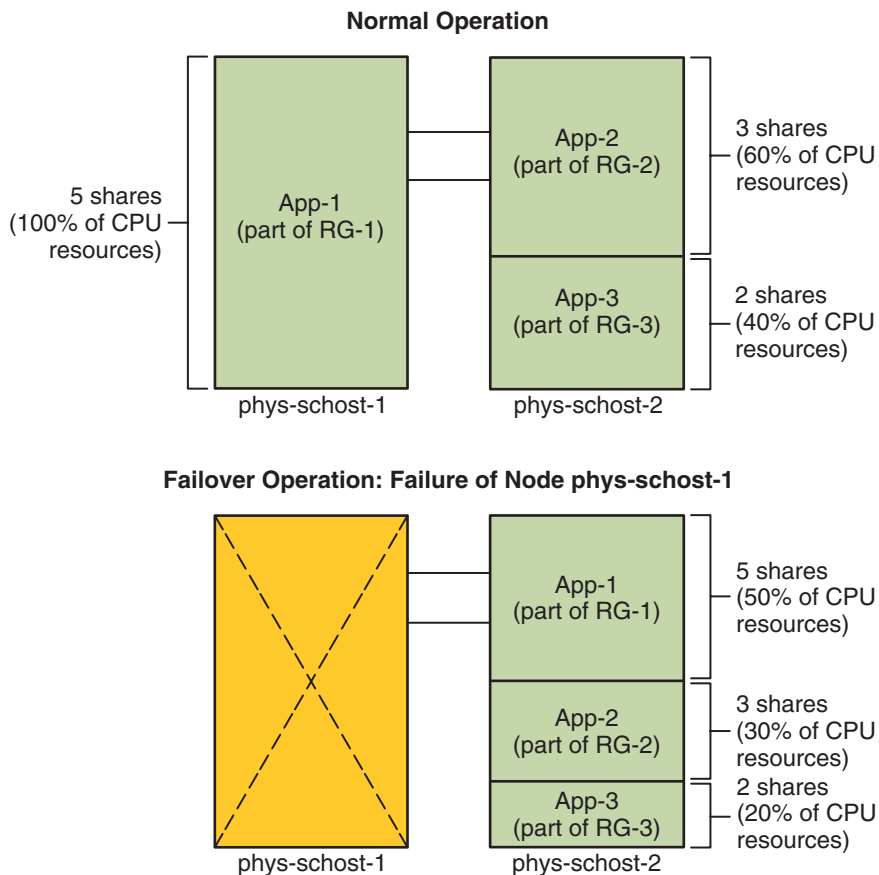

Failover of Resource Group Only

In a configuration in which multiple resource groups have the same default master, a resource group (and its associated applications) can fail over or be switched over to a secondary node. Meanwhile, the default master is running in the cluster.

Note – During failover, the application that fails over is allocated resources as specified in the configuration file on the secondary host. In this example, the project database files on the primary and secondary hosts have the same configurations.

For example, this sample configuration file specifies that Application 1 is allocated 1 share, Application 2 is allocated 2 shares, and Application 3 is allocated 2 shares.

```
Prj_1:106:project for App_1:root::project.cpu-shares=(privileged,1,none)
Prj_2:107:project for App_2:root::project.cpu-shares=(privileged,2,none)
Prj_3:108:project for App_3:root::project.cpu-shares=(privileged,2,none)
```

The following diagram illustrates the normal and failover operations of this configuration, where RG-2, containing Application 2, fails over to *phys-schost-2*. Note that the number of shares assigned does not change. However, the percentage of CPU time available to each application can change, depending on the number of shares that are assigned to each application that demands CPU time.

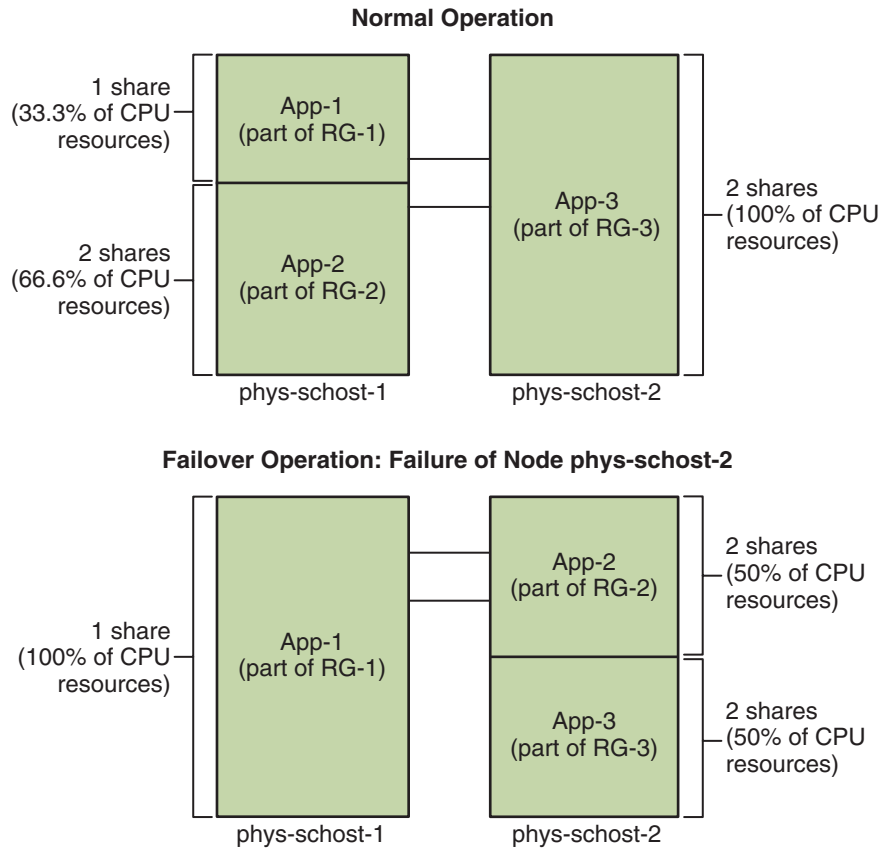

Public Network Adapters and IP Network Multipathing

Clients make data requests to the cluster through the public network. Each cluster Solaris host is connected to at least one public network through a pair of public network adapters.

Solaris Internet Protocol (IP) Network Multipathing software on Sun Cluster provides the basic mechanism for monitoring public network adapters and failing over IP addresses from one adapter to another when a fault is detected. Each host has its own IP network multipathing configuration, which can be different from the configuration on other hosts.

Public network adapters are organized into *IP multipathing groups* (multipathing groups). Each multipathing group has one or more public network adapters. Each adapter in a multipathing group can be active. Alternatively, you can configure standby interfaces that are inactive unless a failover occurs.

The `in.mpathd` multipathing daemon uses a test IP address to detect failures and repairs. If a fault is detected on one of the adapters by the multipathing daemon, a failover occurs. All network access fails over from the faulted adapter to another functional adapter in the

multipathing group. Therefore, the daemon maintains public network connectivity for the host. If you configured a standby interface, the daemon chooses the standby interface. Otherwise, the daemon chooses the interface with the least number of IP addresses. Because the failover occurs at the adapter interface level, higher-level connections such as TCP are not affected, except for a brief transient delay during the failover. When the failover of IP addresses completes successfully, ARP broadcasts are sent. Therefore, the daemon maintains connectivity to remote clients.

Note – Because of the congestion recovery characteristics of TCP, TCP endpoints can experience further delay after a successful failover. Some segments might have been lost during the failover, activating the congestion control mechanism in TCP.

Multipathing groups provide the building blocks for logical host name and shared address resources. You can also create multipathing groups independently of logical host name and shared address resources to monitor public network connectivity of cluster hosts. The same multipathing group on a host can host any number of logical host name or shared address resources. For more information about logical host name and shared address resources, see the *Sun Cluster Data Services Planning and Administration Guide for Solaris OS*.

Note – The design of the IP network multipathing mechanism is meant to detect and mask adapter failures. The design is not intended to recover from an administrator's use of `ifconfig` to remove one of the logical (or shared) IP addresses. The Sun Cluster software views the logical and shared IP addresses as resources that are managed by the RGM. The correct way for an administrator to add or to remove an IP address is to use `clresource` and `clresourcegroup` to modify the resource group that contains the resource.

For more information about the Solaris implementation of IP Network Multipathing, see the appropriate documentation for the Solaris Operating System that is installed on your cluster.

Operating System	Instructions
Solaris 9 Operating System	Chapter 1, “IP Network Multipathing (Overview),” in <i>IP Network Multipathing Administration Guide</i>
Solaris 10 Operating System	Part VI, “IPMP,” in <i>System Administration Guide: IP Services</i>

SPARC: Dynamic Reconfiguration Support

Sun Cluster 3.2 1/09 support for the dynamic reconfiguration (DR) software feature is being developed in incremental phases. This section describes concepts and considerations for Sun Cluster 3.2 1/09 support of the DR feature.

All the requirements, procedures, and restrictions that are documented for the Solaris DR feature also apply to Sun Cluster DR support (except for the operating environment quiescence operation). Therefore, review the documentation for the Solaris DR feature *before* by using the DR feature with Sun Cluster software. You should review in particular the issues that affect non-network IO devices during a DR detach operation.

The *Sun Enterprise 10000 Dynamic Reconfiguration User Guide* and the *Sun Enterprise 10000 Dynamic Reconfiguration Reference Manual* (from the *Solaris 10 on Sun Hardware* collection) are both available for download from <http://docs.sun.com>.

SPARC: Dynamic Reconfiguration General Description

The DR feature enables operations, such as the removal of system hardware, in running systems. The DR processes are designed to ensure continuous system operation with no need to halt the system or interrupt cluster availability.

DR operates at the board level. Therefore, a DR operation affects all the components on a board. Each board can contain multiple components, including CPUs, memory, and peripheral interfaces for disk drives, tape drives, and network connections.

Removing a board that contains active components would result in system errors. Before removing a board, the DR subsystem queries other subsystems, such as Sun Cluster, to determine whether the components on the board are being used. If the DR subsystem finds that a board is in use, the DR remove-board operation is not done. Therefore, it is always safe to issue a DR remove-board operation because the DR subsystem rejects operations on boards that contain active components.

The DR add-board operation is also always safe. CPUs and memory on a newly added board are automatically brought into service by the system. However, the system administrator must manually configure the cluster to actively use components that are on the newly added board.

Note – The DR subsystem has several levels. If a lower level reports an error, the upper level also reports an error. However, when the lower level reports the specific error, the upper level reports Unknown error. You can safely ignore this error.

The following sections describe DR considerations for the different device types.

SPARC: DR Clustering Considerations for CPU Devices

Sun Cluster software does not reject a DR remove-board operation because of the presence of CPU devices.

When a DR add-board operation succeeds, CPU devices on the added board are automatically incorporated in system operation.

SPARC: DR Clustering Considerations for Memory

For the purposes of DR, consider two types of memory:

- Kernel memory cage
- Non-kernel memory cage

These two types differ only in usage. The actual hardware is the same for both types. Kernel memory cage is the memory that is used by the Solaris Operating System. Sun Cluster software does not support remove-board operations on a board that contains the kernel memory cage and rejects any such operation. When a DR remove-board operation pertains to memory other than the kernel memory cage, Sun Cluster software does not reject the operation. When a DR add-board operation that pertains to memory succeeds, memory on the added board is automatically incorporated in system operation.

SPARC: DR Clustering Considerations for Disk and Tape Drives

Sun Cluster rejects dynamic reconfiguration (DR) remove-board operations on active drives on the primary host. You can perform DR remove-board operations on inactive drives on the primary host and on any drives in the secondary host. After the DR operation, cluster data access continues as before.

Note – Sun Cluster rejects DR operations that impact the availability of quorum devices. For considerations about quorum devices and the procedure for performing DR operations on them, see [“SPARC: DR Clustering Considerations for Quorum Devices”](#) on page 96.

See [“Dynamic Reconfiguration With Quorum Devices”](#) in *Sun Cluster System Administration Guide for Solaris OS* for detailed instructions about how to perform these actions.

SPARC: DR Clustering Considerations for Quorum Devices

If the DR remove-board operation pertains to a board that contains an interface to a device configured for quorum, Sun Cluster software rejects the operation. Sun Cluster software also identifies the quorum device that would be affected by the operation. You must disable the device as a quorum device before you can perform a DR remove-board operation.

See [Chapter 6, “Administering Quorum,”](#) in *Sun Cluster System Administration Guide for Solaris OS* for detailed instructions about how administer quorum.

SPARC: DR Clustering Considerations for Cluster Interconnect Interfaces

If the DR remove-board operation pertains to a board containing an active cluster interconnect interface, Sun Cluster software rejects the operation. Sun Cluster software also identifies the interface that would be affected by the operation. You must use a Sun Cluster administrative tool to disable and remove the active interface before the DR operation can succeed.



Caution – Sun Cluster software requires each cluster node to have at least one functioning path to every other cluster node. Do not disable a private interconnect interface that supports the last path to any Solaris host in the cluster.

See [“Administering the Cluster Interconnects”](#) in *Sun Cluster System Administration Guide for Solaris OS* for detailed instructions about how to perform these actions.

SPARC: DR Clustering Considerations for Public Network Interfaces

If the DR remove-board operation pertains to a board that contains an active public network interface, Sun Cluster software rejects the operation. Sun Cluster software also identifies the interface that would be affected by the operation. Before you remove a board with an active network interface present, switch over all traffic on that interface to another functional interface in the multipathing group by using the `if_mpadm` command.



Caution – If the remaining network adapter fails while you are performing the DR remove operation on the disabled network adapter, availability is impacted. The remaining adapter has no place to fail over for the duration of the DR operation.

See “[Administering the Public Network](#)” in *Sun Cluster System Administration Guide for Solaris OS* for detailed instructions about how to perform a DR remove operation on a public network interface.

Frequently Asked Questions

This chapter includes answers to the most frequently asked questions about the Sun Cluster product.

The questions are organized by topic as follows:

- “High Availability FAQs” on page 99
- “File Systems FAQs” on page 100
- “Volume Management FAQs” on page 101
- “Data Services FAQs” on page 101
- “Public Network FAQs” on page 102
- “Cluster Member FAQs” on page 103
- “Cluster Storage FAQs” on page 104
- “Cluster Interconnect FAQs” on page 104
- “Client Systems FAQs” on page 105
- “Administrative Console FAQs” on page 105
- “Terminal Concentrator and System Service Processor FAQs” on page 106

High Availability FAQs

Question: What exactly is a highly available system?

Answer: The Sun Cluster software defines high availability (HA) as the ability of a cluster to keep an application running. The application runs even when a failure occurs that would normally make a host system unavailable.

Question: What is the process by which the cluster provides high availability?

Answer: Through a process known as failover, the cluster framework provides a highly available environment. Failover is a series of steps that are performed by the cluster to migrate data service resources from a failing node to another operational node in the cluster.

Question: What is the difference between a failover and scalable data service?

Answer: There are two types of highly available data services:

- Failover
- Scalable

A failover data service runs an application on only one primary node in the cluster at a time. Other nodes might run other applications, but each application runs on only a single node. If a primary node fails, applications that are running on the failed node fail over to another node. They continue running.

A scalable data service spreads an application across multiple nodes to create a single, logical service. Scalable services leverage the number of nodes and processors in the entire cluster on which they run.

For each application, one node hosts the physical interface to the cluster. This node is called a Global Interface (GIF) node. Multiple GIF nodes can exist in the cluster. Each GIF node hosts one or more logical interfaces that can be used by scalable services. These logical interfaces are called *global interfaces*. One GIF node hosts a global interface for all requests for a particular application and dispatches them to multiple nodes on which the application server is running. If the GIF node fails, the global interface fails over to a surviving node.

If any node on which the application is running fails, the application continues to run on other nodes with some performance degradation. This process continues until the failed node returns to the cluster.

File Systems FAQs

Question: Can I run one or more of the Solaris hosts in the cluster as highly available NFS servers with other Solaris hosts as clients?

Answer: No, do not do a loopback mount.

Question: Can I use a cluster file system for applications that are not under Resource Group Manager control?

Answer: Yes. However, without RGM control, the applications need to be restarted manually after the failure of the node on which they are running.

Question: Must all cluster file systems have a mount point under the `/global` directory?

Answer: No. However, placing cluster file systems under the same mount point, such as `/global`, enables better organization and management of these file systems.

Question: What are the differences between using the cluster file system and exporting NFS file systems?

Answer: Several differences exist:

1. The cluster file system supports global devices. NFS does not support remote access to devices.

2. The cluster file system has a global namespace. Only one mount command is required. With NFS, you must mount the file system on each host.
3. The cluster file system caches files in more cases than does NFS. For example, the cluster file system caches files when a file is being accessed from multiple nodes for read, write, file locks, asynchronous I/O.
4. The cluster file system is built to exploit future fast cluster interconnects that provide remote DMA and zero-copy functions.
5. If you change the attributes on a file (using `chmod`, for example) in a cluster file system, the change is reflected immediately on all nodes. With an exported NFS file system, this change can take much longer.

Question: The file system `/global/.devices/node@nodeID` appears on my cluster nodes. Can I use this file system to store data that I want to be highly available and global?

Answer: These file systems store the global device namespace. These file systems are not intended for general use. While they are global, these file systems are never accessed in a global manner. Each node only accesses its own global device namespace. If a node is down, other nodes cannot access this namespace for the node that is down. These file systems are not highly available. These file systems should not be used to store data that needs to be globally accessible or highly available.

Volume Management FAQs

Question: Do I need to mirror all disk devices?

Answer: For a disk device to be considered highly available, it must be mirrored, or use RAID-5 hardware. All data services should use either highly available disk devices, or cluster file systems mounted on highly available disk devices. Such configurations can tolerate single disk failures.

Question: Can I use one volume manager for the local disks (boot disk) and a different volume manager for the multihost disks?

Answer: This configuration is supported with the Solaris Volume Manager software managing the local disks and Veritas Volume Manager managing the multihost disks. No other combination is supported.

Data Services FAQs

Question: Which Sun Cluster data services are available?

Answer: The list of supported data services is included in the [Sun Cluster Release Notes](#).

Question: Which application versions are supported by Sun Cluster data services?

Answer: The list of supported application versions is included in the [Sun Cluster Release Notes](#).

Question: Can I write my own data service?

Answer: Yes. See the [Chapter 11, “DSDL API Functions,”](#) in *Sun Cluster Data Services Developer’s Guide for Solaris OS* for more information.

Question: When creating network resources, should I specify numeric IP addresses or host names?

Answer: The preferred method for specifying network resources is to use the UNIX host name rather than the numeric IP address.

Question: When creating network resources, what is the difference between using a logical host name (a `LogicalHostname` resource) or a shared address (a `SharedAddress` resource)?

Answer: Except in the case of Sun Cluster HA for NFS, wherever the documentation recommends the use of a `LogicalHostname` resource in a `Failover` mode resource group, a `SharedAddress` resource or `LogicalHostname` resource can be used interchangeably. The use of a `SharedAddress` resource incurs some additional overhead because the cluster networking software is configured for a `SharedAddress` but not for a `LogicalHostname`.

The advantage to using a `SharedAddress` resource is demonstrated when you configure both scalable and failover data services, and want clients to be able to access both services by using the same host name. In this case, the `SharedAddress` resources along with the failover application resource are contained in one resource group. The scalable service resource is contained in a separate resource group and configured to use the `SharedAddress` resource. Both the scalable and failover services can then use the same set of host names and addresses that are configured in the `SharedAddress` resource.

Public Network FAQs

Question: Which public network adapters does the Sun Cluster software support?

Answer: Currently, the Sun Cluster software supports Ethernet (10/100BASE-T and 1000BASE-SX Gb) public network adapters. Because new interfaces might be supported in the future, check with your Sun sales representative for the most current information.

Question: What is the role of the MAC address in failover?

Answer: When a failover occurs, new Address Resolution Protocol (ARP) packets are generated and broadcast to the world. These ARP packets contain the new MAC address (of the new physical adapter to which the host failed over) and the old IP address. When another machine on the network receives one of these packets, it flushes the old MAC-IP mapping from its ARP cache and uses the new one.

Question: Does the Sun Cluster software support setting `local-mac-address?=true`?

Answer: Yes. In fact, IP Network Multipathing requires that `local-mac-address?` *must* be set to `true`.

You can set `local-mac-address` with the `eeprom` command, at the OpenBoot PROM ok prompt in a SPARC based cluster. See the [eeprom\(1M\)](#) man page. You can also set the MAC address with the SCSI utility that you optionally run after the BIOS boots in an x86 based cluster.

Question: How much delay can I expect when IP network multipathing performs a switchover between adapters?

Answer: The delay could be several minutes. The reason is because when an IP network multipathing switchover is performed, the operation sends a gratuitous ARP broadcast. However, you cannot be sure that the router between the client and the cluster uses the gratuitous ARP. So, until the ARP cache entry for this IP address on the router times out, the entry can use the stale MAC address.

Question: How fast are failures of a network adapter detected?

Answer: The default failure detection time is 10 seconds. The algorithm tries to meet the failure detection time, but the actual time depends on the network load.

Cluster Member FAQs

Question: Do all cluster members need to have the same root password?

Answer: You are not required to have the same root password on each cluster member. However, you can simplify administration of the cluster by using the same root password on all nodes.

Question: Is the order in which nodes are booted significant?

Answer: In most cases, no. However, the boot order is important to prevent amnesia. For example, if node two was the owner of the quorum device and node one is down, and then you bring node two down, you must bring up node two before bringing back node one. This order prevents you from accidentally bringing up a node with outdated cluster configuration information.

Question: Do I need to mirror local disks in a cluster node?

Answer: Yes. Though this mirroring is not a requirement, mirroring the cluster node's disks prevents a nonmirrored disk failure from taking down the node. The downside to mirroring a cluster node's local disks is more system administration overhead.

Question: What are the cluster member backup issues?

Answer: You can use several backup methods for a cluster. One method is to have a host as the back up node with a tape drive or library attached. Then use the cluster file system to back up the data. Do not connect this host to the shared disks.

See [Chapter 12, "Backing Up and Restoring a Cluster,"](#) in *Sun Cluster System Administration Guide for Solaris OS* for additional information about how to backup and restore data.

Question: When is a node healthy enough to be used as a secondary node?

Answer: Solaris 9 OS:

After a reboot, a node is healthy enough to be a secondary node when the node displays the login prompt.

Solaris 10 OS:

A node is healthy enough to be a secondary node if the `multi-user-server` milestone is running.

```
# svcs -a | grep multi-user-server:default
```

Cluster Storage FAQs

Question: What makes multihost storage highly available?

Answer: Multihost storage is highly available because it can survive the loss of a single disk, because of mirroring (or because of hardware-based RAID-5 controllers). Because a multihost storage device has more than one host connection, it can also withstand the loss of a single Solaris host to which it is connected. In addition, redundant paths from each host to the attached storage provide tolerance for the failure of a host bus adapter, cable, or disk controller.

Cluster Interconnect FAQs

Question: Which cluster interconnects does the Sun Cluster software support?

Answer: Currently, the Sun Cluster software supports the following cluster interconnects:

- Ethernet (100BASE-T Fast Ethernet and 1000BASE-SX Gb) in both SPARC based and x86 based clusters
- Infiniband in both SPARC based and x86 based clusters
- SCI in SPARC based clusters only

Question: What is the difference between a “cable” and a transport “path”?

Answer: Cluster transport cables are configured by using transport adapters and switches. Cables join adapters and switches on a component-to-component basis. The cluster topology manager uses available cables to build end-to-end transport paths between hosts. A cable does not map directly to a transport path.

Cables are statically “enabled” and “disabled” by an administrator. Cables have a “state” (enabled or disabled), but not a “status.” If a cable is disabled, it is as if it were unconfigured. Cables that are disabled cannot be used as transport paths. These cables are not probed and therefore their state is unknown. You can obtain the state of a cable by using the `cluster status` command.

Transport paths are dynamically established by the cluster topology manager. The “status” of a transport path is determined by the topology manager. A path can have a status of “online” or

“offline.” You can obtain the status of a transport path by using the `clinterconnect status` command. See the `clinterconnect(1CL)` man page.

Consider the following example of a two-host cluster with four cables.

```
node1:adapter0    to switch1, port0
node1:adapter1    to switch2, port0
node2:adapter0    to switch1, port1
node2:adapter1    to switch2, port1
```

Two possible transport paths can be formed from these four cables.

```
node1:adapter0    to node2:adapter0
node2:adapter1    to node2:adapter1
```

Client Systems FAQs

Question: Do I need to consider any special client needs or restrictions for use with a cluster?

Answer: Client systems connect to the cluster as they would to any other server. In some instances, depending on the data service application, you might need to install client-side software or perform other configuration changes so that the client can connect to the data service application. See [Chapter 1, “Planning for Sun Cluster Data Services,” in *Sun Cluster Data Services Planning and Administration Guide for Solaris OS*](#) for more information about client-side configuration requirements.

Administrative Console FAQs

Question: Does the Sun Cluster software require an administrative console?

Answer: Yes.

Question: Does the administrative console have to be dedicated to the cluster, or can it be used for other tasks?

Answer: The Sun Cluster software does not require a dedicated administrative console, but using one provides these benefits:

- Enables centralized cluster management by grouping console and management tools on the same machine
- Provides potentially quicker problem resolution by your hardware service provider

Question: Does the administrative console need to be located “close” to the cluster, for example, in the same room?

Answer: Check with your hardware service provider. The provider might require that the console be located in close proximity to the cluster. No technical reason exists for the console to be located in the same room.

Question: Can an administrative console serve more than one cluster, if any distance requirements are also first met?

Answer: Yes. You can control multiple clusters from a single administrative console. You can also share a single terminal concentrator between clusters.

Terminal Concentrator and System Service Processor FAQs

Question: Does the Sun Cluster software require a terminal concentrator?

Answer: Starting with Sun Cluster 3.0, Sun Cluster software does not require a terminal concentrator. Unlike Sun Cluster 2.2, Sun Cluster 3.0, Sun Cluster 3.1, and Sun Cluster 3.2 do not require a terminal concentrator. Sun Cluster 2.2 required a terminal concentrator for fencing.

Question: I see that most Sun Cluster servers use a terminal concentrator, but the Sun Enterprise E1000 server does not. Why not?

Answer: The terminal concentrator is effectively a serial-to-Ethernet converter for most servers. The terminal concentrator's console port is a serial port. The Sun Enterprise E1000 server doesn't have a serial console. The System Service Processor (SSP) is the console, either through an Ethernet or j tag port. For the Sun Enterprise E1000 server, you always use the SSP for consoles.

Question: What are the benefits of using a terminal concentrator?

Answer: Using a terminal concentrator provides console-level access to each Solaris host from a remote machine anywhere on the network. This access is provided even when the host is at the OpenBoot PROM (OBP) on a SPARC based host or a boot subsystem on an x86 based host.

Question: If I use a terminal concentrator that Sun does not support, what do I need to know to qualify the one that I want to use?

Answer: The main difference between the terminal concentrator that Sun supports and other console devices is that the Sun terminal concentrator has special firmware. This firmware prevents the terminal concentrator from sending a break to the console when it boots. If you have a console device that can send a break, or a signal that might be interpreted as a break to the console, the break shuts down the host.

Question: Can I free a locked port on the terminal concentrator that Sun supports without rebooting it?

Answer: Yes. Note the port number that needs to be reset and type the following commands:

```
telnet tc
Enter Annex port name or number: cli
annex: su -
annex# admin
```

```
admin : reset port-number
admin : quit
annex# hangup
#
```

Refer to the following manuals for more information about how to configure and administer the terminal concentrator that Sun supports.

- [“Overview of Administering Sun Cluster” in *Sun Cluster System Administration Guide for Solaris OS*](#)
- [Chapter 2, “Installing and Configuring the Terminal Concentrator,” in *Sun Cluster 3.1 - 3.2 Hardware Administration Manual for Solaris OS*](#)

Question: What if the terminal concentrator itself fails? Must I have another one standing by?

Answer: No. You do not lose any cluster availability if the terminal concentrator fails. You do lose the ability to connect to the host consoles until the concentrator is back in service.

Question: If I do use a terminal concentrator, what about security?

Answer: Generally, the terminal concentrator is attached to a small network that system administrators use, not a network that is used for other client access. You can control security by limiting access to that particular network.

Question: SPARC: How do I use dynamic reconfiguration with a tape or disk drive?

Answer: Perform the following steps:

- Determine whether the disk or tape drive is part of an active device group. If the drive is not part of an active device group, you can perform the DR remove operation on it.
- If the DR remove-board operation would affect an active disk or tape drive, the system rejects the operation and identifies the drives that would be affected by the operation. If the drive is part of an active device group, go to [“SPARC: DR Clustering Considerations for Disk and Tape Drives” on page 95](#).
- Determine whether the drive is a component of the primary node or the secondary node. If the drive is a component of the secondary node, you can perform the DR remove operation on it.
- If the drive is a component of the primary node, you must switch the primary and secondary nodes before performing the DR remove operation on the device.



Caution – If the current primary node fails while you are performing the DR operation on a secondary node, cluster availability is impacted. The primary node has no place to fail over until a new secondary node is provided.

Index

A

adapters, *See* network, adapters
administration, cluster, 41-97
administrative console, 28-29
 FAQs, 105-106
administrative interfaces, 42
agents, *See* data services
amnesia, 57
APIs, 71-73, 75
application, *See* data services
application communication, 73-74
application development, 41-97
application distribution, 60
attributes, *See* properties

B

backup node, 103-104
board removal, dynamic reconfiguration, 95
boot disk, *See* disks, local
boot order, 103-104

C

cable, transport, 104-105
CCP, 28
CCR, 45-46
CD-ROM drive, 26
client-server configuration, 65
client systems, 27

client systems (*Continued*)

 FAQs, 105
 restrictions, 105

clprivnet driver, 74

cluster

 administration, 41-97
 advantages, 14-15
 application developer view, 18
 application development, 41-97
 backup, 103-104
 board removal, 95
 boot order, 103-104
 configuration, 45-46, 83-91
 data services, 64-71
 description, 14-15
 file system, 51-53, 100-101

 FAQs

See also file system

 HASToragePlus resource type, 52-53
 using, 51-52

 goals, 14-15

 hardware, 15-16, 21-29

 interconnect, 23, 26-27

 adapters, 26

 cables, 27

 data services, 73-74

 dynamic reconfiguration, 96

 FAQs, 104-105

 interfaces, 26

 junctions, 27

 supported, 104-105

 media, 26

cluster (*Continued*)

- members, 22, 44
 - FAQs, 103-104
 - reconfiguration, 44
- nodes, 22-23
- password, 103-104
- public network, 27
- public network interface, 65
- service, 15-16
- software components, 23-24
- storage FAQs, 104
- system administrator view, 16-17
- task list, 18-19
- time, 42
- topologies, 29-37, 38-40

Cluster Configuration Repository, 45-46

Cluster Control Panel, 28

cluster in a box topology, 33

Cluster Membership Monitor, 44

clustered pair topology, 30, 39

clustered-server model, 65

clusters span two hosts topology, 35-36

CMM, 44

- failfast mechanism, 44
 - See also* failfast

concurrent access, 22

configuration

- client-server, 65
- data services, 83-91
- parallel database, 22
- repository, 45-46
- virtual memory limits, 86-87

configurations, quorum, 59-60

console

- access, 28
- administrative, 28
 - FAQs, 105-106
- System Service Processor, 28

Controlling CPU, 82

CPU, control, 82

CPU time, 83-91

D

daemons, `svc.startd`, 81

data, storing, 100-101

data services, 64-71

- APIs, 71-73
- cluster interconnect, 73-74
- configuration, 83-91
- developing, 71-73
- failover, 67-68
- FAQs, 101-102
- fault monitor, 71
- highly available, 43
- library API, 73
- methods, 67
- resource groups, 74-77
- resource types, 74-77
- resources, 74-77
- scalable, 68-69
- supported, 101-102

`/dev/global/` namespace, 49-50

developer, cluster applications, 18

device

- global, 46-47
- ID, 46-47

device group, 47-49

- changing properties, 48-49

device groups

- failover, 47
- multiported, 48-49
- primary ownership, 48-49

devices

- multihost, 24
- quorum, 56-63

DID, 46-47

disk path monitoring, 53-56

disks

- dynamic reconfiguration, 95
- global devices, 46-47, 49-50
- local, 25-26, 46-47, 49-50
 - mirroring, 103-104
 - volume management, 101
- multihost, 46-47, 47-49, 49-50
- SCSI devices, 25

DR, *See* dynamic reconfiguration

driver, device ID, 46-47
 DSDL API, 75
 dynamic reconfiguration, 94-97

- cluster interconnect, 96
- CPU devices, 95
- description, 94
- disks, 95
- memory, 95
- public network, 96-97
- quorum devices, 96
- tape drives, 95

E

E10000, *See* Sun Enterprise E10000

F

failback, 71
 failfast, 44-45
 failover

- data services, 67-68
- device groups, 47
- scenarios, Solaris Resource Manager, 87-91

 failure

- detection, 43
- failback, 71
- recovery, 43

 FAQs, 99-107

- administrative console, 105-106
- client systems, 105
- cluster interconnect, 104-105
- cluster members, 103-104
- cluster storage, 104
- data services, 101-102
- file systems, 100-101
- high availability, 99-100
- public network, 102-103
- System Service Processor, 106-107
- terminal concentrator, 106-107
- volume management, 101

 fault monitor, 71
 fencing, 44

file locking, 51
 file system

- cluster, 51-53, 100-101
- data storage, 100-101
- FAQs, 100-101
- global
 - See* file system, cluster
- high availability, 100-101
- local, 52-53
- mounting, 51-53, 100-101
- NFS, 53, 100-101
- QFS, 53
- syncdir mount option, 53
- UFS, 53
- VxFS, 53

 file systems, using, 51-52
 framework, high availability, 43-46
 Frequently Asked Questions, *See* FAQs

G

global

- device, 46-47, 47-49
 - local disks, 25
 - mounting, 51-53
- interface, 66
 - scalable services, 68
- namespace, 46, 49-50
 - local disks, 25

 global file system, *See* cluster, file system
 global interface node, 66
 /global mount point, 51-53, 100-101
 groups, device, 47-49

H

HA, *See* high availability
 hardware, 15-16, 21-29, 94-97

- See also* disks
- See also* storage

 cluster interconnect components, 26
 dynamic reconfiguration, 94-97
 HAStoragePlus resource type, 52-53, 74-77

high availability

FAQs, 99-100

framework, 43-46

highly available, data services, 43

host name, 65

I

ID

device, 46-47

node, 50

`in.mpathd` daemon, 92

interfaces

See network, interfaces

administrative, 42

IP address, 101-102

IP Network Multipathing, 92-93

failover time, 102-103

IPMP, *See* IP Network Multipathing

K

kernel, memory, 95

L

load balancing, 69-71

local disks, 25-26

local file system, 52-53

`local_mac_address`, 102-103

local namespace, 50

logical host name, 65

compared to shared address, 101-102

failover data services, 67-68

`LogicalHostname` resource type, *See* logical host name

M

MAC address, 102-103

mapping, namespaces, 50

media, removable, 26

membership, *See* cluster, members

memory, 95

mission-critical applications, 62

monitoring

disk path, 53-56

object type, 81

system resources, 82

telemetry attributes, 82

mounting

file systems, 51-53

`/global`, 100-101

global devices, 51-53

with `syncdir`, 53

multi-initiator SCSI, 25

multihost device, 24

multipathing, 92-93

multiported device groups, 48-49

N

N+1 (star) topology, 31-32, 39-40

N*N (scalable) topology, 32

namespaces, 49-50, 50

network

adapters, 27, 92-93

interfaces, 27, 92-93

load balancing, 69-71

logical host name, 65

private, 23

public, 27

dynamic reconfiguration, 96-97

FAQs, 102-103

interfaces, 102-103

IP Network Multipathing, 92-93

resources, 65, 74-77

shared address, 65

Network Time Protocol, 42

NFS, 53

nodes, 22-23

backup, 103-104

boot order, 103-104

global interface, 66

`nodeID`, 50

primary, 48-49, 65

nodes (*Continued*)

- secondary, 48-49, 65
- NTP, 42
- numsecondaries property, 48

O

- object type, system resource, 81
- Oracle Parallel Server, *See* Oracle Real Application Clusters
- Oracle Real Application Clusters, 72

P

- pair+N topology, 31
- panic, 44-45, 45
- parallel database configurations, 22
- password, root, 103-104
- path, transport, 104-105
- per-host address, 73-74
- preferenced property, 48
- primary node, 65
- primary ownership, device groups, 48-49
- private network, 23
- projects, 83-91
- properties
 - changing, 48-49
 - resource groups, 77
 - Resource_project_name, 85-86
 - resources, 77
 - RG_project_name, 85-86
- proxy resource types, 80
- public network, *See* network, public
- pure service, 69

Q

- quorum, 56-63
 - atypical configurations, 62
 - bad configurations, 63
 - best practices, 60
 - configurations, 58-59, 59-60

quorum (*Continued*)

- device, dynamic reconfiguration, 96
- devices, 56-63
- recommended configurations, 61
- requirements, 59-60
- vote counts, 58

R

- recovery
 - failback settings, 71
 - failure detection, 43
- redundant I/O domains topology, 37
- removable media, 26
- Resource Group Manager, *See* RGM
- resource groups, 74-77
 - failover, 67-68
 - properties, 77
 - scalable, 68-69
 - settings, 75-77
 - states, 75-77
- resource management, 83-91
- Resource_project_name property, 85-86
- resource types, 52-53, 74-77
 - proxy, 80
 - SUNW.Proxy_SMF_failover, 80
 - SUNW.Proxy_SMF_loadbalanced, 80
 - SUNW.Proxy_SMF_multimaster, 80
- resources, 74-77
 - properties, 77
 - settings, 75-77
 - states, 75-77
- RG_project_name property, 85-86
- RGM, 67, 74-77, 83-91
- RMAPI, 75
- root password, 103-104

S

- scalable data services, 68-69
- scha_cluster_get command, 74
- scha_privatelink_hostname_node argument, 74
- SCSI, multi-initiator, 25

- scsi-initiator-id property, 25
- secondary node, 65
- server models, 65
- Service Management Facility (SMF), 80-81
- shared address, 65
 - compared to logical host name, 101-102
 - global interface node, 66
 - scalable data services, 68-69
- SharedAddress resource type, *See* shared address
- shutdown, 44-45
- single cluster spans two hosts topology, 34-35
- single-server model, 65
- SMF, *See* Service Management Facility (SMF)
- SMF daemon svc.startd, 81
- software components, 23-24
- Solaris projects, 83-91
- Solaris Resource Manager, 83-91
 - configuration requirements, 85-86
 - configuring virtual memory limits, 86-87
 - failover scenarios, 87-91
- Solaris Volume Manager, multihost devices, 24
- split brain, 57
- SSP, *See* System Service Processor
- sticky service, 69
- storage, 24
 - dynamic reconfiguration, 95
 - FAQs, 104
 - SCSI, 25
- Sun Cluster, *See* cluster
- Sun Cluster Manager, 42
 - system resource usage, 83
- Sun Enterprise E10000, 106-107
 - administrative console, 28
- Sun Management Center (SunMC), 42
- SUNW.Proxy_SMF_failover, resource types, 80
- SUNW.Proxy_SMF_loadbalanced, resource types, 80
- SUNW.Proxy_SMF_multimaster, resource types, 80
- svc.startd, daemons, 81
- syncdir mount option, 53
- system resource, threshold, 82
- system resource monitoring, 82
- system resource usage, 81
- system resources
 - monitoring, 82

- system resources (*Continued*)
 - object type, 81
 - usage, 81
- System Service Processor, 28
 - FAQs, 106-107

T

- tape drive, 26
- telemetry attribute, system resources, 82
- terminal concentrator, FAQs, 106-107
- threshold
 - system resource, 82
 - telemetry attribute, 82
- time, between hosts, 42
- topologies, 29-37, 38-40
 - clustered pair, 30, 39
 - logical domains: cluster in a box, 33
 - logical domains: clusters span two hosts, 35-36
 - logical domains: redundant I/O domains, 37
 - logical domains: single cluster spans two hosts, 34-35
 - N+1 (star), 31-32, 39-40
 - N*N (scalable), 32
 - pair+N, 31

U

- UFS, 53

V

- Veritas Volume Manager, multihost devices, 24
- volume management
 - FAQs, 101
 - local disks, 101
 - multihost devices, 24
 - multihost disks, 101
 - namespace, 49
 - RAID-5, 101
 - Solaris Volume Manager, 101
 - Veritas Volume Manager, 101

vote counts, quorum, 58
VxFS, 53

Z

zones, 77

