

PART NUMBER

**312531901**

VERSION NUMBER

**6.0**

EDITION NUMBER

**2**

# LibraryStation

**CONFIGURATION GUIDE**

PRODUCT TYPE  
**SOFTWARE**







# **LibraryStation**

## **Configuration Guide**

**Release 6.0**

**312531901**

Information contained in this publication is subject to change without notice. Comments concerning the contents of this publication should be directed to:

Global Learning Solutions  
Storage Technology Corporation  
One StorageTek Drive  
Louisville, CO 80028-3526  
USA

sid@stortek.com

### **Export Destination Control Statement**

These commodities, technology or software were exported from the United States in accordance with the Export Administration Regulations. Diversion contrary to U.S. law is prohibited.

### **Restricted Rights**

Use, duplication, or disclosure by the U.S. Government is subject to restrictions as set forth in subparagraph (c) (1) and (2) of the Commercial Computer Software - Restricted Rights at FAR 52.227-19 (June 1987), as applicable.

### **Limitations on Warranties and Liability**

Storage Technology Corporation cannot accept any responsibility for your use of the information in this document or for your use in any associated software program. You are responsible for backing up your data. You should be careful to ensure that your use of the information complies with all applicable laws, rules, and regulations of the jurisdictions in which it is used.

**Warning:** No part or portion of this document may be reproduced in any manner or in any form without the written permission of Storage Technology Corporation.

### **Proprietary Information Statement**

The information in this document, including any associated software program, may not be reproduced, disclosed or distributed in any manner without the written consent of Storage Technology Corporation.

Should this publication be found, please return it to StorageTek, One StorageTek Drive, Louisville, CO 80028-5214, USA. Postage is guaranteed.

### **Second Edition (June 1, 2004)**

StorageTek and the StorageTek logo are trademarks or registered trademarks of Storage Technology Corporation. Other products and names mentioned herein are for identification purposes only and may be trademarks of their respective companies.

© 2004 Storage Technology Corporation. All rights reserved.

## Document Effectivity

---

EC Number	Date	Doc Kit Number	Type	Effectivity
128668	February, 2004	---	First Edition	This document applies to LibraryStation, Version 6.0.
	June, 2004	---	Second Edition	



# Contents

---

<b>What's New with This Release?</b> .....	<b>xi</b>
<b>About this Guide</b> .....	<b>xiii</b>
Intended Audience .....	xiii
Reader's Comments .....	xiii
About the Software .....	xiii
How this Guide is Organized .....	xiv
Conventions Used in this Guide .....	xv
Typographic .....	xv
Symbols .....	xv
Syntax Flow Diagrams .....	xvi
Control Statements .....	xx
Related Publications .....	xxi
Technical Support .....	xxii
<b>Chapter 1. Introduction</b> .....	<b>1</b>
What is LibraryStation? .....	1
How Does LibraryStation Work? .....	1
Request Processing .....	3
StorageTek Library Product Support .....	5
StorageTek ACSs .....	5
StorageTek Cartridge Tape Transports .....	6
StorageTek Media .....	7
<b>Chapter 2. LibraryStation Configuration Overview</b> .....	<b>9</b>
LibraryStation Installation .....	9
Overview of LibraryStation Configuration Tasks .....	9
Typical Configurations .....	10
LibraryStation Client/Server Environments .....	14
Heterogeneous Environment .....	14
Sysplex (Homogeneous Environment) .....	15
Sysplex With Heterogeneous Support for Non-MVS/CSC Clients .....	16
System Redundancy Options .....	17

<b>Chapter 3. Verifying Hardware and Software Requirements</b> .....	<b>19</b>
Hardware Requirements .....	19
Software Requirements .....	20
Communications Interface Software Requirements .....	20
Optional Supporting Software .....	20
<b>Chapter 4. Configuring Communication Facilities</b> .....	<b>21</b>
ONC/RPC Support .....	21
Domain Name Resolution .....	21
Resolving the TCPIP_PREFIX High Level Qualifier .....	22
LU6.2 Support .....	22
VTAM Setup .....	23
APPC/MVS Configuration .....	24
APPC/MVS Operation .....	25
XCF Support .....	25
<b>Chapter 5. Configuring Security Measures</b> .....	<b>27</b>
Drive Access Security .....	27
Volume Access Security .....	27
Network-Level Volume Authorization Checks .....	29
Implementing Network-Level Volume Authorization Checks .....	30
Client-Level Volume Authorization .....	33
Implementing Client-Level Volume Authorization Checks .....	34
Subpool Security Implications .....	36
Command Access Security .....	37
Scratch Pool Processing .....	38
Security Summary .....	40
<b>Chapter 6. Allocating the Persistent Data File</b> .....	<b>41</b>
The PDF in a Multiple Host Environment .....	42
<b>Chapter 7. Configuring the LibraryStation Hostid</b> .....	<b>45</b>
<b>Chapter 8. Configuring Drive Device Numbers</b> .....	<b>47</b>
<b>Chapter 9. Configuring the LSINIT Control Statement</b> .....	<b>53</b>
LSINIT Control Statement Format .....	53
Required Keyword Parameters of LSINIT .....	57
Optional Keyword Parameters of LSINIT .....	59
LSINIT Implications for Multiple MVS Host Installations .....	65
<b>Chapter 10. Configuring the LSDEF Data Set</b> .....	<b>67</b>
Defining LSDEF File Statements .....	67
CLIENTID Statement .....	68
SPNUM Statement .....	69
UNITATTR Statement .....	71
Allocating the LSDEF Data Set .....	72



<b>Chapter 11. Configuring the HSC Started Task Procedure</b> .....	<b>73</b>
<b>Chapter 12. Configuring NCS License Keys</b> .....	<b>75</b>
Overview .....	75
Permanent License Key .....	75
<b>Chapter 13. Reconfiguring the HSC LIBGEN</b> .....	<b>77</b>
<b>Chapter 14. Starting LibraryStation</b> .....	<b>79</b>
<b>Chapter 15. Verifying LibraryStation Configuration</b> .....	<b>81</b>
Step 1: CPA, TCP/IP, and LAN Verification .....	81
Step 2: LibraryStation Verification .....	81
<b>Appendix A. Gathering Diagnostic Materials</b> .....	<b>83</b>
LibraryStation Diagnostic Materials .....	83
Tape Format .....	83
<b>Appendix B. LibraryStation Configuration Worksheet</b> .....	<b>85</b>
Verifying Hardware and Software Requirements (Chapter 3) .....	85
Configuring Security Measures (Chapter 5) .....	86
Configuring the LibraryStation Hostid (Chapter 7) .....	86
Configuring Drive Device Numbers (Chapter 8) .....	87
Configuring the LSINIT Control Statement (Chapter 9) .....	88
Configuring the LSDEF File Data Set (Chapter 10) .....	89
CLIENTID Statement .....	89
SPNUM Statement .....	90
UNITATTR Statement .....	90
<b>Appendix C. Migration and Coexistence</b> .....	<b>91</b>
Migration .....	91
Migration from LibraryStation Release 4.0 or later to Release 6.0 .....	91
Reverse Migration from LibraryStation Release 6.0 to Release 4.x .....	91
Coexistence .....	92
Compatibility With MVS/CSC .....	92
<b>Glossary</b> .....	<b>93</b>
<b>Index</b> .....	<b>99</b>



## Figures

---

Figure 1. Flow of Requests and Responses through LibraryStation .....	4
Figure 2. Typical LibraryStation Configuration for ONC/RPC Clients .....	11
Figure 3. Typical LibraryStation Configuration for LU6.2 Clients .....	12
Figure 4. Typical LibraryStation Sysplex Configuration .....	13
Figure 5. Heterogeneous Environment .....	14
Figure 6. Sysplex Environment .....	15
Figure 7. Sysplex Environment with Heterogeneous Support .....	16
Figure 8. Sample VTAM Setup APPL Statement .....	23
Figure 9. Sample APPC Side Information File - Part 1 .....	24
Figure 10. Sample APPC Side Information File - Part 2 .....	25
Figure 11. Sample SLILIBRY Macro with LibraryStation Hostid .....	45
Figure 12. Sample LIBGEN with LibraryStation Device Numbers .....	49
Figure 13. LSINIT Control Statement Syntax .....	56
Figure 14. Sample LSDEF Data Set Allocation .....	72
Figure 15. Sample HSC Cataloged Procedure Updated for LibraryStation .....	73



## What's New with This Release?

---

LibraryStation 6.0 includes the following enhancements and modifications:

Enhancement/Modification	Publication(s)/ Primary Locations
Support for StorageTek's StreamLine (SL8500) library	<b><i>LibraryStation Configuration Guide</i></b> Chapter 1 <b><i>LibraryStation Operator and System Programmer's Guide</i></b> Chapter 1
Greater than 16 LSM support for each ACS. A maximum of 24 LSMs can be specified.	<b><i>LibraryStation Configuration Guide</i></b> Chapter 1 <b><i>LibraryStation Messages and Codes Guide</i></b> Chapters 1, 2 <b><i>LibraryStation Operator and System Programmer's Guide</i></b> Chapters 1, 3, 5
A single license key can now enable multiple NCS products.	<b><i>LibraryStation Config Guide</i></b> Chapter 12 <b><i>NCS Installation Guide</i></b> Chapter 1
Support for SAS/C 7.0	<b><i>LibraryStation Config Guide</i></b> Chapters 4,11 <b><i>NCS Installation Guide</i></b> Chapter 1
Support for StorageTek's T9840C and T9940B ESCON-attach drives.	<b><i>LibraryStation Config Guide</i></b> Chapter 1 <b><i>LibraryStation Operator and System Programmer's Guide</i></b> Chapter 1
Message additions	<b><i>LibraryStation Messages and Codes Guide</i></b> Chapter 2, Appendix B



## About this Guide

---

This guide describes configuration procedures for LibraryStation Release 6.0.

### Intended Audience

This guide is intended for all LibraryStation users including operators, system programmers, system analysts, storage administrators, system specialists, and operations specialists.

### Reader's Comments

We'd like to know what you think about this guide. E-mail your comments to us directly. Our Internet address is:

`sid@stortek.com`

Be sure to include the part number and title of the guide you are referencing.

### About the Software

LibraryStation 6.0 is supported by this guide.

## How this Guide is Organized

This guide contains the following chapters and appendices:

- **Chapter 1, “Introduction”** provides an overview of LibraryStation.
- **Chapter 2, “LibraryStation Configuration Overview”** provides an overview of LibraryStation configuration tasks.
- **Chapter 3, “Verifying Hardware and Software Requirements”** describes hardware and software components required for LibraryStation configuration.
- **Chapter 4, “Configuring Communication Facilities”** provides procedures for configuring software used for LibraryStation communication.
- **Chapter 5, “Configuring Security Measures”** provides procedures for configuring LibraryStation security.
- **Chapter 6, “Allocating the Persistent Data File”** provides procedures for configuring the LibraryStation Persistent Data File.
- **Chapter 7, “Configuring the LibraryStation Hostid”** provides procedures for configuring the HSC LIBGEN hostid for LibraryStation.
- **Chapter 8, “Configuring Drive Device Numbers”** provides procedures for configuring tape cartridge device numbers.
- **Chapter 9, “Configuring the LSINIT Control Statement”** provides procedures for configuring the LibraryStation LSINIT control statement.
- **Chapter 10, “Configuring the LSDEF Data Set”** provides procedures for configuring the LibraryStation LSDEF data set.
- **Chapter 11, “Configuring the HSC Started Task Procedure”** provides procedures for configuring and updating the HSC Started Task Procedure.
- **Chapter 12, “Configuring NCS License Keys”** describes configuration procedures for the StorageTek LibraryStation license key.
- **Chapter 13, “Reconfiguring the HSC LIBGEN”** provides procedures for reconfiguring the HSC LIBGEN.
- **Chapter 14, “Starting LibraryStation”** provides procedures for starting LibraryStation.
- **Chapter 15, “Verifying LibraryStation Configuration”** provides procedures for verifying LibraryStation configuration.
- **Appendix A, “Gathering Diagnostic Materials”** provides instructions for gathering diagnostic materials for Software Support.
- **Appendix B, “LibraryStation Configuration Worksheet”** provides a worksheet used to record site-specific configuration information.
- **Appendix C, “Migration and Coexistence”** provides migration, coexistence, and compatibility guidelines.



## Conventions Used in this Guide

### Typographic

In the JCL examples in this guide, some fields appear in lower case. You must update these fields to match your installation requirements.

### Symbols

The following symbols are used to highlight text in this guide:



**Note:** Information that may be of special interest to you. Notes are also used to point out exceptions to rules or procedures.



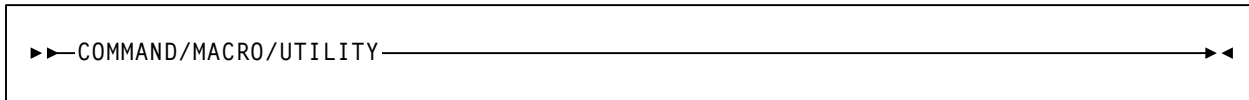
**Warning:** Information necessary to keep you from damaging your hardware or software.

## Syntax Flow Diagrams

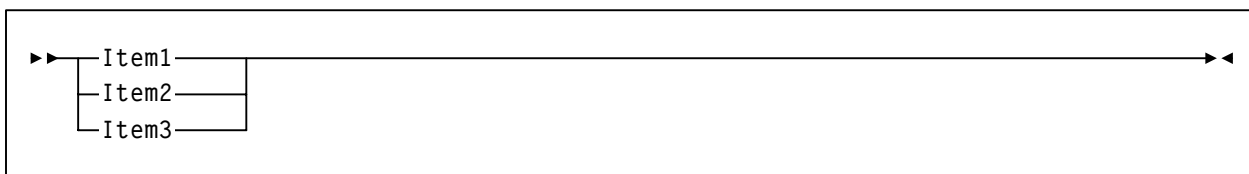
Syntax flow diagramming conventions include the following:

### Flow Lines

Syntax diagrams consist of a horizontal base line, horizontal and vertical branch lines, and the text for a command, control statement, macro, or utility.



or

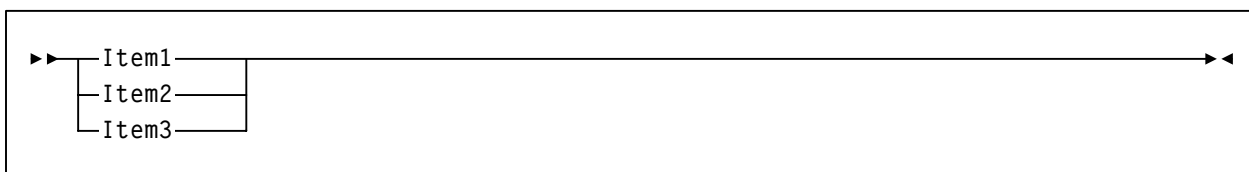


Diagrams are read left to right and top to bottom. Arrows indicate flow and direction.

- a statement begins with ▶▶
- a statement ends with ▶◀
- diagrams continuing to the next line begin with ▶
- fragments begin and end with |

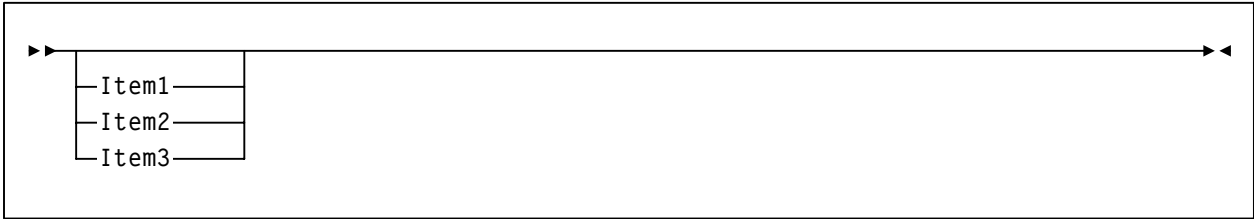
### Single Required Choice

Branch lines (without repeat arrows) indicate that a single choice must be made. If one of the items from which a choice is being made is positioned on the base line of the diagram, a single choice is required.



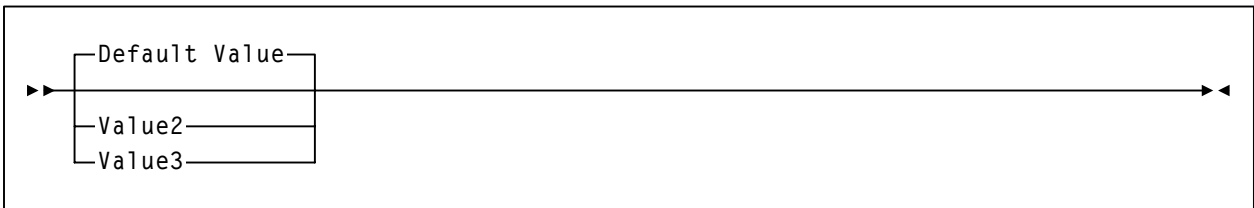
## Single Optional Choice

If the first item is positioned on the line below the base line, a single choice of items in the stack is optional.

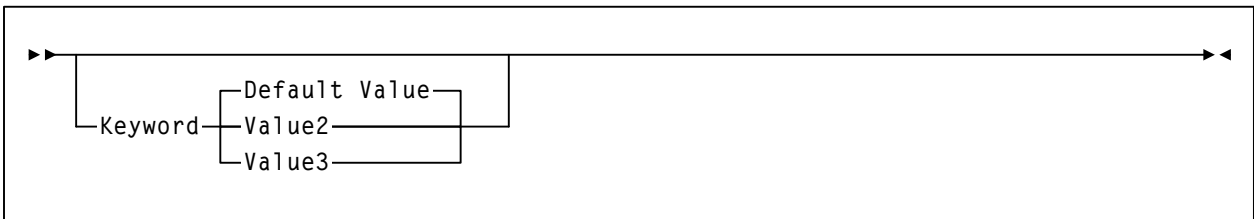


## Defaults

Default values and parameters appear above the base line. In the following example, if a value is not specified with the command, `Default Value` is used by the HSC.

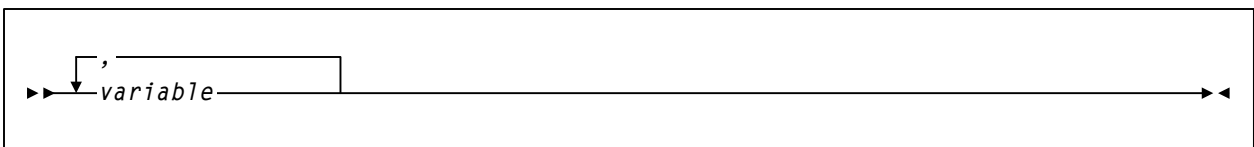


Some keyword parameters provide a choice of values in a stack. When the stack contains a default value, the keyword and the value choices are placed below the base line to indicate that they are optional, and the default value appears above the keyword line. In the following example, if the keyword is not specified with the command, `keyword (Default Value)` is used by the HSC.



## Repeat Symbol

A repeat symbol indicates that more than one choice can be made or that a single choice can be made more than once. The repeat symbol shown in the following example indicates that a comma is required as the repeat delimiter.



## Keywords

All keywords are shown in uppercase or in mixed case. When keywords are not case sensitive, mixed case implies that the lowercase letters may be omitted to form an abbreviation.

## Variables

Italic type is used to indicate a variable.

## Alternatives

A bar (|) is used to separate alternative parameter values.

## Delimiters

If parenthesis (), a comma (,), a semicolon (;), or any other delimiter is shown with an element of the syntax diagram, it must be entered as part of the statement or command unless otherwise stated.

## Ranges

- An inclusive range is indicated by a pair of elements of the same length and data type, joined by a dash. The first element must be strictly less than the second element.
- A hexadecimal range consists of a pair of hexadecimal numbers (for example, 0A2-0AD, or 000-0FC).
- A decimal range consists of a pair of decimal numbers (for example, 1-9, or 010-094). Leading zeros are not required. The decimal portion is referred to as an incremental range. The character positions of the incremental portion of both range elements must match, and the non-incremental characters of the first element must be identical to those of the second element.
- A numeric VOLSER range (*vol-range*) consists of a pair of VOLSER elements containing a decimal numeric portion of 1 to 6 digits (for example, ABC012-ABC025, or X123CB-X277CB). The decimal portion is referred to as an incremental range. The following additional restrictions apply:
  - The character positions of the incremental portion of both range elements must match.
  - The non-incremental characters of the first element must be identical to those of the second element.
  - You cannot increment two portions of a range element. If 111AAA is the first element, you cannot specify 112AAB for the second element.

- If a VOLSER range contains more than one decimal portion, only the right-most portion is valid as the incremental range. For example:

**A00B00**            the largest range that can be specified is A00B00 through A00B99.

**A0B0CC**            the largest range that can be specified is A0B0CC through A0B9CC.

**000XXX**            the largest range that can be specified is 000XXX through 999XXX.

- An alphabetic VOLSER range (*vol-range*) consists of a pair of VOLSER elements containing an incremental portion of 1 to 6 characters (for example, 000AAA-000ZZZ, or 9AAA55-9ZZZ55). This portion is referred to as an incremental range. The following additional restrictions apply:
  - The character positions of the incremental portion of both range elements must match.
  - The non-incremental characters of the first element must be identical to those of the second element.
  - You cannot increment two portions of a range element. If 111AAA is the first element, you cannot specify 112AAB for the second element.
  - The alphabetic portion of the VOLSER range is defined as being from character A to Z. To increment multi-character sequences, each character increments to Z. For instance, ACZ is part of the AAA-AMM range. Examples are:

**A00A0-A99A0**            increments VOLSERS A00A0 through A09A0, then A10A0 through A99A0.

**9AA9A-9ZZ9A**            increments VOLSERS 9AA9A through 9AZ9A, then 9BA9A through 9ZZ9A.

**111AAA-111ZZZ**            increments VOLSERS 111AAA through 111AAZ, then 111ABA through 111ZZZ

**999AM8-999CM8**            increments VOLSERS 999AM8 through 999AZ8, then 999BA8 through 999CM8

**A3BZZ9-A3CDE9**            increments VOLSERS A3BZZ9 through A3CAA9, then A3CAB9 through A3CDE9

**AAAAAA-AAACCC**            increments VOLSERS AAAAAA through AAAAAZ, then AAAABA through AAACCC

**CCCNNN-DDDNNN**            increments VOLSERS CCCNNN through CCCNNZ, then CCCNOA through DDDNNN \*

\* **Caution:** This is a very large range.

The number of volumes in an alphabetic VOLSER range depends on the number of elements in the incrementing portion of the VOLSER range. For an A to Z range in each character position, the number of volumes can be calculated by 26 to the power of the number of positions that are being incremented.

<b>A-Z</b>	$26^1$	26
<b>AA-ZZ</b>	$26^2$	676
<b>AAA-ZZZ</b>	$26^3$	17,576
<b>AAAA-ZZZZ</b>	$26^4$	456,976
<b>AAAAA-ZZZZZ</b>	$26^5$	11,881,376
<b>AAAAAA-ZZZZZZ</b>	$26^6$	308,915,776

## Lists

A list consists of one or more elements. If more than one element is specified, the elements must be separated by a comma or a blank space, and the entire list must be enclosed in parentheses.

## Blanks

Blanks are not allowed between parameters and parentheses, or between parentheses and arguments. For example:

LS C ID(3218) is a valid entry.

LS C ID ( 3218 ) is not.

## Control Statements

The standard syntax conventions for control statements are as follows:

- The only valid control statement information area is from column 2 to column 72. Columns 73-80 are ignored.
- Parameters are separated by one or more blanks or a comma,
- A value is associated with a parameter by an equal (=) sign or by enclosing the value in parentheses, and concatenating it immediately after the parameter.
- Case (upper or lower) is ignored in actual control statements.
- /\* and \*/ can be used to enclose comments in the job stream. Comments cannot be nested.
- The maximum length for a control statement is 32,767 characters.

## Related Publications

The following publications contain information about specific topics relating to the use of LibraryStation.

### StorageTek Nearline Control Solution (NCS) Publications

- *NCS Installation Guide (SMC, MVS/HSC, HTTP Server, MVS/CSC, LibraryStation)*
- *Requesting Help from Software Support*

### StorageTek LibraryStation Publications

- *LibraryStation Operator and System Programmer's Guide*
- *LibraryStation Messages and Codes Guide*

### StorageTek Storage Management Component (SMC) Publications

- *SMC Configuration and Administration Guide*

### StorageTek Host Software Component (MVS/HSC) Publications

- *MVS/HSC Configuration Guide*
- *MVS/HSC Operator's Guide*
- *MVS/HSC System Programmer's Guide*
- *MVS/HSC Messages and Codes Guide*

### StorageTek Client System Component (MVS/CSC) Publications

- *MVS/CSC Configuration Guide*
- *MVS/CSC Operator's Guide*
- *MVS/CSC System Programmer's Guide*
- *MVS/CSC Messages and Codes Guide*

### StorageTek Virtual Storage Manager Publications

- *VTCS Installation and Configuration Guide*
- *VTCS Administration Guide*
- *VTCS Messages and Codes Guide*
- *VTCS Reference*

## Technical Support

StorageTek Software Support and the StorageTek Customer Resource Center (CRC) maintain information about known LibraryStation Release 6.0 product updates. You can contact Software Support or access the CRC for the latest information available concerning product updates (i.e. documentation, PTFs, PUTs).

See the *Requesting Help from Software Support* guide (included in the NCS package) for information about contacting StorageTek for technical support and for requesting changes to software products, or access StorageTek's CRC homepage at:

<http://www.support.storagetek.com>



**Note:** You must obtain a login ID and password in order to access the CRC. You can request a login ID and password from the CRC homepage.



# Chapter 1. Introduction

---

This chapter describes the StorageTek LibraryStation product and its functions. Discussion of LibraryStation request processing and StorageTek library support is also included.

## What is LibraryStation?

LibraryStation provides a communications interface between HSC and a client system running on another host (either MVS or open systems), allowing network clients to access the library services of a StorageTek Nearline Automated Cartridge System (ACS) through the MVS host system. LibraryStation can communicate with the MVS/CSC in an MVS-only environment, or the SMC and the StorageTek HTTP server can provide communication between MVS hosts. LibraryStation executes in the HSC address space on MVS.

LibraryStation provides software support and an interface for the Open Systems Nearline Network protocol. This includes an Open Network Computing Remote Procedure Call (ONC/RPC) client, a System Network Architecture (SNA LU6.2) client, and an MVS cross-system coupling facility (XCF) client. This protocol defines valid requests from network client systems and corresponds to an application layer protocol of the International Standards Organization (ISO) Open Systems Interconnection (OSI) reference model.

Additionally, LibraryStation provides an operator command set for controlling LibraryStation operation through the HSC operator console.

## How Does LibraryStation Work?

LibraryStation acts as a control path interface between client systems and the HSC. Client systems communicate with LibraryStation through two methods. Open Systems Nearline Network protocol requests and corresponding replies are processed by the Client System Interface (CSI) for ONC/RPC clients or the Client Server Communications Interface (CSCI) for SNA LU6.2 and XCF clients of LibraryStation.

A hardware and software connection between the MVS system and network is required:

- For ONC/RPC clients:
  - The hardware connection is provided by a network interface adaptor that converts data on the Ethernet network to IBM channel commands. Depending on the TCP/IP communication product you choose, several types of network interface adapters may be used for a connection to an Ethernet network. Consult your TCP/IP vendor for a list of supported network adapters.
  - The software connection is provided by one of various TCP/IP communication products including IBM TCP/IP and CA Unicenter TCPaccess Communications Server. These products translate the data to a format that is understood by MVS applications such as LibraryStation.
- For SNA LU6.2 clients:
  - The hardware necessary to provide network connectivity between the client system and LibraryStation is not provided by StorageTek. Typical configurations use an IBM 3172 or IBM 3174 Interconnect Controller to connect to a token ring network where the client system is also attached. It is also possible to use channel-to-channel connections where the client resides on another MVS system.
  - The software connection is provided by APPC/MVS and VTAM. APPC/MVS provides a programming interface to LibraryStation while VTAM controls the physical hardware.
- For XCF clients:
  - XCF support runs in MVS 5.2.2 or above, executing as a sysplex environment. To use XCF, and for sysplex itself, you must have a coupling facility (CF) or a channel-to-channel (CTC) device.

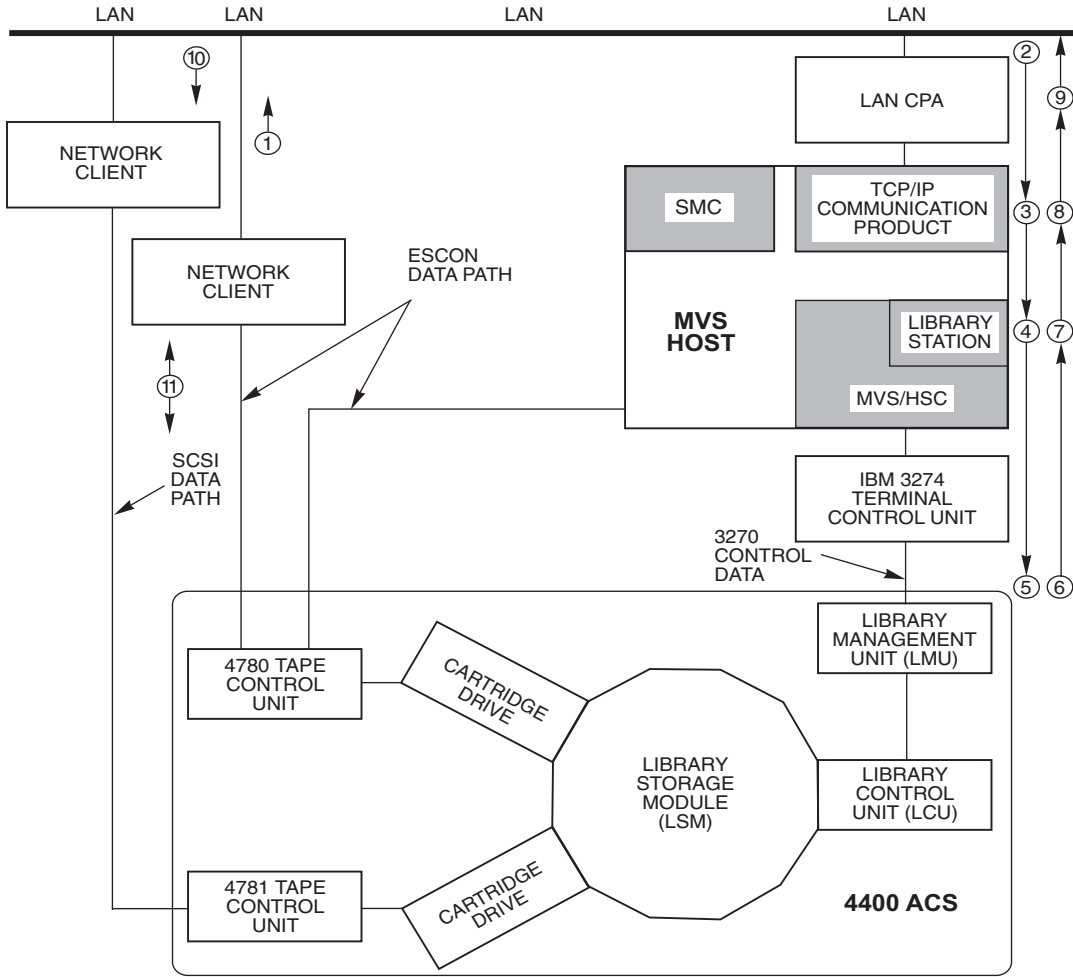
When a client system makes a library services request, such as a mount or dismount request, LibraryStation translates the request into a format that the HSC understands. The HSC in turn delivers the request to the Library Management Unit (LMU) through the use of an establishment controller (an IBM 3174, for example) just as if the request had originated from the HSC.

When the HSC needs to respond to the originator, LibraryStation translates the response from the HSC format to the format expected by the client system. After a cartridge is mounted using this control path sequence, the client system can begin moving data to or from a cartridge drive that is attached to the library and connected directly to the client system. This separate data path uses a channel that is supported by the client; an ESCON, FIPS-60 “Bus and Tag,” or SCSI channel.

## Request Processing

The flow of requests and responses between the network client system and the Library Management Unit (LMU) of the ACS is described below. Communications occur through a control path from the client system, through the HSC host to the LMU and back. Figure 1 on page 4 illustrates the flow of requests and responses. ONC/RPC clients are used in this example.

1. The client system initiates communication with the MVS host by sending an Open Systems Nearline Network (OSNN) protocol request over the network to the network interface adaptor (for example, the StorageTek 9300-001 Control Path Adaptor). This request could specify actions such as a tape volume mount or a query for information.
2. The network interface adaptor passes the packet through the IBM channel to the communication subsystem software on the MVS host, IBM TCP/IP for example.
3. The communication subsystem manages multiple communications connections and directs the communications packet to LibraryStation.
4. LibraryStation interprets the packet's information and protocols. LibraryStation may pass the request to the HSC for further processing and delivery to the LMU, or it may process the request directly.
5. The LMU initiates library operation, including robotic activity.
6. The LMU sends its response to the HSC for further processing and delivery to LibraryStation.
7. LibraryStation interprets the message information and protocols and passes the response to the Communications subsystem.
8. The Communications subsystem provides additional communications information required for the response to be received by the network client and sends the message to the network interface adaptor.
9. The network interface adaptor passes the packet back to the client system through the network (Ethernet, Token Ring, etc.)
10. The client system receives the response message from LibraryStation.
11. Data transfers between the client system and the ACS occur through separate ESCON, FIPS-60 "Bus and Tag" or SCSI data paths.



C46255

**Figure 1. Flow of Requests and Responses through LibraryStation**

# StorageTek Library Product Support

The following sections list the StorageTek Automated Cartridge Subsystems (ACSs), cartridge tape transports, and media supported for LibraryStation 6.0.

## StorageTek ACSs

LibraryStation 6.0 supports the following ACSs:

**Table 1. StorageTek ACSs**

ACS	Description
StreamLine SL8500	<p>A modular library scalable from 1,500 to over 200,000 cartridges in mainframe, Windows, UNIX, and supercomputer environments. The SL8500 includes the following features:</p> <ul style="list-style-type: none"><li>• Four internal rails on which four handbots travel. Optionally, you can upgrade to eight handbots, two per rail, for redundancy. Each rail is considered to be a separate LSM.</li><li>• Internal pass-thru ports (elevators), used to transport cartridges from one rail to another within the library</li><li>• Optional external pass-thru ports (two per rail), used to transport cartridges from one SL8500 library to another</li><li>• Integrated Library Control Unit (LCU) and Library Management Unit (LMU) functionality</li><li>• Compatible transports and associated media</li></ul> <p><b>Notes:</b></p> <ul style="list-style-type: none"><li>• Refer to the appendix “HSC Support of the SL8500” in the <i>HSC Operator’s Guide</i> for more information about the SL8500 library.</li><li>• Refer to the <i>HSC Configuration Guide</i> for SL8500 configuration information.</li></ul>
4400	<p>One or more LSMs with attached Library Control Units (LCUs) and a Library Management Unit (LMU).</p> <ul style="list-style-type: none"><li>• LSMs - 4410 (Standard), 9310 (Powderhorn), 9360 (WolfCreek)</li></ul>
9740 (TimberWolf)	<ul style="list-style-type: none"><li>• One or more 9740 LSMs</li><li>• Integrated LMU</li></ul>
9360 (WolfCreek) stand-alone	<ul style="list-style-type: none"><li>• One or more 9360 LSMs</li><li>• Integrated LMU</li></ul>

## StorageTek Cartridge Tape Transports

LibraryStation 6.0 supports the following cartridge tape transports:

**Table 2. StorageTek Cartridge Tape Transports**

Transport	Description
4480	Provides read/write capability for 18-track recording format and standard capacity cartridge.
4490	Provides read/write capability for 36-track recording format and enhanced capacity cartridge. 4490 transports can also read data recorded in 18-track format.
9490	Provides read/write capability for 36-track recording format and enhanced capacity cartridge. The 9490 tape transport provides improved performance over the 4490 tape transport by supporting a higher data transfer rate and Enterprise Systems Connection (ESCON) attachment.
9490EE	Provides read/write capability for a higher capacity, 36-track ZCART cartridge. 9490EE transports can read any 36-track cartridge and can also write to standard and enhanced capacity cartridges.
SD3	Provides read/write capability for the high-capacity, helical scan recording format.
T9840A	Access-centric transport, provides 20 GB read/write capability for 9840 cartridges at a native, uncompressed transfer rate of 10 MB/sec. Volumes written by T9840A and T9840B transports are interchangeable between the two devices.
T9840B	Access-centric transport, provides 20 GB read/write capability for 9840 cartridges at a native, uncompressed transfer rate of 19 MB/sec. Volumes written by T9840A and T9840B transports are interchangeable between the two devices.
T9840C	Access-centric transport, provides 40GB read/write capability for 9840 cartridges at a native, uncompressed transfer rate of 30 MB/sec. The T9840C can read volumes written by T9840A and T9840B transports, but cannot write to them unless the entire volume is being re-written.
T9940A	Capacity-centric transport, provides 60 GB read/write capability for 9940 cartridges. The T9940A cannot read volumes written by T9940B transports, and cannot write to them unless the entire volume is being re-written.
T9940B	Capacity-centric cartridge tape transport, provides 200 GB read/write capability for 9940 cartridges. The T9940B can read volumes written by T9940A transports, but cannot write to them unless the entire volume is being re-written. With VSM, T9940B transports may <b>only</b> be defined as 3490-image devices. With a native interface, T9940B transports may <b>only</b> be defined as 3590-image devices.

## StorageTek Media

LibraryStation 6.0 supports the following media:

**Table 3. StorageTek Media**

Media	Description
Standard capacity (3480)	cartridge used on any longitudinal transport (i.e. 4480, 4490, 9490, or 9490EE). <b>Note:</b> If data is written to the tape in 36-track mode, the data cannot be read by an 18-track 4480 transport.
Enhanced capacity (ECART)	cartridge used only on 36-track transports (i.e. 4490, 9490, or 9490EE), has a length of 1100 ft. and is visually identified by a two-tone color housing.
Extended-enhanced capacity (ZCART)	cartridge used only on Timberline 9490EE 36-track transports, uses a thinner media to provide twice the capacity of the ECART cartridge.
Helical (SD-3)	cartridge used only on Redwood (SD-3) transports, is visually identified by the leader block on the left side of the cartridge. There are four types of helical cartridges: DD3A (10 GB) DD3B (25 GB) DD3C (50 GB) DD3D (cleaning cartridge)
9840 (STK1)	cartridge used only on T9840 transports, providing storage of up to 40 GB of uncompressed data.  capacity: 20 GB (when written by T9840 A/B transport) 40 GB (when written by T9840C transport)
9940 (STK2)	cartridge used only on T9940 transports, providing storage of up to 200 GB of uncompressed data.  capacity: 60 GB (when written by T9940A transport) 200 GB (when written by T9940B transport)



**Note:** An ACS can contain mixed library transports and media. In addition, 3480-, 3490E-, and helical-type cartridge transports can be attached to the MVS system outside of the library.





## Chapter 2. LibraryStation Configuration Overview

---

### LibraryStation Installation

LibraryStation must be installed prior to performing LibraryStation Configuration tasks. LibraryStation software is installed from the StorageTek distribution tape onto the MVS host system using the IBM SMP/E utility.



**Note:** LibraryStation 6.0 is not a dependent SYSMOD of the HSC base SYSMOD.

Procedures for installing LibraryStation software are contained in the *NCS Installation Guide*.

### Overview of LibraryStation Configuration Tasks

Once LibraryStation installation is complete, you must perform the configuration tasks contained in the remaining chapters of this guide. LibraryStation configuration tasks include the following:

- Verifying Hardware and Software Requirements
- Configuring Communication Facilities
- Configuring Security Measures
- Allocating the Persistent Data File
- Configuring the LibraryStation Hostid
- Configuring Drive Device Numbers
- Configuring the LSINIT Control Statement
- Configuring the LSDEF Data Set
- Configuring the HSC Started Task Procedure
- Configuring the LibraryStation license key
- Reconfiguring the HSC LIBGEN
- Starting LibraryStation
- Verifying LibraryStation Configuration

A configuration worksheet is included in Appendix B of this guide. As you complete configuration tasks, record site-specific information on this worksheet.

## Typical Configurations

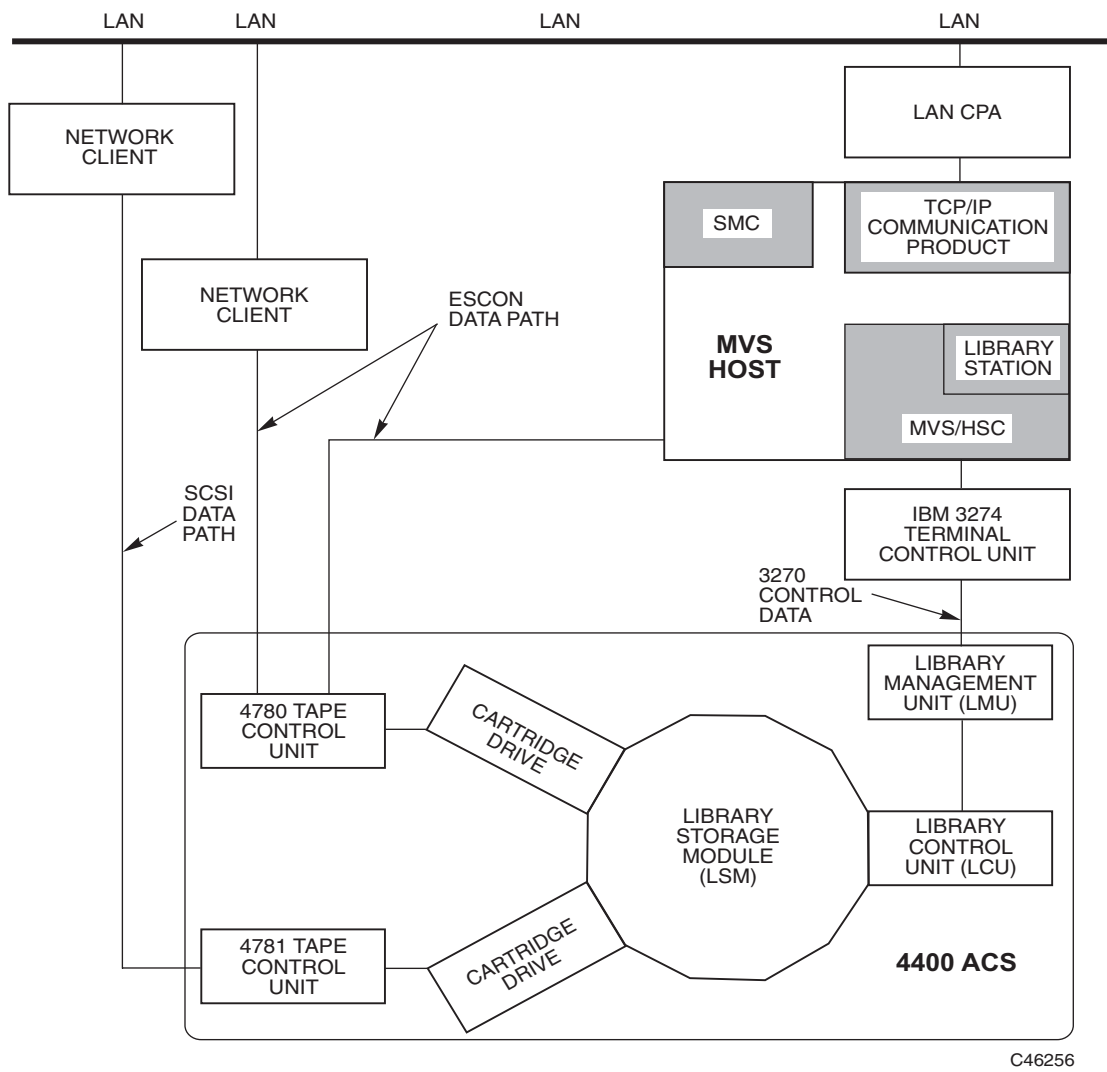
LibraryStation provides the following capabilities that are not found in a normal HSC configuration without LibraryStation:

- The HSC system serves as a conduit for control path communication between network client systems and the ACS system.
- The data path between the Nearline ACS and network client system is independent of the HSC system. Depending on the control unit, the data path can be ESCON, FIPS-60 “Bus and Tag” or SCSI.

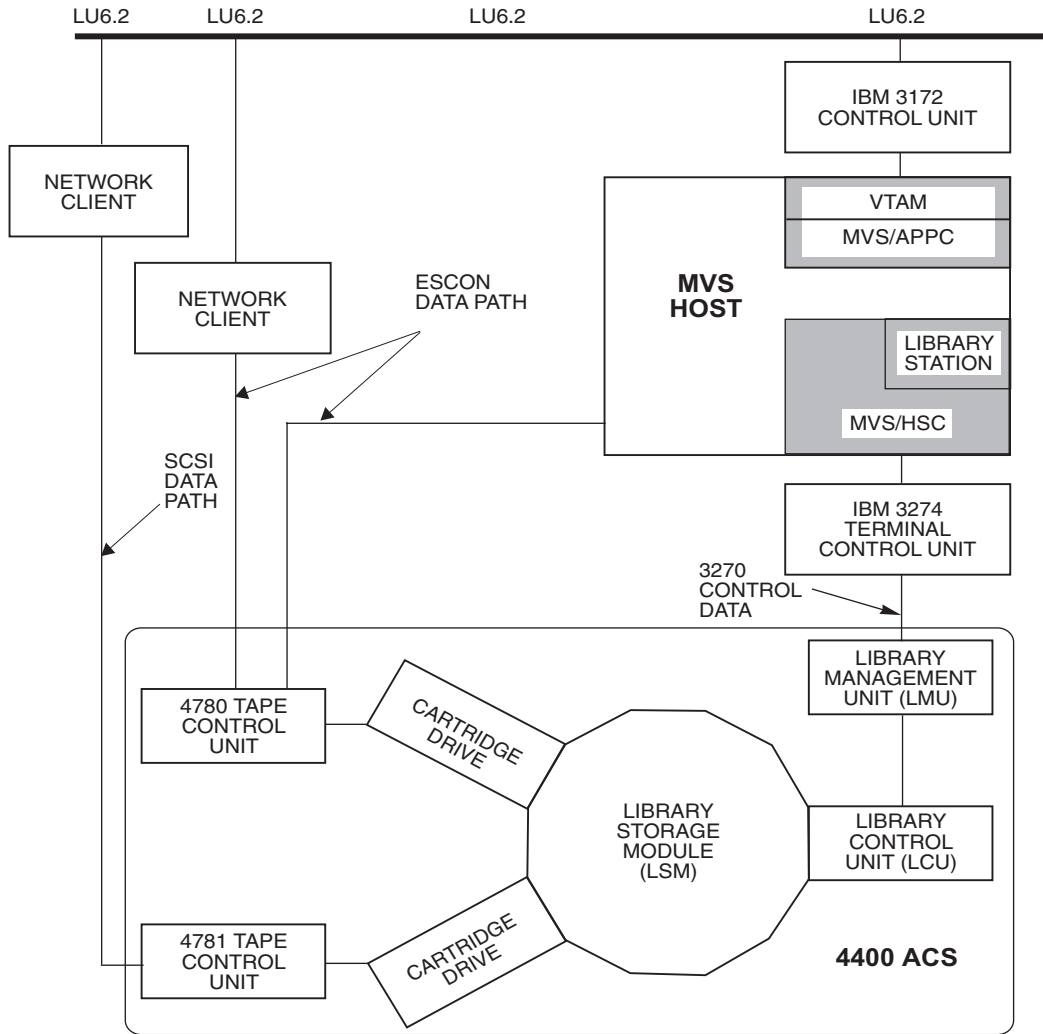
LibraryStation functions are made possible with the addition of four hardware and software elements that are not present in the normal HSC configuration:

1. LibraryStation software for protocol support between the network client system and the HSC host system.
2. TCP/IP communications software for ONC/RPC support, APPC/MVS and VTAM for SNA LU6.2 support.
3. For ONC/RPC support, a network interface adaptor that provides an IBM channel connection to an Ethernet local area network (LAN). Depending on the TCP/IP communication product you choose, various network interface adapters can be used for this connection. Consult your TCP/IP vendor for a list of supported network adapters.
4. For LU6.2 support, many hardware configurations can be used. Typical configurations use an IBM 3172 or 3174 establishment controller to connect to a token ring network.
5. For XCF support, a Coupling Facility (CF) or Channel to Channel (CTC) device is required.
6. A network client system, such as StorageTek’s Client System Component for MVS (MVS/CSC).

Typical LibraryStation configurations are illustrated on the following pages.

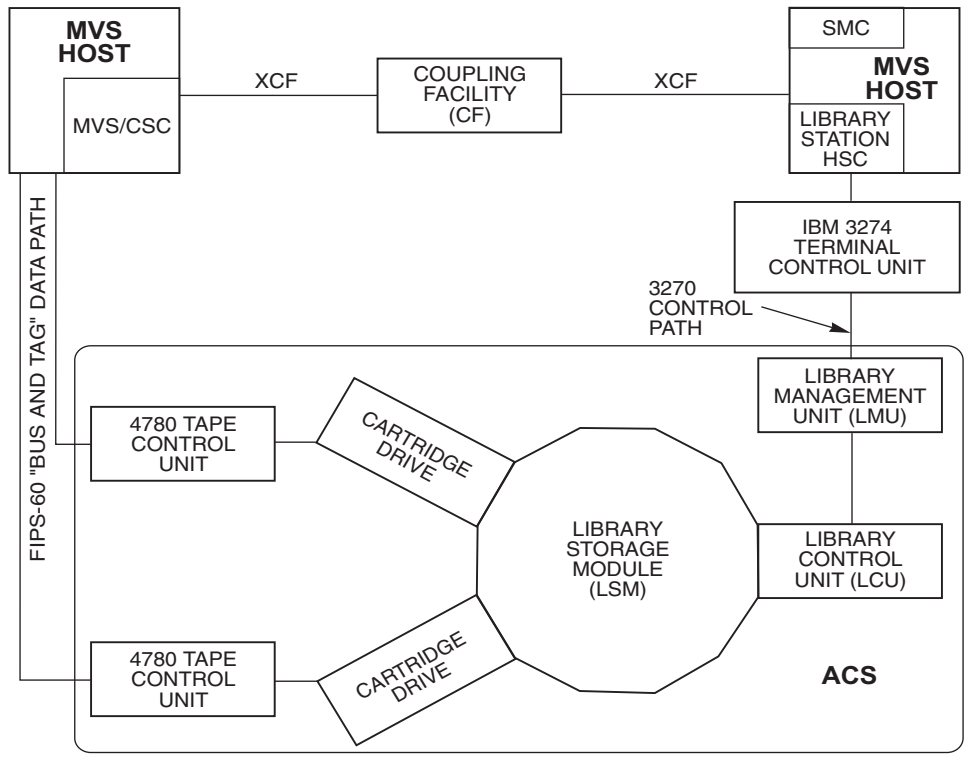


**Figure 2. Typical LibraryStation Configuration for ONC/RPC Clients**



C46107

**Figure 3. Typical LibraryStation Configuration for LU6.2 Clients**



C46139

Figure 4. Typical LibraryStation Sysplex Configuration

# LibraryStation Client/Server Environments

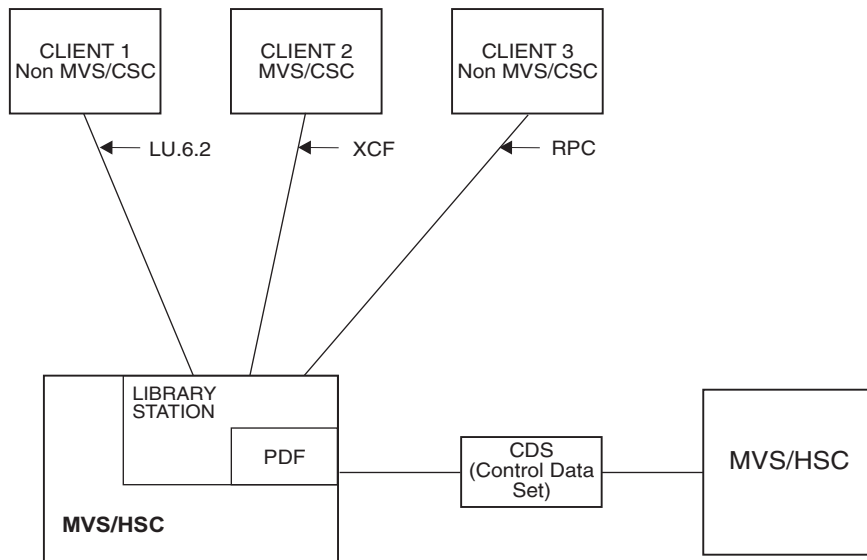
The following sections summarize the various LibraryStation client/server environments:

## Heterogeneous Environment

A heterogeneous environment consists of a single LibraryStation server attached to various clients (including MVS/CSC) using RPC, LU6.2, or XCF communication types.

Non-MVS/CSC clients can issue drive and volume locking requests to serialize resources. Drive and volume locking information is stored in the Persistent Data File (PDF), a component of LibraryStation. The PDF is required and must be enabled using one of the two methods described in Chapter 6, “Allocating the Persistent Data File” on page 41. To ensure the integrity of the information stored in the PDF, only one LibraryStation server can execute in this environment.

The following figure illustrates this client/server environment:



C46257

**Figure 5. Heterogeneous Environment**

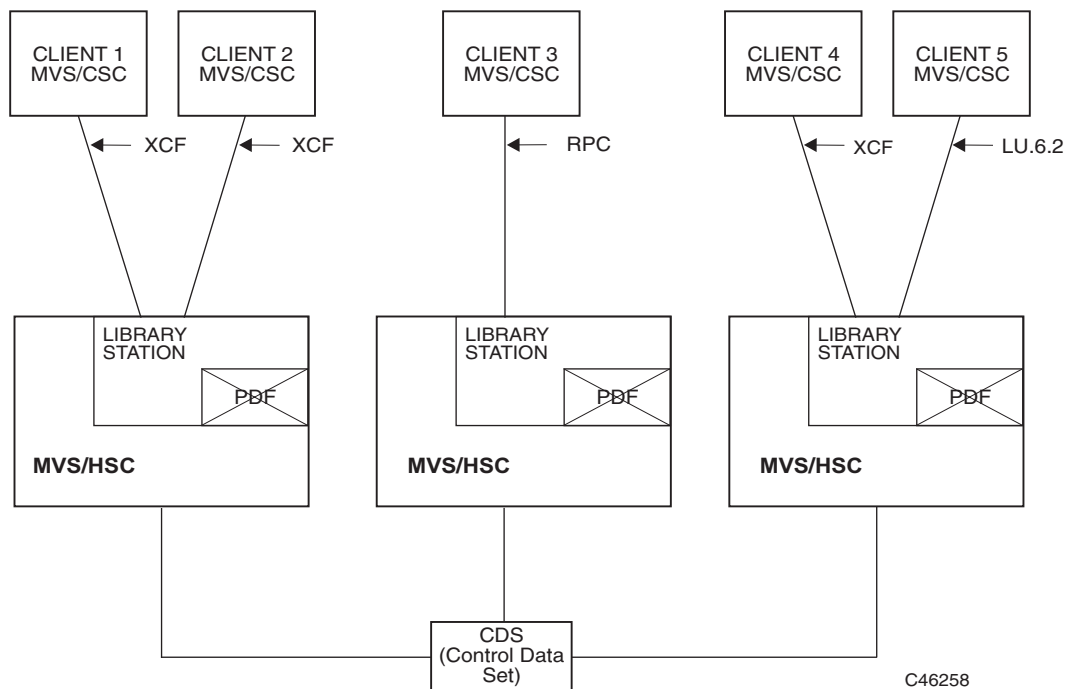
## Sysplex (Homogeneous Environment)

A sysplex, or homogeneous environment consists of a maximum of three LibraryStation servers attached only to MVS/CSC clients using XCF, LU6.2, or RPC communication types.

These MVS/CSC clients utilize Dynamic Server Switching (DSS). Dynamic server switching allows the client to dynamically switch connection to an alternate LCS (Library Control System) when it detects that the current LCS is unavailable. Dynamic server switching is configured for each MVS/CSC client using the MVS/CSC SRVRLIST startup parameter. Refer to the *MVS/CSC Configuration Guide* for more information on dynamic server switching and the SRVRLIST startup parameter.

MVS/CSC clients do not use drive and volume locking. Instead, MVS and related products provide for the sharing and serialization of resources. Thus, a PDF is not needed in this environment and must be disabled for each LibraryStation by specifying the NOPDF keyword in the LSINIT control statement.

The following figure illustrates this client/server environment:



**Figure 6. Sysplex Environment**

## Sysplex With Heterogeneous Support for Non-MVS/CSC Clients

It is possible to add heterogeneous support for non-MVS/CSC clients within a sysplex environment. This is accomplished by allowing only one LibraryStation to initialize with a PDF. The NOPDF keyword MUST be specified in the LSINIT control statement for all other LibraryStations. Non-MVS/CSC clients must attach to the LibraryStation with the PDF using RPC or LU6.2 communication types. By utilizing the PDF, these clients can issue drive and volume locking requests to serialize resources. MVS/CSC clients do not use drive and volume locking. Instead, MVS and related products provide for the sharing and serialization of resources.

To ensure that the MVS/CSC clients do not compromise the integrity of the information stored in the PDF, any client using volume locking must secure the locked volumes using LibraryStation client volume access. Refer to Chapter 5, “Configuring Security Measures” on page 27 for more information.

The following diagram illustrates this client/server environment:

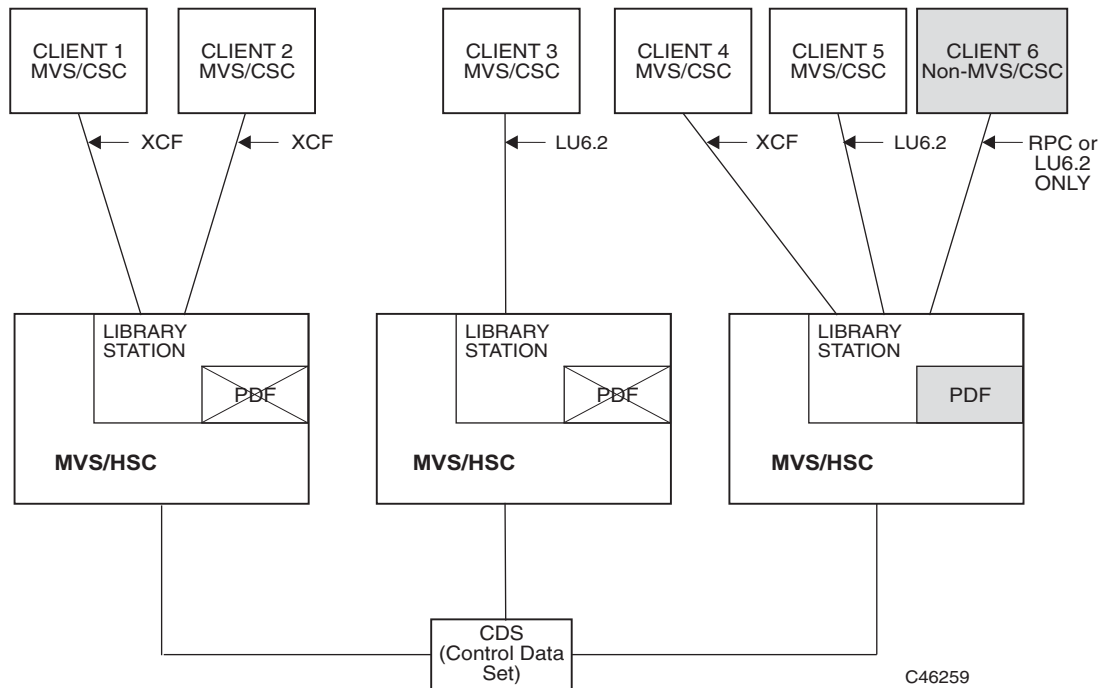


Figure 7. Sysplex Environment with Heterogeneous Support



## System Redundancy Options

The following applies to heterogeneous LibraryStation installations only; it does not apply to MVS sysplex installations.

For system redundancy in the event of a failure on the MVS host system from which LibraryStation is normally executed, LibraryStation software can be made available to more than one MVS host system attached to the same Nearline ACS library complex.

If the HSC host system fails in this scenario, LibraryStation can be automatically initialized on an alternate host system via a host communication request. Or, LibraryStation can be manually initialized from an alternate host system using the LibraryStation LS INit operator command. Refer to the XHREC, HOSTID and DEFER parameters in Chapter 9, “Configuring the LSINIT Control Statement” on page 53.

LibraryStation software can be made available to multiple hosts either by installing it directly on each host or by installing it on DASD that is shared among the hosts. However, each host that will be capable of initializing LibraryStation must also have the HSC, a communications subsystem, and a network interface adaptor installed. The initializing hosts must also access a common PARMLIB data set.



## Chapter 3. Verifying Hardware and Software Requirements

---

LibraryStation requires that certain hardware components and software packages be in place prior to execution.

### Hardware Requirements

Required hardware components must be installed prior to LibraryStation installation.

The following hardware is required for LibraryStation:

- IBM or IBM-compatible processor capable of running MVS/ESA SP 5.2.2 or later.
- StorageTek Nearline Automated Cartridge System (ACS) library hardware.
- For installations using a TCP/IP communications product such as IBM TCP/IP or CA Unicenter TCPaccess Communications Server, a network interface adapter is required. Consult your TCP/IP vendor for a list of supported network adapters.
- For installations using APPC/MVS, the network hardware that provides connectivity to the client must be installed. This hardware is not provided by StorageTek. Typical configurations might use an IBM 3172 or IBM 3174 Interconnect Controller to connect to a token ring network. Channel-to-channel connections are also possible; essentially, any connection that VTAM supports can be used.
- For installations using XCF, a Coupling Facility (CF) or a Channel to Channel (CTC) device.

#### Action Item

Verify that all required hardware packages are installed and check off each installed component on the LibraryStation Configuration Worksheet on page 85.

## Software Requirements

The following software is required on the MVS host system for LibraryStation:

- LibraryStation Release 6.0
- IBM MVS/ESA SP 5.2.2
- StorageTek HSC (MVS/ESA Implementation) 6.0

### Communications Interface Software Requirements

- IBM TCP/IP Release 3.1 or higher, CA Unicenter TCPAccess Release 5.0 or higher, or CA Unicenter TCPAccess X.25 Release 1 or higher is required for ONC/RPC communications.



**Note:** If you are using TCP/IP for communication between HSC/LibraryStation and the MVS/CSC, the TCP/IP Portmapper must be active on both the server and client.

- IBM APPC/MVS communications services are required for SNA LU6.2 communications.
- IBM XCF communications services are required for XCF communications.
- VTAM 3.4 or later (not required for TCP/IP-attached clients)

#### Action Item

Verify that all required software packages are installed and check off each installed component on the LibraryStation Configuration Worksheet on page 85.

## Optional Supporting Software

The following types of software products are not required by LibraryStation but may facilitate usage of LibraryStation under varying site requirements:

- A Tape Management System (TMS) that implements management of tape pools (for example, CA-1)
- A System Authorization Facility (SAF) security system that checks LibraryStation requests for authorization using the IBM MVS RACROUTE request facility (for example, RACF)

Optional software products can be installed at any time before or after LibraryStation software is installed.

## Chapter 4. Configuring Communication Facilities

---

Based on the type of client systems LibraryStation will support, various communications facilities must be installed. This chapter contains information regarding installation and configuration of these facilities.

### ONC/RPC Support

A TCP/IP communications product, such as IBM TCP/IP or CA Unicenter TCPAccess Communications Server, must be installed for LibraryStation to support ONC/RPC clients. Consult your TCP/IP vendor for specific installation procedures.

### Domain Name Resolution

If you are using IBM TCP/IP for TCP/IP communications, the SAS/C socket library uses the following procedure to resolve host names and addresses:



**Note:** If you are using CA Unicenter TCPAccess TCP/IP products, the following procedure does not apply. Contact your CA TCPAccess Network Administrator.

1. The SAS/C socket library looks for the ETC.RESOLV.CONF data set. If this data set is not found, the SAS/C socket library looks for the TCPIP\_PREFIX.ETC.RESOLV.CONF data set; the MVS data set equivalent to /etc/resolv/conf.
  - If it finds either of these data sets, the socket library performs the requested queries through the resolver and returns any answer it receives.
  - If no answer is received, the socket library performs the actions in step 3, below.
  - If neither data set is found, the socket library performs the actions in step 2, below.
2. It looks for the data set in the format of the IBM TCPIP.DATA data set.
  - If the NSINTERADDR statement in this data set specifies the use of the resolver and name server, the socket library performs the specified queries and returns any answer it receives.
  - If no answer is received, the socket library performs the actions in step 3, below.
3. It looks for the TCPIP\_PREFIX.ETC.HOSTS data set; the MVS data set equivalent to /etc/hosts. If it finds the data set, the socket library returns the result, including failure.

The SAS/C environment has a limit of three name servers, and thus the SAS/C socket library only recognizes the first three name servers specified in this data set.



**Note:** Contact your TCP/IP Networking Administrator for details regarding the content and format of the configuration data sets mentioned above.

## Resolving the TCPIP\_PREFIX High Level Qualifier

The high level qualifier for the previously listed data sets defaults to TCPIP (IBM convention), or can be set using the DATASETPREFIX statement in the IBM TCP/IP configuration data set TCPIP.DATA. To access this data set, add the following DD statement to the HSC Started Task procedure:

```
//SYSTCPD DD DSN=ddd.eee.fff(anyname)
```

This DD statement identifies the data set used to obtain parameters defined by the IBM TCPIP.DATA configuration data set. Refer to the *IBM TCP/IP Customization and Administration Guide* for more information.

## LU6.2 Support

IBM APPC/MVS and VTAM are required to support SNA LU6.2 clients.

The following steps must be performed if LibraryStation will be used to communicate with LU6.2 clients. These steps should be performed by an experienced network systems programmer who is familiar with VTAM, APPC/MVS, and the physical network hardware used to connect the client system to MVS. It may also be necessary to involve the network administrator who is responsible for the client system.

Before performing these steps, verify that the following prerequisite requirements are met:

- MVS/ESA 5.2.2 or later is the installed operating system
- VTAM 3.4 or later is installed and operational
- All network hardware used to connect the client system to MVS is installed and properly defined to VTAM.

It may be helpful to have the following manuals available for reference:

- *IBM MVS/ESA Planning: APPC Management*
- *IBM VTAM Customization*
- *IBM VTAM Resource Definition Reference*
- *IBM VTAM Network Implementation Guide*

If you are not familiar with APPC/MVS, StorageTek highly recommends that you take time to familiarize yourself with the *IBM MVS/ESA Planning: APPC Management manual*.



**Note:** The examples provided in this description use LIBSTAT as the Logical Unit (LU) name for LibraryStation. This can be changed to meet any LU naming conventions your installation may require.

## VTAM Setup

1. A local Logical Unit for LibraryStation must be defined with a VTAM application (APPL) definition statement in SYS1.VTAMLST. This is the Logical Unit that the client system will use in order to connect to LibraryStation. The Logical Unit is defined to APPC using an LUADD statement in the APPCPMLS SYS1.PARMLIB member and it is also specified in the APPC side information entry that LibraryStation uses in order to register with APPC.

Details about creating the APPCPMLS member in SYS1.PARMLIB and the APPC side information file are provided later in this description. The following APPL statement can be used:

```
LIBSTAT    APPL    ACBNAME=LIBSTAT,
              APPC=YES,
              AUTOSES=0,
              DDRAINL=NALLOW,
              DLOGMOD=APPCHOST,
              DMINWNL=5,
              DMINWNR=5,
              DRESPL=NALLOW,
              DSESLIM=10,
              LMDENT=19,
              MODETAB=LOGMODES,
              PARSESS=YES,
              SECACPT=CONV,
              SRBEXIT=YES,
              VPACING=1
```

**Figure 8. Sample VTAM Setup APPL Statement**

2. Logon mode entries necessary for LU6.2 sessions must be compiled into the logon mode table that exists in SYS1.VTAMLIB. The required entries are SNASVCMG and APPCHOST. These entries can be found in the SYS1.SAMPLIB member ATBLMODE.

The *IBM MVS/ESA Planning: APPC Management manual* provides more details about defining the local Logical Unit and logon mode entry.



**Note:** Other VTAM setup is required to define the physical connection between the client system and MVS. An experienced network systems programmer should be involved in this setup and it should be completed before installing LibraryStation.

## APPC/MVS Configuration

The setup for APPC/MVS consists of the following steps:

1. Create a member in SYS1.PARMLIB named APPCPMLS with the following information (or add to an existing APPCPMxx member):

```
LUADD ACBNAME(LIBSTAT) BASE NOSCHED TPDATA(side_info_file)
SIDEINFO DATASET(side_info_file)
```

where: *side\_info\_file* is the name of the VSAM KSDS that contains APPC side information for the installation (see step 2).



**Note:** If a Base already exists, do not include “BASE” in the statement above.

The *IBM MVS/ESA Planning: APPC Management* manual describes the APPCPMxx parmlib statement in more detail.

When APPC is started through the use of the START APPC MVS command, you must specify the last two letters of the member name on the START command, as shown in the following example:

```
START APPC,SUB=MSTR,APPC=LS
```

The *IBM MVS/ESA Planning: APPC Management* manual provides detailed information about starting and stopping APPC. It also includes instructions for displaying the status of APPC using the DISPLAY APPC command.

2. Create the APPC side information file and add an entry for LibraryStation.

The following JCL can be used to define and populate an APPC side information file suitable for LibraryStation operation. If your site already has a side information file defined, you only need to run the INITSIDE step.

```
//DEFAPPC JOB job card information
//DEFSIDE EXEC PGM=IDCAMS
//SYSPRINT DD SYSOUT=*
//SYSABEND DD SYSOUT=*
//AMSDUMO DD SYSOUT=*
//SYSIN DD *
DEFINE CLUSTER (NAME(cluster_name) _
VOLUME(volser) _
INDEXED REUSE _
SHAREOPTIONS(3 3) _
RECORDSIZE(248 248) _
KEYS(112 0) _
RECORDS(5 5)) _
DATA _
(NAME(cluster_name.DATA)) _
INDEX _
(NAME(cluster_name.INDEX))
```

Figure 9. Sample APPC Side Information File - Part 1



```

//INITSIDE EXEC PGM=ATBSDFMU
//SYSPRINT DD SYSOUT=*
//SYSSDLIB DD DSN=cluster_name,DISP=SHR
//SYSSDOUT DD SYSOUT=*
//SYSIN DD DATA,DLM='JR'
SIADD
    DESTNAME(LIBSTAT)
    TPNAME(CSCI)
    PARTNER_LU(LIBSTAT)
    MODENAME(APPCHOST)

```

**Figure 10. Sample APPC Side Information File - Part 2**

### *cluster\_name*

The file name specified here is used on the SIDEINFO DATASET statement in the APPCPMLS parmlib member (see step 1 above).

### **PARTNER\_LU**

used by LibraryStation when it registers with the APPC address space. It is also used by the SLGDIAG utility to define the destination Logical Unit. This Logical Unit name must match the name (LIBSTAT) that was chosen on the VTAM APPL statement. See “VTAM Setup” on page 23.

### **MODENAME**

the name of the logon mode that controls the session between LibraryStation and the client application. A sample logon mode (APPCHOST) is provided. See “VTAM Setup” on page 23.

## **APPC/MVS Operation**

Prior to starting LibraryStation, APPC/MVS and VTAM should be up and all physical and logical units used to connect the client system to the LibraryStation Logical Unit should be active. This can be done either manually with operator commands or automatically at IPL. See your network system programmer for help. The *IBM MVS/ESA Planning: APPC/MVS Management Manual* describes the start command for starting APPC/MVS. The *IBM VTAM Operation Manual* describes commands for starting VTAM and for activating logical units.

## **XCF Support**

In a sysplex environment, MVS Cross-system Coupling Facility (XCF) can be used for communication between LibraryStation and MVS/CSC. XCF is only supported by LibraryStation for MVS 5.2.2 or later.

XCF is enabled by the LSINIT COMMTYPE statement and configured with the LSINIT XCFGROUP and XCFMEMBER statements.

In the MVS system PARMLIB, member COUPLExx parameter GROUP is installation-definable but defaults to SLGSTATN. The COUPLExx parameter must match the LibraryStation parameter XCFGROUP.



## Chapter 5. Configuring Security Measures

---

Network client access to library resources is controlled by LibraryStation security measures. Resources that may require access control fall into three categories: tape cartridge drives, volumes, and client commands.

Depending on your security decisions, one or more of the tasks described in this chapter may require specific parameter settings or additional work on your part **before** you reconfigure the HSC LIBGEN.

### Drive Access Security

Access to tape cartridge drives is controlled by limiting the number of drives that are available to LibraryStation. LibraryStation drives are defined in the HSC LIBGEN as belonging to the host associated with the NETHOST keyword in the LSINIT control statement. Drives that are not associated with this hostid are restricted from use by the network.

To restrict the number of tape cartridge drives the network can use, you must define which specific drives are available to LibraryStation. This procedure is described in Chapter 8, “Configuring Drive Device Numbers” on page 47.

### Volume Access Security

LibraryStation provides two levels of access security for client’s volumes. Neither, one, or both can be implemented. One level of security allows protection of MVS volumes from all network clients. The other level of security allows volume access on a client-by-client basis. Both levels are implemented using RACROUTE calls to specify authorization to use the volume.

The IBM RACROUTE request specifies the APPL=’SLGSTATN’ parameter. This can be used by your SAF exits to identify that the request came from LibraryStation.

When using either method of volume authorization checking, you must write security rules to allow or deny access to the volumes. See “Implementing Network-Level Volume Authorization Checks” on page 30 for more information.



**Note:** When a sysplex is running LibraryStations with NOPDF and PDF options, use of LibraryStation volume access security is critical for protection of both MVS and network client volumes.

The following parameters of the LSINIT statement influence both levels of volume authorization checking.

```
LSINIT VSECLOG(YES) AUTHCLS(#LSTAPE) VOLNOPRF(ALLOW)
```

where:

### **VSECLOG(YES)**

Setting the VSECLOG parameter to YES causes volume security violations to be logged on the MVS system log and in the HSC job log. StorageTek recommends that VSECLOG be set to YES during initial testing of volume authorization. After you are satisfied that volume authorization is working as desired, you can change the parameter to NO to stop receiving these messages.

### **AUTHCLS(#LSTAPE)**

This parameter defines the security class to which the volumes are defined. The above example defines a new security class called #LSTAPE. Once you have picked a security class, use that name for the AUTHCLS parameter value.

The default value for AUTHCLS is TAPEVOL. If you are using a security product that also provides the TAPEDSN class, StorageTek recommends that TAPEVOL not be used. Some security products alter the list of users allowed to access a volume when the TAPEDSN class is also being used. This can cause LibraryStation authority checking to fail, thus allowing inappropriate access.

An alternative to the TAPEVOL class is the FACILITY class. This is a defined class to some security products and thus does not require you to create a new security class.

You can define your own security class to be used in the RACROUTE calls. Be sure to follow all the steps required by your security package to define and activate the class.

### **VOLNOPRF(ALLOW)**

Volumes not defined to the security class are considered to be available for any client request. If you have many MVS volumes and you use the RACF security product, you can prevent clients from accessing undefined volumes by setting VOLNOPRF to DENY as a parameter on the LSINIT statement. If a volume is unknown to RACF, read or write access to the volume is denied. VOLNOPRF works in conjunction with VOLACC or VOLAUTH.

#### **Action Item**

Record site specific values for these parameters on the LibraryStation Configuration Worksheet on page 85.

## Network-Level Volume Authorization Checks

When your installation wants to protect MVS volumes from all network clients and does not want to protect one client's volumes from another client, network-level volume authorization checking is a good choice for volume protection.

Network-level volume authorization checks work in the following manner. When a client requests access to a volume, an IBM RACROUTE call with REQUEST=AUTH is issued to the System Authorization Facility (for example, RACF) to determine whether LibraryStation has access to the volume. If LibraryStation's access to the volume is not sufficient, the client request is denied. For example, when a client requests to eject a volume, LibraryStation must have UPDATE authority to that volume for the client eject request to succeed. If LibraryStation has no access or only READ access to the volume, the client eject request fails. The client is notified that the volume is in use. A complete list of client requests with required LibraryStation authority for network-level volume authorization is provided in "Implementing Network-Level Volume Authorization Checks" below.

The VOLAUTH parameter of the LSINIT statement determines if network-level volume authorization is in effect.

```
LSINIT VOLAUTH(YES),VSECLOG(YES),AUTHCLS(#LSTAPE),VOLNOPRF(ALLOW)
```

where:

### **VOLAUTH(YES)**

Setting the VOLAUTH parameter to YES or letting it default to YES enables network-level volume authorization checking.

#### **Action Item**

Record your value for this parameter on the LibraryStation Configuration Worksheet on page 85.

## Implementing Network-Level Volume Authorization Checks

If you plan to require network volume-access security, you must use a security product (for example, RACF) on your MVS system.

To enable this level of volume-access control, you could use the following steps:

1. Create a security id for LibraryStation. LibraryStation issues the RACROUTE REQUEST=AUTH macro from the HSC address space. The security id associated with the RACROUTE request will be the security id defined for the HSC address space. Follow the rules of your security package for defining a security id for a started task. Do not give the security id any special privileges.
2. If you are not using the TAPEVOL or FACILITY security class, create a security class for the tape volumes.
3. Activate the security class you are using.
4. Define volumes to the security class.
5. Write security rules to allow LibraryStation (the HSC started-task security id) the appropriate access to the library volumes.
6. To prevent clients from mounting scratch volumes meant only for HSC use, define separate scratch subpools for LibraryStation. See “Scratch Pool Processing” on page 38 for more information.
7. Verify that the VOLAUTH parameter of the LSINIT statement is set to YES or allowed to default. Refer to Chapter 8, “Configuring Drive Device Numbers” on page 47 for a description of the VOLAUTH parameter.

SAF checks are issued for the following requests:

- Requests requiring a minimum of READ authority:
  - Dismount
  - Mount with read-only option
  - Query\_volume
- Requests requiring a minimum of UPDATE authority:
  - Eject
  - Mount
  - Set\_scratch

If you plan not to require network volume-access security, you should disable it by specifying VOLAUTH(NO) in the LSINIT control statement.

## Example 1 - Restricting all MVS volumes from network client use

To restrict MVS volumes from network client use of any kind, you could use the following steps:

1. Create a security id for LibraryStation by defining a security id for the HSC started task.
2. Using your security product:
  - Use the FACILITY class to define volumes, and activate the class.
  - Reserve volumes 000000-199999 for MVS use only. (Write rules to deny access to these volumes for the LibraryStation security id.)
  - Reserve volumes 200000-200099 for client use. (Write rules to allow UPDATE access to these volumes for the LibraryStation security id.)
3. Set up the LibraryStation scratch pool so that no MVS volumes reside in the pool. To allow this, add the following statement to the HSC parameter data set:

```
SCRPOOL NAME(LIBSTA),RANGE(200000-200099)
```

(The scratch pool is associated with LibraryStation in the next step.)

4. Update the LSINIT control statement in the HSC parameter data set:

```
LSINIT COMMONSP(LIBSTA) AUTHCLS(FACILITY) VSECLOG(YES)  
      NETHOST(hostid)
```

Volume authorization is active by default. All client volumes are in one subpool that does not contain any MVS-only volumes. All volumes are defined to the FACILITY security class and security violations are to be logged on the MVS system log.

As a result, when a client request is received for a volume, RACROUTE is issued. If the volume is in the range for MVS-only volumes, access is denied and message SLS3945I is issued to the MVS system log. If the volume is in the range for client volumes, access is allowed and the client request continues to execute.

## Example 2 - Restricting most MVS volumes from network client use

To restrict most MVS volumes from network client use of any kind, while allowing the clients to share a few MVS volumes in read-only mode, you could use the following steps:

1. Create a security id for LibraryStation by defining a security id for the HSC started task.
2. Use your security product to:
  - Use the FACILITY class to define volumes, and activate the class.
  - Reserve volumes 000000-199999 for MVS use only. (Write rules to deny access to these volumes for the LibraryStation security id.)
  - Reserve volumes 200000-200099 for client use. (Write rules to allow UPDATE access to these volumes for the LibraryStation security id.)
  - Allow the volumes 300000-300005 to be shared by MVS and the clients. Clients are only allowed to read these volumes. (Write rules to allow READ access to these volumes for the LibraryStation security id.)
3. To set up the LibraryStation scratch pool so that no MVS volumes reside in the pool, add the following statement to the HSC parameter data set:

```
SCRPOOL NAME(LIBSTA),RANGE(200000-200099)
```

(The scratch pool is associated with LibraryStation in the next step.)

4. Update the LSINIT control statement in the HSC parameter data set:

```
LSINIT COMMONSP(LIBSTA) AUTHCLS(FACILITY) VSECLOG(YES)  
      NETHOST(hostid)
```

Volume authorization is active by default. This statement defines all client volumes in one subpool that does not contain any MVS-only volumes. All volumes are defined to the FACILITY security class and security violations are to be logged on the MVS system log.

When a client request is received for a volume, RACROUTE is issued. If the volume is in the range for MVS-only volumes, access is denied and message SLS3945I is issued to the MVS system log. If the volume is in the range for client volumes, access is allowed and the client request continues to execute. If the volume is in the shared range of volume serials and the client request requires UPDATE authority, access is denied and message SLS3945I is issued to the MVS system log. If the volume is in the shared range of volume serials and the client request requires READ authority, access is allowed.



## Client-Level Volume Authorization

If you would like to limit the volumes that a specific client can access, use client-level volume authorization. This level associates a security id with a client. This security id is used in the RACROUTE call to determine whether the client has the authority required to perform its request. Client-level volume authorization can be used to protect a client's volume from another client and to protect MVS volumes from specific clients.

When using client-level volume authorization, the clients must be defined in the LSDEF file. The CLIENTID statement in that file associates a security id with the client's network identifier. That security id is used in the RACROUTE call to determine whether the client has authority to the volume. See Chapter 10, "Configuring the LSDEF Data Set" on page 67 for more information on the LSDEF Data Set.

Client-level volume authorization works in the following manner. When a client requests access to a volume, and IBM RACROUTE REQUEST=AUTH call is issued to the System Authorization Facility specifying the client's security id and the volume serial number to determine whether the client has access to the volume. If the client's access to the volume is not sufficient, the client request is denied. For example, when a client requests to eject a volume, the client must have UPDATE authority to that volume for the eject to succeed. If the client has no access or only READ access to the volume, the eject request fails. The client is notified that access has been denied or that the volume is not in the library. The response depends on the network protocol level supported by the client. A complete list of client requests with required client authority for client-level authorization is provided in "Implementing Client-Level Volume Authorization Checks" on page 34.

The VOLACC parameter of the LSINIT statement determines if client-level volume authorization is in effect.

```
LSINIT VOLACC(YES) VSECLOG(YES) AUTHCLS(#LSTAPE) VOLNOPRF(ALLOW)
      VOLAUTH(NO)
```

where:

### **VOLACC(YES)**

Setting the VOLACC parameter to YES enables client-level volume authorization checking. The default is NO.



**Note:** VOLACC(YES) is supported only when COMMTYPE is specified as RPC or LU6.

### **VOLAUTH(NO)**

Network-level volume authorization is active by default. In the example above, network-level volume authorization is turned off. Clients can also be restricted from MVS volumes by using client-level volume authorization checking.

**Action Item**

Record your value for this parameter on the LibraryStation Configuration Worksheet on page 85.

## Implementing Client-Level Volume Authorization Checks

If you plan to require security for volume access on a client level, you must install a security product (for example, RACF) on your MVS host system.

To enable volume-access control at the client level, you could use the following steps:

1. Create a security id for each client.
2. Add a CLIENTID parameter in the LSDEF file for each client. Refer to Chapter 10, “Configuring the LSDEF Data Set” on page 67 for more information.
3. Create a security class for the tape volumes if you are not using the TAPEVOL or FACILITY security class.
4. Activate the security class you are using.
5. Define volumes to the security class.
6. Write security rules to allow the client security id appropriate access to the library volumes.
7. Verify that LSINIT parameter VOLACC is set to YES. Refer to Chapter 9, “Configuring the LSINIT Control Statement” on page 53 for more information.

LibraryStation issues RACROUTE calls for the following client network requests:

- These requests require a minimum of READ authority:
  - Dismount
  - Mount with read-only option
  - Query\_volume
- These requests require UPDATE authority:
  - Eject
  - Lock
  - Mount
  - Mount\_scratch
  - Set\_scratch
  - Unlock

## Example 1 - Separating volumes for two clients and for MVS

To keep volumes separate for two clients and for MVS, you could use the following steps:

1. Use your security package to create a security id for each client in the complex.
2. Update the LSDEF file to associate the network location of the client with its security id. For example:

```
CLIENTID IPADDR(129.xx.xx.xxx) NAME(CLIENT1)
CLIENTID LUNAME(CLINT2LU) NAME(CLIENT2)
```

(In this example, one client is using TCP/IP and the other is using LU6.2.)

3. Use your security package to:
  - Use the FACILITY class to define volumes, and activate the class.
  - Reserve volumes 000000-199999 for MVS use only. (Write rules to deny access to these volumes for both CLIENT1 and CLIENT2.)
  - Reserve volumes 200000-299999 for CLIENT1 use. (Write rules to allow UPDATE access to these volumes for CLIENT1 and rules to deny access to these volumes for CLIENT2.)
  - Reserve volumes 300000-399999 for CLIENT2 use. (Write rules to allow UPDATE access to these volumes for CLIENT2 and rules to deny access to these volumes for CLIENT1.)
4. Update the LSINIT control statement in the HSC parameter data set as follows:

```
LSINIT VOLACC(YES) VOLAUTH(NO) AUTHCLS(FACILITY) VSECLLOG(YES)
```

Volume authorization is active by default. This control statement turns off volume authorization and activates volume-access checking at the client level. Volumes are defined to the FACILITY security class, and security violations are to be logged on the MVS system log.

As a result, when a client request is received for a volume, RACROUTE is issued. If the volume is in the range for MVS-only volumes, access is denied. If the volume is in the range for CLIENT1 volumes, access is allowed for CLIENT1 and denied for CLIENT2. If the volume is in the range for CLIENT2 volumes, access is allowed for CLIENT2 and denied for CLIENT1. Whenever access is denied, message SLS3945I is issued to the MVS system log.

## Volume Security Hierarchy

When both methods of volume security checking are specified (VOLAUTH and VOLACC parameters), the specific client volume-access checking is performed first.

The client commands that access volumes and are under the sphere of both the VOLAUTH and VOLACC parameter checking are:

- Dismount
- Eject
- Mount
- Query\_volume
- Set\_scratch

The client commands that are under the sphere of only the client volume access (VOLACC parameter) are:

- Lock
- Mount\_scratch
- Unlock



**Note:** The *mount with read\_only option* listed under the client volume access is not a separate command. The read\_only option is specified by a parameter of the client MOUNT command.

If you plan not to require volume-access security on a client level, you can leave the VOLACC parameter unspecified in the LSINIT control statement.

## Subpool Security Implications

For installations that use VOLAUTH only, network requests to mount scratch volumes do not pass through the IBM RACROUTE request mechanism. VOLACC issues RACROUTE calls for scratch mounts; VOLAUTH does not.

For VOLAUTH-only installations, network clients can mount any volume that is both identified as a scratch volume in the HSC Control Data Set (CDS), and defined in a scratch subpool known to the client. Consequently, for VOLAUTH-only installations, you must define subpools to contain only those volumes that network clients are allowed to mount. This is done in the HSC SCRPOOL control statement. See “Scratch Pool Processing” on page 38 for more information about defining subpools.

Network requests to mark a volume as scratch go through the IBM RACROUTE request check, preventing clients from scratching a volume they would not normally have access to and then performing mount scratch requests until the desired volume is mounted. However, if the HSC SCRATCH UPDATE utility is run to mark the volume as scratch, and if MVS and the client share a scratch pool, the clients could gain access to the volume.

## Command Access Security

RACF is the only security package supported by LibraryStation for command-level authorization checks. Access to commands is controlled by RACROUTE request calls to the System Authorization Facility (for example, RACF) to determine whether the command can be used by a network-attached user. Commands that SAF indicates cannot be accessed are not available to the client.

If you plan to require security for command access on a client level using RACROUTE calls to the System Authorization Facility (SAF), you must install RACF on your MVS host system, and you must enable the CMDACC parameter (CMDACC(YES)) in the LSINIT control statement. See Chapter 9, “Configuring the LSINIT Control Statement” on page 53.

To enable this level of access control, perform the following steps:

1. Use your security product to create a security id for the client.
2. Notify LibraryStation of the userid for the client by adding a CLIENTID parameter to the LSDEF file for the client. See Chapter 10, “Configuring the LSDEF Data Set” on page 67 for a description of the CLIENTID parameter.
3. Define the commands as applications to the security product as follows:

**Table 4. Command to Application Name Cross Reference**

Command	Application Name
CANCEL	SLGCANCL
CLEAR_LOCK	SLGCLRLK
DISMOUNT	SLGDISMO
EJECT	SLGEJECT
ENTER	SLGENTER
IDLE	SLGIDLE
LOCK	SLGLOCK
MOUNT	SLGMOUNT
MOUNT_SCRATCH	SLGMSCRT
QUERY	SLGQUERY
QUERY_LOCK	SLGQUYLK
SET_SCRATCH	SLGSETSC
START	SLGSTART
UNLOCK	SLGUNLOK
VARY	SLGVARY
VIRTUAL_MOUNT	SLGVMNT

4. Write rules to allow the client to read the application.
5. Activate the APPL class.
6. The startup parameter CMDACC in the LSINIT statement can be used to enable or disable command authorization checks. This parameter is disabled by default. Verify that the CMDACC parameter is set to YES. Refer to Chapter 9, “Configuring the LSINIT Control Statement” on page 53 for a description of the CMDACC parameter.

Commands that SAF indicates cannot be accessed are reported as “access denied” or “invalid command”.

If you plan not to require command access security on a client level, you can leave the CMDACC parameter in the LSINIT control statement unspecified.

## Scratch Pool Processing

LibraryStation relies on HSC to define the scratch pools it uses. HSC has a common, unnamed scratch pool that contains all scratch volumes. It also defines multiple, named scratch subpools that are subsets of the common pool. These scratch subpools are defined in the HSC PARMLIB by SCRPOOL statements. These statements indicate ranges of volumes that belong to the scratch subpool. If a volume also has the “scratch” attribute, then it can be selected for scratch mounting.

```
SCRPOOL NAME(LIBSTAT),RANGE(LS1###-LS13##),LABEL(SL)
SCRPOOL NAME(LSPPOOL),RANGE(LS13#1-LS14##),LABEL(SL)
```



### Notes:

1. If you use the HOSTID parameter on the SCRPOOL statement, it should point to your HSC host.
2. The time taken by Library Station to complete a query scratch request is proportional to the number of volumes included with the RANGE parameter. If you use ranges that include a large number of volumes, a query scratch can take a long time.

The scratch subpools may also be defined using the Scratch Subpool User Exit (SLSUX03), but the SCRPOOL statements are preferred. The ranges of volumes in the SCRPOOL statements can overlap, so some volumes can be in multiple scratch subpools.

LibraryStation only has access to named HSC scratch subpools that are identified for its use. These are identified in two ways.

1. The COMMONSP parameter of the LSINIT statement points LibraryStation’s scratch pool 0 to a named HSC scratch subpool. This scratch pool, and therefore this statement, are required for LibraryStation.

```
COMMONSP(LIBSTAT)
```

2. The SPNUM statement in the LSDEF data set equates a LibraryStation numeric scratch pool (0-65534) to an HSC-named scratch subpool. This statement is useful for clients who use scratch pools other than 0. For example:

```
SPNUM NUM(2) SPNAME(LSPOOL1)
SPNUM NUM(2) SPNAME(LSPOOL2) IPADDR(1.2.3.4)
```

In this example, the client at address 1.2.3.4 would get volumes from LSPOOL2 when referring to pool 2, and all other clients would get volumes from LSPOOL1.

Because HSC scratch subpools are defined during initialization, they, as well as LibraryStation scratch pools, are static. New scratch pools cannot be dynamically defined. New volumes outside the defined range cannot be dynamically included in a scratch pool. Also, a volume can be defined in the ranges for two scratch subpools. Thus, scratching it in one automatically scratches it in the other. For this reason, you may want to avoid overlapping pools if you want to keep volumes separate for various clients or for HSC. If you want distinct subpools for HSC and for clients, you should code the Job Processing User Exit (SLSUX01) not to select from the LibraryStation subpools if an HSC subpool is depleted. LibraryStation scratch requests do not use the exit, so their selection is always from the specified subpool.



**Note:** LibraryStation scratch mount requests have no interface to a Tape Management System (TMS) on MVS, so the subpools used by LibraryStation should not be defined to the TMS. Defining a subpool to the TMS may cause the TMS to have incorrect status for volumes if they are mounted by a client that does not have an interface to the TMS. For a TMS that works on the client side, take special care to keep the HSC scratch information synchronized with that in your TMS, because HSC can change scratch volumes without the knowledge of the client.

If your installation contains volumes stored on various media types, you can segregate them in scratch pools through careful definition of the HSC scratch subpools. Even if you do not segregate the pools, during scratch mounting, LibraryStation picks a volume whose medium is appropriate for the drive type. LibraryStation gets its scratch counts for selection from HSC VOLATTR statements, so VOLATTR statements should be coded for all non-standard volumes in scratch ranges.

LibraryStation has a POOLCHK parameter on the LSINIT statement that affects the scratching of volumes.

- With POOLCHK set to YES (the default), a set scratch request for a volume and a scratch pool ensures that the volume is defined in that pool before scratching the volume.
- With POOLCHK set to NO, no checking is done to see whether the volume is defined in any scratch pool before scratching it.

## Security Summary

The following list summarizes the methods available to you for ensuring that network clients cannot circumvent MVS access controls:

- Restrict the number of tape cartridge drives the network can use in the HSC LIBGEN for the hostid in the NETHOST keyword
- Use SAF security checks for volume access control
- Write rules that grant the HSC update authority for only those volumes the network is permitted to use, and also to prevent MVS users from accessing network client volumes
- Write rules to manage volume access for individual clients
- Define the subpools to contain only volumes the network is permitted to use.
- If you are using RACF, deny access to undefined volumes
- Use SAF security checks for command authorization control

### Action Item

Record your value for this parameter on the LibraryStation Configuration Worksheet on page 85.



## Chapter 6. Allocating the Persistent Data File

---

LibraryStation software includes a Database Manager (DBM) that is initialized during LibraryStation initialization. The DBM is responsible for managing several pertinent data objects that are not maintained by the HSC, including resource locks and drive status.

Data objects managed by the DBM are stored in one or more VSAM files. These files are collectively referred to as the Persistent Data File (PDF).

The PDF contains the following data objects:

- Volume records

Volume records contain only a lockid. They exist only while the volume is locked and are automatically deleted when the volume is unlocked.

- Drive records

A single drive record exists for each drive configured to LibraryStation. Each drive record consists of a lockid as well as status and state information.

- Lockid records

One lockid record exists for each unique lock identifier that has been assigned to the requesting clients. The lockid record contains a lock identifier and the associated owner of the lock.

The PDF VSAM data sets are initially defined during LibraryStation installation. This procedure is contained in the *NCS Installation Guide*.



**Note:** If you are migrating from a previous release of LibraryStation, you must delete the existing PDF and define a new PDF for LibraryStation 6.0. Refer to the *NCS Installation Guide* for this procedure.

After LibraryStation is installed, these data sets can be allocated using either of the following two methods:

- Specify the PDF and PDFX keywords on the LSINIT control statement. This method is required when requesting cross host recovery support.
- Specify the SLSPDF and SLSPDFX DD statements in your HSC Started Task Procedure.

## The PDF in a Multiple Host Environment

LibraryStation software can be installed on or made available to more than one host system in a heterogeneous environment. However, it can only be fully-initialized on one host system at a time.

For system redundancy in the event of a failure, more than one host system can be made capable of fully-initializing LibraryStation.

- Using Cross host recovery (implemented with the XHREC LSINIT parameter), the active LibraryStation automatically notifies standby LibraryStations to begin initialization. The first standby LibraryStation that is notified becomes active.
- LibraryStation can also be manually initiated from an alternate host using the LS INIT operator command.

Refer to the CHREC, HOSTID and DEFER options in Chapter 9, “Configuring the LSINIT Control Statement” for more information.

In an MVS sysplex environment with added heterogeneous support for non-MVS/CSC clients, you must allocate a single Persistent Data File (PDF) using one of the methods described in this chapter.

You must specify the keyword parameter NOPDF in the LSINIT control statement for all other LibraryStations that will be active at the same time. This parameter is not required when defining standby LibraryStations. See Chapter 9, “Configuring the LSINIT Control Statement” on page 53 for more information about the NOPDF and XHREC LSINIT parameters.



### Notes:

- In an MVS sysplex environment with added heterogeneous support for non-MVS/CSC clients, you must allocate a single Persistent Data File (PDF) using one of the methods described in this chapter.

You must specify the keyword parameter NOPDF in the LSINIT control statement for all other LibraryStations that will be active at the same time. This parameter is not required when defining standby LibraryStations. See Chapter 9, “Configuring the LSINIT Control Statement” on page 53 for more information about the NOPDF and XHREC LSINIT parameters.

- A single PDF is defined for LibraryStation, and the host system where LibraryStation is initialized must have access to the DASD volume where the PDF is located. Thus, in a multiple host environment where more than one host is capable of initializing LibraryStation, the PDF must be located on shared DASD that is accessible to each initializing host.
- To prevent the corruption of the PDF, LibraryStation issues a SYSTEMS ENQ. The ENQ QNAME is the HSC ENQ QNAME specified by the MAJNAME parameter of the HSC LIBGEN. The ENQ RNAME is LS:ACTIVE.

If you make LibraryStation software available to more than one host, you are responsible for propagating the SYSTEMS ENQ to each host. This can be done via Global Resource Serialization (GRS) or a functionally equivalent product.



## Chapter 7. Configuring the LibraryStation Hostid

---

A LibraryStation hostid must be defined in the HSC LIBGEN. This hostid is associated in the HSC LIBGEN with the cartridge drives that are assigned to LibraryStation. The hostid you define in this task will be used as the value for the NETHOST parameter in the LSINIT statement.

During operation, the LibraryStation hostid is specified by LibraryStation to the HSC for network drive requests. Additionally, this hostid is required for the HSC Mount and Dismount commands if operators are to mount or dismount volumes on cartridge drives assigned to LibraryStation.



**Note:** The NETHOST parameter specification on the LSINIT control statement must match the hostid that you define in this task. See Chapter 9, “Configuring the LSINIT Control Statement” on page 53 for more information about the NETHOST parameter.

To configure the HSC LIBGEN Hostid for LibraryStation, modify the HSC SLILIBRY macro in the HSC LIBGEN to define the LibraryStation hostid. SLILIBRY defines the global characteristics of the library. The SLILIBRY HOSTID parameter identifies each host that accesses the ACS and is the parameter you will modify to create your LibraryStation hostid.

The following sample illustrates where your hostid appears in the SLILIBRY macro.

```
*
      SLILIBRY  SMF=255.                                X
                HOSTID=(HSC1,LSID)                     X
               >NNLBDRV=(CARAPEA,CARAPEB),             X
                DELDISP=NOSCRTCH,                      X
                ACSLIST=NAMEACS,                       X
                MAJNAME=STKALSQN,                      X
                COMPRFX=#,                             X
                SCRLABL=SL,                            X
                EJCTPAS=GOODDAY,                      X
                CLNPRFX=CLN
*
```

**Figure 11. Sample SLILIBRY Macro with LibraryStation Hostid**

The LibraryStation hostid you define in this task can consist of one to eight alphanumeric characters. You might consider including the letters “LS” in the name to identify it as your LibraryStation hostid. Refer to the *Host Software Component System Programmer’s Guide* for more information about the SLILIBRY macro and the HSC LIBGEN process.

The SLIACS macro no longer requires a STATION parameter for each hostid in the configuration. **This parameter is optional.** If STATION is specified, parameters can be omitted for hosts that are not attached to the ACS by using the comma delimiter as follows:

Example:

```
STATION=( ,STN1)
```

where HOST0 does not have a defined connection and STN1 is a defined connection to Host.

In addition, the SLISTATN macro entry with a dummy address is no longer required and should not be entered.

Refer to the *Host Software Component Configuration Guide* for more information about the macros and parameters mentioned above.

**Action Item**

Enter your LibraryStation hostid on the LibraryStation Configuration Worksheet on page 85.

## Chapter 8. Configuring Drive Device Numbers

---

In this task, you configure device numbers in the HSC LIBGEN for tape cartridge drives that are assigned to LibraryStation.

Device numbers must be assigned in the HSC LIBGEN for network tape cartridge drives used by LibraryStation. The tape cartridge drives represented by the assigned device numbers are associated with LibraryStation via the HSC LIBGEN hostid defined in the previous chapter.



**Note:** Access to tape cartridge drives is controlled by limiting the number of drives that are available to LibraryStation. By not defining MVS drives for the LibraryStation hostid, you prevent network mounts and dismounts on these drives. See Chapter 5, “Configuring Security Measures” on page 27 for more information.

Device numbers can consist of three or four hexadecimal characters. All numbers are valid because device numbers are only associated with the LibraryStation hostid.

In addition, you must collect associated information for each device number you define. The following information is required by the HSC LIBGEN macros for each number:

- The ACS number (hexadecimal) where the drive is located
- The LSM number (hexadecimal) where the drive is located
- The drive panel number (decimal) where the drive is located

Refer to the *Host Software Component Configuration Guide* for more information about the SLILSM, SLIDLIST, and SLIDRIVS macros and the HSC LIBGEN process.

### Action Item

Enter your device numbers and associated location information on the LibraryStation Configuration Worksheet on page 85.

The process of defining device numbers for LibraryStation tape cartridge drives is somewhat dependent on your current configuration and how you intend to control network access to your tape cartridge drives. This process is outlined below in general terms, followed by a sample scenario that illustrates the steps you might take to achieve specific results.

Generally, defining device numbers for LibraryStation drives requires the following steps:

1. Add or modify the SLILSM macro

The SLILSM macro defines the panel numbers for an LSM. If this macro does not already include the drive panels you wish to make available to LibraryStation, modify it to define the physical location of these drive panels.

2. Add or modify the SLIDLIST macro

The SLIDLIST macro identifies which unique host addresses are associated with tape cartridge drives residing on a specific drive panel.

If you modified a SLILSM macro in the previous step, you must create a new SLIDLIST macro for each new panel.

If you did not modify a SLILSM macro, you still must modify existing SLIDLIST macros to define their relationship to the new LibraryStation hostid.



**Note:** HOSTDRV parameter operands in the SLIDLIST macro correspond to HOSTID parameter operands in the SLILIBRY macro.

The association is positional, so that the first hostid identified in the SLILIBRY macro is associated with the first hostdrv identified in the SLIDLIST macro, the second hostid is associated with the second hostdrv, and so on.

If the number of HOSTDRV operands in any SLIDLIST macro do not equal the number of HOSTID operands in the SLILIBRY macro, the HSC cannot be successfully initialized.

3. Add or modify the SLIDRIVS macro

The SLIDRIVS macro identifies whether or not tape cartridge drives in the panel specified in the SLIDLIST macro are available to the hostid associated with the HOSTDRV operand.

If the drives are available to the hostid, assign device numbers in the SLIDRIVS macro.

If the drives are not available to the hostid, enter position holding commas in the SLIDRIVS macro. Device numbers are not assigned.



**Note:** LibraryStation provides no automatic means of sharing tape cartridge drives between the MVS host and client systems. If a drive is being shared, you must use manual procedures to vary the drive offline to MVS and online to the client, and vice versa.

The following sample LIBGEN illustrates the process described above. Note that this sample contains only those macros and parameters that are pertinent to this discussion and does not represent a complete and functional HSC LIBGEN.



```

*
      SLILIBRY  HOSTID=(HSC1,LSID)
                        ACSLIST=NAMEACS
*
NAMEACS  SLIALIST  ACSØ,ACS1
*
ACSØ     SLIACS   LSM=LSMØ,LSM1
*
LSMØ     SLILSM   DRIVE=(1,2,1Ø),
                        DRVELST=(PANEL1,PANEL2,PANEL1Ø)
*
PANEL1   SLIDLIST  HOSTDRV=(DRV1,DRV1)
DRV1     SLIDRIVS  ADDRESS=(41Ø,411,412,413)
*
PANEL2   SLIDLIST  HOSTDRV=(DRV2,DUMMY2)
DRV2     SLIDRIVS  ADDRESS=(414,415,416,417)
DUMMY2   SLIDRIVS  ADDRESS=(,,)
*
PANEL1Ø  SLIDLIST  HOSTDRV=(DUMMY3,DRV3)
DUMMY3   SLIDRIVS  ADDRESS=(,,)
DRV3     SLIDRIVS  ADDRESS=(418,419,41A,41B)
*

```

**Figure 12. Sample LIBGEN with LibraryStation Device Numbers**

This example provides the following conclusions:

- About the system:
  - The SLILIBRY macro indicates there are two hosts, named HSC1 and LSID. The second hostid, LSID, is the LibraryStation hostid.
  - The SLIALIST macro indicates there are two ACSs, represented by ACS0 and ACS1.
  - The assembler label (ACS0) preceding the SLIACS macro indicates the macros that follow are for ACS0.
  - The SLIACS macro indicates there are two LSMs in ACS0, represented by LSM0 and LSM1.
  - The assembler label (LSM0) preceding the SLILSM macro indicates the macros that follow are for LSM0 in ACS0.
- About the drive panels:
  - The DRIVE parameter in the SLILSM macro indicates there are three drive panels (1, 2, and 10) in LSM0. The first and second drive panels are the first and second panels sequentially in the LSM; the third drive panel is the tenth sequential panel in the LSM.

- The DRVELST parameter in the SLILSM macro establishes the assembler labels to be referenced by subsequent SLIDLIST macros. These labels (PANEL1, PANEL2, and PANEL10) correspond positionally to the DRIVE parameter operands, so that PANEL1 represents the first drive panel and PANEL10 represents the third drive panel.
- About PANEL1:
  - The assembler label (PANEL1) preceding the first SLIDLIST macro indicates the macro is for the drive panel represented by PANEL1 in the prior SLILSM macro.
  - The HOSTDRV operands (DRV1,DRV1) indicate by their relative positions that tape cartridge drives on PANEL1 are available to both of the hostids that were established in the SLILIBRY macro.
  - The assembler label (DRV1) preceding the first SLIDRIVS macro indicates the device numbers are being created for tape cartridge drives in PANEL1, which was associated with DRV1 in the previous SLIDLIST macro.
  - The device numbers that are created in the ADDRESS parameter apply to both hosts since the previous SLIDLIST macro made tape cartridge drives on this panel available to both hosts.



**Note:** LibraryStation provides no automatic means of sharing tape cartridge drives between the MVS host and client systems. If a drive is being shared, you must use manual procedures to vary the drive offline to MVS and online to the client and vice versa.

- About PANEL2:
  - The assembler label (PANEL2) preceding the second SLIDLIST macro indicates the macro is for the drive panel represented by PANEL2 in the previous SLILSM macro.
  - The unique HOSTDRV operands (DRV2,DUMMY2) indicate that separate instructions for each host will be provided in the subsequent SLIDRIVS macros.
  - The assembler label (DRV2) preceding the second SLIDRIVS macro indicates the device numbers are being created for drives in PANEL2, which was associated with DRV2 in the previous SLIDLIST macro.
  - Since DRV2 was the first HOSTDRV operand in the previous SLIDLIST macro, this SLIDRIVS macro applies to the first hostid (HSC1) in the SLILIBRY macro.
  - The assembler label (DUMMY2) preceding the third SLIDRIVS macro indicates the device numbers are being created for PANEL2, which was associated with DUMMY2 in the previous SLIDLIST macro.

- Since DUMMY2 was the second HOSTDRV operand in the previous SLIDLIST macro, this SLIDRIVS macro applies to the second hostid (LSID) in the SLILIBRY macro. Since no device numbers are defined here in the ADDRESS parameter, host LSID is precluded from accessing PANEL2 drives.
- Thus, tape cartridge drives in the second drive panel are available to host HSC1 but are not available to LibraryStation.
- About PANEL10:
  - The assembler label (PANEL10) preceding the third SLIDLIST macro indicates the device numbers are being created for tape cartridge drives in the panel represented by PANEL10 in the previous SLILSM macro.
  - The unique HOSTDRV operands (DUMMY3,DRV3) indicate that separate instructions for each host will be provided in the subsequent SLIDRIVS macros.
  - The assembler label (DUMMY3) preceding the fourth SLIDRIVS macro indicates the device numbers are being created for PANEL10, which was associated with DUMMY3 in the previous SLIDLIST macro.
  - Since DUMMY3 was the first HOSTDRV operand in the previous SLIDLIST macro, it applies to the first hostid (HSC1) in the SLILIBRY macro. Since no device numbers are defined here in the ADDRESS parameter, host HSC1 is precluded from accessing PANEL10 drives.
  - The assembler label (DRV3) preceding the fifth SLIDRIVS macro indicates the device numbers are being created for PANEL10, which was associated with DRV3 in the previous SLIDLIST macro.
  - Since DRV3 was the second HOSTDRV operand in the previous SLIDLIST macro, it applies to the second hostid (LSID) in the SLILIBRY macro. Thus, the device numbers that are created here in the ADDRESS parameter apply to LibraryStation only.
  - Further, since no device numbers were created in the SLIDRIVS macro for DUMMY3, drives on PANEL10 are exclusively for access by LibraryStation.



**Note:** Some versions of the *Host Software Component System Programmer's Guide* state that library station device numbers can be set using the HSC Set Utility with the SLISTATN option. This is a generic reference to LMU station device numbers and is not a reference to the LibraryStation product described here. LibraryStation device numbers cannot be set using the SLISTATN option of the HSC Set utility.



## Chapter 9. Configuring the LSINIT Control Statement

---

An LSINIT control statement must be specified in the HSC SLSSYSxx parameter data set to initialize the LibraryStation software with necessary parameters. LibraryStation cannot be initialized unless the LSINIT control statement is present.

In addition to its role in LibraryStation initialization, the LSINIT control statement contains parameter settings that define volume security, the default scratch subpool, the TCP/IP subsystem, and network call/response wait times.

Refer to the *Host Software Component System Programmer's Guide* for more information about the parameter data set and control statement format.



**Note:** Virtual Storage Manager (VSM) support has been added for the LSINIT control statement. Refer to your VTCS publications for more information.

### LSINIT Control Statement Format

Keyword parameters of the LSINIT control statement define how LibraryStation functions at your installation and provide the HSC with information about your software implementation. Keyword parameters can be specified in any order. When not specified, most keywords assume default values.

The following sample illustrates the LSINIT control statement. This example shows the two parameters required in all instances, NETHOST and COMMONSP.

```
LSINIT NETHOST(LSID) COMMONSP(SPØ1)
```

Keyword parameters for the LSINIT control statement are summarized in Table 5 on page 54 and then described individually. NETHOST and COMMONSP are the only parameters required in all instances. NOPDF is required in sysplex environments (see “NOPDF” on page 58). These three parameters are described first. The remaining parameters are described in alphabetical order.

**Table 5. LSINIT Keyword Parameters**

<b>Keyword</b>	<b>Function</b>
COMMONSP	Specifies the HSC common scratch subpool name to be used as the default scratch subpool for LibraryStation
NETHOST	Specifies the LibraryStation hostid to which network drives are assigned
NOPDF	Disables the Persistent Data File (PDF)
AUTHCLS	Specifies the SAF class that should be used with the RACROUTE mechanism if volume authorization checking is active
CMDACC	Specifies whether or not command authorization checks should be performed on a client level
COMMTYPE	Specifies which communication method(s) LibraryStation uses to communicate with clients
CREQLOG	Enables/disables logging of network client mount/dismount requests
DEFER	Allows LibraryStation initialization to be deferred
HOSTID	Specifies the hostid of the HSC system where LibraryStation is executed
LSDEF	Provides the name of a data set that contains various LibraryStation definition statements
PDF	Specifies the data set name to be dynamically allocated as the Persistent Data File
PDFX	Specifies the data set name to be dynamically allocated as the path to the Persistent Data File alternate index
POOLCHK	Specifies whether or not volumes can be scratched when the wrong scratch pool is put in the network scratch request
REQTIME	Defines the amount of time after which LibraryStation drops messages waiting to be sent to clients
RETCOUNT	Defines the number of times that LibraryStation attempts to transmit a message across the network
RETTIME	Defines the minimum amount of time that LibraryStation waits between attempts to establish a network connection
SYMDESTN	Specifies the symbolic destination name that contains the transaction program name and local logical unit name that LibraryStation uses to register with APPC/MVS for SNA LU6.2 communication.
TCPNAME	Specifies any StorageTek compatible TCP/IP communications product
TCPPORT	Specifies a TCP port used for TCP/IP communications.
VOLACC	Specifies whether or not volume authorization checks should be performed on a client level

**Table 5. LSINIT Keyword Parameters (Continued)**

<b>Keyword</b>	<b>Function</b>
VOLAUTH	Specifies whether or not volume authorization checks should be performed on a network level
VOLNOPRF	Specifies, for users of RACF and VOLAUTH, whether or not volumes undefined to RACF may be accessed by network clients
VSECLOG	Specifies whether or not message SLS3945I is issued to the system log when access to a volume is denied
XCFGROUP	Specifies the XCF group name representing the XCF group that LibraryStation uses to register with XCF
XCFMEMBR	Specifies the XCF member name representing the XCF member that LibraryStation uses to register with XCF
XHREC	Enables cross host recovery support

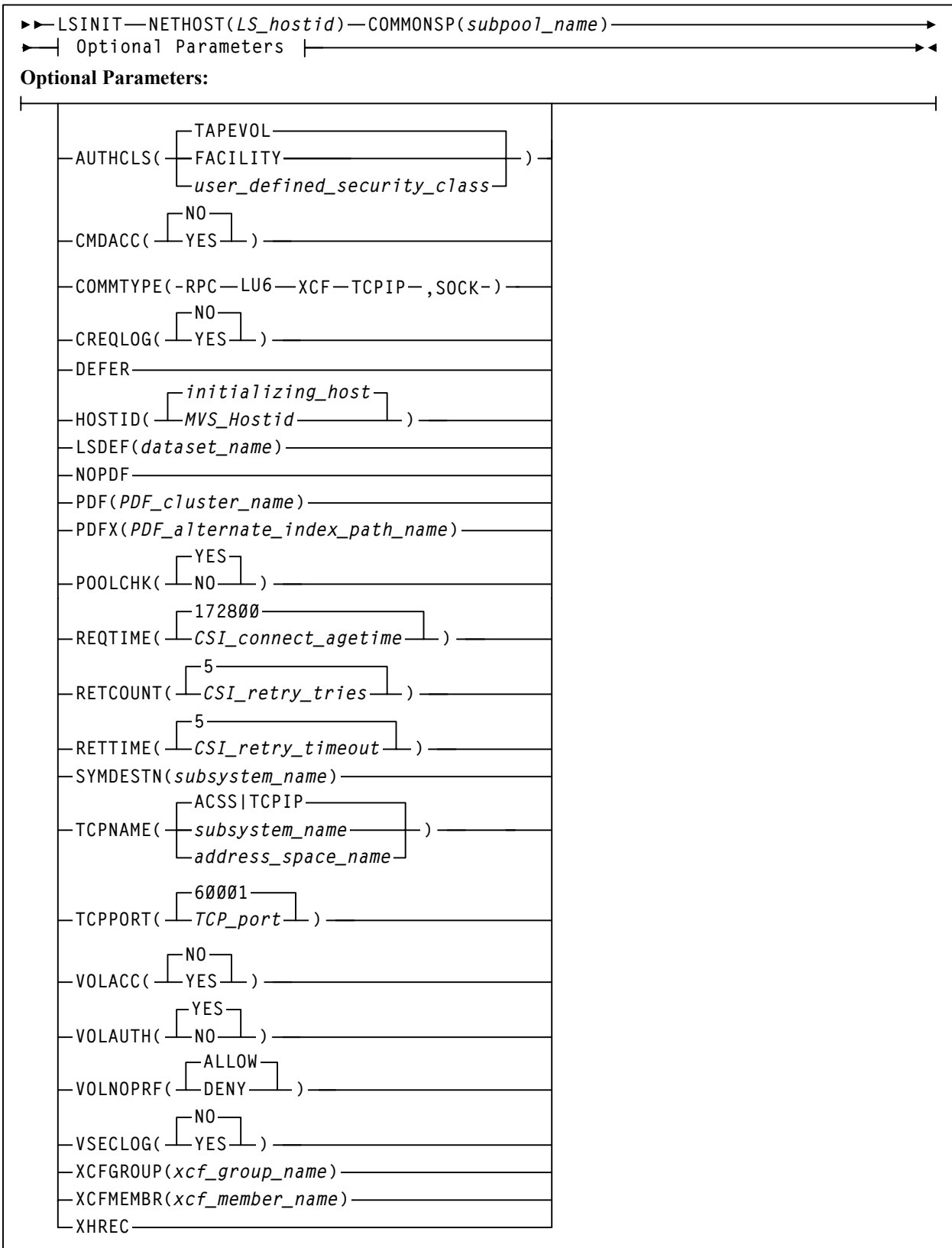


Figure 13. LSINIT Control Statement Syntax





**Note:**

1. NETHOST and COMMONSP are the only required parameters for all installations. All others are optional, with one exception: NOPDF is required in sysplex environments (see “NOPDF” on page 58).
2. You can separate parameters using either blanks or commas.
3. Refer to “Conventions Used in this Guide” on page xv for flow diagram and control statement syntax conventions.

## Required Keyword Parameters of LSINIT

The required keyword parameters for the LSINIT control statement are:

### **NETHOST**(*LS\_hostid*)

Specifies the LibraryStation hostid to which network drives are attached. This parameter is required.

The hostid identified here is supplied to the HSC via the LIBGEN process (see Chapter 7, “Configuring the LibraryStation Hostid” on page 45). The tape cartridge drives that LibraryStation uses are also identified as being attached to this hostid through the HSC LIBGEN process. LibraryStation specifies this hostid to the HSC for network drive requests.



**Note:** Your entry must match the LibraryStation hostid you defined in Chapter 7, “Configuring the LibraryStation Hostid” on page 45.

Refer to Chapter 5, “Configuring Security Measures” on page 27 for information about how this parameter can affect LibraryStation security.

### **COMMONSP**(*subpool\_name*)

Specifies the HSC scratch subpool name to be used as the default scratch pool. This parameter is required.

The SCRPOOL control statement in the HSC PARMLIB is used to define the subpool name and the range of volsers contained in the scratch subpool. For example, the HSC PARMLIB might contain the following definition for the LibraryStation common scratch pool:

```
SCRPOOL NAME=LSPPOOL, RANGE=(085000-089999), LABEL=SL
```

LSINIT would then require the keyword parameter COMMONSP(LSPPOOL).

SCRPOOL control statements can also be specified using the HSC SCRDEF command and control statement. Refer to the *HSC System Programmer's Guide* for more information about SCRDEF.



**Note:** If SCRDEF statements are included in the HSC PARMLIB, they **must precede** the LSINIT statement.

If you want to map additional LibraryStation scratch pools to HSC subpools, use the LSDEF SPNUM statement to map scratch pools other than 0. Refer to “Scratch Pool Processing” on page 38.

Refer to Chapter 5, “Configuring Security Measures” on page 27 for information about how the COMMONSP parameter can affect LibraryStation security.

### **NOPDF**

Disables the Persistent Data File (PDF). This keyword **must** be specified by sysplex installations servicing only MVS/CSC clients using XCF or LU6.2. When the NOPDF keyword is specified, the PDF is disabled. This operational environment would contain multiple LibraryStation programs running in a sysplex environment and servicing only MVS/CSC clients.

It is possible to provide heterogeneous support for non-MVS/CSC clients within a sysplex environment. In this type of installation, you must allocate a PDF for one LibraryStation and specify the NOPDF keyword in the LSINIT control statement for all other LibraryStations.

If the NOPDF keyword is not specified, LibraryStation runs with a PDF enabled and allows clients to issue locking requests. This environment involves a single LibraryStation program running in a sysplex environment.

If the NOPDF keyword is specified, you cannot specify the PDF or PDFX keywords. The default is running with a PDF.

## Optional Keyword Parameters of LSINIT

The optional keyword parameters for the LSINIT control statement are:

### **AUTHCLS([TAPEVOL|FACILITY|*user\_defined\_security\_class*])**

This parameter is optional. TAPEVOL is the default. It specifies the SAF class to be used with the RACROUTE mechanism if volume authorization or volume access is active. Volumes to be protected should be defined as entities in the specified SAF class. The customer can define a new security authorization class for tape volumes. If the customer does so, note that the class must be defined to the security package, added to the user SAF routing table, and activated. If all these steps are not completed, all volumes can be accessed by all clients. LibraryStation recommends using the new VSECLOG parameter to create system log messages along with test volumes defined to the new security class to verify that volume security is working as desired.

The value for the *user\_defined\_security\_class* parameter must consist of four to eight characters. TAPEVOL or FACILITY can't be specified for this value, though derivatives of these words are valid. See Chapter 5, "Configuring Security Measures" on page 27 for more information on configuring security measures.

### **CMDACC([NO|YES])**

Specifies whether command authorization checks should be performed at a client level. These checks are issued through an IBM RACROUTE request to the System Authorization Facility (SAF). The default value is NO.

Refer to Chapter 5, "Configuring Security Measures" for information about how this parameter can impact LibraryStation security.

### **COMMTYPE(RPC LU6 XCF TCPIP)**

Specifies which communication method LibraryStation uses to communicate with clients. The method can be RPC, LU6, XCF, or TCPIP. If more than one is selected, separate them with a space or comma.

- *RPC* is specified if LibraryStation will communicate with ONC/RPC clients only.
- *LU6* is specified if LibraryStation will communicate with SNA LU6.2 clients only.
- *XCF* is specified if LibraryStation will communicate with XCF clients.
- *TCPIP* is specified if LibraryStation will communicate with clients that support CSCI communications using TCP/IP communication method.

If the COMMTYPE keyword is not specified, the default is RPC.

### **CREQLOG([YES|NO])**

Specifies whether or not network client mount/dismount requests are logged. If YES is specified, logging is enabled and message SLS3730I is displayed. This message identifies the network id and client userid of the client that issued the request. In addition:

- If the VOLACC LSINIT parameter is set to YES, message 3728I is displayed.



**Note:** VOLACC(YES) is supported only when COMMTYPE is specified as RPC or LU6.

- If the VOLAUTH LSINIT parameter is set to YES, message 3729I is displayed.

If the CREQLOG LSINIT parameter is set to NO, logging is disabled and no messages are displayed. The default is NO.

### **DEFER**

Specifies that LibraryStation initialization is to be deferred at HSC initialization. If XHREC is also specified on the LSINIT statement, LibraryStation initializes to standby status.

LibraryStation can be started by issuing the LS INIT command. LibraryStation in standby mode can also be started by issuing the LS ACTIVATE STANDBY command or by cross host recovery communication.

Refer to “LSINIT Implications for Multiple MVS Host Installations” on page 65 for more information about situations where you may need to use DEFER.

When DEFER is not specified, LibraryStation is initialized automatically during HSC initialization.

### **HOSTID(MVS\_hostid)**

Specifies the hostid of the MVS host system on which LibraryStation is executed. This host identifier is specified to the HSC via the LIBGEN process. The default is the initializing HSC hostid.



**Note:** In a multiple MVS host configuration, this parameter determines which host will initialize LibraryStation. If you are making LibraryStation available to more than one host system, refer to “LSINIT Implications for Multiple MVS Host Installations” on page 65 for more information about multiple host installation planning.

### **LSDEF(dataset\_name)**

Specifies the name of a data set that contains various LibraryStation definition statements. The name must be fully qualified and cataloged. If the data set named is a partitioned data set, the member name must also be included and the data set name

should be enclosed in single quotation marks. Comment statements beginning with an asterisk in column one are not valid.

Refer to Chapter 10, “Configuring the LSDEF Data Set” on page 67 for information about the statements that can be contained in the data set.

**PDF(*PDF\_cluster\_name*)**

Specifies the data set name to be dynamically allocated as the Persistent Data File. If PDF is specified, PDFX must also be specified. Refer to Chapter 6, “Allocating the Persistent Data File” on page 41 for a description of the Persistent Data File.

**PDFX(*PDF\_alterate\_index\_path\_name*)**

Specifies the data set name to be dynamically allocated as the path to the Persistent Data File alternate index. If PDFX is specified, PDF must also be specified. Be sure to specify the path name to the alternate index and not the name of the alternate index itself. Refer to Chapter 6, “Allocating the Persistent Data File” on page 41 for a description of the Persistent Data File alternate index.

**POOLCHK(*[YES|NO]*)**

Specifies whether a volume can be used as a scratch volume when the wrong scratch pool is specified in the request for a scratch volume. If YES is specified, the volume is checked to see if it can be made a scratch volume and assigned to the indicated scratch pool. If NO is specified, the volume is used as a scratch volume even if the scratch pool specified in the request is not the scratch pool the volume is assigned to through the HSC SCRPOOL statement. The default is YES.

**REQTIME(*CSI\_connect\_asetime*)**

Defines the amount of time (in seconds) after which LibraryStation drops messages waiting to be sent to clients. This parameter is specified only if COMMTYPE is specified as RPC.

The value for REQTIME can be any decimal integer in the range 600 - 31536000. Thus, the maximum is one year. If the value specified is outside this range, REQTIME defaults to 172800 seconds (48 hours). When an invalid REQTIME value is specified using the SET operator command, the last valid REQTIME value is used.

**RETCOUNT(*CSI\_retry\_tries*)**

Defines the number of times LibraryStation attempts to transmit a message across the network. This parameter is specified only if COMMTYPE is specified as RPC.

The value for RETCOUNT can be any decimal integer in the range 0 - 999999999. The default value is 5. Network clients should have a similar retry parameter.

**RETTIME(*CSI\_retry\_timeout*)**

Defines the minimum amount of time (in seconds) that LibraryStation waits between attempts to establish a network connection. This parameter is specified only if COMMTYPE is specified as RPC.

The value for RETTIME can be any decimal integer in the range 0 - 999999999. The default value is 5 seconds. Network clients should have a similar timeout parameter.

### **SYMDESTN(*subsystem\_name*)**

Specifies the symbolic destination name that contains the transaction program name and local logical unit name that LibraryStation uses to register with APPC/MVS for SNA LU6.2 communication. The symbolic destination name must be the name of an entry in the active APPC/MVS side information file that represents LibraryStation. This parameter is used only if COMMTYPE is specified as LU6.

If the SYMDESTN keyword is not specified, the default is LIBSTAT.

Refer to “APPC/MVS Configuration” on page 24 for information about how the side information entry is built.

### **TCPNAME(*[subsystem\_name|address\_space\_name]*)**

Specifies the subsystem name or address space name of the TCP/IP stack used for TCP/IP communications. Valid TCP/IP communications software includes IBM TCP/IP, CA Unicenter TCPaccess Communications Server, and CA Unicenter TCPaccess X.25. This parameter is specified only if COMMTYPE is specified as RPC or TCPIP.

*subsystem\_name* specifies the subsystem name of the TCP/IP stack that was specified during installation of the TCP/IP communications software. It must consist of one to four alphanumeric or national (#, @, \$) characters, the first character being alphabetic or national.

*address\_space\_name* specifies the address space name of the TCP/IP stack that was specified during the installation of the TCP/IP communications software. It must consist of one to eight alphanumeric or national characters.

If TCPNAME is specified, its value is used assuming it is valid. If not specified, the default value (ACSS or TCPIP) is assumed:

- ACSS is the default value for CA Unicenter TCPaccess Communications Server or CA Unicenter TCPaccess X.25.
- TCPIP is the default value for IBM TCP/IP.



**Note:** The LCFSSID keyword parameter is no longer supported by LibraryStation. Using this keyword will generate an error message.

Additionally, when the TCP/IP product specified with a TCPNAME parameter is not active, the following defaults are used:

- If the TCPLINK data set is included in the STEPLIB concatenation, TCPaccess with a default TCPNAME value of ACSS is used.
- If the TCPLINK data set is not included in the STEPLIB concatenation, IBM TCP/IP with a default TCPNAME value of TCPIP is used.

**TCPPORT(*TCP\_port*)**

Specifies a TCP port used for TCP/IP communications. This parameter is specified only if COMMTYPE is specified as RPC or TCPIP.

The value for TCPPORT must be between 1 and 65535. If the value specified is outside this range, TCPPORT takes the default value. The default value is 60001.

**VOLACC(*[NO|YES]*)**

Specifies whether volume authorization checks should be performed on a client level. These checks are issued through the IBM RACROUTE request to the System Authorization Facility (SAF). The default value is NO. For clients to use any volumes with VOLACC(YES), you must have LSDEF CLIENTID statements for those clients.

Refer to Chapter 5, “Configuring Security Measures” on page 27 for information about how this parameter can impact LibraryStation security.

**VOLNOPRF(*[ALLOW|DENY]*)**

Specifies whether volumes not defined to RACF are allowed client read and update access. ALLOW is the default. Either VOLAUTH(YES) or VOLACC(YES) is required for the VOLNOPRF parameter to take effect.

**VOLAUTH(*[YES|NO]*)**

Specifies whether volume authorization checks should be performed on a network level. These checks are issued through the IBM RACROUTE request mechanism to the System Authorization Facility (SAF). The default value is YES.

Refer to Chapter 5, “Configuring Security Measures” on page 27 for information about how this parameter can impact LibraryStation security.

**VSECLLOG(*[NO|YES]*)**

This parameter is optional. It specifies whether message SLS3945I is issued to the system log when access to a volume is denied. NO is the default. Either VOLACC and/or VOLAUTH must be set to YES for this message to be issued.

**XCFGROUP(*xcf\_group\_name*)**

Specifies the XCF group name representing the XCF group LibraryStation uses to register with XCF. One group should be defined for each active LibraryStation and MVS/CSC using XCF. The group name must be one to eight characters (A-Z, 0-9, \$, #, @). However, to avoid using names IBM uses for its XCF groups, avoid A-I or the character string SYS, and do not use the name UNDESIG, which is reserved for the system programmer.

This parameter requires that COMMTYPE(XCF) is also specified.



**XCFMEMBR(*xcf\_member\_name*)**

Specifies the XCF group member name representing the XCF member LibraryStation uses to register with XCF. The number of members depends on the number of LibraryStations and MVS/CSCs. The member name must be one to 16 characters (A-Z, 0-9, \$, #, @).

This parameter requires that COMMTYPE(XCF) is also specified.

**XHREC**

Specifies that cross host recovery be enabled. If XHREC is specified, PDF must also be specified. Only one active LibraryStation can act as a server for open system clients. Cross host recovery allows other LibraryStations to be started as standby servers for the open system clients. The first standby LibraryStation to begin initialization becomes the active LibraryStation. Subsequent LibraryStations initialize to standby status.

If the active LibraryStation terminates, a cross host communication is sent to all HSCs sharing the CDS. The first standby LibraryStation to initialize becomes the active LibraryStation. All LibraryStations that wish to access the PDF and participate in cross host recovery must specify XHREC.

**Action Item**

Enter your LSINIT parameters on the LibraryStation Configuration Worksheet on page 85.

## LSINIT Implications for Multiple MVS Host Installations



**Note:** The following applies to heterogeneous LibraryStation installations only; it does not apply to MVS sysplex installations using XCF.

As previously described in “System Redundancy Options” on page 17, LibraryStation can be made available to more than one MVS host in a library complex, either by installing the software directly on each host or by installing it on DASD that is shared among the hosts.

Making LibraryStation available to more than one host is useful for system redundancy, so that LibraryStation software can be manually initiated from an alternate host if the host that normally initiates LibraryStation fails.

Each host that is capable of initializing LibraryStation to support ONC/RPC clients must have the HSC, TCP/IP, and network interface adaptor installed in addition to the LibraryStation software. Additionally, the hosts must access a common PARMLIB data set.

Each host that is capable of initializing LibraryStation to support SNA LU6.2 clients must have the HSC, APPC/MVS, and physical and logical units installed in addition to the LibraryStation software.

The HOSTID, XHREC, and DEFER parameters on the LSINIT control statement determine how LibraryStation is initialized:

- automatically to active status when the HSC is initialized on that host
- automatically to standby status
- deferred until the LSINIT command is issued

The HOSTID parameter in an LSINIT control statement for each host system determines whether LibraryStation can be initialized from that host.

The XHREC parameter enables cross host communication. The first LibraryStation to initialize becomes active. Subsequent LibraryStations initialize to standby status.

The DEFER parameter defers LibraryStation initialization to active status. When XHREC is also specified, LibraryStation initializes to standby status.

The following scenarios illustrate how this works.

- Scenario #1: A single host that is automatically initialized.

```
LSINIT NETHOST(LSID) COMMONSP(SP01) HOSTID(MVS1)
```

In this scenario, LibraryStation is initialized automatically on host MVS1 when the HSC is initialized on that host.

- Scenario #2: Two hosts, with the second host serving as an alternate host.

```
LSINIT NETHOST(LSID) COMMONSP(SP01) HOSTID(MVS1) DEFER  
LSINIT NETHOST(LSID) COMMONSP(SP01) HOSTID(MVS2) DEFER  
LSINIT HOSTID(MVS1)
```

In this scenario, initialization is deferred for both hosts at HSC initialization. LibraryStation is then initialized on host MVS1 by the LS INit operator command. If host MVS1 fails, host MVS2 can be initialized by an LS INit command issued by the MVS operator at that host system. Scenario #2 also applies to a situation where there are more than two hosts but only the first two are capable of initializing LibraryStation. Since there are no LSINIT statements created for MVS3, MVS4, and so on, those host systems cannot initialize LibraryStation.



**Note:** Even though you can enable LibraryStation to initialize on more than one host, it can only be fully initialized on one host system at a time. Also, each host that is capable of initializing LibraryStation must have access to the DASD volume where the Persistent Data File (PDF) is located.

If you enable LibraryStation to initialize on more than one host, you are responsible for propagating the SYSTEMS ENQ to each host. Failure to do so may corrupt the PDF when an alternate host is initialized or if two hosts attempt to initialize the software at the same time.

Refer to “The PDF in a Multiple Host Environment” on page 42 for more information about PDF requirements in a multiple host environment.

# Chapter 10. Configuring the LSDEF Data Set

---

## Defining LSDEF File Statements

The LSDEF data set contains various LibraryStation definition statements. Valid LSDEF statements for LibraryStation use are described below. Each statement can be included as many times as necessary to define all existing items. For example, there can be a UNITATTR statement for each drive, or an SPNUM statement for each scratch pool.

LSDEF statements are only required in the LSDEF data set under the following circumstances:

- CLIENTID statements are required if you are using volume access control or command access control.
- SPNUM statements are required if you are using scratch pools other than pool number 0 or mapping scratch pools by client.
- UNITATTR statements are required if you have drives in your library that are not 4480s. For LibraryStation, you must add the NETHOST parameter.

You can include non-LibraryStation (e.g. HSC VOLATTR and TAPERREQ statements) in the LSDEF data set, but LibraryStation ignores these statements.



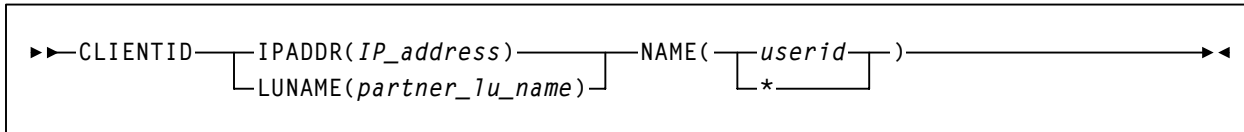
**Note:** Virtual Storage Manager (VSM) support has been added for the LSDEF data set. Refer to your VTCS publications for more information.

## CLIENTID Statement

The CLIENTID statement associates a client to a System Authorization Facility (such as RACF) user identifier.



**Note:** The CLIENTID statement is supported only when COMMTYPE is specified as RPC or LU6.



### IPADDR(*IP\_address*)

Specifies the Internet address of the primary local area network (LAN) or server. The Internet address is in standard Internet dotted decimal format (for example, 128.2.33.9). Valid values can range from 0 to 255.

### LUNAME(*fully\_qualified\_partner\_lu\_name*)

Specifies the logical unit name of the client that communicates with LibraryStation. Specify this keyword value in the format NETID.LUNAME. The value can consist of 3 to 17 alphanumeric characters (including the decimal).

### NAME(*userid*\*)

Specifies the userid that determines if the client is permitted access to the resource. The NAME value can consist of one to eight alphanumeric characters or \*. If the value is specified as \*, the IPADDR or LUNAME is not translated and whatever value is in the packet in the access\_id field is used for authorization checks.

Either IPADDR or LUNAME must be specified.

This association is only used when either the VOLACC or CMDACC parameter of the LSINIT statement is set to YES.

When the same client address is specified on more than one CLIENTID statement, the last statement is used. When the same userid is specified on more than one CLIENTID statement, all associated clients use the same userid.

Refer to Chapter 5, “Configuring Security Measures” on page 27 for additional information about LibraryStation security measures.

#### Action Item

Enter your CLIENTID parameters on the LibraryStation Configuration Worksheet on page 85.

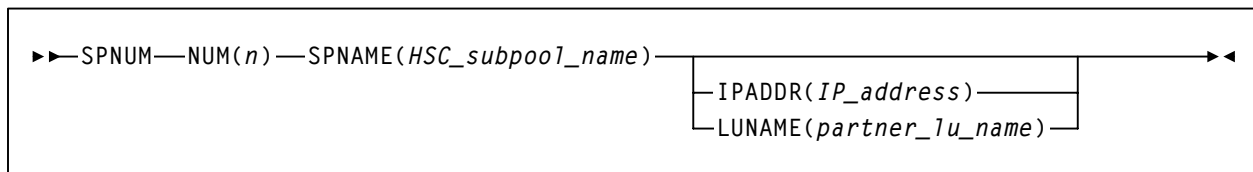
## SPNUM Statement

This statement equates an HSC scratch subpool with a LibraryStation scratch pool.



### Notes:

- The SPNUM statement is supported only when COMMTYPE is specified as RPC or LU6.
- Virtual Storage Manager (VSM) support has been added for the SPNUM statement. Refer to your VTCS publications for more information.



### NUM(*n*)

Specifies the numeric LibraryStation scratch pool to which the HSC scratch subpool defined with a SCRPOOL command is equated to. *n* can have values from 0 to 65534.

### SPNAME(*HSC\_subpool\_name*)

Specifies the name of the HSC scratch subpool that is to be equated to the LibraryStation scratch pool. The SPNAME value can consist of 1 to 13 characters. Blank spaces are not permitted.

### IPADDR(*IP\_address*)

Specifies the Internet address of the primary local area network (LAN) or server. The Internet address is in standard Internet dotted-decimal format (for example, 128.2.33.9). Valid values can range from 0 to 255.

### LUNAME(*fully\_qualified\_partner\_lu\_name*)

Specifies the logical unit name of the client that communicates with LibraryStation. Specify this keyword value in the format NETID.LUNAME. The value can consist of 3 to 17 alphanumeric characters (including the decimal).

There can be several SPNUM statements, each equating an HSC scratch subpool to a LibraryStation scratch pool. If the same value for NUM is specified on more than one SPNUM statement, the last statement is used. If the same HSC scratch subpool name is specified on more than one SPNUM statement, all the associated LibraryStation scratch pools will use the same HSC scratch subpool.

If IPADDR or LUNAME is coded, only requests from the specified client will use that scratch pool mapping. See “Scratch Pool Processing” on page 38 for information about scratch pools.

Example:

```
SPNUM NUM(2) SPNAME(LSPOOL1)  
SPNUM NUM(2) SPNAME(LSPOOL2) IPADDR(1.2.3.4)
```

In this example, the client at address 1.2.3.4 would get volumes from LSPOOL2 when referring to pool 2, and all other clients would get volumes from LSPOOL1.

**Action Item**

Enter your SPNUM parameters on the LibraryStation Configuration Worksheet on page 85.

## UNITATTR Statement

The UNITATTR statement defines the recording technique of a drive.

```
▶▶UNITATTR—ADDRESS—(unit_address)——NETHOST—(host_name)————→  
▶MODEL—(model_number)————→◀
```

### ADDRESS(*unit\_address*,...)

Specifies either the address, a list of addresses, a range of addresses, or the list of ranges of addresses for drives specified to LibraryStation.



**Note:** Duplicate ADDRESS parameters are not allowed. Specifying duplicate ADDRESS parameters results in an error message.

### MODEL(*model\_number*)

Specifies the model number of a drive. From the type of drive specified, the medium used is derived. For valid specifications of the MODEL parameter, refer to the UNITATTR control statement in the *HSC System Programmer's Guide*.

### NETHOST(*host\_name*)

Specifies the name of the host. For LibraryStation to use a UNITATTR statement, the *host\_name* specified must match the host name specified by the NETHOST keyword on the LSINIT control statement. The NETHOST value can consist of one to eight alphanumeric characters.



**Note:** LibraryStation ignores all UNITATTR statements that do not include the NETHOST keyword.

### Action Item

Enter your UNITATTR parameters on the LibraryStation Configuration Worksheet on page 85.

## Allocating the LSDEF Data Set

Once LSDEF statements are defined, you must allocate, catalog, and populate the LSDEF data set. This data set can be a sequential data set or a member of a partitioned data set (PDS).

Perform the following steps:

1. Use the following sample code to allocate and catalog the LSDEF data set.

```
//      EXEC PGM=IEFBR14
//LSDEFDD DD DSN=SLS.LSDEF ,
//      UNIT=SYSDA,SPACE=(TRK,(1,1)),
//      DCB=(RECFM=FB,LRECL=80,BLKSIZE=3120),
//      DISP=(NEW,CATLG)
```

**Figure 14. Sample LSDEF Data Set Allocation**

2. Populate the data set with the LSDEF statements you defined earlier in this chapter. Refer to the statement information you entered on the LibraryStation Configuration Worksheet on page B-6.



## Chapter 11. Configuring the HSC Started Task Procedure

You must update the started task procedure in your system cataloged procedure library to include the LibraryStation load libraries, and if applicable, the Persistent Data File (PDF) DD statements. (Alternately, the PDF and PDFX data files can be allocated dynamically at system initialization by using the PDF and PDFX parameters of the LSINIT statement.)



### Notes:

- If you are a sysplex installation servicing only MVS/CSC clients using XCF or LU6.2, you will only include the LibraryStation load libraries because the PDF is disabled for your installation.
- The LibraryStation (SLCLINK) DD statement **must precede** the HSC (SLSLINK) data set in the STEPLIB concatenation.
- If you are using VSM, you must include the VTCS LINKLIB (SWSLINK). The SWSLINK DD statement **must precede** the HSC (SLSLINK) data set in the STEPLIB concatenation. Refer to your VTCS publications for more information.

The following example represents the base JCL shipped in the LibraryStation SAMPLIB.

```
//SLSØ PROC
//IEFPROC EXEC PGM=SLSBINIT,
// TIME=144Ø,
// REGION=6M,
// DPRTY=(7,5),
// PARM='E(EØ86) F(23) M(ØØ) SSYS(SLSØ)'
//*
//STEPLIB DD DISP=SHR,DSN=SLC.SLCLINK /* LS load mods */
// DD DISP=SHR,DSN=SLS.SLSLINK /* HSC load mods */
// DD DISP=SHR,DSN=SLC.SACLINK /* SAS/C load mods */
// DD DISP=SHR,DSN=SLC.CSLLINK /* SAS/C CSL API */
//*
//SLSPDF DD DISP=OLD,DSN=cluster_name
//SLSPDFX DD DISP=OLD,DSN=path_name
//SLSSYSØØ DD DISP=SHR,DSN=SLS.PARMS
//SLSUEXIT DD DISP=SHR,DSN=your.load.module.library
```

**sysplex installations: DO NOT include the SLSPDF and SLSPDFX DDs.**

Figure 15. Sample HSC Cataloged Procedure Updated for LibraryStation

Perform the following steps to update the started task procedure:

1. Add the LibraryStation load libraries, created during installation, to the STEPLIB DD concatenation. These include the SLCLINK and SACLINK load libraries.
2. The STEPLIB concatenation can dictate which TCP/IP communication stack is used for LibraryStation. If CA Unicenter TCPaccess TCP/IP products are to be used, the TCPLINK data set must be included. Add the following DD statement to the STEPLIB concatenation:

```
DD DSN=IOS.TCPLINK,DISP=SHR /* optional TCP */
```



**Note:** The TCPLINK data set must precede the SACLINK data set in the STEPLIB concatenation.

3. If you are using a TCP/IP product to support ONC/RPC clients, add the following DD statement to the HSC Started Task Procedure:

```
//SYSTCPD DD DSN=ddd.eee.fff(anyname)
```

This DD statement identifies the data set used to obtain parameters defined by the IBM TCPIP.DATA configuration data set. See “ONC/RPC Support” on page 21 for more information.

4. If you are NOT a sysplex installation servicing only MVS/CSC clients using XCF or LU6.2, add the two DD statements required for the Persistent Data File, SLSPDF and SLSPDFX. To do this, replace *cluster\_name* and *path\_name* in the started task procedure with the same data set names you used for *cluster\_name* and *path\_name* in the PDF.



**Note:** Alternately, the PDF and PDFX data sets can be allocated dynamically at system initialization by using the PDF and PDFX parameters of the LSINIT statement. See Chapter 9, “Configuring the LSINIT Control Statement” on page 53 for more information.

5. Verify that REGION=6M or more in the IEFPROC of your started task procedure.
6. If SNA LU6.2 clients are to be supported, LibraryStation requires modules that reside in the MVS data set SYS1.CSSLIB. If SYS1.CSSLIB is not in your installation’s link list, add it to the STEPLIB DD concatenation. SYS1.CSSLIB must be an authorized data set.

## Chapter 12. Configuring NCS License Keys

---

### Overview

License keys are required to initialize NCS product components (HSC, MVS/CSC, LibraryStation), although the requirement is less stringent for the HSC.

You can acquire a license key through the StorageTek Customer Resource Center (CRC) at [www.support.storageitek.com](http://www.support.storageitek.com), or by contacting your StorageTek Software Manufacturing Distribution Representative, Marketing Representative, or Systems Engineer. License Keys are generally issued within 48 hours of receipt of the request.

Once a licence key is issued by StorageTek, you must make the license key information available to the license key validation service. For LibraryStation, this is accomplished using HSC LKEYDEF and LKEYINFO control statements. License keys are validated during initialization and immediately after midnight each day.

### Permanent License Key

To initialize the MVS/CSC and LibraryStation NCS product components, StorageTek requires you to obtain a *permanent license key*. The HSC allows a trial period, but eventually requires a permanent license key as well.

A **single** permanent license key can be used to initialize all StorageTek products you are running. **You cannot acquire different license keys for each product.**

Refer to the *MVS/HSC 6.0 Configuration Guide* for more information about configuring the NCS license key for LibraryStation.



**Note:** The HSC allows a 75-day trial period during which it will initialize and run normally without a license key. This trial period **does not** apply to LibraryStation.



## Chapter 13. Reconfiguring the HSC LIBGEN

---

Earlier, in Chapter 7, “Configuring the LibraryStation Hostid” you modified the HSC LIBGEN in order to define the LibraryStation hostid.

However, these and any other HSC LIBGEN modifications are not effective until you reconfigure the LIBGEN. Reconfiguring the LIBGEN creates a new library control data set. This is accomplished with the MVS Start command, using the Reconfig parameter to start the HSC catalog procedure.

Refer to the *Host Software Component Configuration Guide* for detailed information about reconfiguring the HSC LIBGEN.



**Note:** Some versions of the *Host Software Component System Programmer's Guide* state that library station device numbers can be set using the HSC Set Utility with the SLISTATN option. This is a generic reference to LMU station device numbers and is **not** a reference to the LibraryStation product. LibraryStation device numbers **cannot** be set using the SLISTATN option of the HSC Set utility.



## Chapter 14. Starting LibraryStation

---

LibraryStation requires an LSINIT control statement in order to initialize. This control statement is established in the HSC SLSSYSxx parameter data set during LibraryStation configuration.

Depending on site-specific LSINIT control statement parameters, LibraryStation can be initialized in either of the following ways:

- Automatically, during the HSC initialization process
- Manually, when the LibraryStation LS INit operator command is issued after HSC initialization



### Notes:

- LibraryStation 6.0 requires a valid license key for initialization. See Chapter 12, “Configuring NCS License Keys” on page 75 for more information.
- If LibraryStation is installed on or made available to more than one host system through shared DASD, initialization can be from any host system authorized by the LSINIT control statement parameters to start LibraryStation.

If any syntax errors occur on the LSINIT statement or in processing the options data sets indicated by parameters on the LSINIT statement, error messages will be generated. When an error message is encountered, refer to the *LibraryStation Messages and Codes Guide* for specific message information.

LibraryStation initialization proceeds to a state in which network requests and/or operator requests for LibraryStation services can be processed. Any resources required by LibraryStation are allocated, checks are made to ensure that the communication interface is available, and interfaces to the MVS/HSC are checked for operability. Once LibraryStation initialization is complete, message SLS3352I is issued.

The following conditions cause LibraryStation to be aborted:

- Resources Unavailable

LibraryStation could not acquire the resources necessary to initialize successfully. The SYSLOG is updated with the error condition and LibraryStation terminates.

- Startup Parameter Errors

Errors in the startup LSINIT statement cause LibraryStation to terminate. The SYSLOG is updated with the error condition and LibraryStation terminates.

The following conditions cause LibraryStation to be functionally degraded when initialized:

- ONC/RPC Unavailable

Network communications are unavailable due to an inability to register ONC/RPC services. LibraryStation periodically attempts to register ONC/RPC services.

- MVS/APPC Unavailable

Network communications are unavailable due to an inability for LibraryStation to register with MVS/APPC. This would normally indicate that the MVS/APPC address space is not active. LibraryStation periodically attempts to register with MVS/APPC.

When LibraryStation is aborted for any of the reasons mentioned above, error messages will be generated. When an error message is encountered, refer to the *LibraryStation Messages and Codes Guide* for specific message information.



## Chapter 15. Verifying LibraryStation Configuration

---

Once LibraryStation is installed and all configuration tasks are completed, you can verify the CPA, TCP/IP, and LAN as well as basic LibraryStation operation. Use the following steps:

### Step 1: CPA, TCP/IP, and LAN Verification

Successful installation of the TCP/IP communication product, CPA, and LAN can be verified by initiating commands from other processors on the LAN. These commands could include PING and RPCINFO, which are typically implemented on LAN-connected processors.

- A PING command executed as

```
PING host
```

(where *host* is the name or Internet address of the MVS processor where LibraryStation will execute) should receive a response such as ‘‘host is active.’’

- An RPCINFO command executed as

```
RPCINFO -P host
```

(where *host* is the name or Internet address of the MVS processor where LibraryStation will execute) should receive two or more responses indicating RPC program numbers, versions, protocols, and port numbers for registered RPC programs. When LibraryStation is active, its program number (300031) will be displayed.

### Step 2: LibraryStation Verification

Use the SLGDIAG installation verification program to verify basic operation of LibraryStation independent of network or client activity. SLGDIAG generates basic query, mount, and dismount requests to LibraryStation. When SLGDIAG has executed successfully, LibraryStation is considered to be ready for operation.

Refer to the *LibraryStation Operator and System Programmer’s Guide* for more information about the SLGDIAG installation verification program.



## Appendix A. Gathering Diagnostic Materials

---

During problem resolution, Software Support may request that you provide specific diagnostic material. While printed format may be accepted, machine readable data (on magnetic tape) is preferred. For small amounts of data, Software Support may request that you FAX the data. Doing this may significantly reduce the time needed to resolve your problem.

### LibraryStation Diagnostic Materials

The following LibraryStation diagnostic materials might be requested by Software Support:

- Details of circumstances
- GTF Trace data set
- MVS SYSLOG
- LAN packet trace
- Dump data set
- Startup parameters defined (including LSINIT and LSDEF control statements)
- HSC LIBGEN
- Copy of HSC Control Data Set (CDS)
- Copy of LibraryStation Persistent Data File (PDF)

### Tape Format

If Software Support requests a tape of your diagnostic materials copy the requested files to tape using standard utility programs.

If Software Support requests a tape of your SYSDUMP or SYS1.DUMP, dump using IEBGENER or IPCS DCB=(RECFM=FB,LRECL=4160,BLKSIZE=4160). Failure to follow this requirement may delay problem resolution.

Include a description of the tape contents, including any information necessary for Software Support to retrieve the files from the tape (i.e. tape volume serial number and label attributes, number of tape files, file names and attributes, etc.).

Refer to the *Requesting Help from Software Support* guide for more information.



## Appendix B. LibraryStation Configuration Worksheet

---

Use this worksheet to record site-specific information generated through completion of the configuration tasks included in this book. This worksheet is helpful as a reference for future LibraryStation configuration modifications.

Each section of the worksheet relates to a specific chapter in this book.

### Verifying Hardware and Software Requirements (Chapter 3)

Enter a checkmark for each installed hardware and software component.

<i>X</i>	Hardware Component
	MVS/ESA-capable computer system
	ACS library system
	Network Interface Adaptor
	SNA network hardware
	Coupling Facility (CF) or Channel to Channel (CTC) Device

<i>X</i>	Software Component	Release
	LibraryStation	
	MVS	
	HSC	
	TCP/IP	
	APPC/MVS	
	XCF	
	VTAM	

## Configuring Security Measures (Chapter 5)

Check Yes or No in response to each question.

<b>LibraryStation Security Measures</b>	<b>Yes (X)</b>	<b>No (X)</b>
Do you plan to restrict the number of tape cartridge drives the network can use?		
Do you plan to enable SAF checks?		
Do you have a SAF product installed?		
Do you plan to restrict network access to volumes?		
Do you plan to check volume authorization on a client level?		
Do you plan to define restricted volumes to a security class other than TAPEVOL?		
Are you using RACF and would you like to deny access to undefined volumes?		
Do you plan to check command authorization on a client level?		
Do you want to log volume security violations?		

## Configuring the LibraryStation Hostid (Chapter 7)

Enter the LibraryStation hostid to be defined in the HSC LIBGEN and used as the value for the NETHOST parameter in the LSINIT statement.

LibraryStation NETHOST Hostid:
--------------------------------

## Configuring Drive Device Numbers (Chapter 8)

Enter the device number and associated location information for each tape cartridge drive that will be assigned to LibraryStation.

You must also establish LSDEF UNITATTR statements for non-4480 drives to be used by LibraryStation. Do this on a separate worksheet.

ACS Number	LSM Number	Drive Panel Number	Row Number	Device Numbers	Device Type	UNIT-ATTR Used?

## Configuring the LSINIT Control Statement (Chapter 9)

Enter information about the parameters you will include in the LSINIT statement. At the minimum, you must enter site-specific variable information for NETHOST and COMMONSP. For the remaining parameters, enter information here only if you plan to override default settings. If you have more than one initializing host, prepare a separate worksheet for each host.

Keyword	Enter Parameters for the LSINIT Control Statement
NETHOST (required)	
COMMONSP (required)	
NOPDF	
AUTHCLS	
CMDACC	
COMMTYPE	
CREQLOG	
DEFER	
HOSTID	
LSDEF	
PDF	
PDFX	
POOLCHK	
REQTIME	
RETCOUNT	
RETTIME	
SYMDESTN	
TCPNAME	
VOLACC	
VOLAUTH	
VOLNOPRF	
VSECLOG	
XCFGROUP	
XCFMEMBR	



## Configuring the LSDEF File Data Set (Chapter 10)

Enter information about each of the statements you will include in the LSDEF file. Enter information only if you plan to override the default settings of the statements.

### CLIENTID Statement

Name	IP Address	LU Name

**SPNUM Statement**

<b>Number</b>	<b>Name</b>	<b>IP Address</b>	<b>LU Name</b>

**UNITATTR Statement**

<b>Address</b>	<b>Model</b>	<b>Nethost</b>

## Appendix C. Migration and Coexistence

---

This appendix provides guidelines for migration from previous releases of LibraryStation to LibraryStation 6.0. Reverse migration is also discussed.

In addition, this appendix provides LibraryStation coexistence and compatibility guidelines.



**Note:** Your site may have specific conditions that require special precautions and procedures. If so, contact StorageTek Software Support for assistance.

### Migration

#### Migration from LibraryStation Release 4.0 or later to Release 6.0

Perform the following steps:

1. Ensure that HSC has already been migrated to release 6.0.
2. Make the LibraryStation 6.0 LINKLIB available through the MVS LINKLIST facility or a STEPLIB DD statement in the LibraryStation started task procedure.
3. Make any parameter changes necessary to enable new functionality, if desired.
4. Start LibraryStation 6.0.

#### Reverse Migration from LibraryStation Release 6.0 to Release 4.x

Perform the following steps:

1. Make the LibraryStation 4.x LINKLIB available through the MVS LINKLIST facility or a STEPLIB DD statement in the LibraryStation startup procedure.
2. Ensure the HSC is at release 4.x.
3. Remove any parameters not supported by LibraryStation 4.x.
4. Start LibraryStation 4.x.

## Coexistence

For LibraryStation, the term “coexistence” implies the ability for a specific LibraryStation release to execute with a specific HSC release.

- LibraryStation 6.0 can coexist with HSC release 6.0 only.
- LibraryStation releases prior to 6.0 cannot coexist with HSC 6.0.

## Compatibility With MVS/CSC

LibraryStation 6.0 is compatible with MVS/CSC release 6.0 only.

## Glossary

---

Terms are defined as they are used in the text. If you cannot find a term here, check the index.

### A

**ABEND**— Abnormal end of task.

**ACS**— Automated Cartridge System.

**ACSL**— Automated Cartridge System Library Server.

**ACSLS ONC RPC protocol**— A request processing protocol that defines valid requests from network client systems, corresponding to an application layer of the ISO OSI reference model.

**ACS Library**— A library is composed of one or more Automated Cartridge Systems, attached tape cartridge drives, and cartridges residing in the ACSs.

**Advanced Program to Program Communication (APPC)**— A set of inter-program communication services that support cooperative transaction processing in a SNA network. APPC is the implementation, on a given system, of SNA's logical unit type 6.2.

**APPC/MVS**— The implementation of SNA's 6.2 and related communication services in the MVS base control program.

**Automated Cartridge System**— A fully-automated, cartridge storage and retrieval library subsystem consisting of one or more Library Storage Modules (LSMs) connected by pass-thru ports.

**Automated Cartridge System Library Server** — Unix®-based software that interprets library commands from client applications or library operators and routes them to the appropriate LMU.

### C

**CAP**— Cartridge Access Port. Also, the LibraryStation CAP Request Processor component.

**cartridge tape control unit**— A microprocessor-based unit logically situated between a channel and up to 16 cartridge transports that translates channel commands into transport commands and sends transport status to the channel.

**CDS**— Control Data Set.

**CETI**— Continuously Executing Transport Interface.

**CL**— LibraryStation Common Library component.

**client system**— See network client system.

**Client System Component (CSC)**— Software that provides an interface between the client computing system's operating system and the StorageTek library software, such as LibraryStation and the HSC.

**Client System Interface (CSI)**— The component of the LibraryStation subsystem that provides the RPC server interface to network clients.

**client system user**— A person who executes applications on a client system.

**Continuously Executing Transport Interface (CETI)**— An IBM communications channel protocol.

**Control Data Set (CDS)**— The data set used by the HSC software to control the functions of the ACS.

**Control Path Adaptor (CPA)**— A hardware component required by LibraryStation that converts an Ethernet communications packet to an IBM-compatible communications packet.

**CPA**— Control Path Adaptor.

**CSC**— Client System Component.

**CSE**— Customer Service Engineer.

**CSCI**— Client System Communications Interface

**CSI**— Client System Interface.

**CSR**— Customer Service Representative.

**CSS**— Central Software Support.

**CSSC**— Customer Service Support Center.

## D

**Database Manager (DBM)**— A LibraryStation software component that is responsible for managing pertinent data objects that are not controlled by the HSC, including resource locks and drive status.

**DASD**— Direct Access Storage Device.

**DB**— LibraryStation Persistent Data File Manager component.

**DBM**— Database Manager.

**Direct Access Storage Device (DASD)**— A device in which access time is effectively independent of the location of the data.

**dynamic server switching**— The capability of switching server processors when a system failure occurs on the active server.

## E

**EC**— Error Codes.

**ENQ**— Enquiry character.

**ERP**— European Support Center.

## F

**FIPS**— Federal Information Processing Standard.

## G

**Generalized Trace Facility (GTF)**— A program that records significant system events for use in problem determination.

**GRS**— Global Resource Serialization.

**GTF**— Generalized Trace Facility.

## H

**heterogeneous**— Of a dissimilar type or nature.

**homogeneous**— Of the same or similar type or nature.

**Host Software Component**— The StorageTek software that provides client volume location information through its Control Data Set (CDS) and provides the interface to the Nearline ACS hardware and client operator console.

**HSC**— Host Software Component.

**host system**— A computer that controls the access method for a network and provides services to client systems, such as an MVS host system that provides ACS library services to heterogeneous client systems such as a StorageTek NearNet System.

## I

**IBM**— International Business Machines Corporation.

**id**— Identifier or identification.

**IF**— LibraryStation Information Manager component.

**IPC**— Interprocess Communication.

**IPCS**— Interactive Problem Control System.

**ISO**— International Standards Organization.

**IT**— LibraryStation Initialization/Termination component

**I/O**— Input/output.

## J

**JCL**— Job Control Language.

**Job Control Language**— A control language used to identify a job to an operating system and to describe the job's requirements.

## K

**KSDS**— Keyed Sequential Data Set.

## L

**LAN**— Local Area Network.

**LCF**— Library Communication Facility.

**LCU**— Library Control Unit.

**Library Communication Facility**— Software required by LibraryStation that directs a communications packet to LibraryStation and provides the additional communications information that is required for the message to be accepted by LibraryStation.

**Library Control Unit**— The portion of an LSM that controls the LSM's robotic movements.

**library drive**— A cartridge transport attached to an LSM that is connected to and controlled by a client system.

**Library Management Unit (LMU)**— The portion of the Automated Cartridge System (ACS) that coordinates LSM communication and communicates with the HSC.

**LibraryStation**— Software that allows MVS hosts to share Automated Cartridge System facilities with heterogeneous network client systems.

**Library Storage Module (LSM)**— The portion of the Automated Cartridge System (ACS) that selects, mounts, dismounts, and stores tape cartridges.

**LM**— LibraryStation Library Manager component.

**LO**— LibraryStation Lock Manager component.

**Local Area Network (LAN)**— A data network located on the user's premises that uses serial transmission for direct communication among data stations.

**LMU**— Library Management Unit.

**LP**— Logical Port.

**LS**— LibraryStation.

**LSM**— Library Storage Module.

**LU6.2**— Logical Unit 6.2.

## M

**MT**— LibraryStation Mount Request Processor component.

**MVS**— Multiple Virtual Storage.

**MVS/HSC**— The MVS version of StorageTek Host Software Component software.

## N

**network client system**— A computer that is connected to a host system in a network, such as a StorageTek NearNet system that communicates through an Ethernet network with an MVS host system.

**network interface adaptor**— Equipment that provides an electrical and logical interface between a network and specific equipment attached to the network.

## O

**ONC**— Open Network Computing.

**OS**— LibraryStation Operating System Interface component.

**OSI**— Open Systems Interconnection.

## P

**PCR**— Product Change Request

**Persistent Data File (PDF)**— One or more VSAM data files that contain data objects including resource locks and drive status that are managed by the LibraryStation DBM.

**PDF**— Persistent Data File.

**PN**— Part Number.

**pool**— A collection of tape cartridges having one or more similar features or attributes, such as a pool of scratch tapes.

**Program Change Request (PCR)**— A request for enhancement of a software program.

**Program Temporary Fix (PTF)**— A software program designed to remedy one or a series of defects in an existing software program.

**Program Update Tape (PUT)**— One or more tapes containing updates to a software program.

**PTF**— Program Temporary Fix.

**PUT**— Program Update Tape.

## Q

**QU**— LibraryStation Query Request Processor component.

## R

**RACF**— Resource Access Control Facility.

**Resource Access Control Facility (RACF)**— An IBM-licensed program that provides access control by identifying and verifying the users to the system.

**RPC**— Remote Procedure Call.

## S

**SA**— LibraryStation System Administrator component.

**SAF**— System Authorization Facility.

**SCR**— LibraryStation Scratch Request Processor component.

**scratch**— An attribute of a tape cartridge that indicates it is blank or contains no useful data.

**SCSI**— Small Computer System Interface.

**SL8500**— See StreamLine (SL8500).

**SMC**— Storage Management Component

**SMP/E**— System Modification Program Extended.

**SSR**— Software Support Representative.

**STK**— StorageTek Stock Market symbol.

**StorageTek**— Storage Technology Corporation.

**Storage Management Component (SMC)**— Software interface between IBM's OS/390 and z/OS operating systems and StorageTek real and virtual tape hardware. SMC performs the allocation processing, message handling, and SMS processing for the NCS solution. It resides on the MVS host system with HSC and/or MVS/CSC, and communicates with these products to determine policies, volume locations, and drive ownership.

**StreamLine (SL8500)**— A modular library scalable from 1,500 to over 200,000 cartridges in mainframe, Windows, UNIX, and supercomputer environments. The SL8500 utilizes hot swap components and multiple robots.

**System Authorization Facility (SAF)**— A security program (such as RACF) that provides access control by verifying users who attempt to access the system.

**System Modification Program Extended (SMP/E)**— An IBM-licensed program used to install software programs.

## T

**tape cartridge drive**— A device containing cartridge transports and their associated power and pneumatic supplies.

**TCU**— Tape Control Unit.

**Tape Management System (TMS)**— A program that manages a tape library (such as CA-1), also called a tape library management system (TLMS).

**TCP/IP (Transmission Control Protocol/Internet Protocol)**— A family of protocols that provides communication between two computer systems.

**TMS**— Tape Management System.

## V

**VA**— LibraryStation Vary Request Processor component.

**Virtual Storage Manager (VSM)**— A storage solution that virtualizes volumes and transports in a VTSS buffer in order to improve media and transport use.



**Virtual Tape Control System (VTCS)**— The primary host code for the Virtual Storage Manager (VSM) solution. This code operates in a separate address space, but communicates closely with HSC.

**Virtual Tape Storage Subsystem (VTSS)**— The DASD buffer containing virtual volumes (VTVs) and virtual drives (VTDs). The VTSS is a StorageTek RAID 6 hardware device with microcode that enables transport emulation. The RAID device can read and write “tape” data from/to disk, and can read and write the data from/to a real tape drive (RTD).

**volume identifier**— A six-character string that uniquely identifies a tape cartridge to the database. The tape cartridge must have a matching external label unless a virtual label has been assigned.

**volume**— A tape cartridge or DASD drive.

**volume serial number (volser)**— A six-character alphanumeric label used to identify a tape volume.

**Virtual Storage Access Method (VSAM)**— An access method for indexed or sequential processing of fixed and variable length records on direct access devices.

**VSAM**— Virtual Storage Access Method.

**VTAM**— Virtual Telecommunications Access Method.

**XCF**— The MVS cross-system coupling facility, which allows MVS images connected to a sysplex to communicate with each other.



# Index

---

## A

ACS (Automated Cartridge System) support 5  
APPC/MVS support 24  
audience for this guide xiii  
AUTHCLS keyword parameter, LSINIT 59

## C

cartridge tape drives  
    access security 27  
cartridge tape transports, supported 6  
client/server environments  
    heterogeneous 14  
    sysplex 15  
    sysplex w/support for non-MVS/CSC clients 16  
CLIENTID LSDEF statement 68  
client-level volume authorization 33  
CMDACC keyword parameter, LSINIT 59  
command access security 37  
COMMONSP keyword parameter, LSINIT 58  
COMMTYPE keyword parameter, LSINIT 59  
communication facilities  
    APPC/MVS support 24  
    LU6.2 support 22  
    ONC/RPC support 21  
    VTAM support 23  
    XCF support 25  
communications interface requirements 20  
compatibility, LibraryStation and MVS/CSC 92  
configuration  
    communication facilities 21  
    creating LibraryStation hostid 45  
    drive device numbers 47  
    hardware requirements 19  
    MVS/HSC started task procedure 73  
    optional supporting software 20  
    overview 9  
    Persistent Data File (PDF) 41  
    reconfiguring the MVS/HSC LIBGEN 77

    security measures 27  
    system redundancy 17, 65  
    typical configurations 10  
    verification 81  
    worksheet 85  
configuration worksheet 85  
control statements xx  
conventions used in this guide xv  
creating device numbers 47  
CREQLOG keyword parameter, LSINIT 60  
customer software support xxii

## D

database manager 41  
default scratch subpool 58  
defer initialization at startup 64  
DEFER keyword parameter, LSINIT 60  
description of LibraryStation 1  
device numbers, configuring 47  
domain name resolution 21  
drives, tape cartridge  
    access security 27  
    creating device numbers 47

## E

environments, client/server  
    heterogeneous 14  
    sysplex 15  
    sysplex w/support for non-MVS/CSC clients 16

## F

flow diagrams xvi  
flow of requests and responses 3

## G

glossary 93

guide  
  audience definition xiii  
  conventions xv  
  conventions used in xv  
  organization xiv

## H

hardware components 10  
hardware requirements 19  
heterogeneous environment 14  
Host Software Component  
  LIBGEN 27  
  LSINIT control statement 53  
  started task procedure 73  
hostid  
  creating for LibraryStation 45  
  in LSINIT control statement 53  
  LibraryStation 57  
  MVS 60  
HOSTID keyword parameter, LSINIT 60

## I

initializing LibraryStation 79  
installation, LibraryStation 9

## J

JCL, sample 23, 24, 25, 45, 49, 72, 73

## K

keyword parameters, LSINIT  
  AUTHCLS 59  
  CMDACC 59  
  COMMONSP 58  
  COMMTYPE 59  
  CREQLOG 60  
  DEFER 60  
  HOSTID 60  
  LSDEF 60  
  NETHOST 57  
  NOPDF 58  
  PDF 62  
  PDFX 62  
  POOLCHK 62  
  REQTIME 62  
  RETCOUNT 62  
  RETTIME 62  
  SYMDESTN 63  
  TCPNAME 63  
  TCPPOINT 64  
  VOLACC 64  
  VOLAUTH 64

VOLNOPRF 64  
VSECLOG 64  
XCFGROUP 64  
XCFMEMBR 65  
XHREC 65

## L

LIBGEN, Host Software Component 27  
LIBGEN, MVS/HSC  
  LibraryStation modifications 45  
  reconfiguring 77  
LibraryStation  
  client/server environments 14  
  compatibility with MVS/CSC 92  
  configuration worksheet 85  
  default scratch subpool 58  
  description 1  
  hardware requirements 19  
  hostid 45, 57  
  how it works 1  
  installation 9  
  license key 75  
  LSDEF data set 72  
  LSINIT control statement 53  
  migration and coexistence 91  
  optional supporting software 20  
  request processing 3  
  security measures 27  
  software and hardware components 10  
  starting 79  
license key 75  
LSDEF data set, allocating 72  
LSDEF file statements  
  CLIENTID 68  
  SPNUM 69  
  UNITATTR 71  
LSDEF keyword parameter, LSINIT 60  
LSINIT control statement  
  AUTHCLS keyword parameter 59  
  CMDACC keyword parameter 59  
  COMMONSP keyword parameter 58  
  COMMTYPE keyword parameter 59  
  CREQLOG keyword parameter 60  
  DEFER keyword parameter 60  
  format 53  
  HOSTID keyword parameter 60  
  keyword parameters 54  
  LSDEF keyword parameter 60  
  NETHOST keyword parameter 57  
  NOPDF keyword parameter 58  
  PDF keyword parameter 62  
  PDFX keyword parameter 62  
  POOLCHK keyword parameter 62  
  REQTIME keyword parameter 62  
  RETCOUNT keyword parameter 62

- RETTIME keyword parameter 62
- SYMDESTN keyword parameter 63
- TCPNAME keyword parameter 63
- TCPPORT keyword parameter 64
- VOLACC keyword parameter 64
- VOLAUTH keyword parameter 64
- VOLNOPRF keyword parameter 64
- VSECLOG keyword parameter 64
- XCFGROUP keyword parameter 64
- XCFMEMBR keyword parameter 65
- XHREC keyword parameter 65

LU6.2 support 22

## M

- media, supported 7
- migration and coexistence 91
- multiple host configuration 17

## N

- NETHOST keyword parameter, LSINIT 57
- network-level volume authorization checks 29
- new features xi
- NOPDF keyword parameter, LSINIT 58

## O

- ONC/RPC support 21
- optional software
  - system authorization facility (SAF) 20
  - tape management system (TMS) 20
- organization of this guide xiv
- overview, configuration 9

## P

- PDF keyword parameter, LSINIT 62
- PDFX keyword parameter, LSINIT 62
- Persistent Data File (PDF), allocating 41
- POOLCHK keyword parameter, LSINIT 62
- product support information xxii
- publications, related xxi

## R

- RACROUTE calls 27
- related publications xxii
- REQTIME keyword parameter, LSINIT 62
- request processing 3

- requirements, hardware 19
- RETCOUNT keyword parameter, LSINIT 62
- RETTIME keyword parameter, LSINIT 62

## S

- scratch pool processing 38
- SCRPOOL control statement 36
- security measures
  - client volume authority, defining 64
  - client-level volume authorization 33
  - command access 37
  - command volume authority, defining 59
  - configuring 27
  - drive access 27
  - subpools 36
  - summary 40
  - volume access 27
  - volume authority, defining 64
- SL8500 (StreamLine) library 5, 96
- SLGDIAG utility 81
- software components 10
- SPNUM LSDEF statement 69
- started task procedure, MVS/HSC 73
- starting LibraryStation 79
- subpool security implications 36
- subpool, default scratch, volume security 38
- support, technical xxii
- symbols xv
- SYMDESTN keyword parameter, LSINIT 63
- syntax flow diagrams xvi
- sysplex environment 15
- sysplex w/support for non-MVS/CSC clients 16
- System Authorization Facility (SAF) 27, 29, 33, 37
- system redundancy 17, 65

## T

- tape cartridge drives
  - access security 27
  - creating device numbers 47
- tape format 83
- TCPIP\_PREFIX High Level Qualifier 22
- TCPNAME keyword parameter, LSINIT 63
- TCPPORT keyword parameter, LSINIT 64
- technical support xxii
- typographic conventions xv

## U

UNITATTR LSDEF statement 71

## V

verification, configuration 81

VOLACC keyword parameter, LSINIT 64

VOLAUTH keyword parameter, LSINIT 64

VOLNOPRF keyword parameter, LSINIT 64

volume access security 27

VSECLOG keyword parameter, LSINIT 64

VTAM support 23

## W

worksheet, configuration 85

## X

XCF support 25

XCFGROUP keyword parameter, LSINIT 64

XCFMEMBR keyword parameter, LSINIT 65

XHREC keyword parameter, LSINIT 65









NEED MORE INFORMATION?

[www.storagetek.com](http://www.storagetek.com)



## ABOUT STORAGETEK®

Storage Technology Corporation (NYSE: STK), a \$2 billion worldwide company with headquarters in Louisville, CO, has been delivering a broad range of storage management solutions designed for IT professionals for over 30 years. StorageTek offers solutions that are easy to manage, integrate well with existing infrastructures, and allow universal access to data across servers, media types and storage networks. StorageTek's practical and safe storage solutions for tape automation, disk storage systems and storage integration, coupled with a global services network, provide IT professionals with confidence and know-how to manage their entire storage management ecosystem today and in the future.

StorageTek products are available through a worldwide network. For more information, visit [www.storagetek.com](http://www.storagetek.com), or call 1.800.786.7835.

### WORLD HEADQUARTERS

Storage Technology Corporation  
One StorageTek Drive  
Louisville, Colorado 80028 USA  
Phone: **1.800.877.9220**