

Sun Cluster Data Service for Sun Java System Application Server Guide for Solaris OS



Sun Microsystems, Inc.
4150 Network Circle
Santa Clara, CA 95054
U.S.A.

Part No: 820-5029-10
January 2009, Revision A

Copyright 2009 Sun Microsystems, Inc. 4150 Network Circle, Santa Clara, CA 95054 U.S.A. All rights reserved.

Sun Microsystems, Inc. has intellectual property rights relating to technology embodied in the product that is described in this document. In particular, and without limitation, these intellectual property rights may include one or more U.S. patents or pending patent applications in the U.S. and in other countries.

U.S. Government Rights – Commercial software. Government users are subject to the Sun Microsystems, Inc. standard license agreement and applicable provisions of the FAR and its supplements.

This distribution may include materials developed by third parties.

Parts of the product may be derived from Berkeley BSD systems, licensed from the University of California. UNIX is a registered trademark in the U.S. and other countries, exclusively licensed through X/Open Company, Ltd.

Sun, Sun Microsystems, the Sun logo, the Solaris logo, the Java Coffee Cup logo, docs.sun.com, Java, and Solaris are trademarks or registered trademarks of Sun Microsystems, Inc. or its subsidiaries in the U.S. and other countries. All SPARC trademarks are used under license and are trademarks or registered trademarks of SPARC International, Inc. in the U.S. and other countries. Products bearing SPARC trademarks are based upon an architecture developed by Sun Microsystems, Inc.

The OPEN LOOK and Sun Graphical User Interface was developed by Sun Microsystems, Inc. for its users and licensees. Sun acknowledges the pioneering efforts of Xerox in researching and developing the concept of visual or graphical user interfaces for the computer industry. Sun holds a non-exclusive license from Xerox to the Xerox Graphical User Interface, which license also covers Sun's licensees who implement OPEN LOOK GUIs and otherwise comply with Sun's written license agreements.

Products covered by and information contained in this publication are controlled by U.S. Export Control laws and may be subject to the export or import laws in other countries. Nuclear, missile, chemical or biological weapons or nuclear maritime end uses or end users, whether direct or indirect, are strictly prohibited. Export or reexport to countries subject to U.S. embargo or to entities identified on U.S. export exclusion lists, including, but not limited to, the denied persons and specially designated nationals lists is strictly prohibited.

DOCUMENTATION IS PROVIDED "AS IS" AND ALL EXPRESS OR IMPLIED CONDITIONS, REPRESENTATIONS AND WARRANTIES, INCLUDING ANY IMPLIED WARRANTY OF MERCHANTABILITY, FITNESS FOR A PARTICULAR PURPOSE OR NON-INFRINGEMENT, ARE DISCLAIMED, EXCEPT TO THE EXTENT THAT SUCH DISCLAIMERS ARE HELD TO BE LEGALLY INVALID.

Copyright 2009 Sun Microsystems, Inc. 4150 Network Circle, Santa Clara, CA 95054 U.S.A. Tous droits réservés.

Sun Microsystems, Inc. détient les droits de propriété intellectuelle relatifs à la technologie incorporée dans le produit qui est décrit dans ce document. En particulier, et ce sans limitation, ces droits de propriété intellectuelle peuvent inclure un ou plusieurs brevets américains ou des applications de brevet en attente aux Etats-Unis et dans d'autres pays.

Cette distribution peut comprendre des composants développés par des tierces personnes.

Certains composants de ce produit peuvent être dérivées du logiciel Berkeley BSD, licenciés par l'Université de Californie. UNIX est une marque déposée aux Etats-Unis et dans d'autres pays; elle est licenciée exclusivement par X/Open Company, Ltd.

Sun, Sun Microsystems, le logo Sun, le logo Solaris, le logo Java Coffee Cup, docs.sun.com, Java et Solaris sont des marques de fabrique ou des marques déposées de Sun Microsystems, Inc., ou ses filiales, aux Etats-Unis et dans d'autres pays. Toutes les marques SPARC sont utilisées sous licence et sont des marques de fabrique ou des marques déposées de SPARC International, Inc. aux Etats-Unis et dans d'autres pays. Les produits portant les marques SPARC sont basés sur une architecture développée par Sun Microsystems, Inc.

L'interface d'utilisation graphique OPEN LOOK et Sun a été développée par Sun Microsystems, Inc. pour ses utilisateurs et licenciés. Sun reconnaît les efforts de pionniers de Xerox pour la recherche et le développement du concept des interfaces d'utilisation visuelle ou graphique pour l'industrie de l'informatique. Sun détient une licence non exclusive de Xerox sur l'interface d'utilisation graphique Xerox, cette licence couvrant également les licenciés de Sun qui mettent en place l'interface d'utilisation graphique OPEN LOOK et qui, en outre, se conforment aux licences écrites de Sun.

Les produits qui font l'objet de cette publication et les informations qu'il contient sont régis par la législation américaine en matière de contrôle des exportations et peuvent être soumis au droit d'autres pays dans le domaine des exportations et importations. Les utilisations finales, ou utilisateurs finaux, pour des armes nucléaires, des missiles, des armes chimiques ou biologiques ou pour le nucléaire maritime, directement ou indirectement, sont strictement interdites. Les exportations ou réexportations vers des pays sous embargo des Etats-Unis, ou vers des entités figurant sur les listes d'exclusion d'exportation américaines, y compris, mais de manière non exclusive, la liste de personnes qui font objet d'un ordre de ne pas participer, d'une façon directe ou indirecte, aux exportations des produits ou des services qui sont régis par la législation américaine en matière de contrôle des exportations et la liste de ressortissants spécifiquement désignés, sont rigoureusement interdites.

LA DOCUMENTATION EST FOURNIE "EN L'ETAT" ET TOUTES AUTRES CONDITIONS, DECLARATIONS ET GARANTIES EXPRESSES OU TACITES SONT FORMELLEMENT EXCLUES, DANS LA MESURE AUTORISEE PAR LA LOI APPLICABLE, Y COMPRIS NOTAMMENT TOUTE GARANTIE IMPLICITE RELATIVE A LA QUALITE MARCHANDE, A L'APTITUDE A UNE UTILISATION PARTICULIERE OU A L'ABSENCE DE CONTREFACON.

Contents

Preface	7
1 Installing and Configuring Sun Cluster HA for Sun Java System Application Server Supported Versions as of 9.1	11
Sun Cluster HA for Sun Java System Application Server Overview	12
Highly Available Components	12
Supported Configurations	13
Overview of the Installation and Configuration Process for Sun Cluster HA for Sun Java System Application Server	16
Planning the Sun Cluster HA for Sun Java System Application Server Installation and Configuration	17
Configuration Restrictions and Requirements	18
Installing and Configuring Sun Java System Application Server	18
▼ How to Configure and Activate Network Resources	19
▼ How to Install and Configure the Sun Java System Application Server	20
Verifying the Sun Java System Application Server Supported Versions as of 9.1 Installation and Configuration	21
▼ How to Verify the Installation and Configuration of the Domain Administration Server (DAS)	21
▼ How to Verify the Installation and Configuration of the Node Agents Configured as a Failover Data Service	22
Configuring the Sun Java System Web Server Plugin	24
Using the Sun Java System Application Server With HADB	24
Installing the Sun Cluster HA for Sun Java System Application Server Packages	24
▼ How to Install the Sun Cluster HA for Sun Java System Application Server Packages	25
Registering and Configuring Sun Cluster HA for Sun Java System Application Server Supported Versions as of 9.1	26
Setting Sun Cluster HA for Sun Java System Application Server Extension Properties	27
▼ How to Register and Configure Sun Cluster HA for Sun Java System Application Server as a Failover DAS Component and a Failover NA Component	28

Examples of Registering and Configuring the Failover DAS Component in the Sun Cluster HA for Sun Java System Application Server	30
Example of Creating the Failover Node Agent Component in the Sun Cluster HA for Sun Java System Application Server	32
Configuring the SUNW.HAStoragePlus Resource Type	35
Tuning the Fault Monitor for Sun Cluster HA for Sun Java System Application Server	36
Operations by the Fault Monitor for the DAS Component During a Probe	36
Verifying the Sun Cluster HA for Sun Java System Application Server Installation and Configuration	38
▼ How to Verify the Failover DAS Component	39
▼ How to Verify the Failover Node Agent Component	40
2 Installing and Configuring Sun Cluster HA for Sun Java System Application Server Supported Versions Before 8.1	43
Sun Cluster HA for Sun Java System Application Server Overview	44
Failover Configuration Overview	45
Multiple Masters Configuration Overview	45
Overview of the Installation and Configuration Process for Sun Cluster HA for Sun Java System Application Server	47
Planning the Sun Cluster HA for Sun Java System Application Server Installation and Configuration	48
Configuration Restrictions	48
Configuration Planning Questions	49
Installing and Configuring Sun Java System Application Server	50
▼ How to Configure and Activate Network Resources for a Failover Configuration	50
▼ How to Install and Configure the Sun Java System Application Server	52
Using the Sun Java System Application Server With HADB	56
Configuring the Sun Java System Web Server Plugin	56
Installing the Sun Cluster HA for Sun Java System Application Server Packages	57
Registering and Configuring Sun Cluster HA for Sun Java System Application Server Supported Versions Before 8.1	57
Setting Sun Cluster HA for Sun Java System Application Server Extension Properties	58
▼ How to Register and Configure the Sun Cluster HA for Sun Java System Application Server as a Failover Data Service	59
▼ How to Register and Configure the Sun Cluster HA for Sun Java System Application Server as a Data Service Mastered on Multiple Nodes	61
Configuring the SUNW.HAStoragePlus Resource Type	63

Tuning the Fault Monitor for Sun Cluster HA for Sun Java System Application Server	64
Operations by the Sun Cluster HA for Sun Java System Application Server Fault Monitor During a Probe	64
Verifying the Sun Cluster HA for Sun Java System Application Server Installation and Configuration	66
▼ How to Verify the Sun Cluster HA for Sun Java System Application Server Installation and Configuration	66
A Extension Properties for Sun Cluster HA for Sun Java System Application Server Supported Versions as of 9.1	69
SUNW.jsas Extension Properties	69
SUNW.jsas-na Extension Properties	71
B Extension Properties for Sun Cluster HA for Sun Java System Application Server Supported Versions Before 8.1	73
SUNW.s1as Extension Properties	73
Index	75

Preface

Sun Cluster Data Service for Sun Java System Application Server Guide for Solaris OS explains how to install and configure Sun™ Cluster HA for Sun Java System Application Server.

Note – This Sun Cluster release supports systems that use the SPARC and x86 families of processor architectures: UltraSPARC, SPARC64, AMD64, and Intel 64. In this document, x86 refers to the larger family of 64-bit x86 compatible products. Information in this document pertains to all platforms unless otherwise specified.

This document is intended for system administrators with extensive knowledge of Sun software and hardware. Do not use this document as a planning or presales guide. Before reading this document, you should have already determined your system requirements and purchased the appropriate equipment and software.

The instructions in this book assume knowledge of the Solaris™ Operating System (Solaris OS) and expertise with the volume-manager software that is used with Sun Cluster software.

Using UNIX Commands

This document contains information about commands that are specific to installing and configuring Sun Cluster data services. The document does *not* contain comprehensive information about basic UNIX® commands and procedures, such as shutting down the system, booting the system, and configuring devices. Information about basic UNIX commands and procedures is available from the following sources:

- Online documentation for the Solaris Operating System
- Solaris Operating System man pages
- Other software documentation that you received with your system

Typographic Conventions

The following table describes the typographic conventions that are used in this book.

TABLE P-1 Typographic Conventions

Typeface	Meaning	Example
AaBbCc123	The names of commands, files, and directories, and onscreen computer output	Edit your <code>.login</code> file. Use <code>ls -a</code> to list all files. <code>machine_name% you have mail.</code>
AaBbCc123	What you type, contrasted with onscreen computer output	<code>machine_name% su</code> Password:
<i>aabbcc123</i>	Placeholder: replace with a real name or value	The command to remove a file is <i>rm filename</i> .
<i>AaBbCc123</i>	Book titles, new terms, and terms to be emphasized	Read Chapter 6 in the <i>User's Guide</i> . <i>A cache</i> is a copy that is stored locally. Do <i>not</i> save the file. Note: Some emphasized items appear bold online.

Shell Prompts in Command Examples

The following table shows the default UNIX system prompt and superuser prompt for the C shell, Bourne shell, and Korn shell.

TABLE P-2 Shell Prompts

Shell	Prompt
C shell	<code>machine_name%</code>
C shell for superuser	<code>machine_name#</code>
Bourne shell and Korn shell	<code>\$</code>
Bourne shell and Korn shell for superuser	<code>#</code>

Related Documentation

Information about related Sun Cluster topics is available in the documentation that is listed in the following table. All Sun Cluster documentation is available at <http://docs.sun.com>.

Topic	Documentation
Data service administration	<i>Sun Cluster Data Services Planning and Administration Guide for Solaris OS</i> Individual data service guides
Concepts	<i>Sun Cluster Concepts Guide for Solaris OS</i>
Overview	<i>Sun Cluster Overview for Solaris OS</i>
Software installation	<i>Sun Cluster Software Installation Guide for Solaris OS</i>
System administration	<i>Sun Cluster System Administration Guide for Solaris OS</i>
Hardware administration	<i>Sun Cluster 3.1 - 3.2 Hardware Administration Manual for Solaris OS</i> Individual hardware administration guides
Data service development	<i>Sun Cluster Data Services Developer's Guide for Solaris OS</i>
Error messages	<i>Sun Cluster Error Messages Guide for Solaris OS</i>
Command and function reference	<i>Sun Cluster Reference Manual for Solaris OS</i>

For a complete list of Sun Cluster documentation, see the release notes for your release of Sun Cluster at <http://docs.sun.com>.

Related Third-Party Web Site References

Third-party URLs that are referenced in this document provide additional related information.

Note – Sun is not responsible for the availability of third-party web sites mentioned in this document. Sun does not endorse and is not responsible or liable for any content, advertising, products, or other materials that are available on or through such sites or resources. Sun will not be responsible or liable for any actual or alleged damage or loss caused or alleged to be caused by or in connection with use of or reliance on any such content, goods, or services that are available on or through such sites or resources.

Documentation, Support, and Training

The Sun web site provides information about the following additional resources:

- [Documentation](http://www.sun.com/documentation/) (<http://www.sun.com/documentation/>)
- [Support](http://www.sun.com/support/) (<http://www.sun.com/support/>)
- [Training](http://www.sun.com/training/) (<http://www.sun.com/training/>)

Getting Help

If you have problems installing or using Sun Cluster, contact your service provider and provide the following information:

- Your name and email address (if available)
- Your company name, address, and phone number
- The model number and serial number of your systems
- The release number of the Solaris Operating System (for example, Solaris 10)
- The release number of Sun Cluster (for example, Sun Cluster 3.2)

Use the following commands to gather information about each node on your system for your service provider.

Command	Function
<code>prtconf -v</code>	Displays the size of the system memory and reports information about peripheral devices
<code>psrinfo -v</code>	Displays information about processors
<code>showrev -p</code>	Reports which patches are installed
<code>prtdiag -v</code>	Displays system diagnostic information
<code>/usr/cluster/bin/clnode show-rev</code>	Displays Sun Cluster release and package version information

Also have available the contents of the `/var/adm/messages` file.

Installing and Configuring Sun Cluster HA for Sun Java System Application Server Supported Versions as of 9.1

This chapter describes the procedures to install and configure Sun Cluster HA for Sun Java System Application Server supported versions as of 9.1. You can also use the same procedures to install and configure Sun Cluster HA for GlassFish supported versions as of v2 update release 1.

The procedures for installing and configuring Sun Cluster HA for Sun Java System Application Server supported versions before 8.1 is different from the procedures given in this chapter. For information about installing and configuring Sun Cluster HA for Sun Java System Application Server supported versions before 8.1, see [Chapter 2, “Installing and Configuring Sun Cluster HA for Sun Java System Application Server Supported Versions Before 8.1.”](#)

This chapter contains the following sections.

- “Sun Cluster HA for Sun Java System Application Server Overview” on page 12
- “Overview of the Installation and Configuration Process for Sun Cluster HA for Sun Java System Application Server” on page 16
- “Planning the Sun Cluster HA for Sun Java System Application Server Installation and Configuration” on page 17
- “Installing and Configuring Sun Java System Application Server” on page 18
- “Verifying the Sun Java System Application Server Supported Versions as of 9.1 Installation and Configuration” on page 21
- “Configuring the Sun Java System Web Server Plugin” on page 24
- “Using the Sun Java System Application Server With HADB” on page 24
- “Installing the Sun Cluster HA for Sun Java System Application Server Packages” on page 24
- “Registering and Configuring Sun Cluster HA for Sun Java System Application Server Supported Versions as of 9.1” on page 26
- “Configuring the SUNW.HASStoragePlus Resource Type” on page 35
- “Tuning the Fault Monitor for Sun Cluster HA for Sun Java System Application Server” on page 36
- “Verifying the Sun Cluster HA for Sun Java System Application Server Installation and Configuration” on page 38

Sun Cluster HA for Sun Java System Application Server Overview

This section explains how the Sun Cluster HA for Sun Java System Application Server enables Sun Java System Application Server for high availability. See the *Sun Cluster Data Service Release Notes for Solaris OS* for any new Sun Cluster HA for Sun Java System Application Server installation and configuration information.

See [Chapter 1, “Planning for Sun Cluster Data Services,”](#) in *Sun Cluster Data Services Planning and Administration Guide for Solaris OS* and the *Sun Cluster Overview for Solaris OS* for general information about data services, resource groups, resources, and other related topics.

The Sun Java System Application Server provides a robust Java 2 Enterprise Edition (J2EE™) platform for the development, deployment, and management of enterprise applications. Key features include transaction management, performance, scalability, security, and integration.

The Sun Java System Application Server supports services from web publishing to enterprise-scale transaction processing, while enabling developers to build applications based on JavaServer Pages™ (JSP™), Java servlets, and Enterprise JavaBeans™ (EJB™) technology. The Sun Java System Application Server Enterprise Edition provides advanced clustering and failover technologies. These features enable the user to run scalable and highly available J2EE applications.

Rich clients can directly connect to the Sun Java System Application Server. Web client connections to the Sun Java System Application Server can be directed through a front-end web server. The Sun Java System Application Server provides a pass-through plugin installation for use with the Sun Java System Web Server.

Highly Available Components

The Sun Java System Application Server supported versions as of 9.1 consists of several components.

- Domain Administration Server (DAS)
- Node Agents (NA) and server instances
- Sun Java System Message Queue
- Sun Java System Application Server EE (HADB)

Implementation of the Sun Cluster HA for Sun Java System Application Server does not assume the existence of programs on which your architecture depends. Programs on which your architecture depends such as databases and web servers should be configured to be highly available, but can run on a different cluster.

Highly Available DAS and NA

The Sun Cluster HA for Sun Java System Application Server provides high availability that complements the high availability provided by the Sun Java System Application Server Enterprise Edition. The Sun Cluster HA for Sun Java System Application Server makes the DAS highly available by running it as a failover Sun Cluster data service. The Node Agents are made highly available by running them as a failover Sun Cluster data service. As a functionality provided by the Sun Java System Application Server Enterprise Edition, the Node Agents in turn make the Sun Java System Application Server instances highly available.

Highly Available Message Queue and HADB

The Sun Java System Application Server EE installs the Sun Java System Message Queue and the Sun Java System Application Server EE (HADB).

See *Sun Cluster Data Service for Sun Java System Message Queue Guide for Solaris OS* for information about configuring the Sun Java System Message Queue for high availability.

See *Sun Cluster Data Service for Sun Java System Application Server EE (HADB) Guide for Solaris OS* for information about configuring the Sun Java System Application Server EE (HADB) for high availability.

Supported Configurations

The Sun Cluster HA for Sun Java System Application Server makes the DAS component highly available by configuring it as a failover data service. The DAS must be configured to listen on a failover IP address. When Sun Cluster HA for Sun Java System Application Server detects a failed DAS, the data service restarts the DAS locally or fails it over to another node, depending on the values of the retry count and retry interval.

The Node Agent (NA) component is also configured as a failover data service. A Node Agent may be configured to manage a number of Application Server instances, and the Sun Cluster HA for Sun Java System Application Server data service indirectly manages all of these instances. All the Application Server instances are associated with the Node Agents and the Node Agents are configured to listen on a failover IP address.

If the Application server instances are down, the Node Agents will restart them. Any lost transactions are recovered while the instances are restarting. In the case of a crash of the Sun Cluster node on which the Node Agents and the Application Server instances are running, the Sun Cluster HA for Sun Java System Application Server fails over the Node Agent and the Application Server instances to another Sun Cluster node.

Note – Only one Node Agent resource is created for all the Node Agents configured for one failover IP address. The data service automatically detects the Node Agents that are configured on the failover IP address that is created in the failover resource group.

The following example is a configuration that comprises four Node Agents.

- Node Agent NA1 and its associated server instances I1 and I2 are configured to listen on failover IP address IP1.
- Node Agent NA2 and its associated server instances I3 and I4 are also configured to listen on failover IP address IP1.
- Node Agent NA3 and its associated server instances I5 and I6 are configured to listen on failover IP address IP2.
- Node Agent NA4 and its associated server instances I7 and I8 are also configured to listen on failover IP address IP2.

In this example, you create one resource for Node Agents NA1 and NA2 and all their server instances, and another resource for Node Agents NA3 and NA4 and all their server instances.

A detailed example of creating resources for four Node Agents is provided in [“Example of Creating the Failover Node Agent Component in the Sun Cluster HA for Sun Java System Application Server”](#) on page 32.

In the following sections, only two Node Agents are illustrated.

Before Node Failure

The following figure illustrates the failover DAS and failover Node Agent configuration before any node failure occurs.

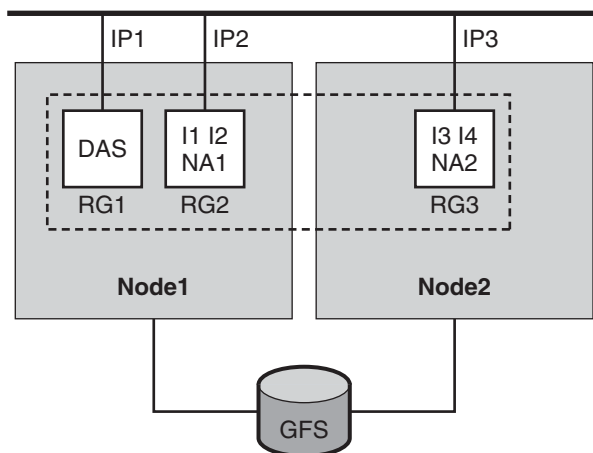

 Domain1

FIGURE 1-1 DAS and Node Agents Configured as Failover—Before Node Failure

The figure illustrates the following setup.

- There are two physical nodes, Node1 and Node2.
- The DAS is contained in the failover resource group RG1 on Node1 and listens on failover IP address IP1.
- The Node Agent NA1 and the Application Server instances I1 and I2 that the Node Agent manages are contained in the resource group RG2 on Node1 and listen on failover IP address IP2.
- The Node Agent NA2 and the Application Server instances I3 and I4 that the Node Agent manages are contained in the resource group RG3 on Node2 and listen on failover IP address IP3.
- There is one domain, Domain1, which contains the DAS and the two Node Agents, as well as all the instances managed by the Node Agents.
- The Application Server is installed on the global file system (GFS) and is accessible to the components on both Node1 and Node2.

Bringing these resource groups online starts the Node Agents, which in turn start the Application Server instances that they manage.

After Node Failure

The following figure illustrates the failover DAS and failover Node Agent configuration after a node failure.

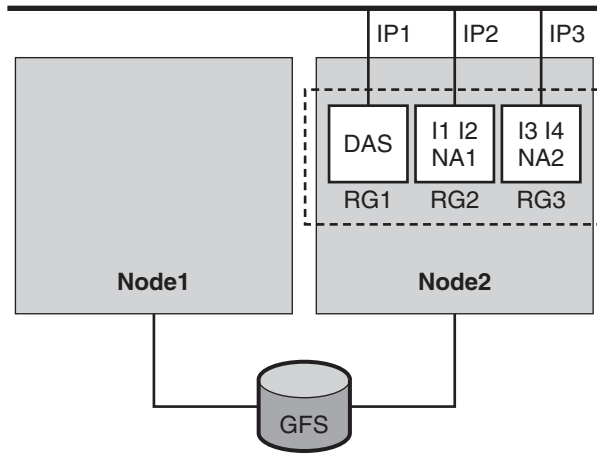

Domain1

FIGURE 1-2 DAS and Node Agents Configured as Failover—After Node Failure

After a failure on Node1, resource groups RG1 and RG2 fail over to Node2. Resource group RG1 contains the DAS and its failover address IP1. Resource group RG2 contains Node Agent NA1, instances I1 and I2, and their failover address IP2.

Note – The Node Agent probe relies upon the DAS for getting the status of the Node Agent. If DAS fails, there is no way to determine the status of the Node Agent. You need to ensure that the DAS is running at all times to know the status of the Node Agent.

Overview of the Installation and Configuration Process for Sun Cluster HA for Sun Java System Application Server

The following table summarizes the tasks for the installation and configuration of Sun Cluster HA for Sun Java System Application Server. Perform these tasks in the order that they are listed.

TABLE 1-1 Task Map: Installing and Configuring the Sun Cluster HA for Sun Java System Application Server

Task	For Instructions
Plan the Sun Cluster HA for Sun Java System Application Server installation and configuration	“Planning the Sun Cluster HA for Sun Java System Application Server Installation and Configuration” on page 17

TABLE 1-1 Task Map: Installing and Configuring the Sun Cluster HA for Sun Java System Application Server (Continued)

Task	For Instructions
Install and configure the Sun Java System Application Server	“Installing and Configuring Sun Java System Application Server” on page 18
Verify the installation and configuration of the Sun Java System Application Server	“Verifying the Sun Java System Application Server Supported Versions as of 9.1 Installation and Configuration” on page 21
Configure the Sun Java System Web Server plugin	“Configuring the Sun Java System Web Server Plugin” on page 24
(Optional) Use the Sun Java System Application Server with HADB	“Using the Sun Java System Application Server With HADB” on page 24
Install the Sun Cluster HA for Sun Java System Application Server package	“How to Install the Sun Cluster HA for Sun Java System Application Server Packages” on page 25
Register and Configure the Sun Cluster HA for Sun Java System Application Server	“Registering and Configuring Sun Cluster HA for Sun Java System Application Server Supported Versions as of 9.1” on page 26
(Optional) Configure the SUNW.HASStoragePlus resource type.	“Configuring the SUNW.HASStoragePlus Resource Type” on page 35
(Optional) Tune the Sun Cluster HA for Sun Java System Application Server fault monitor	“Tuning the Fault Monitor for Sun Cluster HA for Sun Java System Application Server” on page 36
Verify the Sun Cluster HA for Sun Java System Application Server installation and configuration	“Verifying the Sun Cluster HA for Sun Java System Application Server Installation and Configuration” on page 38

Note – If you run multiple data services in your Sun Cluster configuration, you can set up the data services in any order, with the following exception. If the Sun Cluster HA for Sun Java System Application Server depends on Sun Cluster HA for DNS, you must set up DNS first. For details, see [Sun Cluster Data Service for DNS Guide for Solaris OS](#) for details. DNS software is included in the Solaris operating environment. If the cluster will obtain the DNS service from another server, configure the cluster to be a DNS client first.

Planning the Sun Cluster HA for Sun Java System Application Server Installation and Configuration

This section contains the information that you need to plan the installation and configuration of the Sun Cluster HA for Sun Java System Application Server.

Configuration Restrictions and Requirements

Consider the following restrictions and requirements before you start your installation.

- The Sun Java System Application Server can be installed either on the global file system or on a local file system on all the Sun Cluster nodes. The directories for the DAS can be on the global file system or a failover file system, but the directories for the Node Agents must reside on the global file system.
- The DAS must be configured to listen on a failover IP address. Before you start your installation, determine the failover IP address that you plan to use for the DAS.
- The instances and Node Agents must also be configured to listen on failover IP addresses, which are represented by logical host names. Before you start your installation, determine the failover logical host name that you plan to use for each Node Agent.
- Do not use the Sun Java System Application Server administrative tools to start or stop the Sun Java System Application Server instances while application instances are running under Sun Cluster control.
- The Sun Java System Application Server administration password is needed for some administration commands and actions. You must set this password in a file whose syntax is specified in the Sun Java System Application Server documentation. The path to this file must be specified with an extension property when you create the resources. See [“SUNW.jsas Extension Properties” on page 69](#) for a description of this extension property and the syntax of the password entry in the file.
- The Sun Java System Application Server DAS must start without prompting the user for the master password. Therefore, set the `savemasterpassword` option to `true` when you create the DAS.

Installing and Configuring Sun Java System Application Server

This section describes installation and configuration of the Sun Java System Application Server. Only the information that is specific to the Sun Cluster HA for Sun Java System Application Server is included here. See the Sun Java System Application Server documentation for detailed installation instructions, including patch requirements.

Note – The Sun Java System Application Server can be configured to run in a whole root or a sparse root non-global zone, if required.

Note – Before starting your installation, set the `JMS-service` entry in the `domain.xml` file to `REMOTE`.

▼ How to Configure and Activate Network Resources

To enable the components in Sun Java System Application Server to run in Sun Cluster, you must set up the network resources for those components.

- 1 **On a cluster member, become superuser or assume a role that provides `solaris.cluster.modify` and `solaris.cluster.admin` RBAC authorization.**
- 2 **Create a failover resource group to contain the DAS application resources and the network resource that DAS uses.**

The failover IP address is the network resource for the DAS resource.

```
# clresourcegroup create [-n node-zone-list] DAS-resource-group
```

DAS-resource-group

Specifies the name of the DAS resource group. This name can be your choice.

[-n node-zone-list]

Specifies a comma-separated, ordered list of zones that can master this resource group. The format of each entry in the list is *node*. In this format, *node* specifies the node name and *zone* specifies the name of a non-global Solaris zone. To specify the global zone, or to specify a node without non-global zones, specify only *node*.

This list is optional. If you omit this list, the global zone of each cluster node can master the resource group.

- 3 **Add the network resource to the DAS resource group.**

Use the following command to add the failover IP address to the DAS resource group.

```
# clreslogicalhostname create -g DAS-resource-group -h IP-address IP-address
```

-g DAS-resource-group

Specifies the name of the DAS resource group.

-h IP-address

Specifies the failover IP address that is the network resource in this resource group.

Note – If you require a fully qualified hostname, you must specify the fully qualified name with the `-h` option and you cannot use the fully qualified form in the resource name.

4 Bring online the DAS resource group.

Bringing online this resource group enables the failover IP address resource for DAS.

```
# clresourcegroup online DAS-resource-group
```

```
DAS-resource-group
```

Specifies the name of the DAS resource group.

5 Create resource groups for the Node Agents and the network resources that the Node Agents use.

To create a failover resource group for Node Agent, run the following command.

```
# clresourcegroup create [-n node-zone-list NA-resource-group]
```

6 Add the failover logical host name to the resource group.

```
# clreslogicalhostname create -g NA-resource-group -h logical-hostname logical-hostname
```

Note – If you require a fully qualified hostname, you must specify the fully qualified name with the `-h` option and you cannot use the fully qualified form in the resource name.

7 Bring online the Node Agents resource groups.

Bringing online these resource groups enables the failover logical host resources for the Node Agents.

```
# clresourcegroup online NA-resource-group
```

▼ How to Install and Configure the Sun Java System Application Server

1 Follow the instructions in the Sun Java System Application Server Installation and Administration Guide.

The Sun Java System Application Server can be installed on the local file system or on the global file system.

2 When creating the domains, you must create the domain directory in the global file system.

The extension property `Domaindir` for the `SUNW.jsas` resource type specifies the path to the domain directory. See [“SUNW.jsas Extension Properties” on page 69](#).

3 When creating the Node Agents, you must create the Node Agents directory in the global file system.

4 After creating the domain, change all the DAS listener addresses to a failover IP address.

In the `server-config` entry in the file `domain.xml`, change the DAS HTTP, HTTPS, IIOP, and all other listener addresses to the failover IP address that you intend to use in the Sun Cluster DAS resource.

Note – Before you modify the file `domain.xml`, remember to stop all the instances of DAS and Node Agents.

5 Configure the failover logical host names on which the server instances and Node Agents listen.

When the Node Agents and Sun Java System Application Server instances are created, the physical node addresses are set by default in the file `domain.xml`. Therefore, you must change the physical addresses to the failover logical host names that you plan to use for the Node Agents.

The file `nodeagent.properties` in the Node Agent configuration directory contains the entry `agent.client.host=hostname`, where *hostname* specifies the Sun Cluster node on which *Node-Agent-name* is configured to run, and where *Node-Agent-name* is the name of a particular Node Agent.

Verifying the Sun Java System Application Server Supported Versions as of 9.1 Installation and Configuration

Before you install the Sun Cluster HA for Sun Java System Application Server package, verify that the Sun Java System Application Server software is correctly installed and configured to run in a cluster. These procedures do *not* verify that the Sun Java System Application Server application is highly available because you have not yet installed your data service and the application is not yet under cluster control.

▼ How to Verify the Installation and Configuration of the Domain Administration Server (DAS)

In this procedure, a two-node cluster is used, where the nodes are identified as Node1 and Node2. The following actions were performed in “[How to Configure and Activate Network Resources](#)” on page 19.

- The failover DAS resource group *DAS-resource-group* was created.
- The failover IP address *IP-address* was added as a network resource to the resource group.
- The resource group was brought online, and the resources were enabled.

1 On Node1, start DAS manually, using the `asadmin` command.

Note – The DAS must have been configured to listen on the failover IP address *IP-address*.

2 Connect to the administrative console from a browser.

`https://IP-address:port`

3 Verify that you are connected to the administrative console.

4 On Node1, stop DAS manually, using the `asadmin` command.

5 Switch the DAS resource group from Node1 to Node2.

```
# clresourcegroup online -n Node2 DAS-resource-group
```

This step takes the resource group offline from Node1 and brings the same resource group online on Node2. The resource group includes the logical IP address *IP-address*.

6 On Node2, start DAS manually, using the `asadmin` command.

7 Connect to the administrative console from a browser.

`https://IP-address:port`

If you are not able to connect to the administrative console from the browser, perform the following actions.

- Ensure that your installation satisfies the restrictions and requirements in [“Configuration Restrictions and Requirements”](#) on page 18.
- Ensure that you correctly followed the instructions in [“How to Install and Configure the Sun Java System Application Server”](#) on page 20.

8 On Node2, stop DAS manually, using the `asadmin` command.

▼ **How to Verify the Installation and Configuration of the Node Agents Configured as a Failover Data Service**

In this procedure, a two-node cluster is used, where the nodes are identified as Node1 and Node2. The following actions were performed in [“How to Configure and Activate Network Resources”](#) on page 19.

- The failover Node Agent resource group *NA-resource-group* was created.
- The failover logical host *logical-hostname* was added as a network resource to the resource group.
- The resource group was brought online, and the resources were enabled.

1 On Node1, start the Node Agent manually using the `asadmin` command.

This step starts the Node Agent and all the server instances that are configured for this Node Agent.

Note – The Node Agent and the server instances are configured to listen on the failover logical host that is configured in the failover resource group *NA-resource-group*.

2 Connect to the server instances from a browser.

`http://logical-hostname:instance1-port`

`http://logical-hostname:instance2-port`

3 Ensure that you can connect to any application deployed on the server instance.**4 If you are not able to connect to an application deployed on the server instance, perform the following steps.**

- Ensure that the server instances and the Node Agent are configured correctly to listen on the logical host *logical-hostname*.
- Ensure that your installation satisfies the restrictions and requirements described in “[Configuration Restrictions and Requirements](#)” on page 18.
- Ensure that you correctly followed the instructions in “[How to Install and Configure the Sun Java System Application Server](#)” on page 20.

5 On Node1, stop the Node Agent by using the `asadmin` command.

This step stops all the server instances that are configured for this Node Agent.

6 Switch the Node Agent resource group from Node1 to Node2.

```
# clresourcegroup online -n Node2 NA-resource-group
```

This step takes the resource group offline from Node1 and brings the same resource group online on Node2. The resource group includes the logical host *logical-hostname*.

7 On Node2, start the Node Agent manually by using the `asadmin` command.

This step starts the Node Agent and all the server instances that are configured for this Node Agent.

8 Connect to the server instances from a browser.

`http://logical-hostname:instance1-port`

`http://logical-hostname:instance2-port`

- 9 **If you are not able to connect to the server instance from the browser, perform the following steps.**
 - Ensure that the server instances and the Node Agent are configured correctly to listen on the logical host *logical-hostname*.
 - Ensure that your installation satisfies the restrictions and requirements described in “[Configuration Restrictions and Requirements](#)” on page 18.
 - Ensure that you correctly followed the instructions in “[How to Install and Configure the Sun Java System Application Server](#)” on page 20.
- 10 **After successfully verifying the configuration, stop the Node Agent and all the server instances on Node2 by using the `asadmin` command.**

Configuring the Sun Java System Web Server Plugin

The Sun Java System Web Server plugin can be used as a pass-through, load-balancing mechanism with the Sun Java System Application Server. See the Sun Java System Application Server documentation for detailed instructions.

Using the Sun Java System Application Server With HADB

To use the Enterprise Edition of Sun Java System Application Server with HADB enabled in a cluster, install and configure the Sun Cluster data service for Sun Java System Application Server EE (HADB). See [Sun Cluster Data Service for Sun Java System Application Server EE \(HADB\) Guide for Solaris OS](#) for procedural instructions.

Installing the Sun Cluster HA for Sun Java System Application Server Packages

If you did not install the Sun Cluster HA for Sun Java System Application Server packages during your initial Sun Cluster installation, perform this procedure to install the packages. To install the packages, use the Sun Java Enterprise System Common Installer.

Note – You need to install the Sun Cluster HA for Sun Java System Application Server packages in the global cluster and not in the zone cluster.

▼ How to Install the Sun Cluster HA for Sun Java System Application Server Packages

Perform this procedure on each cluster node where you are installing the Sun Cluster HA for Sun Java System Application Server packages.

You can run the Sun Java Enterprise System Common Installer with a command-line interface (CLI) or with a graphical user interface (GUI). The content and sequence of instructions in the CLI and the GUI are similar.

Note – Even if you plan to configure this data service to run in non-global zones, install the packages for this data service in the global zone. The packages are propagated to any existing non-global zones and to any non-global zones that are created after you install the packages.

Before You Begin Ensure that you have the Sun Java™ Availability Suite DVD-ROM.

If you intend to run the Sun Java Enterprise System Common Installer with a GUI, ensure that your DISPLAY environment variable is set.

1 On the cluster node where you are installing the data service packages, become superuser.

2 Load the Sun Java Availability Suite DVD-ROM into the DVD-ROM drive.

If the Volume Management daemon `volld(1M)` is running and configured to manage DVD-ROM devices, the daemon automatically mounts the DVD-ROM on the `/cdrom` directory.

3 Change to the Sun Java Enterprise System Common Installer directory of the DVD-ROM.

- **If you are installing the data service packages on the SPARC® platform, type the following command:**

```
# cd /cdrom/cdrom0/Solaris_sparc
```

- **If you are installing the data service packages on the x86 platform, type the following command:**

```
# cd /cdrom/cdrom0/Solaris_x86
```

4 Start the Sun Java Enterprise System Common Installer.

```
# ./installer
```

5 When you are prompted, accept the license agreement.

If any Sun Java Enterprise System components are installed, you are prompted to select whether to upgrade the components or install new software.

- 6 From the list of Sun Cluster agents under Availability Services, select the data service for Sun Java System Application Server.**
- 7 If you require support for languages other than English, select the option to install multilingual packages.**

English language support is always installed.
- 8 When prompted whether to configure the data service now or later, choose Configure Later.**

Choose Configure Later to perform the configuration after the installation.
- 9 Follow the instructions on the screen to install the data service packages on the node.**

The Sun Java Enterprise System Common Installer displays the status of the installation. When the installation is complete, the wizard displays an installation summary and the installation logs.
- 10 (GUI only) If you do not want to register the product and receive product updates, deselect the Product Registration option.**

The Product Registration option is not available with the CLI. If you are running the Sun Java Enterprise System Common Installer with the CLI, omit this step.
- 11 Exit the Sun Java Enterprise System Common Installer.**
- 12 Unload the Sun Java Availability Suite DVD-ROM from the DVD-ROM drive.**
 - a. To ensure that the DVD-ROM is not being used, change to a directory that does *not* reside on the DVD-ROM.**
 - b. Eject the DVD-ROM.**

```
# eject cdrom
```

Next Steps See [“Registering and Configuring Sun Cluster HA for Sun Java System Application Server Supported Versions Before 8.1” on page 57](#) to register Sun Cluster HA for Sun Java System Application Server and to configure the cluster for the data service.

Registering and Configuring Sun Cluster HA for Sun Java System Application Server Supported Versions as of 9.1

The following procedures explain how to use the Sun Cluster maintenance commands to register and configure the Sun Cluster HA for Sun Java System Application Server. These

instructions explain how to set the extension properties described in [Appendix A, “Extension Properties for Sun Cluster HA for Sun Java System Application Server Supported Versions as of 9.1.”](#)

Both the DAS component and the Node Agent (NA) component are configured as failover services.

Note – See “Tools for Data Service Resource Administration” in *Sun Cluster Data Services Planning and Administration Guide for Solaris OS* for general information about registering and configuring data services.

Setting Sun Cluster HA for Sun Java System Application Server Extension Properties

The sections that follow contain instructions for registering and configuring resources. These instructions explain how to set *only* extension properties that Sun Cluster HA for Sun Java System Application Server requires you to set. For information about all Sun Cluster HA for Sun Java System Application Server extension properties, see [Appendix A, “Extension Properties for Sun Cluster HA for Sun Java System Application Server Supported Versions as of 9.1.”](#) You can update some extension properties dynamically. You can update other properties, however, only when you create or disable a resource. The Tunable entry indicates when you can update a property.

To set an extension property of a resource, include the following option in the `clresource(1CL)` command that creates or modifies the resource:

-p *property=value*

-p *property*

Identifies the extension property that you are setting.

value

Specifies the value to which you are setting the extension property.

You can also use the procedures in [Chapter 2, “Administering Data Service Resources,”](#) in *Sun Cluster Data Services Planning and Administration Guide for Solaris OS* to configure resources after the resources are created.

▼ How to Register and Configure Sun Cluster HA for Sun Java System Application Server as a Failover DAS Component and a Failover NA Component

Note that in “[How to Configure and Activate Network Resources](#)” on page 19 you previously created the failover resource groups for the DAS component and for the NA component, added failover IP addresses and logical hosts to the resource groups, and brought the resource groups online.

- 1 On a cluster member, become superuser or assume a role that provides `solaris.cluster.modify` RBAC authorization.
- 2 Register the `SUNW.jsas` resource type for the DAS component.

```
# clresourcetype register SUNW.jsas
```
- 3 Add the DAS resource instance to the failover resource group that you created for your network resources.

See “[SUNW.jsas Extension Properties](#)” on page 69 for a detailed description of the extension properties for this resource type.

```
# clresource create DAS-resource-group \  
-t SUNW.jsas \  
-p Network_resources_used=logical-hostname \  
-p Adminuser=DAS-admin-username \  
-p Domain_name=domain-name \  
-p Passwordfile=password-file \  
-p Confdir_list=install-directory \  
-p Domaindir=domain-directory DAS-resource
```

DAS-resource-group

Specifies the resource group for the DAS component.

-t *SUNW.jsas*

Specifies the resource type for the DAS component.

-p *Network_resources_used=logical-hostname*

Specifies the failover IP address that is used by DAS.

-p *Adminuser=DAS-admin-username*

Specifies DAS administrative user name.

-p *Domain_name=domain-name*

Specifies the domain name.

-p *Passwordfile=password-file*

Specifies the full path to the file containing the DAS administrative password and master password.

-p `Confdir_list=install-directory`
 Specifies the complete path to the Sun Java System Application Server installation directory. The default value for this extension property is `/opt/SUNWappserver`, which is the standard installation directory.

-p `Domaindir=domain-directory`
 Specifies the full path to the domain directory. This extension property is optional if the domain directory is the default directory that was specified at the installation of the Sun Java System Application Server.

DAS-resource
 Specifies the DAS resource name.

The resource is created in the enabled state.

4 Register the `SUNW.jsas-na` resource type for the Node Agent component.

```
# clresourcetype register SUNW.jsas-na
```

5 Add the Node Agent resource instance to the failover resource group that you created for your network resources.

See “[SUNW.jsas-na Extension Properties](#)” on page 71 for a detailed description of the extension properties for this resource type.

```
# clresource create -g NA-resource-group \  
-t SUNW.jsas-na \  
-p Resource_Dependencies=DAS-resource \  
-p Adminuser=DAS-admin-username \  
-p Confdir_list=install-directory \  
-p Adminhost=DAS-hostname \  
-p Adminport=DAS-port \  
-p Agentdir=NA-directory \  
-p Passwordfile=password-file NA-resource
```

-g `NA-resource-group`
 Specifies the resource group for the Node Agent component.

-t `SUNW.jsas-na`
 Specifies the resource type for the Node Agent component.

-p `Resource_Dependencies=DAS-resource`
 Specifies that the DAS resource must be online before the Node Agent resource can start.

-p `Adminuser=DAS-admin-username`
 Specifies DAS administrative user name.

-p `Confdir_list=install-directory`
 Specifies the complete path to the Sun Java System Application Server installation directory. The default value for this extension property is `/opt/SUNWappserver`, which is the standard installation directory.

- p *Adminhost=DAS-hostname*
Specifies the host name of the DAS.
- p *Adminport=DAS-port*
Specifies the port where DAS listens.
- p *Agentdir=NA-directory*
Specifies the full path to the Node Agents directory.
- p *Passwordfile=password-file*
Specifies the full path to the file containing the DAS administrative password and master password.

NA-resource

Specifies the Node Agent resource name.

The resource is created in the enabled state.

Examples of Registering and Configuring the Failover DAS Component in the Sun Cluster HA for Sun Java System Application Server

These examples assume that the DAS resource group has already been created, the failover IP address has been added to the resource group, and the resource group has been brought online.

EXAMPLE 1-1 Creating a Simple DAS Resource

In this example, the default values for the extension properties are used.

```
# clresource_type register SUNW.jsas

# clresource create -g das-rg \
-t SUNW.jsas \
-p Network_resources_used=IP1 \
-p Adminuser=admin \
-p Domain_name=domain1 \
-p Passwordfile=/global/disk1/passwordfile das-rs
```

In this example, the following values are set.

- The resource name is `das - rs`.
- The resource group is `das - rg`.
- The administrative user is `admin`.
- The domain name is `domain1`.
- The full path to the password file is `/global/disk1/passwordfile`.

EXAMPLE 1-1 Creating a Simple DAS Resource (Continued)

- The Application Server is assumed to be installed in the standard location `/opt/SUNWappserver`, which is the default value of the extension property `Confdir_list`.
- The domain is assumed to be installed in the path that you set at the time of installation. This path is defined by the variable `AS_DEF_DOMAINS` in the file `/opt/SUNWappserver/appserver/config/asenv.conf`. The binaries can be stored in the local file system, but the domain directory must be in the global file system.

EXAMPLE 1-2 Creating a DAS Resource by Specifying the Installation Directory and the Domain Directory

In this example, the Application Server is not installed in the default location and the domain directory is not the default.

```
# clresourcetype register SUNW.jsas

# clresource create -g das-rg \
-t SUNW.jsas \
-p Network_resources_used=IP1 \
-p Adminuser=admin \
-p Domain_name=domain1 \
-p Passwordfile=/global/disk1/passwordfile \
-p Confdir_list=/global/disk1/SUNWappserver \
-p Domaindir=/global/disk1/my-domain das-rs
```

In this example, the following values are set.

- The resource name is `das-rs`.
- The resource group is `das-rg`.
- The administrative user is `admin`.
- The domain name is `domain1`.
- The full path to the password file is `/global/disk1/passwordfile`.
- The Application Server is installed in the directory `/global/disk1/SUNWappserver`.
- The domain directory is `/global/disk1/my-domain`.

EXAMPLE 1-3 Creating a DAS Resource and Specifying a List of URIs to be Monitored

In this example, the extension property `Monitor Uri List` specifies the URI that is serviced by applications on the Application Server. The fault monitor probe monitors this URI to test the functionality of the Application Server.

```
# clresourcetype register SUNW.jsas
```

EXAMPLE 1-3 Creating a DAS Resource and Specifying a List of URIs to be Monitored (Continued)

```
# clresource create -g das-rg \
-t SUNW.jsas \
-p Network_resources_used=IP1 \
-p Adminuser=admin \
-p Domain_name=domain1 \
-p Passwordfile=/global/disk1/passwordfile \
-p Confdir_list=/global/disk1/SUNWappserver \
-p Domaindir=/global/disk1/my-domain \
-p Monitor Uri_List=http://IP1:4848/web-service das-rs
```

In this example, the following values are set.

- The resource name is `das-rs`.
- The resource group is `das-rg`.
- The administrative user is `admin`.
- The domain name is `domain1`.
- The full path to the password file is `/global/disk1/passwordfile`.
- The Application Server is installed in the directory `/global/disk1/SUNWappserver`.
- The domain directory is `/global/disk1/my-domain`.
- The URI to be monitored is `http://IP1:4848/web-service`.

Example of Creating the Failover Node Agent Component in the Sun Cluster HA for Sun Java System Application Server

The example in this section assumes the following configuration, where failover IP addresses are represented by logical host names.

- Node Agent NA1 and its associated server instances I1 and I2 are configured to listen on failover IP address IP1.
- Node Agent NA2 and its associated server instances I3 and I4 are also configured to listen on failover IP address IP1.
- Node Agent NA3 and its associated server instances I5 and I6 are configured to listen on failover IP address IP2.
- Node Agent NA4 and its associated server instances I7 and I8 are also configured to listen on failover IP address IP2.

EXAMPLE 1-4 Creating Failover Node Agent Resources

1. To register the resource type for the Node Agents, the following command is run.

```
# clresourcetype register SUNW.jsas-na
```

2. To create the failover resource group na-rg1 to contain the failover IP address IP1 and the Node Agent resource for Node Agents NA1 and NA2, the following command is run.

```
# clresourcegroup create na-rg1
```

3. To create the failover resource group na-rg2 to contain the failover IP address IP2 and the Node Agent resource for Node Agents NA3 and NA4, the following command is run.

```
# clresourcegroup create na-rg2
```

4. To add the failover IP address resource IP1 to the resource group na-rg1, the following command is run.

```
# clreslogicalhostname create -g na-rg1 -h IP1 IP1
```

Note – If you require a fully qualified hostname, you must specify the fully qualified name with the -h option and you cannot use the fully qualified form in the resource name.

5. To add the failover IP address resource IP2 to the resource group na-rg2, the following command is run.

```
# clreslogicalhostname create -g na-rg2 -h IP2 IP2
```

Note – If you require a fully qualified hostname, you must specify the fully qualified name with the -h option and you cannot use the fully qualified form in the resource name.

6. To create the Node Agent resource na-rs1 in resource group na-rg1, the following command is run.

Note – Only one Node Agent resource is created for all the Node Agents configured for one failover IP address. The data service automatically detects the Node Agents that are configured on the failover IP address that is created in the failover resource group.

In this example, Node Agents NA1 and NA2 and all their server instances (I1, I2, I3, and I4) are configured on IP1, and therefore only one resource, na-rs1 is created for NA1 and NA2.

- Run this command if you use the default values for the extension properties.

EXAMPLE 1-4 Creating Failover Node Agent Resources (Continued)

```
# clresource create -g na-rg1 \
-t SUNW.jsas-na \
-p Resource_Dependencies=das-rs \
-p Adminhost=host-1 \
-p Adminuser=admin \
-p Agentdir=/global/dg1/na-dir \
-p Passwordfile=/global/dg1/p na-rs1
```

- Run this command if the installation is not in the default location, and the administrative port is not the default value.

```
# clresource create -g na-rg1 \
-t SUNW.jsas-na \
-p Resource_Dependencies=das-rs \
-p Adminhost=host-1 \
-p Adminuser=admin \
-p Agentdir=/global/dg1/na-dir \
-p Passwordfile=/global/dg1/p \
-p Confdir_list=/global/disk1/appserver-install-dir \
-p Adminport=6162 na-rs1
```

The resource is created in the enabled state.

7. To create the Node Agent resource na-rs2 in resource group na-rg2, the following command is run.

Note – Only one Node Agent resource is created for all the Node Agents configured for one failover IP address. The data service automatically detects the Node Agents that are configured on the failover IP address that is created in the failover resource group.

In this example, Node Agents NA3 and NA4 and all their server instances (I5, I6, I7, and I8) are configured on IP2, and therefore only one resource, na-rs2 is created for NA3 and NA4.

- Run this command if you use the default values for the extension properties.

```
# clresource create -g na-rg2 \
-t SUNW.jsas-na \
-p Resource_Dependencies=das-rs \
-p Adminhost=host-1 \
-p Adminuser=admin \
-p Agentdir=/global/dg1/na-dir \
-p Passwordfile=/global/dg1/p na-rs2
```

- Run this command if the installation is not in the default location, and the administrative port is not the default value.

EXAMPLE 1-4 Creating Failover Node Agent Resources (Continued)

```
# clresource create -g na-rg2 \
-t SUNW.jsas-na \
-p Resource_Dependencies=das-rs \
-p Adminhost=host-1 \
-p Adminuser=admin \
-p Agentdir=/global/dg1/na-dir \
-p Passwordfile=/global/dg1/p \
-p Confdir_list=/global/disk1/appserver-install-dir \
-p Adminport=6162 na-rs2
```

The resource is created in the enabled state.

8. To bring the Node Agent resource group na-rg1 online, the following command is run.

```
# clresourcegroup online na-rg1
```

By bringing online the resource group na-rg1, you enable the following resources.

- Node Agent NA1 and server instances I1 and I2, which are configured under NA1.
- Node Agent NA2 and server instances I3 and I4, which are configured under NA2.

9. To bring the Node Agent resource group na-rg2 online, the following command is run.

```
# clresourcegroup online na-rg2
```

By bringing online the resource group na-rg2, you enable the following resources.

- Node Agent NA3 and server instances I5 and I6, which are configured under NA3.
- Node Agent NA4 and server instances I7 and I8, which are configured under NA4.

Configuring the SUNW.HASStoragePlus Resource Type

The SUNW.HASStoragePlus resource type performs the same functions as SUNW.HASStorage, and synchronizes actions between HA storage and the data service.

SUNW.HASStoragePlus also has an additional feature to make a local file system highly available.

The SUNW.HASStoragePlus resource type can optionally be configured with the DAS component of the Sun Cluster HA for Sun Java System Application Server. However, the SUNW.HASStoragePlus resource type may *not* be configured with the Node Agent component of this data service.

See “Synchronizing the Startups Between Resource Groups and Device Groups” in *Sun Cluster Data Services Planning and Administration Guide for Solaris OS* for background information.

Tuning the Fault Monitor for Sun Cluster HA for Sun Java System Application Server

The fault monitor for the DAS component of Sun Cluster HA for Sun Java System Application Server supported versions as of 9.1 is contained in a resource whose resource type is `SUNW.j.sas`.

System properties and extension properties of the resource types control the behavior of the fault monitors. The default values of these properties determine the preset behavior of the fault monitors. The preset behavior should be suitable for most Sun Cluster installations. Therefore, you should tune the fault monitors *only* if you need to modify this preset behavior.

Tuning these fault monitors involves the following tasks:

- Setting the interval between fault monitor probes
- Setting the timeout for fault monitor probes
- Defining the criteria for persistent faults
- Specifying the failover behavior of a resource

Perform these tasks when you register and configure Sun Cluster HA for Sun Java System Application Server, as described in “[Registering and Configuring Sun Cluster HA for Sun Java System Application Server Supported Versions as of 9.1](#)” on page 26.

For detailed information about these tasks, see “[Tuning Fault Monitors for Sun Cluster Data Services](#)” in *Sun Cluster Data Services Planning and Administration Guide for Solaris OS*.

This section provides the following information:

- Description of the fault monitor's probing functionality.
- Conditions, messages, and recovery actions associated with unsuccessful probing.
- Conditions and messages associated with successful probing.

Operations by the Fault Monitor for the DAS Component During a Probe

The fault monitor probe for the DAS component of Sun Cluster HA for Sun Java System Application Server sends a request to the server to query the health of the Sun Java System Application Server server. The operations of the fault monitor depend on the setting of the `Monitor Uri List` extension property.

Fault Monitor Operations When the `Monitor Uri List` Property Is Set

When the `Monitor Uri List` extension property is set to a single URI or a list of URIs, the fault monitor probe executes the following steps.

1. The fault monitor probes the Sun Java System Application Server instance according to the time-out value set with the `Probe_timeout` resource property.

2. The probe connects to the Sun Java System Application Server server and performs an HTTP 1.1 GET check by sending a HTTP request and receiving a response to each of the URIs in `Monitor_Uri_List`.

The result of each HTTP request is either failure or success. If all of the requests successfully receive a reply from the Sun Java System Application Server server, the probe returns and continues the next cycle of probing and sleeping.

Heavy network traffic, heavy system load, and misconfiguration can cause the HTTP GET probe to fail. Misconfiguration of the `Monitor_Uri_List` property can cause a failure if a URI in the `Monitor_Uri_List` includes an incorrect port or hostname. For example, if the application server instance is listening on logical host `schost-1` and the URI was specified as `http://schost-2/servlet/monitor`, the probe will try to contact `schost-2` to request `/servlet/monitor`.

3. The probe records a failure in the history log if the reply to the probe is not received within the `Probe_timeout` limit. The probe considers this scenario a failure on the part of the Sun Java System Application Server data service. A Sun Java System Application Server probe failure can be a complete failure or a partial failure.

If the reply to the probe is received within the `Probe_timeout` limit, the HTTP response code is checked. If the response code is 500 Internal Server Error, the probe is considered a complete failure. All other response codes are ignored.

The following are complete probe failures.

- The following error message is received upon failure to connect to the server. The `%s` indicates the hostname and `%d` indicates the port number.

```
Failed to connect to the host <%s> and port <%d>. Receiving a
response code of 500 Internal Server Error HTTP GET
Response Code for probe of %s is 500. Failover will be in
progress
```

- The following error message is received upon failure to successfully send the probe string to the server. The first `%s` indicates the hostname, the `%d` indicates the port number, and the second `%s` indicates further details about the error.

```
Write to server failed: server %s port %d: %s.
```

4. The monitor accumulates partial failures that occur within the `Retry_interval` resource property setting until they equal a complete failure.

The following are partial probe failures:

- The following error message is received when there is a failure to disconnect before the `Probe_timeout` setting lapses. The `%d` indicates the port number and the `%s` indicates the resource name.

```
Failed to disconnect from port %d of resource %s.
```

- Failure to complete all probe steps within `Probe_timeout` time is a partial failure.

- The following error message is received upon failure to read data from the server for other reasons. The first %s indicates the hostname, the %d indicates the port number, and the second %s indicates further details about the error.

Failed to communicate with server %s port %d: %s

5. Based on the history of failures and the setting of the probe parameters, a failure can cause either a local restart or a failover of the data service.

Fault Monitor Operations When the `Monitor_Uri_List` Property Is *Not* Set

When the `Monitor_Uri_List` extension property is *not* set, the fault monitor probe executes the following steps.

1. The fault monitor probes the Sun Java System Application Server instance according to the time-out value set with the `Probe_timeout` resource property.
2. The probe uses the `asadmin` command to get the status of the DAS, as follows:

```
$INSTALL_DIR/appserver/bin/asadmin list-domains --domainidir $DOMAIN_DIR
```

The following environment variables are set.

- `INSTALL_DIR` is the installation location that is set using the `Confdir_list` extension property.
 - `DOMAIN_DIR` is the complete path to the domain directory.
 - `DOMAIN_NAME` is the name of the domain.
3. If the probe determines that the DAS is not running, a complete failure is issued.
 4. Based on the history of failures and the setting of the probe parameters, a failure can cause either a local restart or a failover of the data service.

Verifying the Sun Cluster HA for Sun Java System Application Server Installation and Configuration

This section describes how to verify that Sun Cluster HA for Sun Java System Application Server has been correctly installed and configured so that the Sun Java System Application Server runs as a highly available data service under Sun Cluster.

Note – After installation, use only the cluster administration command `clresourcegroup(1CL)` to manually start and stop Sun Java System Application Server. After you start Sun Java System Application Server, it runs under the control of Sun Cluster software.

▼ How to Verify the Failover DAS Component

The DAS resource group was created in [“How to Configure and Activate Network Resources” on page 19](#).

Perform this procedure on all of the potential primary nodes or zones of the DAS component. This procedure requires a pair of nodes, indicated as Node1 and Node2.

- 1 On a cluster member, Node1, become superuser or assume a role that provides `solaris.cluster.admin` RBAC authorization.**

- 2 Bring the DAS resource group online on Node1.**

```
# clresourcegroup online -n Node1 DAS-resource-group
```

- 3 Connect to the administrative console from a web browser.**

```
https://IP-address:port
```

- 4 Verify that you are connected to the administrative console.**

- 5 Switch the resource group from Node1 to Node2.**

```
# clresourcegroup online -n Node2 DAS-resource-group
```

- 6 Connect to the administrative console from a web browser.**

```
https://IP-address:port
```

- 7 Verify that you are connected to the administrative console.**

If you are not able to connect to the administrative console from the browser, perform the following actions.

- Ensure that your installation satisfies the restrictions and requirements in [“Configuration Restrictions and Requirements” on page 18](#).
- Ensure that you correctly followed the instructions in [“How to Install and Configure the Sun Java System Application Server” on page 20](#).

- 8 Test high availability by killing the DAS process manually.**

The DAS fault monitor detects the unavailability of the process and restarts it locally.

- 9 Test data service functionality by forcing DAS failover.**

Note the values of the standard resource properties `Retry_count` and `Retry_interval`. Kill the DAS process manually a number of times equal to `Retry_count` and within the time period `Retry_interval`. The DAS resource fails over to another cluster member.

10 Verify the DAS failover.

If the DAS resource has not failed over, perform the following actions.

- Check the values of the standard resource properties `Retry_count` and `Retry_interval`.
- Ensure that you correctly followed the instructions in “[Installing the Sun Cluster HA for Sun Java System Application Server Packages](#)” on page 24 and in “[Registering and Configuring Sun Cluster HA for Sun Java System Application Server Supported Versions as of 9.1](#)” on page 26.

▼ How to Verify the Failover Node Agent Component

This procedure is based on a configuration with four Node Agents in two resource groups, as described in “[Example of Creating the Failover Node Agent Component in the Sun Cluster HA for Sun Java System Application Server](#)” on page 32. The resource groups are `na-rg1` and `na-rg2`, the failover IP addresses are `IP1` and `IP2`, and the eight server instances are `Instance1` through `Instance8`. The failover IP addresses are represented by logical host names.

Perform this procedure on all of the potential primary nodes or zones of the Node Agent component. This procedure requires a pair of nodes, indicated as `Node1` and `Node2`.

- 1 On a cluster member, `Node1`, become superuser or assume a role that provides `solaris.cluster.admin` RBAC authorization.**

- 2 Bring the Node Agent resource group `na-rg1` online on `Node1`.**

```
# clresourcegroup online -n Node1 na-rg1
```

- 3 Bring the Node Agent resource group `na-rg2` online on `Node1`.**

```
# clresourcegroup online -n Node1 na-rg2
```

- 4 Connect to the server instances from a web browser.**

```
http://IP1:Instance1-port
http://IP1:Instance2-port
http://IP1:Instance3-port
http://IP1:Instance4-port
http://IP2:Instance5-port
http://IP2:Instance6-port
http://IP2:Instance7-port
http://IP2:Instance8-port
```

- 5 Ensure that you can connect to any application deployed on the server instances.**

If you are not able to connect to the instances from the browser, perform the following actions.

- Ensure that your installation satisfies the restrictions and requirements in “[Configuration Restrictions and Requirements](#)” on page 18.

- Ensure that you correctly followed the instructions in “[How to Install and Configure the Sun Java System Application Server](#)” on page 20.

6 Switch the resource groups from Node1 to Node2.

```
# clresourcegroup online -n Node2 na-rg1  
# clresourcegroup online -n Node2 na-rg2
```

7 After the switchover, repeat [Step 4](#) and [Step 5](#).

8 Test high availability by killing the Node Agent processes manually.

When the Node Agent Process is killed, the Node Agent and all its associated server instances are restarted.

When the application server instances are killed, the Node Agent restarts them. The data service monitors the health of the Node Agent only.

9 Test the data service functionality by forcing a Node Agent resource failover.

Note the values of the standard resource properties `Retry_count` and `Retry_interval`. Kill the Node Agent process manually a number of times equal to `Retry_count` and within the time period `Retry_interval`. The Node Agent resource fails over to another cluster node.

10 When the Node Agents start on another node, repeat [Step 4](#) to test the availability of the server instances.

Installing and Configuring Sun Cluster HA for Sun Java System Application Server Supported Versions Before 8.1

This chapter describes the procedures to install and configure Sun Cluster HA for Sun Java System Application Server supported versions before 8.1.

For information about installing and configuring Sun Cluster HA for Sun Java System Application Server supported versions as of 9.1, see [Chapter 1, “Installing and Configuring Sun Cluster HA for Sun Java System Application Server Supported Versions as of 9.1.”](#)

This chapter contains the following sections.

- “Sun Cluster HA for Sun Java System Application Server Overview” on page 44
- “Overview of the Installation and Configuration Process for Sun Cluster HA for Sun Java System Application Server” on page 47
- “Planning the Sun Cluster HA for Sun Java System Application Server Installation and Configuration” on page 48
- “Installing and Configuring Sun Java System Application Server” on page 50
- “Using the Sun Java System Application Server With HADB” on page 56
- “Configuring the Sun Java System Web Server Plugin” on page 56
- “Installing the Sun Cluster HA for Sun Java System Application Server Packages” on page 57
- “Registering and Configuring Sun Cluster HA for Sun Java System Application Server Supported Versions Before 8.1” on page 57
- “Configuring the SUNW.HAStoragePlus Resource Type” on page 63
- “Tuning the Fault Monitor for Sun Cluster HA for Sun Java System Application Server” on page 64
- “Verifying the Sun Cluster HA for Sun Java System Application Server Installation and Configuration” on page 66

Sun Cluster HA for Sun Java System Application Server Overview

This section explains how the Sun Cluster HA for Sun Java System Application Server enables Sun Java System Application Server for high availability. Consult the *Sun Cluster Data Service Release Notes for Solaris OS* for new Sun Cluster HA for Sun Java System Application Server installation and configuration information.

The Sun Java System Application Server provides a high-performance Java 2 Enterprise Edition (J2EE™) 1.3 compliant platform suitable for broad deployment of application services and web services. This platform is designed to meet the needs of enterprise customers and can run under the control of Sun Cluster software.

The Sun Java System Message Queue is packaged with the Sun Java System Application Server installation. See *Sun Cluster Data Service for Sun Java System Message Queue Guide for Solaris OS* for information about configuring the Sun Java System Message Queue for high availability.

Rich clients can directly connect to the Sun Java System Application Server. Web client connections to the Sun Java System Application Server can be directed through a front-end web server. The Sun Java System Application Server provides a pass-through plugin installation for use with the Sun Java System Web Server.

Implementation of the Sun Cluster HA for Sun Java System Application Server does not assume the existence of programs on which your architecture depends. Programs on which your architecture depends such as databases and web servers should be configured to be highly available, but can run on a different cluster.

See Chapter 1, “Planning for Sun Cluster Data Services,” in *Sun Cluster Data Services Planning and Administration Guide for Solaris OS* and the *Sun Cluster Overview for Solaris OS* for general information about data services, resource groups, resources, and other related topics.

Sun Cluster HA for Sun Java System Application Server supported versions before 8.1 can be configured in either of the following ways.

- Configure the Sun Cluster HA for Sun Java System Application Server as a failover data service that is mastered on one node at a time. See “[How to Register and Configure the Sun Cluster HA for Sun Java System Application Server as a Failover Data Service](#)” on page 59 for procedural information.
- Configure the Sun Cluster HA for Sun Java System Application Server as a service that is mastered on multiple nodes at the same time. See “[How to Register and Configure the Sun Cluster HA for Sun Java System Application Server as a Data Service Mastered on Multiple Nodes](#)” on page 61 for procedural information.

Failover Configuration Overview

The Sun Cluster HA for Sun Java System Application Server is a data service with appropriate extension properties to configure a failover application server mastered by one node at a time. A domain's administrative server can also be made highly available as a failover resource. Web clients can connect directly to the Sun Java System Application Server.

Use of the Sun Java System Application Server command-line or GUI administration tool is restricted in a clustered environment. Before you configure application instances and the administrative server into resource groups, see [“Configuration Restrictions” on page 48](#) for information about using `asadmin` or the Sun Java System Application Server Administrative Interface in your cluster. See [“Configuration Guidelines for Sun Cluster Data Services” in *Sun Cluster Data Services Planning and Administration Guide for Solaris OS*](#) for more information about configuring resources and resource groups.

Use the standard configuration in this section to plan the installation and configuration of the Sun Cluster HA for Sun Java System Application Server. The Sun Cluster HA for Sun Java System Application Server might support additional configurations. However, you must contact your Enterprise Services representative for information on additional configurations.

The following figure illustrates a standard failover configuration for a Sun Java System Application Server that runs on a two-node cluster. See [“Configuration Restrictions” on page 48](#) for additional information about configuring Sun Cluster HA for Sun Java System Application Server as a failover data service.

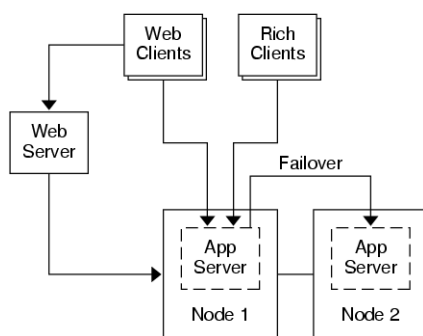

FIGURE 2-1 Two-Node Cluster With Failover Data Service Configuration

Multiple Masters Configuration Overview

You can also configure the Sun Cluster HA for Sun Java System Application Server to be mastered on multiple nodes at the same time. The multiple masters configuration provides scalability by using a front-end web tier to direct requests to the application servers. The

pass-through plugin that the application server provides must be used with a front-end web tier to direct requests to one of the running Sun Java System Application Server instances.

A highly available Sun Java System Web Server is configured to run on the cluster listening on a logical hostname. If the web tier is running on the same cluster as the application server, the plugin should be configured to pass requests to the cluster private IP addresses. The Sun Java System Web Server instance can also be configured to run on a different cluster. If the web tier is running on a separate cluster, the plugin is configured to pass requests to the physical hostnames of the cluster members that can run the Sun Java System Application Server resource. An example of a physical hostname is `phys - schost - 1`.

The Sun Cluster HA for Sun Java System Application Server configurations that are mastered on multiple nodes can use the private interconnect to direct traffic between the Sun Java System Web Server to the Sun Java System Application Server.

Note – If you configure the Sun Cluster HA for Sun Java System Application Server as a service that is mastered on multiple nodes at the same time, you must install and configure the Sun Java System Web Server. The Sun Java System Web Server configuration must be the same on all cluster nodes.

Multiple instances of the Sun Java System Application Server can be load balanced. To enable load-balancing, install the Sun Java System Application Server plugin into the Sun Java System Web Server configuration. The Sun Java System Web Server can be configured as a failover or scalable resource when it is used as a front-end to the Sun Java System Application Server.

The Sun Java System Application Server instance is configured so that its HTTP Listeners listen on all interfaces (0.0.0.0), which is the default for Sun Java System Application Servers.

Note – For a data service mastered on multiple nodes, the IIOP listeners are not highly available.

The following figure illustrates a configuration for a Sun Java System Application Server that masters the resource on two nodes at the same time.

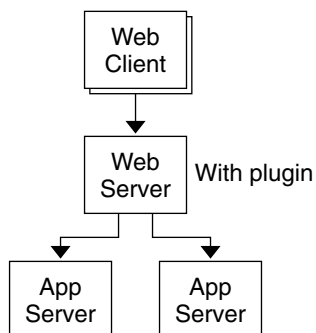

FIGURE 2-2 Two-Node Cluster With Data Service Mastered on Multiple Nodes

Overview of the Installation and Configuration Process for Sun Cluster HA for Sun Java System Application Server

The following table summarizes the tasks for the installation and configuration of Sun Cluster HA for Sun Java System Application Server. Perform these tasks in the order that they are listed.

TABLE 2-1 Task Map: Installing and Configuring the Sun Cluster HA for Sun Java System Application Server

Task	For Instructions
Plan the Sun Cluster HA for Sun Java System Application Server installation and configuration	“Planning the Sun Cluster HA for Sun Java System Application Server Installation and Configuration” on page 48
Install and configure the Sun Java System Application Server	“How to Install and Configure the Sun Java System Application Server” on page 52
(Optional) Use the Sun Java System Application Server with HADB	“Using the Sun Java System Application Server With HADB” on page 56
Install and configure the front-end Sun Java System Web Server	“Configuring the Sun Java System Web Server Plugin” on page 56
Install the Sun Cluster HA for Sun Java System Application Server package	“Installing the Sun Cluster HA for Sun Java System Application Server Packages” on page 57
Register and Configure the Sun Cluster HA for Sun Java System Application Server	“Registering and Configuring Sun Cluster HA for Sun Java System Application Server Supported Versions Before 8.1” on page 57
(Optional) Configure the SUNW.HASStoragePlus resource type.	“Configuring the SUNW.HASStoragePlus Resource Type” on page 63

TABLE 2-1 Task Map: Installing and Configuring the Sun Cluster HA for Sun Java System Application Server (Continued)

Task	For Instructions
(Optional) Tune the Sun Cluster HA for Sun Java System Application Server fault monitor	“Tuning the Fault Monitor for Sun Cluster HA for Sun Java System Application Server” on page 64
Verify the Sun Cluster HA for Sun Java System Application Server installation and configuration	“Verifying the Sun Cluster HA for Sun Java System Application Server Installation and Configuration” on page 66

Note – If you run multiple data services in your Sun Cluster configuration, you can set up the data services in any order, with the following exception. If the Sun Cluster HA for Sun Java System Application Server depends on Sun Cluster HA for DNS, you must set up DNS first. For details, see [Sun Cluster Data Service for DNS Guide for Solaris OS](#) for details. DNS software is included in the Solaris operating environment. If the cluster will obtain the DNS service from another server, configure the cluster to be a DNS client first.

Planning the Sun Cluster HA for Sun Java System Application Server Installation and Configuration

This section contains the information that you need to plan the installation and configuration of the Sun Cluster HA for Sun Java System Application Server.

Configuration Restrictions

Consider the following restrictions and requirements before you start your installation.

- Store static files and data on the local file system of each cluster node. Dynamic data should reside on the cluster file system so that you can view or update the data from any cluster node. The Sun Java System Application Server binaries and configuration files must be highly available and accessible to application server instances that are running on all nodes.
- Do not use the Sun Java System Application Server command-line or GUI administrative tools to start or stop the Sun Java System Application Server instances while application instances are running. Only use these administrative tools while application instances are running if your configuration meets the following conditions.
 - The Sun Java System Application Server is configured as a failover service mastered by one node at a time.
 - All of the application server instances of a domain, including the administrative server, are configured in one resource group.

- If you plan to use the Sun Java System Application Server as a service mastered on multiple nodes, you must set the HTTP and IIOP listeners to listen to the appropriate network resource. This setting is necessary because, by default, the Sun Java System Application Server behavior binds to all IP addresses on the node.
- If you use the Solstice DiskSuite™/Solaris Volume Manager, configure the Sun Java System Application Server software to use UNIX file system (UFS) logging or raw-mirrored metadevices. See the Solstice DiskSuite/Solaris Volume Manager documentation for information on how to configure raw-mirrored metadevices.
- You must set up the hostnames in your name services before you begin the Sun Java System Application Server installation. You must specify a network resource (IP address) that can fail over between nodes.
- You must not remove or relocate any of the installed files or directories that the Sun Java System Application Server installation places on the cluster file system. For example, do not relocate any of the binaries that are installed with the Sun Java System Application Server software.
- You must install the binaries on the local disks.
- You must configure the network resources that clients use to access the data service and bring the logical hostnames online.

Note – If you run the Sun Java System Application Server with another application server that uses the same network resources, configure the servers to listen on different ports. Configuring the listeners on different ports prevents a port conflict between the two servers.

Configuration Planning Questions

Use the questions in this section to plan the installation and configuration of Sun Cluster HA for Sun Java System Application Server.

- Will you run Sun Cluster HA for Sun Java System Application Server as a failover data service or as a service mastered on multiple nodes at the same time?
- What resource groups will you use for network addresses, application resources, and the dependencies between network addresses and application resources?
- What is the logical hostname that clients use to access the data service?
- Where will the system configuration files reside?

Installing and Configuring Sun Java System Application Server

This section describes installation of the Sun Java System Application Server. Only the information that is specific to the Sun Cluster HA for Sun Java System Application Server is included here. See the Sun Java System Application Server documentation for detailed installation instructions, including patch requirements.

▼ How to Configure and Activate Network Resources for a Failover Configuration

If you configure Sun Java System Application Server as a failover service, you must set up the network resources before you install and configure the Sun Java System Application Server. The failover service uses these network resources after installation and configuration in order to run in a cluster.

To perform this procedure, you need the following information about your configuration.

- The names of the cluster nodes that can master the data service.
- The hostnames that are used for configuring the network resource that clients use to access the Sun Java System Application Server. Normally, you set up this hostname when you install the cluster. See the *Sun Cluster Concepts Guide for Solaris OS* for details on network resources.

Note – Perform this procedure on any cluster member.

- 1 On a cluster member, become superuser or assume a role that provides `solaris.cluster.modify` and `solaris.cluster.admin` RBAC authorization.**
- 2 Verify that all of the network addresses that you use have been added to your name service database.**

You should have performed this verification during the Sun Cluster installation. See the planning chapter in the *Sun Cluster Software Installation Guide for Solaris OS*.

Note – To avoid name service look-up failures, ensure that all of the logical hostnames are present in the `/etc/inet/hosts` file on all of the cluster nodes. Configure name service mapping in the `/etc/nsswitch.conf` file on the servers to check the local files before trying to access NIS, NIS+, or DNS.

- 3 Create a failover resource group to contain the network and application resources.**

```
# clresourcegroup create [-n node-zone-list] resource-group
```

resource-group

Specifies the name of the resource group. This name can be your choice.

[-n *node-zone-list*]

Specifies a comma-separated, ordered list of zones that can master this resource group. The format of each entry in the list is *node*. In this format, *node* specifies the node name and *zone* specifies the name of a non-global Solaris zone. To specify the global zone, or to specify a node without non-global zones, specify only *node*.

This list is optional. If you omit this list, the global zone of each cluster node can master the resource group.

4 Add network resources to the resource group.

Use the following command to add a logical hostname to a resource group.

```
# clreslogicalhostname create -g resource-group -h hostname,... [-N netiflist]
```

-g *resource-group*

Specifies the name of the resource group.

-h *hostname, ...*

Specifies a comma-separated list of network resources.

-N *netiflist*

Specifies an optional, comma-separated list that identifies the IP Networking Multipathing groups that are on each node or zone. The format of each entry in the list is *netif@node*. The replaceable items in this format are as follows:

netif Specifies an IPMP group name, such as *sc_ipmp0*, or a public network interface card (NIC). If you specify a public NIC, Sun Cluster attempts to create the required IPMP groups.

node Specifies the name or ID of a node. To specify the global zone, or to specify a node without non-global zones, specify only *node*.

This list is optional. If you omit this list, Sun Cluster attempts to create the required IPMP groups.

Note – If you require a fully qualified hostname, you must specify the fully qualified name with the -h option and you cannot use the fully qualified form in the resource name.

Note – Sun Cluster does not currently support the use of the adapter name for *netif*.

5 Bring the resource group online.

```
# clresourcegroup onLine resource-group
```

▼ How to Install and Configure the Sun Java System Application Server

- 1 **On a cluster member, become superuser or assume a role that provides `solaris.cluster.admin` RBAC authorization.**
- 2 **Determine if you are installing the Sun Java System Application Server on Solaris 8.**
 - If no, proceed to [Step 4](#).
 - If yes, perform the following operations.
 - a. **Run the `setup` command from the `install` directory for the Sun Java System Application Server on all cluster nodes.**
 - b. **Provide the default location for Sun Java System Application Server instances at the `setup` command prompt.**

Place the server configuration directory on a local filesystem by using the default directory, `/var/opt/SUNWappserver7`. When you create server instances that are managed by Sun Cluster, specify a path to the global file system or HAStoragePlus file system. Ensure that all potential masters of a Sun Java System Application Server instance have access to the Sun Java System Application Server instance configuration files.

Note – The domain created by the `setup` command cannot be used by Sun Cluster.

- 3 **If you are installing the Sun Java System Application Server on Solaris 8 or installing the Sun Java System Application Server Enterprise Edition that is not packaged with Solaris 9, proceed to [Step 5](#).**
- 4 **If you are installing the Sun Java System Application Server packaged with Solaris 9, perform the following operations:**
 - a. **Install the Sun Java System Application Server package on all the nodes of the cluster.**
 - b. **Identify a location on a global file system where you intend to keep the application server configuration files.**

You can create a separate directory for this file system.

5 (Optional) On all nodes, create a link to the server configuration directory on the global file system from the default configuration directory.

You can either create a link to the server configuration directory or specify the full path to the location on the global file system when you create the Sun Java System Application Server domains in [Step 8](#).

- To create a link for the Sun Java System Application Server packaged with Solaris 9, the following command is run.

```
# ln -s /global/appserver /var/appserver
```

- To create a link for the unpackaged Sun Java System Application Server, the following command is run.

```
# ln -s /global/appserver /var/opt/SUNWappserver7
```

6 If you are installing the Sun Java System Application Server on Solaris 8, proceed to [Step 8](#).

7 If you are installing the Sun Java System Application Server packaged with Solaris 9, perform the following operations on all nodes:

a. List the Sun Java System Application Server run control scripts.

```
# ls -l /etc/rc?.d/*appserv
/etc/rc0.d/K05appserv
/etc/rc1.d/K05appserv
/etc/rc2.d/K05appserv
/etc/rc3.d/S84appserv
/etc/rc5.d/K05appserv
```

b. Rename the Sun Java System Application Server run control scripts.

Renaming the run control scripts disables the START and STOP run control scripts that you installed as part of the SUNWasr package (or the SUNWasro package if the unbundled Sun Java System Application Server was installed). This step is necessary because Sun Cluster HA for Sun Java System Application Server starts and stops the Sun Java System Application Server instances after you have configured the data service.

```
# mv /etc/rc0.d/K05appserv /etc/rc0.d/k05appserv
# mv /etc/rc1.d/K05appserv /etc/rc1.d/k05appserv
# mv /etc/rc2.d/K05appserv /etc/rc2.d/k05appserv
# mv /etc/rc3.d/S85appserv /etc/rc3.d/s85appserv
# mv /etc/rc5.d/K05appserv /etc/rc5.d/k05appserv
```

Note – The preceding example changes the first letter in the name of the run control script from uppercase to lowercase. However, you can rename the scripts to be consistent with your normal administration practices.

c. Verify that all of the Sun Java System Application Server run control scripts have been renamed.

```
# ls -l /etc/rc?.d/*appserv
/etc/rc0.d/k05appserv
/etc/rc1.d/k05appserv
/etc/rc2.d/k05appserv
/etc/rc3.d/s85appserv
/etc/rc5.d/k05appserv
```

8 Create a domain with configuration information on the global file system.

```
# asadmin create-domain --path /global/appserver/domains \
--adminport=4848 --adminuser admin --adminpassword password scdomain
```

9 Start the domains administrative server.

```
# /global/appserver/domains/scdomain/admin-server/bin/startserv
```

10 Create new application server instances to be made highly available by using the administrative server.

11 Create a log directory on the local disk for each node that the Sun Java System Application Server instance uses.

For the Sun Java System Application Server instance to work correctly, the log directory must be located on each node of the cluster, not on the cluster file system. Choose a location on the local disk that is the same for all the nodes in the cluster.

```
schost-1# mkdir -p /var/pathname/domain/instance/Logs/
```

Note – If you anticipate large log files, ensure that the file system containing the directory has enough space to handle the files.

12 Change the location of the Sun Java System Application Server instance PidLog to reflect the directory that you created in Step 11. To change the location, edit the `init.conf` file located in the server configuration directory.

13 Change the location of `PID_FILE` in the `stopserv` file to match the value of `PidLog` that you set in Step 12.

- 14 **Change the location of the `Log File`, `Log Root`, and `Transaction Log Location` parameters to reflect the directory that you created in [Step 11](#). To change these parameters, use the Sun Java System Application Server Administrative Interface. For instructions on configuration, see the Sun Java System Application Server documentation.**
- 15 **Change the location of the `accessLog` parameter to reflect the directory that you created in [Step 11](#). To change this parameter, use the `asadmin` utility. See the Sun Java System Application Server documentation for instructions.**
- 16 **Ensure that any logical hostnames that the application server uses are configured and are online.**
- 17 **If the application server is configured as a failover service, configure the HTTP listener IP address with the logical IP address and the server name with the logical hostname. If the application server is configured as a service mastered on multiple nodes, proceed to [Step 19](#).**

This operation must be performed on the primary node of the logical host.
- 18 **If the application server is configured as a service mastered on multiple nodes, configure the HTTP listener IP address to `0.0.0.0` and Return Server Name to `localhost`.**
- 19 **Verify that the HTTP listener is returning the correct server name.**

The correct server name is usually the hostname that clients will use to access the resources on the application server.
- 20 **If the application server is configured as a failover service, configure the IIOP listener with the logical IP address for the Sun Cluster HA for Sun Java System Application Server instance. If the application server is configured as a service mastered on multiple nodes, proceed to [Step 21](#).**

If the administrative server is to be made highly available, configure only the HTTP listener, the administrative server does not have an IIOP listener.
- 21 **Disable the Sun Java System Application Server startup of the Message Queue server by unchecking `Start Enable` for the services under JMS.**
- 22 **Start the application server by issuing the `startserv` command.**

```
# /global/appserver/domains/scdomain/server1/bin/startserv
```

If the server does not start, correct the problem. See the Sun Java System Application Server documentation for details.
- 23 **Stop the application server by issuing the `stopserv` command.**

```
# /global/appserver/domains/scdomain/server1/bin/stopserv
```

You must stop the server before you proceed to the next part of the installation and configuration process.

Using the Sun Java System Application Server With HADB

To use the Enterprise Edition of Sun Java System Application Server with HADB enabled in a cluster, install and configure the Sun Cluster data service for Sun Java System Application Server EE (HADB). See *Sun Cluster Data Service for Sun Java System Application Server EE (HADB) Guide for Solaris OS* for procedural instructions.

Configuring the Sun Java System Web Server Plugin

The Sun Java System Web Server plugin can be used as a pass-through load balancing mechanism with Sun Java System Application Server. Only the configuration information that is specific to Sun Cluster HA for Sun Java System Application Server is included here. The requirement for these configuration instructions is the installation of the Sun Java System Web Server plugin. See the Sun Java System Application Server documentation for detailed installation instructions, including patch requirements.

If you are configuring Sun Cluster HA for Sun Java System Application Server as a failover data service, installation of the front-end Sun Java System Web Server is optional.

To configure the Sun Java System Web Server plugin, configure the listeners in the `loadbalancer.xml` file.

- If you are configuring Sun Cluster HA for Sun Java System Application Server as a failover data service, specify the Sun Java System Application Server logical hostname as the listeners in the `loadbalancer.xml` file.

```
<instance name="server1" enabled=true disable-timeout-in-minutes="60"  
listeners="http://foo-lh:80/ " />
```

- If you are configuring Sun Cluster HA for Sun Java System Application Server as a data service mastered on multiple nodes, and if the web server is running on the same cluster as the application server, specify the cluster private IP addresses as the listeners in the `loadbalancer.xml` file.

```
<instance name="server1" enabled=true disable-timeout-in-minutes="60"  
listeners="http://172.16.193.1:80/ http://172.16.194.5:80/ " />
```

Note – You must use the node transport adapter IP addresses in the plugin configuration. To find these IP addresses, execute the `scconf -p | less` command from the primary Sun Cluster node. Note that equivalent hostnames such as `clusternode1-priv` do not work in this configuration, and should not be used.

- If you are configuring Sun Cluster HA for Sun Java System Application Server as a data service mastered on multiple nodes, and if the web server is *not* running on the same cluster as the application server, specify the physical hostnames as the listeners in the `loadbalancer.xml` file.

```
<instance name="server1" enabled=true disable-timeout-in-minutes="60"  
listeners=http://hosta:80/ http://hostb:80/ " />
```

The preceding example assumes that the Sun Java System Application Server instances are configured on port 80 on cluster nodes `hosta` and `hostb`.

Installing the Sun Cluster HA for Sun Java System Application Server Packages

See “[Installing the Sun Cluster HA for Sun Java System Application Server Packages](#)” on page 24 to install Sun Cluster HA for Sun Java System Application Server packages.

Registering and Configuring Sun Cluster HA for Sun Java System Application Server Supported Versions Before 8.1

The following procedures explain how to use the Sun Cluster maintenance commands to register and configure the Sun Cluster HA for Sun Java System Application Server. These instructions explain how to set the extension properties described in [Appendix A, “Extension Properties for Sun Cluster HA for Sun Java System Application Server Supported Versions as of 9.1”](#)

Sun Cluster HA for Sun Java System Application Server supported versions before 8.1, the data service can be configured in the following ways.

- The data service is configured as a failover data service.
- The data service is configured as a service that is mastered by multiple nodes or zones at the same time.

Note – See “Tools for Data Service Resource Administration” in *Sun Cluster Data Services Planning and Administration Guide for Solaris OS* for general information about registering and configuring data services.

To perform these procedures, you need the following information about your configuration.

- The resource type name for the Sun Cluster HA for Sun Java System Application Server data service. In Sun Cluster HA for Sun Java System Application Server supported versions before 8.1, the resource type is `SUNW.s1as`.
- The names of the cluster nodes or zones that can master the data service.
- If you configure Sun Cluster HA for Sun Java System Application Server as a failover data service, you must know the network resource that clients use to access the Sun Cluster HA for Sun Java System Application Server. Normally, you set up this network resource when you install the cluster.
- The ports where the Sun Java System Application Server listens including HTTP and IIOP listeners.
- The path to the server configuration data for the Sun Java System Application Server instance.

Setting Sun Cluster HA for Sun Java System Application Server Extension Properties

The sections that follow contain instructions for registering and configuring resources. These instructions explain how to set *only* extension properties that Sun Cluster HA for Sun Java System Application Server requires you to set. For information about all Sun Cluster HA for Sun Java System Application Server extension properties, see [Appendix A, “Extension Properties for Sun Cluster HA for Sun Java System Application Server Supported Versions as of 9.1.”](#) You can update some extension properties dynamically. You can update other properties, however, only when you create or disable a resource. The Tunable entry indicates when you can update a property.

To set an extension property of a resource, include the following option in the `clresource(1CL)` command that creates or modifies the resource:

`-p property=value`

`-p property`

Identifies the extension property that you are setting

`value`

Specifies the value to which you are setting the extension property

You can also use the procedures in [Chapter 2, “Administering Data Service Resources,”](#) in *Sun Cluster Data Services Planning and Administration Guide for Solaris OS* to configure resources after the resources are created.

▼ How to Register and Configure the Sun Cluster HA for Sun Java System Application Server as a Failover Data Service

Perform the following steps to complete a Sun Cluster HA for Sun Java System Application Server failover configuration. You can also use this procedure to configure a domains administrative server to be a failover resource.

Note that in [“How to Configure and Activate Network Resources for a Failover Configuration”](#) on [page 50](#) you created the failover resource group, added a logical hostname to the resource group, and brought the resource group online.

- 1 **On a cluster member, become superuser or assume a role that provides `solaris.cluster.modify` RBAC authorization.**

- 2 **Register the resource type for the data service.**

```
# clresourcetype register SUNW.s1as
```

- 3 **Add the Sun Java System Application Server resource instance to the failover resource group that you created for your network resources.**

```
# clresource create -g resource-group \  
-t SUNW.s1as \  
-p Network_resources_used=network-resources \  
-p Port_list=port/tcp,port/tcp \  
-p Confdir_list=install-directory/domains/domain/server \  
-p Monitor Uri List=http://logical-hostname[:port][/path] resource
```

```
-g resource-group  
    Specifies the resource group.
```

```
-t SUNW.s1as  
    Specifies the type of resource to add.
```

```
-p Network_resources_used=network-resources  
    Specifies a comma-separated list of network resources in resource-group.
```

```
-p Port_list=port-number/protocol  
    Specifies a comma-separated list of the port number and the protocol to be used, for example, 80/tcp. If the Monitor Uri List is set, the Port_list setting is optional.
```

-p `Confdir_list=install-directory/domains/domain/server`

Specifies a path for your Sun Java System Application Server configuration directory. The `Confdir_list` extension property is required and must have exactly one entry.

-p `Monitor Uri_List=logical-hostname[:port][/path]`

Specifies a comma-separated list of URIs from which Sun Cluster HA for Sun Java System Application Server makes requests. The `Monitor Uri_List` extension property is required if the `Port_list` property is not set.

resource

Specifies the Sun Java System Application Server application resource name.

The resource is created in the enabled state.

4 Verify that the resource group and application server resource is online.

```
# clresourcegroup status
```

```
# ps -ef
```

Example 2-1 Registering and Configuring Sun Cluster HA for Sun Java System Application Server as a Failover Data Service

Cluster Information

- Node names: `phys-schost-1`, `phys-schost-2`
- Logical hostname: `schost-1`
- Resource group: `appsrv-rg` (for all resources)
- Resources: `schost-1` (logical hostname), `appsrv-rs` (Sun Java System Application Server application resource)

1. To create a failover resource group, the following command is run.

```
# clresourcegroup create -n phys-schost-1,phys-schost-2 appsrv-rg
```

2. To add a logical hostname resource to the resource group, the following command is run.

```
# clreslogicalhostname create -g appsrv-rg -h schost-1 schost-1
```

3. To register the `SUNW.s1as` resource type, the following command is run.

```
# clresourcetype register SUNW.s1as
```

4. To create a Sun Java System Application Server resource and add it to the resource group, the following command is run.

```
# clresource create -g appsrv-rg \  
-t SUNW.s1as \  
-p Network_resources_used=schost-1 \  
-p Port_list=80/tcp,3700/tcp \  
\
```

```
-p Confdir_list=/global/appsrv/domains/scdomain/server1 \  
-p Monitor Uri_List=http://schost-1:80/servlet/monitor appsrv-rs
```

5. To bring the application resource group online, the following command is run.

```
# clresourcegroup online appsrv-rg
```

Example 2-2 Registering and Configuring the admin-server as a Failover Data Service

This example shows how the admin-server can be configured as part of the failover resource group created in the previous example.

Cluster Information

- Logical hostname: schost-1
- Resource group: appsrv-rg (for all resources)
- Resources: schost-1 (logical hostname), admin-rs

To create a Sun Java System Application Server resource and add it to the resource group, the following command is run.

```
# clresource create -g appsrv-rg \  
-t SUNW.slas \  
-p Network_resources_used=schost-1 \  
-p Port_list=4848/tcp \  
-p Confdir_list=/global/appsrv/domains/scdomain/admin-server \  
-p Monitor Uri_List=http://schost-1:484 admin-rs
```

▼ How to Register and Configure the Sun Cluster HA for Sun Java System Application Server as a Data Service Mastered on Multiple Nodes

This procedure assumes that you installed the data service package during your initial Sun Cluster HA for Sun Java System Application Server installation. If you did not install the Sun Java System Application Server package as part of your initial installation, go to [“Installing the Sun Cluster HA for Sun Java System Application Server Packages” on page 57](#) to install the data service package.

Before you begin to register and configure Sun Cluster HA for Sun Java System Application Server as a service mastered on multiple nodes at the same time, consider the following requirements.

- You must have the Sun Java System Web Server Plugin installed and configured. See [“Configuring the Sun Java System Web Server Plugin” on page 56](#).

- You must specify at least one entry for the `Monitor_URI_List` extension property. If there are no deployed applications that need to be monitored, use a simple Uniform Resource Identifier (URI) such as `http://localhost/`.

See “[Multiple Masters Configuration Overview](#)” on page 45 for conceptual information related to this procedure.

Note – Do not use the Sun Java System Application Server command-line or GUI administrative tools to start or stop the Sun Java System Application Server instances. The Sun Java System Application Server administrative server might not display the correct status of an application server instance that is configured as a service mastered on multiple nodes.

1 On one of the nodes in the cluster that hosts the application server, become superuser or assume a role that provides `solaris.cluster.modify` RBAC authorization.

2 Add a scalable resource group for the Sun Java System Application Server.

```
# clresourcegroup create [-n node-zone-list] \
-p Maximum primaries=value \
-p Desired primaries=value resource-group
```

3 Register the resource type for the Sun Java System Application Server.

```
# clresourcetype register SUNW.s1as
```

4 Add the Sun Java System Application Server resource instance to the resource group.

```
# clresource create -g resource-group -t SUNW.s1as \
-p Confdir_list=install-directory/domains/domain/server \
-p Monitor Uri List=http://localhost[:port][[/path]] resource
```

```
-t SUNW.s1as
```

Specifies the type of resource to add.

```
-p Confdir_list=install-directory/domains/domain/server
```

Specifies a path for your Sun Java System Application Server configuration directory. The `Confdir_list` extension property is required and must have exactly one entry.

```
-p Monitor Uri List=localhost[:port][[/path]]
```

Specifies URIs from which Sun Cluster HA for Sun Java System Application Server makes requests. The `Monitor Uri List` extension property is required.

```
resource
```

Specifies the Sun Java System Application Server application resource name.

The resource is created in the enabled state.

5 Bring the scalable resource group online.

```
# clresourcegroup online resource-group
```

Example 2-3 Registering and Configuring Sun Cluster HA for Sun Java System Application Server as a Service Mastered on Multiple Nodes

This example shows how to register Sun Cluster HA for Sun Java System Application Server as a service mastered on two nodes at the same time.

Cluster Information

- Node names: phys-schost-1, phys-schost-2
 - Resource group: appsrv-rg (for all resources)
1. To create a scalable resource group, the following command is run.

```
# clresourcegroup create -n phys-schost-1,phys-schost-2 \
-p Maximum primaries=2 \
-p Desired primaries=2 appsrv-rg
```

2. To register the SUNW.s1as resource type, the following command is run.

```
# clresourcetype register SUNW.s1as
```

3. To create a Sun Java System Application Server resource and add it to the resource group, the following command is run.

```
# clresource create -g appsrv-rg -t SUNW.s1as \
-p Confdir_list=/global/appserver/domains/scdomain/server1 \
-p Monitor Uri_List=http://localhost:8000/servlet/monitor appsrv-rs
```

The resource is created in the enabled state.

4. To bring online the application resource group, the following command is run.

```
# clresourcegroup online appsrv-rg
```

Configuring the SUNW.HAStoragePlus Resource Type

The SUNW.HAStoragePlus resource type performs the same functions as SUNW.HAStorage, and synchronizes actions between HA storage and the data service.

SUNW.HAStoragePlus also has an additional feature to make a local file system highly available. Configuration of the SUNW.HAStoragePlus resource type is optional for Sun Cluster HA for Sun Java System Application Server.

See “Synchronizing the Startups Between Resource Groups and Device Groups” in *Sun Cluster Data Services Planning and Administration Guide for Solaris OS* for background information.

Tuning the Fault Monitor for Sun Cluster HA for Sun Java System Application Server

Versions before 8.1 of Sun Cluster HA for Sun Java System Application Server have a fault monitor that is contained in a resource whose resource type is `SUNW.s1as`.

System properties and extension properties of the resource types control the behavior of the fault monitors. The default values of these properties determine the preset behavior of the fault monitors. The preset behavior should be suitable for most Sun Cluster installations. Therefore, you should tune the fault monitors *only* if you need to modify this preset behavior.

Tuning these fault monitors involves the following tasks:

- Setting the interval between fault monitor probes
- Setting the timeout for fault monitor probes
- Defining the criteria for persistent faults
- Specifying the failover behavior of a resource

Perform these tasks when you register and configure Sun Cluster HA for Sun Java System Application Server, as described in [“Registering and Configuring Sun Cluster HA for Sun Java System Application Server Supported Versions Before 8.1”](#) on page 57.

For detailed information about these tasks, see [“Tuning Fault Monitors for Sun Cluster Data Services”](#) in *Sun Cluster Data Services Planning and Administration Guide for Solaris OS*.

This section provides the following information.

- Description of the fault monitor's probing functionality.
- Conditions, messages, and recovery actions associated with unsuccessful probing.
- Conditions and messages associated with successful probing.

Operations by the Sun Cluster HA for Sun Java System Application Server Fault Monitor During a Probe

The Sun Cluster HA for Sun Java System Application Server fault monitor probe sends a request to the server to query the health of the Sun Java System Application Server server. The probe executes the following steps:

1. The fault monitor probes the Sun Java System Application Server instance according to the time-out value set with the `Probe_timeout` resource property.
2. The probe connects to the IP address and port combinations defined by the network resource configuration and the `Port_list` setting for the resource group. If the resource is configured without an empty `Port_list` this step is skipped. If connection succeeds, the probe disconnects. If the connection fails, the failure is recorded.

Heavy network traffic, heavy system load, and misconfiguration can cause the query to fail. Misconfiguration can occur if you did not configure the Sun Java System Application Server server to listen on all of the IP address/port combinations that are probed. The Sun Java System Application Server server should service every port for every IP address that is specified for the resource.

3. The probe connects to the Sun Java System Application Server server and performs an HTTP 1.1 GET check by sending a HTTP request and receiving a response to each of the URIs in `Monitor_Uri_List`.

The result of each HTTP request is either failure or success. If all of the requests successfully receive a reply from the Sun Java System Application Server server, the probe returns and continues the next cycle of probing and sleeping.

Heavy network traffic, heavy system load, and misconfiguration can cause the HTTP GET probe to fail. Misconfiguration of the `Monitor_Uri_List` property can cause a failure if a URI in the `Monitor_Uri_List` includes an incorrect port or hostname. For example, if the application server instance is listening on logical host `schost-1` and the URI was specified as `http://schost-2/servlet/monitor`, the probe will try to contact `schost-2` to request `/servlet/monitor`.

4. The probe records a failure in the history log if the reply to the probe is not received within the `Probe_timeout` limit. The probe considers this scenario a failure on the part of the Sun Java System Application Server data service. A Sun Java System Application Server probe failure can be a complete failure or a partial failure.

If the reply to the probe is received within the `Probe_timeout` limit, the HTTP response code is checked. If the response code is 500 Internal Server Error, the probe is considered a complete failure. All other response codes are ignored.

The following are complete probe failures.

- The following error message is received upon failure to connect to the server. The `%s` indicates the hostname and `%d` indicates the port number.

```
Failed to connect to the host <%s> and port <%d>. Receiving a
response code of 500 Internal Server Error HTTP GET
Response Code for probe of %s is 500. Failover will be in
progress
```

- The following error message is received upon failure to successfully send the probe string to the server. The first `%s` indicates the hostname, the `%d` indicates the port number, and the second `%s` indicates further details about the error.

```
Write to server failed: server %s port %d: %s.
```

5. The monitor accumulates partial failures that occur within the `Retry_interval` resource property setting until they equal a complete failure.

The following are partial probe failures:

- The following error message is received when there is a failure to disconnect before the Probe_timeout setting lapses. The %d indicates the port number and the %s indicates the resource name.

Failed to disconnect from port %d of resource %s.

- Failure to complete all probe steps within Probe_timeout time is a partial failure.
- The following error message is received upon failure to read data from the server for other reasons. The first %s indicates the hostname, the %d indicates the port number, and the second %s indicates further details about the error.

Failed to communicate with server %s port %d: %s

6. Based on the history of failures, a failure can cause either a local restart or a failover of the data service.

Verifying the Sun Cluster HA for Sun Java System Application Server Installation and Configuration

This section describes how to verify correct installation of Sun Cluster HA for Sun Java System Application Server.

Note – After installation, use only the cluster administration command `clresourcegroup(1CL)` to manually start and stop Sun Java System Application Server. After you start Sun Java System Application Server, it runs under the control of Sun Cluster software.

▼ How to Verify the Sun Cluster HA for Sun Java System Application Server Installation and Configuration

- 1 Start the Sun Java System Application Server under the control of Sun Cluster software.
`# clresourcegroup online resource-group`
- 2 Connect to the Sun Java System Application Server by using a browser, and verify that the Sun Java System Application Server software functions correctly.
- 3 Run the `clresourcegroup` command to switch the resource group to another cluster node or zone, such as `node2`.

`# clresourcegroup online -n node2 resource-group`

- 4 **Verify that the resource group and the Sun Java System Application Server resource are online.**
`clresourcegroup status`
`ps -ef`
- 5 **Repeat [Step 2](#) and [Step 3](#) on all of the potential primaries of the Sun Java System Application Server resource groups.**

Extension Properties for Sun Cluster HA for Sun Java System Application Server Supported Versions as of 9.1

Extension properties for the resource types for Sun Cluster HA for Sun Java System Application Server supported versions as of 9.1 are described in the following sections.

- “[SUNW.jsas Extension Properties](#)” on page 69
- “[SUNW.jsas-na Extension Properties](#)” on page 71

For details about system-defined properties, see the `r_properties(5)` man page and the `rg_properties(5)` man page.

SUNW.jsas **Extension Properties**

The `SUNW.jsas` resource type represents the DAS component of supported versions as of 9.1 of the Sun Java System Application Server in a Sun Cluster configuration. The extension properties of this resource type are as follows.

`Adminuser`

The DAS administrative user name.

Data type	String array
Default	No default defined
Range	Not applicable
Tunable	At creation

`Confdir_list`

The complete path to the Sun Java System Application Server installation directory.

Data type	String array
Default	<code>/opt/SUNWappserver</code>
Range	Not applicable

Tunable At creation

Domaindir

The full path to the domain directory. If no value is specified for this property, the value is taken from the variable `AS_DEF_DOMAINS` in the file `/opt/SUNWappserver/appserver/config/asenv.conf`. The variable `AS_DEF_DOMAINS` is set to the default directory that is specified when the Sun Java System Application Server is installed.

Data type String

Default Null

Range Not applicable

Tunable At creation

Domain_name

The domain name.

Data type String

Default No default defined

Range Not applicable

Tunable At creation

Monitor Uri List

A single URI or a comma-separated list of URIs which can be used by the fault monitor to test the functionality of the Sun Java System Application Server.

The syntax of each URI is `http://failover-IP-address:port/path`.

The fault monitor probes the application server by performing an HTTP GET on each URI in the list. Set the `Monitor Uri List` extension property to one or more URIs that are serviced by applications deployed on the Sun Java System Application Server.

Data type String array

Default Null

Range Not applicable

Tunable At any time

Passwordfile

The full path to the file containing the DAS administrative password.

The syntax of the password entry in this file is the following:

`AS_ADMIN_PASSWORD=password`

where *password* is the DAS administrative password. This is the standard syntax used by the Sun Java System Application Server.

Data type	String
Default	No default defined
Range	Not applicable
Tunable	At creation

Probe_timeout

The timeout value (in seconds) for the probe. The value of the Probe_timeout extension property depends on the number of URIs indicated by the Monitor_Uri_List extension property. An additional factor is the amount of time necessary to generate a response to a request of the URIs.

Data type	Integer
Default	180
Range	Minimum = 2
Tunable	At any time

SUNW.jsas-na Extension Properties

The SUNW.jsas-na resource type represents the Node Agent (NA) component of supported versions as of 9.1 of the Sun Java System Application Server in a Sun Cluster configuration. The extension properties of this resource type are as follows.

Adminhost

The host name of the Domain Administration Server.

Data type	String
Default	Null string
Range	Not applicable
Tunable	When disabled

Adminport

The port on which the administration server is listening.

Data type	Integer
Default	4849
Range	Not applicable
Tunable	At any time

Adminuser

The Domain Administration Server administrative user name.

Data type	String
Default	Null string
Range	Not applicable
Tunable	When disabled

Agentdir

The full path to the Node Agents directory.

Data type	String
Default	Null string
Range	Not applicable
Tunable	When disabled

Confdir_list

The full path to the Sun Java System Application Server installation directory.

Data type	String array
Default	/opt/SUNWappserver
Range	Not applicable
Tunable	When disabled

Passwordfile

The full path to the file containing the DAS administrative password and master password.

Data type	String
Default	Null string
Range	Not applicable
Tunable	When disabled

Probe_timeout

The timeout value (in seconds) for the probe.

Data type	Integer
Default	180
Range	Minimum = 2
Tunable	At any time

Extension Properties for Sun Cluster HA for Sun Java System Application Server Supported Versions Before 8.1

This section describes the extension properties for the resource type `SUNW.s1as`, which represents Sun Cluster HA for Sun Java System Application Server supported versions before 8.1 in a Sun Cluster configuration.

For details about system-defined properties, see the `r_properties(5)` man page and the `rg_properties(5)` man page.

`SUNW.s1as` Extension Properties

The extension properties of this resource type are as follows:

`Confdir_list`

The complete path to the configuration directory of a particular instance of the Sun Java System Application Server.

Data type	String array
Default	No default defined
Range	Not applicable
Tunable	At creation

`Monitor Uri List`

A single URI or comma-separated list of URIs which can be used by the fault monitor to test the functionality of the Sun Java System Application Server.

The fault monitor probes the application server by performing an HTTP GET on each URI in the list. Set the `Monitor Uri List` extension property to one or more URIs that are serviced by applications deployed on the Sun Java System Application Server.

Data type	String array
Default	Null

Range	Not applicable
Tunable	At any time

Index

A

- Adminhost extension property, SUNW.jsas-na resource type, 71
- Adminport extension property, SUNW.jsas-na resource type, 71
- Adminuser extension property, SUNW.jsas-na resource type, 71
- Adminuser extension property, SUNW.jsas resource type, 69
- Agentdir extension property, SUNW.jsas-na resource type, 72

C

- clnode command, 10
- commands, node information, 10
- Confdir_list extension property
 - SUNW.jsas-na resource type, 72
 - SUNW.jsas resource type, 69
 - SUNW.s1as resource type, 73
- configuration restrictions
 - supported versions as of 9.1, 18
 - supported versions before 8.1, 48
- configuring
 - network resources, 19, 50
 - SUNW.HAStoragePlus resource type, 35, 63
 - supported versions as of 9.1 as failover, 28-30
 - supported versions before 8.1 as a service mastered on multiple nodes, 61
 - supported versions before 8.1 as failover, 59

D

- Domain Administration Server, 12
- Domain_name extension property, SUNW.jsas resource type, 70
- Domaindir extension property, SUNW.jsas resource type, 70

E

- extension properties
 - SUNW.jsas-na resource type, 71
 - SUNW.jsas resource type, 69
 - SUNW.s1as resource type, 73

F

- failover configuration
 - supported versions as of 9.1, 28-30
 - supported versions before 8.1, 59
- fault monitor
 - supported versions as of 9.1, 36-38
 - supported versions before 8.1, 64-66

G

- global zone, 25

H

help, 10

I

installing

- Sun Cluster HA for Sun Java System Application Server, 24-26, 57
- Sun Java System Application Server, 18, 50
- Sun Java System Web Server Plugin, 24, 56-57

L

local zones, *See* non-global zones

M

messages file, 10

Monitor Uri List extension property

- SUNW.jsas resource type, 70
- SUNW.slas resource type, 73

multiple masters configuration, supported versions before 8.1, 61

N

network resource configuration, 19, 50

non-global zones, 25

P

packages, 24-26, 57

Passwordfile extension property, SUNW.jsas-na resource type, 72

Passwordfile extension property, SUNW.jsas resource type, 70

planning installation

- supported versions as of 9.1, 17-18
- supported versions before 8.1, 48-49

Probe_timeout extension property, SUNW.jsas-na resource type, 72

Probe_timeout extension property, SUNW.jsas resource type, 71

prtconf -v command, 10

prtdiag -v command, 10

psrinfo -v command, 10

R

restrictions

- supported versions as of 9.1, 18
- supported versions before 8.1, 48
- zones, 25

S

scalable, *See* multiple masters configuration

show-rev subcommand, 10

showrev -p command, 10

software packages, 24-26, 57

Sun Cluster HA for Sun Java System Application Server installing, 24-26, 57

- software packages installing, 57

software packages, installing, 24-26

Sun Cluster HA for Sun Java System Application Server supported versions as of 9.1

- configuration restrictions, 18
- configuring for failover, 28-30
- fault monitor, 36-38

- installation task summary, 16-17
- overview, 12-16

Sun Cluster HA for Sun Java System Application Server supported versions before 8.1

- configuration restrictions, 48
- configuring for failover, 59
- configuring for multiple masters, 61
- fault monitor, 64-66
- installation task summary, 47-48
- overview, 44-46

Sun Java System Application Server installation, 18, 50

Sun Java System Application Server supported versions
before 8.1, 43

Sun Java System HADB, 24, 56

Sun Java System Web Server Plugin
installation, 24, 56-57

Sun ONE Application Server, *See* Sun Java System
Application Server supported versions before 8.1

SUNW.HASStoragePlus resource type
configuring for Sun Cluster HA for Sun Java System
Application Server, 35, 63

SUNW.jsas-na resource type, extension properties, 71

SUNW.jsas resource type, extension properties, 69

SUNW.s1as resource type, extension properties, 73

T

technical support, 10

V

/var/adm/messages file, 10

Z

zones, 25

