



Sun Storage J4200/J4400 Array Disk Drive Replacement Guide

Sun Microsystems, Inc.
www.sun.com

Part No. 820-3225-11
April 2008, Revision A

Submit comments about this document at: <http://www.sun.com/hwdocs/feedback>

Copyright 2008 Sun Microsystems, Inc., 4150 Network Circle, Santa Clara, California 95054, U.S.A. All rights reserved.

Sun Microsystems, Inc. has intellectual property rights relating to technology that is described in this document. In particular, and without limitation, these intellectual property rights may include one or more of the U.S. patents listed at <http://www.sun.com/patents> and one or more additional patents or pending patent applications in the U.S. and in other countries.

This document and the product to which it pertains are distributed under licenses restricting their use, copying, distribution, and decompilation. No part of the product or of this document may be reproduced in any form by any means without prior written authorization of Sun and its licensors, if any.

Third-party software, including font technology, is copyrighted and licensed from Sun suppliers.

Parts of the product may be derived from Berkeley BSD systems, licensed from the University of California. UNIX is a registered trademark in the U.S. and in other countries, exclusively licensed through X/Open Company, Ltd.

Sun, Sun Microsystems, the Sun logo, AnswerBook2, docs.sun.com, and Solaris are trademarks or registered trademarks of Sun Microsystems, Inc. in the U.S. and in other countries.

All SPARC trademarks are used under license and are trademarks or registered trademarks of SPARC International, Inc. in the U.S. and in other countries. Products bearing SPARC trademarks are based upon an architecture developed by Sun Microsystems, Inc.

The OPEN LOOK and Sun™ Graphical User Interface was developed by Sun Microsystems, Inc. for its users and licensees. Sun acknowledges the pioneering efforts of Xerox in researching and developing the concept of visual or graphical user interfaces for the computer industry. Sun holds a non-exclusive license from Xerox to the Xerox Graphical User Interface, which license also covers Sun's licensees who implement OPEN LOOK GUIs and otherwise comply with Sun's written license agreements.

U.S. Government Rights—Commercial use. Government users are subject to the Sun Microsystems, Inc. standard license agreement and applicable provisions of the FAR and its supplements.

DOCUMENTATION IS PROVIDED "AS IS" AND ALL EXPRESS OR IMPLIED CONDITIONS, REPRESENTATIONS AND WARRANTIES, INCLUDING ANY IMPLIED WARRANTY OF MERCHANTABILITY, FITNESS FOR A PARTICULAR PURPOSE OR NON-INFRINGEMENT, ARE DISCLAIMED, EXCEPT TO THE EXTENT THAT SUCH DISCLAIMERS ARE HELD TO BE LEGALLY INVALID.

Copyright 2008 Sun Microsystems, Inc., 4150 Network Circle, Santa Clara, Californie 95054, Etats-Unis. Tous droits réservés.

Sun Microsystems, Inc. a les droits de propriété intellectuels relatants à la technologie qui est décrit dans ce document. En particulier, et sans la limitation, ces droits de propriété intellectuels peuvent inclure un ou plus des brevets américains énumérés à <http://www.sun.com/patents> et un ou les brevets plus supplémentaires ou les applications de brevet en attente dans les Etats-Unis et dans les autres pays.

Ce produit ou document est protégé par un copyright et distribué avec des licences qui en restreignent l'utilisation, la copie, la distribution, et la décompilation. Aucune partie de ce produit ou document ne peut être reproduite sous aucune forme, par quelque moyen que ce soit, sans l'autorisation préalable et écrite de Sun et de ses bailleurs de licence, s'il y en a.

Le logiciel détenu par des tiers, et qui comprend la technologie relative aux polices de caractères, est protégé par un copyright et licencié par des fournisseurs de Sun.

Des parties de ce produit pourront être dérivées des systèmes Berkeley BSD licenciés par l'Université de Californie. UNIX est une marque déposée aux Etats-Unis et dans d'autres pays et licenciée exclusivement par X/Open Company, Ltd.

Sun, Sun Microsystems, le logo Sun, AnswerBook2, docs.sun.com, et Solaris sont des marques de fabrique ou des marques déposées de Sun Microsystems, Inc. aux Etats-Unis et dans d'autres pays.

Toutes les marques SPARC sont utilisées sous licence et sont des marques de fabrique ou des marques déposées de SPARC International, Inc. aux Etats-Unis et dans d'autres pays. Les produits portant les marques SPARC sont basés sur une architecture développée par Sun Microsystems, Inc.

L'interface d'utilisation graphique OPEN LOOK et Sun™ a été développée par Sun Microsystems, Inc. pour ses utilisateurs et licenciés. Sun reconnaît les efforts de pionniers de Xerox pour la recherche et le développement du concept des interfaces d'utilisation visuelle ou graphique pour l'industrie de l'informatique. Sun détient une licence non exclusive de Xerox sur l'interface d'utilisation graphique Xerox, cette licence couvrant également les licenciées de Sun qui mettent en place l'interface d'utilisation graphique OPEN LOOK et qui en outre se conforment aux licences écrites de Sun.

LA DOCUMENTATION EST FOURNIE "EN L'ÉTAT" ET TOUTES AUTRES CONDITIONS, DECLARATIONS ET GARANTIES EXPRESSES OU TACITES SONT FORMELLEMENT EXCLUES, DANS LA MESURE AUTORISEE PAR LA LOI APPLICABLE, Y COMPRIS NOTAMMENT TOUTE GARANTIE IMPLICITE RELATIVE A LA QUALITE MARCHANDE, A L'APTITUDE A UNE UTILISATION PARTICULIERE OU A L'ABSENCE DE CONTREFAÇON.



Please
Recycle



Adobe PostScript

Contents

Removing and Replacing a Disk Drive	1
ESD Precautions	1
Disk Drive Components	2
Removing and Replacing a Disk Drive	3
▼ Removing a Disk Drive	3
▼ Replacing a Disk Drive	4
▼ Verify and Complete the Disk Drive Replacement	5
Related Documentation	6

Removing and Replacing a Disk Drive

This document describes replacement procedures for the disk drive customer replaceable unit (CRU) installed in the Sun Storage J4200 and J4400 Arrays. This document assumes you have:

- Identified the disk tray containing the failed disk drive.
- Received the replacement disk drive.

This product is intended for restricted access whereby access is controlled through the use of a means of security (for example, key, lock, tool, or badge access), and personnel authorized for access have been instructed on the reasons for the restrictions and any precautions that need to be taken.

ESD Precautions

When performing this service action, observe the following electrostatic discharge (ESD) precautions:

- Remove all plastic, vinyl, and foam material from the work area.
- Wear an antistatic wrist strap at all times when handling any CRU.
- Before handling any CRU, discharge any static electricity by touching a grounded surface.
- Do not remove a CRU from its antistatic protective bag until you are ready to install it.
- After removing a CRU from the cabinet, immediately place it in an antistatic bag or antistatic packaging.
- Handle any card that is part of a CRU by its edges only and avoid touching the components or circuitry.

- Do not slide a CRU over any surface.
- Limit body movement (which builds up static electricity) during the removal and replacement of a CRU.

Disk Drive Components



Caution – Only trained service personnel should remove the covers on this equipment.

FIGURE 1 illustrates the location of the disk drive components and LEDs.

FIGURE 1 Disk Drive Components

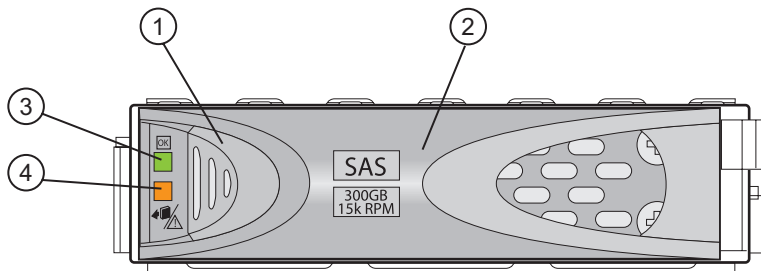

Figure Legend

-
- 1 Release button
 - 2 Disk Ejection Lever
 - 3 Activity LED
 - 4 Locator/Status LED
-

Removing and Replacing a Disk Drive



Caution – The power supplies in this equipment can produce high energy hazards. Only trained personnel with authorized access to this equipment should remove and replace modules in the system.

This section describes how to remove and replace a disk drive.



Caution – The replacement disk drive must be the same capacity and same type as the disk drive it is replacing.



Caution – Never remove a disk drive unless the ID/Status LED is blue (see [FIGURE 1](#)). If you need to remove multiple disk drives, always remove and replace one disk drive at a time.

Note – The disks are hot-swappable and you do not need to disconnect power from the system or other components in order to replace one of these parts.

▼ Removing a Disk Drive

1. From the front of the disk tray, locate the failed disk drive (see [FIGURE 2](#)). The Activity LED is off and the ID/Status LED is blue, indicating that data is not being transferred to or from the disk and that the disk drive is ready to remove.

Caution – Potential loss of data access - Data might be lost if an active disk drive is removed. If you remove an active disk drive accidentally, wait at least 30 seconds before reinserting it.

2. Press the release button in and to the right to release the disk ejection lever.
3. Pull the disk ejection lever fully open to unlock and partially eject the disk drive from the tray.
4. Grasp the middle of the disk drive body and pull it toward you to remove it from the tray.

FIGURE 2 Removing a Failed Disk Drive From a J4200 Array Disk Tray

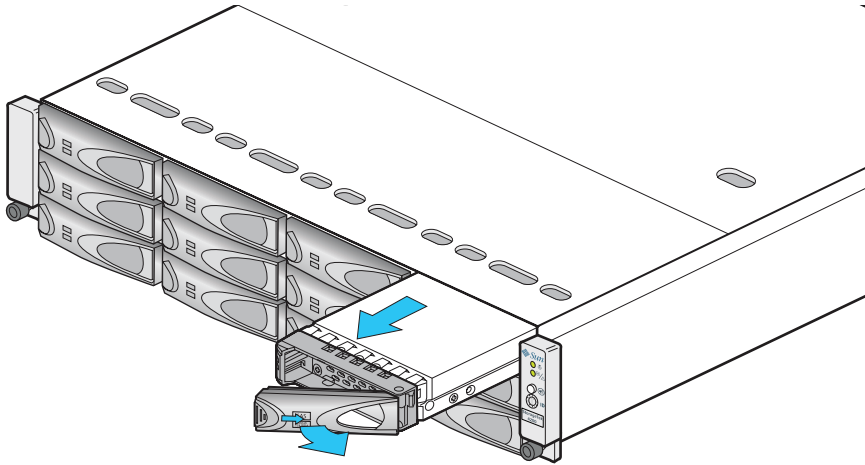

Caution – For products with multiple power cords, all power cords must be disconnected to completely remove power from the system.

▼ Replacing a Disk Drive



Caution – Follow all ESD precautions (see “[ESD Precautions](#)” on page 1) and use care when handling either the new or failed disk drive.

1. **Unpack the new disk drive and do one of the following:**
 - Place the failed disk drive in the packing materials so that you can return it to Sun for proper disposal.
 - Properly dispose of the failed disk drive.
2. **Ensure the new disk drive is the same type and same capacity as the failed disk drive.**
3. **Ensure the disk ejection lever is in the fully extended position (see [FIGURE 3](#)).**
4. **Align the new disk drive with the open slot and slide the drive into the disk tray.**
5. **Push the disk drive into the tray slot until the disk ejection lever engages the tray connectors and begins to swing closed.**

6. Press the disk ejection lever closed until it locks in place to seat the drive and lock it into the tray.

FIGURE 3 Inserting a Disk Drive in a J4400 Array Disk Tray

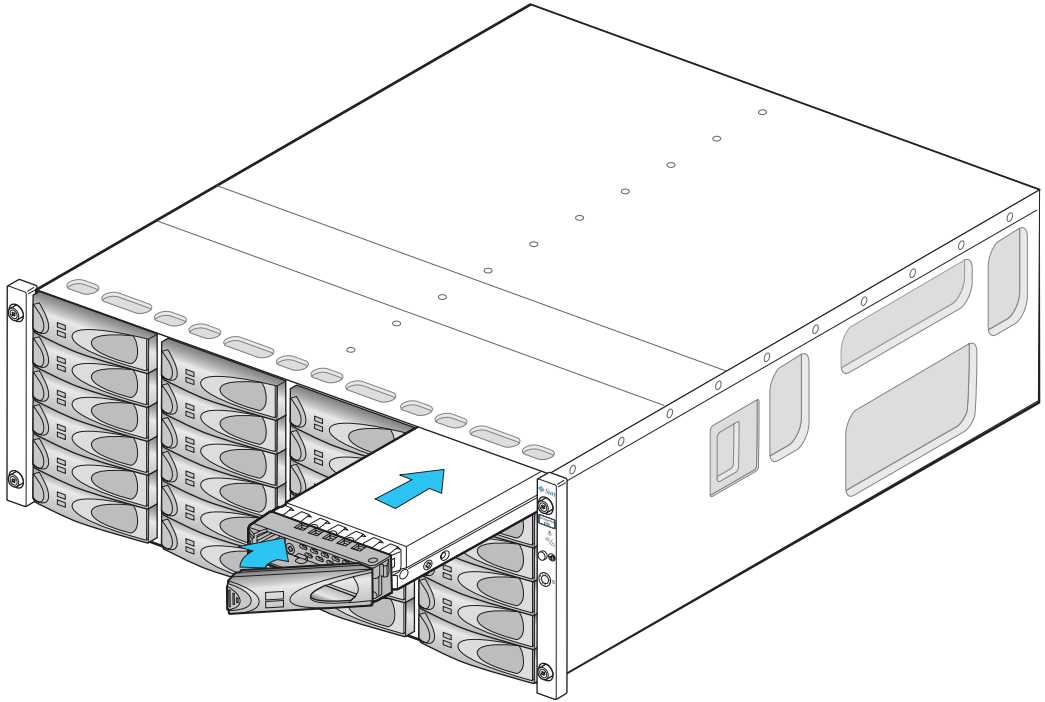

7. After the disk drive is locked in place, the Activity LED will be steady green to indicate a ready state.

▼ Verify and Complete the Disk Drive Replacement

- Verify the Activity LED is steady green.

Related Documentation

For additional information about the Sun Storage J4200/J4400 Array, see the following product documentation:

Application	Title	Part Number
Regulatory and safety information	<i>Sun StorageTek Regulatory and Safety Compliance Manual</i>	96272, Revision A
Multilanguage safety information	<i>Important Safety Information for Sun Hardware Systems</i>	816-7190- <i>nn</i>
Site planning information	<i>Sun Storage J4200/J4400 Array Site Preparation Guide</i>	820-3219- <i>nn</i>
Installation at a glance	<i>Sun Storage J4200 Array Setup Poster</i>	820-3221- <i>nn</i>
Installation at a glance	<i>Sun Storage J4400 Array Setup Poster</i>	820-4691- <i>nn</i>
Complete details of the hardware components, rail and tray installation, and cabling.	<i>Sun Storage J4200/J4400 Array Hardware Installation Guide</i>	820-3218- <i>nn</i>
Late-breaking information not included in the information set	<i>Sun Storage J4200/J4400 Array Release Notes</i>	820-3222- <i>nn</i>
Installation and use of the management software using a GUI	<i>Sun StorageTek Common Array Manager User Guide for the J4000 Array Family</i>	820-3765- <i>nn</i>
Installation and use of the management software using a CLI	<i>Sun StorageTek Common Array Manager CLI Guide for the J4000 Array Family</i>	820-4419- <i>nn</i>
General operation and troubleshooting	<i>Sun Storage J4200/J4400 Array Overview</i>	820-3223- <i>nn</i>
Disk drive replacement procedures	<i>Sun Storage J4200/J4400 Array Disk Drive Replacement Guide</i>	820-3225- <i>nn</i>
SIM board replacement procedures	<i>Sun Storage J4200 Array SIM Board Replacement Guide</i>	820-3226- <i>nn</i>
SIM board replacement procedures	<i>Sun Storage J4400 Array SIM Board Replacement Guide</i>	820-4600- <i>nn</i>
Power supply replacement procedures	<i>Sun Storage J4200 Array Power Supply Replacement Guide</i>	820-3227- <i>nn</i>

Application	Title	Part Number
Fan replacement procedures	<i>Sun Storage J4200 Array Fan Replacement Guide</i>	820-3229- <i>nn</i>
Power supply and fan replacement procedures	<i>Sun Storage J4400 Array Power Supply/Fan Replacement Guide</i>	820-3228- <i>nn</i>
Chassis replacement procedures	<i>Sun Storage J4200 Chassis Replacement Guide</i>	820-4413- <i>nn</i>
Chassis replacement procedures	<i>Sun Storage J4400 Chassis Replacement Guide</i>	820-4601- <i>nn</i>
Rail kit installation procedures	<i>Sun Storage J4200/J4400 Array Rail Kit Installation Guide</i>	820-3764- <i>nn</i>

Service Contact Information

If you need help installing or using this product in the United States, call 1-800-USA-4SUN (872-4786), or go to:

<http://www.sun.com/service/contacting/index.xml>

