



StorageTek™ Host Software Component (HSC)

VM software

Interface to Tape Management Systems

Part Number: 312615601

Revision: B

Version: 6.1

Host Software Component (VM Implementation)

Interface to Tape Management Systems Manual

Release 6.1

312615601

Copyright 2008 Sun Microsystems, Inc., 4150 Network Circle, Santa Clara, California 95054, U.S.A. All rights reserved.

Sun Microsystems, Inc. has intellectual property rights relating to technology that is described in this document. In particular, and without limitation, these intellectual property rights may include one or more of the U.S. patents listed at <http://www.sun.com/patents> and one or more additional patents or pending patent applications in the U.S. and in other countries.

This document and the product to which it pertains are distributed under licenses restricting their use, copying, distribution, and decompilation. No part of the product or of this document may be reproduced in any form by any means without prior written authorization of Sun and its licensors, if any.

Third-party software, including font technology, is copyrighted and licensed from Sun suppliers.

Parts of the product may be derived from Berkeley BSD systems, licensed from the University of California. UNIX is a registered trademark in the U.S. and in other countries, exclusively licensed through X/Open Company, Ltd.

Sun, Sun Microsystems, the Sun logo, Java, AnswerBook2, docs.sun.com, and Solaris are trademarks or registered trademarks of Sun Microsystems, Inc. in the U.S. and in other countries.

All SPARC trademarks are used under license and are trademarks or registered trademarks of SPARC International, Inc. in the U.S. and in other countries. Products bearing SPARC trademarks are based upon an architecture developed by Sun Microsystems, Inc.

The OPEN LOOK and Sun™ Graphical User Interface was developed by Sun Microsystems, Inc. for its users and licensees. Sun acknowledges the pioneering efforts of Xerox in researching and developing the concept of visual or graphical user interfaces for the computer industry. Sun holds a non-exclusive license from Xerox to the Xerox Graphical User Interface, which license also covers Sun's licensees who implement OPEN LOOK GUIs and otherwise comply with Sun's written license agreements.

U.S. Government Rights—Commercial use. Government users are subject to the Sun Microsystems, Inc. standard license agreement and applicable provisions of the FAR and its supplements.

DOCUMENTATION IS PROVIDED "AS IS" AND ALL EXPRESS OR IMPLIED CONDITIONS, REPRESENTATIONS AND WARRANTIES, INCLUDING ANY IMPLIED WARRANTY OF MERCHANTABILITY, FITNESS FOR A PARTICULAR PURPOSE OR NON-INFRINGEMENT, ARE DISCLAIMED, EXCEPT TO THE EXTENT THAT SUCH DISCLAIMERS ARE HELD TO BE LEGALLY INVALID.

Copyright 2008 Sun Microsystems, Inc., 4150 Network Circle, Santa Clara, Californie 95054, Etats-Unis. Tous droits réservés.

Sun Microsystems, Inc. a les droits de propriété intellectuels relatants à la technologie qui est décrit dans ce document. En particulier, et sans la limitation, ces droits de propriété intellectuels peuvent inclure un ou plus des brevets américains énumérés à <http://www.sun.com/patents> et un ou les brevets plus supplémentaires ou les applications de brevet en attente dans les Etats-Unis et dans les autres pays.

Ce produit ou document est protégé par un copyright et distribué avec des licences qui en restreignent l'utilisation, la copie, la distribution, et la décompilation. Aucune partie de ce produit ou document ne peut être reproduite sous aucune forme, par quelque moyen que ce soit, sans l'autorisation préalable et écrite de Sun et de ses bailleurs de licence, s'il y en a.

Le logiciel détenu par des tiers, et qui comprend la technologie relative aux polices de caractères, est protégé par un copyright et licencié par des fournisseurs de Sun.

Des parties de ce produit pourront être dérivées des systèmes Berkeley BSD licenciés par l'Université de Californie. UNIX est une marque déposée aux Etats-Unis et dans d'autres pays et licenciée exclusivement par X/Open Company, Ltd.

Sun, Sun Microsystems, le logo Sun, Java, AnswerBook2, docs.sun.com, et Solaris sont des marques de fabrique ou des marques déposées de Sun Microsystems, Inc. aux Etats-Unis et dans d'autres pays.

Toutes les marques SPARC sont utilisées sous licence et sont des marques de fabrique ou des marques déposées de SPARC International, Inc. aux Etats-Unis et dans d'autres pays. Les produits portant les marques SPARC sont basés sur une architecture développée par Sun Microsystems, Inc.

L'interface d'utilisation graphique OPEN LOOK et Sun™ a été développée par Sun Microsystems, Inc. pour ses utilisateurs et licenciés. Sun reconnaît les efforts de pionniers de Xerox pour la recherche et le développement du concept des interfaces d'utilisation visuelle ou graphique pour l'industrie de l'informatique. Sun détient une licence non exclusive de Xerox sur l'interface d'utilisation graphique Xerox, cette licence couvrant également les licenciées de Sun qui mettent en place l'interface d'utilisation graphique OPEN LOOK et qui en outre se conforment aux licences écrites de Sun.

LA DOCUMENTATION EST FOURNIE "EN L'ÉTAT" ET TOUTES AUTRES CONDITIONS, DECLARATIONS ET GARANTIES EXPRESSES OU TACITES SONT FORMELLEMENT EXCLUES, DANS LA MESURE AUTORISEE PAR LA LOI APPLICABLE, Y COMPRIS NOTAMMENT TOUTE GARANTIE IMPLICITE RELATIVE A LA QUALITE MARCHANDE, A L'APTITUDE A UNE UTILISATION PARTICULIERE OU A L'ABSENCE DE CONTREFAÇON.

We welcome your feedback. Please contact the Sun Learning Services Feedback System at:

SLSFS@Sun.com

or

Sun Learning Services
Sun Microsystems Inc.
One StorageTek Drive
Louisville, CO 80028-3256
USA

Document Effectivity

EC Number	Date	Doc Kit Number	Type	Effectivity
132247	December, 2005	---	Revision A	This document applies to the Host Software Component (VM/HSC), Version 6.1.
---	July, 2008		Revision B	

Contents

What's New With This Release?	xv
About this Guide	xxi
Scope	xxi
Intended Audience	xxi
About the Software	xxi
How this Guide is Organized	xxii
Related Publications	xxiii
Sun StorageTek HSC Publications	xxiii
Additional Information	xxiv
Sun's External Web Site	xxiv
Customer Resource Center	xxiv
Partners Site	xxiv
Hardcopy Publications	xxiv
Customer Support	xxv
Customer-initiated Maintenance	xxv
Sun's Worldwide Offices	xxvi
Chapter 1. General Information	1
Introduction	1
TMS Responsibilities	2
User Interface	2
Tape Resource Allocation	2
Operator Interface	3
TMS Decision Points	3
TMS Initialization	3
Transport Allocation	3
Scratch Allocation	4
Volume Movement	4
Returning a Volume to Scratch Status	4
ACS Information Returned to the TMS	5
Configuration Information	5
Volume Status	5
Volume Location	5
Eligible Transports	5
Movement Status and Error Codes	6
LSM and LMU Status	6

VOLSERs for Scratch Management	6
General TMS to Library Interactions	6
Mount Scenario	7
Dismount Scenario	8
Delayed Dismount Scenario	9
Allocation Interface Scenario	10
TMS Operator Message Interface Scenario	11
IUCV Considerations	13
Additional Considerations	15
Chapter 2. Overview	17
Introduction	17
TMS to ACS Initial Connection	18
Initial Connection Dialog	18
Transport Allocation	18
Allocation Interaction	18
Allocation Dialog	19
Termination of Allocation Interface	20
Operator Message Processing	21
Operator Message Interaction	21
Operator Message Dialog	21
Termination of Operator Message Interface	22
Prop-Detected Dismount	23
Chapter 3. The ACSRQ Macro	27
Introduction	27
ACSRQ Requests	27
Syntax Flow Diagrams	28
Specifying Commands	28
Variables	28
Delimiters	28
Flow Lines	29
Single Required Choice	29
Single Optional Choice	30
Defaults	30
Repeat Symbol	30
Syntax Continuation (Fragments)	31
ACSRQ Macro Syntax	31
DEFPOOL	35
DEFPOOL Considerations	35
Syntax	35
Parameters	35
Response to DEFPOOL Request	37
DEFSCR	38
DEFSCR Considerations	38
Syntax	38

Parameters	38
Response to DEFSCR Request	40
DISMOUNT	41
DISMOUNT Considerations	41
Syntax	41
Parameters	41
Response to DISMOUNT Request	43
EJECT	44
EJECT Considerations	44
Syntax	45
Parameters	45
Response to EJECT Request	48
MOUNT	49
MOUNT Considerations	49
Syntax	49
Parameters	50
Response to MOUNT Request	59
MOVE	60
MOVE Considerations	60
Syntax	60
Parameters	60
Response to MOVE Request	63
QCAP	64
QCAP Considerations	64
Syntax	64
Parameters	64
Response to QCAP Request	67
QCONFIG	68
QCONFIG Considerations	68
Syntax	68
Parameters	68
Response to QCONFIG Request	70
QDRIVES	71
QDRIVES Considerations	71
Syntax	71
Parameters	71
Response to QDRIVES Request	73
QDRLIST	74
QDRLIST Considerations	74
Syntax	75
Parameters	75
Response to QDRLIST Request	85
QEJECT	86
QEJECT Considerations	86
Syntax	86
Parameters	86

Response to QEJECT Request	88
QREQUEST	89
QREQUEST Considerations	89
Syntax	89
Parameters	89
Response to QREQUEST Request	90
QSCRATCH	91
QSCRATCH Considerations	91
Syntax	91
Parameters	91
Response to QSCRATCH Request	100
QVOLUME	101
QVOLUME Considerations	101
Syntax	101
Parameters	101
Response to QVOLUME Request	103
QVOLUME	104
QVOLUME Considerations	104
Syntax	104
Parameters	104
Response to QVOLUME Request	105
SCRATCH	106
SCRATCH Considerations	106
Syntax	106
Parameters	106
Response to SCRATCH Request	108
SELSCR	109
SELSCR Considerations	109
Syntax	109
Parameters	110
Response to SELSCR Request	119
SETOPER	120
SETOPER Considerations	120
Syntax	120
Parameters	120
Response to SETOPER Request	122
STOP	123
STOP Considerations	123
Syntax	123
Parameters	123
Response to STOP Request	125
UNSCRATCH	126
UNSCRATCH Considerations	126
Syntax	126
Parameters	126
Response to UNSCRATCH Request	128

Chapter 4. Interface Data Areas	129
SLX Macro	129
SLX Macro Mapping	132
Cross Reference	146
ACSINT Request DSECT	154
Cross Reference	162
IUB Record Format	164
IUB - IUCV Request Block	164
Cross Reference	166
Glossary	167
Index	183

Figures

- Figure 1. Mount Scenario 7
- Figure 2. Dismount Scenario 8
- Figure 3. Delayed Dismount Scenario 9
- Figure 4. Allocation Interface Scenario 10
- Figure 5. TMS Operator Message Interface Scenario 11
- Figure 6. IUCV CONNECT parameter definitions 13
- Figure 7. IUCV SEND parameter definitions 14
- Figure 8. Process flow example for a QCONFIG Request 18
- Figure 9. Process flow example for a QDRLIST Request 19
- Figure 10. Process flow example for a SELSCR Request 20
- Figure 11. Mount Dialog 22
- Figure 12. Scenario A - Normal Dismount 24
- Figure 13. Scenario B - Dismount already done Automatically 25
- Figure 14. Process flow for the ACSRQ Macro 27

Tables

Table 1.	SLX Macro - Parameter Matrix (Part 1 of 4)	129
Table 2.	SLX Macro - Parameter Matrix (Part 2 of 4)	130
Table 3.	SLX Macro - Parameter Matrix (Part 3 of 4)	130
Table 4.	SLX Macro - Parameter Matrix (Part 4 of 4)	131
Table 5.	SLX Record Format	132
Table 6.	ACSINT Record Format	154
Table 7.	IUB Record Format	164

What's New With This Release?

HSC 6.1 includes the following enhancements and modifications:

Enhancement/Modification	Publication(s)/ Primary Locations
Revision B:	
Support for the SL3000 library.	<p>Installation Guide Chapter 2, Calculating DASD Space</p> <p>Chapter 6, SLILSM, SLIDRIVS macros</p> <p>Chapter 7, Storage Cell Capacity for StreamLine SL3000 Libraries</p> <p>Appendix B, Library Configurations</p> <p>Operator's Guide Chapter 2, CAPPref, DRAin, EJECT, ENter, MODify, MOVE, RElease CAP, Vlew commands</p> <p>System Programmer's Guide Chapter 2, Mixing Media Types and Recording Techniques</p> <p>Chapter 4, AUDIt , EJECT Cartridge, Initialize Cartridge utilities</p> <p>Appendix B, HSC Support for the SL3000 Library</p>

Enhancement/Modification	Publication(s)/ Primary Locations
SL8500 library LSM partitioning.	<p><i>System Programmer's Guide</i> Chapter 3, LMUPATH control statement</p> <p>Chapter 4, SET FREEZE utility</p> <p>Appendix A, HSC Support for the SL8500 Library</p> <p><i>Operator's Guide</i> Chapter 2, Display ACS, Display LSM, and Display Exceptions</p> <p><i>Messages and Codes Guide</i> New messages:</p> <ul style="list-style-type: none"> • SLS0073I • SLS0695I • SLS4232I • SLS4412I • SLS4413I • SLS4643I <p>Changed messages:</p> <ul style="list-style-type: none"> • SLS0653I • SLS0663I • SLS1000I • SLS2008I • SLS4401I • SLS4407I • SLS4610I
Considerations for SL8500 library TCP/IP communications.	<p><i>System Programmer's Guide</i> Appendix A, HSC Support for the SL8500 Library</p>
Dual IP connections to an SL8500 library.	<p><i>System Programmer's Guide</i> Appendix A, HSC Support for the SL8500 Library</p>
Multiple connections to an SL8500 library (HSC 6.1 and later).	<p><i>System Programmer's Guide</i> Appendix A, HSC Support for the SL8500 Library</p>

Enhancement/Modification	Publication(s)/ Primary Locations
Support for T10000 drive encryption recording techniques and model types.	<p><i>System Programmer's Guide</i> Chapter 2, T10000 Drive Encryption</p> <p>Chapter 3, VOLATTR control statement</p> <p>Chapter 4, EJECT Cartridge and Scratch Redistribution utilities</p> <p><i>Interface to Tape Management Systems Guide</i> Chapter 3, MOUNT, QDRLIST, QSCRATCH, and SELSCR requests</p> <p><i>Operator's Guide</i> Chapter 2, Display DRives, Display SCRatch, Display THReshld, EJECT, Warn commands</p>
Support for T9840D drives.	<p><i>Installation Guide</i> Chapter 2, Unit Addresses</p> <p>Chapter 6, SLIDRIVS macro</p> <p>Chapter 12, External Media Requirements</p> <p><i>Operator's Guide</i> Chapter 2, Display Drives, Display SCRatch, Display Mount, THReshld, EJECT, Warn</p> <p><i>System Programmer's Guide</i> Chapter 3, TAPEREQ, UNITATTR, VOLATTR</p> <p>Chapter 4, EJECT, SCRatch Redistribution</p> <p><i>Interface to Tape Management Systems Manual</i> Chapter 3, MOUNT, QDRLIST, QSCRATCH, SELSCR requests</p>

Enhancement/Modification	Publication(s)/ Primary Locations
<p>Support for LTO generation 4 drives.</p> <p>Note: LTO transports are not supported in an MVS environment. These transports are recognized by the HSC but are accessible only to open systems clients using LibraryStation.</p>	<p><i>Installation Guide</i> Chapter 2, Unit Addresses</p> <p>Chapter 6, SLIDRIVS macro</p> <p>Chapter 12, External Media Requirements</p> <p><i>Operator's Guide</i> Chapter 2, Display Drives, Display SCRatch, Display Mount, THReshld, EJECT, Warn</p> <p><i>System Programmer's Guide</i> Chapter 3, TAPEREQ, UNITATTR, VOLATTR</p> <p>Chaper 4, EJECT, SCRatch Redistribution</p> <p>Appendix H, MOUNT, QDRLIST, QSCRATCH, SELSCR</p>
<p>The SLILIBRY macro adds the FUTRACS parameter to allow new ACSs to be added to the library complex.</p>	<p><i>Installation Guide</i> Chapter 6, SLILIBRY macro</p>
<p>The SLILSM macro adds the TYPE=3000 and DOOR=3000 parameters for the SL3000 library.</p>	<p><i>Installation Guide</i> Chapter 6, SLILSM macro</p>
<p>The OPTion command DUPOFL parameter allows the duplicate VOLSER process to continue when the VOLSER being entered exists in an ACS that is disconnected or in an LSM that is offline.</p>	<p><i>Operator's Guide</i> Chapter 4, OPTion command</p>
<p>The LMUPATH control statement PARTID parameter defines a partition ID for an SL3000 or SL8500 library.</p>	<p><i>System Programmer's Guide</i> Chapter 3, LMUPATH control statement</p>
<p>The EJECT Cartridge utility SEQ parameter specifies whether or not CAP eject processing fills the CAP cells in the same order specified by the VOLser parameter.</p>	<p><i>System Programmer's Guide</i> Chapter 4, EJECT Cartridge utility</p>
<p>The LIST diagnostic command has been expanded with more control blocks and enhanced storage dump capability.</p>	<p><i>System Programmer's Guide</i> Chapter 5, LIST command</p>

Enhancement/Modification	Publication(s)/ Primary Locations
Revision A:	
Support for SL8500 Near Continuous Operation (NCO). The main discussion is located in the <i>System Programmer's Guide</i> , Appendix A.	<p>Operator's Guide Chapter 2, MODify command</p> <p>Installation Guide Chapter 6, SLIACS Macro, FUTRLSM parameter</p> <p>System Programmer's Guide Chapter 2, Near Continuous Operation of the SL8500 Library</p> <p>Appendix B, HSC Support for Near Continuous Operation (NCO)</p>
<p>Appendix B, "HSC Support for the SL8500 Library," in the <i>Operator's Guide</i>, has been moved to Appendix A in the <i>System Programmer's Guide</i>.</p> <p>The following new topics are introduced:</p> <ul style="list-style-type: none"> • verifying that SL8500 components are operational before configuring the HSC • merging ACSs • removing PTPs and splitting ACSs • HSC requirements prior to powering down an SL8500. 	<p>System Programmer's Guide Appendix A, HSC Support for the SL8500 Library</p>
The Display DRives operator command has added the BYDrive and BYLoc parameters. BYDrive displays drives by host device address; BYLoc displays drives by location.	<p>Operator's Guide Chapter 2, Display DRives command</p>
The ENter command has added the TLSM parameter, which allows you to specify the LSM to receive entered cartridges.	<p>Operator's Guide Chapter 2, ENter command</p>
The TRace command has added component names for allocation volume lookup and XML interface.	<p>Operator's Guide Chapter 2, TRace command</p>
The TMI EJECT request adds a new parameter, SEQ, which specifies that an SL8500 CAP is either filled sequentially or by magazine/home location proximity.	<p>Interface to Tape Management Systems Manual Chapter 3, EJECT request</p>
The Warn command threshold value has been increased from 9999 to 99,999.	<p>Operator's Guide Chapter 2, Warn command.</p>

About this Guide

Scope

This guide describes configuration procedures for the Sun StorageTek™ Host Software Component (HSC) Interface to Tape Management Systems.

Intended Audience

This document is intended for use by those who develop and maintain tape management systems (TMS) as well as by systems programmers and technical personnel who need to develop or support interfaces with the Sun StorageTek Automated Cartridge System (ACS). This document contains the specifications necessary to design and code two specific interfaces, Allocation and Message, as well as information on initialization and interrupt handling.

The (TMS) interfacing with the Host Software Component (HSC) must be running in the CMS environment.

About the Software

VM/HSC Release 6.1 is supported by this guide.

How this Guide is Organized

This guide contains the following chapters:

- **Chapter 1, “General Information”** describes capabilities and use of the Interface to Tape Management Systems (TMI)
- **Chapter 2, “Overview”** describes various communications connections and dialog processes between the TMI and other components
- **Chapter 3, “The ACSRQ Macro”** describes the available functions of the TMI, including syntax diagrams and a detailed description of each parameter.
- **Chapter 4, “Interface Data Areas”** shows the SLX, ACSINT, and IUB Macros in detail.

A glossary and index are also included.

Related Publications

The following publications contain information about specific topics relating to the HSC.

Sun StorageTek HSC Publications

- *Installation Guide*
- *Operator's Guide*
- *System Programmer's Guide*
- *Interface to Tape Management Systems*
- *Messages and Codes Guide*
- *SCP Messages and Codes Guide*

Additional Information

Sun Microsystems, Inc. (Sun) offers several methods for you to obtain additional information.

Sun's External Web Site

Sun's external Web site provides marketing, product, event, corporate, and service information. The external Web site is accessible to anyone with a Web browser and an Internet connection.

The URL for the Sun external Web site is: <http://www.sun.com>

The URL for Sun StorageTek™ brand-specific information is:
<http://www.sun.com/storagetek>

Customer Resource Center

The Sun StorageTek product Customer Resource Center (CRC) is a Web site that enables members to resolve technical issues by searching code fixes and technical documentation for StorageTek brand products. CRC membership entitles you to other proactive services, such as HIPER subscriptions, technical tips, answers to frequently asked questions, addenda to product documentation books, and online product support contact information. Customers who have a current warranty or a current maintenance service agreement may apply for membership by clicking on the Request Password button on the CRC home page. Sun employees may enter the CRC through the SunWeb PowerPort.

The URL for the CRC is <http://www.support.storagetek.com>

Partners Site

The Sun StorageTek Partners site is a Web site for partners with a Sun StorageTek Partner Agreement. This site provides information about products, services, customer support, upcoming events, training programs, and sales tools to support Sun StorageTek Partners. Access to this site, beyond the Partners Login page, is restricted. On the Partners Login page, Sun employees and current partners who do not have access can request a login ID and password and prospective partners can apply to become Sun StorageTek resellers.

The URL for the Sun StorageTek Partners site is:
<http://members.storagetek.com>

The URL for partners with a Sun Partner Agreement is:
<http://www.sun.com/partners/>

Hardcopy Publications

Contact a Sun sales or marketing representative to order additional paper copies of this publication or to order other Sun StorageTek brand product customer publications in paper format.

Customer Support

Customer support is available 24 hours a day, seven days a week, to customers with Sun or StorageTek maintenance contracts and to Sun employees. You can find additional information about customer support on the Customer Resource Center (CRC) Web site at: <http://www.support.storageitek.com>

Customer-initiated Maintenance

Customer-initiated maintenance begins with a telephone call from you to Sun Microsystems StorageTek Support. You receive immediate attention from qualified Sun personnel, who record problem information and respond with the appropriate level of support.

To contact Sun Microsystems StorageTek Support about a problem:

1. Use the telephone and call:

☎ 800.872.4786 (1.800.USA.4SUN) (inside the United States)

☎ 800.722.4786 (Canada)

For international locations, go to

<http://www.sun.com/service/contacting/solution.html>

for the appropriate telephone number

2. Describe the problem to the call taker. The call taker will ask several questions and will either route your call to or dispatch a support representative.

If you have the following information when you place a service call, the process will be much easier:

Account name	_____
Site location number	_____
Contact name	_____
Telephone number	_____
Equipment model number	_____
Device address	_____
Device serial number (if known)	_____
Urgency of problem	_____
Fault Symptom Code (FSC)	_____
Problem description	_____

Sun's Worldwide Offices

You may contact any of Sun's worldwide offices to discuss complete storage, service, and support solutions for your organization. You can find address and telephone number information on Sun's external Web site at:
<http://www.sun.com/worldwide/>

Chapter 1. General Information

Introduction

A general description of the interfaces between the tape management system (TMS) and the Sun StorageTek Automated Cartridge System (ACS), commonly referred to as the library, includes the following topics:

- TMS responsibilities

The TMS responsibilities section describes the services a TMS provides.

- TMS decision points

The TMS decision points section describes where library interaction assists TMS services for library-managed resources.

- Library information returned to the TMS

The library information section describes information returned as a result of library interaction.

- General TMS/library interactions

The general interactions section describes several scenarios involving TMS to library interaction.

- Inter-user communications vehicle (IUCV) considerations

The IUCV considerations section describes the parameters used with the IUCV macro.

TMS Responsibilities

The TMS has three major functions:

- User interface
- Tape resource allocation
- Operator interface.

User Interface

The TMS is the primary interface between the user and the library. Direct interaction between the library and the user occurs only for certain functions, such as initiating utilities. The TMS validates user access and directs user request to the library.

Tape Resource Allocation

The resources under TMS control include:

- Transports
- Data sets
- Scratch volumes
- Specific volumes.

Transports

The TMS normally has ownership of transports for Automatic Volume Recognition (AVR) and also assigns transports to users requesting tape services. The TMS determines the availability of tape transports for allocation requests. The TMS also knows the media type and density any transport supports. The library assists the TMS in selecting library-controlled transports, when necessary.

Data Sets

The TMS maps data sets to physical volumes and may map external labels to internal labels. The library contains no such information. Scratch volumes The TMS is the final authority concerning the scratch status of volumes. This status also includes scratch subpool membership. In order to automate mount processing for a TMS generating “nonspecific” mounts (requests for scratch volumes that do not specify VOLSERS), the library also retains its own scratch status information. The TMS scratch status list is not considered a list of all available scratches, but rather as a subset of the total number of available scratch volumes.

Specific volumes

The TMS controls which users have access to any specific volume. The library handles volumes it controls at the request of an authorized operator or the TMS.

Operator Interface

Tape mounting, dismounting, and scratch pool selection is handled through message traffic between the TMS and the operator. The library software uses information supplied in messages to the operator to direct mounts, dismounts, etc.

TMS Decision Points

The library influences TMS decisions at the following points:

- TMS initialization
- Transport allocation
- Scratch allocation
- Volume movement
- Returning a volume to scratch status.

TMS Initialization

When the library machine is initialized, establish an IUCV path at TMS start up to determine if the library is operational and communicating. If the library machine is not initialized at TMS start up, establish an IUCV path as soon as possible after library initialization. It is possible to establish and break connection for each transaction, but this causes unnecessary processing. To use IUCV efficiently, a path must be established and maintained throughout the TMS communications session.

Transport Allocation

At allocation time some device separation should occur. Device separation involves deciding if a volume is under library control and assigning from a set of drives one which may satisfy a MOUNT request. The most efficient operation for a library volume, under most circumstances, is to allocate a library transport near the volume. If the volume is not library controlled, a decision must be made if it should be mounted on a library transport. The same decision needs to be made for scratch volumes. The library returns information about the volume status and scratch levels within the library.

Device Separation Impact

Selection of a library transport for a nonlibrary volume requires operator intervention at mount and dismount time. The operator responds to an HSC message, and enters the volume into an LSM.

If no Cartridge Access Port (CAP) has been selected as an enter CAP, an ENter command, and possibly a CAPPref command, must be issued. If the operator response was for a temporary enter of the volume, it is necessary to assign an Eject CAP. The operator must remove the volume before the assigned CAP can be used for another eject.

Selection of a nonlibrary transport for a library volume also requires operator intervention. The operator must eject the volume to manually mount it on another transport. Again, an Eject CAP must be assigned.



Note: See the *HSC Operator's Guide* for descriptions of the CAPPref, Eject, and ENter commands.

Scratch Allocation

If the TMS requests, the library can provide the VOLSER of a scratch volume prior to a MOUNT request. This selection can be rejected or used on the subsequent mount. If this information is not needed, a library nonspecific MOUNT request makes a selection.

Volume Movement

When a mount, dismount, or other movement of a volume is required, the TMS decides whether the library performs the action or if a manual operation is required. The library returns status information for volume movement requests.

Returning a Volume to Scratch Status

It is necessary to keep the TMS and library scratch status synchronized. The earliest time is at dismount, the latest when a TMS scratch pull list is generated. Requests and batch utilities are available to coordinate this activity.

ACS Information Returned to the TMS

Library information returned includes:

- Configuration information
- Volume status
- Volume location
- Eligible transports
- Movement status and error codes
- LSM and LMU status
- VOLSERS for scratch management
- Library scratch information
- Eject status
- Request status.

Configuration Information

Configuration information returned includes:

- Maximum number of transports in the largest ACS
- Number of transports under library control
- Number of ACSs
- Number of LSMs
- Response area sizes.

Volume Status

Volume status includes:

- Volume in a cell
- Volume in a drive
- Volume not in library
- Volume inaccessible
- Volume location uncertain (errant).

Volume Location

Location information consists of:

- ACSid
- LSMid
- Panel location
- Row location
- Column location.

Eligible Transports

Transports eligible from the library perspective are those in the same ACS and configured for this host. Not taken into account are the LSM status (except for scratch selection), the pass-thru port status, or the actual transport availability (attachability, online status).

Movement Status and Error Codes

Volume movement requests return a code indicating the success of the operation. If an error occurs, an additional code corresponding to the message issued to the operator is also returned.

LSM and LMU Status

LSM status is either online or offline. Online indicates that automated mounting can take place. Offline indicates only manual mounting is possible.

LMU status is connected or disconnected. Disconnected indicates that the ACS is not accessible from this host and any activity must be handled from another host.

VOLSERs for Scratch Management

If scratch selection is requested, a VOLSER marked as scratch in the library control data set is returned. This selection causes the volume to be marked as nonscratch.

General TMS to Library Interactions

The following scenarios describe at a high level the use of the library interfaces. Figure 1 on page 7, Figure 2 on page 8, and Figure 3 on page 9 describe mount, dismount, and delayed dismount processing by the TMS. These call the Allocation Interface and Message Interface routines described in Figure 4 on page 10 and Figure 5 on page 11.

For detailed information on invocations of these interfaces refer to “Transport Allocation” on page 18 and “Operator Message Processing” on page 21.

Mount Scenario

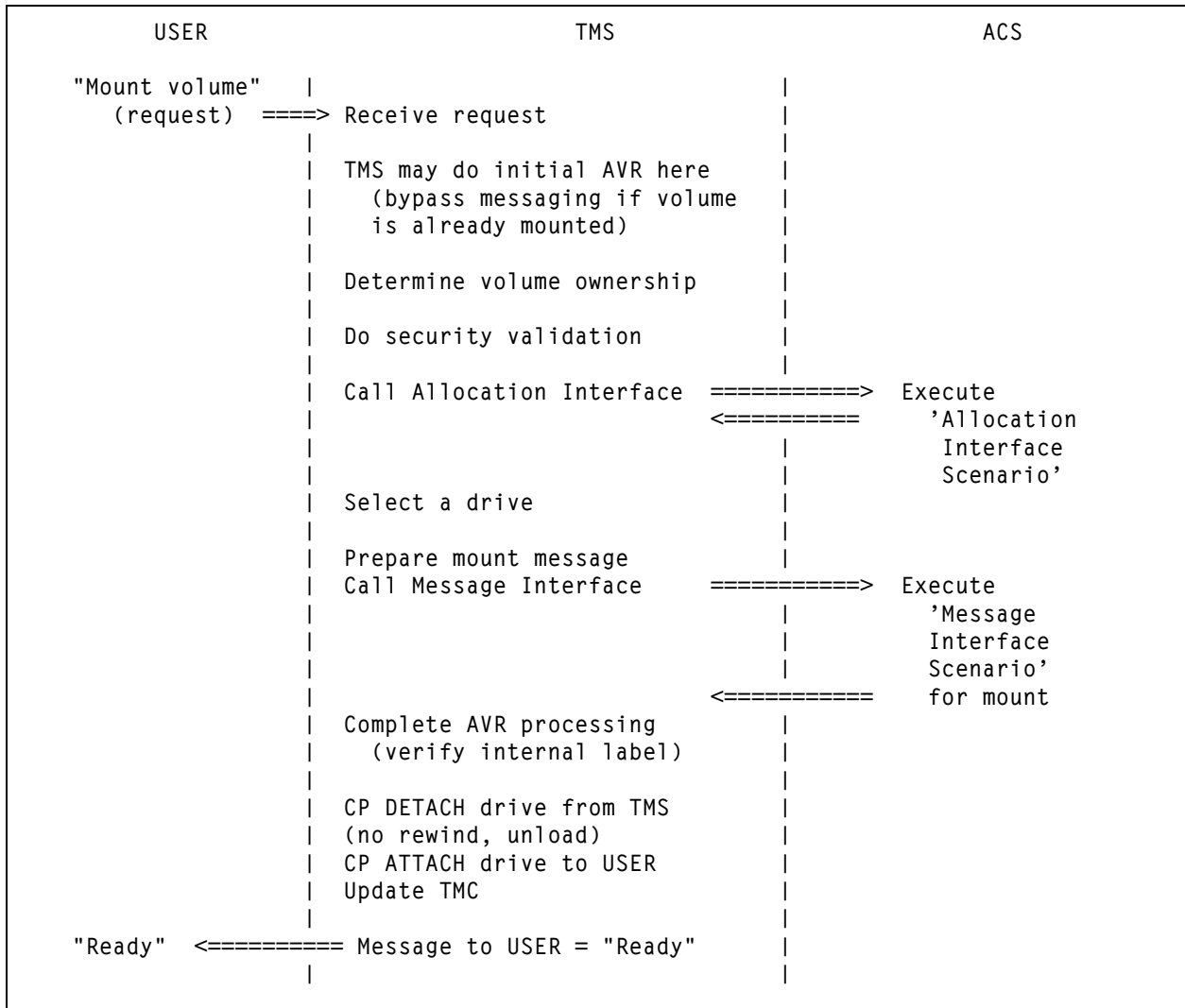

Figure 1. Mount Scenario

Dismount Scenario

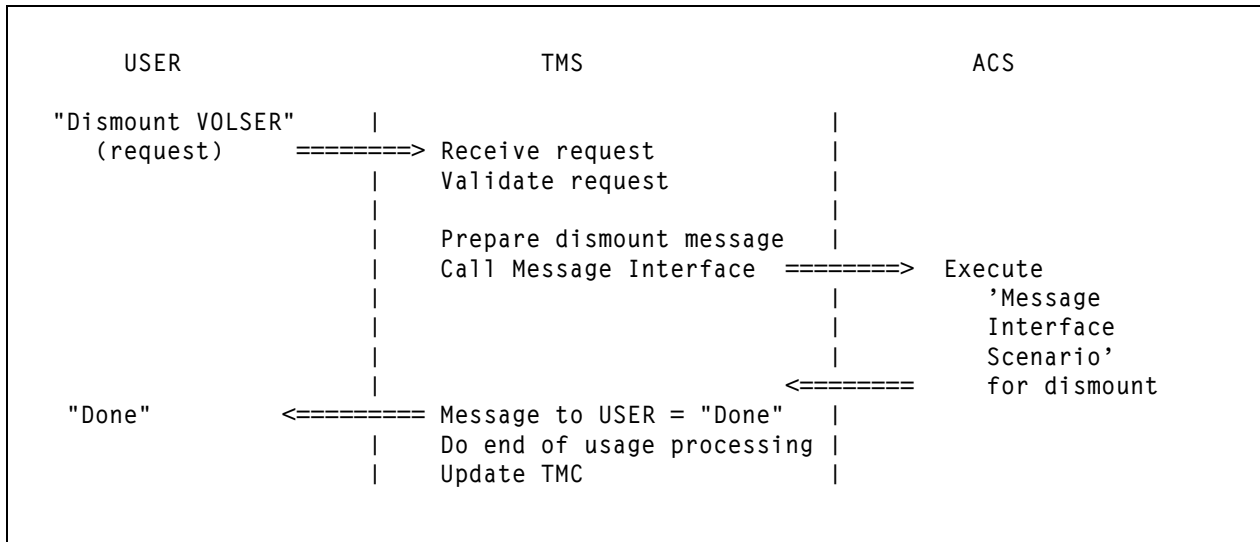

Figure 2. Dismount Scenario

Delayed Dismount Scenario

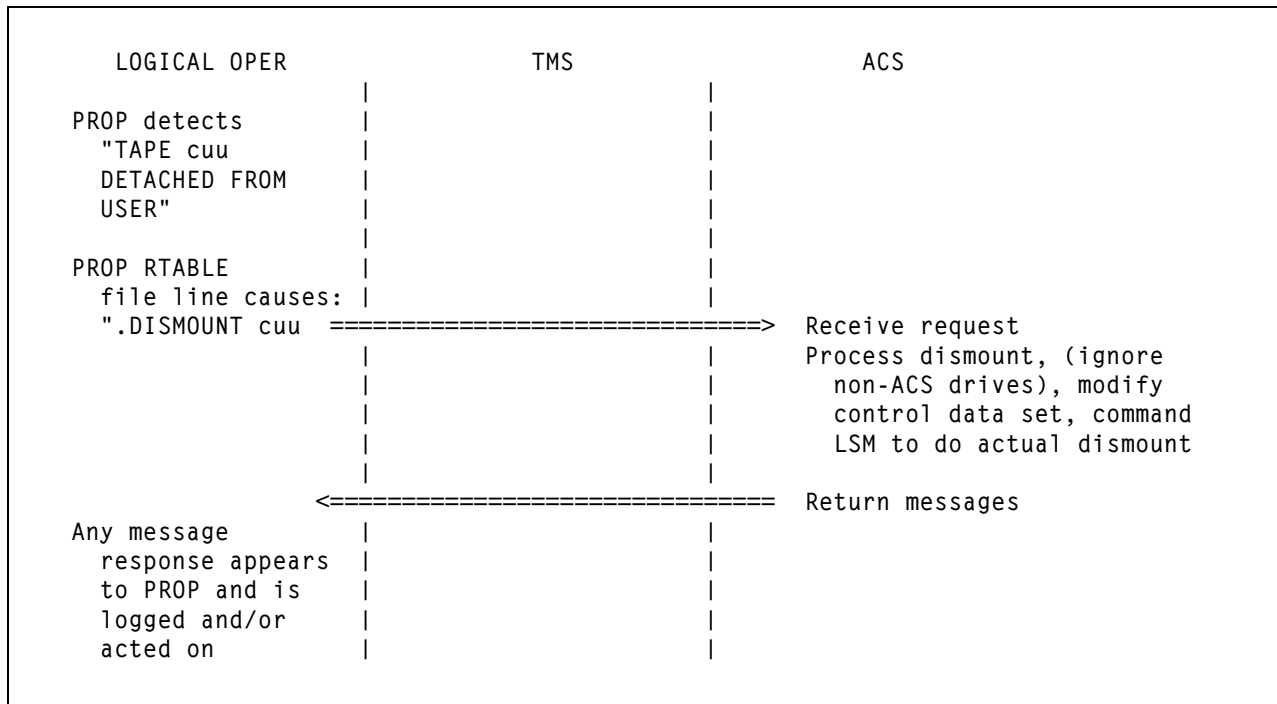

Figure 3. Delayed Dismount Scenario

Allocation Interface Scenario

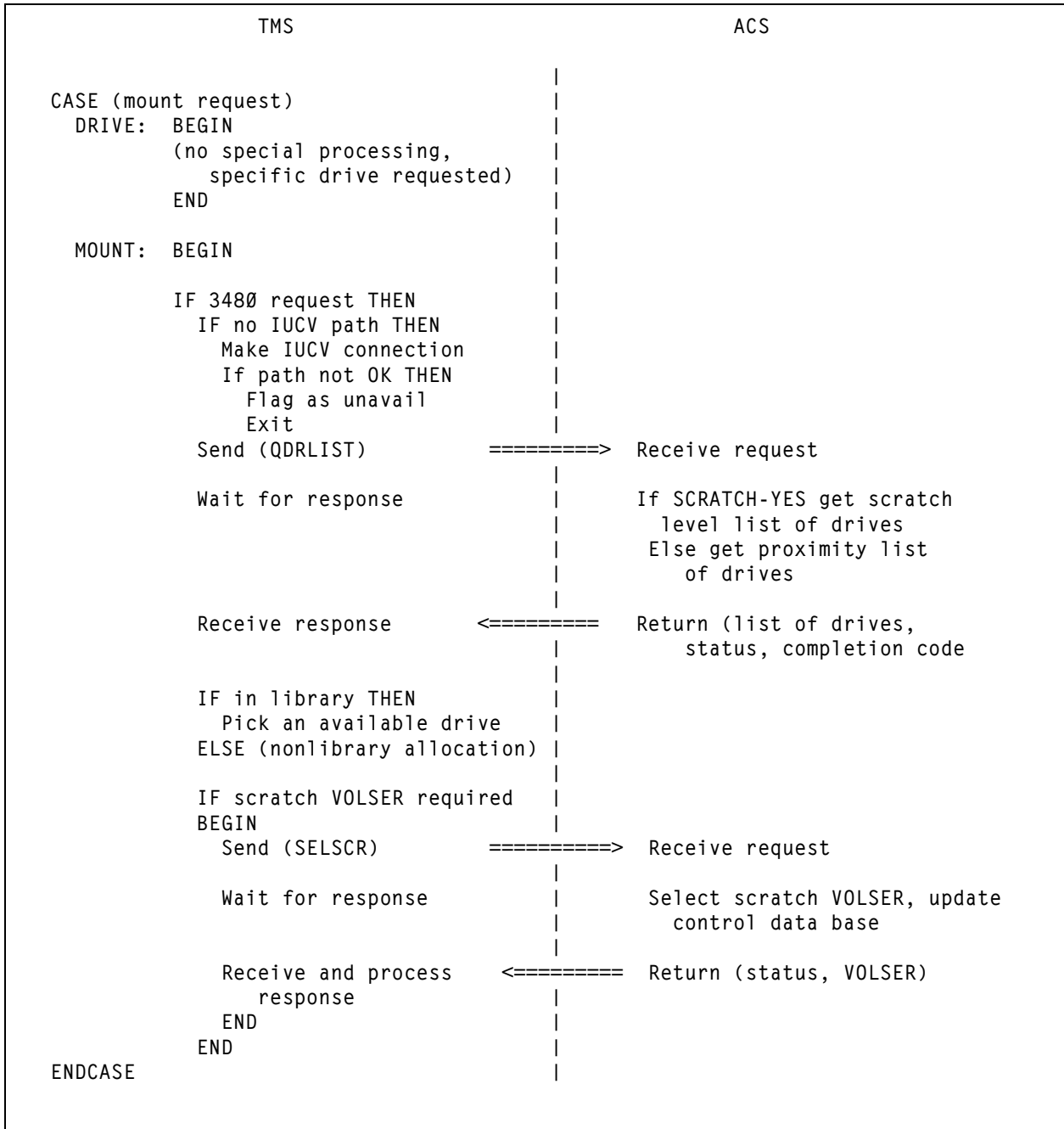
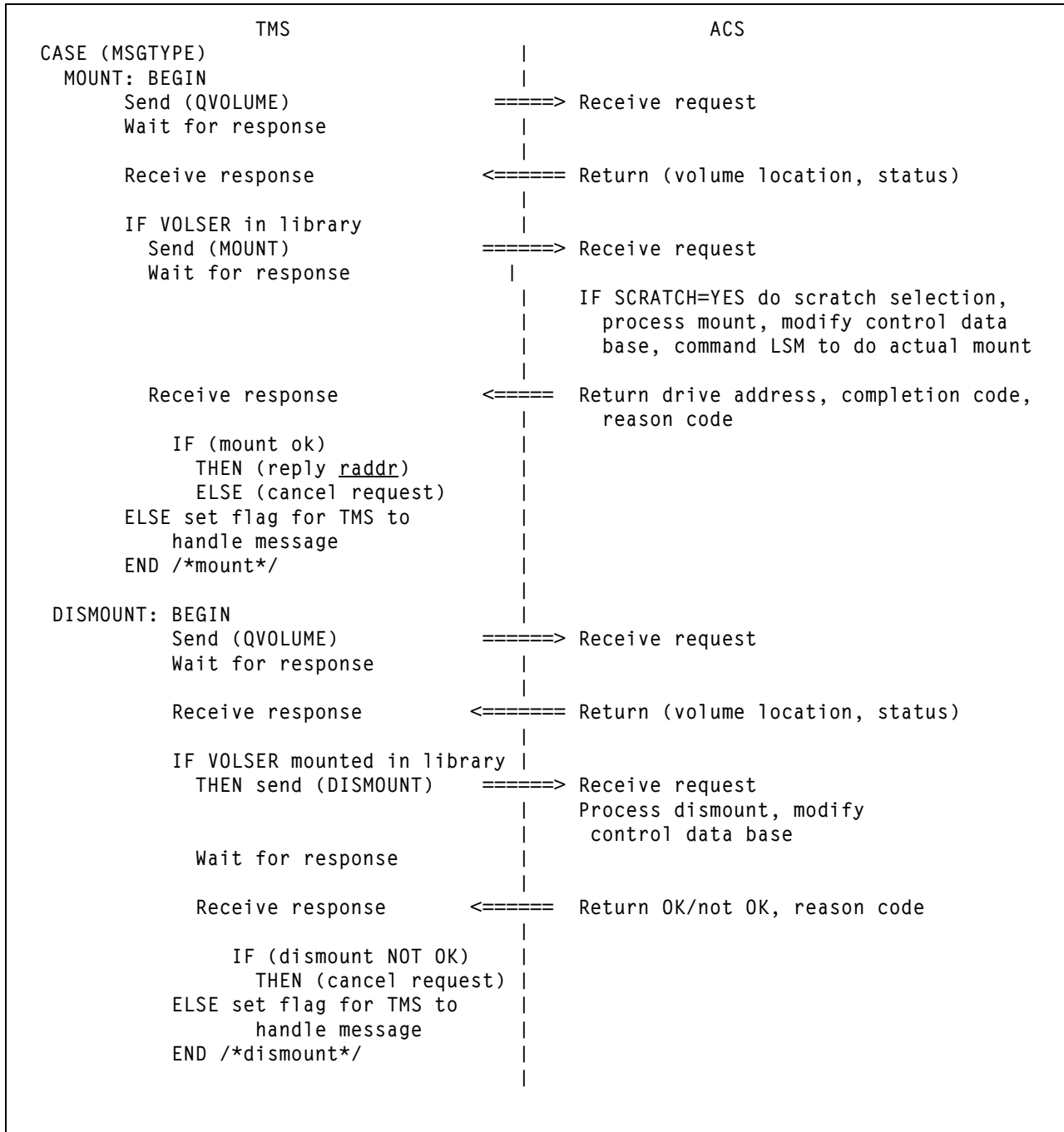

Figure 4. Allocation Interface Scenario

TMS Operator Message Interface Scenario



**Figure 5. TMS Operator Message Interface Scenario
(1 of 2)**

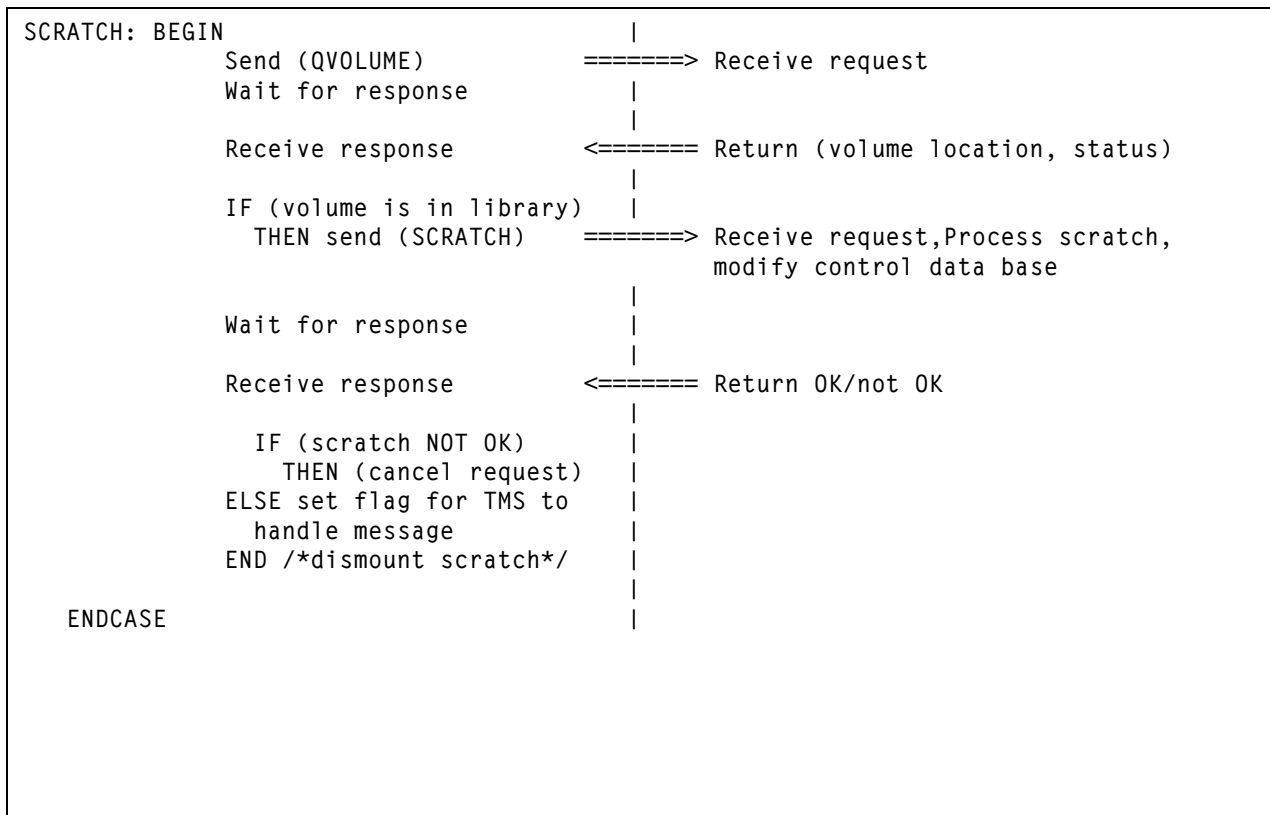

Figure 5. TMS Operator Message Interface Scenario (2 of 2)

IUCV Considerations

The inter-user communication vehicle (IUCV) is an IBM-supplied communications interface.



Note: VMTMI SAMPLE is a sample program illustrating the use of the VM/HSC Tape Management Interface. It can be found on the MAINTSTK userid.

To use IUCV to issue requests, follow these steps:

1. Establish a connection to the ACS service machine using the IUCV CONNECT function.
 - a. Only authorized virtual machines may issue commands to the ACS service machine. To obtain permission, the virtual machine is given command privilege by an AUTHorize command issued to the service machine either in the start up file, or from a previously authorized virtual machine.
 - b. In addition, the virtual machine must be authorized to CP via an IUCV control statement in its CP directory entry. This is typically done by a systems programmer or administrator. Make sure that the OPTION MAXCONN specifies enough paths for your usage.
 - c. To establish this IUCV connection (path), the IUCV macro is issued with the following parameters.

```
IUCV CONNECT,  
  PRMLIST=addr,          * address of IUCV parm list  
  USERID=addr,          * address of CL8 'userid'  
  USERDATA=addr,       * address of CL16 'ddname'  
  PRMDATA=NO             * no parm data in IPARML
```

Figure 6. IUCV CONNECT parameter definitions

where:

userid

is the name of the ACS service machine.

ddname

is the name of the ACS IUCV interface that is requested for connection. It is a 16 byte area:

DC CL8'SLSTLMS'
ddname

DS CL8' '
reserved

On execution of the function, check the PSW condition code. If the condition code is 0, save the path ID from the IPARML area passed to the macro. The program must wait for the ACS service machine to IUCV ACCEPT the pending connection before sending any messages. If no “connection complete” or “path severed” is returned, either the HSC is not up, is not fully initialized, or the IUCV CONNECT requestor specified invalid parameters.

2. Send the message to the ACS service machine using the IUCV SEND function. Specify the following parameters to the IUCV macro:

```
IUCB SEND,  
  PATHID=adpid,  
  TYPE=2WAY,  
  BUFLen=buflen,  
  RBUF=reply,  
  RLEN=reply length
```

Figure 7. IUCV SEND parameter definitions

adpid

is the address of a data area containing the IUCV path ID.

TYPE=2WAY

specifies that an IUCV reply is expected.

buffer

is the address of a buffer containing any valid TMI request.

buflen

is the length of “buffer”.

reply

is the address of the buffer containing the reply.

reply length

is the length of the reply buffer.

3. When you are finished using a connection to the ACS service machine, release the path using the IUCV SEVER function.

Note: The following IUCV parameters are not supported for this interface.

TYPE=1WAY

IUCV REPLY must be issued by the SCP.

TRGCLS= TRGCLS

is ignored by the SCP.

DATA=PRMMSG CP

does not allow the SEND to occur.

PRMMSG=address

CP does not allow the SEND to occur.

PRTY=YES

CP uses this to alter queuing to the ACS service machine. The SCP does not give the message any special handling.

All other IUCV parameters may be used as desired.

Additional Considerations

Three fields in the IUCV parameter list (IPARML) deserve special mention:

- USERID=
- USERDTA=
- UWORD=



Note: See VM/SP System Facilities for Programming or VM/XA CP Programming Services for additional information about the IUCV interface and the parameters listed below.

USERID

This parameter specifies the name of the service machine running the Host Software Component. We suggest that your userid be alterable, rather than hard-coded, to facilitate changes.

USERDTA

This parameter is used to specify the name of the process in the service machine receiving TMS communication (ACSINT). This must be SLSTLMS.

UWORD

This parameter specifies a word which will appear in R0 at interrupt time. It is useful for establishing addressability to a common data area. This contains an area listing pending requests, path status, and configuration values that are referenced in different routines.

Chapter 2. Overview

Introduction

The Host Software Component (HSC), the software portion of the Sun StorageTek Automated Cartridge System (ACS), requires several points of interface with a tape management system (TMS):

- TMS to ACS initial connection
- Transport Allocation
- Operator message processing.

The TMS provides a front end between the ACS and the user, maintaining allocation, data set, and scratch pool services. The ACS provides the TMS with mount/dismount handling and scratch volume selection, and influences the allocation of those volumes and transports under library control.

An invocation macro (ACSRQ) prepares a call to the Inter-User Communications Vehicle (IUCV) to communicate between the TMS and the ACS. The IUCV call itself is made by the TMS.

The following tape management system facilities permit the desired cooperation with the ACS:

- An interface at allocation time to supply device type and scratch information
- An interface at message time to handle the message normally displayed to the operator
- A list of transport addresses which distinguish library from nonlibrary transports
- An IUCV interrupt handler.

TMS to ACS Initial Connection

At initial connection time it is useful to determine the size of the returned data areas for a few of the longer responses. These vary depending on the size of the library and its configuration. These areas are then allocated before their required use.

Initial Connection Dialog

At connection time, a QCONFIG request should be issued to determine the size of the reply data areas that are needed for other requests.

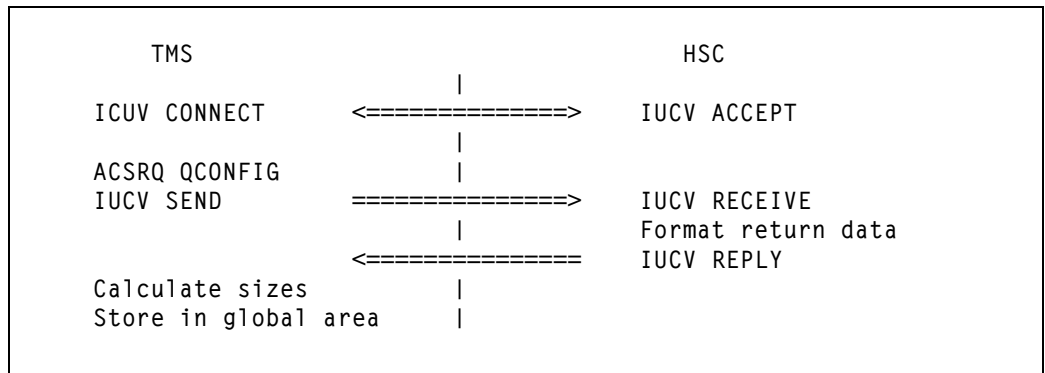

Figure 8. Process flow example for a QCONFIG Request

Transport Allocation

While the TMS is fully responsible for transport allocation, the library assists in this process by presenting a list of transports that are usable for volume mounts, and transport proximity information on an ACS basis.

Proximity is defined in the library in terms of LSMs. The LSM that contains the target volume has the closest proximity; LSMs that are connected by one pass-thru event have the next closest; and so forth. This proximity can extend to at most 15 pass-thru events. The proximity of transports within an LSM is not considered.

The “Allocation Dialog” section describes the interaction between the TMS allocation interface and the HSC.

Allocation Interaction

The TMS service machine receives a request from a virtual machine to mount a volume and invokes the allocation interface routine.

If an IUCV path to the ACS service machine is not established, the tape management system attempts to establish one. If the attempt fails, no allocation assistance takes place, a return code indicates that condition, and a flag may be set to inform the message interface that operator message processing cannot take place since no special allocation has been done.

Allocation Dialog

1. The TMS allocation interface sends a request, using an IUCV message, to the ACS service machine:

```
ACSRQ QDRLIST,VOLSER=voladr
```

An alternate request is:

```
ACSRQ QDRLIST,VOLSER=voladr,COUNT=,LIST=
```

The request above includes the COUNT= and LIST= parameters. These two parameters describe a list of devices considered eligible by the TMS. This information is passed to the HSC.

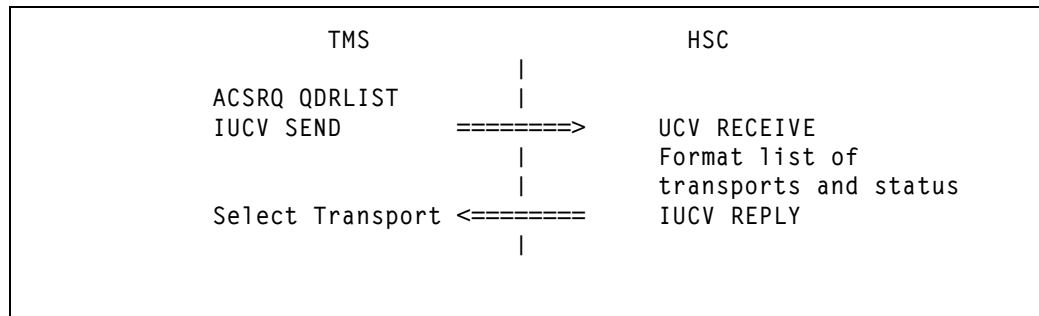

Figure 9. Process flow example for a QDRLIST Request

2. The allocation interface waits for an IUCV REPLY.
3. An HSC routine collects the data, formats the response, and issues an IUCV REPLY. The IUCV REPLY is mapped by the SLX macro.
4. The TMS IUCV support functions notify the waiting allocation process that a response has been received.
5. The allocation interface routine then reformats the reply into a transport preference list (TMS dependent format), comparing the reply to the TMS-managed available transports, and leaves the interface. If the volume is not in the library, the allocation of nonlibrary drives is suggested to satisfy the request.
6. If scratch selection is needed, issue:

```
ACSRQ SELSCR,DRIVE=drivadr
```

This returns a VOLSER and marks the volume as nonscratch in the control data set, or indicates that no scratch volume is available.

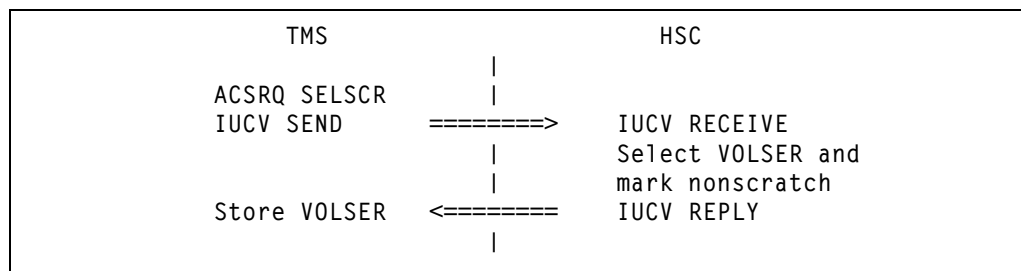

Figure 10. Process flow example for a SELSCR Request



Note: A mounted volume is not available for allocation until the HSC has received a dismount request for it, either explicit or implicit, from the host that mounted it.

Termination of Allocation Interface

Control is returned to the TMS when the allocation interface routine completes processing.

Operator Message Processing

This section describes the interactions between the TMS message interface and the HSC. The “Operator Message Dialog” section outlines the processing of a MOUNT request. Other message interface point requests (e.g. DISMOUNT, SCRATCH), follow a similar sequence of events and are not separately described. The TMS may suppress or change the message based on the completion of the process.

A DISMOUNT request is issued in response to conditions detected by the TMS that require a volume dismount (e.g. the mounted volume is not the one requested), or in the case where the TMS always dismounts volumes after use.

A SCRATCH request is issued by the TMS to return “work” volumes to scratch status. The HSC control data set is updated to reflect these changes.

Operator Message Interaction

The TMS service machine receives a request from a virtual machine to mount a volume. The TMS service machine must have an IUCV path established to send commands to the HSC. A transport has already been selected.

Operator Message Dialog

1. The message interface code determines that the request is for a transport.
2. The message interface may send a request, using an IUCV message, to the ACS service machine to obtain location information.

```
ACSRQ QVOLUME,VOLSER=voladr
```
3. The message interface waits for an IUCV REPLY.
4. The HSC determines the volume status, adds the location data, and issues an IUCV REPLY. Note: If volume status information is retained from the allocation routine, the four previous steps may be omitted.
5. If the volume is in the library, the operator message interface sends a request, using an IUCV message to the ACS service machine, specifying the volume to be mounted and the transport to be used.

```
ACSRQ MOUNT,VOLSER=volser,DRIVE=drivadr,PROTECT=
```

6. The message interface waits for an IUCV REPLY.
7. The HSC MOUNT routine selects the volume.
8. The HSC updates the control data set, commands the LSM to perform the mount, formats a success/failure response, and issues a reply. The IUCV REPLY to the originating message is mapped by the SLX macro.



Note: A MOUNT request directed to a transport containing an unloaded volume, causes a dismount of that volume followed by the requested mount, if the volume was originally mounted by the same host.

9. TMS IUCV support routines notify the waiting message interface that a response has been received.
10. The message interface routine examines the reply to determine if the mount was successful, sets an appropriate return code, and leaves the interface.
11. If the IUCV REPLY (Step 4) indicated that the LSM was in manual mode, the TMS must alternately display the VOLSER and the volume location on the transport display panel. This enables the operator to locate both the volume, and the transport that has been specified for the mount.

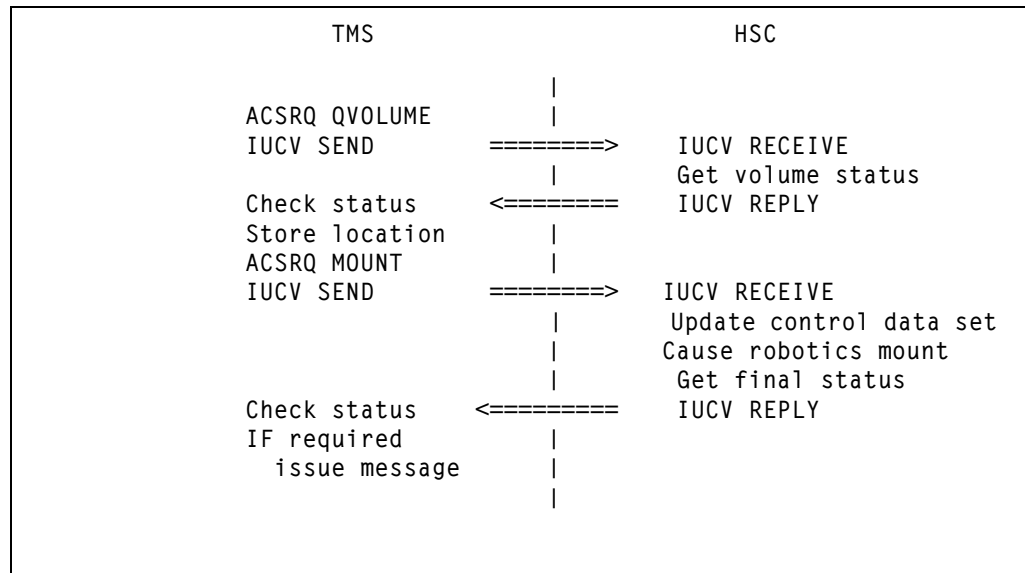

Figure 11. Mount Dialog

Termination of Operator Message Interface

Control returns to the tape management system when the message interface routine completes processing.

Prop-Detected Dismount

When a Sun StorageTek transport attached to a virtual machine is detached, or the virtual machine is logged off, a DETACH message is issued to the VM system operator. If a transport becomes detached while a library volume is mounted, the TMS may not be notified, and would not issue a normal DISMOUNT message to the ACS service machine.

To properly handle the dismount, a VM PROP (PRogrammable OPerator) facility should intercept certain messages and process accordingly.



Note: Like the TMS machine, the PROP machine must be authorized by the ACS service machine for commands. The function called using the PROP RTABLE must have the name of the ACS service machine available.

SLSPROP EXEC, ACSPROP EXEC and RTABLE SAMPLE are supplied as examples. The EXECs can be used unchanged or modified to suit the environment. These should be set up to execute similar to the following sequence:

1. PROP detects the HSC message “MOUNT COMPLETE” and invokes a routine (SLSPROP EXEC) to save the transport address and volume mounted on that transport.
2. PROP detects the DETACH message and invokes a routine (ACSPROP EXEC) to check if a library volume was previously mounted on the drive (saved using SLSPROP EXEC). If so, execute the command:

```
EXEC ACS .DISMOUNT vvvvv1 cuu
```

3. ACS EXEC issues the command using the CP SMSG interface to the ACS service machine.
4. HSC receives the dismount request.

Scenario A - Normal Dismount

If the volume is on the transport, the dismount is processed normally and the process is complete (see Figure 12 on page 24).

Scenario B - Dismount already done automatically

If the transport has already been reallocated and a mount request is issued, HSC finds the previous volume on the transport and automatically starts dismount processing for that volume. When this automatic dismount completes, the new volume is mounted (see Figure 13 on page 25).

5. HSC begins processing the dismount from PROP. It finds that the first volume is no longer on the transport and issues the message:

```
*nn DISMOUNT OF vvvvv1 FROM DRIVE cuu -  
VOLUME vvvvv2 IS MOUNTED. REPLY  
EJECT, IGNORE, OR DISMOUNT (E/I/D)
```

6. PROP intercepts this message and invokes a routine (SLSPROP EXEC) to reply by executing the command:

```
EXEC ACS nn I
```

7. HSC processes the reply and ignores the dismount, issuing message:

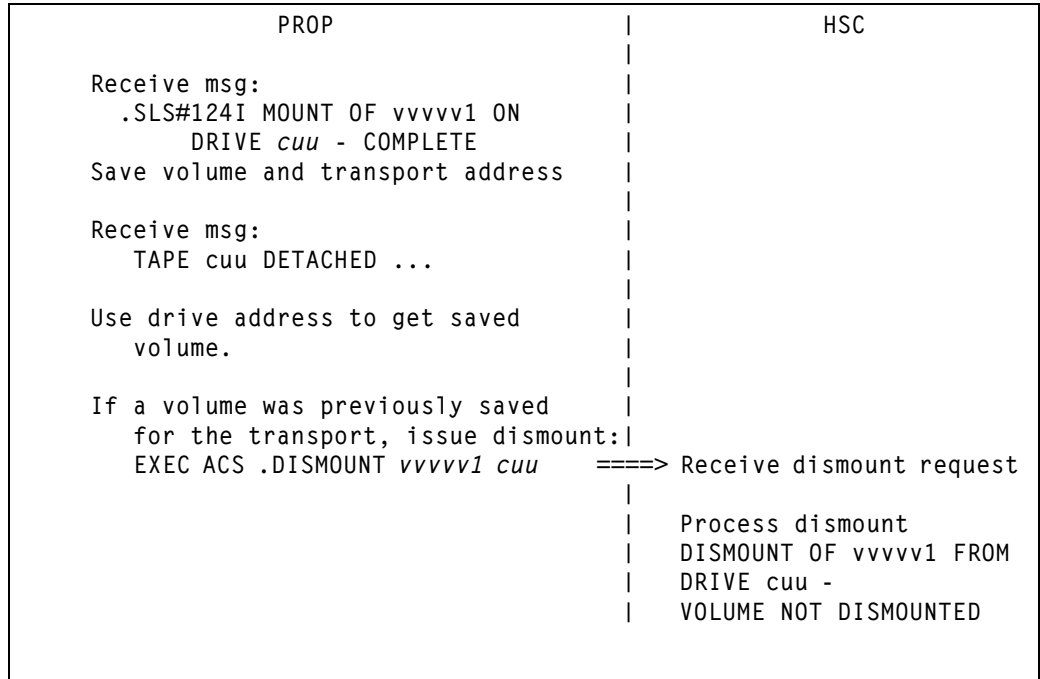

Figure 12. Scenario A - Normal Dismount

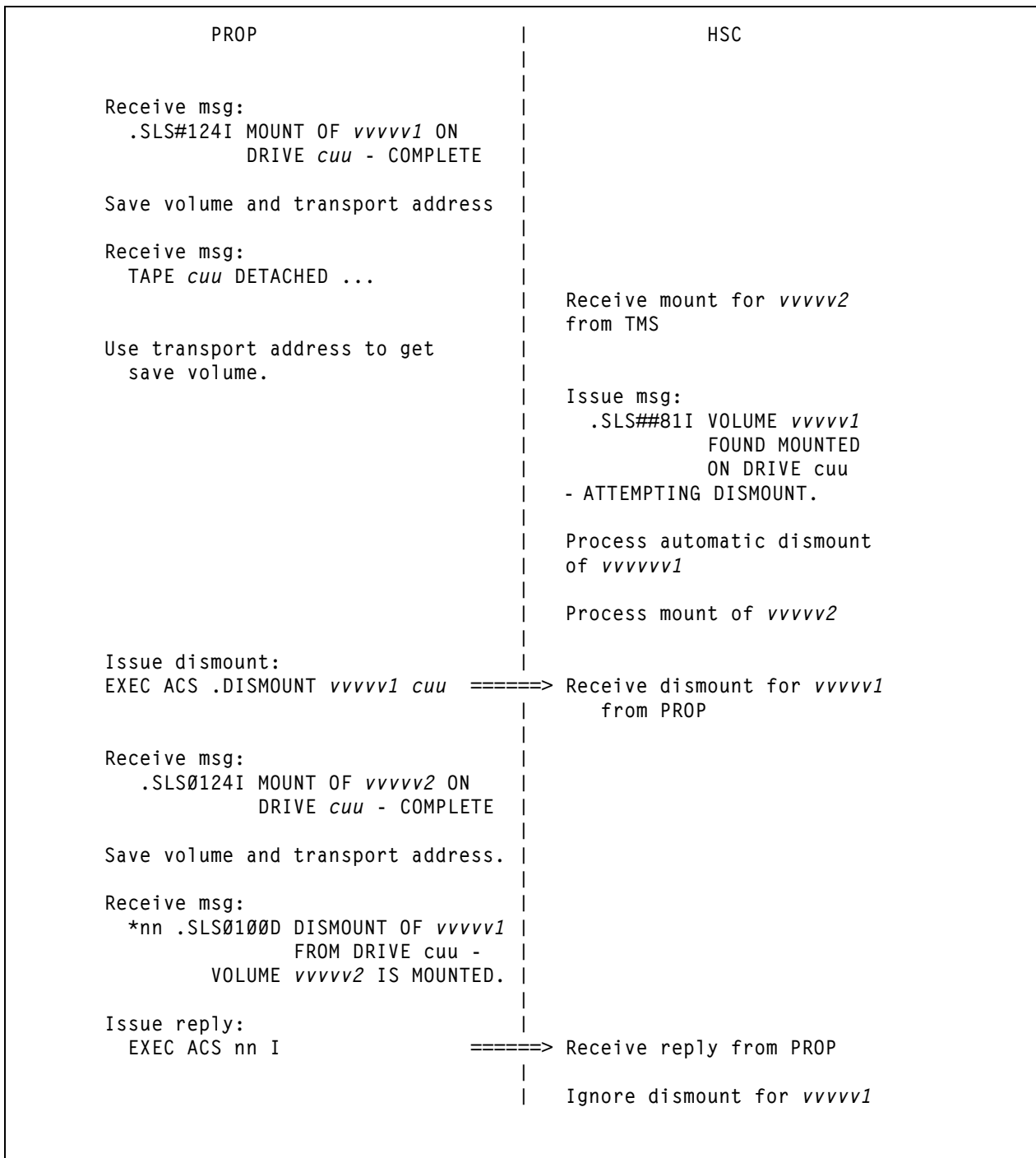

Figure 13. Scenario B - Dismount already done Automatically

Chapter 3. The ACSRQ Macro

Introduction

The tape management system interface uses the ACSRQ invocation macro to prepare an IUCV message that contains a request for the HSC. After the ACSRQ macro returns control to its caller, the TMS routine must issue an IUCV SEND.

ACSRQ Requests

The types of requests used to interact with the library include:

- query information
- set environment parameters
- volume processing.

Invoke all ACS requests through the ACSRQ macro instruction. In general, specify the name of the function to be performed, the address of the data area to be sent (ACSINT), and the other keyword parameters required.

The ACSRQ macro builds the ACS Interface Block (ACSINT) and optionally builds an IPARML for an IUCV SEND. An IUCV instruction referencing the IPARML which has been built should be coded after the ACSRQ macro. The receipt of the ACSINT invokes the proper routines in the HSC and returns information to the sender using an IUCV REPLY.

The IUCV restrictions documented in the IBM VM/SP System Facilities for Programming and VM/XA CP Programming Services apply. Due to the data area sizes, PRMMSG is not supported. BUFLIST and ANSLIST are also not supported.

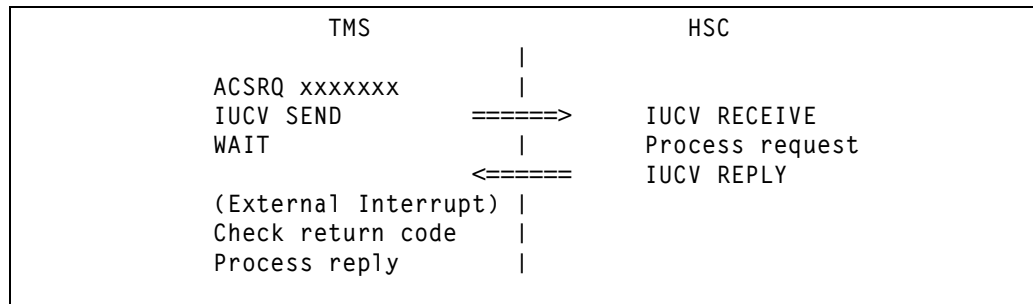

Figure 14. Process flow for the ACSRQ Macro

See “SLX Macro” on page 129 for mapping of the reply area.

Syntax Flow Diagrams

Syntax is illustrated using flow diagrams. These can include the following elements:

- Syntax - the diagram itself.
- Items - individual elements inside the diagram. Items can be keywords, variables, delimiters, operators, fragment references, and separators.
- Groups - a collection of items or other groups.

The following sections describe syntax flow diagram features and include some generic examples.

Specifying Commands

Commands are composed of command names, keyword parameters, and positional parameters. Command names initiate command execution, keyword parameters are operands that contain keywords and their related values, and positional parameters are operands that are identified by their position in the command string rather than by keywords.

- Keyword parameters can be specified in any order. The HSC accepts (tolerates) multiple occurrences of a keyword. The value assigned to a keyword reflects the last occurrence of a keyword within a command.
- Positional parameters must be entered in the order shown in the syntax diagram.
- Uppercase letters indicate the minimum abbreviation for the command name, keyword, or positional parameter.

Variables

Variables are italicized.

Delimiters

If a comma(,), a semicolon(;), or other delimiter is shown with an element of the syntax diagram, it must be entered as part of the statement or command.

Flow Lines

Syntax diagrams consist of horizontal and vertical lines and the text of a command, control statement, macro, or utility.

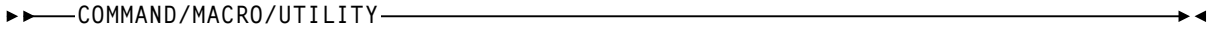

or



Diagrams are read left to right and top to bottom. Arrows indicate flow and direction.

- a statement begins with ▶▶
- a statement ends with ▶◀
- diagrams continuing to the next line begin with ▶
- fragments begin and end with |

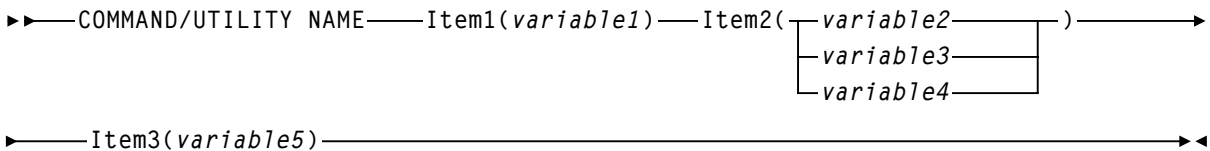

Single Required Choice

Branch lines, without repeat arrows, indicate that a single choice must be made. If one of the items from which a choice is being made is on the base line of the diagram, a single choice is required.

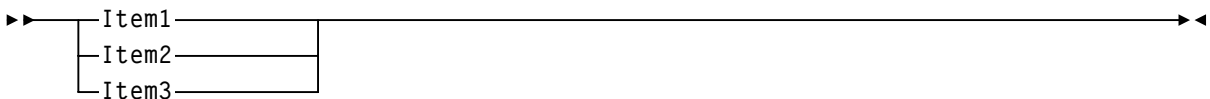

Single Optional Choice

If the first item is on the line below the base line, a single choice of items in the stack is optional.

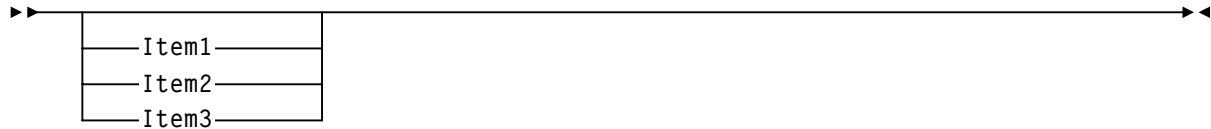

Defaults

Default values and parameters appear above the syntax diagram line. In the following example, if a value is not specified with the command, Default Value is used by the HSC.



Some keyword parameters provide a choice of values in a stack. When the stack contains a default value, the keyword and the value choices are placed below the baseline to indicate that they are optional, and the default value appears above the keyword line. In the following example, if the keyword is not specified with the command, Keyword(Default Value) is used by the HSC.



Repeat Symbol

A repeat symbol indicates that more than one choice can be made or that a single choice can be made more than once. The repeat symbol shown in this example indicates that a comma is required as the repeat separator.



Syntax Continuation (Fragments)

Fragment references direct you to parts (fragments) of the syntax that contain more detail than can be shown in the main syntax diagram.

▶ —COMMAND/UTILITY NAME— | Fragment Reference | —▶

Fragment:

|—Item1([variable1] , [variable3])—▶
 └─[variable2]─┘ └─[variable4]─┘

▶—Item2([variable5] , [variable7])—|
 └─[variable6]─┘ └─[variable8]─┘

ACSRQ Macro Syntax

▶ —ACSRQ—function, parameter ... —▶

where function is one of the following choices, each described in this chapter:

DEFPOOL

Define a scratch subpool

DEFSCR

Define the scratch subpool table

DISMOUNT

Dismount volume

EJECT

Eject volume

MOUNT

Mount volume

MOVE

Move volumes

QCAP

Get CAP information

QCONFIG

Get configuration data

QDRIVES

Get drive information

QDRLIST

Get list of drives for mount

QEJECT

Get eject information

QREQUEST

Get information about queued TMI requests

QSCRATCH

Get LSM scratch counts

QVOLUME

Get volume status

QVOLUSE

Return mounted volume information

SCRATCH

Return a volume to scratch status

SELSCR

Select a scratch volume

SETOPER

Control operator dialog

STOP

Stop a request in process

UNSCRATCH

Change the status of a volume to non-scratch.

and *parameter* describes the parameter(s) valid for specified functions.

,ACCT1=acct1addr

,ACCT2=acct2addr

,ACSID=acsidaddr

,ACSINT=acsintaddr

,CAP=capidaddr

,COL=coladdr

,COUNT=countaddr

,DIALOG=ON|OFF

,DRIVE=driveaddr

,HOSTID=hostidaddr

,IPARML=YES

,LIST=listaddr

,LSM=lsmidaddr

,LTYPE=ltaddr

,MEDIA=medaddr
,NOTIFY=INSDEL/NOINSDEL
,PAN=paneladdr
,PATHID=pathaddr
,PROTECT=YES
,RECTECH=recaddr
,ROW=rowaddr
,RSPADDR=bufadr
,RSPLN=buflen
,SCRATCH=YES
,SCRPOOL=poolidaddr
,SUBPOOL=subpooladdr
,TEXT=textaddr
,TOLSM=lsmidaddr
,TOPAN=paneladdr
,USER=useridaddr
,VOLSER=voladdr

The tape management interface (TMI), which allows users to request query information, volume movement, and scratch volume control services from the HSC, has been expanded to allow media and recording technique to be specified.

The requests that can utilize media and recording technique information include:

- MOUNT
- QDRLIST
- QSCRATCH
- SELSCR.

These requests are described on the following pages.

The following parameters accommodate media and recording technique:

- **,DSN=datasetname**
- **,EXPDT=expirationdate**
- **,JOB=jobname**
- **,MEDIA=mediaaddr**
- **,PGM=pgmname**
- **,RECTECH=rectechaddr**
- **,RETPD=retentionperiod**
- **,STEP=stepname**
- **,VOLTYPE={ Specific|Nonspecific }**



Note: EXPDT and RETPD are mutually exclusive.

With the exception of MEDIA and RECTECH, the parameters shown above are selection criteria (input) parameters taken from the TAPEREQ control statement. MEDIA and RECTECH are media and format requirements (output) parameters also associated with TAPEREQ.

The TMI determines media and recording technique values for a request either by using MEDia and RECtech parameters directly or by searching the TAPEREQ lookup table selection criteria (input) parameters.

The SLX mapping macro has been updated - see “SLX Macro” on page 129 for additional information.



Note: If DSECT=YES is specified, no other functions or parameters are valid. An ACSINT DSECT is built.

DEFPOOL

This request is used to cause entries in the scratch subpool table to be filled. It is issued once for each subpool identifier, in order from 1 to the highest subpool (with no gaps) defined in the DEFSCR request (see “DEFSCR” on page 38). The DEFPOOL requests must be issued after the DEFSCR request. The last DEFPOOL request must be issued before scratch subpool requests are honored.

DEFPOOL Considerations

At least one DEFPOOL request must be issued for each scratch subpool defined in the DEFSCR request. If separate label types are included within a subpool, a DEFPOOL request must be issued for each type. Within a label type (if defined), multiple ranges of VOLSERS may be defined with a single DEFPOOL request.

Syntax

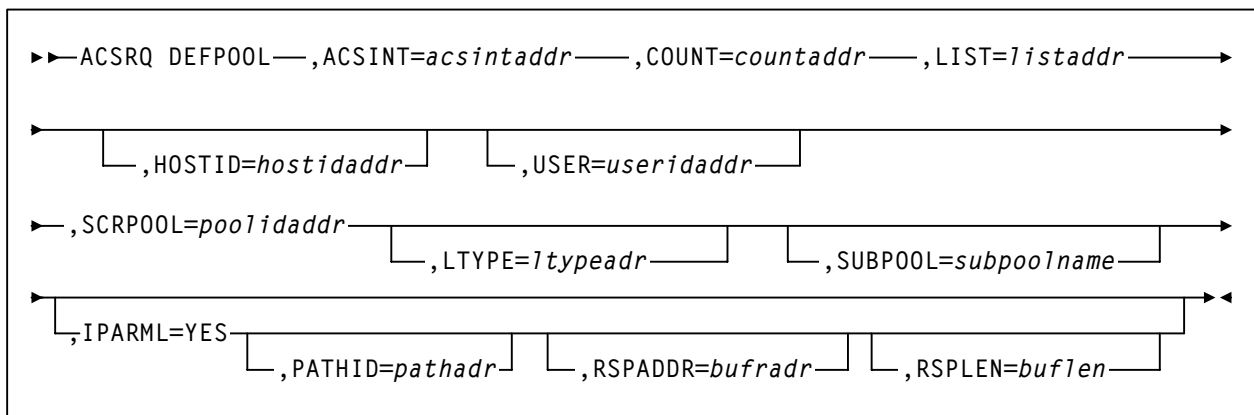

Parameters

ACSINT

acsintaddr specifies the address of the data area being sent to the library service machine. Specify either an RX-type address of the data or the number of the register containing the address of the data. ACSRQ references the ACSINT at this address when filling in the data.

This parameter is required.

COUNT

countaddr specifies the address of a 2-byte field containing the number of VOLSER pairs in the list designated by the LIST parameter. Specify either an RX address of the data or the number of the the register that contains the address of the data.

This parameter is required.

HOSTID

specifies the address of an eight character host ID, left justified and padded with blanks. *hostidaddr* specifies either an RX-type address of the host ID or the register (2) - (12) containing the address of the host ID.

This parameter is optional. If the parameter is not specified, the host ID executing the request is used.

IPARML

yes specifies that the requestor has established addressability to an IUCV IPARML, and that the IPARML is initialized. This parameter defaults to library default type (LDT).

This parameter is optional.

LIST

listaddr specifies the address of the list of the elements. Specify either an RX-type address of the data or the number of a register that contains the address of the data. Each entry of 12 bytes specifies:

- Starting VOLSER (6 bytes) - the low VOLSER for this subpool entry
- Ending VOLSER (6 bytes) - the high VOLSER for this subpool entry

A special form of this parameter, LIST=* indicates to ACSRQ that the list is already appended to the ACSINT data area, and does not need to be moved.

This parameter is required.

PATHID

pathadr specifies the address of a 2-byte IUCV path ID of the library service machine.

Specify either an RX-type address of the data or the number of the register containing the address of the data. This data is used in the IUCV SEND PATHID statement.

PATHID is optional, and valid only if IPARML=YES is specified.

If this parameter is not specified, the subsequent IUCV SEND must specify it.

RSPADDR

bufadr specifies the address of the IUCV answer buffer.

Specify either an RX-type address of the data or the number of the register containing the address of the data. This data is used in the IUCV SEND ANSBUF # statement.

RSPADDR is optional and valid only if IPARML=YES is specified.

If this parameter is not specified, the subsequent IUCV SEND must specify it.

RSPLEN

buflen specifies the address of the length of the IUCV answer buffer.

Specify either an RX-type address of the 2-byte field or the number of the register containing the address of the data. This data is used in the IUCV SEND ANSLEN statement.

RSPLEN is optional and valid only if IPARML=YES is specified.

If this parameter is not specified, the subsequent IUCV SEND must specify it. The response length must be at least the value returned in SLXZDEFP by QCONFIG.

SCRPOOL

poolidaddr specifies the address of the 1-byte scratch subpool index used for this request. The value must be in the range 1-255.

Specify either an RX-type address of the data or the number of the register containing the address of the data.

This parameter is required.

SUBPOOL

subpoolname specifies the address of a 13-character field containing the name of the scratch subpool.

If the subpool name is not provided, the subpool index is converted into three EBCDIC decimal digits and placed in the leftmost three positions of the subpool name.

Specify either an RX-type address of the data or the number of the register containing the address of the data.

This parameter is optional.

USER

useridaddr specifies an 8-byte userid associated with a console ID for the request. Specify either an RX-type address of the data or the number of the register containing the address of the data.

This parameter is optional.

Response to DEFPOOL Request

The DEFPOOL request response consists of a Reply Header. Refer to “SLX Macro” on page 129 for information on the SLX macro.

DEFSCR

DEFSCR

This request is used to cause a scratch subpool table to be built. It is issued once to describe the number of subpool entries, and the number of subpools being defined. DEFPOOL requests (see “DEFPOOL” on page 35) are issued to define these entries in the table.

DEFSCR Considerations

A DEFSCR request may only be issued once during each invocation of the HSC, and should be one of the first requests to the service machine if scratch subpooling is being used.

Syntax

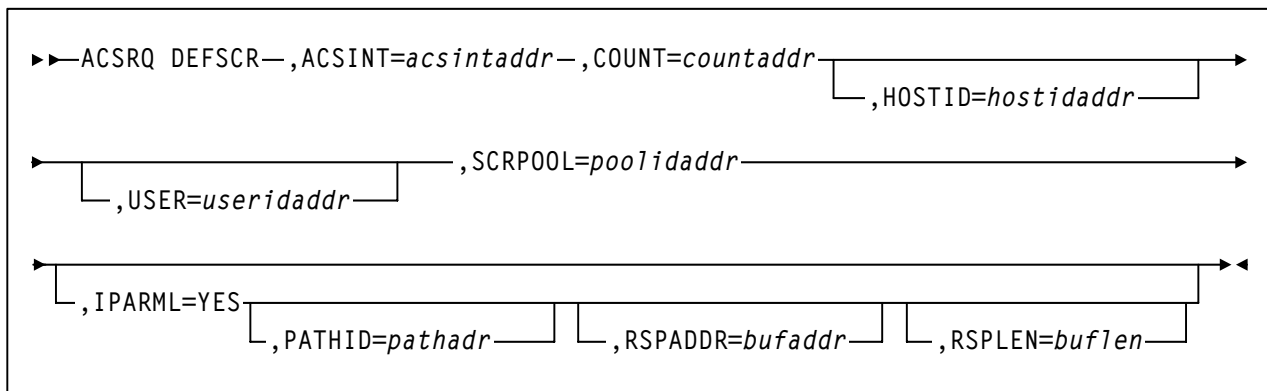

Parameters

ACSINT

acsintaddr specifies the address of the data area being sent to the library service machine.

Specify either an RX-type address of the data or the number of the register containing the address of the data. ACSRQ references the ACSINT at this address when filling in the data.

This parameter is required.

COUNT

countaddr specifies the address of a 2-byte field containing the total number of VOLSER pairs supplied by all subsequent DEFPOOL requests.

Specify either an RX-type address of the data or the number of the register that contains the address of the data.

This parameter is required.

HOSTID

specifies the address of an eight character host ID, left justified and padded with blanks.

hostidaddr specifies either an RX-type address of the host ID or the register (2) - (12) containing the address of the host ID.

This parameter is optional. If the parameter is not specified, the host ID executing the request is used.

IPARML

yes specifies that the requestor has established addressability to an IUCV IPARML, and that the IPARML is initialized.

This parameter is optional.

PATHID

pathadr specifies the address of a 2-byte IUCV path ID of the library service machine.

Specify either an RX-type address of the data or the number of the register containing the address of the data. This data is used in the IUCV SEND PATHID statement.

PATHID is optional, and valid only if IPARML=YES is specified.

If this parameter is not specified, the subsequent IUCV SEND must specify it.

RSPADDR

bufadr specifies the address of the IUCV answer buffer.

Specify either an RX-type address of the data or the number of the register containing the address of the data. This data is used in the IUCV SEND ANSBUF statement.

RSPADDR is optional and valid only if IPARML=YES is specified.

If this parameter is not specified, the subsequent IUCV SEND must specify it.

RSPLEN

buflen specifies the address of the length of the IUCV answer buffer.

Specify either an RX-type address of the 2-byte field or the number of the register containing the address of the data. This data is used in the IUCV SEND ANSLEN statement.

RSPLEN is optional and valid only if IPARML=YES is specified.

If this parameter is not specified, the subsequent IUCV SEND must specify it. The response length must be at least the value returned in SLXZDEFS by QCONFIG.

DEFSCR

SCRPOOL

poolidaddr specifies the address of a 1-byte field containing the number of scratch subpools which will be defined by all subsequent DEFPOOL requests. The value must be in the range 1-255.

This parameter is required.

USER

useridaddr specifies an 8-byte userid associated with a console ID for the request. Specify either an RX-type address of the data or the number of the register containing the address of the data.

This parameter is optional.

Response to DEFSCR Request

The DEFSCR request response consists of a Reply Header. Refer to “SLX Macro Mapping” on page 132 for information on the SLX macro.

DISMOUNT

The DISMOUNT request causes a cartridge to be removed from a specific transport. A library cartridge is moved to an LSM cell (selected by the HSC) and becomes available for future requests; a nonlibrary cartridge is moved to the highest preference CAP so that it can be retrieved by an operator.

DISMOUNT Considerations

The success of a DISMOUNT request depends on whether the transport has received a REWIND/UNLOAD CCW, and also on the operator dialog mode. When SETOPER ,DIALOG=YES is in effect and the transport hasn't yet received a REWIND/UNLOAD CCW, the operator is asked to make a decision. If the operator responds "I", the DISMOUNT request is aborted. When SETOPER ,DIALOG=NO is in effect and the transport hasn't yet received a REWIND/UNLOAD CCW, the DISMOUNT request is aborted.

A DISMOUNT request may cancel a previous MOUNT request for the same transport. This is called "suppression" and occurs when the DISMOUNT request processor is able to abort processing of the previous MOUNT request before the volume is mounted. In this case, the responses to both requests contains the failure return code because no volume movement occurred for either request. However, the response reason codes show the reason for failure as "suppression."

Syntax

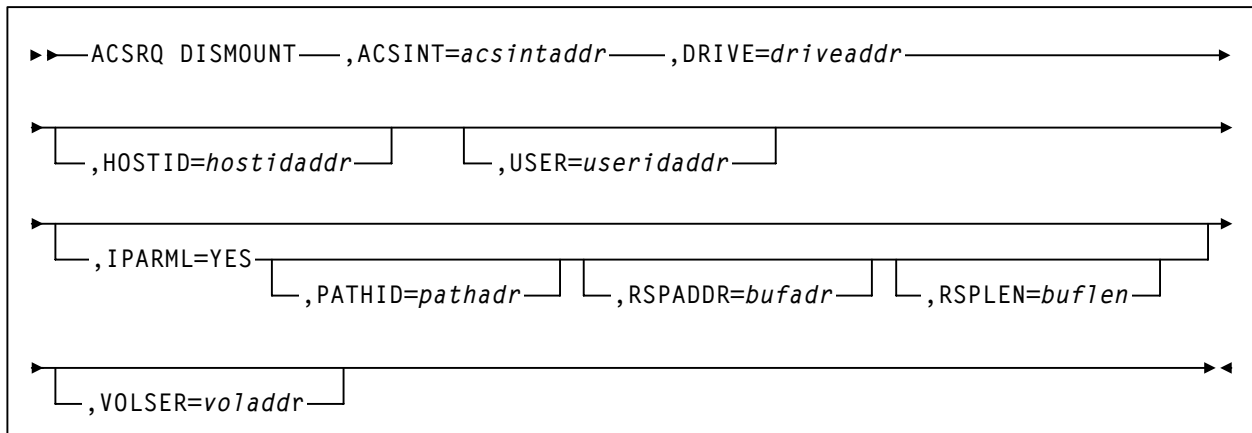

Parameters

ACSINT

acsintaddr specifies the address of the data area being sent to the library service machine.

Specify either an RX-type address of the data or the number of the register containing the address of the data. ACSRQ references the ACSINT at this address when filling in the data.

This parameter is required.

DISMOUNT

DRIVE

driveaddr specifies the address of the 2-byte drive specification (ccua).

Specify either an RX-type address of the data or the number of the register containing the address of the data.

This parameter is required. It specifies the drive from which a volume should be dismounted.

HOSTID

specifies the address of an eight character host ID, left justified and padded with blanks.

hostidaddr specifies either an RX-type address of the host ID or the register (2) - (12) containing the address of the host ID.

This parameter is optional. If the parameter is not specified, the host ID executing the request is used.

IPARML

yes specifies that the requestor has established addressability to an IUCV IPARML, and that the IPARML is initialized.

This parameter is optional.

PATHID

pathadr specifies the address of a 2-byte IUCV path ID of the library service machine.

Specify either an RX-type address of the data or the number of the register containing the address of the data. This data is used in the IUCV SEND PATHID statement.

PATHID is optional, and valid only if IPARML=YES is specified.

If this parameter is not specified, the subsequent IUCV SEND must specify it.

RSPADDR

bufadr specifies the address of the IUCV answer buffer.

Specify either an RX-type address of the data or the number of the register containing the address of the data. This data is used in the IUCV SEND ANSBUF statement.

RSPADDR is optional and valid only if IPARML=YES is specified.

If this parameter is not specified, the subsequent IUCV SEND must specify it.

RSPLEN

buflen specifies the address of the length of the IUCV answer buffer.

Specify either an RX-type address of the 2-byte field or the number of the register containing the address of the data. This data is used in the IUCV SEND ANSLEN statement

RSPLEN is optional and valid only if IPARML=YES is specified.

If this parameter is not specified, the subsequent IUCV SEND must specify it. The response length must be at least the value returned in SLXZDISM by QCONFIG.

USER

useridaddr specifies an 8-byte userid associated with a console ID for the request.

Specify either an RX-type address of the data or the number of the register containing the address of the data.

This parameter is optional.

VOLSER

voladdr specifies the address of a 6-character volume label.

Specify either an RX-type address of the data or the number of the register containing the address of the data.

This parameter is optional. It specifies the VOLSER of the volume to be dismounted. An error will occur if the mounted volume has a different VOLSER.

Response to DISMOUNT Request

The response to a DISMOUNT request is generated when all cartridge movement associated with the request has completed. The response contains a Reply Header and a Message Text Element. The reason code in the Reply Header (SLXSRC) is a binary message number that indicates which HSC message was issued when the DISMOUNT request completed. The Message Text Element contains the complete text of the message specified by the reason code.

Refer to “SLX Macro Mapping” on page 132 for information on the SLX macro.

EJECT

EJECT

The EJECT request initiates the removal of one or more (up to 500) cartridges from the library. The cartridges are moved from LSM cells to the highest preference CAP or to a CAP specified in the request, so they can be retrieved by an operator.

EJECT Considerations

When SETOPER DIALOG=NO is in effect, any EJECT request is considered to be invalid.

A request to eject a volume not located in the control data set is treated as a successful EJECT.

The length of the response may vary considerably, depending on the number of volumes specified in the request. Several values are available in the response from a QCONFIG request for use in determining the appropriate answer buffer length for a particular EJECT request. These values include:

- SLXZEJC1 contains the length of an EJECT response for a single volume. Use this value for the answer buffer length when an EJECT request specifies either VOLSER= or COUNT=1.
- SLXXVOLL contains the length of a single Volume Information Element and SLXXMSGGL contains the length of a single Message Text Element. When an EJECT request specifies COUNT= n , then the answer buffer length is computed using the formula: $((n-1)*(SLXXVOLL+SLXXMSGGL))+SLXZEJC1$.
- SLXZEJCT contains the length of an EJECT response when the maximum number of VOLSERS (500) is specified in the request list. Use this value for the answer buffer length when the above formula cannot be used, and when the requestor can afford to commit a large amount of storage (approximately 78KB) to the request.

Syntax

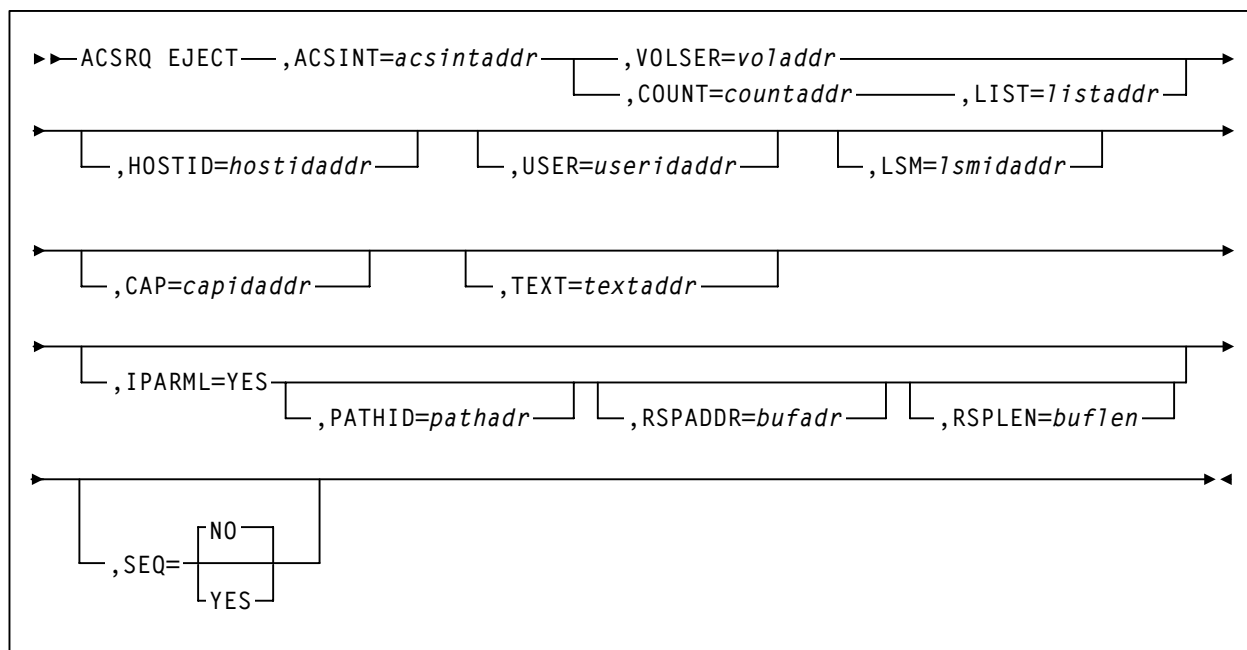

Parameters

ACSINT

acsintaddr specifies the address of the data area being sent to the library service machine.

Specify either an RX-type address of the data or the number of the register containing the address of the data. ACSRQ references the ACSINT at this address when filling in the data.

This parameter is required.

EJECT

CAP specifies the address of the CAP used to satisfy the request. *capidaddr* specifies either the RX-type address of the data or the number of the register containing the address of the data.

The format of *capidaddr* is *AALLCC00*, where *AA* is the ACS number (00-FF hexadecimal), *LL* is the LSM number (00-17 hexadecimal), and *CC* is the CAP number. These identifiers are always followed by 00.

This parameter is optional.

EJECT

COUNT

countaddr specifies the address of a 2-byte field containing the number of VOLSERS in the list designated by the LIST parameter.

Specify either an RX-type address of the data or the number of the register that contains the address of the data.

This parameter is required with the LIST parameter and is mutually exclusive with the VOLSER parameter.

HOSTID

specifies the address of an eight character host ID, left justified and padded with blanks.

hostidaddr specifies either an RX-type address of the host ID or the register (2) - (12) containing the address of the host ID.

This parameter is optional. If the parameter is not specified, the host ID executing the request is used.

IPARML

yes specifies that the requestor has established addressability to an IUCV IPARML, and that the IPARML is initialized.

This parameter is optional.

LIST

listaddr specifies the address of the list of the elements. Specify either an RX-type address of the data or the number of a register that contains the address of the data.

Each element in this list is a 6-byte VOLSER.

A special form of this parameter, LIST=* indicates to ACSRQ that the list is already appended to the ACSINT data area, and does not need to be moved.

This parameter is required with the COUNT parameter and is mutually exclusive with the VOLSER parameter.

LSM

lsmidaddr specifies the address of the LSMid from which the volumes are ejected. If the CAP is not available in the specified LSM, the request fails. If the user does not specify LSM, the HSC chooses a single CAPid in the ACS of the first volume in the list.

The format of an LSMid is *AALL*, where *AA* is the ACS number (00-FF hexadecimal) and *LL* is the LSM number (*LL* is 00-17 hexadecimal). For example, 0102 is ACS 01, LSM 02.

Specify either an RX address of the data or the number of the register containing the address of the LSMid.

This parameter is optional.

PATHID

pathadr specifies the address of a 2-byte IUCV path ID of the library service machine.

Specify either an RX-type address of the data or the number of the register containing the address of the data. This data is used in the IUCV SEND PATHID statement.

PATHID is optional, and valid only if IPARML=YES is specified.

If this parameter is not specified, the subsequent IUCV SEND must specify it.

RSPADDR

bufadr specifies the address of the IUCV answer buffer.

Specify either an RX-type address of the data or the number of the register containing the address of the data. This data is used in the IUCV SEND ANSBUF statement.

RSPADDR is optional and valid only if IPARML=YES is specified.

If this parameter is not specified, the subsequent IUCV SEND must specify it.

RSPLEN

buflen specifies the address of the length of the IUCV answer buffer.

Specify either an RX-type address of the 2-byte field or the number of the register containing the address of the data. This data is used in the IUCV SEND ANSLEN statement.

RSPLEN is optional and valid only if IPARML=YES is specified.

If this parameter is not specified, the subsequent IUCV SEND must specify it. The response length must be determined by one of the methods described in the EJECT Considerations section above.

SEQ

specifies whether or not CAP eject processing fills the CAP cells sequentially or by home location distance.



Note: The SEQ parameter is effective for all LSM types but is used primarily for the SL8500 environment. If sequential order is desired for other LSM types, you must code SEQ=YES.

This parameter is optional.

NO

specifies that the EJECT process order the requested volumes by home location. EJECT fills the CAP or magazine (for the SL8500) according to the volume home location distance to the CAP; that is, volumes closest to the CAP are ejected first.

EJECT

This is the default.

YES

specifies that the EJECT process place cartridges in the CAP beginning with the topmost available CAP cell and continuing sequentially.

TEXT

textaddr specifies a 32-character text string for association with the request.

Specify either an RX-type address of the data or the number of the register containing the address of the data.

This parameter is optional.

USER

useridaddr specifies an 8-byte userid associated with a console ID for the request.

Specify either an RX-type address of the data or the number of the register containing the address of the data.

This parameter is optional.

VOLSER

voladdr specifies the address of a 6-character volume label.

Specify either an RX-type address of the data or the number of the register containing the address of the data.

This parameter is mutually exclusive with the LIST and COUNT parameters. Either VOLSER or LIST and COUNT must be specified.

Response to EJECT Request

The response from an EJECT request consists of one Reply Header and one Volume Information Element, and one Message Text Element for each VOLSER that was specified in the request. Volume Information Elements and Message Text Elements appear in the same order as the VOLSERS in the request.

Refer to “SLX Macro Mapping” on page 132 for information on the SLX macro.

MOUNT

The MOUNT request causes a cartridge to be mounted on a specific transport.

MOUNT Considerations

When a cartridge is mounted, it becomes “selected” and remains in that state until it is dismounted. A cartridge in the “selected” state cannot be used by any of the following requests:

- EJECT
- MOUNT
- SCRATCH
- UNSCRATCH.

An automatic dismount will occur when a MOUNT request is directed to a transport that contains an unloaded cartridge, but only if the unloaded cartridge was originally mounted by the HSC attempting the new mount.

Syntax

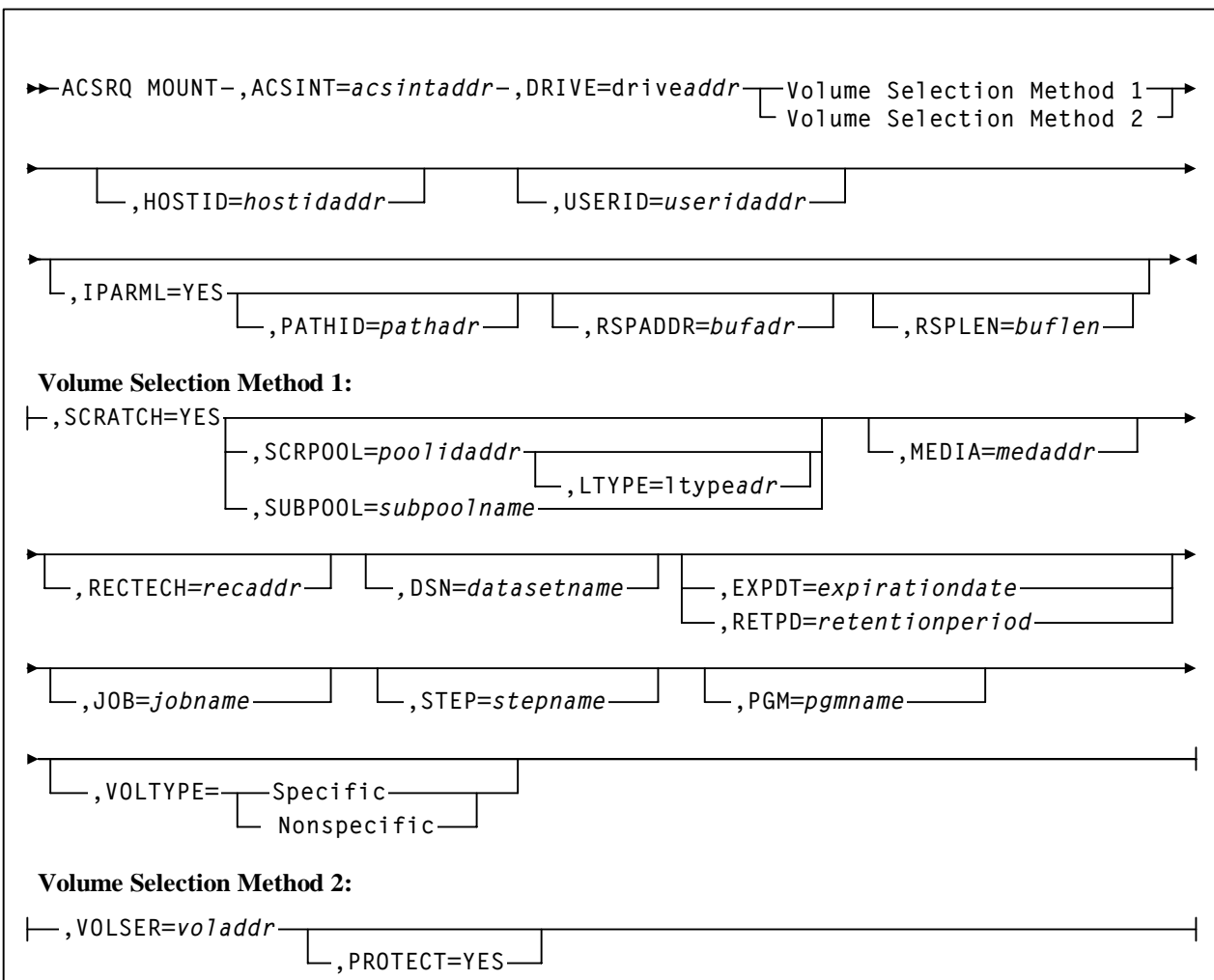

Parameters

ACSINT

acsintaddr specifies the address of the data area being sent to the library service machine.

Specify either an RX-type address of the data or the number of the register containing the address of the data. ACSRQ references the ACSINT at this address when filling in the data.

This parameter is required.

DRIVE

driveaddr specifies the address of the 2-byte drive specification (ccua).

Specify either an RX-type address of the data or the number of the register containing the address of the data.

This parameter is required. It specifies the drive on which the volume is to be mounted.

HOSTID

specifies the address of an eight character host ID, left justified and padded with blanks.

hostidaddr specifies either an RX-type address of the host ID or the register (2) - (12) containing the address of the host ID.

This parameter is optional. If the parameter is not specified, the host ID executing the request is used.

MEDIA

specifies the address of an 8-byte character field containing the media type of the cartridge to be mounted.

This parameter is optional.



Notes:

1. If MEDIA is not specified, the next scratch cartridge is mounted without regard to media type.
2. The SL8500 library supports the T9840A, T9840B, T9840C, T9840D, T9940B, and T10000 media types and recording techniques.
3. The SL3000 library supports the T9840C, T9840D, and T10000 media types and recording techniques.

medaddr

specifies either an RX-type address of the data or the register (2) - (12) containing the address of the data. Valid media types are:

LONGitud

indicates any Standard or ECART cartridge.

Standard

indicates a standard length, 3480 cartridge. It can be read on any longitudinal drives (4480, 4490, 9490, or 9490EE). Data can be written in 36-track mode on 4490, 9490, or 9490EE transports but cannot be read on an 18-track (4480) drive. Synonyms for this type of cartridge include:

- CST
- MEDIA1
- STD
- 1
- 3480

ECART

indicates a 3490E, extended capacity cartridge. It can be used only on a 36-track drive (4490, 9490, or 9490EE). Synonyms include:

- E
- ECCST
- ETAPE
- Long
- MEDIA2
- 3490E

ZCART

indicates a 3490E, extended capacity cartridge that provides greater storage capacity than an ECART. It can be used only on a 9490EE drive. ZCART can be abbreviated as Z.

DD3

indicates any DD3A, DD3B, or DD3C cartridge. HELical is a synonym for DD3.

DD3A, DD3B, DD3C

indicates a helical cartridge. The media indicator in the external label is encoded with the cartridge type (A, B, or C).



Note: DD3A, DD3B, or DD3C can be abbreviated to A, B, or C, respectively.

Types of helical cartridges, along with their associated media capacities, are:

- A — 10GB
- B — 25GB
- C — 50GB.

MOUNT

Data capacity differences between DD3A, DD3B, and DD3C cartridges are related to the length of the tape in the cartridge, not to the recording density of the data.

STK1

indicates any T9840 cartridge.

STK1R

indicates a T9840 cartridge. The media indicator in the external label is encoded with the cartridge type (R). **STK1R** can be abbreviated to **R**.

T9840 cartridge media capacities are 20GB (T9840A and T9840B), 40GB (T9840C), or 75GB (T9840D).

STK2

indicates any T9940 cartridge.

STK2P

indicates a T9940 cartridge. The media indicator in the external label is encoded with the cartridge type (P). **STK2P** can be abbreviated to **P**.

T9940 cartridges media capacities are 60GB (T9940A) or 200GB (T9940B).

T10000T1 or **T1**

indicates a full-capacity 500GB T10000 cartridge. **T10000T1** can be abbreviated as **T1**.

T10000TS or **TS**

indicates a smaller-capacity 120GB T10000 cartridge. **T10000TS** can be abbreviated as **TS**.

RECtech

specifies the address of an 8-byte field containing the recording technique used to record data tracks on the tape surface.

This parameter is optional.



Notes:

1. If **RECtech** is not specified, the next scratch cartridge is mounted depending on the **MEDIA** type that has been specified.
- **The SL8500 library supports the T9840A, T9840B, T9840C, T9840D, T9940B, and T10000 media types and recording techniques.**
 - **The SL3000 library supports the T9840C, T9840D, and T10000 media types and recording techniques.**

recaddr

specifies either an RX-type address of the data or the register (2) - (12) containing the address of the data. Valid recording techniques are:

LONGItud

indicates any device that uses longitudinal recording.

18track

indicates a 4480 transport.

36track

indicates a 4490, 9490, or 9490EE transport (any device that records in 36-track mode).

36Atrack

indicates a 4490 (Silverton) transport.

36Btrack

indicates a 9490 (Timberline) transport.

36Ctrack

indicates a 9490EE transport.

HELical

indicates a device using helical recording.

DD3

indicates a device using helical recording.

STK1R

indicates any 9840 transport.

STK1R34

indicates any 3490E-image 9840 transport.

STK1R35

indicates any 3590-image 9840 transport.

STK1RA

indicates a 3490E or 3590-image T9840A transport.

STK1RA34

indicates a 3490E-image T9840A transport.

STK1RA35

indicates a 3590-image T9840A transport.

STK1RB

indicates a 3490E or 3590-image T9840B transport.

STK1RB34

indicates a 3490E-image T9840B transport.

STK1RB35

indicates a 3590-image T9840B transport.

STK1RAB

indicates a 3490E or 3590-image T9840A or T9840B transport.

STK1RAB4

indicates a 3490E-image T9840A or T9840B transport.

STK1RAB5

indicates a 3590E-image T9840A or T9840B transport.

STK1RC

indicates a 3490E or 3590-image T9840C transport.

STK1RC34

indicates a 3490-image T9840C transport.

STK1RC35

indicates a 3590-image T9840C transport.

STK1RD

indicates any T9840D transport.

STK1RDE

indicates an encryption-enabled T9840D transport.

STK1RDN

indicates a non-encryption enabled T9840D transport.

STK1RD34

indicates a non-encryption enabled 3490E-image T9840D transport.

STK1RD35

indicates a non-encryption enabled 3590-image T9840D transport.

STK1RDE4

indicates an encryption-enabled 3490E-image T9840D transport.

STK1RDE5

indicates an encryption-enabled 3590-image T9840D transport.

STK2P

indicates any 9940 transport.

STK2P34

indicates any 3490E-image 9940 transport.

STK2P35

indicates any 3590-image 9940 transport.

STK2PA

indicates a T9940A transport.

STK2PA34

indicates a 3490E-image T9940A transport.

STK2PA35

indicates a 3590-image T9940A transport.

STK2PB

indicates any T9940B transport.

STK2PB34

indicates a 3490E-image T9940B transport.

STK2PB35

indicates a 3590-image T9940B transport.

T10K

indicates all T10000 transports.

T10KN

indicates all non-encrypted T10000 transports.

T10KE

indicates all encrypted T10000 transports.

T1A

indicates any T10000A transport.

T1AN

indicates a non-encryption enabled 3490E- or 3590-image T10000A transport.

T1A34

indicates a non-encryption enabled 3490E-image T10000A transport.

T1A35

indicates a non-encryption enabled 3590-image T10000A transport.

T1AE

indicates an encryption-enabled 3490E- or 3590-image T10000A transport.

T1AE34

indicates an encryption-enabled 3490E-image T10000A transport.

T1AE35

indicates an encryption-enabled 3590-image T10000A transport.

MOUNT

The following seven parameters are ignored if Media, RECtech, or both are specified.

DSN

datasetname specifies the data set name.

This parameter is optional.

EXPDT

expirationdate specifies the expiration date of the data set in YYDDD or YYY/DDD format.

This parameter is optional.

RETPD

retentionperiod specifies the retention period for the data set in days.

Specify the number of days as a one- to four-digit decimal number.

This parameter is optional.

JOB

jobname specifies the job name.

This parameter is optional.

STEP

stepname specifies the step name.

This parameter is optional.

PGM

pgmname specifies the step name.

This parameter is optional.

VOLTYPE

indicates whether or not a nonspecific volume was requested.

Specific

requests a specific volume to be mounted.

Nonspecific

requests a nonspecific volume to be mounted.

This parameter is optional.

IPARML

yes specifies that the requestor has established addressability to an IUCV IPARML, and that the IPARML is initialized.

This parameter is optional.

LTYPE

ltypeadr specifies the address of a 1-byte field containing the label type for a scratch request.

Specify either an RX-type address of the data or the number of the register containing the address of the data.

X'00' LDT

specifies the library default label type.

X'01' SL

specifies the standard-labeled pool.

X'02' NL

specifies the nonlabeled pool.

X'03' AL

specifies the ANSI-labeled pool.

X'04' NSL

specifies the nonstandard-labeled pool.

This parameter is optional and valid only if SCRPOOL is specified.

PATHID

pathadr specifies the address of a 2-byte IUCV path ID of the library service machine.

Specify either an RX-type address of the data or the number of the register containing the address of the data. This data is used in the IUCV SEND PATHID statement.

PATHID is optional, and valid only if IPARML=YES is specified.

If this parameter is not specified, the subsequent IUCV SEND must specify it.

PROTECT

yes specifies that the volume should be write protected. If PROTECT=YES is not specified, the physical position of the thumbwheel determines whether the volume is write protected.

This parameter is optional and valid only with VOLSER.

RSPADDR

bufadr specifies the address of the IUCV answer buffer.

Specify either an RX-type address of the data or the number of the register containing the address of the data. This data is used in the IUCV SEND ANSBUF statement.

RSPADDR is optional and valid only if IPARML=YES is specified.

If this parameter is not specified, the subsequent IUCV SEND must specify it.

RSPLEN

buflen specifies the address of the length of the IUCV answer buffer.

Specify either an RX-type address of the 2-byte field or the number of the register containing the address of the data. This data is used in the IUCV SEND ANSLEN statement.

RSPLEN is optional and valid only if IPARML=YES is specified.

If this parameter is not specified, the subsequent IUCV SEND must specify it. The response length must be at least the value returned in SLXZMDM by QCONFIG.

SCRATCH

yes specifies that the request is for a nonspecific (scratch) volume. A scratch VOLSER is selected at this time and mounted on the specified transport.

Either SCRATCH=YES or VOLSER must be specified.

SCRPOOL

poolidaddr specifies the address of the 1-byte scratch subpool index used for this request. The value must be in the range 1-255.

Specify either an RX-type address of the data or the number of the register containing the address of the data.

This parameter is optional, and valid only if SCRATCH=YES is specified.

SUBPOOL

subpoolname specifies the address of a 13-character field containing the name of the scratch subpool.

Specify either an RX-type address of the data or the number of the register containing the address of the data.

This parameter is optional, and valid only if SCRATCH=YES is specified.

USER

useridaddr specifies an 8-byte userid associated with a console ID for the request. Specify either an RX-type address of the data or the number of the register containing the address of the data.

This parameter is optional.

VOLSER

voladdr specifies the address of a 6-character volume label.

Specify either an RX-type address of the data or the number of the register containing the address of the data.

Either VOLSER or SCRATCH=YES must be specified. This parameter specifies the VOLSER of the volume to be mounted.

Either VOLSER or SCRATCH=YES must be specified.

Response to MOUNT Request

The response to a MOUNT request is generated when all cartridge movement associated with the request has completed. The response contains a Reply Header, a Message Text Element, and if the request specified SCRATCH=YES, a Volume Information Element. The reason code in the Reply Header (SLXSRC) is a binary message number that indicates which HSC message was issued when the MOUNT request completed. The Message Text Element contains the complete text of the message specified by the reason code. The Volume Information Element is present when the request specified SCRATCH=YES and describes the scratch volume that was mounted.

MOVE

MOVE

The MOVE request causes a volume to be moved to a specific location in the ACS.

MOVE Considerations

The MOVE function allows movement of a single volume to another location within an ACS. The destination of moved volumes may be the same LSM or a different LSM.

The MOVE functions provides volume movement as well as improved tape management control.

Syntax

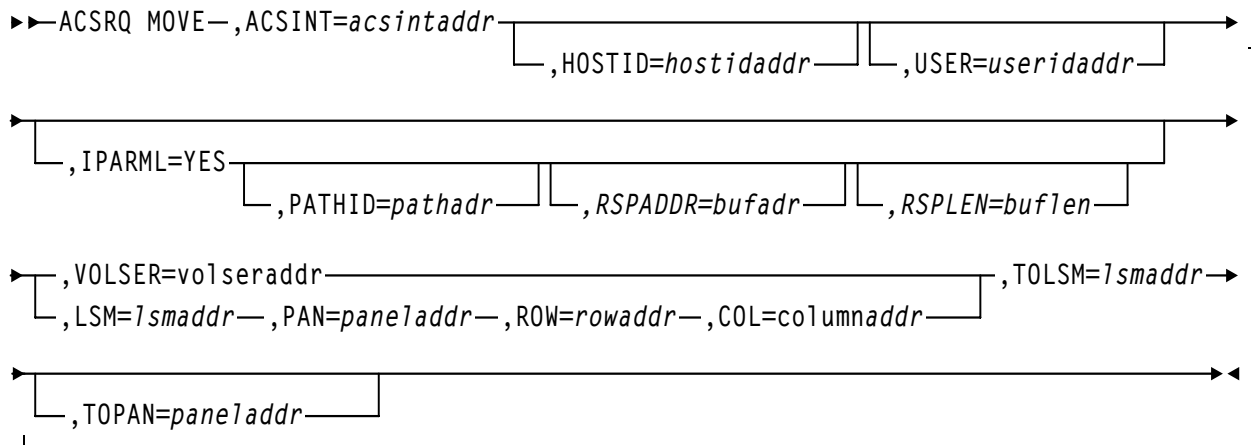

Parameters

ACSINT

acsintaddr specifies the address of the data area being sent to the library service machine.

Specify either an RX-type address of the data or the number of the register containing the address of the data. ACSRQ references the ACSINT at this address when filling in the data.

This parameter is required.

HOSTID

specifies the address of an eight character host ID, left justified and padded with blanks.

hostidaddr specifies either an RX-type address of the host ID or the register (2) - (12) containing the address of the host ID.

This parameter is optional. If the parameter is not specified, the host ID executing the request is used.

USER

useridaddr specifies an 8-byte userid associated with a console ID for the request.

Specify either an RX-type address of the data or the number of the register containing the address of the data.

This parameter is optional.

IPARML

yes specifies that the requestor has established addressability to an IUCV IPARML, and that the IPARML is initialized.

This parameter is optional.

PATHID

pathadr specifies the address of a 2-byte IUCV path ID of the library service machine.

Specify either an RX-type address of the data or the number of the register containing the address of the data. This data is used in the IUCV SEND PATHID statement.

PATHID is optional, and valid only if IPARML=YES is specified.

If this parameter is not specified, the subsequent IUCV SEND must specify it.

RSPADDR

bufadr specifies the address of the IUCV answer buffer.

Specify either an RX-type address of the data or the number of the register containing the address of the data. This data is used in the IUCV SEND ANSBUF # statement.

RSPADDR is optional and valid only if IPARML=YES is specified.

If this parameter is not specified, the subsequent IUCV SEND must specify it.

RSPLEN

buflen specifies the address of the length of the IUCV answer buffer.

Specify either an RX-type address of the 2-byte field or the number of the register containing the address of the data. This data is used in the IUCV SEND ANSLEN statement.

RSPLEN is optional and valid only if IPARML=YES is specified.

If this parameter is not specified, the subsequent IUCV SEND must specify it. The response length must be at least the value returned in SLXZMOVE by QCONFIG.

MOVE

VOLSER

voladdr specifies the address of a volume number.

Specify an RX address of the VOLSER or the register (2-12) containing the address of the VOLSER.

This parameter is required unless LSM is specified.

LSM

specifies the address of an LSMid. The format of an LSMid is *AALL*, where *AA* is the ACS number (00-FF hexadecimal) and *LL* is the LSM number (*LL* is 00-17 hexadecimal). For example, 010A is ACS 01, LSM 10.

Specify either an RX-type address of the LSMid or the register (2) - (12) containing the address of the LSMid.

The COL, PAN, and ROW parameters must accompany the LSM parameter. **This parameter is required if VOL is not specified.**

PAN

paneladdr specifies the address of a panel number. Format of the panel number is *pp*, where *pp* is a decimal number.

Specify an RX address of the panel or the register (2-12) containing the address of the panel number.

PAN is required if LSM is specified.

ROW

rowaddr specifies the address of a row number. Format of the row number is *rr* where *rr* is a decimal number.

Specify an RX address of the row or the register (2-12) containing the address of the row number.

ROW is required if LSM is specified.

COL

coladdr specifies the address of a column number. Format of the column number is *cc*, where *cc* is a decimal number.

Specify an RX address of the column or the register (2-12) containing the address of the column number.

COL is required if LSM is specified.

TOLSM

lsmaddr specifies the address of the LSMid where the volume is moved. The LSMid is two hexadecimal bytes in the format *AALL*, where *AA* is the ACS number (00-FF hexadecimal) and *LL* is the LSM number (*LL* is 00-17 hexadecimal).

lsmaddr specifies either an RX-type address of the LSMid or the register (2) - (12) containing the address of the LSMid.

This parameter is required.

TOPAN

paneladdr specifies the address of a panel number.

Specify an RX address of the panel or the register (2-12) containing the address of the panel number.

This parameter is required.

Response to MOVE Request

The response to a MOVE request is generated when all cartridge movement associated with the request has completed. The response contains a Reply Header, a Message Text Element, and if the request was successful, one Volume Information Element. The reason code in the Reply Header (SLXSRC) is a binary message number that indicates which HSC message was issued when the MOVE request completed. The Message Text Element contains the complete text of the message specified by the reason code.

Refer to “SLX Macro Mapping” on page 132 for information on the SLX macro.

QCAP

QCAP

This request is used to query the capacity and status of a CAP.

QCAP Considerations

If ACSID, LSM, CAP, or LIST and COUNT, are not specified, the data returned is for all CAPs.

Syntax

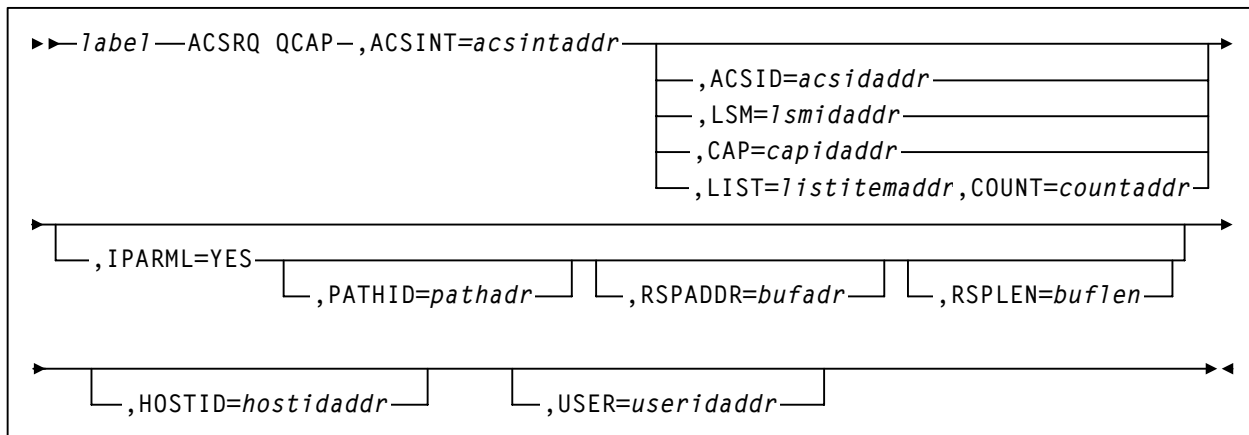

Parameters

ACSID

acsidaddr specifies the address of the ACS used to satisfy the request. The format of *acsidaddr* is *AA*, where *AA* is the ACS number (00-FF hexadecimal). For example, 01, designates ACS 01.

Specify either an RX-type address of the data or the number of the register containing the address of the data.

This parameter is optional. If specified, information about all CAPs in the ACS is returned.

ACSINT

acsintaddr specifies the address of the data area being sent to the library service machine.

Specify either an RX-type address of the data or the number of the register containing the address of the data. ACSRQ references the ACSINT at this address when filling in the data.

This parameter is required.

CAP

specifies the address of the CAP used to satisfy the request. *capidaddr* specifies either the RX-type address of the data or the number of the register containing the address of the data.

The format of *capidaddr* is *AALLCC00*, where *AA* is the ACS number (00-FF hexadecimal), *LL* is the LSM number (00-17 hexadecimal), and *CC* is the CAP number. These identifiers are always followed by 00.

This parameter is optional. If specified, information about the specified CAP is returned.

COUNT

countaddr specifies the address of a two-byte count value. For QCAP, COUNT specifies the number of CAPIDs in the list designated by the corequisite LIST parameter.

This parameter is required when LIST is specified.

HOSTID

specifies the address of an eight character host ID, left justified and padded with blanks.

hostidaddr specifies either an RX-type address of the host ID or the register (2) - (12) containing the address of the host ID.

This parameter is optional. If the parameter is not specified, the host ID executing the request is used.

IPARML

yes specifies that the requestor has established addressability to an IUCV IPARML, and that the IPARML is initialized.

This parameter is optional.

LIST

listitemaddr specifies the address of the list of CAPs to be queried.

Specify either an RX-type address of the data or the number of the register containing the address of the data.

This parameter is optional. If specified, information about all CAPs in the list is returned.

LSM

specifies the address of an LSMid. The format of an LSMid is *AALL*, where *AA* is the ACS number (00-FF hexadecimal) and *LL* is the LSM number (*LL* is 00-17

hexadecimal). For example, 0102 is ACS 01, LSM 02. All values are in hexadecimal format.

Specify either an RX-type address of the LSMid or the register (2) - (12) containing the address of the LSMid. **This parameter is optional.**

If specified, the returned data is for the specific LSM.

If ACSID, LSM, CAP, or LIST and COUNT, are not specified, the data returned is for all CAPs.

PATHID

pathadr specifies the address of a 2-byte IUCV path ID of the library service machine.

Specify either an RX-type address of the data or the number of the register containing the address of the data. This data is used in the IUCV SEND PATHID statement.

PATHID is optional, and valid only if IPARML=YES is specified. If this parameter is not specified, the subsequent IUCV SEND must specify it.

RSPADDR

bufadr specifies the address of the IUCV answer buffer.

Specify either an RX-type address of the data or the number of the register containing the address of the data. This data is used in the IUCV SEND ANSBUF statement.

RSPADDR is optional and valid only if IPARML=YES is specified. If this parameter is not specified, the subsequent IUCV SEND must specify it.

RSPLEN

buflen specifies the address of the length of the IUCV answer buffer.

Specify either an RX-type address of the 2-byte field or the number of the register containing the address of the data. This data is used in the IUCV SEND ANSLEN statement.

RSPLEN is optional and valid only if IPARML=YES is specified.

If this parameter is not specified, the subsequent IUCV SEND must specify it. The response length must be at least the value returned in SLXZQSCR.

USER

useridaddr specifies an 8-byte userid associated with a console ID for the request.

Specify either an RX-type address of the data or the number of the register containing the address of the data.

This parameter is optional.

Response to QCAP Request

The response to the QCAP request contains a Reply Header and a CAP information element containing information about each CAP requested.

Refer to “SLX Macro Mapping” on page 132 for information on the SLX macro.

QCONFIG

QCONFIG

The QCONFIG request is used to obtain summary information about the library configuration and the recommended answer buffer lengths for other TMS interface requests.

QCONFIG Considerations

The QCONFIG request should be the first request issued after an IUCV connection has been established because its response contains a recommended answer buffer length (response length) for each type of TMS interface request.

The length of the QCONFIG response may change from release to release. A TMS should use the following technique to obtain the recommended answer buffer length for a QCONFIG request:

1. Issue a QCONFIG request with answer buffer length of decimal 16. The response from this request consists of a Reply Header, truncated to 16 bytes. The return code in the header is 4, which indicates that the answer buffer was too small to contain the entire response. The word at offset decimal 12, SLXCRLN, contains the recommended answer buffer length for a QCONFIG request.
2. Reissue the QCONFIG request using the recommended answer buffer length.

Syntax

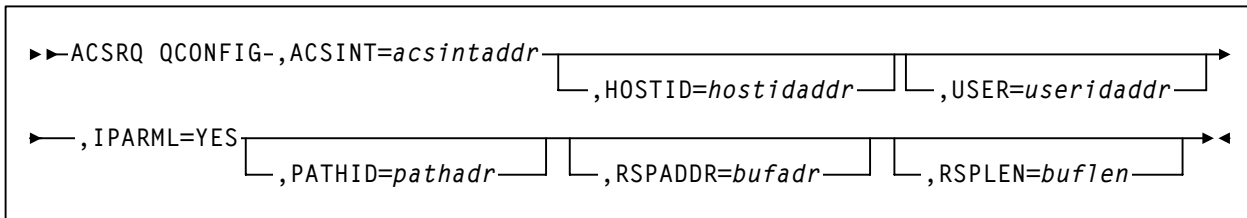

Parameters

ACSINT

acsintaddr specifies the address of the data area being sent to the library service machine.

Specify either an RX-type address of the data or the number of the register containing the address of the data. ACSRQ references the ACSINT at this address when filling in the data.

This parameter is required.

HOSTID

specifies the address of an eight character host ID, left justified and padded with blanks.

hostidaddr specifies either an RX-type address of the host ID or the register (2) - (12) containing the address of the host ID.

This parameter is optional. If the parameter is not specified, the host ID executing the request is used.

IPARML

yes specifies that the requestor has established addressability to an IUCV IPARML, and that the IPARML is initialized.

This parameter is optional.

PATHID

pathadr specifies the address of a 2-byte IUCV path ID of the library service machine.

Specify either an RX-type address of the data or the number of the register containing the address of the data. This data is used in the IUCV SEND PATHID statement.

PATHID is optional, and valid only if IPARML=YES is specified. If this parameter is not specified, the subsequent IUCV SEND must specify it.

RSPADDR

bufadr specifies the address of the IUCV answer buffer.

Specify either an RX-type address of the data or the number of the register containing the address of the data. This data is used in the IUCV SEND ANSBUF statement.

RSPADDR is optional and valid only if IPARML=YES is specified. If this parameter is not specified, the subsequent IUCV SEND must specify it.

RSPLN

buflen specifies the address of the length of the IUCV answer buffer.

Specify either an RX-type address of the 2-byte field or the number of the register containing the address of the data. This data is used in the IUCV SEND ANSLEN statement.

RSPLN is optional and valid only if IPARML=YES is specified. If this parameter is not specified, the subsequent IUCV SEND must specify it. The response length must be determined by the technique described in the QCONFIG Considerations section above.

QCONFIG

USER

useridaddr specifies an 8-byte userid associated with a console ID for the request.

Specify either an RX-type address of the data or the number of the register containing the address of the data.

This parameter is optional.

Response to QCONFIG Request

The QCONFIG response contains a Reply Header and a Configuration Summary Element. Note that the length of each type of response element (e.g., Volume Element) is returned in the Reply Header by QCONFIG.

Refer to “SLX Macro Mapping” on page 132 for information on the SLX macro.

QDRIVES

The QDRIVES request is used to obtain detailed information about all transports and LSMs associated with the library, or with a particular ACS.

QDRIVES Considerations

None.

Syntax

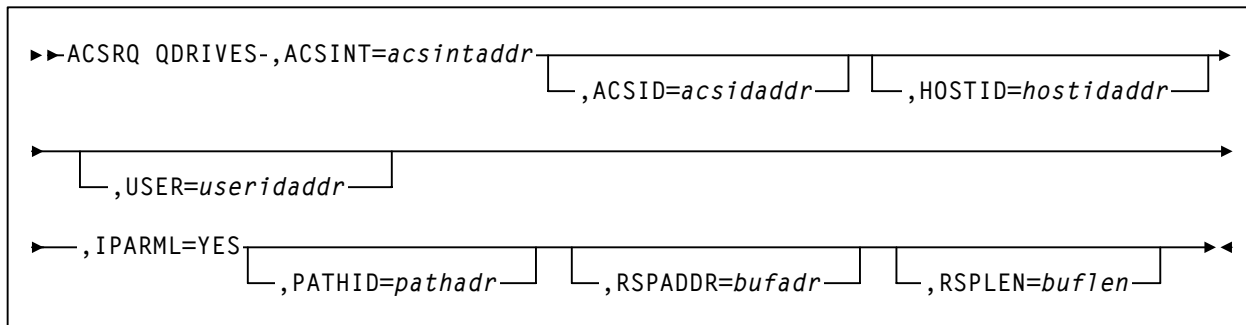

Parameters

ACSID

acsidaddr specifies the address of the ACS used to satisfy the request. Format for the ACSID is *AA*, where *AA* is a decimal number. For example, 01, designates ACS 01. Specify either an RX-type address of the data or the number of the register containing the address of the data.

This parameter is optional. If specified, the data is returned for the specific ACS. If ACSID is not specified, data is returned for all ACSs.

ACSINT

acsintaddr specifies the address of the data area being sent to the library service machine.

Specify either an RX-type address of the data or the number of the register containing the address of the data. ACSRQ references the ACSINT at this address when filling in the data.

This parameter is required.

HOSTID

specifies the address of an eight character host ID, left justified and padded with blanks.

hostidaddr specifies either an RX-type address of the host ID or the register (2) - (12) containing the address of the host ID.

This parameter is optional. If the parameter is not specified, the host ID executing the request is used.

IPARML

yes specifies that the requestor has established addressability to an IUCV IPARML, and that the IPARML is initialized.

This parameter is optional.

PATHID

pathadr specifies the address of a 2-byte IUCV path ID of the library service machine.

Specify either an RX-type address of the data or the number of the register containing the address of the data. This data is used in the IUCV SEND PATHID statement.

PATHID is optional, and valid only if IPARML=YES is specified.

If this parameter is not specified, the subsequent IUCV SEND must specify it.

RSPADDR

bufadr specifies the address of the IUCV answer buffer.

Specify either an RX-type address of the data or the number of the register containing the address of the data. This data is used in the IUCV SEND ANSBUF statement.

RSPADDR is optional and valid only if IPARML=YES is specified.

If this parameter is not specified, the subsequent IUCV SEND must specify it.

RSPLEN

buflen specifies the address of the length of the IUCV answer buffer.

Specify either an RX-type address of the 2-byte field or the number of the register containing the address of the data. This data is used in the IUCV SEND ANSLEN statement.

RSPLEN is optional and valid only if IPARML=YES is specified.

If this parameter is not specified, the subsequent IUCV SEND must specify it. The response length must be at least the value returned in SLXZQDRV by QCONFIG.

USER

useridaddr specifies an 8-byte userid associated with a console ID for the request.

Specify either an RX-type address of the data or the number of the register containing the address of the data.

This parameter is optional.

Response to QDRIVES Request

The QDRIVES response consists of a Reply Header, a Drive Information section, and an LSM Information section. The Drive Information section contains one Drive Information Element for each transport in the library or ACS. The LSM Information section contains one LSM Information Element for each LSM in the library or ACS.

Refer to “SLX Macro Mapping” on page 132 for information on the SLX macro.

QDRLIST

QDRLIST

The QDRLIST request is used to obtain the HSC's recommendation for a library transport to be specified for a subsequent MOUNT request.

QDRLIST Considerations

The HSC makes its recommendation by returning a list of Drive Information Elements which are ordered so that the first element describes the best transport to use, the second element describes the second best transport to use, etc.

When the QDRLIST request specifies a particular cartridge (i.e., VOLSER is specified), the Drive Information Elements are arranged so that the first transport listed is in the LSM that is closest to (or the same as) the LSM containing the cartridge. The last transport listed is in the LSM that is farthest from the LSM containing the cartridge. Only transports in the same ACS as the cartridge are represented in the Drive Information section.

When the QDRLIST request specifies a scratch volume (i.e., SCRATCH=YES is specified), the Drive Information Elements are arranged so the first transport listed is in the LSM containing the most scratch volumes. The last transport listed is in the LSM containing the fewest scratch volumes. All transports in all ACSs are represented in the Drive Information section.

The HSC ignores whether a transport already has a volume mounted, or is in an offline LSM or ACS when it orders the Drive Information Elements.

An optional list of transport addresses may be supplied with the QDRLIST request. If a list is provided, the HSC uses it as a screen while building its response. A Drive Information Element is included in the response only when its transport address is present in the list.

Syntax

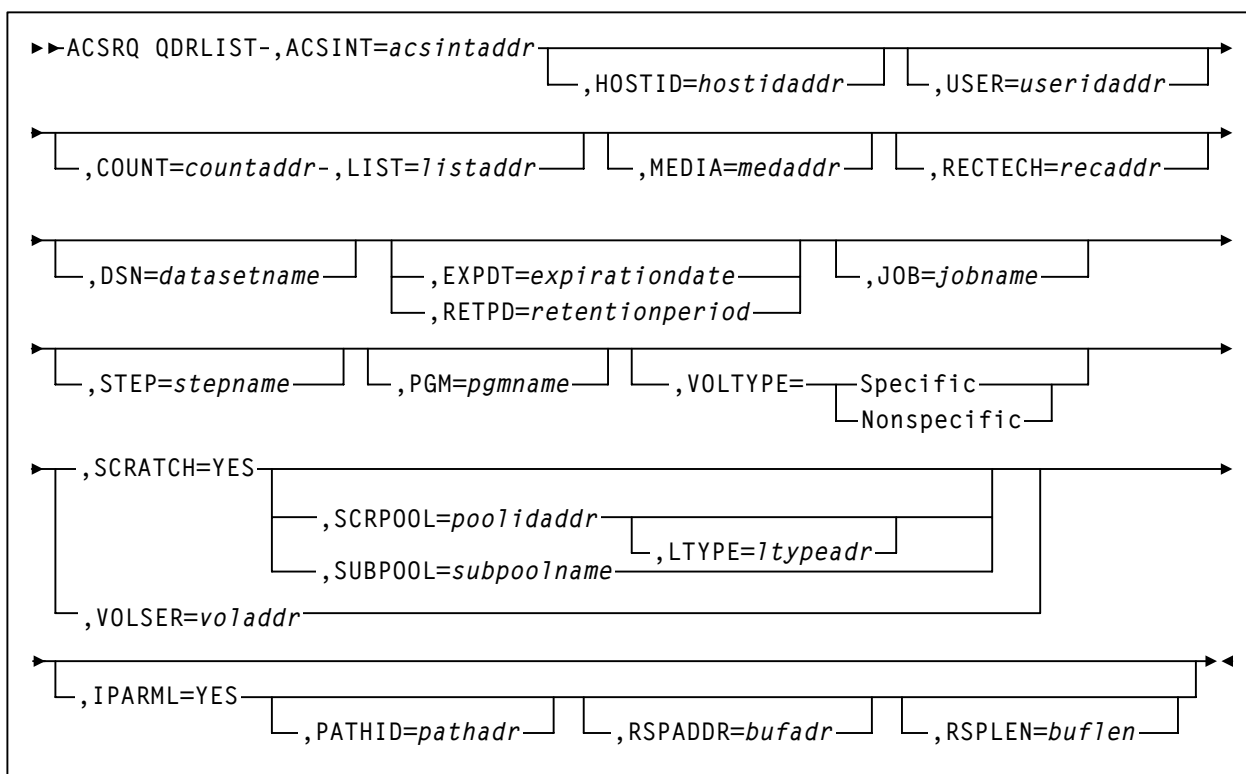

Parameters

ACSINT

acsintaddr specifies the address of the data area being sent to the library service machine.

Specify either an RX-type address of the data or the number of the register containing the address of the data. ACSRQ references the ACSINT at this address when filling in the data.

This parameter is required.

COUNT

countaddr specifies the address of a 2-byte field containing the number of tape drive device addresses in the list designated by the LIST parameter.

Specify either an RX address of the data or the number of the the register that contains the address of the data.

This parameter is required with the LIST parameter.

MEDia

specifies the address of an 8-byte character field containing the media type of the selected transport.

medaddr specifies either an RX-type address of the data or the register (2) - (12) containing the address of the data.

This parameter is optional.



Notes:

1. If MEDia is not specified, transports are selected without regard to media type.
2. **The SL8500 library supports the T9840A, T9840B, T9840C, T9840D, T9940B, and T10000 media types and recording techniques.**
3. **The SL3000 library supports the T9840C, T9840D, and T10000 media types and recording techniques.**

medaddr

specifies either an RX-type address of the data or the register (2) - (12) containing the address of the data. Valid media types are:

LONGItud

indicates any Standard or ECART cartridge.

Standard

indicates a standard length, 3480 cartridge. It can be read on any longitudinal drives (4480, 4490, 9490, or 9490EE). Data can be written in 36-track mode on 4490, 9490, 9490EE transports but cannot be read on an 18-track (4480) drive. Synonyms for this type of cartridge include:

- CST
- MEDIA1
- STD
- 1
- 3480

ECART

indicates a 3490E, extended capacity cartridge. It can be used only on a 36-track drive (4490, 9490, or 9490EE). Synonyms include:

- E
- ECCST
- ETAPE
- Long
- MEDIA2
- 3490E

ZCART

indicates a 3490E, extended capacity cartridge that provides greater storage capacity than an ECART. It can be used only on a 9490EE drive.

DD3

indicates any DD3A, DD3B, or DD3C cartridge. HELical is a synonym for | DD3.



Note: DD3 is not valid when SCRATCH=YES is specified.

DD3A, DD3B, DD3C

indicates a helical cartridge. The media indicator in the external label is encoded with the cartridge type (A, B, or C).



Note: DD3A, DD3B, or DD3C can be abbreviated to A, B, or C, respectively.

Types of helical cartridges, along with their associated media capacities, are:

- A — 10GB
- B — 25GB
- C — 50GB.

Data capacity differences between DD3A, DD3B, and DD3C cartridges are related to the length of the tape in the cartridge, not to the recording density of the data.

STK1

indicates any T9840 cartridge.

STK1R

indicates a T9840 cartridge. The media indicator in the external label is encoded with the cartridge type (R). **STK1R** can be abbreviated to **R**.

T9840 cartridge media capacities are 20GB (T9840A and T9840B), 40GB (T9840C), or 75GB (T9840D).

STK2

indicates any T9940 cartridge.

STK2P

indicates a T9940 cartridge. The media indicator in the external label is encoded with the cartridge type (P). STK2P can be abbreviated to P.

T9940 cartridge media capacities are 60GB (T9940A) or 200GB (T9940B).

T10000T1 or T1

indicates a full-capacity 500GB T10000 cartridge. **T10000T1** can be abbreviated as **T1**.

T10000TS or TS

indicates a smaller-capacity 120GB T10000 cartridge. **T10000TS** can be abbreviated as **TS**.

RECtech

specifies the address of an 8-byte field containing the recording technique used to record data tracks on the tape surface.

recaddr specifies either an RX-type address of the data or the register (2) - (12) containing the address of the data.

This parameter is optional.



Notes:

1. If RECtech is not specified, transports are selected depending on the MEDIA type that has been specified.
2. **The SL8500 library supports the T9840A, T9840B, T9840C, T9840D, T9940B, and T10000 media types and recording techniques.**
3. **The SL3000 library supports the T9840C, T9840D, and T10000 media types and recording techniques.**

recaddr

specifies either an RX-type address of the data or the register (2) - (12) containing the address of the data. Valid recording techniques are:

LONGitud

indicates any device that uses longitudinal recording.

18track

indicates a 4480 transport.

36track

indicates a 4490, 9490, or 9490EE transport (any device that records in 36-track mode).

36Atrack

indicates a 4490 (Silverton) transport.

36Btrack

indicates a 9490 (Timberline) transport.

36Ctrack

indicates a 9490EE transport.

HELical

indicates a device using helical recording.

DD3

indicates a device using helical recording.

STK1R

indicates any 9840 transport.

STK1R34

indicates any 3490E-image 9840 transport.

STK1R35

indicates any 3590-image 9840 transport.

STK1RA

indicates a 3490E or 3590-image T9840A transport.

STK1RA34

indicates a 3490E-image T9840A transport.

STK1RA35

indicates a 3590-image T9840A transport.

STK1RB

indicates a 3490E or 3590-image T9840B transport.

STK1RB34

indicates a 3490E-image T9840B transport.

STK1RB35

indicates a 3590-image T9840B transport.

STK1RAB

indicates a 3490E or 3590-image T9840A or T9840B transport.

STK1RAB4

indicates a 3490E-image T9840A or T9840B transport.

STK1RAB5

indicates a 3590E-image T9840A or T9840B transport.

STK1RC

indicates a 3490E or 3590-image T9840C transport.

STK1RC34

indicates a 3490-image T9840C transport.

STK1RC35

indicates a 3590-image T9840C transport.

STK1RD

indicates any T9840D transport.

STK1RDE

indicates an encryption-enabled T9840D transport.

STK1RDN

indicates a non-encryption enabled T9840D transport.

STK1RD34

indicates a non-encryption enabled 3490E-image T9840D transport.

STK1RD35

indicates a non-encryption enabled 3590-image T9840D transport.

STK1RDE4

indicates an encryption-enabled 3490E-image T9840D transport.

STK1RDE5

indicates an encryption-enabled 3590-image T9840D transport.

STK2P

indicates any 9940 transport.

STK2P34

indicates any 3490E-image 9940 transport.

STK2P35

indicates any 3590-image 9940 transport.

STK2PA

indicates a T9940A transport.

STK2PA34

indicates a 3490E-image T9940A transport.

STK2PA35

indicates a 3590-image T9940A transport.

STK2PB

indicates any T9940B transport.

STK2PB34

indicates a 3490E-image T9940B transport.

STK2PB35

indicates a 3590-image T9940B transport.

T10K

indicates all T10000 transports.

T10KN

indicates all non-encrypted T10000 transports.

T10KE

indicates all encrypted T10000 transports.

T1A

indicates any T10000A transport.

T1AN

indicates a non-encryption enabled 3490E- or 3590-image T10000A transport.

T1A34

indicates a non-encryption enabled 3490E-image T10000A transport.

T1A35

indicates a non-encryption enabled 3590-image T10000A transport.

T1AE

indicates an encryption-enabled 3490E- or 3590-image T10000A transport.

T1AE34

indicates an encryption-enabled 3490E-image T10000A transport.

T1AE35

indicates an encryption-enabled 3590-image T10000A transport.

The following seven parameters are ignored if Media, RECtech, or both are specified.

DSN

datasetname specifies the data set name.

This parameter is optional.

EXPDT

expirationdate specifies the expiration date of the data set in YYDDD or YYYY/DDD format.

RETPD

retentionperiod specifies the retention period for the data set in days. Specify the number of days as a one- to four-digit decimal number.

This parameter is optional.

JOB

jobname specifies the job name.

This parameter is optional.

STEP

stepname specifies the step name.

This parameter is optional.

PGM

pgmname specifies the step name.

This parameter is optional.

VOLTYPE

indicates whether or not a nonspecific volume was requested.

Specific

requests a specific volume to be mounted.

Nonspecific

requests a nonspecific volume to be mounted.

This parameter is optional.

SCRATCH

specifies that the request is for a nonspecific (scratch) volume. If SCRATCH=YES is specified, VOLSER is optional and is used only in messages to the operator.

SCRATCH=(r) - Specifies a register (2) - (12) containing the scratch request flag in byte 1 of the register. If bit SLSXSCR is on, the request is a scratch request.

If SCRATCH=NO is specified or the SCRATCH parameter is omitted, the VOLSER parameter is required.

A VOLSER is selected at this time.

This parameter is required if VOLSER is not specified. Either SCRATCH or VOLSER must be specified.

HOSTID

specifies the address of an eight character host ID, left justified and padded with blanks.

hostidaddr specifies either an RX-type address of the host ID or the register (2) - (12) containing the address of the host ID.

This parameter is optional. If the parameter is not specified, the host ID executing the request is used.

IPARML

yes specifies that the requestor has established addressability to an IUCV IPARML, and that the IPARML is initialized.

This parameter is optional.

LIST

listaddr specifies the address of the list of the elements. Specify either an RX-type address of the data or the number of a register that contains the address of the data.

Each element in this list is a 2-byte drive address (ccua).

A special form of this parameter, LIST=* indicates to ACSRQ that the list is already appended to the ACSINT data area, and does not need to be moved.

This parameter is optional.

LTYPE

ltypeadr specifies the address of a 1-byte field containing the label type for a scratch request.

Specify either an RX-type address of the data or the number of the register containing the address of the data.

X'00' LDT

specifies the library default label type.

X'01' SL

specifies the standard-labeled pool.

X'02' NL

specifies the nonlabeled pool.

X'03' AL

specifies the ANSI-labeled pool.

X'04' NSL

specifies the nonstandard-labeled pool.

This parameter is optional and valid only if SCRPOOL is specified.

PATHID

pathadr specifies the address of a 2-byte IUCV path ID of the library service machine.

Specify either an RX-type address of the data or the number of the register containing the address of the data. This data is used in the IUCV SEND PATHID statement.

PATHID is optional, and valid only if IPARML=YES is specified.

If this parameter is not specified, the subsequent IUCV SEND must specify it

RSPADDR

bufadr specifies the address of the IUCV answer buffer.

Specify either an RX-type address of the data or the number of the register containing the address of the data. This data is used in the IUCV SEND ANSBUF statement.

RSPADDR is optional and valid only if IPARML=YES is specified.

If this parameter is not specified, the subsequent IUCV SEND must specify it.

RSPLEN

buflen specifies the address of the length of the IUCV answer buffer.

Specify either an RX-type address of the 2-byte field or the number of the register containing the address of the data. This data is used in the IUCV SEND ANSLEN statement.

RSPLEN is optional and valid only if IPARML=YES is specified.

If this parameter is not specified, the subsequent IUCV SEND must specify it. The response length must be at least the value returned in SLXZQDRL by QCONFIG.

SCRATCH

yes specifies that the request is for a nonspecific (scratch) volume.

When this option is specified, the order of the returned list of drive elements is determined by the number of scratch volumes in the LSM containing the transport. Transports in the LSM with highest scratch volume count appear first, followed by transports in the LSM with the second highest scratch volume count. Transports in the LSM with the lowest scratch volume count appear last.

Either SCRATCH=YES or VOLSER must be specified.

SCRPOOL

poolidaddr specifies the address of the 1-byte scratch subpool index used for this request. The value must be in the range 1-255.

Specify either an RX-type address of the data or the number of the register containing the address of the data.

This parameter is optional, and valid only if SCRATCH=YES is specified.

SUBPOOL

subpoolname specifies the address of a 13-character field containing the name of the scratch subpool.

Specify either an RX-type address of the data or the number of the register containing the address of the data.

This parameter is optional, and valid only if SCRATCH=YES is specified.

USER

useridaddr specifies an 8-byte userid associated with a console ID for the request.

Specify either an RX-type address of the data or the number of the register containing the address of the data.

This parameter is optional.

VOLSER

voladdr specifies the address of a 6-character volume label.

Specify either an RX-type address of the data or the number of the register containing the address of the data.

Either VOLSER or SCRATCH=YES must be specified. When this option is specified, the order of the returned list of drive elements is determined by the proximity of the specified volume to a transport. Transports in the LSM which holds the specified volume appear first, followed by transports in adjacent LSMs. Transports in the LSM farthest from the specified volume appear last.

Response to QDRLIST Request

The QDRLIST response always contains a Reply Header and a Drive Information section. If VOLSER was specified, the response also contains a Volume Information Element.

Refer to “SLX Macro Mapping” on page 132 for information on the SLX macro.

QEJECT

QEJECT

This request is used to determine the status of individual VOLSER within one or more TMI eject tasks.

QEJECT Considerations

Each tape management interface request is assigned a token number. This token number is available to the operator when submitting a request for tracking or conversational purposes. The HSC allows for a variable number of EJECT requests. The QEJECT request provides the ability to query those requests. Through the use of tokens, a QEJECT request can be issued to query any specific request.

Tokens are obtained using the QREQUEST function.

Syntax

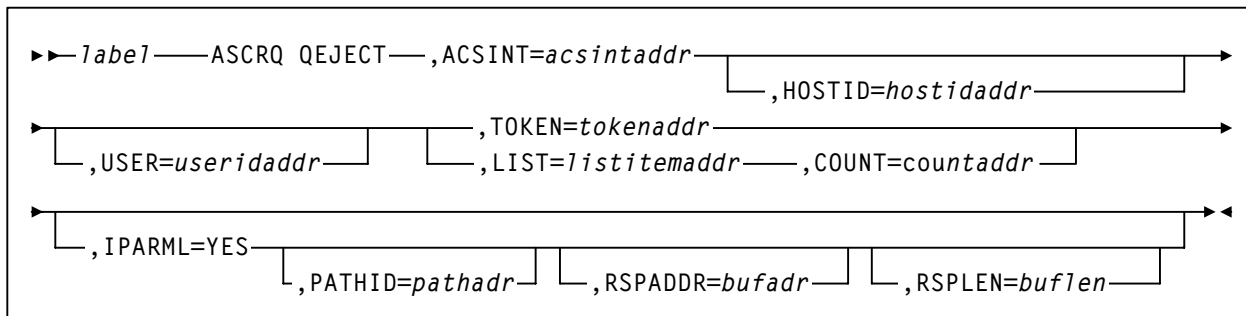

Parameters

ACSINT

acsintaddr specifies the address of the data area being sent to the library service machine.

Specify either an RX-type address of the data or the number of the register containing the address of the data. ACSRQ references the ACSINT at this address when filling in the data.

This parameter is required.

HOSTID

specifies the address of an eight character host ID, left justified and padded with blanks.

hostidaddr specifies either an RX-type address of the host ID or the register (2) - (12) containing the address of the host ID.

This parameter is optional. If the parameter is not specified, the host ID executing the request is used.

IPARML

yes specifies that the requestor has established addressability to an IUCV IPARML, and that the IPARML is initialized.

This parameter is optional.

PATHID

pathadr specifies the address of a 2-byte IUCV path ID of the library service machine.

Specify either an RX-type address of the data or the number of the register containing the address of the data. This data is used in the IUCV SEND PATHID statement.

PATHID is optional, and valid only if IPARML=YES is specified.

If this parameter is not specified, the subsequent IUCV SEND must specify it.

RSPADDR

bufadr specifies the address of the IUCV answer buffer.

Specify either an RX-type address of the data or the number of the register containing the address of the data. This data is used in the IUCV SEND ANSBUF statement.

RSPADDR is optional and valid only if IPARML=YES is specified.

If this parameter is not specified, the subsequent IUCV SEND must specify it.

RSPLEN

buflen specifies the address of the length of the IUCV answer buffer.

Specify either an RX-type address of the 2-byte field or the number of the register # containing the address of the data. This data is used in the IUCV SEND ANSLEN # statement.

RSPLEN is optional and valid only if IPARML=YES is specified.

If this parameter is not specified, the subsequent IUCV SEND must specify it. The response length must be at least the value returned in SLXZQSCR.

TOKEN

specifies that a single token value is present.

tokenaddr specifies either an RX-type address of the token or the register (2) - (12) containing the address of the token received from QREQUEST.

Either the TOKEN parameter, or the LIST and COUNT parameters must be specified.

QEJECT

LIST

specifies the address of the token list received from QREQUEST. *listitemaddr* specifies the RX-type address or register form address of the data. Valid register values are (2) - (12).

Either LIST and COUNT, or TOKEN must be specified.

USER

useridaddr specifies an 8-byte userid associated with a console ID for the request.

Specify either an RX-type address of the data or the number of the register # containing the address of the data.

This parameter is optional.

COUNT

countaddr specifies the address of a two-byte count value. For QEJECT, COUNT specifies the number of TOKENS in the list designated by the corequisite LIST parameter.

This parameter is required when LIST is specified.

Response to QEJECT Request

The response to QEJECT consists of a reply header and a QEJECT information element for each volume subject to a TMI EJECT request matching one of the tokens provided.

Refer to “SLX Macro Mapping” on page 132 for information on the SLX macro.

QREQUEST

This request is used to obtain information about active TMI requests.

QREQUEST Considerations

There are no considerations for QREQUEST.

Syntax

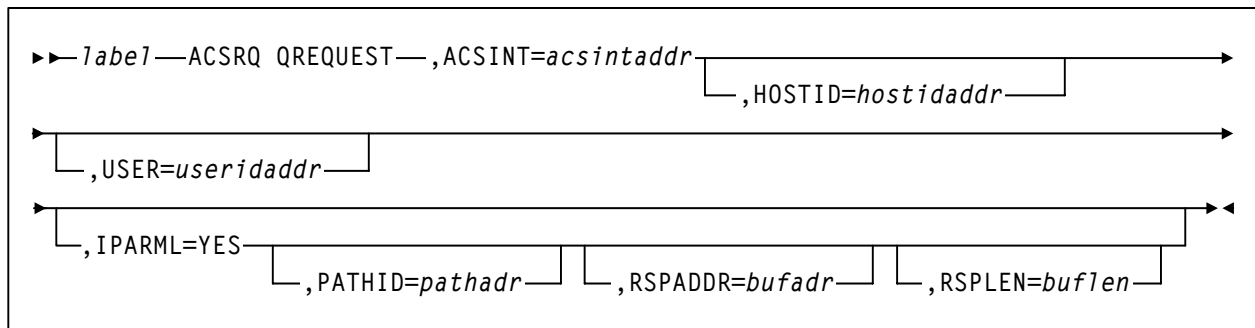

Parameters

ACSINT

acsintaddr specifies the address of the data area being sent to the library service machine.

Specify either an RX-type address of the data or the number of the register containing the address of the data. ACSRQ references the ACSINT at this address when filling in the data.

This parameter is required.

HOSTID

specifies the address of an eight character host ID, left justified and padded with blanks.

hostidaddr specifies either an RX-type address of the host ID or the register (2) - (12) containing the address of the host ID.

This parameter is optional. If the parameter is not specified, the host ID executing the request is used.

IPARML

yes specifies that the requestor has established addressability to an IUCV IPARML, and that the IPARML is initialized.

This parameter is optional.

QREQUEST

PATHID

pathadr specifies the address of a 2-byte IUCV path ID of the library service machine.

Specify either an RX-type address of the data or the number of the register containing the address of the data. This data is used in the IUCV SEND PATHID statement.

PATHID is optional, and valid only if IPARML=YES is specified.

If this parameter is not specified, the subsequent IUCV SEND must specify it.

RSPADDR

bufadr specifies the address of the IUCV answer buffer.

Specify either an RX-type address of the data or the number of the register containing the address of the data. This data is used in the IUCV SEND ANSBUF statement.

RSPADDR is optional and valid only if IPARML=YES is specified.

If this parameter is not specified, the subsequent IUCV SEND must specify it.

RSPLEN

buflen specifies the address of the length of the IUCV answer buffer.

Specify either an RX-type address of the 2-byte field or the number of the register containing the address of the data. This data is used in the IUCV SEND ANSLEN statement.

RSPLEN is optional and valid only if IPARML=YES is specified.

If this parameter is not specified, the subsequent IUCV SEND must specify it. The response length must be at least the value returned in SLXZQSCR.

USER

useridaddr specifies an 8-byte userid associated with a console ID for the request.

Specify either an RX-type address of the data or the number of the register containing the address of the data.

This parameter is optional.

Response to QREQUEST Request

The QREQUEST response contains a reply header and a STOP information element for each active TMI request. Only SLXSTPT (token number) and SLXSTPY (task type) are valid. SLXSTPK (stop status) is always zero.

Refer to “SLX Macro Mapping” on page 132 for information on the SLX macro.

QSCRATCH

The QSCRATCH request is used to obtain detailed information about all LSMs associated with the library, or with a particular ACS. This information includes the number of scratch volumes in each LSM.

QSCRATCH Considerations

When the library and its associated control data set are shared by more than one HSC, then the reported scratch totals may differ from the true totals because they may not account for recent scratch volume activity on other processors. However, each HSC refreshes its scratch volume totals from the control data set every five minutes so the variance should be slight.

Syntax

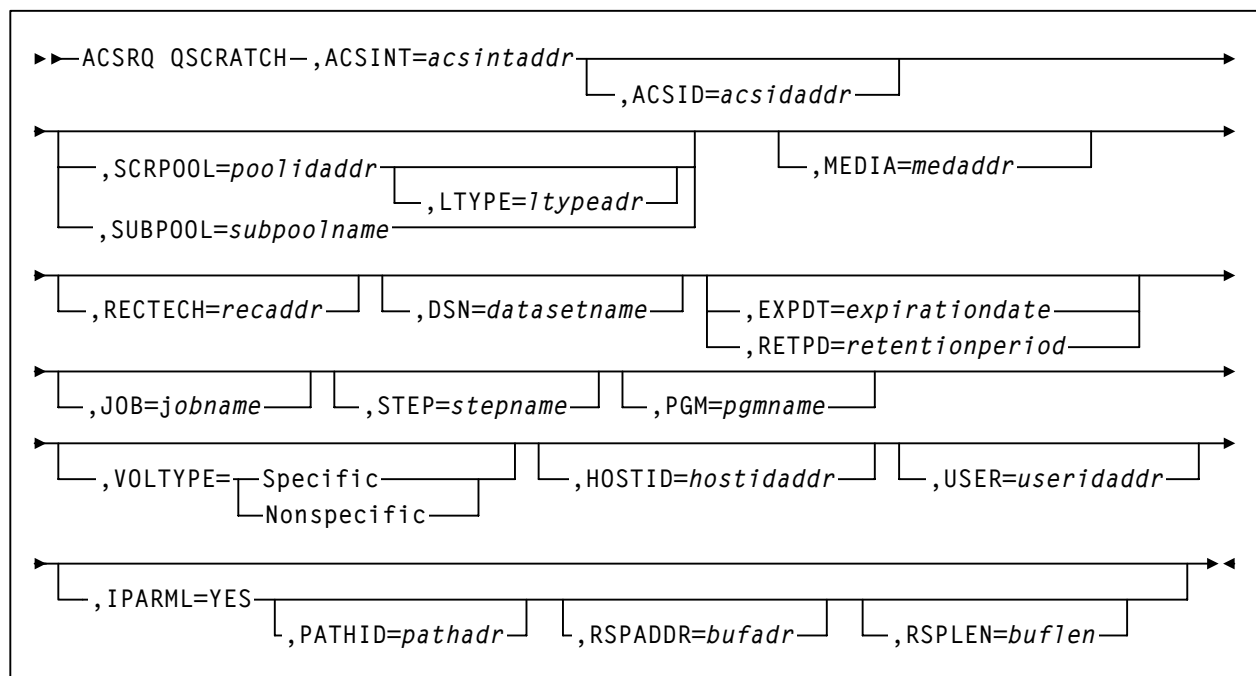

Parameters

ACSID

acsidaddr specifies the address of the ACS used to satisfy the request. Format for the ACSid is AA, where AA is a decimal number. For example, 01, designates ACS 01. Specify either an RX-type address of the data or the number of the register containing the address of the data.

This parameter is optional. If specified, the data is returned for the specific ACS. If ACSID is not specified, data is returned for all ACSs.

ACSINT

acsintaddr specifies the address of the data area being sent to the library service machine.

Specify either an RX-type address of the data or the number of the register containing the address of the data. ACSRQ references the ACSINT at this address when filling in the data.

This parameter is required.

MEDia

specifies the address of an 8-byte character field containing the media type of the requested scratch cartridge.

medaddr specifies either an RX-type address of the data or the register (2) - (12) containing the address of the data.

This parameter is optional.

Notes:

1. If MEDia is not specified, scratch cartridges are selected without regard to media type.
2. **The SL8500 library supports the T9840A, T9840B, T9840C, T9840D, T9940B, and T10000 media types and recording techniques.**
3. **The SL3000 library supports the T9840C, T9840D, and T10000 media types and recording techniques.**

medaddr

specifies either an RX-type address of the data or the register (2) - (12) containing the address of the data. Valid media types are:

LONGitud

indicates any Standard or ECART cartridge.

Standard

indicates a standard length, 3480 cartridge. It can be read on any longitudinal drives (4480, 4490, 9490, or 9490EE). Data can be written in 36-track mode on 4490, 9490, or 9490EE transports but cannot be read on an 18-track (4480) drive. Synonyms for this type of cartridge include:

- CST
- MEDIA1
- STD
- 1
- 3480

ECART

indicates a 3490E, extended capacity cartridge. It can be used only on a 36-track drive (4490, 9490, or 9490EE). Synonyms include:

- E
- ECCST
- ETAPE
- Long
- MEDIA2
- 3490E

ZCART

indicates a 3490E, extended capacity cartridge that provides greater storage capacity than an ECART. It can be used only on a 9490EE drive. ZCART can be abbreviated as Z.

DD3

indicates any DD3A, DD3B, or DD3C cartridge. HELical is a synonym for | DD3.

DD3A, DD3B, DD3C

indicates a helical cartridge. The media indicator in the external label is encoded with the cartridge type (A, B, or C).



Note: DD3A, DD3B, or DD3C can be abbreviated to A, B, or C, respectively.

Types of helical cartridges, along with their associated media capacities, are:

- A — 10GB
- B — 25GB
- C — 50GB.

Data capacity differences between DD3A, DD3B, and DD3C cartridges are related to the length of the tape in the cartridge, not to the recording density of the data.

STK1

indicates any T9840 cartridge.

STK1R

indicates a T9840 cartridge. The media indicator in the external label is encoded with the cartridge type (R). STK1R can be abbreviated to R.

T9840 cartridge media capacities are 20GB (T9840A and T9840B), 40GB (T9840C), or 75GB (T9840D).

STK2

indicates any T9940 cartridge.

STK2P

indicates a T9940 cartridge. The media indicator in the external label is encoded with the cartridge type (P). STK2P can be abbreviated to P.

T9940 cartridges media capacities are 60GB (T9940A) or 200GB (T9940B).

T10000T1 or **T1**

indicates a full-capacity 500GB T10000 cartridge. **T10000T1** can be abbreviated as **T1**.

T10000TS or **TS**

indicates a smaller-capacity 120GB T10000 cartridge. **T10000TS** can be abbreviated as **TS**.

RECtech

specifies the address of an 8-byte field containing the recording technique used to record data tracks on the tape surface.

recaddr specifies either an RX-type address of the data or the register (2) - (12) containing the address of the data.

This parameter is optional.



Notes:

1. If RECtech is not specified, scratch cartridges are selected depending on the MEDIA type that has been specified.
2. **The SL8500 library supports the T9840A, T9840B, T9840C, T9840D, T9940B, and T10000 media types and recording techniques.**
3. **The SL3000 library supports the T9840C, T9840D, and T10000 media types and recording techniques.**

recaddr

specifies either an RX-type address of the data or the register (2) - (12) containing the address of the data. Valid recording techniques are:

LONGItud

indicates any device that uses longitudinal recording.

18track

indicates a 4480 transport.

36track

indicates a 4490, 9490, or 9490EE transport (any device that records in 36-track mode).

36Atrack

indicates a 4490 (Silverton) transport.

36Btrack

indicates a 9490 (Timberline) transport.

36Ctrack

indicates a 9490EE transport.

HELical

indicates a device using helical recording.

DD3

indicates a device using helical recording. STK1R indicates a 9840 transport.

STK1R

indicates any 9840 transport.

STK1R34

indicates any 3490E-image 9840 transport.

STK1R35

indicates any 3590-image 9840 transport.

STK1RA

indicates a 3490E or 3590-image T9840A transport.

STK1RA34

indicates a 3490E-image T9840A transport.

STK1RA35

indicates a 3590-image T9840A transport.

STK1RB

indicates a 3490E or 3590-image T9840B transport.

STK1RB34

indicates a 3490E-image T9840B transport.

STK1RB35

indicates a 3590-image T9840B transport.

STK1RAB

indicates a 3490E or 3590-image T9840A or T9840B transport.

STK1RAB4

indicates a 3490E-image T9840A or T9840B transport.

STK1RAB5

indicates a 3590E-image T9840A or T9840B transport.

STK1RC

indicates a 3490E or 3590-image T9840C transport.

STK1RC34

indicates a 3490-image T9840C transport.

STK1RC35

indicates a 3590-image T9840C transport.

STK1RD

indicates any T9840D transport.

STK1RDE

indicates an encryption-enabled T9840D transport.

STK1RDN

indicates a non-encryption enabled T9840D transport.

STK1RD34

indicates a non-encryption enabled 3490E-image T9840D transport.

STK1RD35

indicates a non-encryption enabled 3590-image T9840D transport.

STK1RDE4

indicates an encryption-enabled 3490E-image T9840D transport.

STK1RDE5

indicates an encryption-enabled 3590-image T9840D transport.

STK2P

indicates any 9940 transport.

STK2P34

indicates any 3490E-image 9940 transport.

STK2P35

indicates any 3590-image 9940 transport.

STK2PA

indicates a T9940A transport.

STK2PA34

indicates a 3490E-image T9940A transport.

STK2PA35

indicates a 3590-image T9940A transport.

STK2PB

indicates any T9940B transport.

STK2PB34

indicates a 3490E-image T9940B transport.

STK2PB35

indicates a 3590-image T9940B transport.

T10K

indicates all T10000 transports.

T10KN

indicates all non-encrypted T10000 transports.

T10KE

indicates all encrypted T10000 transports.

T1A

indicates any T10000A transport.

T1AN

indicates a non-encryption enabled 3490E- or 3590-image T10000A transport.

T1A34

indicates a non-encryption enabled 3490E-image T10000A transport.

T1A35

indicates a non-encryption enabled 3590-image T10000A transport.

T1AE

indicates an encryption-enabled 3490E- or 3590-image T10000A transport.

T1AE34

indicates an encryption-enabled 3490E-image T10000A transport.

T1AE35

indicates an encryption-enabled 3590-image T10000A transport.

The following seven parameters are ignored if Media, RECtech, or both are specified.

DSN

datasetname specifies the data set name.

This parameter is optional.

EXPDT

expirationdate specifies the expiration date of the data set in YYDDD or YYYY/DDD format.

RETPD

retentionperiod specifies the retention period for the data set in days. Specify the number of days as a one- to four-digit decimal number.

This parameter is optional.

JOB

jobname specifies the job name.

This parameter is optional.

STEP

stepname specifies the step name.

This parameter is optional.

PGM

pgmname specifies the step name.

This parameter is optional.

VOLTYPE

indicates whether or not a nonspecific volume was requested.

Specific

requests a specific volume to be mounted.

Nonspecific

requests a nonspecific volume to be mounted.

This parameter is optional.

HOSTID

specifies the address of an eight character host ID, left justified and padded with blanks.

hostidaddr specifies either an RX-type address of the host ID or the register (2) - (12) containing the address of the host ID.

This parameter is optional. If the parameter is not specified, the host ID executing the request is used.

IPARML

yes specifies that the requestor has established addressability to an IUCV IPARML, and that the IPARML is initialized.

This parameter is optional.

LTYPE

ltypeadr specifies the address of a 1-byte field containing the label type for a scratch request.

Specify either an RX-type address of the data or the number of the register containing the address of the data.

X'00' LDT

specifies the library default label type.

X'01' SL

specifies the standard-labeled pool.

X'02' NL

specifies the nonlabeled pool.

X'03' AL

specifies the ANSI-labeled pool.

X'04' NSL

specifies the nonstandard-labeled pool.

This parameter is optional and valid only if SCRPOOL is specified.

PATHID

pathadr specifies the address of a 2-byte IUCV path ID of the library service machine.

Specify either an RX-type address of the data or the number of the register containing the address of the data. This data is used in the IUCV SEND PATHID statement.

PATHID is optional, and valid only if IPARML=YES is specified.

If this parameter is not specified, the subsequent IUCV SEND must specify it.

RSPADDR

bufadr specifies the address of the IUCV answer buffer.

Specify either an RX-type address of the data or the number of the register containing the address of the data. This data is used in the IUCV SEND ANSBUF statement.

RSPADDR is optional and valid only if IPARML=YES is specified.

If this parameter is not specified, the subsequent IUCV SEND must specify it.

RSPLEN

buflen specifies the address of the length of the IUCV answer buffer.

Specify either an RX-type address of the 2-byte field or the number of the register containing the address of the data. This data is used in the IUCV SEND ANSLEN statement.

RSPLEN is optional and valid only if IPARML=YES is specified.

QSCRATCH

If this parameter is not specified, the subsequent IUCV SEND must specify it. The response length must be at least the value returned in SLXZQSCR.

SCRPOOL

poolidaddr specifies the address of the 1-byte scratch subpool index used for this request. The value must be in the range 1-255.

Specify either an RX-type address of the data or the number of the register containing the address of the data.

This parameter is optional.

SUBPOOL

subpoolname specifies the address of a 13-character field containing the name of the scratch subpool.

Specify either an RX-type address of the data or the number of the register containing the address of the data.

This parameter is optional.

USER

useridaddr specifies an 8-byte userid associated with a console ID for the request. Specify either an RX-type address of the data or the number of the register containing the address of the data.

This parameter is optional.

Response to QSCRATCH Request

The QSCRATCH response contains a Reply Header and an LSM Information Element for each LSM.

Refer to “SLX Macro Mapping” on page 132 for information on the SLX macro.

QVOLUME

The QVOLUME request is used to obtain the current library status of one or more (up to 500) cartridges.

QVOLUME Considerations

The length of the response may vary considerably, depending on the number of volumes specified in the request. Several values are available in the response from a QCONFIG request for use in determining the appropriate answer buffer length for a particular QVOLUME request. These values include:

- SLXZQVOL contains the length of a QVOLUME response for a single volume. Use this value for the answer buffer length when a QVOLUME request specifies either VOLSER or COUNT=1.
- SLXXVOLL contains the length of a single Volume Information Element. When a QVOLUME request specifies COUNT=*n*, then the answer buffer length is computed using the formula: $((n-1)*SLXXVOLL)+SLXZQVOL$.
- SLXZVOL contains the length of a QVOLUME response when the maximum number of VOLSERs (500) is specified in the request list. Use this value for the answer buffer length when the above formula cannot be used, and when the requestor can afford to commit a large amount of storage (approximately 16KB) to the request.

Syntax

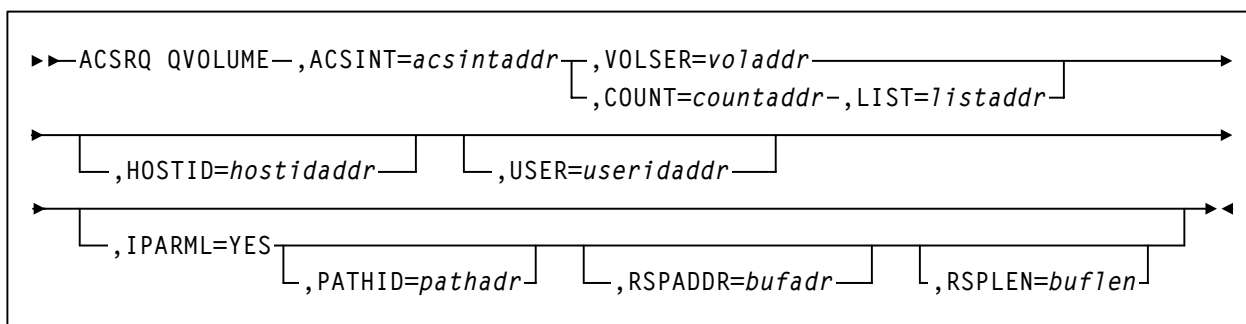

Parameters

ACSINT

acsintaddr specifies the address of the data area being sent to the library service machine.

Specify either an RX-type address of the data or the number of the register containing the address of the data. ACSRQ references the ACSINT at this address when filling in the data.

This parameter is required.

COUNT

countaddr specifies the address of a 2-byte field containing the number of VOLSERS in the list designated by the LIST parameter.

Specify either an RX address of the data or the number of the the register that contains the address of the data.

This parameter is required along with the LIST parameter and is mutually exclusive with the VOLSER parameter.

HOSTID

specifies the address of an eight character host ID, left justified and padded with blanks.

hostidaddr specifies either an RX-type address of the host ID or the register (2) - (12) containing the address of the host ID.

This parameter is optional. If the parameter is not specified, the host ID executing the request is used.

IPARML

yes specifies that the requestor has established addressability to an IUCV IPARML, and that the IPARML is initialized.

This parameter is optional.

LIST

listaddr specifies the address of the list of the elements. Specify either an RX-type address of the data or the number of a register that contains the address of the data.

Each element in this list is a 6-byte VOLSER.

A special form of this parameter, LIST=* indicates to ACSRQ that the list is already appended to the ACSINT data area, and does not need to be moved.

This parameter is required along with the COUNT parameter and is mutually exclusive with the VOLSER=parameter.

PATHID

pathadr specifies the address of a 2-byte IUCV path ID of the library service machine.

Specify either an RX-type address of the data or the number of the register containing the address of the data. This data is used in the IUCV SEND PATHID statement.

PATHID is optional, and valid only if IPARML=YES is specified. If this parameter is not specified, the subsequent IUCV SEND must specify it.

RSPADDR

bufadr specifies the address of the IUCV answer buffer.

Specify either an RX-type address of the data or the number of the register containing the address of the data. This data is used in the IUCV SEND ANSBUF statement.

RSPADDR is optional and valid only if IPARML=YES is specified. If this parameter is not specified, the subsequent IUCV SEND must specify it.

RSPLEN

buflen specifies the address of the length of the IUCV answer buffer.

Specify either an RX-type address of the 2-byte field or the number of the register containing the address of the data. This data is used in the IUCV SEND ANSLEN statement.

RSPLEN is optional and valid only if IPARML=YES is specified.

If this parameter is not specified, the subsequent IUCV SEND must specify it. The response length must be determined by one of the methods described in the QVOLUME Considerations section, above.

USER

useridaddr specifies an 8-byte userid associated with a console ID for the request. Specify either an RX-type address of the data or the number of the register containing the address of the data.

This parameter is optional.

VOLSER

voladdr specifies the address of a 6-character volume label.

Specify either an RX-type address of the data or the number of the register containing the address of the data.

Either VOLSER or LIST must be specified. VOLSER specifies the volume for which status is requested.

This parameter is required and is mutually exclusive with the COUNT parameter.

Response to QVOLUME Request

The QVOLUME response consists of a Reply Header and a Volume Information Element for each VOLSER that was specified in the request. Volume Information Elements appear in the same order as the VOLSERS in the request.

Refer to “SLX Macro Mapping” on page 132 for information on the SLX macro.

QVOLUSE

QVOLUSE

The QVOLUSE request is used to obtain the current status of mounted volumes.

QVOLUSE Considerations

The length of the response may vary considerably, depending on the number of volumes returned by the request.

Syntax

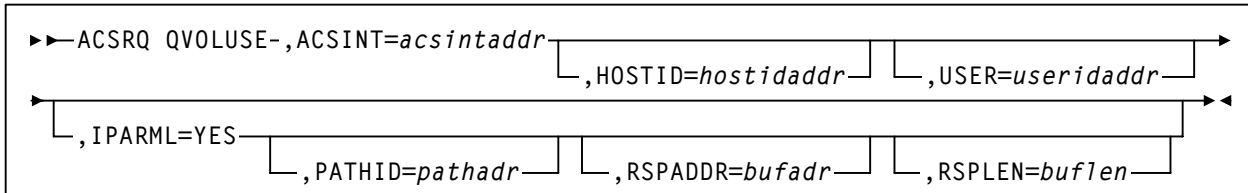

Parameters

ACSINT

acsintaddr specifies the address of the data area being sent to the library service machine.

Specify either an RX-type address of the data or the number of the register containing the address of the data. ACSRQ references the ACSINT at this address **when filling in the data.**

This parameter is required.

HOSTID

specifies the address of an eight character host ID, left justified and padded with blanks.

hostidaddr specifies either an RX-type address of the host ID or the register (2) - (12) containing the address of the host ID.

This parameter is optional. If the parameter is not specified, the host ID executing the request is used.

IPARML

yes specifies that the requestor has established addressability to an IUCV IPARML, and that the IPARML is initialized.

This parameter is optional.

PATHID

pathadr specifies the address of a 2-byte IUCV path ID of the library service machine.

Specify either an RX-type address of the data or the number of the register containing the address of the data. This data is used in the IUCV SEND PATHID statement.

PATHID is optional, and valid only if IPARML=YES is specified.

If this parameter is not specified, the subsequent IUCV SEND must specify it.

RSPADDR

bufadr specifies the address of the IUCV answer buffer.

Specify either an RX-type address of the data or the number of the register containing the address of the data. This data is used in the IUCV SEND ANSBUF statement.

RSPADDR is optional and valid only if IPARML=YES is specified.

If this parameter is not specified, the subsequent IUCV SEND must specify it.

RSPLEN

buflen specifies the address of the length of the IUCV answer buffer.

Specify either an RX-type address of the 2-byte field or the number of the register containing the address of the data. This data is used in the IUCV SEND ANSLEN statement.

RSPLEN is optional and valid only if IPARML=YES is specified.

If this parameter is not specified, the subsequent IUCV SEND must specify it. The response length must be at least the value returned in SLXZQVOL.

USER

useridaddr specifies an 8-byte userid associated with a console ID for the request.

Specify either an RX-type address of the data or the number of the register containing the address of the data.

This parameter is optional.

Response to QVOLUSE Request

The QVOLUSE response consists of a Reply Header and a Volume Information Element for each VOLSER that was returned by the request. Volume Information Elements appear in the same order as the VOLSERS returned by the request.

Refer to “SLX Macro Mapping” on page 132 for information on the SLX macro.

SCRATCH

SCRATCH

The SCRATCH request causes a volume to be placed in scratch status in the library control data set.

SCRATCH Considerations

The specified cartridge must already be in the library. No cartridge movement occurs as the result of a SCRATCH request. However, SCRATCH request processing must select the cartridge (i.e., must acquire exclusive use of the cartridge) in order to change its state. This means that a SCRATCH request will fail if the cartridge is mounted on a drive (see “MOUNT Considerations” on page 49).

Syntax

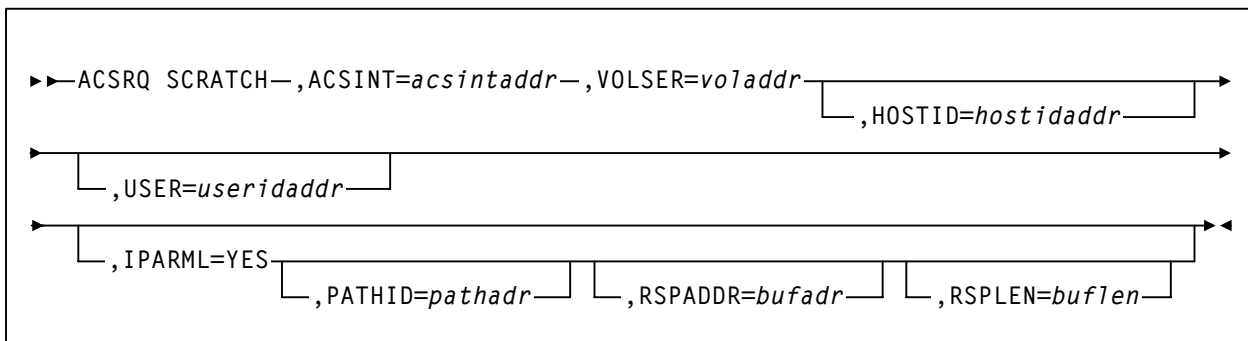

Parameters

ACSINT

acsintaddr specifies the address of the data area being sent to the library service machine.

Specify either an RX-type address of the data or the number of the register containing the address of the data. ACSRQ references the ACSINT at this address when filling in the data.

This parameter is required.

HOSTID

specifies the address of an eight character host ID, left justified and padded with blanks.

hostidaddr specifies either an RX-type address of the host ID or the register (2) - (12) containing the address of the host ID.

This parameter is optional. If the parameter is not specified, the host ID executing the request is used.

IPARML

yes specifies that the requestor has established addressability to an IUCV IPARML, and that the IPARML is initialized.

This parameter is optional.

PATHID

pathadr specifies the address of a 2-byte IUCV path ID of the library service machine.

Specify either an RX-type address of the data or the number of the register containing the address of the data. This data is used in the IUCV SEND PATHID statement.

PATHID is optional, and valid only if IPARML=YES is specified.

If this parameter is not specified, the subsequent IUCV SEND must specify it.

RSPADDR

bufadr specifies the address of the IUCV answer buffer.

Specify either an RX-type address of the data or the number of the register containing the address of the data. This data is used in the IUCV SEND ANSBUF statement.

RSPADDR is optional and valid only if IPARML=YES is specified.

If this parameter is not specified, the subsequent IUCV SEND must specify it.

RSPLEN

buflen specifies the address of the length of the IUCV answer buffer.

Specify either an RX-type address of the 2-byte field or the number of the register containing the address of the data. This data is used in the IUCV SEND ANSLEN statement.

RSPLEN is optional and valid only if IPARML=YES is specified.

If this parameter is not specified, the subsequent IUCV SEND must specify it. The response length must be at least the value returned in SLXZSCR by QCONFIG.

USER

useridaddr specifies an 8-byte userid associated with a console ID for the request.

Specify either an RX-type address of the data or the number of the register containing the address of the data.

This parameter is optional.

SCRATCH

VOLSER

voladdr specifies the address of a 6-character volume label. Specify either an RX-type address of the data or the number of the register containing the address of the data.

This parameter is required. It specifies the volume which is to be marked as scratch.

Response to SCRATCH Request

The response to SCRATCH contains only a Reply Header. Refer to “SLX Macro Mapping” on page 132 for information on the SLX macro.

SELSCR

The SELSCR request causes the HSC to choose a library scratch volume and remove it from scratch status in the library control data set.

SELSCR Considerations

A SELSCR request does not cause any cartridge movement. When neither ACSID nor DRIVE is specified, the HSC searches through all library LSMs and chooses a scratch volume from the LSM containing the most scratch volumes. When ACSID is specified, the HSC only searches LSMs from the specified ACS and chooses a scratch volume from the LSM which holds the most scratch volumes. When DRIVE is specified, the HSC chooses a scratch volume in an LSM containing or closest to the specified drive.

Syntax

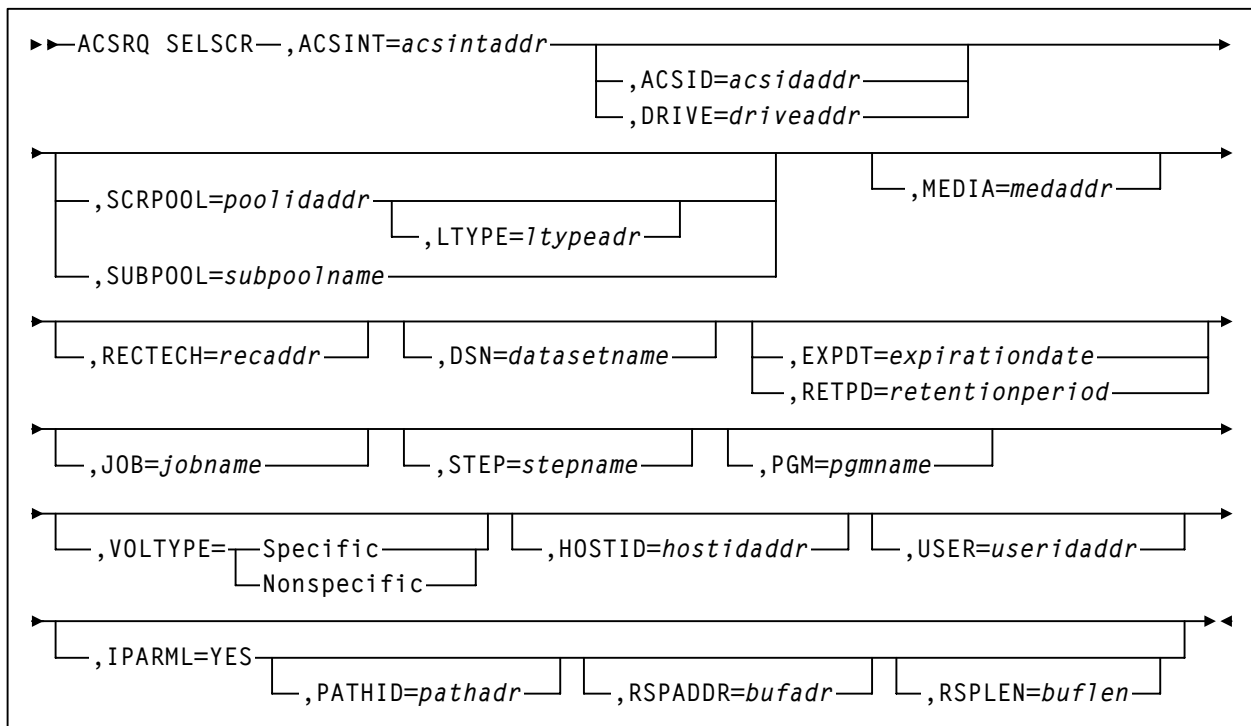

Parameters

ACSID

acsidaddr specifies the address of the ACS used to satisfy the request. Format for the ACSid is AA, where AA is a hexadecimal number 00-FF. For example, 01, designates ACS 01.

Specify either an RX-type address of the data or the number of the register containing the address of the data.

This parameter is optional. If specified, the data is returned for the specific ACS. If ACSID is not specified, data is returned for all ACSs.

This parameter is mutually exclusive with DRIVE.

ACSINT

acsintaddr specifies the address of the data area being sent to the library service machine.

Specify either an RX-type address of the data or the number of the register containing the address of the data. ACSRQ references the ACSINT at this address when filling in the data.

This parameter is required.

DRIVE

driveaddr specifies the address of the 2-byte drive specification (ccua).

Specify either an RX-type address of the data or the number of the register containing the address of the data.

This parameter is optional, and mutually exclusive with ACSID. It specifies the drive which the scratch volume should be near.

MEDia

specifies the address of an 8-byte character field containing the media type of the selected scratch cartridge.

medaddr specifies either an RX-type address of the data or the register (2) - (12) containing the address of the data.

This parameter is optional.



Notes:

1. If MEDia is not specified, scratch cartridges are selected without regard to media type.
2. **The SL8500 library supports the T9840A, T9840B, T9840C, T9840D, T9940B, and T10000 media types and recording techniques.**
3. **The SL3000 library supports the T9840C, T9840D, and T10000 media types and recording techniques.**

medaddr

specifies either an RX-type address of the data or the register (2) - (12) containing the address of the data. Valid media types are:

LONGitud

indicates any Standard or ECART cartridge.

Standard

indicates a standard length, 3480 cartridge. It can be read on any longitudinal drives (4480, 4490, 9490, or 9490EE). Data can be written in 36-track mode on 4490, 9490, or 9490EE transports but cannot be read on an 18-track (4480) drive. Synonyms for this type of cartridge include:

- CST
- MEDIA1
- STD
- 1
- 3480

ECART

indicates a 3490E, extended capacity cartridge. It can be used only on a 36-track drive (4490, 9490, or 9490EE). Synonyms include:

- E
- ECCST
- ETAPE
- Long
- MEDIA2
- 3490E

ZCART

indicates a 3490E, extended capacity cartridge that provides greater storage capacity than an ECART. It can be used only on a 9490EE drive. ZCART can be abbreviated as Z.

DD3

indicates any DD3A, DD3B, or DD3C cartridge. HELical is a synonym for DD3.

DD3A, DD3B, DD3C

indicates a helical cartridge. The media indicator in the external label is encoded with the cartridge type (A, B, or C).



Note: DD3A, DD3B, or DD3C can be abbreviated to A, B, or C, respectively.

Types of helical cartridges, along with their associated media capacities, are:

- A — 10GB
- B — 25GB
- C — 50GB.

Data capacity differences between DD3A, DD3B, and DD3C cartridges are related to the length of the tape in the cartridge, not to the recording density of the data.

STK1

indicates any T9840 cartridge.

STK1R

indicates a T9840 cartridge. The media indicator in the external label is encoded with the cartridge type (R). **STK1R** can be abbreviated to **R**.

T9840 cartridge media capacities are 20GB (T9840A and T9840B), 40GB (T9840C), or 75GB (T9840D).

STK2

indicates any T9940 cartridge.

STK2P

indicates a T9940 cartridge. The media indicator in the external label is encoded with the cartridge type (P). **STK2P** can be abbreviated to **P**.

T9940 cartridges media capacities are 60GB (T9940A) or 200GB (T9940B).

T10000T1 or T1

indicates a full-capacity 500GB T10000 cartridge. **T10000T1** can be abbreviated as **T1**.

T10000TS or TS

indicates a smaller-capacity 120GB T10000 cartridge. **T10000TS** can be abbreviated as **TS**.

RECtech

specifies the address of an 8-byte field containing the recording technique used to record data tracks on the tape surface. *recaddr* specifies either an RX-type address of the data or the register (2) - (12) containing the address of the data.

This parameter is optional.

**Notes:**

1. If RECtech is not specified, scratch cartridges are selected depending on the MEDIA type that has been specified.
2. **The SL8500 library supports the T9840A, T9840B, T9840C, T9840D, T9940B, and T10000 media types and recording techniques.**
3. **The SL3000 library supports the T9840C, T9840D, and T10000 media types and recording techniques.**

recaddr

specifies either an RX-type address of the data or the register (2) - (12) containing the address of the data. Valid recording techniques are:

LONGItud

indicates any device that uses longitudinal recording.

18track

indicates a 4480 transport.

36track

indicates a 4490, 9490, or 9490EE transport (any device that records in 36-track mode).

36Atrack

indicates a 4490 (Silverton) transport.

36Btrack

indicates a 9490 (Timberline) transport.

36Ctrack

indicates a 9490EE transport.

HELical

indicates a device using helical recording.

DD3

indicates a device using helical recording.

STK1R

indicates any 9840 transport.

STK1R34

indicates any 3490E-image 9840 transport.

STK1R35

indicates any 3590-image 9840 transport.

STK1RA

indicates a 3490E or 3590-image T9840A transport.

STK1RA34

indicates a 3490E-image T9840A transport.

STK1RA35

indicates a 3590-image T9840A transport.

STK1RB

indicates a 3490E or 3590-image T9840B transport.

STK1RB34

indicates a 3490E-image T9840B transport.

STK1RB35

indicates a 3590-image T9840B transport.

STK1RAB

indicates a 3490E or 3590-image T9840A or T9840B transport.

STK1RAB4

indicates a 3490E-image T9840A or T9840B transport.

STK1RAB5

indicates a 3590E-image T9840A or T9840B transport.

STK1RC

indicates a 3490E or 3590-image T9840C transport.

STK1RC34

indicates a 3490-image T9840C transport.

STK1RC35

indicates a 3590-image T9840C transport.

STK1RD

indicates any T9840D transport.

STK1RDE

indicates an encryption-enabled T9840D transport.

STK1RDN

indicates a non-encryption enabled T9840D transport.

STK1RD34

indicates a non-encryption enabled 3490E-image T9840D transport.

STK1RD35

indicates a non-encryption enabled 3590-image T9840D transport.

STK1RDE4

indicates an encryption-enabled 3490E-image T9840D transport.

STK1RDE5

indicates an encryption-enabled 3590-image T9840D transport.

STK2P

indicates any 9940 transport.

STK2P34

indicates any 3490E-image 9940 transport.

STK2P35

indicates any 3590-image 9940 transport.

STK2PA

indicates a T9940A transport.

STK2PA34

indicates a 3490E-image T9940A transport.

STK2PA35

indicates a 3590-image T9940A transport.

STK2PB

indicates any T9940B transport.

STK2PB34

indicates a 3490E-image T9940B transport.

STK2PB35

indicates a 3590-image T9940B transport.

T10K

indicates all T10000 transports.

T10KN

indicates all non-encrypted T10000 transports.

T10KE

indicates all encrypted T10000 transports.

T1A

indicates any T10000A transport.

T1AN

indicates a non-encryption enabled 3490E- or 3590-image T10000A transport.

T1A34

indicates a non-encryption enabled 3490E-image T10000A transport.

T1A35

indicates a non-encryption enabled 3590-image T10000A transport.

T1AE

indicates an encryption-enabled 3490E- or 3590-image T10000A transport.

T1AE34

indicates an encryption-enabled 3490E-image T10000A transport.

T1AE35

indicates an encryption-enabled 3590-image T10000A transport.

The following seven parameters are ignored if Media, RECtech, or both are specified.

DSN

datasetname specifies the data set name.

This parameter is optional.

EXPDT

expirationdate specifies the expiration date of the data set in YYDDD or YYYY/DDD format.

RETPD

retentionperiod specifies the retention period for the data set in days.

Specify the number of days as a one- to four-digit decimal number.

This parameter is optional.

JOB

jobname specifies the job name.

This parameter is optional.

STEP

stepname specifies the step name.

This parameter is optional.

PGM

pgmname specifies the step name.

This parameter is optional.

VOLTYPE

indicates whether or not a nonspecific volume was requested.

Specific

requests a specific volume to be mounted.

Nonspecific

requests a nonspecific volume to be mounted.

This parameter is optional.

HOSTID

specifies the address of an eight character host ID, left justified and padded with blanks.

hostidaddr specifies either an RX-type address of the host ID or the register (2) - (12) containing the address of the host ID.

This parameter is optional. If the parameter is not specified, the host ID executing the request is used.

IPARML

yes specifies that the requestor has established addressability to an IUCV IPARML, and that the IPARML is initialized.

This parameter is optional.

LTYPE

ltypeadr specifies the address of a 1-byte field containing the label type for a scratch request.

Specify either an RX-type address of the data or the number of the register containing the address of the data.

X'00' LDT

specifies the library default label type.

X'01' SL

specifies the standard-labeled pool.

X'02' NL

specifies the nonlabeled pool.

X'03' AL

specifies the ANSI-labeled pool. X'04' NSL specifies the nonstandard-labeled pool.

This parameter is optional and valid only if SCRPOOL is specified.

PATHID

pathadr specifies the address of a 2-byte IUCV path ID of the library service machine.

Specify either an RX-type address of the data or the number of the register containing the address of the data. This data is used in the IUCV SEND PATHID statement.

PATHID is optional, and valid only if IPARML=YES is specified.

If this parameter is not specified, the subsequent IUCV SEND must specify it.

RSPADDR

bufadr specifies the address of the IUCV answer buffer.

Specify either an RX-type address of the data or the number of the register containing the address of the data. This data is used in the IUCV SEND ANSBUF statement.

RSPADDR is optional and valid only if IPARML=YES is specified.

If this parameter is not specified, the subsequent IUCV SEND must specify it.

RSPLEN

buflen specifies the address of the length of the IUCV answer buffer.

Specify either an RX-type address of the 2-byte field or the number of the register containing the address of the data. This data is used in the IUCV SEND ANSLEN statement.

RSPLEN is optional and valid only if IPARML=YES is specified.

If this parameter is not specified, the subsequent IUCV SEND must specify it. The response length must be at least the value returned in SLXZGSCR by QCONFIG.

SCRPOOL

poolidaddr specifies the address of the 1-byte scratch subpool index used for this request. The value must be in the range 1-255.

Specify either an RX-type address of the data or the number of the register containing the address of the data.

This parameter is optional.

SUBPOOL

subpoolname specifies the address of a 13-character field containing the name of the scratch subpool.

Specify either an RX-type address of the data or the number of the register containing the address of the data.

This parameter is optional.

USER

useridaddr specifies an 8-byte userid associated with a console ID for the request.

Specify either an RX-type address of the data or the number of the register containing the address of the data.

This parameter is optional.

Response to SELSCR Request

The response to SELSCR contains a Reply Header and a Volume Information Element. The Reply Header contains a return code (SLXCMDRC) indicating the success of the operation. The Volume Information Element describes the selected volume.

Refer to “SLX Macro Mapping” on page 132 for information on the SLX macro.

SETOPER

SETOPER

The SETOPER request specifies the operator interaction mode for subsequent requests.

SETOPER Considerations

When the HSC detects an abnormal occurrence during request processing, it usually asks an operator if it can ignore the occurrence by issuing a WTOR (Write To Operator with Reply). If such a situation occurs while SETOPER ,DIALOG=OFF is in effect, the HSC will abort the request instead of issuing a WTOR. The initial setting is DIALOG=ON, which allows the HSC to issue WTORs.

Syntax

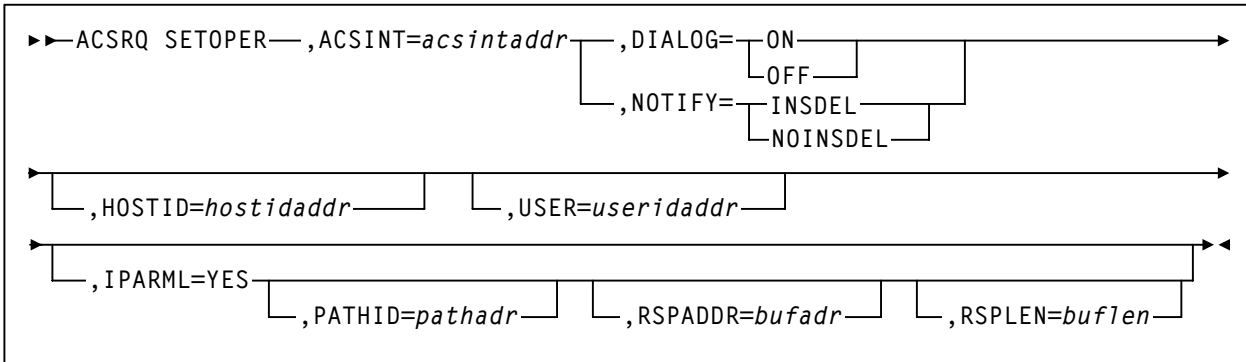

Parameters

ACSINT

acsintaddr specifies the address of the data area being sent to the library service machine.

Specify either an RX-type address of the data or the number of the register containing the address of the data. ACSRQ references the ACSINT at this address when filling in the data.

This parameter is required.

DIALOG

on allows future operator dialog to proceed normally. Request processes are permitted to issue WTORs and receive the operator's replies.

off suppresses future operator dialogs. Any attempt by a request process to issue a WTOR causes the request to fail.

This parameter is required and is mutually exclusive with NOTIFY. A value must be selected for either DIALOG or NOTIFY.

HOSTID

specifies the address of an eight character host ID, left justified and padded with blanks.

hostidaddr specifies either an RX-type address of the host ID or the register (2) - (12) containing the address of the host ID.

This parameter is optional. If the parameter is not specified, the host ID executing the request is used.

IPARML

yes specifies that the requestor has established addressability to an IUCV IPARML, and that the IPARML is initialized.

This parameter is optional.

NOTIFY

insdel enables SMSG notification of the requesting user for CDS insert or delete events.

noinsdel disables SMSG notification for CDS insert or delete events.

This parameter is required and is mutually exclusive with DIALOG. A value must be selected for either NOTIFY or DIALOG.

PATHID

pathadr specifies the address of a 2-byte IUCV path ID of the library service machine.

Specify either an RX-type address of the data or the number of the register containing the address of the data. This data is used in the IUCV SEND PATHID statement.

PATHID is optional, and valid only if IPARML=YES is specified.

If this parameter is not specified, the subsequent IUCV SEND must specify it.

RSPADDR

bufadr specifies the address of the IUCV answer buffer.

Specify either an RX-type address of the data or the number of the register containing the address of the data. This data is used in the IUCV SEND ANSBUF statement.

RSPADDR is optional and valid only if IPARML=YES is specified.

If this parameter is not specified, the subsequent IUCV SEND must specify it.

SETOPER

RSPLEN

buflen specifies the address of the length of the IUCV answer buffer.

Specify either an RX-type address of the 2-byte field or the number of the register containing the address of the data. This data is used in the IUCV SEND ANSLEN statement.

RSPLEN is optional and valid only if IPARML=YES is specified.

If this parameter is not specified, the subsequent IUCV SEND must specify it. The response length must be at least the value returned in SLXZSETO by QCONFIG.

USER

useridaddr specifies an 8-byte userid associated with a console ID for the request. Specify either an RX-type address of the data or the number of the register containing the address of the data.

This parameter is optional.

Response to SETOPER Request

The response to SETOPER contains only a Reply Header.

Refer to “SLX Macro Mapping” on page 132 for information on the SLX macro.

STOP

The STOP request causes a specific TMI request to be terminated.

STOP Considerations

Each tape management interface request is assigned a token number. This token number is available to the operator when submitting a request for tracking or conversational purposes.

The HSC allows for a variable number of EJECT requests. The STOP request provides the ability to interrupt those requests. Through the use of tokens, a STOP request can be issued to terminate any specific request. The STOP request allows a forced, orderly termination of a given unit or units of work. Tokens are obtained using the QREQUEST function.

Syntax

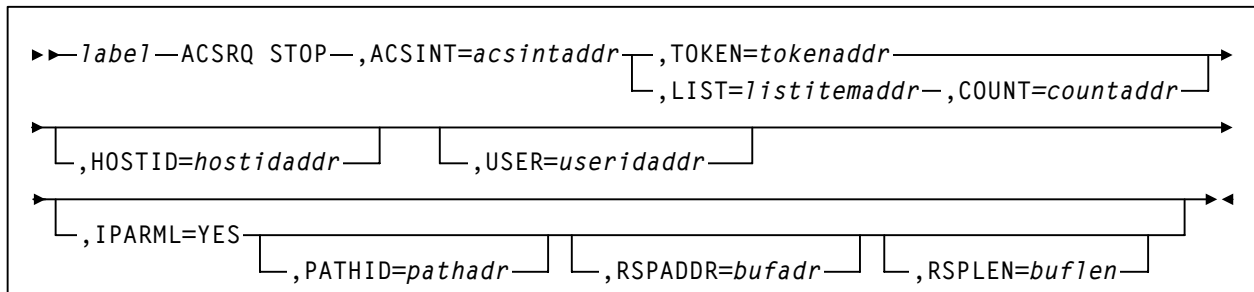

Parameters

ACSINT

acsintaddr specifies the address of the data area being sent to the library service machine.

Specify either an RX-type address of the data or the number of the register containing the address of the data. ACSRQ references the ACSINT at this address when filling in the data.

This parameter is required.

HOSTID

specifies the address of an eight character host ID, left justified and padded with blanks.

hostidaddr specifies either an RX-type address of the host ID or the register (2) - (12) containing the address of the host ID.

This parameter is optional.

If the parameter is not specified, the host ID executing the request is used.

IPARML

yes specifies that the requestor has established addressability to an IUCV IPARML, and that the IPARML is initialized.

This parameter is optional.

LIST

tokenlist specifies either an RX-type address of the list of tokens or the register (2) - (12) containing the address of the list of tokens obtained from QREQUEST.

A special form of this parameter, **LIST=***, indicates that the list immediately follows the parameter list control block.

This parameter is required if TOKEN is not specified.

PATHID

pathadr specifies the address of a 2-byte IUCV path ID of the library service machine.

Specify either an RX-type address of the data or the number of the register containing the address of the data. This data is used in the IUCV SEND PATHID statement.

PATHID is optional, and valid only if IPARML=YES is specified.

If this parameter is not specified, the subsequent IUCV SEND must specify it.

RSPADDR

bufadr specifies the address of the IUCV answer buffer.

Specify either an RX-type address of the data or the number of the register containing the address of the data. This data is used in the IUCV SEND ANSBUF statement.

RSPADDR is optional and valid only if IPARML=YES is specified.

If this parameter is not specified, the subsequent IUCV SEND must specify it.

RSPLEN

buflen specifies the address of the length of the IUCV answer buffer.

Specify either an RX-type address of the 2-byte field or the number of the register containing the address of the data. This data is used in the IUCV SEND ANSLEN statement.

RSPLEN is optional and valid only if IPARML=YES is specified.

If this parameter is not specified, the subsequent IUCV SEND must specify it. The response length must be at least the value returned in SLXZSCR by QCONFIG.

TOKEN

specifies the address of the token obtained from QREQUEST.

tokenaddr specifies either an RX-type address of the token or the register (2) - (12) containing the address of the token.

This parameter is required if LIST is not specified.

COUNT

countaddr specifies the RX or register form address of a two-byte binary field containing the number of entries specified in LIST. Valid register values for RX addressing are (2) - (12). The maximum number of tokens specified is 500. If COUNT is specified without LIST, an error results.

This parameter is required when LIST is specified.

USER

useridaddr specifies an 8-byte userid associated with a console ID for the request.

Specify either an RX-type address of the data or the number of the register containing the address of the data.

This parameter is optional.

VOLSER

voladdr specifies the address of a 6-character volume label.

Specify either an RX-type address of the data or the number of the register containing the address of the data.

This parameter is required. It specifies the volume which is to be removed from scratch status.

Response to STOP Request

The response to a STOP request contains a reply header and a STOP information element for each token specified in the request.

UNSCRATCH

UNSCRATCH

The UNSCRATCH request causes a volume to be removed from scratch status in the library control data set.

UNSCRATCH Considerations

The specified cartridge must already be in the library. No cartridge movement occurs as the result of an UNSCRATCH request. However, UNSCRATCH request processing must select the cartridge (i.e., must acquire exclusive use of the cartridge) in order to change its state. This means that an UNSCRATCH request will fail if the cartridge is mounted on a drive (see “MOUNT Considerations” on page 49).

Syntax

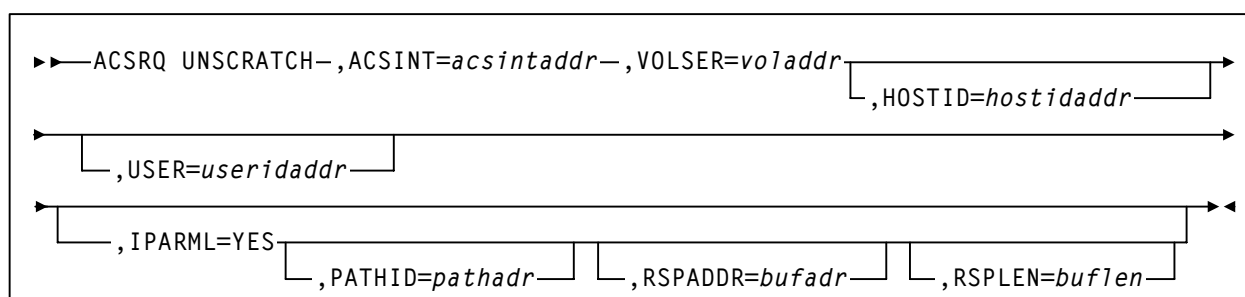

Parameters

ACSINT

acsintaddr specifies the address of the data area being sent to the library service machine.

Specify either an RX-type address of the data or the number of the register containing the address of the data. ACSRQ references the ACSINT at this address when filling in the data.

This parameter is required.

HOSTID

specifies the address of an eight character host ID, left justified and padded with blanks.

hostidaddr specifies either an RX-type address of the host ID or the register (2) - (12) containing the address of the host ID.

This parameter is optional. If the parameter is not specified, the host ID executing the request is used.

IPARML

yes specifies that the requestor has established addressability to an IUCV IPARML, and that the IPARML is initialized.

This parameter is optional.

PATHID

pathadr specifies the address of a 2-byte IUCV path ID of the library service machine.

Specify either an RX-type address of the data or the number of the register containing the address of the data. This data is used in the IUCV SEND PATHID statement.

PATHID is optional, and valid only if IPARML=YES is specified.

If this parameter is not specified, the subsequent IUCV SEND must specify it.

RSPADDR

bufadr specifies the address of the IUCV answer buffer.

Specify either an RX-type address of the data or the number of the register containing the address of the data. This data is used in the IUCV SEND ANSBUF statement.

RSPADDR is optional and valid only if IPARML=YES is specified.

If this parameter is not specified, the subsequent IUCV SEND must specify it.

RSPLEN

buflen specifies the address of the length of the IUCV answer buffer.

Specify either an RX-type address of the 2-byte field or the number of the register containing the address of the data. This data is used in the IUCV SEND ANSLEN statement.

RSPLEN is optional and valid only if IPARML=YES is specified.

If this parameter is not specified, the subsequent IUCV SEND must specify it. The response length must be at least the value returned in SLXZSCR by QCONFIG.

USER

useridaddr specifies an 8-byte userid associated with a console ID for the request.

Specify either an RX-type address of the data or the number of the register containing the address of the data.

This parameter is optional.

UNSCRATCH

VOLSER

voladdr specifies the address of a 6-character volume label.

Specify either an RX-type address of the data or the number of the register containing the address of the data.

This parameter is required. It specifies the volume which is to be removed from scratch status.

Response to UNSCRATCH Request

The response to UNSCRATCH contains only a Reply Header.

Refer to “SLX Macro Mapping” on page 132 for information on the SLX macro.

Chapter 4. Interface Data Areas

SLX Macro

A reply always begins with a header. The header may be followed by one or more “sections”. Each section is a table of “elements” of a particular type (e.g. Volume Information Element). If the Reply Header is aligned on a doubleword boundary, then all subsequent sections and elements are guaranteed to also begin on doubleword boundaries.

A section directory (number/offset/length) is defined in the Reply Header for each possible section type, even though no reply will ever contain all types of sections. The order in which the section directories appear within the header has no relationship to the order in which sections are physically arranged after the header.

A section directory’s number specifies how many elements of that type are actually present in the reply. If a section directory’s number is nonzero, then that section directory’s offset specifies the offset, from the start of the reply header, to the first (or only) element of that type. If a section directory’s number is greater than one, then that section directory’s length, which specifies the length of a single element of that type, must be used to access the second and subsequent elements of that type. For example, add the length to the offset to get the offset to the second element; add in the length again to get the offset to the third element; and so on. The number of elements in each section is variable. The following tables denote which sections of the reply will be returned for a given request.

Table 1. SLX Macro - Parameter Matrix (Part 1 of 4)

Reply Section	DEFPOOL	DEFSCR	DISMOUNT	EJECT	MOUNT	MOVE
Header	1	1	1	1	1	1
Configuration						
CAP						
Qeject						
Stop						
Volume				*	1 - if scratch	1 - if successful
Drive						
LSM						
Message text			1	*	1	1

Table 2. SLX Macro - Parameter Matrix (Part 2 of 4)

Reply Section	QCAP	QCONFIG	QDRIVES	QDRLIST	QEJECT	QREQUEST
Header	1	1	1	1	1	1
Configuration		1				
CAP	1					
Qeject					*	
Stop						1+
Volume				1 - if not scratch		
Drive			1+	1+		
LSM			1+			
Message text						

Table 3. SLX Macro - Parameter Matrix (Part 3 of 4)

Reply Section	QSCRATCH	QVOLUME	QVOLUME	SCRATCH	SELSCR	SETOPER
Header	1	1	1	1	1	1
Configuration						
CAP						
Qeject						
Stop						
Volume		*	*		1	
Drive						
LSM	1+					
Message text						

Table 4. SLX Macro - Parameter Matrix (Part 4 of 4)

Reply Section	UNSCRATCH	STOP	Future Use	Future Use	Future Use
Header	1	1			
Configuration					
CAP					
Qeject					
Stop		1+ (see below)			
Volume					
Drive					
LSM					
Message text					



Notes:

1 = 1 and only 1.

* = EJECT, QEJECT, and QVOLUME are limited by the number of Volume Information Elements contained in the SLX reply area (maximum of 500).

1+ = From 1 to “n” depending on library configuration. The number of elements returned for STOP depends on the number of tokens.

SLX Macro Mapping

Table 5. SLX Record Format

Dec	Hex	Type	Length	Label	Description
<p>SLX - HSC EXTERNAL INTERFACE REPLY</p> <p>FUNCTION:</p> <p>MAPS A REPLY AREA RETURNED BY ONE OF THE FOLLOWING HSC EXTERNAL INTERFACE REQUESTS:</p> <p>DEFPOOL - SPECIFY A SCRATCH POOL'S VOLSER RANGE DEFSCR - SPECIFY NUMBER OF SCRATCH POOLS DISMOUNT - DISMOUNT A VOLUME EJECT - EJECT A VOLUME FROM THE LIBRARY MOUNT - MOUNT A VOLUME MOVE - MOVE A VOLUME QCAP - RETURN CAP SUMMARY QCONFIG - RETURN CONFIGURATION SUMMARY QDRIVES - RETURN DRIVE AND LSM INFORMATION QDRLIST - RETURN DRIVE INFORMATION, ORDERED BY PREFERENCE QEJECT - RETURN EJECT SUMMARY QSCRATCH - RETURN LSM INFORMATION, ORDERED BY PREFERENCE QVOLUME - RETURN VOLUME INFORMATION SCRATCH - CHANGE A VOLUME'S STATUS TO 'SCRATCH' SELSCR - SELECT A SCRATCH VOLUME SETOPER - SET OPERATOR INTERACTION MODE STOP - TERMINATE A PGMI ASYNCHRONOUS TASK VCIRQST - SEND A VCI REQUEST TO HSC VCIRESP - RECEIVE A RESPONSE FOR A VCI REQUEST</p> <p>SPECIAL CONSIDERATIONS:</p> <p>A REPLY ALWAYS BEGINS WITH A HEADER. THE HEADER MAY BE FOLLOWED BY ONE OR MORE "SECTIONS". EACH SECTION IS A TABLE OF "ELEMENTS" OF A PARTICULAR TYPE (E.G. VOLUME INFORMATION ELEMENT). IF THE REPLY HEADER IS ALIGNED ON A DOUBLEWORD BOUNDARY, THEN ALL SUBSEQUENT SECTIONS AND ELEMENTS ARE GUARANTEED TO ALSO BEGIN ON DOUBLEWORD BOUNDARIES.</p> <p>A SECTION DIRECTORY (NUMBER/OFFSET/LENGTH) IS DEFINED IN THE REPLY HEADER FOR EACH POSSIBLE SECTION TYPE, EVEN THOUGH NO REPLY WILL EVER CONTAIN ALL TYPES OF SECTIONS. THE ORDER IN WHICH THE SECTION DIRECTORIES APPEAR WITHIN THE HEADER HAS NO RELATIONSHIP TO THE ORDER IN WHICH SECTIONS ARE PHYSICALLY ARRANGED AFTER THE HEADER.</p> <p>A SECTION DIRECTORY'S NUMBER SPECIFIES HOW MANY ELEMENTS OF THAT TYPE ARE ACTUALLY PRESENT IN THE REPLY. IF A SECTION DIRECTORY'S NUMBER IS NONZERO, THEN THAT SECTION DIRECTORY'S OFFSET SPECIFIES THE OFFSET, FROM THE START OF THE REPLY HEADER, TO THE FIRST (OR ONLY) ELEMENT OF THAT TYPE. IF A SECTION DIRECTORY'S NUMBER IS GREATER THAN ONE, THEN THAT SECTION DIRECTORY'S LENGTH, WHICH SPECIFIES THE LENGTH OF A SINGLE ELEMENT OF THAT TYPE, MUST BE USED TO ACCESS THE SECOND AND SUBSEQUENT ELEMENTS OF THAT TYPE: ADD THE LENGTH TO THE OFFSET TO GET THE OFFSET TO THE SECOND ELEMENT; ADD IN THE LENGTH AGAIN TO GET THE OFFSET TO THE THIRD ELEMENT; AND SO ON.</p>					
HEADER					
0	(0)	STRUCTURE		SLX	
0	(0)	AREA	1	SLXRPLY	REPLY HEADER
0	(0)	CHARACTER	3	SLXHID	HEADER IDENTIFIER
3	(3)	A-ADDR	1	SLXCMDRC	RETURN CODE:
0	(00)	CONST		SLXROK	REQUEST PROCESSED SUCCESSFULLY

Table 5. SLX Record Format

Dec	Hex	Type	Length	Label	Description
4	(04)	CONST		SLXRWARN	REQUEST SUCCESSFUL WITH WARNING SLXSRC WILL PROVIDE THE SPECIFIC REASON FOR THE WARNING
8	(08)	CONST		SLXRBADP	REQUEST FAILED; THE REQUEST BLOCK (MAPPED BY ACSINT) CONTAINED INVALID DATA (E.G., INCOMPATIBLE OPTIONS); SLXSRC (REASON CODE) WILL PROVIDE THE OFFSET OF THE ACSINT FIELD FOUND TO BE IN ERROR.
12	(0C)	CONST		SLXRIERR	REQUEST FAILED; AN UNRECOVERABLE INTERNAL ERROR OCCURRED WHILE PROCESSING THE REQUEST.
16	(10)	CONST		SLXRFAIL	REQUEST FAILED; SLXSRC WILL PROVIDE THE SPECIFIC REASON FOR THE FAILURE.
20	(14)	CONST		SLXRNHSC	REQUEST FAILED - HSC NOT AVAILABLE (MVS ONLY)
24	(18)	CONST		SLXRNAUT	REQUEST FAILED - USER NOT AUTHORIZED. THE REQUEST WAS FAILED BY SLSUX05 OR THE HSC DEFAULT AUTHORIZATION (MVS ONLY)
28	(1C)	CONST		SLXNTCB	REQUEST FAILED - THE CALLER WAS NOT IN TASK MODE (MVS ONLY)
32	(20)	CONST		SLXLOCKD	REQUEST FAILED - THE CALLER HELD AT LEAST ONE LOCK (MVS ONLY)
36	(24)	CONST		SLXTPROT	REQUEST FAILED - THE CALLER DID NOT HAVE FETCH/STORE AUTHORITY TO THE SLSXREQM PARAMETER LIST (MVS ONLY)
40	(28)	CONST		SLXNORSP	REQUEST FAILED - NO RESPONSE ELEMENT WITH THE SPECIFIED TOKEN EXISTED. (MVS ONLY)
44	(2C)	CONST		SLXRBADL	REQUEST FAILED; REPLY AREA PROVIDED BY REQUESTOR WAS TOO SMALL TO CONTAIN ALL REPLY DATA ASSOCIATED WITH THE REQUEST. IF FIELD SLXCRLN IS NON-ZERO, IT CONTAINS THE LENGTH VALUE THAT SHOULD BE SPECIFIED FOR THE REPLY AREA FOR THIS REQUEST. (VM ONLY)

Table 5. SLX Record Format

Dec	Hex	Type	Length	Label	Description
48	(30)	CONST		SLXRNVCI	VCIRQST AND VCIRESP NOT SUPPORTED. EITHER VTCS IS NOT INSTALLED - OR - IS NOT AT THE REQUIRED LEVEL TO SUPPORT THE PGMI VCI RESPONSES.
52	(34)	CONST		SLXREOV	END OF VCI RESPONSES.
56	(38)	CONST		SLXRVNV	VCI REQUEST NOT VALID. THE VCI COMMAND SUPPLIED ON THE VCIRQST STATEMENT IS NOT VALID.
60	(3C)	CONST		SLXRBTOK	THE VCI TOKEN BEING USED TO OBTAIN VCI RESPONSES IS INVALID.
4	(04)	A-ADDR	1	SLXVERS	REPLY VERSION CODE:
7	(07)	CONST	3	SLXVCODE	THIS IS VERSION 9 OF THE REPLY AREA.
5	(5)	HEXSTRING	4	-RESERVED-	RESERVED.
8	(8)	SIGNED-FWORD		SLXSRC	REASON CODE FOR FAILED OPERATION.
32818	(8032)	CONST		SLXTINTR	PGMI TASK INTERRUPTED.
32822	(8036)	CONST		SLXSANF	SEARCH ARGUMENT NOT FOUND.
32826	(803A)	CONST		SLXMSTT	MISMATCHED TOKEN TYPES.
32832	(8040)	CONST		SLXTRNF	TOKEN AREA NOT FOUND.
32848	(8050)	CONST		SLXSFUL	REPLY AREA FULL.
32849	(8051)	CONST		SLXDVMM	DRIVE/MEDIA MISMATCH; THE REQUESTED MEDIA (EITHER DIRECTLY VIA PGMI MEDIA/RECTECH OR INDIRECTLY VIA TAPEREQ) IS NOT COMPATIBLE WITH THE DRIVE SPECIFIED IN THE PGMI CALL.
12	(C)	SIGNED-FWORD	4	SLXCRLN	IF RETURN CODE (SLXCMDRC) IS 2C (SLXRBADL), THEN THIS FIELD CONTAINS EITHER THE MINIMUM ACCEPTABLE REPLY AREA LENGTH FOR THE REQUEST, OR 0 IF THE MINIMUM LENGTH COULDN'T BE DETERMINED. OTHERWISE (I.E., RETURN CODE ISN'T 2C), THIS FIELD CONTAINS THE ACTUAL LENGTH OF THIS REPLY.
16	(10)	SIGNED-FWORD	4	SLXPEOFF	PARAMETER ERROR OFFSET IF SLSXRC <> 0 THEN THIS POINTS TO AN ELEMENT IN A LIST WHERE PROCESSING STOPPED WHEN THE REQUEST WAS EITHER "STOP", "QCAP" OR "QEJECT".

Table 5. SLX Record Format

Dec	Hex	Type	Length	Label	Description
20	(14)	LENGTH		SLXHL	TO MAKE COMPATIBLE WITH MVS CODE
CONFIGURATION SUMMARY SECTION DIRECTORY					
20	(14)	SIGNED-FWORD	4	SLXXCFGN	NUMBER OF CONFIGURATION ELEMENTS PRESENT IN THIS REPLY.
24	(18)	SIGNED-FWORD	4	SLXXCFGO	OFFSET TO CONFIGURATION SECTION, FROM START OF REPLY, OR 0 IF REPLY DOESN'T CONTAIN ANY CONFIGURATION ELEMENTS.
28	(1C)	SIGNED-FWORD	4	SLXXCFGL	LENGTH OF A CONFIGURATION ELEMENT.
VOLUME INFORMATION SECTION DIRECTORY					
32	(20)	SIGNED-FWORD	4	SLXXVOLN	NUMBER OF VOLUME ELEMENTS PRESENT IN THIS REPLY.
36	(24)	SIGNED-FWORD	4	SLXXVOLO	OFFSET TO VOLUME SECTION, FROM START OF REPLY, OR 0 IF REPLY DOESN'T CONTAIN ANY VOLUME ELEMENTS.
40	(28)	SIGNED-FWORD	4	SLXXVOLL	LENGTH OF A VOLUME ELEMENT.
DRIVE INFORMATION SECTION DIRECTORY					
44	(2C)	SIGNED-FWORD	4	SLXXDRVN	NUMBER OF DRIVE ELEMENTS PRESENT IN THIS REPLY.
48	(30)	SIGNED-FWORD	4	SLXXDRVO	OFFSET TO DRIVE SECTION, FROM START OF REPLY, OR 0 IF REPLY DOESN'T CONTAIN ANY DRIVE ELEMENTS.
52	(34)	SIGNED-FWORD	4	SLXXDRVL	LENGTH OF A DRIVE ELEMENT.
LSM INFORMATION SECTION DIRECTORY					
56	(38)	SIGNED-FWORD	4	SLXXLSMN	NUMBER OF LSM ELEMENTS PRESENT IN THIS REPLY.
60	(3C)	SIGNED-FWORD	4	SLXXLSMO	OFFSET TO LSM SECTION, FROM START OF REPLY, OR 0 IF REPLY DOESN'T CONTAIN ANY LSM ELEMENTS.
64	(40)	SIGNED-FWORD	4	SLXXLSML	LENGTH OF AN LSM ELEMENT.
MESSAGE TEXT SECTION DIRECTORY					
WARNING: THIS DIRECTORY DOES NOT EXIST WHEN THE VALUE IN THE REPLY VERSION NUMBER FIELD, SLXVERS, IS LESS THAN 2.					
68	(44)	SIGNED-FWORD	4	SLXXMSGN	NUMBER OF MESSAGE ELEMENTS PRESENT IN THIS REPLY.

Table 5. SLX Record Format

Dec	Hex	Type	Length	Label	Description
72	(48)	SIGNED-FWORD	4	SLXXMSGO	OFFSET TO MESSAGE SECTION, FROM START OF REPLY, OR 0 IF REPLY DOESN'T CONTAIN ANY MESSAGE ELEMENTS.
76	(4C)	SIGNED-FWORD	4	SLXXMSGL	LENGTH OF A MESSAGE ELEMENT.
QCAP INFORMATION SECTION DIRECTORY					
80	(50)	SIGNED-FWORD	4	SLXXCAPN	NUMBER OF CAP ELEMENTS PRESENT IN THIS REPLY.
84	(54)	SIGNED-FWORD	4	SLXXCAPO	OFFSET TO CAP SECTION FROM START OF REPLY.
88	(58)	SIGNED-FWORD	4	SLXXCAPL	LENGTH OF A CAP ELEMENT.
QEJECT INFORMATION SECTION DIRECTORY					
92	(5C)	SIGNED-FWORD	4	SLXXQJTN	NUMBER OF QEJECT ELEMENTS PRESENT IN THIS REPLY.
96	(60)	SIGNED-FWORD	4	SLXXQJTO	OFFSET TO QEJECT SECTION, FROM START OF REPLY.
100	(64)	SIGNED-FWORD	4	SLXXQJTL	LENGTH OF A QEJECT ELEMENT.
STOP INFORMATION SECTION DIRECTORY					
104	(68)	SIGNED-FWORD	4	SLXXSTPN	NUMBER OF STOP ELEMENTS PRESENT IN THIS REPLY.
108	(6C)	SIGNED-FWORD	4	SLXXSTPO	OFFSET TO STOP SECTION, FROM START OF REPLY.
112	(70)	SIGNED-FWORD	4	SLXXSTPL	LENGTH OF A STOP ELEMENT.
QDSN INFORMATION SECTION DIRECTORY					
116	(74)	SIGNED-FWORD	4	SLXXQDSN	NUMBER OF QDSN ELEMENTS PRESENT IN THIS REPLY.
120	(78)	SIGNED-FWORD	4	SLXXQDSO	OFFSET TO QDSM SECTION, FROM START OF REPLY.
124	(7C)	SIGNED-FWORD	4	SLXXQDSL	LENGTH OF AN QDSN ELEMENT.
VCI INFORMATION SECTION DIRECTORY					
128	(80)	SIGNED-FWORD	4	SLXXVCIN	NUMBER OF VCI ELEMENTS PRESENT IN THIS REPLY
132	(84)	SIGNED-FWORD	4	SLXXVCIO	OFFSET TO VCI SECTION FROM START OF REPLY
136	(88)	SIGNED-FWORD	4	SLXXVCIL	LENGTH OF A VCI ELEMENT
140	(8C)	A-ADDR	4	-RESERVED-(9)	RESERVED FOR FUTURE ENTRIES

Table 5. SLX Record Format

Dec	Hex	Type	Length	Label	Description
176	(B0)	AREA	8	SLXEND	LABEL FOR ADDRESSING NEXT AREA.
176	(B0)	LENGTH		SLXL	SLX LENGTH.
176	(B0)	CONST		SLXXSDL	LENGTH OF HEADER.
<p>CONFIGURATION SUMMARY ELEMENT THIS ELEMENT APPEARS IN THE REPLY TO A QCONFIG REQUEST AND SUPPLIES SUMMARY INFORMATION ABOUT THE LIBRARY AND ABOUT REPLY LENGTHS NECESSARY FOR OTHER TYPES OF REQUESTS.</p>					
0	(0)	STRUCTURE		SLXSCFG	CONFIGURATION SUMMARY ELEMENT.
0	(0)	CHARACTER	3	SLXLID	ELEMENT IDENTIFIER.
3	(3)	HEXSTRING	1	-RESERVED-	RESERVED.
4	(4)	CHARACTER	8	SLXLHNAME	HOST NAME.
12	(C)	SIGNED-FWORD	4	SLXLHHT	HOST PULSE VALUE.
16	(10)	SIGNED-FWORD	4	SLXLRSTM	RESERVE TIMEOUT LIMIT.
20	(14)	CHARACTER	8	SLXLQNAME	ENQ MAJOR NAME.
28	(1C)	CHARACTER	8	SLXLEJPS	EJECT COMMAND PASSWORD (ENCRYPTED)
36	(24)	CHARACTER	1	SLXLCMPF	COMMAND PREFIX CHARACTER.
37	(25)	A-ADDR	1	SLXLSCLB	LIBRARY DEFAULT SCRATCH LABEL TYPE CODE:
1	(01)	CONST		SLXLLBSL	STANDARD (SL).
2	(02)	CONST		SLXLLBAL	ASCII (AL).
3	(03)	CONST		SLXLLBNL	NON-LABELED (NL).
4	(04)	CONST		SLXLLBNS	NON-STANDARD LABEL (NSL)
38	(26)	A-ADDR	1	SLXLSMF	SMF RECORD TYPE
39	(27)	HEXSTRING	1	-RESERVED-	RESERVED.
40	(28)	SIGNED-FWORD	4	SLXQMDR	LARGEST NUMBER OF DRIVES IN ANY ACS.
44	(2C)	SIGNED-FWORD	4	SLXQDRCT	NUMBER OF DRIVES IN THE LIBRARY.
48	(30)	SIGNED-FWORD	4	SLXQACNT	NUMBER OF ACSS IN THE LIBRARY.
52	(34)	SIGNED-FWORD	4	SLXQLCNT	NUMBER OF LSMS IN THE LIBRARY.

Table 5. SLX Record Format

Dec	Hex	Type	Length	Label	Description
56	(38)	SIGNED-FWORD	4	SLXZVOL	MAXIMUM LENGTH OF REPLY DATA RETURNED IN RESPONSE TO A QVOLUME REQUEST THAT SPECIFIES THE LARGEST SUPPORTED NUMBER OF VOLUMES (500).
60	(3C)	SIGNED-FWORD	4	SLXZQDRV	MAXIMUM LENGTH OF REPLY DATA RETURNED IN RESPONSE TO A QDRIVES REQUEST.
64	(40)	SIGNED-FWORD	4	SLXZQDRL	MAXIMUM LENGTH OF REPLY DATA RETURNED IN RESPONSE TO A QDRLIST REQUEST.
68	(44)	SIGNED-FWORD	4	SLXQVOL	MAXIMUM LENGTH OF REPLY DATA RETURNED IN RESPONSE TO A QVOLUME REQUEST THAT SPECIFIES ONLY 1 VOLUME.
72	(48)	SIGNED-FWORD	4	SLXZGSCR	MAXIMUM LENGTH OF REPLY DATA RETURNED IN RESPONSE TO A SELSCR REQUEST.
76	(4C)	SIGNED-FWORD	4	SLXZMDM	MAXIMUM LENGTH OF REPLY DATA RETURNED IN RESPONSE TO A MOUNT REQUEST.
80	(50)	SIGNED-FWORD	4	SLXZQSCR	MAXIMUM LENGTH OF REPLY DATA RETURNED IN RESPONSE TO A QSCRATCH REQUEST.
WARNING: THE REMAINING FIELDS OF THIS ELEMENT ARE AVAILABLE FOR VERSION(S) 2 AND ABOVE.					
84	(54)	SIGNED-FWORD	4	SLXZDISM	MAXIMUM LENGTH OF REPLY DATA RETURNED IN RESPONSE TO A DISMOUNT REQUEST.
88	(58)	SIGNED-FWORD	4	SLXZEJCT	MAXIMUM LENGTH OF REPLY DATA RETURNED IN RESPONSE TO AN EJECT REQUEST THAT SPECIFIES THE LARGEST SUPPORTED NUMBER OF VOLUMES (500).
92	(5C)	SIGNED-FWORD	4	SLXZSCR	MAXIMUM LENGTH OF REPLY DATA RETURNED IN RESPONSE TO A SCRATCH REQUEST.
96	(60)	SIGNED-FWORD	4	SLXZDEFP	MAXIMUM LENGTH OF REPLY DATA RETURNED IN RESPONSE TO A DEFPOOL REQUEST.
100	(64)	SIGNED-FWORD	4	SLXZDEFS	MAXIMUM LENGTH OF REPLY DATA RETURNED IN RESPONSE TO A DEFSCR REQUEST.

Table 5. SLX Record Format

Dec	Hex	Type	Length	Label	Description
104	(68)	SIGNED-FWORD	4	SLXZSETO	MAXIMUM LENGTH OF REPLY DATA RETURNED IN RESPONSE TO A SETOPER REQUEST.
WARNING: THE REMAINING FIELDS OF THIS ELEMENT ARE AVAILABLE FOR VERSION(S) 3 AND ABOVE.					
108	(6C)	SIGNED-FWORD	4	SLXZMOVE	MAXIMUM LENGTH OF REPLY DATA RETURNED IN RESPONSE TO AN MOVE REQUEST.
112	(70)	SIGNED-FWORD	4	SLXZEJC1	MAXIMUM LENGTH OF REPLY DATA RETURNED IN RESPONSE TO AN EJECT REQUEST FOR ONLY 1 VOLUME.
WARNING: THE REMAINING FIELDS OF THIS ELEMENT ARE AVAILABLE FOR VERSION(S) 6 AND ABOVE.					
116	(74)	A-ADDR	4	SLXQUCSA	MVS -- ADDRESS OF SLSUXCSA.
120	(78)	SIGNED-FWORD	4	-RESERVED-	RESERVED.
124	(7C)	SIGNED-FWORD	4	SLXQLCAP	NUMBER OF CAPS IN LIBRARY.
128	(80)	SIGNED-FWORD	4	SLXEXLM0	ExLM R15
132	(84)	SIGNED-FWORD	4	SLXEXLM1	ExLM R1
136	(88)	SIGNED-FWORD	4	SLXEXLM2	ExLM R2
140	(8C)	SIGNED-FWORD	4	SLXZQCAP	MAXIMUM LENGTH OF REPLY DATA RETURNED IN RESPONSE TO A QCAP REQUEST.
144	(90)	SIGNED-FWORD	4	SLXZQEJT	MAXIMUM LENGTH OF REPLY DATA RETURNED IN RESPONSE TO A QEJECT REQUEST.
148	(94)	SIGNED-FWORD	4	SLXZSTOP	MAXIMUM LENGTH OF REPLY DATA RETURNED IN RESPONSE TO A STOP REQUEST.
152	(98)	SIGNED-FWORD	4	SLXZQDSN	MAXIMUM LENGTH OF REPLY DATA RETURNED IN RESPONSE TO A QDSN REQUEST.
156	(9C)	SIGNED-FWORD	4	-RESERVED-	RESERVED FUTURE USE.
160	(A0)	SIGNED-HWORD	2	SLXHSCV	HSC VERSION NUMBER
162	(A2)	HEXSTRING	6	-RESERVED-	
168	(A8)	CONST		SLXSCFGL	LENGTH OF A CONFIGURATION ELEMENT.

Table 5. SLX Record Format

Dec	Hex	Type	Length	Label	Description
QDSN INFORMATION ELEMENT					
THIS ELEMENT APPEARS IN THE REPLY TO A QDSN REQUEST AND SUPPLIES SUMMARY INFORMATION ABOUT THE CURRENT REFERENCED DATASETS USED BY THE HSC.					
0	(0)	STRUCTURE		SLXDSNIM	DATASET INFORMATION MAP.
0	(0)	CHARACTER	3	SLXQDID	SECTION IDENTIFIER.
3	(03)	BITSTRING	1	SLXDSFLG	DATASET TYPE.
1	(01)	CONST		SLXDSPRM	CDS PRIMARY.
2	(02)	CONST		SLXDSSEC	CDS SECONDARY.
3	(03)	CONST		SLXDSSBY	CDS STANDBY.
4	(04)	CONST		SLXDVSAT	VOLUME ATTRIBUTES.
5	(05)	CONST		SLXDSUAT	UNIT ATTRIBUTES.
6	(06)	CONST		SLXDSTRQ	TAPEREQS.
7	(07)	CONST		SLXDSPLB	PARMLIB.
8	(08)	CONST		SLXDSJNP	PRIMARY JOURNAL.
9	(09)	CONST		SLXDSJNA	ALTERNATE JOURNAL.
9	(09)	CONST		SLXDSEX	MAX NUMBER OF QDS RETURNED.
4	(04)	CHARACTER	44	SLXDSNAM	DATASET NAME.
48	(30)	CHARACTER	8	SLXDSEMBR	MEMBER NAME.
56	(38)	CHARACTER	6	SLXDSEVOL	VOLUME NAME.
62	(3E)	CHARACTER	8	SLXDSEUNT	UNIT NAME.
70	(46)	CHARACTER	2	-RESERVED-	RESERVED.
72	(48)	CHARACTER	96	-RESERVED-	RESERVED.
168	(A8)	AREA	8	-RESERVED-	ALIGN
168	(A8)	LENGTH		SLXDSENEL	LENGTH OF ONE DATASET ENTRY.
CAP INFORMATION ELEMENT					
THIS ELEMENT SUPPLIES INFORMATION ABOUT A SINGLE LIBRARY CAP					
0	(0)	STRUCTURE		SLXSCAP	
0	(0)	CHARACTER	4	SLXCID	SECTION IDENTIFIER.
4	(4)	HEXSTRING	1	SLXCACS	ACS ADDRESS.
5	(5)	HEXSTRING	1	SLXCLSM	LSM ADDRESS.
6	(6)	HEXSTRING	1	SLXCCAP	CAP NUMBER.

Table 5. SLX Record Format

Dec	Hex	Type	Length	Label	Description
7	(7)	HEXSTRING	1	-RESERVED-	RESERVED.
8	(8)	AREA	2	SLXCSTAT	CAP STATUS.
8	(8)	BITSTRING	1	SLXCSTB1	CAP STATUS.
		1... X'80'		SLXCSTCA	CAP IS ACTIVE.
		.1.. X'40'		SLXCSTNR	CAP NEEDS RECOVERY.
		..1. X'20'		SLXCSTAM	CAP IS IN AUTOMATIC MODE.
		...1 X'10'		SLXCSTCL	CAP IS LINKED.
	 1... X'08'		SLXCSTCO	CAP IS ONLINE.
9	(9)	BITSTRING	1	SLXCSTB2	CAP MODE.
		1... X'80'		SLXCSTIE	CAP IS ENTERING.
		.1.. X'40'		SLXCSTID	CAP IS DRAINING.
		..1. X'20'		SLXCSTIJ	CAP IS EJECTING.
		...1 X'10'		SLXCSTIC	CAP IS CLEANING.
	 1... X'08'		SLXCSTII	CAP IS IDLE .
10	(A)	BITSTRING	1	SLXTYPE	TYPE OF CAP.
		1... X'80'		SLXCTPC	PRIORITY CAP
	1 X'01'		SLXCTCIM	CIMARRON
	1. X'02'		SLXCTCLP	CLIPPER.
	11 X'03'		SLXCTTWS	STANDARD CLIPPER
	1.. X'04'		SLXCTTWO	OPTIONAL CLIPPER
	1.1 X'05'		SLXCTTIM	(9740/TimberWolf)
12	(C)	SIGNED-HWORD	2	SLXCCELL	CELLS IN CAP.
14	(E)	HEXSTRING	1	SLXCNRW	ROWS.
15	(F)	HEXSTRING	1	SLXCNCOL	COLUMNS .
16	(10)	HEXSTRING	1	SLXCCMAG	MAGAZINES.
17	(11)	HEXSTRING	1	SLXCCMGC	CELLS IN MAGAZINE.
18	(12)	CHARACTER	8	SLXCJOB	JOBNAME OF OWNER.
26	(1A)	HEXSTRING	6	-RESERVED-	ALIGN TO DOUBLE WORD
32	(20)	CONST		SLXSCAPL	LENGTH OF A CAP ELEMENT.

Table 5. SLX Record Format

Dec	Hex	Type	Length	Label	Description
QEJECT INFORMATION ELEMENT THIS ELEMENT SUPPLIES INFORMATION ABOUT A SINGLE EJECT VOLUME AND IS REPEATED FOR EACH VOLUME WITHIN AN EJECT LIST					
0	(0)	STRUCTURE		SLXQJT	
0	(0)	CHARACTER	4	SLXQID	SECTION IDENTIFIER.
4	(4)	HEXSTRING	4	SLXQJTT	TOKEN OF EJECT TASK.
8	(8)	HEXSTRING	4	SLXQJTC	EJECT (ACS / LSM / CAP 00)
12	(C)	HEXSTRING	2	SLXQJTS	TARGETED VOLUME EJECT STATUS.
65535	(FFFF)	CONST		SLXQJTN	VOLUME NOT PROCESSED YET.
0	(00)	CONST		SLXQJTD	VOLUME HAS BEEN EJECTED.
14	(E)	HEXSTRING	6	SLXQJTV	VOLUME NUMBER.
20	(14)	HEXSTRING	4	-RESERVED-	ALIGN TO DOUBLE WORD.
24	(18)	CONST		SLXQJTL	LENGTH OF A QEJECT ELEMENT.
STOP INFORMATION ELEMENT THIS ELEMENT SUPPLIES STATUS FOR A TOKEN OF A PGMI TASK REQUESTED TO BE STOPPED. THIS DEFINITION WILL BE REPEATED FOR EACH ELEMENT WITHIN A TASK STOP LIST					
0	(0)	STRUCTURE		SLXSTP	
0	(0)	CHARACTER		SLXSID	SECTION IDENTIFIER.
4	(4)	HEXSTRING	4	SLXSTPT	TOKEN NUMBER.
8	(8)	HEXSTRING	1	SLXSTPY	TARGET PROCESS TYPE.
9	(9)	BITSTRING	1	SLXSTPS	TARGET PROCESS STOP STATUS.
	 X'00'		SLXSTPK	PROCESS MARKED TO STOP.
		111. 111. X'EE'		SLXSTPE	PROCESS DOES NOT SUPPORT STOP.
		1111 1111 X'FF'		SLXSTPN	PROCESS TOKEN NOT FOUND.
10	(A)	HEXSTRING	6	-RESERVED-	ALIGN TO DOUBLE WORD.
16	(10)	CONST		SLXSTPL	LENGTH OF A STOP ELEMENT.
VOLUME INFORMATION ELEMENT THIS ELEMENT SUPPLIES INFORMATION ABOUT A SINGLE VOLUME AND IS REPEATED FOR EACH VOLUME ASSOCIATED WITH A REQUEST. THIS ELEMENT MAY APPEAR IN REPLIES TO THE FOLLOWING REQUESTS: QDRLIST - RETURN DRIVE INFORMATION, ORDERED BY PREFERENCE QVOLUME - RETURN VOLUME INFORMATION SELSCR - SELECT A SCRATCH VOLUME EJECT - EJECT VOLUMES					

Table 5. SLX Record Format

Dec	Hex	Type	Length	Label	Description
0	(0)	STRUCTURE		SLXSVOL	VOLUME INFORMATION ELEMENT.
0	(0)	CHARACTER	3	SLXVID	ELEMENT IDENTIFIER.
3	(3)	BITSTRING	1	SLXVSTA	VOLUME STATUS:
		1... X'80'		SLXVILB	VOLUME IS IN LIBRARY
		. .1.. X'40'		SLXVOHST	VOLUME IS IN USE BY ANOTHER HOST
		. .1. X'20'		SLXVSCR	VOLUME IS CONSIDERED SCRATCH
	1 X'10'		SLXVMAL	VOLUME IS IN MANUAL-MODE LSM.
	 1... X'08'		SLXVDSC	VOLUME IS IN DISCONNECTED ACS.
	1.. X'04'		SLXVMNT	VOLUME IS MOUNTED ON A DRIVE.
	1. X'02'		SLXVERR	VOLUME IS 'ERRANT' (I.E., ITS LOCATION WITHIN THE LIBRARY IS UNCERTAIN).
	1 X'01'		SLXVTV	VOLUME IS A VTCS VIRTUAL VOLUME
4	(4)	CHARACTER	6	SLXVSER	VOLUME SERIAL.
10	(A)	A-ADDR	1	SLXVLC	VOLUME LOCATION CODE:
0	(0)	CONST		SLXVUNK	LOCATION DATA UNAVAILABLE (SLXVLOC IS 0).
1	(1)	CONST		SLXVCEL	LOCATION DATA DESCRIBES A CELL.
2	(02)	CONST		SLXVDRV	LOCATION DATA DESCRIBES A DRIVE.
11	(B)	AREA	5	SLXVLOC	VOLUME LOCATION DATA:
11	(B)	A-ADDR	1	SLXVACS	ACS ID.
12	(C)	A-ADDR	1	SLXVLSM	LSM ID.
13	(D)	A-ADDR	3	SLXVPNL	CELL'S PANEL ID, ROW ID, COLUMN ID.
13	(D)	A-ADDR	2	SLXVDRIV	DRIVE ADDRESS (0CUU).
15	(F)	BITSTRING	1	SLXVSTA2	MORE VOLUME STATUS: EQU X'E0' RESERVED.
		...1 X'10'		SLXVMLMU	VOLUME MEDIA TYPE CAME FROM LMU. EQU X'08' RESERVED.
	1.. X'04'		SLXVMUNR	VOLUME MEDIA TYPE UNREADABLE.

Table 5. SLX Record Format

Dec	Hex	Type	Length	Label	Description
	1. X'02'		SLXVMVLA	VOLUME MEDIA TYPE CAME FROM VOLATTR.
	1 X'01'		SLXVMDFL	VOLUME MEDIA TYPE DEFAULT ASSIGNED.
16	(10)	AREA	8	SLXVTSSN	VTSS NAME
16	(10)	SIGNED-FWORD	4	SLXVDATI	HI-WORD OF TOD AT INSERTION.
20	(14)	SIGNED-FWORD	4	SLXVDATL	HI-WORD OF TOD LAST SELECTION.
24	(18)	SIGNED-FWORD	4	SLXVSCNT	SELECTION COUNT.
28	(1C)	SIGNED-FWORD	4	SLXVDATD	HI-WORD OF TOD LAST MOUNT.
32	(20)	CHARACTER	8	SLXVMED	TYPE OF MEDIA.
40	(28)	CONST		SLXSVOLN	LENGTH OF A VOLUME ELEMENT.
40	(28)	CONST		SLXSVOLL	LENGTH OF A VOLUME ELEMENT.
<p>DRIVE INFORMATION ELEMENT THIS ELEMENT SUPPLIES INFORMATION ABOUT A SINGLE LIBRARY TAPE DRIVE AND IS REPEATED FOR EACH DRIVE ASSOCIATED WITH A REQUEST. THIS ELEMENT MAY APPEAR IN REPLIES TO THE FOLLOWING REQUESTS: QDRIVES - RETURN DRIVE AND LSM INFORMATION QDRLIST - RETURN DRIVE INFORMATION, ORDEREDBY PREFERENCE</p>					
0	(0)	STRUCTURE		SLXSDRV	DRIVE INFORMATION ELEMENT.
0	(0)	CHARACTER	3	SLXDID	ELEMENT IDENTIFIER
3	(3)	BITSTRING	1	SLXDSTA	LIBRARY STATUS:
		...1 X'10'		SLXDMANU	LSM IS IN MANUAL MODE.
	 1... X'08'		SLXDDISC	ACS IS DISCONNECTED.
4	(4)	A-ADDR	1	SLXQDEAC	ACS ID.
5	(5)	A-ADDR	1	SLXQDELS	LSM ID.
6	(6)	A-ADDR	2	SLXQDECU	DRIVE ADDRESS (0CUU).
8	(8)	CHARACTER	8	SLXQDRT	RECORDING TECHNIQUE OF DRIVE
16	(10)	CONST		SLXSDRVL	LENGTH OF A DRIVE ELEMENT.
<p>LSM INFORMATION ELEMENT THIS ELEMENT SUPPLIES INFORMATION ABOUT A SINGLE LSM (LIBRARY STORAGE MODULE) AND IS REPEATED FOR EACH LSM ASSOCIATED WITH A REQUEST. THIS ELEMENT MAY APPEAR IN REPLIES TO THE FOLLOWING REQUESTS: QDRIVES - RETURN DRIVE AND LSM INFORMATION QSCRATCH - RETURN LSM INFORMATION, ORDERED BY PREFERENCE</p>					
0	(0)	STRUCTURE		SLXSLSM	LSM INFORMATION ELEMENT

Table 5. SLX Record Format

Dec	Hex	Type	Length	Label	Description
0	(0)	CHARACTER	3	SLXMID	ELEMENT IDENTIFIER.
3	(3)	BITSTRING	1	SLXMSTAT	LIBRARY STATUS:
		...1 X'10'		SLXMANUL	LSM IS IN MANUAL MODE
	 1... X'08'		SLXMDISC	ACS IS DISCONNECTED.
4	(4)	A-ADDR	1	SLXMACS	ACS ID.
5	(5)	A-ADDR	1	SLXMLSM	LSM ID.
6	(6)	SIGNED-FWORD	1	SLXMADJN	NUMBER OF ADJACENT LSMS.
7	(7)	A-ADDR	1	SLXMADJI(4)	LIST OF LSM IDS OF ADJACENT LSMS (ONLY THE FIRST N IDS ARE VALID, WHERE N IS THE VALUE IN SLXMADJN).
11	(B)	HEXSTRING	1	-RESERVED-	RESERVED.
12	(C)	SIGNED-FWORD	4	SLXMNSCR	NUMBER OF SCRATCH VOLUMES IN THIS LSM.
16	(10)	SIGNED-FWORD	4	SLXMTCEL	TOTAL CELLS IN LSM.
20	(14)	SIGNED-FWORD	4	SLXMFCEL	FREE CELLS IN LSM.
24	(18)	CONST		SLXSLSML	LENGTH OF AN LSM ELEMENT.
<p>MESSAGE TEXT ELEMENT</p> <p>THIS ELEMENT SUPPLIES THE COMPLETE TEXT OF THE MESSAGE WHOSE BINARY MESSAGE ID NUMBER IS REPORTED IN HEADER FIELD SLXSRC. THIS ELEMENT MAY APPEAR IN REPLIES TO THE FOLLOWING REQUESTS:</p> <p>DISMOUNT - DISMOUNT A VOLUME</p> <p>MOUNT - MOUNT A VOLUME</p> <p>MOVE - MOVE A VOLUME</p> <p>EJECT - EJECT VOLUMES</p>					
0	(0)	STRUCTURE		SLXSMSG	MESSAGE TEXT ELEMENT.
0	(0)	CHARACTER	3	SLXGID	ELEMENT IDENTIFIER.
3	(3)	CHARACTER	125	SLXGTEXT	TEXT OF THE MESSAGE WHOSE NUMBER IS IN FIELD SLXSRC OF THE REPLY HEADER.
0	(0)	STRUCTURE		SLXSMSG	
128	(80)	CONST		SLXSMSGGL	LENGTH OF A MESSAGE ELEMENT.

Cross Reference

Name	Len	Offset Value
SLXCACS	000001	04
SLXCCAP	000001	06
SLXCCELL	000002	0C
SLXCCMAG	000001	10
SLXCCMGC	000001	11
SLXCID	000004	00
SLXCJOB	000008	12
SLXCLSM	000001	05
SLXCMDRC	000001	03
SLXCNCOL	000001	0F
SLXCNROW	000001	0E
SLXCRLN	000004	0C
SLXCSTAM	-	20
SLXCSTAT	000002	08
SLXCSTB1	000001	08
SLXCSTB2	000001	09
SLXCSTCA	-	80
SLXCSTCL	-	10
SLXCSTCO	-	08
SLXCSTIC	-	10
SLXCSTID	-	40
SLXCSTIE	-	80
SLXCSTII	-	08
SLXCSTIJ	-	20
SLXCSTNR	-	40
SLXCTCIM	-	01
SLXCTCLP	-	02
SLXCTPC	-	80
SLXCTTIM	-	05
SLXCTTWO	-	04
SLXCTTWS	-	03

Name	Len	Offset Value
SLXCTYPE	000001	0A
SLXDDISC	-	08
SLXDID	000003	00
SLXDMANU	-	10
SLXDSFLG	000001	03
SLXDSJNA	-	09
SLXDSJNP	-	08
SLXDSMAX	-	09
SLXDSTRQ	000008	30
SLXDSTRQ	000044	04
SLXDSNEL	-	A8
SLXDSPLB	-	07
SLXDSPRM	-	01
SLXDSSBY	-	03
SLXDSSEC	-	02
SLXDSTA	000001	03
SLXDSTRQ	-	06
SLXDSUAT	-	05
SLXDSUNT	000008	3E
SLXDVSAT	-	04
SLXDVSOL	000006	38
SLXDVMM	-	8051
SLXEND	000008	B0
SLXEXLM0	000004	80
SLXEXLM1	000004	84
SLXEXLM2	000004	88
SLXGID	000003	00
SLXGTEXT	000125	03
SLXHID	000003	00
SLXHL	-	14
SLXHSCV	000002	A0
SLXL	-	B0

Name	Len	Offset Value
SLXLCMPF	000001	24
SLXLEJPS	000008	1C
SLXLHHBT	000004	0C
SLXLHNAM	000008	04
SLXLID	000003	00
SLXLLBAL	-	02
SLXLLBNL	-	03
SLXLLBNS	-	04
SLXLLBSL	-	01
SLXLOCKD	-	20
SLXLQNAM	000008	14
SLXLRSTM	000004	10
SLXLSCLB	000001	25
SLXLSMF	000001	26
SLXMACS	000001	04
SLXMADJI	000001	07
SLXMADJN	000001	06
SLXMANUL	-	10
SLXMDISC	-	08
SLXMFCEL	000004	14
SLXMID	000003	00
SLXMLSM	000001	05
SLXMNSCR	000004	0C
SLXMSTAT	000001	03
SLXMSTT	-	803A
SLXMTCEL	000004	10
SLXNORSP	-	28
SLXNTCB	-	1C
SLXPEOFF	000004	10
SLXQACNT	000004	30
SLXQDEAC	000001	04
SLXQDECU	000002	06

Name	Len	Offset Value
SLXQDELS	000001	05
SLXQDID	000003	00
SLXQDRCT	000004	2C
SLXQDRT	000008	08
SLXQID	000004	00
SLXQJTC	000004	08
SLXQJTD	-	00
SLXQJTL	-	18
SLXQJTN	-	FFFF
SLXQJTS	000002	0C
SLXQJTT	000004	04
SLXQJTV	000006	0E
SLXQLCAP	000004	7C
SLXQLCNT	000004	34
SLXQMDR	000004	28
SLXQUCSA	000004	74
SLXRBADL	-	2C
SLXRBADP	-	08
SLXRB TOK	-	3C
SLXREOV	-	34
SLXRFAIL	-	10
SLXRIERR	-	0C
SLXRNAUT	-	18
SLXRNHSC	-	14
SLXRN VCI	-	30
SLXROK	-	00
SLXRPLY	000001	00
SLXRVNV	-	38
SLXRWARN	-	04
SLXSANF	-	8036
SLXSCAPL	-	20
SLXSCFGL	-	A8

Name	Len	Offset Value
SLXSDRVL	-	10
SLXSFUL	-	8050
SLXSID	000004	00
SLXSLSML	-	18
SLXSMSGL	-	80
SLXSRC	000004	08
SLXSTPE	-	EE
SLXSTPK	-	00
SLXSTPL	-	10
SLXSTPN	-	FF
SLXSTPS	000001	09
SLXSTPT	000004	04
SLXSTPY	000001	08
SLXSVOLL	-	28
SLXSVOLN	-	28
SLXTINTR	-	8032
SLXTPROT	-	24
SLXTRNF	-	8040
SLXVACS	000001	0B
SLXVCEL	-	01
SLXVCODE	-	07
SLXVDATD	000004	1C
SLXVDATI	000004	10
SLXVDATL	000004	14
SLXVDRIV	000002	0D
SLXVDRV	-	02
SLXVDSC	-	08
SLXVERR	-	02
SLXVERS	000001	04
SLXVID	000003	00
SLXVILB	-	80
SLXVLC	000001	0A

Name	Len	Offset Value
SLXVLOC	000005	0B
SLXVLSM	000001	0C
SLXVMAL	-	10
SLXVMDFL	-	01
SLXVMED	000008	20
SLXVMLMU	-	10
SLXVMNT	-	04
SLXVMUNR	-	04
SLXVMVLA	-	02
SLXVOHST	-	40
SLXVPNL	000003	0D
SLXVSCNT	000004	18
SLXVSCR	-	20
SLXVSER	000006	04
SLXVSTA	000001	03
SLXVSTA2	000001	0F
SLXVTSSN	000008	10
SLXVTV	-	01
SLXVUNK	-	00
SLXXCAPL	000004	58
SLXXCAPN	000004	50
SLXXCAPO	000004	54
SLXXCFGL	000004	1C
SLXXCFGN	000004	14
SLXXCFGO	000004	18
SLXXDRVL	000004	34
SLXXDRVN	000004	2C
SLXXDRVO	000004	30
SLXXLSML	000004	40
SLXXLSMN	000004	38
SLXXLSMO	000004	3C
SLXXMSGL	000004	4C

Name	Len	Offset Value
SLXXMSGN	000004	44
SLXXMSGO	000004	48
SLXXQDSL	000004	7C
SLXXQDSN	000004	74
SLXXQDSO	000004	78
SLXXQJTL	000004	64
SLXXQJTN	000004	5C
SLXXQJTO	000004	60
SLXXSDL	-	B0
SLXXSTPL	000004	70
SLXXSTPN	000004	68
SLXXSTPO	000004	6C
SLXXVCIL	000004	88
SLXXVCIN	000004	80
SLXXVCIO	000004	84
SLXXVOLL	000004	28
SLXXVOLN	000004	20
SLXXVOLO	000004	24
SLXZDEFP	000004	60
SLXZDEFS	000004	64
SLXZDISM	000004	54
SLXZEJCT	000004	58
SLXZEJC1	000004	70
SLXZGSCR	000004	48
SLXZMDM	000004	4C
SLXZMOVE	000004	6C
SLXZQCAP	000004	8C
SLXZQDRL	000004	40
SLXZQDRV	000004	3C
SLXZQDSN	000004	98
SLXZQEJT	000004	90
SLXZQSCR	000004	50

Name	Len	Offset Value
SLXZQVOL	000004	44
SLXZSCR	000004	5C
SLXZSETO	000004	68
SLXZSTOP	000004	94
SLXZVOL	000004	38

ACSINT Request DSECT

The ACSINT is used to pass information between the TMS and the ACS service machine. It is built by the ACSRQ macro when DSECT=YES is specified and is sent using IUCV.

Table 6. ACSINT Record Format

Dec	Hex	Type	Length	Label	Description
ACSINT - TMS INTERFACE REQUEST PARAMETER LIST					
FUNCTION: THIS DEFINES THE DATA PASSED TO THE TMS VIA IUCV IT DEFINES THE VARIOUS FUNCTIONS THAT CAN BE REQUESTED AND THE STRUCTURE PASSED.					
0	(0)	STRUCTURE		ACSINT	TMS INTERFACE PARAMETER LIST:
0	(0)	CHARACTER	4	ACSIHDR	PARAMETER LIST IDENTIFIER.
'ACSI'	(C1C3E2C9)	CHAR CONST		ACSIID	
4	(4)	SIGNED-FWORD	4	ACSILEN	PARAMETER LIST LENGTH.
8	(8)	A-ADDR	1	ACSIVER	PARAMETER LIST VERSION NUMBER.
7	(07)	CONST		ACSIVN	CURRENT VERSION.
9	(9)	A-ADDR	1	ACSIRT	FUNCTION CODE:
0	(00)	CONST		ACSINOOP	NOOP - NO OPERATION.
1	(01)	CONST		ASCIRS01	RESERVED - MVS ONLY.
2	(02)	CONST		ASCIRS02	RESERVED - MVS ONLY.
3	(03)	CONST		ASCIRS03	RESERVED - MVS ONLY.
4	(04)	CONST		ASCISTOP	STOP - STOP AN INTERRUPTABLE PGMI TASK.
5	(05)	CONST		ACSIOPR	SETOPER - SET OPERATOR INTERACTION MODE.
20	(14)	CONST		ACSIQCNF	QCONFIG - RETURN CONFIGURATION SUMMARY.
21	(15)	CONST		ACSIQDRV	QDRIVES - RETURN DRIVE AND LSM INFO.
22	(16)	CONST		ACSIQDRL	QDRLIST - RETURN DRIVE INFORMATION, X .
23	(17)	CONST		ACSIQSCR	QSCRATCH - RETURN SCRATCH COUNT INFO.
24	(18)	CONST		ACSIQVOL	QVOLUME - RETURN VOLUME INFORMATION.

Table 6. ACSINT Record Format

Dec	Hex	Type	Length	Label	Description
25	(19)	CONST		ACSIQEJT	QEJECT - RETURN EJECT STATUS.
26	(1A)	CONST		ACSIQCAP	QCAP - QUERY CAP STATUS.
27	(1B)	CONST		ACSIQVLU	QVOLUSE - RETURN MOUNTED VOLUMES.
28	(1C)	CONST		ACSIQRQS	QREQUEST - RETURN PENDING REQUESTS.
29	(1D)	CONST		ACSIQDSN	QDSN - QUERY DATASET.
40	(29)	CONST		ACSIMNT	MOUNT - MOUNT VOLUME.
41	(29)	CONST		ACSIMOVE	MOVE - MOVE A CARTRIDGE TO AN LSMID X.
42	(2A)	CONST		ACSIDSM	DISMOUNT - DISMOUNT VOLUME.
43	(2B)	CONST		ACSI EJCT	EJECT - EJECT A VOL FROM THE LIBRARY.
60	(3C)	CONST		ACSISSCR	SELSCR - SELECT A SCRATCH VOLUME.
61	(3D)	CONST		ACSISCRA	SCRATCH - CHANGE VOL STATUS TO 'SCRATCH'.
62	(3E)	CONST		ACSIUNSC	UNSCRATCH- CHANGE VOLUME STATUS TO NOT X.
63	(3F)	CONST		ACSIDSCR	DEFSCR - SPECIFY NO. OF SCRATCH POOLS.
64	(40)	CONST		ACSIDPOL	DEFPOOL - SPECIFY A SCRATCH POOL'S VOLSER RANGE.
10	(A)	BITSTRING	1	ACSIFLG1	FLAG BYTE 1: (PGMI CONTROL 1) 1
		1... X'80'		ACSIF180	RESERVED MVS OPTION=SYNC
		.1.. X'40'		ACSIVUSR	USER= SPECIFIED; ACSIUSER CONTAINS NAME
		..1. X'20'		ACSIMANO	DIALOG=OFF SPECIFIED.
		...1 X'10'		ACSIWTOR	DIALOG=ON SPECIFIED.
	 1.. X'08'		ACSINDEL	NOTIFY=INSDel SPECIFIED.
	1.. X'04'		ACSINNDL	NOTIFY=NOINSDel SPECIFIED.

Table 6. ACSINT Record Format

Dec	Hex	Type	Length	Label	Description	
11	(B)1. X'02'	1	ACSIACC1	ACCT1= SPECIFIED ACCOUNTING TOKEN.	
	1 X'01'		ACSIACC2	ACCT2= SPECIFIED ACCOUNTING TOKEN.	
		HEXSTRING		ACSIFLG2	FLAG BYTE 2: (PGMI CONTROL 2).	
		(C)		BITSTRING	ACSIFLG3	FLAG BYTE 3: (MOVEMENT CONTROL 1).
				1... X'80'	ACSIVHST	ACSIHOST CONTAINS HOST_ID.
				.1.. X'40'	ACSIVACS	ACSIACS CONTAINS AN ACSID.
				..1. X'20'	ACSIVLSM	ACSILSMI CONTAINS LSMID.
				...1 X'10'	ACSIVCAP	ACSICAP CONTAINS CAP_ID.
			 1... X'08'	ACSIF308	RESERVED FUTURE USE.
			1.. X'04'	ACSIVVOL	ACSIVOLS CONTAINS A VOLSER.
13	(D)1. X'02'	1	ACSIVLST	ACSILOFF CONTAINS LIST OFFSET.	
	1 X'01'		ACSIVCNT	ACSICNT CONTAINS LIST COUNT.	
		BITSTRING		ACSIFLG4	FLAG BYTE 4: (MOVEMENT CONTROL 2).	
		1... X'80'		ACSIVTLM	ACSITLSM CONTAINS TO LSM_ID.	
		.1.. X'40'		ACSIVTPN	ACSITPAN CONTAINS TO PANEL.	
		..1. X'20'		ACSIF420	RESERVED FUTURE USE.	
		...1 X'10'		ACSIF410	RESERVED FUTURE USE.	
	 1... X'08'		ACSIVPAN	ACSIPAN CONTAINS PANEL NUMBER	
	1.. X'04'		ACSIVROW	ACSIROW CONTAINS ROW NUMBER.	
	1. X'02'		ACSIVCOL	ACSICOL CONTAINS COLUMN NUMBER.	
.... ..1 X'01'	ACSIVDRV	ACSIDRIV CONTAINS DRIVE DEVICE NUMBER.				

Table 6. ACSINT Record Format

Dec	Hex	Type	Length	Label	Description
14	(E)	HEXSTRING	1	ACSIFLG5	FLAG BYTE 5: (MOVEMENT CONTROL 3).
15	(F)	BITSTRING	1	ACSIFLG6	FLAG BYTE 6: (MISCELLANOUS CONTROL 1).
		1... X'80'		ACSIPROT	PROTECT=YES SPECIFIED.
		.1.. X'40'		ACSISCR	SCRATCH=YES SPECIFIED.
		..1. X'20'		ACSIVSCP	ACSIPOOL CONTAINS SCRATCH POOL NUMBER.
		...1 X'10'		ACSISUBN	ACSISUBP CONTAINS SUBPOOL NAME.
	 1... X'08'		ACSIVTKN	ACSITKNO CONTAINS TOKEN NUMBER.
	1.. X'04'		ACSIVTXT	ACSITEXT CONTAINS TEXT STRING.
	1. X'02'		ACSIF602	RESERVED FUTURE USE.
	1 X'01'		ACSIF601	RESERVED FUTURE USE.
16	(10)	HEXSTRING	1	ACSIFLG7	FLAG BYTE 7: (MISCELLANOUS CONTROL 2).
17	(11)	A-ADDR	1	ACSILABT	SCRATCH LABEL TYPE LTYPE= PARAMETER.
	 X'00'		ACSILLDT	LDT (LIBRARY DEFAULT TYPE).
	1 X'01'		ACSILSL	SL (STANDARD LABEL).
	1. X'02'		ACSILAL	AL (ANSI LABEL).
	11 X'03'		ACSILNL	NL (NON-LABELED).
	1.. X'04'		ACSILNS	NSL (NON-STANDARD LABEL).
18	(12)	CHARACTER	8	ACSIUSER	USER NAME USED TO ASSOCIATE CONSOLE ID.
26	(1A)	CHARACTER	8	ACSIACT1	ACCOUNTING TOKEN 1.
34	(22)	CHARACTER	8	ACSIACT2	ACCOUNTING TOKEN 2.
42	(2A)	HEXSTRING	2	-RESERVED-	RESERVE SLACK BYTES.
44	(2C)	SIGNED-FWORD	4	-RESERVED-	RESERVED MVS.
48	(30)	HEXSTRING	4	ACSITKNO	PASS THROUGH TOKEN NUMBER.

Table 6. ACSINT Record Format

Dec	Hex	Type	Length	Label	Description
52	(34)	A-ADDR	4	-RESERVED-	RESERVED MVS.
56	(38)	SIGNED-HWORD	2	ACSICNT	COUNT FROM COUNT= PARAMETER.
58	(3A)	SIGNED-HWORD	2	ACSILOFF	OFFSET, FROM START OF PARAMETER LIST, TO START OF THE ELEMENT LIST AREA.
60	(3C)	CHARACTER			CHARACTER 6 ACSIVOLS VOLSER FROM VOLSER= PARAMETER.
66	(42)	CHARACTER	8	ACSIHOST	ASSOCIATED HOST FROM HOSTID= PARAMETER.
74	(4A)	AREA	4	ACSIALC	ACS / LSM / CAP IDENTIFICATION.
74	(4A)	HEXSTRING	1	ACSIACS	ACS ID NUMBER (AA).
74	(4A)	HEXSTRING	2	ACSILSMI	LSM ID NUMBER (AA0L).
74	(4A)	HEXSTRING	4	ACSICAP	CAP ID NUMBER (AA0LCC00).
74	(4A)	HEXSTRING	3	-RESERVED-	
77	(4D)	HEXSTRING	1	-RESERVED-	NOT IMPLEMENTED (ALWAYS X'00') .
78	(4E)	HEXSTRING	1	ACSIPAN	PANEL FROM PAN= PARAMETER.
79	(4F)	HEXSTRING	1	ACSIROW	ROW FROM ROW= PARAMETER.
80	(50)	HEXSTRING	1	ACSICOL	COLUMN FROM COL= PARAMETER.
81	(51)	HEXSTRING	1	ACSITPAN	TO PANEL FROM TOPAN= PARAMETER.
82	(52)	HEXSTRING	2	ACSITLSM	TO LSM FROM TOLSM= PARAMETER.
84	(54)	A-ADDR	2	ACSIDRIV	DRIVE DEVICE NUMBER FROM DRIVE= PARAMETER.
86	(56)	A-ADDR	1	ACSIPOOL	SCRATCH POOL NUMBER, SCRPOOL= PARAMETER.
87	(57)	CHARACTER	32	ACSITEXT	TEXT ASSOCIATED WITH REQUEST.
119	(77)	CHARACTER	13	ACSISUBP	NAME FROM SUBPOOL= KEYWORD.

Table 6. ACSINT Record Format

Dec	Hex	Type	Length	Label	Description
TAPEREQ INPUT KEY VALUES. THE FOLLOWING VALUES ARE USED AS THE KEY IN SEARCHING THE CURRENT TAPEREQ PARAMETER FILE.					
132	(84)	BITSTRING 1... X'80' .1.. X'40' ..1. X'20' ...1 X'10' 1... X'08'1.. X'04'1. X'02'	1	ACSIFLG8 ACSIFJOB ACSIFSTP ACSIFPGM ACSIFDSN ACSIFEXP ACSIFRET ACSIFVOL	FLAG BYTE 8: (TAPEREQ CONTROL 1). ACSIJOBN PRESENT. ACSISTEP PRESENT. ACSIPGMN PRESENT. ACSIDSN PRESENT. ACSIEXPD PRESENT. ACSIRETP PRESENT. ACSIVOLT PRESENT.
133	(85)	OFFSET		ACSITRI	TAPEREQ INPUT VALUES.
133	(85)	CHARACTER	8	ACSIJOBN	STRING TO MATCH TAPEREQ JOBNAME VALUE.
141	(8D)	CHARACTER	8	ACSISTEP	STRING TO MATCH TAPEREQ STEPNAME VALUE.
149	(95)	CHARACTER	8	ACSIPGMN	STRING TO MATCH TAPEREQ PROGNAME VALUE.
157	(9D)	CHARACTER	44	ACSIDSN	STRING TO MATCH TAPEREQ DSN VALUE.
201	(C0)	HEXSTRING	3	ACSIEXPD	VALUE TO MATCH TAPEREQ EXPDT VALUE
204	(CC)	HEXSTRING	2	ACSIRETP	VALUE TO MATCH TAPEREQ RETPD VALUE.
206	(CE)	CHARACTER	1	ACSIVOLT	STRING TO MATCH TAPEREQ VOLTYPE VALUE .
74	(4A)	LENGTH		ACSITRIL	
TAPEREQ OUTPUT VALUES. THE FOLLOWING VALUES ARE USED AS OVERRIDE (OR SPECIFIC) VALUES TO THE VALUES FOUND IN THE CURRENT TAPEREQ PARAMETER FILE.					
207	(CF)	BITSTRING 1... X'80' .1.. X'40'	1	ACSIFLG9 ACSIFREC ACSIFMED	FLAG BYTE 9: (TAPEREQ CONTROL 2). ACSIRECT PRESENT. ACSIMED PRESENT.

Table 6. ACSINT Record Format

Dec	Hex	Type	Length	Label	Description
208	(D0)	CHARACTER	8	ACSIRECT	RECORDING TECHNIQUE.
216	(D8)	CHARACTER	8	ACSIMED	MEDIA.
224	(E0)	HEXSTRING	256	-RESERVED-	RESERVED FOR FUTURE PARM EXPANSION.
480	(1E0)	AREA	8	-RESERVED-	ALIGNMENT.
480	(1E0)	LENGTH		ACSIHLN	LENGTH OF FIXED AREA.
480	(1E0)	AREA	1	ACSILIST	ELEMENT LIST DESIGNATED BY LIST= PARAMETER BEGINS HERE (FIELD ACSICNT CONTAINS THE NUMBER OF ELEMENTS IN THIS LIST).
2	(02)	CONST		ACSILDRL	LENGTH OF EACH ELEMENT (DRIVE DEVICE NUMBER) IN THE LIST USED BY THE QDRLIST FUNCTION.
1500	(5DC)	CONST		ACSIMDRL	MAXIMUM NUMBER OF ELEMENTS ALLOWED IN THE LIST USED BY THE QDRLIST FUNCTION.
6	(06)	CONST		ACSILVSL	LENGTH OF EACH ELEMENT (VOLSER) IN THE LIST USED BY THE QVOLUME FUNCTION.
500	(1F4)	CONST		ACSIMVSL	MAXIMUM NUMBER OF ELEMENTS ALLOWED IN THE LIST USED BY THE QVOLUME AND EJECT.
12	(0C)	CONST		ACSILPOL	LENGTH OF EACH ELEMENT (VOLSER RANGE PAIR) IN THE LIST USED BY THE DEFPOOL FUNCTION.
250	(FA)	CONST		ACSIMPOL	MAXIMUM NUMBER OF ELEMENTS ALLOWED IN THE LIST USED BY THE DEFPOOL FUNCTION.
4	(04)	CONST		ACSILCAP	LENGTH OF EACH ELEMENT (CAP IDENTIFIER) IN THE LIST USED BY THE QCAP FUNCTION.
500	(1F4)	CONST		ACSIMCAP	MAXIMUM NUMBER OF ELEMENTS ALLOWED IN THE LIST USED BY THE QCAP FUNCTION.

Table 6. ACSINT Record Format

Dec	Hex	Type	Length	Label	Description
4	(04)	CONST		ACSILTOK	LENGTH OF EACH ELEMENT (UNIQUE TOKEN) IN THE LIST USED BY THE QCAP FUNCTION.
500	(1F4)	CONST		ACSIMTOK	MAXIMUM NUMBER OF ELEMENTS ALLOWED IN THE LIST USED BY THE QEJECT/STOP FUNCTIONS.

Cross Reference

Name	Len	Offset Value	Name	Len	Offset Value
ACSIACC1	-	02	ACSIFRET	-	04
ACSIACC2	-	01	ACSIFSTP	-	40
ACSIACS	000001	4A	ACSIFVOL	-	02
ACSIACT1	000008	1A	ACSIF180	-	80
ACSIACT2	000008	22	ACSIF308	-	08
ACSIALC	000004	4A	ACSIF410	-	10
ACSICAP	000004	4A	ACSIF420	-	20
ACSICNT	000002	38	ACSIF601	-	01
ACSICOL	000001	50	ACSIF602	-	02
ACSIDPOL	-	40	ACSIHDR	000004	00
ACSIDRIV	000002	54	ACSIHLN	-	1E0
ACSIDSCR	-	3F	ACSIHOST	000008	42
ACSIDSM	-	2A	ACSIID	-	'CVAL'
ACSIDSN	000044	9D	ACSIJOB	000008	85
ACSIJCT	-	2B	ACSILABT	000001	11
ACSIEXPD	000003	C9	ACSILAL	-	02
ACSIFDSN	-	10	ACSILCAP	-	04
ACSIFEXP	-	08	ACSILDRL	-	02
ACSIFJOB	-	80	ACSILIST	000001	1E0
ACSIFLG1	000001	0A	ACSILLDT	-	00
ACSIFLG2	000001	0B	ACSILNL	-	03
ACSIFLG3	000001	0C	ACSILNS	-	04
ACSIFLG4	000001	0D	ACSILOFF	000002	3A
ACSIFLG5	000001	0E	ACSILPOL	-	0C
ACSIFLG6	000001	0F	ACSILSL	-	01
ACSIFLG7	000001	10	ACSILSMI	000002	4A
ACSIFLG8	000001	84	ACSILTOK	-	04
ACSIFLG9	000001	CF	ACSILVSL	-	06
ACSIFMED	-	40	ACSIMANO	-	20
ACSIFPGM	-	20	ACSIMCAP	-	1F4
ACSIFREC	-	80	ACSIMDRL	-	5DC

Name	Len	Offset Value	Name	Len	Offset Value
ACSIMED	000008	D8	ACSIVTPN	-	40
ACSIMNT	-	28	ACSIVTXT	-	04
ACSIMOVE	-	29	ACSIVUSR	-	40
ACSIMPOL	-	FA	ACSIVVOL	-	04
ACSIMTOK	-	1F4	ACSIWTOR	-	10
ACSIMVSL	-	1F4	ACSIROW	000001	4F
ACSINDEL	-	08	ACSIRS01	-	01
ACSINNDL	-	04	ACSIRS02	-	02
ACSINOOP	-	00	ACSIRS03	-	03
ACSIPAN	000001	4E	ACSIRT	000001	09
ACSIPGMN	000008	95	ACSISCR	-	40
ACSIPOOL	000001	56	ACSISCRA	-	3D
ACSIPROT	-	80	ACSISOPR	-	05
ACSIQCAP	-	1A	ACSISSCR	-	3C
ACSIQCNF	-	14	ACSISTEP	000008	8D
ACSIQDRL	-	16	ACSISTOP	-	04
ACSIQDRV	-	15	ACSISUBN	-	10
ACSIQDSN	-	1D	ACSISUBP	000013	77
ACSIQEJT	-	19	ACSITEXT	000032	57
ACSIQRQS	-	1C	ACSITKNO	000004	30
ACSIVDRV	-	01	ACSITLSM	000002	52
ACSIVER	000001	08	ACSITPAN	000001	51
ACSIVHST	-	80	ACSITRI	-	85
ACSIVLSM	-	20	ACSITRIL	-	4A
ACSIVLST	-	02	ACSIUNSC	-	3E
ACSIVN	-	07	ACSIUSER	000008	12
ACSIVOLS	000006	3C	ACSIVACS	-	40
ACSIVOLT	000001	CE	ACSIVCAP	-	10
ACSIVPAN	-	08	ACSIVCNT	-	01
ACSIVROW	-	04	ACSIVCOL	-	02
ACSIVSCP	-	20			
ACSIVTKN	-	08			
ACSIVTLM	-	80			

IUB Record Format

IUB - IUCV Request Block

The IUB describes an outstanding IUCV request resulting from an IUCV operation. Both the request and the final status are contained in the IUB data structure. The IUB is an IUCV counterpart to the 'IOBLOK' structure used by device management.

Table 7. IUB Record Format

Dec	Hex	Type	Len	Label	Description
IUB - IUCV REQUEST BLOCK					
FUNCTION:					
Describes an outstanding IUCV request resulting from an IUCV operation.					
0	(0)	STRUCTURE		IUB	REQUEST BLOCK.
0	(0)	HEXSTRING	16	IUBQ	IUB QUEUE CHAINING (TO IRT).
12	(C)	CHARACTER	4	IUBEYE	EYEBALL CHARACTERS.
16	(10)	HEXSTRING	16	IUBDABQ	IUB QUEUE CHAINING (TO DAB).
32	(20)	HEXSTRING	1	IUBDAVL	IUB IS AVAILABLE (ACCESS METH.).
33	(21)	HEXSTRING	1	IUBECBKY	STORAGE KEY OF ECB TO POST.
34	(24)	HEXSTRING2		-RESERVED-	RESERVED.
36	(24)	A-ADDR	4	IUBIUBPT	ADDR OF USER'S IUB (ORIGINAL).
40	(28)	A-ADDR	4	IUBTASK	TBLOK ADDR OF REQUESTING TASK.
44	(2C)	A-ADDR	4	IUBIRT	IUBIRT ADDRESS OF IRT.
48	(30)	A-ADDR	1	IUBFLG1	FLAGS.
		1... X'80'		IUBSENT	IUCV REQUEST HAS BEEN ISSUED.
		.1.. X'40'		IUBNPOST	DON'T POST THE ASSOCIATED ECB.
		..1. X'20'		IUBHCOMM	HOST-HOST COMMUNICATION IUB.
	 1... X'08'		IUBLOK	REQUEST ASSOCIATED WITH AN IUCV OP.
49	(31)	A-ADDR	1	IUBCC	IUCV PSW CONDITION CODE.
50	(32)	A-ADDR	1	IUBFLG2	IUCV OPERATION TYPE.
		1... X'80'		IUBREAD	RECEIVE (READ).
		.1.. X'40'		IUBSEND	SEND (WRITE).
		..1. X'20'		IUBREPLY	REPLY (WRITE).
		...1 X'10'		IUBCONN	CONNECT (OPEN).

Table 7. IUB Record Format

Dec	Hex	Type	Len	Label	Description
	 1... X'08'		IUBREJCT	REJECT (WRITE).
51	(33)	A-ADDR	1	-RESERVED-	RESERVED.
52	(34)	A-ADDR	4	IUBECBPT	ADDRESS OF ECB TO POST.
56	(38)	SIGNED-FWORD	4	-RESERVED-	RESERVED.
60	(3C)	A-ADDR	4	IUBORGID	ADDRESS OF ORIGID.
64	(40)	SIGNED-FWORD	4	-RESERVED-	RESERVED.
68	(44)	A-ADDR	4	IUBDCBPT	ADDRESS OF DCB.
72	(48)	LONG-FLOAT	8	-RESERVED-	RESERVED.
OUTGOING IUCV PLIST					
80	(50)	AREA	8	-RESERVED-	FORCE DOUBLEWORD ALIGNMENT.
80	(50)	AREA	40	IUBPARML	IUCV PARM LIST (OUTGOING REQUEST).
80	(50)	LONG-FLOAT	8	IUBPARM1	(DSECT=IPARML).
88	(58)	LONG-FLOAT	8	IUBPARM2	IUBPARML (WORD 2).
96	(60)	LONG-FLOAT	8	IUBPARM3	IUBPARML (WORD 3).
104	(68)	LONG-FLOAT	8	IUBPARM4	IUBPARML (WORD 4).
112	(70)	LONG-FLOAT	8	IUBPARM5	IUBPARM5 IUBPARML (WORD 5).
RETURNING IUCV STATUS					
120	(78)	AREA	8	-RESERVED-	FORCE DOUBLEWORD ALIGNMENT.
120	(78)	AREA	40	IUBEXT	IUCV EXT.INTERRUPT BUFFER (STATUS).
120	(78)	LONG-FLOAT	8	IUBEXT1	(DSECT=IPARML).
128	(80)	LONG-FLOAT	8	IUBEXT2	IUBEXT (WORD 2).
136	(80)	LONG-FLOAT	8	IUBEXT3	IUBEXT (WORD 3).
144	(90)	LONG-FLOAT	8	IUBTEXT4	IUBEXT (WORD 4).
152	(98)	LONG-FLOAT	8	IUBTEXT5	IUBEXT (WORD 5).
160	(A0)	LENGTH		IUBLEN	LENGTH OF IUB.

Cross Reference

Name	Len	Offset Value	Name	Len	Offset Value
IUBCC	000001	31	IUBPARM5	000008	70
IUBCONN	-	10	IUBQ	000016	00
IUBDABQ	000016	10	IUBREAD	-	80
IUBDAVL	000001	20	IUBREJCT	-	08
IUBDCBPT	000004	44	IUBREPLY	-	20
IUBECKBY	000001	21	IUBSEND	-	40
IUBBECBT	000004	34	IUBSENT	-	80
IUBEXT	000040	78	IUBTASK	000004	28
IUBEXT1	000008	78			
IUBEXT2	000008	80			
IUBEXT3	000008	88			
IUBEXT4	000008	90			
IUBEXT5	000008	98			
IUBEYE	000004	0C			
IUBFLG1	000001	30			
IUBFLG2	000001	32			
IUBHCOMM	-	20			
IUBIRT	000004	2C			
IUBIUBPT	-	24			
IUBLEN	-	A0			
IUBLOK	-	08			
IUBNPOST	-	40			
IUBORGID	000004	3C			
IUBPARML	000040	50			
IUBPARM1	000008	50			
IUBPARM2	000008	58			
IUBPARM3	000008	60			
IUBPARM4	000008	68			

Glossary

A

AC— Alternating current.

access method— A technique for moving data between processor storage and I/O devices.

ACS— *See* Automated Cartridge System.

ACSid— An ACSid (*acs-id*) is a hexadecimal value from 00 through FF that identifies the LMU. An ACSid is the result of defining the SLIALIST macro during the library generation (LIBGEN) process. The first ACS listed in this macro acquires a hexadecimal identifier of 00, the second acquires a hexadecimal identifier of 01, and so forth, until all ACSs are identified.

allocation— The selection of a cartridge drive, either inside the library or outside (by the SMC software for SMC allocation, or MVS for MVS allocation without the HSC).

APF— Authorized Program Facility.

APPL— VTAM APPLID definition for the HSC.

archiving— The storage of backup files and associated journals, usually for a given period of time.

Automated Cartridge System (ACS)— The library subsystem consisting of one or two LMUs, and from 1 to 16 attached LSMs.

automated library— *See* library.

automatic mode— A relationship between an LSM and all attached hosts. LSMs operating in automatic mode handle cartridges without operator intervention. This is the normal operating mode of an LSM that has been modified online.

B

basic direct access method (BDAM)— An access method used to directly retrieve or update particular blocks of a data set on a direct access device.

basic sequential access method (BSAM)— An access method for storing and retrieving data blocks in a continuous sequence, using either a sequential access or direct access device.

BDAM— *See* Basic direct access method.

beginning-of-tape (BOT)— The location on a tape where written data begins.

block— A collection of contiguous records recorded as a unit. Blocks are separated by interblock gaps, and each block may contain one or more records.

BOT— *See* beginning-of-tape.

BSAM— *See* Basic Sequential Access Method.

buffer— A routine or storage used to compensate for a difference in rate of data flow, or time of occurrence of events, when transferring data from one device to another.

C

CA-1 (TMS)— Computer Associates Tape Management

System— Third-party software by Computer Associates International, Inc.

CAP— *See* Cartridge Access Port.

capacity— *See* media capacity.

CAPid— A CAPid uniquely defines the location of a CAP by the LSM on which it resides. A CAPid is of the form *AAL:CC* where *AA* is the ACSid, *L* is the LSM number, and *CC* is the CAP number. Some commands and utilities permit an abbreviated CAPid format of *AAL*.

cartridge— The plastic housing around the tape. It is approximately 4 inches (100 mm) by 5 inches (125 mm) by 1 inch (25 mm). The tape is threaded automatically when loaded in a transport. A plastic leader block is attached to the tape for automatic threading. The spine of the cartridge contains a Tri-Optic label listing the VOLSER.

Cartridge Access Port (CAP)— An assembly which allows an operator to enter and eject cartridges during automated operations. The CAP is located on the access door of an LSM.

See also standard CAP, enhanced CAP, priority CAP, WolfCreek CAP, WolfCreek optional CAP, or TimberWolf CAP.

Cartridge Drive (CD)— A device containing two or four cartridge transports with associated power and pneumatic supplies.

Cartridge Scratch Loader— An optional feature for the Cartridge Drive. It allows the automatic loading of premounted tape cartridges or the manual loading of single tape cartridges.

cartridge system tape— Also known as a Standard tape. The basic tape cartridge media that can be used with 4480, 4490, or 9490 Cartridge Subsystems. They are visually identified by a one-color cartridge case.

CAW— *See* Channel Address Word.

CD— *See* Cartridge Drive.

CDRM— Cross Domain Resource Manager definition (if not using existing CDRMs).

CDRSC— Cross Domain Resource definition.

CDS— *See* control data set.

CE— Channel End.

CEL— Customer Emulation Lab. cell. A storage slot in the LSM that is used to store a tape cartridge.

Central Support Remote Center (CSRC)— *See* Remote Diagnostics Center.

CFT— Customer Field Test.

channel— A device that connects the host and main storage with the input and output control units.

Channel Address Word (CAW)— An area in storage that specifies the location in main storage where a channel program begins.

channel command— A command received by a CU from a channel.

Channel Status Word (CSW)— An area in storage that provides information about the termination of I/O operations.

check— Detection of an error condition.

CI— Converter/Interpreter (JES3).

connected mode— A relationship between a host and an ACS. In this mode, the host and an ACS are capable of communicating (at least one station to this ACS is online).

control data set (CDS)— The data set containing all configuration and volume information used by the host software to control the functions of the automated library. Also known as a library control data set.

See also Primary CDS, Secondary CDS, and Standby CDS.

control data set allocation map— A CDS subfile that marks individual blocks as used or free.

control data set data blocks— CDS blocks that contain information about the library and its configuration or environment.

control data set directory— A part of the CDS that maps its subdivision into subfiles.

control data set free blocks— CDS blocks available for future subfile expansion.

control data set pointer blocks— CDS blocks that contain pointers to map data blocks belonging to a subfile.

control data set recovery area— A portion of the CDS reserved for maintaining integrity for updates that affect multiple CDS blocks.

control data set subfile— A portion of the CDS consisting of Data Blocks and Pointer Blocks containing related information.

Control Unit (CU)— (1) A microprocessor-based unit situated logically between a host channel (or channels) and from two to sixteen transports. It functions to translate channel commands into transport commands, send transport status to the channel(s), and pass data between the channel(s) and transport(s). (2) A device that controls I/O operations for one or more devices. cross-host recovery. The ability for one host to perform recovery for another host that has failed.

CSE— Customer Service Engineer.

CSI— Consolidated System Inventory.

CSL— *See* Cartridge Scratch Loader.

CSRC— Central Support Remote Center (*See* Remote Diagnostics Center)

CST— (1) A value that can be specified on the MEDia parameter and that includes only standard capacity cartridge tapes. (2) An alias of Standard. (3) *See* Cartridge System Tape.

CSW— *See* Channel Status Word.

CU— *See* Control Unit.

D

DAE— Dump Analysis Elimination.

DASD— Direct access storage device.

data— Any representations such as characters or analog quantities to which meaning is, or might be, assigned.

Database Heartbeat record (DHB)— The record that contains the names of the control data sets recorded by the HSC and identifies the correct primary, secondary, and standby CDS.

data class— A collection of allocation and space attributes, defined by the storage administrator, that are used to create a data set.

data compaction— An algorithmic data-reduction technique that encodes data from the host and stores it in less space than unencoded data. The original data is recovered by an inverse process called decompression.

data-compaction ratio— The number of host data bytes mathematically divided by the number of encoded bytes. It is variable depending on the characteristics of the data being processed. The more random the data stream, the lower the opportunity to achieve compaction.

Data Control Block (DCB)— A control block used by access routines in storing and retrieving data.

data set— The major unit of data storage and retrieval, consisting of a collection of data in one of several prescribed arrangements and described by control information to which the system has access.

data streaming— A continuous stream of data being transmitted in character or binary-digit form, using a specified format.

DC— Direct current.

DCB— *See* Data Control Block.

DD3— A generic value that can be specified on the MEDia and RECtech parameters and includes all types of helical cartridges and recording techniques.

DD3A, DD3B, DD3C, DD3D— Values that can be specified on the MEDia parameter and include only the specified type of helical cartridge. Aliases are A, B, C, and D, respectively.

DDR— *See* Dynamic Device Reconfiguration.

default value— A value assumed when no value has been specified.

demand allocation— An MVS term meaning that a user has requested a specific unit.

device allocation— The HSC function of *influencing* the MVS device selection process to choose either a manual transport or a transport in a particular ACS, based on the location of the volume (specific requests) or the subpool rules in effect (scratch requests).

device group— A subset of the eligible devices. Device groups are defined by esoteric unit names but also may be created implicitly if common devices exist in different device groups.

device number— A four-digit hexadecimal number that uniquely identifies a device attached to a processor.

device separation— *See* drive exclusion.

DFP— Data Facility Product. A program that isolates applications from storage devices, storage management, and storage device hierarchy management.

DFSMS— Refers to an environment running MVS/ESA SP and DFSMS/MVS, DFSORT, and RACF. This environment helps automate and centralize the management of storage through a combination of hardware, software, and policies.

DFSMS ACS routine— A sequence of instructions for having the system assign data class, storage class, management class, and storage group for a data set.

DHB— *See* Database Heartbeat record.

directed allocation— *See* drive prioritization.

disconnected mode— A relationship between a host and an ACS. In this mode, the host and an ACS are not capable of communicating (there are no online stations to this ACS).

DOMed— Pertaining to a console message that was previously highlighted during execution, but is now at normal intensity.

drive exclusion— (previously referred to as *device separation*) refers to the Storage Management Component (SMC) function of excluding drives for an allocation request based on SMC exclusion criteria. *See* the *SMC Configuration and Administration Guide* for more information.

drive loaded— A condition of a transport in which a tape cartridge has been inserted in the transport, and the tape has been threaded to the beginning-of-tape position.

drive panel— A wall of an LSM that contains tape transports. Drive panels for T9840A transports have either 10 or 20 transports per panel; drive panels for

all other transports contain up to four transports per panel.

drive prioritization— (previously referred to as *directed allocation*) refers to the Storage Management Component (SMC) function of influencing selection of a particular drive based on allocation criteria, including volume location. *See* the *SMC Configuration and Administration Guide* for more information.

DRIVEid— A DRIVEid uniquely defines the location of a tape transport by its location within an LSM. A DRIVEid is of the form *AAL:PP:NN* where *AA* is the ACSid, *L* is the LSM number, *PP* is the panel where the drive is located, and *NN* is the drive number within the panel.

DSI— Dynamic System Interchange (JES3).

dual LMU— A hardware/ μ -software feature that provides a redundant LMU capability.

dual LMU HSC— HSC release 1.1.0 or later that automates a switch-over to the standby LMU in a dual LMU configuration.

dump— To write the contents of storage, or of a part of storage, usually from an internal storage to an external medium, for a specific purpose such as to allow other use of storage, as a safeguard against faults or errors, or in connection with debugging.

Dynamic Device Reconfiguration (DDR)— An MVS facility that allows a dismountable volume to be moved and repositioned if necessary, without abnormally terminating the job or repeating the initial program load procedure.

E

ECAP— *See* enhanced CAP.

ECART— (1) Cartridge system tape with a length of 1100 feet that can be used with 4490 and 9490 Cartridge Drives. These tapes are visually identified by a two-tone (black and tan) colored case. (2) A value that can be specified on the MEDIA parameter and that includes only 36-track enhanced capacity cartridge system tapes. (3) *See* Enhanced Capacity Cartridge System Tape.

ECCST— (1) A value that can be specified on the MEDia parameter and that includes only enhanced capacity cartridge system tapes. (2) An alias of ECART. (3) *See* Enhanced Capacity Cartridge System Tape.

EDL— *See* eligible device list.

EDTGEN— Eligible Device Table Generation. A process used to replace an installation-defined and named representation of the devices that are eligible for allocation.

EETape— *See* Extended Enhanced Tape.

Effective Recording Density— The number of user bytes per unit of length of the recording medium.

eject— The process where the LSM robot places a cartridge in a Cartridge Access Port (CAP) so the operator can remove it from the LSM.

eligible device list— (1) A group of transports that are available to satisfy an allocation request. (2) For JES2 and JES3, a list of devices representing the UNIT parameter specified by way of invoking JCL. The EDL can contain both library and nonlibrary transports depending on the I/O GEN.

enable— The modification of system, control unit, or device action through the change of a software module or a hardware switch (circuit jumper) position.

enhanced CAP (ECAP)— An enhanced CAP contains two forty-cell magazine-style CAPs and a one-cell priority CAP (PCAP). Each forty-cell CAP holds four removable magazines of ten cells each. An LSM access door with an enhanced CAP contains no cell locations for storing cartridges.

See also Cartridge Access Port, standard CAP, priority CAP, WolfCreek CAP, WolfCreek optional CAP, or TimberWolf CAP.

Enhanced Capacity Cartridge System Tape— Cartridge system tape with increased capacity that can be used with 4490 and 9490 Cartridge Drives. These tapes are visually identified by a two-tone (black and tan) housing.

EOF— End-of-File.

EOT— End-of-Tape marker.

EPO— Emergency Power Off.

EREP— Environmental Recording, Editing, Printing.

ERP— *See* error recovery procedures.

error recovery procedures (ERP)— Procedures designed to help isolate and, where possible, to recover from errors in equipment.

esoteric— A user-defined name that groups devices into classes.

ETAPE— (1) A value that can be specified on the MEDia parameter and that includes only enhanced capacity cartridge system tapes. (2) An alias of ECART. (3) *See* Enhanced Capacity Cartridge System Tape.

Extended Capacity Tape— *See* Enhanced Capacity Cartridge System Tape.

Extended Enhanced Tape (EETape)— A synonym for a ZCART, which is a cartridge that can only be used with a 9490EE drive. An EETape (ZCART) provides greater storage capacity than an ECART.

ExtendedStore Library— One or more LSMs with no Cartridge Drives (CDs) that are attached by pass-thru ports to other LSMs (with CDs) in an ACS. These LSMs provide archive storage for cartridges containing less active data sets. Cartridges can be entered and ejected directly into and out of this LSM though either a standard CAP or an enhanced CAP.

F

FDRPAS™— A product from Innovation Data Processing, Inc. that allows two disk devices to be non-disruptively swapped with each other.

FIFO— First in, first out.

file protected— Pertaining to a tape volume from which data can be read only. Data cannot be written on or erased from the tape.

format— The arrangement or layout of data on a data medium.

frozen panel— A panel to which cartridges cannot be moved. This restriction includes allocating new cartridge locations on a panel as a result of:

- a MOVE command, utility, or PGMI request
- cartridge entry into the ACS
- float, scratch dismount, or scratch redistribution processing.

G

GB— Gigabyte, billion (10^9) bytes.

GDG— Generation Data Group. An MVS data set naming convention. Sequence numbers are appended to the basic data set name to track the generations created for that data set.

GDG Separation— Occurs when a Generation Data Group gets separated because the volumes of different generations reside in different locations. Usually, all generations of a GDG are mounted on a single drive to reduce the number of drives needed for a job.

GTF— Generalized Trace Facility. An MVS facility used to trace software functions and events.

H

HDA— Head/disk assembly.

Helical— A generic value that can be specified on the RECTECH parameter and includes all helical transports.

HOSTid— A HOSTid is the host identifier specified in the HOSTID parameter of the SLILIBRY LIBGEN macro. The HOSTid is the SMF system identifier for both JES2 and JES3.

High Watermark Setup (HWS)— In JES3, a setting specified on the HWSNAME initialization statement that reduces the number of devices reserved for a job. JES3 accomplishes this task by assessing each jobstep to determine the maximum number of devices needed for each device type and reserving those devices.

Host Software Component (HSC)— That portion of the Automated Cartridge System which executes on host systems attached to an automated library. This component acts as the interface between the

operating system and the rest of the automated library.

host system— A data processing system that is used to prepare programs and the operating environments for use on another computer or controller.

HSC— *See* Host Software Component.

HWS— *See* High Watermark Setup.

I

ICRC— *See* Improved Cartridge Recording Capability.

ID— Identifier or identification.

IDAX— Interpreter Dynamic Allocation Exit. This is a subfunction of the DFSMS/MVS subsystem request (SSREQ 55) that the MVS JCL Interpreter and dynamic allocation functions issue for calling DFSMS ACS routines for management of the data set requested.

IDRC— Improved Data Recording Capability.

IML— *See* Initial Microprogram Load.

Improved Cartridge Recording Capability (ICRC)— An improved data recording mode that, when enabled, can increase the effective cartridge data capacity and the effective data rate when invoked.

index— A function performed by the cartridge scratch loader that moves cartridges down the input or output stack one cartridge position. A scratch loader can perform multiple consecutive indexes.

INISH deck— A set of JES3 initialization statements.

Initial Microprogram Load (IML)— A process that activates a machine reset and loads system programs to prepare a computer system for operation. Processors having diagnostic programs activate these programs at IML execution. Devices running μ -software reload the functional μ -software usually from a floppy diskette at IML execution.

Initial Program Load (IPL)— A process that activates a machine reset and loads system programs to prepare a computer system for operation. Processors having diagnostic programs activate these

programs at IPL execution. Devices running μ -software reload the functional μ -software usually from a floppy diskette at IPL execution.

initial value— A value assumed until explicitly changed. It must then be explicitly specified in another command to restore the initial value. An initial value for the HSC is the value in effect when the product is installed.

inline diagnostics— Diagnostic routines that test subsystem components while operating on a time-sharing basis with the functional μ -software in the subsystem component.

input stack— The part of the cartridge loader where cartridges are premounted.

intervention required— Manual action is needed.

IPL— *See* Initial Program Load.

ips— Inches per second.

IVP— Installation Verification Programs. A package of programs that is run by a user after the library is installed in order to verify that the library is functioning properly.

J

JCL— *See* Job Control Language.

Job Control Language— Problem-oriented language designed to express statements in a job that are used to identify the job or describe its requirements to an operating system.

journal— The log associated with journaling. The log (stored in a data set) contains a record of completed work and changes to the control data set since the last backup was created.

journaling— A technique for recovery that involves creating a backup control data set and maintaining a log of all changes (transactions) to that data set.

JST— Job Summary Table (JES3).

K

KB— Kilobyte, thousand (10^3) bytes.

keyword parameter— In command and utility syntax, operands that include keywords and their related values (*See* positional parameter).

Values are concatenated to the keyword either by an equal sign, “KEYWORD=value,” or by parentheses, “KEYWORD(value).” Keyword parameters can be specified in any order. The HSC accepts (tolerates) multiple occurrences of a keyword. The value assigned to a keyword reflects the last occurrence of a keyword within a command.

L

LAN— *See* Local Area Network.

LCU— *See* Library Control Unit.

LED— *See* Light Emitting Diode.

LIBGEN— The process of defining the configuration of the automated library to the host software.

library— An installation of one or more ACSs, attached cartridge drives, volumes placed into the ACSs, host software that controls and manages the ACSs and associated volumes, and the library control data set that describes the state of the ACSs.

library control data set— *See* control data set.

Library Control Unit (LCU)— The portion of the LSM that controls the picking, mounting, dismounting, and replacing of cartridges.

Library Management Unit (LMU)— The portion of the ACS that manages from one to sixteen LSMs and communicates with the host CPU.

Library Storage Module (LSM)— The storage area for cartridges plus the robot necessary to move the cartridges. The term LSM often means the LCU and LSM combined.

Light Emitting Diode (LED)— An electronic device used mainly as an indicator on status panels to show equipment on/off conditions.

Linear Tape Open (LTO)— A technology developed jointly by HP, IBM, and Seagate for new tape storage options. LTO technology is an open format, which means that users have multiple sources of products and media.

LMU— See Library Management Unit.

LMUPATH— An HSC control statement contained in the definition data set specified by the LMUPDEF command. An LMUPATH statement allows users to define network LMU attachments.

LMUPDEF— An HSC command used to load the definition data set that contains LMUPATH control statements.

load point— The beginning of the recording area on magnetic tape.

loader— See Cartridge Scratch Loader.

Local Area Network (LAN)— A computer network in which devices within the network can access each other for data transmission purposes. The LMU and attached LCUs are connected with a local area network.

logical ejection— The process of removing a volume from the control data set without physically ejecting it from its LSM location.

Logical End Of Tape— A point on the tape where written data normally ends.

LONG— (1) A value that can be specified on the MEDia parameter and that includes only enhanced capacity cartridge system tapes (not to be confused with LONGitud). (2) An alias of ECART. (3) See Enhanced Capacity Cartridge System Tape.

LONGitud— (1) A generic value that can be specified on the RECtech parameter and includes all 18-track and 36-track devices. (2) A generic value that can be specified on the MEDia parameter and includes all standard and enhanced capacity cartridge system tapes.

LSM— See Library Storage Module.

LSMid— An LSMid (*lsm-id*) is a hexadecimal value that consists of the ACSid and LSM number separated by a colon (i.e., AA:LL, where AA is the ACSid and LL is the LSMid). The LSMid differentiates an LSM from every other LSM in a library.

LSM number— A method used to identify an LSM. An LSM number is the result of defining the SLIACS macro LSM parameter during a LIBGEN.

The first LSM listed in this parameter acquires the LSM number of 00 (hexadecimal), the second LSM listed acquires a hexadecimal number of 01, and so forth, until all LSMs are identified (maximum of 24 or hexadecimal 17).

LTO— See Linear Tape Open.

LTOx— A media type designating either an LTO data cartridge with a capacity between 10GB and 400GB or an LTO cleaning cartridge.

M

machine initiated maintenance— See ServiceTek.

magnetic recording— A technique of storing data by selectively magnetizing portions of a magnetizable material.

magnetic tape— A tape with a magnetizable surface layer on which data can be stored by magnetic recording.

magnetic tape drive— A mechanism for moving magnetic tape and controlling its movement.

maintenance facility— Hardware contained in the CU and LMU that allows a CSE and the RDC to run diagnostics, retrieve status, and communicate with respective units through their control panels.

management class— A collection of management attributes, assigned by the storage administrator, that are used to control the allocation and use of space by a data set.

manual mode— A relationship between an LSM and all attached hosts. LSMs operating in manual mode have been modified offline and require human assistance to perform cartridge operations.

master LMU— The LMU currently controlling the functional work of the ACS in a dual LMU configuration.

MB— Megabyte, million (10^6) bytes.

MDS— Main Device Scheduler (JES3).

MEDia— The parameter used to specify media type.

This is not to be confused with MEDIA1 or MEDIA2, which are values that can be specified on the MEDia parameter.

MEDIA1— (1) A value that can be specified on the MEDIA parameter and that includes only standard capacity cartridge tapes. (2) An alias of Standard.

MEDIA2— (1) A value that can be specified on the MEDIA parameter and that includes only enhanced capacity cartridge system tapes. (2) An alias of ECART. (3) *See* Enhanced Capacity Cartridge System Tape.

media capacity— The amount of data that can be contained on storage media and expressed in bytes of data.

media mismatch— A condition that occurs when the media value defined in a VOLATTR control statement does not match the media value recorded in the CDS VAR record.

micro-software— *See* μ -software under Symbols.

MIM— Multi-Image Manager. Third-party software by Computer Associates International, Inc.

mixed configurations— Installations containing cartridge drives under ACS control and cartridge drives outside of library control. These configurations cause the Host Software Component to alter allocation to one or the other.

MODEL— The parameter used to specify model number.

modem— Modulator/demodulator. An electronic device that converts computer digital data to analog data for transmission over a telecommunications line (telephone line). At the receiving end, the modem performs the inverse function.

monitor— A device that observes, records, and verifies selected system activities to determine significant departure from expected operation.

MSM— Multiple Sessions Management. Third-party software by Computer Associates International, Inc.

N

Near Continuous Operation (NCO) — Facilities and techniques that allow customers to make dynamic changes to the library that do not disrupt the library hardware and environment. In most cases,

users can perform these procedures without requiring the HSC to be terminated and restarted.

O

OCR— Optical Character Recognition.

operating system (OS)— Software that controls the execution of programs that facilitate overall system operation.

output stack— The part of the cartridge loader that receives and holds processed cartridges.

over-limit cleaning cartridge— A cleaning cartridge that has been used more than the value (limit) specified by either the MNTD MAXclean or VOLATTR MAXclean settings. This kind of cartridge may not be able to adequately clean a tape transport, however, it can be mounted and will attempt to execute the cleaning process. *See also* spent cleaning cartridge.

over-use cleaning cartridge— A cartridge that has a usage (select) count over the MAXclean value (*see* over-limit cleaning cartridge) or that has used up its cleaning surface (*see* spent cleaning cartridge).

P

paired-CAP mode— The two forty-cell CAPs in an enhanced CAP function in paired-CAP mode as a single eighty-cell CAP.

PARMLIB control statements— Parameter library (PARMLIB) control statements allow you to statically specify various operation parameters which take effect at HSC initialization. Identifying your system requirements and then specifying the appropriate control statements permits you to customize the HSC to your data center.

pass-thru port (PTP)— A mechanism that allows a cartridge to be passed from one LSM to another in a multiple LSM ACS.

PCAP— *See* priority CAP.

P/DAS— Peer-to-Peer Remote Copy Dynamic Address Switching. An IBM capability to non-disruptively swap PPRC volumes.

Peer-to-Peer Remote Copy (PPRC)— An IBM capability to mirror disk volumes from one storage subsystem to another.

physical end of tape— A point on the tape beyond which the tape is not permitted to move.

playground— The playground is a reserved area of cells where the robot deposits cartridges that it finds in its hands during LSM initialization. Normal LSM initialization recovery processing moves cartridges from the playground cells to either their home cells or their intended destinations, but under abnormal circumstances cartridges may be left in playground cells.

positional parameter— In command and utility syntax, operands that are identified by their position in the command string rather than by keywords (*See* keyword parameter).

Positional parameters must be entered in the order shown in the syntax diagram.

PowderHorn (9310) LSM— A high-performance LSM featuring a high-speed robot. The PowderHorn has a capacity of up to approximately 6000 cartridges.

PPRC— *See* Peer-to-Peer Remote Copy.

primary CDS— The active control data set. It contains the inventory of all cartridges in the library, the library configuration, information about library hardware and resource ownership across multiple processors, and serves as a vehicle of communication between HSCs running on multiple processors.

priority CAP (PCAP)— A one-cell CAP that is part of an enhanced CAP. A PCAP allows a user to enter or eject a single cartridge that requires immediate action.

See also Cartridge Access Port, standard CAP, enhanced CAP, WolfCreek CAP, WolfCreek optional CAP, or TimberWolf CAP.

Program Temporary Fix (PTF)— A unit of corrective maintenance delivered to a customer to repair a defect in a product, or a means of packaging a Small Programming Enhancement (SPE).

Program Update Tape (PUT)— A tape containing a collection of PTFs. PUTs are shipped to customers

on a regular basis under the conditions of the customer's maintenance license.

PTF— *See* Program Temporary Fix.

PTP— *See* pass-thru port.

PUT— *See* Program Update Tape.

Q

QSAM— *See* Queued Sequential Access Method.

Queued Sequential Access Method (QSAM)— An extended version of the basic sequential access method (BSAM). When this method is used, a queue is formed of input data blocks that are awaiting processing or output data blocks that have been processed and are awaiting transfer to auxiliary storage or to an output device.

R

RACF— *See* Resource Access Control Facility.

RDC— *See* Remote Diagnostics Center.

Recording Density— The number of bits in a single linear track measured per unit of length of the recording medium.

RECtech— The parameter used to specify recording technique.

RedWood— (1) The program name of the Sun StorageTek transport that supports a helical recording technique. (2) *See* SD-3.

Remote Diagnostics Center (RDC)— The Remote Diagnostics Center at Sun StorageTek. RDC operators can access and test Sun StorageTek systems and software, through telecommunications lines, from remote customer installations. Also referred to as the Central Support Remote Center (CSRC).

Resource Access Control Facility (RACF)— Security software controlling access to data sets.

S

SCP— *See* System Control Program.

scratch tape subpool— A defined subset of all scratch tapes. Subpools are composed of one or more

ranges of VOLSERS with similar physical characteristics (type of volume {reel or cartridge}, reel size, length, physical location, etc.). Some installations may also subdivide their scratch pools by other characteristics, such as label type (AL, SL, NSL, NL).

The purpose of subpooling is to make sure that certain data sets are built only within particular ranges of volumes (for whatever reason the user desires). If a volume which does not belong to the required subpool is mounted for a particular data set, it is dismounted and the mount reissued.

SD-3— The model number of the Sun StorageTek transport that supports a helical recording technique.

SDLT— *See* SuperDLT.

SDLTx— A media type designating an SDLT data cartridge with a capacity of either 125GB or 160GB.

secondary CDS— The optional duplicate copy of the primary CDS.

secondary recording— A technique for recovery involving maintaining both a control data set and a copy (secondary) of the control data set.

SEN — *See* Significant Event Notification.

SER— Software Enhancement Request.

ServiceTek (machine initiated maintenance)— A unique feature of the ACS in which an expert system monitors conditions and performance of subsystems and requests operator attention before a potential problem impacts operations. Customers can set maintenance threshold levels.

servo— A device that uses feedback from a sensing element to control mechanical motion.

Shared Tape Allocation Manager (STAM)— Third-party software by Computer Associates International, Inc.

Significant Event Notification (SEN) — An HSC facility that allows an application to request notification of specific HSC and VTCS events.

Silverton— *See* 4490 Cartridge Subsystem.

SL3000 library— *See* StreamLine (SL3000) library.

SL8500 library— *See* Streamline (SL8500) library.

Small Programming Enhancement (SPE)— A supplement to a released program that can affect several products or components.

SMC— Storage Management Component.

SMF— System Management Facility. An MVS facility used to record system actions which affect system functionality.

SMP— System Modification Program.

SMP/E— *See* System Modification Program Extended.

SMS— Storage Management Subsystem.

SPE— *See* Small Programming Enhancement.

special use cartridge— A generic description for a type of cartridge used on T9840A drives. These include:

- T9840A cleaning cartridge
- T9840A microcode load cartridge
- T9840A dump collection cartridge.

When an attempt is made to mount a special use cartridge, LMU error response code 1012 is generated.

The error code is defined as “load failure for special use cartridge.”

If the error code is received for a special use cleaning cartridge, it is either ejected or marked as unusable, and it is retained in the ACS (depending on the MNTD EJctauto setting). The HSC does not mount unusable cartridges.

spent cleaning cartridge— A cleaning cartridge that has exhausted its cleaning material and can no longer be used to clean tape transports. *See also* over-limit cleaning cartridge.

SSD— Solid state disk.

STAM— *See* Shared Tape Allocation Manager.

Standard— (1) A value that can be specified on the MEDia parameter and that includes only standard capacity cartridge tapes. (2) *See* Cartridge System Tape.

standard CAP— A standard CAP has a capacity of twenty-one cartridges (three rows of seven cells each). An LSM access door with a standard CAP contains cell locations for storing cartridges.

See also Cartridge Access Port, enhanced CAP, priority CAP, WolfCreek CAP, WolfCreek optional CAP, or TimberWolf CAP.

standard (4410) LSM— An LSM which provides a storage capacity of up to approximately 6000 cartridges.

standby— The status of a station that has been varied online but is connected to the standby LMU of a dual LMU ACS.

standby CDS— The optional data set that contains only one valid record, the Database Heartbeat (DHB). The DHB contains the names of the control data sets recorded by the HSC and is used to identify the correct primary, secondary, and standby CDS.

standby LMU— The redundant LMU in a dual LMU configuration that is ready to take over in case of a master LMU failure or when the operator issues the SWitch command.

station— A hardware path between the host computer and an LMU over which the HSC and LMU send control information.

STD— (1) A value that can be specified on the MEDia parameter and that includes only standard capacity cartridge tapes. (2) An alias of Standard.

STK1— A generic value that can be specified on the MEDia and RECtech parameters and includes all types of T9840A cartridges and recording techniques.

STK1R— Value that can be specified on the MEDia and RECtech parameters and includes only the specified type of T9840A cartridge or recording technique. STK1R can be abbreviated as R.

STK1U— Value that can be specified on the MEDia parameter and includes the specified types of T9840A, T9840B, and T9840C cleaning cartridges. STK1U can be abbreviated as U.

STK1Y— Value that can be specified on the MEDia parameter and includes only the specified type of

T9840D cleaning cartridge. STK1Y can be abbreviated as Y.

STK2— A generic value that can be specified on the MEDia parameter and includes all types of 9940 cartridges and recording techniques.

STK2P— Value that can be specified on the MEDia and RECtech parameters and includes only the specified type of 9940 cartridge or recording technique. STK2P can be abbreviated as P.

STK2W— Value that can be specified on the MEDia parameter and includes only the specified type of 9940 cleaning cartridge. STK2W can be abbreviated as W.

storage class— A named list of storage attributes that identify performance goals and availability requirements for a data set.

storage group— A collection of storage volumes and attributes defined by the storage administrator.

Storage Management Component (SMC)— Required NCS software component that performs the allocation function for NCS, replacing the functions previously performed by HSC and MVS/CSC. The SMC resides on the MVS host with HSC and/or MVS/CSC, and communicates with these products to determine policies, volume locations, and drive ownership.

StreamLine (SL3000) library— A modular library that can scale from 200 to 4500 cartridges in mainframe, Windows, UNIX, and supercomputer environments. The SL3000 utilizes hot swap components and multiple robots.

StreamLine (SL8500) library— A modular library that can scale from 1,500 to over 200,000 cartridges in mainframe, Windows, UNIX, and supercomputer environments. The SL8500 utilizes hot swap components and multiple robots.

StreamLine CAP— The StreamLine CAP contains 3, 13-cell removable magazines. You can also add an optional CAP that has the same configuration.

SuperDLT— The next generation of DLT (Digital Linear Tape) products, which remains a standard for mid-range operating systems.

switchover— The assumption of master LMU functionality by the standby LMU.

SYNCSORT— Third-party software by Syncsort, Inc.; a sort, merge, copy utility program.

System Control Program— The general term to describe a program which controls access to system resources, and allocates those resources among executing tasks.

system-managed storage— Storage that is managed by the Storage Management Subsystem, which attempts to deliver required services for availability, performance, space, and security applications.

System Modification Program Extended— An IBM-licensed program used to install software and software maintenance.

T

T10000 Tape Drive— A cartridge tape drive that features a 500GB cartridge capacity and data transfer rates up to 120MB/sec native, uncompressed. In addition, the T10000 offers media reusability for at least two generations and device-based encryption.

tape cartridge— A container holding magnetic tape that can be processed without separating it from the container.

tape drive— A device that is used for moving magnetic tape and includes the mechanisms for writing and reading data to and from the tape.

tape unit— A device that contains tape drives and their associated power supplies and electronics.

TAPEREQ— An SMC control statement that is contained in the definition data set specified by the TREQDEF command. A TAPEREQ statement defines a specific tape request. It is divided into two parts, the input: job name, step name, program name, data set name, expiration date or retention period, and an indication for specific requests or nonspecific (scratch) requests; and the output: media type and recording technique capabilities.

TDMF™— Transparent Data Migration Facility. A product from Softek Storage Solutions Corp. that allows two disk devices to be non-disruptively swapped with each other.

Timberline— *See* 9490 Cartridge Subsystem.

Timberline EE— *See* 9490EE Cartridge Subsystem.

TimberWolf (9740) LSM— A high performance LSM that provides a storage capacity of up to 494 cartridges. Up to 10 drives (STD, 4490, 9490, 9490EE, T9840A, and SD-3) can be configured. TimberWolf LSMs can only attach to other TimberWolfs.

TimberWolf CAP— The TimberWolf CAP contains either a 10-cell removable magazine or a 14-cell permanent rack. It is not necessary to define a configuration; the HSC receives CAP information directly from the LMU.

See also Cartridge Access Port, standard CAP, enhanced CAP, priority CAP, WolfCreek CAP, or WolfCreek optional CAP.

TP— Tape-to-Print.

transaction— A short series of actions with the control data set. These actions are usually related to a specific function (e.g., Mount, ENter).

transport— An electromechanical device capable of threading tape from a cartridge, moving the tape across a read/write head, and writing data onto or reading data from the tape.

TREQDEF— An SMC command that is used to load the definition data set that contains TAPEREQ control statements.

Tri-Optic label— An external label attached to the spine of a cartridge that is both human and machine readable.

TT— Tape-to-Tape.

U

unit affinity— A request that all cartridges be mounted on a single drive (either for read or write purposes), usually to reduce the number of drives needed for a job.

unit parameter value— A JCL term meaning the value of a JCL UNIT parameter. The value can be a single address of a drive, an esoteric list, or a generic list.

UNITATTR— An SMC control statement that defines the transport's media type and recording technique capabilities.

utilities— Utility programs. The programs that allow an operator to manage the resources of the library and to monitor overall library performance.

V

VAR— *See* Volume Attribute Record.

VAT— *See* Volume Attribute Table Entry.

Virtual Storage Manager (VSM)— A storage solution that virtualizes volumes and transports in a VTSS buffer in order to improve media and transport use.

Virtual Tape Control System (VTCS)— The primary host code for the Virtual Storage Manager (VSM) solution. This code operates in a separate address space, but communicates closely with HSC.

Virtual Tape Storage Subsystem (VTSS)— The DASD buffer containing virtual volumes (VTVs) and virtual drives (VTDs). The VTSS is a Sun StorageTek RAID 6 hardware device with microcode that enables transport emulation. The RAID device can read and write "tape" data from/to disk, and can read and write the data from/to a real tape drive (RTD).

virtual thumbwheel— An HSC feature that allows read-only access to a volume that is not physically write-protected.

VOLATTR— An HSC control statement that is contained in the definition data set specified by the VOLDEF command. A VOLATTR statement defines to the HSC the media type and recording technique of the specified volumes.

VOLDEF— An HSC command that is used to load the definition data set that contains VOLATTR control statements.

VOLSER— A six-character alphanumeric label used to identify a tape volume.

volume— A data carrier that is mounted or dismounted as a unit. (*See* cartridge).

Volume Attribute Record (VAR)— An HSC internal record that contains the data base-resident information of a cartridge entered into the library.

Volume Attribute Table Entry (VAT)— An HSC internal table that contains entries to the intransit record token and the Volume Attribute Record (VAR). The VAT is used as the communications area for internal service calls.

W

WolfCreek (9360) LSM— A smaller capacity high-performance LSM. WolfCreek LSMs are available in 500, 750, and 1000 cartridge capacities (model numbers 9360-050, 9360-075, and 9360-100, respectively). WolfCreek LSMs can be connected by pass-thru ports to 4410, 9310, or other WolfCreek LSMs.

WolfCreek CAP— The standard WolfCreek CAP contains a 20-cell magazine-style CAP and a priority CAP (PCAP).

See also Cartridge Access Port, standard CAP, enhanced CAP, priority CAP, WolfCreek optional CAP, or TimberWolf CAP.

WolfCreek optional CAP— The WolfCreek optional CAP contains a 30-cell magazine-style CAP which is added to the standard WolfCreek CAP.

See also Cartridge Access Port, standard CAP, enhanced CAP, priority CAP, WolfCreek CAP, or TimberWolf CAP.

Write Tape Mark (WTM)— The operation performed to record a special magnetic mark on tape. The mark identifies a specific location on the tape.

WTM— *See* Write Tape Mark.

WTO— Write-to-Operator.

WTOR— Write-to-Operator with reply.

Z

ZCART— (1) Cartridge system tape with a length of 2200 feet that can be used only with 9490EE Cartridge Drives. (2) A value that can be specified on the MEDIA parameter and that includes only 36-track 9490EE cartridge system tapes. (3) *See also* Extended Enhanced Tape.

Symbols

μ-software— Microprogram. A sequence of microinstructions used to perform preplanned functions and implement machine instructions.

Numerics

18-track— A recording technique that uses 18 tracks on the tape. The tape is written in only the forward motion.

18track— A generic value that can be specified on the RECtech parameter and includes all 18-track transports.

3480— (1) A value that can be specified on the MEDia parameter and that includes only standard capacity cartridge tapes. (2) An alias of Standard.

3480X— The 3480 upgrade that supports ICRC.

3490— The IBM cartridge drive that replaced the 3480X and supports ICRC but not 36-track or long tape. It is equivalent to the IBM 3480X.

3490E— (1) The IBM cartridge drive that replaced the 3490 and supports ICRC, 36-track, and long tape. It reads 18-track but does not write 18-track. (2) A value that can be specified on the MEDia parameter and that includes only enhanced capacity cartridge system tapes. (3) An alias of ECART.

3590— The IBM cartridge drive that supports 128-track recording and holds 10GB of uncompressed data. It has the same form factor as a 3490E.

36-track— A recording technique that uses 36 tracks on the tape. 18 tracks of data are written in the forward motion and then an additional 18 tracks in the backward motion for a total of 36.

36track— A generic value that can be specified on the RECtech parameter and includes all 36-track transports.

36Atrack— A value that can be specified on the RECtech parameter and includes only 4490 (Silverton) 36-track transports.

36Btrack— A value that can be specified on the RECtech parameter and includes only 9490 (Timberline) 36-track transports.

36Ctrack— A value that can be specified on the RECtech parameter and includes only 9490EE (Timberline EE) transports.

4410 LSM— *See* standard LSM.

4480 Cartridge Subsystem— Cartridge tape transports that provide read/write capability for 18-track recording format. The Sun StorageTek 4480 Cartridge Subsystem is equivalent to a 3480 device.

4490 Cartridge Subsystem— Cartridge tape transports that provide read/write capability for 36-track recording format and extended capacity tape. 4490 transports can also read data recorded in 18-track format. The Sun StorageTek 4490 Cartridge Subsystem is equivalent to a 3490E device.

3000 library— *See* StreamLine Library (SL3000).

8500 library— *See* StreamLine (SL8500) library.

9310 LSM— *See* PowderHorn LSM.

9360 LSM— *See* WolfCreek LSM.

9490 Cartridge Subsystem— Cartridge tape transports that provide read/write capability for 36-track recording format and extended capacity tape and provide improved performance over the 4490 Cartridge Subsystem. 9490 transports can also read data recorded in 18-track format. The Sun StorageTek 9490 Cartridge Subsystem offers better performance (faster data transfer rate, faster load/unload) than a 3490E device.

9490EE Cartridge Subsystem— A high-performance tape transport that provides read/write capability for Extended Enhanced tape (EETape) cartridges. It is functionally equivalent to the IBM 3490E device.

9740 LSM— *See* TimberWolf LSM.

T9840A Cartridge Subsystem— A high performance tape transport for enterprise and open systems environments that reads and writes T9840A cartridges. T9840As can be defined in 10-drive and 20-drive panel configurations. The T9840A can perform as a standalone subsystem with a cartridge scratch loader attached, or it can be attached to a Sun StorageTek ACS.

T9840B—The Sun StorageTek cartridge transport that reads and writes T9840B cartridges.

T9840C— The Sun StorageTek cartridge transport that reads and writes T9840C cartridges.

T9840D— The Sun StorageTek cartridge transport that reads and writes T9840D cartridges

T9940A— The Sun StorageTek capacity-centric cartridge transport capable of reading and writing 60GB T9940A cartridges.

T9940B— The Sun StorageTek capacity-centric cartridge transport capable of reading and writing 200GB T9940B cartridges.

Index

Numerics

- 4480 Cartridge Subsystem, defined 181
- 4490 Cartridge Subsystem, defined 181
- 9490 Cartridge Subsystem, defined 181
- 9490EE Cartridge Subsystem, defined 181
- 9840 Cartridge Subsystem, defined 181

A

- access method, defined 167
- ACS *See* Automated Cartridge System
- ACSid, defined 167
- allocation, defined 167
- audience for this guide xxv
- Automated Cartridge System (ACS), defined 167

B

- BDAM, defined 167
- BSAM, defined 167

C

- CAPid, defined 168
- cartridge
 - defined 168
 - ECART, defined 170
 - over-limit cleaning cartridge, defined 175
 - over-use cleaning cartridge, defined 175
 - special use cartridge, defined 177
 - spent cleaning cartridge, defined 177
 - ZCART, defined 180
- Cartridge Access Port (CAP)
 - defined 168
 - standard, defined 178
 - TimberWolf, defined 179
 - WolfCreek optional, defined 180
 - WolfCreek, defined 180
- Cartridge Drive (CD), defined 168

- Cartridge Scratch Loader (CSL), defined 168
- CD *See* Cartridge Drive
- CDS *See* control data set
- connected mode, defined 168
- contacting Sun Microsystems StorageTek Support xxv
- control data set (CDS)
 - allocation map, defined 168
 - data blocks, defined 168
 - defined 168
 - directory, defined 168
 - pointer blocks, defined 168
 - recovery area, defined 169
 - subfile, defined 169
- Control Unit (CU), defined 169
- CST, defined 169
- CU *See* Control Unit
- Customer Resource Center (CRC) xxiv
- customer support xxv
- customer-initiated maintenance (CIM) xxv

D

- Database Heartbeat (DHB) record, defined 169
- device group, defined 170
- device number, defined 170
- DFP (Data Facility Product), defined 170
- DFSMS
 - ACS routine, defined 170
 - defined 170
- directed allocation, defined 170
- disconnected mode, defined 170
- DOMed, defined 170
- drive exclusion, defined 170
- drive loaded, defined 170
- drive panel, defined 170
- drive prioritization, defined 170
- DRIVEid, defined 170

dual LMU, defined 170
dump, defined 170
Dynamic Device Reconfiguration (DDR), defined 170

E

ECART
 defined 170
ECCST, defined 171
eject, defined 171
eligible device list, defined 171
Enhanced CAP (ECAP), defined 171
Enhanced Capacity Cartridge System Tape (ECCST), defined 171
esoteric, defined 171
ETAPE, defined 171
Extended Enhanced Tape (EETape), defined 171
ExtendedStore, Library, defined 171

F

FDRPAS, defined 171

G

Generation Data Groups (GDG) separation, defined 172
guide
 audience definition xxi
 organization xxii

H

Helical, defined 172
help, technical support xxiv
Host Software Component (HSC)
 defined 172
host system, defined 172
HOSTid, defined 172

I

Improved Cartridge Recording Capability (ICRC), defined 172
Index, defined 172
INISH deck, defined 172
Initial Microprogram Load (IML), defined 172
Initial Program Load (IPL), defined 172
initial value, defined 173
input stack, defined 173

Installation Verification Programs (IVP), defined 173

J

Job Control Language (JCL)
 defined 173
journaling, defined 173

K

keyword parameter, defined 173

L

LAN, defined 173
LCU *See* Library Control Unit
LIBGEN
 defined 173
library
 defined 173
Library Control Unit (LCU), defined 173
Library Management Unit (LMU)
 defined 173
 standby, defined 178
Library Storage Module (LSM)
 defined 173
 number, defined 174
 standard (4410), defined 178
 TimberWolf (9740), defined 179
 WolfCreek (9360), defined 180
LMU *See* Library Management Unit
LMUPATH control statement
 defined 174
LMUPDEF command and control statement
 defined 174
logical ejection, defined 174
LONGItud, defined 174
LSM *See* Library Storage Module
LSM parameter 62, 65
LSMid, defined 174

M

manual mode
 defined 174
master LMU
 defined 174
media capacity, defined 175
media mismatch, defined 175
MEDia, defined 174

MODEl, defined 175

N

Near Continuous Operation (NCO)
defined 175

O

organization of guide xxii

organization of this guide xxii

output stack, defined 175

over-limit cleaning cartridge
defined 175

over-use cleaning cartridge
defined 175

P

P/DAS, defined 175

Paired-CAP mode, defined 175

partners web site, SUN xxiv

pass-thru port (PTP), defined 175

Peer-to-Peer Remote Copy (PPRC), defined 176

playground, defined 176

positional parameter, defined 176

PowderHorn (9310) LSM, defined 176

primary CDS
defined 176

priority CAP (PCAP), defined 176

Programmatic Interface functions, parameter list
LSM 62, 65

Q

Queued Sequential Access Method (QSAM), defined 176

R

RECtech, defined 176

Remote Diagnostics Center (RDC), defined 176

S

secondary CDS
defined 177

ServiceTek, defined 177

Significant Event Notification (SEN)
defined 177

SL3000 library

media type and recording technique support 50, 52, 76, 78,
92, 94, 110, 113

SL8500 library

media type and recording technique support 50, 52, 76, 78,
92, 94, 110, 113

special use cartridge, defined 177

spent cleaning cartridge
defined 177

standard (4410) LSM, defined 178

standard CAP, defined 178

standby CDS
defined 178

standby LMU
defined 178

standby, defined 178

station, defined 178

storage
class, defined 178
group, defined 178

support, technical xxiv

symbols, μ -software, defined 181

T

T9840B Cartridge Subsystem, defined 182

T9840C Cartridge Subsystem, defined 182

T9940A Cartridge Subsystem, defined 182

T9940B Cartridge Subsystem, defined 182

technical support xxiv

TimberWolf (9740) LSM, defined 179

TimberWolf CAP, defined 179

transport, defined 179

Tri-Optic label, defined 179

troubleshooting xxiv

U

unit affinity, defined 179

V

Virtual Thumbwheel, defined 180

VOLSER
defined 180

volume, defined 180

W

web site, SUN xxiv

WolfCreek (9360) LSM, defined 180
WolfCreek CAP, defined 180
WolfCreek optional CAP, defined 180
worldwide offices, SUN xxvi

Z

ZCART, defined 180



Sun Microsystems, Inc. 4150 Network Circle, Santa Clara, CA 95054 USA Phone 1-650-960-1300 or 1-800-555-9SUN Web sun.com



ARGENTINA: 5411-4317-5636 • AUSTRALIA: 1-800-550-786 • AUSTRIA: 43-1-601-26-0 • BALKANS: 301-6188-111 • BELGIUM: 32-2-704 89 83 • BRAZIL: 55-11-51872100 • BRUNEI: 65-216-8333 • CANADA: 1-800-422-8020 (GENERAL); 416-964-2001 (LEARNING MANAGEMENT SYSTEM SALES, TORONTO) • CHILE: 562-372-4500 • COLOMBIA: 571-629-2323
CZECH REPUBLIC: 420 2 33009311 • DENMARK: 45 4556 5040 • EGYPT: 00 202 570 9442 • FINLAND: 358-9-525-551 • FRANCE: 33-1-41-33-17-17 • GERMANY: 49-89-460-08-2788 • GREECE: 30-01-6188101 • HONG KONG: 852-2877-7077 • HUNGARY: 361-202-4415 • INDIA: 91-80-229-8989 • INDONESIA: 65-216-8333 • IRELAND: 353-1-668-4377
ISRAEL: 972-9-9710500 • ITALY: 39-02-9259511 • JAPAN: 81-3-5779-1820 • KOREA: 82-2-3453-6602 • MALAYSIA: 603-2116-1887 • MIDDLE EAST: 00 9714 3366333 • MEXICO: 525-261-0344 • NETHERLANDS: 31-33-4515200 • NEW ZEALAND: 0800-786-338 • NORTH WEST AFRICA: 00 9714 3366333 • NORWAY: FROM NORWAY: 47-22023950, TO NORWAY: 47-23369650 • PAKISTAN: 00-9714-3366333 • PEOPLE'S REPUBLIC OF CHINA: 8610-6803-5588 • PHILIPPINES: 632-885-7867 • POLAND: 48-22-8747848 • PORTUGAL: 351-21-413-4000 • RUSSIA: 7-095-935-8411 • SAUDI ARABIA: 00 9714 3366333 • SINGAPORE: 65-216-8300 • SOUTH AFRICA: 27-11-256-6300 • SPAIN: 34-902-210-412 • SRI LANKA: 65-2168333 • SWEDEN: 46-8-631 22 00 • SWITZERLAND: 41-1-908-90-50 (GERMAN) 41-22-999-0444 (FRENCH) • TAIWAN: 886-2-25185735 • THAILAND: 662-344-6855 • TURKEY: 90 212 335 22 00 • UNITED KINGDOM: 44-1276-416-520 • UNITED STATES: 1-800-422-8020 • VENEZUELA: 582-905-3800 • VIETNAM: 65-216-8333 • WORLDWIDE HEADQUARTERS: 1-650-960-1300

SUN™ THE NETWORK IS THE COMPUTER ©2006 Sun Microsystems, Inc. All rights reserved. Sun, Sun Microsystems, and the Sun logo are trademarks or registered trademarks of Sun Microsystems, Inc. in the United States and other countries.