



Sun StorageTek™ SL3000 Modular Library System

Systems Assurance Guide

Part Number: 316194102

Revision:AB



Sun StorageTek™ SL3000 Modular Library System

Systems Assurance Guide

Sun Microsystems, Inc.
www.sun.com

Part Number: 316194102
July 2008
Revision: AB

Copyright © 2008 Sun Microsystems, Inc., 4150 Network Circle, Santa Clara, California 95054, U.S.A. All rights reserved.

Sun Microsystems, Inc. has intellectual property rights relating to technology embodied in the product that is described in this document. In particular, and without limitation, these intellectual property rights may include one or more of the U.S. patents listed at <http://www.sun.com/patents> and one or more additional patents or pending patent applications in the U.S. and in other countries.

THIS PRODUCT CONTAINS CONFIDENTIAL INFORMATION AND TRADE SECRETS OF SUN MICROSYSTEMS, INC. USE, DISCLOSURE OR REPRODUCTION IS PROHIBITED WITHOUT THE PRIOR EXPRESS WRITTEN PERMISSION OF SUN MICROSYSTEMS, INC.

Use is subject to license terms. This distribution may include materials developed by third parties. This distribution may include materials developed by third parties. Parts of the product may be derived from Berkeley BSD systems, licensed from the University of California.

UNIX is a registered trademark in the U.S. and in other countries, exclusively licensed through X/Open Company, Ltd. Sun, Sun Microsystems, the Sun logo, Solaris, StorageTek and the StorageTek logo are trademarks or registered trademarks of Sun Microsystems, Inc. in the U.S. and other countries.

Products covered by and information contained in this service manual are controlled by U.S. Export Control laws and may be subject to the export or import laws in other countries. Nuclear, missile, chemical biological weapons or nuclear maritime end uses or end users, whether direct or indirect, are strictly prohibited. Export or reexport to countries subject to U.S. embargo or to entities identified on U.S. export exclusion lists, including, but not limited to, the denied persons and specially designated nationals lists is strictly prohibited. Use of any spare or replacement CPUs is limited to repair or one-for-one replacement of CPUs in products exported in compliance with U.S. export laws. Use of CPUs as product upgrades unless authorized by the U.S. Government is strictly prohibited.

DOCUMENTATION IS PROVIDED "AS IS" AND ALL EXPRESS OR IMPLIED CONDITIONS, REPRESENTATIONS AND WARRANTIES, INCLUDING ANY IMPLIED WARRANTY OF MERCHANTABILITY, FITNESS FOR A PARTICULAR PURPOSE OR NON-INFRINGEMENT, ARE DISCLAIMED, EXCEPT TO THE EXTENT THAT SUCH DISCLAIMERS ARE HELD TO BE LEGALLY INVALID.

Copyright © 2008 Sun Microsystems, Inc., 4150 Network Circle, Santa Clara, California 95054, Etats-Unis. Tous droits réservés.

Sun Microsystems, Inc. détient les droits de propriété intellectuels relatifs à la technologie incorporée dans le produit qui est décrit dans ce document.

En particulier, et ce sans limitation, ces droits de propriété intellectuelle peuvent inclure un ou plus des brevets américains listés à l'adresse <http://www.sun.com/patents> et un ou les brevets supplémentaires ou les applications de brevet en attente aux Etats - Unis et dans les autres pays.

CE PRODUIT CONTIENT DES INFORMATIONS CONFIDENTIELLES ET DES SECRETS COMMERCIAUX DE SUN MICROSYSTEMS, INC. SON UTILISATION, SA DIVULGATION ET SA REPRODUCTION SONT INTERDITES SANS L'AUTORISATION EXPRESSE, ECRITE ET PREALABLE DE SUN MICROSYSTEMS, INC.

L'utilisation est soumise aux termes de la Licence. Cette distribution peut comprendre des composants développés par des tierces parties. Cette distribution peut comprendre des composants développés par des tierces parties. Des parties de ce produit pourront être dérivées des systèmes Berkeley BSD licenciés par l'Université de Californie.

UNIX est une marque déposée aux Etats-Unis et dans d'autres pays et licenciée exclusivement par X/Open Company, Ltd. Sun, Sun Microsystems, le logo Sun, Solaris, StorageTek et le logo StorageTek sont des marques de fabrique ou des marques déposées de Sun Microsystems, Inc. aux Etats-Unis et dans d'autres pays.

Ce produit est soumis à la législation américaine en matière de contrôle des exportations et peut être soumis à la réglementation en vigueur dans d'autres pays dans le domaine des exportations et importations. Les utilisations, ou utilisateurs finaux, pour des armes nucléaires, des missiles, des armes biologiques et chimiques ou du nucléaire maritime, directement ou indirectement, sont strictement interdites. Les exportations ou reexportations vers les pays sous embargo américain, ou vers des entités figurant sur les listes d'exclusion d'exportation américaines, y compris, mais de manière non exhaustive, la liste de personnes qui font objet d'un ordre de ne pas participer, d'une façon directe ou indirecte, aux exportations des produits ou des services qui sont régis par la législation américaine en matière de contrôle des exportations et la liste de ressortissants spécifiquement désignés, sont rigoureusement interdites. L'utilisation de pièces détachées ou d'unités centrales de remplacement est limitée aux réparations ou à l'échange standard d'unités centrales pour les produits exportés, conformément à la législation américaine en matière d'exportation. Sauf autorisation par les autorités des Etats-Unis, l'utilisation d'unités centrales pour procéder à des mises à jour de produits est rigoureusement interdite.

LA DOCUMENTATION EST FOURNIE "EN L'ETAT" ET TOUTES AUTRES CONDITIONS, DECLARATIONS ET GARANTIES EXPRESSES OU TACITES SONT FORMELLEMENT EXCLUES, DANS LA MESURE AUTORISEE PAR LA LOI APPLICABLE, Y COMPRIS NOTAMMENT TOUTE GARANTIE IMPLICITE RELATIVE A LA QUALITE MARCHANDE, A L'APTITUDE A UNE UTILISATION PARTICULIERE OU A L'ABSENCE DE CONTREFACON.

We welcome your feedback. Use the OpinionLab [+] feedback system on the documentation Web site or Send your comments to:

Sun Learning Services
Sun Microsystems, Inc.
500 Eldorado Blvd.
Mailstop: UBRM06-307
Broomfield, CO 80021-6307
USA

Please include the publication name, part number, and edition number in your correspondence if they are available. This will expedite our response.



Please
Recycle



Adobe PostScript

Summary of Changes

EC Number	Date	Revision	Description
EC000348	April 2008	A	Initial release
EC000628	July 2008	AB	Updates to this revision include: <ul style="list-style-type: none">■ Updated the manual “Organization” on page xviii■ Updated “Additional Information” on page xxii■ Updated the total number of CAPs allowed to 10■ Added “Independent Software Vendors” on page 32■ Updated “Systems Assurance” on page 35■ Added “Metric Dimensions” on page 40■ Added “Power Consumption” on page 48■ Updated “Cable Routing” on page 53■ Updated “Seismic or Earthquake Ratings” on page 54■ Updated Chapter 5, “Ordering” on page 85■ Updated Appendix C, “Tape Drives and Media”■ Added “Tape Media W5C Help Sheet” on page 159

Note – Change bars are included in this revision.

Contents

Preface xvii

Terminology xvii

Alert Messages and Notes xvii

Organization xviii

Related Information xix

Training xxi

 Accessing the Learning Management System xxi

 Employee Training xxi

 Partner Training xxi

 Customer Training xxi

Additional Information xxii

 Sun's External Web Site xxii

 Documentation and Download Web Sites xxii

 Partners Site xxii

1. Introduction 1

Modular Design 2

 Base Module 4

 Drive Expansion Module 6

 Cartridge Expansion Module 8

 Parking Expansion Module 9

Physical Capacities 10

Power Options 12

 AC Power Configurations 12

 Power Redundancy 12

 N+1 Power Configuration—Standard 12

2N Power Configuration—Optional	12
AC Power Cables	13
Robotic DC Power Configurations	13
Electronic Control Module DC Power Configurations	13
Single Drive Type DC Power Configurations	14
Mixed Drive Type DC Power Configurations	15
Electronics Control Module	17
Robotic Units	18
Cartridge Access Ports	19
Cooling	20
Library (Electronics Control Module)	20
Tape Drives	20
DC Power Supplies	20
Tape Drives	21
Drive Tray	22
Interfaces	23
Host Connectivity	23
SCSI	24
TCP/IP	24
Connections	24
Network	25
Service	25
Monitoring	25
StorageTek Library Console	26
Web-launched Library Console	27
Security Considerations	27
Client Requirements	27
Web-launched SLConsole Updates	27
Simple Network Management Protocol	28
Library Management Software	29
Nearline Control Solution	29
Storage Management Component	30
Host Software Component	30
Virtual Storage Manager	30

Automated Cartridge System Library Software	31
Independent Software Vendors	32
Standards of Conformance	33
2. Systems Assurance	35
System Assurance Planning Meetings	35
Customer Contact Sheet	37
Sun Microsystems Contact Sheet	38
3. Site Planning	39
Specifications	40
Base Module	42
Drive Expansion Module	42
Cartridge Expansion Module	43
Parking Expansion Module	43
Covers, Doors, and Service Clearances	43
Service Clearances	44
Floor Loading	45
Fire Suppression Planning	46
Environmental Requirements	47
Power Consumption	48
Calculating Power Consumption	49
Installation Considerations	50
Available Space	50
Installation Time and Personnel	50
Pallets	51
Customer's Floor	52
Cable Routing	53
Seismic or Earthquake Ratings	54
Installation Tools—Required	55
Drive Tray Power-on Tool	56
Optional Power Drill	56
Array Extraction Tool	56
Installation Kits	56

AC Power Configurations and Cables	57
Obtaining a Password	58
Installing the Library Console Software	59
Licensing	59
License Key File	59
SL3000 Configuration Work Sheet	60

4. Customer Site Survey 63

Interoperability	63
Site Preparation Checklist	64
System Configuration	69
Applications	71
Databases	73
Hardware Configurations	74
Library	74
Tape Drives	75
Data Cartridges	76
Network and Components	77
ESCON Directors	79
FICON Directors	80
Cables	81
Library Network Cables	81
Tape Drive Cables	81
Using World Wide Names	82
Using Persistent Binding	82
Using Zoning to Isolate Devices and Enhance Security	83

5. Ordering 85

Ordering Flowchart—Just the Facts	85
License Key Files	93
Library Part Number Details	94
X-Option Details	95
Modules	95
Power	95

Partitioning	96
Additional Capacity	96
Ethernet Switch/Harnesses	96
Additional Upgrades	97
Library X-options and Conversion Bills	98
Tape Drive Selection	99
T9840 Tape Drive Marketing Numbers	100
T10000 Tape Drive Marketing Numbers	101
LTO Tape Drive Marketing Numbers	101
Tape Drive X-options and Conversion Bills	102
Cables	103
Fibre Channel and ESCON Cables	103
Fibre Channel Cables	103
Plenum-rated Cables	103
ESCON Cables	105
Ethernet Cables	105

A. Addressing 107

CenterLine Technology	107
Addressing	109
Columns	110
Walls	111
Module Identification Block	111
HLI-PRC Addressing	112
Drive Numbering	114
Out-of-the Box Slot Numbering	115
Default SCSI Element Ordering	117
Slot Maps Illustrated	119
Reserved and System Slots	133

B. Optimization 135

Planning for Content	135
CenterLine Technology and Modular Design	135
Robotic Rails and TallBots	137

Cartridge Access Ports	137
Managing Cartridges	138
Planning for Tape Drives	138
Out-of-the Box Slot Numbering	139
Partitioning	141
Capacity on Demand	141
Rectangular Boundaries	142
Guidelines	144
Planning the Data Path	145
Host Software Precautions	145
Performance Zone	146
Planning the Partitions	147

C. Tape Drives and Media 149

Environmental - Tape Drive	150
Tape Drives	151
Dynamic World Wide Name	151
T9840 Tape Drive Order Numbers	152
T10000 Tape Drive Order Numbers	153
LTO Tape Drive Order Numbers	153
Tape Drive Conversion Part Numbers	154
Media	155
Volume ID Label	155
Ordering Tape Cartridges and Labels	156
Media Part Numbers	157
Tape Media Policies	158
Environmental - Media	158
Tape Media W5C Help Sheet	159

Tables

TABLE 1-1	Accessible Physical Slot Count Per Module	11
TABLE 1-2	Power Cable Part Numbers and Descriptions	13
TABLE 1-3	Tape Drive DC Power Supply Requirements	14
TABLE 1-4	Watts Per Drive	15
TABLE 1-5	Available Watts Per Module	15
TABLE 1-6	DC Power Supplies Per Module	15
TABLE 1-7	Mixed Drive Type Power Configuration—Calculation Example	16
TABLE 1-8	Supported Tape Drives	21
TABLE 1-9	Host Software Compatibility Matrix	29
TABLE 1-10	Program Temporary Fix (PTF) List	30
TABLE 1-11	Standard of Compliance	33
TABLE 2-1	System Assurance Checklist	36
TABLE 3-1	Base Module Specifications	42
TABLE 3-2	Drive Expansion Module Specifications	42
TABLE 3-3	Cartridge Expansion Module Specifications	43
TABLE 3-4	Cartridge Expansion Module Specifications	43
TABLE 3-5	Cartridge Expansion Module Specifications	43
TABLE 3-6	Environmental Specifications	47
TABLE 3-7	Environmental Definitions	47
TABLE 3-8	Power Consumption Quick Reference	48
TABLE 3-9	Installation Time Estimates	50
TABLE 3-10	Installation Tools	55
TABLE 3-11	Power Cable Part Numbers and Descriptions	57
TABLE 3-12	SL3000 Library Configuration	60
TABLE 4-1	Site Preparation Checklist	64
TABLE 4-2	Operating System Survey	69

TABLE 4-3	System Configuration	70
TABLE 4-4	Customer Applications	71
TABLE 4-5	Backup and Archive Software	72
TABLE 4-6	Customer Databases	73
TABLE 4-7	Existing Libraries	74
TABLE 4-8	Tape Drive Types	75
TABLE 4-9	Existing Tape Drives	75
TABLE 4-10	Existing Tape Cartridges	76
TABLE 4-11	Fibre Channel Switches	77
TABLE 4-12	Ethernet Hubs and Switches	77
TABLE 4-13	Fibre Channel Switch Connections	78
TABLE 4-14	ESCON Directors	79
TABLE 4-15	FICON Director Worksheet	80
TABLE 5-1	Ordering Flowchart	86
TABLE 5-2	Library X-Options	98
TABLE 5-3	Tape Drive Selection	99
TABLE 5-4	T9840 Marketing Numbers and Descriptions	100
TABLE 5-5	T10000A Marketing Part Numbers and Descriptions	101
TABLE 5-6	LTO3 and LTO4 Marketing Part Numbers and Descriptions	101
TABLE 5-7	Drive Tray Conversion Kits	102
TABLE 5-8	T-Series Port Conversion Marketing Part Numbers and Descriptions	102
TABLE 5-9	LC-to-SC Adapter Kit	103
TABLE 5-10	Fiber Optic Cables: LC-to-LC, 50/125 Micron, Multimode Cables	103
TABLE 5-11	Fiber Optic Cables: LC-to-SC, 50/125 Micron, Single Mode Cables	104
TABLE 5-12	Fiber Optic Cables: LC-to-LC, 9/125 Micron, Single Mode Cables	104
TABLE 5-13	LC-to-SC, 9/125 Micron Cables	104
TABLE 5-14	ESCON Cables	105
TABLE 5-15	Ethernet Cables	105
TABLE A-1	Addressing Scheme	109
TABLE A-2	Base and Drive Module Tape Drive Numbering Scheme—Software and Hardware	114
TABLE A-3	Reserved/System Slots	133
TABLE B-1	Partition Planning	147
TABLE C-1	Supported Tape Drives	149
TABLE C-2	Environmental Specifications for Tape Drives	150

TABLE C-3	T9840D Marketing Part Numbers and Descriptions	152
TABLE C-4	T9840C Marketing Part Numbers and Descriptions	152
TABLE C-5	T10000A Marketing Part Numbers and Descriptions	153
TABLE C-6	LTO3 and LTO4 Marketing Part Numbers and Descriptions	153
TABLE C-7	Drive Tray Conversion Kits	154
TABLE C-8	T10000A Marketing Part Numbers and Descriptions	154
TABLE C-9	Cartridges for LTO3 and LTO4	157
TABLE C-10	Environmental Specifications for Media	158

Figures

FIGURE 1-1	SL3000 Modular Library System (Configuration Example)	1
FIGURE 1-2	Base Module—Front View	4
FIGURE 1-3	Base Module—Rear View Drawing	5
FIGURE 1-4	Drive Expansion Module with a Base Module	6
FIGURE 1-5	Rear View of the Drive Expansion Module	7
FIGURE 1-6	Cartridge Expansion Module with Base Module	8
FIGURE 1-7	Parking Expansion Module with Base Module	9
FIGURE 1-8	Electronics Control Module	17
FIGURE 1-9	TallBot	18
FIGURE 1-10	Cartridge Access Port and Key Pad	19
FIGURE 1-11	SL3000 Tape Drive Trays	22
FIGURE 1-12	Library Console—Example Screen	26
FIGURE 1-13	SNMP Example	28
FIGURE 1-14	ACSLS Example	31
FIGURE 1-15	Interop Tool	32
FIGURE 3-1	SL3000 Library—Front Door Open	39
FIGURE 3-2	Metric Dimensions	40
FIGURE 3-3	Standard Dimensions	41
FIGURE 3-4	Service Clearances—Minimum and Recommended	44
FIGURE 3-5	Floor Loading—Load Pads	45
FIGURE 3-6	Fire Suppression Ceiling Access (Viewed from the top of the library)	46
FIGURE 3-7	Pallet and Module Shipping Information	51
FIGURE 3-8	Floor Slope	52
FIGURE 3-9	Cable Routing	53

FIGURE 3-10	Seismic Mounting Locations	54
FIGURE A-1	Drive Module Slots	108
FIGURE A-2	Centerline and Column Addressing	110
FIGURE A-3	Module Identification Block	111
FIGURE A-4	Panel Numbering for HLI-PRC Addressing	112
FIGURE A-5	Panel Numbering for HLI-PRC Addressing—Example 1	113
FIGURE A-6	Panel Numbering for HLI-PRC Addressing—Example 2	113
FIGURE A-7	Panel Numbering for HLI-PRC Addressing—Example 3, With two PEMs	113
FIGURE A-8	Slot Numbering—Out-of-the-Box	115
FIGURE A-9	Out-of-the-Box Numbering	116
FIGURE A-10	SCSI Element Numbering	118
FIGURE A-11	SL3000 Slot Map—Base Module (1 of 3)	120
FIGURE A-12	SL3000 Slot Map—Base Module (2 of 3)	121
FIGURE A-13	SL3000 Slot Map—Base Module (3 of 3)	122
FIGURE A-14	SL3000 Slot Map—Drive Expansion Module (1 of 5)	123
FIGURE A-15	SL3000 Slot Map—Drive Expansion Module (2 of 5)	124
FIGURE A-16	SL3000 Slot Map—Drive Expansion Module (3 of 5)	125
FIGURE A-17	SL3000 Slot Map—Drive Expansion Module (4 of 5)	126
FIGURE A-18	SL3000 Slot Map—Drive Expansion Module (5 of 5)	127
FIGURE A-19	SL3000 Slot Map—Cartridge Expansion Module, Back Wall	128
FIGURE A-20	SL3000 Slot Map—Cartridge Expansion Module, Installed on the Right	129
FIGURE A-21	SL3000 Slot Map—Cartridge Expansion Module, Installed on the Left	130
FIGURE A-22	SL3000 Slot Map—Parking Expansion Module, Installed on the Right	131
FIGURE A-23	SL3000 Slot Map—Parking Expansion Module, Installed on the Left	132
FIGURE A-24	Reserved/System Slot Locations— <i>Base Module Only</i>	134
FIGURE B-1	A Matter of Balance	136
FIGURE B-2	Slot Numbering—Out-of-the-Box	139
FIGURE B-3	Out-of-the-Box Numbering	140
FIGURE B-4	Adding Capacity to Partitions	143
FIGURE B-5	Performance Zone	146
FIGURE B-6	Planning for Partitions	148
FIGURE C-1	Tape Cartridge Elements	155

Preface

This guide is intended for Sun StorageTek representatives, partners, customers, and anyone responsible for the planning the installation of a Sun StorageTek SL3000 Modular Library System.

Terminology

The following terminology is used throughout this guide is equivalent unless otherwise noted:

- SL3000 modular library system, SL3000 library, SL3000, or just “library”
- Media, cartridges, data cartridges, volumes, or just “tapes “
- Tape drives, or just “drives”
- Slots (hardware) and cells (software)
- Rail (hardware) and library storage module or LSM (software)
- Automated cartridge system ACS (software)

Alert Messages and Notes

Note – A note provides additional information that is of special interest or might point out exceptions to rules or procedures.



Important:

A message that calls attention to a best practice, configuration, or understanding.



Caution – A caution informs you of conditions that might result in damage to hardware, corruption of data, corruption of application software, or long-term health problems in people. A caution always precedes the information to which it pertains.

Organization

This guide has the following organization:

Chapter	Use this chapter to:
Chapter 1, "Introduction"	Introduce your customer and yourself with the SL3000 Library. Topics in this chapter include: <ul style="list-style-type: none"> ■ Module types ■ Power configurations ■ Capacities for the library ■ Library components (electronics, robotics, cooling, etc.) ■ Tape drives and media ■ Interfaces (host connectivity, service, and monitoring) ■ Library management software and support) ■ Standards of compliance
Chapter 2, "Systems Assurance"	Implement the systems assurance process to ensure that no aspects of the sale and installation are overlooked.
Chapter 3, "Site Planning"	Plan and prepare for the installation. Topics in this chapter include: <ul style="list-style-type: none"> ■ Specifications ■ Environmental requirements and Power consumption ■ Installation considerations ■ Preparing for service and access
Chapter 4, "Customer Site Survey"	Perform a physical and equipment survey of the customer's site, and determine the operating system and data requirements. Checklists include: <ul style="list-style-type: none"> ■ Site Preparation ■ Systems Configuration ■ Hardware ■ Networking
Chapter 5, "Ordering"	Help order the SL3000 library, configurations, X-options, additional features, and conversion bills. Information in this chapter includes: <ul style="list-style-type: none"> ■ Ordering Flowchart or "Just the Facts" ■ Library part number details ■ Library options and features ■ Tape drive selection ■ Tape drive options and conversion bills ■ Cables
Appendix A, "Addressing"	Determine the addressing schemes available with the library.
Appendix B, "Optimization"	Understand how to optimize performance in the library.
Appendix C, "Tape Drives and Media"	Compare and contrast the various tape drives and media that are supported for the library.
"Glossary"	Learn new terms relating to the SL3000 and its components
"Index"	Assist in locating information within this guide.

Related Information

These publications contain additional information:

Publication Description	Part Number
<i>Principles of Operation</i>	31619400x
<i>Systems Assurance Guide</i>	31619410x
<i>Installation Manual</i>	31619420x
<i>Service Manual</i>	31619430x
<i>Operator's Guide</i>	31619440x
<i>SLC Online Help</i>	Ships with the library
<i>SNMP Guide for SL3000 Libraries</i>	31619450x
<i>Interface Reference Manual (SCSI Specification)</i>	31619520x
<i>Safety Compliance Manual</i>	31619560x
<i>T9x40 Tape Drive Systems Assurance Guide</i>	MT5003
<i>T10000 Tape Drive Systems Assurance Guide</i>	TM0002

This table shows the specific documents for the SL3000 library and the audience that document is intended for.

Task/Purpose		Documentation & Audience							
		AE	SE	PS	TS	T3	SR	Partner/OEM	Customer
New Documents	Training		Principles of Operation					Training	
	Site Preparation/Pre-sales	Systems Assurance Guide						Planning	
	Installation			Installation Manual				Install	
	Maintenance				Service Manual			Service	
	Use / Operation				Operator's Guide				
	SLC Online Help				StorageTek Library Console Online Help				
Update Existing	Interface Reference							ISVs, End user's	
	ACSLs							ICAG, Msg, Quick Ref.	
	HSC							Sys. Pgm, Config, Msg, Op,	
	T-Series Drives	Entire Documentation Set requires updates							
	OEM Drives				New Manual				
AE = Account executive, sales and marketing SE = Systems engineer PS = Professional services				TS = Technical specialists (NSSE) T3 = Support (Frontline and Backline) SR = Service representative (CSE)					
Partner and OEM requirements need further definition for level of support and documentation access.									

This table lists the documents, audience, and content in each.

Document	Audience	General Content	Purpose	Deliverable
Principles of Operation	Professional Services Technical Specialists Service Representatives Other	Product description Configurations Capacities Components	Pre-req to Training	PDF
Systems Assurance Guide	Marketing & Sales Systems Engineers Professional Services Technical Specialists Service Representatives Customer	Product description Models and features Dimensions Weights & measures Configurations Capacities Site preparation	Pre-Sales Site Planning Product introduction Readiness	PDF
Installation Manual	Technical Specialists Service Representatives	Installation procedures Checklists Configuration	Installation Configuration Initial testing CLI	PDF
Service Manual	Technical Specialists Service Representatives	Service Removal/Replacement Diagnostics Error log	Service the equipment Fault isolation CLI Configuration	PDF
Operator's Guide	Customers: – Operators – Administrators Technical Specialists Service Representatives	Introduction Operator panels Operator tasks Media and Tape Drive information Online help reference	Library use	PDF
Online Help (SLC)	Customers: – Operators – Administrators Technical Specialists Service Representatives	Online help	Library use	Embedded in product
SNMP Guide	Customers Service Partners	MIB	SNMP use	PDF
Interface Reference Manual	ISVs Partners	SCSI elements Command reference	Support Vendors	PDF
SILKs Reference Guide		To Be Determined		PDF

Training

Sun Learning Services (SLS) has two tools that employees can use to obtain information about and for training.

1. Learning Management System (LMS) enables you to sign up for classes, access training records, start e-learning courses, and much more.
2. MyLearning Portal allows you to find out about the latest learning offerings, find the right learning for your job, watch training videos, and share and collaborate with peers—all from a single site.

You can access both of these tools through the SunWeb Portal at:

<http://sunweb.central.sun.com>

All StorageTek employee technical courses can be accessed from the MyLearning at:

<http://mylearning.central.sun.com>

Accessing the Learning Management System

See the following for more information:

Employee Training

Employees can access the LMS by logging into myHR from the SunWeb Portal and myHR, click on the “My Job & Learning” tab and access the new LMS under the “Learning” channel on the page.

Partner Training

Partner training resources are still available through a version of the Sun Training Access Network (SunTAN), which remains available.

Customer Training

Customers can review the Training Catalog that is available through the Sun Web site:

<http://www.sun.com>

Click on the Training link at the top of the page:

<http://www.sun.com/training>

Additional Information

Sun Microsystems, Inc. (Sun) offers several methods to obtain additional information.

Sun's External Web Site

Sun's external Web site provides marketing, product, event, corporate, and service information. The external Web site is accessible to anyone with a Web browser and an Internet connection.

The URL for the external Web site is: <http://www.sun.com>

The URL for StorageTek™ brand-specific information is:
<http://www.sun.com/storagetek/>

Documentation and Download Web Sites

Web sites that enable customers, members, and employees to search for technical documentation, downloads, patches, features, and articles include:

- Documentation: <http://docs.sun.com/app/docs> (customers)
- Documentation: <http://docs.sfbay.sun.com/app/docs> (internal)
- Sun Partner Exchange: <https://spe.sun.com/spx/control/Login> (partners)

Firmware and graphical user interface download sites:

- Sun Download Center: <http://www.sun.com/download/index.jsp> (customers)
- Uniform Software Repository: <http://dlrequest.sfbay.sun.com:88/usr/login> (internal)

If your customer does not already have a Sun Online Account they will need to register. For a new account, go to: <https://reg.sun.com/register>

For more information about Sun StorageTek products, got to:
http://sunsolve.sun.com/handbook_pub/validateUser.do?target=STK/STK_index

Partners Site

The Sun StorageTek Partners site is a Web site for partners with a StorageTek Partner Agreement. This site provides information about products, services, customer support, upcoming events, training programs, and sales tools to support StorageTek Partners. Access to this site, beyond the Partners Login page, is restricted. On the Partners Login page, employees and current partners who do not have access can request a login ID and password and prospective partners can apply to become StorageTek resellers.

The URL for partners with a Sun Partner Agreement is:
<http://www.sun.com/partners/>

Introduction

The SL3000 is the latest addition to the Sun StorageTek modular library family, which includes the SL500 and SL8500 modular library systems.

This chapter introduces you to the SL3000 library, components, and configurations.

FIGURE 1-1 SL3000 Modular Library System (Configuration Example)

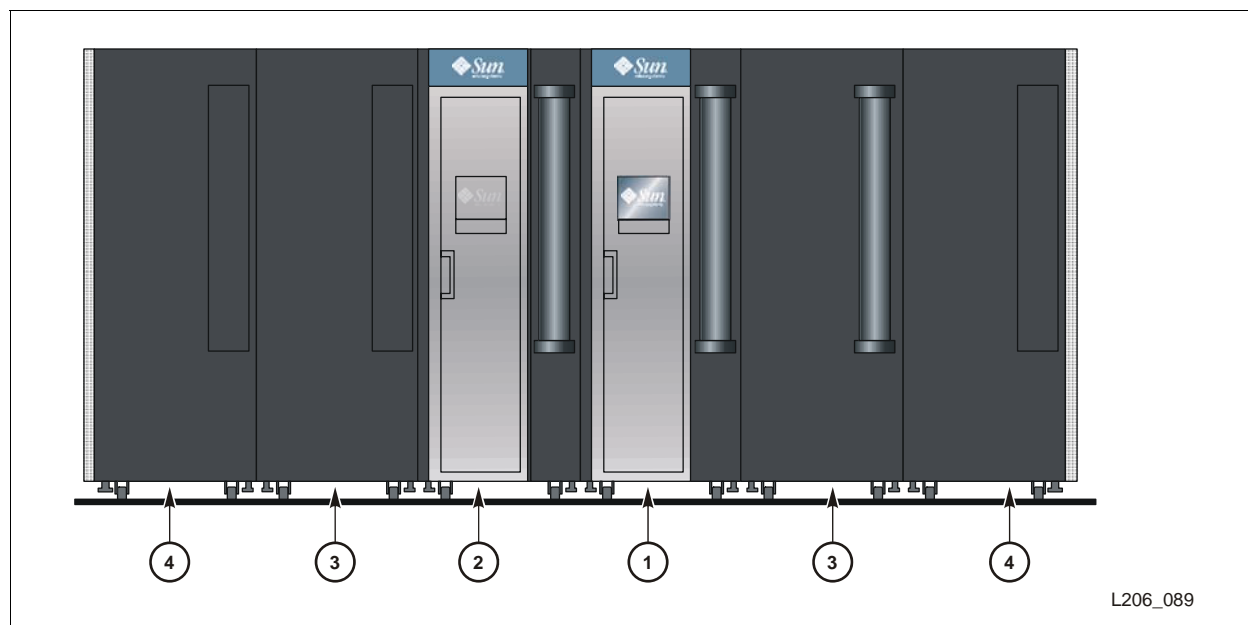

- | | |
|--|---|
| <p>1. Base Module
(required—one per library)</p> <p>2. Drive Expansion Module
(<i>optional</i>, must be installed to the <i>left</i> of the base module—one per library)</p> | <p>3. Cartridge Expansion Module
(maximum of eight per library or six with two Parking Expansion Modules)</p> <p>4. Parking Expansion Module
(maximum of two per library—required for the Dual TallBot feature)</p> |
|--|---|

This library offers customers the benefits of:

- Storage capacity from 200 to more than 5800 slots
- Performance from 1 to 56 tape drives
- Heterogeneous attachments using standard interfaces
- Multiple library management software options and programs

Modular Design

The SL3000 library maintains the fundamentals of a modular design that allows customers the ability to meet the demands of a rapidly growing and constantly changing environment.

The SL3000 library was designed to:

- Address medium to large open systems and entry-level mainframe markets.
- Occupy a standard data center footprint with measurements of approximately*:

Height	198 cm (78 in.)
Depth	124 cm (49 in.)
Length	From: 91.5 cm (36 in.) for the single Base module To: 478 cm (188 in.) with 6 modules (shown above)

*See [Chapter 3, "Site Planning"](#) for specific details.

Modules

There are currently four types of modules in an SL3000 library:

- Base module (Base) one, *required*
- Drive expansion module (DEM)—maximum of one—*on the left side of a base module only*
- Cartridge expansion module (CEM)—maximum of eight (without conversion to parking expansion modules)—*left or right side*
- Parking expansion module (PEM)—maximum of two (converted CEMs with dual TallBot feature)—*left and right ends of the library*

A maximum configuration consists of ten (10) modules.

The modules of the library consist of walls, columns, and rows that house cartridges, tape drives, cartridge access ports, and robotic units.

Addressing

The SL3000 uses five parameters separated by comma's to indicate locations or addresses in the library. These parameters are < L, R, C, S, W >, which is:

- Library (L) = Library number
- Rail (R) = Rail
- Column (C) = Horizontal location in the library
- Side (S) = Walls
- Row (W) = Vertical location in the library

Library and Rail

The library and rail parameters do not apply to this library and are constants. These parameters will always be 1 (one).

Columns

There are two types of columns that provide the *horizontal* locations for components; such as data cartridges, tape drives, and cartridge access ports:

- *Positive numbered* are to the right of the centerline*
- *Negative numbered* are to the left of the centerline*

Note – Centerline* is the left-edge of the Base module.

Columns are numbered from left to right; tape drive arrays have 4 columns per module; media or data cartridge arrays have 6 columns per module.

Side

There are two types of walls in the SL3000 library:

- Front wall parameter is 1
- Rear wall parameter is 2

Rows

Rows provide the *vertical* locations for components and are numbered from the top down from 1 (top) to 52 (bottom).



See [Appendix A, “Addressing”](#) for specifics about the various addressing schemes used with the SL3000 Library.

Base Module

FIGURE 1-2 shows an example of the Base Module. This modules provides an entry level offering that consists of a single frame and centralizes the infrastructure for all other modules in the library. This module includes the power supplies, robotic units, the electronics control module, cartridge access port, storage slots, tape drives, and operator controls.

One Base module—*and only one*—is required for every library installation.

On the front of this module is:

- A single, 26 cartridge–dual magazine–cartridge access port (CAP).
- A service door for library access.
- A front panel with three LEDs: Library Active, Service Required, and Wait.
- Plus an optional feature for a touch screen operator panel or window.

FIGURE 1-2 Base Module—Front View

	Configurations	
	8 drives and CAP (standard) 16 drives and CAP 24 drives and CAP	
	8 drives, CAP, and Operator panel or window ¹ . 16 drives, CAP, and Operator panel or window ¹ . 24 drives, CAP, and Operator panel or window ¹ .	
	¹ Arrays may displace an operator panel or window.	
Dimensions		Measurement
Height		197 cm (77.625 in.) to 200 cm (78.63 in.) fully adjusted
Width		76.75 cm (30.22 in.) without covers 91.5 cm (36 in.) with covers
Depth		124 cm (49 in.)
Weight		Frame only: 361 kg (790 lb)
Service clearance		Front: 46 cm (18 in.) [allow 56 cm (22 in.)] Rear: 81 cm (32 in.)
Both doors open		Total: 262 cm (103 inches)
Side covers		Width: 7.4 cm (2.9 in.) per side cover Cooling clearance: 5 cm (2 in.) ² . Install: 91 cm (36 in.) ³ .
² Recommended cooling clearance. ³ Required to install or remove the sides covers; they swing out and lift off of brackets.		

The Base module can contain up to 24 tape drives in any combination that the library supports—see [“Tape Drives” on page 21](#) for a list and description of these drives.

Physical capacity varies depending on the configuration—see [TABLE 1-1 on page 11](#).

The minimum configuration includes one drive bay that can contain from 1 to 8 tape drives. Two additional drive bays can be added to accommodate either 8 or 16 more drives for a total of 24 drives.

Note – Adding a second drive bay will displace from 55 to 66 cartridge slots; adding a third drive bay will displace from 60 to 72 slots.

The rear door of the Base module allows access to the:

- Electronics control module (ECM)
- Power distribution units (PDUs) and DC power supplies (DCPS)
- Tape drives
- Two 1-unit rack spaces (1 unit = 44.5 mm [1.75 in.]) for vertically mounted auxiliary equipment, such as Ethernet switches (*not for customer use*)

FIGURE 1-3 Base Module—Rear View Drawing

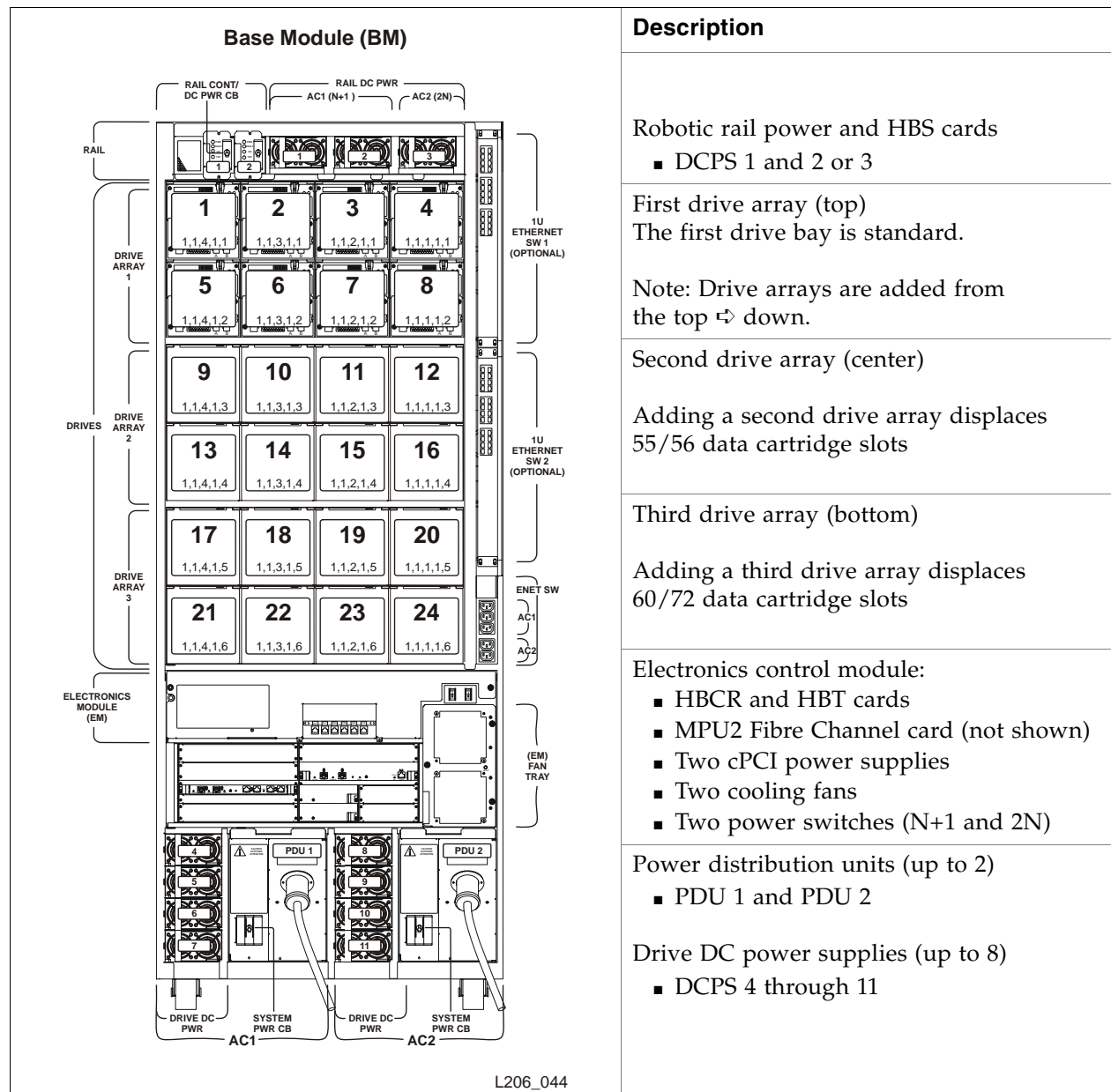

Drive Expansion Module

FIGURE 1-4 shows an example of the Drive Expansion Module (DEM). This module is attached adjacent to the Base module on the **left side only**. The DEM allows further expansion of tape drives and provides additional data cartridge capacity.

One drive expansion module—*and only one*—can be included in an installation. Its position is immediately to the left of the centerline (left edge of the base module).

On the front of this module is space for:

- A service door for library access (standard)
- A front panel with three LEDs: Library Active, Service Required, and Wait
- A single, 26 cartridge-dual magazine, cartridge access port *optional feature*
- Touch screen operator panel *optional feature* if not in the base (or window)

FIGURE 1-4 Drive Expansion Module with a Base Module

	Configurations	
	8 drives	
	16 drives	
	24 drives	
	32 drives	
	8 drives, CAP	
	16 drives, CAP	
	24 drives, CAP	
	32 drives, CAP	
	8 drives, CAP, and Operator panel/Window/Arrays	
16 drives, CAP, and Operator panel/Window/Arrays		
24 drives, CAP, and Operator panel/Window/Arrays		
32 drives, CAP, and Operator panel/Window/Arrays		
Dimensions¹	Measurement	
Height	197 cm (77.625 in.) to 200 cm (78.63 in.)	
Width		
Module-only:	76.75 cm (30.22 in.)	
Base and DEM:	168.2 cm (66.22 in.) with covers	
Depth	124 cm (49 in.)	
Weight	Frame only: 265 kg (584 lb)	
Service clearance	Front: 46 cm (18 in.) Rear: 81 cm (32 in.)	
Both doors open	262 cm (103 inches)	
Side covers ^{2, 3, 4}	Cooling clearance: 5 cm (2 in.) Install: 91 cm (36 in.)	
Notes:		
1. The dimensions of the DEM are the same as the Base module.		
2. When installing additional modules, the covers are removed from the Base and replaced on the ends of the last module in the string.		
3. Required to install or remove the sides covers; they swing out and lift off of brackets.		
4. This is the recommended cooling clearance.		

The DEM comes with slots to support up to 8 tape drives (standard).

Optional features allow the DEM to increase drive capacity from 16, to 24, and 32 additional tape drive slots. These features allow expansion up to a total of 56 tape drives per library.

There is an additional power system integral to the DEM to support the additional tape drives and two 1-unit rack spaces for vertically mounting auxiliary equipment, such as Ethernet switches (not for customer use).

FIGURE 1-5 Rear View of the Drive Expansion Module

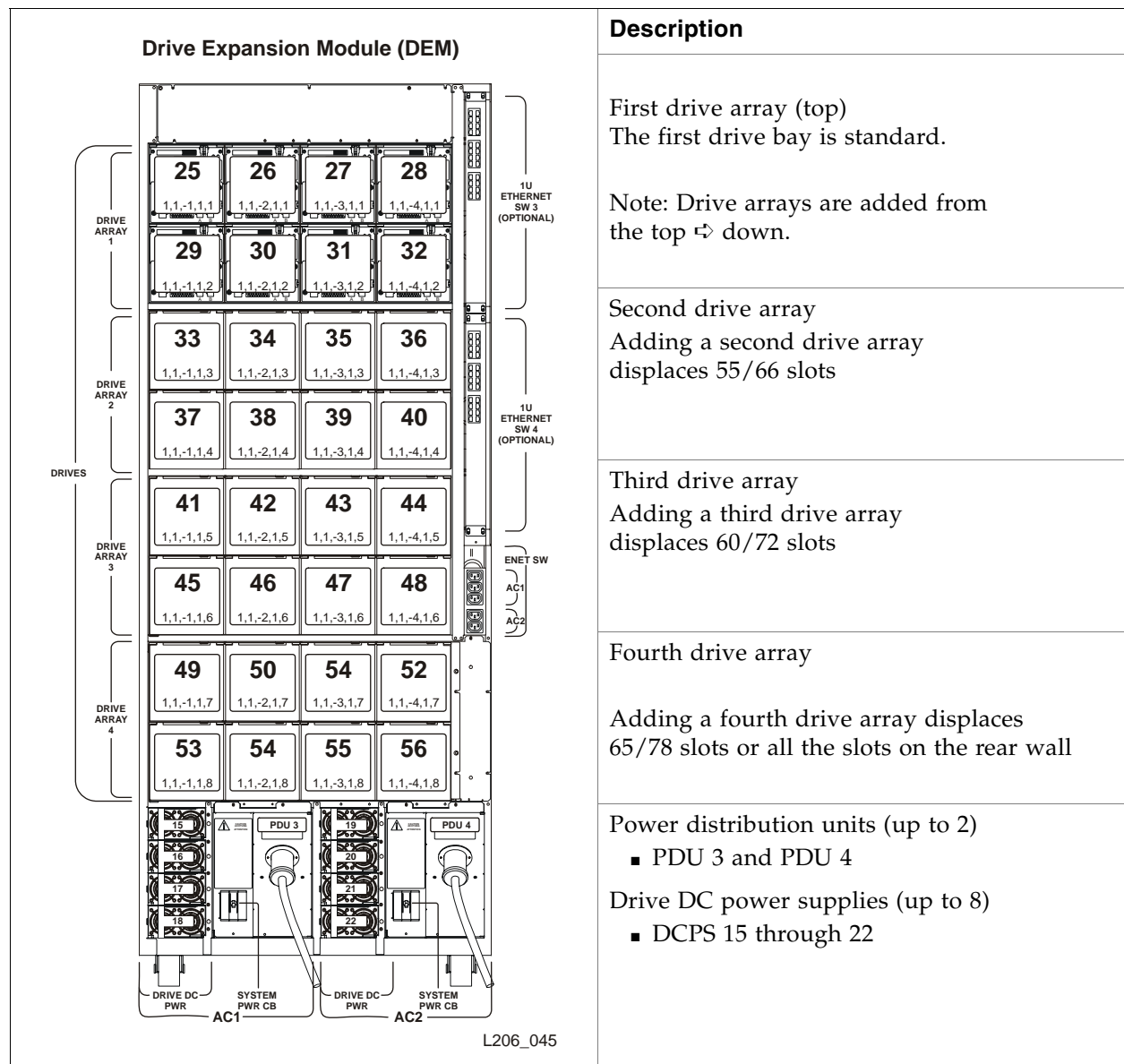

Note: Physical capacity varies depending on the configuration—see [TABLE 1-1 on page 11](#).

Cartridge Expansion Module

FIGURE 1-6 is the Cartridge Expansion Module (CEM) and provides additional cartridge slot capacity and growth—no tape drives are present within this module.

A maximum of eight (8) CEMs are supported on a single library in addition to the Base module (required) and optional drive expansion module if installed.



Important:

- As a best practice, the initial CEM should be installed to the right of a base module, then a second to the left of the drive expansion module. Then again to the right, and the last one to the left. This method provides the best usage of the cartridge slots.

The exception is if an extra CAP is installed and physical capacity is less important than having redundant CAPs. If redundant CAPs are required, install the CEM with a CAP on the left. This assumes no DEM is installed. If one is installed, then place the CEM on the right and install a CAP on the DEM.

- A balance of CEMs—to the left and to the right—provides for the most efficient operation; however, cartridge expansion modules can be installed either all to the left or all to the right. However, this increase the amount of robotic travel results in a decrease of overall library performance.
- When using redundant robotic units, the addition of parking expansion modules in place of the CEMs is required at both ends of the library.

Each CEM adds approximately 438 to 620 data cartridge slots to the library depending on the direction of growth (left or right) and options (CAP or no CAP).

FIGURE 1-6 Cartridge Expansion Module with Base Module

	Configuration (next to Base with 24 drives)	
	CEM (expanded left) CEM with optional CAP (left)	
	CEM (expanded right) CEM with optional CAP (right)	
	Dimensions	Measurement
	Height	197 cm (77.625 in.) to 200 cm (78.63 in.) fully adjusted
	Width	76.75 cm (30.22 in.) 77.5 cm (30.5 in.) with cover
	Depth	80 cm (31.5 in.)
	Weight	Frame only: 175 kg (385 lb)
	Side covers ¹ Side clearance ²	Cooling clearance: 5 cm (2 in.) Install: 91 cm (36 in.)
	Service clearance (Front and Rear)	None required

Base Module | **CEM**

1. When installing additional modules, the covers are removed from existing modules and replaced on the ends of the last module in the string.
2. Required to install or remove the sides covers; they swing out and lift off of brackets.

Parking Expansion Module

FIGURE 1-7 is the Parking Expansion Module (PEM). This module is the same as the cartridge expansion module except with 6 columns of arrays (3 on the front wall and 3 on the rear wall) that are inaccessible. This allows the library to park a defective robot without blocking access to cartridges for the other operational robot.

Notes:

1. Parking expansion modules must be installed as the last module on the right- *and* left-sides of the library string.
2. A PEM is a converted CEM. You cannot order a DEM; you must order two CEMs and convert them to PEMs. Conversion is accomplished by changing an internal module ID label. These labels are shipped with the redundant TallBot feature.
3. The arrays should not be removed to allow the customer to change this module to a CEM; however, any data cartridges in those arrays will be inaccessible.
4. A customer can order an optional CAP when this module is functioning as a parking expansion module. However, a CAP on the right PEM is inaccessible if a TallBot is parked in the right PEM.

FIGURE 1-7 Parking Expansion Module with Base Module

 <p style="text-align: center;">Left Right</p>	Configuration	
	PEM (expanded left) 308 slots PEM (expanded right) 312 slots	620
	Always installed in pairs for the redundant robotics feature.	
	Dimensions¹	Measurement
	Height:	197 cm (77.625 in.) to 200 cm (78.63 in.) fully adjusted
	Width:	76.75 cm (30.22 in.) 77.5 cm (30.5 in.) with cover
	Depth:	80 cm (31.5 in.)
	Weight:	Frame only: 103.4 kg (277 lb)
	Side covers: ² Side clearance: ³	Cooling clearance: 5 cm (2 in.) Install: 91 cm (36 in.)
	Service clearance:	None.
<p>Notes:</p> <ol style="list-style-type: none"> 1. The dimensions of the PEM are the same as the cartridge expansion module. 2. When installing additional modules, the covers are removed from existing modules and replaced on the ends of the last module in the string. 3. Required to install or remove the sides covers; they swing out and lift off of brackets. 		

Physical Capacities

The SL3000 is scalable, with physical storage capacities from 200 to 5821 storage slots. [TABLE 1-1 on page 11](#) provides detailed physical capacities for each module type.

To calculate the total accessible physical storage slots for a configuration, start with the standard configuration slot count, outlined with a heavy border, and then make the appropriate adjustments for options and positioning.

Following are some examples:

- Base Module with operator's panel, a module installed on the right, and three total drive arrays:

$$320 + 0 + 13 - 55 - 60 = 218$$

- DEM, a module installed on the left, window arrays, a CAP, and four drive arrays:

$$410 + 88 + 23 - 77 - 66 - 72 - 78 = 228$$

- CEM installed to the left of CenterLine, a module installed on the left, and a CAP:

$$516 + 104 - 78 = 542$$

- PEMs (always installed in pairs), one with a CAP, one without:

$$308 + 312 - 78 = 542$$

To calculate the final accessible storage capacity, select the slot counts for each module, then add them together to reach the total slot count for the library with the configuration selected.

In addition, the SL3000 features **Capacity on Demand**. This feature allows you to:

- Pay for only the capacity you actually use, then
- Expand capacity—with minimal disruption—when you need it.

See "[Capacity on Demand](#)" on page 141 for details about installing and managing library storage capacity.

TABLE 1-1 Accessible Physical Slot Count Per Module

Module Options	Standalone or Position- Independent	Adjacent Module Installed on the:		Total Count
		Right	Left	
Base Module				
Standard (with viewing window), standalone	320	+13	+88	
With operator's panel	+0			
With window storage arrays		+23		
With second drive array	-55		-66	
With third drive array	-60		-72	
Drive Expansion Module (DEM)				
Standard (with viewing window and no CAP)	—	410	+88	
With window storage arrays	—	+23		
With CAP	—	-77		
With second drive array	—	-55	-66	
With third drive array	—	-60	-72	
With fourth drive array	—	-65	-78	
Cartridge Expansion Module (CEM)				
Standard (no CAP), to the left of CenterLine	516	+0	+104	
Standard (no CAP), to the right of CenterLine	620	+0	+0	
With CAP		-78		
Parking Expansion Module (PEM)				
Standard (no CAP), to the left of CenterLine	—	308		
Standard (no CAP), to the right of CenterLine	—		312	
With CAP	—	-78		
Total accessible storage slot count				

Power Options

SL3000 libraries require that the customer select one of the following, *single phase*, AC power options for the Base and Drive Expansion modules, these are:

- **120 VAC**, 50/60 Hz, at 20 Amps
(range: 100–127 VAC, 47–63 Hz, 16 Amps)
limited support for T9840 and T10000 drives; no redundant TallBot support
- **240 VAC**, 50/60 Hz, at 30 Amps
(range: 200–240 VAC, 47–63 Hz, 24 Amps)—full featured

AC Power Configurations

SL3000 libraries have two power configurations:

- **N+1**, offering DC power redundancy only.
- **2N**, offering both AC and DC power redundancy.

Power Redundancy

The SL3000 provides full redundancy for tape drives, robotics units, and electronics. The following redundancy options are available:

- **N+1**—One AC PDU, with one extra DC power supply for DC power redundancy. This is the standard power configuration for the SL3000. This configuration requires at least a 20 Amp circuit breaker at the customer's branch service panel.
- **2N**—Two PDUs for AC redundancy; each PDU has a set of DC power supplies (N DC power supplies). This configuration requires a second, separate customer power source.
- **2N+1**—Two PDUs for AC redundancy; each PDU has extra DC power supplies for N+1 redundancy for each PDU. The second PDU does not have N+1 for the TallBot.

N+1 Power Configuration—Standard

N+1 is the standard power configuration for the libraries and contains one system power distribution unit (PDU).

Note – The N+1 power configuration offers DC power redundancy only.

The N+1 system PDU connects to the customer's branch circuit and requires at least a 20 Amp circuit breaker at the customer's branch service panel.

2N Power Configuration—Optional

The *optional* 2N power configuration contains two system power distribution units (PDU_1 and PDU_2) and requires a second—separate—customer power source.

Note – The 2N power configuration offers *both* AC and DC power redundancy.

AC Power Cables

TABLE 1-2 lists the cables available from Sun or licensed electricians, which *must* be ordered for the appropriate power configuration. Keep in mind that you must order:

- N+1: One power cord for each, the Base module and DEM if installed.
- 2N: Two power cords for each, the Base module and DEM if installed.

TABLE 1-2 Power Cable Part Numbers and Descriptions

Power Source	Description	Circuit Breaker	Connector Type		Power Cord Length/Type	Part Numbers	
			Wall	Library		Item	X-Option
120 VAC / 20A	Domestic	20 A	L5-20P	L5-20R	3.7 m (12 ft) 12 AWG	419813801	XSL3000-PC20110-Z
240 VAC / 30A	Domestic	30 A	L6-30P	L6-30R	3.7 m (12 ft) 12 AWG	419813701	XSL3000-PC30220-Z
240 VAC / 30A	International	30 A	330P6W	L6-30R	4 m (13 ft) HAR	419813601	XSL3000-IPC30220Z

Robotic DC Power Configurations

Each Base module ships with two 1200 Watt—load sharing—DC power supplies for the robotic units; the location of these supplies determines if it is an N+1 or 2N configuration.

See [FIGURE 1-3 on page 5](#) for the location of these power supplies (on the top of the Base Module).

Electronic Control Module DC Power Configurations

Dual 200 Watt cPCI power supplies distribute power to the electronics control module, which are located below the HBT card, supporting either an N+1 or 2N configuration.

- For an N+1 configuration, two cPCI power supplies are installed on the left.
- For a 2N configuration, one cPCI power supply is installed on each side.

Single Drive Type DC Power Configurations

This library uses 1200 Watt—load sharing—DC power supplies (DCPS) for distribution of +48 VDC power for the tape drives across a power grid.

Each Base module and DEM ship with two (2) DC power supplies. Depending on the number of tape drives ordered, additional power supplies may be required.

To determine the number of supplies required, you must determine:

- Power configuration (120 VAC or 240 VAC)
- Tape drive type (T10000, T9840, or LTO)
- Number of drives

See [TABLE 1-3 on page 14](#) to help determine the number of supplies required.

- This table shows only the installation of a single drive type.
- See [Mixed Drive Types on page 15](#) when mixing tape drives in the same module.

TABLE 1-3 Tape Drive DC Power Supply Requirements

Module Type	PDU Type	Maximum Number of Drive Types			Power Configuration		
		T10000	T9840	LTO	N+1	2N	N+1 & 2N Total
Base	120 VAC	1 – 8	1 – 7	1 – 16	1 + 1 = 2	1 + 1 = 2	2 + 2 = 4
		9 – 13	8 – 12	17 – 24	2 + 1 = 3	2 + 2 = 4	3 + 3 = 6
DEM	120 VAC	1 – 8	1 – 7	1 – 16	1 + 1 = 2	1 + 1 = 2	2 + 2 = 4
		9 – 16	8 – 14	17 – 32	2 + 1 = 3	2 + 2 = 4	3 + 3 = 6
Base	240 VAC	1 – 12	1 – 1	1 – 24	1 + 1 = 2	1 + 1 = 2	2 + 2 = 4
		13 – 24	12 – 22	N/A	2 + 1 = 3	2 + 2 = 4	3 + 3 = 6
		N/A	23 – 24	N/A	3 + 1 = 4	3 + 3 = 6	4 + 4 = 8
DEM	240 VAC	1 – 12	1 – 11	1 – 25	1 + 1 = 2	1 + 1 = 2	2 + 2 = 4
		13 – 24	12 – 22	26 – 32	2 + 1 = 3	2 + 2 = 4	3 + 3 = 6
		25 – 32	23 – 32	N/A	3 + 1 = 4	3 + 3 = 6	4 + 4 = 8

Note: The base and drive expansion modules come with 2 DC power supplies as standard.

Mixed Drive Type DC Power Configurations

When mixing tape drive types in a library, you need to **calculate** the total **Watt consumption** for the selected drives. To do this:

1. Determine the number of tape drives for each drive type.
2. Multiply that by the Watts per drive for each drive type [TABLE 1-4](#).
3. Add the total Watts for all drive types.
4. Use [TABLE 1-5](#) to compare Watts to PDU type.
5. Use [TABLE 1-6](#) to determine the number of DC power supplies needed.

TABLE 1-4 Watts Per Drive

Drive Type	Watts Used by Each Drive	Drives supported by a Power Supply	
		120 VAC	240 VAC
T9840	123.9	7	11
T10000	115.2	8	12
LTO	56.9	16	25

TABLE 1-5 Available Watts Per Module

Module Type	PDU Type	Watts Available for Tape Drives	Watt Limitation per Supply	
			120 VAC	240 VAC
Base	120 VAC	1553	951 W	1426 W
	240 VAC	3234		
DEM	120 VAC	1868	951 W	1426 W
	240 VAC	4313		

TABLE 1-6 DC Power Supplies Per Module

PDU Type	Total Watts	Power Configuration		
		N+1	2N	N+1 & 2N Total
120 VAC	1 - 951	1 + 1 = 2	1 + 1 = 2	2 + 2 = 4
	952 - 1,868	2 + 1 = 3	2 + 2 = 4	3 + 3 = 6
240 VAC	1 - 1,426	1 + 1 = 2	1 + 1 = 2	2 + 2 = 4
	1,427 - 2,852	2 + 1 = 3	2 + 2 = 4	3 + 3 = 6
	2,853 - 4,278	3 + 1 = 4	3 + 3 = 6	4 + 4 = 8

Drive Type	# of Drives	Multiplied By Watts (TABLE 1-4)	Add for Total Watts Per Type	Total Watts (TABLE 1-6)	Power Configuration		
					Option (N+1 or 2N)	PDU Type (TABLE 1-5)	DCPS (TABLE 1-6)

TABLE 1-7 provides an example about how to calculate mixed drive types in both the Base module and drive expansion module:

TABLE 1-7 Mixed Drive Type Power Configuration—Calculation Example

Drive Type	# of Drives	Multiplied By (TABLE 1-4)	Add for Total Watts Per Type	Total Watts (TABLE 1-6)	Power Configuration		
					Option	PDU Type (TABLE 1-5)	DCPS (TABLE 1-6)
Base	T10000	6	115.2	691.2	N+1	120 VAC	not
	T9840	6	123.9		2N	120 VAC	supported
	LTO	8	56.9		N+1	240 VAC	2 + 1 = 3
					2N	240 VAC	2 + 2 = 4
DEM	T10000	4	115.2	460.8	N+1	120 VAC	2 + 1 = 3
	T9840	4	123.9		2N	120 VAC	2 + 2 = 4
	LTO	4	56.9		N+1	240 VAC	2 + 1 = 3
					2N	240 VAC	2 + 2 = 4

Notice in the above example, the:

- Base module requires a 240 VAC PDU with either an N+1 or 2N power option.
- DEM requires either a 120 VAC or 240 VAC PDU with either an N+1 or 2N option.

What you need to order:

Module	PDU Type	Option	DC Redundancy	Minus 2 (-2)	Additional DCPS
Base	120 VAC	N+1			
		2N			
	240 VAC	N+1	2 + 1 = 3	1	1
		2N	2 + 2 = 4	2	2
DEM	120 VAC	N+1	2 + 1 = 3	1	1
		2N	2 + 2 = 4	2	2
	240 VAC	N+1	2 + 1 = 3	1	1
		2N	2 + 2 = 4	2	2



Remember, two DC power supplies are shipped standard for the tape drives, robotics, and electronics control module in the Base module.

Two DC power supplies are shipped standard for the tape drives in the drive expansion module.

You only need to order additional DC power supplies to support the type and number of tape drives for the selected configuration.

Electronics Control Module

All of the electronics, control, and host connectivity is located in the electronics control module (ECM). The ECM is located in the rear of the Base module.

FIGURE 1-8 Electronics Control Module

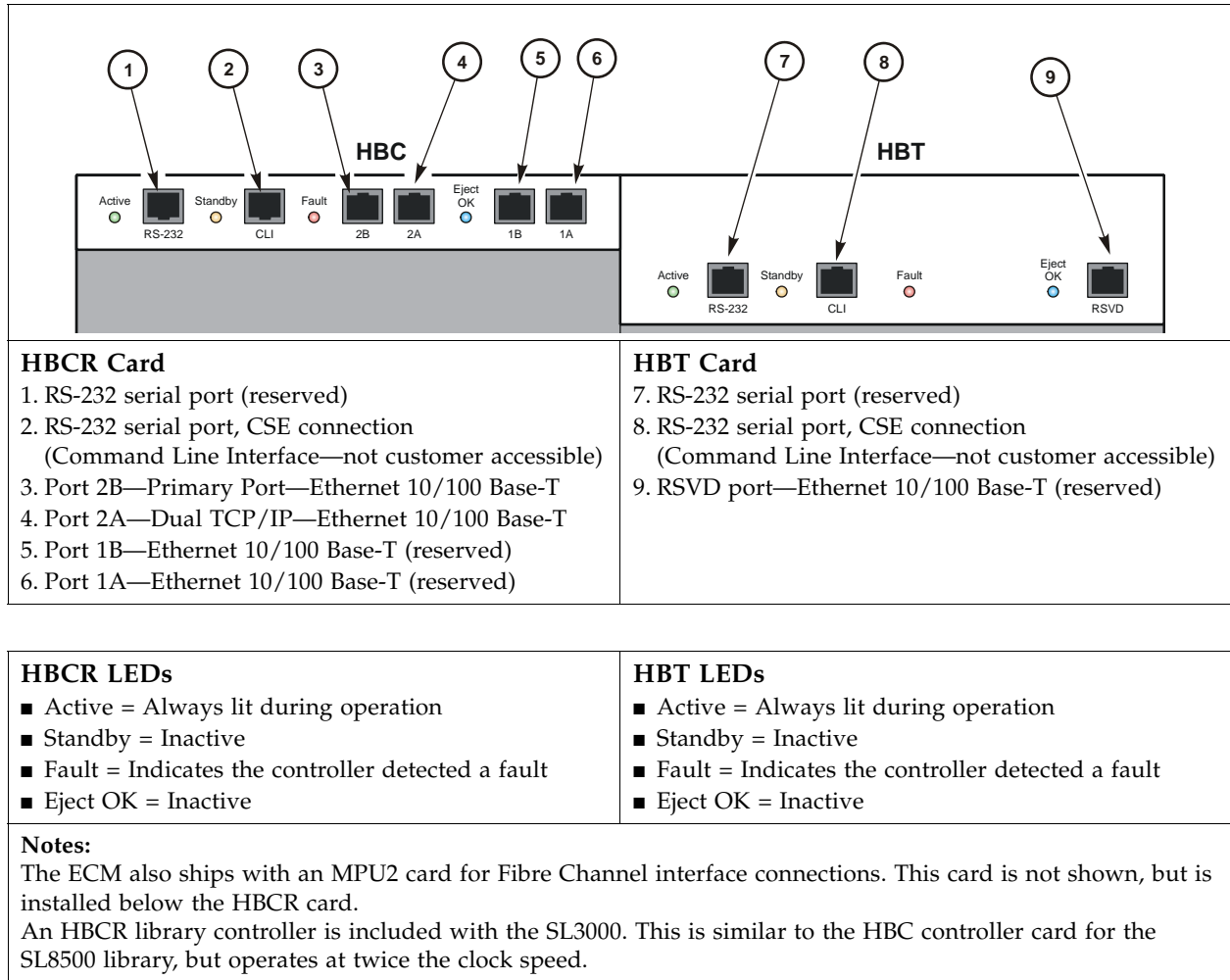

Robotic Units

FIGURE 1-9 TallBot

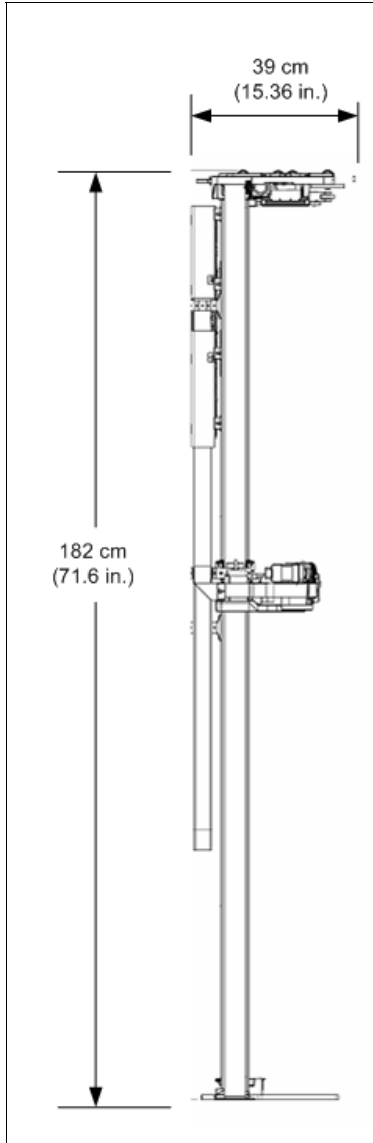

Height	182 cm (71.6 in.)
Width	30 cm (11.84 in.)
Depth	39 cm (15.36 in.)
Weight	8.6 kg (19 lb)

The robotic unit in an SL3000 library is called a TallBot.

Each library can have either one (standard) or two (redundant) TallBots called “Dual Bots.”

TallBots are responsible for the movement and cataloging—or *auditing*—of cartridges throughout the library.

TallBots are driven along two extrusions—called rails—on the rear wall of the library; one rail at the top and one rail attached to the floor. Each module contains pre-installed, segmented extrusions.

Two copper strips are inserted into the *top* extrusion that provide both a power and a signal path for TallBot operation.

- Power comes from +48 VDC, 1200 Watt, load sharing supplies.
- Signals are received and transmitted between the TallBots and the library controller (HBCR card).
- A Rail Power Enable module is installed as a safety circuit for rail power.

Gears on the TallBot motors mesh with molded plastic tracks that are installed within the extrusions.

Handling of the cartridges by the TallBots include:

- Retrieving cartridges—GET operation—from the CAP or slot
- Inserting cartridge—PUT operation—into a CAP or slot
- GETs and PUTs of cartridges to and from wall slots
- Mounts and dismounts of cartridges to and from tape drives

TallBots contain a bar-code scanner that:

- Reads the configuration blocks in each module during library initialization
- Targets on cartridge storage/CAP slots and tape drives
Targets are shaped | \ | similar to an “N”.
- Identifies volume serial numbers (VOLSERs) of cartridges during CAP entries and Audits.

VOLSERs are read during audits and CAP entries only. After that, cartridges are assigned locations within the library—slots.

During GET operations, the library uses the slot locations of the cartridges to complete the required task.

Redundant TallBot—Dual Bot operation offers an option that:

- Increases the speed for robotic operations
- Backs up robotic operation in case one should fail

This option requires 200—240 VAC, 2N power and parking expansion modules at *each* end of the library. A defective TallBot will take itself offline and moves—or is pushed—into one of these modules, allowing the library to continue operations with one TallBot until time can be scheduled to replace the defective TallBot.

Cartridge Access Ports

The cartridge access port—CAP—is a vertically-mounted, rotating cylinder with two removable 13-slot magazines (26 slots total).

- The Base module comes with a CAP as a *standard* feature.
- The drive expansion, cartridge expansion, and parking expansion modules have an *optional* feature to contain a CAP until the upper limit for the total number of CAPs, which is currently 10, is met.

Note – You cannot install a CAP in the right-side Parking Expansion Module.

Each CAP has a small keypad with indicators and a user interface to operate that specific CAP.

FIGURE 1-10 Cartridge Access Port and Key Pad

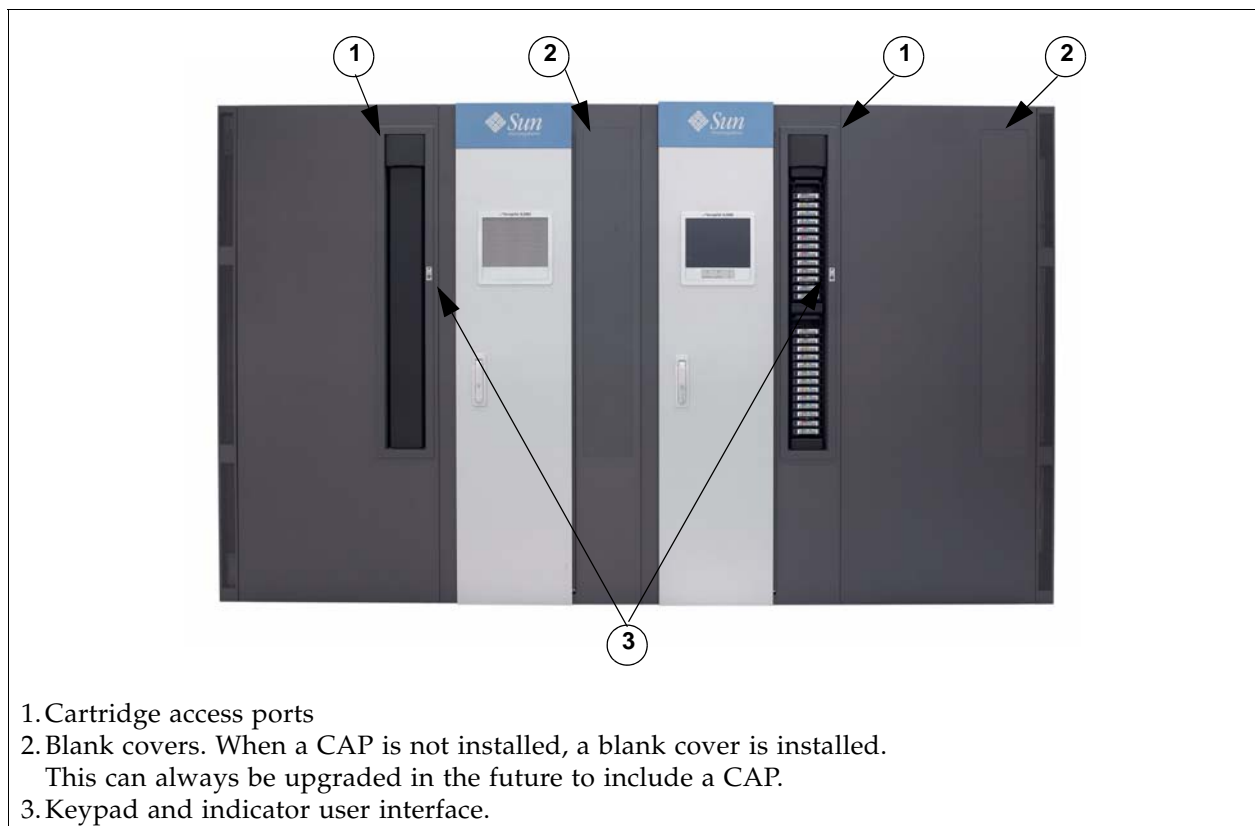

Note – *Best Practices:* If partitioning, Sun recommends installing enough CAPs to provide for each partition that requires a CAP. This allows each partition to contain its own, dedicated CAP.

CAP control is split down the centerline. Therefore, there is a left and right string of CAPs. If a CAP encounters a failure, all CAPs following that one will be unusable until the CAP is serviced. For this reason, Sun recommends installing CAPs in a balanced fashion around the centerline.

Refer to [“Partitioning” on page 141](#) for more information.

Cooling

Cooling within the SL3000 is divided into three areas:

- Library (Electronics control module)
- Tape drives
- DC power supplies

Library (Electronics Control Module)

There are two (2) fans located to the right of the electronics control module that provide cooling for the electronics in the library. Air is drawn from the sides of the library and flows through the fans to the rear of the library.

- These fans are monitored by the HBCR card for proper operation.
- An amber Fault indicator is on the fan assembly to indicate a failure.

While there are two (2) dedicated fans, one (1) fan is sufficient to provide adequate cooling for the library and the electronics. Nevertheless, since the fans can be replaced without interfering with library operations, it is best to replace a defective fan when it is detected.

Tape Drives

Each tape drive tray contains a fan for drive cooling. Power for the fans is supplied through the tape drive's power converter card. Air is drawn from the front of the drive and flows through the fan to the rear of the drive/library.

DC Power Supplies

Each 1200 Watt DC power supply contains a fan that pulls air from the library, through the rear of the supply, and out the rear of the library.

Tape Drives

TABLE 1-8 lists the supported tape drives, interfaces, and media types for the SL3000 library.

TABLE 1-8 Supported Tape Drives

Vendor	Drive Type ²	Interface Type ³	Media
SUN StorageTek	T9840C T9840D * *Encryption feature	Fibre Channel FICON ESCON	9840 VolSafe capable
SUN StorageTek ¹	T9940 will <i>not</i> be supported		9940 is <i>not</i> supported
SUN StorageTek	T10000 A* T10000 B* *Encryption feature	2 Gb/4 Gb Fibre Channel FICON	T0000 Standard, Sport, and VolSafe
IBM	LTO 3 LTO 4	Fibre Channel	LTO 3, LTO 4, and WORM (LT) LTO 2 (read-only) ⁴
HP	LTO 3 LTO 4* *Encryption feature	Fibre Channel	LTO 3, LTO 4, and WORM (LT) LTO 2 (read-only) ⁴
<p>Notes:</p> <ol style="list-style-type: none"> 1. SUN StorageTek T9940 tape drives are <i>not</i> supported. 2. The Quantum SDLT 600 and DLT-S4 tape drives are <i>not</i> supported. 3. The parallel version of the small computer system interface (SCSI) is not a supported connection. 4. LTO 2 media is supported for backward compatibility of LTO products (data migration). <p>Plus future releases of the above tape drive technologies, media, and interfaces</p>			

See [Appendix C, "Tape Drives and Media"](#) for more information.

Drive Tray

A single universal drive tray accommodates the different tape drives and interfaces.

The targeting system is the same as the other StorageTek SL-series libraries (SL500 and SL8500); therefore, the tape drive automation bezels are identical.

The drive trays, however, are different.

Instead of a single layer tray, the SL3000 drive trays have two layers:

- Power supply and connections are on the top, and the
- Tape drive is under the power supply.

FIGURE 1-11 SL3000 Tape Drive Trays

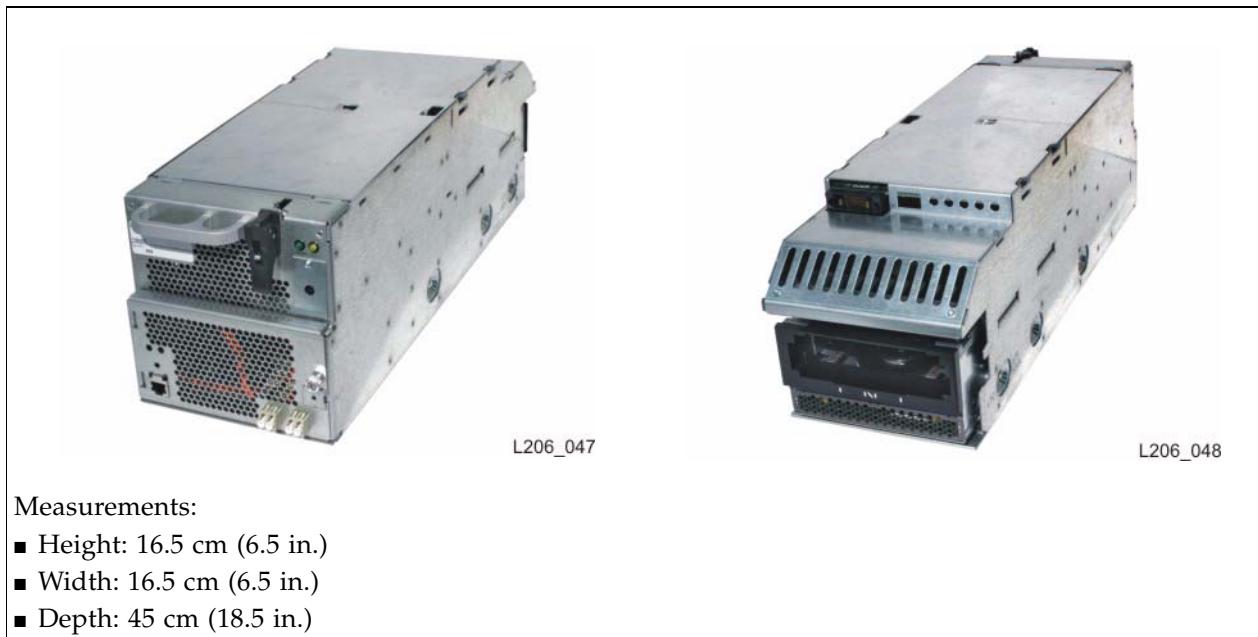

Each tray slides into a drive bay located within an 8-drive array.

A drive array can be removed to expand the cartridge capacity, or installed to increase tape drive capacity.

Internal power supply cards and cabling are unique depending on the drive-type and interface within the drive tray.

Cabling to the drive itself is at the rear of the drive tray and library, then routed through the strain relief system. Cabling access is allowed for both under-floor and ceiling routed cables.

Interfaces

The SL3000 library supports several types of interfaces for a variety of uses and platforms:

- Host connectivity and library management
- Service
- Monitoring

Host Connectivity

There are two types of host connections to the library:

- Small computer system interface (SCSI)¹ over a physical Fibre Channel interface, or
- Ethernet (TCP/IP) using 10/100 Base-T and CAT-5 cables.



Important:

When implementing a new library into a network, it is strongly recommended that the customer, system/network administrator, and a Sun StorageTek representative work closely together to define the configuration.

The design of the SL3000 library allows connection to either Fibre Channel or Ethernet environments. This design allows for several combinations of a host interface in both partitioned and non-partitioned configurations.

- In a non-partitioned configuration, the library can use only *one* (1) interface type—either Fibre Channel or Ethernet (a second Ethernet connection can be used to access StorageTek Library Console)
- In a partitioned configuration, the library can use both interface types.

The library may have only SCSI partitions, only Ethernet partitions, or a combination of both—up to a total of *eight* partitions.

Addressing between these two host connections varies:

- Ethernet hosts use a host library interface -panel, row, column (HLI-PRC) numbering scheme.
- SCSI hosts expect a sequential element numbering scheme with each element type (slots, tape drives, and CAPs) given its own sequential range. SCSI Media Changer-3 (SMC-3) is supported

See [Appendix A, “Addressing”](#) for more information.

The internal “workings” of the library controller uses a:

- Left-to-right, top-to-bottom, rear wall-to-front wall numbering scheme and
- Active regions or boundaries that:
 - Determine the addressing scheme for the library
 - Define partitions
 - Control Capacity on Demand
 - Group slots
 - Identify performance zones

1. SCSI protocol and command set over a physical Fibre Channel interface.

SCSI

Over a physical Fibre Channel connection, the SL3000 library uses the small computer system interface command set.

Note – The Sun StorageTek implementation of Fibre Channel conforms to:

- American National Standards Institute (ANSI), and
- National Committee for Information Technology Standards (NCITS)

Supported topologies include:

Switched Fabric: *This topology is recommended for the library.*

A switched fabric provides dynamic inter-connections between nodes and multiple, simultaneous Fibre Channel connections for the network. If the library is connected to a Fibre Channel switch or fabric-capable host, it configures itself as a switched topology and can support up to 16 million ports logged into the fabric.

Arbitrated Loop: *While the library supports the arbitrated loop topology, this connection scheme is not recommended for new or future implementations. Sun does not recommend the arbitrated loop connection by setting Hard ALPAs (Arbitrated Loop Physical Addresses).*

Arbitrated Loops provide multiple connections for devices that *share a single loop* and allows *only* point-to-point connections between an initiator and target during communications. An arbitrated loop can connect only up to 126 ports.

Refer to the *SL3000 Interface Reference Manual* PN 316195201 for more information. This manual contains information about the small computer system interface command set plus information about Fibre Channel operations, command implementations, topologies, cables, and connectors.

TCP/IP

The library can also use TCP/IP protocol over an Ethernet physical interface, (CAT-5, Ethernet, 10/100 BaseT cable) to manage and communicate with the host and library management applications. This interface enables both:

- Open system platforms with ACSLS
- Enterprise-level mainframes with HSC /VSM

...to connect to and communicate with the library.

The library controller (HBCR card) is responsible for coordinating all component operations within the library and providing the interface connection with the host.

Connections

There are two separate Ethernet connections on the HBCR card for host to library communications—Ports 2A and 2B.

- Port 2A provides the Dual TCP/IP connection—this is an *optional feature* for SL3000 libraries. If not used for Dual TCP/IP, it can be used for connection to StorageTek Library Console.
- Port 2B provides the primary host connection—this is the standard connection for SL3000 libraries.

Both ports comply with the Institute of Electrical and Electronics Engineers standard—IEEE 802.3—for Ethernet networks. Both ports are capable of auto-negotiating the:

- Method of transmission
 - Half-duplex: Transmits data in just one direction at a time
 - Full-duplex: Transmits data in two directions simultaneously
- Speed of the transmission
 - 10Base-T: 10 megabits per second (Mbps)
 - 100Base-T: 100 megabits per second (Mbps)

Network

- Whenever possible, use a dedicated, private network for communication between the library and host management software.

A private network connection using an Ethernet hub or switch is recommended for maximum throughput and minimum resource contention.

- If a shared network is required, these actions can help with the communication between the host and the library:
 - Directly connect the library to a switch.
 - Place the library on its own subnet.
 - Use a managed switch that can:
 - Set priorities on ports to give the host and library higher priority.
 - Provide dedicated bandwidth between the host and the library.
 - Create a VLAN between the host and the library.
- Use a virtual private network (VPN) to insulate host to library traffic.

Service

The command line interface (CLI) is a library interface for **service representatives only**. This interface allows these representatives to configure and diagnose the library.



Note – Customers are not allowed to access the CLI interface. Only trained and qualified Sun Microsystems representatives can access the CLI.

There are two ways to access and use the CLI:

- **Serial Port Connection** on the HBCR card (RS-232) and a HyperTerminal connection to enter the commands.
- **Ethernet Port Connection** (ports 1A, 2A, or 2B) on the HBCR card and use a secure shell (PuTTY) to enter the commands.

Monitoring

There are several ways to monitor this library, using:

- StorageTek Library Console (local and remote)
- Web-launched Library Console
- Simple Network Management Protocol (SNMP)

StorageTek Library Console

The StorageTek Library Console (SLConsole or Library Console) is a graphical user interface that allows management of the library either locally from an operator panel attached to the library or remotely running on a computer (PC) or Solaris workstation.

FIGURE 1-12 Library Console—Example Screen

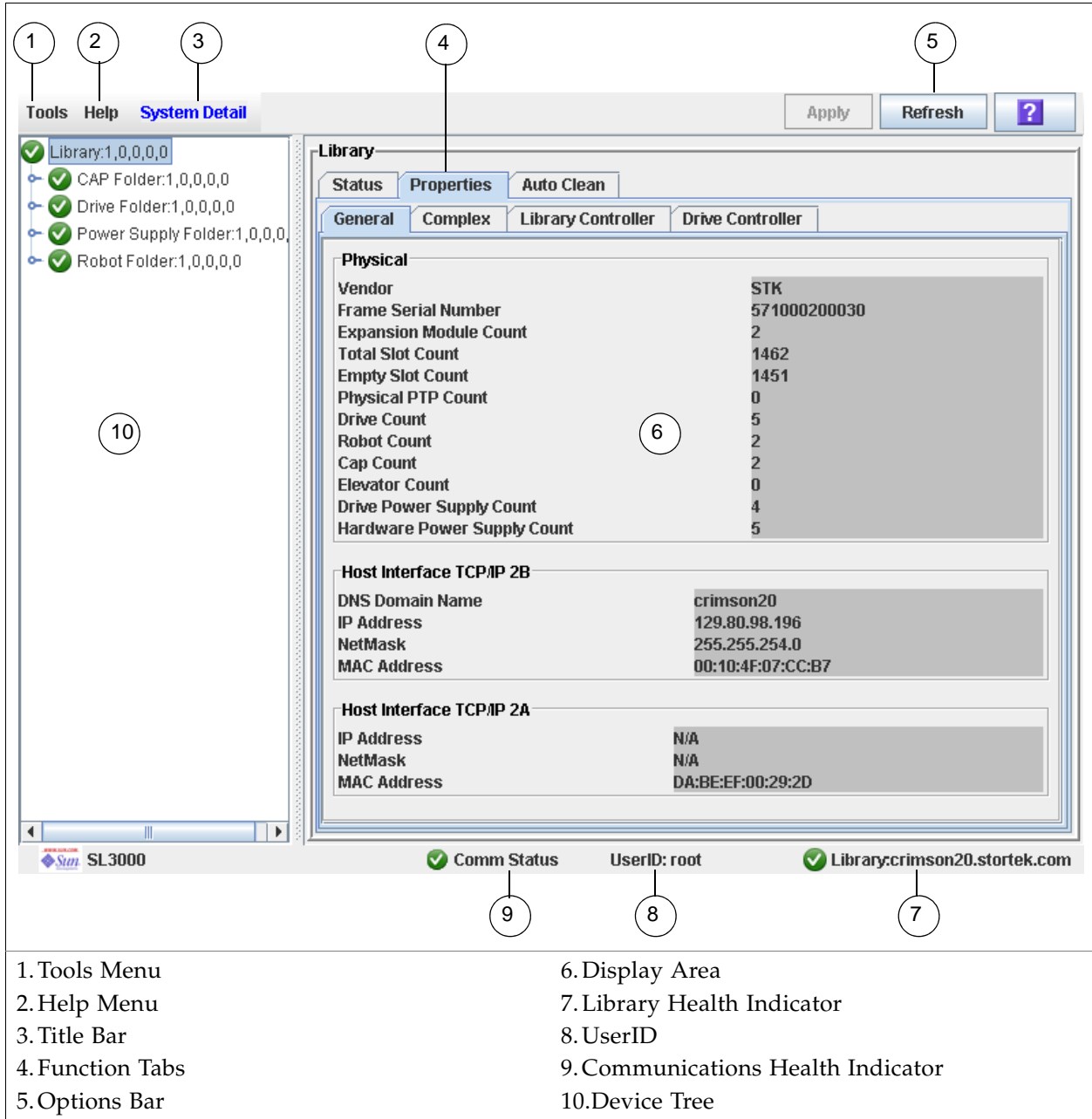

- 1. Tools Menu
- 2. Help Menu
- 3. Title Bar
- 4. Function Tabs
- 5. Options Bar

- 6. Display Area
- 7. Library Health Indicator
- 8. UserID
- 9. Communications Health Indicator
- 10. Device Tree

Web-launched Library Console

The Web-launched library console—also called the SLConsole—is a standard feature of the SL3000 library and is included on a CD shipped with each library. Installing the software on this CD enables the SLConsole to be installed on a centralized Web server. Individual clients can then use a supported Web browser to download the console. Using the SLConsole allows customers to connect to any SL3000 library for which they have a valid user ID.

The Web-launched SLConsole is delivered to clients as a Java Web Start process, which executes outside the browser.

Security Considerations

The Web-launched SLConsole software is digitally signed, which guarantees that it has been issued by Sun Microsystems, Inc. and has not been altered or corrupted since it was created. As a Java Web Start process, the SLConsole includes the security features provided by the Java 2 platform.

The customer is responsible for implementing all appropriate additional security systems, including firewalls and user access.

Client Requirements

Customers can download the SLConsole to clients meeting the following requirements:

Platform	<ul style="list-style-type: none"> ■ Solaris 9—SPARC ■ Solaris 10—SPARC ■ Windows 2003 Server—32-bit ■ Windows XP Client—32-bit ■ Windows Vista—32-bit
Browser	<ul style="list-style-type: none"> ■ Mozilla Firefox, version 1.5 or higher ■ Microsoft Internet Explorer, version 5.5 or higher ■ Java 1.5 Plug-in (the browser will install this automatically if it is not present already)
Other	<ul style="list-style-type: none"> ■ Ethernet connection to the SL3000 library ■ Ethernet connection to the SLConsole server

Web-launched SLConsole Updates

Updates to the SLConsole only need to be installed on the centralized Web server.

Once the updates are installed on the server, they are downloaded automatically to all clients whenever the application is started on the client.

Simple Network Management Protocol

Simple Network Management Protocol (SNMP) is an application layer protocol that performs network management operations over an Ethernet connection using a User Datagram Protocol (UDP/IP).

Occasionally, the library may encounter a condition that an administrator or operator would want to know about, such as an open door that causes the library to stop. These conditions—or alerts—are called SNMP traps.

The Simple Network Management Protocol allows:

- Libraries to inform the systems administrator of potential problems.
- Systems administrators to query the library for configuration, operation, and statistical information.

The SL3000 library supports:

- **SNMPv2c** of the simple network management protocol for machine status queries. Note: with this version, any information transmitted is *not* secure.
- **SNMPv3** of the simple network management protocol is reserved for *proprietary* information. Because this version supports encryption and stronger user identification it is the preferred protocol for proprietary data.

This functionality requires the use of a Management Information Base (MIB) on the controller card. The MIB contains information that specifically describe the library, components, and configuration. [FIGURE 1-13 on page 28](#) illustrates one example of SNMP in a library setting.

FIGURE 1-13 SNMP Example

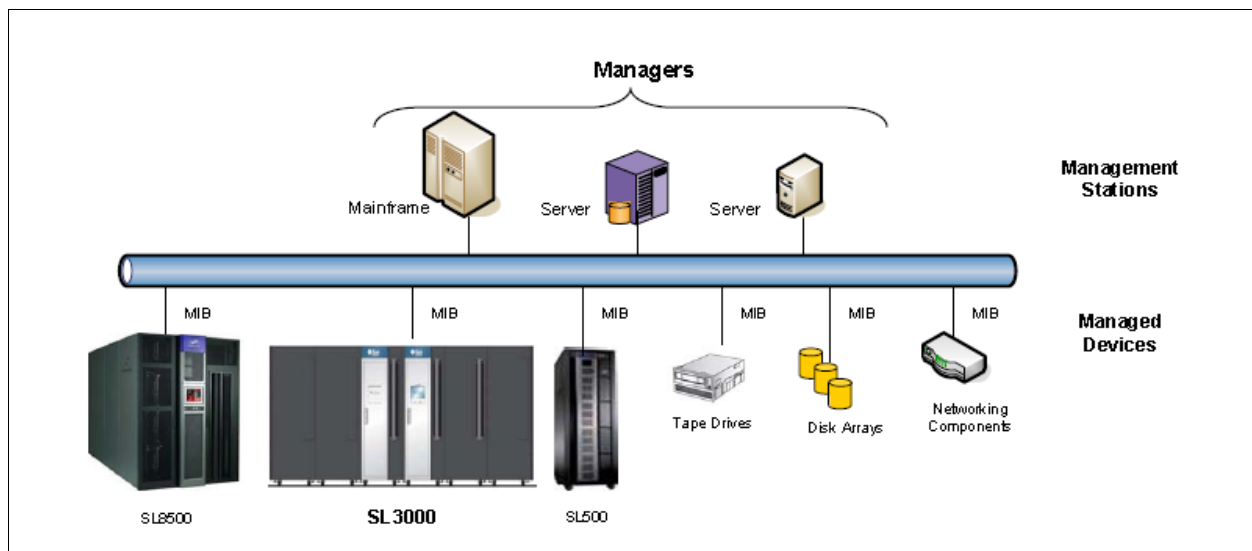

Refer to the *SL3000 SNMP Reference Guide* PN 316194501 for more information.

This reference guide provides information about SNMP and the implementation on Sun StorageTek SL3000 modular libraries.

Library Management Software

Library management software applications control the library, manage the volume database—location and attribute information—plus command activities such as mounts, dismounts, enters, and ejects.

There are several software components depending on the platform, connection type, and operating system that support the SL3000 for both mainframe and open system platforms.

Note – The same library management software the customer currently has and is familiar with can probably be upgraded to support the SL3000 library.

A compatibility matrix for library management software is listed in [TABLE 1-9](#).

TABLE 1-9 Host Software Compatibility Matrix

Product	Required Version
ACSLs	7.3
HSC	6.1 or 6.2
ExHPDM	6.1 or 6.2
ExLM	6.0 or 6.2
ExPR 6.1 or 6.2	6.1 or 6.2
VSM <ul style="list-style-type: none"> ■ VSM4e ■ VSM4 ■ VSM5 	6.1 or 6.2 (include VTCS and VTSS)
VTL <ul style="list-style-type: none"> ■ VTL Plus ■ VTL-E ■ VTL-V 	1.0 or 2.0
ELS (formerly SES)	7.0

Nearline Control Solution

Sun StorageTek Nearline Control Solution (NCS) software provides library management and connectivity with mainframe products such as MVS and VM. This includes the following software applications (and more, not listed):

- Storage Management Component (SMC)
- Host Software Component (HSC)
- Virtual Storage Manager (VSM)

TABLE 1-10 lists the Program Temporary Fixes (PTFs) required for NCS to operate.

TABLE 1-10 Program Temporary Fix (PTF) List

NCS Version	Require
6.1 (MVS)	L1H149V
6.1 (VM)	L1H149U
6.2 (MVS)	L1H149X
6.2 (VM)	L1H149W

Storage Management Component

Storage Management Component (SMC) is a required NCS component and provides:

- The interface between IBM and non-IBM enterprise mainframe operating systems—such as OS/390 and z/OS—and a Sun StorageTek library.
- The allocation processing, message handling, and SMS processing for NCS.
- The MVS host system with HSC, MVS/CSC, or on a remote system using the HTTP server to communicate with the HSC.
- Communications with HSC or MVS/CSC to determine policies, volume locations, and drive ownership.

Host Software Component

When an SL3000 library is in a configuration with an MVS host, the host must run a version of the Sun StorageTek Host Software Component (HSC) along with the Storage Management Component to:

- Influence allocations
- Intercept mount and dismount messages
- Receive requests from the interface and translates them into commands

Virtual Storage Manager

VSM is a virtual tape system that optimizes the tape storage systems for mainframe platforms.

VSM-type solutions consist of a server, disk storage, and front-end software, that complement the physical tape and library products.

The server, disk, and software provide a buffer or cache between the operating systems and the tape drives for storage in a library.

Hardware for a VSM solution consists of:	Software for a VSM solution consists of:
Fault tolerant RAID 6+ disk array	Virtual tape control system (VTCS) software resides on the host operating system in the same address space as HSC.
Library and/or library storage modules (LSMs)	
Real (physical) tape drives (RTDs) in a library	
Multi-volume cartridges (MVCs)—physical cartridges	HSC 6.1+ minimum

Automated Cartridge System Library Software

FIGURE 1-14 on page 31 shows an example of an Automated Cartridge System Library Software (ACSL) configuration.

ACSL is an open systems software package that manages library contents and controls library hardware to mount and dismount cartridges on tape drives.

This application also provides library management services such as cartridge tracking, pooling, reports, and library control. ACSL Version 7.3 or greater is required for interfacing with the SL3000 library.

FIGURE 1-14 ACSL Example

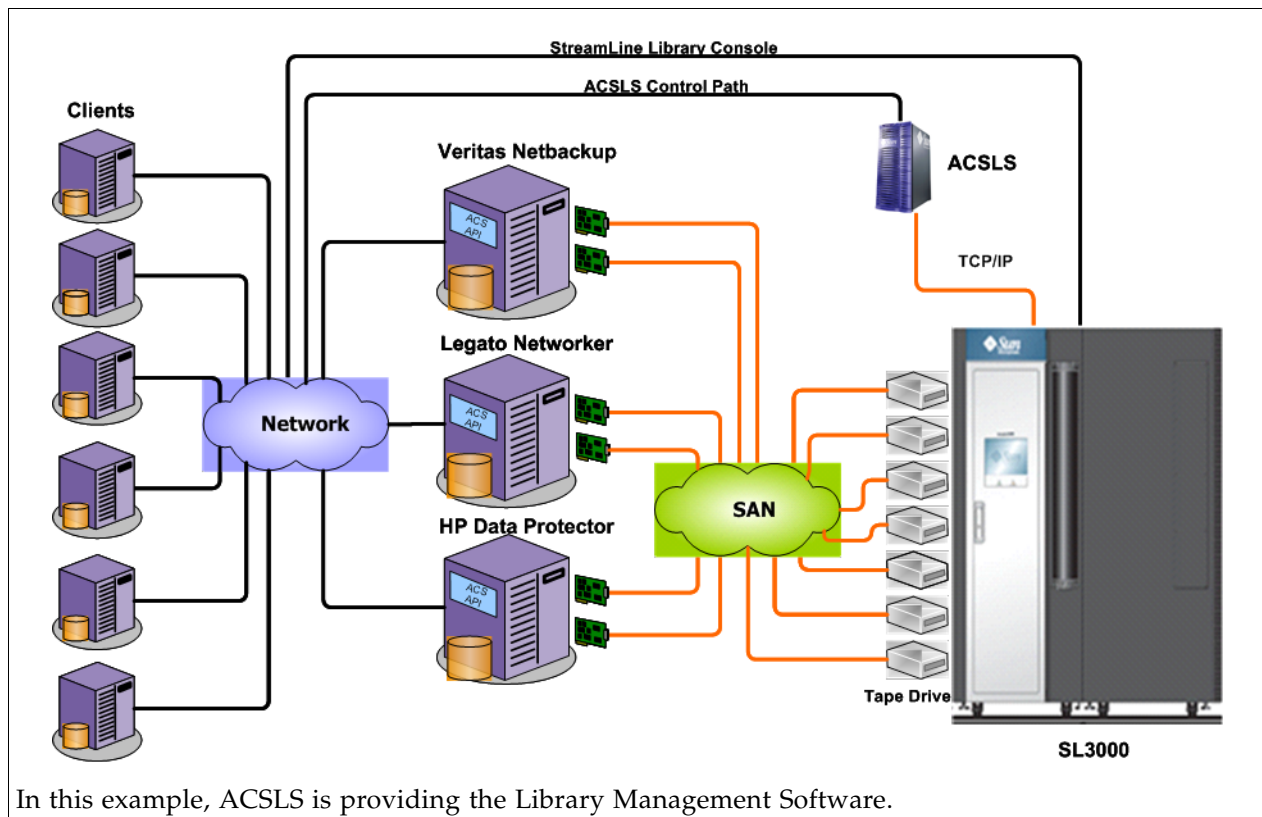

In this example, ACSL is providing the Library Management Software.

If using ACSL, this application is sold to support a certain number of slots.

Make sure to order the appropriate number of slots to match the configuration of the library.

Independent Software Vendors

There are a variety of Independent Software Vendors (ISVs) that have tested their applications and support connection to the SL3000; for example, some applications include:

- BakBone NetVault 7.4+
- CA ArcServe 11.5+
- HP Data Protector 5.5/6.0
- Legato NetWorker 7.3/7.4
- SUN SAM FS 4.6
- Tivoli Storage Manager 5.5.1
- Veritas BackupExec 11.0
- Veritas Netbackup 6.0/6.5

Note – Not every application is listed.

On different platforms, such as:

- HP, HP-UX
- IBM AIX
- Linux, both Red Hat and Suse
- Microsoft Windows
- Sun Solaris

Note – Not every application is tested on every platform or platform version.

Check with a Sun Marketing/Sales Representative, Application Vendor, and the Interoperability Tool at: <https://extranet.stortek.com/interop/interop> to make sure the selected solution (platform, application, tape drives, network, etc.) is supported.

FIGURE 1-15 Interop Tool

The screenshot shows the Sun Interop Tool interface. At the top, there is a navigation bar with the Sun logo and the text "Interop Tool". Below this is a menu bar with options: Home, Filtered Search, Searches, Reports, and User Guide. The main content area is titled "Multi-Selected Storage Search" and features a "Interfaces" section with four radio buttons: All (selected), SCSI Only, FICON Only, and ESCON Only. Below this are several filterable lists:

OS	Application	Device Application
All -- OS	All -- Application	All -- Device Application
AIX 4.3.3 EOL	ACOP/ARX SWITCH	STK:ACSL 7.1 EOL
AIX 5.1	A TEMPO:TIME NAVIGATOR 3.7	STK:ACSL 7.2
AIX 5.2	A TEMPO:TIME NAVIGATOR 4.0	STK:HSC/MSP 6.1 OR LIBSTATION/MSP 6.1
AIX 5.3	A TEMPO:TIME NAVIGATOR 4.1	STK:Lib Attach 1.4.1/ACSL 7.2
CIFS	BAKBOONE:NETVAULT 7.0	STK:Lib Attach 1.4.2 (32bit)/ACSL 7.2
GUARDIAN G06.22	BAKBOONE:NETVAULT 7.3	STK:Lib Attach 1.4.2 (64 bit)/ACSL 7.2

Disk and Library	Tape Drives	HBA	NAS & Middle Ware
All -- Device	All -- Tapes	All -- HBA	All -- Midware
IBM:3584L32 (EMULATED)	HP:LTO GEN 1 (230) EOL	EMULEX:952L	5210
QUANTUM:M1500	HP:LTO GEN 2 (460)	EMULEX:LP10000	5310
QUANTUM:M2500	HP:LTO GEN 2 FC (460)	EMULEX:LP10000DC	5310 GATEWAY
STK:9310	HP:LTO GEN 2 HH (448)	EMULEX:LP10000EXDC	5320
STK:9740	HP:LTO GEN 3 (960)	EMULEX:LP101	5320 GATEWAY
STK:FLX210 EOL	HP:LTO GEN 3 FC (960)	EMULEX:LP1050	ASSURENCY SECUREDATA

Switch	Router	Channel Extender
All -- Switch	All -- Router	All -- Channel Extender
_DIRECT:ATTACH	BROCADE:7420	CISCO:9506 FICON
BROCADE:12000 EOL	BROCADE:7500	CISCO:9509 FICON
BROCADE:12000 FICON	CISCO:92161	MCDATA:EDGE 3000
BROCADE:200E	CHIT:EDGE 3000	MCDATA:USD
BROCADE:2010	MCDATA:1620	MCDATA:USD-X
BROCADE:2050		

At the bottom of the interface, there are "Reset" and "Show Results" buttons. Below these buttons, it states: "There are total 23155485 records".

Standards of Conformance

TABLE 1-11 lists the standards to which the SL3000 complies.

TABLE 1-11 Standard of Compliance

Country	Standard
U.S.A.	Federal Communications Commission (FCC). Title 47, Part 15, Subpart B, and as an Unintentional Radiators Class A
Japan	Voluntary Control Council for Interference (VCCI), Class A (CISPR22)
European Union (CE mark)	Electromagnetic Compatibility Directive 89/336/EEC and 2004/108/EC (including EN55022, EN55024, EN61000-3-2, EN61000-3-3 and amendments)
Australia / New Zealand	EMC Framework AS/NZS 3548
Taiwan	Bureau of Standards, Metrology and Inspection (BSMI) Law, Taiwan CNS13438
Canada	Canadian EMC Law ICES-003
Korea	Korean EMC Law
Emissions	European Union Test Requirements
HF Radiated	EN55022 Class A
HF Conducted	EN55022 Class A
Harmonic Current	EN61000-3-2
Voltage Fluctuations and Flicker	EN61000-3-3
Directive	Description
RoHS	Reduction of Hazardous Substances
WEEE	Waste Electrical and Electronic Equipment (e-waste)
Sun Standard	Description
EDS 3-3	AC Powerline
EDS 5-6	Product Safety Requirements
EDS 6-3	Electrostatic Discharge (ESD) Immunity
CP-7-1-2	Product Safety

Systems Assurance

This chapter contains information about the systems assurance process.

The system assurance process is the exchange of information among team members to ensure that no aspects of the sale, order, installation, and implementation are overlooked. This process promotes an error-free installation and contributes to the overall customer satisfaction.

Systems assurance team members—the customer and Sun representatives—ensure that all aspects of the process are planned carefully and performed efficiently.

System Assurance Planning Meetings

The purpose of the system assurance planning meetings are to:

- Introduce the customer to the SL3000 modular library
- Explain the system assurance process and establish the team
- Prepare for the installation and implementation
- Schedule and track the entire process

[TABLE 2-1 on page 36](#) provides a list of tasks to start with.

Make any adjustments or add more tasks as the team needs to ensure a quality process.

TABLE 2-1 System Assurance Checklist

Task	Completed?
Introduce the Sun team members to the customer. Complete the Team Member Contact sheets. Make additional copies as necessary.	Yes <input type="checkbox"/> No <input type="checkbox"/>
Describe the SL3000 modular library, options, and features for the customer. See Chapter 1, "Introduction" for information and topics.	Yes <input type="checkbox"/> No <input type="checkbox"/>
Identify and define the customer's requirements. <i>Comments:</i> 	Yes <input type="checkbox"/> No <input type="checkbox"/>
Understand the customer's expectations. <i>Comments:</i> 	Yes <input type="checkbox"/> No <input type="checkbox"/>
Review the information in Chapter 3, "Site Planning" <i>Comments:</i> 	Yes <input type="checkbox"/> No <input type="checkbox"/>
Review and complete the surveys in Chapter 4, "Customer Site Survey" <i>Comments:</i> 	Yes <input type="checkbox"/> No <input type="checkbox"/>
Identify any additional items the customer might need. <ul style="list-style-type: none"> ■ Library management software and additional licenses ■ Media—data and cleaning cartridges, labels, media services ■ Tape drives, drive tray conversions, encryption ■ Cables and network components ■ Service delivery platform (SDP) 	Yes <input type="checkbox"/> No <input type="checkbox"/>
Review the Order Work Sheets in Chapter 5, "Ordering" . <i>Comments:</i> 	Yes <input type="checkbox"/> No <input type="checkbox"/>
Determine the installation schedule: Equipment arrival date: _____ Installation date: _____	Yes <input type="checkbox"/> No <input type="checkbox"/>

Customer Contact Sheet

Name: _____
Title: _____
Telephone Number: _____
FAX Number: _____
Cell Phone / Pager: _____
E-mail Address: _____

Name: _____
Title: _____
Telephone Number: _____
FAX Number: _____
Cell Phone / Pager: _____
E-mail Address: _____

Name: _____
Title: _____
Telephone Number: _____
FAX Number: _____
Cell Phone / Pager: _____
E-mail Address: _____

Name: _____
Title: _____
Telephone Number: _____
FAX Number: _____
Cell Phone / Pager: _____
E-mail Address: _____

Note – Customer team members may include: IT professionals, systems and network administrators, finance, security, and facility planners.

Sun Microsystems Contact Sheet

Name: _____
Title: _____
Telephone Number: _____
FAX Number: _____
Cell Phone / Pager: _____
E-mail Address: _____

Name: _____
Title: _____
Telephone Number: _____
FAX Number: _____
Cell Phone / Pager: _____
E-mail Address: _____

Name: _____
Title: _____
Telephone Number: _____
FAX Number: _____
Cell Phone / Pager: _____
E-mail Address: _____

Name: _____
Title: _____
Telephone Number: _____
FAX Number: _____
Cell Phone / Pager: _____
E-mail Address: _____

Note – Sun StorageTek Representatives may include: marketing, sales, and account representatives, systems engineers (SEs), Professional Services (PS), installation coordinators, and trained services personnel.

Site Planning

FIGURE 3-1 SL3000 Library—Front Door Open



This chapter consists in the following topics to assist in planning an installation.

- Specifications:
 - “Metric Dimensions” on page 40
 - “Standard Dimensions” on page 41
 - “Service Clearances” on page 44
 - “Floor Loading” on page 45
 - “Fire Suppression Planning” on page 46
- “Environmental Requirements” on page 47
- “Power Consumption” on page 48
- “Installation Considerations” on page 50
 - “Installation Time and Personnel” on page 50
 - “Customer’s Floor” on page 52
 - “Cable Routing” on page 53
 - “Seismic or Earthquake Ratings” on page 54
- “Obtaining a Password” on page 58
- “Installing the Library Console Software” on page 59
- “SL3000 Configuration Work Sheet” on page 60

Specifications

FIGURE 3-2 Metric Dimensions

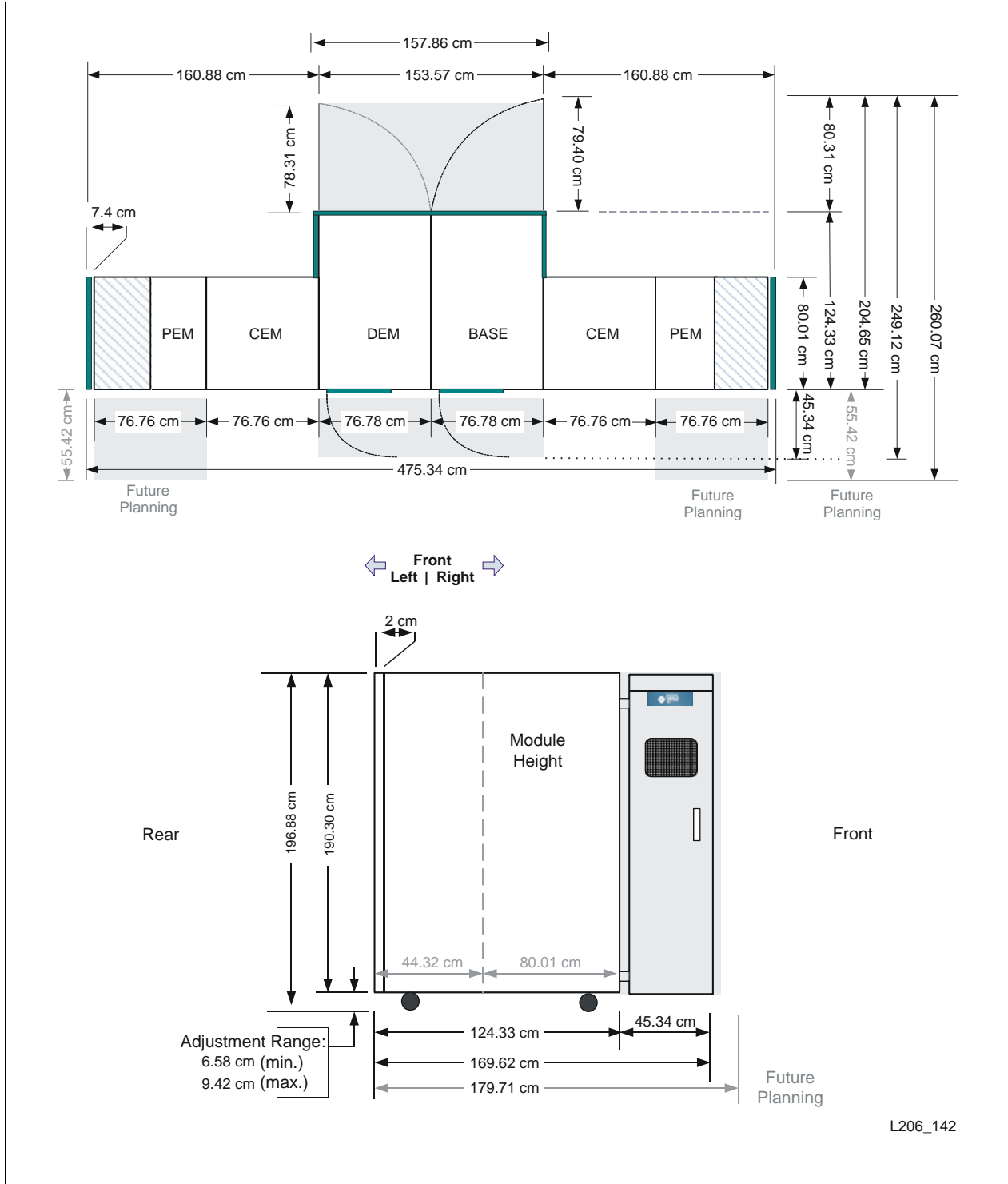

L206_142

FIGURE 3-3 Standard Dimensions

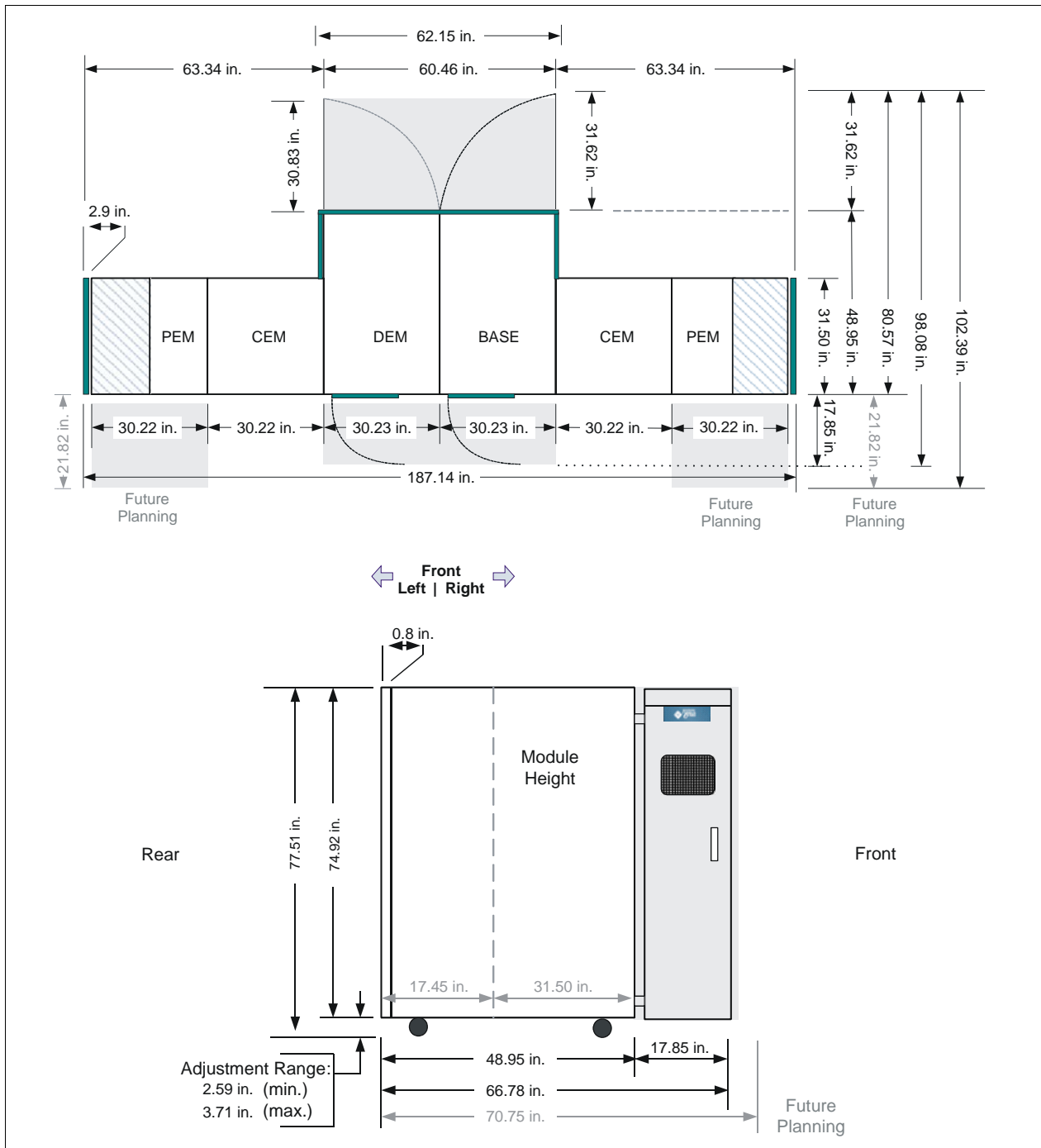

For more specifics see:

■ “Base Module” on page 42	■ “Service Clearances” on page 44
■ “Drive Expansion Module” on page 42	■ “Floor Loading” on page 45
■ “Cartridge Expansion Module” on page 43	■ “Fire Suppression Planning” on page 46
■ “Parking Expansion Module” on page 43	■ “Pallets” on page 51
■ “Covers, Doors, and Service Clearances” on page 43	■ “Customer’s Floor” on page 52

Base Module

TABLE 3-1 Base Module Specifications

Dimension	Measurement
Height	197 cm (77.45 in.) on casters, to 200 cm (78.95 in.), fully adjusted [adjustment = 3.5 cm (1.35 in.)]
Width	76.8 cm (30.23 in.) without covers* 91.6 cm (36.05 in.) with covers*
Depth (doors closed) Depth (with service access)	124.3 cm (48.95 in.) 249.1 cm (98.08 in.)
Weight	<ul style="list-style-type: none"> ■ Frame only = 361 kg (796 lb) ■ Shipping weight = 411 kg (905 lb) ■ Installed, with: <ul style="list-style-type: none"> ■ 8 drives and media = 623 kg (1372 lb) ■ 16 drives and media = 661 kg (1457 lb) ■ 24 drives and media = 687 kg (1514 lb)
Side cover (end cap)	7.4 cm (2.9 in.) width and 18.5 kg (41 lb) per side
<p>*Side Covers: Are shipped with the base module. As you add more modules, the side covers are removed from this module and installed on the new module (either left, right, or both).</p>	

Drive Expansion Module

TABLE 3-2 Drive Expansion Module Specifications

Dimension	Measurement
Height	197 cm (77.45 in.) on casters, to 200 cm (78.95 in.), fully adjusted [adjustment = 3.5 cm (1.35 in.)]
Width (module only)	76.8 cm (30.23 in.) without covers 168.3 cm (66.26 in.) with Base and side covers
Depth (doors closed) Depth (with service access)	124.3 cm (48.95 in.) 249.1 cm (98.08 in.)
Weight	<ul style="list-style-type: none"> ■ Frame only, no CAP = 265 kg (584 lb) ■ Shipping (frame only, no CAP) 314 kg (693 lb) ■ Shipping (frame plus CAP) = 321 kg (708 lb) ■ Installed with: <ul style="list-style-type: none"> ■ 8 drives and media, no CAP = 540 kg (1190 lb) ■ 16 drives and media, no CAP = 596 kg (1314 lb) ■ 24 drives and media, no CAP = 647 kg (1426 lb) ■ 32 drives and media, no CAP = 709 kg (1564 lb) ■ 8 drives and media, with CAP = 582 kg (1284 lb) ■ 16 drives and media, with CAP = 621 kg (1369 lb) ■ 24 drives and media, with CAP = 660 kg (1456 lb) ■ 32 drives and media, with CAP = 723 kg (1594 lb)

Cartridge Expansion Module

TABLE 3-3 Cartridge Expansion Module Specifications

Dimension	Measurement
Height	197 cm (77.45 in.) on casters, to 200 cm (78.95 in.), fully adjusted [adjustment = 3.5 cm (1.35 in.)]
Width	76.8 cm (30.2 in.) without covers 91.5 cm (36 in.) with covers
Depth	77.5 cm (30.5 in.) frame only 81 cm (32 in.) with front and rear covers
Weight	<ul style="list-style-type: none"> ■ Frame only 175 kg (385 lb.) ■ Shipping = 213 kg (469 lb) ■ Installed, with media = 340 kg (749 lb)

Parking Expansion Module

TABLE 3-4 Cartridge Expansion Module Specifications

Dimension	Measurement
Height	197 cm (77.45 in.) on casters, to 200 cm (78.95 in.), fully adjusted [adjustment = 3.5 cm (1.35 in.)]
Width	76.8 cm (30.22 in.) without cover 91.5 cm (36 in.) with cover (end cap)
Depth	77.5 cm (30.5 in.) frame only 81 cm (32 in.) with front and rear covers
Weight	<ul style="list-style-type: none"> ■ Frame only = 122.5 kg (270 lb) ■ Shipping = 213 kg (469 lb)

Covers, Doors, and Service Clearances

TABLE 3-5 Cartridge Expansion Module Specifications

Dimension	Measurement
Height	190 cm (74.9 in.)
Door thickness	2.54 cm (1 in.)
Door latches	2.53 cm (0.9 in.)
Service clearance	Front: 46 cm (18 in.) [allow 56 cm (22 in.)] Rear: 81 cm (32 in.)
Both doors open	Total: 262 cm (103 inches)
Side cover (end cap)	7.4 cm (2.9 in.) width and 18.5 kg (41 lb) per side
*Side Covers: Are shipped with the base module. As you add more modules, the side covers are removed from this module and installed on the new module (either left, right, or both).	

Service Clearances

FIGURE 3-4 Service Clearances—Minimum and Recommended

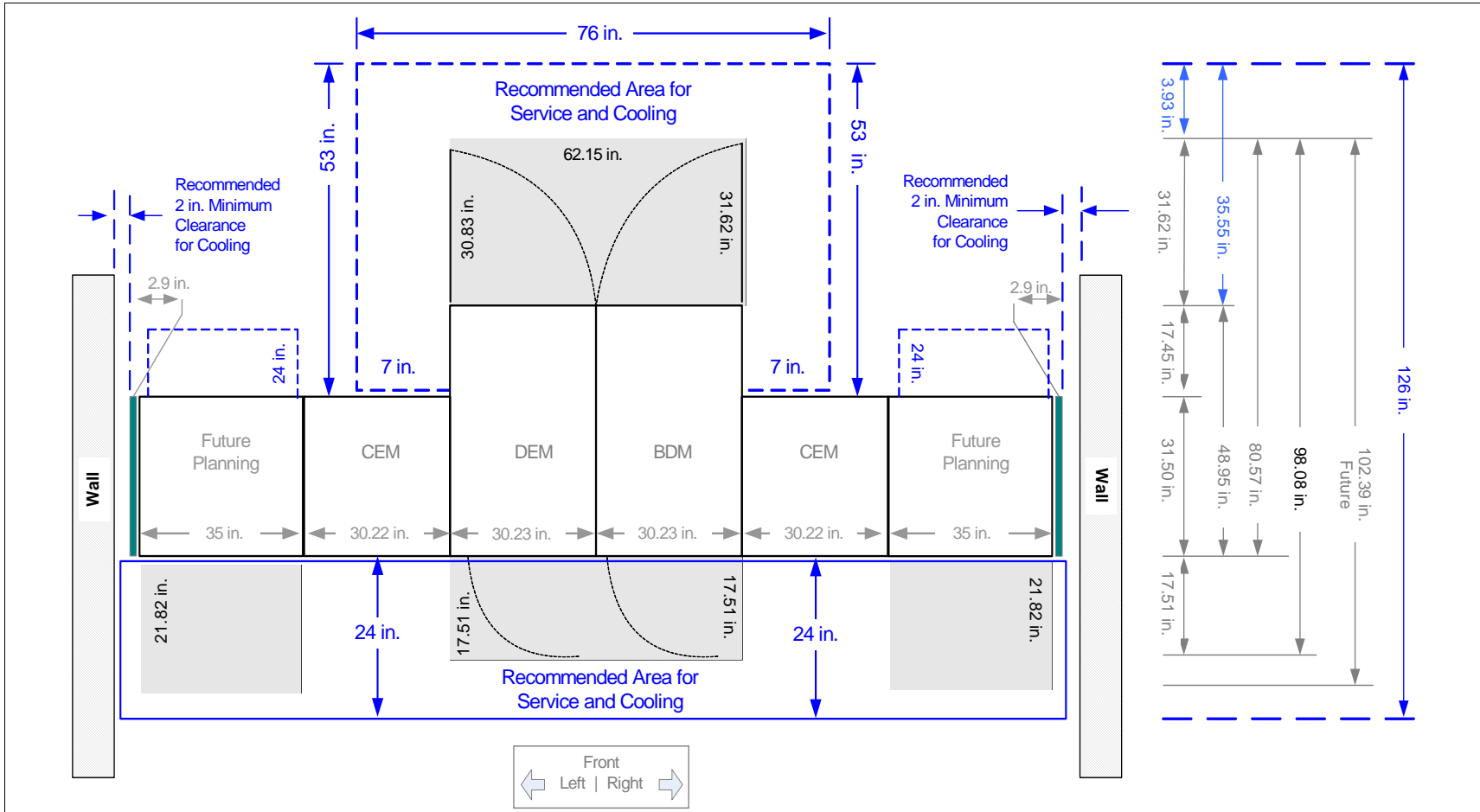

<p>Clearance: Front—Use, Front door opening, CAP processing Rear—Service, tape drives, cabling Sides—Cooling Overall width Overall length—(Variable) Future (front)—Front door opening, CAP processing</p>	<p>Minimum (in black numbers): 44.5 cm (17.51 in.) 80.3 cm (31.62 in.) 5 cm (2 in.) 250 cm (98.08 in.) Variable by number of modules 260 cm (102.39 in.)</p>	<p>Recommended: (in blue numbers) 61 cm (24 in.) 90.3 cm (35.55 in.) 5 cm (2 in.) minimum 320 cm (126 in.) Variable by number of modules 320 (126 in.)</p>
--	---	---

Floor Loading

FIGURE 3-5 Floor Loading—Load Pads

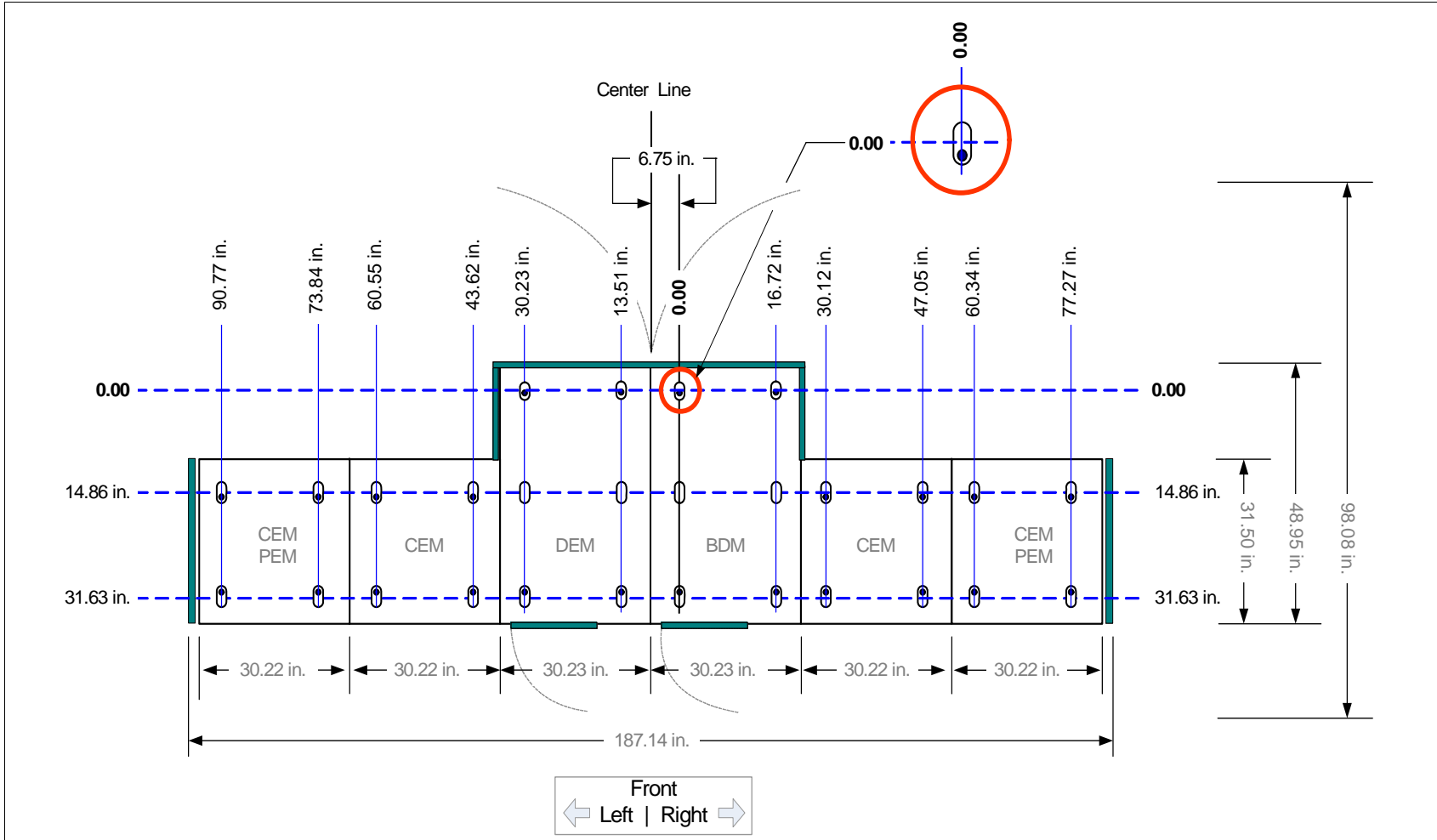

The customer's floor must be capable of supporting 454 kg (1000 lb) per weight distribution pad. This weight represents the modules, with components, and cartridges.

Fire Suppression Planning

The library does *not* ship with a fire suppression system, although features have been incorporated into the library to allow for one. Sun StorageTek Professional Services offers systems which can be installed on site.

FIGURE 3-6 shows the accesses for fire suppression planning.

FIGURE 3-6 Fire Suppression Ceiling Access (Viewed from the top of the library)

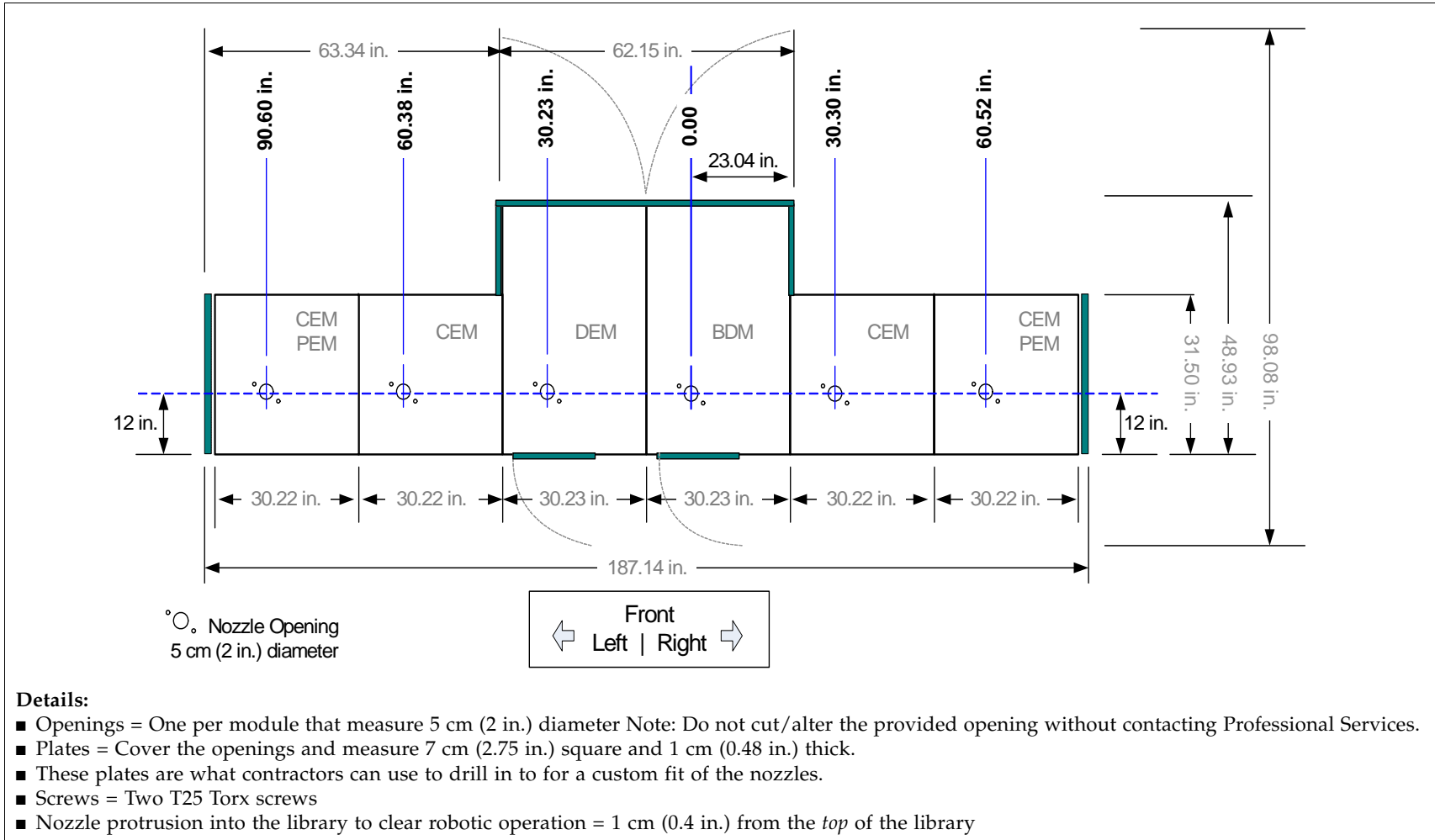

Environmental Requirements

Although the SL3000 library will function over a full list of environmental ranges as specified below, *optimal reliability* is achieved if the environment is maintained between the recommended ranges.

TABLE 3-6 Environmental Specifications

Description	Optimum	Recommended Range	Full Operating Range
Temperature			
Operating	22°C (72°F)	20° – 25°C (68° – 77°F)	+16° to 32°C (60° to +90°F)
Non-operating			+4° to +32°C (+40° to +90°F)
Relative Humidity			
Operating	45%	40% – 50%	20% to 80% (non-condensing)
Non-operating			20% to 80% (non-condensing)
Wet bulb (operating)	25.6°C (78°F) maximum, non-condensing		
Heat Output	See “Power Consumption” on page 48 and “Calculating Power Consumption” on page 49 for details		
Power Consumption			
**Maximum loading includes 56 tape drives, 2 TallBots, and up to six (6) CAPs.			



Important:

Although this equipment is designed to operate in environmental conditions of 20% to 80% humidity, industry best practices recommends computer rooms maintain a relative humidity of 40% to 50% for best performance.

TABLE 3-7 Environmental Definitions

British thermal units (Btu)	A measure of the amount of heat required to raise the temperature of one pound of water one degree Fahrenheit. British thermal units are most commonly associated with power over a unit of time—Btu per hour (Btu/hr).
Relative Humidity	A measure of water vapor in the air.
Temperature	The measurement of hot and cold to specific scales, such as Celsius (also called centigrade) and Fahrenheit. The Celsius temperature scale uses 0° for the freezing point of water and 100° for the boiling point of water. The Fahrenheit temperature scale uses 32° for the freezing point and 212° for the boiling point.
Watt	A watt is a unit of power or the amount of energy per unit of time. Often the term watt is used for expressing energy consumption as kW (kilo-Watts).
Wet bulb	The difference in temperature between wet bulb (humidity) and dry bulb (temperature) provides a measure of atmospheric humidity.

Power Consumption

TABLE 3-8 provides the power consumption (Watts), CO2 emission values, and Btu/hr for the SL3000 library.

TABLE 3-8 Power Consumption Quick Reference

Component	Qty	Idle			Maximum Continuous			
		Watts	CO2 Emissions ¹	Btu/hr	Watts	CO2 Emissions ¹	Btu/hr	
Base Library ² (required) Includes one ECM ³ , one robot ⁴ , and one CAP	1	179	3.668963	611.106	239	4.9	816	
Internal Ethernet Switch (required)	each	40	0.82	136.56	40	0.82	136.56	
<hr/>								
Additional robot (optional) ⁴	1	28	0.573916	95.592	55	1.1	188	
Operator Panel (optional) ⁵	1	29	0.594413	99.006	37	0.8	126	
Additional CAP (optional) ⁶	each	10	0.20497	34.14	14	0.3	47.8	
<hr/>								
Tape Drive and Tray Assembly ⁷	T9840C	each	91.6	1.8775252	312.7224	122.6	2.5	419
	T10000	each	73	1.496281	249.222	115.2	2.4	393
	LTO	each	37	0.758389	126.318	56.9	1.2	194
<hr/>								
Access Expansion Module (Future, check on availability)	each (1 or 2)	8	0.163976	27.312	30	0.6	102	
<hr/>								
Notes:								
1. CO2 Emissions is kg of CO2 per day, which is equal to 0.020497 Watts.								
2. Drive Expansion Module ; use the individual components (CAPs, Ethernet switches, and tape drives). Cartridge Expansion Module ; none required.								
3. Electronic Control Module includes one HBCR and one HBT cards, two cooling fans. [Watts = 141 (idle) 170 (max.); CO2 = 2.89 (idle) 3.48 (max)]								
4. One SL3000 can support up to two robots								
5. One SL3000 can support one Operator Panel								
6. One SL3000 can support up to ten CAPs								
7. Drive Tray includes HBD card, drive DC to DC power supply, fans-if applicable, and the drive itself. The SL3000 supports up to 56 drives total.								

Calculating Power Consumption

To calculate Power and CO2 emissions:

- Use [kg of CO2 per day] equals *.020497 [watts].
- Use the constant that is applicable for your country.

To convert electrical values to British Thermal Units (Btu/hr), multiply the number of Watts by 3.412 or 1 kW = 3.412 Btus.

$$3.41214 \times \text{Watts} = \text{Btu/hr}$$



Many manufacturers publish kW, kVA, and Btus for their equipment. Often, dividing the Btu value by 3412 does not always equal the published kW value.

- Where the information is provided by the manufacturer, use it.
- Where it is not, use the formula.

To calculate Btus:

- Add up all the applicable Wattage values for the configuration.
- Multiply the total Watts sum by 3.412.
- This equals the number of Btu/hr.

For example:

Using the maximum continuous values for the following components

Qty	Component	Watts
1	SL3000 Base module (including one ECM, one Robot, one CAP)	239
1	Internal Ethernet switch	40
16	LTO drives	910.4
Total:		1189.4

Multiply that by 3.412, which equals 4058.2 Btu/hr maximum continuous operation.

Another example:

Qty	Component	Watts
1	SL3000 Base module (including one ECM, one Robot, one CAP)	239
1	Internal Ethernet switches	40
8	T9840 drives	732.8
1	Drive Expansion Module	—
1	Internal Ethernet switch	40
8	T10000 drives	584
4	Cartridge Expansion Modules	—
3	Optional CAPs (3 x 10 Watts)	30
Total:		1665.8

Multiply that by 3.412, which equals 5683.7 Btu/hr maximum continuous operation.

Installation Considerations

The SL3000 library has several installation requirements that must be considered. The following sections outline some basic considerations that must be made when planning for an installation.

Available Space

You and your customer must determine:

- The number and types of modules to be installed.
- Are there additional modules in the future? If so, allow space for this growth.
- The amount of space required to install the equipment.

A suggested working area (not including the space required for the pallets) is approximately 19 m² (200 ft²).

Installation Time and Personnel

TABLE 3-9 shows the estimated times for the installation of modules and components.



At least two qualified service representatives should install the library.

These times **do not** include library initialization, testing, audits, and feature upgrades.

TABLE 3-9 Installation Time Estimates

Module/Component	Time Estimate	Personnel Required	Total Person Hours
Base Module with 8 drives (standard)	3 hours	2	6 hours
Base Module and Drive Expansion Module	4 hours	2	10 hours
Base Module and Cartridge Expansion Module	4 hours	2	8 hours
Each additional Cartridge Expansion Module	2 hours	2	4 hours
Two Parking Expansion Modules	4 hours	2	4 hours
CAPs	1 hour	2	2 hours
Tape Drive (each drive)	0.5 hours	1	0.5 hours
Operator Panel or Window	0.75 hours	1	0.75 hours
Firmware	0.2 hours	1	0.2 hours
Integration and installation of cables, hubs, switches, host attachments	8 hours	1	8 hours
Media install (each)	0.02 hours	1	variable

To achieve the estimated installation time and make the best use of personnel, some tasks can be performed simultaneously. For example, while one person is installing a CAP, the other person could be installing tape drives.

Pallets

The SL3000 library modules and other components are shipped on pallets.

Note – If palletized equipment must be transported on elevators, the cars must be capable of safely handling the weight.

FIGURE 3-7 lists each module and its shipping specifications.

FIGURE 3-7 Pallet and Module Shipping Information



Module	Height	Width	Depth	Weight
Base Drive	216 cm (85 in.)	97 cm (38.3 in.)	134 cm (52.8 in.)	410 kg (905 lb)
Drive Expansion	216 cm (85 in.)	97 cm (38.3 in.)	134 cm (52.8 in.)	321 kg (708 lb)
Cartridge Expansion	216 cm (85 in.)	97 cm (38.3 in.)	95 cm (85 in.)	213 kg (469 lb)
Parking Expansion	216 cm (85 in.)	97 cm (38.3 in.)	95 cm (85 in.)	213 kg (469 lb)



Important: *Possible Physical Injury.*

Either a split-pallet or pallet-ramp design is used to ship and provide safe removal of the module at the customer site. SL3000 library modules are shipped with wheels (casters) already attached to allow for easy positioning within the data center. Once positioned, the modules must be raised from their wheel-base to rest upon load plates for stability and/or leveling purposes.



The suggested library adjustment height is 200 cm (77.6 in.). Therefore, make sure that the top of the library does not interfere with ceiling fixtures in the data center.

Customer's Floor

The library can be installed on a raised, solid, or carpeted floor and have a smooth surface.

- If raised, there should not be ventilation panels directly below the library.
- If solid, to avoid tripping, route cables from the ceiling.
- If carpeted, make sure the carpet is approved for computer-room equipment and provide protection from electrostatic discharge (ESD).

The load-bearing capacity of the customer's floor is another consideration.

- A single Base module, when fully populated, weighs:
 - From 623 kg (1372 lb) with 8 drives and media
 - To 687 kg (1514 lb) with 24 drives and media
- An additional drive expansion module, when fully populated, weighs:
 - From 482 kg (1290 lb) with 8 tape drives
 - To 723 kg (1594 lb) with 32 tape drives

Additionally, since modules are joined together and the TallBots travel along a rail, each module must be adjusted so that TallBots travel along a level plane.

Some customer floors may contain *slight* slopes in them, so these variations must be taken into account. Any excessive out-of-plane conditions could cause binding, premature wear, and damage to the TallBots.

FIGURE 3-8 shows an example of this; allowing for a slope of 3.4 cm (1.35 in.).

FIGURE 3-8 Floor Slope

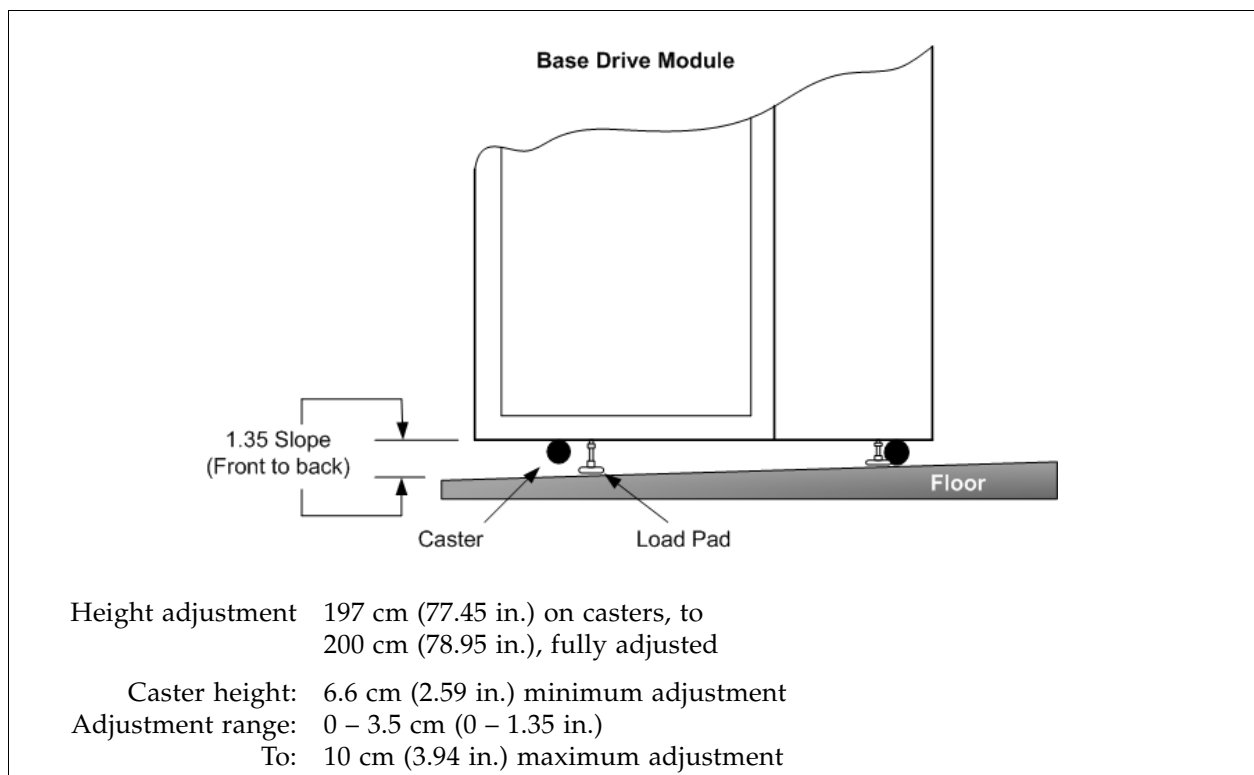

Cable Routing

The SL3000 library has rear door cut-outs on both the *top* and *bottom* of the door to allow for cable routing. This is a 5 cm (2 in.) opening that runs 73 cm (29 in.) along the length of the door with cable routing hardware and reliefs available.

FIGURE 3-9 shows a Base Module rear door with standard 61 cm (24 in.) square floor tiles visible through the door perforations as a comparison. Because of the openings in the rear door, several different floor (or ceiling) cut-outs will work to route cables.

When planning to route cables, make sure to include locations for power, drive interface, library control, and Ethernet cables. As a best practice, when possible, route power cables through one cut-out and signal cables through another cut-out.

FIGURE 3-9 Cable Routing

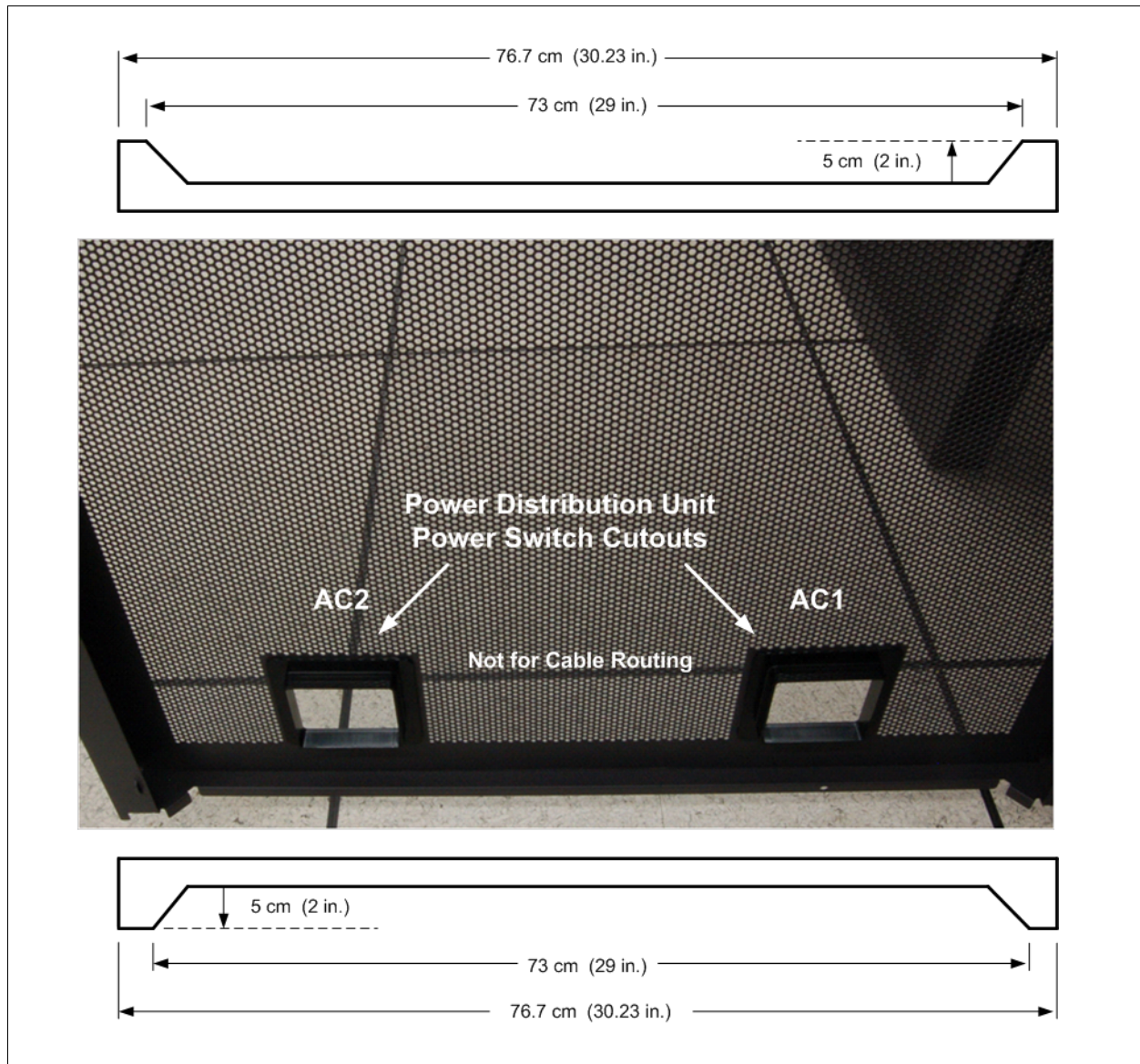

Seismic or Earthquake Ratings

The requirements for seismic compatibility vary dramatically throughout the world. As such, Sun StorageTek does not offer a standard “seismic” feature for the SL3000 modular library.

It is recommended that any customer who has seismic concerns work with local experts who are familiar with the local code and requirements.

Sun Professional Services can also be engaged to help coordinate this activity.



Caution – Bodily injury and equipment damage: A licensed seismic engineer must be consulted to verify seismic zone exposures and adequate site preparation.

For sites in areas of seismic activity, the customer may wish to permanently fix the library position for added stability. The SL3000 library mounting holes designed in the floor of each module where half-inch carriage bolts (mounting studs) can be used to permanently fix the library’s position.

FIGURE 3-10 shows the locations and dimension for the mounting studs.

FIGURE 3-10 Seismic Mounting Locations

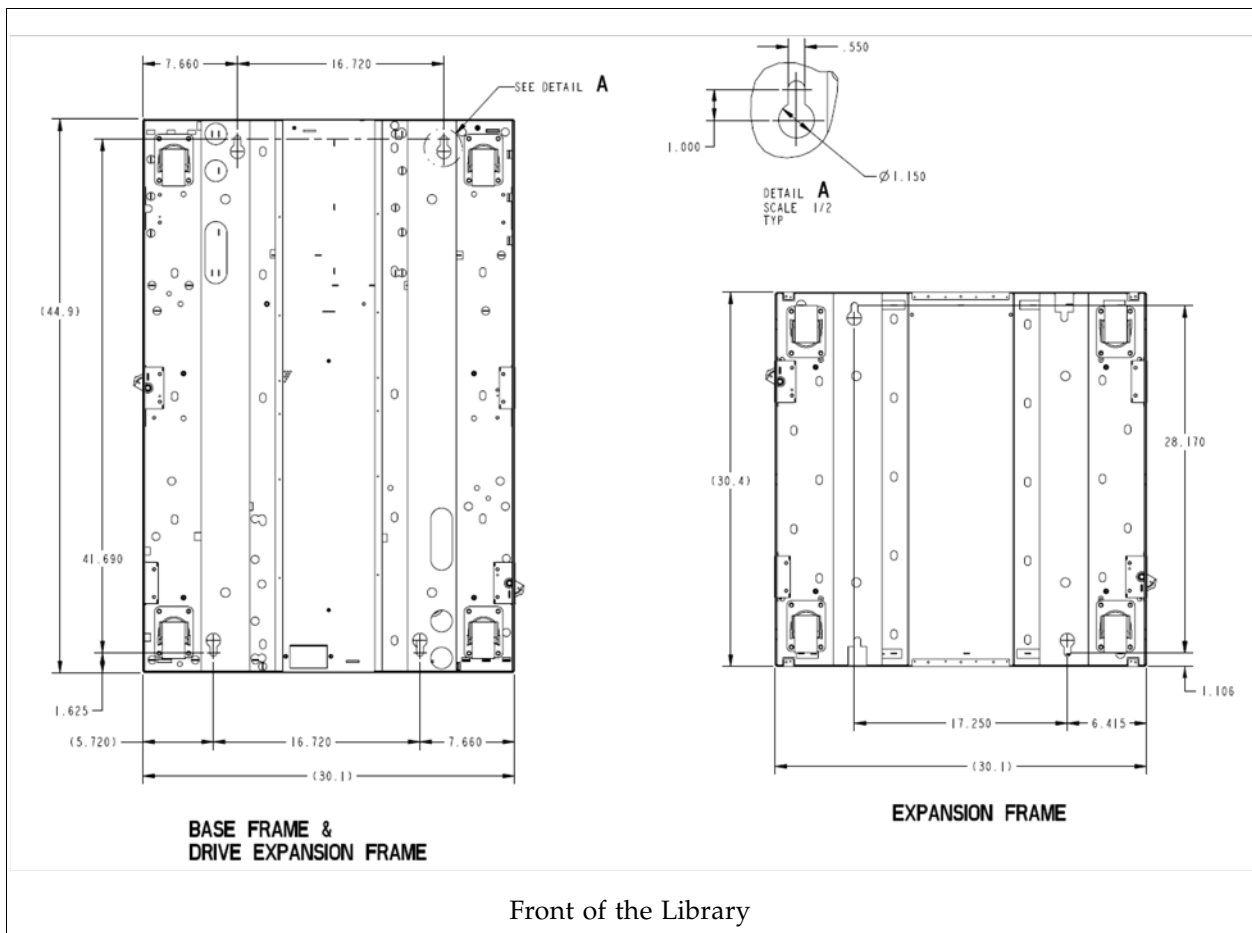

Installation Tools—Required

TABLE 3-10 lists the installation tools required for the SL3000. There is no special district installation toolkit required.

Note – If you already have SL8500 libraries in your area, the extractor, hex wrench and rack alignment tool can also be used for the SL3000; if these few special tools are not available, you must order them separately.

A Web site that lists all tools available is located at the following URL:
http://sunsolve.central.sun.com/handbook_internal/FieldTools/

TABLE 3-10 Installation Tools

Standard Tools	Part Number	Use
Tool bag	24100254	
Torx screwdriver and T8, T10, T15, T25 bits	4850	<ul style="list-style-type: none"> ■ T8: Removal and replacement of the PUK card. ■ T10: Removal and replacement of the PUO, PUW, PUN, PUF, PUZ cards. ■ T15: Removal and replacement of the Operator panel, window, blank plate, arrays and upgrades, PUN, cable routing hardware, accessory card cage, track end stop, and TallBot brushes. ■ T25: Removal and replacement of the CEM shipping brace, track adjustment, CAP screws, Ethernet switch mounting hardware.
3/8-in. drive ratchet wrench	3010420130	See 5/16-in. attachment
Wire side cutters	24100041	Cutting shipping straps
Adjustable wrench (must be adjustable to accept 7/8-in. nut)		Locking the weight distribution pad's nut with the height adjustment bolt.
Phillips screwdriver		
Flat blade screwdriver		
Special Tools		
5/16-in. hex Allen on 3/8-in. drive	3010420646	Module height adjustment, joining modules
9/16-in. socket on 3/8-in.-drive		Module removal from pallet
Copper rail connector extraction tool	313921001	Track terminator removal (supplied with base module installation kit)
Rail separator/joiner	4199410xx	Supplied with base module installation kit. Used for releasing/joining extrusions

TABLE 3-10 Installation Tools (Continued)

Standard Tools	Part Number	Use
Pallet jack	Obtain locally	Movement of pallets
Serial cable for laptop	24100134	CLI access to library
Crossover cable for laptop	24100163	CLI access to library
Drive tray power-on tool	314831204	See description below.

In addition to these tools, the following items are required:

- Flashlight
- Step stool
- Volt/Ohmmeter

Drive Tray Power-on Tool

A tool is available to assist you in removing a stuck tape within a library tape drive. This tool allows you to power-on a drive *outside* the library for the primary function of removing a cartridge stuck within a library drive.

The kit part number is 314831204; which contains the instructions for its use (document 102084) and a drive power cable (part 419632401).

An AC power cord is required to use this tool. You must order this separately:

- Part number 10187018 (Europe)
- Part number 10187019 (North America)

Optional Power Drill

While the amount of fastening hardware is minimal, you may also use a power drill to speed up the process of tightening nuts and screws. If a power drill is used, you must adjust the torque setting to:

- 2.8 Nm (25 in.-lb) for T-25 screws
- 0.6 Nm (5 in.-lb) for T-10 screws

Array Extraction Tool

To facilitate removal of cartridge arrays, an optional array extraction tool can be ordered: part 24100275.

Installation Kits

Installation kits are supplied with each module. These contain the hardware required to install each module. Kit part numbers are:

- 419838301—Base module
- 419844301—Drive expansion and cartridge expansion modules

AC Power Configurations and Cables

SL3000 libraries require that the customer select one of the following, *single phase*, AC power options for the base and drive expansion modules, these are:

- 110 VAC, 50/60 Hz, at 20 Amps (range: 100–127 VAC, 50–60 Hz, 16 Amps)
- 220 VAC, 50/60 Hz, at 30 Amps (range: 200–240 VAC, 50–60 Hz, 24 Amps)

AC power configurations are either N+1 (standard) or 2N (redundant feature).

Make sure to plan for the locations of power cables and list the locations for their associated circuit breakers.

Cables *must* be ordered for the appropriate power configuration.

[TABLE 3-11](#) lists the cables available from Sun or licensed electricians.

Keep in mind that you need to order:

- N+1: One power cord for the Base module and one power cord for the drive expansion module if installed.
- 2N: Two power cords for the Base module and two power cords for the drive expansion module if installed.

TABLE 3-11 Power Cable Part Numbers and Descriptions

Power Source	Description	Circuit Breaker	Connector Type		Power Cord Length/Type	Part Numbers	
			Wall	Library		Item	X-Option
120 VAC / 20A	Domestic	20 A	L5-20P	L5-20R	3.7 m (12 ft) 12 AWG	419813801	XSL3000-PC20110-Z
240 VAC / 30A	Domestic	30 A	L6-30P	L6-30R	3.7 m (12 ft) 12 AWG	419813701	XSL3000-PC30220-Z
240 VAC / 30A	International	30 A	330 P6W	L6-30	4 m (13 ft) 12 AWG	419813601	XSL3000-IPC30220Z
<p>Important: Best practices call for:</p> <ul style="list-style-type: none"> ■ N+1: Two separate power sources for a Base with a DEM installed. ■ 2N: Four separate power sources would be prudent for this same configuration. 							

The cables listed in [TABLE 3-11](#) are available from Sun or licensed electricians.

Keep in mind that you will need:

- One power cable each for the Base module and the drive expansion module in an N+1 power configuration, and
- Two cables each for a 2N power configuration

Obtaining a Password

Sun representatives, partners, and the customer must obtain a password before any configuration of the library is possible. To save time, obtain this password *before* beginning the installation.

The StreamLine Library Console security system (the primary interface to the library) requires activation of the site user accounts with an activation password.

This activation password is only valid the first time logging-in.

Two activation passwords are needed:

- Sun representative (service or partner)
- Customer (administrator or operator)

After initially logging into the Command Line Interface (CLI) with the “service” user ID and service activation password, a prompt is displayed to set a new password. You can then share this new password with other users requiring access to the library.

For the customer, log into the CLI with the “admin” user ID and admin activation password. Customers can then set their new password for the StorageTek Library Console, using the same user account (such as Customer Administrator).

Before you request an Activation Password:

- The person requesting the passwords *must* have a valid User ID and password to access the software keys in the Support Web site:

<http://crcapplications/keyswebapp/>

- The person accessing the CRC with the User ID must be authorized to use the Activation Password application.

(Contact Global Services if you are not able to access the Activation Password application.)

Notes:

- The system validates the above information and retrieves an activation password for the library.
- The activation password is case sensitive. You must type this password exactly as it was issued to you by the Activation Password application.

Installing the Library Console Software

A service representative must load and activate the Library Console software to configure the library and before customer use. Software for the StorageTek Library Console (also called SLC, SLConsole, or Library Console) is download from:

<http://dlrequest.sfbay.sun.com:88/usr/login>

Enter "SLConsole" into the Search block. Service representatives load this software onto a personal computer.

Customers must also load this software to a remote, customer supplied, personal computer, workstation, and optional touch screen operator panel if present.

Licensing

Licensing allows customers to install selected optional features on the SL3000 library. The following features are controlled by the licensing utility:

- Service
- Capacity on Demand
- Partitioning
- Power Supply Information
- Dual Robot
- Dual TCP/IP Port

License Key File

A license key file is typically delivered to the customer from Sun Microsystems, Inc. using e-mail. The license key file is a digitally signed Java Archive (.jar) file that contains one or more license keys for features purchased. In order to ensure that features are installed on the correct library, the license key file includes the serial number of the target library and can only be installed for that library.

All SL3000 features purchased for a library are included in a single license key file.



When the customer orders and installs a new license key file, it overlays any previously installed license on the library.

Therefore, it is *essential* that the contents of a new license key file is verified before installing it. This verification is necessary in order to ensure that the file contains all the features purchased for that library.

If it does not contain all the features purchased, when you install the new file you could potentially remove features that have previously been installed on the library.

SL3000 Configuration Work Sheet

Enter the library and drive configurations in the table below.

TABLE 3-12 SL3000 Library Configuration

Account Information			
Site Location Number:	Account Name:		
Contact phone numbers:			
Library Information			
Library S/N	Library name	Library IP addresses	
	
Number of modules (Total): ____		Number of Slots:	
<input type="checkbox"/> Base	<input type="checkbox"/> DEM	<input type="checkbox"/> CEMs (How many?____)	<input type="checkbox"/> PEMs
CAPs (Total): ____		TallBots: <input type="checkbox"/> 1 <input type="checkbox"/> 2	
Partitioned?	<input type="checkbox"/> Yes <input type="checkbox"/> No	<input type="checkbox"/> TCP/IP <input type="checkbox"/> Fibre Channel	How many?____ How many?____
Host Interface	<input type="checkbox"/> Ethernet <input type="checkbox"/> Fibre Channel	Host software	Version:
Touch Screen Operator Panel?	<input type="checkbox"/> Yes <input type="checkbox"/> No	<input type="checkbox"/> ACSLS <input type="checkbox"/> HSC	
Web-launch SLConsole Server		<input type="checkbox"/> Other:	
Power Configuration	<input type="checkbox"/> N+1	<input type="checkbox"/> 2N	DC Power Supplies
Circuit Breaker Locations:			
Redundant Features			
Number of Tape Drives:	T10000:	T9840:	LTO:
Encryption-capable:	<input type="checkbox"/> Yes <input type="checkbox"/> No	<input type="checkbox"/> Yes <input type="checkbox"/> No	<input type="checkbox"/> Yes <input type="checkbox"/> No

TABLE 3-12 SL3000 Library Configuration (Continued)

Base Module — Tape Drive Information			
Drive Type (model)	Drive Address	Interface Type (FC, FICON, ESCON)	IP Address
1.			. . .
2.			. . .
3.			. . .
4.			. . .
5.			. . .
6.			. . .
7.			. . .
8.			. . .
9.			. . .
10.			. . .
11.			. . .
12.			. . .
13.			. . .
14.			. . .
15.			. . .
16.			. . .
17.			. . .
18.			. . .
19.			. . .
20.			. . .
21.			. . .
22.			. . .
23.			. . .
24.			. . .

TABLE 3-12 SL3000 Library Configuration (Continued)

Drive Expansion Module — Tape Drive Information			
Drive Type (model)	Drive Address	Interface Type (FC, FICON, ESCON)	IP Address
25.			. . .
26.			. . .
27.			. . .
28.			. . .
29.			. . .
30.			. . .
31.			. . .
32.			. . .
33.			. . .
34.			. . .
35.			. . .
36.			. . .
37.			. . .
38.			. . .
39.			. . .
40.			. . .
41.			. . .
42.			. . .
43.			. . .
44.			. . .
45.			. . .
46.			. . .
47.			. . .
48.			. . .
49.			. . .
50.			. . .
51.			. . .
52.			. . .
53.			. . .
54.			. . .
55.			. . .
56.			. . .

Customer Site Survey

Use this chapter to prepare for the installation by reviewing the information and completing the “[Site Preparation Checklist](#)” on page 64

Other information—surveys—in this chapter includes:

- “[System Configuration](#)” on page 69
- “[Applications](#)” on page 71
- “[Databases](#)” on page 73

Existing

- “[Hardware Configurations](#)” on page 74
 - “[Library](#)” on page 74
 - “[Tape Drives](#)” on page 75
 - “[Data Cartridges](#)” on page 76
- “[Network and Components](#)” on page 77
 - “[ESCON Directors](#)” on page 79
 - “[FICON Directors](#)” on page 80
- “[Cables](#)” on page 81

Interoperability



Important:

Not sure if your customer's software of choice supports Sun StorageTek hardware? Do the different network components support each other?

Check out the Interoperability Tool at: <https://extranet.stortek.com/interop/interop>

This tool is designed for connectivity information on all supported products sold through Sun Microsystems, Inc. regardless of whether Sun- or third-party branded. It can assist in completing a product qualification form.

The configurations listed are reflective of the most up-to-date information reported from various sources, including Sun testing labs and our technology partners.

The Interop Tool only lists configurations with valid connectivity, *it does not validate*.

Site Preparation Checklist

Use the following checklist to ensure that the customer is ready to receive the library and to ensure that you are ready to start the installation.

See [Chapter 3, "Site Planning"](#) for supporting information such as measurements, weights, and service clearances.

TABLE 4-1 Site Preparation Checklist

Question	Answer	Comments
Delivery and Handling		
Does the customer have a delivery dock? If not, where will the equipment be delivered?	Yes <input type="checkbox"/> No <input type="checkbox"/>	Important: Check the delivery route that the library must travel from the loading dock to the installation location.
If a delivery dock is available, what are the hours of operation? _____		
Are there street or alley limitations that may hinder the delivery? For example: limited access, one-way traffic, truck size?	Yes <input type="checkbox"/> No <input type="checkbox"/>	Make sure there are no obstructions and that the library will fit through doors, hallways, and into elevators.
Is the dock close to the computer room where the equipment will be installed? If no, how far does the equipment need to be moved?	Yes <input type="checkbox"/> No <input type="checkbox"/> Distance: _____	
Is an elevator required to move the equipment to the appropriate floor? What type of elevator is being used? Such as: Class A or C, freight, low-rise, passenger, service, hydraulic, pneumatic.	Yes <input type="checkbox"/> No <input type="checkbox"/> Description: _____	
What is the capacity of the elevator? What are the dimensions of the elevator?		
Are there any ramps or slopes that you need to move equipment over to get to the installation site? What is the angle?	Yes <input type="checkbox"/> No <input type="checkbox"/> Degrees: _____	
Will there be people available to handle the number of, size of, and weight of the shipping pallets?	Yes <input type="checkbox"/> No <input type="checkbox"/>	
Will there be equipment available to handle the pallets (forklifts or pallet jacks)?	Yes <input type="checkbox"/> No <input type="checkbox"/>	

TABLE 4-1 Site Preparation Checklist (Continued)

Question	Answer	Comments
Is there a <i>staging area</i> where the pallets can be placed with access to the installation site?	Yes <input type="checkbox"/> No <input type="checkbox"/>	
Are there doorway or hallway height and width limitations that may prevent moving the equipment on the shipping pallets? Will you need to <i>unpack</i> the equipment to move it to the installation site?	Yes <input type="checkbox"/> No <input type="checkbox"/> Yes <input type="checkbox"/> No <input type="checkbox"/>	Note: The SL3000 is delivered with casters and can roll into position.
Physical Placement		
The library does not require raised flooring, <i>but it is highly recommended</i> . Does the site have raised flooring? Has the floor been laser-leveled?	Yes <input type="checkbox"/> No <input type="checkbox"/> Yes <input type="checkbox"/> No <input type="checkbox"/>	
Does the customer have floor tile cut-outs available for AC power, interface cables, and vented floor tiles?	Yes <input type="checkbox"/> No <input type="checkbox"/>	
Does the intended site have enough room to install and service the equipment?	Yes <input type="checkbox"/> No <input type="checkbox"/>	
Can the customer's floor support the weight of the library configuration?	Yes <input type="checkbox"/> No <input type="checkbox"/>	
Are there plans for expansion? If so, when? What type of expansion? How many <i>slots</i> does the customer <i>currently</i> have? How many expansion modules does the customer <i>currently</i> have?	Yes <input type="checkbox"/> No <input type="checkbox"/> Date: _____ <input type="checkbox"/> Drives <input type="checkbox"/> Cartridges <input type="checkbox"/> License keys Slots: _____ CEMs: _____	
Can the customer's floor support the weight of future expansions?	Yes <input type="checkbox"/> No <input type="checkbox"/>	
Is the ceiling above the library clear of obstructions such as smoke detectors, sprinklers, and vents.	Yes <input type="checkbox"/> No <input type="checkbox"/>	
Does the equipment need to move over carpet? If so, is there protection from electrostatic discharge (ESD)?	Yes <input type="checkbox"/> No <input type="checkbox"/>	

TABLE 4-1 Site Preparation Checklist (Continued)

Question	Answer	Comments
Environmental		
Does the site meet the environmental requirements for: <ul style="list-style-type: none"> ■ Temperature? ■ Relative Humidity? ■ Air flow (front, back, sides)? ■ Cooling requirements? 	Yes <input type="checkbox"/> No <input type="checkbox"/>	Temperature: 16°–32°C (60°–90°F) Humidity: 20–80%, non-condensing Current measurements: <ul style="list-style-type: none"> ■ Temperature ■ Relative Humidity
Does the site contain features and materials that guard against electrostatic discharge?	Yes <input type="checkbox"/> No <input type="checkbox"/>	
Does the customer have a large dumpster and means to dispose of the packing material? Are there special requirements to dispose of or recycle the packing material, pallets, and cardboard?	Yes <input type="checkbox"/> No <input type="checkbox"/> Yes <input type="checkbox"/> No <input type="checkbox"/>	
Is there concern about Seismic or Earthquake ratings for the SL3000?	Yes <input type="checkbox"/> No <input type="checkbox"/>	
Power		
Does the intended site meet the power requirements for of the equipment?	Yes <input type="checkbox"/> No <input type="checkbox"/>	
Have arrangements been made for a licensed electrician to connect power?	Yes <input type="checkbox"/> No <input type="checkbox"/>	
Does the site have multiple, separate circuits for power redundancy?	Yes <input type="checkbox"/> No <input type="checkbox"/>	For 2N power configurations only
Does the customer plan to use multiple branch circuits for redundancy?	Yes <input type="checkbox"/> No <input type="checkbox"/>	
Building Codes		
Do local, city, state, or federal codes need to be checked and approved for: <ul style="list-style-type: none"> ■ Wiring configurations? ■ Fire suppression requirements? ■ Clearances? ■ Safety? 	Yes <input type="checkbox"/> No <input type="checkbox"/> Yes <input type="checkbox"/> No <input type="checkbox"/> Yes <input type="checkbox"/> No <input type="checkbox"/> Yes <input type="checkbox"/> No <input type="checkbox"/>	
Does the customer require a fire suppression system?	Yes <input type="checkbox"/> No <input type="checkbox"/>	The SL3000 supports a fire suppression system; however, this is the responsibility of the customer, their insurance company, local fire department, and building codes.

TABLE 4-1 Site Preparation Checklist (Continued)

Question	Answer	Comments
Connectivity		
Is the customer using an Open Systems or an Enterprise platform?	Open <input type="checkbox"/> Enterprise <input type="checkbox"/>	
Have you completed the Site Survey forms?	Yes <input type="checkbox"/> No <input type="checkbox"/>	
Have you referred to the Interop Tool at https://extranet.stortek.com/interop/interop/ ?	Yes <input type="checkbox"/> No <input type="checkbox"/>	
Does the customer want to install equipment in the library rack space?	Yes <input type="checkbox"/> No <input type="checkbox"/>	Note: The SL3000 has limited rack space and is for use with drive connectivity: encryption and SDP.
Have you completed a cable plan (configuration drawing)?	Yes <input type="checkbox"/> No <input type="checkbox"/>	
Have you determined the type of and number of cables required? Library: <ul style="list-style-type: none"> ■ Ethernet: Host connections ■ Fibre Channel: Host connections Tape drives: <ul style="list-style-type: none"> ■ Fibre Channel: Data path ■ FICON or ESCON: Data path ■ Ethernet: SDP or encryption 	Yes <input type="checkbox"/> No <input type="checkbox"/>	
Is the customer prepared to supply Ethernet cables for the network?	Yes <input type="checkbox"/> No <input type="checkbox"/>	
Can the customer provide the required number of “static” IP addresses?	Yes <input type="checkbox"/> No <input type="checkbox"/>	
Will interface cables be run from outside the computer room?	Yes <input type="checkbox"/> No <input type="checkbox"/>	Cables that run outside a computer room require flammability ratings of CL2/CL2P.
Tape Drives (See Appendix C, “Tape Drives and Media” on page 149)		
Does the customer have the correct type and number of tape drives?	Yes <input type="checkbox"/> No <input type="checkbox"/>	
Are new or additional drives required? How many? What types?	Yes <input type="checkbox"/> No <input type="checkbox"/> _____ _____	
Are conversions required, such as drive trays, or interface ports (SFPs)? How many?	Yes <input type="checkbox"/> No <input type="checkbox"/> _____	

TABLE 4-1 Site Preparation Checklist (Continued)

Question	Answer	Comments
Media Factors ((See Appendix C, "Tape Drives and Media" on page 149)		
Does the customer have the correct type and number of data cartridges? Are additional cartridges required? Are cleaning cartridges required? Are labels required? How many? What types?	Yes <input type="checkbox"/> No <input type="checkbox"/> Yes <input type="checkbox"/> No <input type="checkbox"/> Yes <input type="checkbox"/> No <input type="checkbox"/> Yes <input type="checkbox"/> No <input type="checkbox"/> _____ _____	
Does the customer need additional CAP magazines, cartridge racks and furniture?	Yes <input type="checkbox"/> No <input type="checkbox"/>	
Human Interface		
Are there any issues that may prevent operators from entering the library? Such as handicapped (wheel-chair), too short to reach drives in the upper bays, too tall to easily enter the library.	Yes <input type="checkbox"/> No <input type="checkbox"/>	The width between the front and rear walls is 45 cm (18 in.), which may be difficult for some to move freely inside the library.
Where will the remote operator panels be located?	Yes <input type="checkbox"/> No <input type="checkbox"/>	
Remote Support		
Will the customer allow StorageTek to use remote support?	Yes <input type="checkbox"/> No <input type="checkbox"/>	
Has the SDP Systems Assurance Guide been completed?	Yes <input type="checkbox"/> No <input type="checkbox"/>	
Has the SDP appliance and mounting hardware been ordered?	Yes <input type="checkbox"/> No <input type="checkbox"/>	
Professional Services, Data Center Services, and Data Migration Services		
Are Professional Services required for: <ul style="list-style-type: none"> ■ Assessments and Migration ■ Fire suppression systems ■ Media conversion services ■ Drive and media relocations ■ Network upgrades ■ Training 	Yes <input type="checkbox"/> No <input type="checkbox"/> Yes <input type="checkbox"/> No <input type="checkbox"/> Yes <input type="checkbox"/> No <input type="checkbox"/> Yes <input type="checkbox"/> No <input type="checkbox"/> Yes <input type="checkbox"/> No <input type="checkbox"/> Yes <input type="checkbox"/> No <input type="checkbox"/>	
Is the customer moving existing products and services to an SL3000 library?	Yes <input type="checkbox"/> No <input type="checkbox"/>	

System Configuration

The following two pages provide space where you can record information about the **customers operating systems** and configurations.

TABLE 4-2 Operating System Survey

Question	Answer
<p>1. How many and what types of operating systems or platforms does the customer have?</p> <p>Open-Systems:</p> <ul style="list-style-type: none"> • Windows: 2000, NT... Make & Model: Quantity: • UNIX: Solaris, AIX, HP-UX... Make & Model: Quantity: • Linux... Make & Model: Quantity: <p>Mainframe:</p> <ul style="list-style-type: none"> • MVS Make & Model: Quantity: • VM Make & Model: Quantity: <p>Other (Specify):</p> <p>Make & Model: Quantity:</p>	
<p>2. Are there plans for:</p> <ul style="list-style-type: none"> • New purchases? • Future upgrades? • If so, what? 	
<p>3. How many systems/servers are used as:</p> <ul style="list-style-type: none"> • Backup servers? • File servers? • Print servers? • Exchange servers? 	

TABLE 4-3 System Configuration

System _____	Processor _____	Processor _____
Vendor Make & Model		
Operating System Type		
Version Number & Patch Level		
Number of Channels		
IP Address		
HBA Vendor & Model		
HBA Firmware Versions		
Switch & Port Numbers		
Switch Make & Model		
ESCD and HCD support		
ESCON Director Make & Model		
ESCON Manager		
FICON support		
EREP		
Ports		
System _____	Processor _____	Processor _____
Vendor Make & Model		
Operating System		
Version Number & Patch Level		
Number of Channels		
IP Address		
HBA Vendor & Model		
HBA Firmware Versions		
Switch & Port Numbers		
Switch Make & Model		
ESCD and HCD support		
ESCON Director Make & Model		
ESCON Manager		
FICON support		
EREP		
Ports		

Applications

The following two pages provide space where you can record information about the **customer's applications**.

TABLE 4-4 Customer Applications

Question	Answer
1. How many servers or systems perform backups? 2. How are backups performed, manually or automatically?	
3. On what days are backups performed? 4. What types of backups are performed and when? <ul style="list-style-type: none"> • Full: • Incremental: • Differential: 5. How many hours are available for: <ul style="list-style-type: none"> • Full backups? • Daily Backups? 	
6. How much data is backed up: <ul style="list-style-type: none"> • Per day? • Per week? • Per month? 7. How much data changes daily (%)?	
8. Are backup windows being met? 9. How long does it actually take? 10. How long should a backup take? 11. Is a different backup schedule needed?	
12. How long does the customer keep the different levels of backed up data? 13. How many copies are made (including the original)? 14. How many copies are archived?	
15. How often are restores necessary? 16. Why are restores necessary? 17. What are the restore requirements? 18. What are the restore objectives?	

TABLE 4-5 Backup and Archive Software

Selection	Type of Backup and Archive Software	Version
<input type="checkbox"/>	VERITAS NetBackup Backup Manager	
<input type="checkbox"/>	IBM Tivoli Storage Manager (TSM)	
<input type="checkbox"/>	Legato NetWorker	
<input type="checkbox"/>	CA Brightstor	
<input type="checkbox"/>	HP Omniback	
<input type="checkbox"/>	ASM	
<input type="checkbox"/>	E-Mail Archive	
<input type="checkbox"/>	SAM FS	
<input type="checkbox"/>	Other (Specify)	

Table 57. Network Management Software

Selection	Type of Network Management	Version
<input type="checkbox"/>	VERITAS	
<input type="checkbox"/>	IBM Tivoli NetView	
<input type="checkbox"/>	HP OpenView	
<input type="checkbox"/>	HP SUNNet	
<input type="checkbox"/>	RMS/GSM	
<input type="checkbox"/>	Other (Specify)	

Table 58. Library Attachment Software

Selection	Type of Library Attachment	Version
<input type="checkbox"/>	HSC	
<input type="checkbox"/>	ACSLs	
<input type="checkbox"/>	ACSLs HA	
<input type="checkbox"/>	Fibre Channel	
<input type="checkbox"/>	Other (Specify)	

Databases

TABLE 4-6 Customer Databases

Question	Answer
1. How much primary storage exists? Total capacity.	
2. What type and size of disk drives does the customer have? Make: Model: Capacity: Quantity:	
Make: Model: Capacity: Quantity:	
3. What is the RAID configuration? 4. What type of Failover product and Version is the customer using?	
5. Does all primary storage require backup? If not, how much does? 6. Are additional storage devices needed?	
7. What Data Base Management Systems (DBMS's) does the customer have? 8. What types of databases need backups? 9. What is the size of the smallest database? 10. What is the size of the largest database? 11. How often does the customer backup each database?	
12. What type of data is the customer backing up? 13. How valuable is the data in each database? 14. Do the different databases have different backup requirements?	
15. How is the customer currently protecting the databases (tape backup, mirroring, snapshot)? 16. If mirroring, how many mirrors? 17. Is mirroring installed because failover is required?	

Hardware Configurations

List any existing hardware the customer currently has:

- Does the customer have any existing libraries? Yes No
- Does the customer have any existing tape drives? Yes No
- Does the customer have any existing media for reuse? Yes No
- Does the customer have an existing storage area network? Yes No
- Are migration services required? Yes No

Library

- Will this SL3000 library be replacing existing libraries? Yes No
- Replacing existing StorageTek libraries? Yes No
- If so, what are the module numbers? _____

TABLE 4-7 Existing Libraries

Libraries	Description
Manufacturer	
Make & Model	
Cartridge Capacity	
Library Management Software	
Interface type	

Manufacturer	
Make & Model	
Cartridge Capacity	
Library Management Software	
Interface type	

Manufacturer	
Make & Model	
Cartridge Capacity	
Library Management Software	
Interface type	

Tape Drives

- Does the customer have existing StorageTek tape drives? Yes No
- Does the customer need more tape drives? Yes No
- What types of drives are needed? _____

TABLE 4-8 Tape Drive Types

Tape Drive Type	Yes	No	Vendor
3480 or 3490-type devices (18/36 track)	<input type="checkbox"/>	<input type="checkbox"/>	
DLT 7000 or 8000	<input type="checkbox"/>	<input type="checkbox"/>	
StorageTek T9840*	<input type="checkbox"/>	<input type="checkbox"/>	
StorageTek T9940	<input type="checkbox"/>	<input type="checkbox"/>	
StorageTek T10000*	<input type="checkbox"/>	<input type="checkbox"/>	
SDLT 320, SDLT 600, or DLT-S4	<input type="checkbox"/>	<input type="checkbox"/>	
LTO Generation 1, 2, 3, or 4*	<input type="checkbox"/>	<input type="checkbox"/>	

Notes: See [TABLE C-7 on page 154](#) for drive tray conversion kits to adapt LTO drives from other Sun StorageTek libraries to SL3000 library operation.
 See the T9X40 and T10000 SAGs for drive tray conversion kits to adapt T9840 and T10000 drives from other Sun StorageTek libraries to SL3000 library operation.

TABLE 4-9 Existing Tape Drives

Tape Drives	Description	Quantity
Manufacturer		
Make & Model		
Manufacturer		
Make & Model		
Manufacturer		
Make & Model		
Manufacturer		
Make & Model		

Does the customer plan to use encryption-capable tape drives? Yes No

Data Cartridges

- Approximately, how many tape cartridges does the customer have? _____
- Does the customer need more tapes? Yes No
- Data cartridges? Yes No
- Cleaning cartridges? Yes No

TABLE 4-10 Existing Tape Cartridges

Tape Cartridges	Description	Quantity
Data Cartridge Type		
Manufacturer		
Data Cartridge Type		
Manufacturer		
Data Cartridge Type		
Manufacturer		
Data Cartridge Type		
Manufacturer		
Data Cartridge Type		
Manufacturer		
Cleaning Cartridge Type		
Manufacturer		
Cleaning Cartridge Type		
Manufacturer		
Cleaning Cartridge Type		
Manufacturer		

Network and Components

- Does the customer have an existing storage area network? Yes No
- Are additional network devices required? Yes No
- What are they? _____
- Does the customer use *zones* in the network? Yes No
- Are there frequent reconfigurations of the network? Yes No
- Are there multiple floors involved with this network? Yes No
- Are there inter-connections of hubs and switches? Yes No
- Are there remote connections to hubs and switches? Yes No
- Is this a campus network? Yes No
- Are trunk cables used? Yes No
- Are patch panels used? Yes No

TABLE 4-11 Fibre Channel Switches

Information	Switch 1	Switch 2	Switch 3
Manufacturer			
Make & Model			
Software version			
Speed			
Number of Ports			
Port types			
GBIC Module types			
Number of Open Ports			
IP Addresses			
IP Addresses			

TABLE 4-12 Ethernet Hubs and Switches

Information	Hub/Switch 1	Hub/Switch 2	Hub/Switch 3
Manufacturer			
Make & Model			
Number of Ports			
Software version			
Speed			
Duplex			
Number of Open Ports			
IP Addresses			
IP Addresses			

TABLE 4-13 Fibre Channel Switch Connections

FC Switch Information	Switch 1	Switch 2	Switch 3
Vendor			
Model Number			
Port 0 Connection and Status			
Port 1 Connection and Status			
Port 2 Connection and Status			
Port 3 Connection and Status			
Port 4 Connection and Status			
Port 5 Connection and Status			
Port 6 Connection and Status			
Port 7 Connection and Status			
Port 8 Connection and Status			
Port 9 Connection and Status			
Port 10 Connection and Status			
Port 11 Connection and Status			
Port 12 Connection and Status			
Port 13 Connection and Status			
Port 14 Connection and Status			
Port 15 Connection and Status			
Port 16 Connection and Status			
Port 17 Connection and Status			
Port 18 Connection and Status			
Port 19 Connection and Status			
Port 20 Connection and Status			
Port 21 Connection and Status			
Port 22 Connection and Status			
Port 23 Connection and Status			
Port 24 Connection and Status			
Port 25 Connection and Status			
Port 26 Connection and Status			
Port 27 Connection and Status			
Port 28 Connection and Status			
Port 29 Connection and Status			
Port 30 Connection and Status			
Port 31 Connection and Status			

ESCON Directors

- How many ESCON Directors does the customer have? _____
- Is an extended distance facility or feature installed? Yes No
- Are patch panels used? Yes No
- How many ports? _____
(18, 36, 72)
- Are trunk cables used? Yes No
How many? _____
- What type of connectors are used? _____
(ST, MTP, ESCON, MTRJ)
- Are couplers used? Yes No
- Are adapters used? Yes No
- Are standard or custom ESCON jumper cables used? Std Custom
- Are there any FICON Bridge Ports? Yes No
- Are Fibre Transport Services used with trunk cables? Yes No

TABLE 4-14 ESCON Directors

Information	Director 1	Director 2	Director 3
Manufacturer			
Make & Model			
Software version			
Ports per card			
Number of LED ports			
Number of XDF ports			
Number of FICON ports			
Number of Bridge cards			
Number of Open ports			
Channel Addresses			
Channel Addresses			
IP Addresses			
IP Addresses			

FICON Directors

FICON products use a mapping layer based on the existing ANSI standards and physical cabling for Fibre Channel but uses different switches called directors similar to ESCON.

- What type of operating system does the customer have? _____
(z/OS, OS/390, 9672 G5/G6, etc.)
- How many FICON Directors does the customer have? _____
- Are cascaded directors used to extend distance? Yes No
- Are patch panels used? Yes No
- How many ports? _____
- Are trunk cables used? Yes No
How many? _____
- What type of connectors are used? _____

TABLE 4-15 FICON Director Worksheet

FICON Director Worksheet								
Manufacturer:				Type:			Model:	
HCD Switch ID: Director Domain ID (@)				Cascaded Directors <input type="checkbox"/> Yes <input type="checkbox"/> No Fabric Name:				
Director F_Ports				Attached N_Ports or E_Ports				
Slot #	Port #	Port Address	Type (LX / SX)	Port Name	Node (CU/Chnl)	Device Type	Model	ISL CU Intf. CHPID

Cables

Cables types and distances that apply to the library and tape drives are explained in the follow sections.

Library Network Cables

The maximum distances that the SL3000 Tape Library supports on a Fibre Channel link is determined by the link speed, the type of fiber (50 or 62.5 micron), and the device to which the library is attached.

The library can be used in a 62.5-micron-cable Storage Area Network (SAN).

However, the cable that connects the library to the network must be a 50-micron cable because the library uses 50-micron cables internally.

Refer to your switch vendor to determine what is supported in the customers storage area network.

In a SAN, the typical support distances for 62.5-micron cables are:

- 4 Gbps link speed = up to 70 m (230 ft)
- 2 Gbps link speed = up to 150 m (492 ft)
- 1 Gbps link speed = up to 175 m (574 ft)

Typical supported distances for 50-micron cables (used to connect with the library) are:

- 4 Gbps link speed = up to 150 m (492 ft)
- 2 Gbps link speed = up to 300 m (984 ft)
- 1 Gbps link speed = up to 500 m (1640 ft)

If your library attaches to a host bus adapter (HBA), refer to the documentation for the HBA for the supported cable distances.

A list of cables is supplied in [“Cables” on page 103](#).

Tape Drive Cables

A list of cables is supplied in [“Cables” on page 103](#).

If the drives are connected to the optional Ethernet switches (see [“Ethernet Switch/Harnesses” on page 96](#)) to connect to the drives, the cable connections between each drive and the switch are at the rear of the base or drive expansion modules.

Using World Wide Names

This section discusses the World Wide Name (WWN) addresses that the SL3000 Tape Library assigns to drives. The WWN does not change when the drive is swapped or replaced and host parameters do not need to be changed or re-configured.

Normally, blocks of World Wide Name (WWN) addresses are assigned to manufacturers by the IEEE Standards Committee and are built into devices during manufacture. In the case of the SL3000 Tape Library, however, the library assigns World Wide Node Names and World Wide Port Names to the drives. This technique is referred to as “library-centric world wide names.” Potential drive slots are each assigned a WWN which does not change when a drive is swapped or replaced.

In the SL3000 Tape Library, a WWN for a drive is implemented through an algorithm that uses the frame serial number of the library and the drive’s position within the library. Only the last two digits change within the library. The second-to-the-last digit represents the frame number (starting at 0 for Frame 1) and the last digit is the drive row (starting at 1). The WWN of the drive is location-dependent and not device-dependent. That is, each time a drive is reset or powered on, the library re-establishes the WWN so that a drive in frame *x*, row *y* always retains the same WWN—host parameters do not need to be changed or re-configured. The library’s configuration can also easily survive a reboot. The following sections describe methods that involve World Wide Names in resolving these issues.

Using Persistent Binding

When a server is booted, devices are discovered and assigned SCSI target and LUN IDs. It is possible for these SCSI assignments to change between boots. Some operating systems do not guarantee that devices will always be allocated the same SCSI target ID after rebooting. Also, some software depends on this association, so you do not want it to change. The issue of SCSI ID assignment is addressed by persistent binding.

Persistent binding is a host bus adapter (HBA) function that allows a subset of discovered targets to be bound between a server and device. Implemented by a World Wide Node Name (WWNN) or World Wide Port Name (WWPN), persistent binding causes a tape drive’s World Wide Name to be bound to a specific SCSI target ID. After a configuration has been set, it survives reboots and any hardware configuration changes because the information is preserved. If a drive needs to be replaced, the new drive assumes the WWNN of the old drive because the WWNN for the drive is location-dependent within the library. Because the WWNN does not change, persistent binding does not need to be changed, which would cause an outage.

Using Zoning to Isolate Devices and Enhance Security

For security reasons, it is important to limit the devices that a server or servers can recognize or access. Also, some performance configurations and Storage Area Network (SAN) configurations can result in a device being seen multiple times from the same server. For example, if you have two host bus adapters (HBAs) from the same server connected to a tape drive in the SL3000 Tape Library, the drive will be detected and appear as two logical devices. That is, there will be two special files for one physical device. Zoning can address these issues.

Zoning allows you to partition your SAN into logical groupings of devices so that each group is isolated from the other and can only access the devices in its own group. Two types of zoning exist: hardware zoning and software zoning. Hardware zoning is based on physical fabric port number. Software zoning is defined with the World Wide Node Name (WWNN) or World Wide Port Name (WWPN).

While zoning can be re-configured without causing an outage, some zoning configurations can become complicated. The advantage of the library's WWNN implementation is that you can avoid the exposure of introducing zoning errors because there is no need to change the zoning configuration if a drive needs service or replacement.

Ordering

Use this chapter to help order the SL3000 library, configurations, X-Options, additional features, and conversion bills.

Information in this chapter includes:

- [“Ordering Flowchart”](#) (below): supplies the ordering process
- [“Library Part Number Details” on page 94](#) lists what is included with each part
- [“Library X-Options” on page 98](#) identifies the upgrades to the library
- [“Tape Drive Selection” on page 99](#) lists the numbers for the tape drives
- [“Tape Drive X-options and Conversion Bills” on page 102](#) identifies upgrades
- [“Cables” on page 103](#) lists the supported interface cables for the library and drives

Ordering Flowchart—Just the Facts

[TABLE 5-1](#) steps you through a typical ordering process for a new SL3000 library.

For more information about capacities, see:

[“Physical Capacities” on page 10](#)

For more information about DC power supplies, see:

[“Single Drive Type DC Power Configurations” on page 14](#)

[“Mixed Drive Type DC Power Configurations” on page 15](#)

For more information about what is included for the initial order (Step 1), see:

[“Library Part Number Details” on page 94](#)

Part numbers are composed of many elements. For example, SL3000-BM1-200-Z is:

- **SL3000** indicates the library model number
- **BM1** indicates a Base module configuration (1)
- **200** indicates the library has a licensed capacity of 200 data cartridges
- **Z** indicates that the drive complies with ROHS requirements

Note – An ‘X’ in front of the model number indicates an X-option, which is an upgrade or conversion—such as: XSL3000-CEM-Z—which adds a Cartridge Expansion module to the base library.

TABLE 5-1 Ordering Flowchart

Step Number	Marketing Number	Comments
<p>1. Base Library. Determine the number of slots required. <i>Suggestion:</i> Identify the number of physical slots currently needed then add some capacity to meet future needs for growth.</p> <p>2. Next, determine the number of licensed cartridge slots needed at this time.</p> <p>3. Select an initial base library configuration from items “a through g” below.</p> <p>4. Select the equivalent installation option.</p>		
a. Up to 343 physical (with 200 to 343 licensed slots) <input type="checkbox"/> Installation <input type="checkbox"/> After hours installation	a. SL3000-BM0-200-Z EIS-SLBASE-E EIS-SLBASE-E-AH	<p>Required</p> <ul style="list-style-type: none"> ■ One of these part numbers is required for the initial order, then build from there. ■ Maximum quantity of 1 is required for a library order. ■ See “Library Part Number Details” on page 94 for a description of what comes with each part number. ■ Additional capacity above either 200 or 700 licensed slots requires an upgrade. <p>See “Additional Capacity” on page 96.</p>
b. Up to 953 physical (with 200 to 953 licensed slots) <input type="checkbox"/> Installation <input type="checkbox"/> After hours installation	b. SL3000-BM1-200-Z EIS-SL3K-BSE1CEM-E EIS-SL3BS1CEM-E-AH	
c. Up to 1557 physical (with 200 to 1557 licensed slots) <input type="checkbox"/> Installation <input type="checkbox"/> After hours installation	c. SL3000-BM2-200-Z EIS-SL3K-BSE2CEM-E EIS-SL3BS2CEM-E-AH	
d. Up to 953 physical (with 200 to 953 licensed slots) <input type="checkbox"/> Installation <input type="checkbox"/> After hours installation	d. SL3000-BM1-700-Z EIS-SL3K-BSE1CEM-E EIS-SL3BS1CEM-E-AH	
e. Up to 1557 physical (with 200 to 1557 licensed slots) <input type="checkbox"/> Installation <input type="checkbox"/> After hours installation	e. SL3000-BM2-700-Z EIS-SL3K-BSE2CEM-E EIS-SL3BS2CEM-E-AH	
f. Up to 2177 physical (with 200 to 2177 licensed slots) <input type="checkbox"/> Installation <input type="checkbox"/> After hours installation	f. SL3000-BM3-700-Z EIS-SL3K-BSE3CEM-E EIS-SL3BS3CEM-E-AH	
g. Up to 2797 physical (with 200 to 5821 licensed slots) <input type="checkbox"/> Installation <input type="checkbox"/> After hours installation	g. SL3000-BM4-700-Z EIS-SL3K-BSE4CEM-E EIS-SL3BS4CEM-E-AH	
<p>Note: Redundant TallBots are not supported for Items a, b, and d (above).</p>		

TABLE 5-1 Ordering Flowchart (Continued)

Step Number	Marketing Number	Comments
<p>5. Order a Drive Expansion Module?</p> <ul style="list-style-type: none"> ■ If you require more than 24 tape drives or ■ If you have a specific configuration need (for example, special drive placement, or to maximize performance) <p> <input type="checkbox"/> Installation <input type="checkbox"/> After hours installation </p>	<p>XSL3000K-DEM200-Z</p> <p>EIS-SL-CEMDEM-E EIS-SL-CEMDEM-E-AH</p>	<p><i>Optional</i></p> <ul style="list-style-type: none"> ■ You can only order a maximum quantity of 1 DEM per library. ■ Ordering a DEM adds <ul style="list-style-type: none"> ■ 200 licensed slots ■ Physical capacity ■ 32 more drive slots
<p>6. Order more Cartridge Expansion Modules</p> <ul style="list-style-type: none"> ■ If ordering Items “a to f” for a base library configuration and you require more licensed or physical slot capacity ■ Then you order more cartridge expansion modules (8 total) to meet the need <p> <input type="checkbox"/> Installation <input type="checkbox"/> After hours installation </p>	<p>XSL3000-CEM-Z</p> <p>EIS-SL-CEMDEM-E EIS-SL-CEMDEM-E-AH</p>	<p><i>Optional</i></p> <ul style="list-style-type: none"> ■ You can order up to 8 CEMs <i>total</i> (max.) per library. ■ This includes all the CEMs bundled with the base library.
<p>7. Order additional Licensed Capacity</p> <p>Remember:</p> <ol style="list-style-type: none"> a. Base library configurations come standard with 200 or 700 slots. b. The DEM adds 200 slots and more physical capacity c. Add larger quantities first, then add more quantities to meet your needs. <ul style="list-style-type: none"> ■ 1,000 incremental slots ■ 500 incremental slots ■ 200 incremental slots ■ 1 incremental slots <p> <input type="checkbox"/> Installation <input type="checkbox"/> After hours installation </p>	<p>XSL3000K-1000SLOT XSL3000K-500-SLOT XSL3000K-200-SLOT XSL3000K-1-SLOT</p> <p>EIS-SL3-CAPY-E EIS-SL3-CAPY-E-AH</p>	<p><i>Optional</i></p> <p>See “License Key Files” on page 93 for more information.</p>
<p>Note: Capacity license keys are customer-installable. Therefore, installation parts are optional. If installation is ordered, only a quantity of 1 install part is needed, regardless of the quantity ordered.</p>		

TABLE 5-1 Ordering Flowchart (Continued)

Step Number	Marketing Number	Comments
8. Decide the type of AC Power required:		Required
<ul style="list-style-type: none"> ■ 200—240 VAC, 30 Amp (PDU) <ul style="list-style-type: none"> <input type="checkbox"/> Installation <input type="checkbox"/> After hours installation 	<ul style="list-style-type: none"> ■ XSL3000-PDU-240-Z EIS-SL3K-PWR-E EIS-SL3K-PWR-E-AH 	At least one PDU is required in each: <ul style="list-style-type: none"> ■ The Base module and ■ The DEM
<ul style="list-style-type: none"> ■ 100—127 VAC, 20 Amp (PDU) <ul style="list-style-type: none"> <input type="checkbox"/> Installation <input type="checkbox"/> After hours installation 	<ul style="list-style-type: none"> ■ XSL3000-PDU-110-Z EIS-SL3K-PWR-E EIS-SL3K-PWR-E-AH 	
<ul style="list-style-type: none"> ■ Are you installing a DEM? If so, the <i>same</i> type PDU must be installed in <i>both</i> the base and DEM. 	<ul style="list-style-type: none"> ■ Increase the quantity to 2 Keep install quantity at 1 	
9. Determine the type of Power Redundancy		Optional
<ul style="list-style-type: none"> ■ N+1 One AC PDU, with one extra DC supply than is required for the drives and TallBot 	XSL3000-DCPWR-Z Use Step 12 to determine the amount of DC power supplies required. No other parts are required.	Also see “ Power Options ” on page 12 and the Power Configuration tables to determine how many DC power supplies are needed.
<ul style="list-style-type: none"> ■ 2N Two AC PDUs, each with its own set of DC power supplies for the drives and the TallBots <p>*Required for dual TallBot operation</p>	XSL3000-DCPWR-Z Double the number of PDUs from above. Use Step 12 to determine the amount of DC power supplies required. No other parts are required	
<ul style="list-style-type: none"> ■ 2N+1 <i>Two</i> AC PDUs, each with <i>one</i> extra DC power supply than is required for the drives and the TallBots. This has N+1 for the first and second PDU. 	Double the number of PDUs from above. In addition, add the following: <ul style="list-style-type: none"> ■ XSL3000-DCPWR-Z, quantity 1 for the TallBot ■ XSL3000-EM-DCPWR-Z, quantity 2 for the ECM ■ XSL3000-DCPWR-Z for some quantity of drives 	
<ul style="list-style-type: none"> <input type="checkbox"/> Installation <input type="checkbox"/> After hours installation 	EIS-SL3K-PWR-E EIS-SL3K-PWR-E-AH	
10. Include Power Cords for the PDU. You need one power cord for every PDU. How many PDUs were selected? <ul style="list-style-type: none"> ■ 200—240 VAC, 30 Amp, U.S. ■ 200—240 VAC, 30 Amp, International ■ 100—127 VAC, 20 Amp No installation parts required.		Required Order one power cord for each PDU ordered. <ul style="list-style-type: none"> ■ XSL3000-PC30220-Z ■ XSL3000-IPC30220-Z ■ XSL3000-PC20110-Z

TABLE 5-1 Ordering Flowchart (Continued)

Step Number	Marketing Number	Comments
<p>11. Drive Bays. This step determines the number needed to support the tape drives. How many tape drives will be installed? Remember to include both new and current (transferred) drives.</p> <p>Base: Remember, one bay is standard</p> <ul style="list-style-type: none"> a. 1 to 8 tape drives (standard) b. 9 to 16 tape drives c. 17 to 24 tape drives <p>DEM: Remember, one bay is standard</p> <ul style="list-style-type: none"> d. 25 to 32 tape drives (standard) e. 33 to 40 tape drives f. 41 to tape drives g. 49 to 56 tape drives <p>Note: This step assumes all available drive bays are filled before ordering more capacity. If this assumption is incorrect—for example, a specific configuration need, special drive placement, or to maximize performance—discuss the configuration options to make sure you have enough drive arrays installed. Also, make sure to order enough drive power supplies to support the tape drives.</p> <p>No installation parts required.</p>	<p>Quantity:</p> <ul style="list-style-type: none"> a. Standard component. No extra parts required b. 2 of XSL3000-DRVARY-Z c. 3 of XSL3000-DRVARY-Z d. 3 of XSL3000-DRVARY-Z plus 1 XSL3000K-DEM200-Z e. 3 of XSL3000-DRVARY-Z plus 2 XSL3000K-DEM200-Z f. 3 of XSL3000-DRVARY-Z plus 3 XSL3000K-DEM200-Z g. 5 of XSL3000-DRVARY-Z plus 4 XSL3000K-DEM200-Z 	<p><i>Optional</i></p> <p>Depends on the number of drives needed. Maximum quantity of:</p> <ul style="list-style-type: none"> ■ 3 in the Base module ■ 4 in the DEM <p>If you have a specific configuration need (for example, a special drive placement, or to maximize performance)</p>
<p>12. Tape Drive DC Power Supplies (DCPS). This is a critical step—Make sure to use the tables provided in TABLE 1-3 on page 14 through TABLE 1-7 on page 16 or the configuration presentation on MySales. You must know:</p> <ul style="list-style-type: none"> a. How many drives are to be installed? (include new and transferred drives) b. What type of drives? (T9840C/D, T10000A/B, or LTO) c. What is the PDU configuration? (From Step 8) d. What is the power redundancy? (From Step 9). <p>Use this information to calculate the number of DC power supplies needed for <i>both</i> the Base module and DEM.</p> <p>No installation parts required for new installations.</p>	<p>XSL3000-DCPWR-Z</p>	<p><i>Optional</i></p> <p>Quantities vary depending on:</p> <ul style="list-style-type: none"> ■ PDU-type ■ Power redundancy ■ Tape drive types ■ Number of drives

TABLE 5-1 Ordering Flowchart (Continued)

Step Number	Marketing Number	Comments
<p>13. Is Partitioning needed? If yes, then add this part. No installation parts required.</p>	<p>XSL3000K-PART</p>	<p><i>Optional</i> 1 per library</p> <p>See “License Key Files” on page 93 for more information.</p>
<p>14. Are extra Cartridge Access Ports needed? If yes, then add this part. How many additional CAPs are needed?</p> <p>Note: One CAP comes standard in the Base module. Each DEM and CEM can support one additional CAP. Make sure you have enough additional modules to support the number of additional CAPs ordered.</p> <p><input type="checkbox"/> Installation <input type="checkbox"/> After hours installation</p>	<p>XSL3000-CAP-Z</p> <p>EIS-SL3K-ACCE-E EIS-SL3K-ACCE-E-AH</p>	<p><i>Optional</i></p> <ul style="list-style-type: none"> ■ One CAP per module ■ Library total = 10 (including the Base)
<p>15. Operator Panel or Window? The Base module and DEM ship with a perforated panel (standard). If this panel is acceptable, no other order is needed. However, two other options are available:</p> <ul style="list-style-type: none"> ■ Local touch screen operator panel (Base module only) <ul style="list-style-type: none"> <input type="checkbox"/> Installation <input type="checkbox"/> After hours installation <p>OR</p> <ul style="list-style-type: none"> ■ Window arrays—adds 23 physical slots (Base or DEM) No installation parts required. 	<ul style="list-style-type: none"> ■ XSL3000-OP-PANL-Z <p>EIS-SL3-OPT-E EIS-SL3-OPT-E-AH</p> <ul style="list-style-type: none"> ■ XSL3000-W-ARRAY-Z 	<p><i>Optional</i></p>
<p>16. Redundant TallBots? Does the customer want dual robotics?</p> <p>Notes:</p> <ol style="list-style-type: none"> a. The library requires 2 PEMs in the library configuration (Step 1). This can be 2 CEMs, then converted to PEMs. b. The library requires a 2N power configuration (Step 9). c. There is a loss of physical capacity when choosing this option. Make sure the library’s physical capacity still meets your needs (See “Physical Capacities” on page 10). <p><input type="checkbox"/> Installation <input type="checkbox"/> After hours installation</p>	<p>XSL3000K-DUALBOTZ</p> <p>EIS-SL3K-BOT-E EIS-SL3K-BOT-E-AH</p>	<p><i>Optional</i> 1 order per library (total of 2 Tallbots)</p>

TABLE 5-1 Ordering Flowchart (Continued)

Step Number	Marketing Number	Comments
<p>17. Decide if the Dual TCP/IP feature (two Ethernet ports) is wanted for host connectivity? If so, add this part. Note: The Dual TCP/IP feature provides <i>dual path</i> functionality, not redundancy. No installation parts required.</p>	XSL3000K-2TCPIP	<i>Optional</i> 1 per library (total of 2 ports)
<p>18. Mainframe connection? Order HSC.</p>	Refer to the HSC documentation	<i>Optional</i>
<p>19. Open systems connection? Order ACSLS</p>	Refer to the ACSLS documentation	<i>Optional</i>
<p>20. AS400 connection? Order ACSLS</p>	Refer to the ACSLS documentation	<i>Optional</i>
<p>21. Order Tape Drives as required. Refer to the Sun StorageTek Tape Drive guides for more information about the T9840 and T10000 tape drives.</p>	<p>See “Tape Drive Selection” on page 99 and:</p> <ul style="list-style-type: none"> ■ T9840 on TABLE 5-4 ■ T10000 on TABLE 5-5 ■ LTO on TABLE 5-6 	<i>Optional</i>
<p>22. Is Tape Drive Encryption wanted? If so, you must order the following parts. These parts are cumulative. Adding these parts expands on the configuration.</p> <ul style="list-style-type: none"> a. Supports drives 1 to 8 (Base) b. Supports drive 9 to 16 (Base) c. Supports drive 17 to 24 (Base) d. Supports drive 1 to 8 (DEM) e. Supports drive 9 to 16 (DEM) f. Supports drive 17 to 24 (DEM) g. Supports drive 24 to 32 (DEM) <p>Note: This step assumes all available drive bays are filled before ordering more capacity. If this assumption is incorrect—for example, a specific configuration need, special drive placement, or to maximize performance—discuss the configuration options to make sure you have enough Ethernet switches and cables.</p>	<ul style="list-style-type: none"> a. XSL3000-ETHRNT1-Z b. XSL3000-ETHRNT2-Z c. XSL3000-ETHRNT3-Z d. XSL3000-ETHRNT1-Z e. XSL3000-ETHRNT2-Z f. XSL3000-ETHRNT3-Z g. XSL3000-ETHRNT4-Z <p>Note: These parts can also provide connection for the Service Delivery Platform (SDP).</p>	<i>Optional</i>
<p>23. Order appropriate Media as needed.</p>	See Appendix C .	<i>Optional</i>
<p>24. Order Cleaning Cartridges as required.</p>	See Appendix C .	<i>Optional</i>

TABLE 5-1 Ordering Flowchart (Continued)

Step Number	Marketing Number	Comments
25. Order drive cables as required.	See “Fibre Channel and ESCON Cables” on page 103.	<i>Optional</i>
26. Order control path cables.	<ul style="list-style-type: none"> ■ Fibre Channel—see “Fibre Channel Cables” on page 103 ■ TCP/IP—see “Ethernet Cables” on page 105 	<i>Optional</i>
27. Order backup and restore Application of choice: <ul style="list-style-type: none"> ■ Solstice Backup™ software ■ VERITAS NetBackup software ■ See additional listings on page 32 	See price book for part numbers and ordering information.	<i>Optional</i>
28. Network Connectivity. Order Ethernet switches and host bus adapters (HBAs)	See price book for part numbers and ordering information.	<i>Optional</i>
Important: The product warranty is void if not installed by a trained professional.		
29. Order product Installation services	See the list of parts in “Library Part Number Details” on page 94. Add installation parts for the corresponding library parts. Note: Not all parts require installation.	<i>Required</i> Professional installation by Sun, a certified reseller, or OEM partner is required.
30. Order Maintenance services	Add the appropriate maintenance service. The library comes standard with: <ul style="list-style-type: none"> ■ One year, ■ Next day warranty 	<i>Optional</i>

License Key Files

License keys are files for new library installations and some upgrades. Any parts that contain the word “KEY” in the short description or “MUST REQUEST LICENSE KEY” in the long description require a license key file to be loaded to the SL3000 library.

To ensure proper license key file creation and delivery:

1. E-mail addresses:

In the footnotes section of your Webdesk quotes you need to place all the e-mail addresses (limit of three addresses) where you want the license key file sent.

The license key file needed for your order will be sent to all these addresses.

The e-mail addresses can be to the AE, SE, CSE, or customer.

Note: The license key file is *customer-installable* so they can be sent directly to the customer if you wish.

2. Only place ONE library on any sales order/quote.

The reason for this requirement is that we have to create the license keys specific to each library. If two libraries are on the same order, we do not know which features should be applied to which library.

3. When ordering upgrades (after the initial installation) the library serial number must be entered into the footnotes area in Webdesk along with the e-mail addresses.

All SL3000 Base libraries require a key to be installed at the initial installation.

Other parts that require licensing are:

- Slot capacity parts
- Drive Expansion Module
- Partitioning
- Dual robot
- Dual TCP/IP

Library Part Number Details

The following describes what is included with each **initial** marketing part number on [page 86](#). Each number comes with the following “standard” components:

- Library controller, two Ethernet ports—only one active port²—for TCP/IP library
- Native Fibre Channel port (MPU2 card) for SCSI-controlled libraries (SMC-3)
- One tape drive bay (holds up to 8 T9840C/D, T10000A/B, or LTO3/4 drives)
- Perforated panel in the front door
- One 26-slot cartridge access port (CAP): with two 13-slot removable magazines
- Two 1200 Watt DC tape drive power supplies
- Two 1200 Watt DC TallBot power supplies
- Two 200 Watt electronics control module power supplies
- StorageTek Library Console (SLC) remote management application

SL3000-BM0-200-Z (base library)—includes:

- Base module
- 200 licensed slots
- 320 physical cartridge slots

SL3000-BM1-200-Z (base library with *one cartridge expansion module*)—includes:

- Base module
- One cartridge expansion module (CEM)
- 200 licensed slots
- 953 physical cartridge slots

SL3000-BM2-200-Z (base library with *two cartridge expansion modules*)—includes:

- Base module
- Two cartridge expansion modules (CEMs)
- 200 licensed slots
- 1557 physical cartridge slots

SL3000-BM1-700-Z (base library with *one cartridge expansion module*)—includes:

- Base module
- One cartridge expansion module (CEM)
- 700 licensed slots (License key to increase capacity from 200 to 700)
- 953 physical cartridge slots

SL3000-BM2-700-Z (base library with *two cartridge expansion modules*)—includes:

- Base module
- Two cartridge expansion modules (CEMs)
- 700 licensed slots (License key to increase capacity from 200 to 700)
- 1557 physical cartridge slots

SL3000-BM3-700-Z (base library with *three cartridge expansion modules*)—includes:

- Base module
- Three cartridge expansion modules (CEMs)
- 700 licensed slots (License key to increase capacity from 200 to 700)
- 2177 physical cartridge slots

SL3000-BM4-700-Z (base library with *four cartridge expansion modules*)—includes:

- Base module
- Four cartridge expansion modules (CEMs)
- 700 licensed slots (License key to increase capacity from 200 to 700)
- 2797 physical cartridge slots

2. Single active port. Ready for optional feature upgrade to Dual TCP/IP (XSL3000K-2TCPIP).

X-Option Details

The following sections list the various X-options available to upgrade your SL3000.

Modules

XSL3000K-DEM200-Z (Drive Expansion Module)—includes:

- Drive expansion module (DEM)
- License key to increase slot capacity by 200 slots
- 498 physical cartridge slots
- One tape drive bay (holds up to 8 T9840C/D, T10000A/B, or LTO3/4 drives)
- Perforated panel in the front door
- One 26-slot cartridge access port (CAP): with two 13-slot removable magazines
- Two 1200 Watt DC tape drive power supplies
- Two 1200 Watt DC TallBot power supplies

XSL3000-CEM-Z (Cartridge Expansion Module)—includes:

- Cartridge expansion module
- No additional licensed cartridge slots
- 516—620 physical cartridge slots
- No additional drive support

Power

XSL3000-PDU-110-Z (AC power distribution unit)

- 100—127 VAC, 20 Amp
- Must order appropriate power cord (see XSL3000-PC20110-Z)

XSL3000-PC20110-Z (Power cord)

- 3.6 m (12 ft) U.S./Japan power cord for XSL3000-PDU-110-Z:
L5-20P wall end plug, L5-20R library end plug

XSL3000-PDU-240-Z (AC power distribution unit)

- 200—240 VAC, 30 Amp
- Must order appropriate power cord, see:
 - XSL3000-PC30220-Z for domestic
 - XSL3000-IPC30220-Z for international

XSL3000-PC30220-Z (Power cord)

- 3.6 m (12 ft) U.S. power cord for XSL3000-PDU-240-Z:
L6-30P wall end plug, L6-30R library end plug

XSL3000-IPC30220-Z (Power cord)

- 4 m International power cord for XSL3000-PDU-240-Z:
330 P6W wall end plug, L6-30R library end plug

XSL3000-DCPWR-Z

- 1200 Watt DC power supply for tape drives and TallBot

XSL3000-EM-DCPWRZ

- 200 Watt power supply for the electronics control module

Partitioning

XSL3000K-PART-Z (Partitioning license)

- Physical partitioning license
- License key file sent through e-mail
- Generic letter sent to acknowledge order

Additional Capacity

XSL3000K-1-SLOT-Z (cartridge license for **one slot**)

- Increases licensed capacity by one slot
- License key sent through e-mail
- Generic letter sent that acknowledges order

XSL3000K-100-SLOT-Z (cartridge license for **100 slots**)

- Increases licensed capacity by one slot
- License key sent through e-mail
- Generic letter sent that acknowledges order

XSL3000K-200-SLOT-Z (cartridge license for **200 slots**)

- Increases licensed capacity by 200 slots
- License key sent through e-mail
- Generic letter sent that acknowledges order

XSL3000K-500-SLOT-Z (cartridge license for **500 slots**)

- Increases licensed capacity by 500 slots
- License key sent through e-mail
- Generic letter sent that acknowledges order

XSL3000K-1000-SLOT-Z (cartridge license for **1,000 slots**)

- Increases licensed capacity by 1,000 slots
- License key sent through e-mail
- Generic letter sent that acknowledges order

Ethernet Switch/Harnesses

XSL3000-ETHRNT1-Z

- 24-port Ethernet switch
- Ethernet cable harness to connect 8 tape drives, Drive Bay Array 1

XSL3000-ETHRNT2-Z

- 24-port Ethernet switch
- Ethernet cable harness to connect 8 tape drives, Drive Bay Array 2

XSL3000-ETHRNT3-Z

- 24-port Ethernet switch
- Ethernet cable harness to connect 8 tape drives, Drive Bay Array 3

XSL3000-ETHRNT4-Z

- 24-port Ethernet switch
- Ethernet cable harness to connect 8 tape drives, Drive Bay Array 4

Additional Upgrades

XSL3000-CAP-Z (Cartridge Access Port)

- One 26-slot CAP, includes two 13-slot removable media magazines
- Set of CAP labels

XSL3000-DRVARY-Z (Drive Bays)

- One Array adds 8 drive bay slots to the base or drive expansion modules

XSL3000-OP-PANL-Z (Operator Panel)

- Local touch screen operator panel

XSL3000-W-ARRAY-Z (Cartridge Arrays)

- Cartridge (slot) arrays for installation in the window area
- Adds 23 additional slots
- No licensed capacity is added

XSL3000K-DUALBOTZ (Redundant TallBot)

- Second TallBot assembly
- Two parking expansion module labels to convert CEMs to PEMs

XSL3000K-2TCPIP (Dual TCP/IP)

- Dual TCP/IP option

Library X-options and Conversion Bills

TABLE 5-2 lists the X-options available and cross-references them with the conversion bills that are included when the feature ships. Required hardware and instructions are included with the module or component.

TABLE 5-2 Library X-Options

X-option	Conversion Bill	Description	Svc Rep's Required	Person Hours
XSL3000-DCPWR-Z	104314	+48 VDC Supply, Load Sharing, Drive	1	0.25
XSL3000-DCPWR-Z	104315	+48 VDC Supply, Load Sharing, Rail	1	0.25
XSL3000-DRVARY-Z	104528	8-Drive Array Assembly	1	2
XSL3000-PDU-110-Z	104537	2N Power, 110 VAC (2)	1	0.25
XSL3000-PDU-240-Z	104536	2N Power, 240 VAC—Domestic (2)	1	0.25
XSL3000-PDU-240-Z	104538	2N Power, 240 VAC—International (2)	1	0.25
XSL3000-EM-DCPWRZ	104590	cPCI Redundancy (Electronics Module 2N power per CCD)	1	1.5
XSL3000-CAP-Z	104526	Cartridge Access Port (CAP)	1	1
XSL3000-CEM-Z	104520	Cartridge Expansion Module	2	4
XSL3000-DEM200-Z	101564	Drive Expansion Module	2	4
XSL3000-OP-PANL-Z	104524	Operator Panel	1	0.5
XSL3000-W-ARRAY-Z	104522	Window	1	0.5
XSL3000K-DUALBOTZ	104638	Redundant TallBot, Requires 2N power	1	0.5
XSL3000K-2TCPIP	104695	Dual TCP/IP Port Key	1	1
XSL3000-ETHRNT1-Z	104691	Ethernet switch/harness, Drive Bay Array 1	1	1
XSL3000-ETHRNT2-Z	104692	Ethernet switch/harness, Drive Bay Array 2	1	1
XSL3000-ETHRNT3-Z	104693	Ethernet switch/harness, Drive Bay Array 3	1	1
XSL3000-ETHRNT4-Z	104694	Ethernet switch/harness, Drive Bay Array 4	1	1
XSL3000K-PART	104700	Partition key	1	1
XSL3000K-1-SLOT	104682	1 Cartridge slot upgrade key	1	1
XSL3000K-100-SLOT	104683	100 Cartridge slot upgrade key	1	1
XSL3000K-200-SLOT	104684	200 Cartridge slot upgrade key	1	1
XSL3000K-500-SLOT	104685	500 Cartridge slot upgrade key	1	1
XSL3000K-1000SLOT	104686	1000 Cartridge slot upgrade key	1	1

Tape Drive Selection

If you have answers to the following questions, the task of locating the pertinent part number becomes much easier:

TABLE 5-3 Tape Drive Selection

Ask your customer...	Tape Drive
What tape drive model is required?	<input type="checkbox"/> T9840C <input type="checkbox"/> T9840D* <input type="checkbox"/> T10000A* <input type="checkbox"/> T10000B* <input type="checkbox"/> HP LTO3 <input type="checkbox"/> HP LTO4* <input type="checkbox"/> IBM LTO3 <input type="checkbox"/> IBM LTO4
What type of host interface is needed?	<input type="checkbox"/> Fibre Channel <input type="checkbox"/> FICON <input type="checkbox"/> ESCON ¹
How many FICON or Fibre Channel interface ports?	<input type="checkbox"/> 1 Port <input type="checkbox"/> 2 Ports
What type of interface transceiver?	<input type="checkbox"/> Longwave ² <input type="checkbox"/> Shortwave ³
* Encryption-capable 1. ESCON drives have only one port. 2. Long wavelength ports require single-mode (9 micron fiber) cables. 3. Short wavelength ports require multimode cables.	

The part numbers are composed of many of the elements listed in the table above. For example, the part number 9840D-FI-S30-1PLZ describes:

- **9840D** indicates the tape drive model number
- **FI** indicates a FICON interface
- **S30** indicates the library model (SL3000)
- **1PL** indicates the drive has a single longwave port (1PL)
- **Z** indicates that the drive complies with ROHS requirements

Another example, the part number Y-LTO4-HP4FC-SL30Z describes:

- **Y** indicates the tape drive is *Used*
- **LTO4** indicates the tape drive model
- **HP4FC** indicates the drive is from HP and it has a 4 Gb Fibre Channel interface
- **SL30Z** indicates the library model (SL3000) and complies with ROHS requirements

[TABLE 5-4](#) through [TABLE 5-6 on page 101](#) list the marketing numbers with descriptions for the tape drives supported in the SL3000 library.

T9840 Tape Drive Marketing Numbers

TABLE 5-4 T9840 Marketing Numbers and Descriptions

Marketing Number	Description
T9840 Model D	
9840D-FC-SL3000Z	T9840D, Fibre Channel, 2Gb, SL3000 ²
9840D-ES-SL3000Z	T9840D, ESCON, SL3000
9840D-FI-S30-1PSZ	T9840D, FICON, 1PSW (single-port short-wave ²), SL3000
9840D-FI-S30-2PSZ	T9840D, FICON, 2PSW (dual-port short-wave ²), SL3000
9840D-FI-S30-1PLZ	T9840D, FICON, 1PLW (single-port long-wave ³), SL3000
9840D-FI-S30-2PLZ	T9840D, FICON, 2PLW (dual-port long-wave ³), SL3000
9840D-FI-S30-2PMZ	T9840D, FICON, 2PMW (one long- and one short- wave ^{2,3}), SL3000
T9840 Model C	
9840C-FC-SL3000Z	T9840C, Fibre Channel, 2Gb, SL3000 ²
9840C-ES-SL3000Z	ESCON, SL3000
9840C-FI-S30-1PSZ	T9840C, FICON, SL3000, 1PSW (single-port short-wave ²)
9840C-FI-S30-2PSZ	T9840C, FICON, SL3000, 2PSW (dual-port short-wave ²)
9840C-FI-S30-1PLZ	T9840C, FICON, SL3000, 1PLW (single-port long-wave ³)
9840C-FI-S30-2PLZ	T9840C, FICON, SL3000, 2PLW (dual-port long-wave ³)
9840C-FI-S30-2PMZ	T9840C, FICON, SL3000, 2PMW (dual-port mixed-wave ^{2,3})
Notes:	
1. Interface transceivers (SFP modules) do not ship with the tape drive for the identified library.	
2. Short wave ports require 50/125 micron cables.	
3. Long wave ports require 9/125 micron cables	

Part Number _____
Quantity _____

Part Number _____
Quantity _____

Part Number _____
Quantity _____

Part Number _____
Quantity _____

T10000 Tape Drive Marketing Numbers

TABLE 5-5 T10000A Marketing Part Numbers and Descriptions

Marketing Number	Description
T10A-4FC-SW-30Z	SL3000 Fibre Channel Drive Short Wavelength
T10A-4FC-LW-30Z	SL3000 Fibre Channel Drive Long Wavelength
T10A-4FC-MW-30Z	SL3000 Fibre Channel Drive Mix Wavelength
T10A-FI-C-SW-30Z	SL3000 FICON Crypto Drive Short Wave
T10A-FI-C-LW-30Z	SL3000 FICON Crypto Drive Long Wave
T10A-2FI-C-MW-30Z	SL3000 FICON Crypto Drive Mix Wave
Notes:	
1. Interface transceivers (SFP modules) do not ship with the tape drive for the identified library.	
2. Long wave ports require 9/125 micron cables.	
3. Short wave ports require 50/125 micron cables.	

LTO Tape Drive Marketing Numbers

TABLE 5-6 LTO3 and LTO4 Marketing Part Numbers and Descriptions

Marketing Number	Description
New Drives	
LTO3-HP4FC-SL3000Z	HP LTO3 FC 4Gbit drive for the SL3000 library
LTO4-HP4FC-SL3000Z	HP LTO4 FC 4Gbit drive for the SL3000 library
LTO3-IB4FC-SL3000Z	IBM LTO3 FC 4Gbit drive for the SL3000 library
LTO4-IB4FC-SL3000Z	IBM LTO4 FC 4Gbit drive for the SL3000 library
LTO4-IB4F-AS4-SL3Z	IBM LTO4 FC 4Gbit drive AS400 attach for SL3000
Used Drives - No Warranty	
Y-LTO3-HP4FC-SL30Z	HP LTO3 FC 4Gbit drive for the SL3000 library
Y-LTO4-HP4FC-SL30Z	HP LTO4 FC 4Gbit drive for the SL3000 library
Y-LTO3-IB4FC-SL30Z	IBM LTO3 FC 4Gbit drive for the SL3000 library
Y-LTO4-IB4FC-SL30Z	IBM LTO4 FC 4Gbit drive for the SL3000 library
Y-LTO4-IB4F-A4SL3Z	IBM LTO4 FC 4Gbit drive AS400 attach for SL3000

Part Number _____

Quantity _____

Part Number _____

Quantity _____

Part Number _____

Quantity _____

Part Number _____

Quantity _____

Tape Drive X-options and Conversion Bills

These tables list the X-options available for converting drives to support the SL3000.

Drive Tray Conversions

TABLE 5-7 Drive Tray Conversion Kits

Drive Type	Marketing Number	Operation Type (Library)
T9840 C/D	9840BCD-FCFI-SL3-Z	T9840 B/C/D FI/FC tray to SL3000
T10000 A/B	T10AB-FCFI-SL3-Z	T10KA/B FI/FC Tray C/B-SL3000
HP LTO 3/4	LTO-HPF-L7S30-CKZ	L180/700/1400
	LTO-HPF-S5S30-CKZ	SL500
IBM LTO 3/4	LTO-IBF-L7S30-CKZ	L180/700/1400/L5500/9310
	LTO-IBF-S5S30-CKZ	SL500

General T-Series Port Conversions

TABLE 5-8 T-Series Port Conversion Marketing Part Numbers and Descriptions

Marketing Number	Conversion Bill	Description
X9840D-1SFP-LWZ		T9840D FC/FI, 1SFP, LW CKIT
X9840D-2SFP-LWZ		T9840D FC/FI, 2SFP, LW CKIT
X9840D-2SFP-MWZ		T9840D FC/FI, 2SFP, MW CKIT
X9840D-1SFP-SWZ		T9840D FC/FI, 1SFP, SW CKIT
X9840D-2SFP-SWZ		T9840D FC/FI, 2SFP, SW CKIT
2 Gigabit Drive		
XT10A-1LW-CKITZ	105119	T10KA 1 Port FICON Long Wave Conversion Kit
XT10A-1SW-CKITZ		T10K 2 Gbit 1 port Short Wave
XT10A-2LW-CKITZ	105120	T10KA 2 Port FICON Long Wave Conversion Kit
XT10A-2MW-CKITZ	105121	T10KA 2 Port FICON Mix Wave Conversion Kit
XT10A-2SW-CKITZ	105118	T10KA 2 Port FICON Short Wave Conversion Kit
XT10A-2-1LW-CKITZ		T10K 2 Gbit Fibre Channel or FICON 1 port LW
XT10A-2-1SW-CKITZ		T10K 2 Gbit Fibre Channel or FICON 1 port SW
XT10A-2-2LW-CKITZ		T10KA 2 Gbit FI or FC 2 port Long Wave Kit
XT10A-2-2MW-CKITZ		T10KA 2 Gbit FI or FC 2 port Mix Wave Kit
XT10A-2-2SW-CKITZ		T10KA 2 Gbit FI or FC 2 port Short Wave Kit
4 Gigabit Drive		
XT10A-4-2LW-CKITZ		T10KA 4 Gbit 2 port Long Wave
XT10A-4-2MW-CKITZ		T10KA 4 Gbit 2 port Mix Wave
XT10A-4-2SW-CKITZ		T10KA 4 Gbit 2 port Short Wave

Cables

Fibre Channel and ESCON Cables

The following tables list the cables available for the SL3000 library and tape drives.

Note – SL3000 drive trays accept only LC fiber cable connectors. If you are using cables with SC connectors, you must use an adapter (see [TABLE 5-9 on page 103](#)).

Fibre Channel Cables

LC connectors are the industry standard for all 2 Gb-capable Fibre Channel devices.

SL3000 drive trays accept only LC fiber cable connectors.

Part numbers and descriptions for Fibre Channel cables are listed in [TABLE 5-10](#) through [TABLE 5-13 on page 104](#). The part number for the LC-to-SC adapter is listed in [TABLE 5-9 on page 103](#).

Plenum-rated Cables

The following tables list cables as either Riser or Plenum. Plenum-rated cables have a higher flammability rating and are used for under-floor applications.

TABLE 5-9 LC-to-SC Adapter Kit

Description	Part
LC-to-SC Adapter kit	315447901
Note – When using cables with SC connectors, you must use an adapter. Library drive trays support <i>only</i> LC connectors.	

TABLE 5-10 Fiber Optic Cables: LC-to-LC, 50/125 Micron, Multimode Cables

Description	Length	Part
Optical Cable, LC to LC Duplex, Riser	3 m (9.8 ft)	CABLE10800340-Z
Optical Cable, LC to LC Duplex, Riser	5 m (16.4 ft)	CABLE10800341-Z
Optical Cable, LC to LC Duplex, Riser	10 m (32.8 ft)	CABLE10800310-Z
Optical Cable, LC to LC Duplex, Riser	50 m (164 ft)	CABLE10800311-Z
Optical Cable, LC to LC Duplex, Riser	100 m (328 ft)	CABLE10800312-Z
Optical Cable, LC to LC Duplex, Plenum	10 m (32.8 ft)	CABLE10800313-Z
Optical Cable, LC to LC Duplex, Plenum	50 m (164 ft)	CABLE10800314-Z
Optical Cable, LC to LC Duplex, Plenum	100 m (328 ft)	CABLE10800315-Z

TABLE 5-11 Fiber Optic Cables: LC-to-SC, 50/125 Micron, Single Mode Cables

Description	Length	Part
Optical Cable, LC-to-SC Duplex, Riser	2 m (6.6 ft)	CABLE10800345-Z
Optical Cable, LC-to-SC Duplex, Riser	5 m (16.4 ft)	CABLE10800346-Z
Optical Cable, LC-to-SC Duplex, Riser	10 m (32.8 ft)	CABLE10800317-Z
Optical Cable, LC-to-SC Duplex, Riser	50 m (164 ft)	CABLE10800318-Z
Optical Cable, LC-to-SC Duplex, Riser	100 m (328 ft)	CABLE10800319-Z
Optical Cable, LC-to-SC Duplex, Plenum	10 m (32.8 ft)	CABLE10800320-Z
Optical Cable, LC-to-SC Duplex, Plenum	50 m (164 ft)	CABLE10800321-Z
Optical Cable, LC-to-SC Duplex, Plenum	100 m (328 ft)	CABLE10800322-Z

TABLE 5-12 Fiber Optic Cables: LC-to-LC, 9/125 Micron, Single Mode Cables

Description	Length	Part
Optical Cable, LC-to-LC Duplex, Riser	3 m (9.8 ft)	CABLE10800302-Z
Optical Cable, LC-to-LC Duplex, Riser	10 m (32.8 ft)	CABLE10800331-Z
Optical Cable, LC-to-LC Duplex, Riser	50 m (164 ft)	CABLE10800333-Z
Optical Cable, LC-to-LC Duplex, Riser	100 m (328 ft)	CABLE10800306-Z
Optical Cable, LC-to-LC Duplex, Plenum	10 m (32.8 ft)	CABLE10800330-Z
Optical Cable, LC-to-LC Duplex, Plenum	50 m (164 ft)	CABLE10800332-Z
Optical Cable, LC-to-LC Duplex, Plenum	100 m (328 ft)	CABLE10800305-Z

TABLE 5-13 LC-to-SC, 9/125 Micron Cables

Description	Length	Part
Optical Cable, LC-to-SC Duplex, Riser	10 m (32.8 ft)	CABLE10800335-Z
Optical Cable, LC-to-SC Duplex, Riser	50 m (164 ft)	CABLE10800337-Z
Optical Cable, LC-to-SC Duplex, Riser	100 m (328 ft)	CABLE10800304-Z
Optical Cable, LC-to-SC Duplex, Plenum	10 m (32.8 ft)	CABLE10800334-Z
Optical Cable, LC-to-SC Duplex, Plenum	50 m (164 ft)	CABLE10800336-Z
Optical Cable, LC-to-SC Duplex, Plenum	100 m (328 ft)	CABLE10800303-Z

ESCON Cables

Part numbers for ESCON cables are listed in [TABLE 5-14](#).

TABLE 5-14 ESCON Cables

Description	Part
13 m (4 ft) Riser	CABLE10800289-Z
31 m (100 ft) Riser	CABLE10800290-Z
61 m (200 ft) Riser	CABLE10800291-Z
107 m (350 ft) Riser	CABLE10800292-Z
13 m (4 ft) Plenum	CABLE10800285-Z
31 m (100 ft) Plenum	CABLE10800286-Z
61 m (200 ft) Plenum	CABLE10800287-Z
107 m (350 ft) Plenum	CABLE10800288-Z

Ethernet Cables

Part numbers for Ethernet cables (for TCP/IP [HLI-PRC] interfaces are listed in [TABLE 5-15](#).

TABLE 5-15 Ethernet Cables

Description	Part
2.4 m (8 ft), 24 AWG, CAT5, Shielded	CABLE10187033-Z
10.7 m (35 ft), 24 AWG, CAT5, Shielded	CABLE10187034-Z

Addressing

This appendix provides information about the various numbering and addressing schemes for the SL3000 library, which include:

- CenterLine Technology with positive and negative column numbers
- Firmware—Library, Rail, Side, Column, Row (L, R, S, C, W)
- Host library interface—panel row column (HLI-PRC)
 - Internal—Software—tape drive numbering
 - External—Physical Hardware—tape drive numbering
- Out-of-the-box numbering (default)
- Small Computer System Interface (SCSI) element numbering

This appendix provides a comparison of the walls and slots in the library.

CenterLine Technology

The SL3000 uses *CenterLine Technology* with its modular design to help balance the work load and improve performance of the library.

Using the left side of the Base module—which is the only “required” module—as the centerline, customers can add other *modules* either to the left and/or to the right.

[FIGURE A-1 on page 108](#) shows the *centerline* and provides some comparisons using minimum to maximum configurations, with the:

- Base module only
- Base and drive expansion modules (DEM)
- Then additions of cartridge expansion modules (CEMs) to both examples

FIGURE A-1 Drive Module Slots

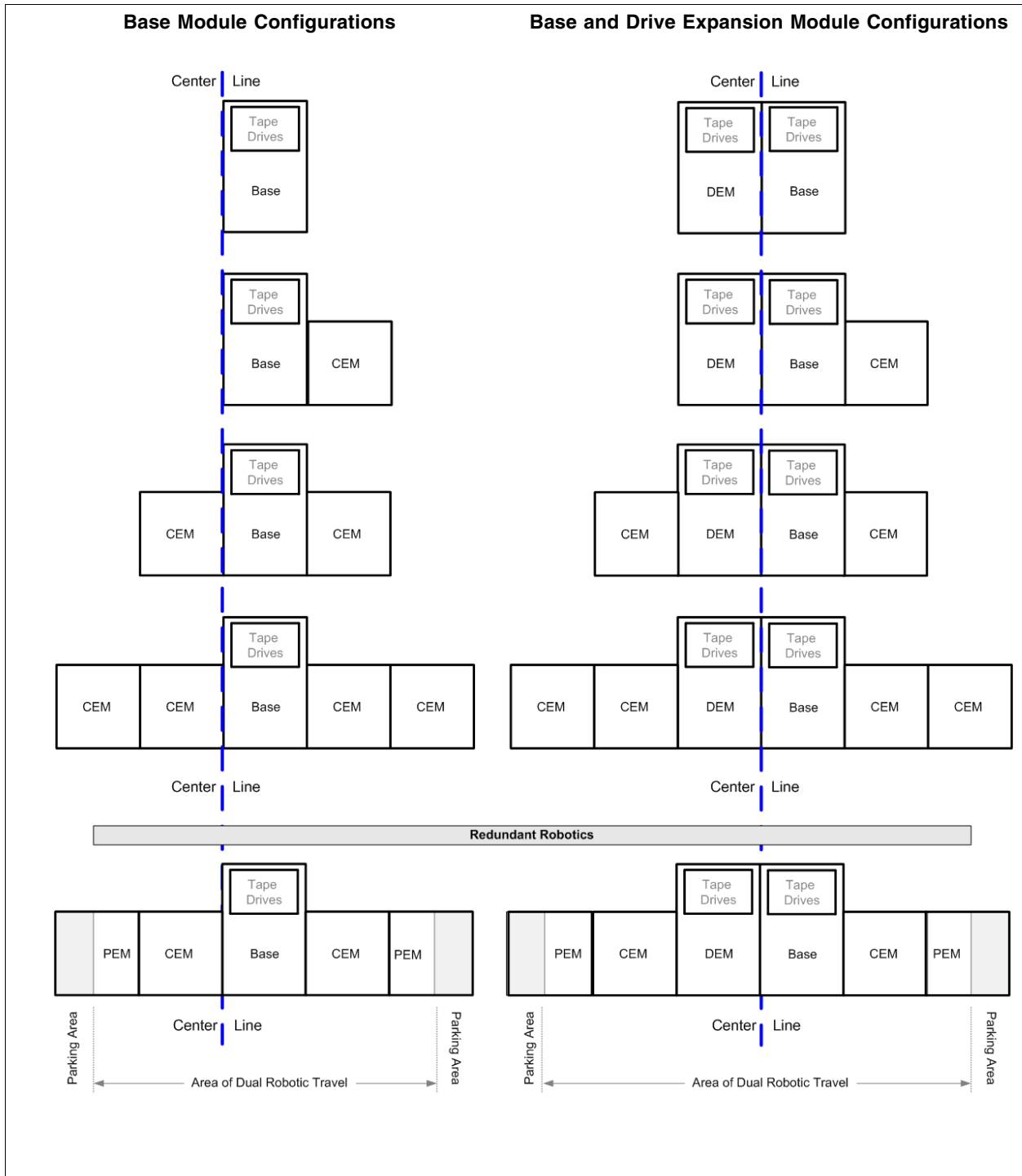

Addressing

The SL3000 employs a fixed module address scheme using five parameters separated by comma's to indicate locations—or addresses—in the library.

These parameters are: L, R, C, S, W

TABLE A-1 Addressing Scheme

Library	This parameter indicates the library number in a complex. The SL3000 does not have Pass-thru Ports; therefore, it is the only library in a complex. This parameter will always be 1.
Rail	The SL3000 only has one rail. This parameter will always be 1.
Column	Columns indicate the horizontal location of a cartridge or drive from the logical center—or centerline—of the library. The numbers get larger as you get farther away from center using: <ul style="list-style-type: none"> ■ A minus sign (-) indicates locations to the left of center. ■ A plus sign (+ or nothing) indicates locations to the right of center. These numbers vary depending on the number of expansion modules added to the library. (Each module has 6 columns)
Side	The side parameter indicates the rear or the front walls of the library. <ul style="list-style-type: none"> ■ Rear wall = 1 ■ Front wall = 2
Row	Rows indicate the vertical location of a cartridge or drive and are numbered from the top (1) down (52). These are always positive numbers.

In summary, columns are numbered using a Centerline³, then going to the left using negative numbers and to the right using positive numbers for the front and rear walls. An example is shown in [FIGURE A-2 on page 110](#).



Important:

This means that, as modules are added, the panel numbering remains constant.

This is a key benefit of a fixed addressing scheme; it allows the library to add licensed capacity with minimal impact.

3. CenterLine Technology not only provides a basis for library addresses and numbering, it also contributes to optimization and library performance.

Columns

Columns indicate the horizontal location of a cartridge or drive from the logical center—or centerline—of the library.

The numbers get larger as you get farther away from center using:

- A minus sign (-) indicates locations to the left of center.
- A plus sign (+, or nothing) indicates locations to the right of center.

These numbers vary depending on the number of expansion modules.

- Each Base and DEM has 4 columns for tape drives;
- Each module has 6 columns for data cartridges.

FIGURE A-2 shows a Base (which is required), a DEM installed to the left, with CEM (one on each end), to show how the columns are numbered for both tape drives and data cartridges.

FIGURE A-2 Centerline and Column Addressing

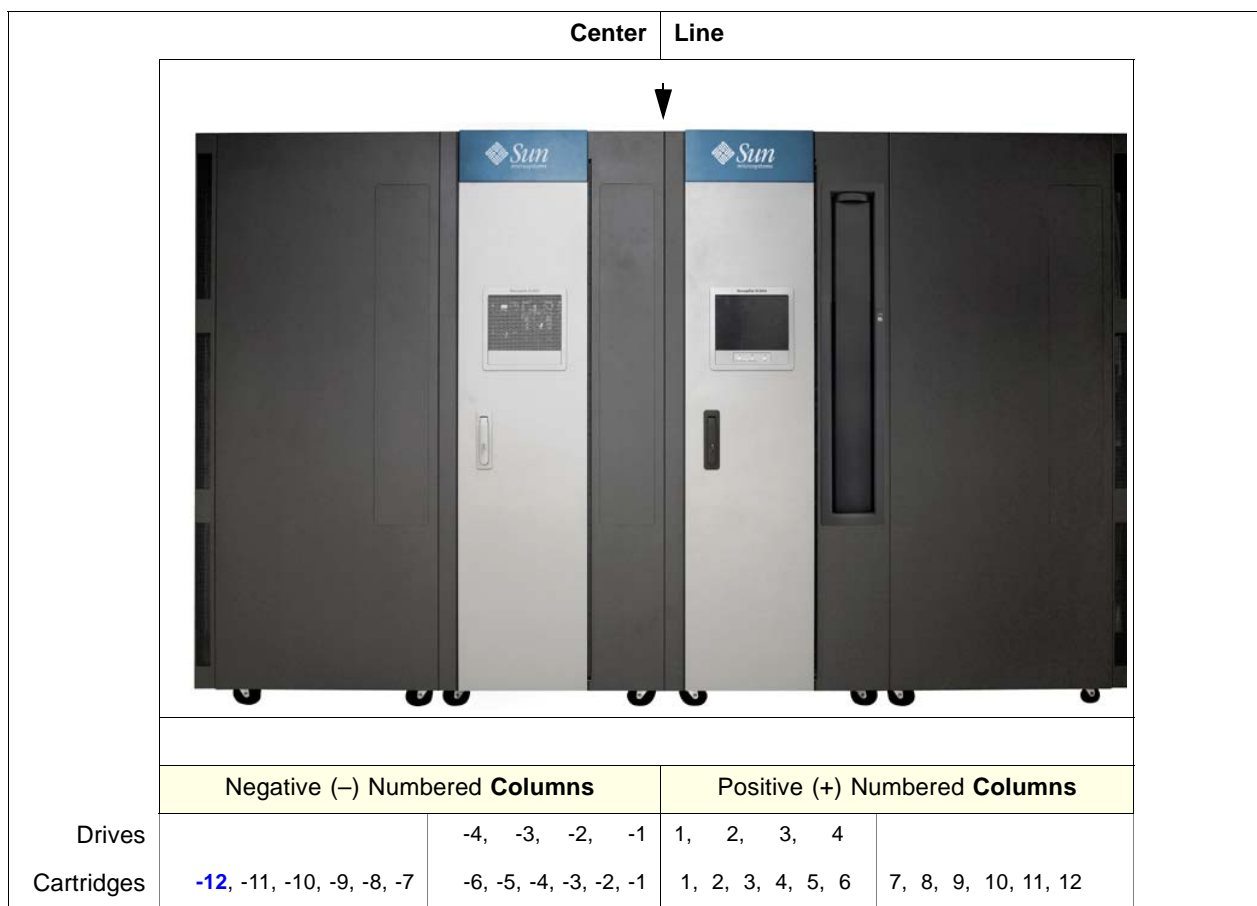

Notes:

- One and only one Base is required for every configuration
- One DEM can be installed directly to the left of the Base or,
- CEMs can be installed to the left and to the right
- Negative numbered columns are to the left of centerline
- Positive numbered columns are to the right of centerline
- The last column on the left is not accessible to allow for robotic clearance of the side cover (in FIGURE A-2 this is column -12)

Walls

The side parameter in the addressing scheme is for the rear or the front walls:

- Rear wall = 1
- Front wall = 2







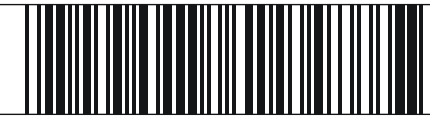

Module Identification Block

Each module has an identification block with labels that identify the configuration for that module. This block is on the lower rear wall in column 4, rows 49, 50, 51, and 52. This block identifies the:

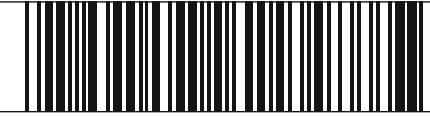
- Type of module
- Back wall configuration
- Front wall configuration
- Options for that module

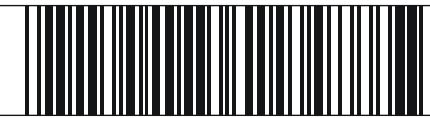
During an initialization, the robotic assembly visits the module identification block to determine the configuration of the module and installed options.

FIGURE A-3 Module Identification Block

<p>BASE DRIVE MODULE 01</p>  	<p>1 Module types:</p> <p>BASE DRIVE MODULE 01/ DRIVE EXPANSION MODULE 01/ CARTRIDGE EXPANSION MODULE 01/ PARKING EXPANSION MODULE 01/</p>
<p>BACK WALL : 1 DRV ARRAY = 8 DRIVES</p>   <p>4198362-XX</p>	<p>2 Back wall configuration:</p> <p>BACK WALL: 1 DRV ARRAY/ = 8 drives BACK WALL: 2 DRV ARRAY/ = 16 drives BACK WALL: 3 DRV ARRAY/ = 24 drives BACK WALL: 4 DRV ARRAY/ = 32 drives BACK WALL: ARRAYS/</p>
<p>FRONT WALL : CART ACCESS PORT</p>  	<p>3 Front wall configuration:</p> <p>FRONT WALL: ARRAYS/ FRONT WALL: CART ACCESS PORT/ FRONT WALL: CAP WINDOW/ FRONT WALL: EMPTY/</p>
<p>OPTION : OP PANEL OR WINDOW</p>  	<p>4 Options:</p> <p>OPTION: ARRAYS/ OPTION: OP PANEL OR WINDOW/ OPTION: EMPTY/ OPTION: SERVICE BAY/ (Parking Expansion Module)</p>

Because the SL3000 library is flexible and modular, you can upgrade or add options without removing and replacing the module. For example:

- Adding another tape drive bay to the rear of the library
- Including a CAP or operator panel to the front of a module

Simply add the upgrade and replace the configuration label for that component.

HLI-PRC Addressing

The host library interface-panel, row, column (HLI-PRC) address is an 8-digit, comma-separated value that represents the library storage module, (LSM), Panel, Row, and Column. This addressing scheme is used by HLI clients, including ACSLS and HSC, to represent library slots accessible to those HLI clients.

Note – The SL3000 firmware address identifies the physical location of the cartridge in the library and the HLI-PRC refers to the address assigned by the host software.

The slot location appears in the following format:

LL	PP	RR	CC
-----------	-----------	-----------	-----------

where,

LL: LSM number (00h)

PP: Panel—Because there is no way to identify negative numbers with this scheme, panel numbers provide the location relative to the Base module. Descending numbers *left* and ascending numbers *right* of the CenterLine.

- Even numbers = rear walls
- Odd numbers = front walls

Panels:

- Base module = Panels 12 and 13
- Drive expansion module added to the left = Panels 10 and 11
- Modules added to the right of the Base = Panels start at 14 and 15 (currently the last module panel numbers are 16 and 17) (for future planning, last module is 23 and 24)

Exception: If a cartridge expansion module is added to the left of the Base module in place of a drive expansion module, that module's panel numbering start at 8 and 9.

This allows for a drive expansion module to be installed at a later date without the necessity of re-numbering the modules.

RR: Row—Vertical location in a number of rows on the panel (0 to 51).

CC: Column—Horizontal location of a specific slot in a row (0 – 5).

FIGURE A-4 Panel Numbering for HLI-PRC Addressing

		Supported Configuration											
		Center						Line					
Rear Wall Panel Numbers		0	2	4	6	8	10	12	14	16	18	20	22
Module		Planning			CEM	CEM	DEM	Base	CEM	CEM	Planning		
Front Wall Panel Numbers		1	3	5	7	9	11	13	15	17	19	21	23

FIGURE A-5 Panel Numbering for HLI-PRC Addressing—Example 1

		Center					Line																	
Module	Cartridge Expansion					Drive Expansion					Base					Cartridge Expansion								
Rear Wall	Panel 8					Panel 10					Panel 12					Panel 14								
Column	0	1	2	3	4	5	0	1	2	3	4	5	0	1	2	3	4	5	0	1	2	3	4	5
< TallBot Area of Travel >																								
Column	0	1	2	3	4	5	0	1	2	3	4	5	0	1	2	3	4	5	0	1	2	3	4	5
Front Wall	Panel 9					Panel 11					Panel 13					Panel 15								

FIGURE A-6 Panel Numbering for HLI-PRC Addressing—Example 2

		Center					Line											
Module	Cartridge Expansion					Base					Cartridge Expansion							
Rear Wall	Panel 8					Panel 12					Panel 14							
Column	0	1	2	3	4	5	0	1	2	3	4	5	0	1	2	3	4	5
< TallBot Area of Travel >																		
Column	0	1	2	3	4	5	0	1	2	3	4	5	0	1	2	3	4	5
Front Wall	Panel 9					Panel 13					Panel 15							

FIGURE A-7 Panel Numbering for HLI-PRC Addressing—Example 3, With two PEMs

		Center					Line																											
Module	PEM		CEM					DEM					Base					CEM					PEM											
Rear Wall	Panel 6		Panel 8					Panel 10					Panel 12					Panel 14					Panel 16											
Column			3	4	5	0	1	2	3	4	5	0	1	2	3	4	5	0	1	2	3	4	5	0	1	2	3	4	5	0	1	2		
< TallBot Area of Travel ⇄																																		
Column			3	4	5	0	1	2	3	4	5	0	1	2	3	4	5	0	1	2	3	4	5	0	1	2								
Front Wall	Panel 7		Panel 9					Panel 11					Panel 13					Panel 15					Panel 17											

Drive Numbering

All of the tape drives in the SL3000 library are physically located in the Base and drive expansion modules.

TABLE A-2 A: shows the *internal—software—mapping (inside the library)*,
TABLE A-2 B: shows the *external—physical—numbering (outside the library)*

TABLE A-2 Base and Drive Module Tape Drive Numbering Scheme—Software and Hardware

A: Internal - Software Drives Numbers (Front View)				B: External - Physical Drive Numbers (Rear View)					
Panel 10 (-) Negative Column Numbers		Panel 12 (+) Positive Column Numbers		Panel 12 (+) Positive Column Numbers		Panel 10 (-) Negative Column Numbers			
Center		Line		Center		Line			
Drive Expansion Module		Base Module		Base Module		Drive Expansion Module			
0	1	2	3	0	1	2	3		
4	5	6	7	4	5	6	7		
8	9	10	11	8	9	10	11		
12	13	14	15	12	13	14	15		
16	17	18	19	16	17	18	19		
20	21	22	23	20	21	22	23		
24	25	26	27	Cartridge Arrays					
28	29	30	31	Electronics Control Module		49	50	51	52
						53	54	55	56

These tables show a matching of drives (the highlighted drives). *For example:*

- Drive expansion module: Internal/software Drive 0 matches with external/physical Drive 28
- Base module: Internal/software Drive 8 matches with external/physical Drive 12
- Base module: Internal/software Drive 23 matches with external physical Drive 21
- Drive expansion module: Internal/software Drive 31 matches with external/physical Drive 53

Out-of-the Box Slot Numbering

There are several factors to be aware of about the operations of the library when configuring and planning for content, these are:

- Default, out-of-the-box behavior
- Partitioning
- Addition of capacity using previously installed slots (Capacity on Demand)

Note – Slot numbering and library addressing are two different functions.

- Slot numbering is an *internal*, library controller, function.
- Library addressing is an *external* design for physical slot location.

FIGURE A-8 shows how the library numbers the slots and uses the following steps to describe it.

Internal slot numbering:

1. *Starts* in the upper left slot on the rear wall of the first module to the left. The numbering counts from **top to bottom** and from **left to right**.
2. When the numbering reaches the last slot on the rear wall it *crosses* sides.
3. Then *continues* at the upper left slot on the front wall of the first module. Counts from top to bottom and from left to right.
4. *Ends* at the lower slot on the front wall of the last module.

FIGURE A-8 Slot Numbering—Out-of-the-Box

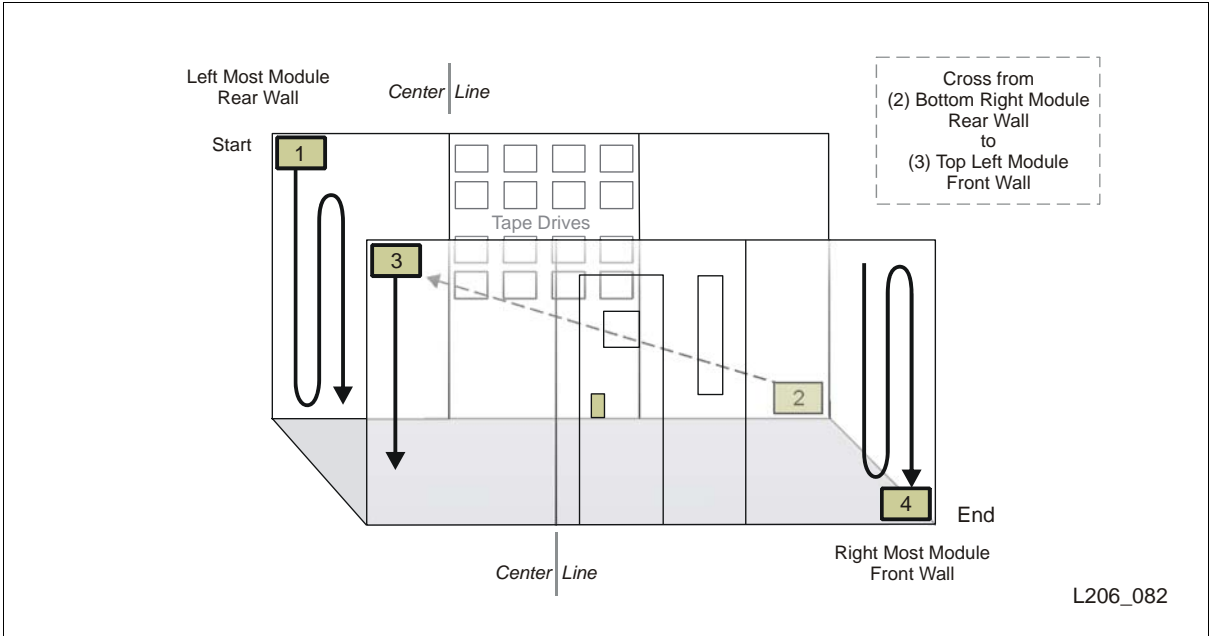

Slot numbering determines which slots are activated when the licensed capacity is applied. For example, if the licensed capacity for the library is 200 slots, the slot numbering for the first 200 is determined by the numbering made available, or active, to the host clients.

Also, if using a SCSI interface, the slot numbering determines the element numbering assigned to each element type and report this to the SCSI clients.

FIGURE A-9 serves as a *default* diagram for the discussions about Partitioning and Capacity on Demand.

This figure has three modules with a capacity of 76 slots and 24 tape drives or three 8-drive bays.

FIGURE A-9 Out-of-the-Box Numbering

Center			Line						
CEM			Base				CEM		
1	11	21	Drv_1	Drv_2	Drv_3	Drv_4	47	57	67
2	12	22	Drv_5	Drv_6	Drv_7	Drv_8	48	58	68
3	13	23	Drv_9	Drv_10	Drv_11	Drv_12	49	59	69
4	14	24	Drv_13	Drv_14	Drv_15	Drv_16	50	60	70
5	15	25	Drv_17	Drv_18	Drv_19	Drv_20	51	61	71
6	16	26	Drv_21	Drv_22	Drv_23	Drv_24	52	62	72
7	17	27	31	35	39	43	53	63	73
8	18	28	32	36	40	44	54	64	74
9	19	29	33	37	41	45	55	65	75
10	20	30	34	38	42	46	56	66	76

Tape drive numbering:

1. Starts in the upper left slot of the first drive bay in the Base module.
The numbering counts from **left to right** then from **top to bottom**, opposite that of the slot numbering.
2. When the numbering reaches the last drive in the Base module, it crosses to the drive expansion module if installed.
3. Then continues at the upper left slot in the first drive bay in the DEM.
Counts from **left to right** then from **top to bottom**.
4. Ends at the lower right slot for the last drive in the DEM.

Default SCSI Element Ordering

Using the concepts described in [“Out-of-the Box Slot Numbering” on page 115](#), this section adds the principles for determining the SCSI Element number sequences in the SL3000 library.



The examples in [FIGURE A-10 on page 118](#) are referenced by looking at the front of the library then viewed *through* the front wall.

These examples are not intended to be an exact representation of the SL3000 library resources.

SCSI Element numbering consists of:

- Storage Elements (slots)—Numbered **top to bottom, left to right**, and back to front.
- Import/Export Elements (CAPs)—Numbered **top to bottom, left to right**.

Note – Storage and Import/Export elements are numbered sequentially by slot. No slots are skipped or are left out.

- Data Transfer Elements (drives)—Numbered **left to right, top to bottom**, starting at the centerline in the Base module and continuing in the DEM if installed.

This numbering scheme allows the user to add a bank of drives and not disturb the ordering of the banks above.

Note – A vacant drive slot when the library powers on will not be included in the element number sequence. This is important to know because Open Systems backup applications do not tolerate Data Transfer Elements that cannot or do not respond when you power-on the library.

Elements in the example in [FIGURE A-10 on page 118](#) include:

- 4 modules—One Base, one DEM, and two CEMs
- 166 data cartridge slots—2000 to 2165
- 38 tape drives—1000 to 1037 (2 tape drives are missing, 1 in each module)
- 2 CAPs, each with 7 slots—slot addresses 10 to 23

FIGURE A-10 SCSI Element Numbering

(Left) Looking From the FRONT of the Library (Right)
 Looking "at" the back wall (through the front wall)

CEM		Center Negative Column Numbers				Line Positive Column Numbers				CEM	
		DEM				Base					
2000	2010	1023	1024	1025	1026	1000	1001	1002	1003	2060	2070
2001	2011	1027	1028		1029	1004	1005	1006	1007	2061	2071
2002	2012	1030	1031	1032	1033	1008	1009	1010	1011	2062	2072
2003	2013	1034	1035	1036	1037	1012	1013	1014	1015	2063	2073
2004	2014	2020	2026	2032	2038	1016		1017	1018	2064	2074
2005	2015	2021	2027	2033	2039	1019	1020	1021	1022	2065	2075
2006	2016	2022	2028	2034	2040	2044	2048	2052	2056	2066	2076
2007	2017	2023	2029	2035	2041	2045	2049	2053	2057	2067	2077
2008	2018	2024	2030	2036	2042	2046	2050	2054	2058	2068	2078
2009	2019	2025	2031	2037	2043	2047	2051	2055	2059	2069	2079

Looking "through" the front wall

CEM		Center Negative Column Numbers				Line Positive Column Numbers				CEM	
		DEM				Base					
2080	2090	2100	2107	CAP 10		2123	2130	CAP 17		2146	2156
2081	2091	2101	2108	11		2124	2131	18		2147	2157
2082	2092	2102	2109	12		2125	2132	19		2148	2158
2083	2093	2103	2110	13		2126	2133	20		2149	2159
2084	2094	2104	2111	14		2127	2134	21		2150	2160
2085	2095	Door Latch	2112	15		Door Latch	2135	22		2151	2161
2086	2096		2113	16			2136	23		2152	2162
2087	2097		2114	2117	2120		2137	2140	2143	2153	2163
2088	2098	2105	2115	2118	2121	2128	2138	2141	2144	2154	2164
2089	2099	2106	2116	2119	2122	2129	2139	2142	2145	2155	2165

Slot Maps Illustrated

[FIGURE A-11 on page 120](#) through [FIGURE A-23 on page 132](#) provide illustrations of the various walls that are available for the SL3000 library.

FIGURE A-11 SL3000 Slot Map—Base Module (1 of 3)

Base Module Configuration Options—Back Wall¹

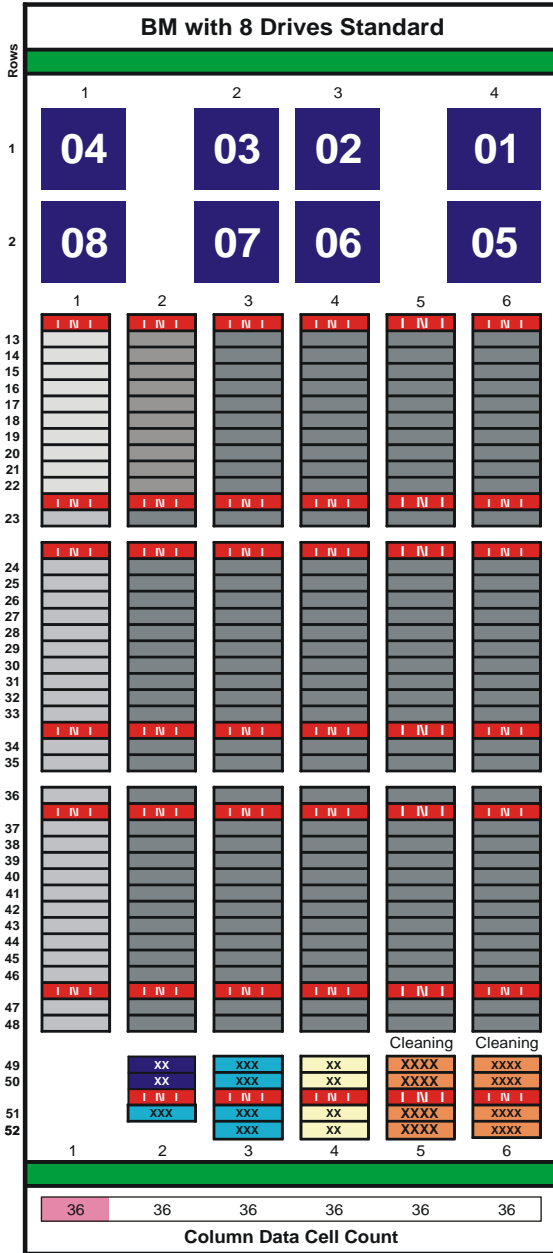

Cartridge row numbering begins with 13.

Configuration 1: 8 Tape Drives (One Drive Array)

Drive Columns 1—4, Rows 1 & 2

Data Cartridge Slots = 180².

Cartridge Columns 1—6³.

Configuration 2: 16 Tape Drives (Two Drive Arrays)

Drive Columns 1—4, Rows 1—4

Data Cartridge Slots = 125².

Cartridge Columns 1—6³.

See [FIGURE A-12 on page 121](#)

Configuration 3: 24 Tape Drives (Three Drive Arrays)

Drive Columns 1—4, Rows 1—6

Data Cartridge Slots = 65².

Cartridge Columns 1—6³.

See [FIGURE A-12 on page 121](#)

Standard Storage Arrays

Reserved (System) Slots (from left to right)

- 2 drop off slots (Column 2, Rows 49 & 50)
- 1 swap slot (Column 2, Row 51)
- Diagnostic slots (Column 3, Rows 49—52)
- 4 slots for the Module Identification Block (Column 4, Rows 49—52)
- 8 slots for cleaning/diagnostic cartridges
 - (Column 5, Rows 49—52)
 - (Column 6, Rows 49—52)

Notes:

1. Perspective is from the front of the module.
2. These slot counts are for a standalone base module. Cartridge arrays in Column 1 are not accessible unless an adjoining module is installed. When another module is added to the left, the slot count will increase by 13, 25 or 36, depending on the number of drive arrays.
3. For locating cartridges, column numbering begins with + 1, counting from the left edge of this module's wall. The positive numbering scheme increments from this module's edge throughout all modules attached to the right. For example, if a module is attached to the right, its column numbering will start with +7.

FIGURE A-12 SL3000 Slot Map—Base Module (2 of 3)

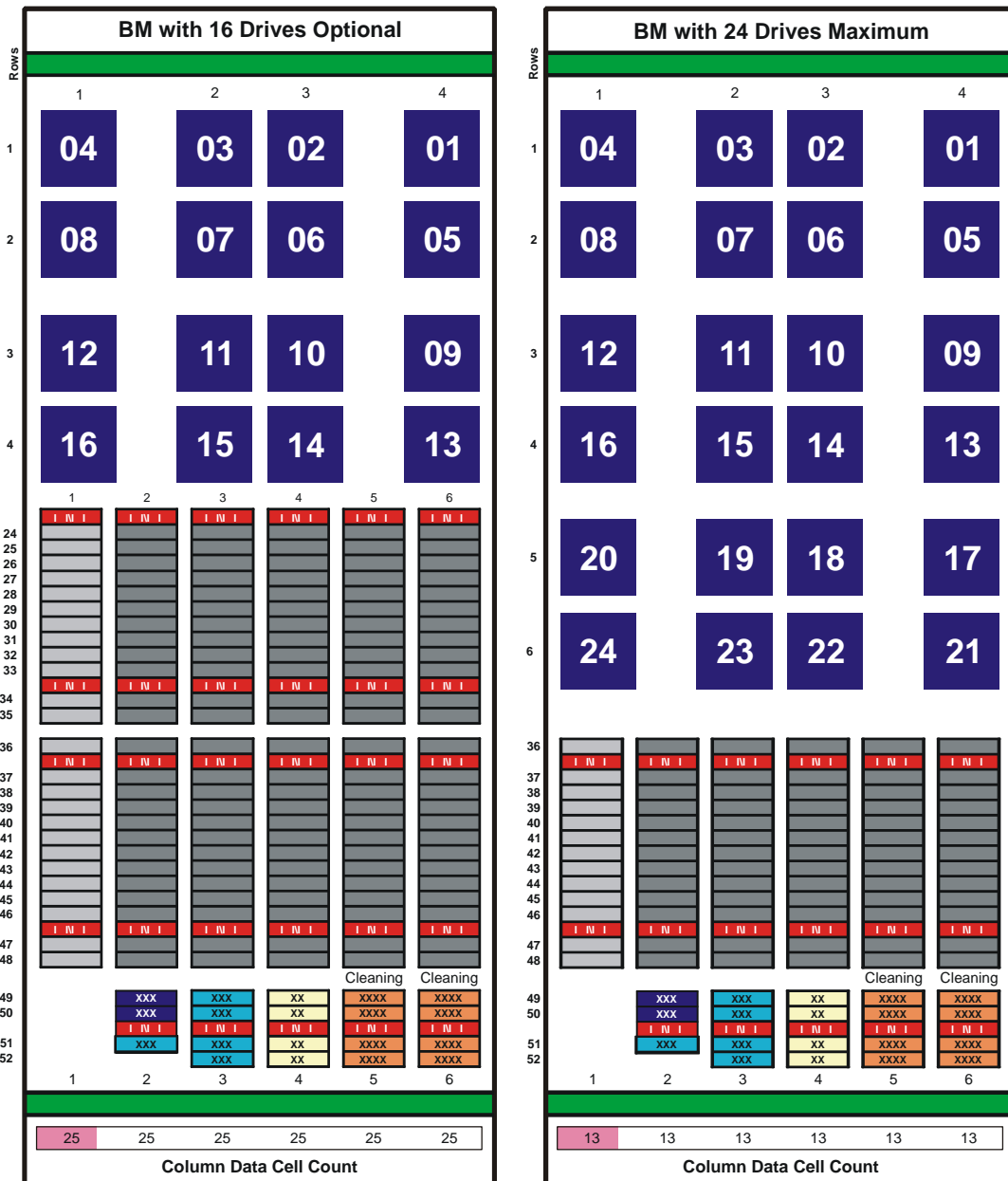

Notes: Perspective is from the front of the library.
 Cartridge arrays in left column not accessible without an adjoining module.
 Data cartridge count:
 – 125 (No expansion)
 – 150 (With expansion left)
 See [FIGURE A-11 on page 120](#) for reserved slots

Notes: Perspective is from the front of the library.
 Cartridge array in left column not accessible without an adjoining module.
 Data cartridge count:
 – 65 (No expansion)
 – 78 (With expansion left)
 See [FIGURE A-11 on page 120](#) for reserved slots

FIGURE A-13 SL3000 Slot Map—Base Module (3 of 3)

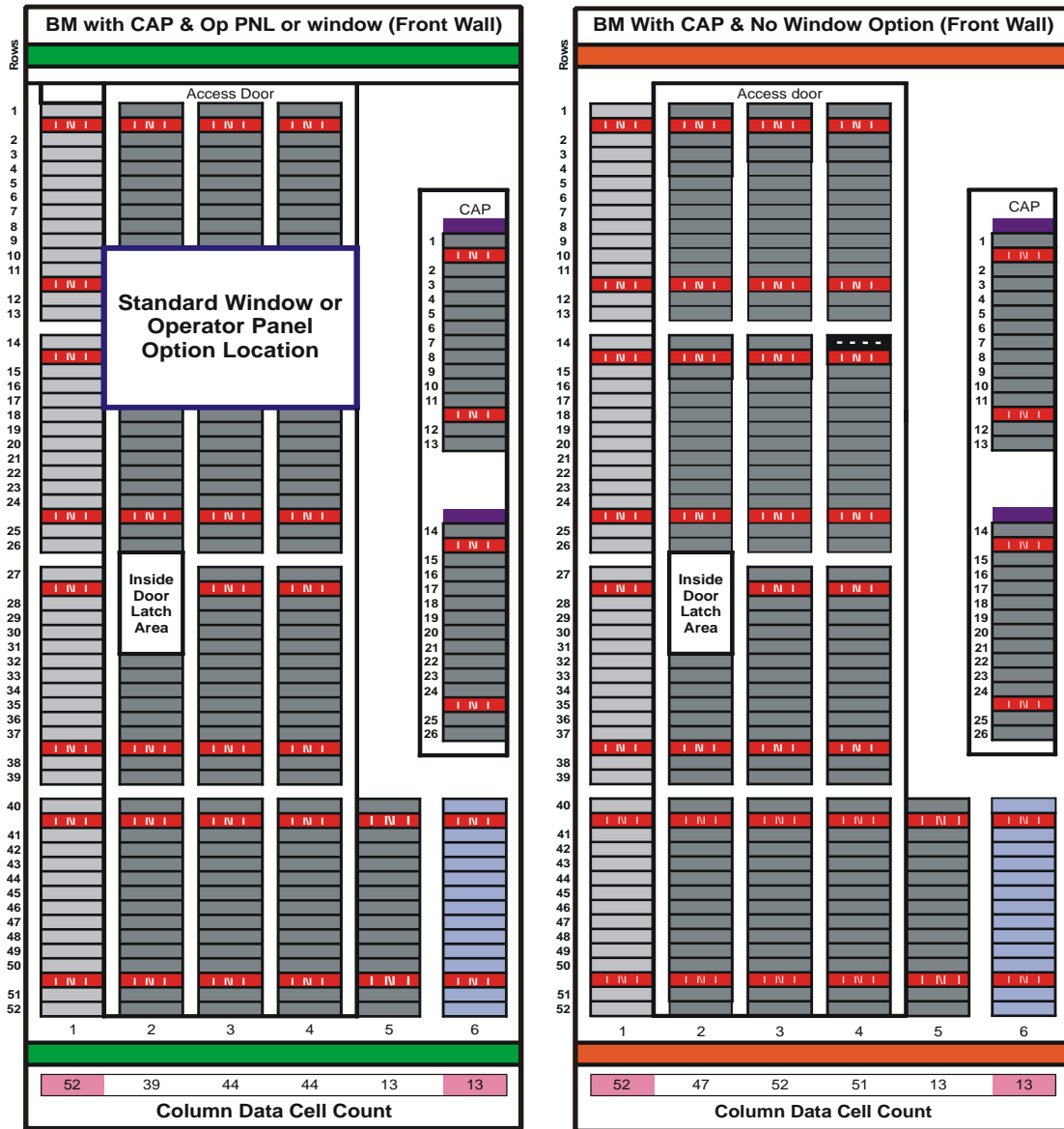

Notes: Perspective is from the front of the library.
 Left column not accessible without an adjoining module.
 Column 1 and array in Column 6 not accessible without an adjoining module.

- Data cartridge count:
- 140 (No expansion)
 - 192 (With expansion left)
 - 153 (With expansion right)
 - 205 (With expansion left & right)

Notes: Perspective is from the front of the library.
 Left column not accessible without an adjoining module.
 Column 1 and array in Column 6 not accessible without an adjoining module.

- Data cartridge count:
- 163 (No expansion)
 - 215 (With expansion left)
 - 176 (With expansion right)
 - 228 (With expansion left & right)

FIGURE A-14 SL3000 Slot Map—Drive Expansion Module (1 of 5)

Configuration Options—Back Wall¹

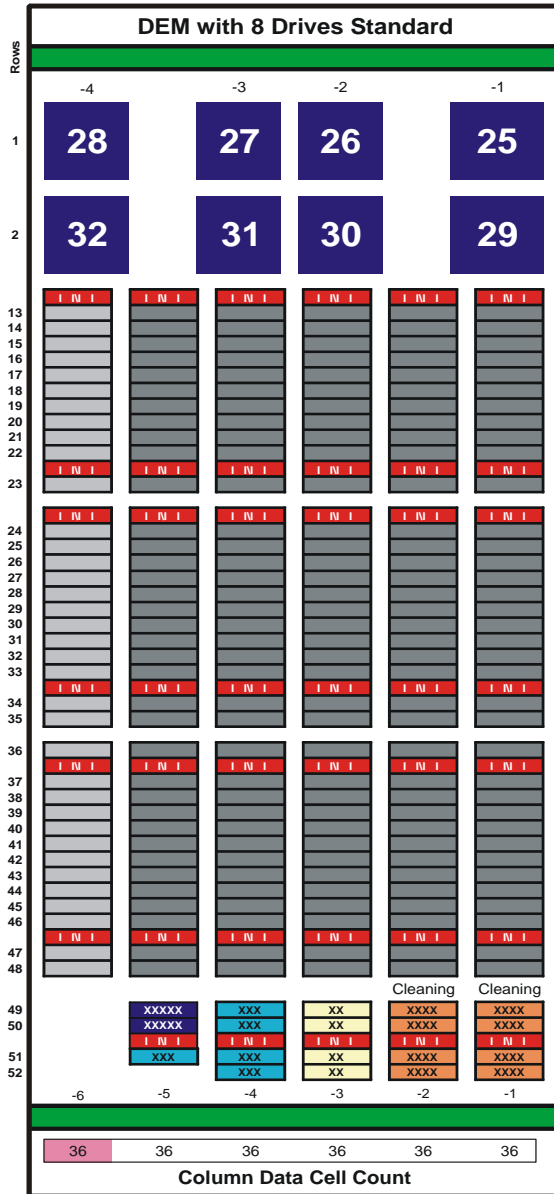

Cartridge row numbering begins with 13

Configuration 1: 8 Tape Drives² (One Drive Array)

Drive Columns -1— -4, Rows 1 & 2
 Data Cartridge Slots = 180³
 Cartridge Columns -1— -6⁴

Configuration 2: 16 Tape Drives (Two Drive Arrays)

Drive Columns -1— -4, Rows 1—4
 Data Cartridge Slots = 125³
 Cartridge Columns -1— -6⁴

See [FIGURE A-15 on page 124](#)

Configuration 3: 24 Tape Drives (Three Drive Arrays)

Drive Columns -1— -4, Rows 1—6
 Data Cartridge Slots = 65³
 Cartridge Columns -1— -6⁴

See [FIGURE A-15 on page 124](#)

Configuration 4: 32 Tape Drives (Four Drive Arrays)

Drive Columns -1— -4, Rows 1—6

See [FIGURE A-16 on page 125](#)

System Slots (from left to right, *not reserved*)

- 3 slots for either diagnostic or cleaning cartridge (Column -5, Rows 49, 50 & 52)
- 4 slots for either diagnostic or cleaning cartridges (Column -5, Rows 49—51)
- 4 slots for the Module Identification Block (Column -3, Rows 49—52)
- 8 slots for either diagnostic or cleaning cartridges
 - (Column -2, Rows 49—52)
 - (Column -1, Rows 49—52)

Notes:

1. Perspective is from the front of the module.
2. Drive slot numbering always begins with 25.
3. These hardware slot counts are for a Drive Expansion Module without an adjoining module to the left. Cartridge arrays in Column -6 are not accessible unless an adjoining module is installed to the left. When another module is added to the left, the slot count will increase by 13, 25 or 36, depending on the number of drive arrays.
4. For locating cartridges, column numbering begins with - 1, counting from the right edge of this module's wall. The negative numbering scheme continues from this module's edge throughout all modules attached to the left. For example, if a module is attached to the left, its column numbering will start with -7.

FIGURE A-15 SL3000 Slot Map—Drive Expansion Module (2 of 5)

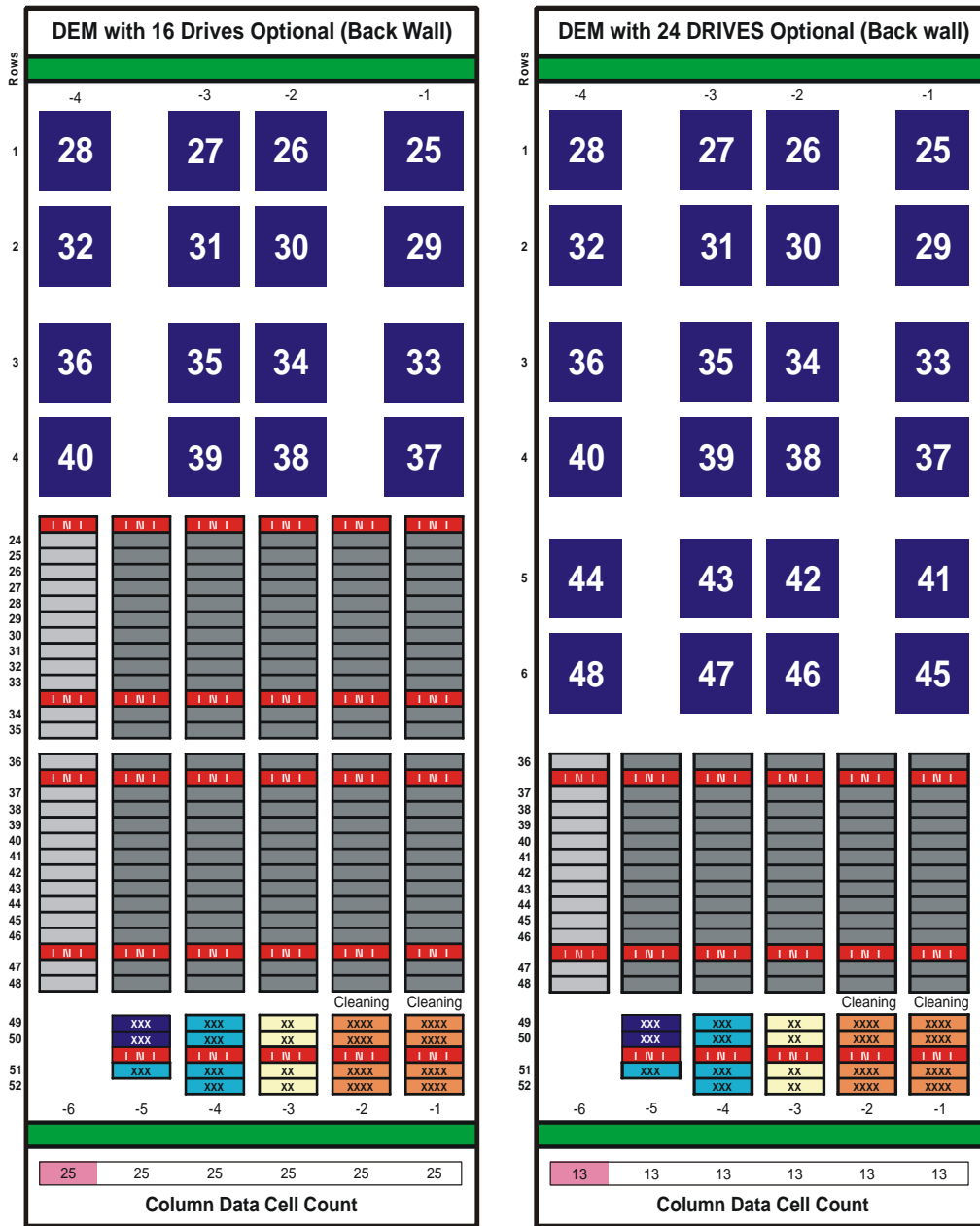

Notes: Perspective is from the front of the module.
Cartridge arrays in left column not accessible without an adjoining module.

Data cartridge count:
 – 125 (No expansion)
 – 150 (With expansion)
 No drop-off/swap slots; all system slots available for DG/CLN

Notes: Perspective is from the front of the module.
Cartridge array in left column not accessible without an adjoining module.

Data cartridge count:
 – 65 (No expansion)
 – 78 (With expansion)
 No drop-off/swap slots; all system slots available for DG/CLN

FIGURE A-16 SL3000 Slot Map—Drive Expansion Module (3 of 5)

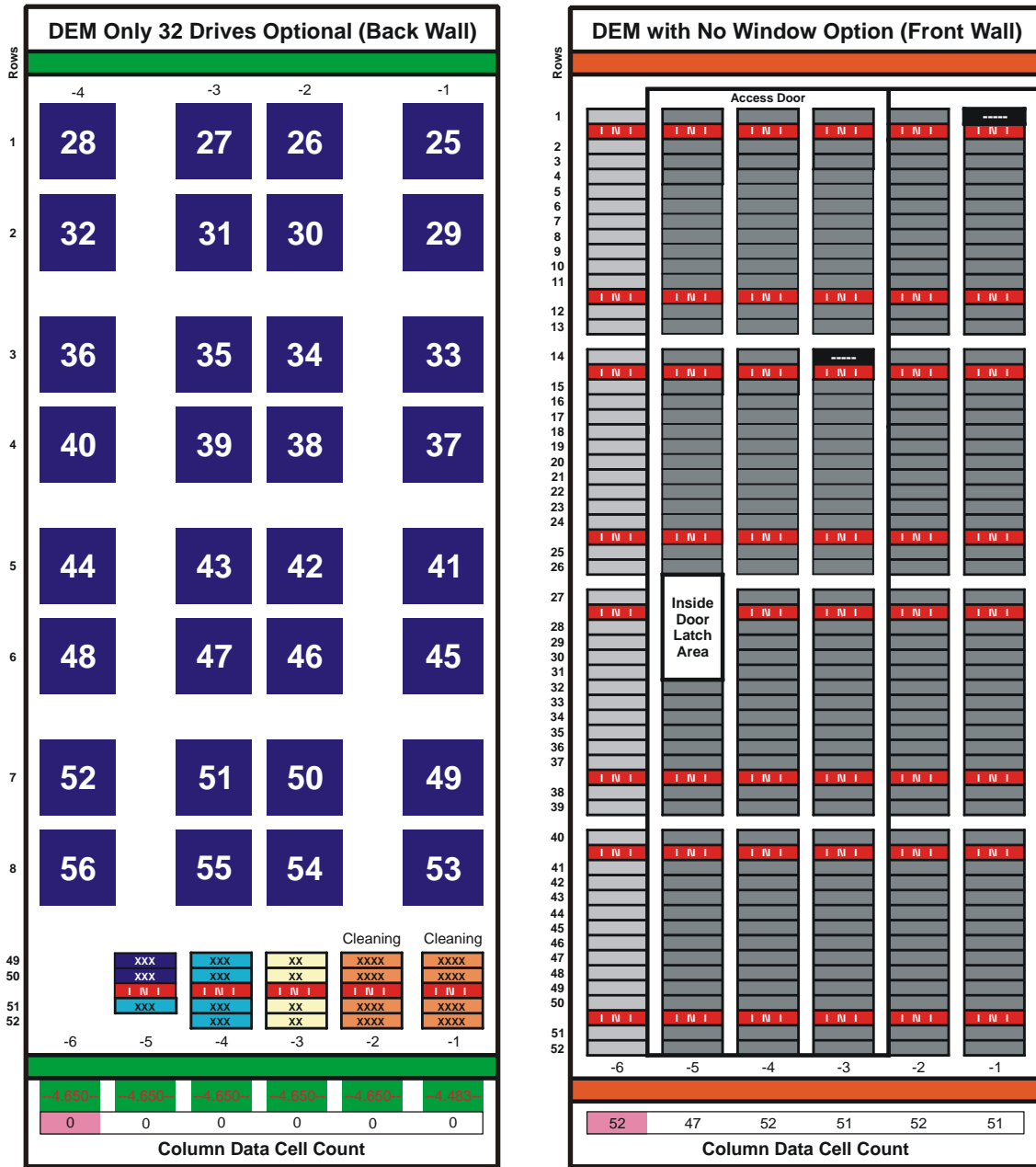

L206_010

Notes: Perspective is from the front of the module.
 No data cartridge slots.
 No drop-off/swap slots; all system slots available for DG/CLN

Notes: Perspective is from the front of the module.
 Left column is not accessible without an adjoining module.

Data cartridge count:
 – 253 (No expansion)
 – 305 (With expansion)

FIGURE A-17 SL3000 Slot Map—Drive Expansion Module (4 of 5)

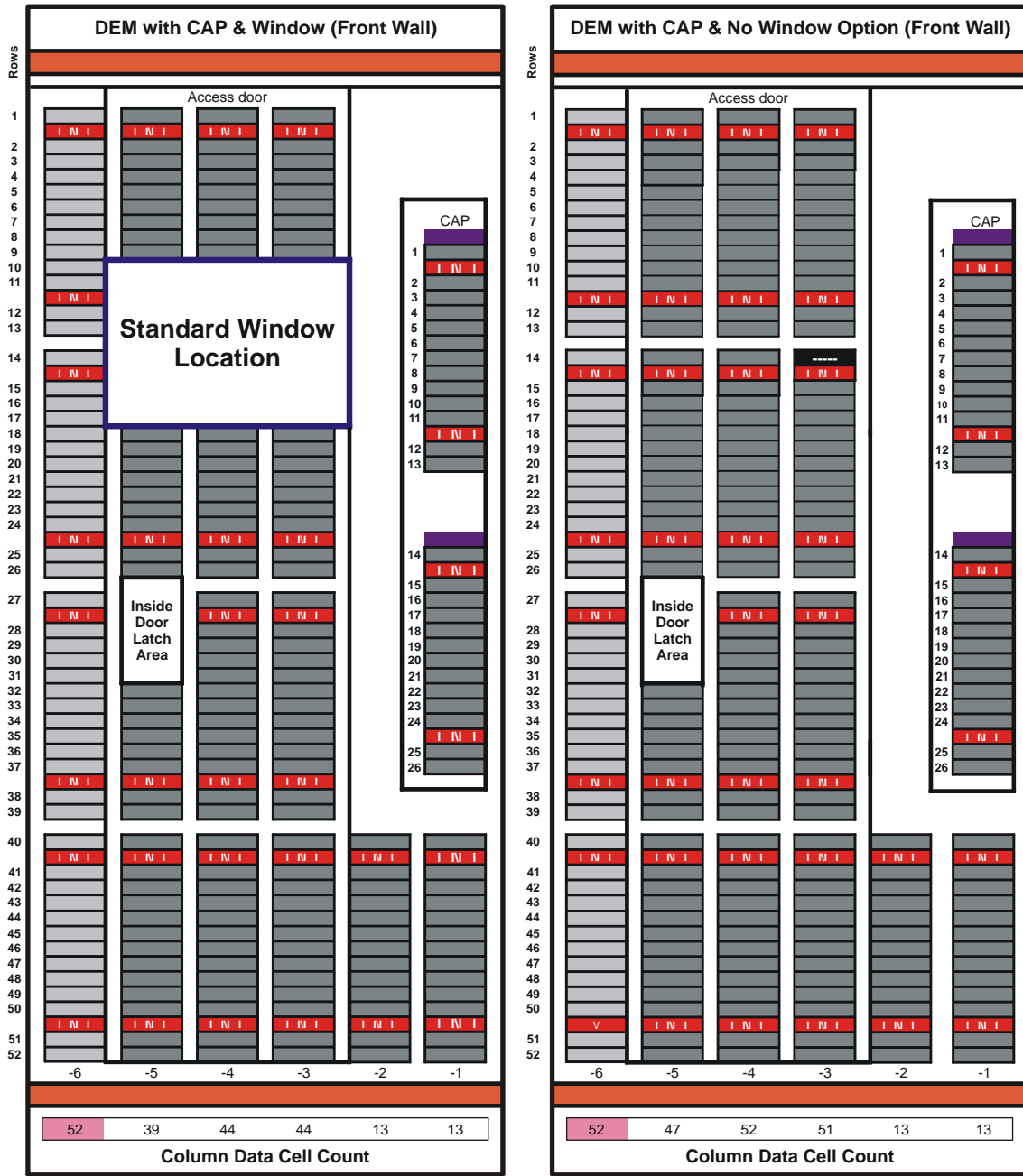

Notes: Perspective is from the front of the module.
 Left column is not accessible without an adjoining module.
 Data cartridge count
 – 153 (No expansion)
 – 205 (With expansion)

Notes: Perspective is from the front of the module.
 Left column is not accessible without an adjoining module.
 Data cartridge count:
 – 176 (No expansion)
 – 228 (With expansion)

FIGURE A-18 SL3000 Slot Map—Drive Expansion Module (5 of 5)

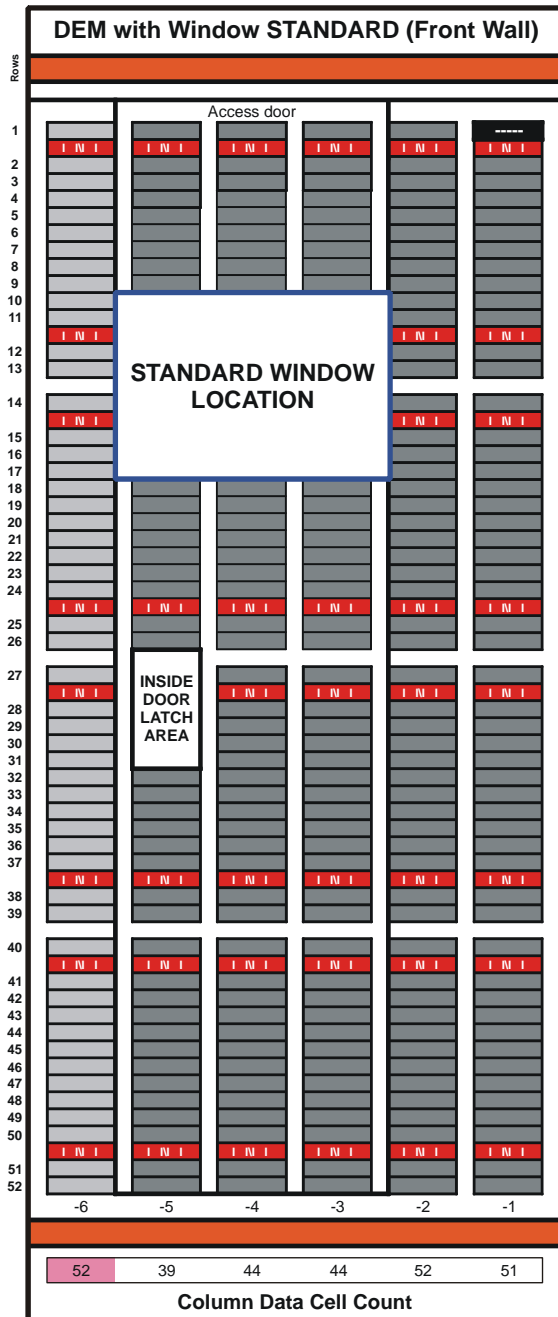

Notes: Perspective is from the front of the module.
 Left column is not accessible without an adjoining module.

Black slot location is inaccessible.

- Data cartridge count
- 230 (No expansion)
 - 282 (With expansion)

L206_099

FIGURE A-19 SL3000 Slot Map—Cartridge Expansion Module, Back Wall

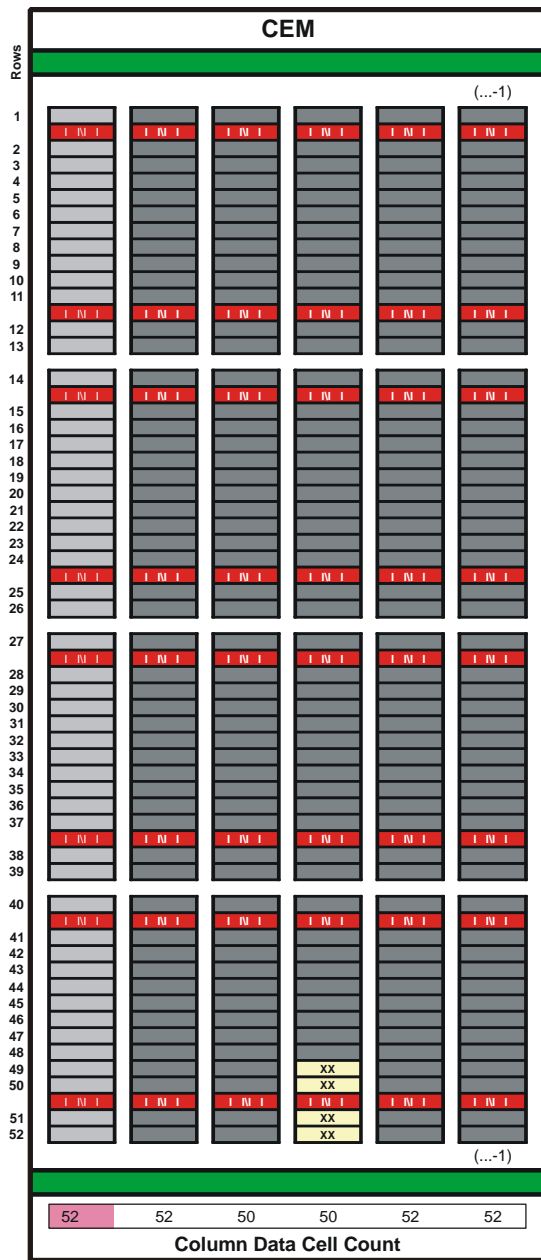

Notes:

- Perspective is from the front of the module.
- This depicts a CEM installed to the left of a module (note the negative numbering for the columns).
- Left column is not accessible without an adjoining module on the *left*. Therefore, if this is the last module on the left, the left column is not accessible (due to robotic hand design).
- If this were installed to the right of a module, the column numbering would continue with positive numbering.
- Both left and right column are accessible when it is installed on the *right* (due to the design of the robotic hand).
- Data cartridge count
 - 256 (No expansion or the last module on the *left*)
 - 308 (With expansion or if the last module installed on the *right*)

FIGURE A-20 SL3000 Slot Map—Cartridge Expansion Module, Installed on the Right

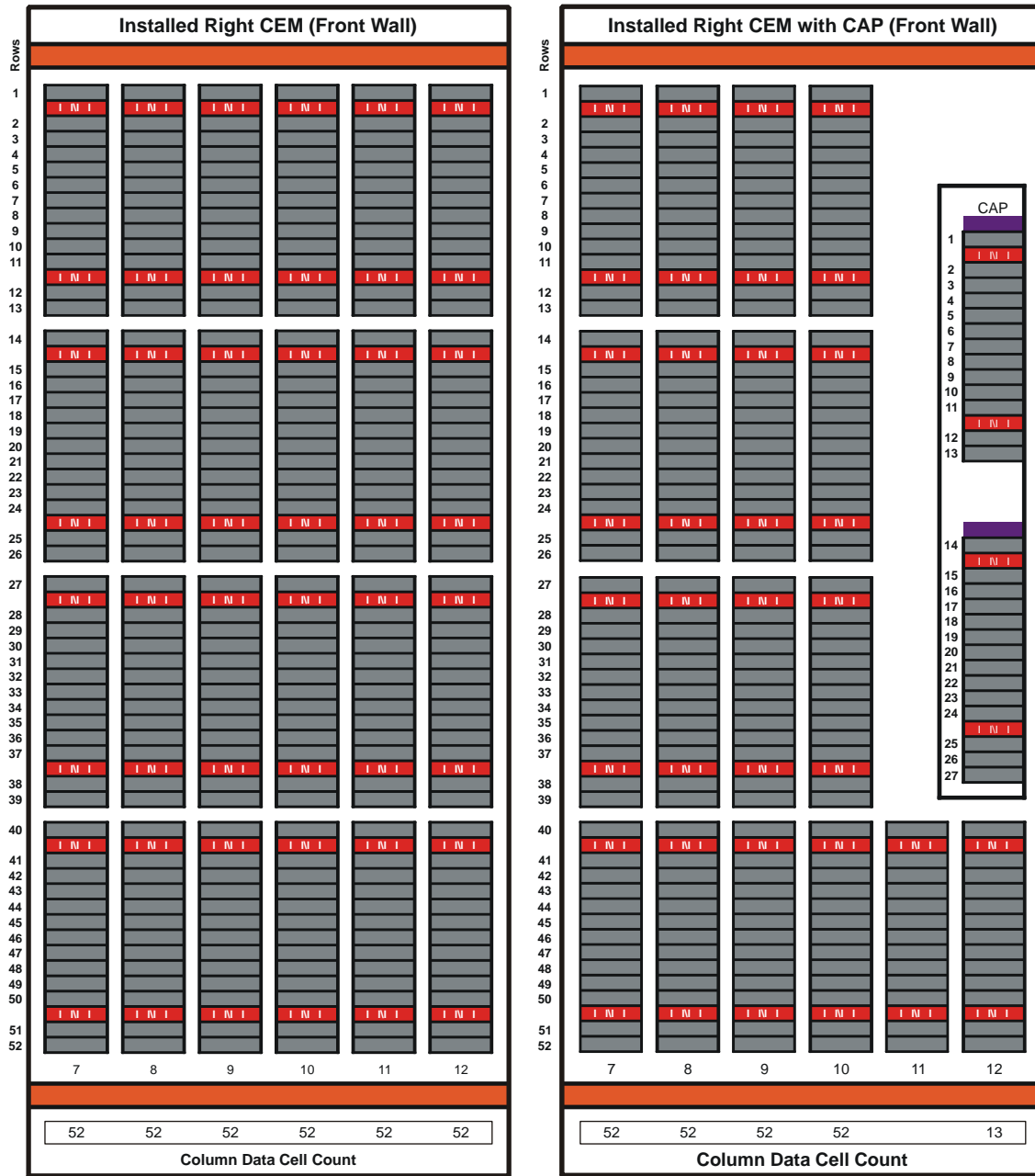

Notes: Perspective is from the front of the module.
Data cartridge count = 312

Notes: Perspective is from the front of the module.
Data cartridge count = 234

FIGURE A-21 SL3000 Slot Map—Cartridge Expansion Module, Installed on the Left



Notes: Perspective is from the front of the module.
 Left column is not accessible without an adjoining module.
 Data cartridge count:
 – 260 (No expansion)
 – 312 (With expansion)

Notes: Perspective is from the front of the module.
 Left column is not accessible without an adjoining module.
 Data cartridge count:
 – 182 (No expansion)
 – 234 (With expansion)

FIGURE A-22 SL3000 Slot Map—Parking Expansion Module, Installed on the Right

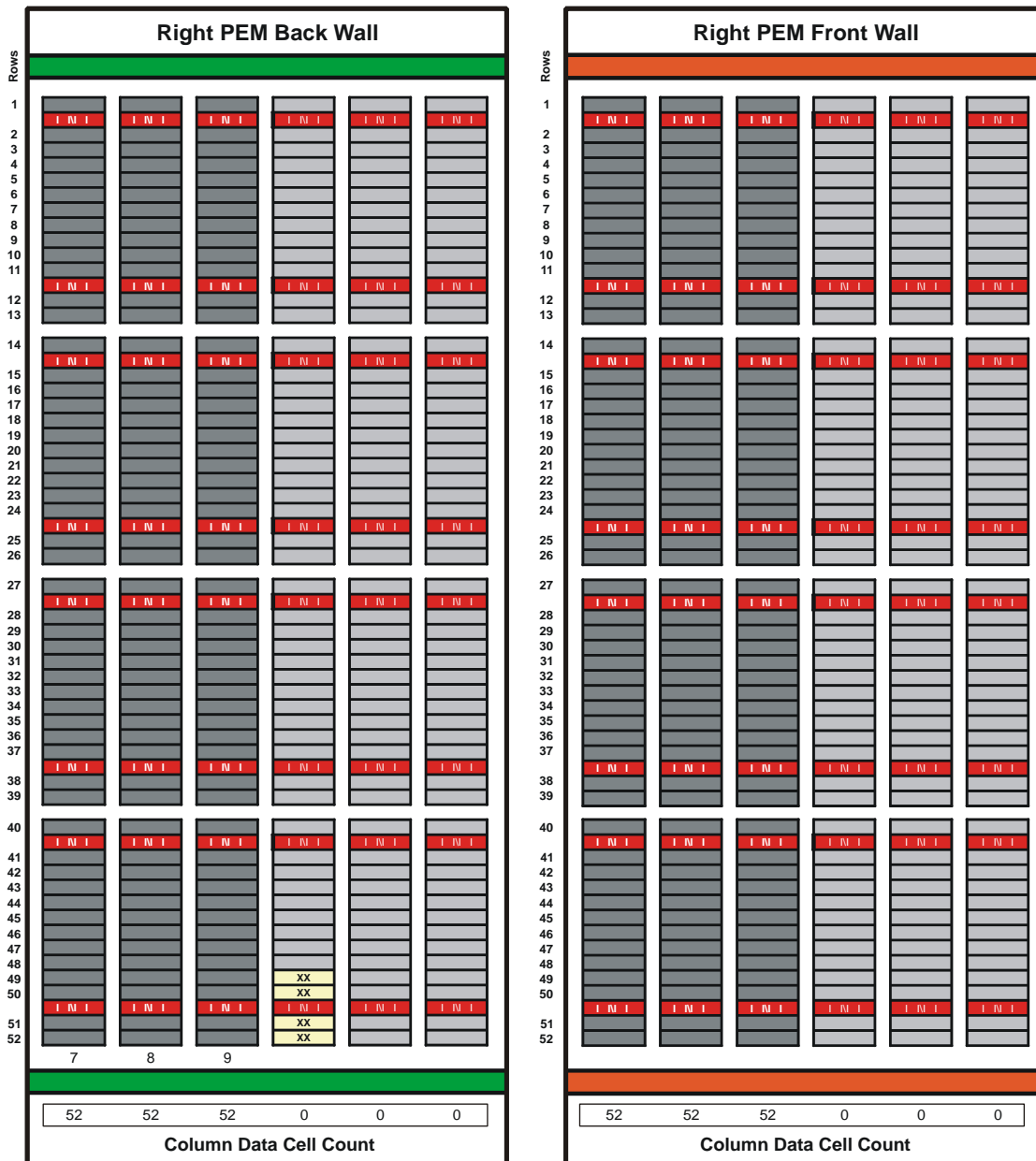

Notes: Perspective is from the front of the module.
 Right 3 columns not accessible (for TallBot parking).
 Data cartridge count = 156
 Four cartridge slots reserved for module identifier block labels.

Notes: Perspective is from the front of the module.
 Right 3 columns not accessible (for TallBot parking).
 Data cartridge count = 156

FIGURE A-23 SL3000 Slot Map—Parking Expansion Module, Installed on the Left



L206_017

Notes: Perspective is from the front of the module.
 Left 3 columns not accessible (for TallBot parking).
 Data cartridge count = 152
 Four cartridge slots reserved for module identifier block labels.

Notes: Perspective is from the front of the module.
 Left 3 columns not accessible (for TallBot parking).
 Data cartridge count = 156

Reserved and System Slots

There are three reserved slots within the base module only.

These slots must be left empty.

Two slots are reserved for drop-off locations and one slot is reserved as a swap slot. All remaining system slots (in both the base and drive expansion modules) can be used for diagnostic or cleaning cartridges.

TABLE A-3 lists the 12 system slots for diagnostic or cleaning cartridges in the base drive module.

Note: there are a total of 17 system slots for diagnostic or cleaning cartridges in the drive expansion module.

There are no reserved slots in drive expansion, cartridge or parking expansion modules.

TABLE A-3 Reserved/System Slots

Slot Locations	Module Type	Use	Location
1, 1, 2, 1, 49—50	Base module	Drop off slots (Reserved)*	Back wall of the Base module
1, 1, -4, 1, 49—50	Drive expansion module	Cleaning/Diagnostic Cartridges	Back wall of the DEM
1, 1, 2, 1, 51	Base module	Swap slot (Reserved)*	Back wall of the Base module
1, 1, -5, 1, 51	Drive expansion module	Cleaning/Diagnostic Cartridges	Back wall of the DEM
1, 1, 5, 1, 49—52 1, 1, 6, 1, 49—52	Base module	Cleaning/Diagnostic Cartridges	Back wall of the Base module
1, 1, -1, 1, 49—52 1, 1, -2, 1, 49—52	Drive expansion module	Cleaning/Diagnostic Cartridges	Back wall of the DEM
Note: Do <i>not</i> place data cartridges in a reserved slot. These slots are masked from the customer's database (that is, an online TallBot will never go to these slots).			

FIGURE A-24 on page 134 shows an example of the reserved/system slots in the *base module*:

1. Drop off slots (2) in column 2, rows 49 and 50—Reserved.
2. Swap slot (1) in column 2, row 51—Reserved.
3. Cleaning/Diagnostic slots (4) in column 3, rows 49, 50, 51, and 52—System.
4. Configuration block in column 4, rows 49, 50, 51, and 52.
5. Cleaning/Diagnostic slots (4) in column 5, rows 49, 50, 51, and 52—System.
6. Cleaning/Diagnostic slots (4) in column 6, rows 49, 50, 51, and 52—System.

FIGURE A-24 Reserved/System Slot Locations—*Base Module Only*

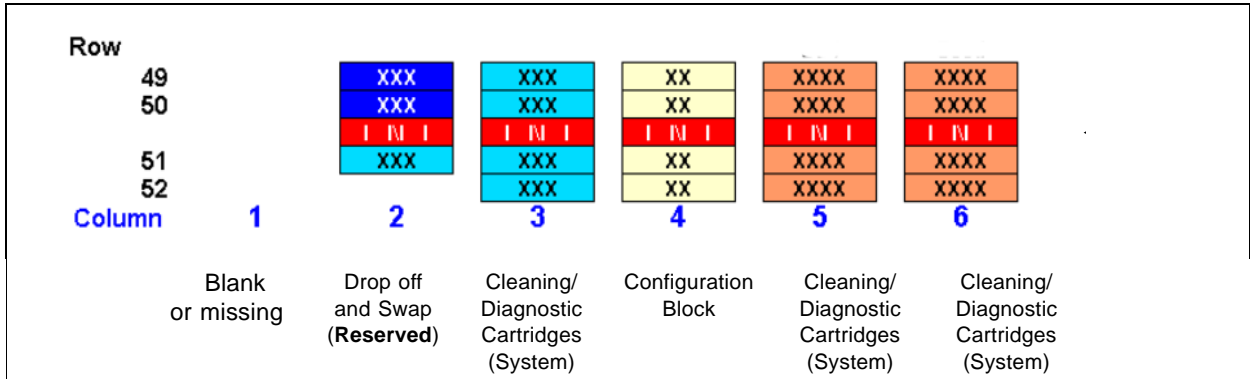

Optimization

This appendix provides information about how to optimize the SL3000 library using content management and the elements of partitioning.

Planning for Content

When planning the content of an SL3000 library, there are no pass-thru mechanisms or elevators that you need to take into consideration. Therefore, the most important aspect is to evaluate *content* with respect to the *physical structure*.

SL3000 physical structure includes:

- CenterLine Technology
- Modular design to increase both cartridge capacity and tape drive performance
- Single rail with one (standard) or two (optional [redundant] feature) TallBots
- Up to six cartridge access ports (CAPs)
- From 1 to 56 tape drives

CenterLine Technology and Modular Design

The SL3000 uses *CenterLine Technology* to help balance the work load and improve performance of the library.

Using the left side of the Base module—which is the only “required” module—as the centerline, customers can add other *modules* either to the left and/or to the right.

[FIGURE B-1 on page 136](#) shows the *centerline* and provides some comparisons using minimum to maximum configurations, with the:

- Base module (BM) only
- Base and drive expansion modules (DEM)
- Additions of cartridge expansion modules (CEMs)

Note – Only the base and drive expansion modules contain tape drives. Cartridge expansion modules contain only data cartridges.

Keep in mind that a balance of modules will balance performance.

FIGURE B-1 A Matter of Balance

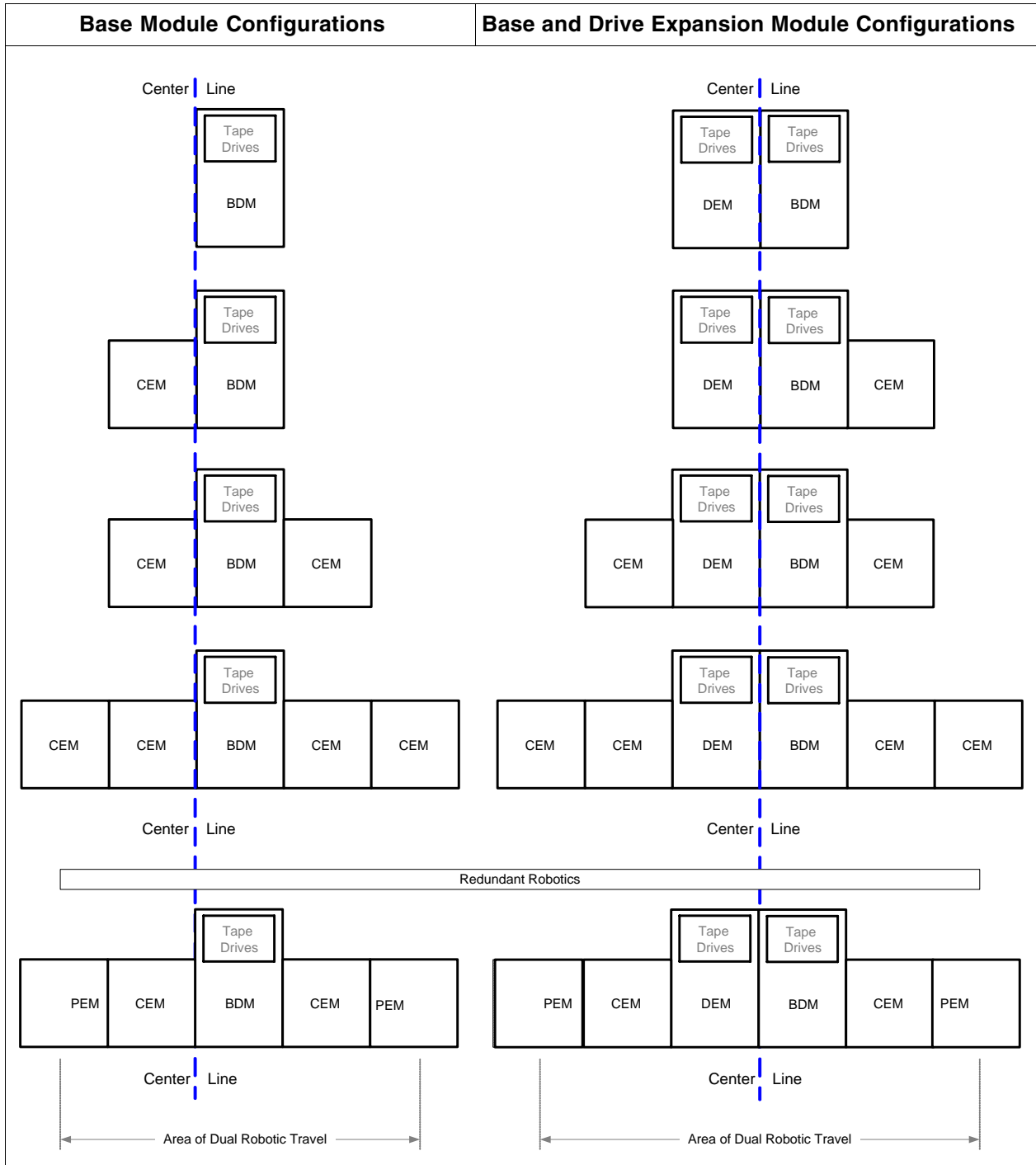

Robotic Rails and TallBots

The *robotic units* in an SL3000 library are called *TallBots*. Each library can have either one (standard) or two (redundant) TallBots that are driven along two extrusions—called rails—on the rear wall of the library.

Rails are continuous and allow the TallBots to travel the length of the library from end-to-end. However, in a dual (2) TallBot configuration, there is a robotic safety zone that prevents collisions, and a requirement for Parking Expansion Modules.

Parking Expansion Modules (PEMs) have an area of inaccessible cartridge slots. In the event of a TallBot failure, the defective TallBot either moves into or is pushed into this inaccessible area while the other—redundant—TallBot continues library operations.

When using redundant TallBots, parking expansion modules must be installed at both ends of the library string. This is shown as the last comparison in [FIGURE B-1 on page 136](#).

Using redundant TallBots for content management offers:

- Increased speed for library operations—two robotic units working in parallel
- Redundant operations should one unit fail

Cartridge Access Ports

The SL3000 can have from one to ten cartridge access ports spread across the entire library. This means the library can have a CAP for each module.

Note – The CAP is a standard feature for the Base and optional features for the DEM and CEMs.

Although, operation of the cartridge access port does not directly affect the performance of the library, here are some guidelines that can help with the overall operation:

- Whenever possible, enter cartridges through the cartridge access ports.
- When planning the workloads, place applications that require significant enters and ejects adjacent to the CAP magazines.



Tip:

Place labels outside on the library wall indicating which CAP and which magazine gets what type of cartridge. For example: Modules to the left of the centerline contain T10000 tape drive media. Use a module with a CAP on the left side to enter and eject those types of cartridges.

This practice will help operators identify what cartridges go to which module.

- When planning the workloads, place applications that require significant enters and ejects in modules that have a CAP.
- Use the *watch_vols* utility for ACSLS.
- Insert cartridges with the correct orientation:
 - Fully seated and laying flat within the slots
 - Parallel to the floor
 - Hub-side down
 - Barcode label pointing out and below the readable characters.

Managing Cartridges

Managing cartridges in the library can have an affect on performance. Some considerations include:

- Use a library management application such as ExLM with HSC to keep active volumes and compatible drives closer together and to migrate less active volumes farther away from the drives.
- Use a *float* option. When float is on, the management software can automatically select a new home slot for a cartridge on a dismount. **Note:** Make sure the library contains enough *free slots* to allow the selection of a new home slot during the dismount.
- Cluster cartridges. Group and/or partition the cartridges by workload with enough tape drives to support the maximum, peak activity.
- Enter cartridges through the CAP.
 - When manually placing cartridges in the library with the front door open, library operations cease and the library management software must perform a full audit to update the library database to match the actual contents.
 - When entering cartridges through the CAP, the library stays online so mounts can continue and the library automatically updates the database.
- Eject cartridges. There are two ways (host functions) to eject cartridges: Ordered and Unordered.
 - When the host specifies an Ordered eject, the library places the cartridges in a specific sequence. This operation is significantly slower than unordered ejects. Ordered ejects are used for vaulting, which simplifies the external operations.
 - When the host specifies an Unordered eject, the library ejects cartridges as it can, often in a random order.
- Manage the available space in the library:
 - Plan for times of peak activity.
 - Keep an adequate supply of scratch cartridges in the library.
 - Move inactive cartridges out of the library to ensure there is adequate space for active cartridges.

Planning for Tape Drives

During the installation, having an understanding about how to logically group and install the tape drives can improve performance. Strategies to use when determining where to install the tape drives include:

- Install tape drives that use the same media types closer to those slots.
For example: Place T9840 drives on the left side of the drive bay with their cartridges to the left; and LTO drives on the right side with their matching media to the right.
- Install enough tape drives to adequately handle peak workloads.
- Configure heavy tape applications so they do not exceed the performance limits of the library configuration.
- Use a tool such as **QuickLine** or a Tape Library Configurator to determine the optimal drive configurations.

Out-of-the Box Slot Numbering

There are several factors to be aware of when configuring and planning for content. These are:

- Default, out-of-the-box behavior
- Partitioning
- Addition of capacity using previously installed slots (Capacity on Demand)

Note – Slot numbering and library addressing are two different functions.

- Slot numbering is an *internal*, library controller, function.
- Library addressing is an *external* design for physical slot location.

FIGURE B-2 shows how the library numbers the slots and uses the following steps to describe it.

Internal slot numbering:

1. **Starts** in the upper left slot on the rear wall of the first module to the left. The numbering counts from top to bottom and from left to right.
2. When the numbering **reaches** the last slot on the rear wall it crosses sides.
3. Numbering **continues** at the upper left slot on the front wall of the first module, counting from top to bottom and from left to right.
4. **Ends** at the lower slot on the front wall of the last module.

FIGURE B-2 Slot Numbering—Out-of-the-Box

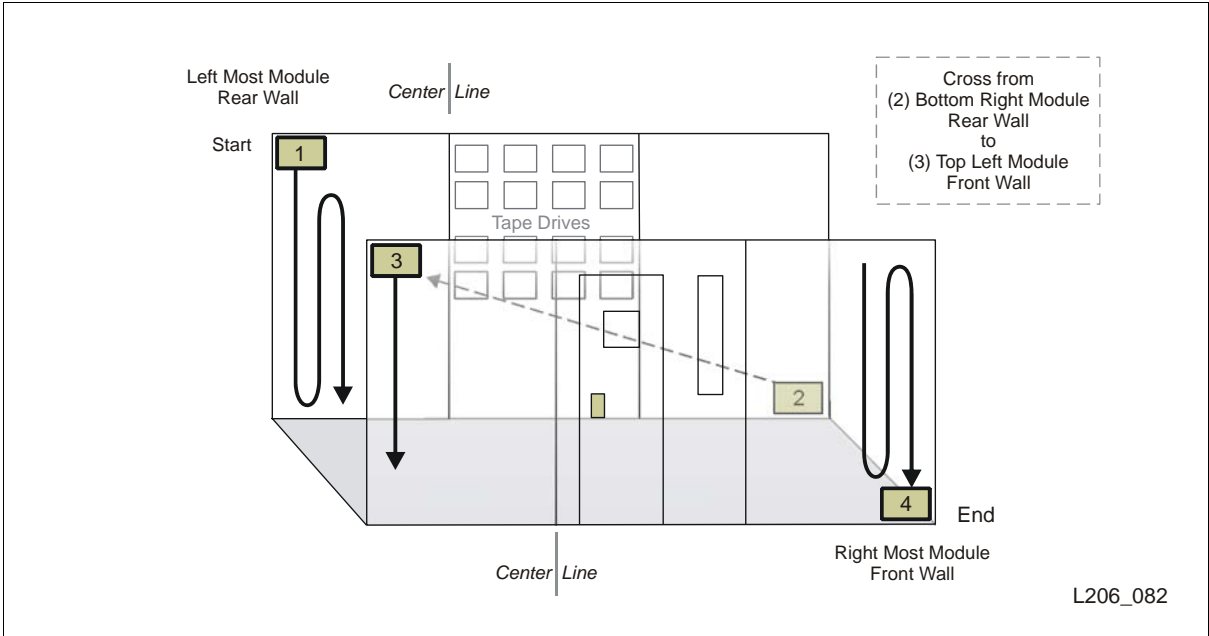

FIGURE B-3 serves as a *example* diagram for the discussions about Partitioning and Capacity on Demand. The actual library layout will depend upon your module configurations.

This figure has three modules with a capacity of 76 slots and 12 tape drives.

FIGURE B-3 Out-of-the-Box Numbering

Center			Line						
CEM			Base Module				CEM		
1	11	21	Drive	Drive	Drive	Drive	47	57	67
2	12	22	Drive	Drive	Drive	Drive	48	58	68
3	13	23	Drive	Drive	Drive	Drive	49	59	69
4	14	24	Drive	Drive	Drive	Drive	50	60	70
5	15	25	Drive	Drive	Drive	Drive	51	61	71
6	16	26	Drive	Drive	Drive	Drive	52	62	72
7	17	27	31	35	39	43	53	63	73
8	18	28	32	36	40	44	54	64	74
9	19	29	33	37	41	45	55	65	75
10	20	30	34	38	42	46	56	66	76

Notice the numbering starts in the upper left corner, counts the slots top to bottom, and left to right. This is the standard behavior of the library for all configurations.

Note – FIGURE B-3 is only an example. There are no default shared resources. All resources must be specifically allocated.

Partitioning

The definition of a partition is “to divide into parts or shares”.

Benefits:

Partitioning a library means the customer can have:

- More than one operating system and application managing the library.
- An improvement in the protection or isolation of files.
- An increase in system and library performance.
- An increase in user efficiency.

Customized fit:

Partitions may be customized to fit different requirements, such as:

- Giving multiple departments, organizations, and companies access to the resources of the library
- Isolating clients at service centers
- Separating different encryption key groups
- Dedicating partitions for special tasks

Defining partitions:

- Partitions are defined by assigning rectangular boundaries.
Currently the SL3000 supports up to *60 rectangular boundaries* per partition within the library.
- As slots are added to a partition they are deducted from the licensed capacity.



Note – If a partition contains slots that are being displaced because an optional CAP is being installed, the customer *must remove all these slots from any partition definitions prior to shutting down the library*. Failure to do this will result in a service call and engineering assistance to recover partition definitions.

Capacity on Demand

Capacity on Demand is a *non-disruptive* optional feature that allows the customer to add capacity to the library using previously installed, yet inactive slots.

Rectangular Boundaries

Rectangular boundaries provide the customer with a resource to better optimize cartridge placement within the library.

To do this, the customer selects boundaries within the library by using the same method as defining a partition.

This rectangular boundary can be just one or two slots, a row, a column, or an entire module.

Available slots use the same numbering scheme of the library within the boundaries—starting in the upper left, then counting to the lower right—for the *licensed capacity* of the library.

1. [FIGURE B-4 on page 143](#), Number 1, shows how the customer has defined:
 - Two selected partitions (A and B) using
 - Four Rectangular boundaries called AR1, BR1, BR2, and BR3
 - For a library licensed for 50 slots
AR1-1 through 20, BR1-1 through 8, BR2-9 through 28, and BR3-29 through 30.

Concentrating on A's boundary are examples of what the customer can do to:

2. Add 5 more slots.
Create two new boundaries under the tape drives ([FIGURE B-4](#), Number 2)
 - AR2 slots 21 through 24 and
 - AR3 slot 25

Note: Because there are no more slots under AR2-24, the customer needed to go to the right and create a boundary for the fifth additional slot (AR3-25), an example of a single slot rectangle boundary.
3. Add 12 more slots.
Create two new boundaries ([FIGURE B-4](#), Number 3)
 - AR2 slots 21 through 28 and
 - AR3 slots 29 through 32

Note: Because there are no more slots to the right of AR2-28, the customer needed to go to another area of the library with installed, yet inactive, slots to continue with the addition. To do this, the boundary AR3 was created to the left of boundary AR1.

FIGURE B-4 Adding Capacity to Partitions

1) Original 50 Active Slots

CEM			Base Module				CEM		
AR1-1	11		Drive	Drive	Drive	Drive	BR2-9	19	BR3-29
2	12		Drive	Drive	Drive	Drive	10	20	30
3	13		Drive	Drive	Drive	Drive	11	21	
4	14		Drive	Drive	Drive	Drive	12	22	
5	15		Drive	Drive	Drive	Drive	13	23	
6	16		Drive	Drive	Drive	Drive	14	24	
7	17				BR1-1	5	15	25	
8	18				2	6	16	26	
9	19				3	7	17	27	
10	20				4	8	18	28	

2) Adding 5 More Slots (AR2-21 to 24) and (AR3-25)

AR1-1	11		Drive	Drive	Drive	Drive	BR2-9	19	BR3-29
2	12		Drive	Drive	Drive	Drive	10	20	30
3	13		Drive	Drive	Drive	Drive	11	21	
4	14		Drive	Drive	Drive	Drive	12	22	
5	15		Drive	Drive	Drive	Drive	13	23	
6	16		Drive	Drive	Drive	Drive	14	24	
7	17		AR2-21	AR3-25	BR1-1	5	15	25	
8	18		22		2	6	16	26	
9	19		23		3	7	17	27	
10	20		24		4	8	18	28	

3) Adding 12 More Slots (AR2-21 to 28) and (AR3-29 to 32)

AR3-29	AR1-1	11	Drive	Drive	Drive	Drive	BR2-9	19	BR3-29
30	2	12	Drive	Drive	Drive	Drive	10	20	30
31	3	13	Drive	Drive	Drive	Drive	11	21	
32	4	14	Drive	Drive	Drive	Drive	12	22	
	5	15	Drive	Drive	Drive	Drive	13	23	
	6	16	Drive	Drive	Drive	Drive	14	24	
	7	17	AR2-21	25	BR1-1	5	15	25	
	8	18	22	26	2	6	16	26	
	9	19	23	27	3	7	17	27	
	10	20	24	28	4	8	18	28	

Guidelines

The SL3000 can support up to *eight* partitions using a variety of interface types: only Ethernet partitions, only SCSI partitions, or combinations of both.

Essential guidelines for understanding partitions are:

- Clear communication between the system programmers, network administrators, library software representatives and administrators, and Sun service representatives.
- Customers must be current on maintenance levels of their library management software.
- A clearly written and drawn out plan for partitioning must be completed and agreed upon by all partition members. A form for the written plan is supplied in “[Planning the Partitions](#)” on page 147; to assist you in drawing out the plan, see [FIGURE B-6](#) on page 148.

Remember:

- One partition will not recognize another partition within the library. Other partitions are either not reported or marked as inaccessible.
- CAPs may be allocated to one or more partitions. *However:*
 - Sharing a CAP between HLI and SCSI partitions is *not* permitted
 - CAP sharing among SCSI partitions is *not recommended*, but Sun supports this.
- Since CAPs can be either shared or dedicated among partitions:
 - Automatic mode for shared CAP operations is not supported
 - Automatic mode for dedicated CAP operations is supported
- If a host has a CAP reserved for enter/eject operations for a partition, no other hosts or partitions can have access to the CAP.

Note: The SL3000 has an optional feature to add cartridge access ports to the drive expansion and cartridge expansion modules for a total of up to *six* CAPs.

Note – For SCSI hosts, automatic CAP mode is supported for one partition at a time *if the shared CAP is associated with that partition*. A shared CAP that has been associated with a partition acts as a dedicated CAP until the association changes.

- Duplicate VOLSERS are supported by the library; however, the library management software may not support this unless the duplicate VOLSERS are in different partitions.
 - With HSC-managed partitions, the duplicate VOLSERS must be in different control data sets.
 - With ACSLS-managed partitions, the duplicate VOLSERS must be on different ACSLS servers.

Planning the Data Path

When planning for partitions, you also need to be aware of the location, quantity, type, and need for the tape drives and media.

Likewise, having a clear understanding about how to logically group and install the tape drives and locate media for the different hosts, control data sets, and interface types is necessary.

When planing for partitions:

- Make sure the tape drive interface supports that operating system.
 - Open system platforms do *not* support ESCON or FICON interfaces.
 - Not all mainframes support Fibre Channel or LTO tape drives.
- Make sure the media types match the application.
- Install tape drives that use the same media types in the same partition.



Important:

Complete a Partition Plan using “[Planning the Partitions](#)” on page 147 and [FIGURE B-6 on page 148](#). Make sure this information is placed with the library or account log.

Host Software Precautions



Important:

When you partition or re-partition a library, you do not have to reboot or IPL the library; however, when you apply the changes to the partitioning, the library will go offline temporarily. For this reason, it is best to minimize any disruptions to the operating systems and library management software before you partition.

The amount of time the library goes offline is minimal, **from 10 to 15 seconds**. However, *this action affects the entire library*, not just the changed partitions.

Any changes of this type are considered disruptive.

An example of a procedure that all hosts (ACSLs or HSC) should follow when partitioning or changing partitions is:

1. Plan the distribution of cartridges, such as enters, ejects, and moves.
2. Stop all host activity, such as mounts and dismounts, enters and ejects, any moves, plus any tape drive activity.
3. For HLI hosts, modify the library offline:
4. Use the remote SLC software to change the partitioning configuration.
5. For HLI hosts, make the hosts accessible to the library by varying the library back online.
 - Audit the library with the host software to update the accessible cartridges and storage slots in the host software’s database.
 - SCSI hosts will need to re-learn the library if anything has changed on their partition.
6. Restart the host activity.

Performance Zone

The performance zone is an area within the SL3000 library that is closest to the tape drives (see [FIGURE B-5 on page 146](#)). Because of the physical location, volumes in this zone have faster access and response times to the tape drives; this includes both front and rear walls.

Selection of the volumes to reside in this zone is critical to obtain the best performance. Limit these volumes to those that benefit most from their location.

Candidates that fit well into the performance zone are:

- Applications such as VSM, HSM, and ABARS
- Volumes that tend to be recalled regularly
- Most recently created volumes
- Volumes that need fast access time
- Volumes that require very few ejects

Volumes that do not meet any of the above criteria should be moved out of this area. Once this zone is full, volumes would extend into the regular storage area.

FIGURE B-5 Performance Zone

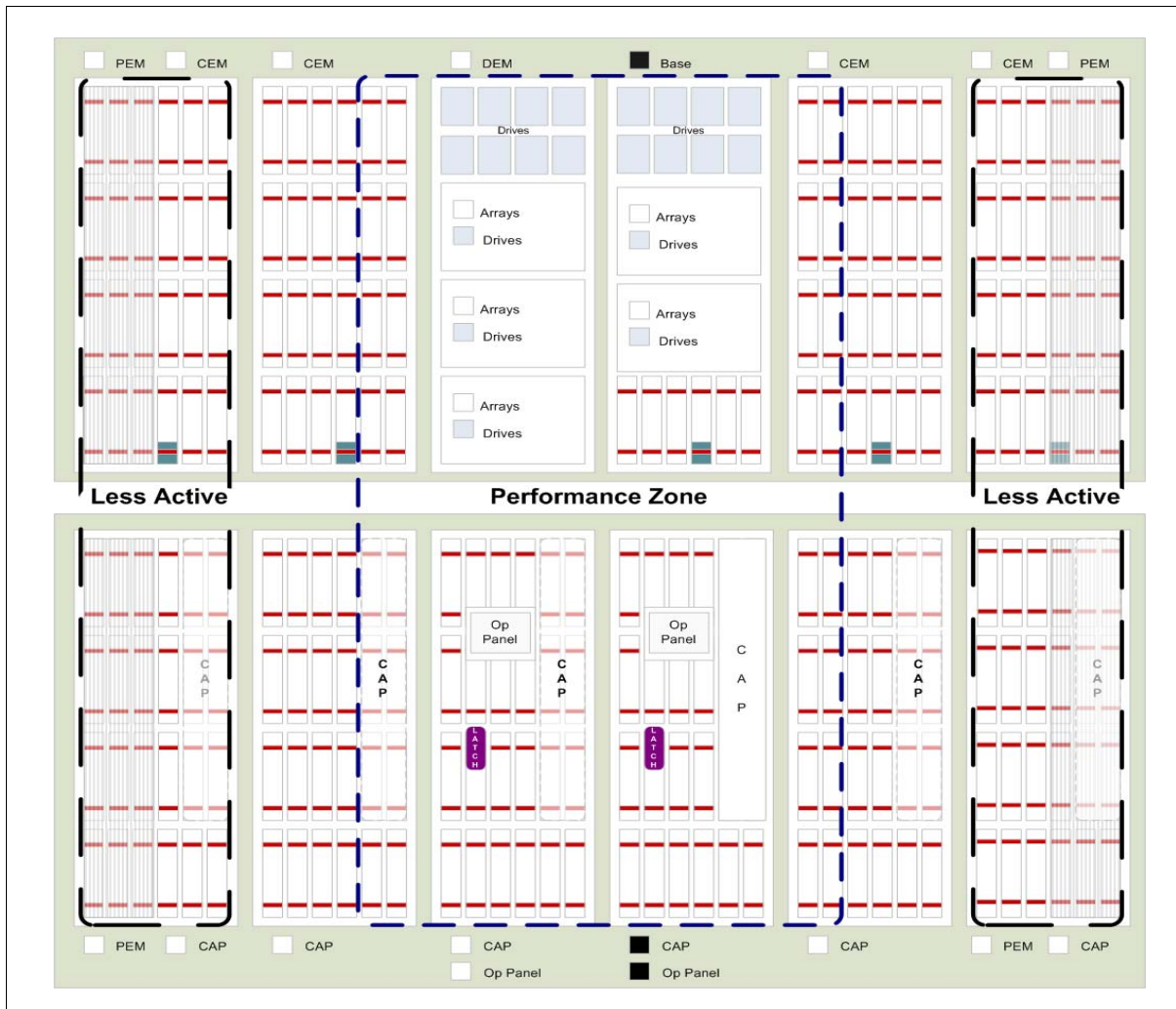

Planning the Partitions

TABLE B-1 Partition Planning

Identify and define the customer requirements				
How many partitions are there in the library? (Eight partitions is the maximum)				
How many slots are there in the library?				
Answer the following for each partition:	Slots	Interface Type	Management Software	Applications
■ How many slots for a partition?	1.	1.	1.	1.
■ What type of operating systems?	2.	2.	2.	2.
■ What type of library management software?	3.	3.	3.	3.
■ What type of applications are being used?	4.	4.	4.	4.
■ CAP planning—HLI, SCSI, shared, dedicated, number of slots?	5.	5.	5.	5.
	6.	6.	6.	6.
	7.	7.	7.	7.
	8.	8.	8.	8.
How many data cartridges are needed?				
How many free slots are needed?				
How many scratch cartridges are needed?				
What type and quantities of tape drives?				

FIGURE B-6 Planning for Partitions

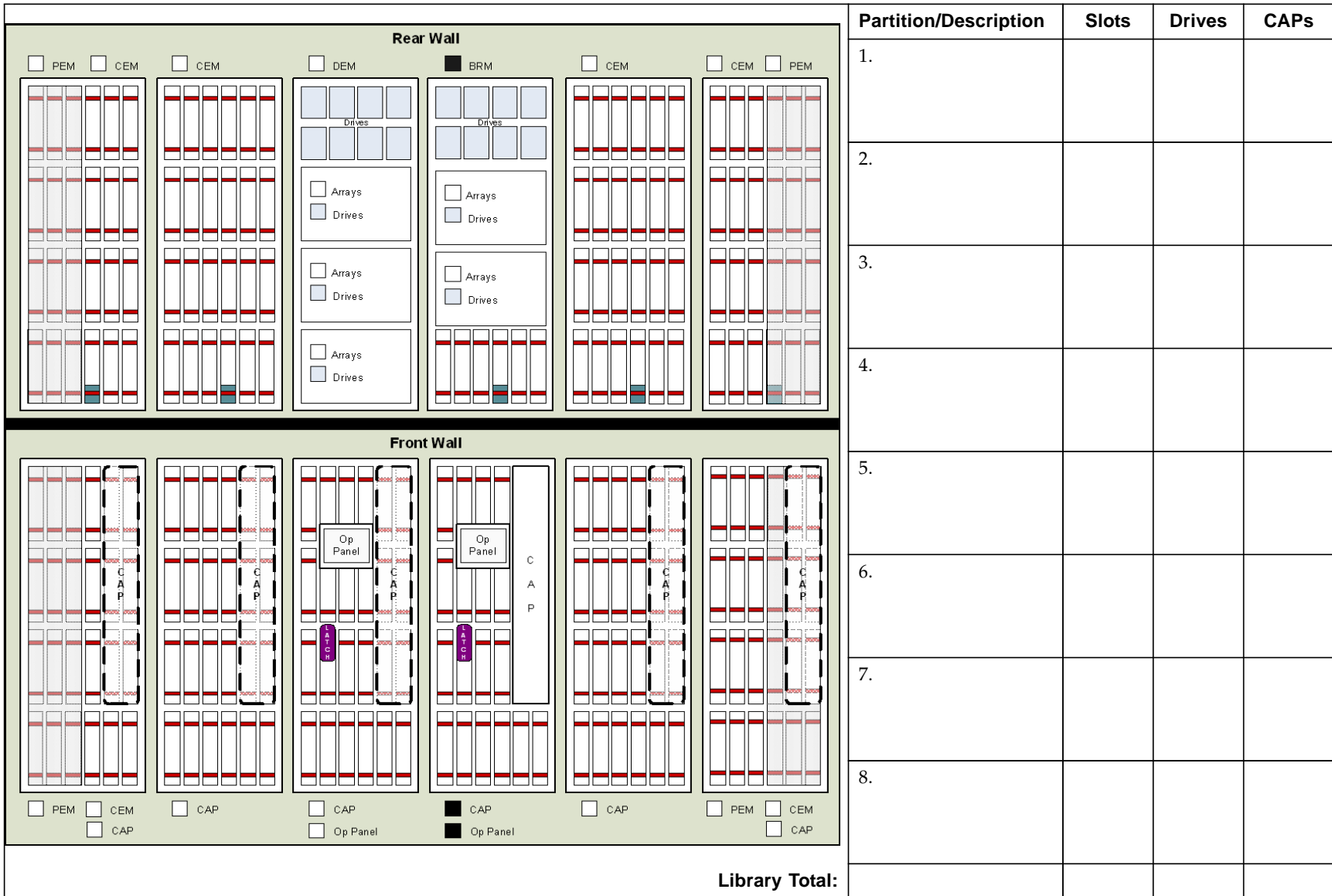

Tape Drives and Media

This appendix provides basic information about the tape drives and tape cartridges supported by the SL3000 library.

The SL3000 library supports a variety of tape drives with one requirement, the interface to these drives must be fiber-optic based (Fibre Channel, FICON, or ESCON). The supported tape drives include:

TABLE C-1 Supported Tape Drives

Vendor	Drive Type ²	Media	Interface Type ³	Firmware ⁵
SUN StorageTek	T9840C	9840 VolSafe capable	Fibre Channel FICON ESCON	
SUN StorageTek	T9840D * *Encryption-capable		Fibre Channel FICON ESCON	142.x07 142.x07 142.x07
SUN StorageTek ¹	T9940 will <i>not</i> be supported			
SUN StorageTek	T10000 A* *Encryption-capable	T0000 Standard, Sport, VolSafe	Fibre Channel FICON	137.113 137.114
	T10000 B* *Encryption-capable		Fibre Channel FICON	138.x06 138.x06
IBM	LTO 3 LTO 4	LTO 3, (read/write) LTO 4, (read/write)	Fibre Channel	
HP	LTO 3 LTO 4* *Encryption feature	WORM-LT (read/write) LTO 2 (read-only) ⁴	Fibre Channel	H44S
<p>Notes:</p> <ol style="list-style-type: none"> SUN StorageTek T9940 tape drives are <i>not</i> supported. The Quantum SDLT 600 and DLT-S4 tape drives are <i>not</i> supported. The parallel version of the small computer system interface (SCSI) is not a supported interface. LTO 2 media is supported for backward compatibility of LTO products (data migration). Minimum level of firmware or higher required. <p>Plus future releases of the above tape drive technologies, media, and interfaces.</p>				

These drives are capable of reading the data recorded by an earlier generation tape drive from the same family.

There are three types of tape cartridges (media) used with these drives:

- Data
- Write once read many (WORM) or VolSafe secure media
- Cleaning

Note – The customer can use their existing cartridges. However, they must be compatible with the supported tape drives and still within their warranty period.

A single universal drive tray accommodates the different drives and interfaces.

This appendix provides basic information about the tape drives and tape cartridges supported by the SL3000 library.

More information about the T-series tape drives is available in the following guides:

T9x40 Tape Drive System Assurance Guide (MT5003)

T10000 Tape Drive System Assurance Guide (TM0002)

Environmental - Tape Drive

The following information is a high-level list of key environment specifications for tape drives (see the datasheet for the specific tape drive model to obtain a complete list). This information is provided to enable you to determine if the drive can operate properly in your environment.

Note – The specifications for your drive might differ from the values shown below.

TABLE C-2 Environmental Specifications for Tape Drives

Parameter	Specification
Operating temperature with media	at 6 cfm airflow: 10°C to 35°C (50°F to 95°F) at 8 cfm airflow: 10°C to 40°C (50°F to 104°F)
Operating <i>non-condensing</i> humidity	20% to 80% RH
Wet bulb temperature, <i>maximum</i>	26°C (78.8°F)
Operating altitude	0 to 4 km (0 to 13,000 ft)
Suspended particle density	<200 µg/m ³

Tape Drives

The SL3000 supports two families of linear-serpentine tape drives:

- Linear Tape-Open (LTO) Ultrium generations 3, 4, and WORM technology
- StorageTek T-Series (T9840C, T9840D, and T10000 series)

The T9840s are *access-centric* tape drives that use a unique dual-reel cartridge design with midpoint load technology. This design enables fast access and reduces latency by positioning the read/write head in the middle of the tape when the cartridge is loaded. With the dual-reel design, the entire tape path is contained within the cartridge, which reduces contamination and enables the drive's fast access. T9840C/D drives are:

- Backward read compatible to the first generation (T9840A) written cartridges
- Not backward write compatible

The T10000 is a *capacity-centric* tape drive that is capable of storing up to 500 GB of uncompressed data on a single-reel cartridge while supporting a throughput rate of 120 MB/s. It uses dual magneto-resistive (MR) heads to provide 32 channels that write data to the tape and read it back.

The LTO Ultrium is a *capacity-centric* tape drive that conforms to an open standard that provides media compatibility across all brands and manufacturers of LTO Ultrium products. The tape cartridge for LTO Ultrium drives is a single-reel hub design. LTO generation 3/4 tape drives are:

- Backward read compatible two generations
- Backward write compatible one generation

Note – The tape drives must support the dynamic World Wide Name feature for them to be varied online by the SL3000 library.

Dynamic World Wide Name

Each connection (port) in a Fibre Channel environment must have a unique ID called the World Wide Name (WWN). The WWN is a 64-bit address that identifies each individual device. When a device logs-in to a Fibre Channel network, the WWN is validated for access by comparing Port Name, Node Name, and Port ID. All three of these identifiers must match or this indicates the configuration has changed and the port is blocked from access.

The dynamic World Wide Name (dWWN) feature assigns world wide names to the library drive slots rather than the drives themselves which allows you to swap or replace devices, such as tape drives, without bringing down the entire operating system.

T9840 Tape Drive Order Numbers

TABLE C-3 T9840D Marketing Part Numbers and Descriptions

Marketing Number	Description
9840D-FC-SL3000Z	T9840D, Fibre Channel SL3000
9840D-FC-SL3000Z	T9840D, Fibre Channel, 2Gb, SL3000
9840D-ES-SL3000Z	T9840D, ESCON, SL3000
9840D-FI-S30-1PLZ	T9840D, FICON, 1PLW (single-port long-wave ²), SL3000
9840D-FI-S30-1PSZ	T9840D, FICON, 1PSW (single-port short-wave ³), SL3000
9840D-FI-S30-2PLZ	T9840D, FICON, 2PLW (dual-port long-wave ²), SL3000
9840D-FI-S30-2PSZ	T9840D, FICON, 2PSW (dual-port short-wave ³), SL3000
9840D-FI-S30-2PMZ	T9840D, FICON, 2PMW (one long- and one short- wave), SL3000
Notes:	
1. Interface transceivers (SFP modules) do not ship with the tape drive for the identified library.	
2. Long wave ports require 9/125 micron cables.	
3. Short wave ports require 50/125 micron cables.	

TABLE C-4 T9840C Marketing Part Numbers and Descriptions

Marketing Number	Description
9840C-ES-SL3000Z	ESCON, SL3000
9840C-FC-SL3000Z	T9840C, Fibre Channel, 2Gb, SL30003
9840C-FI-S30-1PSZ	T9840C, FICON, SL3000, 1PSW (single-port short-wave ⁴)
9840C-FI-S30-2PSZ	T9840C, FICON, SL3000, 2PSW (dual-port short-wave ⁴)
9840C-FI-S30-1PLZ	T9840C, FICON, SL3000, 1PLW (single-port long-wave ⁵)
9840C-FI-S30-2PLZ	T9840C, FICON, SL3000, 2PLW (dual-port long-wave ⁵)
9840C-FI-S30-2PMZ	T9840C, FICON, SL3000, 2PMW (dual-port mixed-wave ^{4,5})
Notes:	
1. Interface transceivers (SFP modules) do not ship with the tape drive for the identified library.	
2. Short wave ports require 50/125 micron cables.	
3. Long wave ports require 9/125 micron cables.	

Part Number _____
 Quantity _____

Part Number _____
 Quantity _____

Part Number _____
 Quantity _____

Part Number _____
 Quantity _____

T10000 Tape Drive Order Numbers

TABLE C-5 T10000A Marketing Part Numbers and Descriptions

Marketing Number	Description
T10A-4FC-LW-30Z	SL3000 Fibre Channel Drive Long Wavelength
T10A-4FC-MW-30Z	SL3000 Fibre Channel Drive Mix Wavelength
T10A-4FC-SW-30Z	SL3000 Fibre Channel Drive Short Wavelength
T10A-FI-C-SW-30Z	SL3000 FICON Crypto Drive Short Wave
T10A-FI-C-LW-30Z	SL3000 FICON Crypto Drive Long Wave
T10A-2FI-C-MW-30Z	SL3000 FICON Crypto Drive Mix Wave
Notes:	
1. Interface transceivers (SFP modules) do not ship with the tape drive for the identified library.	
2. Long wave ports require 9/125 micron cables.	
3. Short wave ports require 50/125 micron cables.	

LTO Tape Drive Order Numbers

TABLE C-6 LTO3 and LTO4 Marketing Part Numbers and Descriptions

Marketing Number	Description
New Drives	
LTO3-HP4FC-SL3000Z	HP LTO3 FC 4Gbit drive for the SL3000 library
LTO4-HP4FC-SL3000Z	HP LTO4 FC 4Gbit drive for the SL3000 library
LTO3-IB4FC-SL3000Z	IBM LTO3 FC 4Gbit drive for the SL3000 library
LTO4-IB4FC-SL3000Z	IBM LTO4 FC 4Gbit drive for the SL3000 library
LTO4-IB4F-AS4-SL3Z	IBM LTO4 FC 4Gbit drive AS400 attach for SL3000
Used Drives - No Warranty	
Y-LTO3-HP4FC-SL30Z	HP LTO3 FC 4Gbit drive for the SL3000 library
Y-LTO4-HP4FC-SL30Z	HP LTO4 FC 4Gbit drive for the SL3000 library
Y-LTO3-IB4FC-SL30Z	IBM LTO3 FC 4Gbit drive for the SL3000 library
Y-LTO4-IB4FC-SL30Z	IBM LTO4 FC 4Gbit drive for the SL3000 library
Y-LTO4-IB4F-A4SL3Z	IBM LTO4 FC 4Gbit drive AS400 attach for SL3000

Part Number _____
Quantity _____

Part Number _____
Quantity _____

Part Number _____
Quantity _____

Part Number _____
Quantity _____

Tape Drive Conversion Part Numbers

These tables list the marketing numbers for convert drives to support the SL3000.

Drive Tray Conversions

TABLE C-7 Drive Tray Conversion Kits

Drive Type	Marketing Number	Operation Type (Library)
T9840 C/D	9840BCD-FCFI-SL3-Z	T9840 B/C/D FI/FC tray to SL3000
T10000 A/B	T10AB-FCFI-SL3-Z	T10KA/B FI/FC Tray C/B-SL3000
HP LTO 3/4	LTO-HPF-L7S30-CKZ	L180/700/1400
	LTO-HPF-S5S30-CKZ	SL500
IBM LTO 3/4	LTO-IBF-L7S30-CKZ	L180/700/1400/L5500/9310
	LTO-IBF-S5S30-CKZ	SL500

General T-Series Port Conversions

TABLE C-8 T10000A Marketing Part Numbers and Descriptions

Marketing Number	Conversion Bill	Description
X9840D-1SFP-LWZ		T9840D FC/FI, 1SFP, LW CKIT
X9840D-2SFP-LWZ		T9840D FC/FI, 2SFP, LW CKIT
X9840D-2SFP-MWZ		T9840D FC/FI, 2SFP, MW CKIT
X9840D-1SFP-SWZ		T9840D FC/FI, 1SFP, SW CKIT
X9840D-2SFP-SWZ		T9840D FC/FI, 2SFP, SW CKIT
2 Gigabit Drive		
XT10A-1LW-CKITZ	105119	T10KA 1 Port FICON Long Wave Conversion Kit
XT10A-1SW-CKITZ		T10K 2 Gbit 1 port Short Wave
XT10A-2LW-CKITZ	105120	T10KA 2 Port FICON Long Wave Conversion Kit
XT10A-2MW-CKITZ	105121	T10KA 2 Port FICON Mix Wave Conversion Kit
XT10A-2SW-CKITZ	105118	T10KA 2 Port FICON Short Wave Conversion Kit
XT10A-2-1LW-CKITZ		T10K 2 Gbit Fibre Channel or FICON 1 port LW
XT10A-2-1SW-CKITZ		T10K 2 Gbit Fibre Channel or FICON 1 port SW
XT10A-2-2LW-CKITZ		T10KA 2 Gbit FI or FC 2 port Long Wave Kit
XT10A-2-2MW-CKITZ		T10KA 2 Gbit FI or FC 2 port Mix Wave Kit
XT10A-2-2SW-CKITZ		T10KA 2 Gbit FI or FC 2 port Short Wave Kit
4 Gigabit Drive		
XT10A-4-2LW-CKITZ		T10KA 4 Gbit 2 port Long Wave
XT10A-4-2MW-CKITZ		T10KA 4 Gbit 2 port Mix Wave
XT10A-4-2SW-CKITZ		T10KA 4 Gbit 2 port Short Wave

Media

The following figure identifies key elements of a tape cartridge by using an LTO cartridge as a representative example. Cartridges have a mechanical write protect switch. The volume ID label is required when the cartridge is used in a library. An access door is present on single reel cartridges, and it opens when the cartridge is loaded in the drive to enable the tape media to be threaded into the tape drive. The LTO cartridge incorporates a pin attached to the leader that is grabbed by the drive mechanics to enable threading of the leader/media onto the internal drive take-up reel.

FIGURE C-1 Tape Cartridge Elements

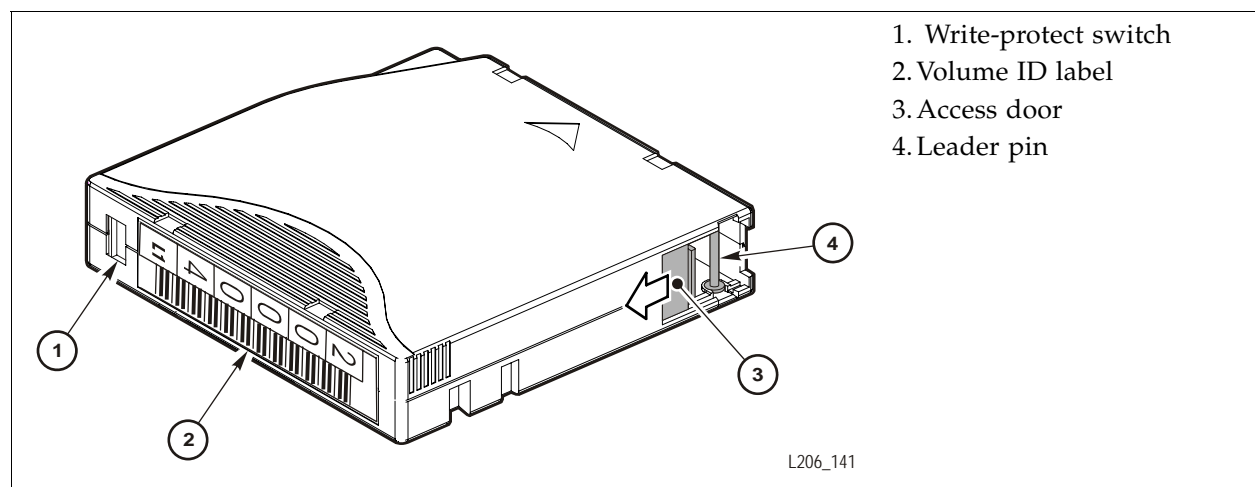

The volume ID label contains human-readable characters and bar codes. The label is based on the Code 39 barcode standard. This standard uses discrete barcodes, which means that a fixed pattern of bars represents a single character. Each character is made up of nine bars—five black bars and four white bars—three of which are wider than the others.

Volume ID Label

The SL3000 supports two categories of media:

- Linear Tape-Open (LTO) generations 3, 4, and WORM technology
- StorageTek T-Series (T9840C, T9840D, and T10000A, T10000B)

LTO tape cartridges require an eight-character label (see the figure above). This label consists of a six-character customer defined volume serial number, the domain type (L), and the media ID for that particular tape drive technology (1, 2, 3 or 4).

The T9840 tape cartridges require a six plus one-character label that consists of the six-character customer label, then a single media ID character (R represents the data cartridge). These labels have a unique barcode format based on the Code 39 standard with a start/stop character—the dollar sign (\$).

The T10000 cartridge uses a label similar to the LTO label. This label requires an eight-character label with domain type (T) and media ID (1).

The VOLSER has a total of six characters.

- The first three are the volume and can be either alpha or numeric.
- The last three are the serial number and are always numeric.

Except with the individual color label options for 9840 cartridges.

If you choose the individual color label options, all characters can be either alpha, numeric, or any combination of the two. With this label option, you can choose a background color for each of the characters.

Note – Most customers use the vibrant color option.

Ordering Tape Cartridges and Labels

Tape cartridges are not shipped as part of the SL3000 modular library system and must be ordered separately.

Notes:

- The customer can use their existing cartridges as long as they are compatible with the supported tape drives and still within their warranty period.
- Professional Services and Data Center Services offer transition support and services to help migrate media and drives.
- Make sure that the customer orders the cartridge tape labels before the installation.
- Labels *cannot* be ordered separately from the tape cartridge.

Sun makes ordering tape cartridges easy.

- Call **1.877.STK.TAPE** to order media from your local Sun reseller or to obtain media pre-sales support.
- E-mail addresses for local support questions:
us.mediaorders@sun.com
EMEA.mediaorders@sun.com
LA.mediaorders@sun.com
- Label kits:

Label kits are available in either 60 or 200 piece quantities. The 60 piece kit has 60 data and 6 cleaning cartridge labels. The 200 piece kit has 200 data and 20 cleaning cartridge labels. The end-user will affix the labels to the cartridges. The label ranges are sequentially numbered, non-repeating and cannot be customized.

Not sure what you need or what some terms mean?

Check out *Sun StorageTek Tape Media A Variety of Storage Options* for more details.

<http://suntape.central.sun.com/media.shtml>

Media Part Numbers

The following table lists the part numbers for LTO3 and LTO4 cartridges.

TABLE C-9 Cartridges for LTO3 and LTO4

Part Number	Description
<i>LTO3 Data Cartridge - 400 Gbyte Capacity</i>	
M-LTO3-CASE-UNLBL	LTO3 media, individual plastic cases, no label, 20 pack
M-LTO3-LBPK-UNLBL	LTO3 media, library 20 pack, no label
M-LTO3-CASE-HOR	LTO3 media, individual plastic cases, hor label, 20 pack
M-LTO3-CASE-VERT	LTO3 media, individual plastic cases, vert label, 20 pack
M-LTO3-LBPK-HOR	LTO3 media, library 20 pack, horizontal label
M-LTO3-LBPK-VERT	LTO3 media, library 20 pack, vertical label
M-LTO3-WORM-UNLBL	LTO3 WORM, individual plastic cases, no label, 20 pack
M-LTO3-WORM-HOR	LTO3 WORM, individual plastic cases, hor label, 20 pack
M-LTO3-WORM-VERT	LTO3 WORM, individual plastic cases, vert label, 20 pack
<i>LTO4 Data Cartridge - 800 Gbyte Capacity</i>	
M-LTO4-CASE-UNLBL	LTO4 media, individual plastic cases, no label, 20 pack
M-LTO4-LBPK-UNLBL	LTO4 media, library 20 pack, no label
M-LTO4-CASE-HOR	LTO4 media, individual plastic cases, hor label, 20 pack
M-LTO4-CASE-VERT	LTO4 media, individual plastic cases, vert label, 20 pack
M-LTO4-LBPK-HOR	LTO4 media, library 20 pack, horizontal label
M-LTO4-LBPK-VERT	LTO4 media, library 20 pack, vertical label
M-LTO4-WORM-UNL	LTO4 WORM, jewel case, no label, 20 pack
M-LTO4-WORM-HOR	LTO4 WORM, hor label, jewel case, 20 pack
M-LTO4-WORM-VERT	LTO4 WORM, vert label, jewel case, 20 pack
<i>Cleaning</i>	
M-LTOCL-5PK-UNLBL	Cleaning cartridge, 5 pack, no label
M-LTOCL-5PK-LBL	Cleaning cartridge, 5 pack, vertical label

Refer to the T-Series Systems Assurance Guides for information about the media part numbers for the T9840 and T10000 tape drives.

- T9840 Systems Assurance Guide, PN: MT5003
- T10000 Systems Assurance Guide, PN: TM0002

Tape Media Policies

There are three media policies:

- *Usage* policy: The tape storage media (tape cartridge) used in a tape drive and/or automated tape system can have a significant impact on the overall performance of the tape drive and/or automated tape
 - Sun warrants tape storage media that is Sun StorageTek branded.
 - The customer can be billed for any service provided by Sun resulting from or related to problems caused by non-Sun StorageTek branded tape storage media.
- *Endorsement* policy: Sun does not certify, recommend or endorse 3rd party brand tape media. Sun only recommends Sun StorageTek brand media for use in Sun StorageTek libraries and tape drives.
- *Cancellation* policy: Purchase Orders for tape media entered into Sun's Order Management system (either 'standalone' or included with Sun hardware, software or services) are non-cancelable, non-returnable, and cannot be reworked.

Note – The customer is liable for the media portion of the purchase order regardless if the hardware, software or services portion of the purchase order is canceled.

Environmental - Media

The following information is a high-level list of key environment specifications for tape media. The values in the table are typical values, but the specific value for your media could be different. See the datasheet for the particular media that supports the tape drives installed in your library.

TABLE C-10 Environmental Specifications for Media

Parameter	Specification
<i>Operating</i>	
Ambient temperature	10°C to 45°C (50°F to 113°F)
Relative humidity <i>non-condensing</i>	20% to 80%
Wet bulb temperature, <i>maximum</i>	26°C (78.8°F)
<i>Storage (day-to-day)</i>	
Ambient temperature	16°C to 35°C (60°F to 95°F)
Relative humidity <i>non-condensing</i>	20% to 80%
Wet bulb temperature, <i>maximum</i>	26°C (78.8°F)

If during storage or transportation a cartridge has been exposed to conditions outside the listed values, condition the media in the operating environment for the time specified by the media manufacturer (the time can vary from 24 to 36 hours).

Tape Media W5C Help Sheet

There are over 180 media part numbers available in the configurator. The following information is available to help:

- Complete the Tape Media portion of the W5C Configurator
- Put together an accurate quote

The Tape Media portion of the configurator is located at:

Tape Storage | Sun StorageTek Tape Media

Notes:

- In the case when information is not available at time of the quote, use T8DT8D as the volume serial number (VOLSER) for a placeholder and the default colors.
- This is the minimum required information to accurately quote Tape Media.
- Options will auto-populate based on previous selections.
- Only the supported options are shown in the following steps (not all the options).

Below are the steps used when putting together the Tape Media configuration.

1. **Media Type:** Select the appropriate media type per customer requirements.

Media Type	Details
9840	Select this media type for T9840C and T9840D tape drives
LTO	Select this media type for LTO3 and LTO4 tape drives
T10K	Select this media type for T10000A and T10000B tape drives

2. **Label Type:** Select the desired label type.

Label Type	Details
Barcode	Select this option for barcode labels
Unlabeled	Select this option for unlabeled media

Note: Select "Unlabeled" if you require label kits without any media.

3. **Function:** Select the function for the media.

Function	Details
Cleaning	Select this option for cleaning cartridges
Data	Select this option for data cartridges
Labels Only	Select this option for barcode label kits without media

4. **Sub-Media:** Select the sub-media type for the drives, such as T9840 "C" or LTO "4".

Sub-Media	Details
C Drive	Select this sub-media type for the T9840 tape drive
D Drive	Select this sub-media type for the T9840 tape drive
Standard Intialized	Select this sub-media type for the T9840 tape drive
Volsafe C Drive	Select this sub-media type for the T9840 tape drive
Volsafe D Drive	Select this sub-media type for the T9840 tape drive
Sport (120G native)	Select this sub-media type for the T10000 tape drives
Standard (500G native)	Select this sub-media type for the T10000 tape drives
Standard (1TB native)	Select this sub-media type for the T10000 tape drives
Volsafe	Select this sub-media type for the T10000 tape drives
Volsafe Sport	Select this sub-media type for the T10000 tape drives
LTO3	Select this sub-media type for LTO tape drives
LTO4	Select this sub-media type for LTO tape drives
WORM	Select this sub-media type for LTO tape drives
Label Kits	Select this sub-media type for label kits (see note)

Label Kit Notes:

- Label kits are available in vertical orientation only.
- Labels can be affixed by the end user.
- There are two different quantities available, 60 or 200.
 - The 60 label kit includes 60 data cartridge labels and 6 cleaning cartridge labels
 - The 200 label kit includes 200 data cartridge labels and 20 cleaning cartridge
- The label ranges are randomly numbered and cannot be customized.
- If customization is required, the preferred supplier is Tri-Optic.
Got to: <http://www.tri-optic.com/> or Contact them at: 1.888.438.8362

5. **Applied Labels:** Select the type of applied label required.
This is the background color for each alpha-numeric character.

Applied Labels	Details
Pastel	For Pastel labels, the following default colors are used for each number in the VOLSER: 0 - Lt Red, 1 - Yellow, 2 - Lt Olive, 3 - Blue, 4 - Lt Orange, 5 - Lt Green, 6 - Orange, 7 - Lt Aqua, 8 - Pink, 9 - Lt Purple. The default alpha characters are black letters on a white background.
Black/White	Label contains black letters/numbers on a white background
Vibrant	For Vibrant labels, the following default colors are used for each number in the VOLSER: 0 - Red, 1 - Yellow, 2 - Lt Green, 3 - Lt Blue, 4 - Grey, 5 - Orange, 6 - Pink, 7 - Drk. Green, 8 - Lt Orange, 9 - Lt Purple. The default alpha characters are black letters on a white background.
Color Scheme Not Applicable	Select this option for Unlabeled media

Applied Label Notes:

- The Black & White palette (black letters on a white background) is standard for all cleaning cartridges for T10K, 9940, 9840, DLT4, SDLT1 tape media.
- The Vibrant palette is standard for all LTO, LTO WORM, 9840 Volsafe, T10000 Volsafe, and T10000 Volsafe Sport data cartridges.
- Only T10000 Standard, T10000 Sport, and 9840 data cartridges are available in Pastel, Black & White, or Vibrant palettes.

6. **Package Type:** Select the appropriate package type per the customer's request.

Package Type	Details
Jewel	Media is packaged in individual plastic jewel cases
Library	Media is packaged in a bulk library pack, no individual jewel cases
Kit	Select this option for a kit of barcode labels without media

7. **Label Alignment:** Select the type of label alignment per the customer's request.

Alignment	Details
Horizontal	VOLSER information can be read from left to right on the media
Vertical	VOLSER information can be read from top to bottom on the media
Orientation Not Applicable	Select this option for unlabeled media

8. **Initialization:** Select the required initialization format per the customer's request.

Format	Details
AS400	Initialization using AS400 format
ASCII	Initialization using ASCII format
EBCDIC	Initialization using EBCDIC format
UNISYS	Initialization using UNISYS format
NA	Select this option if Initialization is not required

Glossary

This glossary defines terms and abbreviations used in this publication.

A

Advanced Encryption

Standard (AES) A FIPS-approved NIST cryptographic standard used to protect electronic data.

Agent The StorageTek T10000 models A and B, T9840D, and the HP LTO4 tape drives are a type of encryption agent once enabled for encrypting data.

Autonomous Lock When autonomous unlock is enabled a quorum of Security Officers is required to unlock a locked KMA. When disabled the KMA can be unlocked by any Security Officer.

C

Cluster A Cluster is a set of Appliances that are grouped together into a single system to enhance fault tolerance, availability, and scalability.

Communications key Adds another layer of encryption and authentication during transmission over a LAN from the token to the drive.

Crypto Key Management

Station See Key Management Station.

Crypto-active And encryption-capable tape drive that has had the encryption feature turned on in the drive.

Crypto-ready A tape drive that has the ability to turn on device encryption and become encryption-capable.

Cryptography The art of protecting information by transforming it (encrypting) into an unreadable format, called cipher text. Only those who possess a special *key* can decipher (decrypt) the message into its original form.

D

Device key Enables the tape drive for encryption. KMS Version 1.x term.

E

EKT Enabling key token (device keys). KMS Version 1.x term.

Enable key Unique 64 character key used to enable the tape drive. See also PC Key.

Encryption The translation of data into a secret code. Encryption is one of the most effective ways to achieve data security. To read an encrypted file, you must have access to a special key or password that enables you to decipher it.

F

FIPS Federal Information Processions Standards. The National Institute of Standards and Technology (NIST) is a non-regulatory federal agency within the U.S. Commerce Department's Technology Administration and Laboratories, which develops and promotes standards and technology, including:

- Computer Security Division and Resource Center (CSRC)
- Federal Information Processing Standards (FIPS)
- For more information visit:
<http://www.nist.gov/>

H

**Hash Message
Authentication Code**

(HMAC) In cryptography, a keyed-Hash Message Authentication Code, or HMAC, is a type of message authentication code (MAC) calculated using a cryptographic hash function in combination with a secret key.

I

Internet Protocol (IP) A protocol used to route data from its source to its destination in an Internet environment.

Internet Protocol (IP)

address A four-byte value that identifies a device and makes it accessible through a network. The format of an IP address is a 32-bit numeric address written as four numbers separated by periods. Each number can be from 0 to 255. For example, 129.80.145.23 could be an IP address.
Also known as TCP/IP address.

K

Key A key in this context is a symmetric data encryption key. Agents can request new key material for encrypting data corresponding to one or more Data Units. A key belongs to a single Key Group so that only Agents associated with the Key Group can access the key.

- Keys**
- A random string of bits generated by the key management station, entered from the keyboard, or purchased. Types of keys include:
 - Device keys enable the tape drive encryption feature.
 - Media keys encrypt and decrypt customer data on a tape cartridge.
 - PC Keys enable the tape drive for encryption.
 - Transmission keys:
 - Communication key adds another layer of encryption (authentication) to the media key during transmission over the LAN from the token to the drive.
 - Split keys are unique to each drive and work with the wrap key for protection.
 - Wrap keys encrypt the media key on the LAN and the token.

Key Group Key Groups are used for organizing keys and associating them with a Key Policy. Key Groups are also used to enforce access to the key material by the Encryption Agents.

Key Policy A Key Policy provides settings for the cryptoperiods to be applied to keys. Each Key Group has a Key Policy, and a Key Policy may apply to zero or more Key Groups. The encryption and decryption cryptoperiods specified on the policy limit the usage of keys and trigger key life cycle events, such as the deactivation or destructions of keys.

Key Management

Appliance (KMA) An appliance for Version 2.0 of the Sun StorageTek encryption solution. The appliance is a proven, dual-core processor with a Solaris 10 operating system that delivers policy-based key management and key provisioning services.

KMS A system providing key management.

Key Management Station

(KMS) The workstation for Version 1.x of the Sun StorageTek encryption solution. The workstation is the central administrative component and manages all cryptographic keys and administrative functions.

KMS Cluster A set of one or more interconnected KMAs. All the KMAs in a KMS Cluster should have identical information.

M

Media key Encrypts and decrypts customer data on a tape cartridge.

N

network An arrangement of nodes and branches that connects data processing devices to one another through software and hardware links to facilitate information interchange.

NIST National Institute of Standards and Technology.

O

OKT Operational key token (media keys). KMS Version 1.x term.

P

PC Key Enables the tape drive to read and write in encrypted mode.

R

Read key This is a media key that is used when reading data from a tape.

Rijndael algorithm An algorithm selected by the U.S. National Institute of Standards and Technology (NIST) for the Advanced Encryption Standard (AES). Pronounced “rain-dahl,” the algorithm was designed by two Belgian cryptologists, Vincent Rijmen and Joan Daemen, whose surnames are reflected in the cipher's name.

RSA In cryptography, **RSA** is an algorithm for public-key cryptography created by Ron Rivest, Adi Shamir, and Leonard Adleman at MIT. The letters **RSA** are the initials of their surnames.

S

Secure Hash Algorithms

(SHA) Secure Hash Algorithms are cryptographic hash functions designed by the National Security Agency (NSA) and published by the NIST as a U.S. Federal Information Processing Standard.

Shamir's Secret Sharing An algorithm in cryptography where a secret is divided into parts, giving each participant its own unique part, where some of the parts or all of them are needed in order to reconstruct the secret. Counting on all participants to combine together the secret might be impractical, and therefore a quorum or threshold scheme is used.

T

T10000 tape drive The T10000 tape drive is a small, modular, high-performance tape drive designed for high-capacity storage of data—up to 500 gigabytes (GB) of uncompressed data.

Token KMS Version 1.x term.

Tokens are handheld, intelligent devices that connect to a token bay with an Ethernet connection. The two roles of the tokens are:

- Enabling key token
- Operational key token

Token bay KMS Version 1.x term.

A chassis that houses the physical tokens and provides power and connectivity for one or two tokens through the rear blind-mating connector. The token bay is compatible with a standard 19-inch rack—a 1U form factor. The token bay comes in two styles: desktop and rack-mount.

Transport Layer Security

(TLS) A cryptographic protocol that provide secure communications on the Internet for such things as web browsing, e-mail, Internet faxing, instant messaging and other data transfers.

W

Wrap key Encrypts the media keys on the LAN and on the token.

Write key This is a media key that is used when writing data to a tape.

Index

Numerics

- 2N (redundant power configuration)
 - conversion bill, 98
 - required for Dual TallBot operation, 88
 - requirements, 12
 - X-option number, 88
- 2N+1 (redundant power configuration)
 - described, 88

A

- AC power
 - cables, listed, 95
 - factors and concerns, 66
 - options
 - explained, 12
 - listed, 88
 - part numbers, 95
- access plates, fire suppression locations, 46
- ACSLs
 - introduction to, 31
 - version supported, 29
- activation
 - passwords, obtaining, 58
 - user accounts, 58
- adapter, SC-to-LC fiber cable connector, 103
- addresses
 - columns, centerline scheme, 110
 - HLL-PRC, 112
 - out-of-the-box slot numbering, 115, 116
 - reserved/system slots, 120 to 125, 133, 134
 - base module, 120 to 121
 - drive expansion module, 123 to 125
 - SCSI elements, 118
 - slot maps, illustrated, 120 to 132
 - system slots

- drive expansion module, 123 to 125
- tape drives
 - HLL-PRC, 114
 - numbering, 114
 - SCSI element numbering, 118
- addressing
 - default slot numbering, 115
 - SCSI element numbering, 118
- alley, delivery limitations, 64
- applications
 - customer survey, 71
 - host software matrix, 29
- arbitrated loop, 24
- archive software, types of, 72
- arrays
 - cartridges, illustrated, 120 to 132
 - extraction tool, 56
 - tape drives
 - illustrated, 120 to 125
 - performance zone, 146
 - planning for optimization, 138, 143
 - X-option, 98
- Automated Cartridge System Library Software
 - configuration example, 31
 - introduction to, 31

B

- backup and archive software types of, 72
- bar-code
 - label standard, 155
 - scanner, 18
- base module
 - installation time estimate, 50
 - installation tool kit, 56
 - reserved slots, 133
 - slot maps, illustrated, 120 to 122

- specifications
 - installed, 4
 - shipping, 51
- Btu/hr, 48
- building code requirements, 66

C

- cable routing, 53
- cables
 - AC power, 13, 57
 - ESCON, 105
 - Ethernet, 105
 - Ethernet switch
 - X-options, 96
 - fiber-optic part numbers/lengths, 103
- CAP
 - base module, 4
 - cartridge expansion module, 8
 - conversion bill number, 98
 - drive expansion module, 6
 - enter/eject cartridges, 138
 - optimizing, 137, 138
 - SCSI element numbering, 118
- capacity
 - licensing, 86, 96
- Capacity on Demand, described, 142
- carpet, survey question, 65
- cartridge
 - elements, described, 155
 - optimization, 138
 - survey, 76
 - volume ID label, 155
- cartridge access port. *See* CAP
- cartridge expansion module
 - conversion bill number, 98
 - installation time estimates, 50
 - slot maps, illustrated, 128 to 130
 - specifications
 - installed, 8
 - shipping, 51
- cartridges
 - cleaning slots, 133
 - data
 - firmware locations, 120 to 132
 - data sheet, 150
 - diagnostic slots, 133
 - drop-off slots, 133
 - float option, 138
 - optimization, 138
 - reserved slots, 133
 - reserved/system slots, 133
 - swap slots, 133
- centerline, 110
- CenterLine Technology, 107
- checklist, 63
- checklist, site preparation, 63
- checklists
 - applications, 71
 - before you install, 64
 - cartridge tapes, 76
 - connectivity, 77
 - data base, 73
 - ESCON, 79
 - existing hardware, 74
 - FICON directors, 80
 - library, 74
 - media, 76
 - network, 77
 - site planning, 64
 - system configuration, 69
 - tape drives, 75
- cleaning cartridges
 - system slots, 134
 - base module, 120 to 121, 134
 - drive expansion module, 123 to 125
 - listed, 133
- CLI
 - activating user accounts, 58
- Client System Component, 29
- clustering
 - cartridges, 138
 - drives, 138
- CO2 emissions, 48
- Code 39 label standard, 155
- column addressing, 110
- components
 - Host Software, 30
 - software, 29
 - library management applications, 29
 - StorageTek Library Console, 26
 - Storage Management, 30
- configurations
 - AC power options, 12
 - site information list, 60
- conformance, standards, 33
- connections

- Fibre Channel (library), 17, 23
- TCP/IP, 17, 24
- connectivity
 - factors for pre-installation, 67
 - matrix and sales tools, 63
- connector types
 - AC, 57
 - AC cables, 13
 - Fibre Channel, 103
 - LC-to-SC adapter kit, 103
 - TCP/IP, 24
- content management
 - cartridges, 138
 - drives, 138
 - media, 138
 - philosophy, 135
 - tape cartridges, 138
 - tape drives, 138
- conversion bills
 - library, 98
- conversion kits, LTO drives, 102, 154
- cooling
 - areas, 20
 - DC power supplies, 20
 - library, 20
 - tape drives, 20
- cooling fans, 20
- customer
 - AC power requirements, 12
 - applications, 71
 - contact sheet, 37
 - hardware configuration, 74
 - satisfaction, process for, 35
 - software, 71
 - system configuration, 70
- Customer Resource Center (CRC), xxii
- cut-outs, floor, 65
- cutouts, floor, 53

D

- Data Base Management Systems, types of, 73
- data base questions, 73
- DC power
 - calculating, 14, 15
 - configurations, 14
 - X-options, 89, 95
- delivery dock, 64
- delivery of the hardware, 64

- diagnostic cartridges
 - system slots
 - base module, 120 to 121, 133, 134
 - drive expansion module, 123 to 125, 133
 - listed, 133
- dimensions
 - base module
 - installed, 4
 - shipping, 51
 - cartridge expansion module
 - installed, 8
 - shipping, 51
 - drive expansion module
 - installed, 6
 - shipping, 51
 - parking expansion module
 - installed, 9
 - shipping, 51
- directors
 - ESCON, 79
 - FICON, 80
- dock availability, 64
- doorway, height, 65
- drive expansion module
 - conversion bill number, 98
 - installation time estimates, 50
 - installation tool kit, 56
 - reserved slots, 133
 - slot maps, illustrated, 123 to 127
 - specifications
 - installed, 6
 - shipping, 51
- drop-off slots
 - base module locations, 133
 - locations, 133
- dual
 - TallBot
 - requirements, 88, 90
 - X-option, 90, 97
 - TCP/IP
 - connections, 24
 - X-option, 91, 97
- dynamic World Wide Name, 151

E

- earthquakes, 54
- eject operations
 - CAP optimization, 138

- cartridges, 138
- electromagnetic, compatibility standards, 33
- elevators, survey question, 64
- ELS, version required, 29
- enter operations
 - CAP optimization, 138
 - cartridges, 138
- environmental factors and concerns, 66
- error indicators
 - fan, electronics control module, 20
 - library controller cards, 17
- error-free installation, 35
- ESCON
 - cables, 105
 - Director survey, 79
- Ethernet
 - cables, 105
 - switch, X-option, 96
 - X-options, 96
- extractor tool, used for power rail, 55

F

- fans
 - DC power supplies, 20
 - library cooling, 20
 - tape drives, 20
- fiber-optic cables
 - part numbers/lengths, 103
- Fibre Channel
 - arbitrated loop, 24
 - cables, 103
 - switch survey, 78
 - switched fabric, 24
 - topology, 24
- FICON
 - Directors, 80
 - survey, 79
- FICON directors, 80
- fire suppression
 - access plates, 46
 - planning, 46
 - site survey, 66
- fire suppression, access plates, 46
- firmware
 - HLI-PRC addresses, 112
- float, option used for optimization, 138
- floor
 - installation requirements, 52

- tile cut-outs availability, 65
- floor cutouts, 53
- forklifts, 64

G

- glossary, 163
- guides, listed, xix

H

- handling factors, 64
- hardware
 - configuration, customer site survey, 74
 - tools required for installation, 55
- HLI-PRC, addressing, 112
- host
 - ACSLs software requirement, 29
 - HSC requirement, 29
 - interfaces, 29
 - NCS PTFs, required, 30
 - software compatibility matrix, 29
- Host Software Component. *See* HSC
- HP
 - LTO drive order numbers, 101, 153
 - media, 155
- HSC
 - description, 30
 - LibStation component, 29
 - version required, 29
- HSC. *See also* host
- hubs and switches, 77

I

- IBM
 - LTO drive order numbers, 101, 153
 - media, 155
- installation
 - AC power cables, 13, 57
 - area, 50
 - ESCON cables, 105
 - fiber-optic cables, 103
 - floor requirements, 52
 - personnel required, 50
 - site planning checklist, 64
 - StorageTek Library Console, 59
 - time estimates, 50
 - tools

- base module kit, 56
- drive expansion module kit, 56
- optional, 56
- required, 55, 56
- interfaces
 - Fibre Channel
 - library, 24
 - tape drive data side, 103
 - TCP/IP
 - library, 91
 - protocol, 24
- interoperability, Web site, 63

L

- labels
 - cartridges, ordering, 156
 - cartridges, types supported, 155
 - module identifier blocks, 111
- LEDs
 - fan fault, 20
 - library controllers, 17
 - optional library operator panel, 4
- library
 - ACSLs requirement, 29
 - HSC requirement, 29
- library management software, types of, 72
- library survey, 74
- licensing
 - partitioning X-option, 96
 - slot counts, 86, 96
 - X-options, 96
- locations
 - reserved slots, 133
 - slot maps, 120 to 132
- locations, slots
 - base module, 120 to 122
 - cartridge expansion module, 128 to 130
 - drive expansion module, 123 to 127
 - out-of-the-box numbering, 115, 116
 - parking expansion module, 131 to 132
 - SCSI element numbering, 118
- locations, tape drives, 114
 - base module, 120 to 121
 - drive expansion module, 123 to 125
 - out-of-the-box numbering, 116
 - SCSI element numbering, 118
- LTO
 - drive order numbers, 101, 153

- drive tray conversion kits, 102, 154
- media, 155

M

- manual organization, xviii
- manuals, listed, xix
- media
 - supported, 155
 - survey, 76
- media optimization, 138
- module
 - ID blocks, 111
- module ID blocks, 111
- MVS general information, 73

N

- Nearline Control Solutions (NCS)
 - PTFs required
 - HSC
 - NCS PTFs required, 30
- network
 - management software, 72
 - SNMP application, 28
 - SNMP example, 28
 - survey, 77

O

- open systems software package, 31
- operating systems and configurations, 69
- operator panel
 - conversion bill number, 98
 - indicators, 4
 - X-option number, 97
- optimization guidelines
 - cartridges, 138
 - media, 138
 - planning, 135
 - tape cartridges, 138
 - tape drives, 138
- options
 - AC power configurations, 12
 - conversion bill numbers, 98
 - listed, 94
- ordering, 85
 - cables
 - ESCON, 105

- Ethernet, 105
- Fibre Channel, 103
- cartridge labels, 156
- cartridges, 156
- flowchart, 86
- LTO drives, 101, 153
- part information/description, 94
- T-Series drives, 150
- X-options, 98

organization of this manual, xviii

out-of-the-box behavior, 115

P

pallet jacks, 64

parking expansion module

- dimensions
 - installed, 9
 - shipping, 51
- installation time estimates, 50
- slot maps, illustrated, 131 to 132

part number

- cable
 - Fibre Channel, 104

part numbers

- AC power cables, 13, 57
- cables
 - ESCON, 105
 - Ethernet, 105
 - Fibre Channel, 103, 104
- conversion bills, 98
- drive tray conversion kits, 102, 154
- installation tools, 55
- library, listed, 94
- tool kit, 55

partitioning

- default slot numbering, 115
- described, 142
- rectangular boundaries, 142
- X-option number, 96

Partner Agreement, xxii

Partners

- contact sheet, 38

Partners Web site, xxii

password, obtaining activation, 58

PDU

- cable part numbers, 13
- connector types, 13, 57
- X-options, 13, 88, 95

performance zone

- described, 146
- illustrated, 99, 100, 101, 102, 146, 152, 153, 154

philosophy for content management, 135

physical

- concerns for site planning, 65
- placement factors for site planning, 65

planning

- checklist, 63
- meetings, for system assurance, 35
- topics, 39

power

- AC
 - cables, 13, 57
 - configurations, 12
 - options, 12
 - redundant, 12, 98
- cable routing, 53
- DC
 - conversion bill numbers, 98
 - cooling fans, 20
 - cPCI supplies, 14, 15
 - load sharing supplies, 14, 15
- factors for pre-installation planning, 66
- requirements, 12
- T9840 power-up tool, 56

power consumption, 48

power rail

- addressing parameter, 2
- extractor tool, 55
- TallBot operation, 18

pre-installation, 63

Program Temporary Fixes (PTFs)

- NCS required, 30

publications, related, xix

R

RAID configuration, site survey, 73

rail

- power enable modules required, 14, 15

ramps or slopes, 64

rectangular boundaries, partitioning, 142

redundant

- AC power, 12, 98
- TallBot
 - conversion bill number, 98
 - requirements, 88
 - X-option number, 97

- related publications, listed, xix
- remote site planning, 68
- replacing existing libraries, 74
- requirements
 - AC power, 12, 88
 - DC power, 15, 89
 - host, 29
- resellers, xxii
- reserved, slots, 133
- reserved/system, slots, 133

S

- safety
 - fire suppression access plates, 46
- scratch
 - cartridge optimization, 138
- SCSI
 - element numbers, 118
 - elements
 - CAP numbering, 118
- seismic compatibility, 54
- shipping
 - module specifications, 51
 - pallets
 - site survey, 64
 - specifications, 51
- Simple Network Management Protocol. *See* SNMP
- site planning checklist, 64
- site preparation checklist, 63
- slope, floor variations, 52
- slots
 - cartridges and tape drives
 - firmware locations, 120 to 132
 - drop-off locations, 133
 - illustrated, 120 to 132
 - out-of-the-box numbering, 115
 - reserved, 133
 - reserved/system, 133
 - swap, 133
- SMC, 30
- SNMP
 - library support, 28
- software
 - ACSLs requirement, 29
 - host interfaces, 29
 - library management applications, 29
 - SNMP protocol supported, 28

- StorageTek Library Console, 26
- software components, 29
- Solaris, loading StorageTek Library Console, 59
- specifications
 - base module, 4
 - cartridge expansion module, 8
 - drive expansion module, 6
 - parking expansion module, 9
 - shipping, 51
- staging area, 50
- standards of conformance, 33
- storage area network, existing, 77
- Storage Management Component, 30
- StorageTek
 - Customer Resource Center (CRC), xxii
 - Partners site, xxii
 - Web site, xxii
- StorageTek Library Console
 - described, 26
 - installation, 59
 - loading software, 59
- Sun
 - Customer Resource Center (CRC), xxii
 - Partners Web site, xxii
 - Web site, xxii
- Sun StorageTek
 - team member contact sheet, 38
- survey, 80
- swap, reserved slot locations, 133
- switched fabric, Fibre Channel topology, 24
- switches and hubs
 - existing network components, 77
- system assurance
 - customer contact sheet, 37
 - planning meeting, 35
 - Sun StorageTek contact sheet, 38
- system configuration work sheet, 70

T

- T10000
 - description, 151, 155
 - description of, 167
 - labels, 155
 - ordering, 150
- T9840
 - description, 151
 - label description, 155
 - power-up tool, 56

- TallBot
 - DC power supplies required, 14, 15
 - illustrated, 18
 - redundant (dual)
 - illustrated, 18
 - requirements, 88
 - redundant (dual), X-option, 90
- tape cartridge content management, 138
- tape drives
 - arrays
 - conversion bill number, 98
 - X-option number, 97
 - content management, 138
 - cooling, 20
 - DC power supplies required, 14, 15
 - dynamic World-Wide Name, 151
 - ordering, 89
 - ordering, Sun StorageTek, 150
 - power calculations, 14, 15
 - SCSI element numbering, 118
 - supported models, 21, 149
 - survey, 75
 - T10000, 151
 - described, 151
 - label description, 155
 - T9840, 151
 - label description, 155
 - power-up tool, 56
- tape drives, conversion kits, LTO, 102, 154
- TCP/IP
 - connection, 17, 24
 - connections, 17, 24
 - interfaces supported, 24
 - protocol, 24
- TCP/IP (dual)
 - connection, 24
 - X-option, 97
 - X-option number, 91
- tools
 - array extraction, 56
 - optional, 56
 - required for installation, 55
 - sales, 63
 - T9840 tape drives, drive power-up, 56
- training, Web sites, xxi
- T-Series
 - label description, 155
 - System Assurance Guides, 150

- T10000, 151
- T9840, 151

V

- VOLSER, description of a volume serial number, 156
- VSM 4, version, 29
- VSM 4, version required, 29
- VTL, version required, 29

W

- walls
 - HLL-PRC numbering, 3
 - illustrated, 120 to 132
 - reserved/system slot locations, 133
- Web site
 - customer training, xxi
 - interoperability, 63
- Web sites, xxii
- Web-launched SLConsole
 - client requirements, 27
 - described, 27
 - security, 27
 - updating on a client, 27
- Windows, loading StorageTek Library Console, 59
- work sheet
 - system configuration, 70
- working area, 50

Sun Microsystems, Inc. 4150 Network Circle, Santa Clara, CA 95054 USA Phone 1-650-960-1300 or 1-800-555-9SUN Web sun.com



ARGENTINA: 5411-4317-5636 • AUSTRALIA: 1-800-550-786 • AUSTRIA: 43-1-601-26-0 • BALKANS: 301-6188-111 • BELGIUM: 32-2-704 89 83 • BRAZIL: 55-11-51872100 • BRUNEI: 65-216-8333 • CANADA: 1-800-422-8020 (GENERAL); 416-964-2001 (LEARNING MANAGEMENT SYSTEM SALES, TORONTO) • CHILE: 562-372-4500 • COLOMBIA: 571-629-2323
CZECH REPUBLIC: 420 2 33009311 • DENMARK: 45 4556 5040 • EGYPT: 00 202 570 9442 • FINLAND: 358-9-525-551 • FRANCE: 33-1-41-33-17-17 • GERMANY: 49-89-460-08-2788 • GREECE: 30-01-6188101 • HONG KONG: 852-2877-7077 • HUNGARY: 361-202-4415 • INDIA: 91-80-229-8989 • INDONESIA: 65-216-8333 • IRELAND: 353-1-668-4377
ISRAEL: 972-9-9710500 • ITALY: 39-02-9259511 • JAPAN: 81-3-5779-1820 • KOREA: 82-2-3453-6602 • MALAYSIA: 603-2116-1887 • MIDDLE EAST: 00 9714 3366333 • MEXICO: 525-261-0344 • NETHERLANDS: 31-33-4515200 • NEW ZEALAND: 0800-786-338 • NORTH WEST AFRICA: 00 9714 3366333 • NORWAY: FROM NORWAY: 47-22023950, TO NORWAY: 47-23369650 • PAKISTAN: 00-9714-3366333 • PEOPLE'S REPUBLIC OF CHINA: 8610-6803-5588 • PHILIPPINES: 632-885-7867 • POLAND: 48-22-8747848 • PORTUGAL: 351-21-413-4000 • RUSSIA: 7-095-935-8411 • SAUDI ARABIA: 00 9714 3366333 • SINGAPORE: 65-216-8300 • SOUTH AFRICA: 27-11-256-6300 • SPAIN: 34-902-210-412 • SRI LANKA: 65-2168333 • SWEDEN: 46-8-631 22 00 • SWITZERLAND: 41-1-908-90-50 (GERMAN) 41-22-999-0444 (FRENCH) • TAIWAN: 886-2-25185735 • THAILAND: 662-344-6855 • TURKEY: 90 212 335 22 00 • UNITED KINGDOM: 44-1276-416-520 • UNITED STATES: 1-800-422-8020 • VENEZUELA: 582-905-3800 • VIETNAM: 65-216-8333 • WORLDWIDE HEADQUARTERS: 1-650-960-1300

SUN™ THE NETWORK IS THE COMPUTER ©2006 Sun Microsystems, Inc. All rights reserved. Sun, Sun Microsystems, and the Sun logo are trademarks or registered trademarks of Sun Microsystems, Inc. in the United States and other countries.