



# Sun StorageTek® SL3000 Modular Library System

**Interface Reference Manual**

Part Number: 316195204

Revision: D





# Sun StorageTek SL3000 Modular Library System

---

Interface Reference Manual

Sun Microsystems, Inc.  
[www.sun.com](http://www.sun.com)

Part Number: 316195204  
April 2008  
Revision: D

Copyright 2007, 2008 Sun Microsystems, Inc., 4150 Network Circle, Santa Clara, California 95054, U.S.A. All rights reserved.

Sun Microsystems, Inc. has intellectual property rights relating to technology that is described in this document. In particular, and without limitation, these intellectual property rights may include one or more of the U.S. patents listed at <http://www.sun.com/patents> and one or more additional patents or pending patent applications in the U.S. and in other countries.

This document and the product to which it pertains are distributed under licenses restricting their use, copying, distribution, and decompilation. No part of the product or of this document may be reproduced in any form by any means without prior written authorization of Sun and its licensors, if any.

Third-party software, including font technology, is copyrighted and licensed from Sun suppliers.

Parts of the product may be derived from Berkeley BSD systems, licensed from the University of California. UNIX is a registered trademark in the U.S. and in other countries, exclusively licensed through X/Open Company, Ltd.

Sun, Sun Microsystems, the Sun logo, Java, AnswerBook2, docs.sun.com, Solaris and StorageTek are trademarks or registered trademarks of Sun Microsystems, Inc. in the U.S. and in other countries.

All SPARC trademarks are used under license and are trademarks or registered trademarks of SPARC International, Inc. in the U.S. and in other countries. Products bearing SPARC trademarks are based upon an architecture developed by Sun Microsystems, Inc.

The OPEN LOOK and Sun™ Graphical User Interface was developed by Sun Microsystems, Inc. for its users and licensees. Sun acknowledges the pioneering efforts of Xerox in researching and developing the concept of visual or graphical user interfaces for the computer industry. Sun holds a non-exclusive license from Xerox to the Xerox Graphical User Interface, which license also covers Sun's licensees who implement OPEN LOOK GUIs and otherwise comply with Sun's written license agreements.

U.S. Government Rights—Commercial use. Government users are subject to the Sun Microsystems, Inc. standard license agreement and applicable provisions of the FAR and its supplements.

DOCUMENTATION IS PROVIDED "AS IS" AND ALL EXPRESS OR IMPLIED CONDITIONS, REPRESENTATIONS AND WARRANTIES, INCLUDING ANY IMPLIED WARRANTY OF MERCHANTABILITY, FITNESS FOR A PARTICULAR PURPOSE OR NON-INFRINGEMENT, ARE DISCLAIMED, EXCEPT TO THE EXTENT THAT SUCH DISCLAIMERS ARE HELD TO BE LEGALLY INVALID.

---

Copyright 2007, 2008 Sun Microsystems, Inc., 4150 Network Circle, Santa Clara, Californie 95054, Etats-Unis. Tous droits réservés.

Sun Microsystems, Inc. a les droits de propriété intellectuels relatants à la technologie qui est décrit dans ce document. En particulier, et sans la limitation, ces droits de propriété intellectuels peuvent inclure un ou plus des brevets américains énumérés à <http://www.sun.com/patents> et un ou les brevets plus supplémentaires ou les applications de brevet en attente dans les Etats-Unis et dans les autres pays.

Ce produit ou document est protégé par un copyright et distribué avec des licences qui en restreignent l'utilisation, la copie, la distribution, et la décompilation. Aucune partie de ce produit ou document ne peut être reproduite sous aucune forme, par quelque moyen que ce soit, sans l'autorisation préalable et écrite de Sun et de ses bailleurs de licence, s'il y en a.

Le logiciel détenu par des tiers, et qui comprend la technologie relative aux polices de caractères, est protégé par un copyright et licencié par des fournisseurs de Sun.

Des parties de ce produit pourront être dérivées des systèmes Berkeley BSD licenciés par l'Université de Californie. UNIX est une marque déposée aux Etats-Unis et dans d'autres pays et licenciée exclusivement par X/Open Company, Ltd.

Sun, Sun Microsystems, le logo Sun, Java, AnswerBook2, docs.sun.com, Solaris, et StorageTek sont des marques de fabrique ou des marques déposées de Sun Microsystems, Inc. aux Etats-Unis et dans d'autres pays.

Toutes les marques SPARC sont utilisées sous licence et sont des marques de fabrique ou des marques déposées de SPARC International, Inc. aux Etats-Unis et dans d'autres pays. Les produits portant les marques SPARC sont basés sur une architecture développée par Sun Microsystems, Inc.

L'interface d'utilisation graphique OPEN LOOK et Sun™ a été développée par Sun Microsystems, Inc. pour ses utilisateurs et licenciés. Sun reconnaît les efforts de pionniers de Xerox pour la recherche et le développement du concept des interfaces d'utilisation visuelle ou graphique pour l'industrie de l'informatique. Sun détient une licence non exclusive de Xerox sur l'interface d'utilisation graphique Xerox, cette licence couvrant également les licenciées de Sun qui mettent en place l'interface d'utilisation graphique OPEN LOOK et qui en outre se conforment aux licences écrites de Sun.

LA DOCUMENTATION EST FOURNIE "EN L'ÉTAT" ET TOUTES AUTRES CONDITIONS, DECLARATIONS ET GARANTIES EXPRESSES OU TACITES SONT FORMELLEMENT EXCLUES, DANS LA MESURE AUTORISEE PAR LA LOI APPLICABLE, Y COMPRIS NOTAMMENT TOUTE GARANTIE IMPLICITE RELATIVE A LA QUALITE MARCHANDE, A L'APTITUDE A UNE UTILISATION PARTICULIERE OU A L'ABSENCE DE CONTREFAÇON.

---

We welcome your feedback.

Please provide your comments using the Feedback option on the documentation Web site:

or contact:

Sun Learning Services  
Sun Microsystems, Inc.  
MS: BRM06-113  
500 Eldorado Blvd.  
Broomfield, CO 80021  
USA

Please include the publication name, part number, and edition number in your correspondence if they are available. This will expedite our response.



Please  
Recycle



# Summary of Changes

---

<b>EC Number</b>	<b>Date</b>	<b>Revision</b>	<b>Description</b>
—	November 2007	A	Engineering release.
—	November 2007	B	Included engineering updates.
—	December 2007	C	Included engineering updates.
EC000348	April 2008	D	Initial release.



# Contents

---

**Summary of Changes** iii

**Contents** v

**Tables** xiii

**Preface** xvii

Organization xvii

Alert Messages xviii

Related Publications xviii

Additional Information xix

    External Web Site xix

    Partners Site xix

    Hardcopy Publications xix

Worldwide Offices xix

**Fiber-optic Safety** xx

    Fiber-optic Cable Installation xxi

    Fiber-optic Cable Handling xxi

**1. Physical Interface** 1

    Implementation 1

    Ports 2

    Topologies 3

        Arbitrated Loop 3

        Private Loop 3

Public Loop	3
Direct Fabric Attachment	3
Cables and Connectors	4
<b>2. Fibre Channel Operations</b>	<b>5</b>
Fibre Channel Levels	5
Terms/Definitions	6
FC-Tape Terms	6
Sun StorageTek Terms	6
Error Detection and Management	7
FC-0 Features	8
FC-0 and Initialization	8
Device States (FC-0, FC-1, FC-2)	8
Power On	8
Not Ready	8
Ready	8
Power Off	8
FC-1 Features	9
FC-1 and Initialization	9
8B/10B Encoding and Decoding	9
Disparity	9
FC-AL Features	10
Initialization	10
Address Processes	11
Open State/Loop Initialization	12
Related Processes	12
Completion Processes	13
Feature Set	14
Login_BB_Credit Equals Zero	15
Open and Close Latencies	15
Fabric F_PORT Attachment Initialization	15
FC-2 Features	16
Login Validation	16
Class of Service Parameters	17



Class 3 Service Parameters, Port Login	18
Class 3 Service Parameters, Fabric Login	19
Basic Commands	21
Extended Commands	21
Responses to Link Services	24
Exchange Management	26
Sequence Management	27
Sequence Errors	28
CRC	28
Timers	29
Arbitrated Loop Timeout	29
Receiver_Transmitter Timeout	29
Error_Detect Timeout	29
Resource Allocation Timeouts	30
Resource Recovery Timeout	30
REC Timeout	30
Upper Level Protocol Timeout	30
FC-3 Common Service Features	31
FC-4 (FCP) Features	33
FCP Process Login Parameters	33
FCP Information Units	35
Command Information Unit	36
Transfer Ready Information Units	37
Data Information Unit	37
Response Information Unit	37
Response Payload	38
Response Codes	38
Task Management Flag and Information Units	41
Public Loop SCSI Target Discovery	42
Private Loop SCSI Target Discovery	42
Clearing the Effects of Fibre Channel Actions	44
Device Reservations	46

<b>3. SCSI Commands</b>	<b>49</b>
Implementation Requirements	49
Command Descriptor Block	50
Control Byte	51
List of Supported Commands	52
Operator Entries for Fibre Channel	53
Initialize Element Status	54
Initialize Element Status With Range	55
Inquiry	56
Standard Inquiry Data Definition	57
Supported Pages Definition	59
Unit Serial Number Page Definition	60
Device Identification Page	61
Log Sense	63
Supported Pages Format Page	64
Last n Errors Events Page Format	64
Mode Select (6)	65
Mode Select (6) Data	66
Mode Select (6) Parameter Header	66
Protocol Specific Logical Unit Page	67
Protocol Specific Port Page	68
Element Address Assignment Mode Page	69
Mode Select (10)	71
Mode Select (10) Data	72
Mode Select (10) Parameter Header	72
Protocol Specific Logical Unit Page	73
Protocol Specific Port Page	74
Element Address Assignment Mode Page	75
Mode Sense (6)	77
Mode Sense (6) Data	79
Mode Sense (6) Parameter Header Definition	79
Protocol Specific Logical Unit Control Page	80
Protocol Specific Port Control Page	81

Element Address Assignment Page Definition	82
Transport Geometry Mode Page Definition	84
Device Capabilities Page Definition	85
Mode Sense (10)	89
Mode Sense (10) Data	91
Mode Sense (10) Parameter Header Definition	91
Protocol Specific Logical Unit Page	92
Protocol Specific Port Control Page	93
Element Address Assignment Page Definition	94
Transport Geometry Mode Page Definition	96
Device Capabilities Page Definition	97
Move Medium	101
Persistent Reserve In	103
Read Keys Data	104
Read Reservations Data	105
Persistent Reserve In Data for Report Capabilities	107
Persistent Reserve Out	109
Registering a Reservation Key	113
Creating a Persistent Reservation	113
Releasing a Persistent Reservation	113
Clearing all Persistent Reservations and Keys	114
Pre-empting Reservations Made by Another Initiator	114
Position to Element	115
Prevent/Allow Medium Removal	116
Read Element Status	117
Read Element Status Data	118
Element Status Data Header Definition	119
Element Status Page Header Definition	120
Medium Transport Element Descriptor Definition	122
Storage Element Descriptor Definition	125
Import/Export Element Descriptor Definitions	128
Data Transfer Element Descriptor Definitions	132
Data Transfer Element Descriptor Definitions	136

Release (6)	140
Report LUNS	141
Report LUNs Data Definition	142
Request Sense	143
Sense Data	144
Request Sense Data Definitions	145
Sense Key	147
Additional Sense Codes and Qualifiers	147
No Sense Key	147
Not Ready Sense Key Codes	148
Not Ready, Cause Not Reportable	148
Not Ready, In Process of Becoming Ready	148
Not Ready, Manual Intervention Required	148
Not Ready, Maintenance Mode	148
Not Ready, Cleaning Cartridge Installed	149
Not Ready, Cartridge Access Port Open	149
Not Ready, LUN Access Not Authorized	149
Hardware Error Sense Key	150
Hardware Error, General	150
Hardware Error, Tape Drive	150
Hardware Error, CAP	150
Hardware Error, Embedded Software	150
Hardware Error, Media Load/Eject Failed	150
Illegal Request Sense Key	151
Unit Attention Sense Key	152
Not Ready to Ready Transition	152
CAP Element Accessed	152
Power On	152
LUN Reset	152
Target Reset	153
Mode Parameters Changed	153
Persistent Reservations/Registrations Preempted or Released	153
Microcode Has Been Changed	153

LUNs Data Has Changed	153
Aborted Command Sense Key	154
Mechanical Positioning Error	154
Initiator Detected Error	154
Command Phase Error	154
Data Phase Error	154
Command Overlap	154
Request Volume Element Address	155
Volume Element Address Header Definition	157
Reserve (6)	158
Element List Descriptor Definitions	159
Other Commands and Reservations	160
Send Diagnostic	161
Send Volume Tag	162
Send Volume Tag Parameter List	163
Test Unit Ready	164
<b>A. Cell Maps</b>	<b>165</b>
Modular Design	165
Addressing	167
Columns	168
Sides	169
Configuration Block	169
Drive Module Slots	170
Module Configurations	170
Base Module Rear Wall	171
Base Module Front Wall	172
Drive Expansion Module Rear Wall	173
Drive Expansion Module Front Wall	174
Left-side Cartridge Expansion Module Rear Wall	175
Left-side Cartridge Expansion Module Front Wall	176
Right-side Cartridge Expansion Module Rear Wall	177
Right-side Cartridge Expansion Module Front Wall	178
Left-side Parking Expansion Module Rear Wall	179

Left-side Parking Expansion Module Front Wall	180
Right-side Parking Expansion Module Rear Wall	181
Right-side Parking Expansion Module Front Wall	182
Capacities	183
Module Comparisons	184

## **B. Content Management and Partitioning 193**

Planning for Content	193
CenterLine Technology and Modular Design	193
Robotic Rails and TallBots	195
Cartridge Access Ports	195
Managing Cartridges	196
Planning for Tape Drives	197
Planning for Capacity and Growth	198
Crimson Slot Capacity	198
Capacity on Demand	199
RealTime Growth™ Technology	199
Out-of-the Box Slot Numbering	200
Default SCSI Element Ordering	202
Partitioning	204
Partitioning Feature	204
Active Regions	205
Guidelines	208
Planning the Data Path	208
Performance Zone	209
Cartridge Access Ports and Partitions	210
Partitions	211
Library Console	212
Host Software Precautions	214
Tasks	215
Planning Partitions	216
<b>Glossary</b>	<b>219</b>
<b>Index</b>	<b>223</b>

# Tables

---

TABLE 1-1	Library Cables and Connectors	4
TABLE 2-1	Fibre Channel Levels	5
TABLE 2-2	Transmission Word	6
TABLE 2-3	End of Frame Delimiters	10
TABLE 2-4	FC-AL Feature Set	14
TABLE 2-5	Library Identification Scheme	16
TABLE 2-6	Start of Frame Delimiters, Class 3	17
TABLE 2-7	Class 3 Service Parameters, Port Login	18
TABLE 2-8	Class 3 Service Parameters, Fabric Login	19
TABLE 2-9	Other FC-2 Features	20
TABLE 2-10	Basic Link Services	21
TABLE 2-11	Extended Link Services	21
TABLE 2-12	Response to Link Services from NL_Ports Not Logged-In	24
TABLE 2-13	FC-4 Link Services	24
TABLE 2-14	Exchange Content Header	26
TABLE 2-15	Sequence Content Header	27
TABLE 2-16	Timer Summary	29
TABLE 2-17	NL_Port Common Service Parameters, Port Login	31
TABLE 2-18	NL_Port Common Service Parameters, Fabric Login	32
TABLE 2-19	PRLI Parameters	33
TABLE 2-20	PRLI Accept FCP Services Parameter Page	34
TABLE 2-21	FCP 8-byte LUN	36
TABLE 2-22	FCP_RSP Payload	38
TABLE 2-23	FCP_RSP Code	39

TABLE 2-24	Command Confirmation Usage	40
TABLE 2-25	FCP Task Management Flags	41
TABLE 2-26	FCP Task Attributes	41
TABLE 2-27	Other FCP Features	42
TABLE 2-28	Clearing Effects	44
TABLE 2-29	Reserve/Release Management Method	46
TABLE 2-30	Persistent Reservation Management Method	47
TABLE 3-1	6-Byte Command Descriptor Block	50
TABLE 3-2	10-Byte Command Descriptor Block	50
TABLE 3-3	12-Byte Command Descriptor Block	50
TABLE 3-4	Control Byte	51
TABLE 3-5	Supported Commands	52
TABLE 3-6	Initialize Element Status Command	54
TABLE 3-7	Initialize Element Status With Range Command	55
TABLE 3-8	Inquiry Command	56
TABLE 3-9	Standard Inquiry Data	57
TABLE 3-10	Supported Pages	59
TABLE 3-11	Unit Serial Number Page	60
TABLE 3-12	Device Identification Page Data	61
TABLE 3-13	Fibre Channel Device Identification	62
TABLE 3-14	Log Sense Command	63
TABLE 3-15	Supported Pages Format Page	64
TABLE 3-16	Last n Errors Events Page	64
TABLE 3-17	Mode Select (6) Command	65
TABLE 3-18	Mode Select Parameter (6) Header	66
TABLE 3-19	Protocol Specific Logical Unit Page	67
TABLE 3-20	Protocol Specific Port Page	68
TABLE 3-21	Mode Select (6) Element Address Assignment Mode Page	69
TABLE 3-22	Mode Select (10) Command	71
TABLE 3-23	Mode Select Parameter Header	72
TABLE 3-24	Protocol Specific Logical Unit Page	73
TABLE 3-25	Protocol Specific Port Page	74
TABLE 3-26	Mode Select (6) Element Address Assignment Mode Page	75



TABLE 3-27	Mode Sense Command	77
TABLE 3-28	Mode Sense (6) Parameter Header	79
TABLE 3-29	Protocol Specific Logical Unit Control Page	80
TABLE 3-30	Protocol Specific Port Control Page	81
TABLE 3-31	Mode Sense (6) Element Address Assignment Page	82
TABLE 3-32	Transport Geometry Mode Page	84
TABLE 3-33	Device Capabilities Page	85
TABLE 3-34	Mode Sense (10) Command	89
TABLE 3-35	Mode Sense Parameter Header Page	91
TABLE 3-36	Protocol Specific Logical Unit Page	92
TABLE 3-37	Protocol Specific Port Control Page	93
TABLE 3-38	Element Address Assignment Page	94
TABLE 3-39	Transport Geometry Mode Page	96
TABLE 3-40	Device Capabilities Page	97
TABLE 3-41	Move Medium Command	101
TABLE 3-42	Persistent Reserve In Command	103
TABLE 3-43	Read Keys Data	104
TABLE 3-44	Read Reservations Data	105
TABLE 3-45	Reservation Descriptors Format	106
TABLE 3-46	Persistent Reserve In Parameter Data for Report Capabilities	107
TABLE 3-47	Read Reservations Parameter Data	108
TABLE 3-48	Persistent Reserve Out Command	109
TABLE 3-49	Persistent Reserve Out Parameter List	111
TABLE 3-50	Persistent Reserve Out Service Actions and Valid Parameters	112
TABLE 3-51	Service Action Reservation Key Information	112
TABLE 3-52	Position to Element Command	115
TABLE 3-53	Prevent/Allow Medium Removal Command	116
TABLE 3-54	Read Element Status Command	117
TABLE 3-55	Element Status Data Header Definition	119
TABLE 3-56	Element Status Page Header	120
TABLE 3-57	Medium Transport Element Descriptor	122
TABLE 3-58	Storage Element Descriptor	125
TABLE 3-59	Import/Export Element Descriptor	128

TABLE 3-60	Data Transfer Element Descriptor When DvcID = 0	132
TABLE 3-61	Data Transfer Element Descriptor When DvcID = 1	136
TABLE 3-62	Release Command (6)	140
TABLE 3-63	Report LUNs Command	141
TABLE 3-64	Report LUNs Data	142
TABLE 3-65	LUN Descriptor	142
TABLE 3-66	Request Sense Command	143
TABLE 3-67	Request Sense Data	145
TABLE 3-68	Sense Key Code Descriptions	147
TABLE 3-69	Not Ready Sense Keys	148
TABLE 3-70	Hardware Error Sense Keys	150
TABLE 3-71	Illegal Request Sense Keys	151
TABLE 3-72	Unit Attention Sense Keys	152
TABLE 3-73	Aborted Command Sense Keys	154
TABLE 3-74	Request Volume Element Address Command	155
TABLE 3-75	Volume Element Address Header	157
TABLE 3-76	Reserve Command	158
TABLE 3-77	Element List Descriptor	159
TABLE 3-78	Send Diagnostic Command	161
TABLE 3-79	Send Volume Tag Command	162
TABLE 3-80	Send Volume Tag Parameter List	163
TABLE 3-81	Test Unit Ready Command	164
TABLE A-1	Addressing Scheme	167
TABLE A-2	Slot Count Per Module and Configuration	183
TABLE B-1	Slot Capacity Concepts	198
TABLE B-2	Steps and Tasks for Partitioning	215
TABLE B-3	Partition Planning	216

# Preface

---

This manual is intended for independent software vendors (ISVs), operating system designers and developers, hardware and software engineers responsible for implementing the small computer system interface (SCSI) over a Fibre Channel physical interface on the Sun StorageTek SL3000 modular library system—referred to in this manual as “the SL3000 library,” or just the “library.”

This manual contains information about the small computer system interface command set plus information about Fibre Channel operations, command implementations, topologies, cables, and connectors.

**Note** – This manual *does not* describe the Fibre Channel operations and commands for the tape drives in the library.

---

## Organization

The organization of this manual is:

Chapter Number and Title	This Chapter...
<a href="#">Chapter 1, “Physical Interface”</a>	Describes the ports, topologies and cable requirements for the Fibre Channel interface.
<a href="#">Chapter 2, “Fibre Channel Operations”</a>	Explains the structure of the Fibre Channel standard and the implications for library operation in an arbitrated loop topology.
<a href="#">Chapter 3, “SCSI Commands”</a>	Lists and defines the small computer system interface (SCSI) command set for the library.
<a href="#">Appendix A, “Cell Maps”</a>	Shows the cell mappings and configurations for the library.
<a href="#">Appendix B, “Content Management and Partitioning”</a>	Provides information about how to optimize the SL3000 library using content management and the elements of partitioning.

---

## Alert Messages

Alert messages call your attention to information that is especially important or that has a unique relationship to the main text or graphic.

**Note** – A note provides additional information that is of special interest. A note might point out exceptions to rules or procedures. A note usually, but not always, follows the information to which it pertains.

---

## Related Publications

For your convenience, the following sections list publications that provide information about the interfaces and libraries mentioned in this manual. Listed publications are subject to change without notice

<b>Publication</b>	<b>Part Number</b>
<i>American National Standard Dictionary for Information Processing Systems</i>	X3/TR-1-82
<i>SCSI-3 Primary Commands (SPC)</i>	X3.301-1997
<i>SCSI-3 Primary Commands (SPC-2)</i>	T10/Project 1236D
<i>SCSI-3 Medium Changer Commands (SMC)</i>	T10/Project 1383D
<i>SCSI-3 Architecture Model (SAM)</i>	X3.270-1996
<i>SCSI Architecture Model – 2 (SAM-2)</i>	T10/Project 1157D
<i>Fibre Channel Physical and Signaling Interface (FC-PH)</i>	X3.230-1994 Revision 4.3
	X3.230-1996 (Amendment 1)
	X3.230-1997 (Amendment 2)
<i>Fibre Channel Physical and Signaling Interface (FC-PH-2)</i>	X3.297-1996 Revision 7.4
<i>Fibre Channel Physical and Signaling Interface (FC-PH-3)</i>	X3.303-199x Revision 9.3
<i>Fibre Channel Arbitrated Loop (FC-AL)</i>	X3.272-1996 Revision 4.5
<i>Fibre Channel Arbitrated Loop (FC-AL-2)</i>	X3.272-199x Revision 7.0
<i>Fibre Channel Protocol for SCSI (FCP)</i>	X3.269-1996 Revision 12
<i>Fibre Channel Protocol for SCSI (FCP-2)</i>	T10/Project 1144D Revision 01
<i>Fibre Channel Tape (FC-Tape)</i>	NCITS TR-XX Revision 1.17

---

## Additional Information

Sun Microsystems, Inc. (Sun) offers several methods for you to obtain additional information.

### External Web Site

Sun's external Web site provides marketing, product, event, corporate, and service information. The external Web site is accessible to anyone with a Web browser and an Internet connection.

The URL for the external Web site is: <http://www.sun.com>

### Partners Site

The Partners Site is a Web site for partners with a Partner Agreement.

This site provides information about products, services, customer support, upcoming events, training programs, and sales tools to support our Partners.

The URL for partners is: <http://www.sun.com/partners/>

### Hardcopy Publications

Contact a Sun StorageTek representative for additional copies of this manual or other Sun StorageTek publications.

---

## Worldwide Offices

You may contact any of Sun's worldwide offices to discuss complete storage, service, and support solutions for your organization.

You can find address and telephone number information on 's external Web site at: <http://www.sun.com/worldwide/>

# Fiber-optic Safety

---



**Warnings:**

- *Possible physical injury. Laser hazard.*  
Never look directly into fiber-optic cable, a fiber-optic connector, or a laser transceiver module. Hazardous conditions may exist from laser power levels that are capable of causing injury to the eye.
  - Use of controls, adjustment or executing procedures other than those specified herein might result in a hazardous laser radiation exposure.
  - Be especially careful when you use optical instruments with this equipment. Such instruments might increase the likelihood of injury to your eyes.
- 

The laser transceivers in fiber-optic equipment can pose dangers to personal safety. Ensure that anyone who works with this Sun StorageTek equipment understands these dangers and follows safety procedures. Ensure that the optical ports of every laser transceiver module are terminated with an optical connector, a dust plug, or cover.

Each fiber-optic interface in this Sun StorageTek equipment contains a laser transceiver that is a Class I Laser Product.

The following warnings apply to Sun StorageTek products that contain a laser or LED device as defined in EN60825-1 and Section 21 CFR 1040 of the Food and Drug Administration (FDA) regulations.

CLASS 1 LASER PRODUCT LASER KLASSE 1 APPAREIL A LASER DE CLASSE 1 COMPLIES WITH 21 CFR 1040.10 AND 1040.11
---

The following is a translation for users in Finland and Sweden who wish to identify laser safety and classification:

CLASS 1 LASER LUOKAN 1 LASERLAITE KLASSE 1 LASER APPARAT
--

## Fiber-optic Cable Installation

Follow these guidelines when you install fiber-optic cables:

### 1. Cable routing:

- **Raised floor:** You may install fiber-optic cables under a raised floor. Route them away from any obstruction, such as existing cables or other equipment.
- **Cable tray or raceway:** Place the cables in position; do not pull them through the cable tray. Route the cables away from sharp corners, ceiling hangers, pipes, and construction activity.
- **Vertical rise length:** Leave the cables on the shipping spool, and lower them from above; do not pull the cables up from below. Use proper cable ties to secure the cable.
- **General:** Do not install fiber-optic cables on top of smoke detectors.

### 2. Cable management:

- Leave at least 4.6 m (15 ft) of cable at each end for future growth.
- Use strain reliefs to prevent the weight of the cable from damaging the connector.
- Review all information in this manual and in any related manuals about safely handling fiber-optic cables.

### 3. Connector protection:

- Insert connectors carefully to prevent damage to the connector or fiber.
- Leave the connector's protective cover in place until you are ready to make connections.
- Replace the connector's protective cover when the connector is disconnected.
- Clean the connector before making a connection. Make sure that there are no obstructions and that keyways are aligned.

## Fiber-optic Cable Handling

Observe these precautions when you handle fiber-optic cables:

- Do not coil the cable to less than 96 mm (3.75 in.) in diameter.
- Do not bend the cable to less than 12 mm (0.5 in.) in radius. StorageTek recommends that a cable's bend radius be no less than 20 times the diameter of the cable.
- Do not pull on the cables; carefully place them into position.
- Do not grasp the cables with pliers, grippers, or side cutters; do not attach pulling devices to the cables or connectors.
- Keep cables away from sharp edges or sharp protrusions that could cut or wear through the cable; make sure that cutouts in the equipment have protective edging.
- Protect the cable from extreme temperature conditions.
- Install the connector's protective cover whenever the connector is not connected.





# Physical Interface

---

This chapter describes the Fibre Channel physical interface to the SL3000 library.

**Note** – The Sun StorageTek implementation of Fibre Channel conforms to the:

- American National Standards Institute (ANSI)
- National Committee for Information Technology Standards (NCITS)

---

## Implementation

Implementations for the SL3000 library includes:

- Arbitrated loop
- FCP (SCSI-3) command set for medium changer devices
- Class 3 level of service
- Private Loop operation
- Public Loop operation
- Direct fabric attach operation
- Hard-assigned port addresses (AL-PA)
- Basic and extended link services
- Connections to an external hub (or switch)
- Data transfer rates of 200 MB/s (2 Gb/s)
- Standard approved length shortwave fibre optic cables
- Multimode laser operating at 780 nanometers (shortwave) non-OFC

## Ports

Library ports are N\*\_Ports in a Fibre Channel topology.

The “N\*” here stands generically for a type of “node” port.

More specifically, the link at the library can be a N\_Port in a point-to-point topology but is more often an NL\_Port in an arbitrated loop topology.

An N\*\_Port supports:

- one media type,
- one media rate, and
- one or more classes of service.

**Note** – Class 3 Service is the only class of service that the SL3000 library supports.

Thus data transmission between N\*\_Ports occurs only if the ports have the same media type, the same media rate, and at least one class of service in common.

In addition, in arbitrated loop topologies, one N\*\_Port typically communicates with only one other N\*\_Port on the loop at a time. For more information about arbitrated loop topologies, see [“Arbitrated Loop” on page 3](#).

When an N\*\_Port is connected to a Fibre Channel fabric, typically through an F\*\_Port, the breadth of possibilities for data transmission increases because the fabric topology permits:

- Many pairs of N\*\_Ports to communicate at the same time
- Communication between dissimilar N\*\_Ports

For more information about the Fibre Channel fabric topology, see [“Direct Fabric Attachment” on page 3](#).

---

# Topologies

Sun StorageTek libraries support the following topologies with single port attachment:

- Arbitrated Loop—private loop
- Arbitrated Loop—public loop
- Direct fabric attachment

## Arbitrated Loop

In a Fibre Channel arbitrated loop, when devices want to communicate on the bus, they must arbitrate and win the connection before communications can begin. Once a device is powered-on and initialized on the loop, it must arbitrate and win to be able to communicate with other devices on the loop.

### Private Loop

If the arbitrated loop is not attached to a Fibre Channel fabric (that is, to an F\*\_port), it is a private loop. A private arbitrated loop can connect up to 126 NL\_ports. Again only point-to-point communication is possible between one initiator and one target at any time. In addition, initiator and target must reside within the same loop.

### Public Loop

If the arbitrated loop contains at least one FL\_port attached to a Fibre Channel fabric it is a public loop. A public loop can contain up to 126 NL\_ports and one FL\_port. If the fabric connects to another arbitrated loop, then an initiator on one public loop might be able to communicate with a target on another.

## Direct Fabric Attachment

The advantage of attaching a library to a fabric is that the fabric can aid the library's communication with a variety of devices. A fabric element might:

- Attach N\*\_Ports with different Media types, Media rates, or Classes of service
- Attach arbitrated loops
- Serve as a root element for distributed fabric elements

A fabric element might support different:

- Port types, Classes of service, Media types, Media rates
- Address assignment methods
- Frame routing techniques

After a frame leaves the source N\*\_Port and enters the fabric, each fabric element selects the next link toward the destination N\*\_Port. Usually the path includes two links between the source N\*\_Port and the destination N\*\_Port.

# Cables and Connectors

Because the link to a port can be driven either optically or electrically, the term “fibre” in Fibre Channel refers to *either* a fiber optic or a copper cable.

Optical transmission occurs over both:

- single and multi-mode fibers using
- both laser and light emitting diodes (LEDs) for
- short (770–850 nm) and long (1300–1360 nm) wavelengths

TABLE 1-1 lists the cable and connector specifications that the library supports. FIGURE 1-1 shows an example of media (cable) identification.

**TABLE 1-1** Library Cables and Connectors

Distance		FC-0 Code	Cable	Type	Connector
Meters	Feet				
2-150	6.5-490	200-M6-SN-1	62.5 µm Multimode	780 nm Shortwave laser w/o OFC	Keyed Duplex LC
2-300	6.5-985	100-M6-SN-I	62.5 µm Multimode	Shortwave laser w/o OFC	Keyed Duplex SC
2-500	6.5-1640	100-M5-SN-I	50 µm Multimode	Shortwave laser w/o OFC	Keyed Duplex SC

**FIGURE 1-1** FC-0 Level Communication—Media or Cable Types

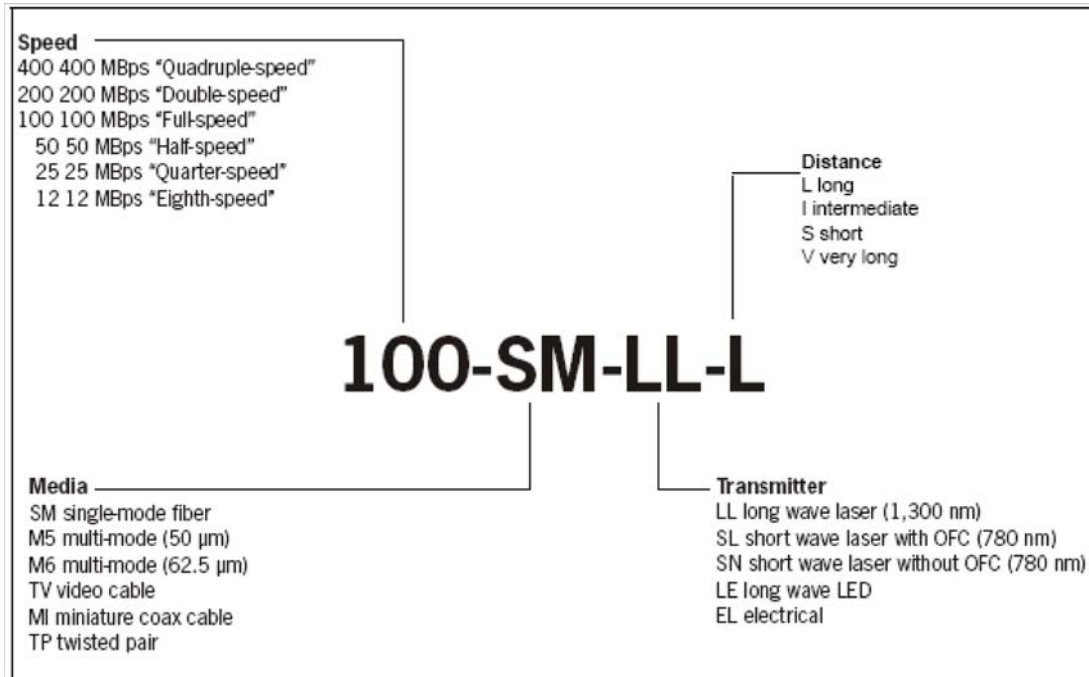

# Fibre Channel Operations

This chapter describes how the SL3000 library operates using Fibre Channel.

## Fibre Channel Levels

TABLE 2-1 shows the five levels and arbitrated loop (FC-AL) grouping of functions for transmission over a Fibre Channel interface.

**TABLE 2-1** Fibre Channel Levels

Levels	Function	Content
FC-4	Upper Level Protocol Mapping	<ul style="list-style-type: none"> <li>■ Mapping of ULP functions</li> </ul>
FC-3	Common Services	
FC-2	Link Service	<ul style="list-style-type: none"> <li>■ Login and Logout services</li> <li>■ Basic Link and Extended Link services</li> </ul>
	Signaling Protocol	<ul style="list-style-type: none"> <li>■ Frames, sequences, and exchanges</li> <li>■ N_Ports, F_Ports, and topologies</li> <li>■ Classes of Service (1, 2, and 3)</li> <li>■ Buffer-to-buffer/end-to-end flow control</li> </ul>
FC-AL	Arbitrated Loop Functions	<ul style="list-style-type: none"> <li>■ Ordered sets for loop arbitration</li> <li>■ Loop initialization</li> <li>■ Physical address assignments</li> </ul>
FC-1	Transmission Protocol	<ul style="list-style-type: none"> <li>■ Encoding and decoding</li> <li>■ Link management</li> <li>■ Error monitoring</li> </ul>
FC-0	Physical Interface	<ul style="list-style-type: none"> <li>■ Transmitters, receivers, and bandwidth</li> </ul>
	Media	<ul style="list-style-type: none"> <li>■ Cables and connectors</li> </ul>

The remaining sections of this chapter explain how these levels work.

# Terms/Definitions

Tables throughout this chapter use the following terms to show compliance with ANSI's Fibre Channel Tape (FC-Tape) Technical Report and to show how Sun StorageTek implements them.

## FC-Tape Terms

**Allowed (A):** Can be used between an initiator and a target (library or tape drive). This status is typically dependent on the particular feature or parameter and its applicability to the request from an initiator.

**Invokable (I):** Can be used between an initiator and a target. For example, if a feature is invoked, the recipient must implement and respond to the feature or parameter.

**Prohibited (P):** Can *not* be used between an initiator and a target.

**Required (R):** *Must* be used between an initiator and a target. Both the initiator and target must implement the feature or parameter.

**Dash (-):** This parameter is not meaningful.

**Blank (0):** The feature is not part of the feature set.

**Initiator:** SCSI device that originates commands.

**Target:** SCSI device that receives commands.

## Sun StorageTek Terms

**Yes (Y):** Sun StorageTek library conforms to that command, feature, or value.

**No (N):** Sun StorageTek library does *not* conform to that command, feature, or value.

**Originate (Orig.):** Originates the exchange or SCSI command from the library.

**Response (Resp.):** Returns an acknowledgement (R\_RDY and/or data) from the library.

**Transmission Word:** A four-byte character containing 32 bits of information. This is the smallest information unit transmitted on Fibre Channel. See [TABLE 2-2](#).

**TABLE 2-2** Transmission Word

Word	Byte 0		Byte 1		Byte 2		Byte 3	
	(MSB) <span style="margin-left: 150px;">Bits</span> (LSB)							
<b>n</b>	31	24	23	16	15	8	7	0
Note:	(MSB) = Most significant bit				(LSB) = Least significant bit			

---

# Error Detection and Management

In the Fibre Channel protocol, error detection falls into two categories: frame errors and link-level errors.

- Frame errors result in missing or corrupted frames, which may ultimately involve the Fibre Channel protocol level to resolve.
- Link-level errors include errors such as loss of signal, loss of synchronization, and timeouts.

Some protocols provide for error detection and management by using timeouts, which is an inefficient mechanism to detect and recover from frame transmission errors.

A problem with Class 3 operation (currently the only FC-2 Service Class supported) is that it offers no confirmation of frame delivery. However, the originator can deduce some delivery of frames from successfully receiving a command when:

- FCP Transfer Ready was sent by the command recipient
- A response was received

Fibre Channel provides no error correction on data during transfers, but it does provide excellent error detection schemes, including:

- 8B/10B encoding and decoding, see [“8B/10B Encoding and Decoding” on page 9](#)
- Disparity, see [“Disparity” on page 9](#)
- Sequence errors and out-of-order delivery, see [“Sequence Errors” on page 28](#)
- Cyclic redundancy checks (CRC) see [“CRC” on page 28](#)

## FC-0 Features

The FC-0 level defines the physical level of the Fibre Channel protocol. This includes media types, connectors, and the optical characteristics that are necessary for connecting ports.

## FC-0 and Initialization

A minimum level of initialization occurs at the FC-0 level.

When the library is powered on, this level assures that the links are active and initializes any shortwave laser transmitters. Longwave laser transmitters and all receivers are ready immediately. The level conveys any loss of signal state to the FC-1 level, which reports it to the FC-2 level.

## Device States (FC-0, FC-1, FC-2)

The following sections describe the relationships between library states and port states and between library states and incoming commands. Communication about device states involves the FC-0, FC-1 and FC-2 levels.

### Power On

When the library completes the power-on process, the Fibre Channel port is enabled and attempts to initialize on the attached Fibre Channel topology.

When the library completes the power-on initialization process, the library transitions from offline to online and is capable of media changer operations.

### Not Ready

Commands like Inquiry that do not require the library to be online will still execute normally.

All other commands that require the library to be online will get a Check Condition status.

### Ready

All available commands may now be executed with the library.

### Power Off

In the process of powering off the library, the Fibre Channel Protocol chips will lose power. If the library is connected to a hub or switch, the hub/switch bypass will be activated. The library has no port bypass capability.



---

## FC-1 Features

The FC-1 level of the Fibre Channel protocol defines the transmission protocol. This level includes the 8B/10B encoding/decoding scheme, word order transmission, and error detection.

### FC-1 and Initialization

During initialization, the FC-1 level provides an encoded bit stream (primitive sequence) to the FC-0 level. When the FC-1 level, in turn, receives a proper bit stream, the FC-1 level converts the stream into a form used by the FC-2 level. The process achieves synchronization for both transmission characters and transmission words.

### 8B/10B Encoding and Decoding

Fibre Channel uses a special process called encoding and decoding that is designed to reduce distortion during transmission and aid in the detection of errors at the receiving port. This process makes it highly likely that single and multiple bit errors are detected.

Besides providing error detection, this process also balances the turning on and off of the light for the loading of the optical fiber transmitters.

The process of encoding uses an algorithm that takes the original 8 bits in each byte and transforms them into 10 bits for transmission. The result is an 8B/10B encoding of a byte which is referred to as a transmission character.

### Disparity

Along with the 8B/10B encoding, Fibre Channel uses another scheme to protect transmission characters and aid in error detection: running disparity. Running disparity adds a second dimension to the transmission of characters. This dimension provides a balance of ones and zeros, which helps protect transmission characters and controls the heat output of the transmitter.

A negative running disparity is maintained following the transmission of the end-of-frame (EOF) delimiter. It remains negative until the transmission of the next start-of-frame delimiter.

Because the running disparity within a frame is variable, two different EOF delimiters are used (see TABLE 2-3), depending on the content of the frame following the transmission of the CRC (see “CRC” on page 28).

**TABLE 2-3** End of Frame Delimiters

Delimiter	Abbreviation	RD	Transmission Word Characters			
EOF Normal	EOFn	Neg.	K28.5	D21.4	D21.6	D21.6
		Pos.	K28.5	D21.5	D21.6	D21.6
EOF Terminate	EOFt	Neg.	K28.5	D21.4	D21.3	D12.3
		Pos.	K28.5	D21.5	D21.3	D21.3
EOF Abort	EOFa	Neg.	K28.5	D21.4	D21.7	D21.7
		Pos.	K28.5	D21.5	D21.7	D21.7
EOF Normal Invalid	EOFni	Neg.	K28.5	D10.4	D21.6	D21.6
		Pos.	K28.5	D10.5	D21.6	D21.6

---

## FC-AL Features

Initialization and other processes take on special attributes and functions in an arbitrated loop topology. The following sections explain these attributes and functions as specified in the Fibre Channel Arbitrated Loop (FC-AL) specification.

### Initialization

Arbitrated loop initialization protocol assigns up to a possible 126 addresses to different ports on the loop and builds a map of these addresses. The following sections describe some loop initialization features that StorageTek libraries perform.

Loop initialization must occur before operations on the loop can begin. The Loop Initialization Primitive (LIP) sequence is a series of initialization frames that establish NL\_Ports on the loop.

Any NL\_Port on the loop is capable of starting an initialization sequence by transmitting LIP. When the next NL\_Port detects the LIP sequence, it retransmits it to the next NL\_Port until the LIP sequence travels around the loop to the NL\_Port initiating the sequence. During loop initialization, NL\_Port addresses (AL\_PA) are assigned (00h to EFh).

NL\_Port addresses (AL\_PA) can be either hard (hardware assigned) or soft (system assigned) during loop initialization.

An NL\_Port attempts to establish its previous acquired address before attempting to acquire another address. This occurs when the NL\_Port is powered on, experiences a power-on reset, recognizes a LIP (AL\_PD or AL\_PS), or experiences any other event that causes the NL\_Port to lose communications.

**Note** – Sun StorageTek libraries may use a hard-assigned address (entered through the Library Console or with the Horizon Library Monitor) and attempt to assign that address during loop initialization. If unable to obtain that address, the libraries accept soft addresses by the system.

## Address Processes

Initialization involves address acquisition as described in the following sections.

### *Arbitrated Loop Physical Address*

When an NL\_Port enters the loop (such as a power-on), it begins initialization to acquire an address and to notify other ports there is a change in configuration.

**Note** – If there is an exchange in process when a LIP begins, that exchange is disrupted and possible frame corruption could occur, which would result in an Upper Level Protocol timeout.

- If the NL\_Port does not have a valid address, it begins the initialization sequence with LIP(F7,F7).
- If the NL\_Port has a valid address, it begins initialization with LIP (F7,AL\_PS).

### *Loop Initialization Fabric Assigned Address*

StorageTek libraries support the process of Loop Initialization Fabric Assigned (LIFA) addresses. This process is supported when the library is operating in Public Loop mode.

### *Loop Initialization Previously Acquired*

StorageTek libraries support the process of Loop Initialization Previously Acquired (LIPA) addresses. This process is supported when the library has previously acquired an address.

### *Loop Initialization Hard Assigned*

StorageTek libraries support the process of Loop Initialization Hard Assigned (LIHA) addresses. This process is supported when the library is first powered-on and a configuration parameter enables it.

*Loop Initialization Soft Assigned*

StorageTek libraries support the process of Loop Initialization Soft Assigned (LISA) addresses. This process is supported when the hard-assigned address has been used by a different device or the hard-assigned addressing is disabled.

*Failure to Obtain a Loop Address*

If an NL\_Port is unable to obtain an address (fabric assigned, previously assigned, hard assigned, or soft assigned), it goes into a non-participating mode and immediately implicitly logs out all NL\_Ports.

If an NL\_Port experiences a power-on reset or recognizes a LIP(AL\_PD,AL\_PS), it is not required to retain a previously acquired address to use during the next loop initialization.

**Open State/Loop Initialization**

The open initializing (OPEN-INIT) state performs the process of loop initialization. When ports are in this state, initialization frames are transmitted and received to identify the temporary loop master and to assign AL\_PA values. Entering this state assumes the loop is operational and sets the Available BB\_Credit equal to zero. See [“Login\\_BB\\_Credit Equals Zero” on page 15](#).

**Related Processes**

The following processes might occur during initialization.

*Loop Initialization Select Master*

StorageTek libraries support the process of selecting a Loop Initialization Select Master (LISM) by using the device with the lowest port address.

**Note** – If an FL\_Port (fabric loop attachment) is present, it assumes the role of Loop Initialization Select Master.

*Loop Initialization Report Position*

StorageTek libraries support the mapping process to build a map of the AL\_PA values according to the library’s position on the loop. The temporary loop master begins the procedure to create a Loop Initialization Report (LIRP).

This initialization report and map is done by using a 1-word frame identifier with an offset value of one (1). As the frame is transmitted around the loop, the next NL\_Port increments the offset by a value of one and stores the information in the AL\_PA map.

### *Selective Reset*

Selective resets perform a reset on the receiving port. These resets are helpful for error recovery or reconfiguration of the loop. Any NL\_Port that uses a selective reset transmits a LIP(AL\_PD,AL\_PS). See [TABLE 2-28](#) for clearing effects.

- AL\_PD field contains the address of the port being reset
- AL\_PS contains the address of the port issuing the reset

### *Loop Failures*

A loop failure is any of the following:

- A loss of signal
- A loss of synchronization for longer than R\_T\_TOV (For more information on R\_T\_TOV, see [“Timers” on page 29.](#))

If a Loop Failure occurs, the L\_Port that detects the failure issues a LIP(F8,AL\_PS) if it has a valid AL\_PA, or LIP (F8, F7) if it does not.

### *Loop Initialization Loop Position*

StorageTek libraries support the process of Loop Initialization Loop Position (LILP) by retransmitting this sequence when required.

## Completion Processes

The following processes occur after loop initialization.

### *Private Loop Initialization Completion*

At this point in loop initialization, a private loop library has completed initialization. It has acquired a private loop address of 00 00 xx. The xx is its assigned AL\_PA.

The library now waits for initiators, on this loop only, to complete a Port Login (PLOGI), to complete a Process Login (PRLI), and then to start executing commands.

### *Public Loop Initialization Completion*

The public loop library has at this point acquired a loop address of 00 00 xx at this point in initialization, where xx is its assigned AL\_PA.

Next, the library will attempt a Fabric Login (FLOGI) with the loop FL\_Port. If the login is not successful, the library will revert back to private loop operation (see [“Private Loop Initialization Completion” on page 13.](#))

With the successful completion of the FLOGI, the library has now acquired its public loop address: DD AA xx. DD is the fabric domain; AA is the fabric area; and xx is the AL\_PA.

The library then attempts to Port Login (PLOGI) with the fabric directory server to register with an RFC-4 request with the name service.

The library now waits for initiators, on either this loop or fabric attached, to complete a Port Login (PLOGI), to complete a Process Login (PRLI), and then to start executing tape commands.

### Feature Set

Sun StorageTek libraries implement the following FC-AL feature set:

**TABLE 2-4** FC-AL Feature Set

Feature	FC-Tape		StorageTek	Notes
	Initiator	Target		
Attempt to acquire Hard Address during LIHA sequence of loop initialization following loss of power, power-on reset, or recognition of LIP (AL_PD or AL_PS)	R	R	Y	4
<b>LILP/LIRP:</b> Loop Master can originate	R	R	Y	
Non-loop Master L_Ports accept	R	R	Y	
<b>Login_BB_Credit:</b> Advertise Login_BB_Credit = 0	A	A	Y	
Advertise Login_BB_Credit > 0	A	A	N	
Accept Login_BB_Credit = 0	R	R	Y	
Accept Login_BB_Credit > 0	R	R	Y	1
LPEyx/LPByx/LPEfx (origination)	A	P	N	2
MRKtx (origination)	P	P	N	3
<b>Open Full Duplex - OPN(yx):</b> Open Originator can send	I	I	N	
Open Recipient accepts	R	R	Y	5
<b>Open Half Duplex - OPN(yy):</b> Open Originator can send	I	I	Y	
Open Recipient accepts	R	R	Y	
<b>Open Multicast/Selective Replicate OPN(yr), OPN(fr):</b> Open Originator	P	P	N	
<b>Notes:</b>				
1. The actual value is between 0 and the LOGIN_BB_Credit.				
2. LPEfx is useful for resetting bypass circuits of NL_Ports that have lost their address.				
3. Any NL_Port receiving an MRK attempts to forward it, StorageTek does not originate it.				
4. This feature is user-configured. The default setting is "Disabled."				
5. Our target will accept the Open Full Duplex, but the FCP simplex protocol does not take advantage of the full duplex capabilities.				

## Login\_BB\_Credit Equals Zero

StorageTek libraries advertise Login\_BB\_Credit =0. When Login\_BB\_Credit=0 at the other L\_Port, the following rules apply:

- The OPN originator must receive R\_RDYs (receiver readys) from the library before transmitting a frame.
- The OPNed responder transmits R\_RDYs for the number of buffers available to receive frames.

**Note** – Sun StorageTek libraries respond with two to four R\_RDYs on an OPN. OPN Originators open as either *full* or *half* duplex, regardless of the value of the Login\_BB\_Credit.

## Open and Close Latencies

When Login\_BB\_Credit=0, a latency exists while before the libraries respond with two (2) R\_RDYs. This exists for every OPN before frame transmission can begin.

Some NL\_Ports reduce CLS latency in another way:

To prevent buffer overruns, a CLS recipient is only required to have maximum Login\_BB\_Credit, granted to any L\_Port buffers, available before receiving the next OPN.

---

# Fabric F\_PORT Attachment Initialization

In the absence of a loop environment the StorageTek tape libraries will attempt to initialize with a fabric. This is accomplished by doing a Fabric Login (FLOGI). The FLOGI process will be attempted in each class of service that the library supports.

Once the FLOGI process is successful the library will attempt to login (PLOGI) with the fabric attached name server, if it exists. This process allows the device to register its presence with the name server such that other initiators may query the name server to find target tape libraries to use.

The library now waits for initiators on the fabric to complete a Port Login (PLOGI), a Process Login (PRLI), and then to start executing commands.

## FC-2 Features

The FC-2 level provides the signaling protocol and specifies the rules and requirements to transfer blocks of data.

The FC-2 level is the most complex level in Fibre Channel protocol and provides the different classes of service, packetizing, sequencing, error detection, and reassembling the transmitted data.

## Login Validation

After initialization is complete, a StorageTek library communicates its ID for login validation. This ID is an IEEE-registered 64-byte identifier. The device identification page (36 bytes) of the Inquiry command indicates the vendor-specific portion of this ID. The vendor-specific portion of the ID includes the library's Port name, Node name, and N\_Port ID. This information is unique for each Fibre Channel card in each library.

The remaining 28 bytes of the library's ID consist of:

- 5h (a Name Address Authority)
- 00104Fh (Sun StorageTek company ID)

**Note** – The following table shows the IEEE-registered format for the full 64-byte identification scheme. The format includes the Name Address Authority (NAA), company ID, and vendor-specific identifier.

**TABLE 2-5** Library Identification Scheme

Most Significant Byte			Least Significant Byte		
63	60	59	36	35	00
NAA		IEEE Company ID		Vendor Specific Identifier	
5h		00 10 4Fh		(assigned per FC board)	

You can view this ID through the "Lib Fibre I/F Config Menu." See the library's operator's guide for instructions on accessing this menu.

Every device on the loop must have a unique ID for login validation.

All ports validate the logins by comparing Port Name, Node Name, and N\_Port ID. All three identifiers must match or this indicates the configuration has changed and requires a Logout (LOGO).

A LOGO terminates all open exchanges between SCSI initiator and target.



## Class of Service Parameters

Fibre Channel provides several different strategies to ensure reliable communications between devices. These strategies are called Classes of Service.

The libraries support the Class 3 level of service which provides no notification of frame delivery or non-delivery. This class of service reduces the number of frames (traffic) on the loop.

The start-of-frame (SOF) delimiter specifies the type of service used for each frame during communications.

[TABLE 2-6](#) indicates the two types of delimiters for Class 3 operations.

**TABLE 2-6** Start of Frame Delimiters, Class 3

Delimiter	Abbreviation	Transmission Word Characters			
SOF Initiate Class 3	SOFi3	K28.5	D21.5	D22.2	D22.2
SOF Normal Class 3	SOFn3	K28.5	D21.5	D22.1	D22.1

**Note:** Intermixing different classes of service is not supported.

The libraries adhere to a set of operating characteristics that ensure inter-operability and reliability within a Class 3 loop environment are maintained.

- [TABLE 2-7 on page 18](#) lists the [Class 3 Service Parameters, Port Login \(PLOGI\)](#)
- [TABLE 2-8 on page 19](#) lists the [Class 3 Service Parameters, Fabric Login \(FLOGI\)](#)

## Class 3 Service Parameters, Port Login

TABLE 2-7 Class 3 Service Parameters, Port Login

Parameters	Word	Bits	Value	FC-Tape
Class validity	0	31	1	1
<b>Service Options:</b>	0	30–16		
Intermix Mode	0	30	0	–
Stacked Connect Requests	0	29–28	00	–
Sequential Delivery	0	27	0	–
Dedicated Simplex	0	26	0	–
Camp-On	0	25	0	–
Buffered Class 1	0	24	0	–
Priority	0	23	0	–
<b>Initiator Control:</b>	0	15–0	–	–
Sequence Initiator X_ID reassignment	0	15–14	00	–
Initial Responder Process_Associator	0	13–12	00	00
Sequence Initiator ACK_0 capable	0	11	0	–
Sequence Initiator ACK_N Capable	0	10	0	–
ACK generation assistance	0	9	0	–
Initiator Data compression capable	0	8	0	0
Initiator Data compression history buffer size = 00b	0	7–6	00	–
Data Encryption Capable	0	5	0	0
Clock Synchronization Capable	0	4	0	P
<b>Recipient Control:</b>	1	31–16	–	–
ACK_0 Capable	1	31	0	–
ACK_N Capable	1	30	0	–
X_ID Interlock	1	29	0	–
Error Policy Supported	1	28–27	0	01
Categories per sequence	1	25–24	00	00
Data compression capable	1	23	0	0
Data compression history buffer size	1	22–21	00	–
Data decryption capable	1	20	0	0
Clock synchronization capable	1	19	0	A
Reserved – fabric-specific	1	18–16	000	0
Receive data field size	1	15–0	0800h	256
<b>Concurrent Sequences &gt; 0</b>	2	31–16	00FFh	1
<b>N_Port End-to-end Credit</b>	2	14–0	0000h	–
<b>Open Sequences per Exchange &gt; 0</b>	3	31–16	0001h	1
<b>Class 6 Multicast RX_ID</b>	3	15–0	0000h	–

## Class 3 Service Parameters, Fabric Login

**TABLE 2-8** Class 3 Service Parameters, Fabric Login

<b>Parameters</b>	<b>Word</b>	<b>Bits</b>	<b>Value</b>	<b>FC-Tape</b>
Class validity	0	31	1	1
<b>Service Options:</b>				
Intermix Mode	0	30	0	–
Stacked Connect Requests	0	29–28	00	–
Sequential Delivery	0	27	1	1
Dedicated Simplex	0	26	0	–
Camp-On	0	25	0	–
Buffered Class 1	0	24	0	–
Reserved	0	23	0	–
<b>Initiator Control:</b>				
Reserved	0	15–0	0000h	–
<b>Recipient Control:</b>				
Reserved	1	31–16	0000h	–
<b>Receive data field size</b> (min, see note)	1	15–0	0000h	256
<b>Concurrent Sequences (min)</b>	2	31–16	0000h	–
<b>N_Port End-to-end Credit</b>	2	15–0	0000h	–
<b>Open Sequences per Exchange (min)</b>	3	31–16	0000h	–
<b>Reserved</b>	3	15-0	0000h	–
<b>Note</b> – This is controlled by a configuration item.				

### Other Signalling Formats and Controls

TABLE 2-9 lists other FC-2 features supported by the libraries:

**TABLE 2-9** Other FC-2 Features

Feature	FC-Tape		StorageTek
	Initiator	Target	
<b>Addressing Scheme:</b> (see note)			
Node Name Format (registered format)	R	R	Y
Port Name Format (registered format)	R	R	Y
<b>Frame Control (F_CTL):</b>			
Continue Sequence Condition	R	R	00
Continuously increasing sequence count during consecutive sequences within an Exchange	R	R	Y
Ignore non zero Continue Sequence values	A	A	Y
Sequence Chaining (C_S bit in F_CTL = 0)	R	R	Y
Optional Headers (all)	P	P	N
<b>Routing Control (R_CTL):</b>			
FC-4 Device_Data frame	R	R	0000
Extended Link_Data frame	R	R	0010
FC-4 Link_Data Frame	R	R	0011
Video_Data Frame	P	P	0100
Basic Link_Data frame	R	R	1000
Link_Control frame			
Class 2	R	R	1100
Class 3	P	P	1100
X_ID Interlock	–	–	N
<b>Note</b> – Node name and Port name are not identical.			

### Link Service Commands

Fibre Channel uses link service commands to manage functions such as port management, Login, Logout, and abort operations. The libraries support both basic and extended link service commands to perform these operations.

## Basic Commands

TABLE 2-10 lists the Basic Link Service commands:

**TABLE 2-10** Basic Link Services

Command	FC-Tape			StorageTek	
	From Initiator	Target Response	From Target	Lib Orig.	Lib Resp.
No Operation (NOP)	P	–	P	–	N
Abort Sequence (ABTS)	I	R	A	Y	Y
Basic Accept (BA_ACC)	A		R	–	Y
Basic Reject (BA_RJT)	A		R	–	Y
Dedicated Connection Preempted (PRMT)	P	–	P	–	N
Remove Connection (RMC) Class 1	P	–	P	–	N

## Extended Commands

TABLE 2-11 lists the Extended Link Service commands:

**Note:** If the library receives a request for Extended Link Services that are not supported, the library returns a Link Services Command Reject (LS\_RJT) with a reason code of “Command Not Supported”.

**TABLE 2-11** Extended Link Services

Command	FC-Tape				StorageTek	
	From Initiator	Target Response	From Target	Initiator Response	Lib Orig.	Lib Resp.
Abort Exchange (ABTX)	P		P		N	–
Accept (ACC)	A		R		Y	Y
Advise Credit (ADVC)	P		P		N	–
Discover Address (ADISC)	I	R	P		N	Y
Discover F_Port Parameters (FDISC)	I		I		N	–
Discover N_Port Parameters (PDISC)	I	R	P		–	Y
Echo	P		P		N	–
Establish Streaming (ESTS)	P		P		N	–
Estimate Credit (ESTC)	P		P		N	–
Fabric Activate Alias_ID (FACT)	P		P		N	–
Fabric Address Notification (FAN)	P	P	P	P	N	–

**TABLE 2-11** Extended Link Services (Continued)

Command	FC-Tape				StorageTek	
	From Initiator	Target Response	From Target	Initiator Response	Lib Orig.	Lib Resp.
Fabric Deactivate Alias_ID (FDACT)	P		P		N	–
Fabric Login (FLOGI)	R	P	R	P	Y	–
Get Alias_ID (GAID)	P		P		N	–
Link Service Reject (LS_RJT)	A		R		Y	Y
Logout (LOGO)	R	R	R	R	Y	Y
Loop Initialize (LINIT)	I		P		N	Y
Loop Port Control (LPC)	I		P		N	N
Loop Status (LSTS)	I		P		N	N
N_Port Activate Alias_ID (NACT)	P		P		N	–
N_Port Deactivate Alias_ID (NDACT)	P		P		N	–
N_Port Login (PLOGI)	R	R	P		N	Y
<b>Process Login: (PRLI)</b>	R	R	P		N	Y
PRLI Common Service Parameters	P	–	P		N	N
Single Service Parameter page per request	R	R	P		N	Y
Multiple Service Parameter pages per request	P	–	P		N	N
ACC contains only those pages specified	–	R	P		N	Y
Accept Response code of Command executed	–	R	P		N	Y
Process Logout (PRLO)	I	R	I	R	Y	Y
Quality of Service Request (QoSR)	P		P		N	–
Read Connection Status Block (RCS)	P		P		N	–
Read Exchange Concise (REC)	I	R	P		N	Y

**TABLE 2-11** Extended Link Services (Continued)

Command	FC-Tape				StorageTek	
	From Initiator	Target Response	From Target	Initiator Response	Lib Orig.	Lib Resp.
Read Exchange Status Block (RES)	P		P		N	–
Read Link Error Status Block (RLS)	I	R	P		N	Y
Request Sequence Initiative (RSI)	A	A	A	A	TBD	TBD
Read Sequence Status Block (RSS)	A	A	A	A	TBD	TBD
Read Timeout Value (RTV)	P		P		N	–
Read VC Status (RVCS)	P		P		N	–
Reinstate Recovery Qualifier (RRQ)	I	R	I	R	Y	Y
Registered State Change Notification (RSCN)	I	R	I	R	N	Y
Report Node Capabilities (RNC)	I	R	P		N	Y
State Change Notification (SCN)	P		P		N	–
State Change Registration (SCR)	I	P	I	P	N	N
Test	P		P		N	–
Test Process Login State	P		P		N	–
Third Party Process Logout (TPRLO)	I	R	P		N	Y

## Responses to Link Services

TABLE 2-12 summarizes the response the libraries generate when receiving different Link Service requests when the library NL\_Port is not currently logged in with the sending NL\_Port.

**TABLE 2-12** Response to Link Services from NL\_Ports Not Logged-In

Frame Received	NL_Port Not Logged In	NL_Port Logged In	Notes
ABTS	Discard and send LOGO	BA_ACC, BA_RJT	2
ADISC	Discard and send LOGO	ACC and LS_RJT	1
FAN	Process the ELS request, no response required	Process the ELS request, no response required.	
LOGO	ACC	ACC	
PDISC	Discard and send LOGO	ACC and LS_RJT	1
PLOGI	ACC, LS_RJT	ACC	
PRLI	Discard and send LOGO	ACC	
PRLO	Discard and send LOGO	ACC and LS_RJT	3
RSCN	Process the ELS request, no response required.	Process the ELS request, no response required.	
Other Link Services	Discard and send LOGO	ACC and LS_RJT	
<p><b>Notes:</b></p> <ol style="list-style-type: none"> <li>All three identifiers must match at login for Accepts (ACC) to be returned: <ul style="list-style-type: none"> <li>N_Port ID,</li> <li>Port Name, and</li> <li>Node Name</li> </ul>                     If all three identifiers do not match, return a logout (LOGO).                      If other conditions prevent execution of the ADISC or PDICS ELS, return a reject (LS_RJT) with the appropriate reason code.                 </li> <li>BA_ACC if valid RX_ID else BA_RJT</li> <li>If PRLI has not been successfully completed, set the reason code to "Image Pair Does Not Exist."</li> </ol>			

**TABLE 2-13** FC-4 Link Services

Command	FC-Tape				StorageTek	
	From Initiator	Target Response	From Target	Initiator Response	Lib Orig.	Lib Resp.
Sequence Retransmission Request (SRR)	I	R	P		N	N



*Frame Format and Header*

FIGURE 2-1 shows the frame format for transmission of data and commands over Fibre Channel.

**FIGURE 2-1** Frame and Frame Header Format

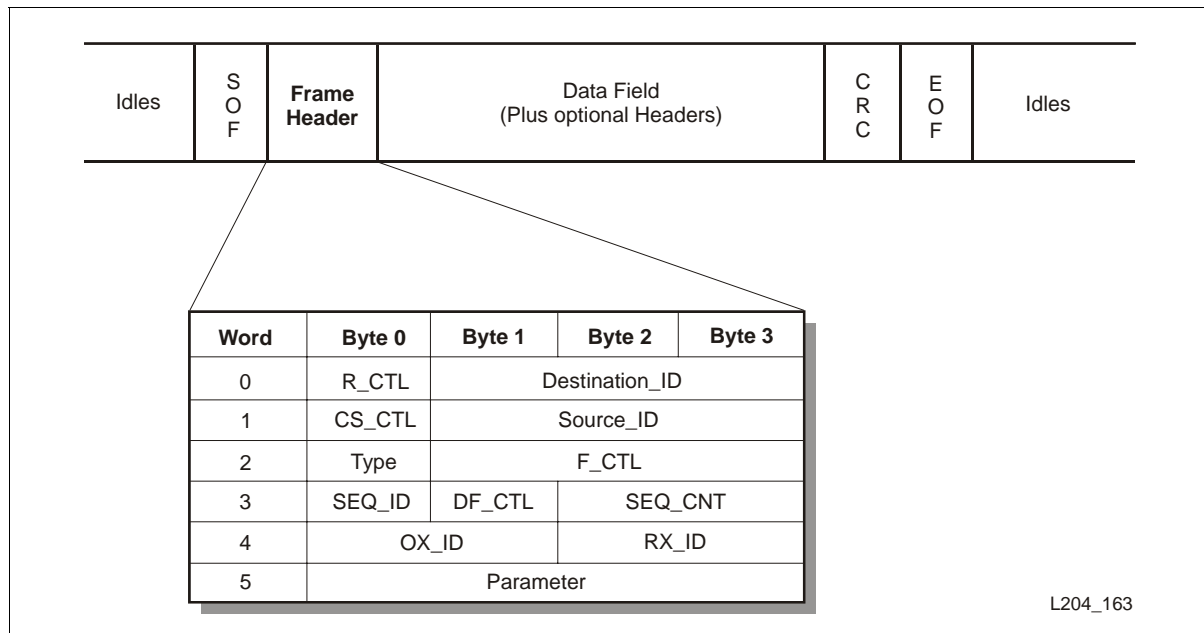

<b>R_CTL</b>	Routing Control: Indicates the type of frame functions
<b>Destination ID</b>	Identifies the port destination
<b>CS_CTL</b>	Class specific control field
<b>Source ID</b>	Identifies the source
<b>Type</b>	Indicates the data structure
<b>F_CTL</b>	Frame Control: Controls information within the frame
<b>SEQ_ID</b>	Sequence Identifier: Identifies sequences within an exchange
<b>DF_CTL</b>	Data Field Control: Indicates optional headers
<b>SEQ_CNT</b>	Sequence Count: Contains frame number within exchange
<b>OX_ID</b>	Originator Exchange ID: Identifies originator of exchange
<b>RX_ID</b>	Responder Exchange ID: Identifies responder of exchange
<b>Parameter</b>	Contains unique parameters for exchange

## Exchange Management

Exchange (X) management is the overall control of operations over the Fibre Channel interface between the originator and responder. Refer to the FC-PH documents for rules and guidelines pertaining to Class 2 operation.

**Note:** For FCP, an exchange is a *single* SCSI command.

There are two fields in the frame header dealing with exchanges:

- OX\_ID = Exchange originator
- RX\_ID = Exchange responder

**TABLE 2-14** Exchange Content Header

Word	Byte 0	Byte 1	Byte 2	Byte 3
0	R_CTL	Destination_ID		
1	CS_CTL	Source_ID		
2	Type	F_CTL		
3	SEQ_ID	DF_CTL	SEQ_CNT	
4	OX_ID		RX_ID	
5	Parameter			

### *Exchange Originator*

The exchange originator assigns a unique OX\_ID to the exchange for the transmission of in-order delivery of frames and assumes the frames are processed in the order received. The exchange is open from the time the first frame is sent until one of the following occurs:

- Timeout
- The exchange is aborted (ABTS or ABTX)
- An end-of-frame (EOF) delimiter is sent with the last sequence bit set
- A Logout (LOGO) is sent to or received from the Exchange responder
- A Link Service Command Reject (LS\_RJT) is sent in response to an ADISC or PDISC during target discovery
- A PLOGI is sent to the Exchange responder

### *Exchange Responder*

The exchange responders assign unique RX\_ID values or use the value of “FFFF.” The exchange responder considers an exchange open from the time it receives the first frame of the first information unit until one of the following occurs:

- The last frame of the last information unit is sent with the last sequence bit set
- The exchange is aborted (ABTS)
- A Logout (LOGO) is sent to, or received from, the Exchange originator
- An LS\_RJT is sent in response to an ADISC or PDISC during target discovery
- A PLOGI is received

## Sequence Management

Sequence management deals with the actual order and transfer of frames across Fibre Channel. The SEQ\_ID and SEQ\_CNT identify the order of frames for reassembly at the responder.

Refer to the FC-PH documents for rules and guidelines pertaining to Class 2 operation.

**TABLE 2-15** Sequence Content Header

Word	Byte 0	Byte 1	Byte 2	Byte 3
0	R_CTL	Destination_ID		
1	CS_CTL	Source_ID		
2	Type	F_CTL		
3	SEQ_ID	DF_CTL	SEQ_CNT	
4	OX_ID		RX_ID	
5	Parameter			

### *Sequence Open*

The library considers a sequence open from the time that the first frame of the sequence (the frame with the SOFi3 delimiter) is sent until one of the following occurs:

- An end-of-frame (EOF) delimiter is sent with the last sequence bit set
- A LOGO is sent to, or received from, the sequence responder
- The sequence is aborted with ABTS

The library as a sequence responder considers a sequence open from the time that the first frame of the Sequence (the frame with the SOFi3 delimiter) is received until one of the following occurs:

- An end-of-frame (EOF) delimiter is sent with the last sequence bit set
- The Sequence is aborted using ABTS
- A LOGO is sent to, or received from, the Sequence originator

### *Sequence Identifier Usage*

The sequence identifier (SEQ\_ID) is a field in the frame header that sets one frame apart from another and indicates the order in which frames occur. The following paragraphs summarize the rules governing the reuse of SEQ\_IDs.

#### **For sequences which transfer Sequence Initiative:**

- An NL\_Port can reuse a SEQ\_ID for the same Exchange following the confirmation of sequence delivery.
- An NL\_Port can reuse the SEQ\_ID with a different exchange (to the same, or a different destination NL\_Port) immediately following transmission of the last frame of the sequence, without waiting for confirmation of Sequence delivery.

**For sequences which do not transfer Sequence Initiative:**

- Consecutive FCP\_DATA Sequences for the same exchange follow the FC-PH rules for streamed sequences which include:
  - The first FCP\_DATA Sequence after transfer of sequence initiative is not a streamed sequence. It can use any eligible SEQ\_ID, and the SEQ\_CNT can be either zero or a continuously increasing number.
  - The second and subsequent sequences within the same exchange are treated as streamed.
- Because frame delivery is not confirmed, the sequence initiator cannot reuse a SEQ\_CNT within a given sequence.

For sequences beginning with a SEQ\_CNT of zero, the SEQ\_CNT cannot wrap when reaching a hexadecimal count of “FFFF”.

For sequences beginning with a SEQ\_CNT of ‘*n*’ (where *n* is not zero), the SEQ\_CNT can wrap when reaching a hexadecimal count of “FFFF” and continue from zero up to a value of *n*-1.

## Sequence Errors

Sequence errors are managed as defined in FC-Tape with the following additions:

1. If a frame with an SOFi3 delimiter is received and the SEQ\_CNT is not equal to zero or +1 from the SEQ\_CNT of the last frame of the previous Sequence of that Exchange.
2. If the SEQ\_CNT of a received frame with an SOFn3 delimiter is not +1 greater than the previous frame received for that Sequence (such as a frame was lost).  
This also detects the case where a frame with an SOFn3 delimiter is received for a SEQ\_ID that is not currently open since the SEQ\_CNT of the previous frame for that sequence is undefined.
3. If a frame with an SOFi3 delimiter is received and the previous sequence of that exchange is still open.
4. If the relative offset in the parameter field of a received frame with an SOFn3 delimiter is not equal to the (relative offset + the payload size) of the previous frame received for that Sequence.
5. If the next frame of a sequence is not received within E\_D\_TOV.
6. If, during the same sequence initiative, a sequence is received which has the same SEQ\_ID as the previous sequence of that exchange.

When a sequence error is detected by the library, it discards that sequence, and all remaining sequences for the exchange containing the sequence in error. The library attempts to take the appropriate action as defined in FCP-2.

## CRC

Fibre Channel adds another level of protection over the content of each frame called a cyclic redundancy check (CRC). Each frame is protected by a 4-byte CRC which provides a separate and independent error detection mechanism.

## Timers

Sun StorageTek libraries use the timer values in [TABLE 2-16](#).

**TABLE 2-16** Timer Summary

Timer	Value	Implemented By		
		Initiator	Target	StorageTek
AL_TIME	15 ms	R	R	Y
R_T_TOV	100 ms	R	R	Y
E_D_TOV	Private = 2 s	R	A <sup>2</sup>	Y
	Public = supplied + 2 s	R	R	Y
R_A_TOV <sub>SEQ_QUAL</sub>	Private = 0 s	R	A <sup>2</sup>	Y
	Public = 10 s (See note 1)			
R_A_TOV <sub>ELS</sub>	Private = 2 s	R	R	Y
	Public = 10 s			
RR_TOV	300 s		R	Y
REC_TOV	> = E_D_TOV + 1 s minimum	R	R	Y
ULP_TOV	>= Operation specific timer + 4 x REC_TOV	R		N

**Notes:**

1. The division of R\_A\_TOV usage differs from the FC-PH because of the unique characteristics of an Arbitrated Loop environment.
2. SCSI target devices that support Class 2 are required to implement this timer.

### Arbitrated Loop Timeout

The Arbitrated Loop timeout value (AL\_TIME) is two times the worst case round-trip latency of a very large loop.

### Receiver\_Transmitter Timeout

The Receiver\_Transmitter timeout value (R\_T\_TOV) is used by the receiver logic to detect a loop failure.

### Error\_Detect Timeout

The Error Detect Timeout value (E\_D\_TOV) is the maximum time permitted for a Sequence Initiator between the transmission of consecutive data frames within a single sequence. This is also the minimum time that a Sequence Recipient waits for the reception of the next frame within a single sequence before recognizing a Sequence timeout.

E\_D\_TOV includes the time required to gain access to the loop in addition to the actual frame transmission time.

## Resource Allocation Timeouts

The Resource Allocation Timeout (R\_A\_TOV) has two components:

- Sequence Qualifiers ( $_{SEQ\_QUAL}$ ) defines the minimum time that an initiator waits before reusing the sequence qualifiers (SEQ\_ID and SEQ\_CNT).
- Extended Link Services ( $_{ELS}$ ) determines the minimum time the Originator of an extended link service request waits for the response to a request as a target.

## Resource Recovery Timeout

The Resource Recovery timeout (RR\_TOV) value is the minimum time the target waits for an initiator to perform an exchange authentication following the completion of the loop initialization.

## REC Timeout

The Read Exchange Concise timeout (REC\_TOV) is used to time reply sequences and a polling interval for REC error detection. Refer to FCPP-2 for a detailed description.

## Upper Level Protocol Timeout

The Upper Level Protocol Timeout (ULP\_TOV) is used by the initiator to time the completion of exchanges associated with the Upper Level Protocol operations. The timeout values vary depending on the operations being timed.

## FC-3 Common Service Features

TABLE 2-17 lists the Common Service Parameters the libraries support for Port Login (PLOGI):

**TABLE 2-17** NL\_Port Common Service Parameters, Port Login

Parameter	Word	Bits	StorageTek	FC-Tape
<b>FC-PH Version:</b>				
Highest Version	0	31–24	09h	X
Lowest Version	0	23–16	09h	20h
Buffer-to-Buffer Credit (min.)	0	15–0	0	0
<b>Common Features:</b>	1	31–16		
Continuously Increasing Relative Offset	1	31	1	1
Random Relative Offset	1	30	0	0
Valid Vendor Version Level	1	29	0	0
N_Port/F_Port	1	28	0	0
Alternate BB_Credit Management	1	27	1	–
E_D_TOV Resolution	1	26	0	–
Reserved	1	25–23	0	–
Dedicated Simplex	1	22	0	–
Reserved	1	21–19	0	–
Dynamic Half Duplex – DHD	1	18	0	–
SEQ_CNT	1	17	0	X
Payload Length	1	16	0	–
Buffer-to-Buffer Receive Data Field Size (min.)	1	15–0	0800h	256
<b>Total Concurrent Sequences (min.)</b>	2	31–16	00FFh	1
<b>Relative Offset by Information Category = (Information Category 1 and 5 only)</b>				
	2	15–0	000Fh	0002h
<b>Error Detect Timeout (E_D_TOV) 2 seconds</b>	3	31–0	000007D0h	000007D0h

TABLE 2-18 lists the Common Service Parameters the libraries support for Fabric Login (FLOGI):

TABLE 2-18 NL\_Port Common Service Parameters, Fabric Login

Parameter	Word	Bits	StorageTek	NL-Port Originator
<b>FC-PH Version:</b>				
Highest Version	0	31–24	09h	X
Lowest Version	0	23–16	09h	20h
Buffer-to-Buffer Credit (min.)	0	15–0	0	–
<b>Common Features:</b>				
Reserved	1	31–30	0	–
Valid Vendor Version Level	1	29	0	0
N_Port/F_Port	1	28	0	0
Alternate BB_Credit Management	1	27	1	1
Reserved	1	26–19	0	–
Dynamic Half Duplex	1	18	0	–
Reserved	1	17	0	–
Payload Length	1	16	0	–
Buffer-to-Buffer Receive Data Field Size (min., see note)	1	15–0	0800h	256
<b>Reserved</b>	2	31–0	0	–
<b>Reserved</b>	3	31–0	0	–
This is controlled by a configuration item.				



## FC-4 (FCP) Features

Fibre Channel Protocol (FCP) provides functions such as login and logout parameters and the transfer of commands and data through the use of Information Units.

### FCP Process Login Parameters

TABLE 2-19 lists Process Login (PRLI) parameters supported:

**TABLE 2-19** PRLI Parameters

Feature	FC-Tape		StorageTek
	Initiator	Target	
Command + Data in same Sequence (Write) = 1	P	P	N
Data Overlay Allowed = 1 (see note)	I	R	Y
Data + Response in same Sequence (Read) = 1	P	P	N
Establish Image Pair (bit 13) = 0	I	R	Y
Establish Image Pair (bit 13) = 1	R	R	Y
SRR/REC Recovery Supported = 1	A	R	N
Confirmed Completion Allowed = 1	I	R	Y
Initiator Function = 1	R	A	N
Originator Process Associator	P	P	N
Originator Process Associator Valid = 1	P	P	N
Responder Process Associator	P	P	N
Responder Process Associator Valid = 1	P	P	N
Read XFER_RDY Disabled = 1	R	R	Y
SCSI Target Function = 1	A	R	Y
Write XFER_RDY Disabled = 1	P	P	N
<b>Note:</b> If the initiator requests it, the use of data overlay is only allowed in response to an SRR (such as with error recovery).			

**TABLE 2-20** PRLI Accept FCP Services Parameter Page

<b>FCP Service Parameters</b>	<b>Word</b>	<b>Bits</b>	<b>StorageTek</b>
SCSI FCP (08h)	0	31–24	x'08'
Reserved	0	23–16	0
Originator Process_Associator Valid	0	15	0
Responder Process_Associator Valid	0	14	0
Image Pair Established	0	13	1
Reserved	0	12	0
Accept Response Code	0	11–8	b'0001'
Reserved	0	7–0	0
Originator Process_Associator	1	31–0	0
Responder Process_Associator	2	31–0	0
Reserved	3	31–10	0
Task Retry Identification Requested	3	9	0
Retry	3	8	0
Confirmed Completion Allowed	3	7	0
Data Overlay Allowed	3	6	0
Initiator Function	3	5	0
Target Function	3	4	1
Obsolete	3	3	0
Obsolete	3	2	0
Read FCP_XFER_RDY Disabled	3	1	1
Write FCP_XFER_RDY Disabled	3	0	0

## FCP Information Units

Information units transfer data to and from the SCSI initiator and SCSI target and include the following required units:

- T1 = Command and Task Management
- T6 = Write Data (such as Mode Select and Write commands)
- T12 = Response Received Confirmation
- I1 = Transfer Ready on a Write Command
- I3= Read Data (such as Mode Sense and Read commands)
- I4 = Response (such as Status)
- I5 = Response with Confirm Request

**FIGURE 2-2** Examples of Read and Write Information Units

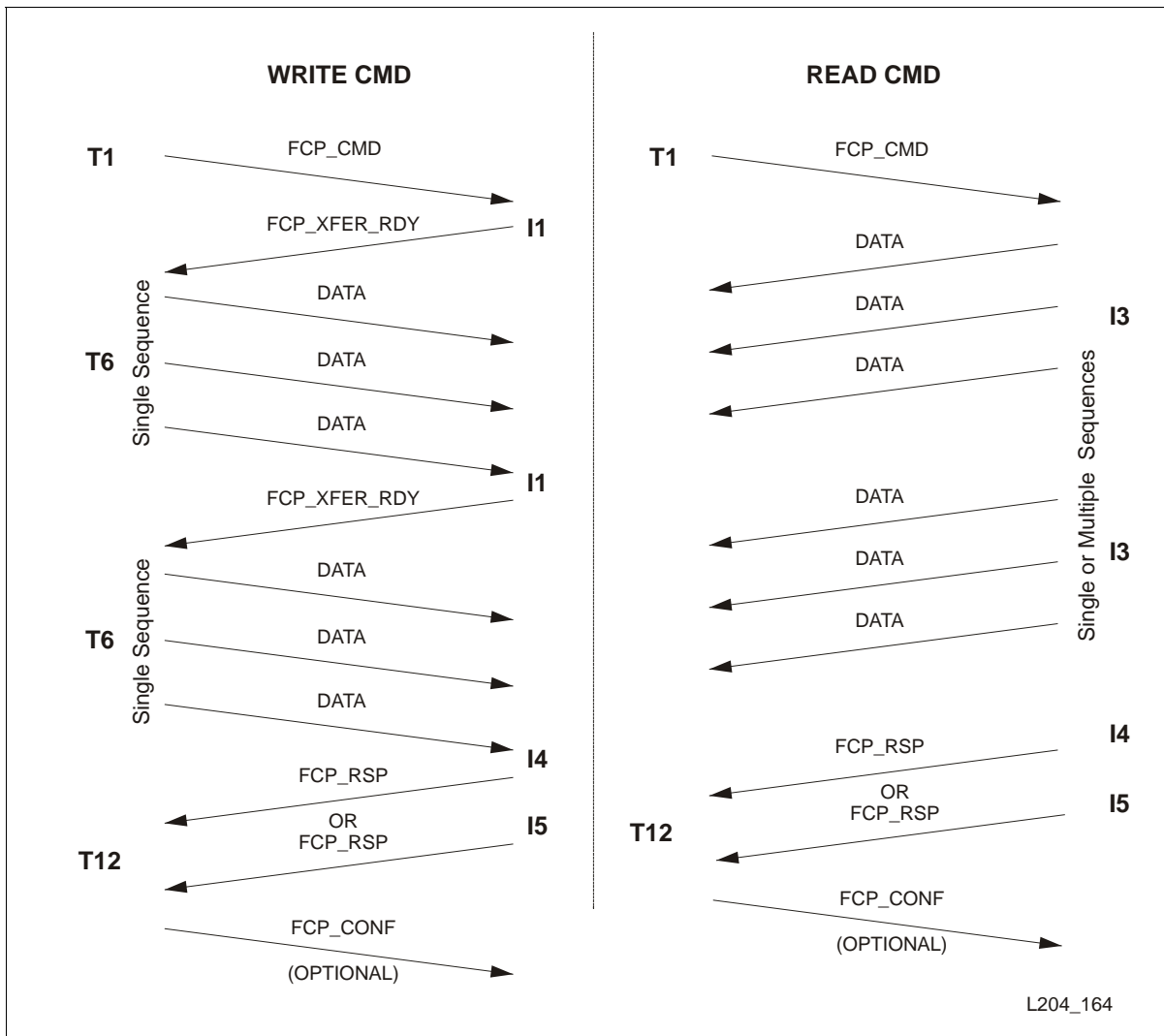

## Command Information Unit

The Command Information Unit (T1) is a single-frame sequence.

The library supports the “first level addressing” LUN field as defined in SAM-2. [TABLE 2-21](#) illustrates this.

**TABLE 2-21** FCP 8-byte LUN

Byte 0	Byte 1	Byte 2	Byte 3	Byte 4	Byte 5	Byte 6	Byte 7
00	LUN	00	00	00	00	00	00

For all commands that transfer data to the library:

FCP\_DL (data length) in the FCP\_CMND payload always equals the number of bytes being transferred for the command.

For SCSI commands that specify the transfer length in blocks in the Command Descriptor Block (CDB), the FCP\_DL equals the Transfer\_Length multiplied by the Block\_Size.

**Note:** If the FCP\_DL value is less than the transfer length, then FCP\_DL data will be transferred and the command will be terminated with Check Condition. The Sense Key will be 5h, the ASC will be 4Bh, and the ASCQ will be 80h.

**For all commands that transfer data from the library:**

The SCSI initiator is responsible for making sure the amount of data returned is equal to the amount specified by FCP\_DL—even if Good Status is returned. If the amount does not match FCP\_DL, a command-specific Upper Level Protocol recovery action must be invoked. Because there are no transfers of Sequence Initiative during read operations, once the SCSI Target receives the T1 Information Unit, it may return Good Status, even though some of the data was not received by the SCSI initiator. This can occur as the result of lost or corrupted frames in the read data.

**Note:** The way a SCSI initiator determines the correct amount of data is returned depends on the implementation and includes counting the number of bytes returned and computing the number of bytes received by use of the relative offsets.

The FCP Command Reference Number (CRN) shall be used to ensure proper ordering of Exchange’s (SCSI commands). CRN usage is enabled based on I\_T\_L nexus by setting the Enable Command Reference Number (ECRN) bit to 1b in the FC Mode Page (19h) for the LUN. Task Management functions shall set the CRN value to 0b. Refer to FCP-2 (4.3 Precise Delivery of SCSI Commands) for a detailed description.

**Note:** The library currently does not support command queuing; thus CRNs are not supported.

## Transfer Ready Information Units

The Transfer Ready Information Unit (I1) is a single-frame sequence.

### For write operations:

The FCP\_XFER\_RDY is sent before each write data sequence.

### For read operations:

The FCP\_XFER\_RDY IU (I2) is not used during read type (data in) operations. This is indicated by setting the 'READ XFER\_RDY DISABLED' bit during process login.

## Data Information Unit

The Data Information Units (T6 and I3) are either single- or multiple-frame sequences.

The FCP\_DATA IU transfers data associated with an operation. This data includes command parameter data (such as Mode Select data) or command response data (such as Mode Sense data).

## Response Information Unit

The Response Information Units (I4) are single- or multiple-frame sequences.

The first two bits (30 and 31) of the first word of a command status frame payload fall into the following categories:

- 00 = Successful and complete
- 01 = Successful but incomplete
- 10 = Unsuccessful but complete
- 11 = Unsuccessful and incomplete

Because the first word of FCP\_RSP frames are reserved in FCP, these bits are set to 0b, regardless of the content of the SCSI Status portion of the payload. SCSI initiators do not rely on word 0, bits 31 and 30 in FCP\_RSP to determine success or completion status of a command. An FCP\_RSP following a data-in sequence (I3) may or may not be treated as a streamed sequence.

### *Residual Checking*

Residual checking falls under the following categories:

- SCSI targets that transfer exactly FCP\_DL data bytes during the FCP\_DATA IUs set the FCP\_RESID\_UNDER to a value of 0b.

When FCP\_RESID\_UNDER is set to 0b, the SCSI initiator tries to determine if all of the expected data was transferred by comparing the FCP\_DL to the actual number of bytes transferred. If these values are not the same, the ULP is notified so that the appropriate action can be taken.

- SCSI targets that transfer less than FCP\_DL data bytes during the FCP\_DATA IUs set the FCP\_RESID\_UNDER to a value of 1b.

If the FCP\_RESID\_UNDER bit is set to 1b, a transfer that did not fill the buffer to the expected displacement. Failure to transfer FCP\_DL bytes does not necessarily indicate an error for some devices and commands.

- If the FCP\_RESID\_OVER bit is set, the transfer was truncated because the data transfer required by the SCSI command extended beyond the displacement value of FCP\_DL. Those bytes that could be transferred without violating the FCP\_DL value may or may not have been transferred.
- Commands that do not contain an FCP\_DATA IUs, FCP\_RESID\_UNDER and FCP\_RESID\_OVER are set to 0b, and the value of the FCP\_RESID is undefined.

## Response Payload

TABLE 2-22 lists the FCP\_RSP payload fields:

**TABLE 2-22** FCP\_RSP Payload

Feature	FC-Tape		StorageTek
	Initiator	Target	
FCP_CONF_REQ	A	R	Y
FCP_SNS_INFO	R	I	Y
FCP_SNS_LEN (total)	R	≤ 128	20
FCP_SNS_LEN_VALID	R	I	Y
Length of Additional Sense Bytes in FCP_SNS_INFO	R	≤ 120	16
FCP_RSP_INFO	R	I	Y
FCP_RSP_LEN	R	0 or 8	8
FCP_RSP_LEN_VALID	R	I	Y
FCP_RESID	R	R	Y
FCP_RESID_OVER	R	I	Y
FCP_RESID_UNDER	R	I	Y

## Response Codes

The Response Code field (FCP\_RSP\_INFO) contains information that describes the failures detected during the execution of an I/O operation and conforms to the following rules:

- The FCP\_RSP\_INFO does not contain link error information because FC-PH provides the mechanisms for presenting these errors.
- The FCP\_RSP\_INFO does not contain SCSI logical unit error information because that information is in the FCP\_STATUS and FCP\_SNS\_INFO fields.
- RSP\_CODE values of 04h and 05h are not valid responses to SCSI commands. The RSP\_CODE is independent of the SCSI Status and should be examined before interpretation of the SCSI Status.
- For other non-zero values of the RSP\_CODE, the SCSI Status may not be valid.

TABLE 2-23 indicates the result of a Task Management function in the RSP\_CODE of the FCP\_RSP\_INFO fields.

**TABLE 2-23** FCP\_RSP Code

RSP_CODE	Description
00	No failure or Task Management complete
01	FCP_DATA length different than BURST_LEN
02	FCP_CMND fields invalid
03	FCP_DATA RO mismatch with FCP_XFER_RDY DATA_RO
04	Task Management function not performed or supported
05	Task Management function supported but not performed
06-FF	Reserved

The FCP\_CONF IU is used by the target to confirm reception of an FCP\_RSP IU at the initiator. Support for the FCP\_CONF IU is negotiated via PRLI. A target request for an FCP\_CONF IU from the initiator is indicated by the target setting the FCP\_CONF\_REQ bit in the FCP\_STATUS field contained in the FCP\_RSP. If the initiator does not need to perform any error detection or recovery procedure, the initiator will send an FCP\_CONF IU if an FCP\_RSP is received with the FCP\_CONF\_REQ bit set in the FCP\_STATUS field.

The initiator will release Exchange information such as the Exchange Status Block (ESB) after the FCP\_CONF is sent. The target will retain Exchange information and associated data until an FCP\_CONF is received. See FCP-2 (4.4 Confirmed Completion of FCP-2 SCSI Commands) for a description of the FCP\_CONF\_REQ bit and FCP\_CONF usage.

The following lists each command and its supported usage of requesting an FCP\_CONF:

<b>No confirm</b>	The library will not set the FCP_CONF_REQ bit in the response to the command. As soon as the response has been transmitted, the exchange is terminated, and there is no FCP-2 Link Level error recovery possible.
<b>Implicit confirm</b>	The library does not set the FCP_CONF_REQ bit in the response to the command. However, the exchange is not terminated until the same initiator sends the next command or until the Resource Recovery timer expires on this exchange. This will allow the initiator to do FCP-2 Link Level error recovery, if necessary, before sending the next command.
<b>Explicit confirm</b>	The library will set the FCP_CONF_REQ bit in the response to a command if the condition in this column is met. This will allow the initiator to do FCP-2 Link Level error recovery, if necessary, before sending the FCP_CONF. If the initiator does not support FCP_CONF, as indicated in its PRLI payload, then the library will not set the FCP_CONF_REQ bit, regardless of the condition being met. But the library will treat it as an Implicit Confirm condition.

**TABLE 2-24** Command Confirmation Usage

Command	No Confirm	Implicit Confirm	Explicit Confirm
<b>Library Motion</b>			
Move Medium	If not, check	Always	Check condition
<b>Non-Customer Data</b>			
Inquiry	Always		
Log Sense	Always		
Mode Select	Always		
Mode Sense	Always		
Persistent Reserve In	Always		
Persistent Reserve Out	Always		
Read Element Status	Always		
Report LUNs	Always		
Request Sense	Always		
Request Volume Element Address	Always		
<b>Miscellaneous</b>			
Initialize Element Status	Always		
Initialize Element Status with Range	Always		
Prevent/Allow Medium Removal	Always		
Position to Element	Always		
Release	Always		
Reserve	Always		
Send Diagnostic	Always		
Send Volume Tag	Always		
Test Unit Ready	Always		
<p><b>Notes:</b></p> <ol style="list-style-type: none"> <li>1. Commands that report Check Condition with the Response Code of Deferred Error (71h) will follow the rules of Explicit Confirm.</li> <li>2. Any command which responds with Check Condition of Overlapped Commands Attempted (Sense Key = Bh, ASC/ASCQ = 4E00h) will follow the rules of Explicit Confirm.</li> </ol>			



## Task Management Flag and Information Units

- All SCSI initiators send Task Management functions using T1.
- All SCSI targets return FCP\_RSP to Task Management functions using I4.

The RSP\_CODE in the FCP\_RSP\_INFO field indicates the result of the Task Management function.

The SCSI Status byte and FCP\_SNS\_INFO are ignored for I4 information units sent in response to a Task Management function.

TABLE 2-25 lists the Task Management Flags the libraries support:

**TABLE 2-25** FCP Task Management Flags

Feature	FC-Tape		StorageTek
	Initiator	Target	
Terminate Task = 1	P	P	N
Clear ACA = 1 (command queuing)	R	R	N
Clear ACA = 1 (no command queuing)	P	P	N
Target Reset = 1	I	R	Y
Clear Task Set = 1	I	R	Y
Abort Task Set = 1	I	R	Y
Logical Unit Reset = 1	I	R	Y

### *Task Attributes*

TABLE 2-26 lists the FCP Task Attributes supported by the libraries:

**TABLE 2-26** FCP Task Attributes

Feature	FC-Tape		StorageTek
	Initiator	Target	
Untagged	R	R	Y
Simple Queue Type (depth = 1)	I	A	Y
Ordered Queue Type	I	A	N
Head of Queue Type	I	A	N
Auto Contingent Allegiance Type	I	A	N

*Other Features*

TABLE 2-27 lists other FCP features supported:

**TABLE 2-27** Other FCP Features

Feature	FC-TAPE		StorageTek
	Initiator	Target	
FCP_LUN (in FCP_Command)	R	R	Y
FCP_LUN (0)	I	R	Y
Inquiry of FCP_LUN (0)	I	R	Y
Inquiry of FCP_LUN (>0)	I	R	Y
Auto Contingent Allegiance (ACA)	A	A	N

## Public Loop SCSI Target Discovery

For public loop SCSI target discovery, the following private loop discovery is used except that discovery of SCSI targets will be performed via the Simple Name Server or RSCN, and the function performed by ADISC/PDISC will be replaced by FAN.

## Private Loop SCSI Target Discovery

When the possibility of a configuration change exists, a SCSI initiator might want to rediscover the new configuration. The SCSI Target Discovery procedure for a SCSI initiator is:

**For all valid AL\_PAs:**

```

OPN(AL_PA)
  IF OPN is successful, then
    Send ADISC or PDISC to D_ID = hex '0000' || AL_PA
    IF LOGO is returned or the Node Name or Port Name has changed, then
      Send PLOGI to D_ID = hex '0000' || AL_PA
      IF PLOGI is successful, then
        IF no hard address conflicts or application tolerant of hard address conflicts
          Send PRLI to D_ID = hex '0000' || AL_PA
          IF PRLI is successful, then
            Send FCP_CMND with INQUIRY CDB to D_ID = hex '0000' ||AL_PA(LUN_0)
          ENDIF
        ENDIF
      ENDIF
    ENDIF
  ENDIF
NEXT AL_PA

```

To determine if an OPN was “successful,” the NL\_Port must be able to:

1. Detect when an OPN has not been intercepted by the designated AL\_PA.
2. Detect that an R\_RDY or CLS has not been received from the AL\_PA specified in an OPN within E\_D\_TOV of sending that OPN.
3. Detect that a CLS was received in response to the OPN.  
In this case, the Target Discovery procedure should be retried at a later time.
4. Detect that the OPN or frame Extended Link Service failed.

If the SCSI Target Discovery procedure revealed a Hard Address conflict (such as an NL\_Port was unable to acquire its hard address), then the application may choose to operate in spite of that conflict.

If this is the case, then the discovery procedure can continue with the PRLI and subsequent SCSI INQUIRY command.

If the application is not tolerant of Hard Address conflicts, the SCSI initiator may choose not to use that NL\_Port.

Using this SCSI Target Discovery procedure, the SCSI initiator has the ability to assemble a database consisting of Node name, Port name, and N\_Port ID.

There are several confirmations a SCSI initiator can perform on that database to determine which SCSI targets it can continue to communicate with, but this document does not define them.

**Note:** Not all initiators perform the exact steps described in the above algorithm. However, a SCSI initiator is required to issue ADISC or PDISC to all SCSI targets it is logged in with within RR\_TOV of receiving LIP if it wants to remain logged in with those SCSI Targets.

The ADISC/PDISC procedure is designed to avoid the abnormal termination of all open Exchanges when a new device is attached to the loop or when a device powers on.

**Note:** Because devices are not required to respond to Class 3 frames that have a D\_ID that does not match the full 24-bit N\_Port identifier of the receiving NL\_Port, timeouts might occur during the SCSI target discovery process if a SCSI initiator sends a frame to a Public NL\_Port using a D\_ID of 0000h || AL\_PA or to a Private NL\_Port using a D\_ID with the upper 16 bits non-zero. Therefore, for performance reasons, SCSI initiators should originate PDISC or ADISC Exchanges by transmitting the ELS Sequence, without waiting for the response. SCSI initiators might need to originate multiple concurrent Exchanges to hide multiple timeouts from the user.

## Clearing the Effects of Fibre Channel Actions

**TABLE 2-28** lists the clearing effects of ULP, FCP, FC-PH, and FC-AL Fibre Channel actions:

**TABLE 2-28** Clearing Effects

FCP SCSI Target Object	Power On Reset	LIP Reset	LOGO PLOGI	ABTS	PRLI PRLO	TPRLO	SCSI Target Reset	Clear Task Set	Abort Task Set	SCSI Log. Unit Reset
<b>PLOGI parameters:</b>										
All logged-in initiators	Y	Y	N	N	N	N	N	N	N	N
Only ports initiating action	-	-	Y	N	N	N	N	N	N	N
<b>Open sequences terminated:</b>										
For all initiator with OPN seq's	Y	Y	N	N	N	Y	Y	Y	N	Y
Only ports initiating action	-	-	Y	N	Y	-	-	-	Y	-
Only for seq. with aborted exchange	-	-	-	Y	-	-	-	-	-	-
<b>Login BB_Credit_CNT:</b>										
All logged-in L_Ports	Y	Y	-	N	N	N	N	N	N	N
Only transmitting ports	-	-	Y							
Hard address acquisition attempted	Y	Y	N	N	N	N	N	N	N	N
<b>PRLI parameters cleared:</b>										
All logged-in initiators	Y	Y	N	N	N	N	N	N	N	N
Only ports of specific type	-	-	N	N	Y	Y	N	N	N	N
Only ports initiating action	-	-	Y	N	Y	N	N	N	N	N
<b>Open exchanges aborted:</b>										
All tasks, all initiators, open tasks	Y	Y	N	N	N	Y	Y	Y	N	Y
All tasks, port initiating action	-	-	Y	N	Y	-	-	-	Y	-
Specific task, port initiating action	-	-	N	Y	N	-	-	-	N	-

TABLE 2-28 Clearing Effects (Continued)

FCP SCSI Target Object	Power On Reset	LIP Reset	LOGO PLOGI	ABTS	PRLI PRLO	TPRLO	SCSI Target Reset	Clear Task Set	Abort Task Set	SCSI Log. Unit Reset
<b>SCSI target mode page parameters restored from saved pages:</b>										
All initiators	Y	Y	N	N	N	Y	Y	N	N	Y
Only ports initiating action	-	-	Y	N	Y	-	-	N	N	-
<b>Pre-existing ACA, UA, and deferred error conditions cleared:</b>										
All initiators	Y	Y	N	N	N	Y	Y	N	N	Y
Only ports initiating action	-	-	Y	N	Y	-	-	N	N	-
<b>Device Reservations</b>										
For all SCSI initiators	Y	Y	N	N	N	Y	Y	N	N	Y
Only for SCSI initiator port initiating action	-	-	Y	N	Y	-	-	N	N	-
<b>Persistent Device Reservations</b>										
For all SCSI initiators	Y	N	N	N	N	N	N	N	N	N
Only for SCSI initiator port initiating action	-	-	N	N	N	-	-	N	N	-
<b>CRN (Command Reference Number)</b>										
For all SCSI initiators	Y	Y	N	N	N	Y	Y	N	N	Y
Only for SCSI initiator port initiating action	-	-	Y	N	Y	-	-	N	N	-
<b>Prevent Allow Medium Removal state</b>										
For all SCSI initiators	Y	Y	N	N	N	Y	Y	N	N	Y
Only for SCSI initiator port initiating action	-	-	N	N	Y	-	-	N	N	-
<b>Exchange Information</b>										
For all SCSI initiators	Y	Y	N	N	N	Y	Y	N	N	Y
Only for SCSI initiator port initiating action	-	-	Y	N	Y	-	-	N	N	-

## Device Reservations

The SL3000 tape library support the Reserve/Release management method and also the Persistent Reservations management method. The Reserve/Release method is defined in the ANSI SCSI-3 Primary Commands (SPC-2) standard. For the reservation restrictions placed on commands for the Reserve/Release management method, see [TABLE 2-29](#).

The Persistent Reservations method is defined in the ANSI SCSI-3 Primary Commands (SPC-3) Standard. For the reservation restrictions placed on the Persistent Reservations management method, see [TABLE 2-30 on page 47](#).

<b>Conflict</b>	Command will not be performed and the library will terminate the command with Reservation Conflict status.
<b>Allowed</b>	Command will be allowed to execute to normal completion.

**TABLE 2-29** Reserve/Release Management Method

<b>Command</b>	<b>Action when Reserved by a different Initiator</b>
Initialize Element (07h)	Conflict
Initialize Element with Range (37h)	Conflict
Inquiry (12h)	Allowed
Log Sense (4Dh)	Allowed
Mode Select (15h/55h)	Conflict
Mode Sense (1Ah/5Ah)	Conflict
Move Medium (A5h)	Conflict
Persistent Reserve In (5Eh)	Conflict
Persistent Reserve Out (5Fh)	Conflict
Position to Element (2Bh)	Conflict
Prevent/Allow Removal (1Eh)	Prevent = 0, allowed Prevent = NZ, conflict
Read Element Status (B8h)	CurData = 0, Conflict, CurData= 1, Allowed
Report LUNs (A0h)	Allowed
Release Unit (17h)	Allowed, the reservation is not released.
Request Sense (03h)	Allowed
Request Volume Element Address (B5h)	Conflict
Reserve Unit (16h)	Conflict
Send Diagnostic (1Dh)	Conflict
Send Volume Tag (B6h)	Conflict
Test Unit Ready (00h)	Conflict

**TABLE 2-30** Persistent Reservation Management Method

<b>Command</b>	<b>From: Non-registered Initiators</b>	<b>From: Registered Initiators</b>
Initialize Element (07h)	Conflict	Allowed
Initialize Element with Range (37h)	Conflict	Allowed
Inquiry (12h)	Allowed	Allowed
Log Sense (4Dh)	Allowed	Allowed
Mode Select (15h/55h)	Conflict	Allowed
Mode Sense (1Ah/5Ah)	Conflict	Allowed
Move Medium (A5h)	Conflict	Allowed
Persistent Reserve In (5Eh)	Allowed	Allowed
Persistent Reserve Out (5Fh)	Register, allowed Reserve, conflict Release, conflict Clear, conflict Preempt, conflict Pre/Abt, conflict Reg/Ign, allowed	Register, allowed Reserve, conflict Release, allowed Clear, allowed Preempt, allowed Pre/Abt, allowed Reg/Ign, allowed
Position to Element (2Bh)	Conflict	Allowed
Prevent/Allow Media Removal (1Eh)	Prevent = 0, allowed Prevent = NZ, conflict	Allowed
Read Element Status (B8h)	CurData = 0, Conflict, CurData= 1, Allowed	Allowed
Release Unit (17h)	Conflict	Allowed
Report LUNs (A0h)	Allowed	Allowed
Request Sense (03h)	Allowed	Allowed
Request Volume Element Address (B5h)	Conflict	Allowed
Reserve Unit (16h)	Conflict	Allowed
Send Diagnostic (1Dh)	Conflict	Allowed
Send Volume Tag (B6h)	Conflict	Allowed
Test Unit Ready (00h)	Conflict	Allowed





## SCSI Commands

---

This chapter lists and describes the small computer system interface command structures for the SL3000 library.

[TABLE 3-5 on page 52](#) contains a list of the commands, command codes, and page numbers that contain a description of the command.

**Note** – This manual does not describe the commands for tape drives. Refer to the tape drive documentation for information about SCSI commands for a tape drive.

---

## Implementation Requirements

The structure for all command descriptor blocks is:

- The first byte contains a:
  - Group Code that provides 8 groups of commands
  - Command Code that provides 32 command codes for each group
- The second byte in all command descriptor blocks:
  - Starts the command parameters
- Additional bytes:
  - Contains command parameters
- Last byte in all command descriptor blocks:
  - Control byte

**Note** – The library is SCSI-3 compliant.

For some commands, a list of parameters accompanies the request during Data Out.

For all commands, if there is an invalid parameter in the command descriptor block, then the device terminates the command without altering the medium.

## Command Descriptor Block

Initiators use three types of CDBs to communicate commands to the targets:

- 6-Byte commands (TABLE 3-1)
- 10-Byte commands (TABLE 3-2)
- 12-Byte commands (TABLE 3-3)

The first byte in the command descriptor block contains an operation code.

**TABLE 3-1** 6-Byte Command Descriptor Block

Byte	Bit							
	7	6	5	4	3	2	1	0
0	Group Code			Command Code				
1	Reserved			Command Parameters				
2-4	Command Parameters							
5	Control Byte							

**TABLE 3-2** 10-Byte Command Descriptor Block

Byte	Bit							
	7	6	5	4	3	2	1	0
0	Operation Code							
1	Reserved			Command Parameters				
2-8	Command Parameters							
9	Control Byte							

**TABLE 3-3** 12-Byte Command Descriptor Block

Byte	Bit							
	7	6	5	4	3	2	1	0
0	Operation Code							
1	Reserved			Command Parameters				
2-9	Command Parameters							
10	Reserved							
11	Control Byte							

## Control Byte

The control byte is the last byte of every Command Descriptor Block and has the following structure:

**TABLE 3-4** Control Byte

Bytes	Bit							
	7	6	5	4	3	2	1	0
5, 9, or 12	Vendor Specific		Reserved			NACA (0)	Flag (0)	Link (0)

- **Vendor Specific**  
Provides additional information about the device or for a command.
- **NACA**  
The normal auto contingent allegiance bit controls the rules for handling an auto contingent condition caused by a command. This bit is set to 0 to indicate that if a contingent allegiance condition occurs, the command will return a check condition.
- **Flag (not supported)**  
This bit causes an interrupt in the initiator allowing a device to respond with intermediate status. This bit is not supported and should be 0.
- **Link (not supported)**  
Allows devices that support command linking to continue the I/O process. This bit is not supported and should be 0.

# List of Supported Commands

**TABLE 3-5** Supported Commands

<b>Command and Page Number</b>	<b>Hex Code</b>
Initialize Element Status on page 54	07
Initialize Element Status With Range on page 55	37
Inquiry on page 56	12
Log Sense on page 63	4D
Mode Select (6) on page 65	15
Mode Select (10) on page 71	55
Mode Sense (6) on page 77	1A
Mode Sense (10) on page 89	5A
Move Medium on page 101	A5
Persistent Reserve In on page 103	5E
Persistent Reserve Out on page 109	5F
Position to Element on page 115	2B
Prevent/Allow Medium Removal on page 116	1E
Read Element Status on page 117	B8
Release (6) on page 140	17
Report LUNS on page 141	A0
Request Sense on page 143	03
Request Volume Element Address on page 155	B5
Reserve (6) on page 158	16
Send Diagnostic on page 161	1D
Send Volume Tag on page 162	B6
Test Unit Ready on page 164	00

---

## Operator Entries for Fibre Channel

The Fibre Channel interface requires configuration of the library's Port 0 address. You may configure the library for soft or hard addressing of this port.

If you configure the library for hard addressing, you may input the Port 0 address yourself through the library's operator panel or through the library's StorageTek Library Console (SLC) if used. Allowable loop addresses are 000d to 125d.

**Note** – Before you input a Port 0 address, you must first set the library's Fibre Channel hard address option to *enabled*.

If you configure the library for soft addressing, you are allowing the Fibre Channel software to configure the Port 0 address. Addresses are assigned in ascending order. For this addressing approach, you must *disable* the Fibre Channel hard address option.

**Note** – The default for the hard address option is *disabled*. See the library operator's guide for additional instructions on setting these values.

## Initialize Element Status

The host uses the Initialize Element Status command (07h) to request an inventory of the cartridge tapes held in the library. The library accepts this command for compatibility, but does not perform any action.

At power-on the library performs an audit of and maintains the inventory during operations. The library also performs an audit after someone has opened and closed the front door.

An initiator can obtain inventory information for the library by using the Read Element Status command.

**TABLE 3-6** Initialize Element Status Command

Byte	Bit							
	7	6	5	4	3	2	1	0
0	Operation Code (07h)							
1	Ignored			Reserved (00h)				
2	Reserved (00h)							
3	Reserved (00h)							
4	Reserved (00h)							
5	Control Byte (00h)							

## Initialize Element Status With Range

The Initialize Element Status With Range command (37h) is a request from the host to perform an inventory of a portion of the cartridge tapes within the library. The library accepts this command for compatibility, but does not perform any action.

At power-on the library performs an audit of and maintains the inventory during operations. The library also performs an audit after someone has opened and closed the front door.

An initiator can obtain inventory information for the library by using the Read Element Status command.

**TABLE 3-7** Initialize Element Status With Range Command

Byte	Bit							
	7	6	5	4	3	2	1	0
0	Operation Code (37h)							
1	Ignored			Reserved (00h)			Fast	Range
2 to 3	(MSB) Element Address							(LSB)
4 to 5	(MSB) Reserved (00h)							(LSB)
6 to 7	(MSB) Number of Elements							(LSB)
8	Reserved (00h)							
9	Control Byte (00h)							

Initialize Element Status with Range Definitions:

<b>Fast</b>	Ignore this field.
<b>Range</b>	Ignore this field.
<b>Element Address</b>	Ignore this field.
<b>Number of Elements</b>	Ignore this field.

# Inquiry

The Inquiry command (12h) requests that the library send to the initiator information regarding the library's parameters.

**TABLE 3-8** Inquiry Command

Byte	Bit							
	7	6	5	4	3	2	1	0
0	Operation Code (12h)							
1	Ignored			Reserved (00h)			CmdDt (0)	EVPD
2	Page Code							
3 to 4	MSB Allocation Length							LSB
5	Control Byte (00h)							

Inquiry Command Definitions:

<b>CmdDt</b>	Command support data is not supported (0).
<b>EVPD</b>	The enable vital product data bit indicates the type of inquiry data the initiator is requesting. Supported values are: <ul style="list-style-type: none"> <li>■ 0 = Request for standard inquiry data</li> <li>■ 1 = Request for vital support product data page</li> </ul>
<b>Page Code</b>	If the EVPD value is 0, this field is set to 00h. If the EVPD value is 1, this field must be: <ul style="list-style-type: none"> <li>■ 00h = Supported vital product pages</li> <li>■ 80h = Unit serial number page</li> <li>■ 83h = Device identification page</li> </ul>
<b>Allocation Length</b>	The library transfers either the number of bytes specified by the Allocation Length field or all of the available inquiry data, whichever is less. This condition is <i>not</i> considered an error.

The library terminates the Data In phase when it has transferred either the number of bytes specified by the Allocation Length field or all of the available inquiry data, whichever is less.

- The data length for standard inquiry data the library returns is 24h (36d) bytes.
- The data length for page 0 is 07h (7d) bytes.
- The data length for the unit serial number page (80h) is 10h (16d) bytes.
- The data length for the device identification page (83h) is 24h (36d) bytes.

**Note** – The Inquiry command returns check condition status only when the requested data cannot be returned. This command will not clear any pending unit attention conditions.



## Standard Inquiry Data Definition

For the Inquiry command, the library returns 24h (36d) bytes of data in this format.

**TABLE 3-9** Standard Inquiry Data

Byte	Bit							
	7	6	5	4	3	2	1	0
0	Peripheral Qualifier			Peripheral Device Type				
1	RMB (1)	Reserved (0)						
2	Version (05h)							
3	Reserved (0)		Norm ACA (0)	HiSup (1)	Response Data Format (2)			
4	Additional Length (n-4)							
5	SCCS (0)	ACC (0)	TPGS (0)		3PC (0)	Reserved (0)		Protect (0)
6	BQue (0)	EncServ (0)	VS (0)	MultiP (0)	MChngr (0)	Reserved (0)		
7	Reserved (0)				LINKED (0)	Rsvd (0)	CmdQue (0)	SftRe (0)
8 to 15	(MSB) Vendor Identification							(LSB)
16 to 31	(MSB) Product Identification							(LSB)
32 to 35	(MSB) Product Revision Level							(LSB)

Standard Inquiry Data Definitions:

- Peripheral Qualifier**
- 000b = Indicates the specified peripheral device type is currently connected to this logical unit.
  - 001b = Indicates the device server is capable of supporting the specified peripheral device type on this logical unit. However, the physical device is not currently connected to this logical unit. This value is returned, when:
    - The command was sent to an HLI library.
    - The command was sent to a Partitioned library with at least one SCSI partition and the SCSI host issuing the command does not have a registered World Wide name within any current partition configuration.
  - 011b = Indicates the command was sent to an unsupported logical unit.

(Note: xxxb indicates binary notation).

- Peripheral Device Type**
- The library returns a value of 8h, which indicates that the library is a medium changer device. If the command is sent to an unsupported logical unit, the value returned is 1Fh.

## Inquiry

<b>RMB</b>	Removable Medium; a value of 1 indicates the medium is removable.
<b>Version</b>	The library returns a value of 5h, which indicates compliance to SCSI-3
<b>NormACA</b>	The Normal Auto Contingent Allegiance (NACA) bit controls the rules for handling an auto contingent condition caused by a command. The library returns a value of 0, indicating it does not support setting the NACA bit to one in the control byte of a CDB.
<b>HiSup</b>	The library returns a value of 1, indicating the library uses the hierarchical addressing model to identify logical units.
<b>Response Data Format</b>	A value of 2 indicates the data found is in accordance with the SCSI-3 specification.
<b>Additional Length</b>	A value of 1Fh indicates there are 31 additional bytes of Standard Inquiry Data available to the initiator.
<b>SCCS</b>	The library returns a value of 0, indicating the library does not contain an embedded storage array controller component.
<b>ACC</b>	The library returns a value of 0, indicating it does not contain an access control coordinator that may be addressed through this logical unit.
<b>TPGS</b>	The Target Port Group Support (TPGS) field returns a value of 0 indicating that the library does not support asymmetric logical unit access. Neither of the Report Target Groups or Set Target Groups commands are supported.
<b>3PC</b>	The library returns a value of 0, indicating third-party commands are not supported.
<b>Protect</b>	The library returns 0 indicating that it does not support protection information.
<b>BQUE</b>	The library returns a value of 0, indicating basic queuing is not supported.
<b>VS</b>	Vendor Specific bit is set to 0, indicating there is no vendor-specific information with this command.
<b>MultiP</b>	The library returns a value of 0, indicating multi-port attachments are not supported.
<b>MChngr</b>	The library is not embedded in or attached to a medium transport element and returns a value of 0.
<b>LINKED</b>	The library returns a value of 0 for the LINKED command bit, indicating linked commands are not supported.
<b>CmdQue</b>	The library returns a value of 0, indicating Command Queuing is not supported.
<b>SftRe</b>	The library returns a value of 0, indicating Soft Reset is not supported.
<b>Vendor Identification</b>	Contains the ASCII character sequence "STK" followed by blanks. If the specified logical unit is not supported, this field contains all blanks.
<b>Product Identification</b>	This field contains the ASCII character sequence "SL3000" followed by blanks.
<b>Product Revision Level</b>	This field contains an ASCII character sequence that represents the product revision level.

### Error Conditions:

- The library returns Check Condition status for the Inquiry command only when a severe error occurs. To recover from a Check Condition status report on the Inquiry command, verify that the Inquiry CDB is OK, and retry the Inquiry command.

## Supported Pages Definition

The library returns the following bytes of supported page data in this format.

**TABLE 3-10** Supported Pages

Byte	Bit							
	7	6	5	4	3	2	1	0
0	Peripheral Qualifier				Peripheral Device Type			
1	Page Code (00h)							
2	Reserved (00h)							
3	Additional Page Length (03h)							
4	Supported Page (00h)							
5	Supported Page (80h)							
6	Supported Page (83h)							

Supported Pages Definitions:

---

<b>Peripheral Qualifier</b>	<ul style="list-style-type: none"> <li>■ 000b = Indicates the specified peripheral device type is currently connected to this logical unit.</li> <li>■ 001b = Indicates the device server is capable of supporting the specified peripheral device type on this logical unit. However, the physical device is not currently connected to this logical unit. This value is returned, when either: <ul style="list-style-type: none"> <li>■ The command was sent to an HLI library.</li> <li>■ The command was sent to a Partitioned library with at least one SCSI partition and the SCSI host issuing the command does not have a registered World Wide name within any current partition configuration.</li> </ul> </li> <li>■ 011b = Indicates the command was sent to an unsupported logical unit.</li> </ul>
-----------------------------	--

(Note: xxxb indicates binary notation).

---

<b>Peripheral Device Type</b>	The library returns a value of 8h, which indicates that the library is a medium changer device. If the command is sent to an unsupported logical unit, the value returned is 1Fh.
-------------------------------	---

---

<b>Page Code</b>	Identifies the page as the supported pages (00h).
------------------	---

---

<b>Additional Page Length</b>	Indicates the remaining bytes in the data: <ul style="list-style-type: none"> <li>■ 03h = Fibre Channel</li> </ul>
-------------------------------	--

---

<b>Supported Page</b>	<ul style="list-style-type: none"> <li>■ 00h = Indicates the first vital page is page 0 (current page)</li> <li>■ 80h = Indicates the second vital page unit serial number, <a href="#">on page 60</a></li> <li>■ 83h = Indicates the third vital page device identification, <a href="#">on page 61</a></li> </ul>
-----------------------	---

---

## Unit Serial Number Page Definition

The library returns 10h (16d) bytes of unit serial number page data in this format.

**TABLE 3-11** Unit Serial Number Page

Byte	Bit							
	7	6	5	4	3	2	1	0
0	Peripheral Qualifier				Peripheral Device Type			
1	Page Code (80h)							
2	Reserved (00h)							
3	Additional Page Length (0Ch)							
4 to 15	(MSB)	Unit Serial Number						(LSB)

Unit Serial Number Page Definitions:

<b>Peripheral Qualifier</b>	<ul style="list-style-type: none"> <li>■ 000b = Indicates the specified peripheral device type is currently connected to this logical unit.</li> <li>■ 001b = Indicates the device server is capable of supporting the specified peripheral device type on this logical unit. However, the physical device is not currently connected to this logical unit. This value is returned, when either:                             <ul style="list-style-type: none"> <li>■ The command was sent to an HLI library.</li> <li>■ The command was sent to a Partitioned library with at least one SCSI partition and the SCSI host issuing the command does not have a registered World Wide name within any current partition configuration.</li> </ul> </li> <li>■ 011b = Indicates the command was sent to an unsupported logical unit.</li> </ul>
-----------------------------	--

(Note: xxxb indicates binary notation).

<b>Peripheral Device Type</b>	The library returns a value of 8h, which indicates that the library is a medium changer device. If the command is sent to an unsupported logical unit, the value returned is 1Fh.
<b>Page Code</b>	This field is set to 80h, identifying the page as the unit serial number page.
<b>Additional Page Length</b>	This field is set to 0Ch, the number of bytes in the product serial number.
<b>Unit Serial Number</b>	<p>This field contains a unique 12-character ASCII identifier for the library.</p> <ul style="list-style-type: none"> <li>■ For example: 571XX0000121</li> </ul> <p>Where: XX indicates the library partition number. For non-partitioned libraries, XX is 00.</p>

## Device Identification Page

The library returns 36d bytes of device identification page data in this format:

**TABLE 3-12** Device Identification Page Data

Byte	Bit								
	7	6	5	4	3	2	1	0	
0	Peripheral Qualifier				Peripheral Device Type				
1	Page Code (83h)								
2	Reserved (00h)								
3	Additional Page Length (20h)								
<b>Node Name Identifier</b>									
4	Protocol Identifier (0)				Code Set (1)				
5	PIV (1)	Rsvd	Association (0)		Identifier Type (3)				
6	Reserved								
7	Identifier Length (08h)								
8 to 15	(MSB)				Identifier				(LSB)
<b>Port Name Identifier</b>									
16	Protocol Identifier (0)				Code Set (1)				
17	PIV (1)	Rsvd	Association (1)		Identifier Type (3)				
18	Reserved								
19	Identifier Length (08h)								
20 to 27	(MSB)				Identifier				(LSB)
<b>Port Number Identifier</b>									
28	Protocol Identifier (0)				Code Set (1)				
29	PIV (1)	Rsvd	Association (1)		Identifier Type (4)				
30	Reserved								
31	Identifier Length (04h)								
32 to 35	(MSB)				Identifier				(LSB)

Device Identification Page Definitions:

<b>Peripheral Qualifier</b>	The library returns a value of 000b indicating the specified peripheral device type is currently connected to this logical unit. If the command is sent to an unsupported logical unit, the value returned is 011b. (Note: xxxb indicates binary notation).
<b>Peripheral Device Type</b>	The library returns a value of 8h, which indicates that the library is a medium changer device. If the command is sent to an unsupported logical unit, the value returned is 1Fh.
<b>Protocol Identifier</b>	This field is set to 0h indicating the Fibre Channel protocol.
<b>Code Set</b>	The library returns a value of 1, indicating the identifier contains binary values.
<b>Identifier Type</b>	<ul style="list-style-type: none"> <li>■ 3 = The identifier field contains a 64-bit IEEE formatted address</li> <li>■ 4 = The identifier field contains a 4-byte port number</li> </ul>
<b>Identifier Length</b>	<ul style="list-style-type: none"> <li>■ 04h = The identifier field is 4-bytes long</li> <li>■ 08h = The identifier field is 8-bytes long</li> </ul>
<b>Identifier</b>	Contains a binary value of the identifier
<b>PIV</b>	The library returns a value of 1, indicating the identifier type is valid
<b>Association</b>	<ul style="list-style-type: none"> <li>■ 0 = Identifier field is associated with the addressed logical unit</li> <li>■ 1 = Identifier field is associated with the port that received the request</li> </ul>

The 36-bytes of the device identification page indicates the vendor-specific portion of the Institute of Electrical and Electronics Engineers (IEEE) registered 64-bit ID for a Fibre Channel library.

The vendor-specific portion of the ID includes the library's Port name, Node name, and N\_Port ID. This information is unique for each Fibre Channel interface card in the library.

The remaining 28 bits of the library's ID consist of:

- Name Address Authority (5h)
- Sun StorageTek company ID (00104Fh)

TABLE 3-13 shows the 64-bit IEEE-registered format that includes the Name Address Authority (NAA), company ID, and vendor-specific identifier.

**TABLE 3-13** Fibre Channel Device Identification

(MSB = 63)		Bits	(LSB = 00)
<b>NAA</b>	<b>IEEE Company ID</b>	<b>Vendor Specific Identifier</b>	
5h	00 10 4F (h)	(Different for every Fibre Channel card)	

**Note** – Every device on the loop must have a unique ID for login validation.

# Log Sense

The Log Sense command (4Dh) enables the library to report its error logs and statistics to the initiator.

**TABLE 3-14** Log Sense Command

Byte	Bit							
	7	6	5	4	3	2	1	0
0	Operation Code (4Dh)							
1	Ignored			Reserved (0)			PPC (0)	SP (0)
2	PC (0)		Page Code					
3	Reserved (00h)							
4	Reserved (00h)							
5 to 6	(MSB) Parameter Pointer						(LSB)	
7 to 8	(MSB) Allocation Length						(LSB)	
9	Control Byte (00h)							

## Log Sense Command Definitions:

<b>PPC</b>	Parameter Pointer Control is not supported (0).
<b>SP</b>	Save Parameters feature is not supported (0).
<b>PC</b>	The library does not support the page control (PC) feature. This field must be zero.
<b>Page Code</b>	<ul style="list-style-type: none"> <li>■ 00h = List Supported pages</li> <li>■ 07h = List Last <i>n</i> Error Events page</li> </ul>
<b>Parameter Pointer</b>	The Parameter Pointer allows an initiator to request data starting at a specific parameter code. This value is set to 00h for page code 0h.
<b>Allocation Length</b>	<p>Specifies the number of bytes the initiator has allocated for data returned from the Log Sense command.</p> <p>A value of 0 is considered an error.</p> <p>The maximum data length for the log sense data that the library can return is 2Eh bytes.</p> <p>The length varies based on the Page Code selected.</p> <ul style="list-style-type: none"> <li>■ 00h = List Supported pages; length is 6h</li> <li>■ 07h = List Last <i>n</i> Error Events page; length is 2Eh</li> </ul>

## Supported Pages Format Page

The Supported Pages Format page lists all the Log Sense page codes supported by the library.

**TABLE 3-15** Supported Pages Format Page

Byte	Bit								
	7	6	5	4	3	2	1	0	
0	Page Code (00h)								
1	Reserved (00h)								
2 to 3	(MSB)	Page Length (02h)						(LSB)	
4	Supported Pages Page Code (00h)								
5	Last n Errors Events Page Code (07h)								

## Last *n* Errors Events Page Format

The Last *n* Errors Event Page does not return specific error information to the library. The operator needs to gather the error information from the Streamline Library Console (SLConsole or SLC) for log information.

**TABLE 3-16** Last *n* Errors Events Page

Byte	Bit								
	7	6	5	4	3	2	1	0	
0	Page Code (07h)								
1	Reserved (00h)								
2 to 3	(MSB)	Page Length ( <i>n</i> - 3)						(LSB)	
4 to <i>n</i>	"Refer to the SLConsole for log information"								



## Mode Select (6)

The 6-byte Mode Select command (15h) enables an initiator to specify certain operating parameters for the library. The library uses the current versions of these parameters to configure itself during power-on or after a logical unit reset.

The library does not support changing Mode parameters. A check condition will be returned, if the SCSI host issues a Mode Select command and attempts to change a mode page.

When the library receives a Mode Select (6) command, the library validates all parameters. If a value is not valid, the library returns the appropriate error message.

**TABLE 3-17** Mode Select (6) Command

Byte	Bit							
	7	6	5	4	3	2	1	0
0	Operation Code (15h)							
1	Ignored			PF (1)	Reserved (0)			SP (0)
2	Reserved (00h)							
3	Reserved (00h)							
4	Parameter List Length							
5	Control Byte							

Mode Select (6) Command Definitions:

<b>PF</b>	Page Format supports SCSI-3 specification and requires a value of 1.
<b>SP</b>	The library does not support the SP function. This field must be zero.
<b>Parameter List Length</b>	<p>00h = No data transferred            Note: A value of 00h is not considered an error.            Any other value is considered an error and is not supported.</p> <ul style="list-style-type: none"> <li>■ 18h = Mode Parameter Header and Element Address Assignment Page are transferred</li> <li>■ 0Ch = Mode Parameter Header and Protocol Specific Logical Unit Control Page are transferred</li> <li>■ 0Ch = Mode Parameter Header and Protocol Specific Port Control Page are transferred</li> </ul>

## Mode Select (6) Data

The initiator must provide mode parameter data in a parameter list including:

- A 4-byte “Mode Select (6) Parameter Header” on page 66
- An 8-byte “Protocol Specific Logical Unit Page” on page 67
- An 8-byte “Protocol Specific Port Page” on page 68
- A 20-byte “Element Address Assignment Mode Page” on page 69

The Mode Select command supports the Element Address Assignment Page, the Protocol Specific Logical Unit Control Page, and the Protocol Specific Control Port Control Page. If the parameter list length field in the command is 0, then no Mode Select data is required.

**Note** – Before issuing any Mode Select commands, an initiator should issue a Mode Sense command with the Page Control field set to 01h, and the Page Code field set to 3Fh to determine which pages are supported, which parameters within the pages are changeable, and the supported length of each page.

## Mode Select (6) Parameter Header

The library accepts a 4-byte Mode Select parameter header as follows:

**TABLE 3-18** Mode Select Parameter (6) Header

Byte	Bit							
	7	6	5	4	3	2	1	0
0	Reserved (00h)							
1	Reserved (00h)							
2	Reserved (00h)							
3	Reserved (00h)							

**Note** – The header definitions for the library must all be 00h.

## Protocol Specific Logical Unit Page

The following table shows the format of the Protocol Specific Logical Unit page.

**TABLE 3-19** Protocol Specific Logical Unit Page

Byte	Bit							
	7	6	5	4	3	2	1	0
0	PS (0)	SPF (0)	Page Code (18h)					
1	Page Length (06h)							
2	Reserved				Protocol Identifier			
3	Reserved							EPDC
4	Reserved							
5	Reserved							
6	Reserved							
7	Reserved							

Protocol Specific Logical Unit Page Definitions:

<b>PS</b>	The Parameters Saveable bit is set to 0.
<b>SPF</b>	The library accepts a value of 0 for the SubPage Format bit, indicating page_0 format is being used.
<b>Protocol Identifier</b>	This field is set to 0h indicating the Fibre Channel protocol.
<b>EPDC</b>	Enable Precise Delivery Checking bit is set to 0 (not supported)

## Protocol Specific Port Page

The following table shows the format of the Protocol Specific Port page.

**TABLE 3-20** Protocol Specific Port Page

Byte	Bit							
	7	6	5	4	3	2	1	0
0	PS (0)	SPF (0)	Page Code (19h)					
1	Page Length (06h)							
2	Reserved				Protocol Identifier			
3	DTFD	PLPB	DDIS	DLM	RHA	ALWI	DTIPE	DTOLI
4	Reserved							
5	Reserved							
6	Reserved					RR_TOV Units		
7	RR_TOV Values							

Protocol Specific Port Page Definitions:

<b>PS</b>	The Parameters Saveable bit is set to 0.
<b>SPF</b>	The library accepts a value of 0 for the SubPage Format bit, indicating page_0 format is being used.
<b>Protocol Identifier</b>	This field is set to 0h indicating the Fibre Channel protocol.
<b>DTFD</b>	Disable Target Fabric Discovery, is set to 0 (not supported)
<b>PLPB</b>	Prevent Loop Port Bypass, is set to 0 (not supported)
<b>DDIS</b>	Disable Discovery, is set to 0 (not supported)
<b>DLM</b>	Disable Loop Master, is set to 0 (not supported)
<b>RHA</b>	Require Hard Address, is set to 0 (not supported)
<b>ALWI</b>	Allow Login Without Loop Initialization, is set to 0 (not supported)
<b>DTIPE</b>	Disable Target Initiated Port Enable, is set to 0 (not supported)
<b>DTOLI</b>	Disable Target Originated Loop Initialization, is set to 0 (not supported)
<b>RR_TOV Units</b>	Resource Recovery Time Out Units, is set to 100b = 10 second units
<b>RR_TOV Values</b>	Resource Recovery Time Out Value, is set to 1Eh = 300 seconds

## Element Address Assignment Mode Page

This table defines the Element Address Assignment Mode page.

**TABLE 3-21** Mode Select (6) Element Address Assignment Mode Page

Byte	Bit								
	7	6	5	4	3	2	1	0	
0	PS (0)	Rsvd (0)	Page Code (1Dh)						
1	Parameter Length (12h)								
2 to 3	(MSB)	First Medium Transport Element Address						(LSB)	
4 to 5	(MSB)	Number of Medium Transport Elements						(LSB)	
6 to 7	(MSB)	First Storage Element Address						(LSB)	
8 to 9	(MSB)	Number of Storage Elements						(LSB)	
10 to 11	(MSB)	First Import/Export Element Address						(LSB)	
12 to 13	(MSB)	Number of Import/Export Elements						(LSB)	
14 to 15	(MSB)	First Data Transfer Element Address						(LSB)	
16 to 17	(MSB)	Number of Data Transfer Elements						(LSB)	
18	Reserved (00h)								
19	Reserved (00h)								

## Mode Select (6) Element Address Assignment Mode Page Definitions:

<b>PS</b>	The Parameters Saveable bit is set to 0.
<b>Page Code</b>	Identifies the Element Address Assignment mode page.
<b>Parameter Length</b>	Indicates the length of the element address assignment parameter list. This field must be 12h, which indicates that there are an additional 12h (18d) bytes of parameter data following this byte.
<b>First Medium Transport Element Address</b>	Identifies the address of the hand in the library. The default value is 0000h. The First Medium Transfer Element address in the Mode Select command must be the same number returned by the Mode Sense Command.
<b>Number of Medium Transport Elements</b>	Identifies the number of hands in the library. The number in the Mode Select command must be the same number returned by the Mode Sense command.
<b>First Storage Element Address</b>	Identifies the starting address of the data cartridge slots in the library, and the default starting address is 7D0h (2000d). The First Storage Element address in the Mode Select command must be the same number returned by the Mode Sense Command.
<b>Number of Storage Elements</b>	Identifies the number of data cartridge slots in the library. This number is based on the configuration of the library and is obtained when the library performs a Mode Sense of mode page 1Dh. The number in the Mode Select command must be the same number returned by the Mode Sense command.
<b>First Import/Export Element Address</b>	Identifies the address of the first Import/Export element. This address is the first CAP element 000Ah (10d). The First Import/Export Element address in the Mode Select command must be the same number returned by the Mode Sense Command.
<b>Number of Import/Export Elements</b>	Identifies the number of Import/Export storage locations. This value is obtained when the library performs a Mode Sense of mode page 1Dh. The number in the Mode Select command must be the same number returned by the Mode Sense command.
<b>First Data Transfer Element Address</b>	Identifies the address of the first tape drive; the default setting address is 3E8h (1000d). The First Data Transfer Element address in the Mode Select command must be the same number returned by the Mode Sense Command.
<b>Number of Data Transfer Elements</b>	Identifies the total number of tape drives installed in the library. This number varies depending on the configuration. Obtain this value by requesting a Mode Sense of mode page 1Dh. The number in the Mode Select command must be the same number returned by the Mode Sense command.

## Mode Select (10)

The 10-byte Mode Select command (55h) enables an initiator to specify certain operating parameters for the library. The library uses the current versions of these parameters to configure itself during power-on or after a logical unit reset.

The library does not support changing Mode parameters. A check condition will be returned, if the SCSI host issues a Mode Select command and attempts to change a mode page.

When the library receives a Mode Select (10) command, the library validates all parameters. If a value is not valid, the library returns the appropriate error message.

**TABLE 3-22** Mode Select (10) Command

Byte	Bit							
	7	6	5	4	3	2	1	0
0	Operation Code (55h)							
1	Ignored			PF (1)	Reserved (0)			SP (0)
2	Reserved (00h)							
3	Reserved (00h)							
4	Reserved (00h)							
5	Reserved (00h)							
6	Reserved (00h)							
7 to 8	(MSB)	Parameter List Length						(LSB)
9	Control Byte							

Mode Select (10) Command Definitions:

<b>PF</b>	Page Format supports SCSI-3 specification and requires a value of 1.
<b>SP</b>	<ul style="list-style-type: none"> <li>■ The library does not support the SP function. This field must be zero.</li> </ul>
<b>Parameter List Length</b>	<ul style="list-style-type: none"> <li>■ 00h = No data transferred A value of 00h is not considered an error. Any other value is considered an error and is not supported.</li> <li>■ 1Ch = Mode Parameter Header and Element Address Assignment Page are transferred</li> <li>■ 10h = Mode Parameter Header and Protocol Specific Logical Unit Page are transferred</li> <li>■ 10h = Mode Parameter Header and Protocol Specific Port Page are transferred</li> </ul>

## Mode Select (10) Data

The initiator must provide mode parameter data in a parameter list including:

- An 8-byte “Mode Select (10) Parameter Header” on page 72
- An 8-byte “Protocol Specific Logical Unit Page” on page 73
- An 8-byte “Protocol Specific Port Page” on page 74
- A 20-byte “Element Address Assignment Mode Page” on page 75

## Mode Select (10) Parameter Header

The library accepts an 8-byte Mode Select parameter header as follows:

**TABLE 3-23** Mode Select Parameter Header

Byte	Bit							
	7	6	5	4	3	2	1	0
0	Reserved (00h)							
1	Reserved (00h)							
2	Reserved (00h)							
3	Reserved (00h)							
4	Reserved (00h)							
5	Reserved (00h)							
6	Reserved (00h)							
7	Reserved (00h)							

**Note** – The header definitions for the library must be all 00h.



## Protocol Specific Logical Unit Page

The following table shows the format of the Protocol Specific Logical Unit page.

**TABLE 3-24** Protocol Specific Logical Unit Page

Byte	Bit							
	7	6	5	4	3	2	1	0
0	PS (0)	SPF (0)	Page Code (18h)					
1	Page Length (06h)							
2	Reserved				Protocol Identifier			
3	Reserved							EPDC
4	Reserved							
5	Reserved							
6	Reserved							
7	Reserved							

Protocol Specific Logical Unit Page Definitions:

<b>PS</b>	The Parameters Saveable bit is set to 0.
<b>SPF</b>	The library accepts a value of 0 for the SubPage Format bit, indicating page_0 format is being used.
<b>Protocol Identifier</b>	This field is set to 0h indicating the Fibre Channel protocol.
<b>EPDC</b>	Enable Precise Delivery Checking bit is set to 0 (not supported)

## Protocol Specific Port Page

The following table shows the format of the Protocol Specific Port page.

**TABLE 3-25** Protocol Specific Port Page

Byte	Bit							
	7	6	5	4	3	2	1	0
0	PS (0)	SPF (0)	Page Code (19h)					
1	Page Length (06h)							
2	Reserved				Protocol Identifier			
3	DTFD	PLPB	DDIS	DLM	RHA	ALWI	DTIPE	DTOLI
4	Reserved							
5	Reserved							
6	Reserved					RR_TOV Units		
7	RR_TOV Values							

Protocol Specific Port Page Definitions:

<b>PS</b>	The Parameters Saveable bit is set to 0.
<b>SPF</b>	The library accepts a value of 0 for the SubPage Format bit, indicating page_0 format is being used.
<b>Protocol Identifier</b>	This field is set to 0h indicating the Fibre Channel protocol.
<b>DTFD</b>	Disable Target Fabric Discovery, is set to 0 (not supported)
<b>PLPB</b>	Prevent Loop Port Bypass, is set to 0 (not supported)
<b>DDIS</b>	Disable Discovery, is set to 0 (not supported)
<b>DLM</b>	Disable Loop Master, is set to 0 (not supported)
<b>RHA</b>	Require Hard Address, is set to 0 (not supported)
<b>ALWI</b>	Allow Login Without Loop Initialization, is set to 0 (not supported)
<b>DTIPE</b>	Disable Target Initiated Port Enable, is set to 0 (not supported)
<b>DTOLI</b>	Disable Target Originated Loop Initialization, is set to 0 (not supported)
<b>RR_TOV Units</b>	Resource Recovery Time Out Units, must be 100b = 10 second units
<b>RR_TOV Values</b>	Resource Recovery Time Out Value, must be 1Eh = 300 seconds

## Element Address Assignment Mode Page

This table defines the Element Address Assignment Mode page.

**TABLE 3-26** Mode Select (6) Element Address Assignment Mode Page

Byte	Bit								
	7	6	5	4	3	2	1	0	
0	PS (0)	Rsvd (0)	Page Code (1Dh)						
1	Parameter Length (12h)								
2 to 3	(MSB)	First Medium Transport Element Address						(LSB)	
4 to 5	(MSB)	Number of Medium Transport Elements						(LSB)	
6 to 7	(MSB)	First Storage Element Address						(LSB)	
8 to 9	(MSB)	Number of Storage Elements						(LSB)	
10 to 11	(MSB)	First Import/Export Element Address						(LSB)	
12 to 13	(MSB)	Number of Import/Export Elements						(LSB)	
14 to 15	(MSB)	First Data Transfer Element Address						(LSB)	
16 to 17	(MSB)	Number of Data Transfer Elements						(LSB)	
18	Reserved (00h)								
19	Reserved (00h)								

## Mode Select (6) Element Address Assignment Mode Page Definitions:

<b>PS</b>	The Parameters Saveable bit is set to 0.
<b>Page Code</b>	Identifies the Element Address Assignment mode page.
<b>Parameter Length</b>	Indicates the length of the element address assignment parameter list. This field must be 12h, which indicates that there are an additional 12h (18d) bytes of parameter data following this byte.
<b>First Medium Transport Element Address</b>	Identifies the address of the hand in the library. The default value is 0000h. The First Medium Transfer Element address in the Mode Select command must be the same number returned by the Mode Sense Command.
<b>Number of Medium Transport Elements</b>	Identifies the number of hands in the library. The number in the Mode Select command must be the same number returned by the Mode Sense command.
<b>First Storage Element Address</b>	Identifies the starting address of the data cartridge slots in the library, and the default starting address is 7D0h (2000d). The First Storage Element address in the Mode Select command must be the same number returned by the Mode Sense Command
<b>Number of Storage Elements</b>	Identifies the number of data cartridge slots in the library. This number is based on the configuration of the library and is obtained when the library performs a Mode Sense of mode page 1Dh. The number in the Mode Select command must be the same number returned by the Mode Sense command.
<b>First Import/Export Element Address</b>	Identifies the address of the first Import/Export element. This address is the first CAP element 000Ah (10d). The First Data Transfer Element address in the Mode Select command must be the same number returned by the Mode Sense Command.
<b>Number of Import/Export Elements</b>	Identifies the number of Import/Export storage locations. This value is obtained when the library performs a Mode Sense of mode page 1Dh. The number in the Mode Select command must be the same number returned by the Mode Sense command.
<b>First Data Transfer Element Address</b>	Identifies the address of the first tape drive; the default setting address is 3E8h (1000d). The First Data Transfer Element address in the Mode Select command must be the same number returned by the Mode Sense Command.
<b>Number of Data Transfer Elements</b>	Identifies the total number of tape drives installed in the library. This number varies depending on the configuration. Obtain this value by requesting a Mode Sense of mode page 1Dh. The number in the Mode Select command must be the same number returned by the Mode Sense command.

## Mode Sense (6)

The 6-byte Mode Sense command (1Ah) enables the library to report its operating mode parameters to the initiator.

- The initiator can request one page or all pages of the mode parameters.
- An initiator can issue a Mode Sense command with the Page Control field set to 01h, and the Page Code field set to 3Fh to determine which:
  - Pages are supported
  - Parameters within the pages are changeable  
However, the library does not support changing any mode parameters.
  - Supported length of each page

**TABLE 3-27** Mode Sense Command

Byte	Bit							
	7	6	5	4	3	2	1	0
0	Operation Code (1Ah)							
1	Ignored			Rsvd	DBD	Reserved (0)		
2	Page Control		Page Code					
3	SubPage Code (00h)							
4	Allocation Length							
5	Control Byte							

## Mode Sense (6) Command Definitions:

<b>DBD</b>	Disable Block Descriptors is ignored.
<b>Page Control</b>	<p>Defines the type of parameters to be returned for the Mode Sense command, values include:</p> <hr/> <p>0h (00b) = Current Values:  The library returns the current values.  Requested pages are returned with each supported parameter set to its current value.  Parameters not supported by the library are set to 0.  Current values for the Element Address Assignment page are based on the configuration of the library.</p> <hr/> <p>1h (01b) = Changeable Values:  The library returns the changeable parameter masks.  All requested pages are returned  Pages indicate which parameters are changeable by the initiator  All bits of changeable parameters are set to 1  All bits of parameters that are not changeable are set to 0</p> <hr/> <p>Note: The library does not support any changeable mode values.</p> <hr/> <p>2h (10b) = Default Values:  The library returns the default values.  Requested pages are returned with each supported parameter set to its default  Parameters not supported by the library are set to 0.  Default values for the Element Address Assignment page are based on the minimum configuration of the library.</p> <hr/> <p>3h (11b) = Saved Values:  The library does not support any savable pages.  If Saved Values are requested, a check condition is returned to the host.</p>
<b>Page Code</b>	<p>Specifies which pages the library returns, including:</p> <ul style="list-style-type: none"> <li>■ 18h = Protocol Specific Logical Unit page</li> <li>■ 19h = Protocol Specific Port Control page</li> <li>■ 1Dh = Element Address Assignment page</li> <li>■ 1Eh = Transport Geometry page</li> <li>■ 1Fh = Device Capabilities page</li> <li>■ 3Fh = All pages (in the above order)</li> </ul>
<b>SubPage Code</b>	Not supported
<b>Allocation Length</b>	<p>Specifies the length of the parameter list the library returns.  The maximum length is 4Ch (76d) bytes.  The length varies based on the Page Code selected:</p> <ul style="list-style-type: none"> <li>■ 4 bytes for the parameter list header (always present)</li> <li>■ 8 additional bytes for the Protocol Specific Logical Unit Control page</li> <li>■ 8 additional bytes for the Protocol Specific Port Control page</li> <li>■ 20 additional bytes for the Element Address Assignment page</li> <li>■ 4 additional bytes for the Transport Geometry page</li> <li>■ 20 additional bytes for the Device Capabilities page</li> </ul> <p>The library transfers the number of bytes specified by the Allocation Length or the available Mode Sense data, whichever is less.</p>

## Mode Sense (6) Data

The library returns the following mode sense data:

- A four-byte Mode Parameter Header followed by
- One mode page or all mode pages in the order specified in the Page Code list.

The mode pages available are those defined for medium changers, including:

- Protocol Specific Logical Unit Control page
- Protocol Specific Port Control page
- Element Address Assignment page
- Transport Geometry page, and
- Device Capabilities page
- The data can be truncated to the length specified in the allocation length field.

## Mode Sense (6) Parameter Header Definition

The following table shows the Mode Sense Parameter Header page.

**TABLE 3-28** Mode Sense (6) Parameter Header

Byte	Bit							
	7	6	5	4	3	2	1	0
0	Mode Data Length							
1	Reserved							
2	Reserved							
3	Block Descriptor Length (00h)							

Mode Sense (6) Parameter Header Page Definitions:

<b>Mode Data Length</b>	This field indicates the number of bytes of parameter information available to be transferred to the initiator, regardless of the allocation length. This field excludes the Mode Data Length byte but includes three additional Mode Parameter Header bytes and any mode pages that follow.
<b>Block Descriptor Length</b>	The library does not support block descriptors (00h).

## Protocol Specific Logical Unit Control Page

The following table shows the format of the Protocol Specific Logical Unit Control page.

**TABLE 3-29** Protocol Specific Logical Unit Control Page

Byte	Bit							
	7	6	5	4	3	2	1	0
0	PS (0)	SPF (0)	Page Code (18h)					
1	Page Length (06h)							
2	Reserved				Protocol Identifier			
3	Reserved							EPDC (0)
4 to 7	(MSB)	Reserved						(LSB)

Fibre Channel Protocol Specific Logical Unit Control Page Definitions:

<b>PS</b>	The Parameters Saveable bit is set to 0.
<b>SPF</b>	The library returns a value of 0 for the SubPage Format bit, indicating page_0 format is being used.
<b>Protocol Identifier</b>	This field is set to 0h indicating the Fibre Channel protocol.
<b>EPDC</b>	Enable Precise Delivery Checking bit is set to 0 (not supported)



## Protocol Specific Port Control Page

The following table shows the format of the Protocol Specific Port Control page.

**TABLE 3-30** Protocol Specific Port Control Page

Byte	Bit							
	7	6	5	4	3	2	1	0
0	PS (0)	Rsvd	Page Code (19h)					
1	Page Length (06h)							
2	Reserved				Protocol Identifier			
3	DTFD	PLPB	DDIS	DLM	DSA	ALWI	DTIPE	DTOLI
4	Reserved							
5	Reserved							
6	Reserved					RR_TOV units		
7	Resource Recovery Time Out Value (RR_TOV)							

Fibre Channel Protocol Specific Port Control Page Definitions:

<b>PS</b>	The Parameters Saveable bit is set to 0.
<b>Protocol Identifier</b>	This field is set to 0h indicating the Fibre Channel protocol.
<b>DTFD</b>	Disable Target Fabric Discovery <ul style="list-style-type: none"> <li>■ 0 = Public Loop behavior supported</li> <li>■ 1 = Private Loop only supported</li> </ul>
<b>PLPB</b>	Prevent Loop Port Bypass is set to 0
<b>DDIS</b>	Disable Discovery is set to 0
<b>DLM</b>	Disable Loop Master is set to 0
<b>DSA</b>	Disable Soft Address is set to 0
<b>ALWI</b>	Allow Login Without Loop Initialization is set to 0
<b>DTIPE</b>	Disable Target Initiated Port Enable is set to 0
<b>DTOLI</b>	Disable Target Originated Loop Initialization is set to 0
<b>RR_TOV units</b>	Resource Recovery Time Out Value Units will always be 100b = 10 second units
<b>RR_TOV</b>	Resource Recovery Time Out Value will always be 1Eh = 300 seconds

## Element Address Assignment Page Definition

This table defines the Element Address Assignment page of the Mode Sense (6) command.

**TABLE 3-31** Mode Sense (6) Element Address Assignment Page

Byte	Bit								
	7	6	5	4	3	2	1	0	
0	PS (0)	Rsvd (0)	Page Code (1Dh)						
1	Parameter Length (12h)								
2 to 3	(MSB)	First Medium Transport Element Address						(LSB)	
4 to 5	(MSB)	Number of Medium Transport Elements						(LSB)	
6 to 7	(MSB)	First Storage Element Address						(LSB)	
8 to 9	(MSB)	Number of Storage Elements						(LSB)	
10 to 11	(MSB)	First Import/Export Element Address						(LSB)	
12 to 13	(MSB)	Number Import/Export Elements						(LSB)	
14 to 15	(MSB)	First Data Transfer Element Address						(LSB)	
16 to 17	(MSB)	Number Data Transfer Elements						(LSB)	
18 to 19	(MSB)	Reserved (00h)						(LSB)	

## Mode Sense (6) Element Address Assignment Page Definitions:

<b>PS</b>	The Parameters Saveable bit is set to 0.
<b>Page Code</b>	Identifies the Element Address Assignment mode page and returns a value of 1Dh.
<b>Parameter Length</b>	Indicates the amount of element address data following this byte and returns a value of 12h.
<b>First Medium Transport Element Address</b>	Identifies the address of the robot and returns a value of 0h.
<b>Number of Medium Transport Elements</b>	Identifies the number of hands within the library.
<b>First Storage Element Address</b>	Identifies the starting address of the data cartridge slots. The default starting address is 7D0h (2000d).
<b>Number of Storage Elements</b>	Identifies the number of data cartridge slots within the library. The total number of data cartridge slots depends on how the library is configured.
<b>First Import / Export Element Address</b>	Identifies the address of the first Import/Export element. The default starting address is 000Ah.
<b>Number of Import / Export Elements</b>	Identifies the total number of import/export slots.
<b>First Data Transfer Element Address</b>	Identifies the address of the first tape transport installed in the library. The default address is 3E8h (1000d).
<b>Number of Data Transfer Elements</b>	Identifies the number of tape drives in the library, and the library returns the configured count.

## Transport Geometry Mode Page Definition

This table defines the Mode Sense Transport Geometry Mode page.

**TABLE 3-32** Transport Geometry Mode Page

Byte	Bit							
	7	6	5	4	3	2	1	0
0	PS (0)	Rsvd	Page Code (1Eh)					
1	Parameter Length (02h)							
2	Reserved (0)							Rotate (0)
3	Member Number in Transport Element Set (00h)							

Transport Geometry Mode Page Definitions:

<b>PS</b>	The Parameters Saveable bit is set to 0.
<b>Page Code</b>	This field identifies the Transport Geometry mode page; the library returns a value of 1Eh.
<b>Parameter Length</b>	This field indicates the number of additional types of transport geometry descriptor data to follow the header. Each descriptor has two bytes of information. The library has one transport mechanism and returns a value of 02h.
<b>Rotate</b>	This field identifies the ability of the transport mechanism to handle two-sided media. The library does not use multiple-sided media and returns a value of 0.
<b>Member Number in Transport Element Set</b>	This field identifies the specific transport element in the system to which this descriptor is applied. The library has one transport element and returns a value of 00h.

## Device Capabilities Page Definition

TABLE 3-33 defines the Device Capabilities page of the Mode Sense command.

**TABLE 3-33** Device Capabilities Page

Byte	Bit							
	7	6	5	4	3	2	1	0
0	PS (0)	Rsvd (0)	Page Code (1Fh)					
1	Parameter Length (12h)							
2	Reserved (0h)				StorDT <sup>1</sup> (1)	StorI/E <sup>2</sup> (1)	StorST <sup>3</sup> (1)	StorMT <sup>4</sup> (0)
3	Reserved (0h)							
4	Reserved (0h)				MT->DT (0)	MT->I/E (0)	MT->ST (0)	MT->MT (0)
5	Reserved (0h)				ST->DT (1)	ST->I/E (1)	ST->ST (1)	ST->MT (0)
6	Reserved (0h)				I/E->DT (1)	I/E->I/E (1)	I/E->ST (1)	I/E->MT (0)
7	Reserved (0h)				DT->DT (1)	DT->I/E (1)	DT->ST (1)	DT->MT (0)
8 to 11	Reserved (00h)							
12	Reserved (0h)				MT<>D T (0)	MT<>I/ E (0)	MT<>ST (0)	MT<>M T (0)
13	Reserved (0h)				ST<>DT (0)	ST<>I/E (0)	ST<>ST (0)	ST<>MT (0)
14	Reserved (0h)				I/E<>D T (0)	I/E<>I/ E (0)	I/E<>ST (0)	I/E<>M T (0)
15	Reserved (0h)				DT->DT (0)	DT<>I/ E (0)	DT<>ST (0)	DT<>M T (0)
16 to 19	Reserved (00h)							
<b>Notes:</b> DT - Data Transfer Element (tape drive) I/E = Import/Export Element (cartridge access port slots) ST = Storage Element (cartridge tape storage slots) MT= Medium Transport (hand)								

## Device Capabilities Page Definitions:

<b>PS</b>	The Parameters Saveable bit is set to 0.
<b>Page Code</b>	This field identifies the Device Capabilities mode page and always contains a value of 1Fh.
<b>Parameter Length</b>	This field indicates the amount of device capabilities data following this byte. The library returns a value of 12h (18d).
<b>StorDT</b>	This field identifies the ability of a tape drive to perform the function of element storage. The library returns a value of 1.
<b>StorI/E</b>	This field identifies the ability of a CAP slot to perform the function of element storage. The library returns a value of 1.
<b>StorST</b>	This field identifies the ability of the data cartridge slots to perform the function of element storage. The library returns a value of 1.
<b>StorMT</b>	This field identifies the ability of the hand to perform the function of element storage. The hand cannot be used as the source or destination of a move. The library returns a value of 0.
<b>MT -&gt; DT</b>	This field identifies the support for the Move Medium command, where the source is the hand, and the destination is a tape drive. The library returns a value of 0.
<b>MT -&gt; I/E</b>	This field identifies the support for the Move Medium command, where the source is the hand, and the destination is a CAP slot. The library returns a value of 0.
<b>MT -&gt; ST</b>	This field identifies the support for the Move Medium command, where the source is the hand, and the destination is a cartridge tape storage slot. The library returns a value of 0.
<b>MT -&gt; MT</b>	This field identifies the support for the Move Medium command, where both the source and the destination is the hand. The library returns a value of 0.
<b>ST -&gt; DT</b>	This field identifies the support for the Move Medium command, where the source is a data cartridge slot, and the destination is a tape drive. The library returns a value of 1.
<b>ST -&gt; I/E</b>	This field identifies the support for the Move Medium command, where the source is a data cartridge slot, and the destination is a CAP slot. The library returns a value of 1.
<b>ST -&gt; ST</b>	This field identifies the support for the Move Medium command, where the source is a data cartridge slot, and the destination is a data cartridge slot. The library returns a value of 1.
<b>ST -&gt; MT</b>	This field identifies the support for the Move Medium command, where the source is a data cartridge slot, and the destination is the hand. The library returns a value of 0.
<b>I/E -&gt; DT</b>	This field identifies the support for the Move Medium command, where the source is a CAP slot, and the destination is a tape drive. The library returns a value of 1.

## Device Capabilities Page Definitions:

<b>I/E-&gt; I/E</b>	This field identifies the support for the Move Medium command, where both the source, and the destination is a CAP slot. The library returns a value of 1.
<b>I/E -&gt; ST</b>	This field identifies the support for the Move Medium command, where the source is a CAP slot, and the destination is a data cartridge slot. The library returns a value of 1.
<b>I/E -&gt; MT</b>	This field identifies the support for the Move Medium command, where the source is a CAP slot, and the destination is the hand. The library returns a value of 0.
<b>DT -&gt; DT</b>	This field identifies the support for the Move Medium command, where the source, and the destination is a tape drive. The library returns a value of 1.
<b>DT -&gt; I/E</b>	This field identifies the support for the Move Medium command, where the source is a tape drive, and the destination is a CAP slot. The library returns a value of 1.
<b>DT -&gt; ST</b>	This field identifies the support for the Move Medium command, where the source is a tape drive, and the destination is a data cartridge slot. The library returns a value of 1.
<b>DT -&gt; MT</b>	This field identifies the support for the Move Medium command, where the source is a tape drive, and the destination 1 element is the hand. The library returns a value of 0.
<b>MT &lt; &gt; DT</b>	This field identifies the support for the Exchange Medium command, where the source and destination 2 elements are the hand, and the destination 1 element is a tape drive. The library returns a value of 0.
<b>MT &lt; &gt; I/E</b>	This field identifies the support for the Exchange Medium command, where the source and destination 2 elements are the hand, and the destination 1 element is a CAP slot. The library returns a value of 0.
<b>MT &lt; &gt; ST</b>	This field identifies the support for the Exchange Medium command, where the source and destination 2 elements are the hand, and the destination 1 element is a data cartridge slot. The library returns a value of 0.
<b>MT &lt; &gt; MT</b>	This field identifies the support for the Exchange Medium command, where the source and destination 2 elements are the hand, and the destination 1 element is the hand. The library returns a value of 0.
<b>ST &lt; &gt; DT</b>	This field identifies the support for the Exchange Medium command, where the source and destination 2 elements are a data cartridge slot, and the destination 1 element is a tape drive. The library returns a value of 0.
<b>ST &lt; &gt; I/E</b>	This field identifies the support for the Exchange Medium command, where the source and destination 2 elements are a data cartridge slot, and the destination 1 element is a CAP slot. The library returns a value of 0.

## Device Capabilities Page Definitions:

<b>ST &lt; &gt; ST</b>	This field identifies support for the Exchange Medium command, where the source and destination 2 elements are a data cartridge slot, and the destination 1 element is a data cartridge slot. The library returns a value of 0.
<b>ST &lt; &gt; MT</b>	This field identifies the support for the Exchange Medium command, where the source and destination 2 elements are a data cartridge slot, and the destination 1 element is the hand. The library returns a value of 0.
<b>I/E &lt; &gt; DT</b>	This field identifies the support for the Exchange Medium command, where the source and destination 2 elements are a CAP slot, and the destination 1 element is a tape drive. The library returns a value of 0.
<b>I/E &lt; &gt; I/E</b>	This field identifies the support for the Exchange Medium command, where the source and destination 2 elements are a CAP slot, and the destination 1 element is a CAP slot. The library returns a value of 0.
<b>I/E &lt; &gt; ST</b>	This field identifies the support for the Exchange Medium command, where the source and destination 2 elements are a CAP slot, and the destination 1 element is a data cartridge slot. The library returns a value of 0.
<b>I/E &lt; &gt; MT</b>	This field identifies the support for the Exchange Medium command, where the source and destination 2 elements are a CAP slot, and the destination 1 element is the hand. The library returns a value of 0.
<b>DT &lt; &gt; DT</b>	This field identifies the support for the Exchange Medium command, where the source and destination 2 elements are a tape drive, and the destination 1 element is a tape drive. The library returns a value of 0.
<b>DT &lt; &gt; I/E</b>	This field identifies the support for the Exchange Medium command, where the source and destination 2 elements are a tape drive, and the destination 1 element is a CAP slot. The library returns a value of 0.
<b>DT &lt; &gt; ST</b>	This field identifies the support for the Exchange Medium command, where the source and destination 2 elements are a tape drive, and the destination 1 element is a data cartridge slot. The library returns a value of 0.
<b>DT &lt; &gt; MT</b>	This field identifies the support for the Exchange Medium command, where the source and destination 2 elements are a tape drive, and the destination 1 element is the hand. The library returns a value of 0.



## Mode Sense (10)

The 10-byte Mode Sense command (5Ah) enables the library to report its operating mode parameters to the initiator.

**TABLE 3-34** Mode Sense (10) Command

Byte	Bit							
	7	6	5	4	3	2	1	0
0	Operation Code (5Ah)							
1	Ignored			LLBA (0)	DBD	Reserved (0)		
2	Page Control		Page Code					
3	SubPage Code (00h)							
4 to 6	(MSB)		Reserved				(LSB)	
7 to 8	(MSB)		Allocation Length				(LSB)	
9	Control Byte							

### Mode Sense (10) Command Definitions:

---

<b>LLBA</b>	The library returns a value of 0, indicating the LONGBLA bit shall be zero in the parameter data returned by the library.
-------------	---

---

<b>DBD</b>	Disable Block Descriptors is ignored.
------------	---------------------------------------

---

<b>Page Control</b>	Defines the type of parameters to be returned for the Mode Sense command, values include:
---------------------	---

---

0h (00b) = Current Values:

The library returns the current values.

Requested pages are returned with each supported parameter set to its current value.

Parameters not supported by the library are set to 0.

Current values for the Element Address Assignment page are based on the configuration of the library.

---

1h (01b) = Changeable Values:

The library returns the changeable parameter masks.

All requested pages are returned

Pages indicate which parameters are changeable by the initiator

All bits of changeable parameters are set to 1

All bits of parameters that are not changeable are set to 0

---

Note: The library does not support any changeable mode values.

---

<b>Page Control</b>	<p>2h (10b) = Default Values:                  The library returns the default values.                  Requested pages are returned with each supported parameter set to its default                  Parameters not supported by the library are set to 0.                  Default values for the Element Address Assignment page are based on the                  minimum configuration of the library.</p>
	<p>3h (11b) = Saved Values:                  The library does not support any savable pages.                  If Saved Values are requested, a check condition is returned to the host.</p>
<b>Page Code</b>	<p>Specifies which pages the library returns, including:</p> <ul style="list-style-type: none"> <li>■ 18h = Protocol Specific Logical Unit page</li> <li>■ 19h = Protocol Specific Port Control page</li> <li>■ 1Dh = Element Address Assignment page</li> <li>■ 1Eh = Transport Geometry page</li> <li>■ 1Fh = Device Capabilities page</li> <li>■ 3Fh = All pages in the above order</li> </ul>
<b>SubPage Code</b>	<p>Not Supported. The library returns a value of 0.</p>
<b>Allocation Length</b>	<p>Specifies the length of the parameter list the library returns.                  The maximum length is 44h (68d) bytes.</p> <p>The length varies based on the Page Code selected:</p> <ul style="list-style-type: none"> <li>■ 8 bytes for the parameter list header (always present)</li> <li>■ 8 additional bytes for the Protocol Specific Logical Unit Control page</li> <li>■ 8 additional bytes for the Protocol Specific Port Control page</li> <li>■ 20 additional bytes for the Element Address Assignment page</li> <li>■ 4 additional bytes for the Transport Geometry page</li> <li>■ 20 additional bytes for the Device Capabilities page</li> </ul> <p>The library transfers the number of bytes specified by the Allocation Length or                  the available Mode Sense data, whichever is less.</p>

## Mode Sense (10) Data

The library returns the following mode sense data:

- A eight-byte Mode Parameter Header followed by:
- One mode page or all mode pages in the order specified in the Page Code list. The mode pages available are those defined for medium changers in the Fibre Channel standard, including a Protocol Specific Logical Unit Control page, Protocol Specific Port Control page, an Element Address Assignment page, a Transport Geometry Mode page, and a Device Capabilities page
- The data can be truncated to the length specified in the allocation length field.

## Mode Sense (10) Parameter Header Definition

The following table shows the Mode Sense Parameter Header page.

**TABLE 3-35** Mode Sense Parameter Header Page

Byte	Bit							
	7	6	5	4	3	2	1	0
0	MSB of Mode Data Length							
1	LSB of Mode Data Length							
2	Reserved							
3	Reserved							
4	Reserved							
5	Reserved							
6	MSB of Block Descriptor Length							
7	LSB of Block Descriptor Length							

Mode Sense (10) Parameter Header Page Definitions:

<b>Mode Data Length</b>	This field indicates the number of bytes of parameter information available to be transferred to the initiator, regardless of the allocation length. This field excludes the Mode Data Length but includes six additional Mode Parameter Header bytes and any mode pages that follow.
<b>Block Descriptor Length</b>	The library does not support block descriptors (00h).

## Protocol Specific Logical Unit Page

The following table shows the format of the Protocol Specific Logical Unit Control page.

**TABLE 3-36** Protocol Specific Logical Unit Page

Byte	Bit							
	7	6	5	4	3	2	1	0
0	PS (0)	SPF (0)	Page Code (18h)					
1	Page Length (06h)							
2	Reserved				Protocol Identifier (0h)			
3	Reserved							EPDC (0)
4 to 7	(MSB)	Reserved						(LSB)

Fibre Channel Protocol Specific Logical Unit Page Definitions:

<b>PS</b>	The Parameters Saveable bit is set to 0.
<b>SPF</b>	The library returns a value of 0 for the SubPage Format bit, indicating page_0 format is being used.
<b>Protocol Identifier</b>	This field is set to 0h indicating the Fibre Channel protocol.
<b>EPDC</b>	Enable Precise Delivery Checking bit is set to 0 (not supported)

## Protocol Specific Port Control Page

The following table shows the format of the Protocol Specific Port Control page.

**TABLE 3-37** Protocol Specific Port Control Page

Byte	Bit							
	7	6	5	4	3	2	1	0
0	PS (0)	Rsvd	Page Code (19h)					
1	Page Length (06h)							
2	Reserved				Protocol Identifier (0h)			
3	DTFD	PLPB	DDIS	DLM	DSA	ALWI	DTIPE	DTOLI
4	Reserved							
5	Reserved							
6	Reserved					RR_TOV units		
7	Resource Recovery Time Out Value (RR_TOV)							

Fibre Channel Protocol Specific Port Specific Control Page Definitions:

<b>PS</b>	The Parameters Saveable bit is set to 0.
<b>Protocol Identifier</b>	This field is set to 0h indicating the Fibre Channel protocol.
<b>DTFD</b>	Disable Target Fabric Discovery <ul style="list-style-type: none"> <li>■ 0 = Public Loop behavior supported</li> <li>■ 1 = Private Loop only supported</li> </ul>
<b>PLPB</b>	Prevent Loop Port Bypass will always be 0
<b>DDIS</b>	Disable Discovery will always be 0
<b>DLM</b>	Disable Loop Master will always be 0
<b>DSA</b>	Disable Soft Address will always be 0
<b>ALWI</b>	Allow Login Without Loop Initialization will always be 0
<b>DTIPE</b>	Disable Target Initiated Port Enable will always be 0
<b>DTOLI</b>	Disable Target Originated Loop Initialization will always be 0
<b>RR_TOV units</b>	Resource Recovery Time Out Value Units will always be 100b = 10 second units
<b>RR_TOV</b>	Resource Recovery Time Out Value will always be 1Eh = 300 seconds

## Element Address Assignment Page Definition

This table defines the Element Address Assignment page of the Mode Sense (10) command.

**TABLE 3-38** Element Address Assignment Page

Byte	Bit								
	7	6	5	4	3	2	1	0	
0	PS (0)	Rsvd (0)	Page Code (1Dh)						
1	Parameter Length (12h)								
2 to 3	(MSB)	First Medium Transport Element Address						(LSB)	
4 to 5	(MSB)	Number of Medium Transport Elements						(LSB)	
6 to 7	(MSB)	First Storage Element Address						(LSB)	
8 to 9	(MSB)	Number of Storage Elements						(LSB)	
10 to 11	(MSB)	First Import/Export Element Address						(LSB)	
12 to 13	(MSB)	Number Import/Export Elements						(LSB)	
14 to 15	(MSB)	First Data Transfer Element Address						(LSB)	
16 to 17	(MSB)	Number Data Transfer Elements						(LSB)	
18 to 19	Reserved (00h)								

## Element Address Assignment Page Definitions:

<b>PS</b>	The Parameters Saveable bit is set to 0
<b>Page Code</b>	Identifies the Element Address Assignment mode page and returns a value of 1Dh.
<b>Parameter Length</b>	Indicates the amount of element address data following this byte and returns a value of 12h.
<b>First Medium Transport Element Address</b>	Identifies the address of the robot and returns a value of 0h.
<b>Number of Medium Transport Elements</b>	Identifies the number of hands within the library and returns a value of 0001h.
<b>First Storage Element Address</b>	Identifies the starting address of the data cartridge slots. The default starting address is 7D0h (2000d).
<b>Number of Storage Elements</b>	Identifies the number of data cartridge slots within the library. The total number of data cartridge slots depends on how the library is configured.
<b>First Import / Export Element Address</b>	Identifies the address of the first Import/Export element. The default starting address is 000Ah.
<b>Number of Import / Export Elements</b>	Identifies the total number of import/export slots.
<b>First Data Transfer Element Address</b>	Identifies the address of the first tape transport installed in the library. The default address is 3E8h (1000d).
<b>Number of Data Transfer Elements</b>	Identifies the number of tape drives in the library, and the library returns the configured count.

## Transport Geometry Mode Page Definition

This table defines the Mode Sense Transport Geometry Mode page.

**TABLE 3-39** Transport Geometry Mode Page

Byte	Bit							
	7	6	5	4	3	2	1	0
0	PS (0)	Rsvd (0)	Page Code (1Eh)					
1	Parameter Length (02h)							
2	Reserved (0)							Rotate (0)
3	Member Number in Transport Element Set (00h)							

Transport Geometry Mode Page Definitions:

<b>PS</b>	The Parameters Saveable bit is set to 0.
<b>Page Code</b>	This field identifies the Transport Geometry mode page. The library returns a value of 1Eh.
<b>Parameter Length</b>	This field indicates the number of additional types of transport geometry descriptor data to follow the header. Each descriptor has two bytes of information. The library has one transport mechanism and returns a value of 02h.
<b>Rotate</b>	This field identifies the ability of the transport mechanism to handle two-sided media.  The library does not use multiple-sided media and returns a value of 0.
<b>Member Number in Transport Element Set</b>	This field identifies the specific transport element in the system to which this descriptor is applied. The library has one transport element and returns a value of 00h.



## Device Capabilities Page Definition

TABLE 3-40 defines the Device Capabilities page of the Mode Sense (10) command.

**TABLE 3-40** Device Capabilities Page

Byte	Bit							
	7	6	5	4	3	2	1	0
0	PS (0)	Rsvd (0)	Page Code (1Fh)					
1	Parameter Length (12h)							
2	Reserved (0h)				StorDT <sup>1</sup> (1)	StorI/E <sup>2</sup> (1)	StorST <sup>3</sup> (1)	StorMT <sup>4</sup> (0)
3	Reserved (0h)							
4	Reserved (0h)				MT->DT (0)	MT->I/E (0)	MT->ST (0)	MT->MT (0)
5	Reserved (0h)				ST->DT (1)	ST->I/E (1)	ST->ST (1)	ST->MT (0)
6	Reserved (0h)				I/E->DT (1)	I/E->I/E (1)	I/E->ST (1)	I/E->MT (0)
7	Reserved (0h)				DT->DT (1)	DT->I/E (1)	DT->ST (1)	DT->MT (0)
8 to 11	Reserved (00h)							
12	Reserved (0h)				MT<>D T (0)	MT<>I/ E (0)	MT<>ST (0)	MT<>M T (0)
13	Reserved (0h)				ST<>DT (0)	ST<>I/E (0)	ST<>ST (0)	ST<>MT (0)
14	Reserved (0h)				I/E<>D T (0)	I/E<>I/ E (0)	I/E<>ST (0)	I/E<>M T (0)
15	Reserved (0h)				DT->DT (0)	DT<>I/ E (0)	DT<>ST (0)	DT<>M T (0)
16 to 19	Reserved (00h)							
<b>Notes:</b> DT - Data Transfer Element (tape drive) I/E = Import/Export Element (cartridge access port slots) ST = Storage Element (cartridge tape storage slots) MT= Medium Transport (hand)								

## Device Capabilities Page Definitions:

<b>PS</b>	The Parameters Saveable bit is set to 0.
<b>Page Code</b>	The Page Code field identifies the Device Capabilities mode page and always contains a value of 1Fh.
<b>Parameter Length</b>	This field indicates the amount of device capabilities data following this byte. The library returns a value of 12h (18d).
<b>StorDT</b>	This field identifies the ability of a tape drive to perform the function of element storage. The library returns a value of 1.
<b>StorI/E</b>	This field identifies the ability of a CAP slot to perform the function of element storage. The library returns a value of 1.
<b>StorST</b>	This field identifies the ability of the data cartridge slots to perform the function of element storage. The library returns a value of 1.
<b>StorMT</b>	This field identifies the ability of the hand to perform the function of element storage. The hand cannot be used as the source or destination of a move. The library returns a value of 0.
<b>MT -&gt; DT</b>	This field identifies the support for the Move Medium command, where the source is the hand, and the destination is a tape drive. The library returns a value of 0.
<b>MT -&gt; I/E</b>	This field identifies the support for the Move Medium command, where the source is the hand, and the destination is a CAP slot. The library returns a value of 0.
<b>MT -&gt; ST</b>	This field identifies the support for the Move Medium command, where the source is the hand, and the destination is a data cartridge slot. The library returns a value of 0.
<b>MT -&gt; MT</b>	This field identifies the support for the Move Medium command, where both the source and the destination is the hand. The library returns a value of 0.
<b>ST -&gt; DT</b>	This field identifies the support for the Move Medium command, where the source is a data cartridge slot, and the destination is a tape drive. The library returns a value of 1.
<b>ST -&gt; I/E</b>	This field identifies the support for the Move Medium command, where the source is a data cartridge slot, and the destination is a CAP slot. The library returns a value of 1.
<b>ST -&gt; ST</b>	This field identifies the support for the Move Medium command, where the source is a data cartridge slot, and the destination is a data cartridge slot. The library returns a value of 1.
<b>ST -&gt; MT</b>	This field identifies the support for the Move Medium command, where the source is a data cartridge slot, and the destination is the hand. The library returns a value of 0.
<b>I/E -&gt; DT</b>	This field identifies the support for the Move Medium command, where the source is a CAP slot, and the destination is a tape drive. The library returns a value of 1.

<b>I/E -&gt; I/E</b>	This field identifies the support for the Move Medium command, where both the source, and the destination is a CAP slot. The library returns a value of 1.
<b>I/E -&gt; ST</b>	This field identifies the support for the Move Medium command, where the source is a CAP slot, and the destination is a data cartridge slot. The library returns a value of 1.
<b>I/E -&gt; MT</b>	This field identifies the support for the Move Medium command, where the source is a CAP slot, and the destination is the hand. The library returns a value of 0.
<b>DT -&gt; DT</b>	This field identifies the support for the Move Medium command, where the source, and the destination is a tape drive. The library returns a value of 1.
<b>DT -&gt; I/E</b>	This field identifies the support for the Move Medium command, where the source is a tape drive, and the destination is a CAP slot. The library returns a value of 1.
<b>DT -&gt; ST</b>	This field identifies the support for the Move Medium command, where the source is a tape drive, and the destination is a data cartridge slot. The library returns a value of 1.
<b>DT -&gt; MT</b>	This field identifies the support for the Move Medium command, where the source is a tape drive, and the destination 1 element is the hand. The library returns a value of 0.
<b>MT &lt; &gt; DT</b>	This field identifies the support for the Exchange Medium command, where the source and destination 2 elements are the hand, and the destination 1 element is a tape drive. The library returns a value of 0.
<b>MT &lt; &gt; I/E</b>	This field identifies the support for the Exchange Medium command, where the source and destination 2 elements are the hand, and the destination 1 element is a CAP slot. The library returns a value of 0.
<b>MT &lt; &gt; ST</b>	This field identifies the support for the Exchange Medium command, where the source and destination 2 elements are the hand, and the destination 1 element is a data cartridge slot. The library returns a value of 0.
<b>MT &lt; &gt; MT</b>	This field identifies the support for the Exchange Medium command, where the source and destination 2 elements are the hand, and the destination 1 element is the hand. The library returns a value of 0.
<b>ST &lt; &gt; DT</b>	This field identifies the support for the Exchange Medium command, where the source and destination 2 elements are a data cartridge slot, and the destination 1 element is a tape drive. The library returns a value of 0.
<b>ST &lt; &gt; I/E</b>	This field identifies the support for the Exchange Medium command, where the source and destination 2 elements are a data cartridge slot, and the destination 1 element is a CAP slot. The library returns a value of 0.
<b>ST &lt; &gt; ST</b>	This field identifies support for the Exchange Medium command, where the source and destination 2 elements are a data cartridge slot, and the destination 1 element is a data cartridge slot. The library returns a value of 0.

<b>ST &lt; &gt; MT</b>	This field identifies the support for the Exchange Medium command, where the source and destination 2 elements are a data cartridge slot, and the destination 1 element is the hand. The library returns a value of 0.
<b>I/E &lt; &gt; DT</b>	This field identifies the support for the Exchange Medium command, where the source and destination 2 elements are a CAP slot, and the destination 1 element is a tape drive. The library returns a value of 0.
<b>I/E &lt; &gt; I/E</b>	This field identifies the support for the Exchange Medium command, where the source and destination 2 elements are a CAP slot, and the destination 1 element is a CAP slot. The library returns a value of 0.
<b>I/E &lt; &gt; ST</b>	This field identifies the support for the Exchange Medium command, where the source and destination 2 elements are a CAP slot, and the destination 1 element is a data cartridge slot. The library returns a value of 0.
<b>I/E &lt; &gt; MT</b>	This field identifies the support for the Exchange Medium command, where the source and destination 2 elements are a CAP slot, and the destination 1 element is the hand. The library returns a value of 0.
<b>DT &lt; &gt; DT</b>	This field identifies the support for the Exchange Medium command, where the source and destination 2 elements are a tape drive, and the destination 1 element is a tape drive. The library returns a value of 0.
<b>DT &lt; &gt; I/E</b>	This field identifies the support for the Exchange Medium command, where the source and destination 2 elements are a tape drive, and the destination 1 element is a CAP slot. The library returns a value of 0.
<b>DT &lt; &gt; ST</b>	This field identifies the support for the Exchange Medium command, where the source and destination 2 elements are a tape drive, and the destination 1 element is a data cartridge slot. The library returns a value of 0.
<b>DT &lt; &gt; MT</b>	This field identifies the support for the Exchange Medium command, where the source and destination 2 elements are a tape drive, and the destination 1 element is the hand. The library returns a value of 0.

## Move Medium

The Move Medium command (A5h) moves a cartridge tape from one specific element location to another specific element location.

The Mode Sense command provides a matrix with the valid source and destination element combinations for the Move Medium command.

The Fast Load option on the library controls the completion of the move command when the destination element is a tape drive. If the fast load option is disabled, the library performs the move motion, and waits until the tape drive load operation completes before returning status for the move command. When the fast load option is enabled, the library performs the move motion, and verifies the tape drive load starts before returning status for the move command.

**TABLE 3-41** Move Medium Command

Byte	Bit							
	7	6	5	4	3	2	1	0
0	Operation Code (A5h)							
1	Ignored			Reserved (00h)				
2 to 3	(MSB) Transport Element Address							(LSB)
4 to 5	(MSB) Source Element Address							(LSB)
6 to 7	(MSB) Destination Element Address							(LSB)
8	Reserved (00h)							
9	Reserved (00h)							
10	Reserved (00h)							Invert (0)
11	Move Option		Control Byte (00h)					

Move Medium Command Definitions:

<b>Transport Element Address</b>	This field defines the robot element to use and should contain the element address 00h. A value of 00h indicates use of the default hand. If any other value is entered it will be ignored.
<b>Source Element Address</b>	This field is the element address from which the cartridge tape is to be removed. This may be a storage slot, a CAP slot, or a tape drive.
<b>Destination Element Address</b>	This field is the element address where the cartridge tape is to be placed. This may be a storage slot, a CAP slot, or a tape drive.
<b>Invert</b>	The library does not support this function and requires a value of 0.
<b>Move Option</b>	<p>These two bits define optional operations associated with the Move Medium command.</p> <ul style="list-style-type: none"> <li>■ 00 = The library performs a normal move medium operation</li> <li>■ 01 = Not supported</li> <li>■ 10 = The library performs a mount operation with write protect enabled. That is, the user can read the data on the cartridge but cannot write to the cartridge. This option is valid only when the destination element address is a data transfer element. If the destination data transfer element (tape drive) does not support this feature or fails to acknowledge the write-protected mount option, the mount fails. In either case, the library returns the Hardware Error sense key (04) with an ASC of 40 and an ASCQ of 02 (Drive Error).</li> <li>■ 11 = The data transfer element specified in the source element field performs a rewind, followed by a unload operation and then the move medium operation. This option is valid only when the source element address is a data transfer element. Use this option with care because it might interfere with operations being performed on the data path of the data transfer element.</li> </ul>

## Persistent Reserve In

The Persistent Reserve In (5Eh) and Persistent Reserve Out (5Fh) commands resolve contention among multiple initiators and multiple-port targets within the system.

The library uses the Persistent Reserve In command to identify which initiators are holding conflicting or invalid persistent reservations.

**TABLE 3-42** Persistent Reserve In Command

Byte	Bit							
	7	6	5	4	3	2	1	0
0	Operation Code (5Eh)							
1	Ignored			Service Action				
2	Reserved (00h)							
3	Reserved (00h)							
4	Reserved (00h)							
5	Reserved (00h)							
6	Reserved (00h)							
7 to 8	(MSB)			Allocation Length				(LSB)
9	Control Byte (00h)							

### Persistent Reserve In Command Descriptions:

**Service Action** This field defines the type of request that is being made to the initiator.

Valid values are 00h, 01h, and 02h.

- 00h = Returns Read Keys Data (see [TABLE 3-43](#))
- 01h = Returns Read Reservations Data (see [TABLE 3-44](#) and [TABLE 3-45](#))
- 02h = Returns Report Capabilities Data (see [TABLE 3-46](#))

Values 03h through 1Fh are reserved.

**Allocation Length** This field indicates how much space has been reserved for the returned parameter list. If the length is not sufficient to contain the entire parameter list, the parameter list will be incomplete. However, a partial list is not an error.

## Read Keys Data

The Read Keys service action requests that the initiator return a list of all the current Reservation keys it has registered.

TABLE 3-43 shows the format of the parameter data returned in response to a Persistent Reserve In command with the Read Keys service action.

**TABLE 3-43** Read Keys Data

Byte	Bit							
	7	6	5	4	3	2	1	0
0 to 3	(MSB) Generation (LSB)							
4 to 7	(MSB) Additional Length (n-7) (LSB)							
	Reservation Key List							
8 to 15	(MSB) First Reservation Key (LSB)							
More	Additional Reservation Keys							
n-7 to n	(MSB) Last Reservation Key (LSB)							

Read Keys Data Definitions:

<b>Generation</b>	This value is a 32-bit counter that is incremented every time a Persistent Reserve Out command requests a Register, a Clear, a Preempt, or a Preempt and Abort operation. It allows the library to verify that its configuration of initiators has not been illegally modified.
<b>Additional Length</b>	This field indicates the number of bytes in the reservation key list.
<b>Reservation Key List</b>	These fields contain all the eight-byte reservation keys that have been registered with the library through a Persistent Reserve Out command.



## Read Reservations Data

The Read Reservations service action requests that the initiator return a description of all current Reservation keys it has registered.

See [TABLE 3-44](#) for the format of the parameter data returned in response to a Persistent Reserve In command with the Read Reservations service action.

**TABLE 3-44** Read Reservations Data

Byte	Bit							
	7	6	5	4	3	2	1	0
0 to 3	Generation (MSB) (LSB)							
4 to 7	Additional Length (n-7) (MSB) (LSB)							
8 to n	Reservation Descriptors (MSB) (LSB)							

Read Reservations Data Definitions:

<b>Generation</b>	This value is a 32-bit counter that is incremented every time a Persistent Reserve Out command requests a Register, a Clear, a Preempt, or a Preempt and Abort operation. It allows the library to verify that its configuration of initiators has not been illegally modified.
<b>Additional Length</b>	This field indicates the number of bytes in the list of reservation descriptors.
<b>Reservation Descriptors</b>	Each persistent reservation for a logical unit has one reservation descriptor that has the format shown in <a href="#">TABLE 3-45</a> .

**TABLE 3-45** Reservation Descriptors Format

Byte	Bit							
	7	6	5	4	3	2	1	0
0 to 7	(MSB) Reservation Key (LSB)							
8 to 11	(MSB) Obsolete (LSB)							
12	Reserved (00h)							
13	Scope				Type			
14 to 15	Obsolete (00h)							

Reservation Descriptors Format Definitions:

<b>Reservation Key</b>	This value indicates the reservation key for the descriptor data that follows.
<b>Scope</b>	The value in the Scope field indicates whether a persistent reservation applies to an entire logical unit or to an element. The only valid value is 0h. 0h = The persistent reservation applies to the logical unit
<b>Type</b>	This value specifies the characteristics of the persistent reservation. Valid values are 3h and 6h. <ul style="list-style-type: none"> <li>■ 3h = Exclusive Access: This value indicates that the initiator holding the persistent reservation has exclusive read and write access. If any other initiator requests a data transfer to or from the target, the result will be a reservation conflict.</li> <li>■ 6h = Exclusive Access, Registrants Only: This value indicates that any currently registered initiator has exclusive read and write access. If any non-registered initiator requests a data transfer to or from the target, the result will be a reservation conflict.</li> </ul>

## Persistent Reserve In Data for Report Capabilities

The format for the parameter data provided in response to a Persistent Reserve In command with the Report Capabilities service action is shown in [TABLE 3-46](#).

**TABLE 3-46** Persistent Reserve In Parameter Data for Report Capabilities

Byte	Bit							
	7	6	5	4	3	2	1	0
0 to 1	(MSB) Length (0008h) (LSB)							
2	Reserved (00h)			CRH (0)	SIP_C (0)	ATP_C (0)	Rsvd (0)	PTPL_C (1)
3	TMV (1)	Reserved (00h)						PTPL_A
4 to 5	(MSB) Persistent Reservation Mask (LSB)							
6 to 7	Reserved (00h)							

Persistent Reserve In parameter data for Report Capabilities Definitions:

<b>Length</b>	This field indicates the length in bytes of the parameter data.
<b>CRH</b>	The Compatibility Reservation Handling bit is set to a value of 0 indicating Reserve/Release commands are processed as defined in SPC-2
<b>SIP_C</b>	The library will return a value of 0 for the Specify Initiator Ports Capable bit, indicating the SPEC_I_PT bit in the PERSISTENT RESERVE OUT command parameter data is not supported.
<b>ATP_C</b>	The library will return a value of 0, indicating the ALL_TG_PT bit in the PERSISTENT RESERVE OUT command parameter data is not supported
<b>PTPL_C</b>	Persist Through Power Loss Capable bit <ul style="list-style-type: none"> <li>■ 0 = The library does not support the persist through power loss capability for persistent reservations and the APTPL bit in the in PERSISTENT RESERVE OUT command parameter data</li> <li>■ 1 = The library supports the persist through power loss capability for persistent reservations and the APTPL bit in the in PERSISTENT RESERVE OUT command parameter data</li> </ul>
<b>TMV</b>	Type Mask Valid bit <ul style="list-style-type: none"> <li>■ 0 = The PERSISTENT RESERVATION TYPE MASK field shall be ignored</li> <li>■ 1 = The PERSISTENT RESERVATION TYPE MASK field contains a bit map indicating which persistent reservation types are supported by the library.</li> </ul>
<b>PTPL_A</b>	Persist Through Power Loss Activated bit <ul style="list-style-type: none"> <li>■ 0 = The persist through power loss capability is not activated.</li> <li>■ 1 = Persist through power loss capability is activated because the most recent successfully completed PERSISTENT RESERVE OUT command with REGISTER or REGISTER AND IGNORE EXISTING KEY or RESERVE or RELEASE service action had the APTPL bit set to one in the parameter data.</li> </ul>

The Persistent Reservation Type Mask field contains a bit map that indicates the persistent reservation types that are supported by the library.

**TABLE 3-47** Read Reservations Parameter Data

Byte	Bit							
	7	6	5	4	3	2	1	0
4	WR_EX_AR (0)	EX_AC_RO (1)	WR_EX_RO (0)	Rsvd	EX_AC (1)	Rsvd	WR_EX (0)	Rsvd
5	Reserved							EX_AC_AR (0)

Read Reservations Parameter Data Definitions:

<b>WR_EX_AR</b>	The library returns a value of 0, indicating the Write Exclusive-All Registrants persistent reservation type is not supported.
<b>EX_AC_RO</b>	The library returns a value of 1, indicating the Exclusive Access-Registrants Only persistent reservation type is supported.
<b>WR_EX_RO</b>	The library returns a value of 0, indicating the Write Exclusive-Registrants Only persistent reservation type is not supported.
<b>EX_AC</b>	The library returns a value of 1, indicating the Exclusive Access- persistent reservation type is supported.
<b>WR_EX</b>	The library returns a value of 0, indicating the Write Exclusive persistent reservation type is not supported.
<b>EX_AC_AR</b>	The library returns a value of 0, indicating the Exclusive Access-All Registrants persistent reservation type is not supported.

# Persistent Reserve Out

The Persistent Reserve Out (5Fh) command reserves a target for the exclusive or shared use of an initiator.

**TABLE 3-48** Persistent Reserve Out Command

Byte	Bit							
	7	6	5	4	3	2	1	0
0	Operation Code (5Fh)							
1	Ignored			Service Action				
2	Scope				Type			
3	Reserved (00h)							
4	Reserved (00h)							
5	Reserved (00h)							
6	Reserved (00h)							
7 to 8	(MSB)	Parameter List Length (18h)						(LSB)
9	Control Byte (00h)							

Persistent Reserve Out Command Definitions:

<b>Service Action</b>	<p>This value indicates the action that will result from the Persistent Reservation Command:</p> <ul style="list-style-type: none"> <li>■ 00h = Register: Register a reservation key with the library without generating a reservation.</li> <li>■ 01h = Reserve: Create a persistent reservation of the scope and type specified in Byte 2.</li> <li>■ 02h = Release: Remove an active persistent reservation.</li> <li>■ 03h = Clear: Clear all persistent reservations for all initiators and reset all reservation keys to 0.</li> <li>■ 04h = Preempt: Remove all reservations and registrations for the initiators associated with the service action reservation key in the parameter list.</li> <li>■ 05h = Preempt and Abort: Perform a Preempt action and, additionally, clear the task set for all initiators associated with the service action reservation key. Also, clear any CAP locks and contingent allegiance in effect for these initiators.</li> <li>■ 06h = Register and Ignore Existing Key: Register a reservation key with the library</li> </ul>
<b>Scope</b>	<p>The value in the Scope field indicates whether a persistent reservation applies to an entire logical unit or to an element. The only valid value is 0h. 0h = The persistent reservation applies to the logical unit</p>
<b>Type</b>	<p>This value specifies the characteristics of the persistent reservation. Valid values are 3h and 6h.</p> <ul style="list-style-type: none"> <li>■ 3h = Exclusive Access: This value indicates that the initiator holding the persistent reservation has exclusive read and write access. If any other initiator requests a data transfer to or from the target, the result will be a reservation conflict.</li> <li>■ 6h = Exclusive Access, Registrants Only: This value indicates that any registered initiator has read and write access. If any non-registered initiator requests a data transfer to or from the target, the result will be a reservation conflict.</li> </ul>
<b>Parameter List Length</b>	<p>This value should always specify a field length of 18h (24d) bytes. The parameter data for the Persistent Reserve Out command includes all fields, even when a field is not required for the specified service action.</p>

The parameter list for the Persistent Reserve Out command has this format:

**TABLE 3-49** Persistent Reserve Out Parameter List

Byte	Bit							
	7	6	5	4	3	2	1	0
0 to 7	(MSB) Reservation Key (LSB)							
8 to 15	(MSB) Service Action Reservation Key (LSB)							
16 to 19	(MSB) Obsolete (LSB)							
20	Reserved (0h)				SPEC-I-PT (0)	ALL-TGT-PT (0)	Rsvd (0)	APTPL (0)
21	Reserved (00h)							
22 to 23	(MSB) Obsolete (LSB)							
24 to n	Additional Parameter Data							

Persistent Reserve Out Parameter List Definitions:

<b>Reservation Key</b>	This field contains an eight-byte value that identifies the initiator.
<b>Service Action Reservation Key</b>	This field contains information needed for four service actions: Register, Register and Ignore Existing Key, Preempt, and Preempt AND abort. See <a href="#">TABLE 3-51</a> for definitions of these actions.
<b>SPEC_I_PT</b>	The Specify Initiator Ports bit is not supported and is set to 0.
<b>ALL-TG-PT</b>	The All Target Ports bit is not supported and is set to 0.
<b>APTPL</b>	The Activate Persist Through Power Loss bit is valid only for the Register Service Action or Register and Ignore Existing Key Service Action. <ul style="list-style-type: none"> <li>■ 0 = The library releases all persistent reservations and removes all registered reservation keys if there is a loss of power.</li> <li>■ 1 = The library retains all persistent reservations and all reservation keys if power is lost and later restored.</li> </ul>

TABLE 3-50 summarizes which fields are set by the application client and interpreted by the library for each service action and scope value.

**TABLE 3-50** Persistent Reserve Out Service Actions and Valid Parameters

Service Action	Allowed Scope	Type	Reservation Key	Service Action Reservation Key	APTPL	ALL_TG_PT	SPEC_I_PT
REGISTER	Ignored	Ignored	Valid	Valid	Valid	Valid	Valid
REGISTER AND IGNORE EXISTING KEYS	Ignored	Ignored	Ignored	Valid	Valid	Valid	Valid
RESERVE	LU_SCOPE	Valid	Valid	Ignored	Ignored	Ignored	Ignored
RELEASE	LU_SCOPE	Valid	Valid	Ignored	Ignored	Ignored	Ignored
CLEAR	Ignored	Ignored	Valid	Ignored	Ignored	Ignored	Ignored
PRE-EMPT	LU_SCOPE	Valid	Valid	valid	Ignored	Ignored	Ignored
PRE-EMPT & ABORT	LU_SCOPE	Valid	Valid	valid	Ignored	Ignored	Ignored

**TABLE 3-51** Service Action Reservation Key Information

If the service action is...	Then the information in the field is...
Register	the new reservation key to be registered
Register and Ignore Existing Key	the new reservation key to be registered
Preempt	the reservation key of the persistent reservation being pre-empted
Preempt and Abort	the reservation key of the persistent reservation being pre-empted
See list of service action values on page <a href="#">on page 110</a> .	



## Registering a Reservation Key

An initiator must register a key before performing any other Persistent Reserve Out commands. To register a key, the initiator sends a Persistent Reserve Out command with the Service Action field set to Register (0h), and the Parameter List length set to 18h. The Scope and Type fields will be ignored. In the parameter data, the Reservation Key field is set to 0h, the Service Action Reservation Key is set to the desired key value and the APTPL bit to 0h. If the initiator is already registered, the key can be changed by sending the same command with the Reservation Key field set to the current reserved key.

A key may be registered without regard to whether one had been previously established by setting the Service Action field to Register and Ignore (06h).

Once an initiator has registered a key, it becomes a registered initiator and can perform other Persistent Reserve functions.

## Creating a Persistent Reservation

To create a Persistent Reservation, a registered initiator sends a Persistent Reserve Out command with a Service Action field of Reserve (01h). The Scope field is set to 0, the Type field to Exclusive Access (03h) or Exclusive Access Registrants Only (06h), and the Parameter List Length to 18h. In the parameter data, the Reservation Key is set to the currently registered key for this initiator, the Service Action Reservation Key field is ignored, and the APTPL bit is set to zero.

A Type field of Exclusive Access will reserve the device for this initiator only. A Type field of Exclusive Access, Registrants Only will allow access by all registered initiators.

When a reservation of type Exclusive Access, Registrants Only is cleared, a unit attention condition is established for the initiators holding the reservation.

## Releasing a Persistent Reservation

To release a Persistent Reservation, a registered initiator sends a Persistent Reserve Out command with a Service Action field of Release (02h). The Scope and Type fields must match those used when making the reservation. The Parameter List Length is set to 18h. In the parameter data, the Reservation Key is set to the currently registered key for this initiator, the Service Action Reservation Key field is ignored and the APTPL bit is set to zero.

When a reservation of type Exclusive Access, Registrants Only is released, a unit attention condition is established for the other registered initiators.

## Clearing all Persistent Reservations and Keys

To clear all Persistent Reservations and key registrations, a registered initiator sends a Persistent Reserve Out command with a Service Action field of Clear (03h). The Scope and Type fields are ignored. The Parameter List Length is set to 18h. In the parameter data, the Reservation Key is set to the currently registered key for this initiator, the Service Action Reservation Key field is ignored and the APTPL bit is set to zero.

Clearing reservations should only be done in an error recovery situation.

## Pre-empting Reservations Made by Another Initiator

A registered initiator can clear active reservations and registration keys by issuing a Persistent Reserve Out command. The Service Action field is set to Pre-empt, the Scope and Type fields are ignored. The Parameter List Length is set to 18h. In the parameter data, the Reservation Key is set to the currently registered key for this initiator. The Service Action Reservation Key field contains the registered key to be cleared. If the Service Action Reservation Key was used to make the currently active persistent reservation, the reservation is released.

If the Service Action field is set to Pre-empt and Abort instead of Pre-empt, all commands belonging to initiators who registered with the cleared key will be aborted.

When a reservation of type Exclusive Access, Registrants Only is Pre-empted, a unit attention condition is established for the Pre-empted initiators.

## Position to Element

The Position to Element command (2Bh) is supported only for compatibility with existing applications. The library accepts this command for compatibility, but does not perform any action.

All parameters in the CDB are validated. If a value is not valid, the library returns the appropriate error message.

**TABLE 3-52** Position to Element Command

Byte	Bit							
	7	6	5	4	3	2	1	0
0	Operation Code (2Bh)							
1	Ignored				Reserved (00h)			
2 to 3	(MSB) Transport Element Address (LSB)							
4 to 5	(MSB) Destination Element Address (LSB)							
6	Reserved (00h)							
7	Reserved (00h)							
8	Reserved (00h)							Invert (0)
9	Control Byte (00h)							

Position to Element Command Definitions:

<b>Transport Element Address</b>	This field defines the hand element to use and should contain the element address of the hand or 00h (0d). A value of 00h (0d) indicates use of the default hand.
<b>Destination Element Address</b>	This field defines the address of the element where the hand is to be positioned.
<b>Invert</b>	The library does not support this function and requires a value of 0.

## Prevent/Allow Medium Removal

The Prevent/Allow Medium Removal command (1Eh) requests that the library enable or disable operator access to the cartridge access port (CAP).

- If allowed, the CAP may be unlocked and opened using the operator panel.
- If prevented, the CAP cannot be unlocked or opened.

This command is independent of device reservations if the Prevent bit is 0.

The library keeps Prevent/Allow data on a per-initiator basis. If any initiator has set a prevent state, the library prevents anyone from opening the CAP.

During power-on and following a reset, all initiators are set to an allow state, which enables operator panel access to the CAP.

**TABLE 3-53** Prevent/Allow Medium Removal Command

Byte	Bit							
	7	6	5	4	3	2	1	0
0	Operation Code (1Eh)							
1	Ignored			Reserved (00h)				
2	Reserved (00h)							
3	Reserved (00h)							
4	Reserved (00h)						Prevent	
5	Control Byte (00h)							

Prevent/Allow Medium Removal Command Definitions:

**Prevent Bit**

The Prevent bit values are:

- 0 = The library allows operator panel access to unlock and open the indicated CAP.
- 1 = The library prevents access to the indicated CAP.

## Read Element Status

The Read Element Status command (B8h) requests that the library return the status of the elements in the library.

**TABLE 3-54** Read Element Status Command

Byte	Bit							
	7	6	5	4	3	2	1	0
0	Operation Code (B8h)							
1	Ignored			VolTag	Element Type Code			
2 to 3	(MSB)		Starting Element Address				(LSB)	
4 to 5	(MSB)		Number of Elements				(LSB)	
6	Reserved (00h)					CurData	DvcID	
7 to 9	(MSB)		Allocation Length				(LSB)	
10	Reserved (00h)							
11	Control Byte (00h)							

### Read Element Status Command Definitions:

**VolTag** This bit indicates whether volume tag (VolTag) information is to be reported in response to this command:

- 0 = Volume Tag information is not reported
- 1 = Volume Tag information is reported.

**Element Type Code** This field specifies the particular element types selected for reporting:

- 0h = All Element Types reported
- 1h = Medium Transport Element (hand)
- 2h = Storage Element (cartridge tape storage slots)
- 3h = Import/Export Element (CAP slots)
- 4h = Data Transfer Element (tape drive)

For an Element Type Code of 0h, the element types are reported in ascending element address order, beginning with the first element greater than or equal to the Starting Element Address.

**Starting Element Address** This field specifies the minimum element address to report. Only elements with an element address greater than or equal to the Starting Element Address are reported. Element descriptor blocks are not generated for undefined element addresses. The Starting Element Address is set to a valid address for the library but does not have to be an address of the type requested in the Element Type Code.

<b>Number of Elements</b>	This field represents the maximum number of element descriptors to be transferred. This is an actual number of element descriptors to be transferred, not an element address range.
<b>CurData</b>	<p>The current data bit specifies that the library shall return element status data without causing device motion.</p> <ul style="list-style-type: none"> <li>■ 0 = Library operations are normal, and library mechanics may become active if needed to gather element static data.</li> <li>■ 1 = The library is responding with data only; no mechanical operations are active</li> </ul> <p>The CurData bit is effectively ignored by the library. The library will perform or not perform mechanical operations to obtain proper information at it's discretion independently of the setting of this bit.</p>
<b>DvcID</b>	<p>The device identification bit indicates whether the return data will contain device identification information.</p> <ul style="list-style-type: none"> <li>■ 0 = The library will not return device identification information.</li> <li>■ 1 = The library will return device identification information only for data transfer elements.</li> </ul>
<b>Allocation Length</b>	<p>This field specifies the length in bytes of the space allocated by the initiator for the transfer of element descriptors. Only complete element descriptors are transferred. Element descriptors are transferred until one of the following conditions is met:</p> <p>All available element descriptors of the type specified in the Element Type Code have been transferred, or</p> <p>The number of element descriptors specified in the Number of Elements field have been transferred, or</p> <p>There is less allocation length space available than required for the next complete element descriptor or header to be transferred.</p>

## Read Element Status Data

The library returns data for a Read Element Status command with this structure:

- An eight-byte Element Status Data header, followed by
- One to four element pages, one page per element type.

A page consists of:

- An eight-byte Element Status Page header, followed by
- One or more Element Descriptors. The format of the descriptor is based on the element type reported in this page. Each element type receives a separate Element Descriptor format.

Data can be truncated based on the length specified in the allocation field.

## Element Status Data Header Definition

The library sends this header once for each Read Element Status command.

**TABLE 3-55** Element Status Data Header Definition

Byte	Bit							
	7	6	5	4	3	2	1	0
0 to 1	(MSB) First Element Address Reported (LSB)							
2 to 3	(MSB) Number of Elements Available (LSB)							
4	Reserved (00h)							
5 to 7	(MSB) Byte Count of Report Available (all pages, n-7) (LSB)							
8 to n	Element Status pages							

Element Status Data Header Definitions:

<b>First Element Address Reported</b>	This field indicates the lowest element address found of the type specified in the Element Type Codes and greater than or equal to the Starting Element Address.
<b>Number of Elements Available</b>	This field indicates the number of elements found of the type specified in the Element Type Codes and greater than or equal to the Starting Element Address. This number is adjusted to be less than or equal to the count specified in the Number of Elements field in the Read Element Status command.
<b>Byte Count of Report Available</b>	This field indicates the number of bytes of element status data available for all elements meeting the requirements of the Read Element Status command. This count does not include the Element Status Data header bytes. This value is not adjusted to match the allocation length from the command.

## Element Status Page Header Definition

The library sends this header once for each type of element descriptor.

**TABLE 3-56** Element Status Page Header

Byte	Bit							
	7	6	5	4	3	2	1	0
0	Reserved				Element Type Code			
1	PVolTag	AVolTag (0)	Reserved (0)					
2 to 3	(MSB) Element Descriptor Length							(LSB)
4	Reserved (00h)							
5 to 7	(MSB) Byte Count of Report Available (all pages, n-7)							(LSB)
8 to n	Element Descriptor(s)							



## Element Status Page Header Definitions:

<b>Element Type Code</b>	This field indicates the specific element type being reported by this element descriptor page. The types are: <ul style="list-style-type: none"> <li>■ 01h = Medium Transport Element (hand)</li> <li>■ 02h = Storage Element (data cartridge slots)</li> <li>■ 03h = Import/Export Element (CAP slots)</li> <li>■ 04h = Data Transfer Element (tape drive)</li> </ul>
<b>PVolTag</b>	This bit indicates if primary volume tag (PVolTag) information has been requested and is present. The possible values indicate: <ul style="list-style-type: none"> <li>■ 0 = Volume Tag information has not been requested. The data is omitted from the element descriptors.</li> <li>■ 1 = Volume Tag information has been requested to be reported and is present.</li> </ul>
<b>AVolTag</b>	The library does not support alternative volume tags (AVolTag) and returns a value of 0.
<b>Element Descriptor Length</b>	This field indicates the total number of bytes contained in a single element descriptor.
<b>Byte Count of Descriptor Data Available</b>	This field indicates the total number of bytes of element descriptor data available for the elements of this element type that meet the requirements of the Read Element Status command. This count does not include the Element Status Page header bytes. This value is not adjusted to match the allocation length.
<b>Element Descriptors</b>	<p>The following sections contain the field definitions for the four types of library elements, which are:</p> <ul style="list-style-type: none"> <li>■ Medium Transport Element (the hand)</li> <li>■ Storage Element (cartridge tape storage slots)</li> <li>■ Import/Export Element (CAP slots)</li> <li>■ Data Transfer Element (tape drives)</li> </ul> <p>Each element descriptor includes the element address and status flags. Each element descriptor might also contain sense key information as well as other information, depending on the element type.</p> <p>The element descriptors for the four types of elements are similar, with the exception of a few fields. Note: The differences in Bytes 02, 06, and 07 for the four element descriptors.</p> <p>The library does not support alternate volume tags. This information is not included in any of the element descriptors.</p>

## Medium Transport Element Descriptor Definition

Medium transport elements are robotic components capable of physically moving cartridges. The Medium Transport Element Descriptor defines the robot characteristics.

**TABLE 3-57** Medium Transport Element Descriptor

Byte	Bit							
	7	6	5	4	3	2	1	0
0 to 1	(MSB) Element Address (LSB)							
2	Reserved (00h)				Except	Rsvd (0)	Full	
3	Reserved (00h)							
4	Additional Sense Code							
5	Additional Sense Code Qualifier							
6	Reserved (00h)							
7	Reserved (00h)							
8	Reserved (00h)							
9	SValid	Invert (0)	Reserved (00h)		ED	Medium Type		
10 to 11	(MSB) Source Storage Element Address (LSB)							
12 to 47	Primary Volume Tag Information Field omitted if PVolTag=0							
48	Reserved (0h)				Code Set (0)			
49	Reserved (0h)				Identifier Type (0)			
50	Reserved (00h)							
51	Identifier Length (0)							
52	Media Domain Field moved up if Primary Volume Tag Information is omitted.							
53	Media Type Field moved up if Primary Volume Tag Information is omitted.							
54 to 55	Reserved (00h) Field moved up if Primary Volume Tag Information is omitted.							

## Medium Transport Element Descriptor Definitions:

<b>Element Address</b>	This field contains the element address of the robot.
<b>Except</b>	This bit indicates the current operational state of the robot: <ul style="list-style-type: none"> <li>■ 0 = The hand is operational.</li> <li>■ 1 = The hand is in an abnormal state. The Additional Sense Code (ASC) and the Additional Sense Code Qualifier (ASCQ) fields contain information regarding the abnormal state. Other fields in the descriptor might be invalid and should be ignored.</li> </ul>
<b>Full</b>	This bit indicates if the hand contains a cartridge tape: <ul style="list-style-type: none"> <li>■ 0 = The hand does not contain a cartridge tape.</li> <li>■ 1 = The hand contains a cartridge tape.</li> </ul> An initiator would see a cartridge in the hand during a Read Element Status only in the case of an anomaly.
<b>Additional Sense Code</b>	This field is valid only if the Except bit is set. In the case of an exception, it contains an ASC as defined for Request Sense data.
<b>Additional Sense Code Qualifier</b>	This field is valid only if the Except bit is set. In the case of an exception, it contains an ASCQ as defined for Request Sense data.
<b>SValid</b>	This bit indicates if the Source Element Address and Invert fields are valid: <ul style="list-style-type: none"> <li>■ 0 = The Source Element Address and Invert fields are not valid.</li> <li>■ 1 = The Source Element Address and Invert fields are valid.</li> </ul>
<b>Invert</b>	The library does not support multi-sided media and returns a value of 0.
<b>ED</b>	<ul style="list-style-type: none"> <li>■ 0 = The element is enabled (for example a magazine or drive has been installed or has been logically enabled)</li> <li>■ 1 = The element is disabled</li> </ul>
<b>Medium Type</b>	This field provides the type of medium currently present in the element as determined by the medium changer. The library returns the following values: <ul style="list-style-type: none"> <li>■ 0h = Unspecified - the medium changer cannot determine the medium type.</li> <li>■ 1h = Data Medium</li> <li>■ 2h = Cleaning Medium</li> </ul>
<b>Source Storage Element Address</b>	This field is valid only if the SValid field is 1. This field contains the address of the last element from which the data cartridge was moved.
<b>Primary Volume Tag Information</b>	When the PVolTag bit is set to 1, the library returns volume tag information. When PVolTag is set to 0, this field is omitted, and the reserved fields below it are moved up. The library volume tag information includes six bytes of left-justified ASCII data that represents volume/serial number data from the cartridge tape. The field is padded to 32 bytes with 26 ASCII spaces. If the label on the cartridge tape is not readable, these 32 bytes will be set to 0. The last four bytes of the Volume Tag Information typically consist of two reserved bytes and two volume sequence bytes. The library does not support sequence numbers. These four bytes are set to 0.
<b>Code Set</b>	This field specifies the code set used for the identifier field and is set to 0 (not supported) for the Medium Transport Element Descriptor: 0h = Reserved

<b>Identifier Type</b>	The Identifier Type field indicates the format and assignment authority for the identifier and is set to 0 (not supported) for the Medium Transport Element Descriptor: 0h = Vendor Specific
<b>Identifier Length</b>	This field indicates the length of the Identifier field and is set to 0 (not supported) for the Medium Transport Element Descriptor. Note: That the combined length of the identifier field and the Identifier Pad is 32 bytes.
<b>Media Domain</b>	<p>The Media Domain field along with the Media Type field provides a hierarchy of information that indicates the type of media in the element:</p> <ul style="list-style-type: none"> <li>■ 00h = The element contains a Half-Inch (T9840) form factor cartridge.</li> <li>■ 43h = The element contains an LTO (or future) cleaning form factor cartridge (43h is 'C').</li> <li>■ 4Ch = The element contains an LTO form factor cartridge (4Ch is 'L').</li> <li>■ 54h = The element contains a T10000 form factor cartridge (54h is 'T').</li> <li>■ FFh = The media domain cannot be determined.</li> </ul> <p>This field is not valid if the Full bit is not set.</p>
<b>Media Type</b>	<p>The Media Type field along with the Media Domain field provides a hierarchy of information that indicates the type of media in the element.</p> <p>If the Media Domain field is 00h, the value reported for the Media Type field identifies in ASCII the type of Half Inch T9840 cartridge:</p> <ul style="list-style-type: none"> <li>■ R = The element contains a 9840 Standard cartridge.</li> <li>■ S = The element contains a future 9840 cartridge.</li> <li>■ T = The element contains a future 9840 cartridge.</li> <li>■ U = The element contains a 9840 Cleaning cartridge.</li> <li>■ Y = The element contains a 9840D Cleaning cartridge.</li> <li>■ FFh = The media type cannot be determined.</li> </ul> <p>If the Media Domain field is 43h (43h is 'C'), the value reported for the Media Type field identifies in ASCII the type of LTO cleaning cartridge:</p> <ul style="list-style-type: none"> <li>■ U = The element contains a Universal LTO cleaning cartridge.</li> <li>■ FFh = The media type cannot be determined.</li> </ul> <p>This field is not valid if the Full bit is not set.</p> <p>If the Media Domain field is 4Ch (4Ch is 'L'), the value reported for the Media Type field identifies in ASCII the type of LTO cartridge:</p> <ul style="list-style-type: none"> <li>■ 1 = The element contains a 100 GB Generation 1 LTO cartridge.</li> <li>■ 2 = The element contains a 200 GB Generation 2 LTO cartridge.</li> <li>■ 3 = The element contains a 400 GB Generation 3 LTO cartridge.</li> <li>■ 4 = The element contains an 800 GB Generation 4 LTO cartridge</li> <li>■ T = The element contains a 400 GB Generation 3 LTO WORM cartridge</li> <li>■ U = The element contains an 800 GB Generation 4 LTO WORM cartridge</li> <li>■ FFh = The media type cannot be determined</li> </ul> <p>This field is not valid if the Full bit is not set.</p> <p>If the Media Domain field is 54h (54h is 'T'), the value reported for the Media Type field identifies in ASCII the type of T10000 cartridge:</p> <ul style="list-style-type: none"> <li>■ 1 = The element contains a T10000 cartridge.</li> <li>■ S = The element contains a T10000 Sport cartridge.</li> <li>■ C = The element contains a T10000 Cleaning cartridge.</li> <li>■ FFh = The media type cannot be determined.</li> </ul>

## Storage Element Descriptor Definition

Storage elements are the main data cartridge slots of the library. The Storage Element Descriptor describes a storage slot.

**TABLE 3-58** Storage Element Descriptor

Byte	Bit							
	7	6	5	4	3	2	1	0
0 to 1	(MSB) Element Address (LSB)							
2	Reserved (00h)				Access (1)	Except	Rsvd (0)	Full
3	Reserved (00h)							
4	Additional Sense Code							
5	Additional Sense Code Qualifier							
6	Reserved (00h)							
7	Reserved (00h)							
8	Reserved (00h)							
9	SValid	Invert (0)	Reserved (00h)		ED	Medium Type		
10 to 11	(MSB) Source Storage Element Address (LSB)							
12 to 47	Primary Volume Tag Information (Field omitted if PVolTag=0)							
48	Reserved (0h)				Code Set (0)			
49	Reserved (0h)				Identifier Type (0)			
50	Reserved (00h)							
51	Identifier Length (0)							
52	Media Domain (Field moved up if Primary Volume Tag Information omitted.)							
53	Media Type (Field moved up if Primary Volume Tag Information omitted.)							
54 to 55	Reserved (00h, 00h) (Field moved up if Primary Volume Tag Information omitted.)							

## Storage Element Descriptor Definitions:

<b>Element Address</b>	This field contains the element address of the storage element reported.
<b>Access</b>	This bit indicates access is allowed to the storage element by the hand. The library returns a value of 1.
<b>Except</b>	This bit indicates the operational state of the storage element: <ul style="list-style-type: none"> <li>■ 0 = The storage element is in a normal state.</li> <li>■ 1 = The storage element is in an abnormal state, and the Additional Sense Code and the Additional Sense Code Qualifier fields contain information regarding the abnormal state. Other fields in the descriptor might be invalid, and should be ignored.</li> </ul>
<b>Full</b>	This field indicates if the storage element contains a cartridge tape: <ul style="list-style-type: none"> <li>■ 0 = The storage element does not contain a cartridge tape.</li> <li>■ 1 = The storage element does contain a cartridge tape.</li> </ul>
<b>Additional Sense Code</b>	This field is valid only if the Except bit is set. In the case of an exception, it contains an ASC as defined for Request Sense data.
<b>Additional Sense Code Qualifier</b>	This field is valid only if the Except bit is set. In the case of an exception, it contains an ASCQ as defined for Request Sense data.
<b>SValid</b>	This bit indicates if the Source Element Address and Invert fields are valid: <ul style="list-style-type: none"> <li>■ 0 = The Source Element Address and Invert fields are not valid.</li> <li>■ 1 = The Source Element Address and Invert fields are valid.</li> </ul>
<b>Invert</b>	The library does not support multi-sided media and returns a value of 0.
<b>ED</b>	<ul style="list-style-type: none"> <li>■ 0 = The element is enabled (for example a magazine or drive has been installed or has been logically enabled)</li> <li>■ 1 = The element is disabled</li> </ul>
<b>Medium Type</b>	This field provides the type of medium currently present in the element as determined by the medium changer. The library returns the following values: <ul style="list-style-type: none"> <li>■ 0h = Unspecified - the medium changer cannot determine the medium type.</li> <li>■ 1h = Data Medium</li> <li>■ 2h = Cleaning Medium</li> </ul>
<b>Source Storage Element Address</b>	This field is valid only if the SValid bit is 1. It contains the address of the last element from which the data cartridge was moved.
<b>Primary Volume Tag Information</b>	When the PVolTag bit is set to 1, the library returns Volume Tag Information. When PVolTag is set to 0, this field is omitted, and the reserved fields below it are moved up. The library Volume Tag Information includes six bytes of left-justified ASCII data, which represents volume/serial number data from the cartridge tape. The field is padded to 32 bytes with 26 ASCII spaces. If the label on the cartridge tape is not readable, these 32 bytes are set to 0. The last four bytes of the Volume Tag Information typically consist of two reserved bytes and 2 volume sequence bytes. The library does not support sequence numbers. These four bytes are set to 0.
<b>Code Set</b>	This field specifies the code set used for the identifier field and is set to 0 (not supported) for the Storage Element Descriptor: 0h = Reserved

<b>Identifier Type</b>	The Identifier Type field indicates the format and assignment authority for the identifier and is set to 0 (not supported) for the Storage Element Descriptor: 0h = Vendor Specific
<b>Identifier Length</b>	This field indicates the length of the Identifier field and is set to 0 (not supported) for the Storage Element Descriptor. Note: That the combined length of the identifier field and the Identifier Pad is 32 bytes.
<b>Media Domain</b>	<p>The Media Domain field along with the Media Type field provides a hierarchy of information that indicates the type of media in the element:</p> <ul style="list-style-type: none"> <li>■ 00h = The element contains a Half-Inch (T9840) form factor cartridge.</li> <li>■ 43h = The element contains an LTO (or future) cleaning form factor cartridge (43h is 'C').</li> <li>■ 4Ch = The element contains an LTO form factor cartridge (4Ch is 'L').</li> <li>■ 54h = The element contains a T10000 form factor cartridge (54h is 'T').</li> <li>■ FFh = The media domain cannot be determined.</li> </ul> <p>This field is not valid if the Full bit is not set.</p>
<b>Media Type</b>	<p>The Media Type field along with the Media Domain field provides a hierarchy of information that indicates the type of media in the element.</p> <p>If the Media Domain field is 00h, the value reported for the Media Type field identifies in ASCII the type of Half Inch T9840 cartridge:</p> <ul style="list-style-type: none"> <li>■ R = The element contains a 9840 Standard cartridge.</li> <li>■ S = The element contains a future 9840 cartridge.</li> <li>■ T = The element contains a future 9840 cartridge.</li> <li>■ U = The element contains a 9840 Cleaning cartridge.</li> <li>■ Y = The element contains a 9840D Cleaning cartridge.</li> <li>■ FFh = The media type cannot be determined.</li> </ul> <p>If the Media Domain field is 43h (43h is 'C'), the value reported for the Media Type field identifies in ASCII the type of LTO cleaning cartridge:</p> <ul style="list-style-type: none"> <li>■ U = The element contains a Universal LTO cleaning cartridge.</li> <li>■ FFh = The media type cannot be determined.</li> </ul> <p>This field is not valid if the Full bit is not set.</p> <p>If the Media Domain field is 4Ch (4Ch is 'L'), the value reported for the Media Type field identifies in ASCII the type of LTO cartridge:</p> <ul style="list-style-type: none"> <li>■ 1 = The element contains a 100 GB Generation 1 LTO cartridge.</li> <li>■ 2 = The element contains a 200 GB Generation 2 LTO cartridge.</li> <li>■ 3 = The element contains a 400 GB Generation 3 LTO cartridge.</li> <li>■ 4 = The element contains an 800 GB Generation 4 LTO cartridge</li> <li>■ T = The element contains a 400 GB Generation 3 LTO WORM cartridge</li> <li>■ U = The element contains an 800 GB Generation 4 LTO WORM cartridge</li> <li>■ FFh = The media type cannot be determined</li> </ul> <p>This field is not valid if the Full bit is not set.</p> <p>If the Media Domain field is 54h (54h is 'T'), the value reported for the Media Type field identifies in ASCII the type of T10000 cartridge:</p> <ul style="list-style-type: none"> <li>■ 1 = The element contains a T10000 cartridge.</li> <li>■ S = The element contains a T10000 Sport cartridge.</li> <li>■ C = The element contains a T10000 Cleaning cartridge.</li> <li>■ FFh = The media type cannot be determined.</li> </ul>

## Import/Export Element Descriptor Definitions

Import/Export elements are the CAP slots of the library. The Import/Export Element Descriptor describes a CAP slot.

**TABLE 3-59** Import/Export Element Descriptor

Byte	Bit							
	7	6	5	4	3	2	1	0
0 to 1	(MSB) Element Address (LSB)							
2	OIR	CMC (0)	InEnab (1)	ExEnab (1)	Access	Except	ImpExp	Full
3	Reserved (00h)							
4	Additional Sense Code							
5	Additional Sense Code Qualifier							
6	Reserved (00h)							
7	Reserved (00h)							
8	Reserved (00h)							
9	SValid	Invert (0)	Reserved (00h)		ED	Medium Type		
10 to 11	(MSB) Source Storage Element Address (LSB)							
12 to 47	Primary Volume Tag Information (Field omitted if PVolTag=0)							
48	Reserved (0h)				Code Set (0)			
49	Reserved (0h)				Identifier Type (0)			
50	Reserved (00h)							
51	Identifier Length (0)							
52	Media Domain (Field moved up if Primary Volume Tag Information omitted.)							
53	Media Type (Field moved up if Primary Volume Tag Information omitted.)							
54 to 55	Reserved (00h, 00h) (Field moved up if Primary Volume Tag Information omitted.)							



## Import/Export Element Descriptor Definitions:

<b>Element Address</b>	This field contains the element address of the import/export element reported.
<b>OIR</b>	Operator Intervention Required bit <ul style="list-style-type: none"> <li>■ 0 = No operator intervention required to make the CAP accessible</li> <li>■ 1 = Operator intervention required to make the CAP accessible</li> </ul>
<b>CMC</b>	This bit is set to 0 indicating the import/export element is a CAP. A CMC bit of zero indicates that exports are to the operator's domain and imports are from the operator's domain. <ul style="list-style-type: none"> <li>■ Media shall not leave the domain of the media changer when prevented by the PREVENT ALLOW MEDIA REMOVAL command (see SPC).</li> </ul>
<b>InEnab</b>	This bit indicates the import/export element supports the movement of cartridge tapes into the library. The library returns a value of 1.
<b>Access</b>	This bit indicates that the import/export element supports the movement of cartridge tapes out of the library. The library returns a value of 1. <ul style="list-style-type: none"> <li>■ 0 = The CAP is open and cannot be accessed by the hand. Or the magazine at the requested Element Address has been removed. Thus the Full and Primary Volume Tag information cannot be determined, and should be ignored. More information about this condition is available through the Additional Sense Code and Additional Sense Code Qualifier fields.</li> <li>■ 1 = The CAP is closed and accessible.</li> </ul>
<b>Except</b>	This bit indicates the operational state of the import/export element: <ul style="list-style-type: none"> <li>■ 0 = The import/export element is in the normal state.</li> <li>■ 1 = The import/export element is in an abnormal state, and the Additional Sense Code and the Additional Sense Code Qualifier fields contain information regarding the abnormal state. Other fields in this descriptor might be invalid, and should be ignored.</li> </ul>
<b>ImpExp</b>	This bit indicates how the cartridge tape was placed in the element: <ul style="list-style-type: none"> <li>■ 0 = The cartridge tape in the import/export element was placed there by the library hand as part of an export operation.</li> <li>■ 1 = The cartridge tape in the import/export element was placed there by an operator as part of an import operation.</li> </ul>
<b>Full</b>	This bit indicates if the import/export element contains a cartridge tape: <ul style="list-style-type: none"> <li>■ 0 = The import/export element does not contain a cartridge tape.</li> <li>■ 1 = The import/export element does contain a cartridge tape.</li> </ul>
<b>Additional Sense Code</b>	This field is valid only if the Except bit is set. In the case of an exception, it contains an ASC as defined for Request Sense data.
<b>Additional Sense Code Qualifier</b>	This field is valid only if the Except bit is set. In the case of an exception, it contains an ASCQ as defined for Request Sense data.
<b>SValid</b>	This bit indicates if the Source Element Address and Invert fields are valid: <ul style="list-style-type: none"> <li>■ 0 = The Source Element Address and Invert fields are not valid.</li> <li>■ 1 = The Source Element Address and Invert fields are valid.</li> </ul>
<b>Invert</b>	The library does not support multi-sided media. The information reported is 0.

<b>ED</b>	<ul style="list-style-type: none"> <li>■ 0 = The element is enabled (for example a magazine or drive has been installed or has been logically enabled)</li> <li>■ 1 = The element is disabled</li> </ul>
<b>Medium Type</b>	<p>This field provides the type of medium currently present in the element as determined by the medium changer.</p> <p>The library returns the following values:</p> <ul style="list-style-type: none"> <li>■ 0h = Unspecified - the medium changer cannot determine the medium type.</li> <li>■ 1h = Data Medium</li> <li>■ 2h = Cleaning Medium</li> </ul>
<b>Source Storage Element Address</b>	<p>This field is valid only if the SValid bit is 1. It contains the address of the last element from which the data cartridge was moved.</p>
<b>Primary Volume Tag Information</b>	<p>When the PVolTag bit is set to 1, the library returns Volume Tag Information. When PVolTag is set to 0, this field is omitted, and the reserved fields below it are moved up.</p> <p>The library Volume Tag Information includes 6 bytes of left-justified ASCII data which represents volume/serial number data read from the cartridge tape. The field is padded to 32 bytes with 26 ASCII spaces. If the label on the cartridge tape is not readable, these 32 bytes will be set to 0.</p> <p>The last four bytes of the Volume Tag Information consist of two reserved bytes and two-volume sequence bytes. The library does not support sequence numbers. These four bytes are set to 0.</p>
<b>Code Set</b>	<p>This field specifies the code set used for the identifier field and is set to 0 (not supported) for the Import/Export Element Descriptor</p> <p>0h = Reserved</p>
<b>Identifier Type</b>	<p>The Identifier Type field indicates the format and assignment authority for the identifier and is set to 0 (not supported) for the Import/Export Element Descriptor:</p> <p>0h = Vendor Specific</p>
<b>Identifier Length</b>	<p>This field indicates the length of the Identifier field and is set to 0 (not supported) for the Import/Export Element Descriptor.</p> <p>Note: That the combined length of the identifier field and the Identifier Pad is 32 bytes.</p>
<b>Media Domain</b>	<p>The Media Domain field along with the Media Type field provides a hierarchy of information that indicates the type of media in the element:</p> <ul style="list-style-type: none"> <li>■ 00h = The element contains a Half-Inch (T9840) form factor cartridge.</li> <li>■ 43h = The element contains an LTO (or future) cleaning form factor cartridge (43h is 'C').</li> <li>■ 4Ch = The element contains an LTO form factor cartridge (4Ch is 'L').</li> <li>■ 54h = The element contains a T10000 form factor cartridge (54h is 'T').</li> <li>■ FFh = The media domain cannot be determined.</li> </ul> <p>This field is not valid if the Full bit is not set.</p>

---

**Media Type**

The Media Type field along with the Media Domain field provides a hierarchy of information that indicates the type of media in the element.

If the Media Domain field is 00h, the value reported for the Media Type field identifies in ASCII the type of Half Inch T9840 cartridge:

- R = The element contains a 9840 Standard cartridge.
- S = The element contains a future 9840 cartridge.
- T = The element contains a future 9840 cartridge.
- U = The element contains a 9840 Cleaning cartridge.
- Y = The element contains a 9840D Cleaning cartridge.
- FFh = The media type cannot be determined.

If the Media Domain field is 43h (43h is 'C'), the value reported for the Media Type field identifies in ASCII the type of LTO cleaning cartridge:

- U = The element contains a Universal LTO cleaning cartridge.
- FFh = The media type cannot be determined.

This field is not valid if the Full bit is not set.

If the Media Domain field is 4Ch (4Ch is 'L'), the value reported for the Media Type field identifies in ASCII the type of LTO cartridge:

- 1 = The element contains a 100 GB Generation 1 LTO cartridge.
- 2 = The element contains a 200 GB Generation 2 LTO cartridge.
- 3 = The element contains a 400 GB Generation 3 LTO cartridge.
- 4 = The element contains an 800 GB Generation 4 LTO cartridge
- T = The element contains a 400 GB Generation 3 LTO WORM cartridge
- U = The element contains an 800 GB Generation 4 LTO WORM cartridge
- FFh = The media type cannot be determined

This field is not valid if the Full bit is not set.

If the Media Domain field is 54h (54h is 'T'), the value reported for the Media Type field identifies in ASCII the type of T10000 cartridge:

- 1 = The element contains a T10000 cartridge.
  - S = The element contains a T10000 Sport cartridge.
  - C = The element contains a T10000 Cleaning cartridge.
  - FFh = The media type cannot be determined.
-

## Data Transfer Element Descriptor Definitions

Data transfer elements are the tape drives in the library. The Data Transfer Element Descriptor Definitions page describes a tape drive. The following table shows the data returned when the **DvcID bit in the command is set to 0**.

**TABLE 3-60** Data Transfer Element Descriptor When DvcID = 0

Byte	Bit							
	7	6	5	4	3	2	1	0
0 to 1	(MSB) Element Address (LSB)							
2	Reserved (0h)				Access	Except	Rsvd (0)	Full
3	Reserved (00h)							
4	Additional Sense Code							
5	Additional Sense Code Qualifier							
6	Reserved (00h)							
7	Reserved (00h)							
8	Reserved (00h)							
9	SValid	Invert (0)	Reserved (00h)		ED	Medium Type		
10 to 11	(MSB) Source Storage Element Address (LSB)							
12 to 47	Primary Volume Tag Information (Field omitted if PVolTag = 0)							
48	Reserved (0h)				Code Set (0)			
49	Reserved (0h)				Identifier Type (0)			
50	Reserved (00h)							
51	Identifier Length (0)							
52	Media Domain (Field moved up if Primary Volume Tag information omitted.)							
53	Media Type (Field moved up if Primary Volume Tag information omitted.)							
54	Transport Domain (Field moved up if Primary Volume Tag information omitted.)							
55	Transport Type (Field moved up if Primary Volume Tag information omitted.)							
56 to 87	(MSB) Transport Serial Number (LSB)							

## Data Transfer Element Descriptor When DvcID = 0 Definitions:

<b>Element Address</b>	This bit contains the element address of the data transfer element reported.
<b>Access</b>	This bit indicates access is allowed to the data transfer element by the hand: <ul style="list-style-type: none"> <li>■ 0 = Access is not allowed to the tape drive element by the hand. This will be the case when a cartridge tape is loaded and in use by the tape drive. The tape is set to ejected before it becomes accessible.</li> <li>■ 1 = The tape drive is accessible.</li> </ul>
<b>Except</b>	This bit indicates the operational state of the data transfer element: <ul style="list-style-type: none"> <li>■ 0 = The data transfer element is in the normal state.</li> <li>■ 1 = The data transfer element is in an abnormal state, and the Additional Sense Code and the Additional Sense Code Qualifier fields contain information regarding the abnormal state. Other fields in this descriptor might be invalid, and should be ignored.</li> </ul>
<b>Full</b>	This bit indicates if the data transfer element contains a cartridge tape: <ul style="list-style-type: none"> <li>■ 0 = The data transfer element does not contain a cartridge tape.</li> <li>■ 1 = The data transfer element does contain a cartridge tape.</li> </ul>
<b>Additional Sense Code</b>	This field is valid only if the Except bit is set. In the case of an exception, it contains an ASC as defined for Request Sense data.
<b>Additional Sense Code Qualifier</b>	This field is valid only if the Except bit is set. In the case of an exception, it contains an ASCQ as defined for Request Sense data.
<b>SValid</b>	This bit indicates if the Source Element Address and Invert fields are valid: <ul style="list-style-type: none"> <li>■ 0 = The Source Element Address and Invert fields are not valid.</li> <li>■ 1 = The Source Element Address and Invert fields are valid.</li> </ul>
<b>Invert</b>	The library does not support multi-sided media and returns a value of 0.
<b>ED</b>	<ul style="list-style-type: none"> <li>■ 0 = The element is enabled (for example a magazine or drive has been installed or has been logically enabled)</li> <li>■ 1 = The element is disabled</li> </ul>
<b>Medium Type</b>	This field provides the type of medium currently present in the element as determined by the medium changer. The library returns the following values: <ul style="list-style-type: none"> <li>■ 0h = Unspecified - the medium changer cannot determine the medium type.</li> <li>■ 1h = Data Medium</li> <li>■ 2h = Cleaning Medium</li> </ul>
<b>Source Storage Element Address</b>	This field is valid only if the SValid bit is 1. It contains the address of the last element from which the data cartridge was moved.
<b>Primary Volume Tag Information</b>	<p>When the PVolTag bit is set to 1, the library returns Volume Tag Information. When PVolTag is set to 0, this field is omitted, and the reserved fields below it are moved up.</p> <p>The library Volume Tag Information includes 6 bytes of left-justified ASCII data which represents volume/serial number data read from the cartridge tape. The field is padded to 32 bytes with 26 ASCII spaces. If the label on the cartridge tape is not readable, these 32 bytes will be set to 0.</p> <p>The last four bytes of the Volume Tag Information have two reserved bytes and two volume sequence bytes. The library does not support sequence numbers. These four bytes are set to 0.</p>

<b>Code Set</b>	This field specifies the code set used for the identifier field and is set to 0 (not supported) for the Data Transfer Element Descriptor (DvcID = 0): 0h = Reserved
<b>Identifier Type</b>	The Identifier Type field indicates the format and assignment authority for the identifier and is set to 0 (not supported) for the Data Transfer Element Descriptor (DvcID = 0): 0h = Vendor Specific
<b>Identifier Length</b>	This field indicates the length of the Identifier field and is set to 0 (not supported) for the Data Transfer Element Descriptor (DvcID = 0)
<b>Media Domain</b>	<p>The Media Domain field along with the Media Type field provides a hierarchy of information that indicates the type of media in the element:</p> <ul style="list-style-type: none"> <li>■ 00h = The element contains a Half-Inch (T9840) form factor cartridge.</li> <li>■ 43h = The element contains an LTO (or future) cleaning form factor cartridge (43h is 'C').</li> <li>■ 4Ch = The element contains an LTO form factor cartridge (4Ch is 'L').</li> <li>■ 54h = The element contains a T10000 form factor cartridge (54h is 'T').</li> <li>■ FFh = The media domain cannot be determined.</li> </ul> <p>This field is not valid if the Full bit is not set.</p>
<b>Media Type</b>	<p>The Media Type field along with the Media Domain field provides a hierarchy of information that indicates the type of media in the element.</p> <p>If the Media Domain field is 00h, the value reported for the Media Type field identifies in ASCII the type of Half Inch T9840 cartridge:</p> <ul style="list-style-type: none"> <li>■ R = The element contains a 9840 Standard cartridge.</li> <li>■ S = The element contains a future 9840 cartridge.</li> <li>■ T = The element contains a future 9840 cartridge.</li> <li>■ U = The element contains a 9840 Cleaning cartridge.</li> <li>■ Y = The element contains a 9840D Cleaning cartridge.</li> <li>■ FFh = The media type cannot be determined.</li> </ul> <p>If the Media Domain field is 43h (43h is 'C'), the value reported for the Media Type field identifies in ASCII the type of LTO cleaning cartridge:</p> <ul style="list-style-type: none"> <li>■ U = The element contains a Universal LTO cleaning cartridge.</li> <li>■ FFh = The media type cannot be determined.</li> </ul> <p>This field is not valid if the Full bit is not set.</p> <p>If the Media Domain field is 4Ch (4Ch is 'L'), the value reported for the Media Type field identifies in ASCII the type of LTO cartridge:</p> <ul style="list-style-type: none"> <li>■ 1 = The element contains a 100 GB Generation 1 LTO cartridge.</li> <li>■ 2 = The element contains a 200 GB Generation 2 LTO cartridge.</li> <li>■ 3 = The element contains a 400 GB Generation 3 LTO cartridge.</li> <li>■ 4 = The element contains an 800 GB Generation 4 LTO cartridge</li> <li>■ T = The element contains a 400 GB Generation 3 LTO WORM cartridge</li> <li>■ U = The element contains an 800 GB Generation 4 LTO WORM cartridge</li> <li>■ FFh = The media type cannot be determined</li> </ul> <p>This field is not valid if the Full bit is not set.</p>

<b>Media Type (cont.)</b>	<p>If the Media Domain field is 54h (54h is 'T'), the value reported for the Media Type field identifies in ASCII the type of T10000 cartridge:</p> <ul style="list-style-type: none"> <li>■ 1 = The element contains a T10000 cartridge.</li> <li>■ S = The element contains a T10000 Sport cartridge.</li> <li>■ C = The element contains a T10000 Cleaning cartridge.</li> <li>■ FFh = The media type cannot be determined.</li> </ul>
<b>Transport Domain</b>	<p>The Transport Domain field with the Transport Type field provide a hierarchy of information that indicates the type of data transfer element installed:</p> <ul style="list-style-type: none"> <li>■ 00h = The element contains a Half-Inch (T9840) form factor cartridge.</li> <li>■ 4Ch = The element supports LTO form factor cartridges (4Ch is 'L').</li> <li>■ 54h = The element contains a T10000 form factor cartridge (54h is 'T').</li> <li>■ FFh = The element domain cannot be determined.</li> </ul>
<b>Transport Type</b>	<p>If the Transport Domain field is 00h, the value of the Transport Type field indicates that the drive installed is:</p> <ul style="list-style-type: none"> <li>■ 01h = A StorageTek T9840B drive.</li> <li>■ 02h = A StorageTek T9840A drive.</li> <li>■ 03h = A StorageTek T9840A drive in 3590 emulation mode.</li> <li>■ 07h = A StorageTek T9840B drive in 3590 emulation mode.</li> <li>■ 0Bh = A StorageTek T9840C drive.</li> <li>■ 0Ch = A StorageTek T9840C drive in 3590 emulation mode.</li> <li>■ 12h = A StorageTek T9840D drive.</li> <li>■ 13h = A StorageTek T9840D drive in 3590 emulation mode.</li> <li>■ 14h = A StorageTek T9840D Encrypting drive.</li> <li>■ 15h = A StorageTek T9840D Encrypting drive in 3590 emulation mode.</li> <li>■ FFh = The type cannot be determined.</li> </ul> <p>If the Transport Domain field is 4Ch (4Ch is 'L'), the value in the Transport Type field indicates that the drive installed is:</p> <ul style="list-style-type: none"> <li>■ 36h = An HP Generation 3 LTO drive.</li> <li>■ 37h = An IBM Generation 3 LTO drive.</li> <li>■ 38h = A Quantum Generation 3 LTO drive.</li> <li>■ 39h = An HP Generation 4 LTO drive.</li> <li>■ 3Ah = An IBM Generation 4 LTO drive</li> <li>■ FFh = The type cannot be determined.</li> </ul> <p>If the Transport Domain field is 54h (54 is 'T'), the value reported for the Transport Type field identifies in ASCII the type of the T10000 cartridge:</p> <ul style="list-style-type: none"> <li>■ 0Dh = A StorageTek T10000A drive.</li> <li>■ 0Eh = A StorageTek T10000A drive in 3590 emulation mode.</li> <li>■ 18h = A StorageTek T10000A Encrypting drive.</li> <li>■ 19h = A StorageTek T10000A Encrypting drive in 3590 emulation mode.</li> <li>■ 1Ah = A StorageTek T10000B drive.</li> <li>■ 1Bh = A StorageTek T10000B drive in 3590 emulation mode.</li> <li>■ 1Ch = A StorageTek T10000B Encrypting drive.</li> <li>■ 1Dh = A StorageTek T10000B Encrypting drive in 3590 emulation mode.</li> <li>■ FFh = The type cannot be determined.</li> </ul>
<b>Transport Serial Number</b>	<p>Thirty-two ASCII characters represent the unique transport serial number. For tape drives with less than 32 bytes of ASCII serial number data, the value is left-justified and the unused LSB bytes contain ASCII blanks. If the serial number is not available from a tape drive that should support an ASCII serial number, ASCII blanks are returned. Left justification in this 32-byte field provides space for serial numbers of varying lengths.</p>

## Data Transfer Element Descriptor Definitions

Data transfer elements are the tape drives in the library. The Data Transfer Element Descriptor Definitions page describes a tape drive. The following table shows the data returned when the **DvcID bit in the command is set to 1**.

**TABLE 3-61** Data Transfer Element Descriptor When DvcID = 1

Byte	Bit							
	7	6	5	4	3	2	1	0
0 to 1	(MSB) Element Address (LSB)							
2	Reserved (0)				Access	Except	Rsvd (0)	Full
3	Reserved (00h)							
4	Additional Sense Code							
5	Additional Sense Code Qualifier							
6	Reserved (00h)							
7	Reserved (00h)							
8	Reserved (00h)							
9	SValid	Invert (0)	Reserved (00h)		ED	Medium Type		
10 to 11	(MSB) Source Storage Element Address (LSB)							
12 to 47	Primary Volume Tag Information (Field omitted if PVolTag = 0)							
48	Reserved (0h)				Code Set (2)			
49	Reserved (0h)				Identifier Type (0)			
50	Reserved (00h)							
51	Identifier Length (x)							
52 to 52+x-1 (x bytes)	Identifier							
32-x bytes	Identifier Pad							
84	Media Domain							
85	Media Type							
86	Transport Domain							
87	Transport Type							



## Data Transfer Element Descriptor (DvcID = 1) Definitions:

<b>Element Address</b>	This bit contains the element address of the data transfer element reported.
<b>Access</b>	This bit indicates access is allowed to the data transfer element by the hand: <ul style="list-style-type: none"> <li>■ 0 = Access is not allowed to the tape drive element by the hand. This will be the case when a cartridge tape is loaded and in use by the tape drive. The tape must be ejected before it becomes accessible.</li> <li>■ 1 = The tape drive is accessible.</li> </ul>
<b>Except</b>	This bit indicates the operational state of the data transfer element: <ul style="list-style-type: none"> <li>■ 0 = The data transfer element is in the normal state.</li> <li>■ 1 = The data transfer element is in an abnormal state, and the Additional Sense Code and the Additional Sense Code Qualifier fields contain information regarding the abnormal state. Other fields in this descriptor might be invalid, and should be ignored</li> </ul>
<b>Full</b>	This bit indicates if the data transfer element contains a cartridge tape: <ul style="list-style-type: none"> <li>■ 0 = The data transfer element does not contain a cartridge tape.</li> <li>■ 1 = The data transfer element does contain a cartridge tape.</li> </ul>
<b>Additional Sense Code</b>	This field is valid only if the Except bit is set. In the case of an exception, it contains an ASC as defined for Request Sense data.
<b>Additional Sense Code Qualifier</b>	This field is valid only if the Except bit is set. In the case of an exception, it contains an ASCQ as defined for Request Sense data.
<b>SValid</b>	This bit indicates if the Source Element Address and Invert fields are valid: <ul style="list-style-type: none"> <li>■ 0 = The Source Element Address and Invert fields are not valid.</li> <li>■ 1 = The Source Element Address and Invert fields are valid.</li> </ul>
<b>Invert</b>	The library does not support multi-sided media and returns a value of 0.
<b>ED</b>	<ul style="list-style-type: none"> <li>■ 0 = The element is enabled (for example a magazine or drive has been installed or has been logically enabled)</li> <li>■ 1 = The element is disabled</li> </ul>
<b>Medium Type</b>	This field provides the type of medium currently present in the element as determined by the medium changer. The library returns the following values: <ul style="list-style-type: none"> <li>■ 0h = Unspecified - the medium changer cannot determine the medium type.</li> <li>■ 1h = Data Medium</li> <li>■ 2h = Cleaning Medium</li> </ul>
<b>Source Storage Element Address</b>	This field is valid only if the SValid bit is 1. It contains the address of the last element from which the data cartridge was moved.
<b>Primary Volume Tag Information</b>	When the PVolTag bit is set to 1, the library returns Volume Tag Information. When PVolTag is set to 0, this field is omitted, and the reserved fields below it are moved up. The library Volume Tag Information includes 6 bytes of left-justified ASCII data which represents volume/serial number data read from the cartridge tape. The field is padded to 32 bytes with 26 ASCII spaces. If the label on the cartridge tape is not readable, these 32 bytes will be set to 0. The last four bytes of the Volume Tag Information have two reserved bytes and two volume sequence bytes. The library does not support sequence numbers. These four bytes are set to 0.
<b>Code Set</b>	This field specifies the code set used for the identifier field: 2h = The identifier contains ASCII graphic codes (code values 20h through 7Eh).

<b>Identifier Type</b>	<p>The Identifier Type field indicates the format and assignment authority for the identifier:</p> <p>0h = No assignment authority was used, and consequently there is no guarantee that the identifier is globally unique. In other words, the identifier is vendor specific.</p>
<b>Identifier Length</b>	<p>This field indicates the length of the Identifier field. Note: That the combined length of the Identifier field and the Identifier Pad is 32 bytes.</p>
<b>Identifier</b>	<p>This field contains the device identification of the type indicated in the Identifier Type field and in the format specified in the Code Set field.</p>
<b>Identifier Pad</b>	<p>This field contains binary zeros if the identifier is binary. This field contains ASCII blanks if the identifier is ASCII. The number of zeros or blanks depends on the length of the Identifier field. Note: That the combined length of the Identifier field and the Identifier Pad is 32 bytes.</p>
<b>Media Domain</b>	<p>The Media Domain field along with the Media Type field provides a hierarchy of information that indicates the type of media in the element:</p> <ul style="list-style-type: none"> <li>■ 00h = The element contains a Half-Inch (T9840) form factor cartridge.</li> <li>■ 43h = The element contains an LTO (or future) cleaning form factor cartridge (43h is 'C').</li> <li>■ 4Ch = The element contains an LTO form factor cartridge (4Ch is 'L').</li> <li>■ 54h = The element contains a T10000 form factor cartridge (54h is 'T').</li> <li>■ FFh = The media domain cannot be determined.</li> </ul> <p>This field is not valid if the Full bit is not set.</p>
<b>Media Type</b>	<p>The Media Type field, along with the Media Domain field, provides a hierarchy of information that indicates the type of media in the element. The Media Type field along with the Media Domain field provides a hierarchy of information that indicates the type of media in the element.</p> <p>If the Media Domain field is 00h, the value reported for the Media Type field identifies in ASCII the type of Half Inch T9840 cartridge:</p> <ul style="list-style-type: none"> <li>■ R = The element contains a 9840 Standard cartridge.</li> <li>■ S = The element contains a future 9840 cartridge.</li> <li>■ T = The element contains a future 9840 cartridge.</li> <li>■ U = The element contains a 9840 Cleaning cartridge.</li> <li>■ Y = The element contains a 9840D Cleaning cartridge.</li> <li>■ FFh = The media type cannot be determined.</li> </ul> <p>If the Media Domain field is 43h (43h is 'C'), the value reported for the Media Type field identifies in ASCII the type of LTO cleaning cartridge:</p> <ul style="list-style-type: none"> <li>■ U = The element contains a Universal LTO cleaning cartridge.</li> <li>■ FFh = The media type cannot be determined.</li> </ul> <p>This field is not valid if the Full bit is not set.</p> <p>If the Media Domain field is 4Ch (4Ch is 'L'), the value reported for the Media Type field identifies in ASCII the type of LTO cartridge:</p> <ul style="list-style-type: none"> <li>■ 1 = The element contains a 100 GB Generation 1 LTO cartridge.</li> <li>■ 2 = The element contains a 200 GB Generation 2 LTO cartridge.</li> <li>■ 3 = The element contains a 400 GB Generation 3 LTO cartridge.</li> <li>■ 4 = The element contains an 800 GB Generation 4 LTO cartridge</li> <li>■ T = The element contains a 400 GB Generation 3 LTO WORM cartridge</li> <li>■ U = The element contains an 800 GB Generation 4 LTO WORM cartridge</li> <li>■ FFh = The media type cannot be determined</li> </ul> <p>This field is not valid if the Full bit is not set.</p>

<b>Media Type (cont.)</b>	<p>If the Media Domain field is 54h (54h is 'T'), the value reported for the Media Type field identifies in ASCII the type of T10000 cartridge:</p> <ul style="list-style-type: none"> <li>■ 1 = The element contains a T10000 cartridge.</li> <li>■ S = The element contains a T10000 Sport cartridge.</li> <li>■ C = The element contains a T10000 Cleaning cartridge.</li> <li>■ FFh = The media type cannot be determined.</li> </ul>
<b>Transport Domain</b>	<p>The Transport Domain field with the Transport Type field provide a hierarchy of information that indicates the type of data transfer element installed:</p> <ul style="list-style-type: none"> <li>■ 01h = The transport supports DLT/SDLT form factor cartridges.</li> <li>■ 4Ch = The transport supports LTO form factor cartridges (4Ch is 'L').</li> <li>■ FFh = The transport domain cannot be determined.</li> </ul>
<b>Transport Type</b>	<p>If the Transport Domain field is 00h, the value of the Transport Type field indicates that the drive installed is:</p> <ul style="list-style-type: none"> <li>■ 01h = A StorageTek T9840B drive.</li> <li>■ 02h = A StorageTek T9840A drive.</li> <li>■ 03h = A StorageTek T9840A drive in 3590 emulation mode.</li> <li>■ 07h = A StorageTek T9840B drive in 3590 emulation mode.</li> <li>■ 0Bh = A StorageTek T9840C drive.</li> <li>■ 0Ch = A StorageTek T9840C drive in 3590 emulation mode.</li> <li>■ 12h = A StorageTek T9840D drive.</li> <li>■ 13h = A StorageTek T9840D drive in 3590 emulation mode.</li> <li>■ 14h = A StorageTek T9840D Encrypting drive.</li> <li>■ 15h = A StorageTek T9840D Encrypting drive in 3590 emulation mode.</li> <li>■ FFh = The type cannot be determined.</li> </ul> <p>If the Transport Domain field is 4Ch (4Ch is 'L'), the value in the Transport Type field indicates that the drive installed is:</p> <ul style="list-style-type: none"> <li>■ 36h = An HP Generation 3 LTO drive.</li> <li>■ 37h = An IBM Generation 3 LTO drive.</li> <li>■ 38h = A Quantum Generation 3 LTO drive.</li> <li>■ 39h = An HP Generation 4 LTO drive.</li> <li>■ 3Ah = An IBM Generation 4 LTO drive</li> <li>■ FFh = The type cannot be determined.</li> </ul> <p>If the Transport Domain field is 54h (54 is 'T'), the value reported for the Transport Type field identifies in ASCII the type of the T10000 cartridge:</p> <ul style="list-style-type: none"> <li>■ 0Dh = A StorageTek T10000A drive.</li> <li>■ 0Eh = A StorageTek T10000A drive in 3590 emulation mode.</li> <li>■ 18h = A StorageTek T10000A Encrypting drive.</li> <li>■ 19h = A StorageTek T10000A Encrypting drive in 3590 emulation mode.</li> <li>■ 1Ah = A StorageTek T10000B drive.</li> <li>■ 1Bh = A StorageTek T10000B drive in 3590 emulation mode.</li> <li>■ 1Ch = A StorageTek T10000B Encrypting drive.</li> <li>■ 1Dh = A StorageTek T10000B Encrypting drive in 3590 emulation mode.</li> <li>■ FFh = The type cannot be determined.</li> </ul>

## Release (6)

The 6-byte Release command (17h) enables the initiator to release unit or element reservations of the library as set using a previous Reserve command.

Performing a unit release of a library that has no active reservations is not considered an error. Only the initiator that performed the reservation can release the reservation. If another initiator attempts to release a unit reservation, the library returns good status, but does not release the reservation.

**TABLE 3-62** Release Command (6)

Byte	Bit							
	7	6	5	4	3	2	1	0
0	Operation Code (17h)							
1	Ignored			Reserved (0h)				Element
2	Reservation Identification							
3	Reserved (00h)							
4	Reserved (00h)							
5	Control Byte (00h)							

### Release Element Definitions:

<b>Element</b>	<p>This bit indicates if the release is an element release:</p> <ul style="list-style-type: none"> <li>■ 0 = The library or any elements reserved by the initiator are to be released from reserved status.</li> <li>■ 1 = The reserved elements associated with the Reservation Identification field from this initiator are to be released from reserved status.</li> </ul>
<b>Reservation Identification</b>	<p>This field is a value established by the initiator in a previous Reserve command.</p> <p>The field identifies the specific element reservation to be released. If an invalid Reservation Identification is specified, the library returns a Check Condition status. If the Element bit is 0, ignore this field.</p>

# Report LUNS

The Report LUNS command (A0h) returns to the initiator the known LUNs to which the initiator can send commands.

**TABLE 3-63** Report LUNs Command

Byte	Bit							
	7	6	5	4	3	2	1	0
0	Operation Code (A0h)							
1	Ignored			Reserved (0h)				
2	Select Report							
3 to 5	Reserved (0h)							
6 to 9	(MSB)	Allocation Length						(LSB)
10	Reserved (00h)							
11	Control Byte (00h)							

Report LUNs command Definitions:

<b>Select Report</b>	<p>This field specifies the type of logical unit addresses that shall be reported.</p> <ul style="list-style-type: none"> <li>■ 00h = LUN addresses reported shall be limited to the following addressing: <ul style="list-style-type: none"> <li>■ LUN addressing method;</li> <li>■ Peripheral device addressing method; and</li> <li>■ Flat space addressing method.</li> </ul> </li> <li>■ 02h = All LUNS accessible to the initiator for this port are accessible</li> </ul>
<b>Allocation Length</b>	<p>This field specifies the number of bytes that the initiator has allocated for data to be returned from the Report LUNs command.</p> <p>The Allocation must be at least 16 bytes.</p> <p>If it is less, a check condition is returned with the sense key set to illegal request and the additional sense data set to invalid field in the command descriptor block (CDB).</p>

## Report LUNs Data Definition

The library returns the following data for the Report LUNs command.

**TABLE 3-64** Report LUNs Data

Byte	Bit							
	7	6	5	4	3	2	1	0
0 to 3	(MSB) LUN list length							(LSB)
4 to 7	Reserved (0)							
8 to 15	(MSB) First LUN Descriptor							(LSB)
n -7 to n	(MSB) Last LUN Descriptor (n)							(LSB)

Report LUNs Data Definitions:

<b>LUN list length</b>	The library returns the length in bytes of the LUN list that is available for transfer. It is equal to 8 times the number of available logical units for the initiator. For example: If the allocation length is 16 bytes and 2 logical units are available, this command will return the 8-byte header and 1 logical unit descriptor; however, the LUN list length will still be 16 because 16 bytes were available if the allocation length was sufficient.
------------------------	--

**TABLE 3-65** LUN Descriptor

Byte	Bit							
	7	6	5	4	3	2	1	0
0	Address Method		Bus ID (0h)					
1	Single Level LUN Address							
2 to 3	Second Level LUN Address (00h)							
4 to 5	Third Level LUN Address (00h)							
6 to 7	Fourth Level LUN Address (00h)							

LUN Descriptor Data:

<b>Address Method</b>	This is set to 0h indicating single level LUN addressing is used.
<b>Bus ID</b>	This is set to 0h indicating a logical unit at the current level.
<b>Single Level LUN Address</b>	This is the value of the LUN
<b>Second, Third, and Fourth Level LUN Address</b>	Set to 00h for single level addressing

# Request Sense

The Request Sense command (03h) requests the library transfer sense data to the initiator.

**TABLE 3-66** Request Sense Command

Byte	Bit							
	7	6	5	4	3	2	1	0
0	Operation Code (03h)							
1	Ignored			Reserved (00h)				Desc (0h)
2	Reserved (00h)							
3	Reserved (00h)							
4	Allocation Length							
5	Control Byte (00h)							

Request Sense Command Definitions:

<b>Desc</b>	The Desc bit indicates which sense data format shall be returned. The library accepts a value of 0, indicating fixed format sense data is returned.
<b>Allocation Length</b>	This field specifies the number of bytes that the initiator has allocated for returned sense data. The library provides a maximum of 14h (20d) bytes of sense data.

## Sense Data

Sense data is available when:

- The previous command to the specified I\_T\_L nexus terminated with Check Condition status. Multiple errors might occur during the processing of a single SCSI command. The sense key reflects the first error that occurred.
- The previous command to the specified I\_T\_L nexus terminated with an unexpected bus free error. (Sense data might be available in this case, but not always.)
- The Request Sense command was issued to an unsupported LUN. In this case, the library does not return a check condition and returns sense data:
  - Sense Key set to Illegal Request (05h)
  - ASC set to Logical Unit Not Supported (25h)
  - ASCQ set to 00h

If no sense data is available for the specified I\_T\_L nexus, the library returns sense data:

- Sense Key set to No Sense (0h)
- ASC set to No Additional Sense Information (00h)
- ASCQ set to 00h

The library returns Check Condition status for a Request Sense command only to report errors specific to the command itself.

For example:

- A non-zero reserved bit is detected in the CDB.

If a recovered error occurs during the execution of a Request Sense command, the library returns the sense data with Good status. If the library returns a Check Condition status for a Request Sense command, the sense data might be invalid.

For example:

- A non-zero reserved bit is detected in the CDB.

If a recovered error occurs during the execution of a Request Sense command, the library returns the sense data with Good status. If the library returns a Check Condition status for a Request Sense command, the sense data might be invalid.



## Request Sense Data Definitions

TABLE 3-67 shows the Request Sense Data Definitions.

**TABLE 3-67** Request Sense Data

Byte	Bit							
	7	6	5	4	3	2	1	0
0	Valid (0)	Error Code (70h)						
1	Segment Number (00h)							
2	Reserved (0h)				Sense Key			
3 to 6	(MSB)	Information (00h)						(LSB)
7	Additional Sense Length (n-7)							
8 to 11	(MSB)	Command Specific Information (00h)						(LSB)
12	Additional Sense Code							
13	Additional Sense Code Qualifier							
14	Field Replaceable Unit Code (00h)							
15	SKSV	C/D	Reserved (0)		BPV (0)	Bit Pointer (0h)		
16 to 17	(MSB)	Field Pointer						(LSB)
18	Reserved (00h)							
19	Reserved (00h)							

## Request Sense

### Request Sense Data Definitions:

<b>Valid</b>	This bit indicates if the Information field contains valid data. The library does not return data in the Information field. The value is 0.
<b>Error Code</b>	This bit indicates if the error is current or deferred. The library returns only current errors. The value is 70h.
<b>Segment Number</b>	The library does not support segment numbers and returns a value of 00h.
<b>Sense Key</b>	The Sense Key (SK) field, with the Additional Sense Code and Additional Sense Code Qualifier fields, describes the error.
<b>Information</b>	The library does not support this field and returns a value of 00h.
<b>Additional Sense Length</b>	This field indicates the Additional Sense Length provided by the library excluding this byte. The typical value is 0Ch (12d).
<b>Command Specific Information</b>	The library does not support this field and returns a value of 00h.
<b>Additional Sense Code</b>	The Additional Sense Code (ASC) field, with the Sense Key and Additional Sense Code Qualifier fields, describes the error.
<b>Additional Sense Code Qualifier</b>	The Additional Sense Code Qualifier (ASCQ) field, with the Sense Key and Additional Sense Code fields, describes the error.
<b>Field Replaceable Unit Code</b>	The library does not support this field and returns a value of 00h.
<b>SKSV (Sense Key Specific Valid)</b>	When the Sense Key Specific Valid bit is set to 1, the fields C/D and Field pointer are valid. Otherwise, ignore these fields.
<b>C/D (Command/Data)</b>	Command/Data indicates whether the Check Condition status resulted from an illegal parameter in either the command descriptor block (Command) or the parameter list (Data) <ul style="list-style-type: none"> <li>■ 0 = Illegal parameter in the parameter list.</li> <li>■ 1 = Illegal parameter in the command descriptor block.</li> </ul>
<b>BPV (Bit Pointer Valid)</b>	The library does not support the Bit Pointer Valid (BPV) field and returns a value of 0.
<b>Bit Pointer</b>	The library does not support this field and returns a value of 0h.
<b>Field Pointer</b>	This field contains the number of the byte where the error occurred. Byte numbers start at 00. When a multiple-byte field is in error, the Field Pointer contains the value of the most significant byte of the field, which is the byte with the lowest byte number. For example, if a field consists of bytes 02, 03, and 04, the most significant byte is 02.

## Sense Key

The Sense Key field provides basic information about an error.

[TABLE 3-68](#) lists the Sense Keys with an explanation for each code. The Sense Key field, with the Additional Sense Code and Additional Sense Code Qualifier fields, provides a description about the error.

See [“Additional Sense Codes and Qualifiers” on page 147](#) for more information.

**TABLE 3-68** Sense Key Code Descriptions

Code	Error	Description
0h	No Sense	Indicates there is no specific sense key information to be reported. A sense key of 0 indicates a successful command.
2h	Not Ready	Indicates the addressed logical unit is not ready for library motion commands (library is not initialized, device is not ready).
4h	Hardware Error	Indicates the device detected an unrecoverable hardware failure while performing the command or during a self-test.
5h	Illegal Request	Indicates an illegal parameter in the command descriptor block or in the parameter list data.
6h	Unit Attention	Indicates a power-on or reset has occurred to the device, or a not ready-to-ready transition has occurred, or an I/O element has been accessed. Also, this may indicate mode parameters have changed, or the microcode has been changed.
Bh	Aborted Command	Indicates the device aborted the command. The initiator might be able to recover by trying the command again.

## Additional Sense Codes and Qualifiers

Bytes 12 and 13 of the sense data contain the Additional Sense Code (ASC) and Additional Sense Code Qualifier (ASCQ) fields. These codes provide additional device-specific information about the error or exception.

Each code contains a unique combination of the sense key, additional sense code, and additional sense code qualifier. The following pages describe the error codes for the library grouped by type of sense key.

### No Sense Key

The library returns a No Sense Key (00h) when sense is requested, but no error has occurred. The ASC and ASCQ values are zero.

## Not Ready Sense Key Codes

If a command is sent when the library is not ready, it generates a Not Ready error code. The following codes describe the conditions of the library that can generate Not Ready codes.

**TABLE 3-69** Not Ready Sense Keys

Description	Sense Key	ASC	ASCQ
Not Ready, Cause Not Reportable	2h	04h	00h
Not Ready, In Process of Becoming Ready	2h	04h	01h
Not Ready, Manual Intervention Required	2h	04h	03h
Not Ready, Maintenance Mode	2h	04h	81h
Not Ready, Cleaning Cartridge Installed	2h	30h	03h
Not Ready, Cartridge Access Port Open	2h	3Ah	02h
Not Ready, LUN Access Not Authorized	2h	74h	71h

### Not Ready, Cause Not Reportable

The library detected a not ready state after execution of the command was started.

### Not Ready, In Process of Becoming Ready

The library is initializing and performing an audit. Initialization occurs in a number of situations, including power-on, after the door has been opened then closed, as part of the Send Diagnostic command, when requested from the operator panel, and as part of a recovery during certain failures.

### Not Ready, Manual Intervention Required

Manual intervention errors include: the front door is open, the CAP is open, the library is in maintenance mode, or the library is in an inoperable state.

- If the library front door is open, closing the door causes the library to reinitialize and go into a ready state.
- If the library is in an inoperable state, reinitialize the library using the operator panel.
- If the library is in maintenance mode, take the library out of this mode using the operator panel or CSE port.

### Not Ready, Maintenance Mode

The library was placed in maintenance mode from the operator panel or CSE port.

## Not Ready, Cleaning Cartridge Installed

The library is performing an Auto Clean function on the data transfer element (tape drive) requested.

**Note** – While the cleaning cartridge remains in the drive, the library processes host commands normally. If a host requests a data mount to the drive being cleaned, then the library rejects the command and sends the Not Ready sense key (02), with ASC 30 and ASCQ 03 (Cleaning Cartridge Installed).

The host receives the data mount error for the duration of the cleaning time. Cleaning times vary, depending on the type of drive, the cleaning cartridge, robotic times, and potential retry operations. The time required to clean a 9840 is about 30 seconds. The time required to clean a DLT drive varies with the number of times the cleaning tape is used. The tape is good for 20 uses. Each time you use it takes longer than the last time because the operation goes farther on the tape cartridge. The longest cycle, cleaning cycle (20), takes approximately 5 minutes and 15 seconds.

## Not Ready, Cartridge Access Port Open

The library detected that the CAP is open and a SCSI command was issued to access the CAP.

## Not Ready, LUN Access Not Authorized

This sense data is returned, when the library is either an HLI library or a Partitioned Library with at least one SCSI partition. In the case of an HLI library, this sense data is returned to alert the host that the library cannot execute SCSI commands. If the library has at least one SCSI partition, this sense data is returned when the SCSI host issuing the command does not have a registered World Wide Name within any current partition configuration.

## Hardware Error Sense Key

The library generates a Hardware Error sense key if a hardware or firmware error is detected during command execution. The following pages describe the conditions that generate hardware errors.

**TABLE 3-70** Hardware Error Sense Keys

Description	Sense Key	ASC	ASCQ
Hardware Error, General	4h	40h	01h
Hardware Error, Tape Drive	4h	40h	02h
Hardware Error, Cartridge Access Port	4h	40h	03h
Hardware Error, Imbedded Software	4h	44h	00h
Hardware Error/Media Load/Eject Failed	4h	53h	00h

### Hardware Error, General

The library generates a general hardware error when it detects an internal electronics error during a command. This includes the electronics, vision system, and robotics of the library.

### Hardware Error, Tape Drive

The library generates a tape-drive error when an operation to the drive fails. The problem could be the tape drive or the interface between the library and tape drive.

### Hardware Error, CAP

The library generates a hardware error when the CAP fails.

### Hardware Error, Embedded Software

The library generates a hardware error when an unexpected condition is detected by the embedded software that controls the SCSI interface. This error is used for arbitrary limitations of the embedded software.

### Hardware Error, Media Load/Eject Failed

The library generates a hardware error when a load or eject fails to complete.

## Illegal Request Sense Key

Any illegal parameters in a command descriptor block (CDB) or parameter list for a particular command generate an Illegal Request sense key (see [TABLE 3-71](#)).

In some cases, additional information is available in Byte 15 of the sense data, which includes the sense-key-specific-value (SKSV) and command/data (C/D) fields. This information indicates the byte in the command descriptor block or the parameter list, which is in error.

If available, the SKSV bit in the sense data is set to 1.  
See [“Request Sense” on page 143](#) for more information.

**TABLE 3-71** Illegal Request Sense Keys

Description	Sense Key	ASC	ASCQ	SKSV
Parameter Length Error	5h	1Ah	00h	Yes
Invalid Command	5h	20h	00h	Yes
Invalid Element	5h	21h	01h	No
Invalid Field in CDB	5h	24h	00h	Yes
Logical Unit Not Supported	5h	25h	00h	No
Invalid Field in Parameters	5h	26h	00h	Yes
Invalid Release of Persistent Reservation	5h	26h	04h	No
Incompatible Medium	5h	30h	00h	No
Saving Parameters Not Supported	5h	39h	00h	Yes
Medium Not Present, Drive Not Unloaded	5h	3Ah	00h	No
Destination Element Full	5h	3Bh	0Dh	No
Source Element Empty	5h	3Bh	0Eh	No
Magazine Removed	5h	3Bh	12h	No
Insufficient Resources	5h	55h	03h	No

## Unit Attention Sense Key

The library generates a Unit Attention sense key for *all* initiators if the library needs to inform the host of an asynchronous event. The following pages describe library conditions that generate Unit Attention errors.

**TABLE 3-72** Unit Attention Sense Keys

Description	Sense Key	ASC	ASCQ
Not Ready-to-Ready Transition	06h	28h	00h
CAP Element Accessed	06h	28h	01h
Power On Occurred	06h	29h	01h
LUN Reset	06h	29h	03h
Target Reset	06h	29h	03h
Mode Parameters Changed	06h	2Ah	01h
Reservations Preempted	06h	2Ah	03h
Reservations Released	06h	2Ah	04h
Registrations Preempted	06h	2Ah	05h
Microcode Has Been Changed	06h	3Fh	01h
LUNs Data Has Changed	06h	3Fh	0Eh

### Not Ready to Ready Transition

The library generates this type of Unit Attention when the library transitions to a ready state from a not ready state. This transition can occur following any conditions that cause a not ready state. A Unit Attention is generated for all initiators.

### CAP Element Accessed

The library generates this type of Unit Attention when the operator opens and closes the CAP. Issue a Read Element Status command to obtain an updated inventory. A Unit Attention is generated for all initiators.

### Power On

The library generates this type of Unit Attention when the library is powered-on, IPLed from the operator panel, or reset over the interface. A Unit Attention is generated for all initiators.

### LUN Reset

The library generates this type of Unit Attention to all initiators after the library is clear of all I/O processes following the LUN reset.



## Target Reset

The library generates this type of Unit Attention to all initiators after the library is clear of all I/O processes following the Target reset.

## Mode Parameters Changed

The library generates this type of Unit Attention when a different initiator performs a Mode Select operation. Issuing a Mode Sense command can retrieve the current parameters. This Unit Attention is issued for all initiators except the one that performed the Mode Select.

## Persistent Reservations/Registrations Preempted or Released

The library generates these types of Unit Attention sense keys when one initiator has its persistent reservations or registrations cleared by another initiator.

## Microcode Has Been Changed

The library issues this Unit Attention sense key after executing a Write Buffer command to update the functional microcode for the library.

## LUNs Data Has Changed

The library generates this type of Unit Attention to all initiators when the library has changed.

## Aborted Command Sense Key

The library generates an Aborted Command error code when a SCSI command is aborted because of a SCSI protocol error. The initiator might not register a Check Condition status related to these errors because of the nature of the aborted commands, but the sense data is available. The following pages describe the conditions of the library that generates Aborted Commands.

**TABLE 3-73** Aborted Command Sense Keys

Description	Sense Key	ASC	ASCQ
Mechanical Positioning Error	0Bh	15h	01h
Initiator Detected Error	0Bh	48h	00h
Command Phase Error	0Bh	4Ah	00h
Data Phase Error	0Bh	4Bh	00h
Command Overlap	0Bh	4Eh	00h

### Mechanical Positioning Error

The library detected an error while trying to position a mechanism and the operation could not be completed.

### Initiator Detected Error

The library receives an Initiator Detected Error message from the initiator, and the operation could not be completed.

### Command Phase Error

The library detected a command phase error and the operation could not be completed.

### Data Phase Error

The library detected a data phase error and the operation could not be completed.

### Command Overlap

The library detected another command from an initiator while one was already in process.

## Request Volume Element Address

The Request Volume Element Address command (B5h) requests that the library return the results of a previous Send Volume Tag command.

**TABLE 3-74** Request Volume Element Address Command

Byte	Bit							
	7	6	5	4	3	2	1	0
0	Operation Code (B5h)							
1	Ignored			VolTag	Reserved (0h)			
2 to 3	(MSB)		Starting Element Address				(LSB)	
4 to 5	(MSB)		Number of Elements				(LSB)	
6	Reserved (00h)							
7 to 9	(MSB)		Allocation Length				(LSB)	
10	Reserved (00h)							
11	Control Byte (00h)							

## Request Volume Element Address Command Descriptions:

<b>VolTag (Volume Tag)</b>	<p>This bit indicates whether volume tag (VolTag) information is to be reported in response to this command:</p> <ul style="list-style-type: none"> <li>■ 0 = Volume Tag information is not reported.</li> <li>■ 1 = Volume Tag information is reported.</li> </ul>
<b>Starting Element Address</b>	<p>This field specifies the minimum element address to report. Only elements with an address greater than or equal to the Starting Element Address are reported.</p> <p>The Starting Element Address must be a valid address for the library but does not have to be an address of the type requested in the Element Type Code.</p>
<b>Number of Elements</b>	<p>This field represents the maximum number of element descriptors to be transferred.</p>
<b>Allocation Length</b>	<p>This field specifies the length in bytes of the space allocated by the initiator for the transfer of element descriptors. Only complete element descriptors are transferred. Element descriptors are transferred until one of the following conditions is met:</p> <ul style="list-style-type: none"> <li>All available element descriptors of the type specified in the Element Type Code have been transferred.</li> <li>The number of element descriptors specified in the Number of Elements field has been transferred.</li> <li>There is less allocation length space available than required for the next complete element descriptor or header to be transferred.</li> </ul>
<b>Request Volume Element Address Data</b>	<p>The library returns data for a Request Volume Element Address command in:</p> <ul style="list-style-type: none"> <li>■ An eight-byte Volume Element Address header, followed by</li> <li>■ One to four element pages, one page per element type. A page consists of: <ul style="list-style-type: none"> <li>■ An eight-byte Element Status Page header, followed by</li> <li>■ One or more Element Descriptors.</li> </ul> </li> </ul> <p>The format of the descriptor is based on the element type reported in this page. There is a separate Element Descriptor format for each element type. The data can be truncated based on the length specified in the allocation length field.</p>

## Volume Element Address Header Definition

The Volume Element Address Header is sent once for each command.

**TABLE 3-75** Volume Element Address Header

Byte	Bit							
	7	6	5	4	3	2	1	0
0 to 1	(MSB) First Element Address Reported (LSB)							
2 to 3	(MSB) Number of Elements Available (LSB)							
4	Reserved (0h)			Send Action Code (5h)				
5 to 7	(MSB) Byte Count of Report Available (all pages, n-7) (LSB)							
8 to n	Element Status pages							

Volume Element Address Header Definitions:

<b>First Element Address Reported</b>	This field indicates the lowest element address found of the type specified in the Element Type Codes and greater than/equal to the starting address.
<b>Number of Elements Available</b>	This field indicates the number of elements found of the type specified in the Element Type Codes and greater than or equal to the Starting Element Address. This number is adjusted to be less than or equal to the count specified in the Number of Elements field.
<b>Send Action Code</b>	This field contains the value of the send action code field from the previous Send Volume Tag command. The value is 5h.
<b>Byte Count of Report Available</b>	This field indicates the number of bytes of element status data available for all elements that meet the requirements of the Request Volume Element Address command. This count does not include the Element Status Data header bytes. This value is not adjusted to match the allocation length from the command.
<b>Element Status Pages</b>	The element pages returned by a Request Volume Element Address command are the same format as returned by the Read Element Status command. See <a href="#">“Read Element Status” on page 117</a> for more information.

## Reserve (6)

The 6-byte Reserve command (16h) allows the initiator to perform unit reservations or element reservations. Unit reservations are reservations of the library as a whole. Element reservations are reservations of specific elements of the library.

**TABLE 3-76** Reserve Command

Byte	Bit							
	7	6	5	4	3	2	1	0
0	Operation Code (16h)							
1	Ignored			Obsolete (0h)				Element
2	Reservation Identification							
3 to 4	(MSB) Element List Length (LSB)							
5	Control Byte (00h)							

Reserve (6) Command Definitions:

<b>Element</b>	This bit indicates if the reserve is an element reserve. The library supports reservation at the element level: <ul style="list-style-type: none"> <li>■ 0 = The entire library unit is reserved.</li> <li>■ 1 = A series of elements—identified by the Reservation Identification field and specified by the Element List Descriptor—is reserved.</li> </ul>
<b>Reservation Identification</b>	This field is a value established by an initiator to identify a specific element reservation request. The library supports a maximum of 64 element reservations. <b>Note</b> – Ignore this field if the Element bit is not set.
<b>Element List Length</b>	This field indicates the length in bytes of the Element List that follows the command. The list may include a maximum of 16 Element List Descriptors, each of which is 6 bytes long. Valid values are 0, 6, and increments of 6 up to the maximum of 60h (96d). If the value is 0 and the Element bit is set, no elements are reserved. <b>Note</b> – Ignore this field if the Element bit is not set.

## Element List Descriptor Definitions

An Element List is required if the Element bit is set. The list consists of 0 to 16 instances of the Element List Descriptor.

**TABLE 3-77** Element List Descriptor

Byte	Bit							
	7	6	5	4	3	2	1	0
0 to 1	(MSB) Reserved (00h) (LSB)							
2 to 3	(MSB) Number of Element (LSB)							
4 to 5	(MSB) Element Address (LSB)							

Element List Descriptor Definitions:

<b>Number of Elements</b>	This field indicates the number of elements of a specific type (data cartridge slots, CAP slots, or tape drives) to be reserved. If the value of this field is 0, all elements starting at the Element Address through the last element address for that library are reserved
<b>Element Address</b>	This field indicates the address of the element or the starting address of a series of elements to be reserved.

## Other Commands and Reservations

Unit and element reservations are released or canceled by:

- A “Release” command from the same initiator
- An interface reset.
- A Task Management reset:
  - LUN Reset
  - Target Reset
- A power-on reset of the library

If the library is reserved as a unit, the library processes only the following commands from another initiator:

- Prevent/Allow Medium Removal with Prevent bits set to 0
- Inquiry
- Release
- Report LUNs
- Request Sense
- Log Sense
- Read Element Status with the CurData bit set to 1

**Note** — As of the publication date of this document, the CurData bit had not been fully implemented.

All other commands result in a Reservation Conflict status (18h).

An element reservation may be used to modify or supersede a previous element reservation by the same initiator. If the superseding reservation does not result in any reservation conflicts or error conditions, the previous reservation is released, and the new reservations are completed. A unit reservation of the library supersedes any previous element reservations by the same initiator.



## Send Diagnostic

The Send Diagnostic command (1Dh) requests the library to perform a self-diagnostic test. The library may support some self tests in the future but for now considers this command to be a no-operation.

The self-test includes initialization diagnostics and calibration of the library. The extended diagnostics provide random cartridge motions and additional calibration features.

The library blocks while a diagnostic test is being performed. This can take several minutes, and time-outs should be adjusted accordingly.

The library returns status based on the diagnostic test result. The Receive Diagnostic command is not used.

**TABLE 3-78** Send Diagnostic Command

Byte	Bit							
	7	6	5	4	3	2	1	0
0	Operation Code (1Dh)							
1	Ignored			PF (1)	Rsvd (0)	SelfTest (1)	DevOfl (0)	UnitOfl (0)
2	Reserved (00h)							
3 to 4	(MSB)			Parameter List Length				(LSB)
5	Control Byte (00h)							

### Send Diagnostic Command Descriptions:

<b>PF</b>	The library accepts the page format (PF) specified by SCSI-3. The value of PF should be 1. However, the library accepts a 0 for self test.
<b>SelfTest</b>	The library accepts a value of 1, indicating a request to the library to complete the library's default test.
<b>DevOfl</b>	This feature is not supported by the library; the value is set to 0.
<b>UnitOfl</b>	This feature is not supported by the library; the value is set to 0.
<b>Parameter List Length</b>	For the self-test option, a value of 0h is required. For extended diagnostics, a value of 8h is required. (not supported)

## Send Volume Tag

The Send Volume Tag command (B6h) is a request for the library to transfer a volume tag template. The template corresponds to a VOLSER label template and is used by the library to search for desired elements. A subsequent Request Volume Element Address command is used to transfer the results of this search.

**TABLE 3-79** Send Volume Tag Command

Byte	Bit							
	7	6	5	4	3	2	1	0
0	Operation Code (B6h)							
1	Ignored			Rsvd (0)	Element Type Code			
2 to 3	(MSB) Starting Element Address							(LSB)
4	Reserved (00h)							
5	Reserved (00h)			Send Action Code (5h)				
6	Reserved (00h)							
7	Reserved (00h)							
8 to 9	(MSB) Parameter List Length							(LSB)
10	Reserved (00h)							
11	Control Byte (00h)							

### Send Volume Tag Command Descriptions:

<b>Element Type Code</b>	<p>This field specifies the element types selected for reporting by this command:</p> <ul style="list-style-type: none"> <li>■ 0h = All Element Types reported</li> <li>■ 1h = Medium Transport Element (hand)</li> <li>■ 2h = Storage Element (cartridge tape storage slots)</li> <li>■ 3h = Import/Export Element (CAP slots)</li> <li>■ 4h = Data Transfer Element (tape drive)</li> </ul> <p>For an Element Type Code of 0h, the element types are reported in ascending element address order, beginning with the first element greater than or equal to Starting Element Address.</p>
<b>Starting Element Address</b>	<p>This field specifies the element address at which to start the search. Only elements with an element address greater than or equal to the Starting Element Address are reported.</p> <p>The Starting Element Address must be a valid address for the library, but does not have to be an address of the type requested in the Element Type Code.</p>
<b>Send Action Code</b>	<p>This field specifies the function to be performed. The library only supports the translate and search primary volume tag function. The value is 5h.</p>

<b>Parameter List Length</b>	This field indicates the length in bytes of the Parameter List that follows the command: <ul style="list-style-type: none"> <li>■ 00h = No data is transferred</li> <li>■ 28h = A Volume Identification Template is transferred</li> <li>■ A value of 0 is not considered an error.</li> </ul>
------------------------------	--

## Send Volume Tag Parameter List

The Send Volume Tag command requires a parameter list that defines the volume template to search for.

**TABLE 3-80** Send Volume Tag Parameter List

Byte	Bit							
	7	6	5	4	3	2	1	0
0 to 31	(MSB)	Volume Identification Template						(LSB)
32	Reserved (00h)							
33	Reserved (00h)							
34 to 35	(MSB)	Minimum Volume Sequence Number						(LSB)
36	Reserved (00h)							
37	Reserved (00h)							
38 to 39	(MSB)	Maximum Volume Sequence Number						(LSB)

- **Volume Identification Template**

This ASCII field specifies a volume identification search template. A maximum of 6 ASCII characters may be used. The first 00 hex terminates the volume identification search template. The remaining characters are set to 0.

- Characters allowed are the same as those used on the cartridge VOLSER labels and include characters A through Z, digits 0 through 9, and special characters that include the dollar sign (\$), the pound character (#), and the ASCII space character.

The wild-card characters "\*" and "?" (2Ah and 3Fh) also may be used.

- **Minimum Volume Sequence Number**

Sequence numbers are not supported on the library; ignore this field.

- **Maximum Volume Sequence Number**

Sequence numbers are not supported on the library; ignore this field.

## Test Unit Ready

The Test Unit Ready command (00h) allows the initiator to determine if the library is powered-on and ready to accept additional commands. This is not a request for a library self-test.

The Test Unit Ready command returns a Good status if the library is ready to accept additional commands. This command also returns a Check Condition if the library is not ready or if there are pending Unit Attentions.

**TABLE 3-81** Test Unit Ready Command

Byte	Bit							
	7	6	5	4	3	2	1	0
0	Operation Code (00h)							
1	Ignored			Reserved (00h)				
2	Reserved (00h)							
3	Reserved (00h)							
4	Reserved (00h)							
5	Control Byte (00h)							

## Cell Maps

---

This appendix contains the following topics:

- [““Module Comparisons” on page 184” on page 165](#)
- [“Addressing” on page 167](#)
- [“Module Configurations” on page 170](#)
- [“Capacities” on page 183](#)
- [“Module Comparisons” on page 184](#)

---

## Modular Design

The SL3000 library maintains the fundamentals of a modular design that allows customers the ability to meet the demands of a rapidly growing and constantly changing environment.

### Modules

There are four types of modules in an SL3000 library:

- Base module, one, *required*
- Drive expansion module (DEM) one, *on the left side only*
- Cartridge expansion module (CEM) *left or right side*
- Parking expansion module (PEM) *left and right side*

The modules of the library consists of walls, columns, and rows that house cartridges, tape drives, cartridge access ports, and robotic units.

## Addressing

The SL3000 uses five parameters separated by comma's to indicate locations or addresses in the library. These parameters are < L, R, C, S, W >, which is:

- Library (L) = Library number
- Rail (R) = Rail
- Column (C) = Horizontal location in the library
- Side (S) = Walls
- Row (W) = Vertical location in the library

## Columns

There are two types of columns that provide the *horizontal* locations for components; such as cartridges, tape drives, and cartridge access ports:

- *Positive numbered*, which are to the right of the centerline\*
- *Negative numbered*, which are to the left of the centerline\*

**Note** – Centerline\* is the left-edge of the Base module.

## Walls

There are two types of walls in the SL3000 library:

- Front wall
- Rear wall

## Rows

Rows provide the *vertical* locations for components and are numbered from the top down from 1 (top) to 52 (bottom).

## Any Cartridge, Any Slot™

Mixed media storage slots are used to hold the cartridges. This allows the SL3000 library to support the Sun StorageTek Any Cartridge, Any Slot™ feature and accept a variety of media types.

# Addressing

The SL3000 employs a fixed module address scheme using five parameters separated by comma's to indicate locations—or addresses—in the library. These parameters are: < L, R, C, S, W >

**TABLE A-1** Addressing Scheme

Library	This parameter indicates the library number. This parameter will always be 1.
Rail	The SL3000 only has one rail. This parameter will always be 1.
Column	Columns indicate the horizontal location of a cartridge or drive from the logical center—or centerline—of the library. The numbers get larger as you get farther away from center using: <ul style="list-style-type: none"> <li>■ A minus sign (-) indicates locations to the left of center.</li> <li>■ A plus sign (+ or nothing) indicates locations to the right of center.</li> </ul> These numbers vary depending on the number of expansion modules added to the library. (Each module has 6 columns)
Side	The side parameter indicates the rear or the front walls of the library. <ul style="list-style-type: none"> <li>■ Rear wall = 1</li> <li>■ Front wall = 2</li> </ul>
Row	Rows indicate the vertical location of a cartridge or drive and are numbered from the top (1) down (52). These are always positive numbers.

In summary, columns are numbered using a Center Line<sup>1</sup>, then going to the left using negative numbers and to the right using positive numbers for the front and rear walls. An example is shown in [FIGURE A-1 on page 168](#).

---

**Important:**

This means that, as modules are added, the panel numbering remains constant.

---

This is a key benefit of a fixed addressing scheme; it allows the library to add licensed capacity with minimal impact.

---

1. CenterLine Technology not only provides a basis for library addresses and numbering, it also contributes to optimization and library performance.

## Columns

Columns indicate the horizontal location of a cartridge or drive from the logical center—or centerline—of the library.

The numbers get larger as you get farther away from center using:

- A minus sign (-) indicates locations to the left of center.
- A plus sign (+, or nothing) indicates locations to the right of center.

These numbers vary depending on the number of expansion modules.

- Each Base and DEM has 4 columns for tape drives;
- Each module has 6 columns for data cartridges.

**FIGURE A-1** shows a Base (which is required), a DEM installed to the left, with CEM (one on each end), to show how the columns are numbered for both tape drives and data cartridges.

**FIGURE A-1** Centerline and Column Addressing

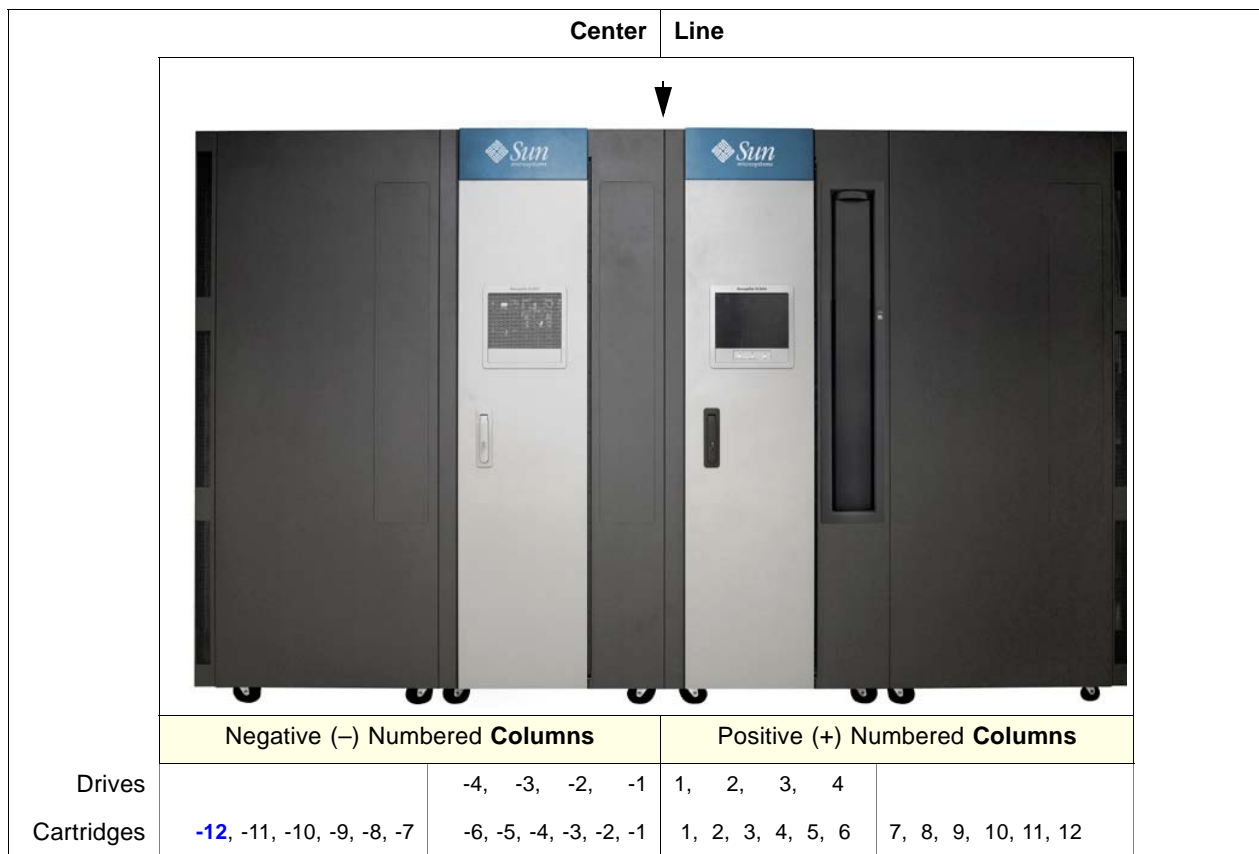

**Notes:**

- One and only one Base is required for every configuration
- One DEM can be installed directly to the left of the Base or,
- CEMs can be installed to the left and to the right
- Negative numbered columns are to the left of centerline
- Positive numbered columns are to the right of centerline
- The last column on the left is not accessible to allow for robotic clearance of the side cover (in **FIGURE A-1** this is column -12)



## Sides

The side parameter in the addressing scheme is for the rear or the front walls:

- Rear wall = 1
- Front wall = 2

## Configuration Block

Each module in the SL3000 library has a configuration block on the lower rear wall in column 4, rows 49, 50, 51, and 52. This block identifies the:

- Type of module
- Back wall configuration
- Front wall configuration
- Options for that module

During an initialization, the robotic assembly visits this configuration block to determine the configuration of the module.

**FIGURE 0-1** Configuration Block

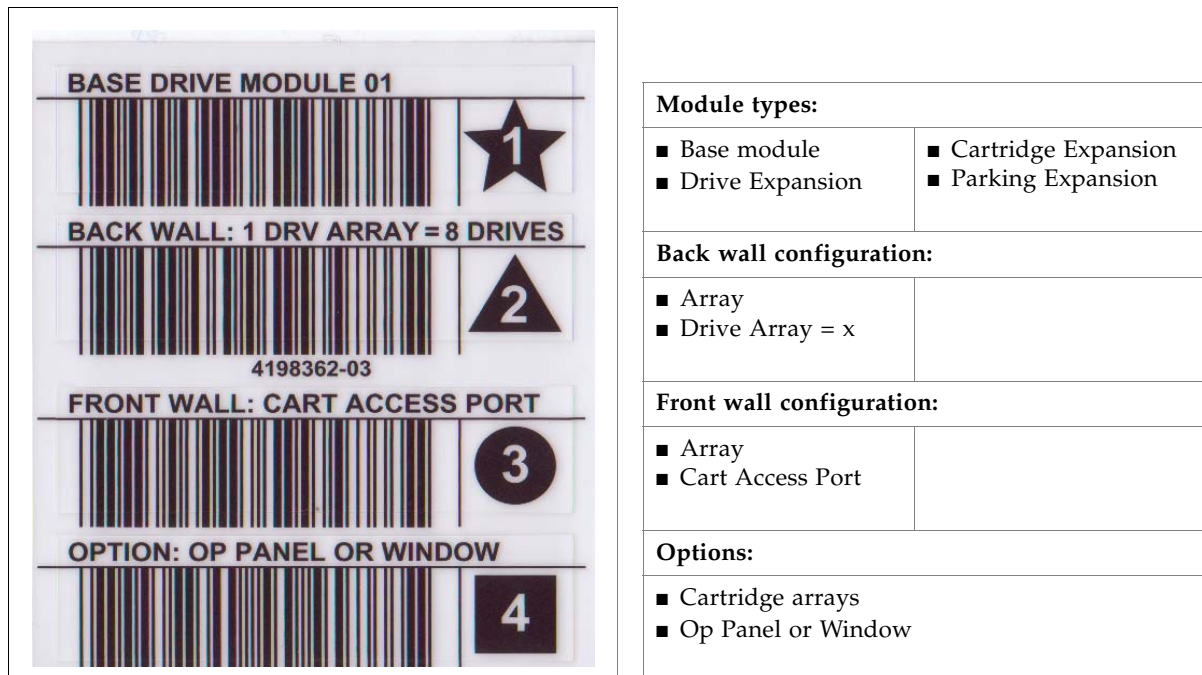

Because the SL3000 library is flexible and modular, you can upgrade or add options without removing and replacing the module. For example:

- Adding another tape drive bay to the rear of the library
- Including a CAP or operator panel to the front of a module

Simply add the upgrade and replace the configuration label for that component.

## Drive Module Slots

Both the Base module and the Drive Expansion Module have special slots on the lower rear wall. These slots provide special yet specific functions for the library and tape drives.

FIGURE A-2 shows an example of these slots:

1. Swap slots (2) in column 2, rows 49 and 50.
2. Diagnostic slot (1) in column 2, row 51.
3. Diagnostic slot (4) in column 3, rows 49, 50, 51, and 52.
4. Configuration block in column 4, rows 49, 50, 51, and 52.
5. Cleaning cartridges (4) in column 5, rows 49, 50, 51, and 52.
6. Cleaning cartridges (4) in column 6, rows 49, 50, 51, and 52.

**FIGURE A-2** Drive Module Slots

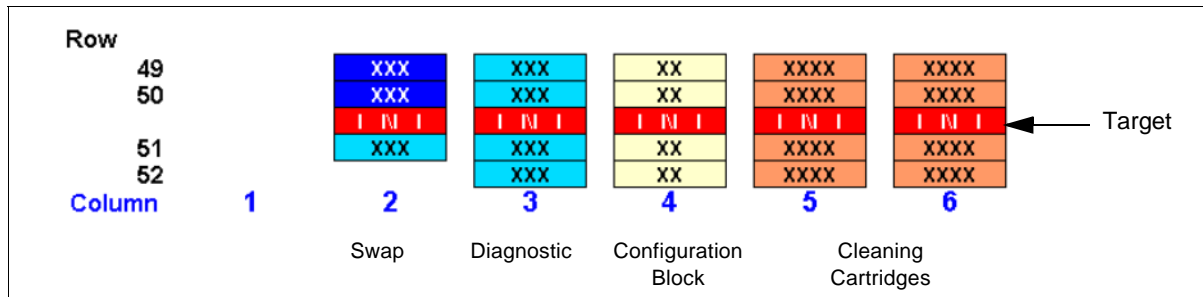

---

## Module Configurations

FIGURE A-3 on page 171 through FIGURE A-14 on page 182 show the different modules with their various front and rear wall configurations and capacities.

TABLE A-2 on page 183 lists the capacity of the different modules. To calculate the final storage capacity, select the slot counts for each module, then add them together to reach the total for the library configuration.

FIGURE A-15 on page 184 through FIGURE A-21 on page 190 show a module comparison with features included.

## Base Module Rear Wall

The rear wall of the Base module has three (3) configurations. These configurations are based on the number of tape drive bays that are installed.

- Each drive bay holds up to eight tape drives.
- As you add a drive bay, you lose data cartridge slots.
- This module has positive numbered columns

**FIGURE A-3** Base Module—Rear Wall

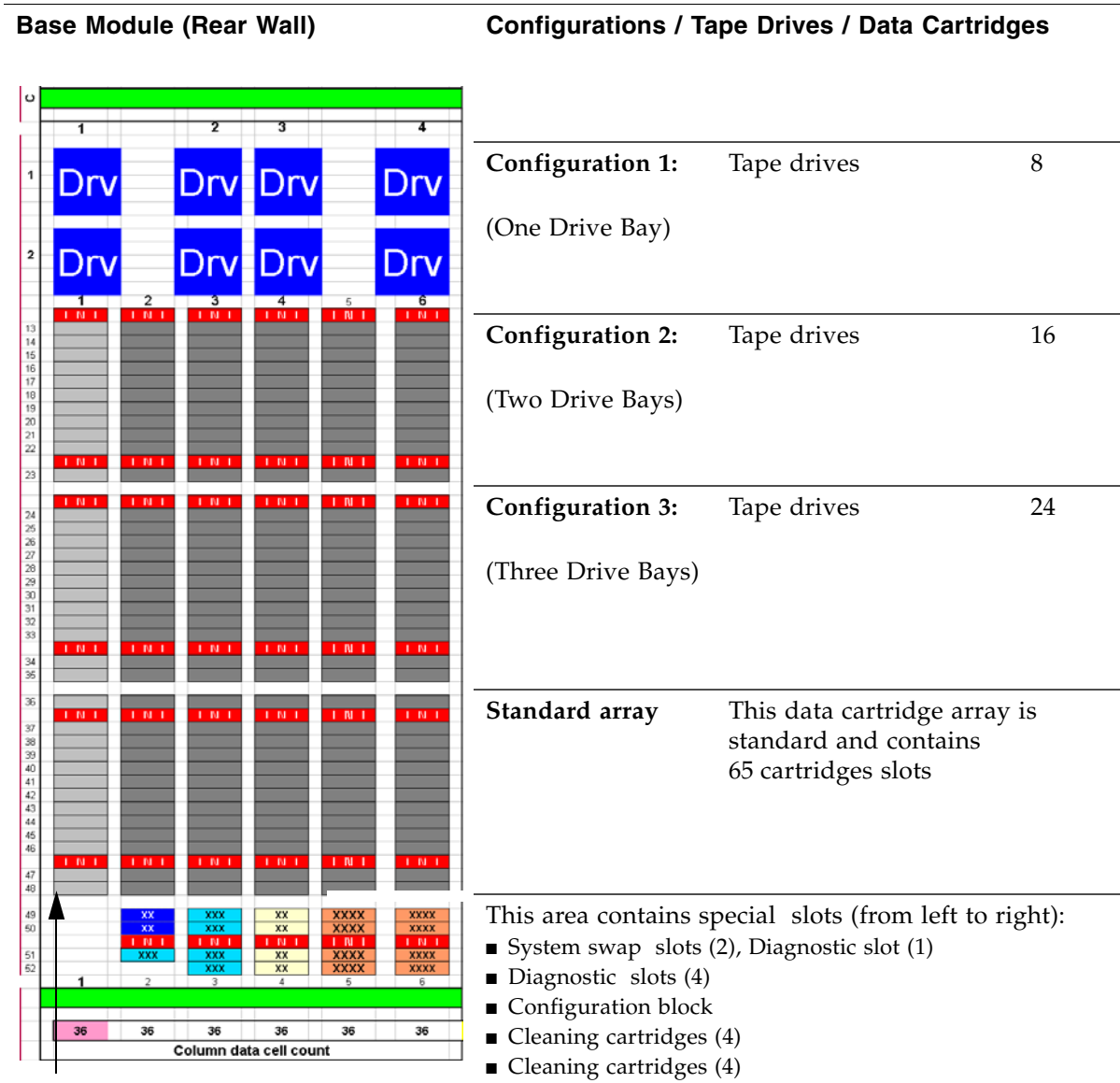

**Note – Left-side expansion area.** If this is the last module in the string on the left side, this column of arrays is not accessible to allow for the end cap (cover) and robotics end-stops. When another module is added to the left, the library regains the capacity (36, 25, or 13 slots) in this module.

## Base Module Front Wall

The front wall of the Base module has three (3) configurations. These configurations are based on optional features.

FIGURE A-4 shows a configuration with a 26-slot cartridge access port (CAP), door latch, viewing window or optional operator panel, and right-side expansion area.

FIGURE A-4 Base Module—Front Wall

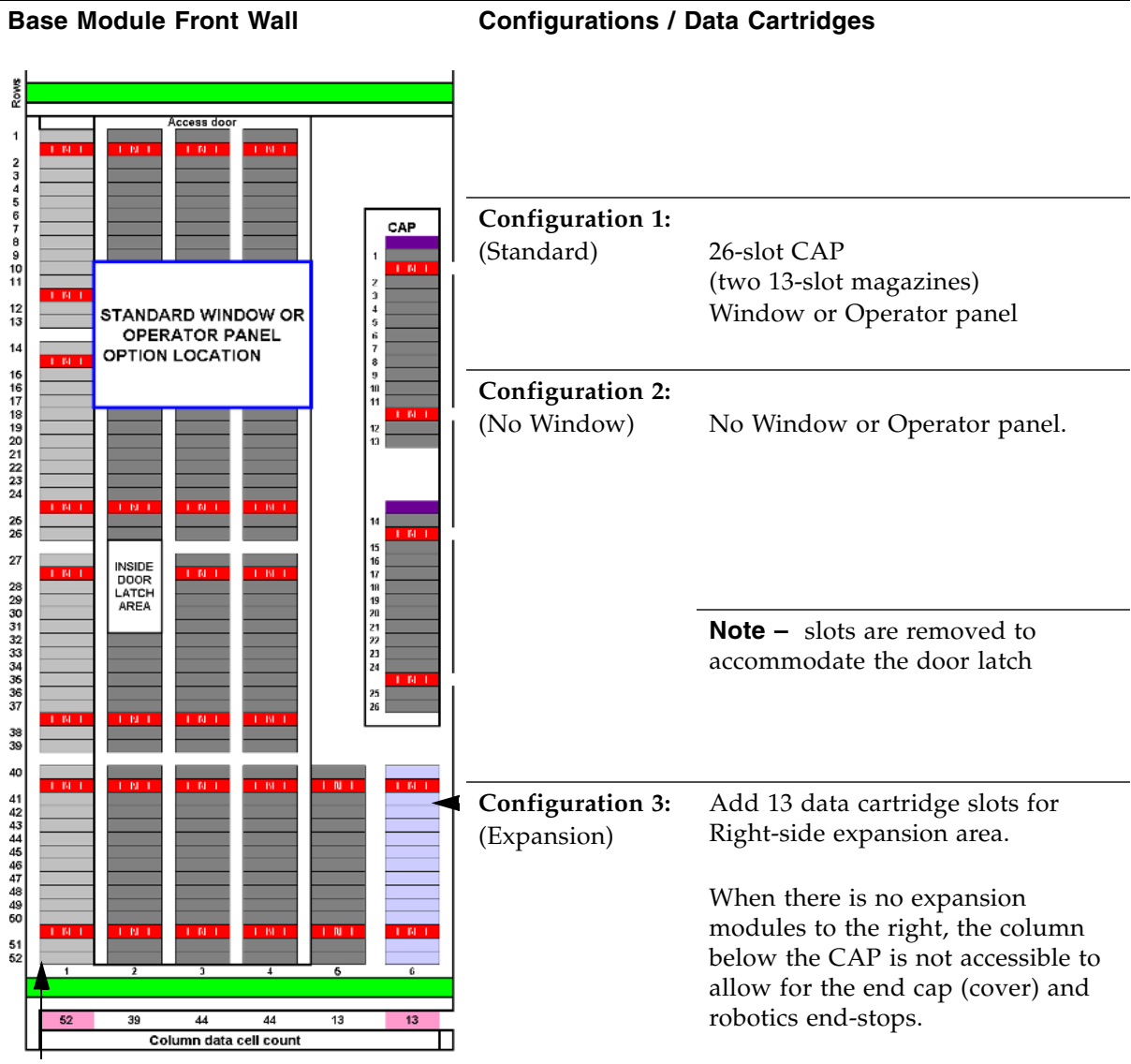

**Note – Left-side expansion area.** If this is the last module in the string on the left side, this column of arrays is not accessible to allow for the end cap (cover) and robotics end-stops. When another module is added to the left, the library regains the capacity (52 slots) in this module.

## Drive Expansion Module Rear Wall

The rear wall of the drive expansion module has four (4) configurations. These configurations are based on the number of tape drive bays that are installed.

- Each drive bay holds up to eight tape drives.
- As you add a drive bay, you lose data cartridge slots.
- This module has negative numbered columns.

**FIGURE A-5** Drive Expansion Module—Rear Wall

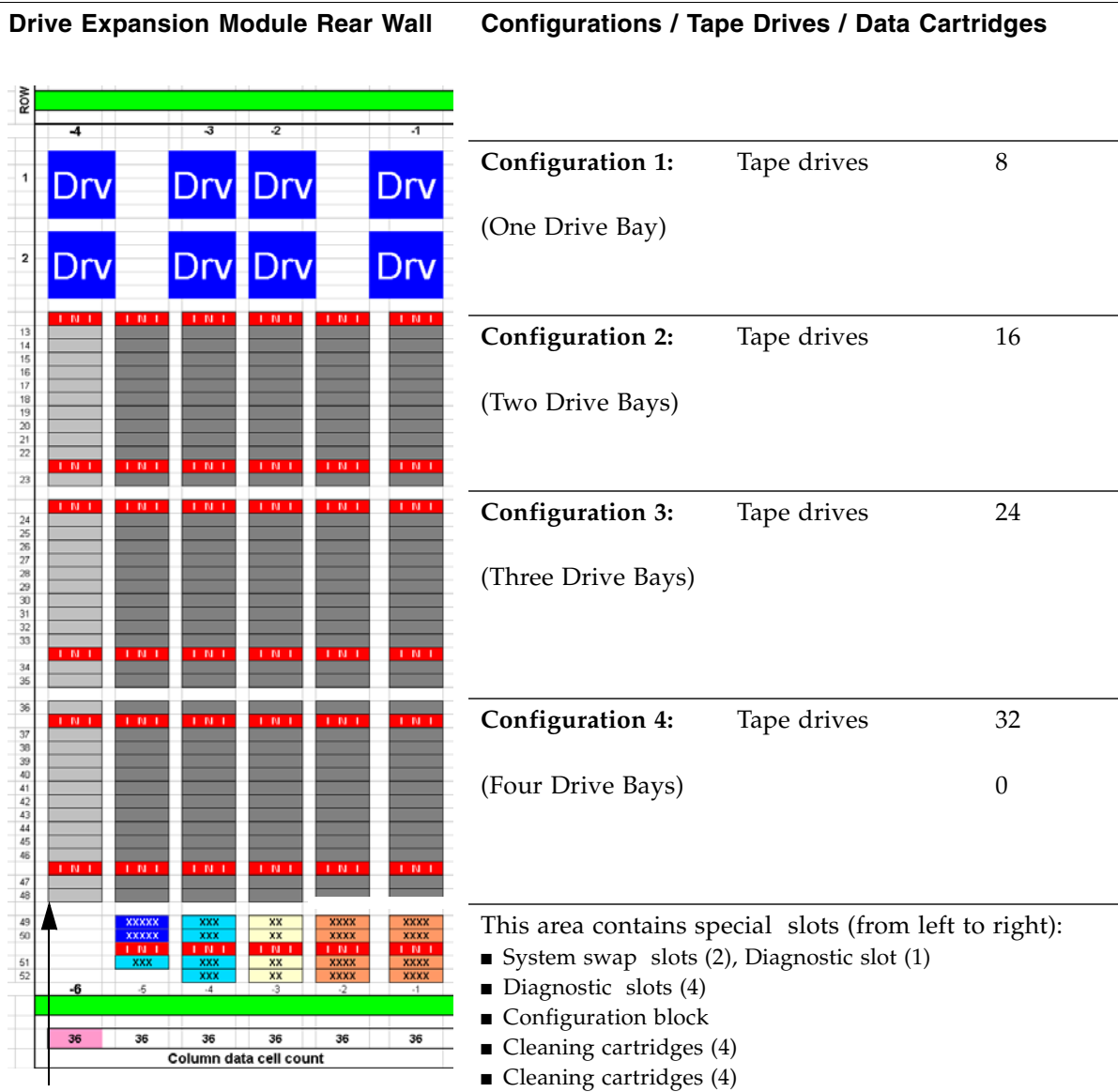

**Note – Left-side expansion area.** If this is the last module in the string on the left side, this column of arrays is not accessible to allow for the end cap (cover) and robotics end-stops. When another module is added to the left, the library regains the capacity (36, 25, 13, or no additional slots) in this module.

## Drive Expansion Module Front Wall

The front wall of the drive expansion module has four (4) configurations. These configurations are based on optional features added to the front wall.

- This module has negative numbered columns.

FIGURE A-6 shows a configuration with a 26-slot cartridge access port, door latch, and viewing window or optional operator panel.

FIGURE A-6 Drive Expansion Module—Front Wall

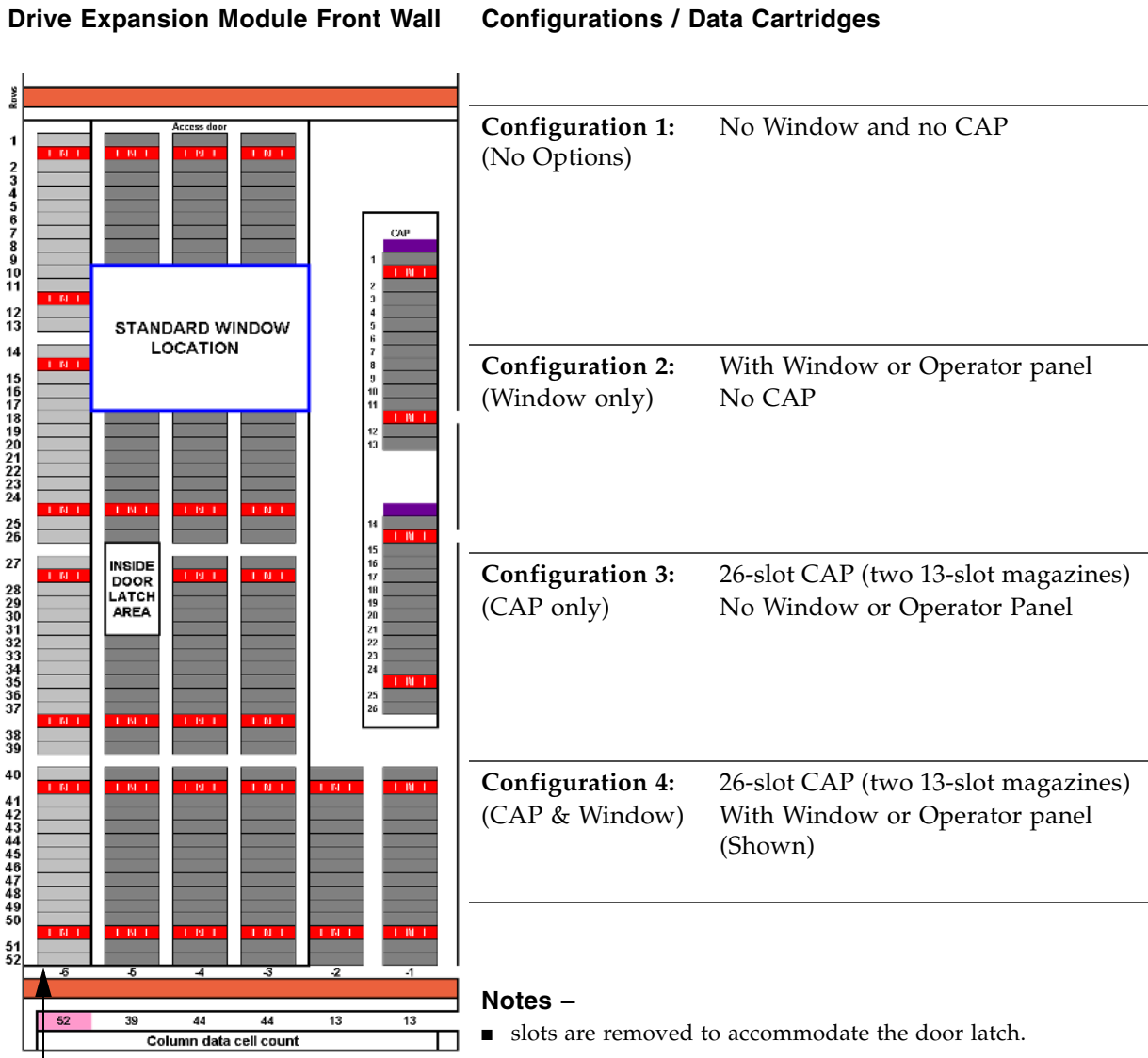

**Note – Left-side expansion area.** If this is the last module in the string on the left side, this column of arrays is not accessible to allow for the end cap (cover) and robotics end-stops. When another module is added to the left, the library regains the capacity (52 slots) in this module.

# Left-side Cartridge Expansion Module Rear Wall

The rear wall of the *left-side* cartridge expansion module has one (1) configuration.

- This module has negative numbered columns.

**FIGURE A-7** Left-side Cartridge Expansion Module—Rear Wall

## Left Cartridge Expansion Module Rear Wall Configurations

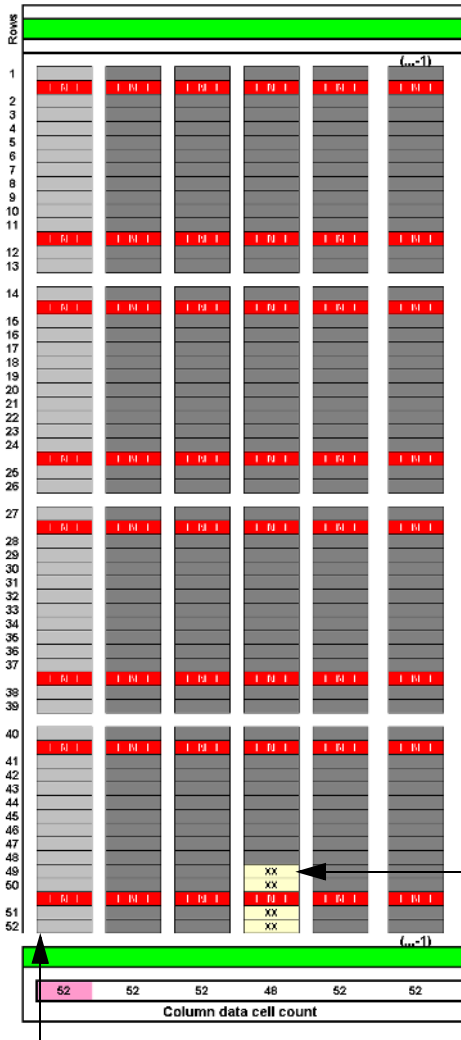

Configuration 1:

■ Configuration block

**Note – Left-side expansion area.** If this is the last module in the string on the left side, this column of arrays is not accessible to allow for the end cap (cover) and robotics end-stops. When another module is added to the left, the library regains the capacity (52 slots) in this module.

## Left-side Cartridge Expansion Module Front Wall

The front wall of the *left-side* cartridge expansion module has two (2) configurations. These configurations are based on the optional CAP feature.

- This module has negative numbered columns.

**FIGURE A-8** Left-side Cartridge Expansion Module—Front Wall

### Left Cartridge Expansion Module Front Wall Configurations

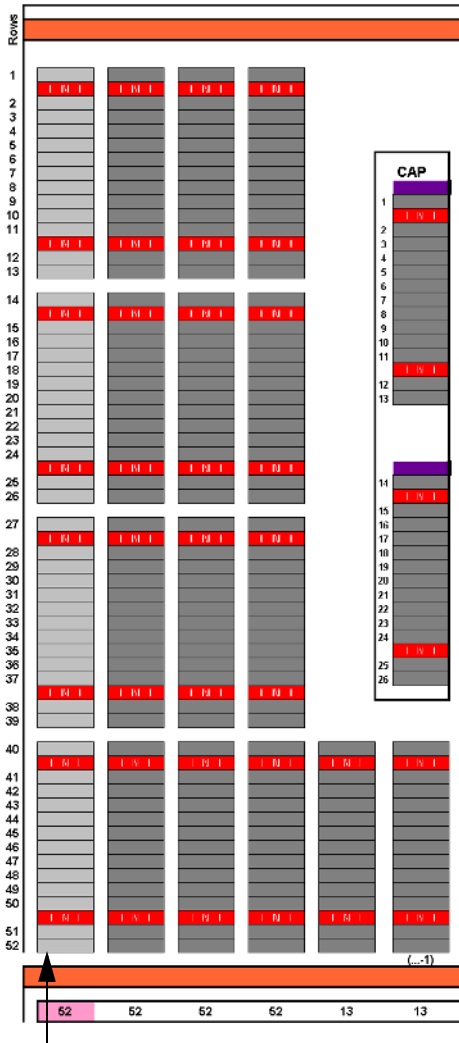

**Configuration 1:**  
(Standard)

**Configuration 2:**  
(Optional CAP) (Shown)

**Note – Left-side expansion area.** If this is the last module in the string on the left side, this column of arrays is not accessible to allow for the end cap (cover) and robotics end-stops. When another module is added to the left, the library regains the capacity (52 slots) in this module.



# Right-side Cartridge Expansion Module Rear Wall

The rear wall of the *right-side* cartridge expansion module has one configuration.

**FIGURE A-9** Right-side Cartridge Expansion Module—Rear Wall

## Right Cartridge Expansion Module Rear Wall Configuration

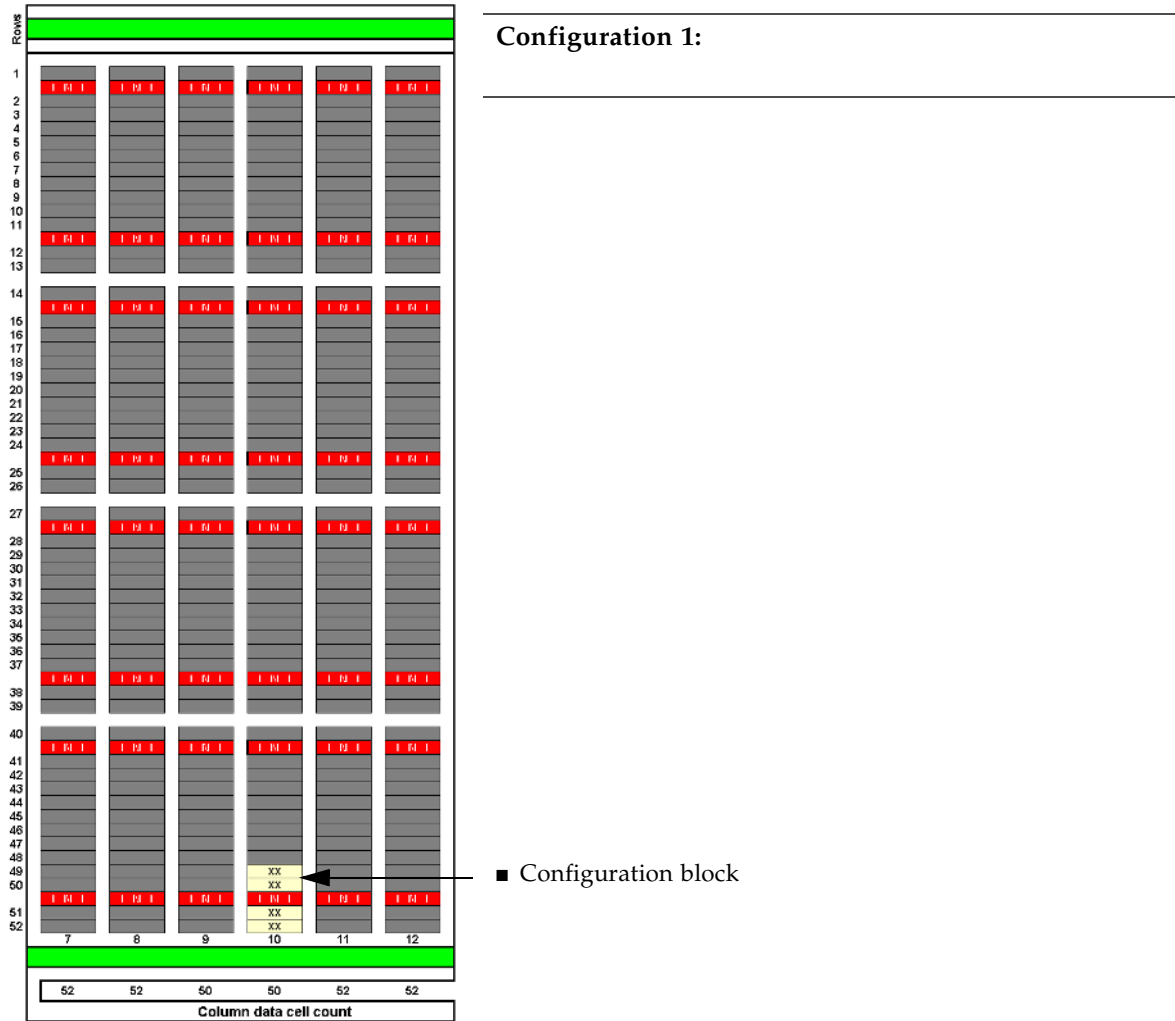

## Right-side Cartridge Expansion Module Front Wall

The front wall of the *right-side* cartridge expansion module has two configurations. These configurations are based on the optional CAP feature.

**FIGURE A-10** Right-side Cartridge Expansion Module—Front Wall

### Right Cartridge Expansion Module Front Wall Configurations

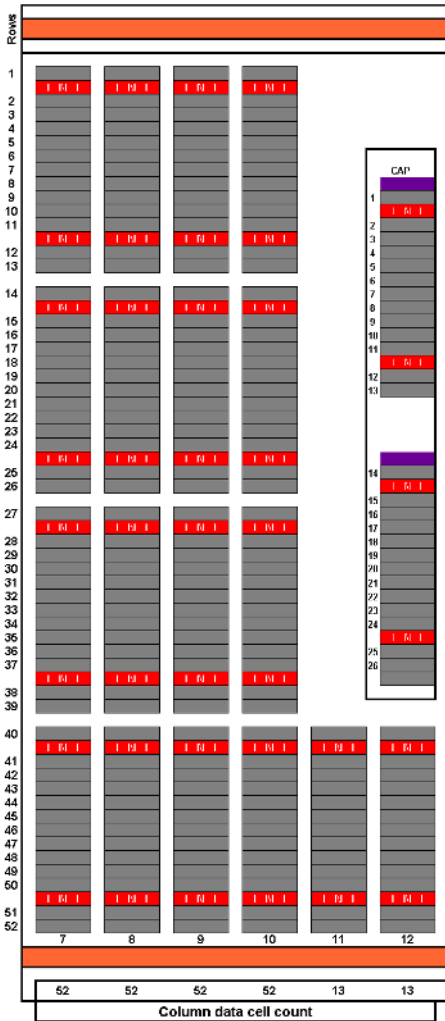

**Configuration 1:**  
(Standard)

**Configuration 2:**  
(Optional CAP) (Shown)

# Left-side Parking Expansion Module Rear Wall

The rear wall of the *left-side* parking expansion module has one configuration.

- This module has negative numbered columns.

**FIGURE A-11** Left-side Parking Expansion Module—Rear Wall

## Left Parking Expansion Module Rear Wall Configuration

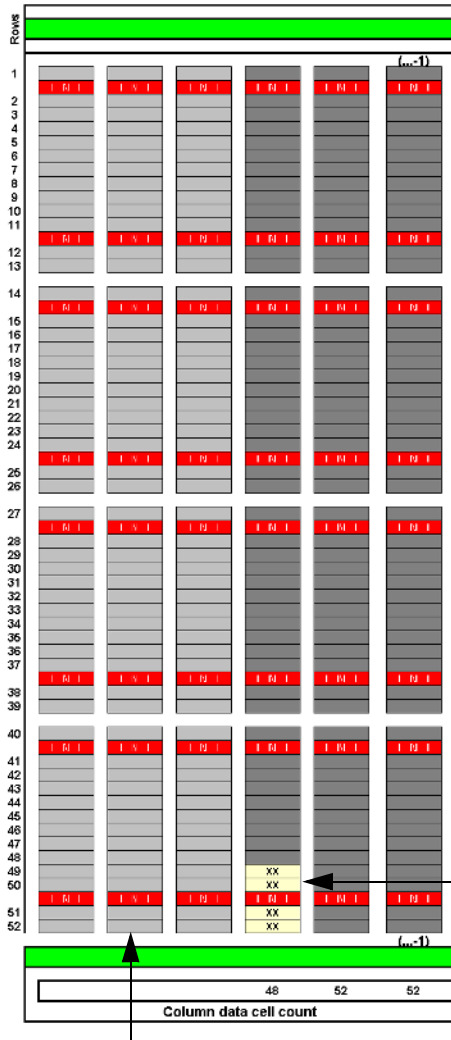

### Configuration 1:

The parking expansion module is a special cartridge expansion module designed to park a defective robotic unit in a dual robotic configuration.

### Notes –

1. The PEM is always the last module in the string on both the left and right sides.
2. To accommodate the robotic unit, the last three (3) columns on both the front and back walls are vacant.
3. The cartridge arrays can still be present, but any cartridge in those slots is inaccessible.

If at a later date the customer wants to expand by adding another module to the left or right, simply add the module and change the labels on the configuration block.

- Configuration block  
This block removes four (4) slots from the total count. All other PEMs have a slot count of 156.

**Note – Left-side parking area.** When this CEM is the last module in the string on the left side and configured as a PEM, these 3 column of arrays is not accessible to allow for a defective robotics unit. When another module is added to the left, the library regains this capacity (156 slots).

## Left-side Parking Expansion Module Front Wall

The front wall of the *left-side* parking expansion module has one configuration.

- This module has negative numbered columns.

**FIGURE A-12** Left-side Parking Expansion Module—Front Wall

### Left Parking Expansion Module Front Wall Configurations

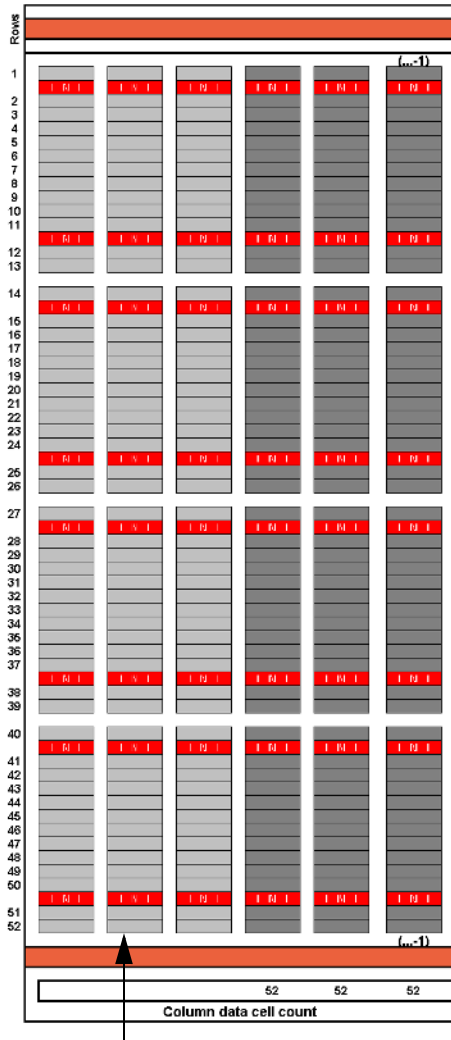

#### Configuration 1:

The parking expansion module is a special cartridge expansion module designed to park a defective robotic unit in a dual robotic configuration.

#### Notes –

1. The PEM is always the last module in the string on both the left and right sides.
2. To accommodate the robotic unit, the last three (3) columns on both the front and back walls are vacant.
3. The cartridge arrays can still be present, but any cartridge in those slots is inaccessible.

If at a later date the customer wants to expand by adding another module to the left or right, simply add the module and change the labels on the configuration block.

**Note – Left-side parking area.** When this CEM is the last module in the string on the left side and configured as a PEM, these 3 column of arrays is not accessible to allow for a defective robotics unit. When another module is added to the left, the library regains this capacity (156 slots).

# Right-side Parking Expansion Module Rear Wall

The rear wall of the *right-side* parking expansion module has one configuration.

**FIGURE A-13** Right-side Parking Expansion Module—Rear Wall

## Right Parking Expansion Module Rear Wall Configuration

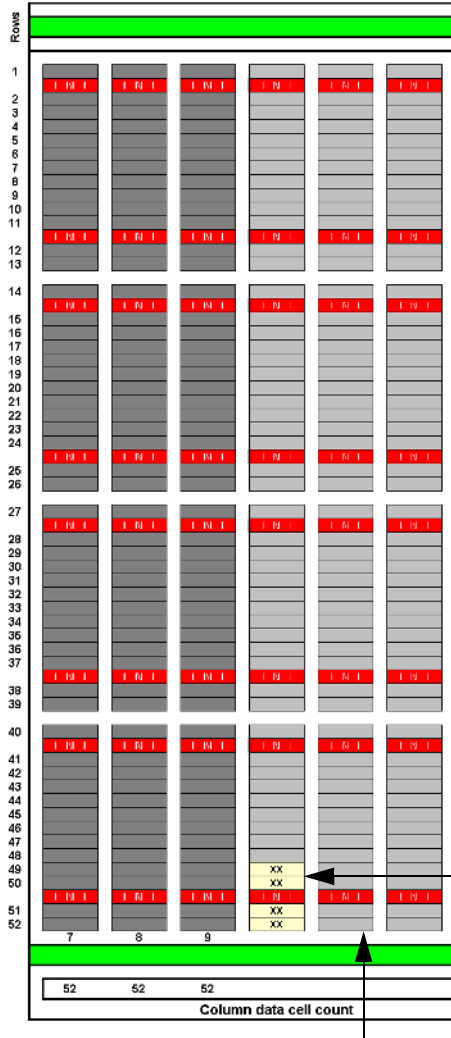

### Configuration 1:

The parking expansion module is a special cartridge expansion module designed to park a defective robotic unit in a dual robotic configuration.

### Notes –

1. The PEM is always the last module in the string on both the left and right sides.
2. To accommodate the robotic unit, the last three (3) columns on both the front and back walls are vacant.
3. The cartridge arrays can still be present, but any cartridge in those slots is inaccessible.

If at a later date the customer wants to expand by adding another module to the left or right, simply add the module and change the labels on the configuration block.

- Configuration block  
This block is outside the data cartridge slot area.

**Note – Right-side parking area.** When this CEM is the last module in the string on the right side and configured as a PEM, these 3 column of arrays is not accessible to allow for a defective robotics unit. When another module is added to the right, the library regains this capacity (152 slots).

## Right-side Parking Expansion Module Front Wall

The front wall of the *right-side* parking expansion module has one configuration.

**FIGURE A-14** Right-side Parking Expansion Module—Front Wall

### Right Parking Expansion Module Front Wall Configuration

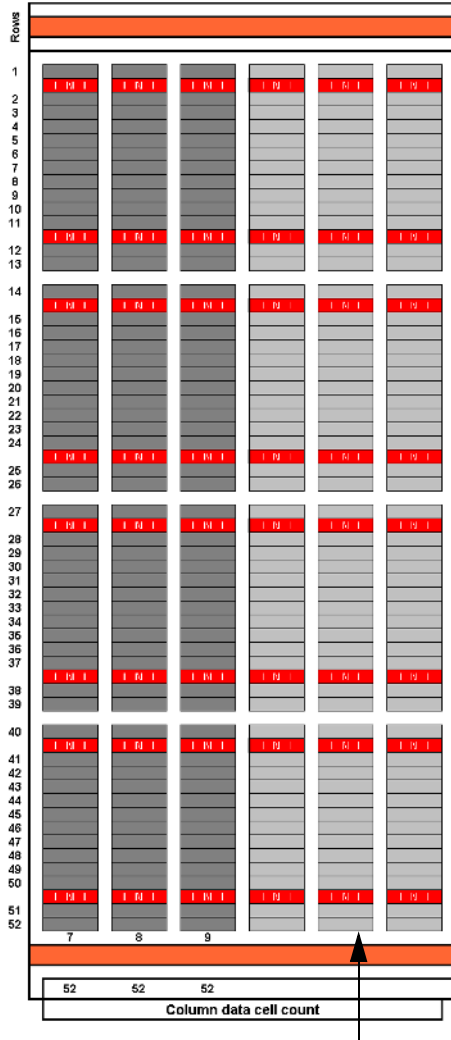

#### Configuration 1:

The parking expansion module is a special cartridge expansion module designed to park a defective robotic unit in a dual robotic configuration.

#### Notes –

1. The PEM is always the last module in the string on both the left and right sides.
2. To accommodate the robotic unit, the last three (3) columns on both the front and back walls are vacant.
3. The cartridge arrays can still be present, but any cartridge in those slots is inaccessible.

If at a later date the customer wants to expand by adding another module to the left or right, simply add the module and change the labels on the configuration block.

**Note – Right-side parking area.** When this CEM is the last module in the string on the right side and configured as a PEM, these 3 column of arrays is not accessible to allow for a defective robotics unit. When another module is added to the right, the library regains this capacity (156 slots).

# Capacities

To calculate the final storage capacity, select the slot counts for each module, then add them together to reach the total slot count.

**TABLE A-2** Slot Count Per Module and Configuration

Drives and Options	Standalone	Nothing to the		Surrounded (both sides)	Total Selection
		Left	Right		
<b>Base Module Slot Counts</b>					
8 drives, with CAP	343	356	431	444	
16 drives, with CAP	288	301	365	378	
24 drives, with CAP	228	241	293	306	
8, Window/Op panel, and CAP	320	333	408	421	
16, Window/Op panel, and CAP	265	278	342	355	
24, Window/Op panel, and CAP	205	218	270	283	
<b>Drive Expansion Module Slot Counts</b>					
8 drives	—	433	—	521	
16 drives	—	378	—	455	
24 drives	—	318	—	383	
32 drives	—	253	—	305	
8 drives, with CAP	—	356	—	444	
16 drives, with CAP	—	301	—	378	
24 drives, with CAP	—	241	—	306	
32 drives, with CAP	—	176	—	228	
8, with Window/Op panel	—	410	—	498	
16, with Window/Op panel	—	355	—	432	
24, with Window/Op panel	—	295	—	360	
32, with Window/Op panel	—	230	—	282	
8, Window/Op panel, and CAP	—	333	—	421	
16, Window/Op panel, and CAP	—	278	—	355	
24, Window/Op panel, and CAP	—	218	—	283	
32, Window/Op panel, and CAP	—	153	—	205	
<b>Cartridge Expansion Module Slot Counts</b>					
No CAP	—	516	—	620	
With CAP	—	438	—	542	
<b>Parking Expansion Module Slot Counts</b>					
Always Add	620	—	—	—	
<b>Add all module slot counts selected for the total number of library slots</b>					

# Module Comparisons

FIGURE A-15 Base Module Rear Wall

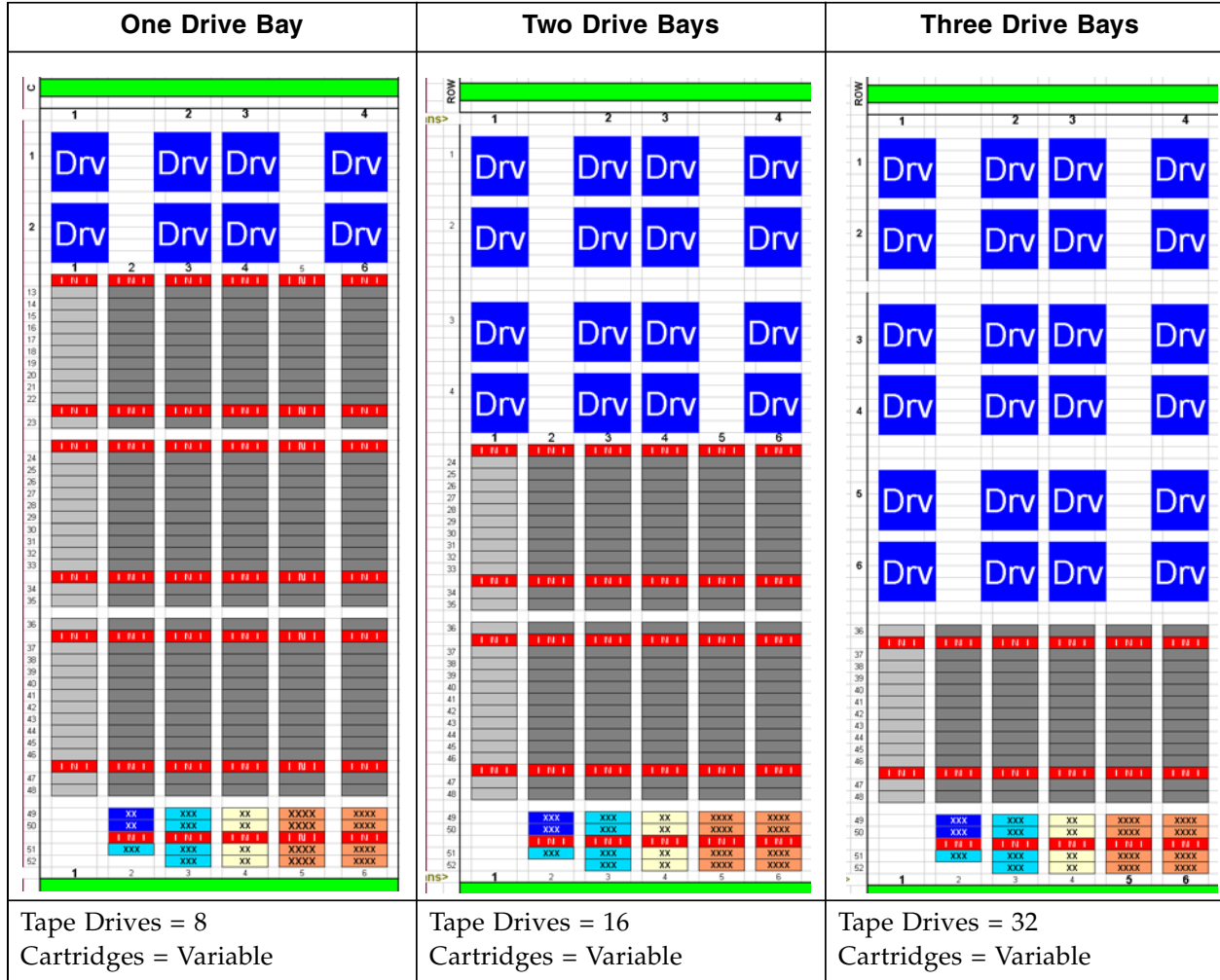



FIGURE A-16 Base Module Front Wall

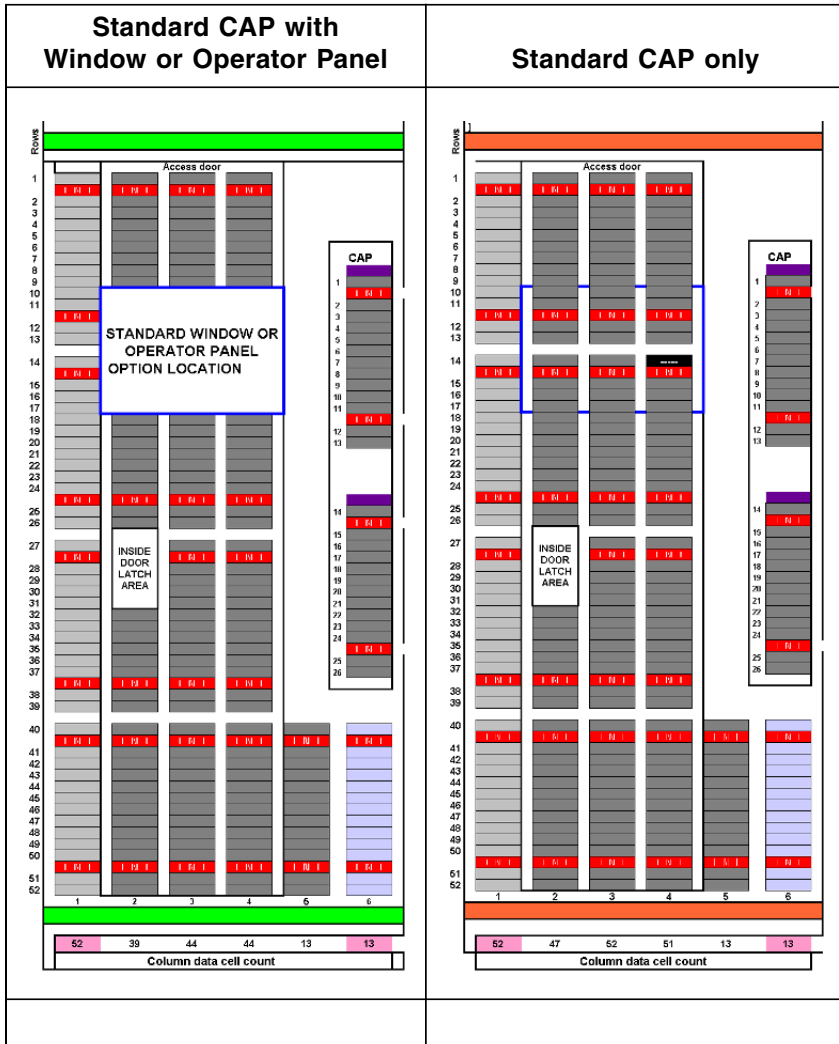

FIGURE A-17 Drive Expansion Module Rear Wall

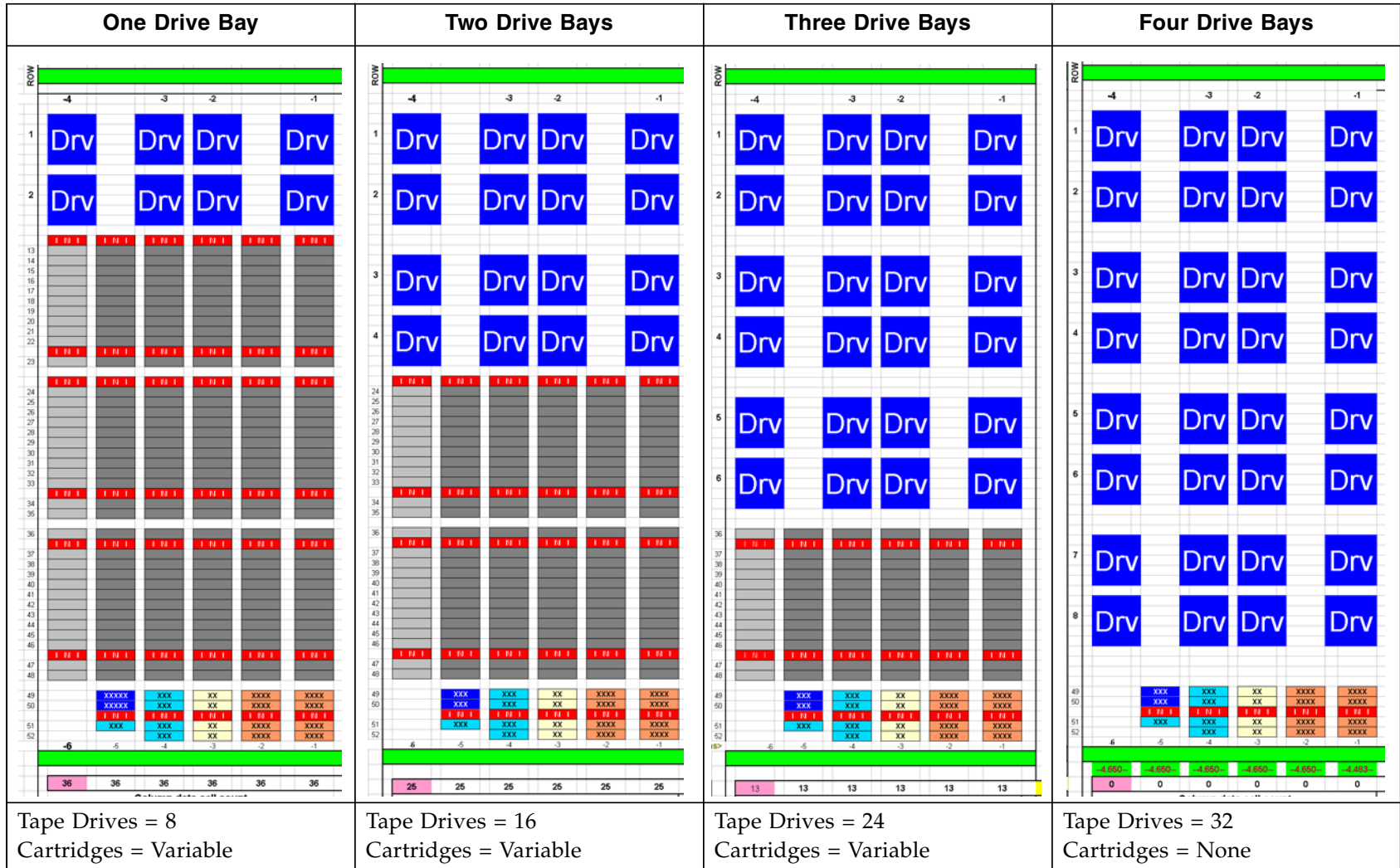

FIGURE A-18 Drive Expansion Module Front Wall

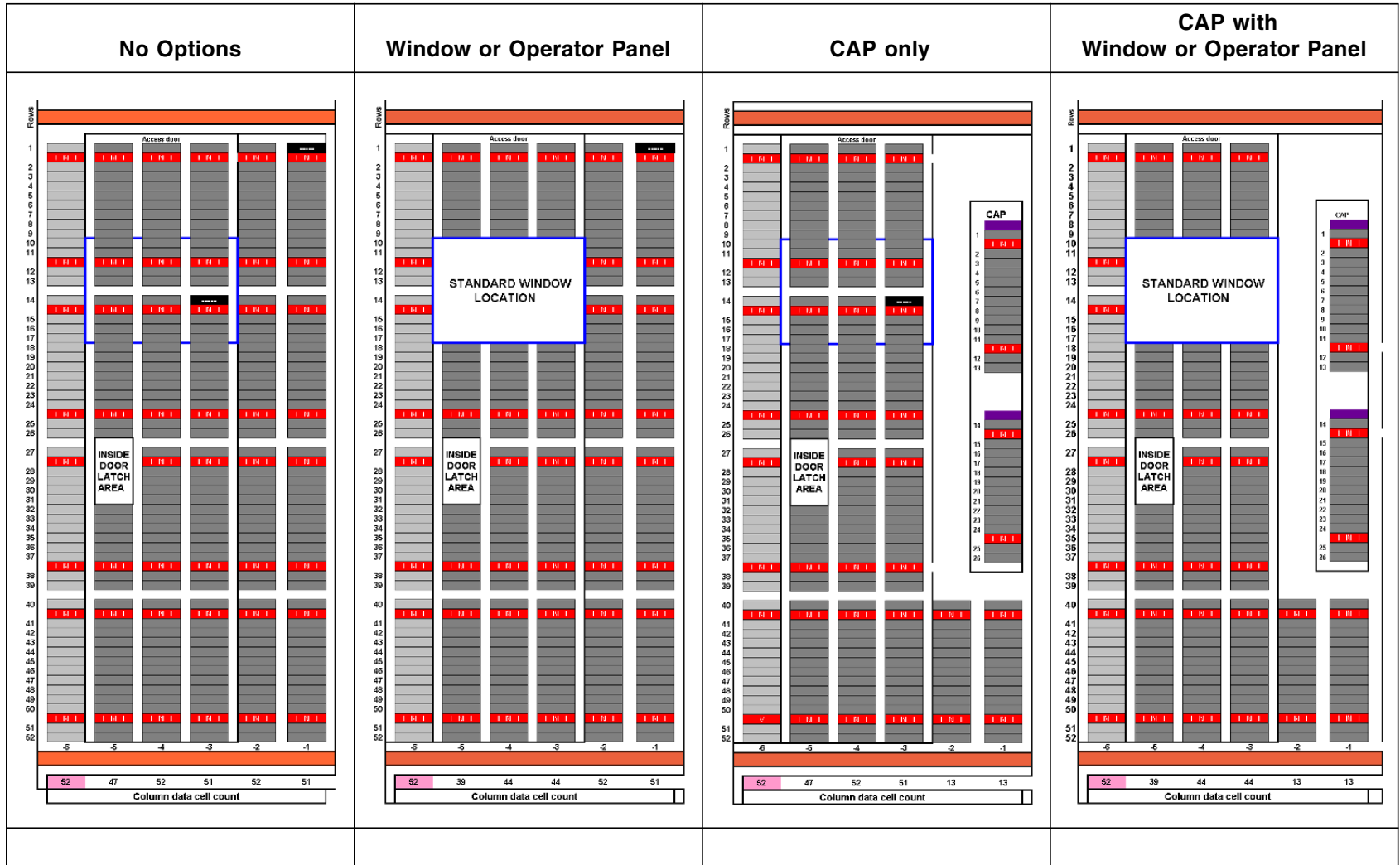
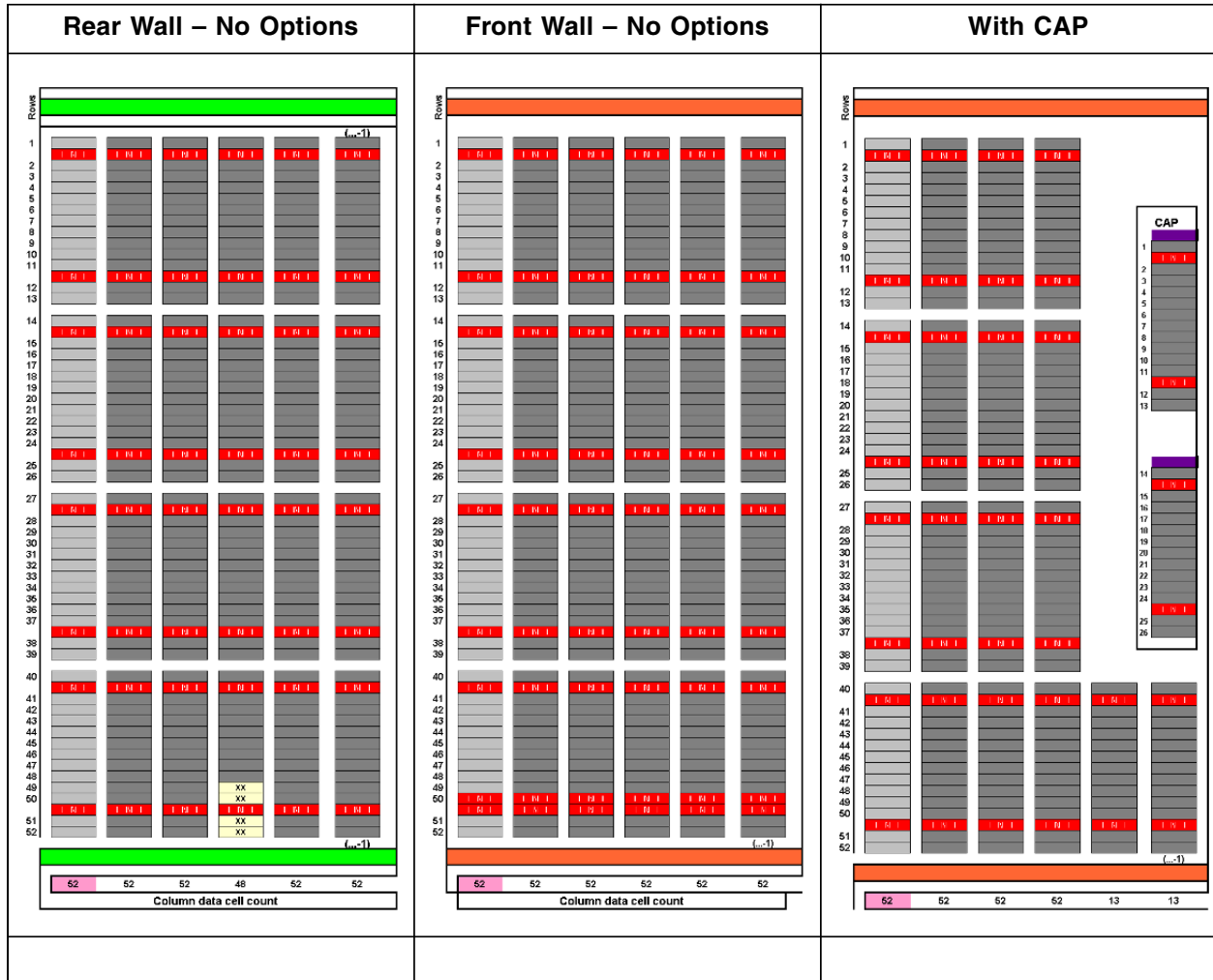

FIGURE A-19 Left Side Cartridge Expansion Module



**FIGURE A-20** Right Side Cartridge Expansion Module

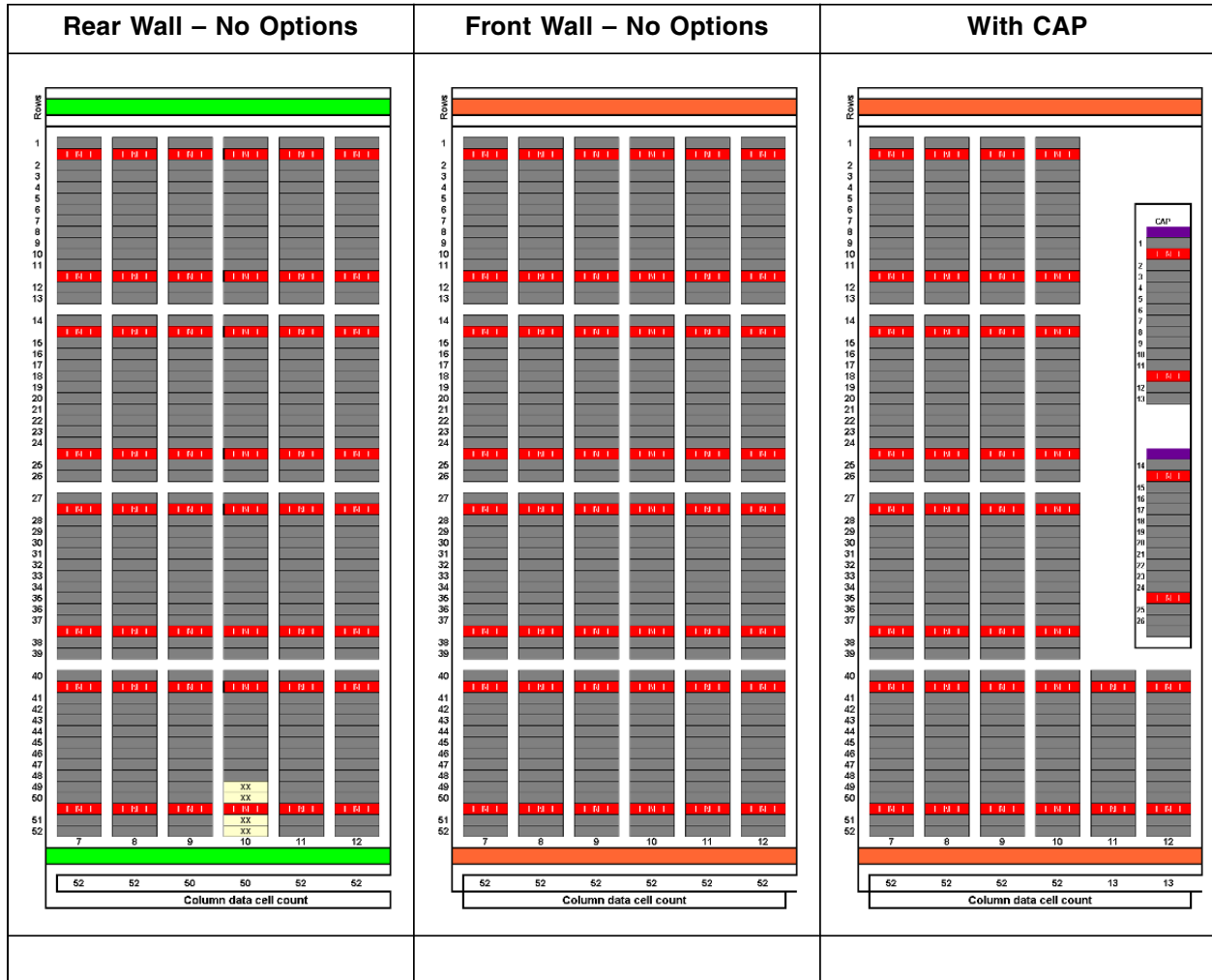

FIGURE A-21 Parking Expansion Modules

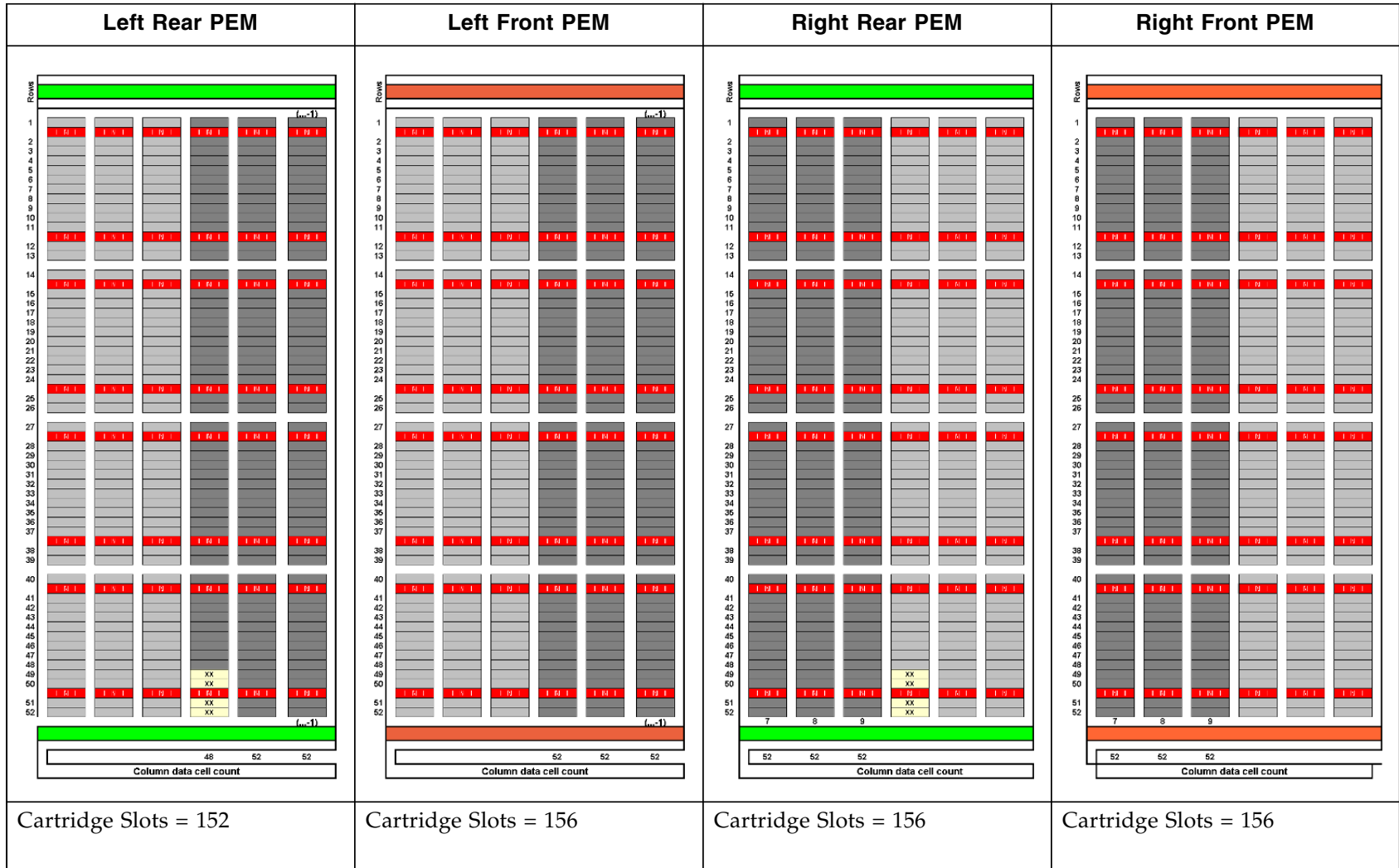
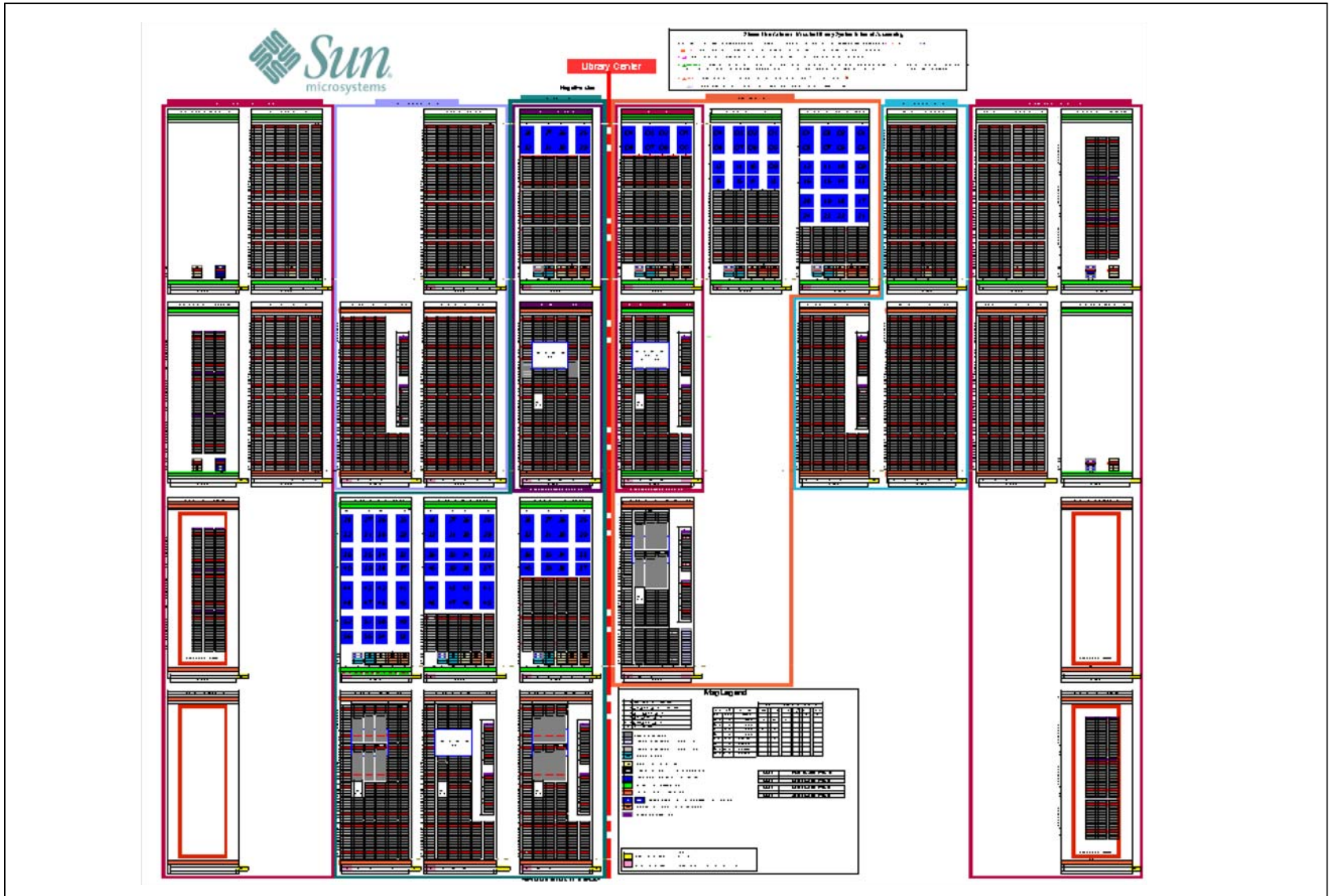

FIGURE A-22 SL3000 Slot Map







# Content Management and Partitioning

---

This appendix provides information about how to optimize the SL3000 library using content management and the elements of partitioning.

---

## Planning for Content

When planning the content of an SL3000 library, the most important aspect is to evaluate *content* with respect to the *physical structure*.

SL3000 physical structure includes:

- CenterLine Technology
- Modular design to increase both cartridge capacity and tape drive performance
- Single rail with one (standard) or two (optional–redundant–feature) TallBots
- Multiple cartridge access ports (CAPs)
- From 1 to 56 tape drives

## CenterLine Technology and Modular Design

The SL3000 uses *CenterLine Technology* to help balance the work load and improve performance of the library.

Using the left side of the Base module—which is the only “required” module—as the centerline, customers can add other *modules* either to the left and/or to the right.

[FIGURE B-1 on page 194](#) shows the *centerline* and provides some comparisons using minimum to maximum configurations, with the:

- Base module only
- Base and Drive Expansion Modules (DEM)
- Then additions of Cartridge Expansion Modules (CEMs) to both examples

**Note** – Only the base drive and the drive expansion modules contain tape drives. The cartridge expansion modules contain only data cartridges.

**Keep in mind that a balance of modules will balance performance.**

**FIGURE B-1 A Matter of Balance**

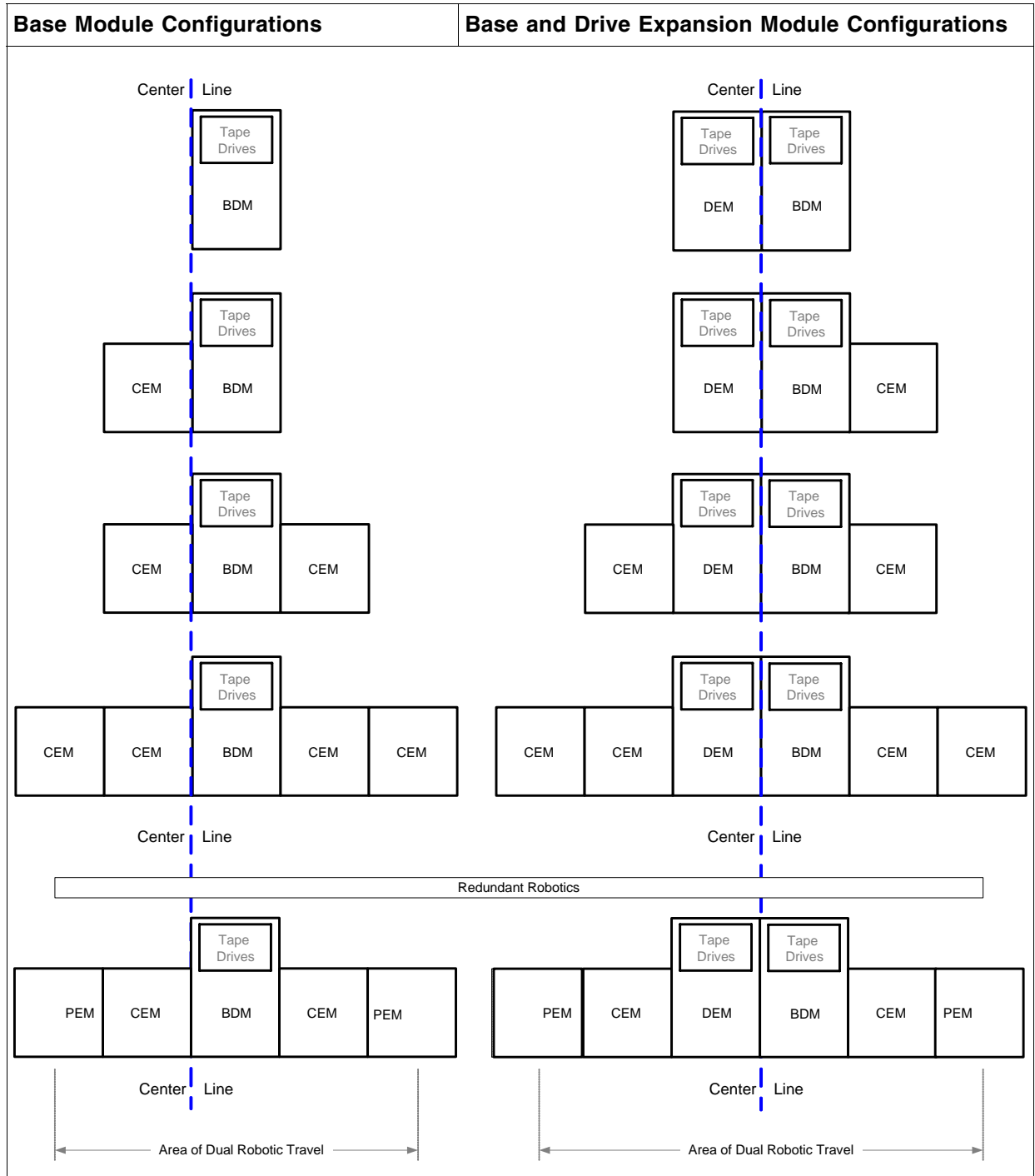

## Robotic Rails and TallBots

The *robotic units* in an SL3000 library are called *TallBots*. Each library can have either one (standard) or two (redundant) TallBots that are driven along two extrusions—called rails—on the rear wall of the library.

Rails are continuous and allow the TallBots to travel the length of the library from end-to-end. However, in a dual (2) TallBot configuration, there is a robotic safety zone that prevents collisions and a requirement for Parking Expansion Modules.

Parking Expansion Modules (PEMs) provide an area for a defective TallBot to reside without blocking any cartridge slots. In the event of a TallBot failure, the defective TallBot either moves in to or is pushed in to this parking module while the other—redundant—TallBot continues with library operations.

When using redundant TallBots, parking expansion modules must be installed at both ends of the library string. This is shown as the last comparison in [FIGURE B-1 on page 194](#).

Using redundant TallBots for content management offers:

- Increased throughput for library operations
- Redundant operations should one unit fail

## Cartridge Access Ports

The SL3000 supports multiple cartridge access ports that spread across the entire library.

**Note** – The CAP is a standard feature for the Base module and optional features for the Drive and Cartridge Expansion Modules.

Although, operation of the cartridge access port does not directly affect the performance of the library, here are some guidelines that can help with the overall operation.

- Whenever possible, enter cartridges through the cartridge access ports.
- When planning the workloads, place applications that require significant enters and ejects adjacent to the CAP magazines.
- When planning the workloads, place applications that require significant enters and ejects in modules that have a CAP.
- Use the *watch\_vols* utility for ACSLS.
- Insert cartridges with the correct orientation:
  - Fully seated and lay flat in the slots
  - Parallel to the floor
  - Hub-side down
  - Barcode label pointing out and below the readable characters.

CAPs may be shared between HLI partitions, but not across partitions of differing interface types.

- It is recommended that each SCSI partition has a CAP dedicated to it.
- If CAPs are shared between SCSI partitions, the operator must use the Shared CAP Assignment screen in SLC to manage the use of those CAPs.

Host client access to shared SCSI CAPs must also be carefully managed.

- If multiple CAPs are being shared across SCSI partitions, it is recommended that a common group of CAPs be identified and shared between all SCSI partitions involved.

*For example:* Sharing one CAP as an individual in one partition and as part of a group of CAPs in another partition is not recommended.

If a SCSI partition shares the CAPs with another partition, the operator must use the CAP Association function in SLC to associate the partition to its CAPs prior to initiating an enter or eject operation. See “Associate a Partition to Its Shared CAPs” in the SL3000 Users Guide for the detailed procedure.

A partitioned-CAP association gives a partition exclusive ownership of its shared CAPs, similar to a CAP reservation. This ensures that cartridges are always entered into the correct partition and prevents other partitions from taking ownership of a shared CAP that is already in use.

If the Shared CAP Assignment is not utilized it is possible for a host on one partition to leave the CAPs in a state that the next host will not be able to unlock/open the CAPs without additional operator intervention.



**Tip:**

Place labels outside on the library wall indicating which CAP gets what type of cartridge or which partition that CAP is dedicated to or shared with.

For example: Modules to the left of the centerline contain T10000 media. Use a module with a CAP on the left side to enter and eject those types of cartridges. This practice will help operators identify what cartridges go to which module.

## Managing Cartridges

Managing cartridges—or how cartridges are entered, ejected, and configured **using active regions**<sup>1</sup>—in the library can have an effect on performance.

Some considerations include:

- Use a library management application such as ExLM with HSC to keep active volumes and compatible drives closer together and to migrate less active volumes farther away from the drives.
- Use a *float* option. Float is a library management application that can automatically select a new home slot for a cartridge on a dismount. However, you need to make sure the library contains enough *free slots* to allow the selection of a new home during the dismount.
- Cluster cartridges. Group and/or partition the cartridges by workload with enough tape drives to support the maximum, peak activity.
- Enter cartridges through the CAP.
  - When manually placing cartridges in the library with the front door open, library operations cease and the library management software must perform a *full* audit to update the library database to match the actual contents.
  - When entering cartridges through the CAP, the library stays online so mounts and dismounts can continue, and the library *automatically* tracks volumes and update the library database with the locations.

1. See Capacity on Demand and active regions [on page 205](#).

- Eject cartridges. Some applications can eject cartridges in two ways: Ordered and Unordered.
  - When you specify an Ordered eject, the application places the cartridges in a specific sequence. This operation is significantly slower than unordered ejects. Ordered ejects are used for *vaulting*, which simplifies the external operations.
  - When you specify an Unordered eject, the application ejects cartridges as it can, often in a random order.
- Manage the available space in the library:
  - Plan for times of peak activity.
  - Keep an adequate supply of scratch cartridges in the library.
  - Make sure the library contains enough free slots.
  - Move inactive cartridges out of the library to ensure there is adequate space for active cartridges.

## Planning for Tape Drives

During the installation, having an understanding about how to logically group and install the tape drives can improve performance. Strategies to use when determining where to install the tape drives include:

- Install tape drives that use the same media types closer to those slots.  
*For example:* Place T9840 drives on left side of the drive bay with cartridges to the left; and LTO drives on the right with the media to match going to the right.
- Install enough tape drives to adequately handle peak workloads.
- Configure heavy tape applications so they do not exceed the performance limits of the library configuration.

# Planning for Capacity and Growth

The SL3000 library provides several ways to accommodate growing data storage needs:

- Addition of library modules—left, right, or both.
- Capacity on Demand
  - Activation of slots without service representative involvement
  - Requires the installation of slots or modules up front
- Flexible partitions
- Easily reallocate resources as needs change

## Crimson Slot Capacity

There are four concepts that are important to understand regarding the SL3000 library and the slot capacity.

**TABLE B-1** Slot Capacity Concepts

<b>Installed Physical Slots</b>	All the slots that have been installed in the library. These slots are not necessarily usable by the customer, but they have been installed in the SL3000.
<b>Accessible Physical Slots</b>	These slots are available for use in the SL3000. These slots have been licensed and activated for use. There are two reasons slots might be inaccessible, they are: <ul style="list-style-type: none"> <li>■ Reserved for library special slots (diagnostic, cleaning, swap)</li> <li>■ Restricted robotic access (such as the last column on the left module)</li> </ul> Note: Inaccessible slots due to restricted robotic access become available when another module is installed to the outside of the module where the inaccessible slots are located.
<b>Licensed Slot Capacity</b>	The licensed slot capacity defines the number of slots that can be activated in the library. The SL3000 ships with a default of 200 licensed slots. All other licensed capacity must be ordered and installed using a <i>license key file</i> .
<b>Active Slots</b>	Active slots are those slots that are available for use by the end user. Active slots must be physically installed, accessible, and licensed in the SL3000.

## Capacity on Demand

Capacity on Demand is a *non-disruptive* optional feature that allows the customer to add capacity to the library using previously installed, yet inactive slots.

The installed physical capacity is separate from the licensed capacity. The advantage of Capacity on Demand is that the customer only buys the storage that they need and not all the storage that is installed.

Licensed capacity can be purchased in multiple increments:

- 1 slot
- 100 slot
- 200 slot
- 500 slot
- 1000 slot

When a customer purchases a license to use more physical storage an encrypted *license key file* is sent through e-mail. The file is then loaded into the library using the StorageTek Library Console (SLC).

## RealTime Growth™ Technology

Because the physical and the licensed slot capacities are separate, the customer has the option of installing physical capacity in advance before they are ready to activate these slots.

The advantage of installing physical capacity in advance is that now, scaling the library is non-disruptive, quick, and easy to accomplish.

Sun StorageTek offers several Base module bundles that allows customers to easily install and get started using this RealTime Growth Technology. These are:

- Base plus 1 CEM with 200 licensed slots
- Base plus 2 CEMs with 200 licensed slots
- Base plus 2 CEMs with 700 licensed slots
- Base plus 3 CEMs with 700 licensed slots
- Base plus 4 CEMs with 700 licensed slots

Whenever building an SL3000 configuration, there are two basic slot capacity questions you need to answer:

1. How many slots does the customer need to license or use?
2. How many cartridge slots does the customer want to physically install?

# Out-of-the Box Slot Numbering

There are several factors to be aware of about the operations of the library when configuring and planning for content, these are:

- Default, out-of-the-box behavior
- Partitioning
- Addition of capacity using previously installed slots (Capacity on Demand)

**Note** – Slot numbering and library addressing are two different functions.

- Slot numbering is an *internal*, library controller, function.
- Library addressing is an *external* design for physical slot location.

**FIGURE B-2** shows how the library numbers the slots and uses the following steps to describe it.

**Internal slot numbering:**

1. *Starts* in the upper left slot on the rear wall of the first module to the left. The numbering counts from **top to bottom** and from **left to right**.
2. When the numbering reaches the last slot on the rear wall it *crosses* sides.
3. Then *continues* at the upper left slot on the front wall of the first module. Counts from top to bottom and from left to right.
4. *Ends* at the lower slot on the front wall of the last module.

**FIGURE B-2** Slot Numbering

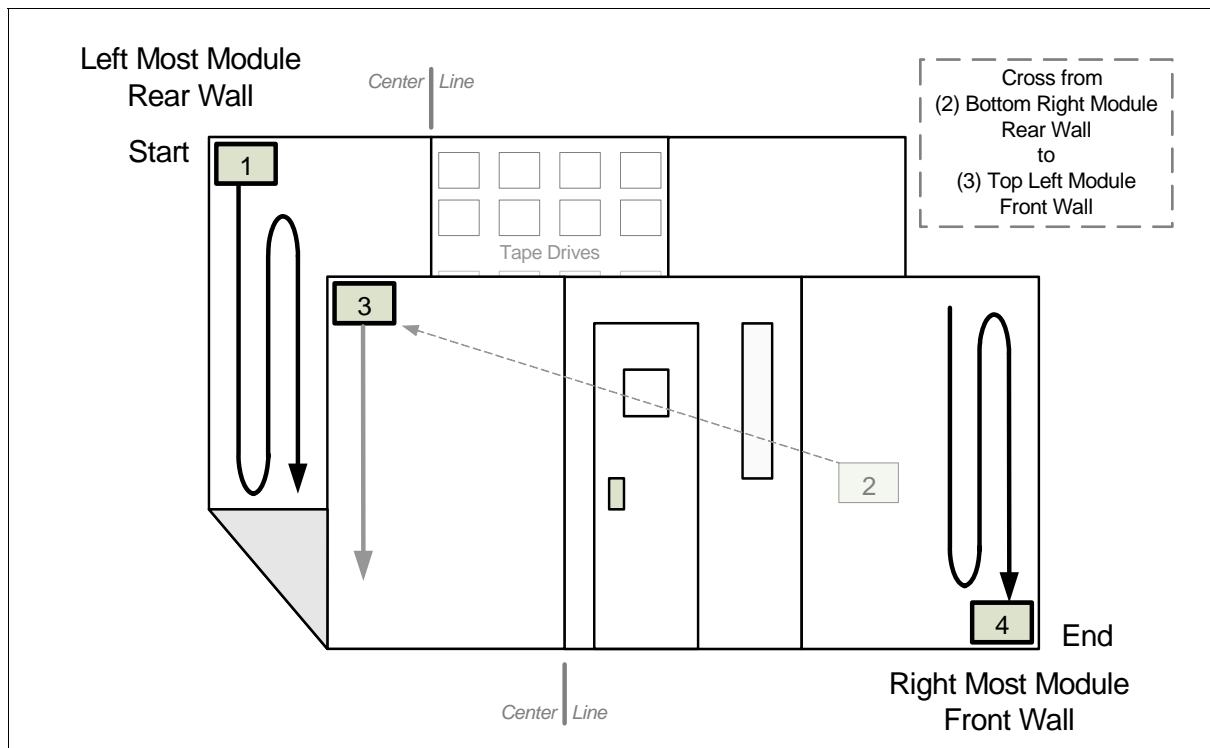



Slot numbering determines which slots are activated when the licensed capacity is applied. For example, if the licensed capacity for the library is 200 slots, the slot numbering for the first 200 is determined by the numbering made available, or active, to the host clients.

Also, if using a SCSI interface, the slot numbering determines the element numbering assigned to each element type and report this to the SCSI clients.

FIGURE B-3 serves as a *default* diagram for the discussions about Partitioning and Capacity on Demand.

This figure has three modules with a capacity of 76 slots and 24 tape drives or three 8-drive bays.

**FIGURE B-3** Out-of-the-Box Numbering

Center			Line						
CEM			Base				CEM		
1	11	21	Drv_1	Drv_2	Drv_3	Drv_4	47	57	67
2	12	22	Drv_5	Drv_6	Drv_7	Drv_8	48	58	68
3	13	23	Drv_9	Drv_10	Drv_11	Drv_12	49	59	69
4	14	24	Drv_13	Drv_14	Drv_15	Drv_16	50	60	70
5	15	25	Drv_17	Drv_18	Drv_19	Drv_20	51	61	71
6	16	26	Drv_21	Drv_22	Drv_23	Drv_24	52	62	72
7	17	27	31	35	39	43	53	63	73
8	18	28	32	36	40	44	54	64	74
9	19	29	33	37	41	45	55	65	75
10	20	30	34	38	42	46	56	66	76

**Tape drive numbering:**

1. Starts in the upper left slot of the first drive bay in the Base Module.  
The numbering counts from **left to right** then from **top to bottom**, opposite that of the slot numbering.
2. When the numbering reaches the last drive in the Base Module, it crosses to the Drive Expansion Module if installed.
3. Then continues at the upper left slot in the first drive bay in the DEM.  
Counts from **left to right** then from **top to bottom**.
4. Ends at the lower right slot for the last drive in the DEM.

---

## Default SCSI Element Ordering

Using the concepts described in “[Out-of-the Box Slot Numbering](#)” on page 200, this section adds the principles for determining the SCSI Element number sequences in the SL3000 library.



The examples in [FIGURE B-4 on page 203](#) are referenced by looking at the front of the library then viewed *through* the front wall. These examples are not intended to be an exact representation of the SL3000 library resources.

### SCSI Element numbering consists of:

- Storage Elements (slots)—Numbered **top to bottom, left to right**, and back to front.
- Import/Export Elements (CAPs)—Numbered **top to bottom, left to right**.  
**Note** – Storage and Import/Export elements are numbered sequentially by slot. No slots are skipped or are left out.
- Data Transfer Elements (drives)—Numbered **left to right, top to bottom**, starting at the centerline in the Base Module and continuing in the DEM if installed.

This numbering scheme allows the user to add a bank of drives and not disturb the ordering of the banks above.

**Note** – A vacant drive slot when the library powers on will not be included in the element number sequence. This is important to know because Open Systems backup applications do not tolerate Data Transfer Elements that cannot or do not respond when you power-on the library.

Elements in [FIGURE B-4 on page 203](#) include:

- 4 modules—One Base, one DEM, and two CEMs
- 66 data cartridge slots—2000 to 2065
- 38 tape drives—1000 to 1037 (2 tape drives are missing, 1 in each module)
- 2 CAPs, each with 7 slots—10 to 23

**FIGURE B-4** SCSI Element Numbering

( Left ) Looking From the FRONT of the Library ( Right )  
Looking at the back wall through the front wall

		Center				Line					
		Negative Column Numbers				Positive Column Numbers					
CEM		DEM				Base				CEM	
2000	2010	1023	1024	1025	1026	1000	1001	1002	1003	2060	2070
2001	2011	1027	1028		1029	1004	1005	1006	1007	2061	2071
2002	2012	1030	1031	1032	1033	1008	1009	1010	1011	2062	2072
2003	2013	1034	1035	1036	1037	1012	1013	1014	1015	2063	2073
2004	2014	2020	2026	2032	2038	1016		1017	1018	2064	2074
2005	2015	2021	2027	2033	2039	1019	1020	1021	1022	2065	2075
2006	2016	2022	2028	2034	2040	2044	2048	2052	2056	2066	2076
2007	2017	2023	2029	2035	2041	2045	2049	2053	2057	2067	2077
2008	2018	2024	2030	2036	2042	2046	2050	2054	2058	2068	2078
2009	2019	2025	2031	2037	2043	2047	2051	2055	2059	2069	2079

Looking through the front wall

		Center				Line					
		Negative Column Numbers				Positive Column Numbers					
CEM		DEM				Base				CEM	
2080	2090	2100	2107	CAP 10		2123	2130	CAP 17		2146	2156
2081	2091	2101	2108	11		2124	2131	18		2147	2157
2082	2092	2102	2109	12		2125	2132	19		2148	2158
2083	2093	2103	2110	13		2126	2133	20		2149	2159
2084	2094	2104	2111	14		2127	2134	21		2150	2160
2085	2095	Door Latch	2112	15		Door Latch	2135	22		2151	2161
2086	2096		2113	16			2136	23		2152	2162
2087	2097	2114	2117	2120		2137	2140	2143		2153	2163
2088	2098	2105	2115	2118	2121	2128	2138	2141	2144	2154	2164
2089	2099	2106	2116	2119	2122	2129	2139	2142	2145	2155	2165

---

# Partitioning

The definition of a partition is to divide into parts or shares.

**Benefits:**

Partitioning a library means the customer can have:

- Multiple libraries from one physical piece of hardware
- More than one operating system and application manage the library.
- An improvement in the protection or isolation of files.
- An increase in system and library performance.
- An increase in user efficiency.

**Customized fit:**

Partitions may be customized to fit different requirements, such as:

- Giving multiple departments, organizations, and companies access to appropriate sized library resources
- Isolating clients at service centers
- Separating different encryption key groups
- Dedicating partitions for special tasks

**Defining partitions:**

- Partitions are defined by assigning active regions.  
Currently the SL3000 supports up to *100 active regions* per partition.
- As slots are added to a partition they are deducted from the licensed capacity.

**Tip:**

Ideally, you would want to set up partitions that allow for future growth in mind. Allowing room for growth allows the customer to activate slots within a partition using Capacity on Demand.

For example: One of the customer's active regions has 50 slots defined; however, only 30 slots are active. This leaves the customer with 20 inactive slots that can be activated at a later date using Capacity on Demand; which does not require a service call to implement. This is the easiest and least disruptive growth path:

1. Install extra physical capacity.
2. Define partitions large enough to accommodate future growth.
3. Adjust the library capacity to meet current demands.

## Partitioning Feature

Partitioning is an option; licensing is required to enable this feature. To license and create partitions requires the use of the StorageTek Library Console or remote SLC software.

1. Make sure the library is licensed, or obtain a license, for the partitioning feature.
2. Use the remote SLC software to partition the library; you can not use the touch screen operator panel. See [“Library Console” on page 212](#) for examples.
3. Uses the Library Console to assign tape drives and CAPs.
4. Obtain additional licenses to use Capacity on Demand and increase the capacity.

## Active Regions

Active regions provide the customer with a resource to better optimize cartridge placement within the library.

To do this, the customer selects active regions in the library by using the same method as defining a partition—creating rectangular boundaries of slots.

These rectangular boundaries can be just one or two slots, a row, a column, or an entire module.

Available slots use the same numbering scheme of the library within the active regions—start in the upper left, then count to the lower right—for the *licensed capacity* of the library.

1. [FIGURE B-5 on page 206](#) shows how the customer has defined:
  - Two Active regions (A and B) using
  - Four Rectangular zones called AR1, BR1, BR2, and BR3
  - For a library licensed for 50 slots  
AR1-1 through 20, BR1-1 through 8, BR2-9 through 28, and BR3-29 through 30.

Concentrating on active region A are examples of what the customer can do to:

2. Add 5 more slots. Create two new active regions under the tape drives
  - AR2 slots 21 through 24 and
  - AR3 slot 25

Note: Because there are no more slots under AR2-24, the customer needed to go to the right and create an active region for the fifth additional slot (AR3-25), an example of a single slot rectangle boundary.

3. Add 12 more slots. Create two new active regions
  - AR2 slots 21 through 28 and
  - AR3 slots 29 through 32

Note: Because there are no more slots to the right of AR2-28, the customer needed to go to another area of the library with installed, yet inactive, slots to continue with the addition. To do this, the active region AR3 was created to the left of the active region AR1.

**FIGURE B-5** Adding Capacity to Active Regions

1) Original 50 Active Slots

CEM			Base				CEM		
AR1-1	11		Drive	Drive	Drive	Drive	BR2-9	19	BR3-29
2	12		Drive	Drive	Drive	Drive	10	20	30
3	13		Drive	Drive	Drive	Drive	11	21	
4	14		Drive	Drive	Drive	Drive	12	22	
5	15		Drive	Drive	Drive	Drive	13	23	
6	16		Drive	Drive	Drive	Drive	14	24	
7	17				BR1-1	5	15	25	
8	18				2	6	16	26	
9	19				3	7	17	27	
10	20				4	8	18	28	

2) Adding 5 More Active Slots (AR2-21 to 24) and (AR3-25)

AR1-1	11		Drive	Drive	Drive	Drive	BR2-9	19	BR3-29
2	12		Drive	Drive	Drive	Drive	10	20	30
3	13		Drive	Drive	Drive	Drive	11	21	
4	14		Drive	Drive	Drive	Drive	12	22	
5	15		Drive	Drive	Drive	Drive	13	23	
6	16		Drive	Drive	Drive	Drive	14	24	
7	17		AR2-21	AR3-25	BR1-1	5	15	25	
8	18		22		2	6	16	26	
9	19		23		3	7	17	27	
10	20		24		4	8	18	28	

3) Adding 12 More Active Slots (AR2-21 to 28) and (AR3-29 to 32)

AR3-29	AR1-1	11	Drive	Drive	Drive	Drive	BR2-9	19	BR3-29
30	2	12	Drive	Drive	Drive	Drive	10	20	30
31	3	13	Drive	Drive	Drive	Drive	11	21	
32	4	14	Drive	Drive	Drive	Drive	12	22	
	5	15	Drive	Drive	Drive	Drive	13	23	
	6	16	Drive	Drive	Drive	Drive	14	24	
	7	17	AR2-21	25	BR1-1	5	15	25	
	8	18	22	26	2	6	16	26	
	9	19	23	27	3	7	17	27	
	10	20	24	28	4	8	18	28	

The examples in [FIGURE B-5 on page 206](#) use active region with boundaries that fit the specific capacity of the library. Then, when increasing the capacity, more active regions are defined.

The examples in [FIGURE B-6](#) use active regions defined with larger boundaries than the capacity. These regions already provide for an expansion for growth without the need to create additional regions.

1. Again, the customer defines:
  - Two Active regions (A and B) using
  - Two Rectangular zones called AR1 and BR1
  - For a library licensed for 50 slots

The customer defines each region to include:

- 25 active cartridges with
  - 5 slots each for growth
2. Concentrating on Active Region A (AR1), the customer licenses and adds 5 more slots to this partition—capacity increases without the need to define more regions.

**FIGURE B-6** Active Region Capacities

1) Original 50 Active Slots			Each region contains growth for 5 additional cartridges						
CEM			Base				CEM		
AR1-1	11	21	Drive	Drive	Drive	Drive	BR1-1	11	21
2	12	22	Drive	Drive	Drive	Drive	2	12	22
3	13	23	Drive	Drive	Drive	Drive	3	13	23
4	14	24	Drive	Drive	Drive	Drive	4	14	24
5	15	25	Drive	Drive	Drive	Drive	5	15	25
6	16	—	Drive	Drive	Drive	Drive	6	16	—
7	17	—					7	17	—
8	18	—					8	18	—
9	19	—					9	19	—
10	20	—					10	20	—

**2) Licensing and adding 5 more slots to active region AR1 (slots 26 through 30)**

AR1-1	11	21	Drive	Drive	Drive	Drive	BR1-1	11	21
2	12	22	Drive	Drive	Drive	Drive	2	12	22
3	13	23	Drive	Drive	Drive	Drive	3	13	23
4	14	24	Drive	Drive	Drive	Drive	4	14	24
5	15	25	Drive	Drive	Drive	Drive	5	15	25
6	16	26	Drive	Drive	Drive	Drive	6	16	—
7	17	27					7	17	—
8	18	28					8	18	—
9	19	29					9	19	—
10	20	30					10	20	—

## Guidelines

The SL3000 can support up to *eight* partitions using a variety of interface types: only Ethernet partitions, only SCSI partitions, or combinations of both.

Essential guidelines for understanding partitions are:

- Clear communication between the system programmers, network administrators, library software representatives and administrators, and Sun service representatives.
- Knowing what partitions exist, their boundaries, and who has access to the specific partitions that are configured. Setting up a partition requires some important considerations:
  - Slots and tape drives are allocated to a specific partition and cannot be shared across other partitions.
  - Partition users must anticipate how much storage is needed for their resident data cartridges and the amount of free slots required for both current use and potential growth.
  - CAP assignments are also critical. CAPs can either be shared or dedicated resources. If dedicated, no other partitions can use that CAP.
- Customers must be current on maintenance levels of their library management software.
- The SCSI element numbering within partitioned libraries is continuous for each partition, even if slot locations for each partition are non-contiguous.

### Remember:

- Each partition acts as an independent library.
- One partition will not recognize another partition within the library—it views other partitions as new or unallocated.
- Automatic mode is not supported in a partitioned library. However, if using a dedicated CAP for that partition, automatic mode is supported.
- Duplicate VOLSERS are supported by the library; however, the library management software may not; unless, the duplicate VOLSERS are in different partitions.

## Planning the Data Path

When planning for partitions, you also need to be aware of the location, quantity, type, and need for the tape drives and media. Having an understanding about how to logically group and install the tape drives and locate the media for the different hosts, control data sets, interface types, and partitions is necessary.

When planing for partitions:

- Make sure the tape drive interface supports that operating system.
  - Open system platforms do not support ESCON or FICON interfaces.
  - Not all mainframes support Fibre Channel interfaces or LTO tape drives.
- Make sure the media types match the application.
- Install tape drives that use the same media types in the same partition.
- Make sure there are enough scratch cartridges and free slots to support the application and workload.



## Performance Zone

The performance zone is an area within the SL3000 library that is closest to the tape drives. Because of the physical location, volumes in this zone have faster access and response times to the tape drives, this includes both from the front and rear walls.

Selection of the volumes to reside in this zone is critical to obtain the best performance. Limit these volumes to those that benefit most from:

Candidates that fit well into the performance zone are:

- Applications such as VSM, HSM, and ABARS
- Volumes that tend to be recalled regularly
- Volumes that need fast access time
- Volumes that require very few ejects

Examples include, the most recently created volumes or volumes that are mounted repeatedly.

Volumes that do not meet any of the above criteria should be moved out of this area. Once this zone is full, volumes would extend into the regular storage area.

**FIGURE B-7** Performance Zone

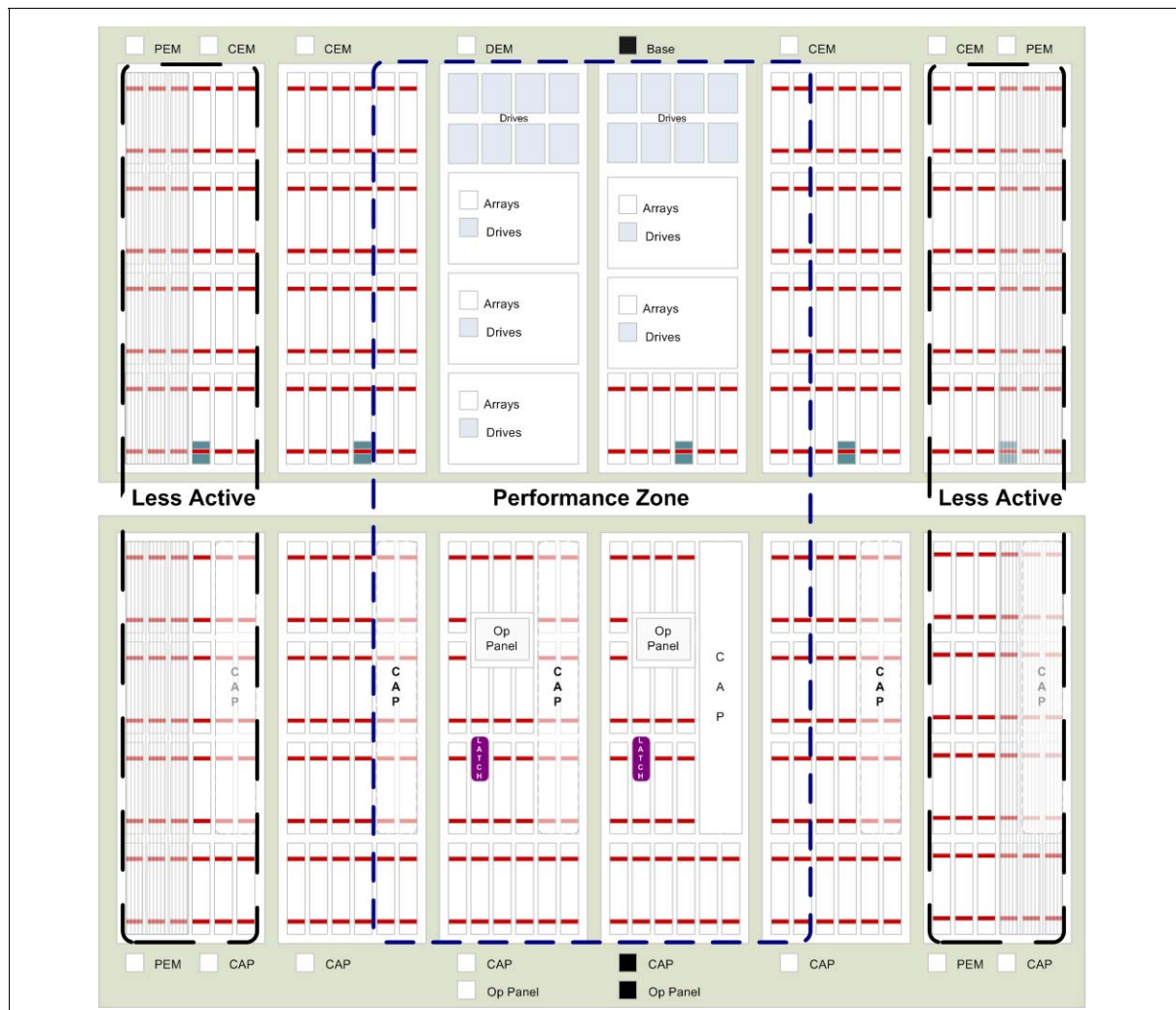

## Cartridge Access Ports and Partitions

The SL3000 library can have multiple, optional CAPs. With this option, assigning CAPs to partitions can have an effect on performance.

- CAPs can either be shared or dedicated resources.
- If dedicated, no other partitions can use that CAP.



**Tip:**

Ideally, you would want to assign a CAP close to the partition it serves. To assign a CAP on the opposite end of the library from the partition would be an impact on library performance.

**FIGURE B-8** Cartridge Access Port Examples

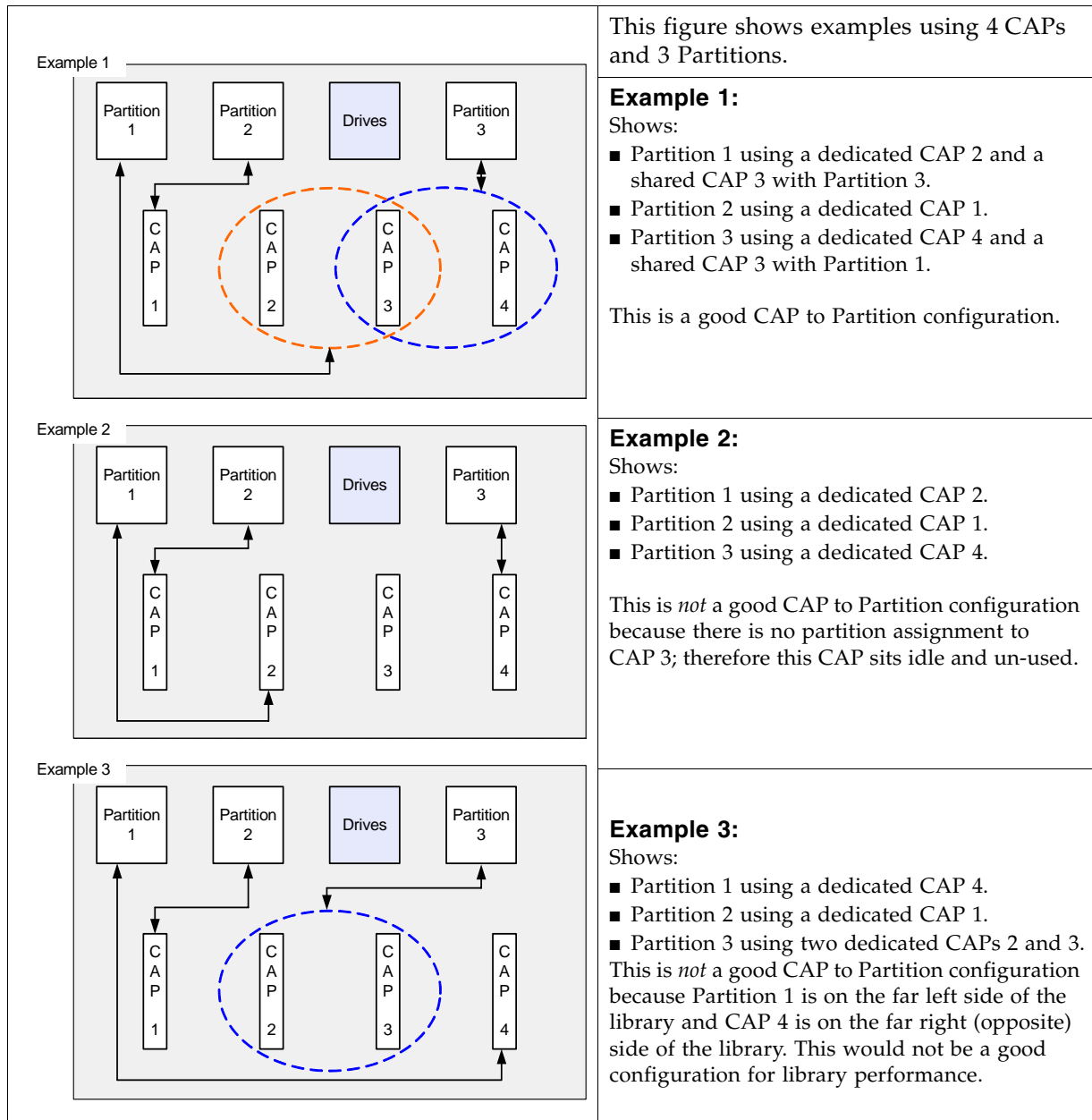

## Partitions

CAPs may be shared between HLI partitions, but not across partitions of differing interface types.

- It is recommended that each SCSI partition has a CAP dedicated to it.
- If CAPs are shared between SCSI partitions, the operator must use the Shared CAP Assignment screen in SLC to manage the use of those CAPs.

Host client access to shared SCSI CAPs must also be carefully managed.

- If multiple CAPs are being shared across SCSI partitions, it is recommended that a common group of CAPs be identified and shared between all SCSI partitions involved.

*For example:* Sharing one CAP as an individual in one partition and as part of a group of CAPs in another partition is not recommended.

If a SCSI partition shares the CAPs with another partition, the operator must use the CAP Association function in SLC to associate the partition to its CAPs prior to initiating an enter or eject operation. See “Associate a Partition to Its Shared CAPs” in the SL3000 Users Guide for the detailed procedure.

A partitioned-CAP association gives a partition exclusive ownership of its shared CAPs, similar to a CAP reservation. This ensures that cartridges are always entered into the correct partition and prevents other partitions from taking ownership of a shared CAP that is already in use.

If the Shared CAP Assignment is not utilized it is possible for a host on one partition to leave the CAPs in a state that the next host will not be able to unlock/open the CAPs without additional operator intervention.

---

# Library Console

Customers use the StorageTek Library Console to define partitions using four steps and a graphical interface.

FIGURE B-9 shows some examples of the Library Console partitioning process, including:

- Instruction screen
- Partition design screen
- Reports and Summary screen

FIGURE B-9 Library Console Partitioning

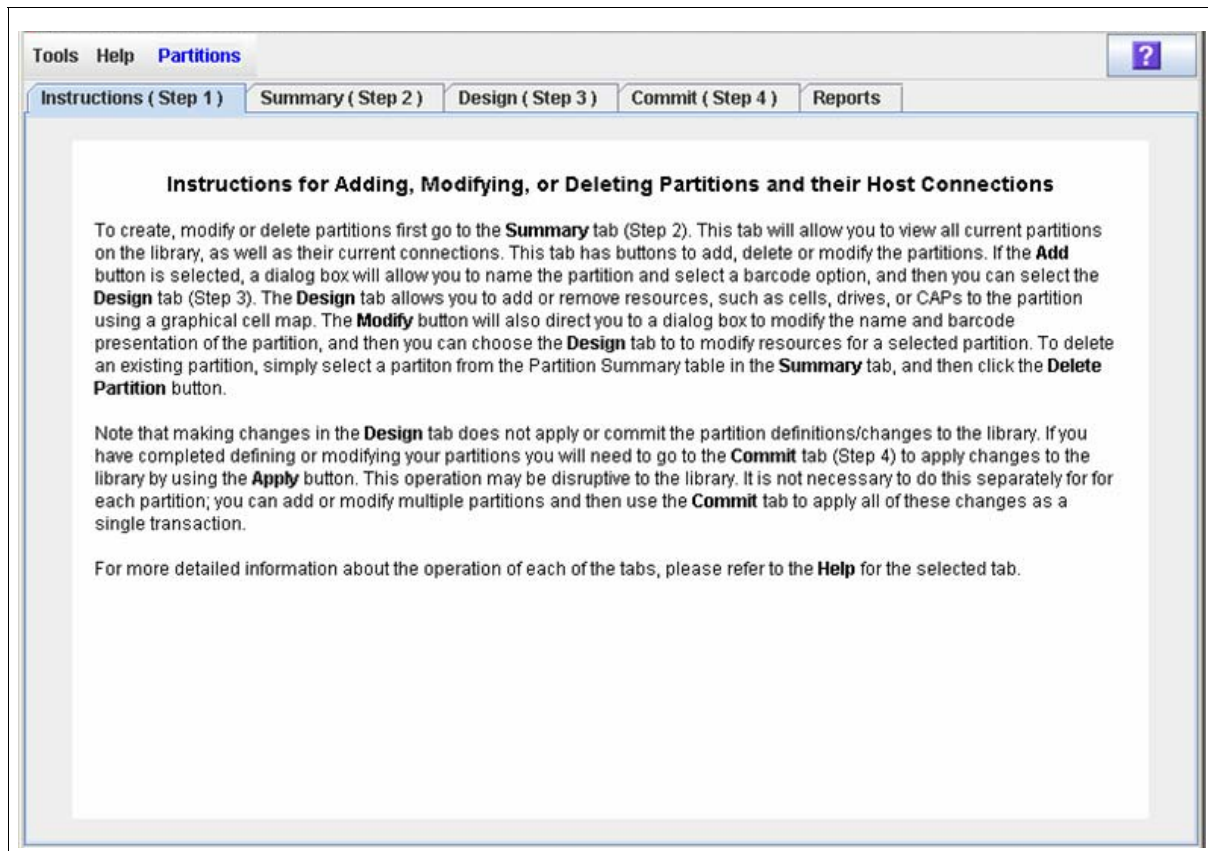

FIGURE B-9 Library Console Partitioning (Continued)

The screenshot displays the Library Console Partitioning interface. The top section shows a grid of storage cells for 'Base Module 7', divided into 'Front Wall' and 'Back Wall'. The cells are color-coded: yellow for 'Partition 1', red for 'Other Partitions', and white with an 'X' for 'Not Accessible'. A 'CAP' (Cartridge Access Port) column is visible between the walls. The interface includes a 'Tools Help Partitions' menu, a 'Verify Refresh' button, and a 'Partitions' tab. Below the grid, there are controls for 'Partition: 1', 'Select by: Cell', and 'Add Remove' options. A summary table for 'Partition 1' is shown, along with a legend for the cell colors.

--- Totals For Partition 1 ---

Allocated Storage Cells	825
Allocated Drives	10
Allocated CAP Cells	0

--- Available Totals ---

Unallocated Storage Cells	0
Unallocated Drives	0
Unallocated CAP Cells	0
Available Capacity	-782

Legend

- Not Accessible
- Unallocated
- Partition 1
- Other Partitions
- Cartridge

The bottom section of the screenshot shows the 'Host Connections Summary' dropdown menu. Below it is a table titled 'Partitions' with the following data:

Partition ID	Partition Name	Connectio Type	Storage Cells	Media In Storage Cells	%Storage Cells w/ Media	Drives	CAP Cells	* Total Media	Active Cells
1	ONEONE	HLI	1539	37	2.4%	16	26	37	0

\* NOTE: The Total Media column includes media currently found in CAPs, drives and storage cells

Host Connections (HLI Partitions do not have Host Connections)

Initiator WWPN	Library Controller Port	LUN	Partition ID

Buttons: Print... Save To File...

System status: Sun SL3000, Comm Status (green checkmark), UserID: root, Library: crimson20 (warning icon)

## Host Software Precautions

---

**Important:**

When you partition or re-partition a library, you do not have to reboot or IPL the library; however, when you apply the changes to the partitioning, the library will go offline temporarily. For this reason, it is best to minimize any disruptions to the operating systems and library management software before you partition.

The amount of time the library goes offline is minimal, up to **15 seconds**. However, this action affects the entire library whether we think it may not.

Any changes of this type are considered disruptive.

---

**Note** – If you install a tape drive into a drive bay already allocated to the partition without making other partition changes that require an “APPLY,” a reboot or IPL will be required for SCSI to see and report the new tape drive.

An example of a procedure that all hosts (ACSL, HSC, and SCSI) should follow when partitioning or changing partitions is:

1. Plan the distribution of cartridges, such as enters, ejects, and moves.
2. Set up the new partitions using the the remote SLC software\*, but *do not* commit.
3. Momentarily stop all host activity, such as mounts and dismounts, enters and ejects, any moves, plus any tape drive activity.
4. Using the remote SLC software, commit the new partitioning configuration.
5. Restart the host activity.

**Note** – You must use the remote SLC software to create and commit the partitions. This is because selecting the desired slots from the touch screen operator panel is not easy.

# Tasks

One essential message for content management and partitioning is planning.

**TABLE B-2** Steps and Tasks for Partitioning

✓	Step	Task	Responsibility*
<input type="checkbox"/>	<b>1. Team</b>	Create a Team.  When planning for content and partitions, use a process similar to that of the system assurance process; which is the exchange of information among team members to ensure all aspects of the implementation are planned carefully and performed efficiently. Team members should include representatives from both the customer and Sun Microsystems.	<ul style="list-style-type: none"> <li>■ Customer</li> <li>■ Administrators</li> <li>■ Operators</li>   <li>■ Sun SE, PS</li> <li>■ Sun Svc Rep</li> </ul>
<input type="checkbox"/>	<b>2. Codes</b>	Review the software and firmware requirements. Update as required.	<ul style="list-style-type: none"> <li>■ Customer</li> <li>■ Sun SE, PS</li> <li>■ Sun Svc Rep</li> </ul>
<input type="checkbox"/>	<b>3. Planning</b>	<ul style="list-style-type: none"> <li>■ Create a planning team</li> <li>■ Define the customer expectations</li> <li>■ Complete the assessment</li> <li>■ Identify the configurations</li> <li>■ Complete the planning diagrams</li> </ul>	<ul style="list-style-type: none"> <li>■ Customer</li> <li>■ Administrators</li>   <li>■ Sun SE, PS</li> <li>■ Sun Svc Rep</li> </ul>
<input type="checkbox"/>	<b>4. Media</b>	<ul style="list-style-type: none"> <li>■ Verify the distribution of cartridges and required tape drives are available and ready.</li> </ul>	<ul style="list-style-type: none"> <li>■ Customer</li> <li>■ Operators</li> </ul>
<input type="checkbox"/>	<b>5. Library</b>	<ul style="list-style-type: none"> <li>■ Install and configure a library (if necessary).</li> </ul>	<ul style="list-style-type: none"> <li>■ Sun Svc Rep</li> </ul>
<input type="checkbox"/>	<b>6. License</b>	<ul style="list-style-type: none"> <li>■ License the partitioning feature.</li> </ul>	<ul style="list-style-type: none"> <li>■ Customer</li> <li>■ Administrators</li> <li>■ Sun Svc Rep</li> </ul>
<input type="checkbox"/>	<b>7. Partitions</b>	<ul style="list-style-type: none"> <li>■ Create partitions.</li> </ul>	<ul style="list-style-type: none"> <li>■ Customer</li> <li>■ Administrators</li> <li>■ Operators</li> </ul>
<input type="checkbox"/>	<b>8. Hosts</b>	<ul style="list-style-type: none"> <li>■ Momentarily stop all host activity if currently connected.</li> </ul>	<ul style="list-style-type: none"> <li>■ Customer</li> </ul>
<input type="checkbox"/>	<b>9. Use</b>	Instruct the customer how to: <ul style="list-style-type: none"> <li>■ Partition and re-partition the library</li> <li>■ Override a CAP reservation</li> </ul>	<ul style="list-style-type: none"> <li>■ Customer</li> <li>■ Sun SE, PS</li> <li>■ Sun Svc Rep</li> </ul>
<input type="checkbox"/>	<b>10. Reference</b>	Make sure the customer has access to the appropriate documents.	<ul style="list-style-type: none"> <li>■ Customer</li> <li>■ Sun SE, PS</li> <li>■ Sun Svc Rep</li> </ul>
<ul style="list-style-type: none"> <li>■ SE = Systems engineer</li> <li>■ PS = Professional services representative</li> <li>■ Service = Sun Service representative (Svc Rep)</li> <li>■ Customer = System administrators, network administrators, system programmers, operators</li> </ul>			

# Planning Partitions

**TABLE B-3** Partition Planning

Identify and define the customer requirements							
What type of operating systems?							
What type of library management software?							
What type of applications are being used?							
How many partitions are there in the library?							
How many slots are there in the library?							
<b>Answer the following for each partition:</b>		<b>Slots</b>	<b>CAPs</b>	<b>Cartridges</b>	<b>Free Slots</b>	<b>Scratch</b>	<b>Drives</b>
<ul style="list-style-type: none"> <li>■ How many slots?</li> <li>■ What CAPs for that partition? Dedicated or Shared?</li> <li>■ How many cartridges are needed?</li> <li>■ How many free slots?</li> <li>■ How many scratch tapes?</li> <li>■ What type and quantity of drives?</li> </ul>	1.						
	2.						
	3.						
	4.						
	5.						
	6.						
	7.						
	8.						
<b>Comments:</b>							



**FIGURE B-10** Planning for Partitions



Planning for Partitions

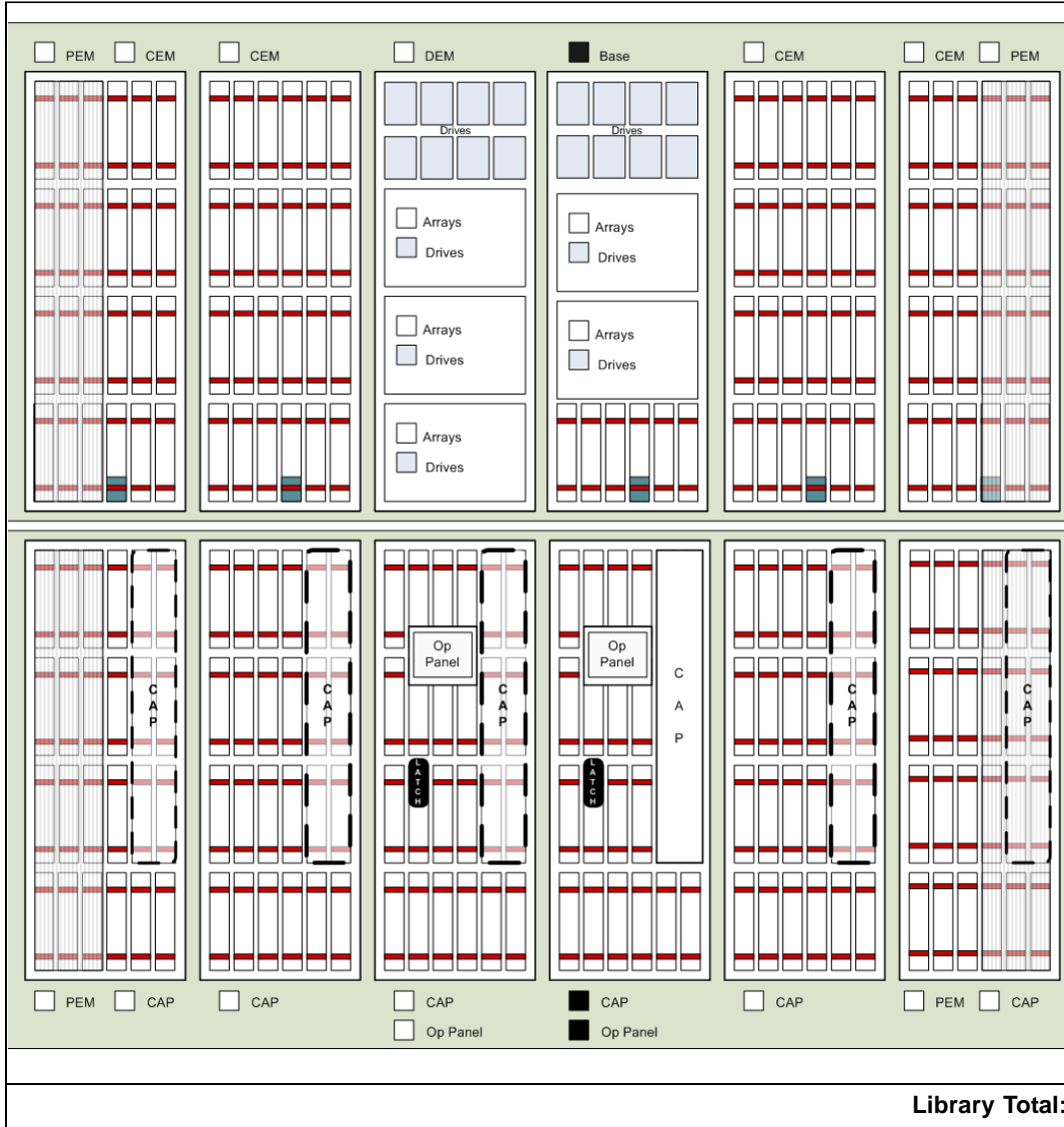

Partition/Description	Slots	Drives	CAPs
1.			
2.			
3.			
4.			
5.			
6.			
7.			
8.			
<b>Library Total:</b>			

# Glossary

---

This glossary defines terms and abbreviations in this and other product related publications.

## A

**activate** Enable for use. To make available.

**active region** A rectangular boundary outlining slots and tape drives to narrow the scope of resources for capacity or partitioning rules.

**active slots** Active slots are those slots that are available for use by the end user.

**accessible physical slots** These slots have been licensed and activated for use.

**allocated** Resource included in a partition. This can apply to slots (cells), tape drives, and cartridge access ports.

**Any Cartridge, Any Slot™** The technology that allows seamless sharing of different media types and drives without hard partitions.

**array** A partitioned unit that holds multiple objects, such as cartridges or drive tray assemblies.

**asynchronous (ASYNC)** Not synchronized; not occurring at regular, predetermined intervals. Asynchronous transmissions send one data character at a time, at irregular intervals, rather than in one steady stream; a start bit and a stop bit notify the receiver when the transmission begins and ends. *Contrast with* synchronous.

**audit** *See* host audit and security audit.

**Automated Cartridge System Library Software (ACSL)** Software that manages library contents and controls library hardware to

mount and dismount cartridges on tape drives for open systems environments.

## B

**Base module** Provides the entry level offering that consists of a single frame. This module centralizes the infrastructure for all other modules in the library and includes power supplies, robotic units, the electronic control module, cartridge access port, storage slots, tape drives, and operator controls.

**BDM** *See* Base module.

**bulk load** Manually loading cartridges into the library, for example, during library installation.

## C

**capacity** The number of slots available for use by a host client in a library or partition.

**Capacity on Demand** A process by which a customer purchases additional slots and grows the library capacity with minimal impact to host applications.

**cartridge access port (CAP)** A device in the library that allows an operator to insert or remove cartridges during library operations. *Synonymous with* import/export mail slot in SCSI and open system libraries.

**Cartridge Expansion Module (CEM)** Provides additional cartridge slot capacity and growth—no tape drives are in this module.

This module can be installed to the left, to the right, or both until the maximum number of modules for that library is allowed.

**cell** The location in the library in which a tape cartridge is stored. *Synonymous with slot.*

**cell array** An array that holds multiple cartridges when not in use.

**cleaning cartridge** A tape cartridge that contains special material to clean the tape path in a transport or drive.

## D

**data cartridge** A term used to distinguish a cartridge onto which a tape drive may write data from a cartridge used for cleaning or diagnostic purposes.

**diagnostic cartridge** A data cartridge with a "DG" label that service representatives use for diagnostic routines.

**drive bay** A group of eight drive slots that can be installed in either a Base Module or Drive Expansion Module. Each slots can hold one tape drive tray assembly.

**Drive Expansion Module (DEM)** This module allows further expansion of tape drives and provides additional data cartridge capacity. This module, and only one of this module type, can only be attached to the left of the base module.

**drive tray assembly** The mechanical structure that houses a tape drive, fan assembly, power and logic cards, cables, and connectors for data and logic cables.

**drop-off slots** slots used to hold a cartridge in the event of a robot failure that occurs while a cartridge is in the robot hand.

## E

**ECM** *See* electronics control module.

**electronics control module** The assembly that:

- Processes commands from host systems
- Coordinates the activities of the library
- Monitors status

**Ethernet** A local-area, packet-switched network technology. The Ethernet connection in an

SL3000 Library uses a 10 or 100 Megabytes-per-second (MB/s) LAN.

**export** The action in which the library places a cartridge into the cartridge access port so that the operator can remove the cartridge from the library. *Synonymous with eject.*

## F

**failover** The act of moving to a secondary or redundant path when the primary path fails.

**Fibre Channel** A bi-directional, full-duplex, point-to-point, serial data channel structured for high performance capacity.

- Fibre Channel is an interconnection of multiple communication ports, called N\_Ports. These ports are interconnected by a switching network, called a fabric.
- Fibre Channel is a generalized transport mechanism with no protocol of its own.
- Fibre Channel does not have a native input/output command set, but uses existing protocols such as SCSI.

## G

**get** An activity in which a robot obtains a cartridge from a slot or drive.

## H

**HLI-PRC address** A four-digit, comma-separated value (L,P,R,C) that represents LSM, Panel, Row, and Column. This addressing scheme is used by host LMU interface (HLI) clients, including ACSLS and HSC, to represent library components accessible to those HLI clients.

**host audit** The process of updating the cartridge VOLIDs and locations (collected by a security audit) in a host CDS. This audit is initiated by a host command.

**Host Software Component (HSC)** (1) A host-resident software package, implemented on mainframe operating systems (such as MVS), that influences device allocation and intercepts

mount and dismount requests to automate these requests.

## I

**import** The process of placing a cartridge into the cartridge access port so that the library can insert it into a storage cell. *Synonymous with enter.*

**installed physical slots** All the slots that have been installed in the library.

## L

**library console** *See* StorageTek Library Console.

**license** *See* License Key.

**licensed capacity** The amount of slots available to that library.

**licensed slot capacity** The licensed slot capacity defines the number of slots that can be activated in the library.

**license file** Digitally signed file containing one or more license keys.

**License Key** An indicator stating whether a particular feature is available.

**licensed** Means a particular feature is available.

## M

**magazine** A removable array that holds cartridges and is placed into the cartridge access port (CAP).

## O

**operator panel** *See* touch screen operator control panel.

## P

**Parking Expansion Module (PEM)** Allows the library to park a defective robot without

blocking access to cartridges for the other, operational, robot.

**partition** A subset or portion of an entire physical library that presents itself to a host client as an independent library.

- Slots and tape drives included in one partition cannot be seen by another partition.
- Cartridge access ports (CAPs) may either be shared between partitions or dedicated to one partition only.

**partitioned** One physical library sub-divided into one or more logical parts; each acting as an independent library.

**put** An activity in which a robot places a cartridge into a slot or drive.

## R

**rail** (1) That portion of the upper robot track assembly that provides power and communication to the robot.

**rail assembly** The mechanism on which the robot travels between cartridge arrays and tape drives.

**reach mechanism** A component of the robot that moves the gripper to get or put a cartridge at a designated location.

**robot** A mechanism that moves horizontally along a track in the Product Name to transport tape cartridges to and from other locations in the library. *Also called* a TallBot.

## S

**security audit** The process of reading and storing in Product Name library memory the VOLIDs and locations of all cartridges in the library. *See also* host audit.

**service area** An area between the access doors of the library (both front and rear) for service representatives to perform maintenance.

**StorageTek Library Console™** The operator panel software application used for the SL3000.

## **StorageTek SL3000 Modular Library System**

An automated tape library comprised of:

- Base module
- Cartridge expansion modules (CEM)
- Drive expansion module (DEM)
- Parking expansion modules (PEM)

## **T**

**TallBot** The robotic unit in an SL3000 library is called a TallBot. Each library can have either one (standard) or two (redundant) TallBots.

**tape cartridge** A container holding magnetic tape that can be processed without separating the tape from the container. The library uses data, diagnostic, and cleaning cartridges. These cartridges are not interchangeable.

**tape drive** An electromechanical device that moves magnetic tape and includes mechanisms for writing and reading data to and from the tape.

**touch screen operator control panel** An optional feature consisting of a flat-panel display with a touch screen interface and a panel mount computer.

## **U**

**U** A standard unit of measurement of vertical space inside a rack-mount cabinet equal to 44.5 mm (1.75 in.).

# Index

---

## Numerics

8B/10B encoding, 9

## A

abort

- exchange, 21
- sequences, 21

ABTS, 21

ABTX, 21

acquiring addresses, 11

active regions, 205

address failures, 12

addressing, 167

- columns, 168

addressing parameters, 167

ADISC, 21, 43

ADVC, 21

advise credit, 21

AL\_PA, 10

AL\_PD, 11

AL\_PS, 11

AL\_TIME, 29

alert messages in manual, xviii

Allowed (definition of), 6

Any cartridge, Any slot, 166

arbitrate to win loop, 3

arbitrated loop

- physical address, 10
- timeout value, 29

attributes, task, 41

## B

Base Drive Module, 171

basic link

- data frame, 20
- services, 21

BB\_Credit, 31, 32

boundaries rectangular, 205

buffer-to-buffer credit, 31, 32

## C

camp on, 18, 19

CAP, partition planning, 210

capacity, 183

Capacity on Demand, 199

cartridge access ports

- enter/eject cartridges, 196

Cartridge Expansion Module, 175

cartridges

- optimization, 196

CDB, 50

Cell Map, 191

centerline, 168

CenterLine Technology, 193

Class 3 service

- general, 17
- parameters, 19
  - Fabric login, 19
  - port login, 18

clearing effects, Fibre Channel, 44

clearing Persistent Reservations & Keys, 114

close latencies, 15

clustering

- cartridges, 196
- drives, 197

codes

- FCP response, 38

column addressing, 168

column, address, 167

command

- confirmation, Fibre Channel, 40
- control byte, 51
- descriptor blocks, 50
- information unit, 36

Commands

- operation code, 50

commands

- no operation (NOP), 21
- Release, 140

commands and data, PRLI, 33

- commands, Fibre Channel
  - basic, 21
  - extended, 21
  - link service, 20
- commands, Fibre Channel. See also commands, 21
- company ID, 16
- configuration block, 169
- connection status block, 22
- content management, 193
  - cartridges, 196
  - drives, 196
  - media, 196
  - philosophy, 193
  - tape cartridges, 196
  - tape drives, 197
- control byte, 51
- CRC, (cyclic redundancy check), 28
- creating a Persistent Reservation, 113
- credits, zero, 15
- cyclic redundancy checks, 28

## D

- data
  - and response, in same sequence, 33
  - field size, 31, 32
  - information unit, 37
- data path, partition planning, 208
- decoding, 9
- dedicated simplex, 18
- delimiters
  - end-of-frame, 10
  - start-of-frame, 17
- device
  - reservations, 46
  - states, 8
- discover
  - address, 21
  - parameters, 21
  - SCSI target
    - private loop, 42
    - public loop, 42
- disparity, 9
- Drive Expansion Module, 173
- drive module slots, 170

## E

- E\_D\_TOV, 29
- echo, 21
- eject
  - cartridges, 197
  - optimization, 197
- encoding, 9
- end-of-frame delimiters, 10

- enter
  - cartridges, 196
  - optimization, 196
- EOF, 10
- errors
  - detection, 7
  - link error status block, 23
  - sequence, 28
- errors. See also failures
- establish
  - image pair, PRLI, 33
  - streaming, 21
- ESTC, 21
- estimate credit, 21
- ESTS, 21
- exchange
  - identifier, 25
  - management, 26
  - originator, 26
  - read status block, 23
  - responder, 26
- extended link
  - data frame, 20
  - service commands, 21

## F

- F\_CTL features, 20
- fabric
  - attachment initialization, 15
  - login, 22
- failures
  - error detection, 7
  - loop, 13
- failures. See also errors, 28
- FAN, 42
- FC Tape terms, 6
- FC-0
  - and device states, 8
  - and initialization, 8
  - defined, 8
- FC-1
  - and initialization, 9
  - defined, 9
  - disparity, 9
  - encoding/decoding, 9
- FC-2
  - Class 3 service, 17
  - frame format/header, 25
- FC-3, 31
- FC-4, 33
- FCP
  - other features, 42
  - task attributes, 41
- FCP\_RSP, 38



- fiber-optic cables
  - connectors, xxi
  - handling precautions, xxi
  - installation, xxi
- Fibre Channel
  - basic link service commands, 21
  - class 3 service
    - parameters, Fabric login, 19
    - parameters, port login, 18
  - clearing effects, 44
  - command confirmation, 40
  - extended link service commands, 21
  - FC-0, 8
  - FC-1, 9
  - FC-3, 31
  - FC-4, 33
  - frame format, 25
  - levels, 5
  - link service commands, 20
  - response to link services, 24
  - See also commands
  - tape terms, 6
  - terms in manual, 6
  - timers, 29
  - versions, 31, 32

- float
  - optimization, 196

- FLOGI, 22

- frame
  - control features, 20
  - header
    - contents, 25
    - exchange management, 26
    - format, 25
    - illustration of, 25
    - sequence management, 27

## G

- GAID, 22
- get alias, 22
- glossary, 219

## H

- hardcopy publications, xix
- head of queue, 41
- header frame, contents of, 25

## I

- identifier, sequence, 27
- Information Units
  - command, 36
  - data, 37
  - response, 37
  - transfer ready, 37
- initialization completion

- private loop, 13
- public loop, 13
- initiator
  - control, 18, 19
  - definition of, 6
- installation, fiber-optic cables, xxi
- interlock, 20
- intermix mode, 18, 19
- Invokable (definition of), 6

## L

- latencies, 15
- library
  - system assurance, 215
  - walls, 166
- library address, 167
- library capacity, 183
- licensing, 204
- LIFA, 11
- LIHA, 11
- LILP, 13
- link
  - error status block, 23
- link service
  - commands, 20
  - extended commands, 21
  - responses to, 24
- LIPA, 11
- LIRP, 12
- LISA, 12
- LISM, 12
- login credits, 15
- LOGO, 16, 22
- logout services, 22
- loop
  - addresses, 11
  - failures, 13
  - master, 12
- loop initialization
  - fabric assigned address, 11
  - hard assigned, 11
  - loop position, 13
  - previously acquired, 11
  - report position, 12
  - soft assigned, 12

## M

- management, Fibre Channel
  - error detection, 7
  - exchange, 26
  - sequence, 27
- master loop initialization, 12
- media optimization, 196

- modular design, 165
- module capacity, 183
- module comparisons, 184
- module types, 169
- modules, 165

## N

- N\_Port
  - alias, 22
- negative numbers, 167
- no operation (NOP), command, 21
- NOP (no operation command), 21
- notes, description of, xviii

## O

- open
  - latencies, 15
  - originators, 15
  - sequence, 27
- optimization guidelines
  - cartridges, 196
  - media, 196
  - planning, 193
  - tape cartridges, 196
  - tape drives, 197
- optional headers, 20
- ordered queue, 41
- organization of information in this manual, xvii
- originator, exchange, 26
- out-of-the-box behavior, 200
- OX\_ID, 26

## P

- parameters, 167
- Parking Expansion Module, 179
- partition, 204
- partitioning feature, 204
- partitioning is planning, 215
- Partners Web site, xix
- payload response, 38
- PDISC, 43
- performance zone, 209
- Persistent Reservation
  - clearing, 114
  - creating, 113
  - releasing, 113
- philosophy for content management, 193
- positive numbers, 167
- precautions, handling fiber-optic cables, xxi
- preempting reservations, 114
- private loop initialization completion, 13
- PRLI, 22

- PRLO, 22
- process
  - login (PRLI), 22
  - logout (PRLO), 22
- Process Associator, 33
- process, for system assurance, 215
- Prohibited (definition of), 6
- public loop initialization completion, 13
- Publications, related to this manual, xviii

## Q

- quality of service, 22
- queue types
  - head of queue, 41
  - ordered, 41
  - simple, 41
  - untagged, 41

## R

- R\_A\_TOV, 30
- R\_CTL features, 20
- R\_T\_TOV, 13, 29
- rail address, 167
- RCS, 22
- read
  - connection status, 22
  - timeout value, 23
- REC\_TOV, 30
- receiver\_transmitter timeout, 29
- recipient control, 18, 19
- rectangular boundaries, 205
- registered state change status, 23
- registering a Reservation Key, 113
- reinstate recovery qualifier, 23
- related publications, xviii
- relative offset, 31
- Release command, 140
- releasing a Persistent Reservation, 113
- remove connection, 21
- report node capabilities, 23
- request sequence initiative, 23
- Required (definition of), 6
- RES, 23
- reservation
  - device, 46
- Reserve command
  - element list definitions, 159
- residual checking, 37
- resource
  - allocation timeouts, 30
  - recovery timeout, 30
- responder, exchange, 26

- response, Fibre Channel
  - codes, 38
  - information unit, 37
  - payload, 38
  - to link services, 24
- RLS, 23
- RMC, 21
- RNC, 23
- robotic units, 195
- routing control, 20
- row address, 167
- RR\_TOV, 30
- RRQ, 23
- RSCN, 23, 42
- RSI, 23
- RSS, 23
- RTV, 23
- running disparity, 9
- RVCS, 23
- RX\_ID, 26

**S**

- safety
  - fiber optics, xx
- same sequence transmissions, 33
- SCN, 23
- SCR, 23
- scratch
  - cartridge optimization, 197
- selective resets, 13
- sense length, 38
- SEQ\_CNT, 27
- SEQ\_ID, 27
- sequence
  - chaining, 20
  - concurrent, 31
  - errors, 28
  - identifier, 27
  - management, 27
  - open, 27
  - retransmission request, 24
  - status block, 23
- sequential delivery, 18, 19
- service, Fibre Channel
  - options, 18, 19
  - parameters
    - class 3, 19
    - port login, class 3, 18
- side address, 167
- simple queue, 41
- Slot Map, 191
- slot numbering, 200
- slots (See also cell), 165

- SOF, 17
- SRR, 24
- stacked requests, 18, 19
- start-of-frame delimiters, 17
- state change
  - notification, 23
  - registration, 23
- steps for partitioning, 215
- storage capacity, 183
- StorageTek
  - Web site, xix
- Sun
  - Web site, xix
  - worldwide offices, xix
- system assurance
  - process overview, 215

## T

- TallBots, 195
- tape cartridge content management, 196
- tape drive
  - content management, 197
- Target (definition of), 6
- target discovery, 42
- task attributes, 41
- tasks for partitioning, 215
- tasks, for partitioning, 215
- team members, 215
- terms
  - FC Tape, 6
  - StorageTek, 6
- test process login state, 23
- third party process logout, 23
- timeout values
  - arbitrated loop, 29
  - error detect, 29
  - read exchange concise, 30
  - receiver\_transmitter, 29
  - resource allocation, 30
  - resource recovery, 30
  - upper level protocol, 30
- timers, 29
- TPRLO, 23
- transfer ready information unit, 37
- transmission word, 6

## U

- ULP\_TOV, 30
- untagged queue, 41
- Upper Level Protocol timeout, 30

## V

- VC status, 23

**W**

walls, 166

**X**

XFER\_RDY Disabled, 33

**Z**

zero credits, 15



Sun Microsystems, Inc. 4150 Network Circle, Santa Clara, CA 95054 USA Phone 1-650-960-1300 or 1-800-555-9SUN Web [sun.com](http://sun.com)



ARGENTINA: 5411-4317-5636 • AUSTRALIA: 1-800-550-786 • AUSTRIA: 43-1-601-26-0 • BALKANS: 301-6188-111 • BELGIUM: 32-2-704 89 83 • BRAZIL: 55-11-51872100 • BRUNEI: 65-216-8333 • CANADA: 1-800-422-8020 (GENERAL); 416-964-2001 (LEARNING MANAGEMENT SYSTEM SALES, TORONTO) • CHILE: 562-372-4500 • COLOMBIA: 571-629-2323  
CZECH REPUBLIC: 420 2 33009311 • DENMARK: 45 4556 5040 • EGYPT: 00 202 570 9442 • FINLAND: 358-9-525-551 • FRANCE: 33-1-41-33-17-17 • GERMANY: 49-89-460-08-2788 • GREECE: 30-01-6188101 • HONG KONG: 852-2877-7077 • HUNGARY: 361-202-4415 • INDIA: 91-80-229-8989 • INDONESIA: 65-216-8333 • IRELAND: 353-1-668-4377  
ISRAEL: 972-9-9710500 • ITALY: 39-02-9259511 • JAPAN: 81-3-5779-1820 • KOREA: 82-2-3453-6602 • MALAYSIA: 603-2116-1887 • MIDDLE EAST: 00 9714 3366333 • MEXICO: 525-261-0344 • NETHERLANDS: 31-33-4515200 • NEW ZEALAND: 0800-786-338 • NORTH WEST AFRICA: 00 9714 3366333 • NORWAY: FROM NORWAY: 47-22023950, TO NORWAY: 47-23369650 • PAKISTAN: 00-9714-3366333 • PEOPLE'S REPUBLIC OF CHINA: 8610-6803-5588 • PHILIPPINES: 632-885-7867 • POLAND: 48-22-8747848 • PORTUGAL: 351-21-413-4000 • RUSSIA: 7-095-935-8411 • SAUDI ARABIA: 00 9714 3366333 • SINGAPORE: 65-216-8300 • SOUTH AFRICA: 27-11-256-6300 • SPAIN: 34-902-210-412 • SRI LANKA: 65-2168333 • SWEDEN: 46-8-631 22 00 • SWITZERLAND: 41-1-908-90-50 (GERMAN) 41-22-999-0444 (FRENCH) • TAIWAN: 886-2-25185735 • THAILAND: 662-344-6855 • TURKEY: 90 212 335 22 00 • UNITED KINGDOM: 44-1276-416-520 • UNITED STATES: 1-800-422-8020 • VENEZUELA: 582-905-3800 • VIETNAM: 65-216-8333 • WORLDWIDE HEADQUARTERS: 1-650-960-1300

**SUN™** THE NETWORK IS THE COMPUTER ©2006 Sun Microsystems, Inc. All rights reserved. Sun, Sun Microsystems, and the Sun logo are trademarks or registered trademarks of Sun Microsystems, Inc. in the United States and other countries.