

Netra™ st D130 Installation and Maintenance Manual



THE NETWORK IS THE COMPUTER™

Sun Microsystems, Inc.
901 San Antonio Road
Palo Alto, CA 94303-4900 USA
650 960-1300 Fax 650 969-9131

Part No.: 806-1489-10
November 1999, Revision A

Send comments about this document to: docfeedback@sun.com

Copyright 1999 Sun Microsystems, Inc., 901 San Antonio Road, Palo Alto, California 94303-4900 U.S.A. All rights reserved.

This product or document is protected by copyright and distributed under licenses restricting its use, copying, distribution, and decompilation. No part of this product or document may be reproduced in any form by any means without prior written authorization of Sun and its licensors, if any. Third-party software, including font technology, is copyrighted and licensed from Sun suppliers .

Parts of the product may be derived from Berkeley BSD systems, licensed from the University of California. UNIX is a registered trademark in the U.S. and other countries, exclusively licensed through X/Open Company, Ltd. For Netscape Communicator™, the following notice applies: Copyright 1995 Netscape Communications Corporation. All rights reserved.

Sun, Sun Microsystems, the Sun logo, SunStore, AnswerBook2, docs.sun.com, Netra, Solstice DiskSuite, SunSwift, and Solaris are trademarks, registered trademarks, or service marks of Sun Microsystems, Inc. in the U.S. and other countries. All SPARC trademarks are used under license and are trademarks or registered trademarks of SPARC International, Inc. in the U.S. and other countries. Products bearing SPARC trademarks are based upon an architecture developed by Sun Microsystems, Inc.

The OPEN LOOK and Sun™ Graphical User Interface was developed by Sun Microsystems, Inc. for its users and licensees. Sun acknowledges the pioneering efforts of Xerox in researching and developing the concept of visual or graphical user interfaces for the computer industry. Sun holds a non-exclusive license from Xerox to the Xerox Graphical User Interface, which license also covers Sun's licensees who implement OPEN LOOK GUIs and otherwise comply with Sun's written license agreements.

RESTRICTED RIGHTS: Use, duplication, or disclosure by the U.S. Government is subject to restrictions of FAR 52.227-14(g)(2)(6/87) and FAR 52.227-19(6/87), or DFAR 252.227-7015(b)(6/95) and DFAR 227.7202-3(a).

DOCUMENTATION IS PROVIDED "AS IS" AND ALL EXPRESS OR IMPLIED CONDITIONS, REPRESENTATIONS AND WARRANTIES, INCLUDING ANY IMPLIED WARRANTY OF MERCHANTABILITY, FITNESS FOR A PARTICULAR PURPOSE OR NON-INFRINGEMENT, ARE DISCLAIMED, EXCEPT TO THE EXTENT THAT SUCH DISCLAIMERS ARE HELD TO BE LEGALLY INVALID.

Copyright 1999 Sun Microsystems, Inc., 901 San Antonio Road, Palo Alto, Californie 94303-4900 U.S.A. Tous droits réservés.

Ce produit ou document est protégé par un copyright et distribué avec des licences qui en restreignent l'utilisation, la copie, la distribution, et la décompilation. Aucune partie de ce produit ou document ne peut être reproduite sous aucune forme, par quelque moyen que ce soit, sans l'autorisation préalable et écrite de Sun et de ses bailleurs de licence, s'il y en a. Le logiciel détenu par des tiers, et qui comprend la technologie relative aux polices de caractères, est protégé par un copyright et licencié par des fournisseurs de Sun.

Des parties de ce produit pourront être dérivées des systèmes Berkeley BSD licenciés par l'Université de Californie. UNIX est une marque déposée aux Etats-Unis et dans d'autres pays et licenciée exclusivement par X/Open Company, Ltd. La notice suivante est applicable à Netscape Communicator™ : Copyright 1995 Netscape Communications Corporation. All rights reserved.

Sun, Sun Microsystems, le logo Sun, SunStore, AnswerBook2, docs.sun.com, Netra, Solstice DiskSuite, SunSwift, et Solaris sont des marques de fabrique ou des marques déposées, ou marques de service, de Sun Microsystems, Inc. aux Etats-Unis et dans d'autres pays. Toutes les marques SPARC sont utilisées sous licence et sont des marques de fabrique ou des marques déposées de SPARC International, Inc. aux Etats-Unis et dans d'autres pays. Les produits portant les marques SPARC sont basés sur une architecture développée par Sun Microsystems, Inc.

L'interface d'utilisation graphique OPEN LOOK et Sun™ a été développée par Sun Microsystems, Inc. pour ses utilisateurs et licenciés. Sun reconnaît les efforts de pionniers de Xerox pour la recherche et le développement du concept des interfaces d'utilisation visuelle ou graphique pour l'industrie de l'informatique. Sun détient une licence non exclusive de Xerox sur l'interface d'utilisation graphique Xerox, cette licence couvrant également les licenciés de Sun qui mettent en place l'interface d'utilisation graphique OPEN LOOK et qui en outre se conforment aux licences écrites de Sun.

CETTE PUBLICATION EST FOURNIE "EN L'ETAT" ET AUCUNE GARANTIE, EXPRESSE OU IMPLICITE, N'EST ACCORDEE, Y COMPRIS DES GARANTIES CONCERNANT LA VALEUR MARCHANDE, L'APTITUDE DE LA PUBLICATION A REpondre A UNE UTILISATION PARTICULIERE, OU LE FAIT QU'ELLE NE SOIT PAS CONTREFAISANTE DE PRODUIT DE TIERS. CE DENI DE GARANTIE NE S'APPLIQUERAIT PAS, DANS LA MESURE OU IL SERAIT TENU JURIDIQUEMENT NUL ET NON AVENU.



Adobe PostScript

Contents

Preface	xi
Regulatory Compliance Statements	xv
Declaration of Conformity	xix
Safety Agency Compliance Statements	xxi
1. Netra st D130 Storage Enclosure Overview	1
Components at the Front of the Enclosure	2
Front Panel	2
Front Panel LEDs	3
Components at the Back of the Enclosure	4
Power Switch	5
SCSI ID Switch	5
Back Panel LEDs	6
Internal Components	8
Power Supply	8
Cooling System	9
Disk Drives	11
Foam Fillers	12

Netra st D130 Software Considerations	12
2. Electrical Requirements and Cable Assembly	13
AC Source Site Requirements	13
DC Source Site Requirements	14
Overcurrent Protection Requirements	15
DC Supply and Ground Conductor Requirements	15
Assembling the DC Input Power Cable	16
Required Connection Materials	16
Isolating the Chassis Ground Connection	23
3. Installing the Netra st D130 Storage Enclosure	25
Hardware Requirements	25
Preparing for Installation	26
▼ To Prepare the Host System	26
▼ To Set the SCSI IDs for the Drives	27
Installing the Netra st D130 Storage Enclosure	27
Mounting the Storage Enclosure in a Rack	27
Connecting the SCSI Cables	28
Connecting the Power Cable	30
Powering On and Off	33
▼ To Power On the Storage Enclosure	33
▼ To Power Off the Storage Enclosure	34
4. Adding, Removing, and Replacing Disk Drives	35
Adding a Disk Drive	35
▼ To Add a Disk Drive	36
Performing the Software Configuration Procedures	37
Removing and Replacing a Disk Drive	39

- ▼ To Remove a Disk Drive 39
 - ▼ To Replace a Disk Drive 41
- A. System Specifications 43**

Figures

FIGURE 1-1	Netra st D130 Storage Enclosure	1
FIGURE 1-2	Removing the Front Panel	2
FIGURE 1-3	Front Panel LEDs	3
FIGURE 1-4	Netra st D130, Rear View	4
FIGURE 1-5	Power Switch	5
FIGURE 1-6	SCSI ID Switch	5
FIGURE 1-7	Back Panel LEDs	6
FIGURE 1-8	Auto Termination Indication LEDs Lit in UltraSCSI or Wide SCSI Daisy-Chain	7
FIGURE 1-9	Auto Termination Indication LEDs Lit in a Narrow SCSI Daisy-Chain	8
FIGURE 1-10	Netra st D130 Rear View (AC Version)	9
FIGURE 1-11	Netra st D130 Rear View (DC Version)	9
FIGURE 1-12	Airflow Requirements (Front and Rear)	10
FIGURE 1-13	Airflow Requirements (Open Rack)	10
FIGURE 1-14	Airflow Requirements (Closed Rack)	11
FIGURE 2-1	DC Connector	16
FIGURE 2-2	Strain Relief Housing	17
FIGURE 2-3	Cage Clamp Operating Lever	17
FIGURE 2-4	Power Connector on the DC Power Supply	17
FIGURE 2-5	Stripping the Insulation From the Wire	18
FIGURE 2-6	Opening the DC Connector Cage Clamp Using the Cage Clamp Operating Lever	19

FIGURE 2-7	Opening the DC Connector Cage Clamp Using a Screwdriver	20
FIGURE 2-8	Assembling the DC Input Power Cable	20
FIGURE 2-9	Inserting the Bottom Portion of the Strain Relief Housing	21
FIGURE 2-10	Routing the Wires Out of the Bottom Portion of the Strain Relief Housing	22
FIGURE 2-11	Securing the Wires to the Strain Relief Housing	22
FIGURE 2-12	Assembling the Strain Relief Housing	23
FIGURE 3-1	Locating the SCSI ID Switch	27
FIGURE 3-2	Netra st D130 Rear View (AC Version)	28
FIGURE 3-3	Daisy-Chaining Netra st D130 Storage Enclosures	29
FIGURE 3-4	Daisy-Chaining a Netra st D130 Storage Enclosure with a Narrow SCSI Device	30
FIGURE 3-5	Netra st D130 Rear View (AC Version)	31
FIGURE 3-6	Connecting the DC Grounding Cable	31
FIGURE 3-7	Connecting the DC Input Power Cable to the DC Connector	32
FIGURE 3-8	Disconnecting the DC Input Power Cable from the DC Connector	33
FIGURE 4-1	Removing the Front Panel	36
FIGURE 4-2	Adding a Disk Drive	37
FIGURE 4-3	Removing and Replacing a Disk Drive	40

Tables

TABLE 1-1	Front Panel LEDs	3
TABLE 1-2	Auto Termination Indication LEDs	6
TABLE 2-1	AC Power Requirements	13
TABLE 2-2	DC Power Requirements	14
TABLE A-1	Physical Specifications	43
TABLE A-2	AC Power Requirements	44
TABLE A-3	DC Power Requirements	44
TABLE A-4	Environmental Specifications	45

Preface

The *Netra st D130 Installation and Maintenance Manual* provides installation and configuration information and service procedures for the Netra™ st D130 storage enclosure. These instructions are designed for an experienced system administrator.

How This Book Is Organized

Chapter 1 describes the Netra st D130 storage enclosure.

Chapter 2 gives electrical information for the Netra st D130 storage enclosure.

Chapter 3 gives instructions for installing the Netra st D130 storage enclosure.

Chapter 4 gives the procedures for removing, replacing, or adding disk drives to the Netra st D130 storage enclosure.

Appendix A gives the system specifications for the Netra st D130 storage enclosure.

Using UNIX Commands

This document may not contain information on basic UNIX® commands and procedures such as shutting down the system, booting the system, and configuring devices.

See one or more of the following for this information:

- *Solaris Handbook for Sun Peripherals*
- AnswerBook2™ online documentation for the Solaris™ software environment

- Other software documentation that you received with your system

Typographic Conventions

TABLE P-1 Typographic Conventions

Typeface	Meaning	Examples
AaBbCc123	The names of commands, files, and directories; on-screen computer output	Edit your <code>.login</code> file. Use <code>ls -a</code> to list all files. % You have mail.
AaBbCc123	What you type, when contrasted with on-screen computer output	% su Password:
<i>AaBbCc123</i>	Book titles, new words or terms, words to be emphasized	Read Chapter 6 in the <i>User's Guide</i> . These are called <i>class</i> options. You <i>must</i> be superuser to do this.
	Command-line variable; replace with a real name or value	To delete a file, type <code>rm filename</code> .

Shell Prompts

TABLE P-2 Shell Prompts

Shell	Prompt
C shell	<i>machine_name</i> %
C shell superuser	<i>machine_name</i> #
Bourne shell and Korn shell	\$
Bourne shell and Korn shell superuser	#

Related Documentation

TABLE P-3 Related Documentation

Application	Title	Part Number
Late-breaking information	Netra st D130 Product Notes	806-1490-10

Accessing Sun Documentation Online

The `docs.sun.comsm` web site enables you to access Sun technical documentation on the Web. You can browse the `docs.sun.com` archive or search for a specific book title or subject at:

`http://docs.sun.com`

Sun Welcomes Your Comments

We are interested in improving our documentation and welcome your comments and suggestions. You can email your comments to us at:

`docfeedback@sun.com`

Please include the part number (806-1489-10) of your document in the subject line of your email.

Regulatory Compliance Statements

Your Sun product is marked to indicate its compliance class:

- Federal Communications Commission (FCC) — USA
- Department of Communications (DOC) — Canada
- Voluntary Control Council for Interference (VCCI) — Japan

Please read the appropriate section that corresponds to the marking on your Sun product before attempting to install the product.

FCC Class A Notice

This device complies with Part 15 of the FCC Rules. Operation is subject to the following two conditions:

1. This device may not cause harmful interference.
2. This device must accept any interference received, including interference that may cause undesired operation.

Note: This equipment has been tested and found to comply with the limits for a Class A digital device, pursuant to Part 15 of the FCC Rules. These limits are designed to provide reasonable protection against harmful interference when the equipment is operated in a commercial environment. This equipment generates, uses, and can radiate radio frequency energy, and if it is not installed and used in accordance with the instruction manual, it may cause harmful interference to radio communications. Operation of this equipment in a residential area is likely to cause harmful interference, in which case the user will be required to correct the interference at his own expense.

Shielded Cables: Connections between the workstation and peripherals must be made using shielded cables to comply with FCC radio frequency emission limits.

Modifications: Any modifications made to this device that are not approved by Sun Microsystems, Inc. may void the authority granted to the user by the FCC to operate this equipment.

FCC Class B Notice

This device complies with Part 15 of the FCC Rules. Operation is subject to the following two conditions:

1. This device may not cause harmful interference.
2. This device must accept any interference received, including interference that may cause undesired operation.

Note: This equipment has been tested and found to comply with the limits for a Class B digital device, pursuant to Part 15 of the FCC Rules. These limits are designed to provide reasonable protection against harmful interference in a residential installation. This equipment generates, uses and can radiate radio frequency energy and, if not installed and used in accordance with the instructions, may cause harmful interference to radio communications. However, there is no guarantee that interference will not occur in a particular installation. If this equipment does cause harmful interference to radio or television reception, which can be determined by turning the equipment off and on, the user is encouraged to try to correct the interference by one or more of the following measures:

- Reorient or relocate the receiving antenna.
- Increase the separation between the equipment and receiver.
- Connect the equipment into an outlet on a circuit different from that to which the receiver is connected.
- Consult the dealer or an experienced radio/television technician for help.

Shielded Cables: Connections between the workstation and peripherals must be made using shielded cables in order to maintain compliance with FCC radio frequency emission limits.

Modifications: Any modifications made to this device that are not approved by Sun Microsystems, Inc. may void the authority granted to the user by the FCC to operate this equipment.

DOC Class A Notice - Avis DOC, Classe A

This Class A digital apparatus meets all requirements of the Canadian Interference-Causing Equipment Regulations.
Cet appareil numérique de la classe A respecte toutes les exigences du Règlement sur le matériel brouilleur du Canada.

DOC Class B Notice - Avis DOC, Classe B

This Class B digital apparatus meets all requirements of the Canadian Interference-Causing Equipment Regulations.
Cet appareil numérique de la classe B respecte toutes les exigences du Règlement sur le matériel brouilleur du Canada.

VCCI 基準について

クラス A VCCI 基準について

クラス A VCCI の表示があるワークステーションおよびオプション製品は、クラス A 情報技術装置です。これらの製品には、下記の項目が該当します。

この装置は、情報処理装置等電波障害自主規制協議会 (VCCI) の基準に基づくクラス A 情報技術装置です。この装置を家庭環境で使用すると電波妨害を引き起こすことがあります。この場合には使用者が適切な対策を講ずるよう要求されることがあります。

クラス B VCCI 基準について

クラス B VCCI の表示  があるワークステーションおよびオプション製品は、クラス B 情報技術装置です。これらの製品には、下記の項目が該当します。

この装置は、情報処理装置等電波障害自主規制協議会 (VCCI) の基準に基づくクラス B 情報技術装置です。この装置は、家庭環境で使用することを目的としていますが、この装置がラジオやテレビジョン受信機に近接して使用されると、受信障害を引き起こすことがあります。取扱説明書に従って正しい取り扱いをしてください。

BSMI Class A Notice

The following statement is applicable to products shipped to Taiwan and marked as Class A on the product compliance label.

警告使用者：

這是甲類的資訊產品，在居住的環境中使用時，可能會造成射頻干擾，在這種情況下，使用者會被要求採取某些適當的對策。

Declaration of Conformity

Agency Model Number: CYT1A (AC version)
CYT1D (DC version)

Product Name: Netra st D130

This product has been tested and complies with the following rules and requirements.

EMC

USA—FCC Class A

This device complies with Part 15 of the FCC Rules. Operation is subject to the following two conditions:

1. This device may not cause harmful interference.
2. This device must accept any interference received, including interference that may cause undesired operation.

European Union—EC

This equipment complies with the following requirements of the EMC Directive 89/336/EEC:

EN55022/CISPR22 (1985)	Class A
EN50082-1 IEC801-2 (1991)	4 kV (Direct), 8 kV (Air)
IEC801-3 (1984)	3 V/m
IEC801-4 (1988)	1.0 kV Power Lines, 0.5 kV Signal Lines
EN61000-3-2/IEC1000-3-2 (1994)	Pass

Safety

This equipment complies with the following requirements of the Low Voltage Directive 73/23/EEC:

EC Type Examination Certificates:

EN60950/IEC950 (1993)

EN60950 - Evaluated to all CB Scheme Country Deviations

Supplementary Information

This product was tested and complies with all the requirements for the CE Mark (when connected to a Sun workstation or server).

/S/

Dennis P. Symanski
Manager, Product Compliance

DATE

Sun Microsystems, Inc.
901 San Antonio Road, M/S UMPK15-102
Palo Alto, CA 94303, USA

Tel: 650-786-3255
Fax: 650-786-3723

/S/

John Shades
Quality Assurance Manager

DATE

Sun Microsystems Scotland, Limited
Springfield, Linlithgow
West Lothian, EH49 7LR
Scotland, United Kingdom

Tel: 0506-670000
Fax: 0506 760011

Safety Agency Compliance Statements

Read this section before beginning any procedure. The following text provides safety precautions to follow when installing a Sun Microsystems product.

Safety Precautions

For your protection, observe the following safety precautions when setting up your equipment:

- Follow all cautions and instructions marked on the equipment.
- Ensure that the voltage and frequency of your power source match the voltage and frequency inscribed on the equipment's electrical rating label.
- Never push objects of any kind through openings in the equipment. Dangerous voltages may be present. Conductive foreign objects could produce a short circuit that could cause fire, electric shock, or damage to your equipment.

Symbols

The following symbols may appear in this book:



Caution – There is risk of personal injury and equipment damage. Follow the instructions.



Caution – Hot surface. Avoid contact. Surfaces are hot and may cause personal injury if touched.



Caution – Hazardous voltages are present. To reduce the risk of electric shock and danger to personal health, follow the instructions.

On – Applies AC power to the system.

Depending on the type of power switch your device has, one of the following symbols may be used:



Off - Removes AC power from the system.



Standby – The On/Standby switch is in the standby position.

Modifications to Equipment

Do not make mechanical or electrical modifications to the equipment. Sun Microsystems is not responsible for regulatory compliance of a modified Sun product.

Placement of a Sun Product



Caution – Do not block or cover the openings of your Sun product. Never place a Sun product near a radiator or heat register. Failure to follow these guidelines can cause overheating and affect the reliability of your Sun product.



Caution – The workplace-dependent noise level defined in DIN 45 635 Part 1000 must be 70Db(A) or less.

SELV Compliance

Safety status of I/O connections comply to SELV requirements.

Power Cord Connection



Caution – Sun products are designed to work with single-phase power systems having a grounded neutral conductor. To reduce the risk of electric shock, do not plug Sun products into any other type of power system. Contact your facilities manager or a qualified electrician if you are not sure what type of power is supplied to your building.



Caution – Not all power cords have the same current ratings. Household extension cords do not have overload protection and are not meant for use with computer systems. Do not use household extension cords with your Sun product.



Caution – The AC version of your Sun product is shipped with a grounding type (three-wire) power cord. To reduce the risk of electric shock, always plug the cord into a grounded power outlet.



Caution – In order to remove all power from this unit, disconnect all power cords.



Caution – Netra st D130 units are designed to work with either AC or DC power, depending on the power pack included with the product. Units designed to work with DC power are shipped with a connector to be used with a customer supplied 48V power cord for the customer to connect to the DC power source. Always connect DC powered units to a DC power source only.

The following caution applies only to devices with a Standby power switch:



Caution – The power switch of this product functions as a standby type device only. The power cord serves as the primary disconnect device for the system. Be sure to plug the power cord into a grounded power outlet that is nearby the system and is readily accessible. Do not connect the power cord when the power supply has been removed from the system chassis.

System Unit Cover



Caution – Do not operate Sun products without the top cover in place. Failure to take this precaution may result in personal injury and system damage.

Laser Compliance Notice

Sun products that use laser technology comply with Class 1 laser requirements.

Class 1 Laser Product
Luokan 1 Laserlaitte
Klasse 1 Laser Apparat
Laser Klasse 1

Einhaltung sicherheitsbehördlicher Vorschriften

Auf dieser Seite werden Sicherheitsrichtlinien beschrieben, die bei der Installation von Sun-Produkten zu beachten sind.

Sicherheitsvorkehrungen

Treffen Sie zu Ihrem eigenen Schutz die folgenden Sicherheitsvorkehrungen, wenn Sie Ihr Gerät installieren:

- Beachten Sie alle auf den Geräten angebrachten Warnhinweise und Anweisungen.
- Vergewissern Sie sich, daß Spannung und Frequenz Ihrer Stromquelle mit der Spannung und Frequenz übereinstimmen, die auf dem Etikett mit den elektrischen Nennwerten des Geräts angegeben sind.
- Stecken Sie auf keinen Fall irgendwelche Gegenstände in Öffnungen in den Geräten. Leitfähige Gegenstände könnten aufgrund der möglicherweise vorliegenden gefährlichen Spannungen einen Kurzschluß verursachen, der einen Brand, Stromschlag oder Geräteschaden herbeiführen kann.

Symbole

Die Symbole in diesem Handbuch haben folgende Bedeutung:



Achtung – Gefahr von Verletzung und Geräteschaden. Befolgen Sie die Anweisungen.



Achtung – Hohe Temperatur. Nicht berühren, da Verletzungsgefahr durch heiße Oberfläche besteht.



Achtung – Gefährliche Spannungen. Anweisungen befolgen, um Stromschläge und Verletzungen zu vermeiden.

Ein – Setzt das System unter Wechselstrom.

Je nach Netzschaltertyp an Ihrem Gerät kann eines der folgenden Symbole benutzt werden:



Aus – Unterbricht die Wechselstromzufuhr zum Gerät.



Wartezustand (Stand-by-Position) - Der Ein-/Wartezustand-Schalter steht auf Wartezustand. Änderungen an Sun-Geräten.

Nehmen Sie keine mechanischen oder elektrischen Änderungen an den Geräten vor. Sun Microsystems, übernimmt bei einem Sun-Produkt, das geändert wurde, keine Verantwortung für die Einhaltung behördlicher Vorschriften

Aufstellung von Sun-Geräten



Achtung – Um den zuverlässigen Betrieb Ihres Sun-Geräts zu gewährleisten und es vor Überhitzung zu schützen, dürfen die Öffnungen im Gerät nicht blockiert oder verdeckt werden. Sun-Produkte sollten niemals in der Nähe von Heizkörpern oder Heizluftklappen aufgestellt werden.



Achtung – Der arbeitsplatzbezogene Schalldruckpegel nach DIN 45 635 Teil 1000 beträgt 70Db(A) oder weniger.

Einhaltung der SELV-Richtlinien

Die Sicherung der I/O-Verbindungen entspricht den Anforderungen der SELV-Spezifikation.

Anschluß des Netzkabels



Achtung – Sun-Produkte sind für den Betrieb an Einphasen-Stromnetzen mit geerdetem Nulleiter vorgesehen. Um die Stromschlaggefahr zu reduzieren, schließen Sie Sun-Produkte nicht an andere Stromquellen an. Ihr Betriebsleiter oder ein qualifizierter Elektriker kann Ihnen die Daten zur Stromversorgung in Ihrem Gebäude geben.



Achtung – Nicht alle Netzkabel haben die gleichen Nennwerte. Herkömmliche, im Haushalt verwendete Verlängerungskabel besitzen keinen Überlastungsschutz und sind daher für Computersysteme nicht geeignet.



Achtung – Die Wechselstromversion Ihres Sun-Gerätes wird mit einem dreiadrigen Netzkabel für geerdete Netzsteckdosen geliefert. Um die Gefahr eines Stromschlags zu reduzieren, schließen Sie das Kabel nur an eine fachgerecht verlegte, geerdete Steckdose an.



Achtung – Trennen Sie alle Stromkabel, um die gesamte Stromzufuhr zu diesem Gerät zu unterbrechen.



Achtung – Netra st D130-Einheiten wurden für die Stromversorgung mit Wechsel- oder Gleichstrom entwickelt. Die Stromversorgung hängt vom mitgeliefertem Netzteil ab. Die Einheiten, die mit Gleichstrom betrieben werden, werden mit einem 48V-Stecker geliefert, um dem Kunden den Anschluß an die Gleichstromquelle zu ermöglichen. Schließen Sie Gleichstromeinheiten ausschließlich an Gleichstromquellen an.

Die folgende Warnung gilt nur für Geräte mit Wartezustand-Netzschalter:



Achtung – Der Ein/Aus-Schalter dieses Geräts schaltet nur auf Wartezustand (Stand-By-Modus). Um die Stromzufuhr zum Gerät vollständig zu unterbrechen, müssen Sie das Netzkabel von der Steckdose abziehen. Schließen Sie den Stecker des Netzkabels an eine in der Nähe befindliche, frei zugängliche, geerdete Netzsteckdose an. Schließen Sie das Netzkabel nicht an, wenn das Netzteil aus der Systemeinheit entfernt wurde.

Gehäuseabdeckung



Achtung – Bei Betrieb des Systems ohne obere Abdeckung besteht die Gefahr von Stromschlag und Systemschäden.

Einhaltung der Richtlinien für Laser

Sun-Produkte, die mit Laser-Technologie arbeiten, entsprechen den Anforderungen der Laser Klasse 1.

Class 1 Laser Product
Luokan 1 Laserlaite
Klasse 1 Laser Apparat
Laser Klasse 1

Conformité aux normes de sécurité

Ce texte traite des mesures de sécurité qu'il convient de prendre pour l'installation d'un produit Sun Microsystems.

Mesures de sécurité

Pour votre protection, veuillez prendre les précautions suivantes pendant l'installation du matériel :

- Suivre tous les avertissements et toutes les instructions inscrites sur le matériel.
- Vérifier que la tension et la fréquence de la source d'alimentation électrique correspondent à la tension et à la fréquence indiquées sur l'étiquette de classification de l'appareil.
- Ne jamais introduire d'objets quels qu'ils soient dans une des ouvertures de l'appareil. Vous pourriez vous trouver en présence de hautes tensions dangereuses. Tout objet conducteur introduit de la sorte pourrait produire un court-circuit qui entraînerait des flammes, des risques d'électrocution ou des dégâts matériels.

Symboles

Vous trouverez ci-dessous la signification des différents symboles utilisés :



Attention: – risques de blessures corporelles et de dégâts matériels. Veuillez suivre les instructions.



Attention: – surface à température élevée. Évitez le contact. La température des surfaces est élevée et leur contact peut provoquer des blessures corporelles.



Attention: – présence de tensions dangereuses. Pour éviter les risques d'électrocution et de danger pour la santé physique, veuillez suivre les instructions.



MARCHE – Votre système est sous tension (courant alternatif).

Un des symboles suivants sera peut-être utilisé en fonction du type d'interrupteur de votre système:



ARRÊT - Votre système est hors tension (courant alternatif).



VEILLEUSE – L'interrupteur Marche/Veilleuse est en position « Veilleuse ».

Modification du matériel

Ne pas apporter de modification mécanique ou électrique au matériel. Sun Microsystems n'est pas responsable de la conformité réglementaire d'un produit Sun qui a été modifié.

Positionnement d'un produit Sun



Attention: – pour assurer le bon fonctionnement de votre produit Sun et pour l'empêcher de surchauffer, il convient de ne pas obstruer ni recouvrir les ouvertures prévues dans l'appareil. Un produit Sun ne doit jamais être placé à proximité d'un radiateur ou d'une source de chaleur.



Attention: – Le niveau de pression acoustique au poste de travail s'élève selon la norme DIN 45 635 section 1000, à 70 dB (A) ou moins.

Conformité SELV

Sécurité : les raccordements E/S sont conformes aux normes SELV.

Connexion du cordon d'alimentation



Attention: – les produits Sun sont conçus pour fonctionner avec des alimentations monophasées munies d'un conducteur neutre mis à la terre. Pour écarter les risques d'électrocution, ne pas brancher de produit Sun dans un autre type d'alimentation secteur. En cas de doute quant au type d'alimentation électrique du local, veuillez vous adresser au directeur de l'exploitation ou à un électricien qualifié.



Attention: – tous les cordons d'alimentation n'ont pas forcément la même puissance nominale en matière de courant. Les rallonges d'usage domestique n'offrent pas de protection contre les surcharges et ne sont pas prévues pour les systèmes d'ordinateurs. Ne pas utiliser de rallonge d'usage domestique avec votre produit Sun.



Attention: – La version pour courant alternatif de votre produit Sun a été livrée équipée d'un cordon d'alimentation à trois fils (avec prise de terre). Pour écarter tout risque d'électrocution, branchez toujours ce cordon dans une prise mise à la terre.



Attention: – Pour mettre le système hors tension, il est impératif de débrancher tous les cordons d'alimentation.



Attention: – les unités Netra st D130 sont conçues pour fonctionner avec une alimentation en courant alternatif ou en courant continu, selon le bloc d'alimentation inclus avec le produit. Les unités conçues pour fonctionner en courant continu sont livrées avec un connecteur pour cordon d'alimentation 48 V (non fourni) que le client utilisera pour connecter l'unité à la source d'alimentation CC. Connectez toujours les unités alimentées en courant continu à une source d'alimentation CC, à l'exclusion de toute autre.

L'avertissement suivant s'applique uniquement aux systèmes équipés d'un interrupteur VEILLEUSE:



Attention: – le commutateur d'alimentation de ce produit fonctionne comme un dispositif de mise en veille uniquement. C'est la prise d'alimentation qui sert à mettre le produit hors tension. Veuillez donc à installer le produit à proximité d'une prise murale facilement accessible. Ne connectez pas la prise d'alimentation lorsque le châssis du système n'est plus alimenté.

Couvercle



Attention: – il est dangereux de faire fonctionner un produit Sun sans le couvercle en place. Si l'on néglige cette précaution, on encourt des risques de blessures corporelles et de dégâts matériels.

Conformité aux certifications Laser

Les produits Sun qui font appel aux technologies lasers sont conformes aux normes de la classe 1 en la matière.

Class 1 Laser Product
Luokan 1 Laserlaitte
Klasse 1 Laser Apparat
Laser Klasse 1

Normativas de seguridad

El siguiente texto incluye las medidas de seguridad que se deben seguir cuando se instale algún producto de Sun Microsystems.

Precauciones de seguridad

Para su protección observe las siguientes medidas de seguridad cuando manipule su equipo:

- Siga todas las avisos e instrucciones marcados en el equipo.
- Asegúrese de que el voltaje y la frecuencia de la red eléctrica concuerdan con las descritas en las etiquetas de especificaciones eléctricas del equipo.
- No introduzca nunca objetos de ningún tipo a través de los orificios del equipo. Pueden haber voltajes peligrosos. Los objetos extraños conductores de la electricidad pueden producir cortocircuitos que provoquen un incendio, descargas eléctricas o daños en el equipo.

Símbolos

En este libro aparecen los siguientes símbolos:



Precaución – Existe el riesgo de lesiones personales y daños al equipo. Siga las instrucciones.



Precaución – Superficie caliente. Evite el contacto. Las superficies están calientes y pueden causar daños personales si se tocan.



Precaución – Voltaje peligroso presente. Para reducir el riesgo de descarga y daños para la salud siga las instrucciones.



Encendido – Aplica la alimentación de CA al sistema.

Según el tipo de interruptor de encendido que su equipo tenga, es posible que se utilice uno de los siguientes símbolos:



Apagado - Elimina la alimentación de CA del sistema.



En espera – El interruptor de Encendido/En espera se ha colocado en la posición de En espera.

Modificaciones en el equipo

No realice modificaciones de tipo mecánico o eléctrico en el equipo. Sun Microsystems no se hace responsable del cumplimiento de las normativas de seguridad en los equipos Sun modificados.

Ubicación de un producto Sun



Precaución – Para asegurar la fiabilidad de funcionamiento de su producto Sun y para protegerlo de sobrecalentamientos no deben obstruirse o taparse las rejillas del equipo. Los productos Sun nunca deben situarse cerca de radiadores o de fuentes de calor.



Precaución – De acuerdo con la norma DIN 45 635, Parte 1000, se admite un nivel de presión acústica para puestos de trabajo máximo de 70Db(A).

Cumplimiento de la normativa SELV

El estado de la seguridad de las conexiones de entrada/salida cumple los requisitos de la normativa SELV.

Conexión del cable de alimentación eléctrica



Precaución – Los productos Sun están diseñados para trabajar en una red eléctrica monofásica con toma de tierra. Para reducir el riesgo de descarga eléctrica, no conecte los productos Sun a otro tipo de sistema de alimentación eléctrica. Póngase en contacto con el responsable de mantenimiento o con un electricista cualificado si no está seguro del sistema de alimentación eléctrica del que se dispone en su edificio.



Precaución – No todos los cables de alimentación eléctrica tienen la misma capacidad. Los cables de tipo doméstico no están provistos de protecciones contra sobrecargas y por tanto no son apropiados para su uso con computadores. No utilice alargadores de tipo doméstico para conectar sus productos Sun.



Precaución – Con la versión para CA del producto Sun se proporciona un cable de alimentación con toma de tierra. Para reducir el riesgo de descargas eléctricas conéctelo siempre a un enchufe con toma de tierra.



Precaución – Para cortar el suministro eléctrico de esta unidad, desconecte todos los cables de alimentación.



Precaución – El diseño de las unidades Netra st D130 permite su funcionamiento con alimentación de CA o CC, según el tipo de alimentación para el que esté preparado su producto. Las unidades destinadas a su funcionamiento con CC se entregan con un conector que debe usarse con un cable de alimentación de 48 V del cliente, a fin de que este último se pueda conectar a la fuente de alimentación de CC. Conecte siempre las unidades preparadas para CC únicamente a fuentes de alimentación de CC.

La siguiente advertencia se aplica solamente a equipos con un interruptor de encendido que tenga una posición "En espera":



Precaución – El interruptor de encendido de este producto funciona exclusivamente como un dispositivo de puesta en espera. El enchufe de la fuente de alimentación está diseñado para ser el elemento primario de desconexión del equipo. El equipo debe instalarse cerca del enchufe de forma que este último pueda ser fácil y rápidamente accesible. No conecte el cable de alimentación cuando se ha retirado la fuente de alimentación del chasis del sistema.

Tapa de la unidad del sistema



Precaución – Es peligroso hacer funcionar los productos Sun sin la tapa superior colocada. El hecho de no tener en cuenta esta precaución puede ocasionar daños personales o perjudicar el funcionamiento del equipo.

Aviso de cumplimiento con requisitos de láser

Los productos Sun que utilizan la tecnología de láser cumplen con los requisitos de láser de Clase 1.

Class 1 Laser Product
Luokan 1 Laserlaite
Klasse 1 Laser Apparat
Laser Klasse 1

GOST-R Certification Mark

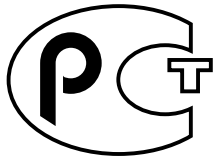

Netra st D130 Storage Enclosure Overview

This chapter describes the Netra st D130 storage enclosure hardware, except for the hard drives. For information on the drives, refer to the documents that you received with them. The Netra st D130 disk unit is a single-ended UltraSCSI unit that is 1.73 inches (or 1U) in height. The thinness of the unit enables you to stack up to 40 units in a single 72-inch tall rack. The Netra st D130 storage enclosure has a single power supply (available in AC or DC versions) and up to three hot-pluggable, single-ended UltraSCSI hard disk drives.

This chapter is organized as follows:

- “Components at the Front of the Enclosure” on page 2
- “Components at the Back of the Enclosure” on page 4
- “Internal Components” on page 8

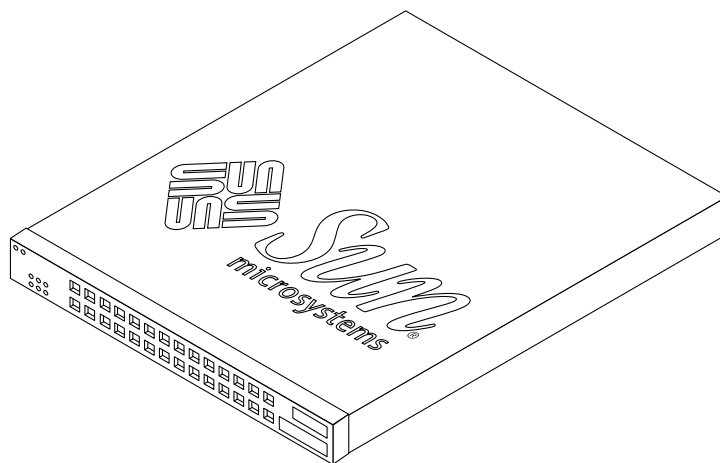

FIGURE 1-1 Netra st D130 Storage Enclosure

Components at the Front of the Enclosure

Front Panel

The front panel can be removed to allow access to the hard disk drives. The Netra st D130 storage enclosure can accept up to three 1-inch high drives.

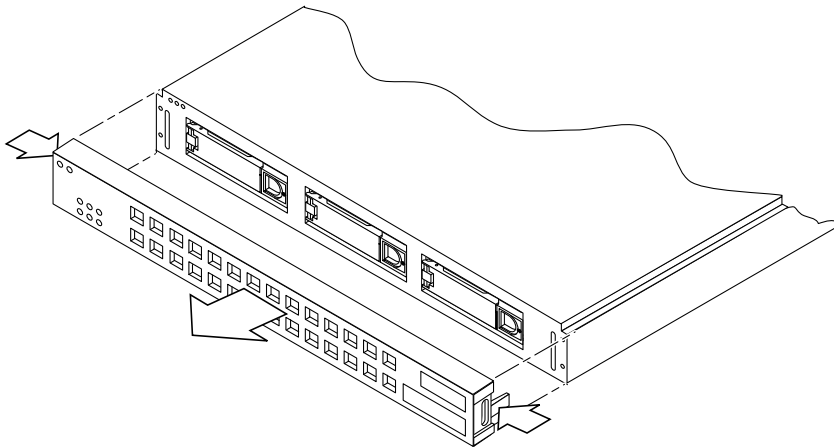

FIGURE 1-2 Removing the Front Panel

Front Panel LEDs

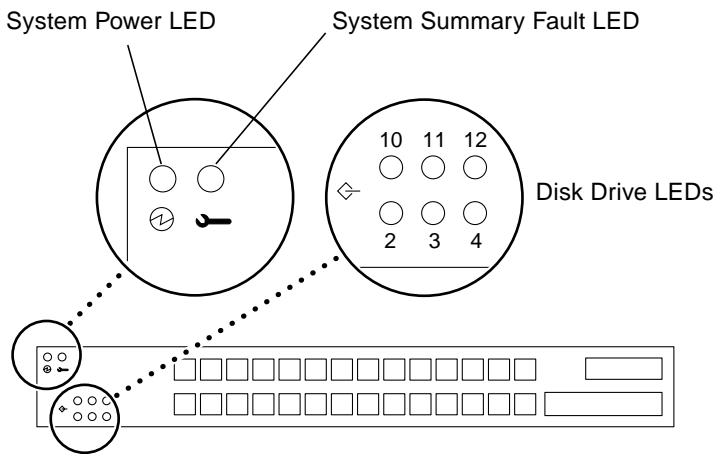

FIGURE 1-3 Front Panel LEDs

TABLE 1-1 Front Panel LEDs

LED	Color	Meaning	Action
System Power	Green	The enclosure is powered on.	No action is necessary.
	Unlit	The enclosure is powered off.	No action is necessary.
System Summary Fault	Green	The enclosure is performing normally.	No action is necessary.
	Amber	A component other than a disk drive has failed, such as the power supply or a fan. The System Summary Fault LED does not indicate if a disk drive has failed. The Disk Drive LEDs give diagnostic information on the disk drives.	You must replace the entire Netra st D130 storage enclosure. Remove all disk drives before returning the enclosure (see “To Remove a Disk Drive” on page 39). Contact your local Sun service representative for more details.

TABLE 1-1 Front Panel LEDs (Continued)

LED	Color	Meaning	Action
Disk Drive	Solid green	A disk drive is present in that slot but is not active. The Disk Drive LED also gives the SCSI ID for that disk drive.	No action is necessary.
	Flashing green	A disk drive is present in that slot and is active.	No action is necessary.
	Unlit	No disk drive is present in that slot, or the disk drive has failed.	If a disk drive is present in that slot and the Disk Drive LED is unlit, then you must replace the disk drive. See "Removing and Replacing a Disk Drive" on page 39.

Note – If a disk drive is under an unusually heavy load (for example, if the drive is being reformatted), the Disk Drive LED may be unlit for a long period of time, even though the drive has not failed. You should see a message in your console window telling you that the disk drive is offline if the disk drive has truly failed.

Components at the Back of the Enclosure

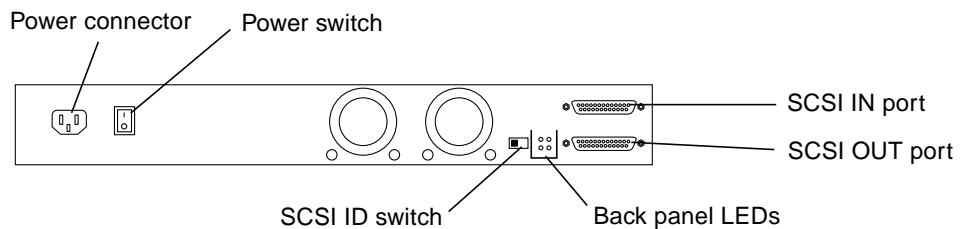

FIGURE 1-4 Netra st D130, Rear View

Power Switch

The Netra st D130 storage enclosure has one rocker power switch to control the power supply.

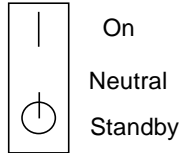

FIGURE 1-5 Power Switch

- On – The power supply provides power to the enclosure.
- Neutral – When the switch is released from the ON position, the switch settles into the Neutral position and the power supplies remain on.
- Standby – The power supply does not provide power to the enclosure.



Caution – Placing the power switch in the Standby position does not completely remove power to the enclosure. AC or DC input will continue to flow to the power supply until you unplug the power cable from the electrical outlet.

SCSI ID Switch

The SCSI ID switch sets the SCSI IDs for the disk drives.

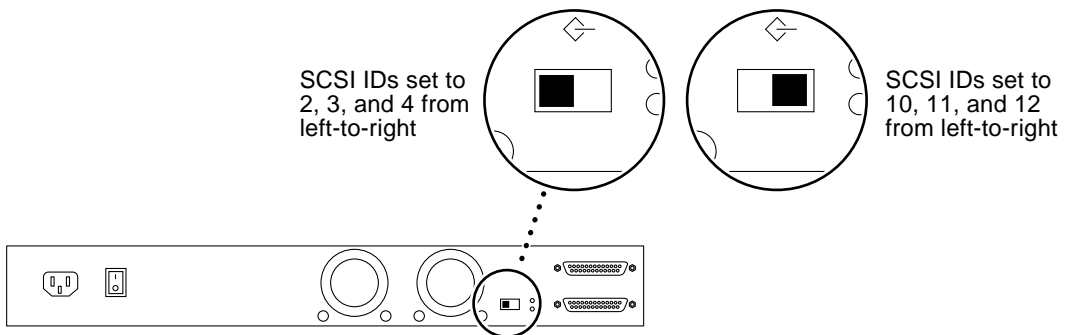

FIGURE 1-6 SCSI ID Switch

Back Panel LEDs

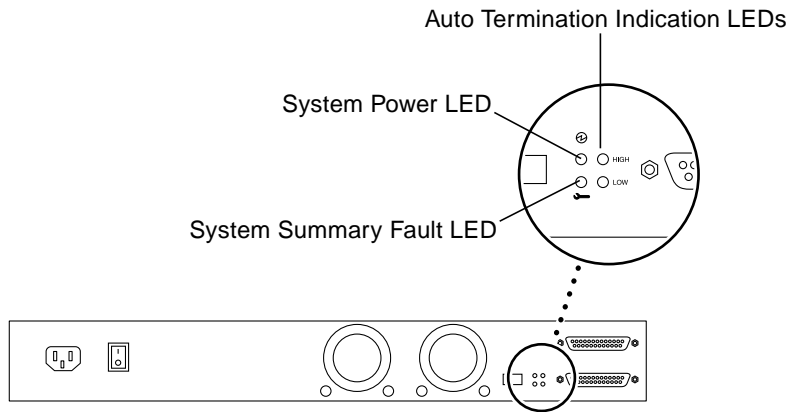

FIGURE 1-7 Back Panel LEDs

System Power and System Summary Fault LEDs

The System Power and System Summary Fault LEDs give the same diagnostic information as the System Power and System Summary Fault LEDs at the front of the enclosure. Refer to TABLE 1-1 on page 3 for more information.

Auto Termination Indication LEDs

The Auto Termination Indication LEDs indicate if the Netra st D130 storage enclosure is part of an UltraSCSI, wide SCSI or narrow SCSI daisy-chain. It also indicates its position in the daisy-chain.

TABLE 1-2 Auto Termination Indication LEDs

High	Low	Meaning
Off	Off	The Netra st D130 storage enclosure is the first device in the UltraSCSI or wide SCSI daisy-chain; another device follows it.
On	On	The Netra st D130 storage enclosure is the last or only device in the UltraSCSI or wide SCSI daisy-chain.
On	Off	A narrow SCSI device follows the Netra st D130 storage enclosure in the daisy-chain.
Off	On	N/A

Note – UltraSCSI devices (such as the Netra st D130 storage enclosure) at the end of a daisy-chain do not require a terminator, but some wide SCSI devices at the end of a daisy-chain do require a terminator. Refer to the documentation that came with your wide SCSI device to determine if it needs a terminator or not. Narrow SCSI devices at the end of a daisy-chain always require a terminator.

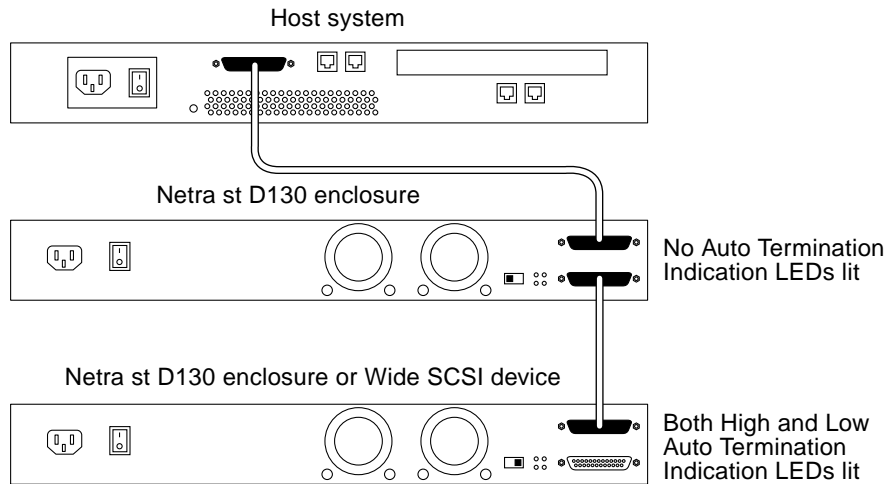

FIGURE 1-8 Auto Termination Indication LEDs Lit in UltraSCSI or Wide SCSI Daisy-Chain

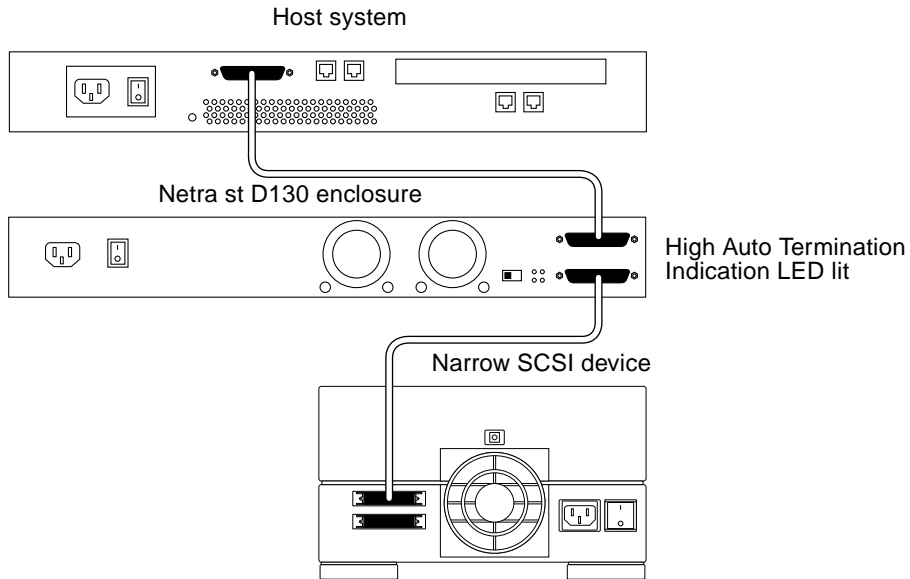

FIGURE 1-9 Auto Termination Indication LEDs Lit in a Narrow SCSI Daisy-Chain

Internal Components

Power Supply

The Netra st D130 storage enclosure has a single power supply that provides power to the internal components. The power supply in your system is either AC- or DC-powered.

AC Version

The power supplies on the AC version convert incoming AC voltage to outgoing DC voltages.

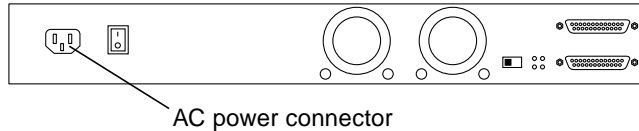

FIGURE 1-10 Netra st D130 Rear View (AC Version)

DC Version

The power supply on the DC version converts incoming -48 VDC voltage to outgoing DC voltages. The DC version has two connectors so you can connect a single Netra st D130 storage enclosure to two different -48V DC power sources. Each DC power source should have a 10-amp circuit breaker.

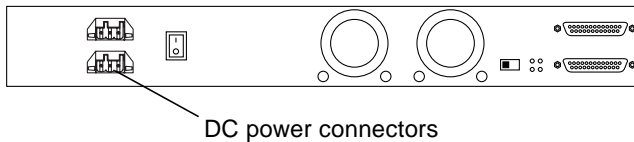

FIGURE 1-11 Netra st D130 Rear View (DC Version)

Cooling System

The cooling requirements are as follows:

1. Ensure adequate airflow through the system. The internal fans can achieve a maximum airflow of approximately 30 cfm in free air.
2. The air is drawn through the front of the enclosure and expelled from the rear of the enclosure.

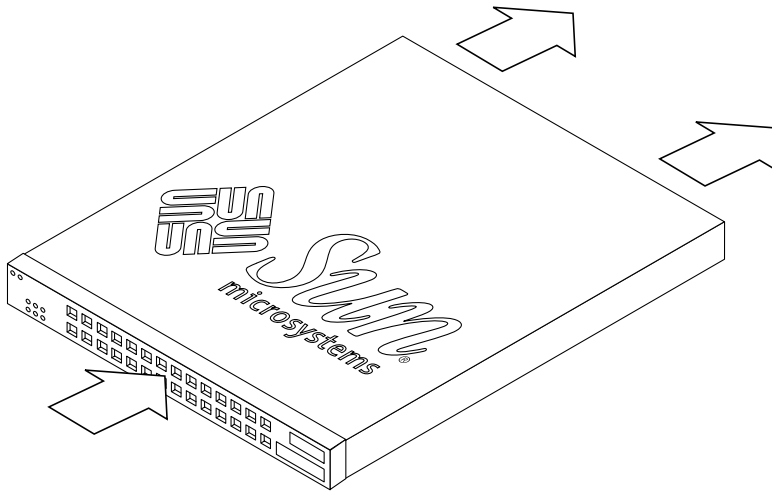

FIGURE 1-12 Airflow Requirements (Front and Rear)

3. Airflow requirements differ for an open-rack system and a closed-rack system, as shown in the following illustrations.

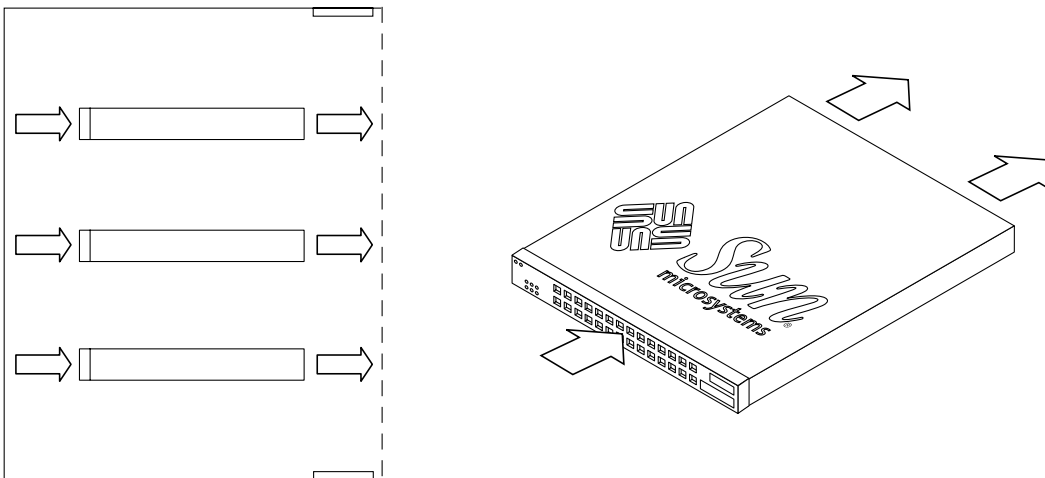

FIGURE 1-13 Airflow Requirements (Open Rack)

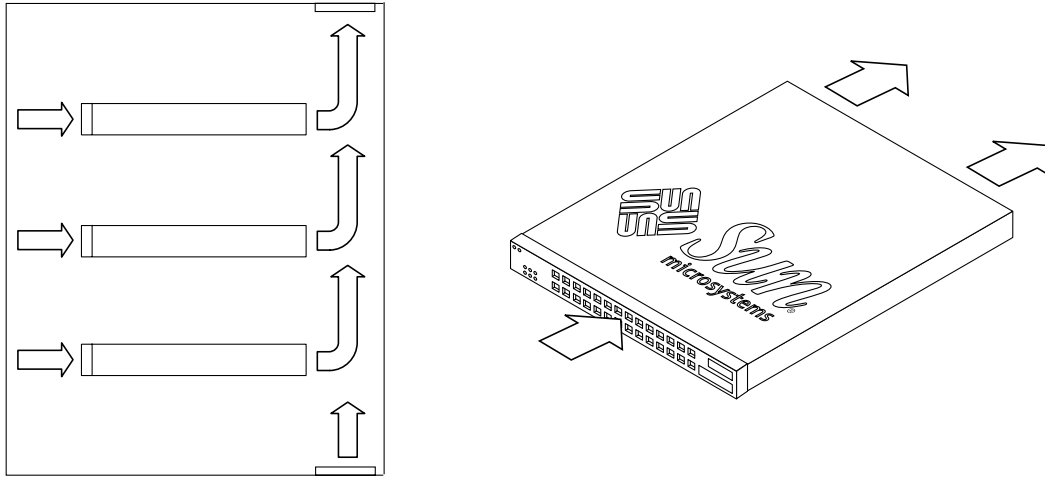

FIGURE 1-14 Airflow Requirements (Closed Rack)



Caution – If the Netra st D130 storage enclosure is installed in a closed or multi-unit rack assembly, the operating ambient temperature of the rack environment may exceed the room ambient. Ensure that the rack environment ambient temperature does not exceed 55° Celsius (131° Fahrenheit).

Disk Drives

The disk drives in the Netra st D130 storage enclosure are all hot-pluggable. See the documentation that comes with your system for information about the drives installed in your system. The SCSI IDs for the disk drives in the Netra st D130 storage enclosure are set using the SCSI ID switch at the rear of the enclosure. Refer to the drive LEDs on the front of the Netra st D130 storage enclosure or the SCSI ID switch at the rear of the enclosure to determine the SCSI IDs that you have assigned to the drives in your enclosure.

Foam Fillers

If you ordered a Netra st D130 storage enclosure with fewer than three disk drives, foam fillers occupy the holes for the empty slots. The foam fillers are air baffles. They allow the storage enclosure to maintain maximum cooling. If any slot does not contain a disk drive, you must fill the slot with a foam filler so the unit will cool properly.

Netra st D130 Software Considerations

The Netra st D130 storage enclosure can be used as additional disk storage for an existing host system; it can also be used in conjunction with Veritas VxVm or the Solstice DiskSuite™ software in a RAID-based system.

Electrical Requirements and Cable Assembly

This chapter provides electrical information for both the AC- and DC-powered versions of the Netra st D130 storage enclosure.

This chapter is organized as follows:

- “AC Source Site Requirements” on page 13
- “DC Source Site Requirements” on page 14
- “Assembling the DC Input Power Cable” on page 16
- “Isolating the Chassis Ground Connection” on page 23

AC Source Site Requirements

TABLE 2-1 AC Power Requirements

Electrical Element	Requirement
Voltage	100 VAC to 240 VAC (nominal)
Frequency	47–63 Hz
Input current	< 2.0 amps @ 100 VAC (150 W)
Max. surge current	100 amp peaks

- Overcurrent protection devices must be provided as part of each host equipment rack.
- Circuit breakers are located between the AC source and the Netra st D130 storage enclosure.

- Circuit breakers must not trip when presented with inrush current of 100 amps lasting 5 ms.

Note – Overcurrent protection devices must meet applicable national and local electrical safety codes and be approved for the intended application.

You can disconnect the power for servicing in any of the following ways:

- Disconnect the power cord from the connector on the AC power supply at the rear of the enclosure.
- Turn off the circuit breakers in the rack where the enclosure is mounted.
- Disconnect the main plug from the AC source.

Ensure that all methods of disconnecting the power remain accessible after installation.



Caution – External filtering and surge suppression devices may be required on the power feeds where branch circuit electromagnetic characteristics are unknown.

DC Source Site Requirements

TABLE 2-2 DC Power Requirements

Electrical Element	Requirement
Voltage	-48 VDC
Input current	< 4.0 amps @ -40 VDC (150 W)
Max. input surge current	20 amps peaks

- Electrically isolated from any AC source
- Reliably connected to earth (the battery room positive bus is connected to ground)
- Capable of providing up to 200 watts of continuous power per feed pair

Note – The DC version of the Netra st D130 storage enclosure must be installed in a *restricted access location*. Per the intent of the National Electrical Code, a restricted access location is an area intended for qualified or trained personnel only and has access controlled by some sort of locking mechanism, such as a key lock or an access card system.

Overcurrent Protection Requirements

- Overcurrent protection devices must be provided as part of each equipment rack.
- Circuit breakers must be located between the DC power source and the Netra st D130 storage enclosure. You should use two 10-amp double-pole fast trip DC-rated circuit breakers for each power supply.

Note – Overcurrent protection devices must meet applicable national and local electrical safety codes and be approved for the intended application.

DC Supply and Ground Conductor Requirements

- Suitable conductor material: copper only
- Power supply connections through the input connector: 12 AWG (between the Netra st D130 and the circuit breaker). There are three conductors:
 - -48V
 - Ground connection to the power supply
 - -48V Return
- System ground conductor: 8 AWG (to be connected to the chassis)
- Cable insulation rating: minimum of 75C, low smoke fume (LSF), flame retardant
- Cable type to be one of the following:
 - UL style 1028 or other UL 1581(VW-1) compliant equivalent
 - IEEE 383 compliant
 - IEEE 1202-1991 compliant
- Branch circuit cable insulation color: per applicable National Electrical Codes
- Grounding cable insulation color: green/yellow

Assembling the DC Input Power Cable

Follow these instructions to assemble the DC input power cable, which will be used to connect the DC power supply in your Netra st D130 storage enclosure to the DC power source.

Required Connection Materials

The following DC connection materials are provided with every Netra st D130 storage enclosure for connection to the -48V DC power source:

- Four WAGO DC connectors (two DC connectors for input cables and two spare DC connectors)
- Four WAGO DC strain relief housings (two strain relief housings for input cables and two spare strain relief housings)
- One cage clamp operating lever
- Four tie wraps

The following figures show the DC connector, strain relief housing, and cage clamp operating lever. You can order additional DC connection materials through Sun Microsystems (X949A).

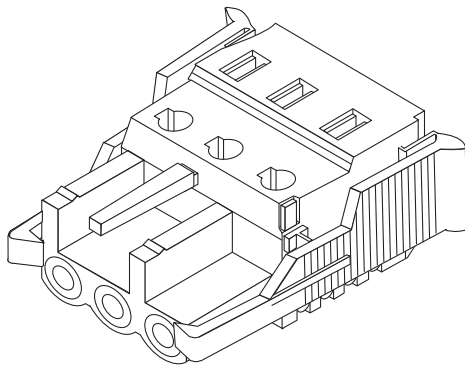

FIGURE 2-1 DC Connector

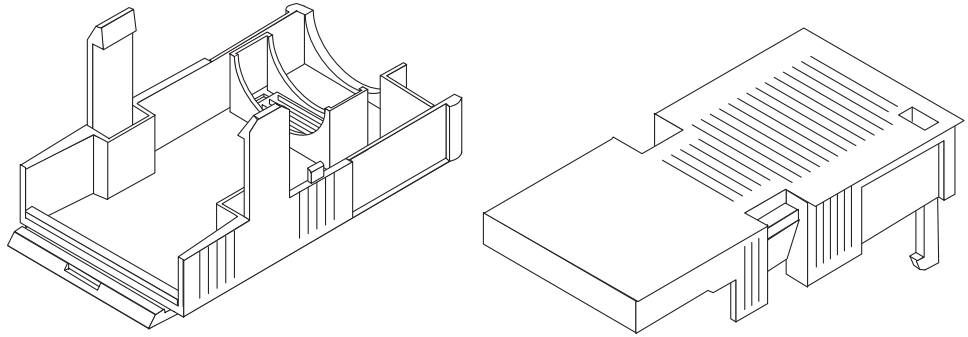

FIGURE 2-2 Strain Relief Housing

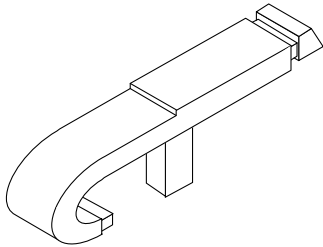

FIGURE 2-3 Cage Clamp Operating Lever

The following figure shows the power connector on the DC power supply.

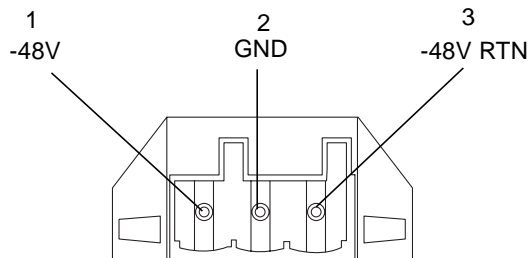

FIGURE 2-4 Power Connector on the DC Power Supply

▼ To Assemble the DC Input Power Cable

1. Turn off power to the DC power source through the circuit breakers.



Caution – Do *not* proceed with these instructions until you have turned off the power to the DC power source through the circuit breakers.

2. Get a DC connector from the ship kit.
3. Locate the three wires coming from the DC power source that will be used in the connection to your unit:
 - -48V
 - GND (Ground)
 - -48V Return
4. Strip 5/16 of an inch (8 mm) of insulation from each of the wires coming from the DC power source.

Do not strip more than 5/16 of an inch (8 mm) from each wire. Doing so will leave uninsulated wire exposed from the DC connector after the assembly is complete.

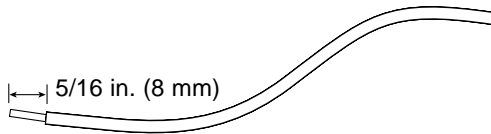

FIGURE 2-5 Stripping the Insulation From the Wire

5. Insert the tip of the cage clamp operating lever into the rectangular hole directly above the hole in the DC connector where you want to insert the first wire and press down on the cage clamp operating lever.

This opens the cage clamp for this section of the DC connector.

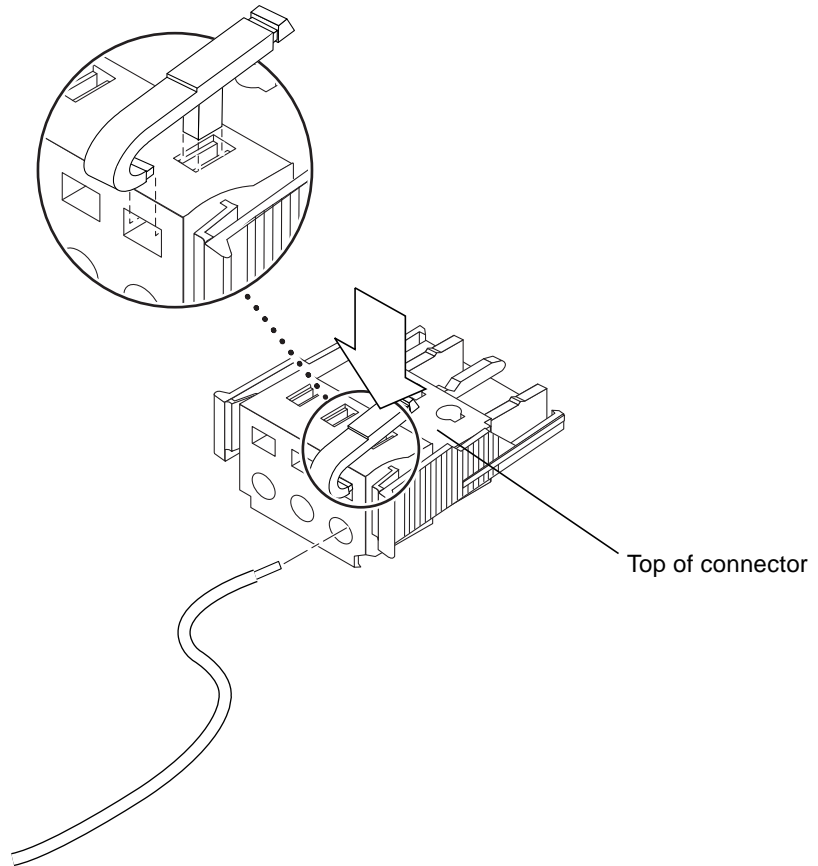

FIGURE 2-6 Opening the DC Connector Cage Clamp Using the Cage Clamp Operating Lever

You can also open the DC connector cage clamp by inserting a small flat-blade screwdriver into the rectangular hole directly above the hole in the DC connector where you want to insert the first wire and pressing down on the screwdriver.

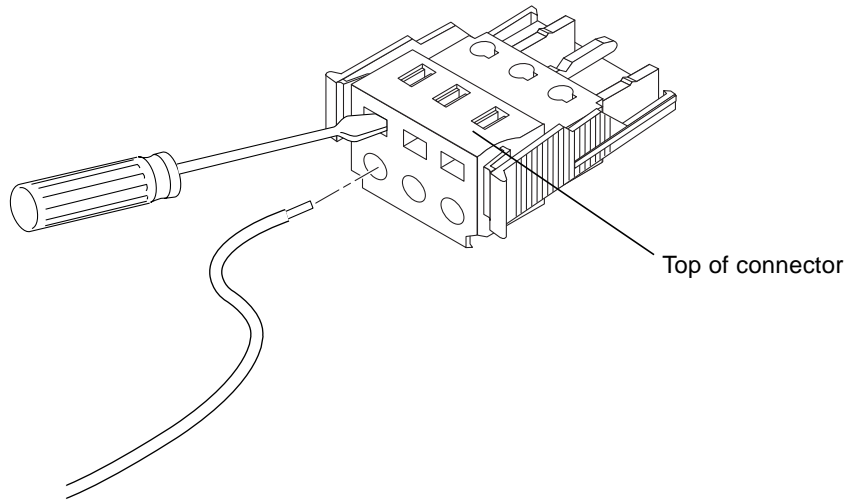

FIGURE 2-7 Opening the DC Connector Cage Clamp Using a Screwdriver

- 6. Feed the exposed section of the appropriate wire into that hole in the DC connector.**

FIGURE 2-8 shows which wires should be inserted into each hole in the DC connector.

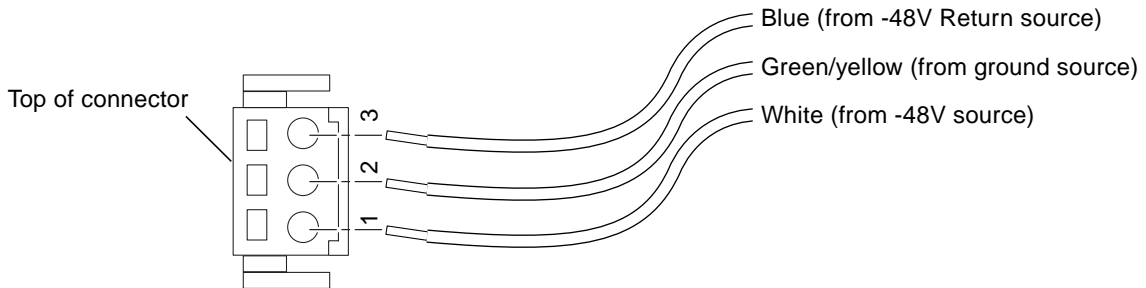

FIGURE 2-8 Assembling the DC Input Power Cable

- 7. Repeat Step 5 and Step 6 for the other two wires to complete the assembly of the DC input power cable.**

- 8. Repeat Step 3 through Step 7 to create a second DC input power cable.**

The first DC input power cable should be connected to DC power source A and the second DC input power cable should be connected to DC power source B.

If you need to remove a wire from the DC connector, insert the cage clamp operating lever or a small screwdriver into the slot directly above the wire and press down (FIGURE 2-6 and FIGURE 2-7).

▼ To Install the Strain Relief Housings

1. **Take the DC connector and insert the bottom portion of the strain relief housing into the notch on the DC connector until it snaps into place.**

Make sure the strain relief housing snaps into place on the DC connector; you will not be able to complete the assembly correctly if the strain relief housing is not secure.

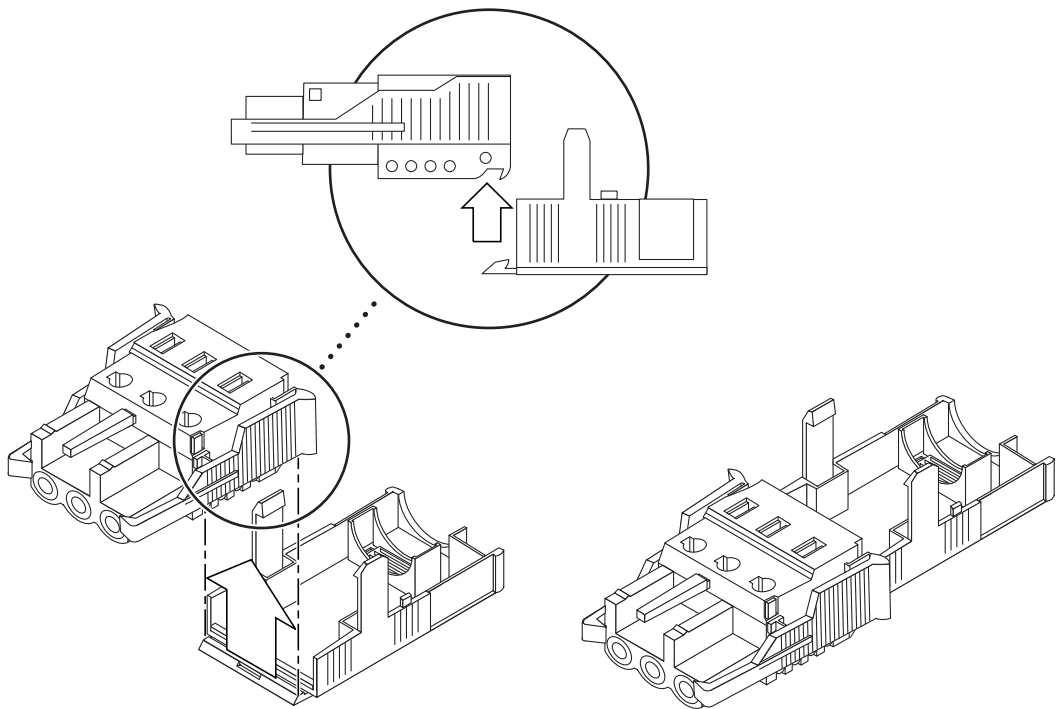

FIGURE 2-9 Inserting the Bottom Portion of the Strain Relief Housing

2. **Route the three wires coming from the DC power source through the opening at the end of the bottom portion of the strain relief housing.**

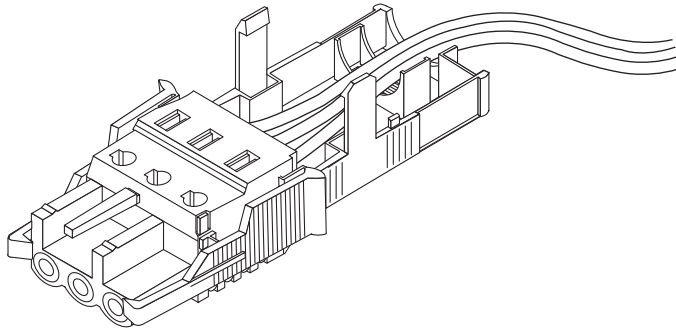

FIGURE 2-10 Routing the Wires Out of the Bottom Portion of the Strain Relief Housing

- 3. Get the tie wrap and insert it into the bottom portion of the strain relief housing.**

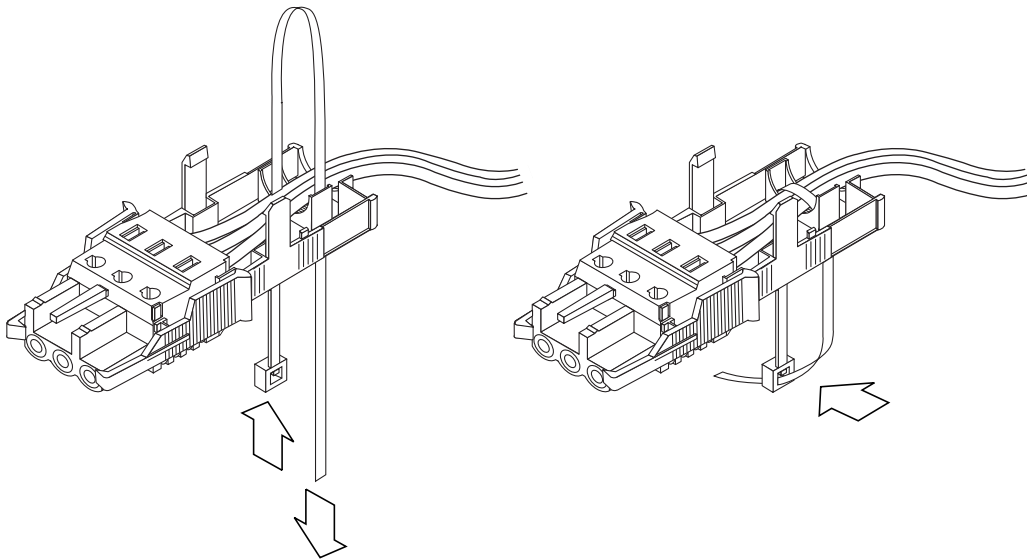

FIGURE 2-11 Securing the Wires to the Strain Relief Housing

- 4. Loop the tie wrap over the wires and back out of the strain relief housing and tighten the tie wrap to secure the wires to the strain relief housing.**
- 5. Lower the top portion of the strain relief housing so that the three prongs on the top portion insert into the openings in the DC connector, and push the top and bottom portions of the strain relief housing together until they snap into place.**

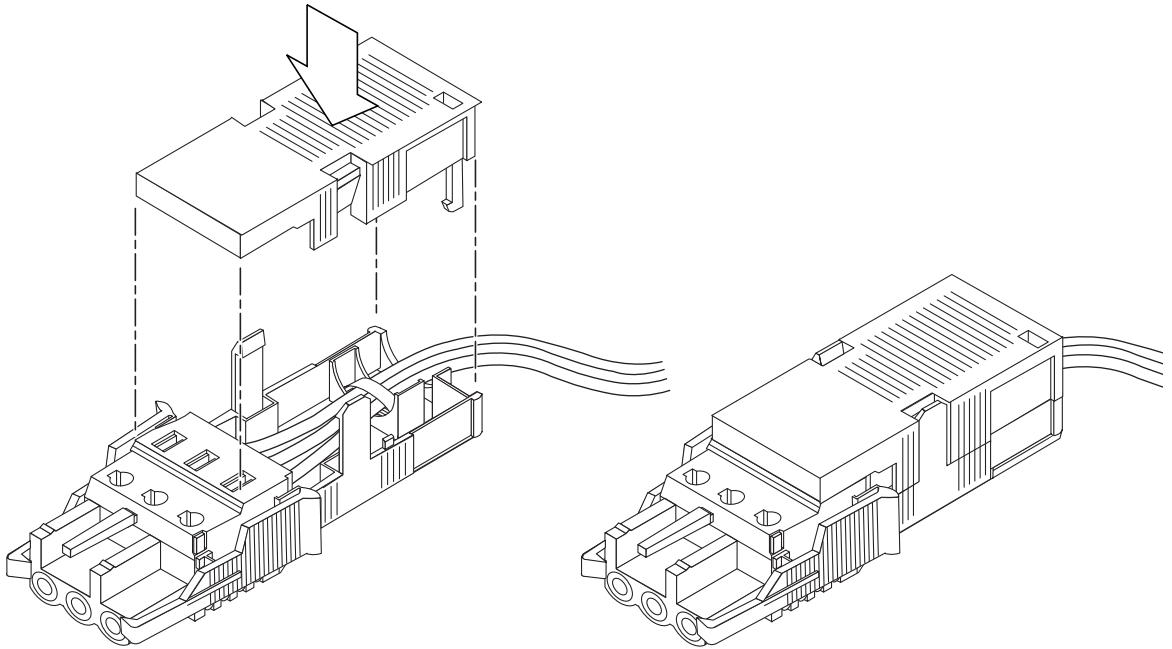

FIGURE 2-12 Assembling the Strain Relief Housing

Isolating the Chassis Ground Connection

Every Netra st D130 storage enclosure is shipped out of the factory with the chassis ground connected to the common output return through two screws on the power supply at the rear of the enclosure. If you want to isolate this connection, follow the instructions in the *Netra st D130 Product Notes*.

Installing the Netra st D130 Storage Enclosure

This chapter provides instructions on how to prepare the area, connect the cables, and power on the storage enclosure.

This chapter is organized as follows:

- “Hardware Requirements” on page 25
 - “Preparing for Installation” on page 26
 - “Installing the Netra st D130 Storage Enclosure” on page 27
 - “Powering On and Off” on page 33
-

Hardware Requirements

The following hardware is included with every Netra st D130 storage enclosure:

- UltraSCSI cables
- Power connections, depending on the type of storage enclosure:
 - AC version – one AC power cord
 - DC version – four DC connectors are provided to form input cables for connecting to DC sources with a 10-amp breaker for each source (two DC connectors for input cables and two spare DC connectors). Four strain relief housings (two for the input cables and two spares) and one cage clamp operating lever are also included.

You must also have the following hardware at your site to successfully install your Netra st D130 storage enclosure:

- A host system with a single-ended UltraSCSI on-board port, or
- A host adapter board installed in the host system. For Netra systems, use either of the following boards:
 - SunSwift™ 10/100 Ethernet/UltraSCSI PCI adapter, Model X1032A
 - Dual-channel single-ended UltraSCSI PCI adapter, Model X6540A

For UltraSCSI functionality, the host or host adapter to which you connect your Netra st D130 storage enclosure must be capable of UltraSCSI speeds. You can connect a Netra st D130 storage enclosure to a wide or narrow SCSI-capable host adapter, but in such a case, the enclosure performs at a lower speed.

Preparing for Installation

Before you can install the Netra st D130 storage enclosure, you must first prepare your host system and set the SCSI IDs for the drives.

▼ To Prepare the Host System

1. **Read any Product Notes for updated product information.**
2. **Prepare the site for the installation, including determining site power and sizing requirements.**
Refer to Appendix A for power, size, and weight statistics.
3. **Halt operations and power off your host system.**
Refer to your host system documentation for instructions on powering off the system.
4. **Install a host adapter card into your host system, if necessary.**
Refer to the documentation that shipped with the adapter card for installation instructions.
5. **Have software documents (on the system CD) available during the installation.**

▼ To Set the SCSI IDs for the Drives

1. Determine which SCSI target addresses are available on your host system.

Refer to the *Solaris Handbook for Sun Peripherals* in the *Solaris AnswerBook* online documentation for information on how to determine which SCSI target IDs are available for your system.

2. At the rear of the enclosure, locate the SCSI ID switch.

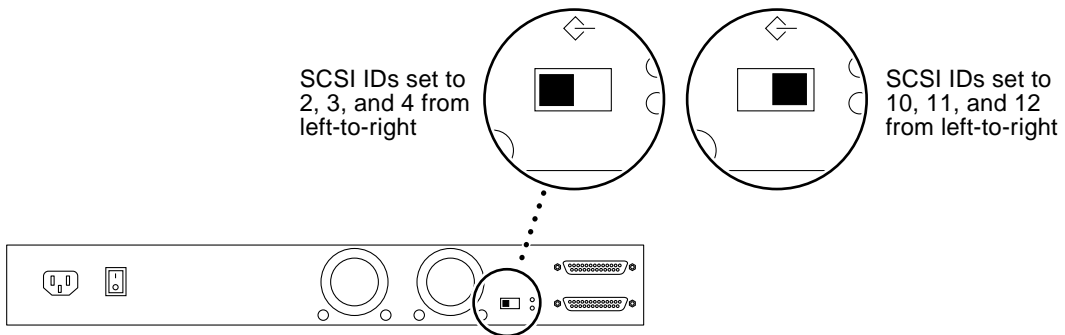

FIGURE 3-1 Locating the SCSI ID Switch

3. Move the SCSI ID switch to the setting that you want to use to set the SCSI IDs for the disk drives in the Netra st D130 storage enclosure.

Verify that the SCSI IDs that you want to use for the drives in your Netra st D130 storage enclosure are not being used already by your host system or by other peripherals connected to your host system. If you are daisy-chaining two Netra st D130 storage enclosures together, you must set the enclosures to two different SCSI ID settings.

Installing the Netra st D130 Storage Enclosure

Mounting the Storage Enclosure in a Rack

Refer to the *Netra st D130 Product Notes* for instructions on mounting the Netra st D130 storage enclosure into a rack.

Connecting the SCSI Cables

▼ To Connect the SCSI Cables

1. Verify that the host system has been powered down.

Refer to “To Prepare the Host System” on page 26 for more information.

2. Get the 2-meter SCSI cable from the ship kit and connect one end of the SCSI cable to your host system.

You can connect the SCSI cable to an UltraSCSI PCI host adaptor or the on-board SCSI port, as long as it's an UltraSCSI port. Refer to the documentation that came with your host system for the location of the UltraSCSI port on the host system.

3. Connect the other end of the SCSI cable to the SCSI IN port at the rear of the Netra st D130 storage enclosure.

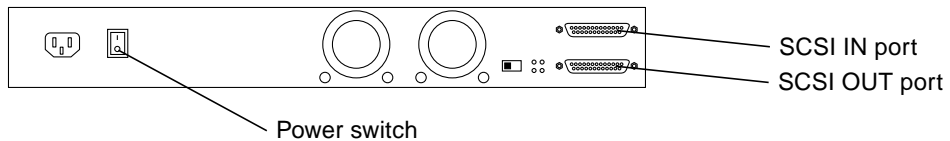

FIGURE 3-2 Netra st D130 Rear View (AC Version)

4. Determine if this Netra st D130 storage enclosure is at the beginning or the end of the SCSI chain.

- If this storage enclosure is at the *end* of the SCSI chain (you are not connecting any other peripherals to your host system), go to “Connecting the Power Cable” on page 30.
- If this storage enclosure is at the *beginning* of the SCSI chain (if you are going to daisy-chain another Netra st D130 storage enclosure or peripheral off of this one), keep the following things in mind:
 - You cannot daisy-chain more than two Netra st D130 storage enclosures together.
 - You must verify that the SCSI IDs assigned to the disk drives in the second Netra st D130 storage enclosure or other peripheral are not already being used anywhere else in the daisy-chain. Refer to “To Set the SCSI IDs for the Drives” on page 27 for the SCSI IDs used for the disk drives in Netra st D130 storage enclosures. Refer to the *Solaris Handbook for Sun Peripherals* available in the *Solaris AnswerBook* online documentation for information on how to determine which SCSI target IDs are available for your system.

Keep in mind that if you connected the SCSI cable to the on-board UltraSCSI port on your host system, you must verify that the SCSI IDs assigned to the disk drives in the second Netra st D130 storage enclosure or peripheral are not already being used by any peripherals installed in the host system.

- The overall SCSI bus length cannot exceed 6 meters. The SCSI bus length for the cables inside the Netra st D130 storage enclosure is 1 meter. If you are connecting another type of peripheral in this daisy-chain, refer to the documentation that you received with that peripheral for its internal SCSI bus length.

5. Get the .36-meter SCSI cable from the ship kit.

6. Connect one end of the SCSI cable to the SCSI OUT port of the first Netra st D130 storage enclosure.

7. Connect the other end of the SCSI cable to the SCSI IN port on the second Netra st D130 storage enclosure or peripheral.

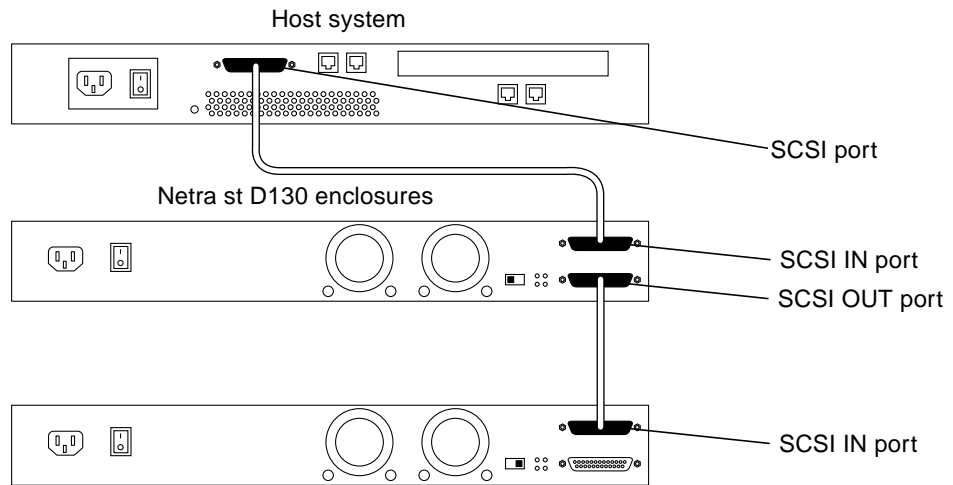

FIGURE 3-3 Daisy-Chaining Netra st D130 Storage Enclosures

8. Determine if you need to install an external terminator at the end of the SCSI daisy-chain.

- If the last device in the SCSI daisy-chain is a Netra st D130 storage enclosure or some other type of *UltraSCSI* device, do not install an external terminator on the device. The on-board autoterminator in the device functions in *UltraSCSI* mode.
- If the last device in the SCSI daisy-chain is a *wide* SCSI device, install an external terminator on the SCSI OUT port on that device if it requires one. Refer to the documentation that came with your wide SCSI device to determine if it needs an external terminator or not.

- If the last device in the SCSI daisy-chain is a *narrow* SCSI device, install an external terminator on the SCSI OUT port on that device.

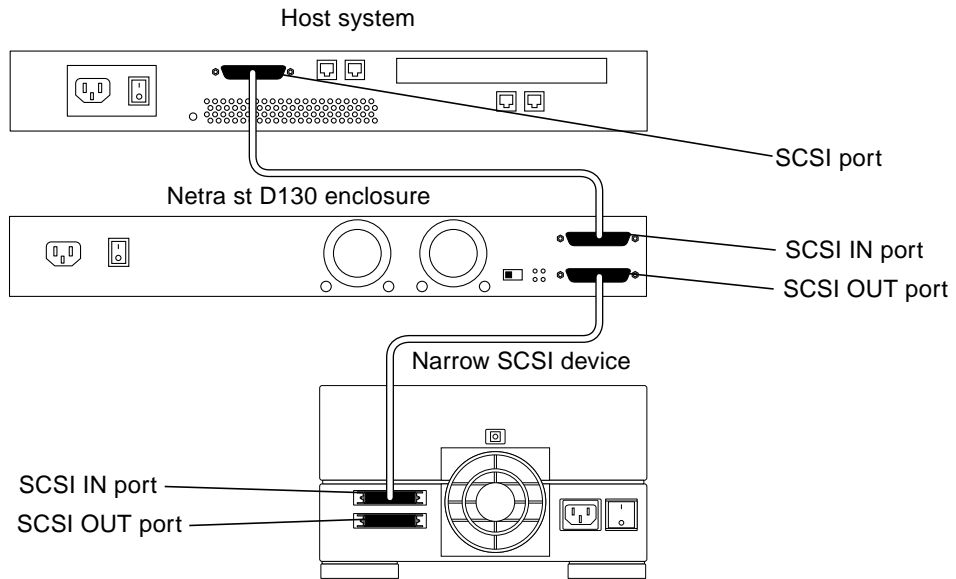

FIGURE 3-4 Daisy-Chaining a Netra st D130 Storage Enclosure with a Narrow SCSI Device

Connecting the Power Cable

The procedures for connecting the power cable vary depending on whether you have the AC or the DC version of the Netra st D130 system.

- “AC Version” on page 31
- “DC Version” on page 31

AC Version



Caution – Ensure that the connection of multiple units to the supply circuit does not overload the supply overcurrent protection or supply wiring. Refer to the Netra st D130 storage enclosure nameplate electrical ratings when determining the correct branch circuit rating for your installation.

- **Connect the AC power cable to the AC power connector.**

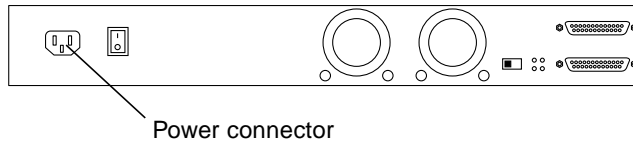

FIGURE 3-5 Netra st D130 Rear View (AC Version)

DC Version

1. **Get a DC grounding cable and two star washers.**
2. **Position and align the DC grounding cable against the two DC grounding lug nuts at the rear of the Netra st D130 storage enclosure.**

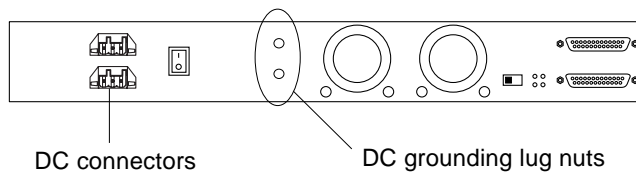

FIGURE 3-6 Connecting the DC Grounding Cable

3. **Place the star washers between the DC grounding cable and the two bolts that you will use to secure one end of the grounding cable to the two lug nuts.**
4. **Tighten the two bolts to secure the grounding cable to the two lug nuts.**
5. **Secure the other end of the grounding cable to the earth ground in the building.**
If you are installing the Netra st D130 storage enclosure in a rack, you can secure the grounding cable to a proper grounding point on the rack, as long as the rack is properly grounded to the earth ground in the building.
6. **Verify that the DC power source is off through the circuit breakers.**



Caution – Do *not* proceed with these instructions until you have verified that the power is off to the DC power source through the circuit breakers.

7. Verify that the DC input power cables are connected to the DC power source through the circuit breakers.

The first DC input power cable should be connected to DC power source A, and the second DC input power cable should be connected to DC power source B. Refer to “Assembling the DC Input Power Cable” on page 16 if you have not already assembled the DC input cables.

8. Connect one DC input power cable to a DC connector at the rear of the Netra st D130 storage enclosure.

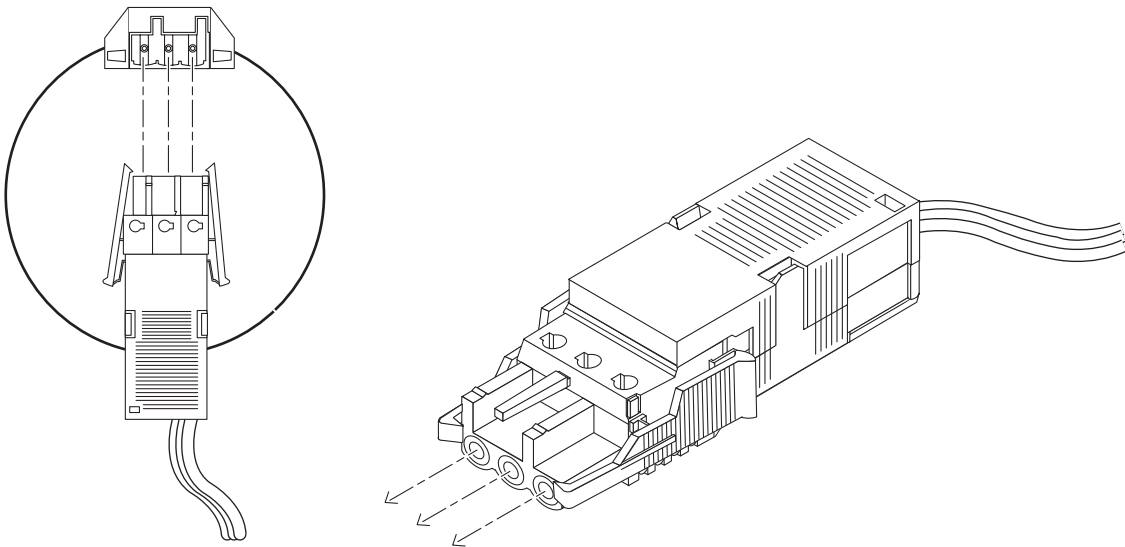

FIGURE 3-7 Connecting the DC Input Power Cable to the DC Connector

9. Repeat Step 8, connecting the second DC input power cable to the other DC connector at the rear of the enclosure.

Refer to FIGURE 3-6 for the locations of the DC connectors on the DC power supplies at the rear of the enclosure.

10. Turn on the circuit breakers to provide power to the enclosure.

To disconnect the DC input power cable from the DC connector, squeeze the two tabs on the sides of the DC input power cable and gently disconnect the DC input power cable from the DC power supply.

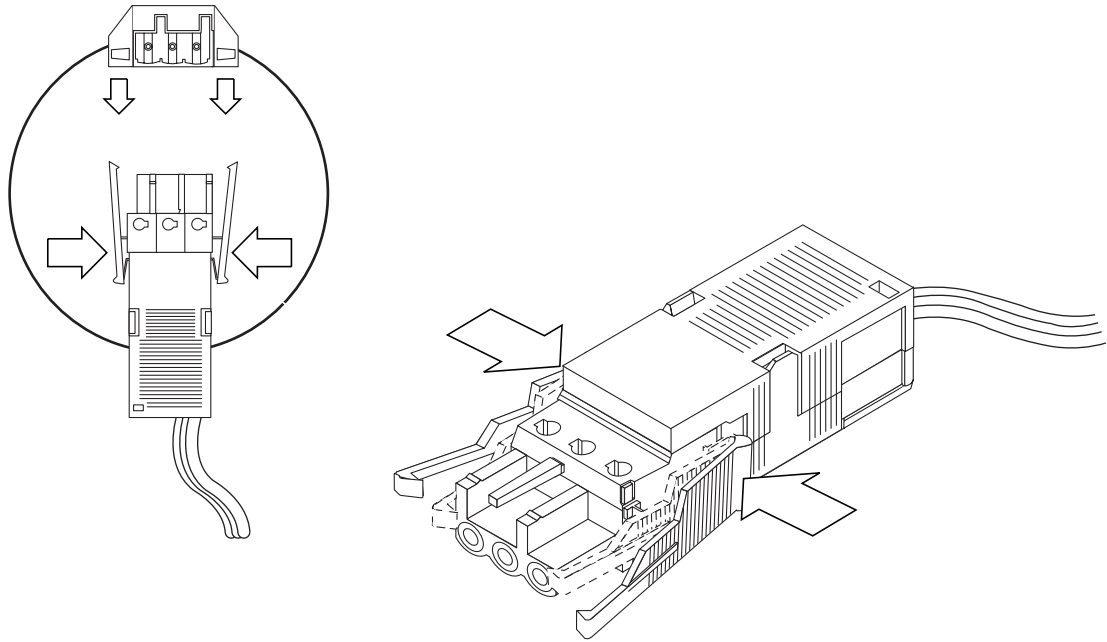

FIGURE 3-8 Disconnecting the DC Input Power Cable from the DC Connector

Powering On and Off

▼ To Power On the Storage Enclosure

- 1. Press the power switch at the rear of the storage enclosure to the On (|) position.**
See FIGURE 3-2 for the location of the power switch. Note that when you release the power switch, it settles into the center (neutral) position and the power remains on.
- 2. Reboot using the `boot -r` command on your host system so that it recognizes the Netra st D130 storage enclosure.**
- 3. Verify that the storage enclosure is running properly.**

Refer to Chapter 1 “Netra st D130 Storage Enclosure Overview” for descriptions of the LEDs at the front and back of the Netra st D130 storage enclosure and what each LED indicates.

▼ To Power Off the Storage Enclosure



Caution – Before turning off the system power, exit from the operating system. Failure to do so may cause data loss.

1. **If necessary, notify users that the system is going down.**
2. **Back up system files and data, if necessary.**
3. **Halt the operating system.**
4. **Press the power system switch on the storage enclosure to the standby position.**
5. **Verify that the System Power LED is off.**
6. **Disconnect the power cable from the power connector at the rear of the storage enclosure.**



Caution – Even with the power switch in the standby position, power remains connected to the enclosure, and potentially dangerous voltages is present in the power supply. You must unplug the power cable to completely remove power to the enclosure.

Adding, Removing, and Replacing Disk Drives

This chapter gives hardware and software instructions for adding, removing, and replacing disk drives in a Netra st D130 storage enclosure.

This chapter is organized as follows:

- “Adding a Disk Drive” on page 35
 - “Removing and Replacing a Disk Drive” on page 39
-

Adding a Disk Drive

This section contains information on how to configure your storage enclosure when you add a disk drive while the power is on and the operating system is running. This is called *hot-plugging*.

The way you add a disk drive depends on the software application you are using. For each application, decide where to install the new disk drive, add the drive, and then reconfigure the operating environment. Each application is different.

In all cases, you must select a slot, physically install the disk drive, and configure the Solaris environment to recognize the drive. You must then configure your application to accept the new disk drive.



Caution – These procedures should be performed only by a qualified system administrator. Performing hot-plug operations on an active disk drive can result in data loss or corruption.

Note – You cannot mix and match capacities of disk drives in the Netra st D130 storage enclosure.

▼ To Add a Disk Drive

1. **Remove the front panel by pressing the latches on both ends and pulling the panel away from the enclosure.**

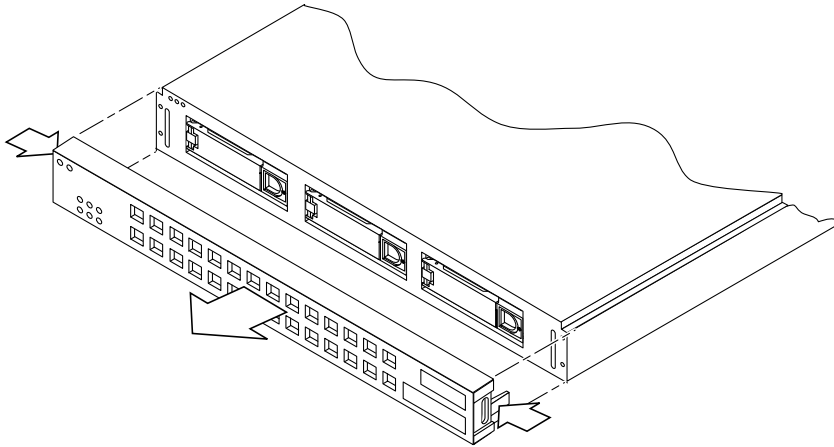

FIGURE 4-1 Removing the Front Panel

2. **Select any available slot in the Netra st D130 storage enclosure for the new disk drive.**
Make a note of which slot you choose for reference when you configure the software environment.
3. **Remove the foam filler.**
Store the foam filler in a safe place for future use.
4. **Hold the locking handle open on the disk drive.**
Push in the direction of the arrow to release the latch.

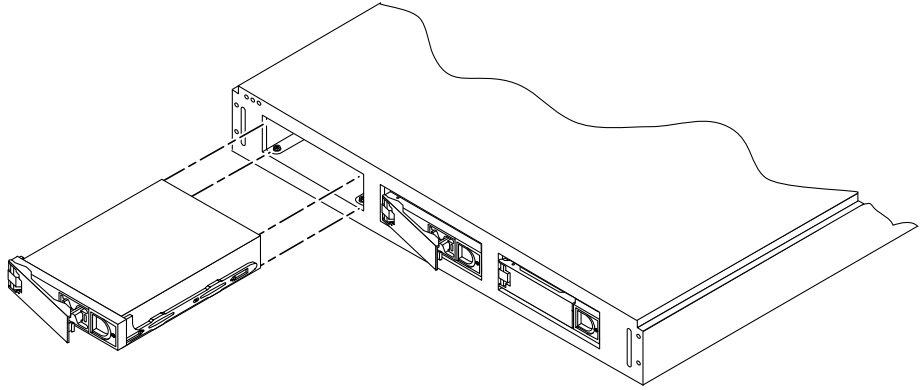

FIGURE 4-2 Adding a Disk Drive

- 5. Slide the replacement disk drive into the vacant slot.**
- 6. Gently push the drive until the locking handle engages.**
- 7. Close the locking handle completely, using gentle downward pressure.**

When the drive is firmly installed, it will spin up automatically.

See “SCSI ID Switch” on page 5 to find the SCSI ID of the drive you added.

Performing the Software Configuration Procedures

When you add a disk drive, you must create a new device entry for the drive in the `/devices`, `/dev/dsk`, and `/dev/rdisk` hierarchies. The new drive is assigned a name associated with the slot in the Netra st D130 storage enclosure into which the drive was installed.

▼ To Create a New Solaris Device Entry

The naming convention for disks attached to a host adapter is `cwt.xdysz`, where:

- `w` corresponds to the controller in your system
- `x` corresponds to the SCSI target of the disk
- `y` is the logical unit for the disk drive (always 0)
- `z` is the slice (or partition) on the disk.

For example, if the Netra st D130 storage enclosure is connected to a host adapter corresponding to controller `c2`, and a drive was added to the second slot in a Netra st D130 storage enclosure with the SCSI ID switch in the leftmost position (which assigns SCSI IDs 2, 3, and 4 to the drives inside the enclosure), the new drive appears as `/dev/dsk/c2t3d0s[0-7]` and `/dev/rdisk/c2t3d0s[0-7]`.

1. Use the `drvconfig` and `disks` commands to add the new device:

```
# drvconfig
# disks
```

2. Verify that the new disk has been added:

```
# ls -l /dev/dsk/c1t3d0s*
```

where `c1t3d0s*` is the expected device name for the new drive in the third slot.

The new disk drive is now available for use as a block or character device. Refer to the `sd(7)` man pages for further details.

▼ **To Configure a New Disk Drive Within Your Application**



Caution – These procedures should be performed only by a qualified system administrator. Performing hot-plug operations on an active disk drive can result in data loss.

Use the following procedure to configure a slice (single physical partition) on a disk to be used with a UNIX file system (UFS). For instructions on configuring a disk within a Veritas VxVM or Solstice DiskSuite application, refer to the documentation that came with your application.

1. Verify that the device label meets your requirements.

You can use the `prtvtoc` command to inspect the label for your disk. To modify the label, use the `format` command. Refer to the `prtvtoc(1M)` and `format(1M)` man pages for more information.

2. Once you have selected a disk slice for your UFS file system, create a file system on the slice.

```
# newfs /dev/rdsk/cwtxdysz
```

Refer to the `newfs(1M)` man page for more information.

3. If necessary, create a mount point for the new file system:

```
# mkdir mount-point
```

where *mount-point* is a fully qualified path name. Refer to the `mount(1M)` man page for more information.

4. After the file system and mount point have been created, modify the `/etc/vfstab` file to reflect the new file system.

See the `vfstab(4)` man page for more details.

5. Mount the new file system using the `mount` command:

```
# mount mount-point
```

where *mount-point* is the directory you created.

The file system is ready to be used.

Removing and Replacing a Disk Drive

The Netra st D130 storage enclosure comes configured with 1-inch high drives. The procedure for removing and replacing the drives differs only in the software you use to control the disks. In all cases the hard disks are hot-pluggable.

▼ To Remove a Disk Drive



Caution – If the Netra st D130 storage enclosure is running and a drive slot does not contain a disk drive or foam filler, the Netra st D130 storage enclosure will not cool properly and may overheat. If you are not replacing the disk drive immediately, you must install a foam filler in the empty slot. The foam fillers are air baffles. They allow the system to maintain maximum cooling. Verify that you have either a replacement drive or a foam filler handy before removing a disk drive from the enclosure unless you are returning a defective Netra st D130 storage enclosure.

1. Ensure there is no activity to the drives.

If the Disk Drive LED for that disk drive is flashing green, the drive is still active. When the Disk Drive LED is lit solid green, then the drive is no longer active and it is safe to remove it.

2. Prepare the software environment to remove the drive.

See the documentation that came with your software for application-specific instructions that you might need to perform before you can remove the disk drive.

3. Remove the front panel by pressing the latches on both ends and pulling the panel away from the enclosure (FIGURE 4-1).

4. Unlatch the drive bracket handle to release it.

Push in the direction of the arrow to release the latch.

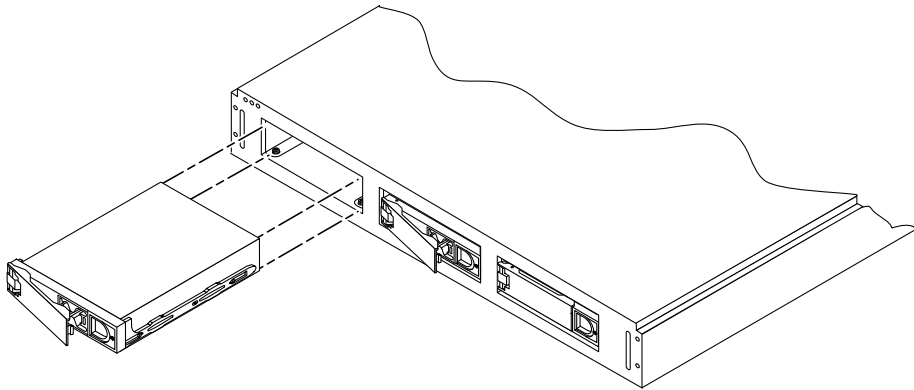

FIGURE 4-3 Removing and Replacing a Disk Drive

5. Pull the bracket handle out and swing it open.

6. Continue to pivot the disk drive bracket handle against the chassis, applying mild pressure, until the drive disconnects.

7. Slide the drive out.

8. Determine if you are going to replace the disk drive immediately or not.

- If you are going to replace the disk drive immediately, go to “To Replace a Disk Drive” on page 41.
- If you are not going to replace the disk drive immediately, determine if you are returning a defective Netra st D130 storage enclosure.
 - If you are returning a defective enclosure, leave the drive bays empty.
 - If you are not returning a defective enclosure, insert a foam filler in the empty drive slot.

▼ To Replace a Disk Drive

Note – You cannot mix and match capacities of disk drives in the Netra st D130 storage enclosure.

1. **If necessary, refer to the documentation that came with your Veritas VxVM or Solstice DiskSuite software for any procedures that you might have to perform before you can replace the disk drive.**
2. **Hold the locking handle on the disk drive open.**
3. **Slide the replacement disk drive into the vacant slot.**
4. **Gently push the drive until the locking handle engages.**
5. **Close the locking handle completely, using gentle inward pressure.**
6. **Replace the front panel.**

System Specifications

This appendix gives the system specifications for the Netra st D130 storage enclosure.

- “Physical Specifications” on page 43
- “Electrical Specifications” on page 44
- “Environmental Specifications” on page 45

Physical Specifications

TABLE A-1 Physical Specifications

Measure	Metric	English
Width	43.6 cm	17.17 in.
Depth	47.2 cm	18.58 in.
Height	4.4 cm	1.73 in. 1 rack unit (1U)
Weight, without disk drives	5.9 kg	13 lbs
Weight, fully loaded	8.16 kg	18 lbs

Electrical Specifications

TABLE A-2 AC Power Requirements

Electrical Element	Requirement
Voltage	100 VAC to 240 VAC (nominal)
Frequency	47-63 Hz
Input current	< 2.0 amps @ 100 VAC (150 W)
Max. surge current	100 amp peaks

TABLE A-3 DC Power Requirements

Electrical Element	Requirement
Voltage	-48 VDC
Input current	< 4.0 amps @ -40 VDC (150 W)
Max. input surge current	20 amps peaks

Environmental Specifications

TABLE A-4 Environmental Specifications

Climate Control	Location	Minimum to Maximum Range
Temperature (dry bulb)	Operating	0°C to 40°C (32°F to 104°F)
	Storage	-25°C to 65°C (-13°F to 149°F)
	Transit	-25°C to 65°C (-13°F to 149°F)
Short term (96 consecutive hrs)	Operating	-5°C to 55°C (23°F to 131°F)
	Nonoperating	-40°C to 70°C (-40°F to 158°F)
Temperature derating (max.)	Operating	3.3°C per 1000m (1.7°F per 1000 ft) above sea level
Relative humidity (non-condensing)	Operating	5% to 90%
	Storage	5% to 95%
	Transit	5% to 95%
Short term (96 consecutive hrs)	Operating	5% to 90%
	Non-operating	5% to 95%
Altitude (based on drives)	Operating	0m to 3000m (0 ft to 10,000 ft) above sea level
	Storage	0m to 12,000m (0 ft to 40,000 ft) above sea level
	Transit	0m to 12,000m (0 ft to 40,000 ft) above sea level
Heat dissipation (maximum)	Operating	150 watts, 512 BTU per hour
Sound power	Operating	6.0B, in accordance with ISO 9296
	Idle	6.0B, in accordance with ISO 9296
Earthquake	Location	NEBS requirements for earthquake zone 4

Note – If you plan to operate the controller module at altitudes between 1000m and 3000m (3280 ft and 9850 ft), you must lower the environmental temperature 3.3° C (1.7° F) for every 1000m (3280 ft) above sea level.

Index

A

AC version

- connecting power cables, 31
- power requirements, 13, 44
- power supply, 9

airflow requirements, 10

Auto Termination Indication LED, 6

B

back panel LEDs, 6

C

connecting

- DC grounding cable, 31
- power cables, 30
- SCSI cables, 28

cooling system, 9

D

DC grounding cable, connecting, 31

DC input power cable assembling, 16

DC version

- assembling the DC input power cable, 16
- connecting power cables, 31
- connection materials, 16
- DC supply and ground conductor, 15

overcurrent protection, 15

power requirements, 14, 44

power supply, 9

Declaration of Conformity, xix

description, 1

Disk Drive LED, 4

disk drives

- adding, 36
- description, 11
- naming conventions, 37
- removing, 39
- replacing, 41
- software configuration procedures, 37

E

electrical specifications, 44

environmental specifications, 45

F

foam fillers, 12

front door, 2

front panel LEDs, 3

H

hardware requirements, 25

- I**
 - installing the enclosure, 27

- L**
 - LEDs
 - Auto Termination Indication, 6
 - back panel, 6
 - Disk Drive, 4
 - front panel, 3
 - System Power, 3, 6
 - System Summary Fault, 3, 6

- P**
 - physical specifications, 43
 - power cables, connecting, 30
 - power supply
 - AC version, 9
 - DC version, 9
 - power switch, 5
 - powering off the enclosure, 34
 - powering on the enclosure, 33
 - preparing the host system, 26
 - product description, 1

- R**
 - Regulatory Compliance Statements, xv
 - removing a disk drive, 39

- S**
 - Safety Agency Compliance Statements, xxi
 - SCSI cables, connecting, 28
 - SCSI ID switch, 5
 - SCSI IDs, setting, 5, 27
 - SCSI ports, location, 28
 - software considerations, 12
 - Solaris device entry, 37
 - source site requirements
 - AC version, 13
 - DC version, 14
 - specifications
 - electrical, 44
 - environmental, 45
 - physical, 43
 - System Power LED, 3, 6
 - System Summary Fault LED, 3, 6