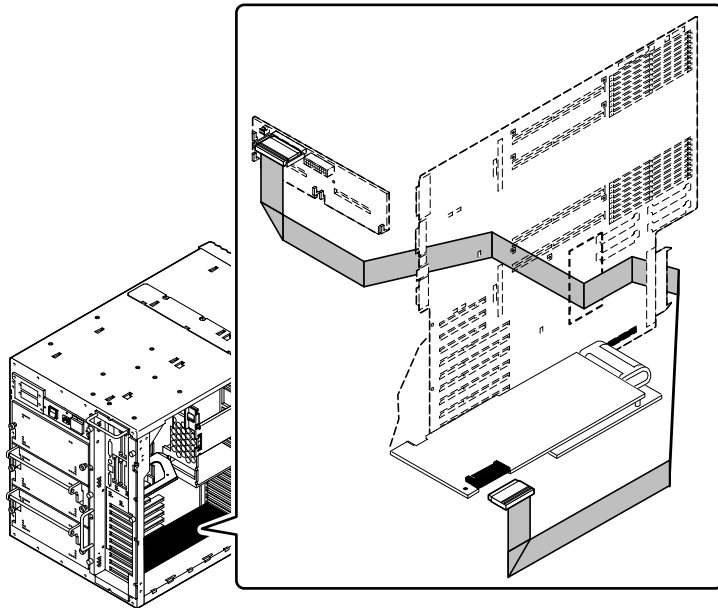

Installing the UltraSCSI Data Cable

This booklet describes how to install the Sun Enterprise™ 450 4-slot UltraSCSI data cable.

What to Do

Refer to your *Ultra Enterprise 450 Server Owner's Guide* for complete instructions on the following procedures.

1. **Verify that you have the Sun Enterprise 450 4-slot UltraSCSI data cable, part number 530-2730.**
2. **Remove the 4-slot UltraSCSI data cable from the system.**
Refer to "How to Remove the 4-Slot UltraSCSI Data Cable."
3. **Install the new 4-slot UltraSCSI data cable.**
Refer to "How to Install the 4-Slot UltraSCSI Data Cable."
 - a. **Connect the data cable to the UltraSCSI backplane.**
The cable connector with the tabs attaches to the UltraSCSI backplane.
 - b. **Route the data cable from the UltraSCSI backplane to the SRC/P Controller.**
Route the data cable through the system following the same path as the 4-slot UltraSCSI data cable.



- c. **Connect the UltraSCSI data cable to the channel 0 connector on the SRC/P Controller card.**

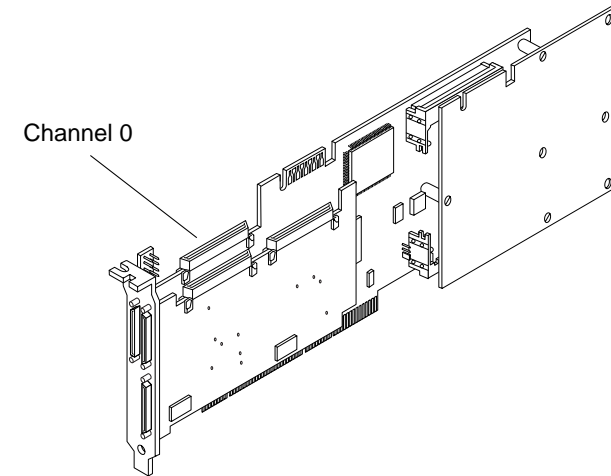

4. **Reassemble the system.**
Refer to "How to Install the 4-Slot UltraSCSI Data Cable."

What Next

Before the system can properly recognize the new SRC/P Controller, you must verify that the card is installed correctly, reconfigure the system, and reboot the system. Refer to the following documentation for complete information.

- "How to Issue a Reconfiguration Reboot" in the *Ultra Enterprise 450 Server Owner's Guide*
 - *Sun StorEdge SRC/P Intelligent SCSI Raid Controller User's Guide*
-

Sun Documentation on the Web

The docs.sun.comsm web site enables you to access Sun technical documentation on the Web. You can browse the docs.sun.com archive or search for a specific book title or subject at:

<http://docs.sun.com>

Sun Welcomes Your Comments

We are interested in improving our documentation and welcome your comments and suggestions. You can email your comments to us at:

docfeedback@sun.com

Please include the part number (8xx-xxxx-xx) of the document in the subject line of your email.

Copyright 1999 Sun Microsystems, Inc. All rights reserved. Use is subject to license terms. Third-party software, including font technology, is copyrighted and licensed from Sun suppliers. Sun, Sun Microsystems, the Sun Logo, AnswerBook2, Ultra Enterprise, docs.sun.com, and Solaris are trademarks or registered trademarks of Sun Microsystems, Inc. in the U.S. and other countries. **RESTRICTED RIGHTS:** Use, duplication, or disclosure by the U.S. Government is subject to restrictions of FAR 52.227-14(g)(2)(6/87) and FAR 52.227-19(6/87), or DFAR 252.227-7015(b)(6/95) and DFAR 15.227.7202-3(a).

Copyright 1999 Sun Microsystems, Inc. Tous droits réservés. Distribué par des licences qui en restreignent l'utilisation. Le logiciel détenu par des tiers, et qui comprend la technologie relative aux polices de caractères, est protégé par un copyright et licencié par des fournisseurs de Sun. Sun, Sun Microsystems, le logo Sun, AnswerBook2, Ultra Enterprise, docs.sun.com, et Solaris sont des marques de fabrique ou des marques déposées de Sun Microsystems, Inc. aux Etats-Unis et dans d'autres pays

 Please Recycle Sun Microsystems, Inc. • 901 San Antonio Road • Palo Alto, CA 94303-4900
USA • 650 960-1300 • Fax 650 969-9131



Part Number: 806-4040-10
February 2000, Revision 01



Sun Enterprise™ 450 4-Slot UltraSCSI Data Cable Installation Guide

