



PART NUMBER
MP4007

EDITION NUMBER
12

FLEXLINE™ SHARED VIRTUAL ARRAY® (SVA™)

9500/V960/V2X/V2X2 DISK SYSTEMS

PEER-TO-PEER CONFIGURATION AND USER'S GUIDE

PRODUCT TYPE
HARDWARE



FlexLine 9500/
V960/
V2X/V2X2
Peer-to-Peer
Remote Copy
Configuration & User's Guide

FlexLine FLX 9500/V960/V2X/V2X2 Peer-to-peer Remote Copy Configuration Guide

Information contained in this publication is subject to change. In the event of changes, the publication will be revised. The latest version of this document may be found on the Web at:

glfsfs@stortek.com

This publication is a PDF file on that site and may be downloaded. Comments and suggestions regarding this publication may be sent to the address below. Be sure to include the publication title and revision level. Or, for online comments, use the e-mail address: diskpubs_feedback@storagetek.com.

StorageTek
Manager, Enterprise Learning Products Development
One StorageTek Drive
Louisville, Colorado
80028-3256

About This Manual

This manual is intended as an overview of the steps and processes involved in the implementation of Peer to Peer Remote Copy, (PPRC), on the StorageTek SVA DASD platform.

For V2Xf PPRC operation, see "FICON Peer-to-Peer Remote Copy Configuration Guide (P/N MO9211x e).

Additional information on the Configuration, and syntax of the various PPRC commands and functions can be obtained from the following IBM Manuals:

SC35-0169-xx *Remote Copy Administrators Guide & Reference*

SG24-5338-xx *RAMAC Virtual Array: Implementing PPRC* (Red book)

SG24-2595-xx *Planning For IBM Remote Copy*

SC35-0169-xx *Remote Copy Administrator's Guide and Reference*

SG24-4724-xx *P/DAS and IBM 3390-6 RAMAC Array Family Enhancements*

Who Should Read This Book

The information in this book is for the use of the customer, StorageTek marketing representatives, CSEs, and independent consultants involved with sales of the SVA.

Copyright Statement

StorageTek and the StorageTek logo are trademarks or registered trademarks of Storage Technology Corporation. Other products and names mentioned herein are for identification purposes only and may be trademarks of their respective companies.

Contents

Preface	11
Notices	11
United States FCC Compliance Statement	11
CISPR 22 and EN55022 Warning	11
Japanese Compliance Statement	11
Taiwan Warning Label Statement	12
Internal Code License Statement	12
Alert Messages	15
Mensajes de alerta	15
Copyright Statement	16
Export Destination Control Statement	16
Disclaimer of Warranties and Limitation of Liability	16
Information Control	16
History of Changes	17
General PPRC Information	21
Overview	21
SVA Version Compatibility	21
VCU Restrictions	22
Minimum Microcode Levels	22
Mainframe	22
PPRC Features, Model, and Microcode Matrices	23
Power PPRC Non-WAN	23
Power PPRC WAN	24
Open Systems PPRC	24
Standard PPRC	24
Installation Planning	25
Basic SVA Installation Planning	25
Configuration Symmetry Considerations	25
Volumes	25
Primary Volumes	25
Secondary Volumes	25
Links	25
Paths	25
ESCON Channels	26
Disaster Recovery	26
PPRC Secondary Devices Recovery	26
For V2X:	26
For FLX 9500 and FLX V960:	27
PPRC Installation Checklist	28
Mainframe Power PPRC Direct	29
Overview	29
Uni-directional and Bi-directional	30
Considerations	30
Power PPRC Direct Connection	30
Secondary Volumes	31
Operational Procedures	31
SSID	31
Data Migration	31
Critical Primary and Alternate System Data Sets	31

Establishing A Power PPRC Direct Mode Environment	32
Detaching a Power PPRC Connection in the Direct Mode Environment	32
Paths in a Power PPRC Environment	33
PPRC Commands for OS390	33
CDELPAIR	34
CDELPATH	34
CESTPAIR	35
CESTPATH	37
CGROUP	39
CQUERY	40
CRECOVER	41
CSUSPEND	41
MODE(COPY), MODE(NOCOPY), And MODE(RESYNC) Options For The CESTPAIR Command.	42
Data Bridge Device:	42
Status Bridge Device:	42
Non-Bridge Volume:	43
Volume Status	43
SVA Configurations	44
Uni-Directional	44
Uni-directional Configuration Example	45
SVA1 (Primary).	45
SVA2 (Secondary)	45
PPRC Logical Configuration.	46
Establish Path and Pair Command Line Examples	46
Bi-Directional	47
Bi-directional Configuration Example	48
SVA1	48
SVA2	48
PPRC Logical Configuration.	49
Establish Path and Pair Command Line Examples	49
PPRC Dynamic Address Switching (P/DAS)	52
Configuration Symmetry Considerations	52
Requirements	52
Software	52
Source Volume	52
Target Volume	53
PPRC Status	53
P/DAS Commands	53
STOP	53
SWAP	53
RESUME	54
P/DAS Non-Sysplex Operation	54
P/DAS SYSPLEX Operation	54
GDPS Considerations	55
Reject Establish Pair when Secondary Online.	56
Proxy PPRC	56
Open Systems Power PPRC Direct	59
Software Installation and Configuration	59
Considerations	59
SSIDs	59
Secondary Volumes	59

Large LUN PPRC	60
Open Systems PPRC Commands	60
Command Parameters	61
Establish a Path	61
Displaying Path Status Information	61
Delete a Path	61
Establish a Pair	61
Displaying Pair Status Information	61
Suspend a PPRC Pair	62
Recover a Secondary Volume	62
Delete a Pair.	62
Command Examples:	62
Defining a Path:	62
Removing Paths:	63
Create a Pair with an Existing Known Secondary:	63
Suspend a Pair of Devices:	64
Resync a Suspended Pair:	64
Delete a Pair:	64
Define a Data Bridge Device:	64
Define a Status Bridge Device:	64
Define a New Device and Create a Pair:	64
SVA Configurations	64
Uni-Directional	65
Uni-Directional Configuration Example	65
SVA1 (Primary).	65
SVA2 (Secondary)	65
PPRC Logical Configuration.	66
Establish Path and Pair Command Line Examples	66
Bi-Directional	68
Bi-directional Configuration Example	69
SVA1 (Primary).	69
SVA2 (Secondary)	69
PPRC Logical Configuration.	70
Establish Path and Pair Command Line Examples	70
SVAC PPRC Configuration	73
Creating a PPRC Pair	73
Reviewing Information on a PPRC Pair	79
Deleting a PPRC Pair.	80
Power PPRC Wide Area Network (WAN)	83
Overview	83
Supported WAN Standards	85
Considerations	85
WAN Connections	85
Secondary Volumes	86
Operational Procedures	86
Setting Up a Power PPRC WAN Mode Environment.	86
Detaching A Power PPRC Wan Mode Environment	87
Disaster Recovery	87
PPRC Link Download Notification	87
PPRC SnapShot	89
About SnapShot	89
About PPRC SnapShot	89

PPRC SnapShot Performance	90
PPRC SnapShot Reliability	90
PPRC SnapShot Variations	90
PPRC SnapShot Considerations	91
FLX V2X PPRC Snap-to-Primary	92
Basic Operation	92
Snap-to-Primary Considerations	94
Symptoms	94
SIBBATCH	94
SIBADMIN	94
DFSMSdss	95
SVAA CLI	95
Suspending the PPRC Pair	95
Terminating and Recovering PPRC	97
Recovering PPRC After Various Events	97
IML (cold start - EPO or CPD) of Primary subsystem:	97
IML (cold start - EPO or CPD) of Secondary subsystem:	98
NDCL on the Primary subsystem:	99
NDCL on the Secondary Subsystem:	99
New Options for Terminating PPRC	101
TERM ALL (PPRC):	101
Termination Procedure:	101
To reestablish the PPRC environment:	103
TERM BRDG (TERM ALL PPRC BRIDGES and PATHS):	103
Termination Procedure:	103
To reestablish the PPRC environment:	103
PPRC Link Down Notification	105
IGF52xA Message Replies	107
IGF53xA Actions	111
ACTION 1.	111
ACTION 2.	111
ACTION 3.	112
ACTION 4.	112
Mainframe Troubleshooting	113
PPRC Command Failure	113
GTF Trace Print	115
Missing Channel End Device End Messages	119
CNT Interface Card Resets	119
Valid Return Codes	120
Command Failures	120
Backward Compatibility	121
Introduction	121
How it Works	121
Functionality	121
SVAA Open PPRC	121
PPRC SnapShot	122
Snap to Primary	122
PowerPPRC	122
Error reporting FSCs for Establish Paths	122

List of Figures

Figure 1	One Bridge Power PPRC Direct Connection	29
Figure 2	Path Status	40
Figure 3	Volume Status	41
Figure 4	Uni-Directional PPRC Physical Connections	45
Figure 5	Uni-Directional PPRC Logical Connections	46
Figure 6	Bi-Directional PPRC Physical Connections	48
Figure 7	Bi-Directional PPRC Logical Connections	49
Figure 8	Uni-Directional PPRC Physical Connections	65
Figure 9	Uni-Directional PPRC Logical Connections	66
Figure 10	Bi-Directional PPRC Physical Connections	69
Figure 11	Bi-Directional PPRC Logical Connections	70
Figure 12	Select PPRC	73
Figure 13	Selecting Configuration Wizard	74
Figure 14	Selecting a PPRC Action	74
Figure 15	Primary and Secondary Subsystem Selection	75
Figure 16	Information Loading	75
Figure 17	Interface Configuration Selection	76
Figure 18	Bridge Pair FDID Selection	77
Figure 19	Configuration Information	78
Figure 20	Main Menu with PPRC Pairs shown	78
Figure 21	Selecting a PPRC Pair For Deletion	79
Figure 22	PPRC Pair Information	80
Figure 23	Deleting a PPRC Pair	81
Figure 24	Deleted Pair Information Box	81
Figure 25	Confirmation Box	81
Figure 26	Power PPRC WAN Block Diagram	83
Figure 27	PPRC SnapShot Block Diagram	90
Figure 28	Configuration Example 1	92
Figure 29	Configuration Example 2	93
Figure 30	CM17 Screen	101
Figure 31	CH17 Help Screen	102
Figure 32	CH17 Help Screen Continued	102
Figure 33	CNT Interface Card Reset Button Location	120
Figure 34	PPRC Triangle Configuration Example	121

Preface

Notices

Please read the following compliance and warning statements for this product.

Caution: Potential equipment damage: Cables that connect peripherals must be shielded and grounded; refer to cable descriptions in the instruction manuals. Operation of this equipment with cables that are not shielded and not correctly grounded might result in interference to radio and TV reception.

Changes or modifications to this equipment that are not expressly approved in advance by StorageTek will void the warranty. In addition, changes or modifications to this equipment might cause it to create harmful interference.

United States FCC Compliance Statement

The following compliance statement pertains to Federal Communications Commission Rules 47 CFR 15.105:

Note: This equipment has been tested and found to comply with the limits for a Class A digital device pursuant to part 15 of the FCC Rules. These limits are designed to provide reasonable protection against harmful interference when the equipment is operated in a commercial environment. This equipment generates, uses, and can radiate radio frequency energy and, if not installed and used in accordance with the instruction manual, may cause harmful interference to radio communications. Operation of this equipment in a residential area is likely to cause harmful interference in which case the user will be required to correct the interference at his or her own expense.

CISPR 22 and EN55022 Warning

This is a Class A product. In a domestic environment this product may cause radio interference in which case the user may be required to take adequate measures.

Japanese Compliance Statement

The following compliance statement in Japanese pertains to VCCI EMI regulations:

この装置は、情報処理装置等電波障害自主規制協議会（VCCI）の基準に基づくクラスA情報技術装置です。この装置を家庭環境で使用すると電波妨害を引き起こすことがあります。この場合には使用者が適切な対策を講ずるよう要求されることがあります。

English translation: This is a Class A product based on the Technical Requirement of the Voluntary Control Council for Interference by Information Technology (VCCI). In a domestic environment, this product may cause radio interference, in which case the user may be required to take corrective actions.

Taiwan Warning Label Statement

The following warning label statement (in Kanji) pertains to BSMI regulations in Taiwan, R.O.C.:

警告使用者：這是甲類的資訊產品，在居住的環境中使用時，可能會造成射頻干擾，在這種情況下，使用者會被要求採取某些適當的對策

English translation: This is a Class A product. In a domestic environment, this product may cause radio interference, in which case, the user may be required to take adequate measures.

Internal Code License Statement

The following is the Internal Code License Agreement from StorageTek:

NOTICE

INTERNAL CODE LICENSE

PLEASE READ THIS NOTICE CAREFULLY BEFORE INSTALLING AND OPERATING THIS EQUIPMENT. THIS NOTICE IS A LEGAL AGREEMENT BETWEEN YOU (EITHER AN INDIVIDUAL OR ENTITY), THE END USER, AND STORAGE TECHNOLOGY CORPORATION ("STORAGETEK"), THE MANUFACTURER OF THE EQUIPMENT. BY OPENING THE PACKAGE AND ACCEPTING AND USING ANY UNIT OF EQUIPMENT DESCRIBED IN THIS DOCUMENT, YOU AGREE TO BECOME BOUND BY THE TERMS OF THIS AGREEMENT. IF YOU DO NOT AGREE WITH THE TERMS OF THIS AGREEMENT, DO **NOT** OPEN THE PACKAGE AND USE THE EQUIPMENT. IF YOU DO NOT HAVE THE AUTHORITY TO BIND YOUR COMPANY, DO **NOT** OPEN THE PACKAGE AND USE THE EQUIPMENT. IF YOU HAVE ANY QUESTIONS, CONTACT THE AUTHORIZED STORAGETEK DISTRIBUTOR OR RESELLER FROM WHOM YOU ACQUIRED THIS EQUIPMENT. IF THE EQUIPMENT WAS OBTAINED BY YOU DIRECTLY FROM STORAGETEK, CONTACT YOUR STORAGETEK REPRESENTATIVE.

1. **Definitions:** The following terms are defined as follows:

- A. "Derivative works" are defined as works based upon one or more preexisting works, such as a translation or a musical arrangement, or any other form in which a work may be recast, transformed, or adapted. A work consisting of editorial revision, annotations,

elaboration, or other modifications which, as a whole, represent an original work of authorship, is a Derivative work.

- B. "Internal Code" is Microcode that (i) is an integral part of Equipment, (ii) is required by such Equipment to perform its data storage and retrieval functions, and (iii) executes below the user interface of such Equipment. Internal code does not include other Microcode or software, including data files, which may reside or execute in or be used by or in connection with such Equipment, including, without limitation, Maintenance Code.
 - C. "Maintenance Code" is defined as Microcode and other software, including data files, which may reside or execute in or be used by or in connection with Equipment, and which detects, records, displays, and/or analyzes malfunctions in the Equipment.
 - D. "Microcode" is defined as a set of instructions (software) that is either imbedded into or is to be loaded into the Equipment and executes below the external user interface of such Equipment. Microcode includes both Internal Code and Maintenance Code, and may be in magnetic or other storage media, integrated circuitry, or other media.
2. The Equipment you have acquired by purchase or lease is manufactured by or for StorageTek and contains Microcode. By accepting and operating this Equipment, you acknowledge that StorageTek or its licensor(s) retain(s) ownership of all Microcode, as well as all copies thereof, that may execute in or be used in the operation or servicing of the Equipment and that such Microcode is copyrighted by StorageTek or its licensor(s).
 3. StorageTek hereby grants you, the end user of the Equipment, a personal, nontransferable (except as permitted in the transfer terms below), nonexclusive license to use each copy of the Internal Code (or any replacement provided by StorageTek or your authorized StorageTek distributor or reseller) which license authorizes you, the end user, to execute the Internal Code solely to enable the specific unit of Equipment for which the copy of Internal Code is provided to perform its data storage and retrieval functions in accordance with StorageTek's (or its licensor's) official published specifications.
 4. Your license is limited to the use of the Internal Code as set forth. You may not use the Internal Code for any other purpose. You may not, for example, do any of the following:
 - A. (i) access, copy, display, print, adapt, alter, modify, patch, prepare Derivative works of, transfer, or distribute (electronically or otherwise) or otherwise use the Internal Code;
 - (ii) reverse assemble, decode, translate, decompile, or otherwise reverse engineer the Internal Code (except as decompilation may

be expressly permitted under applicable European law solely for the purpose of gaining information that will allow interoperability when such information is not otherwise readily available); or

(iii) sublicense, assign, or lease the Internal Code or permit another person to use such Internal Code, or any copy of it.

5. Nothing in the license set forth above or in this entire Notice shall convey, in any manner, to you any license to or title to or other right to use any Maintenance code, or any copy of such Maintenance Code. Maintenance Code and StorageTek's service tools and manuals may be kept at your premises, or they may be supplied with a unit of Equipment sent to you and/or included on the same media as Internal Code, but they are to be used only by StorageTek's customer service personnel or those of an entity licensed by StorageTek, all rights in and to such Maintenance Code, service tools and manuals being reserved by StorageTek or its licensors. You agree that you shall not use or attempt to use the Maintenance Code or permit any other third party to use and access such Maintenance Code.
 - A. You, the end user, agree to take all appropriate steps to ensure that all of your obligations set forth in this Notice are extended to any third party having access to the Equipmen
6. You may transfer possession of the Internal Code to another party only with the transfer of the Equipment on which its use is authorized, and your license to use the Internal Code is discontinued when you are no longer an owner or a rightful possessor of the Equipment. You must give such transferee all copies of the Internal Code for the transferred Equipment that are in your possession, along with a copy of all provisions of this Notice.
 - A. Any such transfer by you is automatically (without further action on the part of either party) expressly subject to all the terms and conditions of this Notice passing in full to the party to whom such Equipment is transferred, and such transferee accepts the provisions of this license by initial use of the Internal Code. You cannot pass to the transferee of the Equipment any greater rights than granted under this Notice, and shall hold StorageTek harmless from any claim to the contrary by your transferee or its successors or assigns. In addition, the terms and conditions of this Notice apply to any copies of Internal Code now in your possession or use or which you hereafter acquire from either StorageTek or another party.
7. You acknowledge that copies of both Internal Code and Maintenance Code may be installed on the Equipment before shipment or included with the Equipment and other material shipped to you, all for the convenience of StorageTek's service personnel or service providers

licensed by StorageTek, and that during the warranty period, if any, associated with the Equipment, and during periods in which the Equipment is covered under a maintenance contract with StorageTek or service providers licensed by StorageTek, both Internal Code and Maintenance Code may reside and be executed in or used in connection with such Equipment, and you agree that no rights to Maintenance Code are conferred upon you by such facts.

- A. StorageTek or the licensed service provider may keep Maintenance Code and service tools and manuals on your premises but they are to be used only by StorageTek's customer service personnel or those of service providers licensed by StorageTek. You further agree that upon
- (i) any termination of such warranty period or maintenance contract period; or
 - (ii) transfer of possession of the Equipment to another party, StorageTek and its authorized service providers shall have the right with respect to the affected Equipment to remove all service tools and manuals and to remove or disable all Maintenance Code and/or replace Microcode which includes both Internal Code and Maintenance Code with Microcode that consists only of Internal Code.

Alert Messages

Alert messages call your attention to information that is especially important or that has a unique relationship to the main text or graphic.

Note: A note provides additional information that is of special interest. A note might point out exceptions to rules or procedures. A note usually, but not always, follows the information to which it pertains.

Caution: *informs you of conditions that might result in damage to hardware, corruption of data, or corruption of application software. A caution always precedes the information to which it pertains.*

Warning: A warning alerts you to conditions that might result in long-term health problems, injury, or death. A warning always precedes the information to which it pertains.

Mensajes de alerta

Los mensajes de alerta llaman la atención hacia información de especial importancia o que tiene una relación específica con el texto principal o los gráficos.

Nota: Una nota expone información adicional que es de interés especial. Una nota puede señalar excepciones a las normas o procedimientos. Por lo general, aunque no siempre, las notas van después de la información a la que hacen referencia.

Precaución: Una precaución informa sobre situaciones que podrían conllevar daños del hardware, de los datos o del software de aplicación.

Las precauciones van siempre antes de la información a la que hacen referencia.

Advertencia: Una advertencia llama la atención sobre condiciones que podrían conllevar problemas de salud crónicos, lesiones o muerte. Las advertencias van siempre antes de la información a la que hacen referencia.

Copyright Statement

StorageTek and the StorageTek logo are trademarks or registered trademarks of Storage Technology Corporation. Other products and names mentioned herein are for identification purposes only and may be trademarks of their respective companies.

Export Destination Control Statement

These commodities, technology or software were exported from the United States in accordance with the Export Administration Regulations. Diversion contrary to U.S. law is prohibited.

Disclaimer of Warranties and Limitation of Liability

Storage Technology Corporation has no liability for your use of this publication or any associated hardware, software or spare parts. You are responsible for any damage resulting from use of this publication, and any associated hardware, software or spare parts, including loss of data. You are responsible for backing up your data. Use of this publication, and the associated hardware, software and spare parts, should be in accordance with this publication and all other product specifications and instructions and in compliance with all applicable terms, conditions, laws, rules and regulations.

STORAGETEK MAKES NO WARRANTIES OF ANY KIND AND EXPRESSLY DISCLAIMS ALL EXPRESS AND IMPLIED WARRANTIES, INCLUDING IMPLIED WARRANTIES OF MERCHANTABILITY OR FITNESS FOR A PARTICULAR PURPOSE. STORAGETEK SHALL NOT BE LIABLE FOR ANY DIRECT, INDIRECT, SPECIAL, CONSEQUENTIAL, INCIDENTAL OR PUNITIVE DAMAGES RESULTING FROM USE OF THIS PUBLICATION OR ANY ASSOCIATED HARDWARE, SOFTWARE OR SPARE PARTS, INCLUDING LOSS OF DATA, EXCEPT FOR PERSONAL INJURY DIRECTLY CAUSED BY USE OF THIS PUBLICATION.

Information Control

The information in this document, including any associated software program, may not be reproduced, disclosed or distributed in any manner without the written consent of Storage Technology Corporation.

Should this publication be found, please return it to StorageTek, One StorageTek Drive, Louisville, CO 80028-5214, USA. Postage is guaranteed.

History of Changes

Rev A – Initial release. December 1999.

Rev B – First reissue. June 2000. Minor changes made in addition to:

- Adding the chapters on Power PPRC Direct and Power PPRC Wide Area Network (WAN). Standard PPRC became chapter one.
- Updated some graphics.
- Added “Proxy PPRC” information.
- Added “Large LUN” information.
- Added primary and secondary restrictions to a cluster for code levels below 1.5 and for 1.5 and above.

Rev C – Second reissue. November 2000. Minor changes made in addition to:

- References to “Copy All” and “No Copy” were change to the correct terms of “MODE(COPY)” and “MODE(NOCOPY).”
- In Chapter 3, clarification added regarding using an ESCON director.

Rev D – Third reissue. April 2001. Minor changes made in addition to:

- Added a note in chapter 1 that proxy PPRC does not support the freeze and thaw commands.
- Reference to the PPRC Emergency Bridge Disconnect information in the operations and recovery book added in Chapter 1.
- MIH information added in Chapter 3.
- SnapShot information moved to its own chapter.
- Added WAN Standards in Chapter 3.

Rev E – Fourth reissue. July 2001. Minor changes in addition to:

- Standard PPRC no longer supported; changed Chapter 1.
- Updated some figures and associated text.
- Added the PPRC Bridge Disconnect information to the Power PPRC Direct chapter and the PPRC WAN chapters.
- Updated the uni-directional and bi-directional PPRC configuration examples.

Rev F – Fifth reissue. March 2002. Minor changes in addition to:

- Changed item two of the Power PPRC Direct from not recommended to not supported.
- Added Open Systems PPRC chapter.
- Added Proxy PPRC chapter.
- Large LUN information moved to chapter six.

- Added Operational Procedures to chapters two and three.
- Added Command Examples to chapter six.
- Open systems command line examples added.

Rev G – Sixth reissue. December, 2002. Minor changes in addition to:

- Added Appendix C
- Updated the SVA Version Compatibility statements of Chapter 1.
- Changed the text of Consistency Group on page 22.
- Added T3 information in considerations of WAN.
- Added caution statement regarding DDSR in Chapter 2.
- Added time-out statement as a note under version compatibility in Chapter 1.

Rev H – Seventh reissue. March, 2003. Minor changes in addition to:

- Clarified the VCU restrictions for WAN under open systems attach in chapter 1.
- Invalid DDSR information in the second chapter removed.
- Added duplex pending information to the Snap-to-Primary section in chapter five.
- Added Appendix D.
- Secondary Volume information added in chapters two, three, and four.

Rev i – Eighth reissue. March, 2003. Minor changes in addition to:

- Changed “logical volumes” to “functional volumes” for clarity.
- Added the ICKDSF command conversion table in chapter two.
- Added the microcode matrices in chapter one.

Rev J – Ninth reissue. December, 2003. Minor changes in addition to:

- Added SVAC configuration information to chapter two.
- Added list of figures.

Rev K – Tenth reissue. April, 2004. Minor changes in addition to:

- Added “PPRC Link Download Notification” on page 87.
- Added “Valid Return Codes” on page 120
- Added “Command Failures” on page 120
- CNT Interface Card Resets moved to page 119

Rev L – Eleventh reissue. July, 2004. Minor changes and rebranding in addition to:

- Added the chapter “Terminating and Recovering PPRC” on page 97.
- Added the chapter “PPRC Link Down Notification” on page 105.

Rev M – Twelveth reissue. September, 2004. Minor changes and corrections in addition to:

- Added caution statement under CGROUP FREEZE on page 39.
- Added caution statement under Disaster Recovery on page 26.

This chapter contains general information on Peer-to-Peer Remote Copy (PPRC) – “Standard PPRC.” This information, the commands, and definitions apply to either Power PPRC Direct or Power PPRC WAN, unless otherwise specified in the individual chapters on these two StorageTek versions of PPRC.

Standard PPRC is supported by the FLX 9500. Standard PPRC is NOT supported by the FLX V960, FLX V2X, or FLX V2X2.

Overview

Peer-to-Peer Remote Copy is a hardware solution activated by MVS TSO and DFS functions and commands that enable the shadowing of application system data.

The application system data is updated on the “primary” subsystem volumes (i.e.: primary DASD) by application system users. This data is copied to “secondary” subsystem volumes (i.e.: secondary DASD) by the primary subsystem.

PPRC provides a synchronous data copying capability by sending updates directly from the primary storage control unit to the secondary storage control unit. Because of this, there is no disk data loss in the event of an outage at the primary site.

PPRC provides an image copy of a volume on an update-for-update basis. There is a one-to-one correspondence between each record on the primary volume and each record on the secondary volume. PPRC can be used to shadow ANY data, (system or application data) that is required for recovery at the secondary site.

PPRC is implemented almost entirely in the Licensed Internal Code (LIC). Software commands are available to initiate, monitor, and recover PPRC-managed data.

SVA Version Compatibility

Also see [“Backward Compatibility” on page 121](#) for more information regarding mixing models of the SVA in the PPRC environment.

Notes:

1. PPRC between any model SVA and another vendor’s subsystem is not supported.
2. StorageTek implemented a timing change concurrent with the introduction of PPRC capability on the FLX V2X product. This timing change applies to I/Os issued to the *secondary volumes from the primary FLX V2X SVA*. The timing change reduces the time allotted for

I/Os to secondary PPRC volumes from the primary FLX V2X SVA to ten (10) seconds. This I/O timer change applies to any I/O issued to a PPRC secondary volume from an FLX V2X regardless of the product type of the secondary volume (FLX 9500, FLX V960 or FLX V2X). If the I/O issued from an FLX V2X to a PPRC secondary volume does not complete within 10 seconds then the PPRC pair is immediately suspended. It will then be the responsibility of the customer to take the actions required to re-sync any suspended pair or pairs.

On prior products the primary volume would be unavailable to the host until the PPRC I/O to the secondary volume completed or until a much longer I/O timer expired (approximately seven minutes on prior products). This timer change is expected to be a factor anytime the secondary volume is unavailable for more than ten seconds.

Secondary volume unavailability times of greater than ten seconds can be caused by loss of power to the secondary subsystem, link failures, warm-boots, some cache re-inits, etc.

This timing change was made to minimize the unavailability of primary PPRC volumes. Depending on the operating system, PPRC configuration and applications involved, access to the primary volume can be critical to keeping a sysplex or geoplex environment operational.

VCU Restrictions

For PPRC connections between an FLX V2X and an FLX V960 or FLX 9500, the designated logical address (VCU number) in the link parameter must be 0 - 3. For PPRC connections between two FLX V2X machines, the VCU number may be from 0 - F. See [Table 10, "Link Parameter Meanings," on page 38.](#)

Minimum Microcode Levels

The following is a list of the *minimum* microcode levels required on each feature.

- FLX 9500 PPRC – E01.00.38.00
- FLX 9500 Power PPRC – E01.05.37.00
- FLX 9500 Power PPRC WAN – E01.05.37.00
- FLX 9500 Proxy PPRC – E02.02.13.00
- FLX V960 Open Systems PPRC – A01.01.44.00
- FLX V960 Power PPRC – A01.00.21.00
- FLX V2X PPRC – B01.02.00.00
- FLX V2X Snap-to-Primary – B01.02.00.00

Mainframe

Power PPRC WAN can only be used between:

- An FLX V2X and an FLX V2X.
- AN FLX V960 and an FLX V960

- An FLX 9500 and another FLX 9500 (both using microcode version E01.05.37.00 or higher)

Power PPRC non-WAN can only be used between:

- AN FLX V2X and an FLX V2X.
- AN FLX V2X and either an FLX V960 (using microcode version A01.00.21.00 or higher) or an FLX 9500 (using microcode version E02.05 or higher)
- AN FLX V960 and an FLX V960
- AN FLX V960 and an FLX 9500 (using microcode version E02.02.13 or higher)
- AN FLX 9500 and another FLX 9500 (both using microcode version E02.02.13 or higher)

PPRC Features, Model, and Microcode Matrices

Note: The microcode requirement indicates the minimum level required to support this feature, NOT the recommended level.

Power PPRC Non-WAN

Table 1 Power PPRC Non-WAN

From	To		
	FLX V2X	FLX V960	FLX 9500
FLX V2X	B01.02.00.00	A01.02.24.00	E02.05
	B01.02.00.00	B01.02.00.00	B01.02.00.00
FLX V960	B01.02.00.00	A01.00.21.00	E02.02.13.00
	A01.02.24.00	A01.00.21.00	A01.00.21.00
FLX 9500	B01.02.00.00	A01.00.21.00	E01.05.37.00 ^a
	E02.05	E02.02.13.00	E01.05.37.00 ^a

a. Proxy PPRC and PPRC SnapShot - 9500 E02.02.13.00.

Power PPRC WAN

Table 2 Power PPRC WAN

From	To		
	FLX V2X	FLX V960	FLX 9500
FLX V2X	B01.02.00.00	Not Available	Not Available
	B01.02.00.00		
FLX V960	Not Available	A01.00.21.00	Not Available
		A01.00.21.00	
FLX 9500	Not Available	Not Available	E01.05.37.00 ^a
			E01.05.37.00 ^a

a. Proxy PPRC and PPRC SnapShot - 9500 E02.02.13.00.

Open Systems PPRC

Table 3 Open Systems PPRC

From	To	
	FLX V2X	FLX V960
FLX V2X	B01.02.00.00	A01.01.44.00 ^a
	B01.02.00.00	B01.02.00.00 ^a
FLX V960	B01.02.00.00	A01.01.44.00
	A01.01.44.00	A01.01.44.00

a. Open systems PPRC WAN is not supported between a V2X and a V960.

Standard PPRC

Table 4 Standard PPRC

From	To	
	FLX 9500	FLX 9393
FLX 9500	E01.00.38.00	Not Available
	E01.00.38.00	
FLX 9393	Not Available	T04.05.38.00
		K05.02.10.00
		T04.05.38.00
		K05.02.10.00

Installation Planning

Basic SVA Installation Planning

When the SVA installation is being planned, the key is to include PPRC planning from the start. If you can have a say over the planning for the MVS unit addresses and SSID's on the SVA, then the PPRC implementation will be much easier. Also see *Shared Virtual Array SnapShot for OS/390 Installation, Customization, and Maintenance*.

Configuration Symmetry Considerations

To insure that both subsystems involved in a PPRC relationship can fully support the production configuration in the event of a disaster, it is good practice to make sure that the Physical Capacity (PCAP) of each subsystem is the same as the other. In mixed-model PPRC configurations (such as a V960 and a 9500), such configuration symmetry may not be possible, and this should be considered in the design and implementation of your disaster recovery strategy.

Volumes

Primary Volumes

All volumes that are being mirrored under PPRC control are called PRIMARY volumes. A primary volume can be copied to only one secondary volume. A PPRC volume can be ONLY a primary or secondary – not both at the same time.

Secondary Volumes

PPRC volumes that are receiving the mirrored primary data are called secondary volumes. Like 3990 Dual-Copy secondary volumes, they are physically protected from non-PPRC updates, and MUST be offline to all connected hosts.

Links

PPRC links are the physical ESCON connections between two SVAs. If Bi-Directional PPRC is required, you must have a minimum of two links, (one for each direction).

Paths

A PPRC path is a logical connection between two logical control units used by PPRC. PPRC paths use SVA logical channels.

You can define multiple paths across a single PPRC link.

For PPRC to be able to access all volumes, you must have a minimum of 1 Link, and a path defined for each Virtual Control Unit (VCU)¹ that controls primary and secondary volumes.

ESCON Channels

To enable PPRC to function properly, there must be dedicated ESCON cables, laid between the SVA subsystems. These cables must be dedicated to each SVA for the sole purpose of processing PPRC copies. These ESCON cables can only carry updates 'one-way', therefore each ESCON cable is dedicated to sending data from a specific SVA to a specific SVA.

Disaster Recovery

For controlling access to PPRC resources, refer to the *IBM Remote Copy Administrator's Guide and Reference*.

PPRC Secondary Devices Recovery

Note: A recovered secondary PPRC volume cannot be paired with another volume on the same SVA as the original primary PPRC volume unless the original primary PPRC volume has been terminated from PPRC operation.

Note: Check for the latest information on Terminating and Recovering PPRC on the StorageTek Web site. Look for a Tech Tip under Current Products > Disk > and then the model of SVA.

For V2X:

In the event that the primary SVA has become disabled, use the following procedure to recover PPRC secondary volumes so the host can access these volumes. This procedure works for Direct PPRC and WAN PPRC.

1. Use the following menu sequence to get to the CD24 Customer Configurable Items screen.

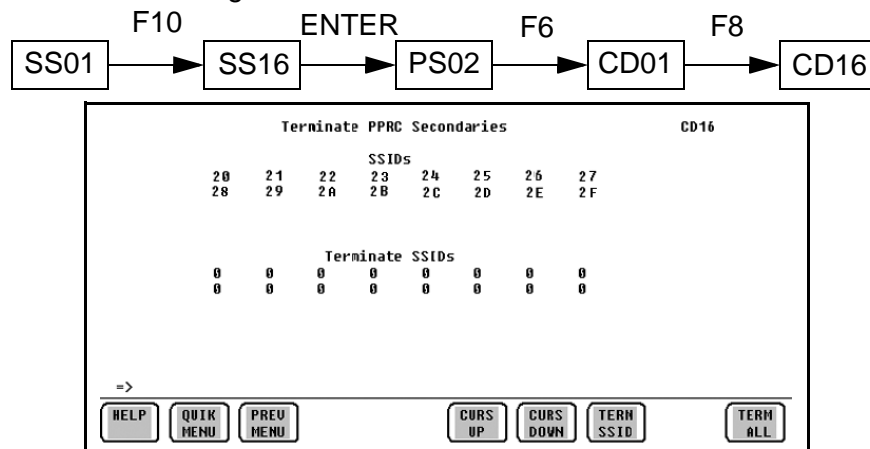

1. A Virtual Control Unit is also known on the host end as a Logical Control Unit. For all intents and purposes, they are the same thing.

- At the CD16 screen, press the [F8] or the [F10] key as required to terminate the PPRC secondaries.
- The CD16 screen will show a warning. Press the [F9] key for Yes.

Note: All devices that were PPRC secondary devices will be put in the simplex state. **Exception:** devices that are members of a bridge pair are **not** terminated (i.e. not put in the simplex state).

The SVA will do a warm start at this time.

For FLX 9500 and FLX V960:

In the event that one of the SVAs has become disabled, use the following procedure to break the bridge connection so the operating SVA can be IMLed. This procedure works for Direct PPRC and WAN PPRC.

- Use the following menu sequence to get to the CD24 Customer Configurable Items screen.

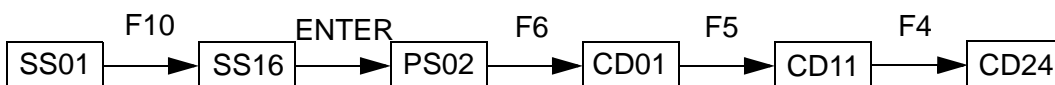

Customer Configurable Items		CD24
Customer Logon Password:	A0022222	(8 digits, start with A)
CSE Low Security Logon Password:	B0022222	(8 digits, start with B)
CSRC Low Security Conn Password:	22222	
CSRC Connection Security:	0	(1 = High 0 = Low)
Allow CSRC Connection:	1	(1 = Yes 0 = No)
PROD DAC:	/ /	: :
F4 - Terminate PPRC Secondaries F8 - IML the Subsystem F5 - Reset Data Assurance Check F9 - Power off the Subsystem => F10 - Make Requested Modifications		
HELP	QUICK MENU	PREV MENU
TERM PPRC	RST DCHK	CURS UP
CURS DOWN	IML SSVS	PWR OFF
MOD CCFG		

- At the CD24 screen, press the [F4] key to terminate the PPRC secondaries.
- The CD24 screen will show a warning. Press the [F9] key for Yes. The SVA will do a warm start at this time.

Notes: At this writing, note number one below is valid and note number two should be ignored. At a later date, a microcode update will invalidate note number one below and note number two will be valid. Check with either your StorageTek Service Representative or a StorageTek Marketing Representative to see which note applies.

- All volumes that were PPRC secondary volumes will be put in the simplex state. Primary status bridge volumes will also be put in the simplex state. Secondary status bridge volumes will NOT be put in a simplex state.
- All volumes that were PPRC secondary volumes will be put in the simplex state. **Exception:** volumes that are members of a bridge pair are NOT terminated (i.e. not put in the simplex state).

PPRC Installation Checklist

Perform the following actions to install PPRC:

1. Ensure that Subsystem IDs (SSIDs) have been assigned for each Virtual Control Unit (VCU) in each subsystem that will be involved in PPRC operations.
2. Enter these SSIDs into the subsystem(s).
3. Review the sections titled [“Considerations” on page 30](#), and [“Operational Procedures” on page 31](#).
4. Install the PPRC option.

Overview

Power PPRC Direct is Standard PPRC except that it allows for multiple track transfers from SVA to SVA without the handshaking protocol for each track. It allows chaining of unrelated tracks, reducing arbitration and de-selection or release of the link for each track transfer.

The principal advantage of Power PPRC Direct is the reduction in the number of PPRC start I/Os when transferring data tracks from the primary system to the secondary system. If a significant number of data tracks are being transferred to a secondary system, this can result in a considerable savings in time. A customer may establish as many as four direct bridge pairs, per direction, between the systems. Only one bridge path is shown in [Figure 1](#).

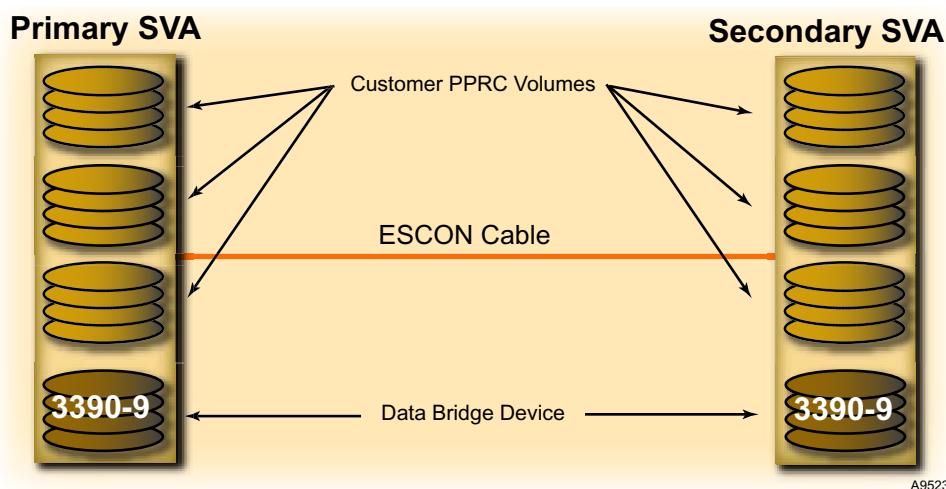

A95230

Figure 1 One Bridge Power PPRC Direct Connection

The cost to the customer is one 3390-9 functional volume on each end per bridge pair. This functional volume is the “Data Bridge Device.” This must be a newly created volume². The primary SVA uses its “Data Bridge Device” to transfer the data to the secondary SVA. The secondary SVA uses its “Data Bridge Device” to transfer the arriving data to its PPRC volumes. The “Data Bridge Devices” on each end are known as the “Data Bridge Pair.” See [“MODE\(COPY\), MODE\(NOCOPY\), And MODE\(RESYNC\) Options For The CESTPAIR Command.”](#) on page 42.

Once the initial handshaking between the two SVAs is complete, track after track of data may be transferred between the SVAs without further (ESCON) handshaking overhead. Once the transfer of a track is complete and ending status has been written to the secondary PPRC volumes, the

2. An existing volume may be deleted and then redefined.

secondary bridge will send confirmation to the primary bridge. After receiving this confirmation, the bridge will send the next track of data while the primary volume will send a data end to the host processor, indicating that the data has been successfully stored on the secondary SVA. In the event of a failure, an error message will be sent to the host processor.

The distance limitation between the primary and secondary SVA is the same as for the Standard PPRC.

The commands for Power PPRC Direct are the same as those used in the Standard PPRC.

Caution: Potential Data Loss - StorageTek strongly recommends that you do not initialize bridge volumes with ICKDSF, and that all bridge volumes remain offline at all times. Failure to do so could result in loss of data on the data bridge volume and other undesirable effects. The SVA forces the bridge volume to be offline.

Caution: Potential Data Loss - Ordinarily, StorageTek strongly discourages running DDSR while synchronizing or re-synchronizing PPRC pairs except as noted below.

For FLX V960s at microcode level A01.02.24.00 or higher and FLX V2Xs a customer may run DDSR during a PPRC synchronizing or re-synchronizing operation, but the DDSR operation will NOT complete against the volume being synchronized or re-synchronized. However, the customer will NOT receive an indication of this problem.

Therefore, if dynamic DDSR is used at the site, then interval DDSR must be run on PPRC volumes either during or after synchronizing or re-synchronizing actions.

Uni-directional and Bi-directional

Power PPRC Direct supports both uni-directional and bi-directional PPRC. For information on uni-directional PPRC, [see “Uni-Directional” on page 44.](#) For information on bi-directional PPRC, [see “Bi-Directional” on page 47.](#)

Considerations

Power PPRC Direct Connection

There are a number of considerations for use of the Power PPRC Direct connection:

1. PowerPPRC requires the use of ICE2 cards. For MVS this means a loss of 32 logical paths per ICE2 card. Use the information in the planning guide for a discussion of just what happens to the 512 logical paths when doing PPRC.

Logical paths do not exist in Open Systems – they will lose available slots for FC cards.

2. Routing ESCON cables for bridge volumes through an ESCON director is not supported.

3. The designation of one functional volume on each end for each bridge path. This volume is used to stage and transfer the data to the other storage system and is not available to the customer for conventional data storage. (See [Figure 1 on page 29.](#))
4. The data bridge volumes must be a 3390-9.
5. StorageTek does not support secondary PPRC pair volumes in an SVA that is being used to support both a PPRC WAN (which does not support bi-directional PPRC) AND a local Power PPRC Direct setup configured for bi-directional use.

Secondary Volumes

- Devices must be defined with the volume type and CKD enabled; initialization with ICKDSF is not required.
- All established PPRC secondary volumes must be OFFLINE. The OFFLINE parameter may be specified in the Hardware Configuration Definition (HCD).

Note: For an MVS guest system, ensure that the volumes are also offline on the VM LPAR.

- Host access, except for allowed commands, to secondary volumes will be prevented.
- Do not attempt to establish a PPRC pair that includes an ECAM volume.
- Verify secondary volumes to be designated for PPRC usage do not include critical data that will be overwritten.

Operational Procedures

SSID

SSIDs must be defined on the primary and secondary SVAs before enabling PPRC.

The SSIDs cannot be altered in an enabled PPRC environment. To change the SSIDs, PPRC must be disabled. SSIDs must be unique and defined in the hexadecimal range of 0001 to FFFF.

Data Migration

Prior to establishing PPRC pairs, complete all data migration to the primary volumes. Otherwise, performance will be degraded.

Critical Primary and Alternate System Data Sets

StorageTek recommends the allocation of a critical primary system data set and its alternate on separate simplex volumes and SVAs without PPRC connectivity between them. Implement this recommendation to the extent possible in the operational environment to minimize time-outs or extended error recovery exposures.

One case of critical data sets are the primary and alternate COUPLE data sets in a sysplex environment. For example, allocate the primary COUPLE data set on a simplex volume on a PPRC primary SVA, and the alternate on a simplex volume on another SVA without PPRC connectivity to the first SVA.

Use the virtual architecture of the SVA to its advantage by allocating a critical dataset on a volume by itself.

Establishing A Power PPRC Direct Mode Environment

1. Define one to four Data Bridge volumes on the primary SVA and the same number on the secondary SVA with the following conditions:
 - The volume type must be 3390-9.
 - There should be one bridge pair per physical link to be used for PPRC paths.
 - The data bridge volumes can be on any of the SVA volume addresses (FDID).
 - The data bridge volumes are not required to be in the same SSID as the data storage volumes, which will be PPRC pairs.
2. Using the “CESTPATH” (alteriointerface -addpath) command, establish one or more PPRC paths from the primary SVA to the secondary SVA.

Caution: Potential Data Loss - The secondary volume will be overwritten when the pair is established.

3. Using the “CESTPAIR” (alterdevice -addrpairs) command, establish a Bridge pair between the Data Bridge volumes. The Data Bridge pairs must be established prior to establishing non-bridge pairs. The number of bridge pairs allowed is equivalent to the number of PPRC links.
4. Determine which data storage volumes on each subsystem are to be used to establish PPRC pairs.
5. Using the “CESTPAIR” (alterdevice -addrpairs) command, establish PPRC pairs between the selected volumes.

Detaching a Power PPRC Connection in the Direct Mode Environment

1. Using the “CDELPAIR” (alterdevice - deletercpairs) command, terminate all PPRC pairs between non-bridge volumes.
2. Using the “CDELPAIR” (alterdevice - deletercpairs) command, terminate the Bridge pair between the Bridge volumes using the CDELPAIR command. Bridge pairs must be terminated after terminating non-bridge pairs.
3. Using the “CDELPATH” command, terminate the PPRC paths from the primary SVA to the secondary SVA.

Paths in a Power PPRC Environment

To modify paths in a Power PPRC environment, the CESTPATH command can be reissued to change the pathing (NOT the link addresses) of data and Bridge volumes taking into account following restrictions:

1. Link addresses can not be changed.
2. A link can be removed from the pathing except for the last link.
3. A link may be added to the pathing, this may however require an additional bridge pair.
4. As long as a PPRC pair exists, a path to its secondary control unit is required so the last path to the secondary control unit cannot be deleted.

PPRC Commands for OS390

Notes:

1. For open systems PPRC commands, see , [“Open Systems Power PPRC Direct” on page 59](#).
2. To invoke the equivalent PPRC configuration commands in a VM environment use the Device Support Facilities; ICKDSF PPRCOPY command for CKD volumes (also available in OS390). Refer to the Device Support Facilities User's Guide and Reference for complete details on the commands and parameters.

[Table 5](#) lists the PPRC commands, and the volume to which the command can be issued. [Table 6](#) is a cross reference between ICKDSF and OS390 commands.

Table 5 PPRC Commands for OS390

Command	Can Command be issued to a:	
	Primary	Secondary
“CDELPAR”	Yes	No
“CDELPATH”	Yes	No
“CESTPAIR”	Yes	No
“CESTPATH”	Yes	No
“CGROUP”	Yes	No
“CQUERY”	Yes	Yes
“CRECOVER”	No	Yes
“CSUSPEND”	Yes	Yes

Table 6 OS390 – ICKDSF Command Cross Reference

OS390 command	ICKDSF PPRCOPY parameter
CESTPATH	ESTPATH
CDELPATH	DELPATH
CESTPAIR	ESTPAIR
CDELPAIR	DELPAIR
CSUSPEND	SUSPEND
CRECOVER	RECOVER
CQUERY	QUERY

CDELPAIR

The CDELPAIR command deletes the relationship between a primary and secondary DASD volume. You would use this command to remove volumes from PPRC control.

The syntax of this command is as follows:

```
CDELPAIR DEVN(X'2154') PRIM(X'2001' 0003033 X'54') SEC(X'1001'
0003053 X'54')
```

Table 7 CDELPAIR Command Parameters

Parameter	Meaning
DEVN(X'2154')	This specifies the volume number of the primary volume.
PRIM(X'2001')	This value is the SSID where the Primary volume is allocated.
3033	This value is the right most seven digits of the serial number of the SVA for the primary volume ^a . Leading zeros can be excluded.
X'54'	This is the HEX Channel Connection address of the primary volume (Is always the same as the last two digits of the DEVN).
SEC(X'1001')	This value is the SSID where the secondary volume is allocated.
3053	This value is the right most seven digits of the serial number of the SVA for the secondary volume. Leading zeros can be excluded.
X'54'	This is the HEX Channel Connection address of the secondary volume.

a. Using all twelve digits of the SVA's serial number will result in error messages.

CDELPATH

The CDELPATH command is used to delete all established ESCON paths between a primary and secondary SVA logical control unit.

Only active paths to the specified SSID are affected; all paths to other SSIDs are unaffected.

The syntax of the command is as follows:

```
CDELPATH DEVN (X'2154') PRIM(X'2001' 0003033) SEC(X'1001' 0003053)
```

Table 8 CDELPATH Command Parameters

Parameter	Meaning
DEVN(X'2154')	This specifies the volume number of ANY volume attached to the SSID whose paths you wish to delete.
PRIM(X'2001')	This value is the SSID where the Primary volume is allocated
3033	This value is the serial number of the SVA for the primary volume - leading zeros can be excluded.
SEC(X'1001')	This value is the SSID where the secondary volume is allocated
3053	This value is the serial number of the SVA for the secondary volume. Leading zeros can be excluded.

CESTPAIR

The CESTPAIR command is used to specify the PRIMARY and SECONDARY volume that the user wants to establish as a PPRC pair.

Note: The SVA has 256 asynchronous operation buffers available to handle asynchronous operations. CESTPAIR with any copy MODE is considered to be an asynchronous operation. If there are 256 asynchronous operations in progress, any further CESTPAIR commands are rejected (FSC 0576) until a buffer is released by the microcode when an asynchronous operation completes. CESTPAIR is considered to be complete when the pair goes DUPLEX (becomes synchronized).

The primary and secondary volumes must have the same number of tracks on each cylinder, and the same number of bytes on each track.

The syntax of the command is as follows:

```
CESTPAIR DEVN(X'2154') PRIM(X'2001' 0003033 X'54') SEC(X'1001' 0003053 X'54')
```

The explanation of the above parameters is the same as the explanation for the “CDELPAIR” command, except, in this command, you are establishing the PPRC pair, not deleting it.

Additional parameters for the CESTPAIR command are as follows:

Table 9 CESTPAIR Command Parameters

Parameter Name	Parameter Value
MODE	Specifies one of the following PPRC modes: MODE(COPY) , MODE(NOCOPY) , and MODE(RESYNC) with MODE(COPY) being the default. See “MODE(COPY), MODE(NOCOPY), And MODE(RESYNC) Options For The CESTPAIR Command.” on page 42.
PACE	Specifies the number of tracks to be copied prior to a host interrupt. Note: PACE is not used by any SVA.
CRIT	Specifies the PPRC data synchronization mode. CRIT(NO) means that when the primary volume goes into SUSPEND mode subsequent write commands to the volume are accepted. CRIT(YES) means that when the primary volume goes into SUSPEND mode, subsequent write commands to the volume may be rejected. Note: The SVA/RVA will honor both CRIT(YES) and CRIT(NO). When CRIT(YES) is specified and the primary volume goes into SUSPEND mode, if the reason for the suspend is that there are no paths available between the primary and secondary subsystem, then the primary subsystem will unit check subsequent writes to the primary volume. CRIT(YES) is not recommended as it can cause unit checks on the primary volume which can cause host jobs to fail. Instead, the “CGROUP” FREEZE and “CGROUP” RUN commands should be used for consistency groups.
MSGREQ	This parameter is only valid in COPY mode. This option is either YES or NO, and NO is the default.

For a full explanation of the above options, please refer to the IBM book *Remote Copy Administrators Guide*.

An example of a batch job to create a PPRC pair is shown on the next page.

```
//JOBCARD.....
//
//CESTPAIR EXEC PGM=IKJEFT01
//SYSTSPRT DD SYSOUT=H
//SYSTSIN DD *
  CESTPAIR +
  DEVN(X'1000') +
  PRIM(X'1000' 0003033 X'00') +
  SEC(X'2000' 0003053 X'00') +
  CRIT(N) MODE(NOCOPY)
```

/*

CESTPATH

The CESTPATH command is used to establish ESCON PPRC paths between a primary and secondary SVA SSID. Each CESTPATH command can establish up to four paths (one for each link cable) from a primary to a secondary SSID.

ESCON PPRC paths between SVA's are UNI-DIRECTIONAL. Include all links in a single CESTPATH command.

Notes:

1. Subsequent CESTPATH commands, should they occur, will replace any previously used CESTPATH commands and the information contained therein. Therefore, any additional CESTPATH commands will need to contain the earlier command's information should it still be valid.
2. The primary device used to submit the CESTPATH command must also be defined on the secondary prior to executing the command.

The syntax of the CESTPATH command is as follows:

```
CESTPATH DEVN(X'1022') PRIM(X'1000' 0003053) SEC(X'2000 0003033)
LINK(X'00200000' X'00610000' X'00300000' X'00710000') CGROUP (Y)
```

Note: At the end of the CESTPATH command is the parameter "CGROUP." The default value is NO, and that value is used if YES is not specified as shown.

The explanations for the DEVN, PRIM and SEC commands are the same as the explanations in the "CDELPATH" command.

The **Consistency Grouping (CGROUP) parameter** is a feature that enables the primary and secondary SSIDs to respond to the CGROUP command. When the subsystem internally suspends a PPRC primary volume that uses consistency group enabled PPRC paths (normally due to loss of communication with the secondary subsystem) the volume goes into a long busy state for 2 minutes to prevent reads and writes to that volume of the consistency group, and it sends Format F Message B sense data to the host. Host automation software, such as Geographically Dispersed Parallel Sysplex (GDPS)³, reacts to this sense data by causing a CGROUP command to be issued with the Freeze option. This causes suspension of other enabled primary volumes in the VCU (i.e. in the consistency group), removal of PPRC paths to the specified secondary subsystem VCU, and a second 2-minute long busy state. Host automation software then issues a CGROUP command with the Run option. This clears the long busy state so that reads and writes to the primary volumes can resume.

If the Freeze order is not received within the first long busy period, all members of the consistency group may not go suspended. If the Run

3. An IBM software package.

order is not received within the second long busy period, that long busy period expires and reads and writes to the primary volumes can resume.

The **LINK parameter** specifies the addressing path to be used by PPRC to send updates from the primary volume to the secondary volume. You can specify up to four addresses here to plan for performance and redundancy.

The values of the link address are as follows:

Table 10 Link Parameter Meanings

Parameter	Meaning
ffff	Primary volume cluster and interface values. See the table below for the ffff values. The value of ffff depends on the ICE card and ESCON connector on that ICE card.
gg	Destination Link address
hh	The Destination Logical Address (VCU number).

Table 11 Link Parameter ICE2 Card Location Values

ffff Values	ICE2 Card Location (card slot) ^{a b}							
	00	01	02	03	10	11	12	13
Top ESCON Connector	0000	0020	0040	0060	0010	0030	0050	0070
Bottom ESCON Connector	0001	0021	0041	0061	0011	0031	0051	0071

a. ICE3 cards cannot be used for PPRC operation.

b. The card slot in the IBM books is known as a SAID (System Adapter Identifier).

An example of a batch job to create PPRC paths from the first five VCUs of the primary subsystem to the first five VCUs of the secondary subsystem is shown below. The fifth and last example is establishing a path through a switch; all others are done point to point.

```
//JOB CARD.....
//
//CESTPATH EXEC PGM=IKJEFT01
//SYSTSPRT DD SYSOUT=H
//SYSTSIN DD *
CESTPATH +
DEVN(X'1000') +
PRIM(X'1000' 0003033) +
SEC(X'2000' 0003053) +
```

```

LINK(X'00000000' X'00400000' X'00100000' X'00500000')
CESTPATH +
DEVN(X'1100') +
PRIM(X'1001' 0003033) +
SEC(X'2001' 0003053) +
LINK(X'00000001' X'00400001' X'00100001' X'00500001')
CESTPATH +
DEVN(X'1200') +
PRIM(X'1002' 0003033) +
SEC(X'2002' 0003053) +
LINK(X'00000002' X'00400002' X'00100002' X'00500002')
CESTPATH +
DEVN(X'1300') +
PRIM(X'1003' 0003033) +
SEC(X'2003' 0003053) +
LINK(X'00000003' X'00400003' X'00100003' X'00500003')
CESTPATH +
DEVN(X'1400') +
PRIM(X'1004' 0003033) +
SEC(X'2004' 0003053) +
LINK(X'00000003' X'00400003' X'00100003' X'00500003')
/*

```

CGROUP

The CGROUP command is used to control operations for multiple PPRC volume pairs in a single SSID. This command allows you to suspend or resume all operations for all PPRC volumes in a single SSID.

You must issue a separate CGROUP command to suspend or resume operations on each SSID.

The syntax of the CGROUP command is as follows:

```
CGROUP DEVN(X'2154') PRIM(X'2001' 0003033) SEC(X'1001'
0003053) {FREEZE | RUN}
```

The explanations for the DEVN, PRIM and SEC commands are the same as the explanations in the “CDELPATH” command.

The explanation for the FREEZE and RUN parameters are as follows:

- **FREEZE** – Specifies that all PPRC operations for the SSID are to be stopped.

Caution: Potential Performance Issues - CGROUP FREEZE function will fail (FSC 0B39) for any VCU that contains one or more PPRC pairs between SCSI devices.

- **RUN** – Specifies that write operations to primary volumes for the SSID can be resumed.

CQUERY

The CQUERY command is used to query the status of one volume of a PPRC pair, or all the paths associated with the SSID for the named volume number.

CQUERY can be issued to either the primary, or secondary volume in a PPRC pair.

The syntax of the CQUERY command is as follows:

```
CQUERY DEVN(X'2154') xxxxxx
```

The optional parameter (xxxxxx) is as follows:

Table 12 CQUERY Command Parameters

Parameter	Meaning
PATHS	PPRC will display all the paths associated with this volume (or SSID), and the current status of each path (an example of the result of this command can be seen in Figure 2 on page 40). If this parameter is not used, it defaults to VOLUME.
VOLUME	“Volume” will display the volume status of the specified volume. This is the default parameter (see Figure 3 for an example of the output from this display).

Note: The following two figures are just examples.

```
*****PPRC CQUERY REMOTE COPY-PATHS*****
*PRIMARY UNIT: SERIAL#=000000003033 SSID=2001 *
*          FIRST          SECOND          THIRD          FOURTH          *
*          SECONDARY      SECONDARY      SECONDARY      SECONDARY      *
*SERIAL NO: 00000003053 *
*          SSID: 1001 *
*          PATHS: 4 4 4 4 *
*          SAID DEST S* SAID DEST S* SAID DEST S* SAID DEST S* *
*          --- --- -- --- --- -- --- --- -- --- --- -- *
*          1: 0020 0001 01 0000 0000 01 0060 0002 01 0060 0003 01 *
*          1: 0060 0001 01 0030 0000 01 0030 0002 01 0030 0003 01 *
*          1: 0030 0001 01 0070 0000 01 0070 0002 01 0070 0003 01 *
*          1: 0070 0001 01 0020 0000 01 0020 0002 01 0020 0003 01 *
*
*S*=PATH STATUS: *
*00=NO PATH 01=ESTABLISHED 02=INIT FAILED *
*03=TIME OUT 04=NO RESOURCES AT PRI 05=NO RESOURCE AT SEC *
*06=SERIAL# MISMATCH 07=SEC SSID MISMATCH 08=ESCON LINK OFFLINE *
*09=ESTABLISH RETRY 0A=PATH ACTIVE TO HOST 0B=PATH TO SAME CLUSTER*
*10=CONFIGURATION ERROR *
*****
```

Figure 2 Path Status

```
*****PPRC CQUERY REMOTE COPY-VOLUME*****
*          (PRIMARY) (SECONDARY)*
*          SSID CCA SSID CCA *
*DEVICE LEVEL STATE PATH STATUS SERIAL# SERIAL# *
```



```

*-----
* 2155    PRIMARY    DUPLEX    ACTIVE    200155    100155    *
*          CRIT(NO)                00000003033  000000030053*
*
*PATHS    SAID/DEST    STATUS    DESCRIPTION
*-----
* 4       0020 0001    01       PATH ESTABLISHED...
* 4       0050 0001    01       PATH ESTABLISHED...
* 4       0030 0001    01       PATH ESTABLISHED...
* 4       0070 0001    01       PATH ESTABLISHED...
*****

```

Figure 3 Volume Status

CRECOVER

The CRECOVER command is used to allow the secondary system to gain control of a DASD volume on its SSID. This command will force the secondary volume into simplex mode to establish control of the volume.

You can vary this volume online after this process if you wish.

The syntax of the CRECOVER command is as follows:

```

CRECOVER DEVN(X'2154') PRIM(X'2001' 0003033 X'54')
SEC(X'1001' 0003053 X'50') ID(xxxxxx yyyyyy)

```

The explanations for the DEVN, PRIM and SEC commands are the same as the explanations in the **CDELP** command.

The optional parameter ID(xxxxxx yyyyyy) is used as follows:

Table 13 CRECOVER Command Parameters

Parameter	Meaning
xxxxxx	Specifies the old volser. If used without a new volser, yyyyyy, this will verify the state, and set the volume to simplex mode.
yyyyyy	Specifies a new volser to be written to the volume.

CSUSPEND

The CSUSPEND command is used to suspend all PPRC operations between a primary and secondary volume pair. No write data is transferred to the secondary volume.

The primary subsystem still records all cylinders that have changed on the primary volume.

The CSUSPEND command can be directed to either the primary, or secondary volume of a PPRC volume pair.

This command differs from the CGROUP FREEZE command in that the CGROUP command will suspend all PPRC operations to all of the volumes on an entire SSID, whereas this command will suspend all PPRC operations to a specific volume on any SSID.

On StorageTek products, the CSUSPEND command will suspend the primary by just putting in the primary DEVN volume.

Caution: Service Interruption - Use of the parameter PRIMARY will cause a unit check on the SVA.

The syntax of the CSUSPEND command is as follows:

```
CSUSPEND DEVN(X'2154) PRIM(X'2001' 0003033 X'54')
SEC(X'1001' 0003053 X'54') {PRIMARY | QUIESCE}
```

The optional parameters PRIMARY and QUIESCE are **NOT** used on an SVA.

The explanations for the DEVN, PRIM and SEC commands are the same as the explanations in the “CDELPAIR” command.

MODE(COPY), MODE(NOCOPY), And MODE(RESYNC) Options For The CESTPAIR Command.

The MODE parameter values (COPY, NOCOPY, and RESYNC) will cause the subsystem to react differently depending on the type of volume (bridge vs. non-bridge volume) to which the CESTPAIR command is issued.

Data Bridge Device:

When a CESTPAIR MODE(COPY) is issued to a data bridge volume, subsequent CESTPAIR MODE(COPY) commands issued to non-bridge volumes will do their synchronizations in parallel, resulting in faster syncing times, but slower response to updates from the hosts during the synchronization(s).

MODE(COPY) is the default option when establishing data bridge pairs.

When a CESTPAIR MODE(NOCOPY) is issued to a data bridge volume, subsequent CESTPAIR MODE(COPY) commands issued to non-bridge volumes will do their synchronizations in serial, one volume pair at a time. The serial synchronization process uses the Data Bridge Pairs to do the synchronization, following an internal SnapShot of the entire non-bridge volume to a data bridge volume, to rapidly synchronize each Non Bridge Pair with a minimum load on SVA resources. This option results in slower synchronization, when 2 or more non-bridge pairs are being established in rapid succession, and faster response to updates from the host(s) during the synchronization(s).

When a CESTPAIR MODE(RESYNC) is issued to a data bridge volume it is rejected since a volume must be in SUSPENDED state when this option is processed, and bridge pairs never go suspended.

StorageTek recommends that all of the 1 to 4 data bridge pairs be established with the same MODE(COPY, or NOCOPY) option.

The selection of MODE(COPY, NOCOPY) on a data bridge pair has no effect on SVA performance after all volume pairs are synchronized to the DUPLEX state.

Status Bridge Device:

The CESTPAIR command should not be issued to a Status Bridge volume. Status Bridge pairs are established internally by the subsystem when

CESTPAIR commands are issued to data bridge volumes, in a PPRC WAN environment.

Non-Bridge Volume:

When a CESTPAIR MODE(COPY) is issued to a non-bridge volume, the pair goes into the DUPLEX PENDING state. The pair is then synchronized (all the data on the primary volume is copied to the secondary volume). When the synchronization is complete the pair goes into the DUPLEX state.

The method used to perform the synchronization is determined by the MODE(COPY, NOCOPY) selected for the CESTPAIR command used to establish the data bridge pairs.

MODE(COPY) is the default option when establishing non-bridge pairs.

When a CESTPAIR MODE(NOCOPY) is issued to a non-bridge volume, the volume goes directly into the DUPLEX state, since the user is indicating that no synchronization needs to be performed, by choosing this option.

Selecting the MODE(NOCOPY) option implies that:

1. You know that the primary volume currently contains no customer data, or
2. You know that the volume pair is already synchronized, or
3. You plan to synchronize the volume pair by another process; such as by using this volume pair as the target pair of a PPRC Snap command.

When a CESTPAIR MODE(RESYNC) is issued to a non-bridge volume, the volume must be in a SUSPENDED state. The state of the pair is changed to DUPLEX PENDING; then the pair is re-synchronized. The only tracks that the subsystem has to re-synchronize are those tracks that have been updated by a host since the pair went into the SUSPENDED state.

Selecting the MODE(RESYNC) option implies that this non-bridge pair was previously synchronized in the DUPLEX state, and then the pair was placed in SUSPENDED state.

Note: DDSR should be suspended during volume synchronization.

Volume Status

To successfully manage the PPRC environment, you need to be aware of the different states of the PPRC paired volumes. To determine the state of a PPRC volume, you would issue the “CQUERY” command to the required volume. An example of the command has been shown in a previous section.

At any given time, a volume can be in one of the states shown in [Table 14 on page 44](#):

Table 14 Volume Status Parameters

Parameter	Meaning
Simplex	The initial state of a volume that has not had the CESTPAIR command run against it.
Duplex Pending	The initial state of a PPRC defined volume pair when a CESTPAIR with MODE(COPY) or MODE(RESYNC) is used. When in a duplex pending state, if you issue the CQUERY command against the volume, the bottom right corner of the display will indicate the amount of data copied to the secondary volume, before the volume goes into the duplex state.
Duplex	This is the state of a volume pair after the copying from the primary volume is complete, and the volume pair is fully synchronized.
Suspended	This is the state of a volume pair when the primary and secondary SVA's cannot keep the PPRC volume pairs synchronized, or when a CSUSPEND command has been issued to either the primary, or secondary volume in a PPRC pair. For the duration of a suspended state, the PPRC primary volume's storage control will record the cylinders that have been updated. When a CESTPAIR command with the RESYNC parameter is issued, only the data in the cylinders that have been changed is copied to the secondary volume to restore the synchronized, duplex state.

SVA Configurations

PPRC can be configured in one of two ways, uni-directional or bi-directional.

Uni-Directional

This configuration physically splits the two SVA's, and has a primary SVA containing only primary PPRC volumes, and a secondary SVA containing only secondary PPRC volumes.

In this configuration, ALL PPRC ESCON channels will transmit data from the primary SVA to the secondary SVA.

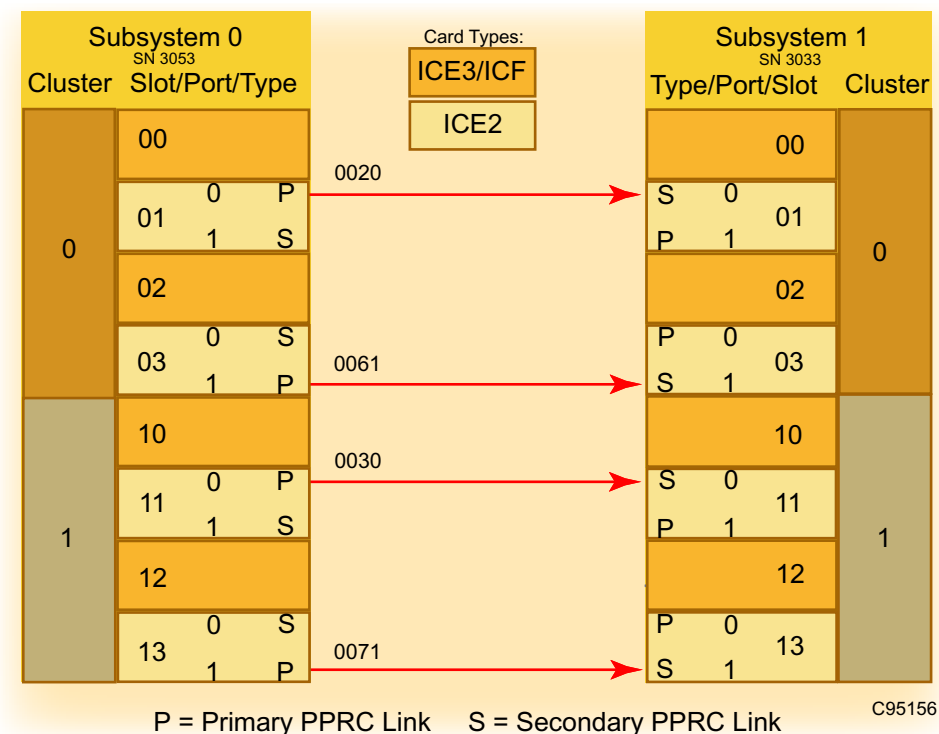

Figure 4 Uni-Directional PPRC Physical Connections

Notes:

1. Either port may be used on an ICE2 card. The above figure is just an example and does show some flexibility in the configuration.
2. The numbers on the links in the above figure are the location values (SAIDs – also see [Table 11 on page 38](#)).

Attention: The secondary volumes should be varied offline before the PPRC pair is established.

Uni-directional Configuration Example⁴

SVA1 (Primary)

Serial Number	3053			
Subsystem ID's	1000	1001	1002	1003
Device Address	1000-10FF	1100-11FF	1200-12FF	1300-13FF

SVA2 (Secondary)

Serial Number	3033			
Subsystem ID's	2000	2001	2002	2003
Device Address	2000-20FF	2100-21FF	2200-22FF	2300-23FF

When configuring the PPRC pairs, try to configure the pairs with corresponding addresses, so that if the Primary PPRC volume on SVA1 is

4. Only four control units are shown for clarity. In the case of an FLX V2X/V2X2 SVA there could be up to 16.

volume address 12AA, then the secondary PPRC unit address on SVA2 will be 22AA.

PPRC Logical Configuration

The logical view of the 'uni-directional' PPRC cables for the above example is shown in [Figure 5](#).

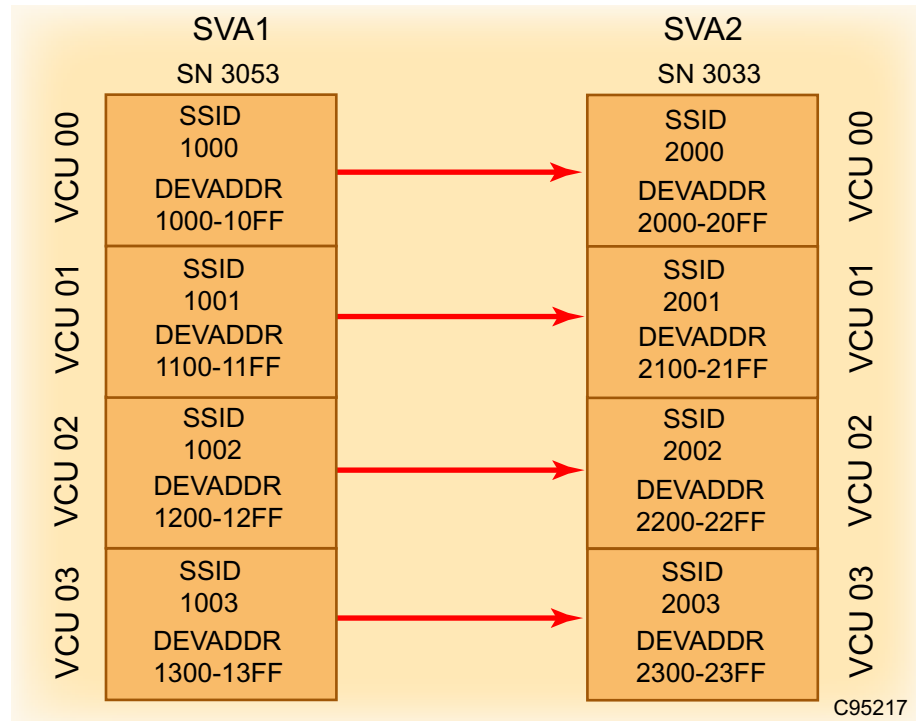

Figure 5 Uni-Directional PPRC Logical Connections

Note: The address ranges shown in the above figure are one more address than the customer will have for data. One address (a 3390-9 volume) is the bridge volume's address. If the SVA is configured with 3390-3 volumes, then three of them will be lost to make the bridge volume as it takes three 3390-3 volumes to make one 3390-9 volume.

Establish Path and Pair Command Line Examples

The following is an *partial example* of the syntax for the Establish Path (CESTPATH) and Establish Pair (CESTPAIR) commands for the above example, using [Figure 4 on page 45](#) for the physical connections and [Figure 5](#) (above) for the logical connections. Not all volumes were configured in this example - only three logical volumes are shown for each VCU.

SN 7825

For VCU 0

```
CESTPATH DEVN(X'1022') PRIM(X'1000' 0003053) SEC(X'2000 0003033)
LINK(X'00200000' X'00610000' X'00710000' X'00300000')
```

```
CESTPAIR DEVN(X'10AA') PRIM(X'1000' 0003053 X'AA') SEC(X'2000'
0003033 X'AA')
```

Note: This first volume defined for this VCU is the bridge volume.

CESTPAIR DEVN(X'10AB') PRIM(X'1000' 0003053 X'AB') SEC(X'2000'
0003033 X'AB')

CESTPAIR DEVN(X'10AC') PRIM(X'1000' 0003053 X'AC') SEC(X'2000'
0003033 X'AC')

For VCU 1

CESTPATH DEVN(X'1103') PRIM(X'1001' 0003053) SEC(X'2001 0003033)
LINK(X'00200001' X'00610001' X'00710001' X'00300001')

Note: This first volume defined for this VCU is the bridge volume.

CESTPAIR DEVN(X'1110') PRIM(X'1001' 0003053 X'10') SEC(X'2001'
0003033 X'10')

CESTPAIR DEVN(X'1111') PRIM(X'1001' 0003053 X'11') SEC(X'2001'
0003033 X'11')

CESTPAIR DEVN(X'1112') PRIM(X'1001' 0003053 X'12') SEC(X'2001'
0003033 X'12')

For VCU 2

CESTPATH DEVN(X'1203') PRIM(X'1002' 0003053) SEC(X'2002 0003033)
LINK(X'00200002' X'00610002' X'00710002' X'00300002')

CESTPAIR DEVN(X'1220') PRIM(X'1002' 0003053 X'20') SEC(X'2002'
0003033 X'20')

Note: This first volume defined for this VCU is the bridge volume.

CESTPAIR DEVN(X'1221') PRIM(X'1002' 0003053 X'21') SEC(X'2002'
0003033 X'21')

CESTPAIR DEVN(X'1222') PRIM(X'1002' 0003053 X'22') SEC(X'2002'
0003033 X'22')

For VCU 3

CESTPATH DEVN(X'1303') PRIM(X'1003' 0003053) SEC(X'2003 0003033)
LINK(X'00200003' X'00610003' X'00710003' X'00300003')

CESTPAIR DEVN(X'13D0') PRIM(X'1003' 0003053 X'D0') SEC(X'2003'
0003033 X'D0')

Note: This first volume defined for this VCU is the bridge volume.

CESTPAIR DEVN(X'13D1') PRIM(X'1003' 0003053 X'D1') SEC(X'2003'
0003033 X'D1')

CESTPAIR DEVN(X'13D2') PRIM(X'1003' 0003053 X'D2') SEC(X'2003'
0003033 X'D2')

Bi-Directional

To efficiently use the four internal processors in each cluster of the SVA, StorageTek recommends the following configuration for bi-directional Power PPRC Direct⁵. This configuration logically splits each SVA into a

5. Power Wide Area Network PPRC does not support bi-directional PPRC except as noted in "Considerations" on page 85.

'sending' and 'receiving' configuration, which will allow you to have primary and secondary PPRC volumes on EACH SVA, and you will be able to send and receive PPRC data on each SVA. (See [Figure 6](#).) This configuration is suggested so one SVA's processor is not paired with another SVA's processor, setting up a situation where they could begin sending or receiving an I/O at the same time, resulting in a time-out situation.

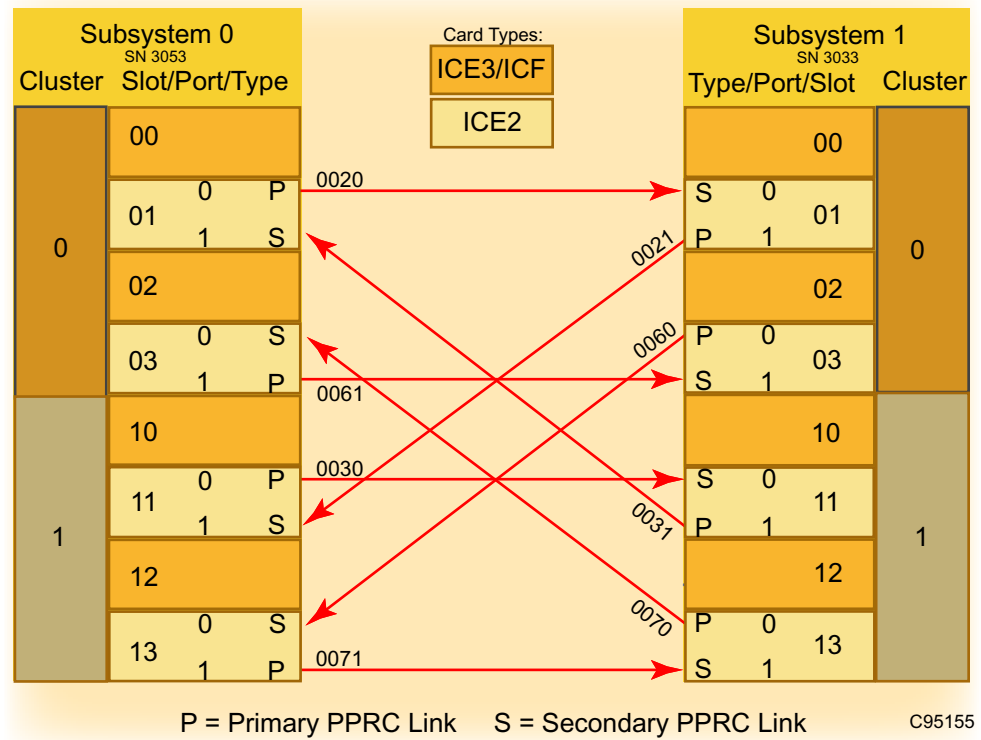

Figure 6 Bi-Directional PPRC Physical Connections

Notes:

1. Either port may be used on an ICE2 card. The above figure is just an example and does show some flexibility in the configuration⁶.
2. The numbers on the links in the above figure are the location values (SAIDs – also see [Table 11 on page 38](#)).

Attention: The secondary volumes should be varied offline before the PPRC pair is established.

Bi-directional Configuration Example

SVA1

Serial Number 3053

Subsystem ID's 1000 1001 1002 1003

Device Address 1000-10FF 1100-11FF 1200-12FF 1300-13FF

SVA2

Serial Number 3033

6. Only four control units are shown for clarity. In the case of an FLX V2X, there could be up to 16.

Subsystem ID's	2000	2001	2002	2003
Device Address	2000-20FF	2100-21FF	2200-22FF	2300-23FF

When configuring the PPRC pairs, try to configure the pairs with corresponding addresses, so that if the Primary PPRC volume on SVA1 is volume address 12AA, then the secondary PPRC address on SVA2 will be 22AA.

PPRC Logical Configuration

The logical view of the 'bi-directional' PPRC cables for the above example is shown in [Figure 7](#) below.

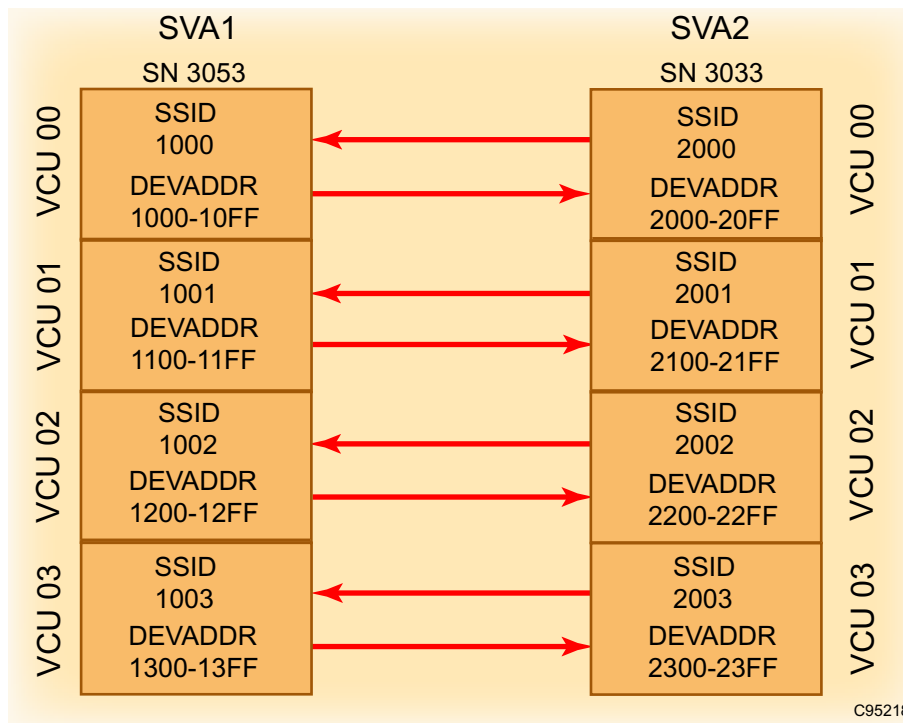

Figure 7 Bi-Directional PPRC Logical Connections

Note: The address ranges shown in the above figure is two more addresses than the customer will have for data. Two addresses (3390-9 volumes) are the bridge volume's addresses (one for each direction). If the SVA is configured with 3390-3 volumes, then six of addresses will be lost to make the bridge volumes as it takes three 3390-3 volumes to make one 3390-9 volume.

Establish Path and Pair Command Line Examples

The following is a *partial example* of the syntax for the Establish Path (CESTPATH) and Establish Pair (CESTPAIR) commands for the above example, using [Figure 6 on page 48](#) for the *physical connections* and [Figure 7](#) above for the *logical connections*. Not all volumes were configured in this example - only three logical volumes are shown for each VCU.

SVA 3053:**For VCU 0**

CESTPATH DEVN(X'1022') PRIM(X'1000' 0003053) SEC(X'2000 0003033)
LINK(X'00200000' X'00610000' X'00300000' X'00710000')

CESTPAIR DEVN(X'10AA') PRIM(X'1000' 0003053 X'AA') SEC(X'2000'
0003033 X'AA')

Note: This first volume defined for this VCU is the bridge volume.

CESTPAIR DEVN(X'10AB') PRIM(X'1000' 0003053 X'AB') SEC(X'2000'
0003033 X'AB')

CESTPAIR DEVN(X'10AC') PRIM(X'1000' 0003053 X'AC') SEC(X'2000'
0003033 X'AC')

For VCU 1

CESTPATH DEVN(X'1103') PRIM(X'1001' 0003053) SEC(X'2001 0003033)
LINK(X'00200001' X'00610001' X'00300001' X'00710001')

CESTPAIR DEVN(X'1110') PRIM(X'1001' 0003053 X'10') SEC(X'2001'
0003033 X'10')

Note: This first volume defined for this VCU is the bridge volume.

CESTPAIR DEVN(X'1111') PRIM(X'1001' 0003053 X'11') SEC(X'2001'
0003033 X'11')

CESTPAIR DEVN(X'1112') PRIM(X'1001' 0003053 X'12') SEC(X'2001'
0003033 X'12')

For VCU 2

CESTPATH DEVN(X'1203') PRIM(X'1002' 0003053) SEC(X'2002 0003033)
LINK(X'00200002' X'00610002' X'00300002' X'00710002')

CESTPAIR DEVN(X'1220') PRIM(X'1002' 0003053 X'20') SEC(X'2002'
0003033 X'20')

Note: This first volume defined for this VCU is the bridge volume.

CESTPAIR DEVN(X'1221') PRIM(X'1002' 0003053 X'21') SEC(X'2002'
0003033 X'21')

CESTPAIR DEVN(X'1222') PRIM(X'1002' 0003053 X'22') SEC(X'2002'
0003033 X'22')

For VCU 3

CESTPATH DEVN(X'1303') PRIM(X'1003' 0003053) SEC(X'2001 0003033)
LINK(X'00200003' X'00610003' X'00300003' X'00710003')

CESTPAIR DEVN(X'13D0') PRIM(X'1003' 0003053 X'D0') SEC(X'2003'
0003033 X'D0')

Note: This first volume defined for this VCU is the bridge volume.

CESTPAIR DEVN(X'13D1') PRIM(X'1003' 0003053 X'D1') SEC(X'2003'
0003033 X'D1')

CESTPAIR DEVN(X'13D2') PRIM(X'1003' 0003053 X'D2') SEC(X'2003'
0003033 X'D2')

SVA 3033:**For VCU 0**

CESTPATH DEVN(X'2003') PRIM(X'2000' 0003033) SEC(X'1000 0003053)
LINK(X'00210000' X'00600000' X'00310000' X'00700000')

CESTPAIR DEVN(X'20BA') PRIM(X'2000' 0003033 X'BA') SEC(X'1000'
0003053 X'BA')

Note: This first volume defined for this VCU is the bridge volume.

CESTPAIR DEVN(X'20BB') PRIM(X'2000' 0003033 X'BB') SEC(X'1000'
0003053 X'AB')

CESTPAIR DEVN(X'20BC') PRIM(X'2000' 0003033 X'BC') SEC(X'1000'
0003053 X'AC')

For VCU 1

CESTPATH DEVN(X'2103') PRIM(X'2001' 0003033) SEC(X'1001 0003053)
LINK(X'00210001' X'00600001' X'00310001' X'00700001')

CESTPAIR DEVN(X'2030') PRIM(X'2001' 0003033 X'30') SEC(X'1001'
0003053 X'10')

Note: This first volume defined for this VCU is the bridge volume.

CESTPAIR DEVN(X'2031') PRIM(X'2001' 0003033 X'31') SEC(X'1001'
0003053 X'11')

CESTPAIR DEVN(X'2032') PRIM(X'2001' 0003033 X'32') SEC(X'1001'
0003053 X'12')

For VCU 2

CESTPATH DEVN(X'2203') PRIM(X'2002' 0003033) SEC(X'1002 0003053)
LINK(X'00210002' X'00600002' X'00310002' X'00700002')

CESTPAIR DEVN(X'2040') PRIM(X'2002' 0003033 X'40') SEC(X'1002'
0003053 X'20')

Note: This first volume defined for this VCU is the bridge volume.

CESTPAIR DEVN(X'2041') PRIM(X'2002' 0003033 X'41') SEC(X'1002'
0003053 X'21')

CESTPAIR DEVN(X'2042') PRIM(X'2002' 0003033 X'42') SEC(X'1002'
0003053 X'22')

For VCU 3

CESTPATH DEVN(X'2303') PRIM(X'2003' 0003033) SEC(X'1003 0003053)
LINK(X'00210003' X'00600003' X'00310003' X'00700003')

CESTPAIR DEVN(X'20E0') PRIM(X'2003' 0003053 X'E0') SEC(X'1003'
0003033 X'D0')

Note: This first volume defined for this VCU is the bridge volume.

CESTPAIR DEVN(X'20E1') PRIM(X'2003' 0003053 X'E1') SEC(X'1003'
0003033 X'D1')

CESTPAIR DEVN(X'20E2') PRIM(X'2003' 0003053 X'E2') SEC(X'1003'
0003033 X'D2')

PPRC Dynamic Address Switching (P/DAS)⁷

PPRC Dynamic Address Switching (P/DAS) is a software function that provides the ability to redirect all application I/O from one PPRC volume to another volume.

P/DAS allows application-transparent switching of I/O to support the following tasks:

- Planned Outages (volume or subsystem)
- Device migration
- Workload movement

P/DAS commands allow the system operator to redirect application I/Os that are currently sent to the primary volume, to go to the secondary volume of the PPRC pair instead.

All I/O redirection is managed at the I/O supervisor level, and is transparent to any application program that uses the volume.

Configuration Symmetry Considerations

To insure that both subsystems involved in a PPRC relationship can fully support the production configuration in the event of a disaster, it is good practice to make sure that the Physical Capacity (PCAP) of each subsystem is the same as the other. In mixed-model PPRC configurations (such as a V960 and a 9500), such configuration symmetry may not be possible, and this should be considered in the design and implementation of your disaster recovery strategy.

Requirements

The following software and environmental conditions must be met before a P/DAS operation is attempted:

Software

The OS/390 or z/OS operating system must be a release level currently supported by IBM.

1. DFSMS 1.2.0 and above (With PTFs)
2. PPRC functions installed on MVS

Source Volume

1. Must be the PRIMARY volume of a PPRC pair
2. Must be online to the system
3. Cannot be part of an active XRC session
4. Cannot have any active paging data sets in use

7. PPRC Dynamic Address Switching (P/DAS) is a utility that allows the redirection of all I/O from a primary PPRC volume to a secondary PPRC volume.

5. Cannot have any outstanding reserves (you must cancel any jobs that have outstanding reserves prior to issuing the P/DAS commands)

Target Volume

1. Must be the SECONDARY volume of a PPRC pair
2. Must not have any target volume allocations to it.
3. Must be offline or the swap is rejected.

PPRC Status

The PPRC status of the volumes to be swapped MUST be DUPLEX, and fully synchronized.

P/DAS Commands

STOP

To suspend I/O's to the primary volume you wish to switch, you must initiate the P/DAS operation by issuing an IOACTION STOP command on all systems that are attached to the primary volume specified by DEV=pppp

All I/O that is issued to the primary volume remains queued in the MVS system until you issue an IOACTION RESUME command.

The Syntax of the command is as follows:

```
IOACTION STOP,DEV=pppp
```

The MVS system will issue the following messages to the operator console of all systems when the I/O for the primary volume has been stopped on that system:

```
IOS600I IOACTION - THE FOLLOWING DEVICE(S) HAVE BEEN STOPPED :dev1
IOS601I IOACTION - DEVICES REMAIN IN THE STOPPED STATE. USE THE 'D
IOS,STOP' COMMAND TO DISPLAY THE DEVICES
```

SWAP

Once you have received the IOS600I message on ALL systems, which you entered the P/DAS STOP command, you should then issue the swap command for the volume pairs involved in the P/DAS operation.

The SWAP command directs the system to switch the source volume pppp with the target volume ssss, and prepares the system to redirect all I/Os issued originally to volume pppp to the target volume ssss.

The syntax of the command is:

```
SWAP pppp,ssss
```

Once you have issued the P/DAS SWAP command, P/DAS will perform its own validation to ensure the swap can be completed successfully.

If conditions exist that could cause a data integrity exposure, P/DAS ends the swap and generates an error message that will give a reason for the termination.

When the SWAP command has been accepted by the system, you will receive the following MVS message:

```
IGF520A VERIFICATION COMPLETE : REPLY 1 TERMINATE PAIR, AND SWAP |
2 SWITCH PAIR, AND SWAP | 3 CONTINUE SWAP | 4 TERMINATE SWAP
```

You must reply to this message based on the reply options contained in [on page 107](#).

When the swap has completed, you will receive the following message:

```
IGF505I SWAP FROM pppp to ssss COMPLETE
```

RESUME

Once you have received the IGF502A message on ALL attached systems, you must then RESUME all operations to the volume.

To resume all operations you must issue the IOACTION RESUME command on ALL systems attached to volume ssss. (You must issue this command to volume ssss, as this is now the primary volume).

The syntax of the command is:

```
IOACTION RESUME,DEV=ssss
```

Once all application I/O's have been completed, you will receive the following message to indicate that the P/DAS operation has completed:

```
IOS607I IOACTION - THE FOLLOWING DEVICE(S) HAVE BEEN RESUMED:
dev, dev1
```

P/DAS Non-Sysplex Operation

The following describes the sequence of commands to initiate a P/DAS operation in a non-sysplex, shared DASD environment. The primary (source) volume is referred to as *pppp*, and the secondary, (target) volume is referred to as *ssss*.

Before starting a P/DAS operation, you must identify all systems having access to the volumes to be switched.

The following P/DAS commands **MUST** be issued on **ALL** systems connected to the volumes being switched.

The sequence of events to initiate a P/DAS swap of volumes is as follows:

1. Stop all I/O's to the PRIMARY volume by issuing the IOACTION STOP command.
2. Swap the Primary and Secondary volumes to the system (direct all new I/O's to the new volume), by issuing the IOACTION SWAP command.
3. Resume all I/O's to the new Primary volume by issuing the IOACTION RESUME command.

P/DAS SYSPLEX Operation

In a sysplex environment, P/DAS operations are similar to those described in the previous pages.

Before initiating P/DAS operations in a sysplex environment, you must choose one system to be the “main system.”

As with the non-sysplex environment, you MUST enter ALL of the following commands on ALL systems attached to the swap DASD.

1. Issue the following stop command:

```
ROUTE *ALL,IOACTION,STOP,DEV=pppp
```

2. Issue the swap command as follows:

```
ROUTE *ALL,SWAP,DEV=pppp ssss
```

P/DAS will now perform its validation checks, and if successful, will issue the following message:

```
IGF520A VERIFICATION COMPLETE.....
```

Reply to the above message as per the instructions for a non-sysplex P/DAS swap.

3. When you have replied to the verification message on ALL systems, you will be able to issue the resume command, the command is as follows:

```
ROUTE *ALL,IOACTION RESUME DEV=SSSS
```

GDPS Considerations

The sequence of events in regards to establishing and deleting pairs is unpredictable. This in combination with Power PPRC and its bridges poses some challenges. For Power PPRC to be implemented properly the bridges pairs must be established before all user data volume pairs and can only be deleted after all data volumes are gone. So to avoid most problems inside GDPS with Power PPRC keep control of the bridges outside GDPS. This means however that procedures may need adjustment for manual intervention which would carry out manipulation of bridges (and possibly its paths). Even if this recommendation is followed, errors may get reported when GDPS tries to delete paths (because bridges are still active on them). Based on this, information following is recommended for using Power PPRC with GDPS:

- If a VCU is available that is not under control of GDPS, use this for the location of the bridges. This will also avoid error messages with delete path commands.
- If the previous recommendation is not feasible, make sure that the bridge volumes are NOT defined to GDPS. StorageTek then highly recommends that the customer prepare jobs for establishing paths and pairs of the bridge volumes for each and every scenario that can be executed under GDPS. StorageTek also recommends that people managing GDPS are aware of the manual intervention points in their scenarios.

Reject Establish Pair when Secondary Online

Note: This change only applies to the E02.05, A01.02 and B01.01 release of FLX V2X microcode.

StorageTek added a change to protect the customer from deleting data when establishing a PPRC pair when the secondary is online to another host. However, the change does allow the pair to be established for PDAS. The rules are as follows:

Reject Establish Secondary Rule:

- If the volume was never a primary prior to the request and the volume is online then the request is rejected.
- If the volume was a primary and then it was terminated and then the host issued writes to the volume then the request is rejected.

Allow Establish Secondary Rules:

- If the volume was not a primary and the volume is not online then the request is allowed.
- If the volume was a primary and then it was terminated and the host did not do writes then the request is allowed.

Proxy PPRC

Proxy PPRC exploits the ultra-high availability characteristics of OS/390 architecture to provide remote disk mirroring functionality with full synchronization for mixed OS/390 and UNIX/NT environments. Proxy PPRC works for the open systems environment by exploiting the OS/390 synchronous remote mirroring technology used by hundreds of accounts worldwide. Open systems volumes designated for PPRC are replicated from the primary system to the secondary system as conventional OS/390 volumes, even though they are defined for open systems use. The setup and restore functions are handled by tested OS/390 procedures. No actual PPRC functions are required by any open systems platform.

Notes:

1. Proxy PPRC does not support the freeze and thaw commands.
2. Proxy PPRC only works in the FLX V2X, FLX V960s using microcode 1.1 and higher, and FLX 9500s using microcode version 2.2 and higher.

Caution: potential Data Loss - If the client writes to the primary volume of a SCSI PPRC pair, then it is possible that one or more write operations will not be sent to the primary subsystem since the typical open systems host buffers write operations. In this case, since the primary subsystem has not received the write command(s), the secondary will not reflect those write command(s). In the event of a system failure at the primary site, the secondary volume may not have the latest data if there are write commands that had been buffered in the open systems host. This can occur on Unix, NT,

Windows 2000, and other open systems hosts. These buffered writes may include application data and file system meta data. The recovery process on the secondary should include running file system checks to ensure recovery of the file system structures that may have been affected by buffered meta data writes.

Open Systems Power PPRC Direct

Note: The FLX 9500 does not support Power PPRC Direct in the open systems environment.

Power PPRC Direct is Standard PPRC except that it allows for multiple track transfers from SVA to SVA without the handshaking protocol for each track. It allows chaining of unrelated tracks, reducing arbitration and de-selection or release of the link for each track transfer.

For the open systems user, Power PPRC Direct allows unrelated data to be chained to the secondary, thus reducing overhead associated with transfers to the secondary SVA, resulting in better throughput.

Software Installation and Configuration

Power PPRC in the open systems environment is accomplished by means of the Shared Virtual Array Administrator (SVAA). The user/customer will use the SVAA to designate specific volumes on a primary SVA as PPRC bridge volumes. Likewise on the secondary SVA(s), specific volumes will be designated as PPRC bridge volumes. Once these volumes are defined, SVAA can establish the bridge volume pairs.

See the SVAA installation, customization, and maintenance manual for the open systems host that will be doing the PPRC operation.

Notes:

1. The CGROUP command is **NOT** supported by Open Systems Power PPRC.
2. All bridge volumes must be empty at the time they are designated for PPRC use.

Considerations

SSIDs

SSIDs must be defined on the primary and secondary SVAs. SSIDs must be unique and defined in the hexadecimal range of 0001 to FFFF. The SSIDs cannot be altered in an enabled PPRC environment. To change SSIDs, PPRC must be disabled.

Secondary Volumes

- All established PPRC secondary volumes must be OFFLINE.
- Host access, except for allowed commands, to secondary volumes or LUNs will be prevented.
- Do not attempt to establish a PPRC pair that includes an ECAM device.

- Verify secondary volumes to be designated for PPRC usage do not include critical data that will be overwritten.

Large LUN PPRC

The SVA has a “Large LUN” option. A “Large LUN” is any LUN with more than one Logical Device included in it. By including more than one Logical Device in a LUN, you can greatly increase the capacity of what the SCSI host views as a single logical data storage area. The considerations for LUNs and Large LUNs are:

1. SVA LUNs can be either 3390-3 (SCSI A) or 3390-9 (SCSI B) emulation, but 3380 emulations are not supported for open systems attach.
2. All SCSI LUNs must be CKD and CKD R/W enabled to allow the PPRC commands to work.
3. All of the functional volumes set up as a large LUN must be designated for PPRC, not just the first volume. The actual PPRC operation is carried out by the SVA which sees the large LUN as a collection of conventional SCSI volumes.
4. The Primary and Secondary LUNs must be identical, this includes Large LUNs, otherwise the PPRC fails. This is true for CKD devices as well.

Open Systems PPRC Commands

The PPRC commands are listed below with a brief description of each command.

The table below contains a list of the PPRC commands and the device to which the command can be issued:

Table 15 Open Systems PPRC Commands

Command	Can command be issued to a:	
	Primary	Secondary
alteriointerface	Yes	No
displayiointerface	Yes	Yes
definedevice	Yes	No
alterdevice	Yes	Yes
displaydevice	Yes	Yes

Note: For FLX V2X SVAs, also see [“Reject Establish Pair when Secondary Online” on page 56](#).

Command Parameters

Establish a Path

The *addpath* parameter on the *alteriointerface* command is used to create a logical path between a Primary and Secondary SVA SSID. Each SSID is a manually assigned value and corresponds to a VCU within the SVA. Each VCU/SSID can address a range of 256 devices (VCU 0: 000-0FF, VCU 1: 100-1FF, VCU 2: 200-2FF, and so on for either four VCUs in the earlier SVAs or all 16 VCUs for the V2X) and therefore proper paths must be established from SSID to SSID before pairs can be established within those SSID's. Paths between SVA's are uni-directional, with one SVA acting as Primary and the other as Secondary. A link option exists for specifying the destination address when using an ESCON director.

Displaying Path Status Information

The *pprcinfo* parameter on the *displayiointerface* command is used to display the current PPRC path configuration information for the specified subsystem. Information such as Interface ID, Internal IFID, Primary SSID, Secondary VCU, Secondary SSID and Secondary Serial Number are displayed.

Delete a Path

The *deletepath* parameter is used on the *alteriointerface* command to delete all logical paths associated with a primary VCU or SSID. Only active paths on the specified VCU or SSID are removed, all other paths associated with other VCU's or SSID's are unaffected.

Establish a Pair

The *addrcpairs* parameter on the *alterdevice* or *definedevice* commands is used to specify the Primary and Secondary volumes that the user wants to establish as a PPRC pair. The Primary and Secondary volumes must be of the same type, that is have the same size in terms of number of tracks and cylinders. To create a pair, there are three possible options, COPY, NOCOPY or RESYNC.

Displaying Pair Status Information

The status of Primary and Secondary volumes of a PPRC pair is displayed using the *displaydevice* command. The PPRC STATE column indicates the status of any device that is part of a PPRC pair. For data volumes, Data Bridge Volumes and Status Bridge Volumes, information such as Primary or Secondary and Pending (being synchronized), Duplex (fully synchronized) or Suspended (not currently being kept in sync) is displayed.

Suspend a PPRC Pair

The *suspend* parameter on the *alterdevice* command will place both the Primary and Secondary volumes into a suspended state and stop the transfer of updates from the Primary to the Secondary volume. The Primary volume will keep track of updates while in a suspended state and transfer only those updated tracks to the Secondary when a *resync* command is issued. This command can be issued to either the Primary or Secondary volume.

Recover a Secondary Volume

The *recover* parameter on the *alterdevice* command is issued to a Secondary volume to release it from being part of the PPRC environment and gain control of it on the Secondary subsystem. In normal operation, all access to an active Secondary volume is prevented.

Delete a Pair

The *deletercpairs* parameter is used on the *alterdevice* command to delete the logical connection between a primary and secondary volume. You would use this command to remove devices from PPRC control.

Command Examples:

See [Table 15 on page 60](#) for a list of the commands used in the examples below.

Note: In the examples below, not all possible combinations are shown.

Defining a Path:

A path may be defined by the SVAA in the following ways:

```
altioint -subsys XXX -ifid c.i -addpath -ssid 2001 -trgssid 1001 -
trgssname YYY -linkdest gg
```

Notes:

1. *c.i* = cluster.interface
2. *gg* is defined in [Table 10 on page 38](#).

```
altioint -subsys XXX -ifid c.i -addpath -ssid 2001 -trgssid 1001 -
trgserialnumber 3053 -linkdest gg
```

```
altioint -subsys XXX -ifid c.i -addpath -ssid 2001 -trgvcu 0 -
trgssname YYY -linkdest gg
```

```
altioint -subsys XXX -ifid c.i -addpath -ssid 2001 -trgvcu 0 -trg-
serialnumber 3053 -linkdest gg
```

```
altioint -subsys XXX -ifid c.i -addpath -ssid 2001 -trgvcssid
0.1001 -trgssname YYY -linkdest gg
```

```
altioint -subsys XXX -ifid c.i -addpath -ssid 2001 -trgvcssid
0.1001 -trgserialnumber 3053 -linkdest gg
```

```

altioint -subsys XXX -ifid c.i -addpath -vcu 0 -trgssid 1001 -
trgssname YYY -linkdest gg
altioint -subsys XXX -ifid c.i -addpath -vcu 0 -trgssid 1001 -trg-
serialnumber 3053 -linkdest gg
altioint -subsys XXX -ifid c.i -addpath -vcu 0 -trgvcu 0 -trgssname
YYY -linkdest gg
altioint -subsys XXX -ifid c.i -addpath -vcu 0 -trgvcu 0 -trgseri-
alnumber 3053 -linkdest gg
altioint -subsys XXX -ifid c.i -addpath -vcu 0 -trgvcussid 0.1001 -
trgssname YYY -linkdest gg
altioint -subsys XXX -ifid c.i -addpath -vcu 0 -trgvcussid 0.1001 -
trgserialnumber 3053 -linkdest gg

```

Removing Paths:

A path may be removed by the SVAA in the following ways:

```

altioint -subsys XXX -ifid c.i -deletepath -ssid 2001 -trgssid
1001
altioint -subsys XXX -ifid c.i -deletepath -vcu 0 -trgssid 1001
altioint -subsys XXX -ifid c.i -deletepath -ssid 2001 -trgvcu 0
altioint -subsys XXX -ifid c.i -deletepath -vcu 0 -trgvcu 0
altioint -subsys XXX -ifid c.i -deletepath -ssid 2001 -trgssid
1001 -trgserialnumber 3053
altioint -subsys XXX -ifid c.i -deletepath -vcu 0 -trgssid 1001 -
trgssname YYY
altioint -subsys XXX -ifid c.i -deletepath -ssid 2001 -trgvcu
dtrgserialnumber 3053
altioint -subsys XXX -ifid c.i -deletepath -vcu 0 -trgvcu 0 -trgss-
name YYY

```

Create a Pair with an Existing Known Secondary:

A pair may be created with an existing known secondary by SVAA in the following ways:

```

altdev -subsys XXX -fdid 54 -addrpairs -trgssname YYY -trgssid
1001
altdev -subsys XXX -fdid 54 -addrpairs -trgserialnumber 3053 -
trgssid 1001
altdev -subsys XXX -fdid 54 -addrpairs -trgssname YYY -trgvcu 0
altdev -subsys XXX -fdid 54 -addrpairs -trgserialnumber 3053 -
trgvcu 0
altdev -subsys XXX -fdid 54 -addrpairs -trgssname YYY -trgssid
1001 -trgid 54

```

```
altdev -subsys XXX -fdid 54 -addrpairs -trgserialnumber 3053 -
trgssid 1001 -trgid 54
```

```
altdev -subsys XXX -fdid 54 -addrpairs -trgssname YYY -trgvcu 0 -
trgid 54
```

```
altdev -subsys XXX -fdid 54 -addrpairs -trgserialnumber 3053 -
trgvcu 0 -trgid 54
```

Suspend a Pair of Devices:

```
altdev -subsys LOCAL -fdid 256 -modifrcpairs -mode suspend
```

Resync a Suspended Pair:

```
altdev -subsys LOCAL -fdid 256 -addrpairs -mode resync -trgssname
REMOTE -trgvcu 2
```

Delete a Pair:

A pair may be deleted by the SVAA in the following ways:

```
altdev -subsys XXX -fdid 54,55 -deletercpairs
```

```
altdev -subsys XXX -fdid 54:55 -deletercpairs
```

```
altdev -subsys XXX -fdid 54 -deletercpairs
```

Define a Data Bridge Device:

```
defdev -subsys LOCAL -fdid 48 -devtyp DATABRIDGE -name BRIDGE
```

Define a Status Bridge Device:

```
defdev -subsys LOCAL -fdid 49 -devtyp STATUSBRIDGE -name STATUS
```

Define a New Device and Create a Pair:

```
defdev -subsys LOCAL -fdid 35d -devtyp SCSIB -scsiaddr 4.0.22 -
name PPRC4 -ckdena YES -ckdrw YES -addrpairs -trgid 5d -trgvcu 3 -
mode copy -trgserialnumber 475
```

The explanation of the command is: You are defining a device (defdev) on subsystem LOCAL (-subsys LOCAL) Functional Device ID 35D (-fdid 35d) device type SCSIB (-devtyp SCSIB), with a SCSI address of Domain 4, Target 0, LUN 22 (-scsiaddr 4.0.22) and giving it a name of PPRC4 (-name PPRC4). You are then going to make it the primary in a PPRC pair command (-addrpairs), you are copying the entire contents (-mode copy) and the serial number of the PPRC Secondary unit is 475, and your PPRC secondary device is within VCU 3 (-trgvcu 3) and therefore has the FDID of 35D (-trgid 5d).

SVA Configurations

PPRC can be configured in one of two ways, uni-directional or bi-directional.

Uni-Directional

This configuration physically splits the two SVA's, and has a primary SVA containing only primary PPRC volumes, and a secondary SVA containing only secondary PPRC volumes.

In this configuration, ALL PPRC ESCON channels will transmit data from the primary to the secondary SVA.

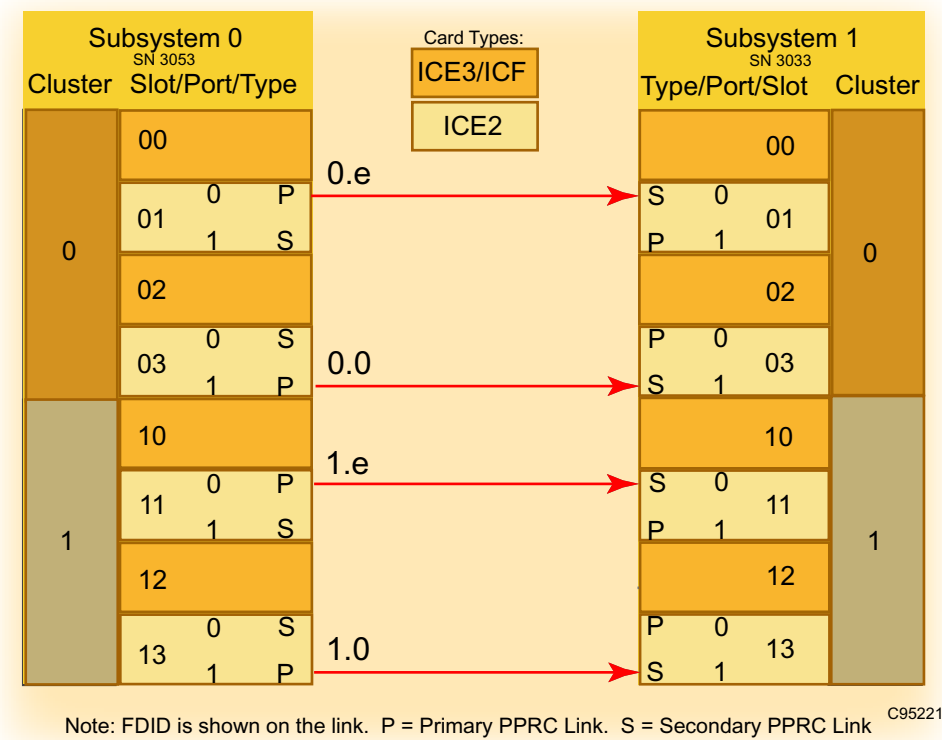

Figure 8 Uni-Directional PPRC Physical Connections

Note: Either port may be used on an ICE2 card being used for PPRC. The above figure is just an example and does show some flexibility in the configuration⁸.

Attention: The secondary volumes should be unmounted before the PPRC pair is established.

Uni-Directional Configuration Example

SVA1 (Primary)

Serial Number ⁹	3053			
VCU	0	1	23	
FDID	000-0FF	100-1FF	200-2FF	300-3FF

SVA2 (Secondary)

Serial Number	3033			
VCU	0	1	2	3

8. Only four control units are shown for clarity. In the case of a FLX V2X, there could be up to 16.

9. Name may be substituted for serial number, in which case this would be SVA1 for this example.

FDID 000-0FF 100-1FF 200-2FF 300-3FF

When configuring the PPRC pairs, try to configure the pairs with corresponding addresses, so that if the Primary PPRC volume on SVA1 is FDID 2AA, then the secondary PPRC FDID on SVA2 will be 2AA.

PPRC Logical Configuration

The logical view of the 'uni-directional' PPRC cables for the above example is shown in [Figure 9](#).

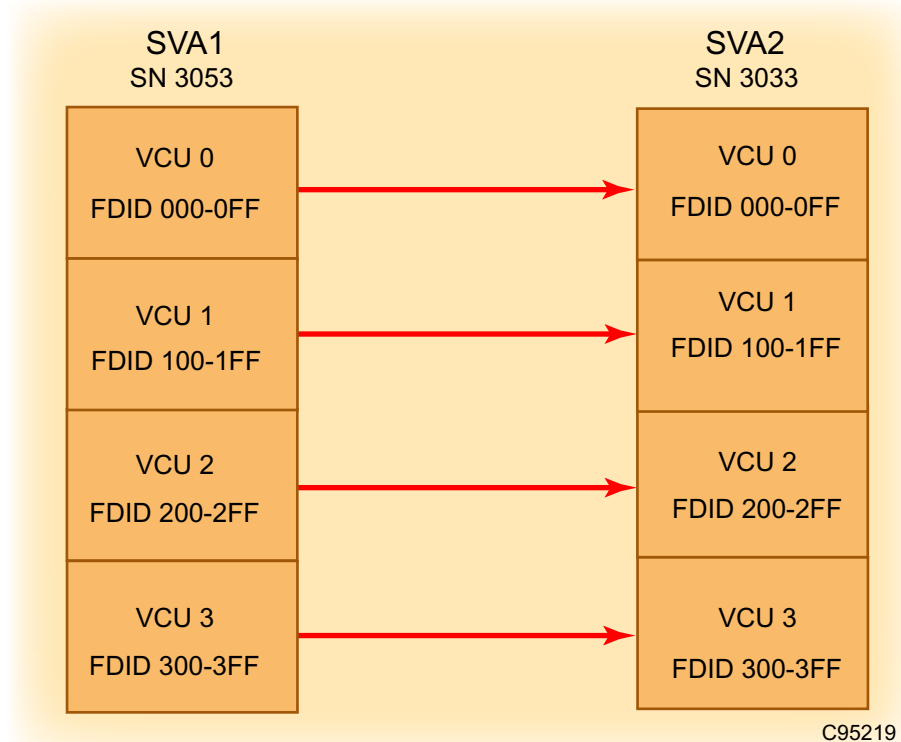

Figure 9 Uni-Directional PPRC Logical Connections

Note: One bridge pair is needed for each physical link. For example, the figure above shows four physical links, therefore there would be four bridge pairs. If there was only one physical link with pathing for all four VCUs, there would only be one bridge pair.

Establish Path and Pair Command Line Examples

The following is a *partial example* of the syntax for the Establish Path (altiointerface) and Establish Pair (alterdevice (assuming all devices are defined)) commands for the above example, using [Figure 8 on page 65](#) for the physical connections and [Figure 9](#) (above) for the logical connections. Not all devices were configured in this example - only three logical devices are shown for each VCU.

Note: This example assumes that the SVAA has access to the secondary subsystem and that secondary volumes exist and are unmounted.

For SVA 3053:

Create Bridge Volumes

Primary SVA (SN 3053)

```
defdev -subsys SVA1 -fdid 10 -devtyp DATABRIDGE -name BRIDGE10
```

Secondary SVA (SN 3033)

```
defdev -subsys SVA2 -fdid 10 -devtyp DATABRIDGE -name BRIDGE10
```

Establish Paths

```
altioint -subsys SVA1 -ifid 0.e,0.o,1.e,1.o -addpath -vcu 0 -
trgssname SVA2 - trgvcu 0
```

Establish Pairs

Bridge Pairs

Primary SVA

```
altdev -subsys SVA1 -fdid 10 -addrcpairs -trgssname SVA2 -trgvcu 0
-trgid 10
```

“Normal” Pairs

```
altdev -subsys SVA1 -fdid aa:ac -addrcpairs -trgssname SVA2 -
trgvcu 0 -trgid aa:ac
```

For four VCU's it would be:

Create Bridge Volumes

```
defdev -subsys SVA1 -fdid 10 -devtyp DATABRIDGE -name BRIDGE10
defdev -subsys SVA1 -fdid 110 -devtyp DATABRIDGE -name BRIDG110
defdev -subsys SVA1 -fdid 210 -devtyp DATABRIDGE -name BRIDG210
defdev -subsys SVA1 -fdid 310 -devtyp DATABRIDGE -name BRIDG310
defdev -subsys SVA2 -fdid 10 -devtyp DATABRIDGE -name BRIDGE10
defdev -subsys SVA2 -fdid 110 -devtyp DATABRIDGE -name BRIDG110
defdev -subsys SVA2 -fdid 210 -devtyp DATABRIDGE -name BRIDG210
defdev -subsys SVA2 -fdid 310 -devtyp DATABRIDGE -name BRIDG310
```

Note: One or more bridge volumes have to exist on each SVA.

Establish Paths

```
altioint -subsys SVA1 -ifid 0.e,0.o,1.e,1.o -addpath -vcu 0,1,2,3
-trgssname SVA2 - trgvcu 0,1,2,3
```

Establish Pairs

Bridge Pairs

```
altdev -subsys SVA1 -fdid 10 -addrcpairs -trgssname SVA2 -trgvcu 0
-trgid 10
```

```
altdev -subsys SVA1 -fdid 110 -addrcpairs -trgssname SVA2 -trgvcu
1 -trgid 10
```

```
altdev -subsys SVA1 -fdid 210 -addrcpairs -trgssname SVA2 -trgvcu
2 -trgid 10
```

```
altdev -subsys SVA1 -fdid 310 -addrcpairs -trgssname SVA2 -trgvcu
3 -trgid 10
```

“Normal” Pairs

```
altdev -subsys SVA1 -fdid aa:ac -addrcpairs -trgssname SVA2 -
trgvcu 0 -trgid aa:ac
```

```
altdev -subsys SVA1 -fdid 1aa:1ac -addrcpairs -trgssname SVA2 -
trgvcu 1 -trgid aa:ac
```

```
altdev -subsys SVA1 -fdid 2aa:2ac -addrcpairs -trgssname SVA2 -
trgvcu 2 -trgid aa:ac
```

```
altdev -subsys SVA1 -fdid 3aa:3ac -addrcpairs -trgssname SVA2 -
trgvcu 3 -trgid aa:ac
```

Bi-Directional

To efficiently use the four internal processors in each cluster of the SVA, StorageTek recommends the following configuration for bi-directional Power PPRC Direct¹⁰. This configuration logically splits each SVA into a ‘sending’ and ‘receiving’ configuration, which will allow you to have primary and secondary PPRC volumes on EACH SVA, and you will be able to send and receive PPRC data on each SVA. (See [Figure 10 on page 69](#).) This configuration is suggested so one SVA’s processor is not paired with another SVA’s processor, setting up a situation where they could begin sending or receiving an I/O at the same time, resulting in a time-out situation.

10. Power Wide Area Network PPRC does not support bi-directional PPRC except as noted in [“Considerations” on page 85](#).

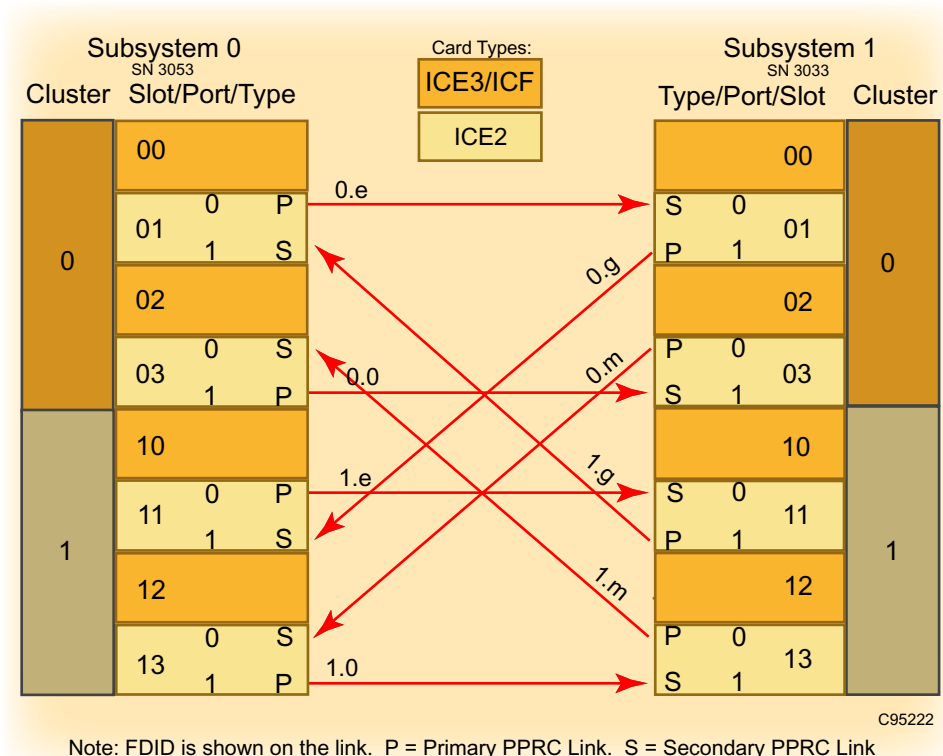

Figure 10 Bi-Directional PPRC Physical Connections

Note: Either port may be used on an ICE2 card. The above figure is just an example and does show some flexibility in the configuration¹¹.

Attention: The secondary volumes should be unmounted before the PPRC pair is established.

Bi-directional Configuration Example

SVA1 (Primary)

Serial Number ¹²	3053			
VCU	0	1	2	3
FDID	000-0FF	100-1FF	200-2FF	300-3FF

SVA2 (Secondary)

Serial Number	3033			
VCU	0	1	2	3
FDID	000-0FF	100-1FF	200-2FF	300-3FF

When configuring the PPRC pairs, try to configure the pairs with corresponding addresses, so that if the Primary PPRC volume on SVA1 is FDID 2AA, then the secondary PPRC FDID on SVA2 will be 2AA.

11. Only four control units are shown for clarity. In the case of a V2X, there could be up to 16.

12. Name may be substituted for serial number, in which case this would be SVA1 for this example.

PPRC Logical Configuration

The logical view of the 'bi-directional' PPRC cables for the above example is shown in [Figure 11](#) below.

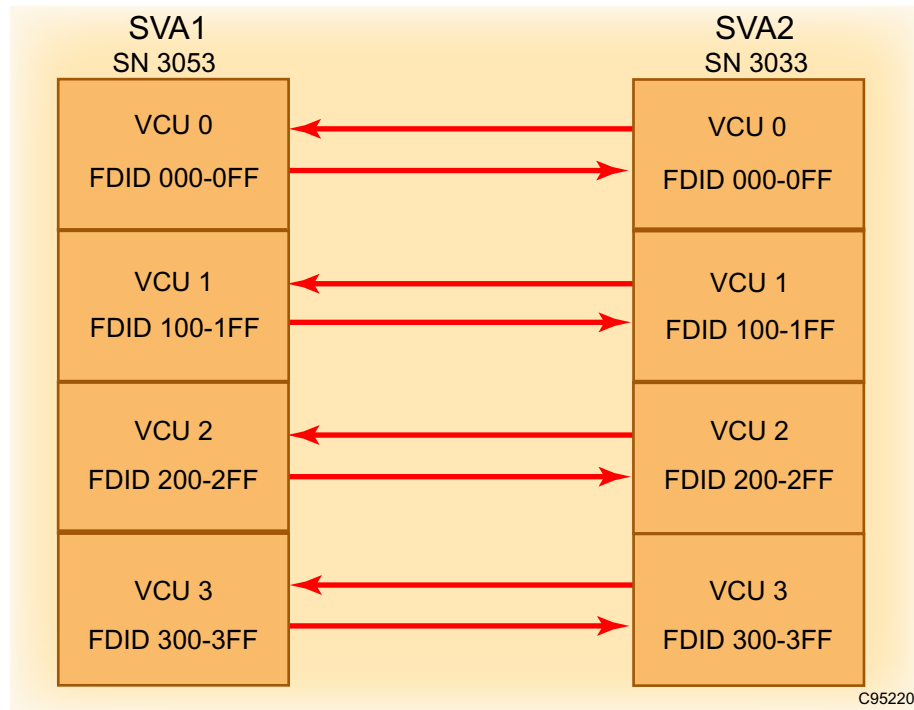

Figure 11 Bi-Directional PPRC Logical Connections

Note: One bridge pair is needed for each physical link. For example, the figure above shows eight physical links, therefore there would be eight bridge pairs. If there was only two physical links with pathing for all four VCUs, there would only be two bridge pairs.

Establish Path and Pair Command Line Examples

The following is a *partial example* of the syntax for the Establish Path (altiointerface) and Establish Pair (altdevice) commands for the above example, using [Figure 10 on page 69](#) for the *physical connections* and [Figure 11](#) above for the *logical connections*. Not all devices were configured in this example - only three logical devices are shown for each VCU.

See [Table 15 on page 60](#) for a list of the commands used in the examples below.

This is a limited example for bi-directional PPRC showing only VCU 0.

Note: This example assumes that the SVAA has access to the secondary subsystem and that secondary volumes exist and are unmounted.

For SVA 3053 - SVA1 (assuming SVAA has access to the secondary subsystem):

Create Bridge Volumes

Primary SVA (SN 3053)

```
defdev -subsys SVA1 -fdid 10 -devtyp DATABRIDGE -name BRIDGE10
```

```
defdev -subsys SVA1 -fdid 11 -devtyp DATABRIDGE -name BRIDGE11
```

Secondary SVA (SN 3033)

```
defdev -subsys SVA2 -fdid 10 -devtyp DATABRIDGE -name BRIDGE10
```

```
defdev -subsys SVA2 -fdid 11 -devtyp DATABRIDGE -name BRIDGE11
```

Establish Paths

Primary SVA

```
altioint -subsys SVA1 -ifid 0.e,0.o,1.e,1.o -addpath -vcu 0 -
trgssname SVA2 - trgvcu 0
```

Secondary SVA

```
altioint -subsys SVA2 -ifid 0.g,0.m,1.g,1.m -addpath -vcu 0 -
trgssname SVA1 - trgvcu 0
```

Establish Pairs

Bridge Pairs

Primary SVA

```
altdev -subsys SVA1 -fdid 10 -addrcpairs -trgssname SVA2 -trgvcu 0
-trgid 10
```

Secondary SVA

```
altdev -subsys SVA2 -fdid 11 -addrcpairs -trgssname SVA1 -trgvcu 0
-trgid 11
```

'Normal' Pairs.

```
altdev -subsys SVA1 -fdid aa:ac -addrcpairs -trgssname SVA2 -
trgvcu 0 -trgid aa:ac
```

```
altdev -subsys SVA2 -fdid bb:bc -addrcpairs -trgssname SVA1 -
trgvcu 0 -trgid bb:bc
```

For four VCU's it would be:

Create Bridge Volumes

Primary SVA

```
defdev -subsys SVA1 -fdid 10 -devtyp DATABRIDGE -name BRIDGE10
```

```
defdev -subsys SVA1 -fdid 11 -devtyp DATABRIDGE -name BRIDGE11
```

```
defdev -subsys SVA1 -fdid 110 -devtyp DATABRIDGE -name BRIDG110
```

```
defdev -subsys SVA1 -fdid 111 -devtyp DATABRIDGE -name BRIDG111
```

```
defdev -subsys SVA1 -fdid 210 -devtyp DATABRIDGE -name BRIDG210
```

```
defdev -subsys SVA1 -fdid 211 -devtyp DATABRIDGE -name BRIDG211
```

```
defdev -subsys SVA1 -fdid 310 -devtyp DATABRIDGE -name BRIDG310
```

```
defdev -subsys SVA1 -fdid 311 -devtyp DATABRIDGE -name BRIDG311
```

Secondary SVA

```
defdev -subsys SVA2 -fdid 10 -devtyp DATABRIDGE -name BRIDGE10
```

```
defdev -subsys SVA2 -fdid 11 -devtyp DATABRIDGE -name BRIDGE11
defdev -subsys SVA2 -fdid 110 -devtyp DATABRIDGE -name BRIDG110
defdev -subsys SVA2 -fdid 111 -devtyp DATABRIDGE -name BRIDG111
defdev -subsys SVA2 -fdid 210 -devtyp DATABRIDGE -name BRIDG210
defdev -subsys SVA2 -fdid 211 -devtyp DATABRIDGE -name BRIDG211
defdev -subsys SVA2 -fdid 310 -devtyp DATABRIDGE -name BRIDG310
defdev -subsys SVA2 -fdid 311 -devtyp DATABRIDGE -name BRIDG311
```

Establish Paths

Primary SVA

```
altioint -subsys SVA1 -ifid 0.e,0.o,1.e,1.o -addpath -vcu 0,1,2,3
-trgssname SVA2 - trgvcu 0,1,2,3
```

Secondary SVA

```
altioint -subsys SVA2 -ifid 0.g,0.m,1.g,1.m -addpath -vcu 0,1,2,3
-trgssname SVA1 - trgvcu 0,1,2,3
```

Establish Pairs

Bridge Pairs

Primary SVA

```
altdev -subsys SVA1 -fdid 10 -addrcpairs -trgssname SVA2 -trgvcu 0
-trgid 10
altdev -subsys SVA1 -fdid 110 -addrcpairs -trgssname SVA2 -trgvcu
1 -trgid 10
altdev -subsys SVA1 -fdid 210 -addrcpairs -trgssname SVA2 -trgvcu
2 -trgid 10
altdev -subsys SVA1 -fdid 310 -addrcpairs -trgssname SVA2 -trgvcu
3 -trgid 10
```

Secondary SVA

```
altdev -subsys SVA2 -fdid 11 -addrcpairs -trgssname SVA1 -trgvcu 0
-trgid 11
altdev -subsys SVA2 -fdid 111 -addrcpairs -trgssname SVA1 -trgvcu
1 -trgid 11
altdev -subsys SVA2 -fdid 211 -addrcpairs -trgssname SVA1 -trgvcu 2
-trgid 11
altdev -subsys SVA2 -fdid 311 -addrcpairs -trgssname SVA1 -trgvcu
3 -trgid 11
```

“Normal” Pairs

```
altdev -subsys SVA1 -fdid aa:ac -addrcpairs -trgssname SVA2 -
trgvcu 0 -trgid aa:ac
altdev -subsys SVA2 -fdid bb:bc -addrcpairs -trgssname SVA1 -
trgvcu 0 -trgid bb:bc
```



```

altdev -subsys SVA1 -fdid 1aa:1ac -addrpairs -trgssname SVA2 -
trgvcu 1 -trgid aa:ac

altdev -subsys SVA2 -fdid 1bb:1bc -addrpairs -trgssname SVA1 -
trgvcu 1 -trgid bb:bc

altdev -subsys SVA1 -fdid 2aa:2ac -addrpairs -trgssname SVA2 -
trgvcu 2 -trgid aa:ac

altdev -subsys SVA2 -fdid 2bb:2bc -addrpairs -trgssname SVA1 -
trgvcu 2 -trgid bb:bc

altdev -subsys SVA1 -fdid 3aa:3ac -addrpairs -trgssname SVA2 -
trgvcu 3 -trgid aa:ac

altdev -subsys SVA2 -fdid 3bb:3bc -addrpairs -trgssname SVA1 -
trgvcu 3 -trgid bb:bc

```

SVAC PPRC Configuration

Note: Menu content of the figures below are examples. The actual content of many of these screens will vary from one installation to another.

Creating a PPRC Pair

From the SVAC's PC, and using the Shared Virtual Array Administrator, use the following procedure to set up the PPRC configuration.

1. Left-click on "PPRC" from the top menu bar as shown in Figure 12.

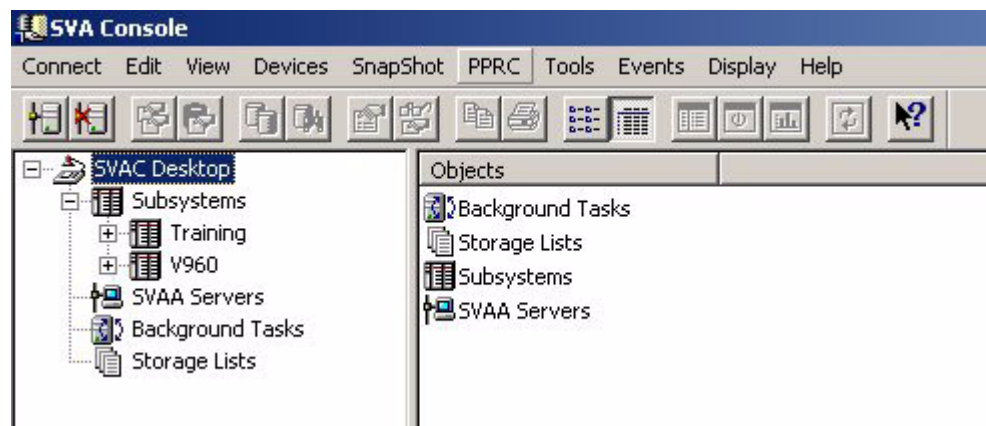

Figure 12 Select PPRC

- From the selection menu that appears, left-click on “Configuration Wizard” as shown in Figure 13.

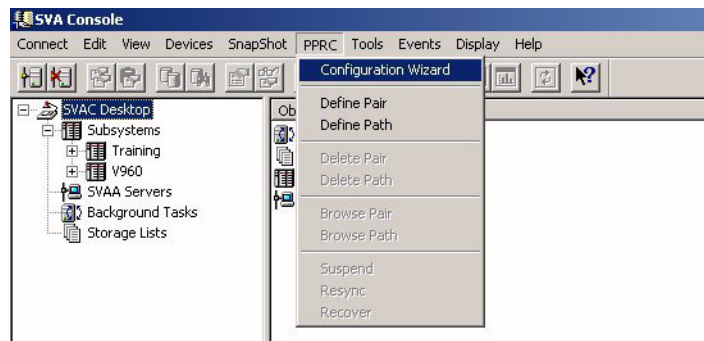

Figure 13 Selecting Configuration Wizard

- With Configuration Wizard selected, the dialogue box of Figure 14 appears. Left-click on the “Next” button.

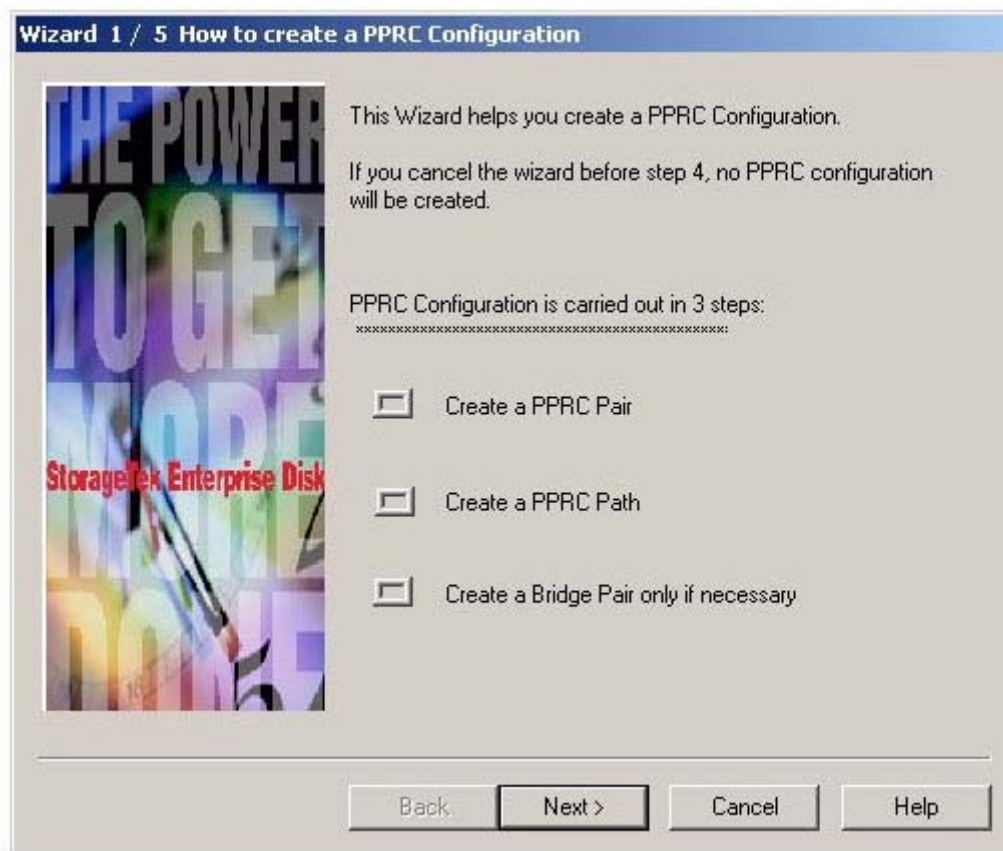

Figure 14 Selecting a PPRC Action.

- The dialogued box of Figure 15 appears. Select the primary and secondary subsystems and their FDIDs.

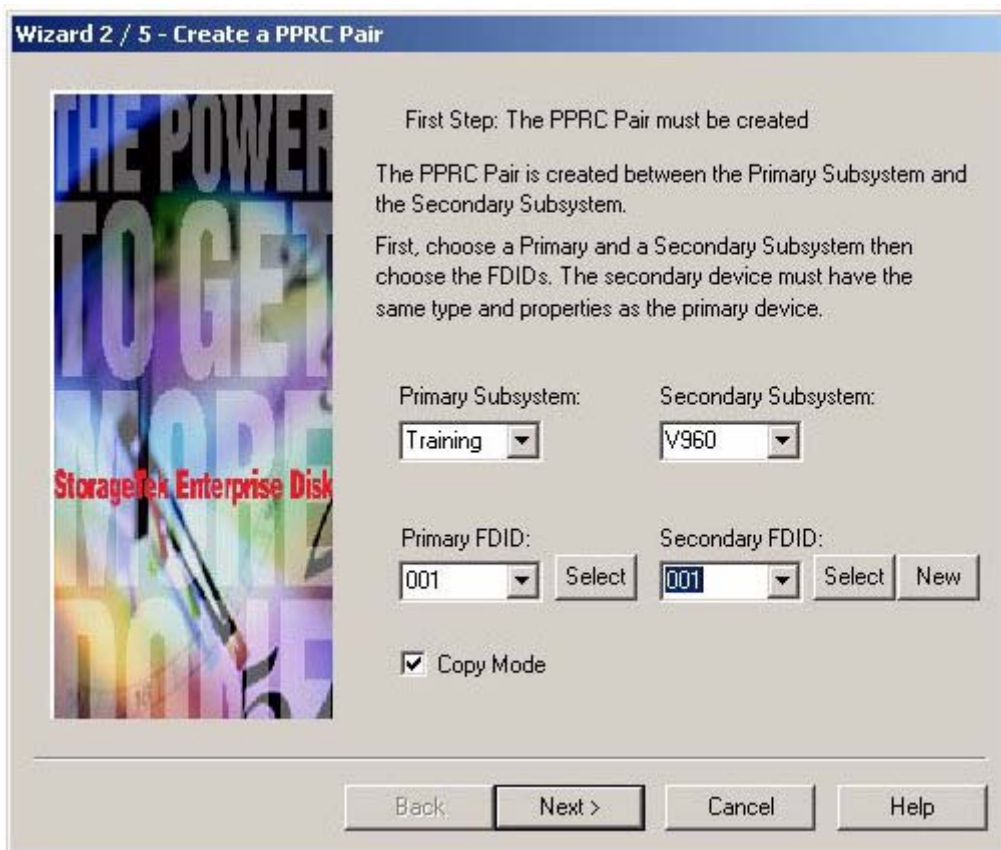

Figure 15 Primary and Secondary Subsystem Selection

Note: Leave the “Copy Mode” box selected.

- Left-click on the “Next” button.
- The dialogue box of Figure 16 will appear briefly.

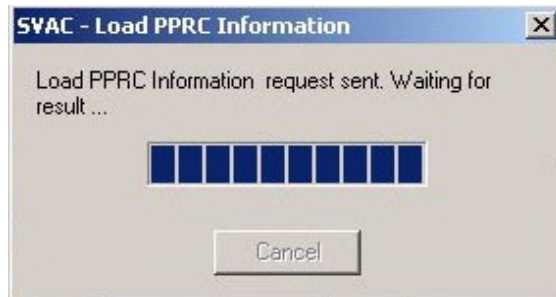

Figure 16 Information Loading

- The dialogue box of Figure 17 appears. Select the IFID path with the interface cables being dedicated to PPRC operation in the primary

subsystem. Mode has a default setting of 00 and would only be changed if there was an ESCON director in the path.

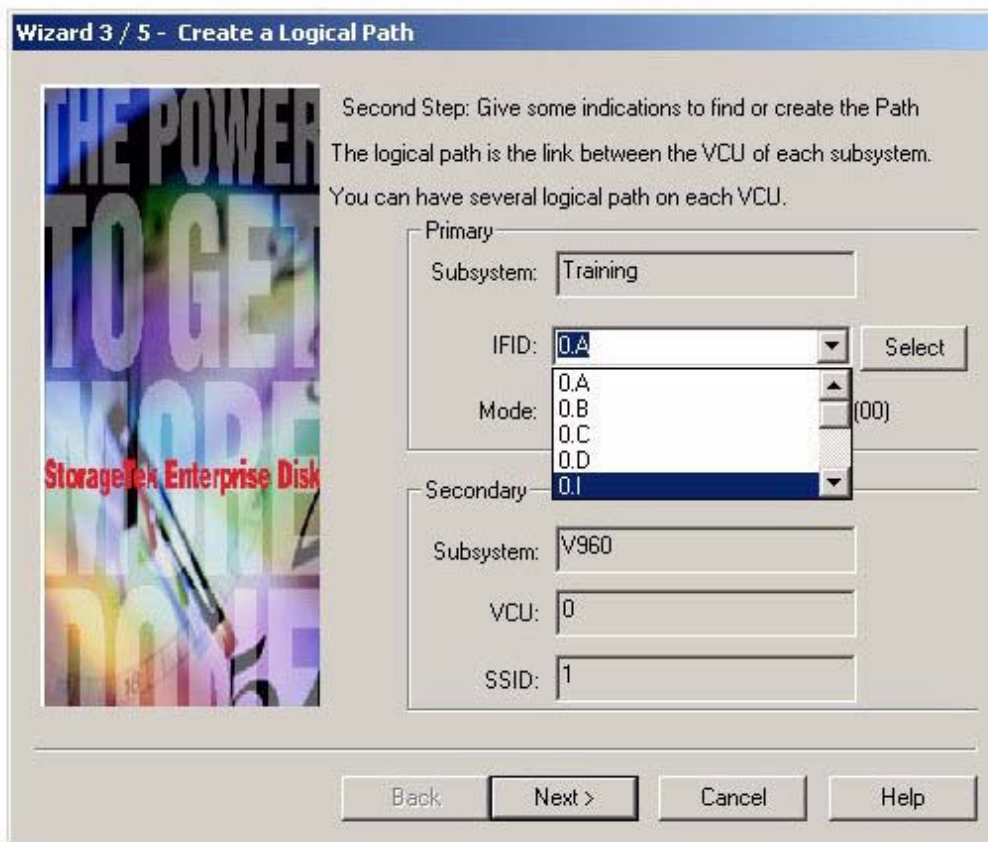

Figure 17 Interface Configuration Selection

8. Left-click on the “Next” button.

9. The dialogue box of Figure 18 appears. Select the FDID of the bridge pairs and name them. Here they are shown as being FDID of 006 named “bridge.”

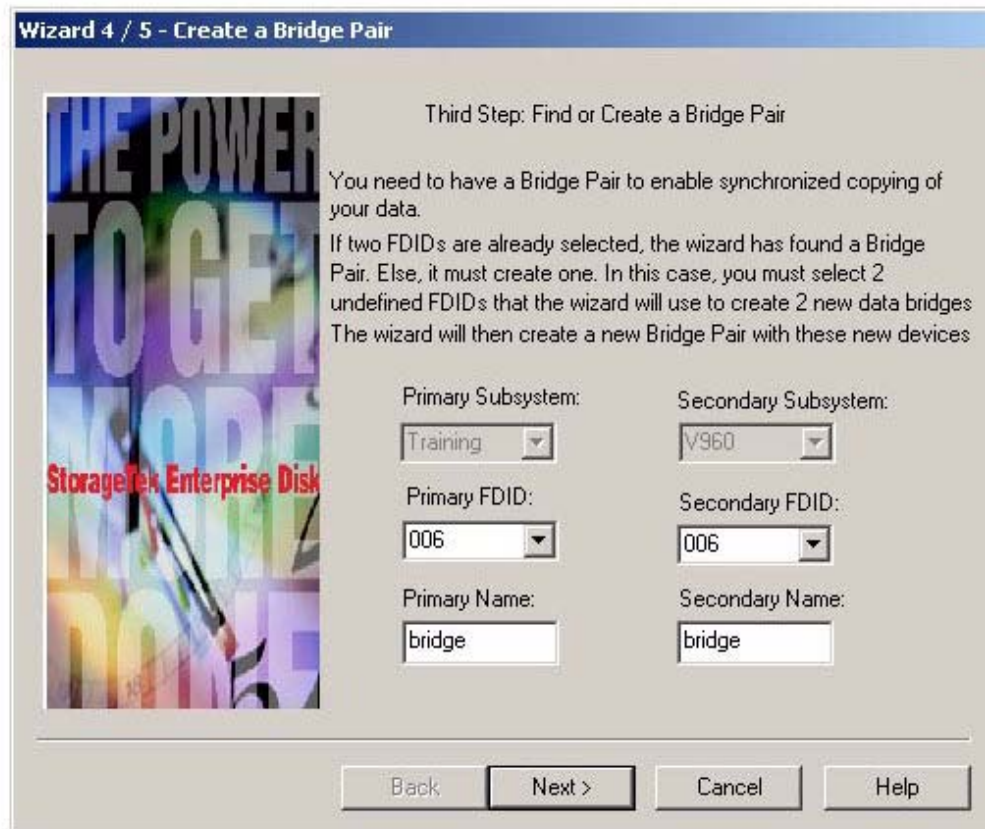

Figure 18 Bridge Pair FDID Selection

Note: Neither the FDID nor the name has to be the same in both subsystems.

10. Left-click on “Next.”
11. The dialogue box shown in Figure 16 on page 75 will appear briefly.
12. The information screen of Figure 19 appears. **Check the information on this screen carefully.**

Note: The content of the screen below is just an example. The actual content of the screen should be what you had entered in the previous steps.

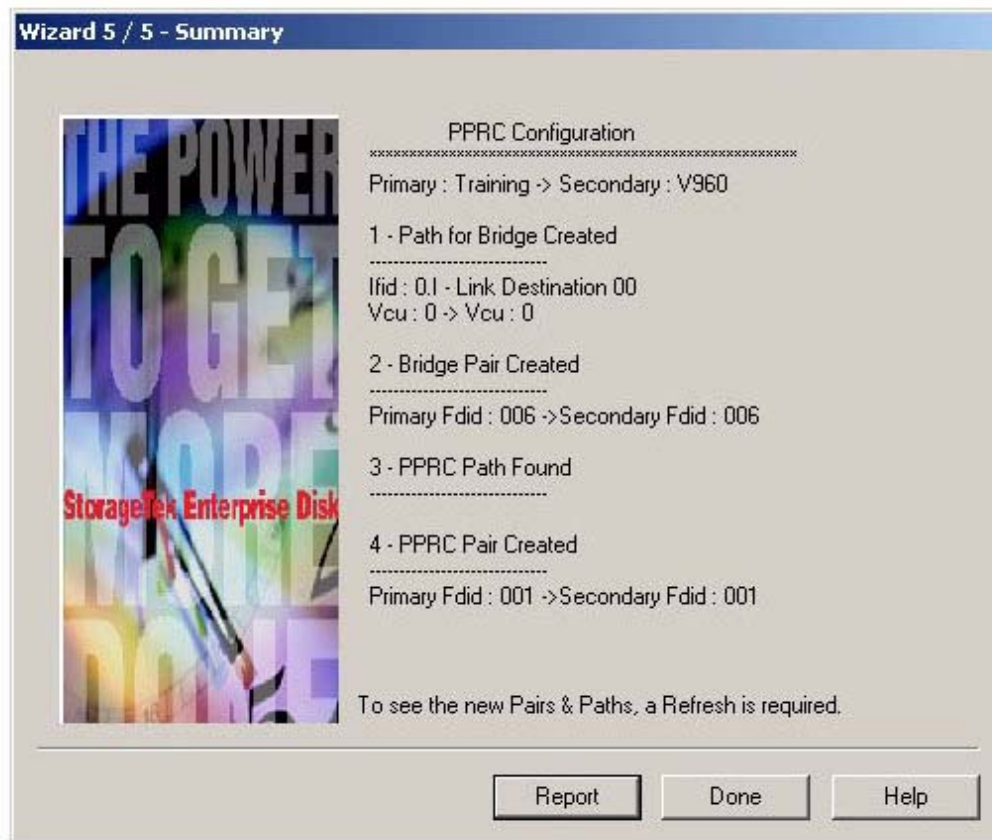

Figure 19 Configuration Information

Note: Clicking on "Report" will create a text file of this screen's information with the file name of wizardReport.doc. This file can be found in the same directory as the SVAA files.

13. Left-click on "Done."

14. The screen shown in Figure 20 appears, showing the PPRC pairs.

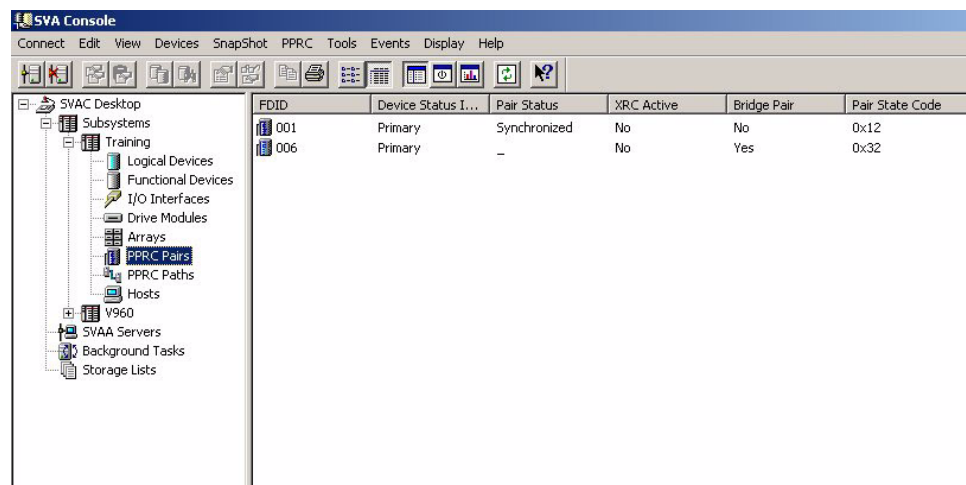

Figure 20 Main Menu with PPRC Pairs shown

Reviewing Information on a PPRC Pair

To review information on an existing PPRC pair, do the following:

1. From the SVAC's PC, and using the Shared Virtual Array Administrator, left-click on "PPRC Pairs" as shown in the left side of Figure 21.
2. Right-click on the desired PPRC pair to select it and bring up the selection menu as shown in Figure 21.

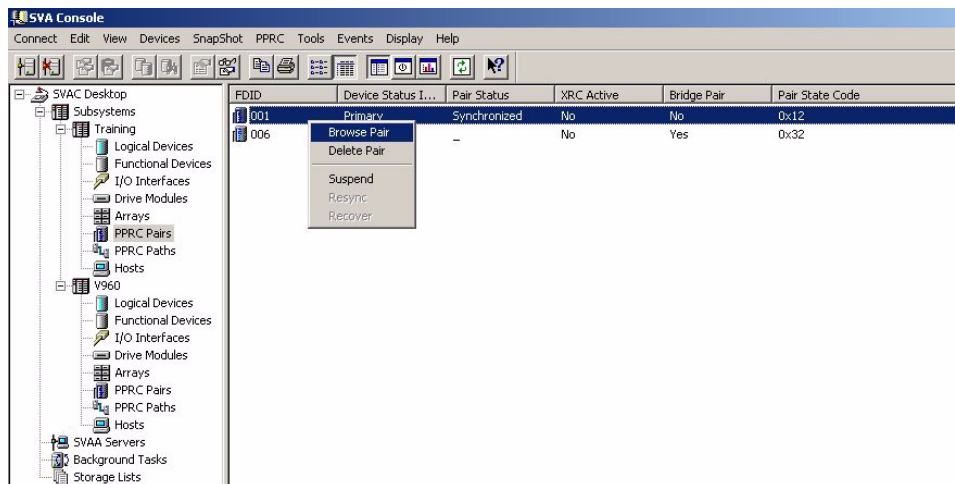

Figure 21 Selecting a PPRC Pair For Deletion.

3. Click on the line "Browse Pair."

- The information on the selected pair appears in a dialogue box as shown in Figure 22. The content of Figure 22 is just an example; the actual content is site dependant.

SVAC - Browse a PPRC Pair

Browse a PPRC Pair

Pair Status

Primary FDID: 001

Secondary Primary Status: primary duplex 0x12

Bridge Secondary Status: full copy mode 0x02

Configuration

Primary Subsystem: Training Secondary Subsystem: 00001007

Primary ID: 01 Secondary ID (Target ID): 01

Primary Device Name: pprcs Secondary Device Name:

Primary SSID: 16 Secondary SSID: 1

Primary VCU: 0 Secondary VCU:

Monitoring

Retransmission % Synchronized: 100

Critical State Next cylinder synchronized: ffff

Path Active Last cylinder synchronized: ffff

Suspended Time:

Close

Figure 22 PPRC Pair Information

Note: Nothing should be changed in this screen.

- Left-click on “Close” when you are done.

Deleting a PPRC Pair

To delete a PPRC pair, do the following:

- From the SVAC’s PC, and using the Shared Virtual Array Administrator, select “PPRC Pairs” in the left part of the display as shown in Figure 23.

- Right-click on the undesired pair to highlight it and bring up the selection menu as shown in Figure 23.

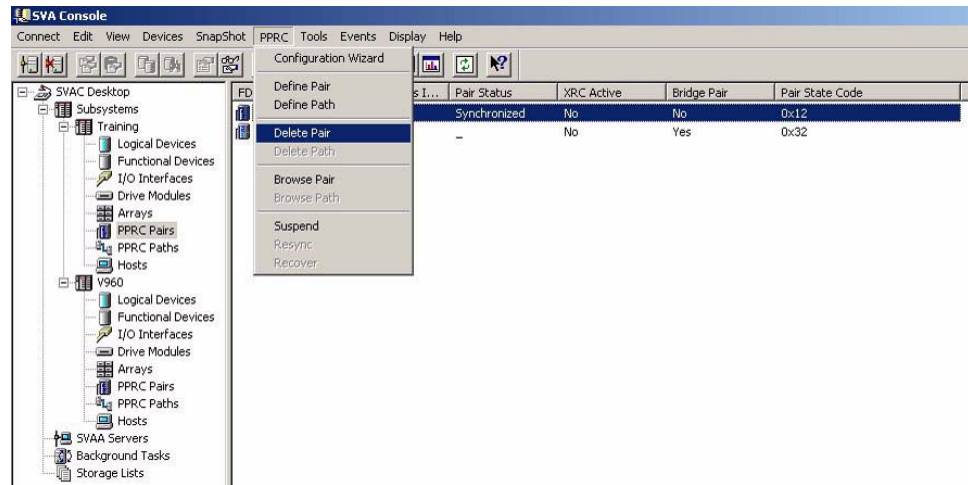

Figure 23 Deleting a PPRC Pair.

- Click on the line “Delete Pair.”
- The information box of Figure 24 appears. **Make sure this is the pair you wish to delete.**

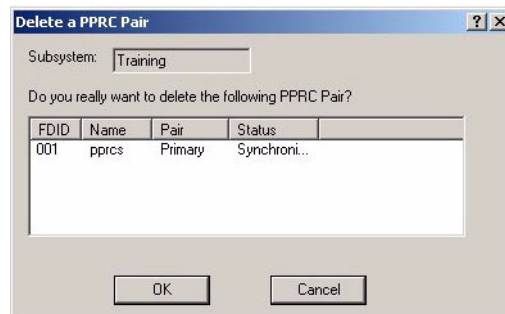

Figure 24 Deleted Pair Information Box

- Click on “Ok” to delete the pair.
- The confirmation box of Figure 25 appears. If this is still the desired action, left-click on “Ok.”

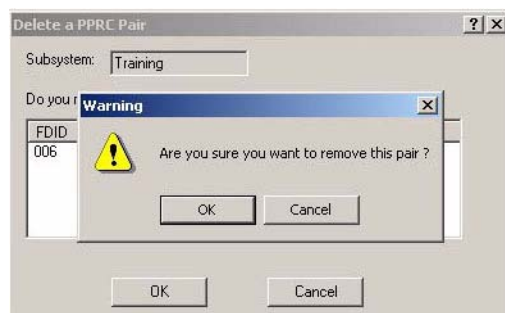

Figure 25 Confirmation Box

Power PPRC Wide Area Network (WAN)

Caution: Performance Issues - StorageTek has only tested its products on the CNT Ultraset Storage Director. While other brands of channel extenders may work with StorageTek products, StorageTek cannot guarantee the results. StorageTek will work with a customer using another brand of channel extender, but will require financial compensation for time and material spent on anything beyond a minimal diagnostic effort.

Note: Like models of the SVA must be used for PPRC WAN. E.g.: FLX 9500 to FLX 9500, FLX V960 to FLX V960, or FLX V2X to FLX V2X. You cannot mix the model types over a PPRC WAN connection.

Overview

Power PPRC WAN offers the ability to use PPRC over very long distances using WAN facilities. Power PPRC WAN may be used in both the mainframe and open systems environments. A minimal configuration is shown by the dark lines in Figure 26 and an optional set of connections are shown in grey.

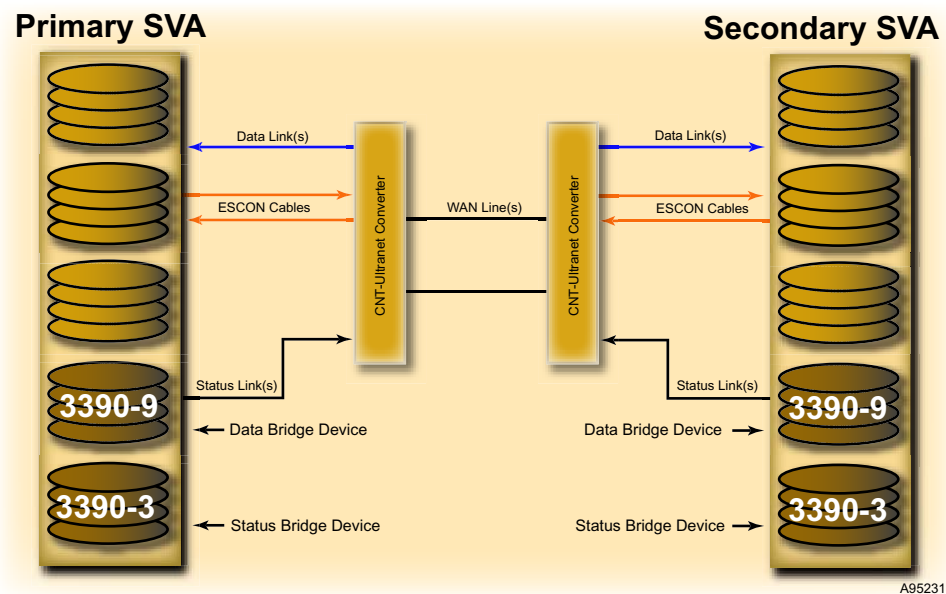

Figure 26 Power PPRC WAN Block Diagram

Note: WAN connections over a satellite link are not allowed.

The cost to the customer is one 3390-3 and one 3390-9 functional volumes on each end per WAN bridge path. These functional volumes are the “Data Bridge Device” (the 3390-9 device) and the “Status Bridge Device” (the 3390-3 device) as shown in Figure 26. These must be a

newly created devices¹³. The primary SVA uses its Data Bridge Device to stage the data tracks for a transfer to a secondary SVA. The secondary SVA uses its Data Bridge Device to store the arriving data tracks prior to writing them to the PPRC devices. Both SVAs use the Status Bridge Devices to store the status packets. See [“MODE\(COPY\), MODE\(NOCOPY\), And MODE\(RESYNC\) Options For The CESTPAIR Command.” on page 42.](#)

The Power PPRC WAN process starts with a handshaking protocol between the primary SVA and the primary CNT Ultraset Storage Director¹⁴. Once the initial handshaking between the primary SVA and the primary CNT Ultraset Storage Director is complete, frame after frame of data may be transferred to the CNT Ultraset Storage Director without further overhead. The primary CNT Ultraset Storage Director begins transferring data frames over a WAN line to the secondary CNT Ultraset Storage Director. The secondary CNT Ultraset Storage Director transfers the data frames over an ESCON cable to the secondary SVA. As the secondary SVA writes each data frame to the appropriate PPRC device, it generates a status packet (one for each data frame) on its Status Bridge Device. The secondary SVA transfers the status packet to the secondary CNT Ultraset Storage Director. The secondary CNT Ultraset Storage Director then ships the status packets back to the primary CNT Ultraset Storage Director. The primary CNT Ultraset Storage Director transfers the status packet to the Status Bridge Device in the primary SVA. When the primary SVA has received a status packet, it will send a device end to the host processor indicating that the data transfer to the secondary SVA was successful. In the event of a data transfer failure, the primary SVA sends the host processor an error message.

Caution: Potential Data Loss - StorageTek strongly recommends that you do not initialize bridge volumes with ICKDSF, and that all bridge volumes remain offline at all times. Failure to do so could result in loss of data on the data bridge volume and other undesirable effects. The SVA release forces the bridge volume to be offline.

Note: In the open systems environment, there is no “online” or “offline.” Care must be taken to avoid overwriting the bridge volumes.

13. Existing devices may be deleted and redefined; just be sure there isn't any valid data on that device!

14. The CNT Ultraset Storage Director accommodates differences in protocol, eliminates unnecessary handshaking, and accommodates any differences in data rates between the selected WAN and the ESCON interface. A CNT Ultraset Storage Director is sometimes abbreviated to CNT USD. There is a specific PPRC-support feature for the CNT Ultraset Storage Director, the StorageTek Packet Event Driver, necessary to run Power PPRC WAN protocols.

Supported WAN Standards

The [Table 16](#) (below) lists the WAN facilities supported by PPRC WAN using the CNT Ultraset Storage Directors.

Table 16 Wide Area Network Standards

WAN Standard	Comments
ATM (Europe)	SONet over OC3 in North America, (Synchronous Digital Hierarchy (SDH) over STM1)
DS3 (North America)	DS3 (T3) (approximately 43 Mb/sec. payload)
E3 (Europe)	E3 (32.768Mb/sec. payload)

Considerations

WAN Connections

There are considerations for use of the PPRC WAN connection:

Note: For FLX V2X SVAs, also see ["Reject Establish Pair when Secondary Online" on page 56](#).

1. PowerPPRC requires the use of ICE2 cards. For MVS this means a loss of 32 logical paths per ICE2 card. Use the information in the planning guide for a discussion of just what happens to the number of logical paths when doing PPRC.

Logical paths do not exist in Open Systems – they will loose available slots for FC cards.

2. The ESCON cables cannot be routed through an ESCON director if it is set to dynamic mode. *If an ESCON director is used, it must be set to static mode.*
3. There is an expense of two functional volumes for each WAN bridge. These volumes are used to stage and transfer the data to the other storage system and are not available to the customer.
4. The data bridge volumes must be a 3390-9. Any other device type will be rejected with an error message.
5. The status bridge volumes must be 3390-3. Any other device type will be rejected with an error message.

Note: The data bridge and corresponding status bridge must be within the same SSID. The bridge volumes are not required to be in the same SSID as the data storage volumes, which will be PPRC pairs.

6. Bi-directional PPRC WAN over a single WAN line is not supported. To accomplish pseudo bi-directional PPRC, you will need a second WAN line. In effect, this is just having a uni-directional PPRC WAN setup on each end.

7. StorageTek does not support secondary PPRC pair devices in an SVA that is being used to support both a PPRC WAN AND a local Power PPRC Direct setup configured for bi-directional use.
8. StorageTek highly discourages the use of just one T3 line for WAN PPRC operations.

Secondary Volumes

- **Mainframe** – All established PPRC secondary volumes must be OFFLINE. The OFFLINE parameter may be specified in the Hardware Configuration Definition (HCD).
- **Open Systems** – All established PPRC secondary volumes must be OFFLINE.
- Host access, except for allowed commands, to secondary volumes will be prevented.
- Do not attempt to establish a PPRC pair that includes an ECAM device.
- Verify secondary volumes to be designated for PPRC usage do not include critical data that will be overwritten.

Operational Procedures

Setting Up a Power PPRC WAN Mode Environment

1. For each WAN line, define one Data Bridge device on the primary SVA and one on the secondary SVA. The device type must be 3390-9.
 2. For each WAN line, define one Status Bridge device on the primary SVA and one on the secondary SVA. The device type must be 3390-3.
 3. Using the “**CESTPATH**” (alteriointerface -addpath) command, establish a PPRC path from the primary SVA to the secondary SVA. Two paths are required for each WAN line, one for Data Bridge use and the other for Status Bridge use.
 4. Using the “**CESTPAIR**” (alterdevice -addrpairs) command, establish a Bridge pair between the Data Bridge devices. The Data Bridge pairs must be established first. The Status Bridge pair is then implicitly established on the mainframe. For open systems attach, use alterdevice to establish bridge pairs between the status bridge devices. The direction of one PPRC path is implicitly reversed to allow one path from the secondary SVA to the primary SVA for the Status Bridge.
 5. Determine which data storage devices on each subsystem are to be used to establish PPRC pairs.
- Note:** If the secondary device isn't empty, the data can be overwritten when the pair is established.
6. Using the “**CESTPAIR**” (alterdevice -deleterpairs) command, establish PPRC pairs between the selected devices.

Detaching A Power PPRC Wan Mode Environment

1. Using the “[CDELPAIR](#)” (alterdevice -deletercpairs) command, terminate all PPRC pairs between non-Bridge devices.
2. Using the “[CDELPAIR](#)” (alterdevice -deletercpairs) command, terminate the Bridge pair between the Bridge devices. This also implicitly deletes the Status Bridge pair and reverses the Status Bridge path so that it appears as originally established.
3. Using the “[CDELPATH](#)” (alterdevice -deletopath) command, terminate the PPRC paths from the primary SVA to the secondary SVA.

Disaster Recovery

Note: These are PPRC WAN only cases.

1. Issue the “[CRECOVER](#)” (alterdevice -modifyrcpairs recover) command to the primary status volume.
2. When either the primary or secondary SVA is lost, the status bridge will be in an unknown state. Clear that by powering off the surviving SVA and then powering it back on. The power sequence on will ensure that the path status is re-initialized. In addition, follow the normal resetting of the CNT box during the Power on sequence (see “[CNT Interface Card Resets](#)” on page 119).

PPRC Link Download Notification

When a PPRC link goes down (i.e.: when a “lights-out” condition or fatal check 2 condition is detected on the link) the SVA issues a Service Information Message (SIM) to be presented to each attached mainframe host from the primary subsystem. The SIM is sent when a subsequent Start I/O (SIO) is received from an attached host. The user should see a SIM message on the MVS console (IEA480E) that identifies the ICE card port that is associated with the “down-link” condition. The ICE card port (0 - F) is found in the least significant digit of the first four digits of the REFCODE field of the message (See [Table 17, “ICE Card Location and Port Identification From the REFCODE,”](#) on page 87). For example:

- If REFCODE = 3FD0... the incident was on ICE00 top port.
- If REFCODE = 3FDF... the incident was on ICE13 bottom port.

Table 17 ICE Card Location and Port Identification From the REFCODE

REFCODE	ICE Card Slot and Port location	REFCODE	ICE Card Slot and Port location
3FD0	ICE00 top	3FD8	ICE10 top
3FD1	ICE00 bottom	3FD9	ICE10 bottom
3FD2	ICE01 top	3FDA	ICE11 top
3FD3	ICE01 bottom	3FDB	ICE11 bottom

Table 17 ICE Card Location and Port Identification From the REFCODE (Continued)

REFCODE	ICE Card Slot and Port location	REFCODE	ICE Card Slot and Port location
3FD4	ICE02 top	3FDC	ICE12 top
3FD5	ICE02 bottom	3FDD	ICE12 bottom
3FD6	ICE03 top	3FDE	ICE13 top
3FD7	ICE03 bottom	3FDF	ICE13 bottom

Notes:

1. The SVA does not report the recovery of the link. The user can issue a PPRC Query TSO command (CQUERY) at any time to check the status of the PPRC paths/links.
2. If a PPRC link is unplugged and then plugged back in, and then a CQUERY command is issued, the CQUERY output should show the affected PPRC path has recovered due to internal automatic link recovery.

About SnapShot

StorageTek's unique virtual storage architecture has the capability of replicating data without copying data. This capability is known as SnapShot, and it consists of Licensed Internal Code (LIC) that runs on the SVA or 9393 hardware, and SnapShot host software.

The process of performing the SnapShot replication function is known as "snapping" data, and the result is known simply as a "snap". The object to be replicated is called the "source" and the result of the replication is called the "target".

SnapShot replicates S/390 volumes or SCSI partitions by copying pointers to the data, instead of physically copying the data itself. Two (or more) independent sets of pointers make the data appear as if it were two (or more) physically separate copies. Updates can occur simultaneously to the original data and to the replicated data, without compromising the integrity of the data in either.

Furthermore, a snap requires only the minimal host CPU, memory, and channel resources necessary to communicate a snap request from the host to the subsystem. Since the actual snapping is performed within the subsystem, no data is transferred across channels or through memory, and the time it takes to create backups or make test versions of the data available to an application is dramatically reduced. The only physical back-end storage allocated by the subsystem is for:

- The original S/390 volume or SCSI volume (shared between the source and target).
- Any changes made to the source.
- Any changes made to the target.

About PPRC SnapShot

PPRC SnapShot is a high visibility data transfer solution that gives you:

- the integrity of synchronized production and backup copies of vital disk data on both local and remote systems,
- the fast recovery of your operations in the event of a disaster. You can restart your applications at the secondary site using the disk backup copies instead of waiting for vital data on tape to be restored,
- and an easy way to run a disaster recovery test at the secondary site from the backup copy.

You can generate disaster recovery test data without moving or copying data, or using the actual backup copy of your data – and, without using additional disk space!

PPRC SnapShot Performance

SnapShot allows data to be replicated *without* host CPU cycles and *without* taking additional disk space, but it is restricted to the boundaries of a single subsystem. With PPRC SnapShot, you can snap a PPRC primary source volume to a PPRC primary target volume, and the corresponding PPRC secondary source volume will simultaneously snap to its corresponding PPRC secondary target volume.

PPRC SnapShot Reliability

If a warm start occurs during a PPRC Snapshot, the PPRC Snapshot must be rerun after the warm start completes, otherwise there is no assurance about the state of the data contained on either the target primary or target secondary volumes. This restriction is consistent with current SnapShot functionality. PPRC SnapShot is designed to maintain or improve overall subsystem reliability.

PPRC SnapShot Variations

Figure 27 (below) shows an allowed PPRC SnapShot variation. Also see “FLX V2X PPRC Snap-to-Primary” on page 92.

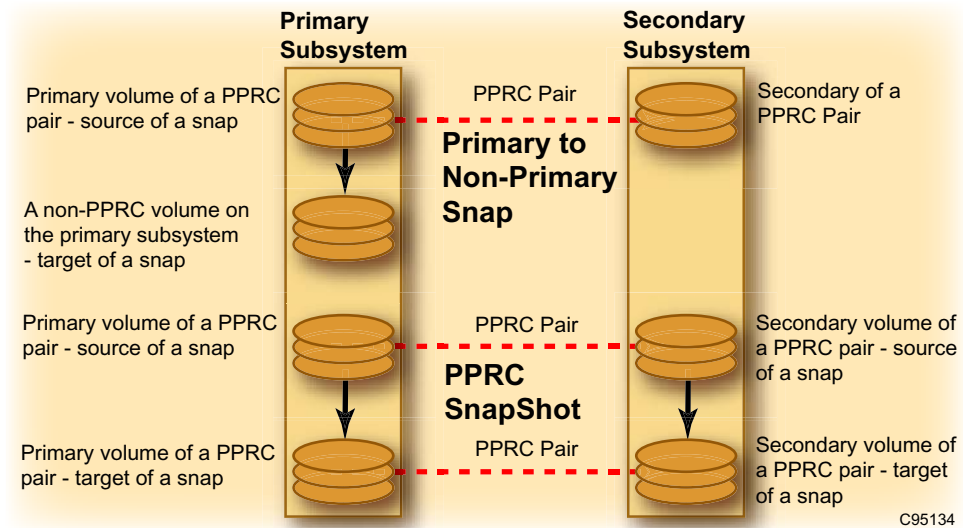

Figure 27 PPRC SnapShot Block Diagram

The following points should be remembered when the PPRC SnapShot configuration is installed:

- PPRC SnapShot is supported by most SVA models. Check with your StorageTek marketing representative to see if your SVA is supported.
- The PSPAM feature diskettes for SnapShot (SNAP-001 or SNAP-002), Power PPRC (PPRC-002), and PPRC SnapShot (PPRC-SNAP) must

be ordered and installed on each machine participating in a PPRC SnapShot relationship, otherwise the PPRC SnapShot will fail.

- PPRC paths must be established for both source and target control units in order to establish PPRC pairs. Once the PPRC paths are established, the PPRC pairs may be established.
- PPRC SnapShot requires that the secondary source and target volumes be in the same subsystem (see the bottom half of [Figure 27 on page 90](#)).

Note: The latest SVAA PTF maintenance should be obtained and installed prior to using PPRC SnapShot.

PPRC SnapShot Considerations

The following points should be remembered once PPRC SnapShot is installed and ready for use:

- If you are using PPRC SnapShot to snap an entire volume from one PPRC pair to another, you may establish the secondary pair (which is going to be the target of the SNAP) using the “MODE(NOCOPY)” option because all data is overwritten. However, if you are using PPRC SnapShot to snap data sets from one PPRC pair to another, ***it is mandatory, for data integrity reasons***, that you establish the PPRC pairs using the “MODE(COPY)” option so that the data contained on the source primary and secondary volumes are equivalent.
- A PPRC SnapShot¹⁵ will fail unless the source and all potential target volumes are in the proper PPRC configuration. The proper PPRC configuration is defined as when both the source and target volumes of a SnapShot are also PPRC Primary Volumes whose PPRC Secondaries reside on the same subsystem. A PPRC SnapShot performs no volume selection when the non-specific allocation of volumes using MVS esoteric or generic unit names, or when using SMS-managed volume selection (when SnapShot Volume Preferencing is enabled for the subsystem) is requested.
- For data set level PPRC SnapShots of multi-volume data sets, each source volume of the multi-volume data set must reside on a PPRC primary volume.
- You can PPRC SnapShot any data from a primary volume onto a volume that is not part of a PPRC pair without modifying the PPRC state of the primary volume. See [“PPRC SnapShot Variations” on page 90](#).
- You can use PPRC SnapShot from a primary volume to another primary volume which is in either a DUPLEX or SUSPENDED state. Dataset SnapShot only supports snap to a DUPLEX volume and will make the volume go DUPLEX PENDING, after which it is no longer

15. A PPRC SnapShot is a Snapshot where source and target volume are PPRC *primary* volumes.

eligible for another snap until the volume becomes DUPLEX. When volume SnapShot is used to a suspended volume, the SnapShot command is ONLY carried out on the primary side and not on the secondary side.

- PPRC SnapShot cannot be used to snap Power PPRC bridge volumes.
- PPRC SnapShot cannot be used to snap PPRC secondary volumes since host read or write operations are not allowed to secondary volumes.

FLX V2X PPRC Snap-to-Primary

Basic Operation

Notes:

1. The secondary can be an FLX 9500, an FLX V960, or an FLX V2X (with later operating code). The FLX 9500 and FLX V960 cannot be a primary.
2. The PPRC SnapShot feature is required for PPRC Snap-to-Primary.

Snap-to-Primary provides a clean, asynchronous PPRC mirror for customers applications that cannot tolerate the write time penalty for a synchronous mirror.

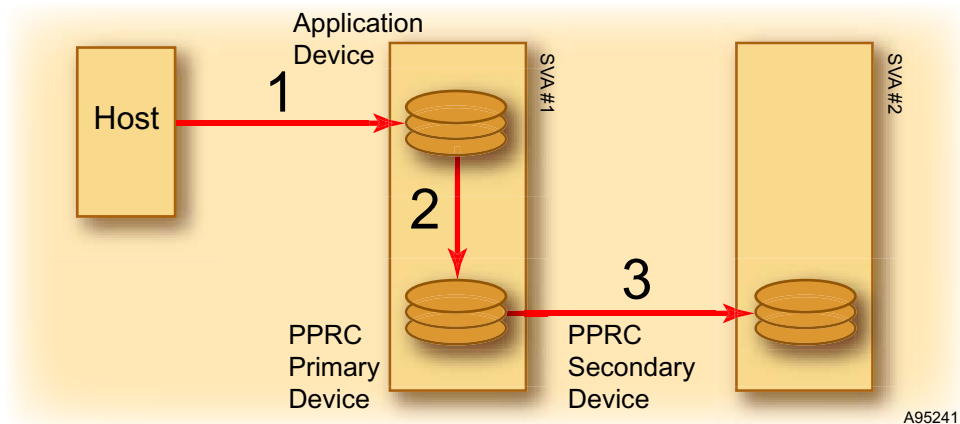

Figure 28 Configuration Example 1

In the above example:

1. The host writes to simplex application volumes at full processing speed.
2. At intervals the application volume is Snap-to-Primary copied to the PPRC primary volume.
3. The PPRC primary volume goes into duplex pending state while the PPRC secondary volume is synchronized with the PPRC primary volume. The PPRC primary volume then returns to duplex state. At this point a recoverable backup copy exists on both the primary SVA and the secondary SVA.

The interval for making snap copies can be timer driven or event driven:

- **Timer Driven** – the interval needs to be long enough that the PPRC primary volume has time to return to duplex state before the next interval.
- **Event Driven** – (e.g. when the application is running on a database) at intervals, the database will flush its buffers to sync up the storage volume with its buffers. This event then calls the snap copy to the PPRC primary volume. This sequence will cause the snap copies to be made when the database is in a recoverable state.

With this configuration we always have a good backup volume on the primary SVA. The secondary SVA will usually have a good backup volume. However, the backup volume on the secondary may be fuzzy if the process stops while the volumes are synchronizing in the duplex pending state.

We can be better protected on the secondary SVA by adding another step to the process that utilizes PPRC SnapShot.

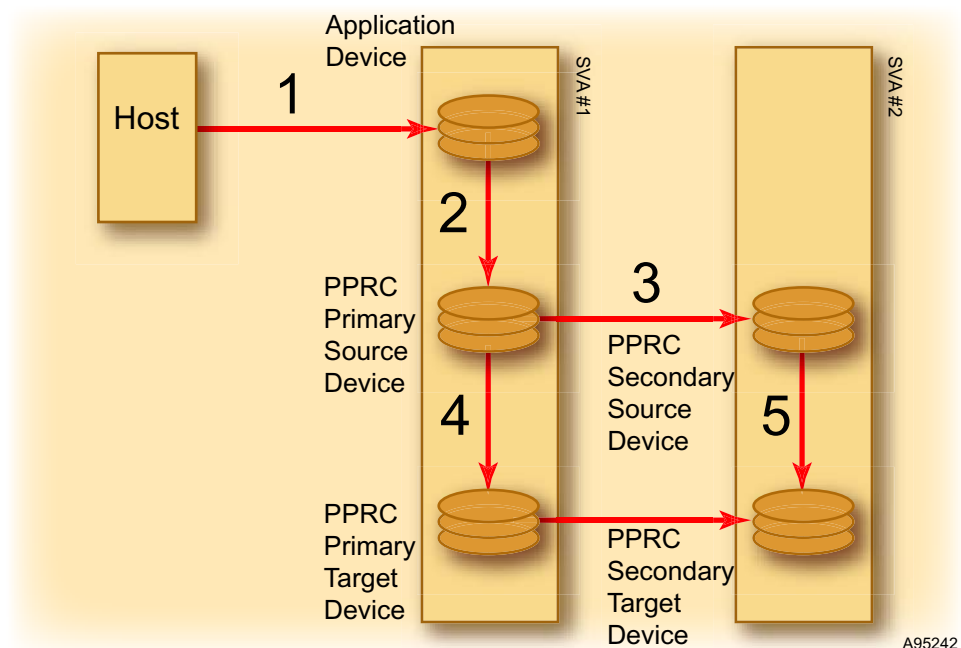

Figure 29 Configuration Example 2

In the above example:

1. The host writes to simplex application volumes at full processing speed.
2. At intervals the application volume is Snap-to-Primary copied to the PPRC primary volume.
3. The PPRC primary volume goes into duplex pending state while the PPRC secondary volume is synchronized with the PPRC primary volume. The PPRC primary volume then returns to duplex state.

4. When the PPRC primary volume returns to duplex state, then perform a PPRC SnapShot copy from the PPRC primary source volume to the PPRC primary target volume.
5. PPRC SnapShot will automatically mirror a snap copy from the PPRC secondary source volume to the PPRC SnapShot secondary target volume.

After the PPRC pair returns to the duplex state, and we have performed the PPRC Snap, then we have on the primary SVA two clean first generation backup volumes. On the secondary SVA we also have two clean first generation backup volumes. This condition continues until the next backup interval begins.

Snap-to-Primary Considerations

At the B01.01.34.00 or above level of FLX V2X microcode, multiple successive Snap-to-Primary operations to the same PPRC Primary volume may result in failures when the PPRC Primary volume is in the Duplex Pending state. This consideration applies to both data set and volume level Snap-to-Primary operations to the same PPRC Primary volume.

Customers can choose to wait until the PPRC pair has returned to the Duplex state before attempting the next Snap-to-Primary, or suspend the pair using the technique described below.

Note: Check with a StorageTek customer service representative or your StorageTek marketing representative for microcode updates that may change this consideration.

Symptoms

Note: The terms “volume” and “device” are interchangeable.

SIBBATCH

Customers encountering this situation using SIBBATCH in batch jobs will receive a return code of 12 and the following error message:

```
SIB4672S Subsystem MYSUBSYS, HSI rc=13, pmRecvM80: HSgetMsg id=80
cc=9 rc=50
```

The ECAM Completion Code of 9 and Reason Code of 50 indicates that the failure is due to the PPRC Primary being in the Duplex Pending state.

SIBADMIN

Customers encountering this situation using SIBADMIN in TSO/ISPF will receive a return code of 12 and the following error messages:

```
SIB4672S Subsystem MYSUBSYS, HSI rc=13, pmRecvM80: HSgetMsg id=80
cc=9 rc=50
SIB4617I 12:17:24 SnapShot completed, rc=12.
SIB4608S The SNAP subcommand aborted, rc=12.
```

DFSMSDss

Customers encountering this situation using DFSMSDss in batch jobs will receive a return code of 4 and the following error message:

```
ADR935W (001)-TOMI (02), A FAILURE OCCURED WHILE ATTEMPTING TO
PERFORM FAST REPLICATION FOR DATA SET data.set.name ON VOLUME
volser.
DIAGNOSTIC INFORMATION: 00001791-0000001D
```

The System Data Mover (SDM) Return Code of 00001791 indicates that the SnapShot operation failed, and the SDM Reason Code of 0000001D indicates that the failure is due an unexpected or busy condition with the SVA.

SVAA CLI

Customers encountering this situation using the SVAA CLI will receive one of the following error messages:

```
SIB> SIB9633E ERROR: Request failed. SIB9004E LLAPI exception
occurred in partition request: executing SnapShot com.storag-
etek.blackhawk.api.LLAPIException: Unknown LLAPI error code:
196630
```

or,

```
SIB> SIB9633E ERROR: Request failed. SIB9004E LLAPI exception
occurred in partition request: executing SnapShot com.storag-
etek.blackhawk.api.LLAPIException: SnapShot failed processing on
device. Device is in PPRC Pending state.
```

Suspending the PPRC Pair

As mentioned earlier, multiple successive Snap-to-Primary operations to the same PPRC Primary volume may result in failures when the PPRC Primary volume is in the Duplex Pending state. To avoid this condition, do the following:

1. Establish the appropriate PPRC paths as you normally would.
2. Establish the appropriate PPRC pairs and allow them to fully synchronize into the Duplex state.
3. Suspend the appropriate PPRC pairs.
4. Execute Snap-to-Primary operations to the suspended PPRC Primaries.
5. Re synchronize (un-suspend) the PPRC pairs using the CESTPAIR command with the MODE(RESYNC) parameter and allow them to fully synchronize into the Duplex state.
6. Re-suspend the appropriate PPRC pairs.
7. Repeat steps 4-6 as needed.

Terminating and Recovering PPRC

Applicable Products: V2X, V2X2

Recovering PPRC After Various Events

Note: This information is correct for B01.07 code, dated 05-18-04. A review is in progress to provide similar information for B01.06 code and for older SVA products.

Reference the following matrix for instructions on how to recover from any of the four events listed.

Table 18. PPRC Recovery Actions

Condition / Event	Action
IML (cold start – EPO or CPD) of Secondary subsystem.	Go to “IML (cold start - EPO or CPD) of Primary subsystem:” below.
NDCL on the Primary subsystem.	Go to “IML (cold start - EPO or CPD) of Secondary subsystem:” on page 98.
NDCL on the Secondary subsystem.	Go to “NDCL on the Primary subsystem:” on page 99.
IML (cold start – EPO or CPD) of Secondary subsystem.	Go to “NDCL on the Secondary Subsystem:” on page 99.

IML (cold start - EPO or CPD) of Primary subsystem:

1. Power PPRC Direct (non-WAN):

Condition:

- Primary data volumes go SUSPENDED (reason 9 = suspended by IML)
- Primary data bridge volumes go SIMPLEX
- All PPRC paths are removed and bridge info is initialized

Recovery: (On the Primary subsystem)

- Re-establish PPRC paths to the Secondary subsystem
- Re-establish bridge pairs
- Re-sync the data volumes

2. Power PPRC WAN:

Condition:

- Primary data volumes go SUSPENDED (reason 9 = suspended by IML)
- Primary and secondary bridge volumes go SIMPLEX
- All PPRC paths are removed and bridge info is initialized

Recovery:

On the Secondary subsystem:

- Use the TERM BRDG option; this will cause a warm start of the Secondary subsystem.

On the Primary subsystem (after the Secondary subsystem warm start):

- Reestablish PPRC paths to the Secondary subsystem
- Reestablish bridge pairs
- Re-sync the data volumes

IML (cold start - EPO or CPD) of Secondary subsystem:

1. Power PPRC Direct (non-WAN):

Condition:

On the Secondary subsystem:

- Secondary data volumes go SUSPENDED (reason 9 = suspended by IML)
- Secondary data bridge volumes remain DUPLEX

On the Primary subsystem:

- Primary data volumes may go SUSPENDED due to loss of communication with the secondary subsystem during the IML (they go SUSPENDED if they are syncing, or if a host write is issued to them and communication with the Secondary subsystem isn't reestablished within an internal PPRC timeout period)
- Primary data bridge volumes remain DUPLEX

Recovery:

On the Primary subsystem:

- CQUERY all VCUs in which PPRC paths have been established to verify the PPRC paths are still operational [optional]
- Re-sync the SUSPENDED data volumes

2. Power PPRC WAN:

Condition:

On the Secondary subsystem:

- Secondary data volumes go SUSPENDED (reason 9 = suspended by IML)
- Primary and secondary bridge volumes go SIMPLEX
- All PPRC status paths are removed and bridge info is initialized

On the Primary subsystem:

- Primary data volumes may go SUSPENDED due to loss of communication with the secondary subsystem during the IML (they go SUSPENDED if they are syncing, or if a host write is issued to them and communication with the Secondary subsystem isn't reestablished within an internal PPRC timeout period)
- Primary data bridge volumes remain DUPLEX

Recovery:

On the Primary subsystem:

- Use the TERM BRDG option; this will cause a warm start of the Primary subsystem
- Re-establish PPRC paths to the Secondary subsystem
- Re-establish bridge pairs by issuing CESTPAIR to the data bridge volume
- Re-sync the SUSPENDED data volumes

NDCL on the Primary subsystem:

Caution: Potential Data Loss - NDCL causes a warm start.

Note: The following information pertains only to the subsystem status. To help avoid host problems see the recommendation below.

1. Power PPRC Direct (non-WAN):

Condition:

- Primary data volumes PPRC state is unaffected.
- Data bridge volumes remain DUPLEX

Recovery:

No recovery required.

2. Power PPRC WAN:

Condition:

- Primary data volumes PPRC state is unaffected.
- Data bridge volumes remain DUPLEX

Recovery:

No recovery required.

RECOMMENDATION:

To avoid problems at the host level with regard to sysplex timers, etc. it is recommended that PRIOR to the NDCL that a CSUSPEND be issued for all volumes. Then after the NDCL is complete resync all volumes.

NDCL on the Secondary Subsystem:

Caution: Potential Data Loss - NDCL causes a warm start.

Note: The following information pertains only to the subsystem status. To help avoid host problems see the recommendation below.

1. Power PPRC Direct (non-WAN):

Condition:

On the Secondary subsystem:

- Secondary data volume PPRC state is unaffected (exception: if a DAC (Data Assurance Check) condition is detected during the NDCL, secondary data volumes go SUSPENDED)
- Secondary data bridge volumes remain DUPLEX

On the Primary subsystem:

- Primary data volumes may go SUSPENDED due to loss of communication with the secondary subsystem during the warm start (they go SUSPENDED if they are syncing, or if a host write is issued to them and communication with the secondary subsystem isn't reestablished within an internal PPRC timeout period)
- Primary data bridge volumes remain DUPLEX

Recovery:

- Re-sync the SUSPENDED data volumes

2. Power PPRC WAN:

Condition:

On the Secondary subsystem:

- Secondary data volume PPRC state is unaffected (exception: if a DAC (Data Assurance Check) condition is detected during the NDCL, secondary data volumes go SUSPENDED)
- Bridge volumes remain DUPLEX

On the Primary subsystem:

- Primary data volumes may go SUSPENDED due to loss of communication with the secondary subsystem during the warm start (they go SUSPENDED if they are syncing, or if a host write is issued to them and communication with the secondary subsystem isn't reestablished within an internal PPRC timeout period)
- Bridge volumes remain DUPLEX

Recovery:

- Re-sync the SUSPENDED data volumes

RECOMMENDATION:

To avoid problems at the host level with regard to sysplex timers, etc. it is recommended that PRIOR to the NDCL that a CSUSPEND be issued for all volumes. Then after the NDCL is complete resync all volumes.

New Options for Terminating PPRC

There are situations that our customers have run into that have prevented them from cleaning-up PPRC using existing host-initiated commands or operator panel options.

Caution: Potential Data Loss - These options should not be used unless normal host issued commands fail to successfully terminate PPRC.

Two new options, initiated at the subsystem operator panel, are included in A01.05 and B01.07 code releases:

Note: A B-level password is required for these operations.

TERM ALL (PPRC):

Termination Procedure:

Caution: Potential Data Loss - These actions must be taken on BOTH the primary and secondary subsystems.

1. Use the following menu tree to get to the CM17 screen

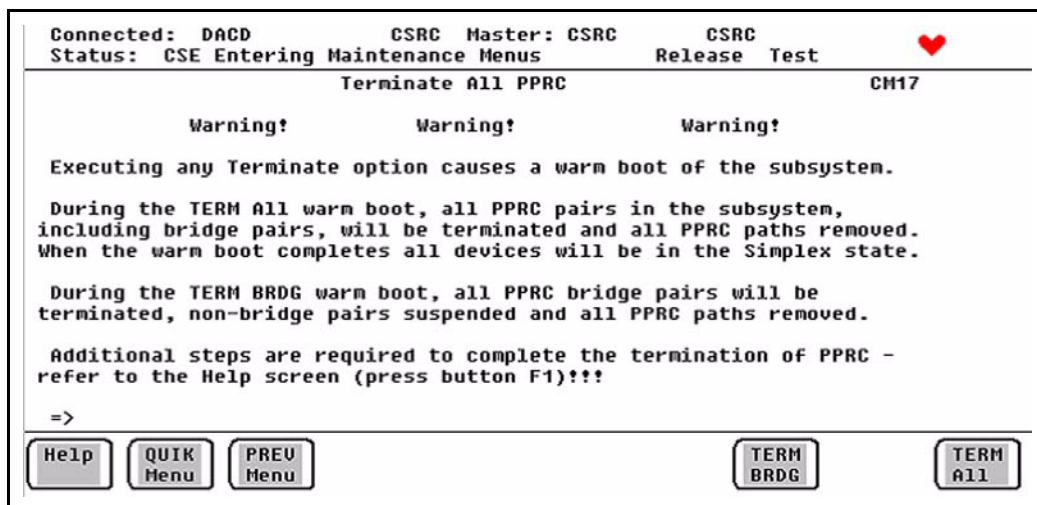
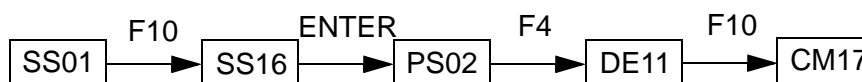

Figure 30 CM17 Screen

The help screens for the CM17 screen are shown below:

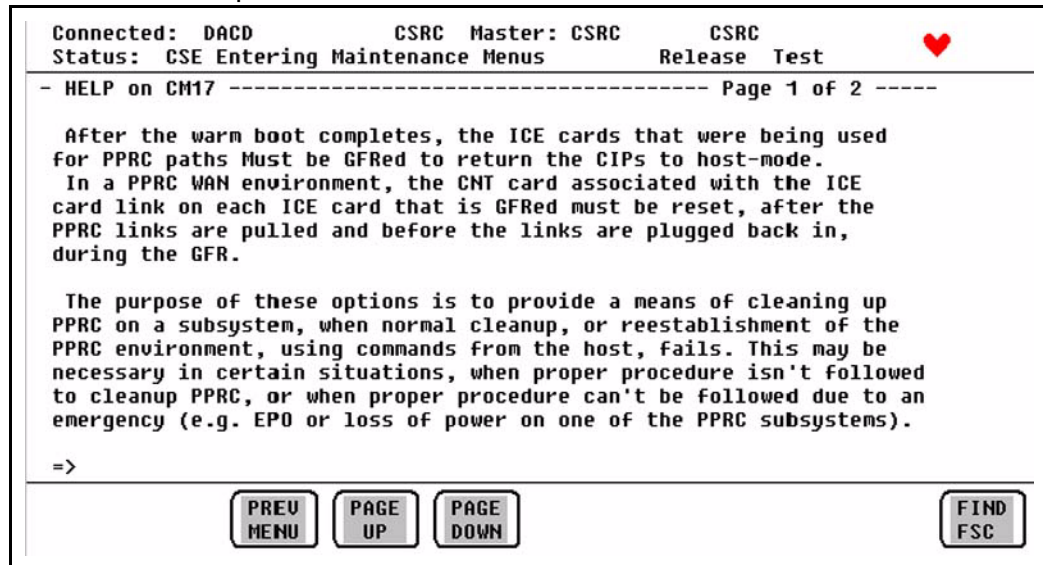

Figure 31 CH17 Help Screen

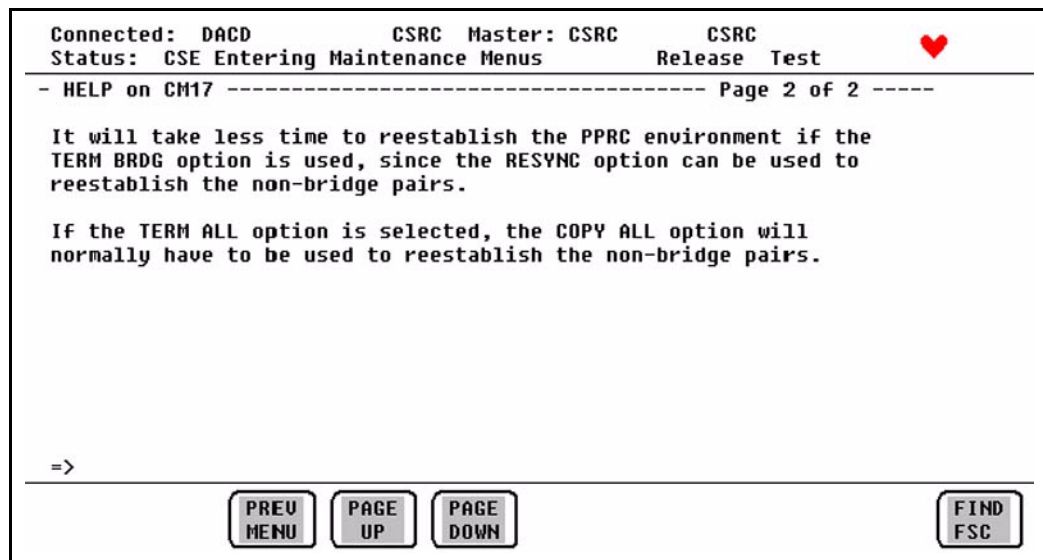

Figure 32 CH17 Help Screen Continued

2. Press **[F8]** to terminate PPRC.

The subsystem will go through a check zero (FSC 3A7B) warmstart sequence.

All devices that are PPRC pair members (primary and secondary, bridge and non-bridge devices) will be returned to the SIMPLEX state (i.e. will be terminated), and all PPRC paths will be removed, during the warmstart.

After the warmstart, and before reestablishing the PPRC environment, the ICE cards formerly used for PPRC paths, must be GFR'd (no replace) to change the mode of the CIPs (Channel Interface Processors) on those cards to host-mode, and the CNT boxes (in a PPRC WAN environment) must be reset. These actions must be taken on BOTH the primary and secondary subsystems.

To reestablish the PPRC environment:

With this option, the customer will have to reestablish PPRC from scratch:

- Issue CESTPATH commands to establish PPRC paths
- CESTPAIR commands to pair up the bridge devices
- CESTPAIR commands to pair up the non-bridge devices using the COPY ALL option

TERM BRDG (TERM ALL PPRC BRIDGES and PATHS):

Caution: Potential Data Loss - These actions must be taken on BOTH the primary and secondary subsystems.

Termination Procedure:

Use the following menu tree to get to the CM17 screen (see Figure 30 on page 101).

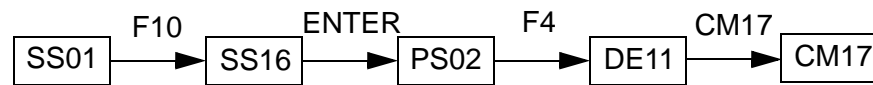

- The subsystem will go through a CK0 (fsc 3a6e) warmstart sequence.
- Non-bridge pair members will be put in the SUSPENDED state, bridge pairs members will be returned to the SIMPLEX state (i.e. will be terminated), and all PPRC paths will be removed, during the warmstart.
- After the warmstart, and before reestablishing the PPRC environment, the ICE cards formerly used for PPRC paths, must be GFR'd (no replace) to change the mode of the CIPs (Channel Interface Processors) on those cards to host-mode, and the CNT boxes (in a PPRC WAN environment) must be reset. These actions must be taken on BOTH the primary and secondary subsystems.

To reestablish the PPRC environment:

- Issue CESTPATH commands to reestablish PPRC paths
- Issue CESTPAIR commands to reestablish the bridge pairs
- Issue CESTPAIR commands with the RESYNC option to resynchronize the non-bridge pairs

The RESYNC option normally takes much less time than the COPY ALL option, since only the tracks that have been updated on the primary devices, between the time problems were encountered with PPRC and the issuing of the CESTPAIR commands to reestablish the pairs, will have to be updated on the secondary devices.

PPRC Link Down Notification

When a PPRC link goes down (i.e.: when a “lights-out” condition or fatal check 2 condition is detected on the link) the SVA issues a Service Information Message (SIM) to be presented to each attached mainframe host from the primary subsystem. The SIM is sent when a subsequent Start I/O (SIO) is received from an attached host. The user should see a SIM message on the MVS console (IEA480E) that identifies the ICE card port that is associated with the “down-link” condition. The ICE card port (0 - F) is found in the least significant digit of the first four digits of the REFCODE field of the message (See [Table 19, “ICE Card Location and Port Identification From the REFCODE,”](#) on page 105). For example:

- If REFCODE = 3FD0... the incident was on ICE00 top port.
- If REFCODE = 3FDF... the incident was on ICE13 bottom port.

Table 19 ICE Card Location and Port Identification From the REFCODE

REFCODE	ICE Card Slot and Port location	REFCODE	ICE Card Slot and Port location
3FD0	ICE00 top	3FD8	ICE10 top
3FD1	ICE00 bottom	3FD9	ICE10 bottom
3FD2	ICE01 top	3FDA	ICE11 top
3FD3	ICE01 bottom	3FDB	ICE11 bottom
3FD4	ICE02 top	3FDC	ICE12 top
3FD5	ICE02 bottom	3FDD	ICE12 bottom
3FD6	ICE03 top	3FDE	ICE13 top
3FD7	ICE03 bottom	3FDF	ICE13 bottom

Notes:

1. The SVA does not report the recovery of the link. The user can issue a PPRC Query TSO command (CQUERY) at any time to check the status of the PPRC paths/links.
2. If a PPRC link is unplugged and then plugged back in, and then a CQUERY command is issued, the CQUERY output should show the affected PPRC path has recovered due to internal automatic link recovery.

IGF52xA Message Replies

The operators reply to the IGF52xA Message directs the P/DAS¹⁶ action, as described in the following table.

In some cases, the activities performed by the P/DAS operation are based on a combination of the operator reply, and the environment at the time that the P/DAS swap request is made.

Your Reply:	Results in this system action:	Notes:
Terminate pair, and swap (IGF520A)	<p>This reply directs the system to perform the following functions:</p> <ol style="list-style-type: none">1. End PPRC pair and stop copy operations. Other PPRC operations for other pairs continue unchanged2. Redirect all application I/O from the source volume <i>pppp</i> to the target volume <i>ssss</i>. Application I/O is not affected by the volume switch. The I/Os only update the secondary volume from this point on, and the primary and secondary volumes will no longer contain the same data.	<p>In a sysplex, issue this reply from the 'Main system' only.</p> <p>USES: For volume migration scenarios where the source volume is no longer going to be used, and you want to swap your primary and secondary volumes.</p>

16. PPRC Dynamic Address Switching (P/DAS) is a utility that allows the redirection of all I/O from a primary PPRC volume to a secondary PPRC volume.

Your Reply:	Results in this system action:	Notes:
Switch pair, and swap (IGF520A)	<p>This reply redirects application I/O to the secondary volume. The system takes action based on the PPRC environment that is in effect at the time of the swap request. The action performed depends on two conditions</p> <ol style="list-style-type: none"> 1. How the PPRC paths are currently established. 2. Whether the target volume is the same size as the source volume. <p>The resulting system actions are summarized in “IGF53xA Actions” on page 111.</p>	<p>In a sysplex, issue this reply from the ‘Main system’ only.</p> <p>USES: For volume or subsystem maintenance, and/or workload movement.</p>
Continue Swap (IGF520A, IGF521A or IGF522A)	<p>This Reply prompts the system to redirect application I/Os from the primary volume to the secondary volume.</p> <p>Thus, all I/Os that were directed to the source (primary) volume <i>pppp</i>, are now directed to the target (secondary) volume <i>ssss</i>.</p> <p>After completion of this option, volume <i>pppp</i> is no longer involved in any operation.</p>	<p>This reply is valid within sysplex and nonsysplex environments. In a sysplex, issue this reply from any system.</p> <p>USES: to remove a primary volume from the OS/390 configuration.</p>

Your Reply:	Results in this system action:	Notes:
<p>Try Again (IGF521A or IGF522A)</p>	<p>This reply directs the system to perform the following functions:</p> <ol style="list-style-type: none"> 1. End the pair, and return both volumes to simplex state. This is the equivalent of issuing the CDELP AIR PPRC command. 2. Establish a new PPRC pair in the reverse direction. The new path is from the new primary (originally the secondary volume <i>ssss</i>) to the new secondary (originally the primary volume <i>pppp</i>). This is the equivalent of issuing the CESTPATH and CESTPAIR PPRC commands for this pair. 3. Immediately suspend the new PPRC operation. This will force all changes made to the secondary volume to be recorded in the bit-maps for the operation. The changes are not copied to the original primary volume <i>pppp</i>. This is the equivalent of issuing a CSUSPEND PPRC command for the PPRC pair just established. 4. Redirect application I/Os from the primary volume to the secondary volume. This now means that all I/Os that were directed to the primary volume, are now directed to the secondary volume. When this has completed, the primary volume, <i>pppp</i> is no longer involved in any operations. 	<p>Before this option is used, paths should have been established in the opposite direction from the secondary (target) volume's SSID, to the primary (source) volumes SSID.</p> <p>In a sysplex, issue this reply from any system.</p>

Your Reply:	Results in this system action:	Notes:
Terminate Swap (IGF520A, IGF521A or IGF522A)	This is a request to end the swap operation. The following message is issued to the SYSLOG IGF512I SWAP FROM pppp TERMINATED – SWAP TERMINATED BY OPERATOR P/DAS returns an error code of 16 to the system	In a sysplex , issue this reply from any system.

The following specific actions relate to actions detailed in [“IGF52xA Message Replies” on page 107](#), based on your existing OS/390 environment.

ACTION 1.

There are PPRC paths in place from the primary volume to the secondary volume and also from the secondary to the primary. The source and target volumes have equivalent volume geometry.

Given the above environment, selecting ‘switch pair, and swap’ directs P/DAS to perform the following actions:

1. End the current PPRC pair
2. Establish a new PPRC pair (with NOCOPY) to activate copying in the reverse direction
3. Immediately suspend the PPRC operation. All changes made to the secondary (target) are recorded in bit-maps, but not copied to the original primary (source) volume
4. Redirect all application I/O to the secondary (target) volume. The change is made transparent to the application programs.

The changes that occur between the swap and the subsequent re-synchronization of the volume pairs are maintained on the old secondary volume. The changed updated tracks will be copied back to the original primary and the volumes will become duplexed PPRC pairs again

ACTION 2.

There are PPRC paths in place from the primary volume to the secondary volume and also from the secondary to the primary. The target volume has a greater volume capacity than the source volume.

In this situation, ‘switch pair, and swap’ directs P/DAS to issue the following additional message to the SYSLOG:

```
IGF522A UNABLE TO SWITCH, FROM DEVICE IS SMALLER THAN TO  
DEVICE: REPLY 1 TO CONTINUE SWAP | 2 TO TERMINATE SWAP
```

Select one of the message options, as described in [“IGF52xA Message Replies” on page 107](#).

If you chose to continue with the swap, the changes that occur between the swap and the subsequent re-synchronization of the volume pairs will not be maintained on the old secondary volume.

ACTION 3.

A PPRC path exists from the primary to the secondary, but not in the reverse direction. The primary and secondary volumes have the same physical capacity.

In this situation, 'switch pair, and swap' directs P/DAS to issue the following message to the SYSLOG:

```
IGF521I NO PATH IN OPPOSITE DIRECTION: REPLY 1 TO CONTINUE  
SWAP | 2 TRY AGAIN | 3 TERMINATE SWAP
```

Select one of the messages as described in ["IGF52xA Message Replies" on page 107](#).

ACTION 4.

A PPRC path exists from the primary to the secondary, but not in the reverse direction. The primary and secondary volumes do not have the same physical capacity. P/DAS takes no special action to use the additional capacity on the target volume.

In this situation, 'switch pair, and swap' directs P/DAS to issue the following message to the SYSLOG:

```
IGF521I NO PATH IN OPPOSITE DIRECTION: REPLY 1 TO CONTINUE  
SWAP | 2 TRY AGAIN | 3 TERMINATE SWAP
```

Select one of the message options, as described in ["IGF52xA Message Replies" on page 107](#), if you reply '2', (try again), the following message is issued, requiring an operator reply:

```
IGF522A UNABLE TO SWITCH, FROM DEVICE IS SMALLER THAN TO  
DEVICE: REPLY 1 TO CONTINUE SWAP | 2 TO TERMINATE SWAP
```

Select one of the message options, as described in ["IGF52xA Message Replies" on page 107](#).

PPRC Command Failure

In the event a PPRC command fails and the message(s) around this failure do not conclusively indicate what the problem is, use following four step procedure to diagnose the problem.

1. Run a GTF trace with the following parameters for tracing IO of the failing command:

```
TRACE=IOP,SSCHP,CCWP
IO=SSCH=(pppp,ssss)
CCW=(SI,DATA=80)
END
```

Where *pppp* and *ssss* is the device number of the primary and secondary volume. The least that is required is the primary volume device number.

2. Rerun the command and stop GTF.
3. Run a TSO batch job with following DD statements:
 - IPCSDDIR, with an IPCS dump directory that can be used for printing the trace, and,
 - TRACE, which points to the output data set of the GTF trace.
4. Print the GTF trace using following TSO statements:

```
IPCS NOPARM
DROPDUMP DD(TRACE)
SETDEF DD(TRACE) LIST NOCONFIRM
GTF
```

The output of Step 4 will look as shown in [“GTF Trace Print” on page 115](#). In the printout, near the bottom, will be a line which contains EOS (End Of Sense). The CCW data that follows contains the sense bytes, as documented in the SVA Reference guide under the heading ECKD 32-Byte Sense Information Summary, appears after the EOS (see [page 119](#)). Bytes 22 and 23 contain the Fault Symptom Code (FSC).

Following is a table of FSC's that could be observed:

Table 20 PPRC Associated Fault Symptom Codes

FSC	Meaning
0576	Maximum number of CESTPAIR in progress (256)
05AD	The PPRC logical path is not established between the source device in the primary SSID and the target device in the secondary SSID. Establish a PPRC path between the primary SSID and the secondary SSID prior to establishing the PPRC pair.
05EB	Invalid SSID or serial number in statement for secondary
0B35	CDELPAIR of bridge unsuccessful because there are still primary volumes active (delete them first)
0B3E	CCA, SSID and/or serial number mismatch with DEVN value
0B4A	Secondary volume is online. Vary the paths and devices offline prior to establishing the PPRC pairs.

GTF Trace Print

96224

**** GTF TRACING ENVIRONMENT ****

Release: SP6.0.9 FMID: JBB6609 System name: C060

CPU Model: 9672 Version: 82 Serial no. 125874

SSCH.... 2469 ASCB.... 00F99680 CPUID... 0000 JOB..... SSMJYY2E RST..... 0E70C2B0
VST..... 020672B0

DSID.... 00000000 CC..... 00 ORB..... 00F3CEA8 02C0F000 0E70C2B0
SEEKA... 00000000 00000000

GPMSK... 00 OPT..... C0 FMSK.... 00 DVRID... 14
IOSLVL.. 01

UCBLVL.. 01 UCBWGT.. 00 BASE.... 2469

GMT-02/04/2002 15:03:52.826468 LOC-02/04/2002 16:03:52.826468

CCW CHAIN FORMAT 1 SSCH DEV..... 2469 ASCB....
00F99680 CPU..... 0000

JOB..... SSMJYY2E

020672B0 64600040 149C88D0

020672B8 FA600100 149C8910

020672C0 54200030 149C8A10

IO..... 2469 ASCB.... 00F99680 CPUID... 0000 JOB..... SSMJYY2E PSW..... 070E0000
00000000

IRB..... 00C04007 0E70C2C8 0C000008 00200002 00000000 TCB..... 00AE0500
SENSE... N/A

FLA..... 00 OPT..... C0 DVRID... 14 IOSLVL.. 01
UCBLVL.. 01

UCBWGT.. 00 BASE.... 2469

GMT-02/04/2002 15:03:52.826995 LOC-02/04/2002 16:03:52.826995

```

CCW CHAIN          FORMAT 1          IO          DEV..... 2469    ASCB.....
00F99680 CPU..... 0000

JOBN.... SSMJYY2E

020672B0 64600040 149C88D0 3990EC33 900AD000 30962024 0D0B000F | .....}..O..... |
                                E000E5A2 05940222 13090674 0D0B000F | \.VS.M..... |
                                0D0D000F 0D19001E 24240602 DFEE0001 | ..... |
                                06770800 00007900 21600000 00000000 | .....-..... |
020672B8 FA600100 149C8910 CC010100 4040F3F3 F9F0C2F3 C3E2E3D2 | .... 3390B3CSTK |
                                F0F2F0F0 F0F0F0F0 F0F0F6F1 F1F80169 | 02000000006118.. |
                                CC000000 4040F3F3 | .... 33 |
                                *** Back half of split data ***
                                00000000 00000000 80000001 FA005900 | ..... |
                                0021C069 6969010D 01400000 00000000 | ..{..... |
                                **** 000008 CONSECUTIVE BYTES ARE ZERO ****
020672C0 54200030 149C8A10 0169FF01 000000C0 00000060 00000059 | .....{...-..... |
                                58000000 00000000 00000000 00010000 | ..... |
                                00000000 00000021 | ..... |
SSCH.... 2469    ASCB.... 00F99680 CPUID... 0000    JOBN.... SSMJYY2E RST..... 0E70C2D8
VST..... 020672D8
                                DSID.... 00000000 CC..... 00    ORB.... 00F3CEA8 02C0F000 0E70C2D8
SEEKA... 00000000 00000000
                                GPMSK... 00    OPT..... C0    FMSK.... 00    DVRID... 14
IOSLVL.. 01

```

UCBLVL.. 01 UCBWGT.. 00 BASE.... 2469
GMT-02/04/2002 15:03:52.827339 LOC-02/04/2002 16:03:52.827339

CCW CHAIN FORMAT 1 SSCH DEV..... 2469 ASCB....
00F99680 CPU..... 0000

JOBN.... SSMJYY2E

020672D8 27200021 149C8A88 62016969 F0F0F0F0 F0F0F0F0 F6F1F1F8 |000000006118 |
0021F0F0 F0F0F0F0 F0F0F6F0 F1F00011 | ..000000006010.. |

**** 000001 CONSECUTIVE BYTES ARE ZERO ****

IO..... 2469 ASCB.... 00F99680 CPUID... 0000 JOBN.... SSMJYY2E PSW..... 070E0000
00000000

IRB..... 00C04017 0E70C2E0 06000000 00200001 00000000 TCB..... 00AE0500

SENSE... N/A

FLA..... 00 OPT..... C0 DVRID... 14 IOSLVL.. 01

UCBLVL.. 01

UCBWGT.. 00 BASE.... 2469

GMT-02/04/2002 15:03:52.829432 LOC-02/04/2002 16:03:52.829432

1 CCW CHAIN FORMAT 1 IO DEV..... 2469 ASCB....
00F99680 CPU..... 0000

JOBN.... SSMJYY2E

020672D8 27200021 149C8A88 62016969 F0F0F0F0 F0F0F0F0 F6F1F1F8 |000000006118 |
0021F0F0 F0F0F0F0 F0F0F6F0 F1F00011 | ..000000006010.. |

**** 000001 CONSECUTIVE BYTES ARE ZERO ****

SSCH.... 2469 ASCB.... 00F99680 CPUID... 0000 JOBN.... SSMJYY2E RST..... 00FF65B0
VST..... 00FC25B0

```

          DSID.... 00000000 CC..... 00          ORB..... 00F3CEA8 02C02000 00FF65B0
SEEKA... 00000000 00000000
          GPMSK... 20          OPT..... 80          FMSK.... 00          DVRID... 01
IOSLVL.. 01
          UCBLVL.. 01          UCBWGT.. 00          BASE.... 2469
          GMT-02/04/2002 15:03:52.829486  LOC-02/04/2002 16:03:52.829486

```

```

          CCW CHAIN          FORMAT 1          SSCH          DEV..... 2469          ASCB....
00F99680 CPU..... 0000
          JOB..... SSMJYY2E
          00FC25B0 04200020 0073C520
          EOS..... 2469          ASCB.... 00F99680 CPUID... 0000          JOB..... SSMJYY2E PSW..... 070E0000
00000000
          IRB..... 00C04007 00FF65B8 0C000000 00200000 00000000 TCB..... N/A
SENSE... 8000
          FLA..... 01          OPT..... 80          DVRID... 01          IOSLVL.. 01
UCBLVL.. 01
          UCBWGT.. 00          BASE.... 2469
          GMT-02/04/2002 15:03:52.830543  LOC-02/04/2002 16:03:52.830543

```

```

          CCW CHAIN          FORMAT 1          EOS          DEV..... 2469          ASCB....
00F99680 CPU..... 0000
          JOB..... SSMJYY2E
          00FC25B0 04200020 0073C520 80000000 6900000F 520000BB 79000010 | ..... |
          420017E6 21210B3E 000040E3 00000000 | ...W..... T.... |

```

Notes:

1. The End of Sense (EOS) mentioned earlier in the text is the bolded EOS four lines from the bottom of this GTF trace.
2. Normally when running this procedure you would be trying to further define a “command reject.” The command reject is indicated by an 80 appearing at the start of the sense bytes as shown above by the underlined 80.
3. The FSC (0B3E) is shown above in the different and bolded type face.

Missing Channel End Device End Messages

Missing channel end Device end messages can appear when issuing an ECAM request to a PPRC primary volume and the secondary is in a check0/warm start sequence. The host will enter error recovery and reset the volume and re-drive the ECAM request.

CNT Interface Card Resets

In a Power PPRC WAN setup, there are situations when it is necessary to cold IML both the primary and secondary SVAs or it becomes desirable to reverse the direction of the PPRC link. *Before starting this cold IML or direction reversal, the customer must physically locate the UltraNet Storage Director - eXtended interface cards to which these SVAs are attached* – there may be other SVAs or other devices connected to the UltraNet Storage Director - eXtended.

For a cold IML, once the interface cards have been located, begin the IML of the SVAs, then press the reset button on the interface cards of the UltraNet Storage Director - eXtended (see [Figure 33 on page 120](#)).

For direction reversal, delete the PPRC link, press the reset buttons on the interface cards of the UltraNet Storage Director - eXtended (see [Figure 33](#)), then re-establish the PPRC link in the opposite direction.

DO NOT reset unaffected interface cards.

Note: StorageTek does not recommend that a pencil of any type be used to push the reset button; use a pen or a straightened paperclip.

Caution: Potential Data Loss - DO NOT reset the UltraNet Storage Director - eXtended by cycling the main breaker! Use the reset button located on the front of the interface card.



Figure 33 CNT Interface Card Reset Button Location

Valid Return Codes

The IBM PPRC configuration commands only allow for the following return codes:

- RC=0 – command completed successfully
- RC=4 – command partially completed
- RC=8 – command did not successfully complete
- RC=12 – command failed syntax and validity checking before any I/O was sent

Command Failures

A command usually fails because some of the required information was entered into the command improperly such as a Primary or Secondary sequence number, SSID or device. But the problem could be a link or other less obvious failure. In that case, start a GTF trace for the device on which the failing PPRC command is issued against, rerun the command, and then call STK support with the GTF trace results for problem diagnosis.

Introduction

This appendix defines the variations that are supported between the FLX V2X, FLX V960, and FLX 9500 (i.e. the “PPRC Triangle Configuration”). Figure 34 below is an example of the “PPRC Triangle Configuration”.

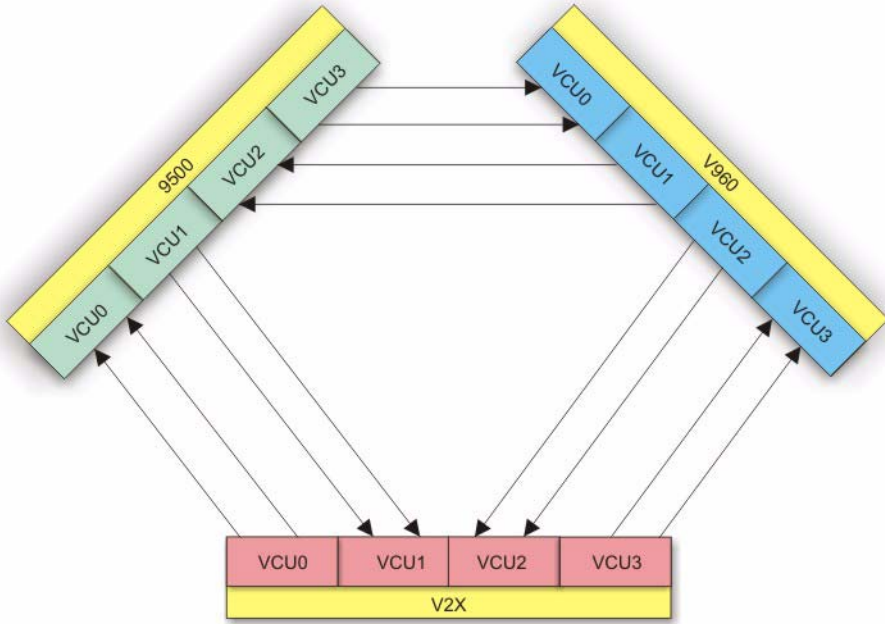

C95254

Figure 34 PPRC Triangle Configuration Example

How it Works

Backward compatibility provides the capability of using existing equipment (FLX V960’s and FLX 9500’s) to communicate to/from an FLX V2X machine in a PPRC environment. This environment is better known as the “PPRC Triangle” and supports bi-directional PPRC between FLX V2X, FLX V960, and FLX 9500 SVAs.

Functionality

The following is a list of the PPRC related functionality and supported control unit models.

SVAA Open PPRC

- FLX V2X → FLX V960 (VCU 0 to VCU3 only)
- FLX V2X → FLX 9500 (VCU 0 to VCU3 only)
- FLX V960 → FLX 9500
- FLX V960 → FLX V2X (VCU0 to VCU3 only)

PPRC SnapShot

- FLX V2X → FLX V960 (VCU0 to VCU3 only)
- FLX V2X → FLX 9500 (VCU0 to VCU3 only)
- FLX V960 → FLX V2X (VCU0 to VCU3 only)
- FLX 9500 → FLX V2X (VCU0 to VCU3 only)
- FLX V960 → FLX 9500
- FLX 9500 → FLX V960

Snap to Primary

- FLX V2X → FLX V960 (VCU0 to VCU3 only)
- FLX V2X → FLX 9500 (VCU0 to VCU3 only)

PowerPPRC

- FLX V2X → FLX V960 (VCU0 to VCU3 only)
- FLX V2X → FLX 9500 (VCU0 to VCU3 only)
- FLX V960 → FLX 9500
- FLX 9500 → FLX V960
- FLX V960 → FLX V2X (VCU0 to VCU3 only)
- FLX 9500 → FLX V2X (VCU0 to VCU3 only)

Error reporting FSCs for Establish Paths

Establishing paths where primary VCU number is 4-F and Secondary VCU number is 0-3

- FLX V2X → FLX V9600B34
- FLX V2X → FLX 95000B34
- FLX V960 → FLX 950005A6
- FLX 9500 → FLX V96005A6

Establishing paths where primary VCU number is 0-3 and Secondary VCU number is 4-F

- FLX V2X → FLX V9600B34
- FLX V2X → FLX 95000B34
- FLX V960 → FLX 95000B34
- FLX 9500 → FLX V9600B34



NEED MORE INFORMATION?
www.storagetek.com

ABOUT STORAGETEK

Storage Technology Corporation (NYSE: STK) is a \$2 billion global company that enables businesses, through its information lifecycle management strategy, to align the cost of storage with the value of information. The company's innovative storage solutions manage the complexity and growth of information, lower costs, improve efficiency and protect investments. For more information, visit www.storagetek.com, or call 1.800.275.4785 or 01.303.673.2800.

WORLD HEADQUARTERS

Storage Technology Corporation
One StorageTek Drive
Louisville, Colorado 80028 USA
1.800.525.0369

© 2004 Storage Technology Corporation, Louisville, CO. All rights reserved. Printed in USA. StorageTek and the StorageTek logo are registered trademarks of Storage Technology Corporation. Other names mentioned may be trademarks of Storage Technology Corporation or other vendors/manufacturers.

StorageTek equipment is manufactured from new parts, or new and used parts. In some cases, StorageTek equipment may not be new and may have been previously installed. Regardless, StorageTek's standard warranty terms apply, unless the equipment is specifically identified by StorageTek as "used" or "refurbished."

Replacement parts provided under warranty or any service offering may be either new or equivalent-to-new, at StorageTek's option. Specifications/features may change without notice.