

# **Oracle® Shop Floor Management**

User's Guide

Release 12.2

**Part No. E48944-01**

September 2013

Oracle Shop Floor Management User's Guide, Release 12.2

Part No. E48944-01

Copyright © 1996, 2013, Oracle and/or its affiliates. All rights reserved.

Primary Author: Reena Titus

Oracle and Java are registered trademarks of Oracle and/or its affiliates. Other names may be trademarks of their respective owners.

Intel and Intel Xeon are trademarks or registered trademarks of Intel Corporation. All SPARC trademarks are used under license and are trademarks or registered trademarks of SPARC International, Inc. AMD, Opteron, the AMD logo, and the AMD Opteron logo are trademarks or registered trademarks of Advanced Micro Devices. UNIX is a registered trademark of The Open Group.

This software and related documentation are provided under a license agreement containing restrictions on use and disclosure and are protected by intellectual property laws. Except as expressly permitted in your license agreement or allowed by law, you may not use, copy, reproduce, translate, broadcast, modify, license, transmit, distribute, exhibit, perform, publish, or display any part, in any form, or by any means. Reverse engineering, disassembly, or decompilation of this software, unless required by law for interoperability, is prohibited.

The information contained herein is subject to change without notice and is not warranted to be error-free. If you find any errors, please report them to us in writing.

If this is software or related documentation that is delivered to the U.S. Government or anyone licensing it on behalf of the U.S. Government, the following notice is applicable:

U.S. GOVERNMENT END USERS: Oracle programs, including any operating system, integrated software, any programs installed on the hardware, and/or documentation, delivered to U.S. Government end users are "commercial computer software" pursuant to the applicable Federal Acquisition Regulation and agency-specific supplemental regulations. As such, use, duplication, disclosure, modification, and adaptation of the programs, including any operating system, integrated software, any programs installed on the hardware, and/or documentation, shall be subject to license terms and license restrictions applicable to the programs. No other rights are granted to the U.S. Government.

This software or hardware is developed for general use in a variety of information management applications. It is not developed or intended for use in any inherently dangerous applications, including applications that may create a risk of personal injury. If you use this software or hardware in dangerous applications, then you shall be responsible to take all appropriate fail-safe, backup, redundancy, and other measures to ensure its safe use. Oracle Corporation and its affiliates disclaim any liability for any damages caused by use of this software or hardware in dangerous applications.

This software or hardware and documentation may provide access to or information on content, products, and services from third parties. Oracle Corporation and its affiliates are not responsible for and expressly disclaim all warranties of any kind with respect to third-party content, products, and services. Oracle Corporation and its affiliates will not be responsible for any loss, costs, or damages incurred due to your access to or use of third-party content, products, or services.

---

# Contents

## Send Us Your Comments

## Preface

## 1 Shop Floor Management Overview

Overview of Shop Floor Management.....	1-1
Shop Floor Management Flow.....	1-2
Enhanced Shop Floor Execution.....	1-3
Detailed Scheduling.....	1-3
Multilevel Bills of Material.....	1-4
Inverse Component Usage.....	1-6
Fixed Component Usage.....	1-7
Component Shrinkage.....	1-8
Network Routings.....	1-8
Enhanced Lot Functionality.....	1-9
Lot Attributes.....	1-10
Capturing Attributes During Lot Based Jobs Execution.....	1-10
Co-Products.....	1-11
Operation Yields.....	1-11
Integration with Oracle Applications.....	1-11
Component Picking.....	1-12
Completions into License Plate Numbers.....	1-12

## 2 Setting Up

Overview of Setting Up .....	2-1
Related Product Setup Steps.....	2-2

Setup Flowchart and Checklist.....	2-3
Setup Steps.....	2-5
Defining Parameters.....	2-10
Defining and Viewing Lot Sector Extensions.....	2-15
Defining Standard Operation Details.....	2-17
Attaching Files to Job Operations.....	2-19
Setting Up Shop Floor Management Attributes.....	2-19
Profile Options.....	2-21

### 3 Network Routings

Overview of Network Routings .....	3-1
Creating a Network Routing.....	3-4
Modifying Network Routings.....	3-11
Importing Routings.....	3-12
Defining Alternate Resources for Standard Operations.....	3-13
Defining Operation Yield Values on Routings.....	3-15
Calculating Lead Times.....	3-16
Integration with Advanced Supply Chain Planning.....	3-20
Integration with Outside Processing.....	3-21

### 4 Shop Floor Execution

Overview of Shop Floor Execution.....	4-1
Shop Floor Modeling.....	4-1
Shop Floor Execution.....	4-23

### 5 Lot Transactions

Overview of Lot Transactions.....	5-2
Creating a Lot Based Job.....	5-3
Overview of Sales Order Reservation for Lot Based Jobs.....	5-12
Overview of Lot Moves.....	5-14
Performing Lot Move Transactions.....	5-14
Operation Jumps.....	5-18
Viewing Status and Resources.....	5-20
Integration with Oracle Advanced Supply Chain Planning (ASCP).....	5-20
Capturing and Modifying Detailed Job Level Plan Recommendations.....	5-21
Changing the Recommended Path of a Job to an Intended Path for Future Operations.....	5-21
Viewing Plan Resource Details.....	5-22
Updating Plan Components.....	5-23
Updating Plan Phantom Components.....	5-25
Mass Refresh of Open Jobs.....	5-26

Refresh BOM/Routing of Open Lot Based Jobs with Revision Dates.....	5-28
Overview of Advanced Lot Transactions.....	5-29
WIP Lot Transactions.....	5-30
Creating WIP Lot Transactions.....	5-31
Inventory Lot Transactions.....	5-36
Creating Inventory Lot Transactions.....	5-37
Lot Attributes in Inventory Lot Transactions.....	5-39
Creating Lots for New Sectors.....	5-44
Kanban Replenishment on Lot Based Jobs.....	5-48
Lot Based Job Reporting.....	5-49
Lot Based Job Component Pick Release.....	5-50
Pending Transactions Report.....	5-51
Integration with Outside Processing.....	5-52

## **6 Lot and Serial Controlled Assemblies**

Creating a Job with Lot/Serial Controlled Assembly.....	6-1
Serial Generation during Job Creation and Job Move.....	6-1
Executing Manufacturing Transactions.....	6-4
Completing the Job into Inventory.....	6-24

## **7 Resource Scheduling Workbench**

Overview of Resource Scheduling Workbench.....	7-1
Using the Resource Scheduling Workbench.....	7-2
Defining User Preferences.....	7-3
Job Operation Bars.....	7-5
Navigation.....	7-6
Viewing Property Windows.....	7-7
Capacity Exceptions.....	7-9
Showing Select Resources and Resource Load Versus Capacity Panes.....	7-10
Selecting a Resource.....	7-10
Adjusting Resource Capacity.....	7-12
Rescheduling Jobs, Operations, and Resources in the Gantt Chart.....	7-14
Rescheduling Start and End Dates.....	7-14
Resource Transfer.....	7-16
Transferring Work to an Instance.....	7-17
Transferring Work Between Instances.....	7-17
Transferring Work Between Alternate Resources.....	7-18
Launching the HTML User Interface.....	7-18

<b>8</b>	<b>Lot Genealogy</b>	
	Overview of Lot Genealogy.....	8-1
	Displaying Genealogy and Where-Used Views.....	8-2
	Genealogy of Lot/Serial Controlled Assemblies.....	8-8
	Genealogy with Lot Serial Attributes.....	8-9
<b>9</b>	<b>Co-Products</b>	
	Overview of Co-Products.....	9-1
	Defining Co-Products.....	9-2
	Define Time Phased Split Percentages Window.....	9-4
	Substitute Components Window.....	9-6
	Component Details Window.....	9-6
<b>10</b>	<b>Costing in Oracle Shop Floor Management</b>	
	Overview of Lot Based Job Costing.....	10-2
	Cost Rollup for Network Routings.....	10-2
	Standard Cost Update for Lot Based Jobs.....	10-2
	Phantom Routings.....	10-3
	Lot Based Jobs Transaction Costing.....	10-3
	Move Transaction Costing.....	10-3
	Estimated Scrap Accounting.....	10-3
	Operation Yield.....	10-6
	Disabling Estimated Scrap and Operation Yield Accounting.....	10-19
	Non Standard Expense Lot Based Jobs.....	10-20
	WIP Lot Based Jobs Transaction Costing.....	10-21
	Lot Split Transactions.....	10-21
	Merge Lots.....	10-22
	Bonus Lots.....	10-24
	Update Quantity.....	10-25
	Update Routing and Update Assembly.....	10-26
	Lot Based Transaction are Integrated into Cost Manager.....	10-27
	Transaction Import through MES.....	10-27
	WIP Value Summary.....	10-27
	Reports.....	10-27
<b>11</b>	<b>Closing Lot Based Jobs</b>	
	Closing Lot Based Jobs.....	11-1
	Unclosing Lot Based Jobs.....	11-6

Purging Lot Based Job Move Transactions.....	11-8
<b>A Windows and Navigator Paths</b>	
Windows and Navigator Paths.....	A-1
<b>B Support for OSFM Transactions in Various User Interface Modes</b>	
Support for OSFM Transactions in Various User Interface Modes.....	B-1
<b>Index</b>	





---

# Send Us Your Comments

## Oracle Shop Floor Management User's Guide, Release 12.2

### Part No. E48944-01

Oracle welcomes customers' comments and suggestions on the quality and usefulness of this document. Your feedback is important, and helps us to best meet your needs as a user of our products. For example:

- Are the implementation steps correct and complete?
- Did you understand the context of the procedures?
- Did you find any errors in the information?
- Does the structure of the information help you with your tasks?
- Do you need different information or graphics? If so, where, and in what format?
- Are the examples correct? Do you need more examples?

If you find any errors or have any other suggestions for improvement, then please tell us your name, the name of the company who has licensed our products, the title and part number of the documentation and the chapter, section, and page number (if available).

Note: Before sending us your comments, you might like to check that you have the latest version of the document and if any concerns are already addressed. To do this, access the new Oracle E-Business Suite Release Online Documentation CD available on My Oracle Support and [www.oracle.com](http://www.oracle.com). It contains the most current Documentation Library plus all documents revised or released recently.

Send your comments to us using the electronic mail address: [appsdoc\\_us@oracle.com](mailto:appsdoc_us@oracle.com)

Please give your name, address, electronic mail address, and telephone number (optional).

If you need assistance with Oracle software, then please contact your support representative or Oracle Support Services.

If you require training or instruction in using Oracle software, then please contact your Oracle local office and inquire about our Oracle University offerings. A list of Oracle offices is available on our Web site at [www.oracle.com](http://www.oracle.com).



---

# Preface

## Intended Audience

Welcome to Release 12.2 of the *Oracle Shop Floor Management User's Guide*.

This guide assumes you have a working knowledge of the following:

- The principles and customary practices of your business area.
- Oracle Shop Floor Management.

If you have never used Oracle Shop Floor Management, Oracle suggests you attend one or more of the Oracle Shop Floor Management training classes available through Oracle University.

- The Oracle Applications graphical user interface.

To learn more about the Oracle Applications graphical user interface, read the *Oracle E-Business Suite User's Guide*.

See Related Information Sources on page xii for more Oracle E-Business Suite product information.

## Documentation Accessibility

For information about Oracle's commitment to accessibility, visit the Oracle Accessibility Program website at <http://www.oracle.com/pls/topic/lookup?ctx=acc&id=docacc>.

## Access to Oracle Support

Oracle customers have access to electronic support through My Oracle Support. For information, visit <http://www.oracle.com/pls/topic/lookup?ctx=acc&id=info> or visit <http://www.oracle.com/pls/topic/lookup?ctx=acc&id=trs> if you are hearing impaired.

## Structure

- 1 Shop Floor Management Overview**
- 2 Setting Up**
- 3 Network Routings**
- 4 Shop Floor Execution**
- 5 Lot Transactions**
- 6 Lot and Serial Controlled Assemblies**
- 7 Resource Scheduling Workbench**
- 8 Lot Genealogy**
- 9 Co-Products**
- 10 Costing in Oracle Shop Floor Management**

*The Oracle Cost Management User's Guide* is a prerequisite for understanding this chapter. Since lot based jobs use Standard Costing, sections specific to other costing methods may be skipped.

- 11 Closing Lot Based Jobs**
- A Windows and Navigator Paths**
- B Support for OSFM Transactions in Various User Interface Modes**

## Related Information Sources

### **Oracle Bills Of Material User's Guide**

This guide describes how to create various bills of materials to maximize efficiency, improve quality and lower cost for the most sophisticated manufacturing environments. By detailing integrated product structures and processes, flexible product and process definition, and configuration management, this guide enables you to manage product details within and across multiple manufacturing sites.

### **Oracle Cost Management User's Guide**

This guide describes how to use Oracle Cost Management in either a standard costing or average costing organization. Cost Management can be used to cost inventory, receiving, order entry, and work in process transactions. It can also be used to collect transaction costs for transfer to Oracle Projects. Cost Management supports multiple cost elements, multiple sub elements, and activity-based costing. It also provides comprehensive valuation and variance reporting.

### **Oracle General Ledger User's Guide**

This guide explains how to plan and define your chart of accounts, accounting period types and accounting calendar, functional currency, and set of books. It also describes how to define journal entry sources and categories so you can create journal entries for your general ledger. If you use multiple currencies, use this manual when you define additional rate types, and enter daily rates. This manual also includes complete information on implementing Budgetary Control.

### **Oracle Inventory User's Guide**

This guide describes how to define items and item information, perform receiving and

inventory transactions, maintain cost control, plan items, perform cycle counting and physical inventories, and set up Oracle Inventory.

### **Oracle Purchasing User's Guide**

This guide describes how to create and approve purchasing documents, including requisitions, different types of purchase orders, quotations, RFQs, and receipts. This guide also describes how to manage your supply base through agreements, sourcing rules and approved supplier lists. In addition, this guide explains how you can automatically create purchasing documents based on business rules through integration with Oracle Workflow technology, which automates many of the key procurement processes.

### **Oracle Quality User's Guide**

This guide describes how Oracle Quality can be used to meet your quality data collection and analysis needs. This guide also explains how Oracle Quality interfaces with other Oracle Manufacturing applications to provide a closed loop quality control system.

### **Oracle Work in Process User's Guide**

This guide describes how Oracle Work in Process provides a complete production management system. Specifically this guide describes how discrete, repetitive, assemble-to-order, project, flow, and mixed manufacturing environments are supported.

## **Integration Repository**

The Oracle Integration Repository is a compilation of information about the service endpoints exposed by the Oracle E-Business Suite of applications. It provides a complete catalog of Oracle E-Business Suite's business service interfaces. The tool lets users easily discover and deploy the appropriate business service interface for integration with any system, application, or business partner.

The Oracle Integration Repository is shipped as part of the E-Business Suite. As your instance is patched, the repository is automatically updated with content appropriate for the precise revisions of interfaces in your environment.

You can navigate to the Oracle Integration Repository through Oracle E-Business Suite Integrated SOA Gateway.

## **Do Not Use Database Tools to Modify Oracle E-Business Suite Data**

Oracle **STRONGLY RECOMMENDS** that you never use SQL\*Plus, Oracle Data Browser, database triggers, or any other tool to modify Oracle E-Business Suite data unless otherwise instructed.

Oracle provides powerful tools you can use to create, store, change, retrieve, and maintain information in an Oracle database. But if you use Oracle tools such as SQL\*Plus to modify Oracle E-Business Suite data, you risk destroying the integrity of

your data and you lose the ability to audit changes to your data.

Because Oracle E-Business Suite tables are interrelated, any change you make using an Oracle E-Business Suite form can update many tables at once. But when you modify Oracle E-Business Suite data using anything other than Oracle E-Business Suite, you may change a row in one table without making corresponding changes in related tables. If your tables get out of synchronization with each other, you risk retrieving erroneous information and you risk unpredictable results throughout Oracle E-Business Suite.

When you use Oracle E-Business Suite to modify your data, Oracle E-Business Suite automatically checks that your changes are valid. Oracle E-Business Suite also keeps track of who changes information. If you enter information into database tables using database tools, you may store invalid information. You also lose the ability to track who has changed your information because SQL\*Plus and other database tools do not keep a record of changes.

---

# Shop Floor Management Overview

This chapter covers the following topics:

- Overview of Shop Floor Management
- Shop Floor Management Flow
- Enhanced Shop Floor Execution
- Detailed Scheduling
- Multilevel Bills of Material
- Inverse Component Usage
- Fixed Component Usage
- Component Shrinkage
- Network Routings
- Enhanced Lot Functionality
- Lot Attributes
- Co-Products
- Operation Yields
- Integration with Oracle Applications
- Component Picking
- Completions into License Plate Numbers

## Overview of Shop Floor Management

Oracle Shop Floor Management manages complex shop floor information and bridges the gap between Oracle Manufacturing and the shop floor by expanding the capabilities of Oracle's Manufacturing Applications. It enhances the core product by making integrated shop floor/MES information available at the enterprise level to combine manufacturing excellence with customer responsiveness. Oracle Shop Floor

Management uses a single data repository to guarantee information consistency for manufacturing execution. You can create and release discrete jobs and lot based jobs in the same manufacturing organization. The major features include:

- MES/ERP (Enterprise Resource Planning) integration
- Network routings
- Complex lot transactions
- Lot Genealogy
- Operation yield costing
- Co-product definition
- Enhanced Shop Floor Execution
- Detailed Scheduling

## **Shop Floor Management Flow**

The process flow begins when a primary component for the lot based job is created. When the lot is created and released, it moves through a series of operations to an inventory location, where it becomes an Inventory Lot. The Inventory Lot then moves into the next bill of material level, becoming a new WIP Lot. The new WIP lot moves through a series of operations, and is completed into inventory location for the next sector. This process is repeated through each sector until the last sector is complete.

The following graphic displays the Shop Floor Management flow described above.



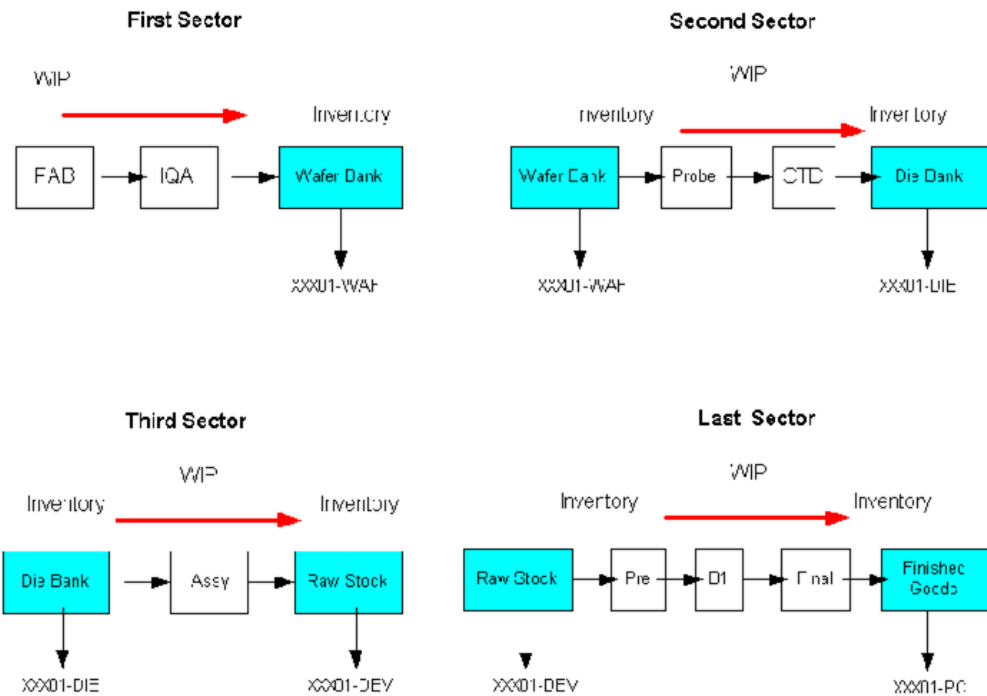

## Enhanced Shop Floor Execution

Enhanced Shop Floor Execution provides you with an interface to perform multiple shop floor functions without you having to navigate to a number of transaction windows. It helps you to do and view various transactions, and to track the manufacturing of goods at the factory shop floor. Apart from configuring the workstation to any role of action, like display, security and transactions, it also helps you to *view the jobs* assigned to specific work centers, to view requirements and provides instructions required to perform the job.

## Detailed Scheduling

Detailed Scheduling provides a more granular organization or department level, real-time scheduling tool. It helps you to perform the following tasks:

- To calculate the portion of the job already completed before the plan start date and schedule only the unfinished portion.
- To plan for components on a BOM, consumed on a 'lot basis' rather than on a basis that is proportional to the quantity of finished product being produced.
- To support Sequence dependent setups, which allow you to minimize the number of changeovers from one setup type to another by grouping activities of the same

setup type in a production run. These are scheduled to the Resource Instance Level.

- To have a better view of available information in Enhanced Gantt chart and planner's workbench for you to plan shop floor management activities in a detailed manner.
- To support 'hot' (high priority) test lots, where a portion of the lot is tested in a semiconductor industry.
- To support burn-in operation, where several lots are processed together, which needs a multilevel batch resource support.
- A resource centric workbench based on the constrained engine to perform functions like:
  - Drag and drop job bars from one time period to another
  - Change job priorities
  - Change material or resource requirements

**Note:** For Detailed Scheduling to function, Shop Floor Management must be integrated with Oracle Advanced Planning.

## Multilevel Bills of Material

The relationship between the items that represent the different forms the lot takes is stored as a multilevel bill of material. These items are called the primary assembly of that level of the bill. Each of these primary assembly items has its own routing.

A lot sector converts inventory lot components into a lot based job. When the job is completed it becomes an inventory lot for the next lot sector.

Lot based jobs support operation pull, push, and phantom supply types. Other supply types are not currently supported. Oracle Shop Floor Management does not currently support assembly pull supply type.

## Phantoms

Phantom assemblies are non-stocked assemblies used to group material. In discrete jobs, all routing operations are known. In lot based jobs, only the first operation is known. The difference in using a phantom supply type in lot based jobs is:

- Lot based jobs consider only the components and resource on the primary path of the routing if the Use Phantom Routing flag is set to Yes. Otherwise it considers all the components of the phantom in the primary and alternate path.

- Material requirements are exploded during job creation for the first operation, and during the subsequent move or jump operation.
- While performing update routing or update assembly transactions at the Queue intraoperation step, if you have phantom exploded components at the current operation—you must manually reverse the charges.

Before using phantom assemblies, the following parameters in Oracle Bills of Material need to be set:

- Use Phantom Routings—Indicates if the resource and overhead costs (including those for outside processing resources assigned to phantom routing operations) associated with the components are ignored, or charged to the job's assembly. Also determines whether only the components on the primary path, or all the components in the primary and alternate are exploded.
- Inherit Phantom Operation Sequence—This parameter is used by discrete and lot based jobs; the phantom routing operation sequence number is always inherited from the parent network operation sequence.

The following table explains the behavior of the phantom assemblies based on the BOM parameter set up for phantoms:

Scenario	Name of the Parameter	Setting	Behavior
Scenario 1	BOM: Use phantom routing	Yes	Material in primary path is exploded
Scenario 1	BOM: Inherit phantom operation sequence	Yes	The lot based job does not inherit phantom operation sequence from the phantom network but the operation sequence number is always inherited from the parent network operation sequence.
Scenario 2	BOM: Use phantom routing	No	Material in primary and alternate path is exploded. No resource requirement is created

Scenario	Name of the Parameter	Setting	Behavior
Scenario 2	BOM: Inherit phantom operation sequence	No	The lot based job does not inherit phantom operation sequence from the phantom network but the operation sequence number is always inherited from the parent network operation sequence.
Scenario 3	BOM: Use phantom routing	Yes	Not Applicable
Scenario 3	BOM: Inherit phantom operation sequence	No	Not Applicable

**Note:** Oracle Shop Floor Management has some limitations while using the phantom supply type material:

- If the Bill of Material of the assembly calls for a phantom supply type material at the first operation, the Lot Creation window does not allow you to create the job and a warning message is displayed.
- Phantom material is always a non stocked item.
- You are not allowed to update the phantom supply type material using Material Transaction window.

## Inverse Component Usage

In the Die Bank of a Semiconductor Manufacturing Business, you must calculate and enter the Bills of Material component quantity field with at least 38 decimal points. To capture inverse usage, you can model inverse component usage through the Inverse Usage field in Bills of Material window. The resulting quantity per assembly is stored unrounded to accurately determine the total required quantity of a component for a job. Storing the exact fractional quantity per assembly prevents any undesirable component usage variances that might occur in lot based jobs with large build quantities. This helps you to easily define and update Co-Product and Bills of Material.

**To capture inverse usage**

1. Navigate to Bills of Material window.
2. Enter the item number in the Item field.
3. Enter the component name in the component field.
4. Enter the inverse value of the component in the Inverse Usage field.

Now the component quantity that you need is displayed accurately in the Quantity field.

The inverse usage value will be displayed as inverse of component quantity while querying an existing Bill of Material or any BOM reports.

Inverse usage is also displayed in Lot Creation window, Lot Based Job window, WIP Material Requirements window, and Components Substitutes window.

Oracle Shop Floor Management Plan Details shows the inverse usage for both primary and substitute components.

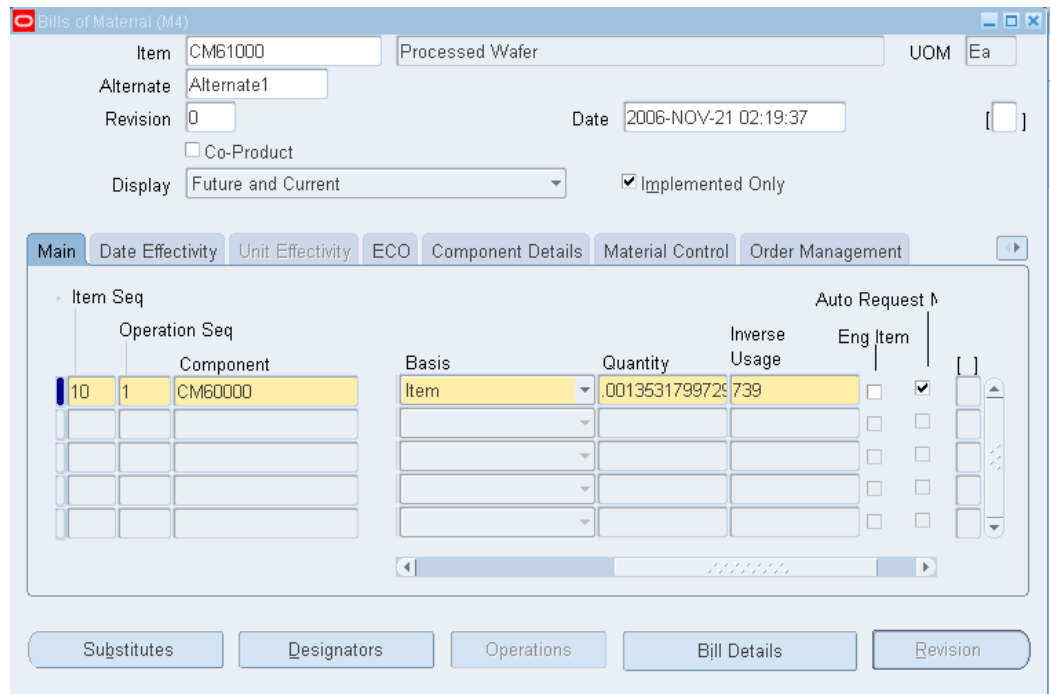

## Fixed Component Usage

Oracle Shop Floor Management gives you the ability to define components with Basis as lot and issue a fixed quantity irrespective of the job quantity. You can define a fixed usage for components on a bill of material, such that the total quantity required remains the same regardless of the build quantity. The information is copied on an item bill when a copy is created for use on a specific job.

You can use the Bills of Material window to set the basis type as either Item or Lot in the list box 'Basis' to calculate material requirements.

If basis is set to Item, the material requirement depends on the Job Quantity.

If the basis is set to Lot then the material requirement is a fixed quantity as specified in the BOM and not depend on the job quantity.

Lot-based Components can assume any supply type similar to the item based component. You have to define fixed usages of a component item irrespective of its parent item's build quantity.

## Component Shrinkage

You can maintain the value of Quantity Per Assembly at job level independent of Component Yield Factor in Oracle Work in Progress. This parameter enables you to use the component yield factor and required quantity separately on the bill of material for planning purposes. Or exclude yield and shrinkage if it is not appropriate for shop floor execution—eliminating decimal quantities that can inflate component related transactions. This functionality applies to discrete jobs, repetitive schedules, flow schedules, and lot based jobs.

Include Component Yield check box in the WIP parameters under Material tab is checked by default. This means that yield is taken into account while deriving backflush quantity to retain the existing system behavior. You can either factor component yield or exclude component yield to prevent incorrect inflation of backflush quantities to an amount greater than actual use.

See: Component Yield and Shrinkage, *Oracle Work in Process User's Guide*.

## Network Routings

Oracle Shop Floor Management provides flexible routing ability for lot based jobs. This type of routing is used in businesses such as the semiconductor industry where the paths that jobs take is not always known or understood at the time the job is created. Depending on the initial operation, subsequent operation paths are decided.

Flexible, or network routings enable you to define all possible operations paths that a job can take. This networked predefined path definition provides for dynamic flexible operation. Numerous possibilities are defined as part of a routing network, any one being selectable based on the outcome of the last operation within the job performed.

The routing network must have only one beginning and one ending operation. As the job goes through the production cycle, you build a history of operations that the WIP lot actually moves, selectable from the possibilities defined in the network.

A network of operations is available to model your shop floor, define possible rework points, or define a linear path. It consists of a series of nodes and paths which make up the routing network, and it is referenced by the Move Lot Based Jobs window to determine which operations a job can traverse.

You can also import network routings from 3P route builders into Oracle Shop Floor Management. Complete interface support is available that lets you import and modify network routings.

## Enhanced Lot Functionality

### Lot Transactions

WIP Lot Move transactions reference network routings and intraoperation steps. You can jump to other operations not defined on a network routing, and also put a job on hold at any operation.

The flow of a lot begins when a WIP Lot is created for the first sector's primary component and released. When it is completed, it becomes an Inventory lot and can be issued to the next sector as the primary component. Oracle Shop Floor Management lot transactions include:

- Network routing moves
- Operation jumps
- Lot splitting
- Lot merging
- Lot renaming
- Bonus lots
- Translate lots
- Transfer lots
- Operation holds

### Lot Based Material Support for Lot Based Job

Lot Based Material Support enables you to define a fixed usage quantity for components on a bill of material (item bill), so that the total quantity required remains the same, regardless of the build quantity. When defined on an item bill, the information is copied when a copy of the bill is created for use on a specific job or schedule. This means that the Lot Based Material usage quantity is fixed, irrespective of the Lot or Job quantity.

## Lot Genealogy

The Lot Genealogy enables you to view the genealogy, or historical production information of a lot. It provides you with detailed lot information about the sectors the lot has moved through, and related lot transactions. It also enables you to view forward and backward direction or genealogy. View Genealogy to view historical informations in the Lot Genealogy window, see: *Displaying Genealogy and Where Used Views*, page 8-2.

## Genealogy Enhancements

You can also trace defects in lots, and track changes that the lot might have undergone from the expected at the Outsourced Processing levels. Genealogy tracks the product's complete life cycle.

## Lot Attributes

Lot attributes are key information elements that you can track with lot numbers. There are many attributes that you can track using Shop Floor Management. Lot attributes are entered as descriptive flex fields, and you can track attributes by item, and define attributes for validation requirements.

You can capture and track attributes of a lot based job during execution, from a lot start to completion. Attributes can be transferred from an inventory lot to a lot based job during the lot creation process, which would then be tracked through execution. When a job is completed, the job attributes are transferred to the resulting inventory lot.

## Capturing Attributes During Lot Based Jobs Execution

You can capture attributes of a Work in Process (WIP) lot during job execution. When a job is completed, the job attributes are transferred to the resulting inventory lot.

While executing WIP lot transactions such as a split or a merge, then the lot attributes from the parent or representative job transfer to the new lot. You can then update lot attributes on the resulting job if required. You can also capture or update lot attributes during a move transaction. Lot Genealogy displays details of lot attributes associated with a job. If an OSFM organization is set up for shop floor transactions, then you can also view details from the Materials Workbench.

Oracle Shop Floor Management does not currently support the following attribute functionality:

- Attribute based planning using Oracle Advanced Planning and Scheduling
- Capturing attributes using Kanban replenishment



## Co-Products

Oracle Shop Floor Management co-products extend standard Oracle Bills of Material definitions. You can use the Define Co-Products window to define an item as the primary component of several end items (for example, one ungraded die which produces several die grades). You define the primary end item and the expected distribution across all the end items. Upon entering this information in the Define Co-Products window, the bill of material of the end items are automatically created. You can also define co-product split percentages across different time periods.

## Operation Yields

Operation Yield costing enables you to include the cost of operation yield in the cost rollup of an assembly. You can also track the operation yield related variance by operation for lot based jobs. Oracle Shop Floor Management costing includes the following features:

- *Yield Definitions*—yields are defined at the operations level allowing cumulative and reverse cumulative yield calculations at every operation.
- *Costing Support*—cost rollup considers material, overhead and resource costs using operation yield at the operation rather than the shrinkage.

**Note:** Oracle Shop Floor Management only uses the standard costing method.

## Integration with Oracle Applications

Oracle Shop Floor Management expands the capabilities of Oracle's Manufacturing applications by making integrated shop floor information available at the enterprise level to combine manufacturing capabilities with customer responsiveness. This integration information allows scheduling and execution components to work together for job releases on the shop floor.

Oracle Shop Floor Management integrates with the following Oracle applications:

- Inventory
- Bills of Material
- Work in Process
- Cost Management
- Quality

- Warehouse Management
- Advanced Supply Chain Planning

If you enable Oracle Manufacturing Scheduling at the organization level, then you can use the Scheduler Workbench to schedule discrete jobs created in lot based organizations.

**Note:** Oracle Shop Floor Management does not integrate with Oracle Master Scheduling and MRP.

## Component Picking

You can perform component picking transactions for lot based jobs using the rules based system in Oracle Warehouse Management. The Component Pick Release window is used to select requirements and create move orders. It is a graphical workbench that displays fields applicable to the job or schedule type accessed. The features in component picking for lot based jobs include:

- Material source is based on Oracle Inventory allocation rules or Oracle Warehouse Management rules recommendations
- The status for lot based jobs picked must be Released or Complete - Charges Allowed
- Components are picked based on the network routing
- Move order quantities are calculated as assemblies per operation multiplied by the number of components, or:

The sum of all the quantities in each intraoperation step (Queue, Run, To Move, Reject and Scrap)

Multiplied by the component's quantity per assembly

## Related Topics

Overview of Component Picking, *Oracle Work In Process User's Guide*

Navigating on the Component Pick Release Window , *Oracle Work In Process User's Guide*

Using the Component Pick Release Window , *Oracle Work In Process User's Guide*

## Completions into License Plate Numbers

If Oracle Warehouse Management is installed, you can use License Plate Number

functionality for tracking completions. License plate numbers are unique identifiers for tracking the contents of containers in receiving, work in process, inventory, shipping, and in transit. You can perform assembly completions into license plate numbers. The container's genealogy provides content and transaction history for each license plate.

## **Related Topics**

Explaining LPN and Cross Docking Put Away in the *Oracle Warehouse Management User's Guide*

Explaining License Plate Management, *Oracle Warehouse Management User's Guide*



---

## Setting Up

This chapter covers the following topics:

- Overview of Setting Up
- Overview setting up
- Related Product Setup Steps
- Setup Flowchart and Checklist
- Setup Steps
- Defining Parameters
- Defining and Viewing Lot Sector Extensions
- Defining Standard Operation Details
- Attaching Files to Job Operations
- Setting Up Shop Floor Management Attributes
- Profile Options

### Overview of Setting Up

This section contains an overview of the steps to complete setting Oracle Shop Floor Management. For instructions on how to complete each task, see the setup sections indicated in each step.

Setup involves several phases, including setting up other applications including Oracle Inventory, Oracle Bills of Material, and Oracle Work in Process. You may not need to perform some of the steps below if you've already performed a common-application setup.

### Set Up Oracle Applications Technology

The setup steps in this chapter describe how to implement Oracle Applications specific to Oracle Shop Floor Management. You need to complete several other setup steps, including:

- Performing system-wide setup tasks, such as configuring concurrent managers and printers
- Managing data security, which includes setting up responsibilities to allow access to a specific set of business data and transactions, and assigning individual users to one or more of these responsibilities

## Related Product Setup Steps

Oracle Shop Floor Management requires that Oracle Bills of Material, Oracle Cost Management, Oracle Inventory, and Oracle Work in Process are set up first.

### Oracle Inventory

Set up Oracle Inventory as described in Overview of Setting Up, *Oracle Inventory User's Guide*. Ensure that all the following steps have been completed:

- Create your organizations
- Define your organization parameters
- Define items and item costs
- Define your units of measure
- Define your subinventories
- Define your stock locators
- Define WIP supply types

### Oracle Bills of Material

Set up Oracle Bills of Material as described in Overview of Setting Up, *Oracle Bills of Material User's Guide*. Ensure that all the following steps have been completed:

- Define resources
- Define your departments
- Define your standard operations
- Create your workday calendar

## Oracle Cost Management

Set up Oracle Bills of Material as described in Overview of Setting Up, *Oracle Cost Management User's Guide*. Ensure that all the following steps have been completed:

- Define your cost types and cost elements
- Define your default WIP accounting classes for categories
- Define resources, material sub-elements, overheads, and overhead defaults

## Oracle Work in Process

Set up Oracle Bills of Material as described in Overview of Setting Up, *Oracle Work in Process User's Guide*. Ensure that all the following steps have been completed:

- Define WIP accounting class types
- Define WIP parameters

## Setup Flowchart and Checklist

Some of the steps outlined in this flowchart and setup checklist are:

- Required
- Required Step With Defaults
- Optional

Required Step With Defaults refers to setup functionality that comes with pre-seeded, default values in the database; however, you should review those defaults and decide whether to change them to suit your business needs. If you need to change them, you should perform that setup step. You need to perform optional steps only if you plan to use the related feature or complete certain business functions.

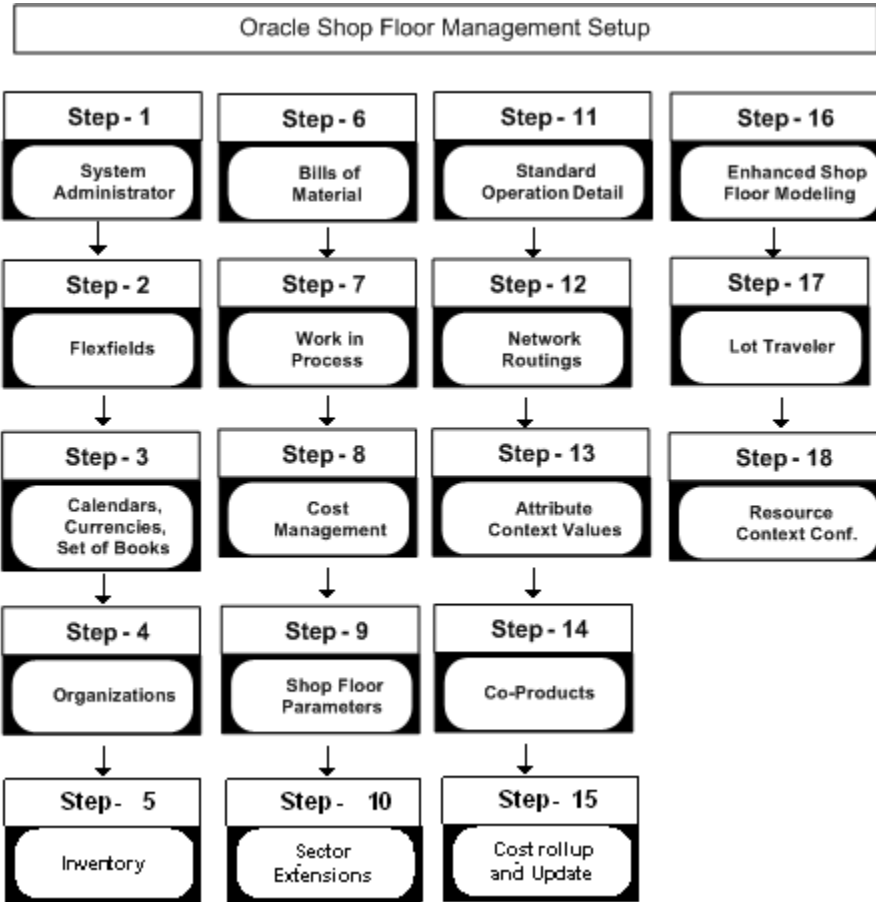

## Setup Checklist

The following table lists setup steps. After you log on to Oracle Applications, complete these required steps to implement Oracle Shop Floor Management.

### *Required Setup Steps*

Step No.	Step
Step 1	Set Up System Administrator
Step 2	Set Up Key Flexfields
Step 3	Set Up Calendars, Currencies, and Set of Books
Step 4	Set Up Organizations



<b>Step No.</b>	<b>Step</b>
Step 5	Set Up Oracle Inventory
Step 6	Set Up Oracle Bills of Material
Step 7	Set Up Oracle Work in Process
Step 8	Set Up Oracle Cost Management
Step 9	Define Oracle Shop Floor Management Parameters
Step 10	Define Sector Extensions
Step 11	Define Standard Operation Details
Step 12	Create Network Routings
Step 13	Define Attribute Context Values
Step 14	Define Co-Products
Step 15	Perform Cost Rollup and Cost Update for Assemblies
Step 16	Enhanced Shop Floor Modeling
Step 17	Lot Traveler
Step 18	Resource Context Configuration

## Setup Steps

### Step 1: Set Up System Administrator (Required)

This step is performed while setting up different Oracle Applications products and involves the following tasks:

- Defining a Responsibility. See: Oracle Application Object Library Security, *Oracle E-Business Suite Security Guide*

- Set up printers (optional). See: *Setting Up Printers, Oracle E-Business Suite Setup Guide*

## **Step 2: Set Up Key Flexfields (Required)**

You need to coordinate the flexfields of other applications you have set up before defining key flexfields here. See: *Oracle E-Business Suite Flexfields Guide*.

## **Step 3 (Required): Set Up Calendars, Currencies, and Set of Books**

This step is performed while setting up different Oracle Applications products. This step involves the following tasks:

- Set up calendars by defining period types, accounting calendar, transaction calendar, and workday calendar
- Define currencies and currency rates
- Assign your set of books to a responsibility
- Set up accounting code combinations

See: *Oracle General Ledger User's Guide*.

## **Step 4: Set Up Organizations**

You may not need to perform this step if you have already installed and set up Oracle inventory or performed a common-applications set up. This step involves the following tasks, for more information.

- Define organization lookups
- Define business groups
- Define organizations
- Define human resources organizations
- Define legal entities organizations
- Set up inventory organizations
- Define organization hierarchies
- Assign business groups and operating units to responsibilities

## Step 5: Set Up Inventory

This step includes defining Oracle Inventory components including:

- Define organizations
- Define items
- Define units of measure
- Define subinventories
- Define stock locators
- Define WIP supply types

**Note:** Organizations for Oracle Shop Floor Management should meet the following conditions: Standard Costing Method, Inventory Parameters Lot Uniqueness set to None, and WIP Parameter Default Lot Number Type set to Job Name.

## Step 6: Set Up Oracle Bills of Material

This step includes defining Oracle Bills of Material components including:

- Define BOM parameters
- Define resources
- Define department classes
- Define your departments
- Define your standard operations
- Create your workday calendar

**Note:** Lot based jobs support operation pull, push, and phantom supply types—other supply types are not currently supported.

## Step 7: Set Up Oracle Work in Process

This step includes defining Oracle Work in Process components including:

- Define WIP accounting classes

The WIP accounting class types used for Oracle Shop Floor Management are *Lot Based Standard Discrete* and *Expense Non-standard Lot Based*. See:

- Define WIP parameters

**Note:** Organizations for Oracle Shop Floor Management should set WIP Parameters Default Lot Number Type to Job Name, and Requisition Creation time to At Operation.

## Step 8: Set Up Oracle Cost Management

This step includes defining Oracle Cost Management components including:

- Define cost types
- Define your default WIP accounting classes for categories
- Define resources, material sub-elements, overheads, and overhead defaults
- Define costs for your item numbers

**Note:** Oracle Shop Floor Management only uses the standard costing method.

## Step 9: Define Oracle Shop Floor Management Parameters

This step defines default values for the transactions you are creating including:

- Designations for lots created
- Designations for jobs completed
- Define accounts for miscellaneous transactions
- Define default WIP Accounting class for lot based jobs and non-standard lot based jobs
- Define co-product supply for lot based jobs
- Define options for Move In, Move Out, and Move To Next\_Op

See: Defining Parameters, page 2-10, and WIP Accounting Classes, *Oracle Work in Process User's Guide*

## Step 10: Define Sector Extension Code

Sector extension codes are associated with assemblies and subinventories. These codes are appended to the job name when the assembly is completed to the subinventory.

**Note:** Subinventories are valid stocking points when they are associated with sector extension codes.

See: Defining and Viewing Lot Sector Extensions, page 2-15.

## Step 11: Define Standard Operation Details

This step defines the steps within an operation that are mandatory, and the location used for stocking points. See: Defining Standard Operation Details, page 2-17.

You can configure Move In, Move Out, and Move To Next Operation based on Standard Operation level or Organization level (see Step 9).

## Step 12: Create Network Routings

In this step you create a network of operations which include primary paths and alternate paths. You can define a separate routing for each item. See: Creating a Network Routing, page 3-4

## Step 13: Define Attribute Context Values

In this step you define context values for Shop Floor Management attributes. See: Setting Up Shop Floor Management Attributes, page 2-19

## Step 14: Define Co-Products

Co-product functionality gives you the ability to define an item as the primary component of several end items; the bill of material of the end items are automatically created. See: Defining Co-Products, page 9-2

## Step 15: Perform Cost Rollup and Cost Update for Assemblies

Oracle Shop Floor Management provides operation yield costing that enables you to include operation yields in the cost rollup of an assembly. This step updates those calculations into the cost of your products. See: Bills and Cost Rollups, *Oracle Cost Management User's Guide*

## Step 16: Enhanced Shop Floor Modeling

Shop Floor Modeling provides configuration for **operator access** and **responsibility**

**exclusions** that enable you to identify yourself and your related responsibilities in a multiple user window.

**Dispatch lists** are configured to your varying requirements. Entries in the scheduled dispatch list are sorted in the scheduled order in which they are picked up for work on that resource.

You can configure Move In, Move Out, and Move To Next Op based on Standard Operation level or Organization level.

The job is put on hold when the yield goes below the lowest acceptable yield set for that operation. **Low Yield** is a situation when the actual scrap quantity in an operation is higher than the quantity derived from the Lowest Acceptable Yield.

Additionally, Shop Floor Modeling provides you with codes and descriptions for **Scrap**, **Bonus** and in case a resource is down.

## Step 17: Lot Traveler

Shop Floor Modeling provides a snapshot of the manufacturing data on the job progress. Specifically on operations, quantity, start and completion dates, and the details the lot has undergone. Additionally it also provides information on future operations.

Lot Traveler is shown in a different way for split and merge transactions. For a split lot, the lot traveler shows only operations that are performed after the split transaction. For a merged lot, the lot traveler shows operations that are performed prior to merge transaction also.

## Step 18: Resource Context Configuration

Shop Floor Modeling also provides Resource Context Configuration. This configuration is based on two context types:

- *Resource based*: 'Resource as a context' enables you to capture and view resource statuses such as Up, Down and Acknowledge Down.
- *Operation based*: 'Operation as a context' enables you to capture and view resource statuses such as Up, Down, and Acknowledge Down. Operation based configurations enable you to view details for all resources defined for that operation.

## Defining Parameters

The Oracle Shop Floor Management parameters define operation movement and default values for the transactions you are creating.

## **Shop Floor Parameters:**

### **To define Shop Floor Management parameters**

1. Navigate to the Shop Floor Management Parameters window.
2. In the Lot Based Jobs region, set the value you want to use when lots are created and completed.
  - In the New Lot Separator field, the default value is a dash character (-) and can be changed to any value. When lots are created, split, or renamed—the resulting lot designation is the original lot number, followed by this value, followed by sequential numbering. See: WIP Lot Transactions, page 5-30, Inventory Lot Transactions, page 5-36

The screenshot shows the 'Shop Floor Management Parameters (M4)' window with the following settings:

- Lot Based Jobs:**
  - New Lot Separator: \*
  - Job Completion Separator: -
  - Default Accounting Class: FAB-WAC-M4 Fabrication
  - Reuse Job Name: Yes
  - Create Job Level BOM and Routing Copies: Yes
  - Undo Last Move:
  - Honor Kanban Size:
  - Co Products Supply Default:
- Accounts:**
  - Estimated Scrap Accounting: Enabled
  - Miscellaneous Transaction Account: 01-514-7740-0000-000
- Transactions:**
  - Enable Inventory Lot Transactions:
  - Jump From Queue: Charge Operation
- Move Options:**
  - Move In: Optional
  - Move To Next Operation: Optional
- Move Out:**
  - Default for Move to Next Operation: Yes

- In the Job Completion Separator field, the default value is a dash character (-) and can be changed to any value. When lots are completed the resulting lot designation is the original lot number, followed by this value, followed by the lot sector extension. See: Create Lot Move Transactions, page 5-14.

**Note:** Do not use the same character value in both the job completion separator, and in a segment of the job name. This creates an error in the resulting lot name.

After you save your work, you can change these values if the jobs have not been completed.

- The Undo Last Move indicator lets you undo the last move transaction. This indicator must be selected for the functionality to be defaulted on the Move Transaction window. See: Create Lot Move Transactions, page 5-14
- Honor Kanban Size parameter is used to determine whether to create a lot based job quantity equal to kanban size when components are pushed from an



inventory lot during kanban replenishment. If this indicator is not selected, then lot based jobs are created for the maximum number of assemblies which can be built using the selected component lot. If the indicator is selected, then the application will honor the kanban lot size.

- In the Co Products Supply Default field, the default value is empty, but can be selected. If the indicator is selected, then planning will take into consideration supply for the co-products.
- In the Default Accounting Class field, enter the accounting class to be used as the default accounting class in the Lot Based Jobs window. If no other rules, like getting the accounting class based on the item or subinventory association, return an accounting class then this default accounting class will be used.
- The Reuse Job Name parameter gives you the option to use an existing job name while creating new lots. You can choose either Yes or No from the list box. You can update this parameter whenever you want. It works independently and does not have any impact on other parameters.

While defining OSFM parameters for a new organization or setting this parameter for the first time for an organization that already has OSFM parameters, it will be defaulted to Yes and you can opt for your choice and save it. See: Overview of Lot Transactions, page 5-2

When the parameter value is Yes, then the sector extension is appended to the job name, when the job is completed or cancelled. When the parameter value is No, it is not appended.

- The Create Job Level BOM and Routing Copies field reflects the setting of the site level profile WSM: Create Job Level BOM and Routing Copies, which is applicable to all OSFM enabled organizations.

**Note:** The WSM: Create Job Level BOM and Routing Copies profile option is no longer updatable and the value is always Yes. This means that copies of BOM and routing are always created at job level.

3. In the Accounts region, enter defaults for estimated scrap and miscellaneous transactions.

- The Estimated Scrap Accounting field is used to disable scrap and operation yield calculations. The default value is Enabled, and the values are as follows:  
*Enabled:* The application calculates Operation Yield Accounting and Estimated Scrap Absorption when creating transactions for lot based jobs. The Scrap Account field is required when defining a department in the Departments window.

*Disabled:* Operation Yield Accounting and Estimated Scrap Absorption are not calculated. The Scrap Account is not a required field in the Departments window; you can enter an account number at the time of the scrap transaction.

**Note:** For an organization, which has Estimated Scrap Accounting enabled, the application defaults the scrap absorption accounts defined in the department for Scrap and Bonus accounts and uses them for Scrap and Bonus transactions in MoveOut page.

For an organization, which has Estimated Scrap Accounting disabled, you should personalize the MoveOut page to enable the accounts region and enter Scrap/Bonus accounts during scrap and bonus transactions.

**Caution:** This action is only for HTML UI and there is no change for Forms UI.

- In the Miscellaneous Transactions Account field enter the account to be used when issuing or receiving material.
4. In the Transaction region, set the value you want to use when the transactions are complete.
- If you do not have Oracle Warehouse Management installed, select the Enable Inventory Lot Transactions indicator. This indicates that the Oracle Shop Floor Management Inventory Lot Transactions API is used for importing transactions into Oracle Applications.
  - If Oracle Warehouse Management (WMS) is installed, then Warehouse Management System users are encouraged to use WMS for Inventory Lot Transactions. You can run these transactions through the Warehouse Management System mobile (RF) user interface. You can view Inventory Lot Transactions performed in Warehouse Management in the Lot Genealogy window.
  - The Jump from Queue field is used to specify if material, resources and overhead charges of an operation are to be charged when you jump from queue of the operation. The default value is Charge Operation.

*Ignore Operation:* Ignores the operation, therefore material resources and overhead charges at the From operation are not charged.

*Charge Operation:* Materials, resources and overhead is charged at the From Operation.

5. In the Move Options region, set to Optional or Always for Move In and Move To Next Op fields.
  - The Move In transaction is used to move a lot from Queue intraoperation to Run intraoperation, where the lot will be picked up and worked on.
  - Move To Next Op transaction enables you to transfer a lot from the To Move intraoperation to the Queue of the next operation.

If your Organization requires tracking Move In and Move To Next Op, then you can choose them from your system.

*Always:* Move In or Move To Next Op is a required step for every operator.

*Optional:* If Move In is Optional, you can choose to perform the Move In or directly perform the Move Out transaction. If Move To Next Op is Optional, during Move Out transaction, you can either stay at the current operation or move directly to the next operation.

*Never:* Move In or Move To Next Op is never performed and is covered by Move Out transaction.

6. In the Move Out region, set the default value to either Yes or No.
  - The Move Out field reports completed work and results, while transferring a lot from the Run intraoperation to To Move intraoperation or next operation Queue intraoperation.
  - If Move To Next Op is Yes, then moving to next operation as part of Move Out transaction defaults to Yes, otherwise by default it stays in the current operation (No).
7. Save your work.

## Defining and Viewing Lot Sector Extensions

A different item number is associated with the lot for each stage on the shop floor. The relationship between the item numbers for these different stages is stored in a multilevel bill of material. A lot sector is a level of the bill that converts Inventory lot components into a lot based job. When the job is completed it becomes an Inventory lot for the next lot sector.

**Note:** The profile option WSM: Complete Job Sector Lot Extension Level defines the extension appended to the lot sector. See: Profile Options, page 2-21

**To define and view the Lot sector extension codes:**

1. Navigate to the Sector Extensions and Item/Subinventory Association window.

The Find Sector Extension window displays. You can query lot sector extensions by subinventory name, item name, or both.

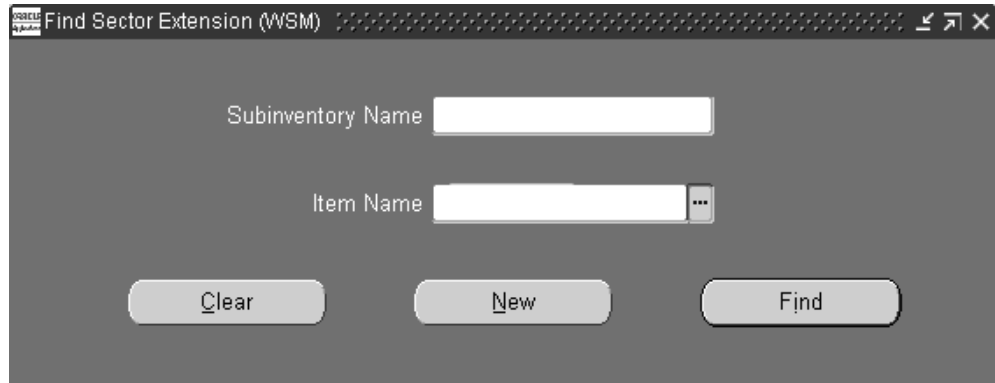

The screenshot shows a window titled "Find Sector Extension (WSM)". It contains two text input fields: "Subinventory Name" and "Item Name". Below the input fields are three buttons: "Clear", "New", and "Find".

2. If you are searching for an existing lot sector extension, enter search criteria and choose Find. Choose New to create a new record.

The Sector Extension and Item/Subinventory window displays.

3. Enter a unique value in the Sector Extension Code field, and a description.

Sector Extension Code **ASSY** Assembly

Accounting Class **WAC-C** WAC-C for WSM

Item Subinventory

Item	Description
WSM-EndProd	End Product for WSM
WSM-FG	Finished Good
WSM_ITEM_D	WSM_ITEM_D
DEMO-WSM-FG1	Demo WSM Finished Good
WSM_ITEM_E	Test BDM for WSM
AS-ASS-C1	Assembly from AS-ASS-B1

4. Select an accounting class from the Accounting Class Code list of values window.
5. In the Item tab, select the item numbers to assign to this lot sector.
6. In the Subinventory tab, select the subinventory location associated with this sector extension. See: Assigning Items to a Subinventory., *Oracle Inventory User's Guide*
7. Save your work.

**Note:** Subinventories are valid stocking points when they are associated with sector extension codes. An item or subinventory is associated with only one sector extension.

## Defining Standard Operation Details

Operation code information for standard operations is defined on the Standard Operation Details window. This window sets the intraoperation steps that are mandatory and subinventory location used as the stocking point.

**Note:** The fields in the Operation Details form have been moved to

BOM Standard Operation form and it has been obsolete.

**To define standard operation:**

1. Navigate to the Standard Operation window.
2. Select an operation code in the Standard Operation field.

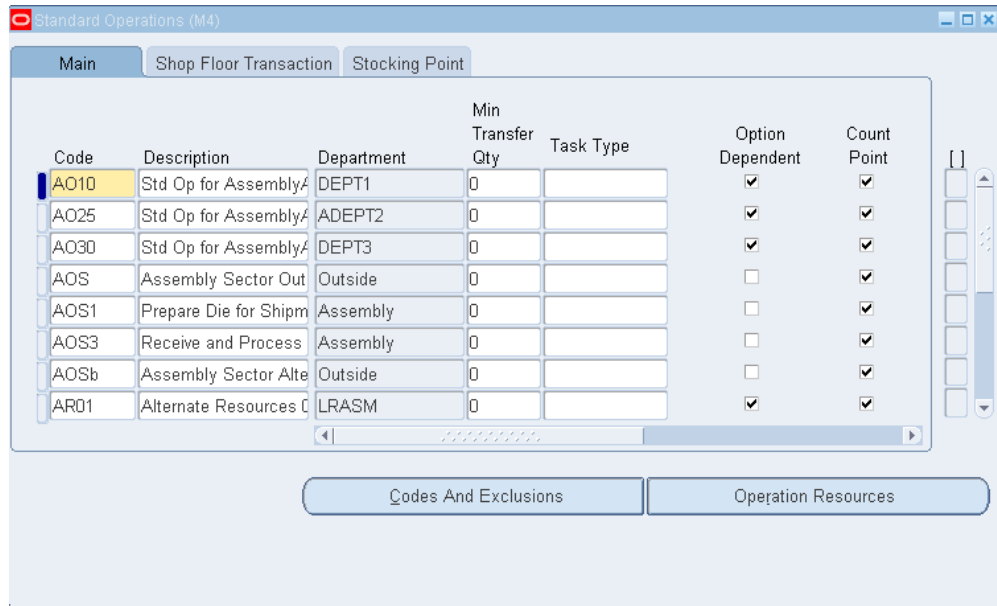

3. Select Main tab to enter Description, Department, Minimum Transfer Quantity and Task Type. Check the fields that are mandatory for your operation.
4. Select Shop Floor Transaction tab. Check the steps that you want as mandatory within an operation. See: *Intraoperation Steps, Oracle Work in Process User's Guide*.

**Note:** For Shop Floor UI, checked implies mandatory and unchecked implies optional, while for WIP Parameters intraoperation setup, checked implies allowed (optional) and unchecked implies disallowed (never). Also, note that it is a standard operation-level setup in Shop Floor, whereas WIP Parameters setup is at organization level.

5. Select Stocking Point tab Subinventory field, select the default location that completed material from this operation that is to be placed.  
If this subinventory is locator controlled, the Stock Locator field is enabled.
6. Choose Codes and Exclusions to enter Bonus Codes, Scrap Codes and

Responsibility Exclusions for this operation.

**Note:** The Code that appears here is the Meaning of the Code that you have defined in the Lookup windows of Resource/Scrap/Bonus Downcodes.

Minimum Transfer Quantity is not relevant for lot based jobs.

7. Choose Operation Resources to add resources and details on scheduling and costing for the resource.
8. Save your work.

## Attaching Files to Job Operations

You can attach explanatory files, such as text, images, spreadsheets and video files to lot-based job operations. If you define the attachment to the operation in the Standard Operations window, then it is linked to the routing when created in the Routing Network window. You can delete and add new files as required.

**Note:** Similar type of attachments can be done for jobs also.

When a job is created in the Lot Based Job window, the attachment of the first operation is automatically copied from the network routing. Attachments are also copied from the network routing during lot move transactions, splitting lots, and updating routings or assemblies. If you are performing an operation jump in a network routing, attachments are copied from the operation as defined in the Standard Operations window.

**Note:** Until Patchset H, the first and last operation is copied into the job. Going forward, only the first operation is copied into a Lot Based Job.

## Related Topics

Attachments, *Oracle E-Business Suite User's Guide*.

Attaching Files to Jobs, Schedule, and Operations, *Oracle Work in Process User's Guide*.

## Setting Up Shop Floor Management Attributes

Lot attributes are key information elements that you can track with lot numbers. There are many attributes that you can track using Shop Floor Management. Lot attributes are entered as descriptive flexfields, and you can track attributes by item, and define attributes for validation requirements.

See: Set Up Item Attributes, *Oracle Warehouse Management User's Guide*.

Lot and Serial Attribute Setup, *Oracle Warehouse Management Implementation Guide*.

### **Lot Attributes:**

#### **To define lot attribute context value**

1. Navigate to the Descriptive Flexfield Segments window.
2. Select the flashlight icon from the tool bar, and then select the Oracle Inventory Application with the Title, Lot Attributes.
3. Unfreeze the Flexfield Definition by deselecting the Freeze Flexfield Definition indicator.
4. In the Context Field Values region, select a row, then click the New icon. A blank row is added for you to create an attribute group.
5. Enter the attribute group name in the Code field.
6. Optionally, enter a Description for this attribute group.
7. Select Segments to add attributes to the attribute group you just created.
8. Enter a Number to sequence the data.
9. Define the Name of the specific attribute. The Window Prompt defaults to this name.
10. Select a Column value.
11. Select a Value Set, or optionally, choose New to create a new one.
12. If the Displayed indicator is selected, then this attribute appears for you when defining data for an asset within the Asset Group (for example, CARS) associated with the attribute group (for example, NAMEPLATE) that this attribute (for example, Make) resides in.
13. Optionally, select the Enabled indicator to enable the attribute for availability when defining assets.
14. Save your work, and return to the Descriptive Flexfield Segments window.
15. Select the Freeze Flexfield Definition indicator. Failure to do this prevents you from querying the segments from the Attribute window.
16. Save your work.



You can capture attributes of a Work in Process (WIP) lot during job execution. See *Capturing Attributes*, page 5-51.

17. Choose Submit to run the report.

## Profile Options

During your implementation, you set a value for the profile option used in Oracle Shop Floor Management to specify how the application controls access and processes data.

Generally, your system administrator sets up and updates profile option values. The *Oracle Applications System Administration User's Guide* contains more information on profile options.

The table uses the following values to describe profile option controls for columns *User*, *System Admin User*, *System Admin Resp*, *System Admin App*, and *System Admin Site*:

- **Yes:** You can update the profile option.
- **View Only:** You can view the profile option value in the Profiles window, but you cannot change it.
- **No:** You cannot view or change the profile option value.

The table displays the recommended settings for these profile options.

Profile Option	User	System Admin. User	System Admin. Resp.	System Admin. App.	System Admin. Site	Required	Default Value
WSM: Allow Operation Jumps	View Only	Yes	Yes	Yes	Yes	Optional	Yes
WSM: Complete Job Sector Lot Extension Level	View Only	View Only	View Only	View Only	Yes	Optional	

Profile Option	User	System Admin. User	System Admin. Resp.	System Admin. App.	System Admin. Site	Required	Default Value
WSM: Maximum Number of Import Lot Job Workers	View Only	View Only	View Only	View Only	Yes	Optional	10
WSM: Maximum Number of Rows Processed By a Lot Based Job Worker as a Batch	Yes	Yes	Yes	Yes	Yes	Optional	1000
TP: WSM: Open Interface Successful transactions archive days	Yes	Yes	Yes	Yes	Yes	Optional	365

## WSM: Allow Operation Jumps

Controls whether operation jumps can be performed in the Move Transactions window.  
User Values are:

- *Yes*: Enables you to skip operations or jump to any standard operation defined in the network routing
- *No*: You are not allowed to skip operations or jump other operations in the network routing

### **WSM: Complete Job Sector Lot Extension Level**

Controls whether to use the Item level or Subinventory level sector extension when a job is completed. See: Defining and Viewing Lot Sector Extensions, page 2-15 User Values are Item or Subinventory:

- If a sector lot extension is defined at both Item and Subinventory level, and this profile is set to Subinventory, the job appends the sector lot extension from the subinventory.
- If the profile is set to Item or is not defined, the job appends the sector lot extension from the item level.

### **WSM: Maximum Number of Import Lot Job Workers**

Controls the maximum number of workers that can be launched in parallel to process the Lot Based Job Import records.

### **WSM: Maximum Number of Rows Processed by a Lot Based Job Worker as a Batch**

Controls the maximum number of rows in the Lot Based Job Import interface that can be processed as a batch by each worker launched to import lot based jobs.

### **WSM: Open Interface Successful Transactions Archive Days**

Controls when the Move processor deletes the successfully processed lot move interface rows. User Value defaults to 365 Days. User Values are entered in Days.



---

## Network Routings

This chapter covers the following topics:

- Overview of Network Routings
- Creating a Network Routing
- Modifying Network Routings
- Importing Routings
- Defining Alternate Resources for Standard Operations
- Defining Operation Yield Values on Routings
- Calculating Lead Times
- Integration with Advanced Supply Chain Planning
- Integration with Outside Processing

### Overview of Network Routings

Network routings in Oracle Shop Floor Management, comprise all possible operations defined for manufacturing a particular assembly. While discrete jobs use standard routings, lot based jobs use network routings. The primary feature of network routings is, based on the results of an operation, to define different paths for the next operation. However, there must be a unique start and last operation defined in the network. When this information is captured, a network of operations is available for processing a lot based job on the shop floor.

You define two major aspects to create this functionality. First, all the possible allowable operations are defined in the Oracle Shop Floor Management Routings window as shown in the following illustration. Operation yield information for costing updates is also defined in the Operation Yield tab of this window.

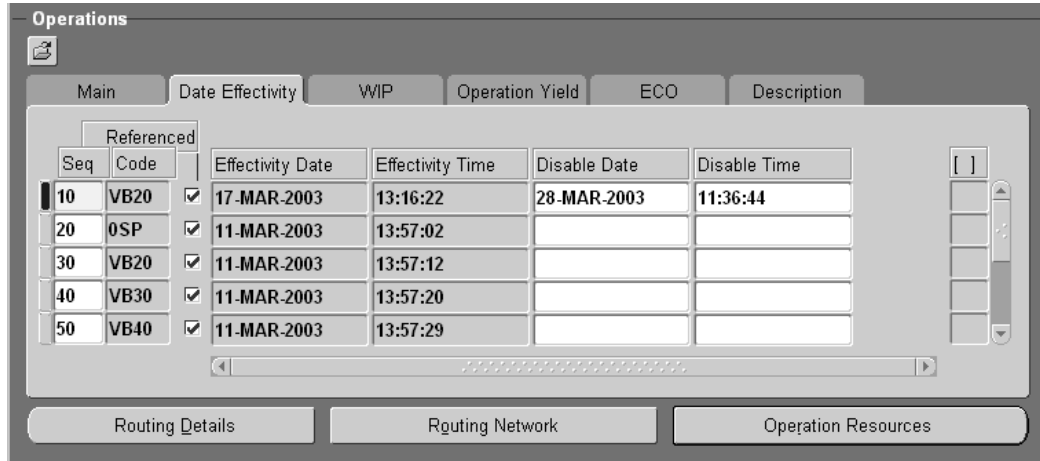

Next, the network operations are defined in the Routing Network window. Here the primary and alternate paths are outlined, and the percentage each is likely to be used. This percentage is used by Advanced Supply Chain Planning.

The combination of definitions provides for dynamic, flexible operation of a job. There are numerous possibilities in executing a routing and any one of these can be based on the outcome of the last operation performed. However, there must be a unique starting operation and a unique ending operation in the entire network.

As seen in this illustration, the first example shows the Network—that is, the entire network of the routing and all operations that the WIP Lot can use.

### Network Relationships

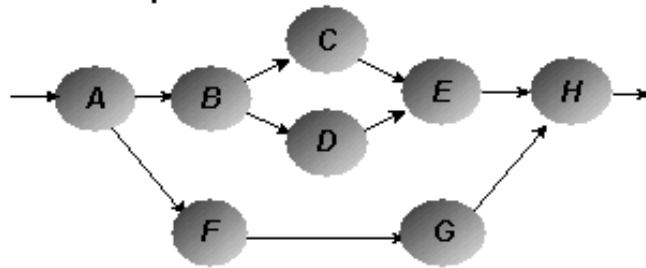

### Primary Path

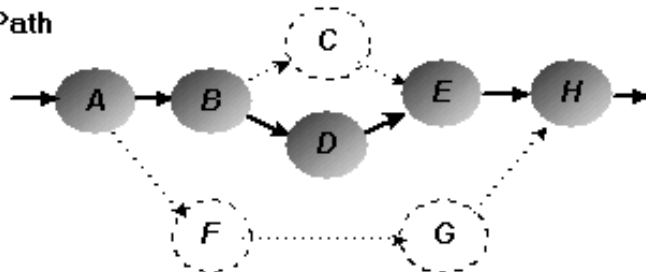

### Actual Completion Path

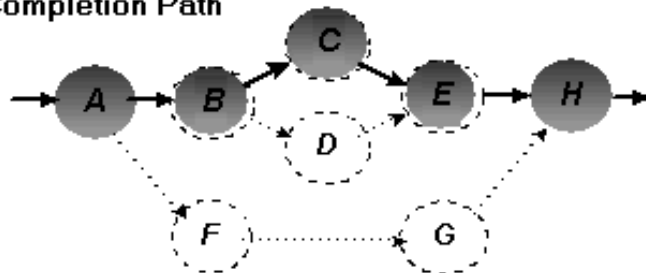

The next example—Primary Path—shows the main path that a job is most likely to follow.

And the third example—Actual Completion Path—shows the real route a particular job moved. This path could be the primary path or any of the other valid paths defined in the network. In the illustration, the job deviates from the primary path after operation B, and moves to operation C instead of D.

Once a complete network routing is defined for a sector, a WIP lot begins at the first operation of the network. As the job completes the first step, you select the next operation in the network. This can be the operation on the primary path, or any valid alternate paths. The process continues until the job reaches the last step when the job is completed.

## Creating a Network Routing

The network routing defines different paths for the next operation. Oracle Shop Floor Management enables you to use both standard and non-standard operations in network routings, and supports repeating operations—standard and non-standard.

### To create a network routing

#### To create a network routing:

1. Navigate to the Routings window in the Oracle Shop Floor Management menu and enter information to define this item's routing.

This includes item number, alternate routing designator, revision, operation sequence, operation code, department, effective date, effective time, disabled date and disabled time. See: *Creating a Routing, Oracle Bills of Material User's Guide*.

**Note:** When jobs are moved through network routing or WIP lot transactions are performed, Oracle Shop Floor Management considers an operation effective if the job's routing revision is greater than or equal to the operations effective date and less than or equal to its disable date if defined. In addition, a component is considered as effective if its effective date is less than or equal to the job's BOM revision date.

The operation sequence numbers entered for each operation in this window do not signify the order of the particular operation in Oracle Shop Floor Management. The actual operation sequencing is built as you choose the operations based on the network path.



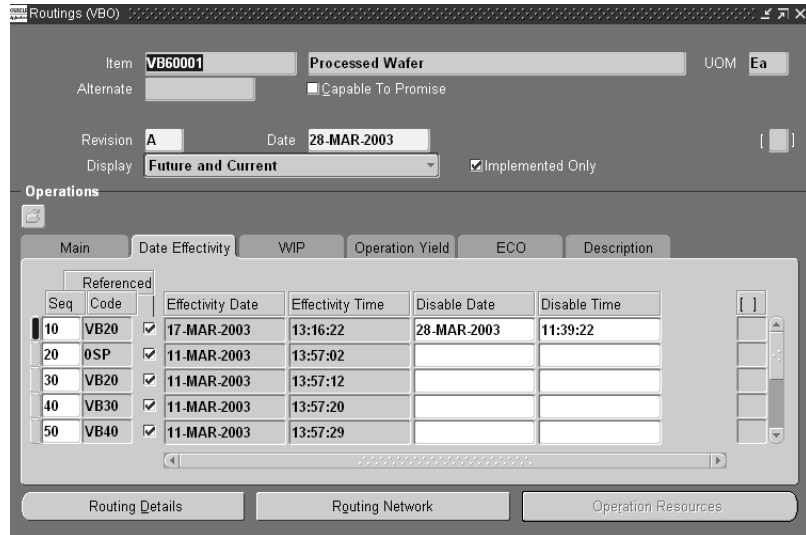

2. Choose Routing Details to enter completion subinventory and locator information, or to view a common routing.

The completion subinventory defaults from the stocking point of the last operation. See: Completion Subinventory and Locator Fields, *Oracle Bills of Material User's Guide*..

You can unreference a standard operation at this time. This lets you enter more resource information for that particular operation. You can also enter any alternate resources or additional resources by unreferencing a standard operation.

3. Save your work.
4. Choose Routing Details to enter the Serial Start Operation.

This operation is defaulted to the lot based job. If the routing is defined for a Lot and Serial Controlled Assembly, then Serialization Start Operation Sequence should be specified in the Routing Details window.

5. Choose Routing Network.

The Routing Network window displays the assembly item number and alternate number.

**Note:** If you do not save your record in the Routings window, then you cannot enter data on the Routing Network window.

From Seq	Code	From Op Description	From Dept	To Seq	Code	To Op Description	To Dept	Primary or Alternate Path	Planning %
10	PB10	Load Probe Machine	Probe	20	PB20	Probe Machine	Probe	PRIMARY	90
10	PB10	Load Probe Machine	Probe	80	DG01	DG osp op 1	dg_osp_d1	ALTERNATE	10
20	PB20	Probe Machine	Probe	30	PB30	Unload Probe Machi	Probe	PRIMARY	100
30	PB30	Unload Probe Machin	Probe	40	PB40	Review Probe Result	Probe	PRIMARY	100
40	PB40	Review Probe Results	Probe	50	PB45	Re-Probe	Probe	ALTERNATE	20
40	PB40	Review Probe Results	Probe	60	PB50	Disposition Probe	Probe	PRIMARY	80
50	PB45	Re-Probe	Probe	70			Probe	ALTERNATE	100
70			Probe	60	PB50	Disposition Probe	Probe	ALTERNATE	100
80	DG01	DG osp op 1	dg_osp_d1	60	PB50	Disposition Probe	Probe	ALTERNATE	100

6. Select or enter operation sequence information.  
 For standard operations, select the operation sequence code in the From Sequence field—operation code, description, and department automatically display.  
 For non-standard operations, enter the operation sequence code in the From Sequence field—the department automatically displays.
7. Select the operation sequence code in the To Sequence field—operation code, description, and department automatically display.
8. Select either primary or alternate path for this operation.  
 Primary indicates that this is a routing path used most often, while alternate indicates that it is used as a backup. This window validates that the primary path is a complete chain of operations from start to end.  
 You can have only one unique primary path. Loops are not permitted in the primary path but are in the alternate paths.
9. In the Planning % field, enter the percentage that this path is used.  
 Percentages for all the paths—originating from any node in the routing network, or ending on any node—must total 100 percent.
10. Repeat Steps 5 through 7 for all the operations in the routing network.  
 Only one first operation and one last operation are allowed in the routing network.
11. Save your work.

**To specify serialization start operation sequence:**

1. Navigate to the Network Routing window.
2. Choose Routing Details.

3. Specify serial start operation in Serialization Start Op Seq field.

The screenshot shows a software window titled "Routing Details (M4)". The window contains several input fields and sections:

- Item:** CJ-ASSY11
- Alternate:** (empty)
- Product Family:** (empty)
- Assembly - Lot/Serial:** (empty)
- Priority:** (empty)
- Serialization Start Op Seq:** 10
- Completion:**
  - Subinventory:** FABSUB
  - Locator:** (empty)
- Comment:** (empty text area)
- Common Routing:**
  - Item:** (empty)

### To define an operation effectivity:

Navigate to the Routings window.

1. Enter information to define this item routing.
2. Select the Date Effectivity tabbed region.
3. For the first operation sequence, select a Disable Date and Disable Time

**Note:** The effectivity of an operation in a routing is determined by the job routing revision date, rather than the transaction date.

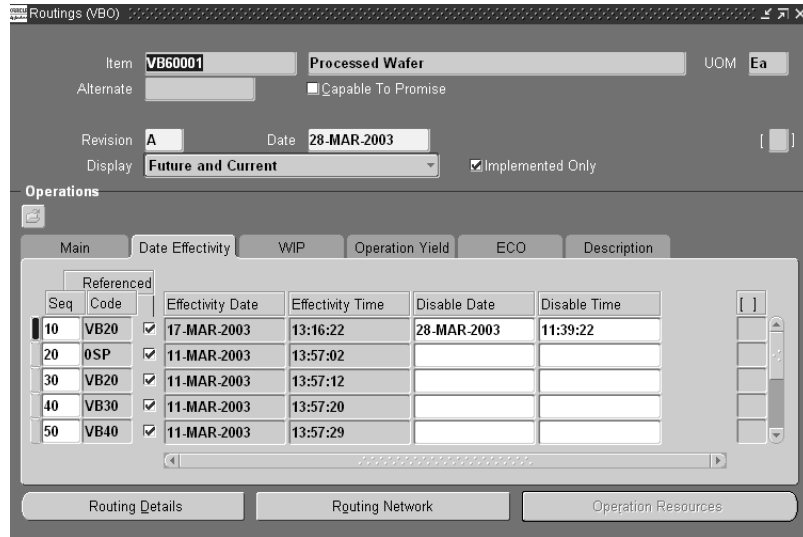

4. Save the change before enabling the new operation.
5. Enter the Effective Date for the new operation.
6. Save your work.
7. Choose Operation Resource to view the details on resource and resource usage at this operation.

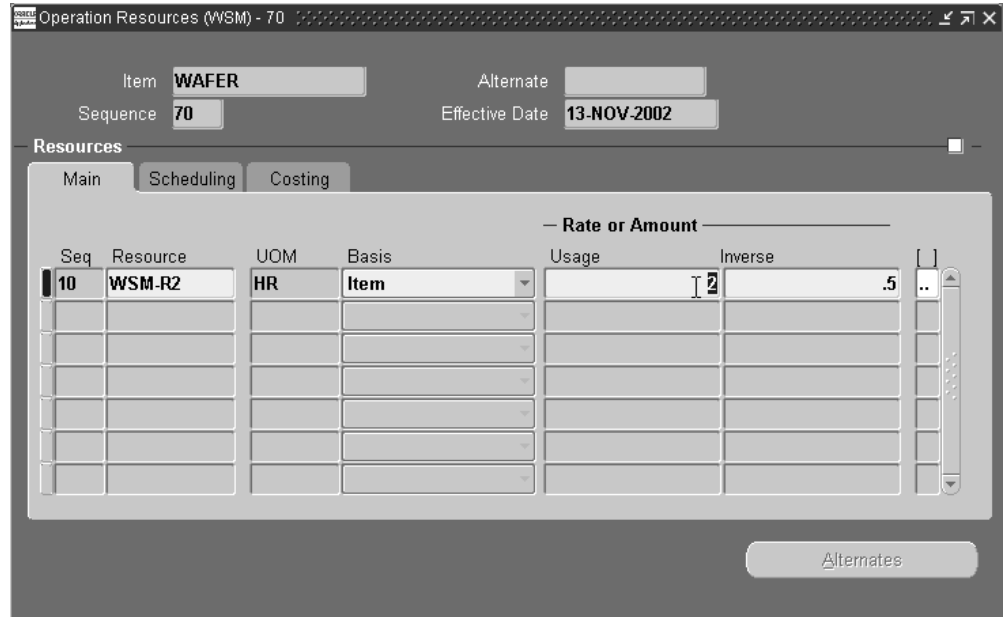

8. Navigate to the Bills of Material window.
9. Select values in the From and To Effectivity Date fields for the first component.
10. Select values in the From and To Effectivity Date fields for your new component.
11. Save your work.

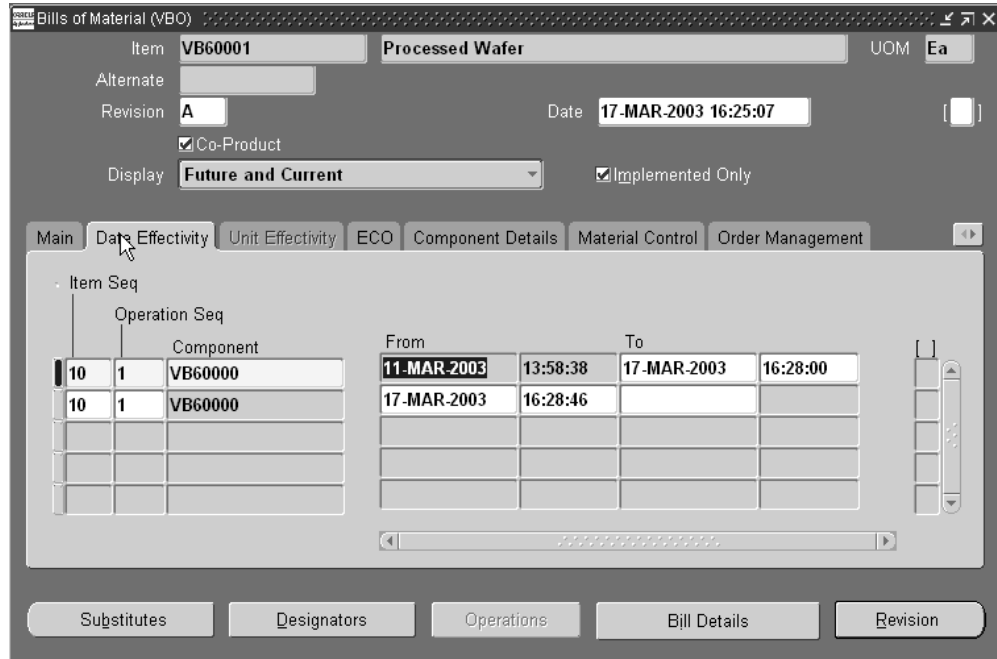

12. Navigate to Lot Based Jobs window.

Operation Effectivity and the Component Effectivity defined earlier can be seen when you create a lot based job using the revision date for the routing or Bill of Material.

If the system date is greater than the job start date, then the system date is used for the routing revision date and the BOM revision date

You can change this system default date to any date to implement the operation or component effectivity.

13. Save your work.

**Note:** Lot based jobs explode the material and resource requirement for the first operation only. At the time of job creation, the BOM revision and routing revision is copied into the job and the material.

## Restrictions

**Note:** If you enter job completion date and not BOM revision date, then the BOM revision date will be defaulted with the completion date.

## Modifying Network Routings

You can modify network routings in several different ways:

### To add or modify a network routing:

1. Navigate to the Routings window in the Oracle Shop Floor Management menu.
2. If you are adding a new operation, enter this operation in the Main tab of the Routings window.

3. Save your work.
4. Choose Routing Network.  
The Routing Network window displays with the assembly item number and network.
5. Modify networks per your new requirements. Paths that are not required can be deleted— with the exception of the first or last operation of a network routing.
6. Save your work.

#### **To delete network routing paths:**

1. Navigate to the Routing Network window.

Select the routing path you want to delete, and choose delete from the Edit menu.

Delete Standard operations from a routing in the Standard Operations window. See: Operations, *Oracle Bills of Materials User's Guide*.

You must enter a delete group before deleting operations from a network routing. In addition, if an operation from a network routing is being made ineffective or deleted, then OSFM checks for current jobs at that operation and displays a caution message if appropriate.

2. Save your work.

**Note:** You are not allowed to delete the first or last operation of a network routing, and the last operation of a network cannot be changed. Therefore, it is recommended that you model the last operation as a dummy operation to leverage and maximize the power of network routings.

## **Importing Routings**

### **Importing Operations in a Network Routing**

The Routing Open Interface program enables you to import routing information. Imported routing details include routing revision, operation, instruction, and resource information. See: Importing Bills and Routings, *Oracle Bills of Material User's Guide*.

### **Importing Network Routings**

You can import complete network routings and the primary and alternate network path definitions using Open Interface Tables. The BOM Business Objects API performs the



necessary validations for network paths. You can also update the existing operations with the routing effectivity date changes, or implement time phased yield values for different operations of a routing. See: Bills of Material Business Object Interface, *Oracle Manufacturing APIs and Open Interfaces Manual*.

## Related Topics

Primary and Alternate Routings, *Oracle Bills of Material User's Guide*

Routing Revisions, *Oracle Bills of Material User's Guide*

Operations, *Oracle Bills of Material User's Guide*

Creating a Routing, *Oracle Bills of Material User's Guide*

Completion Subinventory and Locator, *Oracle Bills of Material Users Guide*

## Defining Alternate Resources for Standard Operations

You can define alternate resources while defining standard operations. Standard operations contain the alternate resources. Alternate resources connect to primary resources using a substitute group number. When an operation is referenced in the network routing, the application copies the alternate resources and primary resources to the routing operation. Oracle Advanced Planning also uses this data while planning for operations.

You can also assign substitute group numbers and replacement group numbers. See: Assigning Operation Resources, *Oracle Bills of Material User's Guide*.

### To define alternate resources for standard operations:

1. Navigate to the Standard Operations window.
2. Select an operation and choose Operation Resources. The Resources window appears.

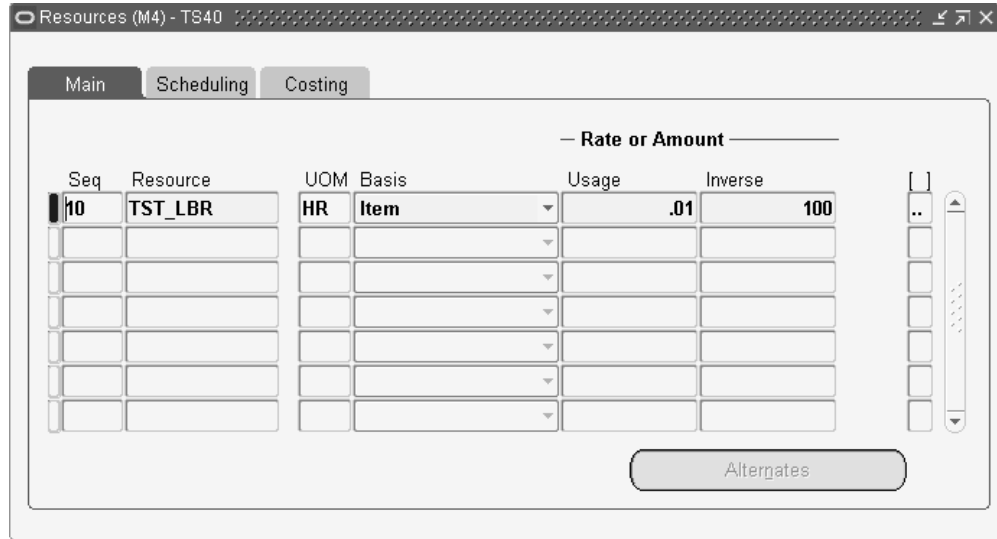

3. Choose Alternates. The Operation Alternate Resources window appears.

4. Select the resource Name.

You can add any resource that is assigned to the department of the operation you have selected. You can also add any multidepartmental resource.

5. Select a resource Basis. The options are as follows:

**Item:** Charge and schedule the resource on an item-by-item basis. Select Item when resource times and costs are dependent on the job or schedule quantity, such as when charging per unit labor costs.

**Lot:** Charge and schedule the resource on a one per job or schedule basis. Select Lot when resource times and costs are independent of quantity, such as when setting up a machine to run an entire job.

You cannot update the resource basis if you have charged against the resource.

6. Enter the Usage Rate or Amount Value or Inverse.

**Value:** Enter a Value if you know how much of the resource is consumed at the operation (per item or per lot) given the resource UOM. For example, if your manufacturing process consumes a mold (resource UOM=Ea) for every 5 items produced, enter a Value of 0.2 (1/5). When you enter the Value of 0.2, the Inverse is automatically calculated as 5. In other words, producing one unit consumes 0.2 of the mold.

**Inverse:** Enter an inverse amount if you know the number of units a resource can process given the resource UOM. For example, if you can process 10 units on a lathe (resource UOM = HR) in an hour, enter an inverse amount of 10. When you enter the inverse amount of 10, the value is automatically calculated as 0.1 (1/10). In other

words, each unit takes 0.1 hours to process.

You cannot enter a quantity less than zero for resources with time-based units of measure. When you enter the usage rate or amount, the inverse usage rate or amount is automatically supplied.

7. Save your work.

## Defining Operation Yield Values on Routings

### To define yield values on a routing:

1. Navigate to the Routings window and enter the item number.

This includes item number, alternate item number, revision, display option, operation sequence, operation code, department, and date ranges, see: *Creating a Routing, Oracle Bills of Material User's Guide*.

Seq	Code	Yield	CUM Yield	Reverse CUM Yield	Net Planning %	Include In Rollup
10	FB10	.9	.9	.4212	100	<input checked="" type="checkbox"/>
20	FB20	.8	.72	.48	80	<input checked="" type="checkbox"/>
30	FB25	.7	.63	.42	20	<input type="checkbox"/>
40	FB30	.6	.4212	.6	100	<input checked="" type="checkbox"/>

2. Choose the Operation Yield tab.

The values you entered for operation sequence and operation code number are displayed in this tab.

3. In the Yield field, enter a value for component yield for first operation.

This is the percent of the amount of a component required for an assembly plus the amount lost while building an assembly. For example, a yield factor of 0.90 means

that only 90% of the usage quantity of the component on a bill actually becomes part of the finished assembly.

4. Check the Include in Rollup check box if you want the items, resources, and overhead in this operation to be included in the cost rollup. Otherwise leave the box unchecked.

The Include in Rollup check box defines if the operation is going to be included in the standard cost rollup. All operations, both primary and alternate, are defined on this form. You do not want all operations, both primary and alternate, to be included in the standard cost. When checking the box, make sure you want that operation to be included. If all operations are checked, including operations in the alternate paths, this would lead to an exaggerated standard cost and could create large variances.

Ideally, you should check the Include in Rollup flag for all operations on the primary path.

**Note:** Oracle Shop Floor Management only uses the standard costing method.

5. Select the Operation Yield indicator if you want this operation's yield to be calculated.
6. Repeat steps 3 through 7 for all the operations in the routing.
7. Save your work.

#### **To calculate cumulative yield and reverse cumulative yield:**

1. Navigate to the Routings window and enter the item number.
2. Choose the Operation Yield tab.
3. Select Calculate Operation Yields from the Tools menu.

This will calculate cumulative yield and reverse cumulative yield for the routing. When the calculations are computed, a note will appear letting you know the process is complete. Choose OK in the Note window. The CUM Yield, Reverse CUM Yield, and Net Planning % fields are then populated.

4. Save your work.

## **Calculating Lead Times**

You can calculate Manufacturing Lead Times and roll up Cumulative Lead Times from the Tools menu of the Routings form.

When you choose the responsibility: Shop Floor Manager, the Network Routings form will have two options such as Compute Lead Times and Rollup Lead Times by default in the Tools menu.

**Note:** You need not do any customizations to use these options. They appear by default. However, to remove these options from the default settings, switch to System Administrator responsibility and query on Shop Floor Manager responsibility. In the Function field of the Menus form, add Routings: LeadTimes followed by Bills of Material: LeadTimes. Save the form. Navigate to Routings form in the Oracle Shop Floor Management menu to continue your operation without these options in the Tools menu.

## Computing Lead Times

You can use this option to calculate manufacturing lead times for the selected item in the Network Routings form. The calculation updates the lead time attributes of this manufacturing item, irrespective of whether you manually maintain this item's lead times or not. Changes to routing and resource usages can impact an item's lead times. After each change you make to a routing (adjusting usages, adding operations, etc.), recalculate the manufacturing lead time for the item.

### To compute lead times

1. Navigate to the Routings window
2. Click Tools menu to select Compute Lead Times

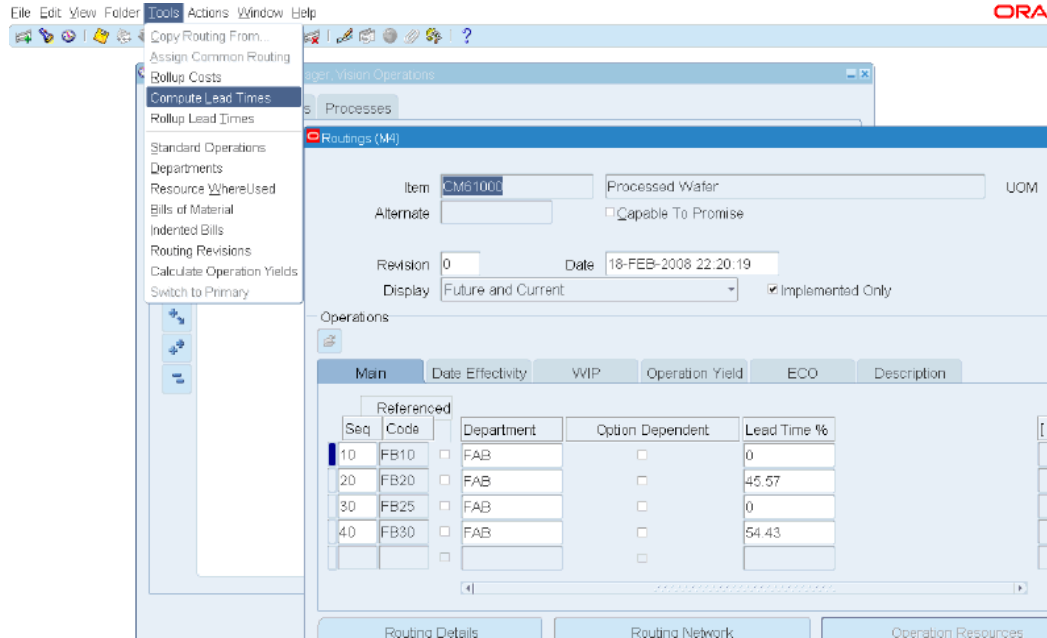

**Caution:** Lead time for items with network routings is calculated using resources only on the primary path, although this may not be the path with the least lead time.

## Rollup Lead Times

You can use this option to roll up the cumulative lead times after every change made to a bill (adding components, assigning to a different operation, etc.) or the item lead times. Changes to the indented bill of material and component lead times can impact a parent item's cumulative lead times.

1. Navigate to the Routings window
2. Click Tools menu to select Rollup Lead Times

**Note:** This option is also available in the Tools menu of the Bills of Material form.

## To calculate Manufacturing Lead Times and roll up Cumulative Lead Times using the concurrent request:

You can also calculate Manufacturing Lead Times and roll up Cumulative Lead Times for the same item (and more items) by using the concurrent request.

1. Navigate to Shop Floor Manager, Vision Operations: Manufacturing Manager

2. Double click Bills of Materials
3. Double click Routing
4. Click Lead Times
  - Submit a New Request page appears
5. Select your option of Single Request or Request Set and click OK
  - Calculate Lead Times page appears.
6. Select Calculate Manufacturing Lead Times GUI from the list of values in the Names field to calculate Manufacturing Lead Times
7. Select Rollup Cumulative Lead Times GUI to roll up Cumulative Lead Times

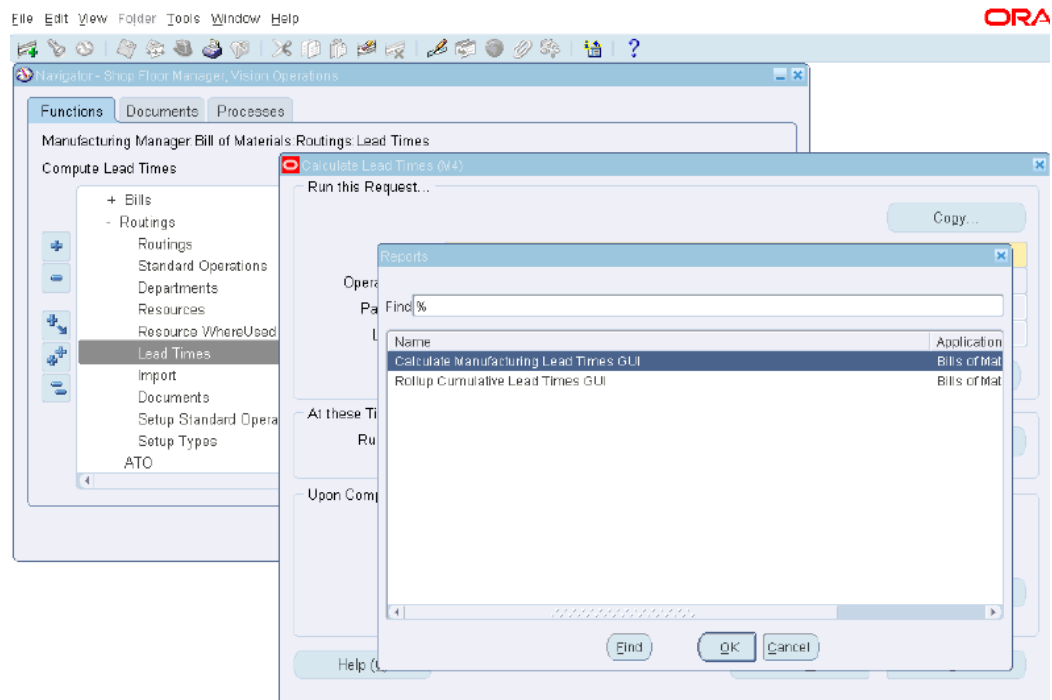

**Important:** For all scheduled time elements, which are less than the standard workday, the system will compute the lead time day by dividing the lead time element by 24. Note that all the Item Lead Time attributes are in days. The standard workday is defined in the workday calendar.

## Lead Time Settings in Network Routings form

When computing manufacturing lead times, operation and resource offsets are automatically assigned to a routing.

### Lead Time Percent:

Optionally, you can enter the item's manufacturing lead time percent required to complete all previous operations on the routing. For example, if the manufacturing lead time equals 10 days and all previous operations combined require 2 days, the lead time percent for the current operation is 20%.

The screenshot shows the 'Routings (M4)' form with the following details:

- Item: AS80000, Final Chip Assembly, UOM: Ea
- Alternate: Alternate1, Capable To Promise:
- Revision: 0, Date: 08-JAN-2008 12:05:32
- Display: Future and Current, Implemented Only:

The 'Operations' section includes a table with the following data:

Seq	Code	Department	Option Dependent	Lead Time %
10	AS10	<input checked="" type="checkbox"/> Assembly	<input type="checkbox"/>	
20	AS20	<input checked="" type="checkbox"/>		
30	AS30	<input checked="" type="checkbox"/>		
40	AS40	<input checked="" type="checkbox"/>		

The 'Operation Resources (M4) - 10' window shows the following resource details:

Seq	Resource	Available 24 Hours	Schedule Seq	Group Number	Assigned Units	Schedule	Offset %	Principal Flag	Setup Type
10	ASM_LBR_1	<input type="checkbox"/>	10		1	Yes		<input type="checkbox"/>	

### Offset Percent:

For example, a value of 50 means that you utilize the resource when the routing is 50% complete. This value is automatically calculated when you compute the lead time for the assembly.

## Integration with Advanced Supply Chain Planning

Integration with Advanced Supply Chain Planning can be accomplished using one of the following methods:

- The primary path
- Cumulative percentages



- Deriving the percentages based on resource availability

With the primary path method, orders are scheduled on the primary path. The cumulative percentages method takes advantage of the pre-calculated accumulated percentages from various paths on the network routing to guide scheduling. The third method, derives percentages based on resource availability, analyzes the current conditions on the shop floor and intelligently chooses alternate paths and determines the quantity which needs to be processed on each path.

The reverse cumulative yields specified at the operation sequence level are captured in a snapshot by Advanced Supply Chain Planning and used to derive the component requirements. Advanced Supply Chain Planning loads resources using the inflated quantities derived from reverse cumulative yields at different operation sequences.

## Related Topics

Oracle Advanced Supply Chain Planning, *Oracle Advanced Supply Chain Planning User's Guide* .

Constraint Types, *Oracle Advanced Supply Chain Planning User's Guide*.

Items, *Oracle Advanced Supply Chain Planning User's Guide*.

Manufacturing Resources, *Oracle Advanced Supply Chain Planning User's Guide*.

## Integration with Outside Processing

Using Outside Processing (OSP), you can include supplier-sourced components and resources in the manufacturing process. An OSP operation requires one or more OSP resources, which in turn must be associated with departments with location. In addition, a separate OSP item must be created to receive and charge the outside work (this item is associated with the resource). When creating the OSP item, the Purchasing Tabs of the Item window must have OSP-related settings, i.e. Purchased, Purchasable, Outside Processing Item must be checked. The list price must be specified in the purchasing master organization for generating purchase orders. See: Outside Processing, *Oracle Work in Process User's Guide*. Features of outside processing for lot based jobs include:

- Setup
- Outside Processing Scenarios
- Job Creation/Update
- WIP Lot Transactions
- Move Transactions
- Defining Network Routings



---

# Shop Floor Execution

## Overview of Shop Floor Execution

Oracle Shop Floor Management provides you with a functionality to carry out and view various transactions to track the progress of manufacturing of goods at the factory shop floor. It addresses the requirements of two different roles at the shop floor:

- **The shop floor operator:** a human resource whose main task is to operate a particular machine and report progress made on it.
- **The shop floor supervisor:** whose main task is to oversee the shop floor and help resolve issues relating to machine and human resources on the shop floor to meet the desired production and other set objectives.

Some of the tasks that you perform on a factory shop floor can be clearly assigned to one of the roles mentioned above, but there are other tasks which might be a part of both. With Shop Floor Execution system, you can actually configure the screens according to the user roles.

Oracle Shop Floor Management also provides you with a set of new screens and functionality for the Shop Floor Operator and a set of additional screens and functionality for the Shop Floor Supervisor. These screens for the shop Floor Operator helps the operator to carry out his duties in a cohesive fashion and in an easy way within a framework of logical screen flows. It helps the Shop Floor Supervisor to set the configurations in such a way to have a better control over the business practices in the organization and make the UIs more user friendly for the operators in his shop floor.

## Shop Floor Modeling

Shop Floor Modeling provides you with better configuration capabilities. It provides you with improved shop floor control through

- Granular access management for operators/supervisors

- Better information availability at manufacturing operations
- Improved management of individual operations
- Availability of real-time information

## Defining Reason Codes

If a given standard operation has scrap codes defined, then the Show Scrap Code flag displays the scrap codes for you to enter the scrap quantity against each of the scrap code during Move Out.

### To define Scrap Codes

1. Navigate to the Shop Floor Manager:Routings:Scrap Codes window.
2. Enter Code, Meaning and Description of the code in the Manufacturing: Scrap Codes Lookups window that appears.

**Note:** Enter numeric value in the Code field.

Code	Meaning	Description	Tag	From	To	Enabled
1	S100	Physical Damage		24-JUL-2006		<input checked="" type="checkbox"/>
11	Defect 1	Defect 1		24-JUL-2006		<input checked="" type="checkbox"/>
12	Defect 2	Defect 2		24-JUL-2006		<input checked="" type="checkbox"/>
13	Defect 3	Defect 3		24-JUL-2006		<input checked="" type="checkbox"/>
14	Defect 4	Defect 4		24-JUL-2006		<input checked="" type="checkbox"/>
15	Defect 5	Defect 5		24-JUL-2006		<input checked="" type="checkbox"/>
16	Defect 6	Defect 6		24-JUL-2006		<input checked="" type="checkbox"/>
2	S101	Material Defect		24-JUL-2006		<input checked="" type="checkbox"/>
3	S102	Process Defect		24-JUL-2006		<input checked="" type="checkbox"/>
4	S103	Out of Tolerance		24-JUL-2006		<input checked="" type="checkbox"/>

### To define Bonus Codes

1. Navigate to the Shop Floor Manager:Routings:Bonus Codes window.
2. Enter Code, Meaning and Description of the code in the Manufacturing: Bonus

Codes Lookups window that appears.

**Note:** Enter numeric value in the Code field.

Code	Meaning	Description	Tag	From	To	Enabled
1	B100	Salvage		24-JUL-2006		<input checked="" type="checkbox"/>
11	Bonus 1	Bonus 1		24-JUL-2006		<input checked="" type="checkbox"/>
12	Bonus 2	Bonus 2		24-JUL-2006		<input checked="" type="checkbox"/>
13	Bonus 3	Bonus 3		24-JUL-2006		<input checked="" type="checkbox"/>
14	Bonus 4	Bonus 4		24-JUL-2006		<input checked="" type="checkbox"/>
15	Bonus A	Bonus A		24-JUL-2006		<input checked="" type="checkbox"/>
16	Bonus B	Bonus B		24-JUL-2006		<input checked="" type="checkbox"/>
17	Bonus C	Bonus C		24-JUL-2006		<input checked="" type="checkbox"/>
2	B101	Rework		24-JUL-2006		<input checked="" type="checkbox"/>
3	B102	Downgraded		24-JUL-2006		<input checked="" type="checkbox"/>

### To define Resource Down Codes

1. Navigate to the Shop Floor Manager:Routings:Resource Down Codes window.
2. Enter Code, Meaning and Description of the code in the Manufacturing: Resource Down Codes Lookups window that appears.

**Note:** Enter numeric value in the Code field.

Manufacturing: Resource Down Codes Lookups

Type: BOM\_RESOURCE\_DOWNCODES  
 Meaning: Resource Down Codes  
 Application: Bills of Material  
 Description: Resource Down Codes

Access Level:  
 User  
 Extensible  
 System

Code	Meaning	Description	Tag	Effective Dates		Enabled	[ ]
				From	To		
11	Break Down	Break Down		10-JAN-2007		<input checked="" type="checkbox"/>	
12	Electrical Fault	Electrical Fault		10-JAN-2007		<input checked="" type="checkbox"/>	
13	Hydraulic Failure	Hydraulic Failure		10-JAN-2007		<input checked="" type="checkbox"/>	
14	Others	Others		10-JAN-2007		<input checked="" type="checkbox"/>	
15	Preventive Maintenan	Preventive Maintenance		10-JAN-2007		<input checked="" type="checkbox"/>	
						<input type="checkbox"/>	
						<input type="checkbox"/>	
						<input type="checkbox"/>	
						<input type="checkbox"/>	
						<input type="checkbox"/>	

## Low Yield Trigger

You can put a job on hold by defining the lowest acceptable yield for a given standard operation.

### To define Low Yield Trigger

1. Navigate to the Standard Operations window.
2. Choose Shop Floor Transactions tab.
3. Select a Code and enter the Lowest Acceptable Yield.

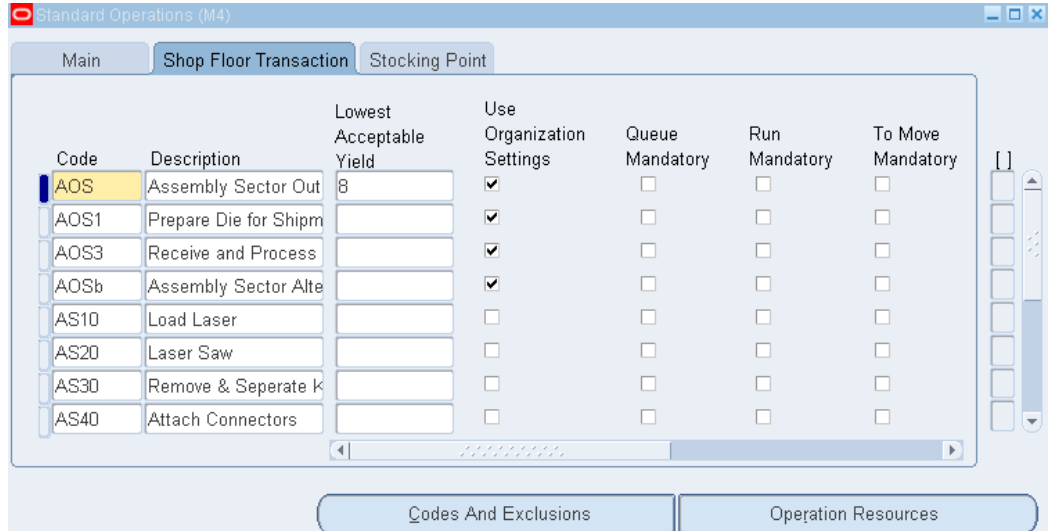

## Responsibility Access Configuration

Shop Floor Modeling Configuration Capabilities enable you to query the responsibility of the user and configure the transaction settings accordingly.

### To configure responsibilities for Shop Floor Manager and Operator

1. Navigate to MES Supervisor Workbench.
2. Choose Configuration tab.

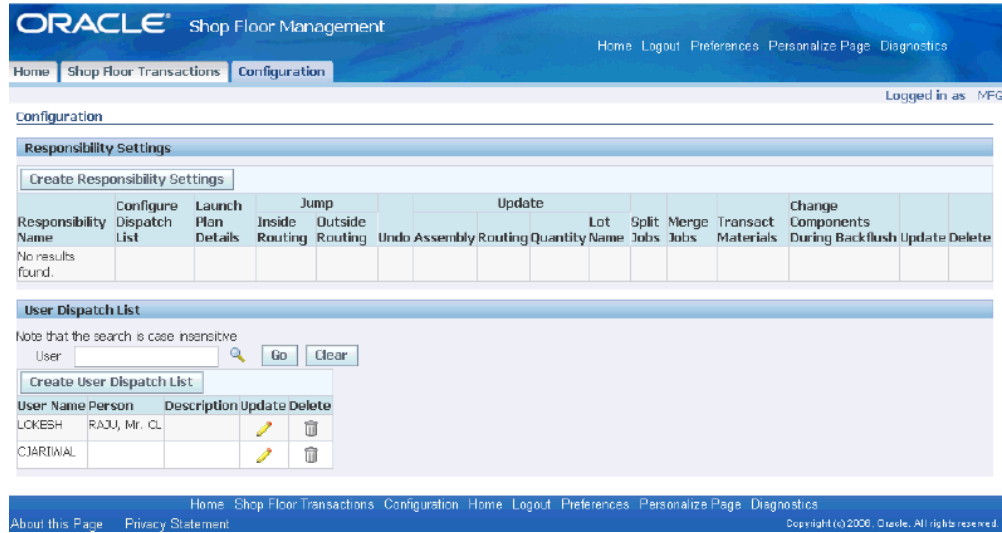

3. Choose Create Responsibility Settings.
4. Enter the responsibility of the user in the Responsibility region.

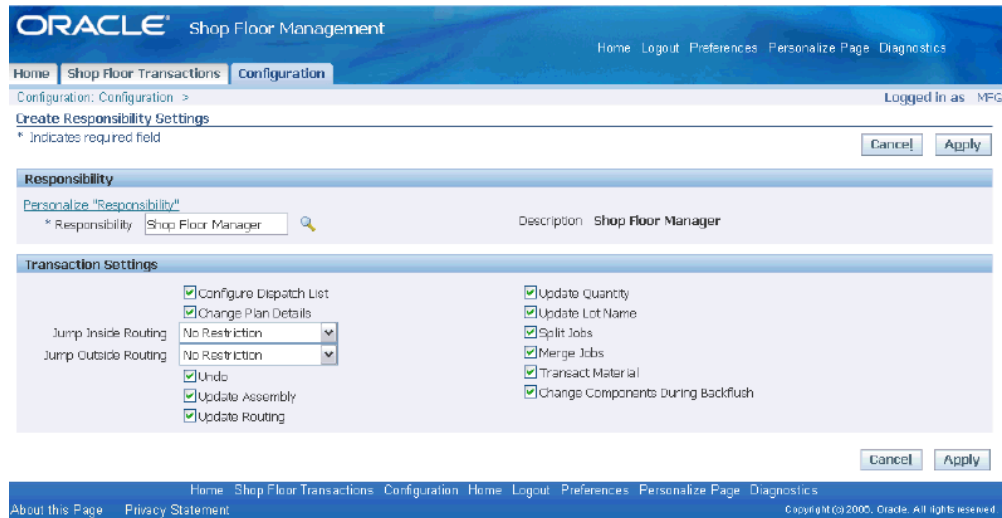

5. Select the transactions that you want this user to perform.
6. Click Apply.



ORACLE® Shop Floor Management

Home Logout Preferences Personalize Page Diagnostics

Home Shop Floor Transactions Configuration

Logged In as MFG

Confirmation  
Configuration settings for the responsibility Shop Floor Manager created

Configuration

**Responsibility settings**

Create Responsibility Settings

Responsibility Name	Configure Dispatch List	Launch Plan Details	Jump		Update							Change Components During Backflush	Update	Delete	
			Inside Routing	Outside Routing	Undo	Assembly	Routing	Quantity	Lot Name	Split Jobs	Merge Jobs				Transact Materials
Shop Floor Manager	Yes	Yes	No Restriction	No Restriction	Yes	Yes	Yes	Yes	Yes	Yes	Yes	Yes	Yes		

**User Dispatch List**

Note that the search is case insensitive

User

Create User Dispatch List

User Name	Person	Description	Update	Delete
LOKESH	RAJU, Mr. CL			
CJARIWAL				

## Responsibility Exclusion Configuration

With Shop Floor Modeling Responsibility Exclusions, you can list out responsibilities who are not allowed to perform transactions at a given standard operation.

### To exclude responsibility

1. Navigate to Standard Operations window.
2. Choose an operation by clicking the Main tab.
3. Click Codes And Exclusions.
4. Choose Responsibility Exclusions tab on the Codes And Exclusions window that appears.
5. Choose the list of Responsibilities for exclusion.

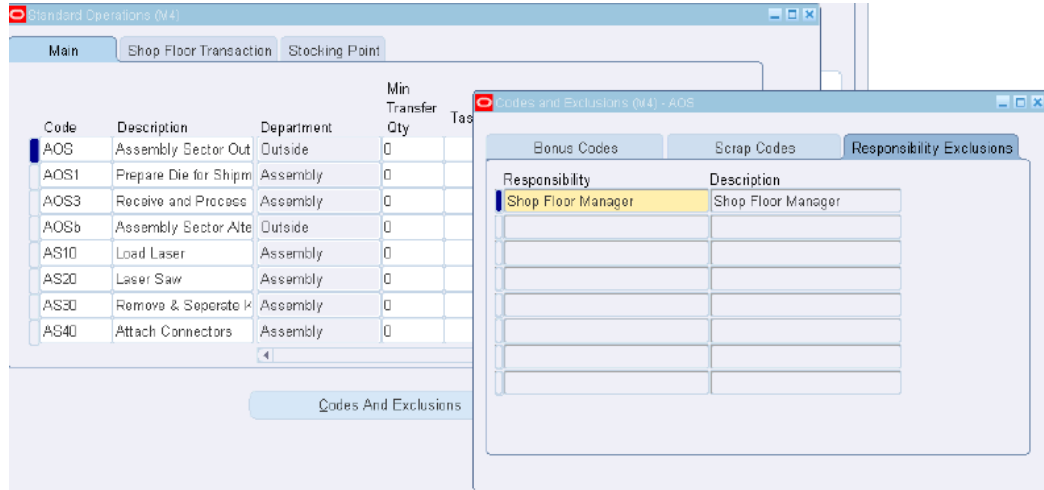

## Dispatch List Configuration

Shop Floor Modeling Configuration Capabilities allow you to list out a set of jobs or Work Orders for an operator to view and then execute in a given sequence on the shop floor.

### To configure Dispatch List Search Criteria

1. Navigate to Shop Floor Manager: Supervisor Workbench.
2. Select Configuration tab.
3. Select Create User Dispatch List in the User Dispatch List region.

**ORACLE** Shop Floor Management

Close Window Preferences Personalize Page Diagnostics

Home Shop Floor Transactions Configuration

Configuration Configuration > Create User Dispatch List

Logged in as MFG

\* Indicates required field

Cancel Apply

**User**

Personalize "User"

\* User SFM Description Jeffrey Bigalow

Person Bigalow, Mr. Jeffrey

**Dispatch List Search Criteria**

Personalize "Dispatch List Search Criteria"

Job Op Type Current and Scheduled Instance

\* Organization M4 View Today Only

Department Assembly Scheduled Op Time From 08 : 00 AM

Op Code Enter dependent information last, for example enter organization before department. Duration 08 : 00

Resources

Cancel Apply

4. Enter the user.
5. Enter dispatch list details for individual users.
6. Click Apply

Confirmation

User Dispatch Settings for the user SFM created

Configuration

**Responsibility Settings**

Create Responsibility Settings

Responsibility Name	Configure Dispatch List	Launch Plan Details	Jump Inside Routing	Jump Outside Routing	Undo	Assembly	Routing	Quantity	Name	Lot	Split	Merge	Jobs	Jobs	Materials	Transact	Change Components During Backflush	Update	Delete
No results found.																			

**User Dispatch List**

Note that the search is case insensitive

User [ ] Go Clear

Create User Dispatch List

User Name	Person	Description	Update	Delete
SFM	Bigalow, Mr. Jeffrey		[Pencil]	[Trash]
LKESH	RAJU, Mr. CL		[Pencil]	[Trash]
CIARIWAL			[Pencil]	[Trash]

Home Shop Floor Transactions Configuration Close Window Preferences Personalize Page Diagnostics

About this Page Privacy Statement Copyright (c) 2000, Oracle. All rights reserved.

## Lot Traveler Template Assignment

You can associate a **Lot Traveler** template for each Inventory Item or Inventory Item Category. When you create a lot based job, you can choose to view the lot traveler, save it, or print it. This is a look up between item or item category and the stored template. You can use this to generate the Lot Traveler.

Navigate to Lot Traveler Template windows to assign a Lot Traveler Template to an

inventory item or item category.

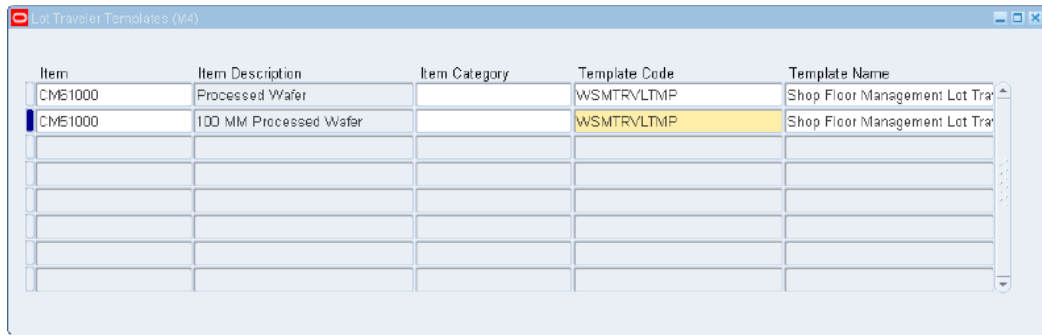

Item	Item Description	Item Category	Template Code	Template Name
CME1000	Processed Wafer		WSMTRVLTMP	Shop Floor Management Lot Tra
CME1000	100 MM Processed Wafer		WSMTRVLTMP	Shop Floor Management Lot Tra

## Resource Context Configuration

If you configure resource as a context, then you can capture and view resource statuses like Up, Down, and Acknowledged Down.

**Caution:** Changing from one context to another will render deletion of all existing context definitions.

### To define resource-based context details

1. Navigate to Shop Floor Manager: Supervisor Workbench.
2. Enter Organization.
3. Select Resource-Based as Context Type.
4. Click Add Context Details.

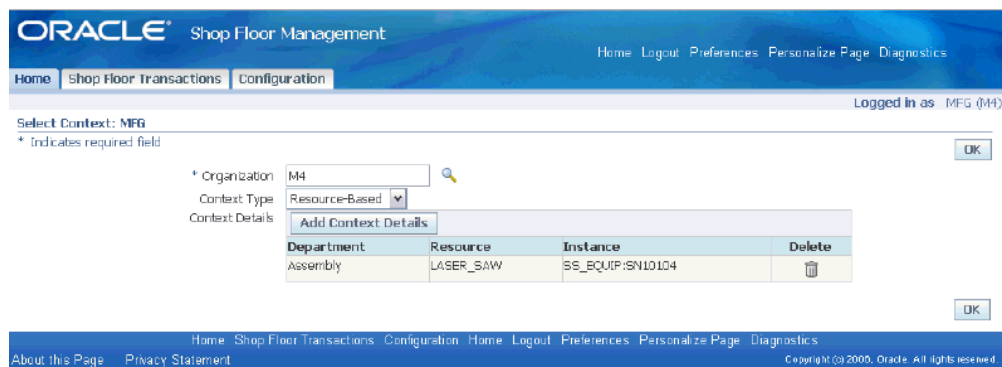

ORACLE Shop Floor Management

Home Logout Preferences Personalize Page Diagnostics

Home Shop Floor Transactions Configuration

Logged in as MFG (M4)

Select Context: MFG

\* Indicates required field

\* Organization: M4

Context Type: Resource-Based

Context Details

Department	Resource	Instance	Delete
Assembly	LASER_SAW	SS_EQUIP:SN10104	

About this Page Privacy Statement

Home Shop Floor Transactions Configuration Home Logout Preferences Personalize Page Diagnostics

Copyright (c) 2000, Oracle. All rights reserved.

5. Enter Department, Resource, and Instance details.

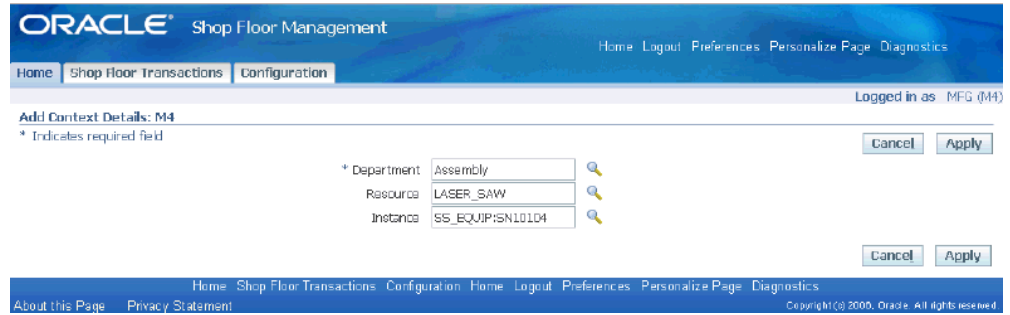

6. Click Apply.  
Repeat steps 4 to 6 to add as many departments, resources, and instances as needed.
7. Click OK.

## Operation-Based Context Configuration

With operation as a context configuration you can capture and view resource statuses like Up, Down, and Acknowledge Down and also see details for all resources defined for that operation.

### To define operation-based context details

1. Navigate to Shop Floor Manager: Supervisor Workbench.
2. Enter Organization.
3. Select Operation-Based as Context Type.
4. Click Add Context Details.



5. Enter Department and Operation details.

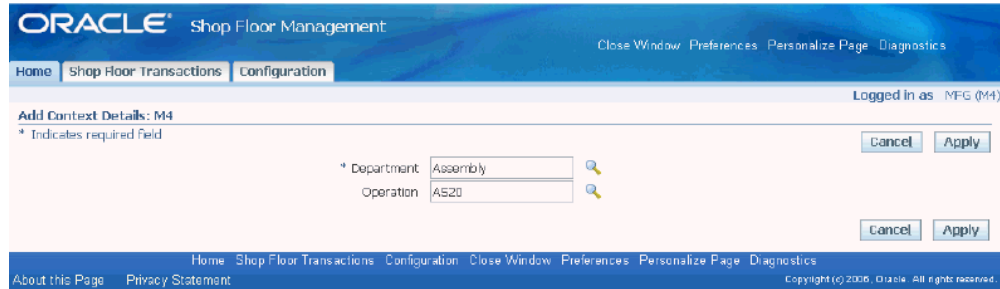

6. Click Apply.  
Repeat steps 4 to 6 to add as many departments and operations as needed.
7. Click OK.

## Overview of Shop Floor Intraoperation Transactions

Shop Floor operations are driven by a process of Move In (pick up a lot from queue and start work), Move Out (complete work and report results) and Move To Next Operation (transfer lot to next operation).

Move Out is a required step to report results of the work done. You can choose Yes or No to track Move In and Move To Next Operation.

At the organization level, if Move In and Move To Next Operation are set to Always, then they are required steps for every operator. However, these settings can be overridden at the standard operation level through Organization Settings flag. If Move In is Optional, the operator can choose to perform Move In or directly perform Move Out transaction. If Move In is Never, then the operator will always directly perform Move Out transaction.

Likewise, if Move To Next Operation is Optional, during Move Out the operator can choose to stay at the current operation (to be followed by a separate Move To Next Operation transaction) or directly move to the next operation.

Move In and Move To Next Operation can be controlled at the standard operation level as well. If the check box for Use Organization Settings in the Standard Operations setup form is unchecked, then any settings at the standard operation level will supersede the settings at the organization level.

Since Move In, Move Out and Move To Next Operation correspond to movements between start and target intraoperation steps, standard operation level control is merged with pre-existing Mandatory Intraoperation step settings. To make a Move In transaction as a required step Always, the supervisor should select that standard operation's Run or Move In Mandatory Intraoperation Step check box. Leaving it unselected will make it Optional only when flag Use Organization Settings is not checked. Likewise, to make Move To Next Operation as Always, the supervisor should select the To Move or Move To Next Operation check box and unselect it for making it



**Move In = Always**  
**Move To Next Op = Never**

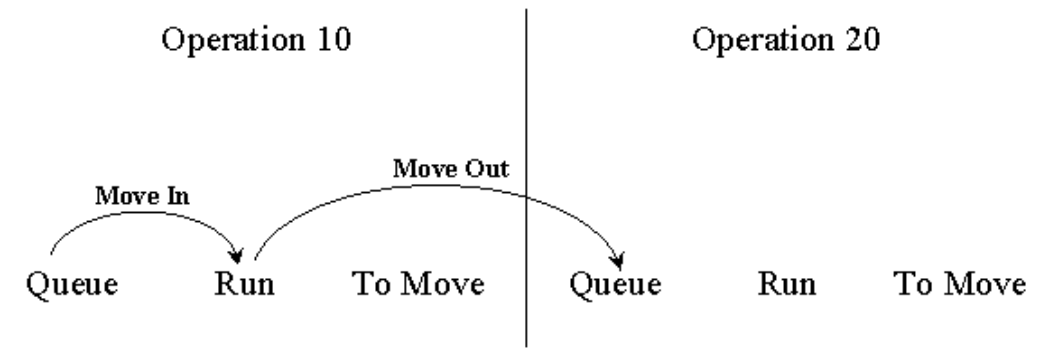

### Case 3

- Move In set to Always at Organization or Standard Operation level
- Move To Next Operation set to Optional at Organization or Standard Operation level
- Organization's WIP Parameters Intraoperation steps for Run and To Move are selected



**Move In = Always**  
**Move To Next Op = Optional**

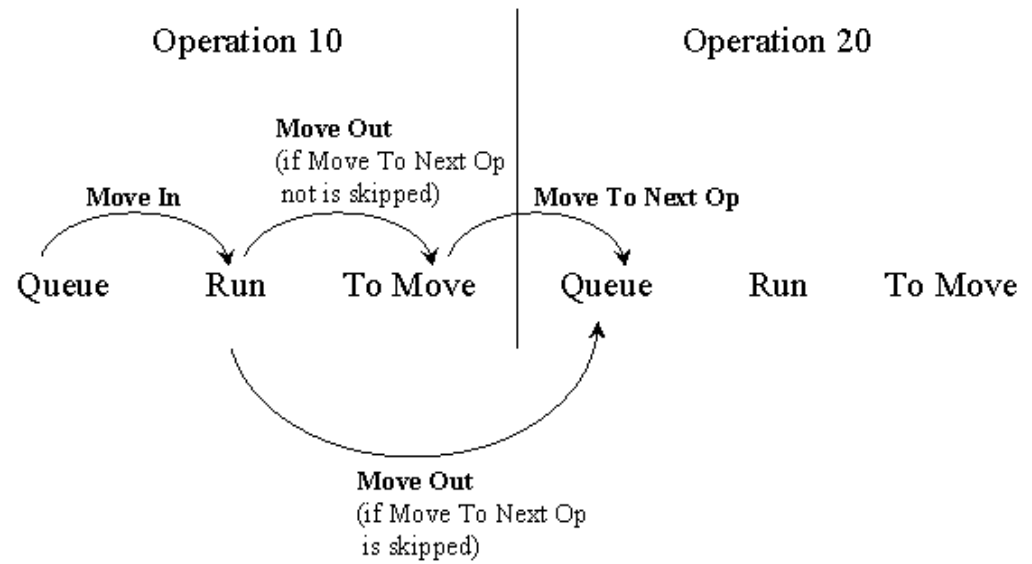

#### Case 4

- Move In set to Never at Organization or Standard Operation level
- Move To Next Operation set to Always at Organization or Standard Operation level
- Organization's WIP Parameters Intraoperation Steps for Run are not selected and To Move is selected

**Move In = Never**  
**Move To Next Op = Always**

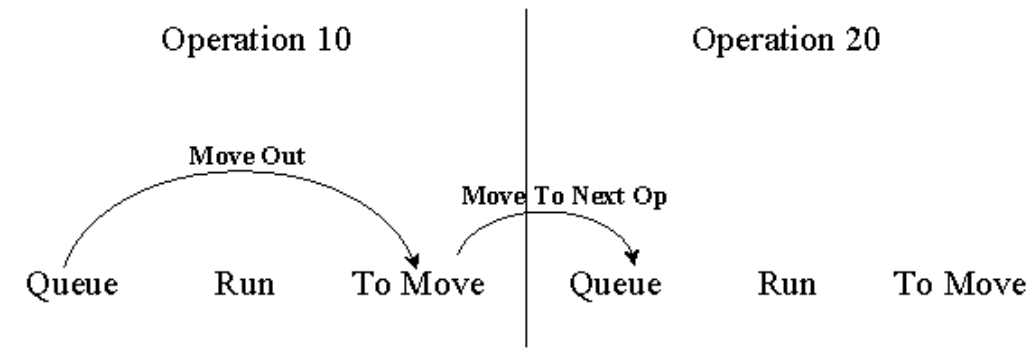

**Case 5**

- Move In set to Never at Organization or Standard Operation level
- Move To Next Operation set to Never at Organization or Standard Operation level
- Organization's WIP Parameters Intraoperation Steps for Run and To Move are not selected

**Move In = Never**  
**Move To Next Op = Never**

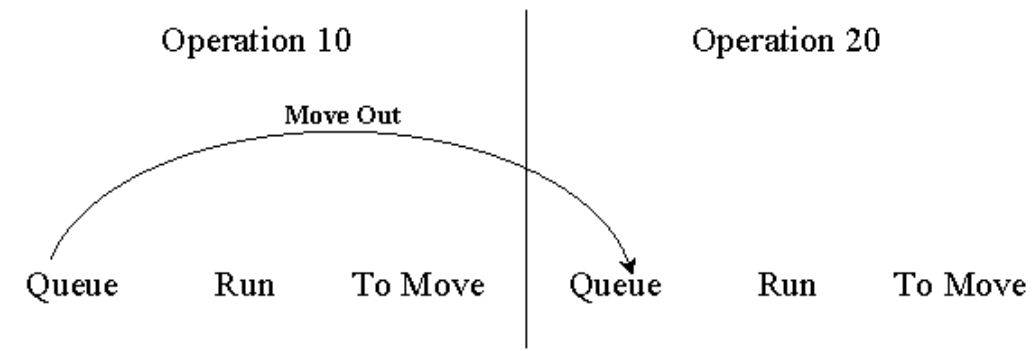

**Case 6**

- Move In set to Never at Organization or Standard Operation level
- Move To Next Operation set to Optional at Organization or Standard Operation level

- Organization's WIP Parameters Intraoperation Steps for Run are not selected and To Move is selected

**Move In = Never**  
**Move To Next Op = Optional**

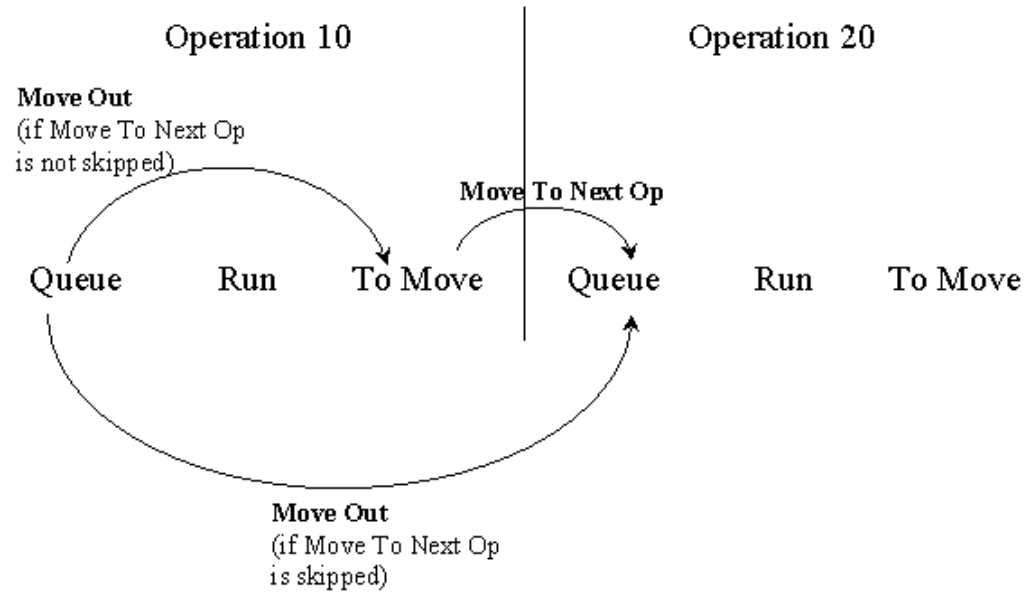

### Case 7

- Move In set to Optional at Organization or Standard Operation level
- Move To Next Operation set to Always
- Organization's WIP Parameters Intraoperation Steps for Run and To Move are checked

**Move In = Optional**  
**Move To Next Op = Always**

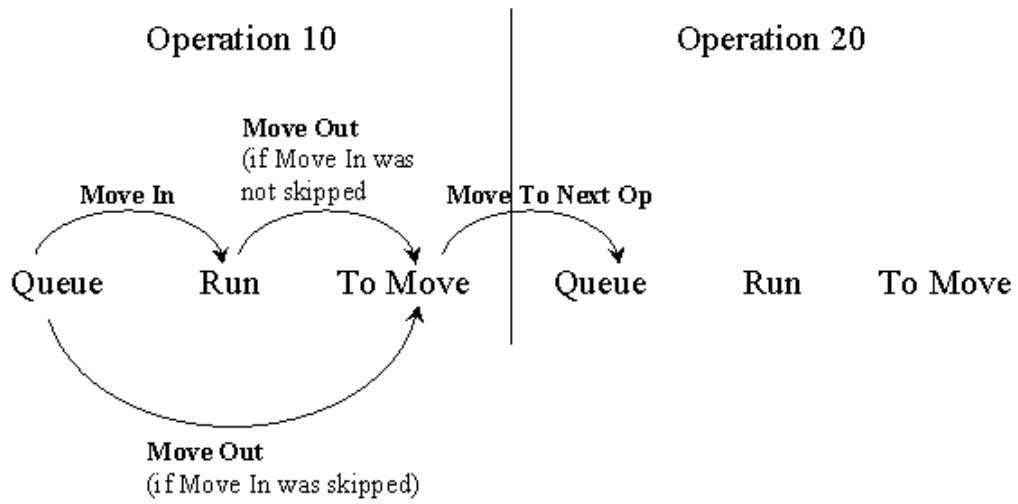

#### Case 8

- Move In set to Optional at Organization or Standard Operation level
- Move To Next Operation set to Never
- Organization's WIP Parameters Intraoperation Steps for Run are selected and To Move is not selected

**Move In = Optional**  
**Move To Next Op = Never**

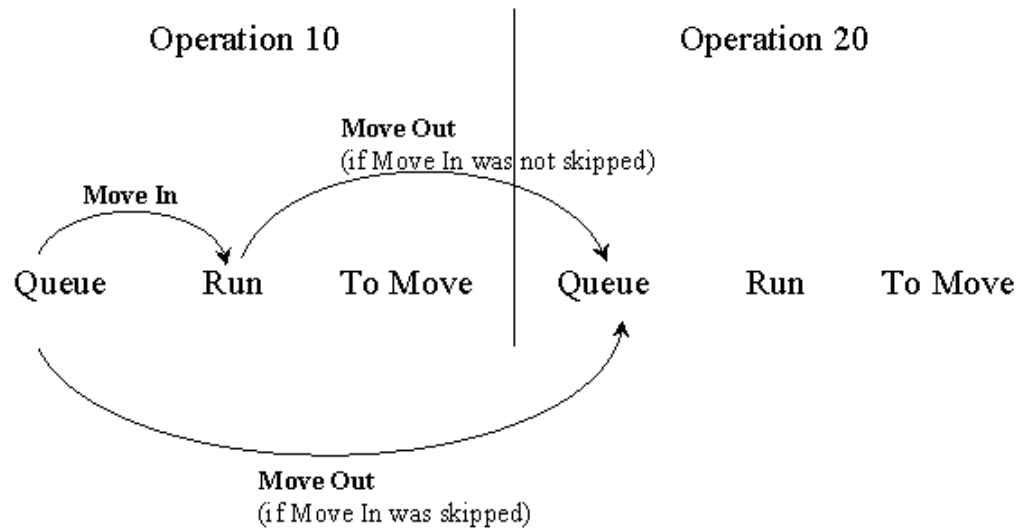

### Case 9

- Move In set to Optional at Organization or Standard Operation level
- Move To Next Operation set to Optional at Organization or Standard Operation level
- Organization's WIP Parameters Intraoperation Steps for Run and To Move are selected

**Move In = Optional**  
**Move To Next Op = Optional**

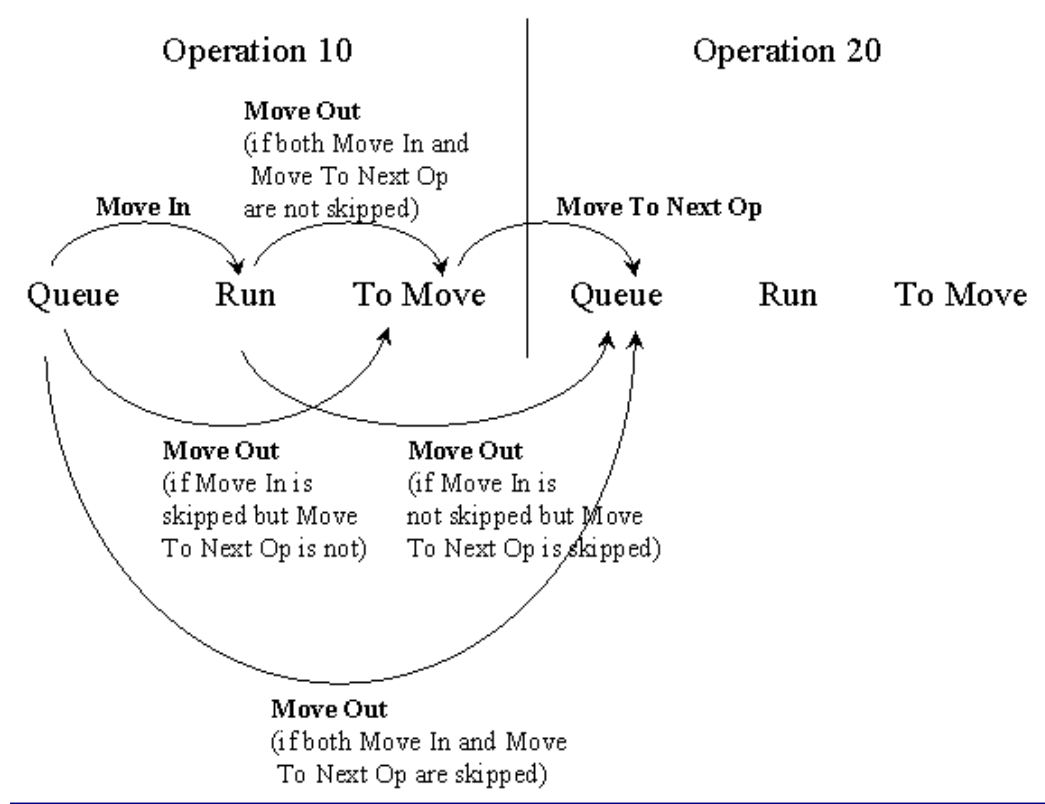

**Intraoperation Definitions based on Shop Floor Execution Transactions**

**Move In**

*Move In:* capture an action of putting a lot at the Run intraoperation from the 'Queue'. This signifies an action when a machine actually starts working on the job. You have three options to control the requirement of a Move In transaction. For a given operation, the operator picks up a lot from his/her job queue, loads machines, and starts work on the job.

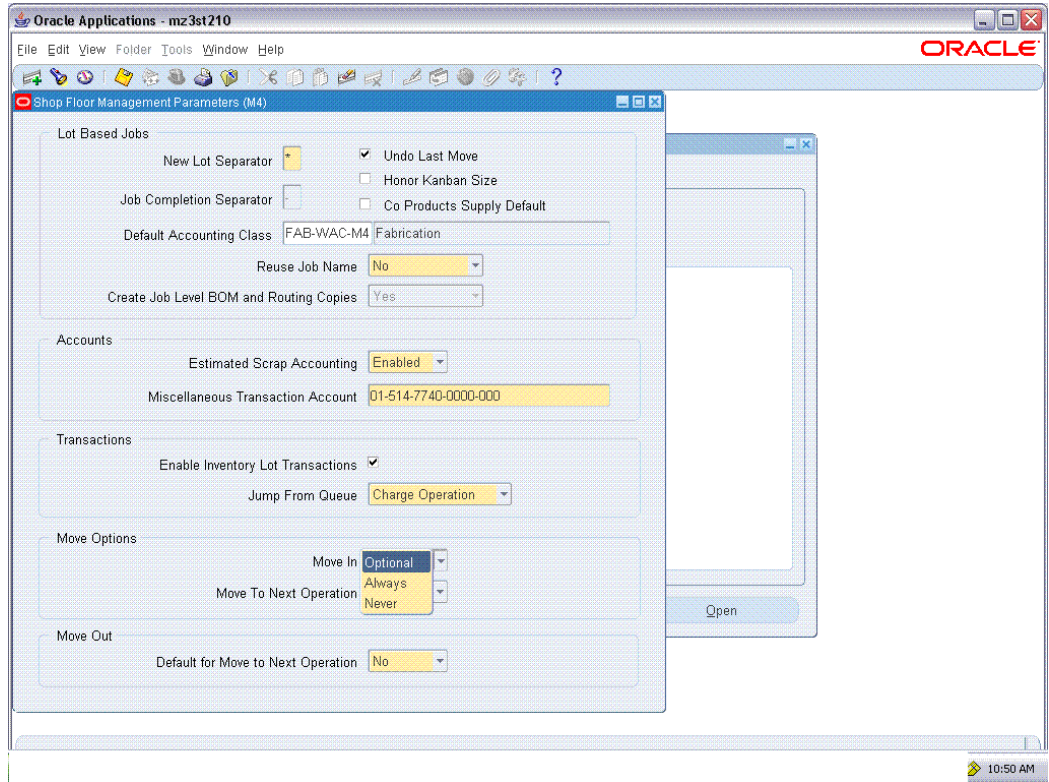

## Move Out

*Move Out*: capture an action of transferring a lot from the Run intraoperation to the To Move intraoperation. This signifies an action when a machine completes working on the job. Based on this setting, by default you can either move to next operation's Queue intraoperation step or stay at this operation's To Move intraoperation step. You can still override the choice at the time of doing Move Out transaction. For a given operation, an operator completes work on the current job and notes any results.

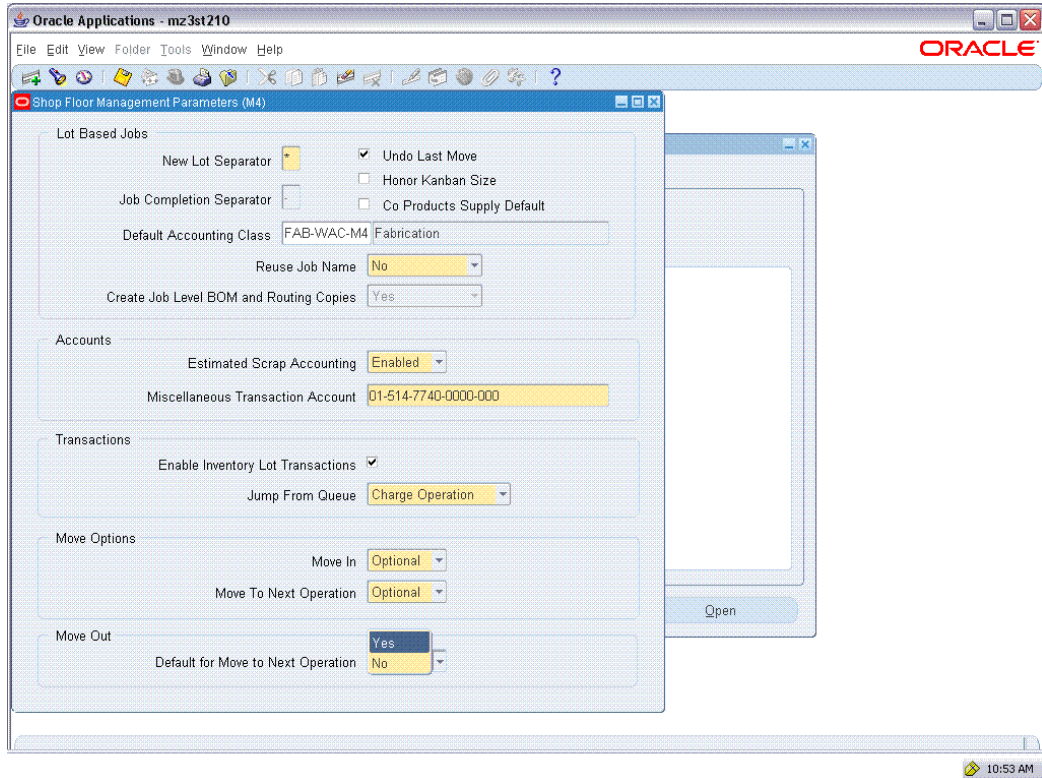

## Move To Next Operation

*Move To Next Operation*: capture an action of transferring a lot from the 'To Move' intraoperation to the 'Queue' of the next operation. It is an action signifying that a job is transferred to the next operation after the completion of the previous operation. You have three options to move a job to the next operation as a part of Move Out transaction: always or never or make it optional. If Never, then you must perform a separate Move To Next Operation transaction. If Optional, then you have a choice to perform a separate Move To Next Operation transaction based on the selection during Move Out.



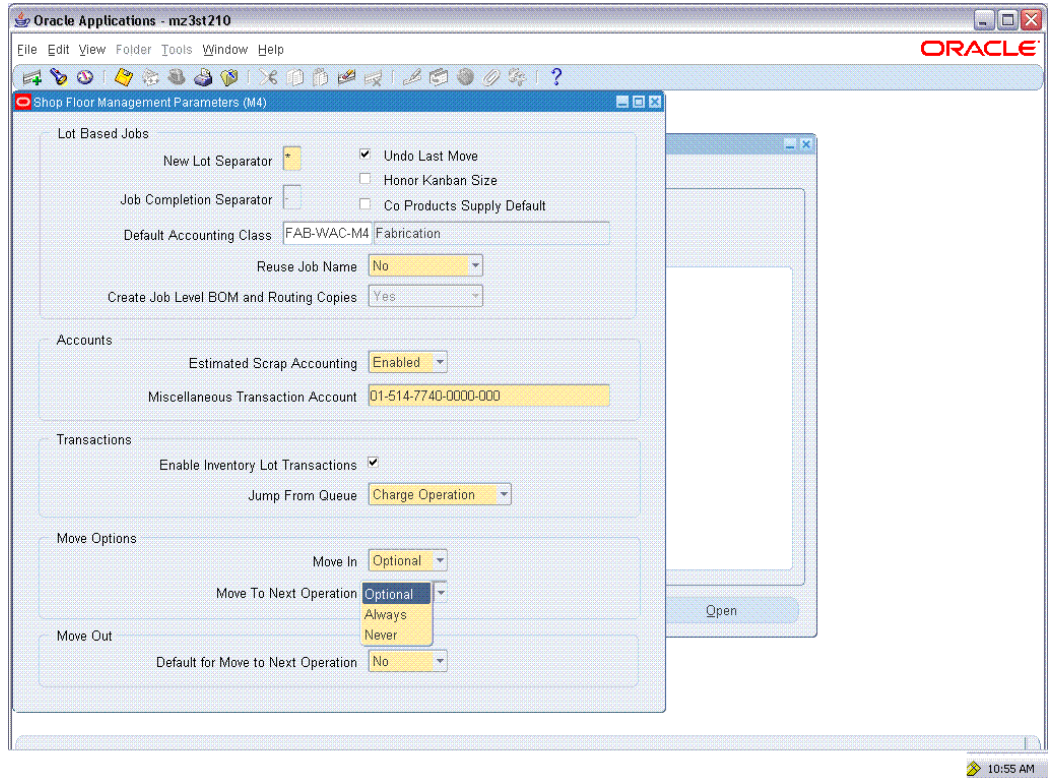

## Shop Floor Execution

Oracle Shop Floor Management provides enhanced Shop Floor execution capabilities that help you to generate more comprehensive and valuable reports for manufacturing operations. With its integration with Oracle Advanced Supply Chain Planning you can generate real-time information on the shop floor.

New HTML UIs are provided for Resource Context Definition, Responsibility and Dispatch List configuration, and Executing shop floor transactions, Lot Traveler, etc.

**Note:** The new HTML UIs are also referred to as Manufacturing Execution System for Oracle Shop Floor Management.

## Supervisor Workbench

Using this function, a shop floor supervisor can perform the following:

- View the status of the resource, resource instance
- Search jobs by using search criteria
- Configure responsibility settings and dispatch lists

**Current Resource Status**  
 Last Refreshed: 30-Nov-2006 05:01:34

Select	Department	Resource	Instance	Status Code	Down	Expected Up Date	Last Event Date	Reported By	Current Job Op	Next Maintenance Date	View Maintenance Orders
<input type="radio"/>	FAB	STEPPER							Multiple Jobs	No asset maintenance work order is scheduled.	
<input type="radio"/>	FAB	STEPPER	STEPPER_2							No asset maintenance work order is scheduled.	

## Dispatch List: Search Criteria

Dispatch List is a list of jobs or Work Orders that you can view and then execute on the shop floor in a given sequence. Your actions are based on the configuration of your responsibility.

You can also search dispatch lists based on resource or instance.

### To search dispatch list

1. Navigate to MES Supervisor Current Resource Status. Current Resource Status page appears.
2. Choose Shop Floor Transactions. The Job Operations UI window appears.
3. Select a Job Op Type from the list.
4. Enter Organization.
5. Enter the department name.
6. Enter Operation or Resource.

For Resource, optionally enter specific Resource Instance.

For Current and Scheduled Job Op type, you can also search based on scheduled operation from and to dates. For each day in that range, specify start time and shift by selecting Scheduled Op Time and Duration fields. For Completed Job Op type, use actual dates.

**Job Operations**  
\* Indicates required field

**Search**

Personalize "Search"

\* Job Op Type: Current and Scheduled  
 \* Organization: Completed  
 Department: Current and Scheduled  
Enter dependent information last, for example enter organization before department.  
 Operation: AS20  
 Resource:

Instance:   
 View Today Only  
 Scheduled Op Time From: 09:00 AM  
 Duration: 08:00

Personalize Flow Layout  
 Personalize Flow Layout: (CurAndSchedJobOpRN)  
 Personalize "Current and Scheduled Job Op Summa..."

Select Job \* Action: View Job Operation

Select	Job	Routing Op	Op Code	Step	Assembly	Assembly Quantity	UOM	Resource	Instance	Batch Id	Scheduled Op Date Start	Completion	Move In	Move Out
<input type="radio"/>	RA_LB1102*1	20	20	AS20	To move	LRAS1005	9	Ea	LASER_SAW		2006-Oct-19 07:06:00	2006-Oct-19 07:06:04		

**Configuration**

**Responsibility Settings**

Responsibility Name	Configure Dispatch List	Launch Plan Details	Jump		Update							Change Components During Backflush	Update Del	
			Inside Routing	Outside Routing	Undo	Assembly	Routing	Quantity	Name	Split Jobs	Merge Jobs			Transact Materials
Shop Floor Operator	Yes	Yes	No Restriction	No Restriction	Yes	Yes	Yes	Yes	Yes	Yes	Yes	No	Yes	

**User Dispatch List**

Note that the search is case insensitive

User:

User Name	Person	Description	Update	Delete
CLRAJU	Supervisor1, Mr. ShopFloor			
NH				
WSM4	Operator2, Mrs. ShopFloor			
KARNATAR	Natarajan, Mr. Karthik			

The supervisor can choose at the responsibility level if the Operator Responsibility has access for defining his or her own dispatch list. This is controlled by the Configure Dispatch List flag in the Responsibility Settings of the Supervisor Configuration page. If the flag is No, then the Operator cannot configure his own dispatch list. In that case, the supervisor configures dispatch list for each operator. If the flag is Yes, then the Operator can configure his own dispatch list by clicking the Change Dispatch List Options button on the Dispatch List.

*Create Responsibility Settings:* Access to various actions performed on the jobs for different responsibilities are set here.

*Dispatch List configuration:* Dispatch List Search Criteria are configured for users (especially operators).

## Current Resource Status

You can manage resources on the shop floor by recording Resource Down Time. You can update resource status, specify Down Code and enter operator details.

### To update resource status

1. Navigate to MES Supervisor Current Resource Status.
2. Select a resource from the Current Resource Status page.
3. Select resource Update Status.
4. Update the Resource Status.
5. Choose Apply.

The screenshot shows the Oracle Shop Floor Management interface. The page title is 'ORACLE Shop Floor Management'. The navigation bar includes 'Home', 'Shop Floor Transactions', and 'Configuration'. The user is logged in as 'MFG (M)'. The main heading is 'Report Resource Status: STEPPER'. Below this, there is a form with the following fields:

- \* Resource Status: A dropdown menu with 'Up' selected.
- Comments: A text area with a search icon.
- Reported By: A text field containing 'Smith, Mr. Jonathan' with a search icon.
- \* Reported Date: A text field containing '2006-Nov-23 03:39:07' with a calendar icon.

There are 'Cancel' and 'Apply' buttons at the bottom right of the form. The footer contains 'About this Page', 'Privacy Statement', and 'Copyright (c) 2006, Oracle. All rights reserved.'

## Event Log

You can view event log for a resource for Specific or All Resource Statuses or for a selected period.

### To view event log for a resource

1. Navigate to MES Supervisor Current Resource Status
2. Select a resource.
3. Choose Event Log.
4. Select View Event and choose a possible value.
5. Select the From date from the calendar icon.
6. Modify the Report Date To. The current date is defaulted.

## 7. Select Go.

The screenshot shows the Oracle Shop Floor Management interface. At the top, there are navigation links: Home, Shop Floor Transactions, and Configuration. The user is logged in as MFG (M). The main section is titled "Resource Event Log: STEPPER". Below this is a search area with a "Personalize 'Search'" link. The search criteria include:
 

- \* View Event: All
- \* Report Date From: 2006-Nov-01 15:49:59
- \* Report Date To: 2006-Nov-22 02:22:02

 A "Go" button is present. Below the search area is a table titled "Personalize 'Resource Event Log Summary Table'". The table has columns: Event Date, Reported By, Event Type, Down Code, and Comments. The data rows are:
 

Event Date	Reported By	Event Type	Down Code	Comments
2006-Nov-14 22:29:37	RAJU, Mr. CL	Up		SS1
2006-Nov-14 22:30:05	RAJU, Mr. CL	Down		SS2
2006-Nov-14 22:31:54	RAJU, Mr. CL	Up		SS3
2006-Nov-14 22:32:12	RAJU, Mr. CL	Down		SS4
2006-Nov-14 22:34:33	RAJU, Mr. CL	Up		
2006-Nov-14 22:38:17	RAJU, Mr. CL	Down		
2006-Nov-15 23:14:22	Operator2, Mrs. ShopFloor	Up		
2006-Nov-15 23:14:49	Operator2, Mrs. ShopFloor	Down		

## Operator Workstation

Using the Operator Dispatch List function, you can view the Dispatch List as configured by the supervisor. Operator can configure the Dispatch List as it is enabled for that responsibility (like Shop Floor Operator).

Operator can select jobs and then execute various actions as configured in the responsibility settings.

The screenshot shows the Oracle Shop Floor Management Operator Workstation interface. At the top, there are navigation links: Diagnostics, Home, Logout, and Preferences. The user is logged in as RANGAPPA (M4, Assembly, SF01). The main section is titled "Operator Workstation". Below this is a "Refresh Page" button and a "Change Dispatch List Options" button. The interface displays the following information:
 

- Job Op Type: M4
- Organization: Assembly
- Department: SF01
- Op Code: SF01
- Resource: SF01
- Instance: Search Today Only: Yes
- Scheduled Op Time From: 08:00:00
- Duration: 08:00:00

 Below this is a "Select Job" section with a "View Job Operation" dropdown and a "Go" button. The main table is titled "Report Resource Status" and has columns: Select Job, Job Op, Routing Op, Op Code, Step, Assembly, Quantity, UOM, Resource, Instance, Batch, Scheduled Op Date (Start, Completion), Move In, Move Out, and Move To Next Op. The data rows are:
 

Select Job	Job Op	Routing Op	Op Code	Step	Assembly	Quantity	UOM	Resource	Instance	Batch	Scheduled Op Date	Start	Completion	Move In	Move Out	Move To Next Op
LB1_201	30	10	SF01	To move	CSLT110	12	Ea	MC100			01-Aug-2006 03:39:00	01-Aug-2006 03:39:00				
LS_LB12	10	10	SF01	Run	CSLT110	4	Ea	MC100			31-Jul-2006 06:27:00	31-Jul-2006 06:27:00				
LS_LB13	10	10	SF01	Run	CSLT110	5	Ea	MC100			31-Jul-2006 06:28:00	31-Jul-2006 06:28:00				
LB1_102_NEW	20	10	SF01	Queue	CSLT110	15	Ea	MC100			01-Aug-2006 01:07:00	01-Aug-2006 01:07:00				

## Move In transaction

You can move a job into an operation, that is, from Queue to Run. You can also capture



data on Resource Instance Details, Operation Start and Expected Completion Date and Time, and the operator who worked on the Instance.

*Resource Instance Details:* capture the actual machine on which the job is done and the actual start and expected completion time of the resource used in doing the transaction.

**Note:** Actual completion time is recorded during Move Out transaction.

*Operation Start and Expected Completion Date and Time:* capture the actual start and expected completion time for each operation of the job.

*Operator Details:* capture the name of the person who executed the operation and the name of the person who captured the transaction data.

**Note:** You can update the data entered at this stage during a Move Out transaction.

### To do a Move In transaction

1. Select a job in the Dispatch List.
2. Click on Move In link. The Move In page of the selected job appears with Resource Usage and transaction details.
3. Enter details and choose Apply.

The screenshot shows the Oracle Shop Floor Management interface for a 'Move In' transaction. The page title is 'ORACLE Shop Floor Management' with navigation links for 'Close Window', 'Preferences', 'Personalize Page', and 'Diagnostics'. The breadcrumb trail is 'Home > Shop Floor Transactions > Configuration'. The main heading is 'Move In: RT\_103(20)' with a note '\* Indicates required field'. There are 'Cancel' and 'Apply' buttons at the top right.

**Resource Usage**

Resource	Instance	Instance Operator	Start Date	Expected Completion Date
LASER_SAW		Smith, Mr. Jonathan	2006-Nov-22 03:57:56	

**Transaction Detail**

Operator	Smith, Mr. Jonathan	* Transaction Date	2006-Nov-22 03:57:56 (example: 2006-Nov-22 11:45:00)
Start Date	2006-Nov-22 03:57:56 (example: 2006-Nov-22 11:45:00)	Transaction Reason	
Expected Completion Date		Transaction Reference	

At the bottom, there are 'Cancel' and 'Apply' buttons, and a footer with 'About this Page', 'Privacy Statement', and 'Copyright (c) 2006, Oracle. All rights reserved.'

### Move Out a transaction

You can move a job out of an operation, that is, from Run to To Move. You can also capture:

- *Operation Start and Completion Date and Time*: capture actual start and completion time for each operation of the job.
- *Operator Details*: capture the name of the person who captured the transaction data.
- *Job Quantity - Bonus*: capture increase in job quantity, while executing a move transaction and specify the bonus quantity against each of the Bonus Code.
- *Job Quantity - Scrap*: specify scrap quantity against scrap code.

### To do a Move Out transaction

1. Select a job in the Dispatch List.
2. Click on Move Out link. The Move Out page of the selected job appears with assembly quantities, scrap, bonus and transaction details.
3. Enter details and choose Continue.

ORACLE Shop Floor Management

Home Logout Preferences Personalize Page Diagnostic

Home Shop Floor Transactions Configuration

Shop Floor Transactions: Shop Floor Transactions >

Move Out: RA\_LB1101\*1(20)

\* Indicates required field

Cancel Co

Quantities Usages Next Operation Lot Attributes

**Assembly Quantities**

Personalize "Assembly Quantities"

UOM	Ea
Move In	8
* Move Out	8
Bonus	0
Scrap	0

**Serial Numbers**

Personalize "Serial Numbers"

**Scrap**

Personalize "Scrap"

Personalize "Scrap Serials Table"

Serial Number

**Bonus**

Personalize "Bonus"

Personalize "Bonus Serials Table"

Serial Number

*Alert for Low Yield during Move Out*: If the yield goes below the Lowest Acceptable Yield set for that standard operation, then the job is put on hold. When you query, the status shows On Hold in the Lot Based Jobs window.

Select Usages tab to issue backflush components that are lot and/or serial controlled.

Select Next Operation tab to see the operations as per the network routing sequence. You can choose operations on primary or secondary path as defined.

Select Lot Attributes tab to enter or update lot.

### Move to Next Operation

You can move a job to the next operation, that is, from To Move to Queue of next operation. You can capture transaction details and details of the next operation.

#### To do a Move To Next Operation transaction

1. Select a job in the Dispatch List.
2. Click on Move To Next Op. The Move To Next Op page appears with transaction and next operation details.
3. Enter details and choose Apply.



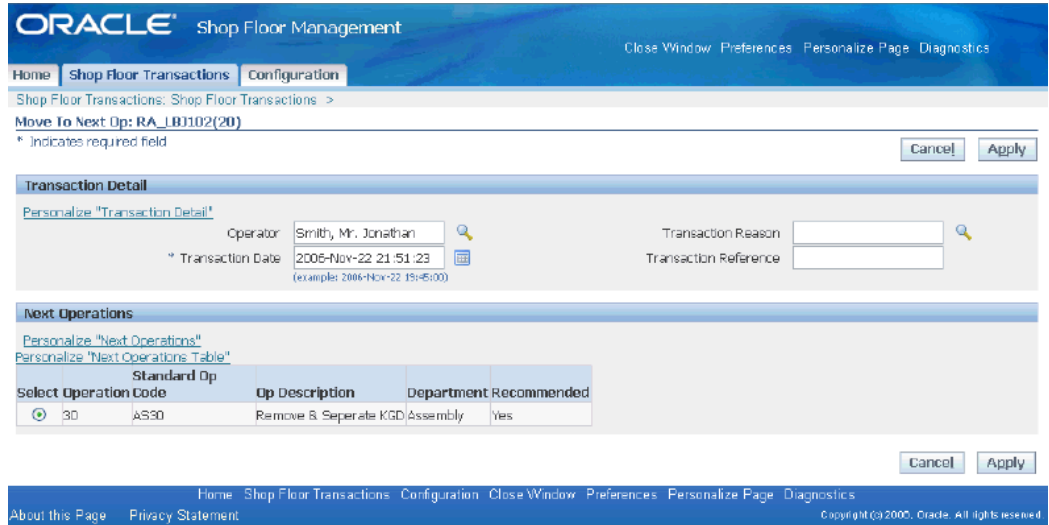

## Undo Move

By Undo Move transaction, you can bring the job back to the previous operation. You can view the operator details, and the details of the present and previous operations. You can capture the transaction time and the name of the operator, performing the Undo Move.

**Note:** Move transactions performed in HTML UIs can alone be undone using the Undo Move transaction.

You can undo a transaction only for Job Move. You cannot undo immediately after you perform a WIP Lot transaction. Undo Move on a completed job returns the assembly from Inventory to WIP.

### To do Undo transaction

1. Select a job in the Dispatch List.
2. Choose Undo Move as Job Action.
3. Click Go. Undo page appears with present and previous operation details and transaction details.
4. Enter transaction details and select Apply.

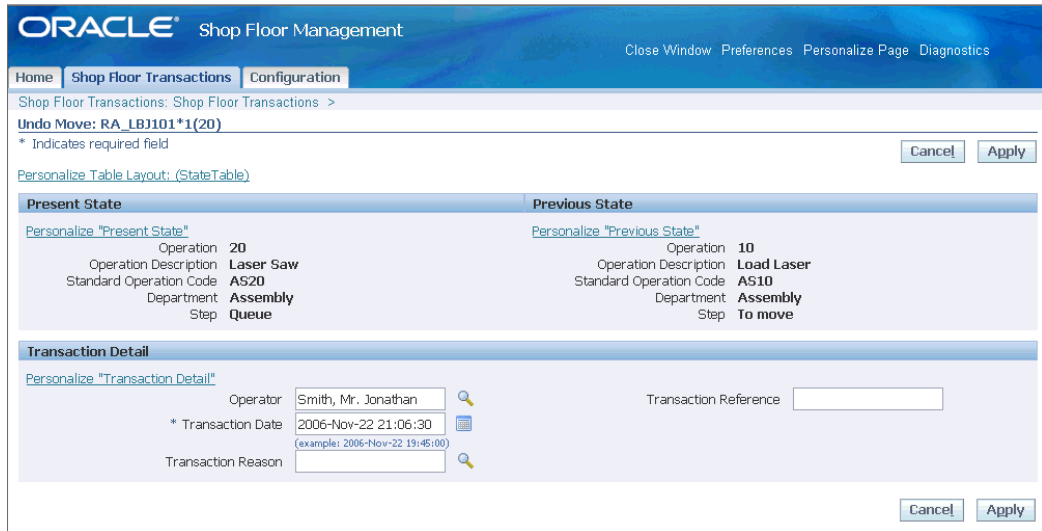
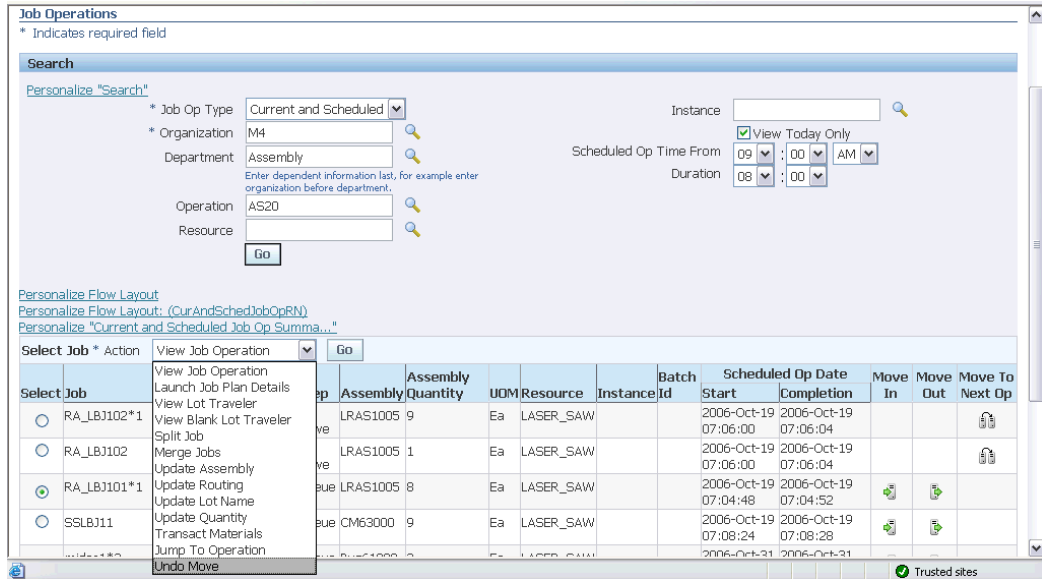

## Jump To Operation

You can use the Jump To Operation to go to an operation, which is not the next operation in sequence as defined in the network routing. You can capture the name of the operator, the jump type, whether it is inside or outside routing and details of destination operation.

### To Jump to an operation

1. Select a Job in the Dispatch List.
2. Choose Jump To Operation as Job Action.

3. Select Go. The Jump To Operation page appears.
4. Enter required operation changes and choose Apply.

## WIP Lot transactions

Oracle Shop Floor Management provides you the ability to do WIP Lot transactions of split, merge, update quantity, update assembly, update routing and update lot name using HTML UIs.

### To do a WIP Split Transaction

1. Navigate to Operator Workstation.
2. Select a Job in the Dispatch List.
3. Choose Split Job as Action to execute a WIP Split Transaction.

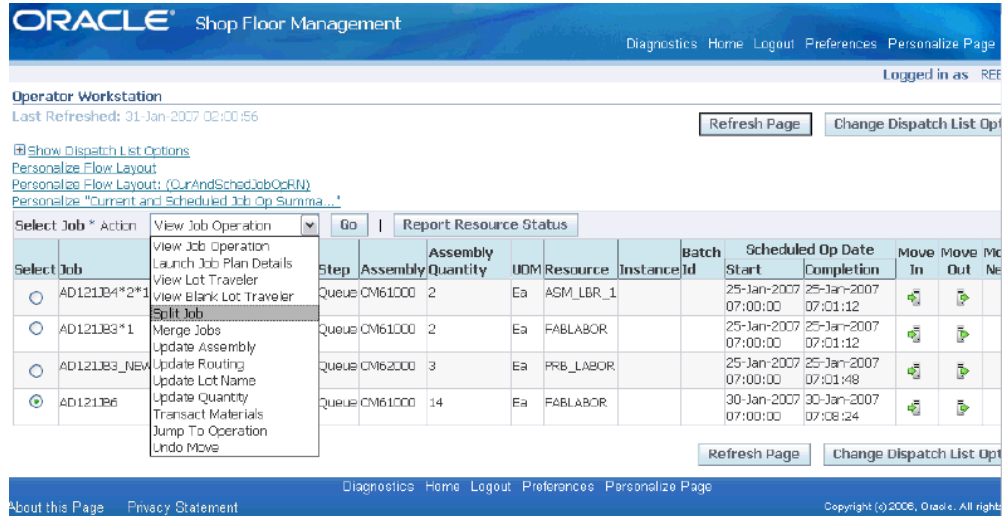

- Click Go.
- The Split HTML page appears.
- Split the starting job into required number of resulting jobs.
- Enter quantity details.

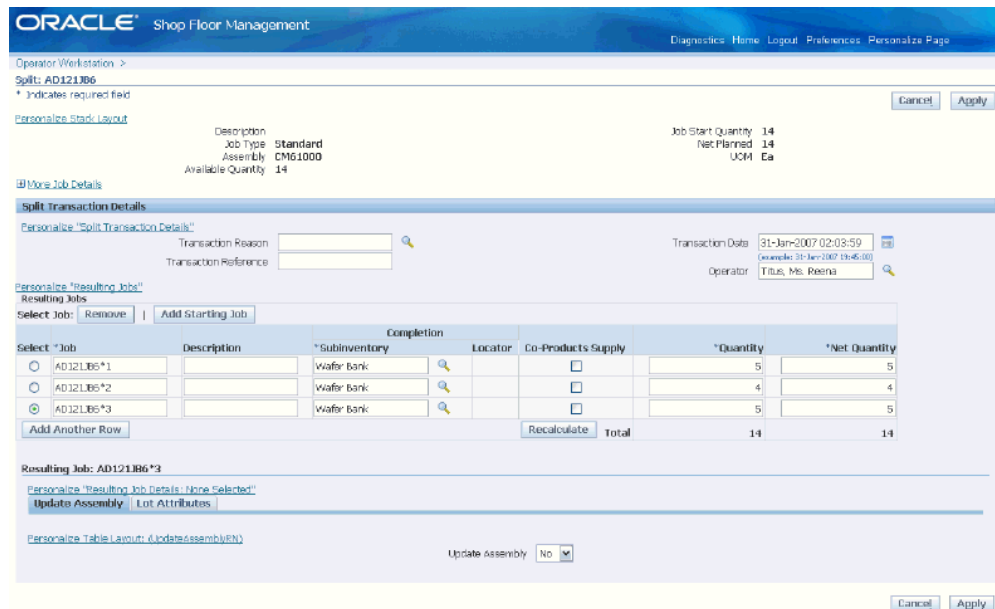

You can also update the assembly of the resulting job.

- Click Apply.
- You can see the split jobs in the dispatch list.

ORACLE Shop Floor Management

Diagnostics Home Logout Preferences Personalize Page

Logged In as: REBKA (HR)

Operator Workstation  
Last Refreshed: 01-Jan-2007 00:00:36

Refresh Page Change Dispatch List Options

Show Dispatch List Options  
Personalize Flow Layout  
Personalize Flow Layout (Current Schedule Only)  
Personalize Summary and Scheduled Job Op Summaries...

Select Job \* Action View Job Operation Go | Report Resource Status

Select Job	Job Op	Routing Op	Op Code	Step	Assembly	Assembly Quantity	UDM Resource	Instance Id	Batch	Start	Scheduled Op Date	Completion	Move In	Move Out	Move To Next Op
<input type="radio"/> AD121353_NEW	20	10	FB10	Queue	CM61000	3	Ea	FABLABOR		25-Jan-2007 07:00:00	25-Jan-2007 07:01:46				
<input type="radio"/> AD121354*2*1	20	10	A510	Queue	CM61000	2	Ea	ASM_LBR_1		25-Jan-2007 07:00:00	25-Jan-2007 07:01:12				
<input type="radio"/> AD121353*1	10	10	FB10	Queue	CM61000	2	Ea	FABLABOR		25-Jan-2007 07:00:00	25-Jan-2007 07:01:12				
<input type="radio"/> AD121356*2	10	10	FB10	Queue	CM61000	4	Ea	FABLABOR		30-Jan-2007 07:00:00	30-Jan-2007 07:02:24				
<input type="radio"/> AD121356*3	10	10	FB10	Queue	CM61000	5	Ea	FABLABOR		30-Jan-2007 07:00:00	30-Jan-2007 07:03:00				
<input type="radio"/> AD121356*1	10	10	FB10	Queue	CM61000	5	Ea	FABLABOR		30-Jan-2007 07:00:00	30-Jan-2007 07:03:00				

Refresh Page Change Dispatch List Options

About this Page Privacy Statement

Diagnostics Home Logout Preferences Personalize Page

Copyright © 2006, Oracle. All rights reserved.

### To do a WIP Merge Transaction

1. Navigate to Operator Workstation.
2. Select a Job in the Dispatch List.
3. Choose Merge Jobs as Job Action to execute a WIP Merge Transaction.
4. Click Go  
The Merge HTML page appears.
5. Merge the required jobs into one job.

ORACLE Shop Floor Management

Home | Shop Floor Transactions | Configuration

Shop Floor Transactions: Shop Floor Transactions >

Merge: AD121B3

\* Indicates required field

Transaction Reason:

Transaction Reference:

Standard Op Code: **FB10**

Op Department: **FAB**

Transaction Date: 30-Jan-2007 01:16:37

Operator: Smith, Mr. Jonathan

Op Description: Load Stepper Machine

Op Step: Queue

Cancel Apply

**Jobs To Be Merged**

Personalize: "Jobs To Be Merged?"

Personalize: "Starting Job"

Select Job:

Select Job Name	Description	Representative	Assembly	Quantity	Net Planned
<input type="radio"/> AD121B3		✓	CM61000	3	3
<input type="radio"/> AD121B4*1			CM61000	3	3

Starting Job Details

**Merged Job Details**

Personalize: "Merged Job Details"

\* Job Name: AD121B3

\* Subinventory: Wafer Bank

Locator:

Job Description:

Merged Quantity: 6

\* Merged Net Planned: 0

Co-Products Supply

Cancel Apply

Home | Shop Floor Transactions | Configuration | Home | Logout | Preferences | Personalize Page | Diagnostics

About this Page | Privacy Statement

Copyright © 2006, Oracle. All rights reserved.

6. Click Apply.

You can see the merged job in the dispatch list. You can also make one of them as a representative job.

**To update Job Quantity**

1. Navigate to Operator Workstation.
2. Select a Job in the Dispatch List.
3. Choose Update Quantity as Job Action.
4. Click Go.
5. Update the quantity of the job in the Quantity field.

ORACLE Shop Floor Management

Home | Shop Floor Transactions | Configuration

Shop Floor Transactions: Shop Floor Transactions >

Update Quantity: AD121004\*2

\* Indicates required field

Personalize Stack Layout

Description  
Job Type: Standard  
Assembly: CM61000  
Available Quantity: 3

Job Start Quantity: 3  
Net Planned: 3  
UCM: Ea

More Job Details

Transaction Details

Personalize Transaction Details

Transaction Reason  
Transaction Reference  
Transaction Date: 30-Jan-2007 01:10:08  
(example: 30-Jan-2007 13:45:00)  
Operator: Smith, M.: Jonathan  
Quantity: 5

\* Net Planned: 5  
\* Subinventory: Wafer Bank  
Locator  
Bonus Account Alias  
\* Bonus Account Number: 01-514-5240-0000-000

Cancel Apply

About this Page Privacy Statement

Home Shop Floor Transactions Configuration Home Logout Preferences Personalize Page Diagnostics

Copyright © 2006, Oracle. All rights reserved.

6. Click Apply.

You can see the job with the updated quantity in the Dispatch List.

#### To update Job's Assembly

1. Navigate to Operator Workstation.
2. Select a Job in the Dispatch List.
3. Choose Update Assembly as Job Action.
4. Click Go.
5. Update the assembly of the job in the Assembly field.

ORACLE Shop Floor Management

Home | Shop Floor Transactions | Configuration

Shop Floor Transactions: Shop Floor Transactions >

Update Assembly: AD121805

\* Indicates required field

Personalize Stack Layout

Description  
Job Type: Standard  
Assembly: CM61000  
Available Quantity: 3

Job Start Quantity: 5  
Net Planned: 5  
UOM: Ea

More Job Details

Transaction Details

Personalize "Transaction Details"

Transaction Reason:

Transaction Reference:

Transaction Date: 30-Jan-2007 01:50:43

Operator: Smith, Mr. Jonathan

\* Assembly: CSLT110

Bill Alternate:

Bill Revision: 0

Bill Revision Date: 30-Jan-2007 00:00:00

Routing Alternate: alternate1

\* Routing Revision: 0

\* Routing Revision Date: 30-Jan-2007 01:53:10

\* Target Routing Op Seq: 10

Target Op Description: Prepare Shipment for Fab Outside Processing

Target Op Code: F001

Target Op Department: FAB

\* SubInventory: Wafer Bank

Locator:

Cancel Apply

About this Page Privacy Statement Home Shop Floor Transactions Configuration Home Logout Preferences Personalize Page Diagnostics Copyright © 2006, Oracle. All rights reserved.

6. Click Apply.

You can see the job with the updated assembly in the Dispatch List.

**Note:** The job with updated assembly will show in the Dispatch List only if the target operation matches the dispatch list configuration for department, operation or resource.

**To update Job's Routing**

1. Navigate to Operator Workstation.
2. Select a Job in the Dispatch List.
3. Choose Update Routing as Job Action.
4. Click Go.
5. Enter the Routing Alternate of the job in the Transaction Details region.



ORACLE Shop Floor Management

Home Shop Floor Transactions Configuration

Shop Floor Transactions: Shop Floor Transactions >

Update Routing: AD121304\*2\*1

\* Indicates required field

Personalize Stack Layout

Description	Standard	Job Start Quantity	2
Job Type	Standard	Net Planned	2
Assembly	CM61000	UOM	Ea
Available Quantity	2		

More Job Details

Transaction Details

Personalize "Transaction Details"

Transaction Reason		* Routing Revision	0
Transaction Reference		* Routing Revision Date	30-Jan-2007 23:13:08
Transaction Date	30-Jan-2007 23:12:42	* Target Routing Op Seq	10
Operator	Smith, Mr. Jonathan	Target Op Description	Load Laser
Bill Alternates		Target Op Code	AS10
Bill Revision	0	Target Op Department	Assembly
Bill Revision Date	30-Jan-2007 23:12:42	* Subinventory	Raw Stock
Routing Alternates	Alternate1	Locator	

Cancel Apply

Home Shop Floor Transactions Configuration Close Window Preferences Personalize Page Diagnostics

About this Page Privacy Statement Copyright (c) 2006, Oracle. All rights reserved.

6. Click Apply.

### To update Lot Name

1. Navigate to Operator Workstation.
2. Select a Job in the Dispatch List.
3. Choose Update Lot Name as Job Action.
4. Click Go.
5. Update the job name in the Job Name field.

ORACLE Shop Floor Management

Home Logout Preferences Personalize Page Diagnostics

Home Shop Floor Transactions Configuration

Shop Floor Transactions: Shop Floor Transactions >

Update Lot Name: AD121303

\* Indicates required field

Personalize Stack Layout

Description	Standard	Job Start Quantity	3
Job Type	Standard	Net Planned	3
Assembly	CM61000	UOM	Ea
Available Quantity	3		

More Job Details

Transaction Details

Personalize "Transaction Details"

Transaction Reason		* Job Name	AD121303_NEW
Transaction Reference		Description	
Transaction Date	30-Jan-2007 03:16:30	* Subinventory	Welder Bank
Operator	Smith, Mr. Jonathan	Locator	

Cancel Apply

Home Shop Floor Transactions Configuration Home Logout Preferences Personalize Page Diagnostics

About this Page Privacy Statement Copyright (c) 2006, Oracle. All rights reserved.

6. Click Apply.

You can see the job with the updated job name in the Dispatch List.

ORACLE Shop Floor Management

Home Logout Preferences Personalize Page Diagnostics

Shop Floor Transactions: Shop Floor Transactions > Logged in as: MFG (nrl)

Job Operations

\* Indicates required field

Search

Personalize Search:

\* Job Op Type: Current and Scheduled

\* Organization: MFG

Department:

Operation:

Resource:

Instance:

Scheduled Op Time From: 09:00:00 AM

Duration: 08:00:00

View Today Only

Go

Personalize Flow Layout

Personalize Flow Layout (Current and Scheduled Job Op)

Personalize Current and Scheduled Job Op Summary

Select Job \* Action View Job Operation Go

Select Job	Job Op	Routing Op	Op Code	Stop	Assembly Quantity	UGM	Resource	Instance	Batch	Scheduled Op Date	Move In	Move Out	Move To Next Op	
										Start Completion				
<input type="radio"/>	AD121B3*1	10	10	FB10	Queue CM61000	2	Ea	FABLABOR		25-Jan-2007 07:00:00	25-Jan-2007 07:01:12			
<input type="radio"/>	AD121B4*2*1	10	10	FB10	Queue CM61000	2	Ea	FABLABOR		25-Jan-2007 07:00:00	25-Jan-2007 07:01:12			
<input type="radio"/>	AD121B3_NEW	10	10	FB10	Queue CM61000	3	Ea	FABLABOR		25-Jan-2007 07:00:00	25-Jan-2007 07:01:40			
<input type="radio"/>	AD121B4*1	10	10	FB10	Queue CM61000	3	Ea	FABLABOR		25-Jan-2007 07:00:00	25-Jan-2007 07:01:48			
<input type="radio"/>	AD121B4*2*2	10	10	FB10	Queue CM61000	1	Ea	FABLABOR		25-Jan-2007 07:00:00	25-Jan-2007 07:00:56			
<input type="radio"/>	AD121B6	10	10	FB10	Queue CM61000	5	Ea	FABLABOR		30-Jan-2007 07:00:00	30-Jan-2007 07:03:00			
<input type="radio"/>	AD121B5	10	10	FB10	Queue CM61000	5	Ea	FABLABOR		30-Jan-2007 07:00:00	30-Jan-2007 07:03:00			

## Material Transactions

You can transact materials in HTML UIs. You can perform Issue, Return, Negative Issue and Negative Return transactions

*Backflush*: issue component during Move Out. You can backflush lot and serial controlled components.

*Material Issue*: You can issue lot and serial controlled components. You can do Lot Creation only in windows and not in HTML UI.

### To do a Backflush transaction

1. Navigate to Operator Workstation.
2. Select a job in the dispatch list.
3. Execute a Move Out transaction for the job selected.  
The Move Out HTML page appears.
4. Choose Usages tab.
5. Select the component to be issued for the job.

**ORACLE** Shop Floor Management Close Window Preferences Personalize Page Diagnostics

Home Shop Floor Transactions Configuration

Shop Floor Transactions: Shop Floor Transactions >

Move Out: TestL01(10)

\* Indicates required field Cancel Continue

Quantities Usages Next Operation Lot Attributes

---

**Backflush Components**

Personalize: Back Layout: (BackflushComponentsRN)

\* Indicates required field

Select Component:  Enter Multiple Lot And Serial Action:

Select *Component	UOM	Quantity		Revision	*Subinventory	Locator	UOM	Transaction		Serial	
		Required	Onhand					*Quantity	Lot	From	To
<input type="radio"/> CM62000	Ea	10	0		Store		Ea	10	ABC		

Detail: CM62000

---

**Resource Usage**

Personalize: Resource Usage\*

Resource	Resource Instance	Instance Operator	Start Date	Completion Date
No results found.				

---

**Transaction Detail**

Operator:

Start Date:

Completion Date:

\* Transaction Date:

Transaction Reason:

Transaction Reference:

### To do a Material Issue transaction

1. Navigate to Operator Workstation.
2. Select a job in the dispatch list.
3. Choose Transact Materials as Job Action.
4. Click Go.  
The Transact Material HTML page appears.
5. Select a component to be issued for this job.

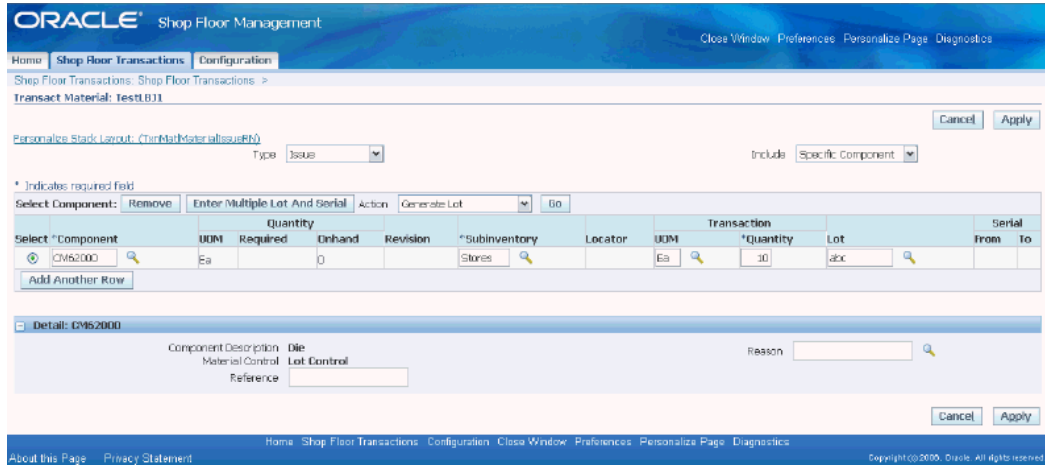

You can view these material transactions from the Job Operation HTML page in the Components region of the Usage tab.



You can perform transactions like material return, negative issue, negative return, and also enter multiple lot and serial details for the transacted components.

## Job Operation Details

Oracle Shop Floor Management gives you detailed information of job operation. You can view the details of serial number and reason codes for a lot and serial controlled assembly, job quantity details, component and resource usage and requirement details, lot attribute details and job attachments in HTML UI page.

*Job Operation Resource Requirements:* You can view a complete list of resources required for the operation when a job is selected from a dispatch list or when you manually

query.

*Job Operation Component Requirements:* You can view component requirements for each item in the dispatch list or for the lots selected using selected criteria, and view availability of the component.

*Job Operation Progress:* You can report on what you have accomplished on a particular job.

*Attachments:* In addition, you can also view attachment of a job. The attachment can be a text, a diagram, work instruction or specifications, which the operator can use as a reference on the shop floor.

### To view job operation

1. Navigate to Operator Workstation.
2. Select a job in the dispatch list.
3. Choose View Job Operation as Job Action.  
The Job Operation HTML page appears.
4. Select Quantities tab to view job quantity details.

ORACLE Shop Floor Management

Home Logout Preferences Personalize Page Diagnostics

Home Shop Floor Transactions Configuration

Shop Floor Transactions: Shop Floor Transactions > Logged in as MFG (M4)

Job Operation: AD121JB1(10)

Standard Operation Code FB10  
Operation Description Load Stepper Machine

Move To Next Op (2) Launch Job Plan Details Go

Intrap Step To move

Additional Details

Serial Number And Reason Codes Quantities Usage Requirements Lot Attributes

Assembly Quantities

UCM	Ea
Move In	5
Move Out	5
Bonus	0
Scrap	0

Instructions

Select Details Source	Entity Value	Attachment Sequence Title
No results found.		

Return to Previous Page

Move To Next Op (2) Launch Job Plan Details Go

5. Select Usage tab to view component and resource usage details.

Standard Operation Code: FB10  
Operation Description: Load Stepper Machine

Additional Details: Serial Number And Reason Codes, Quantities, Usage, Requirements, Lot Attributes

**Usage**

Components

Details	Component	Required Quantity	Issued Quantity	UOM Basis	Quantity Per Assembly	Inverse Usage	Component Yield	Supply Type	Supply Subinventory	Supply Locator
Show	CM3000	10	0	Ea	Item 1	1	1	Assembly Pull	Stores	
Show	CM3200	10	0	Ea	Item 1	1	1	Operation Pull	Stores	

Resource

Select Details	Resource	Instance	Operator	Start Date	Completion Date	Total Units	UOM
No results found.							

Usage Dates

Start Date	Completion Date	Units	UOM
No results found.			

Instructions

Select Details	Source	Entity Value	Attachment	Sequence	Title
No results found.					

6. Select Requirements tab to view component and resource requirement details.

Standard Operation Code: FB10  
Operation Description: Load Stepper Machine

Additional Details: Serial Number And Reason Codes, Quantities, Usage, Requirements, Lot Attributes

**Requirements**

Components

Details	Component	Required Quantity	Onhand Quantity	UOM Basis	Quantity Per Assembly	Inverse Usage	Component Yield	Date Required	Supply Type	Supply Subinventory	Supply Locator
Show	CM3000	10	1000	Ea	Item 1	1	1	06-Feb-2007 07:00:00	Assembly Pull	Stores	
Show	CM3200	10	1000	Ea	Item 1	1	1	06-Feb-2007 07:00:00	Operation Pull	Stores	

Resources

Select Details	Schedule Sequence	Resource Instance	Scheduled Start Date	Scheduled Completion Date	Usage Rate or Amount	Required Units	UOM Basis	Scheduled Setup	Type
Show		FA2LABCR	06-Feb-2007 07:00:00	06-Feb-2007 07:06:00	0.01	0.1	HR	Item	Yes

Scheduled Usage Dates

Start Date	Completion Date	Units	UOM
06-Feb-2007 07:00:00	06-Feb-2007 07:06:00	0.1	HR

Instructions

Select Details	Source	Entity Value	Attachment	Sequence	Title
No results found.					

## Job Plan Details

You can view the recommended path of the job, routing operation details, resource details, and component details in the Job Plan Details page.

### To view job plan details

1. Navigate to Operator Workstation.

2. Select a job in the dispatch list.
3. Select Launch Job Plan Details to view Plan details.  
The Plan Details HTML page appears.
4. Choose Update Recommended Path to update the recommended path in the Recommended field.

**ORACLE Shop Floor Management** Home Logout Preferences Personalize Page Diagnostics

Home Shop Floor Transactions Configuration

Shop Floor Transactions: Shop Floor Transactions >

Plan Details: AD121JB1

Job Description: Quantity Remaining **5**  
 Assembly: **CM61000** UOM: **Ea**  
 Assembly Description: **Processed Wafer** Coproducts Supply: **No**  
 Released Date: **31-Jan-2007 21:04:38** Current Routing Operation Sequence: **10**  
 Scheduled Start Date: **01-Feb-2007 07:00:00** Current Operation Code: **FB10**  
 Scheduled Completion Date: **01-Feb-2007 07:06:07** Current Operation Department: **FAB**  
 Requested Due Date: Routing Refresh Date: **31-Jan-2007 21:04:39**

Show Additional Details

**Operations**

View: All Operations

Update Recommended Path

Routing Operation Sequence	Code	Department	Operation Description	Start Date	Completion Date	Scheduled Quantity	Yield	Recommended	Details
10	FB10	FAB	Load Stepper Machine	01-Feb-2007 07:00:00	01-Feb-2007 07:03:00	5	1	<input checked="" type="checkbox"/>	<a href="#">Details</a>
20	FB20	FAB	Stepper Machine	01-Feb-2007 07:03:00	01-Feb-2007 07:03:07	5	1	<input checked="" type="checkbox"/>	<a href="#">Details</a>
30	FB25	FAB	Stepper Machine 2				1	<input type="checkbox"/>	<a href="#">Details</a>
40	FB30	FAB	Unload Stepper Machine	01-Feb-2007 07:03:07	01-Feb-2007 07:06:07	5	1	<input checked="" type="checkbox"/>	<a href="#">Details</a>

**ORACLE Shop Floor Management** Home Logout Preferences Personalize Page Diagnostics

Home Shop Floor Transactions Configuration

Shop Floor Transactions: Shop Floor Transactions > Plan Details: AD121JB1 >

Update Recommended Path: AD121JB1

Cancel Apply

Job Name: **AD121JB1** Job Description:  
 Assembly: **CM61000** Assembly Description: **Processed Wafer**  
 Routing Reference: Alternate Routing Designator  
 Routing Revision Date: **31-Jan-2007 21:04:28** Routing Revision: **0**

Details	From Sequence	From Code	To Sequence	To Code	Planning Percent	Recommended	Transition Type
Show 10	FB10	20	FB20	100	<input checked="" type="checkbox"/>	Primary	
Show 20	FB20	30	FB25	20	<input type="checkbox"/>	Alternate	
Show 20	FB20	40	FB30	80	<input checked="" type="checkbox"/>	Primary	
Show 30	FB25	40	FB30	100	<input type="checkbox"/>	Alternate	

Cancel Apply

Home Shop Floor Transactions Configuration Home Logout Preferences Personalize Page Diagnostics

About this Page Privacy Statement Copyright (c) 2009, Oracle. All rights reserved.

5. Click Details to view routing operation details of the required routing operation sequence.  
The HTML page for the selected operation appears.
6. Select Resources tab to see the resource details of the routing operation.

ORACLE Shop Floor Management

Home | Shop Floor Transactions | Configuration

Shop Floor Transactions: Shop Floor Transactions > Plan Details: AD121UB1 >

Operation: 10

Operation Seq Num: 10 Scheduled Quantity: 5  
 Operation Code: FB10 Start Date: 01-Feb-2007 07:00:00  
 Department: FAB Completion Date: 01-Feb-2007 07:03:00

Yield: 1

Hide Details

**Operation Yield**

Cumulative Yield	Net Planning Percent
Reverse Cumulative Yield	Include In Rollup: Yes

**WIP**

Count Point: Yes	Autocharge: Yes
Backflush: Yes	Minimum Transfer Quantity: 0

**Other**

Description: Load Stopper Machine	Effectivity Date: 28-Feb-2001 00:00:00
Option Dependent: No	Disable Date:
Operation Lead Time Percent: 0	

Resources | Components

Resource	Sequence	Schedule Sequence	Substitute Group	Resource	Start Date	Completion Date	Usage Rate/Amount	Required Units	UCM Basis	Scheduled Source	Phantom Details
10				FABLABOR	01-Feb-2007 07:00:00	01-Feb-2007 07:03:00	0.01	0.05	HR	Item	Yes

About this Page | Privacy Statement

Copyright ©2006, Oracle. All rights reserved.

- Select Components tab to view the component details of the routing operation, swap components, and change required quantity.

ORACLE Shop Floor Management

Home | Shop Floor Transactions | Configuration

Shop Floor Transactions: Shop Floor Transactions > Plan Details: AD121UB1 >

Operation: 10

Operation Seq Num: 10 Scheduled Quantity: 5  
 Operation Code: FB10 Start Date: 01-Feb-2007 07:00:00  
 Department: FAB Completion Date: 01-Feb-2007 07:03:00

Yield: 1

Hide Details

**Operation Yield**

Cumulative Yield	Net Planning Percent
Reverse Cumulative Yield	Include In Rollup: Yes

**WIP**

Count Point: Yes	Autocharge: Yes
Backflush: Yes	Minimum Transfer Quantity: 0

**Other**

Description: Load Stopper Machine	Effectivity Date: 28-Feb-2001 00:00:00
Option Dependent: No	Disable Date:
Operation Lead Time Percent: 0	

Resources | Components

Select Component: Update

Select	Details	Component	Required Quantity	Onhand Quantity	Quantity Per UOM Assembly	Inverse Usage	Component Basis Yield	Date Required	Supply Type	Supply Subinventory	Supply Locator	Source Phantom
<input type="radio"/>	<input type="checkbox"/>	0ME0000	5	10000	Ea 1	1	Item 1	01-Feb-2007 07:00:00	Assembly Pull	Stores		
Description: Raw Water		Include in Cost Rollup: Yes		Component Remarks								
Born Item Type: Standard												

Cancel Apply

**Note:** The required quantity of a component with negative quantity per assembly is calculated considering the yield of the operation for which the component is required.

See: Calculating Required Quantity for Components with Negative Quantity Per



## Quality Data Collection

You can define collection plan in quality module, invoke the plan during Move Out operation, specify quality data for the elements, and update or delete quality data during an operation.

### To view, enter and update quality data

1. Execute a Move Out transaction.
2. Update quantities in the Move Out page that appears.
3. Click Continue.
4. Click on the link in the column Add Child Data.

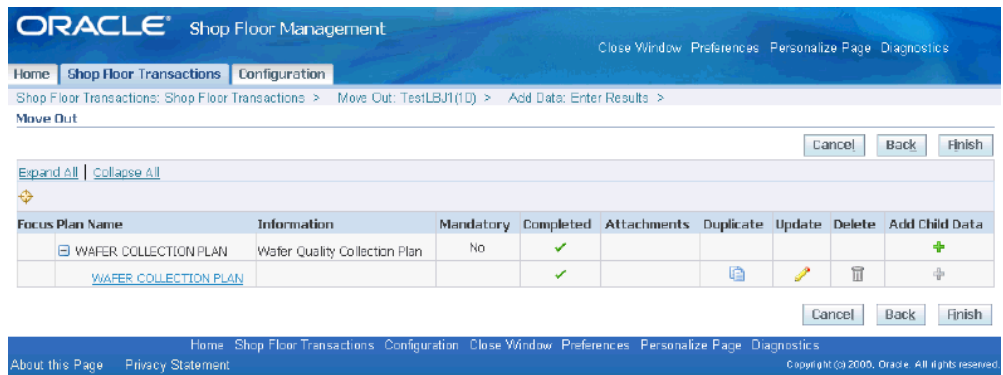

5. Specify quality data for the data elements in the Add Data page that appears.

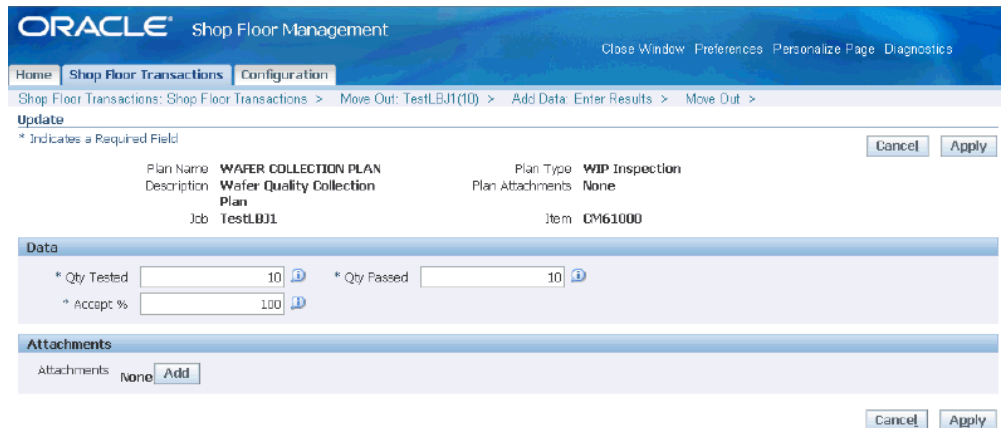

## Lot Traveler

You can generate Lot Traveler and Blank Lot Traveler for jobs that are Released, Under Execution and Completed.

A lot traveler is a snapshot of manufacturing data on the job progress. It gives you the complete data on operations, quantity, starting or completion date details that the lot has undergone.

You can view lot traveler from windows as well as HTML interfaces.

### Viewing lot traveler from HTML UI

1. Select a job from the Dispatch List.

The screenshot displays the Oracle Shop Floor Management interface. At the top, there are navigation tabs for 'Home', 'Shop Floor Transactions', and 'Configuration'. Below this, the page title is 'Shop Floor Transactions: Shop Floor Transactions >' and the user is logged in as 'as'. The main section is titled 'Job Operations' and includes a search form with fields for Job Op Type (Current and Scheduled), Organization (M4), Department (Assembly), Operation (AS20), and Resource. There are also fields for Instance, Scheduled Op Time From (09:00 AM), and Duration (08:00). A 'Go' button is present. Below the search form, there are links to 'Personalize Flow Layout' and 'Personalize "Current and Scheduled Job Op Summa...".

The Dispatch List table is shown below, with columns for Job, Action, Assembly, Quantity, UOM, Resource, Instance, Batch, Scheduled Op Date (Start and Completion), Move In, and Move Out. The first row is highlighted, showing Job RT\_103, Action View Lot Traveler, Assembly LRAS1005, Quantity 9, UOM Ea, Resource LASER\_SAW, Instance, Batch, Start 2006-Nov-22 07:06:00, Completion 2006-Nov-22 07:06:04, Move In, and Move Out.

Select Job	* Action	Assembly	Quantity	UOM	Resource	Instance	Batch	Scheduled Op Date	Move In	Move Out
RT_103	View Lot Traveler	LRAS1005	9	Ea	LASER_SAW			2006-Nov-22 07:06:00 2006-Nov-22 07:06:04		
SSBUG3	View Blank Lot Traveler	CM63000	2	Ea	LASER_SAW			2006-Nov-06 07:06:00 2006-Nov-06 07:06:04		
SSBUG3*1	Update Assembly	CM63000	3	Ea	LASER_SAW			2006-Nov-06 07:04:48 2006-Nov-06 07:04:52		

2. Select Job Action as View Lot Traveler.
3. Select View Blank Traveler for a blank template.

Job Name	RT_103	Start Quantity	10
Job Description		Net Planned Quantity	10
Assembly	LRAS1005	Remaining Quantity	9
Assembly Description	Assembly - Lot and Serial	Completed Quantity	0
Current Job Operation Sequence	20	Scrap Quantity	1
Current Routing Operation Sequence	20		

Operation Sequence		Standard Operation Code	Scheduled Dates		Scheduled Quantity	Actual Dates		Actual Quantities					
Job	Routing		Start	Completion		Start	Completion	In Queue	Running	To Move	Bonus	Scrapped	Completed
10	10	AS10	2006-Nov-22 07:00:00	2006-Nov-22 07:06:00				0	0	0	0	1	10
20	20	AS20	2006-Nov-22 07:06:00	2006-Nov-22 07:06:04				9	0	0	0	0	0
	30	AS30	2006-Nov-22 07:06:04	2006-Nov-22 07:12:04	10								

Job Name	RT_103	Start Quantity	10
Job Description		Net Planned Quantity	10
Assembly	LRAS1005	Remaining Quantity	10
Assembly Description	Assembly - Lot and Serial	Completed Quantity	0
Current Job Operation Sequence		Scrap Quantity	0
Current Routing Operation Sequence			

Operation Sequence		Standard Operation Code	Scheduled Dates		Scheduled Quantity	Actual Dates		Actual Quantities					
Job	Routing		Start	Completion		Start	Completion	In Queue	Running	To Move	Bonus	Scrapped	Completed
	10	AS10	2006-Nov-22 07:00:00	2006-Nov-22 07:06:00									
	20	AS20	2006-Nov-22 07:06:00	2006-Nov-22 07:06:04	10								
	30	AS30	2006-Nov-22 07:06:04	2006-Nov-22 07:12:04	10								

The Lot Traveler displays the details of the job and all the transactions the job has undergone.

### Viewing lot traveler from lot based jobs form

1. Navigate to Lot Based Jobs window and open a job.
2. Select View Lot Traveler from the Tools menu.
3. Select View Blank Traveler for a blank template.

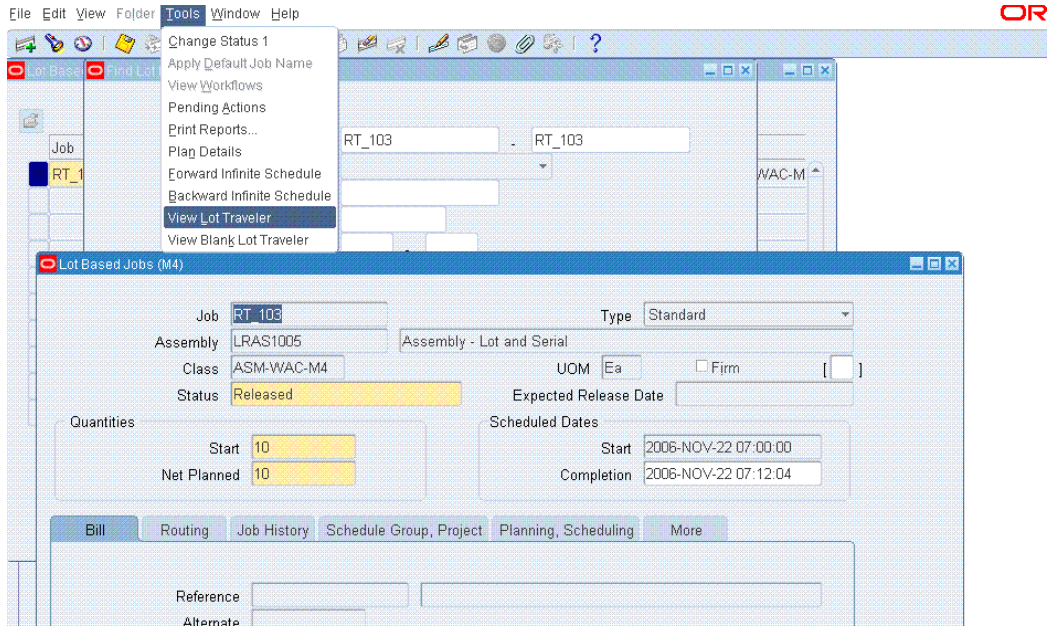

---

## Lot Transactions

This chapter covers the following topics:

- Overview of Lot Transactions
- Creating a Lot Based Job
- Overview of Sales Order Reservation for Lot Based Jobs
- Overview of Lot Moves
- Performing Lot Move Transactions
- Operation Jumps
- Viewing Status and Resources
- Integration with Oracle Advanced Supply Chain Planning (ASCP)
- Capturing and Modifying Detailed Job Level Plan Recommendations
- Changing the Recommended Path of a Job to an Intended Path for Future Operations
- Viewing Plan Resource Details
- Updating Plan Components
- Updating Plan Phantom Components
- Mass Refresh of Open Jobs
- Refresh BOM/Routing of Open Lot Based Jobs with Revision Dates
- Overview of Advanced Lot Transactions
- WIP Lot Transactions
- Creating WIP Lot Transactions
- Inventory Lot Transactions
- Creating Inventory Lot Transactions
- Lot Attributes in Inventory Lot Transactions

- Creating Lots for New Sectors
- Kanban Replenishment on Lot Based Jobs
- Lot Based Job Reporting
- Lot Based Job Component Pick Release
- Pending Transactions Report
- Integration with Outside Processing

## Overview of Lot Transactions

Oracle Shop Floor Management uses WIP lots and Inventory lots to create transactions. WIP lot transactions let you perform various work in process transactions during the production cycle, such as lot split, merge, part number change, and bonus (creating a new lot that is entirely new or from scrap).

The process flow of a lot begins when a WIP lot based job is created for the first sector's primary assembly. The WIP lot is created and released, moves through a series of operations, and is completed into an inventory location where it is an inventory lot. Upon completion, the WIP lot has the sector extension code appended that is assigned to the corresponding item subinventory. You can continue to use the same job name or lot name throughout the production process where the part number changes with each sector. For the bill of material, the part being completed in a sector becomes the primary component of the part being made in the next sector.

The Inventory lot then moves into the next sector. This move consists of creating a new WIP lot for the primary assembly of the next bill level (the next sector), and issuing the primary assembly from the previous sector to this new WIP lot. After WIP lot creation and issue of the primary component, the job moves through a series of operations, and is completed into inventory location. This process is repeated through each sector until the last sector is complete.

Oracle Shop Floor Management stores detailed information of each and every job. During manufacturing execution, you can make job level changes as follows:

- Changing the recommended path of a job to any other valid intended path for future operations.
- Changing component requirements or specifying component substitutes for future operations.
- Using alternate resources. This is done through the resource centric workbench.
- Using the workbench to reassign job operations to different time periods.
- A new html User Interface (UI) provides detailed planning recommendations on the components, resources, and the network path of a job. Similar changes to the job can also be accomplished through open interface tables.

**Note:** Lot based jobs are not considered in the Oracle Master Scheduling and MRP, Oracle Order Management, or Oracle Project Management applications.

**Note:** In OSFM organizations, unique serial numbers should be set within organization and across organizations.

## Reuse of Lot Names

With this new functionality you have the choice to create lots with the same name as the earlier sector.

### Default Job Name in Lot Creation form

When you create a lot in Lot Creation form, you have the option of job names being defaulted with the same name as that of the parent lot or different name from that of the parent lot. If you set Reuse Job Name to No, then the newly created jobs will have names with the job separator appended to the parent lot name. If Reuse Job Name is set to Yes, then the newly created jobs will be defaulted with the same name as the parent lot, provided there is only one resulting job. If there are multiple resulting jobs, then the first job will have the same name as the parent lot and the remaining jobs will have names appended with job separator.

**Note:** There is no change in the validation for job creation in any other functional flow.

### Job Name appended with Sector Extension

When you cancel a job or perform WIP lot transactions like split, merge, complete scrap, and job completion on a job, the job name will be appended with sector extension.

- If the parameter Reuse Job Name is set to Yes the job name will be appended with sector extension.
- If the parameter Reuse Job Name is set to No, then the job name will not be appended with sector extension.
- While performing assembly returns or updating status of cancelled job to released/unreleased status, the sector extension of the job irrespective of the value set for the Reuse Job Name parameter is trimmed. See: Defining Parameters, page 2-10

## Creating a Lot Based Job

After you have completed setup steps for defining your item numbers, assemblies, bills

of material, and network routings—the next step is to create a lot based job for the first sector. The Lot Based Jobs window is used to define lots for the first sector of the manufacturing process and links them to assemblies on the shop floor. The lots for the other sectors are created using the Lot Creation window, see: *Creating Lots for New Sectors*, page 5-44.

You cannot create lot based jobs for serial controlled assemblies without lot control. The assembly must be lot controlled as well. This restriction applies to the jobs created using windows and interfaces.

**Note:** Lot based jobs support operation pull, push, and phantom supply types. Other supply types are not currently supported.

**Note:** Assembly Lot Number field in Lot Entry and Serial Entry window in Material Issue transactions, is not applicable for Lot Based Jobs.

### **Non-standard Lot Based Jobs**

You can create non-standard lot based jobs. Standard jobs control the material, resources, and operations required to build an assembly and collect costs. Non-standard jobs control material and collect costs for miscellaneous activity. These jobs can be used on expense work orders for testing, prototypes, and rework where operation yield costing is not considered. You can perform all transactions on a non-standard lot based job like move, scrap, jump, undo, completion, return, material transactions; all WIP lot transactions like bonus, split, merge, update routing, update assembly, update quantity and update lot name. Non-standard lot based jobs use WIP accounting class type *Expense Non-standard Lot Based*. See: *WIP Accounting Classes, Oracle Work in Process User's Guide*.

For non-standard jobs, you can choose whether to specify a subinventory or not. Thus subinventory is defaulted during job creation. If a subinventory is specified, you can complete the job into an inventory lot.

You can perform the update of BOM and routing reference id's provided the job is unreleased. To update any reference id, you have to provide the reference id, revision date and the alternate designator.

#### **See Also**

Overview of Setting Up, *Oracle Inventory User's Guide*

Overview of Setting Up, *Oracle Bills of Material User's Guide*

Creating a Network Routing, page 3-4

Closing Lot Based Jobs, page 11-1



## To find lot based jobs:

1. Navigate to the Lot Based Jobs window.

The Find Lot Based Jobs window displays.

2. Enter your search criteria.

You can query by job name, assembly, accounting class, a range of start dates, a range of completion dates, or job status. You can combine or omit criteria as required.

The screenshot shows the 'Find Lot Based Jobs (M4)' window. It features several search criteria fields: 'Jobs' (with a dropdown arrow), 'Type' (with a dropdown arrow), 'Assembly', 'Schedule Group', 'Build Seqs' (with a range selector), 'Class', 'Start Dates' (with a range selector), and 'Completion Dates' (with a range selector). Below these fields is a 'Status' section containing checkboxes for 'Unreleased', 'Released', 'Complete', and 'On Hold', and a dropdown menu currently set to 'Closed'. At the bottom of the window are three buttons: 'Clear', 'New (A)', and 'Find'.

3. Choose Find to display the Lot Based Jobs Summary window.

- Select a lot based job and choose one of the following actions.
- View Genealogy to view historical informations in the Lot Genealogy window, see: Displaying Genealogy and Where used Views, page 8-2.
- The Operations window is used to view the resource requirement for the lot-based job.
- The lot-based job provides the resource details for the first operation during job

creation and the resource requirement for the other operations are shown whenever the job is moved to this operation.

- Components to access the Material Requirements window displaying all the components for this job
- Open to display the details of this job in the Lot Based Jobs window.
- You can choose Plan Details from the Tools menu to open the UI and view the planned operation details.

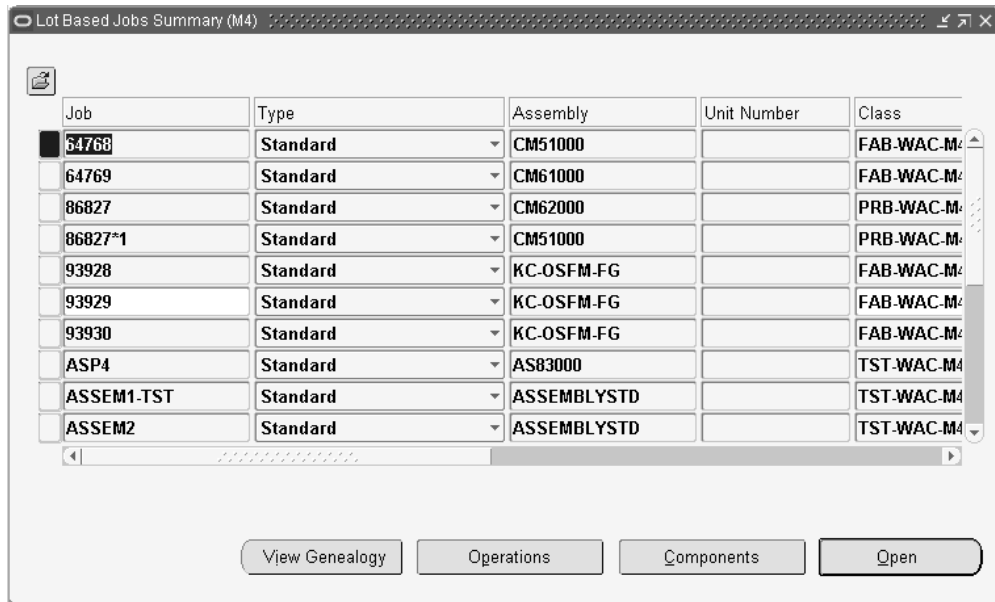

4. If you are creating a new lot, Choose New (A).

### Creating Lot Based Jobs:

#### To create lot based jobs

1. Navigate to the Lot Based Jobs window. The Find Lot Based Jobs window displays.
2. If you are creating a new lot, Choose New (A). The Lot Based Jobs window opens.
3. Enter the name of the job in the Job field.

Oracle Work in Process discrete jobs and Shop Floor Management lot based jobs must not use the same value for Job name. In the Job Type field, the value defaults to standard. Oracle Shop Floor Management uses both standard and non-standard jobs.

As you proceed with the manufacturing process, the job name changes as lots are

created, split, renamed, and completed. While creating lots, the name cannot exceed 80 characters.

**Note:** Do not use the same character value for both the job completion separator, and in a segment of the job name. When lots are completed the resulting lot designation is the original lot number, followed by the job separator value, followed by the lot sector extension. Using the same character value creates an error in the resulting lot name.

4. Select the assembly in the Assembly field.

The screenshot shows the 'Lot Based Jobs (M4)' form. The 'Job' field is 'RESJOB\_UOM' and 'Type' is 'Standard'. The 'Assembly' field is 'CSLT120' with a description 'Computer System- Lap Top MODEL120'. The 'Class' is 'ASM-WAC-M4' and 'UCM' is 'Ea'. The 'Status' is 'Released'. The 'Expected Release Date' is empty. In the 'Quantities' section, 'Start' and 'Net Planned' are both '36'. In the 'Scheduled Dates' section, 'Start' is '25/07/2006 07:00:00' and 'Completion' is '25/07/2006 07:43:16'. There are tabs for 'Bill', 'Routing', 'Job History', 'Schedule Group, Project', 'Planning, Scheduling', and 'More'. Below the tabs are fields for 'Reference', 'Alternate', 'Revision', 'Revision Date', and 'Supply Type' (set to 'Based on Bill'). At the bottom are buttons for 'Sales Orders', 'Serial Numbers', 'Lot Attributes', 'Operations', and 'Components'.

5. Select the job status in the Status field.

When you define a job, its status defaults to Unreleased but can be changed to Release or On Hold.

6. Use the Firm indicator to firm this job.

Firming a job prevents planning suggestions for rescheduling. However, lot based jobs are not considered in the Oracle Master Scheduling and MRP, but are planned in Oracle Advanced Supply Chain Planning. This field is not used by non-standard jobs.

7. In the Quantities region, enter the Job quantity of the job or lot in the Start field.

When you enter a Job start quantity for the Lot Based job using bills and routings, the component material requirements and resource equipment for the First Operation will be exploded into this Job.

You can change the quantity on jobs without transactions.

8. In the MRP net field, the quantity is derived from the job start quantity.  
Oracle Shop Floor Management does not integrate with Oracle Master Scheduling/MRP. This field supports Oracle Advanced Planning and Scheduling, applications.
9. In the Dates region, enter a value in either the Start or Completion field.  
If you enter a start date, the completion date is forward scheduled. Similarly, if you enter a completion date, the start date is backward scheduled.
10. Save your work.

**Note:** Lot based jobs create the material and resource requirement for the first operation only. The material and resource requirement is exploded whenever the job is moved to the corresponding operation, including the last operation.

If you choose Launch Plan Details from the Tools menu, then you can view all planned operation details.

#### **To assign an alternate bill of material or revision**

1. On the Bill tab in the Alternate field, select the alternate bill of material.
2. You can select an alternate bill of material if an alternate has been defined. See: Primary and Alternate Routings, *Oracle Bills of Material User's Guide*.
3. In the Revision field, select the bill of material revision.
4. Select the bill of material revision's date and time.  
Bill revision and date determine which version of the bill, and therefore which components are on the bill of material.
5. In the Supply Type field, the value defaults to Operation Pull.  
Lot based jobs support only operation pull, push, and phantom supply types.
6. Save your work.

#### **To assign the appropriate routing if the job has multiple routings**

1. On the Routing tab, select the routing you want to use in the Routing field.
2. Routings must be defined for this assembly, see: Creating a Network Routing, page 3-4.

3. In the Revision field, select the revision number of this routing.  
The date of the lot based job can be used to derive the routing revision.
4. In the Revision field, select the date and time if you want to update the values derived from the routing.
5. In the Subinventory field, the location (and locator, if existing) display for where this job completes.  
Subinventory fields default from the routing. They are not required for non-standard jobs—you can remove these values if this job will not be completed into inventory.
6. Save your work.

### **Scheduling Lot Based Jobs:**

#### **To schedule lot based jobs**

Enter or select either the Start and/or completion date and time. If you enter one date and time, the other date is calculated as per the routing schedule in the primary path.

**Note:** Lead time is used for scheduling discrete jobs that have no routing defined. Lot based jobs are not scheduled using lead time. Scheduling in lot based jobs is always done based on the resources in the primary path of network routing.

### **Viewing Component Requirements:**

#### **To view component requirements**

Choose Components. The Material Requirements window displays showing all the components of this job.

You can view component requirements for all planned operations by using the option Plan Details from the Tools menu.

You can view the component requirement from the Lot Based Jobs window by clicking the Component button, but this will contain components for performed operations and the current operation only.

#### **To view the components of all the operations:**

1. Click on the Tools menu and select the option Plan Details. The Plan Details page appears.
2. Click on the Details icon for the corresponding Routing Operation Sequence. The Operation page for that particular routing sequence appears.

- Click on the Components tab to view the components available for that particular operation.

### Calculating Required Quantity for Components with Negative Quantity Per Assembly

#### 1. Querying the Existing Components of a Job

If the Supply Type of a component is Push, the quantity per assembly is negative, and the job is a Lot Based Job, then the required quantity is calculated as follows:

The screenshot shows the 'Material Requirements (M4)' window. At the top, there are input fields for Job (LN146\*1-ASM), Assembly (SC6301), Start Date (06/06/2005 13:16:10), Line, and Operation Seq Num. Below these are tabs for Main, Quantities (selected), Repetitive Quantities, Supply, Comment, and ATP. The main area contains a table with the following columns: Component, Basis, UOM, Type, Per Assembly, Inverse Usage, Yield, Required, Issued, Open, and On Hand. The first row of data is for Component SC5200, with Basis Ea, UOM Item, Type Item, Per Assembly 1, Inverse Usage 1, Yield blank, Required 1400, Issued 1400, Open blank, and On Hand 6800. Below the table are buttons for 'Select All' and 'Check ATP'.

Component	Basis	UOM	Type	Per Assembly	Inverse Usage	Yield	Required	Issued	Open	On Hand
SC5200	Ea	Item	Item	1	1		1400	1400		6800

- Case 1**

If the operation at which the component used is Current Operation and the quantity is in Queue or Run. Also, if the component is at an operation for which the quantity is at Queue or Run, the required quantity displayed is calculated as:

$$\text{Quantity Per Assembly} * \text{Quantity in Queue or Run} * \text{Operation Yield}$$

- Case 2**

If the operation is Current Operation and the quantity is at To Move.  
 If the component is at an operation for which the quantity is at To Move, the required quantity displayed is calculated as:

$$\text{Quantity Per Assembly} * (\text{Quantity Completed} - \text{Quantity Scrapped})$$

**Note:** The actual quantity output from the To Move operation

is only considered and not the yield from that operation.

- **Case 3**

If the component is at any of the previous operations, then the required quantity is also calculated in the same way as in Case 2

Quantity Per Assembly \* (Quantity Completed - Quantity Scrapped)

**Note:** The actual quantity output from the previous operation is only considered and not the yield from that operation.

## 2. Updating the Existing Records

You can update the components at any operation; for example, it may be in Run/Queue/To Move.

- **Case 1**

If you change the Quantity Per Assembly, then you must proportionately change the displayed Required Quantity.

**Caution:** Note that you are only changing the display value of the Required Quantity and not the value in the system.

- **Case 2**

You can also update the required quantity of the component at any operation.

**Note:** You cannot update the component details in the Lot Based Job window.

## Viewing, Entering, and Updating Lot Attributes:

### To view, enter, and update lot attributes

1. Choose Lot Attributes. The Lot Attributes window appears and displays the lot number and attributes of this job.

If you are entering or updating lot attributes, then enter or update attributes with appropriate values for Warehouse Management and Inventory attributes based on the lot attributes setup that you or your system administrator have completed.

The screenshot shows a window titled "Lot Attributes". It contains the following fields and values:

- Attribute Name: GSUBLOC
- SUB: MMMBULK
- LOC: MMB.1.1

At the bottom right, there are four buttons: OK, Cancel, Clear, and Help.

2. Choose OK to save and return to the Lot Based Jobs window.
3. Choose Cancel if you do not want to save the lot attribute changes.

If you are only viewing the lot attributes without making changes, then you can choose OK or Cancel.

4. Save your work.

**Note:** If you do not enter a required segment value, then an error message appears. If you wish to view detailed information for an error message, then you must execute the concurrent request Get Messages using the parameter DB\_TO\_RUNTIME with a specific Language.

## Overview of Sales Order Reservation for Lot Based Jobs

Oracle Shop Floor Management reserves a lot based job for an open sales order created for an assembly item. It also initiates updating of reservations when a lot based job is modified.

### To reserve a lot based job against a sales order

1. Create a Lot Based Job.
2. Reserve Lot Based Job in the status Unreleased or Released or On Hold against a Sales Order using Item Reservation form (Inventory: Onhand > Reservation).
3. Enter Sales Order information using the Demand tab in the Item Reservation window.
4. Enter Lot Based Job information selecting the Supply tab in the Item Reservation window.
5. Choose Supply type as Job or Schedule (Lot Based Job) to reserve against a lot based job.



All Lot Based Jobs in Unreleased or Released or On hold status with net quantity greater than zero are eligible for creating reservations.

6. Enter the Lot Based Job in the Header Number field.

Reservations will be transferred from the Job (Lot) to Inventory Lot during assembly completion. Inventory Lot is reserved for the Sales Order.

7. Save your work.

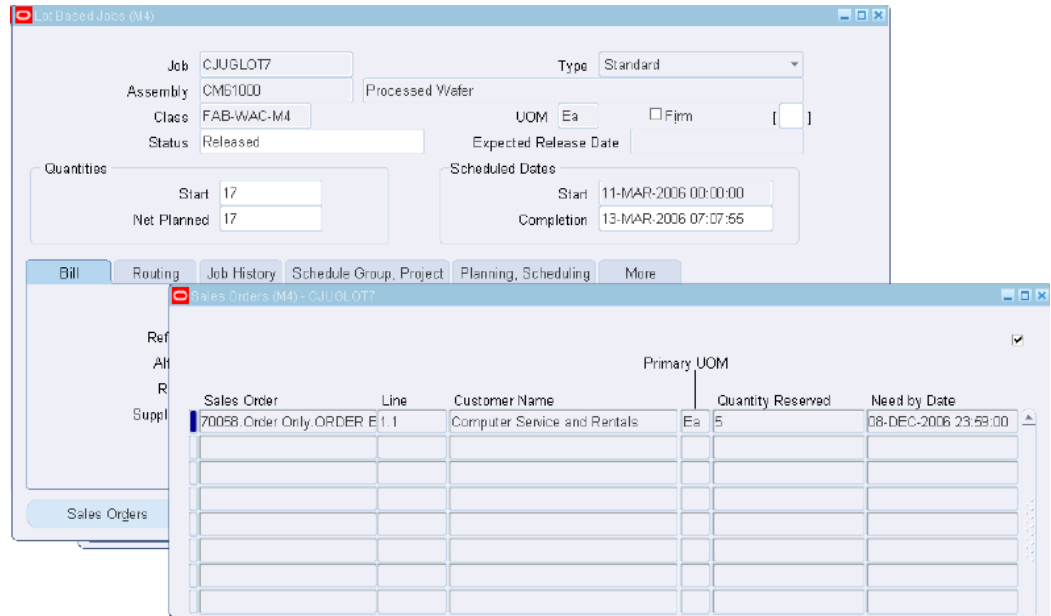

### To view lot based job reservations against sales order

Choose Sales Orders button in the Lot based Jobs form. The Sales Order window displays Sales Order information on Reserved Jobs. You can reserve one job to one sales order or multiple sales order. Similarly, you can reserve multiple jobs to one sales order or multiple sales orders.

### To initiate updation of reservations

- When you change the job status from Released to Cancel, the reservation will be deleted.
- If you change the net quantity of the job to be less than the reserved quantity, the reservation will be updated.

### To update reservations during move transactions

- During moves, if available quantity falls below the net quantity, a warning is shown.
- During split and merge transactions, you have to manually transfer reservations to

new child jobs.

- Reservation will be transferred to inventory from the lot based job on assembly completion transaction.
- During assembly return transaction, reservations transferred from job to inventory on assembly completion will be reversed.

#### **To update reservations during WIP lot transactions**

- *Split*: If one of the resulting lots is same as the starting lot, then Reservation Quantity changes with respect to job Net Planned Quantity of the resulting lot.  
If all the resulting lots are different from the starting lots, then the reservation is deleted.
- *Merge*: If the starting jobs are of different assemblies, only the representative job's reservations will be transferred to the resulting job.  
If the starting jobs are of same assembly, all the starting job reservations will be transferred to the resulting job.
- *Update Assembly*: Existing reservations against the lot based job are deleted during Update assembly transaction.
- *Update Quantity*: If the net quantity of the starting job is modified to be less than the starting job's reserved quantity, then reserved quantity is updated accordingly. If the starting job net quantity becomes zero, the reservation is deleted.

## **Overview of Lot Moves**

Lot based jobs support network routing. Based on the results of an operation, you can define different paths for the next operation. Therefore, two distinct lot based jobs for a particular assembly with the same routing, could move through different manufacturing operations in that routing.

In comparison to the Move Transaction window for discrete jobs in Oracle Work in Process, the Move Lot Based Jobs window is more restrictive in the options when moving the lot through the routing. With the exception of scrap transactions, all move transactions are for the entire lot quantity. When a job is completed, the job name is automatically renamed using the lot sector extension, see: Defining and Viewing Lot Sector Extensions, page 2-15.

## **Performing Lot Move Transactions**

You can move assemblies within an operation or from one operation to the next using the Move Lot Based Job window. This window is modeled after the Move Transactions window in Oracle Work in Process. See: Move Transactions, *Oracle Work in Process*

*User's Guide.*

You can execute all move transactions with scrap simultaneously during job execution from the move transactions user interface in the Move Lot Based Job window. This reduces the number of transactions, and captures good and bad quantity in the operation.

**Guidelines for Combined Move and Scrap Transactions:**

- Generally, move and scrap will not work if the backflush flag in the Routing window on the From operation or the To operation is turned off.
- If the Jump From Scrap parameter in the OSFM Parameters window is set to ignore operation, then you cannot scrap at the From operation when executing a Jump and Scrap.
- If the job is at the Queue of an operation and Run is a mandatory intraoperation step, then you cannot execute a Move and Scrap in that operation. You must first move to Run, and then Move and Scrap will work.
- If run of the next operation is mandatory, then you cannot move and scrap in the next operation. Move and scrap is possible in the From operation if the Run in the From operation is not mandatory.

When using Oracle Advanced Planning the To Operations field in the Move Lot Based Job window provides guidance on the next recommended operation based on Oracle Advanced Planning inputs, or the user recommendations, whichever is the most recent.

**To perform lot move transactions:**

1. Navigate to the Move Lot Based Jobs window.
2. In the Assembly or Job field, select either an item assembly number or lot job number.

Depending on which value you enter, the defaulting information for the corresponding field displays.

Move Lot Based Job (M4)

Assembly: CME1000    Processed Wafer:    Routing Revision: 0  
 Job: PMOVE\_JOB    UOM: Ea    Bill Revision: 0

Transaction Type:  
 Move     Partial  
 Complete     Undo  
 Return     Jump

Job Seq	Code	Department	Step
From: 10	FB10	FAB	Queue
To: 20	FB20	FAB	Queue

Transaction:  
 Serial Tracking  
 UOM: Ea  
 Available: 10    Job Name: PMOVE\_JOB  
 Move Quantity: 7    Job Name: PMOVE\_JOB\*1  
 Remaining Quantity: 3  
 Scrap Quantity:    Job Name: PMOVE\_JOB\*1  
 Scrap At Job Seq:    Job Name: PMOVE\_JOB\*1  
 Date: 20/07/2006 09:23:22

Scrap Account:  
 Alias:    Number:    Reason:    Reference: [ ]

Manual Resources Exist

Buttons: Enter Serials    Associate Serials    Lot Attributes    Statuses    Resources    Save (S)

3. Move displays in the Transaction Type region.

Move transaction type indicates moving from one operation to another. Complete transaction type is active only when the job is moving to the last operation and last intraoperation step. See: Move Transaction Types, Oracle Work in Process User's Guide.

Select the Undo Last Move check box if you want the option of cancelling the last move transaction. The Undo Last Move indicator on the Shop Floor Parameter window must be selected to enable this functionality.

4. Select the Partial check box if you want to move a job partially to the next operation in sequence, when required, or within an operation from one intraoperation step to another. Partial check box is clear by default.

Enter the quantity (from the Available quantity) you want to partially move to the next operation in the Move Quantity field.

The original job with the partial quantity moves to the specified next operation, the split part (child job) of the original job will remain at the same operation level with the difference in the original quantity.

The remaining quantity is displayed in the Remaining Qty field. The check box is defaulted for the next move transaction. If the Partial check box is checked, the Move Quantity and Remaining Quantity cannot be zero.

You can move a partial quantity of a job during a Move transaction. A new job is created for the remaining quantity, while the partial quantity is moved with the parent job. It is equivalent to a combination of a WIP Split transaction in the background and a Move transaction.

Partial Move is not supported with the Move and Scrap transaction. It is also not

supported for jobs at Run interoperation step.

5. In the Operations region, enter operation sequence values in the To row.  
Values in the From row are defaulted based on the current status of the lot job. The information for Operation Code, Department, and Operation Step automatically displays, see: *Operations, Oracle Bills of Material User's Guide*.  
The To row permits moves only to those operations which are valid, based on network. However, you can jump to any operation not defined in the network routing. See: *Operation Jumps, page 5-18*.
6. If there is quantity to scrap, enter Scrap Quantity in the Transaction region.
7. Enter the Scrap At Job Seq to define the operation wherein the quantity should be scrapped. You can scrap at the From operation or the To operation.  
When executing a move and scrap transaction at the first operation, you cannot scrap and move in one step. This must be completed in two steps, and Lot Genealogy will display as a scrap transaction followed by a move transaction. See: *Operations, Oracle Inventory User's Guide*.  
If the estimated scrap accounting is enabled, and you are moving material to scrap in this transaction, then Alias information displays in the Scrap Account region. Otherwise, it will be a blank field that you can update.  
The scrap account alias number is an easily recognized name or label representing an account charged on miscellaneous transactions. This is used for viewing, reporting, and reserving. The scrap account number displays. See: *Defining Account Aliases, Oracle Inventory User's Guide*.
8. If manual resources exist for the completed operation, then the Manual Resource Exist indicator is selected. If there are Manual resources at the operation that is being completed, then the application notifies you that manual resources exist at the operation so that you can manually charge them. See: *Charging Resources with Move Transactions, Oracle Work in Process User's Guide*.
9. In the Reason field, select a transaction reason. See: *Defining Transaction Reasons, Oracle Inventory User's Guide*.
10. In the Reference field, enter any descriptive information to identify transactions, used on standard reports.
11. Choose Save to save the transaction.
12. If the supply type of the component at the operation is Operation Pull, then the Backflush window displays any consolidated component requirements for the move and scrap (if scrap is applicable) as a single transaction, . If the item quantities, and the lot and serial numbers are correct, then choose Done to complete

the move and scrap transaction.

**Note:** You can update the material requirements for the current operation using the Update Material Requirements window. However, if you undo the transaction and execute a forward move to the same operation, then the application backflushes the components according to the BOM option A, and copy tables in option A. Any change in material requirements done before that operation will be lost. You can change material requirements for future operations using the html UI. These material requirement changes will be referenced and never deleted.

**To view, enter, and update lot attributes:**

Choose Lot Attributes. The Lot Attributes window appears and displays the lot number and attributes of this job.

13. Choose Attributes in the Lot Attributes window. A new Lot Attributes window appears.

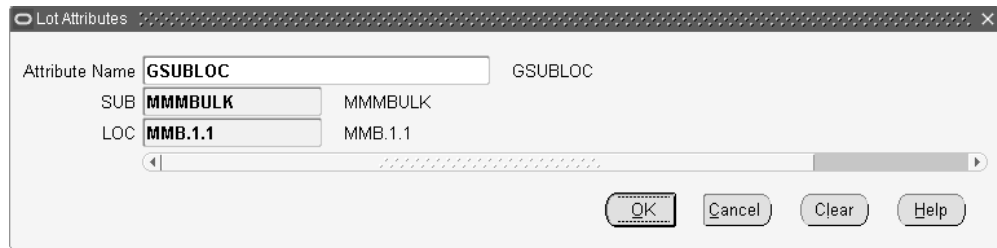

14. Select an Attribute from the list of values.
15. Enter parameter and segment values.
16. Choose OK.
17. Save your work.

## Operation Jumps

The operation jump functionality enables you to skip operations in a routing, or jump to any operation not defined in the network routing. To use this functionality, set the following parameters:

- Oracle Shop Floor Management profile option, Allow Operation Jumps is set to Yes. See: Profile Options, page 2-21
- Work in Process Parameters window, set the Move Transaction Parameter – Allow

## Creation of New Operations—to Yes

- Oracle Shop Floor Management Parameters window, set the parameter Jump From Queue according to your need. See: Defining Parameters, page 2-10.

### To perform an operation jump:

1. Navigate to the Move Lot Based Jobs window.
2. In the Assembly or Job field, select either an item assembly number or lot job number.

Depending on which value you enter, the defaulting information for the From the Transaction Type region, check the Jump check box.

3. In the To row, enter any operation sequence number which is greater than the From operation sequence number.
4. Select an operation code and the step for the operation to which you want to jump.
5. Create remaining transactions as described in Creating Lot Move Transactions, page 5-14.

After completing the jump operation, you can move to any of the operations defined in the original routing to complete the balance of operations.

6. Save your work.

## Viewing Status and Resources

### Related Topics

**To view shop floor statuses:**

Choose Statuses. See: Assigning and Viewing Shop Floor Statuses, *Oracle Work in Process User's Guide*.

**To view shop floor resources:**

Choose Resources. See: Charging Resources with Move Transactions, *Oracle Work in Process User's Guide*.

## Integration with Oracle Advanced Supply Chain Planning (ASCP)

Oracle Shop Floor Management integrates with Oracle Advanced Planning and Scheduling. Oracle Advanced Planning collects data for lot based jobs on the shop floor and performs high level planning, and suggests creation of new lot based jobs, if required. Lot based jobs contain plan information. This plan information comes from the following three sources:

- Oracle Advanced Planning modifies plans for existing jobs, or specifies plans for the newly created jobs.
- You can change the plan information on the lot based job.

You can specify or change the following on a lot based job, one job at a time:

- Specify or change the path that is planned to be traversed on the network routing. This involves operations that you intend to perform for this job that form a path on the network routing.
- Specify or change the component that is used for the operations. You can specify substitute components on the routing. You can indicate your preference of which component to use among the alternates that are available.
- Specify or change the resources used for the operations. You can specify alternate resources on a network routing and can indicate your preference of which resource to use. If the resource has instances, then you can specify the specific instance that would be used for the specific lot based job.

The Oracle Shop Floor User Interface (UI) for capturing and altering planning preferences is an enhancement to the shop floor scheduling process. The UI for capturing and altering planning preferences streamlines the shop floor scheduling process. You can access the UI for capturing and altering planning preferences through a BLAF-compliant web interface.



## Capturing and Modifying Detailed Job Level Plan Recommendations

You can capture and modify detailed Oracle Advanced Planning recommendations for job and operation start dates, completion dates, component details, and resource details. You must also choose the primary path planning option in the planning parameters of Oracle APS. The application uses recommendations on component substitutes and alternate resources received from planning and scheduling systems, or you can enter these manually.

Oracle Advanced Planning plans materials and resources for a job based on the primary path of the routing. During execution, you can change the planned execution as follows:

- Changing the recommended path of a job to any other intended path for future operations.
- Changing component requirements or specifying component substitutes for future operations.
- Using alternate resources. This is done through the resource centric workbench.
- Change planned operation yield.

An HTML User Interface (UI) provides detailed planning recommendations on the components, resources, and the network path of a job. You can use this UI to make any job level changes described above, except changing to alternate resources. See: Rescheduling Jobs, Operations, and Resources in the Gantt Chart, page 7-14

You can also implement all Oracle Advanced Planning recommendations and changes using open interface tables. Interfaces can be used to populate data from third party planning applications.

## Changing the Recommended Path of a Job to an Intended Path for Future Operations

You can change the recommended path of a job to any other intended path for future operations using the Update Plan Recommended Path UI window.

### **To update the plan recommended path:**

1. Navigate to the Lot Based jobs window and open a job.
2. Select Plan Details from the tools menu.

The Oracle Shop Floor Management HTML Plan Details UI window appears. The Header region displays job details and the Operations region displays operations for the job. In the Operations region, the default view shows the recommended operations in their order on the recommended path. The view can be changed to

show all operations.

ORACLE Shop Floor Management

Home Logout Preferences Personalize Page Diagnostics

Home Shop Floor Transactions Configuration

Shop Floor Transactions: Shop Floor Transactions >

Plan Details: AD121JB1

Job Description: Quantity Remaining: 5  
 Assembly: CM61000 UOM: Ea  
 Assembly Description: Processed Wafer Coproducts Supply: No  
 Released Date: 31-Jan-2007 21:04:38 Current Routing Operation Sequence: 10  
 Scheduled Start Date: 01-Feb-2007 07:00:00 Current Operation Code: FB10  
 Scheduled Completion Date: 01-Feb-2007 07:06:07 Current Operation Department: FAB  
 Requested Due Date: Routing Refresh Date: 31-Jan-2007 21:04:39

Show Additional Details

Operations

View: All Operations

Update Recommended Path

Routing Operation Sequence	Code	Department	Operation Description	Start Date	Completion Date	Scheduled Quantity	Yield	Recommended	Details
10	FB10	FAB	Load Stepper Machine	01-Feb-2007 07:00:00	01-Feb-2007 07:03:00	5	1	<input checked="" type="checkbox"/>	[Details]
20	FB20	FAB	Stepper Machine	01-Feb-2007 07:03:00	01-Feb-2007 07:03:07	5	1	<input checked="" type="checkbox"/>	[Details]
30	FB25	FAB	Stepper Machine 2				1	<input type="checkbox"/>	[Details]
40	FB30	FAB	Unload Stepper Machine	01-Feb-2007 07:03:07	01-Feb-2007 07:06:07	5	1	<input checked="" type="checkbox"/>	[Details]

- Choose Update Recommended Path in the operations region to make changes to the recommended components and quantities. The Update Recommended Path UI window appears. Select or clear the recommendations to create a new recommended path.

ORACLE Shop Floor Management

Home Logout Preferences Personalize Page Diagnostics

Home Shop Floor Transactions Configuration

Shop Floor Transactions: Shop Floor Transactions > Plan Details: AD121JB1 >

Update Recommended Path: AD121JB1

Cancel Apply

Job Name: AD121JB1 Job Description: Processed Wafer  
 Assembly: CM61000 Assembly Description: Processed Wafer  
 Routing Reference: Alternate Routing Designator  
 Routing Revision Date: 31-Jan-2007 21:04:28 Routing Revision: 0

Details	From Sequence	From Code	To Sequence	To Code	Planning Percent	Recommended	Transition Type
Show	10	FB10	20	FB20	100	<input checked="" type="checkbox"/>	Primary
Show	20	FB20	30	FB25	20	<input type="checkbox"/>	Alternate
Show	20	FB20	40	FB30	80	<input checked="" type="checkbox"/>	Primary
Show	30	FB25	40	FB30	100	<input type="checkbox"/>	Alternate

Cancel Apply

Home Shop Floor Transactions Configuration Home Logout Preferences Personalize Page Diagnostics

About this Page Privacy Statement Copyright (c) 2009, Oracle. All rights reserved.

- Choose Apply to save your changes and return to the Plan Details UI window, or choose cancel to discard any changes.

## Viewing Plan Resource Details

You can view details for a recommended resource, and view alternate resources using the Plan Resource Details window from the HTML UI.

## To view plan resource details for a recommended resource:

1. Navigate to the Lot Based Jobs window and open a job.
2. Select Plan Details from the tools menu. The Plan Details UI window appears.
3. Choose Details from a Routing Operation Sequence. The Plan Operation Details UI displays.
4. Choose Details.

The Plan Resource Details window appears.

**ORACLE Shop Floor Management**

Home | Shop Floor Transactions | Configuration | Home | Logout | Preferences | Personalize Page | Diagnostics

Shop Floor Transactions: Shop Floor Transactions > Plan Details: AD12UB1 >  
Operation: 10

Cancel Apply

Operation Seq Num: 10 Scheduled Quantity: 5  
Operation Code: FB10 Start Date: 01-Feb-2007 07:00:00  
Department: FAB Completion Date: 01-Feb-2007 07:03:00  
Yield: 1

Slide Details

**Operation Yield**

Cumulative Yield	Net Planning Percent
Reverse Cumulative Yield	Include In Rollup: Yes

**WIP**

Count Point: Yes	Autocharge: Yes
Backflush: Yes	Minimum Transfer Quantity: 0

**Other**

Description: Load Stepper Machine	Effectively Date: 29-Feb-2001 00:00:00
Option Dependent: No	Disable Date:
Operation Lead Time Percent: 0	

**Resources Components**

Resource	Sequence	Schedule	Sequence	Substitute Group	Resource	Start Date	Completion Date	Usage Rate/Amount	Required Units	UCM Basis	Scheduled	Source	Phantom	Details
10					FABLABOR	01-Feb-2007 07:00:00	01-Feb-2007 07:03:00	0.01	0.05	HR	Item	Yes		

Cancel Apply

About this Page | Privacy Statement | Home | Shop Floor Transactions | Configuration | Home | Logout | Preferences | Personalize Page | Diagnostics | Copyright (c) 2007, Oracle. All rights reserved.

## Updating Plan Components

You can view and change the recommended plan components using the Update Components UI window.

### To update the recommended plan components:

1. Navigate to the Lot Based Jobs window and open a job.
2. Select Plan Details from the tools menu. The Plan Details UI window appears.
3. Choose the Details icon for a Routing Operation Sequence. The Plan Resources and Components Details UI window appears.

ORACLE Shop Floor Management

Home | Shop Floor Transactions | Configuration

Shop Floor Transactions: Shop Floor Transactions > Plan Details: AD121JB1 >

Operation: 10

Operation Seq Num: 10      Scheduled Quantity: 5  
 Operation Code: FB10      Start Date: 01-Feb-2007 07:00:00  
 Department: FAB      Completion Date: 01-Feb-2007 07:03:00  
 Yield: 1

Hide Details

**Operation Yield**

Cumulative Yield      Net Planning Percent  
 Reverse Cumulative Yield      Include In Rollup: Yes

**WIP**

Count Point: Yes      Autocharge: Yes  
 Backflush: Yes      Minimum Transfer Quantity: 0

**Other**

Description: Load Stripper      Effectivity Date: 28-Feb-2001  
 Machine      00:00:00  
 Option Dependent: No      Disable Date:  
 Operation Lead Time Percent: 0

Resources | **Components**

Select Component: Update

Select	Details	Component	Required Quantity	Onhand Quantity	Quantity Per UOM	Inverse Usage	Component Basis Yield	Date Required	Supply Type	Supply Subinventory	Supply Locator	Source Phantom
<input type="radio"/>	CM60000	5	10000	Ea	1	1	Item	01-Feb-2007 07:00:00	Assembly Pull	Stores		
Description:		Raw Wafer	Include in Cost Rollup:	Yes								
Item Type:		Standard	Component Remarks									

Cancel    Apply

4. Choose Components to display component information.
5. Select a Component and choose Update.
6. Select a component line and choose Recommend. The Update Components UI window appears.

ORACLE Shop Floor Management

Close Window | Preferences | Personalize Page | Diagnostics

Home | Shop Floor Transactions | Configuration

Shop Floor Transactions: Shop Floor Transactions > Plan Details: AD121JB1 > Operation: 10 >

**Update Component: CM60000**

Operation Seq Num: 10      Operation Code: FB10  
 Operation Department: FAB      Scheduled Quantity:  
 Backflush: Yes

Select Component: Recommend

Select	Component	Quantity Per Assembly	Inverse Usage	Component Basis Yield	Supply Type	Supply Subinventory	Supply Locator	Required Quantity	Onhand Quantity	UOM	Primary	Recommended
<input checked="" type="radio"/>	CM60000	1	1	Item	1	Assembly Pull	Stores		10000	Ea	<input checked="" type="checkbox"/>	<input checked="" type="checkbox"/>

Cancel    Apply

7. Enter any changes to Required Quantity and choose Apply to save your changes. Choose Cancel to discard any changes and return to the Plan Resources and Components window.

**Note:** If you make changes to the plan details of an operation

through the HTML UI, then changes are effective the next time you come to that operation. To make changes to the current operation in real-time, use WIP windows.

## Updating Plan Phantom Components

You can use the Update Phantom Component UI window to view and change the recommended phantom components. If you have a BOM with the phantom supply type for one of the components, then you can view phantom details in the UI. If you have substitutes for an item, then you can also choose substitutes. See: *Phantoms*, page 1-4 and *Phantom Routings*, page 10-3.

See also: *Phantoms in Lot Based Jobs*, *Oracle Bills of Material User's Guide*.

### **To update plan phantom components:**

1. Navigate to the Lot Based Jobs window and open a job.
2. Choose Plan Details from the Tools menu. The Plan Details UI window appears.
3. Choose the Details icon for a Routing Operation Sequence. The Plan Resource and Components UI window appears.
4. Choose Components to display component information.
5. Select the Phantom component that you want to make changes to, and choose Update.
6. Select a phantom component and choose Recommend. The Update Phantoms UI window appears.



7. Select the Phantom and enter any Required Quantity changes. Choose Apply to save changes, or choose cancel to discard any changes and return to the Plan Resources and Components UI window.

## Mass Refresh of Open Jobs

Changes in Bills of Material (BOM) and Routings are not currently distributed to open jobs at the shop floor. By default, this concurrent program does not refresh copies of any open lot based jobs. These changes come into effect only when new jobs are created. With the WSM: Create Job Level BOM and Routing Copies profile option you can update changes in all open lot based jobs, or a user defined subset of these jobs by using the Refresh Open Job Copies concurrent program. By default, changes are not saved to the open jobs, and you must set the following parameters.

### To update open lot based jobs:

1. Navigate to the WSM\_REFRESH\_JOBS Parameters window.
2. Enter Yes or No to Refresh All Open Jobs. (Required)

You can refresh all open jobs with any status except Closed by entering Yes for Refresh All Open Jobs. If this value is Yes, then the application ignores all other search parameters, and refreshes BOM and Routing copies for all open lot based jobs in the current organization. If this value is No, then additional job selection criteria are required.

3. Enter a range of jobs to refresh in the From Job Name and To Job Name fields (Optional).

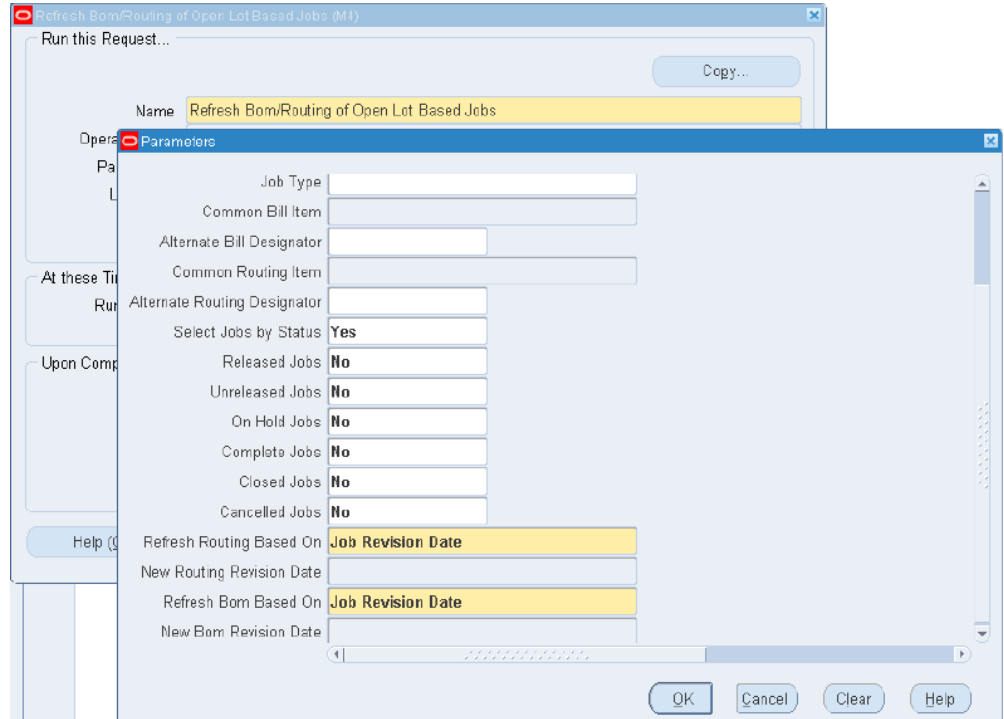

4. Enter a Job Assembly (Optional).
5. Enter the Job Type (Optional).
6. Enter a Common Bill Item and Alternate Bill Designator (Optional).
7. Enter a Common Routing Item and Alternate Routing Designator (Optional).
8. Enter Yes or No to Select Jobs by Status.

If you select No, then the application refreshes the specified jobs and does not consider job status. If you select Yes, then the application considers each of the job status values that you select.

9. Choose OK.

The WSM\_REFRESH\_JOBS window displays the request information.

10. Choose Submit.

**Note:** If the Refresh Open Job Copies concurrent program runs, and the Infinite Scheduler program runs to assign dates on the jobs. If scheduled dates are not available, the Resource Centric Work bench will not show these jobs or operations in the Workbench user interface.

Refresh Open Job Copies updates copy tables, but does not refresh current operation information. Refreshing copy tables is intended to update future operations with changes. Any changes made to the current operation from the User Interface are not captured by the Resource Scheduling Workbench or lot based job. If you intend to make changes to current operations, then you must use WIP windows.

## Refresh BOM/Routing of Open Lot Based Jobs with Revision Dates

Refresh BOM/Routing of Open Lot Based Jobs functionality is used to propagate the changes made to bills of material and routing of an assembly to the jobs that were created for the assembly prior to the changes. This enables the jobs to get the new (or changed) details of the BOM/Routing that are refreshed based on the routing revision date.

Previously, the changes made to BOM/Routing were effective as on Routing Revision Date. To update the routing revision date on the job and incorporate the changes, you have to do Update Routing transaction through the OSFM WIP Lot Transaction. But if the changes made to BOM/Routing are not effective as on the Routing Revision Date, then the changes will not be updated on the job.

Refresh BOM/Routing of Open Lot Based Jobs with Revision Dates refreshes all selected jobs based on New Revision Dates or Current Job Revision Dates, depending on the parameters you select. If you update the job's BOM or Routing, then Refresh Job Copies concurrent request runs to successfully update plan details of the job.

Four parameters are added to Refresh BOM/Routing of Open Lot Based Jobs concurrent request, so that you can refresh all selected jobs either as per Job Revision Date or New Revision Date. These parameters (two for BOM and two for Routing) are:

### 1. Refresh Routing Based On:

This has three values.

- *Job Revision Date*: If you select this option, then the job is refreshed based on the job's current Revision Date.
- *New Revision Date-All Jobs*: If you select this option, then enter a new date for the New Routing Revision Date parameter. Job's plan details are updated based on the new date.
- *New Revision Date-Job Revision Date less than new date*: If you select this option, then enter a new date for the New Routing Revision Date parameter. In this case, the job is refreshed in the following ways:
  1. If the job's current revision date is less than New Routing Revision Date, then the application updates the job's plan details based on the New Routing Revision Date.



2. If the job's current revision date is greater than New Routing Revision Date, then the application updates the job's plan details based on the job's current Revision date.
2. **New Routing Revision Date:** Enter a New Routing Revision Date to refresh whenever required as described in the previous option.

The two similar parameters for BOM are Refresh BOM Based On and New BOM Revision Date. The preceding descriptions apply for BOM as it is for Routing.

## Overview of Advanced Lot Transactions

Oracle Shop Floor Management provides the ability to split lots, merge lots, and perform additional other advanced lot transactions. Lots exist at different production points as either WIP lots or Inventory lots. Two windows, one for the WIP lot and the other for Inventory lot, give you the ability to perform various work in process and inventory transactions so you can divide, combine, rename existing lots, or create new lots from scrapped material. These windows enable you to do the following actions:

### WIP Lot Transactions

- *Lot Splitting:* divide a lot into two or more resulting lots: split a released lot into two or more resulting lots that can have different resource, material requirements, and different operations.
- *Lot Merging:* combine multiple lots of the same item into one resulting lot. The jobs to be merged must be at the same operation, department and intraoperation step. Identical assemblies are not required.
- *Update Assembly:* change the item, quantity, or revision of an existing lot and move it to another assembly. The lot number is renamed in these transactions.
- *Bonus:* recover scrap quantities to create a new lot, or create an entirely new lot.

Use the WIP Lot Transactions window for these transactions.

### Inventory Lot Transactions

- *Subinventory Transfer:* move a lot from one subinventory/locator to another subinventory/locator.

Use the Inventory Lot Transactions window for this transaction.

## WIP Lot Transactions

WIP Split and Merge functionality provides business solutions on the shop floor so you can do the following tasks:

*Lot Splitting:* You can divide a lot into any number of child lots. The parent lot can be at any operation in the routing and may have created material, resource and cost transactions. The split lots have a value proportional to the number of units being split away. Scrap and variance due to scrap are associated with the lot number in the scrap transaction. Child lots have their own routings and bills of material, and you can create transactions against different child lots immediately after a split. Backward movement for a split transaction is not allowed. The transaction processing for splits is not linked to the cost processing for splits, as transactions may be entered into the system via the interface at any time. When a lot is split into multiple children, the standard costs collected at the starting job are redistributed to the resulting jobs.

New lot numbers are automatically assigned to the child lots of a split transaction, but can be changed. New lots are independent entities linked by a transaction history associating their genealogy.

The split transaction can update the assembly of the child job while performing the split transaction. This provides greater flexibility and reduces the number of transactions. Support for combined split and update assembly transactions are also available through open interfaces.

*Lot Merging:* Multiple lots with identical assemblies can be combined to create a single parent lot. Only lots at the same intraoperation step are merged. The new job is now at the operation where the lots were merged.

*Lot Bonus:* You can increase the work order quantity, and credit a bonus account for the transaction. You can also simulate a recover transaction to start a lot on a given routing at a given step, and credit a bonus for the transaction.

*Update Assembly:* One product can be translated into another product—that is—change the item, quantity, revision, or routing of an existing lot and move it to another assembly. There are no costing implications in this transaction. You can also switch to an alternate routing on the same operation step.

If the translation is updating the routing, then the WIP lot is updated with an alternate network routing defined for the assembly. When this type of translation is performed at the queue intraoperation step, the operation characteristics correspond to the same operation, if existing, in the new routing. You can also update the routing revision, or routing revision date without changing the alternate designator. It is mandatory to provide the starting operation if the job is at a To Move intraoperation step.

If the user specifies a new BOM revision or BOM revision date during an update routing transaction through the WIP lot transaction interface, then it would be honored and the job would have the revised BOM revision and BOM revision date after the transaction. The job plan operations and components would be based on the new routing revision date and the new BOM revision date. The revision date would be

honored both for standard jobs as well as for non-standard jobs. Note that this feature is not supported through forms. Update of BOM alternate is not allowed when carrying out an update routing transaction.

*Assigning Starting Operation for Child Lots:* A lot can be split into several child lots and processed on different routings, potentially creating other assemblies. Starting operation for the child lots is the same as the parent lot operation at the time of the split. For bonus lots, you can start a child lot at any operation sequence number on a given routing, otherwise it defaults to the queue step at the first operation. The operation history before the split is saved for all lots, used for scrap and standard cost update valuation.

**Note:** WIP lot transactions proceed when requisitions have been created for the current operation. A warning message appears prompting you to proceed with the transaction, or cancel. If you execute the transaction, then you must cancel the requisitions manually.

In Oracle Shop Floor Management, Move and completion are a job level transaction and user should not allow WIP completion at a Serial level.

## Creating WIP Lot Transactions

### To enter WIP lot transactions:

1. Navigate to the WIP Lot Transactions window.
2. Select a transaction type.

Your choices are Bonus, Merge, Split, Update Assembly, Update Lot Name, Update Quantity, or Update Routing. See: WIP Lot Transactions, page 5-30.

Status defaults to Pending, and is updated to Completed when the transaction is saved. The database does not store any records with a status of Pending.

Select the job type (standard or non standard) for the type of jobs the transaction is to be performed on.

**Note:** WIP lot transactions cannot be performed across job types.

The Costed field is updated after costing program is executed.

3. In the Reference field, you can enter any descriptive information regarding this transaction.

4. Optionally, you can select the purpose of this transaction in the Reason field.
5. Follow the procedures for the transaction you want to create, Your choices are Bonus, Merge, Split, Update Assembly, Update Lot Name, Update Quantity, or Update Routing.

**Note:** WIP lot transactions proceed when requisitions have been created for the current operation. A warning message appears prompting you to proceed with the transaction, or cancel. If you execute the transaction, then you must cancel the requisitions manually.

### Viewing, Entering, and Updating Lot Attributes:

#### To view lot attributes for the starting lots

1. Choose Lot Attributes. If the starting lot has lot attributes, then the lot attributes window appears with attributes.
2. Choose WMS or INV attribute to view the individual segments of the respective attribute.
3. Choose OK when you are finished viewing the attributes.

### To view, enter, and update lot attributes for the resulting lot

1. Choose Lot Attributes.
2. If you are entering or updating lot attributes, then enter and update attributes with appropriate values for WMS and INV attributes based on the lot attributes setup that you or your system administrator completed. The WMS attributes for the resulting lot are inherited from the starting lot only if the source and resulting lot's assemblies have the same context. In case of a merge transaction, the WMS attributes are inherited from the representative lot of the starting lot. The INV attributes are always inherited from the source lot whether the context of the source and resulting lot is same or not. In case of a merge transaction, the WMS attributes are inherited from the representative lot.
3. Choose OK to save and return to the WIP Lot Transactions window.
4. Choose Cancel if you do not want to save the lot attribute changes.

The screenshot shows a dialog box titled "Lot Attributes". It contains three input fields with corresponding labels to their right. The first field is "Attribute Name" with the value "GSUBLOC". The second field is "SUB" with the value "MMMBULK". The third field is "LOC" with the value "MMB.1.1". Below the input fields is a horizontal scrollbar. At the bottom of the dialog are four buttons: "OK", "Cancel", "Clear", and "Help".

### To create WIP lot bonus transactions:

Select the bonus transaction type.

1. In the Resulting Job region, in the Job Information tab, enter the new lot number.
2. Enter a lot number, description, assembly number, quantity, and bonus account number.
3. In the Others tab, the accounting class is defaulted but you can select another one from the list of values. You can start a bonus lot at any operation on the primary path, however, the default is the queue step at the first operation.
4. Optionally, you can change the Start and Completion dates.
5. You can also enter routing and bill of material information in the Routing Information and the BOM and More tabs.
6. Save your work.

### **To create WIP lot merge transactions:**

Select the merge transaction type.

1. In the Starting Job region, in the Lot Number field, select the lot numbers of the parent lots you want to merge.  
  
The lot details display: assembly number, operation sequence number, intraoperation step, operation code, quantity remaining in the lot, alternate routing, and start date.
2. Check the Representative Lot check box for one lot in this group whose characteristics will represent the merged lot.  
  
The attributes of the representative lot are used for the resulting merged lot.
3. In the Resulting Job region, in the Job tab, enter the new lot number.  
  
You can also select the name of any of the starting lots you are merging. The parent assembly number is transferred from the original lot number. The quantity in the Resulting Quantity field is the sum of all the original lots.  
  
You cannot update Accounting Class for non-bonus WIP Lot transactions. You cannot update Start and Completion Dates except for any WIP transaction other than bonus where you can provide the start date and completion dates.
4. You can also enter routing and bill of material information in the Routing Information and the BOM and More tabs.
5. Save your work.

### **To create WIP lot split transactions:**

Select the split transaction type.

1. In the Starting Job region, in the Lot Number field, select the lot number of the parent lot to split.  
  
The lot details display: assembly number, operation sequence number, intraoperation step, operation code, quantity remaining in the lot, alternate routing, and start date.
2. In the Resulting Job region, in the Job tab, the new lot number displays.  
  
The system automatically assigns a new lot number according to your setup in the Shop Floor Management Parameters window, see: Defining Parameters, page 2-10. When a lot is split, the new resulting lot designation is the original lot number, followed by the lot separator value set in the parameter, followed by sequential numbering.  
  
The representative lot is transferred from the original lot number. Enter the

quantity in the Resulting Quantity field.

3. Select the Change Assembly indicator to execute a split and update transaction.  
The Change Assembly indicator is active only when you select the split transaction type. The split transaction can now update the assembly of the child job while performing the split transaction. You cannot clear (uncheck) this indicator, therefore, you must exit and open the window.
4. If you select the Change Assembly indicator, then enter a new Assembly and Resulting Quantity.  
You cannot update Accounting Class for non-bonus WIP Lot transactions. You cannot update Start and Completion Dates except for any WIP transaction other than bonus where you can provide the start date and completion dates.
5. You can also enter routing and bill of material information in the Routing Information and the BOM and More tabs.
6. Save your work.

### **To create WIP lot update transactions:**

Select the update transaction type you want to perform.

Your choices are Update Assembly, Update Lot Name, Update Quantity, or Update Routing.

1. In the Starting Lot region, in the Lot Number field, select the lot number to update.  
The lot details display: assembly number, operation sequence number, intraoperation stop, standard operation code, quantity remaining in the lot, alternate routing, and start date.
2. Different fields in the Resulting Lot region need to be updated, depending on which transaction you are creating.  
For Update Assembly, in the Job Information tab, select the new assembly number in the Assembly field.  
For Update Lot Name, in the Job Information tab, enter the new lot name in the Lot Number field.  
For Update Quantity, in the Job Information tab, enter the new quantity in the Resulting quantity field.  
Enter the bonus account number in the Others tab.  
For Update Routing, add routing data in the Routing Information tab.  
You cannot update Accounting Class for non-bonus WIP Lot transactions. You cannot update Start and Completion Dates except for any WIP transaction other

than bonus where you can provide the start date and completion dates.

3. You can also enter routing and bill of material information in the Routing Information and the BOM and More tabs.
4. Save your work.

**Note:** While performing Update Routing or Update Assembly transactions at the Queue intraoperation step, if you have phantom exploded components at the current operation—you must manually reverse the charges.

## Inventory Lot Transactions

- Inventory Lot transactions enable you to split, merge, translate, and transfer inventory lots in Oracle Shop Floor Management. You cannot execute inventory lot transactions for lot and serial controlled items. You have two methods of performing inventory lot transactions:
- Perform inventory lot transactions using OSFM windows.
- Perform inventory lot transactions through the Oracle Warehouse Management mobile interface. See: *Mobile Interface, Oracle Warehouse Management*.

**Caution:** Different types of attributes, such as Inventory (INV) Item Lot and Warehouse Management (WMS) Item Lot, are not validated when performing inventory lot transactions using the OSFM windows. Item level attributes such as Lot Split Enabled and Lot Merge Enabled are not validated using OSFM windows, although they are enabled for Warehouse Management Mobile Interface.

Inventory lot transactions are not supported for serial controlled assemblies.

When importing using an interface, the import fails and the log file contains an error message.

*Lot Splitting:* You can divide a lot into any number of child lots. The split lots have a value proportional to the number of units being split away. When a lot is split into multiple children, the costs allocated to the starting lot are reallocated to the resulting lots.

New lot numbers are automatically assigned to the child lots of a split transaction, and can be changed. New lots are independent entities linked by a transaction history associating their genealogy.



*Lot Merging:* Multiple lots with identical assemblies can be combined to create a single merged lot.

The assemblies for the lot is automatically moved to the current operation.

*Lot Translating:* Enables users to either change the name of an inventory lot to another name, or convert one product to another product. For example, you can change the lot name, item, revision, or subinventory of an existing lot and move it to another assembly. Lot genealogy captures all transactions.

*Lot Transferring:* A lot can be moved from one subinventory location to another.

## Creating Inventory Lot Transactions

### To create inventory lot transactions:

1. Navigate to the Inventory Lot Transactions window.

2. Select a transaction type.

Your choices are Split, Merge, Translate, Transfer. See: Inventory Lot Transactions, page 5-36.

3. The Transaction Date displays the current date, and you can change this date.

4. Optionally, you can select the purpose of this transaction in the Reason field.

5. In the Reference field, enter any descriptive information to identify transactions, used on standard reports.

Transaction Type: Split  
 Transaction Date: 29-NOV-2006 22:37:07  
 Reason:   
 Reference:   
 Transaction Id:

Starting Lots

Lot Number	Representative Lot	Item	Rev	Quantity	Subinventory	Locator
CJUGLOT12	<input checked="" type="checkbox"/>	CJ-ASSY3		6	FABSUB	
	<input type="checkbox"/>					
	<input type="checkbox"/>					
	<input type="checkbox"/>					

Resulting Lots

Lot Number	Item	Rev	Quantity	Subinventory	Locator
CJUGLOT12*2	CJ-ASSY3		3	FABSUB	
CJUGLOT12*3	CJ-ASSY3		3	FABSUB	

- In the Starting Lot region, select a lot in the Lot Number field.  
 The lot details display: item number, quantity, subinventory location, and locator.  
 In the Resulting Lot region, depending on the type of transaction you are creating, different information is needed to complete the transaction.
- For split transactions, select the lot to split in the Starting Lot region.  
 In the Resulting Lot region—the system automatically assigns new lot numbers according to your setup in the Shop Floor Management Parameters window, see: Defining Parameters, page 2-10. When new lots are created, the resulting lot designation is the original lot number, followed by the lot separator value set in the parameter, followed by sequential numbering.  
 The lot details are transferred from the original lot number: item number, quantity, subinventory location, and locator. Enter the quantity of the new lot in the Quantity field. You can also change the subinventory location.  
 If a co-product definition is defined, then there should be no date in the future where the split percentages remain undefined. For this reason, you cannot change existing date ranges. If you want to change date ranges, then define new dates that overlap with existing dates.
- For merge transactions, select the lots to combine in the Starting Lot region.  
 In the Resulting Lot region, the last lot number you select is the lot number used for all the merged lots. The resulting lot name defaults from the representative lot

name of the Starting Lots region. You can indicate the representative lot by selecting the Representative Lot check box of a lot number in the Starting Lots region.

The lot details are transferred from the original lot number: item number, routing revision level, quantity, subinventory location, and locator. The quantity of the all the combined lots is the value in the Quantity field. You can change the subinventory location.

9. For lot translating transactions, select the lot you want to rename in the Starting Lot region.

In the Resulting Lot region—select the new name for the lot. You can change the item number in the Item field and the subinventory location, if required.

10. For lot transferring transactions, select the lot to move in the Starting Lot region.

In the Resulting Lot region—you can change the subinventory location.

11. Save your work.

## Lot Attributes in Inventory Lot Transactions

You can do transactions like split, merge, update lot name and update assembly and is supported only in Forms. You can do Inventory Lot Transactions only for Lot Controlled Items and **not** for Lot/Serial Controlled Items.

You can query the lot and check the details through the Genealogy windows. See: Lot Genealogy, page 8-2.

### Split:

Lot attributes specified during Job Creation, Execution, or Completion get transferred from the job (WIP lot) to the inventory lot.

Lot attributes of the Starting Lot defaults to the Resulting Lots and you can update them, if required.

1. Navigate to Inventory Lot Transactions window.
2. Select Split as Transaction Type.
3. Enter Lot Number in the Starting Lots region to query.
4. Click Lot Attributes in the Starting Lots region.

The Lot Attributes window appears displaying the Lot Number and the WMS and Inventory lot attributes.

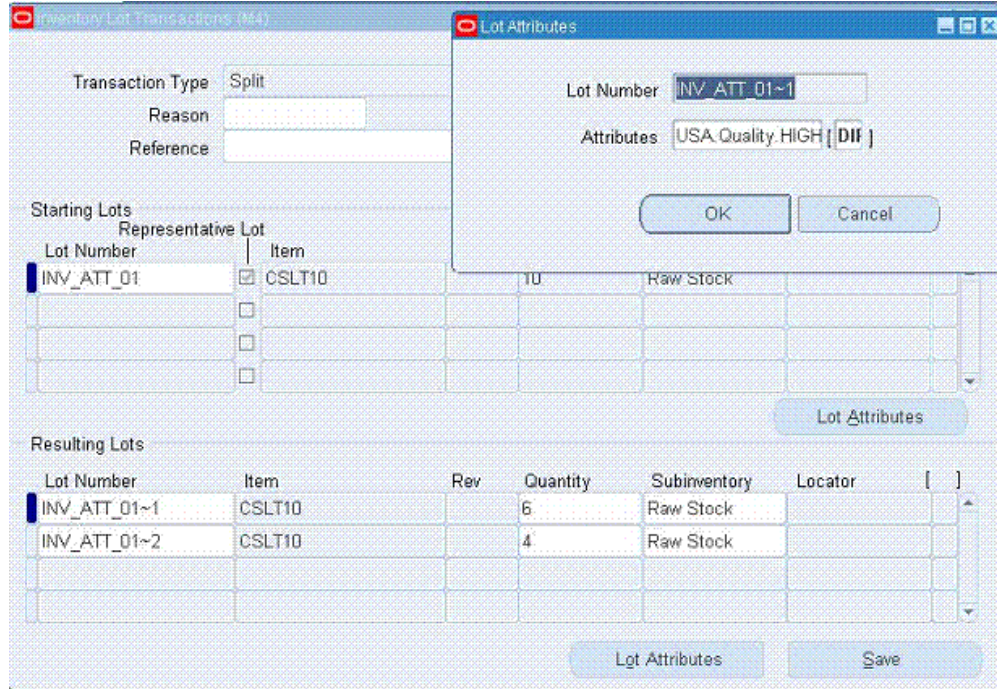

5. Click OK.
  6. Enter split lot details.
  7. Click Lot Attributes in the Resulting Lots region.
- Inventory lot attributes default and update them if required.

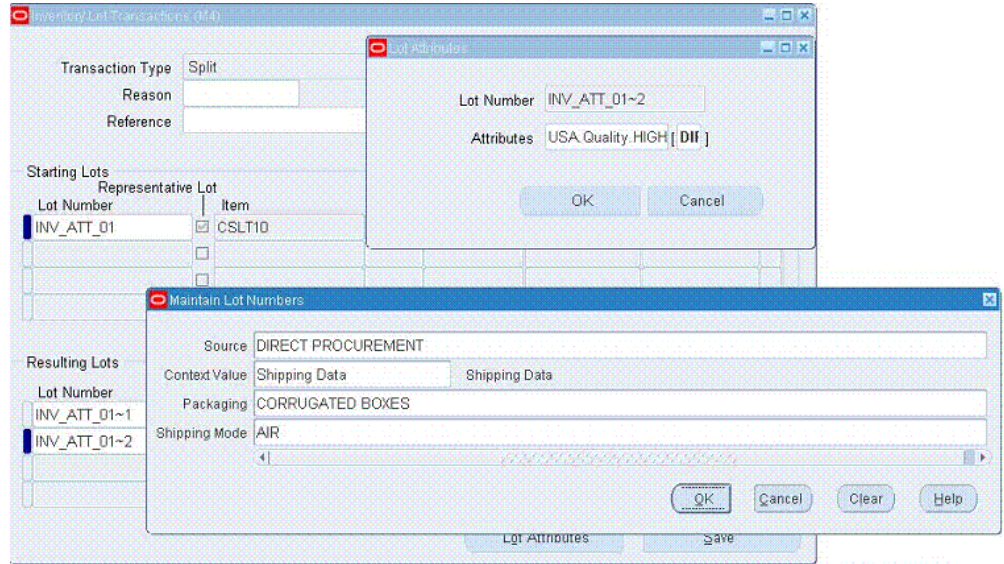

### Merge:

Lot attributes of the Representative Lot are transferred to the Resulting Lot and you can update them if required.

1. Navigate to Inventory Lot Transactions window.
2. Select Merge as Transaction Type.
3. Enter Lot Number in the Starting Lots region.
4. To check the lot attributes, click Lot Attributes in the Starting Lots region.

The Lot Attributes window appears displaying the lot number and the WMS and inventory lot attributes.

5. Click OK.
6. Click Lot Attributes of the Resulting Lots region.  
The Lot Attributes window of the resulting lot appears.
7. Check and update the Inventory Lot Attributes.

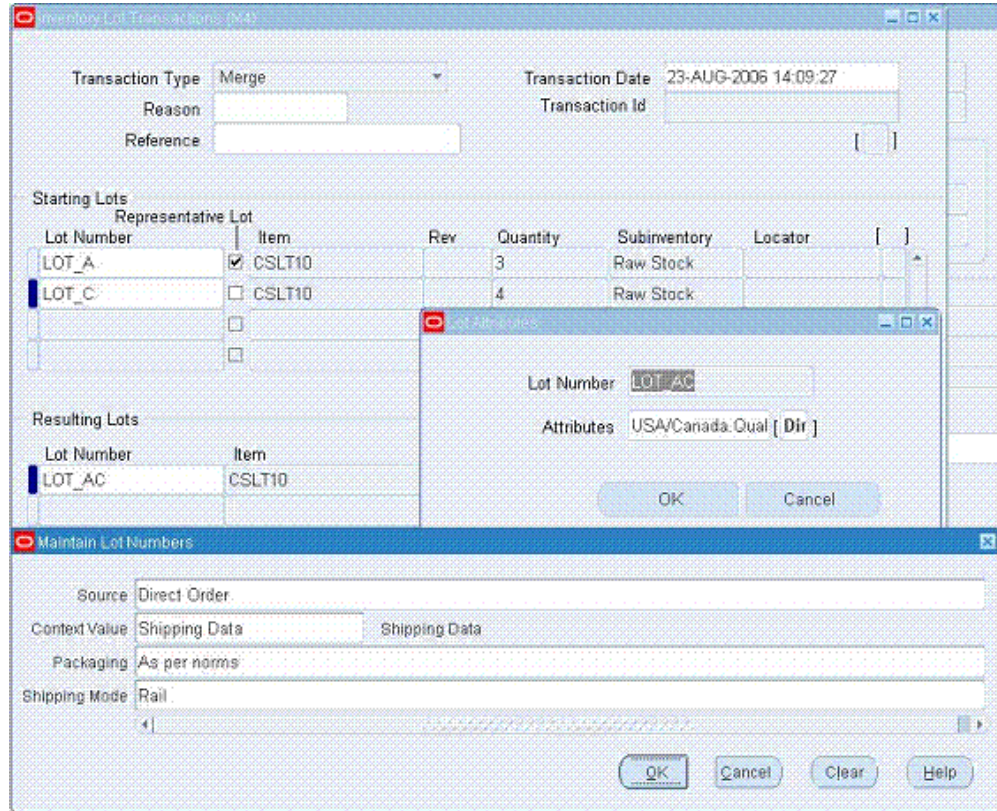

8. Click OK.

### Translate:

#### Update Lot Name

Lot attributes are transferred to the Resulting Lot and you can update them if required.

1. Navigate to Inventory Lot Transactions window.
2. Select Translate as Transaction Type.
3. Enter Lot Number in the Starting Lots region.
4. To check the lot attributes, click Lot Attributes in the Starting Lots region.

The Lot Attributes window appears displaying the lot number and the WMS and inventory lot attributes.

5. Click OK.
6. Update the Lot Name of the resulting lot in the Resulting Lots region.



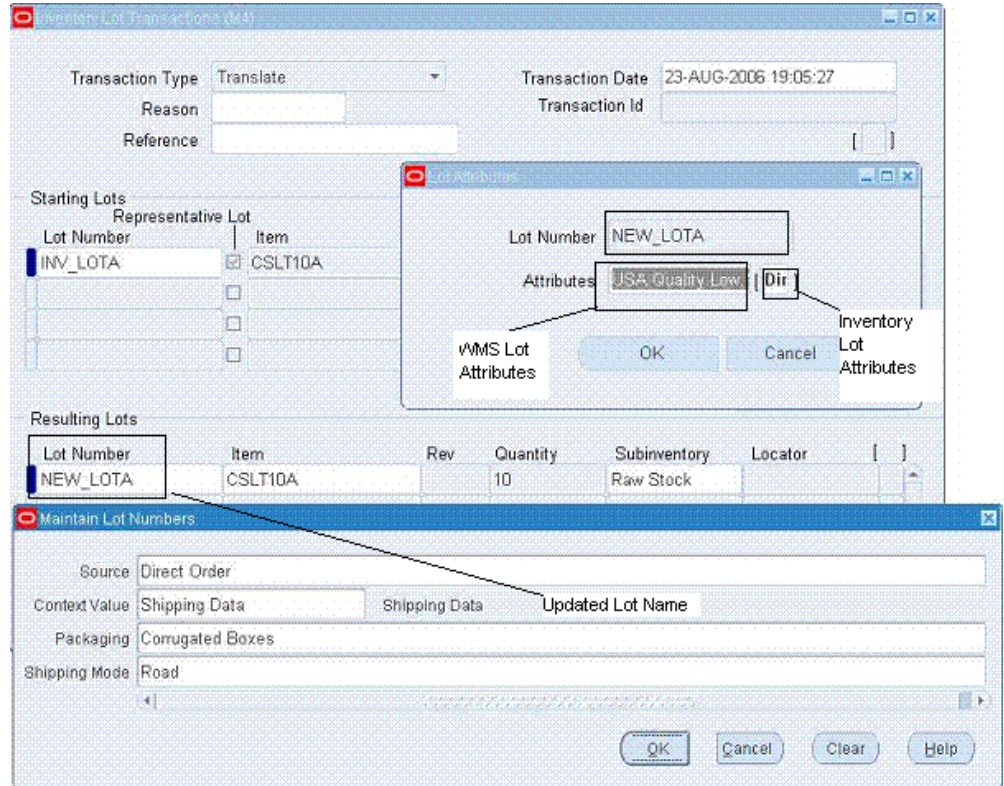

7. Click Lot Attributes.

The Lot Attributes window appears.

8. Update the inventory lot attributes for the updated lot name.

### Update Assembly

Inventory lot attributes get transferred to the Resulting Lot and can be updated, if required.

9. Update the assembly of the resulting lot in the Item column of the Resulting Lots region.

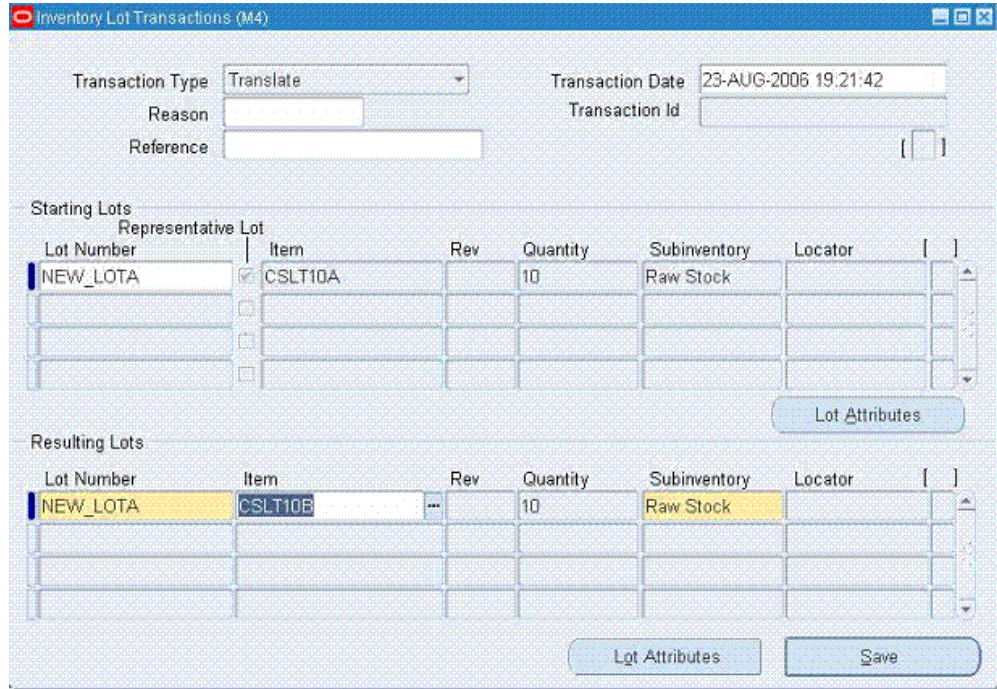

10. Click Lot Attributes.  
The Lot Attributes window appears.
11. Update inventory lot attributes.

## Creating Lots for New Sectors

The Assemblies manufactured in the first sector are getting completed into the respective subinventories. Now this lot is ready for the subsequent use in the next sector. The next step is to define the jobs in the subsequent sectors using the Lot Creation window. When a lot based job is created using lot the creation feature, it is assumed that the starting component is issued to this job. Therefore, the starting component is pushed into this job ignoring the supply type defined for the component in the first operation.

### To create lots on the shop floor:

1. Navigate to the Lot Creation window.
2. Select an Inventory lot number in the Starting Lot field.  
Information displays for subinventory location, locator number, item number and description, revision number, quantity on hand, and quantity available to transact.
3. In the Job Information tab, the resulting job name will be defaulted based on the



Reuse Job Name parameter. When multiple jobs are created, the first job name will be defaulted based on the Reuse Job Name parameter and the remaining jobs will be defaulted with the starting lot number, followed by the New Lot Separator value, followed by sequential numbering. You can also define the revision number and revision date for bill of material and routing in order to use the component and operations effectivity.

Information displays in the following fields and can be changed: Accounting Class, Completion Subinventory and Locator.

**Note:** Please note that the starting component with phantom supply type in the first operation of the subsequent sector assembly bill of material is not allowed. Therefore, the Lot Creation window does not permit you to create the lot based job with phantom supply type material in the first operation.

If you define two components in the first operation, then only one is pushed into this job based on the starting lot selected.

Starting Lot

Starting Lot: adlot1      Attributes: [ ]

Item: ADPRICMP1      Lot-Controlled Primary Component

Revision: [ ]

Subinventory: Stores      Locator: [ ]

Quantity On Hand: 960      Available: 960

Resulting Lots

Job Information    Quantity    Planning

Resulting Lot	Assembly	Alternate Routing	Rev	Routing Revision Date	Alternate BOM	Rev	[ ]
adlot1*2	ASSY1	Alternate1	0				

Starting Serials    Resulting Serials    Lot Attributes    Save

### Using Substitutes during Lot Creation

You can also create a lot based job from a substitute item. For example, Item A is an assembly item and Item B is the component for Item A. In the event of nonavailability of Item B, you can identify an alternate item or a substitute item for Item B from Bills of Material of Item A. You can enter an inventory lot number for this alternate or substitute item and create a lot based job for Item A.

When you enter a lot number in the lot creation form, all other information of that starting lot default. In the resulting lot assembly, you can select the assembly of the substitute component for which the lot based job is being created.

1. Substitute component should be at the first operation and it should not be a phantom component, i.e., Supply Type of primary component of the substitute component should not be phantom in bills of material.
2. If the same component is present as substitute and primary component at the first operation, then it is treated as primary component.
3. If the same component is a substitute of two primary components in the same bills of material, then it is treated as a substitute of primary component with minimum sequence number in bills of material.

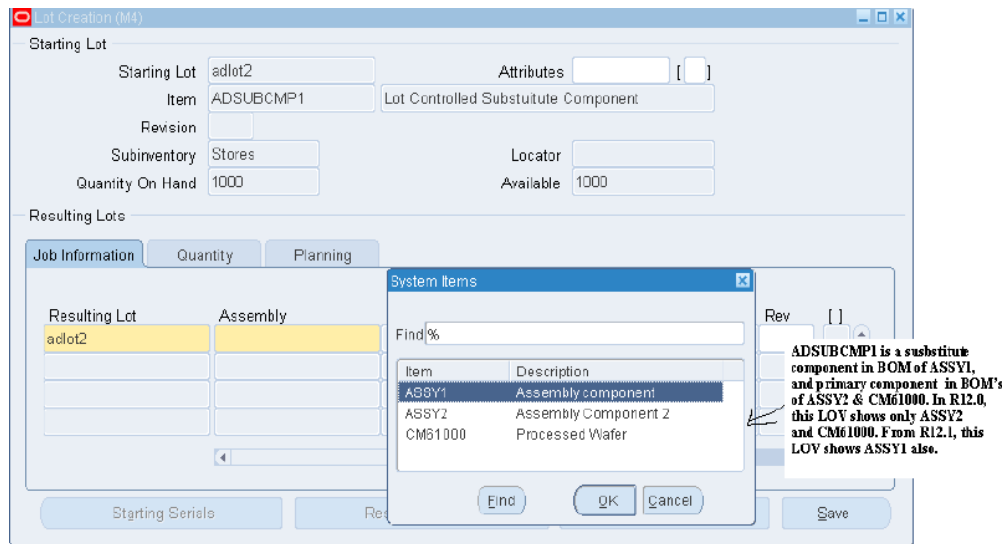

ADSUBCMP1 is a primary component in BOM of ASSY2 and CM61000.

ADSUBCMP1 is a substitute component in BOM of ASSY1.

You can now create a lot by issuing primary as well as substitute components.

4. In the Quantity tab—The Job Quantity for this job is derived based on starting lot quantity available under this lot number, and you can change the job quantity. You can also create multiple jobs for different assemblies and quantities. The application creates multiple jobs and pushes this lot into the jobs. You can also create a job with less than the defaulted quantity. If you create a job using less than the starting lot quantity in the subinventory, then the remaining quantity of the starting lot remains in the subinventory, and you can use this for subsequent job creation. You can also issue a starting component for the quantity more than or less than the component required quantity suggested by the application. In this case, you can

enter the required value in the Component Quantity Issued field. In addition, the following information is available in this tab:

- Component usage per assembly
- Component requirement for the job quantity
- Start Job Quantity
- MRP Net

You can change some of these values depending on the transactions performed for this lot.

5. In the Planning tab, Start Date and Completion Date values display and can be changed. Choose the Co-Products Supply check box to indicate that resulting lots are used as co-product supply.

If the inventory lot from which the new WIP lot is created, and the new WIP lot have the same attribute context, then lot attributes will be copied to the new WIP lot. If they have different context, then enter lot attributes as follows.

**To view lot attributes for starting lots:**

1. Choose Attributes.

If the starting lot contains attributes, then the lot attributes window appears.

2. Choose WMS or INV attributes to view individual segments of the attribute.
3. Choose OK when you are finished viewing the attribute.

**To view, enter, and update lot attributes for the resulting lot:**

1. Navigate to the WIP Lot Transactions window.
2. Choose Lot Attributes.

**Note:** If you are entering or updating lot attributes, then enter and update attributes with appropriate values for WMS and INV attributes based on the lot attributes setup that you or your system administrator have performed. The WMS attributes for the resulting lot are inherited from the starting lot only if the source and resulting lot's assemblies have the same context. In case of a merge transaction, the WMS attributes are inherited from the representative lot of the starting lot. The INV attributes are always inherited from the source lot whether the context of the source and

resulting lot is same or not. In case of a merge transaction, the WMS attributes are inherited from the representative lot.

3. Choose OK to save your work and return to the WIP Lot Transactions window, or choose cancel to discard changes.

**Note:** If you are only viewing lot attributes and are not making changes, then you can choose OK or Cancel to return to the WIP Lot Transactions window.

## Kanban Replenishment on Lot Based Jobs

Kanban is a pull based replenishment process in a manufacturing system. You can create lot based and discrete jobs to replenish empty kanbans. In addition, Kanban supports creation of lot based jobs by selecting the starting inventory lot during Kanban replenishment process.

The following are major features of Kanban support on lot-based jobs:

- During Kanban replenishment process, you can choose the starting inventory lot for the item attached to first operation. This is similar to lot-based job creation using the Lot Creation window.
- Use the Honor Kanban Size parameter to create a lot based job quantity equal to kanban size when components are pushed from an inventory lot during kanban replenishment. If this check box is not selected, lot based jobs are created for the maximum number of assemblies which can be built using the selected component lot. If the check box is selected, the application will honor the kanban lot size.

Lot Based Jobs (VBO)

Job: 39622      Type: Standard

Assembly: Die      Die

Class: STDLBJ      UOM: Ea

Status: Released       Firm

**Quantities**      **Dates**

Start: 9800      Start: 28-MAR-2003 11:44:00

MRP Net: 9800      Completion: 28-MAR-2003 11:44:00

Bill    Routing    Job History    Schedule Group, Project    Planning, Scheduling    More

Demand Class:      Kanban: 509

Lot Number: 39622

Description: Job Mass Loaded on 28-MAR-2003 11:44:23

**Overcompletion**

Tolerance Type:      Tolerance Value:     

Operations    Components

- After a job is created using Kanban replenishment, you can query the Lot Based Job window to view Kanban information.
- If the assembly from replenishment lot based job is completed, then the supply status of a production Kanban is updated to Full.
- Shop Floor Management allows jobs with a Kanban reference to be merged with another job with a different kanban reference (case 1), or a job with a kanban reference with a job without any reference (case 2). In the first case, one of the jobs is the representative lot, for that WIP lot the net effect from a kanban standpoint is the same as a quantity update. But for a nonrepresentative lot, the quantity become zero and the corresponding Kanban card status is set to Empty, and the job should not be referenced. In the second case, if the Kanban reference job is the representative lot, then the net effect from a Kanban standpoint is the same as a quantity update for that job. Otherwise, the quantity becomes zero, the corresponding Kanban card status is set to Empty, and the job should not be referenced. See: Defining Kanban Pull Sequences, *Oracle Inventory User's Guide*.

## Lot Based Job Reporting

The following Oracle Work in Process reports support lot based job reporting:

Discrete Job Data Report, *Oracle Work in Process User's Guide*.

Discrete Job Listing Report, *Oracle Work in Process User's Guide*.

Discrete Job Routing Sheet, *Oracle Work in Process User's Guide*.

WIP Accounting Classes Report, *Oracle Work in Process User's Guide*.

WIP Outside Processing Report, *Oracle Work in Process User's Guide*.

Discrete Job Shortage Report, *Oracle Work in Process User's Guide*.

Job lot Composition Report, *Oracle Work in Process User's Guide*.

Discrete Job Value Report, *Oracle Work in Process User's Guide*.

WIP Value Report, *Oracle Work in Process User's Guide*.

## Lot Based Job Component Pick Release

**To run the Lot Based Job Component Pick Release (SRS) report:**

1. Navigate to the Lot Based Job Reports window.
2. Select the Lot Based Job Component Pick Release (SRS) report from the Name list of values.

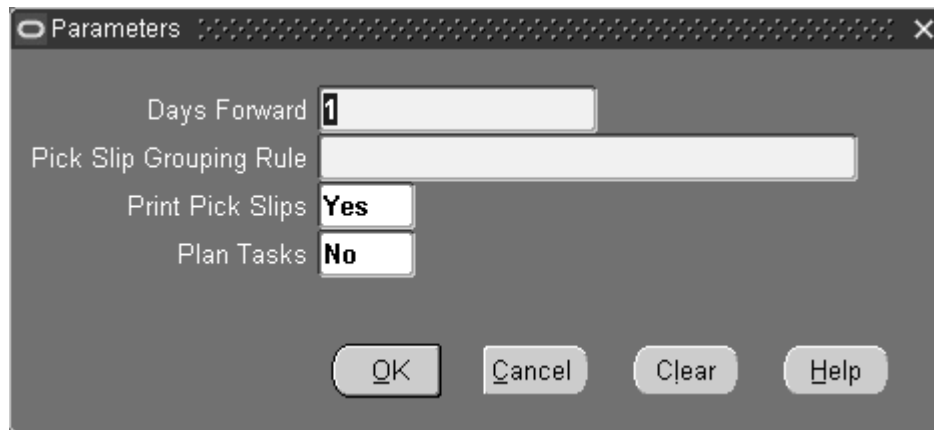

The screenshot shows a dialog box titled "Parameters" with a close button (X) in the top right corner. It contains four input fields and four buttons. The first field is "Days Forward" with the value "1". The second field is "Pick Slip Grouping Rule" which is empty. The third field is "Print Pick Slips" with the value "Yes". The fourth field is "Plan Tasks" with the value "No". At the bottom, there are four buttons: "OK", "Cancel", "Clear", and "Help".

3. Enter Days Forward.
4. Enter the Pick Slip Grouping Rule from the list of values.
5. Optionally, enter Print Pick Slips for the list of values.
6. Optionally, enter Plan Tasks from the list of values.
7. Choose OK.
8. Choose Submit to run the report.

## Pending Transactions Report

If there are pending transactions associated with a lot based job, then the lot based job cannot be closed. You can report on all pending transactions for a given set of jobs and review to take appropriate action before launching the close job program. The close job program provides selection criteria with an option to eliminate jobs with pending transactions. The Pending transaction report can be used during period closing.

### To run the Pending Transactions Report:

1. Navigate to the Lot Based Job Reports window.
2. Select the Pending Transactions Report from the Name list of values. The Parameters window appears.

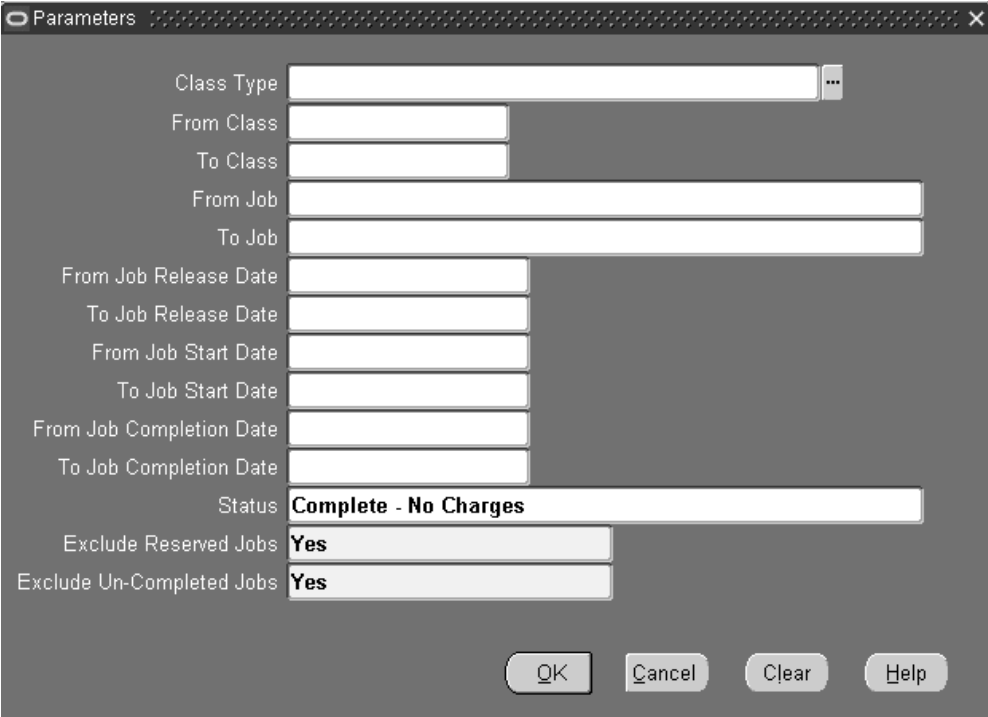

The screenshot shows a 'Parameters' dialog box with the following fields and values:

Class Type	<input type="text"/>
From Class	<input type="text"/>
To Class	<input type="text"/>
From Job	<input type="text"/>
To Job	<input type="text"/>
From Job Release Date	<input type="text"/>
To Job Release Date	<input type="text"/>
From Job Start Date	<input type="text"/>
To Job Start Date	<input type="text"/>
From Job Completion Date	<input type="text"/>
To Job Completion Date	<input type="text"/>
Status	Complete - No Charges
Exclude Reserved Jobs	Yes
Exclude Un-Completed Jobs	Yes

Buttons: OK, Cancel, Clear, Help

3. Enter report parameters.
4. Choose OK.
5. Choose Submit to run the report.

## Integration with Outside Processing

Outside Processing enables you to include supplier-sourced components and resources in the manufacturing process. Key features of outside processing for lot based jobs include the following:

### Setup

Setup is needed for Inventory, Bills of Material and Cost Management, Purchasing, and Work in Process. See: *Outside Processing, Oracle Work in Process User's Guide*.

**Requisition Creation Time:** To enable outside processing (OSP), you need to set requisition creation time in the WIP parameters window. In WIP discrete jobs, the At Job and Schedule Release setting creates purchase requisitions for all OSP operations in the routing, while the At Operation setting creates purchase requisitions only when a job reaches the queue of an OSP operation. In Shop Floor Management, you may not know the next operation in advance (i.e. due to network routing and jump transactions), therefore, purchase requisitions are only created at the queue of an outside processing operation. To support this, At Job and Schedule Release and At Operation behave identically for Shop Floor Management. The recommended setup for the parameter is At Operation.

**Note:** For Manual setting, all purchase requisitions must be created manually. See:

*Outside Processing, Oracle Work in Process User's Guide*

**OSP Resource, Department, Item:** An OSP operation requires one or more OSP resources, which in turn must be associated with departments with a location. In addition, a separate OSP item must be created to receive and charge the outside work (this item is associated with the resource). When creating the OSP item, the Purchasing Tabs of the Item window must have OSP-related settings (i.e. Purchased, Purchasable, Outside Processing Item must be checked.) The list price must be specified in the purchasing master organization for generating purchase orders. See: *Outside Processing, Oracle Work in Process User's Guide*.

**Routing:** To associate an OSP resource with a routing (either directly or using standard operations), you must specify a charge type (either at the resource, the standard operation or the routing level). For Shop Floor Management, charge type PO Receipt should be used for OSP operations. PO Move, which moves any received quantity to the queue of the next operation in WIP discrete jobs, is not supported (i.e., error message appears in jobs with this setting). With lot based jobs, the next operation is not predetermined and partial receipts should not be moved until the entire quantity is received. See: *Outside Processing, Oracle Work in Process User's Guide*.



## Outside Processing Scenarios

Automatic creation of purchase requisitions generally occurs when a job moves forward to or starts at the queue of an OSP operation (there are exceptions, such as Undo back to an OSP operation queue).

You should expect a warning message at the queue of an OSP operation when performing a transaction that would invalidate one or more purchase requisitions. You should manually cancel or update purchase requisitions for such transactions. Note that these warning messages appear even for purchase requisitions that have not yet been completely processed by the purchasing transaction manager (i.e., are still in purchase requisition interface tables) as well as for purchase orders.

As discussed in routings setup, charge type PO Move is desupported. You are allowed to create operations in a routing with charge type PO Move, but are not able to start at or move to PO Move OSP operations.

## Job Creation/Update

- **Lot Based Job Creation/Lot Creation:** Starting a job at an OSP results in automatic purchase requisition creation. For the define Lot Based Job and Lot Creation windows, the starting operation, which is always the first operation of the routing, would need to have an OSP resources for this to occur. Creating a lot based job to start at a PO Move OSP operation gives an error and not allow the transaction to be saved (applies for both released and unreleased status).
- **Lot Based Job Update:** Creating a job as unreleased status will not result in purchase requisition creation, but upon changing the status to released, a purchase requisition is created if the starting operation is OSP. Increasing job quantity through the Lot Based Job window at an OSP operation causes a new purchase requisition to be created for the additional quantity. Changing job status from released to unreleased where the first operation is OSP would mean that a purchase requisition should no longer exist and will result in warning.

**Note:** Going forward for lot-based job, for the first operation, the need by date would be same as the scheduled completion date of the first operation. For lot based job first unit completion date is same as last unit completion date of any operation. For subsequent OSP operations (not first in the routing) too, need by date would be calculated based on the scheduled completion date of the operation. Currently it is being calculated by adding lead times to SYSDATE.

## WIP Lot Transactions

- **Split/Merge:** Performing WIP lot transactions that have new resulting jobs, such as

split or merge, would mean that purchase requisitions or purchase orders for the starting jobs would need to be cancelled manually. Note that instead of canceling all purchase requisitions or purchase orders for starting jobs and creating new purchase requisitions for resulting jobs, you can keep existing purchase requisitions or purchase orders by updating their distribution. Also note if a purchase requisition, purchase order is kept because a starting job retained quantity and became a resulting job, then the quantity listed on that purchase requisition or purchase order would need to be updated manually.

- **Update Routing/Assembly:** Updating the routing or assembly for a job to start at an OSP results in purchase requisition creation. If you are leaving the queue of an OSP operation, this would imply a purchase requisition is being abandoned in the old routing and would need to be manually cancelled. Attempting to update routing or assembly to start at a PO Move OSP operation will result in an error message and will not save.
- **Update Quantity:** Increasing job quantity through the WIP Lot Transactions window at an OSP operation causes a new purchase requisition to be created for the additional quantity.
- **Bonus:** For a bonus WIP lot transaction, we can start at any operation queue and expect automatic creation of a purchase requisition if an OSP resource is present. Starting a bonus job at any operation which has a resource of charge type PO Move result in an error.

## Move Transactions

- **Move:** Moving a job to the queue of any OSP operation results in the automatic creation of purchase requisitions. Moving to a PO Move OSP operation results in an error. You can move from an OSP operation without formally receiving the OSP item.
- **Jump:** Jumping to the queue of an OSP operation, both inside and outside the routing, results in the creation of a purchase requisition. A jump from an OSP operation queue (with Charge Jump From Queue set to OFF) results in a warning to manually cancel purchase requisitions. Jumping to a PO Move OSP operation results in an error.
- **Undo:** Performing an undo back to an OSP operation queue does not result in purchase requisition creation. An undo at an OSP operation result in a warning, since a purchase requisition may be abandoned.

## Defining Network Routings

A warning is given if an outside processing resource of charge type PO Move is associated with an operation in the Network Routing window.

---

## Lot and Serial Controlled Assemblies

### Creating a Job with Lot/Serial Controlled Assembly

With Oracle Shop Floor Management transactions like Job Creation, Lot Creation, Move transaction, WIP lot transactions you can enter serial numbers for assembly items. To use this functionality, set Oracle Shop Floor Management Network Routings.

Support for Lot and Serial Controlled Assemblies functionality helps you to assign a serial number to each unit of an item to track it, trace each item from the warehouse to the production process and to the shop and track batches of items throughout their movement in and out of inventory.

See Creating a Lot Based Job, page 5-10.

1. The serial controlled assemblies with item attribute Serial Generation as Predefined are alone supported.
2. Transactions are done in the same way as it is done for Lot based jobs, but differs only for serial generation and handling. You have to go to additional user interfaces to perform actions.
3. Serial tagging functionality is not supported for organizations which are enabled for Shop Floor Management. If the organization is enabled for Shop Floor Management, then the serial tagging assignment defined at the item level is ignored.

### Serial Generation during Job Creation and Job Move

**To assign serial numbers:**

1. Create a lot based job from the Lot Based Jobs window.

2. Click on Serial Numbers button.
3. Enter serial numbers to the assembly item in the Associate Serial Numbers window.

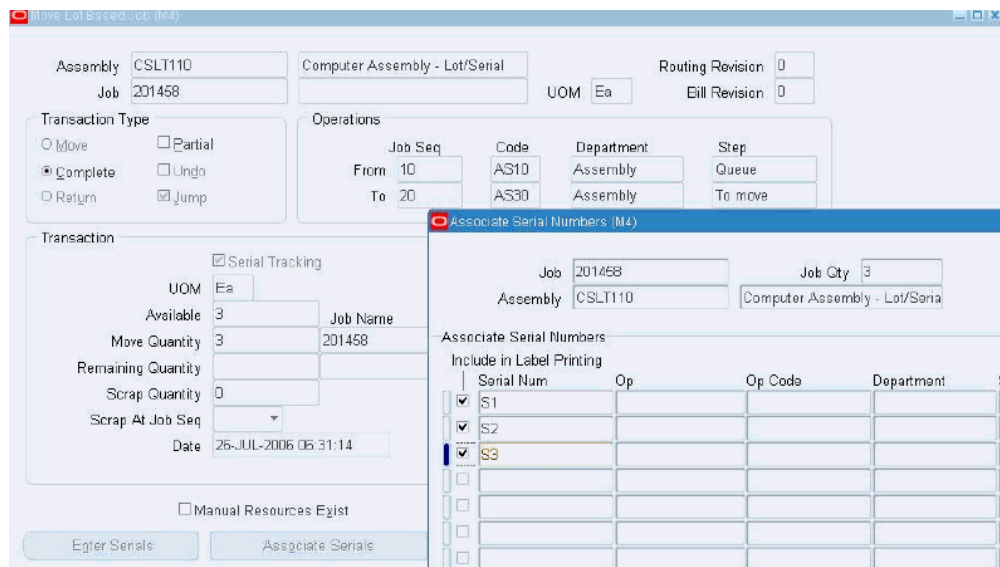

4. Click Generate/Associate.  
You can assign existing serial numbers with the status 'Defined but not used' and 'Issued out of stores' to the current job. You can also generate new serial numbers.
5. You can modify the serial attributes in the Attributes column.
6. Check 'Include in Label Printing' to initiate the printing of labels for serial numbers on the job if the printing setups are completed in Inventory.

### To serial track a job during move transactions:

You can start to serial track a job during move transactions from Move Lot Based Jobs window.

- Select Serial Tracking in the Transaction region to track the job from this move transaction.

When the job is moved out of Queue of a Serialization Start Operation intraoperation step, serial tracking is automatically enabled.

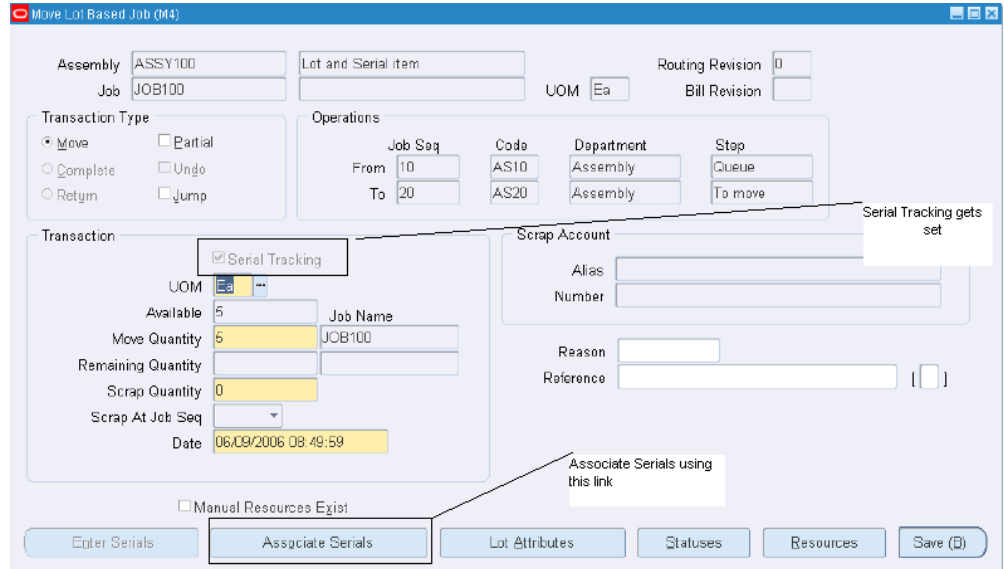

- Select Associate Serials to generate and associate serials during Move transaction.
- Click Enter Serials and specify serials to be scrapped during the Move transaction.
- Click Enter Serials and specify serials for remaining quantity during Partial Move transaction.

### Manual Entry and Auto Generation of Serial Numbers:

- You can manually enter serial numbers by specifying serials in the Serial Num column.
- You can also automatically generate by specifying the quantity in Serial Number Qty to Generate/Associate field.
- And you can also associate predefined serial numbers to a job.

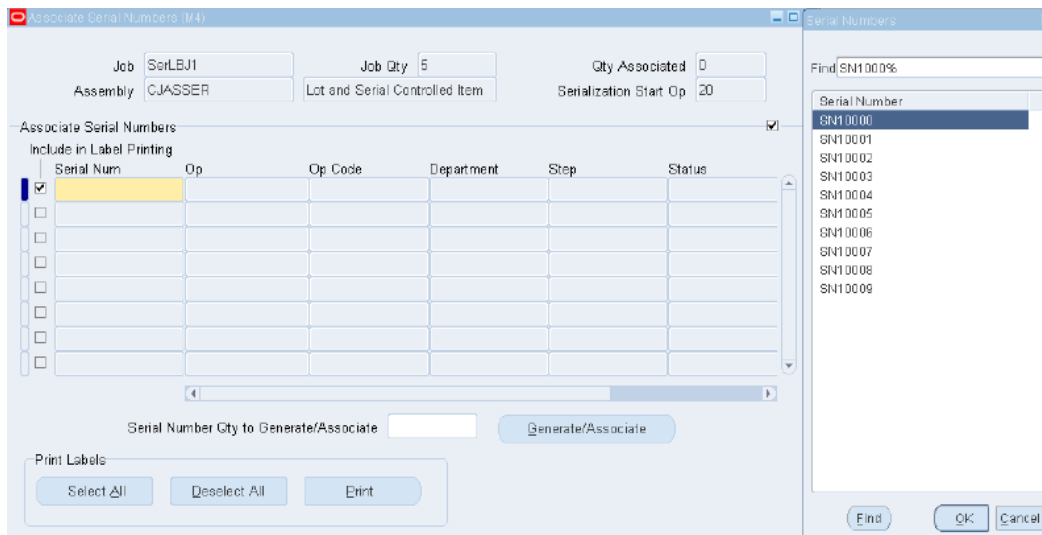
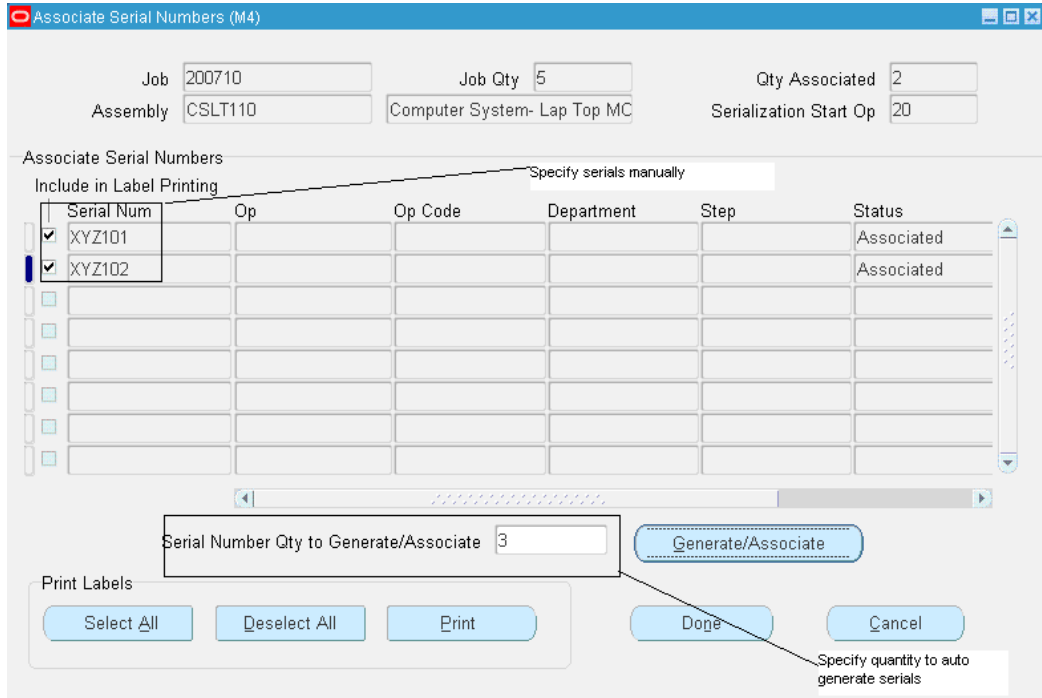

## Executing Manufacturing Transactions

See Performing Lot Move Transactions, page 5-14

## Job Move Transactions:

### Partial Move

1. Navigate to Move Lot Based Job window.
2. Set the Partial check box.
3. Click Enter Serials.

Job Serial Numbers window lists the serials of the job.

4. Select the serial number to be associated with the Remaining quantity of the job.  
The balance serials move with the job.

The screenshot shows the 'Move Lot Based Job (M4)' window. The 'Transaction Type' section has 'Move' selected and 'Partial' checked. The 'Operations' table shows Job Seq 10 to 20, Code FB10 to FB20, Department FAB, and Step Queue. The 'Transaction' section shows UOM Ea, Available 5, Move Quantity 4, Remaining Quantity 1, and Date 13-FEB-2007 22:11:51. The 'Scrap Account' section has Alias and Number fields. The 'Reason' field is empty. The 'Manual Resources Exist' checkbox is unchecked. Buttons at the bottom include Enter Serials, Associate Serials, Lot Attributes, Statues, Resources, and Save (B).

Job Seq	Code	Department	Step
From 10	FB10	FAB	Queue
To 20	FB20	FAB	Queue

UOM	Ea	Job Name	SerLBJ1
Available	5	Job Name	SerLBJ1*1
Move Quantity	4		
Remaining Quantity	1		
Scrap Quantity			
Scrap At Job Seq			
Date	13-FEB-2007 22:11:51		

### Scrap

1. Navigate to Move Lot Based Job window.
2. Specify the quantity to be scrapped in the Scrap Quantity field.
3. Click Enter Serials to select the serials for the quantity to be scrapped in the Job Serial Numbers window that appears.

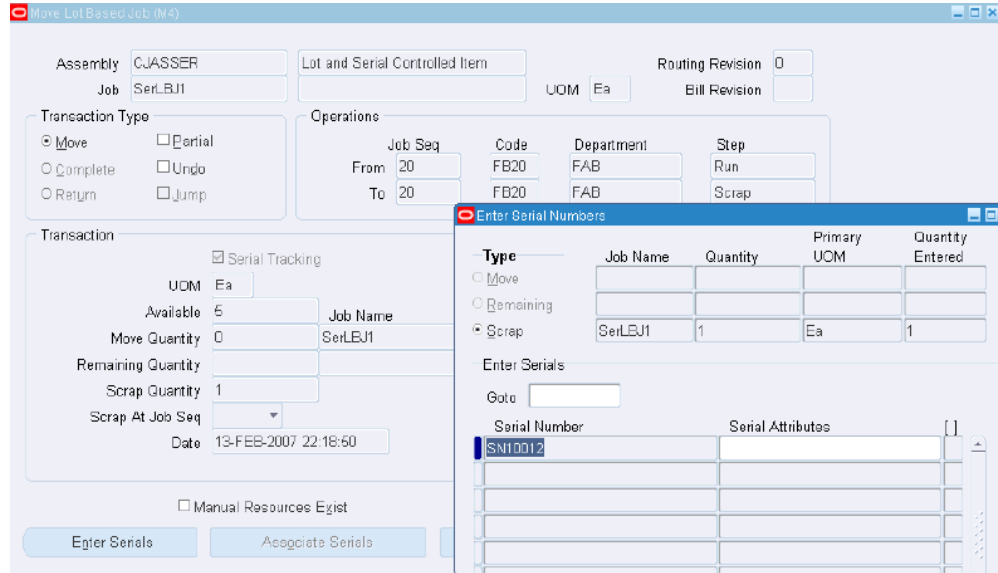

4. Click OK.

### Assembly Completion

1. Navigate to Move Lot Based Job window.
2. Select Complete as the Transaction Type.

If this is the last operation and if the transaction done is To Move, then the job is complete in the shop floor.

3. Click Associate Serials to check and update the serials.



Assembly: CJASSER  
 Job: SerLBJ1  
 Lot and Serial Controlled Item: [ ]  
 UOM: Ea  
 Routing Revision: [ ]  
 Bill Revision: [ ]

Transaction Type:  
 Move  Serial  
 Complete  Ungo  
 Return  Jump

Job Seq	Code	Department	Step
From 20	FB20	FAB	Run
To 40	FB30	FAB	To move

Transaction:  
 Serial Tracking  
 UOM: Ea  
 Available: 4  
 Move Quantity: 4  
 Remaining Quantity: [ ]  
 Scrap Quantity: 0  
 Scrap At Job Seq: [ ]  
 Date: 13-FEB-2007 22:24:47  
 Job Name: SerLBJ1

Scrap Account:  
 Alias: [ ]  
 Number: [ ]  
 Reason: [ ]  
 Reference: [ ]

Manual Resources Exist

Buttons: Enter Serials, Associate Serials, Lot Attributes, Statuses, Resources, Save (B)

4. Navigate to Manufacturing Manager: Inventory: On-hand, Availability: On-hand Quantity.

The Query Material page appears.

5. Enter Description.
6. Click Find.

The Material Workbench page appears showing the lot and its serials availability in the Inventory.

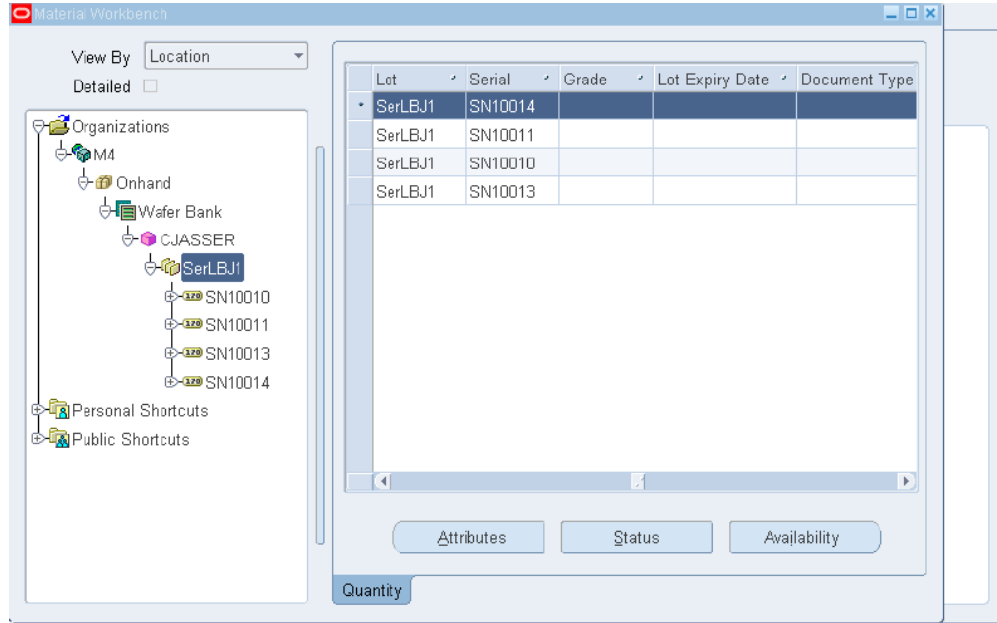

## Return

You can return the completed assembly to the previous step by this process. You have the ability to return a serial item from an assembly.

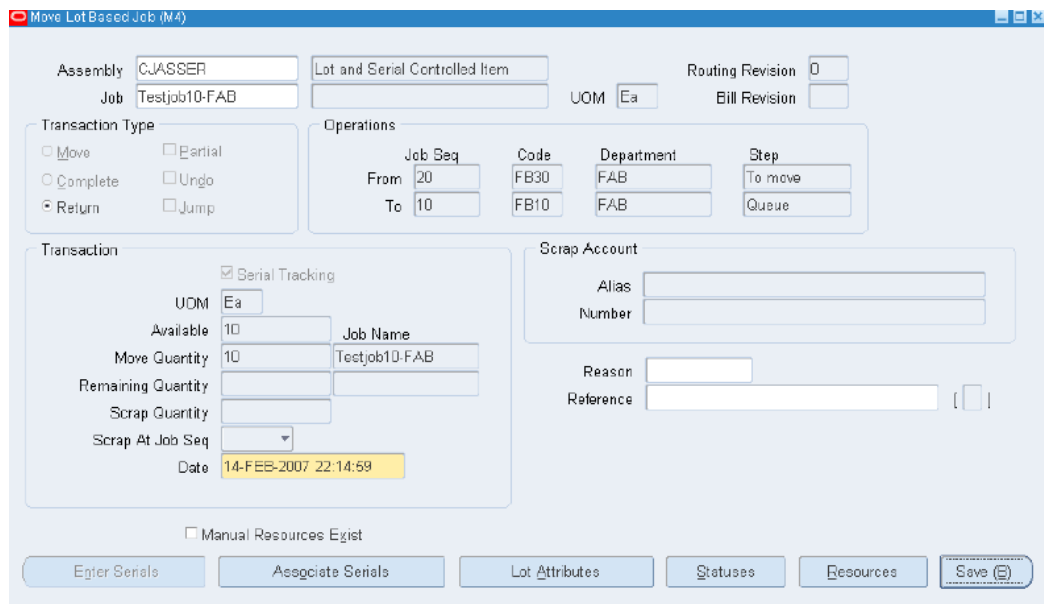

**Note:** Serial numbers completed during the completion transaction will be returned to the job.

Only those serial item(s) issued during job completion to the assembly

can be returned, while returning a serial item from an assembly.

Return transaction will fail if any of the completed serial numbers has its status other than 'Reside In stores'.

## Undo

Click Undo if you want to undo the previous Move transaction.

- If a serial number for an item is generated during a transaction and that transaction is reversed, then the serial number will also remain with the job. You have the option to delete the serial and generate a new one.
- Undoing of a move transaction from which the job is serial tracked will revert the status of the serial number from 'In Progress' to assigned.

Move Lot Based Job (M4)

Assembly: CJASSER, Job: Testjob10, Lot and Serial Controlled Item: , UOM: Ea, Routing Revision: 0, Bill Revision:

Transaction Type:  Move,  Complete,  Return,  Partial,  Undo,  Jump

Job Seq	Code	Department	Step
From: 30	FE20	FAB	To move
To: 10	FB10	FAB	Queue

Transaction:  Serial Tracking, UOM: Ea, Available: 10, Move Quantity: 10, Job Name: Testjob10, Remaining Quantity: , Scrap Quantity: , Scrap At Job Seq: , Date: 14-FEB-2007 22:20:28

Scrap Account: Alias: , Number: , Reason: , Reference: [ ]

Manual Resources Exist

Buttons: Enter Serials, Associate Serials, Lot Attributes, Statuses, Resources, Save (S)

## Jump

- If you want to jump to an operation, which is not in the job sequence that the assembly will take, then enter the job sequence in the To field of Job Seq and the Step in that operation. Click Jump and Save.
- You have the choice to serial track from the To operation. Serial Tracking gets mandatory only after executing Serial Start Operation or at Job Completion.

### Issuing Lot/Serial Component to a Lot/Serial Assembly:

You can optionally link the component serial numbers with assembly serial number when you do Component Issue Transactions (Lot Creation, Backflush, and Material Transaction) using forms.

### Backflush

You can enter the component serial numbers to be issued to a lot based job and also link the assembly serial number using the form during backflush transaction.

1. Enter the lot/serial controlled component to be backflushed for the assembly in the Bills of Material window. Select Material Control tab to enter the Supply Type.
2. Navigate to Lot Based Jobs window. Create a job for the assembly and associate serial numbers.
3. Navigate to Move Lot Based Job window and execute a Move transaction.

The component required at this operation is backflushed.

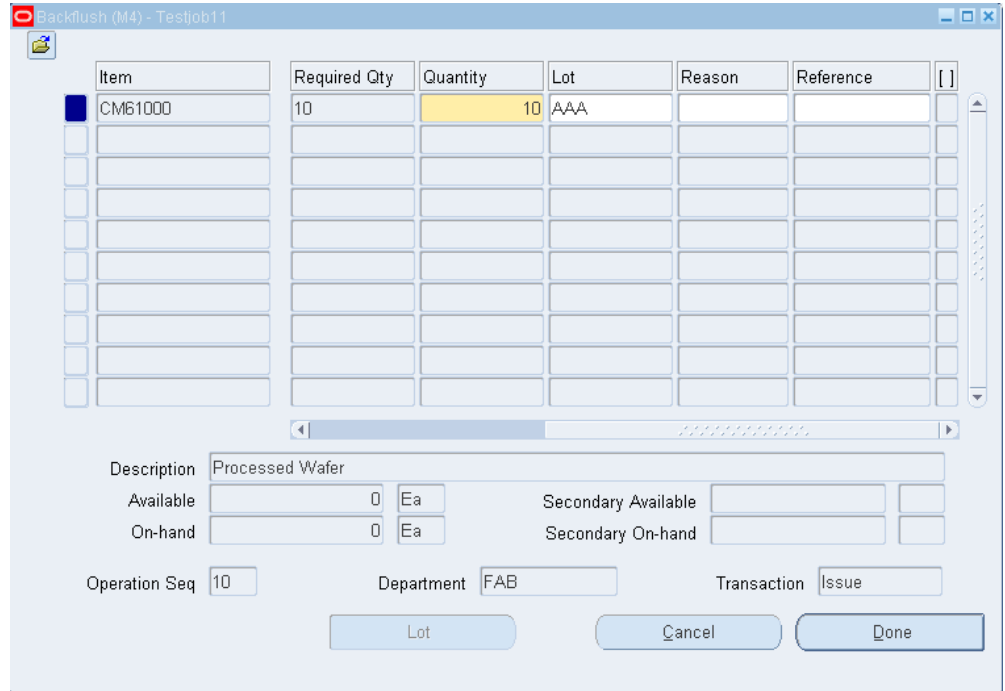

- Select Lot in the Backflush window.  
The Lot Entry window appears.

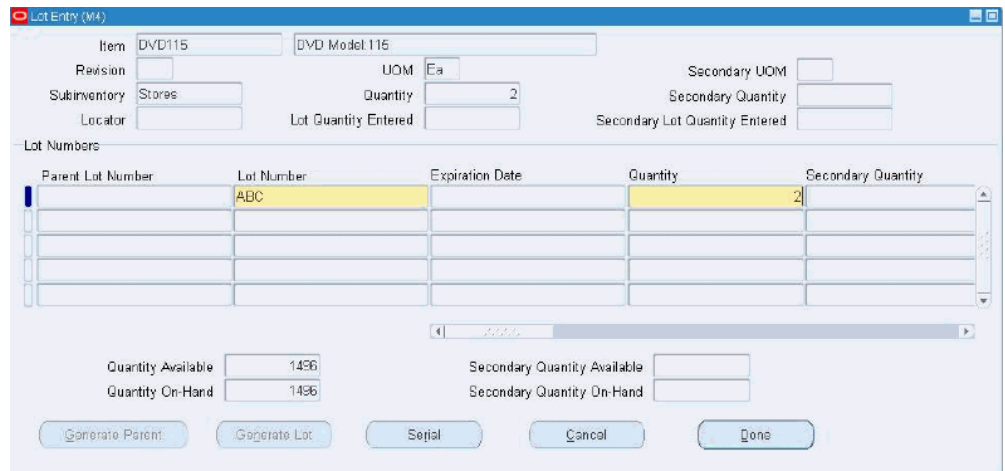

- Enter the lot number for the backflushed component.
- Click Serial in the Lot Entry window.  
The Serial Entry window appears.

Serial Entry (M4)

Item: DVD115      DVD Model: 115

Revision:      UOM: Ea

Lot: ABC      Quantity: 2

Subinventory: Stores      Quantity Entered: 2

Locator:     

---

**Serial Number Entry Mode**

Ranges       Individual

Start Serial Number	End Serial Number	Manufacturer's Serial Number	Assembly Lot Number	Assembly Serial Number	Attributes	
DVDS0005	DVDS0005			CSS0009		
DVDS0006	DVDS0006			CSS0010		

Done      Cancel

7. Enter Serial numbers for the backflushed component in the Start Serial Number column.
8. You can associate the component serials issued to each of the assembly serials through the column Assembly Serial Number.

**Material Issue**

1. To manually issue the material needed for the assembly, select the job and issue the components through the Material Transaction window.
2. Click Continue.  
The WIP Issue window appears.
3. Choose Lot/Serial to enter lot details for the issued component.

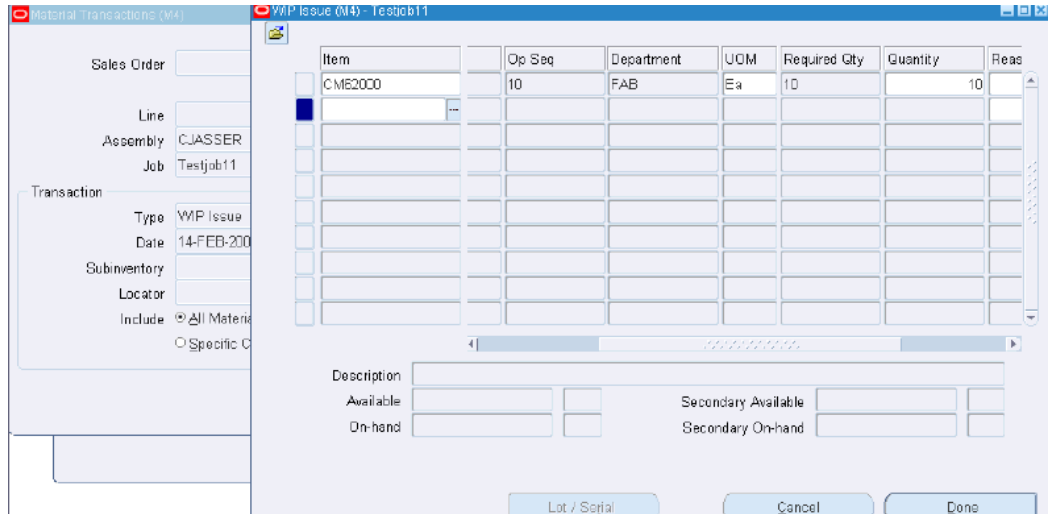

### Lot Creation

1. Navigate to Define Co-products window.
2. Enter a component as Co-Product for the particular component in the Co-Product column.

Define Co-products (M4)

Component: CSLT110A

Component Description: Computer Assembly - Lot/Serial

Usage: Value 1, Inverse 1, Basis Item

Effective Dates: From 01-AUG-2006 06:46:08, To

Buttons: Details, Substitutes

**Co-Products**

Co-Product	Rev	Primary	Alternate Bill	Co-Product Description
CSLT110B	0	<input checked="" type="checkbox"/>	<input type="checkbox"/>	Computer Assembly - Lot/Serial
		<input type="checkbox"/>	<input type="checkbox"/>	
		<input type="checkbox"/>	<input type="checkbox"/>	
		<input type="checkbox"/>	<input type="checkbox"/>	

Buttons: Split Percentage, View BOM

3. Navigate to Lot Based Jobs window and assign serials to the job.
4. Navigate to Lot Creation window.
5. Select Job Information tab in the Resulting Lots region to enter the job information for the resulting lot and assembly.



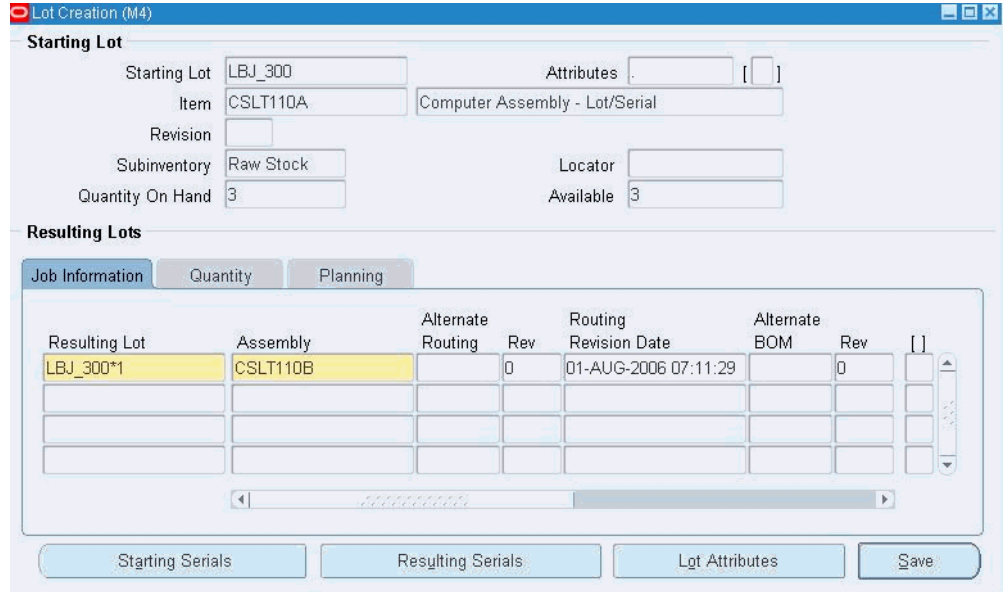

6. Select Quantity tab to view the job quantity details for the Resulting Lot.

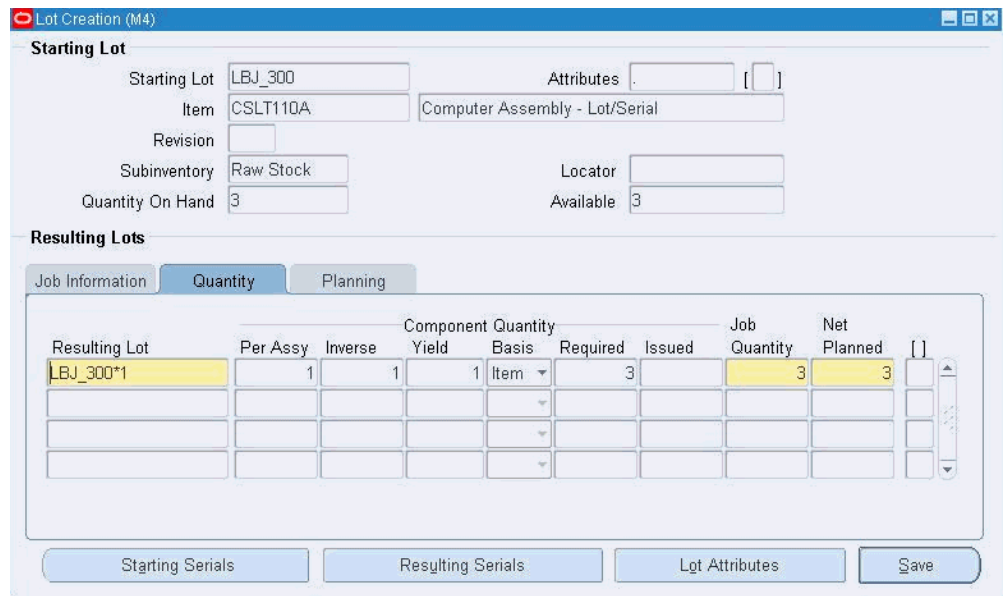

7. Click Resulting Serials to specify serials for the resulting lot.

**Note:** You have to specify the Resulting Lot's Serials first, only then Starting Lot's Serials can be issued to the resulting Lot's serials.

The Associate Serial Numbers window appears.

8. Assign serials to the resulting job.
9. Click Done.
10. Click Starting Serials to assign serials of the starting lot to the serials of the resulting lot.

The Serial Entry window appears. Issue the serials of the starting lot to the serials of the resulting lot.

11. Click Done.

### **WIP Lot Transactions:**

You can do WIP lot transactions for lot based jobs created for serial controlled assemblies using the WIP Lot Transactions form.

See WIP Lot Transactions, page 5-30 and Creating WIP Lot Transactions, page 5-31.

### **Split**

1. Navigate to WIP Lot Transactions window.
2. Select Split as Transaction Type.
3. Split the starting job into required resulting jobs with appropriate resulting quantity.
4. Click Serial Numbers in the Resulting Job region to associate serials to the resulting jobs.

The Associate Serial Numbers to Resulting Jobs window appears.

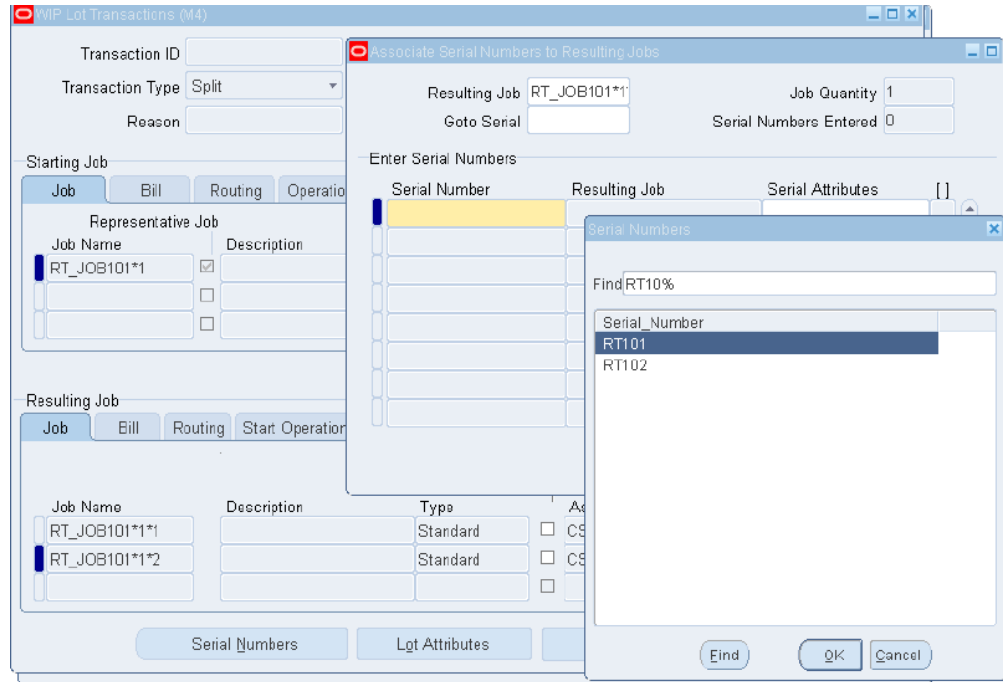

5. Select a serial from the Serial Numbers window for the resulting job chosen.

### Merge

1. Navigate to WIP Lot Transactions window.
2. Select Merge as Transaction Type.
3. Merge the starting jobs into a resulting job in the Resulting Job region.
4. Click Serial Numbers in the Resulting Job region to assign the serials of the starting jobs to the resulting job.

WIP Lot Transactions (M4)

Transaction ID:  Transaction Date: 19-FEB-2007 00:43:39 Status: Pending

Transaction Type: Merge Job Type: Standard Costed:

Reason:  Reference:

Starting Job

Job Bill Routing Operation Others

Representative Job

Job Name	Description	Type	Assembly	Available Quantity	Net Planned	
LN127	Original SC6300 qty: 3430	Standard	SC6400	3430	3430	<input type="checkbox"/>
LN127*1	Original SC6300 qty: 980	Standard	SC6401	980	980	<input type="checkbox"/>
						<input type="checkbox"/>

Serial Numbers Lot Attributes

Resulting Job

Job Bill Routing Start Operation Others

Update Assembly

Job Name	Description	Type	Update Assembly	Assembly	Resulting Quantity	Net Planned	
LN127	Original SC6300 qty: 3430	Standard	<input type="checkbox"/>	SC6400	4410	4410	<input type="checkbox"/>
			<input type="checkbox"/>				<input type="checkbox"/>
			<input type="checkbox"/>				<input type="checkbox"/>

Serial Numbers Lot Attributes Cancel Save

### Update Quantity

1. Navigate to WIP Lot Transactions window.
2. Select Update Quantity as Transaction Type.
3. Enter the starting job in the Starting Job region.
4. Update the job quantity in the Resulting Quantity column of the Resulting Job region.
5. Click Serial Numbers to assign serial numbers for the updated quantity.  
The Associate Serial Numbers window appears.
6. Click Done to save the transaction.

WIP Lot Transactions (M4)

Transaction ID:  Transaction Date: 22-AUG-2006 17:15:17 Status: Pending

Transaction Type: Update Quantity Job Type: Standard Costed:

Reason:  Reference:

Starting Job

Job Bill Routing Operation Others

Representative Job					
Job Name	Description	Type	Assembly	Available Quantity	Net Planned
WLT_UPQTY		Standard	CSLT110	1	1

Serial Numbers Lot Attributes

Resulting Job

Job Bill Routing Start Operation Others

Update Assembly					
Job Name	Description	Type	Assembly	Resulting Quantity	Net Planned
WLT_UPQTY		Standard	<input type="checkbox"/> CSLT110	2	2
			<input type="checkbox"/>		
			<input type="checkbox"/>		

Serial Numbers Lot Attributes Cancel Save

### Update Assembly

1. Navigate to WIP Lot Transactions window.
2. Select Update Assembly as Transaction Type.
3. Enter the starting job in the Starting Job region.
4. Update the job assembly in the Assembly column of the Resulting Job region.

**Note:** You cannot update this with an assembly that is not lot/serial controlled.

WIP Lot Transactions (M4)

Transaction ID:  Transaction Date: 18-FEB-2007 00:00:00 Status: Pending

Transaction Type: Update Assembly Job Type: Standard Costed:

Reason:  Reference:

Starting Job

Job Bill Routing Operation Others

Representative Job

Job Name	Description	Type	Assembly	Available Quantity	Net Planned	
SerLBJ1*2	<input checked="" type="checkbox"/> Original CJASSER qty: 2	Standard	CM61000	2	2	<input type="checkbox"/>
	<input type="checkbox"/>					<input type="checkbox"/>
	<input type="checkbox"/>					<input type="checkbox"/>

Serial Numbers Lot Attributes

Resulting Job

Job Bill Routing Start Operation Others

Update Assembly

Job Name	Description	Type	Update Assembly	Assembly	Resulting Quantity	Net Planned	
SerLBJ1*2		Standard	<input type="checkbox"/>	CJ-ASSY11	2		<input type="checkbox"/>
			<input type="checkbox"/>				<input type="checkbox"/>
			<input type="checkbox"/>				<input type="checkbox"/>

Serial Numbers Lot Attributes Cancel Save

### Update Routing

1. Navigate to WIP Lot Transactions window.
2. Select Update Routing as Transaction Type.
3. Enter the starting job in the Starting Job region.
4. Select Routing tab in the Resulting Job region.
5. Update the Alternate column with alternate routing of the assembly.

WIP Lot Transactions (M4)

Transaction ID:  Transaction Date: 19-FEB-2007 00:59:43 Status: Pending

Transaction Type: Update Routing Job Type: Standard Costed:

Reason:  Reference:

Starting Job

Job Bill **Routing** Operation Others

Representative Job

Job Name	Reference	Alternate	Rev	Revision Date	Subinventory	Locator
AD121JB1	<input checked="" type="checkbox"/>	<input type="text"/>	0	19-FEB-2007 00:23	Wafer Bank	<input type="text"/>
<input type="text"/>	<input type="checkbox"/>	<input type="text"/>	<input type="text"/>	<input type="text"/>	<input type="text"/>	<input type="text"/>
<input type="text"/>	<input type="checkbox"/>	<input type="text"/>	<input type="text"/>	<input type="text"/>	<input type="text"/>	<input type="text"/>

Serial Numbers Lot Attributes

Resulting Job

Job Bill **Routing** Start Operation Others

Job Name	Reference	Alternate	Rev	Revision Date	Subinventory	Locator
<input type="text"/>	<input type="checkbox"/>	Alternate	0	19-FEB-2007 01:03	Wafer Bank	<input type="text"/>
<input type="text"/>	<input type="checkbox"/>	<input type="text"/>	<input type="text"/>	<input type="text"/>	<input type="text"/>	<input type="text"/>
<input type="text"/>	<input type="checkbox"/>	<input type="text"/>	<input type="text"/>	<input type="text"/>	<input type="text"/>	<input type="text"/>

Serial Numbers Lot Attributes Cancel Save

### Update Lot Name

1. Navigate to WIP Lot Transactions window.
2. Select Update Lot Name as Transaction Type.
3. Enter the starting job in the Starting Job region.
4. Update the Job Name column in the Resulting Job region with new job name.

WIP Lot Transactions (M4)

Transaction ID:  Transaction Date: 19-FEB-2007 01:21:27 Status: Pending

Transaction Type: Update Lot Name Job Type: Standard Costed:

Reason:  Reference:

Starting Job

Job Bill Routing Operation Others

Representative Job

Job Name	Description	Type	Assembly	Available Quantity	Net Planned	
LN127	<input checked="" type="checkbox"/> Original SC6300 qty: 3430	Standard	SC6400	4410	4410	<input type="checkbox"/>
	<input type="checkbox"/>					<input type="checkbox"/>
	<input type="checkbox"/>					<input type="checkbox"/>

Serial Numbers Lot Attributes

Resulting Job

Job Bill Routing Start Operation Others

Job Name	Description	Type	Update Assembly	Assembly	Resulting Quantity	Net Planned	
NEWLN127	Original SC6300 qty: 3430	Standard	<input type="checkbox"/>	SC6400	4410		<input type="checkbox"/>
			<input type="checkbox"/>				<input type="checkbox"/>
			<input type="checkbox"/>				<input type="checkbox"/>

Serial Numbers Lot Attributes Cancel Save

### Bonus

1. Navigate to WIP Lot Transactions window.
2. Select Bonus as Transaction Type.
3. Enter the bonus job details for a lot/serial assembly in the Resulting Job region.



Transaction ID: [ ] Transaction Date: 19-FEB-2007 01:32:50 Status: Pending  
Transaction Type: Bonus Job Type: Standard Costed: [ ]  
Reason: [ ] Reference: [ ]

Starting Job

Job Bill Routing Operation Others

Job Name	Description	Type	Assembly	Available Quantity	Net Planned
[ ]	[ ]	[ ]	[ ]	[ ]	[ ]
[ ]	[ ]	[ ]	[ ]	[ ]	[ ]
[ ]	[ ]	[ ]	[ ]	[ ]	[ ]

Serial Numbers Lot Attributes

Resulting Job

Job Bill Routing Start Operation Others

Job Name	Description	Type	Update Assembly	Assembly	Resulting Quantity	Net Planned
BONUSLOT	[ ]	Standard	<input type="checkbox"/>	CSLT110	5	5
[ ]	[ ]	[ ]	<input type="checkbox"/>	[ ]	[ ]	[ ]
[ ]	[ ]	[ ]	<input type="checkbox"/>	[ ]	[ ]	[ ]

Serial Numbers Lot Attributes Cancel Save

## Viewing and Updating Serial Numbers in WIP Lot Transactions:

### To view serial numbers for the starting job

- Navigate to the WIP Lot Transactions window.
- Choose Serial Numbers of the Starting Job region. The Associate Serial Numbers window appears.

### To view, update serial numbers for the resulting job

- Choose Serial Numbers of the Resulting Jobs region. The Associate Serial Numbers window appears.

If current operation is at Queue, no component issued to an operation before the current operation is allowed to be linked to the serial numbers corresponding to update quantity assembly serial numbers.

If current operation is at To move, no component issued to the current operation or an operation before the current operation is allowed to be linked to the serial numbers corresponding to update quantity assembly serial numbers.

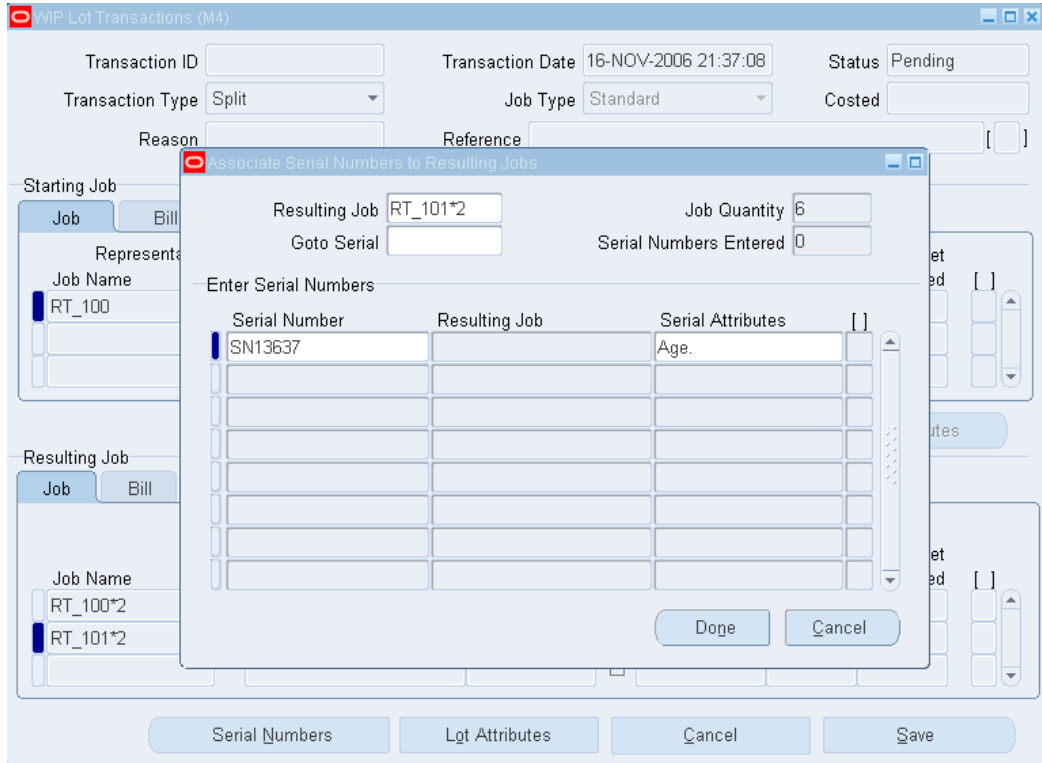

*Split:* Choose Serial Numbers of the Resulting Jobs region. Associate Serial Numbers to Resulting Jobs window appears. Reassociate the parent job's serial number to the child job. You can navigate to a serial number using the Goto Serial field.

*Merge:* You can reassign serial numbers of starting jobs to child jobs. You cannot merge serial tracked jobs with non-serial tracked jobs. You cannot merge jobs if serial number of the nonrepresentative job already exists for the representative job's assembly.

## Completing the Job into Inventory

### To view lot and serial details in the Material Workbench

1. Navigate to Inventory> On-hand, Availability> On-hand Quantity.

The Query Material window appears.

2. Enter search criteria.

3. Click Find.

The Material Workbench window appears.

You can view the genealogy of the completed lot in the left pane. The right pane shows the lot and its serials available in the Inventory.

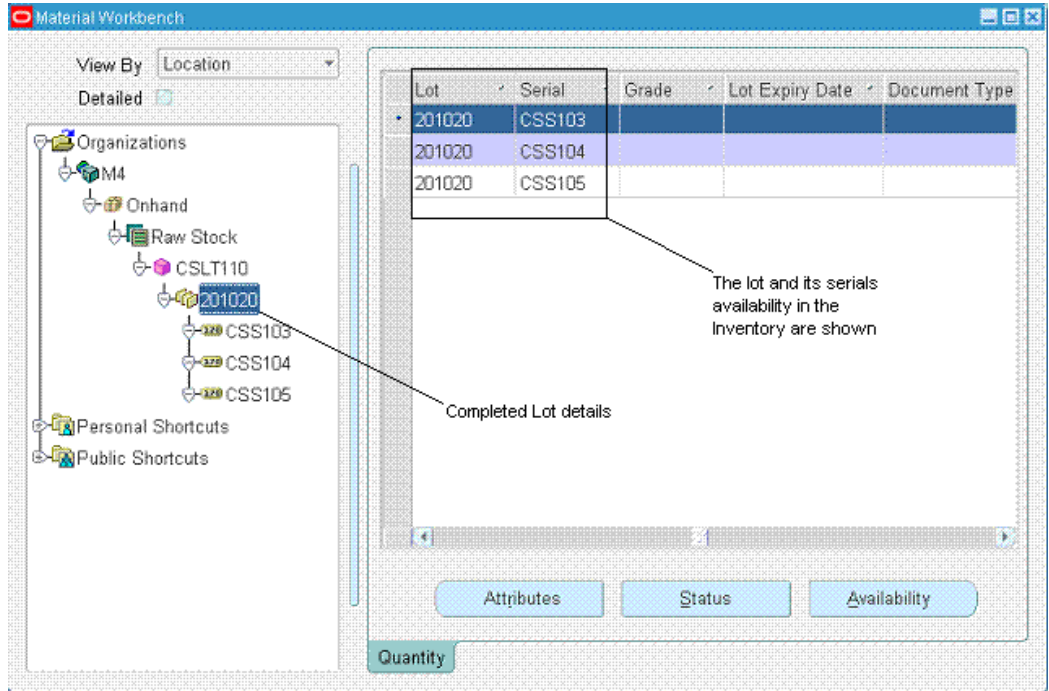

**Note:** Transactions like Job Creation, Lot Creation, Job Move, and WIP Lot can be executed for a lot and serial controlled assemblies through HTML user interfaces.



---

# Resource Scheduling Workbench

This chapter covers the following topics:

- Overview of Resource Scheduling Workbench
- Using the Resource Scheduling Workbench
- Defining User Preferences
- Job Operation Bars
- Navigation
- Viewing Property Windows
- Capacity Exceptions
- Showing Select Resources and Resource Load Versus Capacity Panes
- Selecting a Resource
- Adjusting Resource Capacity
- Rescheduling Jobs, Operations, and Resources in the Gantt Chart
- Rescheduling Start and End Dates
- Resource Transfer
- Transferring Work to an Instance
- Transferring Work Between Instances
- Transferring Work Between Alternate Resources
- Launching the HTML User Interface

## Overview of Resource Scheduling Workbench

The Resource Centric Gantt provides a graphical display of your shop floor by resource, and make it extremely easy for you to visualize the workload on any given resource. By providing a resource centric view, it is easy to pinpoint resource overloads and find

bottlenecks on your shop floor.

You can view the graphical representation of the released lot based jobs. The workbench displays completed, current, and future operations for all jobs for a particular resource, or set of resources. Color codes represent operation stages.

You can use the workbench to:

- View resource overloads and update resource capacities.
- Update operation start and end dates.
- Change to an alternate resource.
- Assign a resource instance or change to a different resource instance.
- Use the Oracle Shop Floor Management HTML user interface to change recommended paths, or choose substitute components.

If changes are made, then you can reschedule the entire shop floor based on midpoint, forward, or reverse scheduling. The scheduling is based on the infinite scheduling method.

This section includes the following topics:

## Using the Resource Scheduling Workbench

Launch the Resource Scheduling Workbench by navigating to the Resource Scheduling Workbench for Lot Based Jobs window from the Resource Scheduling Workbench menu item in Oracle Shop Floor Management responsibility.

The workbench appears and shows all the jobs in the Navigator hierarchy and Gantt Chart panes.

The navigator on the left side of the workbench displays the resources, and the Gantt Chart pane displays graphical bars that represent the job operation that the resource is used in.

My Resources is the root in the navigator, and contain no resources the first time you open the workbench. The resources that you select and the display order are saved in User Preferences.

If you drill down a level from the resource, then you will see all resource instances for that resource. Person type instances also display under Resources in the navigator. You can assign the same person to multiple resources.

The Resource in the navigator is a combination of the resource and owning department, and any instances under that resource belong to the department.

The bars in the timeline represent the job operations where the resource is being used. The duration of the bar depicts the start and end times of the resource used in that job operation.

- Each job and operation bar has a label that represents the job, operation, and department where the resource is used. You can customize labels in the Preferences window.
- If a resource is used in multiple job and operations, and those job and operations overlap, then the bars overlap in a cascading pattern.
- The current operation of a lot-based job displays in a different color.

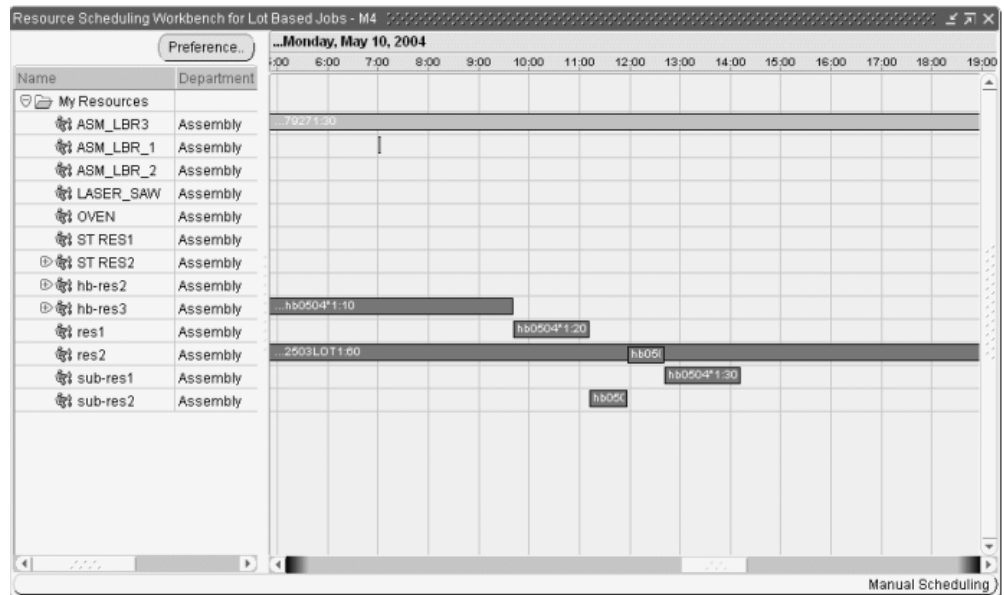

## Defining User Preferences

The user preferences let you select the resources to initially display in the Gantt chart. The resources in the unselected list display in a navigator by department, with the resources that the department owns being the second level in the navigator.

### To define user preferences:

1. Navigate to the Resource Scheduling Workbench for Lot Based Jobs window.
2. Choose Preference to select resources for displaying in the workbench.
3. Select resources you want to view in the Unselected region and move them to the My Resources region.

When the resource you select is moved to the My Resources region, the workbench displays the resource name followed by the owning department. The order in which resources display in the navigator are determined by the order in the My Resources region. If you select the Department category in the Unselected region

and move it to the My Resources region, then all resources for that department will be included in the My Resources region.

You can change the display order of the resources by selecting the resource in the My Resources region and using the arrows to move the resources. Any resources that remain in the Unselected list will not display in the workbench.

4. Enter the Default Scale at Startup value.
5. Enter the default Row Height.
6. Select the Bar Text. You can display the assembly name or the job name.
7. Select the Lot Based Job Status values to display on the gantt chart. Only the Job Status values selected will display on the gantt.
8. Choose the Make Changes Permanent indicator to save the changes to the My Resources region when choosing OK.



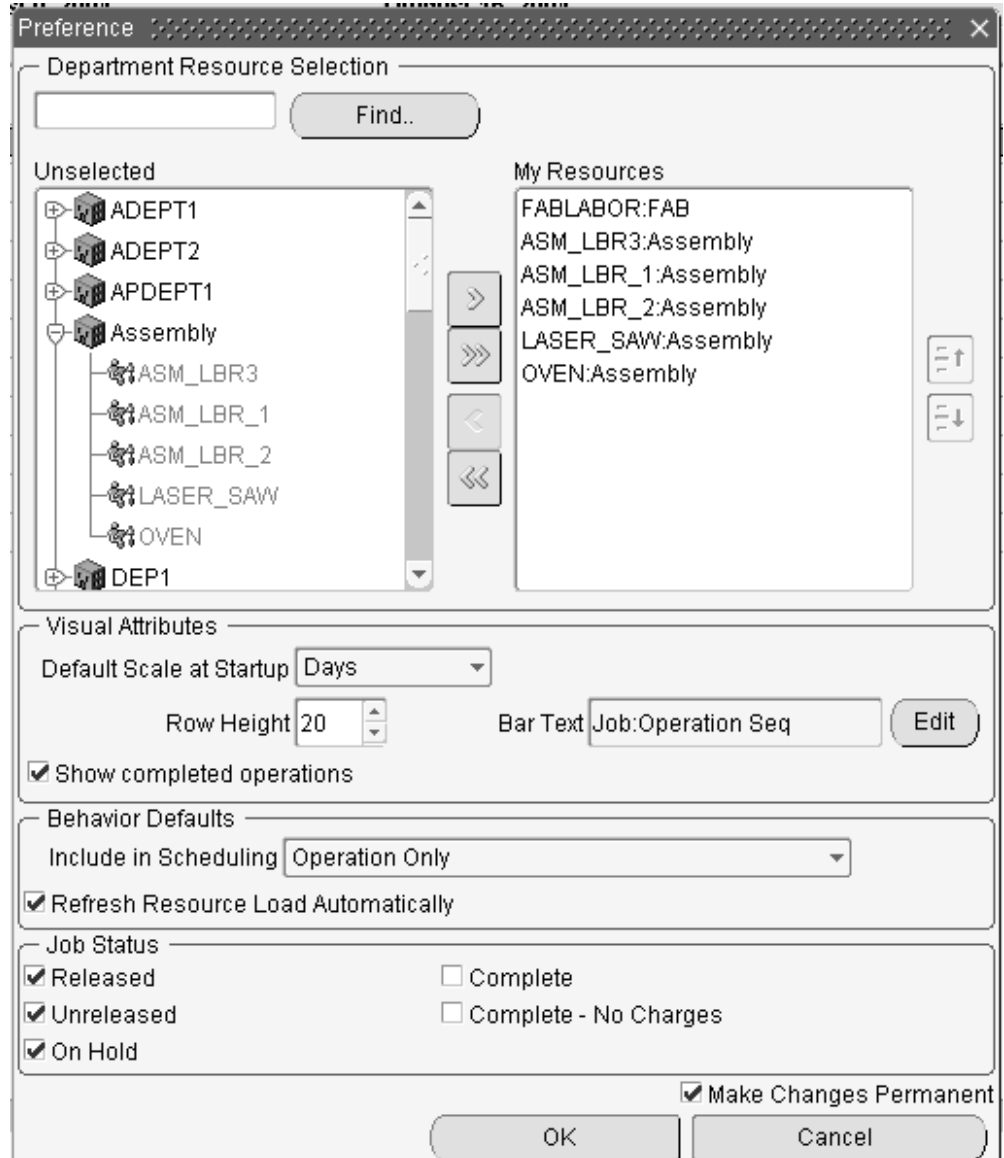

## Job Operation Bars

The bars in the timeline represent the job operations where the resource is being used. The duration of the bar represents the start and end times of the resource used in that job operation.

- Each job and operation contain a label that represents the job, operation, and department where the resource is being used.
- If a resource is used in multiple job and operations, and those job and operations overlap, then the bars overlap and display in a cascading pattern.

- The current operation of a lot-based job displays in a different color.

## Instance

Instances are shown beneath the resource node in the navigator.

- Job Operations assigned to a specific instance display on the timeline at the instance level.
- Job Operations that are not assigned to a specific instance display at the resource level.

## Batchable Resources

The job operations where batchable resources are used overlap.

## Alternate Resources

Alternate Resources display on the navigator and timeline.

## Setup Time

Setup time for the resource displays as a separate bar from the job operation bar. The color of the bar for setup time displays as a different color from the job operation bar.

## Bar Color

The color scheme for operations are:

- Grey: completed operations
- Blue: current and future operations
- Red: current operation deleted from path

## Navigation

### Job Operation

If you position the cursor over a job operation, then that job operation bar is selected. If you keep the cursor over the bar, a tool tip appears, giving details about the job operation.

## Simultaneous and Batched Resources

If you position the cursor over a job operation that contains a simultaneous resource, then any other corresponding simultaneous job operation resources are selected. Similarly, if you place the cursor over a job/operation for a batched resource, then all other job/operations in that batch will also be selected.

## Progress Indicator Bars

The bars in the gantt chart contain a progress indicator. Since a lot-based job does not have partial completion, this indicator displays either 0% or 100%. This displays separate completed operations from those not completed.

## Selecting Overlapped Bars

If you select a bar that is in a group of overlapping bars, then that bar appears at the top of the group. The vertical position of the bar will not change, and the bar will remain on top as long as the mouse button is pressed. Once the mouse button is released the bar will return back to its original position.

## Viewing Property Windows

Property windows for jobs, operations, or resources are available in the Gantt Chart pane. These windows contain information about dates, quantities, descriptions of the scheduling data. See: Job Properties Window, Operation Properties Window, and Resource Properties Window.

### To view a property window

- Right click on a job, operation, or resource in the navigator hierarchy or Gantt Chart pane.
- Right click on a job, operation, or resource.

A drop-down menu appears.

Choose Properties. The property window for the respective job, operation, or resource displays.

bus1:30	
General	
Operation Code	FOS3
Operation	30
Resource Seq	10
Department	FAB
Lot Based Job	bus1
Job Description	
Assembly	SMC2400
Assembly Description	Processed Wafer
Requested Job Start Date	
Requested Job Due Date	
Firm	No
Utilization	100.0%
Efficiency	100.0%
Usage Rate Or Amount	100.0
UOM	HR
Basis	Item
Assigned Units	1.0
Required Resource Units	500.0
Adjusted Resource Time	500.0
Touch Time	500.0
Resource Start Date	27-JUL-2004 16:18:00
Resource End Date	19-OCT-2004 20:17:51
Setup	
Batch	
Batch Load	

## Job View

Right click on an operation resource bar, select menu "View Job Information" and a job view will appear on the bottom of the window.

## Job Operation Property

Right click on the operation in "Job View" area, select menu "Properties", a property window for the job operation will show up.

## Load Graph

A load graph will be available to display at the bottom of the window. You would be able to toggle the display of the load graph on/off, by pressing the load graph icon on the toolbar.

You will be able to select the resources to display on the Load Graph, by clicking the Select Resource(s) button. The name of the resources that you selected would then be displayed for each row on the load graph. The resources you select are the department resources, and will be displayed as the resource name followed by the owning department.

In addition to viewing the load graph and then selecting resources via the Select Resource(s) button, you will also be able to view the load for a resource by right clicking it in the tree. By right clicking the resource in the tree a popup menu will appear, and from there you may pick the View Resource Load option. Choosing that option will automatically display the load graph (if it isn't already displayed) and will show the load for the resource.

## Capacity Exceptions

You can define capacity exceptions by right clicking on the resource (or instance) in the workbench, or by right clicking on the resource (or instance) in the load graph region. Choosing Change Capacity displays the Capacity Change window.

## Reason Codes

When defining a capacity exception, you can define an exception a reason. Navigate to the Resource Capacity Change Reasons window to define reason codes. You can apply reason codes to the capacity changes when defining exceptions in the Bills of Material window or in the workbench.

The pre-seeded Reason codes include:

- Breakdown
- Scheduled Maintenance
- Plant Shutdown
- In training
- Not available

## Displaying Resource Unavailable Time

If a capacity exception brings the availability for the resource to zero, then capacity

exceptions for a resource display on the timeline. The exception displays as a shaded region on the timeline and is the same color for displaying weekends.

Capacity exceptions display at both the resource and resource instance level.

## Showing Select Resources and Resource Load Versus Capacity Panes

The Resource Scheduling Workbench lets you show or hide job operations from the resources listed, and the resources in relationship to the capacity available. You can identify problems for analysis so that tasks can be modified. For example, the order in which the resource performs these tasks or the shifting the tasks across the other resources.

### To show the Select Resources and Resource Load Versus Capacity Panes

- Choose the Resource Load indicator from the View menu.
- Choose Show/Hide Resource Load from the toolbar.

The Select Resources and Resource Load Versus Capacity panes appear.

### To hide the Select Resources and Resource Load Versus Capacity Panes

- Choose the Resource Load indicator again from the View menu.
- Choose Show/Hide Resource again from the View menu or toolbar.

The Select Resources and Resource Load Versus Capacity panes do not appear.

## Selecting a Resource

You can select a specific resource. If you are uncertain of the resource name, expand a job and an operation and view the specific resource of interest. Select a resource bar with your mouse pointer (yellow text bubble appears which indicates the name of the resource). The name of the resource is also available on the Resource Properties window.

### To select a resource:

1. In the Select Resource(s) pane choose the Select Resources button.

The Select Resource(s) window appears.

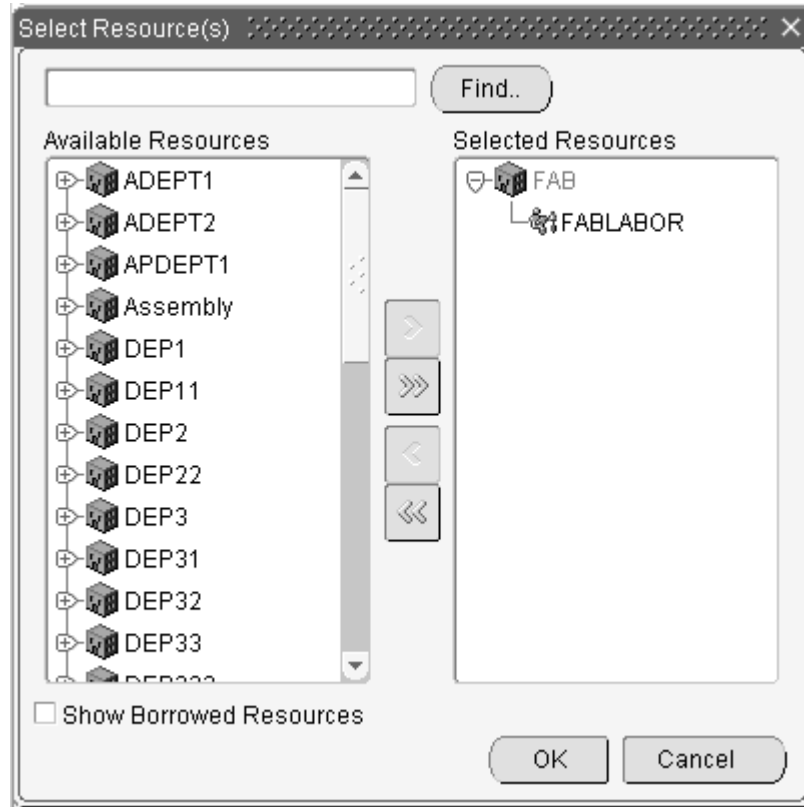

2. In the Available Resources pane select a resource or an instance.

3. Choose the right arrow button.

The resource appears in the Selected Resources pane.

4. Choose OK.

The name and description of the resource appears in the Select Resources pane and its corresponding graphic display for the resource appears in the Resource Load Versus Capacity pane. This represents the resource load for all jobs on the shop floor requiring this resource. The default graphic view is Table. The Required and Available key indicators appear.

5. From the graphic drop-down menu choose Continuous.

A continuous line graph appears. The Required, Available, and Overload key indicators appear.

6. From the graphic drop-down menu choose Bar.

A bar graph appears. The Required and Available key indicators appear.

## Adjusting Resource Capacity

You can adjust resource capacity to respond to machine or personnel availability. This includes:

- Delete or add a day of capacity, adjusting for overtime shifts or shop closures
- Add or delete resource units when either extra resources are obtainable or resources are unavailable
- Adjust Assigned Units or Usage Rate for the resource on the job routing

Simulation sets are used to link resource changes for scheduling. Simulation sets are defined, associated to resources in Oracle Bills of Material, and linked to Work in Process scheduling in Work in Process Parameters window.

There are two methods for adjusting resource capacity:

1. Navigate to the Departments window in Oracle Bills of Material, and from there access the Resources, Shifts, and Capacity Changes windows.
2. Access the Capacity Changes window directly from the Resource Scheduling Workbench.

### **To adjust resource capacity through Bill of Materials:**

1. Navigate to the Departments window from Oracle Bills of Materials.
2. Choose Resources to navigate to the Resources window.
3. Select a resource, then choose Shifts.  
The Shifts window displays. This window is used to assign shifts to the resource from those assigned to the workday calendar.
4. Select a shift and choose Capacity Changes to define capacity changes for a shift.  
The Capacity Changes window displays. Capacity modifications include adding or deleting days.
5. Select the designated simulation set defined on the Work in Process Parameters window.
6. Save your work.
7. In the Resource Scheduling Workbench, select Refresh Resource Load from the View menu to display your changes.
8. Select Schedule Multiple Work Orders to apply these capacity adjustments to the



shop floor schedule.

**Note:** If you select an alternate resource, make changes to the current operation, and save the job in the workbench, then changes do not display in the html based User Interface. The application stores changes made to the current operation in the WIP tables, not Shop Floor Management copy tables. Shop Floor copy tables store information from the last APS and Infinite Scheduler manual change.

### **To adjust directly from the Scheduler Workbench:**

Select Resource Load from the View menu or toolbar to display the Resource Load versus Capacity pane.

1. Choose Resources in the Select Resource(s) pane.

If the resource is scheduled by instance, and you want to adjust capacity, then select the instance in the Available Resource(s) pane. If you select the resource and not the instance, then the only action you can perform is deleting a day.

2. When the resources display on the workbench, select and right-click on the resource you want to adjust.

A list appears.

3. Choose Change Capacity. The Capacity Changes window displays. A resource must be assigned to a department and a shift to display this window.

The Resource and Department fields display the resource name and the department it is assigned. The Simulation Set field displays the simulation set used to link resource changes to available resource capacity.

The Schedule by Instance field displays Yes or No depending on whether the resource has specified instances (machine or labor type). This is set on the Resources window, the Schedule by Instance indicator.

In the Capacity Changes region of the window, you can change or add information depending on the resource definition.

If you select a resource scheduled by instance, then the only available value in the Action field is Delete a Day. For these resources, access the instance to adjust capacity.

4. In the Shift field, select available shifts from the list of values.

Shifts are defined on the Shifts window when you are assigning a resource to a department.

5. Select the action you want to perform. The choices are Add Capacity, Delete a Day,

Reduce Capacity, or Add a Day.

You can only delete work days, and only add non-work days.

6. If you are adding or reducing capacity, select the capacity units you want to change.  
The value in the Units field is defaulted from the assigned units of the resource to this department, and can be changed.
7. In the Date fields, From and To, select the dates for this capacity action to occur.
8. In the Time fields, From and To, the values default from the shift information, but can be changed.
9. Save your work.
10. Select Refresh Resource Load to display your changes.

## Rescheduling Jobs, Operations, and Resources in the Gantt Chart

You can manually reschedule the start and end dates of a job, operation, or resource:

- Grab and drag the start or end of a bar
- Use the Edit Schedule window

You can invoke the Bar Inspector window that shows the start and end dates of a selected job, operation, or resource.

## Rescheduling Start and End Dates

You can manually reschedule any job, operation, or resource without regard for constraints or scheduling rules.

### **To manually forward or backward reschedule using the pointer:**

1. Point at the start or end of a job, operation, or resource bar.
2. Click and drag to the right (forward) or left (backward).
3. The beginning or end of the bar moves to the right or left, respectively.
4. Save your work.

### **To manually forward or backward reschedule using the editor:**

5. Right click on any bar.  
A list appears.

6. Choose Edit Schedule.

The Edit Schedule window appears.

7. In the Start Date and/or End Date fields, enter the new start and/or end date for the required job or operation.

8. Choose Apply.

The bar moves to the new start and/or end date.

9. Save your work.

**Modifying Times:** You can only change or reschedule a job operation in terms of time by dragging the bar. You cannot alter the duration (width) of the bar.

You can use the snap to feature to align when dragging. This feature helps to eliminate small gaps between operations that may be too small to visually see on the gantt chart.

**Note: To use the Snap To feature:**

Right click on the job operation bar that you wish to move. A menu will appear.

10. Choose Snap To from the menu

11. Choose Snap Left or Snap Right. Snapping left aligns the starting time of your job operation to the next closest start or end time of another job operation. Snapping right aligns the ending time of your job operation to the next closest starting or ending time of the nearest job operation.

The behavior of rescheduling a job operation varies with the type of resources the job operation uses.

**Single Resource:**

A single resource refers to a resource that is not batched or simultaneous.

**To reschedule a job operation using single resources:**

1. Click and drag the job operation bar. When you release the bar, a small window appears and displays scheduling information.
2. Choose Schedule to schedule around the job operation resource bar that you dragged. Choose Cancel if you don't want to perform the change. Choosing Cancel will close the window, and move the bar back to its original location
3. Choose Schedule to schedule the job. The job is scheduled according to the

following rules:

- The job operation resource or operation resource instance you dragged is locked at the location you dragged it to, and the application schedules any prior or future operation resources around it.
  - The job is midpoint forward scheduled from the starting date of the job operation resource that you dragged.
  - The application backward schedules any prior operations.

### **To schedule reschedule a job operation using simultaneous resources:**

Simultaneous resources are those resources that are performing at the same time as another resource, and will occur within the same job operation of a given job.

1. Select the job operation you wish to modify and drag the bar.

If you are dragging the job operation, then other instances of the same job operation containing a simultaneous resource will first remain at the original location, but will move the same amount as the operation you are dragging when you release the mouse.

2. Release the bar. Scheduling in this scenario is similar to using a single resource. When using simultaneous resources, scheduling considers multiple job operation resources.

### **Rescheduling Instances:**

Dragging (changing time) of a job operation bar at the instance level will be similar to the other procedures. There are a couple of things to note, however, and these are listed below:

- If the job operation you are dragging is spread across several instances, we will still only show the one job operation bar move as you drag, but the scheduler will move the other instances accordingly once it completes.
- We will never re-dispatch the job operation to other instances.

## **Resource Transfer**

Using the Resource Centric Gantt, you can transfer work from one resource to another. There are three types of transfers that can occur:

- transferring work to an instance
- transferring work between instances

- alternating resources.

## Transferring Work to an Instance

Transferring work to an instance involves moving the job operation from the resource level node to an instance node. By performing this action, you are taking a job operation that was previously unassigned, and assigning it to an instance.

### To transfer work to an instance:

1. Select a job operation resource to transfer to an instance and drag the bar vertically to the instance you want to assign it to.

The following conditions exist while dragging to the instance:

- You can only drag in the vertical direction and cannot change the job operation time.
    - If there is work scheduled at the instance you are dragging to, then you can drag and drop the bar there.
    - If you are dragging a resource that has more than one assigned unit, then the application distributes the units between the instances when you execute the assignment. If a resource has two assigned units after you execute the drag to a resource instance, then the application assigns the other assigned unit to any other remaining instance. This behavior also applies to person type instances.
2. Choose Schedule.

## Transferring Work Between Instances

### To transfer work between instances:

1. Select the job operation for the instance you want to transfer from, and drag the bar to the instance to transfer to.

The conditions for dragging between instances are as follows:

- You can only drag in the vertical direction and cannot change the time of the operation.
    - If there is work scheduled at the instance you are dragging to, then you can drag and drop the bar there.
2. Choose Schedule.

## Transferring Work Between Alternate Resources

Transferring work to an alternate resource may be done at both the resource level and instance level. If you assign a job operation that is associated with a particular instance to an alternate, then the job operation will be assigned at the resource level on the alternate (i.e., It will no longer be associated with an instance).

### To transfer work to an alternate resource:

1. Right click on the job operation bar that to assign. The Alternate Resource window appears.
2. Choose Alternate.
3. Choose Schedule.

When you choose Schedule, the scheduler executes, and when the scheduling is complete, a dialog displays any exceptions, if any.

## Launching the HTML User Interface

### To launch the HTML User Interface:

1. Navigate to the Resource Scheduling Workbench.
2. Right click a job or operation bar in the Gantt Chart region.
3. Select View Job Information from the drop down menu. The Job Information region displays a new graphical region at the bottom of the Gantt Chart region that displays the job information.

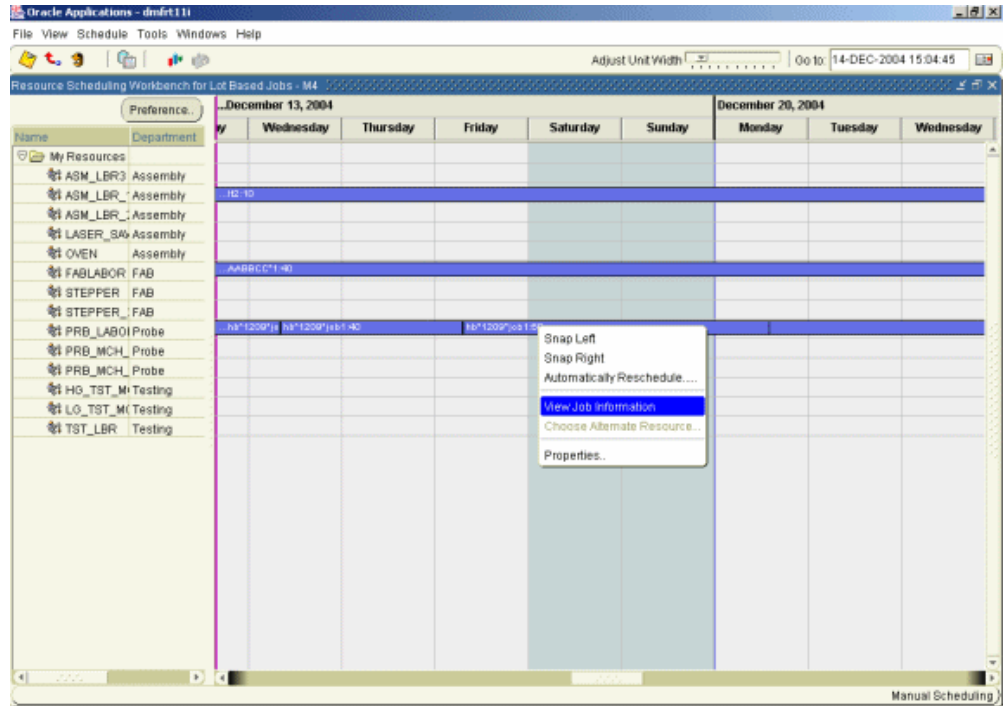

4. Right click a job bar in the Job Information region.

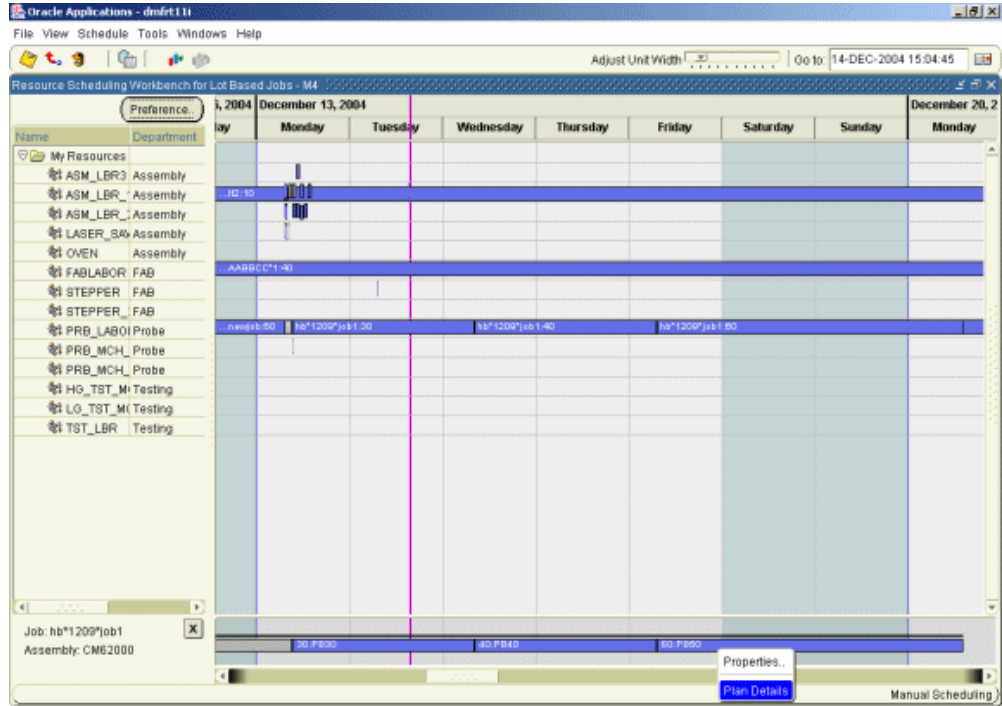

5. Select Plan Details from the list. The Plan Details HTML window appears and displays the plan details of the job. You can make changes to the lot-based job from the Plan Details HTML window.

See: Integration with Oracle Advanced Supply Chain Planning (ASCP), page 5-20 for using the HTML UI for changing plan information on the lot based job.



Plan Details: hb\*1209\*job1 - Microsoft Internet Explorer

Address: http://ap6134r.us.oracle.com:8012/OA\_HTML/RF.jsp?function\_id=1023974&resp\_id=224350&resp\_appl\_id=4106&security\_group\_id=0&lang\_code=US&param=f1M,q3B6

**ORACLE** [Diagnostics](#) [Close Window](#) [Preferences](#)

### Plan Details: hb\*1209\*job1

Job Description		Quantity Remaining	1500
Assembly	<b>CM62000</b>	UOM	<b>Ea</b>
Assembly Description	<b>Die</b>	Coproducts Supply	<b>Yes</b>
Released Date	<b>09-Dec-2004 17:05:10</b>	Current Routing Operation Sequence	<b>30</b>
Scheduled Start Date	<b>10-Dec-2004 07:00:00</b>	Current Operation Code	<b>PB30</b>
Scheduled Completion Date	<b>20-Dec-2004 14:00:07</b>	Current Operation Department	<b>Probe</b>
Requested Due Date		Routing Refresh Date	<b>09-Dec-2004 17:05:10</b>

[Show Additional Details](#)

#### Operations

View:  Recommended Path

[Update Recommended Path](#)

Routing Operation Sequence	Code	Department	Operation Description	Start Date	Completion Date	Scheduled Quantity	Yield	Details
10	PB10	Probe	Load Probe Machine	10-Dec-2004 07:00:00	13-Dec-2004 09:00:00	1000	1	<a href="#">Details</a>
20	PB20	Probe	Probe Machine	13-Dec-2004 09:00:00	13-Dec-2004 09:00:07	1000	1	<a href="#">Details</a>
30	PB30	Probe	Unload Probe Machine	13-Dec-2004 09:00:07	14-Dec-2004 11:00:07	1000	1	<a href="#">Details</a>
40	PB40	Probe	Review Probe Results	15-Dec-2004 08:00:07	17-Dec-2004 07:00:07	1500	1	<a href="#">Details</a>
60	PB50	Probe	Disposition Probe	17-Dec-2004 07:00:07	20-Dec-2004 14:00:07	1500	1	<a href="#">Details</a>

[Diagnostics](#) | [Close Window](#) | [Preferences](#)

Copyright 2000-2004 Oracle Corporation. All rights reserved. [About this Page](#) [Privacy Statement](#)



---

# Lot Genealogy

This chapter covers the following topics:

- Overview of Lot Genealogy
- Displaying Genealogy and Where-Used Views
- Genealogy of Lot/Serial Controlled Assemblies
- Genealogy with Lot Serial Attributes

## Overview of Lot Genealogy

Using Lot genealogy, you can view the historical production information of a lot. It provides you with detailed information about where the lot has moved, subinventory stocking points, lot transaction types, and forward and backward tracking. You can view information regarding inventory and WIP lots such as splits, merges, issues, and completions as they progress on the shop floor. The Lot Genealogy window shows how a WIP lot becomes an Inventory lot and vice versa. Lot Genealogy provides you with the ability to do the following:

- View the record of the products created by the lot's transactions
- View all the components used in the lot transactions
- Display detailed information about Inventory and WIP lots created
- See the lineage of where the lot was used

The following graphic displays the historical production of a lot. It shows the detailed information a lot moves through to become a finished good.

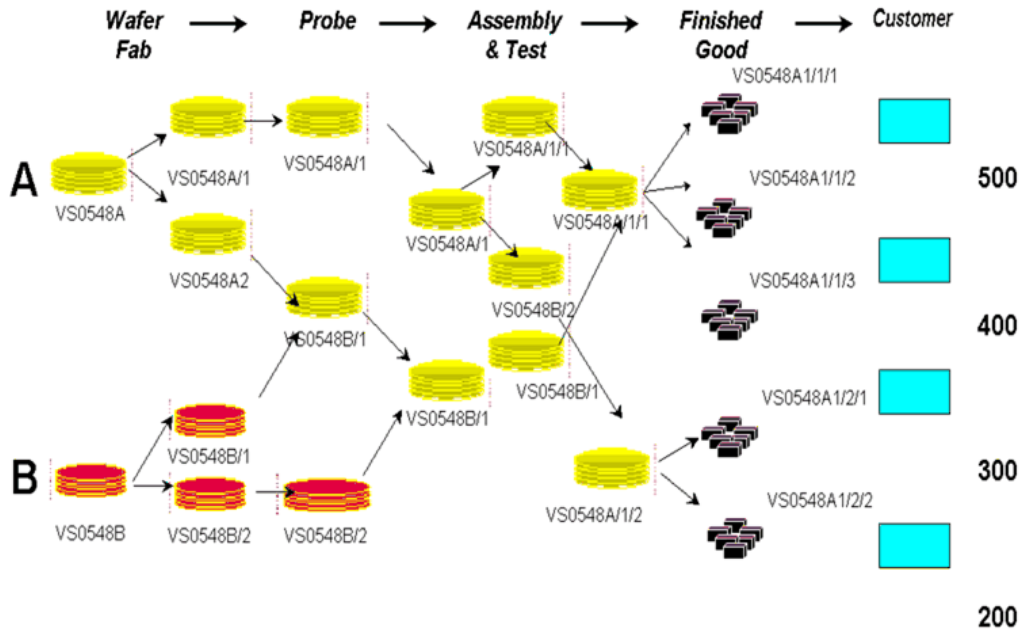

## Displaying Genealogy and Where-Used Views

You can view historical information for lot-based jobs in the Lot Genealogy window. This graphical interface provides an integrated view of genealogy information for discrete jobs, lot-based jobs, and Oracle Warehouse Management inventory transactions. You can view both material and lot-based job transaction information.

### To view lot based job transaction genealogy:

1. Select Genealogy from the menu.
2. When the Find Lots/Jobs window appears, select the Jobs indicator.

Find Lots/Jobs (M4)

Inventory Lots     Jobs     Batches

Jobs [ ] - [ ]

Assembly [ ]

Description [ ]

Status [ ]

Start Dates [ ] [ ]

Completion Dates [ ] [ ]

Attributes [ ]

Clear Find

3. Enter your search criteria.

You can query by Jobs, Assembly, job Status, a range of Start Dates, a range of Completion Dates, and Attributes. You can combine or omit criteria as required.

4. Choose Find.

The Jobs Summary window appears with the records that meet your criteria, and displays job Name, Status, Assembly, and Start and Completion dates.

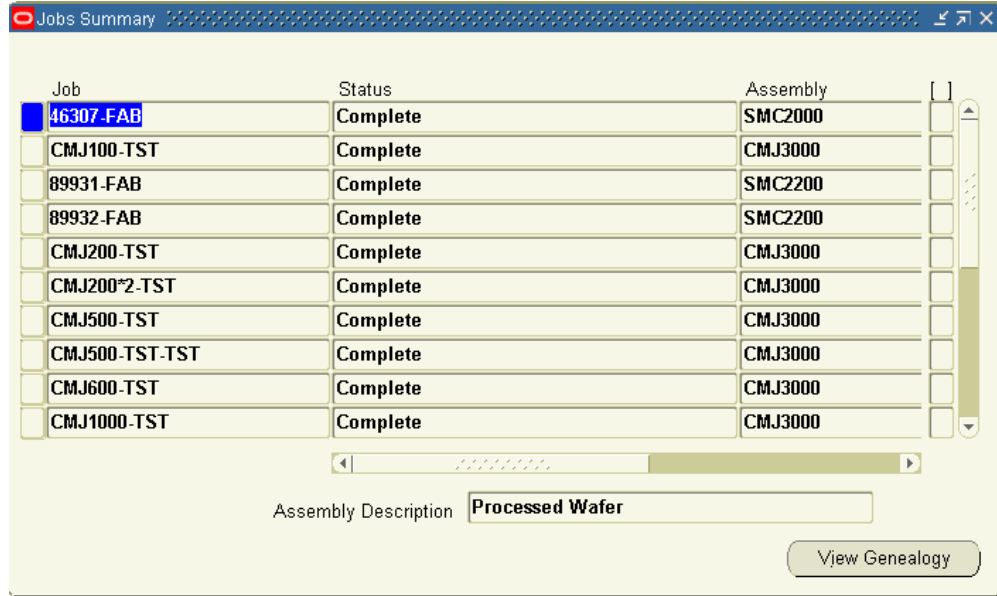

5. Select a record and choose View Genealogy.

The Genealogy window displays. The left pane is in a Navigator hierarchy format containing two tabs for different views. The right pane displays job detail and transaction information.

6. Select the Source or Where Used tab in the left pane to view genealogy information.

Source displays the source of the record you are viewing. It is designated by assembly name, appended by the job name at the top node of the navigator. For example, you may be producing a specific job from components of a particular lot. Material used in this assembly and job combination is expanded under the top node.

Where Used displays the assembly using this material and the Lot and Serial components issued to the resulting lot. It is designated by assembly name, appended by the job name at the top node of the tree. The assembly and job combinations using this top record expand below it.

When you select the Where Used view, information is listed in order of oldest to current, from top to bottom of the navigator. The first record of the query is the parent lot, and the records following are the children and grandchildren of this lot.

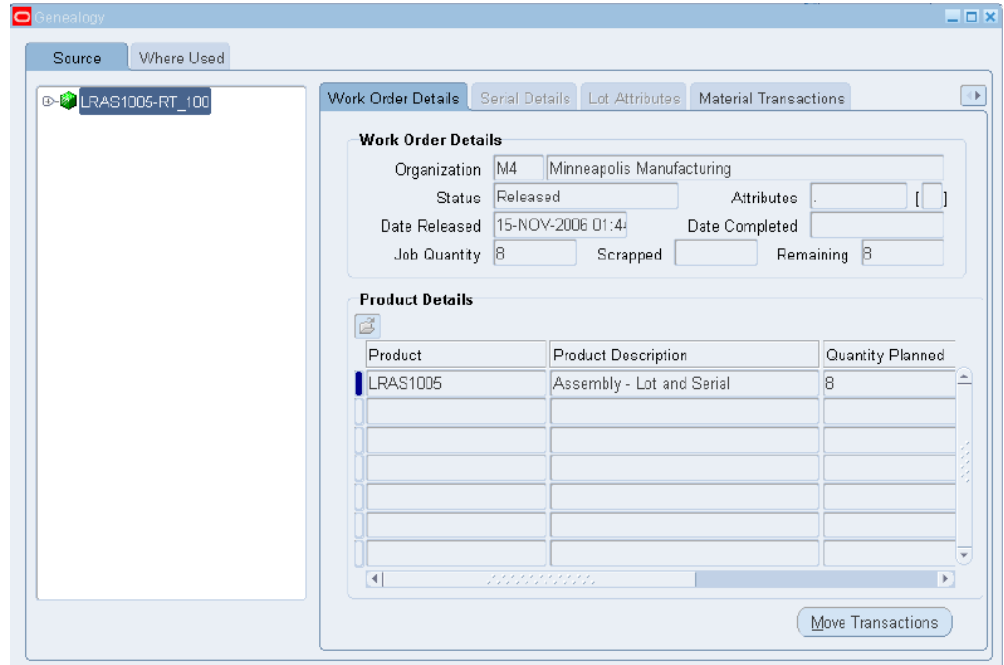

- In the right pane, information about the job displays in the Work Order Details region and details about the product in the Product Details region. Select the Material Transactions or Lot Based Job Transactions tab to view shop floor work performed.

The Work Order Details tab displays details of the resulting lot on the left pane. It displays information about the product in the Product Details region.

The Serial Details tab displays Inventory Serial Attributes and Warehouse Management System Serial Attributes like Tested By, Context Value, Color and Thickness in the Attributes field. In the left pane, serial details for the component of the Starting Lot displays if you select Where Used tab.

The Lot Attributes tab displays WMS lot attributes and Inventory lot attributes.

The Material Transactions tab displays historical transaction information for the record selected on the hierarchical tree. This pane displays the transaction date, transaction type such as component issues or assembly completions, quantity, and item number.

The Pending Txns and Allocations tab displays transaction date, transaction type, transaction quantity and transaction details.

Quality Collections tab displays item details and Collection Plan, Plan type and Description.

The Lot Based Job Transactions tab displays the Oracle Shop Floor Management transactions such as splitting, merging, bonus lots, and updating assemblies. It displays the previous values for WIP Lot Name, Start Quantity, and Assembly

number—and the resulting values after the transaction.

8. Choose Move Transactions to access the View Move Transactions window. See: Viewing Move Transactions, Oracle Work in Process User's Guide.

If a job contains no move transactions, then a message appears stating that this job has no move transactions, or the transactions for this job have been purged.

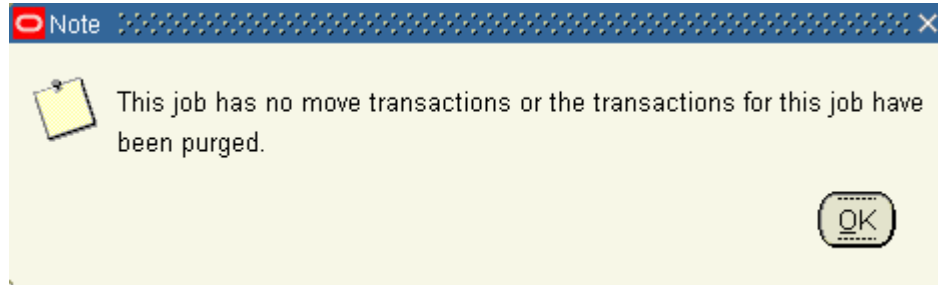

9. If move transactions exist, then the View Move Transactions window appears, and you can view move transaction details.
10. The View Move Transactions window contains the following three tabs that you can choose.
  - Job or Schedule Header
    - Operations, Quantities
    - Scrap, Comments



View Move Transactions

Job or Schedule Header    Operations, Quantities    Scrap, Comments

Transaction				Transaction
Date	Job	Assembly	Line	ID
03-NOV-2004 03:30:38	46307-FAB	SMC2000		15184904
03-NOV-2004 03:28:29	46307-FAB	SMC2000		15184895
03-NOV-2004 03:25:06	46307-FAB	SMC2000		15184880

Transaction Date: 03-NOV-2004 03:30:38    Job: 46307-FAB  
 Assembly: SMC2000    Line:

View Move Transactions

Job or Schedule Header    Operations, Quantities    Scrap, Comments

From Operation				To Operation			
Seq	Code	Department	Step	Seq	Code	Department	Step
10019	FB25	FAB	To move	10029	FB30	FAB	To move
10009	FB20	FAB	To move	10019	FB25	FAB	To move
10	FB10	FAB	Queue	10009	FB20	FAB	To move

Transaction Date: 03-NOV-2004 03:30:38    Job: 46307-FAB  
 Assembly: SMC2000    Line:

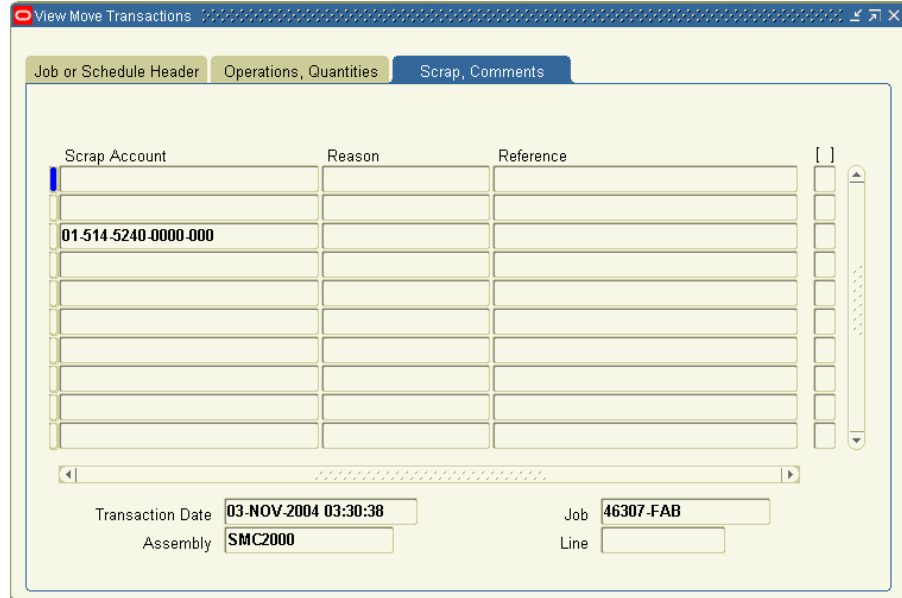

11. Close the windows when finished.

## Genealogy of Lot/Serial Controlled Assemblies

See: Displaying Genealogy and Where-Used Views, page 8-2

1. Select a job from the Jobs Summary window.
2. Click View Genealogy.  
The Genealogy window appears.
3. Select Where Used tab in the left pane to view genealogy information.
4. Select Serial Details in the right pane to view the item and serial details assigned to the lot.

Genealogy and details of the starting job, serial assigned to the starting job, genealogy and details of the resulting job, and the serial assigned to the resulting job appear.

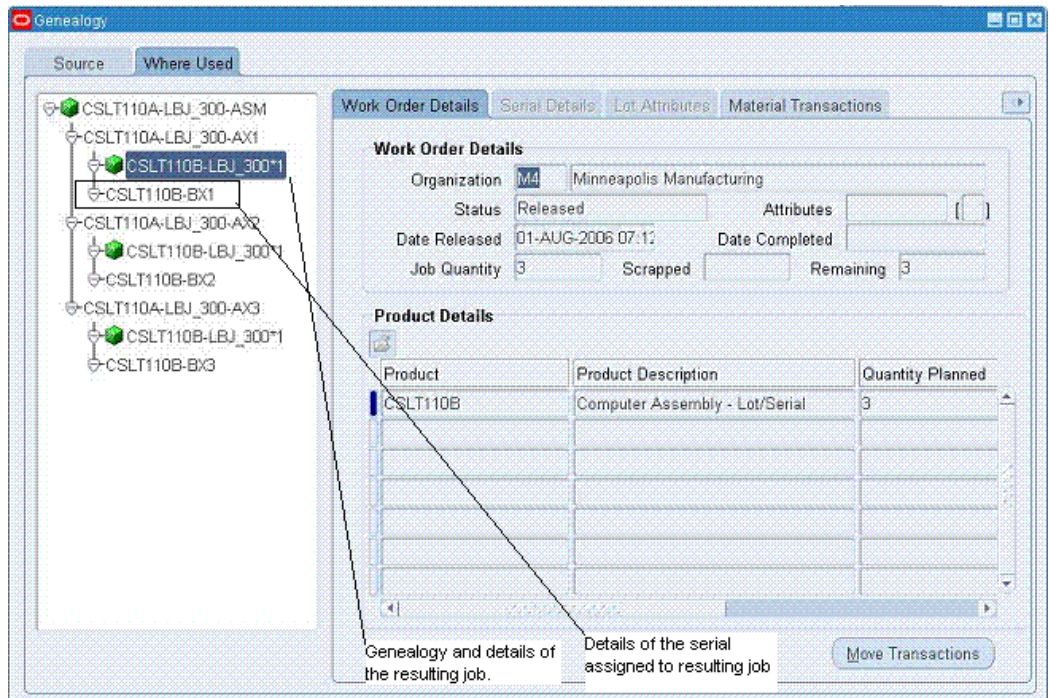
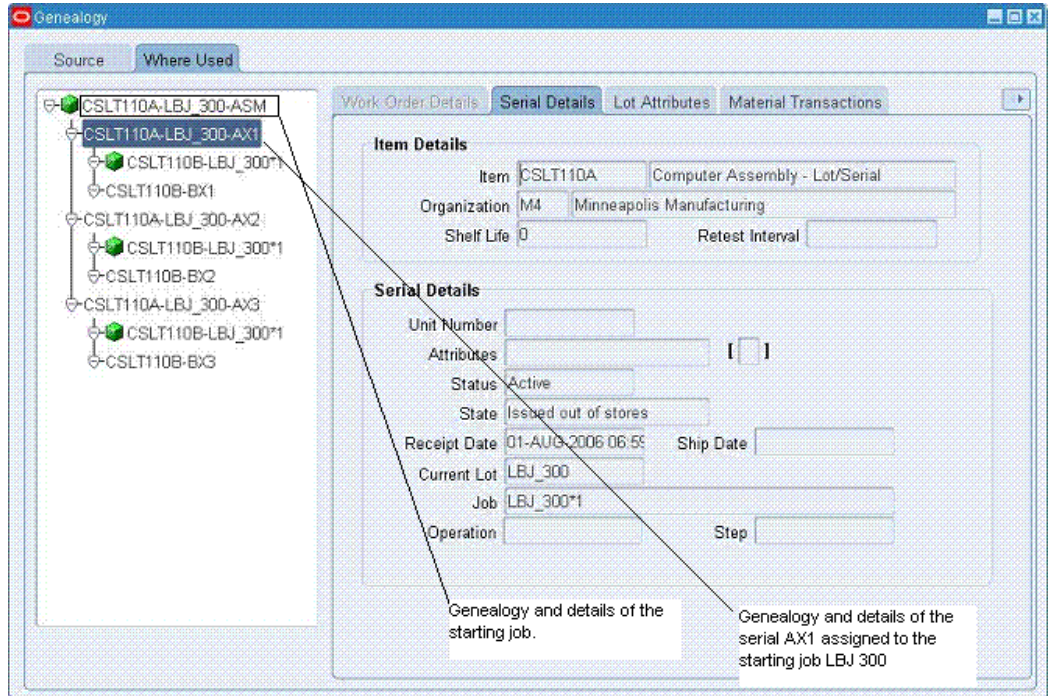

## Genealogy with Lot Serial Attributes

1. Navigate to Manufacturing Manager: Inventory: On-hand, Availability: Lots.

2. Enter lot name to query in the Find Lots/Jobs window.  
The Item Lots window appears.
3. Select the lot.
4. Click View Genealogy.  
The Genealogy window appears.
5. Select Where Used tab in the left pane to check the lot details of the starting lot.

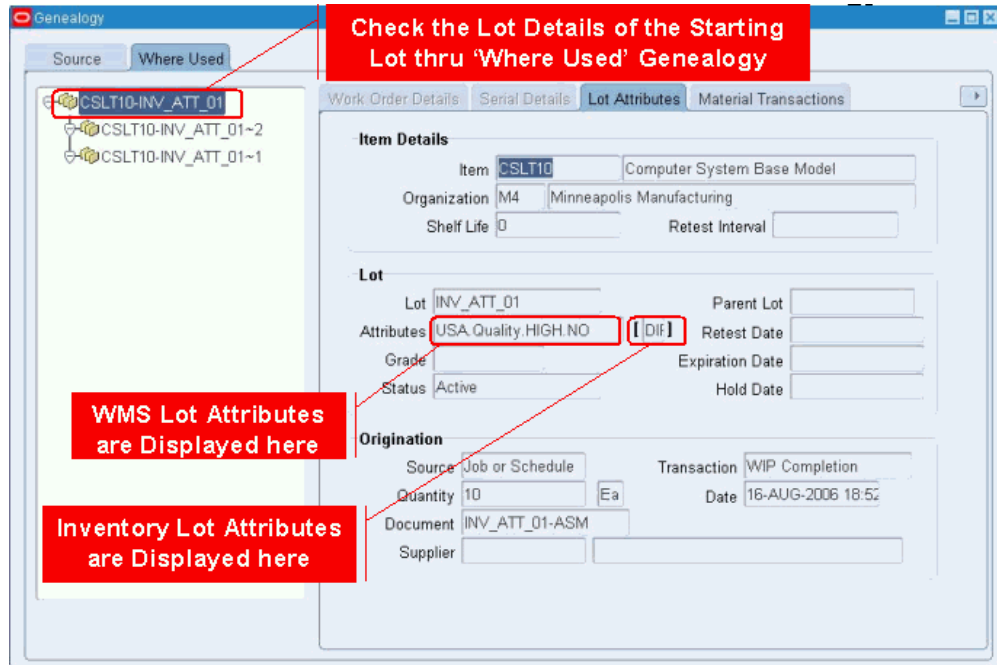

6. Select Lot Attributes in the right pane to view the Inventory Serial Attributes and Warehouse Management System Serial Attributes.

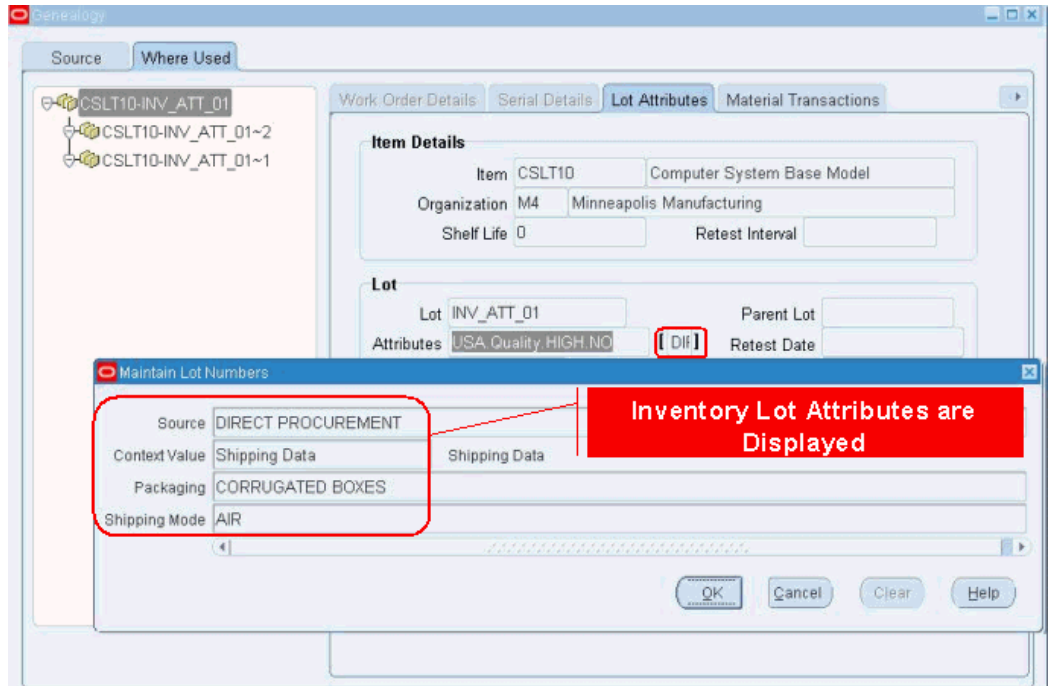



---

## Co-Products

This chapter covers the following topics:

- Overview of Co-Products
- Defining Co-Products
- Define Time Phased Split Percentages Window
- Substitute Components Window
- Component Details Window

### Overview of Co-Products

Co-products are assemblies or products belonging to the same product family, and manufactured from the same primary component. When you define co-products, you specify the assemblies, their planning percentages, and the primary component. One of the assemblies is the primary co-product and the others are the non-primary co-products. When you define the co-product group, corresponding bill of materials are created using both the primary bill of material and non-primary bill (or common bill) components. When you create co-products:

- Define an item as the primary component of several end items.
- Define the expected distribution across all the end items. When you create this information in the Define Co-Products window, the Bills of Material of the end items are automatically created.
- Associate a rank and a distribution percentage for the co-products.

Oracle Shop Floor Management is integrated with Oracle Planning enabling you to perform transactions such as implementing planned orders as lot based jobs and rescheduling existing lot based jobs from the Planner's Workbench.

## Defining Co-Products

### To define co-products:

1. Navigate to the Define Co-Products window.

You can query an existing co-product relationship using the search criteria.

2. If you are searching for an existing co-product, choose Find and enter your search criteria.
3. If you are creating a new co-product, choose New from the File menu.

4. Select an item number in the Component field.

The assembly's description and, if existing, alternate designator displays.

5. In the Usage region, enter data in to the Value and Inverse fields to define the quantity used.

Value is the quantity of the component needed to create the assembly, that is, the quantity of the component needed for each of the co-products. The Inverse is automatically calculated. It is an inverse quantity, one quantity of the component will make that quantity of the co-product.

In the Basis field, enter the type of the Co-Product of the component to fix the material usage.

6. In the Effectivity Dates region, enter values From and To if this component is to be disabled at a future date.

Optionally, you can enter data to define an alternate or substitute component. See: Substitute Components Window, page 9-6.



7. You can view information in the Component Details window.

This window enables you to view Bill of Material information for the component. See: Component Details Window, page 9-6, .

8. In the Co-Products region, enter the Co-Product item name in the Co-Product field.

The item number's Revision level and Engineering Change Number displays.

9. If this is the primary co-product, then choose the Primary check box.

There should be only one primary co-product for a component. Non primary co-products are set up as common bills of material with the primary co-product's bill. The primary co-product's bill may be an alternate or a primary bill.

10. Save your work.

The completed transaction creates a BOM for each of the co-products entered with the main item in the components header zone as the component.

When committed, you can enter split percentages for the co-products in the Define Time Phased Split Percentages window. By default, 100% is populated for the primary co-product and 0% for the secondary co-products. The user can move to the split percentages zone by pressing the Split Percentage button.

## Define Time Phased Split Percentages Window

Use this window to update co-product split percentages, or add split effectivity date range information.

In the manufacturing process, output of the final product can improve with time. For example, in the semiconductor industry, the quality of a wafer can improve during its life cycle. Early in the life cycle, the same component wafer may produce a lower percentage of high performance chips. Late in the life cycle, the same component item may produce a much higher percentage of high performance chips. You can model this process by providing different sets of planning percentages for resulting co-products from the same component over specific time periods.

### **To enter time phased co-products split percentages:**

1. From the Define Co-products window, choose Split Percentage. The Define Time Phased Split Percentages window appears.
2. Enter the Split Effectivity From date.
3. Enter the Split Effectivity To date.
4. Save the split percentages for a given range before entering percentages for a new range.

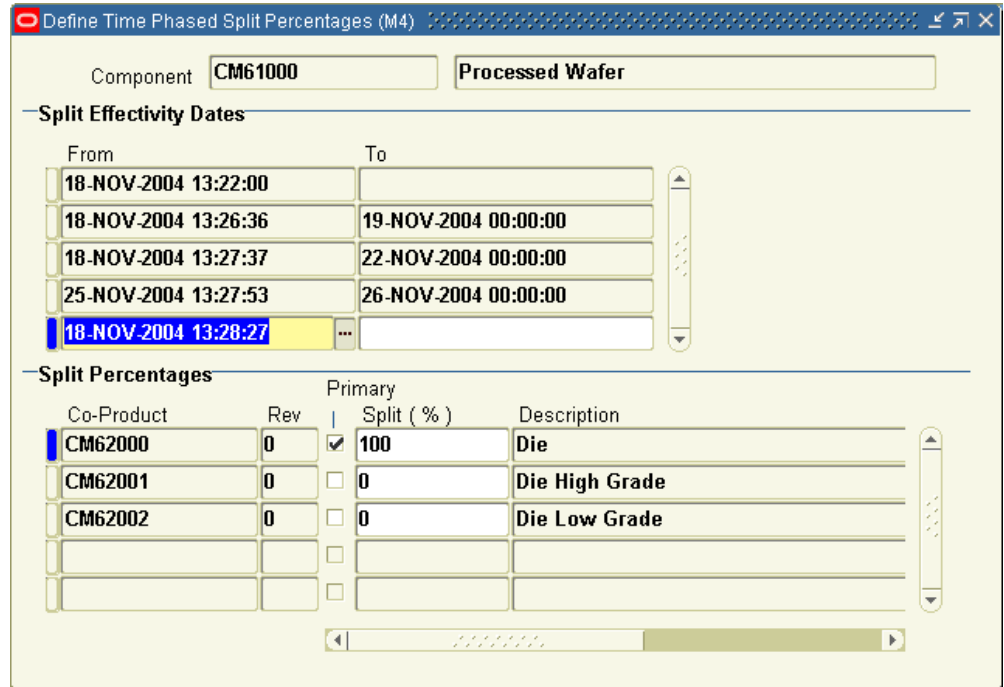

5. Enter split percentage values between 0 and 100.
6. Save the split percentages before entering percentages for a new range.
7. Save your work.

When you save split percentages, current date ranges displayed in the window can change as follows, depending on the effective and disable dates that you enter:

- When the co-product definition is saved, for the time range from the date on which co-product definition is created till infinite date in future. This is to ensure that split percentage can be found for a co-product on any date after the co-product is defined.
- When the effectivity date entered should be greater than the current date.
- If the new time range is overlapping with one or more existing time ranges, then the overlapping time range will have the split percentages entered against the new time range. Existing date ranges will be shortened so that the overlapping region falls under the new range.
- If any existing range completely overlaps the new range, then split percentage data for this range will be deleted.

**Note:** If you want to add a new Secondary co-product, then use the

Define Co-products window. You cannot add a new secondary co-product from the Define Time Phased Split Percentages window. The Define Time Phased Split Percentages window only lets you modify the split percentage of exiting co-products.

## Substitute Components Window

### To define substitute components:

1. Navigate to the Define Co-products window.
2. Select an item number in the Component field.
3. Choose Substitutes.

The Substitute Components window displays.

The screenshot shows the 'Substitute Components (M4)' window. At the top, there are input fields for 'Component' (CM61000), 'Description' (Processed Wafer), and 'Effective Date' (18-NOV-2004). Below these is a section titled 'Substitute Components' with a checked checkbox. This section contains a table with the following columns: 'Substitute Component', 'Description', 'UOM', and 'Usage Value'. The first row in the table is highlighted in yellow and contains the following data: 'CM63000', 'Raw Chip', 'Ea', and '.01'. There are three empty rows below the first one.

Substitute Component	Description	UOM	Usage Value
CM63000	Raw Chip	Ea	.01

4. Default information default displays component item number, description, effective date, and alternate bill of material.
5. In the Substitute Components region, enter the item number in the Substitute Component field, and the quantity used in the Usage Value field.
6. Save your work.

## Component Details Window

This window enables you to enter corresponding bill of material information for the component.

### To define component details:

1. Navigate to the Define Co-Products window.
2. Select an item number in the Component field.
3. Choose Details.

The Component Details window displays default information for the Planning Percent, Yield, Item Type, Status, and Include in Cost Rollup fields and check box.

The screenshot shows a window titled "Component Details (M4)". The fields are as follows:

Planning %	100	Item Type	Subassembly
Yield	1	Status	Active
<input checked="" type="checkbox"/> Include In Cost Rollup			
<b>Material Control</b>			
Supply Type	Operation Pull		
Subinventory		Locator	
Comments			

4. In the Material Control region—the Supply Type field defaults to Operation Pull, and the Subinventory and Locator fields default to the values set up for this item number.

Optionally, you can update the Subinventory and Comments fields. In the Comments field you can enter a notation about information on this window. For example, a comment about why this part is not considered in a cost rollup if that check box is not marked.

**Note:** Co-product component details, once entered, are updated on the corresponding bill of material window.



---

## Costing in Oracle Shop Floor Management

*The Oracle Cost Management User's Guide* is a prerequisite for understanding this chapter. Since lot based jobs use Standard Costing, sections specific to other costing methods may be skipped.

This chapter covers the following topics:

- Overview of Lot Based Job Costing
- Cost Rollup for Network Routings
- Standard Cost Update for Lot Based Jobs
- Phantom Routings
- Lot Based Jobs Transaction Costing
- Move Transaction Costing
- Estimated Scrap Accounting
- Operation Yield
- Disabling Estimated Scrap and Operation Yield Accounting
- Non Standard Expense Lot Based Jobs
- WIP Lot Based Jobs Transaction Costing
- Lot Split Transactions
- Merge Lots
- Bonus Lots
- Update Quantity
- Update Routing and Update Assembly
- Lot Based Transaction are Integrated into Cost Manager
- Transaction Import through MES
- WIP Value Summary

- Reports

## Overview of Lot Based Job Costing

Many companies, such as those in the semiconductor industry, need to account for estimated scrap at each operation of a job. Operation yield is expressed as the compliment of the estimated scrap at each operation. When defining an item's routing, you can enter operation yields at each operation on that routing, and specify whether that operation's yield is to be rolled up into the assembly cost.

The cost rollup includes this estimated yield loss absorption. During a lot's WIP execution, operation yield cost is charged to the lot. Any difference between estimated scrap absorption and actual scrap is tracked by operation and by department.

Oracle Shop Floor Management includes the following features:

- Define operation level yields on the routing of a product
- Collect actual yields for a lot at all the required operations
- Calculate yield loss as part of the cost of the product

## Related Topics

Defining Operation Yield Values on Routings, page 3-15.

Bills and Cost Rollups, *Oracle Cost Management User's Guide*.

Selecting and Item / Cost Type Association, *Oracle Cost Management User's Guide*.

## Cost Rollup for Network Routings

Cost Rollup considers material, overhead, and resource costs using the reverse cumulative yield as well as component and manufacturing shrinkage. The operation yield is factored into the rollup cost for the assembly if the Include in Rollup and the Operation Yield Enable flags are enabled for the operation on the routing. The operation is included in the cost rollup if the Include in Rollup flag is enable, irrespective of whether the operation lies on the primary or alternate path.

## Standard Cost Update for Lot Based Jobs

As in discrete jobs, Standard Cost Update revalues job balances , creates accounting adjustments and prints the adjustments along with the new job values in the standard cost WIP adjustment report. However, new department-based overheads are not added to prior operations for lot based jobs. These new overheads are only included in future operations on the job.

Adjustments to the job are generally offset by the standard cost adjustment account on



the WIP accounting class. However, adjustments to WIP relieved value due to scrap in standard lot based jobs, are offset by the department actual scrap account. Also, the adjustment to the Estimated Scrap due to the standard cost update is offset by the department Estimated Scrap Absorption account. Standard Cost Update does not adjust existing jobs for changes made to the operation yield.

## Phantom Routings

The department on the phantom routing should be the same as the department of the operation that uses the phantom. This is important because estimated scrap accounting is based on the operation department.

Operation yields in phantom routing are not included (rollup) into the parent operation's yield. See: *Phantoms in Lot Based Jobs, Oracle Bills of Material User's Guide*.

## Lot Based Jobs Transaction Costing

There are seven types of WIP lot transactions available to lot based jobs including split, merge, update assembly, bonus, update routing, update quantity, and update lot number. Oracle Shop Floor Management enables you to include operation yields in the cost of an assembly for lot based jobs. During a lot's progression on the shop floor the following transactions require costing: move, scrap, split, merge, bonus, and update quantity.

## Move Transaction Costing

A move transaction moves assemblies within an operation, such as from queue to run, or from one operation to the next. Move transactions can automatically launch backflushing, charge resources and overheads. Manufacturing transactions created manually by the user, or due to backflush by the move processor, are costed similar to standard discrete jobs. See: *Manufacturing Standard Cost Transactions, Oracle Work in Process User's Guide*.

## Estimated Scrap Accounting

As the WIP Lot progresses through each operation in the job, the department tied to the operation receives credit as Estimated Scrap Absorption for additional cost due to the operation yield. The job is debited as Estimated Scrap for this same cost.

Consider an operation 10, department A, with operation yield of 70%. If 100 units were sent into operation 10 in order to produce 10 completed units, then at 100% yield, the unit cost of the assembly is assumed to be \$10. However, at the estimated yield of 70%, the unit cost is  $(100 * 10)/70$

Hence the additional cost per unit assembly due to operation yield is

$$(100 \times 10) / 70 - 10 = 10 * (1/0.7 - 1) = 10 * [(1-0.7)/0.7]$$

Estimated Scrap per unit = (Total operation cost per unit through the current operation + Total Estimated Scrap Cost per unit through the previous operation) \* [(1 - op.yield)/op.yield]

Dollars absorbed by the department due to good units completed in an operation = Estimated Scrap per unit \* Number of good units that passed through the operation.

The accounting entries for estimated scrap absorption transaction are:

Account	Debit	Credit
WIP Valuation Estimated Scrap Account	XX	
Department Estimated Scrap Absorption Account		XX

Consider a second operation 20 following operation 10 from the previous example:

Suppose that, out of the 70 good units that were sent into operation 20, 5 units were scrapped at operation 20. Since these have absorbed the additional cost due to estimated scrap in each of the previous operations (operation 10 in the present example), it is essential to reverse the estimated scrap absorption that has been done for the scrapped units.

Net Reversal = (Total estimated scrap per unit through the previous operation) \* Number of units actually scrapped

Account	Debit	Credit
Department Actual Scrap Account	XX	
WIP valuation Estimated Scrap Account		XX

The assembly scrap is charged based on the job requirements to the actual scrap account defined for the department. See: Assembly Scrap Transactions, *Oracle Cost Management User's Guide*.

<b>Account</b>	<b>Debit</b>	<b>Credit</b>
Department Actual Scrap Account	XX	
WIP Valuation Accounts		XX

Completion transactions relieve the WIP Valuation Accounts of the accounting class and charge the inventory valuation accounts based on the assembly's standard cost (Frozen). The operation yield cost is relieved from the Estimated Scrap Account.

<b>Account</b>	<b>Debit</b>	<b>Credit</b>
INV Valuation Material Account	7.0	
INV Valuation Material Overhead Account	1.2	
INV Valuation Resource Account	3.5	
INV Valuation Overhead Account	2.3	
INV Valuation Outside Processing Account	2.0	
WIP Valuation Material Account		6.0
WIP Valuation Material Overhead Account		1.0
WIP Valuation Resource Account		3.0
WIP Valuation Overhead Account		2.0
WIP Valuation Outside Processing Account		1.0

Account	Debit	Credit
WIP Valuation Estimated Scrap Account		3.0

**Note:** The WIP Estimated Scrap is allocated to the five INV accounts.

As in discrete jobs, the job close process writes off any remaining balances in the WIP Valuation Accounts to the respective variance account. The balance in the Estimated Scrap Account is written off the accounting class Estimated Scrap Variance Account.

Account	Debit	Credit
WIP Estimated Scrap Variance Account	XX	
WIP Valuation Estimated Scrap Accounts		XX

The estimated scrap variance is primarily caused by deviations from the standard BOM or Routing. The difference between the estimated scrap absorption and actual scrap is the indicator reflecting the department's performance.

## Operation Yield

Costing in Lot based jobs supports Estimated Scrap Accounting and Bonus during move transaction.

### Operation Yield: An Example

You can specify the yield at every operation. These yields can be rolled up to the assembly cost. Lot based jobs support Estimated Scrap Accounting, which helps you to track the performance of each department.

**Operation Yield** is defined as the complement of the estimated scrap at each operation.

Operation yield can be factored into the assembly cost by using the Include In Rollup and Op Yield Enabled flag. You can track the difference between estimated scrap absorption and actual scrap according to departments and thereby keep a track of the efficiency of each department.

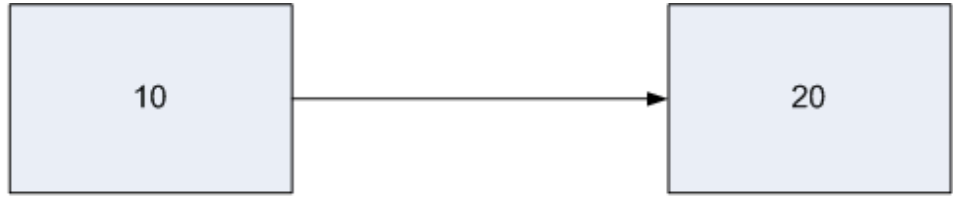

Op. Cost : \$12.00  
Yield : 0.8

Op. Cost : \$2.00  
Yield : 0.8

Consider a lot size of 100	:	
Value incurred in Operation 10	:	\$1200.00
Number of good units completed	:	80
Cost per good unit	:	$1200/80 = \$15$
Additional cost at operation	:	
10 due to operation yield	:	$\$15 - \$12 = \$3$
Value incurred in Operation 10	:	\$1200.00
Value incurred in Operation 20	:	\$160.00
Number of good units completed	:	64
Cost per good unit	:	$(1200 + 160)/64 = \$21.25$
Additional cost at operation 20	:	
due to operation yield	:	$\$21.25 - (\$12 + \$3 + \$2) =$ \$4.25

**Operation Yield: Formula**

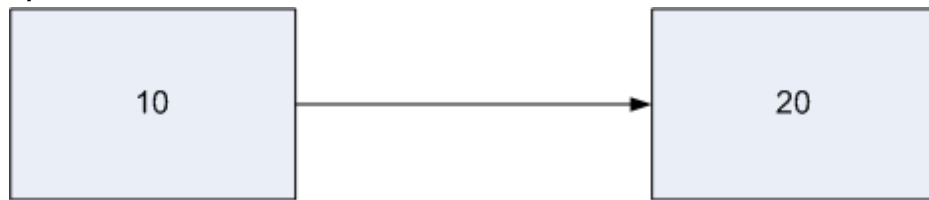

Op. Cost : \$12.00  
Yield : 0.8  
Yield Cost\*: \$3.00

Op. Cost : \$2.00  
Yield : 0.8  
Yield Cost\*: \$4.25

\* Op. Yield Cost = (Σ Op. Cost through this op + Σ Yield Cost through Prev. Op ) \* {(1-yield)/yield}

Op yield for Operation 10 =  $12 * (1-0.8)/0.8 = 12*0.2/0.8 = 12*1/4 = \$3.00$

Op yield for Operation 20 =  $(12 + 2 + 3) * (1-0.8)/0.8 = 17*0.2/0.8 = 17*1/4 = \$4.25$

Assembly cost =  $(12 + 2) + (3 + 4.25) = \$21.25$

## Setup

Actual Scrap account and Estimated Scrap Absorption Account are mandatory for every department.

Estimated Scrap Account is defined for the WIP Accounting Class. You can specify that the operation yield is to be considered while rolling up the cost for the assembly.

You can enable or disable estimated scrap accounting through Shop Floor Management Parameters. See: Defining Parameters, page 2-10

**To enable Operation Yield for the operation:**

1. Navigate to the Routings window in the Oracle Shop Floor Management menu
2. Enter item in the Item field
3. Select Operation Yield tab in the Operations region
4. Select Op Yield Enabled check box for the corresponding operation sequence

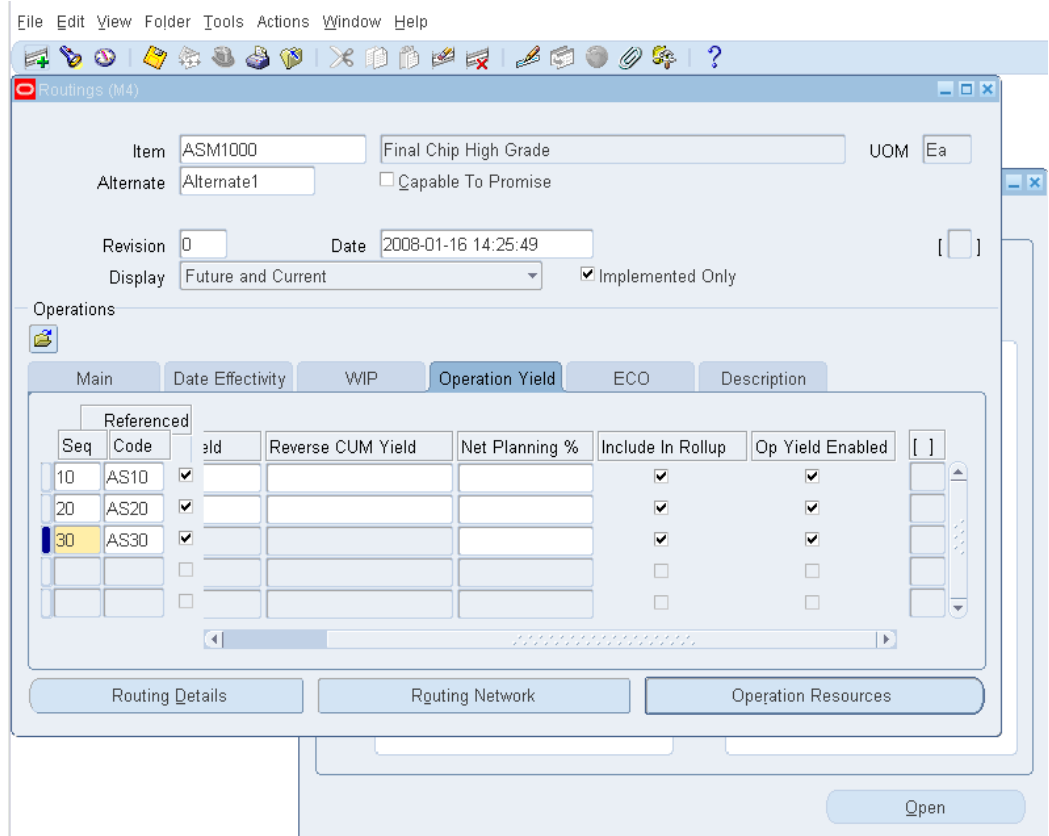

## Estimated Scrap Accounting

You can track the difference between estimated scrap absorption and actual scrap according to departments. As lot progresses through operations, departmental Estimated Scrap Absorption Account receives a credit for the additional cost due to operation yield. The WIP Accounting Class Estimated Scrap Account gets a debit for the same amount.

**Setup: Example**

BOM

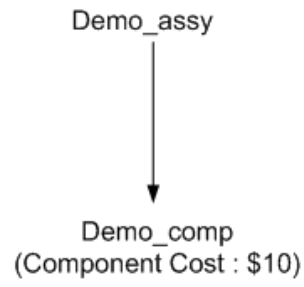

Routing

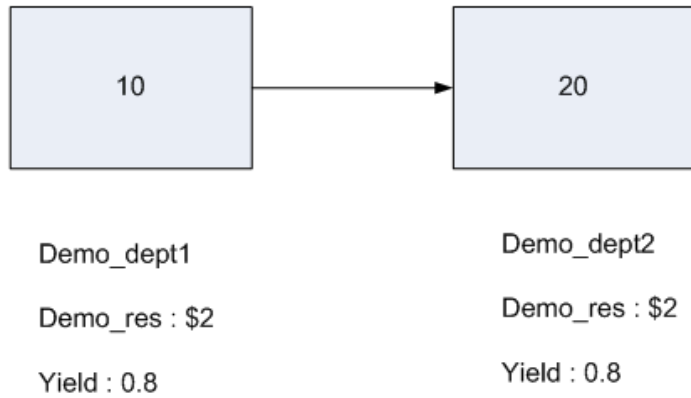



**Estimated Scrap Accounting: Example**

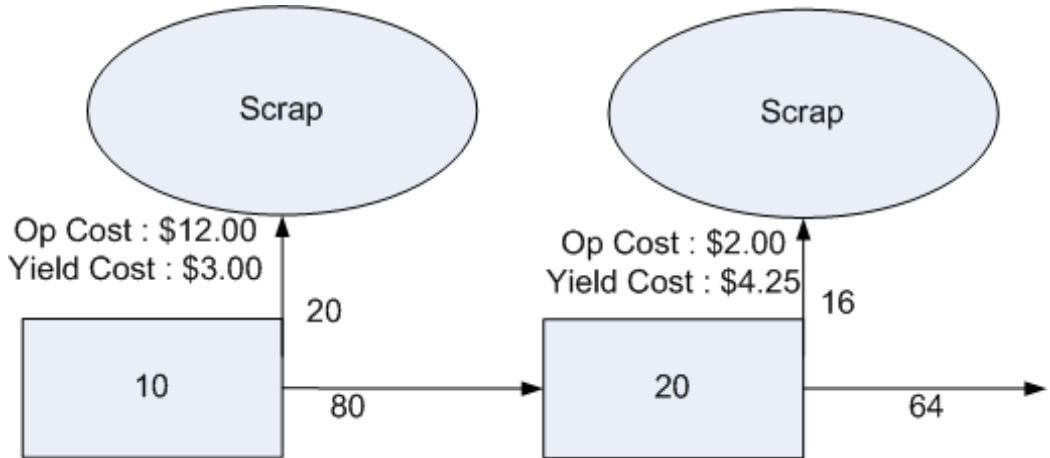

Est. Yield : 0.8  
Actual Yield : 0.8

Dr. WIP Material            1000  
    Cr. Inventory                1000  
Dr. WIP Resource            200  
    Cr. Resource Abs            200  
Dr. Dept10 Actual Scrap    240  
    Cr. WIP Material            200  
    Cr. WIP Resource            40

Est. Yield : 0.8  
Actual Yield : 0.8

**Dr. WIP Est Scrap            240**  
**Cr. Dept10 Est Scrap Abs    240**

Est. Scrap In : \$240  
Est. Scrap Out : \$0  
Net Activity : \$240

Dr. WIP Resource	32	
Cr. Resource Abs		32
Dr. Dept20 Actual Scrap	224	
Cr. WIP Material		160
Cr. WIP Resource		64

<b>Dr. Dept20 Actual Scrap</b>	<b>48</b>	
<b>Cr. WIP Est Scrap</b>		<b>48</b>

Est. Scrap In : \$240  
 Est. Scrap Out : \$48  
 Net Activity : \$192

Dr. WIP Resource	128	
Cr. Resource Abs		128
Dr. Inventory	1360	
Cr. WIP Material		640
Cr. WIP Resource		256
Cr. WIP Est Scrap		464

<b>Dr. WIP Est Scrap</b>	<b>272</b>	
<b>Cr. Dept20 Abs</b>		<b>272</b>

Est. Scrap In : \$512  
 Est. Scrap Out : \$512  
 Net Activity : \$0

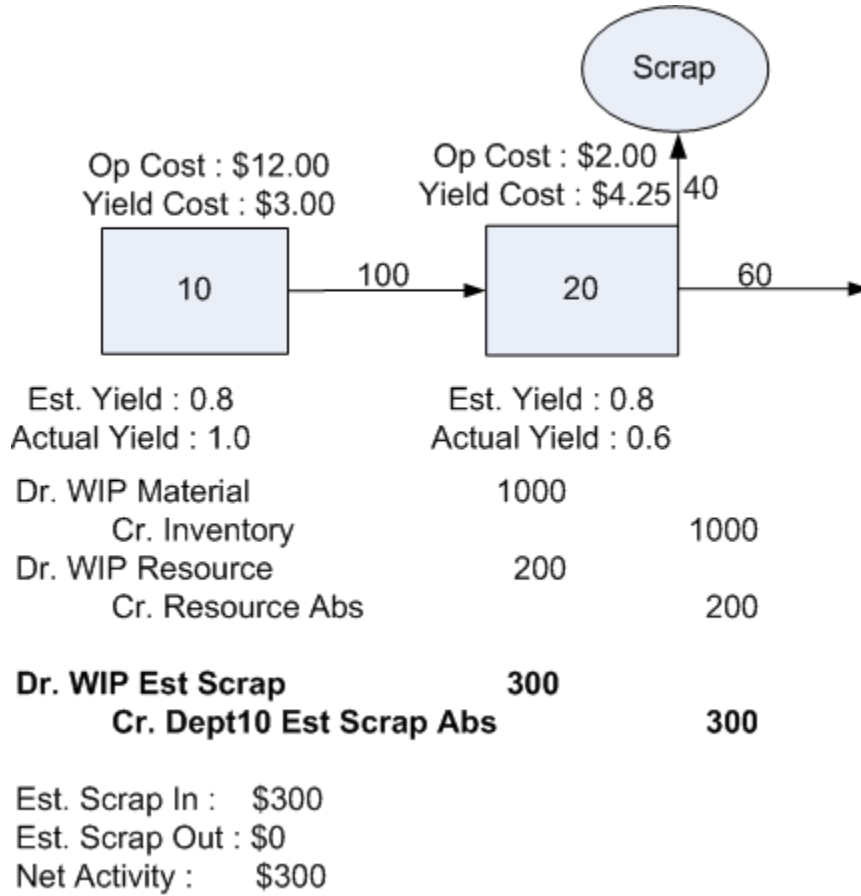

Dr. WIP Resource	80	
Cr. Resource Abs		80
Dr. Dept20 Actual Scrap	560	
Cr. WIP Material		400
Cr. WIP Resource		160
<b>Dr. Dept20 Actual Scrap</b>	<b>120</b>	
<b>Cr. WIP Est Scrap</b>		<b>120</b>

Est. Scrap In : \$300  
 Est. Scrap Out : \$120  
 Net Activity : \$180

Dr. WIP Resource	120	
Cr. Resource Abs		120
Dr. Inventory	1275	
Cr. WIP Material		600
Cr. WIP Resource		240
Cr. WIP Est Scrap		435
<b>Dr. WIP Est Scrap</b>	<b>255</b>	
<b>Cr. Dept20 Abs</b>		<b>255</b>

Est. Scrap In : \$555  
 Est. Scrap Out : \$555  
 Net Activity : \$0

## WIP Lot Transactions

In WIP Lot Transactions, only Split, Merge, Bonus, and Update Quantity affect costing.

WIP Lot Split Transaction

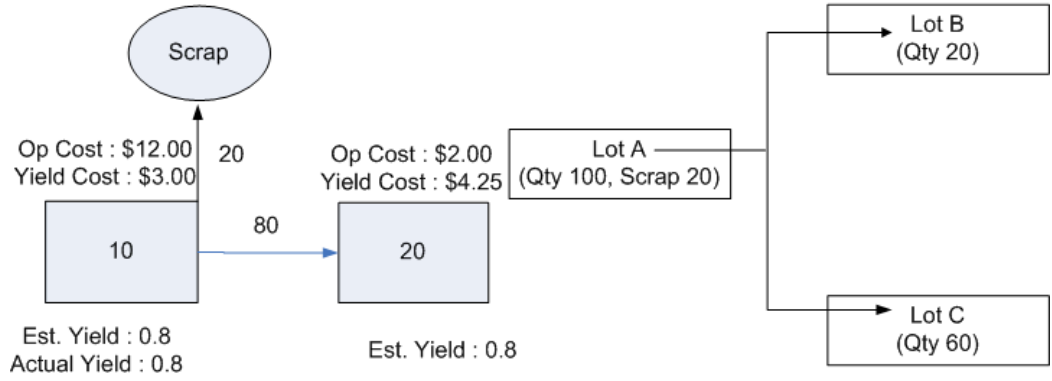

Dr. WIP Material	1000	
Cr. Inventory		1000
Dr. WIP Resource	200	
Cr. Resource Abs		200
Dr. Dept10 Actual Scrap	240	
Cr. WIP Material		200
Cr. WIP Resource		40

<b>Dr. WIP Est Scrap</b>	<b>240</b>	
<b>Cr. Dept10 Est Scrap Abs</b>		<b>240</b>

Est. Scrap In : \$240  
 Est. Scrap Out : \$0  
 Net Activity : \$240

Dr. Lot B WIP Material	200	
Dr. Lot C WIP Material	600	
Cr. Lot A WIP Material		800

Dr. Lot B WIP Resource	40	
Dr. Lot B WIP Resource	120	
Cr. Lot A WIP Material		160

<b>Dr. Lot B WIP Est Scrap</b>	<b>60</b>	
<b>Cr. Lot B Dept10 Abs</b>		<b>60</b>
<b>Dr. Lot C WIP Est Scrap</b>	<b>180</b>	
<b>Cr. Lot C Dept10 Abs</b>		<b>180</b>
<b>Dr. Lot A Dept10 Abs</b>	<b>240</b>	
<b>Cr. Lot A WIP Est Scrap</b>		<b>240</b>

WIP Lot Merge Transaction

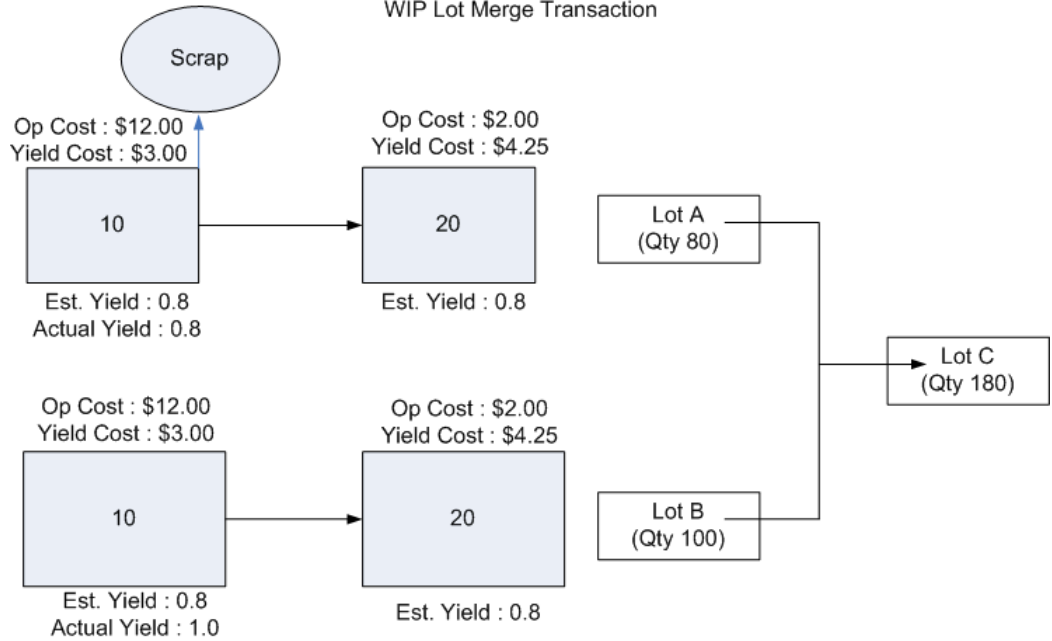

Dr. Lot C WIP Material	1800	
Cr. Lot A WIP Material		800
Cr. Lot B WIP Material		1000
Dr. Lot C WIP Resource	360	
Cr. Lot A WIP Resource		160
Cr. Lot B WIP Material		200
<b>Dr. Lot C WIP Est Scrap</b>	<b>540</b>	
<b>Cr. Lot C Dept10 Abs</b>		<b>540</b>

### WIP Lot Bonus Transaction

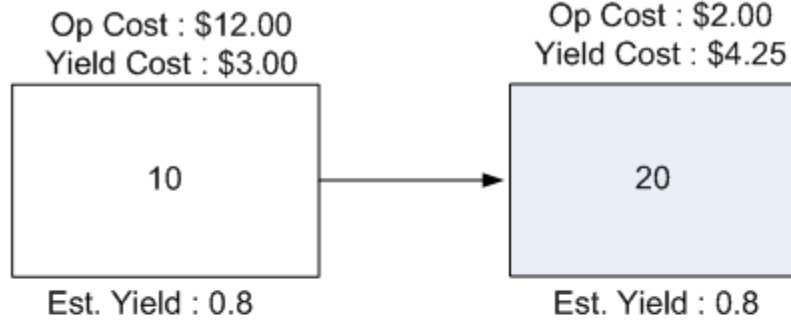

Dr. WIP Material	1000	
Cr. Bonus Acct		1000
Dr. WIP Resource	200	
Cr. Bonus Acct		200
<b>Dr. WIP Est Scrap</b>	<b>300</b>	
<b>    Cr. Bonus Acct</b>		<b>300</b>

Est. Scrap In : \$300.00  
 Est. Scrap Out : \$0  
 Net Activity : \$300.00

### WIP Lot Update Quantity Transaction

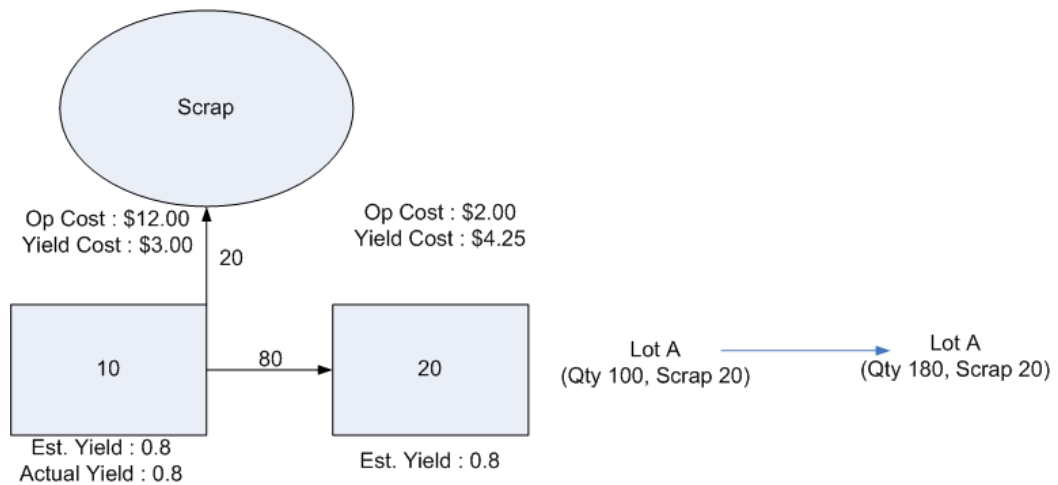



Dr. WIP Material	1000	
Cr. Inventory		1000
Dr. WIP Resource	200	
Cr. Res Abs		200
Dr. Dept10 Actual Scrap	240	
Cr. WIP Material		200
Cr. WIP Resource		40
<b>Dr. WIP Est Scrap</b>	<b>240</b>	
<b>Cr. Dept10 Est Scrap Abs</b>		<b>240</b>

Est. Scrap In : \$240  
Est. Scrap Out : \$0  
Net Activity : \$240

Dr. Lot A WIP Material	800	
Cr. Bonus Acct		800
Dr. Lot A WIP Resource	160	
Cr. Bonus Acct		160
<b>Dr. Lot A WIP Est Scrap</b>	<b>240</b>	
<b>Cr. Lot B Dept10 Abs</b>		<b>240</b>

Est. Scrap In : \$480  
Est. Scrap Out : \$0  
Net Activity : \$480

## Disabling Estimated Scrap and Operation Yield Accounting

In some industries, such as the metals industry, there is no need to do estimated scrap absorption accounting as the scrapped items may be reused as a separate product. In addition, there may be no need to relieve cost from the job at the time of scrap.

You can choose to disable estimated scrap accounting for any organization to simplify accounting setups and variance analysis. The Estimated Scrap Accounting flag is on the Shop Floor Parameter window. You can change the value on this field only if all lot based jobs are in one of the following statuses - Unreleased, Closed, On hold, or Canceled.

If this field is set to enabled, the scrap transaction cost is relieved from the job and the scrap account is required on the Departments window. Estimated Scrap Accounting is

performed as the job is moved from one operation to the next.

When it is set to disabled, there is no Estimated Scrap Accounting. The Estimated Scrap Absorption and the actual Scrap accounts are not required on the Departments window. Other aspects of this feature include:

- You may rollup cost into an updateable Cost Type with or without operation yield costing.
- The Assembly Cost Rollup does not change because cost is calculated based on the Include In Rollup and Operation Yield Enabled flags in the network routing. These flags are independent to the Estimated Scrap Accounting decision.
- If the standard cost (Frozen Cost Type) is based on operation yield costing, the estimated scrap cost is included in the five cost elements for both Inventory Valuation and job completion costing. There will be no credit to the WIP Estimated Scrap Account for Assembly Completion transactions.
- At the time of the scrap transaction, you can enter a scrap account on the Move Lot Based Jobs window to relieve costs from the work order. Generally, if your standard cost is based on Yield Costing, you will not provide a scrap account and leave the scrap in the job. If your standard cost is not based on Yield Costing, you will provide a scrap account and the job will be relieved of scrap. In either case, the quantity scrapped in the operation is updated.
- The operation yield costing and scrap costing decision should be the same for an item. This consistency will reduce variance. However you may decide differently for different items.

## Non Standard Expense Lot Based Jobs

Consider the following when working with non standard expense lot based jobs.

- Non Standard Expense Lot Based Jobs disable Estimated Scrap accounting whether or not Estimate Scrap accounting is enabled at the Inventory Organization level.
- Non Standard Expense Discrete Jobs are not earn Material Overhead on completion, and is not be revalued by standard cost update.
- Unlike Non Standard Expense Discrete Jobs, variances in Non Standard Expense Lot Based Jobs are not flushed out at period close.
- You can perform WIP lot transactions on non standard lot based jobs. The costing of these transactions is similar to that of standard lot based jobs.

## WIP Lot Based Jobs Transaction Costing

There are seven types of WIP lot transactions available to lot based jobs including split, merge, update assembly, bonus, update routing, update quantity, and update lot number. WIP Lot Transaction can be done at the queue or to move intraoperation steps. However, it is not recommended that scrap transactions followed by WIP Lot transactions be performed at the queue intraoperation step.

**Note:** Performing scrap transactions in a separate operation allows for more intuitive costing.

During a lot's progression on the shop floor the following transactions have costing implications:

- Lot Split Transactions
- Lot Merge Transaction
- Bonus Transactions
- Update Quantity Transactions

Lot Based charges include lot based resources, lot based departmental overheads, and resource based overheads based on lot based resources.

## Lot Split Transactions

When you divide a single parent lot into multiple child lots, the actual costs of materials and resources issued to the parent lot (including lot based resources and overheads) are reallocated to the child lots, based on the quantity ratios. The actual costs (the net value remaining in the parent lot) are reallocated to the child lots on a sub-elemental basis. If the net value for any sub-element is negative, it is not reallocated to the child lots and is remain in the parent.

At the time of a split, WIP Lot Spit transactions are created, that will adjust the WIP value of the parent lot and resulting lots with the appropriate balance.

Consider a lot A of size 10 with material charges of \$100, items based resource charges of \$50, and lot based resource charges of \$50. One item is scrapped, resulting in a relief of \$20.

The net balance in lot A is  $(\$200 - \$20) = \$180$ .

If this lot were split into lot B of size 4 and lot C of size 5, the net balance is proportionally reallocated to the child lots. The parent receive a credit of \$180, and the children receive a debit based on the quantity ratio:

Lot B receive a debit of  $(4/9) * \$180 = \$80$

Lot C receive a debit of  $(5/9) * \$180 = \$100$

The accounting entries are:

Account	Debit	Credit
WIP Valuation Accounts for resulting lots	XX	
WIP Valuation Accounts for starting lot		XX

The estimated scrap absorption in the parent is reversed for the charge that has been reallocated to the child lots. Each child lot receive a debit for the additional cost due to operation yield based on the charge that has been reallocated to it.

For the starting lot:

Account	Debit	Credit
Department Estimated Scrap Absorption Account	XX	
WIP Valuation Estimated Scrap Accounts		XX

For resulting lot:

Account	Debit	Credit
WIP Valuation Estimated Estimated Scrap Account	XX	
Department Estimated Scrap Absorption Accounts		XX

**Note:** Cost incurred by the scrapped quantity remain in lot A.

## Merge Lots

When combining several lots into a single existing lot, the cost of materials and

resources is reallocated to the resulting lot. The cost is proportionately reallocated to the resulting lot, based on the costs incurred by the representative lot. The net value in the representative lot is reallocated to the resulting lot on a sub-element basis. If the net value for any sub-element is negative, it is not reallocated to the resulting lot and will remain in the parent.

The lot based charges are not proportioned and the resulting lot incur the same lot based charges as the representative lot. Lot based charges incurred by the nonrepresentative lots are not charged to the resulting lot.

Consider a lot A of size 10 with a material charge of \$100, item based resource charges of \$50. In addition, A has a charge of \$100, which is incurred because component E was pushed to the lot.

Consider a lot B of size 10 with a material charge of \$100, item based source charges of \$50, and lot based resource charges of \$50. In addition, B has a charge of \$200, which it incurred because a different component F was pushed to the lot.

Merge lot A and B into a lot C of size 20. Choose A as the representative lot.

Since A is the representative lot, all charges in C are based on charges incurred by lot A. Hence lot C will receive a debit of:  $[(20/10) * (\text{item based charged})] + (\text{lot based charges}) = [(20/10) * (\$250)] + (\$50) = \$550$ .

Lot A receive a credit of:  $(10/20) * \$500 + \$50 = \$300$

Lot B receive a credit of:  $(10/20) * \$500 = \$250$

The additional charges of \$200 that was incurred by lot B, but not by lot A, remain in lot B. The lot based charges incurred by B is not charged to the resulting lot and remain in lot B. Lot B therefore have a net balance of \$150.

The accounting entries are:

Account	Debit	Credit
WIP Valuation Accounts for resulting lot	XX	
WIP Valuation Accounts for starting lots		XX

The estimated scrap absorption in the starting lots are reversed for the charge that has been reallocated to the resulting lot. The resulting lot absorb the additional cost due to operation yield based on the charge that has been reallocated to it.

For the starting lots:

Account	Debit	Credit
Department Estimated Scrap Absorption Account	XX	
WIP Valuation Estimated Scrap Accounts		XX

For the resulting lot:

Account	Debit	Credit
WIP Valuation Estimated Scrap Account	XX	
Department Estimated Scrap Absorption Account		XX

## Bonus Lots

You can create bonus lots to perform operations on assemblies that were previously scrapped. The quantity starts in the intraoperation step of queue of the starting operation. Therefore, components at the starting operation are not automatically charged when the bonus lot is created. The standard cost of the assembly through the previous operation is credited to the bonus account. The account is often the scrap account. Operation yield is calculated for all previous operations, based on standards.

Consider an assembly A with a component B (\$10) and a resource R1 (\$2) at operation 10. It also has a component C (\$20) and a resource R2 (\$1) at operation 20.

Create a bonus lot, lot-A of size 10 at operation 20. The lot incurs all charges in operation 10. Since the lot is at the intraoperation step of queue at operation 20, charges in operation 20 are not included in the bonus lot.

Hence lot-A incurs a charge of:  $10 * \$10 + 10 * \$2 = \$120$ .

The accounting entries are:

Account	Debit	Credit
WIP Valuation Accounts for bonus lots	XX	

Account	Debit	Credit
Bonus Account (user specified)		XX

The bonus lot also receives a debit for the additional cost due to operation yield based on the charge that it has incurred.

Account	Debit	Credit
WIP Valuation Estimated Scrap Account	XX	
Bonus Account (user specified)		XX

Based on this, a job bonused in at sequence 10 (the first sequence) is like a new job that has just been opened. As this is the first operation in the routing there will not be any costs incurred from a previous operation. If it is opened at a later operation such as 20 it will incur the standard cost from 10 or up through the previous operation and not any cost for the current operation.

An example of how a bonus transaction should be done at an operation other than the first operation is shown in the following section:

**Example**

1. Create a job with 1000 at operation 10, where 1000 components are issued to the job
2. Scrap 200 at operation 10 and complete 800 good at operation 10
3. Move 800 through operation 20 and complete
4. Bonus in a job of 200 at queue of 20. (It will be valued at standard cost as having completed operation 10 including starting material. The standard cost of the assembly through the previous operation is credited to the bonus account. The account is often the scrap account.)
5. Move 200 out of operation 20 and complete

## Update Quantity

You can increase the quantity remaining in a job using the update quantity transaction. Cost incurred by the job (except lot based cost) will be proportionately debited to the job, based on the new quantity and the net value remaining in the job. The net value

remaining in the parent job is reallocated on a sub-elemental basis. If the net value for any sub-element is negative, it is not reallocated to the resulting lot.

The lot based charges are not proportioned in the update lot.

The credit is to the account specified while creating the update quantity transaction and is often the scrap account.

Consider a lot A of size 10 with a material charge of \$100, lot based resource charge of \$50, and resource based overhead charges of \$20 from overheads associated to the lot based resources.

Update the quantity in lot A to 20.

The cost incurred in the new lot is:  $[\$100 * (20/10) + \$50 + \$20 = \$270$

The non-lot based charges of \$100 are proportioned. The remaining lot based charges are not proportionate and remain in the job. Hence lot A receive a credit of \$100.

The accounting for the new charges to the job are:

Account	Debit	Credit
WIP Valuation Account	XX	
Bonus Account (user specified)		XX

The updated lot also receive a debit for the additional cost due to operation yield based on the additional charge that it has occurred.

The accounting entries are:

Account	Debit	Credit
WIP Valuation Estimated Scrap Account	XX	
Bonus Account (user specified)		XX

## Update Routing and Update Assembly

While performing update routing or update assembly transactions at the queue intraoperation step, if you have manual resources and overheads or push component on the current operation, you must manually reverse the charges.



## Lot Based Transaction are Integrated into Cost Manager

All transactions for the lot based jobs, including WIP lot transactions, are costed by the cost manager. In the sequence in which they occurred. If costing fails for any of these transactions, all subsequent transactions for lot based jobs in that organization will be suspended until that error is corrected.

## Transaction Import through MES

To correctly cost WIP lot transactions, it is essential to cost the transactions in a sequence. The cost manager sequentially cost all transactions based on the date on which they occurred. However, if a transaction with a prior date is imported through MES, there is a possibility that some subsequent WIP lot transactions on the job have already been costed. The WIP lot transactions are not reflex the late transactions.

If this timing problem is significant, you can use the date cutoff feature to shut off the cost manager until all relevant transaction on the job have been imported. You can set the date cutoff to process for anytime range you wish. This way all transactions are correctly processed in sequence. See: *Cost Manager, Oracle Cost Management User's Guide*.

## WIP Value Summary

You can use the WIP Value Summary window to view cost elements, if transaction related to the job have been costed. The estimated scrap cost incurred and relieved is displayed in the Operation Yield tab. You can also drill down to the detailed accounting distributions that contributed to the WIP value.

## Reports

The work in process reports enable you to view calculations of estimated scrap incurred, estimated scrap relieved, and estimated scrap variances on lot based jobs, in addition to the five cost elements (Material, Material Overhead, Resource, Overhead, Outside Processing). See: *Discrete Job Value Report, Oracle Work in Process User's Guide*.

You can analyze these cost by work order, as well as track departmental performance using the discrete job value report. See: *WIP Value Report, Oracle Work in Process User's Guide*.

For more information on Manufacturing Resources, Items, Constraint Types, and Oracle Advanced Supply Chain Planning, refer to *Oracle Advanced Supply Chain Planning Implementation and User's Guide*, *Oracle Risk Optimization User's Guide*, and *Oracle Global Order Promising Implementation and User's Guide*.



---

## Closing Lot Based Jobs

This chapter covers the following topics:

- Closing Lot Based Jobs
- Unclosing Lot Based Jobs
- Purging Lot Based Job Move Transactions

### Closing Lot Based Jobs

You can close lot based jobs using the Close Lot Based Jobs (Form) window or the Close Lot Based Jobs Submit Requests (SRS) window. The choice depends on your requirements.

The Close Lot Based Jobs (Form) window enables you to:

- Submit and process lot based job close requests
- Specify the actual close date, this can be different than the transaction date
- View the pending transaction summaries before closing
- Using summary form you can close multiple lot based jobs

The Close Lot Based Jobs Submit Requests window enables you to:

Submit the concurrent request to close the lot based job. To use the request option, you need to specify the parameter using different criteria like set of jobs, release date, job status, actual close date. This provides the ability to close the multiple lot based jobs

The business requirements for closing the lot based job using forms or reports are the same. You cannot close a job that has pending material, resource, or move transactions including those that the concurrent manager has not processed. Also you cannot close a job that has uncosted material transactions. Prior to closing lot based jobs, you can review job value information using the Job Value Report, which lists standard and non-standard asset jobs, or the Expense Job Value Report, which lists non-standard

expense jobs. You can also see the summary of pending transaction while using Lot Based Jobs close using forms.

**To close a lot based job using the Close Lot Based Jobs window:**

1. Navigate to the Close Lot Based Jobs window.

The Find Lot Based Jobs window displays.

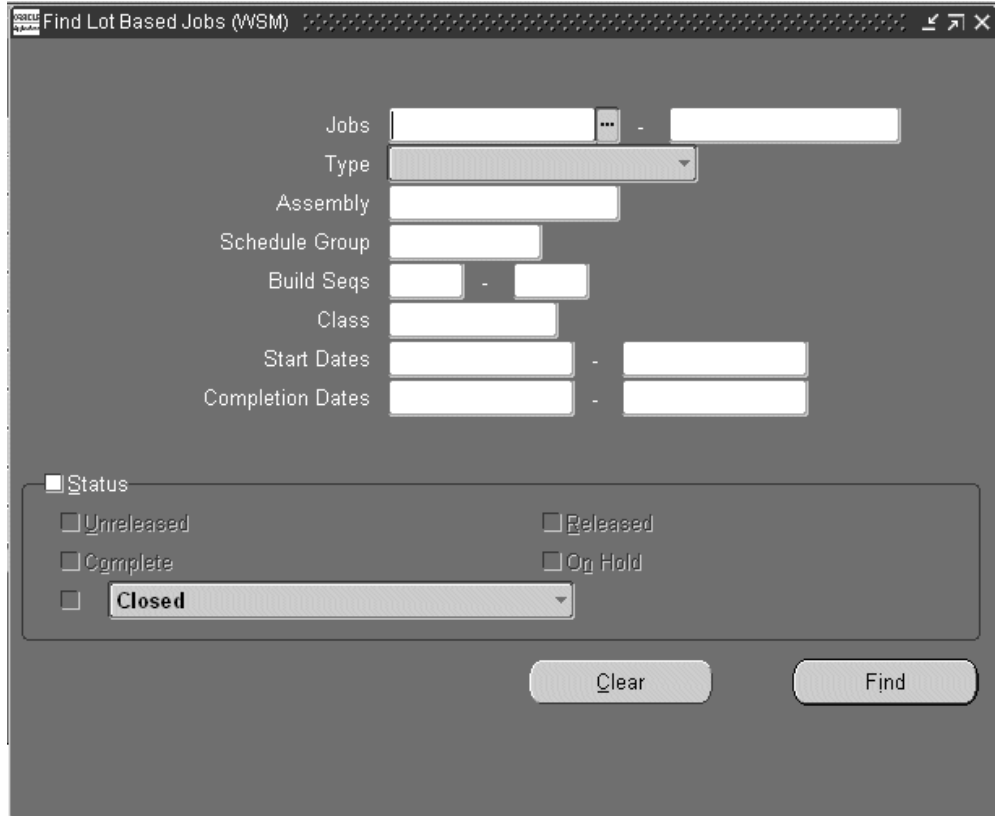

2. Enter your criteria and choose Find.

The Close Lot Based Jobs Summary window displays.

3. Select a job, or multiple jobs, and choose Open to display the Close Lot Based Jobs window.

You can only close jobs with statuses of Cancelled, Complete, Complete – No Charges, Failed Bill Load, Failed Close, Failed Routing Load, On Hold, Released, and Unreleased.

4. Select Transaction Summary from the Tools menu to view all pending transactions.  
Only jobs without pending transactions can be closed.

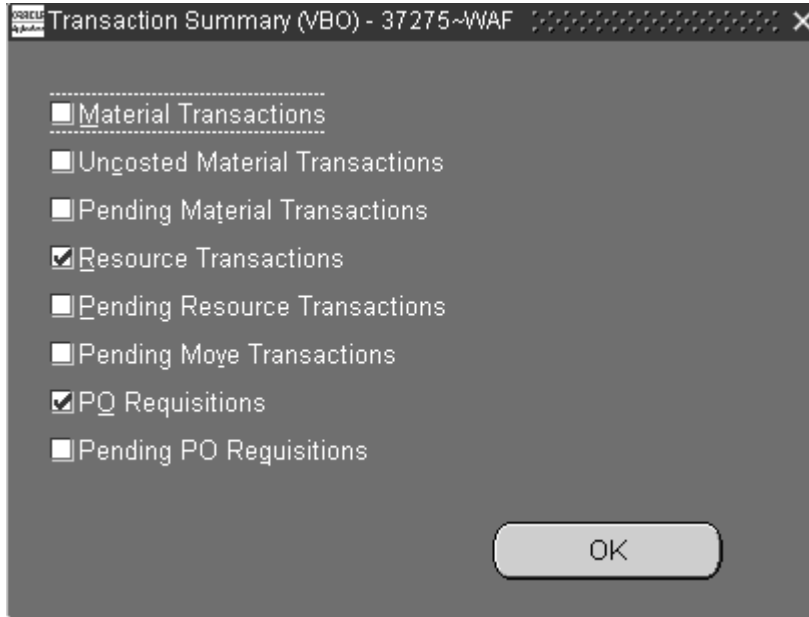

5. Select Close from the Tools menu to display the Close Lot Based Jobs Request window. This window is used to select close options.

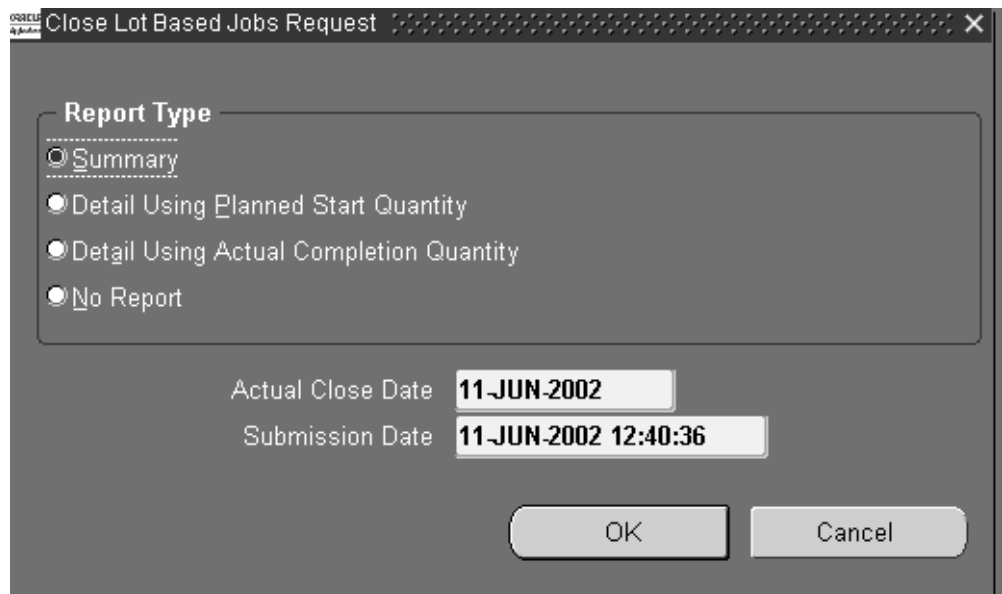

6. Select a report type.

Reports are printed, per the Report Type specified, after the close process computes job close variances. The Discrete Job Value Report – Standard Costing is printed when standard lot based jobs and non-standard asset jobs are closed. The Expense Job Value Report is printed when expense non-standard jobs are closed. Report

Type options and formats are as follows:

- *Summary*: Lists each job and includes job header, period-to-date summary, and cumulative-to-date summary information.
  - *Detail Using Planned Start Quantity*: Lists each job using the planned start quantity of the job to calculate the material usage variance.
  - *Detail Using Actual Completion Quantity*: Lists each job using the actual completion quantity of the job to calculate the material usage variance.
  - *No Report*: Does not print a report.

7. Select an Actual Close Date, the system date is the default.

8. Select a Submission Date and time, the system date and time is the default.

9. Choose OK to submit this request.

Only those jobs with appropriate statuses are closed. The statuses of jobs that are being closed are changed to Pending Close until the close process completes.

**To close a lot based job using Submit Requests:**

Navigate to the Close Lot Based Jobs (SRS) window. The Parameters window appears.

Parameters

Class Type

From Class

To Class

From Job

To Job

From Job Release Date

To Job Release Date

From Job Start Date

To Job Start Date

From Job Completion Date

To Job Completion Date

Status **Complete - No Charges**

Exclude Reserved Jobs **Yes**

Exclude Un-Completed Jobs **Yes**

Exclude Jobs with Pending Trans **Yes**

Report Type **Summary**

Actual Close Date **26-MAR-2003**

OK Cancel Clear Help

10. Select an accounting class in the Class Type field, or range of accounting classes in the From and To Class fields.

The options are Standard discrete, Asset non- standard, or Expense non- standard. If you do not select a class type, the system closes job for all class types.

If you select a class type, you can only select accounting classes of that class type. If you do not select a To Class, all jobs from the From Class forward are closed. If you do not select a From Class, all jobs through the To Class are closed.

11. Select a range of lot based jobs to close in the From and To Job fields.

If this field is left blank, all jobs that fit the close requirements are closed.

12. You can select a range of job release dates, job start dates, job completion dates in the From and To fields.

13. Select a job Status.

You can only close jobs with one with the following statuses: Cancelled, Complete, Complete – No Charges, Failed Bill Load, Failed Close, Failed Routing Load, On Hold, Release, or Unreleased.

14. Exclude Reserved Jobs parameter gives you the option to exclude or include jobs linked to sales orders from the processing.

15. Exclude incompleting jobs parameter gives you the option to exclude or include jobs having a status other than Complete from the processing.
16. Enter Yes in the Exclude Jobs with Pending Transactions field. If you enter Yes, then the application excludes jobs having pending transactions.
17. Select a Report Type.

Reports are printed, per the Report Type specified, after the close process computes job close variances. The Discrete Job Value Report – Standard Costing is printed when standard lot based jobs and non-standard asset jobs are closed. The Expense Job Value Report is printed when expense non-standard jobs are closed. Report Type options and formats are as follows:

- *Summary*: Lists each job and includes job header, period- to- date summary, and cumulative- to- date summary information.
  - *Detail using planned start quantity*: Lists each job using the planned start quantity of the job to calculate the material usage variance.
  - *Detail using actual completion quantity*: Lists each job using the actual completion quantity of the job to calculate the material usage variance.
  - *No Report*: Does not print a report.

18. Choose OK to submit the request.

See: Running Reports and Programs, *Oracle E-Business Suite User's Guide*.

## Related Topics

Overview of Function Security, *Oracle E-Business Suite Security Guide*.

Discrete Job Value Report, *Oracle Work In Process User's Guide*.

## Unclosing Lot Based Jobs

You can use the Unclose Lot Based Jobs window to reopen jobs that are closed. You cannot unclose a job that does not have a status of Closed. This function is not available if the job was closed in an accounting period that is currently closed.

Information associated with a job is not deleted when the job is closed. You can view information for closed discrete jobs. You cannot purge Lot Based Job record. You also can print reports on closed jobs and closed job values. See: Discrete Job Data Report., *Oracle Work in Process User's Guide* Discrete Job Value Report, *Oracle Work in Process User's Guide*.



**Note:** Only jobs closed in error should be unclosed, and this should be done immediately after the close. If assembly costs are rolled up between the time you close then unclose a job, your costs may be incorrect because the unclosure process does *not* revalue the job.

**To unclosure a lot based job:**

1. Navigate to the Unclose Lot Based Jobs window.  
The Find Lot Based Jobs window displays.
2. Enter your criteria and choose Find.  
The Unclose Lot Based Jobs Summary window displays.
3. Select a job, or multiple jobs, and choose Open to display the Unclose Lot Based Jobs window.

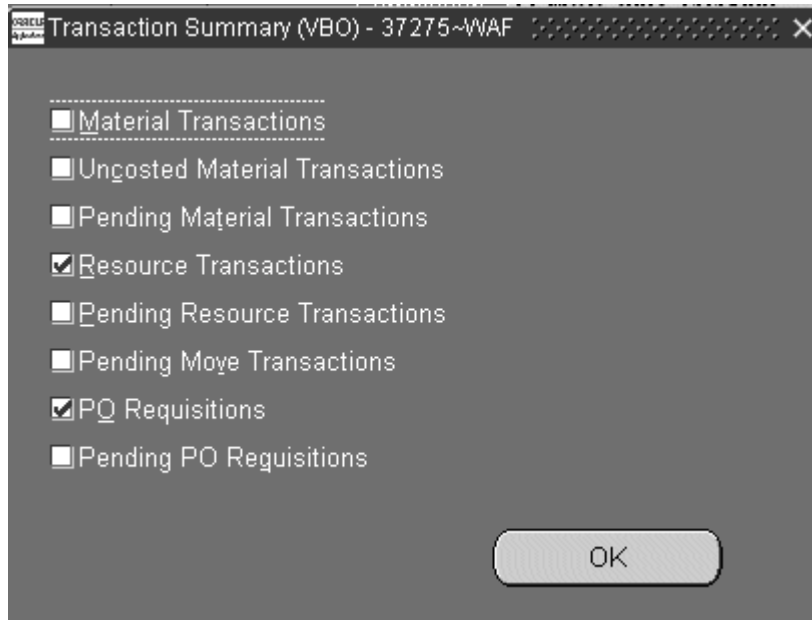

4. Select Transaction Summary from the Tools menu to view all pending transactions.
5. Select Unclose from the Tools menu.  
A Decision window displays prompting you about proceeding with this action.

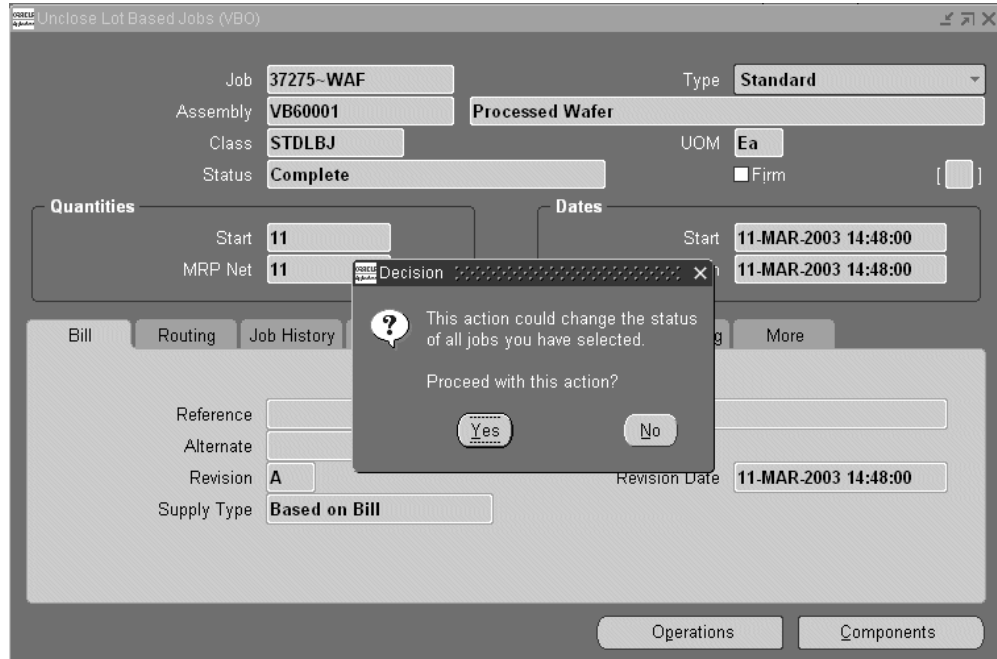

6. Choose Yes to unclose your job.

## Restrictions

**Note:** You must have System Administrator's responsibility to add unclose lot based jobs function as required.

## Purging Lot Based Job Move Transactions

You can purge data related to move transactions of historical jobs based on specific parameters from a closed accounting period using the Purge Lot Based Jobs concurrent program. Genealogy links are preserved by retaining all header information for each job and WIP lot transactions such as split and merge.

Days Before Cutoff Date is a new parameter introduced for the OSFM purge request. This is used to limit Jobs selection. If specified it will consider jobs where 'Date Closed' is between (Cutoff Date-Days Before Cutoff Date) - Cutoff Date. If value for this parameter is not specified (null) then system will consider all jobs where Date Closed is less than or equal to Cutoff Date.

### To purge lot based job transactions:

1. Navigate to the Purge Lot Based Jobs Parameters window.

2. Job type defaults to Lot Based Jobs.

The screenshot shows a 'Parameters' dialog box with the following fields and values:

Job Type	Lot Based Jobs
Action Type	Purge and Report
Jobs From	
Jobs To	
Assembly	
Cutoff Date	30-NOV-2003
Details	Yes
Move Transactions	Yes
Resource Transactions	Yes
Report Type	Summary

Buttons at the bottom: OK, Cancel, Clear, Help.

3. Enter the Action Type.
4. Enter the Jobs From and Jobs To fields to define a range of lot based jobs to purge.
5. Enter the Assembly.
6. Enter the Cutoff date for the closed inventory accounting period.
7. Purge Selection Criteria: Details, Move Transactions, Resource transactions default to Yes for purging.

**Note:** You cannot purge Lot based jobs header data (as header information is required for Lot Genealogy).

8. Enter the Report Type.
9. Choose OK. The Purge Lot Based Jobs window displays request details.
10. Choose Submit to run this request.



---

## Windows and Navigator Paths

This appendix covers the following topics:

- Windows and Navigator Paths

### Windows and Navigator Paths

The following table shows how to find detailed information described in other manuals.

---

Advanced Supply Chain Planning	Refer to the Oracle Advanced Supply Chain Planning, Oracle Risk Optimization, and Oracle Global Order Promising User's Guide
BOM	Refer to the Oracle Bill of Materials User's Guide
Inventory	Refer to the Oracle Inventory User's Guide
Quality	Refer to the Oracle Quality User's Guide
User	Refer to the Oracle Application User's Guide
WIP	Refer to the Oracle Work in Process User's Guide

---

The following table shows windows and navigation paths for Oracle Shop Floor Management.

<b>Window Name</b>	<b>Navigation Path</b>
Alternates	Shop Floor > Routings > Alternates BOM > Setup > Alternates
Calculate Cumulative Yield for Network Routing	Shop Floor > Run Requests
Close Lot Based Jobs	Shop Floor > Lot Transactions > Close Lot Based Jobs Close Lot Based Jobs (Form)
Component Details	Shop Floor > Co-Products > Define Co-Products > Details
Component Pick Release	Shop Floor > Lot Transactions > Component Pick Release > Find Lot Based Jobs
Departments	Shop Floor > Routings > Departments BOM > Routings > Departments
Lot Based Jobs	Shop Floor > Lot Based Jobs > Find Lot Based Jobs
Lot Based Transaction Cost Manager	Shop Floor > Run Requests > Lot Based Transaction Cost Manager
Lot Based Jobs Summary	Shop Floor > Lot Based Jobs > Find Lot Based Jobs > Find
Lot Creation	Shop Floor > Lot Transactions > Lot Creation
Define Co-Products	Shop Floor > Co-Products
Inventory Lot Transactions	Shop Floor > Lot Transactions > Inventory Lot Transactions
Lot Creation	Shop Floor > Lot Transactions > Lot Creation
Lot Genealogy	Shop Floor > Lot Genealogy > Find Lots/Jobs > Jobs Summary > View Genealogy >
Material Requirements	Shop Floor > Lot Based Jobs > Find Lot Based Jobs > Lot Based Jobs > Components

<b>Window Name</b>	<b>Navigation Path</b>
Move Lot Based Jobs	Shop Floor > Lot Transactions > Move Transactions
Operation Resources	Shop Floor > Network Routings > Routings > Operation Resources
Operations	Shop Floor > Lot Based Jobs > Find Lot Based Jobs > Lot Based Jobs > Operations
Personal Profile Values	Shop Floor > Other > Profile
Resource Transactions	Shop Floor > Lot Transactions > Resource Transactions WIP > Resource Transactions > Resource Transactions
Routing Details	Shop Floor > Network Routings > Routings > Routing Details
Routing Network	Shop Floor > Network Routings > Routings > Network Routing
Routings	Shop Floor > Network Routings
Sector Extensions and Item/Subinventory Association	Shop Floor > Setup > Sector Extensions > Find Sector Extension
Shop Floor Management Parameters	Shop Floor > Setup > Parameter
Standard Operations	Shop Floor > Routings > Standard Operations
Substitute Components	Shop Floor > Co-Products > Define Co-Products > Substitutes
Substitute Co-Products	Shop Floor > Co-Products > Define Co-Products > Co-Product Substitutes
WIP Lot Transactions	Shop Floor > Lot Transactions > WIP Lot Transactions
WIP Lot Transactions Processor	Shop Floor > Run Requests > WIP Lot Transactions Processor

---

<b>Window Name</b>	<b>Navigation Path</b>
WIP Value Summary	Shop Floor > Lot Transactions > View Transactions > WIP Value Summary

---



---

## Support for OSFM Transactions in Various User Interface Modes

### Support for OSFM Transactions in Various User Interface Modes

*User Interface Support for OSFM Transactions*

S. No.	Transaction	Forms	HTML	Interface	Mobile	Remarks
1.1.	<b>Job Creation</b>	Y	N	Y	N	
1.1.1.	Lot Attributes	Y	N	Y	N	
1.1.2.	Serial Attributes	Y	N	Y	N	
1.2.	<b>Lot Creation</b>	Y	N	Y	N	
1.2.1.	Lot Controlled Assemblies	Y	N	Y	N	
1.2.2.	Lot and Serial Controlled Assemblies	Y	N	N	N	

S. No.	Transaction	Forms	HTML	Interface	Mobile	Remarks
1.2.3.	Lot Attributes	Y	N	Y	N	
1.2.4.	Serial Attributes	Y	N	N	N	
1.3.	Update Unreleased Job	Y	N	Y	N	
1.4	Update Released Job	Y	N	Y	N	
1.5	<b>Change Job Status</b>					
1.5.1.	Close	Y	N	N	N	
1.5.2.	Unclose	Y	N	N	N	
1.5.3.	Purge	Y	N	N	N	
1.5.4.	Release	Y	N	Y	N	
1.5.5.	Hold	Y	N	Y	N	
1.5.6.	Cancel	Y	N	Y	N	
2.1.	Move	Y	Y	Y*	N	*Move from an intraop step to any intraop step of next operation not supported

S. No.	Transaction	Forms	HTML	Interface	Mobile	Remarks
2.1.1.	Move In	N	Y	N	N	Moving into an operation
2.1.2.	Move Out	N	Y	N	N	Moving out of an operation
2.1.3.	Move To Next Op	N	Y	N	N	Moving to the next operation
2.2.	Partial Move	Y	N	N	N	
2.3.	Backflush	Y	Y	Y	N	
2.4.	Scrap					
2.4.1.	Moving to Intraop Step Scrap	Y	N	Y	N	
2.4.2.	Move and Scrap	Y	Y	Y	N	Combined Move and Scrap Transaction
2.4.3.	Scrap Codes	Y	Y*	N	N	*Scrap Quantity can be specified against Scrap Codes
2.5.	Bonus Quantity	N	Y	N	N	

S. No.	Transaction	Forms	HTML	Interface	Mobile	Remarks
2.5.1.	Bonus Codes	N	Y*	Y	N	*Bonus Codes can be specified for Bonus Quantity
2.6.	Completion	Y	Y	Y	N	
2.7.	Return	Y	Y	Y	N	
2.8.	Undo	Y	Y	Y	N	
2.9.	Jump	Y	Y	Y	N	
2.10.	Serial Generation during Move	Y	N	N	N	
2.11.	Lot Attributes during Move	Y	Y	Y	N	
2.12.	Serial Attributes during Move	Y	N	Y	N	
2.13.	Capture Actual Start Date	N	Y	N	N	Actual Start Date/Time of the operation is captured
3.	<b>WIP Lot Transactions</b>					

S. No.	Transaction	Forms	HTML	Interface	Mobile	Remarks
3.1.	Split	Y	Y	Y	N	
3.2.	Merge	Y	Y	Y	N	
3.3.	Update Quantity	Y	Y	Y	N	
3.4.	Update Assembly	Y	Y	Y	N	
3.5.	Update Routing	Y	Y	Y	N	
3.6.	Update Lot Name	Y	Y	Y	N	
3.7.	Bonus	Y	N	Y	N	
3.8.	Update Lot Attributes	Y	Y	Y	N	
3.9.	Update Serial Attributes	Y	N	Y	N	
	<b>Lot/Serial Support: WIP Lot Transactions</b>					
3.10.	Split	Y	Y	Y	N	
3.11.	Merge	Y	Y	Y	N	
3.12.	Update Quantity	Y	Y	Y	N	
3.13.	Update Assembly	Y	Y	Y	N	

<b>S. No.</b>	<b>Transaction</b>	<b>Forms</b>	<b>HTML</b>	<b>Interface</b>	<b>Mobile</b>	<b>Remarks</b>
3.14.	Update Routing	Y	Y	Y	N	
3.15.	Update Lot Name	Y	Y	Y	N	
3.16.	Bonus	N	N	N	N	
4.	<b>Inventory Lot Transactions</b>					
4.1.	Split	Y	N	Y	Y*	*Serial Controlled Items not supported by INV on Mobile
4.2.	Merge	Y	N	Y	Y*	*Serial Controlled Items not supported by INV on Mobile
4.3.	Translate	Y	N	Y	Y*	*Serial Controlled Items not supported by INV on Mobile
4.4.	Transfer	Y	N	Y	Y	
4.5.	Update Lot Attributes	Y	N	Y	Y	
4.6.	Update Serial Attributes	N	N	Y	N	

<b>S. No.</b>	<b>Transaction</b>	<b>Forms</b>	<b>HTML</b>	<b>Interface</b>	<b>Mobile</b>	<b>Remarks</b>
5.	<b>Material Transactions</b>					
5.1.	Issue Material to Job	Y	Y	Y	Y*	*OSFM Jobs not supported in Mobile
5.2.	Return Material to Inventory	Y	Y	Y	Y*	*OSFM Jobs not supported in Mobile
6.	<b>Change Current Operation Details</b>					
6.1.	Change Resource	Y	N	Y	N	
6.2.	Change Components	Y	Y	Y	N	
6.3.	Change Recommended Path	N	Y	Y	N	
6.4.	Change Resource Usage/Instances	N	Y	Y	N	
7.	<b>Change Plan Details</b>					

S. No.	Transaction	Forms	HTML	Interface	Mobile	Remarks
7.1.	Change Resource (Future Operation)	N	Y*	Y	N	*Only substitutions to predefined alternate resources possible
7.2.	Change Components (Future Operation)	N	Y*	Y	N	*Only substitutions to predefined alternate components possible
7.3.	Change Recommended Path	N	Y	Y	N	
7.4.	Change Resource Usage/Instances (Future Operation)	N	N	Y	N	
7.5.	Change Operation Yield	N	Y	Y	N	
7.6.	Infinite Rescheduling	Y	N	Y	N	
7.7.	Detailed Scheduling	N	N	Y	N	Constrained or Finite Scheduling
8.	<b>Co-Product</b>					
8.1.	Define Co-Product	Y	N	N	N	



S. No.	Transaction	Forms	HTML	Interface	Mobile	Remarks
8.2.	Update Co-Product	Y	N	N	N	
9.	<b>BOM and Routing</b>					
9.1.	Define BOM	Y	N	Y	N	
9.2.	Update BOM	Y	N	Y	N	Updating BOM does not update Co-Product definition
9.3.	Define Network Routing	Y	N	Y	N	
9.4.	Update Network Routing	Y	N	Y	N	
10.						
10.1.	Setup: Defining an Item as Serial Controlled	Y	N	Y	N	
10.2.	Setup: Serialization Start Operation in the Routing	Y	N	N	N	
10.3.	Generation of Serials	Y	N	Y	N	

S. No.	Transaction	Forms	HTML	Interface	Mobile	Remarks
10.4.	Association of Serials	Y	N	Y	N	
10.5.	Lot/Serial Support in Job Move Transactions	Y	Y	Y	N	
10.6.	Lot/Serial Component Issue: Material Transaction	Y	Y	N	N	
10.7.	Lot/Serial Component Issue: Backflush Transaction	Y	Y	N	N	
10.8.	Managing Attributes	Y	Y*	Y	N	*Only Lot Attributes supported in HTML
10.9.	Genealogy of Lot/Serial	Y	N	-	N	

---

# Index

## Symbols

80 character limit, 5-7

---

## C

Component Details window, 9-6  
Component picking transactions for lot based jobs, 1-12  
component shrinkage, 1-8  
component usage, 1-7  
Compute lead time  
    Routings, 3-16  
Co-products, 1-11  
    overview, 9-1  
Co Products Supply Default, 2-13  
Cost rollup  
    routing, 10-2

---

## D

Default Accounting Class, 2-13  
Defining  
    lot sector extension codes, 2-16  
    parameters, 2-10  
    standard operation details, 2-18  
Defining Co-Products  
    co-products, 9-2

---

## E

Estimated scrap accounting, enabling and disabling, 2-13

---

## G

Genealogy  
    lot/serial controlled assembly, 8-8  
    lot serial attributes, 8-9  
Genealogy Enhancements, 1-10

---

## I

Inventory  
    Job Completion, 6-24  
Inventory Lot Transactions, 5-36  
    Lot Attributes  
        Split, Merge, Translate, 5-39  
Inventory Lot Transactions API, enabling, 2-14  
inverse component usage, 1-6

---

## L

License plate numbers, 1-12  
Lot  
    transactions, 1-9  
Lot/Serial Controlled Assemblies, 6-1  
Lot Based Job Component Pick Release, 5-50  
Lot based jobs  
    creating, 5-3  
    resources, viewing, 5-20  
    status, viewing, 5-20  
    transaction costing, 10-3, 10-21  
    view component requirements, 5-9  
    view lot attributes, 5-11, 5-18, 5-32  
Lot Based Material Support, 1-9  
Lot based transaction cost manager, 10-27  
Lot Creation window, 5-44  
Lot Genealogy, 1-10  
    genealogy view, 8-2

- overview, 8-1
- where-used view, 8-2
- Lot Genealogy overview, 8-1
- Lot moves
  - overview, 5-14
- Lot move transactions
  - creating, 5-14
- Lots
  - assigning starting operation for child lots, 5-31
  - bonus, 5-29, 5-30
  - enhanced functionality, 1-9
  - genealogy, 1-10
  - merging, 5-29, 5-30, 5-37
  - move transactions, 5-14
  - splitting, 5-29, 5-30, 5-36
  - transaction costing, 10-3, 10-21
  - transfer, 5-29
  - transferring, 5-37
  - translating, 5-37
  - update assembly, 5-29, 5-30
- Lot sector extensions, 2-15
- Lot Separator field, 2-11
- Lot transactions, 1-9

## **M**

---

- Manufacturing Transactions
  - Partial Move, 6-4
- Multilevel bill of material, 1-4

## **N**

---

- Network routings, 1-8
  - adding and changing, 3-11
  - calculating cumulative yield and reverse cumulative yield, 3-16
  - creating, 3-4, 3-7
  - defining yield values, 3-15
  - deleting, 3-12
  - flow illustration, 3-2
  - overview, 3-1
- Non-standard lot based jobs, 5-4

## **O**

---

- Operation jumps, 5-19
- Operation yield
  - defining values on routings, 3-15

- Operation cost, 10-6
  - overview, 10-2
- Operation yields, 1-11
- Oracle Advanced Supply Chain Planning Integration
  - network routings, 3-20
- OSFM Transactions
  - Interface Modes, B-1
- Outside Processing Integration
  - network routings, 5-52
- Overview
  - co-products, 9-1
  - lot moves, 5-14
  - network routings, 3-1
  - of lot transactions, 5-2
  - setting up, 2-1
  - Shop Floor Management, 1-1

## **P**

---

- Phantom assemblies, 1-4
- Profile option, Allow operation jumps, 2-21
- Profile option, WSM
  - Allow Operation Jumps, 2-22
  - Complete Job Sector Lot Extension Level, 2-23
  - Delete successfully processed move transaction, 2-23
  - Maximum Number of Import Lot Job Workers, 2-23
  - Maximum Number of Rows Processed by a Lot Based Job Worker as a Batch, 2-23

## **R**

---

- Refresh BOM/Routing
  - Open Lot based jobs, 5-28
- Representative Lot check box, 5-34
- Rescheduling Jobs, Operations, and Resources
  - gantt chart, 7-14
- Reuse Job Name
  - Sector extension, 2-10
- Revision Dates, 5-28
- Rollup lead time
  - Bills of Material, 3-16
- Routing Network window, 3-5

## **S**

---

- sales order, 5-12
- scrap code, 4-1
- Serial Generation
  - Job Creation, 6-1
- Setup
  - checklist, 2-4
  - flowchart, 2-3
  - related product setup steps, 2-2
- shop floor execution, 4-23
- Shop floor execution, 4-1
- Shop Floor Management flow, 1-2
- Standard cost update, 10-2
- Standard Operation Details, 2-17
- Standard Operation Details window, 2-17
- Substitute Components window, 9-6

## **U**

---

- Undo Last Move, 2-12, 5-16

## **W**

---

- WIP lot bonus transactions
  - creating, 5-33
- WIP lot merge transactions
  - creating, 5-34
- WIP lot split transactions
  - creating, 5-34
- WIP lot transactions, 5-30
  - creating, 5-31
- WIP lot update transactions, 5-35
- WIP value summary, 10-27

