

# Pillar Axiom 600



PILLAR AXIOM

---

Part Number 4420-00108-0700  
Pillar Axiom release 4.3  
2011 October

Copyright © 2011, Oracle and/or its affiliates. All rights reserved.

This software and related documentation are provided under a license agreement containing restrictions on use and disclosure and are protected by intellectual property laws. Except as expressly permitted in your license agreement or allowed by law, you may not use, copy, reproduce, translate, broadcast, modify, license, transmit, distribute, exhibit, perform, publish or display any part, in any form, or by any means. Reverse engineering, disassembly, or decompilation of this software, unless required by law for interoperability, is prohibited.

The information contained herein is subject to change without notice and is not warranted to be error-free. If you find any errors, please report them to us in writing.

If this is software or related documentation that is delivered to the U.S. Government or anyone licensing it on behalf of the U.S. Government, the following notice is applicable:

U.S. GOVERNMENT RIGHTS Programs, software, databases, and related documentation and technical data delivered to U.S. Government customers are "commercial computer software" or "commercial technical data" pursuant to the applicable Federal Acquisition Regulation and agency-specific supplemental regulations. As such, the use, duplication, disclosure, modification, and adaptation shall be subject to the restrictions and license terms set forth in the applicable Government contract, and, to the extent applicable by the terms of the Government contract, the additional rights set forth in FAR 52.227-19, Commercial Computer Software License (December 2007). Oracle USA, Inc., 500 Oracle Parkway, Redwood City, CA 94065.

This software or hardware is developed for general use in a variety of information management applications. It is not developed or intended for use in any inherently dangerous applications, including applications that may create a risk of personal injury. If you use this software or hardware in dangerous applications, then you shall be responsible to take all appropriate fail-safe, backup, redundancy, and other measures to ensure its safe use. Oracle Corporation and its affiliates disclaim any liability for any damages caused by use of this software or hardware in dangerous applications.

Oracle and Java are registered trademarks of Oracle and/or its affiliates. Other names may be trademarks of their respective owners.

This software or hardware and documentation may provide access to or information on content, products and services from third parties. Oracle Corporation and its affiliates are not responsible for and expressly disclaim all warranties of any kind with respect to third-party content, products, and services. Oracle Corporation and its affiliates will not be responsible for any loss, costs, or damages incurred due to your access to or use of third-party content, products, or services.

---

Copyright © 2011, Oracle et/ou ses affiliés. Tous droits réservés.

Ce logiciel et la documentation qui l'accompagne sont protégés par les lois sur la propriété intellectuelle. Ils sont concédés sous licence et soumis à des restrictions d'utilisation et de divulgation. Sauf disposition de votre contrat de licence ou de la loi, vous ne pouvez pas copier, reproduire, traduire, diffuser, modifier, breveter, transmettre, distribuer, exposer, exécuter, publier ou afficher le logiciel, même partiellement, sous quelque forme et par quelque procédé que ce soit. Par ailleurs, il est interdit de procéder à toute ingénierie inverse du logiciel, de le désassembler ou de le décompiler, excepté à des fins d'interopérabilité avec des logiciels tiers ou tel que prescrit par la loi.

Les informations fournies dans ce document sont susceptibles de modification sans préavis. Par ailleurs, Oracle Corporation ne garantit pas qu'elles soient exemptes d'erreurs et vous invite, le cas échéant, à lui en faire part par écrit.

Si ce logiciel, ou la documentation qui l'accompagne, est concédé sous licence au Gouvernement des Etats-Unis, ou à toute entité qui délivre la licence de ce logiciel ou l'utilise pour le compte du Gouvernement des Etats-Unis, la notice suivante s'applique :

U.S. GOVERNMENT RIGHTS. Programs, software, databases, and related documentation and technical data delivered to U.S. Government customers are "commercial computer software" or "commercial technical data" pursuant to the applicable Federal Acquisition Regulation and agency-specific supplemental regulations. As such, the use, duplication, disclosure, modification, and adaptation shall be subject to the restrictions and license terms set forth in the applicable Government contract, and, to the extent applicable by the terms of the Government contract, the additional rights set forth in FAR 52.227-19, Commercial Computer Software License (December 2007). Oracle America, Inc., 500 Oracle Parkway, Redwood City, CA 94065.

Ce logiciel ou matériel a été développé pour un usage général dans le cadre d'applications de gestion des informations. Ce logiciel ou matériel n'est pas conçu ni n'est destiné à être utilisé dans des applications à risque, notamment dans des applications pouvant causer des dommages corporels. Si vous utilisez ce logiciel ou matériel dans le cadre d'applications dangereuses, il est de votre responsabilité de prendre toutes les mesures de secours, de sauvegarde, de redondance et autres mesures nécessaires à son utilisation dans des conditions optimales de sécurité. Oracle Corporation et ses affiliés déclinent toute responsabilité quant aux dommages causés par l'utilisation de ce logiciel ou matériel pour ce type d'applications.

Oracle et Java sont des marques déposées d'Oracle Corporation et/ou de ses affiliés. Tout autre nom mentionné peut correspondre à des marques appartenant à d'autres propriétaires qu'Oracle.

Ce logiciel ou matériel et la documentation qui l'accompagne peuvent fournir des informations ou des liens donnant accès à des contenus, des produits et des services émanant de tiers. Oracle Corporation et ses affiliés déclinent toute responsabilité ou garantie expresse quant aux contenus, produits ou services émanant de tiers. En aucun cas, Oracle Corporation et ses affiliés ne sauraient être tenus pour responsables des pertes subies, des coûts occasionnés ou des dommages causés par l'accès à des contenus, produits ou services tiers, ou à leur utilisation.

---

# Table of Contents

## Preface

### Part I: Introduction to Cabling Pillar Axiom 600 Systems

Sheet 1 About This Reference. . . . .	13
Cautions and Warnings. . . . .	13
Sheet 2 Introduction to Cabling the Pillar Axiom 600 System. . . . .	14
About Cabling a Pillar Axiom 600 System. . . . .	14
Configuration Limits for a Pillar Axiom 600 System. . . . .	15
Supported Hardware Components. . . . .	16
About Cable Labels. . . . .	19
Compatibility Matrix: Ports, Cables, and Connector Types. . . . .	20
Cables and Connectors. . . . .	21
Effects of Cable Types on Fabric Speed. . . . .	23
Cable Handling Tips. . . . .	24
Clean Fiber Optic Cables. . . . .	25

### Part II: Cabling Pillar Axiom 600 Systems Using One Slammer and SATA Bricks Only

Sheet 3 Cabling Example: 1-Slammer System Using SATA Bricks. . . . .	26
Sample Wiring Diagram for a 1x2 System Using SATA Bricks. . . . .	26
Notes on the 1x2 SATA Wiring Diagram. . . . .	26
Sample Wiring Diagram for a 1x6 System Using SATA Bricks. . . . .	27
Notes on the 1x6 SATA Wiring Diagram. . . . .	28
Control Unit (CU) Cross Connections for One Slammer. . . . .	29
Sheet 4 Cabling Block Diagram: A 1-Slammer System. . . . .	30
Block Diagram for a 1x32 System Using SATA Bricks. . . . .	30
Notes on the 1x32 Block Diagram. . . . .	30
Sheet 5 High Density Rack Configuration Using 230 V, 30 A Power. . . . .	32
Hardware Component Mapping in Racks Having 230 V, 30 A PDUs. . . . .	32
Notes on Component Mapping within Racks Having 230 VAC, 30 A PDUs. . . . .	33
Sheet 6 High Density Rack Configuration Using Four PDUs or 3-Phase Power. . . . .	34
Hardware Component Mapping in Racks Having Four PDUs or 3-Phase PDUs. . . . .	34
Notes on Component Mapping within Racks Having Four PDUs or 3-Phase PDUs. . . . .	35
Sheet 7 SSF Cable Connection List (Slammer Plus Bricks 1–8). . . . .	36
Cable the Slammer and SATA Bricks 1–8. . . . .	36
Notes on Cabling SATA Bricks 1–8. . . . .	36
Sheet 8 SSF Cable Connection List (Bricks 9–16). . . . .	38
Cable SATA Bricks 9–16. . . . .	38
Notes on Cabling SATA Bricks 9–16. . . . .	38
Sheet 9 SSF Cable Connection List (Bricks 17–24). . . . .	39
Cable SATA Bricks 17–24. . . . .	39
Notes on Cabling SATA Bricks 17–24. . . . .	39
Sheet 10 SSF Cable Connection List (Bricks 25–32). . . . .	40
Cable SATA Bricks 25–32. . . . .	40
Notes on Cabling SATA Bricks 25–32. . . . .	40
Sheet 11 PMI Cable Connection List and Schematic. . . . .	41
Private Management Interface (PMI) Connections in a 1-Slammer System. . . . .	41
Schematic of PMI Ethernet Connections in a 1-Slammer System. . . . .	41

### Part III: Cabling Pillar Axiom 600 Systems Using Two Slammers and SATA Bricks Only

Sheet 12 Cabling Example: 2-Slammer System Using SATA Bricks. . . . .	43
Sample Wiring Diagram for a 2x2 System Using SATA Bricks. . . . .	43
Notes on the 2x2 Wiring Diagram for SATA Bricks. . . . .	44
Control Unit (CU) Cross Connections for Two Slammers. . . . .	44
Sheet 13 Cabling Block Diagram: A 2-Slammer System. . . . .	46
Block Diagram for a 2x64 System Using SATA Bricks. . . . .	46
Notes on the 2x64 Block Diagram for SATA Bricks. . . . .	46

Sheet 14 Cable Connection List (Slammers Plus Bricks 1–8).	48
Cable the Slammers and SATA Bricks 1–8.	48
Notes on Cabling SATA Bricks 1–8.	48
Sheet 15 SSF Cable Connection List (Bricks 9–16).	50
Cable SATA Bricks 9–16.	50
Notes on Cabling SATA Bricks 9–16.	50
Sheet 16 Cable Connection List (Bricks 17–24).	51
Cable SATA Bricks 17–24.	51
Notes on Cabling SATA Bricks 17–24.	51
Sheet 17 Cable Connection List (Bricks 25 and Up).	52
Cable SATA Bricks 25–32.	52
Notes on Cabling SATA Bricks 25–32.	52
Cabling Configurations of More Than 32 SATA Bricks.	52
Sheet 18 PMI Cable Connection List and Schematic.	54
Private Management Interface (PMI) Connections in a 2-Slammer System.	54
Schematic of PMI Ethernet Connections in a 2-Slammer System.	54
Sheet 19 Schematic of a SATA Brick Cascade (String).	56
Diagram of Stringing SATA Bricks.	56
Notes on Stringing Bricks.	56
<b>Part IV: Cabling Pillar Axiom 600 Systems Using One or Two Slammers and FC Bricks</b>	
Sheet 20 Cabling Example: 1-Slammer System Using FC Bricks.	57
Sample Wiring Diagram for a 1x2 System Using FC Bricks.	57
Notes on the 1x2 Wiring Diagram for FC Bricks.	57
Sample Wiring Diagram for a 1x4 System Using FC Bricks.	58
Notes on the 1x4 Wiring Diagram for FC Bricks.	58
Sheet 21 Cabling Block Diagram: A 1-Slammer System Using FC Bricks.	60
Block Diagram for a 1x8 System Using FC Bricks.	60
Notes on the 1x8 Block Diagram for FC Bricks.	60
Cable the Slammer and FC Bricks.	61
Sheet 22 Cabling Block Diagram: A 2-Slammer System Using FC Bricks.	63
Block Diagram for a 2x16 System Using FC Bricks.	63
Notes on the 2x16 Wiring Diagram for FC Bricks.	63
Cable the Slammers and FC Bricks.	64
Sheet 23 Cabling Example: Mix of FC and SATA Bricks.	66
Sample Wiring Diagram for a Mix of Brick Types.	66
Notes on the Wiring Diagram for a Mix of Brick Types.	66
Sheet 24 Cabling Block Diagram: A 1-Slammer System Using FC and SATA Bricks.	68
Block Diagram for a 1x16 System Using FC and SATA Bricks.	68
Notes on the 1x16 Block Diagram for FC and SATA Bricks.	68
Block Diagram for Expanding an Initial Configuration of FC Bricks.	69
Notes for Adding SATA Bricks to a Set of FC Bricks.	70
Sheet 25 Cabling Block Diagram: A 2-Slammer System Using FC and SATA Bricks.	71
Block Diagram for a 2x24 System Using FC and SATA Bricks.	71
Notes on the 2x24 Block Diagram for FC and SATA Bricks.	71
Cable the SATA and FC Bricks.	72
<b>Part V: Cabling Pillar Axiom 600 Systems Using Three Slammers</b>	
Sheet 26 Cross Connections for 3-Slammer Systems.	73
Control Unit (CU) Cross Connections for Three Version 1 Slammers.	73
Control Unit (CU) Cross Connections for Three Version 2 Slammers.	74
Control Unit (CU) Cross Connections for Three Mixed Version Slammers.	76
Sheet 27 Brick Connections for 3-Slammer Systems.	79
Block Diagram: Connecting Bricks to Three Slammers.	79
Cable the Slammers and Bricks.	80
Sheet 28 PMI Connections for 3-Slammer Systems.	82
Schematic of PMI Ethernet Connections in a 3-Slammer System.	82
Private Management Interface (PMI) Connections in a 3-Slammer System.	82
<b>Part VI: Cabling Pillar Axiom 600 Systems Using Four Slammers</b>	
Sheet 29 Cross Connections for Four Slammers.	84
Control Unit (CU) Cross Connections for Four Version 1 Slammers.	84
Control Unit (CU) Cross Connections for Four Version 2 Slammers.	85
Control Unit (CU) Cross Connections for Four Mixed Version Slammers.	87
Sheet 30 Connections for 32 Bricks in 4-Slammer Systems.	90
Block Diagram: Connecting Four Slammers to 32 Bricks.	90

---

Cable 32 Bricks to Four Slammers. . . . .	91
Sheet 31 Connections for 64 Bricks in a 4-Slammer System. . . . .	93
Block Diagram: Connecting Four Slammers to 64 Bricks. . . . .	93
Cable 64 Bricks to Four Slammers. . . . .	94
Sheet 32 PMI Connections for 4-Slammer Systems. . . . .	96
Schematic of PMI Ethernet Connections in a 4-Slammer System. . . . .	96
Private Management Interface (PMI) Connections in a 4-Slammer System. . . . .	96
<b>Part VII: Appendixes</b>	
Appendix A Swapping SSF Cables When Expanding a System. . . . .	98
Cabling Practices for the Pillar Axiom 600 System. . . . .	100
<b>Index. . . . .</b>	<b>105</b>

---

## List of Figures

Figure 1 Brick connections in strings. . . . .	14
Figure 2 Pillar Axiom 600 back-end cabling overview. . . . .	15
Figure 3 PIM versions. . . . .	17
Figure 4 Version 1 SATA RAID controller. . . . .	18
Figure 5 Version 2 SATA RAID controller. . . . .	18
Figure 6 Version 1 FC RAID controller in an FC RAID Brick. . . . .	18
Figure 7 Version 2 FC RAID controller in an FC RAID Brick. . . . .	19
Figure 8 RAID controller FRU in a FC Expansion Brick. . . . .	19
Figure 9 FC cable label sample. . . . .	20
Figure 10 Labels at the end of the cables. . . . .	20
Figure 11 Sample cabling for a 1x2 Pillar Axiom 600 system with SATA Bricks. . . . .	26
Figure 12 Sample cabling for a 1x6 system with SATA Bricks. . . . .	28
Figure 13 Cabling single Slammer CU cross connections. . . . .	29
Figure 14 Cabling block diagram for a 1x32 system (SATA Bricks only). . . . .	30
Figure 15 High-density rack configuration with 230 v, 30 A PDUs (1-Slammer system). . . . .	32
Figure 16 High-density rack configuration with four PDUs (1-Slammer system). . . . .	34
Figure 17 Alternate high-density rack configuration with 3-phase PDUs. . . . .	35
Figure 18 PMI Ethernet schematic (1-Slammer system). . . . .	41
Figure 19 PMI Ethernet schematic (1-Slammer system). . . . .	42
Figure 20 Sample cabling for a 2-Slammer system (SATA Bricks only). . . . .	43
Figure 21 Cabling CU cross connections for two version 2 Slammers. . . . .	45
Figure 22 Cabling block diagram for 2x64 systems (SATA Bricks only). . . . .	46
Figure 23 PMI Ethernet schematic (2-Slammer system). . . . .	54
Figure 24 PMI Ethernet schematic (2-Slammer system). . . . .	55
Figure 25 Generalized cascade of three SATA Bricks. . . . .	56
Figure 26 Sample cabling for 1X2 Pillar Axiom 600 system with FC Bricks. . . . .	57
Figure 27 Sample cabling for 1x4 Pillar Axiom 600 systems with FC Bricks. . . . .	58
Figure 28 Cabling block diagram for 1-Slammer systems with FC Bricks. . . . .	60
Figure 29 Cabling block diagram for 2-Slammer systems with FC Bricks. . . . .	63
Figure 30 Sample cabling for an FC RAID Brick, an FC Expansion Brick, and two SATA Bricks. . . . .	66
Figure 31 Cabling block diagram for 1-Slammer systems with FC and SATA Bricks. . . . .	68
Figure 32 Cabling block diagram for expanding 1-Slammer systems with SATA Bricks. . . . .	69
Figure 33 Cabling block diagram for 2-Slammer systems with full complement of FC Bricks and eight SATA Bricks. . . . .	71
Figure 34 Cabling CU cross connections for a 3-Slammer configuration (version 1 PIMs). . . . .	73
Figure 35 Cabling CU cross connections for a 3-Slammer configuration (version 2 PIMs). . . . .	75
Figure 36 Cabling CU cross connections for a 3-Slammer configuration (mixed PIM versions). . . . .	77
Figure 37 Connecting a 3-Slammer configuration to 32 Bricks. . . . .	79
Figure 38 PMI Ethernet schematic (3-Slammer system). . . . .	82
Figure 39 PMI Ethernet schematic (3-Slammer system). . . . .	83
Figure 40 Cabling CU cross connections for a 4-Slammer configuration (version 1 PIMs). . . . .	84

---

Figure 41 Cabling CU cross connections for a 4-Slammer configuration (version 2 PIMs). . . . .	86
Figure 42 Cabling CU cross connections for a 4-Slammer configuration (mixed PIM versions). . . . .	88
Figure 43 Connecting a 4-Slammer configuration to 32 Bricks. . . . .	90
Figure 44 Connecting Bricks 17 through 32 to the existing strings. . . . .	92
Figure 45 Connecting a 4-Slammer configuration to 64 Bricks. . . . .	93
Figure 46 PMI Ethernet schematic (4-Slammer system). . . . .	96
Figure 47 PMI Ethernet schematic (4-Slammer system). . . . .	97

---

## List of Tables

Table 1 Additional information resources. . . . .	11
Table 2 Typography to mark certain content. . . . .	11
Table 3 Contacts at Pillar Data Systems. . . . .	12
Table 4 Configuration limits for a Pillar Axiom 600 system. . . . .	15
Table 5 Brick Configuration limits for the Pillar Axiom 600 system. . . . .	15
Table 6 Slammer series compatibility list of supported FRUs. . . . .	16
Table 7 Compatibility list for supported ports, cables, and connector types. . . . .	20
Table 8 Cables and connectors. . . . .	21
Table 9 FC cable connections for the Slammer and the first and second sets of four SATA Bricks. . . . .	36
Table 10 FC cable connections for the third and fourth sets of four SATA Bricks (1-Slammer system). . . . .	38
Table 11 FC cable connections for the fifth and sixth sets of four SATA Bricks (1-Slammer system). . . . .	39
Table 12 FC cable connections for the seventh and eighth sets of four SATA Bricks (1-Slammer system). . . . .	40
Table 13 Cable connections for the PMI (1-Slammer system). . . . .	41
Table 14 Rack space requirements for a 16-Brick system: 54 U (two racks). . . . .	46
Table 15 Rack space requirements for a 32-Brick system: 92 U (three racks). . . . .	47
Table 16 FC cable connections for two Slammers and the first set of eight SATA Bricks. . . . .	48
Table 17 FC cable connections for the second set of eight SATA Bricks (2-Slammer system). . . . .	50
Table 18 FC cable connections for the third set of eight SATA Bricks (2-Slammer system). . . . .	51
Table 19 FC cable connections for the fourth set of eight SATA Bricks (2-Slammer system). . . . .	52
Table 20 Cabling configurations having more than 32 SATA Bricks. . . . .	52
Table 21 Ethernet cable connections for PMI (2-Slammer system). . . . .	54
Table 22 FC cable connections for one Slammer and eight FC Bricks. . . . .	61
Table 23 FC cable connections for two Slammers and 16 FC Bricks. . . . .	64
Table 24 3-Slammer cross connection configuration (version 1 PIMs). . . . .	74
Table 25 3-Slammer cross connection configuration (version 2 PIMs). . . . .	76
Table 26 3-Slammer cross connection configuration (mixed PIM versions). . . . .	78
Table 27 Cable connections for three Slammers and 16 Bricks. . . . .	80
Table 28 Connections for additional Bricks. . . . .	81
Table 29 Ethernet cable connections for PMI (3-Slammer system). . . . .	83
Table 30 4-Slammer cross connection configuration. . . . .	85
Table 31 Slammer cross connection configuration for a 4-Slammer configuration (version 2 PIMs). . . . .	87
Table 32 Slammer cross connection configuration for a 4-Slammer configuration (mixed version PIMs). . . . .	89
Table 33 Cable connections for four Slammers and 16 Bricks. . . . .	91
Table 34 Cable connections for four Slammers and 32 Bricks. . . . .	94
Table 35 Ethernet cable connections for PMI (4-Slammer system). . . . .	97
Table 36 Swapping Slammer cables that cross connect version 1 PIMs. . . . .	98
Table 37 Swapping Slammer cables that cross connect version 2 PIMs. . . . .	98
Table 38 Swapping head-of-string Brick cables. . . . .	99
Table 39 Cabling principles (system level issues). . . . .	100
Table 40 Cabling principles (system size related issues). . . . .	100



---

Table 41 Cabling principles (Slammer connection issues). . . . .	101
Table 42 Cabling principles (Brick connection issues). . . . .	101
Table 43 Cabling principles (Mixing Brick types). . . . .	102
Table 44 Cabling principles (FC Expansion Bricks). . . . .	102
Table 45 Cabling principles (Brick order in strings). . . . .	102
Table 46 Cabling principles (Brick balance in strings). . . . .	103
Table 47 Cabling principles (Brick adds on strings). . . . .	103

# Preface

## Audience

This documentation is intended for service technicians, field engineers, and other individuals who install, maintain, and troubleshoot Oracle's Pillar Axiom 600 storage systems.

You should have the necessary skills and experience in using:

- Computer hardware and its operation.
- Electrostatic discharge (ESD) procedures.

To perform any of the following tasks, you should also have a basic understanding and working knowledge of Oracle's Pillar Axiom 600 systems:

- Cable the Storage System Fabric (SSF) and private management interface (PMI) easily.
- Enhance the throughput of an existing system by adding and cabling one or more Slammer storage controllers into an existing system.
- Enhance the capacity of an existing system by adding and cabling one or more Brick storage enclosures into an existing system.

## Before You Read This Reference

Being familiar with certain other technical documentation for Oracle's Pillar Axiom 600 helps you succeed in the use of this guide.

This reference contains information about the backend Storage System Fabric (SSF) and private management interface (PMI) cabling of an Oracle's Pillar Axiom 600 system. Refer to the *Pillar Axiom 600 Hardware Installation Guide* to cable the Pilot management controller to the customer LAN, the Slammer to the data network, and the power cables.

In addition to this reference, review the late-breaking information described in the *Pillar Axiom Customer Release Notes*. That document contains important information that was not available at the time this reference was published, including:

- Slammer and Brick configuration limits
- Network requirements
- System limits
- Known issues
- Errata for technical documents, including this reference

Refer to the *Pillar Axiom 600 Service Guide* for procedural and reference information to remove and insert the various field replaceable units (FRUs) within a Pillar Axiom 600 system.

## How This Reference Is Organized

This reference provides reference information for cabling the Storage System Fabric (SSF), a private interconnect (PI) among the Bricks and Slammers in an Oracle Pillar Axiom 600 system.

The reference is divided into seven major parts:

- Part I provides an introduction to cabling the PI.
- Part II provides cabling examples, block diagrams, and port-to-port cabling connections for 1-Slammer systems configured with serial ATA (SATA) Bricks.
- Part III provides cabling examples, block diagrams, and port-to-port cabling connections for 2-Slammer systems configured with SATA Bricks.
- Part IV provides cabling examples, block diagrams, and port-to-port cabling connections for 1 and 2-Slammer systems configured with Fibre Channel (FC) Bricks.
- Part V provides cabling examples, block diagrams, and port-to-port cabling connections for 3-Slammer systems.
- Part VI provides cabling examples, block diagrams, and port-to-port cabling connections for 4-Slammer systems.
- Part VII provides two appendixes that provide:

- Connection lists that show required cable swaps when adding additional Slammers to a system. Note that upgrade information is beyond the scope of this book.
- General cabling rules.

## Related Documentation

Table 1 Additional information resources

Description	Title
The definitions of terms found in Oracle's Pillar Axiom 600 documentation.	<i>Pillar Axiom Glossary</i>
Instructions for installing hardware components into Pillar Axiom racks and non-Pillar racks.	<i>Pillar Axiom 600 Hardware Installation Guide</i>
Removal and insertion instructions for field replaceable units (FRUs).	<i>Pillar Axiom 600 Service Guide</i>
Any late breaking information regarding Oracle's Pillar Axiom systems.	<i>Pillar Axiom Customer Release Notes</i>

## Access Documentation

Technical documentation (including installation, service, cabling, integration, and administration guides) for Oracle's Pillar Axiom 600 storage system is available from several sources.

<b>Pillar Axiom Storage Services Manager</b>	Log in to your Pillar Axiom system. Navigate to the <b>Support</b> area in the Pillar Axiom Storage Services Manager and select the <b>Documentation</b> link.
<b>Pillar Axiom HTTP access</b>	For Pillar Axiom systems running release 5.0 (and higher) software, point your browser to <code>http://system-name-IP/documentation.php</code> , where <i>system-name-IP</i> is the name or the public IP address of your system.
<b>Internet</b>	<a href="http://support-portal.pillardata.com/csportal/login.seam">Customer support portal</a> ( <a href="http://support-portal.pillardata.com/csportal/login.seam">http://support-portal.pillardata.com/csportal/login.seam</a> ). Log in and click <b>Documents</b> in the left navigation pane.
<b>Product CD-ROM</b>	Insert the Technical Documentation CD-ROM (came with your Pillar Axiom system) into the CD player and open the <code>DocMenu</code> PDF.

**Tip:** To search all technical documents on the CD-ROM, click **Search all PDFs** in the top right corner.

## Typographical Conventions

Table 2 Typography to mark certain content

Convention	Meaning
<i>italics</i>	Within normal text, words in italics indicate: <ul style="list-style-type: none"> <li>• A reference to a book title.</li> <li>• New terms and emphasized words.</li> <li>• Command variables.</li> </ul>
monospace	Indicates one of the following, depending on the context: <ul style="list-style-type: none"> <li>• The name of a file or the path to the file.</li> <li>• <i>Output</i> displayed by the system on the command line.</li> </ul>
<b>monospace</b> (bold)	<i>Input</i> provided by an administrator on the command line.
>	Indicates a menu item or a navigation path in a graphical user interface (GUI). For example, "Click <b>Storage &gt; Clone LUNs</b> " means to click the <b>Clone LUNs</b> link on the <b>Storage</b> page in the graphical user interface (GUI).
...	Used within an expression of a navigation path or within a cascading menu structure. The ellipsis indicates that one or more steps have been omitted from the path or menu structure. For example, in the <b>Groups &gt; Volume Groups &gt; Actions &gt; ... &gt;</b>

Table 2 Typography to mark certain content (continued)

Convention	Meaning
	<b>Data Protection &gt; Create</b> menu structure, the ... implies that one or more menu items have been omitted.

## Pillar Contacts

Table 3 Contacts at Pillar Data Systems

For help with...	Contact...
Error messages, usage questions, and other support issues	US and Canada: 877-4PILLAR (1-877-474-5527) Europe: +800 PILLAR FS (+800 74 55 27 37) Asia Pacific: +1-408-518-4515 South Africa: +0 800 980 400 Have your system serial number ready. <a href="mailto:support@pillardata.com">support@pillardata.com</a> <a href="http://support-portal.pillardata.com/csportal/login.seam">Customer support portal</a> (http://support-portal.pillardata.com/csportal/login.seam)
Training (custom or packaged)	<a href="http://www.pillardata.com/support-education/training/">Training and Education</a> (http://www.pillardata.com/support-education/training/)
Sales and general contact information	<a href="http://www.pillardata.com/company/contact">Company contacts</a> (http://www.pillardata.com/company/contact)
Documentation improvements and resources	<a href="mailto:docs@pillardata.com">docs@pillardata.com</a> <a href="http://www.pillardata.com/techdocs">Technical documents</a> (http://www.pillardata.com/techdocs) (Log in with your username and password, and select Documents.)

# Part I: Introduction to Cabling Pillar Axiom 600 Systems

SHEET 1

## About This Reference

### Cautions and Warnings

Hazard signal words conform to the American National Standards Institute (ANSI) Z535.4-2002 meanings.

 **Caution** Indicates a potentially hazardous situation that, if not avoided, may result in minor or moderate injury or data loss.

 **Warning** Indicates a potentially hazardous situation that, if not avoided, could result in death or serious injury.

 **Danger** Indicates an imminently hazardous situation that, if not avoided, will result in death or serious injury.

**Important!** To emphasize a point, to remind you of something, or to indicate potential problems in the outcome of the in-process task.

SHEET 2

## Introduction to Cabling the Pillar Axiom 600 System

### About Cabling a Pillar Axiom 600 System

The Pillar Axiom 600 system is a scalable storage system that consists of a Pilot management controller, at least one Slammer storage controller, and some number of Brick storage enclosures depending upon your system model.

Cabling the Pillar Axiom 600 systems consists of two parts:

- Front-end cabling, which involves connecting the Slammer to the customer's data network, and connecting the Pilot to the customer's management network. The Pilot connection uses Ethernet. The Slammer cable connections to the data network uses Fiber Channel (FC) or Ethernet, depending on the Slammer.
- Back-end cabling, which involves cabling the Storage System Fabric (SSF), sometimes referred to as the private interconnect, or simply PI, and the private management interface (PMI).

Pillar Axiom 600 systems transmit data among its hardware components (Bricks, Slammers, and the Pilot) through the SSF and PMI cabling.

The SSF cables provide the inter and intra-cabling connections between the Bricks and the Slammers to support all data traffic, the cross connections among the Slammer control units (CUs), and the cross connections among the Brick CUs.

The fast Ethernet network between the Pilot and the Slammers in a Pillar Axiom 600 system is called the PMI. The PMI also includes the cross connections between the Slammer CUs as well as the cross connections between the Pilot CUs. These cross connections between the Pilot CUs permit each CU to monitor the heartbeat of the other CU. The heartbeat connection allows the passive Pilot CU to induce a failover, if the active Pilot CU fails.

The Pilot has no physical connection to the user data and, therefore, no cable connection exists between the Pilot and the Bricks.

Bricks are connected together in Brick strings. The Brick at the head of the string connects to the Slammer. Each of the other Bricks in the string connect to the previous Brick in the string. A Brick that is higher in a string is one that is closer to the Slammer or head of the string. A Brick that is lower in a string is one that is further from the Slammer or the head of the string.

Figure 1 provides a symbolic illustration of the Brick connections in a string within a Pillar Axiom 600 system.

Figure 1 Brick connections in strings

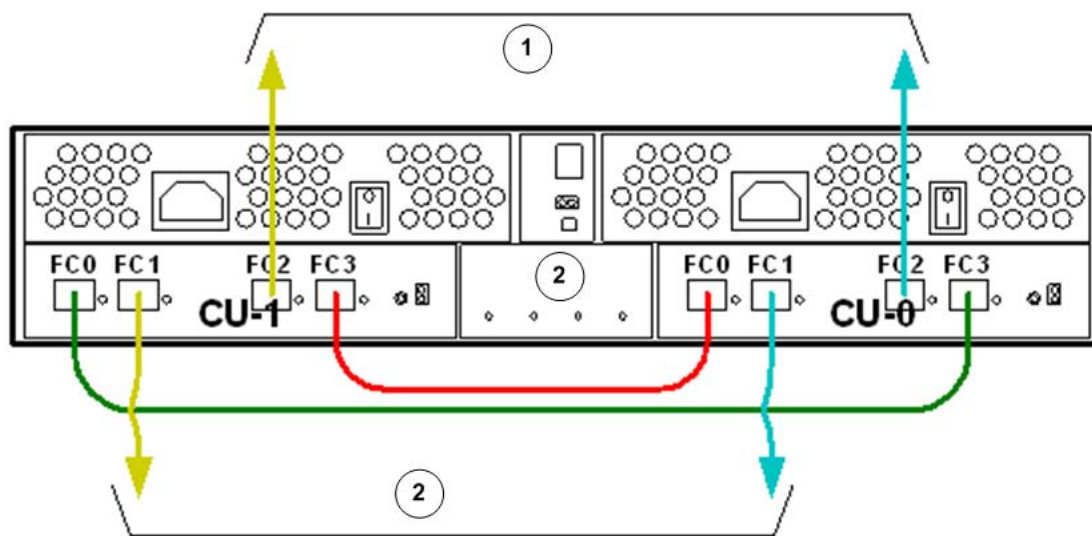

- Legend**
- 1 Brick connections to Slammer or to Bricks higher in the string
  - 2 Brick connections to other Bricks lower in the string

Figure 2 provides a symbolic illustration of the back-end cabling in a sample Pillar Axiom 600 system.

Figure 2 Pillar Axiom 600 back-end cabling overview

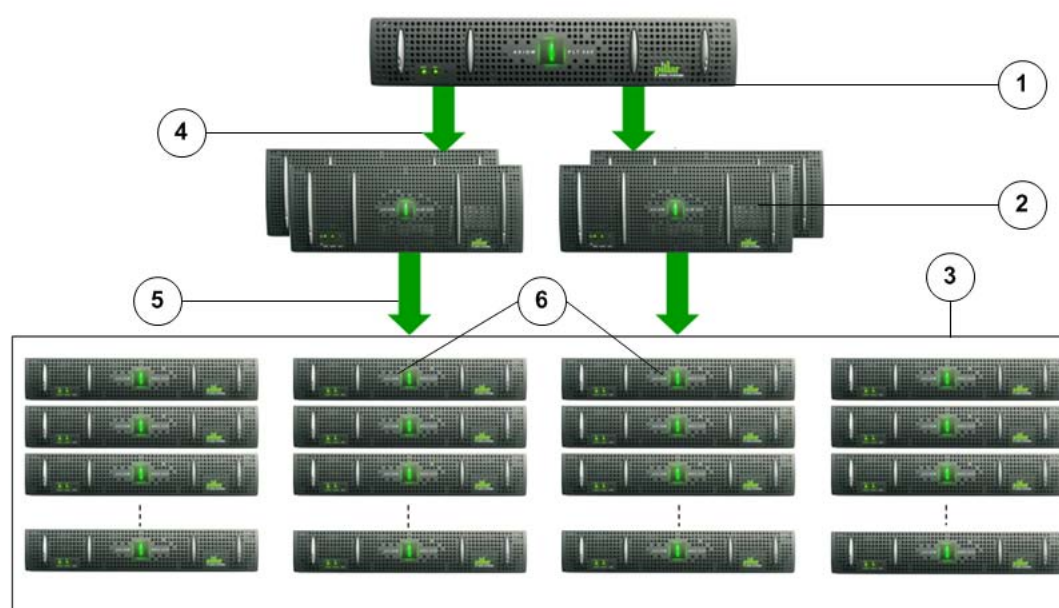

Legend	
1	Pilot
2	Slammers
3	Bricks
4	PMI cabling among the Pilot and Slammers
5	SSF cabling among the Slammers and Bricks
6	Brick strings, in which Bricks are connected to each other and the Brick at the head of the string is connected to the Slammer

## Configuration Limits for a Pillar Axiom 600 System

The minimum configuration of the Pillar Axiom 600 system is:

- One Pilot
- One Slammer
- One Brick

The maximum configuration of the Pillar Axiom 600 system is:

- One Pilot
- Four Slammers
- 64 Bricks

Table 4 defines the maximum configuration limits for a Pillar Axiom 600 system. The maximum number of Bricks that a Pillar Axiom 600 system can support depends on the number of Slammers in the system. The maximum configurations are given in terms of width (the number of strings), depth (the number of Bricks for each string), and the maximum number of Bricks that the system supports.

Table 4 Configuration limits for a Pillar Axiom 600 system

Number of Slammers	Maximum number of strings	Maximum number of Bricks in a string	Maximum number of Bricks in the system
1	4	8	32
2	8	8	64
3	8	8	64
4	16	8	64

Brick storage enclosures can contain Fibre Channel (FC), Serial ATA (SATA), or solid state drives (SSDs), depending upon the type of RAID controllers. Table 5 further classifies the configuration limits by the type of Bricks in the Pillar Axiom 600 system. The maximum number of a specific Brick (SATA, FC, or SSD) allowed in the Pillar Axiom 600 system also depends on the number of Slammers in the system.

Table 5 Brick Configuration limits for the Pillar Axiom 600 system

Number of Slammers	Maximum number of SATA Bricks	Maximum number of FC Bricks	Maximum number of SSD Bricks
1	32	32	8

Table 5 Brick Configuration limits for the Pillar Axiom 600 system (continued)

Number of Slammers	Maximum number of SATA Bricks	Maximum number of FC Bricks	Maximum number of SSD Bricks
2	64	32	16
3	64	32	16
4	64	32	32

For single-Slammer Pillar Axiom 600 configurations, the minimum number of Bricks is one. However, for mixed configurations, the minimum number of Bricks is three, as outlined below:

- For a mix of FC and SATA (or SSD) Bricks: 2 SATA (or SSD) + 1 FC or 2 FC + 1 SATA (or SSD).
- For a mix of SSD and SATA Bricks: 2 SATA + 1 SSD or 2 SSD + 1 SATA.

Pillar Axiom 600 systems support up to 32 FC Bricks, or 64 SATA Bricks, or 32 SSD Bricks or any combination of these three types, provided there are no more than 64 total Bricks, 32 FC Bricks or 32 SSD Bricks in the system.

**Important!** Contact the Pillar World Wide Customer Support Center for any newly available, time-sensitive information regarding cabling. Also, refer to the Pillar Axiom *Customer Release Notes* for the latest system configurations.

## Supported Hardware Components

Pillar Axiom 600 systems support different versions of hardware that may impact the cable connections.

Pillar Axiom 600 supports only factory parts.



### Caution

Hardware that does not conform to Pillar Axiom specifications or is not a factory-supplied part voids the warranty and may compromise data integrity. For Pillar Axiom hardware specifications, refer to the *Pillar Axiom 600 Service Guide* for your system.

Different versions are available for the following Pillar Axiom 600 hardware components that may impact cabling:

- Slammer storage controllers
- Private interface modules (PIMs)
- Serial ATA (SATA) RAID controllers
- FC RAID (FCR) controllers

## Supported Slammer Storage Controllers

Slammers are available in three different series and are classified based on the versions of hardware components that the Slammer supports such as the motherboard, the network interface module (NIM), and the private interface module (PIM).

The table below lists these Slammers and the field replaceable units (FRUs) associated with them, including their part numbers.

Table 6 Slammer series compatibility list of supported FRUs

Slammer series	Supported motherboard	Supported NIMs	Supported PIMs
Series 1: 1400-00052-2X	1450-00185-XX	1450-00132-XX 1450-00135-XX 1450-00168-XX 1450-00169-XX	1450-00138-XX 1450-00193-XX
Series 2: 1400-00058-2X and 1400-00058-3X	1450-00199-XX	1450-00132-XX 1450-00135-XX 1450-00168-XX 1450-00169-XX	1450-00138-XX 1450-00193-XX
Series 3: 1400-00076-3X and 1400-00080-3X	1450-00219-XX	1450-00132-XX 1450-00135-XX 1450-00168-XX	1450-00193-XX



Table 6 Slammer series compatibility list of supported FRUs (continued)

Slammer series	Supported motherboard	Supported NIMs	Supported PIMs
		1450-00169-XX 1450-00257-XX 1450-00261-XX	

## Supported Private Interconnect Modules (PIMs)

Each Slammer series contains a different version of private interconnect module (PIM). Because these PIMs differ, the cabling of these PIMs differs as well.

The types of connectors and cables for these PIM versions are listed as follows:

- 13-port (FC) PIM, referred to as version 1 supports HSSDC type connectors and cables. These cables allow a fabric speed of 2 Gb/s.
- 16-port (FC) PIM, referred to as version 2 supports small form-factor pluggable (SFP) type connectors. These SFPs can be 2 Gb/s copper cables or 4 Gb/s fibre cables, depending on what other components are installed on the Pillar Axiom 600 system.

Figure 3 indicates the hardware versions available for the PIM.

Figure 3 PIM versions

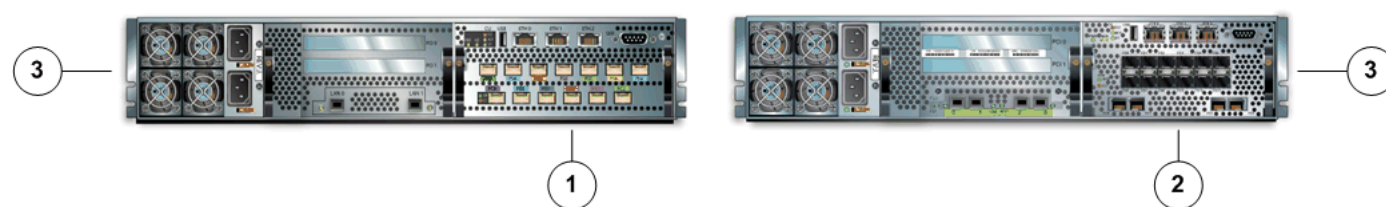

### Legend

- |   |                           |
|---|---------------------------|
| 1 | Version 1 PIM             |
| 2 | Version 2 PIM             |
| 3 | Slammer control unit (CU) |

**Note:** A Slammer contains two homogeneous control units (CUs). Both CUs contain either version 1 or version 2 PIMs. In the above image, only one of those CUs is shown.

Because version 1 and version 2 PIMs use different protocols, version 1 and version 2 PIMs cannot co-exist in the same Slammer chassis. In other words, you cannot use one version to replace the other. You can, however, replace all version 1 PIMs in the Slammer with version 2 PIMs, if you replace all version 1 PIMs at the same time.

**Note:** A multi-Slammer Pillar Axiom 600 system can contain a mix of version 1 and version 2 Slammers. However, a given Slammer cannot mix PIM versions.

**Important!** Pillar Axiom 600 offers a set of SFP modules for version 2 PIMs, version 2 SATA RAID controllers, and version 2 FC RAID controllers. When using optical connections, use only factory provided SFP modules for version 2 PIMs. When using copper connections, use only Pillar provided FC copper cables.

### Caution

Use of any non-Pillar SFP modules or cables can lead to performance and reliability issues when unqualified SFPs are used. Use of third party SFPs can also void the warranty of your Pillar Axiom 600 system, if the third party SFP module is determined to be the cause of any problems within the Pillar Axiom 600 system.

The cabling of the Fiber Channel (FC) fabric among the Slammer CUs and the Brick CUs differ, depending on the version of PIM in the Slammer.

## Supported SATA RAID controllers

Each Slammer series contains a different version of SATA RAID controller. Because these SATA RAID controllers differ, the cabling of these SATA RAID controllers differ as well.

The types of ports in these SATA RAID controller versions are listed as follows:

- Version 1 (legacy) controllers have one set of four Fibre Channel (FC) ports and appear in the GUI as type SATA.
- Version 2 controllers have two pair of FC ports and appear in the GUI as type SATA V2.

The following figure depicts the Version 1 SATA RAID controller.

Figure 4 Version 1 SATA RAID controller



**Legend**

- |   |                                 |
|---|---------------------------------|
| 1 | SATA version 1 Brick            |
| 2 | SATA version 1 RAID controllers |

Figure 5 Version 2 SATA RAID controller

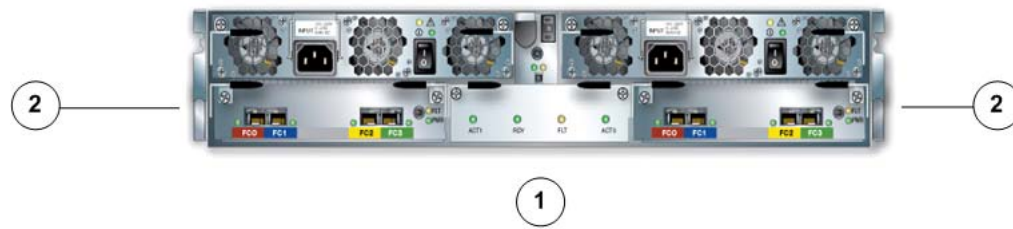

**Legend**

- |   |                                 |
|---|---------------------------------|
| 1 | SATA version 2 Brick            |
| 2 | SATA version 2 RAID controllers |

Because version 1 and version 2 SATA controllers use different internal communication protocols, these two types of SATA controllers cannot co-exist in the same Brick chassis. In other words, you cannot use a version 2 SATA controller to replace a legacy version 1 controller. A Pillar Axiom 600 system can, however, contain a mix of version 1 and version 2 SATA Bricks.

**Note:** A Brick contains two homogeneous control units (CUs). Both CUs contain either version 1 or version 2 SATA RAID controllers.

Additionally, the cabling of the Fiber Channel (FC) fabric among the Brick CUs and the Slammers differs, depending on the version of SATA controller in the Brick.

**Supported FC RAID Controllers**

Each Slammer series contains a different version of Fiber Channel RAID (FCR) controller. Because these FC RAID controllers differ, the cabling of these FC RAID controllers differ as well.

FC RAID controllers are located in Bricks. The cabling of these controllers depends on the version of the controller.

The types of connectors and cables for these FC RAID controller versions are listed as follows:

- Version 1 (legacy) FC RAID (FCR) controllers that appears in the GUI as type FC.
- Version 2 FC RAID (FCR) controllers that appears in the GUI as type FC V2.
- FC Expansion (FCE) controllers have ports PNet0, PNet1, J0, and J1 to connect to an FCE Brick.

**Note:** Each Expansion controller provides the FC RAID Brick to which it is connected access to six drives in the FC Expansion Brick.

The following figure shows a version 1 FC RAID controller for an FC RAID Brick.

Figure 6 Version 1 FC RAID controller in an FC RAID Brick

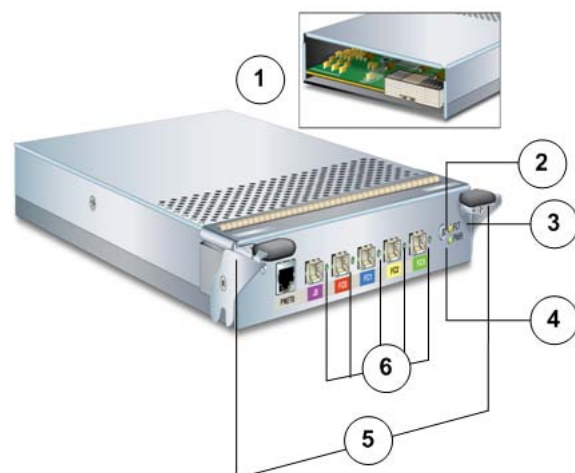

**Legend**

- |   |                                       |   |                     |
|---|---------------------------------------|---|---------------------|
| 1 | Back view of version 1 FCR controller | 4 | Power LED           |
| 2 | Screw                                 | 5 | Locking tabs        |
| 3 | Fault (FLT) LED                       | 6 | FCR controller LEDs |

The following figure shows a version 2 FC RAID controller for an FC RAID Brick.

Figure 7 Version 2 FC RAID controller in an FC RAID Brick

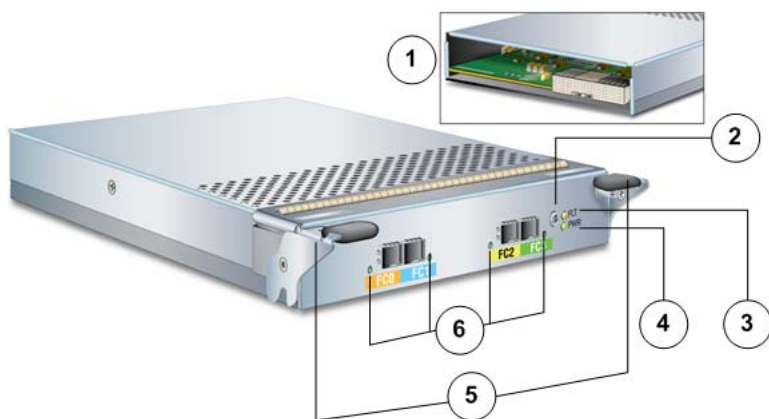

<b>Legend</b>	1 Back view of version 2 FCR controller	4 Power LED	
	2 Screw	5 Locking tabs	
	3 Fault (FLT) LED	6 FCR controller LEDs	

**Note:** The FC RAID controllers displayed above are representative. The FC RAID controllers that are installed in your Brick may differ. The following figure shows a RAID controller for an FC Expansion Brick.

Figure 8 RAID controller FRU in a FC Expansion Brick

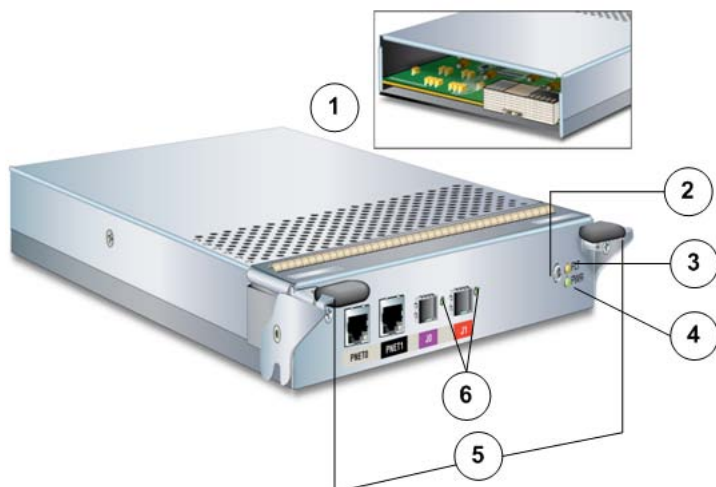

<b>Legend</b>	1 Back view of FCE controller	4 Power LED	
	2 Screw	5 Locking tabs	
	3 Fault (FLT) LED	6 FCE controller LEDs	

## About Cable Labels

The cables that provide the pathways for the Storage System Fabric (SSF) are labeled at each end using a label. The label wraps around the cable and sticks to itself in a way that provides a colored flag with printed information such as shown in the figure below. The printing is duplicated at each end of the label so that it can be read from either side.

Figure 9 provides an illustration of a sample cable label.

Figure 9 FC cable label sample

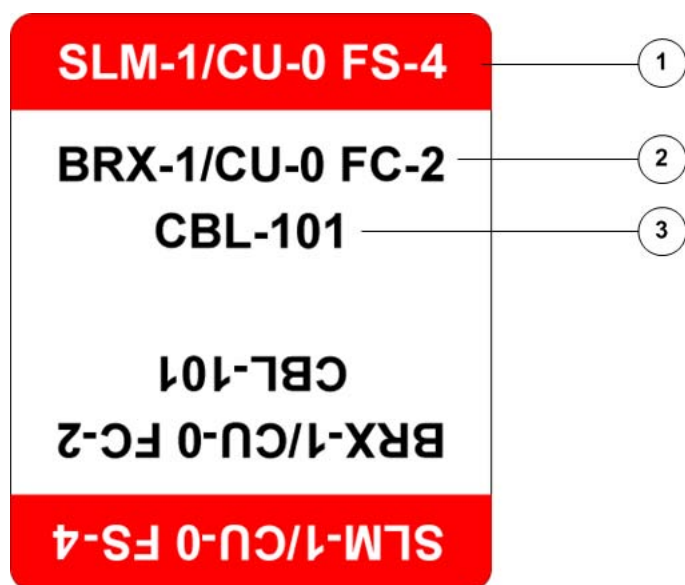

**Legend**

- 1 Slammer 1, CU 0, FS port number 4
- 2 Brick 1, CU 0, FC port number 2
- 3 Cable number

**Note:** This cable number is the same at both ends of the cable and is useful when tracing the other end of a loose cable in a cabinet.

Figure 10 provides an example of how the cable labels are wrapped at both ends of the cable.

Figure 10 Labels at the end of the cables

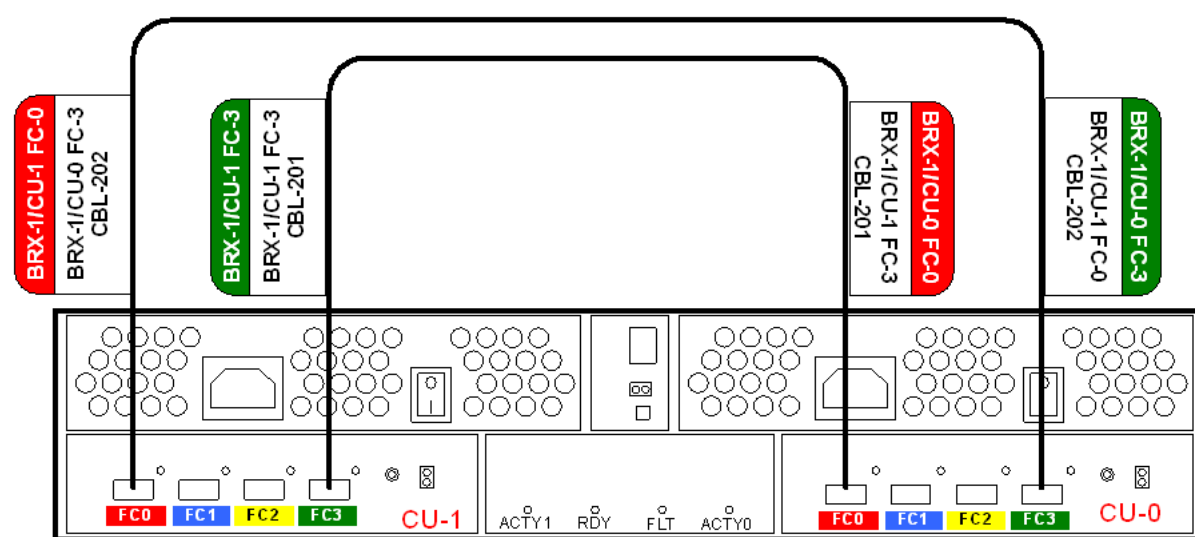

## Compatibility Matrix: Ports, Cables, and Connector Types

Table 7: Compatibility list for supported ports, cables, and connector types describes the compatibility between different versions of hardware, the arrangement of FC and FS ports on the Slammers and Bricks, and the connector and cable types.

Table 7 Compatibility list for supported ports, cables, and connector types

Hardware system component	Version	No. of FC ports	FC and FS ports on each CU	Connector type	Cable type for version 1 Bricks	Cable type for version 2 Bricks	Crossover cables to connect opposite Brick CUs and intra- and inter-Slammer CUs
Slammer PIM	Version 1	13	2 rows	HSSDC2	HSSDC2	HSSDC2-SFP	HSSDC2
Slammer PIM	Version 2	16	2 rows	SFP	HSSDC2-SFP	SFP-SFP copper, if there are any version 1 hardware components on the system SFP-SFP optical, if all	SFP-SFP copper, if there are any version 1 hardware components on the system SFP-SFP optical, if all

Table 7 Compatibility list for supported ports, cables, and connector types (continued)

Hardware system component	Version	No. of FC ports	FC and FS ports on each CU	Connector type	Cable type for version 1 Bricks	Cable type for version 2 Bricks	Crossover cables to connect opposite Brick CUs and intra- and inter-Slammer CUs
						hardware components on the system are version 2.	hardware components on the system are version 2.
Brick	Version 1	4	1 group of 4	HSSDC2	HSSDC2	HSSDC2-SFP	HSSDC2
Brick	Version 2	4	2 groups of 2	SFP	HSSDC2-SFP	SFP-SFP copper, if there are any version 1 hardware components on the system SFP-SFP optical, if all hardware components on the system are version 2.	SFP-SFP copper, if there are any version 1 hardware components on the system SFP-SFP optical, if all hardware components on the system are version 2.

## Cables and Connectors

Several different cables and connectors can be used to connect the various components of the Pillar Axiom 600 system.

Table 8 provides a list of the cables and connectors.

Table 8 Cables and connectors



Type	Description	Part number	Cable length	Illustration
Fiber Channel (FC) (HSSDC2-HSSDC2) cables	Used in Pillar Axiom 600 configurations with version 1 hardware: <ul style="list-style-type: none"> <li>Version 1 PIMs</li> <li>Version 1 SATA RAID controllers</li> <li>Version 1 FC RAID controllers</li> <li>Version 1 FC Expansion (FCE) controllers</li> </ul>	6051-00021-00	6.56 feet (2 m)	
		6051-00026-00	1.64 feet (0.5 m)	
Small form-factor pluggable FC cables	Used in Pillar Axiom 600 configurations with version 2 hardware: <ul style="list-style-type: none"> <li>Version 2 PIMs</li> <li>Version 2 SATA RAID controllers</li> </ul>	6051-00085-00	3.28 feet (1 m)	
		6051-00086-00	6.56 feet (2 m)	
		6051-00087-00	1.64 feet (0.5 m)	

Table 8 Cables and connectors (continued)





Type	Description	Part number	Cable length	Illustration
or SFP-SFP cables	<ul style="list-style-type: none"> <li>Version 2 FC RAID controllers</li> </ul>			
SFP Plus modules and cables: (Optical and copper)	Used with Pillar Axiom 600 configurations of: <ul style="list-style-type: none"> <li>10 Gb/s Ethernet connections in NAS Slammers</li> <li>8 Gb/s Fibre Channel (FC) connections in SAN Slammers</li> </ul>	3131-02860-00	16.40 ft (5m)  <b>Note:</b> Passive copper cables are available with the SFP Plus module attached to each end of the cable for use with 10 Gb/s NAS only.	
Hybrid adapter FC cables or SFP-HSSDC2 cables	Used in Pillar Axiom 600 configurations where there is a mixture of version 1 hardware interconnected with version 2 hardware.	6051-00088-00	6.56 feet (2 m)	
Optical cables	Used in Pillar Axiom 600 configurations for a 4 Gb/s Storage System Fabric (SSF) speed with: <ul style="list-style-type: none"> <li>Series 2 Slammers</li> <li>Version 2 PIMs,</li> <li>Version 2 SATA RAID controllers</li> <li>Version 2 FC RAID controllers (FCR)</li> </ul>	6051-00090-00:	1.64 feet (0.5 m)	
		6051-00031-00	3.28 feet (1 m)	
		6051-00091-00	6.56 feet (2 m)	
		6051-00032-00	9.84 feet (3 m)	
		6051-00096-00	164.042 feet (50 m)	
SFP-optical cable with pluggable transceiver	Used in Pillar Axiom 600 configurations for a 4 Gb/s Storage System Fabric (SSF) speed with : <ul style="list-style-type: none"> <li>Series 2 Slammers</li> <li>Version 2 PIMs</li> <li>Version 2 SATA RAID controllers</li> <li>Version 2 FC RAID controllers (FCR)</li> </ul>	3131-02727-00		

Table 8 Cables and connectors (continued)

Type	Description	Part number	Cable length	Illustration
Serial null modem cable	Connects the two control units (CUs) of the Pilot and establishes a heartbeat connection.	6050-00054-00	1.1 feet (0.36 m)	
Ethernet cables	Ethernet cables connect the two CUs of the Pilot to support the Intelligent Platform Management Interface (PMI).	6051-00045-00	1.64 feet (0.5 m)	
		6051-00046-00	1.64 feet (0.5 m)	
		6051-00047-00	1.64 feet (0.5 m)	
	Ethernet cables are used to establish a fast Ethernet network between the Pilot and the Slammers.	6051-00057-00	6.56 feet (2 m)	
		6051-00058-00	6.56 feet (2 m)	

**Caution**

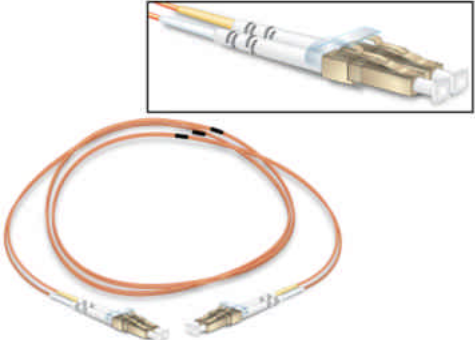
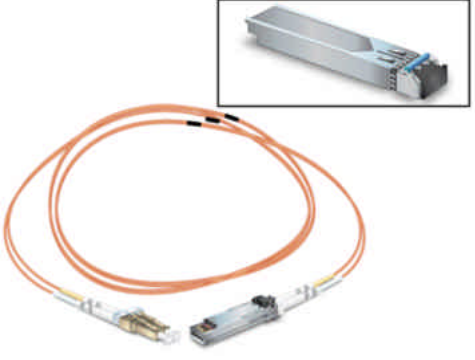
To disconnect the cables from the HSSDC connectors, carefully grasp the cable connector and, while pushing the connector gently into the socket, press the latch on the top of the connector to unlatch it.

**Caution**

To disconnect the cables from the SFP connectors, carefully grasp the cable connector and, while pushing the connector gently into the socket, press the latch on the bottom of the connector to unlatch it. Then, gently pull the connector straight out to release the connector with the cable.

The following cable lengths are used to connect the various components within the Pillar Axiom 600 system:

- Cable lengths for Slammer to Brick connections: 6.56 feet (2.0 m)
- Cable lengths for Brick to Brick (FC-1 to FC-2) connections: 6.56 feet (2.0 m)
- Cable lengths for cross connections between the CUs of the Brick (FC-0 to FC-3) depend on the Brick type:
  - Version 1 SATA Bricks: 1.64 feet (0.5 m)
  - Version 2 SATA Bricks: 3.28 feet (1.0 m)
  - Version 1 FC RAID (FCR) Bricks: 1.64 feet (0.5 m)
  - Version 2 FC RAID (FCR) Bricks: 3.28 feet (1.0 m)
  - Version 1 FC Expansion (FCE) Bricks: 1.64 feet (0.5 m)

A 164.042 feet (50 m) optical connection is qualified for cases where a number of Bricks must be installed in a rack that is not immediately adjacent to the rest of the Pillar Axiom 600 system. Following rules apply to this optical connection:

- Use the 164.042 feet (50 m) optical cable only for a system with an all optical Storage System Fabric (SSF).
- Only a Brick connection may use the 164.042 feet (50 m) optical cable.
- Only one long optical cable link is supported on each Brick string. This optical cable link consists of two optical cables of 164.042 feet (50 m) length.
- The long optical cable link may be between the Slammer and the Brick at the head of the Brick string or between any other Bricks in the string.
- More than one Brick string in a Pillar Axiom 600 system may use a long optical cable link of length 164.042 feet (50 m).

## Effects of Cable Types on Fabric Speed

The Storage System Fabric (SSF) can operate at 2 Gb/s (copper) or 4 Gb/s (optical) depending on the hardware that you have configured and on the cabling you have installed.

For the SSF back-end fabric to operate at 4 Gb/s, the following conditions must be met:

- Both control units (CUs) in all the Slammers must contain a combination of only version 2 PIMs.
- Both CUs in all the Bricks must contain only version 2 SATA RAID controllers or version 2 FC RAID (FCR) controllers.
- All ports on the version 2 PIMs, version 2 SATA RAID controllers, and version 2 FC RAID controllers (FCR) must contain only 4 Gb/s small form-factor pluggable (SFP) connectors.
- The patch cables connecting these 4 Gb/s SFPs must be optical.

**Important!** Factory provides a set of SFPs for version 2 PIMs, version 2 SATA RAID controllers, and version 2 FC RAID (FCR) controllers.



#### Caution

Use of any non-factory SFP or cable can lead to performance and reliability issues when unqualified SFPs are used. Use of third party SFPs can also void the warranty of your Pillar Axiom 600 system, if the third party SFP or cable is determined to be the cause of any problems within the Pillar Axiom 600 system.

If any of the following conditions are true, the back-end fabric operates at 2 Gb/s:

- A version 1 FC Brick is configured into the storage array.
- A version 1 SATA Brick or version 1 PIM is included in the configuration.
- An HSSDC2 (high-speed serial data connection)-to-HSSDC2 copper cable is used.
- An SFP-to-SFP copper cable is used.
- An SFP-to-HSSDC2 hybrid copper cable is used.

**Note:** 2 Gb/s optical SFPs should not be inserted into any fabric port when the SSF is configured to run at 4 Gb/s. If such an SFP is inserted into a fabric port, the system disables the port, even after a restart of the Pillar Axiom 600 system.

## Cable Handling Tips

High speed data optic cables are delicate and can easily be damaged. The cable plug ends and connectors are also sensitive to dirt and contaminants. Follow these tips when handling cables.

- Do not bend the cables beyond its minimum bend radius (MBR). MBR is the tightest bend that the cable can safely tolerate during or after installation. The MBR for all data cables is two inches (5.1 cm).
- If you do not know the MBR, do not bend the cable to a radius of less than two inches (5.1 cm). Also, the permanent bend radius of the cable is usually larger than the temporary bend radius.
- Do not pull any cable or plug with a force exceeding five inches (12.7 cm.).
- Do not use force or rock the connector from side to side or up and down to remove the connector because this action can damage the socket.
- Do not pull the cables using a mechanical device. If you need to pull a cable, pull by hand.
- Leave some slack in the cables to allow insertion and removal of connectors.
- String cables with service loops so that it is possible to remove FRUs without removing the cables.
- Use only soft velcro or equivalent ties for routing or grouping cables. Do not use hard plastic ties or other hard cinching type of wraps. Using hard plastic ties can cause performance degradation and cable damage.
- Ensure no damage occurs during cable routing by not leaving cables exposed in high traffic areas.
- Do not set any hardware components or other objects on top of the cables.
- Do not let the cables get pinched by closed doors or door lock hardware.
- Do not twist the cables.
- Do not wrap the fiber optic cables around your hands, arms, or shoulders, as this may result in causing sharp bends or a small coiling radius. This can also impart a twist to the cable upon uncoiling.
- Do not install cables in such a way that they are supported by other cables or any other SSF cables.
- Support Fiber Channel (FC) cables such that they are not supported by their connectors.
- Do not plug the high-speed serial data cables (HSSDC) into the small form factor pluggable (SFP) ports. Do not plug the SFP cables or transceivers to the HSSDC ports. Either of these actions may cause damage to the plug and connector.
- Use both hands to disconnect the connector in a module overly populated with cables and connectors. Do not disturb or deflect other plugs or cables during the removal operation.



**⚠ Caution**

To disconnect the cables from the HSSDC2 connectors, carefully hold the cable connector and, while pushing the connector gently into the socket, press the latch on the top of the connector to unlatch it. Merely grasping the latch or jerking and pulling at the connector will not fully disengage the connector but will damage the connector.

**⚠ Caution**

To disconnect the cables from the SFP connectors, carefully grasp the cable connector and, while pushing the connector gently into the socket, press the latch on the bottom of the connector to unlatch it. Then, gently pull the connector straight out to release the connector with the cable

**Important!** SFP sockets have the latch on the top and the bottom in the private interconnect module (PIM) and at the bottom on the Brick. Be careful when connecting or disconnecting the SFP connectors.

## Clean Fiber Optic Cables

Follow these tips to clean fiber optic cables.

- Keep the end caps of the plugs installed whenever the plug is not installed.
- Have a fiber optic cable cleaning kit available while handling fiber optic cables. A fiber optic cable cleaning kit includes the following items:
  - Lint-free wipes
  - Isopropyl alcohol (IPA)
  - Special fiber optic cleaning swabs
  - Canned pressurized air

**Tip:** Pre-moistened fiber optic wipes may be substituted for the wipes and IPA.

- 1 To clean a fiber optic plug, blow away any dust particles from the connector surface (particularly the sides and end face of the connector) using canned pressurized air. Hold the nozzle of the optical duster approximately two inches (5.08 centimeters) away from the connector and provide three to five short blasts of air. Fold a wipe in half and place the wipe on a hard surface. Moisten the wipe with isopropyl alcohol. Hold the face of the cable connector to the wipe and slide it gently across the moistened area in one sweeping move.
- 2 To clean a fiber optic connector receptacle, blow away any dust particles from the inside surface of the connector (particularly the inside walls of the alignment sleeve) using canned pressurized air. Hold the nozzle of the optical duster approximately two inches (5.08 centimeters) away from the connector and provide three to five short blasts of air. Moisten the end of a swab with isopropyl alcohol and insert the swab into the cable receptacle. Move the swab in and out two or three times and then remove it and discard. Dry the inside of the receptacle by holding canned pressurized air approximately two inches (5.08 centimeters) away from the end and provide three to five short blasts of air.

**Important!** Never reuse swabs.

# Part II: Cabling Pillar Axiom 600 Systems Using One Slammer and SATA Bricks Only

SHEET 3

## Cabling Example: 1-Slammer System Using SATA Bricks

### Sample Wiring Diagram for a 1x2 System Using SATA Bricks

The figure illustrates the cabling of a Pillar Axiom 600 system with a configuration of one Slammer and two Bricks. The scheme shown is for a Slammer that uses version 1 PIMs and Bricks that use version 1 SATA RAID controllers.

Figure 11 Sample cabling for a 1x2 Pillar Axiom 600 system with SATA Bricks

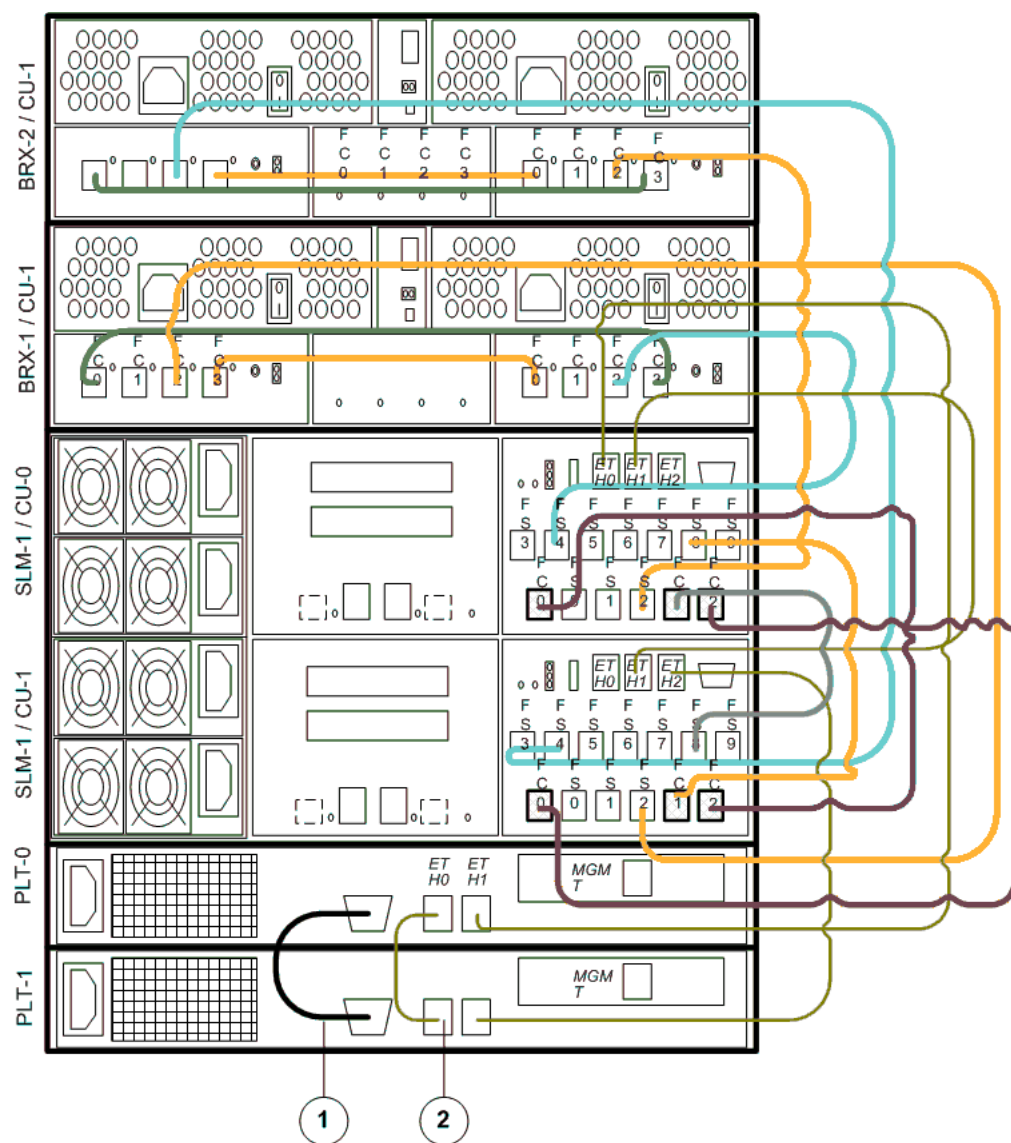

Legend	Description
1	Serial null modem cable connects Pilot CU0 (PLT-0) to Pilot CU1 (PLT-1) for the system heartbeat.
2	1.64 feet (0.5 m) Cat 5e Ethernet cable cross connects the Ethernet ports (ETH0) between the two Pilot CUs that support the Intelligent Platform Management Interface (IPMI).

**Note:** Cross controller cabling for single Slammer systems using version 1 PIMs are internally hardwired. Cross controller cabling for single Slammer systems using version 2 PIMs must be explicitly connected with an SFP-to-SFP cable.

**Note:** The above diagram shows the logical connections, not the physical layout of the cables.

### Notes on the 1x2 SATA Wiring Diagram

To cable version 2 SATA Bricks, use the same port connections as those shown in the diagram.

When cabling the fabric, be aware of the following facts:

- Private interconnect module (PIM) and SATA RAID controller connections:
  - Version 1 PIMs and SATA RAID controllers both use HSSDC2 (high-speed serial data connection) type connections.

- Version 2 PIMs and SATA RAID controllers both use SFP (small form-factor pluggable) type connections.
- When connecting a version 1 component to a version 2 component, use a hybrid HSSDC2-to-SFP adapter cable.
- Cable lengths:
  - The cable lengths for Slammer-to-Brick connections are 6.56 ft (2.0 m).
  - Cable lengths for Brick-to-Brick (FC-1 to FC-2) connections are also 6.56 ft (2.0 m).
  - Cable lengths for cross connections (FC-0 to FC-3) between Brick control units (CUs) depend on the Brick type:
    - Version 1 Bricks: 1.64 ft (0.5 m)
    - Version 2 Bricks: 3.28 ft (1.0 m)

## Sample Wiring Diagram for a 1x6 System Using SATA Bricks

The figure below is an example of cabling a Pillar Axiom 600 system. The scheme shown is for a hardware configuration of one Slammer that uses version 1 private interconnect modules (PIMs) and six Bricks that use version 1 SATA RAID controllers.



- Cable lengths:
  - The cable lengths for Slammer-to-Brick connections are 6.56 ft (2.0 m).
  - Cable lengths for Brick-to-Brick (FC-1 to FC-2) connections are also 6.56 ft (2.0 m).
  - Cable lengths for cross connections (FC-0 to FC-3) between Brick control units (CUs) depend on the Brick type:
    - Version 1 Bricks: 1.64 ft (0.5 m)
    - Version 2 Bricks: 3.28 ft (1.0 m)

## Control Unit (CU) Cross Connections for One Slammer

The illustration below depicts version 2 private interconnect modules (PIMs) contained within the CUs of a single Slammer.

Figure 13 Cabling single Slammer CU cross connections

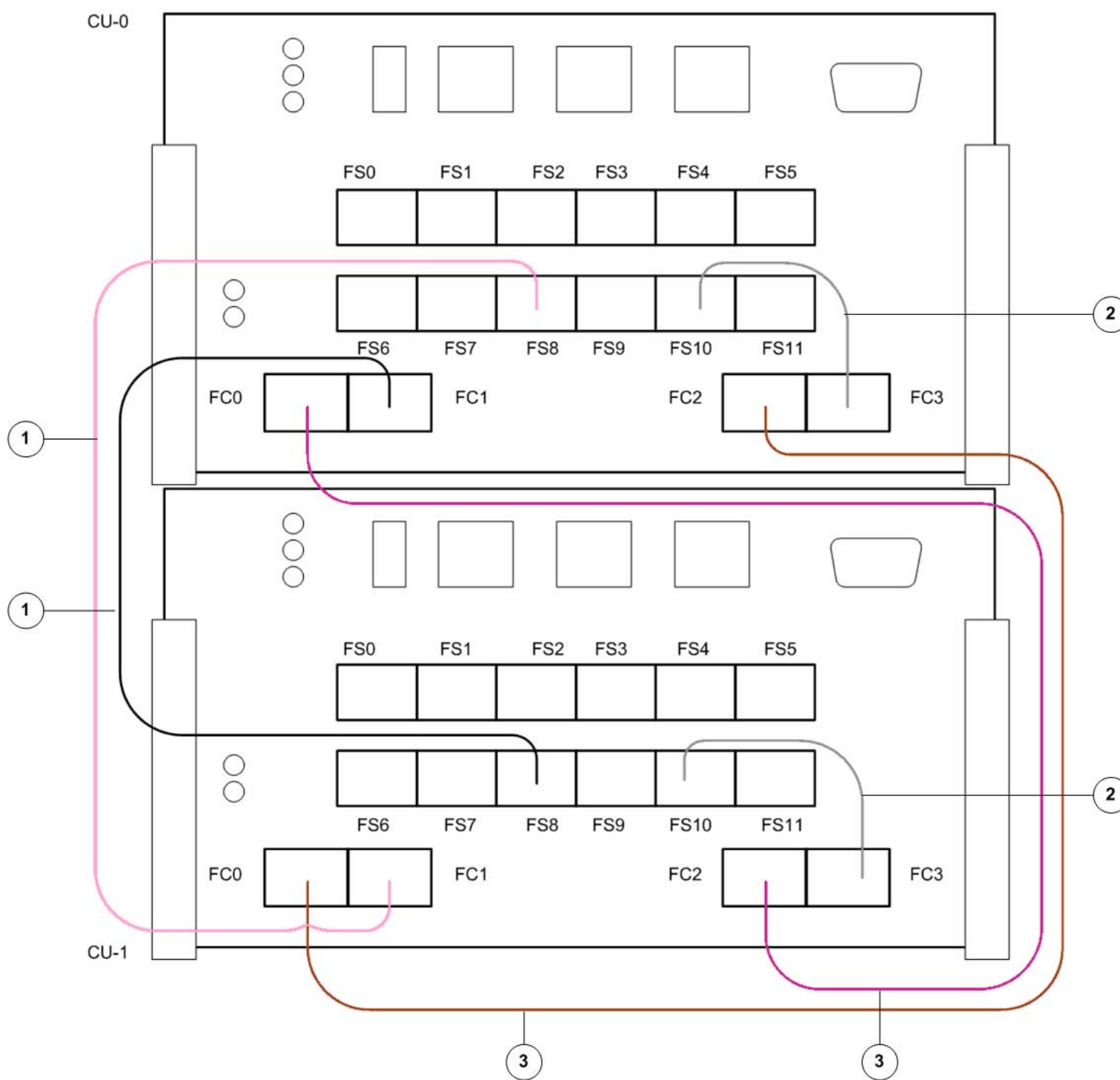

Legend	Description
1	Cross connection within Slammer CU's
2	Connection from the Slammer CU to the fabric switch in the PIM.
3	Cabling between the two Slammer CUs using 1.64 feet (0.5 m) SFP cables for 2 Gb/s or optical cables for 4 Gb/s.

The cross controller cabling between the Slammer CUs and the fabric switch in the PIM is internally hard wired in version 1 PIMs. In Slammer with version 2 PIMs, ports FC3 and FS10 are externally connected using an SFP to SFP cable.

**Caution** Do not remove the connection between the Slammer CU to the fabric switch in the PIM, unless advised by the Pillar World Wide Customer Support Center. If the connection between the Slammer CU to the fabric switch in the PIM is removed, all Brick ports and Slammer CU ports on the PIM will be brought offline. If the topology check fails for this connection, no further topology checks will be conducted and the Pillar Axiom 600 system will not be able to power up.

## SHEET 4

## Cabling Block Diagram: A 1-Slammer System

## Block Diagram for a 1x32 System Using SATA Bricks

The figure below illustrates the stringing of 32 Bricks in a 1-Slammer Pillar Axiom 600 system. The scheme shown in this figure maps four Brick strings, each string being eight Bricks deep.

**Important!** The following block diagram is for reference only. Actual cabling information is provided in [Table 9](#).

Figure 14 Cabling block diagram for a 1x32 system (SATA Bricks only)

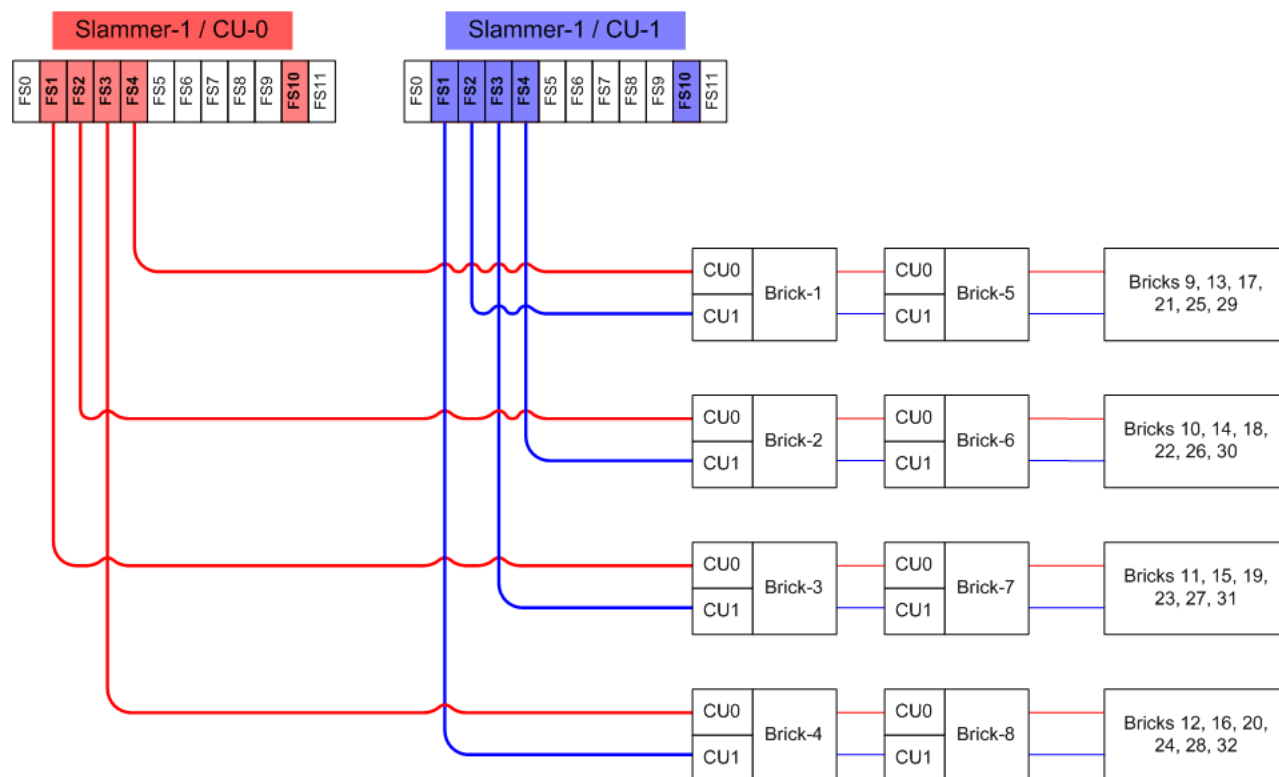

For information on the cross connections between the two CUs of each Brick, see the FC-0 to FC-3 cross connections specified in [Table 9](#).

## Notes on the 1x32 Block Diagram

- Single Slammer systems support a maximum of four Brick strings.
- For the Pillar Axiom 600 system, a string may contain up to eight Bricks.
- The order that Bricks are to be added to a system that has one Slammer storage controller (NAS or SAN) is illustrated in [Figure 14](#).
- The minimum configuration includes BRX-1 and BRX-2. Add subsequent Bricks so that load imbalance between Fibre Channel (FC) switches and FC loops is minimized. Add Bricks to strings so that the number of Bricks in any string differs by no more than two between the longest and the shortest string.
- It is recommended that you use a Brick scalability strategy that includes the following points:
  - First connect all four Brick strings to the Slammers using one Brick before building onto the end of any string.
  - Add additional Bricks using the connectivity illustrated in [Figure 14](#). The cable connections are defined in the tables beginning with [Table 9](#). See also: [Figure 25](#).
- The cabling scheme illustrated in [Figure 14](#) conforms to the following conventions:
  - Slammers**
    - On single Slammer systems, FC-0 on one control unit (CU) connects to FC-2 on the other CU.
    - FC-1 on one CU connects to FS-8 on the other CU.
    - FS-1, FS-2, FS-3, and FS-4 are used for Brick connections.
    - On systems with two or more Slammers, FC-0 connects to FS-7.
    - On systems with two or more Slammers, FC-2 connects to FS-9.
    - On 3-Slammer systems, FS-4 and FS-5 are reserved for Slammer (FC) to switch connections.

- On 3-Slammer and larger systems, FS-6 is reserved for the cascade (switch-to-switch) connection.
- Bricks**
- FC-0 is connected to FC-3 of the opposite CU on the same Brick.
  - FC-1 connects to FC-2 in the same CU of a downstream Brick.
  - FC-2 connects to a Slammer FS port or to FC-1 in the same CU of an upstream Brick.
- The configuration of systems upgraded in the field may differ somewhat from those built in the factory.

SHEET 5

## High Density Rack Configuration Using 230 V, 30 A Power

### Hardware Component Mapping in Racks Having 230 V, 30 A PDUs

The figure below illustrates a high-density configuration using 230 VAC, 30 A power distribution units (PDUs).

Figure 15 High-density rack configuration with 230 v, 30 A PDUs (1-Slammer system)

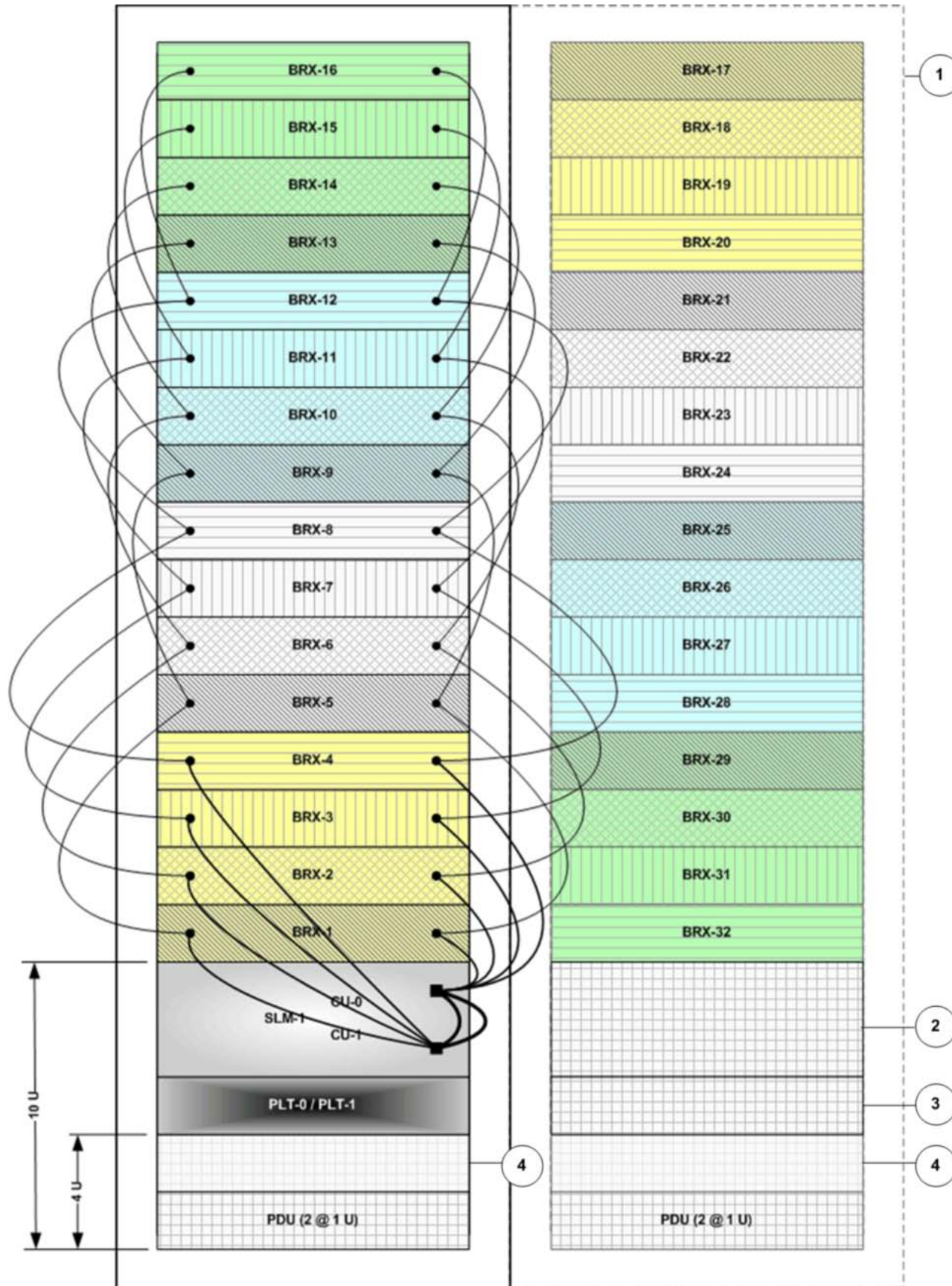

- Legend**
- 1 Optional second rack. Cabling is not shown for this rack. To cable this rack, follow the connection specifications in [Table 11](#).
  - 2 Reserved for second Slammer.
  - 3 Reserved.
  - 4 A minimum of 2 U of clear space is needed between the PDU and the Pilot chassis to allow access to and routing of power cords.



## Notes on Component Mapping within Racks Having 230 VAC, 30 A PDUs

- This configuration may require disruption to service when expanding the system. For example, to add a second Slammer to the first rack, providing the rack has 12 or fewer Bricks installed, a disruptive upgrade is required. The second Slammer would be installed in place of BRX-1 and BRX-2. Contact the Pillar World Wide Customer Support Center for detailed instructions in such a scenario.
- Two rack units are reserved at the bottom of the rack for PDUs. Running the full rack with two 1 U PDUs requires 230 VAC, 30 A for each circuit. This configuration also requires use of multi-leg power cords, such as a "Y" cord, to utilize the available space efficiently.
- All PDUs mount with the circuit breaker accessible from the back of the rack.
- The cable paths that are shown indicate only internal Storage System Fabric (SSF) Fibre Channel (FC) connectivity. Specific ports are not shown.
- This drawing shows an arrangement of Bricks so that the 6.6 ft (2 m) interconnect cables can be utilized throughout the configuration for all needed connections.

**Tip:** Dress all SSF cables to the right side of the rack (when viewed from the back) to facilitate FRU replacement with a minimum number of cable disconnections.



Do not place the 6.56 feet (2 m) cables so that they hang from the SFP connector.



Do not rest power or other private interconnect (PI) cables on the Brick cross over cables.

SHEET 6

# High Density Rack Configuration Using Four PDUs or 3-Phase Power

## Hardware Component Mapping in Racks Having Four PDUs or 3-Phase PDUs

The following two figures illustrate high-density configurations using four power distribution units (PDUs) or 3-phase PDUs.

Figure 16 High-density rack configuration with four PDUs (1-Slammer system)

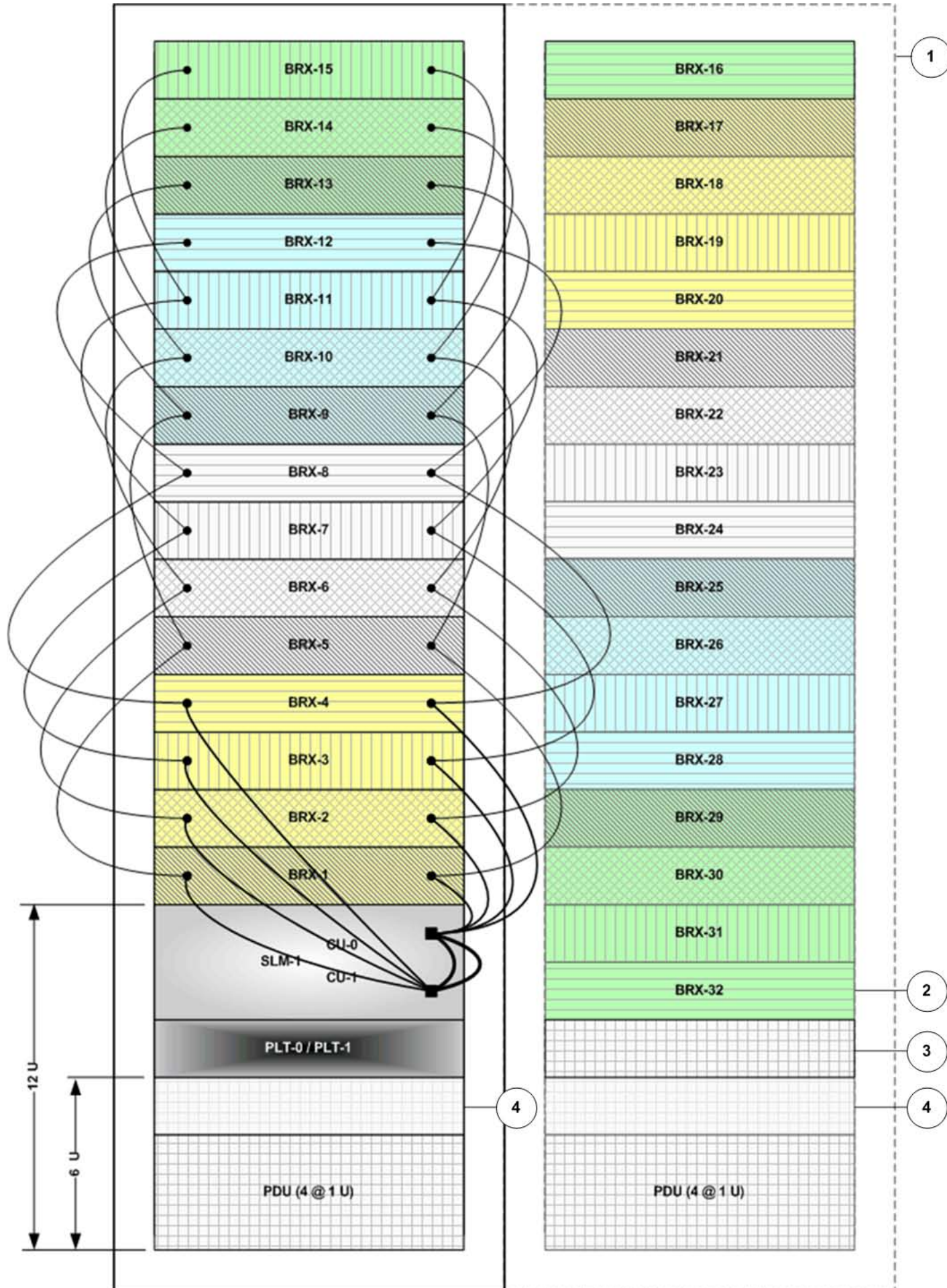

- Legend**
- 1 Optional second rack. Cabling is not shown for this rack. To cable this rack, follow the connection specifications in [Table 9](#).
  - 2 If you install a second Slammer, install it in place of BRX-32 and the reserved space immediately below.
  - 3 Reserved.
  - 4 A minimum of 2 U of clear space is needed between the PDU and the Pilot chassis to allow access to and routing of power cords.

Figure 17 Alternate high-density rack configuration with 3-phase PDUs

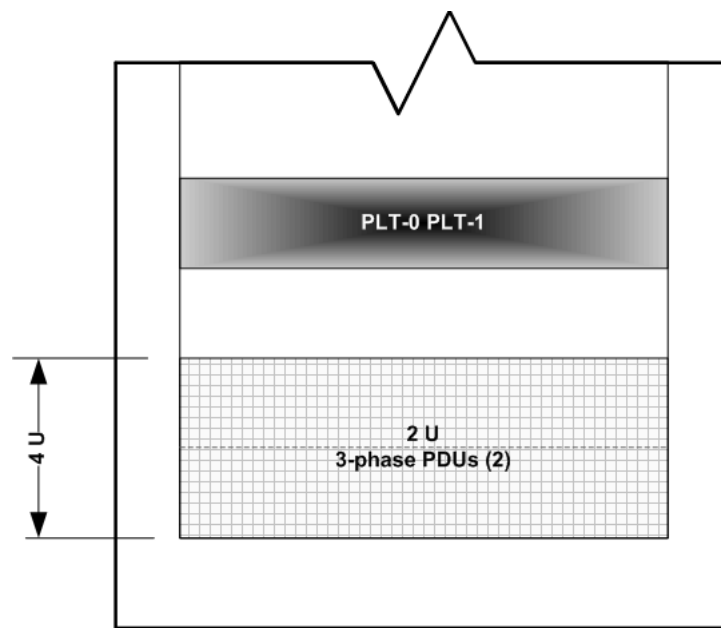

### Notes on Component Mapping within Racks Having Four PDUs or 3-Phase PDUs

- 3-phase power distribution units (PDUs) mount with the circuit breaker accessible at the front.
- Four rack units (RU) are reserved at the bottom of the rack for PDUs. These PDUs mount with their circuit breakers accessible from the back of the rack.
- If you add a second Slammer, you may need to re-cable the Bricks. Re-cabling is best done with a disruptive upgrade.

SHEET 7

# SSF Cable Connection List (Slammer Plus Bricks 1–8)

## Cable the Slammer and SATA Bricks 1–8

The table below specifies all Fibre Channel (FC) cables and their connections for the Slammer and the first and second sets of four SATA Bricks in a 1-Slammer system. All such interconnections are part of the Storage System Fabric (SSF).

Table 9 FC cable connections for the Slammer and the first and second sets of four SATA Bricks

Slammer-to-Slammer Connections		Brick Connections			
Version 1 PIMs	Version 2 PIMs	Cable	From Chassis / CU / Port	To Chassis / CU / Port	Cable Length
From: Chassis / CU / Port	To: Chassis / CU / Port	<b>Brick Connections</b>			
SLM-1 / CU-0 FC-1	SLM-1 / CU-1 FS-8	For BRX-1:			
SLM-1 / CU-1 FC-1	SLM-1 / CU-0 FS-8	CBL-101	SLM-1 / CU-0 FS-4	BRX-1 / CU-0 FC-2	2
SLM-1 / CU-0 FC-0	SLM-1 / CU-1 FC-2	CBL-102	SLM-1 / CU-1 FS-2	BRX-1 / CU-1 FC-2	2
SLM-1 / CU-1 FC-0	SLM-1 / CU-0 FC-2		BRX-1 / CU-0 FC-0	BRX-1 / CU-1 FC-3	0.5
			BRX-1 / CU-1 FC-0	BRX-1 / CU-0 FC-3	0.5
		For BRX-2:			
		CBL-103	SLM-1 / CU-0 FS-2	BRX-2 / CU-0 FC-2	2
		CBL-104	SLM-1 / CU-1 FS-4	BRX-2 / CU-1 FC-2	2
			BRX-2 / CU-0 FC-0	BRX-2 / CU-1 FC-3	0.5
			BRX-2 / CU-1 FC-0	BRX-2 / CU-0 FC-3	0.5
		For BRX-3:			
		CBL-105	SLM-1 / CU-0 FS-1	BRX-3 / CU-0 FC-2	2
		CBL-106	SLM-1 / CU-1 FS-3	BRX-3 / CU-1 FC-2	2
			BRX-3 / CU-0 FC-0	BRX-3 / CU-1 FC-3	0.5
			BRX-3 / CU-1 FC-0	BRX-3 / CU-0 FC-3	0.5
		For BRX-4:			
		CBL-107	SLM-1 / CU-0 FS-3	BRX-4 / CU-0 FC-2	2
		CBL-108	SLM-1 / CU-1 FS-1	BRX-4 / CU-1 FC-2	2
			BRX-4 / CU-0 FC-0	BRX-4 / CU-1 FC-3	0.5
			BRX-4 / CU-1 FC-0	BRX-4 / CU-0 FC-3	0.5
		The first set of four Bricks is directly connected to Slammer FS ports.			
		The second set of four Bricks is connected to the first set.			
		For BRX-5:			
		CBL-109	BRX-1 / CU-0 FC-1	BRX-5 / CU-0 FC-2	2
		CBL-110	BRX-1 / CU-1 FC-1	BRX-5 / CU-1 FC-2	2
			BRX-5 / CU-0 FC-0	BRX-5 / CU-1 FC-3	0.5
			BRX-5 / CU-1 FC-0	BRX-5 / CU-0 FC-3	0.5
		For BRX-6:			
		CBL-111	BRX-2 / CU-0 FC-1	BRX-6 / CU-0 FC-2	2
		CBL-112	BRX-2 / CU-1 FC-1	BRX-6 / CU-1 FC-2	2
			BRX-6 / CU-0 FC-0	BRX-6 / CU-1 FC-3	0.5
			BRX-6 / CU-1 FC-0	BRX-6 / CU-0 FC-3	0.5
		For BRX-7:			
		CBL-113	BRX-3 / CU-0 FC-1	BRX-7 / CU-0 FC-2	2
		CBL-114	BRX-3 / CU-1 FC-1	BRX-7 / CU-1 FC-2	2
			BRX-7 / CU-0 FC-0	BRX-7 / CU-1 FC-3	0.5
			BRX-7 / CU-1 FC-0	BRX-7 / CU-0 FC-3	0.5
		For BRX-8:			
		CBL-115	BRX-4 / CU-0 FC-1	BRX-8 / CU-0 FC-2	2
		CBL-116	BRX-4 / CU-1 FC-1	BRX-8 / CU-1 FC-2	2
			BRX-8 / CU-0 FC-0	BRX-8 / CU-1 FC-3	0.5
			BRX-8 / CU-1 FC-0	BRX-8 / CU-0 FC-3	0.5

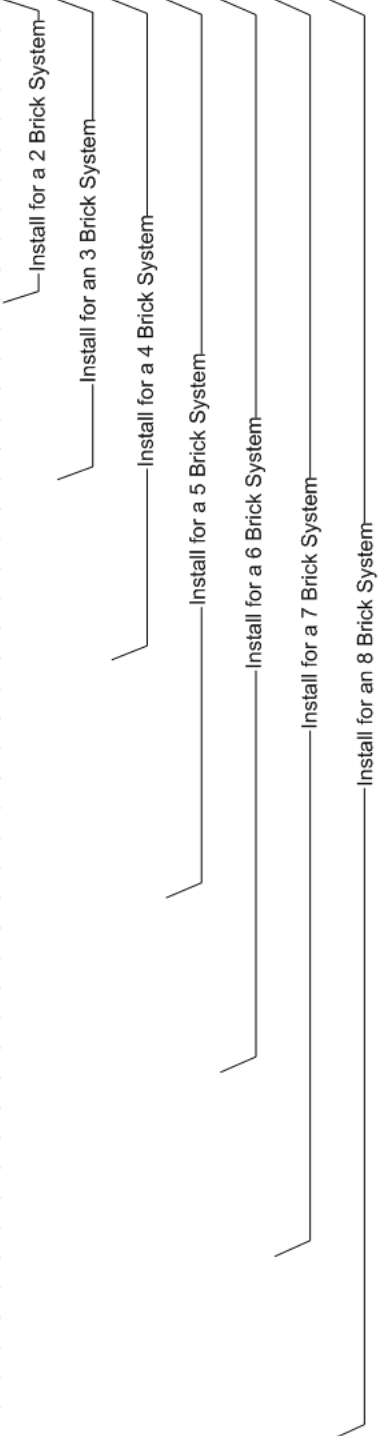

## Notes on Cabling SATA Bricks 1–8

- Private interconnect module (PIM) and SATA RAID controller connections:
  - Version 1 PIMs and SATA RAID controllers both use HSSDC2 (high-speed serial data connection) type connections.
  - Version 2 PIMs and SATA RAID controllers both use SFP (small form-factor pluggable) type connections.
  - When connecting a version 1 component to a version 2 component, use a hybrid HSSDC2-to-SFP adapter cable.

- Cable lengths:
  - The cable lengths for Slammer-to-Brick connections are 6.56 ft (2.0 m).
  - Cable lengths for Brick-to-Brick (FC-1 to FC-2) connections are also 6.56 ft (2.0 m).
  - Cable lengths for cross connections (FC-0 to FC-3) between Brick control units (CUs) depend on the Brick type:
    - Version 1 Bricks: 1.64 ft (0.5 m)
    - Version 2 Bricks: 3.28 ft (1.0 m)
- The Storage System Fabric (SSF) cabling scheme is based on the following conventions:
  - Slammers and Bricks (all chassis) are numbered starting with 1.
  - Designators within Slammer and Brick chassis are numbered from 0 (zero), as in CU-0, FC-0, and so on.
  - The Pilot has two CUs: PLT-0 and PLT-1.
- SSF cabling for 1-Slammer systems is based on the following principles:
  - Slammers:**
    - FC-0 connects to FC-2 (on the same Slammer, but opposite CU).
    - FC-1 connects to FS-8 (on the same Slammer, but opposite CU).
    - FS-1, FS-2, FS-3, and FS-4 are used for Brick connections.
  - Bricks:**
    - FC-0 connects to FC-3 of the opposite CU on the same Brick.
    - FC-1 connects to a FC-2 of a downstream Brick.
    - FC-2 connects to a Slammer FS port or to FC-1 of an upstream Brick.
- In addition to the FC cables identified in [Table 9](#), install the private management interface (PMI) cables specified in [Table 13](#).
- To cable additional Bricks into a 1-Slammer system, see [Table 10](#).

SHEET 8

# SSF Cable Connection List (Bricks 9–16)

## Cable SATA Bricks 9–16

To install these Bricks, install all cables specified in the following tables and in the following order:

- 1 [Table 9: FC cable connections for the Slammer and the first and second sets of four SATA Bricks.](#)
- 2 [Table 10: FC cable connections for the third and fourth sets of four SATA Bricks \(1-Slammer system\)](#) (depending on the number of Bricks in your configuration).

The table below specifies all Fibre Channel (FC) cables and their connections for the third and fourth sets of four Bricks. These interconnections extend the Storage System Fabric (SSF).

**Table 10 FC cable connections for the third and fourth sets of four SATA Bricks (1-Slammer system)**

Cable	From Chassis / CU / Port	To Chassis / CU / Port	Cable Length (M)
For BRX-9:			
CBL-117	BRX-5 / CU-0 FC-1	BRX-9 / CU-0 FC-2	2
CBL-118	BRX-5 / CU-1 FC-1	BRX-9 / CU-1 FC-2	2
	BRX-9 / CU-0 FC-0	BRX-9 / CU-1 FC-3	0.5
	BRX-9 / CU-1 FC-0	BRX-9 / CU-0 FC-3	0.5
For BRX-10:			
CBL-119	BRX-6 / CU-0 FC-1	BRX-10 / CU-0 FC-2	2
CBL-120	BRX-6 / CU-1 FC-1	BRX-10 / CU-1 FC-2	2
	BRX-10 / CU-0 FC-0	BRX-10 / CU-1 FC-3	0.5
	BRX-10 / CU-1 FC-0	BRX-10 / CU-0 FC-3	0.5
For BRX-11:			
CBL-121	BRX-7 / CU-0 FC-1	BRX-11 / CU-0 FC-2	2
CBL-122	BRX-7 / CU-1 FC-1	BRX-11 / CU-1 FC-2	2
	BRX-11 / CU-0 FC-0	BRX-11 / CU-1 FC-3	0.5
	BRX-11 / CU-1 FC-0	BRX-11 / CU-0 FC-3	0.5
For BRX-12:			
CBL-123	BRX-8 / CU-0 FC-1	BRX-12 / CU-0 FC-2	2
CBL-124	BRX-8 / CU-1 FC-1	BRX-12 / CU-1 FC-2	2
	BRX-12 / CU-0 FC-0	BRX-12 / CU-1 FC-3	0.5
	BRX-12 / CU-1 FC-0	BRX-12 / CU-0 FC-3	0.5
The fourth set of Bricks is connected to the third set of Bricks:			
For BRX-13:			
CBL-125	BRX-9 / CU-0 FC-1	BRX-13 / CU-0 FC-2	2
CBL-126	BRX-9 / CU-1 FC-1	BRX-13 / CU-1 FC-2	2
	BRX-13 / CU-0 FC-0	BRX-13 / CU-1 FC-3	0.5
	BRX-13 / CU-1 FC-0	BRX-13 / CU-0 FC-3	0.5
For BRX-14:			
CBL-127	BRX-10 / CU-0 FC-1	BRX-14 / CU-0 FC-2	2
CBL-128	BRX-10 / CU-1 FC-1	BRX-14 / CU-1 FC-2	2
	BRX-14 / CU-0 FC-0	BRX-14 / CU-1 FC-3	0.5
	BRX-14 / CU-1 FC-0	BRX-14 / CU-0 FC-3	0.5
For BRX-15:			
CBL-129	BRX-11 / CU-0 FC-1	BRX-15 / CU-0 FC-2	2
CBL-130	BRX-11 / CU-1 FC-1	BRX-15 / CU-1 FC-2	2
	BRX-15 / CU-0 FC-0	BRX-15 / CU-1 FC-3	0.5
	BRX-15 / CU-1 FC-0	BRX-15 / CU-0 FC-3	0.5
For BRX-16:			
CBL-131	BRX-12 / CU-0 FC-1	BRX-16 / CU-0 FC-2	2
CBL-132	BRX-12 / CU-1 FC-1	BRX-16 / CU-1 FC-2	2
	BRX-16 / CU-0 FC-0	BRX-16 / CU-1 FC-3	0.5
	BRX-16 / CU-1 FC-0	BRX-16 / CU-0 FC-3	0.5

## Notes on Cabling SATA Bricks 9–16

To cable additional Bricks into a 1-Slammer system, see [Table 11](#).

SHEET 9

## SSF Cable Connection List (Bricks 17–24)

### Cable SATA Bricks 17–24

To install these Bricks, install all cables specified in the following tables and in the following order:

- 1 Table 9: FC cable connections for the Slammer and the first and second sets of four SATA Bricks.
- 2 Table 10: FC cable connections for the third and fourth sets of four SATA Bricks (1-Slammer system).
- 3 The appropriate cables in the table below (depending on the number of Bricks in your configuration).

The table below specifies all Fibre Channel (FC) cables and their connections for the fifth and sixth set of four Bricks. These interconnections extend the Storage System Fabric (SSF).

Table 11 FC cable connections for the fifth and sixth sets of four SATA Bricks (1-Slammer system)

Cable	From Chassis / CU / Port	To Chassis / CU / Port	Cable Length (M)
For BRX-17:			
CBL-133	BRX-13 / CU-0 FC-1	BRX-17 / CU-0 FC-2	2
CBL-134	BRX-13 / CU-1 FC-1	BRX-17 / CU-1 FC-2	2
	BRX-17 / CU-0 FC-0	BRX-17 / CU-1 FC-3	0.5
	BRX-17 / CU-1 FC-0	BRX-17 / CU-0 FC-3	0.5
For BRX-18:			
CBL-135	BRX-14 / CU-0 FC-1	BRX-18 / CU-0 FC-2	2
CBL-136	BRX-14 / CU-1 FC-1	BRX-18 / CU-1 FC-2	2
	BRX-18 / CU-0 FC-0	BRX-18 / CU-1 FC-3	0.5
	BRX-18 / CU-1 FC-0	BRX-18 / CU-0 FC-3	0.5
For BRX-19:			
CBL-137	BRX-15 / CU-0 FC-1	BRX-19 / CU-0 FC-2	2
CBL-138	BRX-15 / CU-1 FC-1	BRX-19 / CU-1 FC-2	2
	BRX-19 / CU-0 FC-0	BRX-19 / CU-1 FC-3	0.5
	BRX-19 / CU-1 FC-0	BRX-19 / CU-0 FC-3	0.5
For BRX-20:			
CBL-139	BRX-16 / CU-0 FC-1	BRX-20 / CU-0 FC-2	2
CBL-140	BRX-16 / CU-1 FC-1	BRX-20 / CU-1 FC-2	2
	BRX-20 / CU-0 FC-0	BRX-20 / CU-1 FC-3	0.5
	BRX-20 / CU-1 FC-0	BRX-20 / CU-0 FC-3	0.5
The sixth set of Bricks is connected to the fifth set of Bricks:			
For BRX-21:			
CBL-141	BRX-17 / CU-0 FC-1	BRX-21 / CU-0 FC-2	2
CBL-142	BRX-17 / CU-1 FC-1	BRX-21 / CU-1 FC-2	2
	BRX-21 / CU-0 FC-0	BRX-21 / CU-1 FC-3	0.5
	BRX-21 / CU-1 FC-0	BRX-21 / CU-0 FC-3	0.5
For BRX-22:			
CBL-143	BRX-18 / CU-0 FC-1	BRX-22 / CU-0 FC-2	2
CBL-144	BRX-18 / CU-1 FC-1	BRX-22 / CU-1 FC-2	2
	BRX-22 / CU-0 FC-0	BRX-22 / CU-1 FC-3	0.5
	BRX-22 / CU-1 FC-0	BRX-22 / CU-0 FC-3	0.5
For BRX-23:			
CBL-145	BRX-19 / CU-0 FC-1	BRX-23 / CU-0 FC-2	2
CBL-146	BRX-19 / CU-1 FC-1	BRX-23 / CU-1 FC-2	2
	BRX-23 / CU-0 FC-0	BRX-23 / CU-1 FC-3	0.5
	BRX-23 / CU-1 FC-0	BRX-23 / CU-0 FC-3	0.5
For BRX-24:			
CBL-147	BRX-20 / CU-0 FC-1	BRX-24 / CU-0 FC-2	2
CBL-148	BRX-20 / CU-1 FC-1	BRX-24 / CU-1 FC-2	2
	BRX-24 / CU-0 FC-0	BRX-24 / CU-1 FC-3	0.5
	BRX-24 / CU-1 FC-0	BRX-24 / CU-0 FC-3	0.5

### Notes on Cabling SATA Bricks 17–24

To cable additional Bricks into a 1-Slammer system, see Table 12.

SHEET 10

# SSF Cable Connection List (Bricks 25–32)

## Cable SATA Bricks 25–32

To install these Bricks, install all cables specified in the following tables and in the following order:

- 1 [Table 9: FC cable connections for the Slammer and the first and second sets of four SATA Bricks.](#)
- 2 [Table 10: FC cable connections for the third and fourth sets of four SATA Bricks \(1-Slammer system\).](#)
- 3 [Table 11: FC cable connections for the fifth and sixth sets of four SATA Bricks \(1-Slammer system\).](#)
- 4 The appropriate cables in the table below (depending on the number of Bricks in your configuration).

The table below specifies all Fibre Channel (FC) cables and their connections for the seventh and eighth set of four Bricks. These interconnections extend the Storage System Fabric (SSF).

**Table 12 FC cable connections for the seventh and eighth sets of four SATA Bricks (1-Slammer system)**

Cable	From Chassis / CU / Port	To Chassis / CU / Port	Cable Length (M)
For BRX-25:			
CBL-149	BRX-21 / CU-0 FC-1	BRX-25 / CU-0 FC-2	2
CBL-150	BRX-21 / CU-1 FC-1	BRX-25 / CU-1 FC-2	2
	BRX-25 / CU-0 FC-0	BRX-25 / CU-1 FC-3	0.5
	BRX-25 / CU-1 FC-0	BRX-25 / CU-0 FC-3	0.5
For BRX-26:			
CBL-151	BRX-22 / CU-0 FC-1	BRX-26 / CU-0 FC-2	2
CBL-152	BRX-22 / CU-1 FC-1	BRX-26 / CU-1 FC-2	2
	BRX-26 / CU-0 FC-0	BRX-26 / CU-1 FC-3	0.5
	BRX-26 / CU-1 FC-0	BRX-26 / CU-0 FC-3	0.5
For BRX-27:			
CBL-153	BRX-23 / CU-0 FC-1	BRX-27 / CU-0 FC-2	2
CBL-154	BRX-23 / CU-1 FC-1	BRX-27 / CU-1 FC-2	2
	BRX-27 / CU-0 FC-0	BRX-27 / CU-1 FC-3	0.5
	BRX-27 / CU-1 FC-0	BRX-27 / CU-0 FC-3	0.5
For BRX-28:			
CBL-155	BRX-24 / CU-0 FC-1	BRX-28 / CU-0 FC-2	2
CBL-156	BRX-24 / CU-1 FC-1	BRX-28 / CU-1 FC-2	2
	BRX-28 / CU-0 FC-0	BRX-28 / CU-1 FC-3	0.5
	BRX-28 / CU-1 FC-0	BRX-28 / CU-0 FC-3	0.5
The eighth set of Bricks is connected to the seventh set of Bricks:			
For BRX-29:			
CBL-157	BRX-25 / CU-0 FC-1	BRX-29 / CU-0 FC-2	2
CBL-158	BRX-25 / CU-1 FC-1	BRX-29 / CU-1 FC-2	2
	BRX-29 / CU-0 FC-0	BRX-29 / CU-1 FC-3	0.5
	BRX-29 / CU-1 FC-0	BRX-29 / CU-0 FC-3	0.5
For BRX-30:			
CBL-159	BRX-26 / CU-0 FC-1	BRX-30 / CU-0 FC-2	2
CBL-160	BRX-26 / CU-1 FC-1	BRX-30 / CU-1 FC-2	2
	BRX-30 / CU-0 FC-0	BRX-30 / CU-1 FC-3	0.5
	BRX-30 / CU-1 FC-0	BRX-30 / CU-0 FC-3	0.5
For BRX-31:			
CBL-161	BRX-27 / CU-0 FC-1	BRX-31 / CU-0 FC-2	2
CBL-162	BRX-27 / CU-1 FC-1	BRX-31 / CU-1 FC-2	2
	BRX-31 / CU-0 FC-0	BRX-31 / CU-1 FC-3	0.5
	BRX-31 / CU-1 FC-0	BRX-31 / CU-0 FC-3	0.5
For BRX-32:			
CBL-163	BRX-28 / CU-0 FC-1	BRX-32 / CU-0 FC-2	2
CBL-164	BRX-28 / CU-1 FC-1	BRX-32 / CU-1 FC-2	2
	BRX-32 / CU-0 FC-0	BRX-32 / CU-1 FC-3	0.5
	BRX-32 / CU-1 FC-0	BRX-32 / CU-0 FC-3	0.5

## Notes on Cabling SATA Bricks 25–32

1–Slammer systems do not support more than 32 Bricks.



## PMI Cable Connection List and Schematic

### Private Management Interface (PMI) Connections in a 1-Slammer System

The table below specifies all the Ethernet cables and their connections for the PMI in all 1-Slammer systems, regardless of how many Bricks are configured. The PMI also requires a null modem cable connection between the serial ports of each Pilot CU.

Table 13 Cable connections for the PMI (1-Slammer system)

Cable	Chassis / CU / Port		Chassis / CU / Port	
CBL-60	PLT-0	ETH-0	PLT-1	ETH-0
CBL-61	PLT-0	ETH-1	SLM-1 / CU-0	ETH-0
CBL-63	PLT-1	ETH-1	SLM-1 / CU-1	ETH-2
CBL-65	SLM-1 / CU-0	ETH-1	SLM-1 / CU-1	ETH-1

The schematic below illustrates the Ethernet and null modem connections for the PMI in a 1-Slammer system.

Figure 18 PMI Ethernet schematic (1-Slammer system)

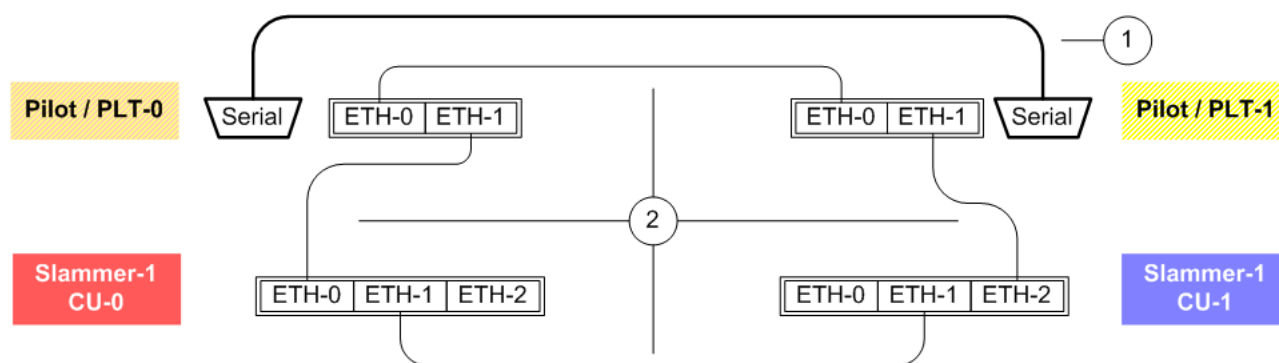

Legend	
1	Serial null modem cable.
2	Cat-5 Ethernet cables.

### Schematic of PMI Ethernet Connections in a 1-Slammer System

PMI (Private Message Interface) cabling refers to the fast Ethernet network between the Pilot and the Slammers and the heartbeat connection between the two control units (CUs) of the Pilot.

PMI cabling includes the following connections:

- Intra-Pilot cabling for a heartbeat between the two CUs of the Pilot using the serial null modem cable.
- Intra-Pilot cabling between the ETH-0 port on both CUs of the Pilot using 1.64 feet (0.5 m) Cat-5 Ethernet cables.
- PMI cabling connections between the Slammer and the Pilot, where the Ethernet ports on the Pilot CUs connect to the Ethernet ports on the Slammer CUs using 6.56 feet (2 m) Cat-5 Ethernet cables.
- Intra-Slammer PMI cabling connections between the Slammer CUs, where the Ethernet ports within the CUs of the Slammer are connected.

**Note:** The PMI cabling connections remain the same, regardless of whether the Slammer is a SAN Slammer or a NAS Slammer. The PMI cabling connections remain the same, irrespective of whether the Slammer is a 1-Slammer or a multi-Slammer configuration.

The schematic below illustrates the Ethernet connections for the PMI in a 1-Slammer system.

Figure 19 PMI Ethernet schematic (1-Slammer system)

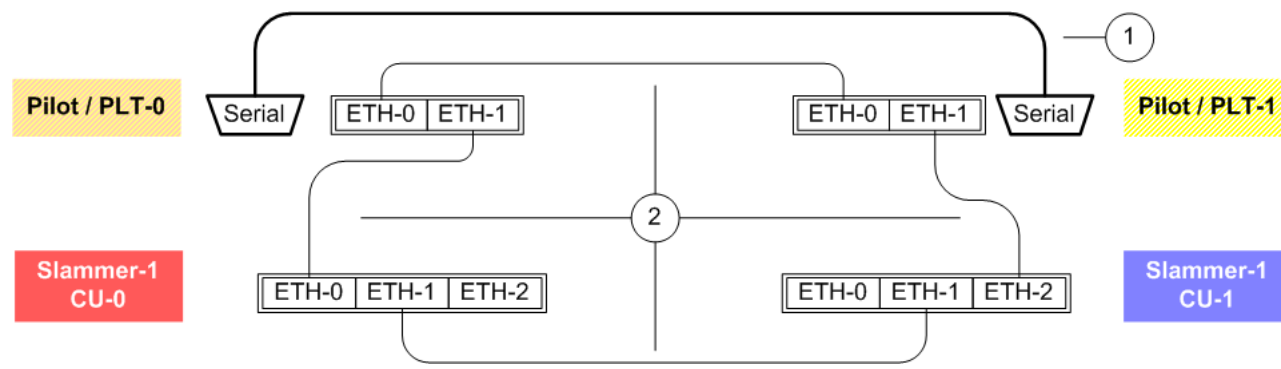

- Legend**
- 1 Serial null modem cable.
  - 2 Cat-5 Ethernet cables.

For more information on connecting the CUs of a Pilot, refer to the *Pillar Axiom 600 Hardware Installation Guide*.

# Part III: Cabling Pillar Axiom 600 Systems Using Two Slammers and SATA Bricks Only

SHEET 12

## Cabling Example: 2-Slammer System Using SATA Bricks

### Sample Wiring Diagram for a 2x2 System Using SATA Bricks

The figure below is a conceptual example of cabling a 2-Slammer Pillar Axiom 600 system. The scheme shown is for a hardware configuration of two version 1 Slammers and two version 1 SATA Bricks.

Figure 20 Sample cabling for a 2-Slammer system (SATA Bricks only)

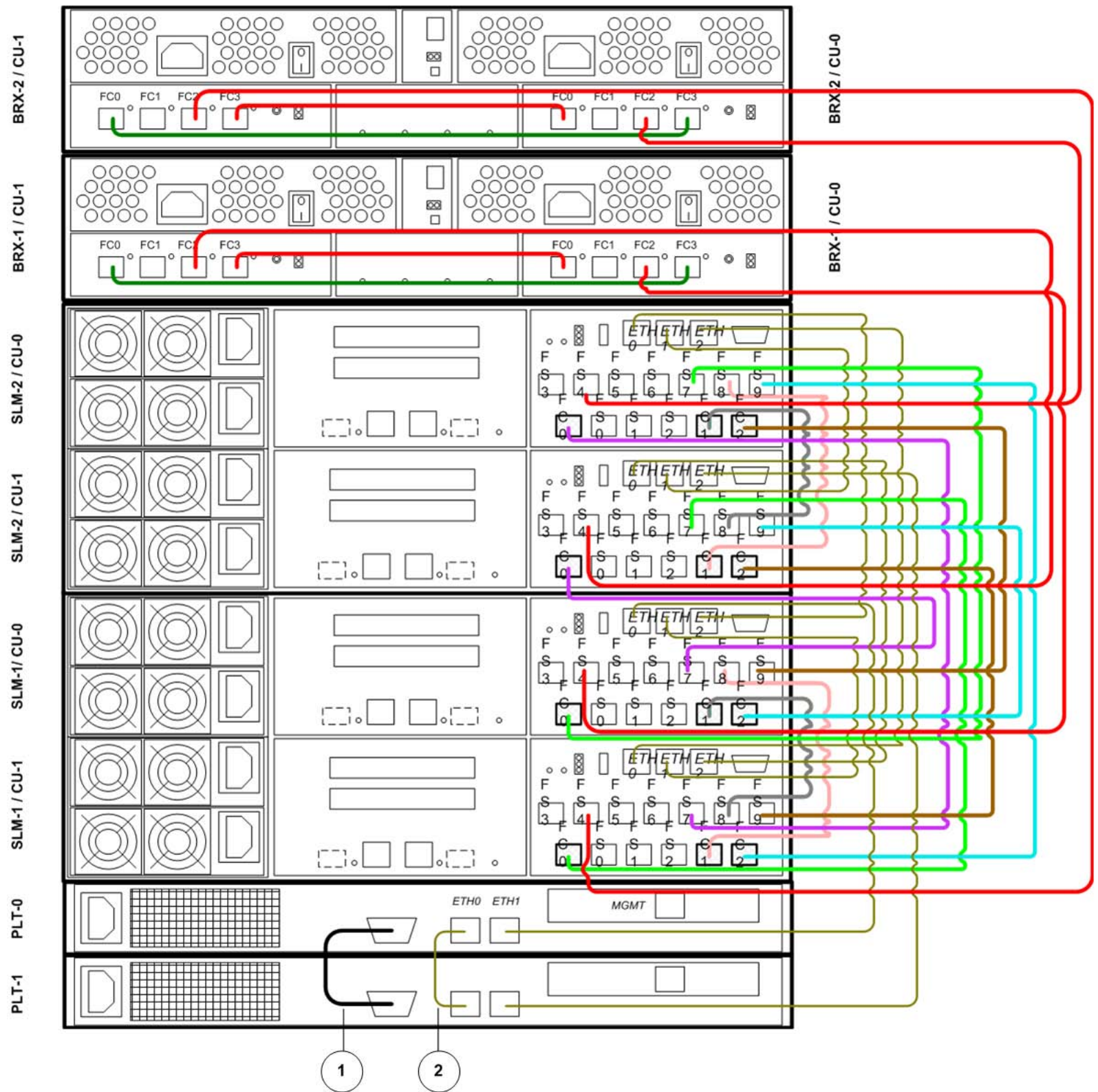

- Legend**
- 1 Serial null modem cable.
  - 2 Cross connect on the port that supports the Intelligent Platform Management Interface (IPMI). These ports are labeled ETH-0.
- Note:** The location of these ports on your Pilot control units may differ from this illustration.

**Note:**  
This diagram shows the logical connections, not the physical layout of the cables.

## Notes on the 2x2 Wiring Diagram for SATA Bricks

- Cabling of the Storage System Fabric (SSF) is the same for NAS and SAN Slammers. The Slammers depicted in [Figure 20](#) are NAS Slammers.
- The system configuration shown in [Figure 20](#) uses version 1 private interconnect modules (PIMs) and version 1 SATA RAID controllers. Version 2 SATA controllers are cabled using the same port connections. For the cross connections for a version 2 PIM, see [Table 9](#).
- Private interconnect module (PIM) and SATA RAID controller connections:
  - Version 1 PIMs and SATA RAID controllers both use HSSDC2 (high-speed serial data connection) type connections.
  - Version 2 PIMs and SATA RAID controllers both use SFP (small form-factor pluggable) type connections.
  - When connecting a version 1 component to a version 2 component, use a hybrid HSSDC2-to-SFP adapter cable.
- Cable lengths:
  - The cable lengths for Slammer-to-Brick connections are 6.56 ft (2.0 m).
  - Cable lengths for Brick-to-Brick (FC-1 to FC-2) connections are also 6.56 ft (2.0 m).
  - Cable lengths for cross connections (FC-0 to FC-3) between Brick control units (CUs) depend on the Brick type:
    - Version 1 Bricks: 1.64 ft (0.5 m)
    - Version 2 Bricks: 3.28 ft (1.0 m)
- Color codes of the Fibre Channel (FC) cables in [Figure 20](#) are determined as follows:
  - Slammer FC-*x* to FS-*y* cable color coding follows the lowest SLM-*a*, CU-*b* port color.
  - The illustration shows a Pilot, two Slammers, and two Bricks.
  - This drawing shows only the internal cabling among the units included in the illustration. A working Pillar Axiom 600 system would have additional connections for the following components:
    - Power
    - Customer host system (up to 32, depending on the type of network interface module used and the number of Slammers)
    - Management Ethernet connections to customer equipment (two)
    - Brick FC connections (up to 64) to support the Storage System Fabric (SSF)

## Control Unit (CU) Cross Connections for Two Slammers

The illustration below depicts version 2 private interconnect modules (PIMs) contained within the CUs of two Slammers.

Figure 21 Cabling CU cross connections for two version 2 Slammers

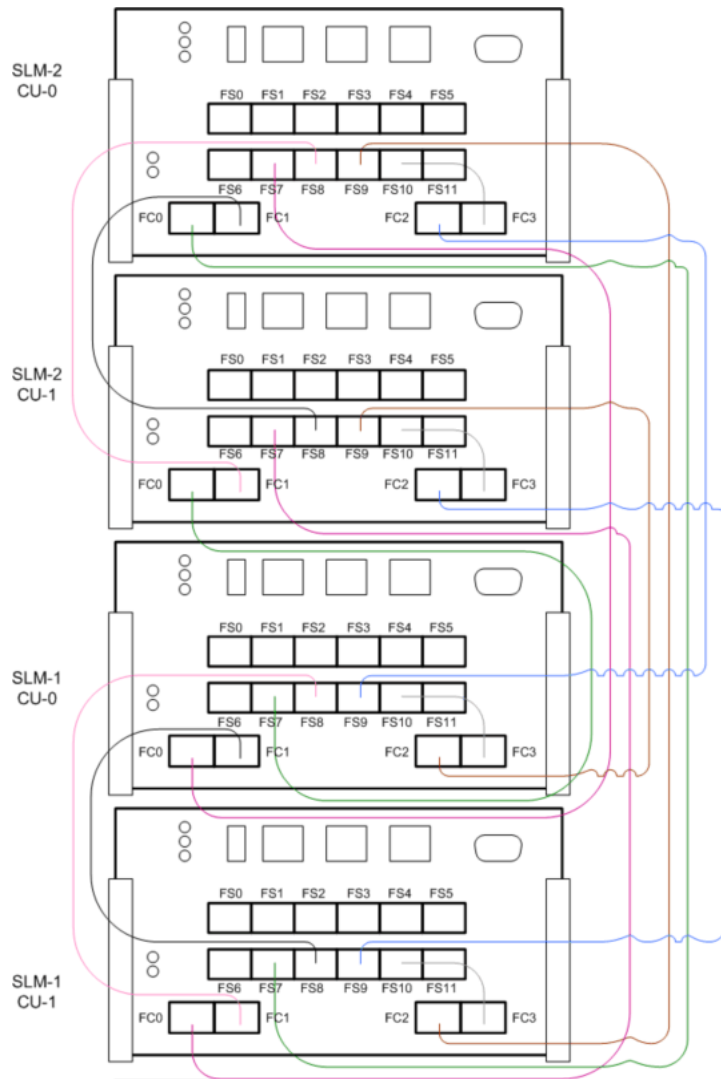

- Ports FC0, FC2, FS7, and FS9 connect the two Slammers together.
- The Fibre Channel (FC) ports connect the Fibre Channel ASIC to the Fibre Channel Switch through the FS ports.
- Port FC0 connects to port FS7 on the opposite Slammer:
  - SLM-1 CU-0 FC0 connects to SLM-2 CU-0 FS7
  - SLM-1 CU-1 FC0 connects to SLM-2 CU-1 FS7
  - SLM-1 CU-0 FS7 connects to SLM-2 CU-1 FC0
  - SLM-1 CU-1 FS7 connects to SLM-2 CU-0 FC0
- Port FC2 connects to FS9 on the opposite CU of the other Slammer:
  - SLM-1 CU-0 FC2 connects to SLM-2 CU-1 FS9
  - SLM-1 CU-1 FC2 connects to SLM-2 CU-0 FS9
  - SLM-1 CU-0 FS9 connects to SLM-2 CU-0 FC2
  - SLM-1 CU-1 FS9 connects to SLM-2 CU-1 FC2

SHEET 13

## Cabling Block Diagram: A 2-Slammer System

### Block Diagram for a 2x64 System Using SATA Bricks

The figure below illustrates the stringing of 64 Bricks in a 2-Slammer Pillar Axiom 600 system. The stringing scheme maps eight Brick strings, each string being eight Bricks deep.

**Important!** This illustration is for reference only. Actual cabling information begins with [Table 16](#).

Figure 22 Cabling block diagram for 2x64 systems (SATA Bricks only)

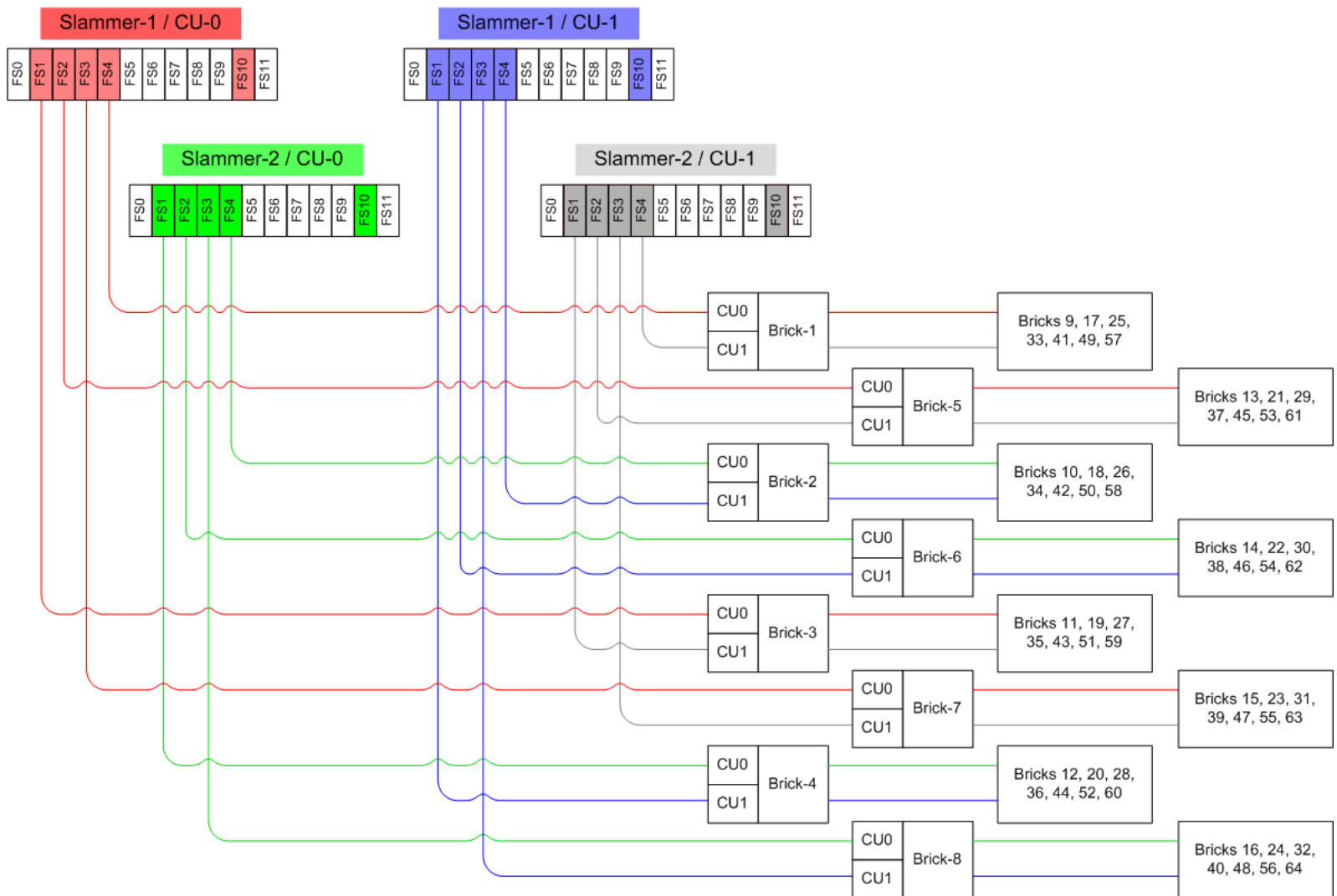

For information regarding the cross connections between the two control units of each Brick, see the FC-0 to FC-3 cross connections specified in [Table 16](#).

### Notes on the 2x64 Block Diagram for SATA Bricks

- Two Slammer systems contain at most eight Brick strings. For the Pillar Axiom 600, a string may contain up to eight Bricks.
- Add Bricks to strings so that the number of Bricks in any string differs by no more than two between the longest and the shortest string.
- [Figure 22](#), shows the order that Bricks are to be added to a system that has two Slammer storage controllers (NAS or SAN) and up to 64 Bricks.
- The entire Storage System Fabric (SSF) uses 2 Gb/s Fibre Channel (FC) patch cables throughout.
- Large two Slammer systems require up to four racks.

**Note:** Contact Pillar World Wide Customer Support Center to clarify the PDU requirements for the various configurations of Brick types and Brick numbers.  
Here are two examples:

Table 14 Rack space requirements for a 16-Brick system: 54 U (two racks)

Component	Height (rack units)	Quantity	Rack space
Pilot	2	1	2

Table 14 Rack space requirements for a 16-Brick system: 54 U (two racks) (continued)

Component	Height (rack units)	Quantity	Rack space
Slammer	4	2	8
Brick	2	16	32
PDU	1	8	8
Clearance	2	2	4

Table 15 Rack space requirements for a 32-Brick system: 92 U (three racks)

Component	Height (rack units)	Quantity	Rack space
Pilot	2	1	2
Slammer	4	2	8
Brick	2	32	64
PDU	1	12	12
Clearance	2	3	6

- We recommend a Brick scalability strategy that includes the following points:
  - First connect all eight Brick strings to the Slammers with one Brick before building onto the end of any string.
  - Add additional Bricks using the connectivity illustrated in [Figure 22](#) and defined in the tables beginning with [Table 16](#).  
*See also: [Figure 25: Generalized cascade of three SATA Bricks.](#)*
- This arrangement of Slammer-to-Bricks connections satisfies the following criteria:
  - Each Brick has one connection to the first Slammer and one connection to the second Slammer.
  - Brick CU-0 ports are connected to Slammer CU-0 ports. Brick CU-1 ports are connected to Slammer CU-1 ports.
  - For each Brick, the two Slammer connections use the same Slammer port number but on opposite CUs.
  - Load across Slammer CUs is balanced as Bricks are added to the system.
- The configuration of systems upgraded in the field may differ somewhat from those built in the factory.

SHEET 14

# Cable Connection List (Slammers Plus Bricks 1–8)

## Cable the Slammers and SATA Bricks 1–8

The table below specifies all Fibre Channel (FC) cables and their connections for the two Slammers and the first set of eight Bricks. All such interconnections are part of the Storage System Fabric (SSF).

Table 16 FC cable connections for two Slammers and the first set of eight SATA Bricks

Slammer-to-Slammer Connections		Brick Connections	
Version 1 PIMs		From:	To:
Chassis / CU / Port	Chassis / CU / Port	Chassis / CU / Port	Chassis / CU / Port
SLM-1 / CU-0 FC-0	SLM-2 / CU-0 FS-7	For BRX-1:	
SLM-1 / CU-0 FC-1	SLM-1 / CU-1 FS-8	SLM-1 / CU-0 FS-4	BRX-1 / CU-0 FC-2
SLM-1 / CU-0 FC-2	SLM-2 / CU-1 FS-9	SLM-2 / CU-1 FS-4	BRX-1 / CU-1 FC-2
		BRX-1 / CU-0 FC-0	BRX-1 / CU-1 FC-3
		BRX-1 / CU-1 FC-0	BRX-1 / CU-0 FC-3
SLM-1 / CU-1 FC-0	SLM-2 / CU-1 FS-7		
SLM-1 / CU-1 FC-1	SLM-1 / CU-0 FS-8	For BRX-2:	
SLM-1 / CU-1 FC-2	SLM-2 / CU-0 FS-9	SLM-2 / CU-0 FS-4	BRX-2 / CU-0 FC-2
		SLM-1 / CU-1 FS-4	BRX-2 / CU-1 FC-2
		BRX-2 / CU-0 FC-0	BRX-2 / CU-1 FC-3
		BRX-2 / CU-1 FC-0	BRX-2 / CU-0 FC-3
SLM-2 / CU-0 FC-0	SLM-1 / CU-1 FS-7		
SLM-2 / CU-0 FC-1	SLM-2 / CU-1 FS-8	For BRX-3:	
SLM-2 / CU-0 FC-2	SLM-1 / CU-0 FS-9	SLM-1 / CU-0 FS-1	BRX-3 / CU-0 FC-2
		SLM-2 / CU-1 FS-1	BRX-3 / CU-1 FC-2
		BRX-3 / CU-0 FC-0	BRX-3 / CU-1 FC-3
		BRX-3 / CU-1 FC-0	BRX-3 / CU-0 FC-3
SLM-2 / CU-1 FC-0	SLM-1 / CU-0 FS-7		
SLM-2 / CU-1 FC-1	SLM-2 / CU-0 FS-8	For BRX-4:	
SLM-2 / CU-1 FC-2	SLM-1 / CU-1 FS-9	SLM-2 / CU-0 FS-1	BRX-4 / CU-0 FC-2
		SLM-1 / CU-1 FS-1	BRX-4 / CU-1 FC-2
		BRX-4 / CU-0 FC-0	BRX-4 / CU-1 FC-3
		BRX-4 / CU-1 FC-0	BRX-4 / CU-0 FC-3
		For BRX-5:	
		SLM-1 / CU-0 FS-2	BRX-5 / CU-0 FC-2
		SLM-2 / CU-1 FS-2	BRX-5 / CU-1 FC-2
		BRX-5 / CU-0 FC-0	BRX-5 / CU-1 FC-3
		BRX-5 / CU-1 FC-0	BRX-5 / CU-0 FC-3
		For BRX-6:	
		SLM-2 / CU-0 FS-2	BRX-6 / CU-0 FC-2
		SLM-1 / CU-1 FS-2	BRX-6 / CU-1 FC-2
		BRX-6 / CU-0 FC-0	BRX-6 / CU-1 FC-3
		BRX-6 / CU-1 FC-0	BRX-6 / CU-0 FC-3
		For BRX-7:	
		SLM-1 / CU-0 FS-3	BRX-7 / CU-0 FC-2
		SLM-2 / CU-1 FS-3	BRX-7 / CU-1 FC-2
		BRX-7 / CU-0 FC-0	BRX-7 / CU-1 FC-3
		BRX-7 / CU-1 FC-0	BRX-7 / CU-0 FC-3
		For BRX-8:	
		SLM-2 / CU-0 FS-3	BRX-8 / CU-0 FC-2
		SLM-1 / CU-1 FS-3	BRX-8 / CU-1 FC-2
		BRX-8 / CU-0 FC-0	BRX-8 / CU-1 FC-3
		BRX-8 / CU-1 FC-0	BRX-8 / CU-0 FC-3

Version 2 PIMs	
From:	To:
Chassis / CU / Port	Chassis / CU / Port
SLM-1 / CU-0 FC-0	SLM-2 / CU-0 FS-7
SLM-1 / CU-0 FC-1	SLM-1 / CU-1 FS-8
SLM-1 / CU-0 FC-2	SLM-2 / CU-1 FS-9
SLM-1 / CU-0 FC-3	SLM-1 / CU-0 FS-10
SLM-1 / CU-1 FC-0	SLM-2 / CU-1 FS-7
SLM-1 / CU-1 FC-1	SLM-1 / CU-0 FS-8
SLM-1 / CU-1 FC-2	SLM-2 / CU-0 FS-9
SLM-1 / CU-1 FC-3	SLM-1 / CU-1 FS-10
SLM-2 / CU-0 FC-0	SLM-1 / CU-1 FS-7
SLM-2 / CU-0 FC-1	SLM-2 / CU-1 FS-8
SLM-2 / CU-0 FC-2	SLM-1 / CU-0 FS-9
SLM-2 / CU-0 FC-3	SLM-2 / CU-0 FS-10
SLM-2 / CU-1 FC-0	SLM-1 / CU-0 FS-7
SLM-2 / CU-1 FC-1	SLM-2 / CU-0 FS-8
SLM-2 / CU-1 FC-2	SLM-1 / CU-1 FS-9
SLM-2 / CU-1 FC-3	SLM-2 / CU-1 FS-10

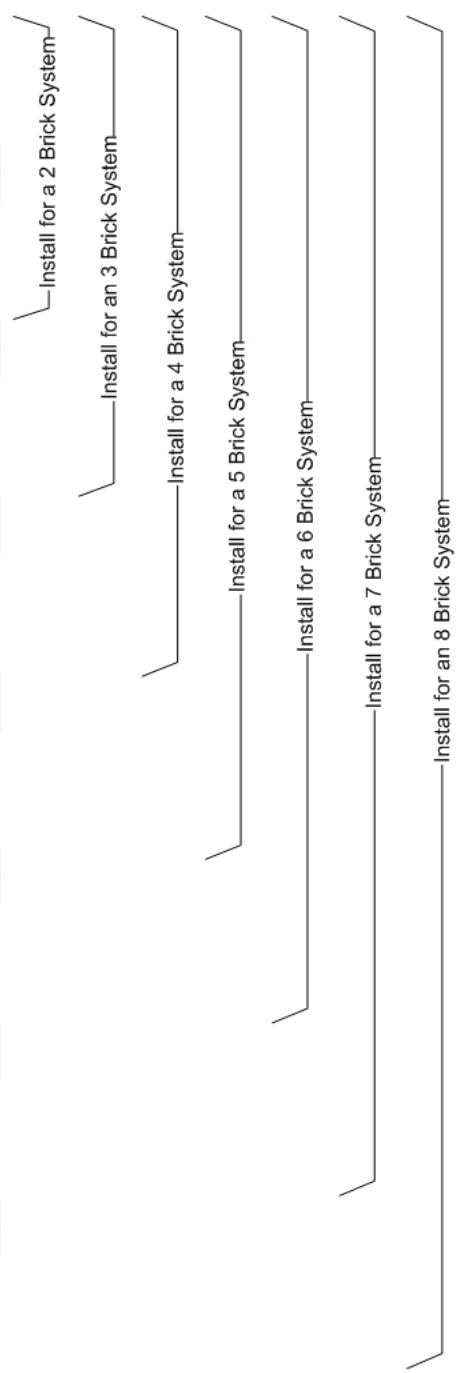

## Notes on Cabling SATA Bricks 1–8

- Install all cables specified, depending on the number of Bricks in the system.
- Private interconnect module (PIM) and SATA RAID controller connections:
  - Version 1 PIMs and SATA RAID controllers both use HSSDC2 (high-speed serial data connection) type connections.
  - Version 2 PIMs and SATA RAID controllers both use SFP (small form-factor pluggable) type connections.
  - When connecting a version 1 component to a version 2 component, use a hybrid HSSDC2-to-SFP adapter cable.
- Cable lengths:
  - The cable lengths for Slammer-to-Brick connections are 6.56 ft (2.0 m).
  - Cable lengths for Brick-to-Brick (FC-1 to FC-2) connections are also 6.56 ft (2.0 m).



- Cable lengths for cross connections (FC-0 to FC-3) between Brick control units (CUs) depend on the Brick type:
  - Version 1 Bricks: 1.64 ft (0.5 m)
  - Version 2 Bricks: 3.28 ft (1.0 m)
- The Storage System Fabric (SSF) cabling scheme is based on the following conventions:
  - Slammers and Bricks (all chassis) are numbered starting with 1.
  - Designators within Slammer and Brick chassis are numbered starting from 0 (zero), as in CU-0, FC-0, and so on.
  - The Pilot has two control units (CUs): PLT-0 and PLT-1.
- SSF cabling in 2-Slammer systems is based on the following principles:
  - Slammers:
    - FC-0 in one Slammer connects to FS-7 in the other Slammer. See [Table 16](#).
    - For systems with one Slammer containing version 1 private interconnect modules (PIMs) and the other containing version 2 PIMs, the FC-0 to FS-7 connection is made with an HSSDC2-to-SFP adapter cable.
    - FC-1 connects to FS-8 in the opposite CU in the same Slammer.
    - FC-2 in one Slammer connects to FS-9 in the other Slammer. See [Table 16](#).  
**Note:** For systems with one Slammer containing version 1 PIMs and the other containing version 2 PIMs, the FC-2 to FS-9 connection is made with an HSSDC2-to-SFP adapter cable.
    - For version 2 Slammers, FC-3 connects to FS-10.
    - FS-1, FS-2, FS-3, and FS-4 are used for Brick connections.
    - The following connections are reserved for configurations of more than two Slammers:
      - FS-4 and FS-5 are reserved for Slammer FC-to-switch connections in 3- and 5-Slammer configurations.
      - FS-6 is reserved for the cascade (switch-to-switch) connection in 3-Slammer and larger configurations.
  - Bricks:
    - FC-0 connects to FC-3 of the opposite CU in the same Brick.
    - FC-1 connects to FC-2 in the same CU of a downstream Brick.
    - FC-2 connects to a Slammer FS port or to FC-1 in the same CU of an upstream Brick.
- In addition to the FC cables identified in [Table 16](#), install the private management interface (PMI) Ethernet cables specified in [Table 21](#).
- To cable additional Bricks into a 2-Slammer system, see [Table 17](#).

SHEET 15

## SSF Cable Connection List (Bricks 9–16)

### Cable SATA Bricks 9–16

To install these Bricks, install all cables specified in the following tables and in the indicated order:

- 1 [Table 16: FC cable connections for two Slammers and the first set of eight SATA Bricks.](#)
- 2 The appropriate cables in the table below (depending on the number of Bricks in your configuration).

The table below specifies all Fibre Channel (FC) cables and their connections for the second set of eight Bricks. All such interconnections are part of the Storage System Fabric (SSF).

Table 17 FC cable connections for the second set of eight SATA Bricks (2-Slammer system)

	From	To	
	Chassis / CU / Port	Chassis / CU / Port	
<b>For BRX-9:</b>			
	BRX-1 / CU-0 FC-1	BRX-9 / CU-0 FC-2	2
	BRX-1 / CU-1 FC-1	BRX-9 / CU-1 FC-2	2
	BRX-9 / CU-0 FC-0	BRX-9 / CU-1 FC-3	0.5
	BRX-9 / CU-1 FC-0	BRX-9 / CU-0 FC-3	0.5
<b>For BRX-10:</b>			
	BRX-2 / CU-0 FC-1	BRX-10 / CU-0 FC-2	2
	BRX-2 / CU-1 FC-1	BRX-10 / CU-1 FC-2	2
	BRX-10 / CU-0 FC-0	BRX-10 / CU-1 FC-3	0.5
	BRX-10 / CU-1 FC-0	BRX-10 / CU-0 FC-3	0.5
<b>For BRX-11:</b>			
	BRX-3 / CU-0 FC-1	BRX-11 / CU-0 FC-2	2
	BRX-3 / CU-1 FC-1	BRX-11 / CU-1 FC-2	2
	BRX-11 / CU-0 FC-0	BRX-11 / CU-1 FC-3	0.5
	BRX-11 / CU-1 FC-0	BRX-11 / CU-0 FC-3	0.5
<b>For BRX-12:</b>			
	BRX-4 / CU-0 FC-1	BRX-12 / CU-0 FC-2	2
	BRX-4 / CU-1 FC-1	BRX-12 / CU-1 FC-2	2
	BRX-12 / CU-0 FC-0	BRX-12 / CU-1 FC-3	0.5
	BRX-12 / CU-1 FC-0	BRX-12 / CU-0 FC-3	0.5
<b>For BRX-13:</b>			
	BRX-5 / CU-0 FC-1	BRX-13 / CU-0 FC-2	2
	BRX-5 / CU-1 FC-1	BRX-13 / CU-1 FC-2	2
	BRX-13 / CU-0 FC-0	BRX-13 / CU-1 FC-3	0.5
	BRX-13 / CU-1 FC-0	BRX-13 / CU-0 FC-3	0.5
<b>For BRX-14:</b>			
	BRX-6 / CU-0 FC-1	BRX-14 / CU-0 FC-2	2
	BRX-6 / CU-1 FC-1	BRX-14 / CU-1 FC-2	2
	BRX-14 / CU-0 FC-0	BRX-14 / CU-1 FC-3	0.5
	BRX-14 / CU-1 FC-0	BRX-14 / CU-0 FC-3	0.5
<b>For BRX-15:</b>			
	BRX-7 / CU-0 FC-1	BRX-15 / CU-0 FC-2	2
	BRX-7 / CU-1 FC-1	BRX-15 / CU-1 FC-2	2
	BRX-15 / CU-0 FC-0	BRX-15 / CU-1 FC-3	0.5
	BRX-15 / CU-1 FC-0	BRX-15 / CU-0 FC-3	0.5
<b>For BRX-16:</b>			
	BRX-8 / CU-0 FC-1	BRX-16 / CU-0 FC-2	2
	BRX-8 / CU-1 FC-1	BRX-16 / CU-1 FC-2	2
	BRX-16 / CU-0 FC-0	BRX-16 / CU-1 FC-3	0.5
	BRX-16 / CU-1 FC-0	BRX-16 / CU-0 FC-3	0.5

### Notes on Cabling SATA Bricks 9–16

To cable additional Bricks into a 2-Slammer system, see [Table 18](#).

SHEET 16

## Cable Connection List (Bricks 17–24)

### Cable SATA Bricks 17–24

To install these Bricks, install all cables specified in the following tables and in the indicated order:

- 1 [Table 16: FC cable connections for two Slammers and the first set of eight SATA Bricks.](#)
- 2 [Table 17: FC cable connections for the second set of eight SATA Bricks \(2-Slammer system\).](#)
- 3 Depending on the number of Bricks in your configuration, the appropriate cables in the table below.

The table below specifies all Fibre Channel (FC) cables and their connections for the third set of eight Bricks. All such interconnections are part of the Storage System Fabric (SSF).

Table 18 FC cable connections for the third set of eight SATA Bricks (2-Slammer system)

	From	To	
	Chassis / CU / Port	Chassis / CU / Port	
<b>For BRX-17:</b>	BRX-9 / CU-0 FC-1	BRX-17 / CU-0 FC-2	2
	BRX-9 / CU-1 FC-1	BRX-17 / CU-1 FC-2	2
	BRX-17 / CU-0 FC-0	BRX-17 / CU-1 FC-3	0.5
	BRX-17 / CU-1 FC-0	BRX-17 / CU-0 FC-3	0.5
<b>For BRX-18:</b>	BRX-10 / CU-0 FC-1	BRX-18 / CU-0 FC-2	2
	BRX-10 / CU-1 FC-1	BRX-18 / CU-1 FC-2	2
	BRX-18 / CU-0 FC-0	BRX-18 / CU-1 FC-3	0.5
	BRX-18 / CU-1 FC-0	BRX-18 / CU-0 FC-3	0.5
<b>For BRX-19:</b>	BRX-11 / CU-0 FC-1	BRX-19 / CU-0 FC-2	2
	BRX-11 / CU-1 FC-1	BRX-19 / CU-1 FC-2	2
	BRX-19 / CU-0 FC-0	BRX-19 / CU-1 FC-3	0.5
	BRX-19 / CU-1 FC-0	BRX-19 / CU-0 FC-3	0.5
<b>For BRX-20:</b>	BRX-12 / CU-0 FC-1	BRX-20 / CU-0 FC-2	2
	BRX-12 / CU-1 FC-1	BRX-20 / CU-1 FC-2	2
	BRX-20 / CU-0 FC-0	BRX-20 / CU-1 FC-3	0.5
	BRX-20 / CU-1 FC-0	BRX-20 / CU-0 FC-3	0.5
<b>For BRX-21:</b>	BRX-13 / CU-0 FC-1	BRX-21 / CU-0 FC-2	2
	BRX-13 / CU-1 FC-1	BRX-21 / CU-1 FC-2	2
	BRX-21 / CU-0 FC-0	BRX-21 / CU-1 FC-3	0.5
	BRX-21 / CU-1 FC-0	BRX-21 / CU-0 FC-3	0.5
<b>For BRX-22:</b>	BRX-14 / CU-0 FC-1	BRX-22 / CU-0 FC-2	2
	BRX-14 / CU-1 FC-1	BRX-22 / CU-1 FC-2	2
	BRX-22 / CU-0 FC-0	BRX-22 / CU-1 FC-3	0.5
	BRX-22 / CU-1 FC-0	BRX-22 / CU-0 FC-3	0.5
<b>For BRX-23:</b>	BRX-15 / CU-0 FC-1	BRX-23 / CU-0 FC-2	2
	BRX-15 / CU-1 FC-1	BRX-23 / CU-1 FC-2	2
	BRX-23 / CU-0 FC-0	BRX-23 / CU-1 FC-3	0.5
	BRX-23 / CU-1 FC-0	BRX-23 / CU-0 FC-3	0.5
<b>For BRX-24:</b>	BRX-16 / CU-0 FC-1	BRX-24 / CU-0 FC-2	2
	BRX-16 / CU-1 FC-1	BRX-24 / CU-1 FC-2	2
	BRX-24 / CU-0 FC-0	BRX-24 / CU-1 FC-3	0.5
	BRX-24 / CU-1 FC-0	BRX-24 / CU-0 FC-3	0.5

### Notes on Cabling SATA Bricks 17–24

To cable additional SATA Bricks into a 2-Slammer system, see [Table 19](#).

SHEET 17

## Cable Connection List (Bricks 25 and Up)

### Cable SATA Bricks 25–32

To install these Bricks, install all cables specified in the following tables and in the indicated order:

- 1 [Table 16: FC cable connections for two Slammers and the first set of eight SATA Bricks.](#)
- 2 [Table 17: FC cable connections for the second set of eight SATA Bricks \(2-Slammer system\).](#)
- 3 [Table 18: FC cable connections for the third set of eight SATA Bricks \(2-Slammer system\).](#)
- 4 Depending on the number of Bricks in your configuration, the appropriate cables in the table below.

The table below specifies all Fibre Channel (FC) cables and their connections for the fourth set of eight SATA Bricks. All such interconnections are part of the Storage System Fabric (SSF).

Table 19 FC cable connections for the fourth set of eight SATA Bricks (2-Slammer system)

	From Chassis / CU / Port	To Chassis / CU / Port	
<b>For BRX-25:</b>			
	BRX-17 / CU-0 FC-1	BRX-25 / CU-0 FC-2	2
	BRX-17 / CU-1 FC-1	BRX-25 / CU-1 FC-2	2
	BRX-25 / CU-0 FC-0	BRX-25 / CU-1 FC-3	0.5
	BRX-25 / CU-1 FC-0	BRX-25 / CU-0 FC-3	0.5
<b>For BRX-26:</b>			
	BRX-18 / CU-0 FC-1	BRX-26 / CU-0 FC-2	2
	BRX-18 / CU-1 FC-1	BRX-26 / CU-1 FC-2	2
	BRX-26 / CU-0 FC-0	BRX-26 / CU-1 FC-3	0.5
	BRX-26 / CU-1 FC-0	BRX-26 / CU-0 FC-3	0.5
<b>For BRX-27:</b>			
	BRX-19 / CU-0 FC-1	BRX-27 / CU-0 FC-2	2
	BRX-19 / CU-1 FC-1	BRX-27 / CU-1 FC-2	2
	BRX-27 / CU-0 FC-0	BRX-27 / CU-1 FC-3	0.5
	BRX-27 / CU-1 FC-0	BRX-27 / CU-0 FC-3	0.5
<b>For BRX-28:</b>			
	BRX-20 / CU-0 FC-1	BRX-28 / CU-0 FC-2	2
	BRX-20 / CU-1 FC-1	BRX-28 / CU-1 FC-2	2
	BRX-28 / CU-0 FC-0	BRX-28 / CU-1 FC-3	0.5
	BRX-28 / CU-1 FC-0	BRX-28 / CU-0 FC-3	0.5
<b>For BRX-29:</b>			
	BRX-21 / CU-0 FC-1	BRX-29 / CU-0 FC-2	2
	BRX-21 / CU-1 FC-1	BRX-29 / CU-1 FC-2	2
	BRX-29 / CU-0 FC-0	BRX-29 / CU-1 FC-3	0.5
	BRX-29 / CU-1 FC-0	BRX-29 / CU-0 FC-3	0.5
<b>For BRX-30:</b>			
	BRX-22 / CU-0 FC-1	BRX-30 / CU-0 FC-2	2
	BRX-22 / CU-1 FC-1	BRX-30 / CU-1 FC-2	2
	BRX-30 / CU-0 FC-0	BRX-30 / CU-1 FC-3	0.5
	BRX-30 / CU-1 FC-0	BRX-30 / CU-0 FC-3	0.5
<b>For BRX-31:</b>			
	BRX-23 / CU-0 FC-1	BRX-31 / CU-0 FC-2	2
	BRX-23 / CU-1 FC-1	BRX-31 / CU-1 FC-2	2
	BRX-31 / CU-0 FC-0	BRX-31 / CU-1 FC-3	0.5
	BRX-31 / CU-1 FC-0	BRX-31 / CU-0 FC-3	0.5
<b>For BRX-32:</b>			
	BRX-24 / CU-0 FC-1	BRX-32 / CU-0 FC-2	2
	BRX-24 / CU-1 FC-1	BRX-32 / CU-1 FC-2	2
	BRX-32 / CU-0 FC-0	BRX-32 / CU-1 FC-3	0.5
	BRX-32 / CU-1 FC-0	BRX-32 / CU-0 FC-3	0.5

### Notes on Cabling SATA Bricks 25–32

2-Slammer systems support configurations of up to 64 Bricks. To cable additional SATA Bricks into a 2-Slammer system, continue cabling them using the pattern illustrated in [Table 20](#).

### Cabling Configurations of More Than 32 SATA Bricks

Table 20 Cabling configurations having more than 32 SATA Bricks

To cable this Brick...	Connect it to this Brick...	To cable this Brick...	Connect it to this Brick...
BRX-33	BRX-25	BRX-49	BRX-41

Table 20 Cabling configurations having more than 32 SATA Bricks (continued)

To cable this Brick...	Connect it to this Brick...	To cable this Brick...	Connect it to this Brick...
BRX-34	BRX-26	BRX-50	BRX-42
BRX-35	BRX-27	BRX-51	BRX-43
BRX-36	BRX-28	BRX-52	BRX-44
BRX-37	BRX-29	BRX-53	BRX-45
BRX-38	BRX-30	BRX-54	BRX-46
BRX-39	BRX-31	BRX-55	BRX-47
BRX-40	BRX-32	BRX-56	BRX-48
BRX-41	BRX-33	BRX-57	BRX-49
BRX-42	BRX-34	BRX-58	BRX-50
BRX-43	BRX-35	BRX-59	BRX-51
BRX-44	BRX-36	BRX-60	BRX-52
BRX-45	BRX-37	BRX-61	BRX-53
BRX-46	BRX-38	BRX-62	BRX-54
BRX-47	BRX-39	BRX-63	BRX-55
BRX-48	BRX-40	BRX-64	BRX-56

See also:

[Figure 22: Cabling block diagram for 2x64 systems \(SATA Bricks only\).](#)

[Figure 25: Generalized cascade of three SATA Bricks.](#)

SHEET 18

## PMI Cable Connection List and Schematic

### Private Management Interface (PMI) Connections in a 2-Slammer System

The table below specifies all Ethernet cables and their connections for the PMI in all 2-Slammer systems, regardless of how many Bricks are configured.

Table 21 Ethernet cable connections for PMI (2-Slammer system)

From chassis / CU / port	To chassis / CU / port
PLT-0 ETH0	PLT-1 ETH0
PLT-0 ETH1	SLM-1 / CU-0 / ETH0
PLT-1 ETH1	SLM-2 / CU-1 / ETH2
SLM-1 / CU-0 / ETH1	SLM-1 / CU-1 / ETH1
SLM-1 / CU-0 / ETH2	SLM-2 / CU-0 / ETH0
SLM-1 / CU-1 / ETH2	SLM-2 / CU-1 / ETH0
SLM-2 / CU-0 / ETH1	SLM-2 / CU-1 / ETH1
SLM-2 / CU-0 / ETH2	SLM-1 / CU-1 / ETH0

The schematic below illustrates the Ethernet connections for the PMI in a 2-Slammer system.

Figure 23 PMI Ethernet schematic (2-Slammer system)

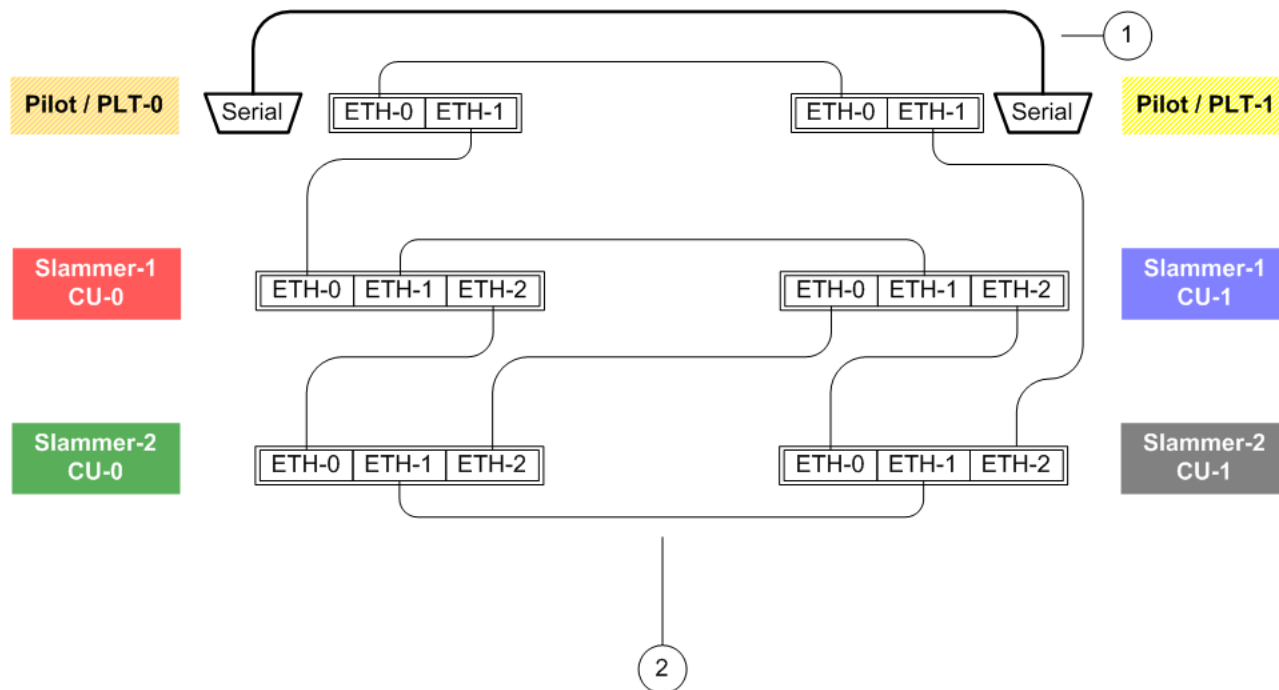

- Legend**
- 1 Serial null modem cable.
  - 2 Cat-5 Ethernet cables.

In addition to the Ethernet cables, PMI requires a null modem cable connection between the serial ports of each Pilot control unit.

### Schematic of PMI Ethernet Connections in a 2-Slammer System

The schematic below illustrates the Ethernet connections for the private management interface (PMI) in a 2-Slammer system.

Figure 24 PMI Ethernet schematic (2-Slammer system)

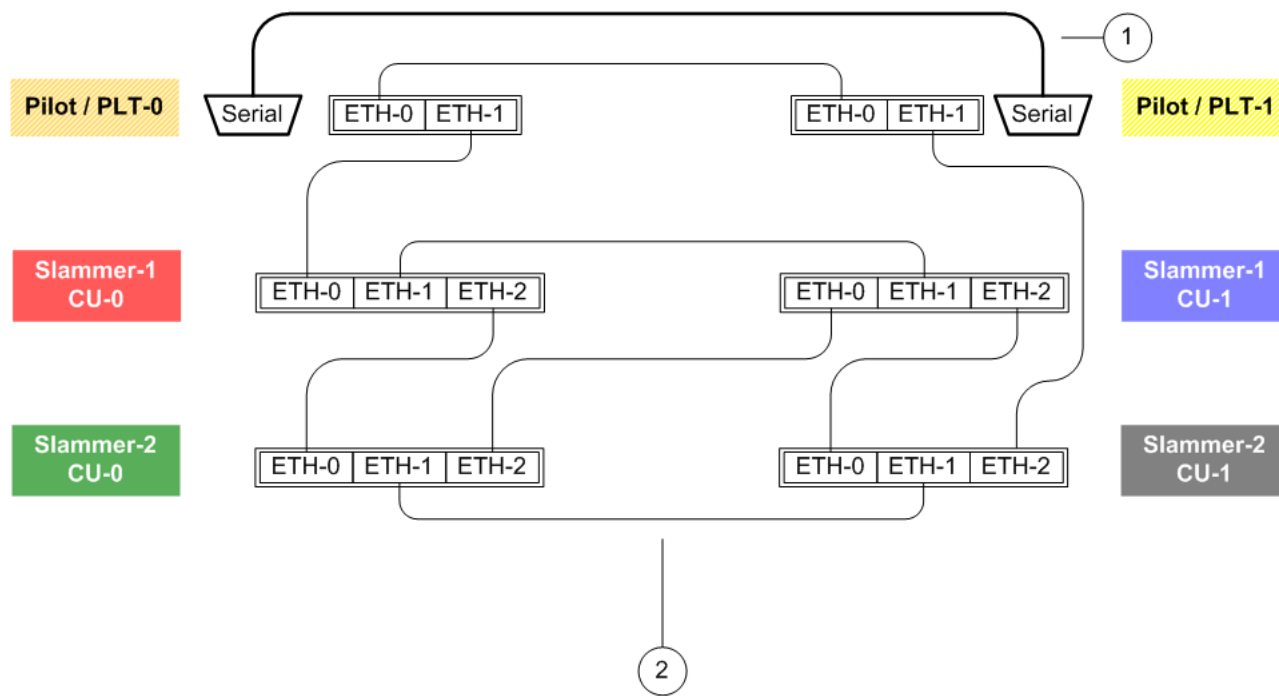

- Legend**
- 1 Serial null modem cable.
  - 2 Cat-5 Ethernet cables.

SHEET 19

## Schematic of a SATA Brick Cascade (String)

### Diagram of Stringing SATA Bricks

The figure below illustrates the general scheme to cascade (or string) SATA Bricks ( $N$  can have a value from 1 to 8).

Figure 25 Generalized cascade of three SATA Bricks

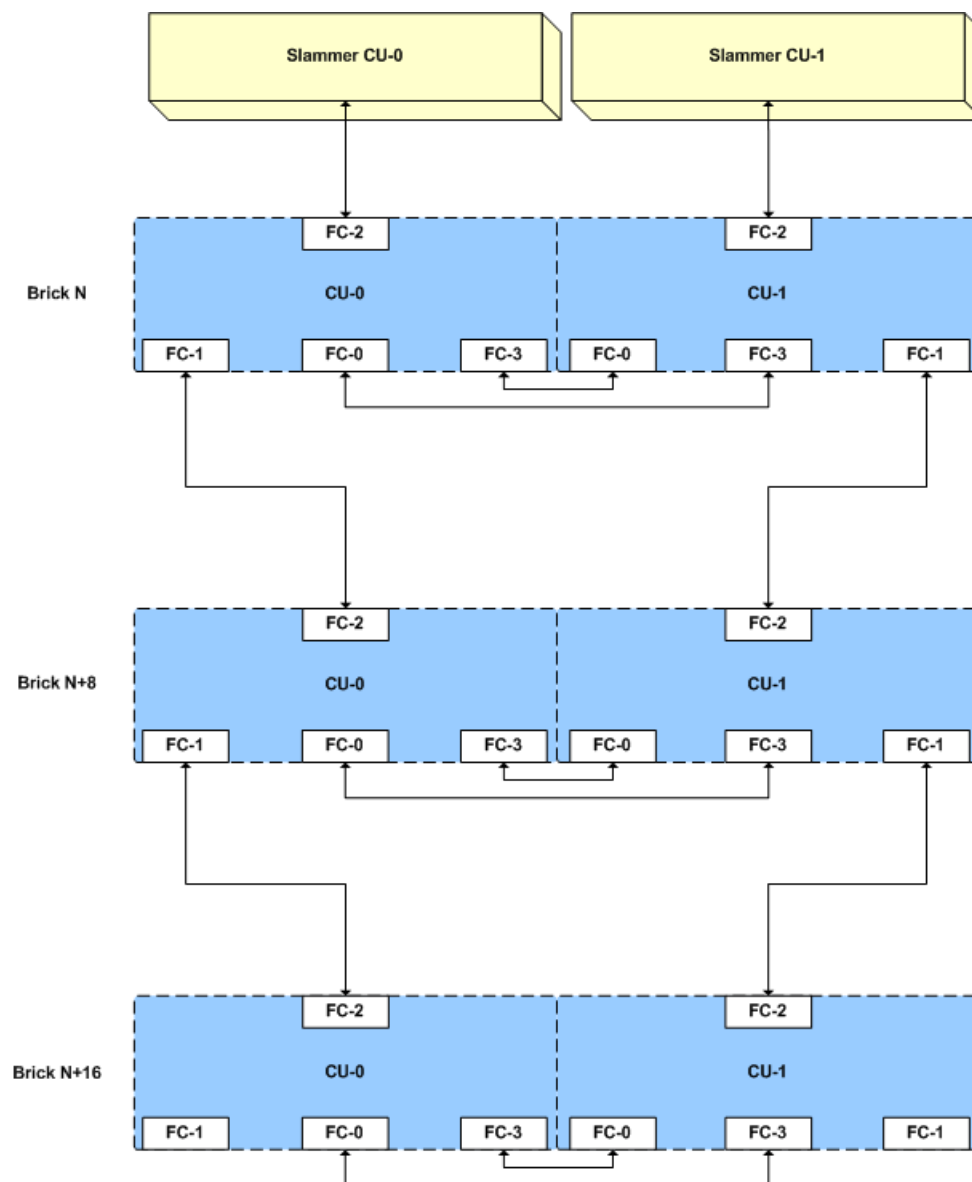

### Notes on Stringing Bricks

This schematic applies *only* to SATA Bricks. For a schematic showing an intermix of SATA and Fibre Channel (FC) Bricks, see:

- [Figure 26: Sample cabling for 1X2 Pillar Axiom 600 system with FC Bricks.](#)
- [Figure 30: Sample cabling for an FC RAID Brick, an FC Expansion Brick, and two SATA Bricks.](#)



# Part IV: Cabling Pillar Axiom 600 Systems Using One or Two Slammers and FC Bricks

SHEET 20

## Cabling Example: 1-Slammer System Using FC Bricks

### Sample Wiring Diagram for a 1x2 System Using FC Bricks

The figure illustrates the cabling of a Pillar Axiom 600 system with a configuration of one Slammer and two Bricks. The scheme shown is for version 1 private interconnect modules (PIMs) and a NAS Slammer. It defines the Slammer-to-Brick connections and the Brick-to-Brick connections required to connect Fibre Channel (FC) Bricks to a Slammer.

Figure 26 Sample cabling for 1X2 Pillar Axiom 600 system with FC Bricks

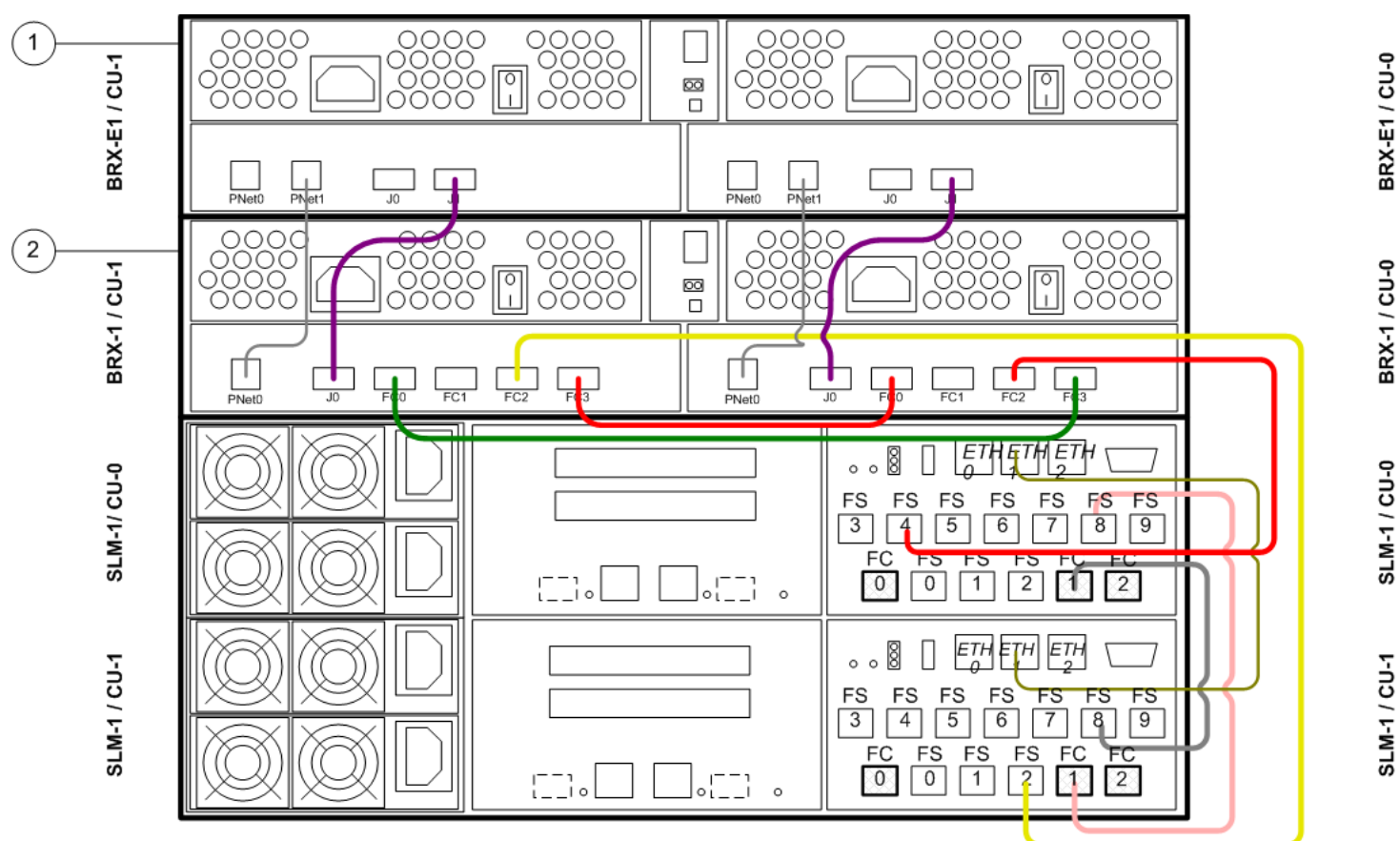

Legend	
1	Typical FC Expansion Brick.
2	Typical FC RAID Brick.

**Note:** The above diagram shows the logical connections, not the physical layout of the cables.

### Notes on the 1x2 Wiring Diagram for FC Bricks

- The diagram shows only the internal cabling among the units included in the illustration. A working Pillar Axiom 600 system would have additional connections for the following components:
  - Power.
  - Customer host system.
  - Private management interface (PMI) Ethernet connections to the Pilot.
  - Management Ethernet connections to customer equipment.
  - Additional Brick connections to support the Storage System Fabric (SSF).
- SSF cabling is the same for NAS and SAN Slammers. Also, a Pilot management controller is not shown but is needed to complete the Pillar Axiom 600 system.
- Brick strings consist of SATA Bricks, Fibre Channel (FC) Bricks, solid state drive (SSD) Bricks, or a combination of these. An FC RAID Brick can be paired with one FC Expansion Brick.

- FC RAID Bricks are identified with a tag such as BRX-*n*. The *n* value indicates the order of adding this FC Brick to the system, when counting all FC RAID and SATA Bricks on the system.
- FC Expansion Bricks are designated as BRX-E*n*. The *n* value indicates the order of adding the Brick to the system, when counting all Expansion Bricks on the system.
- Color codes of the FC cables in the diagram are defined as follows:
  - Slammer FC-*x* to FS-*y* cable color coding follows the lowest SLM-*a*, CU-*b* port color.
  - PNet cables are gray.

### Sample Wiring Diagram for a 1x4 System Using FC Bricks

The figure below is a conceptual example of cabling Fibre Channel (FC) Brick storage enclosures. It defines the Slammer-to-Brick connections and the Brick-to-Brick connections required to connect FC Bricks to a Slammer. This principle applies regardless how many Slammers comprise the Pillar Axiom 600 system.

Figure 27 Sample cabling for 1x4 Pillar Axiom 600 systems with FC Bricks

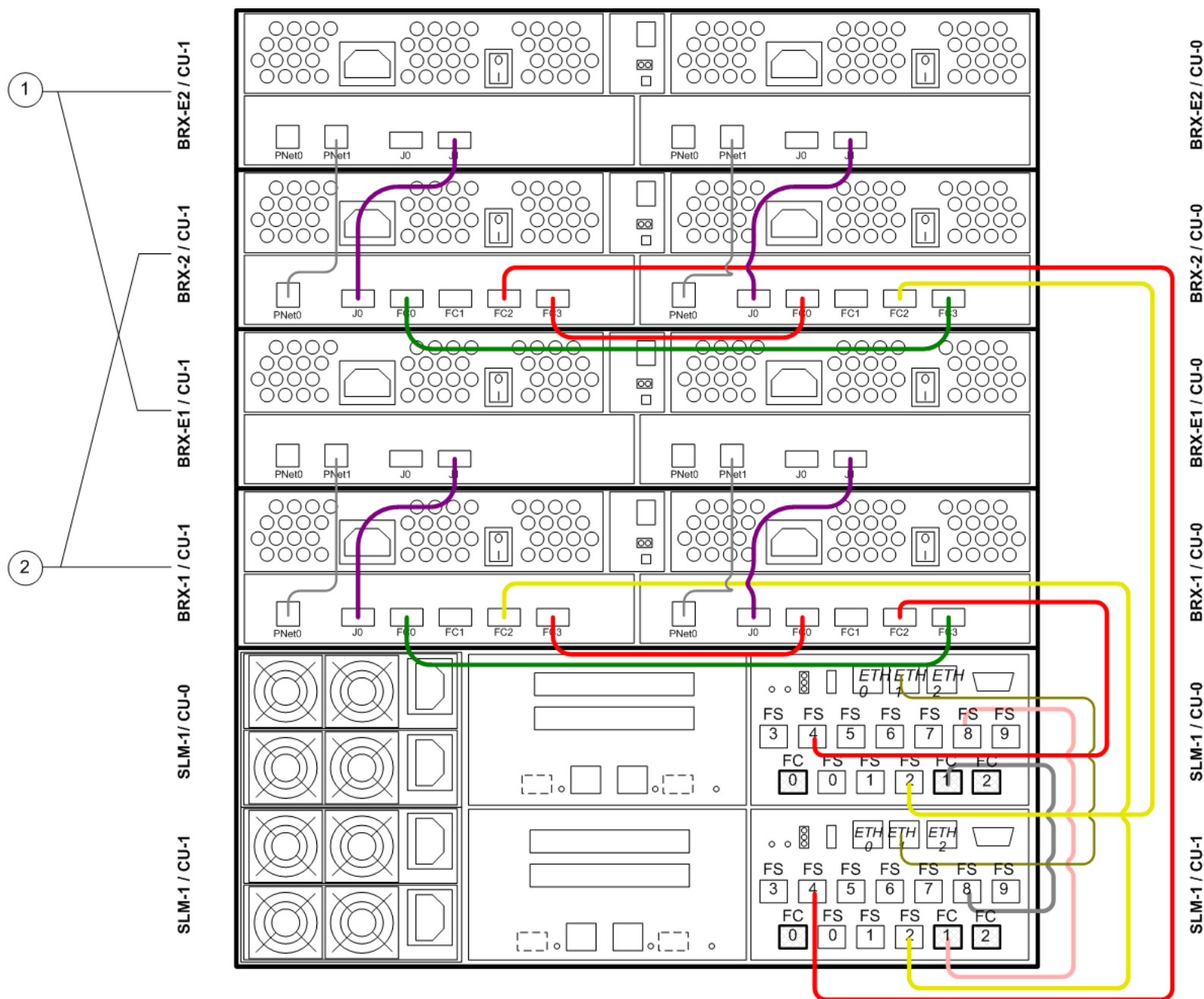

- Legend**
- 1 Typical FC Expansion Brick.
  - 2 Typical FC RAID Brick.

### Notes on the 1x4 Wiring Diagram for FC Bricks

- Figure 26 shows the logical connections, not the physical layout of the cables.
- Figure 26 includes version 1 private interconnect modules.
- The Slammer depicted in Figure 26 is a NAS Slammer. Storage System Fabric (SSF) cabling is the same for NAS and SAN Slammers. Also, a Pilot management controller is not shown but is needed to complete the Pillar Axiom 600 system.
- Brick strings consist of SATA Bricks, FC Bricks, or a combination of the two. FC RAID Bricks can exist alone or be paired with one FC Expansion Brick.

- FC RAID Bricks are identified with a tag such as BRX- $n$ . The  $n$  value indicates the order of adding this FC Brick to the system, when counting all FC RAID and SATA Bricks on the system.
- FC Expansion Bricks are designated as BRX-E $n$ . The  $n$  value indicates the order of adding the Brick to the system, when counting all Expansion Bricks on the system.
- Color codes of the FC cables in [Figure 26](#) are defined as follows:
  - Slammer FC- $x$  to FS- $y$  cable color coding follows the lowest SLM- $a$ , CU- $b$  port color.
  - PNet cables are gray.
- [Figure 26](#) shows only the internal cabling among the units included in the illustration. A working Pillar Axiom 600 system would have additional connections for the following components:
  - Power.
  - Customer host system.
  - Private management interface (PMI) Ethernet connections to the Pilot.
  - Management Ethernet connections to customer equipment.
  - Additional Brick FC connections to support the Storage System Fabric (SSF).
- Slammer-to-Slammer and Slammer-to-Pilot connections are defined beginning in the following sections:
  - [Cabling Example: 1-Slammer System Using SATA Bricks.](#)
  - [Cabling Example: 2-Slammer System Using SATA Bricks.](#)

## SHEET 21

## Cabling Block Diagram: A 1-Slammer System Using FC Bricks

## Block Diagram for a 1x8 System Using FC Bricks

The figure below illustrates the stringing of eight Fibre Channel (FC) Bricks in a 1-Slammer Pillar Axiom 600 system. The stringing scheme maps four Brick strings, each being two Bricks deep.

Figure 28 Cabling block diagram for 1-Slammer systems with FC Bricks

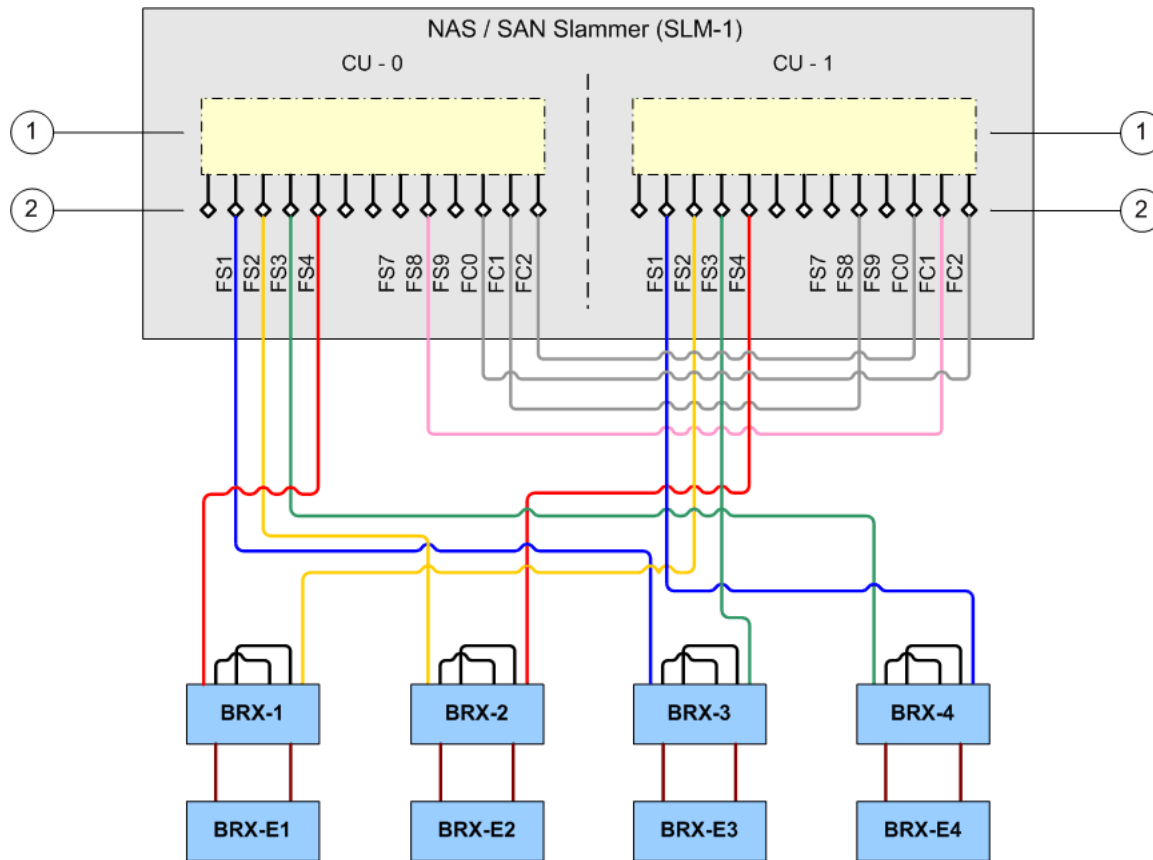

<b>Legend</b>	1 Private interconnect module (PIM) (version 1).	2 Ports ( ◊ ) on the PIM.
---------------	--	---------------------------

**Important!** This illustration is for reference only and does not show the RJ-45 cables that interconnect the FC RAID and FC Expansion Brick pairs. The PIM connections represent those for a version 1 PIM. For the cross connections for a version 2 PIM, see [Table 9](#).

## Notes on the 1x8 Block Diagram for FC Bricks

- In [Figure 28](#), FC RAID Bricks are at the head of the string (first row). FC Expansion Bricks are in the second row.
- [Figure 28](#) shows the order that Bricks are to be added to a system.
- 1-Slammer systems contain at most four Brick strings.
- An FC Brick string is limited to four FC Bricks (zero or one FC Expansion Brick for each FC RAID Brick).
- SATA Bricks containing hard drives (HDDs) or solid state drive (SSDs) can be added to an FC Brick string.
- A string may contain at most one SSD Brick and the SSD Brick must be at the beginning of the Brick string.
- Install all FC and Ethernet cables for Slammer-to-Slammer and Slammer-to-Pilot connections. For 1-Slammer systems, see:
  - [Table 9: FC cable connections for the Slammer and the first and second sets of four SATA Bricks.](#)
  - [Table 13: Cable connections for the PMI \(1-Slammer system\).](#)
- Install Slammer-to-Brick and Brick-to-Brick connections according to the specifications in [Table 22](#).
- FC Bricks use 2 Gb FC patch cables.

## Cable the Slammer and FC Bricks

The table below specifies all FC cables and their connections for the Slammer and the eight FC Bricks (four FC RAID Bricks and four FC Expansion Bricks). All such interconnections are part of the Storage System Fabric (SSF).

Table 22 FC cable connections for one Slammer and eight FC Bricks

Case 1:	Single Slammer -- all FC Bricks			
	From	To		
	Chassis / CU / Port	Chassis / CU / Port		
For BRX-1:	SLM-1 / CU-0 FS-4	BRX-1 / CU-0 FC-2		
	SLM-1 / CU-1 FS-2	BRX-1 / CU-1 FC-2		
	BRX-1 / CU-0 FC-0	BRX-1 / CU-1 FC-3		
	BRX-1 / CU-1 FC-0	BRX-1 / CU-0 FC-3		
For BRX-E1:	BRX-1 / CU-0 J0	BRX-E1 / CU-0 J1		
	BRX-1 / CU-1 J0	BRX-E1 / CU-1 J1		
	BRX-1 / CU-0 PNet-0	BRX-E1 / CU-0 PNet-1		RJ-45 cable
	BRX-1 / CU-1 PNet-0	BRX-E1 / CU-1 PNet-1		RJ-45 cable
For BRX-2:	SLM-1 / CU-0 FS-2	BRX-2 / CU-0 FC-2		
	SLM-1 / CU-1 FS-4	BRX-2 / CU-1 FC-2		
	BRX-2 / CU-0 FC-0	BRX-2 / CU-1 FC-3		
	BRX-2 / CU-1 FC-0	BRX-2 / CU-0 FC-3		
For BRX-E2:	BRX-2 / CU-0 J0	BRX-E2 / CU-0 J1		
	BRX-2 / CU-1 J0	BRX-E2 / CU-1 J1		
	BRX-2 / CU-0 PNet-0	BRX-E2 / CU-0 PNet-1	RJ-45 cable	
	BRX-2 / CU-1 PNet-0	BRX-E2 / CU-1 PNet-1	RJ-45 cable	
For BRX-3:	SLM-1 / CU-0 FS-1	BRX-3 / CU-0 FC-2		
	SLM-1 / CU-1 FS-3	BRX-3 / CU-1 FC-2		
	BRX-3 / CU-0 FC-0	BRX-3 / CU-1 FC-3		
	BRX-3 / CU-1 FC-0	BRX-3 / CU-0 FC-3		
For BRX-E3:	BRX-3 / CU-0 J0	BRX-E3 / CU-0 J1		
	BRX-3 / CU-1 J0	BRX-E3 / CU-1 J1		
	BRX-3 / CU-0 PNet-0	BRX-E3 / CU-0 PNet-1	RJ-45 cable	
	BRX-3 / CU-1 PNet-0	BRX-E3 / CU-1 PNet-1	RJ-45 cable	
For BRX-4:	SLM-1 / CU-0 FS-3	BRX-4 / CU-0 FC-2		
	SLM-1 / CU-1 FS-1	BRX-4 / CU-1 FC-2		
	BRX-4 / CU-0 FC-0	BRX-4 / CU-1 FC-3		
	BRX-4 / CU-1 FC-0	BRX-4 / CU-0 FC-3		
For BRX-E4:	BRX-4 / CU-0 J0	BRX-E4 / CU-0 J1		
	BRX-4 / CU-1 J0	BRX-E4 / CU-1 J1		
	BRX-4 / CU-0 PNet-0	BRX-E4 / CU-0 PNet-1	RJ-45 cable	
	BRX-4 / CU-1 PNet-0	BRX-E4 / CU-1 PNet-1	RJ-45 cable	

When cabling the fabric, be aware of the following facts:

- Private interconnect module (PIM) and SATA RAID controller connections:
  - Version 1 PIMs and SATA RAID controllers both use HSSDC2 (high-speed serial data connection) type connections.
  - Version 2 PIMs and SATA RAID controllers both use SFP (small form-factor pluggable) type connections.
  - When connecting a version 1 component to a version 2 component, use a hybrid HSSDC2-to-SFP adapter cable.
- Cable lengths:
  - The cable lengths for Slammer-to-Brick connections are 6.56 ft (2.0 m).
  - Cable lengths for Brick-to-Brick (FC-1 to FC-2) connections are also 6.56 ft (2.0 m).
  - Cable lengths for cross connections (FC-0 to FC-3) between Brick control units (CUs) depend on the Brick type:

- Version 1 Bricks: 1.64 ft (0.5 m)
- Version 2 Bricks: 3.28 ft (1.0 m)

SHEET 22

## Cabling Block Diagram: A 2-Slammer System Using FC Bricks

### Block Diagram for a 2x16 System Using FC Bricks

The figure below illustrates the stringing of 16 Fibre Channel (FC) Bricks in a 2-Slammer Pillar Axiom 600 system that uses version 1 private interconnect modules (PIMs). The stringing scheme maps eight Brick strings, each being two Bricks deep.

Figure 29 Cabling block diagram for 2-Slammer systems with FC Bricks

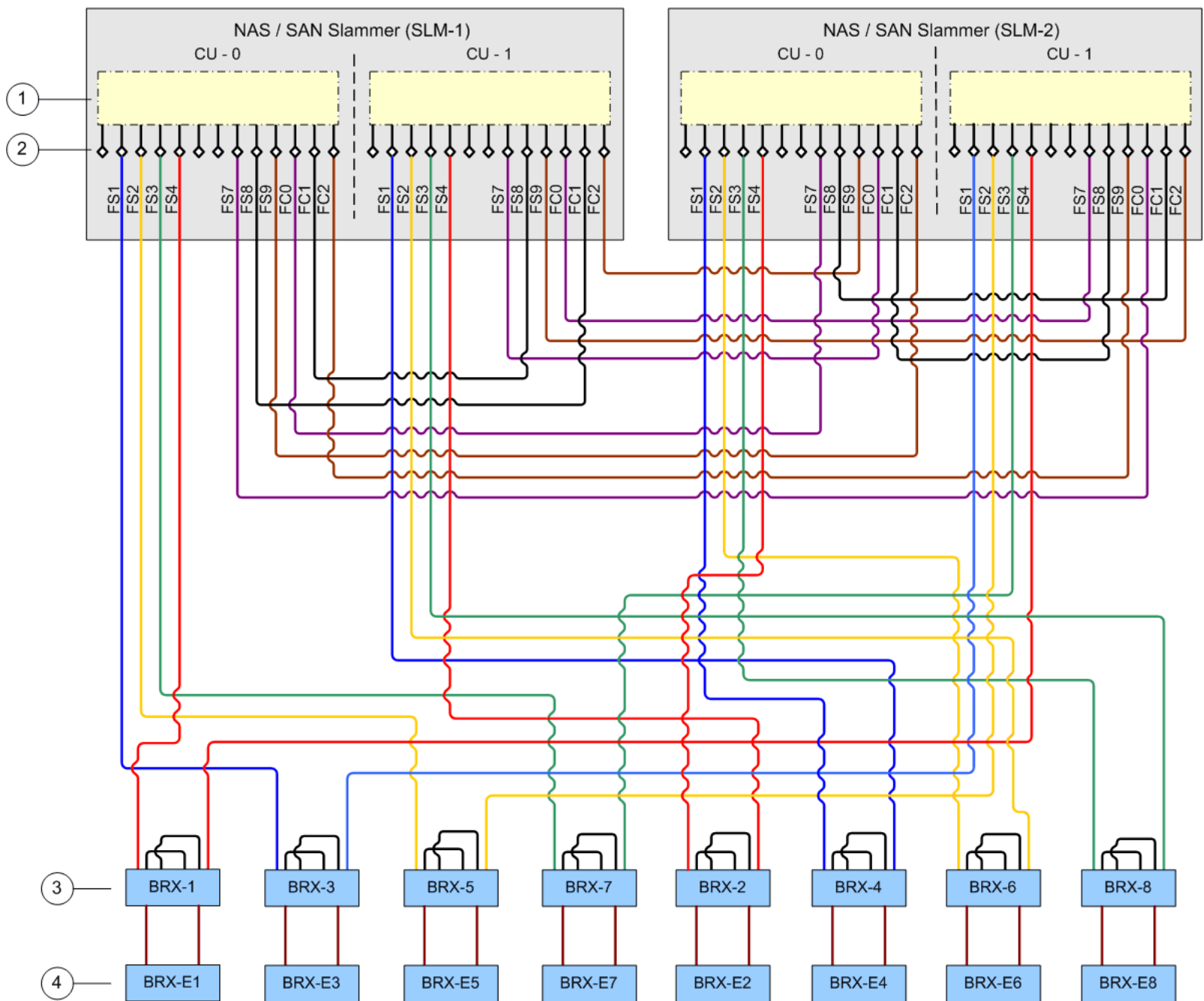

<b>Legend</b>	1 Private interconnect module (PIM) (version 1).	3 FC RAID Bricks.
	2 Ports ( ◊ ) on the PIM.	4 FC Expansion Bricks.

**Important!** This illustration is for reference only.

### Notes on the 2x16 Wiring Diagram for FC Bricks

- 2-Slammer systems contain at most eight Brick strings.
- A 2x16 system consisting entirely of Fibre Channel (FC) Bricks requires two 42 U racks. Because FC Bricks require slightly more power than do SATA Bricks, a single rack (containing a Pilot and two Slammers) can support only 13 FC Bricks.
- A FC Brick string is limited to four FC RAID Bricks.
- A FC Expansion Brick must connect to a FC RAID Brick.
- Install all FC and Ethernet cables for Slammer-to-Slammer and Slammer-to-Pilot connections. For 2-Slammer systems, see:
  - [Table 16: FC cable connections for two Slammers and the first set of eight SATA Bricks.](#)

- [Table 21: Ethernet cable connections for PMI \(2-Slammer system\).](#)
- Install Slammer-to-Brick and Brick-to-Brick connections according to the drawing in [Figure 29](#).
- FC RAID Bricks are at the head of the string (first row) in both figures. FC Expansion Bricks are in the second row.
- [Figure 29](#) shows the order that Bricks are to be added to a system.
- The entire Storage System Fabric (SSF) uses 2 Gbs FC patch cables throughout.

## Cable the Slammers and FC Bricks

The table below specifies all FC cables and their connections for two Slammers and the 16 FC Bricks (eight FC RAID Bricks and eight FC Expansion Bricks). All such interconnections are part of the Storage System Fabric (SSF).

**Table 23 FC cable connections for two Slammers and 16 FC Bricks**

Case 2:	Two Slammers—all FC Bricks		
	From	To	
	Chassis / CU / Port	Chassis / CU / Port	
For BRX-1:	SLM-1 / CU-0 FS-4	BRX-1 / CU-0 FC-2	
	SLM-2 / CU-1 FS-4	BRX-1 / CU-1 FC-2	
	BRX-1 / CU-0 FC-0	BRX-1 / CU-1 FC-3	
	BRX-1 / CU-1 FC-0	BRX-1 / CU-0 FC-3	
For BRX-E1:	BRX-1 CU-0 J0	BRX-E1 / CU-0 J1	
	BRX-1 CU-1 J0	BRX-E1 / CU-1 J1	
	BRX-1 CU-0 Pnet-0	BRX-E1 / CU-0 Pnet-1	RJ-45 cable
	BRX-1 CU-1 Pnet-0	BRX-E1 / CU-1 Pnet-1	RJ-45 cable
For BRX-2:	SLM-2 / CU-0 FS-4	BRX-2 / CU-0 FC-2	
	SLM-1 / CU-1 FS-4	BRX-2 / CU-1 FC-2	
	BRX-2 / CU-0 FC-0	BRX-2 / CU-1 FC-3	
	BRX-2 / CU-1 FC-0	BRX-2 / CU-0 FC-3	
For BRX-E2:	BRX-2 CU-0 J0	BRX-E2 / CU-0 J1	
	BRX-2 CU-1 J0	BRX-E2 / CU-1 J1	
	BRX-2 CU-0 Pnet-0	BRX-E2 / CU-0 Pnet-1	RJ-45 cable
	BRX-2 CU-1 Pnet-0	BRX-E2 / CU-1 Pnet-1	RJ-45 cable
For BRX-3:	SLM-1 / CU-0 FS-1	BRX-3 / CU-0 FC-2	
	SLM-2 / CU-1 FS-1	BRX-3 / CU-1 FC-2	
	BRX-3 / CU-0 FC-0	BRX-3 / CU-1 FC-3	
	BRX-3 / CU-1 FC-0	BRX-3 / CU-0 FC-3	
For BRX-E3:	BRX-3 CU-0 J0	BRX-E3 / CU-0 J1	
	BRX-3 CU-1 J0	BRX-E3 / CU-1 J1	
	BRX-3 CU-0 Pnet-0	BRX-E3 / CU-0 Pnet-1	RJ-45 cable
	BRX-3 CU-1 Pnet-0	BRX-E3 / CU-1 Pnet-1	RJ-45 cable
For BRX-4:	SLM-2 / CU-0 FS-1	BRX-4 / CU-0 FC-2	
	SLM-1 / CU-1 FS-1	BRX-4 / CU-1 FC-2	
	BRX-4 / CU-0 FC-0	BRX-4 / CU-1 FC-3	
	BRX-4 / CU-1 FC-0	BRX-4 / CU-0 FC-3	
For BRX-E4:	BRX-4 CU-0 J0	BRX-E4 / CU-0 J1	
	BRX-4 CU-1 J0	BRX-E4 / CU-1 J1	
	BRX-4 CU-0 Pnet-0	BRX-E4 / CU-0 Pnet-1	RJ-45 cable
	BRX-4 CU-1 Pnet-0	BRX-E4 / CU-1 Pnet-1	RJ-45 cable
For BRX-5:	SLM-1 / CU-0 FS-2	BRX-5 / CU-0 FC-2	
	SLM-2 / CU-1 FS-2	BRX-5 / CU-1 FC-2	
	BRX-5 / CU-0 FC-0	BRX-5 / CU-1 FC-3	
	BRX-5 / CU-1 FC-0	BRX-5 / CU-0 FC-3	
For BRX-E5:	BRX-5 CU-0 J0	BRX-E5 / CU-0 J1	
	BRX-5 CU-1 J0	BRX-E5 / CU-1 J1	
	BRX-5 CU-0 Pnet-0	BRX-E5 / CU-0 Pnet-1	RJ-45 cable
	BRX-5 CU-1 Pnet-0	BRX-E5 / CU-1 Pnet-1	RJ-45 cable
For BRX-6:	SLM-2 / CU-0 FS-2	BRX-6 / CU-0 FC-2	
	SLM-1 / CU-1 FS-2	BRX-6 / CU-1 FC-2	
	BRX-6 / CU-0 FC-0	BRX-6 / CU-1 FC-3	
	BRX-6 / CU-1 FC-0	BRX-6 / CU-0 FC-3	
For BRX-E6:	BRX-6 CU-0 J0	BRX-E6 / CU-0 J1	
	BRX-6 CU-1 J0	BRX-E6 / CU-1 J1	
	BRX-6 CU-0 Pnet-0	BRX-E6 / CU-0 Pnet-1	RJ-45 cable
	BRX-6 CU-1 Pnet-0	BRX-E6 / CU-1 Pnet-1	RJ-45 cable
For BRX-7:	SLM-1 / CU-0 FS-3	BRX-7 / CU-0 FC-2	
	SLM-2 / CU-1 FS-3	BRX-7 / CU-1 FC-2	
	BRX-7 / CU-0 FC-0	BRX-7 / CU-1 FC-3	
	BRX-7 / CU-1 FC-0	BRX-7 / CU-0 FC-3	
For BRX-E7:	BRX-7 CU-0 J0	BRX-E7 / CU-0 J1	
	BRX-7 CU-1 J0	BRX-E7 / CU-1 J1	
	BRX-7 CU-0 Pnet-0	BRX-E7 / CU-0 Pnet-1	RJ-45 cable
	BRX-7 CU-1 Pnet-0	BRX-E7 / CU-1 Pnet-1	RJ-45 cable
For BRX-8:	SLM-2 / CU-0 FS-3	BRX-8 / CU-0 FC-2	
	SLM-1 / CU-1 FS-3	BRX-8 / CU-1 FC-2	
	BRX-8 / CU-0 FC-0	BRX-8 / CU-1 FC-3	
	BRX-8 / CU-1 FC-0	BRX-8 / CU-0 FC-3	
For BRX-E8:	BRX-8 CU-0 J0	BRX-E8 / CU-0 J1	
	BRX-8 CU-1 J0	BRX-E8 / CU-1 J1	
	BRX-8 CU-0 Pnet-0	BRX-E8 / CU-0 Pnet-1	RJ-45 cable
	BRX-8 CU-1 Pnet-0	BRX-E8 / CU-1 Pnet-1	RJ-45 cable

When cabling the fabric, be aware of the following facts:

- Private interconnect module (PIM) and SATA RAID controller connections:
  - Version 1 PIMs and SATA RAID controllers both use HSSDC2 (high-speed serial data connection) type connections.
  - Version 2 PIMs and SATA RAID controllers both use SFP (small form-factor pluggable) type connections.
  - When connecting a version 1 component to a version 2 component, use a hybrid HSSDC2-to-SFP adapter cable.
- Cable lengths:
  - The cable lengths for Slammer-to-Brick connections are 6.56 ft (2.0 m).
  - Cable lengths for Brick-to-Brick (FC-1 to FC-2) connections are also 6.56 ft (2.0 m).



- Cable lengths for cross connections (FC-0 to FC-3) between Brick control units (CUs) depend on the Brick type:
  - Version 1 Bricks: 1.64 ft (0.5 m)
  - Version 2 Bricks: 3.28 ft (1.0 m)

## SHEET 23

## Cabling Example: Mix of FC and SATA Bricks

## Sample Wiring Diagram for a Mix of Brick Types

The figure below is a conceptual example of cabling a mix of Fibre Channel (FC) and version 1 SATA Brick storage enclosures. This figure defines the Brick-to-Brick connections required to connect such a mix.

**Caution** Before you mix FC and SATA Bricks, contact the Pillar World Wide Customer Support Center for the best practice approach.

Figure 30 Sample cabling for an FC RAID Brick, an FC Expansion Brick, and two SATA Bricks

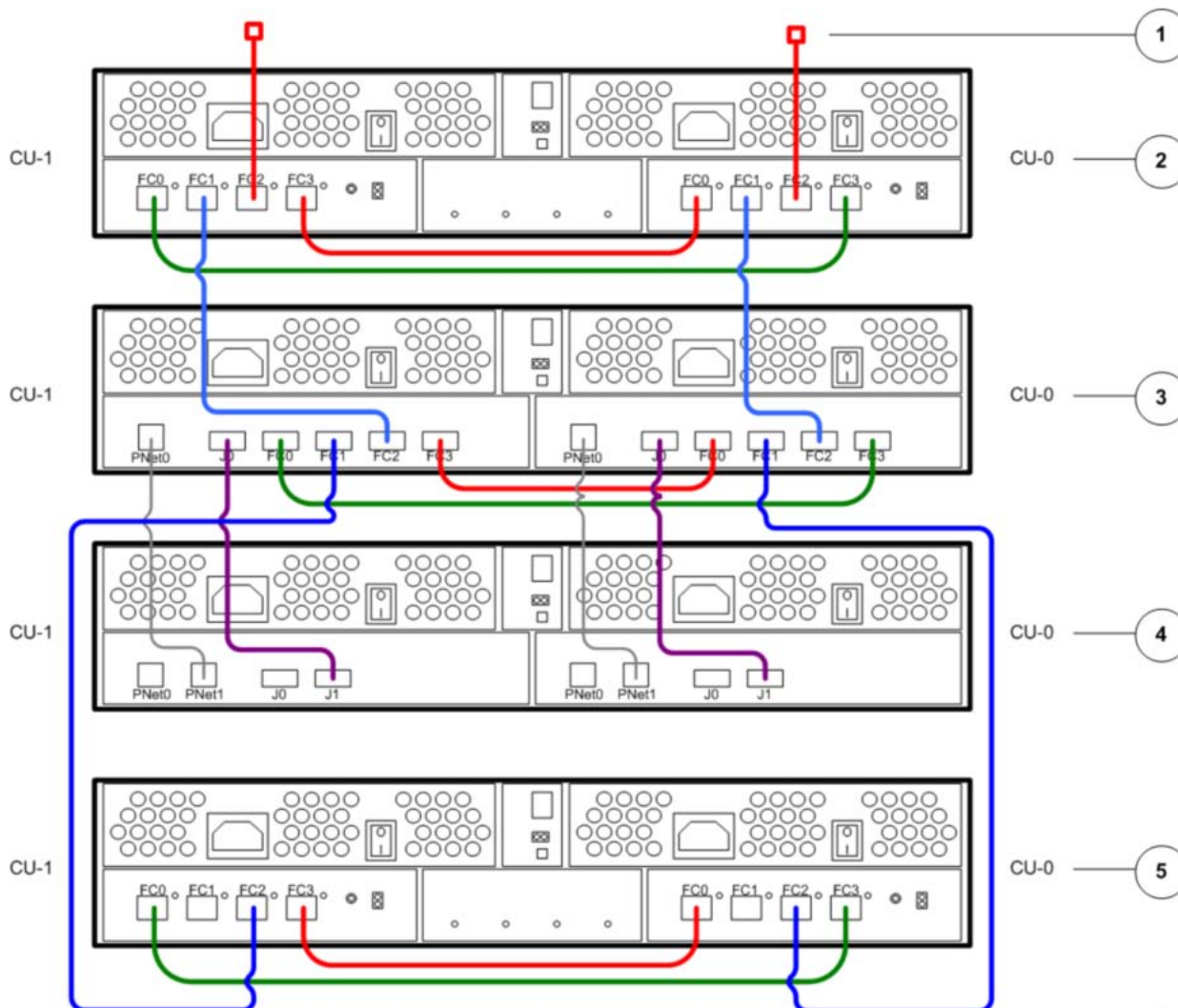

Legend	
1	Connection to a Slammer or an upstream Brick.
2	Upstream SATA Brick (version 1).
3	FC RAID Brick.
4	FC Expansion Brick.
5	Downstream SATA Brick (version 1).

**Important!** This illustration is for reference only.

## Notes on the Wiring Diagram for a Mix of Brick Types

- Note the relative load factor of the various Brick types, when balancing mixed storage across Brick strings.
- An FC RAID Brick or an FC Expansion Brick is approximately equivalent of two SATA Bricks *version 2*. Therefore, there can be a maximum of four Fibre Channel (FC) Bricks in a string compared to eight SATA Bricks in the string.
- A string may contain at most one SSD Brick and the SSD Brick must be at the beginning of the Brick string.
- The cabling of version 2 SATA Bricks is the same as the cabling shown in [Figure 30](#).
- [Figure 30](#) shows a single FC RAID Brick fully connected:
  - Downstream to a SATA Brick.
  - Upstream to an FC Expansion Brick.

- Downstream to another SATA Brick.
- When adding Bricks to systems in the field, FC Bricks may be added onto SATA Brick strings and SATA Bricks may be added onto FC Brick strings. [Figure 30](#) illustrates how to cable for both scenarios.

## Cabling Block Diagram: A 1-Slammer System Using FC and SATA Bricks

### Block Diagram for a 1x16 System Using FC and SATA Bricks

The figure below illustrates the stringing of a full complement of eight Fibre Channel (FC) Bricks and eight SATA Bricks in a 1-Slammer Pillar Axiom 600 system that uses version 1 private interconnect modules (PIMs). The stringing scheme maps four Brick strings, each being four Bricks deep.

**Caution** Before you mix FC and SATA Bricks, contact the Pillar World Wide Customer Support Center for the best practice approach.

Figure 31 Cabling block diagram for 1-Slammer systems with FC and SATA Bricks

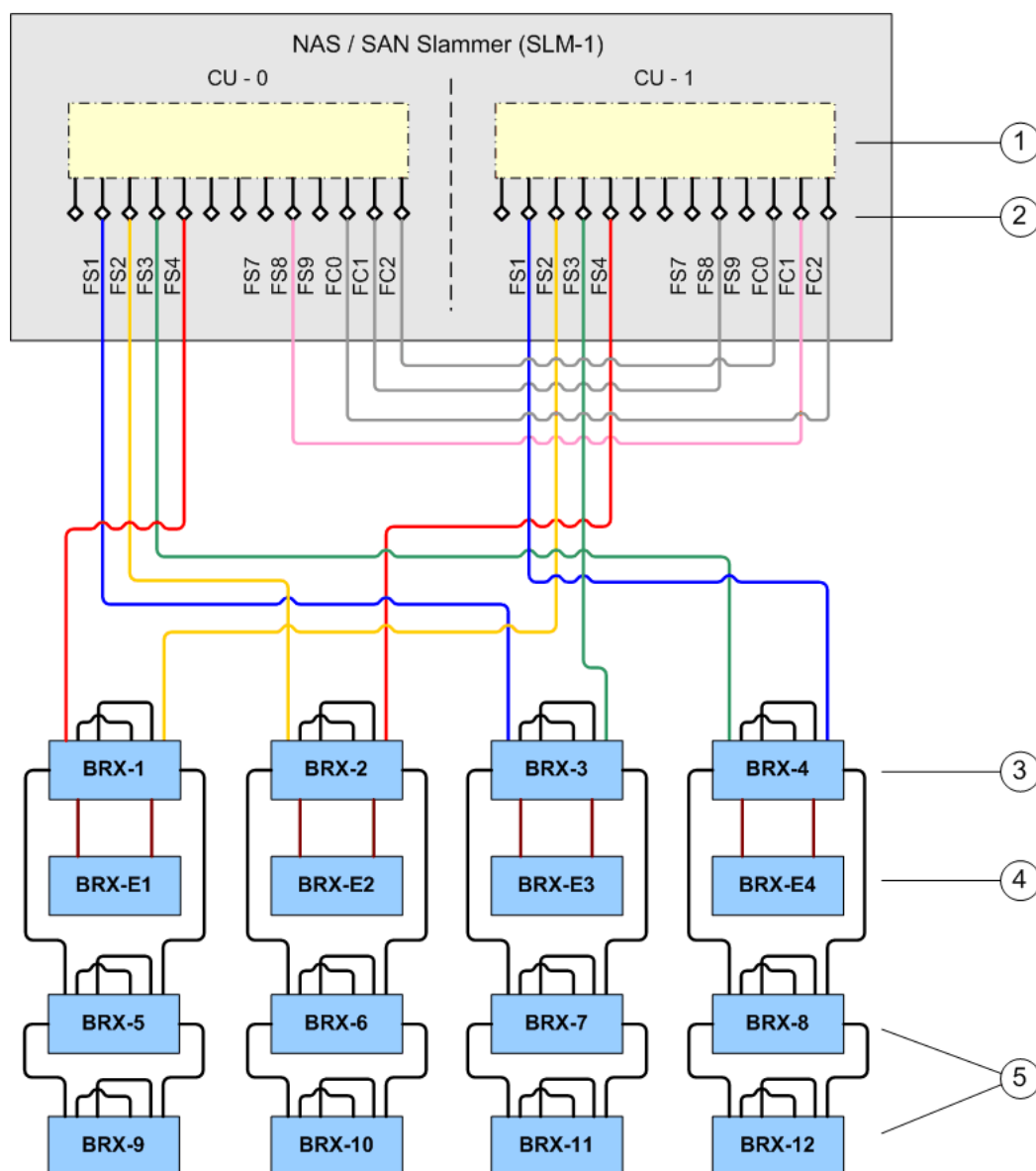

<b>Legend</b>	1 Private interconnect module (PIM) (version 1).	4 FC Expansion Bricks.
	2 A port ( ◊ ) on the private interconnect module.	5 SATA Bricks containing hard drives (HDDs).
	3 FC RAID Bricks.	

**Important!** This illustration is for reference only.

### Notes on the 1x16 Block Diagram for FC and SATA Bricks

- SATA Bricks containing solid-state drives (SSDs) or hard drives (HDDs) can be mixed with Fibre Channel (FC) Bricks.
- A string may contain at most one SSD Brick and the SSD Brick must be at the beginning of the Brick string.
- [Figure 31](#) represents how a mix of FC and HDD-based SATA Bricks would be built in manufacturing.
- The control unit (CU) cross connections for version 2 Slammer private interconnect modules (PIMs) are different. For the cross connections for a version 2 PIM, see [Table 9](#).
- A 1x16 system consisting entirely of FC Bricks requires two 42 U racks. Because FC Bricks require slightly more power than do SATA Bricks, a single rack can support only 15 FC Bricks.

- Bricks should be added to strings so that the number of Bricks in any string differs by no more than two between the longest and the shortest string.
- For the Pillar Axiom 600, a string may contain up to eight Bricks.
- A FC Brick string is limited to four FC RAID Bricks.
- A FC Expansion Brick must connect to a FC RAID Brick.
- The ports used for adding FC RAID Bricks and SATA Bricks progress in the same sequence. Doing so allows a consistent connection pattern for both FC and SATA Bricks.
- Install all FC and Ethernet cables for Slammer cross connections and Slammer-to-Pilot connections:
  - [Table 9: FC cable connections for the Slammer and the first and second sets of four SATA Bricks.](#)
  - [Table 13: Cable connections for the PMI \(1-Slammer system\).](#)
- Install Slammer-to-Brick and Brick-to-Brick connections, in this order:
  - First, FC Brick connections, which are defined in [Table 22](#).
  - Then, SATA Brick connections, which are defined in [Table 9](#).
- As shown in [Figure 31](#), FC RAID Bricks are in the first row while FC Expansion Bricks are in the second row.
- The entire Storage System Fabric (SSF) uses 2 Gb FC patch cables throughout.
- The configuration of systems upgraded in the field may differ somewhat from those built in the factory.

### Block Diagram for Expanding an Initial Configuration of FC Bricks

The figure below illustrates how to expand an initial configuration of Fibre Channel (FC) Bricks using SATA Bricks. This example shows the result of a system that has an initial configuration of three FC Bricks, which is then expanded by adding two SATA Bricks.

**Note:** An acceptable alternate configuration for the SATA addition would connect BRX-5 to BRX-4 to improve balance across the Slammer ports.

Figure 32 Cabling block diagram for expanding 1-Slammer systems with SATA Bricks

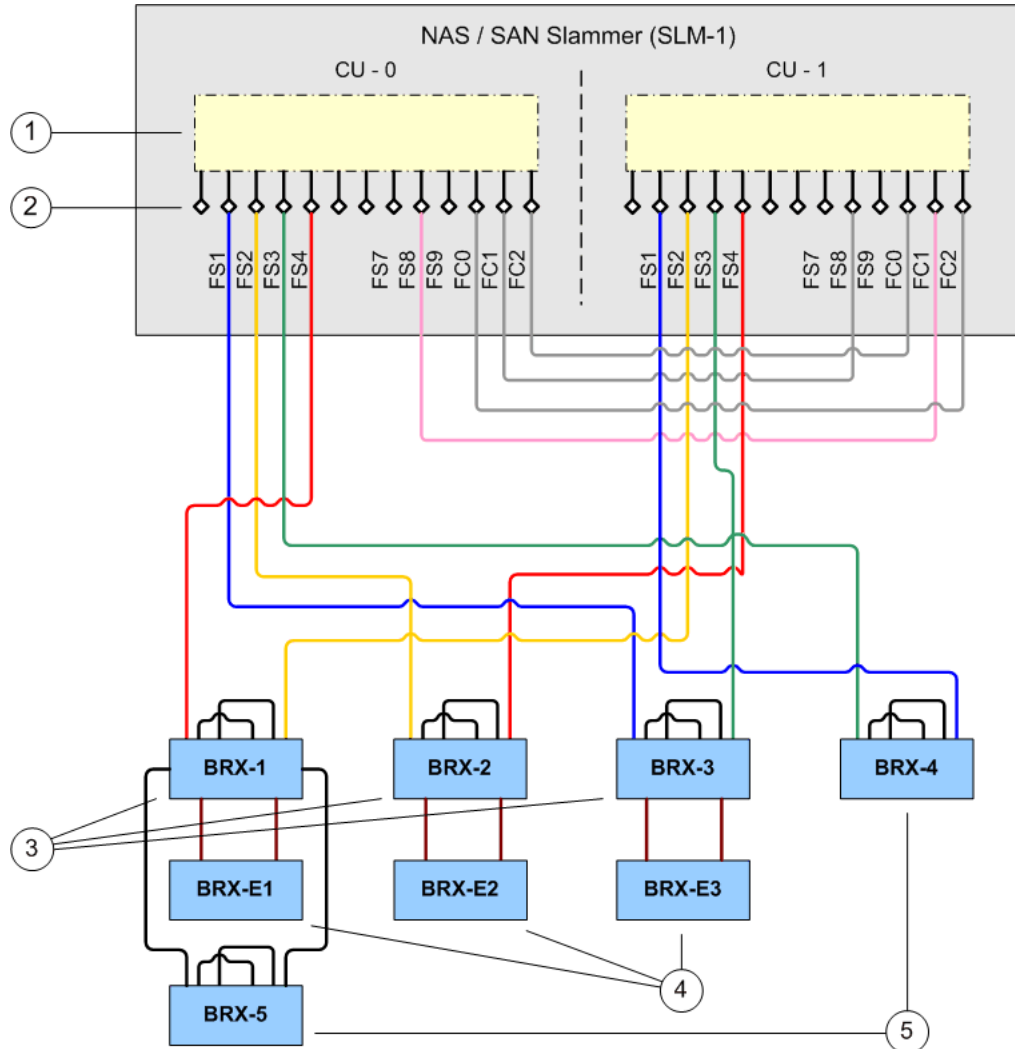

<b>Legend</b>	1 Private interconnect module (PIM) (version 1).	4 FC Expansion Bricks.
	2 Ports ( ◊ ) on the private interconnect module.	5 SATA Bricks.
	3 FC RAID Bricks.	

**Important!** This illustration is for reference only. It shows version 1 PIMs in the Slammer. For the cross connections for a version 2 PIM, see [Table 9](#).

## Notes for Adding SATA Bricks to a Set of FC Bricks

- Private interconnect module (PIM) and SATA RAID controller connections:
  - Version 1 PIMs and SATA RAID controllers both use HSSDC2 (high-speed serial data connection) type connections.
  - Version 2 PIMs and SATA RAID controllers both use SFP (small form-factor pluggable) type connections.
  - When connecting a version 1 component to a version 2 component, use a hybrid HSSDC2-to-SFP adapter cable.
- Cable lengths:
  - The cable lengths for Slammer-to-Brick connections are 6.56 ft (2.0 m).
  - Cable lengths for Brick-to-Brick (FC-1 to FC-2) connections are also 6.56 ft (2.0 m).
  - Cable lengths for cross connections (FC-0 to FC-3) between Brick control units (CUs) depend on the Brick type:
    - Version 1 Bricks: 1.64 ft (0.5 m)
    - Version 2 Bricks: 3.28 ft (1.0 m)
- The total number of Bricks supported in a system is specified in the *Pillar Axiom Customer Release Notes*.
- The total number of Bricks (both FC and SATA) in any string is limited to eight.

SHEET 25

## Cabling Block Diagram: A 2-Slammer System Using FC and SATA Bricks

### Block Diagram for a 2x24 System Using FC and SATA Bricks

The figure below illustrates the stringing of a full complement of eight Fibre Channel (FC) Brick pairs (one RAID Brick plus one Expansion Brick) to eight SATA Bricks in a 2-Slammer Pillar Axiom 600 system. The stringing scheme maps eight Brick strings, each being three Bricks deep.

**Caution** Before you mix FC and SATA Bricks, contact the Pillar World Wide Customer Support Center for the best practice approach.

Figure 33 Cabling block diagram for 2-Slammer systems with full complement of FC Bricks and eight SATA Bricks

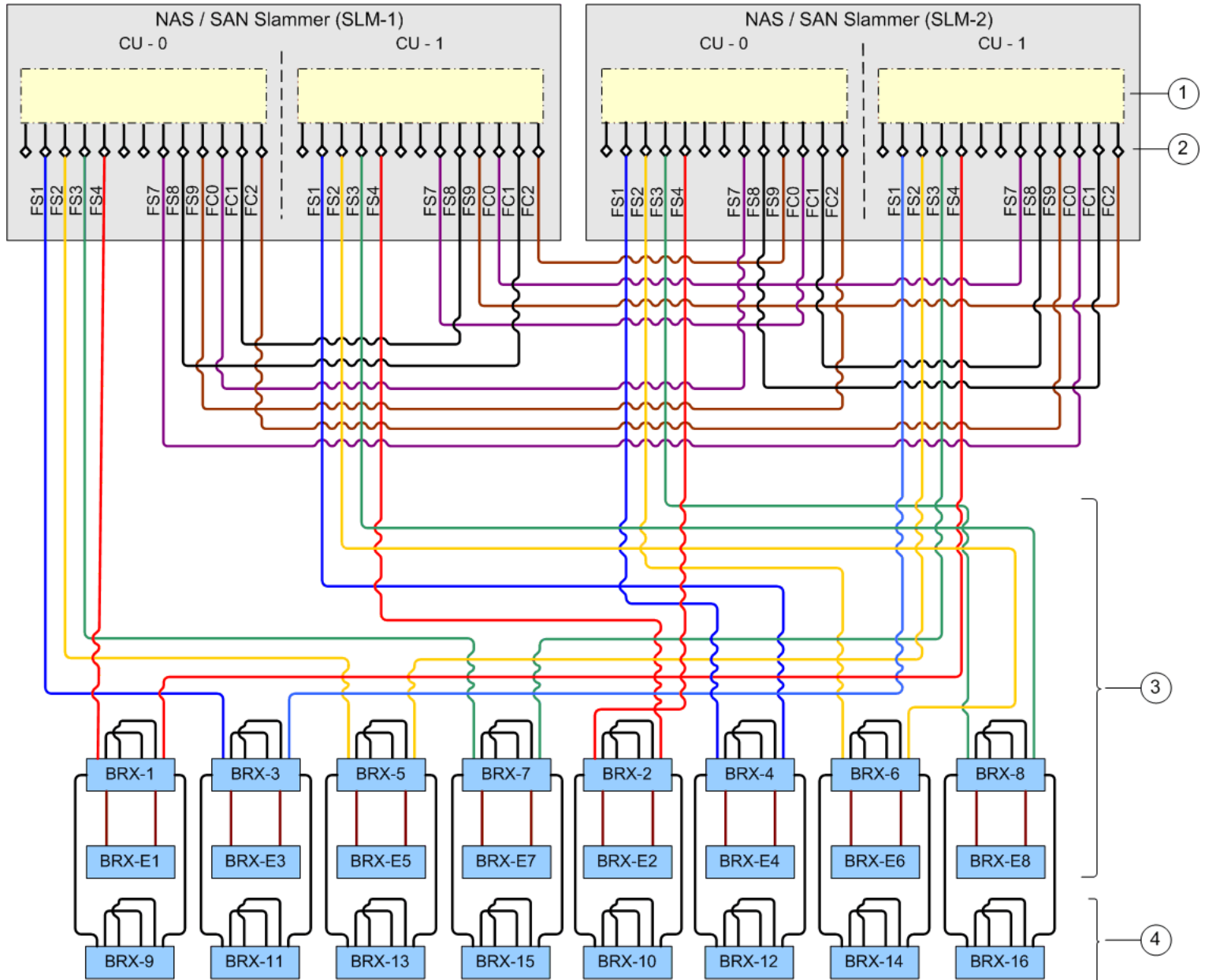

<b>Legend</b>	1 Private interconnect module (PIM) (version 1).	3 FC RAID Brick and Expansion Brick pair connections (closest to the Slammers).
	2 Ports (◇) on the PIM.	4 SATA Brick connections.

**Important!** This illustration is for reference only. It shows version 1 PIMs in the two Slammers. For the cross connections for a version 2 PIM, see [Table 9](#).

### Notes on the 2x24 Block Diagram for FC and SATA Bricks

- Bricks should be added to strings so that the number of Bricks in any string differs by no more than two between the longest and the shortest string.
- For the Pillar Axiom 600 system, a string may contain up to eight SATA Bricks.
- A FC Brick string is limited to four FC RAID Bricks.
- A FC Expansion Brick must connect to a FC RAID Brick.

- [Figure 33](#) illustrates a 2x24 system that includes just eight SATA Bricks. A 2-Slammer system can support up to 64 Bricks (a combination of SATA and FC).
- The entire Storage System Fabric (SSF) uses 2 Gb FC patch cables throughout.
- The configuration of systems upgraded in the field may differ somewhat from those built in the factory.
- For complete information on cabling rules, see [Summary of Cabling Rules](#).

## Cable the SATA and FC Bricks

When cabling the fabric, be aware of the following:

- Private interconnect module (PIM) and SATA RAID controller connections:
    - Version 1 PIMs and SATA RAID controllers both use HSSDC2 (high-speed serial data connection) type connections.
    - Version 2 PIMs and SATA RAID controllers both use SFP (small form-factor pluggable) type connections.
    - When connecting a version 1 component to a version 2 component, use a hybrid HSSDC2-to-SFP adapter cable.
  - Cable lengths:
    - The cable lengths for Slammer-to-Brick connections are 6.56 ft (2.0 m).
    - Cable lengths for Brick-to-Brick (FC-1 to FC-2) connections are also 6.56 ft (2.0 m).
    - Cable lengths for cross connections (FC-0 to FC-3) between Brick control units (CUs) depend on the Brick type:
      - Version 1 Bricks: 1.64 ft (0.5 m)
      - Version 2 Bricks: 3.28 ft (1.0 m)
- 1 Install all Ethernet cables for Slammer-to-Pilot connections.  
See [Table 21](#).
  - 2 Install all FC cables for Slammer control unit (CU) cross connections.  
The cross connecting of Slammer CUs depends on the version of private interconnect module used in the Slammers. See [Table 16](#).
  - 3 Install all Slammer-to-SATA Brick connections.  
See [Table 16](#).
  - 4 If any of the SATA Bricks identified in the first row of [Figure 33](#) (BRX-1 through BRX-8) are not installed, connect the corresponding FC RAID Brick to the Slammer ports.  
To determine which Slammer ports to use, see [Table 23](#).
  - 5 Install the FC Expansion Bricks.  
See [Table 23](#).



# Part V: Cabling Pillar Axiom 600 Systems Using Three Slammers

SHEET 26

## Cross Connections for 3-Slammer Systems

### Control Unit (CU) Cross Connections for Three Version 1 Slammers

This block diagram illustrates how to cable the Slammer cross connections in a 3-Slammer configuration that uses all version 1 private interconnect modules (PIMs).

Figure 34 Cabling CU cross connections for a 3-Slammer configuration (version 1 PIMs)

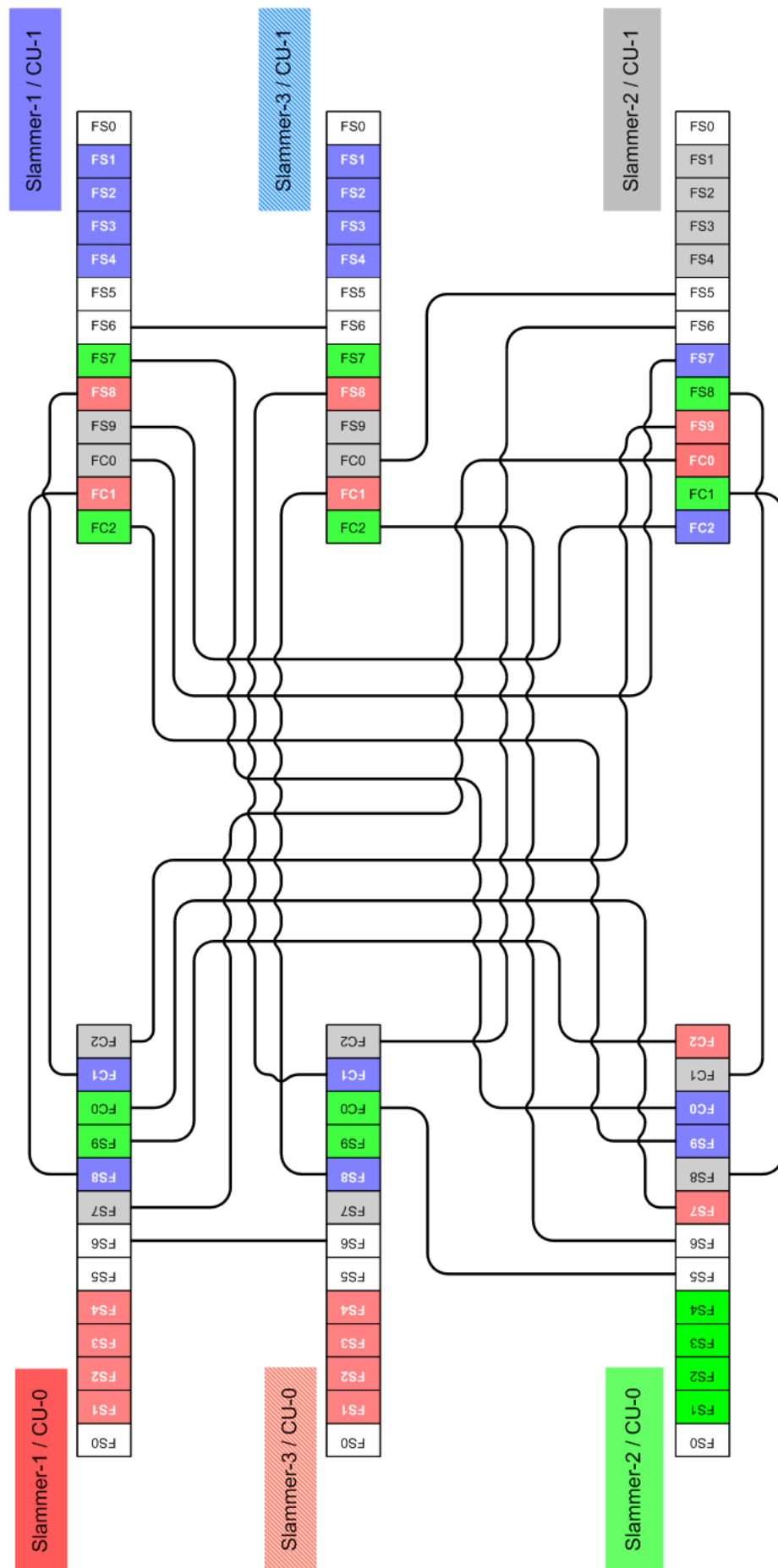

The following table defines, cable by cable, the cross connections among the version 1 PIMs that are contained in the three Slammers.

Table 24 3-Slammer cross connection configuration (version 1 PIMs)

From Chassis / CU / Port	To Chassis / CU / Port
SLM-1 / CU-0 FC-0	SLM-2 / CU-0 FS-7
SLM-1 / CU-0 FC-1	SLM-1 / CU-1 FS-8
SLM-1 / CU-0 FC-2	SLM-2 / CU-1 FS-9
SLM-1 / CU-1 FC-0	SLM-2 / CU-1 FS-7
SLM-1 / CU-1 FC-1	SLM-1 / CU-0 FS-8
SLM-1 / CU-1 FC-2	SLM-2 / CU-0 FS-9
SLM-2 / CU-0 FC-0	SLM-1 / CU-1 FS-7
SLM-2 / CU-0 FC-1	SLM-2 / CU-1 FS-8
SLM-2 / CU-0 FC-2	SLM-1 / CU-0 FS-9
SLM-2 / CU-1 FC-0	SLM-1 / CU-0 FS-7
SLM-2 / CU-1 FC-1	SLM-2 / CU-0 FS-8
SLM-2 / CU-1 FC-2	SLM-1 / CU-1 FS-9
SLM-3 / CU-0 FC-0	SLM-2 / CU-0 FS-5
SLM-3 / CU-0 FC-1	SLM-3 / CU-1 FS-8
SLM-3 / CU-0 FC-2	SLM-2 / CU-1 FS-6
SLM-3 / CU-0 FS-6	SLM-1 / CU-0 FS-6
SLM-3 / CU-1 FC-0	SLM-2 / CU-1 FS-5
SLM-3 / CU-1 FC-1	SLM-3 / CU-0 FS-8
SLM-3 / CU-1 FC-2	SLM-2 / CU-0 FS-6
SLM-3 / CU-1 FS-6	SLM-1 / CU-1 FS-6

- Ports FC0, FC2, and FS6 are used to connect the third Slammer to the first and second Slammer.
- The Fibre Channel (FC) ports connect the Fibre Channel ASIC to the Fibre Channel Switch through the FS ports:
  - SLM-3 CU-0 FC0 connects to SLM-2 CU-0 FS5
  - SLM-3 CU-1 FC0 connects to SLM-2 CU-1 FS5
  - SLM-3 CU-0 FC2 connects to SLM-2 CU-1 FS6
  - SLM-3 CU-1 FC2 connects to SLM-2 CU-0 FS6
  - SLM-3 CU-0 FS6 connects to SLM-1 CU-0 FS6
  - SLM-3 CU-1 FS6 connects to SLM-1 CU-1 FS6

## Control Unit (CU) Cross Connections for Three Version 2 Slammers

This block diagram illustrates how to cable the Slammer cross connections in a 3-Slammer configuration that uses all version 2 private interconnect modules (PIMs).

Figure 35 Cabling CU cross connections for a 3-Slammer configuration (version 2 PIMs)

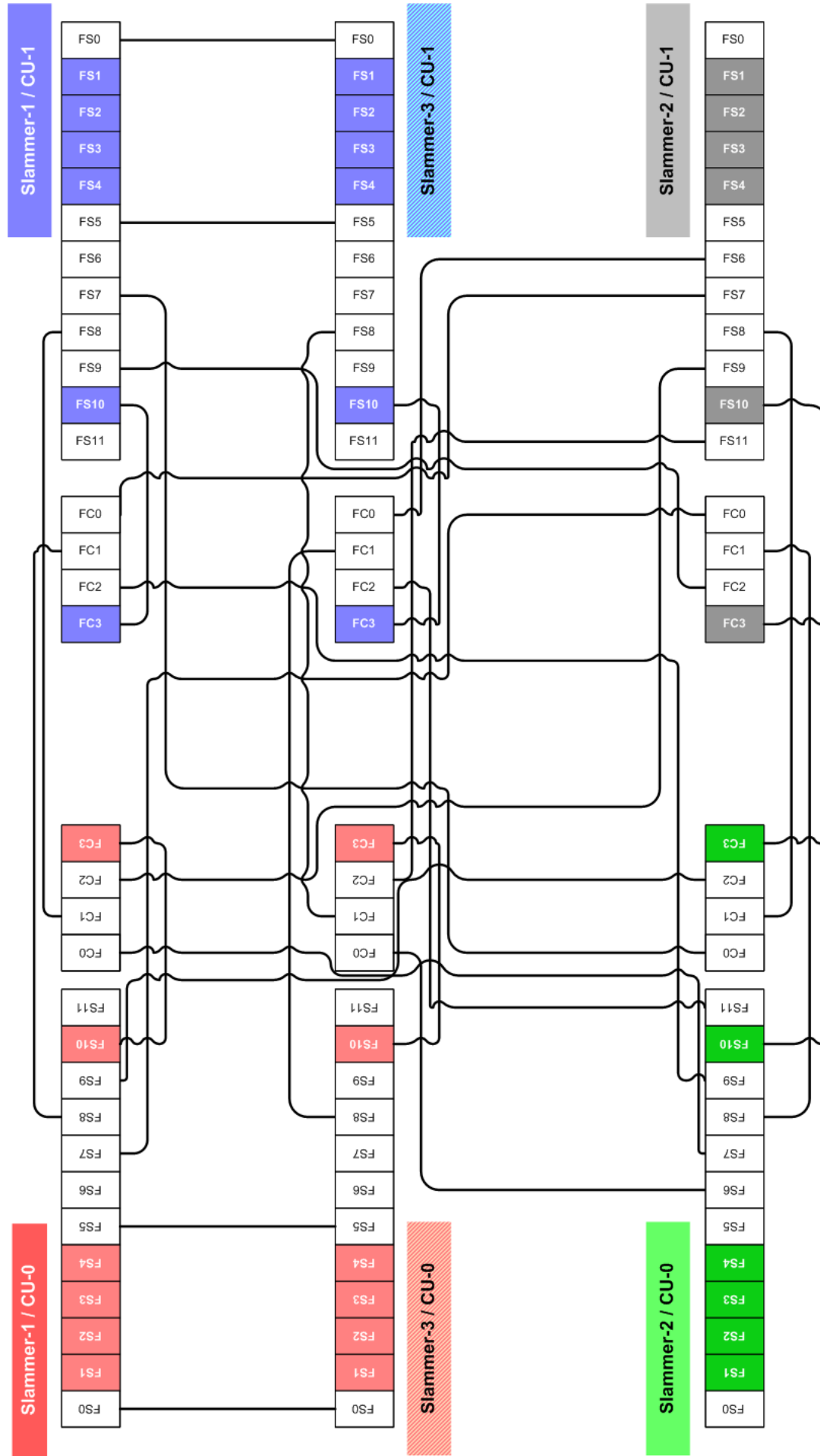

The following table defines the CU cross connections among the version 2 PIMs that are contained in the three Slammers, cable by cable.

Table 25 3-Slammer cross connection configuration (version 2 PIMs)

From	To
Chassis / CU / Port	Chassis / CU / Port
SLM-1 / CU-0 FC-0	SLM-2 / CU-0 FS-7
SLM-1 / CU-0 FC-1	SLM-1 / CU-1 FS-8
SLM-1 / CU-0 FC-2	SLM-2 / CU-1 FS-9
SLM-1 / CU-0 FC-3	SLM-1 / CU-0 FS-10
SLM-1 / CU-1 FC-0	SLM-2 / CU-1 FS-7
SLM-1 / CU-1 FC-1	SLM-1 / CU-0 FS-8
SLM-1 / CU-1 FC-2	SLM-2 / CU-0 FS-9
SLM-1 / CU-1 FC-3	SLM-1 / CU-1 FS-10
SLM-2 / CU-0 FC-0	SLM-1 / CU-1 FS-7
SLM-2 / CU-0 FC-1	SLM-2 / CU-1 FS-8
SLM-2 / CU-0 FC-2	SLM-1 / CU-0 FS-9
SLM-2 / CU-0 FC-3	SLM-2 / CU-0 FS-10
SLM-2 / CU-1 FC-0	SLM-1 / CU-0 FS-7
SLM-2 / CU-1 FC-1	SLM-2 / CU-0 FS-8
SLM-2 / CU-1 FC-2	SLM-1 / CU-1 FS-9
SLM-2 / CU-1 FC-3	SLM-2 / CU-1 FS-10
SLM-3 / CU-0 FC-0	SLM-2 / CU-0 FS-6
SLM-3 / CU-0 FC-1	SLM-3 / CU-1 FS-8
SLM-3 / CU-0 FC-2	SLM-2 / CU-1 FS-11
SLM-3 / CU-0 FC-3	SLM-3 / CU-0 FS-10
SLM-3 / CU-0 FS-0	SLM-1 / CU-0 FS-0
SLM-3 / CU-0 FS-5	SLM-1 / CU-0 FS-5
SLM-3 / CU-1 FC-0	SLM-2 / CU-1 FS-6
SLM-3 / CU-1 FC-1	SLM-3 / CU-0 FS-8
SLM-3 / CU-1 FC-2	SLM-2 / CU-0 FS-11
SLM-3 / CU-1 FC-3	SLM-3 / CU-1 FS-10
SLM-3 / CU-1 FS-0	SLM-1 / CU-1 FS-0
SLM-3 / CU-1 FS-5	SLM-1 / CU-1 FS-5

- Ports FC0, FC2, and FS6 are used to connect the third Slammer to the first and second Slammer.
- The Fibre Channel (FC) ports connect the Fibre Channel ASIC to the Fibre Channel Switch through the FS ports:
  - SLM-3 CU-0 FC0 connects to SLM-2 CU-0 FS5
  - SLM-3 CU-1 FC0 connects to SLM-2 CU-1 FS5
  - SLM-3 CU-0 FC2 connects to SLM-2 CU-1 FS6
  - SLM-3 CU-1 FC2 connects to SLM-2 CU-0 FS6
  - SLM-3 CU-0 FS6 connects to SLM-1 CU-0 FS6
  - SLM-3 CU-1 FS6 connects to SLM-1 CU-1 FS6

## Control Unit (CU) Cross Connections for Three Mixed Version Slammers

This block diagram illustrates how to cable the Slammer cross connections in a 3-Slammer configuration that uses both version 1 and version 2 private interconnect modules (PIMs).

**Note:** A particular Slammer cannot contain a version 1 private interconnect module (PIM) in one control unit (CU) and a version 2 PIM in the other CU. Both CUs must contain the same version of PIM.

Figure 36 Cabling CU cross connections for a 3-Slammer configuration (mixed PIM versions)

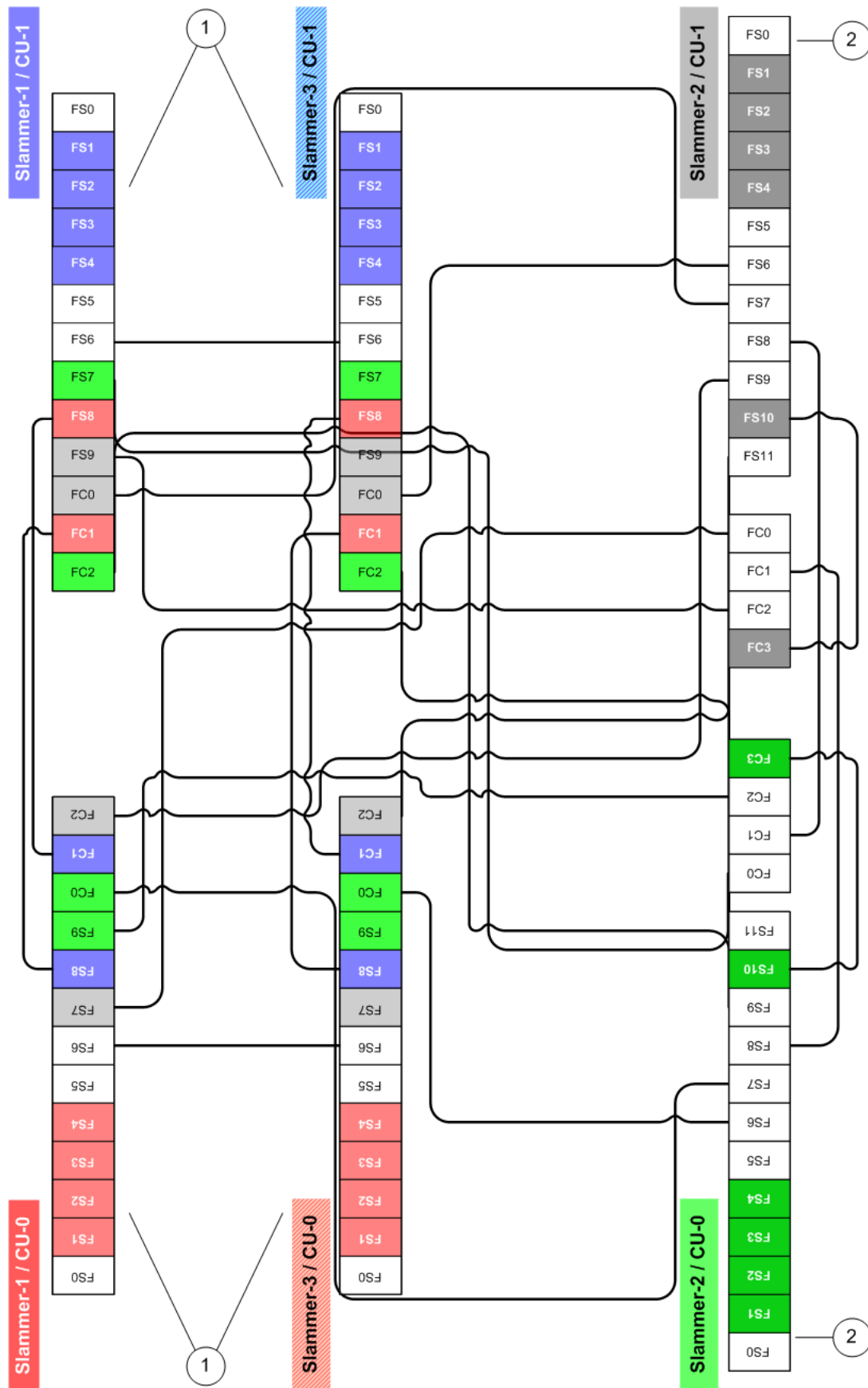

<b>Legend</b>	1 Slammers with version 1 PIMs.	2 Slammer with version 2 PIMs.
---------------	---------------------------------	--------------------------------

**Tip:** As noted above, Slammer-1 and Slammer-3 contain version 1 PIMs and Slammer-2 contains version 2 PIMs. This configuration is the only one that is supported for a 3-Slammer system. Furthermore, when you add a version 2 Slammer to an existing 2-Slammer configuration that contains version 1 PIMs, you must re-cable the previous Slammer-2 so that it becomes Slammer-3.

**Important!** When upgrading to this mixed configuration from a 2-Slammer system that uses version 1 PIMs only, the upgrade is disruptive. A disruptive upgrade means that you must shut down and restart the system. The restart needs to occur because the version 1 Slammer that was previously cabled to the Bricks as Slammer-2 is now cabled as Slammer-3.

The following table defines the CU cross connections, cable by cable, among two version 1 Slammers and one version 2 Slammer.

Table 26 3-Slammer cross connection configuration (mixed PIM versions)

From	To
Chassis / CU / Port	Chassis / CU / Port
SLM-1 / CU-0 FC-0	SLM-2 / CU-0 FS-7
SLM-1 / CU-0 FC-1	SLM-1 / CU-1 FS-8
SLM-1 / CU-0 FC-2	SLM-2 / CU-1 FS-9
SLM-1 / CU-1 FC-0	SLM-2 / CU-1 FS-7
SLM-1 / CU-1 FC-1	SLM-1 / CU-0 FS-8
SLM-1 / CU-1 FC-2	SLM-2 / CU-0 FS-9
SLM-2 / CU-0 FC-0	SLM-1 / CU-1 FS-7
SLM-2 / CU-0 FC-1	SLM-2 / CU-1 FS-8
SLM-2 / CU-0 FC-2	SLM-1 / CU-0 FS-9
SLM-2 / CU-0 FC-3	SLM-2 / CU-0 FS-10
SLM-2 / CU-1 FC-0	SLM-1 / CU-0 FS-7
SLM-2 / CU-1 FC-1	SLM-2 / CU-0 FS-8
SLM-2 / CU-1 FC-2	SLM-1 / CU-1 FS-9
SLM-2 / CU-1 FC-3	SLM-2 / CU-1 FS-10
SLM-3 / CU-0 FC-0	SLM-2 / CU-0 FS-6
SLM-3 / CU-0 FC-1	SLM-3 / CU-1 FS-8
SLM-3 / CU-0 FC-2	SLM-2 / CU-1 FS-11
SLM-3 / CU-0 FS-6	SLM-1 / CU-0 FS-6
SLM-3 / CU-1 FC-0	SLM-2 / CU-1 FS-6
SLM-3 / CU-1 FC-1	SLM-3 / CU-0 FS-8
SLM-3 / CU-1 FC-2	SLM-2 / CU-0 FS-11
SLM-3 / CU-1 FS-6	SLM-1 / CU-1 FS-6

SHEET 27

# Brick Connections for 3-Slammer Systems

## Block Diagram: Connecting Bricks to Three Slammers

This diagram illustrates how to connect Brick strings to the Slammers and Bricks to Bricks in a 3-Slammer, 32-Brick (8-string) configuration.

Figure 37 Connecting a 3-Slammer configuration to 32 Bricks

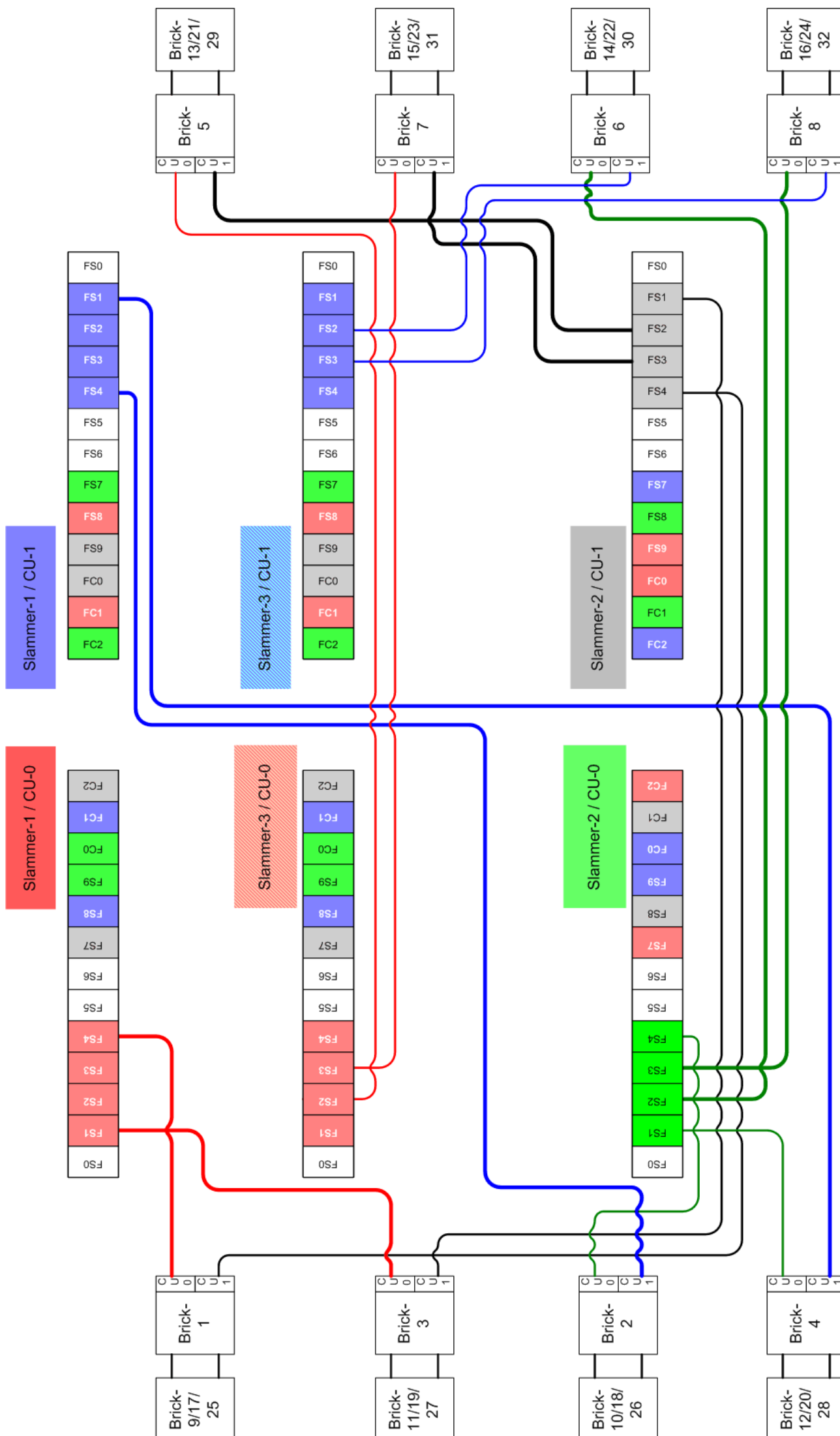

## Cable the Slammers and Bricks

These tables define the Brick connections in 3-Slammer configurations, cable by cable.

The Slammer-to-Brick and Brick-to-Brick connections identified below correspond to [Figure 37](#).

Table 27 Cable connections for three Slammers and 16 Bricks

<b>BRX-1:</b>	SLM-1 / CU-0 FS-4	BRX-1 / CU-0 FC-2
	SLM-2 / CU-1 FS-4	BRX-1 / CU-1 FC-2
	BRX-1 / CU-0 FC-0	BRX-1 / CU-1 FC-3
	BRX-1 / CU-1 FC-0	BRX-1 / CU-0 FC-3
<b>BRX-2:</b>	SLM-2 / CU-0 FS-4	BRX-2 / CU-0 FC-2
	SLM-1 / CU-1 FS-4	BRX-2 / CU-1 FC-2
	BRX-2 / CU-0 FC-0	BRX-2 / CU-1 FC-3
	BRX-2 / CU-1 FC-0	BRX-2 / CU-0 FC-3
<b>BRX-3:</b>	SLM-1 / CU-0 FS-1	BRX-3 / CU-0 FC-2
	SLM-2 / CU-1 FS-1	BRX-3 / CU-1 FC-2
	BRX-3 / CU-0 FC-0	BRX-3 / CU-1 FC-3
	BRX-3 / CU-1 FC-0	BRX-3 / CU-0 FC-3
<b>BRX-4:</b>	SLM-2 / CU-0 FS-1	BRX-4 / CU-0 FC-2
	SLM-1 / CU-1 FS-1	BRX-4 / CU-1 FC-2
	BRX-4 / CU-0 FC-0	BRX-4 / CU-1 FC-3
	BRX-4 / CU-1 FC-0	BRX-4 / CU-0 FC-3
<b>BRX-5:</b>	SLM-3 / CU-0 FS-2	BRX-5 / CU-0 FC-2
	SLM-2 / CU-1 FS-2	BRX-5 / CU-1 FC-2
	BRX-5 / CU-0 FC-0	BRX-5 / CU-1 FC-3
	BRX-5 / CU-1 FC-0	BRX-5 / CU-0 FC-3
<b>BRX-6:</b>	SLM-2 / CU-0 FS-2	BRX-6 / CU-0 FC-2
	SLM-3 / CU-1 FS-2	BRX-6 / CU-1 FC-2
	BRX-6 / CU-0 FC-0	BRX-6 / CU-1 FC-3
	BRX-6 / CU-1 FC-0	BRX-6 / CU-0 FC-3
<b>BRX-7:</b>	SLM-3 / CU-0 FS-3	BRX-7 / CU-0 FC-2
	SLM-2 / CU-1 FS-3	BRX-7 / CU-1 FC-2
	BRX-7 / CU-0 FC-0	BRX-7 / CU-1 FC-3
	BRX-7 / CU-1 FC-0	BRX-7 / CU-0 FC-3
<b>BRX-8:</b>	SLM-2 / CU-0 FS-3	BRX-8 / CU-0 FC-2
	SLM-3 / CU-1 FS-3	BRX-8 / CU-1 FC-2
	BRX-8 / CU-0 FC-0	BRX-8 / CU-1 FC-3
	BRX-8 / CU-1 FC-0	BRX-8 / CU-0 FC-3
<b>BRX-9:</b>	BRX-1 / CU-0 FC-1	BRX-9 / CU-0 FC-2
	BRX-1 / CU-1 FC-1	BRX-9 / CU-1 FC-2
	BRX-9 / CU-0 FC-0	BRX-9 / CU-1 FC-3
	BRX-9 / CU-1 FC-0	BRX-9 / CU-0 FC-3
<b>BRX-10:</b>	BRX-2 / CU-0 FC-1	BRX-10 / CU-0 FC-2
	BRX-2 / CU-1 FC-1	BRX-10 / CU-1 FC-2
	BRX-10 / CU-0 FC-0	BRX-10 / CU-1 FC-3
	BRX-10 / CU-1 FC-0	BRX-10 / CU-0 FC-3
<b>BRX-11:</b>	BRX-3 / CU-0 FC-1	BRX-11 / CU-0 FC-2
	BRX-3 / CU-1 FC-1	BRX-11 / CU-1 FC-2
	BRX-11 / CU-0 FC-0	BRX-11 / CU-1 FC-3
	BRX-11 / CU-1 FC-0	BRX-11 / CU-0 FC-3
<b>BRX-12:</b>	BRX-4 / CU-0 FC-1	BRX-12 / CU-0 FC-2
	BRX-4 / CU-1 FC-1	BRX-12 / CU-1 FC-2
	BRX-12 / CU-0 FC-0	BRX-12 / CU-1 FC-3
	BRX-12 / CU-1 FC-0	BRX-12 / CU-0 FC-3
<b>BRX-13:</b>	BRX-5 / CU-0 FC-1	BRX-13 / CU-0 FC-2
	BRX-5 / CU-1 FC-1	BRX-13 / CU-1 FC-2
	BRX-13 / CU-0 FC-0	BRX-13 / CU-1 FC-3
	BRX-13 / CU-1 FC-0	BRX-13 / CU-0 FC-3
<b>BRX-14:</b>	BRX-6 / CU-0 FC-1	BRX-14 / CU-0 FC-2
	BRX-6 / CU-1 FC-1	BRX-14 / CU-1 FC-2
	BRX-14 / CU-0 FC-0	BRX-14 / CU-1 FC-3
	BRX-14 / CU-1 FC-0	BRX-14 / CU-0 FC-3
<b>BRX-15:</b>	BRX-7 / CU-0 FC-1	BRX-15 / CU-0 FC-2
	BRX-7 / CU-1 FC-1	BRX-15 / CU-1 FC-2
	BRX-15 / CU-0 FC-0	BRX-15 / CU-1 FC-3
	BRX-15 / CU-1 FC-0	BRX-15 / CU-0 FC-3
<b>BRX-16:</b>	BRX-8 / CU-0 FC-1	BRX-16 / CU-0 FC-2
	BRX-8 / CU-1 FC-1	BRX-16 / CU-1 FC-2
	BRX-16 / CU-0 FC-0	BRX-16 / CU-1 FC-3
	BRX-16 / CU-1 FC-0	BRX-16 / CU-0 FC-3

The following notes will help you successfully cable the system:

- Private interconnect module (PIM) and SATA RAID controller connections:
  - Version 1 PIMs and SATA RAID controllers both use HSSDC2 (high-speed serial data connection) type connections.
  - Version 2 PIMs and SATA RAID controllers both use SFP (small form-factor pluggable) type connections.
  - When connecting a version 1 component to a version 2 component, use a hybrid HSSDC2-to-SFP adapter cable.
- Cable lengths:
  - The cable lengths for Slammer-to-Brick connections are 6.56 ft (2.0 m).
  - Cable lengths for Brick-to-Brick (FC-1 to FC-2) connections are also 6.56 ft (2.0 m).
  - Cable lengths for cross connections (FC-0 to FC-3) between Brick control units (CUs) depend on the Brick type:
    - Version 1 Bricks: 1.64 ft (0.5 m)
    - Version 2 Bricks: 3.28 ft (1.0 m)



Connect additional Bricks beyond the 16 explicitly defined in the preceding table by following the pattern shown for Bricks 9 through 16. The Brick numbers in each string are shown in [Figure 37](#) and in the following table:

**Table 28 Connections for additional Bricks**

Head of string	Second Brick	Third Brick	Fourth Brick
BRX-1	BRX-9	BRX-17	BRX-25
BRX-2	BRX-10	BRX-18	BRX-26
BRX-3	BRX-11	BRX-19	BRX-27
BRX-4	BRX-12	BRX-20	BRX-28
BRX-5	BRX-13	BRX-21	BRX-29
BRX-6	BRX-14	BRX-22	BRX-30
BRX-7	BRX-15	BRX-23	BRX-31
BRX-8	BRX-16	BRX-24	BRX-32

SHEET 28

## PMI Connections for 3-Slammer Systems

### Schematic of PMI Ethernet Connections in a 3-Slammer System

This schematic illustrates the Pilot-to-Slammer and Slammer-to-Slammer connections comprising the private management interface (PMI) in a 3-Slammer system.

Figure 38 PMI Ethernet schematic (3-Slammer system)

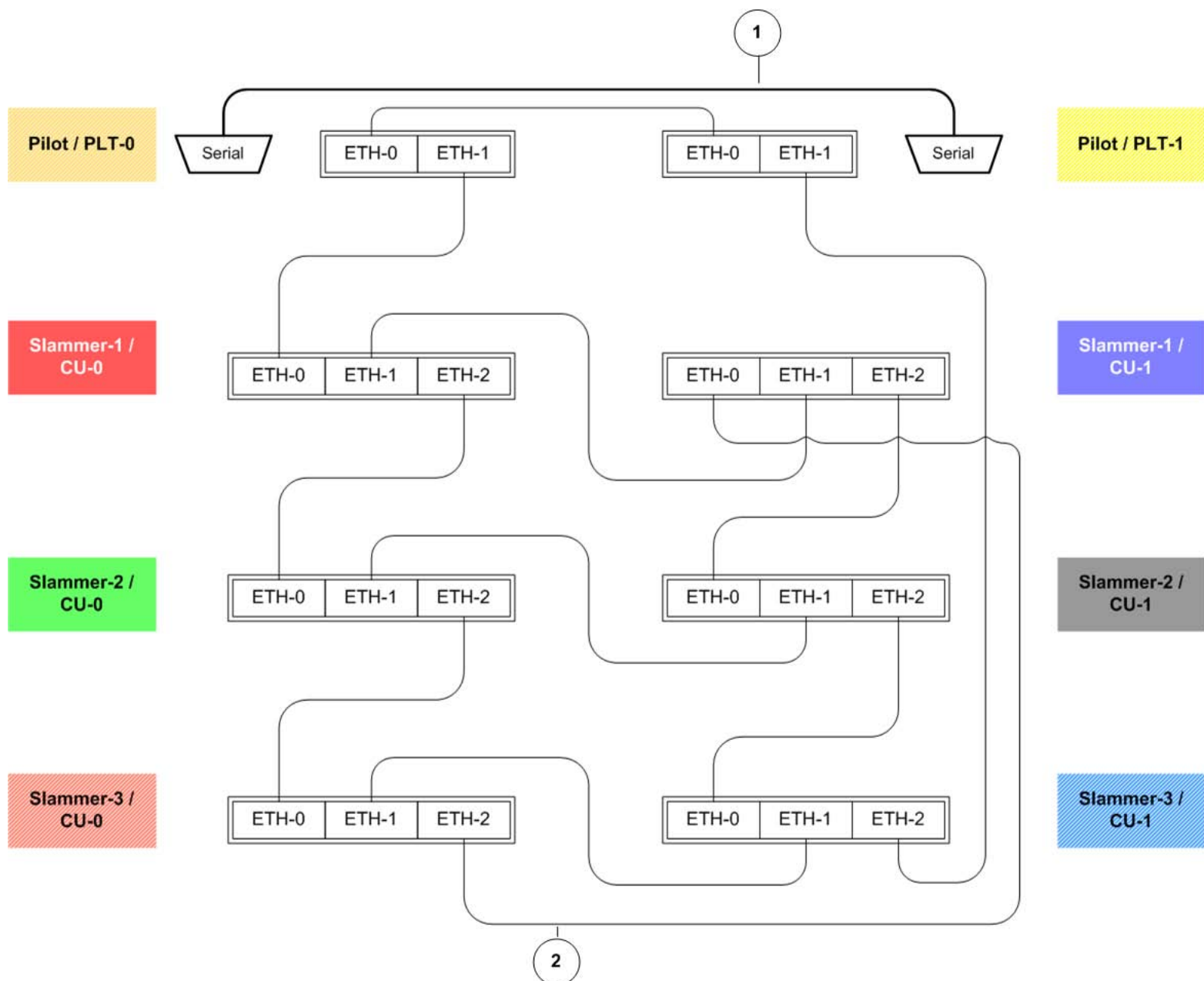

**Legend** 1 Null modem cable.

2 Cat-5 Ethernet cables.

### Private Management Interface (PMI) Connections in a 3-Slammer System

This table defines how to connect the Cat-5 Ethernet cables between the Pilot and the Slammers and among the Slammers themselves in a 3-Slammer system.

Table 29 Ethernet cable connections for PMI (3-Slammer system)

From	To
Chassis / CU / Port	Chassis / CU / Port
PLT-0 ETH0	PLT-1 ETH0
PLT-0 ETH1	SLM-1 / CU-0 ETH0
PLT-1 ETH1	SLM-3 / CU-1 ETH2
SLM-1 / CU-0 ETH1	SLM-1 / CU-1 ETH1
SLM-1 / CU-0 ETH2	SLM-2 / CU-0 ETH0
SLM-1 / CU-1 ETH2	SLM-2 / CU-1 ETH0
SLM-2 / CU-0 ETH1	SLM-2 / CU-1 ETH1
SLM-2 / CU-0 ETH2	SLM-3 / CU-0 ETH0
SLM-2 / CU-1 ETH2	SLM-3 / CU-1 ETH0
SLM-3 / CU-0 ETH1	SLM-3 / CU-1 ETH1
SLM-3 / CU-0 ETH2	SLM-1 / CU-1 ETH0

This schematic illustrates the Pilot-to-Slammer and Slammer-to-Slammer connections comprising the PMI in a 3-Slammer system.

Figure 39 PMI Ethernet schematic (3-Slammer system)

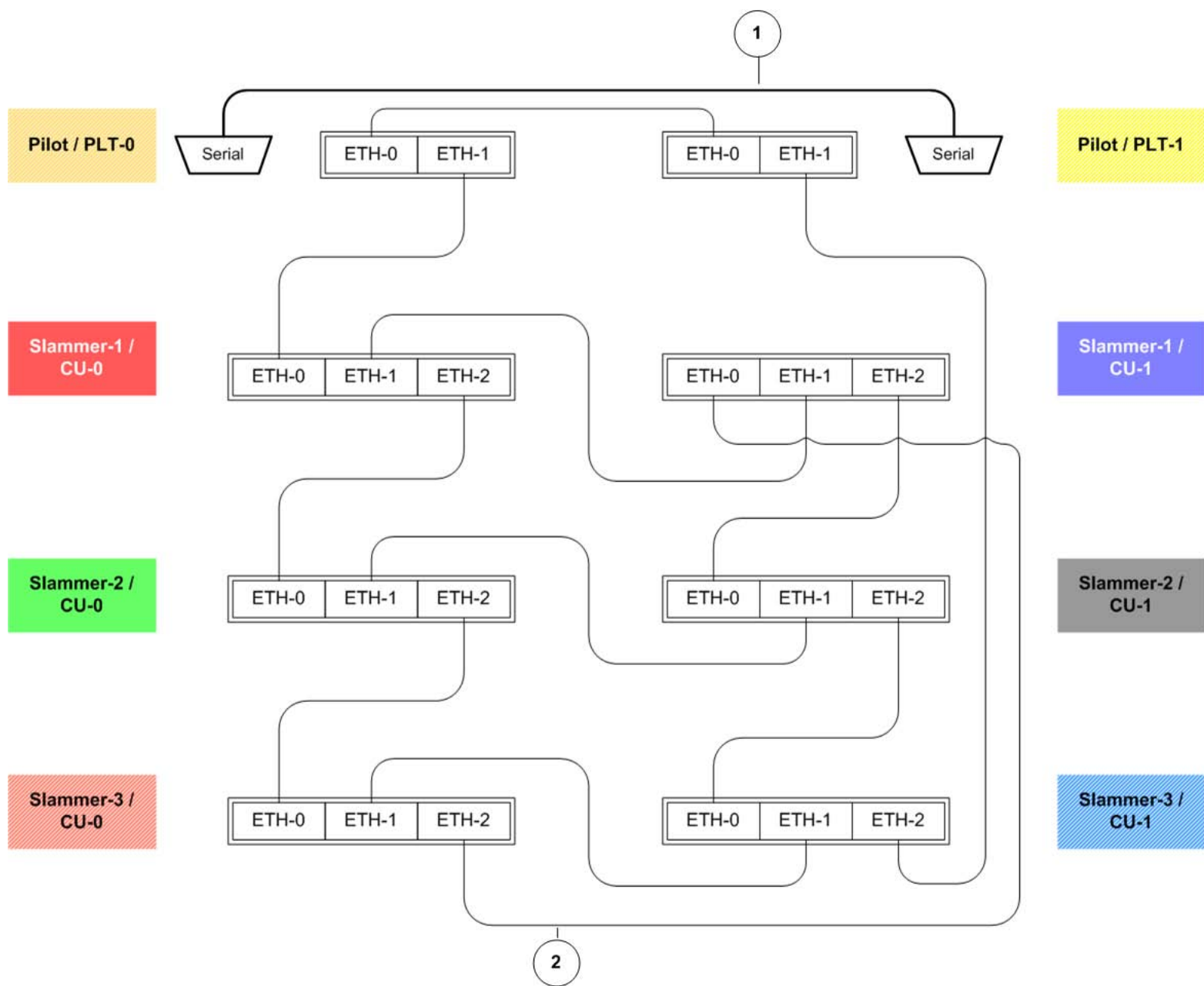

- Legend**
- 1 Null modem cable.
  - 2 Cat-5 Ethernet cables.

In addition to the Ethernet cables, PMI requires a null modem cable connection between the serial ports of each Pilot CU.

# Part VI: Cabling Pillar Axiom 600 Systems Using Four Slammers

SHEET 29

## Cross Connections for Four Slammers

### Control Unit (CU) Cross Connections for Four Version 1 Slammers

This diagram illustrates how to cable the Slammer cross-connections in a 4-Slammer configuration that uses version 1 private interconnect modules (PIMs) only.

Figure 40 Cabling CU cross connections for a 4-Slammer configuration (version 1 PIMs)

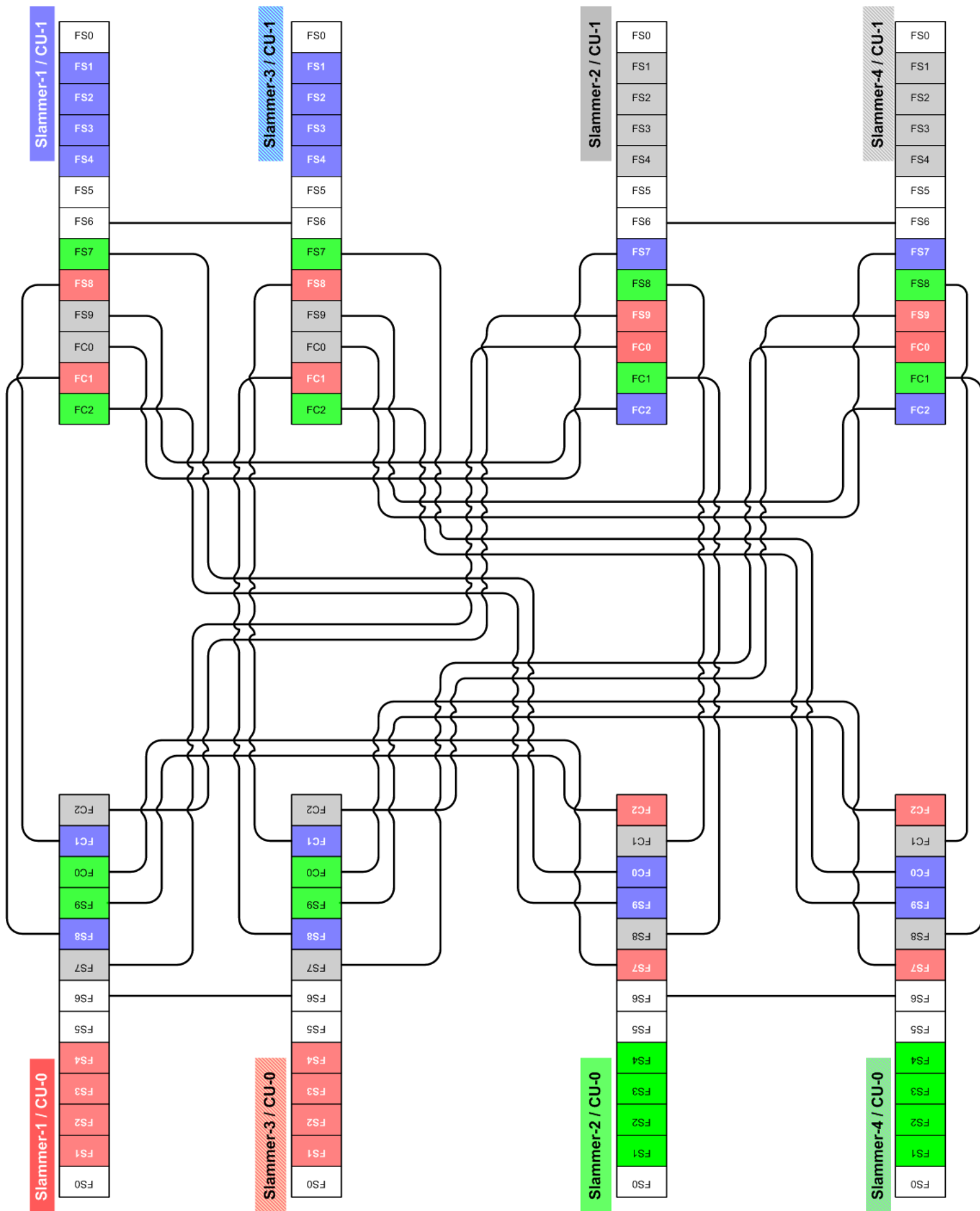

The following table defines the CU cross connections among four version 1 Slammers, cable by cable.

Table 30 4-Slammer cross connection configuration

Chassis / CU / Port	Chassis / CU / Port
SLM-1 / CU-0 FC-0	SLM-2 / CU-0 FS-7
SLM-1 / CU-0 FC-1	SLM-1 / CU-1 FS-8
SLM-1 / CU-0 FC-2	SLM-2 / CU-1 FS-9
SLM-1 / CU-1 FC-0	SLM-2 / CU-1 FS-7
SLM-1 / CU-1 FC-1	SLM-1 / CU-0 FS-8
SLM-1 / CU-1 FC-2	SLM-2 / CU-0 FS-9
SLM-2 / CU-0 FC-0	SLM-1 / CU-1 FS-7
SLM-2 / CU-0 FC-1	SLM-2 / CU-1 FS-8
SLM-2 / CU-0 FC-2	SLM-1 / CU-0 FS-9
SLM-2 / CU-1 FC-0	SLM-1 / CU-0 FS-7
SLM-2 / CU-1 FC-1	SLM-2 / CU-0 FS-8
SLM-2 / CU-1 FC-2	SLM-1 / CU-1 FS-9
SLM-3 / CU-0 FC-0	SLM-4 / CU-0 FS-7
SLM-3 / CU-0 FC-1	SLM-3 / CU-1 FS-8
SLM-3 / CU-0 FC-2	SLM-4 / CU-1 FS-9
SLM-3 / CU-0 FS-6	SLM-1 / CU-0 FS-6
SLM-3 / CU-1 FC-0	SLM-4 / CU-1 FS-7
SLM-3 / CU-1 FC-1	SLM-3 / CU-0 FS-8
SLM-3 / CU-1 FC-2	SLM-4 / CU-0 FS-9
SLM-3 / CU-1 FS-6	SLM-1 / CU-1 FS-6
SLM-4 / CU-0 FC-0	SLM-3 / CU-1 FS-7
SLM-4 / CU-0 FC-1	SLM-4 / CU-1 FS-8
SLM-4 / CU-0 FC-2	SLM-3 / CU-0 FS-9
SLM-4 / CU-0 FS-6	SLM-2 / CU-0 FS-6
SLM-4 / CU-1 FC-0	SLM-3 / CU-0 FS-7
SLM-4 / CU-1 FC-1	SLM-4 / CU-0 FS-8
SLM-4 / CU-1 FC-2	SLM-3 / CU-1 FS-9
SLM-4 / CU-1 FS-6	SLM-2 / CU-1 FS-6

- Ports FC0, FC2, FS6, FS7, and FS9 are used to connect the fourth Slammer to the first, second, and the third Slammer.
- The Fibre Channel (FC) ports connect the Fibre Channel ASIC to the Fibre Channel switch through the FS ports
  - SLM-4 CU-0 FC0 connects to SLM-3 CU-1 FS7
  - SLM-4 CU-1 FC0 connects to SLM-3 CU-0 FS7
  - SLM-4 CU-0 FC2 connects to SLM-3 CU-0 FS9
  - SLM-4 CU-1 FC2 connects to SLM-3 CU-1 FS9
  - SLM-4 CU-0 FS6 connects to SLM-2 CU-0 FS6
  - SLM-4 CU-1 FS6 connects to SLM-2 CU-1 FS6
  - SLM-4 CU-0 FS7 connects to SLM-3 CU-0 FC0
  - SLM-4 CU-1 FS7 connects to SLM-3 CU-1 FC0
  - SLM-4 CU-0 FS9 connects to SLM-3 CU-1 FC2
  - SLM-4 CU-1 FS9 connects to SLM-3 CU-0 FC2

## Control Unit (CU) Cross Connections for Four Version 2 Slammers

This diagram illustrates how to cable the Slammer cross-connections in a 4-Slammer configuration that uses version 2 private interconnect modules (PIMs) only.

Figure 41 Cabling CU cross connections for a 4-Slammer configuration (version 2 PIMs)

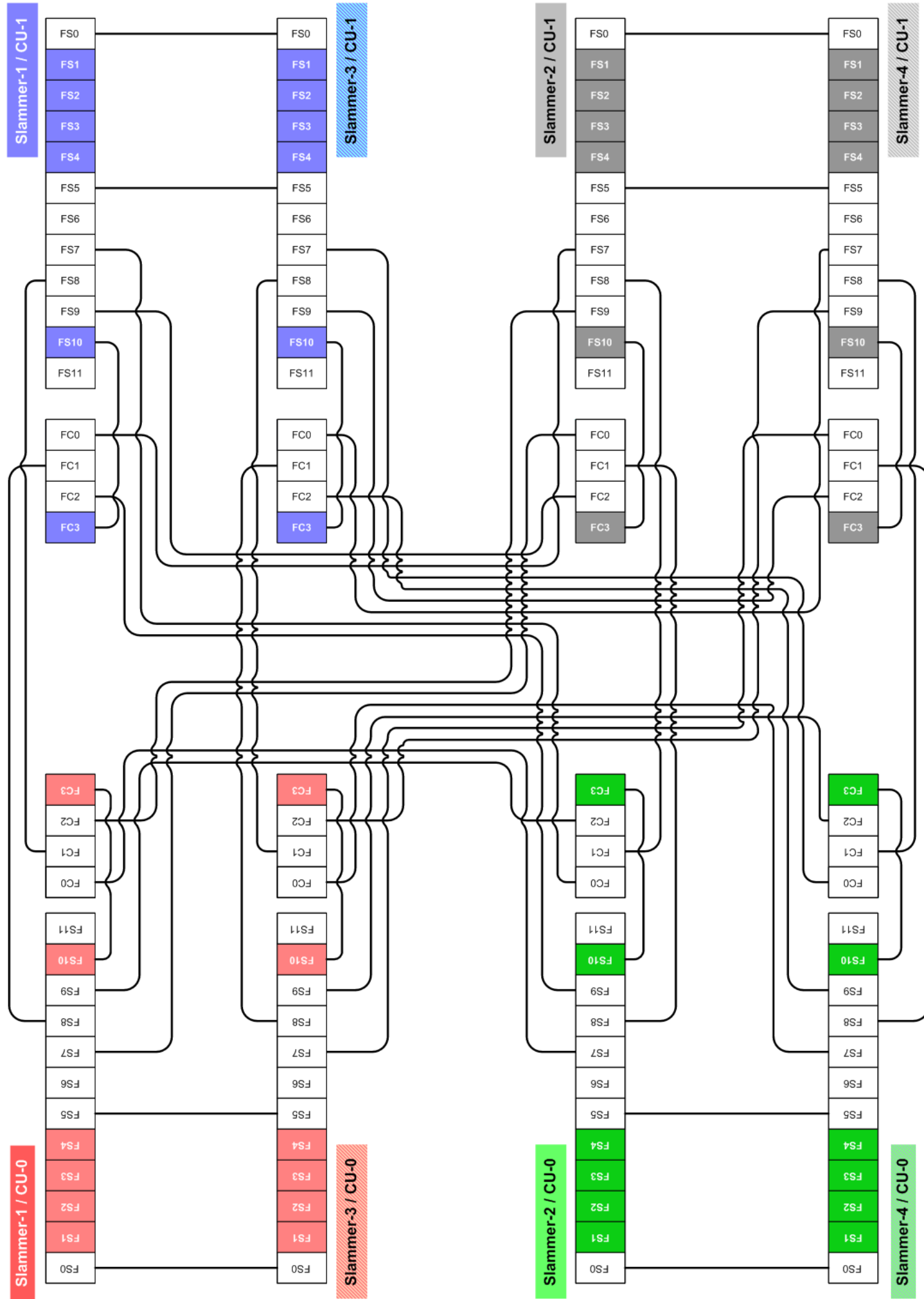

The following table defines the CU cross connections among the version 2 PIMs that are contained in the four Slammers, cable by cable.

Table 31 Slammer cross connection configuration for a 4-Slammer configuration (version 2 PIMs)

From	To
Chassis / CU / Port	Chassis / CU / Port
SLM-1 / CU-0 FC-0	SLM-2 / CU-0 FS-7
SLM-1 / CU-0 FC-1	SLM-1 / CU-1 FS-8
SLM-1 / CU-0 FC-2	SLM-2 / CU-1 FS-9
SLM-1 / CU-0 FC-3	SLM-1 / CU-0 FS-10
SLM-1 / CU-1 FC-0	SLM-2 / CU-1 FS-7
SLM-1 / CU-1 FC-1	SLM-1 / CU-0 FS-8
SLM-1 / CU-1 FC-2	SLM-2 / CU-0 FS-9
SLM-1 / CU-1 FC-3	SLM-1 / CU-1 FS-10
SLM-2 / CU-0 FC-0	SLM-1 / CU-1 FS-7
SLM-2 / CU-0 FC-1	SLM-2 / CU-1 FS-8
SLM-2 / CU-0 FC-2	SLM-1 / CU-0 FS-9
SLM-2 / CU-0 FC-3	SLM-2 / CU-0 FS-10
SLM-2 / CU-1 FC-0	SLM-1 / CU-0 FS-7
SLM-2 / CU-1 FC-1	SLM-2 / CU-0 FS-8
SLM-2 / CU-1 FC-2	SLM-1 / CU-1 FS-9
SLM-2 / CU-1 FC-3	SLM-2 / CU-1 FS-10
SLM-3 / CU-0 FC-0	SLM-4 / CU-0 FS-7
SLM-3 / CU-0 FC-1	SLM-3 / CU-1 FS-8
SLM-3 / CU-0 FC-2	SLM-4 / CU-1 FS-9
SLM-3 / CU-0 FC-3	SLM-3 / CU-0 FS-10
SLM-3 / CU-0 FS-0	SLM-1 / CU-0 FS-0
SLM-3 / CU-0 FS-5	SLM-1 / CU-0 FS-5
SLM-3 / CU-1 FC-0	SLM-4 / CU-1 FS-7
SLM-3 / CU-1 FC-1	SLM-3 / CU-0 FS-8
SLM-3 / CU-1 FC-2	SLM-4 / CU-0 FS-9
SLM-3 / CU-1 FC-3	SLM-3 / CU-1 FS-10
SLM-3 / CU-1 FS-0	SLM-1 / CU-1 FS-0
SLM-3 / CU-1 FS-5	SLM-1 / CU-1 FS-5
SLM-4 / CU-0 FC-0	SLM-3 / CU-1 FS-7
SLM-4 / CU-0 FC-1	SLM-4 / CU-1 FS-8
SLM-4 / CU-0 FC-2	SLM-3 / CU-0 FS-9
SLM-4 / CU-0 FC-3	SLM-4 / CU-0 FS-10
SLM-4 / CU-0 FS-0	SLM-2 / CU-0 FS-0
SLM-4 / CU-0 FS-5	SLM-2 / CU-0 FS-5
SLM-4 / CU-1 FC-0	SLM-3 / CU-0 FS-7
SLM-4 / CU-1 FC-1	SLM-4 / CU-0 FS-8
SLM-4 / CU-1 FC-2	SLM-3 / CU-1 FS-9
SLM-4 / CU-1 FC-3	SLM-4 / CU-1 FS-10
SLM-4 / CU-1 FS-0	SLM-2 / CU-1 FS-0
SLM-4 / CU-1 FS-5	SLM-2 / CU-1 FS-5

- Ports FC0, FC2, FS6, FS7, and FS9 connect the fourth Slammer to the first, second, and the third Slammer.
- The Fibre Channel (FC) ports connect the FC ASIC to the FC switch through the FS ports
  - SLM-4 CU-0 FC0 connects to SLM-3 CU-1 FS7
  - SLM-4 CU-1 FC0 connects to SLM-3 CU-0 FS7
  - SLM-4 CU-0 FC2 connects to SLM-3 CU-0 FS9
  - SLM-4 CU-1 FC2 connects to SLM-3 CU-1 FS9
  - SLM-4 CU-0 FS6 connects to SLM-2 CU-0 FS6
  - SLM-4 CU-1 FS6 connects to SLM-2 CU-1 FS6
  - SLM-4 CU-0 FS7 connects to SLM-3 CU-0 FC0
  - SLM-4 CU-1 FS7 connects to SLM-3 CU-1 FC0
  - SLM-4 CU-0 FS9 connects to SLM-3 CU-1 FC2
  - SLM-4 CU-1 FS9 connects to SLM-3 CU-0 FC2

## Control Unit (CU) Cross Connections for Four Mixed Version Slammers

This block diagram illustrates how to cable the Slammer cross-connections in a 4-Slammer configuration that uses Slammers that contain both version 1 and version 2 private interconnect modules (PIMs).

**Note:** A particular Slammer cannot contain a version 1 PIM in one CU and a version 2 PIM in the other CU. Both CUs must contain the same version of PIM.

Figure 42 Cabling CU cross connections for a 4-Slammer configuration (mixed PIM versions)

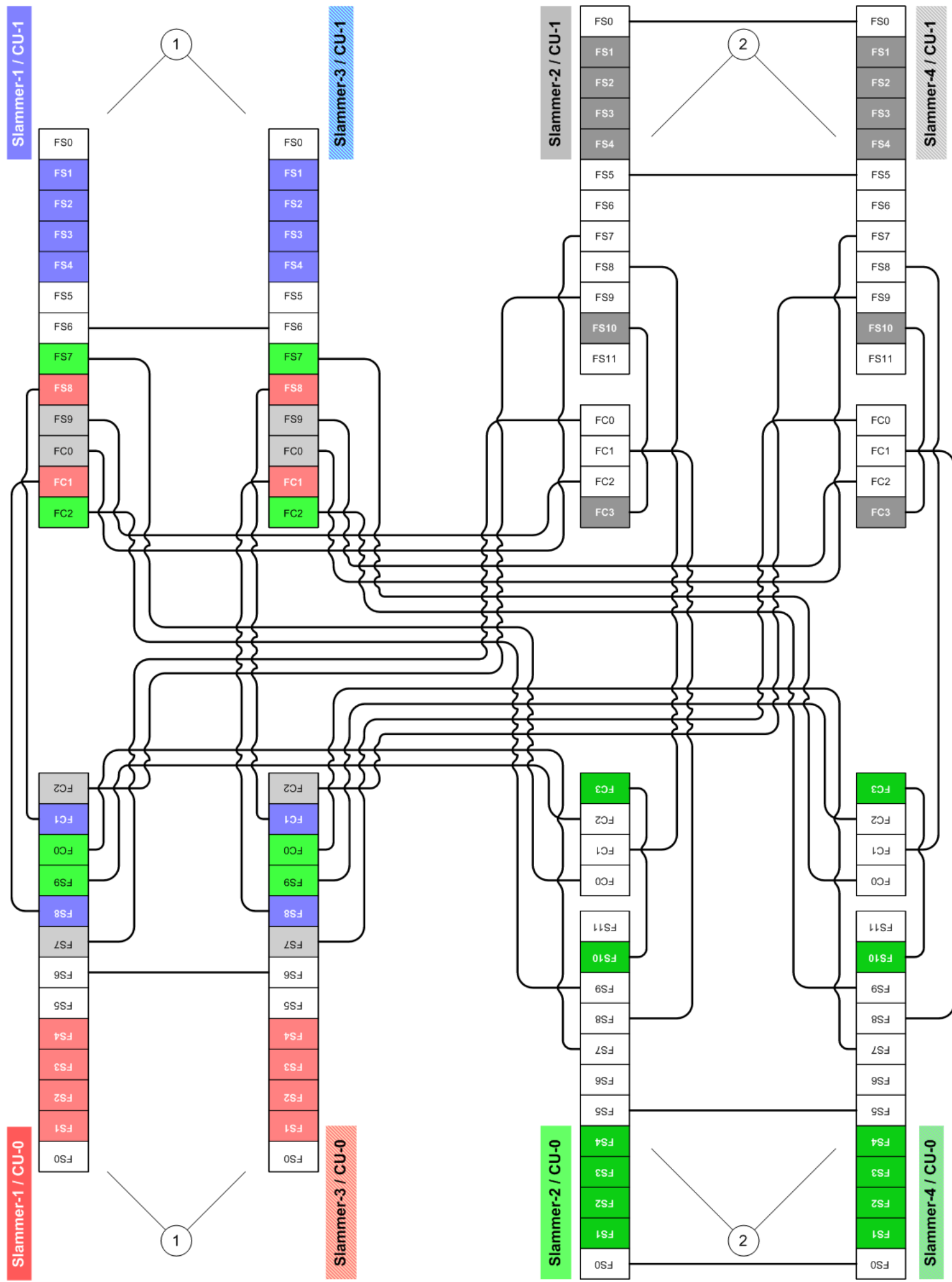

<b>Legend</b>	1 Slammers with version 1 PIMs.	2 Slammers with version 2 PIMs.
---------------	---------------------------------	---------------------------------

**Tip:** As noted above, Slammer-1 and Slammer-3 contain version 1 PIMs and Slammer-2 and Slammer-4 contain version 2 PIMs. This configuration is the only one that is supported for a mixed 4-Slammer system.

The following table defines the control unit (CU) cross connections, cable by cable, among two version 1 and two version 2 Slammers.



Table 32 Slammer cross connection configuration for a 4-Slammer configuration (mixed version PIMs)

From	To
Chassis / CU / Port	Chassis / CU / Port
SLM-1 / CU-0 FC-0	SLM-2 / CU-0 FS-7
SLM-1 / CU-0 FC-1	SLM-1 / CU-1 FS-8
SLM-1 / CU-0 FC-2	SLM-2 / CU-1 FS-9
SLM-1 / CU-1 FC-0	SLM-2 / CU-1 FS-7
SLM-1 / CU-1 FC-1	SLM-1 / CU-0 FS-8
SLM-1 / CU-1 FC-2	SLM-2 / CU-0 FS-9
SLM-2 / CU-0 FC-0	SLM-1 / CU-1 FS-7
SLM-2 / CU-0 FC-1	SLM-2 / CU-1 FS-8
SLM-2 / CU-0 FC-2	SLM-1 / CU-0 FS-9
SLM-2 / CU-0 FC-3	SLM-2 / CU-0 FS-10
SLM-2 / CU-1 FC-0	SLM-1 / CU-0 FS-7
SLM-2 / CU-1 FC-1	SLM-2 / CU-0 FS-8
SLM-2 / CU-1 FC-2	SLM-1 / CU-1 FS-9
SLM-2 / CU-1 FC-3	SLM-2 / CU-1 FS-10
SLM-3 / CU-0 FC-0	SLM-4 / CU-0 FS-7
SLM-3 / CU-0 FC-1	SLM-3 / CU-1 FS-8
SLM-3 / CU-0 FC-2	SLM-4 / CU-1 FS-9
SLM-3 / CU-0 FS-6	SLM-1 / CU-0 FS-6
SLM-3 / CU-1 FC-0	SLM-4 / CU-1 FS-7
SLM-3 / CU-1 FC-1	SLM-3 / CU-0 FS-8
SLM-3 / CU-1 FC-2	SLM-4 / CU-0 FS-9
SLM-3 / CU-1 FS-6	SLM-1 / CU-1 FS-6
SLM-4 / CU-0 FC-0	SLM-3 / CU-1 FS-7
SLM-4 / CU-0 FC-1	SLM-4 / CU-1 FS-8
SLM-4 / CU-0 FC-2	SLM-3 / CU-0 FS-9
SLM-4 / CU-0 FC-3	SLM-4 / CU-0 FS-10
SLM-4 / CU-0 FS-0	SLM-2 / CU-0 FS-0
SLM-4 / CU-0 FS-5	SLM-2 / CU-0 FS-5
SLM-4 / CU-1 FC-0	SLM-3 / CU-0 FS-7
SLM-4 / CU-1 FC-1	SLM-4 / CU-0 FS-8
SLM-4 / CU-1 FC-2	SLM-3 / CU-1 FS-9
SLM-4 / CU-1 FC-3	SLM-4 / CU-1 FS-10
SLM-4 / CU-1 FS-0	SLM-2 / CU-1 FS-0
SLM-4 / CU-1 FS-5	SLM-2 / CU-1 FS-5

SHEET 30

## Connections for 32 Bricks in 4-Slammer Systems

### Block Diagram: Connecting Four Slammers to 32 Bricks

This diagram illustrates the connection of Brick strings to the Slammers and Bricks to Bricks in a 4-Slammer, 32-Brick (8-string) configuration.

Figure 43 Connecting a 4-Slammer configuration to 32 Bricks

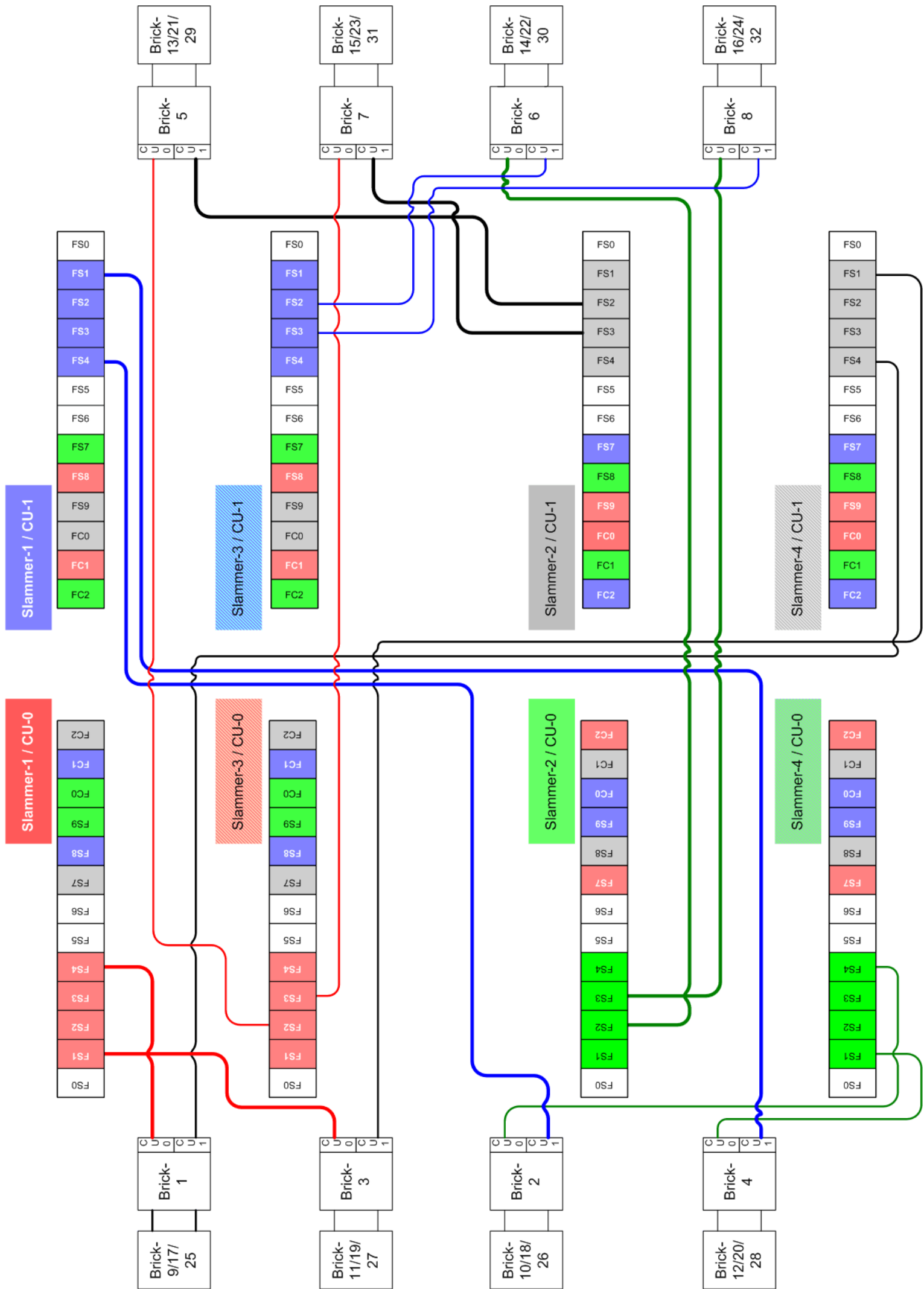

**Note:** Eight strings is recommended for configurations of up to 16 Bricks but is optional for larger systems.

**Important!** This illustration is for reference only. Although the illustration shows version 1 PIMs, the Brick cabling for version 2 PIMs uses the same ports.

## Cable 32 Bricks to Four Slammers

These tables specify, cable by cable, how to connect Brick strings to the Slammers and Bricks to Bricks in a 4-Slammer, 32 Brick (8-string) configuration.

These SSF cabling tables correspond to the diagram in [Figure 43](#).

Table 33 Cable connections for four Slammers and 16 Bricks

<b>BRX-1:</b>	SLM-1 / CU-0 FS-4	BRX-1 / CU-0 FC-2
	SLM-4 / CU-1 FS-4	BRX-1 / CU-1 FC-2
	BRX-1 / CU-0 FC-0	BRX-1 / CU-1 FC-3
	BRX-1 / CU-1 FC-0	BRX-1 / CU-0 FC-3
<b>BRX-2:</b>	SLM-4 / CU-0 FS-4	BRX-2 / CU-0 FC-2
	SLM-1 / CU-1 FS-4	BRX-2 / CU-1 FC-2
	BRX-2 / CU-0 FC-0	BRX-2 / CU-1 FC-3
	BRX-2 / CU-1 FC-0	BRX-2 / CU-0 FC-3
<b>BRX-3:</b>	SLM-1 / CU-0 FS-1	BRX-3 / CU-0 FC-2
	SLM-4 / CU-1 FS-1	BRX-3 / CU-1 FC-2
	BRX-3 / CU-0 FC-0	BRX-3 / CU-1 FC-3
	BRX-3 / CU-1 FC-0	BRX-3 / CU-0 FC-3
<b>BRX-4:</b>	SLM-4 / CU-0 FS-1	BRX-4 / CU-0 FC-2
	SLM-1 / CU-1 FS-1	BRX-4 / CU-1 FC-2
	BRX-4 / CU-0 FC-0	BRX-4 / CU-1 FC-3
	BRX-4 / CU-1 FC-0	BRX-4 / CU-0 FC-3
<b>BRX-5:</b>	SLM-3 / CU-0 FS-2	BRX-5 / CU-0 FC-2
	SLM-2 / CU-1 FS-2	BRX-5 / CU-1 FC-2
	BRX-5 / CU-0 FC-0	BRX-5 / CU-1 FC-3
	BRX-5 / CU-1 FC-0	BRX-5 / CU-0 FC-3
<b>BRX-6:</b>	SLM-2 / CU-0 FS-2	BRX-6 / CU-0 FC-2
	SLM-3 / CU-1 FS-2	BRX-6 / CU-1 FC-2
	BRX-6 / CU-0 FC-0	BRX-6 / CU-1 FC-3
	BRX-6 / CU-1 FC-0	BRX-6 / CU-0 FC-3
<b>BRX-7:</b>	SLM-3 / CU-0 FS-3	BRX-7 / CU-0 FC-2
	SLM-2 / CU-1 FS-3	BRX-7 / CU-1 FC-2
	BRX-7 / CU-0 FC-0	BRX-7 / CU-1 FC-3
	BRX-7 / CU-1 FC-0	BRX-7 / CU-0 FC-3
<b>BRX-8:</b>	SLM-2 / CU-0 FS-3	BRX-8 / CU-0 FC-2
	SLM-3 / CU-1 FS-3	BRX-8 / CU-1 FC-2
	BRX-8 / CU-0 FC-0	BRX-8 / CU-1 FC-3
	BRX-8 / CU-1 FC-0	BRX-8 / CU-0 FC-3
<b>BRX-9:</b>	BRX-1 / CU-0 FC-1	BRX-9 / CU-0 FC-2
	BRX-1 / CU-1 FC-1	BRX-9 / CU-1 FC-2
	BRX-9 / CU-0 FC-0	BRX-9 / CU-1 FC-3
	BRX-9 / CU-1 FC-0	BRX-9 / CU-0 FC-3
<b>BRX-10:</b>	BRX-2 / CU-0 FC-1	BRX-10 / CU-0 FC-2
	BRX-2 / CU-1 FC-1	BRX-10 / CU-1 FC-2
	BRX-10 / CU-0 FC-0	BRX-10 / CU-1 FC-3
	BRX-10 / CU-1 FC-0	BRX-10 / CU-0 FC-3
<b>BRX-11:</b>	BRX-3 / CU-0 FC-1	BRX-11 / CU-0 FC-2
	BRX-3 / CU-1 FC-1	BRX-11 / CU-1 FC-2
	BRX-11 / CU-0 FC-0	BRX-11 / CU-1 FC-3
	BRX-11 / CU-1 FC-0	BRX-11 / CU-0 FC-3
<b>BRX-12:</b>	BRX-4 / CU-0 FC-1	BRX-12 / CU-0 FC-2
	BRX-4 / CU-1 FC-1	BRX-12 / CU-1 FC-2
	BRX-12 / CU-0 FC-0	BRX-12 / CU-1 FC-3
	BRX-12 / CU-1 FC-0	BRX-12 / CU-0 FC-3
<b>BRX-13:</b>	BRX-5 / CU-0 FC-1	BRX-13 / CU-0 FC-2
	BRX-5 / CU-1 FC-1	BRX-13 / CU-1 FC-2
	BRX-13 / CU-0 FC-0	BRX-13 / CU-1 FC-3
	BRX-13 / CU-1 FC-0	BRX-13 / CU-0 FC-3
<b>BRX-14:</b>	BRX-6 / CU-0 FC-1	BRX-14 / CU-0 FC-2
	BRX-6 / CU-1 FC-1	BRX-14 / CU-1 FC-2
	BRX-14 / CU-0 FC-0	BRX-14 / CU-1 FC-3
	BRX-14 / CU-1 FC-0	BRX-14 / CU-0 FC-3
<b>BRX-15:</b>	BRX-7 / CU-0 FC-1	BRX-15 / CU-0 FC-2
	BRX-7 / CU-1 FC-1	BRX-15 / CU-1 FC-2
	BRX-15 / CU-0 FC-0	BRX-15 / CU-1 FC-3
	BRX-15 / CU-1 FC-0	BRX-15 / CU-0 FC-3
<b>BRX-16:</b>	BRX-8 / CU-0 FC-1	BRX-16 / CU-0 FC-2
	BRX-8 / CU-1 FC-1	BRX-16 / CU-1 FC-2
	BRX-16 / CU-0 FC-0	BRX-16 / CU-1 FC-3
	BRX-16 / CU-1 FC-0	BRX-16 / CU-0 FC-3

The following notes will help you successfully cable the system:

- Private interconnect module (PIM) and SATA RAID controller connections:
  - Version 1 PIMs and SATA RAID controllers both use HSSDC2 (high-speed serial data connection) type connections.
  - Version 2 PIMs and SATA RAID controllers both use SFP (small form-factor pluggable) type connections.
  - When connecting a version 1 component to a version 2 component, use a hybrid HSSDC2-to-SFP adapter cable.
- Cable lengths:
  - The cable lengths for Slammer-to-Brick connections are 6.56 ft (2.0 m).
  - Cable lengths for Brick-to-Brick (FC-1 to FC-2) connections are also 6.56 ft (2.0 m).
  - Cable lengths for cross connections (FC-0 to FC-3) between Brick control units (CUs) depend on the Brick type:
    - Version 1 Bricks: 1.64 ft (0.5 m)
    - Version 2 Bricks: 3.28 ft (1.0 m)

Additional Bricks beyond the 16 explicitly defined above are to be connected following the pattern for Bricks 9 through 16 above. The Brick numbers in each string are shown in the following figure, which corresponds to the diagram in [Figure 43](#).

**Figure 44** Connecting Bricks 17 through 32 to the existing strings

Brx- 1	9	17	25
Brx- 2	10	18	26
Brx- 3	11	19	27
Brx- 4	12	20	28
Brx- 5	13	21	29
Brx- 6	14	22	30
Brx- 7	15	23	31
Brx- 8	16	24	32

**Note:** When adding a fourth Slammer, make sure that the first Brick string that is directly attached to the new Slammer is a SATA Brick (version 2) or an FC RAID Brick (version 2). This practice helps to avoid an excess of radiated emissions and to comply with electro-magnetic (EMI) limits. Any existing SATA Brick (version 1) or FC RAID Brick (version 1) can cascade from the first Brick string of version 2 Bricks (SATA or FC RAID) attached to the new Slammer. The first Brick string must always be an SFP-SFP connection instead of an SFP-HSSDC2 hybrid connection.

## Connections for 64 Bricks in a 4-Slammer System

### Block Diagram: Connecting Four Slammers to 64 Bricks

This diagram illustrates how to connect Brick strings to the Slammers and Bricks to Bricks in a 4-Slammer, 64 Brick (16-string) configuration.

Figure 45 Connecting a 4-Slammer configuration to 64 Bricks

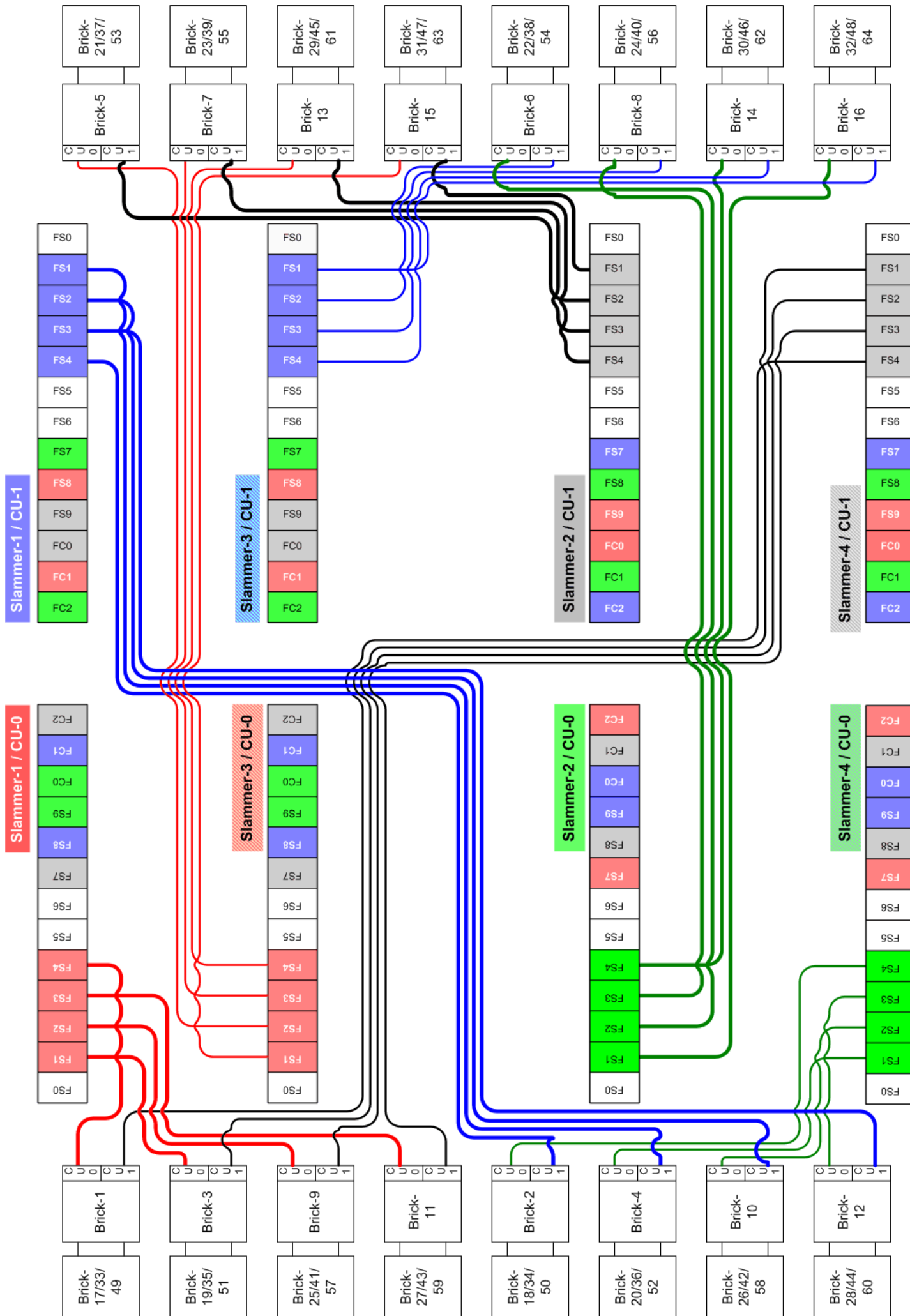

**Note:** Using 16 strings is optional but recommended for configurations above 32 Bricks.

**Important!** This illustration is for reference only. Although the illustration shows version 1 PIMs, the Brick cabling for version 2 PIMs uses the same ports.

## Cable 64 Bricks to Four Slammers

These tables specify, cable by cable, how to connect Brick strings to the Slammers and Bricks to Bricks in a 4-Slammer, 32-Brick (8-string) configuration.

These SSF cabling figures correspond to the diagram in [Figure 43](#).

Table 34 Cable connections for four Slammers and 32 Bricks

BRX-1:	SLM-1 / CU-0 FS-4	BRX-1 / CU-0 FC-2
	SLM-4 / CU-1 FS-4	BRX-1 / CU-1 FC-2
	BRX-1 / CU-0 FC-0	BRX-1 / CU-1 FC-3
	BRX-1 / CU-1 FC-0	BRX-1 / CU-0 FC-3
BRX-2:	SLM-4 / CU-0 FS-4	BRX-2 / CU-0 FC-2
	SLM-1 / CU-1 FS-4	BRX-2 / CU-1 FC-2
	BRX-2 / CU-0 FC-0	BRX-2 / CU-1 FC-3
	BRX-2 / CU-1 FC-0	BRX-2 / CU-0 FC-3
BRX-3:	SLM-1 / CU-0 FS-1	BRX-3 / CU-0 FC-2
	SLM-4 / CU-1 FS-1	BRX-3 / CU-1 FC-2
	BRX-3 / CU-0 FC-0	BRX-3 / CU-1 FC-3
	BRX-3 / CU-1 FC-0	BRX-3 / CU-0 FC-3
BRX-4:	SLM-4 / CU-0 FS-1	BRX-4 / CU-0 FC-2
	SLM-1 / CU-1 FS-1	BRX-4 / CU-1 FC-2
	BRX-4 / CU-0 FC-0	BRX-4 / CU-1 FC-3
	BRX-4 / CU-1 FC-0	BRX-4 / CU-0 FC-3
BRX-5:	SLM-3 / CU-0 FS-2	BRX-5 / CU-0 FC-2
	SLM-2 / CU-1 FS-2	BRX-5 / CU-1 FC-2
	BRX-5 / CU-0 FC-0	BRX-5 / CU-1 FC-3
	BRX-5 / CU-1 FC-0	BRX-5 / CU-0 FC-3
BRX-6:	SLM-2 / CU-0 FS-2	BRX-6 / CU-0 FC-2
	SLM-3 / CU-1 FS-2	BRX-6 / CU-1 FC-2
	BRX-6 / CU-0 FC-0	BRX-6 / CU-1 FC-3
	BRX-6 / CU-1 FC-0	BRX-6 / CU-0 FC-3
BRX-7:	SLM-3 / CU-0 FS-3	BRX-7 / CU-0 FC-2
	SLM-2 / CU-1 FS-3	BRX-7 / CU-1 FC-2
	BRX-7 / CU-0 FC-0	BRX-7 / CU-1 FC-3
	BRX-7 / CU-1 FC-0	BRX-7 / CU-0 FC-3
BRX-8:	SLM-2 / CU-0 FS-3	BRX-8 / CU-0 FC-2
	SLM-3 / CU-1 FS-3	BRX-8 / CU-1 FC-2
	BRX-8 / CU-0 FC-0	BRX-8 / CU-1 FC-3
	BRX-8 / CU-1 FC-0	BRX-8 / CU-0 FC-3
BRX-9:	SLM-1 / CU-0 FS-2	BRX-9 / CU-0 FC-2
	SLM-4 / CU-1 FS-2	BRX-9 / CU-1 FC-2
	BRX-9 / CU-0 FC-0	BRX-9 / CU-1 FC-3
	BRX-9 / CU-1 FC-0	BRX-9 / CU-0 FC-3
BRX-10:	SLM-4 / CU-0 FS-2	BRX-10 / CU-0 FC-2
	SLM-1 / CU-1 FS-2	BRX-10 / CU-1 FC-2
	BRX-10 / CU-0 FC-0	BRX-10 / CU-1 FC-3
	BRX-10 / CU-1 FC-0	BRX-10 / CU-0 FC-3
BRX-11:	SLM-1 / CU-0 FS-3	BRX-11 / CU-0 FC-2
	SLM-4 / CU-1 FS-3	BRX-11 / CU-1 FC-2
	BRX-11 / CU-0 FC-0	BRX-11 / CU-1 FC-3
	BRX-11 / CU-1 FC-0	BRX-11 / CU-0 FC-3
BRX-12:	SLM-4 / CU-0 FS-3	BRX-12 / CU-0 FC-2
	SLM-1 / CU-1 FS-3	BRX-12 / CU-1 FC-2
	BRX-12 / CU-0 FC-0	BRX-12 / CU-1 FC-3
	BRX-12 / CU-1 FC-0	BRX-12 / CU-0 FC-3
BRX-13:	SLM-3 / CU-0 FS-4	BRX-13 / CU-0 FC-2
	SLM-2 / CU-1 FS-4	BRX-13 / CU-1 FC-2
	BRX-13 / CU-0 FC-0	BRX-13 / CU-1 FC-3
	BRX-13 / CU-1 FC-0	BRX-13 / CU-0 FC-3
BRX-14:	SLM-2 / CU-0 FS-4	BRX-14 / CU-0 FC-2
	SLM-3 / CU-1 FS-4	BRX-14 / CU-1 FC-2
	BRX-14 / CU-0 FC-0	BRX-14 / CU-1 FC-3
	BRX-14 / CU-1 FC-0	BRX-14 / CU-0 FC-3
Fo BRX-15:	SLM-3 / CU-0 FS-1	BRX-15 / CU-0 FC-2
	SLM-2 / CU-1 FS-1	BRX-15 / CU-1 FC-2
	BRX-15 / CU-0 FC-0	BRX-15 / CU-1 FC-3
	BRX-15 / CU-1 FC-0	BRX-15 / CU-0 FC-3
BRX-16:	SLM-2 / CU-0 FS-1	BRX-16 / CU-0 FC-2
	SLM-3 / CU-1 FS-1	BRX-16 / CU-1 FC-2
	BRX-16 / CU-0 FC-0	BRX-16 / CU-1 FC-3
	BRX-16 / CU-1 FC-0	BRX-16 / CU-0 FC-3
BRX-17:	BRX-1 / CU-0 FC-1	BRX-17 / CU-0 FC-2
	BRX-1 / CU-1 FC-1	BRX-17 / CU-1 FC-2
	BRX-17 / CU-0 FC-0	BRX-17 / CU-1 FC-3
	BRX-17 / CU-1 FC-0	BRX-17 / CU-0 FC-3
BRX-18:	BRX-2 / CU-0 FC-1	BRX-18 / CU-0 FC-2
	BRX-2 / CU-1 FC-1	BRX-18 / CU-1 FC-2
	BRX-18 / CU-0 FC-0	BRX-18 / CU-1 FC-3
	BRX-18 / CU-1 FC-0	BRX-18 / CU-0 FC-3
BRX-19:	BRX-3 / CU-0 FC-1	BRX-19 / CU-0 FC-2
	BRX-3 / CU-1 FC-1	BRX-19 / CU-1 FC-2
	BRX-19 / CU-0 FC-0	BRX-19 / CU-1 FC-3
	BRX-19 / CU-1 FC-0	BRX-19 / CU-0 FC-3
BRX-20:	BRX-4 / CU-0 FC-1	BRX-20 / CU-0 FC-2
	BRX-4 / CU-1 FC-1	BRX-20 / CU-1 FC-2
	BRX-20 / CU-0 FC-0	BRX-20 / CU-1 FC-3
	BRX-20 / CU-1 FC-0	BRX-20 / CU-0 FC-3
BRX-21:	BRX-5 / CU-0 FC-1	BRX-21 / CU-0 FC-2
	BRX-5 / CU-1 FC-1	BRX-21 / CU-1 FC-2
	BRX-21 / CU-0 FC-0	BRX-21 / CU-1 FC-3
	BRX-21 / CU-1 FC-0	BRX-21 / CU-0 FC-3
BRX-22:	BRX-6 / CU-0 FC-1	BRX-22 / CU-0 FC-2
	BRX-6 / CU-1 FC-1	BRX-22 / CU-1 FC-2
	BRX-22 / CU-0 FC-0	BRX-22 / CU-1 FC-3
	BRX-22 / CU-1 FC-0	BRX-22 / CU-0 FC-3
BRX-23:	BRX-7 / CU-0 FC-1	BRX-23 / CU-0 FC-2
	BRX-7 / CU-1 FC-1	BRX-23 / CU-1 FC-2
	BRX-23 / CU-0 FC-0	BRX-23 / CU-1 FC-3
	BRX-23 / CU-1 FC-0	BRX-23 / CU-0 FC-3
BRX-24:	BRX-8 / CU-0 FC-1	BRX-24 / CU-0 FC-2
	BRX-8 / CU-1 FC-1	BRX-24 / CU-1 FC-2
	BRX-24 / CU-0 FC-0	BRX-24 / CU-1 FC-3
	BRX-24 / CU-1 FC-0	BRX-24 / CU-0 FC-3
BRX-25:	BRX-9 / CU-0 FC-1	BRX-25 / CU-0 FC-2
	BRX-9 / CU-1 FC-1	BRX-25 / CU-1 FC-2
	BRX-25 / CU-0 FC-0	BRX-25 / CU-1 FC-3
	BRX-25 / CU-1 FC-0	BRX-25 / CU-0 FC-3
BRX-26:	BRX-10 / CU-0 FC-1	BRX-26 / CU-0 FC-2
	BRX-10 / CU-1 FC-1	BRX-26 / CU-1 FC-2
	BRX-26 / CU-0 FC-0	BRX-26 / CU-1 FC-3
	BRX-26 / CU-1 FC-0	BRX-26 / CU-0 FC-3
BRX-27:	BRX-11 / CU-0 FC-1	BRX-27 / CU-0 FC-2
	BRX-11 / CU-1 FC-1	BRX-27 / CU-1 FC-2
	BRX-27 / CU-0 FC-0	BRX-27 / CU-1 FC-3
	BRX-27 / CU-1 FC-0	BRX-27 / CU-0 FC-3
BRX-28:	BRX-12 / CU-0 FC-1	BRX-28 / CU-0 FC-2
	BRX-12 / CU-1 FC-1	BRX-28 / CU-1 FC-2
	BRX-28 / CU-0 FC-0	BRX-28 / CU-1 FC-3
	BRX-28 / CU-1 FC-0	BRX-28 / CU-0 FC-3
BRX-29:	BRX-13 / CU-0 FC-1	BRX-29 / CU-0 FC-2
	BRX-13 / CU-1 FC-1	BRX-29 / CU-1 FC-2
	BRX-29 / CU-0 FC-0	BRX-29 / CU-1 FC-3
	BRX-29 / CU-1 FC-0	BRX-29 / CU-0 FC-3
BRX-30:	BRX-14 / CU-0 FC-1	BRX-30 / CU-0 FC-2
	BRX-14 / CU-1 FC-1	BRX-30 / CU-1 FC-2
	BRX-30 / CU-0 FC-0	BRX-30 / CU-1 FC-3
	BRX-30 / CU-1 FC-0	BRX-30 / CU-0 FC-3
BRX-31:	BRX-15 / CU-0 FC-1	BRX-31 / CU-0 FC-2
	BRX-15 / CU-1 FC-1	BRX-31 / CU-1 FC-2
	BRX-31 / CU-0 FC-0	BRX-31 / CU-1 FC-3
	BRX-31 / CU-1 FC-0	BRX-31 / CU-0 FC-3
BRX-32:	BRX-16 / CU-0 FC-1	BRX-32 / CU-0 FC-2
	BRX-16 / CU-1 FC-1	BRX-32 / CU-1 FC-2
	BRX-32 / CU-0 FC-0	BRX-32 / CU-1 FC-3
	BRX-32 / CU-1 FC-0	BRX-32 / CU-0 FC-3

The following notes will help you successfully cable the system:

- Private interconnect module (PIM) and SATA RAID controller connections:
  - Version 1 PIMs and SATA RAID controllers both use HSSDC2 (high-speed serial data connection) type connections.
  - Version 2 PIMs and SATA RAID controllers both use SFP (small form-factor pluggable) type connections.
  - When connecting a version 1 component to a version 2 component, use a hybrid HSSDC2-to-SFP adapter cable.
- Cable lengths:
  - The cable lengths for Slammer-to-Brick connections are 6.56 ft (2.0 m).
  - Cable lengths for Brick-to-Brick (FC-1 to FC-2) connections are also 6.56 ft (2.0 m).
  - Cable lengths for cross connections (FC-0 to FC-3) between Brick control units (CUs) depend on the Brick type:
    - Version 1 Bricks: 1.64 ft (0.5 m)
    - Version 2 Bricks: 3.28 ft (1.0 m)

**Note:** Additional Bricks beyond the 32 explicitly defined above are to be connected following the pattern shown for Bricks 17 through 32. The Brick numbers in each string are shown in the diagram in [Figure 45](#).

**Note:** When adding a fourth Slammer, make sure that the first Brick string that is directly attached to the new Slammer is a SATA Brick (version 2) or an FC RAID Brick (version 2). This practice helps to avoid an excess of radiated emissions and to comply with electro-magnetic (EMI) limits. Any existing SATA Brick (version 1) or FC RAID Brick (version 1) can cascade from the first Brick string of version 2 Bricks (SATA or FC RAID) attached to the new Slammer. The first Brick string must always be an SFP-SFP connection instead of an SFP-HSSDC2 hybrid connection.



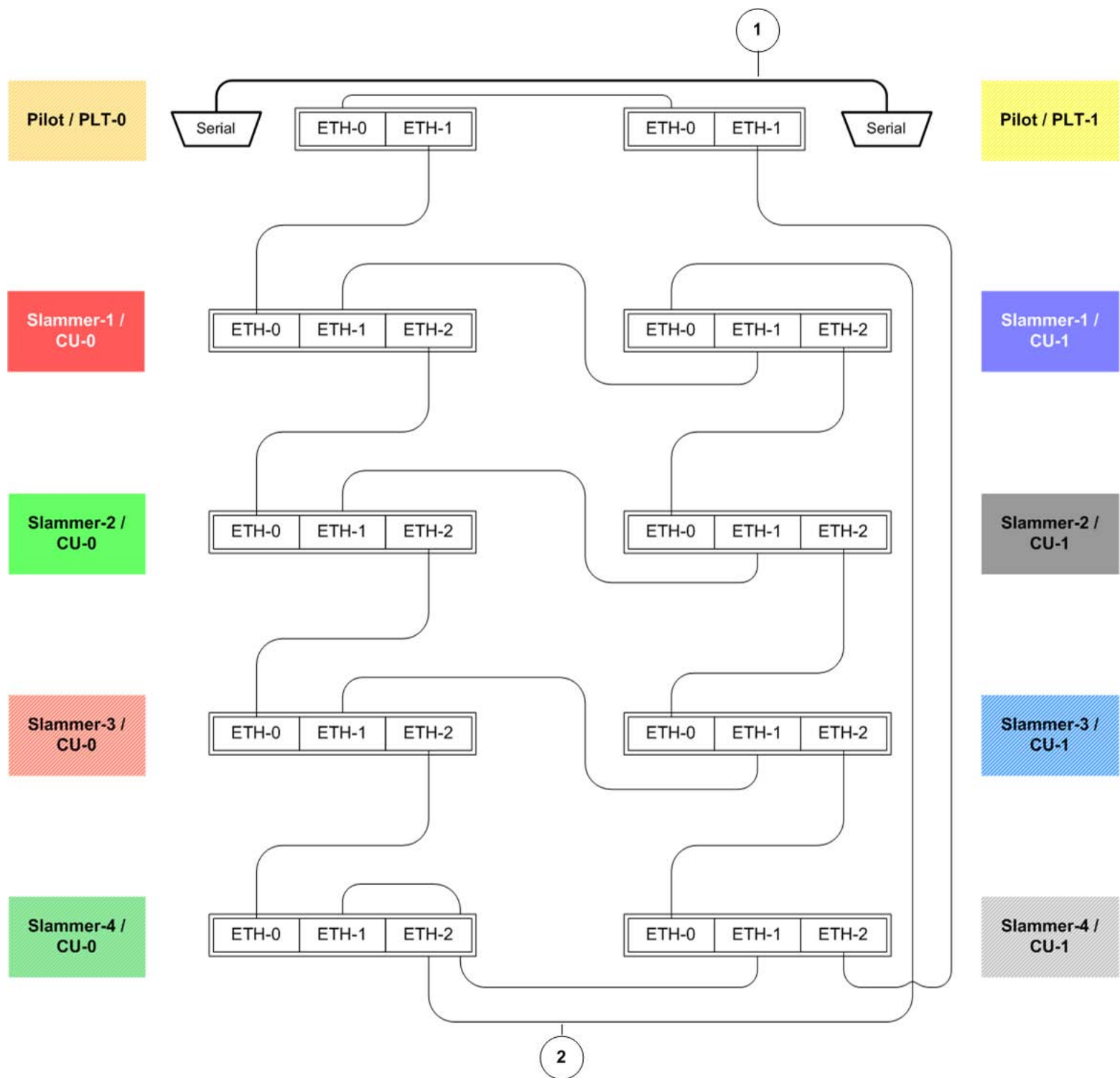

Table 35 Ethernet cable connections for PMI (4-Slammer system)

From	To
Chassis / CU / Port	Chassis / CU / Port
PLT-0 ETH0	PLT-1 ETH0
PLT-0 ETH1	SLM-1 / CU-0 ETH0
PLT-1 ETH1	SLM-4 / CU-1 ETH2
SLM-1 / CU-0 ETH1	SLM-1 / CU-1 ETH1
SLM-1 / CU-0 ETH2	SLM-2 / CU-0 ETH0
SLM-1 / CU-1 ETH2	SLM-2 / CU-1 ETH0
SLM-2 / CU-0 ETH1	SLM-2 / CU-1 ETH1
SLM-2 / CU-0 ETH2	SLM-3 / CU-0 ETH0
SLM-2 / CU-1 ETH2	SLM-3 / CU-1 ETH0
SLM-3 / CU-0 ETH1	SLM-3 / CU-1 ETH1
SLM-3 / CU-0 ETH2	SLM-4 / CU-0 ETH0
SLM-3 / CU-1 ETH2	SLM-4 / CU-1 ETH0
SLM-4 / CU-0 ETH1	SLM-4 / CU-1 ETH1
SLM-4 / CU-0 ETH2	SLM-1 / CU-1 ETH0

This schematic illustrates the Pilot-to-Slammer and Slammer-to-Slammer connections comprising the PMI in a 4-Slammer system.

Figure 47 PMI Ethernet schematic (4-Slammer system)



**Legend** 1 Null modem cable.

2 Cat-5 Ethernet cables.

In addition to the Ethernet cables, PMI requires a null modem cable connection between the serial ports of each Pilot CU.

# Part VII: Appendixes

## APPENDIX A

### Swapping SSF Cables When Expanding a System

When adding an additional Slammer to a Pillar Axiom 600 system, you need to move some Fibre Channel (FC) cables to different ports on the private interconnect module (PIM). The cable swapping differs depending on the PIM.

Table 36 Swapping Slammer cables that cross connect version 1 PIMs

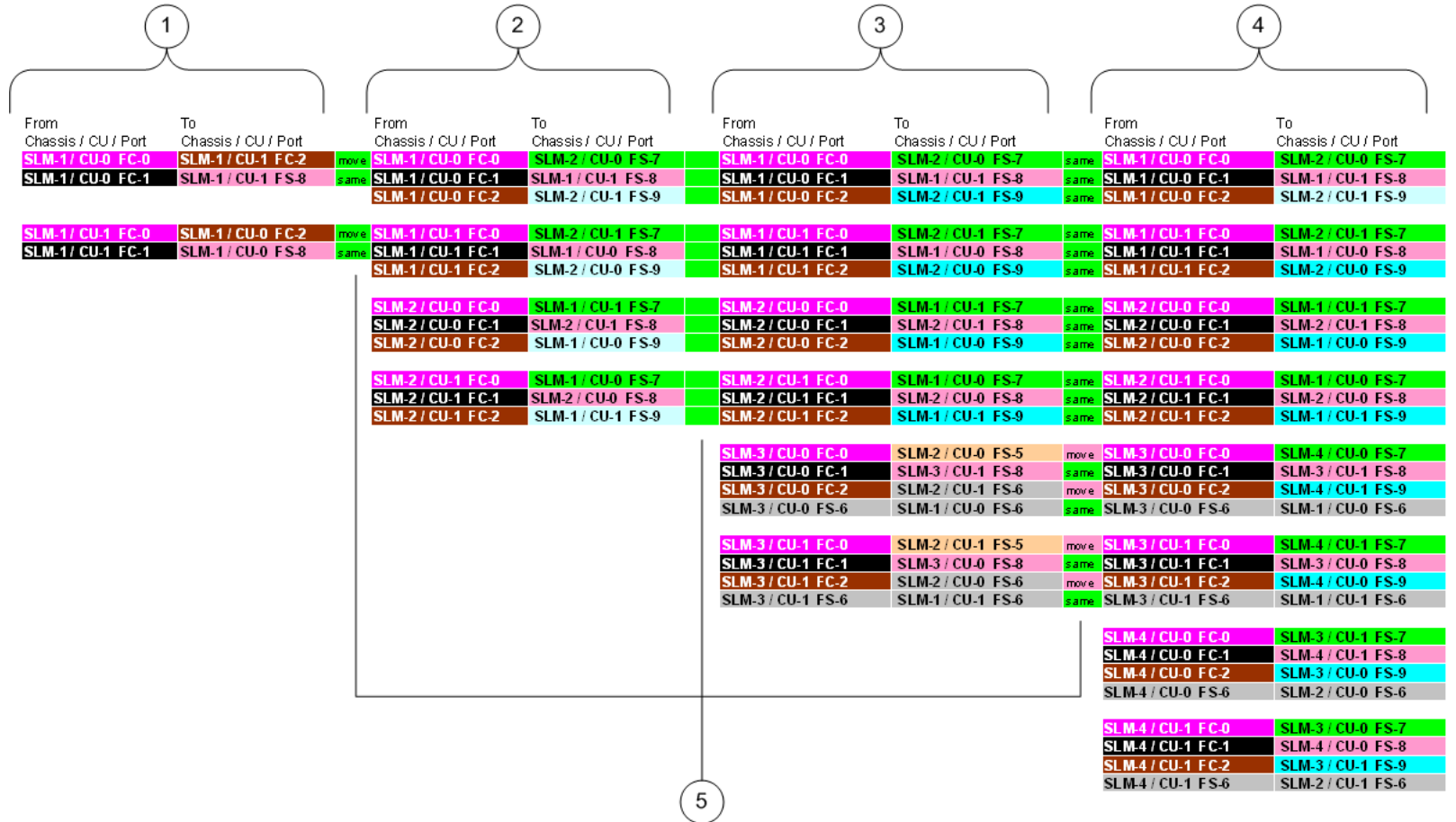
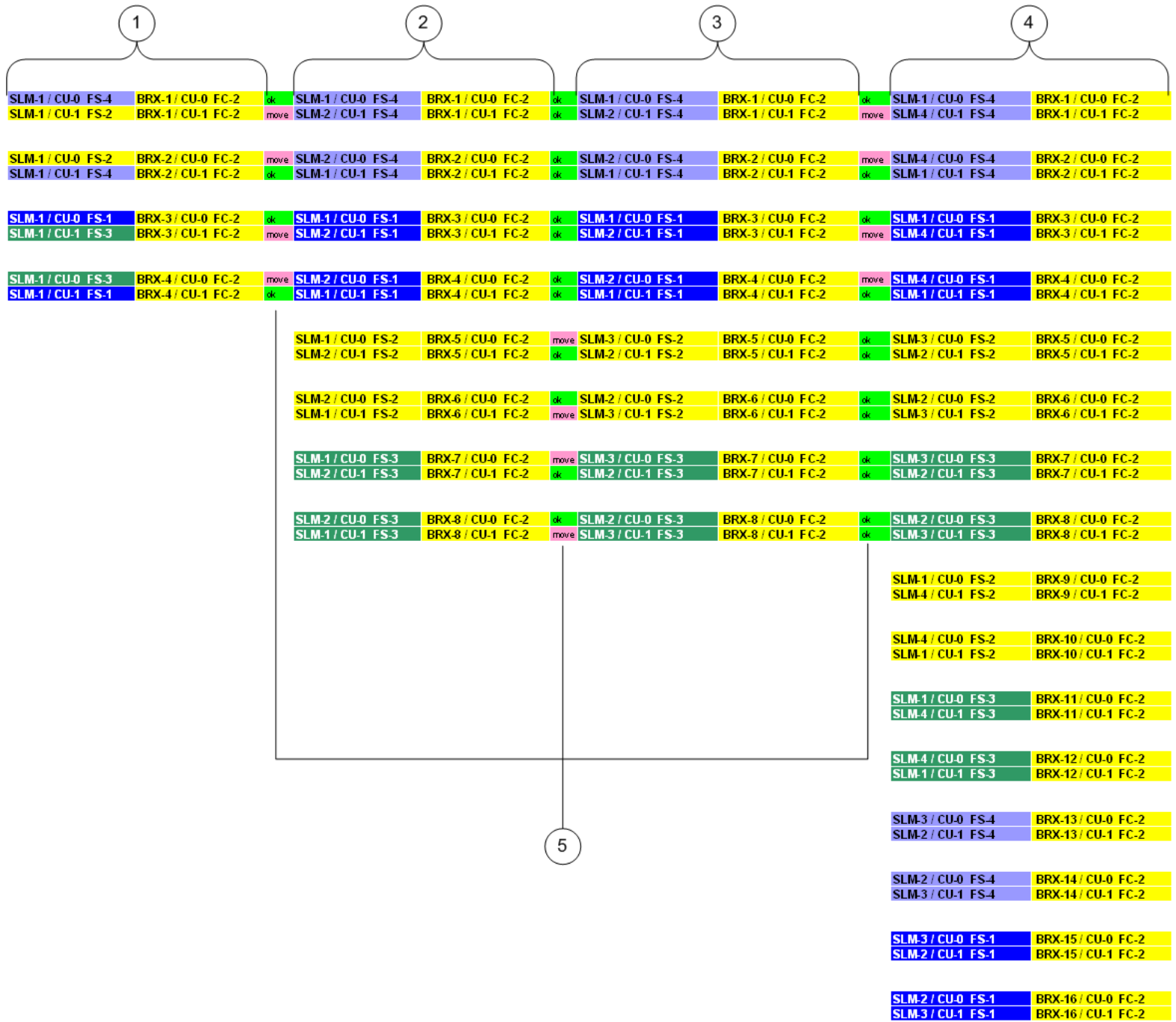

Table 37 Swapping Slammer cables that cross connect version 2 PIMs



<b>Legend</b>	1 First Slammer.
	2 Second Slammer.
	3 Third Slammer.
	4 Fourth Slammer.
	5 Move the red FC cables when expanding the system to the next larger configuration.

Table 38 Swapping head-of-string Brick cables



<b>Legend</b>	1 First Slammer.
	2 Second Slammer.
	3 Third Slammer.
	4 Fourth Slammer.
	5 Move the red FC cables when expanding the system to the next larger configuration.

## Cabling Practices for the Pillar Axiom 600 System

Follow these fundamental rules and guidelines for cabling Fiber Channel (FC), Serial ATA (SATA), and Solid State Drive (SSD) Bricks in a Pillar Axiom 600 system.

All cabling rules and guidelines are categorized into three categories based on the Pillar Axiom 600 system used. Cabling practices are also categorized based on their impact on the system in case of non-compliance.

**ALL: Rules that apply to all Pillar Axiom 600 systems include:**

Cabling requirements: Stringent requirements for the system to work. Non-negotiable and integral to the system design.

Cabling rules: Stringent rules indicating functional limitations of the system. If these rules are not followed, the system is considered unsupported.

Cabling guidelines: Guidelines or best practices unless circumstances prevent strict adherence to these cabling guidelines.

**NEW: Rules that apply to new Pillar Axiom 600 systems and can be applied to all Pillar Axiom 600 systems include:**

Manufacturing practices: Documented procedures followed by Pillar operations for new systems that allow each Pillar Axiom 600 system to be configured in a consistent manner.

**FIELD: Rules that apply to Pillar Axiom 600 systems in the field include:**

Field practices: Practices that attempt to optimize high availability, performance, troubleshooting and customer requirements. However, field best practices cannot override cabling rules that apply to all systems. Pertain to Pillar Axiom 600 systems that exist in the field and whose system configurations have evolved over time due to numerous configuration modifications.

[Table 39: Cabling principles \(system level issues\)](#) defines the Pillar Axiom 600 system characteristics that must be considered while cabling the Pillar Axiom 600 system.

**Table 39 Cabling principles (system level issues)**

Cabling principle	Applicability
The Storage System Fabric (SSF) in a Pillar Axiom 600 system must use either all copper or all optical connections. Note the exceptions in <a href="#">Table 41: Cabling principles (Slammer connection issues)</a> that apply to the Slammer control unit (CU) connections in single Slammer systems.	ALL
Pillar Axiom 600 systems that include any version 1 Bricks or any version 1 PIMs must use only copper connections.	ALL
All new Pillar Axiom 600 systems (shipped after January 31, 2011) have version 2 Bricks and use optical connections.	NEW
Pillar Axiom 600 systems are cabled according to the cabling diagrams in the <i>Pillar Axiom 600 SSF Cabling Reference</i> .	ALL
Use cables that are appropriate for the type of Brick and other hardware components on the Pillar Axiom 600 system. For more information, see the <i>Pillar Axiom 600 SSF Cabling Reference</i> .	ALL
Pillar Axiom systems that are upgraded in the field might have a Brick string configuration that is different from a Pillar Axiom system built in the factory, especially when systems are upgraded non-disruptively. However, rules that apply to all systems always apply to systems upgraded in the field.	FIELD

[Table 40: Cabling principles \(system size related issues\)](#) defines the influence of system size or configuration on the cabling of the Pillar Axiom 600 system.

**Table 40 Cabling principles (system size related issues)**

Cabling principle	Applicability
Pillar Axiom 600 systems with one Slammer have a maximum of four Brick strings.	ALL
Pillar Axiom 600 systems with two or three Slammers have a maximum of eight Brick strings.	ALL

**Table 40 Cabling principles (system size related issues) (continued)**

Cabling principle	Applicability
Pillar Axiom 600 systems with four Slammers have a maximum of 16 Brick strings, but may be configured with eight Brick strings. However, it is recommended that systems using more than 32 Bricks are configured with 16 Brick strings.	ALL
In Pillar Axiom 600 systems with two Slammers, the Brick at the head of the string must be connected to Slammer 1 and Slammer 2.	ALL
In Pillar Axiom 600 systems with three Slammers, the Bricks at the head of the string must be connected to Slammer 1 or Slammer 3, and to Slammer 2.	ALL
In Pillar Axiom 600 systems with four Slammers, the Bricks at the head of the string must be connected to Slammer 1 or Slammer 2 and to Slammer 3 or Slammer 4.	ALL
Pillar Axiom 600 systems with more than 48 Bricks must use all optical connections. Contact the Pillar World Wide Customer Support Center to upgrade any Pillar Axiom system with more than 32 FC Bricks (version 2). If Bricks are added later, a re-cabling may be necessary to ensure that there are no more than eight Bricks on any Brick string.	ALL
Pillar Axiom systems that are upgraded by adding an additional Slammer can run with the same number of Brick strings from the prior configuration. However, if Bricks are added later, a re-cabling may be necessary to ensure that there are no more than eight Bricks on any Brick string.	FIELD

[Table 41: Cabling principles \(Slammer connection issues\)](#) defines the principles pertinent to connecting Slammers within a Pillar Axiom 600 system.

**Table 41 Cabling principles (Slammer connection issues)**

Cabling principle	Applicability
The Brick at the head of the string must connect to two Slammer ports on different Slammer control units (CUs).	ALL
In Pillar Axiom 500 and 600 systems, Bricks must always be connected to FS ports on Slammers, never to the FC ports. In Pillar Axiom 300 systems, all ports on the private interconnect module (PIM) on the Slammer are labeled as FC ports. Thus, in Pillar Axiom 300 systems, Bricks connect to FC1 through FC4 ports.	ALL
Bricks at the head of the string connect to ports on different Slammer CUs. For example: The Brick CU0 FC2 port must connect to a Slammer CU0 PIM; The Brick CU1 FC2 port must connect to a Slammer CU1 PIM.	ALL
Version 2 Slammer PIMs must have an external cable that connects each FC3 port to an FS10 port in the PIM on that CU. This external cable connection is in addition to those required for version 1 PIMs.	ALL
Slammer to Slammer and Slammer to Brick connections have either all copper or all optical connections. Single Slammer systems connect Slammer ports FC0 and FC2 from CU0 to CU1 and CU1 to CU0. Only these links may be optical when the rest of the system is connected with copper cables.	ALL

[Table 42: Cabling principles \(Brick connection issues\)](#) defines the principles pertinent to connecting Bricks within a Pillar Axiom 600 system.

**Table 42 Cabling principles (Brick connection issues)**

Cabling principle	Applicability
Each Brick in the Brick string connects to the previous Brick in the string. The Brick at the head of the string connects to Slammer ports. The cable connections in a Brick string are serial. Thus, if one or more cables to a Brick are disconnected, all the Bricks beneath it in the Brick string are disconnected from the string.	ALL
The FC2 port in a Brick is the input port. The Brick at the head of the string connects port FC2 on the Brick to ports on different Slammer CUs. For Bricks that are not at the head of the string, the Brick CU0 FC2 port must connect to the CU0 FC1 port of the next Brick, higher in the string. Similarly, the CU1 FC2 port must connect to the CU1 FC1 port of the next Brick higher in the string.	ALL
The FC0 port of each Brick CU must connect to the FC3 port of the other CU in the same Brick. The two FC0 to FC3 connections on each Brick are cross-over connections.	ALL

**Table 42 Cabling principles (Brick connection issues) (continued)**

Cabling principle	Applicability
The FC1 port is Brick is the output port. The FC1 port on each Brick CU is either left empty or connects to the FC2 port of the same CU of the next Brick lower in the string.	ALL
FC RAID Bricks and SSD Bricks use Slammer ports in the same order as SATA Bricks. This cabling scheme fosters balance among the Brick strings while maintaining a predictable assignment of Bricks to strings. A given Brick should always be on a specific string with specific Slammer ports.	NEW
Cable labels on both ends of the cables are used to indicate port connections for all cables.	NEW

[Table 43: Cabling principles \(Mixing Brick types\)](#) defines the principles that must be followed when mixing Brick types in strings within a Pillar Axiom 600 system.

**Table 43 Cabling principles (Mixing Brick types)**

Cabling principle	Applicability
Brick strings may contain combinations of FC RAID Bricks, FC Expansion Bricks, SATA Bricks (version 2), and SSD Bricks.	ALL
SATA (version 1) Bricks must not be in the same string as an FC RAID Brick or a SATA Brick (version 2) or an SSD Brick. This guideline is strongly recommended to enhance supportability. Existing Pillar Axiom systems may not meet this guideline. Contact the Pillar World Wide Customer Support Center for guidance.	ALL
A Brick string may contain up to eight SATA Bricks (version 1 or version 2), but they cannot be mixed. This guideline is strongly recommended to enhance supportability.	ALL
A Brick string may contain up to four FC RAID Bricks (version 1), each of which may optionally be connected to an FC Expansion Brick. A Brick string may include up to eight FC Bricks (version 2).	ALL
A Brick string may contain up to two SSD Bricks. However, it is recommended that only one SSD Brick is placed on a Brick string.	ALL

[Table 44: Cabling principles \(FC Expansion Bricks\)](#) defines the principles that must be followed when cabling FC Expansion Bricks in strings within a Pillar Axiom 600 system.

**Table 44 Cabling principles (FC Expansion Bricks)**

Cabling principle	Applicability
FC RAID Bricks (version 1) can be configured alone or in pairs of one FC RAID Brick (version 1) and one FC Expansion Brick (version 1). FC RAID Bricks (version 2) do not support FC Expansion Bricks.	ALL
FC Expansion Bricks are connected to FC RAID Bricks (version 1) using the J0, J1, and PNet ports. One FC Expansion Brick is supported with one FC RAID Brick (version 1). For more information, see <i>Pillar Axiom 600 SSF Cabling Reference</i> .	ALL

[Table 45: Cabling principles \(Brick order in strings\)](#) defines the order in which different Bricks are placed in the string within a Pillar Axiom 600 system.

**Table 45 Cabling principles (Brick order in strings)**

Cabling principle	Applicability
The functionality or performance of Bricks is not affected by their relative position in a Brick string.	ALL
Factory manufacturing practice places SSD Bricks at the head of string position followed by FC Bricks, and then SATA Bricks.	NEW
When adding Bricks to an existing system, attach the new Brick to the last Brick on a string. <b>Note:</b> The practice of adding Bricks to the last Brick on the string is recommended for non-disruptive upgrades and for existing customer systems. The goal in the field must be to perform non-disruptive upgrades, if at all possible.	FIELD

[Table 46: Cabling principles \(Brick balance in strings\)](#) defines the balance that must be maintained between the various Brick types in the Brick strings within a Pillar Axiom 600 system.

Table 46 Cabling principles (Brick balance in strings)

Cabling principle	Applicability
A string may contain up to eight Bricks. (FC Expansion Bricks (version 1) are not included in this number)	ALL
When additional Bricks are added or when SSF performance issues occur, it may be necessary to rearrange the Bricks between strings to better balance the system.	NEW
Bricks in a Pillar Axiom 600 system can follow a heuristic balance or a numerical balance defined by manufacturing practices.	ALL
A numerical balance allocates Bricks to strings uniformly without regard to the type of Brick. The longest and shortest Brick strings differ by at most one Brick, with the exception of FC Expansion Bricks.	NEW
<p>Some rules have been developed to achieve a heuristic balance on Brick strings. The heuristic balance on Brick strings helps to optimize performance on larger systems with mixed Brick types. Brick strings are balanced on the basis of load factors allocated to the different Brick types as follows:</p> <ul style="list-style-type: none"> <li>• SATA Brick: Load factor 1</li> <li>• FC RAID Brick: Load factor 2</li> <li>• SSD Brick: Load factor 4</li> </ul> <p>Version 1 and version 2 of all Brick types are allocated the same load factor.</p> <p><b>Note:</b> The recommendation to not mix SATA Bricks (version 1) with other Brick types overrides load factor considerations on Brick strings.</p>	FIELD

[Table 47: Cabling principles \(Brick adds on strings\)](#) defines the procedures to be followed when adding Bricks on Brick strings within a Pillar Axiom 600 system.

Table 47 Cabling principles (Brick adds on strings)

Cabling principle	Applicability
Bricks may be added to a Pillar Axiom 600 system without disrupting client data availability. However, considerable care must be taken while performing non-disruptive Brick adds. If there is any sign of excessive disruption of the SSF fabric, disconnect or power down the last Brick that was added to the Pillar Axiom 600 system and contact the Pillar World Wide Customer Support Center.	FIELD
While adding new Bricks, consider rewiring the strings if the existing Pillar Axiom system is not fully compliant with specified cabling rules. For example: If the Pillar Axiom system has Brick strings that mix SATA Brick (version 1) with other types of Bricks or if a better balance (heuristic or numerical) is required between the Brick strings to achieve performance goals. Appropriate rewiring can help to isolate problems in the internal SSF fabric. However, rewiring is usually a disruptive operation and thus, not always possible.	FIELD
<p><b>Recommended method for a non-disruptive Brick add:</b></p> <p>Cable all the new Bricks to the Pillar Axiom 600 system without powering them on. Then, power on the Bricks at the rate of one or two at a time.</p> <p><b>Note:</b> When adding a Brick, verify if the Slammer FS and FC port LEDs turn amber. If the Slammer FC and FS port LEDs continue to display amber for three minutes, power off the Brick that was last added to the Pillar Axiom system.</p> <p><b>Note:</b> When adding a Brick to a Pillar Axiom 600 system, check for the appearance of topology discovery tasks. Topology discovery tasks are normal if they do not repeat or last more than five minutes. If a topology discovery task completes and then recurs after five minutes have passed, power off the last Brick that was added to the Pillar Axiom 600 system and contact the Pillar World Wide Customer Support Center for assistance.</p> <p><b>Note:</b> After adding a Brick, check the status of the LUNs. If any LUN goes offline, power off the last Brick that was added and contact the Pillar World Wide Customer Support Center for assistance.</p>	FIELD
<p><b>Alternate method for non-disruptive Brick add: (Used only when recommended by the Pillar World Wide Customer Support Center)</b></p> <p>Add the new Bricks to the rack along with the crossover cables. Power on the Bricks and wait for the Bricks to initialize. Connect the Bricks to the Pillar Axiom 600 system, one Brick at a time.</p>	FIELD
The Brick type and the Brick model number must both be compatible with the installed software version and the compatibility matrix on the Pillar Axiom 600 system. If the Brick type is supported and the Brick model number is not supported, update the compatibility matrix to the	FIELD

Table 47 Cabling principles (Brick adds on strings) (continued)

Cabling principle	Applicability
appropriate version. If the Brick type is not supported, the Pillar Axiom 600 software must be updated before the Brick can be added to the system.	
<p>After a successful Brick add, conduct the following checks:</p> <ul style="list-style-type: none"> <li>• Verify that there is only one version of firmware for the Brick type that was added. Also, verify that the firmware version is correct for the installed Pillar Axiom 600 release.</li> <li>• Verify that there are no topology discovery tasks in progress and no repeating topology tasks.</li> <li>• Verify that the system capacity has been increased by the amount of storage available from the newly added Bricks.</li> </ul> <p><b>Note:</b> If any of the above-mentioned tests fail, contact the Pillar World Wide Customer Support Center for assistance.</p> <p><b>Tip:</b> After the RAID controllers finish initializing, scrubbing normally starts on the drives. Scrubbing causes all the drive LEDs to blink rapidly even with no host I/O activity.</p>	FIELD



---

# Index

## A

additional resources *11*  
audience *10*

## B

block diagram, cabling  
  1-Slammer systems  
    expanding with FC Bricks *69*  
    FC & SATA Bricks *68*  
    FC Bricks *60*  
    SATA Bricks *30*  
  2-Slammer systems  
    FC & SATA Bricks *71*  
    FC Bricks *63*  
    SATA Bricks *46*  
  3-Slammer systems *79*  
  4-Slammer systems  
    32 Brick configuration *90*  
    64 Brick configuration *93*  
book organization *10*  
Brick storage enclosures  
  cabling rules summary *100*  
  cascade schematic *56*  
  scalability strategy *30*  
  string port mapping *56*  
  types of FC RAID controllers *18*  
  versions of SATA controller *17*

## C

cable connections (Ethernet)  
  1-Slammer systems *41*  
  2-Slammer systems *54*  
  3-Slammer systems *82*  
  4-Slammer systems *96*  
cable connections (Fibre Channel)  
  block diagram, cabling, FC & SATA Brick  
    1-Slammer systems *68*  
    2-Slammer systems *71*  
  block diagram, cabling, FC Brick  
    1-Slammer systems *60*  
    2-Slammer systems *63*  
    3-Slammer systems *79*  
    4-Slammer systems (32 Bricks) *90*  
    4-Slammer systems (64 Bricks) *93*  
  block diagram, cabling, SATA Brick  
    1-Slammer systems *30*  
    2-Slammer systems *46*  
    3-Slammer systems *79*  
    4-Slammer systems (32 Bricks) *90*  
    4-Slammer systems (64 Bricks) *93*  
  block diagram, expanding with FC Bricks *69*  
  Bricks 01-08, SATA  
    1-Slammer systems *36*  
    2-Slammer systems *48*  
  Bricks 09-16, SATA  
    1-Slammer systems *38*  
    2-Slammer systems] *50*  
  Bricks 17-24, SATA  
    1-Slammer systems *39*  
    2-Slammer systems *51*  
  Bricks 25-32, SATA  
    1-Slammer systems *40*  
    2-Slammer systems *52*  
  Bricks 32-64, SATA  
    2-Slammer systems *52*  
  cascading Bricks  
    2-Slammer systems *56*  
  FC Bricks  
    1-Slammer systems *61*  
    2-Slammer systems *64*  
    sample cabling with SATA Bricks *66*  
    sample cabling without SATA *57, 58*  
  sample cabling  
    1-Slammer systems *26, 27*  
    2-Slammer systems *43*  
    FC & SATA Bricks *66*  
    FC Bricks without SATA *57, 58*  
  Slammer cross connections

  1 Slammer *36*  
  2 Slammers *48*  
  3 Slammers (v1, v2) *76*  
  3 Slammers (v1) *73*  
  3 Slammers (v2) *74*  
  4 Slammers (v1, v2) *87*  
  4 Slammers (v1) *84*  
  4 Slammers (v2) *85*  
  Slammer to FC Bricks *61*  
  Slammer to SATA Bricks *36*  
  Slammer-to-Brick connections  
    3 Slammers *80*  
    4 Slammers *91, 94*  
  swapping cables when expanding *98*  
cable labels, FC *19*  
cable swapping  
  when adding a Slammer  
    with version 1 PIMs *98*  
    with version 2 PIMs *98*  
cable types *21*  
  Ethernet cable *21*  
  HSSDC2 to HSSDC2 cable *21*  
  Hybrid SFP to HSSDC2 cable *21*  
  optical cable *21*  
  serial null modem cable *21*  
  SFP to optical cable *21*  
  SFP to SFP cable *21*  
cabling  
  best practices *100*  
  guidelines *100*  
  manufacturing practices *100*  
  Pillar Axiom 600 *14*  
  private management interface (PMI) *14*  
  rules *100*  
  Storage System Fabric (SSF) *14*  
cabling impact  
  hardware versions *16*  
cascading Bricks *56*  
caution signal words *13*  
cautions  
  unsupported hardware *16*  
compatibility matrix  
  cables *20*  
  connectors *20*  
  hardware components *20*  
  ports *20*  
components  
  Pillar Axiom 600 *14*  
components, Pillar Axiom 600 hardware  
  supported hardware *16*  
configuration limits  
  Pillar Axiom 600 *15*  
configuration, rack  
  using 230 V, 20 A PDUs *32*  
  using 3-phase PDUs *34*  
  using four PDUs *34*  
connector types *21*  
contact information *12*  
conventions  
  typographical *11*  
cross connections  
  1 Slammer *36*  
    diagram *29*  
  2 Slammers *48*  
    diagram *44*  
  3 Slammers (v1, v2) *76*  
  3 Slammers (v1) *73*  
  3 Slammers (v2) *74*  
  4 Slammers (v1, v2) *87*  
  4 Slammers (v1) *84*  
  4 Slammers (v2) *85*

## D

danger signal words *13*  
documentation  
  accessing *11*  
  hazard signal words *13*  
  related to cabling *11*

documentation support *12*  
dressing SSF cables *33*

## E

education programs *12*  
Ethernet cables *21*  
Ethernet connections  
  1-Slammer systems PMI *41*  
  2-Slammer systems PMI *54*  
  3-Slammer systems PMI *82*  
  4-Slammer systems PMI *96*  
expanding a system  
  cable swaps *98*  
  with FC Bricks *69*  
experience, required *10*

## F

fabric speed *23*  
  effect of cable types *23*  
FC & SATA Bricks  
  block diagram, cabling  
    1-Slammer systems *68*  
  sample cabling *66*  
FC Bricks  
  block diagram for expanding a system *69*  
  cabling  
    1-Slammer systems *61*  
    2-Slammer systems *64*  
  sample cabling  
    with SATA Bricks *66*  
    without SATA Bricks *57, 58*  
FC RAID controllers  
  versions *18*  
FC RAID controllers, Brick  
  types *18*  
fiber optic cables  
  handle *24*  
Fibre Channel (FC) Bricks  
  cabling rules summary *100*

## H

hardware  
  versions *16, 17*  
hardware versions  
  cabling impact *16*  
hardware, Pillar Axiom 600  
  supported components *16*  
help  
  online *12*  
how to  
  cable PMI *14*  
  cable SSF *14*  
  handle fiber optic cables *24*  
HSSDC2 cables *21*  
hybrid cables *21*

## I

Intelligent Platform Management Interface (IPMI) cabling, Pilot  
  1-Slammer systems *26, 27*  
  2-Slammer systems *43*  
  3-Slammer systems *82*  
  4-Slammer systems *96*

## L

labels, FC cable *19*

## M

mixed Brick types  
  cabling block diagrams  
    1-Slammer system *68*  
    2-Slammer system *71*  
  connection rules *100*  
multiple racks  
  using 230 V, 20 A PDUs *32*  
  using four PDUs or 3-phase power *34*

## O

online documents *11*  
online help *12*  
optical cables *21*  
organization, book *10*

## P

Pillar Axiom 600  
  configuration limits *15*  
Pillar Data Systems support site *12*  
Pilot cabling  
  1-Slammer systems *26, 27*

  2-Slammer systems *43*  
  3-Slammer systems *82*  
  4-Slammer systems *96*  
port mapping, Brick  
  in strings *56*  
private interconnect modules (PIMs), Slammer  
  versions *17*  
private interface module (PIM)  
  versions *16, 17*  
private management interface (PMI)  
  1-Slammer systems  
    cabling *41*  
    schematic *41*  
  2-Slammer systems  
    cabling *54*  
    schematic *54*  
  3-Slammer systems  
    cabling *82*  
    schematic *82*  
  4-Slammer systems  
    cabling *96*  
    schematic *96*  
  cabling *14*  
product support *12*

## R

rack configuration  
  using 230 V, 20 A PDUs *32*  
  using 3-phase PDUs *34*  
  using four PDUs *34*  
rack space requirements  
  2-Slammer systems  
    16 Bricks *46*  
    32 Bricks *47*  
raid controllers  
  versions *16*  
related books *11*  
requisite reading *10*

## S

sales information *12*  
sample cabling  
  1-Slammer systems *26, 27*  
  2-Slammer systems *43*  
  FC Bricks  
    with SATA Bricks *66*  
    without SATA Bricks *57, 58*  
SATA RAID controllers, Brick  
  versions *17*  
scalability strategy, Brick *30*  
  cascade schematic *56*  
  list of points  
    2-Slammer systems *47*  
Serial ATA (SATA) Bricks  
  cabling rules summary *100*  
serial null modem cable *21*  
SFP cables *21*  
Slammer  
  series *16*  
Slammer series *16*  
Slammer storage controllers  
  Brick connections  
    1 Slammer *36*  
    2 Slammers *48*  
    3 Slammers *80*  
    4 Slammers *91, 94*  
  cable swaps when adding Slammers  
    with version 1 PIMs *98*  
    with version 2 PIMs *98*  
  cross connect  
    1 Slammer *36*  
    1 Slammer (diagram) *29*  
    2 Slammers *48*  
    2 Slammers (diagram) *44*  
    3 Slammers (v1, v2) *76*  
    3 Slammers (v1) *73*  
    3 Slammers (v2) *74*  
    4 Slammers (v1, v2) *87*  
    4 Slammers (v1) *84*  
    4 Slammers (v2) *85*  
  versions of PIMs *17*  
Slammer-to-Brick connections  
  1 Slammer *36*  
  2 Slammers *48*  
  3 Slammers *80*  
  4 Slammers *91, 94*  
Solid State Drive (SSD) Bricks  
  cabling rules summary *100*  
SSF.

---

*See* Storage System Fabric (SSF).  
Storage System Fabric (SSF)  
  cabling *14*  
    1-Slammer systems *36*  
    2-Slammer systems *48*  
    3-Slammer systems *80*  
    4-Slammer systems *91, 94*  
  cabling rules summary *100*  
  dressing the FC cables *33*  
  FC Brick cabling  
    1-Slammer systems *61*  
    2-Slammer systems *64*  
  swapping cables when expanding *98*  
strings, Brick  
  port mapping *56*  
supported hardware components *16*  
swapping cables when expanding a system *98*

**T**  
technical documents  
  accessing *11*  
technical support *12*  
training programs *12*  
typographical conventions *11*

**V**  
versions  
  FC RAID controllers *18*  
  hardware *16, 17*  
  private interface module (PIM) *16, 17*  
  raid controllers *16*  
  SATA RAID controllers *17*

**W**  
warning signal words *13*