

**Oracle® Fusion Applications Product Information Management
Implementation Guide**

11g Release 6 (11.1.6)

Part Number E20387-06

September 2012

Oracle® Fusion Applications Product Information Management Implementation Guide

Part Number E20387-06

Copyright © 2011-2012, Oracle and/or its affiliates. All rights reserved.

Authors: Brent Bosin, Hugh Mason, Doug Myers, Mark Sawtelle, Catherine Bauer, Essan Ni Jirman, Tina Brand

This software and related documentation are provided under a license agreement containing restrictions on use and disclosure and are protected by intellectual property laws. Except as expressly permitted in your license agreement or allowed by law, you may not use, copy, reproduce, translate, broadcast, modify, license, transmit, distribute, exhibit, perform, publish, or display any part, in any form, or by any means. Reverse engineering, disassembly, or decompilation of this software, unless required by law for interoperability, is prohibited.

The information contained herein is subject to change without notice and is not warranted to be error-free. If you find any errors, please report them to us in writing.

If this is software or related documentation that is delivered to the U.S. Government or anyone licensing it on behalf of the U.S. Government, the following notice is applicable:

U.S. GOVERNMENT END USERS: Oracle programs, including any operating system, integrated software, any programs installed on the hardware, and/or documentation, delivered to U.S. Government end users are "commercial computer software" pursuant to the applicable Federal Acquisition Regulation and agency-specific supplemental regulations. As such, use, duplication, disclosure, modification, and adaptation of the programs, including any operating system, integrated software, any programs installed on the hardware, and/or documentation, shall be subject to license terms and license restrictions applicable to the programs. No other rights are granted to the U.S. Government.

This software or hardware is developed for general use in a variety of information management applications. It is not developed or intended for use in any inherently dangerous applications, including applications that may create a risk of personal injury. If you use this software or hardware in dangerous applications, then you shall be responsible to take all appropriate fail-safe, backup, redundancy, and other measures to ensure its safe use. Oracle Corporation and its affiliates disclaim any liability for any damages caused by use of this software or hardware in dangerous applications.

Oracle and Java are registered trademarks of Oracle Corporation and/or its affiliates. Other names may be trademarks of their respective owners.

Intel and Intel Xeon are trademarks or registered trademarks of Intel Corporation. All SPARC trademarks are used under license and are trademarks or registered trademarks of SPARC International, Inc. AMD, Opteron, the AMD logo, and the AMD Opteron logo are trademarks or registered trademarks of Advanced Micro Devices. UNIX is a registered trademark of The Open Group.

This software or hardware and documentation may provide access to or information on content, products and services from third parties. Oracle Corporation and its affiliates are not responsible for and expressly disclaim all warranties of any kind with respect to third-party content, products, and services. Oracle Corporation and its affiliates will not be responsible for any loss, costs, or damages incurred due to your access to or use of third-party content, products, or services.

Contents

1 Overview

Product Management Offering: Overview	1-1
Getting Started with an Implementation: Overview	1-2
Manage Application Implementation	1-3

2 Define Synchronization of Users and Roles from LDAP

User and Role Synchronization: Explained	2-1
--	-----

3 Manage Units of Measure

Units of Measure, Unit of Measure Classes, and Base Units of Measure: How They Fit Together	3-1
Assigning Base Units of Measure to Unit of Measure Classes: Examples	3-2
Defining Unit of Measure Standard Conversions: Examples	3-2
FAQs for Manage Units of Measure	3-3

4 Maintain Common Reference Objects

Maintain Common Reference Objects: Overview	4-1
Define Application Taxonomy	4-1
Define Reference Data Sharing	4-4
Define Lookups	4-8
Manage Messages	4-15
Define ISO Reference Data	4-17
Manage Data Security Policies	4-21
Define Document Sequences	4-30
Define Trees	4-34
Define Profile Options	4-49
Define Flexfields	4-58
Define Attachments	4-101
Set Activity Stream Options	4-105
Manage Menu Customizations	4-105
Manage Applications Core Common Reference Objects: Manage Applications Core Messages	4-106
Manage Applications Core Common Reference Objects: Manage Applications Core Administrator Profile Values	4-107

5 Define Implementation Users

Initial Security Administration: Critical Choices	5-1
Initial Security Administration: Worked Example	5-3

6 Define Currencies and Currency Rates

Manage Currencies	6-1
Manage Conversion Rate Types	6-3

7 Define Enterprise Structures

Enterprise Structures: Overview	7-1
Enterprise Structures Business Process Model: Explained	7-3
Global Enterprise Configuration: Points to Consider	7-5
Modeling Your Enterprise Management Structure in Oracle Fusion: Example	7-5
Define Initial Configuration with the Enterprise Structures Configurator	7-8
Define Reference Data Sharing	7-33
Define Enterprise: Manage Enterprise HCM Information	7-40
Define Enterprise: Manage Locations	7-41
Define Geographies	7-43
Define Legal Jurisdictions and Authorities	7-57
Define Legal Entities: Manage Legal Entity	7-63
Define Legal Entities: Manage Legal Entity HCM Information	7-68
Define Legal Entities: Manage Legal Entity Tax Profile	7-73
Define Legal Entities: Define Legal Reporting Units	7-77
Define Chart of Accounts for Enterprise Structures: Manage Chart of Accounts	7-78
Define Chart of Accounts for Enterprise Structures: Manage Chart of Accounts Value	
Sets	7-92
Define Chart of Accounts for Enterprise Structures: Manage Account Hierarchies	7-95
Define Chart of Accounts for Enterprise Structures: Manage Accounting Calendars	7-113
Define Accounting Configurations of Enterprise Structures: Manage Primary or	
Secondary Ledgers	7-117
Define Accounting Configurations of Enterprise Structures: Specify Ledger Options ...	7-125
Define Accounting Configurations of Enterprise Structures: Manage Reporting	
Currencies	7-129
Define Business Units: Manage Service Provider Relationships	7-132
Define Business Units: Specify Customer Contract Management Business Function	
Properties	7-135
Define Business Units: Specify Supplier Contract Management Business Function	
Properties	7-138
Define Business Units: Assign Business Unit Business Function	7-140
Define Business Units: Manage Business Units	7-142
Define Workforce Structures: Manage Enterprise HCM Information	7-143
Define Workforce Structures: Manage Locations	7-144
Define Workforce Structures: Manage Divisions	7-145
Define Workforce Structures: Manage Departments	7-148
Define Workforce Structures: FAQs for Manage Job Families	7-151
Define Workforce Structures: Manage Job	7-151
Define Workforce Structures: Manage Person Search Relevance Profile Option Values	
.....	7-153

Define Facilities: Manage Facility Shifts, Workday Patterns, and Schedules	7-154
Define Facilities: Manage Inventory Organizations	7-157
Define Facilities: Manage Item Organizations	7-162

8 Define Workforce Profiles

Profile Management: Explained	8-1
Oracle Fusion Profile Management Components: How They Work Together	8-2
Oracle Fusion Profile Management, Performance Management, Goal Management, and Talent Review: How They Work Together	8-3
Define Talent Profile Settings	8-4
Define Talent Profile Content	8-10
Define Talent Profiles	8-20

9 Define Social Networking

How can I enable social networking features	9-1
---	-----

10 Define Security for Supply Chain Management

Security Tasks: Highlights	10-1
Defining Security After Enterprise Setup: Points to Consider	10-4
Security Tasks and Oracle Fusion Applications: How They Fit Together	10-8
Security Tasks: Overview	10-11
Define Data Security	10-15
Define Users	10-27
FAQs for Manage Users	10-42

11 Define Automated Governance, Risk, and Performance Controls

Segregation of Duties: Explained	11-1
Segregation of Duties in the Security Reference Implementation: Explained	11-2
Defining Segregation of Duties Policies: Points To Consider	11-4
Managing Segregation of Duties Risks and Violations: Critical Choices	11-6
Role Provisioning and Segregation of Duties: How They Work Together	11-8

12 Define Approval Management for Supply Chain Management

Approval Management: Highlights	12-1
---------------------------------------	------

13 Define Help Configuration

Define Help Configuration: Overview	13-1
Set Help Options	13-1
FAQs for Assign Help Text Administration Duty	13-4
Manage Help Security Groups	13-4
Help File Customization	13-5

Embedded Help Customization	13-15
-----------------------------------	-------

14 Define Source Systems

Source Systems: Explained	14-1
Source System Entities: Explained	14-2
FAQs for Define Source Systems	14-2

15 Define Application Toolkit Configuration

Define Application Toolkit Configuration: Overview	15-1
Map Reports to Work Areas	15-1
Set Watchlist Options	15-3

16 Define WebLogic Communication Services Configuration

Click to Dial: Explained	16-1
Click-to-Dial: Top Tasks	16-4
Configuring PSTN Gateway Address Using Topology Manager: Worked Example	16-5

17 Define Product Information Management Configuration

Product Management Features by License: Overview	17-1
Define Basic Items	17-1
Managing Product Child Value Sets: Explained	17-2
Managing Default Item Class: Explained	17-3
Managing Item Statuses: Explained	17-3
Managing Item Types: Explained	17-4
Managing Cross-Reference Types: Explained	17-4
Importing Items: Explained	17-4
Managing Related Item Subtypes: Explained	17-5
Managing Descriptive Flexfields for Items: Explained	17-5
FAQs for Define Basic Items	17-7
What's the difference between lifecycle phase types and lifecycle phases	17-7
Define Basic Product Structure	17-7
Managing Item Structure Type Details: Explained	17-8
Define Basic Catalogs	17-9
Assigning Items to Categories: Explained	17-13
Publishing Catalogs: Explained	17-14
FAQs for Define Basic Catalogs	17-14
Define Advanced Items	17-16
Transactional Attributes: Explained	17-17
FAQs for Define Advanced Items	17-20
Define Change Orders	17-20
Define Product Rules	17-26
Define New Item Requests	17-31
New Item Request Definition Phase: Explained	17-32
New Item Requests Workflow Processes: Explained	17-32

New Item Request Approval Phase: Explained	17-33
FAQs for New Item Requests and Change Orders	17-33
Can I mark item definitions as mandatory	17-33
Can I enforce New Item Request mandatory steps on the user side	17-34
Can new item requests be automatically promoted and demoted	17-34
Can Request Comment notification be skipped in a new item request in open status	17-34
Can I make changes to item organization assignment and route it for approval through a change order	17-34
Can Request Comment notification be skipped in a change order in open status	17-35
How can I view the mandatory definitions when defining an item, viewing notifications or from new item request details page	17-35
What does All Values Required mean	17-35
Can mandatory definitions be inherited	17-35
Define Product Source Systems	17-35
Define Customers for Product Management	17-36
Defining the Import Process for Customers and Consumers: Points to Consider	17-36
Performing What-If Analysis on Data Import Batches: Worked Example	17-38
Defining the Import Process for Customers and Consumers: Worked Example	17-40
FAQs for Define Customers for Product Management	17-42
How can I view the errors that occurred during preimport processing	17-43
What happens if I purge a data import batch	17-43
Why can't I purge a data import batch	17-43
Why did I receive a message that the data enrichment process was declined	17-43
Can I try and import a batch again	17-43
Why can't I view the import process details	17-43
How can I create item relationships between items and customers	17-43
Define Advanced Catalogs	17-44
Define Data Quality for Products	17-44

18 Regional and Local Area Search

Regional Item Work Area Search	18-1
Local Item Search Parameters	18-3

19 Define Transactional Business Intelligence Configuration

Define Transactional Business Intelligence Configuration: Highlights	19-1
Access to Person Data	19-1

20 Define Extensions: Define Custom Enterprise Scheduler Jobs

Managing Job Definitions: Highlights	20-1
Managing List of Values Sources: Highlights	20-2
Customization and Sandboxes	20-3

21 Moving Common Reference Objects

Moving Common Reference Objects: Overview	21-1
Business Objects for Moving Common Reference Objects: Points to Consider	21-1
Moving Related Common Reference Objects: Points to Consider	21-8
Using Seed Data Framework to Move Common Reference Objects: Points to Consider	21-9

Preface

This Preface introduces the guides, online help, and other information sources available to help you more effectively use Oracle Fusion Applications.

Oracle Fusion Applications Help

You can access Oracle Fusion Applications Help for the current page, section, activity, or task by clicking the help icon. The following figure depicts the help icon.



You can add custom help files to replace or supplement the provided content. Each release update includes new help content to ensure you have access to the latest information. Patching does not affect your custom help content.

Oracle Fusion Applications Guides

Oracle Fusion Applications guides are a structured collection of the help topics, examples, and FAQs from the help system packaged for easy download and offline reference, and sequenced to facilitate learning. You can access the guides from the **Guides** menu in the global area at the top of Oracle Fusion Applications Help pages.

Note

The **Guides** menu also provides access to the business process models on which Oracle Fusion Applications is based.

Guides are designed for specific audiences:

- **User Guides** address the tasks in one or more business processes. They are intended for users who perform these tasks, and managers looking for an overview of the business processes. They are organized by the business process activities and tasks.
- **Implementation Guides** address the tasks required to set up an offering, or selected features of an offering. They are intended for implementors. They are organized to follow the task list sequence of the offerings, as displayed within the Setup and Maintenance work area provided by Oracle Fusion Functional Setup Manager.
- **Concept Guides** explain the key concepts and decisions for a specific area of functionality. They are intended for decision makers, such as chief financial officers, financial analysts, and implementation consultants. They are organized by the logical flow of features and functions.

- **Security Reference Manuals** describe the predefined data that is included in the security reference implementation for one offering. They are intended for implementors, security administrators, and auditors. They are organized by role.

These guides cover specific business processes and offerings. Common areas are addressed in the guides listed in the following table.

Guide	Intended Audience	Purpose
Common User Guide	All users	Explains tasks performed by most users.
Common Implementation Guide	Implementors	Explains tasks within the Define Common Applications Configuration task list, which is included in all offerings.
Information Technology Management, Implement Applications Guide	Implementors	Explains how to use Oracle Fusion Functional Setup Manager to plan, manage, and track your implementation projects, migrate setup data, and validate implementations.
Technical Guides	System administrators, application developers, and technical members of implementation teams	Explain how to install, patch, administer, and customize Oracle Fusion Applications.

For guides that are not available from the Guides menu, go to Oracle Technology Network at <http://www.oracle.com/technetwork/indexes/documentation>.

Other Information Sources

My Oracle Support

Oracle customers have access to electronic support through My Oracle Support. For information, visit <http://www.oracle.com/pls/topic/lookup?ctx=acc&id=info> or visit <http://www.oracle.com/pls/topic/lookup?ctx=acc&id=trs> if you are hearing impaired.

Use the My Oracle Support Knowledge Browser to find documents for a product area. You can search for release-specific information, such as patches, alerts, white papers, and troubleshooting tips. Other services include health checks, guided lifecycle advice, and direct contact with industry experts through the My Oracle Support Community.

Oracle Enterprise Repository for Oracle Fusion Applications

Oracle Enterprise Repository for Oracle Fusion Applications provides visibility into service-oriented architecture assets to help you manage the lifecycle of your software from planning through implementation, testing, production,

and changes. In Oracle Fusion Applications, you can use the Oracle Enterprise Repository for Oracle Fusion Applications at <http://fusionappsoer.oracle.com> for:

- Technical information about integrating with other applications, including services, operations, composites, events, and integration tables. The classification scheme shows the scenarios in which you use the assets, and includes diagrams, schematics, and links to other technical documentation.
- Publishing other technical information such as reusable components, policies, architecture diagrams, and topology diagrams.

Documentation Accessibility

For information about Oracle's commitment to accessibility, visit the Oracle Accessibility Program website at <http://www.oracle.com/us/corporate/accessibility/index.html>.

Comments and Suggestions

Your comments are important to us. We encourage you to send us feedback about Oracle Fusion Applications Help and guides. Please send your suggestions to oracle_fusion_applications_help_ww_grp@oracle.com. You can use the **Send Feedback to Oracle** link in the footer of Oracle Fusion Applications Help.

Overview

Product Management Offering: Overview

By implementing the Product Management offering, your enterprise can configure how to create and manage items, catalogs, and related processes. Before you begin, use the Getting Started page in the Setup and Maintenance work area to access reports for each offering, including full lists of setup tasks, descriptions of the options and features that you can select when you configure the offering, and lists of business objects and enterprise applications that are associated with the offering.

The first implementation step is to configure the offerings in the Setup and Maintenance work area by selecting the offerings and options that you want to make available to implement. For the Product Management offering, you can select the following options:

- Product Management (this option also has associated features that you can select to configure)
- Product Model
- Basic Product Structures
- Basic Catalogs
- Product and Catalog Management
- Change Orders
- Product Rules
- Advanced Product Structures
- New Item Requests
- Product Hub
- Product Source Systems
- Advanced Catalogs
- Data Quality for Products
- Product Information Management Business Intelligence Analytics
- Product Management Business Intelligence Analytics

Next, create one or more implementation projects for the offerings and options that you want to implement first, which generates task lists for each project. The application implementation manager can customize the task list and assign and track each task.

If you select all of the options, then the generated task list for this offering contains the following groups of tasks:

- Define Common Applications Configuration for Product Management
- Define Product Information Management Configuration
- Define Transactional Business Intelligence Configuration

- Define Extensions for Product Management

Define Common Applications Configuration for Product Management

Use this task list to manage definitions that are used across offerings, which typically apply to multiple products and product families. These definitions include enterprise structures, workforce profiles, security, and approval rules, among others.

You can find other information that supports the common implementation tasks in the Oracle Fusion Applications Concepts Guide.

Define Product Information Management Configuration

Use this task list to configure items, product structures, catalogs, change orders, rules, new item requests, product source systems, and data quality.

Define Transactional Business Intelligence Configuration

Use this task list to configure Oracle Transactional Business Intelligence for ad hoc reporting, including managing the repository, connections, presentation catalog, and currency type display.

Define Extensions for Product Management

Use this task list to define extensions such as custom Oracle Enterprise Scheduler jobs.

You can also customize and extend applications using other tools. For more information, see the Oracle Fusion Applications Extensibility Guide.

Getting Started with an Implementation: Overview

To start an Oracle Fusion Applications implementation, you must setup one or more initial users using the super user that was created during installation and provisioning of the Oracle Fusion Applications environment. Because Oracle Fusion Applications is secure as delivered, the process of enabling the necessary setup access for initial users requires several specialized steps when getting started with an implementation.

The following high level steps are required for starting an implementation.

1. As the Oracle Identity Management Administration user, provision the IT Security Manager job role with roles for user and role management.
This step enables the super user account, which is provisioned with the IT Security Manager job role, to create implementation users.
2. As the Oracle Fusion Applications installation super user, perform the following tasks once you have selected an offering to implement and generated the setup tasks needed to implement the offering.
 - a. Synchronize users and roles in the Lightweight Directory Access Protocol (LDAP) store with HCM user management by using the Run User and Roles Synchronization Process task.
 - b. Create an IT security manager user by using the Create Implementation Users task.
 - c. Provision the IT security manager with the IT Security Manager role by using the Provision Roles to Implementation Users task.
3. As the newly created IT security manager user, sign in to Oracle Fusion Applications and set up at least one implementation user for setting up enterprise structures.

- a. Create an implementation user by using the Create Implementation Users task.
- b. Provision the implementation user with the Application Implementation Manager job role or the Application Implementation Consultant job role by using the Provision Roles to Implementation Users task. The Application Implementation Consultant job role inherits from all product-specific application administrators and entitles the necessary View All access to all secured object.
- c. Optionally, create a data role for an implementation user who needs only the limited access of a product-specific Application Administrator by using the Create Data Role for Implementation Users. Then assign the resulting data role to the implementation user by using the Provision Roles to Implementation Users task.

The figure shows the task flow from provisioning the IT Security Manager job role with the user and role management entitlement to creating and provisioning implementation users for enterprise setup.

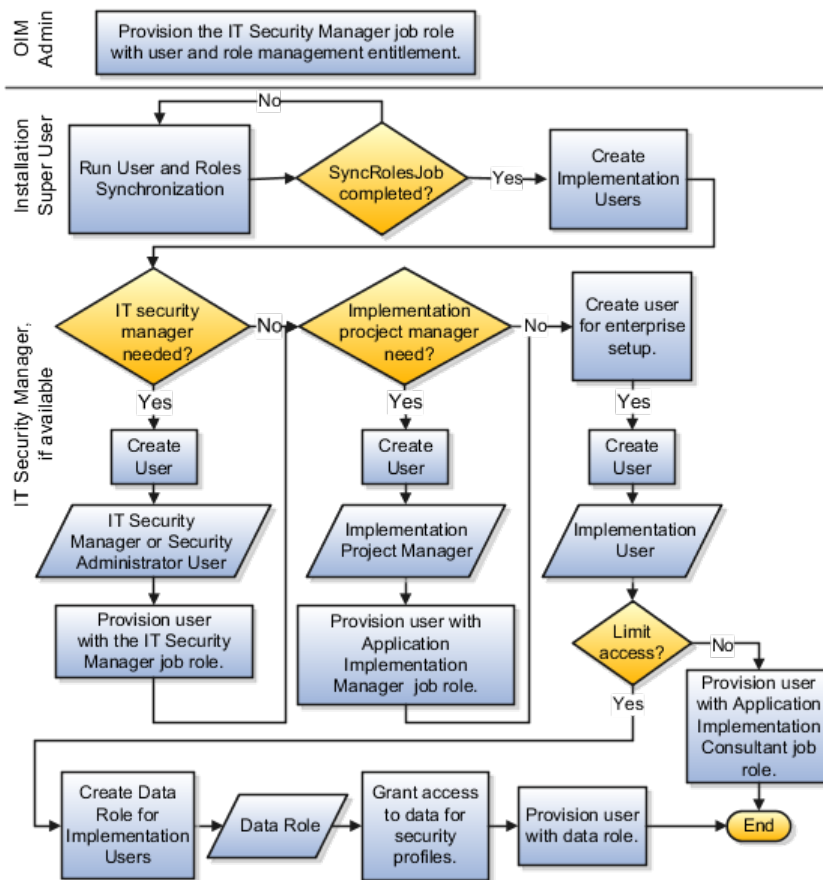

Manage Application Implementation

Manage Application Implementation: Overview

The Manage Applications Implementation business process enables rapid and efficient planning, configuration, implementation, deployment, and ongoing maintenance of Oracle Fusion applications through self-service administration.

The Setup and Maintenance work area offers you the following benefits:

- Prepackaged lists of implementation tasks

Task lists can be easily configured and extended to better fit with business requirements. Auto-generated, sequential task lists include prerequisites and address dependencies to give full visibility to end-to-end setup requirements of Oracle Fusion applications.

- Rapid start

Specific implementations can become templates to facilitate reuse and rapid-start of consistent Oracle Fusion applications setup across many instances.

- Comprehensive reporting

A set of built-in reports helps to analyze, validate and audit configurations, implementations, and setup data of Oracle Fusion applications.

With Oracle Fusion Functional Setup Manager you can:

- Learn about and analyze implementation requirements.
- Configure Oracle Fusion applications to match your business needs.
- Get complete visibility to setup requirements through guided, sequential task lists downloadable into Excel for project planning.
- Enter setup data through easy-to-use user interfaces available directly from the task lists.
- Export and import data from one instance to another for rapid setup.
- Validate setup by reviewing setup data reports.
- Implement all Oracle Fusion applications through a standard and consistent process.

There are several documentation resources available for learning how to configure Oracle Fusion Applications.

- Functional Setup Manager Developer's Guide
- Common Implementation Guide
- Customer Data Management Implementation Guide
- Enterprise Contracts Implementation Guide
- Marketing Implementation Guide
- Sales Implementation Guide
- Fusion Accounting Hub Implementation Guide
- Financials Implementation Guide

- Compensation Management Implementation Guide
- Workforce Deployment Implementation Guide
- Workforce Development Implementation Guide
- Incentive Compensation Implementation Guide
- Procurement Implementation Guide
- P6 EPPM Administrator's Guide for an Oracle Database
- P6 EPPM Administrator's Guide for Microsoft SQL Server Database

Implementation Projects: Explained

An implementation project is the list of setup tasks you need to complete to implement selected offerings and options. You create a project by selecting the offerings and options you want to implement together. You manage the project as a unit throughout the implementation lifecycle. You can assign these tasks to users and track their completion using the included project management tools.

Maintaining Setup Data

You can also create an implementation project to maintain the setup of specific business processes and activities. In this case, you select specific setup task lists and tasks

Exporting and Importing

Implementation projects are also the foundation for setup export and import. You use them to identify which business objects, and consequently setup data, you will export or import and in which order.

Selecting Offerings

When creating an implementation project you see the list of offerings and options that are configured for implementation. Implementation managers specify which of those offerings and options to include in an implementation project. There are no hard and fast rules for how many offerings you should include in one implementation project. The implementation manager should decide based on how they plan to manage their implementations. For example, if you will implement and deploy different offerings at different times, then having separate implementation projects will make it easier to manage the implementation life cycles. Furthermore, the more offerings you included in an implementation project, the bigger the generated task list will be. This is because the implementation task list includes all setup tasks needed to implement all included offerings. Alternatively, segmenting into multiple implementation projects makes the process easier to manage.

Offerings: Explained

Offerings are application solution sets representing one or more business processes and activities that you typically provision and implement as a unit.

They are, therefore, the primary drivers of functional setup of Oracle Fusion applications. Some of the examples of offerings are Financials, Procurement, Sales, Marketing, Order Orchestration, and Workforce Deployment. An offering may have one or more options or feature choices.

Implementation Task Lists

The configuration of the offerings will determine how the list of setup tasks is generated during the implementation phase. Only the setup tasks needed to implement the selected offerings, options and features will be included in the task list, giving you a targeted, clutter-free task list necessary to meet your implementation requirements.

Enabling Offerings

Offerings and their options are presented in an expandable and collapsible hierarchy to facilitate progressive decision making when specifying whether or not an enterprise plans to implement them. An offering or its options can either be selected or not be selected for implementation. Implementation managers decide which offerings to enable.

Provisioning Offerings

The Provisioned column on the Configure Offerings page shows whether or not an offering is provisioned. While you are not prevented from configuring offerings that have not been provisioned, ultimately the users are not able to perform the tasks needed to enter setup data for those offerings until appropriate enterprise applications (Java EE applications) are provisioned and their location (end point URLs) is registered.

Options: Explained

Each offering in general includes a set of standard functionality and a set of optional modules, which are called options. For example, in addition to standard Opportunity Management, the Sales offering includes optional functionality such as Sales Catalog, Sales Forecasting, Sales Prediction Engine, and Outlook Integration. These optional functions may not be relevant to all application implementations. Because these are subprocesses within an offering, you do not always implement options that are not core to the standard transactions of the offering.

Feature Choices: Explained

Offerings include optional or alternative business rules or processes called feature choices. You make feature selections according to your business requirements to get the best fit with the offering. If the selected offerings and options have dependent features then those features are applicable when you implement the corresponding offering or option. In general, the features are set with a default configuration based on their typical usage in most implementations. However, you should always review the available feature choices for their selected offerings and options and configure them as appropriate for the implementation.

You can configure feature choices in three different ways:

Yes or No

If a feature can either be applicable or not be applicable to an implementation, a single checkbox is presented for selection. Check or uncheck to specify yes or no respectively.

Single Select

If a feature has multiple choices but only one can be applicable to an implementation, multiple choices are presented as radio buttons. You can turn on only one of those choices.

Multi-Select

If the feature has multiple choices but one or more can be applicable to an implementation then all choices are presented with a checkbox. Select all that apply by checking the appropriate choices.

Define Synchronization of Users and Roles from LDAP

User and Role Synchronization: Explained

Oracle Identity Management (OIM) maintains Lightweight Directory Access Protocol (LDAP) user accounts for users of Oracle Fusion applications. OIM also stores the definitions of abstract, job, and data roles and holds information about roles provisioned to users. During implementation, any existing information about users, roles, and roles provisioned to users must be copied from the LDAP directory to the Oracle Fusion Applications tables. Once the Oracle Fusion Applications tables are initialized with this information, it is maintained automatically. To perform the initialization, you run the process Retrieve Latest LDAP Changes.

Note

For security and audit best practice, implementation users have person records and appropriate role-based security access. So that appropriate roles can be assigned to implementation users, you must run the process Retrieve Latest LDAP Changes before you create implementation users.

During initial implementation, the installation super user performs the task Run User and Role Synchronization Process to run the Retrieve Latest LDAP Changes process.

Tip

The user name and password of the installation super user are created during installation provisioning of Oracle Fusion Applications. For details of the user name and password, contact your system administrator or the person who installed Oracle Fusion Applications.

Manage Units of Measure

Units of Measure, Unit of Measure Classes, and Base Units of Measure: How They Fit Together

Define units of measure, unit of measure classes, and base units of measure for tracking, moving, storing, and counting items.

The Quantity unit of measure class contains the units of measure Box of 8, Box of 4, and Each. The unit of measure Each is assigned as the base unit of measure.

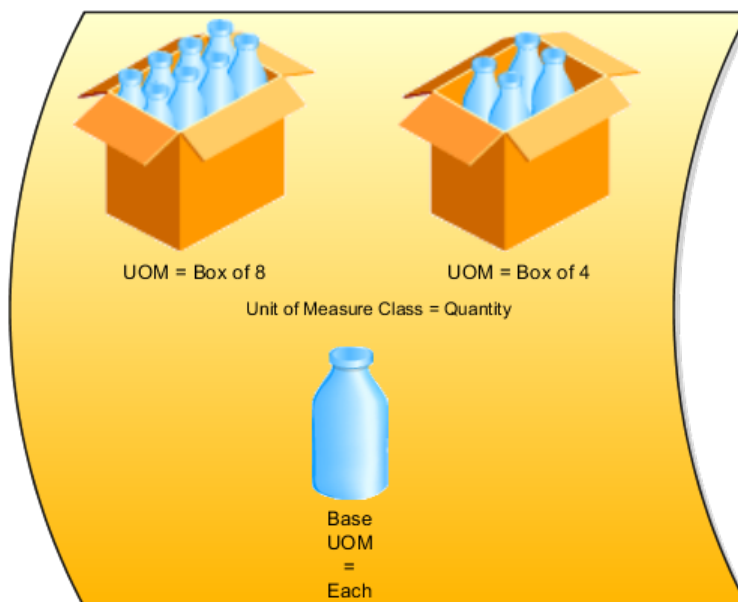

Unit of Measure Classes

Unit of measure classes represent groups of units of measure with similar characteristics such as area, weight, or volume.

Units of Measure

Units of measure are used by a variety of functions and transactions to express the quantity of items. Each unit of measure you define must belong to a unit of measure class.

Base Units of Measure

Each unit of measure class has a base unit of measure. The base unit of measure is used to perform conversions between units of measure in the class. For this reason, the base unit of measure should be representative of the other units of measure in the class, and should generally be one of the smaller units. For example, you could use CU (cubic feet) as the base unit of measure for a unit of measure class called Volume.

Assigning Base Units of Measure to Unit of Measure Classes: Examples

Each unit of measure class must have a base unit of measure.

Scenario

This table lists examples of unit of measure classes, the units of measure in each unit of measure class, and the unit of measure assigned as the base unit of measure for each unit of measure class. Note that each base unit of measure is the smallest unit of measure in its unit of measure class.

Unit of Measure Class	Units of Measure	Base Unit of Measure
Quantity	dozen box each	each
Weight	pound kilogram gram	gram
Time	hour minute second	second
Volume	cubic feet cubic centimeters cubic inches	cubic inches

Defining Unit of Measure Standard Conversions: Examples

A unit of measure standard conversion specifies the conversion factor by which the unit of measure is equivalent to the base unit of measure.

Scenario

This table lists examples of unit of measure classes, one unit of measure included in each class, the base unit of measure for the unit of measure class, and the conversion factor defined for the unit of measure.

Unit of Measure Class	Unit of Measure	Base Unit of Measure	Conversion Factor
Quantity	dozen	each	12 (1 dozen = 12 each)
Weight	pound	gram	454 (1 pound = 454 grams)
Time	minute	second	60 (1 minute = 60 seconds)

FAQs for Manage Units of Measure

What's a unit of measure standard conversion?

A unit of measure standard conversion defines the conversion factor by which the unit of measure is equivalent to the base unit of measure that you defined for the unit of measure class. Defining a unit of measure standard conversion allows you to perform transactions in units other than the primary unit of measure of the item being transacted. The standard unit of measure conversion is used for an item if an item-specific unit of measure conversion has not been defined.

What's a UOM interclass conversion?

A UOM interclass conversion defines the conversion between the source base unit of measure ("From Base UOM") in one unit of measure class ("From Class") and the destination base unit of measure ("To Base UOM") in a different unit of measure class ("To Class").

For example, the item is gasoline. The From Base UOM (of the From Class called "volume") is liters. The To Base UOM (of the To Class called "quantity") is Barrels. The conversion is 158.76 liters (volume) to 1 barrel of oil (quantity).

What's a UOM intraclass conversion?

A UOM intraclass conversion specifies the conversion between a unit of measure (the "From UOM") and the base unit of measure of the same class.

For example, the item is soda pop. The unit of measure class is Quantity. The From UOM is Case (CS). The base unit of measure is Each (EA). The conversion is 24, to specify that 1 CS = 24 EA.

Maintain Common Reference Objects

Maintain Common Reference Objects: Overview

The Maintain Common Reference Objects task list contains Oracle Fusion Middleware Extensions for Applications (Applications Core) tasks that support implementation of common behaviors, such as data security or reference data sets.

Use this task list to manage common reference objects that are defined centrally and shared across applications, in addition to those that are specific to Applications Core functionality. You can access this task list by starting in the Setup and Maintenance Overview page and searching for common reference object task lists.

Note

Offerings also include application-specific tasks for managing Applications Core objects. For example, the Financials offering includes tasks such as Manage Receivables Descriptive Flexfields, and Manage Receivables Lookups.

For more information on configuring custom objects, see the Oracle Fusion Applications Extensibility Guide.

To make the Maintain Common Reference Objects task list available in your implementation project, go to **Setup and Maintenance Overview - Configure Offerings**, and for a specific offering, select the Maintain Common Reference Objects feature choice.

Define Application Taxonomy

Application Taxonomy: Highlights

Application taxonomy is the organization of Oracle application components and functions in a hierarchical structure, from product lines to logical business areas. This hierarchy represents a breakdown of products into units based on how applications are installed and supported. Maintain this hierarchy on the Manage Taxonomy Hierarchy page, which you can access by starting in the Setup and Maintenance Overview page and searching for the Manage Taxonomy Hierarchy task.

A detailed introduction to application taxonomy is provided in the Oracle Fusion Applications Developer's Guide.

Hierarchy

- The application taxonomy hierarchy contains various levels and types of nodes, or modules.

See: Characteristics of the Level Categories

See: Benefits of a Logical Hierarchy

Usage

- Use application taxonomy to understand relationships among applications and between an application and its files. This information is helpful in managing various phases of the product lifecycle.

See: How to Manage the Lifecycle

Modules in Application Taxonomy: Explained

A module is any node in the application taxonomy hierarchy. The top level of the hierarchy is product line, followed by product family, application, and logical business area. There can be multiple levels of logical business areas, with one or more nested within a parent logical business area.

Product Line

A product line is a collection of products under a single brand name, for example, Oracle Fusion.

Product Family

A product family is a collection of products associated with a functional area that may or may not be licensed together as a single unit, for example Financials.

Application

An application is a single product within a product family, containing closely related features for a specific business solution, for example General Ledger.

Logical Business Area

A logical business area is a collection of business object definitions organized into a logical grouping. It contains the model objects, services, and UI components for those business objects. Logical business areas have their own hierarchy levels and in some cases can be two or three levels deep. Each leaf node has at least one business object and service, up to a maximum of four business objects and associated services. A logical business area with more than four business objects are further refined with child logical business area levels. Each of these parent-child levels is represented by a directory in the physical package hierarchy.

Managing Modules in Application Taxonomy: Points to Consider

Manage modules on the Create Child Module or Edit Module page, which you can access by starting in the Setup and Maintenance Overview page and searching for the Manage Taxonomy Hierarchy task. When you create a module, it is a child of the currently selected node in the application taxonomy hierarchy. This determines which values are available, for example for module type. Once created, you cannot delete the module or move it elsewhere in the hierarchy. As you create or edit modules, consider the following points regarding specific fields.

Identifiers

Module ID is the unique primary key for nodes in the taxonomy table. When you create a module, an ID is automatically generated. Once the module is created, you cannot update the ID.

Module key and alternative ID are additional identifiers of the module, presented in a way that is easier to read than the module ID. The module key is a string identifier, for example AP for the Oracle Fusion Payables application. The alternative ID is a numeric identifier, for example 1 for the Oracle Fusion product line. These IDs are provided for the product line, product family, and application modules, but you can optionally add them for logical business areas and new custom modules.

Note

Do not change the module key or alternative ID for predefined modules.

The product code is relevant only to application and logical business area modules. You can leave the field blank for other module types. The product code for applications is the short name that can be displayed in lists of application values, for example FND for Oracle Fusion Middleware Extensions for Applications.

Names

Module name is the logical name for the module and is always available. The name must be unique among nodes in the same hierarchy level with the same parent, but try to make it as unique in the whole hierarchy as possible.

The user name and description can appear to users in other parts of Oracle Fusion Applications, so make sure that the values are something that users know to represent the module.

Usage Types

Though you can update the usage type to reflect the current state of the module, just doing so does not affect the actual state. For example, setting a module as installed does not mean it is actually installed if the installation itself has not taken place. Installation refers to operations related to laying down all the

components needed to create an Oracle Fusion Applications environment, while deployment is the process that starts the managed servers and clusters and facilitates the actual use of product offerings. A licensed module is available for installation and deployment, and a deployed module is considered actively used when actually used by users.

Seed Data

If seed data is allowed, then seed data such as flexfields and lookups can be extracted for the module using seed data loaders. By default, extract is allowed for all predefined modules of type application and logical business area.

Associations

You can associate a logical domain to modules of type product family, as well as one or more enterprise applications to modules of type application. This association represents the relationship between the taxonomy modules and the corresponding domain and enterprise applications stored in the Oracle Fusion Applications Functional Core (ASK) tables.

Define Reference Data Sharing

Reference Data Sharing: Explained

Reference data sharing facilitates sharing of configuration data such as jobs and payment terms, across organizational divisions or business units. You define reference data sets and determine how the data is shared or partitioned. Use reference data sets to reduce duplication and maintenance by sharing common data across business entities where appropriate. Depending on the requirement (specific or common), each business unit can maintain its data at a central location, using a set of values either specific to it or shared by other business units.

You can share reference data after it is filtered on the basis of sets. A common reference data set is available as the default set, which can be assigned to several business units sharing the same reference data. For commonly used data such as currencies, you can use the common reference data set and assign it to multiple business units in various countries that use the same currency. In cases where the default set cannot be assigned to an entity, you can create specific sets. The data set visible on the transactional page depends on the sharing method used to share reference data.

For example, XYZ Corporation uses the same grades throughout the entire organization. Instead of managers in different business units setting up the same grades, XYZ Corporation decides to create a set called Grades and assign the grades reference data group for all business units in the organization to the Grades set, so that the grades can be shared.

Note

For specific information on configuring reference data sharing for a particular object or product, refer to its product documentation.

Reference Data Sets: Explained

Reference data sets are logical groups of reference data that can be accessed by various transactional entities depending on the business context. Oracle Fusion Applications contains a common reference data set as well as an enterprise set that may be used as a default set. Depending on your business requirement you can create and maintain additional reference data sets, while continuing to use the common reference data set.

Consider the following scenario.

Your enterprise can decide that some aspects of corporate policy should affect all business units and leave other aspects to the discretion of the business unit manager. This allows your enterprise to balance autonomy and control for each business unit. For example, if your enterprise holds business unit managers accountable for their profit and loss, but manages working capital requirements at a corporate level, you can let managers define their own sales methods, but define payment terms centrally. In this case, each business unit would have its own reference data set for sales methods, and there would be one central reference data set for payment terms assigned to all business units.

Partitioning

The partitioning of reference data and creation of data sets enable you to create reference entities across tables or lookup types, and share modular information and data processing options among business units. With the help of partitioning, you can choose to create separate sets and subsets for each business unit depending upon its business requirement, or create common sets or subsets to enable sharing reference data between several business units, without the need for duplicating the reference data. Partitioning provides you the flexibility to handle the reference data in a way appropriate to your business needs.

The following figure illustrates the reference data sharing method (assignment to one set only, with common values) where the user can access the data assigned to a specific set in a particular business unit, as well as access the data assigned to the common set.

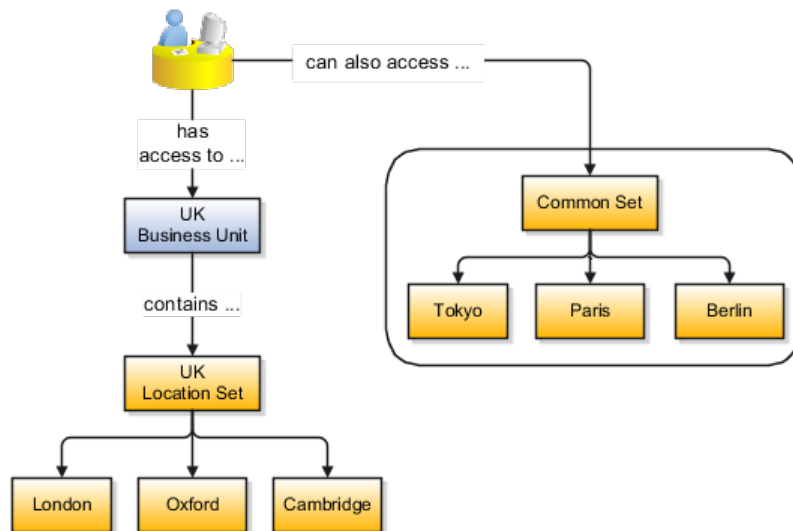

Reference Data Sets and Sharing Methods: Explained

Oracle Fusion Applications reference data sharing feature is also known as SetID. The reference data sharing functionality supports operations in multiple ledgers, business units, and warehouses, thereby reducing the administrative burden and decreasing the time needed to implement new business units. For example, you can share sales methods, transaction types, or payment terms across business units or selected other data across asset books, cost organizations, or project units.

The reference data sharing features use reference data sets to which reference data is assigned. The reference data sets group assigned reference data. The sets can be understood as buckets of reference data assigned to multiple business units or other application components.

Reference Data Sets

You begin this part of your implementation by creating and assigning reference data to sets. Make changes carefully as changes to a particular set will affect all business units or application components using that set. You can assign a separate set to each business unit for the type of object that is being shared. For example, assign separate sets for payment terms, transaction types, and sales methods to your business units.

Your enterprise can decide that some aspects of corporate policy should affect all business units and leave other aspects to the discretion of the business unit manager. This allows your enterprise to balance autonomy and control for each business unit. For example, if your enterprise holds business unit managers accountable for their profit and loss, but manages working capital requirements at a corporate level, you can let managers define their own sales methods, but define payment terms centrally. In this case, each business unit would have its own reference data set for sales methods, and there would be one central reference data set for payment terms assigned to all business units.

The reference data sharing is especially valuable for lowering the cost of setting up new business units. For example, your enterprise operates in the hospitality industry. You are adding a new business unit to track your new spa services. The hospitality divisional reference data set can be assigned to the new business unit to quickly setup data for this entity component. You can establish other business unit reference data in a business unit specific reference data set as needed

Reference Data Sharing Methods

There are variations in the methods used to share data in reference data sets across different types of objects. The following list identifies the methods:

- Assignment to one set only, no common values allowed. The simplest form of sharing reference data that allows assigning a reference data object instance to one and only one set. For example, Asset Prorate Conventions are defined and assigned to only one reference data set. This set can be shared across multiple asset books, but all the values are contained only in this one set.
- Assignment to one set only, with common values. The most commonly used method of sharing reference data that allows defining reference data

object instance across all sets. For example, Receivables Transaction Types are assigned to a common set that is available to all the business units without the need to be explicitly assigned the transaction types to each business unit. In addition, you can assign a business unit specific set of transaction types. At transaction entry, the list of values for transaction types includes transaction types from the set assigned to the business unit, as well as transaction types assigned to the common set that is shared across all business units.

- Assignment to multiple sets, no common values allowed. The method of sharing reference data that allows a reference data object instance to be assigned to multiple sets. For instance, Payables Payment Terms use this method. It means that each payment term can be assigned to one or more than one set. For example, you assign the payment term Net 30 to several sets, but the payment term Net 15 is assigned to only your corporate business unit specific set. At transaction entry, the list of values for payment terms consists of only one set of data; the set that is assigned to the transaction's business unit.

Note: Oracle Fusion Applications contains a reference data set called Enterprise. Define any reference data that affects your entire enterprise in this set.

Assigning Reference Data Sets to Reference Objects: Points to Consider

You can assign the reference data sets to reference objects on the Manage Reference Data Set Assignments page. For multiple assignments, you can classify different types of reference data sets into groups and assign them to reference entity objects. The assignment takes into consideration the determinant type, determinant, and reference group, if any.

Determinant Types

The partitioned reference data is shared based on a business context setting called the determinant type. It is the point of reference used in the data assignment process. The following table lists the determinant types used in the reference data assignment.

Type	Description
Asset Book	Information about the acquisition, depreciation, and retirement of an asset that belongs to a ledger or a business unit.
Business Unit	The departments or organizations within an enterprise.
Cost Organization	The organization used for cost accounting and reporting on various inventory and cost centers within an enterprise.
Project Unit	A logical organization within an enterprise that is responsible for enforcing consistent project management practices.
Reference Data Set	References to other shared reference data sets.

Determinant

The determinant or determinant value is the value that corresponds to the selected determinant type. The determinant is one of the criteria for selecting the appropriate reference data set. For example, when managing set assignments for the set determinant type, Reference Data Set is the determinant type, and you would enter the corresponding set code value as the corresponding determinant value.

Reference Groups

A transactional entity may have multiple reference entities (generally considered to be setup data) that are treated in the same manner because of commonness in implementing business policies and legal rules. Such reference entities in your application are grouped into logical units called reference groups, based on the functional area and the partitioning requirements that they have in common. For example, all tables and views that define Sales Order Type details might be part of the same reference group.

Note

The reference groups are predefined in the reference groups table and are available for selection and assignment.

Define Lookups

Lookups: Explained

Lookups are lists of values in applications. You define a list of values as a lookup type consisting of a set of lookup codes, each code's translated meaning, and optionally a tag. End users see the list of translated meanings as the available values for an object.

Lookups provide a means of validation and lists of values where valid values appear on a list with no duplicate values. For example, an application might store the values Y and N in a column in a table, but when displaying those values in the user interface, Yes or No (or their translated equivalents) should be available for end users to select. For example, the two lookup codes Y and N are defined in the REQUIRED_INDICATOR lookup type.

In another example, a lookup type for marital status has lookup codes for users to specify married, single, or available legal partnerships.

Lookup Type	Lookup Code	Meaning	Tag
MAR_STATUS	M	Married	
	S	Single	
	R	Registered Partner	+NL
	DP	Domestic Partner	-FR, AU

In this case, tags are used for localizing the codes. All legislations list Married and Single. Only the Dutch legislation lists Registered Partner. And all legislations except France and Australia also list Domestic Partner.

When managing lookups, you need to understand the following.

- Using lookups in applications
- Customization levels
- Accessing lookups
- Enabling lookups
- The three kinds of lookups: standard, common, and set enabled

Using Lookups in Applications

Use lookups to provide validation or a list of values for a user input field in a user interface.

An example of a lookup used for validation is a flexfield segment using a table-validated value set with values from a lookup type. An example of a lookup in a list of values is a profile option's available values from which users select one to set the profile option. Invoice Approval Status gives the option of including payables invoices of different approval statuses in a report. The lookup code values include All so that users can report by all statuses: Approved, Resubmitted for approval, Pending or rejected, and Rejected.

Customization Level

The customization level of a lookup type determines whether the lookups in that lookup type can be edited. This applies data security to lookups.

Some lookup types are locked so no new codes and other changes can be added during implementation or later, as needed. Depending on the customization level of a lookup type, you may be able to change the codes or their meanings. Some lookups are designated as extensible, so new lookup codes can be created during implementation, but the meanings of predefined lookup codes cannot be modified. Some predefined lookup codes can be changed during implementation or later, as needed.

The customization levels are user, extensible, and system. The following table shows which lookup management tasks are allowed at each customization level.

Allowed Task	User	Extensible	System
Deleting a lookup type	Yes	No	No
Inserting new codes	Yes	Yes	No
Updating start date, end date, and enabled fields	Yes	Yes, only if the code is not predefined data	No
Deleting codes	Yes	Yes, only if the code is not predefined data	No
Updating tags	Yes	No	No
Updating module	Yes	No	No

Predefined data means LAST_UPDATED_BY = SEED_DATA_FROM_APPLICATION.

If a product depends on a lookup, the customization level should be system or extensible to prevent deletion.

Once the customization level is set for a lookup type, it cannot be modified. The customization level for lookup types created using the Define Lookups page is by default set at the User level.

Standard, Common, and Set-Enabled Lookups

The available kinds of lookups are as follows.

Lookup	Description
Standard	Lists the available codes and translated meanings
Set enabled	Additionally associates a reference data set with the lookup codes
Common	Legacy lookups

Standard lookups are the simplest form of lookup types consisting only of codes and their translated meaning. They differ from common lookups only in being defined in the standard lookup view.

Common lookups exist for reasons of backward compatibility and differ from standard lookups only in being defined in the common lookup view.

Set enabled lookup types store lookup codes that are enabled for reference data sharing. At runtime, a set-enabled lookup code is visible because the value of the determinant identifies a reference data set in which the lookup code is present.

Accessing Lookups

Standard, set-enabled, and common lookups are defined in the Standard, Set-enabled, and Common views, respectively. Applications development may define lookups in an application view to restrict the UI pages where they may appear.

In lookups management tasks, lookups may be associated with a module in the application taxonomy to provide a criteria for narrowing a search or limiting the number of lookups accessed by a product specific task such as Manage Purchasing Lookups.

Enabling Lookups

A lookup type is reusable for attributes stored in multiple tables.

Enable lookups based on the following.

- Selecting an **Enabled** check box

- Specifying an enabled start date, end date, or both
- Specifying a reference data set determinant

If you make changes to a lookup, users must sign out and back in before the changes take effect. When defining a list of values for display rather than validation, limit the number of enabled lookup codes to a usable length.

Managing a Standard Lookup: Example

Creating a new standard lookup involves creating or selecting a lookup type to which the lookup code belongs, and determining appropriate values for the lookup codes and their meanings.

Note

You can only create or edit the lookup codes for a particular lookup type if its customization level supports it.

Creating a Lookup Type Called COLORS

Your enterprise needs a list of values for status to be used on various objects such as processes or users. The lookups are colors, so the lookup type you create is COLORS.

Lookup type parameters	Value
Lookup type name	COLORS
Meaning	Status
Description	Status by color
Module	Oracle Fusion Middleware Extensions for Applications

The lookup codes you define for the COLORS lookup type are, BLUE, RED, GREEN, and YELLOW.

Lookup Code	Meaning	Enabled	Display Sequence
BLUE	Urgent	No	4
RED	Stop	Yes	1
GREEN	Go	Yes	3
YELLOW	Caution	Yes	2

Understanding the Resulting Data Entry List of Values

Users need to respond to a process question by indicating whether to stop it, use caution, go ahead, or complete it urgently.

The list of values for the COLORS lookup type includes the meanings for the enabled codes.

Displayed Value	Hidden ID
Stop	RED
Caution	YELLOW
Go	GREEN

Analysis

The BLUE lookup code was not enabled and does not appear in the list of values. The display sequence of values in the list of values is alphabetical unless you enter a number manually to determine the order of appearance. Number 1 indicates the value listed first in the list of values.

Note

Only lookups that are enabled and active, meaning between start and end dates, are visible.

When users enter one of the values from the list of values for the lookup type COLORS, the transaction table records the lookup code. In this example, the code is stored in the Status column

Transaction number	User name	Status
1	Jane	RED
2	Bob	YELLOW
3	Alice	BLUE

The status for one user is BLUE because at the time they entered a value, BLUE was enabled. Disabling a lookup code does not affect transaction records in which that code is stored. Data querying and reporting have access to disabled lookup codes in transaction tables.

Managing Set-Enabled Lookups: Examples

Creating a new set-enabled lookup is similar to creating a standard lookup with the addition of specifying a reference data set determinant for the lookup codes.

Note

You can only create or edit the lookup codes for a particular lookup type if its customization level supports it.

The reference data set for a set-enabled lookup code is part of its foreign key. This is unlike other set-enabled entities.

Selecting a Reference Group for a Set-Enabled Lookup Type

By specifying a reference group for a set-enabled lookup type you indicate which reference data set assignments are available for its lookup codes. For example a COLORS lookup type might be set enabled for a Countries reference group that includes the US and EU reference data set assignments.

Selecting a Reference Data Set for a Set-Enabled Lookup

The reference data set determines which lookup code is included in the list of values. If a COLORS lookup type contains a RED, YELLOW, ORANGE, and GREEN lookup code, you can enable one RED lookup as coming from the US reference data set and another RED lookup as coming from the EU reference data set with divergent meanings.

Reference Data Set	Lookup Code	Lookup Meaning
US	RED	Red
US	YELLOW	Yellow
US	GREEN	Green
EU	RED	Rouge
EU	ORANGE	Orange

In addition to divergent meanings for lookup codes based on associated reference data set, some lookup codes may be unique to one or another reference data set as the ORANGE lookup is to the EU reference data set in this example.

In another example, a lookup type called HOLD_REASON provides a list of reasons for applying a hold to a contract renewal. Reference data sets determine which codes are included in the hold reason list of values.

Reference Data Set	Lookup Code	Lookup Meaning
US	SEC	SEC Compliance Review
US	DIR	Needs Director's Approval
US	VP	Needs Vice President's Approval
CHINA	CSRC	Pending China Securities Regulatory Commission Review
CHINA	PR	Needs President's Approval
COMMON	REQUESTED	Customer Request

Using the Manage Set Assignments task, you have defined assignments that designate the China business unit to refer to the CHINA and the US business unit to refer to the US and all business units to refer to the COMMON set. When end users place a contract hold in the US business unit, only the three reason codes in US_SET are available. When placing a contract hold in the China business, only the two codes in China_SET are available.

FAQs for Define Lookups

How can I edit lookups?

You can edit the existing lookup codes of a lookup type or add new lookup codes on the Define Lookups pages, which you can access by starting in the Setup and Maintenance work area and searching for lookup tasks. You can edit the existing lookup codes of a lookup type, or add new lookup codes to a lookup type, if the customization level for the lookup type supports editing.

Why can't I see my lookup types?

Lookups are listed by lookup type. Typically lookup types are managed using tasks that handle a group of related lookups, such as Manage Geography Lookups. Each task gives you access only to certain lookup types. The generic tasks provide access to all lookup types of a kind, such as all common lookups using the Manage Common Lookups task.

If existing lookups are not available to the tasks of the Define Lookups activity, they may be validated for use in a lookup view that is not central to all applications or whose owning application has not been specified in a lookup view.

Lookups can only be managed in the Define Lookups tasks if the lookup's view application is the standard lookups view, common lookups view, or set-enabled lookups view. Lookups defined in an application view can only be managed by following instructions provided by the owning application.

Note

A lookup type and its codes can only be defined in one lookup view.

What's the difference between a lookup type and a value set?

A lookup type consists of lookup codes that are the values in a static list of values. Lookup code validation is a one to one match.

A table-validated value set can consist of values that are validated through a SQL statement, which allows the list of values to be dynamic.

Tip

A table validated value set can be defined based on any table, including the lookups table. This allows a lookup type to be made into a table-validated value set that can be used in flexfields.

Area of Difference	Lookup Type	Value Set
List of values	Static	Dynamic if Table validation type
Validation of values	One to one match of meaning to code included in a lookup view, or through the determinant of a reference data set	By format or inclusion in a table
Format type of values	char	varchar2, number, and so on
Length of value	Text string up to 30 characters	Any type of variable length from 1 to 4000
Duplication of values	Never. Values are unique.	Duplicate values allowed
Management	Managed by both administrators and end-users, except system lookups or predefined lookups at the system customization level, which cannot be modified.	Maintained by administrators, except some product flexfield codes, such as GL for Oracle Fusion General Ledger, which are maintained by end users

A lookup type cannot make use of a value from a value set.

Value sets can make use of standard, common, or set-enabled lookups.

Both lookup types and value sets are used to create lists of values from which users select values.

What's a lookup tag used for?

Tags on lookup codes allow you to add a label to your lookup codes.

Lookup tags are unvalidated and uninterpreted by lookups. A tag can be used to categorize lookups based on facilitating searches or guiding how a lookup should be used.

Document what the tag on a lookup represents and how to use it.

Manage Messages

Messages: Highlights

The message dictionary contains messages that tell users about business rule errors, such as missing or incorrect data, and how to resolve them, to warn users about the consequences of intended actions, and provide information in log files. These messages are defined for specific applications and modules, but a few are common messages that can be used in any application. All applications also use messages stored outside of the message dictionary.

The message dictionary is described in the Oracle Fusion Applications Developer's Guide, and other messages in the Oracle Fusion Middleware Web User Interface Developer's Guide for Oracle Application Development Framework.

Managing Messages

- Use the Manage Messages page to create and edit custom messages in the message dictionary, as well as edit predefined messages. Do not delete predefined messages unless you are sure that they are not used anywhere. Refer to the Oracle Fusion Applications Developer's Guide.

See: Introduction to Message Dictionary Messages

- Messages outside of the message dictionary, for example confirmations and field validations, are managed in Oracle Application Development Framework Faces components or through message resource bundles used for translation. Refer to the Oracle Fusion Middleware Web User Interface Developer's Guide for Oracle Application Development Framework.

See: Displaying Hints and Error Messages for Validation and Conversion

See: Internationalizing and Localizing Pages

Creating and Editing Messages: Highlights

Each message in the message dictionary has many attributes and components, including message properties, text, and tokens, that you define when creating or editing the message.

Details about these messages are described in the Oracle Fusion Applications Developer's Guide.

Message Properties

- The message type identifies the type of information that the message contains.

See: Understanding Message Types

- The message name and number are identifiers for the message. There are specific message number ranges for predefined messages in each application, and you should not edit numbers assigned to predefined messages. When creating custom messages, use only message numbers within the 10,000,000 to 10,999,999 range.

See: About Message Names

See: About Message Numbers

- The translation notes for predefined messages might contain internal content that you can disregard.

See: About Translation Notes

- The message category, severity, and logging enabled option are related to the incident and logging process.

See: About Grouping Messages by Category and Severity

See: Understanding Incidents and Diagnostic Logs with Message Dictionary

Message Text and Tokens

- The message text comprises various components, some of which are displayed only to select users. To determine which component of the message text is displayed to a particular user, set the Message Mode profile option (FND_MESSAGE_MODE) at the user level for that user. The message component short text is visible to all users and therefore, the profile option does not apply to this component. Also, the profile option applies only to messages in the message dictionary.

See: About Message Components

- Tokens are variables that represent values to be displayed in the message text.

See: About Tokens

Common Messages: Points to Consider

Common messages, which have message names that begin with FND_CMN and message numbers between 0 and 999, are used throughout Oracle Fusion Applications. Each common message can appear in multiple places in any product family. For example, the FND_CMN_NEW_SRCH message can be used for any search to indicate that no results were found. Common messages that are of type error or warning are part of the message dictionary.

Editing Common Messages

Because a common message can be used in any application, consider the ramifications if you edit any aspect of the message, including incident and logging settings. Changes would be reflected in all instances where the message is used. For example, if you change the message text, make sure that the text would make sense to all users across Oracle Fusion Applications who might see it.

Creating Common Messages

You can create custom common messages for use in multiple places within a single product. Do not begin the message name with FND_CMN, but use another suitable convention. The message number should be within the range that is designated for the product.

Define ISO Reference Data

Defining Currencies: Points to Consider

When creating or editing currencies, consider these points relevant to entering the currency code, date range, or symbol for the currency.

Currency Codes

You cannot change a currency code after you enable the currency, even if you later disable that currency.

Date Ranges

Users can enter transactions denominated in the currency only for the dates within the specified range. If you do not enter a start date, then the currency is valid immediately. If you do not enter an end date, then the currency is valid indefinitely.

Symbols

Even if you enter a symbol for a currency, the symbol is not always displayed when an amount is displayed in this currency. Some applications use currency

symbols when displaying amounts. Others, like Oracle Fusion General Ledger, do not.

Euro Currency Derivation: Explained

Use the Derivation Type, Derivation Factor, and Derivation Effective Date fields to define the relationship between the official currency (Euro) of the European Monetary Union (EMU) and the national currencies of EMU member states. For each EMU currency, you define its Euro-to-EMU fixed conversion rate and the effective starting date.

Note

If you need to use a different currency code for Euro, you can disable the predefined Euro currency and create a new one.

Derivation Type

The **Euro currency** derivation type is used only for the Euro, and the **Euro derived** derivation type identifies national currencies of EMU member states. All other currencies do not have derivation types.

Derivation Factor

The derivation factor is the fixed conversion rate by which you multiply one Euro to derive the equivalent EMU currency amount. The Euro currency itself should not have a derivation factor.

Derivation Effective Date

The derivation effective date is the date on which the relationship between the EMU currency and the Euro begins.

Natural Languages: Points to Consider

Natural languages are all the languages that humans use, written and spoken. If a language is enabled, then users can associate it with entities, for example as languages spoken by sales representatives. When managing natural languages, consider tasks to perform and best practices for entering particular values.

Tasks

Once you add a language, it cannot be deleted, just disabled. You can optionally associate natural languages with International Organization for Standardization (ISO) languages and territories, just for reference.

Values

When you create a natural language, use the alpha-2 ISO code as the language code, or, if not available, then alpha-3. If the language is not an ISO language, then use **x-** as a prefix for the code, for example **x-ja** for a Japanese dialect.

Use the **sgn** code of ISO-639-2 for sign languages, followed by territory code, for example **sgn-US** for American Sign Language. You can also use Internet Assigned Numbers Authority (IANA) language tags.

The natural language description should be the language name with territory name in parenthesis where needed, for example **English (Australia)** and **English (Canada)**.

FAQs for Define ISO Reference Data

When do I create or edit territories?

Edit territory descriptions to determine how they are displayed in lists of country values throughout Oracle Fusion Applications. The predefined territories are all countries from the International Organization for Standardization (ISO) 3166 standard. You usually would not edit territory names or codes.

Do not edit National Language Support (NLS) territory codes, which are identifiers used in the system, unless you need to change the association between ISO and system territory. You usually would not edit the default currency, which is the value that defaults in the **Currency** field in Oracle Fusion Applications user preferences after the user first selects a territory.

Create territories if new countries emerge and the system has not yet been patched with the latest ISO country values.

When do I create or edit industries?

Edit industry descriptions to determine how they are displayed in Oracle Fusion Applications. You usually would not edit industry names, which are from the North American Industry Classification System (NAICS). Enabled industries are mainly used in the context of customization, though these values can also appear in any application.

Create industries if you have particular ones you need, for example for customization, that are not included in the NAICS standard.

When do I associate industries with territories?

Optionally associate industries with territories to provide an industry in territory value, used for customization. For example, administrators can customize a page in one way for users within an industry in one country, and another way for users within the same industry in another country. The administrator would select the appropriate industry in territory value to set the customization context.

When do I create or enable currencies?

Create currencies to use, for example for reporting purposes, if they are not already provided. All currencies from the International Organization for Standardization (ISO) 4217 standard are provided.

Enable any currency other than USD for use in Oracle Fusion Applications, for example for displaying monetary amounts, assigning to sets of books, entering transactions, and recording balances. Only USD is enabled by default.

What's the difference between precision, extended precision, and minimum accountable unit for a currency?

Precision is the number of digits to the right of the decimal point used in regular currency transactions. Extended precision is the number of digits to the right of the decimal point used in calculations for this currency, and it must be greater than or equal to the standard precision. For example, USD would have 2 for precision because amounts are transacted as such, for example \$1.00. For calculations, for example adding USD amounts, you might want the application to be more precise than two decimal digits, and would enter an extended precision accordingly.

Note

Some applications use extended precision. Others, such as Oracle Fusion General Ledger, do not.

Minimum accountable unit is the smallest denomination for the currency. For example, for USD that would be .01 for the cent. This unit does not necessarily correspond to the precision for all currencies.

What's a statistical unit currency type?

The statistical unit currency type is used only for the Statistical (STAT) currency. The Statistical currency is used to record statistics such as the number of items bought and sold. Statistical balances can be used directly in financial reports, allocation formulas, and other calculations.

When do I create or edit ISO languages?

You can edit the names and descriptions of International Organization for Standardization (ISO) languages to determine how they are displayed in lists of ISO language values in Oracle Fusion Applications. The ISO languages are from the ISO 639 standard. If there were changes to the ISO standard and the system has not yet been patched with the latest ISO values, you can update the ISO alpha-2 code or add languages as needed.

When do I edit languages?

Installed languages automatically appear on the Manage Languages page, so you do not manually enter newly installed languages. This page contains all languages available for installation and translation in Oracle Fusion Applications. Each dialect is treated as a separate language. The language codes and names are values used by the system.

You generally would not edit any of the detailed fields unless you really need to and know what they are.

When do I create or edit time zones?

Though all standard time zones are provided, optionally enable only a subset for use in lists of time zone values in Oracle Fusion Applications. You can add time

zones if new zones became standard and the system has not yet been patched with the latest values.

Manage Data Security Policies

Data Security in the Security Reference Implementation: Explained

The reference implementation contains a set of data security policies that can be inspected and confirmed to be suitable or a basis for further implementation using the Authorization Policy Manager (APM).

The security implementation of an enterprise is likely a subset of the reference implementation, with the enterprise specifics of duty roles, data security policies, and HCM security profiles provided by the enterprise.

The business objects registered as secure in the reference implementation are database tables and views.

Granting or revoking object entitlement to a particular user or group of users on an object instance or set of instances extends the base Oracle Fusion Applications security reference implementation without requiring customization of the applications that access the data.

Data Security Policies in the Security Reference Implementation

The data security policies in the reference implementation entitle the grantee (a role) to access instance sets of data based on SQL predicates in a WHERE clause.

Tip

When extending the reference implementation with additional data security policies, identify instance sets of data representing the business objects that need to be secured, rather than specific instances or all instances of the business objects.

Predefined data security policies are stored in the data security policy store, managed in the Authorization Policy Manager (APM), and described in the Oracle Fusion Applications Security Reference Manual for each offering. A data security policy for a duty role describes an entitlement granted to any job role that includes that duty role.

Warning

Review but do not modify HCM data security policies in APM except as a custom implementation. Use the HCM Manage Data Role And Security Profiles task to generate the necessary data security policies and data roles.

The reference implementation only enforces a portion of the data security policies in business intelligence that is considered most critical to risk management without negatively affecting performance. For performance reasons it is not practical to secure every level in every dimension. Your enterprise

may have a different risk tolerance than assumed by the security reference implementation.

HCM Security Profiles in the Security Reference Implementation

The security reference implementation includes some predefined HCM security profiles for initial usability. For example, a predefined HCM security profile allows line managers to see the people that report to them.

The IT security manager uses HCM security profiles to define the sets of HCM data that can be accessed by the roles that are provisioned to users

Data Roles

The security reference implementation includes no predefined data roles to ensure a fully secured initial Oracle Fusion Applications environment.

The security reference implementation includes data role templates that you can use to generate a set of data roles with entitlement to perform predefined business functions within data dimensions such as business unit. Oracle Fusion Payables invoicing and expense management are examples of predefined business functions. Accounts Payable Manager - US is a data role you might generate from a predefined data role template for payables invoicing if you set up a business unit called US.

HCM provides a mechanism for generating HCM related data roles.

Data Security: Explained

By default, users are denied access to all data.

Data security makes data available to users by the following means.

- Policies that define grants available through provisioned roles
- Policies defined in application code

You secure data by provisioning roles that provide the necessary access. Enterprise roles provide access to data through data security policies defined for the inherited application roles.

When setting up the enterprise with structures such as business units, data roles are automatically generated that inherit job roles based on data role templates. Data roles also can be generated based on HCM security profiles. Data role templates and HCM security profiles enable defining the instance sets specified in data security policies.

When you provision a job role to a user, the job role implicitly limits data access based on the data security policies of the inherited duty roles. When you provision a data role to a user, the data role explicitly limits the data access of the inherited job role to a dimension of data.

Data security consists of privileges conditionally granted to a role and used to control access to the data. A privilege is a single, real world action on a

single business object. A data security policy is a grant of a set of privileges to a principal on an object or attribute group for a given condition. A grant authorizes a role, the grantee, to actions on a set of database resources. A database resource is an object, object instance, or object instance set. An entitlement is one or more allowable actions applied to a set of database resources.

Data is secured by the following means.

Data security feature	Does what?
Data security policy	Grants access to roles by means of entitlement
Role	Applies data security policies with conditions to users through role provisioning.
Data role template	Defines the data roles generated based on enterprise setup of data dimensions such as business unit.
HCM security profile	Defines data security conditions on instances of object types such as person records, positions, and document types without requiring users to enter SQL code
Masking	Hides private data on non-production database instances
Encryption	Scrambles data to prevent users without decryption authorization from reading secured data

The sets of data that a user can access via roles are defined in Oracle Fusion Data Security. Oracle Fusion Data Security integrates with Oracle Platform Security Services (OPSS) to entitle users or roles (which are stored externally) with access to data. Users are granted access through the entitlement assigned to the roles or role hierarchy with which the user is provisioned. Conditions are WHERE clauses that specify access within a particular dimension, such as by business unit to which the user is authorized.

Data Security Policies

Data security policies articulate the security requirement "Who can do What on Which set of data," where 'Which set of data' is an entire object or an object instance or object instance set and 'What' is the object entitlement.

For example, accounts payable managers can view AP disbursements for their business unit.

Who	can do	what	on which set of data
Accounts payable managers	view	AP disbursements	for their business unit

A data security policy is a statement in a natural language, such as English, that typically defines the grant by which a role secures business objects. The grant records the following.

- Table or view
- Entitlement (actions expressed by privileges)

- Instance set (data identified by the condition)

For example, disbursement is a business object that an accounts payable manager can manage by payment function for any employee expenses in the payment process.

Note

Some data security policies are not defined as grants but directly in applications code. The security reference manuals for Oracle Fusion Applications offerings differentiate between data security policies that define a grant and data security policies defined in Oracle Fusion applications code.

A business object participating in a data security policy is the database resource of the policy.

Data security policies that use job or duty roles refer to data security entitlement.

For example, the data security policy for the Accounts Payable Manager job role refers to the view action on AP disbursements as the data security entitlement.

Important

The duty roles inherited by the job role can be moved and job roles reassembled without having to modify the data security.

As a security guideline, data security policies based on user session context should entitle a duty role. This keeps both function and data security policies at the duty role level, thus reducing errors.

For example, a Sales Party Management Duty can update Sales Party where the provisioned user is a member of the territory associated with the sales account. Or the Sales Party Management Duty can update Sales Party where the provisioned user is in the management chain of a resource who is on the sales account team with edit access. Or the Participant Interaction Management Duty can view an Interaction where the provisioned user is a participant of the Interaction.

For example, the Disbursement Process Management Duty role includes entitlement to build documents payable into payments. The Accounts Payable Manager job role inherits the Disbursement Process Management Duty role. Data security policies for the Disbursement Process Management Duty role authorize access to data associated with business objects such as AP disbursements within a business unit. As a result, the user provisioned with the Accounts Payable Manager job role is authorized to view AP disbursements within their business unit.

A data security policy identifies the entitlement (the actions that can be made on logical business objects or dashboards), the roles that can perform those actions, and the conditions that limit access. Conditions are readable WHERE clauses. The WHERE clause is defined in the data as an instance set and this is then referenced on a grant that also records the table name and required entitlement.

Data Roles

Data roles are implemented as job roles for a defined set of data.

A data role defines a dimension of data within which a job is performed. The data role inherits the job role that describes the job. For example, a data role entitles a user to perform a job in a business unit.

The data role inherits abstract or job roles and is granted data security privileges. Data roles carry the function security privileges inherited from job roles and also the data security privilege granted on database objects and table rows.

For example, an accounts payables specialist in the US Business Unit may be assigned the data role Accounts Payables Specialist - US Business Unit. This data role inherits the job role Accounts Payables Specialist and grants access to transactions in the US Business Unit.

A data role may be granted entitlement over a set people.

For example, a Benefits Administrator A-E is allowed to administer benefits for all people that have a surname that begins with A-E.

Data roles are created using data role templates. You create and maintain data roles in the Authorization Policy Manager (APM). Use the Manage Data Roles and Security Profiles task to create and maintain HCM data roles in Oracle Fusion HCM.

HCM Security Profiles

HCM security profiles are used to secure HCM data, such as people and departments. You use HCM security profiles to generate grants for an enterprise role. The resulting data role with its role hierarchy and grants operates in the same way as any other data role.

For example, an HCM security profile identifies all employees in the Finance division.

Oracle Fusion Payroll uses HCM security profiles to secure project organizations. Applications outside of HCM can use the HCM Data Roles UI pages to give their roles access to HR people.

Masking and Encryption

Oracle Fusion Applications uses masking to protect sensitive data from view by unauthorized users. Encryption APIs mask sensitive fields in applications user interfaces. Additionally, Oracle Data Masking is available for masking data in non-production instances and Oracle Transparent Data Encryption is available for protecting data in transit or in backups independent of managing encryption keys.

Database Resources and Data Security Policies: How They Work Together

A data security policy applies a condition and allowable actions to a database resource for a role. When that role is provisioned to a user, the user has access to data defined by the policy. In the case of the predefined security reference implementation, this role is always a duty role. Data roles generated to inherit

the job role based on data role templates limit access to database resources in a particular dimension, such as the US business unit.

The database resource defines and instance of a data object. The data object is a table, view, or flexfield.

The following figure shows the database resource definition as the means by which a data security policy secures a data object. The database resource names the data object. The data security policy grants to a role access to that database resource based on the policy's action and condition.

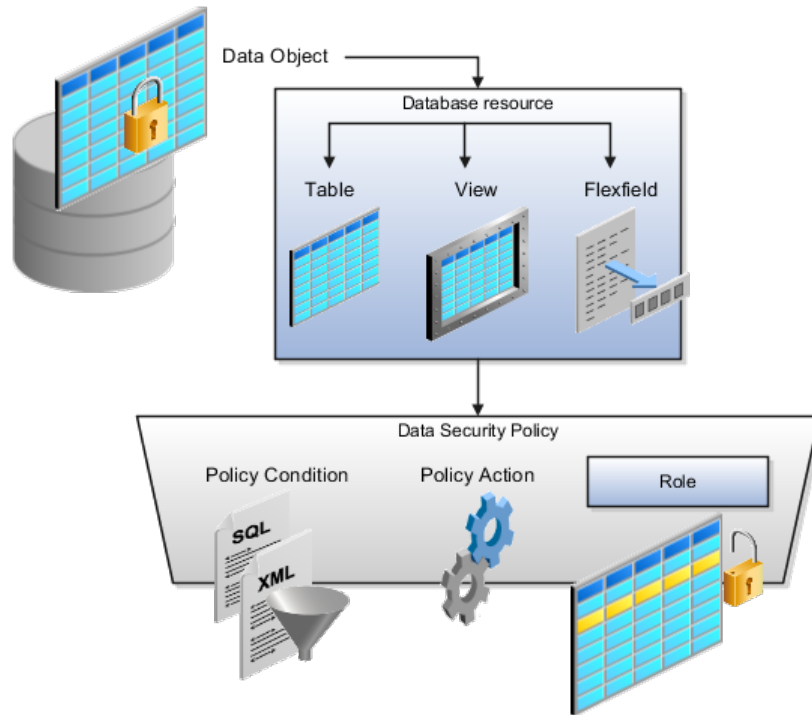

Database Resources

A database resource specifies access to a table, view, or flexfield that is secured by a data security policy.

- Name providing a means of identifying the database resource
- Data object to which the database resource points

Data Security Policies

Data security policies consist of actions and conditions for accessing all, some, or a single row of a database resource.

- Condition identifying the instance set of values in the data object
- Action specifying the type of access allowed on the available values

Note

If the data security policy needs to be less restrictive than any available database resource for a data object, define a new data security policy.

Actions

Actions correspond to privileges that entitle kinds of access to objects, such as view, edit, or delete. The actions allowed by a data security policy include all or a subset of the actions that exist for the database resource.

Conditions

A condition is either a SQL predicate or an XML filter. A condition expresses the values in the data object by a search operator or a relationship in a tree hierarchy. A SQL predicate, unlike an XML filter, is entered in a text field in the data security user interface pages and supports more complex filtering than an XML filter, such as nesting of conditions or sub queries. An XML filter, unlike a SQL predicate, is assembled from choices in the UI pages as an AND statement.

Tip

An XML filter can be effective in downstream processes such as business intelligence metrics. A SQL predicate cannot be used in downstream metrics.

Securing Data Access: Points to Consider

Oracle Fusion Applications supports securing data through role-based access control (RBAC) by the following methods.

Method of securing data	Reason	Example
Data roles apply explicit data security policies on job and abstract roles	Appropriate for job and abstract roles that should only access a subset of data, as defined by the data role template that generates the data role or by HCM security profiles.	Accounts Payable Manager - US data role to provide an accounts payable manager in the US business unit with access to invoices in the US business unit.
Data security policies	Define data access for application roles and provide inheriting job and abstract roles with implicit data security	Projects

If a user has access to the same function through different roles that access different data sets, then the user has access to a union of those data sets.

When a runtime session is created, Oracle Platform Security Services (OPSS) propagates only the necessary user to role mapping based on Oracle Fusion Data Security grants. A grant can specify entitlement to the following.

- Specific rows of data (data object) identified by primary key
- Groups of data (instance set) based on a predicate that names a particular parameter
- Data objects or instance sets based on runtime user session variables

Data is either identified by the primary key value of the row in the table where the data is stored. Or data is identified by a rule (SQL predicate) applied to the WHERE clause of a query against the table where the data is stored.

Grants

Oracle Fusion Data Security can be used to restrict the following.

- Rows that are returned by a given query based on the intended business operation
- Actions that are available for a given row

Grants control which data a user can access.

Note

Attribute level security using grants requires a data security policy to secure the attribute and the entitlement check enforces that policy.

A grant logically joins a user or role and an entitlement with a static or parameterized object instance set. For example, `REGION='WEST'` is a static object instance set and `REGION=&GRANT_ALIAS.PARAMETER1` is a parameterized object instance set. In the context of a specific object instance, grants specify the allowable actions on the set of accessible object instances. In the database, grants are stored in `FND_GRANTS` and object instance sets are stored in `FND_OBJECT_INSTANCE_SETS`. Object access can be tested using the privilege check application programming interface (API).

Securing a Business Object

A business object is a logical entity that is typically implemented as a table or view, and corresponds to a physical database resource. The data security policies of the security reference implementation secure predefined database resources. Use the Manage Data Security Policies task to define and register other database resources.

Data security policies identify sets of data on the registered business object and the actions that may be performed on the business object by a role. The grant can be made by data instance, instance set or at a global level..

Note

Use parameterized object instance sets whenever feasible to reduce the number of predicates the database parses and the number of administrative intervention required as static object instances sets become obsolete. In HCM, security profiles generate the instance sets.

Data Role Templates: Explained

You use data role templates to generate data roles. You generate such data roles, and create and maintain data role templates in the Authorization Policy Manager (APM).

Note

HCM data roles are generated using the Manage Data Roles and Security Profiles task, which uses HCM security profiles, not data role templates, to define the data security condition.

The following attributes define a data role template.

- Template name
- Template description
- Template group ID
- Base roles
- Data dimension
- Data role naming rule
- Data security policies

The data role template specifies which base roles to combine with which dimension values for a set of data security policies. The base roles are the parent job or abstract roles of the data roles.

Note

Abstract, job, and data roles are enterprise roles in Oracle Fusion Applications. Oracle Fusion Middleware products such as Oracle Identity Manager (OIM) and Authorization Policy Manager (APM) refer to enterprise roles as external roles. Duty roles are implemented as application roles in APM and scoped to individual Oracle Fusion Applications.

The dimension expresses stripes of data, such as territorial or geographic information you use to partition enterprise data. For example, business units are a type of dimension, and the values picked up for that dimension by the data role template as it creates data roles are the business units defined for your enterprise. The data role template constrains the generated data roles with grants of entitlement to access specific data resources with particular actions. The data role provides provisioned users with access to a dimensional subset of the data granted by a data security policy.

An example of a dimension is a business unit. An example of a dimension value is a specific business unit defined in your enterprise, such as US. An example of a data security policy is a grant to access a business object such as an invoice with a view entitlement.

When you generate data roles, the template applies the values of the dimension and participant data security policies to the group of base roles.

The template generates the data roles using a naming convention specified by the template's naming rule. The generated data roles are stored in the Lightweight Directory Access Protocol (LDAP) store. Once a data role is generated, you provision it to users. A user provisioned with a data role is granted permission to access the data defined by the dimension and data security grant policies of the data role template.

For example, a data role template contains an Accounts Payable Specialist role and an Accounts Payable Manager role as its base roles, and region as its dimension, with the dimension values US and UK. The naming convention is [base-role-name]:[DIMENSION-CODE-NAME]. This data role template generates four data roles.

- Accounts Payable Specialist - US (business unit)
- Accounts Payable Specialist - UK (business unit)
- Accounts Payable Manager - US (business unit)
- Accounts Payable Manager - UK (business unit)

Making Changes To Data Role Templates

If you add a base role to an existing data role template, you can generate a new set of data roles. If the naming rule is unchanged, existing data roles are overwritten.

If you remove a base role from a data role template and regenerate data roles, a resulting invalid role list gives you the option to delete or disable the data roles that would be changed by that removal.

Making Changes to Dimension Values

If you add a dimension value to your enterprise that is used by a data role template, you must regenerate roles from that data role template to create a data role for the new dimension. For example if you add a business unit to your enterprise, you must regenerate data roles from the data role templates that include business unit as a dimension.

If you add or remove a dimension value from your enterprise that is used to generate data roles, regenerating the set of data roles adds or removes the data roles for those dimension values. If your enterprise has scheduled regeneration as an Oracle Enterprise Scheduler Services process, the changes are made automatically.

For information on working with data role templates, see the Oracle Fusion Middleware Administrator's Guide for Authorization Policy Manager (Oracle Fusion Applications Edition).

Define Document Sequences

Document Sequences: Explained

In Oracle Fusion Applications, each business document or business event is uniquely identified by a document sequence number that you assign to it. However, the document sequencing feature must be turned on (enabled) on the business document or event to allow the assignment. For example, if document sequencing is enabled, you can assign a document sequence number

to an invoice that gets generated in response to a purchase order. You can use document sequences as a proof to track successfully executed transactions as well as failed transactions. Additionally, a document sequence helps in generating an audit trail, which can be used to identify how a particular transaction passed through various applications.

Document sequencing can be managed automatically, manually, and gaplessly.

Note

Plan your document sequencing carefully before you use the options available in the application to apply sequence numbers. Avoid changes to the options after you saved your work on the Manage Document Sequences and Manage Document Sequence Categories pages.

Automatic Sequencing

Automatic document sequencing assigns a unique number to each document as it is generated, and this unique number is stored in the database. The numbering is sequential by date and time of creation. If you define a sequence to automatically number documents, you can provide an initial value to begin the sequence. In absence of a custom value, the default value 1 is used.

Manual Sequencing

Manual sequencing requires you to assign a unique number to each document before it is generated. In manual sequencing, the numerical ordering and completeness of a transaction is not enforced. Users can skip or omit numbers when entering the sequence value. However, each time that a number is assigned, the application validates its uniqueness.

Gapless Sequencing

Gapless sequencing is similar to automatic sequencing. It automatically generates a unique number for each document, but does that only for successfully generated documents. As a result, the sequence is maintained for all the documents that are generated, and no sequence numbers are lost due to incomplete or failed document generation.

Important

Use this type of sequencing only if necessary because it may affect the performance of the system and slow down transaction processing.

Sequential Numbering Enforced Profile Options

The Sequential Numbering Enforced profile validates the documents being created and applies the relevant document sequence, based on the selected option. The following options are available:

- **Always Used:** Sequential numbering is enforced for all document categories. When this option is set, users cannot create a document if its document category is not assigned any active document sequence. The system displays an error.
- **Partially Used:** Sequential numbering is enforced for all document categories. However, if no sequence is available for the document, the

system displays a warning. Users can either proceed without a document sequence or create and assign a document sequence before proceeding.

- **Not Used:** Sequential numbering is not enforced. In this mode, although the documents created do not require a document sequence to be assigned, the system checks for the uniqueness of the document number provided. The system does not display any warning or error.

Restriction

At the site level, the profile is by default set to Partially Used. Avoid changing this option as doing so may interfere with the validation logic and the data that was stored using the earlier option may not appear. However, you can change the option at the product or user level.

Document Sequence Categories: Explained

A document sequence category is a set of documents that share similar characteristics and that are formed into a logical group. Document sequence categories simplify the task of assigning number sequences to specific documents. Instead of assigning a number to each document, you assign a document sequence to one or more document sequence categories. The document sequence category automatically takes care of numbering the documents.

A document sequence category identifies the database table that stores documents resulting from transactions that your users enter. When you assign a sequence to a category, the sequence numbers the documents that are stored in a particular table. You must create document sequence categories to be able to manage the task of assigning document sequences.

Restriction

Once a document sequence category is created, you cannot change the application, the category code, or the table name. Therefore, carefully consider these details and plan your document sequencing requirement before you begin working with the application.

Once you create a document sequence category, it is available for use under the **Document Sequences: Assignments** section on the Manage Document Sequences page. The **Category** field contains the name of the document sequence category. After you create a document sequence, you can assign it to a document sequence category.

Document Sequences: Points to Consider

Sequencing documents is an important business and legal requirement. Certain aspects of the defining process are permanent and cannot be modified later. Therefore, it is important that you first decide the appropriate document sequence to use for a set of documents. You must also decide beforehand the type of document sequencing, because you are not allowed to switch to other types once a sequence is assigned to a document sequence category. Make a

note of the details such as the document sequence and document sequence category so that you can refer to them at a later point in time. Also note if there are any restrictions or configuration prerequisites before you define document sequencing.

Note

Products that implement document sequencing have specifications about its usage. Refer to the corresponding product documentation for specific details and also to determine if there are any restrictions or configuration prerequisites.

Creating and Editing Document Sequences

You can create document sequences that are automatic, manual, or gapless, depending on the business or legal requirement. By default, the current date is considered as the start date. If the end date is left blank, it means that the sequence definition never expires. Among the several options used in creating and editing document sequences, the following options are functionally more important and therefore need to be carefully determined:

- **Determinant Type:** Select to limit the document sequencing activity to certain documents that belong to a specific business entity, such as Ledger, Tax Registration, and so on.
- **Initial Value:** Enter a value for the first document in your sequence. This field applies only to sequences with automatic or gapless numbering types. Sequence numbers should not be greater than eight digits. If you leave this field blank, the first document is automatically assigned a value of 1. Once a document sequence is defined, you cannot change this initial value.

Creating and Editing Document Sequence Categories

Document sequence categories are defined to make it easy to assign document sequence definitions to a group of documents instead of to individual documents. Each document sequence category is mapped to a specific table, where the documents belonging to that category are stored. The table must already be enabled for document sequencing. When specifying the table, you must consider the following points:

- When the sequential numbering feature checks for completeness or generates a report, it locates the category's documents in the table.
- You can select only tables belonging to the application associated with the category.
- Once a category is defined, you cannot change the choice of table.

Assigning Document Sequences

Identify the documents to be numbered before assigning them a document sequence. For each document sequence, there can be only one active assignment to a document sequence category, a method code, and a determinant value (if applicable). As part of the assignment, specify whether the document is created automatically (for example, due to a batch process, or manually through a

form). If you do not specify an end date, the assignment continues to remain active throughout the process cycle. If a determinant type was specified for the document sequence, then enter a specific determinant value related to the selected determinant type.

At runtime, when users create documents, the document sequence to be assigned is determined by finding the active assignment that matches the correct combination of category, numbering method, and the date range containing the transaction date.

Auditing Document Sequences

You can audit document sequences, if required, to provide an audit trail of the document sequences used in a specific product. However, before enabling the audit functionality for a document sequence, you must have created an audit table for the specific document sequence, using appropriate details. Enabling the audit functionality is permitted only for newly created document sequences. You cannot audit document sequences that are already in use by a specific product.

For more information about defining a document sequence audit table, see the Oracle Fusion Applications Developer's Guide.

Define Trees

Trees: Overview

Use the tree management feature in Oracle Fusion applications to organize data into hierarchies. A hierarchy contains organized data and enables the creation of groups and rollups of information that exist within an organization. Trees are hierarchical structures that enable several data management functions such as better access control, application of business rules at various levels of hierarchies, improved query performance, and so on.

For example, XYZ Corporation has two departments: Marketing and Finance. The Finance department has two functional divisions: Receivables and Payables. Defining a tree for the XYZ Corporation establishes a hierarchy between the organization and its departments, and between the departments and their respective functional divisions. Such a hierarchical modeling of organizational data could be used for executing several data management functions within that organization.

You can create one or more versions of trees, and they can be labeled for better accessibility and information retrieval. You can create trees for multiple data sources, which allow the trees to be shared across Oracle Fusion applications.

Tree Structures

A tree structure is a representation of the data hierarchy, and guides the creation of a tree. A tree is an instance of the hierarchy as defined in the tree structure. Tree structures enable you to enforce business rules to which the data must adhere.

The root node is the topmost node of a tree. Child nodes report to the root node. Child nodes at the same level, which report to a common parent node, are called

siblings. Leaves are details branching off from a node but not extending further down the tree hierarchy.

Tree Versions

A tree is created having only one version. However, users can create more than one tree version depending on the need, and they can make changes to those versions. Depending on varying requirements, users can create one or more tree versions and publish all of them or some of them by making the versions active at the same time. Similar to any other version control system, versions of trees are maintained to keep track of all the changes that a tree undergoes in its life cycle.

Tree Labels

Tree labels are short names associated with trees and tree structures and point directly to the data source. Tree labels are automatically assigned to the tree nodes. You can store labels in any table and register the label data source with the tree structure.

Manage Tree Structures

Tree Structures: Explained

A tree structure defines the hierarchy for creating trees and prescribes rules based on which trees are created, versioned, and accessed. You can associate multiple data sources with a tree structure. A tree is an instance of this hierarchy. Every tree structure can contain one or more trees.

You can create tree structures specific to an application but you can share tree structures across applications. If you apply version control to the tree structure, it is carried over to the trees that are based on the tree structure. Each tree version contains at least one root node. Occasionally, a tree version may have more than one root node.

An administrator controls the access to tree structures through a set of rules that are periodically audited for validity.

Tree Structure Definition: Points to Consider

Defining a tree structure involves specifying several important pieces of information on the **Create Tree Structure: Specify Definition** page.

Tree Node Selection

The **Tree Node** table displays data in nodes that exist in the data hierarchy. You must select the correct and most appropriate tree node table to be able to define the tree structure, based on the tree hierarchy you want to establish. This selection also affects the level of security that is set on a tree node and its child entities.

Tree Sharing Mode

The following options are used to determine the mode of sharing a tree structure across the applications.

- Open: Indicates that the tree is associated with all reference data sets.
- Set ID: Indicates that the tree will be associated with a specific reference data set.

Creation Mode

Indicates the source where the tree structure is being defined. For predefined tree structures select Oracle and for custom structures, select Customers.

Customization

You can customize the predefined tree structures as well as the ones that you created. However, customizing the predefined tree structures involves certain level of access restrictions, and will be limited to specific tree nodes and downwards in hierarchy.

Multiple Tree Versions

One or more trees and tree versions can be based on a tree structure. A tree structure can have one or more trees and tree versions based on it. Usually, only one active version is permitted at any given point of time. However, depending on the requirement, you can allow two or more tree versions to be in the active state for the same date range. This flexibility allows you to choose the tree version that you want to implement.

Managing Tree Structures: Points to Consider

You can create, edit, and delete tree structures depending upon the requirement. You can also audit and change the status a tree structure.

Creating and Editing Tree Structures

You can create trees on the basis of a tree structure. When you edit an active tree structure, the status of the tree structure and all associated trees and their versions change to draft. To reuse a tree structure, you can create a copy of it without copying the associated trees and tree versions. If you delete a tree structure, all the associated trees and tree versions are automatically deleted.

Note

For specific information on working with the predefined tree structures that exist in an Oracle Fusion application, refer to the specific product documentation.

Setting Status

If you change the status of a tree structure, the status of the trees and tree versions associated with that tree structure also changes.

The following table lists the different statuses of a tree structure.

Status	Meaning
Draft	Yet to be published or is in a modified state.

Active	In use and based on which one or more trees or tree versions are created.
Inactive	Not in use.

Tree Structure Audit Results: Explained

Use the tree structure audit results to verify the tree structure's correctness and data integrity. The audit results include the following details:

- The name of the validator, which is a specific validation check
- The result of the validation, including a detailed message
- Corrective actions to take if there are any validation errors

Running an Audit

Setting the status of a tree structure to active automatically triggers an audit of that tree structure. You can also manually trigger an audit on the manage Tree Structures page, using **Actions - Audit**. The Tree Structure Audit Result table shows a list of validations that ran against the selected tree structure.

Validation Details

The following table lists the validators used in the audit process and describes what each validator checks for. It also lists possible causes for validation errors and suggests corrective actions.

Validator	Description (what is checked)	Possible Cause for Validation Failure	Suggested Corrective Action
Restrict By Set ID	On the Manage Tree Structures: Specify Data Sources page, if the Set ID check box is selected to enable the Restrict Tree Node List of Values Based on option for a tree structure, each of its data source view objects must have a reference data set attribute. This validation does not take place when the check box is not selected.	Even when the check box is selected, one or more of its data source view objects does not contain a reference data set attribute.	If reference data set restriction is required for this tree structure, include a reference data set attribute on all data sources. Otherwise, deselect the check box.
Row Flattened Table Name	On the Manage Tree Structures: Specify Performance Options page, a valid row flattened table must be specified for the tree structure. It can either be the standard row flattened table <code>FND_TREE_NODE_RF</code> or a custom table.	<ul style="list-style-type: none"> • The specified table does not exist in the database. • The specified table does not contain the same columns as the <code>FND_TREE_NODE_RF</code> table. 	Correct the row flattened table definition.

<p>Available Label Data Sources</p>	<p>On the Manage Tree Structures: Specify Data Sources page, if a labeling scheme is specified for the tree structure by selecting a list item from the Labeling Scheme list box, the label data source view object specified for each data source must be accessible, and the primary keys must be valid. This restriction does not apply when you select None from the Labeling Scheme list box.</p>	<ul style="list-style-type: none"> • Any of the specified label data source view objects do not exist. • Any of the specified label data source view objects do not have primary keys. • When a label data source view object is initially defined, the database registers the primary keys for the view object. If the view object is later modified such that its primary keys no longer match the primary keys that were registered earlier, this validation fails. 	<ul style="list-style-type: none"> • Correct the specified label data source view object. • Correct the primary keys of the specified label data source view object. • Either correct the primary keys in the label data source view object to match the primary keys that were earlier registered in <code>FND_TS_DATA_SOURCE</code>, or correct the primary keys registered in that table to match the new view object definition.
-------------------------------------	---	---	---

Available Data Sources	Each data source view object specified for the tree structure must be accessible, and all its primary key attributes must be valid.	<ul style="list-style-type: none"> • Any of the specified data source view objects do not exist. • When a data source view object is initially defined, the database automatically registers the primary keys for the view object if the Use non-defined primary key columns check box on the Data Source dialog box is not selected. If the check box is selected, the database registers the primary keys specified explicitly by the user on the Add Data Source dialog box. If the registered primary keys contain any duplicates, this validation fails. • The Use non defined primary key columns check box is selected in a data source, but the list of specified primary key columns does not match the primary keys defined in the corresponding data source view object. • Any common attribute that exists in both the data source view object and the tree node view object is not of the same data type in both view objects. 	<ul style="list-style-type: none"> • Correct the specified data source view object. • Correct the duplicate column in the registered primary keys. • Correct the primary keys of the specified data source view object. • Correct any mismatch in data types.
------------------------	---	---	---

Column Flattened Table Name	On the Manage Tree Structures: Specify Performance Options page, a valid column flattened table must be specified for the tree structure. It can either be the standard row flattened table <code>FND_TREE_NODE_CF</code> or a custom table.	<ul style="list-style-type: none"> The specified table does not exist in the database. The specified table does not contain the same columns as the <code>FND_TREE_NODE_CF</code> table. 	Correct the column flattened table definition.
Restrict by Date	On the Manage Tree Structures: Specify Data Sources page, if the Date Range check box is selected to enable the Restrict Tree Node List of Values Based on option for a tree structure, each of its data source view objects must have effective start date and effective end date attributes. This validation does not take place when the check box is not selected.	Even when the check box is selected, one or more of its data source view objects does not contain effective start date and effective end date attributes.	If the date restriction is required for this tree structure, include the effective start date and effective end date attributes on all data sources. Otherwise, deselect the check box.
Tree Node Table Name	On the Manage Tree Structures: Specify Definition page, a valid tree node table must be specified for the tree structure. It can either be the standard row flattened table <code>FND_TREE_NODE</code> or a custom table.	<ul style="list-style-type: none"> No table is specified in the Tree Node Table field. The specified table does not exist in the database. The specified table does not contain the same columns as the <code>FND_TREE_NODE</code> table. 	Correct the tree node table definition.
Allow Node Level Security	If the Allow Node Level Security option is set to No for the tree structure, the same option cannot be set to Yes on any of its data sources. This is a database setting that is not visible on the Manage Tree Structures page.	The option is set to No for the tree structure but one or more associated data sources have that option set to Yes.	Correct the option setting in the tree structure and their data sources.

Specifying Data Sources for Tree Structures: Points to Consider

The data sources provide the items for establishing hierarchy in a tree structure. In the tree management infrastructure, these data sources are Oracle Application

Development Framework (ADF) business components view objects, which are defined by application development.

Labeling Schemes

Selecting a labeling scheme determines how the tree nodes are labeled. You may select a labeling scheme to assign at the data source level, at the parent node level, or keep it open for customer assignment. You may also choose not to have any labeling scheme. However, if you decide to use any of the labeling schemes, you may need to select the following additional options, to restrict the list of values that appear under the selected tree node.

- **Allow Ragged Nodes:** To include nodes that have no child nodes, and are shorter than the remaining nodes in the entire hierarchy.
- **Allow Skip Level Nodes:** To include nodes that are at the same level but have parent nodes at different levels.

Restriction of Tree Node Values

You can decide the depth of the tree structure by selecting an appropriate value from the list. Keeping the depth limit open renders an infinite list of values. Using the following options, you can restrict the list of values that appear for selection under a specific tree node.

- **Date Range:** Specifies whether a selection of nodes should be restricted to the same date range as the tree version.
- **Allow Multiple Root Nodes:** Allows you to add multiple root nodes when creating a tree version.
- **Reference Data Set:** Specifies whether a selection of nodes should be restricted to the same set as the tree.

Data Source Values and Parameters

Tree data sources have optional data source parameters with defined view criteria and associated bind variables. You can specify view criteria as a data source parameter when creating a tree structure, and edit the parameters when creating a tree. Multiple data sources can be associated with a tree structure and can have well-defined relationships among them.

Note

Parameter values customized at the tree level override the default values specified at the tree-structure level.

The data source parameters are applied to any tree version belonging to that data source, when performing node operations on the tree nodes. Data source parameters also provide an additional level of filtering for different tree structures. The tree structure definition supports three data source parameter types.

- **Bound Value:** Captures any fixed value, which is used as part of the view criteria condition.
- **Variable:** Captures and binds a dynamic value that is being used by the data source view object. This value is used by the WHERE condition of the data flow.
- **View Criteria:** Captures the view criteria name, which is applied to the data source view object.

You can also specify which of the data source parameters are mandatory while creating or editing the tree structure.

View objects from the ADF business components are used as data sources. To associate the view object with the tree structure, you can pick the code from ADF business component view objects and provide the fully qualified name of the view object, for example, oracle.apps.fnd.applcore.trees.model.view.FndLabelVO.

Specifying Performance Options for a Tree Structure: Points to Consider

Tree structures are heavily loaded with data. As a tree management guideline, use the following settings to improve performance of data rendering and retrieval.

- Row Flattening
- Column Flattening
- Column Flattened Entity Objects
- ADF Business Component View Objects

Row Flattening

Row flattening optimizes parent-child information for run-time performance by storing additional rows in a table for instantly finding all descendants of a parent without initiating a CONNECT BY query. Row flattening eliminates recursive queries, which allows operations to perform across an entire subtree more efficiently.

To store row flattened data for the specific tree structure, users can either use the central `FND_TREE_NODE_RF` table or they can register their own row flattened table. For example, in a table, if Corporation is the parent of Sales Division (Corporation-Sales Division), and Sales Division is the parent of Region (Sales Division-Region), a row-flattened table contains an additional row with Corporation directly being the parent of Region (Corporation-Region).

Column Flattening

Column flattening optimizes parent-child information for run-time performance by storing an additional column in a table for all parents of a child.

To store column flattened data for the specific tree structure, users can either use the central `FND_TREE_NODE_CF` table or they can register their own column flattened table. For example, in a table, if Corporation is the parent of Sales Division (Corporation-Sales Division), and Sales Division is the parent of Region (Sales Division-Region), a flattened table in addition to these columns, contains three new columns: Region, Sales Division, and Corporation. Although positioned next to each other, the column Region functions at the lower level and Corporation at the higher level, retaining the data hierarchy.

Column Flattened Entity Objects

In the absence of a column-flattened table, if you need to generate the business component view objects for your tree structure for the flattened table, use the tree management infrastructure to correctly provide the fully qualified name of the entity object for the column flattened table.

ADF Business Component View Objects

View objects from the ADF business components can also be used as data sources, eliminating the need to create new types of data sources. This field is to store the fully qualified name for the business component view object generated by the tree management for business intelligence reporting and usage. The business component view object is a combination of the tree data source and column flattened entity. Using this option prevents data redundancy and promotes greater reuse of existing data, thereby improving the performance of the tree structure.

Manage Tree Labels

Tree Labels: Explained

Tree labels are tags that are stored on tree nodes. You can store labels in any table and register the label data source with the tree structure. When a labeling scheme is used for trees, the selected labels are stored in the tree label entity and each tree node contains a reference to a tree label in the labeling scheme.

The following table lists the three ways in which tree labels are assigned to the tree nodes.

Labeling Scheme	Description
Level	Labels that are automatically assigned based on the data source to which the tree node belongs. A level label points to a specific data source. For example, in a tree that reflects the organizational hierarchy of an enterprise, all division nodes appear on one level and all department nodes on another.
Group	Labels that you can arbitrarily assign to tree nodes.
Depth	Labels that are automatically assigned based on the depth of the tree node within the tree. No manual assignment is performed. <hr/> Note In an unbalanced hierarchy, a level may not be equal to depth.

Manage Trees and Tree Versions

Managing Trees and Tree Versions: Points to Consider

You can create and edit trees and tree versions depending upon the requirement. A tree can have one or more tree versions. Typically, when changes are made to an existing tree, a new version is created and published.

Creating and Editing Trees

Trees are created based on the structure defined in the tree structure. You can create trees, modify existing trees, and delete trees. If you want to copy an existing tree, you can duplicate it. However, only the tree is duplicated and not its versions.

Creating a tree involves specifying the tree definition and specifying the labels that are used on its nodes. If the selected tree structure has data sources and parameters defined for it, they appear on the page allowing you to edit the parameter values at the tree node level.

Note

Parameter values customized at the tree level will override the default values specified at the tree-structure level.

Creating and Editing Tree Versions

Tree versions are created at the time of creating trees. A tree must contain a version.

Editing an existing tree provides you the choice to update the existing version. You can also edit the existing version that lies nested under the tree in the search results.

When you edit a tree version bearing Active status, the status changes to Draft until the modifications are saved or cancelled.

Tree Version Audit Results: Explained

Use the tree version audit results to verify the tree version's correctness and data integrity. The audit results include the following details:

- The name of the validator, which is a specific validation check
- The result of the validation, including a detailed message
- Corrective actions to take if there are any validation errors

Running an Audit

An audit automatically runs whenever a tree version is set to active. You can also manually trigger an audit on the Manage Trees and Tree Versions page, using **Actions - Audit**. The Tree Version Audit Result table shows a list of validations that ran against the selected tree version.

Validation Details

The following table lists the validators used in the audit process and describes what each validator checks for. It also lists possible causes for validation errors and suggests corrective actions.

Validator	Description (what is checked)	Possible Cause for Validation Failure	Suggested Corrective Action
Effective Date	The effective start and end dates of the tree version must be valid.	The effective end date is set to a value that is not greater than the effective start date.	Modify the effective start and end dates such that the effective start date is earlier than the effective end date.
Root Node	On the Manage Tree Structures: Specify Data Sources page, if the Allow Multiple Root Nodes check box for the Restrict Tree Node List of Values Based on option is not selected, and if the tree structure is not empty, the tree version must contain exactly one root node. This validation does not take place if the check box is selected.	Even if the check box is deselected, the tree version has multiple root nodes.	Modify the tree version such that there is exactly one root node.
Data Source Max Depth	For each data source in the tree structure, on the Data Source dialog box, if the data source is depth-limited, the data in the tree version must adhere to the specified depth limit. This validation does not apply to data sources for which the Maximum Depth field is set to Unlimited .	The tree version has data at a depth greater than the specified depth limit on one or more data sources.	Modify the tree version such that all nodes are at a depth that complies with the data source depth limit.
Duplicate Node	On the Data Source dialog box, if the Allow Duplicates check box is not selected, the tree version should not contain more than one node with the same primary key from the data source. If the check box is selected, duplicate nodes are permitted.	Even when the check box is deselected, the tree version contains duplicate nodes.	Remove any duplicate nodes from the tree version.

Available Node	All nodes in the tree version should be valid and available in the underlying data source.	<ul style="list-style-type: none"> • A node in the tree version does not exist in the data source. Deleting data items from the data source without removing the corresponding nodes from the tree version can result in orphaned nodes in the tree version. For example, if you added node A into your tree version, and subsequently deleted node A from the data source without removing it from the tree version, the validation fails. • The tree version contains a tree reference node, which references another tree version that does not exist. 	Remove any orphaned nodes from the tree version. Update tree reference nodes so that they reference existing tree versions.
Node Relationship	All nodes must adhere to the relationships mandated by the data sources registered in the tree structure.	The tree structure has data sources arranged in a parent-child relationship, but the nodes in the tree do not adhere to the same parent-child relationship. For example, if the tree structure has a Project data source with a Task data source as its child, Task nodes should always be under Project nodes in the tree version. This validation fails if there are instances where a Project node is added as the child of a Task node.	Modify the tree version such that the nodes adhere to the same parent-child relationships as the data sources.

SetID Restricted Node	On the Manage Tree Structures: Specify Data sources page, if the Set ID check box is selected to enable the Restrict Tree Node List of Values Based on option for each tree node, the underlying node in the data source must belong to the same reference data set as the tree itself. This restriction does not apply when the check box is not selected.	Even when the check box is selected, the tree version has nodes whose data source values belong to a different reference data set than the tree.	Modify the tree version such that all nodes in the tree have data sources with reference data set matching that of the tree.
Label Enabled Node	On the Manage Tree Structures: Specify Data Sources page, if a labeling scheme is specified for the tree structure by selecting a list item from the Labeling Scheme list box, all nodes should have labels. This restriction does not apply when you select None from the Labeling Scheme list box.	The tree structure has a labeling scheme but the tree version has nodes without labels.	Assign a label to any node that does not have a label.

Date Restricted Node	On the Manage Tree Structures: Specify Data Sources page, if the Date Range check box is selected to enable the Restrict Tree Node List of Values Based on option for a tree structure, each node in the underlying data source must have an effective date range same as the effective date range of the tree version. This restriction does not apply if the check box is not selected.	Even when the check box is selected, there are data source nodes that have a date range beyond the tree version's effective date range. For example, if the tree version is effective from Jan-01-2012 to Dec-31-2012, all nodes in the tree version must be effective from Jan-01-2012 to Dec-31-2012 at a minimum. It is acceptable for the nodes to be effective for a date range that extends partly beyond the tree version's effective date range (for example, the node data source value is effective from Dec-01-2011 to Mar-31-2013). It is not acceptable if the nodes are effective for none or only a part of the tree version's effective date range (for example, the node data source value are effective only from Jan-01-2012 to June-30-2012).	Ensure that all nodes in the tree version have effective date range for the effective date range for the tree version.
Multiple Active Tree Version	On the Manage Tree Structures: Specify Definition page, if the Allow Multiple Active Tree Versions check box is not selected for the tree structure, there should not be more than one active tree version under a tree at any time. This restriction does not apply if the check box is selected.	Even when the check box is not selected, there is more than one active tree version in the tree for the same date range.	Set no more than one tree version to Active within the same date range and set the others to inactive or draft status.
Range Based Node	On the Data Source dialog box, if the Allow Range Children check box is not selected, range-based nodes are not permitted from that data source. This restriction does not apply if the check box is selected.	Even when the check box is not selected, there are range-based nodes from a data source.	Ensure that any range nodes in your tree version are from a data source that allows range children.

Terminal Node	On the Data Source dialog box, if the Allow Use as Leaves check box is not selected, values from that data source cannot be added as leaves (terminal nodes) to the tree version. This restriction does not apply if the check box is selected.	Even when the check box is not selected, values from a data source are added as leaf nodes (terminal nodes).	Modify the tree version such that all terminal nodes are from data sources for which this check box is selected.
Usage Limit	On the Data Source dialog box, if the Use All Values option is selected to set the Usage Limit for the data source, every value in the data source must appear as a node in the tree. This restriction does not apply if None option is selected.	Even if the Use All Values option is selected, there are values in the data source that are not in the tree version.	For each data source value that is not yet available, add nodes to the tree version.

Trees and Data Sources: How They Work Together

Data sources form the foundation for tree management in Oracle Fusion Applications. Tree structures, trees, and tree versions establish direct and real-time connectivity with the data sources. Changes to the data sources immediately reflect on the **Manage Trees and Tree Versions** page and wherever the trees are being used.

Metadata

Tree structures contain the metadata of the actual data that is used in Oracle Fusion Applications. Tree structures contain the core business logic that is manifested in trees and tree versions.

Data Storage

Trees and tree versions are built upon the tree structures. They employ the business rules defined in the tree structures and allow an application to select and enable a subset of trees to fulfill a specific purpose in that application.

Access Control

Source data is mapped to tree nodes at different levels in the database. Therefore, changes you make to the tree nodes affect the source data. Access control set on trees prevents unwanted data modifications in the database. Access control can be applied to the tree nodes or anywhere in the tree hierarchy.

Adding Tree Nodes: Points to Consider

Tree nodes are points of data convergence that serve as the building blocks of a tree structure. Technically, the node may be stored either in a product-specific table or in an entity that has been established by tree management as the default storage mechanism. However, since all data in Oracle Fusion Applications

usually have a storage home, only user-created data needs to be stored in an entity.

Nodes are attached to tree versions. Whenever you create or edit a tree version, you need to specify its tree node.

Managing Tree Nodes

You can create, modify, or delete tree nodes on the **Tree Version: Specify Nodes** page. To add a tree node, ensure that the tree structure with which the tree version is associated is mapped to a valid data source. You can also duplicate a tree node if the multiple root node feature is enabled.

Node Levels

In most trees, all nodes at the same level represent the same kind of information. For example, in a tree that reflects the organizational hierarchy, all division nodes appear on one level and all department nodes on another. Similarly, in a tree that organizes a user's product catalog, the nodes representing individual products might appear on one level and the nodes representing product lines on the next higher level.

When levels are not used, the nodes in the tree have no real hierarchy or reporting structure but do form a logical summarization structure. Strictly enforced levels mean that the named levels describe each node's position in the tree. This is natural for most hierarchies. Loosely enforced levels mean that the nodes at the same visual level of indentation do not all represent the same kind of information, or nodes representing the same kind of information appear at multiple levels. With loosely enforced levels, users assign a level to each node individually. The level is not tied to a particular visual position.

Node Types

A tree node has the following node types.

- **Single:** Indicates that the node is a value by itself.
- **Range:** Indicates that the node represents a range of values and possibly could have many children. For example, a tree node representing account numbers 10000 to 99999.
- **Referenced Tree:** Indicates that the tree node is actually another version for the tree based on the same tree structure, which is not physically stored in the same tree. For example, a geographic hierarchy for the United States can be referenced in a World geographic hierarchy.

Define Profile Options

Profile Options: Explained

Profile options manage configuration data centrally and influence the behavior of applications. Profile options serve as permanent user preferences and application configuration parameters. You configure profile options with settings for specific contexts or groups of users. Users customize how their user interfaces look and behave by changing the values of available profile options.

Profile options store the following kinds of information.

Type of Information	Profile Option Example
User preferences	Settings to provide access to social networking features
Installation information	Setting to identify the location of a portal
Configuration choices	Settings to change user interface skins and behaviors
Processing options	Settings to affect how much information to log either for an entire site or a specific user

You can add and configure new profile options in addition to configuring predefined profile options that are implemented as updateable.

Profile Option Definition and Configuration

Application developers add new profile options and configure ones that are not to be updated by other users. Application administrators and implementation consultants configure profile options with profile option values that are implemented as updatable.

Profile option definitions consist of the following.

- Profile option name
- Application and module in the application taxonomy
- Profile option values
- Profile options categories
- Profile option levels
- Profile option level hierarchy

Profile options can appear on any user interface page without indication that a profile option is what is being set.

Profile Option Values

Some profile options have predefined profile option values.

The Manage Profile Option Values task flow allows an administrator to set updatable profile option values at the available levels, including the user level. You can access the Manage Profile Option Values task starting in the Setup and Maintenance Overview page and searching for profile option tasks.

You can set profile option values at different levels: site, product, and user. The following table provides examples.

Profile Option Level	Value of the Profile Option Level	Profile Option Value	Effect
User	Manager1	UK pound sterling	Access to site and all products shows UK pounds sterling in effect

User	Manager2	US dollar	Access to site and all products shows US dollars in effect
Product	Financials for EMEA	Euro	Unless superseded by a user level value, Euros in effect for Financials for EMEA applications
Site	Site	UK pound sterling	UK pounds sterling in effect for all other users and products

Context such as user session or accessed product determines which profile option value is associated with the profile option name. In the example, if manager1 does not set a profile option value for this profile option, access to Financials for EMEA shows currency in Euros; and access to other products shows currency in UK pounds sterling.

Profile Option Categories

Categories group profile options based on their functional area. Profile option categories facilitate searching and defining data security.

For example, in Oracle Fusion Receivables, the Transactions profile option category groups profile options related to setting how Receivables transactions are to be processed, such as Require Adjustment Reason.

A profile option can be in more than one category.

Profile Option Hierarchies and Levels

Application developers specify at which hierarchy level a profile option is enabled. The predefined profile option hierarchy levels are site, product, and user.

The hierarchy levels specified in the profile option definition determine the context in which a profile option value may be set. If the profile option value at a particular level is updatable, an administrator can update the profile option value for that context.

Note

Profile options should only be enabled for context levels that are appropriate for that profile option. For example, a profile option indicating a global configuration setting should not be enabled at the user level, if users cannot choose a different value for that setting.

For security, one level in the hierarchy is designated as a user level. A profile option may be enabled at any or all hierarchy levels. When enabled at all levels, the predefined ordering of profile option hierarchy levels gives precedence to the values that are set at the user level over values set at the product and site levels, and precedence to values set at the product level to values set at the site level. If there is no value for the current user, then the product value applies. If there is no value for the user or product, then the site value applies.

The table shows the predefined profile option hierarchy and ordering.

Hierarchy Level	Priority When Multiple Levels Set	Effect on Applications	Example
Site	Lowest	Affect all applications for a given implementation	Currency for the site is set to Euros.
Product	Supersedes Site	Affect all applications of a product family such as Financials	Currency for the Financials products set to UK pound sterling.
User	Highest, supersedes Product	Affect only the experience of the current user	Currency for the user of Financials applications set to US dollars.

You can configure updatable values for profile options at one or more levels depending on which levels are enabled in the profile option definition. When a profile is set at more than one level, higher levels of specificity override lower levels of specificity.

In the example, if the currency setting for the site is UK pounds sterling, but the Financials division works in the Netherlands using the Euro, a manager in the US can override that product level setting at the user level to use US dollars when accessing Financials applications.

In another example, if a profile option called Printer is set only at the site and product levels. When a user logs on, the Printer profile option assumes the value set at the product level, since it is the highest level setting for the profile.

Tip

Set site-level profile option values before specifying values at any other level. The profile option values specified at the site-level work as defaults until profile option values are specified at the other levels.

Planning Profile Options: Points to Consider

Plan profile options before defining and configuring them.

The following aspects assist you in better planning how to manage profile options.

- Profile option tasks
- Before creating a profile option
- Profile options data model

Profile Option Tasks

Users may be able to set their own profile options, depending on settings in the profile option definition. However, not all profile options are visible to end users, and some profile options, while visible, may not be updated by end users.

The following table lists tasks and considerations relevant to planning profile options.

Tasks	Role	Considerations
Planning, creating, and editing a new profile option	Applications developer	Since profile options are for permanent settings, do not use profiles options to cache temporary session attributes. Add capacity for user preferences and system configuration. Customize profile options with values, value behaviors, validation, category values, and security. Define the levels at which the profile option is enabled.
Configure values in an existing profile option	Applications developer, application administrator, and implementation consultant	Manage the values for existing profile options.
Create and edit profile option categories	Applications developer, application administrator, and implementation consultant	Manage categories for organizing existing profile options.

Note

Since a profile option enables a behavior in an application user interface or across applications, a value change made by an end user is reflected in the UI page for managing profile option values.

Before Creating a Profile Option

Profile options are best defined for managing configuration data centrally and influencing the behavior of applications.

If the purpose of a profile option setting is specific to a piece of data (typically setup data), it is best implemented as an attribute of that data.

Do not use profile options for behavior that is not configurable.

Profile options exist independent of role.

Do not use profile options to implement function security. For example, an application should not check for a profile option value set to yes to provide access to a page. Do not use profile options to implement data security, such as a profile option value that must be set to a specific value to provide view access to an entity.

Do not use profile options to capture a dynamic system states, such as data stored in a temporary table. Use Global Variables for temporary states instead.

Evaluate if there is a genuine need before creating a profile option. Do not force users to make a decision about an aspect of their application use that is of no concern.

Evaluating need includes looking for duplicate or similar profile options, even in other products, before creating a new one. For example, you do not need multiple profile options to choose a preferred currency.

Profile Options Data Model

The profile option data model illustrates the relationships among profile option elements.

The figure shows the data model of profile option entities.

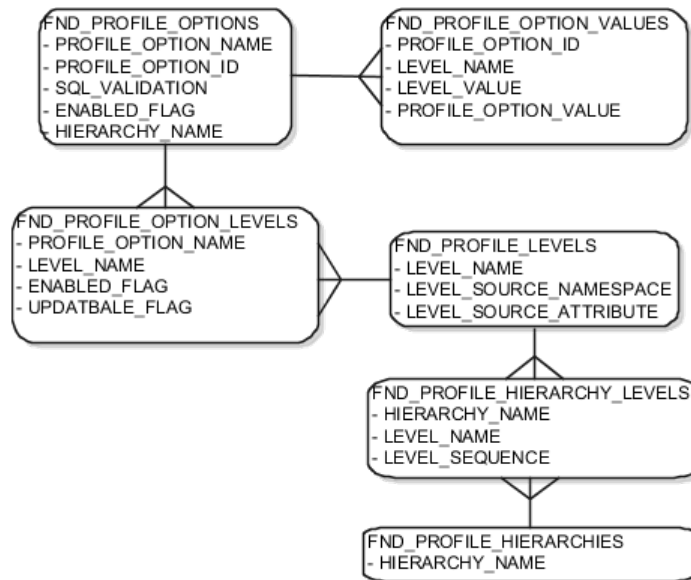

For more information about planning profile options, see the Oracle Fusion Applications Developer's Guide.

Managing Profile Options: Points to Consider

A profile option definition consists of a name for the profile option and valid values. It is defined within a module of the application taxonomy. Application developers manage profile options to create new profile options or modify existing profile option definitions, which includes specifying the levels at which a profile option is enabled and defining values. Implementation consultants and application administrators configure existing profile options by managing the profile option's updatable values, and creating categories that group profile options.

Configuring a Profile Option

A profile option definition includes information about the owning application and module in the application taxonomy. A start or end date, or both may limit when a profile option is active. The profile option definition may include an SQL validation statement that determines which values are valid, and the hierarchy levels at which the profile option is enabled and updatable.

To be visible to users, a profile option must be user enabled. You can also allow user updates of the profile option, which means users can make changes to the validation and the profile option level information.

Profile option levels specify at which context level profile values may be enabled or updated. .

Profile options should only be enabled for context levels that are appropriate for that profile option. For example, a profile option indicating a global configuration setting should not be enabled at the user level, if users cannot choose a different value for that setting.

SQL Validation

The SQL validation of the profile option definition determines what valid profile option values are available. In the absence of validation, any value is valid.

For example, SQL validation provides a means of defining a list of values for the valid values of the profile option. The SQL validation can use lookups to provide the valid values for profile options, such as the lookup codes of the YES_NO lookup type.

With a profile option called DEFAULT_LANGUAGE, you can configure the following validation.

```
SELECT DESCRIPTION Language, NLS_LANGUAGE
FROM FND_LANGUAGES_VL
WHERE INSTALLED_FLAG IN ('B','I')
ORDER BY DESCRIPTION
```

This results in the following list of values based on data in FND_LANUGUAGE_VL.

Display Value	Hidden Value
American English	US
French	F
Spanish	E

Hidden values must be varchar2(2000).

Profile options generally provide configuration values within a particular context. Though you can create a profile option to be global, think of global values as default values to avoid storing inappropriate configuration information as profile option values. Create global profile options that have corresponding contextual levels.

Managing Profile Option Categories: Points to Consider

Use profile option categories to group profile options.

Organizing Profile Options in Categories

As a guideline, group profile options in a single category if the profile options affect the same feature, or if an administrator would likely want to see the profile options in the results of a single search.

Application developers are responsible for the initial groupings and then administrators can make changes based on their specific needs. Administrators can categorize profile options and then easily search on profile options by category.

Tip

Define profile option categories first and assign new profile options to existing categories rather than defining profile options first and then defining categories to categorize them.

Adding New Profile Option Categories

You can add new categories or add profiles to an existing category.

You can create a profile option category by duplicating an existing category and editing it for a new grouping of profile options. You can add multiple profile options to a category. A profile option can exist in multiple categories.

Profile Option Order in a Category

Specify a profile option sequence to determine the order of profile options when queried by profile option category.

Viewing and Editing Profile Option Values: Points to Consider

A profile option value consists of the value and the context or level where the value is set. You specify the context with a pairing of the profile option value's level and level value, such as the product level and the level value GL for Oracle Fusion General Ledger. Adding or modifying profile option values can include deciding which valid values are enabled or updatable at which level.

The SQL validation of the profile option definition determines what valid profile option values are available. In the absence of validation, any value is valid.

Profile Option Levels and User Session Context

Site level profile option values affect the way all applications run for a given implementation. Product level profile option values affect the way applications owned by a particular product code behave. For example, a product may use profile options set at the product level to determine how regions provided by a common module such as those available from Oracle Fusion Trading Community Model or Customer Relationship Management (CRM) display in a particular work area or dashboard. User level profile option values affect the way applications run for a specific application user

Whichever profile option value is most specific to a user session, that is the value at which the profile option is set for the user session.

For example, the predefined FND_LANGUAGE profile option sets the default language. In addition to a site level value, you can define a value for various product or user levels.

Level Name	Level Value	Profile Option Value
Site	InFusion	American English
Product	Customer Center	French
Product	CRM Application Composer	American English
User	Application Administrator	American English
User	Hima	Hindi

Values at the site level take effect for any user unless overridden by a different value set at the more specific levels of product and user. Product level profile option values affect the way applications owned by a particular product code behave. In addition to user level profile option values in applications, selections may be available in the user preferences workspace.

The following table demonstrates the FND_LANGUAGE profile option settings that would apply to specific users, based on the example above. For example, the user Hima is using the CRM Application Composer product, in the InFusion site. The example above shows that this profile option is set to Hindi at the user level for Hima. Because user is the highest applicable level for Hima, the applicable profile option value is Hindi for Hima.

Site	Product	User	Highest Available Level	Active Profile Option Value
InFusion	CRM Application Composer	Hima	User	Hindi
Acme	Payables	Application Administrator	User	American English
InFusion	Customer Center	Guillaume	Product	French
InFusion	Payables	Implementation Consultant	Site	American English
Acme	Payables	Implementation Consultant	none	no value

Note

More than one site level value is relevant in an enterprise with multiple tenants using a single instance of Oracle Fusion Applications.

Effect of Changes to Profile Option Values

Any change you make to a user level profile option has an immediate effect on the way applications run for that session. When you sign in again, changes made to your user level profile options in a previous session are still in effect. When you change profile option value at the product level and no user level values are set, you see the update immediately, but other users may not see the changed value until signing out and back in. When you change a profile option value and

the new value affects other users, the change takes effect only when users sign in the next time.

Changes to site level profile options take effect for any user session that is started after the setting has been changed. Changes to site or user level profile options do not affect any user sessions that are already in progress when the change is made.

Changes to site or user level profile options take effect for any C or PL/SQL processes, such as scheduled jobs, that are launched after the setting has been changed. Profile option changes do not affect C or PL/SQL processes that are already running.

Define Flexfields

Flexfields: Overview

Flexfields are a mechanism for configuring and extending applications to meet enterprise-specific needs. Using flexfields, you can extend application objects to capture data that would not otherwise be tracked by the application, or configure intelligent key codes comprised of meaningful parts according to your business practices. Flexfields encapsulate all of the pieces of information related to a specific purpose, such as a key identifying a particular purchase, or the components of a student's contact information, or the features of a product in inventory.

A flexfield is an extensible data field consisting of subfields. Each subfield is a flexfield segment. You configure segments to capture enterprise-specific information. Each segment captures a single atomic value, has a name, and maps to a pre-reserved column in the applications database.

Flexfields allow enterprise requirements to be met without changing the data model. Different data can be captured on the same database table.

Application developers create a flexfield and register it so that it is available for configuration. Administrators and implementation consultants setup or configure segments and other properties of the available flexfields. End users see flexfield segments as attributes of information displayed in the application user interface. They enter a value for the attribute. The value may be selected from a list of valid values or entered as free-form text that complies with formatting rules.

Manage flexfields using tasks you access by starting in the Setup and Maintenance Overview page.

Tip

Use the **Business Object** parameter to search Application Key Flexfields, Application Descriptive Flexfields, and Application Extensible Flexfields to find all tasks related to flexfields. To manage any flexfield across all Oracle Fusion Applications products, search for the Define Flexfields task list and access the Manage Descriptive Flexfields, Manage Extensible Flexfields, and Manage Key Flexfields tasks.

Types of Flexfields

The following three types of flexfields are available in Oracle Fusion Applications and provide a means to customize applications features without programming.

- Key
- Descriptive
- Extensible

For example, in Oracle Fusion Financials, key flexfields represent objects such as accounting codes and asset categories. Generally, correct operations of a product depend on key flexfield setup. In Oracle Fusion Payables, a descriptive flexfield expands a customizable area of an invoices page by providing subfields for collecting invoice details. You can implement these subfields, which are descriptive flexfield segments, as context sensitive so they appear only when needed. Extensible flexfields are similar to descriptive flexfields, but provide additional advanced features. Generally setup of descriptive and extensible flexfields is optional because their segments capture additional information that is stored attributes on an entity

Segments

All flexfields consist of segments. Segments represent attributes of information. They can appear globally wherever the flexfield is implemented, or based on a structure or context.

You define the appearance and meaning of individual segments when configuring a flexfield.

A key flexfield segment commonly describes a characteristic of the entity identified by the flexfield, such as a part number structured to include information about the type, color, and size of an item. A descriptive flexfield segment represents an attribute of information that describes a characteristic of the entity identified on the application page, such as details about a device containing components, some of which are globally present on the page while others are contextually dependent on the category of the device.

Value Sets

A value set is a predefined, named group of values that can be used to validate the content of a flexfield segment.

You configure a flexfield segment with a value set that establishes the valid values that an end user can enter for the segment. You define the values in a value set, including such characteristics as the length and format of the values. You can specify formatting rules, or specify values from an application table or predefined list. Multiple segments within a flexfield, or multiple flexfields, can share a single value set.

Structure and Context

Key flexfields have structure. Descriptive flexfields and extensible flexfields have context.

Each key flexfield structure is a specific configuration of segments. Adding or removing segments, or rearranging their order, produces a different structure. The database columns on which segments in different structures are based can be reused in as many structures as desired.

Descriptive flexfield segments can be context-sensitive, which means available to an application based on a context rather than globally available wherever the flexfield appears. (which means available to an application based on a context value rather than globally available wherever the flexfield appears. A descriptive flexfield context is a set of context-sensitive segments that store information related to the same context value. You define contexts as part of configuring a descriptive flexfield. End users see global segments, as well as any context-sensitive segments that apply to the selected context value.

Extensible flexfield segments are made available to an application based upon a category value. An extensible flexfield context serves as a container for related segments, used to organize the various segments that are applicable to a category value. You define contexts with context-sensitive segments and associate them to categories as part of configuring an extensible flexfield. End users see the segments displayed in subregions, one for each context associated to the selected category value.

In descriptive flexfields and extensible flexfields, the database columns on which context-sensitive segments are based can be reused in as many contexts as desired.

Deployment

A flexfield must be deployed to display its current definition in a runtime application user interface. For example, if the deployment status is Edited, the flexfield segments may appear in the UI based on the flexfield definition at the time of last deployment, rather than the current definition.

You can deploy a flexfield as a sandbox for testing the configuration before deploying it to the mainline for all users.

Runtime Appearance

In an application user interface, descriptive flexfield segments appear as label and field pairs or as a table of fields where the column headers correspond to the labels. The fields represent the flexfield segments and accept entered input or a selection from a list of choices that correspond to the segment's assigned value set. Extensible flexfield segments appear grouped within labeled regions, where each grouping is a context and the region labels are the context names.

Use the **Highlight Flexfields** command in the Administration menu of the Setup and Maintenance work area to identify the location of the descriptive and key flexfields on the runtime page. Flexfields in highlight mode display an information icon to access details about the flexfield, and an edit icon to manage the flexfield.

All segments of a single flexfield are grouped together by default. The layout and positions of the flexfield segments depend on where the application developer places the flexfield on the page. Flexfields may also be presented in a separate section of the page, in a table, or on their own page or subwindow.

You can use Oracle Composer to edit the layout, position, or other display features of the flexfield segments.

Flexfields and Oracle Fusion Application Architecture: How They Work Together

Administrators configure flexfield segments to capture data that represents the values of attributes. Flexfield segments represent attributes of entities (business objects). Most business objects are enabled for descriptive flexfields. Some business objects are enabled for extensible flexfields.

The figure shows the layers of a flexfield: the business entity table and metadata in the database, business components that are Application Development Framework (ADF) objects or ADFbc objects derived from the metadata and stored in the Metadata Services Repository (MDS), and the user interface where the input fields defined by the flexfield segments are rendered. The flexfield definition consists of all the metadata defined during configuration and stored in the database.

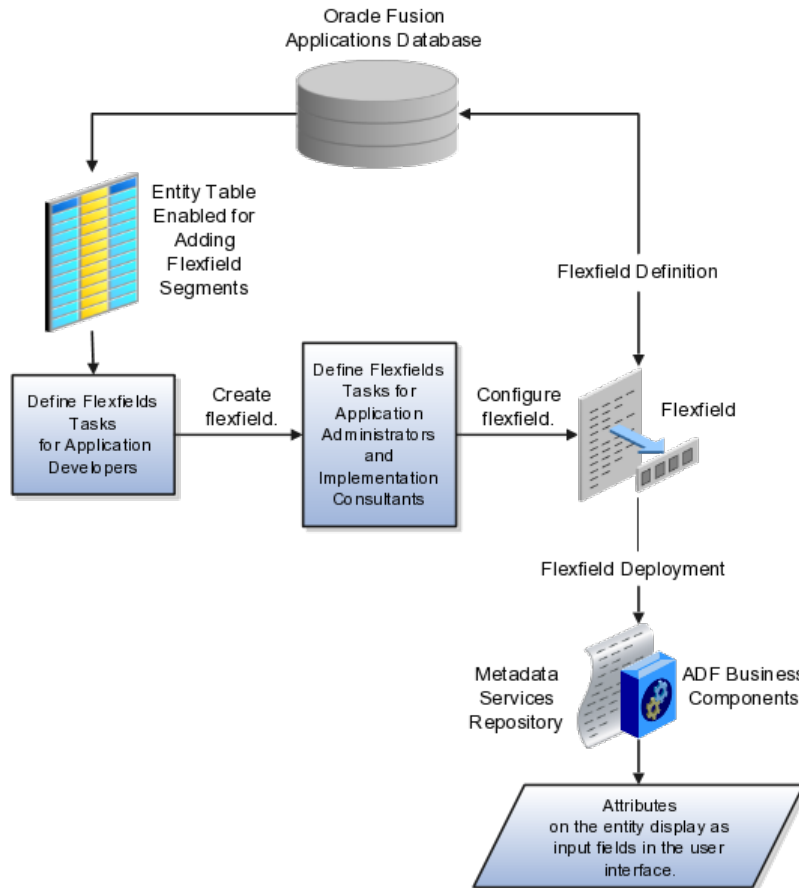

Application developers create a flexfield and register it so that it is available for configuration. Administrators and implementation consultants configure segments and other properties of the available flexfields. This information is stored as additional flexfield metadata in the database. Deploying the flexfield generates ADF business components based on the flexfield metadata in the database.

Integration

A flexfield affects the Web Services Description Language (WSDL) schemas exposed by ADF services and used by SOA composites. The Web services that expose base entity data also expose flexfield segment data.

Attributes incorporate into SOA infrastructure (BPEL, Rules) and integrate with business intelligence (Oracle Business Intelligence, Extended Spread Sheet Database (ESSbase)).

Flexfield configurations are preserved across Oracle Fusion Applications updates.

Deployment

The metadata for the flexfield is stored in the application database as soon as you save your configuration changes. Deploying the flexfield generates the ADF business components so that the runtime user interface reflects the latest definition of the flexfield in the metadata.

Importing and Exporting

You can export and import flexfields with a deployment status of Deployed or Deployed to Sandbox across instances of Oracle Fusion Applications using the Setup and Maintenance Overview page. Ensure a flexfield is eligible for migration (by verifying that it has successfully deployed) prior to attempting the migration.

Runtime

For a flexfield to reflect the latest flexfield definition at runtime it must be deployed. The user interface accesses a business object and the deployed flexfield definition indicates which business object attributes the flexfield captures values for. If you add display customizations for a flexfield using Oracle Composer, these are customizations on the page so that the same flexfield segments can appear differently on various different pages.

Values entered for segments are validated using value sets.

Flexfield Management

Managing Flexfields: Points to Consider

Managing flexfields involves, registering, planning, and configuring flexfields.

You plan and configure the registered flexfields provided in your applications by applications developers. How you configure flexfield segments determines how the flexfield segments appear to end users. Optionally, you can customize the UI page to change how the flexfield segments appear to end users on that page.

The figure shows the processes involved in making flexfields available to end users. The tasks in the Define Flexfields activity allow administrators to configure and deploy flexfields. If you deploy a flexfield to a sandbox and decide not to make further changes, you select the flexfield in the Manage Flexfields tasks of the Define Flexfields activity and deploy the flexfield in the mainline so it is available to users.

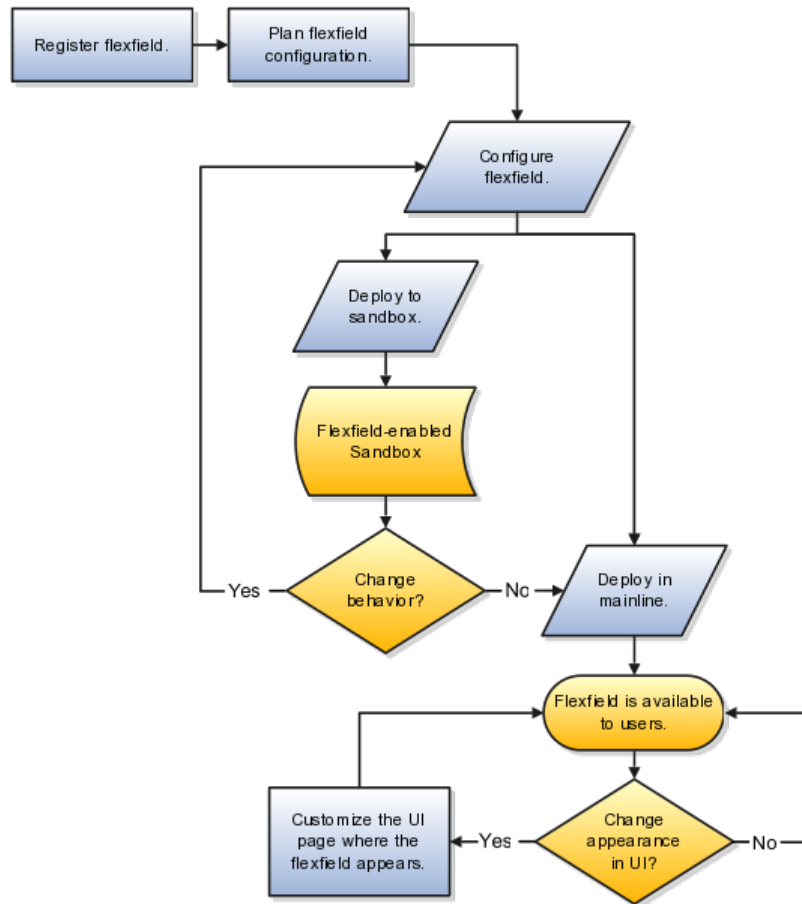

Registering Flexfields

Application development registers flexfields so they are available to administrators and implementation consultants for configuration.

Application development creates the capacity of database tables to support flexfields so an enterprise can capture specific information about an entity. Many flexfields are predefined in Oracle Fusion Applications.

A flexfield must be registered before it can be configured.

For more information on registering flexfields, see Oracle Fusion Applications: Developer's Guide.

Planning Flexfields

All flexfields consist of segments which represent attributes of an entity. The values an end user inputs for an attribute are stored in a column of the entity table. Application development enables columns of entity tables for use in flexfields during flexfield registration.

A flexfield must be registered before it can be configured. Before configuring new flexfield segments for your enterprise, be sure to plan their implementation carefully.

For more information on planning flexfield configuration, see Oracle Fusion Applications Extensibility Guide.

Configuring Flexfields

Administrators or implementors configure flexfields so they meet the needs of the enterprise. Some flexfields require configuration to make an application operate correctly.

Configuring a flexfield includes the following.

- Defining value sets against which the values entered by end users are validated
- Defining the structure or context of the segments in the flexfield
- Specifying the prompt, length and data type of each flexfield segment
- Specifying valid values for each segment, and the meaning of each value within the application

Tip

As a flexfield guideline, define value sets before configuring the flexfield, because you assign value sets to each segment as you configure a flexfield.

Some descriptive flexfields provide parameters that are attributes of the same or related entity objects. You use parameters to set the initial value or derivation value of an attribute from external reference data, such as a column value or a session variable, rather than from user input.

Note

Adding segments to represent additional attributes is considered a custom task. For more information, see the Oracle Fusion Applications Extensibility Guide.

For more information on adding columns to a table, see the Oracle Fusion Applications Developer's Guide.

For more information on configuring flexfields for custom attributes, see also the Oracle Fusion Applications Extensibility Guide.

Enabling a Flexfield Segment for Business Intelligence

You can enable key flexfield segment instances and descriptive flexfield segments for business intelligence if the flexfield is registered in the database as an Oracle Business Intelligence-enabled flexfield. For more information on enabling segments for business intelligence, see points to consider when enabling key and descriptive flexfield segments for business intelligence.

Deploying Flexfields

After you configure or change a flexfield, you must deploy it to make the latest definition available to end users.

You deploy a flexfield in the mainline for general use in a test or production environment, or you can deploy a flexfield as a flexfield-enabled sandbox to confirm that it is correctly configured before deploying it to the mainline.

Deploying a flexfield results in a deployment status. Once deployed, the deployment status indicates the state of the currently configured flexfield relative to the last deployed definition

Optionally Changing How Flexfield Segments Appear in a User Interface Page

The flexfield attributes you define integrate with the user interface pages where users access the attributes' business object. Application development determines the UI pages where business objects appear and the display patterns used by default to render flexfield segments.

You can customize the appearance of the flexfield segments in the UI page using Oracle Composer once the flexfield is deployed to the mainline.

For more information on customizing flexfield appearance with Oracle Composer, see guidance on customizing existing pages in Oracle Fusion Applications Extensibility Guide.

For more information on planning flexfields or customizing them beyond the configuration possible in the Define Flexfields tasks, see Oracle Fusion Applications Extensibility Guide.

For more information on creating flexfields and adding them to a UI page, see Oracle Fusion Applications Developer's Guide.

Identifying Flexfields on a Runtime Page

The **Highlight Flexfields** command in the Administration menu of the Setup and Maintenance work area identifies the location of descriptive and key flexfields on the runtime page by displaying an information icon for accessing details about each flexfield.

Even if a flexfield has not yet been deployed and does not appear on the runtime page in normal view, it appears in the Highlight Flexfield view for that page. **Highlight Flexfields** accesses the current flexfield metadata definition.

Use the highlighted flexfield's edit icon to manage the descriptive or key flexfield directly. Alternatively, note a highlighted flexfield's name to search for it in the tasks for managing flexfields.

Flexfield Segment Properties: Explained

Independent of the value set assigned to a segment, segments may have properties such as validation.

Range Validation of Segments

Range validation enables you to enforce an arithmetic inequality between two segments of a flexfield. For example, a product must be ordered before it can be shipped, so the order date must be on or before the ship date, and consequently the order date segment value must be less than or equal to the ship date segment value. You can use range validation to ensure this relationship.

The conditions for range validation are as follows.

- Segments must be configured for range validation in pairs, one with the low value and one with the high value.
- Both segments must be the same data type.
- Both segments must be part of the same structure in a key flexfield or part of the same context in a descriptive flexfield or extensible flexfield.
- The low value segment must have a lower sequence number than the high value segment.
- Non-range validated segments can exist between a range validated pair, but range validated pairs cannot overlap or be nested.

You can configure as many range validated pairs as you want within the same flexfield. Your application automatically detects and applies range validation to the segment pairs that you define, in sequence order. It must encounter a low value segment first, and the next range validated segment it encounters must be a high value segment. These two segments are assumed to be a matching pair. The low value and the high value can be equal.

Code Naming Conventions

When entering codes such as segment code, enter a code consisting of the characters A-Z, a-z, 0-9, with a non-numeric leading character.

The code is used in the flexfield's element in the XML schema for web services. You can maximize the readability of the schema by naming codes with a leading alphabetic character followed by alphanumeric characters. The use of spaces, underscores, multi-byte characters, and leading numeric characters, which are all encoded in XML schemas, make the codes in the schema element difficult to read.

This applies to context code in descriptive and extensible flexfields, and to structure instance code in key flexfields.

Flexfields and Value Sets: How They Work Together

Value sets are specific to your enterprise. When gathering information using flexfields, your enterprise's value sets validate the values your users enter based on how you defined the value set.

You can assign a value set to any number of flexfield segments in the same or different flexfields. Value set usage information indicates which flexfields use the value set.

Defining and Assigning Value Sets

As a flexfield guideline, define value sets before configuring the flexfield, because you assign value sets to each segment as you configure a flexfield.

Caution

Be sure changes to a shared value set are compatible with all flexfield segments using the value set.

Shared Value Sets

When you change a value in a shared value set, the change affects the value set for all flexfields that use that value set. The advantage of a shared values set is that a single change propagates to all usages. The drawback is that the change shared across usages may not be appropriate in every case.

Deployment

When you deploy a flexfield, the value sets assigned to the segments of the flexfield provide end users with the valid values for the attributes represented by the segments.

Defaulting and Deriving Segment Values: Explained

To populate a flexfield segment with a default value when a row is created, specify a default type of constant or parameter and a default value.

To synchronize a segment's value with another field's value whenever it changes, specify the derivation value to be the flexfield parameter from which to derive the attribute's value. Whenever the parameter value changes, the attribute's value is changed to match. If you derive an attribute from a parameter, consider making the attribute read-only, as values entered by users are lost whenever the parameter value changes.

When defaulting or deriving a default value from a parameter, only those attributes designated by development as parameters are available to be chosen.

Different combinations of making the segments read only or editable in combination with the default or derivation value or both, have different effects.

Initial runtime behavior corresponds to the row for the attribute value being created in the entity table. If the default value is read only, it cannot subsequently be changed through the user interface. If the default value is not read only, users can modify it. However, if the segment value is a derived value, a user-modified segment value is overwritten when the derivation value changes.

Default Type	Default value specified?	Derivation value specified?	Initial runtime behavior	Runtime behavior after parameter changes
None	No	Yes	No initial segment value	Changed parameter derivation value updates segment value
Constant	Yes	No	Default segment value	N/A
Constant	Yes	Yes	Default segment value	Changed parameter derivation value updates segment value
Parameter	Yes	No	Default segment value is the parameter's default value	N/A

Parameter	Yes	Yes, and same as default value	Default segment value is parameter's default and derivation value	Changed parameter derivation value updates segment value
Parameter	Yes	Yes, and different from default value	Default segment value is parameter's default value	Changed parameter default value does not update segment value. Only the changed derivation value updates the segment value.

Flexfield Usages: Explained

Usage affects various aspects of flexfields. The usage of the flexfield is set when the flexfield is registered and specifies the application and table with which the flexfield is associated.

Entity usage indicates the table containing the segments of a flexfield.

A flexfield can have multiple usages. The first table registered for a flexfield is the master usage. Segments are based on the master usage, and other usages of the same table for the same flexfield use the same segment setup, though the column names optionally may have a differentiating prefix.

Extensible Flexfields

You can configure different behavior for extensible flexfield contexts at the usage level. The usage of an extensible flexfield context determines in which scenarios or user interfaces the segments of a context appear to end users. For example, if a Supplier page displays an extensible flexfield's supplier usage and a buyer page displays that same extensible flexfield's buyer usage, a context that is associated to the supplier usage but not the buyer usage displays only on the supplier page and not the buyer page.

Value Sets

The usage of value sets specifies the segments where the value set is assigned.

Flexfield Deployment

Flexfield Deployment: Explained

To use a flexfield at runtime, the flexfield must have been deployed at least once. Deployment generates or refreshes the Application Development Framework (ADF) business component objects that render the flexfield in a user interface. Flexfields are deployed for the first time during the application provisioning process.

After you configure or change a flexfield, you must deploy it to make the latest definition available to end users. You can deploy a flexfield to a sandbox for testing or to the mainline for use.

Deployment Status

Every flexfield has a deployment status.

A flexfield can have the following deployment statuses.

Deployment Status	Meaning
Edited	The flexfield metadata definition has not been deployed yet. Updates of the metadata definition are not applied in the runtime environment yet.
Patched	The flexfield metadata definition has been modified through a patch or through a data migration action, but the flexfield has not yet been deployed so the updated definition is not reflected in the runtime environment.
Deployed to Sandbox	The current metadata for the flexfield is deployed in ADF artifacts and available as a flexfield-enabled sandbox. The status of the sandbox is managed by the Manage Sandboxes task available to the Administrator menu of the Setup and Maintenance work area.
Deployed	The current metadata for the flexfield is deployed in ADF artifacts and available to end users. There have not been any changes to the flexfield since it was last deployed in the mainline.
Error	The deployment attempt in the mainline failed.

Note

Whenever a value set definition changes, the deployment status of a flexfield that uses that value set changes to edited. If the change results from a patch, the deployment status of the flexfield changes to patched.

Initial Deployment Status of Flexfields

The Oracle Fusion Applications installation loads flexfield metadata into the database. This initial load sets the flexfield status to Edited to indicate that the flexfield has not been deployed yet. The application provisioning process during installation deploys the predefined flexfields of the provisioned applications, which sets their status to Deployed if no errors are encountered.

When accessing a provisioned application, deployed flexfields are ready to use. In some cases, flexfield availability at runtime requires setup, such as defining key flexfields.

Metadata Validation

Use the Validate Metadata command to view possible metadata errors before attempting to deploy the flexfield. Metadata validation is the initial phase of the Deploy and Deploy to Sandbox commands. By successfully validating metadata before running the deployment commands, you can avoid failures in the metadata validation phase of a deployment attempt. Errors in the metadata validation phase of deployment cause the deployment attempt to abort. Metadata validation results do not affect the deployment status of a flexfield.

Flexfield Deployment Status: How It Is Calculated

Flexfield deployment status indicates how the flexfield metadata definition in the Oracle Fusion Applications database relates to the Application Development Framework (ADF) business components generated into a Metadata Services (MDS) repository.

Settings That Affect Flexfield Deployment Status

If you have made a change to a flexfield and expect a changed deployment status, be sure you have saved your changes. No settings affect flexfield deployment status.

How Flexfield Deployment Status Is Calculated

If the flexfield definition has been edited through the Define Flexfields activity task flows, the status is Edited. The latest flexfield metadata definition in the Oracle Fusion application diverges from the latest deployed flexfield definition. Any change, including if a value set used in a flexfield changes, changes the deployment status to Edited. If a flexfield has never been deployed, its status is Edited.

Note

When an application is provisioned, the provisioning framework attempts to deploy all flexfields in that application.

If you deploy the flexfield to a sandbox successfully, the status is Deployed to Sandbox. The latest flexfield metadata definition in the Oracle Fusion application matches the metadata definition that generated ADF business components in a sandbox MDS repository. Whether the sandbox is active or not does not affect the deployment status. If the flexfield was deployed to a sandbox and has not been edited or re-deployed to the mainline since then, the status remains Deployed to Sandbox independent of whether the sandbox is active, or who is viewing the status.

If you deploy the flexfield successfully, meaning to the mainline, the status is Deployed. The latest flexfield metadata definition in the Oracle Fusion application matches the metadata definition that generated ADF business components in a mainline MDS repository. Change notifications are sent when a flexfield is deployed successfully to the mainline.

If either type of deployment fails so the current flexfield definition is not deployed, the status is Error. The deployment error message gives details about the error. The latest flexfield metadata definition in the Oracle Fusion application likely diverges from the latest successfully deployed flexfield definition.

If the flexfield definition has been modified by a patch, the status is Patched. The latest flexfield metadata definition in the Oracle Fusion application diverges from the latest deployed flexfield definition. If the flexfield definition was Deployed before the patch and then a patch was applied, the status changes to Patched. If the flexfield definition was Edited before the patch and then a patch was applied, the status will remain at Edited to reflect that there are still changes (outside of the patch) that are not yet in effect.

When a deployment attempt fails and you can access the Deployment Error Message for details.

Deploying a Flexfield-Enabled Sandbox: How It Works With Mainline Metadata

The flexfield definition in a sandbox corresponds to the flexfield metadata definition in the Oracle Fusion Applications database at the time the flexfield was deployed to the sandbox. When the flexfield is ready for end users, the flexfield must be deployed to the mainline.

A flexfield-enabled sandbox uses the following components.

- Flexfield metadata in the Oracle Fusion Applications database
- Flexfield business components in a sandbox Metadata Services (MDS) repository
- User interface customizations for the flexfield in the mainline MDS repository

The figure shows the two types of deployment available in the Manage Flexfields activity. Deploying a flexfield to a sandbox creates a sandbox MDS repository for the sole purpose of testing flexfield behavior. The sandbox is only accessible to the administrator who activates and accesses it, not to users generally. Deploying a flexfield to the mainline applies the flexfield definition to the mainline MDS repository where it is available to end users. After deploying the flexfield to the mainline, customize the page where the flexfield segments appear. Customization of the page in the sandbox MDS repository cannot be published to the mainline MDS repository.

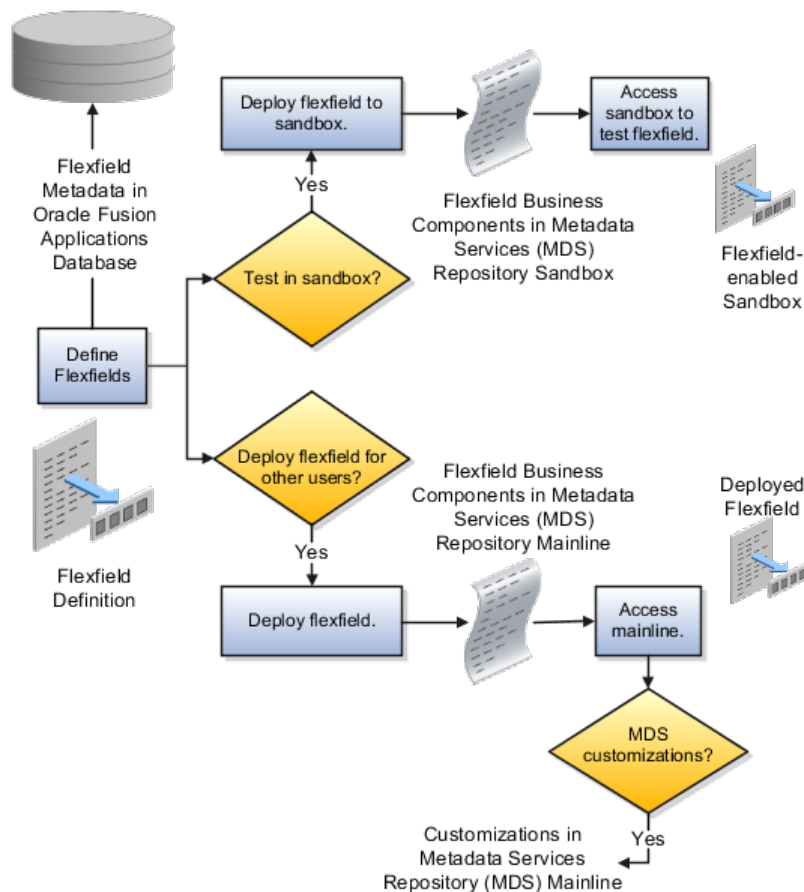

Sandbox Metadata Services Repository Data

Deploying the flexfield to a sandbox generates the Application Development Framework (ADF) business components of a flexfield in a sandbox MDS repository for testing in isolation.

Warning

Do not make changes to flexfield segment display features in a flexfield-enabled sandbox as these changes will be lost when deploying the flexfield to the mainline.

Mainline Metadata Services Repository Data

The Oracle Fusion Applications database stores the single source of truth about a flexfield. From this the ADF business component objects that implement the flexfield in the runtime user interface are generated in the mainline MDS repository when the flexfield is deployed.

Deploying a Flexfield-Enabled Sandbox: Points to Consider

Deploying a flexfield to a sandbox creates a flexfield-enabled sandbox . Each flexfield-enabled sandbox contains only one flexfield.

You can test the runtime behavior of a flexfield in the flexfield-enabled sandbox. If changes are needed, return to the Define Flexfield tasks to change the flexfield definition.

When you deploy a flexfield to sandbox, the process reads the metadata about the segments from the database, generates flexfield Application Development Framework (ADF) business component artifacts based on that definition, and stores in the sandbox only the generated artifacts derived from the definition.

Sandbox MDS Repository Data

The sandbox data allows you to test the flexfield in isolation without first deploying it in the mainline where it could be accessed by users.

Warning

Do not make changes to flexfield segment display features in a flexfield-enabled sandbox as these changes will be lost when deploying the flexfield to the mainline.

Managing a Flexfield-Enabled Sandbox

When you deploy a flexfield as a sandbox, that flexfield-enabled sandbox automatically gets activated in your user session. When you sign back in to see the changes, the sandbox is active in your session.

You can only deploy a flexfield to a sandbox using the Define Flexfields task flow pages.

You also can use the Manage Sandboxes feature in the Administration menu of the Setup and Maintenance work area to activate, access, or delete a flexfield-enabled sandbox.

Note

Whether you use the Define Flexfields or Manage Sandboxes task flows to access a flexfield-enabled sandbox, you must sign out and sign back in before you can see the changes you deployed in the runtime.

You cannot publish the flexfield from the sandbox to the mainline. You must use the Define Flexfields task flow pages to deploy the flexfield for access by users of the mainline because the flexfield configuration in the mainline is the single source of truth.

Deploying Flexfields Using the Command Line: Explained

You can use the Manage Key Flexfields, Manage Descriptive Flexfields, and Manage Extensible Flexfields tasks to deploy flexfields. You can also use WebLogic Server Tool (WLST) commands for priming the Metadata Services (MDS) repository with predefined flexfield artifacts and for deploying flexfields.

The table describes the available commands.

WebLogic Server Tool Command	Description
<code>deployFlexForApp</code>	Deploys all flexfields for the specified enterprise application. Only flexfields whose status is other than deployed are affected by this command unless the option is enabled to force all flexfields to be deployed regardless of deployment status. Initial application provisioning runs this command to prime the MDS repository with flexfield artifacts.
<code>deployFlex</code>	Deploy a single flexfield regardless of deployment status
<code>deployPatchedFlex</code>	Deploys flexfield changes that have been delivered using a flexfield Seed Data Framework (SDF) patch. Deploys flexfields that have a Patched deployment status.
<code>deleteFlexPatchingLabels</code>	Displays MDS label of flexfield changes for viewing and deleting patching labels.

Executing these commands outputs a report at the command line. The report provides the following information for every flexfield that is processed.

- Application identity (APPID)
- Flexfield code
- Deployment result, such as success or error

In case of errors, the report lists the usages for which the errors were encountered. If a runtime exception occurs, the output displays the traceback

information. For each WLST flexfield command, adding the `reportFormat='xml'` argument returns the report as an XML string.

Consider the following aspects of command line deployment.

- Preparing to use the WLST flexfield commands
- Using the `deployFlexForApp` command
- Using the `deployFlex` command
- Using the `deployPatchedFlex` command
- Using the `deleteFlexPatchingLabels` command
- Exiting the WLST and checking the results

Preparing To Use the WLST Flexfield Commands

You can only execute the WLST flexfield commands on a WebLogic Administration Server for a domain that has a running instance of the Oracle Fusion Middleware Extensions for Applications (Applications Core) Setup application.

For more information on deploying the Applications Core Setup application, see the Oracle Fusion Applications Developer's Guide.

Ensure that the AppMasterDB data source is registered as a JDBC data source with the WebLogic Administration Server and points to the same database as the ApplicationDB data source.

Start the WebLogic Server Tool (WLST) tool, if it is not currently running.

UNIX:

```
sh $JDEV_HOME/oracle_common/common/bin/wlst.sh
```

Windows:

```
wlst.cmd
```

Connect to the server, replacing the user name and password arguments with your WebLogic Server user name and password.

```
connect('wls_username', 'wls_password', 'wls_uri')
```

The values must be wrapped in single-quotes. The `wls_uri` value is typically `T3://localhost:7101`.

For more information on the WLST scripting tool, see the Oracle Fusion Middleware Oracle WebLogic Scripting Tool.

Using the `deployFlexForApp` Command

The `deployFlexForApp` command translates the product application's predefined flexfield metadata into artifacts in the MDS repository.

Important

This command is run automatically when you provision applications. However, after custom applications development, you must run the `deployFlexForApp` command after you configure your application to read the flexfield artifacts from the MDS repository and before you log into the application for the first time, even if there is no predefined flexfield metadata.

This command does not deploy flexfields that have a status of Deployed unless the force parameter is set to `'true'` (the default setting is `'false'`).

For more information on priming the MDS partition with configured flexfield artifacts, see the Oracle Fusion Applications Developer's Guide.

From the WLST tool, execute the following commands to deploy the artifacts to the MDS partition, replacing `product_application_shortname` with the application's short name wrapped in single-quotes.

```
deployFlexForApp('product_application_shortname'[, 'enterprise_id']
[, 'force'])
```

In a multi-tenant environment, replace `enterprise_id` with the Enterprise ID to which the flexfield is mapped. Otherwise, replace with `'None'` or do not provide a second argument.

To deploy all flexfields regardless of their deployment status, set force to `'true'` (the default setting is `'false'`). If you want to deploy all flexfields in a single-tenant environment, you either can set `enterprise_id` to `'None'`, or you can use the following signature:

```
deployFlexForApp(applicationShortName='product_application_shortname', force='true')
```

Tip

The application's short name is the same as the application's module name.

For more information about working with application taxonomy, see the Oracle Fusion Applications Developer's Guide.

Using the `deployFlex` Command

From the WLST tool, execute the following command to deploy a flexfield, replacing `flex_code` with the code that identifies the flexfield, and replacing `flex_type` with the flexfield's type, which is either DFF, KFF, or EFF.

```
deployFlex('flex_code', 'flex_type')
```

The values must be wrapped in single-quotes.

Using the `deployPatchedFlex` Command

Use the `deployPatchedFlex` command for situations where the patching framework does not invoke the command, such as when an application has been patched offline.

If the installation is multi-tenant enabled, the command deploys all patched flexfields for all enterprises. This command is not intended to be invoked manually.

Check with your provisioning or patching team, or the task flows for managing flexfields, to verify that the flexfield has a Patched deployment status.

From the WLST tool, execute the following command to deploy the artifacts to the MDS partition of all flexfields that have a READY status.

```
deployPatchedFlex()
```

Execute the following command to deploy all flexfields that have either a READY status or an ERROR status.

```
deployPatchedFlex(mode='RETRY')
```

Using the deleteFlexPatchingLabels Command

Whenever you deploy flexfield changes to MDS using the `deployPatchedFlex()` WLST command, an MDS label is created in the format `FlexPatchingWatermarkdate+time`. Use the `deleteFlexPatchingLabels` command to inquire about and delete these labels.

From the WLST tool, execute the `deployPatchedFlex()` command with no arguments to delete the flexfield patching labels.

To output a list of flexfield patching labels, execute the command with the `infoOnly` argument, as follows:

```
deleteFlexPatchingLabels(infoOnly='true')
```

Exiting the WLST and Checking the Results

To exit the tool, execute the following command.

```
disconnect()
```

Optionally, sign into the application, access user interface pages that contain flexfields, and confirm the presence of flexfields for which configuration exists, such as value sets, segments, context, or structures.

Manage Value Sets

Value Sets: Explained

A value set is a set of valid values that you assign to a flexfield segment.

An end user enters a value into a flexfield segment while using the application. The flexfield validates the segment against the set of valid values that you configured as a value set and assigned to the segment.

For example, you can define a required format, such as a five digit number, or a list of valid values, such as green, red, and blue.

Flexfield segments are usually validated, and typically each segment in a given flexfield uses a different value set. You can assign a single value set to more than one segment, and you can share value sets among different flexfields.

Caution

Be sure changes to a shared value set are compatible with all flexfields segments using the value set.

Defining value sets involves making decisions about the following.

- Validation
- Security
- Precision and scale
- Usage and deployment

Validation

The following types of validation are available for value sets.

- Format only, where end users enter data rather than selecting values from a list
- Independent, a list of values consisting of valid values you specify
- Dependent, a list of values where a valid value derives from the independent value of another segment
- Subset, where the list of values is a subset of the values in an existing independent value set
- Table, where the values derive from a column in an application table and the list of values is limited by a WHERE clause

A segment that uses a format only value set does not present a list of valid values to users.

You can build a tree structure from the values in an independent value set whose data type is character.

Note

Adding table validated value sets to the list of available value sets available for configuration is considered a custom task.

For more information, see the Oracle Fusion Applications Extensibility Guide.

Security

Value set security only works in conjunction with usage within flexfield segments. If a value set is used standalone, meaning outside a flexfield, value set security is not applied, but Oracle Fusion data security is enforced.

You can specify that data security be applied to the values in flexfield segments that use a value set. Based on the roles provisioned to users, data security policies determine which values of the flexfield segment end users can view or modify.

Value set security applies at the value set level. If a value set is secured, every usage of it in any flexfield is secured. It is not possible to disable security for individual usages of the same value set.

Value set security applies to independent, dependent, or table-validated value sets.

Value set security applies mainly when data is being created or updated, and to key flexfield combinations tables for query purposes. Value set security does not determine which descriptive flexfield data is shown upon querying.

Security conditions defined on value sets always use table aliases. When filters are used, table aliases are always used by default. When predicates are defined for data security conditions, make sure that the predicates also use table aliases.

For key flexfields, the attributes in the view object that correspond to the code combination ID (CCID), structure instance number (SIN), and data set number (DSN) cannot be transient. They must exist in the database table. For key flexfields, the SIN segment is the discriminator attribute, and the CCID segment is the common attribute.

Precision and Scale

For a value set with the data type Number, you can specify the precision (maximum number of digits user can enter) or scale (maximum number of digits following the decimal point).

Usage and Deployment

The usage of a value set is the flexfields where that value set is used. The deployment status of flexfields in which the value set is used indicates the deployment status of the value set instance.

The figure shows a value set used by a segment in a key flexfield and the context segment of a descriptive flexfield.

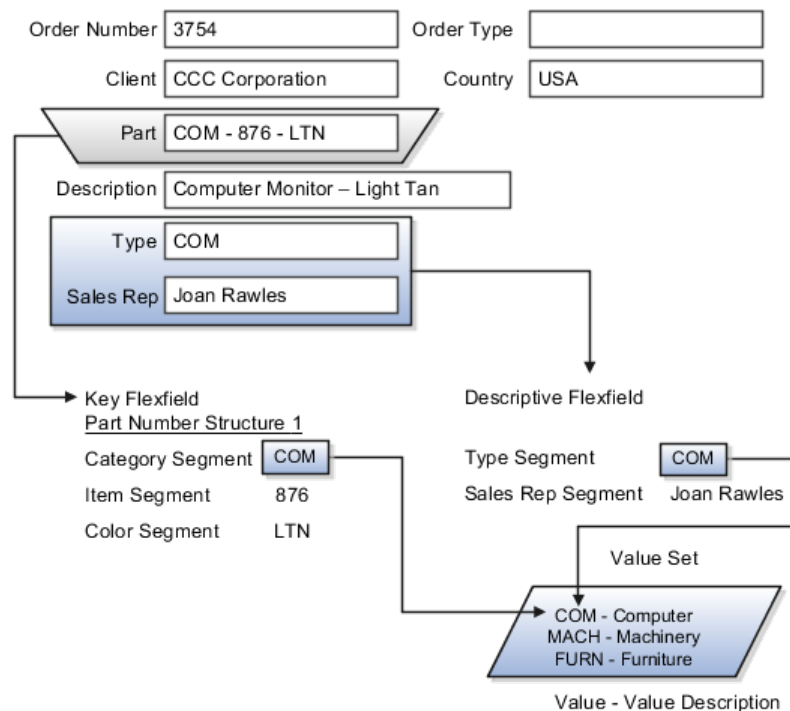

For most value sets, when you enter values into a flexfield segment, you can enter only values that already exist in the value set assigned to that segment.

Global and context-sensitive segment require a value set. You can assign a value set to a descriptive flexfield context segment. If you specify only context values, not value sets for contexts, the set of valid values is equal to the set of context values.

Defining Value Sets: Critical Choices

Validation and usage of value sets determine where and how end users access valid values for attributes represented by flexfield segments.

Tip

As a flexfield guideline, define value sets before configuring the flexfield, because you assign value sets to each segment as you configure a flexfield.

Value Sets for Context Segments

When assigning a value set to a context segment, you can only use table-validated or independent value sets. The data type must be character and the maximum length of the values being stored must not be larger than column length of the context.

Format Only Validation

The format only validation type enables end users to enter any value, as long as it meets your specified formatting rules. That is, the value must not exceed the maximum length you define for your value set, and it must meet any format requirements for that value set.

For example, if the value set allows only numeric characters, your user could enter the value 456 (for a value set with maximum length of three or more), but could not enter the value ABC. A format only value set does not otherwise restrict the range of different values that users can enter. For numeric values, you can also specify if a numeric value should be zero filled or how many digits should follow the radix separator.

Interdependent Value Sets

You cannot specify a dependent value set for a given segment without having first defined an independent value set that you apply to another segment in the same flexfield. You use a dependent value set to limit the list of values for a given segment based on the value that the end user has chosen for a related independent segment. The available values in a dependent list and the meaning of a given value depend on which value was selected for the independently validated segment.

For example, you could define an independent value set of U.S. states with values such as CA, NY, and so on. Then you define a dependent value set of U.S. cities, with values such as San Francisco and Los Angeles that are valid for the independent value CA, and New York City and Albany that are valid for the independent value NY. In the UI, only the valid cities can be selected for a given state.

Because you define a subset value set from an existing independent value set, you must define the independent value set first. End users do not need to choose a value for another segment first to have access to the subset value set.

Table Validation

Typically, you use a table-validated set when the values you want to use are already maintained in an application table (for example, a table of vendor names). Table validation allows you to enable a segment to depend upon multiple prior segments in the same context or structure.

Table-validated value sets have unique values across the table, irrespective of bind variables. The WHERE clause fragment of the value set is considered if it does not have bind variables. If it has bind variables, the assumption is that the values are unique in the value set.

Range

In the case of format, independent, or dependent value sets, you can specify a range to further limit which values are valid. You can specify a range of values that are valid within a value set. You can also specify a range validated pair of segments where one segment represents the low end of the range and another segment represents the high end of the range

For example, you might specify a range for a format-only value set with format type Number where the user can enter only values between 0 and 100. If you use a table value set, you cannot reference flexfield segments in the WHERE clause of the value set. For example, the WHERE clause cannot reference a segment or a value set.

Security

In the case of independent and dependent values, you can specify that data security be applied to the values in segments that use a value set. Based on the roles provisioned to users, data security policies determine which values of the flexfield segment end users can view or modify.

When you enable security on a table-validated value sets, the security rule that is defined is absolute and not contingent upon the bind variables (if any) that may be used by the WHERE clause of the value set. For example, suppose a table-validated value set has a bind variable to further filter the value list to x, y and z from a list of x, y, z, xx, yy, zz. The data security rule or filter written against the value set should not assume anything about the bind variables; it must assume the whole list of values is available and write the rule, for example, to allow x, or to allow y and z. By default in data security all values are denied, and show only rows to which access has been provided.

Maintenance

There is no need to define or maintain values for a table-validated or subset value set, as the values are managed as part of the referenced table or independent value set, respectively.

If your application has more than one language installed, or there is any possibility that you might install one or more additional languages for your

application in the future, select **Translatable**. This does not require you to provide translated values now, but you cannot change this option if you decide to provide them later.

For more information about defining value sets, see the Oracle Fusion Applications Extensibility Guide.

Manage Descriptive Flexfields

Descriptive Flexfields: Explained

Descriptive flexfields provide a way to add custom attributes to entities, and define validation and display properties for them. These attributes are generally standalone. They don't necessarily have anything to do with each other and are not treated together as a combination.

All Oracle Fusion Applications business entities that you can access are enabled for descriptive flexfields. Descriptive flexfields are optional. You can choose to configure and expose segments for the descriptive flexfield defined and registered in your database, or not.

A descriptive flexfield provides a set amount of segments for an entity. The segments of a descriptive flexfield are made available to end users as individual fields in the application user interface.

Context

A descriptive flexfield can have only one context segment to provide context sensitivity.

The same underlying column can be used by different segments in different contexts. For example, you can define a Dimensions context that uses the ATTRIBUTE1 column for height, the ATTRIBUTE2 column for width, and the ATTRIBUTE3 column for depth. You can also define a Measurements context that uses the same columns for other attributes: the ATTRIBUTE1 column for weight, the ATTRIBUTE2 column for volume, and the ATTRIBUTE3 column for density.

Segments and Contexts

Descriptive flexfield segments are of the following types.

Segment Type	Runtime Behavior
Global segment	Always available
Context segment	Determines which context-sensitive segments are displayed
Context-sensitive segment	Displayed depending on the value of the context segment

In the figure, a descriptive flexfield has one context segment called Category for which there are three values: Resistor, Battery, and Capacitor. In addition, the descriptive flexfield consists of two global segments that appear in each of the

contexts, and three context-sensitive segments that only appear in the context in which they are configured.

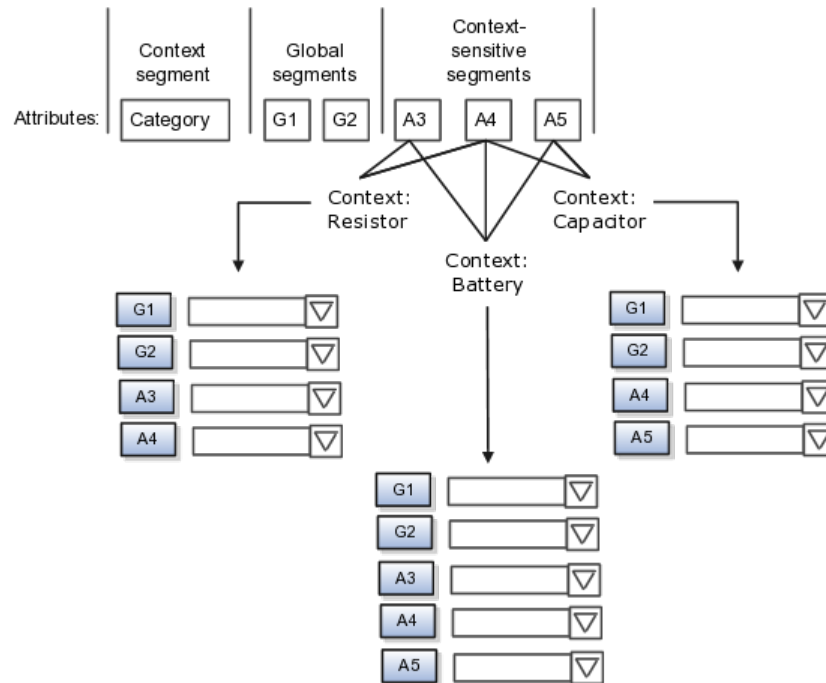

Application development determines the number of segments available for configuring. During implementation you determine which attributes to add using the available segments, and the context values and the combination of attributes in each context. A segment can be used for different attributes, such as Height in Context1 and Color in Context2. Each segment of a descriptive flexfield that you make available to end users is exposed in the user interface as an individual field.

Value Sets

For each global and context-sensitive segment, you configure the values allowed for the segment and how the values that end users enter are validated, including interdependent validation among the segments.

Managing Descriptive Flexfields: Points to Consider

Configuring descriptive flexfields involves managing the available flexfields registered with your Oracle Fusion Applications database and configuring their flexfield-level properties, defining and managing descriptive flexfield contexts, and configuring global and context-sensitive segments.

Every descriptive flexfield is registered to include a context segment, which you may choose to use or not.

Segments

You can assign sequence order numbers to global segments and to context-sensitive segments in each context. Segment display is always in a fixed order.

You cannot enter a number for one segment that is already in use for a different segment.

Value sets are optional for context segments. The value set that you specify for a context segment consists of a set of context codes, each of which corresponds to a context that is appropriate for the descriptive flexfield. If you do not specify a value set for a context segment, the valid values for that context segment are derived from the context codes. The definition of each context segment specifies the set of context-sensitive segments that can be presented when that context code is selected by the end user.

For reasons of data integrity, you cannot delete an existing context. Instead, you can disable the associated context value in its own value set by setting its end date to a date in the past.

You can configure the individual global segments and context-sensitive segments in a descriptive flexfield. These segment types are differentiated by their usage, but they are configured on application pages that use most of the same properties.

Usages

Descriptive flexfield usages allow for the same definition to be applied to multiple entities. Descriptive flexfield tables define the placeholder entity where the flexfield segment values are stored once you have configured the descriptive flexfield.

Parameters

Parameters are public arguments to a descriptive flexfield. Parameters provide outside values in descriptive flexfield validation. Parameters can be referenced by the logic that derives the default segment value and in table-validated VALUE set WHERE clauses.

Delimiters

A segment delimiter or separator visually separates segment values when the flexfield is displayed as a string of concatenated segments.

Enabling Descriptive Flexfield Segments for Business Intelligence: Points to Consider

A descriptive flexfield that is registered in the database as enabled for Oracle Business Intelligence (BI) includes a BI Enabled setting for each of its segments. When a global, context, or context-sensitive segment is BI-enabled, it is available for use in Oracle Business Intelligence.

The following aspects are important in understanding BI-enabled flexfield segments.

- Flattening business components to use BI-enabled segments in Oracle BI.
- Equalizing context-sensitive segments to prevent duplication and complexity in the flattened components

- Mapping attributes of flattened business components to logical objects in Oracle BI.
- Managing the labels that map segments to logical objects in Oracle BI.

After you deploy a business intelligence-enabled flexfield, import the flexfield changes into the Oracle Business Intelligence repository to make use of the newly-generated attributes in business intelligence applications. For additional information about import, refer to the Oracle Fusion Middleware Metadata Repository Builder's Guide for Oracle Business Intelligence Enterprise Edition (Oracle Fusion Applications Edition).

Flattening

When you deploy a business intelligence-enabled descriptive flexfield, the deployment process generates an additional set of flattened business components for use in Oracle BI. The flattened business components include attributes for business intelligence-enabled segments only.

Flattened components include one attribute for the BI-enabled context-segment, and one attribute for each business intelligence-enabled global segment. For BI-enabled context-sensitive segments, if you assigned a label to the segment, the flattened components include an additional single attribute representing segments with that label. If you did not assign a label, the flattened components include a discrete attribute for each BI-enabled context-sensitive segment in each context.

Equalization

You can prevent duplication and the extra workload and complexity that result from the flattening process by assigning a label to any set of context-sensitive segments that serve the same purpose in different contexts. BI-enabled context-sensitive segments that have labels are equalized so that the flattened business components include one attribute for each label, consolidated across contexts. Non-labeled context-sensitive segments are not equalized across context values, so the flattened components include a separate attribute for each context-sensitive segment for each context value.

Note

It may not be possible to equalize similarly labeled segments if they have incompatible data types or value set types.

Mapping to Logical Objects in Business Intelligence

Assign a label to a global segment, context segment, or context-sensitive segment to map the corresponding attribute in the flattened components to a logical object in Oracle Business Intelligence. Using labels to map segments to BI logical objects minimizes the steps for importing the flexfield into Oracle Business Intelligence.

Note

Assigning a label to a context-sensitive segment serves to equalize the attribute across contexts, as well as map the equalized attribute to business intelligence.

Managing Labels

You may assign a predefined label (if available) to segments or create new labels for assignment, as needed. Specify a code, name, and description to identify each label. In the BI Object Name field, enter the name of the logical object in Oracle Business Intelligence to which the segment label should map during import. Specifying the BI logical object minimizes the steps for importing the flexfield into Oracle Business Intelligence and helps to equalize context-sensitive segments across contexts.

If no labels are assigned to a BI-enabled segment, or the BI Object Name on the assigned label does not exist in business intelligence, you must manually map the segment to the desired logical object when importing into Oracle Business Intelligence.

In addition, context-sensitive segments without labels cannot be equalized across context values. The flattened components include a separate attribute for each non-labeled context-sensitive segment in each context.

Manage Extensible Flexfields

Extensible Flexfields: Explained

Extensible flexfields are like descriptive flexfields, with some additional features.

- You can add as many context-sensitive segments to the flexfield as you need. You are not dependent on the number of segments predefined and registered for the flexfield.
- You can configure a one-to-many relationship between the entity and its extended attribute rows.
 - A row of data can have multiple contexts associated with it.
 - A row of data can have multiple occurrences of the same context.
- You can configure contexts in groups so the attributes in the context always appear together in the user interface.
- You can use existing hierarchical categories so that entities inherit the contexts that are configured for their parents. Contexts are reusable throughout categories.
- You can specify view and edit privileges for the extensible flexfield segments to control who sees the attributes and who can change the attribute's values.

When you configure a context for multiple rows per entity, the segments are displayed as a table.

Unlike descriptive flexfields, the extension columns corresponding to extensible flexfields segments are part of extension tables, separate from the base application table. Unlike descriptive flexfield contexts, the set of attributes in an extensible flexfield context remains constant and does not differ by context value.

An extensible flexfield describes an application entity, with the runtime ability to expand the database that implementation consultants can use to define the data structure that appears in the application.

Extensible flexfields support one-to-many relationships between the entity and the extended attribute rows.

Usages

As with descriptive flexfields, you can define multiple usages for an extensible flexfield, which enables several application tables to share the same flexfield.

For example, a flexfield for shipping options can be used by both a Supplier table and a Buyer table. In addition, you can associate a context with one, some, or all of the flexfield's usages. Thus, with the shipping information example, you can associate a warehouse context with the Supplier usage, a delivery location context with the Buyer usage, and a ship-via context with all usages.

Categories

Extensible flexfields support multiple contexts, and the contexts can be grouped into categories. Every extensible flexfield has at least one category, or root category, and some extensible flexfields support a hierarchy of categories, where a given category can inherit contexts from its parent categories.

You can define categories for extensible flexfields, and you can associate any combination of contexts with a given category.

For example, the Electronics and Computers category hierarchy might include a Home Entertainment category, which in turn might include an Audio category and a TV category, and so on. The Home Entertainment product might have contexts that specify voltage, dimensions, inputs and outputs. Contexts are reusable within a given extensible flexfield. For example, the dimensions context could be assigned to any category that needs to include dimensional information.

Pages

Extensible flexfields allow you to combine contexts into groups known as pages, which serve to connect the contexts so they will always be presented together in the application user interface.

Each application page corresponds to one extensible flexfield category, with a separate region of the page for each associated context.

Managing Extensible Flexfields: Points to Consider

Configuring extensible flexfields involves managing the available flexfields registered with your application database and configuring their flexfield-level properties, defining contexts, categories, and pages, and configuring the segments for each extensible flexfield.

Contexts

A context can be defined as single row or multi row. Single row contexts are the same as descriptive flexfields contexts. A single row context has only one set of context-sensitive segments. A multi-row context enables you to associate multiple sets of values with the same object instance.

For example, for a BOOK table, you could create a multi-row context named chapters that contains a chapter segment and a number of pages segment. Multiple chapters can then be associated with each book in the BOOK table.

Set the context to translatable so free-form text entered by end users is stored in the language of the user's locale, and different translations of that text can be stored in other languages. Segments in the translated contexts should utilize format-only value sets for storing free-form, user-entered text.

Categories

A category is a grouping of related data items that can be considered to belong together. You can associate any combination of contexts with a given category.

A category hierarchy logically organizes a set of categories.

For example, the Electronics and Computers category hierarchy might include a Computer category and a Home Entertainment category, which in turn might include an Audio category and a TV category, and so on.

A category can be a child or sibling of an existing category. The hierarchy can be as simple or as complex as desired, with any combination of zero or more sibling categories and zero or more child categories. If no category is defined, the data items are grouped under a single predefined default category.

Each category has associated contexts that store relevant information about a data item in that category. For example, a Home Entertainment product has contexts that specify Voltage, Dimensions, Inputs and Outputs. Contexts are reusable within a given extensible flexfield; the Dimensions context could be assigned to any category that needs to include dimensional information.

If a hierarchy includes child categories, each child category inherits the contexts from its parent category; for example, the Home Entertainment category inherits Voltage and Dimensions from the Electronics and Computers category.

Each extensible flexfield is associated with a particular category hierarchy. You can think of category hierarchies as the defining framework for extensible flexfields and their contexts. A category hierarchy specifies which contexts are valid for each category.

An extensible flexfield can include multiple contexts which you define to support a given category. These contexts can be suitable for a variety of different purposes, but within a particular category, some contexts might be considered to be related to, or dependent on, each other. You can combine these contexts into groups known as pages, which serve to connect the contexts so they will always be presented together in the application user interface.

For example, the Home Entertainment category might have an Electrical Specifications page that contains the Voltage, Inputs and Outputs contexts, and

a Physical Specifications page that contains the Dimensions and Form Factor contexts.

Indexed Segments

You can designate an extensible flexfield segment as indexed so that it is one of the selectively required attributes an end user can use in an attribute search. If you indicate in the Manage Extensible Flexfield UI page that a segment should be indexed, the column representing the segment must be added to the database index. This is commonly done by a database administrator (DBA).

When an extensible flexfield with indexed segments is deployed, search task flows are generated along with the other flexfield artifacts and specify the indexed attributes as selectively required. In the deployed extensible flexfield's search task flow, an end user must specify at least one of the indexed attributes in the search criteria. This prevents non-selective searches which could cause performance issues.

For example, if you index the memory and processor attributes and ensure that the corresponding columns in the database are indexed, an end user can search an item catalog for computers by entering processor or memory or both as a search criterion. No search is performed if an end user enters an attribute as search criteria that is not indexed.

Manage Key Flexfields

Key Flexfields: Explained

Key flexfields provide a means to capture a key such as a part number, a job code, or an account code. A key flexfield consists of one or more segments, where each segment can have a meaning.

For example, a part number 10-PEN-BLA-450 might correspond to a black pen from vendor #450 sold by division #10 (office supplies). Behind the scenes, the application uses a unique number, 13452, for this part, but the end user always see the 10-PEN-BLA-450 part number.

The following aspects are important to understanding key flexfields.

- Architecture
- Segments and segment labels
- Structures
- Segment and structure instances
- Combinations
- Dynamic combination creation
- Security

Key flexfields are not optional. You must configure key flexfields to ensure that your applications operate correctly. You configure and maintain key flexfield definitions with the Manage Key Flexfields task.

Architecture

When you configure a key flexfield, you define metadata about the key flexfield such as how many segments are in a structure, how many structures the flexfield uses, what value sets each segment uses, and so on. This is flexfield metadata stored in flexfield metadata tables.

Based on the flexfield metadata, actual part numbers are captured at runtime as a combination of segment values and stored in a combinations table. A combinations table contains all the segment columns for a flexfield, plus a unique ID column and a structure instance number column that differentiates multiple arrangements of the segment columns.

For example, a part number that can be comprised of multiple segments can be represented by a key flexfield. A part number key flexfield has a corresponding combinations table, where the flexfield stores a list of the complete codes, with one column for each segment of the code, together with the corresponding unique ID and structure instance number for the code. When users define a new part number or maintain existing part numbers in the parts catalog, they directly maintain rows in the combination table.

The foreign key table contains a different business entity than the combinations table. For example, the business entity in the foreign key table is order lines or invoice lines that contain foreign key references to parts for ordering and so on. Any number of foreign key tables can reference a particular entity represented by a key flexfield.

Segments and Segment Labels

A key flexfield consists of segments. Segments consist of a prompt, a short prompt, display width, a number that determines where in the sequence of a key flexfield structure the segment exists, the range type and the column name of the attribute being captured by the segment, a default value set and a label for the segment. A segment label identifies a particular segment of a key flexfield. Segment labels are defined and made available by applications development.

Applications identify a particular segment for some purpose such as security or computations. Segment name or segment order cannot reliably identify a segment because key flexfield segments can be configured to appear in any order with any prompts. A segment label functions as a tag for a segment.

For example, Oracle Fusion General Ledger needs to identify which segment in the Accounting Flexfield contains balancing information and which segment contains natural account information. General Ledger uses a segment label to determine which segment you are using for natural account information. When you define your Accounting Flexfield, you must specify which segment label apply to which segments.

Some labels must be unique, and cannot be applied to more than one segment in each structure. Other labels are required, and must be applied to at least one segment in each structure.

A segment label orients an end user's search of segments, such as the Cost Center label for all segments across key flexfields that capture a value for cost center.

Structures

A key flexfield structure definition includes the number of segments and their order.

In some applications, different users need to see different segment structures for the same flexfield. A key flexfield can have multiple structures if registered to support more than one structure.

The flexfield can display different fields for different end users based on a data condition in your application data, such as the value of another field entered by the end user or the user's role. For example, the correctly formatted local postal address for customer service inquiries differs based on locale. A postal address key flexfield could display different segments and prompts for different end users based on a location condition in your application data, such as the user's role or a value entered by the user.

Each structure can have one or more segments. Thus a segment is a child of a structure. If you want to store a particular segment, such as Cost Center, in two different structures, you must define the segment separately in each structures.

Each structure may have one or more structure instances. Each instance of a structure shares the same number and order of segments, but differs in the allowable values or value sets that validate the segments.

Structure and Segment Instances

You can define multiple configurations of a key flexfield structure. These structure instances have the same segment structure, in the same sequence order. They differ primarily in how each segment is validated. You define a structure instance for each key flexfield and each key flexfield structure instance.

The segments in a key flexfield structure instance are segment instances. A segment instance is a segment with a specific value set assigned to it.

If a key flexfield has been registered with a tree structure, you can specify a tree code for a segment instance, where the tree code defines a hierarchical relationship between the segment values.

Combinations

A combination is a complete code, or combination of segment values that makes up the code, that uniquely identifies an object.

For example, each part number is a single combination, such as PAD-YEL-11x14 or 01-COM-876-7BG-LTN. In these combinations, the hyphen is the segment separator. If you had ten parts you would define ten combinations. A valid combination is simply an existing or new combination that can currently be used because it is not out of date or disabled, and does not violate cross-validation or security rules. A combination has different segments depending on the flexfield structure being used for that combination. Any combination is associated with only one particular flexfield structure.

Many Oracle Fusion Applications products refer to a key flexfield combination by using the name of the entity or the key flexfield itself. For example, Oracle

Fusion Assets uses the asset key flexfield and refers to one of its combinations as an asset key or asset key flexfield. In another example, other Oracle Fusion Applications products including Oracle Fusion General Ledger (GL) refer to combinations of the accounting flexfield as account or GL account.

Each key flexfield has one corresponding table, known as the combinations table, where the flexfield stores a list of the complete codes, with one column for each segment of the code, together with the corresponding unique ID number (a code combination ID number or CCID) for that code. Then, other tables in the application have a column that stores just the unique ID for the code. For example, you may have a part number code, such as PAD-YEL-11x14. The Parts combinations table stores that code along with its ID, 57494. If your application allows you to take orders for parts, you might then have an Orders table that stores orders for parts. That Orders table would contain a single column that contains the part ID, 57494, instead of several columns for the complete code PAD-YEL-11x14.

Typically one combinations page maintains the key flexfield, where the key flexfield is the representation of an entity in your application. The combinations page is where you maintain individual combinations, such as part numbers.

Dynamic Combination Creation

Dynamic combination creation is the insertion of a new valid combination into a combinations table from a page other than the combinations page.

Dynamic combination creation may be enabled at the following levels.

Level Of Dynamic Combination Creation	Controlled By:
Flexfield	Application development
Each usage or reference to the key flexfield	Application development
Structure instance	Administrators and implementation consultants
Other	Administrators and implementation consultants

If your key flexfield or certain usages or references of the key flexfield do not permit dynamic combination creation, you may control whether dynamic combination creation is enabled for each structure instance. If enabled, a user can enter a new combination of segment values using the flexfield window from a foreign key page. For example, when entering a transaction, a GL user can enter a new expense account code combination for an account that does not yet exist. Your application creates the new account by inserting the new combination into the combinations table behind the scenes. Assuming that the new combination satisfies any existing cross-validation rules, the flexfield inserts the new combination into the combinations table, even though the combinations table is not the underlying table for the foreign key page.

Managing Key Flexfields: Points to Consider

Consider the plans for a key flexfield, security, and resulting runtime pages when configuring key flexfields.

Planning

Plan structures carefully and allow for future needs.

Caution

Do not change the number, order, and maximum length of segments once you have acquired flexfield data.

Structure Delimiters

A delimiter separates the segments when they appear to end users. The delimiter value of a structure specifies the character used to visually separate segment values when the key flexfield is displayed as a string of concatenated segments in the UI.

Tip

Choose the delimiter value of your key flexfield carefully so that it does not conflict with the flexfield data. For example, if your data frequently contains periods, such as in monetary or numeric values, do not use a period as your segment separator. Any character you expect to appear frequently in your segment values or descriptions is not a good choice for the delimiter.

If you change the configuration of a key flexfield, such as the delimiter, the change affects the previously stored key flexfields with that structure.

Security

Oracle Fusion data security enforces value set security.

Within key flexfields, value set security applies to the selection of the individual segment values in the segment list of values. When selecting a key flexfield segment value from the combination table, data security allows display of only the combinations whose segment values you have access to. Applications development controls whether or not value set security rules propagate to the foreign key table. By default they do.

Runtime Pages

Application development determines the user interface (UI) pages used to render flexfields. The types of key flexfield UI pages are as follows.

- Combinations pages where underlying entity objects use the combinations table itself
- Foreign key pages where the underlying entity objects contain a foreign key reference to the combinations table
- Partial usage page where some or all of the key flexfield's segment columns are in a product table

The same key flexfield can be used in different ways on different pages.

A page with a foreign key reference has a base table or view that contains a foreign key reference to a combinations table with the actual flexfield segment columns. This allows manipulating rows containing code combination IDs (CCID).

A page with partial usage of a key flexfield presents segments that are defined on a product's transactional table in addition to being defined on a combinations table. In the case of a partial usage page, it is possible that only part of the configuration is visible. This allows the key flexfield to behave more like a descriptive flexfield.

A code combination maintenance page or combinations page presents the combinations table. This allows directly creating and maintaining code combinations. The combinations table contains all key flexfield segment columns and a unique ID column.

A typical application has one and only one combinations page. An application might not have a combinations page if it does not support maintenance by administrators.

A page containing a search region enables end users to select which attributes of the key flexfield view object to use as criteria to search for flexfield metadata.

For example, you can configure seven segments for the Account key flexfield. In a foreign key reference page, end users see the typical key flexfield picker with all seven segments where they can search for combinations. In a partial usage page using the same key flexfield, end users potentially could see only a single segment such as the Cost Center labeled segment, or they might see multiple segments but displayed as individual segments rather than as a picker for choosing combinations.

For more information on key flexfield pages, see the Oracle Fusion Applications Developer's Guide.

Key Flexfield Structures: Explained

A key flexfield structure arranges the segments of a key so you can reuse a single key flexfield in multiple combinations of the same or a subset of segments. Multiple instances of a single structure can accommodate differences in the value sets assigned to the structure's segments.

The structure determines the following aspects of a key flexfield.

- The segments to include
- The order of the segments
- Segment labels on the included segments
- Properties for each segment applied to the instances of the segments in an instance of the structure

Managing Key Flexfield Structures

All the segments defined for a key flexfield are available to be included in a key flexfield structure.

You can define as many segments as there are defined segment columns in your key flexfield combinations table.

Restriction

Be sure to add segments in the order that your key requires. Once deployed, the order cannot be changed.

Enable segments to indicate that they are in use. A flexfield does not display disabled segments in runtime.

Tip

To protect the integrity of your data, disable a segment if you have already used it to enter data.

Key Flexfield Structure Instances and Segment Instances: Explained

A key flexfield structure can have one or more alternate structure instances.

The instances of a key flexfield structure share the following aspects of the structure.

- The same set of segments
- The same arrangement of segments
- The same properties at the segment and structure levels

Differences among structure instances at the structure level include whether dynamic combination creation is allowed.

Differences among segment instances at the structure instance level include the following.

- Value set
- Default type and default value
- Tree code
- Whether the segment is any of the following
 - Required
 - Displayed
 - Enabled for business intelligence
 - Optional or required as a query criterion

For example, you could use one group of value sets for the US and another for France.

The figure shows two structures instances for a part number structure. The structures differ in the number of segments and the segment separators used. The structure instances of a structure share all properties that are defined for the structure, but can vary in the properties defined at the structure instance or segment instance level, such as the value set assigned to the segment instances.

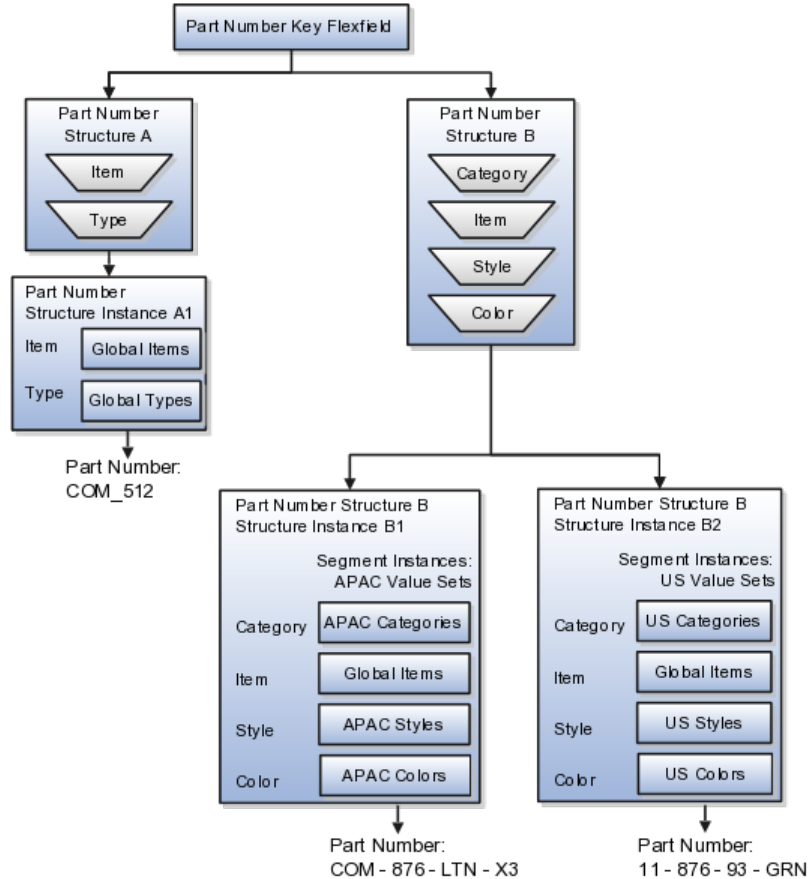

Query Required Segment Instances

You can designate a key flexfield segment instance as query required so that it is one of the selectively required attributes an end user can use in a key flexfield combination search. If you indicate in the Manage Key Flexfields UI page that a segment instance should be indexed, the column representing the segment must be added to the database index. This is commonly done by a database administrator (DBA).

Following deployment, the combination picker of the key flexfield displays the query required attributes as selectively required. An end user must specify at least one of the query required attributes in the search criteria. This prevents non-selective searches that could cause performance issues.

For example, if you mark the cost center and account attributes as query required and ensure that the corresponding columns in the database are indexed, an end user can search for combinations by entering cost center or account or both as a search criterion. No search is performed if an end user does not enter at least one query required attribute as search criteria.

Tip

Index the Structure Instance Number column on your combinations table to improve performance.

Dynamic Combinations

If a key flexfield supports dynamic combination creation, you can choose to enable this feature by selecting **Dynamic Combination Creation Allowed**. This will allow end users to enter values at runtime that produce new code combinations for the flexfield. If not enabled, new valid combinations can only be entered using the combinations table for the flexfield.

Trees

If a tree code has been defined for the value set assigned to the segment instance, and you assign the tree code to the segment instance, tree hierarchy search operations are available on the segment values.

For a segment instance to be based on a tree, the following must be true.

- Application development registered the key flexfield with a tree structure.
- A tree code for that tree structure exists.
- The tree code that includes tree versions containing the values of the value set assigned to the segment instance.
- You assign the desired tree code directly to the segment instance.

Provided these conditions are satisfied, different segment instances that use the same value set can be assigned the same or different tree codes, meaning they use a different hierarchy definition over the same values.

Enabling Key Flexfield Segments for Business Intelligence: Points to Consider

A key flexfield that is registered in the database as enabled for Oracle Business Intelligence (BI) includes a BI Enabled setting for each of its segment instances. When a segment instance is BI-enabled, it is available for use in Oracle Business Intelligence.

The following aspects are important in understanding BI-enabled key flexfield segments.

- Flattening business components to use BI-enabled segments in Oracle BI.
- Equalizing segments to prevent duplication and complexity in the flattened component.
- Mapping attributes of flattened business components to logical objects in Oracle BI.
- Managing the labels that map segments to logical objects in Oracle BI.

After you deploy a business intelligence-enabled flexfield, import the flexfield changes into the Oracle Business Intelligence repository to make use of the newly generated attributes in business intelligence applications. For additional information about import, refer to the Oracle Fusion Middleware Metadata Repository Builder's Guide for Oracle Business Intelligence Enterprise Edition (Oracle Fusion Applications Edition).

Flattening

When you deploy a business intelligence-enabled key flexfield, the deployment process generates an additional set of flattened business components for use in business intelligence. The flattened business components include attributes for business intelligence-enabled segment instances only.

If you assigned a label to a segment, the flattened components include a single attribute representing all segment instances with that label. If you did not assign a label, the flattened components include a discrete attribute for each BI-enabled segment instance in each structure.

Equalization

You can prevent duplication and the extra workload and complexity that result from the flattening process by assigning a label to any set of segments that serve the same purpose in different structures. BI-enabled segments that have labels are equalized so that the flattened business components include one attribute for each label, consolidated across structures. Non-labeled segments are not equalized across structures, so the flattened components include a separate attribute for each segment for each structure.

Note

It may not be possible to equalize similarly labeled segments if they have incompatible data types or value set types.

Mapping to Logical Objects in Business Intelligence

Assign a label to a segment to map the corresponding attribute in the flattened components to a logical object in Oracle Business Intelligence. Using labels to map segments to BI logical objects minimizes the steps for importing the flexfield into Oracle Business Intelligence.

Note

Assigning a label to a segment serves to equalize the attribute across structures, as well as map the equalized attribute to business intelligence.

Managing Labels

You may assign a predefined label (if available) to segments or create new labels for assignment, as needed. Specify a code, name, and description to identify each label. In the BI Object Name field, enter the name of the logical object in Oracle Business Intelligence to which the segment label should map during import. Specifying the BI logical object minimizes the steps for importing the flexfield into Oracle Business Intelligence and helps to equalize context-sensitive segments across structures.

If no labels are assigned to a BI-enabled segment, or the BI Object Name on the assigned label does not exist in business intelligence, you must manually map the segment to the desired logical object when importing into Oracle Business Intelligence.

In addition, segments without labels cannot be equalized across structures. The flattened components include a separate attribute for each non-labeled segment in each structure.

Note

Segment labels serve other functions as well, as presented in Key Flexfields: Explained.

Key Flexfields: Example

A key flexfield can capture expense account information.

Scenario

When entering details for each expense, the user specifies an account to which the expense is charged.

Entering Expense Accounts

A user interface for entering expenses gives the user the option of selecting an expense account that identifies the cost center and other details needed for processing the expense.

Analysis

The expense account field is a foreign key reference to a code combination (EXPENSE_LINES.EXPENSE_ACCOUNT = ACCOUNTS.CCID).

Code Combination Table for Entering Accounts and Employees

The code combination table supports entering account information, such as for expense accounts.

The figure shows the origin in the code combination table of the account specified by the user. The code combination ID record stores the information of the key flexfield segments used to assemble the expense account based on the key flexfield configuration.

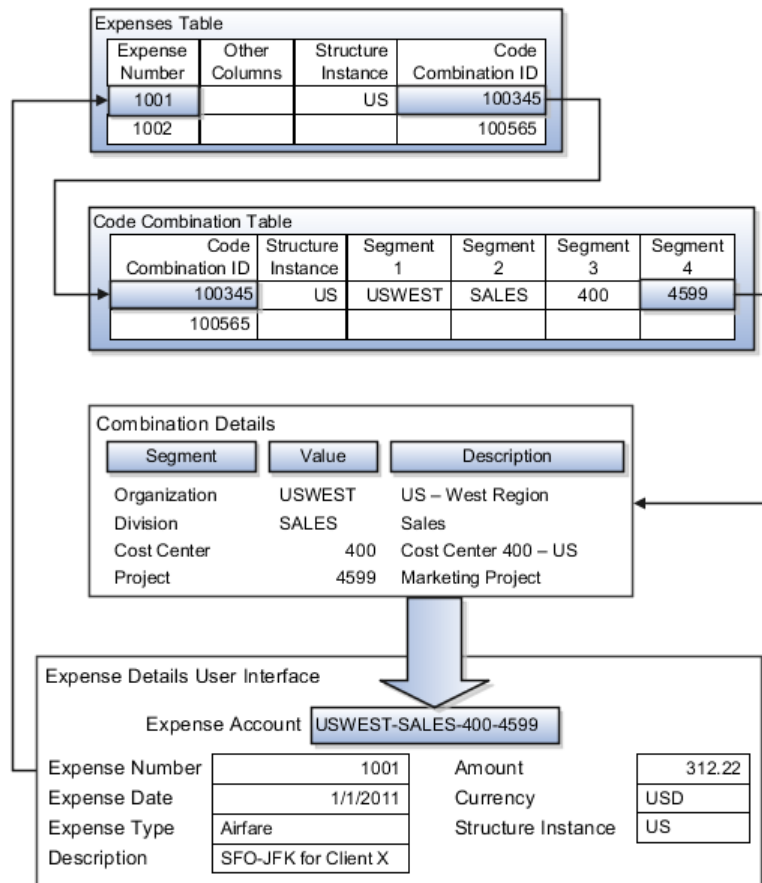

The combinations page, which is the maintenance page for the key flexfield, is for managing rows in the combination table. In this example, managing the combinations means adding or editing account numbers that adhere to the key flexfield metadata rules.

The figure shows the code combination details for the example expense account reflected in the flexfield configuration and the code combination table.

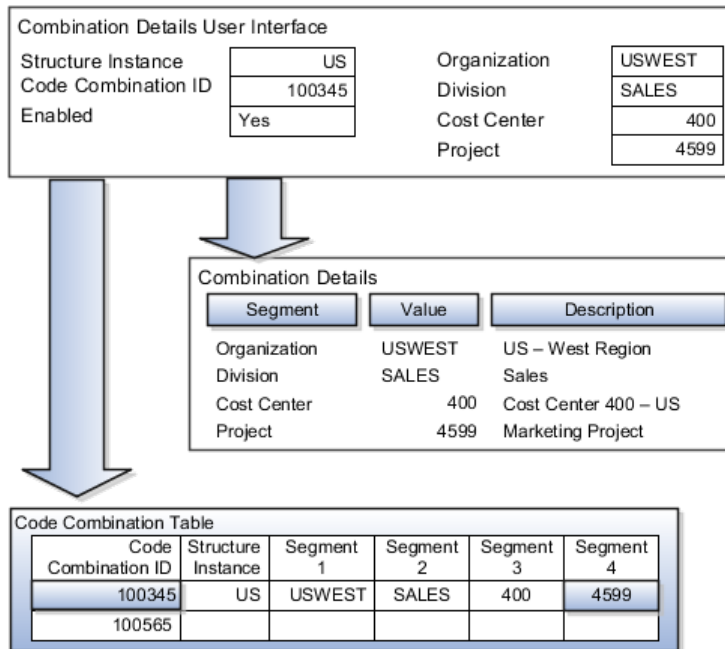

If dynamic combination creation is not enabled, then when entering an expense line, the user can only select an account that already exists in the ACCOUNTS (combinations) table. If they require an account that does not exist, they must consult with the appropriate application administrator who can add the account to the combinations table.

If dynamic combination creation is enabled, then when entering an expense line, the user can either select a pre-existing account, or type in a new account that created dynamically on the fly in the ACCOUNTS (combinations) table. Once the new combination is created, the same user can refer to it on the expense line.

When managing employee information, the user specifies the cost center that the employee belongs to. The cost center field corresponds to a single, labeled segment of the Account Key Flexfield and has metadata defined such as the allowable value set for that segment.

In this figure, instead of specifying a cost center ID reference to an account, only the Cost Center segment is used and the value is stored directly on the employee table.

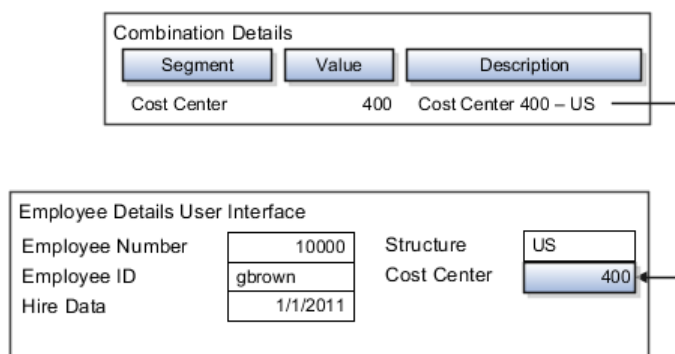

FAQs for Define Flexfields

Why did my flexfield changes not appear in the runtime UI?

The ADF business components or artifacts of a flexfield, which are generated into an metadata services (MDS) repository when the flexfield is deployed, are cached within a user session. You must sign out and back in again to view flexfield definition changes reflected in the runtime application user interface page.

A flexfield's status relative to its deployment determines whether the flexfield segments as currently defined in the metadata are available to end users. The flexfield segments seen by end users in the runtime correspond to the flexfield definition that was last deployed successfully.

What happens if a value set is security enabled?

Value set security is a feature that enables you to secure access to value set values based on the end user's role in the system.

As an example, suppose you have a value set of US state names. When this value set is used to validate a flexfield segment, and users can select a value for the segment, you can use value set security to restrict them to selecting only a certain state or subset of states based on their assigned roles in the system.

For example, Western-region employees may choose only California, Nevada, Oregon, and so on as valid values. They cannot select non-Western-region states. Eastern-region employees may choose only New York, New Jersey, Virginia, and so on as valid values, but cannot select non-Eastern-region states. Value set security is implemented using Oracle Fusion Applications data security.

How can I set a default value for a flexfield segment?

When you define or edit a flexfield segment, you specify a default value from the values provided by the value set assigned to that segment.

You can set the default value to be a parameter, which means the entity object attribute to which the parameter you choose is mapped will provide the initial default value for the segment.

You can set to be a constant, if appropriate to the data type of the value set assigned to the segment.

In addition to an initial default value, you can set a derivation value for updating the attribute's value every time the parameter value changes. The parameter you choose identifies the entity object source attribute. Any changes in the value of the source attribute during runtime are reflected in the value of the segment.

If the display type of the segment is a check box, you can set whether the default value of the segment is checked or unchecked.

Define Attachments

Attachments: Explained

Attachments are pieces of supplementary information that users can associate with specific business objects such as expense reports or purchase orders. Attachments can be URLs, desktop files, text, or in cases where available, repository folders. For any given business object, a user may be able to only view attachments, or also create, delete, or edit attachments, depending on security. For more information on an introduction to attachments, see the Oracle Fusion Applications Developer's Guide.

Repository

Attachments are stored in a content server, the Oracle Enterprise Content Management document repository. Users have no real interaction with the repository unless the repository mode is enabled for attachments on specific business objects. In which case, users can share attachments among objects, update attachments by checking them out of and back in to the repository, and perform other tasks. Access to attachment files is controlled by a digital signing mechanism. Depending on security, users might have direct access to the repository.

Security

Data security that applies to a specific business object also applies to attachments for that object, as determined by the attachment entity defined for the object. For example, if a user has no access to a specific expense report, then the same user cannot access attachments for the expense report. You can also use attachment categories to control access and actions on attachments, based on roles associated with the category. For more information on securing attachments, see the Oracle Fusion Applications Developer's Guide.

Attachment Entities: Explained

An attachment entity is usually a database entity, for example a table or view, that represents a business object attachments can be associated with. Each attachment UI must be defined with a corresponding attachment entity, which not only identifies the business object to attach to, but also controls what users can do. Attachment entities are used only in the context of attachments and exist separately from the database entities that they are based on.

Edit and create attachment entities on the Manage Attachment Entities page, which you can access by starting in the Setup and Maintenance Overview page and searching for the Manage Attachment Entities task. Though you would generally use predefined attachment entities with attachment UIs, you might need to create new entities, for example when developing custom UIs.

Entity Names

An attachment entity name should match the name of the table or view that represents the business object to attach to. The name is also used in the

repository folder that is automatically created to store attachments for the entity. The attachment entity display name should be something that users know to represent the business object.

Database Resource

The data security policies associated with the database resource defined for the attachment entity would apply to attachments for that entity. For example, based on the database resource for the expense reports attachment entity, the same policies apply to attachments for expense reports. The database resource value must match the value in the OBJ_NAME column in the FND_OBJECTS table for the business object that the entity represents.

Enabling Security

Security based on the database resource associated with the attachment entity is always in effect. What you can enable or disable is security based on attachment categories. If any of the attachment categories associated with the attachment entity has data security defined, then that security applies to this entity only if enabled.

Attachment Entities and Attachment Categories: How They Work Together

The association between attachment entities and categories determines which categories can be used for an entity. For example, categories associated with the expense report attachment entity are available to be implemented in attachment UIs for expense reports. You can define these associations when managing either entities or categories. Any association changes in either the Manage Attachment Entities or Manage Attachment Categories page are reflected on the other page. You can access either page by starting in the Setup and Maintenance Overview page and searching for attachment tasks.

Managing Entities

You determine which attachment categories are relevant to a particular entity on the Manage Attachment Entities page, and each entity must have at least one category. Depending on configuration, any or all of the available categories for that entity are used. For example, you assign three categories to the expense reports attachment entity. For a particular expense report page with attachments functionality, you can customize the attachments component to specify which of the three categories are used. Based on your selection, the data security defined for each category, if any, is applied to attachments on that page if the attachment entity has category-based security enabled.

Managing Categories

If you create an attachment category and need to assign it to multiple attachment entities, use the Manage Attachment Categories page. The association means the same as the association on the Manage Attachment Entities page.

Attachments Troubleshooting: Explained

Attachments UIs for users to add and manage attachments are fully functional as is, and users usually would not encounter issues. If you customize attachments in any way, for example by creating additional attachment categories and implementing data security on them, then some issues might arise.

Issue: Unable to View, Add, Update, or Delete Attachments

Users encounter issues when trying to view attachments or perform actions such as adding attachments.

- Users can no longer see specific attachments that they were previously able to see.
- Likewise, they can no longer update or delete attachments.
- Users get an error stating that they do not have permission to add attachments.

Resolution

Use the Manage Attachment Entities page to ensure that attachment categories are associated to the relevant attachment entity. For example, if users can no longer see attachments for an expense report, then search for the expense report attachment entity and assign all necessary categories to it. You might need to check with your system administrator or help desk to determine the exact entity used on the page with the expenses attachments or what categories to assign.

If data security is implemented on the categories for the attachment entity, then verify that the Enable Security check box is selected in the Manage Attachment Entities page for that entity. Make sure that users have a role with the privileges shown in the following table, to view, add, update, or delete attachments with a specific attachment category.

Action	Privilege
View	Read Application Attachment (FND_READ_APPLICATION_ATTACHMENT_DATA)
Add or Update	Update Application Attachment (FND_UPDATE_APPLICATION_ATTACHMENT_DATA)
Delete	Delete Application Attachment (FND_DELETE_APPLICATION_ATTACHMENT_DATA)

For example, if users have the Read Application Attachment privilege for all categories associated with the expense report attachment entity, except the Receipts attachment category, then they can view all expense report attachments except those created with the Receipts category. Likewise, if users do not have the Update Application Attachment privilege for any attachment categories tied to the expense report attachment entity, then they cannot create any attachments at all for expense reports.

For more information on attachment category data security, see the Oracle Fusion Applications Developer's Guide.

Finally, certain attachments UI for users have predefined restrictions on categories in place. Your developers can also introduce additional filters to determine which document categories are available for a specific page. Check with your developers or help desk.

Issue: Missing Attachment Category

Users can see existing attachments, but the attachments no longer have an attachment category value.

Resolution

When the attachment was added, at least one category existed for the corresponding attachment entity, as otherwise the attachment could not have been added. Since then, the entity was edited so that it no longer has any assigned categories, so the user cannot see the category associated with that attachment.

Use the Manage Attachment Entities page to reassign attachment categories to the relevant attachment entity. For example, if users can no longer see the Receipts attachment category for an attachment to an expense report, then search for the expense report attachment entity and assign to it the Receipts category. You might need to check with your system administrator or help desk to determine the exact entity used on the page with the expenses attachments or what additional categories to assign.

Finally, certain attachments UI for users have predefined restrictions on categories in place. Your developers can also introduce additional filters to determine which document categories are available for a specific page. Check with your developers or help desk.

FAQs for Define Attachments

What's an attachment category?

An attachment category is used to classify and secure attachments. Each attachment user interface must be defined with at least one category for users to be able to add attachments. If there are multiple categories, users can view them and select one when adding attachments. For example, attachments for an expense report can be categorized as receipts, scanned invoice images, and so on.

You can also associate roles with categories to determine user access and actions for attachments, based on the categories assigned to the attachment entity. For example, security for expense report attachments can be based in part on the categories assigned to the expense report attachment entity. You can define multiple categories per module, and add and manage custom categories for your own purposes. For more information on attachment category data security, see the Oracle Fusion Applications Developer's Guide.

Use the Manage Attachment Categories page, which you can access by starting in the Setup and Maintenance Overview page and searching for the Manage Attachment Categories task.

Set Activity Stream Options

Activity Stream Options: Highlights

Activity Stream is a region on the Oracle Fusion Applications Welcome dashboard and other pages in various applications. Users track the activities and transactions of other users in this region. You can set options that affect the all Activity Stream regions for all users across your site. Individual users can still override your settings through Activity Stream preferences.

Activity stream settings are described in the Oracle Fusion Middleware User's Guide for Oracle WebCenter Portal: Spaces. When you read content from that guide, note that:

- Your setup applies to all users, not just yourself or any individual user.
- You can disregard discussions about how to access the settings, because you access the Set Activity Stream Options page by starting in the Setup and Maintenance Overview page and searching for the Set Activity Stream Options task.

Setting Activity Stream Options

- Define the types of users to display activities about in the Activity Stream region, the types of activities to track, and other settings.

See: Setting Activity Stream Preferences

Manage Menu Customizations

Managing Menu Customizations: Highlights

You can customize the Navigator menu, which is the main menu of Oracle Fusion Applications and is always available in the global area. Use the Manage Menu Customizations page, which you can access by starting in the Setup and Maintenance Overview page and searching for the Manage Menu Customization task.

An overview of customizing the Navigator menu is provided in the Oracle Fusion Applications Extensibility Guide. Details of the values you enter to define menu items are provided in the Oracle Fusion Applications Developer's Guide.

Overview

- Navigator menu customization involves managing items, which are nodes in the menu that take the user to the desired destination, and groups, which are categories of items. The label is the menu item or group text displayed to users, and only rendered items and groups are visible to users. Items and groups that are not rendered are displayed in italics in

the menu customization pages. Refer to the Oracle Fusion Applications Extensibility Guide.

See: Customizing the Navigator Menu

Menu Items

When you customize items in the Navigator menu, you determine if the item takes users to a specific page in Oracle Fusion Applications or to another application or Web site. The details of what you enter to define the menu item depend on the type of destination. If you duplicate a menu item, the new item appears below the selected source item.

- For menu items to an Oracle Fusion Applications page, do not enter anything in the Destination field, but specify the focus view ID of the target page, Web application, secured resource name, application stripe, and page parameters list. The secured resource name identifies the page definition file that is used to secure resource grants for the page, for example `oracle.apps.view.pageDefs.CaseList_Form_Attach_UIShellPagePageDef`. The application stripe is the partition for the application in the policy store, for example `crm`. If you enter both a secured resource name and an application stripe, then the menu item is rendered only if the logged-in user has permission to view that secured resource. If either value is missing, then the item is not secured. Refer to the Oracle Fusion Applications Developer's Guide.

See: Menu Attributes Added by Oracle Fusion Middleware Extensions for Applications

- For menu items to another application or Web site, enter only the full URL in the Destination field.

Manage Applications Core Common Reference Objects: Manage Applications Core Messages

Common Messages: Points to Consider

Common messages, which have message names that begin with `FND_CMN` and message numbers between 0 and 999, are used throughout Oracle Fusion Applications. Each common message can appear in multiple places in any product family. For example, the `FND_CMN_NEW_SRCH` message can be used for any search to indicate that no results were found. Common messages that are of type error or warning are part of the message dictionary.

Editing Common Messages

Because a common message can be used in any application, consider the ramifications if you edit any aspect of the message, including incident and logging settings. Changes would be reflected in all instances where the message is used. For example, if you change the message text, make sure that the text would make sense to all users across Oracle Fusion Applications who might see it.

Creating Common Messages

You can create custom common messages for use in multiple places within a single product. Do not begin the message name with FND_CMN, but use another suitable convention. The message number should be within the range that is designated for the product.

Manage Applications Core Common Reference Objects: Manage Applications Core Administrator Profile Values

Creating and Editing Messages: Highlights

Each message in the message dictionary has many attributes and components, including message properties, text, and tokens, that you define when creating or editing the message.

Details about these messages are described in the Oracle Fusion Applications Developer's Guide.

Message Properties

- The message type identifies the type of information that the message contains.

See: Understanding Message Types

- The message name and number are identifiers for the message. There are specific message number ranges for predefined messages in each application, and you should not edit numbers assigned to predefined messages. When creating custom messages, use only message numbers within the 10,000,000 to 10,999,999 range.

See: About Message Names

See: About Message Numbers

- The translation notes for predefined messages might contain internal content that you can disregard.

See: About Translation Notes

- The message category, severity, and logging enabled option are related to the incident and logging process.

See: About Grouping Messages by Category and Severity

See: Understanding Incidents and Diagnostic Logs with Message Dictionary

Message Text and Tokens

- The message text comprises various components, some of which are displayed only to select users. To determine which component of the message text is displayed to a particular user, set the Message Mode

profile option (FND_MESSAGE_MODE) at the user level for that user. The message component short text is visible to all users and therefore, the profile option does not apply to this component. Also, the profile option applies only to messages in the message dictionary.

See: About Message Components

- Tokens are variables that represent values to be displayed in the message text.

See: About Tokens

Profile Options and Related General Preferences: How They Work Together

Some Oracle Fusion Middleware Extensions for Applications profile options are related to general preferences in the global area.

Preferences

The related general preferences are Default Application Language, Territory, Date Format, Time Format, Currency, and Time Zone. When the user changes any of these preferences, the stored values in LDAP are updated accordingly.

Profile Options

The corresponding profile options are Default Language, Default Territory, Default Date Format, Default Time Format, Default Currency, and Default User Time Zone. No matter what you set for these profile options at any level, the preferences settings, or LDAP values, take precedence. The profile option value is used only if the LDAP value is not available. Updating the profile option value does not automatically update the value in LDAP or preferences.

Document Sequences: Explained

In Oracle Fusion Applications, each business document or business event is uniquely identified by a document sequence number that you assign to it. However, the document sequencing feature must be turned on (enabled) on the business document or event to allow the assignment. For example, if document sequencing is enabled, you can assign a document sequence number to an invoice that gets generated in response to a purchase order. You can use document sequences as a proof to track successfully executed transactions as well as failed transactions. Additionally, a document sequence helps in generating an audit trail, which can be used to identify how a particular transaction passed through various applications.

Document sequencing can be managed automatically, manually, and gaplessly.

Note

Plan your document sequencing carefully before you use the options available in the application to apply sequence numbers. Avoid changes to the options

after you saved your work on the Manage Document Sequences and Manage Document Sequence Categories pages.

Automatic Sequencing

Automatic document sequencing assigns a unique number to each document as it is generated, and this unique number is stored in the database. The numbering is sequential by date and time of creation. If you define a sequence to automatically number documents, you can provide an initial value to begin the sequence. In absence of a custom value, the default value 1 is used.

Manual Sequencing

Manual sequencing requires you to assign a unique number to each document before it is generated. In manual sequencing, the numerical ordering and completeness of a transaction is not enforced. Users can skip or omit numbers when entering the sequence value. However, each time that a number is assigned, the application validates its uniqueness.

Gapless Sequencing

Gapless sequencing is similar to automatic sequencing. It automatically generates a unique number for each document, but does that only for successfully generated documents. As a result, the sequence is maintained for all the documents that are generated, and no sequence numbers are lost due to incomplete or failed document generation.

Important

Use this type of sequencing only if necessary because it may affect the performance of the system and slow down transaction processing.

Sequential Numbering Enforced Profile Options

The Sequential Numbering Enforced profile validates the documents being created and applies the relevant document sequence, based on the selected option. The following options are available:

- **Always Used:** Sequential numbering is enforced for all document categories. When this option is set, users cannot create a document if its document category is not assigned any active document sequence. The system displays an error.
- **Partially Used:** Sequential numbering is enforced for all document categories. However, if no sequence is available for the document, the system displays a warning. Users can either proceed without a document sequence or create and assign a document sequence before proceeding.
- **Not Used:** Sequential numbering is not enforced. In this mode, although the documents created do not require a document sequence to be assigned, the system checks for the uniqueness of the document number provided. The system does not display any warning or error.

Restriction

At the site level, the profile is by default set to Partially Used. Avoid changing this option as doing so may interfere with the validation logic and the data that was stored using the earlier option may not appear. However, you can change the option at the product or user level.

Define Implementation Users

Initial Security Administration: Critical Choices

After installation and provisioning, and before setting up enterprise structures and implementing projects, you must establish required entitlement for the super user account and at least one implementation user to proceed with the implementation. Once initial enterprise structure setup is complete, additional users may be created through processes available in Human Capital Management (HCM).

Initial security administration consists of the following.

- Preparing the IT Security Manager job role
- Synchronizing users and roles from Lightweight Directory Access Protocol (LDAP) with HCM
- Creating implementation users
- Optionally creating data roles for implementation users
- Provisioning implementation users with roles

Once the first implementation project begins and the enterprise work structure is set up, use standard user and security management processes such as the Manage Users task to create and manage additional users. Do not use the Create Implementation Users task after your enterprise has been set up.

Preparing the IT Security Manager Job Role

Initially the super user is not provisioned to manage users and roles.

You must add the following Oracle Identity Management (OIM) roles to the IT Security Manager job role's role hierarchy to enable the super user to create one or more initial implementation users.

- Identity User Administrators
- Role Administrators

Additionally, you must assign the Xellerate Users organization to the IT Security Manager role.

Synchronizing Users and Roles from LDAP

After configuring an offering and setting up the task lists for implementation, the Run User and Roles Synchronization Process task is available to the super user for synchronizing users and roles in the LDAP store with Oracle Fusion Human Capital Management (HCM).

Defining Initial Implementation Users

The super user is provisioned with roles that provide broad access to Oracle Fusion Middleware and Oracle Fusion Applications administration, and is not suitable as an implementation user in most enterprises. The super user should define at least one implementation user, which consists of creating the user account and provisioning it with at least the Application Implementation Consultant and Application Implementation Manager job roles.

As a security guideline, define an IT security manager user who in turn defines one or more implementation users to set up enterprise structures. The IT security manager users can provision the implementation user with the Application Implementation Consultant role, which entitles access to all enterprise structures. Or the IT security manager can create a data role that restricts access to enterprise structures of a specific product and provisioning that role.

Depending on the size of your implementation team, you may only need a single implementation user for security administration, implementation project management, enterprise structures setup, and application implementation. That single user must then be provisioned with all indicated roles, and therefore broad access.

Creating Implementation Users

The super user creates one or more implementation users by performing the Create Implementation Users task.

Note

This initial implementation user is a user account created in Oracle Identity Management only, specifically for setting up enterprise structures, and is not related to a real person or identity such as a user defined in HCM.

Creating Data Roles for Implementation Users

As an alternative to provisioning an implementation user with the Application Implementation Consultant role to access all enterprise structures, you may need implementation users with access restricted to enterprise structures for specific products. In this case, use the Create Data Roles for Implementation Users task to create a data role based on a job role with less broad access, such as the HCM Application Administrator job role.

Provisioning Roles to Implementation Users

After creating an implementation user, you must provision the user with one or more roles by performing the Provision Roles to Implementation Users task.

For example, assign a role to the implementation user that provides the access necessary for setting up the enterprise. Depending on need, provision to the implementation user the predefined Applications Implementation Consultant role or a product family-specific administrator data role, such as a data role based on the predefined Financials Applications Administrator.

Caution

The Application Implementation Consultant has broad access. It is a very useful role for experimentation or setting up a pilot environment, but may not be suitable for implementation users in a full implementation project.

Initial Security Administration: Worked Example

This example illustrates initial security administration after having installed and provisioned an Oracle Fusion Applications environment.

In Oracle Fusion Applications, you manage users and security through Oracle Fusion Human Capital Management (HCM) user management flows, which are included in each of the offering task lists. However, the HCM task flows require that enterprise structures have been set up, and yet to add users who can set up enterprise structures you need to have set up HCM. Therefore, you need to create one or more initial implementation users who are responsible for providing the following.

- Users and their applications security management
- Implementation project management
- Initial enterprise structures management

The following table summarizes key decisions for this scenario.

Decision	In this Example
How to sign in to Oracle Fusion Applications for the first time	Use the super user account that was created when installing and provisioning Oracle Fusion Applications (for example, FAADMIN).
How to ensure that the roles and users in the Lightweight Directory Access Protocol (LDAP) store match what is available for selection when defining implementation users	Perform the Run User and Roles Synchronization Process task.
How to create a first implementation user	Prepare the IT Security Manager job role for user and role management so the super user and any other user provisioned with the IT Security Manager job role can manage users and roles.
How to establish security administration users	Define an IT security manager user provisioned with the IT Security Manager job role.
How to establish an implementation user with access to set up enterprise structures	Define an implementation user provisioned with the Application Implementation Consultant job role.

You create an initial implementation user by performing the following tasks.

1. The Oracle Identity Management System Administrator user provisions the IT Security Manager job role with roles for user and role management.

2. The Oracle Fusion Applications super user synchronizes LDAP users with HCM user management so that users can be provisioned with roles through HCM.
3. The Oracle Fusion Applications super user performs the Create Implementation Users task to create one or more IT security manager and administrator users provisioned with security administrative entitlement.
4. The IT Security Manager user signs in to Oracle Fusion Applications and performs the Create Implementation Users task to create implementation managers and users.
5. The IT Security Manager user provisions implementation users for enterprise structure setup.

Note

The following tasks assume that the super user has configured an offering and set up task lists. When not following a task flow within an activity, you can find tasks in **Navigator > Tools > Setup and Maintenance > All Tasks** . Search for the task and click its **Go to Task** icon in the search results.

Preparing the IT Security Manager Role

The super user that was created when installing and provisioning Oracle Fusion Applications (for example, FAADMIN) has all necessary access for implementing Oracle Fusion Applications and administering security. This access is provided by the following roles:

- Application Implementation Consultant
- IT Security Manager

Neither of these roles provides access needed for creating and managing Oracle Fusion Applications users. Therefore, you must add the following two OIM roles to the IT Security Manager role:

- Identity User Administrators
- Role Administrators

The following procedure is prerequisite to an IT security manager or administrator creating an initial one or more implementation users.

1. While signed into Oracle Identity Manager as the OIM System Administrator user, click the **Administration** link in the upper right of the Oracle Identity Manager.

This accesses the Welcome to Identity Manager Delegated Administration menu.

2. In the Roles list of tasks, click **Advanced Search - Roles**. Search for the Identity Users Administrators role by entering the role name in **Display Name** and clicking **Search**.

In the Search Results, click the role's Display Name.

3. On the Hierarchy tab, select **Inherits From** and click **Add**.

4. In the Add Parent Role to: IDENTITY USER ADMINISTRATORS window, select the role category: Common - Job Roles and add the IT Security Manager.

Click the arrow icon to show the list of available roles. Select IT Security Manager and move it to the **Roles to Add** list. Click **Save**.

5. Search for the Role Administrators role, and repeat steps 1 to 4 to add that role to the IT Security Manager role's role inheritance.
6. Assign the IT Security Manager role to the Xellerate Users organization.
 - a. In the Welcome to Identity Manager Delegated Administration menu (see step 1, above), in the Organizations list of tasks, click **Advanced Search - Organizations**.
 - b. Search for the Xellerate Users organization by entering Xellerate Users in **Display Name** and clicking **Search**.
 - c. In the Search Results, click the organization's Display Name. The Xellerate Users page appears.
 - d. Click the **Administrative Roles** link in the row of links above the Xellerate Users.
 - e. In **Filter By Role Name** of the Details window, enter the following string:

IT_SECURITY_MANAGER

Click **Find**.

- f. Enable Read, Write, Delete, and Assign.
- g. Click **Assign**.
- h. Click **Confirm**.

Synchronizing Users and Roles from LDAP

Lightweight Directory Access Protocol (LDAP) must be synchronized with HCM user management so that users can be provisioned with roles through HCM.

1. Sign in to Oracle Fusion Applications using the super user's user name (for example FAADMIN) and password.

If you do not know the super user name and password, check with your system administrator or the person who installed Oracle Fusion Applications. For more information about account creation in Oracle Fusion Applications provisioning, see the Oracle Fusion Applications Installation Guide.

2. Perform the Run User and Roles Synchronization Process task by clicking **Submit** in the Process Details page.

The SyncRolesJob process takes some time to complete the first time it is run.

3. Monitor completion of the SyncRolesJob process from **Navigator > Tools > Scheduled Processes** before continuing with creating implementation users.

Defining an IT Security Manager User

The super user has broad access to Oracle Fusion Middleware and Oracle Fusion Applications administration. Due to this broad access, your enterprise needs users dedicated to managing users and applications security, such as an IT security manager user.

1. While signed in as the Oracle Fusion Applications super user, access the Create Implementation Users task and create an IT security manager.

The Oracle Identity Manager appears.

2. Click **Create User**.

For details, see the Creating Users section in the Oracle Fusion Middleware User's Guide for Oracle Identity Manager.

3. Provide the following attributes:

Attribute	Value	Example
Last name	<any valid string>	Smith
Organization	Xellerate Users	N/A
User type	Non Worker	N/A
User login	<any valid string>	IT_SECURITY_MANAGER
Login password	<any valid string>	SeKur1TyPa\$\$w0Rd

Note

In Oracle Fusion Applications, an implementation user is a user account created in OIM only, specifically for implementation tasks, and is not related to a real person or identity such as a user defined in HCM.

4. Click **Save**.
5. On the Roles tab in the IT_SECURITY_MANAGER user creation task flow, click **Assign**.
6. In the Add Role window, search for the IT Security Manager role and click **Add**.

Defining an Implementation User for Enterprise Structures Setup

1. Sign in to Oracle Fusion Applications using the IT security manager user's name and password.
2. Create and provision an implementation user using the same task flow as for creating the IT security manager user in the previous section, except provision the following roles.
 - Application Implementation Manager
 - Application Implementation Consultant

Note

For an implementation to begin, at least one user must be provisioned with the Application Implementation Manager role, and another or the same user must be provisioned with the Application Implementation Consultant role. The Application Implementation Consultant has broad access too set up all enterprise structures.

Define Currencies and Currency Rates

Manage Currencies

Defining Currencies: Points to Consider

When creating or editing currencies, consider these points relevant to entering the currency code, date range, or symbol for the currency.

Currency Codes

You cannot change a currency code after you enable the currency, even if you later disable that currency.

Date Ranges

Users can enter transactions denominated in the currency only for the dates within the specified range. If you do not enter a start date, then the currency is valid immediately. If you do not enter an end date, then the currency is valid indefinitely.

Symbols

Even if you enter a symbol for a currency, the symbol is not always displayed when an amount is displayed in this currency. Some applications use currency symbols when displaying amounts. Others, like Oracle Fusion General Ledger, do not.

Euro Currency Derivation: Explained

Use the Derivation Type, Derivation Factor, and Derivation Effective Date fields to define the relationship between the official currency (Euro) of the European Monetary Union (EMU) and the national currencies of EMU member states. For each EMU currency, you define its Euro-to-EMU fixed conversion rate and the effective starting date.

Note

If you need to use a different currency code for Euro, you can disable the predefined Euro currency and create a new one.

Derivation Type

The **Euro currency** derivation type is used only for the Euro, and the **Euro derived** derivation type identifies national currencies of EMU member states. All other currencies do not have derivation types.

Derivation Factor

The derivation factor is the fixed conversion rate by which you multiply one Euro to derive the equivalent EMU currency amount. The Euro currency itself should not have a derivation factor.

Derivation Effective Date

The derivation effective date is the date on which the relationship between the EMU currency and the Euro begins.

FAQs for Manage Currencies**When do I create or enable currencies?**

Create currencies to use, for example for reporting purposes, if they are not already provided. All currencies from the International Organization for Standardization (ISO) 4217 standard are provided.

Enable any currency other than USD for use in Oracle Fusion Applications, for example for displaying monetary amounts, assigning to sets of books, entering transactions, and recording balances. Only USD is enabled by default.

What's the difference between precision, extended precision, and minimum accountable unit for a currency?

Precision is the number of digits to the right of the decimal point used in regular currency transactions. Extended precision is the number of digits to the right of the decimal point used in calculations for this currency, and it must be greater than or equal to the standard precision. For example, USD would have 2 for precision because amounts are transacted as such, for example \$1.00. For calculations, for example adding USD amounts, you might want the application to be more precise than two decimal digits, and would enter an extended precision accordingly.

Note

Some applications use extended precision. Others, such as Oracle Fusion General Ledger, do not.

Minimum accountable unit is the smallest denomination for the currency. For example, for USD that would be .01 for the cent. This unit does not necessarily correspond to the precision for all currencies.

What's a statistical unit currency type?

The statistical unit currency type is used only for the Statistical (STAT) currency. The Statistical currency is used to record statistics such as the number of items bought and sold. Statistical balances can be used directly in financial reports, allocation formulas, and other calculations.

Manage Conversion Rate Types

Creating Conversion Rate Types: Critical Choices

Maintain different conversion rates between currencies for the same period with the Oracle Fusion General Ledger conversion rate types functionality. Four predefined daily conversion rate types are seeded: **Spot**, **Corporate**, **User**, and **Fixed**, allowing you to use different rate types for different business needs. During journal entry, the conversion rate is provided automatically by the General Ledger based on the selected conversion rate type and currency, unless the rate type is **User**. For **User** rate types, you must enter the conversion rate. Define additional rate types as needed. Set your most frequently used rate type as the default. Conversion rate types cannot be deleted.

Assign conversion rate types to automatically populate the associated rate for your period average and period end rates for the ledger. For example, you can assign the predefined rate type **Spot** to populate your period average rates and the predefined rate type **Corporate** to populate your period end rates. Period average and period end rates are used in translation of account balances.

Conversion rate types are used to automatically assign a rate when you perform the following accounting functions:

- Convert foreign currency journal amounts to ledger currency equivalents
- Convert journal amounts from source ledgers to reporting currencies or secondary ledgers
- Run Revaluation or Translation processes

In creating new conversion rates, decide whether to do the following:

- Enforce inverse relationships
- Select pivot currencies
- Select contra currencies
- Enable cross rates and allow cross rate overrides
- Maintain cross rate rules

Enforce Inverse Relationships

Check the **Enforce Inverse Relationship** check box to specify whether or not to enforce the automatic calculation of inverse conversion rates when defining daily rates.

Action	Results
Checked	<p>When you enter a daily rate to convert currency A to currency B, General Ledger automatically calculates the inverse rate, currency B to A, and enters it in the adjacent column. If either rate is changed, the application automatically recalculates the other rate.</p> <p>You can update the application calculated inverse rate, but once you do, the related rate is updated. The check box enforces that the inverse relationship is maintained but does not prevent you from updating the rates.</p>
Unchecked	<p>General Ledger calculates the inverse rate but you can change the rate and update the daily rates table without the corresponding rate being updated.</p>

Select Pivot Currencies

Select a pivot currency that is commonly used in your currency conversions. A pivot currency is the central currency that interacts with contra currencies. For example, you set up a daily rate between the US dollar (USD) and the Euro currency (EUR) and another between the USD and the Canadian dollar (CAD). USD is the pivot currency in creating a rate between EUR and CAD. EUR and CAD are the contra currencies. Select the pivot currency from the list of values which contains those currencies that are enabled, effective, and not a statistical (STAT) currency. The description of the pivot currency is populated automatically based on the currency definition.

If you want the application to create cross rates against a base currency, define the base currency as the pivot currency. Selected pivot currencies can be changed in the Rate Types page.

Select Contra Currencies

Select currencies available on the list of values as contra currencies. The available currencies are those currencies which are enabled, effective, not STAT currency, and not the pivot currency selected earlier. The description of the contra currency is populated automatically based on the currency definition. Add or delete contra currencies in the Contra Currencies region of the Rate Types page.

Enable Cross Rates and Allow Cross Rate Overrides

Check the **Enable Cross Rates** check box to calculate conversion rates based on defined currency rate relationships. General Ledger calculates cross rates

based on your defined cross rate rules. Associate your cross rate rules with a conversion rate type, pivot currency, and contra currencies. Cross rates facilitate the creation of daily rates by automatically creating the rates between contra currencies based on their relationship to a pivot currency. If the **Enable Cross Rates** check box is changed to unchecked after entering contra currencies, the application stops calculating cross rates going forward for that particular rate type. All the earlier calculated cross rates for that rate type remain in the database unless you manually delete them.

For example, if you have daily rates defined for the pivot currency, USD to the contra currency, EUR, and USD to another contra currency, CAD, the application will automatically create the rates between EUR to CAD and CAD to EUR. This prevents the need to manually define the EUR to CAD and CAD to EUR rates.

Check the **Allow Cross Rates Override** check box to permit your users to override application generated cross rates. If you accept the default of unchecked, the application generated cross rates cannot be overridden

Maintain Cross Rate Rules

Define or update your cross rate rules at any time by adding or removing contra currency assignments. Add a contra currency to a cross rate rule and run the Daily Rates Import and Calculation process to generate the new rates. If you remove a cross rate rule or a contra currency from a rule, any cross rates generated previously for that contra currency remain unless you manually delete them. Changes to the rule are not retroactive and will not affect previously stored cross rates. The Cross Rate process generates as many rates as possible and skips currencies where one component of the set is missing.

Note

With a defined web service that extracts daily currency conversion rates from external services, for example Reuters, currency conversion rates are automatically updated for the daily rates and all cross currency relationships.

Using Rate Types: Examples

There are four seeded conversion rate types in Oracle Fusion applications:

- Spot
- Corporate
- User
- Fixed

Scenario

You are the general ledger accountant for InFusion America Inc. You are entering a journal entry to capture three transactions that were transacted in three different foreign currencies:

- Canadian dollar (CAD): A very stable currency

- Mexican Peso (MXP): A fluctuating currency
- Hong Kong dollar (HKD): An infrequently used currency

You enter two lines with accounts and amounts for each foreign currency transaction. Based on your company procedures, you select the appropriate rate type to populate the rate for **Corporate** and **Spot** rate types from your daily rates table. You manually enter the current rate for the **User** rate type.

Currency Selected	Rate Type Selected	Reason
CAD	Corporate	Entered a periodic type of transaction. Your company has established a daily rate to use for the entire month across divisions for all transactions in CAD. CAD is a stable currency that only fluctuates slightly over the month.
MXP	Spot	Entered a periodic type of transaction. Your company enters daily rates each day for MXP because this currency is unstable and fluctuates.
HKD	User	Entered a one time transaction. Your company does not maintain daily rates in HKD.

Note

Your company does not currently use the **Fixed** rate type. From January 1, 1999, the conversion rate of the French franc (FRF) against the euro currency (EUR) was set at a fixed rate of 1 EUR to 6.55957 FRF. Your French operations were started in 2007, so you maintain all your French business records in the EUR.

Manage Daily Rates

Entering Daily Rates Manually: Worked Example

You are required to enter the daily rates for currency conversion from Great Britain pounds sterling (GBP) to United States dollars (USD) each day for your company InFusion America Inc.

Oracle Application Development Framework (ADF) Desktop Integration is an Excel add-in that must be loaded onto each client. Because ADF Desktop Integration is an add-in to Microsoft Office products, you can use this feature only if they have Microsoft Excel 2007 or above, Internet Explorer 7 or above, and Microsoft Windows 7, XP Professional SP2, or Vista. Users must download the installation files from **Navigator - Tools - Download Desktop Integrator Installer**.

Entering Daily Rates

1. Navigate to the Period Close work area.

Use the Period Close work area to link to close processes and currency process.

2. Click the Manage Currency Rates link.

Use the Currency Rates Manager page to create, edit, and review currency rate types, daily rates, and historical rates.

3. Click the Daily Rates tab.

Use the Daily Rates tab to review and enter currency rates.

4. Click the Create in Spreadsheet button.

Use the Create Daily Rates spreadsheet to enter daily rates in a template that you can save and reuse.

5. Click in the From Currency field. Select the GBP - Pound Sterling list item.

6. Click in the To Currency field. Select the USD - US Dollar list item.

7. Click in the Conversion Rate field. Select the Spot list item

8. Click in the From Conversion field. Enter the desired information into the From Conversion field. Enter a valid value e.g. "8/1/2011".

9. Click in the To Conversion Date field. Enter the desired information into the To Conversion Date field. Enter a valid value e.g. "8/1/2011".

10. Click in the Conversion Rate field. Enter the desired information into the Conversion Rate field. Enter a valid value e.g. "1.33225".

11. Click the Submit button. Click the OK button twice.

12. Review the Record Status column to verify that all rows were loaded successfully.

13. Save the template to use to enter daily rates frequently. You can save the spreadsheet to either a local drive or a shared network drive.

Updating Currency Rates: Worked Example

You are required to change today's daily rates that were already entered. The rates you are changing are for currency conversion from Great Britain pounds sterling (GBP) to United States dollars (USD) for your company InFusion America Inc.

Currency conversion rates were entered by an automatic load to the Daily Rates table. They can also be entered through a spreadsheet.

Updating Currency Rates

1. Navigate to the Period Close work area.

Use the Period Close work area to link to close processes and currency process.

2. Click the Manage Currency Rates link.

Use the Currency Rates Manager page to create, edit, and review currency rate types, daily rates, and historical rates.

3. Click the Daily Rates tab.
Use the Daily Rates tab to review and enter currency rates.
4. Click the From Currency list. Select the GBP - Pound Sterling list item.
5. Click the To Currency list. Select the USD - US Dollar list item.
6. Enter the dates for the daily rates that you are changing. Enter today's date.
7. Click the Rate Type list. Select the Spot list item.
8. Click the Search button.
9. Click in the Rate field. Enter the new rate of 1.7 in the Rate field.
10. Click in the Inverse Rate field. Enter the new inverse rate of 0.58822 in the Inverse Rate field.
11. Click the Save button.

FAQs for Manage Conversion Rate Types

What's the difference between spot, corporate, user, and fixed rate types?

Spot, corporate, user, and fixed conversion rate types differ based on the fluctuations of your entered foreign currency and your company procedures for maintaining daily rates.

Rate Type	Usage
Spot	For currencies with fluctuating conversion rates or when exact currency conversion is needed.
Corporate	For establishment of a standard rate across your organization for a stable currency.
User	For infrequent entries where your daily rates for the entered foreign currency are not set up.
Fixed	For rates where the conversion is constant between two currencies.

If you have infrequent foreign currency transactions, the user rate type can simplify your currency maintenance while providing an accurate conversion rate on the date of the transaction.

Define Enterprise Structures

Enterprise Structures: Overview

Oracle Fusion Applications have been designed to ensure your enterprise can be modeled to meet legal and management objectives. The decisions about your implementation of Oracle Fusion Applications are affected by your:

- Industry
- Business unit requirements for autonomy
- Business and accounting policies
- Business functions performed by business units and optionally, centralized in shared service centers
- Locations of facilities

Every enterprise has three fundamental structures, legal, managerial, and functional, that are used to describe its operations and provide a basis for reporting. In Oracle Fusion, these structures are implemented using the chart of accounts and organizations. Although many alternative hierarchies can be implemented and used for reporting, you are likely to have one primary structure that organizes your business into divisions, business units, and departments aligned by your strategic objectives.

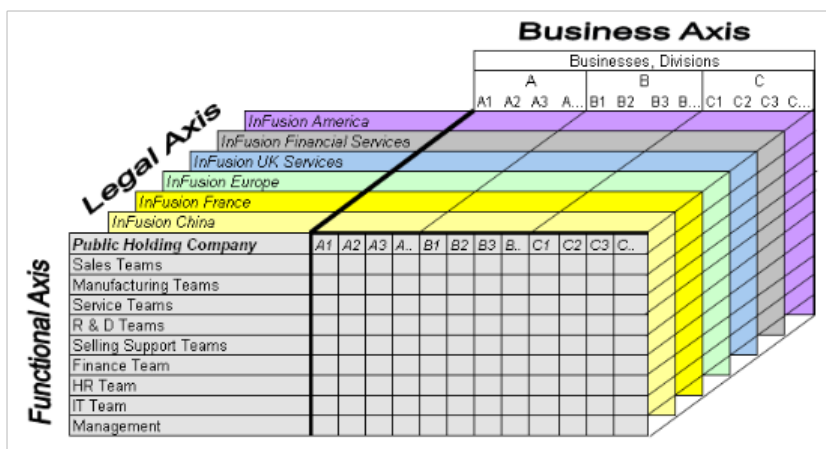

Legal Structure

The figure above shows a typical group of legal entities, operating various business and functional organizations. Your ability to buy and sell, own, and

employ comes from your charter in the legal system. A corporation is a distinct legal entity from its owners and managers. The corporation is owned by its shareholders, who may be individuals or other corporations. There are many other kinds of legal entities, such as sole proprietorships, partnerships, and government agencies.

A legally recognized entity can own and trade assets and employ people in the jurisdiction in which it is registered. When granted these privileges, legal entities are also assigned responsibilities to:

- Account for themselves to the public through statutory and external reporting
- Comply with legislation and regulations
- Pay income and transaction taxes
- Process value added tax (VAT) collection on behalf of the taxing authority

Many large enterprises isolate risk and optimize taxes by incorporating subsidiaries. They create legal entities to facilitate legal compliance, segregate operations, optimize taxes, complete contractual relationships, and isolate risk. Enterprises use legal entities to establish their enterprise's identity under the laws of each country in which their enterprise operates.

In the figure above, a separate card represents a series of registered companies. Each company, including the public holding company, InFusion America, must be registered in the countries where they do business. Each company consists of various divisions created for purposes of management reporting. These are shown as vertical columns on each card. For example, a group might have a separate company for each business in the United States (US), but have their United Kingdom (UK) legal entity represent all businesses in that country. The divisions are linked across the cards so that a business can appear on some or all of the cards. For example, the air quality monitoring systems business might be operated by the US, UK, and France companies. The list of business divisions is on the Business Axis. Each company's card is also horizontally striped by functional groups, such as the sales team and the finance team. This functional list is called the Functional Axis. The overall image suggests that information might, at a minimum, be tracked by company, business, division, and function in a group environment. In Oracle Fusion Applications, the legal structure is implemented using legal entities.

Management Structure

Successfully managing multiple businesses requires that you segregate them by their strategic objectives, and measure their results. Although related to your legal structure, the business organizational hierarchies do not need to be reflected directly in the legal structure of the enterprise. The management structure can include divisions, subdivisions, lines of business, strategic business units, and cost centers. In the figure above, the management structure is shown on the Business Axis. In Oracle Fusion Applications, the management structure is implemented using divisions and business units.

Functional Structure

Straddling the legal and business organizations is a functional organization structured around people and their competencies. For example, sales, manufacturing, and service teams are functional organizations. This functional

structure is represented by the Functional Axis in the figure above. You reflect the efforts and expenses of your functional organizations directly on the income statement. Organizations must manage and report revenues, cost of sales, and functional expenses such as research and development (R&D) and selling, general, and administrative (SG&A) expenses. In Oracle Fusion Applications, the functional structure is implemented using departments and organizations, including sales, marketing, project, cost, and inventory organizations.

Enterprise Structures Business Process Model: Explained

In Oracle Fusion Applications, the Enterprise Performance and Planning Business Process Model illustrates the major implementation tasks that you perform to create your enterprise structures. This process model includes the Set Up Enterprise Structures business process, which consist of implementation activities that span many product families. Information Technology is a second Business Process Model which contains the Set Up Information Technology Management business process. Define Reference Data Sharing is one of the activities in this business process and is important in the implementation of the enterprise structures. This activity creates the mechanism to share reference data sets across multiple ledgers, business units, and warehouses, reducing the administrative burden and decreasing the time needed to implement.

The following figure and chart describes the Business Process Model structures and activities.

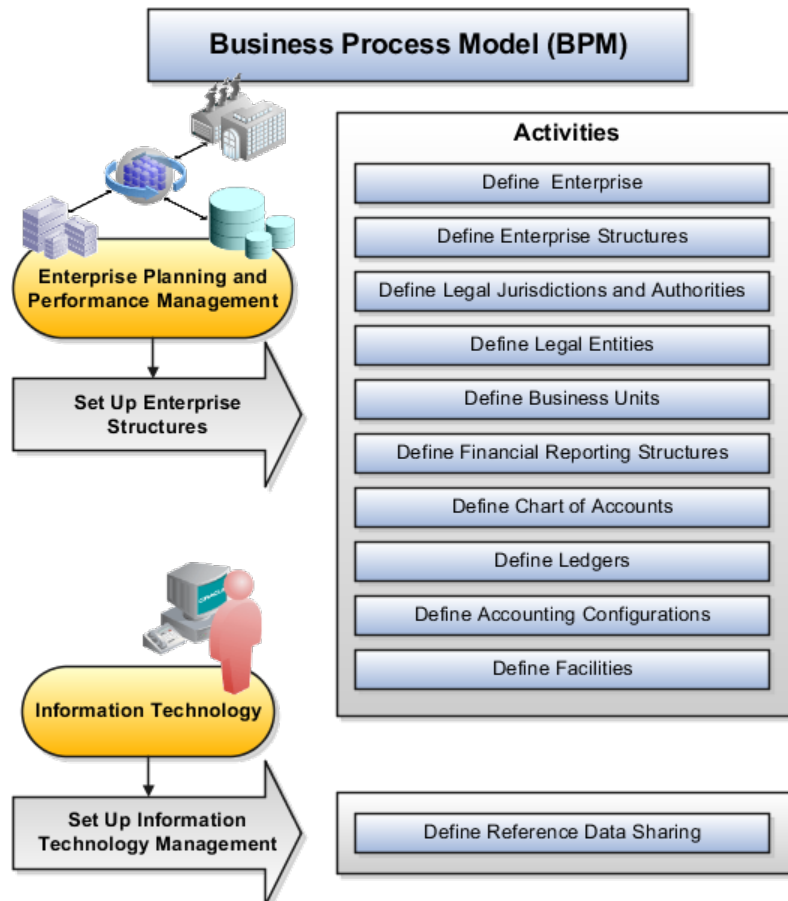

BPM Activities	Description
Define Enterprise	Define the enterprise to capture the name of the deploying enterprise and the location of the headquarters. There is normally a single enterprise organization in a production environment. Multiple enterprises are defined when the system is used to administer multiple customer companies, or when you choose to set up additional enterprises for testing or development.
Define Enterprise Structures	Define enterprise structures to represent an organization with one or more legal entities under common control. Define internal and external organizations to represent each area of business within the enterprise.
Define Legal Jurisdictions and Authorities	Define information for governing bodies that operate within a jurisdiction.
Define Legal Entities	Define legal entities and legal reporting units for business activities handled by the Oracle Fusion Applications.
Define Business Units	Define business units of an enterprise to allow for flexible implementation, to provide a consistent entity for controlling and reporting on transactions, and to be an anchor for the sharing of sets of reference data across applications.
Define Financial Reporting Structures	Define financial reporting structures, including organization structures, charts of accounts, organizational hierarchies, calendars, currencies and rates, ledgers, and document sequences which are used in organizing the financial data of a company.
Define Chart of Accounts	Define chart of accounts including hierarchies and values to enable tracking of financial transactions and reporting at legal entity, cost center, account, and other segment levels.
Define Ledgers	Define the primary accounting ledger and any secondary ledgers that provide an alternative accounting representation of the financial data.
Define Accounting Configurations	Define the accounting configuration that serves as a framework for how financial records are maintained for an organization.
Define Facilities	Define inventory, item, and cost organizations. Inventory organizations represent facilities that manufacture or store items. The item master organization holds a single definition of items that can be shared across many inventory organizations. Cost organizations group inventory organizations within a legal entity to establish the cost accounting policies.
Define Reference Data Sharing	Define how reference data in the applications is partitioned and shared.

Note

There are product specific implementation activities that are not listed here and depend on the applications you are implementing. For example, you can

Global Enterprise Configuration: Points to Consider

Start your global enterprise structure configuration by discussing what your organization's reporting needs are and how to represent those needs in the Oracle Fusion Applications. Consider deployment on a single instance, or at least, on as few instances as possible, to simplify reporting and consolidations for your global enterprises. The following are some questions and points to consider as you design your global enterprise structure in Oracle Fusion.

- Enterprise Configuration
- Business Unit Management
- Security Structure
- Compliance Requirements

Enterprise Configuration

What is the level of configuration needed to achieve the reporting and accounting requirements? What components of your enterprise do you need to report on separately? Which components can be represented by building a hierarchy of values to provide reporting at both detail and summary levels? Where are you on the spectrum of centralization versus decentralization?

Business Unit Management

What reporting do I need by business unit? How can you set up your departments or business unit accounts to achieve departmental hierarchies that report accurately on your lines of business? What reporting do you need to support the managers of your business units, and the executives who measure them? How often are business unit results aggregated? What level of reporting detail is required across business units?

Security Structure

What level of security and access is allowed? Are business unit managers and the people that report to them secured to transactions within their own business unit? Are the transactions for their business unit largely performed by a corporate department or shared service center?

Compliance Requirements

How do you comply with your corporate external reporting requirements and local statutory reporting requirements? Do you tend to prefer a corporate first or an autonomous local approach? Where are you on a spectrum of centralization, very centralized or decentralized?

Modeling Your Enterprise Management Structure in Oracle Fusion: Example

This example uses a fictitious global company to demonstrate the analysis that can occur during the enterprise structure configuration planning process.

Scenario

Your company, InFusion Corporation, is a multinational conglomerate that operates in the United States (US) and the United Kingdom (UK). InFusion

has purchased an Oracle Fusion enterprise resource planning (ERP) solution including Oracle Fusion General Ledger and all of the Oracle Fusion subledgers. You are chairing a committee to discuss creation of a model for your global enterprise structure including both your US and UK operations.

InFusion Corporation

InFusion Corporation has 400 plus employees and revenue of \$120 million. Your product line includes all the components to build and maintain air quality monitoring (AQM) systems for homes and businesses. You have two distribution centers and three warehouses that share a common item master in the US and UK. Your financial services organization provides funding to your customers for the start up costs of these systems.

Analysis

The following are elements you need to consider in creating your model for your global enterprise structure.

- Your company is required to report using US Generally Accepted Accounting Principles (GAAP) standards and UK Statements of Standard Accounting Practice and Financial Reporting Standards. How many ledgers do you need to achieve proper statutory reporting?
- Your managers need reports that show profit and loss (revenue and expenses) for their lines of business. Do you use business units and balancing segments to represent your divisions and businesses? Do you secure data by two segments in your chart of accounts which represents each department and legal entity or one segment that represents both to produce useful, but confidential management reports?
- Your corporate management requires reports showing total organizational performance with drill down capability to the supporting details. Do you need multiple balancing segment hierarchies to achieve proper rollup of balances for reporting requirements?
- Your company has all administrative, account payables, procurement, and human resources functions performed at their corporate headquarters. Do you need one or more business unit in which to perform all these functions? How will your shared service center be configured?

Global Enterprise Structure Model

The following figure and table summarize the model that your committee has designed and uses numerical values to provide a sample representation of your structure. The model includes the following recommendations:

- Creation of three separate ledgers representing your separate legal entities:
 - InFusion America Inc.
 - InFusion Financial Services Inc.
 - InFusion UK Services Ltd.
- Consolidation of results for system components, installations, and maintenance product lines across the enterprise

- All UK general and administrative costs processed at the UK headquarters
- US Systems' general and administrative costs processed at US Corporate headquarters
- US Financial Services maintains its own payables and receivables departments

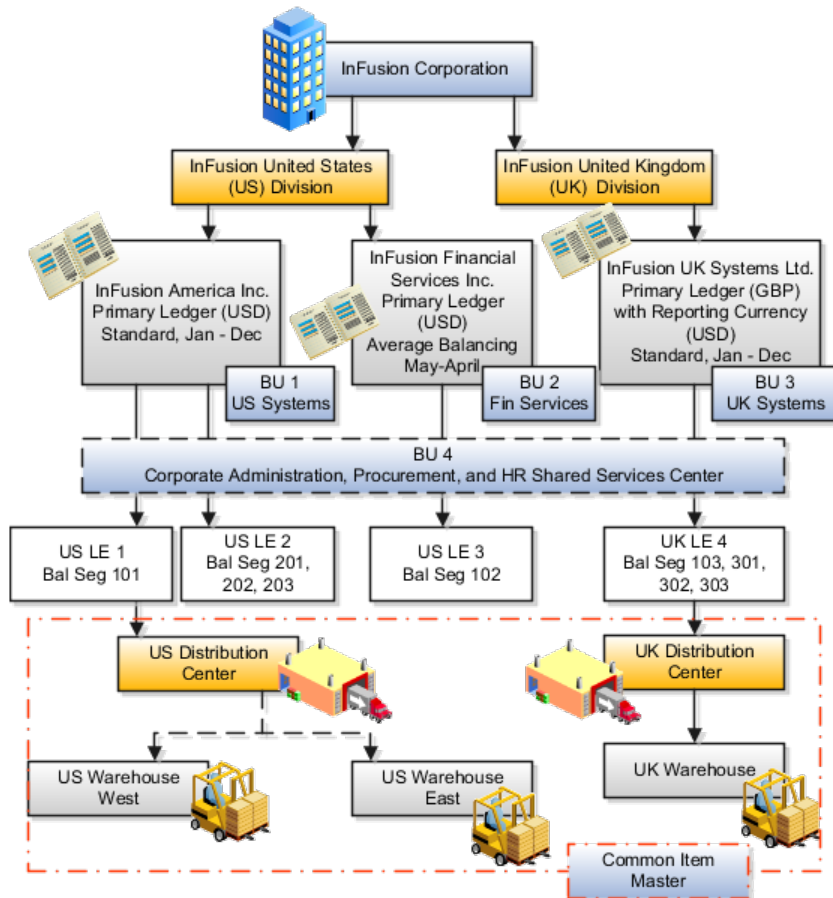

Real World Entity	Entity Name	Enterprise	Legal Entity	BSV	Ledger	BU	Cost Center	Dept	Item Master Org	Inventory Org
Enterprise	InFusion Group	M								
Company	US LE 1		M	O	O					
Company	US LE 2		M	O	O					
Company	US LE 3		M	O	O					
Company	UK LE 4		M	O	O					
Business Unit	US Systems BU 1					M				
Business Unit	FIN Services BU 2					M				
Business Unit	UK Systems BU 3					M				
Division	InFusion UK			O			O			
Division	InFusion US			O			O			
Headquarters	BU 4					M				
Shared Service Center	BU 4					M				
Department	AP Department						O	M		
List of Items	Common Item Master								O	
Distribution Center	US Distribution Center									O
Distribution Center	UK Distribution Center									O
Warehouse	US Warehouse West									O
Warehouse	US Warehouse East									O
Warehouse	UK Warehouse									O
BSV = Balancing Segment Value										
BU = Business Unit										
Dept = Department										
Org = Organization										
M = Mandatory Setup										
O = Optional Setup										

In this chart, the green globe stands for mandatory and gold globe stands for optional setup. The following statements expand on the data in the chart.

- The enterprise is mandatory because it serves as an umbrella for the entire implementation. All organizations are created within an enterprise.
- Legal entities are also mandatory. They can be optionally mapped to balancing segment values or represented by ledgers. Mapping balancing segment values to legal entities is mandatory if you plan to use the intercompany functionality.
- At least one ledger is mandatory in an implementation in which you record your accounting transactions.
- Business units are also mandatory because financial transactions are processed in business units.
- A shared service center is optional, but if used, must be a business unit.
- Divisions are optional and can be represented with a hierarchy of cost centers or by a second balancing segment value.
- Departments are mandatory because they track your employees.
- Optionally, add an item master organization and inventory organizations if you are tracking your inventory transactions in Oracle Fusion Applications.

Note

Some Oracle Fusion Human Capital Management and Customer Relationship Management implementations do not require recording of accounting transactions and therefore, do not require implementation of a ledger.

Note

The InFusion Corporation is a legal entity but is not discussed in this example.

Define Initial Configuration with the Enterprise Structures Configurator

Establishing Enterprise Structures Using the Enterprise Structures Configurator: Explained

The Enterprise Structures Configurator is an interview-based tool that guides you through the process of setting up a basic enterprise structure. By answering questions about your enterprise, the tool creates a structure of divisions, legal entities, business units, and reference data sets that reflects your enterprise structure. After you create your enterprise structure, you also follow a guided process to determine whether or not to use positions, and whether to set up additional attributes for jobs and positions. After you define your enterprise structure and your job and position structures, you can review them, make any necessary changes, and then load the final configuration.

This figure illustrates the process to configure your enterprise using the Enterprise Structures Configurator.

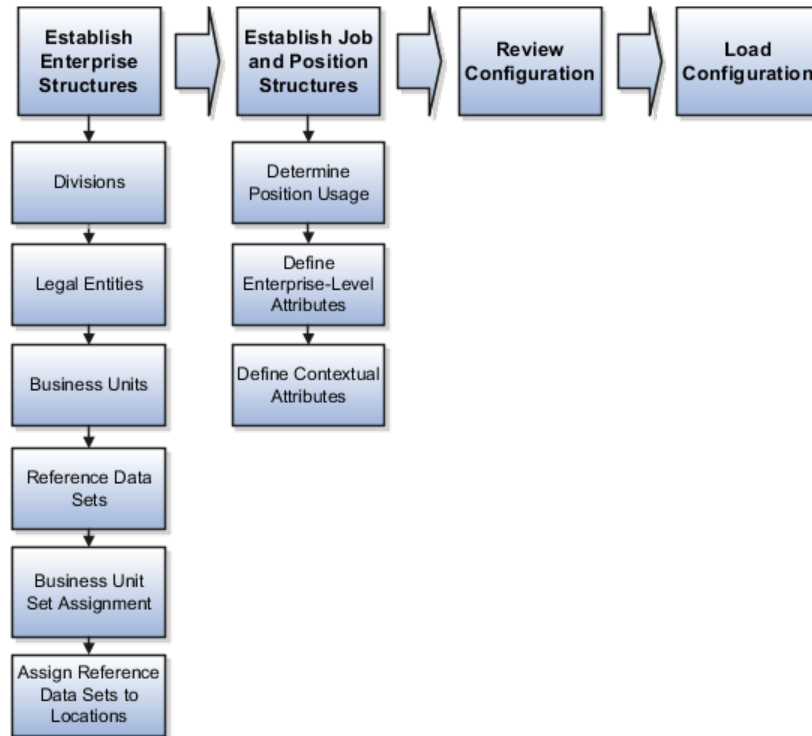

To be able to use the Enterprise Structures Configurator, you must select the Enterprise Structures Guided Flow feature for your offerings on the Configure Offerings page in the Setup and Maintenance work area. If you do not select this feature, then you must set up your enterprise structure using individual tasks provided elsewhere in the offerings, and you cannot create multiple configurations to compare different scenarios.

Establish Enterprise Structures

To define your enterprise structures, you use the guided flow within the Establish Enterprise Structures task to enter basic information about your enterprise, such as the primary industry and the location of your headquarters. You then create divisions, legal entities, business units, and reference data sets. The Establish Enterprise Structures task enables you to create multiple enterprise configurations so that you can compare different scenarios. Until you load a configuration, you can continue to create and edit multiple configurations until you arrive at one that best suits your enterprise.

Establish Job and Position Structures

You also use a guided process to determine whether you want to use jobs only, or jobs and positions. The primary industry that you select in the Establish Enterprise Structures task provides the application with the information needed to make an initial recommendation. You can either accept the recommendation, or you can answer additional questions about how you manage people in your enterprise, and then make a selection. After you select whether to use jobs or positions, the guided process prompts you to set up a descriptive flexfield structure for jobs, and for positions if you have chosen to use them. Descriptive

flexfields enable you to capture additional information when you create jobs and positions.

Review Configuration

Finally, you can review a summary of the results of the two interview processes. For each configuration, the online summary lists the divisions, legal entities, business units, reference data sets, and job and position structures that the application will create when you load the configuration.

For a more detailed analysis of a configuration, you can access the Technical Summary Report. This report lists the same information as the online summary, but also lists the following information that will be created by the application when you load the configuration, based on your configuration:

- Legislative data groups (the application creates one legislative data group for each country that is identified in the configuration.)
- Name of the legislative data group that will be assigned to the payroll statutory unit that is generated for each legal entity.
- Organization hierarchy.

The Technical Summary report also lists the default settings that will be loaded for these fields, which you access from the Manage Enterprise HCM Information task: **Worker Number Generation**, **Employment Model** and **Allow Employment Terms Override**. You can print the Technical Summary Report for each of your configurations and compare each scenario.

Note

If your PDF viewer preferences are set to open PDFs in a browser window, the Technical Summary report replaces the Oracle Fusion application. Use your browser's Back button to return to the application.

Load Configuration

You can load only one configuration. When you load a configuration, the application creates the divisions, legal entities, business units, and so on. After you load the configuration, you then use individual tasks to edit, add, and delete enterprise structures.

Designing an Enterprise Configuration: Example

This example illustrates how to set up an enterprise based on a global company operating mainly in the US and the UK with a single primary industry.

Scenario

InFusion Corporation is a multinational enterprise in the high technology industry with product lines that include all the components that are required to build and maintain air quality monitoring (AQM) systems for homes and businesses. Its primary locations are in the US and the UK, but it has smaller outlets in France, Saudi Arabia, and the United Arab Emirates (UAE).

Enterprise Details

In the US, InFusion employs 400 people and has a company revenue of \$120 million. Outside the US, InFusion employs 200 people and has revenue of \$60 million.

Analysis

InFusion requires three divisions. The US division will cover the US locations. The Europe division will cover the UK and France. Saudi Arabia and the UAE will be covered by the Middle East division.

InFusion requires legal entities with legal employers, payroll statutory units, tax reporting units, and legislative data groups for the US, UK, France, Saudi Arabia, and UAE, in order to employ and pay its workers in those countries.

InFusion requires a number of departments across the enterprise for each area of business, such as sales and marketing, and a number of cost centers to track and report on the costs of those departments.

InFusion requires business units for human capital management (HCM) purposes. InFusion has general managers responsible for business units within each country. Those business units may share reference data. Some reference data can be defined within a reference data set that multiple business units may subscribe to. Business units are also required for financial purposes. Financial transactions are always processed within a business unit.

Based on this analysis, InFusion requires an enterprise with multiple divisions, ledgers, legal employers, payroll statutory units, tax reporting units, legislative data groups, departments, cost centers, and business units.

This figure illustrates the enterprise configuration that results from the analysis of InFusion Corporation.

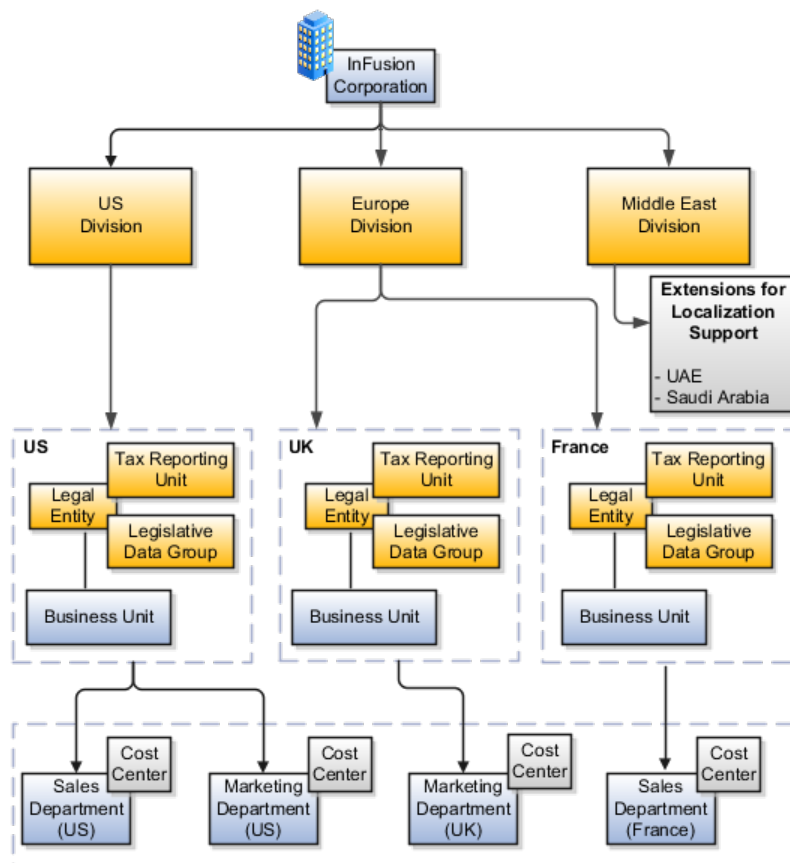

Division: Explained

Managing multiple businesses requires that you segregate them by their strategic objectives and measure their results. Responsibility to reach objectives can be delegated along the management structure. Although related to your legal structure, the business organizational hierarchies do not need to reflect directly the legal structure of the enterprise. The management entities and structure can include divisions and subdivisions, lines of business, and other strategic business units, and include their own revenue and cost centers. These organizations can be included in many alternative hierarchies and used for reporting, as long as they have representation in the chart of accounts.

Divisions

A division refers to a business oriented subdivision within an enterprise, in which each division organizes itself differently to deliver products and services or address different markets. A division can operate in one or more countries, and can be comprised of many companies or parts of different companies that are represented by business units.

A division is a profit center or grouping of profit and cost centers, where the division manager is responsible for attaining business goals including profit goals. A division can be responsible for a share of the company's existing product lines or for a separate business. Managers of divisions may also have return on investment goals requiring tracking of the assets and liabilities of the division. The division manager reports to a top corporate executive.

By definition a division can be represented in the chart of accounts. Companies may choose to represent product lines, brands, or geographies as their divisions: their choice represents the primary organizing principle of the enterprise. This may coincide with the management segment used in segment reporting.

Oracle Fusion Applications supports a qualified management segment and recommends that you use this segment to represent your hierarchy of business units and divisions. If managers of divisions have return on investment goals, make the management segment a balancing segment. Oracle Fusion applications allows up to three balancing segments. The values of the management segment can be comprised of business units that roll up in a hierarchy to report by division.

Historically, divisions were implemented as a node in a hierarchy of segment values. For example, Oracle E-Business Suite has only one balancing segment, and often the division and legal entity are combined into a single segment where each value stands for both division and legal entity.

Use of Divisions in Oracle Fusion Human Capital Management (HCM)

Divisions are used in HCM to define the management organization hierarchy, using the generic organization hierarchy. This hierarchy can be used to create organization based security profiles.

Legal Entities: Explained

A legal entity is a recognized party with rights and responsibilities given by legislation.

Legal entities have the right to own property, the right to trade, the responsibility to repay debt, and the responsibility to account for themselves to regulators, taxation authorities, and owners according to rules specified in the relevant legislation. Their rights and responsibilities may be enforced through the judicial system. Define a legal entity for each registered company or other entity recognized in law for which you want to record assets, liabilities, expenses and income, pay transaction taxes, or perform intercompany trading.

A legal entity has responsibility for elements of your enterprise for the following reasons:

- Facilitating local compliance
- Taking advantage of lower corporation taxation in some jurisdictions
- Preparing for acquisitions or disposals of parts of the enterprise
- Isolating one area of the business from risks in another area. For example, your enterprise develops property and also leases properties. You could operate the property development business as a separate legal entity to limit risk to your leasing business.

The Role of Your Legal Entities

In configuring your enterprise structure in Oracle Fusion Applications, you need to understand that the contracting party on any transaction is always the legal entity. Individual legal entities own the assets of the enterprise, record sales and pay taxes on those sales, make purchases and incur expenses, and perform other transactions.

Legal entities must comply with the regulations of jurisdictions, in which they register. Europe now allows for companies to register in one member country and do business in all member countries, and the US allows for companies to register in one state and do business in all states. To support local reporting requirements, legal reporting units are created and registered.

You are required to publish specific and periodic disclosures of your legal entities' operations based on different jurisdictions' requirements. Certain annual or more frequent accounting reports are referred to as statutory or external reporting. These reports must be filed with specified national and regulatory authorities. For example, in the United States (US), your publicly owned entities (corporations) are required to file quarterly and annual reports, as well as other periodic reports, with the Securities and Exchange Commission (SEC), who enforces statutory reporting requirements for public corporations.

Individual entities privately held or held by public companies do not have to file separately. In other countries, your individual entities do have to file in their own name, as well as at the public group level. Disclosure requirements are diverse. For example, your local entities may have to file locally to comply with local regulations in a local currency, as well as being included in your enterprise's reporting requirements in different currency.

A legal entity can represent all or part of your enterprise's management framework. For example, if you operate in a large country such as the United Kingdom or Germany, you might incorporate each division in the country as a separate legal entity. In a smaller country, for example Austria, you might use a single legal entity to host all of your business operations across divisions.

Creating Legal Entities in the Enterprise Structures Configurator: Points to Consider

Using the Enterprise Structures Configurator (ESC), you can create legal entities for your enterprise automatically, based on the countries in which divisions of your business operate, or you can upload a list of legal entities from a spreadsheet.

Automatically Creating Legal Entities

If you are not certain of the number of legal entities that you need, you can create them automatically. To use this option, you first identify all of the countries in which your enterprise operates. The application opens the Map Divisions by Country page, which contains a matrix of the countries that you identified, your enterprise, and the divisions that you created. You select the check boxes where your enterprise and divisions intersect with the countries to identify the legal entities that you want the application to create. The enterprise is included for situations where your enterprise operates in a country and acts on behalf of several divisions within the enterprise and is a legal employer in a country. If you select the enterprise for a country, the application creates a country holding company.

The application automatically creates the legal entities that you select, and identifies them as payroll statutory units and legal employers. For each country that you indicated that your enterprise operates in, and for each country that you created a location for, the application also automatically creates a legislative data group.

Any legal entities that you create automatically cannot be deleted from the Create Legal Entities page within the Enterprise Structures Configurator. You must return to the Map Divisions by Country page and deselect the legal entities that you no longer want.

Example: Creating Legal Entities Automatically

InFusion Corporation is using the ESC to set up their enterprise structure. They have identified two divisions, one for Lighting, and one for Security. The Lighting division operates in Japan and the US, and the Security division operates in the UK and India.

This figure illustrates InFusion Corporation's enterprise structure.

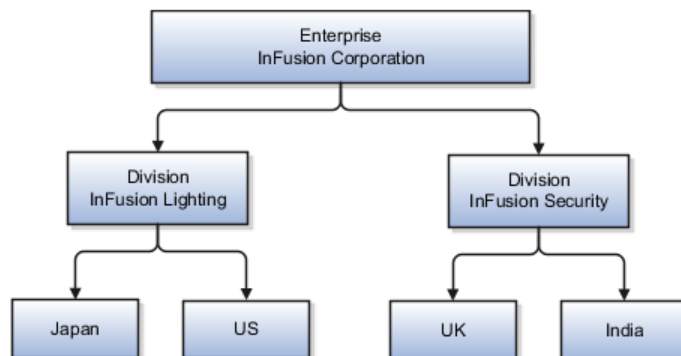

This table represents the selections that InFusion Corporation makes when specifying which legal entities to create on the Map Divisions by Country page.

Country	Enterprise	InFusion Lighting	InFusion Security
Japan	No	Yes	No
US	No	Yes	No
UK	No	No	Yes
India	No	No	Yes

Based on the selections made in the preceding table, the ESC creates the following four legal entities:

- InFusion Lighting Japan LE
- InFusion Lighting US LE
- InFusion Security UK LE
- InFusion Security India LE

Creating Legal Entities Using a Spreadsheet

If you have a list of legal entities already defined for your enterprise, you can upload them from a spreadsheet. To use this option, you first download a spreadsheet template, then add your legal entity information to the spreadsheet, and then upload directly to your enterprise configuration. You can export and import the spreadsheet multiple times to accommodate revisions.

Legal Entity in Oracle Fusion: Points to Consider

Oracle Fusion Applications support the modeling of your legal entities. If you make purchases from or sell to other legal entities, define these other legal entities in your customer and supplier registers, which are part of the Oracle Fusion Trading Community Architecture. When your legal entities are trading with each other, you represent both of them as legal entities and also as customers and suppliers in your customer and supplier registers. Use legal entity relationships to determine which transactions are intercompany and require intercompany accounting. Your legal entities can be identified as legal employers and therefore, are available for use in Human Capital Management (HCM) applications.

There are several decisions that need to be considered in creating your legal entities.

- The importance of legal entity in transactions
- Legal entity and its relationship to business units
- Legal entity and its relationship to divisions
- Legal entity and its relationship to ledgers
- Legal entity and its relationship to balancing segments
- Legal entity and its relationship to consolidation rules
- Legal entity and its relationship to intercompany transactions

- Legal entity and its relationship to worker assignments and legal employer
- Legal entity and payroll reporting
- Legal reporting units

The Importance of Legal Entity in Transactions

All of the assets of the enterprise are owned by individual legal entities. Oracle Fusion Financials allow your users to enter legal entities on transactions that represent a movement in value or obligation.

For example, the creation of a sales order creates an obligation for the legal entity that books the order to deliver the goods on the acknowledged date, and an obligation of the purchaser to receive and pay for those goods. Under contract law in most countries, damages can be sought for both actual losses, putting the injured party in the same state as if they had not entered into the contract, and what is called loss of bargain, or the profit that would have made on a transaction.

In another example, if you revalued your inventory in a warehouse to account for raw material price increases, the revaluation and revaluation reserves must be reflected in your legal entity's accounts. In Oracle Fusion Applications, your inventory within an inventory organization is managed by a single business unit and belongs to one legal entity.

Legal Entity and Its Relationship to Business Units

A business unit can process transactions on behalf of many legal entities. Frequently, a business unit is part of a single legal entity. In most cases the legal entity is explicit on your transactions. For example, a payables invoice has an explicit legal entity field. Your accounts payables department can process supplier invoices on behalf of one or many business units.

In some cases, your legal entity is inferred from your business unit that is processing the transaction. For example, your business unit A agrees on terms for the transfer of inventory to your business unit B. This transaction is binding on your default legal entities assigned to each business unit. Oracle Fusion Procurement, Oracle Fusion Projects, and Oracle Fusion Supply Chain applications rely on deriving the legal entity information from the business unit.

Legal Entity and Its Relationship to Divisions

The division is an area of management responsibility that can correspond to a collection of legal entities. If desired, you can aggregate the results for your divisions by legal entity or by combining parts of other legal entities. Define date-effective hierarchies for your cost center or legal entity segment in your chart of accounts to facilitate the aggregation and reporting by division. Divisions and legal entities are independent concepts.

Legal Entity and Its Relationship to Ledgers

One of your major responsibilities is to file financial statements for your legal entities. Map legal entities to specific ledgers using the Oracle Fusion General Ledger Accounting Configuration Manager. Within a ledger, you can optionally map a legal entity to one or more balancing segment values.

Legal Entity and Its Relationship to Balancing Segments

Oracle Fusion General Ledger supports up to three balancing segments. Best practices recommend that one of these segments represents your legal entity to ease your requirement to account for your operations to regulatory agencies, tax authorities, and investors. Accounting for your operations means you must produce a balanced trial balance sheet by legal entity. If you account for many legal entities in a single ledger, you must:

1. Identify the legal entities within the ledger.
2. Balance transactions that cross legal entity boundaries through intercompany transactions.
3. Decide which balancing segments correspond to each legal entity and assign them in Oracle Fusion General Ledger Accounting Configuration Manager. Once you assign one balancing segment value in a ledger, then all your balancing segment values must be assigned. This recommended best practice facilitates reporting on assets, liabilities, and income by legal entity.

Represent your legal entities by at least one balancing segment value. You may represent it by two or three balancing segment values if more granular reporting is required. For example, if your legal entity operates in multiple jurisdictions in Europe, you might define balancing segment values and map them to legal reporting units. You can represent a legal entity by more than one balancing segment value, do not use a single balancing segment value to represent more than one legal entity.

In Oracle Fusion General Ledger, there are three balancing segments. You can use separate balancing segments to represent your divisions or strategic business units to enable management reporting at the balance sheet level for each division or business unit. For example, use this solution to empower your business unit and divisional managers to track and assume responsibility for their asset utilization or return on investment. Using multiple balancing segments is also useful when you know at the time of implementation that you are disposing of a part of a legal entity and need to isolate the assets and liabilities for that entity.

Note

Implementing multiple balancing segments requires every journal entry that is not balanced by division or business unit, to generate balancing lines. Also, you cannot change to multiple balancing segments easily after you have begun to use the ledger because your historical data is not balanced by the new multiple balancing segments. Restating historical data must be done at that point.

To use this feature for disposal of a part of a legal entity, implement multiple balancing segments at the beginning of the legal entity's corporate life or on conversion to Oracle Fusion.

If you decided to account for each legal entity in a separate ledger, there is no requirement to identify the legal entity with a balancing segment value within the ledger.

Note

While transactions that cross balancing segments don't necessarily cross legal entity boundaries, all transactions that cross legal entity boundaries must cross balancing segments. If you make an acquisition or are preparing to dispose of a portion of your enterprise, you may want to account for that part of the enterprise in its own balancing segment even if it is not a separate legal entity. If you do not map legal entities sharing the same ledger to balancing segments, you will not be able to distinguish them using the intercompany functionality or track their individual equity.

Legal Entity and Its Relationship to Consolidation Rules

In Oracle Fusion Applications you can map legal entities to balancing segments and then define consolidation rules using your balancing segments. You are creating a relationship between the definition of your legal entities and their role in your consolidation.

Legal Entity and its Relationship to Intercompany Transactions

Use Oracle Fusion Intercompany functionality for automatic creation of intercompany entries across your balancing segments. Intercompany processing updates legal ownership within the enterprise's groups of legal entities. Invoices or journals are created as needed. To limit the number of trading pairs for your enterprise, set up intercompany organizations and assign them to your authorized legal entities. Define processing options and intercompany accounts to use when creating intercompany transactions and to assist in consolidation elimination entries. These accounts are derived and automatically entered on your intercompany transactions based on legal entities assigned to your intercompany organizations.

Intracompany trading, in which legal ownership isn't changed but other organizational responsibilities are, is also supported. For example, you can track assets and liabilities that move between your departments within your legal entities by creating departmental level intercompany organizations.

Note

In the Oracle Fusion Supply Chain applications, model intercompany relationships using business units, from which legal entities are inferred.

Legal Entity and Its Relationship to Worker Assignments and Legal Employer

Legal entities that employ people are called legal employers in the Oracle Fusion Legal Entity Configurator. You must enter legal employers on worker assignments in Oracle Fusion HCM.

Legal Entity and Payroll Reporting

Your legal entities are required to pay payroll tax and social insurance such as social security on your payroll. In Oracle Fusion Applications, you can register payroll statutory units to pay and report on payroll tax and social insurance on behalf of many of your legal entities. As the legal employer, you might be required to pay payroll tax, not only at the national level, but also at the local level. You meet this obligation by establishing your legal entity as a place of work within the jurisdiction of a local authority. Set up legal reporting units to represent the part of your enterprise with a specific legal reporting obligation.

You can also mark these legal reporting units as tax reporting units, if the legal entity must pay taxes as a result of establishing a place of business within the jurisdiction.

Business Units: Explained

A business unit is a unit of an enterprise that performs one or many business functions that can be rolled up in a management hierarchy. A business unit can process transactions on behalf of many legal entities. Normally, it will have a manager, strategic objectives, a level of autonomy, and responsibility for its profit and loss. Roll business units up into divisions if you structure your chart of accounts with this type of hierarchy. In Oracle Fusion Applications, you assign your business units to one primary ledger. For example, if a business unit is processing payables invoices they will need to post to a particular ledger. This assignment is mandatory for your business units with business functions that produce financial transactions.

In Oracle Fusion Applications, use business unit as a securing mechanism for transactions. For example, if you run your export business separately from your domestic sales business, secure the export business data to prevent access by the domestic sales employees. To accomplish this security, set up the export business and domestic sales business as two separate business units.

The Oracle Fusion Applications business unit model:

- Allows for flexible implementation
- Provides a consistent entity for controlling and reporting on transactions
- Anchors the sharing of sets of reference data across applications

Business units process transactions using reference data sets that reflect your business rules and policies and can differ from country to country. With Oracle Fusion Application functionality, you can choose to share reference data, such as payment terms and transaction types, across business units, or you can choose to have each business unit manage its own set depending on the level at which you wish to enforce common policies.

In countries where gapless and chronological sequencing of documents is required for subledger transactions, define your business units in alignment with your ledger definition, because the uniqueness of sequencing is only ensured within a ledger. In these cases, define a single ledger and assign one legal entity and business unit.

In summary, use business units in the following ways:

- Management reporting
- Processing of transactions
- Security of transactional data
- Reference data definition and sharing

Brief Overview of Business Unit Security

Business units are used by a number of Oracle Fusion Applications to implement data security. You assign data roles to your users to give them access to data in business units and permit them to perform specific functions on this data. When a business function is enabled for a business unit, the application can trigger

the creation of data roles for this business unit based on the business function's related job roles.

For example, if a payables invoicing business function is enabled, then it is clear that there are employees in this business unit that perform the function of payables invoicing, and need access to the payables invoicing functionality. Therefore, based on the correspondence between the business function and the job roles, appropriate data roles are generated automatically. Use Human Capital Management (HCM) security profiles to administer security for employees in business units.

Creating Business Units in the Enterprise Structures Configurator: Points to Consider

Business units are used within Oracle Fusion applications for management reporting, processing of transactions, and security of transactional data. Using the Enterprise Structures Configurator (ESC), you create business units for your enterprise either automatically or manually.

Automatically Creating Business Units

To create business units automatically, you must specify the level at which to create business units. Business units within your enterprise may be represented at the business function level, such as Sales, Consulting, Product Development, and so on, or they may be represented at a more detailed level, where a business unit exists for each combination of countries in which you operate and the functions in those countries.

You can automatically create business units at the following levels:

- Country
- Country and Division
- Country and business function
- Division
- Division and legal entity
- Division and business function
- Business function
- Legal entity
- Business function and legal entity

Select the option that best meets your business requirements, but consider the following:

- If you use Oracle Fusion Financials, the legal entity option is recommended because of the manner in which financial transactions are processed.
- The business unit level that you select determines how the application automatically creates reference data sets.

After you select a business unit level, the application generates a list of business units, and you select the ones you want the application to create. If you select a

level that has two components, such as country and division, then the system displays a table listing both components, and you select the check boxes at the intersections of the components.

The business units listed by the application are suggestions only, and are meant to simplify the process to create business units. You are not required to select all of the business units suggested. When you navigate to the next page in the ESC guided flow, which is the Manage Business Units page, you cannot delete any of the business units that were created automatically. You must return to the Create Business Units page and deselect any business units that you no longer want.

Example: Selecting Business Unit Levels

InFusion Corporation is using the Enterprise Structures Configurator to set up their enterprise structure. They have identified two divisions, one for Lighting, and one for Security. They operate in four countries: US, UK, Japan, and India, and they have created a legal entity for each of the countries. The sales and marketing functions are based in both India and Japan, while the US and the UK have only the sales function.

This figure illustrates InFusion Corporation's enterprise structure.

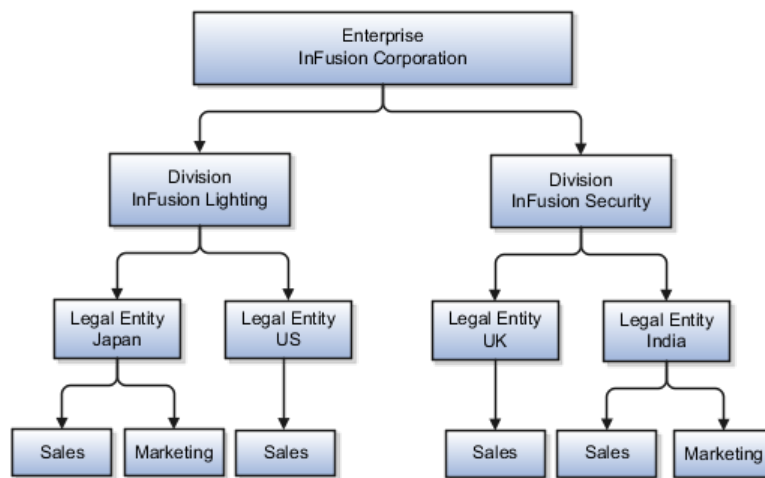

The following table lists the options for business unit levels and the resulting business units that the application suggests for InFusion Corporation.

Business Unit Level	Suggested Business Units
Country	<ul style="list-style-type: none"> • US • UK • Japan • India
Country and Division	<ul style="list-style-type: none"> • InFusion Lighting: Japan • InFusion Lighting: US • InFusion Security: UK • InFusion Security: India

Country and business function	<ul style="list-style-type: none"> • Sales: Japan • Marketing: Japan • Sales: US • Sales: UK • Marketing: India • Sales: India
Division	<ul style="list-style-type: none"> • InFusion Lighting • InFusion Security
Division and Legal Entity	<ul style="list-style-type: none"> • InFusion Lighting: Japan • InFusion Lighting: US • InFusion Security: UK • InFusion Security: India
Division and Business Function	<ul style="list-style-type: none"> • InFusion Lighting, Sales • InFusion Lighting, Marketing • InFusion Security, Sales • InFusion Security, Marketing
Business Function	<ul style="list-style-type: none"> • Sales • Marketing
Legal Entity	<ul style="list-style-type: none"> • Legal Entity: Japan • Legal Entity: US • Legal Entity: UK • Legal Entity India
Legal Entity and Business Function	<ul style="list-style-type: none"> • Legal Entity: Japan, Sales • Legal Entity: Japan, Marketing • Legal Entity: US, Sales • Legal Entity: UK, Sales • Legal Entity India, Marketing • Legal Entity India, Sales

Manually Creating Business Units

If none of the levels for creating business units meets your business needs, you can create business units manually, and you create them on the Manage Business Units page. If you create business units manually, then no reference data sets are created automatically. You must create them manually as well.

Reference Data Sets and Sharing Methods: Explained

Oracle Fusion Applications reference data sharing feature is also known as SetID. The reference data sharing functionality supports operations in multiple

ledgers, business units, and warehouses, thereby reducing the administrative burden and decreasing the time needed to implement new business units. For example, you can share sales methods, transaction types, or payment terms across business units or selected other data across asset books, cost organizations, or project units.

The reference data sharing features use reference data sets to which reference data is assigned. The reference data sets group assigned reference data. The sets can be understood as buckets of reference data assigned to multiple business units or other application components.

Reference Data Sets

You begin this part of your implementation by creating and assigning reference data to sets. Make changes carefully as changes to a particular set will affect all business units or application components using that set. You can assign a separate set to each business unit for the type of object that is being shared. For example, assign separate sets for payment terms, transaction types, and sales methods to your business units.

Your enterprise can decide that some aspects of corporate policy should affect all business units and leave other aspects to the discretion of the business unit manager. This allows your enterprise to balance autonomy and control for each business unit. For example, if your enterprise holds business unit managers accountable for their profit and loss, but manages working capital requirements at a corporate level, you can let managers define their own sales methods, but define payment terms centrally. In this case, each business unit would have its own reference data set for sales methods, and there would be one central reference data set for payment terms assigned to all business units.

The reference data sharing is especially valuable for lowering the cost of setting up new business units. For example, your enterprise operates in the hospitality industry. You are adding a new business unit to track your new spa services. The hospitality divisional reference data set can be assigned to the new business unit to quickly setup data for this entity component. You can establish other business unit reference data in a business unit specific reference data set as needed

Reference Data Sharing Methods

There are variations in the methods used to share data in reference data sets across different types of objects. The following list identifies the methods:

- Assignment to one set only, no common values allowed. The simplest form of sharing reference data that allows assigning a reference data object instance to one and only one set. For example, Asset Prorate Conventions are defined and assigned to only one reference data set. This set can be shared across multiple asset books, but all the values are contained only in this one set.
- Assignment to one set only, with common values. The most commonly used method of sharing reference data that allows defining reference data object instance across all sets. For example, Receivables Transaction Types are assigned to a common set that is available to all the business units without the need to be explicitly assigned the transaction types to each business unit. In addition, you can assign a business unit specific set of transaction types. At transaction entry, the list of values for transaction

types includes transaction types from the set assigned to the business unit, as well as transaction types assigned to the common set that is shared across all business units.

- Assignment to multiple sets, no common values allowed. The method of sharing reference data that allows a reference data object instance to be assigned to multiple sets. For instance, Payables Payment Terms use this method. It means that each payment term can be assigned to one or more than one set. For example, you assign the payment term Net 30 to several sets, but the payment term Net 15 is assigned to only your corporate business unit specific set. At transaction entry, the list of values for payment terms consists of only one set of data; the set that is assigned to the transaction's business unit.

Note: Oracle Fusion Applications contains a reference data set called Enterprise. Define any reference data that affects your entire enterprise in this set.

Business Units and Reference Data Sets: How They Work Together

Reference data sharing is a feature within Oracle Fusion that enables you to group set-enabled reference data such as jobs or grades so that the data can be shared across different parts of the organization. Sets also enable you to filter reference data at the transaction level so that only data that has been assigned to certain sets is available to select. To filter reference data, Oracle Fusion Human Capital Management (HCM), applications use the business unit on the transaction. To set up reference data sharing in Oracle Fusion HCM, you create business units and sets, and then assign the sets to the business units.

Common Set Versus Specific Sets

Some reference data in your organization may be considered global, and should therefore be made available for use within the entire enterprise. You can assign this type of data to the Common Set, which is a predefined set. Regardless of the business unit on a transaction, reference data that has been assigned to the Common Set will always be available, in addition to the reference data that has been assigned to the set that corresponds to the business unit on the transaction.

Other types of reference data may be specific to certain business units, so you want to restrict the use of the data to those business units. In this case, you can create sets specifically for this type of data, and assign the sets to the business units.

Business Unit Set Assignment

When you assign reference data sets to business units, you assign a default reference data set that will be used for all reference data types for that business unit. You can override the set assignment for one or more data types.

Example: Assigning Sets to Business Units

InFusion Corporation has two divisions: Lighting and Security, and the divisions each have two locations. Each location has one or more business functions.

The following figure illustrates the structure of InFusion Corporation.

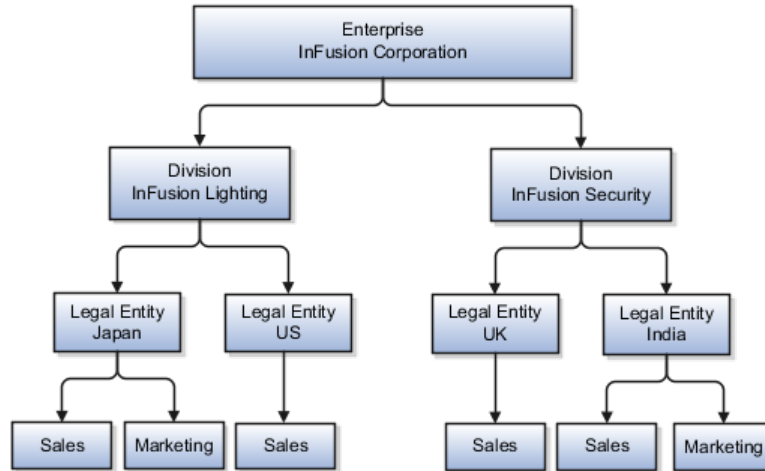

When deciding how to create business units, InFusion decides to create them using the country and business function level. Therefore, they created the following business units:

- Sales_Japan
- Marketing_Japan
- Sales_US
- Sales_UK
- Marketing_India
- Sales_India

Because locations, departments, and grades are specific to each business unit, InFusion does not want to share these types of reference data across business units. They will create a reference data set for each business unit so that data of those types can be set up separately. Because the jobs in the Sales business function are the same across many locations, InFusion decides to create one additional set called Jobs and they will override the set assignment for the Jobs reference data group and assign it to the Jobs set. Based on these requirements, they create the following sets:

- Sales_Japan_Set
- Mktg_Japan_Set
- Sales_US_Set
- Sales_UK_Set
- Mktg_India_Set
- Sales_India_Set
- Grades_Set

InFusion assigns business units to sets as follows:

Business Unit	Default Set Assignment	Set Assignment Overrides
Sales_Japan	Sales_Japan_Set for grades, departments, and locations	Jobs set for jobs

Marketing_Japan	Mktg_Japan_Set for grades, departments, and locations	None
Sales_US	Sales_US_Set for grades, departments, and locations	Jobs set for jobs
Sales_UK	Sales_UK_Set for grades, departments, and locations	Jobs set for jobs
Marketing_India	Mktg_India_Set for grades, departments, and locations	None
Sales_India	Sales_India_Set for grades, departments, and locations	Jobs set for jobs

When setting up grades, departments, and locations for the business units, InFusion will assign the data to the default set for each business unit. When setting up jobs, they will assign the Jobs set and will assign the Common Set to any jobs that may be used throughout the entire organization.

When using grades, departments, and locations at the transaction level, users will be able to select data from the set that corresponds to the business unit that they enter on the transaction, and any data that was assigned to the Common Set. For example, for transactions for the Marketing_Japan business unit, grades, locations, and departments from the Mktg_Japan_Set will be available to select, as well as from the Common Set.

When using jobs at the transaction level, users will be able to select jobs from the Jobs set and from the Common Set when they enter one of the Sales business units on the transaction. For example, when a manager hires an employee for the Sales_India business unit, the list of jobs will be filtered to show jobs from the Jobs set and from the Common Set.

The following figure illustrates what sets of jobs can be accessed when a manager creates an assignment for a worker.

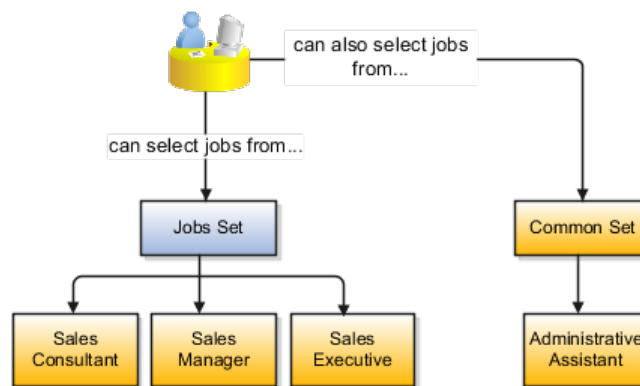

Creating Reference Data Sets in the Enterprise Structures Configurator: Explained

If you created business units automatically, then the Enterprise Structures Configurator automatically creates reference data sets for you. The Enterprise Structures Configurator creates one reference data set for each business unit. You

can add additional sets, but you cannot delete any of the sets that were created automatically.

A standard set called the Enterprise set is predefined.

Common Set

The common set is a predefined set that enables you to share reference data across business units. When you select set-enabled data at the transaction level, the list of values includes data in both the common set and the set associated with the data type for the business unit on the transaction. For example, when you create an assignment, the list of values for grades will include both grades in the common set and in the set that is assigned to grades for the business unit in which you creating the assignment.

Jobs and Positions: Critical Choices

Jobs and positions represent roles that enable you to distinguish between tasks and the individuals who perform those tasks. The key to whether to use jobs or positions is how each is used. Positions offer a well-defined space independent of the person performing the job. Jobs are a space defined by the person. A job can be defined globally in the Common Set, whereas a position is defined within one business unit.

You can update the job and department of a position at any time. This is useful if you hire someone into a new role and want to transfer the position to another department.

During implementation, one of the earliest decisions you will make is whether to use jobs or a combination of jobs and positions. The determinants for this decision are:

- The primary industry of your enterprise
- How you manage your people

Primary Industry of Your Enterprise

Primary industries and how they usually set up their workforce are listed in the table below.

Primary Industry	Workforce Setup
Mining	Positions
Utilities	Positions
Manufacturing	Positions
Retail Trade	Positions
Transportation and Warehousing	Positions
Educational Services	Positions
Public Transportation	Positions
Agriculture, Forestry, Fishing, and Hunting	Jobs

Construction	Jobs
Wholesale Trade	Jobs
Information	Jobs
Finance and Insurance	Jobs
Professional, Scientific, and Technical Services	Jobs
Management of Companies and Enterprises	Jobs
Administrative and Support and Waste Management and Remediation Services	Jobs
Arts, Entertainment, and Recreation	Jobs
Accommodation and Food Services	Jobs
Other Services (Except Public Administration)	Jobs

Management of People

The following table displays suggestions of whether to use jobs or a combination of jobs and positions based on your industry and how you manage your employees when there is turnover.

Industry	We always replace employees by rehiring to same role	We replace the head count, but the manager can use the head count in a different job	We rehire to the same position, but the manager can request a reallocation of budget to a different post
Project (An industry that supports project-based forms of organization in which teams of specialists from both inside and outside the company report to project managers.)	Positions	Jobs	Jobs
Controlled (An industry that is highly structured in which all aspects of work and remuneration are well organized and regulated.)	Positions	Positions	Positions
Manufacturing	Positions	Jobs	Positions
Retail	Positions	Jobs	Positions
Education	Positions	Jobs	Positions
Other	Positions	Jobs	Jobs

Positions: Examples

Positions are typically used by industries that use detailed approval rules, which perform detailed budgeting and maintain head counts, or have high turnover rates.

Retail Industry

ABC Corporation has high turnover. It loses approximately 5% of their cashiers monthly. The job of cashier includes three positions: front line cashier, service desk cashier, and layaway cashier. Each job is cross trained to take over another cashier position. When one cashier leaves from any of the positions, another existing cashier from the front line, service desk or layaway can assist where needed. . But to ensure short lines and customer satisfaction, ABC must replace each cashier lost to turnover.

Since turnover is high in retail it is better for this industry to use positions. There is an automatic vacancy when an employee terminates employment. The position exists even when there are no holders. This is important if the person who leaves the company is a manager or supervisor with direct reports. All direct reports continue reporting to the position even if it is empty. You do not need to reassign these employees to another manager or supervisor; the replacement manager is assigned to the existing position.

Also, an advantage to using positions is that when you hire somebody new many of the attributes are defaulted in from the position. This speeds up the hiring process.

This figure illustrates the retail position setup.

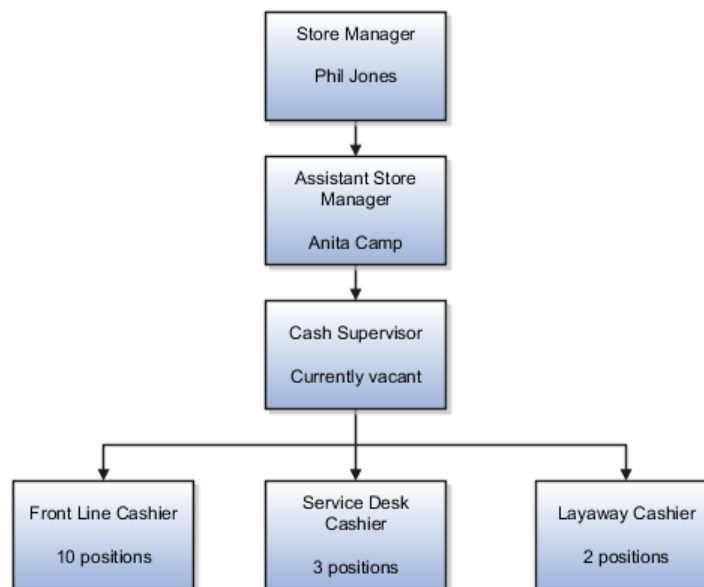

Health Care Industry

The hospital has a structured head count and detailed budgeting. For example, a specific number of surgeons, nurses, and interns of various types are needed. These positions need to be filled in order for the hospital to run smoothly. Use jobs and positions if you need to apply detailed head count rules.

Health care is an industry that needs to regulate employment, roles, and compensation according to strict policies and procedures. Fixed roles tend to endure over time, surviving multiple incumbents. Industries that manage roles rather than individuals, where roles continue to exist after individuals leave, typically model the workforce using positions.

This figure illustrates the hospital position setup.

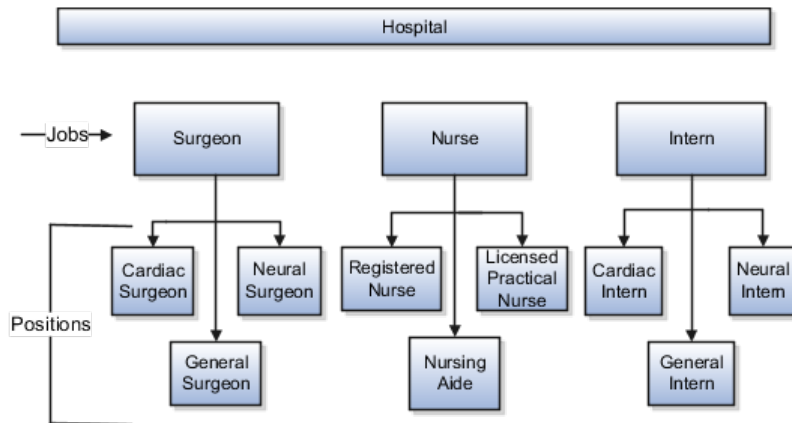

Jobs: Example

Jobs are typically used without positions by service industries where flexibility and organizational change are key features.

Software Industry

For example, XYZ Corporation has a director over the departments for developers, quality assurance, and technical writers. Recently, three developers have left the company. The director decides to redirect the head count to other areas. Instead of hiring all three back into development, one person is hired to each department, quality assurance, and technical writing.

In software industries, the organization is fluid. Using jobs gives an enterprise the flexibility to determine where to use head count, because the job only exists through the person performing it. In this example, when the three developers leave XYZ Corporation, their jobs no longer exist, therefore the corporation has the flexibility to move the headcount to other areas.

This figure illustrates the software industry job setup.

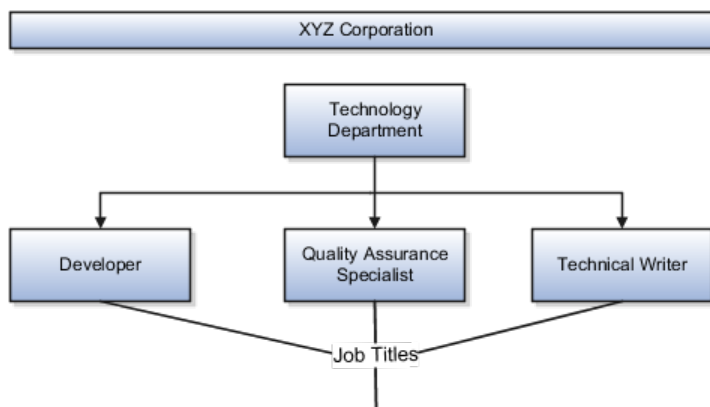

Job and Position Structures: Explained

Job and position structures identify the descriptive flexfield structure that enables you to specify additional attributes that you want to capture when you

define jobs and positions. Job and position attributes provide further detail to make jobs and positions more specific. You also use attributes to define the structure of your jobs and positions. You can specify attributes at the enterprise level for jobs and positions, at the business unit level for positions, and at the reference data set level for jobs. Job and position structures are optional.

Enterprise-Level Job Attributes

When you define a job, you enter a value for the name of the job. To make job names more specific, set up attributes that enable you to identify additional details about the job, such as the nature of the work that is performed or the relative skill level required for the job. If these attributes apply to all jobs within your enterprise, set up enterprise-level job attributes. Standard capabilities mean that you can use the different segments of the name to identify common jobs or job holders for analysis or compensation, or for grouping records in reports, for example, to find all jobs of a specific job type. You should not use attributes with values that change regularly, for example, salary ranges or expense approval levels that change every year.

This figure illustrates how job type and job level provide further details for the HR Application Specialist job.

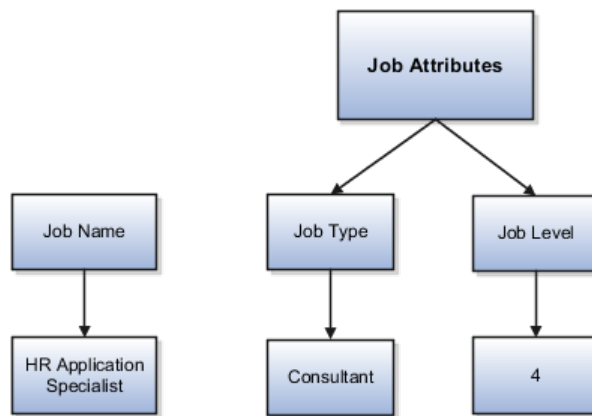

Enterprise-Level Position Attributes

Position attributes at the enterprise level are similar to those for jobs. Each position that you define identifies a specific role in the enterprise, which you can manage independently of the person in the position, and it will belong to one specific department or organization. The name of each position must be unique. To simplify the process of managing unique names for positions, set up enterprise-level attributes to identify separate components of the position name. For example, you can set up an attribute for position title and one for position number. When defining the attributes that make up the structure of a position name you should also consider if any of your attributes are part of the definition of a common job type. Using job types for a position can help you manage common information that applies to many different positions. For example you can define a job type of Manager.Level 1 and use this for comparison of positions across departments or lines or business, or for setting common job requirements. You can then define multiple manager type positions in your HR department, each of which has responsibility for a different management function or group.

This figure illustrates how title and position number provide further details for the manager position.

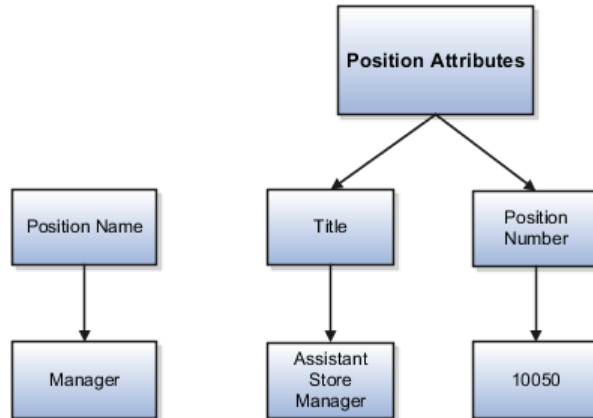

Business Unit-Level Attributes for Positions

If you have information that you want to capture for positions that is specific to each business unit, then you can define attributes at the business unit level for positions. When you create positions, these attributes appear in addition to any enterprise-level attributes. For example, you may want to identify the sales region for all positions in the sales business unit. You can set up a text attribute called Sales Region and use it to enter the necessary information when creating positions for the sales business unit.

Reference Data Set-Level Attributes for Jobs

If you have information for jobs that applies to specific reference data sets, set up attributes for jobs at the reference data set level. When you create jobs, these attributes appear in addition to any enterprise-level attributes. For example, you may want to identify all information technology (IT) jobs within a specific set. You can set up a text attribute called Function and use it to enter IT in jobs that you create that perform an IT function within a specific set.

FAQs for Define Initial Configuration

What happens if I don't use the Enterprise Structures Configurator to set up my enterprise structures?

The Enterprise Structures Configurator is an interview-based tool that guides you through setting up divisions, legal entities, business units, and reference data sets. The tool also enables you to assign reference data sets to business units and locations. You can set up multiple configurations to perform what-if scenarios, and then print each configuration to compare the resulting enterprise structure. If you do not use the Enterprise Structures Configurator, then you must set up your enterprise structure using the individual tasks that correspond to each enterprise component. In addition, you will not be able to set up multiple configurations and compare different scenarios. It is recommended that you use the Enterprise Structures Configurator.

What's an ultimate holding company?

The legal entity that represents the top level in your organization hierarchy, as defined by the legal name entered for the enterprise. This designation is used

only to create an organization tree, with the ultimate holding company as the top level, divisions and country holding companies as the second level, and legal employers as the third level.

What's the default reference data set?

The reference data set that is assigned to a business unit for all reference data groups, such as grades, locations, departments, and jobs. You can override the default reference data set for any reference data group.

What happens if I override the set assignment?

For the selected business unit, you can override the default reference data set for one or more reference data groups. For example, assume you have three reference data groups: Vision 1 SET, Vision 2 SET, and Vision 3 SET, where Vision SET 1 is the default set for business unit United Kingdom Vision 1 BU. You can override the default so that grades are assigned to Vision 2 SET, departments are assigned to Vision 3 SET, and jobs are assigned to the default set, Vision 3 SET.

Define Reference Data Sharing

Reference Data Sharing: Explained

Reference data sharing facilitates sharing of configuration data such as jobs and payment terms, across organizational divisions or business units. You define reference data sets and determine how the data is shared or partitioned. Use reference data sets to reduce duplication and maintenance by sharing common data across business entities where appropriate. Depending on the requirement (specific or common), each business unit can maintain its data at a central location, using a set of values either specific to it or shared by other business units.

You can share reference data after it is filtered on the basis of sets. A common reference data set is available as the default set, which can be assigned to several business units sharing the same reference data. For commonly used data such as currencies, you can use the common reference data set and assign it to multiple business units in various countries that use the same currency. In cases where the default set cannot be assigned to an entity, you can create specific sets. The data set visible on the transactional page depends on the sharing method used to share reference data.

For example, XYZ Corporation uses the same grades throughout the entire organization. Instead of managers in different business units setting up the same grades, XYZ Corporation decides to create a set called Grades and assign the grades reference data group for all business units in the organization to the Grades set, so that the grades can be shared.

Note

For specific information on configuring reference data sharing for a particular object or product, refer to its product documentation.

Reference Data Sets: Explained

Reference data sets are logical groups of reference data that can be accessed by various transactional entities depending on the business context. Oracle Fusion Applications contains a common reference data set as well as an enterprise set that may be used as a default set. Depending on your business requirement you can create and maintain additional reference data sets, while continuing to use the common reference data set.

Consider the following scenario.

Your enterprise can decide that some aspects of corporate policy should affect all business units and leave other aspects to the discretion of the business unit manager. This allows your enterprise to balance autonomy and control for each business unit. For example, if your enterprise holds business unit managers accountable for their profit and loss, but manages working capital requirements at a corporate level, you can let managers define their own sales methods, but define payment terms centrally. In this case, each business unit would have its own reference data set for sales methods, and there would be one central reference data set for payment terms assigned to all business units.

Partitioning

The partitioning of reference data and creation of data sets enable you to create reference entities across tables or lookup types, and share modular information and data processing options among business units. With the help of partitioning, you can choose to create separate sets and subsets for each business unit depending upon its business requirement, or create common sets or subsets to enable sharing reference data between several business units, without the need for duplicating the reference data. Partitioning provides you the flexibility to handle the reference data in a way appropriate to your business needs.

The following figure illustrates the reference data sharing method (assignment to one set only, with common values) where the user can access the data assigned to a specific set in a particular business unit, as well as access the data assigned to the common set.

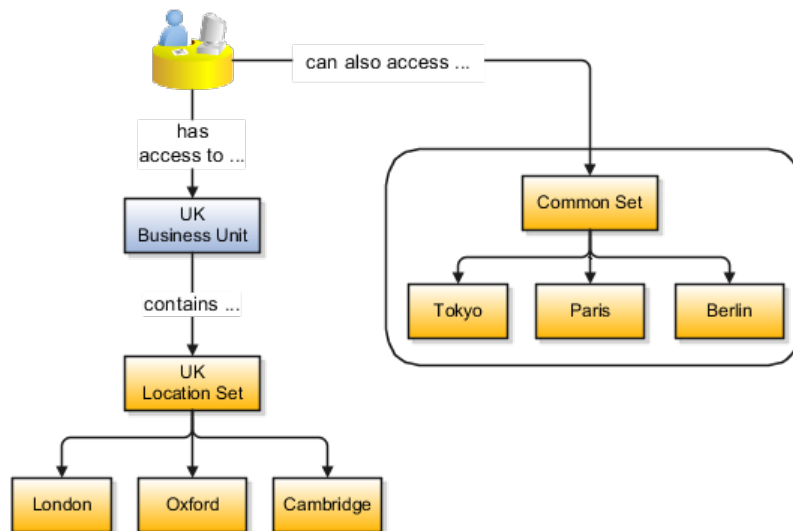

Reference Data Sets and Sharing Methods: Explained

Oracle Fusion Applications reference data sharing feature is also known as SetID. The reference data sharing functionality supports operations in multiple ledgers, business units, and warehouses, thereby reducing the administrative burden and decreasing the time needed to implement new business units. For example, you can share sales methods, transaction types, or payment terms across business units or selected other data across asset books, cost organizations, or project units.

The reference data sharing features use reference data sets to which reference data is assigned. The reference data sets group assigned reference data. The sets can be understood as buckets of reference data assigned to multiple business units or other application components.

Reference Data Sets

You begin this part of your implementation by creating and assigning reference data to sets. Make changes carefully as changes to a particular set will affect all business units or application components using that set. You can assign a separate set to each business unit for the type of object that is being shared. For example, assign separate sets for payment terms, transaction types, and sales methods to your business units.

Your enterprise can decide that some aspects of corporate policy should affect all business units and leave other aspects to the discretion of the business unit manager. This allows your enterprise to balance autonomy and control for each business unit. For example, if your enterprise holds business unit managers accountable for their profit and loss, but manages working capital requirements at a corporate level, you can let managers define their own sales methods, but define payment terms centrally. In this case, each business unit would have its own reference data set for sales methods, and there would be one central reference data set for payment terms assigned to all business units.

The reference data sharing is especially valuable for lowering the cost of setting up new business units. For example, your enterprise operates in the hospitality industry. You are adding a new business unit to track your new spa services. The hospitality divisional reference data set can be assigned to the new business unit to quickly setup data for this entity component. You can establish other business unit reference data in a business unit specific reference data set as needed

Reference Data Sharing Methods

There are variations in the methods used to share data in reference data sets across different types of objects. The following list identifies the methods:

- Assignment to one set only, no common values allowed. The simplest form of sharing reference data that allows assigning a reference data object instance to one and only one set. For example, Asset Prorate Conventions are defined and assigned to only one reference data set. This set can be shared across multiple asset books, but all the values are contained only in this one set.
- Assignment to one set only, with common values. The most commonly used method of sharing reference data that allows defining reference data

object instance across all sets. For example, Receivables Transaction Types are assigned to a common set that is available to all the business units without the need to be explicitly assigned the transaction types to each business unit. In addition, you can assign a business unit specific set of transaction types. At transaction entry, the list of values for transaction types includes transaction types from the set assigned to the business unit, as well as transaction types assigned to the common set that is shared across all business units.

- Assignment to multiple sets, no common values allowed. The method of sharing reference data that allows a reference data object instance to be assigned to multiple sets. For instance, Payables Payment Terms use this method. It means that each payment term can be assigned to one or more than one set. For example, you assign the payment term Net 30 to several sets, but the payment term Net 15 is assigned to only your corporate business unit specific set. At transaction entry, the list of values for payment terms consists of only one set of data; the set that is assigned to the transaction's business unit.

Note: Oracle Fusion Applications contains a reference data set called Enterprise. Define any reference data that affects your entire enterprise in this set.

Assigning Reference Data Sets to Reference Objects: Points to Consider

You can assign the reference data sets to reference objects on the Manage Reference Data Set Assignments page. For multiple assignments, you can classify different types of reference data sets into groups and assign them to reference entity objects. The assignment takes into consideration the determinant type, determinant, and reference group, if any.

Determinant Types

The partitioned reference data is shared based on a business context setting called the determinant type. It is the point of reference used in the data assignment process. The following table lists the determinant types used in the reference data assignment.

Type	Description
Asset Book	Information about the acquisition, depreciation, and retirement of an asset that belongs to a ledger or a business unit.
Business Unit	The departments or organizations within an enterprise.
Cost Organization	The organization used for cost accounting and reporting on various inventory and cost centers within an enterprise.
Project Unit	A logical organization within an enterprise that is responsible for enforcing consistent project management practices.
Reference Data Set	References to other shared reference data sets.

Determinant

The determinant or determinant value is the value that corresponds to the selected determinant type. The determinant is one of the criteria for selecting the appropriate reference data set. For example, when managing set assignments for the set determinant type, Reference Data Set is the determinant type, and you would enter the corresponding set code value as the corresponding determinant value.

Reference Groups

A transactional entity may have multiple reference entities (generally considered to be setup data) that are treated in the same manner because of commonness in implementing business policies and legal rules. Such reference entities in your application are grouped into logical units called reference groups, based on the functional area and the partitioning requirements that they have in common. For example, all tables and views that define Sales Order Type details might be part of the same reference group.

Note

The reference groups are predefined in the reference groups table and are available for selection and assignment.

Items and Supplier Site Reference Data Sharing: Explained

Some products required special logic for reference data sharing and have implemented their own domain specific ways for sharing data.

Items and supplier sites are two such product specific reference data objects that use product specific mechanisms to share data.

Items

If you share your items across warehouses or manufacturing facilities, you can access them through a common item master. Configure one or multiple item masters for your enterprise, based your enterprise structure. A single item master is recommended because it provides simpler and more efficient maintenance. However, in rare cases, it may be beneficial to keep multiple item masters. For example, if you acquire another enterprise and need to continue to operate your lines of business separately, maintaining a second item master might be the best decision.

Suppliers Sites

You can approve particular suppliers to supply specified commodities and authorize your business units to buy from those suppliers when the need arises. For example, you might be a household cleaning products manufacturer and need dyes, plastics, and perfumes to make your products. You purchase from a central supplier 70% of your perfume supplies with an additional supplier, in reserve, from whom you purchase the remaining 30%. At the same time, each of your business units purchases plastics and dyes from the same supplier, but from different local supplier sites to save transportation costs.

To implement business unit specific supplier sites, Oracle Fusion Procurement supports a method for defining suppliers sites as owned and managed by the business unit responsible for negotiating the supplier terms. Your other business units that have a service provider relationship defined with your procurement business unit, subscribe to the supplier sites using the supplier site assignments feature. In addition, Procurement allows sharing of the following procurement data objects across business units:

- Supplier qualification data, such as approved supplier lists
- Catalog content, such as agreements, smart forms, public shopping lists, and content zones
- Procurement configuration data

FAQs for Define Reference Data Sharing

What reference data objects can be shared across business units?

The following list contains the reference data objects for the Oracle Fusion Applications that can be shared across business units and the method in which the reference data for each is shared.

Application Name	Reference Data Object	Method of Sharing
Trading Community Model	Customer Account Relationship	Assignment to one set only, with common values
Trading Community Model	Customer Account Site	Assignment to one set only, with common values
Trading Community Model	Sales Person	Assignment to one set only, with common values
Opportunity Management	Sales Method Group	Assignment to one set only, with common values
Work Management	Assessment Templates	Assignment to one set only, with common values
Enterprise Contracts	Contract Types	Assignment to one set only, with common values
Sales	Sales Method	Assignment to one set only, with common values
Common Components	Activity Templates	Assignment to one set only, with common values
Payables	Payment Terms	Assignment to multiple sets, no common values allowed
Receivables	Accounting Rules	Assignment to one set only, with common values
Receivables	Aging Buckets	Assignment to one set only, with common values
Receivables	Auto Cash Rules	Assignment to one set only, with common values
Receivables	Collectors	Assignment to one set only, with common values
Receivables	Lockbox	Assignment to one set only, with common values

Receivables	Memo Lines	Assignment to one set only, with common values
Receivables	Payment Terms	Assignment to one set only, with common values
Receivables	Remit To Address	Assignment to one set only, with common values
Receivables	Revenue Contingencies	Assignment to one set only, with common values
Receivables	Transaction Source	Assignment to one set only, with common values
Receivables	Transaction Type	Assignment to one set only, with common values
Advanced Collections	Collections Setups	Assignment to one set only, with common values
Advanced Collections	Dunning Plans	Assignment to one set only, with common values
Tax	Tax Classification Codes	Assignment to one set only, with common values
Performance Management	Performance Templates	Assignment to one set only, with common values
Human Resources	Departments	Assignment to one set only, with common values
Human Resources	Jobs	Assignment to one set only, with common values
Human Resources	Locations	Assignment to one set only, with common values
Human Resources	Grades	Assignment to one set only, with common values
Project Billing	Project and Contract Billing	Assignment to multiple sets, common values not allowed
Project Foundation	Project Accounting Definition	Assignment to one set only, no common values allowed
Project Foundation	Project Rates	Assignment to one set only, with common values
Distributed Order Orchestration	Hold Codes	Assignment to one set only, with common values
Distributed Order Orchestration	Orchestration Process	Assignment to one set only, with common values

What reference data objects can be shared across asset books?

The following list contains the reference data objects for Oracle Fusion Assets that can be shared across asset books and the method in which the reference data for each is shared.

Application Name	Reference Data Object	Method of Sharing
Assets	Bonus Rules	Assignment to one set only, no common values allowed

Assets	Depreciation Ceilings	Assignment to one set only, no common values allowed
Assets	Depreciation Methods	Assignment to one set only, with common values
Assets	Asset Descriptions	Assignment to one set only, no common values allowed
Assets	Property Types	Assignment to one set only, with common values
Assets	Prorate Conventions	Assignment to one set only, no common values allowed
Assets	Asset Queue Names	Assignment to one set only, with common values
Assets	Retirement Types	Assignment to one set only, with common values
Assets	Unplanned Types	Assignment to one set only, with common values

What reference data objects can be shared across cost organizations?

The following list contains the reference data objects for Oracle Fusion Cost Management that can be shared across cost organizations and the method in which the reference data for each is shared.

Application Name	Reference Data Object	Method of Sharing
Cost Management	Cost Structure	Assignment to one set only, no common values allowed

What reference data objects can be shared across project units?

The following list contains the reference data objects for Oracle Fusion Project Foundation that can be shared across project units and the method in which the reference data for each is shared.

Application Name	Reference Data Object	Method of Sharing
Project Foundation	Project Definition	Assignment to multiple sets, no common values allowed
Project Foundation	Project Transaction Types	Assignment to multiple sets, no common values allowed

Define Enterprise: Manage Enterprise HCM Information

Enterprise: Explained

An enterprise consists of legal entities under common control and management.

Enterprise Defined

When implementing Oracle Fusion Applications you operate within the context of an enterprise that has already been created in the application for you. This is either a predefined enterprise or an enterprise that has been created in the application by a system administrator.

An enterprise organization captures the name of the deploying enterprise and the location of the headquarters. There is normally a single enterprise organization in a production environment. Multiple enterprises are defined when the system is used to administer multiple customer companies, for example, multiple tenants, or when a customer chooses to set up additional enterprises for testing or development.

Oracle Fusion Applications offers capabilities for multiple tenants to share the same applications instance for some human resources processes. If you offer business process outsourcing services to a set of clients, each of those clients may be represented as an enterprise within an Oracle Fusion Application instance. To support this functionality, system owned reference data such as sequences, sets, and flexfields are also defined within an enterprise.

In Oracle Fusion Applications, an organization classified as an enterprise is defined before defining any other organizations in the HCM Common Organization Model. All other organizations are defined as belonging to an enterprise.

Managing Enterprise Information for Non-Oracle Fusion HCM Users: Explained

The Manage Enterprise HCM Information task includes default settings for your enterprise such as the employment model, worker number generation, and so on. If you are not implementing Oracle Fusion Human Capital Management (HCM), then the only action you may need to perform using this task is to change the enterprise name, if necessary. The other settings are HCM-specific and are not relevant outside of Oracle Fusion HCM.

Define Enterprise: Manage Locations

Locations: Explained

A location identifies physical addresses of a workforce structure, such as a department or a job. You can also create locations to enter the addresses of external organizations that you want to maintain, such as employment agencies, tax authorities, and insurance or benefits carriers.

The locations that you create exist as separate structures that you can use for reporting purposes, and also in rules that determine employee eligibility for various types of compensation and benefits. You enter information about a location only once. Subsequently, when you set up other workforce structures you select the location from a list.

Location Sets

When you create a location, you must associate it with a set. Only those users who have access to the set's business unit can access the location set and other associated workforce structure sets, such as those that contain departments and jobs.

You can also associate the location to the common set so that users across your enterprise can access the location irrespective of their business unit. When users search for locations, they can see the locations that they have access to along with the locations in the common set.

The following figure shows how locations sets restrict access to users.

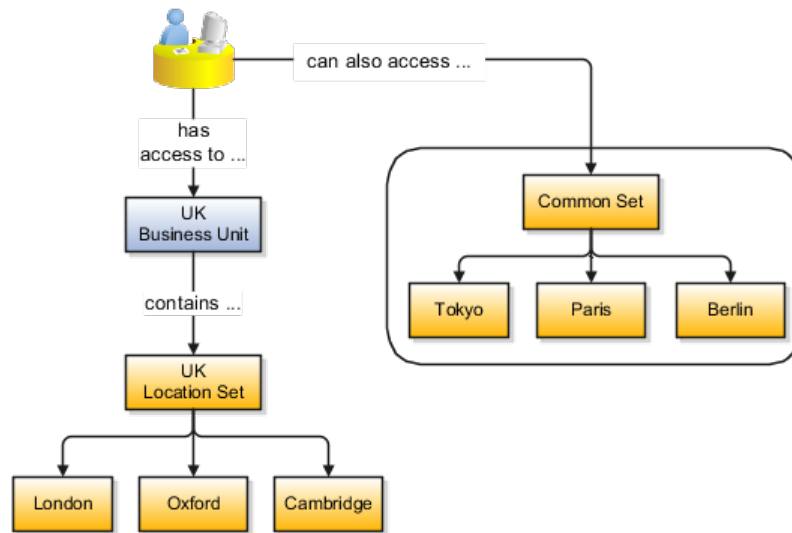

Creating Multiple Locations Simultaneously

If you have a list of locations already defined for your enterprise, you can upload them from a spreadsheet. To use this option, you first download a spreadsheet template, then add your location information to the spreadsheet, and then upload directly to your enterprise configuration. You can upload the spreadsheet multiple times to accommodate revisions.

FAQs for Manage Locations

Why can't I see my location in the search results?

You can search for approved locations only. Also, if you created a location in Oracle Fusion Trading Community Model, then you can't access that location from Oracle Fusion Global Human Resources. For use in Oracle Fusion HCM, you must recreate the location from the Manage Locations page.

What happens if I select a geographic hierarchy node when I'm creating or editing a location?

The calendar events that were created for the geographical node start to apply for the location and may impact the availability of worker assignments at

that location. The geographical hierarchy nodes available for selection on the Locations page display from a predefined geographic hierarchy.

What happens if I select an inventory organization when I'm creating or editing a location?

The location is available for selection in purchase documents of that inventory organization in Oracle Fusion Inventory Management. If you don't select an inventory organization, then the location is available in purchase documents across all inventory organizations.

What happens if I inactivate a location?

Starting from the effective date that you entered, you can no longer associate the location with other workforce structures, assignments, or applications. If the location is already in use, it will continue to be available to the components that currently use it.

How can I associate a location with an inventory organization?

From the Manage Locations page in Oracle Fusion Global Human Resources.

To appear on the Create or Edit Location pages, your inventory organization must be effective on today's date and must exist in the location set that you selected.

Define Geographies

Defining Address Cleansing: Explained

Address cleansing provides a way to validate, correct, and standardize addresses that are entered in a user interface. Geography validation only validates the geography attributes of an address, for example, State, City, and Postal codes; address cleansing validates both the geography attributes and the address line attributes.

Address cleansing can only be used through the Oracle Fusion Trading Community Data Quality product, because the feature is delivered using Data Quality integration. You need to ensure that you have a license for the countries that will use Trading Community Data Quality data cleansing.

You can specify the real time address cleansing level for each country by choosing either **None**, meaning that there is no real time address cleansing, or by choosing **Optional**, meaning that you will have the choice to cleanse addresses. Once you have enabled address cleansing for a country a **Verify Address** icon appears at address entry points in the application. You can then click the icon to perform address cleansing and receive a corrected, standardized address. If Trading Community Data Quality does not find a matching address the application will alert you.

Geography Structure, Hierarchy, and Validation: How They Fit Together

There are three components that are dependent on each other when defining a country: geography structure, geography hierarchy, and geography validation. Every country has to have the geography structure defined first before the hierarchy can be defined, and the geography hierarchy has to be defined before the validation can be defined.

Geography Structure

Firstly, you need to create a geography structure for each country to define which geography types are part of the country structure, and how the geography types are hierarchically related within the country structure. For example, you can create geography types called State, City, and Postal Code. Then you can rank the State geography type as the highest level within the country, the City as the second level, and the Postal Code as the lowest level within the country structure. Geography structure can be defined using the **Manage Geographies** task, or can be imported using tasks in the **Define Geographies** activity.

Geography Hierarchy

Once the geography structure is defined, the geographies for each geography type can be added to the hierarchy. For example, below the United States you can create a geography called California using a State geography type.

As part of managing the geography hierarchy you can view, create, edit, and delete the geographies for each geography type in the country structure. You can also add a primary and alternate name and code for each geography. A geography hierarchy can be created using the **Manage Geographies** task, or can be imported using tasks in the **Define Geographies** activity.

Geography Validation

After defining the geography hierarchy, you need to specify the geography validations for the country. You can choose which address style formats you would like to use for the country, and for each selected address style format you can map geography types to address attributes. You can also select which geography types should be included in geography or tax validation, and which geography types will display in a list of values during address entry in other user interfaces. The geography validation level for the country, such as error or warning, can also be selected.

Geography Structures: Explained

A geography structure is a hierarchical grouping of geography types for a country. For example, the geography structure for the United States is the geography type of State at the top, then followed by the County, then the City, and finally the Postal Code.

You can use the geography structure to establish:

- How geographies can be related
- The types of geographies you can define for the country

How Geographies Can Be Related

You can determine how a country's geographies are hierarchically related by creating the hierarchy of the geography types in the geography structure. When you define a country's structure the country geography type is implicitly at the top of the geography structure, and the numbering of the subsequent levels start with 1 as the next geography level after country.

You must add a geography type as a level in the country structure before you can define a geography for that geography type in a country. For example, before defining the state of California, the State geography type must be added to the United States country structure. Only one geography type can be used for each level, you cannot define more than one geography type at the same level.

Note

After you first define a country structure you can only add geography types below the current lowest level, and delete geography types without defined geographies.

To simplify the creation of a country structure you can copy a structure from another country, and then amend the geography type hierarchy for the country.

The Types of Geographies You Can Define for the Country

The application provides you with a set of available master reference geography types. If required, you can create a geography type before adding it to the country structure. Each geography type is added below the current lowest level.

Note

If you want to delete a geography type that is not at the lowest level in the country structure, then you have to delete the geography type level and all the levels below it.

A geography type that you create within the country structure can be used for other country structures as well.

Geography Hierarchy: Explained

Geography hierarchy is a data model that lets you establish conceptual parent-child relationships between geographies. A geography, such as Tokyo or Peru, describes a boundary on the surface of the earth. The application can extrapolate information based on this network of hierarchical geographical relationships.

For example, in the geography hierarchy the state of California is defined as the parent of San Mateo county, which is the parent of Redwood City, which is

the parent of the postal code 94065. If you enter just 94065, the application can determine that the postal code is in California, or that the corresponding city is Redwood City.

The application leverages geography hierarchy information to facilitate business processes that rely on geography information, for example, tax calculation, order sourcing rules, sales territory definition. The geography hierarchy information is centrally located in the Trading Community Model and shared among other application offerings.

The top level of the geography hierarchy is Country, so the hierarchy essentially contains countries and their child geographies. Other aspects of the geography hierarchy include:

- Geography
- Geography type
- Geography usage
- Master reference geography hierarchy
- User defined zones

Geography

A geography is a boundary such as a country, state, province or city. It is a physical space with boundaries that is a defined instance of a geography type. For example, San Jose is a geography of the City geography type.

Geography Type

Geography types are a divisional grouping of geographies, which can be either geopolitical (for example, City, Province, and District) or user defined (for example, Continent, Country Regions, Tax Regions).

Geography Usage

Geography usage indicates how a geography type or geography is used in the application. A master reference geography always has the usage of Master Reference. User defined zones can have the usages of Tax, Shipping, or Territory, based on what is relevant for their purpose.

Master Reference Geography Hierarchy

The geography hierarchy data is considered to be the single source of truth for geographies. It is all the data, including geography types and geographies, that you define and maintain in the Trading Community Model tables.

The geography usage for the entire hierarchy is the master reference, and defined geography types and geographies are considered as master reference geography types and geographies. For example, Country is a universally recognized geography type, and United States is considered a master geography.

User Defined Zones

User defined zones are a collection of geographical data, created from master reference data for a specific purpose. For example, territory zones are collections of master reference geographies ordered in a hierarchy. Tax and shipping zones are collections of master reference geographies without a hierarchical grouping.

Geography Validation: Explained

Geography validation determines the geography mapping and validation for a country's address styles, as well as the overall geography validation control for a country.

The **No Styles Format** address style format is the default address style format for a country. By defining the mapping and validation for this format you will ensure that validations can be performed for any address in the country. After the **No Styles Format** is defined you can set up additional mapping for specific address styles.

For each address style format, you can define the following:

- Map to attribute
- Enable list of values
- Tax validation
- Geography validation
- Geography validation control

Map to Attribute

For every address style format, you can map each geography type to an address attribute. For example, you can map the **State** geography type to the **State** address attribute for the United States, or map the **State** geography type to the **County** address attribute for the United Kingdom. The geography types that appear are based on how the country structure is defined. The list of address attributes that appear are based on address formats delivered with the application, or your customer defined address formats.

Note

You only need to map geography types that you want to use for geography or tax validation purposes.

Enable List of Values

Once a geography type is mapped to an attribute, then you can specify whether the geography type will appear in a list of values during address entry in user interfaces. It is very important to review carefully if you want to enable a list of values. You should only enable a list of values if you have sufficient geography data imported or created for that geography. Once you have enabled a list of

values for an address attribute, you can only select the geography data available for the geography type. This means that if a specific geography value is not available in the geography hierarchy, you cannot create an address with a different geography value.

Tax Validation

You can also specify whether a geography type will be included in tax validation. For example, for the United States North America address style format you specify that County, State, and City are used for tax validation. This will mean that when a transaction involves an address with the North America address style, the address must have the correct county, state, and city combination based on the geography hierarchy data, to be considered valid for tax calculation.

Geography Validation

You can specify whether a geography type will be included in geography validation. This will mean that, for example, when the user enters a United States address using the North America address style format, the address must have the correct country, state, and postal code combination based on geography hierarchy data to be considered geographically valid.

If an address element is mapped to a geography type, but not selected for geography validation usage, then during address entry suggested values will be provided for the address element, but the address element will not be validated.

Note

For either the tax or geography validation, do not skip more than one consecutive level unless you are certain that the selected geography types can uniquely identify geographies. For example, the United States country structure is: State, County, City, and Postal Code, and you want to select just State and Postal Code for geography or tax validation. However, for the combination of California and 94065, the city can be either Redwood Shores or Redwood City. In this case, you should also select at least the City geography type for geography or tax validation.

Geography Validation Control

You can select the geography validation level for a country. Validation will check if the entered address maps to the geography hierarchy data available for the country, and the geography validation control determines whether you can save an address that did not pass validation during address entry. For example, if the validation level is **Error**, then an address cannot be saved if the values do not match the geography hierarchy data.

These are the geography validation levels you can choose:

- **Error** - only completely valid addresses can be saved, with all mandatory address elements entered.
- **No Validation** - all addresses can be saved including incomplete and invalid addresses.

Regardless of the result of validation, the validation process will try to map any address attribute to a geography of the country, and store any mapping it could establish based on the available data. This is called **Geography Name Referencing** and it is executed as part of validation. The result of this referencing is used in several business processes in the application to map an address to a specific geography or zone.

Note

The Geography Dimension value in territories is derived from sell-to addresses of sales accounts. To use geography dimensions in territories, ensure that the geography elements in addresses, such as state, city, and postal code, are validated. You can do so by enabling geography validation for each country using the Manage Geographies task. While doing so, ensure that at least one level in the geography hierarchy is enabled for geography validation. It is recommended that you enable geography validation for all geography levels that you intend to use for territory definition for each country. You can enable a list of values containing specific geography elements. This will help users search and select appropriate geography values during addresses entry and eliminate all possibilities of wrong address entry. You can also set geography validation control to Error in the Manage Geography Validation page. This ensures that users can only use valid geography elements in addresses. If you have already created addresses before setting up geography validation for a country, you must execute the Run Maintain Geography Name Referencing task for that country after enabling geography validation to ensure that all your geography elements are validated.

Importing Geographies: Explained

A geography, such as Tokyo or Peru, describes a boundary on the surface of the earth. You can create new geographies by importing data through interface tables. There are two options for populating the interface tables: using the tool of your preference to load the data or using file-based data import. If you plan to provide the data details in a source file, use the file-based import feature. If you will populate the interface table directly, run the geography loader process to import the data. Having a good understanding of the import entity, interface table, and destination table will help you prepare your import data.

Consider the following when importing geographies:

- File-based import option
- Geography loader process option
- Import object entity, interface table, and destination tables

File-Based Import Option

The file-based import process reads the data included in your XML or text file, populates the interface tables, and imports the data into the application destination tables. The **File-Based Data Import Setup and Maintenance** task list includes the tasks needed to configure the geography import object, create source file mappings, and schedule the import activities.

Geography Loader Process Option

Populate the interface table with your import data, then navigate to the **Run Geography Loader Setup and Maintenance** task to schedule the import of data from the interface table to the destination table.

Import Object Entity, Interface Table, and Destination Tables

The geography import object consists of one entity and interface table that forms the geography. If you are using file-based import, you can map your source file data to import entity attributes that correspond to the interface table columns. The import activity process populates the interface table based on the mapping and your source file. If using the geography loader scheduled process, populate the interface table directly using your preferred tool. If you need the unique IDs of existing application data for your import data, use the **Define Data Export Setup and Maintenance** task list to export the information.

Note

Spreadsheets containing detailed information about each interface table, including the import attributes, corresponding interface table columns, defaults, and validations, are available from the Oracle Enterprise Repository by searching on a specific interface table name or initiating a search using the **FusionApps: Interface Table** asset type.

The following lists the object entity, tables, and resulting application object:

File-Based Import Entities	Interface Tables	Destination Tables	Application Object
ImpGeography	HZ_IMP_GEOGRAPHIES	HZ_GEOGRAPHIES HZ_GEOGRAPHY_IDEN HZ_GEOGRAPHY_TYPE HZ_HIERARCHY_NODE	Geography

Importing Geographies Using File-based Data Import: Worked Example

This example demonstrates how to import data using the File-Based Data Import tool. In this particular example you have a source file containing geography data that you want to import into the application, so that the geography data can be used for uses related to locations, such as real time address validation and tax purposes.

The following table summarizes the key decisions for this scenario:

Decisions to Consider	In This Example
What type of object are you importing?	Geography
What file type are you using for your source data?	Text file

Where are you uploading your source data file from?	Your desktop
What data type is your source data file?	Comma separated
Which fields are you importing into Oracle Fusion applications?	All, except for the RecordTypeCode field
When do you want to process the import?	Immediately

These are the steps that are required to create an import activity and submit the import:

1. Determine what information is in the source file.
2. Create and schedule the import activity.
3. Monitor the import results.

Prerequisites when importing additional geography data after your initial import

1. You need to ensure that the combination of Source ID and Parent Source ID values are unique for each row of data within a single import. However, your source data files do not need to have the same Source ID and Parent Source ID values as your previously imported geography data. If the geography structure levels and the parents for each geography value are the same, the changed IDs will not affect the import.
2. Ensure that all of the parents of a child geography are included in your data file so that the child geography can be added. For example, if you originally imported US, CA, and San Francisco, and now you want to import the city of San Jose in CA, then your data file needs to include US, CA, and San Jose.
3. Check that your source data file has the correct values for the geography data that you have already loaded. For example, if your initial import included the value US for country and CA as state, and in a subsequent import you have California as a state, your geography import will result in two state records (CA and California) in the application data, with the US as the country parent.

Determine what information is in the source file

1. Your source geography data files should include a unique Source ID value for each row of data, and a Parent Source ID value which identifies the parent of that row of geography data. Source IDs, or Parent Source IDs, should not exceed 18 characters. An example of geography source data could be as follows:

Geography Level	Name	Source ID	Parent Source ID
1 (Country)	US	1	
2 (State)	CA	11	1
3 (County)	Alameda	111	11
4 (City)	Pleasanton	1111	111
4 (City)	Dublin	1112	111

Create and schedule the import activity

You create an import activity, enter the import details, and schedule the import. An import activity definition provides the instructions for the import processing - this includes selecting the source file, or file location; mapping fields from the source file to the Oracle Fusion object and attribute; and scheduling the import.

1. Navigate to Setup and Maintenance and search for the Manage File Import Activities task. Click **Go to Task**.
2. In the Manage Import Activities page, click the **Create** icon.
3. In the Create Import Activity: Set Up page, create an import activity for the Geography object type by completing the fields, as shown in this table:

Field	Value
Name	Master Reference Geographies
Object	Geography
File Type	Text File
File Selection	Specific file
Upload From	Desktop
File Name	Choose relevant file from desktop
Data Type	Comma separated

Note

Ensure that the file type that you select in the Create Import Activity: Set Up page matches the file type of the source data file.

4. Click **Next**.
5. On the Create Import Activity: Map Fields page, map each field from your source file to the Oracle Fusion object and attribute, as shown in this example:

Column Header	Example Value	Ignore	Object	Attribute
Primary Geography Name	Primary Geography Name	United States	Imp Geography	Primary Geography Name
Country Code	US	No	Imp Geography	Country Code
Record Type Code	0	Yes	Imp Geography	Record Type Code
Source ID	10265	No	Imp Geography	Source ID
Parent Source ID	1053	No	Imp Geography	Parent Source ID

If you do not want to import a column in the text file you can select **Ignore**.

Note

If you have any difficulties mapping the fields from your source file to the relevant Oracle Fusion applications object, you can use the import object spreadsheets for reference.

6. Click **Next**.
7. On the Create Import Activity: Create Schedule page, select **Immediate** in the Schedule field so that the import will start immediately.

Instead of immediately importing the data, you can choose a date and time to start the import. You can also specify if the import will be repeated, and the frequency of the repeated import.

8. Click **Next**.

Monitor the import results

You monitor the progress of the Import Activity processing, and view completion reports for both successful records and errors.

1. On the Create Import Activity: Review and Activate page, you verify your import details in the Import Details, File Details, Import Options, and Schedule sections.
2. Your import details are correct so you click **Activate** to submit the import.

Once the import activity has completed, the Status field value will change to **Completed**.

Importing and Exporting Territory Geography Zones: Explained

Territory geography zones are geographical boundaries that you can set up to replicate your organization's regions, such as a Pacific Northwest sales region. You can set up territory geography zones in one Oracle Fusion applications instance, and then after the territory geography zones are defined you can export the territory zones and import them into another Oracle Fusion applications instance.

To define your territory geography zones and then import your territory zones into another Oracle Fusion applications instance, you need to complete the following steps:

1. Import the master reference geography data into the Oracle Fusion application.
2. Define your territory geography zones using the Manage Territory Geographies task.
3. Export the territory geography zones.

4. Import the territory geography zones into another Oracle Fusion applications instance.

Import the master reference geography data

Firstly, you need to import the master reference geography data. Master reference geography data consists of geography elements such as country, state, and city, and is required for any geographical information you store in the application, such as address information used in customer and sales records. For more information, refer to the Geography Hierarchy: Explained topic listed in the related topics section. Master reference geography data can be imported into the application using the Manage File Import Activities task in Setup and Maintenance - refer to the Importing Master Reference Geography Data: Worked Example topic listed in the related topics section for more information.

Define your territory geography zones

Once the master reference geography data has been imported, you can then create your territory geography zones in the application using the Manage Territory Geographies task in Setup and Maintenance. For more information, refer to the Managing Territory Geographies: Worked Example topic listed in the related topics section.

Export the territory geography zones

Once you have completed importing the master reference geography data and defining your territory geography zone tasks, you can create a configuration package to export the territory zone data. For more information, refer to the Exporting Setup Data demo listed in the related topics section.

Import the territory geography zones

Once you have downloaded your configuration package for your territory geography zone setup, you can import the territory zones into another Oracle Fusion application instance. For more information, refer to the Importing Setup Data listed in the related topics section.

Note

Ensure that you import your master reference geography data into the new Oracle Fusion instance before you import the configuration package.

Managing Geography Structures, Hierarchies, and Validation: Worked Example

This example shows how to start the configuration of the geography structure, hierarchy, and validation for the country geography of the United Kingdom.

The following table summarizes the key decisions for this scenario.

Decisions to Consider	In This Example
Copy an existing country structure?	No, create a new country structure.
What is the structure of the geography types?	Create geography types with the following ranking structure: <ul style="list-style-type: none"> 1. County 2. Post Town
What is the geography hierarchy?	Create the following hierarchy: <ul style="list-style-type: none"> 1. Country of United Kingdom 2. County of Berkshire 3. Post Town of Reading
Which address style format will you use when mapping geography validations?	The default address style format, called the No Styles Format.
Are you using Oracle Fusion Tax for tax purposes?	No, do not select Tax Validation for the geography types.

Add the County and Post Town geography types to the geography structure. Then add the geographies for the County and Post Town geography types to define the geography hierarchy. Finally, specify the geography validations for the geography types you have added to the geography structure.

Defining the geography structure

You add the County and Post Town geography types to the United Kingdom geography structure.

1. On the Manage Geographies page, enter GB in the **Code** field. Click **Search**.
2. On the Manage Geographies page, click **Structure Defined**.
3. On the Manage Geography Structure page, click the **Create** button next to the **Copy Country Structure From** field.
4. In the Geography Structure section, select the County list item in the **Add Geography Type** field.
5. Click **Add**.
6. Select the Post Town list item in the **Add Geography Type** field.
7. Click **Add**.

Defining the geography hierarchy

You want to begin to create the geography hierarchy for the United Kingdom, so you add the geographies for the County and Post Town geography types using the geography hierarchy User Interfaces. You can also use the Manage File Import Activities task to import geography hierarchies using a csv or xml file.

1. On the Manage Geographies page, enter GB in the **Code** field. Click **Search**.
2. On the Manage Geographies page, click **Hierarchy Defined**.
3. On the Manage Geography Hierarchy page, Geography Hierarchy section, click the United Kingdom to highlight the table row.

4. Click the **Create** button.
5. In the **Create County** page, Primary and Alternate Names section, enter Berkshire in the **Name** field.
6. Click **Save and Close**.
7. On the Manage Geography Hierarchy page, Geography Hierarchy section, click Berkshire to highlight the table row.
8. Click the **Create** button.
9. In the **Create Post Town** page, Primary and Alternate Names section, enter Reading in the **Name** field.
10. Click Save and Close.

Defining the geography validations

Now you want to specify the geography validations for the geography types you have added to the United Kingdom. You define the geography mapping and validation for the United Kingdom default address style format. You map the geography types to attributes, enable the geography types for Lists of Values and Geography validation, and set the geography validation level.

1. On the Manage Geographies page, click **Validation Defined**.
2. On the Manage Geography Validation page, Address Style section, click **No Styles Format** to highlight the table row.
3. For the County geography type, click the **County** list item in the **Map to Attribute** field.
4. Click the **Enable List of Values** option for the County geography type.
5. Click the **Geography Validation** option for the County geography type.
6. For the Post Town geography type, click the **City** list item in the **Map to Attribute** field.
7. Click the **Geography Validation** option for the Post Town geography type.
8. In the Geography Validation Control section, click the **Error** list item in the **Geography Validation Level for Country** field.
9. Click **Save and Close**.

FAQs for Define Geographies

When do I define address cleansing?

When address data entered into the application needs to conform to a particular format, in order to achieve consistency in the representation of addresses. For example, making sure that the incoming data is stored following the correct postal address format.

Why can't I update a geography structure by copying an existing country structure?

You can only update a geography structure by adding existing geography types, or by creating new geography types and then adding them to the geography

structure. You can only copy an existing country structure when you are defining a new country structure.

Why can't I delete a level of the country geography structure?

If a geography exists for a country geography structure level then you cannot delete the level. For example, if a state geography has been created for the United States country geography structure, then the State level cannot be deleted in the country geography structure.

Can I add any geography to the geography hierarchy?

Yes. However, the geography type for the geography that you want to add must be already added to the country geography structure.

Can I edit a specific geography in the geography hierarchy?

Yes. In the Manage Geography Hierarchy page you can edit details such as the geography's date range, primary and alternate names and codes, and parent geographies.

How can I add a geography that is the level below another geography in a geography hierarchy?

Select the geography that you want your geography to be created below, and then click the **Create** icon. This will allow you to create a geography for a geography type that is the level below the geography type you selected. The structure of the country's geography types are defined in the Manage Geography Structure page.

Define Legal Jurisdictions and Authorities

Jurisdictions and Legal Authorities: Explained

You are required to register your legal entities with legal authorities in the jurisdictions where you conduct business. Register your legal entities as required by local business requirements or other relevant laws. For example, register your legal entities for tax reporting to report sales taxes or value added taxes.

Legal Jurisdictions and Authorities

Define jurisdictions and related legal authorities to support multiple legal entity registrations, which are used by Oracle Fusion Tax and Oracle Fusion Payroll. When you first create a legal entity, the Oracle Fusion Legal Entity Configurator automatically creates one legal reporting unit for that legal entity with a registration.

Jurisdictions: Explained

Jurisdiction is a physical territory such as a group of countries, country, state, county, or parish where a particular piece of legislation applies. French Labor

Law, Singapore Transactions Tax Law, and US Income Tax Laws are examples of particular legislation that apply to legal entities operating in different countries' jurisdictions. Judicial authority may be exercised within a jurisdiction.

Types of jurisdictions are:

- Identifying Jurisdiction
- Income Tax Jurisdiction
- Transaction Tax Jurisdiction

Identifying Jurisdiction

For each legal entity, select an identifying jurisdiction. An identifying jurisdiction is your first jurisdiction you must register with to be allowed to do business in a country. If there is more than one jurisdiction that a legal entity needs to register with to commence business, select one as the identifying jurisdiction. Typically the identifying jurisdiction is the one you use to uniquely identify your legal entity.

Income tax jurisdictions and transaction tax jurisdictions do not represent the same jurisdiction. Although in some countries, the two jurisdictions are defined at the same geopolitical level, such as a country, and share the same legal authority, they are two distinct jurisdictions.

Income Tax Jurisdiction

Create income tax jurisdictions to properly report and remit income taxes to the legal authority. Income tax jurisdictions by law impose taxes on your financial income generated by all your entities within their jurisdiction. Income tax is a key source of funding that the government uses to fund its activities and serve the public.

Transaction Tax Jurisdiction

Create transaction tax jurisdictions through Oracle Fusion Tax in a separate business flow, because of the specific needs and complexities of various taxes. Tax jurisdictions and their respective rates are provided by suppliers and require periodic maintenance. Use transaction tax jurisdiction for legal reporting of sales and value added taxes.

Legal Authorities: Explained

A legal authority is a government or legal body that is charged with powers to make laws, levy and collect fees and taxes, and remit financial appropriations for a given jurisdiction.

Legal Authorities

For example, the Internal Revenue Service is the authority for enforcing income tax laws in United States. In some countries, such as India and Brazil, you are required to print legal authority information on your tax reports. Legal authorities are defined in the Oracle Fusion Legal Entity Configurator. Tax authorities are a subset of legal authorities and are defined using the same setup flow.

Legal authorities are not mandatory in Oracle Fusion Human Capital Management (HCM), but are recommended and are generally referenced on statutory reports.

Creating Legal Jurisdictions, Addresses and Authorities: Examples

Define legal jurisdictions and related legal authorities to support multiple legal entity registrations, which are used by Oracle Fusion Tax and Oracle Fusion Payroll.

Legal Jurisdictions

Create a legal jurisdiction by following these steps:

1. Navigate to the **Manage Legal Jurisdictions** page from the **Setup and Maintenance** work area by querying on the **Manage Legal Jurisdictions** task and selecting **Go to Task**.
2. Select **Create**.
3. Enter a unique **Name**, United States Income Tax.
4. Select a **Territory**, United States.
5. Select a **Legislative Category**, Income tax.
6. Select **Identifying**, Yes. Identifying indicates the first jurisdiction a legal entity must register with to do business in a country.
7. Enter a **Start Date** if desired. You can also add an **End Date** to indicate a date that the jurisdiction may no longer be used.
8. Select a **Legal Entity Registration Code**, EIN or TIN.
9. Select a **Legal Reporting Unit Registration Code**, Legal Reporting Unit Registration Number.
10. Optionally enter one or more **Legal Functions**.
11. Select **Save and Close**.

Legal Addresses for Legal Entities and Reporting Units

Create a legal address for legal entities and reporting units by following these steps:

1. Navigate to the **Manage Legal Address** page from the **Setup and Maintenance** work area by querying on the **Manage Legal Address** task and selecting **Go to Task**.
2. Select **Create**.
3. Select **Country**.
4. Enter **Address Line 1**, Oracle Parkway.
5. Optionally enter **Address Line 2**, and **Address Line 3**.
6. Enter or Select **Zip Code**, 94065.
7. Select **Geography** 94065 and **Parent Geography** Redwood Shores, San Mateo, CA.

8. Optionally enter a **Time Zone**, US Pacific Time.
9. Select **OK**.
10. Select **Save and Close**.

Legal Authorities

Create a legal authority by following these steps:

1. Navigate to the **Manage Legal Authorities** page from the **Setup and Maintenance** work area by querying on the **Manage Legal Authorities** task and selecting **Go to Task**.
2. Enter the **Name**, California Franchise Tax Board.
3. Enter the **Tax Authority Type**, Reporting.

Note

Create an address for the legal authority.

-
4. Select **Create**.
 5. The **Site Number** is automatically assigned.
 6. Optionally enter a **Mail Stop**.
 7. Select **Country**, United States
 8. Enter **Address Line 1**, 121 Spear Street, Suite 400.
 9. Optionally enter **Address Line 2**, and **Address Line 3**.
 10. Enter or Select **Zip Code**, 94105.
 11. Select **Geography** 94105 and **Parent Geography** San Francisco, San Francisco, CA.
 12. Select **OK**.
 13. Optionally enter a **Time Zone**, US Pacific Time.
 14. Optionally click the **One-Time Address** check box.
 15. The **From Date** defaults to today's date. Update if necessary.
 16. Optionally enter a **To Date** to indicate the last day the address can be used.

Note

You can optionally enter **Address Purpose** details.

-
17. Select **Add Row**.
 18. Select **Purpose**.
 19. The **Purpose from Date** will default to today's date.
 20. Optionally enter a **Purpose to Date**.
 21. Select **OK**.
 22. Select **Save and Close**.

Creating Legal Entities, Registrations, and Reporting Units: Examples

Define a legal entity for each registered company or other entity recognized in law for which you want to record assets, liabilities, and income, pay transaction taxes, or perform intercompany trading.

Legal Entity

From within an implementation project, create a legal entity by following these steps:

Note

Working within an implementation project is required because you select a scope value within an implementation project. The scope value is the legal entity that you will create or select to work within for your implementation project.

-
1. Navigate to an implementation project that contains the **Define Legal Entities** task list from the **Setup and Maintenance** work area.
 2. Select **Go to Task** for the **Define Legal Entities** task list within the implementation project.

Note

The following message appears:

You must first select a scope value to perform the task.

- Select and add an existing scope value to the implementation project.
- Create a new scope value and then add it to the implementation project.

-
3. Select **Create New**.
 4. From the **Manage Legal Entities** page select **Create**.
 5. Accept the default **Country**, United States.
 6. Enter **Name**, InFusion USA West.
 7. Enter **Legal Entity Identifier**, US0033.
 8. Optionally enter **Start Date**. When the start date is blank the legal entity is effective from the creation date.
 9. Optionally enter an **End Date**.
 10. Optionally, if your legal entity should be registered to report payroll tax and social insurance, select the **Payroll statutory unit** check box.
 11. Optionally, if your legal entity has employees, select the **Legal employer** check box.
 12. Optionally, if this legal entity is not a payroll statutory unit, select an existing payroll statutory unit to report payroll tax and social instance on behalf of this legal entity.

Note

Enter the **Registration Information**.

13. Accept the default **Identifying Jurisdiction**, United States Income Tax.
 14. Search for and select a **Legal Address**, 500 Oracle Parkway, Redwood Shores, CA 94065.
-

Note

The legal address must have been entered previously using the **Manage Legal Address** task.

15. Select **OK**.
16. Optionally enter a **Place of Registration**.
17. Enter the **EIN or TIN**.
18. Enter the **Legal Reporting Unit Registration Number**.
19. Select **Save and Close** to navigate back to the Manage Legal Entities page.
20. Select **Done** to return to your implementation project. An issue with the done button has been fixed in 11g Release 1 (11.1.4).
21. In the **Legal Entity** choice list in the implementation project (just below the implementation project name and code), click **Select and Add Legal Entity** to choose the legal entity that you just created, and set the scope for the remainder of your setup.
22. Search for and select your legal entity from the **Manage Legal Entities** page.
23. Select **Save and Close**.

This sets the scope for your task list to the selected legal entity, as indicated in the **Legal Entity** choice list above the **Tasks and Task Lists** table.

Legal Entity Registrations

A legal entity registration with the same name as that of the legal entity will be created by default. To verify this, locate the **Manage Legal Entity Registrations** task and then select **Go to Task**. To create another registration for the legal entity follow these steps:

1. Navigate to your implementation project from the **Setup and Maintenance** work area. Verify that the parent **Legal Entity** scope value is set correctly.
2. Expand the **Define Legal Entities** task list within the implementation project.
3. Select **Manage Legal Entity Registrations Go to Task**.
4. Select **Create**.
5. Enter **Jurisdiction**.

6. Enter **Registered Address**.
7. Enter **Registered Name**.
8. Optionally enter **Alternate Name, Registration Number, Place of Registration, Issuing Legal Authority, and Issuing Legal Authority Address, Start Date, and End Date**.
9. **Save and Close**.

Legal Reporting Unit

When a legal entity is created, a legal reporting unit with the same name as that of the entity is also automatically created. To create more legal reporting units or modify the settings follow these steps:

1. Navigate to your implementation project from the **Setup and Maintenance** work area. Verify that the parent **Legal Entity** scope value is set correctly.
2. Select **Go to Task** for the **Define Legal Entities** task list within the implementation project.
3. Select **Create**.
4. Enter **Territory, United States**.
5. Enter **Name**.
6. Optionally enter a **Start Date**.

Note

Enter **Registration Information**.

-
7. Search for and select **Jurisdiction**.

Note

Enter **Main Legal Reporting Unit** information.

-
8. Select the value Yes or No for the **Main Legal Reporting Unit**. Set value to yes only if you are creating a new main (primary) legal reporting unit.
 9. Enter the **Main Effective Start Date, 1/1/11**.
 10. **Save and Close**.

Define Legal Entities: Manage Legal Entity

Legal Entities: Explained

A legal entity is a recognized party with rights and responsibilities given by legislation.

Legal entities have the right to own property, the right to trade, the responsibility to repay debt, and the responsibility to account for themselves to regulators, taxation authorities, and owners according to rules specified in the relevant legislation. Their rights and responsibilities may be enforced through the judicial system. Define a legal entity for each registered company or other entity

recognized in law for which you want to record assets, liabilities, expenses and income, pay transaction taxes, or perform intercompany trading.

A legal entity has responsibility for elements of your enterprise for the following reasons:

- Facilitating local compliance
- Taking advantage of lower corporation taxation in some jurisdictions
- Preparing for acquisitions or disposals of parts of the enterprise
- Isolating one area of the business from risks in another area. For example, your enterprise develops property and also leases properties. You could operate the property development business as a separate legal entity to limit risk to your leasing business.

The Role of Your Legal Entities

In configuring your enterprise structure in Oracle Fusion Applications, you need to understand that the contracting party on any transaction is always the legal entity. Individual legal entities own the assets of the enterprise, record sales and pay taxes on those sales, make purchases and incur expenses, and perform other transactions.

Legal entities must comply with the regulations of jurisdictions, in which they register. Europe now allows for companies to register in one member country and do business in all member countries, and the US allows for companies to register in one state and do business in all states. To support local reporting requirements, legal reporting units are created and registered.

You are required to publish specific and periodic disclosures of your legal entities' operations based on different jurisdictions' requirements. Certain annual or more frequent accounting reports are referred to as statutory or external reporting. These reports must be filed with specified national and regulatory authorities. For example, in the United States (US), your publicly owned entities (corporations) are required to file quarterly and annual reports, as well as other periodic reports, with the Securities and Exchange Commission (SEC), who enforces statutory reporting requirements for public corporations.

Individual entities privately held or held by public companies do not have to file separately. In other countries, your individual entities do have to file in their own name, as well as at the public group level. Disclosure requirements are diverse. For example, your local entities may have to file locally to comply with local regulations in a local currency, as well as being included in your enterprise's reporting requirements in different currency.

A legal entity can represent all or part of your enterprise's management framework. For example, if you operate in a large country such as the United Kingdom or Germany, you might incorporate each division in the country as a separate legal entity. In a smaller country, for example Austria, you might use a single legal entity to host all of your business operations across divisions.

Legal Entity in Oracle Fusion: Points to Consider

Oracle Fusion Applications support the modeling of your legal entities. If you make purchases from or sell to other legal entities, define these other legal entities in your customer and supplier registers, which are part of the Oracle Fusion Trading Community Architecture. When your legal entities are trading with each other, you represent both of them as legal entities and also as

customers and suppliers in your customer and supplier registers. Use legal entity relationships to determine which transactions are intercompany and require intercompany accounting. Your legal entities can be identified as legal employers and therefore, are available for use in Human Capital Management (HCM) applications.

There are several decisions that need to be considered in creating your legal entities.

- The importance of legal entity in transactions
- Legal entity and its relationship to business units
- Legal entity and its relationship to divisions
- Legal entity and its relationship to ledgers
- Legal entity and its relationship to balancing segments
- Legal entity and its relationship to consolidation rules
- Legal entity and its relationship to intercompany transactions
- Legal entity and its relationship to worker assignments and legal employer
- Legal entity and payroll reporting
- Legal reporting units

The Importance of Legal Entity in Transactions

All of the assets of the enterprise are owned by individual legal entities. Oracle Fusion Financials allow your users to enter legal entities on transactions that represent a movement in value or obligation.

For example, the creation of a sales order creates an obligation for the legal entity that books the order to deliver the goods on the acknowledged date, and an obligation of the purchaser to receive and pay for those goods. Under contract law in most countries, damages can be sought for both actual losses, putting the injured party in the same state as if they had not entered into the contract, and what is called loss of bargain, or the profit that would have made on a transaction.

In another example, if you revalued your inventory in a warehouse to account for raw material price increases, the revaluation and revaluation reserves must be reflected in your legal entity's accounts. In Oracle Fusion Applications, your inventory within an inventory organization is managed by a single business unit and belongs to one legal entity.

Legal Entity and Its Relationship to Business Units

A business unit can process transactions on behalf of many legal entities. Frequently, a business unit is part of a single legal entity. In most cases the legal entity is explicit on your transactions. For example, a payables invoice has an explicit legal entity field. Your accounts payables department can process supplier invoices on behalf of one or many business units.

In some cases, your legal entity is inferred from your business unit that is processing the transaction. For example, your business unit A agrees on terms for the transfer of inventory to your business unit B. This transaction is binding on your default legal entities assigned to each business unit. Oracle Fusion Procurement, Oracle Fusion Projects, and Oracle Fusion Supply Chain applications rely on deriving the legal entity information from the business unit.

Legal Entity and Its Relationship to Divisions

The division is an area of management responsibility that can correspond to a collection of legal entities. If desired, you can aggregate the results for your divisions by legal entity or by combining parts of other legal entities. Define date-effective hierarchies for your cost center or legal entity segment in your chart of accounts to facilitate the aggregation and reporting by division. Divisions and legal entities are independent concepts.

Legal Entity and Its Relationship to Ledgers

One of your major responsibilities is to file financial statements for your legal entities. Map legal entities to specific ledgers using the Oracle Fusion General Ledger Accounting Configuration Manager. Within a ledger, you can optionally map a legal entity to one or more balancing segment values.

Legal Entity and Its Relationship to Balancing Segments

Oracle Fusion General Ledger supports up to three balancing segments. Best practices recommend that one of these segments represents your legal entity to ease your requirement to account for your operations to regulatory agencies, tax authorities, and investors. Accounting for your operations means you must produce a balanced trial balance sheet by legal entity. If you account for many legal entities in a single ledger, you must:

1. Identify the legal entities within the ledger.
2. Balance transactions that cross legal entity boundaries through intercompany transactions.
3. Decide which balancing segments correspond to each legal entity and assign them in Oracle Fusion General Ledger Accounting Configuration Manager. Once you assign one balancing segment value in a ledger, then all your balancing segment values must be assigned. This recommended best practice facilitates reporting on assets, liabilities, and income by legal entity.

Represent your legal entities by at least one balancing segment value. You may represent it by two or three balancing segment values if more granular reporting is required. For example, if your legal entity operates in multiple jurisdictions in Europe, you might define balancing segment values and map them to legal reporting units. You can represent a legal entity by more than one balancing segment value, do not use a single balancing segment value to represent more than one legal entity.

In Oracle Fusion General Ledger, there are three balancing segments. You can use separate balancing segments to represent your divisions or strategic business units to enable management reporting at the balance sheet level for each division or business unit. For example, use this solution to empower your business unit and divisional managers to track and assume responsibility for their asset utilization or return on investment. Using multiple balancing segments is also useful when you know at the time of implementation that you are disposing of a part of a legal entity and need to isolate the assets and liabilities for that entity.

Note

Implementing multiple balancing segments requires every journal entry that is not balanced by division or business unit, to generate balancing lines. Also, you

cannot change to multiple balancing segments easily after you have begun to use the ledger because your historical data is not balanced by the new multiple balancing segments. Restating historical data must be done at that point.

To use this feature for disposal of a part of a legal entity, implement multiple balancing segments at the beginning of the legal entity's corporate life or on conversion to Oracle Fusion.

If you decided to account for each legal entity in a separate ledger, there is no requirement to identify the legal entity with a balancing segment value within the ledger.

Note

While transactions that cross balancing segments don't necessarily cross legal entity boundaries, all transactions that cross legal entity boundaries must cross balancing segments. If you make an acquisition or are preparing to dispose of a portion of your enterprise, you may want to account for that part of the enterprise in its own balancing segment even if it is not a separate legal entity. If you do not map legal entities sharing the same ledger to balancing segments, you will not be able to distinguish them using the intercompany functionality or track their individual equity.

Legal Entity and Its Relationship to Consolidation Rules

In Oracle Fusion Applications you can map legal entities to balancing segments and then define consolidation rules using your balancing segments. You are creating a relationship between the definition of your legal entities and their role in your consolidation.

Legal Entity and its Relationship to Intercompany Transactions

Use Oracle Fusion Intercompany functionality for automatic creation of intercompany entries across your balancing segments. Intercompany processing updates legal ownership within the enterprise's groups of legal entities. Invoices or journals are created as needed. To limit the number of trading pairs for your enterprise, set up intercompany organizations and assign them to your authorized legal entities. Define processing options and intercompany accounts to use when creating intercompany transactions and to assist in consolidation elimination entries. These accounts are derived and automatically entered on your intercompany transactions based on legal entities assigned to your intercompany organizations.

Intracompany trading, in which legal ownership isn't changed but other organizational responsibilities are, is also supported. For example, you can track assets and liabilities that move between your departments within your legal entities by creating departmental level intercompany organizations.

Note

In the Oracle Fusion Supply Chain applications, model intercompany relationships using business units, from which legal entities are inferred.

Legal Entity and Its Relationship to Worker Assignments and Legal Employer

Legal entities that employ people are called legal employers in the Oracle Fusion Legal Entity Configurator. You must enter legal employers on worker assignments in Oracle Fusion HCM.

Legal Entity and Payroll Reporting

Your legal entities are required to pay payroll tax and social insurance such as social security on your payroll. In Oracle Fusion Applications, you can register payroll statutory units to pay and report on payroll tax and social insurance on behalf of many of your legal entities. As the legal employer, you might be required to pay payroll tax, not only at the national level, but also at the local level. You meet this obligation by establishing your legal entity as a place of work within the jurisdiction of a local authority. Set up legal reporting units to represent the part of your enterprise with a specific legal reporting obligation. You can also mark these legal reporting units as tax reporting units, if the legal entity must pay taxes as a result of establishing a place of business within the jurisdiction.

Define Legal Entities: Manage Legal Entity HCM Information

HCM Organization Models: Examples

These examples illustrate different models for human capital management (HCM) organizations. Each example includes a legislative data group (LDG). LDGs are not an organization classification, but they are included in the example to show how you associate them with a payroll statutory unit to partition payroll data.

Simple Configuration

This example illustrates a simple configuration that does not include any tax reporting units. The legal employer and payroll statutory units are the same, sharing the same boundaries. Reporting can only be done at a single level. Countries such as Saudi Arabia and the United Arab Emirates (UAE) might use this type of model, as reporting in these countries is done at the legal entity level.

This figure illustrates a simple configuration where the enterprise has only one legal entity that is both a payroll statutory unit and a legal employer.

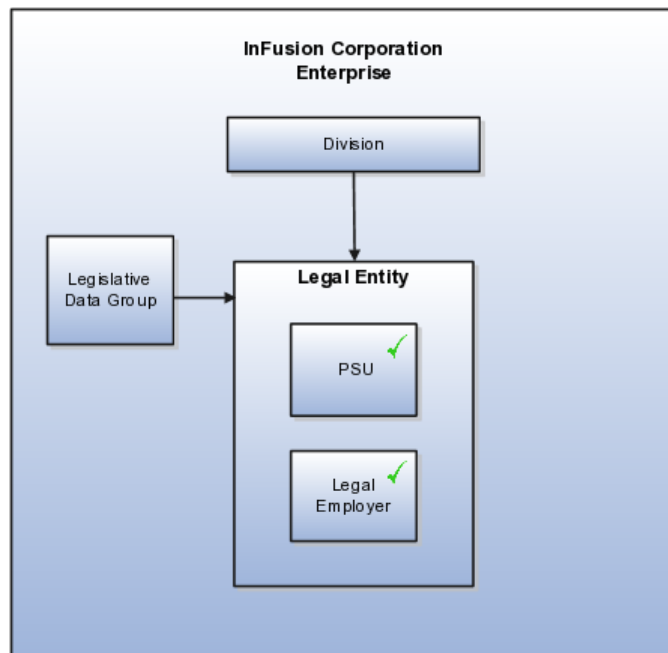

Multiple Legal Employers and Tax Reporting Units Under One Payroll Statutory Unit

This example illustrates a more complex configuration. In this enterprise, one legal entity, InFusion US, is defined as a payroll statutory unit and has two separate legal entities, which are also legal employers. This model shows multiple legal employers that are associated with a single payroll statutory unit, and how tax reporting units are always associated with a specific legal employer (or employers) through the payroll statutory unit. The implication is that payroll statutory reporting boundaries vary from human resources (HR) management, and the balances can be categorized separately by either payroll statutory unit, legal employer, or tax reporting unit. This configuration is based on tax filing requirements, as some tax-related payments and reports are associated with a higher level than employers. An example of a country that might use this model is the US.

This figure illustrates an enterprise that has one payroll statutory unit and multiple legal employers and tax reporting units.

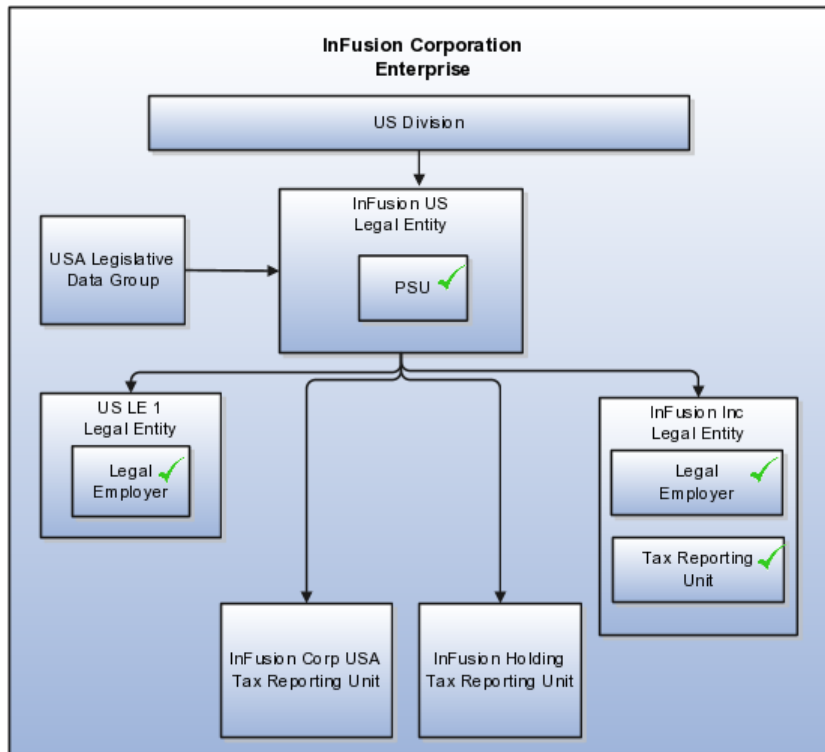

One Payroll Statutory Unit and Two Tax Reporting Units That Are Subsidiaries of the Legal Entity

This model makes no distinction between a legal employer and a payroll statutory unit. Tax reporting units are defined as subsidiaries to the legal entity. In this enterprise, legal entity is the highest level of aggregation for payroll calculations and reporting, and statutory reporting boundaries are assumed to be the same for both payroll and HR management. An example of a country that might use this model is France.

This figure illustrates an example of an organization with one legal entity that is both a legal employer and a payroll statutory unit and that has two tax reporting units.

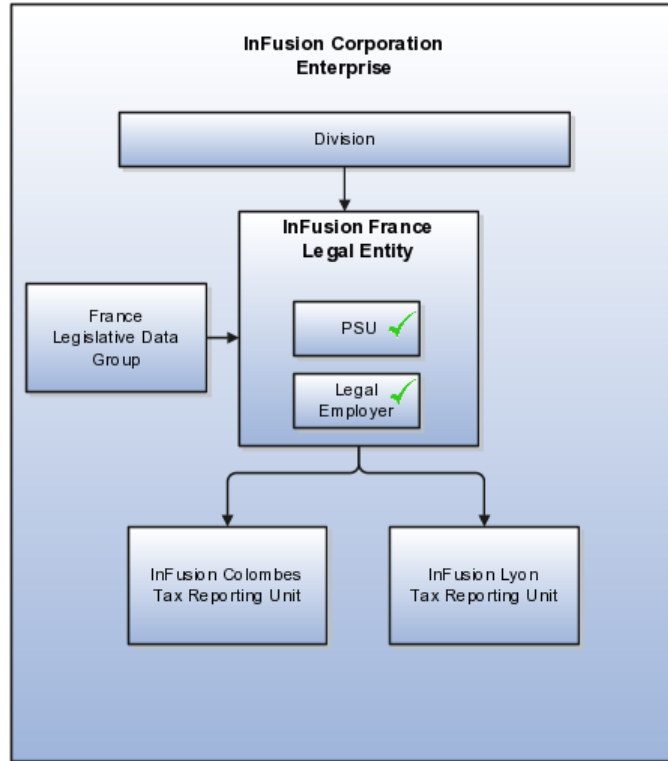

One Payroll Statutory Unit with Several Tax Reporting Units That Are Independent from the Legal Employer

In this model, the enterprise has one legal entity, and legal employers and tax reporting units are independent from each other within a payroll statutory unit, because there is no relationship from a legal perspective. Therefore, you can run reporting on both entities independently. Using this model, you would not typically need to report on tax reporting unit balances within a legal employer, and balances can be categorized by either or both organizations, as required. An example of a country that might use this model is India.

This figure illustrates an enterprise with one legal entity that is a payroll statutory unit and a legal employer, and the tax reporting units are independent from the legal employer.

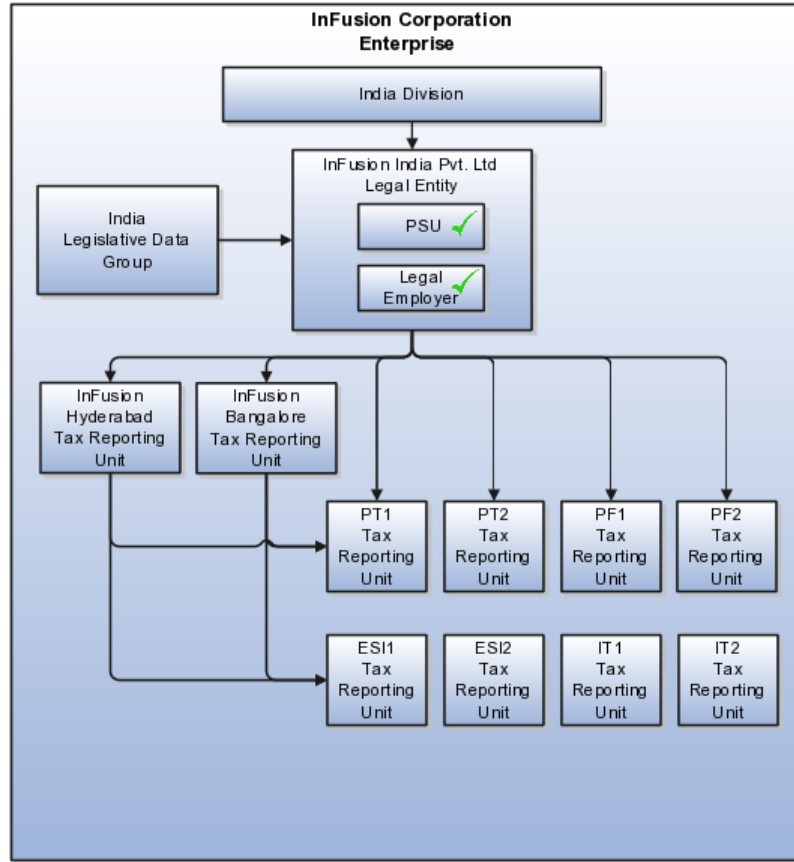

Multiple Payroll Statutory Units with Several Tax Reporting Units that are Independent from the Legal Employer

In this model, the enterprise has two legal entities, and legal employers and tax reporting units are independent from each other within a payroll statutory unit, because there is no relationship from a legal perspective. Therefore, you can run reporting on both entities independently. Using this model, you would not typically need to report on tax reporting unit balances within a legal employer, and balances can be categorized by either or both organizations, as required. An example of a country that might use this model is the United Kingdom (UK).

This figure illustrates an enterprise with two legal entities, and legal employers and tax reporting units are independent from each other.



Payroll Statutory Units, Legal Employers, and Tax Reporting Units: How They Work Together

When you set up legal entities, you can identify them as legal employers and payroll statutory units, which makes them available for use in Oracle Fusion Human Capital Management (HCM). A tax reporting unit is created automatically when you add a legal entity and identify it as a payroll statutory unit. Depending on how your organization is structured, you may have only one legal entity that is also a payroll statutory unit and a legal employer, or you may have multiple legal entities, payroll statutory units, and legal employers.

Legal Employers and Payroll Statutory Unit

Payroll statutory units enable you to group legal employers so that you can perform statutory calculations at a higher level, such as for court orders or for United Kingdom (UK) statutory sick pay. In some cases, a legal employer is also a payroll statutory unit. However, your organization may have several legal employers under one payroll statutory unit. A legal employer can belong to only one payroll statutory unit.

Payroll Statutory Units and Tax Reporting Units

Payroll statutory units and tax reporting units have a parent-child relationship, with the payroll statutory unit being the parent.

Tax Reporting Units and Legal Employers

Tax reporting units are indirectly associated with a legal employer through the payroll statutory unit. One or more tax reporting units can be used by a single legal employer, and a tax reporting unit can be used by one or more legal employers. For example, assume that a single tax reporting unit is linked to a payroll statutory unit. Assume also that two legal employers are associated with this payroll statutory unit. In this example, both legal employers are associated with the single tax reporting unit.

FAQs for Manage Legal Entity HCM Information

What's a legal employer?

A legal employer is a legal entity that employs workers. You define a legal entity as a legal employer in the Oracle Fusion Legal Entity Configurator.

The legal employer is captured at the work relationship level, and all employment terms and assignments within that relationship are automatically with that legal employer. Legal employer information for worker assignments is also used for reporting purposes.

What's a payroll statutory unit?

Payroll statutory units are legal entities that are responsible for paying workers, including the payment of payroll tax and social insurance. A payroll statutory unit can pay and report on payroll tax and social insurance on behalf of one or many legal entities, depending on the structure of your enterprise. For example, if you are a multinational, multicompany enterprise, then you register a payroll statutory unit in each country where you employ and pay people. You can optionally register a consolidated payroll statutory unit to pay and report on workers across multiple legal employers within the same country. You associate a legislative data group with a payroll statutory unit to provide the correct payroll information for workers.

Define Legal Entities: Manage Legal Entity Tax Profile

Party Tax Profiles: Explained

A tax profile is the body of information that relates to a party's transaction tax activities. A tax profile can include main and default information, tax registration, tax exemptions, party fiscal classifications, tax reporting codes, configuration options, and service subscriptions.

Set up tax profiles for the following parties involved in your transactions:

- **First parties:** All legal entities, legal reporting units, and business units in your organization that have a transaction tax requirement.
- **Third parties:** Your customers and suppliers and their locations and banks.
- **Tax authorities:** Parties that administer tax rules and regulations.

First Parties

Set up tax profiles for your first party legal entities, legal reporting units, and business units.

First party legal entities identify your organization to the relevant legal authorities, for example, a national or international headquarters. Legal entities let you more accurately model your external relationships to legal authorities. The relationships between first party legal entities and the relevant tax authorities normally control the setup of the transaction taxes required by your business. Under most circumstances the tax setup is used and maintained based on the configuration of the legal entity. Enter the default information, party fiscal classifications, tax reporting codes, and configuration options for your legal entities. You can also specify if you are using the tax services of an external service provider for tax calculation.

First party legal reporting units identify each office, service center, warehouse and any other location within the organization that has a tax requirement. A legal reporting unit tax profile is automatically created for the headquarter legal entity. Set up additional legal reporting unit tax profiles for those needed for tax purposes. For legal reporting units, enter the default information, tax registrations, party fiscal classifications, and tax reporting codes. Also, define tax reporting details for your VAT and global tax reporting needs for tax registrations of tax regimes that allow this setup.

Business units organize your company data according to your internal accounting, financial monitoring, and reporting requirements. To help you manage the tax needs of your business units, you can use the business unit tax profile in either of two ways:

- Indicate that business unit tax setup is used and maintained based on the configuration of the associated legal entity at transaction time. The tax setup of the associated legal entity setup is either specific to the legal entity or shared across legal entities using the Global Configuration Owner setup.
- Indicate that tax setup is used and maintained by a specific business unit. Create configuration options for the business unit to indicate that the subscribed tax content is used for the transactions created for the business unit.

For business units that maintain their own setup, enter the default information, tax reporting codes, configuration options, and service providers as required.

Third Parties

Set up third party tax profiles for parties with the usage of customer, supplier, and their sites. Enter the default information, tax registrations, party fiscal classifications, and reporting codes required for your third parties or third party sites. You can set up tax exemptions for your customers and customer sites.

Banks are also considered third parties. When a bank is created, the tax registration number specified on the bank record is added to the party tax profile record in Oracle Fusion Tax. You can not modify the party tax profile for a bank as it is view only. You can only modify the bank record itself.

Note

Setting up party tax profiles for third parties is not required. Taxes are still calculated on transactions for third parties that do not have tax profiles

Tax Authorities

Set up a tax authority party tax profile using the Legal Authorities set up task. The tax authority party tax profile identifies a tax authority party as a collecting authority or a reporting authority or both. A collecting tax authority manages the administration of tax remittances. A reporting tax authority receives and processes all company transaction tax reports.

The collecting and reporting tax authorities appear in the corresponding list of values on all applicable Oracle Fusion Tax pages. All tax authorities are available in the list of values as an issuing tax authority.

Specifying First Party Tax Profile Options: Points to Consider

Set up first party tax profiles for all legal entities, legal reporting units, and business units in your organization that have a transaction tax requirements. How you set up your first parties can impact the tax calculation on your transactions.

The first party tax profile consists of:

- **Defaults and controls:** Applicable to legal entities and legal reporting units. Business units that use their own tax setup do not have defaults and controls.
- **Tax registrations:** Applicable to legal reporting units.
- **Party fiscal classifications:** Applicable to legal entities and legal reporting units.
- **Tax reporting codes:** Applicable to legal entities, legal reporting units, and business units who do not use the tax setup of the legal entity.
- **Configuration options:** Applicable to legal entities and business units who do not use the tax setup of the legal entity.
- **Service subscriptions:** Applicable to legal entities and business units who do not use the tax setup of the legal entity.

Defaults and Controls

The following table describes the defaults and controls available at the first party tax profile level:

Option	Description
Set as self-assessment (reverse charge)	Automatically self-assess taxes on purchases.
Rounding Level	Perform rounding operations on the: <ul style="list-style-type: none"> • Header: Applies rounding to calculated tax amounts once for each tax rate per invoice. • Line: Applies rounding to the calculated tax amount on each invoice line.

Rounding Rule	<p>The rule that defines how the rounding should be performed on a value involved in a taxable transaction. For example, up to the next highest value, down to the next lowest value, or nearest.</p> <hr/> <p>Note</p> <p>If you defined a rounding precedence hierarchy in the configuration owner tax option settings for the combination of configuration owner and event class, Oracle Fusion Tax considers the rounding details in the applicable tax profile.</p>
Set Invoice Values as Tax Inclusive	<p>This first party intends to send or receive invoices with invoice line amount inclusive of the tax amount.</p> <hr/> <p>Note</p> <p>This option overrides the tax inclusive handling setting at the tax level, but not at the tax rate level.</p>

Tax Registrations

You must set up a separate tax registration to represent each distinct registration requirement for a first party legal reporting unit. Oracle Fusion Tax uses tax registrations in tax determination and tax reporting. If your first party has more than one tax registration under the same tax regime, then the application considers the tax registration in the order: tax jurisdiction; tax; tax regime.

You must enable the **Use tax reporting configuration** option on the first party tax regime to allow entry of global tax reporting configuration details during tax registration setup for legal reporting units for these tax regimes.

Party Fiscal Classifications

If applicable, associate first party fiscal classification codes with this party. The party fiscal classification codes you enter become part of tax determination for invoices associated with this party. Specify start and end dates to control when these fiscal classifications are applicable for this party and transaction.

For legal entities, you can view the associated legal classifications that were assigned to the tax regime defined for this first party. The legal classifications are used in the tax determination process, similarly to the party fiscal classifications.

Tax Reporting Codes

Set up tax reporting types to capture additional tax information on transactions for your tax reports for your first parties. Depending on the tax reporting type code, you either enter or select a tax reporting code for this party. Specify start and end dates to control when these tax reporting codes are applicable.

Configuration Options

The legal entities and business units in your organization are each subject to specific sets of tax regulations as designated by the tax authorities where you do

business. Use configuration options to associate legal entities and business units with their applicable tax regimes. You can set up tax configuration options when you create a tax regime or when you create a party tax profile. Both setup flows display and maintain the same party and tax regime definitions.

Service Subscriptions

Oracle Fusion Tax lets you use the tax services of external service providers for tax calculation of US Sales and Use Tax on Receivables transactions. The setup for provider services is called a service subscription. A service subscription applies to the transactions of one configuration option setup for a combination of tax regime and legal entity or business unit. Set up service subscriptions when you create a tax regime or when you create a party tax profile for a first party legal entity or business unit.

FAQs for Manage Legal Entity Tax Profile

When does a party tax profile get created for a legal entity?

The legal entity party tax profile is automatically created when a legal entity record is created. If a legal entity party tax profile record is not created, for example, when a legal entity is created through a back-end process, a legal entity party tax profile is created upon saving the tax regime when a legal entity is subscribed to or upon saving the configuration owner tax options when they are defined for the legal entity. Otherwise, create a party tax profile using the Create Legal Entity Tax Profile page. You can edit the tax profile that was automatically generated with the relevant tax information, but it is not required.

Define Legal Entities: Define Legal Reporting Units

Planning Legal Reporting Units: Points to Consider

Each of your legal entities has at least one legal reporting unit. Legal reporting units can also be referred to as establishments. You can define either domestic or foreign establishments. Define legal reporting units by physical location, such as a sales office, or by logical unit, such as groups of employees subject to different reporting requirements. For example, define logical legal reporting units for both salaried and hourly paid employees.

Another example of logical reporting units is in the Human Capital Management (HCM) system where you use your legal reporting units to model your tax reporting units. A tax reporting unit is used to group workers for the purpose of tax reporting.

Planning Legal Reporting Units

Plan and define your legal reporting units at both the local and national levels if you operate within the administrative boundaries of a jurisdiction that is more granular than country. For example, your legal entity establishes operation in a country that requires reporting of employment and sales taxes locally as well as nationally. Therefore, you need more than one legally registered location to meet this legal entity's reporting requirements in each local area. Additionally, legal

entities in Europe operate across national boundaries, and require you to set up legal reporting units for the purposes of local registration in each country. There can be multiple registrations associated with a legal reporting unit. However, there can be only one identifying registration, defined by the legal authority used for the legal entity or legal reporting unit, associated with the legal reporting unit.

Define Chart of Accounts for Enterprise Structures: Manage Chart of Accounts

Chart of Accounts: Explained

The chart of accounts is the underlying structure for organizing financial information and reporting. An entity records transactions with a set of codes representing balances by type, expenses by function, and other divisional or organizational codes that are important to its business.

A well-designed chart of accounts provides the following benefits:

- Effectively manages an organization's financial business
- Supports the audit and control of financial transactions
- Provides flexibility for management reporting and analysis
- Anticipates growth and maintenance needs as organizational changes occur
- Facilitates an efficient data processing flow
- Allows for delegation of responsibility for cost control, profit attainment, and asset utilization
- Measures performance against corporate objectives by your managers

The chart of accounts facilitates aggregating data from different operations, from within an operation, and from different business flows, thus enabling the organization to report using consistent definitions to their stakeholders in compliance with legislative and corporate reporting standards and aiding in management decisions.

Best practices include starting the design from external and management reporting requirements and making decisions about data storage in the general ledger, including thick versus thin general ledger concepts.

Thick Versus Thin General Ledger: Critical Choices

Thick versus thin general ledger is standard terminology used to describe the amount of data populated and analysis performed in your general ledger. Thick and thin are the poles; most implementations are somewhere in between. Here are some variations to consider:

- A general ledger used in conjunction with an enterprise profitability management (EPM) product, which has data standardized from each operation, is designed as a thin general ledger. Use this variation if your

solution is project based, and Oracle Fusion Projects is implemented. More detailed reporting can be obtained from the Projects system. In the thin general ledger, business units, divisions, and individual departments are not represented in the chart of accounts.

- A general ledger, with segments representing all aspects and capturing every detail of your business, with frequent posting, many values in each segment, and many segments, is called a thick general ledger. A thick general ledger is designed to serve as a repository of management data for a certain level of management. For example, a subsidiary's general ledger is designed to provide the upper management enough data to supervise operations, such as daily sales, without invoice details or inventory without part number details.
- A primary ledger and a secondary ledger, where one is a thick general ledger and the other a thin general ledger, provides dual representation for reporting requirements that require more than one ledger.

Thin General Ledger

With a thin general ledger, you use the general ledger for internal control, statutory reporting, and tracking of asset ownership. You minimize the data stored in your general ledger. A thin general ledger has many of the following characteristics:

- Minimal chart of accounts
 - Short list of cost centers
 - Short list of natural accounts
 - Short list of cost accounts
 - Summary level asset and liability accounts
 - Low number of optional segments
- Infrequent posting schedule

A thin general ledger has natural accounts at a statutory reporting level, for example, payroll expense, rent, property taxes, and utilities. It has cost centers at the functional expense level, such as Research and Development (R&D) or Selling, General, and Administrative (SG&A) expense lines, rather than at department or analytic levels. It omits business unit, division, and product detail.

One example of an industry that frequently uses a thin general ledger is retail. In a retail organization, the general ledger tracks overall sales numbers by region. A retail point of sales product tracks sales and inventory by store, product, supplier, markup, and other retail sales measures.

Thick General Ledger

With a thick general ledger, you use the general ledger as a detailed, analytic tool, performing analytic functions directly in the general ledger. Data is broken down by many reporting labels, and populated frequently from the subledgers.

You maximize the data stored in the general ledger. A thick general ledger has many of the following characteristics:

- Maximum use of the chart of accounts
 - Long list of natural accounts
 - Long list of cost centers
 - Long list of costing accounts
 - Detailed asset and liability accounts
- Frequent posting schedule

In a thick general ledger, you obtain detail for cost of goods sold and inventory balances and track property plant and equipment at a granular level. Cost centers represent functional expenses, but also roll up to departmental or other expense analysis levels. Using product and location codes in optional segments can provide reporting by line of business. Posting daily, at the individual transaction level, can maximize the data stored in the general ledger.

One example of an industry that frequently uses a thick general ledger is electronic manufacturers. Detail on the revenue line is tagged by sales channel. Product is structured differently to provide detail on the cost of goods sold line, including your bill of materials costs. The general ledger is used to compare and contrast both revenue and cost of goods sold for margin analysis.

Other Considerations

Consider implementing a thick ledger if there are business requirements to do any of the following:

- Track entered currency balances at the level of an operational dimension or segment of your chart of accounts, such as by department or cost center
- Generate financial allocations at the level of an operational dimension or segment
- Report using multiple layered and versioned hierarchies of the operational dimension or segment from your general ledger

Consider implementing a thin ledger in addition to a thick ledger, if there are additional requirements for:

- Minimal disclosure to the authorities in addition to the requirements listed above. For example, in some European countries, fiscal authorities examine ledgers at the detailed account level.
- Fiscal only adjustments, allocations, and revaluations, which don't impact the thick general ledger.

The important consideration in determining if a thick ledger is the primary or secondary ledger is your reporting needs. Other considerations include how the values for an operational dimension or segment are derived and the amount of resources used in reconciling your different ledgers. If values for the operational dimension are always entered by the user like other segments of the accounting flexfield, then a thick primary ledger is the better choice.

However, if values for the operational dimension or segment are automatically derived from other attributes on the transactions in your subledger accounting rules, rather than entered in the user interface, then use a thick secondary ledger. This decision affects the amount of:

- Storage and maintenance needed for both the general ledger and subledger accounting entries
- System resources required to perform additional posting
- In summary, you have:
 - Minimum demand on storage, maintenance, and system resources with the use of a thin ledger
 - Greater demand on storage, maintenance, and system resources with the use of a thick ledger
 - Greatest demand on storage, maintenance and system resources with the use of both thick and thin ledgers

Note

Generally speaking, there is a tradeoff between the volume of journals and balances created and maintained versus system resource demands. Actual performance depends on a wide range of factors including hardware and network considerations, transaction volume, and data retention policies.

Summary

The factors you need to consider in your decision to use a thick or thin general ledger for your organization, are your:

- Downstream EPM system and its capabilities
- Business intelligence system and its capabilities
- Subledger systems and their capabilities and characteristics, including heterogeneity
- General ledger reporting systems and their capabilities
- Maintenance required for the thick or thin distributions and record keeping
- Maintenance required to update value sets for the chart of accounts segments
- Preferences of the product that serves as a source of truth
- Level at which to report profitability including gross margin analysis
- Industry and business complexity

Chart of Accounts: How Its Components Fit Together

There are several important elements to the basic chart of accounts in Oracle Fusion Applications: a structure that defines the account values, segments, and their labels, and rules (security and validation). Account combinations link

the values in the segments together and provide the accounting mechanism to capture financial transactions.

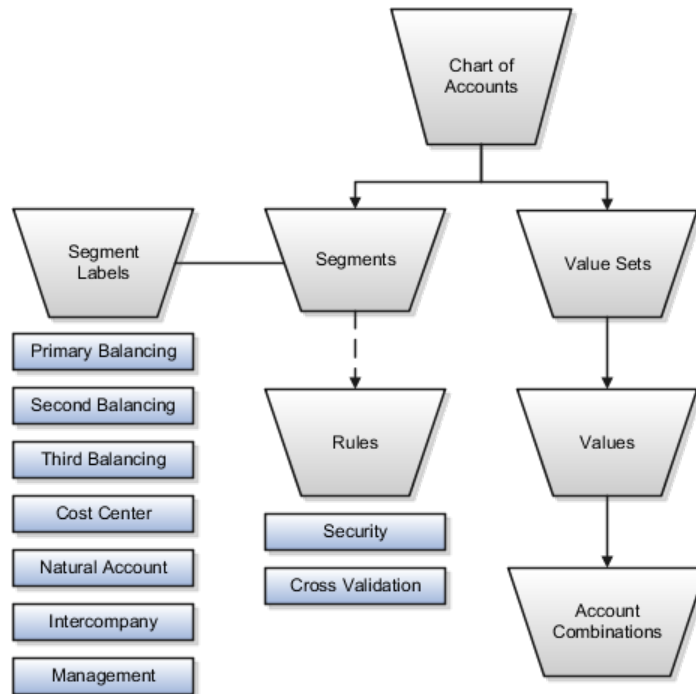

Chart of Accounts

The chart of accounts defines the number and attributes of various segments, including the order of segments, the width of segments, prompts, and segment labels, such as balancing, natural account, and cost center.

The chart of accounts further defines the combination of value sets associated with each segment of the chart of accounts, as well as the type, default value, additional conditions designating the source of the values using database tables, and the required and displayed properties for the segments.

Segments

A chart of accounts segment is a component of the account combination. Each segment has a value set attached to it to provide formatting and validation of the set of values used with that segment. The combination of segments creates the account combination used for recording and reporting financial transactions. Examples of segments that may be found in a chart of accounts are company, cost center, department, division, region, account, product, program, and location.

Value Sets and Values

The value sets define the attributes and values associated with a segment of the chart of accounts. You can think of a value set as a container for your values. You can set up your flexfield so that it automatically validates the segment values that you enter against a table of valid values. If you enter an invalid segment value, a list of valid values appears automatically so that you can select a valid value. You can assign a single value set to more than one segment, and you can share value sets across different flexfields.

Segment Labels

Segment labels identify certain segments in your chart of accounts and assign special functionality to those segments. Segment labels were referred to as flexfield qualifiers in Oracle E-Business Suite. Here are the segment labels that are available to use with the chart of accounts.

- **Balancing:** Ensures that all journals balance for each balancing segment value or combination of multiple balancing segment values to use in trial balance reporting. There are three balancing segment labels: primary, second, and third balancing. The primary balancing segment label is required.
- **Cost Center:** Facilitates grouping of natural accounts by functional cost types, accommodating tracking of specific business expenses across natural accounts. As cost centers combine expenses and headcount data into costs, they are useful for detailed analysis and reporting. Cost centers are optional, but required if you are accounting for depreciation, additions, and other transactions in Oracle Fusion Assets, and for storing expense approval limits in Oracle Fusion Expense Management.
- **Natural Account:** Determines the account type (asset, liability, expense, revenue, or equity) and other information specific to the segment value. The natural account segment label is required.
- **Management:** Optionally, denotes the segment that has management responsibility, such as the department, cost center, or line of business. Also can be attached to the same segment as one of the balancing segments to make legal entity reporting more granular.
- **Intercompany:** Optionally, assigns the segment to be used in intercompany balancing functionality.

Note

All segments have a segment qualifier that enables posting for each value. The predefined setting is Yes to post.

Account Combinations

An account combination is a completed code of segment values that uniquely identifies an account in the chart of accounts, for example 01-2900-500-123, might represent InFusion America (company)-Monitor Sales (division)-Revenue (account)-Air Filters (product).

Rules

The chart of accounts uses two different types of rules to control functionality.

- **Security rules:** Prohibit certain users from accessing specific segment values. For example, you can create a security rule that grants a user access only to his or her department.
- **Cross-validation rules:** Control the account combinations that can be created during data entry. For example, you may decide that sales cost centers 600 to 699 should enter amounts only to product sales accounts 4000 to 4999.

Creating One Chart of Accounts Structure with Many Instances: Example

In Oracle Fusion General Ledger, the chart of accounts model is framed around the concept of a chart of accounts structure, under which one or more chart of accounts structure instances can be created.

Scenario

Your company, InFusion Corporation, is a multinational conglomerate that operates in the United States (US) and the United Kingdom (UK). InFusion has purchased an Oracle Fusion enterprise resource planning (ERP) solution including Oracle Fusion General Ledger and all of the Oracle Fusion subledgers. You are chairing a committee to discuss creation of a model for your global financial reporting structure including your charts of accounts for both your US and UK operations.

InFusion Corporation

InFusion Corporation has 400 plus employees and revenue of \$120 million. Your product line includes all the components to build and maintain air quality monitoring (AQM) systems for homes and businesses.

Analysis

In Oracle Fusion General Ledger, the chart of accounts model is framed around the concept of a chart of accounts structure, under which one or more chart of accounts structure instances can be created.

The chart of accounts structure provides the general outline of the chart of accounts and determines the number of segments, the type, the length, and the label (qualifier) of each segment. This forms the foundation of the chart of accounts definition object.

For each chart of accounts structure, it is possible to associate one or more chart of accounts structure instances. Chart of accounts structure instances under the same structure share a common configuration with the same segments, in the same order, and the same characteristics. Using one chart of accounts structure with multiple instances simplifies your accounting and reporting.

At the chart of accounts structure instance level, each segment is associated with a value set that conforms to the characteristic of that segment. For example, you assign a value set with the same segment type and length to each segment. You are using hierarchies with your chart of accounts segments. Each structure instance segment is assigned a tree code to indicate the source of the hierarchy information for the associated value set. The same value set can be used multiple times within the same or across different chart of accounts instances within the same structure or in different structures. This functionality reduces your segment value creation and maintenance across your charts of accounts.

The collective assignment of value sets to each of the segments forms one chart of accounts instance. At the chart of accounts structure instance level, you can select to enable dynamic insertion. Dynamic insertion allows the creation of account code combinations automatically the first time your users enter that new account combination. The alternative is to create them manually. By deciding to

enable dynamic insertion, you save data entry time and prevent delays caused by the manual creation of new code combinations. Well defined cross validation rules help prevent the creation of inappropriate account code combinations.

Perform deployment after a new chart of accounts structure and structure instances are defined or any of their modifiable attributes are updated. Deployment validates and regenerates the necessary objects to enable your charts of accounts and chart of accounts structure instances. By unifying and standardizing your organization's chart of accounts, you are positioned to take full advantage of future functionality in Oracle Fusion General Ledger.

In summary, you are recommending to your company to unify the organization's chart of accounts in a single chart of accounts structure based on chart of accounts commonalities across ledgers. You have also decided to use the chart of accounts structure instance construct to serve different accounting and reporting requirements by using value sets specific to each of your entities.

Creating Chart of Accounts Structure and Instances: Examples

In Oracle Fusion General Ledger, the chart of accounts model is framed around the concept of a chart of accounts structure, under which one or more chart of accounts structure instances can be created. A chart of accounts structure defines the key attributes for your chart of accounts, such as the number of segments, the segment sequences, the segment names, segment prompts, segment labels, for example natural account and primary balancing, and default value sets.

The chart of accounts instance is exposed in the user interfaces and processes. By default, a chart of accounts instance inherits all the attributes of the chart of accounts structure, meaning that all instances of the same structure share a common shape and have the same segments in the same order. However, at the chart of accounts instance level, you can override the default value set assignments for your segments and assign a unique account hierarchy that determines the parent and child relationships between the value set values. At the chart of accounts instance level, determine if allow dynamic insertion is enabled to generate new account combinations dynamically instead of creating them manually.

Chart of Account Structure

You are creating a chart of accounts structure as you setup your chart of accounts for your enterprise, InFusion America, Inc. Follow these steps:

1. Navigate to the **Manage Chart of Accounts** page from the Functional Setup Manger by querying on **Manage Chart of Accounts** and clicking on the **Go To Task**.
2. Select **General Ledger** from the Module list of values and click **Search**.
3. Click **Manage Structures** to open the **Manage Key Flexfield Structures** page.
4. Select the **General Ledger** row and click the **Create** to open the **Create Key Flexfield Structure** page.
5. Enter a unique Structure Code, **INFUSION_AM_COA_STRUCTURE**, and Name, **InFusion America COA Structure**. Provide an optional Description, **InFusion America Inc. Chart of Accounts Structure**.

6. Select the - Delimiter to visually separate your segment values.
7. Click **Save**.
8. To create a new segment, click the **Create** to open the **Create Key Flexfield Segment** page.
 - a. Enter the following parameters:

Parameter	Value
Segment Code	INFUSION_AM_CO
Name	InFusion America Company
Description	InFusion America Inc. Company
Sequence Number	1
Prompt	Company
Short Prompt	CO
Display Width	2
Column Name	Segment1
Default Value Set Code	INFUSION_AM_COMPANY

- b. Select a segment label, **Primary Balancing Segment**, to indicate its purpose within your chart of accounts.

Note

Two segment labels are required: primary balancing segment and natural account segment. These labels are not used with each other or with other labels in a specific segment.

- c. Click **Save and Close**.
 - d. Click **Done**.
 - e. Define additional segments following the same process.

Chart of Account Instance

You are creating a chart of accounts instance as you setup your chart of accounts for your enterprise, InFusion America, Inc. Follow these steps:

1. Navigate to the **Manage Chart of Accounts** page from the Functional Setup Manger by querying on **Manage Chart of Accounts** and clicking on the **Go To Task**.
2. Select **General Ledger** from the Module list of values and click **Search**.
3. Select the **General Ledger** row and click **Manage Structure Instances** to open the **Manage Key Flexfield Structure Instance** page.
4. Click the **Create** icon to open the **Create Key Flexfield Structure Instance** page.
5. Enter a unique Structure Instance Code, **INFUSION_AM_COA_INSTANCE**, and Name, **InFusion America COA**

Instance. Provide an optional Description, **InFusion America Inc. Chart of Accounts Structure Instance.**

6. Select **Dynamic combination creation allowed** to indicate that you want to dynamically generate account combinations.
7. Associate your instance with your Structure Name, **InFusion America Structure.**

Note

By default, an instance inherits the key attributes of the associated structure. Some attributes, such as the value set assigned to each the segment, can be modified.

-
8. Click **Save.**
 9. Optionally, select the segment row and click **Edit** to modify instance segments.
 10. Check **Required, Displayed, and Business intelligence enabled** check boxes.

Note

The Business Intelligence check box is only valid when enabled on segments with segment labels. Check the Required and Displayed options for all segments including those intended for future use. The recommended best practice is to define one segment for future use and set a default value. This ensures room for expansion in your chart of accounts and that the extra segment is populated in the account combinations.

-
11. Click **OK.**
 12. Click **Save and Close.**
 13. Define additional instances following the same process.

Note

Alternatively, proceed directly with creating your value set values by selecting the corresponding **Value Set Code** in the Segment Instances table.

-
14. Click **Done.**
 15. Click **Deploy Flexfield.**
 16. Click **OK.**

Balancing Segments: Explained

Balancing segments ensure that all journals balance for each balancing segment value or combination of multiple balancing segment values. You can secure access to your primary balancing segment values only with data access sets. The general ledger application automatically calculates and creates balancing lines as required in journal entries. For example, recognizing an entity's receivable

and the other entity's payable. There are three balancing segment labels: primary, second, and third balancing. The primary balancing segment label is required.

By enabling multiple balancing segments for your chart of accounts, it is possible to produce financial statements for each unique combination of segment values across not only one, but two or even three qualified balancing segments. This ability provides you greater insights into your operations as it affords you visibility along the critical fiscal dimensions you use to plan, monitor, and measure your financial performance.

The following explains processes that use balancing segments.

- Intercompany balancing: Adds lines to unbalanced journals using intercompany rules.
- Opening first period of the new accounting year: Calculates retained earnings amounts at the level of granularity that totals revenue and expense account balances for multiple balancing segment value combinations. This applies to standard and average balances.
- Importing journals: Adds lines using the suspense account on unbalanced journals.
- Posting journals: Adds additional lines to unbalanced journals for the following enabled account types:
 - Suspense
 - Rounding
 - Net income
 - Retained earnings
 - Cumulative translation adjustments from replication of revaluation journals to reporting currencies and for multiple reporting currency account type specific conversion
- Posting prior period journals: Calculates any income statement impact and posts to the appropriate retained earnings account.
- Translating balances: Supports multiple balancing segments for the following accounts:
 - Retained earnings: Calculated translated retained earnings are post to the retained earnings accounts by balancing segment. Retained earnings represents the summing of the translated revenue and expense accounts across multiple balancing segment values.
 - Cumulative translation adjustment: Amounts posted by balancing segment to these accounts represents currency fluctuation differences between ranges of accounts which use different rate types. For example, period end rates are used for asset and liability accounts and historical rates for equity accounts.
- Revaluing Balances: Supports multiple balancing segments when calculating gain or loss accounts.

- **Creating Opening Balances:** Initializes reporting currency balances by converting from the total primary currency. Any difference in the reporting currency amounts is offset by populating retained earnings accounts.
- **Closing year end:** Supports multiple balancing segments when calculating the income statement offset and closing account in the closing journals.

Multiple Balancing Segments: Points to Consider

Oracle Fusion General Ledger supports tracking financial results at a finer level of granularity than a single balancing segment. In addition to the required primary balancing segment for the chart of accounts, which is typically associated with the company dimension of a business organization, two additional segments of the chart of accounts can be optionally qualified as the second and third balancing segments respectively. Possible chart of accounts segments that can be tagged as these additional balancing segments include cost center or department, additional aspects of a business commonly used in measuring financial results.

There are several points to consider in using multiple balancing segments:

- Journal entry processing
- Implementation timing
- Change options
- Migration adjustments

Journal Entry Processing

Multiple balancing segments ensure that account balances come from journal entries where the debits equal the credits, and thus, the financial reports are properly generated for each unique instance of account value combinations across the balancing segments. Consider this option carefully as it provides more granular reporting but requires more processing resources.

Implementation Timing

When considering implementing the optional second and third balancing segments, keep in mind that these chart of accounts segment labels are set from the beginning of time and are actively used by your ledgers. This is important to ensure that balances are immediately maintained in accordance with the necessary balancing actions to produce consistent financial reporting for the desired business dimensions. Multiple balancing segment ledgers that are not maintained from the beginning of time require extensive manual balance adjustments to catch up and realign the balances in accordance with the multiple balancing segments.

Note

Do not set a segment already qualified as a natural account or intercompany segment as any of the three balancing segments. Validations are not performed

when segment labels are assigned, so verify that all are assigned correctly before using your chart of accounts.

Change Options

Once a segment has been enabled and designated as a balancing segment, you must not change the segment. Do not disable the segment or remove the segment labels. These settings must be consistently maintained throughout the life of the chart of accounts to control the accuracy and integrity of the financial data.

Migration Adjustments

For charts of accounts migrated from Oracle E-Business Suite to Oracle Fusion General Ledger that use a segment with the secondary balance tracking segment qualifier, steps must be taken to ensure the proper transition to the second and third balancing segments. The required adjustments are extensive.

For ledgers associated with a migrated chart of accounts, its balances must be adjusted manually to be consistent with the second and third balancing segments as though these segment labels have been in place since the beginning of entries for these ledgers. This requires recomputing and updating of the following processes to reflect the correct balancing for each unique combination of segment values across the additional second and third balancing segments.

- Intercompany balancing
- Suspense posting
- Rounding imbalance adjustments on posting
- Entered currency balancing
- Revaluation gains or losses
- Retained earnings calculations at the opening of each new fiscal year
- Cumulative translation adjustments during translation

Note

All previously translated balances must also be purged, and new translations run to properly account for translated retained earnings and cumulative translation adjustments with the correct level of balancing.

Using Multiple Balancing Segments: Example

This simple example illustrates balancing along two balancing segments for a simple chart of accounts with three segments.

Scenario

Your company has a chart of accounts with two balancing segments and three segments, qualified as follows:

- Company: Primary balancing segment

- Cost Center: Second balancing segment
- Account: Natural account segment

The following multiple company and cost center journal has been entered to transfer advertising and phone expense from Company 1, Cost Center A to Company 2, Cost Center B.

Account	Debit	Credit
Company 1-Cost Center A-Advertising Expense Account	600	
Company 2-Cost Center B-Advertising Expense Account		600
Company 1-Cost Center A-Phone Expense Account	800	
Company 2-Cost Center B-Phone Expense Account		800

During the posting process, the last four lines are created to balance the entry across the primary and second balancing segments, company and cost center.

Account	Debit	Credit
Company 1-Cost Center A-Advertising Expense Account	600	
Company 2-Cost Center B-Advertising Expense Account		600
Company 1-Cost Center A-Phone Expense Account	800	
Company 2-Cost Center B-Phone Expense Account		800
Company 1-Cost Center A-Balancing Account		600
Company 2-Cost Center B-Balancing Account	600	
Company 1-Cost Center A-Balancing Account		800
Company 2-Cost Center B-Balancing Account	800	

FAQs for Manage Charts of Accounts

How can I use future accounting segments?

To plan for future growth in the business organization that requires additional segments in the chart of accounts, extra segments can be added to the chart of accounts structure during your original implementation. Since all segments of the chart are required and have to be enabled, these unused segments can be assigned value sets that have a single value in the chart of accounts structure instance. This value is set as a default for that segment so that the extra segments are automatically populated when an account code combination is used.

Define Chart of Accounts for Enterprise Structures: Manage Chart of Accounts Value Sets

Chart of Accounts Values Sets: Critical Choices

A value set is the collection of account values that are associated with a segment of a chart of accounts structure instance. When creating values sets, consider the following critical choices:

- Module Designation
- Validation Type
- Format Assignments
- Security Rules
- Values Definition

Module Designation

The module designation is used to tag value sets in Oracle Fusion Applications and sets the value sets apart during upgrades and other processes. Chart of accounts value sets upgraded from Oracle E-Business Suite Release 12 generically bear the module value of **Oracle Fusion Middleware**. When creating new value sets for a chart of accounts, the module can be specified as **Oracle Fusion General Ledger** to distinctly identify its intended use in an accounting flexfield, basically a chart of accounts.

Validation Type

Assign one of the following validation types to chart of accounts value sets:

- **Independent:** The values are independently selected when filling out the segment in the account combination.
- **Table Validated:** The values are stored in an external table to facilitate maintenance and sharing of the reference data.

Format Assignments

Value sets for chart of accounts must use the **Value Data Type** of **Character**. The **Value Subtype** is set to **Text**. These two settings support values that are both numbers and characters, which are typical in natural account segment values. Set the maximum length of the value set to correspond to the length of the chart of accounts segment to which it is assigned. Best practices recommend restricting values to **Upper Case Only** or **Numeric** values that are zero filled by default.

Security Rules

If flexfield data security rules are to be applied to the chart of accounts segment associated with the value set, the **Enable Security** check box must be checked for the assigned value set. In addition, assign a data security resource name to

enable creation of a data security object automatically for the value set. The data security object is used in the definition of flexfield data security rules.

Value Definition

Once these basic characteristic are defined for the value set, values can be added to the set in the Manage Values page.

- Set the values to conform to the value set length and type.
- Enter the value, its description, and its attributes including the **Enable** check box, **Start Date**, and **End Date**.
- Assign the following attributes: **Parent** or **Summary** check box, **Posting is allowed**, and **Budgeting is allowed**.

Note

If the value set is used with a natural account segment, the value also requires you set the **Natural Account Type**, with one of the following values: **Asset**, **Liability**, **Equity**, **Revenue** or **Expense**. Other attributes used are **Third Party Control Account**, **Reconciliation** indicator, and **Financial Category** used with Oracle Transaction Business Intelligence reporting.

Oracle Fusion General Ledger best practice is to define the values for the value set after the value set is assigned to a chart of accounts structure instance. Otherwise you are not able to define the mandatory value attributes, such as summary flag, posting allowed, and account type for natural account segment. The attributes must be added after the value set is assigned to a chart of accounts structure instance.

Creating a Value Set for Your Chart of Accounts: Example

Create your value sets before creating your chart of accounts. A value set can be shared by different charts of accounts or across different segments of the same chart of accounts.

Scenario

You are creating a company value set to be used in your chart of accounts for your enterprise, InFusion America, Inc. Follow these steps:

1. Navigate to the **Manage Chart of Accounts Value Sets** task from within your implementation project and click the **Go to Task**.
2. Click the **Create** icon on the toolbar of the Search Results table. The **Create Value Set** page opens.
3. Enter a unique Value Set Code, **InFusion America Company**, and an optional Description, **Company values for InFusion America Inc.**
4. Select **General Ledger** from the list in the Module field.
5. Select **Independent** as Validation Type.
6. Select **Character** as the Validation Data Type.
7. Click **Save and Close**.

Configuring Chart of Account Segment for Business Intelligence: Explained

To map the Oracle Fusion General Ledger Accounting Flexfield in Oracle Transaction Business Intelligence (BI) Repository file (RPD) for Oracle Fusion Financials, populate values in the Manage Key Flexfields user interface. These values enable the Chart of Accounts segments for Oracle Fusion Transactional BI and provide the mapping with BI Object names that are used as dimension for each of the Chart of Accounts segments.

Check each of the Chart of Accounts segments' **BI enabled** check box on all segments that you intend to map in the RPD by performing the following steps:

1. From your implementation project or the **Setup and Maintenance** page, query for **Manage Key Flexfields** and select the **Go to Task**.
2. Enter GL# in the **Key Flexfield Code** field.
3. Click **Search** button.
4. Click on **Manage Structure Instances** button.
5. Click the **Search** button.
6. Click on the desired chart of accounts and **Edit** icon.
7. Click on the desired segment and the **Edit** icon.
8. Edit each of the segments by checking the **BI enabled** check box.
9. Click on **Save** button. This should be done for all segments in every **Chart of Accounts Structure Instance** that you intend to be mapped in RPD.
10. Click the **Save and Close** button and the **Done** button.

Populate the **BI Object Name** for each of the **Segment Labels**. This name is the logical table name in the RPD which would be used as the dimension for the corresponding segment. Perform the following steps:

1. From your implementation project or the **Setup and Maintenance** page, query for **Manage Key Flexfields** and select the **Go to Task**.
2. Enter GL# in the **Key Flexfield Code** field.
3. Query for GL# as **Key Flexfield Code** in **Manage Key Flexfields** page.
4. Click **Search** button.
5. Chose **Actions** menu and click on **Manage Segment Labels**
6. Populate the **BI Object Name** for all the segment labels that are need to be mapped in the RPD.

Segment Label Code	BI Object Name
FA_COST_CTR	Dim - Cost Center
GL_BALANCING	Dim - Balancing Segment
GL_ACCOUNT	Dim - Natural Account Segment

7. Click the **Save** button.

Note

For all the non qualified segment labels, the **BI Object Name** should be populated with one of the following:

- Dim - GL Segment1
- Dim - GL Segment2
- Dim - GL Segment3
- Dim - GL Segment4
- Dim - GL Segment5
- Dim - GL Segment6
- Dim - GL Segment7
- Dim - GL Segment8
- Dim - GL Segment9
- Dim - GL Segment10

Deploy the flexfield using the **Deploy Flexfield** button from **Manage Key Flexfields** page.

Define Chart of Accounts for Enterprise Structures: Manage Account Hierarchies

Trees: Overview

Use the tree management feature in Oracle Fusion applications to organize data into hierarchies. A hierarchy contains organized data and enables the creation of groups and rollups of information that exist within an organization. Trees are hierarchical structures that enable several data management functions such as better access control, application of business rules at various levels of hierarchies, improved query performance, and so on.

For example, XYZ Corporation has two departments: Marketing and Finance. The Finance department has two functional divisions: Receivables and Payables. Defining a tree for the XYZ Corporation establishes a hierarchy between the organization and its departments, and between the departments and their respective functional divisions. Such a hierarchical modeling of organizational data could be used for executing several data management functions within that organization.

You can create one or more versions of trees, and they can be labeled for better accessibility and information retrieval. You can create trees for multiple data sources, which allow the trees to be shared across Oracle Fusion applications.

Tree Structures

A tree structure is a representation of the data hierarchy, and guides the creation of a tree. A tree is an instance of the hierarchy as defined in the tree structure. Tree structures enable you to enforce business rules to which the data must adhere.

The root node is the topmost node of a tree. Child nodes report to the root node. Child nodes at the same level, which report to a common parent node, are called siblings. Leaves are details branching off from a node but not extending further down the tree hierarchy.

Tree Versions

A tree is created having only one version. However, users can create more than one tree version depending on the need, and they can make changes to those versions. Depending on varying requirements, users can create one or more tree versions and publish all of them or some of them by making the versions active at the same time. Similar to any other version control system, versions of trees are maintained to keep track of all the changes that a tree undergoes in its life cycle.

Tree Labels

Tree labels are short names associated with trees and tree structures and point directly to the data source. Tree labels are automatically assigned to the tree nodes. You can store labels in any table and register the label data source with the tree structure.

Manage Tree Structures

Tree Structures: Explained

A tree structure defines the hierarchy for creating trees and prescribes rules based on which trees are created, versioned, and accessed. You can associate multiple data sources with a tree structure. A tree is an instance of this hierarchy. Every tree structure can contain one or more trees.

You can create tree structures specific to an application but you can share tree structures across applications. If you apply version control to the tree structure, it is carried over to the trees that are based on the tree structure. Each tree version contains at least one root node. Occasionally, a tree version may have more than one root node.

An administrator controls the access to tree structures through a set of rules that are periodically audited for validity.

Tree Structure Definition: Points to Consider

Defining a tree structure involves specifying several important pieces of information on the **Create Tree Structure: Specify Definition** page.

Tree Node Selection

The **Tree Node** table displays data in nodes that exist in the data hierarchy. You must select the correct and most appropriate tree node table to be able to define the tree structure, based on the tree hierarchy you want to establish. This selection also affects the level of security that is set on a tree node and its child entities.

Tree Sharing Mode

The following options are used to determine the mode of sharing a tree structure across the applications.

- Open: Indicates that the tree is associated with all reference data sets.
- Set ID: Indicates that the tree will be associated with a specific reference data set.

Creation Mode

Indicates the source where the tree structure is being defined. For predefined tree structures select Oracle and for custom structures, select Customers.

Customization

You can customize the predefined tree structures as well as the ones that you created. However, customizing the predefined tree structures involves certain level of access restrictions, and will be limited to specific tree nodes and downwards in hierarchy.

Multiple Tree Versions

One or more trees and tree versions can be based on a tree structure. A tree structure can have one or more trees and tree versions based on it. Usually, only one active version is permitted at any given point of time. However, depending on the requirement, you can allow two or more tree versions to be in the active state for the same date range. This flexibility allows you to choose the tree version that you want to implement.

Managing Tree Structures: Points to Consider

You can create, edit, and delete tree structures depending upon the requirement. You can also audit and change the status a tree structure.

Creating and Editing Tree Structures

You can create trees on the basis of a tree structure. When you edit an active tree structure, the status of the tree structure and all associated trees and their versions change to draft. To reuse a tree structure, you can create a copy of it without copying the associated trees and tree versions. If you delete a tree structure, all the associated trees and tree versions are automatically deleted.

Note

For specific information on working with the predefined tree structures that exist in an Oracle Fusion application, refer to the specific product documentation.

Setting Status

If you change the status of a tree structure, the status of the trees and tree versions associated with that tree structure also changes.

The following table lists the different statuses of a tree structure.

Status	Meaning
Draft	Yet to be published or is in a modified state.

Active	In use and based on which one or more trees or tree versions are created.
Inactive	Not in use.

Tree Structure Audit Results: Explained

Use the tree structure audit results to verify the tree structure's correctness and data integrity. The audit results include the following details:

- The name of the validator, which is a specific validation check
- The result of the validation, including a detailed message
- Corrective actions to take if there are any validation errors

Running an Audit

Setting the status of a tree structure to active automatically triggers an audit of that tree structure. You can also manually trigger an audit on the manage Tree Structures page, using **Actions - Audit**. The Tree Structure Audit Result table shows a list of validations that ran against the selected tree structure.

Validation Details

The following table lists the validators used in the audit process and describes what each validator checks for. It also lists possible causes for validation errors and suggests corrective actions.

Validator	Description (what is checked)	Possible Cause for Validation Failure	Suggested Corrective Action
Restrict By Set ID	On the Manage Tree Structures: Specify Data Sources page, if the Set ID check box is selected to enable the Restrict Tree Node List of Values Based on option for a tree structure, each of its data source view objects must have a reference data set attribute. This validation does not take place when the check box is not selected.	Even when the check box is selected, one or more of its data source view objects does not contain a reference data set attribute.	If reference data set restriction is required for this tree structure, include a reference data set attribute on all data sources. Otherwise, deselect the check box.
Row Flattened Table Name	On the Manage Tree Structures: Specify Performance Options page, a valid row flattened table must be specified for the tree structure. It can either be the standard row flattened table <code>FND_TREE_NODE_RF</code> or a custom table.	<ul style="list-style-type: none"> • The specified table does not exist in the database. • The specified table does not contain the same columns as the <code>FND_TREE_NODE_RF</code> table. 	Correct the row flattened table definition.

<p>Available Label Data Sources</p>	<p>On the Manage Tree Structures: Specify Data Sources page, if a labeling scheme is specified for the tree structure by selecting a list item from the Labeling Scheme list box, the label data source view object specified for each data source must be accessible, and the primary keys must be valid. This restriction does not apply when you select None from the Labeling Scheme list box.</p>	<ul style="list-style-type: none"> • Any of the specified label data source view objects do not exist. • Any of the specified label data source view objects do not have primary keys. • When a label data source view object is initially defined, the database registers the primary keys for the view object. If the view object is later modified such that its primary keys no longer match the primary keys that were registered earlier, this validation fails. 	<ul style="list-style-type: none"> • Correct the specified label data source view object. • Correct the primary keys of the specified label data source view object. • Either correct the primary keys in the label data source view object to match the primary keys that were earlier registered in <code>FND_TS_DATA_SOURCE</code>, or correct the primary keys registered in that table to match the new view object definition.
-------------------------------------	---	---	---

<p>Available Data Sources</p>	<p>Each data source view object specified for the tree structure must be accessible, and all its primary key attributes must be valid.</p>	<ul style="list-style-type: none"> • Any of the specified data source view objects do not exist. • When a data source view object is initially defined, the database automatically registers the primary keys for the view object if the Use non-defined primary key columns check box on the Data Source dialog box is not selected. If the check box is selected, the database registers the primary keys specified explicitly by the user on the Add Data Source dialog box. If the registered primary keys contain any duplicates, this validation fails. • The Use non defined primary key columns check box is selected in a data source, but the list of specified primary key columns does not match the primary keys defined in the corresponding data source view object. • Any common attribute that exists in both the data source view object and the tree node view object is not of the same data type in both view objects. 	<ul style="list-style-type: none"> • Correct the specified data source view object. • Correct the duplicate column in the registered primary keys. • Correct the primary keys of the specified data source view object. • Correct any mismatch in data types.
-------------------------------	--	---	---

Column Flattened Table Name	On the Manage Tree Structures: Specify Performance Options page, a valid column flattened table must be specified for the tree structure. It can either be the standard row flattened table <code>FND_TREE_NODE_CF</code> or a custom table.	<ul style="list-style-type: none"> The specified table does not exist in the database. The specified table does not contain the same columns as the <code>FND_TREE_NODE_CF</code> table. 	Correct the column flattened table definition.
Restrict by Date	On the Manage Tree Structures: Specify Data Sources page, if the Date Range check box is selected to enable the Restrict Tree Node List of Values Based on option for a tree structure, each of its data source view objects must have effective start date and effective end date attributes. This validation does not take place when the check box is not selected.	Even when the check box is selected, one or more of its data source view objects does not contain effective start date and effective end date attributes.	If the date restriction is required for this tree structure, include the effective start date and effective end date attributes on all data sources. Otherwise, deselect the check box.
Tree Node Table Name	On the Manage Tree Structures: Specify Definition page, a valid tree node table must be specified for the tree structure. It can either be the standard row flattened table <code>FND_TREE_NODE</code> or a custom table.	<ul style="list-style-type: none"> No table is specified in the Tree Node Table field. The specified table does not exist in the database. The specified table does not contain the same columns as the <code>FND_TREE_NODE</code> table. 	Correct the tree node table definition.
Allow Node Level Security	If the Allow Node Level Security option is set to No for the tree structure, the same option cannot be set to Yes on any of its data sources. This is a database setting that is not visible on the Manage Tree Structures page.	The option is set to No for the tree structure but one or more associated data sources have that option set to Yes.	Correct the option setting in the tree structure and their data sources.

Specifying Data Sources for Tree Structures: Points to Consider

The data sources provide the items for establishing hierarchy in a tree structure. In the tree management infrastructure, these data sources are Oracle Application

Development Framework (ADF) business components view objects, which are defined by application development.

Labeling Schemes

Selecting a labeling scheme determines how the tree nodes are labeled. You may select a labeling scheme to assign at the data source level, at the parent node level, or keep it open for customer assignment. You may also choose not to have any labeling scheme. However, if you decide to use any of the labeling schemes, you may need to select the following additional options, to restrict the list of values that appear under the selected tree node.

- **Allow Ragged Nodes:** To include nodes that have no child nodes, and are shorter than the remaining nodes in the entire hierarchy.
- **Allow Skip Level Nodes:** To include nodes that are at the same level but have parent nodes at different levels.

Restriction of Tree Node Values

You can decide the depth of the tree structure by selecting an appropriate value from the list. Keeping the depth limit open renders an infinite list of values. Using the following options, you can restrict the list of values that appear for selection under a specific tree node.

- **Date Range:** Specifies whether a selection of nodes should be restricted to the same date range as the tree version.
- **Allow Multiple Root Nodes:** Allows you to add multiple root nodes when creating a tree version.
- **Reference Data Set:** Specifies whether a selection of nodes should be restricted to the same set as the tree.

Data Source Values and Parameters

Tree data sources have optional data source parameters with defined view criteria and associated bind variables. You can specify view criteria as a data source parameter when creating a tree structure, and edit the parameters when creating a tree. Multiple data sources can be associated with a tree structure and can have well-defined relationships among them.

Note

Parameter values customized at the tree level override the default values specified at the tree-structure level.

The data source parameters are applied to any tree version belonging to that data source, when performing node operations on the tree nodes. Data source parameters also provide an additional level of filtering for different tree structures. The tree structure definition supports three data source parameter types.

- **Bound Value:** Captures any fixed value, which is used as part of the view criteria condition.
- **Variable:** Captures and binds a dynamic value that is being used by the data source view object. This value is used by the WHERE condition of the data flow.
- **View Criteria:** Captures the view criteria name, which is applied to the data source view object.

You can also specify which of the data source parameters are mandatory while creating or editing the tree structure.

View objects from the ADF business components are used as data sources. To associate the view object with the tree structure, you can pick the code from ADF business component view objects and provide the fully qualified name of the view object, for example, oracle.apps.fnd.applcore.trees.model.view.FndLabelVO.

Specifying Performance Options for a Tree Structure: Points to Consider

Tree structures are heavily loaded with data. As a tree management guideline, use the following settings to improve performance of data rendering and retrieval.

- Row Flattening
- Column Flattening
- Column Flattened Entity Objects
- ADF Business Component View Objects

Row Flattening

Row flattening optimizes parent-child information for run-time performance by storing additional rows in a table for instantly finding all descendants of a parent without initiating a CONNECT BY query. Row flattening eliminates recursive queries, which allows operations to perform across an entire subtree more efficiently.

To store row flattened data for the specific tree structure, users can either use the central `FND_TREE_NODE_RF` table or they can register their own row flattened table. For example, in a table, if Corporation is the parent of Sales Division (Corporation-Sales Division), and Sales Division is the parent of Region (Sales Division-Region), a row-flattened table contains an additional row with Corporation directly being the parent of Region (Corporation-Region).

Column Flattening

Column flattening optimizes parent-child information for run-time performance by storing an additional column in a table for all parents of a child.

To store column flattened data for the specific tree structure, users can either use the central `FND_TREE_NODE_CF` table or they can register their own column flattened table. For example, in a table, if Corporation is the parent of Sales Division (Corporation-Sales Division), and Sales Division is the parent of Region (Sales Division-Region), a flattened table in addition to these columns, contains three new columns: Region, Sales Division, and Corporation. Although positioned next to each other, the column Region functions at the lower level and Corporation at the higher level, retaining the data hierarchy.

Column Flattened Entity Objects

In the absence of a column-flattened table, if you need to generate the business component view objects for your tree structure for the flattened table, use the tree management infrastructure to correctly provide the fully qualified name of the entity object for the column flattened table.

ADF Business Component View Objects

View objects from the ADF business components can also be used as data sources, eliminating the need to create new types of data sources. This field is to store the fully qualified name for the business component view object generated by the tree management for business intelligence reporting and usage. The business component view object is a combination of the tree data source and column flattened entity. Using this option prevents data redundancy and promotes greater reuse of existing data, thereby improving the performance of the tree structure.

Manage Tree Labels

Tree Labels: Explained

Tree labels are tags that are stored on tree nodes. You can store labels in any table and register the label data source with the tree structure. When a labeling scheme is used for trees, the selected labels are stored in the tree label entity and each tree node contains a reference to a tree label in the labeling scheme.

The following table lists the three ways in which tree labels are assigned to the tree nodes.

Labeling Scheme	Description
Level	Labels that are automatically assigned based on the data source to which the tree node belongs. A level label points to a specific data source. For example, in a tree that reflects the organizational hierarchy of an enterprise, all division nodes appear on one level and all department nodes on another.
Group	Labels that you can arbitrarily assign to tree nodes.
Depth	Labels that are automatically assigned based on the depth of the tree node within the tree. No manual assignment is performed. <hr/> Note In an unbalanced hierarchy, a level may not be equal to depth.

Manage Trees and Tree Versions

Managing Trees and Tree Versions: Points to Consider

You can create and edit trees and tree versions depending upon the requirement. A tree can have one or more tree versions. Typically, when changes are made to an existing tree, a new version is created and published.

Creating and Editing Trees

Trees are created based on the structure defined in the tree structure. You can create trees, modify existing trees, and delete trees. If you want to copy an existing tree, you can duplicate it. However, only the tree is duplicated and not its versions.

Creating a tree involves specifying the tree definition and specifying the labels that are used on its nodes. If the selected tree structure has data sources and parameters defined for it, they appear on the page allowing you to edit the parameter values at the tree node level.

Note

Parameter values customized at the tree level will override the default values specified at the tree-structure level.

Creating and Editing Tree Versions

Tree versions are created at the time of creating trees. A tree must contain a version.

Editing an existing tree provides you the choice to update the existing version. You can also edit the existing version that lies nested under the tree in the search results.

When you edit a tree version bearing Active status, the status changes to Draft until the modifications are saved or cancelled.

Tree Version Audit Results: Explained

Use the tree version audit results to verify the tree version's correctness and data integrity. The audit results include the following details:

- The name of the validator, which is a specific validation check
- The result of the validation, including a detailed message
- Corrective actions to take if there are any validation errors

Running an Audit

An audit automatically runs whenever a tree version is set to active. You can also manually trigger an audit on the Manage Trees and Tree Versions page, using **Actions - Audit**. The Tree Version Audit Result table shows a list of validations that ran against the selected tree version.

Validation Details

The following table lists the validators used in the audit process and describes what each validator checks for. It also lists possible causes for validation errors and suggests corrective actions.

Validator	Description (what is checked)	Possible Cause for Validation Failure	Suggested Corrective Action
Effective Date	The effective start and end dates of the tree version must be valid.	The effective end date is set to a value that is not greater than the effective start date.	Modify the effective start and end dates such that the effective start date is earlier than the effective end date.
Root Node	On the Manage Tree Structures: Specify Data Sources page, if the Allow Multiple Root Nodes check box for the Restrict Tree Node List of Values Based on option is not selected, and if the tree structure is not empty, the tree version must contain exactly one root node. This validation does not take place if the check box is selected.	Even if the check box is deselected, the tree version has multiple root nodes.	Modify the tree version such that there is exactly one root node.
Data Source Max Depth	For each data source in the tree structure, on the Data Source dialog box, if the data source is depth-limited, the data in the tree version must adhere to the specified depth limit. This validation does not apply to data sources for which the Maximum Depth field is set to Unlimited .	The tree version has data at a depth greater than the specified depth limit on one or more data sources.	Modify the tree version such that all nodes are at a depth that complies with the data source depth limit.
Duplicate Node	On the Data Source dialog box, if the Allow Duplicates check box is not selected, the tree version should not contain more than one node with the same primary key from the data source. If the check box is selected, duplicate nodes are permitted.	Even when the check box is deselected, the tree version contains duplicate nodes.	Remove any duplicate nodes from the tree version.

Available Node	All nodes in the tree version should be valid and available in the underlying data source.	<ul style="list-style-type: none"> • A node in the tree version does not exist in the data source. Deleting data items from the data source without removing the corresponding nodes from the tree version can result in orphaned nodes in the tree version. For example, if you added node A into your tree version, and subsequently deleted node A from the data source without removing it from the tree version, the validation fails. • The tree version contains a tree reference node, which references another tree version that does not exist. 	Remove any orphaned nodes from the tree version. Update tree reference nodes so that they reference existing tree versions.
Node Relationship	All nodes must adhere to the relationships mandated by the data sources registered in the tree structure.	The tree structure has data sources arranged in a parent-child relationship, but the nodes in the tree do not adhere to the same parent-child relationship. For example, if the tree structure has a Project data source with a Task data source as its child, Task nodes should always be under Project nodes in the tree version. This validation fails if there are instances where a Project node is added as the child of a Task node.	Modify the tree version such that the nodes adhere to the same parent-child relationships as the data sources.

SetID Restricted Node	On the Manage Tree Structures: Specify Data sources page, if the Set ID check box is selected to enable the Restrict Tree Node List of Values Based on option for each tree node, the underlying node in the data source must belong to the same reference data set as the tree itself. This restriction does not apply when the check box is not selected.	Even when the check box is selected, the tree version has nodes whose data source values belong to a different reference data set than the tree.	Modify the tree version such that all nodes in the tree have data sources with reference data set matching that of the tree.
Label Enabled Node	On the Manage Tree Structures: Specify Data Sources page, if a labeling scheme is specified for the tree structure by selecting a list item from the Labeling Scheme list box, all nodes should have labels. This restriction does not apply when you select None from the Labeling Scheme list box.	The tree structure has a labeling scheme but the tree version has nodes without labels.	Assign a label to any node that does not have a label.

Date Restricted Node	On the Manage Tree Structures: Specify Data Sources page, if the Date Range check box is selected to enable the Restrict Tree Node List of Values Based on option for a tree structure, each node in the underlying data source must have an effective date range same as the effective date range of the tree version. This restriction does not apply if the check box is not selected.	Even when the check box is selected, there are data source nodes that have a date range beyond the tree version's effective date range. For example, if the tree version is effective from Jan-01-2012 to Dec-31-2012, all nodes in the tree version must be effective from Jan-01-2012 to Dec-31-2012 at a minimum. It is acceptable for the nodes to be effective for a date range that extends partly beyond the tree version's effective date range (for example, the node data source value is effective from Dec-01-2011 to Mar-31-2013). It is not acceptable if the nodes are effective for none or only a part of the tree version's effective date range (for example, the node data source value are effective only from Jan-01-2012 to June-30-2012).	Ensure that all nodes in the tree version have effective date range for the effective date range for the tree version.
Multiple Active Tree Version	On the Manage Tree Structures: Specify Definition page, if the Allow Multiple Active Tree Versions check box is not selected for the tree structure, there should not be more than one active tree version under a tree at any time. This restriction does not apply if the check box is selected.	Even when the check box is not selected, there is more than one active tree version in the tree for the same date range.	Set no more than one tree version to Active within the same date range and set the others to inactive or draft status.
Range Based Node	On the Data Source dialog box, if the Allow Range Children check box is not selected, range-based nodes are not permitted from that data source. This restriction does not apply if the check box is selected.	Even when the check box is not selected, there are range-based nodes from a data source.	Ensure that any range nodes in your tree version are from a data source that allows range children.

Terminal Node	On the Data Source dialog box, if the Allow Use as Leaves check box is not selected, values from that data source cannot be added as leaves (terminal nodes) to the tree version. This restriction does not apply if the check box is selected.	Even when the check box is not selected, values from a data source are added as leaf nodes (terminal nodes).	Modify the tree version such that all terminal nodes are from data sources for which this check box is selected.
Usage Limit	On the Data Source dialog box, if the Use All Values option is selected to set the Usage Limit for the data source, every value in the data source must appear as a node in the tree. This restriction does not apply if None option is selected.	Even if the Use All Values option is selected, there are values in the data source that are not in the tree version.	For each data source value that is not yet available, add nodes to the tree version.

Trees and Data Sources: How They Work Together

Data sources form the foundation for tree management in Oracle Fusion Applications. Tree structures, trees, and tree versions establish direct and real-time connectivity with the data sources. Changes to the data sources immediately reflect on the **Manage Trees and Tree Versions** page and wherever the trees are being used.

Metadata

Tree structures contain the metadata of the actual data that is used in Oracle Fusion Applications. Tree structures contain the core business logic that is manifested in trees and tree versions.

Data Storage

Trees and tree versions are built upon the tree structures. They employ the business rules defined in the tree structures and allow an application to select and enable a subset of trees to fulfill a specific purpose in that application.

Access Control

Source data is mapped to tree nodes at different levels in the database. Therefore, changes you make to the tree nodes affect the source data. Access control set on trees prevents unwanted data modifications in the database. Access control can be applied to the tree nodes or anywhere in the tree hierarchy.

Adding Tree Nodes: Points to Consider

Tree nodes are points of data convergence that serve as the building blocks of a tree structure. Technically, the node may be stored either in a product-specific

table or in an entity that has been established by tree management as the default storage mechanism. However, since all data in Oracle Fusion Applications usually have a storage home, only user-created data needs to be stored in an entity.

Nodes are attached to tree versions. Whenever you create or edit a tree version, you need to specify its tree node.

Managing Tree Nodes

You can create, modify, or delete tree nodes on the **Tree Version: Specify Nodes** page. To add a tree node, ensure that the tree structure with which the tree version is associated is mapped to a valid data source. You can also duplicate a tree node if the multiple root node feature is enabled.

Node Levels

In most trees, all nodes at the same level represent the same kind of information. For example, in a tree that reflects the organizational hierarchy, all division nodes appear on one level and all department nodes on another. Similarly, in a tree that organizes a user's product catalog, the nodes representing individual products might appear on one level and the nodes representing product lines on the next higher level.

When levels are not used, the nodes in the tree have no real hierarchy or reporting structure but do form a logical summarization structure. Strictly enforced levels mean that the named levels describe each node's position in the tree. This is natural for most hierarchies. Loosely enforced levels mean that the nodes at the same visual level of indentation do not all represent the same kind of information, or nodes representing the same kind of information appear at multiple levels. With loosely enforced levels, users assign a level to each node individually. The level is not tied to a particular visual position.

Node Types

A tree node has the following node types.

- **Single:** Indicates that the node is a value by itself.
- **Range:** Indicates that the node represents a range of values and possibly could have many children. For example, a tree node representing account numbers 10000 to 99999.
- **Referenced Tree:** Indicates that the tree node is actually another version for the tree based on the same tree structure, which is not physically stored in the same tree. For example, a geographic hierarchy for the United States can be referenced in a World geographic hierarchy.

Importing Segment Values and Hierarchies: Explained

Use Import Segment Values and Hierarchies process to load segment values and hierarchies if you maintain your chart of accounts reference data outside Oracle Fusion applications. You can load your segment values and hierarchies by populating two tables: `GL_SEGMENT_VALUES_INTERFACE` table and

GL_SEGMENT_HIER_INTERFACE table, and running the Import Segment Values and Hierarchies process.

Note

You can load data to interface tables using predefined templates and the Load Interface File for Import scheduled process, which are both part of the External Data Integration Services for Oracle Cloud feature. For other implementations, optionally use this feature only if you have SFTP configured for it.

The GL_SEGMENT_VALUES_INTERFACE and GL_SEGMENT_HIER_INTERFACE tables

You can use GL_SEGMENT_VALUES_INTERFACE to load segment values and GL_SEGMENT_HIER_INTERFACE to load segment value hierarchies to Oracle Fusion applications. You can find details of the columns of the interface table in Oracle Enterprise Repository (OER) for Oracle Fusion Applications.

Assigning Values for Columns in the GL_SEGMENT_VALUES_INTERFACE table

You must enter values in all columns of the interface table that require values, which includes all of the not null columns, in order for the Import Segment Values and Hierarchies process to be successful. Enter values in the following required columns of the interface table:

Column Name	Value
STATUS_CODE	Enter the value NEW to indicate that you are bringing new segment value data.
VALUE_SET_CODE	Enter the value set code for the segment values.
VALUE	Enter the segment value.
SUMMARY_FLAG	Select N if the segment value is a child value or Y if the segment value is a parent value.
ENABLED_FLAG:	Select Y to enable the segment value. Enter N to disable the segment value.
ACCOUNT_TYPE:	Enter the natural account type if the segment value is for natural account segment. Valid values are: A for Assets, L for Liabilities, E for Expenses, O for Owner's Equities, and R for Revenues.
ALLOW_POSTING_FLAG	Select Y if posting is allowed for this segment value. Select N if posting is not allowed.
OBJECT_VERSION_NUMBER	Enter default value of 1.

You can enter values for the following optional columns:

Column Name	Value
START_DATE_ACTIVE	Enter the start date of the segment value
END_DATE_ACTIVE	Enter the end date of the segment value.
THIRD_PARTY_CTRL_ACCOUNT	Enter the third party control account value. Valid values are: CUSTOMER, SUPPLIER, R for Restrict Manual Journals, Y, and N.

FINANCIAL_CATEGORY	Enter a financial category value for Oracle Transactional Business Intelligence reporting. Valid values are values defined in the FINANCIAL_CATEGORY lookup type.
DESCRIPTION	There are different description columns for different languages. To see segment value description in a different language installation, you need to populate the segment description for that language too.

The following columns should be left as null as Import Segment Values and Hierarchies process uses them for internal processing or does not use them in the current release.

- CREATION_DATE
- CREATED_BY
- LAST_UPDATE_DATE
- LAST_UPDATE_LOGIN
- LAST_UPDATED_BY
- SEGMENT_VALUE_INTERFACE_ID
- REQUEST_ID
- LOAD_REQUEST_ID

Assigning Values for Columns in the GL_SEGMENT_HEIR_INTERFACE table

You must enter values in all columns of the interface table that require values, which includes all of the not null columns, in order for the Import Segment Values and Hierarchies process to be successful. Enter values in the following required columns of the interface table:

Column Name	Value
STATUS_CODE	Enter the value NEW to indicate that you are bringing new hierarchy data.
VALUE_SET_CODE	Enter the value set code for the segment values.
TREE_CODE	Enter the hierarchy name (tree code).
TREE_VERSION NAME	Enter the hierarchy version name (tree version name).
TREE_VERSION_START_DATE_ACTIVE	Enter the date that the tree version is activated.
TREE_VERSION_END_DATE_ACTIVE	Enter the date that the tree version is inactivated.
VALUE	Enter the segment value.
PARENT_VALUE	Select N if the segment value is a child value or Y if the segment value is a parent value.
DEPTH	Enter the depth of the hierarchy which shows the many ancestors the segment value has in the hierarchy.
OBJECT_VERSION_NUMBER	Enter default value of 1.

The following columns should be left as null as Import Segment Values and Hierarchies process uses them for internal processing or does not use them in the current release.

- CREATION_DATE
- CREATED_BY
- LAST_UPDATE_DATE
- LAST_UPDATE_LOGIN
- LAST_UPDATED_BY
- SEGMENT_VALUE_INTERFACE_ID
- REQUEST_ID
- LOAD_REQUEST_ID

Loading Data to the Segment Value and Hierarchies Interface Tables: Explained

Load the segment values and hierarchies to the interface table by using the following steps.

1. Load segment values and hierarchies to comma separated values (csv) files. You can use the sample csv file or xls file that's provided in Oracle Enterprise Repository (OER) for Oracle Fusion Applications as a reference.
2. Upload the comma separated values (csv) file to the secure FTP server.
3. Run the Load Interface File for Import process.
4. After the data is loaded to the interface table, you can run the Import Segment Values and Hierarchies process to load the segment values and hierarchies.

Define Chart of Accounts for Enterprise Structures: Manage Accounting Calendars

Defining Accounting Calendars: Critical Choices

Define an accounting calendar to create your accounting year and the periods it contains. Specify common calendar options that the application uses to automatically generate a calendar with its periods. Specifying all the options makes defining a correct calendar easier and more intuitive with fewer errors. The choices you make when specifying the following options are critical, because it is difficult to change your accounting calendar after a period status is set to open or future enterable.

- Start Date
- Period Frequency
- Adjusting Period Frequency

- Period Name Format

Note

In Oracle Fusion, the common calendar types, monthly, weekly, 4-4-5, 4-5-4, 5-4-4, 4-week, quarterly, and yearly, are automatically generated. This functionality makes it easier to create and maintain accounting calendars. By using the period frequency option, you no longer have to go through the tedious task of defining each period manually.

Start Date

If you plan to run translation, specify a calendar start date that is a full year before the start date of the year of the first translation period for your ledger. Translation cannot be run in the first period of a calendar. Consider how many years of history you are going to load from your previous system and back up the start date for those years plus one more. You cannot add previous years once the first calendar period has been opened.

Period Frequency

Use period frequency to set the interval for each subsequent period to occur, for example, monthly, quarterly, or yearly. If you select the period frequency of Other, by default, the application generates the period names, year, and quarter number. You specify the start and end dates. You must manually enter the period information. For example, select the period frequency of Other and enter 52 as the number of periods when you want to define a weekly calendar. For manually entered calendars, when you click the **Add Year** button, the application creates a blank year. Then, you must manually enter the periods for the new year. The online validation helps prevent erroneous entries.

Note

In Oracle Fusion applications a calendar can only have one period frequency and period type. Therefore, if you have an existing calendar with more than one period type associated with it, during the upgrade from Oracle E-Business Suite, separate calendars are created based on each calendar name and period type combination.

Adjusting Period Frequency

Use the adjusting period frequency to control when the application creates adjusting periods. For example, some of the frequencies you select add one adjusting period at year end, two at year end, or one at the end of each quarter. The default is None which adds no adjusting periods. If you select the frequency of Other, the **Number of Adjusting Periods** field is displayed. Enter the number of desired adjusting periods and then, manually define them.

Period Name Format Region

The **User-Defined Prefix** field in the Period Name Format region is an optional feature that allows you to enter your own prefix. For example, define a weekly calendar and then enter a prefix of Week, - as the separator, and the period name

format of Period numberYY fiscal year. The application creates the names of Week1-11, Week2-11, through Week52-11. The options for the **Format** field are predefined values. The list of values is filtered based on the selected separator and only displays the options that match the selected separator.

The year displayed in the period names is based on the selected period name format and the dates the period covers or if the period crosses years, on the year of the start date of the period. For example, April 10, 2010 to May 9, 2010 has the period name of Apr-10 and December 10, 2010 to January 9, 2011 has the name of Dec-10. If period frequency is Other, then the period format region is hidden. The application generates a temporary period name for calendars with period frequency of Other, using a fixed format of Period numberYY. You can override this format with your own customized period names.

Note

For an accounting calendar that is associated with a ledger, changing period names or adding a year updates the accounting period dimension in the balances cubes.

Calendar Validation: How It Works with the Accounting Calendar

Calendar validation is automatic and prevents serious problems when you begin using the calendar. Once you set a calendar period status to open or future enterable, you cannot edit the period.

Settings That Affect Calendar Validation

The calendar validation runs automatically when you save the calendar.

How the Calendar Is Validated

The following table lists the validation checks performed when the accounting calendar is saved.

Validation Performed	Example of Data
Unique period number	2 assigned for two periods
Unique period name	Jan-11 entered twice
Period number beyond the maximum number of periods per year	13 for a 12 period calendar with no adjusting periods
Entered period name contains spaces	Jan 11
Single or double quotes in the period name	Jan '11
Nonadjusting periods with overlapping dates	01-Jan-2011 to 31-Jan-2011 and 30-Jan-2011 to 28-Feb-2011
Period date gaps	01-Jan-2011 to 28-Jan-2011 and 31-Jan-2011 to 28-Feb-2011
Missing period numbers	Periods 1 through 6 defined for a twelve month calendar
Period number gaps	1, 3, 5

Period numbers not in sequential order by date	Period 1 covers 01-Jan-2011 to 31-Jan-2011 and period 2 covers 01-Mar-2011 to 31-Mar-2011, and period 3 covers 01-Feb-2011 to 28-Feb-2011.
Quarter number gaps	1, 3, 4
Quarters not in sequential order by period	1, 3, 2, 4
Period start or end dates more than one year before or after the fiscal year	July 1, 2010 in a 2012 calendar

FAQs for Manage Accounting Calendars

How can I identify errors in my accounting calendar?

Oracle Fusion General Ledger identifies erroneous entries online as you enter a new calendar or change data on an existing calendar. The application also automatically validates the data when you save the calendar.

What's the difference between calendar and fiscal period naming?

The period naming format determines the year that is appended to the prefix for each period in the calendar. For the example, your accounting year has a set of twelve accounting period with a start date of September 1, 2011 and the end date is August 31, 2012, with each period's date range following the natural calendar month date range.

Calendar period naming format: Select the calendar period format to append the period's start date's year to the prefix. For the period covering September 1, 2011 to December 31, 2011, then 2011 or just 11, depending on the period format selected, is appended to each period's name. For the remaining periods covering January 1, 2012 to August 31, 2012, then 2012 or 12, is appended to each period's name.

Fiscal period naming format: Select the fiscal period format to always append the period's year assignment to the prefix. If the accounting periods in the set of twelve are all assigned the year of 2012, then 2012 or just 12, depending on the period format selected, is appended to the period name of all 12 periods.

When do I update an existing calendar?

Update an existing calendar before the new periods are needed as future periods, based on the future period setting in your accounting configuration. If a complete year has been defined and validated, use the **Add Year** button to add the next year quickly. Accept or change the new rows as required. For example, with the Other frequency type calendar, dates may differ from what the application generates.

What happens if I upgrade my calendar from Oracle E-Business Suite Release 12?

The migration script assigns a period frequency that most closely matches your Oracle E-Business Suite Release 12 calendar. When you use the Oracle Fusion

applications Add Year functionality for the first time, you have an opportunity to review and change the period frequency. The Calendar Options page opens only for calendars upgraded from Release 12 to allow one time modification.

Make your changes to the period frequency, adjusting period frequency, and period name format, including the prefix and separator, as needed. Changes can not conflict with the existing upgraded calendar definition. Update the calendar name and description in the calendar header, as needed, for all calendars. Period details for a new year will be generated automatically based on the latest calendar options. You can also manually update the calendar. The modified calendar options affect future years only.

Define Accounting Configurations of Enterprise Structures: Manage Primary or Secondary Ledgers

Accounting Configuration Offerings: Overview

The Setup and Maintenance work area in the Oracle Fusion Applications is used to manage the configuration of legal entities, ledgers, and reporting currencies that comprise your accounting configuration. To create a new legal entity or ledger, your implementation consultant or system administrator must create an implementation project. This implementation project can be populated by either adding a financials related offering or one or more task lists.

Note

Setup tasks that are not related to the ledger or legal entity specific setup tasks can be invoked from either an implementation project or launched directly from the Setup and Maintenance work area.

There are two offerings predefined for financial implementations.

- The Oracle Fusion Accounting Hub offering is used to add the Oracle Fusion General Ledger and Oracle Fusion Subledger Accounting application features to an existing enterprise resource planning (ERP) system to enhance the current reporting and analysis.
- The Oracle Fusion Financials offering, which includes the Oracle Fusion General Ledger and Oracle Fusion Subledger Accounting application features, as well as at least one of the subledger financial applications.

When adding an offering to an implementation project, implementation consultants can customize the tasks displayed by adding additional tasks to the implementation project.

Ledgers and Subledgers: Explained

Oracle Fusion Applications reflect the traditional segregation between the general ledger and associated subledgers. Detailed transactional information is captured in the subledgers and periodically imported and posted in summary or detail to the ledger.

A ledger determines the currency, chart of accounts, accounting calendar, ledger processing options, and accounting method for its associated subledgers. Each accounting setup requires a primary ledger and optionally, one or more secondary ledgers and reporting currencies. Reporting currencies are associated with either a primary or secondary ledger.

The number of ledgers and subledgers is unlimited and determined by your business structure and reporting requirements.

Single Ledger

If your subsidiaries all share the same ledger with the parent company or they share the same chart of accounts and calendar, and all reside on the same applications instance, you can consolidate financial results in Oracle Fusion General Ledger in a single ledger. Use Oracle Fusion Financial Reporting functionality to produce individual entity reports by balancing segments. General Ledger has three balancing segments that can be combined to provide detailed reporting for each legal entity and then rolled up to provide consolidated financial statements.

Multiple Ledgers

Accounting operations using multiple ledgers can include single or multiple applications instances. You need multiple ledgers if one of the following is true:

- You have companies that require different account structures to record information about transactions and balances. For example, one company may require a six-segment account, while another needs only a three-segment account structure.
- You have companies that use different accounting calendars. For example, although companies may share fiscal year calendars, your retail operations require a weekly calendar, and a monthly calendar is required for your corporate headquarters.
- You have companies that require different functional currencies. Consider the business activities and reporting requirements of each company. If you must present financial statements in another country and currency, consider the accounting principles to which you must adhere.

Subledgers

Oracle Fusion Subledgers capture detailed transactional information, such as supplier invoices, customer payments, and asset acquisitions. Oracle Fusion Subledger Accounting is an open and flexible application that defines the accounting rules, generates detailed journal entries for these subledger transactions, and posts these entries to the general ledger with flexible summarization options to provide a clear audit trail.

Ledgers: Points to Consider

Companies account for themselves in primary ledgers, and, if necessary, secondary ledgers and reporting currencies. Your transactions from your

subledgers are posted to your primary ledgers and possibly, secondary ledgers or reporting currencies. Local and corporate compliance can be achieved through an optional secondary ledger, providing an alternate accounting method, or in some cases, a different chart of accounts. Your subsidiary's primary and secondary ledgers can both be maintained in your local currency, and you can convert your local currency to your parent's ledger currency to report your consolidated financial results using reporting currencies or translation.

Primary Ledgers

A primary ledger is the main record-keeping ledger. Like any other ledger, a primary ledger records transactional balances by using a chart of accounts with a consistent calendar and currency, and accounting rules implemented in an accounting method. The primary ledger is closely associated with the subledger transactions and provides context and accounting for them.

To determine the number of primary ledgers, your enterprise structure analysis must begin with your financial, legal, and management reporting requirements. For example, if your company has separate subsidiaries in several countries worldwide, enable reporting for each country's legal authorities by creating multiple primary ledgers that represent each country with the local currency, chart of accounts, calendar, and accounting method. Use reporting currencies linked to your country specific primary ledgers to report to your parent company from your foreign subsidiaries. Other considerations, such as corporate year end, ownership percentages, and local government regulations and taxation, also affect the number of primary ledgers required.

Secondary Ledgers

A secondary ledger is an optional ledger linked to a primary ledger for the purpose of tracking alternative accounting. A secondary ledger can differ from its primary ledger by using a different accounting method, chart of accounts, accounting calendar, currency, or processing options. All or some of the journal entries processed in the primary ledger are transferred to the secondary ledger, based on your configuration options. The transfers are completed based on the conversion level selected. There are four conversion levels:

- **Balance:** Only Oracle Fusion General Ledger balances are transferred to the secondary ledger.
- **Journal:** General Ledger journal posting process transfers the journal entries to the secondary ledger.
- **Subledger:** Oracle Fusion Subledger Accounting creates subledger journals to subledger level secondary ledgers as well as reporting currencies.
- **Adjustments Only:** Incomplete accounting representation that only holds adjustments. The adjustments can be manual or detailed adjustments from Subledger Accounting. This type of ledger must share the same chart of accounts, accounting calendar, and period type combination, and currency as the associated primary ledger.

Note

A full accounting representation of your primary ledger is maintained in any subledger level secondary ledger.

Secondary ledgers provide functional benefits, but produce large volumes of additional journal entry and balance data, resulting in additional performance and memory costs. When adding a secondary ledger, consider your needs for secondary ledgers or reporting currencies, and select the least costly data conversion level that meets your requirements. For secondary ledgers, the least costly level is the adjustment data conversion level because it produces the smallest amount of additional data. The balance data conversion level is also relatively inexpensive, depending upon how often the balances are transferred from the primary to the secondary ledger. The journal and subledger data conversion levels are much more expensive, requiring duplication of most general ledger and subledger journal entries, as well as general ledger balances.

For example, you maintain a secondary ledger for your International Financial Reporting Standards (IFRS) accounting requirements, while your primary ledger uses US Generally Accepted Accounting Principles (GAAP). You decided to select the subledger level for your IFRS secondary ledger. However, since most of the accounting is identical between US GAAP and IFRS, a better solution is to use the adjustment only level for your secondary ledger. The subledger level secondary ledger requires duplication of most subledger journal entries, general ledger journal entries, and general ledger balances. With the adjustment only level, your secondary ledger contains only the adjustment journal entries and balances necessary to convert your US GAAP accounting to the IFRS accounting, which uses a fraction of the resources that are required by full subledger level secondary ledger.

Following are scenarios that may require different combinations of primary and secondary ledgers:

- The primary and secondary ledgers use different charts of accounts to meet varying accounting standards or methods. A chart of accounts mapping is required to instruct the application how to propagate balances from the source (primary) chart of accounts to the target (secondary) chart of accounts.
- The primary and secondary ledgers use different accounting calendars to comply with separate industry and corporate standards.

Note

Use the same currency for primary and secondary ledgers to avoid difficult reconciliations, if you have the resources to support the extra posting time and data storage. Use reporting currencies or translations to generate the different currency views needed to comply with internal reporting needs and consolidations.

Reporting Currencies

Reporting currencies maintain and report accounting transactions in additional currencies. Each primary and secondary ledger is defined with a ledger currency

that is used to record your business transactions and accounting data for that ledger. It is advisable to maintain the ledger in the currency in which the majority of its transactions are denominated. For example, create, record, and close a transaction in the same currency to save processing and reconciliation time. Compliance, such as paying local transaction taxes, is also easier using a local currency. Many countries require that your accounting records be kept in their national currency.

If you need to maintain and report accounting records in different currencies, you do this by defining one or more reporting currencies for the ledger. There are three conversion levels for reporting currencies:

- **Balance:** Only General Ledger balances are converted into the reporting currency using translation.
- **Journal:** General Ledger journal entries are converted to the reporting currency during posting.
- **Subledger:** Subledger Accounting creates subledger reporting currency journals along with primary ledger journals.

Note

A full accounting representation of your primary ledger is maintained in any subledger level reporting currency. Secondary ledgers cannot use subledger level reporting currencies.

Of the three data conversion levels available, the balance data conversion level is typically the least expensive, requiring duplication of only the balance level information. The journal and subledger data conversion levels are more expensive, requiring duplication of most general ledger and subledger journal entries, as well as general ledger balances.

Do not use journal or subledger level reporting currencies if your organization has only an infrequent need to translate your financial statements to your parent company's currency for consolidation purposes. Standard translation functionality meets this need. Consider using journal or subledger level reporting currencies when any of the following conditions exist.

- You operate in a country whose unstable currency makes it unsuitable for managing your business. As a consequence, you need to manage your business in a more stable currency while retaining the ability to report in the unstable local currency.
- You operate in a country that is part of the European Economic and Monetary Union (EMU), and you choose to account and report in both the European Union currency and your National Currency Unit (NCU).

Note

The second option is rare since most companies have moved beyond the initial conversion to the EMU currency. However, future decisions could add other countries to the EMU, and then, this option would again be used during the conversion stage.

Financial Ledgers: How They Fit Together

Oracle Fusion Applications is an integrated suite of business applications that connects and automates the entire flow of the business process across both front and back office operations and addresses the needs of a global enterprise. The process of designing the enterprise structure, including the accounting configuration, is the starting point for an implementation. This process often includes determining financial, legal, and management reporting requirements, setting up primary and secondary ledgers, making currency choices, and examining consolidation considerations.

This figure shows the enterprise structure components and their relationships to each other. Primary ledgers are connected to reporting currencies and secondary ledgers to provide complete reporting options. Legal entities are assigned to ledgers, both primary and secondary, and balancing segments are assigned to legal entities. Business units must be connected to both a primary ledger and a default legal entity. Business units can record transactions across legal entities.

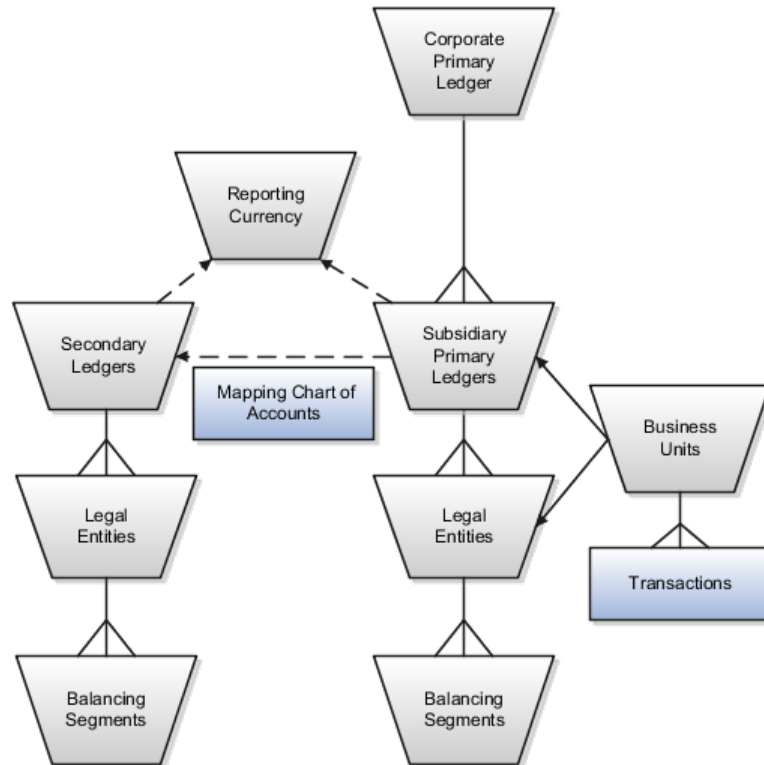

Primary Ledgers

A primary ledger is the main record-keeping ledger. Create a primary ledger by combining a chart of accounts, accounting calendar, ledger currency, and accounting method. To determine the number of primary ledgers, your enterprise structure analysis must begin with determining financial, legal, and management reporting requirements. For example, if your company has separate subsidiaries in several countries worldwide, create multiple primary ledgers representing each country with the local currency, chart of accounts, calendar, and accounting method to enable reporting to each country's legal authorities.

If your company just has sales in different countries, with all results being managed by the corporate headquarters, create one primary ledger with multiple balancing segment values to represent each legal entity. Use secondary ledgers or reporting currencies to meet your local reporting requirements, as needed. Limiting the number of primary ledgers simplifies reporting because consolidation is not required. Other considerations such as corporate year end, ownership considerations, and local government regulations, also affect the number of primary ledgers required.

Secondary Ledgers

A secondary ledger is an optional ledger linked to a primary ledger. A secondary ledger can differ from its related primary ledger in chart of accounts, accounting calendar, currency, accounting method, or ledger processing options. Reporting requirements, for example, that require a different accounting representation to comply with international or country-specific regulations, create the need for a secondary ledger.

Below are scenarios and required action for different components in primary and secondary ledgers:

- If the primary and secondary ledgers use different charts of accounts, the chart of accounts mapping is required to instruct the system how to propagate journals from the source chart of accounts to the target chart of accounts.
- If the primary and secondary ledgers use different accounting calendars, the accounting date and the general ledger date mapping table will be used to determine the corresponding non-adjusting period in the secondary ledger. The date mapping table also provides the correlation between dates and non-adjusting periods for each accounting calendar.
- If the primary ledger and secondary ledger use different ledger currencies, currency conversion rules are required to instruct the system on how to convert the transactions, journals, or balances from the source representation to the secondary ledger.

Note: Journal conversion rules, based on the journal source and category, are required to provide instructions on how to propagate journals and types of journals from the source ledger to the secondary ledger.

Reporting Currencies

Reporting currencies are the currency you use for financial, legal, and management reporting. If your reporting currency is not the same as your ledger currency, you can use the foreign currency translation process or reporting currencies functionality to convert your ledger account balances in your reporting currency. Currency conversion rules are required to instruct the system on how to convert the transactions, journals, or balances from the source representation to the reporting currency.

Legal Entities

Legal entities are discrete business units characterized by the legal environment in which they operate. The legal environment dictates how the legal entity should perform its financial, legal, and management reporting. Legal entities generally have the right to own property and the obligation to comply with

labor laws for their country. They also have the responsibility to account for themselves and present financial statements and reports to company regulators, taxation authorities, and other stakeholders according to rules specified in the relevant legislation and applicable accounting standards. During setup, legal entities are assigned to the accounting configuration, which includes all ledgers, primary and secondary.

Balancing Segments

You assign primary balancing segment values to all legal entities before assigning values to the ledger. Then, assign specific primary balancing segment values to the primary and secondary ledgers to represent nonlegal entity related transactions such as adjustments. You can assign any primary balancing segment value that has not already been assigned to a legal entity. You are allowed to assign the same primary balancing segment values to more than one ledger. The assignment of primary balancing segment values to legal entities and ledgers is performed within the context of a single accounting setup. The Balancing Segment Value Assignments report is available to show all primary balancing segment values assigned to legal entities and ledgers across accounting setups to ensure the completeness and accuracy of their assignments. This report allows you to quickly identify these errors and view any unassigned values.

Business Units

A business unit is a unit of an enterprise that performs one or many business functions that can be rolled up in a management hierarchy. When a business function produces financial transactions, a business unit must be assigned a primary ledger, and a default legal entity. Each business unit can post transactions to a single primary ledger, but it can process transactions for many legal entities. Normally, it will have a manager, strategic objectives, a level of autonomy, and responsibility for its profit and loss. You define business units as separate tasks generally done after the accounting setup steps.

The business unit model:

- Allows for flexible implementation
- Provides a consistent entity for controlling and reporting on transactions
- Enables sharing of sets of reference data across applications

For example, if your company requires business unit managers to be responsible for managing all aspects of their part of the business, then consider using two balancing segments, company and business unit to enable the production of business unit level balance sheets and income statements.

Transactions are exclusive to business units. In other words, you can use business unit as a securing mechanism for transactions. For example, if you have an export business that you run differently from your domestic business, use business units to secure members of the export business from seeing the transactions of the domestic business.

Creating Primary Ledgers: Example

Create a primary ledger as your main record-keeping ledger. Like any other ledger, a primary ledger records transactional balances by using a chart of

accounts with a calendar, currency, and accounting rules implemented in an accounting method. The primary ledger is closely associated with the subledger transactions and provides context and accounting for them.

Scenario

Your company, InFusion Corporation is implementing Oracle Fusion Applications. You have been assigned the task of creating a primary ledger for your InFusion America entity.

1. Navigate to the **Define Accounting Configurations** task list and open **Manage Primary Ledgers** from within your implementation project. Click the **Go to Task**.
2. Click the **Create** icon.
3. Enter the following values:

Field	Value
Name	InFusion America
Description	InFusion America primary ledger for recording transactions.
Chart of Accounts	InFusion America Chart of Accounts
Accounting Calendar	Standard Monthly
Currency	USD
Accounting Method	Standard Accrual

4. Click **Save and Edit Task List** to navigate back to the accounting configuration task list.

Note

You cannot change the chart of accounts, accounting calendar, or currency for your ledger after you save your ledger.

Define Accounting Configurations of Enterprise Structures: Specify Ledger Options

Specifying Ledger Options: Worked Example

This example demonstrates specifying the ledger options for your primary ledger. Your company, InFusion Corporation, is a multinational conglomerate that operates in the United States (US) and the United Kingdom (UK). InFusion has purchased an Oracle Fusion enterprise resource planning (ERP) solution including Oracle Fusion General Ledger and all of the Oracle Fusion subledgers.

After completing your InFusion America Primary Ledger, select **Specify Ledger Options** under the Define Accounting Configuration task list on the Functional Setup Manager page.

Note

Both primary and secondary ledgers are created in the same way and use the same user interface to enable their specific ledger options.

Reviewing General Region Options

1. Accept the **Name** and **Description** defaults for the ledger selected.
2. Review the **Currency** and **Chart of Accounts** for the specified ledger, which are automatically populated.

Setting Accounting Calendar Region Options

1. Review the **Accounting Calendar** that defaults from your ledger.
2. Select Jan-2011 as the **First Open Period** for your ledger.

Important: Select a period after the first defined period in the ledger calendar to enable running translation. You cannot run translation in the first defined period of a ledger calendar. In this example, your calendar began with Jan-2010.

3. Enter 3 for the **Number of Future Enterable Periods**.

Any value between 0 and 999 periods can be specified to permit entering journals but not posting them in future periods. Minimize the number of open and future periods to prevent entry in the wrong period.

Selecting the Subledger Accounting Region Options

1. Accept the default **Accounting Method** from your ledger.
2. Select US American English as your **Journal Language**.

Completing the Period Close Region Options

1. Enter your **Retained Earnings Account**:
101-00-31330000-0000-000-0000-0000.

This account is required for the General Ledger to perform the movement of revenue and expense account balances to this account at the end of the accounting year.

2. Enter your **Cumulative Translation Adjustment Account**:
101-00-31350000-0000-000-0000-0000.

Note: The Cumulative Translation Adjustment (CTA) account is required for ledgers running translation.

3. Do not enter a **Default Period End Rate Type** or **Default Period Average Rate Type**.

The values entered here are used as the default for balance level reporting currency processing. InFusion America Primary Ledger is using the subledger level reporting currency processing.

Specifying the Journal Processing Region Options

1. Specify the Balance options as outlined in the following table.

Option	Setting
Enable Suspense	General Ledger
Default Expense Account	101-00-98199999-0000-000-0000-0000
Rounding Account	101-10-98189999-0000-000-0000-0000
Entered Currency Balancing Account	101-10-98179999-0000-000-0000-0000
Balancing Threshold Percent	10

2. Click all the following Entry options listed in the table.

Option	Description
Enable journal approval	Click to enable journal approval functionality. Approval rules must be created in the Oracle Fusion Approvals Management (AMX).
Notify when prior period journal	Notify the user when a prior period date is selected on a journal entry.
Allow mixed and statistical journals	Enter both monetary and statistical amounts on the same line in a journal entry.
Validate reference date	Requires a reference date in an open or future enterable period.

3. Click the **Separate journals by accounting date during journal import** for the Import option to create individual journal entries for each accounting date.
4. For the Reversal options, select InFusion America Accrual Set from the list of values in the **Journal Reversal Criteria Set** field and click the **Launch AutoReverse after open period** to reverse accrual journal entries automatically when a new period is opened.
5. Click the **Enable intercompany accounting** for the Intercompany option to enable automatic balancing by the application for primary, second, and third balancing segments (if implemented) on intercompany journal entries and transactions.

Note: To complete the intercompany accounting functionality, you must define intercompany rules.

FAQs for Specify Ledger Options

What happens if I change the cumulative adjustment account?

To avoid data corruption, your cumulative adjustment account (CTA) can only be changed if you first perform the following set of steps:

- Purge all translated balances
- Change the CTA account

- Rerun translation

What happens if I change the retained earnings account?

To avoid data corruption, your retained earnings account can only be changed if you first perform the following set of steps:

- Enter and post journals to bring the ending balances for your income statement accounts to zero at the end of each accounting year
- Purge actual translated balances
- Update the retained earnings account
- Reverse the journal entries use to bring the ending account balances to zero and rerun translation

Assigning Legal Entities and Balancing Segments: Examples

Optionally, assign legal entities and balancing segments to your accounting configuration.

Assign Legal Entities

Assign one or more legal entities to your configuration by following these steps:

1. Navigate to the **Assign Legal Entities** task. Click the **Go to Task**.
2. Click the **Select and Add** icon.
3. Click **Search**. Select your legal entities.
4. Click **Apply**. Click **Done**.
5. Click **Save and Close**.

Assign Balancing Segments to Legal Entities

Assign balancing segment values to your legal entities by following these steps:

1. Navigate to the **Assign Balancing Segment Values to Legal Entities** task. Click the **Go to Task**.
2. Click the **Create** icon.
3. Select the balancing segment value. Optionally, add a Start Date.
4. Click **Save and Close** to close the create page.
5. Click **Save and Close**.

Assign Balancing Segments to Ledgers

Assign balancing segment values directly to your ledger by following these steps:

1. Navigate to the **Assign Balancing Segment Value to Ledger** task. Click the **Go to Task**.
2. Select the balancing segment value.
3. Optionally enter a start date.

4. Click **Save and Close**.

Note

The balancing segment values that are assigned to the ledger represent nonlegal entity transactions, such as adjustments. If you use legal entities, you must assign balancing segment values to all legal entities before assigning values to the ledger. The only available balancing segment values that can be assigned to ledgers are those not assigned to legal entities.

Define Accounting Configurations of Enterprise Structures: Manage Reporting Currencies

Reporting Currency Balances: How They Are Calculated

Reporting currency balances, set at the journal or subledger level, are updated when journal entries that originate in Oracle Fusion General Ledger are posted and converted to your reporting currencies. This process includes General Ledger manual journals, periodic journals, and allocations, and at the subledger level, journals from Oracle Fusion Subledger Accounting and imported from sources other than your Oracle Fusion subledgers. When you post a journal in a ledger that has one or more reporting currencies defined, the posting process creates new journals converted to each of your reporting currencies and includes them in the same batch as the original journal with a status of Posted.

Settings That Affect

Reporting currencies share a majority of the ledger options with their source ledger. For example, the reporting currency uses the same suspense account and retained earnings accounts as its source ledger. However, there are certain options that need to be set specifically for the reporting currencies. For example, reporting currencies are maintained at one of these three currency conversion levels:

- **Balance Level:** Only balances are maintained in the reporting currency using the General Ledger Translation process.
- **Journal Level:** Journal entries and balances are converted to the reporting currency by the General Ledger Posting process.
- **Subledger Level:** Subledger Accounting creates reporting currency journals for subledger transactions. General Ledger converts journals that originated in General Ledger or that are imported from sources other than the Oracle Fusion subledgers. The full accounting representation of your primary ledger is maintained in the subledger level reporting currency.

Note

Secondary Ledgers cannot use subledger level reporting currencies.

There are multiple dependencies between a reporting currency and its source ledger. Therefore, it is important that you complete your period opening tasks, daily journal or subledger level reporting currencies accounting tasks, and

period closing tasks in the correct order. Some guidelines are presented in the table below.

Type	Task
Period Opening Tasks	Open the accounting period in both your ledger and reporting currencies before you create or import journals for the period. Converted journals are only generated in your reporting currency if the period is open or future enterable.
Daily Tasks	Enter the daily conversion rates to convert your journals to each of your reporting currencies.
Period Closing Tasks	<ul style="list-style-type: none"> • Finish entering all regular and adjusting journals for the period in your ledger. • Post all unposted journals in your ledger if not already done in the previous step. • Post all unposted journals in your reporting currencies if not already done in the previous step. • Run Revaluation in both your ledger and reporting currencies. Post the resulting revaluation batches in each ledger. • As needed, translate balances in your ledger. • Generate needed reports from both your ledger and reporting currencies. • Close your accounting period in both your ledger and reporting currencies.

How Reporting Currencies Are Calculated

If you use reporting currencies at the journal or subledger level, when you create accounting, post journal entries, or translate balances, journals are posted in your reporting currency. General Ledger and Subledger Accounting automatically generate journals in your reporting currencies where the entered currency amounts are converted to the reporting currency amounts. Other factors used in the calculation of reporting currency balances are listed:

- **Manual Journals:** Enter a manual journal batch in your reporting currency at the journal or subledger level by using the Create Journals page. Select the journal or subledger level reporting currency from the ledger's list of values and continue in the same manner as entering any other manual journal.
- **Conversion Rounding:** Use the reporting currency functionality to round converted and accounted amounts using the same rounding rules used throughout your Oracle Fusion Applications. The reporting currency functionality considers several factors that are a part of the currencies predefined in your applications, including:
 - **Currency Precision:** Number of digits to the right of the decimal point used in currency transactions.

- Minimum Accountable Unit: Smallest denomination used in the currency. This might not correspond to the precision.
- Converted Journals: Generate and post automatically, using the General Ledger Posting process, journals in your reporting currencies when you post the original journals in the source ledger for the following types of journals:
 - Manual journals
 - Periodic and allocation journals
 - Unposted journals from non-Oracle subledger applications
 - Unposted journals from any Oracle Fusion subledger that does not support reporting currency transfer and import
 - Optionally, revaluation journals
- Unconverted Journals: Rely on the subledger accounting functionality to converted and transfer Oracle Fusion subledger journals for both the original journal and the reporting currency journal to the General Ledger for import and posting. The reporting currency conversion for these journals is not performed by the General Ledger.
- Approving Journals: Use the journal approval feature to process reporting currency journals through your organization's approval hierarchy. You can enable journal approval functionality separately in your source ledger and reporting currencies.
- Document Numbers: Accept the default document numbers assigned by the General Ledger application to your journal when you enter a journal in your ledger. The converted journal in the reporting currency is assigned the same document number. However, if you enter a journal in the reporting currency, the document number assigned to the journal is determined by the reporting currency.
- Sequential Numbering: Enable sequential numbering if you want to maintain the same numbering in your reporting currency and source ledger for journals, other than those journals for Oracle Fusion subledgers. Do not create separate sequences for your reporting currencies. If you do, the sequence defined for the reporting currencies is used and can cause document numbers not to be synchronized between the ledger and reporting currencies.

Note

If the Sequential Numbering profile option is set to **Always Used** or **Partially Used** and you define an automatic document numbering sequence, General Ledger enters a document number automatically when you save your journal. If you use manual numbering, you can enter a unique document number.

- Revaluation: Run periodically revaluation in your ledger and reporting currencies as necessary to satisfy the accounting regulations of the country in which your organization operates.

- Account Inquiries: Perform inquiries in the reporting currency. Drill down to the journal detail that comprises the reporting currency balance. If the journal detail is a converted journal that was converted automatically when the original journal was posted in the source ledger, you can drill down further to see the source ledger currency journal amounts.

Note

Be careful when changing amounts in a reporting currency, since the changes are not reflected in your source ledger. Making journal entry changes to a reporting currency makes it more difficult to reconcile your reporting currency to your source ledger. In general, enter or change your journals in your source ledger, and then allow posting to update the reporting currency.

Note

If you use reporting currencies at the journal or subledger level, statistical journals are generated for your reporting currencies, but the journals are not affected by the currency conversion process.

Define Business Units: Manage Service Provider Relationships

Shared Service Centers: Explained

Oracle Fusion Applications allows defining relationships between business units to outline which business unit provides services to the other business units.

Service Provider Model

In Oracle Fusion Applications V11.0, the service provider model centralizes only the procurement business function. Your business units that have the requisitioning business function enabled can define relationships with business units that have the procurement business function enabled. These service provider business units will process requisitions and negotiate supplier terms for their client business units.

This functionality is used to frame service level agreements and drive security. The definition of service provider relationships provides you with a clear record of how the operations of your business are centralized. For other centralized processing, business unit security is used (known in Oracle EBS as Multi-Org Access Control). This means that users who work in a shared service center have the ability to get access and process transactions on behalf of many business units.

Shared Service Center: Points to Consider

Oracle Fusion applications supports shared service centers in two ways. First, with business unit security, which allows your shared service centers personnel to process transactions for other business units called clients. This was the foundation of Multi Org Access Control in the Oracle E-Business Suite.

Second, the service provider model expands on this capability to allow a business unit and its personnel in a shared service center to work on transactions of the client business units. It is possible to view the clients of a service provider business unit, and to view service providers of a client business unit.

Your shared service centers provide services to your client business units that can be part of other legal entities. In such cases, your cross charges and recoveries are in the form of receivables invoices, and not merely allocations within your general ledger, thereby providing internal controls and preventing inappropriate processing.

For example, in traditional local operations, an invoice of one business unit cannot be paid by a payment from another business unit. In contrast, in your shared service center environment, processes allowing one business unit to perform services for others, such as paying an invoice, are allowed and completed with the appropriate intercompany accounting. Shared service centers provide your users with access to the data of different business units and can comply with different local requirements.

Security

The setup of business units provides you with a powerful security construct by creating relationships between the functions your users can perform and the data they can process. This security model is appropriate in a business environment where local business units are solely responsible for managing all aspects of the finance and administration functions.

In Oracle Fusion applications, the business functions your business unit performs are evident in the user interface for setting up business units. To accommodate shared services, use business unit security to expand the relationship between functions and data. A user can have access to many business units. This is the core of your shared service architecture.

For example, you take orders in many business units each representing different registered legal entities. Your orders are segregated by business unit. However, all of these orders are managed from a shared service order desk in an outsourcing environment by your users who have access to multiple business units.

Benefits

In summary, large, medium, and small enterprises benefit from implementing share service centers. Examples of functional areas where shared service centers are generally implemented include procurement, disbursement, collections, order management, and human resources. The advantages of deploying these shared service centers are the following:

- Reduce and consolidate the number of control points and variations in processes, mitigating the risk of error.
- Increase corporate compliance to local and international requirements, providing more efficient reporting.
- Implement standard business practices, ensuring consistency across the entire enterprise and conformity to corporate objectives.

- Establish global processes and accessibility to data, improving managerial reporting and analysis.
- Provide quick and efficient incorporation of new business units, decreasing startup costs.
- Establish the right balance of centralized and decentralized functions, improving decision making.
- Automate self-service processes, reducing administrative costs.
- Permit business units to concentrate on their core competencies, improving overall corporate profits.

Service Provider Model: Explained

In Oracle Fusion applications, the service provider model defines relationships between business units for a specific business function, identifying one business in the relationship as a service provider of the business function, and the other business unit as its client.

Procurement Example

The Oracle Fusion Procurement product family has taken advantage of the service provide model by defining outsourcing of the procurement business function. Define your business units with requisitioning and payables invoicing business functions as clients of your business unit with the procurement business function. Your business unit responsible for the procurement business function will take care of supplier negotiations, supplier site maintenance, and purchase order processing on behalf of your client business units. Subscribe your client business units to the supplier sites maintained by the service providers, using a new procurement feature for supplier site assignment.

In the InFusion example below, business unit four (BU4) serves as a service provider to the other three business units (BU1, BU2, and BU3.) BU4 provides the corporate administration, procurement, and human resources (HR) business functions, thus providing cost savings and other benefits to the entire InFusion enterprise.

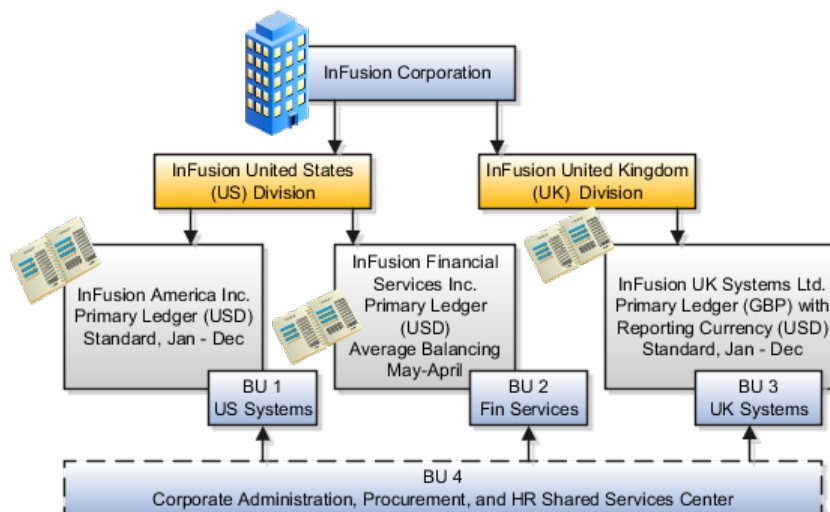

Define Business Units: Specify Customer Contract Management Business Function Properties

Customer Contracts Business Unit Setup: Explained

Using the **Specify Customer Contract Management Business Function Properties** task, available by navigating to Setup and Maintenance work area and searching on the task name, you can specify a wide variety of business function settings for customer contracts in a specific business unit. The selections you make for these business functions impact how Oracle Fusion Enterprise Contracts behaves during contract authoring.

Using the **Specify Customer Contract Management Business Function Properties** task, manage these business function properties:

- Enable related accounts
- Set currency conversion details
- Manage project billing options
- Set up the Contract Terms Library

The setup options available for the Contract Terms Library are applicable to both customer and supplier contracts, and are described in the business unit setup topic for the Contract Terms Library. That topic is available as a related link to this topic.

Enabling Related Customer Accounts

Contract authors can specify bill-to, ship-to, and other accounts for the parties in a contract. Enable the related customer accounts option if you want accounts previously specified as related to the contract party to be available for selection.

Managing Currency Conversion Options

If your organization plans to transact project-related business in multiple currencies, then select the multicurrency option. This allows a contract author to override a contract's currency, which defaults from the ledger currency of the business unit. It also enables the contract author to specify currency conversion attributes to use when converting from the bill transaction currency to the contract currency and from the invoice currency to the ledger currency.

In the Bill Transaction Currency to Contract Currency region, enter currency conversion details that will normally be used, by all contracts owned by this business unit, to convert transaction amounts in the bill transaction currency to the contract currency. Newly created contracts contain the default currency conversion values, but you can override the values on any contract, if needed.

In the Invoice Currency to Ledger Currency region:

- Enter invoice transaction conversion details if the invoice and ledger currencies can be different.
- Enter revenue transaction conversion details if the revenue and ledger currencies can be different for as-incurred and rate-based revenue.

Managing Project Billing Options

The options available for selection in the Project Billing region control the behavior of project invoicing and revenue recognition for contracts with project-based work.

Project billing can behave differently for external contracts (customer billing) or intercompany and interproject contracts (internal billing).

Set these options, which apply to all contracts:

- Select the **Transfer Revenue to General Ledger** option if you want to create revenue accounting events and entries, and transfer revenue journals to the general ledger. If this option is not selected, then revenue can still be generated, but will not be transferred to the general ledger.
- Indicate if a reason is required for credit memos that are applied to invoices.

There are two sets of the following options, one for customer billing and a second for internal billing:

- Select an invoice numbering method, either **Manual** or **Automatic**. The invoice numbering method is the method that Oracle Fusion Receivables uses to number its invoices, upon release of draft invoices from Project Billing.
 - If the invoice numbering method is **Manual**, then select an invoice number type, which sets the type of Receivables invoice numbers that are allowed. Valid values are **Alphanumeric** and **Numeric**.
 - If the invoice numbering method is **Automatic**, then enter the next invoice number to use when generating Receivables invoice numbers.
- Select the Receivables batch source to use when transferring invoices to Receivables.

Set this option only for customer billing:

- Indicate if you want contract authors to manually enter the Receivables transaction type on the customer contracts they create.

Contract Terms Library Business Unit Setup: Explained

You can specify a wide variety of Contract Terms Library settings for either customer or supplier contracts within each business unit, by using either the **Specify Customer Contract Management Business Function Properties** or the **Specify Supplier Contract Management Business Function Properties** tasks. These tasks are available by navigating to the **Setup and Maintenance** work area and searching on the task name.

For the Contract Terms Library in each business unit, you can:

- Enable clause and template adoption.
- Set the clause numbering method.
- Enable the Contract Expert feature.

- Specify the layout for printed clauses and contract deviation reports.

Enabling Clause Adoption

If you plan to use clause adoption in your implementation, then set up the following:

- Specify a global business unit

You must designate one of the business units in your organization as the global business unit by selecting the **Global Business Unit** option. This makes it possible for the other local business units to adopt and use approved content from that global business unit. If the **Global Business Unit** option is not available for the business unit you are setting up, this means that you already designated another business unit as global.

- Enable automatic adoption

If you are implementing the adoption feature, then you can have all the global clauses in the global business unit automatically approved and available for use in the local business by selecting the **Autoadopt Global Clauses** option. If you do not select this option, the employee designated as the Contract Terms Library Administrator must approve all global clauses before they can be adopted and used in the local business unit. This option is available only for local business units.

- Specify the administrator who approves clauses available for adoption

You must designate an employee as the Contract Terms Library administrator if you are using adoption. If you do not enable automatic adoption, then the administrator must adopt individual clauses or localize them for use in the local business unit. The administrator can also copy over any contract terms templates created in the global business unit. The clauses and contract terms templates available for adoption are listed in the administrator's Terms Library work area.

Setting Clause Numbering Options

You can set up automatic clause numbering for the clauses in the business unit by selecting Automatic in the **Clause Numbering** field and entering a Document Sequence Category you previously set up in the **Clause Sequence Category** field. If clause numbering is manual, contract terms library administrators must enter unique clause numbers each time they create a clause.

You can choose to display the clause number in front of the clause title in contracts by selecting the **Display Clause Number in Clause Title** option.

Enabling Contract Expert

You must select the **Enable Contract Expert** option to be able to use the Contract Expert feature in a business unit. This setting takes precedence over enabling Contract Expert for individual contract terms templates.

Specifying the Printed Clause and Deviations Report Layouts

For each business unit, you can specify the Oracle BI Publisher RTF file that serves as the layout for:

- The printed contract terms

Enter the RTF file you want used for formatting the printed clauses in the **Clause Layout Template** field.

- The contract deviations report

The RTF file you select as the **Deviations Layout Template** determines the appearance of the contract deviations report PDF. This PDF is attached to the approval notification sent to contract approvers.

Define Business Units: Specify Supplier Contract Management Business Function Properties

Supplier Contracts Business Unit Setup: Explained

Using the **Specify Supplier Contract Management Business Function Properties** task, available by selecting Setup and Maintenance from the Tools menu and searching on the task name, you can specify a variety of business function settings for supplier contracts in a specific business unit.

The selections you make for these business functions impact how the Contract Terms Library behaves during supplier contract authoring.

Managing Contract Terms Library Setup Options

The setup options available for the Contract Terms Library are applicable to both customer and supplier contracts, and are described in the business unit setup topic for the Contract Terms Library. That topic is available as a related link to this topic.

Contract Terms Library Business Unit Setup: Explained

You can specify a wide variety of Contract Terms Library settings for either customer or supplier contracts within each business unit, by using either the **Specify Customer Contract Management Business Function Properties** or the **Specify Supplier Contract Management Business Function Properties** tasks. These tasks are available by navigating to the **Setup and Maintenance** work area and searching on the task name.

For the Contract Terms Library in each business unit, you can:

- Enable clause and template adoption.
- Set the clause numbering method.
- Enable the Contract Expert feature.
- Specify the layout for printed clauses and contract deviation reports.

Enabling Clause Adoption

If you plan to use clause adoption in your implementation, then set up the following:

- Specify a global business unit

You must designate one of the business units in your organization as the global business unit by selecting the **Global Business Unit** option. This makes it possible for the other local business units to adopt and use approved content from that global business unit. If the **Global Business Unit** option is not available for the business unit you are setting up, this means that you already designated another business unit as global.

- Enable automatic adoption

If you are implementing the adoption feature, then you can have all the global clauses in the global business unit automatically approved and available for use in the local business by selecting the **Autoadopt Global Clauses** option. If you do not select this option, the employee designated as the Contract Terms Library Administrator must approve all global clauses before they can be adopted and used in the local business unit. This option is available only for local business units.

- Specify the administrator who approves clauses available for adoption

You must designate an employee as the Contract Terms Library administrator if you are using adoption. If you do not enable automatic adoption, then the administrator must adopt individual clauses or localize them for use in the local business unit. The administrator can also copy over any contract terms templates created in the global business unit. The clauses and contract terms templates available for adoption are listed in the administrator's Terms Library work area.

Setting Clause Numbering Options

You can set up automatic clause numbering for the clauses in the business unit by selecting Automatic in the **Clause Numbering** field and entering a Document Sequence Category you previously set up in the **Clause Sequence Category** field. If clause numbering is manual, contract terms library administrators must enter unique clause numbers each time they create a clause.

You can choose to display the clause number in front of the clause title in contracts by selecting the **Display Clause Number in Clause Title** option.

Enabling Contract Expert

You must select the **Enable Contract Expert** option to be able to use the Contract Expert feature in a business unit. This setting takes precedence over enabling Contract Expert for individual contract terms templates.

Specifying the Printed Clause and Deviations Report Layouts

For each business unit, you can specify the Oracle BI Publisher RTF file that serves as the layout for:

- The printed contract terms

Enter the RTF file you want used for formatting the printed clauses in the **Clause Layout Template** field.

- The contract deviations report

The RTF file you select as the **Deviations Layout Template** determines the appearance of the contract deviations report PDF. This PDF is attached to the approval notification sent to contract approvers.

Define Business Units: Assign Business Unit Business Function

Business Functions: Explained

A business unit can perform many business functions in Oracle Fusion Applications. Prior to Oracle Fusion Applications, operating units in Oracle E-Business Suite were assumed to perform all business functions, while in Oracle PeopleSoft, each business unit had one specific business function. Oracle Fusion Applications blends these two models and allows defining business units with one or many business functions.

Business Functions

A business function represents a business process, or an activity that can be performed by people working within a business unit and describes how a business unit is used. The following business functions exist in Oracle Fusion applications:

- Billing and revenue management
- Collections management
- Customer contract management
- Customer payments
- Expense management
- Incentive compensation
- Marketing
- Materials management
- Inventory management
- Order fulfillment orchestration
- Payables invoicing
- Payables payments
- Procurement
- Procurement contract management
- Project accounting
- Receiving
- Requisitioning
- Sales

Although there is no relationship implemented in Oracle Fusion Applications, a business function logically indicates a presence of a department in the business unit with people performing tasks associated with these business functions.

A business unit can have many departments performing various business functions. Optionally, you can define a hierarchy of divisions, business units, and departments as a tree over HCM organization units to represent your enterprise structure.

Note

This hierarchy definition is not required in the setup of your applications, but is a recommended best practice.

Your enterprise procedures can require a manager of a business unit to have responsibility for their profit and loss statement. However, there will be cases where a business unit is performing only general and administrative functions, in which case your manager's financial goals are limited to cost containment or recovering of service costs. For example, if a shared service center at the corporate office provides services for more commercially-oriented business units, it does not show a profit and therefore, only tracks its costs.

In other cases, where your managers have a responsibility for the assets of the business unit, a balance sheet can be produced. The recommended best practice to produce a balance sheet, is to setup the business unit as a balancing segment in the chart of accounts. The business unit balancing segment can roll up to divisions or other entities to represent your enterprise structure.

When a business function produces financial transactions, a business unit must be assigned to a primary ledger, and a default legal entity. Each business unit can post transactions to a single primary ledger, but it can process transactions for many legal entities.

The following business functions generate financial transactions and will require a primary ledger and a default legal entity:

- Billing and revenue management
- Collections management
- Customer payments
- Expense management
- Materials management
- Payables invoicing
- Project accounting
- Receiving
- Requisitioning

Business Unit Hierarchy: Example

For example, your InFusion America Company provides:

- Air quality monitoring systems through your division InFusion Air Systems
- Customer financing through your division InFusion Financial Services

The InFusion Air Systems division further segments your business into the System Components and Installation Services subdivisions. Your subdivisions are divided by business units:

- System Components by products: Air Compressors and Air Transmission
- Installation Services by services: Electrical and Mechanical

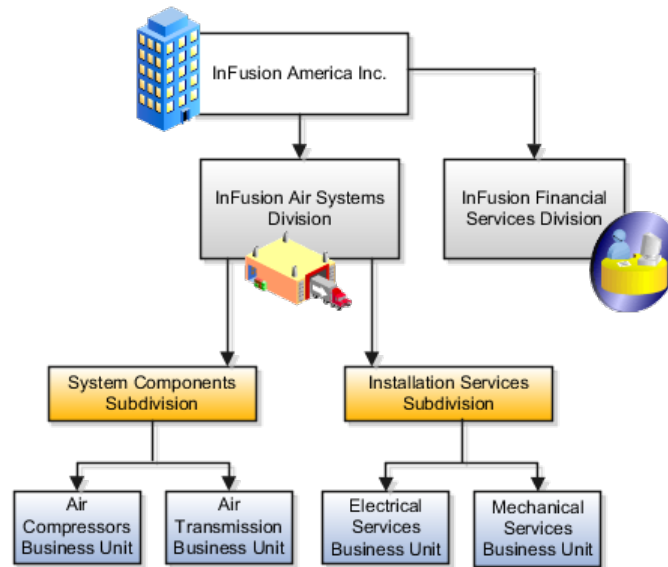

Oracle Fusion applications facilitates independent balance sheet rollups for legal and management reporting by offering up to three balancing segments. Hierarchies created using the management segment can provide the divisional results. For example, it is possible to define management segment values to correspond to business units, and arrange them in a hierarchy where the higher nodes correspond to divisions and subdivisions, as in the Infusion US Division example above.

Define Business Units: Manage Business Units

Business Units: Explained

A business unit is a unit of an enterprise that performs one or many business functions that can be rolled up in a management hierarchy. A business unit can process transactions on behalf of many legal entities. Normally, it will have a manager, strategic objectives, a level of autonomy, and responsibility for its profit and loss. Roll business units up into divisions if you structure your chart of accounts with this type of hierarchy. In Oracle Fusion Applications, you assign your business units to one primary ledger. For example, if a business unit is processing payables invoices they will need to post to a particular ledger. This assignment is mandatory for your business units with business functions that produce financial transactions.

In Oracle Fusion Applications, use business unit as a securing mechanism for transactions. For example, if you run your export business separately from your domestic sales business, secure the export business data to prevent access by the domestic sales employees. To accomplish this security, set up the export business and domestic sales business as two separate business units.

The Oracle Fusion Applications business unit model:

- Allows for flexible implementation
- Provides a consistent entity for controlling and reporting on transactions
- Anchors the sharing of sets of reference data across applications

Business units process transactions using reference data sets that reflect your business rules and policies and can differ from country to country. With Oracle Fusion Application functionality, you can choose to share reference data, such as payment terms and transaction types, across business units, or you can choose to have each business unit manage its own set depending on the level at which you wish to enforce common policies.

In countries where gapless and chronological sequencing of documents is required for subledger transactions, define your business units in alignment with your ledger definition, because the uniqueness of sequencing is only ensured within a ledger. In these cases, define a single ledger and assign one legal entity and business unit.

In summary, use business units in the following ways:

- Management reporting
- Processing of transactions
- Security of transactional data
- Reference data definition and sharing

Brief Overview of Business Unit Security

Business units are used by a number of Oracle Fusion Applications to implement data security. You assign data roles to your users to give them access to data in business units and permit them to perform specific functions on this data. When a business function is enabled for a business unit, the application can trigger the creation of data roles for this business unit based on the business function's related job roles.

For example, if a payables invoicing business function is enabled, then it is clear that there are employees in this business unit that perform the function of payables invoicing, and need access to the payables invoicing functionality. Therefore, based on the correspondence between the business function and the job roles, appropriate data roles are generated automatically. Use Human Capital Management (HCM) security profiles to administer security for employees in business units.

Define Workforce Structures: Manage Enterprise HCM Information

Managing Enterprise Information for Non-Oracle Fusion HCM Users: Explained

The Manage Enterprise HCM Information task includes default settings for your enterprise such as the employment model, worker number generation, and so on. If you are not implementing Oracle Fusion Human Capital Management (HCM), then the only action you may need to perform using this task is to change the enterprise name, if necessary. The other settings are HCM-specific and are not relevant outside of Oracle Fusion HCM.

Define Workforce Structures: Manage Locations

Locations: Explained

A location identifies physical addresses of a workforce structure, such as a department or a job. You can also create locations to enter the addresses of external organizations that you want to maintain, such as employment agencies, tax authorities, and insurance or benefits carriers.

The locations that you create exist as separate structures that you can use for reporting purposes, and also in rules that determine employee eligibility for various types of compensation and benefits. You enter information about a location only once. Subsequently, when you set up other workforce structures you select the location from a list.

Location Sets

When you create a location, you must associate it with a set. Only those users who have access to the set's business unit can access the location set and other associated workforce structure sets, such as those that contain departments and jobs.

You can also associate the location to the common set so that users across your enterprise can access the location irrespective of their business unit. When users search for locations, they can see the locations that they have access to along with the locations in the common set.

The following figure shows how locations sets restrict access to users.

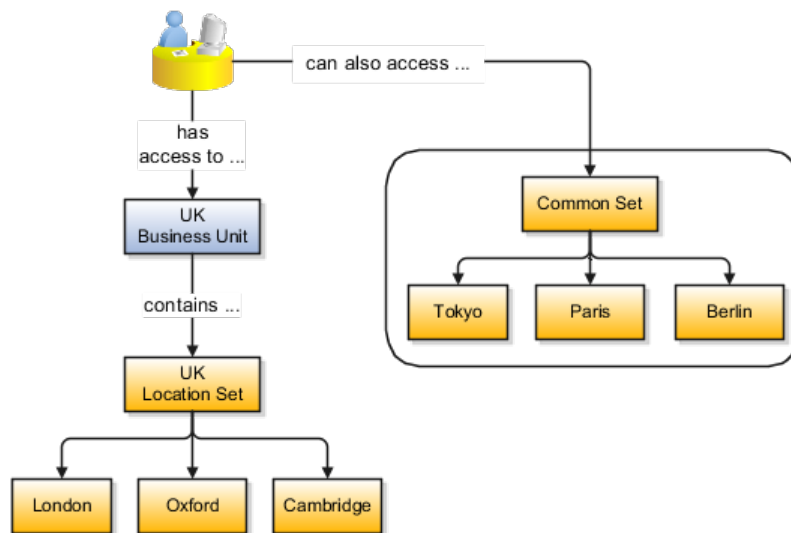

Creating Multiple Locations Simultaneously

If you have a list of locations already defined for your enterprise, you can upload them from a spreadsheet. To use this option, you first download a spreadsheet template, then add your location information to the spreadsheet, and then upload directly to your enterprise configuration. You can upload the spreadsheet multiple times to accommodate revisions.

Define Workforce Structures: FAQs for Manage Locations

Why can't I see my location in the search results?

You can search for approved locations only. Also, if you created a location in Oracle Fusion Trading Community Model, then you can't access that location from Oracle Fusion Global Human Resources. For use in Oracle Fusion HCM, you must recreate the location from the Manage Locations page.

How can I associate a location with an inventory organization?

From the Manage Locations page in Oracle Fusion Global Human Resources.

To appear on the Create or Edit Location pages, your inventory organization must be effective on today's date and must exist in the location set that you selected.

What happens if I select an inventory organization when I'm creating or editing a location?

The location is available for selection in purchase documents of that inventory organization in Oracle Fusion Inventory Management. If you don't select an inventory organization, then the location is available in purchase documents across all inventory organizations.

What happens if I select a geographic hierarchy node when I'm creating or editing a location?

The calendar events that were created for the geographical node start to apply for the location and may impact the availability of worker assignments at that location. The geographical hierarchy nodes available for selection on the Locations page display from a predefined geographic hierarchy.

What happens if I inactivate a location?

Starting from the effective date that you entered, you can no longer associate the location with other workforce structures, assignments, or applications. If the location is already in use, it will continue to be available to the components that currently use it.

Define Workforce Structures: Manage Divisions

Division: Explained

Managing multiple businesses requires that you segregate them by their strategic objectives and measure their results. Responsibility to reach objectives can be delegated along the management structure. Although related to your legal structure, the business organizational hierarchies do not need to reflect directly the legal structure of the enterprise. The management entities and structure can include divisions and subdivisions, lines of business, and other strategic business units, and include their own revenue and cost centers. These organizations can

be included in many alternative hierarchies and used for reporting, as long as they have representation in the chart of accounts.

Divisions

A division refers to a business oriented subdivision within an enterprise, in which each division organizes itself differently to deliver products and services or address different markets. A division can operate in one or more countries, and can be comprised of many companies or parts of different companies that are represented by business units.

A division is a profit center or grouping of profit and cost centers, where the division manager is responsible for attaining business goals including profit goals. A division can be responsible for a share of the company's existing product lines or for a separate business. Managers of divisions may also have return on investment goals requiring tracking of the assets and liabilities of the division. The division manager reports to a top corporate executive.

By definition a division can be represented in the chart of accounts. Companies may choose to represent product lines, brands, or geographies as their divisions: their choice represents the primary organizing principle of the enterprise. This may coincide with the management segment used in segment reporting.

Oracle Fusion Applications supports a qualified management segment and recommends that you use this segment to represent your hierarchy of business units and divisions. If managers of divisions have return on investment goals, make the management segment a balancing segment. Oracle Fusion applications allows up to three balancing segments. The values of the management segment can be comprised of business units that roll up in a hierarchy to report by division.

Historically, divisions were implemented as a node in a hierarchy of segment values. For example, Oracle E-Business Suite has only one balancing segment, and often the division and legal entity are combined into a single segment where each value stands for both division and legal entity.

Use of Divisions in Oracle Fusion Human Capital Management (HCM)

Divisions are used in HCM to define the management organization hierarchy, using the generic organization hierarchy. This hierarchy can be used to create organization based security profiles.

Adding a New Division After Acquiring a Company: Example

This example shows how to restructure your enterprise after acquiring a new division.

Scenario

You are part of a senior management team at InFusion Corporation. InFusion is a global company with organizations in the United States (US), the United Kingdom (UK), France, China, Saudi Arabia, and the United Arab Emirates (UAE). Its main area of business is in the high tech industry, and it has just acquired a new company. You must analyze their current enterprise structure and determine what new organizations you need to create to accommodate the new company.

Details of the Acquired Company

The acquired company is a financial services business based in Germany. Because the financial services business differs significantly from the high tech business, you want to keep the financial services company as a separate business with all the costs and reporting rolling up to the financial services division.

Analysis

The following table summarizes the key decisions that you must consider when determining what new organizations to set up and how to structure the enterprise.

Decision to Consider	In This Example
Create location?	The financial services company is based in Frankfurt as are the departments, so you need to create only one location.
Create separate division?	Yes. Although the new division will exist within the current enterprise structure, you want to keep the financial services company as a separate line of business. Creating a separate division means you can manage the costs and reporting separately from the InFusion Corporation. It also means you do not have to modify any existing organizations in the enterprise setup.
Create business unit?	Yes. The financial services business requires you to create several jobs that do not exist in your high tech business. You can segregate the jobs that are specific to financial services in a new business unit.
How many departments?	The financial services company currently has three departments for sales, accounting, and marketing. As you have no plans to downsize or change the company, you can create three departments to reflect this structure.
How many cost centers?	Although you can have more than one cost center tracking the costs of a department, you decide to create one cost center for each department to track costs.
How many legal entities?	<p>Define a legal entity for each registered company or other entity recognized in law for which you want to record assets, liabilities, and income, pay transaction taxes, or perform intercompany trading. In this case, you need only one legal entity.</p> <p>You must define the legal entity as a legal employer and payroll statutory unit. As the new division operates in Germany only, you can configure the legal entity to suit Germany legal and statutory requirements.</p> <hr/> <p>Note</p> <p>When you identify the legal entity as a payroll statutory unit, the application transfers the legal reporting unit that is associated with that legal entity to Oracle Fusion HCM as a tax reporting unit.</p>

Create legislative data group?	Yes. Because you currently do not employ or pay people in Germany, you must create one legislative data group to run payroll for the workers in Germany.
--------------------------------	--

Based on the analysis, you must create the following:

- One new division
- One new location
- Three new departments
- Three new cost centers
- One new legal entity
- One new legislative data group

The following figure illustrates the structure of InFusion Corporation after adding the new division and the other organizations.

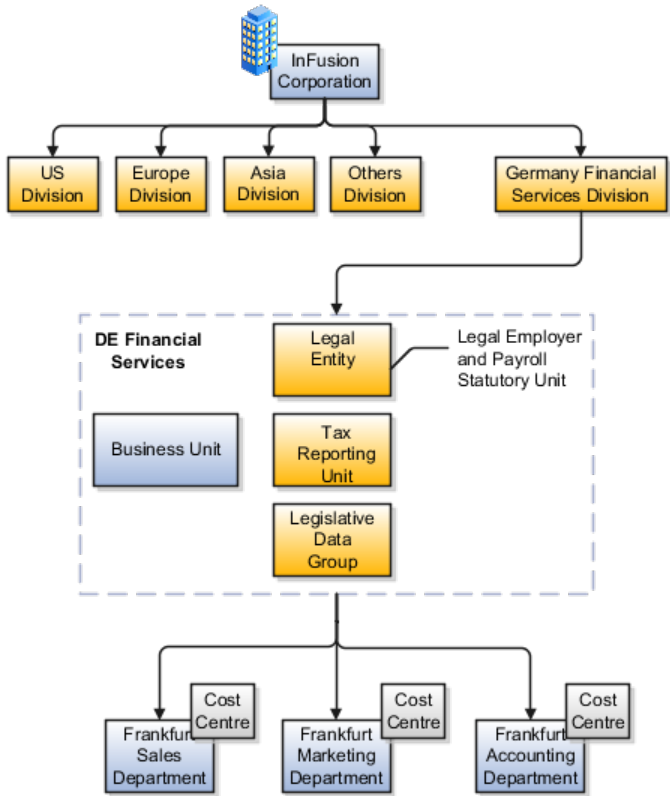

Define Workforce Structures: Manage Departments

Cost Centers and Departments: Explained

A cost center represents the smallest segment of an organization for which costs are collected and reported. A department is an organization with one or more

operational objectives or responsibilities that exist independently of its manager and has one or more workers assigned to it.

The following two components need to be considered in designing your enterprise structure:

- Cost centers
- Departments

Cost Centers

A cost center also represents the destination or function of an expense as opposed to the nature of the expense which is represented by the natural account. For example, a sales cost center indicates that the expense goes to the sales department.

A cost center is generally attached to a single legal entity. To identify the cost centers within a chart of accounts structure use one of these two methods:

- Assign a cost center value in the value set for each cost center. For example, assign cost center values of PL04 and G3J1 to your manufacturing teams in the US and India. These unique cost center values allow easy aggregation of cost centers in hierarchies (trees) even if the cost centers are in different ledgers. However, this approach will require defining more cost center values.
- Assign a balancing segment value with a standardized cost center value to create a combination of segment values to represent the cost center. For example, assign the balancing segment values of 001 and 013 with cost center PL04 to represent your manufacturing teams in the US and India. This creates 001-PL04 and 013-PL04 as the cost center reporting values.

The cost center value of PL04 has a consistent meaning. This method requires fewer cost center values to be defined. However, it prevents construction of cost center hierarchies using trees where only cost center values are used to report results for a single legal entity. You must specify a balancing segment value in combination with the cost center values to report on a single legal entity.

Departments

A department is an organization with one or more operational objectives or responsibilities that exist independently of its manager. For example, although the manager may change, the objectives do not change. Departments have one or more workers assigned to them.

A manager of a department is typically responsible for:

- Controlling costs within their budget
- Tracking assets used by their department
- Managing employees, their assignments, and compensation

Note

The manager of a sales department may also be responsible for meeting the revenue targets.

The financial performance of departments is generally tracked through one or more cost centers. In Oracle Fusion Applications, departments are defined and classified as Department organizations. Oracle Fusion Human Capital Management (HCM) assigns workers to departments, and tracks the headcount at the departmental level.

The granularity of cost centers and their relationship to departments varies across implementations. Cost center and department configuration may be unrelated, identical, or consist of many cost centers tracking the costs of one department.

Department Classifications: Points to Consider

A department can be classified as a project organization, sales and marketing organization, or cost organization.

Oracle Fusion Human Capital Management (HCM) uses trees to model organization hierarchies. It provides seeded tree structures for department and other organizational hierarchies that can include organizations with any classification.

Project Organization

Classify departments as a project owning organization to enable associating them with projects or tasks. The project association is one of the key drivers for project access security.

In addition, you must classify departments as project expenditure organizations to enable associating them to project expenditure items. Both project owning organizations and project expenditure organizations can be used by Oracle Fusion Subledger Accounting to derive accounts for posting Oracle Fusion Projects accounting entries to Oracle Fusion General Ledger.

Sales and Marketing Organization

In Oracle Fusion Customer Relationship Management (CRM), you can define sales and marketing organizations. Sales organization hierarchies are used to report and forecast sales results. Sales people are defined as resources assigned to these organizations.

In some enterprises, the HCM departments and hierarchies correspond to sales organizations and hierarchies. It is important to examine the decision on how to model sales hierarchies in relationship to department hierarchies when implementing customer relationship management to eliminate any possible redundancy in the definition of the organizations.

The following figure illustrates a management hierarchy, in which the System Components Division tracks its expenses in two cost centers, Air Compressors and Air Transmission. At the department level, two organizations with a classifications of Department are defined, the Marketing Department and Sales Department. These two departments can be also identified as a Resource Organizations, which will allow assigning resources, such as sales people, and other CRM specific information to them. Each department is represented in the chart of accounts by more than one cost center, allowing for granular as well as hierarchical reporting.

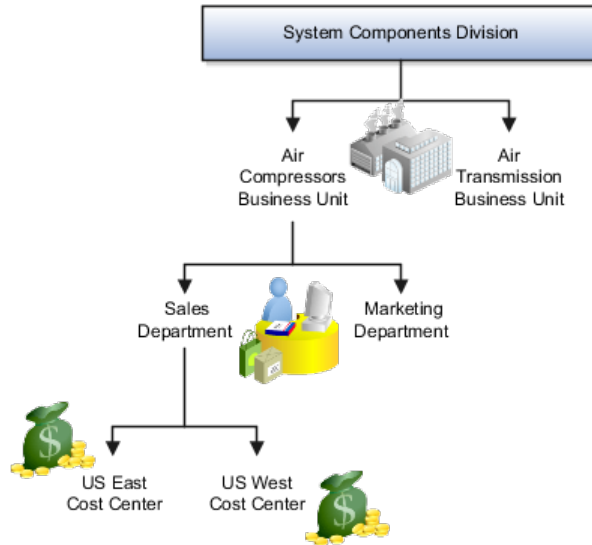

Cost Organization

Oracle Fusion Costing uses a cost organization to represent a single physical inventory facility or group of inventory storage centers, for example, inventory organizations. This cost organization can roll up to a manager with responsibility for the cost center in the financial reports.

A cost organization can represent a costing department. Consider this relationship when determining the setup of departments in HCM. There are no system dependencies requiring these two entities, cost organization and costing department, be set up in the same way.

Define Workforce Structures: FAQs for Manage Job Families

What's the difference between a job set and a job family?

A job family is a group of jobs that have different but related functions, qualifications, and titles. They are beneficial for reporting. You can define competencies for job families by associating them with model profiles.

A job set is an organizational partition of jobs. For example, a job set can be global and include jobs for use in all business units, or it can be restricted to jobs for a specific country or line of business. When you select a job, for a position or an assignment, the available jobs are those in the set associated with the business unit in which you are working, and also those in the Common set.

Define Workforce Structures: Manage Job

Jobs: Explained

As part of your initial implementation, you specify whether to use jobs and positions, or only jobs. Jobs are typically used without positions by service industries where flexibility and organizational change are key features.

Basic Details

Basic details for a job include an effective start date, a job set, a name, and a code.

A job code must be unique within a set. Therefore, you can create a job with the code DEV01 in the US set and another job with the same code in the UK set. However, if you create a job with the code DEV01 in the Common set, then you cannot create a job with the same code in any other set.

Benchmark Information

You can identify a job as being a benchmark job. A benchmark job represents other jobs in reports and salary surveys. You can also select the benchmark for jobs. Benchmark details are for informational purposes only. A progression job is the next job in a career ladder.

Progression Information

Progression jobs enable you to create a hierarchy of jobs and are used to provide the list of values for the Job field in the Promote Worker and Transfer Worker tasks. The list of values includes the next three jobs in the progression job hierarchy. For example, assume that you create a job called Junior Developer and select Developer as the progression job. In the Developer job, you select Senior Developer as the progression job. When you promote a junior developer, the list of values for the new job will include Developer and Senior Developer. You can select one of these values, or select another one.

Jobs and Grades

You can assign grades that are valid for each job. If you are using positions, then the grades that you specify for the job become the default grades for the position.

Evaluation Criteria

You can define evaluation criteria for a job, including the evaluation system, a date, and the unit of measure for the system. One predefined evaluation system is available, and that is the Hay system. An additional value of Custom is included in the list of values for the Evaluation System field, but you must add your own criteria and values for this system.

Uploading Jobs Using a Spreadsheet

If you have a list of jobs already defined for your enterprise, you can upload them from a spreadsheet. To use this option, you first download a spreadsheet template, then add your job information to the spreadsheet, and then upload directly to your enterprise configuration. You can upload the spreadsheet multiple times to accommodate revisions.

Jobs: Example

Jobs are typically used without positions by service industries where flexibility and organizational change are key features.

Software Industry

For example, XYZ Corporation has a director over the departments for developers, quality assurance, and technical writers. Recently, three developers have left the company. The director decides to redirect the head count to other areas. Instead of hiring all three back into development, one person is hired to each department, quality assurance, and technical writing.

In software industries, the organization is fluid. Using jobs gives an enterprise the flexibility to determine where to use head count, because the job only exists through the person performing it. In this example, when the three developers leave XYZ Corporation, their jobs no longer exist, therefore the corporation has the flexibility to move the headcount to other areas.

This figure illustrates the software industry job setup.

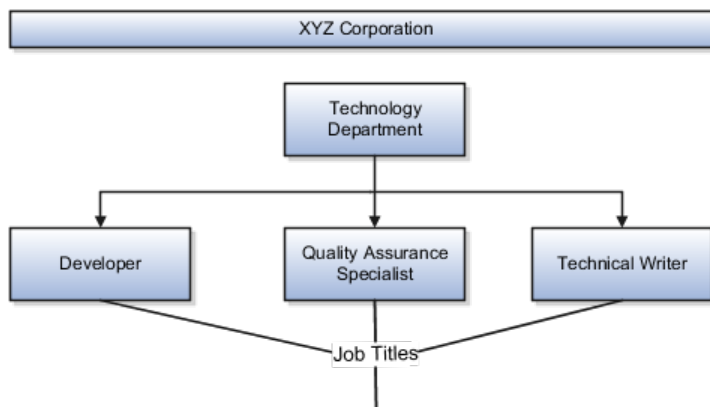

Define Workforce Structures: Manage Person Search Relevance Profile Option Values

Search Relevance Profile Options: Explained

The strength of the relationship between the person performing a gallery search and each person whose assignment appears in the search results can determine the order of the results: the stronger the relationship, the closer to the top of the results an assignment appears. The search relevance profile options control how the strength of the relationship between the searcher and the search result is calculated.

Weighting Profile Options

Using the following profile options, you can change the weighting applied to the relevant factors.

Profile Option	Description
HR: Organization Hierarchy Weight	Specifies the weighting applied to the relationship strength value for the organization hierarchy proximity factor.

HR: Position Hierarchy Weight	Specifies the weighting applied to the relationship strength value for the position hierarchy proximity factor.
HR: Manager Hierarchy Weight	Specifies the weighting applied to the relationship strength value for the manager hierarchy proximity factor.
HR: Location Proximity Weight	Specifies the weighting applied to the relationship strength value for the location proximity factor.
HR: Selection History Weight	Specifies the weighting applied to the relationship strength value for the selection history factor.
HR: Social Network Weight	Specifies the weighting applied to the relationship strength value for the social network factor.

The default value of each weighting profile option is 0.5. To increase the relevance of a factor relative to other factors, you increase its weighting; to decrease its relevance, you reduce its weighting.

HR: Selection History Timeout

The number of times the searcher selects a person's assignment from the search results during a specified period, which is 7 days by default, is recorded automatically. You can specify this period for the enterprise on the HR: Selection History Timeout profile option.

HR: Maximum Hierarchy Proximity

When the searcher's primary assignment is in the same organization, position, or manager hierarchy as a person's assignment, the strength of the relationship depends on their proximity to each other in the hierarchy. The maximum number of hierarchy boundaries to include in the calculation is 4 by default. You can set this value for the enterprise on the HR: Maximum Hierarchy Proximity profile option.

HR: Relationship Priority Factor

The searcher can specify a rating for a search result, and each rating is associated with a multiplying factor. On this profile option, you can specify the highest possible multiplying factor that can be applied to a search result. By default, the multiplying factor is 2. If you increase its value, you increase the significance of the searcher's own ratings relative to other factors.

Define Facilities: Manage Facility Shifts, Workday Patterns, and Schedules

Schedule Components: How They Fit Together

Schedules are comprised of workday patterns and exceptions. Workday patterns are comprised of shifts. You can also create exceptions, nonworking days, to the schedules.

Begin by creating shifts and then assigning those shifts to workday patterns. Next, create a schedule that is a collection of workday patterns and any exception dates.

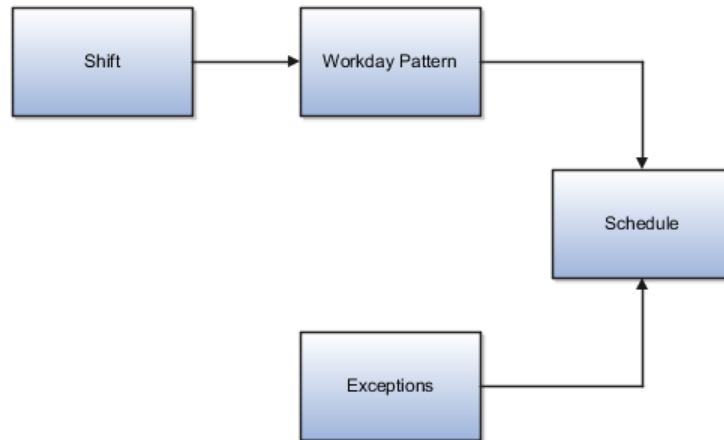

Shift

A shift is a period of time, typically expressed in hours, and it can be defined by a start time and an end time, or a duration. A shift can be for a work period or a off period. You can create time, duration, and elapsed shifts.

Workday Pattern

A workday pattern is a collection of shifts for a specific number of days. You can create time, duration, and elapsed workday patterns.

Exception

An exception is a record of a date that overrides the availability of a resource to which a schedule has been assigned. For example, a resource is assigned a schedule that includes December 25 as a working day. An exception can be created for December 25 and applied to that schedule to override resource availability for that date. Exceptions can also be for a date time period such as 9 a.m. to 11 a.m. on December 25th.

Schedule

A schedule is defined by a start date, an end date, and a sequence of workday patterns to be followed between those dates. A schedule can also contain

exception dates that override the availability of resources to which the schedule is assigned. Quarter types such as 4-4-5, 4-5-4 are supported.

Managing Shifts: Examples

A shift is a period of time, typically expressed in hours, that is used to build workday patterns. Workday patterns are used to build schedules. There are multiple types of shifts you can create. The following scenarios illustrate each type.

Managing Time Shifts

Next month you are adding a second shift for your manufacturing operations. This new shift will start right after your regular first shift. You can create a time shift that starts at 4:00 p.m. and ends at 12:00 a.m. There are restrictions in updating existing shifts and patterns. Shifts and patterns cannot be updated if the change affects a schedule, that is they are associated to a schedule. If a shift is created but not assigned to a pattern (or assigned to a pattern but the pattern is not assigned to a schedule) it can be updated. If a pattern is created and not assigned to a schedule it can be updated.

Managing Time Shifts with Punch Details

Your division has decided that the employees in the office must clock in and out for lunch starting next week. All employees will take the same lunch hour. Add punch shift details to the existing shift so that employees punch in at 8:00 a.m.; they punch out for lunch from 11:30 a.m. to 12:30 p.m.; they punch back in at 12:30 p.m.; and they punch out for the day at 5:00 p.m.

Managing Time Shifts with Flexible Details

Jorge Sanchez is a contractor who is starting work in your department next week. His hours will be flexible, so you need to create a new time shift with flexible details that he can use to record his time. He will have a flexible start time from 7:00 a.m. to 9:00 a.m. and a flexible end time from 4:00 p.m. to 6:00 p.m. His core work hours will be from 9:00 a.m. to 4:00 p.m.

Managing Duration Shifts

One of the divisions in your organization does not use fixed start and end times for its daily shifts; the division only records the total duration of the shift and indicates if resources are available or not during that time. All of the employees in the division are available for 24 hours straight, and then they are not available for the next 24 hours. You should create a duration shift that indicates that resources are available for 24 hours, and create a second duration shift that indicates that resources are not available for 24 hours.

Managing Elapsed Shifts

The employees in the Human Resources department all work 8 hours a day, but the start and end times vary by employee. Some employees start as early as 6:00 a.m., while others don't start until 9:00 a.m. Create an elapsed shift with a duration of 8 hours, where all employees are assumed to be available for the number of hours in the shift at any time during the day.

Managing Workday Patterns: Examples

A workday pattern is a collection of shifts for a specific number of days. There are multiple types of workday patterns you can create. The following scenarios illustrate each type.

Managing Time Workday Patterns

Your department works a Monday through Friday workweek with 8 hour shifts each day. Time patterns always have time shifts. That is, the shift will have start time and end time. You can create a time workday pattern with a length of 7 days and details of an 8 hour time shift for days 1 through 5. Days 6 and 7 are considered nonworking days.

Managing Duration Workday Patterns

A new group of employees starts next month, and each employee will work a schedule where he or she is available for 10 hours, and then not available for the next 16 hours, and then available for 10 hours again, and so on. This pattern starts on midnight of the first day of the next month. Create a duration workday pattern with a 10-hour available duration shift, followed by a 16-hour not available duration shift. Do not specify the pattern length or start and end days, and the pattern will repeat for the length of the schedule to which it is associated.

Managing Elapsed Workday Patterns

In the summer, several divisions in your organization work only 4 hours on Fridays. They work extended hours on Wednesdays and Thursdays to cover the 4 hours they will not work on Fridays. Create an elapsed workday pattern with a length of 7 days. Days 1 and 2 will have an 8-hour shift assigned, while days 3 and 4 will have a 10-hour shift assigned. Finally, day 5 will have a 4-hour shift assigned. As in the time workday pattern, days 6 and 7 are considered nonworking days.

Define Facilities: Manage Inventory Organizations

Inventory Organizations: Explained

An inventory organization is a logical or physical entity in the enterprise that is used to store definitions of items or store and transact items.

You select the following usages in the inventory organization's properties:

- Item management
- Item and inventory management

Item Management

Inventory organizations used for item management, which are the same as item organizations, store only definitions of items. Use inventory organizations for item management when the storage or movement of inventory does not need to be physically or financially tracked. For example, in a retail implementation you can create an inventory organization for item management to store the names

of items that are listed by and sold through each retail outlet, while a different system tracks physical inventory and transactions. If it is necessary in the future, you can change an inventory organization's usage from item management to item and inventory management in the inventory organization's properties.

Item and Inventory Management

Inventory organizations used for item and inventory management store and transact items, in addition to item definitions. An inventory organization used for item and inventory management is associated with one business unit, one legal entity, and one primary ledger. Use inventory organizations for item and inventory management when the storage or movement of inventory needs to be physically and financially tracked. Inventory organizations used for item and inventory management can represent facilities such as manufacturing centers, warehouses, or distribution centers. You cannot change an inventory organization's use from item and inventory management to item management.

Inventory Organization: Critical Choices

In Oracle Fusion, storage facilities, warehouses, and distribution centers are implemented as inventory organizations.

Inventory organizations are:

- Managed by a business unit, with the materials management business function enabled.
- Mapped to a legal entity and a primary ledger.

There are two types of inventory organizations:

- Manufacturing facilities
- Storage facilities

Storage and manufacturing facilities are related to other organizational entities through a business unit that stores, manufactures, and distributes goods through many factories, warehouses, and distribution centers. The material parameters are set for both the facilities, enabling movement of material in the organization. This business unit has the business function of Materials Management enabled. Oracle Fusion Applications allow many inventory organizations to be assigned to one business unit.

Note

Currently, Oracle Fusion Applications do not include manufacturing capabilities, so setup your manufacturing facilities outside of Oracle Fusion applications.

Distribution Center as an Inventory Organization

A distribution center can store inventory that is the responsibility of different business units. In this situation, assign an inventory organization to each business unit as a representation of the inventory in the distribution center. The multiple inventory organizations representing the inventory are defined with the same location to show that they are a part of the same distribution center.

In the following figure the two business units, Air Compressors and Air Transmission, share one distribution center in Atlanta. The two inventory

organizations, Air Compressors and Air Transmission represent the inventory for each business unit in the Atlanta distribution center and are both assigned the Atlanta location.

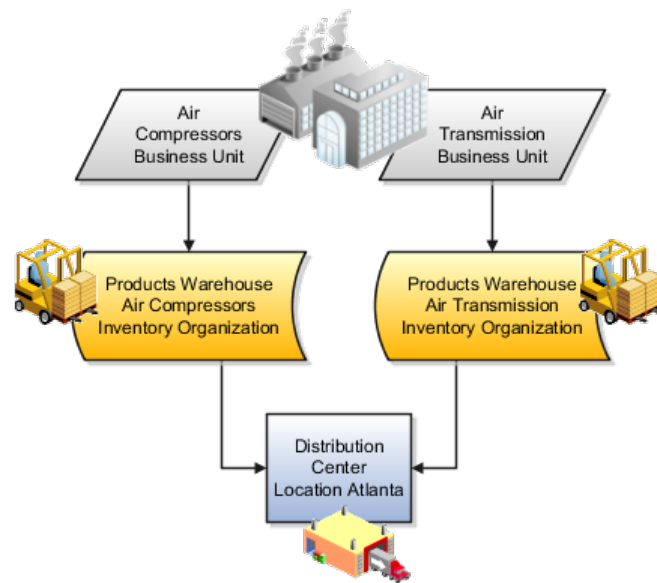

Legal Entities Own Inventory Organizations

A legal entity owns the inventory located in a storage or manufacturing facility. This ownership is assigned through the relationship of the inventory organization representing the inventory and the legal entity assigned to the inventory organization. The legal entity assigned to the inventory organization shares the same primary ledger as the inventory organization's business unit.

The inventory is tracked in the inventory organization owned by the legal entity of which the business unit is part. All transactions are accounted for in the primary ledger of the legal entity that owns the inventory.

The figure below illustrates the inventory owned by InFusion Air Quality legal entity. The InFusion Air Quality legal entity is associated with the Air Compressors business unit, which is associated with the two Air Compressors inventory organizations. Therefore, InFusion Air Quality legal entity owns the entire inventory in both the Dallas and Atlanta locations.

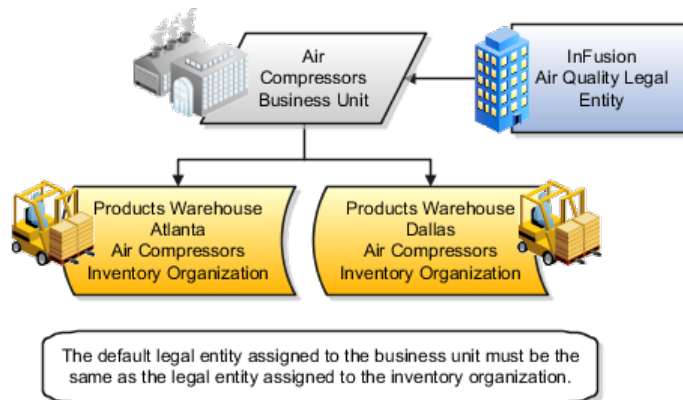

Facility Schedules Are Associated with Inventory Organizations

A prerequisite to defining an inventory organization is to define a facility schedule. Oracle Fusion Applications allow you to associate an inventory organization with a schedule.

Facility schedules allow creating workday calendars for inventory organizations that are used in the Oracle Fusion Supply Chain Management product family. For example, use workday calendars in the scheduling of cycle counts and calculating transit time.

Inventory Organization Prerequisites: Points to Consider

You can create a new inventory organization, or select an existing organization to define as an inventory organization.

Before creating inventory organizations:

- Set up inventory organization dependencies
- Plan inventory organization parameters

Setting Up Inventory Organization Dependencies

When you create an inventory organization, you must associate it to dependencies, such as business units and legal entities. For this reason, create these dependencies before creating an inventory organization.

Planning Inventory Organization Parameters

Before creating an inventory organization, plan the inventory organization's parameters

Consider the following when planning to configure an inventory organization's parameters

- Which schedule to use
- Which inventory organization to serve as the item master organization
- Whether to configure locator control and if so, the level at which to enforce the locator control
- How you want to configure movement request settings such as pick slip batch size and replenishment movement request grouping

Consider the size of your operation, your usage of subinventories, and the type of labor or equipment required when considering whether you want to use organization- or subinventory-level replenishment movement request grouping.

- How you want to configure lot, serial, and packing unit generation settings

To make appropriate choices for these settings, you should be familiar with:

- Your company's guidelines for creating lot names, serial numbers, and packing unit numbers
- Whether your company requires you to assign the same lot number to multiple items in the same organization, or a specific lot number to only one item in the same organization
- Whether your company requires you to place purchase order or shipping order material under lot control
- How you want to configure item sourcing details, such as the picking rule to use, and whether to specify the inventory organization as a logistics services organization

Rounding the Reorder Quantity: How It Affects Min-Max Planning Reorder Calculations

When you specify to round reorder quantities, min-max planning reorders for item subinventories are automatically rounded up or down.

Settings That Affect Rounding the Reorder Quantity

Reorder quantities for an item subinventory are calculated based on:

- The setting that you select for the **Round Order Quantity** parameter on the Manage Inventory Organization Parameters page, General tab, of the inventory organization containing the item subinventory
- The value that you specify for the **Fixed Lot Multiple** text box on the Add Item to Subinventory window

How Rounding the Reorder Quantity Affects Min-Max Planning Reorder Quantity Calculations

If you enable rounding the reorder quantity for the inventory organization, and specify the fixed lot multiple for the item subinventory, the reorder quantity is rounded up. If you disable rounding the reorder quantity for the inventory organization, and specify the fixed lot multiple for the item subinventory, the reorder quantity is rounded down.

Note

To round reorder quantities, you must specify a fixed lot multiple.

Example: Rounding the Reorder Quantity

Assume that the reorder quantity is 24. If you enable rounding the reorder quantity and specify 10 for the fixed lot multiple, the reorder quantity is rounded up to 30. If you disable rounding the reorder quantity and keep the fixed lot multiple at 10, the reorder quantity is rounded down to 20.

Selecting Lot Number Uniqueness Control: Critical Choices

Select one of the following lot number uniqueness control options to apply to the items in your inventory organization:

- No uniqueness control
- Across items

No Uniqueness Control

You can assign the same lot number to multiple items in the same inventory organization and across inventory organizations. The following table provides an example of how lot numbers are generated when uniqueness control is not applied, both within and across inventory organizations.

Within Inventory Organization	Across Inventory Organizations
Item AS100 (printer) / Lot LN100	Item AS100 (printer) / Lot LN100
Item AS101 (laptop computer) / Lot LN100	Item AS101 (laptop computer) / Lot LN100

Across Items

You can only assign a unique lot number to a single item in one inventory organization. If the same item is also in a different inventory organization, you must assign that item a unique lot number. The following table provides an example of how lot numbers are generated when uniqueness control is applied across items, both within and across inventory organizations.

Within Inventory Organization	Across Inventory Organizations
Item AS100 (printer) / Lot LN100	Item AS100 (printer) / Lot LN300
Item AS101 (laptop computer) / Lot LN200	Item AS101 (laptop computer) / Lot LN400

FAQs for Manage Inventory Organizations

What happens if I select the Supplier item sourcing type for replenishment?

Items are replenished from an external supplier.

What happens if I create an inventory organization as a logistics services organization?

The inventory organization is not costed, and shipment lines from different logistics service provider customers cannot be packed in the same packing unit.

Define Facilities: Manage Item Organizations

Item Organization: Explained

An item organization defines an item when inventory balances are not stored and inventory storage or inventory movement is not reflected in the Oracle

Fusion Applications. For example, you would use an item organization in a retail scenario, if you need to know the items that are listed by and sold through each retail outlet even though inventory and transactions are recorded in another system. In Oracle Fusion Customer Relationship Management (CRM), item organizations are used to define sales catalogs.

Note

- Items belong to an item organization.
 - Item attributes that are associated with financial and accounting information are hidden from the item if it exists within the item organization.
 - Item organizations can be changed by administrators to an inventory organization by updating the necessary attributes. There is no difference in the way items are treated in these two types of organizations except that there cannot be any financial transactions in the downstream applications for items that are assigned to an item organization.
-

Item Master Organization: Explained

An item master organization lists and describes items that are shared across several inventory organizations or item organization.

The following example shows the choice between inventory organizations that track inventory transactions, stored in two warehouses, and item organizations that just track items, listed in two sales catalogs.

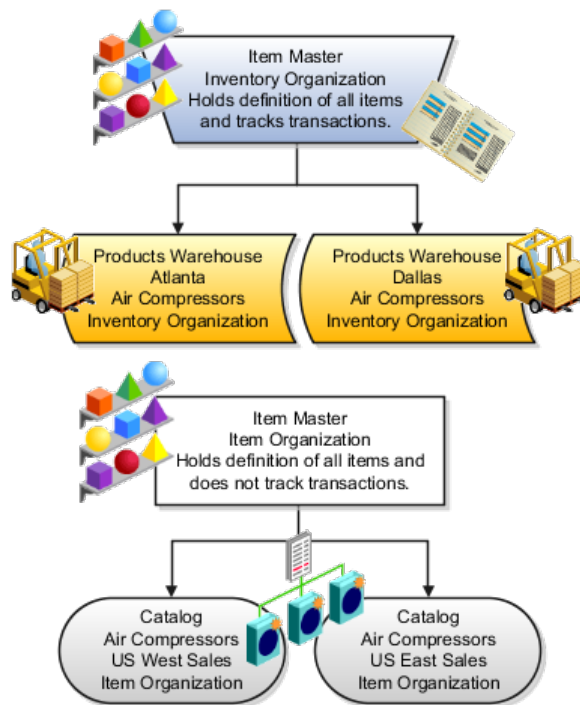

For the most efficient processing, you should:

- Have a single item master
- Include an item and its definition of form, fit, and function only once in the item master
- Separate the item master organization from organizations that store and transact items

Note

Oracle Fusion allows multiple item masters, however, use this capability cautiously. If you acquire a company, there may be value in allowing the old item master to exist for a transition period. If you manage your subsidiaries as separate businesses, there may be reduced value in a single item master.

Define Workforce Profiles

Profile Management: Explained

Profile management provides a framework for developing and managing talent profiles that meet your industry or organizational requirements. Profiles summarize the qualifications and skills of a person or a workforce structure such as a job or position. Profiles are valuable for tracking workers' skills, competencies, and accomplishments, and for various talent management activities, such as career planning, identifying training needs, performance management, and in the recruitment process for identifying job requirements and suitable applicants.

This topic discusses:

- Profile search
- Profile comparison
- Best-fit analysis

Profile Search

You can search profiles for workers, jobs, and positions with certain criteria. For example, an HR (Human Resources) specialist in London who is looking to fill an applications developer position from within the company can search for profiles of all workers who are based in London and have experience with Java and PL/SQL.

Profile Comparison

Using the comparison feature, you can compare profiles to determine next career moves or training needs for workers, and identify suitable candidates for jobs. For example, if John is looking for his next career move, he can compare his profile to that of a job to determine whether his competency ratings match the targeted competency ratings in a job profile. For example, if his Teamwork rating is 3 and the Product Strategy Teamwork requirement is 4, he has a deficiency of -1. John and his manager can use this gap to drive development plans and for other talent management-related functions.

Best-Fit Analysis

Use the best-fit analysis to determine the person profile that most closely matches a job profile, or the job profile that is the best match for a person profile. For example, if you are trying to fill a Developer vacancy, and the job profile requires a B.S. degree in Computer Science, level 4 expertise coding Java, and a Teamwork rating of at least 3, you can review an automatically-generated list of workers who most closely match this set of requirements. You can also use the best-fit analysis to find workers who are similar to a selected worker, or jobs that are similar to a selected job.

Oracle Fusion Profile Management Components: How They Work Together

You can configure Oracle Fusion Profile Management to meet your business requirements using these components: the content library, profiles and profile types, content subscribers, educational establishments, instance qualifier sets, and rating models.

This figure illustrates how the components of Profile Management fit together.

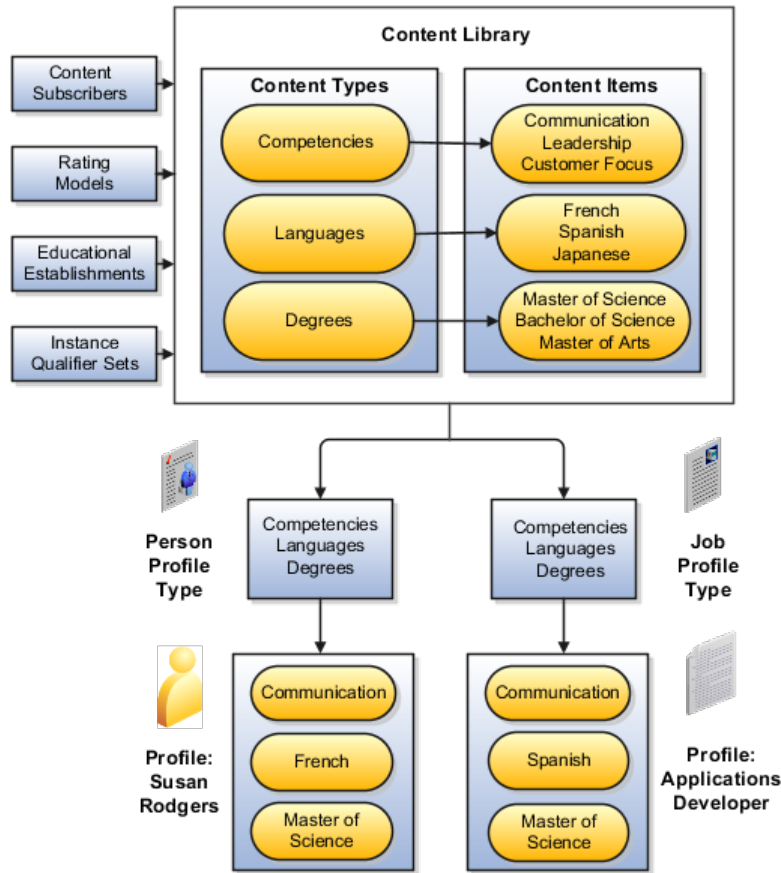

Content Library

The content library provides the foundation for profiles as it stores both content types and content items.

Profile Types

Profile types are templates that you use to create profiles. Profile types determine whether the profile is for a person or for a workforce structure such as a job or a position, and the content of the profile. You select content types from the content library to create content sections for the profile type.

Profiles

You create person profiles for individual workers and model profiles for workforce structures, such as a jobs or positions. The information that you complete for the profile is determined by how the profile type has been set up. For example, a person profile might contain information about a person's education, language skills, competencies, and activities and interests. A job profile might contain information about the requirements for the job, such as competencies, language skills, degrees, or certifications.

Content Subscribers

Content subscribers are applications external to Oracle Fusion Profile Management that use content types.

Educational Establishments

You can define educational establishments for workers to use when they add education information, such as degrees, to their profile.

Instance Qualifier Sets

You assign instance qualifiers to content types. Instance qualifier sets uniquely identify multiple instances of a content item on a profile. For example, if multiple people update a performance rating for a competency on a worker's profile, instance qualifiers provide a unique identifier to each instance of the competency so that you can determine who provided each rating.

Rating Models

When you create content types in the content library, you can attach rating models to determine the scale for measuring performance and proficiency. You can also use rating models to measure the risk and impact of loss for workers, and to measure their potential.

Oracle Fusion Profile Management, Performance Management, Goal Management, and Talent Review: How They Work Together

Oracle Fusion Profile Management supports talent management business processes in these products:

- Oracle Fusion Performance Management
- Oracle Fusion Goal Management
- Oracle Fusion Talent Review

Oracle Fusion Performance Management

Oracle Fusion Performance Management uses the rating models that you define in Profile Management to rate workers on their performance. When you define a performance document template, you can specify whether the ratings and comments from managers and workers are uploaded automatically to workers' profiles when the performance document is finalized. Instance qualifier sets distinguish the manager ratings from the workers' self ratings. Performance Management also uses competencies from the content library in performance documents.

Oracle Fusion Goal Management

You can set up a content type relationship between the Goals content type and other content types, such as the Competencies content type and the Memberships content type. Using these relationships, you can then set up target outcomes for goals. Target outcomes are the content items within the content type that is related to the Goals content type. For example, if you set up a relationship between the Goals content type and the Competencies content type, workers can add a target outcome of a specific competency to their goals. In this case, the specific competency is the content item within the Competencies content type. When workers complete the goal, their profiles are updated to include the competency.

Oracle Fusion Talent Review

Oracle Fusion Talent Review uses information from the Performance and Potential and Risk of Loss sections within a worker's profile to build the analytics that are part of the talent review process. These sections are defined as content types within the content library and included in the person profile type. When a talent review is complete, workers' profiles are updated automatically with the performance and potential ratings given during calibration discussions.

Instance qualifier sets enable you to distinguish the talent review rating from ratings given by the worker's manager, a peer, or perhaps the worker's self-evaluation.

Define Talent Profile Settings

Profile Management Lookups: Explained

This topic identifies common lookups that are profile management-related and have user or extensible customization levels. Review these lookups, and update them as appropriate to suit enterprise requirements.

Profile Management Lookups

Profile management lookups are described in the following table.

Lookup Type	Description	Customization Level
HRT_CONTENT_SUPP_CODE	Codes to identify where the content type originated, such as from the customer or from a third party. HR specialists assign supplier codes when setting up new content types.	Extensible
HRT_COMPETENCY_EVAL_TYPE	Types of competency ratings, such as self, supervisor, and peer. Evaluation types are used in instance qualifier sets to identify the role of the person who provided a competency rating for a worker.	User
HRT_DEGREE_LEVEL	Required levels of education for a job or position profile, such as a Bachelor's Degree or Masters degree.	User
HRT_DURATION	Time periods for when a worker would like to make a career move. Workers select a duration for their career move in the career preferences information on the career planning card.	User
HRT_EDUCATION_LEVEL	Types of education that a degree provides, such as a Bachelor's degree or one year college. HR specialists use education levels when creating content items in the Degrees content type.	User
HRT_IMPORTANCE	Values for the importance level of each content type. Importance values are used in the best-fit analysis calculation.	User
HRT_NOTES_TYPE	Values for categories of notes, such as external, internal, and so on.	User
HRT_PAY_FREQUENCY	Frequencies at which a worker is paid. Workers specify a preferred pay frequency when they edit their work requirements on the experience and qualifications card.	User

HRT_READINESS	Time periods in which a worker will be ready for advancement to a specified job or position profile. Managers and human resource (HR) specialists use readiness levels when editing the talent ratings information on workers' career planning cards.	User
HRT_RISK_REASON	Reasons for why a worker is at risk for leaving the company. Managers and HR specialists use risk reasons when editing the talent ratings information on workers' career planning cards.	User
HRT_SATISFACTION_METHOD	Methods by which an item such as a competency is verified, such as assessment or demonstration. Managers and HR specialists use these values to identify the method that was used to evaluate the proficiency of a worker in a particular skill or quality.	User
HRT_TASK_PRIORITY	Codes for the priority of a task, such as High, Medium, and so on. Talent review facilitators specify a priority when assigning tasks during a talent review.	Extensible
HRT_TASK_TYPE	Categories of tasks, such as Preparation, Presentation, and so on. Talent review facilitators specify a task type when assigning tasks during a talent review.	Extensible
HRT_TRAVEL_FREQUENCY	Percentages of time a worker is expected to travel for a job or position, for example, 25 percent or 50 percent. Managers and HR specialists specify the required travel frequency on job and position profiles. Workers also specify a travel frequency when they edit their work requirements on the experience and qualifications card.	User
HRT_VALIDITY_PERIOD	Periods of time for which content items such as licenses and certifications are valid. Managers and human resource (HR) specialists select validity periods when setting up content items for the Licenses and Certifications content type.	User
HRT_WORK_DAYS	Work days for a job or position, such as Monday through Friday. Managers and HR specialists specify the expected work days on job and position profiles.	User

HRT_WORK_HOURS	Work hours for a job or position, such as 9:00 a.m. to 5:00 p.m. Managers and HR specialists specify the expected work hours on job and position profiles.	User
----------------	--	------

Value Sets: Explained

A value set is a set of valid values that you assign to a flexfield segment.

An end user enters a value into a flexfield segment while using the application. The flexfield validates the segment against the set of valid values that you configured as a value set and assigned to the segment.

For example, you can define a required format, such as a five digit number, or a list of valid values, such as green, red, and blue.

Flexfield segments are usually validated, and typically each segment in a given flexfield uses a different value set. You can assign a single value set to more than one segment, and you can share value sets among different flexfields.

Caution

Be sure changes to a shared value set are compatible with all flexfields segments using the value set.

Defining value sets involves making decisions about the following.

- Validation
- Security
- Precision and scale
- Usage and deployment

Validation

The following types of validation are available for value sets.

- Format only, where end users enter data rather than selecting values from a list
- Independent, a list of values consisting of valid values you specify
- Dependent, a list of values where a valid value derives from the independent value of another segment
- Subset, where the list of values is a subset of the values in an existing independent value set
- Table, where the values derive from a column in an application table and the list of values is limited by a WHERE clause

A segment that uses a format only value set does not present a list of valid values to users.

You can build a tree structure from the values in an independent value set whose data type is character.

Note

Adding table validated value sets to the list of available value sets available for configuration is considered a custom task.

For more information, see the Oracle Fusion Applications Extensibility Guide.

Security

Value set security only works in conjunction with usage within flexfield segments. If a value set is used standalone, meaning outside a flexfield, value set security is not applied, but Oracle Fusion data security is enforced.

You can specify that data security be applied to the values in flexfield segments that use a value set. Based on the roles provisioned to users, data security policies determine which values of the flexfield segment end users can view or modify.

Value set security applies at the value set level. If a value set is secured, every usage of it in any flexfield is secured. It is not possible to disable security for individual usages of the same value set.

Value set security applies to independent, dependent, or table-validated value sets.

Value set security applies mainly when data is being created or updated, and to key flexfield combinations tables for query purposes. Value set security does not determine which descriptive flexfield data is shown upon querying.

Security conditions defined on value sets always use table aliases. When filters are used, table aliases are always used by default. When predicates are defined for data security conditions, make sure that the predicates also use table aliases.

For key flexfields, the attributes in the view object that correspond to the code combination ID (CCID), structure instance number (SIN), and data set number (DSN) cannot be transient. They must exist in the database table. For key flexfields, the SIN segment is the discriminator attribute, and the CCID segment is the common attribute.

Precision and Scale

For a value set with the data type Number, you can specify the precision (maximum number of digits user can enter) or scale (maximum number of digits following the decimal point).

Usage and Deployment

The usage of a value set is the flexfields where that value set is used. The deployment status of flexfields in which the value set is used indicates the deployment status of the value set instance.

The figure shows a value set used by a segment in a key flexfield and the context segment of a descriptive flexfield.

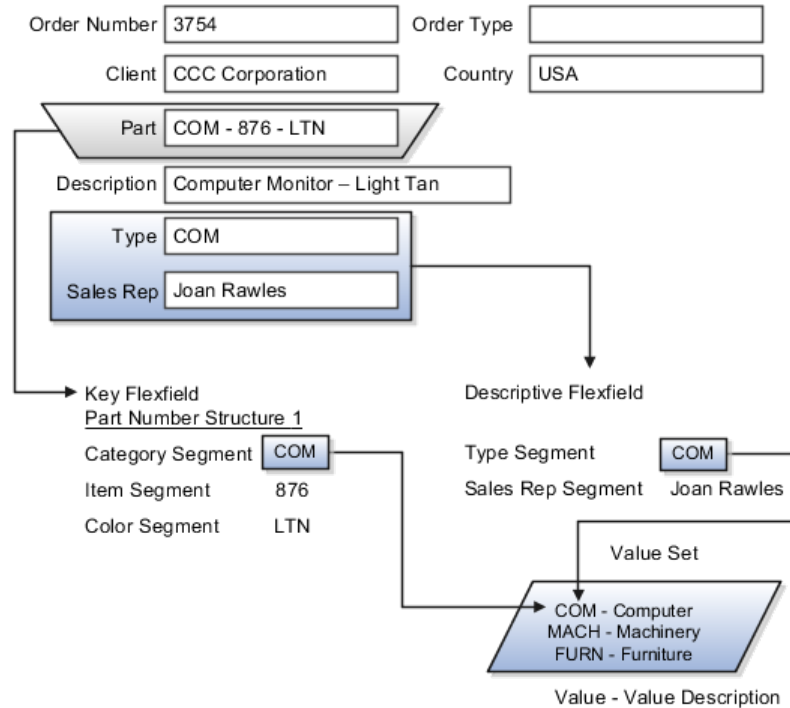

For most value sets, when you enter values into a flexfield segment, you can enter only values that already exist in the value set assigned to that segment.

Global and context-sensitive segment require a value set. You can assign a value set to a descriptive flexfield context segment. If you specify only context values, not value sets for contexts, the set of valid values is equal to the set of context values.

Defining Value Sets: Critical Choices

Validation and usage of value sets determine where and how end users access valid values for attributes represented by flexfield segments.

Tip

As a flexfield guideline, define value sets before configuring the flexfield, because you assign value sets to each segment as you configure a flexfield.

Value Sets for Context Segments

When assigning a value set to a context segment, you can only use table-validated or independent value sets. The data type must be character and the maximum length of the values being stored must not be larger than column length of the context.

Format Only Validation

The format only validation type enables end users to enter any value, as long as it meets your specified formatting rules. That is, the value must not exceed the maximum length you define for your value set, and it must meet any format requirements for that value set.

For example, if the value set allows only numeric characters, your user could enter the value 456 (for a value set with maximum length of three or more), but could not enter the value ABC. A format only value set does not otherwise restrict the range of different values that users can enter. For numeric values, you can also specify if a numeric value should be zero filled or how many digits should follow the radix separator.

Interdependent Value Sets

You cannot specify a dependent value set for a given segment without having first defined an independent value set that you apply to another segment in the same flexfield. You use a dependent value set to limit the list of values for a given segment based on the value that the end user has chosen for a related independent segment. The available values in a dependent list and the meaning of a given value depend on which value was selected for the independently validated segment.

For example, you could define an independent value set of U.S. states with values such as CA, NY, and so on. Then you define a dependent value set of U.S. cities, with values such as San Francisco and Los Angeles that are valid for the independent value CA, and New York City and Albany that are valid for the independent value NY. In the UI, only the valid cities can be selected for a given state.

Because you define a subset value set from an existing independent value set, you must define the independent value set first. End users do not need to choose a value for another segment first to have access to the subset value set.

Table Validation

Typically, you use a table-validated set when the values you want to use are already maintained in an application table (for example, a table of vendor names). Table validation allows you to enable a segment to depend upon multiple prior segments in the same context or structure.

Table-validated value sets have unique values across the table, irrespective of bind variables. The WHERE clause fragment of the value set is considered if it does not have bind variables. If it has bind variables, the assumption is that the values are unique in the value set.

Range

In the case of format, independent, or dependent value sets, you can specify a range to further limit which values are valid. You can specify a range of values that are valid within a value set. You can also specify a range validated pair of segments where one segment represents the low end of the range and another segment represents the high end of the range.

For example, you might specify a range for a format-only value set with format type Number where the user can enter only values between 0 and 100. If you use a table value set, you cannot reference flexfield segments in the WHERE clause of the value set. For example, the WHERE clause cannot reference a segment or a value set.

Security

In the case of independent and dependent values, you can specify that data security be applied to the values in segments that use a value set. Based on the

roles provisioned to users, data security policies determine which values of the flexfield segment end users can view or modify.

When you enable security on a table-validated value sets, the security rule that is defined is absolute and not contingent upon the bind variables (if any) that may be used by the WHERE clause of the value set. For example, suppose a table-validated value set has a bind variable to further filter the value list to x, y and z from a list of x, y, z, xx, yy, zz. The data security rule or filter written against the value set should not assume anything about the bind variables; it must assume the whole list of values is available and write the rule, for example, to allow x, or to allow y and z. By default in data security all values are denied, and show only rows to which access has been provided.

Maintenance

There is no need to define or maintain values for a table-validated or subset value set, as the values are managed as part of the referenced table or independent value set, respectively.

If your application has more than one language installed, or there is any possibility that you might install one or more additional languages for your application in the future, select **Translatable**. This does not require you to provide translated values now, but you cannot change this option if you decide to provide them later.

For more information about defining value sets, see the Oracle Fusion Applications Extensibility Guide.

Define Talent Profile Content

Rating Models: Explained

Use rating models to rate workers on their performance and level of proficiency in the skills and qualities that are set up on the person profile. You can also use rating models to specify target proficiency levels for items on a model profile, so that the model profile can be compared to workers' profiles.

To rate workers on their performance and proficiency, you attach rating models to the content types that are included in the person profile, and then workers can be rated on the items within the type. For example, you can rate workers on the Communication content item within the Competencies content type.

For model profiles, you can specify target proficiency levels for items on the profile, so that the model profile can be compared to workers' profiles. Using the ratings, managers can compare a model profile to workers' profiles to determine the best person suited to fill a position. Workers can compare their profile to model profiles to identify other positions within the organization that they are suited for, or to identify gaps in skills that they need to fill before applying for other positions.

Rating models that measure workers' potential and the impact and risk of loss are also available.

Rating models can include some or all of the following components, depending on the use for the model:

- Rating levels

- Review points
- Rating categories
- Distributions

Rating Levels

Rating levels identify the qualitative values, such as 1, 2, 3, or 4, that you use to rate a worker.

For rating models that are used by Oracle Fusion Performance Management, the following applies:

- You must define numeric ratings for rating models that you use with performance documents that use calculated ratings.
- You must define rating levels using whole numbers, with the highest number indicating the best rating, for the Performance Management analytics to render correctly. Rating levels determine high and low ratings in the analytics.

Review Points

Define review points for rating models that you use with performance documents that use the sum or band calculation method. The review points and point ranges that you define for the rating model are used to calculate ratings.

Rating Categories

Rating categories enable you to group rating levels together for analysis tools used in the talent review process, such as the box chart that is used in the talent review process. You can group rating levels into categories such as low, medium, and high, and those categories then become the labels for the analytic. You should not change rating categories after setting them up, as the changes could affect the analytic.

Distributions

Oracle Fusion Compensation Management and Oracle Fusion Performance Management both use rating model distributions to determine the targeted minimum and maximum percentage of workers that should be given each rating level. Compensation Management uses the distribution values that you set up directly on rating models. However, you can set up distributions at the performance template level for rating models that are used in Performance Management.

Content Types: Explained

Content types are the skills, qualities, and qualifications that you want to track in talent profiles. The content library contains predefined content types such as competencies, languages, and degrees, but you can create new content types as needed. You can also create free-form content types.

Content types contain:

- Properties
- Relationships
- Subscribers

Note

Free-form content types do not contain relationships or properties. You add properties for free-form content types when you add them to a profile type.

Properties

For each content type, you define the properties that all content items of the content type can or must have. To define properties of the content type, you select fields to be displayed when setting up the content items and the attributes of those fields. The attributes that you specify for each field are: field label, default value, whether the field is required, and whether the field is hidden, display-only, or editable. If the field is attached to a predefined list of values, you also specify the source of the list.

Relationships

Specify where one content type is a parent of another, or where one content type supports another. Content items of content types with relationships inherit the relationship. You cannot create two kinds of relationships between two types or create a relationship between a type and itself. For example, content type A cannot be both the parent and child of content type B. A content type cannot be related to itself.

Subscribers

Specify the subscriber codes of the applications or other Oracle Fusion products that use each content type. If you do not specify a subscriber code for the content type, you cannot view the content type in other applications. For example, if you add a new content type called Corporate Citizenship to the person profile type, you cannot view the content section for Corporate Citizenship in person profiles until you add the new content type to the HRMS content subscriber code.

Content Type Relationships: Examples

Content relationships enable you to associate content items of related content types with each other. The following scenarios illustrate the use of content type relationships.

Tracking Product Expertise

The Resource Manager component of Oracle Fusion Trading Community Model uses content type relationships to track the areas of expertise of workers. Using the predefined content type relationship where the Categories content type is a parent of Products, and Products is a parent of Components, resource managers can keep track of the categories, products, and components that are considered to be their areas of expertise for their resources.

Note

Because these content types and relationships are applicable only to the Resource Manager component of Oracle Fusion Trading Community Model, this product is the only predefined content subscriber to these content types.

Specifying Target Outcomes for Goals

To help your workers manage their goals, you want them to associate their goals with target outcomes, which are content types such as Competencies

and Memberships. To accomplish this, you can set up a relationship on the Competencies content type where Competencies is supported by Goals. Workers can then set up goals that have a specific competency as a target outcome.

Content Items: Explained

Content items are the individual skills, qualities, and qualifications within the content types in the content library. For example, within the Competencies content type, communication is a content item. You can create content items to meet your business needs.

This topic discusses:

- Item properties
- Related content items
- Proficiency descriptions

Item Properties

Content items inherit the fields and field properties that you define for the content type to which the item belongs. For example, one of the fields defined for the Memberships content type is ITEM_DESCRIPTION field. The attributes of this field are set up so that the label is Description, the field is editable, and the field does not require an entry. When you set up a content item for the Memberships content type, you will see a field labeled Description, in which you can enter text to describe the agency, but the field will not be required.

Related Content Items

If the content type for which you are creating an item has related content types, then you can enter the related content items for the item. For example, if you have a content type relationship where the Competencies content type is supported by the Goals content type, then on the content items for competencies, you can enter the related goals.

Proficiency Descriptions

If the content item belongs to a content type that has a rating model defined for it, then you can either use the existing descriptions for the ratings within the model, or define descriptions for the ratings that are specific to the content item. When ratings are given for the content item, the descriptions defined for the item are used instead of those on the rating model.

Creating Content Types and Content Items: Worked Example

This example demonstrates how to set up a new content type and content items to track the corporate citizenship activities of your workers so that you can rate them on their involvement in the organization. This example also demonstrates how to set up a rating model to be used with the content type and add the new content type to the person profile.

The following table summarizes key decisions for this scenario.

Decisions to Consider	In This Example
Can a predefined rating model be used to rate corporate citizenship?	No. The predefined rating models do not have relevant rating descriptions.

Should the content type be a free-form content type?	No. Content items are needed, and the content should be stored in the content library.
What field and properties should the content type contain?	<p>Add two fields to the content type:</p> <ul style="list-style-type: none"> • ITEM_TEXT_20 • RATING_MODEL_ID <p>The ITEM_TEXT_20 field will have a label of Comments, and will be used to enter comments about the workers' corporate involvement. The RATING_MODEL_ID field will have a label of Company Contribution and will be used to attach the rating model for corporate citizenship to the content type.</p> <p>Both fields should require entry and should be editable.</p>
Does the content type need any content subscribers?	Yes. In order to be visible on the person profile, the new content type must be added to the HRMS content subscriber code.
What content items are needed to track the required information?	<ul style="list-style-type: none"> • Corporate social responsibility • Corporate environmental responsibility • Corporate industrial citizenship • Corporate state citizenship • Corporate borough, council, or municipal citizenship
When the content type is added to the person profile as a content section, what properties should the fields contain?	Both the Comments field and the Company Contribution fields should display in the detail view of the content section, they should be required, and they should be included in search results.

To track corporate citizenship for your workers, complete the following tasks:

- Create a rating model.
- Create a content type.
- Create content items.
- Add the content type to the person profile type.

Creating a Rating Model

1. In the Setup and Maintenance work area, search for the **Manage Profile Rating Models** task and click **Go to Task**.
2. On the Manage Rating Models page, click **Create**.
3. On the Create Rating Model page, complete the following fields, as shown in this table. Use the default values except where indicated.

Field	Value
Code	Citizenship
Rating Name	Corporate Citizenship

Description	Rating model for corporate citizenship
--------------------	--

4. On the Rating Levels tab, complete the following fields, as shown in this table.

Rating Level	Name	Short Description
1	Demonstrates limited or unused influence.	Limited
2	Demonstrates clear evidence of influence.	Clear Evidence
3	Provides a successful image of the company as socially responsible in limited environments.	Successful Image
4	Actively called upon to use influence as a corporate representative in selected environments.	Influential in Selected Environments
5	Demonstrates high level of influence and is able to operate effectively in all environments.	High Level of Influence

5. Click **Save and Close**.

Creating a Content Type

1. In the Setup and Maintenance work area, search for the **Manage Profile Content Types** task and click **Go to Task**.
2. On the Manage Content Types page, click **Create**.
3. On the Create Content Type page, add a content type by completing the following fields, as shown in this table. Use the default values except where indicated.

Field	Value
Code	Citizenship
Name	Corporate Citizenship
Description	Ratings for corporate citizenship behaviors for workers.

4. Set up the following field properties, as shown in this table. Use the default values except where indicated.

Field Name	Field Label	Required	Display Option
ITEM_TEXT_20	Comments	Selected	Editable
RATING_MODEL_	Company Contribution	Selected	Editable

5. Click **Save and Close**.
6. On the Manage Content Types page, select the **Corporate Citizenship** content type and click **Edit**.
7. On the Edit Content Type page, select the **Subscribers** tab.
8. On the Subscribers tab, click **Add**.
9. In the Subscriber Code field, select **HRMS**.
10. Click **Save and Close**.

Creating Content Items

1. In the Setup and Maintenance work area, search for the **Manage Profile Content Items** task and click **Go to Task**.
2. On the Manage Content Items page, click **Create**.
3. In the Create Content Item dialog box, complete the following fields, as shown in this table.

Field	Value
Content Type	Corporate Citizenship
Content Item	Corporate Social Responsibility

4. On the Create Content Item: Corporate Social Responsibility page, select the **Corporate Citizenship** rating model in the **Rating** field.
5. Click **Save and Close**.
6. Repeat steps 2 through 5 to add content items for Corporate Environmental Responsibility, Corporate Industrial Citizenship, Corporate State Citizenship, and Corporate Borough, Council, or Municipal Citizenship.

Adding the Corporate Citizenship Content Type to the Person Profile Type

1. In the Setup and Maintenance work area, search for the **Manage Profile Types** task and click **Go to Task**.
2. On the Manage Profile Types page, locate the Person profile type and click **Edit**.
3. On the Edit Profile Type: Person page, select the **Content Sections** tab.
4. In the Content Sections region, click **Add Content Section**.
5. In the Content Types dialog box, select **Citizenship**.
6. In the Content Sections region, click **Citizenship**.
7. On the Content Section page, set up the following field properties, as shown in this table. Use the default values except where indicated.

Column Name	Display Flag	Required	Searchable
ITEM_TEXT240_1	Detail	Selected	Selected
RATING_LEVEL_I	Detail	Selected	Selected

8. On the Edit Profile Type: Person page, click **Save and Close**.
9. In the Content Access Section region, click **Add**.
10. In the Role field, select **Employee**.
11. Select the **Update** check box.
12. Click **Add**.
13. In the Role field, select **Manager**.
14. Click **OK**.
15. Click **Add**.
16. In the Role field, select **HR Specialist**.
17. Click **OK**.
18. On the Edit Profile Type: Person page, click **Save and Close**.

Free-Form Content Types: Worked Example

This example demonstrates how to set up a free-form content type, add it to the HRMS content subscriber code, and then add the content type to the person profile type.

Your company wants to track the previous employment information for workers, including employer name, dates of employment, and job description. However, you do not want to set up and maintain content items for each employer, and this information applies only to person profiles. You decide to use a free-form content type for this information. You can set up the free-form content type with minimal information, and then when you add it to the person profile as a content section, you can define properties for employer name, dates of employment, and job description. Workers can complete their employment information on their profile based on how you set up the content section. The following table summarizes key decisions for this scenario.

Decisions to Consider	In This Example
Should the content type be a free-form content type?	Yes. Content items are not needed, and the content should not be stored in the content library.
Does the content type need any content subscribers?	Yes. In order to be visible on the person profile, the new content type must be added to the HRMS content subscriber code.
When the content type is added to the person profile as a content section, what fields are needed?	To capture the previous employer, a text field is needed. To capture employment dates, two date fields are needed. To capture job description, another text field is needed. Therefore, the following fields must be added: <ul style="list-style-type: none"> • ITEM_TEXT30_1 • ITEM_DATE_1 • ITEM_DATE_2 • ITEM_TEXT240_1

What properties are needed for the ITEM_TEXT30_1 field?	The field should not be required and the information should not be available as search criteria, so you need only set up these field properties as follows: <ul style="list-style-type: none"> • Label: Previous Employer • Display: Detail (section should appear in detail view of profile)
What properties are needed for the ITEM_DATE_1 field?	The field should not be required and the information should not be available as search criteria, so you need only set up these field properties as follows: <ul style="list-style-type: none"> • Label: From Date • Display: Detail
What properties are needed for the ITEM_DATE_2 field?	The field should not be required and the information should not be available as search criteria, so you need only set up these field properties as follows: <ul style="list-style-type: none"> • Label: To Date • Display: Detail
What properties are needed for the ITEM_TEXT240_1 field?	The field should not be required and the information should not be available as search criteria, so you need only set up these field properties as follows: <ul style="list-style-type: none"> • Label: Job Description • Display: Detail
What role access should be granted for the content section?	Employees, managers, and HR specialists should all have access to update the section.

To set up a free-form content type to track previous employment information for workers, you must:

- Set up a free-form content type
- Add the free-form content type to the person profile type

Setting Up a Free-Form Content Type

1. In the Setup and Maintenance work area, search for the **Manage Profile Content Types** task and click **Go to Task**.
2. On the Manage Content Types page, click **Create**.
3. On the Create Content Type page, complete the following fields, as shown in this table.

Field	Value
Code	PREVEMP
Name	Previous Employment
Description	Track previous employment information for workers.

4. Select the **Free-Form Type** check box.

5. Click **Save and Close**.
6. On the Manage Content Types page, select the **Previous Employment** content type and click **Edit**.
7. On the Edit Content Type page, select the **Subscribers** tab.
8. On the Subscribers tab, select HRMS in the **Subscriber Code** field.
9. Click **Save and Close**.

Adding the Free-Form Content Type to the Person Profile Type

1. In the Setup and Maintenance work area, search for the **Manage Profile Types** task and click **Go to Task**.
2. On the Manage Profile Types page, select the **Person** profile type, and click **Edit**.
3. On the Edit Profile Type: Person page, select the **Content Sections** tab and click **Add Content Section**.
4. In the Content Types dialog box, select the **Previous Employment** content type.
5. In the Content Sections region, click the **Previous Employment** content type and enter the following properties on the Content Section page, as shown in this table.

Column Name	Label	Display
ITEM_TEXT30_1	Previous Employer	Detail
ITEM_DATE_1	From Date	Detail
ITEM_DATE_2	To Date	Detail
ITEM_TEXT240_1	Job Description	Detail

6. In the Content Access Section region, click **Add**.
7. In the Role field, select **Employee**.
8. Select the **Update** check box.
9. Click **Add**.
10. In the Role field, select **Manager**.
11. Click **OK**.
12. Click **Add**.
13. In the Role field, select **HR Specialist**.
14. Click **OK**.
15. On the Edit Profile Type: Person page, click **Save and Close**.

FAQs for Define Talent Profile Content

What's a rating category?

A label for a grouping of rating levels. Rating categories are used in talent management processes such as performance management and talent reviews to group ratings for analysis tools such as the performance and potential box chart.

Why are some content type relationships not editable?

You can edit any content type relationships that you define. However, the relationships that are predefined cannot be changed.

How can I define a relationship between the Goals content type and other content types?

Set up the relationship on the content type that you want to relate to goals using the relationship type: Is supported by. For example, if you want to define a relationship between the Goals content type and the Competencies content type, set up the relationship on the Competencies content type, instead of the Goals content type.

What's a free-form content type?

Free-form content types enable you to capture information in a profile that you do not need to store in the content library. For example, you can set up a free-form content type to store information about the previous employment information for your workers.

A free-form content type contains only a code, name, and a description, and does not have any properties defined for it until you add it to a profile type. Free-form content types do not include any content items.

Why can't I change the relationship type of a content item?

A content item's relationship type is derived from its content type, and you cannot change it. You can only change relationships at the content type level. You cannot change predefined relationships.

Define Talent Profiles

Profile Types: Explained

Profile types include person profile types and model profile types. The person profile type is the template that you use to create profiles of your workers. The person profile contains the skills, qualities, and qualifications that you want to track for your workers. The person profile type is predefined, and you can have only one. Model profile types are templates for workforce structures such as jobs and positions. Model profiles identify the targeted and required skills and qualifications for a job or position, and also identify work requirements, such as work schedule and travel frequency. You can set up multiple model profile types.

To define profile types, you first specify whether the profile type is a person or model profile. For model profiles, you also specify the workforce structures for which the model profile can be used. For example, if you specify that the model profile can be used for jobs and positions, then you can use the profile

type to create both job and position profiles. To define the structure of the profile type, you add one or more content sections using content types from the content library and free-form content types. Define the following for each content section:

- Instance qualifier sets
- Section properties
- Role access

Instance Qualifier Sets

If you have defined instance qualifier sets for the content type, you select the instance qualifier set to use for the sections.

Section Properties

The properties determine the fields and how they are displayed when you create profiles based on the type. For example, properties determine the label for the field, whether the field is required, and whether the field should be included in profile searches. For sections with content types from the content library, you can use the field properties as they have been defined in the content library, or add, remove, or change the properties to suit the content section. You define all of the properties for free-form content types.

Role Access

You can specify the user roles, such as Employee or Manager, that can view the content section, and which user roles have access to update the section.

Instance Qualifier Sets: Explained

An instance qualifier set is a group of codes that you use to uniquely identify different occurrences of the same profile item within the Competency content type. Instance qualifiers typically identify the role of the person who edited a competency. For example, if a worker, the worker's peer, and the worker's manager all enter a rating for a competency on the worker's profile, instance qualifier sets uniquely identify each instance, or, the rating given by each different role. Uniquely identifying different instances of competencies enables you to specify which instance is used when you view or compare profiles.

Each instance qualifier contains a code and a description, which indicate the role or the application that updated the competency. For example, P is the code that is used when an employee's peer rates the employee and T is used for the rating that results from the talent review meeting. You can use the predefined codes and descriptions, or you can create your own.

In addition to the code and description, each instance qualifier has the following properties:

- Priority
- Employer and manager views

- Search ability
- Default instance qualifier for employer and manager

Priority

Priority determines the order in which different instances of a competency are displayed, and also determines which instance to use when searching and comparing profiles. The lowest number indicates the highest priority.

Employer and Manager Views

Employer and manager views determine which instances are visible to employees and to managers.

Search Ability

You can specify whether items that have been assigned the instance qualifier code should be included in profile searches. For example, you might not want the ratings for competencies given by peers to display when other workers are searching person profiles.

Default Instance Qualifier for Employee and Manager

You can specify the default instance qualifier to use when managers and employees update a competency. Each time an employee or manager updates a competency, the record is assigned the instance qualifier code that is identified as the employee or manager default code.

Define Social Networking

How can I enable social networking features?

Set the Social Networking Features Enabled profile option to "Y" on the Manage Social Networking Profile Option Values page. If you enable this profile option, users can access the following features:

- Kudos
- Message board
- Activity stream
- Connections
- Personal status

Note

If you disable social networking features, users can continue to access the bookmarks they created from the Bookmarks region in the Activities and Interests card on the My Portrait tab. Also, the spaces that users are a member of continue to appear in the Spaces region.

Define Security for Supply Chain Management

Security Tasks: Highlights

Security tasks include the following.

- Security setup
- Security implementation and administration

Note

Security setup and administration tasks typically use integrated user interface pages that are provided by the following products.

- Oracle Identity Manager (OIM)
- Oracle Authorization Policy Manager (APM)
- Oracle Fusion Human Capital Management (HCM) products
- Oracle Application Access Control Governor (AACG) in Governance, Risk, and Compliance Controls (GRCC)

Security setup and administrative tasks performed by product administrators and implementation consultants, such as managing HCM security profiles, are presented in the documentation for those products.

Set Up the IT Security Manager Job Role

Provision the IT Security Manager job role with roles for user and role management.

- Using the OIM Administrator user name and password, sign in to Oracle Identity Manager (OIM). Refer to the Oracle Fusion Middleware Enterprise Deployment Guide for Oracle Identity Management (Oracle Fusion Applications Edition).

See: Creating Users and Groups for Oracle Identity Manager

- Open the IT Security Manager job role's attributes and use the Hierarchy tab to add the User Identity Administrators role and the Role Administrators role in the OIM Roles category using the Add action. Use the Delegated Administration menu to search for the Xellerate Users organization and assign it to the IT Security Manager role. Refer to the Oracle Fusion Middleware User's Guide for Oracle Identity Manager.

See: User Management Tasks

Prerequisite Tasks for Security Administration

Sign into Oracle Fusion Applications for the first time with the Installation Super User account to synchronize LDAP users with HCM user management and create an IT security manager user account and provision it with the IT Security Manager role.

- The super user account is established during installation. Refer to the Oracle Fusion Applications Installation Guide.
- Synchronize LDAP users with HCM user management by performing the Run User and Roles Synchronization Process task. Monitor completion of the predefined Enterprise Scheduler job SyncRolesJob.
- Create a user account and provision it with roles. Refer to the Oracle Fusion Middleware User's Guide for Oracle Identity Manager.

See: Managing Users

- As a security guideline, provision a dedicated security professional with the IT Security Manager role as soon as possible after initial security setup and revoke that role from users provisioned with the Application Implementation Consultant role. If entitled to do so, see Security Tasks and Oracle Fusion Applications: How They Fit Together for details about provisioning the IT security manager.

Required Security Administration Tasks

Establish at least one implementation user and provision that user with sufficient access to set up the enterprise for all integrated Oracle Fusion Middleware and all application pillars or partitions.

- Perform the initial security tasks. If entitled to do so, see Initial Security Administration: Critical Choices.
- Sign in to Oracle Fusion Applications using the IT security manager's or administrator's user name and password, and create and provision users who manage your implementation projects and set up enterprise structures by performing the Create Implementation Users task. Refer to the Oracle Fusion Middleware User's Guide for Oracle Identity Manager.

See: User Management Tasks

- Create a data role for implementation users who will set up HCM that grants access to data in secured objects required for performing HCM setup steps. Provision the implementation user with this View All data role. See "Creating an HCM Data Role: Worked Example."

- For an overview of security tasks from the perspective of an applications administrator, refer to the Oracle Fusion Applications Administrator's Guide

See: Securing Oracle Fusion Applications

Optional Security Administration Tasks

Once initial security administration is complete and your enterprise is set up with structures such as business units, additional security administration tasks are optional and based on modifying and expanding the predefined security reference implementation to fit your enterprise. See points to consider for defining security, data security and trading partner security after enterprise setup.

- Create users. Refer to the Oracle Fusion Middleware User's Guide for Oracle Identity Manager.

See: Creating Users

- Provision users with roles. Refer to the Oracle Fusion Middleware User's Guide for Oracle Identity Manager.

See: Adding and Removing Roles

- You manage users and job roles, including data and abstract roles, in Oracle Identity Management user interface pages. Refer to the Oracle Fusion Middleware User's Guide for Oracle Identity Manager.

See: User Interfaces

- You manage duties, security policies, and data role templates in the Authorization Policy Manager. Refer to the Oracle Fusion Middleware Authorization Policy Manager Administrator's Guide (Oracle Fusion Applications Edition).

See: Managing Oracle Fusion Applications Data Security Policies

- You manage role provisioning rules in Human Capital Management (HCM). If entitled to do so, see Role Mappings: Explained.
- For a complete description of the Oracle Fusion Applications security reference implementation, see the Oracle Fusion Applications Security Reference Manuals for each offering.
- For a detailed functional explanation of the Oracle Fusion Applications security approach, refer to the following guides.

See: Oracle Fusion Applications Security Guide

See: Oracle Fusion Applications Security Hardening Guide

- Since security in Oracle Fusion Applications is based on integrations with Oracle Identity Management in Fusion Middleware, security features in the database, and Governance, Risk, Compliance, and Controls, additional resources in support of performing security tasks include the following.
 - Authorization Policy Manager (APM) is available in Oracle Fusion Applications through integration with Oracle Identity Management

(OIM). Authorization policy management involves managing duty roles, data role templates, and data security policies. Refer to the Oracle Fusion Middleware Authorization Policy Manager Administrator's Guide (Oracle Fusion Applications Edition).

See: Getting Started With Oracle Authorization Policy Manager

- Oracle Identity Management (OIM) is available in Oracle Fusion Applications through integration with Oracle Fusion Middleware. Identity management in Oracle Fusion Application involves creating and managing user identities, creating and linking user accounts, managing user access control through user role assignment, managing enterprise roles, and managing workflow approvals and delegated administration.

See: Oracle Fusion Middleware User's Guide for Oracle Identity Manager

- Oracle Fusion Applications is certified to integrate with Applications Access Controls Governor (AACG) in the Oracle Governance, Risk and Compliance Controls (GRCC) suite to ensure effective segregation of duties (SOD).

See: Oracle Application Access Controls Governor Users Guide

See: Oracle Application Access Controls Governor Implementation Guide

- Configure and manage auditing. Refer to the Oracle Fusion Middleware Application Security Guide.

See: Configuring and Managing Auditing

Defining Security After Enterprise Setup: Points to Consider

After the implementation user has set up the enterprise, further security administration depends on the requirements of your enterprise.

The Define Security activity within the Information Technology (IT) Management business process includes the following tasks.

- Import Worker Users
- Import Partner Users
- Manage Job Roles
- Manage Duties
- Manage Application Access Controls

If no legacy users, user accounts, roles, and role memberships are available in the Lightweight Directory Access Protocol (LDAP) store, and no legacy workers are available in Human Resources (HR), the implementation user sets up new users and user accounts and provisions them with roles available in the Oracle Fusion Applications reference implementation.

If no legacy identities (workers, suppliers, customers) exist to represent people in your enterprise, implementation users can create new identities in Human

Capital Management (HCM), Supplier Portal, and Customer Relationship Management (CRM) Self Service, respectively, and associate them with users.

Before Importing Users

Oracle Identity Management (OIM) handles importing users.

If legacy employees, contingent workers, and their assignments exist, the HCM Application Administrator imports these definitions by performing the Load Batch Data task. If user and role provisioning rules have been defined, the Load Batch Data process automatically creates user and role provisioning requests as the workers are created.

Once the enterprise is set up, performing the Load Batch Data task populates the enterprise with HR workers in records linked by global user ID (GUID) to corresponding user accounts in the LDAP store. If no user accounts exist in the LDAP store, the Load Batch Data task results in new user accounts being created. Worker email addresses as an alternate input for the Load Batch Data task triggers a search of the LDAP for user GUIDs, which may perform more slowly than entering user names.

In the security reference implementation, the HCM Application Administrator job role hierarchy includes the HCM Batch Data Loading Duty role, which is entitled to import worker identities. This entitlement provides the access necessary to perform the Load Batch Data task in HCM.

Note

The Import Person and Organization task in the Define Trading Community Import activity imports the following resources, creates users, and links the resources to users for use in CRM.

- Internal employees
- Contingent workers
- External partner contacts
- Partner companies
- Legal entities
- Customers
- Consumers

If role provisioning rules have been defined, the Import Person and Organization task automatically provisions role requests as the users are created.

Import Users

If legacy users (identities) and user accounts exist outside the LDAP store that is being used by the Oracle Fusion Applications installation, the IT security manager has the option to import these definitions to the LDAP store by performing the Import Worker Users and Import Partner Users tasks.

If no legacy users or user accounts can be imported or exist in an LDAP repository accessible to Oracle Identity Management (OIM), the IT security manager creates users manually in OIM or uses the Load Batch Data task to create users from imported HR workers.

Once users exist, their access to Oracle Fusion Applications is dependent on the roles provisioned to them in OIM or Human Capital Management. Use the Manage HCM Role Provisioning Rules task to define rules that determine what roles are provisioned to users.

Importing user identities from other applications, including other Oracle Applications product lines, is either a data migration or manual task. Migrating data from other Oracle Applications includes user data. For more information about importing users, see the Oracle Fusion Middleware Developer's Guide for Oracle Identity Manager.

In the security reference implementation, the IT Security Manager job role hierarchy includes the HCM Batch Data Loading Duty and the Partner Account Administration Duty. These duty roles provide entitlement to import or create users. The entitlement Load Batch Data provides the access necessary to perform the Import Worker Users task in OIM. The entitlement Import Partner entitlement provides the access necessary to perform the Import Partner Users task in OIM.

Manage Job Roles

Job and abstract roles are managed in OIM. This task includes creating and modifying job and abstract roles, but not managing role hierarchies of duties for the jobs.

Note

Manage Job Roles does not include provisioning job roles to users. Provisioning users is done in OIM, HCM, CRM or Oracle Fusion Supplier Portal.

Roles control access to application functions and data. Various types of roles identify the functions performed by users.

The Oracle Fusion Applications security reference implementation provides predefined job and abstract roles. In some cases, the jobs defined in your enterprise may differ from the predefined job roles in the security reference implementation. The predefined roles and role hierarchies in Oracle Fusion may require changes or your enterprise may require you to create new roles. For example, you need a job role for a petty cash administrator, in addition to an accounts payable manager. The security reference implementation includes a predefined Accounts Payable Manager, and you can create a petty cash administrator role to extend the reference implementation.

In the security reference implementation, the IT Security Manager job role hierarchy includes the Enterprise Role Management Duty role, which is entitled to manage job and abstract roles (the entitlement is Manage Enterprise Role). This entitlement provides the access necessary to perform the Manage Job Roles task in OIM.

Manage Duties

A person with a job role must be able to perform certain duties. In the Oracle Fusion Applications security reference implementation, enterprise roles inherit duties through a role hierarchy. Each duty corresponds to a duty role. Duty roles

specify the duties performed within applications and define the function and data access granted to the enterprise roles that inherit the duty roles.

Managing duties includes assigning duties to job and abstract roles in a role hierarchy using Authorization Policy Manager (APM). If your enterprise needs users to perform some actions in applications coexistent with Oracle Fusion applications, you may wish to remove the duty roles that enable those actions. For details about which duty roles are specific to the products in an offering, see the Oracle Fusion Applications Security Reference Manual for each offering.

OIM stores the role hierarchy and the spanning of roles across multiple pillars or logical partitions of applications.

In cases where your enterprise needs to provide access to custom functions, it may be necessary to create or modify the duty roles of the reference implementation.

Tip

As a security guideline, use only the predefined duty roles, unless you have added new applications functions. The predefined duty roles fully represent the functions and data that must be accessed by application users and contain all appropriate entitlement. The predefined duty roles are inherently without segregation of duty violations of the constraints used by the Application Access Controls Governor.

In the security reference implementation, the IT Security Manager job role hierarchy includes the Application Role Management Duty role, which is entitled to manage duty roles (the entitlement is Manage Application Role). This entitlement provides the access necessary to perform the Manage Duties task in APM.

Note

Product family administrators are not entitled to create role hierarchies or manage duty roles and must work with the IT security manager to make changes such as localizing a duty role to change a role hierarchy. Setup for localizations is documented in HCM documentation.

Manage Application Access Controls

Prevent or limit the business activities that a single person may initiate or validate by managing segregation of duties policies in the Application Access Controls Governor (AACG) .

Note

In AACG, segregation of duties policies are called access controls or segregation of duties controls.

In the security reference implementation, the IT Security Manager job role hierarchy includes the Segregation of Duties Policy Management Duty role, which is entitled to manage segregation of duties policies (the entitlement is Manage Segregation of Duties Policy). This entitlement provides the access necessary to perform the Manage Application Access Controls task in AACG.

Security Tasks and Oracle Fusion Applications: How They Fit Together

The major security tasks and their order within the context of an overall Oracle Fusion Applications implementation extend from security setup through production deployment audits.

The Oracle Fusion business process model (BPM) provides a sequence of security implementation tasks that includes the following.

- Security setup (Define Common Applications Configuration activity)
 - Define Implementation Users task group (optional)
 - Create Implementation Users task
 - Create Data Role for Implementation Users task
 - Provision Roles to Implementation Users task
 - Define security - tasks vary depending on deployed Oracle Fusion product family
 - Revoke Data Role from Implementation Users task
 - Import Worker Users task
 - Import Partner Users task
 - Manage Duties task
 - Manage Job Roles task
 - Manage Application Access Controls task
 - Define Automated Governance, Risk, and Performance Controls activity
 - Manage Application Access Controls task (AACG settings)
 - Manage Application Preventive Controls task
 - Manage Application Transaction Controls task
 - Manage Application Configuration Controls task
- User and role provisioning tasks
 - Implement Role Request and Provisioning Controls activity
 - Import Worker Users task
 - Import Partner Users task
 - Self Request User Roles task
 - Approve User and Role Provisioning Requests task

- Assign User Roles task
- Manage Supplier User Roles and User Role Usages task
- Map and Synchronize User Account Details task
- Tasks for viewing account details for self or others
- Tasks for applying and managing various role provisioning rules
- Tasks for running synchronization processes
- Security implementation and ongoing maintenance after setup (Manage IT Security activity)
 - Implement Function Security Controls
 - Create Job Role task
 - Import Worker Users task
 - Import Partner Users task
 - Manage Duties task
 - Manage Job Roles task
 - Manage Users task
 - Implement Data Security Controls
 - Manage Data Security Policies task
 - Manage Role Templates task
 - Manage Encryption Keys task
 - Manage Segment Security task
 - Manage Data Access Sets task
 - Define Security Profiles task group
 - Auditing tasks
 - Manage Security Audit, Compliance and Reporting activity
 - Manage Application Access Controls task

Note

Go live deployment does not require lockdown or specific security tasks because security is enforced across the test to production information life cycle.

Required Roles

The Oracle Fusion Applications installation process sets up a single, super user provisioned with the following enterprise roles.

- Application Implementation Consultant
- IT Security Manager
- Application Administrators for the provisioned products

Initial security administration includes provisioning the IT Security Manager role with Oracle Identity Management (OIM) roles that carry entitlement for user and role management.

- Identity User Administrator
- Role Administrator

Additionally, the Xellerate Users organization must be assigned to the IT Security Manager role.

Important

As a security guideline, provision a dedicated security professional with the IT Security Manager role at the beginning of an implementation, and revoke that role from users provisioned with the Application Implementation Consultant role.

Tools Used to Perform Security Tasks

Security tasks are supported by tools within both Oracle Fusion Applications and Oracle Fusion Middleware.

The figure lists the tasks associated with each of the integrated products and pillars of an Oracle Fusion Applications deployment.

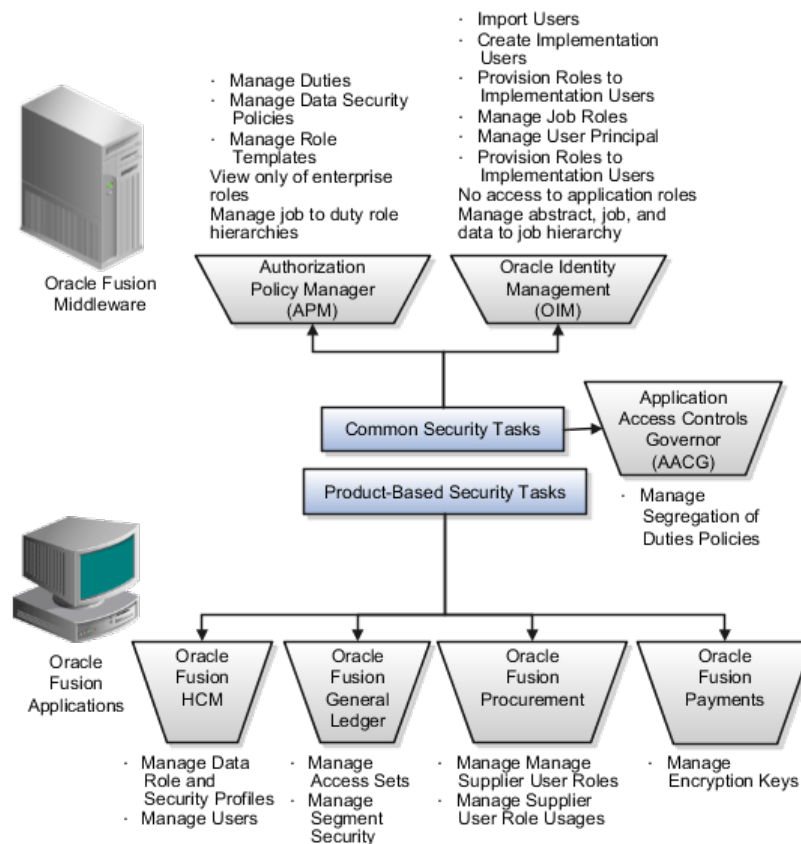

Security Tasks: Overview

Security tasks span multiple business processes and are performed by various roles using numerous integrated tools.

The following table shows the business process model (BPM) tasks and tools used to support securing Oracle Fusion Applications.

Example Task	Oracle BPM Task	Supporting Tools	Details
View duty roles inherited by a job role	Manage Duties	<ul style="list-style-type: none"> Authorization Policy Manager (APM) 	Each logical partition or pillar contains a collection of application roles, and function and data security policies.
View entitlement or policies carried by a job role	Manage Duties	<ul style="list-style-type: none"> APM 	In LDAP, the policy store stores application roles and the identity store stores enterprise roles.
Add a job role to a role hierarchy	Manage Job Roles	<ul style="list-style-type: none"> Oracle Identity Management (OIM) 	The identity store in LDAP stores enterprise roles.
Add a duty role to a role hierarchy	Manage Duties	<ul style="list-style-type: none"> APM 	LDAP stores the role hierarchy and the spanning of roles across multiple pillars or logical partitions.
Create a hierarchy of enterprise (abstract, job, data) roles	Manage Job Roles	<ul style="list-style-type: none"> OIM 	
Create a hierarchy of (application) duty roles	Manage Duties	<ul style="list-style-type: none"> APM 	
Create a new job role	Manage Job Roles	<ul style="list-style-type: none"> OIM 	The identity store in LDAP stores enterprise roles.
Change duty roles inherited by a job or abstract role	Manage Duties	<ul style="list-style-type: none"> APM 	The policy store stores duty roles. The identity store stores enterprise roles. Some duty roles may enable actions and their associated users interface features that your enterprise does not want users to perform in Oracle Fusion applications.
Create a new duty role	Manage Duties	<ul style="list-style-type: none"> APM 	All functions and actions in Oracle Fusion Applications that need to be secured are covered by the reference implementation. In some cases, especially with function customizations, a new duty role may be needed.

View Segregation of Duties (SOD) policies respected by a duty role	Manage Application Access Controls	<ul style="list-style-type: none"> Application Access Controls Governor (AACG) in Governance, Risk, and Compliance Controls (GRCC) 	The Security Reference Manuals (SRM) document the segregation of duties (SOD) policies respected within each job role
View SOD policy violations carried by the duty roles inherited by a job role	Manage Application Access Controls	<ul style="list-style-type: none"> AACG in GRCC 	The Security Reference Manuals (SRM) document the SOD policies respected within each job role
View SOD policy violations	Manage Segregation of Duties Policies	<ul style="list-style-type: none"> AACG in GRC 	The SRM documents the SOD conflicts for each job role
View the data security policies carried by a job, abstract, and data roles	Manage Data Security Policies	<ul style="list-style-type: none"> APM 	<p>Oracle Fusion Data Security stores data security policies in the policy store.</p> <p>Data security can also be defined in application pages provided by Oracle Middleware Extensions for Applications (FND)</p>
Create and update HCM security profiles	Manage Data Role and Security Profiles	<ul style="list-style-type: none"> Oracle Fusion HCM 	This task does not include assigning data roles to the users, which is supported by user provisioning tasks.
Create (generate) a data role	<ol style="list-style-type: none"> Manage Role Templates Manage Data Roles and Security Profiles 	<ul style="list-style-type: none"> APM Oracle Fusion HCM 	<p>Data roles are generated automatically based on data role templates and enterprise setup. Changes to data role templates generate new or changed data roles.</p> <p>Create data roles in HCM using the Manage Data Roles and Security Profiles task.</p>
Create a new data security policy (not through generated data roles based on data role templates or HCM security profiles)	Manage Data Security Policies	<ul style="list-style-type: none"> APM 	Data security can also be defined in application pages provided by Oracle Middleware Extensions for Applications (FND)
View data role templates defined by a product	Manage Role Templates	<ul style="list-style-type: none"> APM 	
Create or edit an existing data role template	Manage Role Templates	<ul style="list-style-type: none"> APM 	

Secure common objects such as attachment categories or profile options	Manage Data Security Policies	<ul style="list-style-type: none"> • APM 	Data security can also be defined in application pages provided by Oracle Middleware Extensions for Applications (FND)
View, create, update encryption keys used to secure attributes of personally identifiable information	Manage Encryption Keys	<ul style="list-style-type: none"> • Oracle Fusion Payments 	
View, create, update Data Access Sets used to secure Ledgers and Ledger Sets	Manage Data Access Sets	<ul style="list-style-type: none"> • Oracle Fusion General Ledger 	
View, create, update accounting flexfield segment security rules	Manage Security Segments	<ul style="list-style-type: none"> • Oracle Fusion General Ledger 	
View or update the set of job roles that can be provisioned to supplier users	Manage Supplier User Role	<ul style="list-style-type: none"> • Supplier Portal • Sourcing 	These tools are in the Oracle Fusion Procurement product family
Determine the supplier job roles that the supplier self service administrator can provision to supplier users	Manage Supplier User Role Usages	<ul style="list-style-type: none"> • Supplier Portal • Sourcing 	These tools are in the Oracle Fusion Procurement product family
Set default supplier job roles based on the set of supplier roles that are defined by performing the Manage Supplier User Roles task	Manage Supplier User Role Usages	<ul style="list-style-type: none"> • Supplier Portal • Sourcing 	These tools are in the Oracle Fusion Procurement product family
Create a new implementation user	Create Implementation Users	<ul style="list-style-type: none"> • OIM 	
Import legacy users	<ul style="list-style-type: none"> • Import Worker Users • Import Partner Users 	<ul style="list-style-type: none"> • OIM 	
Create a new user	Manage Users	<ul style="list-style-type: none"> • HCM 	<p>HCM creates a new user and identity when a new worker is created. The Hire Employee and Add Contingent Worker tasks also result in new user creation requests.</p> <p>Creating a new user automatically triggers role provisioning requests based on role provisioning rules.</p>

Provision roles to a user	<ol style="list-style-type: none"> 1. Provision Roles to Implementation Users 2. Manage Users 	<ul style="list-style-type: none"> • OIM • Oracle Fusion HCM • Oracle Fusion CRM • Oracle Fusion Suppliers 	<p>Implementation users are provisioned through OIM since HCM is not setup at the start of the implementation. The Provision Roles to Implementation Users is not needed once implementation is complete.</p> <p>Once HCM is setup, HCM is used to provision roles to non-implementation users by performing the Manage Users task. Human Resources (HR) transaction flows such as Hire and Promote also provision roles.</p> <p>Once supplier users are setup, Supplier Model can be used by internal users to maintain supplier user accounts or supplier users can maintain their accounts in Supplier Portal.</p>
View the job, abstract, and data roles provisioned to a user	<ol style="list-style-type: none"> 1. Manage Users 2. Manage User Principal 3. Provision Roles to Implementation Users 	<ul style="list-style-type: none"> • Human Capital Management (HCM) • OIM 	<p>LDAP stores users, roles and provisioning information.</p> <p>The Manage User Principal and Provision Roles to Implementation Users tasks are not needed once implementation is complete.</p>
Revoke role from user.	Manage Users	<ul style="list-style-type: none"> • HCM 	You can revoke roles from various Human Resources task flows, the HCM Manage Users task and OIM. User termination includes role revocation.
Approve role provisioning or user account request.	Approve User and Role Provisioning Requests	<ul style="list-style-type: none"> • OIM 	
View audit logs	Not applicable	<ul style="list-style-type: none"> • Oracle Enterprise Manager 	Viewing audit logs is a Oracle Fusion Middleware function and not represented by an Oracle Fusion Applications BPM task.

For more information about provisioning identities and configuring audit policies, see the Oracle Fusion Applications Administrator's Guide.

There may be more than one navigation path to the graphical user interface in which the task is performed. You can access most security tasks by starting in the Setup and Maintenance Overview page and searching for security tasks and task lists.

Define Data Security

Data Security: Explained

By default, users are denied access to all data.

Data security makes data available to users by the following means.

- Policies that define grants available through provisioned roles
- Policies defined in application code

You secure data by provisioning roles that provide the necessary access. Enterprise roles provide access to data through data security policies defined for the inherited application roles.

When setting up the enterprise with structures such as business units, data roles are automatically generated that inherit job roles based on data role templates. Data roles also can be generated based on HCM security profiles. Data role templates and HCM security profiles enable defining the instance sets specified in data security policies.

When you provision a job role to a user, the job role implicitly limits data access based on the data security policies of the inherited duty roles. When you provision a data role to a user, the data role explicitly limits the data access of the inherited job role to a dimension of data.

Data security consists of privileges conditionally granted to a role and used to control access to the data. A privilege is a single, real world action on a single business object. A data security policy is a grant of a set of privileges to a principal on an object or attribute group for a given condition. A grant authorizes a role, the grantee, to actions on a set of database resources. A database resource is an object, object instance, or object instance set. An entitlement is one or more allowable actions applied to a set of database resources.

Data is secured by the following means.

Data security feature	Does what?
Data security policy	Grants access to roles by means of entitlement
Role	Applies data security policies with conditions to users through role provisioning.

Data role template	Defines the data roles generated based on enterprise setup of data dimensions such as business unit.
HCM security profile	Defines data security conditions on instances of object types such as person records, positions, and document types without requiring users to enter SQL code
Masking	Hides private data on non-production database instances
Encryption	Scrambles data to prevent users without decryption authorization from reading secured data

The sets of data that a user can access via roles are defined in Oracle Fusion Data Security. Oracle Fusion Data Security integrates with Oracle Platform Security Services (OPSS) to entitle users or roles (which are stored externally) with access to data. Users are granted access through the entitlement assigned to the roles or role hierarchy with which the user is provisioned. Conditions are WHERE clauses that specify access within a particular dimension, such as by business unit to which the user is authorized.

Data Security Policies

Data security policies articulate the security requirement "Who can do What on Which set of data," where 'Which set of data' is an entire object or an object instance or object instance set and 'What' is the object entitlement.

For example, accounts payable managers can view AP disbursements for their business unit.

Who	can do	what	on which set of data
Accounts payable managers	view	AP disbursements	for their business unit

A data security policy is a statement in a natural language, such as English, that typically defines the grant by which a role secures business objects. The grant records the following.

- Table or view
- Entitlement (actions expressed by privileges)
- Instance set (data identified by the condition)

For example, disbursement is a business object that an accounts payable manager can manage by payment function for any employee expenses in the payment process.

Note

Some data security policies are not defined as grants but directly in applications code. The security reference manuals for Oracle Fusion Applications offerings differentiate between data security policies that define a grant and data security policies defined in Oracle Fusion applications code.

A business object participating in a data security policy is the database resource of the policy.

Data security policies that use job or duty roles refer to data security entitlement.

For example, the data security policy for the Accounts Payable Manager job role refers to the view action on AP disbursements as the data security entitlement.

Important

The duty roles inherited by the job role can be moved and job roles reassembled without having to modify the data security.

As a security guideline, data security policies based on user session context should entitle a duty role. This keeps both function and data security policies at the duty role level, thus reducing errors.

For example, a Sales Party Management Duty can update Sales Party where the provisioned user is a member of the territory associated with the sales account. Or the Sales Party Management Duty can update Sales Party where the provisioned user is in the management chain of a resource who is on the sales account team with edit access. Or the Participant Interaction Management Duty can view an Interaction where the provisioned user is a participant of the Interaction.

For example, the Disbursement Process Management Duty role includes entitlement to build documents payable into payments. The Accounts Payable Manager job role inherits the Disbursement Process Management Duty role. Data security policies for the Disbursement Process Management Duty role authorize access to data associated with business objects such as AP disbursements within a business unit. As a result, the user provisioned with the Accounts Payable Manager job role is authorized to view AP disbursements within their business unit.

A data security policy identifies the entitlement (the actions that can be made on logical business objects or dashboards), the roles that can perform those actions, and the conditions that limit access. Conditions are readable WHERE clauses. The WHERE clause is defined in the data as an instance set and this is then referenced on a grant that also records the table name and required entitlement.

Data Roles

Data roles are implemented as job roles for a defined set of data.

A data role defines a dimension of data within which a job is performed. The data role inherits the job role that describes the job. For example, a data role entitles a user to perform a job in a business unit.

The data role inherits abstract or job roles and is granted data security privileges. Data roles carry the function security privileges inherited from job roles and also the data security privilege granted on database objects and table rows.

For example, an accounts payables specialist in the US Business Unit may be assigned the data role Accounts Payables Specialist - US Business Unit. This data role inherits the job role Accounts Payables Specialist and grants access to transactions in the US Business Unit.

A data role may be granted entitlement over a set people.

For example, a Benefits Administrator A-E is allowed to administer benefits for all people that have a surname that begins with A-E.

Data roles are created using data role templates. You create and maintain data roles in the Authorization Policy Manager (APM). Use the Manage Data Roles and Security Profiles task to create and maintain HCM data roles in Oracle Fusion HCM.

HCM Security Profiles

HCM security profiles are used to secure HCM data, such as people and departments. You use HCM security profiles to generate grants for an enterprise role. The resulting data role with its role hierarchy and grants operates in the same way as any other data role.

For example, an HCM security profile identifies all employees in the Finance division.

Oracle Fusion Payroll uses HCM security profiles to secure project organizations. Applications outside of HCM can use the HCM Data Roles UI pages to give their roles access to HR people.

Masking and Encryption

Oracle Fusion Applications uses masking to protect sensitive data from view by unauthorized users. Encryption APIs mask sensitive fields in applications user interfaces. Additionally, Oracle Data Masking is available for masking data in non-production instances and Oracle Transparent Data Encryption is available for protecting data in transit or in backups independent of managing encryption keys.

Defining Data Security After Enterprise Setup: Points to Consider

After the implementation user has set up the enterprise, further security administration depends on the requirements of your enterprise.

The Define Data Security activity within the Information Technology (IT) Management business process includes the following tasks.

- Manage Data Access Sets
- Manage Segment Security
- Manage Role Templates
- Manage Data Security Policies
- Manage Encryption Keys

These tasks address data security administration. For information on using the user interface pages for setting up and managing data security, see the Oracle

Note

The Manage Data Role and Security Profiles task, and all other HCM security profile setup tasks are documented in Human Capital Management (HCM) documentation.

Manage Data Access Sets

Data access sets define a set of access privileges to one or more ledgers or ledger sets.

The information on ledgers that are attached to data access sets are secured by function security. Users must have access to the segment values associated with the data access sets to access the corresponding GL account.

In the security reference implementation, the IT Security Manager job role hierarchy includes the Data Access Administration Duty role, which is entitled to manage data access sets (the entitlement is Define General Ledger Data Access Set). This entitlement provides the access necessary to perform the Manage Data Access Sets task in General Ledger.

Manage Segment Security

Balancing or management segment values can secure data within a ledger.

Segment values are stored in GL_ACCESS_SET_ASSIGNMENTS and secured by restrictions, such as Exclude, on parameters that control the set of values that a user can use during data entry.

In the security reference implementation, the IT Security Manager job role hierarchy includes the Application Key Flexfield Administration Duty role, which is entitled to manage application key flexfields (the entitlement is Manage Application Key Flexfield). This entitlement provides the access necessary to perform the Manage Segment Security task in General Ledger.

Manage Role Templates

Data role templates automatically create or update data roles based on dimensions such as business unit. As an enterprise expands, data role templates trigger replication of roles for added dimensions. For example, when creating a new business unit, a data role template generates a new Accounts Payables Manager data role based on the Financials Common Module Template for Business Unit Security data role template.

In the security reference implementation, the IT Security Manager job role hierarchy includes the Application Role Management Duty role, which is entitled to manage data role templates (the entitlement is Manage Role Template). This entitlement provides the access necessary to perform the Manage Role Templates task in APM.

Manage Data Security Policies

Data security grants provisioned to roles are data security policies. The security reference implementation provides a comprehensive set of predefined data security policies and predetermined data security policies based on data role templates.

Data security policies are available for review in Authorization Policy Manager (APM). Data security policies are implemented by grants stored in Oracle Fusion Data Security (FND_GRANTS).

Data security policies secure the database resources of an enterprise. Database resources are predefined applications data objects and should not be changed. However, for cases where custom database resources must be secured objects, the IT security manager is entitled to manage database resources and create new data security policies.

Warning

Review but do not modify HCM data security policies in APM except as a custom implementation. Use the HCM Manage Data Role And Security Profiles task to generate the necessary data security policies and data roles.

In the security reference implementation, the IT Security Manager job role hierarchy includes the Application Role Management Duty role, which is entitled to manage data security policies (the entitlement is Manage Data Security Policy). This entitlement provides the access necessary to perform the Manage Data Security Policies task in APM.

Manage Encryption Keys

Create or edit encryption keys held in Oracle Wallet to secure Personally Identifiable Information (PII) attributes. This task is only available when Payments is implemented.

In the security reference implementation, the IT Security Manager job role hierarchy includes the Payments Data Security Administration Duty role, which is entitled to manage encryption keys that secure PII (the entitlement is Manage Wallet). This entitlement provides the access necessary to perform the Manage Encryptions Keys task in Payments.

Data Security in the Security Reference Implementation: Explained

The reference implementation contains a set of data security policies that can be inspected and confirmed to be suitable or a basis for further implementation using the Authorization Policy Manager (APM).

The security implementation of an enterprise is likely a subset of the reference implementation, with the enterprise specifics of duty roles, data security policies, and HCM security profiles provided by the enterprise.

The business objects registered as secure in the reference implementation are database tables and views.

Granting or revoking object entitlement to a particular user or group of users on an object instance or set of instances extends the base Oracle Fusion Applications security reference implementation without requiring customization of the applications that access the data.

Data Security Policies in the Security Reference Implementation

The data security policies in the reference implementation entitle the grantee (a role) to access instance sets of data based on SQL predicates in a WHERE clause.

Tip

When extending the reference implementation with additional data security policies, identify instance sets of data representing the business objects that need to be secured, rather than specific instances or all instances of the business objects.

Predefined data security policies are stored in the data security policy store, managed in the Authorization Policy Manager (APM), and described in the Oracle Fusion Applications Security Reference Manual for each offering. A data security policy for a duty role describes an entitlement granted to any job role that includes that duty role.

Warning

Review but do not modify HCM data security policies in APM except as a custom implementation. Use the HCM Manage Data Role And Security Profiles task to generate the necessary data security policies and data roles.

The reference implementation only enforces a portion of the data security policies in business intelligence that is considered most critical to risk management without negatively affecting performance. For performance reasons it is not practical to secure every level in every dimension. Your enterprise may have a different risk tolerance than assumed by the security reference implementation.

HCM Security Profiles in the Security Reference Implementation

The security reference implementation includes some predefined HCM security profiles for initial usability. For example, a predefined HCM security profile allows line managers to see the people that report to them.

The IT security manager uses HCM security profiles to define the sets of HCM data that can be accessed by the roles that are provisioned to users

Data Roles

The security reference implementation includes no predefined data roles to ensure a fully secured initial Oracle Fusion Applications environment.

The security reference implementation includes data role templates that you can use to generate a set of data roles with entitlement to perform predefined business functions within data dimensions such as business unit. Oracle Fusion Payables invoicing and expense management are examples of predefined business functions. Accounts Payable Manager - US is a data role you might generate from a predefined data role template for payables invoicing if you set up a business unit called US.

HCM provides a mechanism for generating HCM related data roles.

Securing Data Access: Points to Consider

Oracle Fusion Applications supports securing data through role-based access control (RBAC) by the following methods.

Method of securing data	Reason	Example
Data roles apply explicit data security policies on job and abstract roles	Appropriate for job and abstract roles that should only access a subset of data, as defined by the data role template that generates the data role or by HCM security profiles.	Accounts Payable Manager - US data role to provide an accounts payable manager in the US business unit with access to invoices in the US business unit.
Data security policies	Define data access for application roles and provide inheriting job and abstract roles with implicit data security	Projects

If a user has access to the same function through different roles that access different data sets, then the user has access to a union of those data sets.

When a runtime session is created, Oracle Platform Security Services (OPSS) propagates only the necessary user to role mapping based on Oracle Fusion Data Security grants. A grant can specify entitlement to the following.

- Specific rows of data (data object) identified by primary key
- Groups of data (instance set) based on a predicate that names a particular parameter
- Data objects or instance sets based on runtime user session variables

Data is either identified by the primary key value of the row in the table where the data is stored. Or data is identified by a rule (SQL predicate) applied to the WHERE clause of a query against the table where the data is stored.

Grants

Oracle Fusion Data Security can be used to restrict the following.

- Rows that are returned by a given query based on the intended business operation

- Actions that are available for a given row

Grants control which data a user can access.

Note

Attribute level security using grants requires a data security policy to secure the attribute and the entitlement check enforces that policy.

A grant logically joins a user or role and an entitlement with a static or parameterized object instance set. For example, `REGION='WEST'` is a static object instance set and `REGION=&GRANT_ALIAS.PARAMETER1` is a parameterized object instance set. In the context of a specific object instance, grants specify the allowable actions on the set of accessible object instances. In the database, grants are stored in `FND_GRANTS` and object instance sets are stored in `FND_OBJECT_INSTANCE_SETS`. Object access can be tested using the privilege check application programming interface (API).

Securing a Business Object

A business object is a logical entity that is typically implemented as a table or view, and corresponds to a physical database resource. The data security policies of the security reference implementation secure predefined database resources. Use the Manage Data Security Policies task to define and register other database resources.

Data security policies identify sets of data on the registered business object and the actions that may be performed on the business object by a role. The grant can be made by data instance, instance set or at a global level..

Note

Use parameterized object instance sets whenever feasible to reduce the number of predicates the database parses and the number of administrative intervention required as static object instances sets become obsolete. In HCM, security profiles generate the instance sets.

Manage Data Security Policies

Database Resources and Data Security Policies: How They Work Together

A data security policy applies a condition and allowable actions to a database resource for a role. When that role is provisioned to a user, the user has access to data defined by the policy. In the case of the predefined security reference implementation, this role is always a duty role. Data roles generated to inherit the job role based on data role templates limit access to database resources in a particular dimension, such as the US business unit.

The database resource defines and instance of a data object. The data object is a table, view, or flexfield.

The following figure shows the database resource definition as the means by which a data security policy secures a data object. The database resource names the data object. The data security policy grants to a role access to that database resource based on the policy's action and condition.

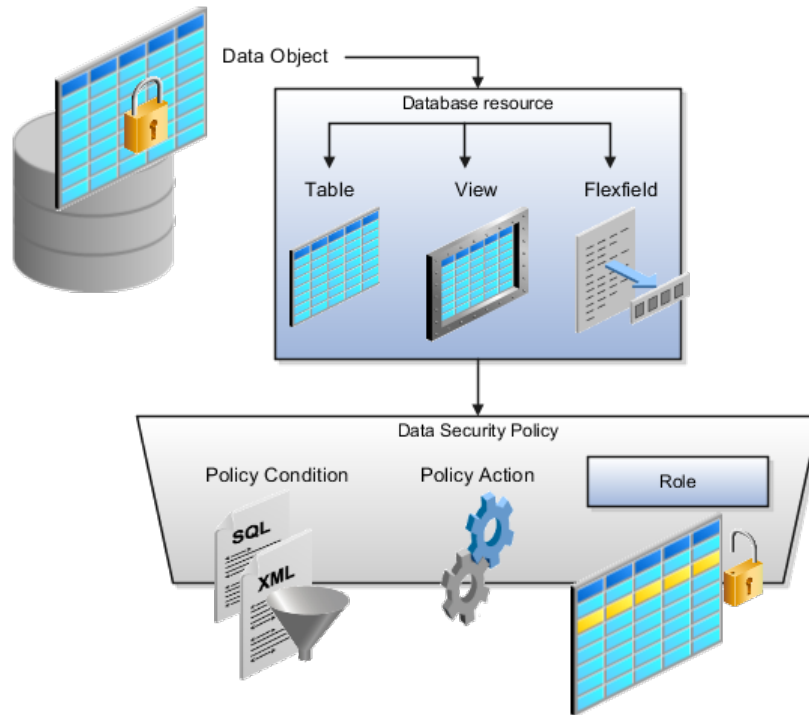

Database Resources

A database resource specifies access to a table, view, or flexfield that is secured by a data security policy.

- Name providing a means of identifying the database resource
- Data object to which the database resource points

Data Security Policies

Data security policies consist of actions and conditions for accessing all, some, or a single row of a database resource.

- Condition identifying the instance set of values in the data object
- Action specifying the type of access allowed on the available values

Note

If the data security policy needs to be less restrictive than any available database resource for a data object, define a new data security policy.

Actions

Actions correspond to privileges that entitle kinds of access to objects, such as view, edit, or delete. The actions allowed by a data security policy include all or a subset of the actions that exist for the database resource.

Conditions

A condition is either a SQL predicate or an XML filter. A condition expresses the values in the data object by a search operator or a relationship in a tree hierarchy. A SQL predicate, unlike an XML filter, is entered in a text field in the data security user interface pages and supports more complex filtering than an XML filter, such as nesting of conditions or sub queries. An XML filter, unlike a SQL predicate, is assembled from choices in the UI pages as an AND statement.

Tip

An XML filter can be effective in downstream processes such as business intelligence metrics. A SQL predicate cannot be used in downstream metrics.

Manage Role Templates

Data Role Templates: Explained

You use data role templates to generate data roles. You generate such data roles, and create and maintain data role templates in the Authorization Policy Manager (APM).

Note

HCM data roles are generated using the Manage Data Roles and Security Profiles task, which uses HCM security profiles, not data role templates, to define the data security condition.

The following attributes define a data role template.

- Template name
- Template description
- Template group ID
- Base roles
- Data dimension
- Data role naming rule
- Data security policies

The data role template specifies which base roles to combine with which dimension values for a set of data security policies. The base roles are the parent job or abstract roles of the data roles.

Note

Abstract, job, and data roles are enterprise roles in Oracle Fusion Applications. Oracle Fusion Middleware products such as Oracle Identity Manager (OIM) and Authorization Policy Manager (APM) refer to enterprise roles as external

roles. Duty roles are implemented as application roles in APM and scoped to individual Oracle Fusion Applications.

The dimension expresses stripes of data, such as territorial or geographic information you use to partition enterprise data. For example, business units are a type of dimension, and the values picked up for that dimension by the data role template as it creates data roles are the business units defined for your enterprise. The data role template constrains the generated data roles with grants of entitlement to access specific data resources with particular actions. The data role provides provisioned users with access to a dimensional subset of the data granted by a data security policy.

An example of a dimension is a business unit. An example of a dimension value is a specific business unit defined in your enterprise, such as US. An example of a data security policy is a grant to access a business object such as an invoice with a view entitlement.

When you generate data roles, the template applies the values of the dimension and participant data security policies to the group of base roles.

The template generates the data roles using a naming convention specified by the template's naming rule. The generated data roles are stored in the Lightweight Directory Access Protocol (LDAP) store. Once a data role is generated, you provision it to users. A user provisioned with a data role is granted permission to access the data defined by the dimension and data security grant policies of the data role template.

For example, a data role template contains an Accounts Payable Specialist role and an Accounts Payable Manager role as its base roles, and region as its dimension, with the dimension values US and UK. The naming convention is [base-role-name]:[DIMENSION-CODE-NAME]. This data role template generates four data roles.

- Accounts Payable Specialist - US (business unit)
- Accounts Payable Specialist - UK (business unit)
- Accounts Payable Manager - US (business unit)
- Accounts Payable Manager - UK (business unit)

Making Changes To Data Role Templates

If you add a base role to an existing data role template, you can generate a new set of data roles. If the naming rule is unchanged, existing data roles are overwritten.

If you remove a base role from a data role template and regenerate data roles, a resulting invalid role list gives you the option to delete or disable the data roles that would be changed by that removal.

Making Changes to Dimension Values

If you add a dimension value to your enterprise that is used by a data role template, you must regenerate roles from that data role template to create a

data role for the new dimension. For example if you add a business unit to your enterprise, you must regenerate data roles from the data role templates that include business unit as a dimension.

If you add or remove a dimension value from your enterprise that is used to generate data roles, regenerating the set of data roles adds or removes the data roles for those dimension values. If your enterprise has scheduled regeneration as an Oracle Enterprise Scheduler Services process, the changes are made automatically.

For information on working with data role templates, see the Oracle Fusion Middleware Administrator's Guide for Authorization Policy Manager (Oracle Fusion Applications Edition).

Define Users

Securing Identities and Users: Points To Consider

Identity covers all aspects of an entity's existence within the contexts in which it is used. The identity of an enterprise user consists of HR attributes, roles, resources, and relationships.

HR attributes include identifying information about a user that is relatively static and well understood, such as first and last name, title, and job function.

Roles are part of a user's identity and define the user's purpose and responsibilities.

Within identity management, resources define what a user can and does do. In an enterprise, this typically translates into what resources a user has access to, what privileges they have on that resource, and what they have been doing on that resource. Resources can be application accounts or physical devices such as laptops or access cards. The enterprise owns the resources, secures them, and manages access to the resources by managing the user's identity and access.

Relationships establish the portion of user identities that involve organizational transactions such as approvals.

An Oracle Fusion Applications user and corresponding identity are usually created in a single transaction, such as when a worker is created in Human Resources (HR). That transaction automatically triggers provisioning requests for the user based on role provisioning rules.

User accounts for some identities that are not employees, such as partner contacts, may be created in a later transaction using an identity that is already created in the identity store. Supplier contacts are created in the Supplier Model, not HR.

Stores

Various locations store identity and user data.

Identity data consists of the following.

- HR person records
- Oracle Fusion Trading Community Model party records

In Oracle Fusion Applications, identities and users correspond one to one, but not all identities correspond to a user, and not all users are provisioned with an identity. Some identities stored in HR and Trading Community Model may not be provisioned to user accounts and therefore are not synchronized with Oracle Identity Management (OIM). For example, a contact for a prospective customer is an identity in Trading Community Model but may not be provisioned with a user account in OIM. Some users stored in the Lightweight Directory Access Protocol (LDAP) store may not be provisioned with identities. For example, system user accounts used to run Web services to integrate third party services with Oracle Fusion Applications are not associated with a person record in HR or Trading Community Model. Some identifying credentials such as name, department, e-mail address, manager, and location are stored with user data in the LDAP store.

Importing Users

You can import users or user attributes in bulk from existing legacy identity and user stores.

Your tasks may include the following.

- Create users in bulk
- Update specific attributes for all users, such as postal code
- Link users to HR or Trading Community Model persons
- Monitor progress of the import process
- Correct errors & re-import
- Export users in bulk
- Import and export users using a standard plain text data interchange format like Lightweight Data Interchange Format (LDIF)

You can reserve a specific user name not currently in use for use in the future, or release a reserved username from the reservation list and make it available for use. Between a user registration request and approved registration, Oracle Fusion Applications holds the requested user name on the reservation list, and releases the name if an error occurs in the self-registration process or the request is rejected. Self-registration processes check the reservation list for user name availability and suggest alternative names.

Provisioning Events

New identities, such as new hires, trigger user and role provisioning events. In addition to user creation tasks, other tasks, such as Promote Worker or Transfer

Worker, result in role provisioning and recalculation based on role provisioning rules.

When an identity's attributes change, you may need to provision the user with different roles. Role assignments may be based on job codes, and a promotion triggers role provisioning changes. Even if the change in the identities attributes requires no role assignment change, such as with a name change, OIM synchronizes the corresponding user information in the LDAP store.

Deactivating or terminating an identity triggers revocation of some roles to end all assignments, but may provision new roles needed for activities, such as a pay stub review. If the corresponding user for the identity was provisioned with a buyer role, terminating the identity causes the user's buyer record in Procurement to be disabled, just as the record was created when the user was first provisioned with the buyer role.

Notifications and Audits

Oracle Fusion Applications provides mechanisms for notifying and auditing requests or changes affecting identities and users.

Oracle Fusion Applications notifies requestors, approvers, and beneficiaries when a user account or role is provisioned. For example, when an anonymous user registers as a business-to-customer (B2C) user, the B2C user must be notified of the registration activation steps, user account, password and so on once the approver (if applicable) has approved the request and the user is registered in the system.

User ID and GUID attributes are available in Oracle Fusion Applications session information for retrieving authenticated user and identity data.

End user auditing data is stored in database WHO columns and used for the following activities.

- Setting up sign-in audit
- Using the application monitor
- Notifying of unsuccessful sign ins
- Sign-in audit reports

You can conduct real time audits that instantiate a runtime session and impersonate the target user (with the proxy feature) to test what a user has access to under various conditions such as inside or outside firewall and authentication level.

For information on configuring audit policies and the audit store, see the Oracle Fusion Applications Administrator's Guide.

Delegated Administration

You can designate local administrators as delegated administrators to manage a subset of users and roles.

Delegated administrators can be internal or external persons who are provisioned with a role that authorizes them to handle provisioning events for a subset of users and roles.

For example, internal delegated administrators could be designated to manage users and roles at the division or department level. External delegated administrators could be designated to manage users and roles in an external organization such as a primary supplier contact managing secondary users within that supplier organization.

You can also define delegated administration policies based on roles. You authorize users provisioned with specific roles named in the policy to request a subset of roles for themselves if needed, such as authorizing a subset of roles for a subset of people. For example, the policy permits a manager of an Accounts Payables department to approve a check run administrator role for one of their subordinates, but prohibits the delegated administrator from provisioning a budget approver role to the subordinate.

Credentials

You activate or change credentials on users by managing them in Oracle Identity Management (OIM)

Applications themselves must be credentialed to access one another.

Oracle Fusion Applications distinguishes between user identities and application identities (APPID). Predefined application identities serve to authorize jobs and transactions that require higher privileges than users.

For example, a payroll manager may submit a payroll run. The payroll application may need access to the employee's taxpayer ID to print the payslip. However, the payroll manager is not authorized to view taxpayer IDs in the user interface as they are considered personally identifiable information (PII).

Calling applications use application identities (APPID) to enable the flow of transaction control as it moves across trust boundaries. For example, a user in the Distributed Order Orchestration product may release an order for shipping. The code that runs the Pick Notes is in a different policy store than the code that releases the product for shipment. When the pick note printing program is invoked it is the Oracle Fusion Distributed Order Orchestration Application Development Framework (ADF) that is invoking the program and not the end user.

Manage HCM Role Provisioning Rules

Role Provisioning and Deprovisioning: Explained

A user's access to data and functions depends on the user's roles: users have one or more roles that enable them to perform the tasks required by their jobs or

positions. Roles must be provisioned to users; otherwise, users have no access to data or functions.

Role Provisioning Methods

Roles can be provisioned to users:

- Automatically
- Manually, using delegated administration:
 - Users such as line managers and human resource specialists can provision roles manually to other users.
 - Users can request roles for themselves.

For both automatic and manual role provisioning, you create a role mapping to identify when a user becomes eligible for a role.

Oracle Identity Management (OIM) can be configured to notify users when their roles change; notifications are not issued by default.

Role Types

Data roles, abstract roles, and job roles can be provisioned to users. Roles available for provisioning include predefined roles, HCM data roles, and roles created using OIM.

Automatic Role Provisioning

A role is provisioned to a user automatically when at least one of the user's assignments satisfies the conditions specified in the relevant role-mapping definition. The provisioning occurs when the assignment is either created or updated. For example, when a person is promoted to a management position, the line manager role is provisioned automatically to the person if an appropriate role mapping exists. Any change to a person's assignment causes the person's automatically provisioned roles to be reviewed and updated as necessary.

Role Deprovisioning

Automatically provisioned roles are deprovisioned automatically as soon as a user no longer satisfies the role-mapping conditions. For example, a line manager role that is provisioned to a user automatically is deprovisioned automatically when the user ceases to be a line manager.

Automatically provisioned roles can be deprovisioned manually at any time.

Manually provisioned roles are deprovisioned automatically only when all of the user's work relationships are terminated; in all other circumstances, users retain manually provisioned roles until they are deprovisioned manually.

Changes to Assignment Managers

When a person's line manager is changed, the roles of both new and previous line managers are updated as necessary. For example, if the person's new line manager now satisfies the conditions in the role mapping for the line manager

role, and the role is one that is eligible for autoprovisioning, then that role is provisioned automatically to the new line manager. Similarly, if the previous line manager no longer satisfies the conditions for the line manager role, then that role is deprovisioned automatically.

Roles at Termination

When a work relationship is terminated, all automatically provisioned roles for which the user does not qualify in other work relationships are deprovisioned automatically. Manually provisioned roles are deprovisioned automatically only if the user has no other work relationships; otherwise, the user retains all manually provisioned roles until they are deprovisioned manually.

Automatic deprovisioning can occur either as soon as the termination is submitted or approved or on the day after the termination date. The user who is terminating the work relationship selects the appropriate deprovisioning date.

Role mappings can provision roles to users automatically at termination. For example, the locally defined roles Retiree and Beneficiary could be provisioned to users at termination based on assignment status and person type values.

If a termination is later reversed, roles that were deprovisioned automatically at termination are reinstated and post-termination roles are deprovisioned automatically.

Date-Effective Changes to Assignments

Automatic role provisioning and deprovisioning are based on current data. For a future-dated transaction, such as a future promotion, role changes are identified and role provisioning occurs on the day the changes take effect, not when the change is entered. The process Send Pending LDAP Requests identifies future-dated transactions and manages role provisioning and deprovisioning at the appropriate time. Note that such role-provisioning changes are effective as of the system date; therefore, a delay of up to 24 hours may occur before users in other time zones acquire the access for which they now qualify.

Role Mappings: Explained

User access to data and functions is determined by abstract, job, and data roles, which are provisioned to users either automatically or manually. To enable a role to be provisioned to users, you define a relationship, known as a mapping, between the role and a set of conditions, typically assignment attributes such as department, job, and system person type. In a role mapping, you can select any role stored in the Lightweight Directory Access Protocol (LDAP) directory, including Oracle Fusion Applications predefined roles, roles created in Oracle Identity Management (OIM), and HCM data roles.

The role mapping can support:

- Automatic provisioning of roles to users
- Manual provisioning of roles to users
- Role requests from users
- Immediate provisioning of roles

Automatic Provisioning of Roles to Users

A role is provisioned to a user automatically if:

- At least one of the user's assignments satisfies all conditions associated with the role in the role mapping.
- You select the **Autoprovision** option for the role in the role mapping.

For example, for the HCM data role Sales Manager Finance Department, you could select the **Autoprovision** option and specify the following conditions.

Attribute	Value
Department	Finance Department
Job	Sales Manager
Assignment Status	Active

The HCM data role Sales Manager Finance Department is provisioned automatically to users with at least one assignment that satisfies all of these conditions.

Automatic role provisioning occurs as soon as the user is confirmed to satisfy the role-mapping conditions, which can be when the user's assignment is either created or updated. The provisioning process also removes automatically provisioned roles from users who no longer satisfy the role-mapping conditions.

Note

The automatic provisioning of roles to users is effectively a request to OIM to provision the role. OIM may reject the request if it violates segregation-of-duties rules or fails a custom OIM approval process.

Manual Provisioning of Roles to Users

Users such as human resource (HR) specialists and line managers can provision roles manually to other users; you create a role mapping to identify roles that can be provisioned in this way.

Users can provision a role to other users if:

- At least one of the assignments of the user who is provisioning the role (for example, the line manager) satisfies all conditions associated with the role mapping.
- You select the **Requestable** option for the role in the role mapping.

For example, for the HCM data role Quality Assurance Team Leader, you could select the **Requestable** option and specify the following conditions.

Attribute	Value
Manager with Reports	Yes
Assignment Status	Active

Any user with at least one assignment that satisfies both of these conditions can provision the role Quality Assurance Team Leader manually to other users, who are typically direct and indirect reports.

If the user's assignment subsequently changes, there is no automatic effect on roles provisioned by this user to others; they retain manually provisioned roles until either all of their work relationships are terminated or the roles are manually deprovisioned.

Role Requests from Users

Users can request roles when reviewing their own account information; you create a role mapping to identify roles that users can request for themselves.

Users can request a role if:

- At least one of their own assignments satisfies all conditions associated with the role mapping.
- You select the **Self-requestable** option for the role in the role mapping.

For example, for the Expenses Reporting role you could select the **Self-requestable** option and specify the following conditions.

Attribute	Value
Department	ABC Department
System Person Type	Employee
Assignment Status	Active

Any user with at least one assignment that satisfies all of these conditions can request the role. The user acquires the role either immediately or, if approval is required, once the request is approved. Self-requested roles are classified as manually provisioned.

If the user's assignment subsequently changes, there is no automatic effect on self-requested roles. Users retain manually provisioned roles until either all of their work relationships are terminated or the roles are manually deprovisioned.

Immediate Provisioning of Roles

When you create a role mapping, you can apply autoprovisioning from the role mapping itself.

In this case, all assignments and role mappings in the enterprise are reviewed. Roles are:

- Provisioned immediately to all users who do not currently have roles for which they are eligible
- Deprovisioned immediately from users who are no longer eligible for roles that they currently have

Immediate autoprovisioning from the role mapping enables bulk automatic provisioning of roles to a group of users who are identified by the role-mapping conditions. For example, if you create a new department after a merger, you

can provision relevant roles to all users in the new department by applying autoprovisioning immediately.

To provision roles immediately to a single user, the user's line manager or an HR specialist can autoprovision roles from that user's account.

Role-Mapping Names

The names of role mappings must be unique in the enterprise. You are recommended to devise a naming scheme that reveals the scope of each role mapping. For example:

Name	Description
Autoprovisioned Roles Sales Department	Mapping includes all roles provisioned automatically to anyone in the sales department
Benefits Specialist Autoprovisioned	Mapping defines the conditions for autoprovisioning the Benefits Specialist role
Line Manager Requestable Roles	Mapping includes all roles that a line manager can provision manually to direct and indirect reports

Role Mappings: Examples

Roles must be provisioned to users explicitly, either automatically or manually; no role is provisioned to a user by default. This topic provides some examples of typical role mappings to support automatic and manual role provisioning.

Creating a Role Mapping for Employees

You want all employees in your enterprise to have the Employee role automatically when they are hired. In addition, employees must be able to request the Expenses Reporting role when they need to claim expenses. Few employees will need this role, so you decide not to provision it automatically to all employees.

You create a role mapping called All Employees and enter the following conditions.

Attribute	Value
System Person Type	Employee
Assignment Status	Active

In the role mapping you include the:

- Employee role, and select the **Autoprovision** option
- Expenses Reporting role, and select the **Self-requestable** option

You could create a similar role mapping for contingent workers called All Contingent Workers, where you would set the system person type to contingent worker.

Note

If the Employee and Contingent Worker roles are provisioned automatically, pending workers acquire them when their periods of employment or placements start. If they need roles before then, you create a separate role mapping for the pending worker system person type.

Creating a Role Mapping for Line Managers

Any type of worker can be a line manager in the sales business unit. You create a role mapping called Line Manager Sales BU and enter the following conditions.

Attribute	Value
Business Unit	Sales
Assignment Status	Active
Manager with Reports	Yes

You include the Line Manager role and select the **Autoprovision** option. This role mapping ensures that the Line Manager role is provisioned automatically to any worker with at least one assignment that matches the role-mapping conditions.

In the same role mapping, you could include roles that line managers in this business unit can provision manually to other users by selecting the roles and marking them as requestable. Similarly, if line managers can request roles for themselves, you could include those in the same role mapping and mark them as self-requestable.

Creating a Role Mapping for Retirees

Retirees in your enterprise need a limited amount of system access to manage their retirement accounts. You create a role mapping called All Retirees and enter the following conditions.

Attribute	Value
System Person Type	Retiree
Assignment Status	Inactive

You include the locally defined role Retiree in the role mapping and select the **Autoprovision** option. When at least one of a worker's assignments satisfies the role-mapping conditions, the Retiree role is provisioned to that worker automatically.

Creating a Role Mapping for Sales Managers

Grade 6 sales managers in the sales department need the Sales Manager role. In addition, sales managers need to be able to provision the Sales Associate role to other workers. You create a role mapping called Sales Managers Sales Department and enter the following conditions.

Attribute	Value
Department	Sales

Job	Sales manager
Grade	6
Assignment Status	Active

In the role mapping, you include the:

- Sales Manager role, and select the **Autoprovision** option
- Sales Associate role, and select the **Requestable** option

Import Worker Users

Defining Security After Enterprise Setup: Points to Consider

After the implementation user has set up the enterprise, further security administration depends on the requirements of your enterprise.

The Define Security activity within the Information Technology (IT) Management business process includes the following tasks.

- Import Worker Users
- Import Partner Users
- Manage Job Roles
- Manage Duties
- Manage Application Access Controls

If no legacy users, user accounts, roles, and role memberships are available in the Lightweight Directory Access Protocol (LDAP) store, and no legacy workers are available in Human Resources (HR), the implementation user sets up new users and user accounts and provisions them with roles available in the Oracle Fusion Applications reference implementation.

If no legacy identities (workers, suppliers, customers) exist to represent people in your enterprise, implementation users can create new identities in Human Capital Management (HCM), Supplier Portal, and Customer Relationship Management (CRM) Self Service, respectively, and associate them with users.

Before Importing Users

Oracle Identity Management (OIM) handles importing users.

If legacy employees, contingent workers, and their assignments exist, the HCM Application Administrator imports these definitions by performing the Load Batch Data task. If user and role provisioning rules have been defined, the Load Batch Data process automatically creates user and role provisioning requests as the workers are created.

Once the enterprise is set up, performing the Load Batch Data task populates the enterprise with HR workers in records linked by global user ID (GUID)

to corresponding user accounts in the LDAP store. If no user accounts exist in the LDAP store, the Load Batch Data task results in new user accounts being created. Worker email addresses as an alternate input for the Load Batch Data task triggers a search of the LDAP for user GUIDs, which may perform more slowly than entering user names.

In the security reference implementation, the HCM Application Administrator job role hierarchy includes the HCM Batch Data Loading Duty role, which is entitled to import worker identities. This entitlement provides the access necessary to perform the Load Batch Data task in HCM.

Note

The Import Person and Organization task in the Define Trading Community Import activity imports the following resources, creates users, and links the resources to users for use in CRM.

- Internal employees
- Contingent workers
- External partner contacts
- Partner companies
- Legal entities
- Customers
- Consumers

If role provisioning rules have been defined, the Import Person and Organization task automatically provisions role requests as the users are created.

Import Users

If legacy users (identities) and user accounts exist outside the LDAP store that is being used by the Oracle Fusion Applications installation, the IT security manager has the option to import these definitions to the LDAP store by performing the Import Worker Users and Import Partner Users tasks.

If no legacy users or user accounts can be imported or exist in an LDAP repository accessible to Oracle Identity Management (OIM), the IT security manager creates users manually in OIM or uses the Load Batch Data task to create users from imported HR workers.

Once users exist, their access to Oracle Fusion Applications is dependent on the roles provisioned to them in OIM or Human Capital Management. Use the Manage HCM Role Provisioning Rules task to define rules that determine what roles are provisioned to users.

Importing user identities from other applications, including other Oracle Applications product lines, is either a data migration or manual task. Migrating data from other Oracle Applications includes user data. For more information

about importing users, see the Oracle Fusion Middleware Developer's Guide for Oracle Identity Manager.

In the security reference implementation, the IT Security Manager job role hierarchy includes the HCM Batch Data Loading Duty and the Partner Account Administration Duty. These duty roles provide entitlement to import or create users. The entitlement Load Batch Data provides the access necessary to perform the Import Worker Users task in OIM. The entitlement Import Partner entitlement provides the access necessary to perform the Import Partner Users task in OIM.

Manage Job Roles

Job and abstract roles are managed in OIM. This task includes creating and modifying job and abstract roles, but not managing role hierarchies of duties for the jobs.

Note

Manage Job Roles does not include provisioning job roles to users. Provisioning users is done in OIM, HCM, CRM or Oracle Fusion Supplier Portal.

Roles control access to application functions and data. Various types of roles identify the functions performed by users.

The Oracle Fusion Applications security reference implementation provides predefined job and abstract roles. In some cases, the jobs defined in your enterprise may differ from the predefined job roles in the security reference implementation. The predefined roles and role hierarchies in Oracle Fusion may require changes or your enterprise may require you to create new roles. For example, you need a job role for a petty cash administrator, in addition to an accounts payable manager. The security reference implementation includes a predefined Accounts Payable Manager, and you can create a petty cash administrator role to extend the reference implementation.

In the security reference implementation, the IT Security Manager job role hierarchy includes the Enterprise Role Management Duty role, which is entitled to manage job and abstract roles (the entitlement is Manage Enterprise Role). This entitlement provides the access necessary to perform the Manage Job Roles task in OIM.

Manage Duties

A person with a job role must be able to perform certain duties. In the Oracle Fusion Applications security reference implementation, enterprise roles inherit duties through a role hierarchy. Each duty corresponds to a duty role. Duty roles specify the duties performed within applications and define the function and data access granted to the enterprise roles that inherit the duty roles.

Managing duties includes assigning duties to job and abstract roles in a role hierarchy using Authorization Policy Manager (APM). If your enterprise needs users to perform some actions in applications coexistent with Oracle Fusion

applications, you may wish to remove the duty roles that enable those actions. For details about which duty roles are specific to the products in an offering, see the Oracle Fusion Applications Security Reference Manual for each offering.

OIM stores the role hierarchy and the spanning of roles across multiple pillars or logical partitions of applications.

In cases where your enterprise needs to provide access to custom functions, it may be necessary to create or modify the duty roles of the reference implementation.

Tip

As a security guideline, use only the predefined duty roles, unless you have added new applications functions. The predefined duty roles fully represent the functions and data that must be accessed by application users and contain all appropriate entitlement. The predefined duty roles are inherently without segregation of duty violations of the constraints used by the Application Access Controls Governor.

In the security reference implementation, the IT Security Manager job role hierarchy includes the Application Role Management Duty role, which is entitled to manage duty roles (the entitlement is Manage Application Role). This entitlement provides the access necessary to perform the Manage Duties task in APM.

Note

Product family administrators are not entitled to create role hierarchies or manage duty roles and must work with the IT security manager to make changes such as localizing a duty role to change a role hierarchy. Setup for localizations is documented in HCM documentation.

Manage Application Access Controls

Prevent or limit the business activities that a single person may initiate or validate by managing segregation of duties policies in the Application Access Controls Governor (AACG) .

Note

In AACG, segregation of duties policies are called access controls or segregation of duties controls.

In the security reference implementation, the IT Security Manager job role hierarchy includes the Segregation of Duties Policy Management Duty role, which is entitled to manage segregation of duties policies (the entitlement is Manage Segregation of Duties Policy). This entitlement provides the access necessary to perform the Manage Application Access Controls task in AACG.

Manage Users

Creating Users: Worked Example

You can create users by entering basic person and employment data. A user account is created automatically for a person when you create the user record. You can assign the users Oracle Fusion Human Capital Management (HCM) and non-HCM data roles, each providing access to specific functions and data. This example demonstrates how to create a user and assign roles to the user.

Note

This user management functionality is available for HCM Foundation and Oracle Fusion Workforce Directory Management (WDM) users only.

Decisions to Consider	In this Example
For whom are you creating the user record?	Gail Williams
What is the user account name?	Same as the e-mail ID, gail.williams@vision.com
Where is Gail employed?	Gail is an employee of Vision Corporation, and works in the Human Resources (HR) department in the Canada office.
What roles must be provisioned to Gail?	Autoprovision the employee role. Gail is responsible for processing workers' expense claims so provision the role Expense Claims Administrator manually to Gail.

Prerequisites

1. Create a role mapping called All Employees and enter the following conditions.

Attribute	Value
System Person Type	Employee
Assignment Status	Active

In the role mapping you include the:

- Employee role, and select the **Autoprovision** option
- Expense Claims Administrator role, and select the **Self-requestable** option

Creating a User

1. On the Search Person page, click the **Create** icon to open the Create User page.
2. Complete the fields, as shown in this table:

Field	Value
Last Name	Williams
First Name	Gail
E-Mail	gail.williams@vision.com
Hire Date	4/12/11

3. In the User Details region, leave the User Name field blank. The user name defaults to the user's e-mail ID.
4. In the Employment Information region, select the person type **Employee** and complete the fields as shown in the table:

Field	Value
Legal Employer	Vision Corporation
Business Unit	Vision Canada
Department	Human Resources

Assigning Roles to the User

1. Click **Autoprovision Roles** to provision the employee role to the user.
2. Click **Add Role**.
3. Search for and select the **Expense Claims Administrator** role.
4. Click **Save and Close**. The user account is created and the roles are assigned to the user immediately.

FAQs for Manage Users

What happens if I send the user name and password?

An e-mail containing the user name and password is sent to the user's primary work e-mail address. If the user has no primary work-email address, then the user name and password are sent to the primary work e-mail address of the user's line manager, if available; otherwise, no notification is sent.

You can select **Send user name and password** only if these details have not already been sent for this user: the user name and password can be sent once only for any user. If this option is available for selection but you do not select it, then you can run the process Send User Name and Password E-Mail Notifications later to notify users of their user names and passwords.

Define Automated Governance, Risk, and Performance Controls

Segregation of Duties: Explained

Segregation of duties (SOD) separates activities such as approving, recording, processing, and reconciling results so an enterprise can more easily prevent or detect unintentional errors and willful fraud. SOD policies, called access control policies in Application Access Controls Governor (AACG), exert both preventive and detective effects.

SOD policies constrain duties across roles so that unethical, illegal, or damaging activities are less likely. SOD policies express constraints among roles. Duty role definitions respect segregation of duties policies.

Application Access Controls Governor

You manage, remediate, and enforce access controls to ensure effective SOD using the Application Access Controls Governor (AACG) product in the Oracle Governance, Risk and Compliance Controls (GRCC) suite.

AACG applies the SOD policies of the Oracle Fusion Applications security reference implementation using the AACG Oracle Fusion Adapter.

AACG is integrated with Oracle Identity Management (OIM) in Oracle Fusion Applications to prevent SOD control violations before they occur by ensuring SOD compliant user access provisioning. SOD constraints respect provisioning workflows. For example, when provisioning a Payables role to a user, the SOD policy that ensures no user is entitled to create both an invoice and a payment prevents the conflicting roles from being provisioned. AACG validates the request to provision a user with roles against SOD policies and provides a remediating response such as approval or rejections if a violation is raised.

Use AACG to for the following.

- Define SOD controls at any level of access such as in the definition of an entitlement or role.
- Simulate what-if SOD scenarios to understand the effect of proposed SOD control changes.

- Use the library of built-in SOD controls provided as a security guideline.

Managing Segregation of Duties

SOD policies express incompatible entitlement or incompatible access points into an application. In GRCC, an access point is the lowest level access for a particular application. In GRCC, entitlement is a grouping of access points. As a security guideline, group the lowest level access points or define the SOD policy at the access level causing the least amount of change. Business activities are enabled at access points. In Oracle Fusion Applications, the hierarchy of access points in descending levels is users, roles, and entitlement.

Note

AACG entitlements are logical groupings of security objects that represent Oracle Fusion Application access points such as roles or entitlement.

Note

In AACG, segregation of duties policies are called access controls.

Oracle Fusion Applications does not predefine business logic for dealing with SOD conflicts. Oracle Fusion Applications does define a set of states where role requests are suspended pending resolution of SOD violations the role request introduces. In most cases, Oracle Fusion Applications invokes OIM to handle role requests. Enterprises define SOD resolution rules when defining SOD policy.

Remediating Segregation of Duties Policy Violations

The risk tolerance of your enterprise determines what duties must be segregated and how to address violations.

AACG assists in remediation of violations with a guided simulation that identifies corrective action. You determine the exact effects of role and entitlement changes prior to putting them into production, and adjust controls as needed.

For information on managing segregation of duties, see the Oracle Application Access Controls Governor Implementation Guide and Oracle Application Access Controls Governor User's Guide.

Segregation of Duties in the Security Reference Implementation: Explained

Segregation of duties (SOD) is a special case of function security enforcement. A segregation of duties conflict occurs when a single user is provisioned with a role or role hierarchy that authorizes transactions or operations resulting in the possibility of intentional or inadvertent fraud.

The predefined SOD policies result in duty separation with no inherent violations. For example, an SOD policy prevents a user from entitlement to create both payables invoices and payables payments.

However, the most common duties associated with some job and abstract roles could conflict with the predefined segregation of duties. A predefined role hierarchy or job or abstract role may include such common duties that are incompatible according to a segregation of duties policy. For example, the predefined Accounts Payable Supervisor job role includes the incompatible duties: Payables Invoice Creation Duty and Payables Payment Creation Duty.

Every single predefined duty role is free from an inherent segregation of duties violation. For example, no duty role violates the SOD policy that prevents a user from entitlement to both create payables invoices and payables payments.

Jobs in the reference implementation may contain violations against the implemented policies and require intervention depending on your risk tolerance, even if you define no additional jobs or SOD policies.

Provisioning enforces segregation of duties policies. For example, provisioning a role to a user that inherits a duty role with entitlement to create payables invoices enforces the segregation of duties policy applied to that duty role and ensures the user is not also entitled to create a payables payment. When a role inherits several duty rules that together introduce a conflict, the role is provisioned with a violation being raised in the Application Access Controls Governor (AACG). If two roles are provisioned to a user and introduce a segregation of duties violation, the violation is raised in AACG.

Note

SOD policies are not enforced at the time of role definition.

Aspects of segregation of duties policies in the security reference implementation involve the following.

- Application Access Controls Governor (AACG)
- Conflicts defined in segregation of duties policies
- Violations of the conflicts defined in segregation of duties policies

Application Access Controls Governor (AACG)

AACG is a component of the Governance, Risk, and Compliance Controls (GRCC) suite of products where segregation of duties policies are defined.

- Define SOD controls at any level of access such as in the definition of an entitlement or role.
- Simulate what-if SOD scenarios to understand the effect of proposed SOD control changes.
- Use the library of built-in SOD controls provided as a security guideline.

Your risk tolerance determines how many duties to segregate. The greater the segregation, the greater the cost to the enterprise in complexity at implementation and during maintenance. Balance the cost of segregation with the reduction of risk based on your business needs.

Conflicts

An intra-role conflict occurs when a segregation of duties policy expresses constraints within the construct of a single role (entitlement and duties) that creates violations.

Tip

As a security guideline, use only the predefined duty roles, unless you have added new applications functions. The predefined duty roles fully represent the functions and data that must be accessed by application users and contain all appropriate entitlement. The predefined duty roles are inherently without segregation of duty violations of the constraints used by the Application Access Controls Governor.

Violations

A segregation of duties violation occurs when a policy is defined that allows a segregation of duties conflict to occur.

Notifications report conflicts to the requester of the transaction that raised the violation. Oracle Identity Management (OIM) shows the status of role requests indicating if a segregation of duties violation has occurred.

For information on configuring audit policies, see the Oracle Fusion Applications Administrator's Guide.

For more information on managing segregation of duties, see the Oracle Application Access Controls Governor Implementation Guide and Oracle Application Access Controls Governor User's Guide.

Defining Segregation of Duties Policies: Points To Consider

Segregation of duties (SOD) policies express incompatibilities enforced to control access in defined contexts.

In Oracle Fusion Applications, SOD policies protect against the following incompatibilities.

- Privilege X is incompatible with privilege Y
- Role A is incompatible with role B
- Any privileges in role A are incompatible with any privileges in role B.
- Privilege X is incompatible with any privileges in role B.

The following examples of SOD policies illustrate incompatible entitlement.

- No user should have access to Bank Account Management and Supplier Payments duties.

- No user should have access to Update Supplier Bank Account and Approve Supplier Invoice entitlement.

Data Contexts

You can extend SOD policies to control access to specific data contexts.

For example, no single individual must be able to source a supplier in a business unit and approve a supplier invoice in the same business unit.

Exclusion and Inclusion Conditions

SOD policies may include exclusion conditions to narrow the SOD scope and reduce false positive violations, or inclusion conditions to broaden the scope.

Conditions apply to access points globally, to policies, or to access paths defined by policies. Access path conditions can exclude a user from a role, an Oracle Fusion Applications entitlement from a role, or a permission from an Oracle Fusion Applications entitlement.

The following global exclusion conditions are predefined in Oracle Fusion Applications and available when creating SOD policies.

- User Status
- User Name
- Enterprise Role
- Action
- Business Unit
- Within Same Business Unit

Enforcement

Oracle Fusion Applications enforces SOD policies under the following circumstances.

- When granting entitlement to a role
- When provisioning a role to a user

For information on managing segregation of duties, see Oracle Application Access Controls Governor Implementation Guide and Oracle Application Access Controls Governor User's Guide.

Note

SOD policies are not enforced at the time of role definition.

A single SOD policy can include entitlement from multiple instances of a single enterprise resource planning environment. For example, one SOD policy is

enforced in implementation, test, and production instances of Oracle Fusion Applications.

Managing Segregation of Duties Risks and Violations: Critical Choices

You assess and balance the cost of duty segregation against reduction of risk based on the requirements of your enterprise.

The types of people who resolve SOD conflicts include the following.

- Administrator of an external program such as the Procurement Administrator for the supplier portal or the Partner Manager for the PRM Program
- Senior executive spanning multiple organizations in an enterprise with opposing interests
- Risk management professional implementing an Oracle Governance, Risk and Compliance Controls (GRCC) initiative
 - Predefines a set of conditions and informs access provisioning staff to approve requests and prove the exception based on certain conditions
 - Allows defining rules to route SOD violations for approval

You view and respond to risks and violations in the Application Access Controls Governor (AACC).

You may wish to override an SOD violation. For example, the Accounts Payable Supervisor includes incompatible duties to create both invoices and payments. When you provision this job role to a user, you may waive the violation in the AACC. You may waive the violation for the currently provisioned user, for the SOD policy that raised the violation, or for the SOD policy within a particular data set, such as a business unit.

The risk tolerance of your enterprise guides how you respond to conflicts. For example, a user may be provisioned with both the role of Order Manager and Shipping Agent. The Order Manger role entitles the user to enter orders, which could result in exploitation when filling shipping quotas. You can remove the entitlement to enter orders that the Order Manger job role inherits from the Orchestration Order Scheduling Duty role. Or you could segregate the shipping and order entry duties by defining an SOD policy that allows a user to have either job role but not both.

False Positives

False positives can be SOD policy violations that are not actually violations, or are violations within your risk tolerance and therefore do not require corrective action.

You can reduce false positives by the following methods.

- Define exclusion conditions that can be applied to individual or groups of policies.
- Define logically complex SOD policies that enforce more exacting specifications.
- Determine whether conflicts should be prevented, monitored, or subjected to approval during provisioning.

Path Level Detection

Conflict analysis detects a user's multiple paths to one or more conflicting access points.

For example, a user may be able to reach a single access point through one or more roles, or by one entitlement leading to another through submenus to a function that represents a risk. The resulting conflict path shows if the conflict is generated by inappropriate role provisioning or configuration of applications. The audit shows the paths from any number of users to any number of access points involved in conflicts, which lets you visualize the root cause and remediate effectively.

AACG assigns one or more users to review all paths involved in a given conflict so that the entire conflict can be addressed in a coherent way.

Waiving or Accepting Violations

AACG lets you accept or waive a violation. Your reasons may include that you accept the risk or will define compensating controls.

A waiver may apply to the current user, constraint, or constraint within a dimension such as the business unit.

Resolving Conflicts

The risk tolerance of the enterprise determines whether a segregation of duties conflict must be removed from the security reference implementation.

The following approaches resolve conflicts.

- Change the segregation of duties policy.
- Ensure a job role does not contain incompatible duties.
- Define data security policies that restrict authorized access by incompatible duties.

Changing a segregation of duties policy may not be possible in most cases. For example, a policy that segregates creation of payables invoice from making payables payments should be preserved, even if the Accounts Payables Manager job role includes a duty role for each activity. To prevent an accounts payables manager from being authorized to perform both duties, or from being authorized to make payables payments to self and direct reports, the Accounts Payables Manager job role must be changed. The security implementation can be changed to include two job roles that segregate the incompatible duties. Added data security policy grants can restrict the access to at risk data.

For information on managing segregation of duties, see the Oracle Application Access Controls Governor Implementation Guide and Oracle Application Access Controls Governor User's Guide.

Role Provisioning and Segregation of Duties: How They Work Together

Segregation of duties (SOD) checks occur when roles are assigned to users. The checks are based on Oracle Application Access Controls Governor (AACG) policies. The Oracle Identity Management (OIM) integration includes predefined routing rules for remediation in the Manage IT Security business process.

External users such as suppliers or partners need to be provisioned with roles to facilitate access to parent company interfaces and data. The process by which such provisioning requests are approved in Oracle Fusion Applications helps explain the request flows and possible outcomes.

Note

In Oracle Identity Management (OIM), external users means users who are not specific to applications, such as enterprise roles or the absence of entitlement to access an application.

The figure shows the role provisioning request flow. OIM uses AACG to check segregation of duties violations.

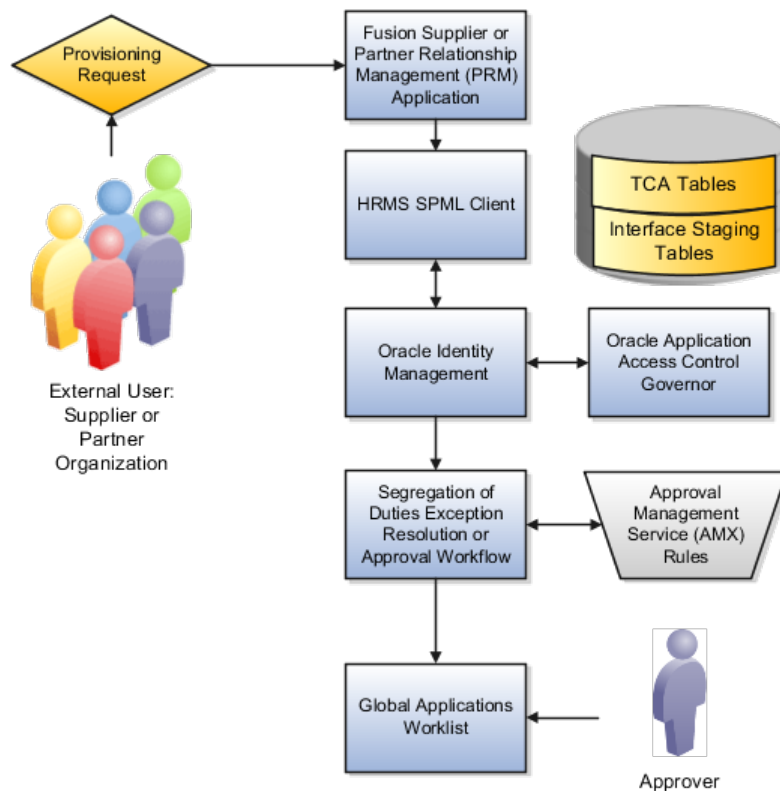

Tables

A supplier or partner requests admission to a program using an implementation of the Supplier Portal Submission. The submission is captured in one or both of the following tables in advance of approving or rejecting the supplier or partner.

- Oracle Fusion Trading Community Model
- Interface Staging

Oracle Fusion Applications collects the employee names for the supplier or partner company at the time the company submits its request to join the program so that all employees accessing Oracle Fusion Applications on behalf of the supplier or partner are provisioned.

AACG in the Oracle Governance, Risk and Compliance Controls (GRCC) suite is certified to synchronize with the policy and identity stores for all pillars or partitions of Oracle Fusion Applications and integrated with the Oracle Fusion Applications security approach to roll up entitlements (by means of duty roles) to the roles that are provisioned to internal users. SOD policies can be defined and enforced at any level of authorization. For external users, SOD policies use attribute information stored in the Trading Community Model tables.

OIM and the SPML Client

Enterprise business logic may qualify the requester and initiate a role provisioning request by invoking the Services Provisioning Markup Language (SPML) client module, as may occur during onboarding of internal users with Human Capital Management (HCM), in which case the SPML client submits an asynchronous SPML call to OIM. Or OIM handles the role request by presenting roles for selection based on associated policies.

OIM recognizes the role provisioning request and initiates a call to AACG.

OIM apprises the SPML client of the current state of the role provisioning request as SOD_CHECK_IN_PROGRESS.

OIM stores the SOD check result as part of OIM audit data.

OIM apprises SPML client of the current state of the SPML request. The provisioning is either still in progress with segregation of duties being checked, or conflicts were found. If conflicts exist, AACG rejects the request and notifies the application.

Status	Conflicts	Current State
SOD_CHECK_IN_PROGRESS	Unknown	Request sent to AACG and waiting for response
SOD_REMEDIATION_IN_PROGRESS	Conflict found	AACG detected violations and remediation is in progress
SOD_CHECK_APPROVED	No conflict found	No SOD violations found
SOD_CHECK_REJECTED	Conflict found	AACG detected violations that cannot be remediated
SOD_REMEDIATION_APPROVED	Conflict found	AACG detected violations that are approved

SOD_REMEDIATION_REJECTED	Conflict found	AACG detected violations that are rejected by approver
--------------------------	----------------	--

In the absence of an SOD exception, OIM provisions all relevant users.

Note

When a partner user is provisioned, all employees of the partner enterprise are provisioned. SOD checks occur when an external user requests to join a program, because SOD policies operate across Oracle Fusion Applications, not at the individual level. Supplier or partner company user requests are not approved if there is an SOD conflict against the supplier company.

OIM provides AACG with the details of SOD exception approval workflow. AACG audits the outcome for use in future detective controls and audit processes.

Oracle Application Access Controls Governor

AACG may respond with the following.

- Roles may be provisioned to the external user or its employees because no SOD conflict is found
- SOD conflict is found and request is denied because the relevant SOD policy is to be strictly enforced and no exception approval should be allowed
- SOD conflict is found and the exception to the policy is allowed, so the request goes through additional processing, such as an approval process.

Supplier or Partner Relationship Management responds to an SOD exception by updating Trading Community Model tables with the current state. An enterprise may elect to implement a landing pad that offers external users a means of addressing the SOD problem by providing more information or withdrawing the request.

SOD violation checking occurs during role implementation and provisioning, and can be turned on or off if AACG is provisioned and enabled as part of the Oracle Fusion Applications deployment.

Segregation of Duties Exception Resolution or Approval Workflow

Depending upon status, OIM kicks off an auditable SOD exception resolution workflow. Resolution can be conditional based on approval or requirements such as contracts being met.

If one of the paths for exception resolution is to get an approval, then the SOD exception resolution drives the approval using AMX. Standard AMX rules, not business rules, resolve the approval for the SOD exception, including the following.

- Organizational hierarchies
- Multiple mandatory and optional approvers

- Rerouting and approval delegation

The approver resolution uses AMX Rules Designer to access various user attributes and organizational hierarchies managed in Oracle Fusion Applications repositories. This information is typically not available in OIM or the LDAP identity store repository. Enterprises can define additional approval rules using AMX Thin Client.

The SOD Exception Approver gets a notification through supported channels that a new request is awaiting approval. The approver signs in to the global SOA federated worklist application that aggregates all pending worklist items for the user from all Oracle Fusion applications and logical partitions or pillars of applications. The SOD exception approval tasks show up in the same list.

The SOD exception approval task shows the details of the SPML request and SOD Provisioning results in a page rendered by OIM. The approver may take one of the following actions.

- Approve the request as it is
- Reject the request

If the approver approves the request, OIM sends an SOD_REMEDIATION_APPROVED status to the SPML client.

If the approver rejects the request, OIM sends an SOD_REMEDIATION_REJECTED status to the SPML client. The provisioning request is considered completed with a failure outcome and the external users is notified. Oracle Fusion Applications updates the Trading Community Model tables with the rejected status

Remediation Task Assignments

The SOD remediation tasks are assigned based on the role being requested.

1. If the role requested is Chief Financial Officer, the SOD remediation task is assigned to the IT Security Manager role.
2. If the SOD violation results from a policy where the SOD control tag is the Information Technology Management business process and the control priority is 1, the SOD remediation task is assigned to Application Administrator role.
3. In all other scenarios, the SOD remediation task is assigned to the Controller role.

For more information about configuring audit policies, see the Oracle Fusion Applications Administrator's Guide.

For information on managing segregation of duties, see the Oracle Application Access Controls Governor Implementation Guide and Oracle Application Access Controls Governor User's Guide.

Define Approval Management for Supply Chain Management

Approval Management: Highlights

Use approval management to determine the policies that apply to approval workflows for particular business objects such as expense reports. For example, you can specify levels of approval for expense reports over a particular amount, to reflect your own corporate policies. You also determine the groups of users who act on these workflow tasks, for example, the chain of approvers for expense reports.

Approval management is fully described in the Oracle Fusion Middleware Modeling and Implementation Guide for Oracle Business Process Management. Though the concepts described there apply also to Oracle Fusion Applications, the only setup relevant to Oracle Fusion Applications involves approval groups and task configuration. Customization of approval workflows themselves is described in the Oracle Fusion Applications Extensibility Guide.

Overview

- Approval management is an extension of the human workflow services of Oracle SOA Suite. Refer to the Oracle Fusion Middleware Modeling and Implementation Guide for Oracle Business Process Management.

See: Introduction to Approval Management

See: Understanding Approval Management Concepts

Approval Groups and Task Configuration

- An approval group consists of a name and a predefined set of users configured to act on a task in a certain pattern. Refer to the Oracle Fusion Middleware Modeling and Implementation Guide for Oracle Business Process Management.

See: Administering Approval Groups

- Task configuration involves managing policies that control approval flows. Refer to the Oracle Fusion Middleware Modeling and Implementation Guide for Oracle Business Process Management.

See: Using Task Configuration

- To configure a predefined approval policy, select the predefined rule set and click the Edit task icon button.
- To disable a predefined rule set, select the Ignore this participant check box for that rule set.
- To edit the rules within a predefined rule set, you can insert, update, or delete from the seeded rules as needed while in edit mode.
- You can configure a specific rule to automatically approve without being sent to any approver. Modify the routing for that rule so that it is sent to the initiator (which means the requestor is the approver), set the Auto Action Enabled option to True, and enter APPROVE in the Auto Action field.

Customization

- You can optionally customize predefined approval workflows, for example add post-approval activities or additional stages. Refer to the Oracle Fusion Applications Extensibility Guide.

See: Customizing and Extending SOA Components

Define Help Configuration

Define Help Configuration: Overview

The Define Help Configuration task list contains tasks that let you set up and maintain Oracle Fusion Applications Help for all users. Use the Set Help Options task to determine if certain aspects of Oracle Fusion Applications Help are available to users and to control how aspects of the help site work. Use the Assign Help Text Administration Duty and Manage Help Security Groups tasks to set up customization of help content.

After performing the help configuration tasks, you can review the predefined help and consider whether to add or customize any content. You can also customize help that is embedded in the application, for example hints and help windows, using other tools such as Oracle JDeveloper and Oracle Composer.

Use the Setup and Maintenance work area to access the tasks in the Define Help Configuration task list.

Set Help Options

Help Feature Choices and Help Options: Points to Consider

Help feature choices on the Configure Offerings page in the Setup and Maintenance work area control the look and behavior of Oracle Fusion Applications Help, and also determine which help options are available. Help options are setup options on the Set Help Options page.

Local Installation of Help

Select the Local Installation of Help feature choice so that the Define Help Configuration task list appears in your implementation project, and you can select two additional features (Access to Internet-Based Help Features and Help Customization) to control the fields available on the Set Help Options page.

Access to Internet-Based Help Features

Select this feature choice to provide users access to features that involve navigation to sites on the Web. If you select this feature choice, then the Web Sites Available from Help Site section is available on the Set Help Options page.

Important

Some help includes links to the Oracle Fusion Applications Technology Library. If you select this feature, then these links open the library on the Oracle Technology Network Web site. If you do not select this feature, then your service administrator (Oracle Cloud implementations) or system administrator (other implementations) must download the library from Oracle Technology Network (<http://www.oracle.com/technetwork/documentation/default-1577155.html>) and put all the content from within the extracted folder (for example E28271_01) directly into the appmgr/APPLTOP/fusionapps/applications/ahc/afh/reference/TechLib folder.

Help Customization

Select the Help Customization feature choice if you intend to customize predefined help or add your own files to help. For example, you can add internal policies or procedures as help, and Oracle User Productivity Kit content, if any. Not selecting this feature choice only hides the relevant setup options; help customization is not disabled for users with customization access. To disable help customization, remove the Oracle Fusion Help Text Administration duty from the job roles where it is predefined.

If you select this feature choice, then the Custom Help Security feature choice is available, as well as all these sections on the Set Help Options page:

- Custom Help
- User Productivity Kit
- Privacy Statement

Custom Help Security

Select this feature choice if you want certain help files to be available only to a restricted set of users. You can define the user groups allowed to view corresponding help files. Do not select this feature choice if you do not have this requirement, because the feature can have an impact on performance.

If you select the Custom Help Security feature choice, then the Manage Help Security Groups task is available in the Define Help Configuration task list in your implementation project. There are no help options associated with this feature choice.

Administering Collaboration Features and Announcements in Help: Points to Consider

Announcements and collaboration features (discussions, ratings and comments) allow users to share information regarding help and the subjects that particular help files cover. The collaboration features are also used elsewhere in Oracle Fusion Applications. Discussions may not be available in Oracle Cloud implementations.

Use the Set Help Options page in the Setup and Maintenance work area to enable the announcements and discussions features and to set options about

ratings. When administering these features, consider the purpose of each feature and points that are specific to Oracle Fusion Applications Help.

Announcements

Use announcements to broadcast information to all users of your help site. You can provide information about help, for example new custom help that was recently added, or about anything that users should take note of, for example a change in company policy. Announcements can appear on any of the tabs on the home page of Oracle Fusion Applications Help. You can target specific user groups by posting announcements to specific tabs, for example, posting information related to implementation to the Functional Setup tab.

Only users with the Oracle Fusion Help Text Administration duty role have access to the Manage Announcements icon button in the Announcements sections. They can create, edit, and delete announcements for the tab that they are on, and set the date range for when each announcement is to be displayed.

Discussions

Users can use discussions to post questions or comments about subjects covered in specific help files. For example, after reading help on expense reports, users might have questions or comments about company policies or processes for expenses. Other users who later access this help file would benefit from the information in the discussion.

You can set a help option to enable discussions. Each help file would contain a **Discuss** link that all users can use to read discussions about that file. They can also start a discussion topic or post to existing topics. These discussions are visible only to users in your enterprise.

Important

Do not enable discussions until servers for discussions are up and running.

Only users with the appropriate administrator role can moderate discussions. For more information on granting the administrator role on the discussions server, see the Oracle Fusion Middleware Administrator's Guide for Oracle WebCenter Portal.

Ratings and Comments

Users can rate any help file on a five star system and provide feedback about the content. This information is helpful to other users in deciding which help file to open. Help files with a higher average rating are listed first in help windows, and in the help listings you see as you browse using the help navigators.

The scope of ratings and reviews is limited to your enterprise.

FAQs for Set Help Options

?

When do I link to the Oracle User Productivity Kit library from the help site?

Provide a link to your Oracle User Productivity Kit (UPK) library if you have UPK licensed and custom UPK content to share with your users. You give them

access to a library of custom UPK content in addition to any custom UPK demos that you added to the help site itself. UPK demos that you add as custom help are available only in the See It mode, so the library can include the same demo in other modes. If you have UPK versions earlier than 3.6.1, then you cannot add UPK demos as custom help, so the link is the only way for users to access custom UPK content from the help site.

How can I find the URL to the Oracle User Productivity Kit library?

The URL to enter on the Set Help Options page should be the full path from the Web server where you are hosting your Oracle User Productivity Kit (UPK) content to the index.html file that opens the table of contents for the library, for example, `http://<your domain>.com/UPKcontent/PlayerPackage/index.html`. In this example, you or your UPK administrator would publish one UPK player package that contains all the content to be linked to from Oracle Fusion Applications Help, as well as the index.html file, and place the PlayerPackage folder in a manually created folder called UPKcontent on the Web server.

FAQs for Assign Help Text Administration Duty

Who can add and manage custom help?

Users with the Oracle Fusion Help Text Administration duty role have access to customize help in Oracle Fusion Applications Help. This duty is assigned by default to various job roles, in particular the administrators for product families.

You can assign the duty role to other users who need access to customize help. Use the Manage Duties task in the Setup and Maintenance work area to search for the Oracle Fusion Help Text Administration duty role on the Role Catalog page, and map additional job roles to this duty role.

Manage Help Security Groups

Creating Help Security Groups: Worked Example

This example demonstrates how to create a help security group to define a set of job roles that have access to help. The help security group can then be assigned to particular help files so that only users with any of the defined roles have access to the help.

The following table summarizes key decisions for this scenario.

Decisions to Consider	In This Example
What type of users do you need to limit help access to?	Human resources (HR) specialists
Is there a specific time period for which this access is needed?	No, the help files should always be viewed only by the HR specialists
Where do you want this group to appear in the list of values for help security groups?	First

Define a help security group and assign a duty role to the group.

1. From the Setup and Maintenance work area, find the Manage Help Security Groups task and click **Go to Task**.
2. On the Manage Help Security Groups page, add a new row.
3. Complete the fields, as shown in this table. Leave the start and end dates blank.

Field	Value
Help Security Group	HR
Meaning	HR Only
Description	Viewing by HR specialists only
Display Sequence	1

4. Click **Save**.
5. With your new help security group selected, go to the Associated Roles section and add a new row.
6. Select **PER_HUMAN_RESOURCE_SPECIALIST** as the role name.
7. Click **Save and Close**.

You have created a new lookup code for the Help Security Groups lookup type, which is a standard lookup. The lookup code has the name, meaning, and description that you defined for the help security group.

You have also created a data security policy for the help database resource, specifying that the Human Resource Specialist role can view help that is defined with the HR security group. If you go to the Manage Database Resources and Policies page and find the database resource, or object, **ATK_KR_TOPICS**, then you can see the policy for the Human Resource Specialist role, with the condition that the column name, **SECURITY_CODE**, is equal to the value **HR**.

Help File Customization

Help File Customization: Overview

If you have the appropriate job roles, then you can customize the help files in the help site. Use the Manage Custom Help page to maintain both predefined and custom help files. You can create, duplicate, edit, and delete custom files, or set their status to Active or Inactive. For predefined files, you can only duplicate them or set their status. For each help file, predefined or custom, use help locations to determine where the help file appears in the application and in the help site. You have various options in how you add custom help, for example by uploading a file or specifying a URL.

Note

To make a copy of all custom help for testing, migration, or other purposes, use the export and import feature in the Setup and Maintenance work area.

There are various ways to access help customization.

- Many help files can be accessed from help windows in the application. If you want to customize help in the context of a help window, for example create a custom help file and add a link to it from a specific help window, then start by opening that help window. When you click the **Manage Custom Help** link, you go to the Manage Custom Help page, and the help location fields are automatically populated with values that correspond to the help window. This way you can easily select existing files to add to the same help location, and when you create a new file, the same help location appears by default.
- Open the Manage Custom Help page directly from the home page of Oracle Fusion Applications Help or from search result pages.
- To edit a specific file, you can either find it in the Manage Custom Help page, or open the file itself and click the **Edit** link.
- Likewise, you can find glossary terms in the Manage Custom Help page, or click the **Glossary** link in the global area to open the Glossary tab, search for the term, and click **Edit**.

Note

When you search in the Manage Custom Help page, make sure that the **Custom Help Only** check box is not selected if you are looking for predefined help.

If your enterprise has purchased Oracle User Productivity Kit (UPK) content, then your administrator can also add a **UPK** item to the **Help** menu in the global area of Oracle Fusion Applications. When users select this menu item, they access UPK content specific to the page that they are on.

Help Locations: Explained

Help locations determine where users can find help files, custom or not, from either the application or the help site.

Help locations include:

- Page or section values
- Help hierarchies
- Primary locations

Page or Section Values

The value in the **Page or Section** field on the help customization pages represents where users can click a help icon to open a help window that contains

a link to the help file. In most cases, this value represents a page or region header in the application. Help windows are also available on specific tabs or windows, and in the Setup and Maintenance work area for specific task lists or tasks. You can associate a help file with multiple page or section values, or with none at all.

The page or section value reflects the logical navigation to the help window. For example, **Edit Opportunity page, Revenue tab, Recommendations window** does not mean that the help file is available in three different places. The help icon is in the Recommendations window, which is accessed from the Revenue tab on the Edit Opportunity page.

If the value suggests multiple locations, for example **Create and Edit Opportunity pages**, then the help file is available from the page header of both the Create Opportunity and Edit Opportunity pages. If the page or section value is, for example, a dashboard region that appears in multiple dashboards, then the value does not specify the page name but just the region. The help file is available from that region in multiple dashboards.

Help Hierarchies

Help files are associated with help hierarchies, which are used to categorize help files and aid users in finding help. Each help file can have multiple hierarchies, with at least one of type Business Processes. The business process hierarchy is based on the Business Process Management model. Every page or section value is predefined with a specific business process hierarchy. If you select a page or section without entering a business process hierarchy, the predefined hierarchy appears by default.

The Search by Business Process navigator in the help site is based on the business process hierarchy. For example, if you assign two business process hierarchies to a help file, users can find the file in both locations in the navigator. When the user clicks **More Help** from a help window, all help files assigned to the same business process hierarchy as the page or section value are returned as search results.

Similarly, the Search by Product navigator is based on the Product hierarchy type, in which level 1 is the product family, level 2 is the product, and level 3 is the business activity owned by that product.

The Search by Functional Setup navigator is based on the Functional Setup hierarchy type. The level 1 nodes for this hierarchy are:

- Functional Setup Manager, which includes help about using the Setup and Maintenance work area.
- Guides, which contains level 2 nodes that correspond to business areas and setup offerings. All the user reference and functional setup PDF guides are included.
- Offerings, which contains level 2 nodes for each setup offering, and lower levels for the main task lists in the offerings. Help for the task lists and tasks are included.

The Search by Common Tasks navigator is based on the Welcome hierarchy type. The level 1 nodes represent categories of functional areas common to all users.

Primary Locations

The primary location of a help file designates the hierarchy that is displayed for the help file in search results and within the help content as breadcrumbs. You cannot change the primary location of a help file that came with your help installation. Primary locations of predefined help are based on the business process hierarchy, while custom help files can have primary locations based on hierarchies of any type.

Editing Predefined Help and Glossary Terms: Points to Consider

When you open any predefined help file, including glossary terms, that came with Oracle Fusion Applications Help, you can see an edit option if you have roles allowing edit access. When you edit predefined help, keep in mind:

- What happens to the original help file
- Where predefined help appears
- Considerations specific to glossary terms

What Happens to the Original Files

When you edit predefined help, you are actually creating a new custom help file based on the original file, with the same help locations. The customized version replaces the original, which becomes inactive and hidden from users. You can display both versions by reactivating the original in the Manage Custom Help page.

Note

In the Search Results: Existing Help region on the Manage Custom Help page, there is no option to edit predefined help. You can duplicate a predefined help file, edit the copy, and optionally inactivate the original.

Where Predefined Help Appears

All predefined help comes with preassigned help locations, including at least one based on the hierarchy of type Business Processes. Many also have predefined page or section values that indicate where the help can be accessed from help windows in the application.

To change where predefined help appears, either in the help site navigators or in the application, create a duplicate in the Manage Custom Help page. Change or add help locations to your custom copy, and inactivate the original.

Even though glossary terms do not appear in the help site navigators, you still need to enter at least one help location to categorize the glossary term.

Considerations Specific to Glossary Terms

When you edit a predefined glossary term, the original term becomes inactive. Existing links to the glossary term, from other predefined and custom help

files, will automatically point to your custom version. If you later inactivate the custom glossary term, make sure to activate the original term so that the links still work.

Links in Custom Help: Points to Consider

When you create or edit custom help, follow best practices when you include links to help files or other content. If you are working on custom help created by duplicating a predefined help file, then you may see existing links from the original file in the Help Content section. The types of links that you can work with include:

- Related help links
- Standard hypertext links
- Links to documentation library content
- Glossary term links

For all link types, except the standard hypertext links, you must create or edit custom help with a Text or Desktop source type. In other words, you must type the help content directly in the application or use an HTML file that you upload to help. For standard hypertext links, the source type can also be URL.

Related Help Links

Related help is the section at the end of help files that contains links to other help files. The syntax for related help contains a comma-separated list of title IDs that represent help files.

This figure provides an example of related links code.

```
OfaRelatedTopics(CREATE_AUTOMATIC_POSTING_CRITERIA_S_0000,  
JOURNAL_ENTRIES_HOW_THEY_RE_RECORDE_0000)
```

- You can delete this code to remove all related help, or delete title IDs to remove individual links (for example, CREATE_AUTOMATIC_POSTING_CRITERIA_S_0000).
- To replace existing links or add new links, you need to retain the code syntax and enter desired title IDs. To find title IDs, search for the help files on the Manage Custom Help page. Title IDs are displayed in the search results, but the **Title ID** column is hidden by default.

Standard Hypertext Links

You can create standard hypertext links to any file or Web site as long as you ensure the stability and validity of the links, including links to other help files, custom or not. These links can appear anywhere in the body of your help file as long as they come before any related help links.

In the Help Content section, highlight the text that you want to use as link text and click the **Add Link** icon button.

For links to other help files, open the file to which you want to link, and click the **E-Mail** link. Use the URL in the autogenerated e-mail text as the link to the file.

Links to Documentation Library Content

The syntax for links to HTML files in documentation libraries, for example the Oracle Fusion Applications Technology Library, is:

```
<span class="HP_topic-link_bridgeDocument-linkToSTDoc_"><?ofa  
linkToSTDoc(WCSUG4636) ?><span class="HP_topic-linktext_">Understanding  
Tags</span><?ofa endLink ?></span>.
```

WCSUG4636 is the anchor ID and Understanding Tags is the link text. You can:

- Modify the link by replacing the existing anchor ID or editing the link text, or both.
- Remove the link by deleting all the code for it.
- Create links to documentation library content by following the same syntax. These links can appear anywhere in the body of your help file as long as they come before any related help links.

Important

To ensure that you are linking to a supported documentation library, enter anchor IDs only from documentation libraries that are linked from predefined help topics.

Glossary Term Links

Glossary term links provide definitions in a note box when users hover over the term in help files.

This figure shows an example of code for a glossary term link.

```
OfaGlossaryTerm("accounting period", ACCOUNTING_PERIOD_0001)
```

In this example, `accounting period` is the link text, or glossary term, and `ACCOUNTING_PERIOD_001` is the identifier, or title ID.

- To remove the link but retain the text, delete all the code except the term itself.
- To add glossary term links, you must follow the link syntax and use the correct title ID for the glossary term. You can find title IDs in the search results of the Manage Custom Help page.

Note

If your custom help has glossary terms and the source type is Desktop File, then make sure before uploading that the quotes around the glossary term are actual quotation marks in raw HTML, not `"`. Otherwise, quotation marks will appear when users view the help file.

Customizing PDF Guides: Worked Example

This example demonstrates how to customize a PDF guide that came with Oracle Fusion Applications Help. This guide is currently not available from any help window in the application.

The following table summarizes key decisions for this scenario.

Decisions to Consider	In This Example
What changes do you need to make to the guide?	Change the title of a chapter and remove a section in that chapter, to hide content about a particular subject
Which help window should the customized guide appear in?	The help window for the entire Welcome dashboard of Oracle Fusion Applications
Which help navigators should the customized guide appear in, and on which node?	Same as the original guide, plus the path associated with the help window
Do you want to limit access to the customized guide?	No, same as the original guide

Edit a copy of the original PDF guide, and use the Manage Custom Help page to replace the original PDF guide with your new file.

Copying and Editing the PDF Guide

1. Open the original PDF guide from the help site and save a copy to your desktop. Leave open the help file for the guide.
2. Using a PDF editor application, change the title of the chapter wherever the chapter title appears. Delete the content you want to hide from users.
3. Make sure that your new PDF guide is less than 6 MB.

Replacing the Original PDF Guide

1. In the help file that you still have open for the original PDF guide, click the **Edit** link.
2. On the Create Help page, use the default values except where indicated.
3. Update the title to the name that you want to display to users.
4. In the **File Name** field, browse for and select your customized guide.
5. Delete any keywords or parts of the description relevant to the content you removed from the PDF guide.
6. Add a help location with the Business Processes hierarchy type and select **Information Technology Management** as the level 1 node, **Manage Enterprise Application Software** as the level 2 node, and **Use Applications** as the level 3 node.
7. Select **Welcome page** in the **Page or Section** column.
8. Click **Save and Close**. The help file for the original PDF guide is automatically set to inactive.

Adding Custom UPK Content to Help: Worked Example

This example demonstrates how to add custom Oracle User Productivity Kit (UPK) topics as demo help files. These help files function like any predefined help file for demos. You can search and include these files in help windows and navigators as you would other help.

In this scenario, you are adding two demos about social networking, to appear in help windows on the Welcome dashboard.

Note

Your demo must be made with UPK 3.6.1 or later to be added as help.

The following table summarizes key decisions for this scenario.

Decisions to Consider	In This Example
What UPK content do you want to add to help?	From a UPK module containing five topics, add two as custom demos on the help site
Which help navigators should each demo appear in, and on which node?	Because the two demos are about social networking: <ul style="list-style-type: none">• Search by Common Tasks navigator, under the Collaboration node• Search by Business Process navigator, under Information Technology Management - Manage Networking and Communications - Manage Social Networking Capabilities
Which help window should each demo appear in?	On the Welcome dashboard of Oracle Fusion Applications, one demo goes in the help window in the Activity Stream region, and the other in the People Connection region
Do you want to limit access to the help files for the demos?	No
Do you want the help files to appear in the New and Updated pane?	Yes

Generate a report of UPK document IDs, which you will use when creating custom help, to identify the UPK topics that you want to add. Publish the UPK module as a player package, then create custom help for the UPK topics that you want to use as help demos.

Generating a UPK Document ID Report

1. In the UPK Developer, select **Details View**.
2. Right-click any column header, for example Name, and select **Column Chooser**.
3. In the Column Chooser dialog box, click and drag the Document ID column header and drop it after the Name column. Close the Column Chooser dialog box.
4. From the File menu, select to print, and save the output as a Microsoft Excel file to your desktop.

Creating the Player Package

1. From the UPK Developer, make sure that the topics that you want to add as demos have the See It play mode. The topics can also have other modes, but only the See It mode is included in the custom help file.
2. Publish the module, specifying any location for the output and selecting to publish the selection only.
3. In the Formats section of the Publish Content window, select the **Player** check box under the **Deployment** check box group.
4. In the Player section, select the **Include HTML Web Site** check box, to ensure that the custom help file includes a text-only version of the UPK topic.
5. Finish the publishing process, after optionally setting other options.
6. Navigate to the location where you specified the output to be generated.
7. In the Publishing Content folder, copy the PlayerPackage folder and add it to the web server where you store UPK content.

Creating Custom Help for Demos

1. Open the help window in the Activity Stream region on the Welcome dashboard of Oracle Fusion Applications, and click **Manage Custom Help**.
2. On the Manage Custom Help page, the page or section and hierarchy values are populated with the values for the Activity Stream region.
3. Click **Create**.
4. On the Create Help page, complete the fields in the General Information section, as shown in this table. Use the default values except where indicated.

Field	Value
Title	The name of the UPK topic.
Source Type	Oracle User Productivity Kit
File Location	The full URL of the player package folder on the Web server, for example, <code>http://<your domain>.com/UPKcontent/PlayerPackage.</code>
Document ID	The document ID of the UPK topic to add to the help window in the Activity Stream region. You can copy and paste this ID from the Microsoft Excel file that you generated earlier.
Help Type	Demo
Help Security Group	Unsecured
Keywords	Terms relevant to the demo.
Description	Summary of the demo.
Include in New and Updated pane	Selected

The Help Location section contains values for the help window in the Activity Stream region. This help file will also appear in the Search by Business Process navigator under this predefined hierarchy.

5. Click **Save and Close**.
6. On the Manage Custom Help page, open the help locations for the help file that you just created.
7. Add a help location with the Welcome hierarchy type and select **Collaboration Features** as the level 1 node.
8. Add another help location with the Business Processes hierarchy type and select **Information Technology Management** as the level 1 node, **Manage Networking and Communications** as the level 2 node, and **Manage Social Networking Capabilities** as the level 3 node.
9. Click **Save and Close**.
10. Starting at the Connections region, repeat steps 1 to 9 for the other UPK topic that you want to add.

FAQs for Help File Customization

How can I restrict help content to specific user roles?

When you create or edit help, select a help security group that represents the set of roles that you want to have access to the help. If you do not see the Security Group field, then your administrator has not selected the Custom Help Security feature choice. The Unsecured group has no associated roles, so anyone can view the help. The predefined Secured group includes all internal employees and contingent workers, unless this group has been edited. You can create security groups and associate roles using the Manage Help Security Groups page, which you can access by starting in the Setup and Maintenance Overview page and searching for the Manage Help Security Groups task. Your new security groups are immediately available for use to secure new or edited help files.

Why can't I select and add help to a location?

You must specify a page or section to add the existing help to. To ensure that help is added to the correct help window, go to the page or section in the application, click the **Help** icon, and click the **Manage Custom Help** link in the help window. Alternatively, in the Manage Custom Help page, search for at least a page or section and a level 1 value for the Business Processes hierarchy type before selecting the **Select and Add** option.

You cannot select and add help to a particular hierarchy, on the Manage Custom Help page, without a page or section. To add just a hierarchy, search for the help file, add a new help location, and specify only the hierarchy information.

What happens to custom help when a help patch is applied?

Oracle Fusion Applications Help patches update all help files, both active and inactive, except custom help. Custom help files are not affected by patches.

Consider reviewing inactive files to see if you want to activate the updated version, or to make similar edits to the custom versions of those files, if any.

Embedded Help Customization

Customizing Embedded Help: Highlights

You can customize help that is embedded in the application, for example hints and help windows, for all users of Oracle Fusion Applications.

Embedded help customization is fully described in the Oracle Fusion Applications Extensibility Guide.

- Edit, create, or delete hint text that appears on hover over buttons, links, icons, or tab titles.

See: Customizing or Adding Bubble Embedded Help

- Edit, create, or delete other types of embedded help.

See: Customizing or Adding Static Instructions, In-field Notes, Terminology Definitions, and Help Windows

Define Source Systems

Source Systems: Explained

Source systems are used to import data into Oracle Fusion Applications, and are used within the application to identify source data information. You can specify whether the source system is a Spoke system, such as a legacy system, or a Purchased system, such as data from a third party provider. You can also specify what type of data will be imported using the source system, for example, you can specify that a source system will import trading community members.

You can configure the following for a source system:

- Source system code, name, and description
- Source system type
- Enable for Items, Trading Community Members, Order Orchestration and Planning, and Assets

Source System Code, Name, and Description

You can create a source system code to uniquely identify the source system. Source system codes are used by the application when creating references between source IDs and the Oracle Fusion Applications database IDs. You can create a source system name and description to provide information that is more descriptive than the source system code.

Note

You cannot update the source system code once you have created the source system.

Source System Type

You must set up a source system as either a Spoke system, such as a legacy system, or a Purchased system, such as data from Dun & Bradstreet.

Enable for Items, Trading Community Members, Order Orchestration and Planning, and Assets

You should select which types of entities will be imported from the source system into the Oracle Fusion Applications database from the following:

- Items
- Trading Community Members
- Order Orchestration and Planning
- Assets

You can select one or more of these entity types as required for the source system. It is important to enable the correct entity types because each import UI filters source systems based on their entity type. For example, if a source system is enabled for Trading Community Members, Items, and Assets, then the source system can be selected as a data source in the Trading Community Members, Items, and Asset import UIs, but the source system cannot be selected in the Orchestration and Planning import UI.

Source System Entities: Explained

Source System Entities are the entities, such as addresses and parties, which can be imported using a specified source system.

When you import data from a source system, all of the entities in the source system data will be imported. Within the Source System Entities UI, you can choose to allow multiple source references, which allows multiple records from a source system to map to a single trading community record.

FAQs for Define Source Systems

What happens if I allow multiple source system references?

Allowing multiple source system references means that when you import data from a source system you can merge multiple, or duplicate, source system records and create one record in the Oracle Fusion Applications database.

If you do not allow multiple source system references then an Oracle Fusion Applications database record will be created for every source system record. This means that you could potentially create duplicate records in the Oracle Fusion Applications database.

Define Application Toolkit Configuration

Define Application Toolkit Configuration: Overview

Oracle Fusion Application Toolkit (ATK) is an application that provides various core components of Oracle Fusion Applications, including the Welcome dashboard, Oracle Fusion Applications Help, the Reports and Analytics pane, and the Watchlist feature. Use the Define Application Toolkit Configuration task list to set up and maintain some of these components for all users, and the Define Help Configuration task list for Oracle Fusion Applications Help.

Note

The Define Application Toolkit Configuration task list is available in implementation projects only if the Application Toolkit Component Maintenance feature choice is selected.

Use the Setup and Maintenance work area to access the tasks in the Define Application Toolkit Configuration task list.

Map Reports to Work Areas

Additional Report Setup in the Context of the Reports and Analytics Pane: Highlights

Aside from determining which work areas a specific report is mapped to, you can perform additional setup for reports in the context of the Reports and Analytics pane. You can set up report permissions, and enable Oracle Business Intelligence (BI) Publisher reports for scheduled submission.

This additional setup is described in the Oracle Fusion Middleware User's Guide for Oracle Business Intelligence Enterprise Edition (Oracle Fusion Applications Edition) and the Oracle Fusion Applications Extensibility Guide.

Report Permissions

- You can restrict access to specific reports for specific users, and this security is not limited to the Reports and Analytics pane. Refer to the

Oracle Fusion Middleware User's Guide for Oracle Business Intelligence Enterprise Edition (Oracle Fusion Applications Edition).

See: Assigning Permissions

Oracle Business Intelligence Publisher Reports Submission

- Oracle BI Publisher reports must be registered as processes with Oracle Enterprise Scheduler to be enabled for scheduling. This registration also enables a Schedule link for the report in the Reports and Analytics Pane. Refer to the Oracle Fusion Applications Extensibility Guide, and perform the following steps in the specified order.
 - Create an Oracle Enterprise Scheduler job definition for the report.
See: Tasks Required to Run Custom Reports with Oracle Enterprise Scheduler Service
 - Specify the job definition details in the report's properties.
See: Enabling Reports for Scheduling from the Reports and Analytics Pane

FAQs for Map Reports to Work Areas

How can I set up the Reports and Analytics pane for all users?

You can remove any currently mapped report from the Reports and Analytics pane, or add mappings to reports from the Oracle Business Intelligence (BI) Presentation catalog. To access the setup, click **Edit Settings** in the Reports and Analytics pane, or use the Map Reports to Work Areas task in the Setup and Maintenance work area. If you do the former, then you can set up only the Reports and Analytics pane on the work area that you are in.

If you do the latter, then you can select a work area to set up. If you do not see the desired work area, most likely you do not have access to it due to security. You can request to be granted a role that has access to the work area, or another administrator or business user with access to the work area can be granted the Reports and Analytics Region Administration Duty to be able to map reports to the work area.

Tip

On the Map Reports to Work Areas page only, you can also use the Synchronize button to remove mappings to reports that are no longer in the catalog, for all work areas at once.

Any changes you make in either UI apply to all users with access to the mapped work area.

Why can't I see reports when mapping reports to work areas for the Reports and Analytics pane?

It is possible that there are no reports currently mapped to the work area that you select in the Map Reports to Work Areas page. Alternatively, reports are mapped, but you do not see them due to security.

Similarly, in the list of all available reports from the catalog, you can see only the reports that you have access to. You can request to be granted a role that has access to the reports that you want to map, or another administrator or business user with access to those reports can be granted the Reports and Analytics Region Administration Duty to be able to map reports to work areas.

Why can't I see reports when I edit settings for the Reports and Analytics pane?

In the Edit Settings window, you may not be able to see a currently mapped report because you do not have access to it due to security.

Similarly, in the list of all available reports from the catalog, you can see only the reports that you have access to. You can request to be granted a role that has access to the reports that you want to map, or another administrator or business user with access to those reports can be granted the Reports and Analytics Region Administration Duty to be able to map reports to work areas.

Set Watchlist Options

Watchlist Setup: Points to Consider

For all users across the site, you can disable or enable predefined Watchlist categories and items, edit their names, and determine how often item counts refresh. You cannot delete predefined Watchlist categories and items, nor create any for the site. Users can create their own Watchlist items through saved searches.

Access the Set Watchlist Options page by starting in the Setup and Maintenance Overview page and searching for the Set Watchlist Options task.

Disabling Predefined Categories and Items

Use the Set Watchlist Options page to enable or disable predefined Watchlist categories and items. Disabling any category or item also disables associated processes involved in calculating the Watchlist item counts for all users. These processes include creating data caches, performing security checks, invoking services across domains, running queries, and so on.

An item with the **Predefined** type represents the actual predefined Watchlist item that appears in the Watchlist. If you disable this type of Watchlist item, then:

- The item is not available for users to display in their watchlist
- The item is removed from any watchlist where it is currently displayed

A Watchlist item with the **User-created saved search** type does not appear in the Watchlist; it controls the display of the **Manage Watchlist** button or menu item in pages with saved searches. If you disable this type of Watchlist item, then:

- The **Manage Watchlist** option is not available to users in the corresponding work area, so users cannot use their own saved searches as

Watchlist items. A message is displayed to users when they try to use this option.

- Any user-defined saved searches from that work area already used as Watchlist items are no longer available in the users' watchlist. The user-defined saved searches are still available to be used for searching, but not for the Watchlist.

If you disable a Watchlist category, then the category is not available for users to include in their watchlist, and all Watchlist items within the category are also disabled.

Ultimately, the Watchlist for any user contains the subset of categories and items that are enabled in the Set Watchlist Options page:

- Plus any items based on user-defined saved searches
- Minus any categories or items that the user chooses to hide using Watchlist preferences
- Minus any items with no results found, if the user chooses to hide such items using Watchlist preferences

Specifying Refresh Intervals

All Watchlist items have a predefined refresh interval, which controls how often the query that calculates the count for a Watchlist item can be run. Use the Set Watchlist Options page to edit the interval values. What you specify as the refresh interval for a Watchlist item of type User-created Saved Search applies to all Watchlist items based on saved searches created by users on the corresponding search page.

When the user is in the Welcome dashboard with the Watchlist open for at least two and a half minutes, the query automatically runs for all Watchlist items if no refresh already ran in this user session. To subsequently run the query again, users can manually refresh the Watchlist region. The **Refresh** icon is enabled after five minutes since the last refresh.

Note

During a refresh, the query runs for an individual Watchlist item only if the time since the last query for this item is equal to or greater than the specified refresh interval. Since the manual refresh of the entire Watchlist is not available until five minutes after the last refresh, you should not set a Watchlist item refresh interval that is less than five minutes.

When users open Watchlist from the global area, a refresh automatically runs if five minutes have passed since the last refresh. During this refresh, the query runs for an individual Watchlist item only if the time since the last query for this item is equal to or greater than the specified refresh interval.

For example, you set the interval to eight minutes for a particular Watchlist item. When the user signs in and goes to the Welcome dashboard, with the Watchlist open, the query automatically runs for this Watchlist item after two and a half

minutes. Every two and a half minutes after, a check is performed for stale counts and new cached counts are displayed.

Five minutes after the query ran, the **Refresh** icon is enabled and the user performs a manual refresh. However, the query does not run for this Watchlist item, because the refresh interval is eight minutes. The user navigates away from the Welcome dashboard and opens the Watchlist from the global area six minutes later. A refresh automatically runs because more than five minutes have passed since the last refresh. This time, the query runs for this Watchlist item because it has been more than eight minutes since the query last ran for this item.

Editing Predefined Category and Item Names

Predefined Watchlist category and item names are stored as meanings of standard lookups. Lookup types for predefined categories end with WATCHLIST, for example EXM_EXPENSES_WATCHLIST. Edit the lookup type meaning to change the category name. To change item names, edit lookup code meanings for that lookup type.

Define WebLogic Communication Services Configuration

Click to Dial: Explained

Use Click to Dial to place a call to a contact from a hyperlink on the phone number or phone icon.

Here are a few topics that are important to know when using Click to Dial:

- Normal call flow
- Interaction Records and Notes
- Operational Notes

Note

Click to Dial must be enabled to make calls using the various contact information pages and pop-up UIs. When enabled, phone numbers appear as hyperlinks. Interaction logging is available if that feature is enabled. If interaction logging is available, a note indicating that fact will be displayed in the UI. See Click to Dial: Top Tasks for more information about enabling these features.

Normal Call Flow

Click to Dial uses a call-the-caller-then-call-the-callee procedure for completing a phone call. That format and the normal flow of this procedure are described below.

- **You initiate a call**

If you see a small orange square next to a contact or customer name, click the square to display further details, including phone numbers. To place a call, place your mouse over the phone number hyperlink and click.

Note

Click to Dial does not work on phone numbers that are marked with a Do Not Call icon.

-
- **Select a Calling Phone**

Choose the calling phone number. Usually the calling phone is a number from your profile information. Alternately, if you need to use a phone not in your profile, you can specify a different number to originate your call.

- **Call Flow**

After you select the calling phone number, the system calls you back on that number, waits for you to answer, and then calls the person for whom the call is intended.

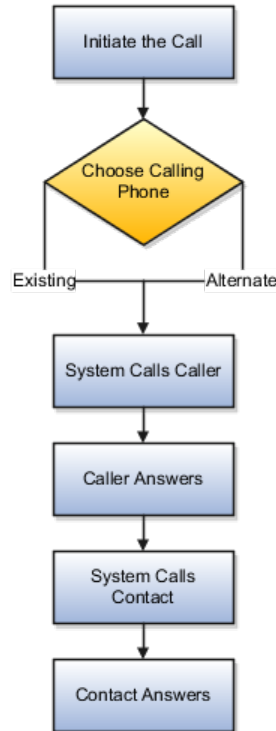

Interaction Records and Notes

Click to Dial automatically creates an interaction record of the call, when that feature is enabled. The details window that provides the phone number may also show an Interaction icon that you can click to display a list of interaction records to edit, for example to provide a description of the call. The window may also provide a notes feature that you can use to record notes during the call.

Interaction Logging

The interaction record is logged as soon as the call is either successfully set up or known to have failed.

The interaction log records the customer, call participants, a timestamp noting the start time of the call, the direction of the communication, in or outbound, and

the resolution code. The description is automatically updated with these three items:

- Call ID from OWLCS
- Your chosen phone number
- Contact phone number

The call resolution code is determined from OWLCS and recorded in the interaction:

OWLCS Call Status	Resolution Code in Interaction
CallConnected	CALL ANSWERED
CallAborted	FAILED
CallHangUp	FAILED
CalledPartyBusy	NOT AVAILABLE
CalledPartyNoAnswer	NOT AVAILABLE
CalledPartyNotReachable	NOT AVAILABLE
CallingPartyBusy	FAILED
CallingPartyNoAnswer	FAILED
CallingPartyNotReachable	FAILED

Editing interactions

Once the call is established, if Interactions is available, you can use the Interactions icon on the UI to launch the interaction record list view. Select the current interaction record to edit it.

Operational Notes

Because of the call-the-caller-then-call-the-callee format, there are some conditions that may occur due to several calling situations. Some of these conditions are described below:

- Why don't I hear a ring-back tone? As soon as you answer the system call-back, the system immediately dials the contact. You won't hear a ring-back tone as in a normal outbound phone call. However, you can tell that the call attempt is progressing because:
 - The phone indicates that the connection is active. If the call to the contact reaches a busy tone or the call attempt times out, the connection is dropped.
 - The dialing window stays on the screen while the call attempt is progressing. It disappears when the connection is either successfully established or fails.
- What if your phone is busy and the call-back goes directly to voice mail? Normally this would not happen because you would not initiate a new call when you are already busy on another call. However, this situation could occur due to a race condition, that is where another incoming call reaches your phone before the Click to Dial call-back. When this happens, two different scenarios could occur:

- If your phone is configured for busy-forward-all-to-voice-mail, the Click to Dial call would be forwarded to your voice mail, and the system thinks that the caller has answered the call and will proceed to call the contact. On answering, the contact hears your voice-mail greeting.
- If your phone is capable of presenting a second call to the user, as is supported by many office phones and mobile phones, then you can still answer the Click to Dial call and there is no issue.
- What if you wait too long to answer the call-back? In other words, you wait longer than the ring-no-answer-forward-to-voice-mail timer on the phone system and the call goes to voice mail. Normally, this would not happen because you are expecting the inbound call after you started the call, and would answer promptly. However, if for some reason you do not answer and allow the call to ring-no-answer-forward to voice mail, then the system would think that you have answered the call and will proceed to call the contact. On answering, the contact hears your voice-mail greeting.
- What if the contact does not answer in 30 seconds and the system abandons the call attempt? If the contact's voice mail is configured to answer after 30 seconds, you will not be able to leave a message.

Click-to-Dial: Top Tasks

Click-to-Dial is a feature of the customer contact process. Phone communication to customers and employees is initiated with a click of the mouse, leveraging your customer contact information and the application context. The Click-to-Dial feature uses Oracle WebLogic Communication Services, OWLCS, to enable communications. Applications that provide the Click-to-Dial functionality do so primarily through contextual actions in the application.

Additionally, Click-to-Dial utilizes Oracle Fusion Interactions as an optional transaction logging feature that will track information about the call such as the customer, call participants, a timestamp noting the start time of the call, the direction of the communication, in or outbound, and the resolution code.

Click-to-Dial integrates with your telephony environment and must be manually enabled in your deployment. This topic highlights what is required to set up the Click-to-Dial feature and to implement logging of the calls made using the Click-to-Dial feature.

Terms used in setting up these communications

- PSTN: Public switched telephone network is the network of the world's public circuit-switched telephone networks.
- SIP: Session initiation protocol, an open signaling protocol standard that is used to set up phone calls
- TPCC: Third Party Call Control enables an application to control the telephony network to set up calls automatically.
- OWLCS: Oracle WebLogic Communication Services. Offers the TPCC service to Fusion applications and sets up the calls via SIP integration with the telephony network.

The set up task list Define WebLogic Communication Services Configuration delineates four tasks required for the correct configuration and implementation of Click-to-Dial. There is an optional task, separate from the set up task list, required for implementing Interaction logging.

Information about implementing Click-to-Dial can be found in the Oracle Fusion Applications Administrator's Guide. Detailed information about configuring and maintaining WebLogic Communication Services is found in the Oracle WebLogic Communication Services Administrator's Guide

Configure and Deploy WebLogic Server

- Deploy WebLogic Communication Services: After the Oracle WebLogic communication server is deployed, this manual task activates the server.

See: Oracle WebLogic Communication Services Administrator's Guide

Integrate Communications Services

- Integrate WebLogic Communication Services with Telephony Network: This manual task integrates communications within the telephony environment. OWLCS must be configured to interface with the specific characteristics of the telephony network.

See: Managing Oracle WebLogic Communication Services for Click-to-Dial Functionality

Specify the Domain and Address

- Register a URL for the telephony gateway or soft switch for SIP domain: This task defines the Server protocol, defaulted to http, the external server host address and external server port address. The Associated Modules section is not required for setup. You can also perform this as a manual task using the Oracle Fusion Topology Manager to configure the address of the SIP Public Switched Telephone Network (PSTN) gateway or SIP soft switch serving the users within that domain. This address is needed by Click-to-Dial to correctly form the SIP addresses required by WebLogic Communication Services. See the link to Configuring PSTN Gateway Address Using Topology Manager: Worked Example.

Enable Click-to-Dial

- After configuring the server and defining the SIP domain, perform the Enable Click-to-Dial task. This task sets the value of the profile option Enable Click-to-Dial to 'Yes.'

Call Logging via Fusion Interactions

- To initiate the Interaction based logging for Click-to-Dial, set the profile option Call Interaction Logging Enabled to 'YES.'

Configuring PSTN Gateway Address Using Topology Manager: Worked Example

This example demonstrates how, during the implementation of the **Register URL for the telephony gateway or soft switch for SIP domain** task,

you must manually configure the PSTN gateway address by registering HzCTDPstnGatewayApp to a given environment using Oracle Fusion Topology Registration

These steps configure the address of the SIP Public Switched Telephone Network (PSTN) gateway or SIP soft switch serving the users within that domain. This address is needed by Click to Dial to correctly form the SIP addresses required by WebLogic Communication Services.

For example: SIP:+1650-555-1212@pstn_gateway.oracle.com;user=phone where pstn_gateway.oracle.com is the SIP domain. The SIP domain can also be expressed in the format 10.1.1.1 (IP address).

Configuring PSTN using the Topology Manager

1. Sign in to Oracle Fusion Applications as a user that has **application implementation consultant** and **WebLogic Services administration** roles
2. In Fusion Applications Setup and Maintenance, click Register Enterprise Applications from the regional area under **Topology Registration**
3. On the Register Enterprise Applications page, click the plus icon to add an enterprise application. An Add Enterprise Application popup appears
4. Enter the new application information: Click Search in the Enterprise Application list field. Enter **HzCTDPstnGatewayApp** in the name field and click Search. Click OK.
5. Enter the other fields in the Add Enterprise Application popup

Field	Value
Name	HzCTDPstnGatewayApp
Server Protocol	SIP This field is ignored by click-to-dial. Oracle WebLogic Communication Service (OWLCS) always uses the SIP protocol.
External Server Host	10.143.167.91 (Used as an example) A host name can be used instead of an IP address.
External Server Port	0 (Used as an example) This field is ignored by click to dial.

6. Click Save and Close

Define Product Information Management Configuration

Product Management Features by License: Overview

Product Information Management is comprised of three products.

- Oracle Fusion Product Model
- Oracle Fusion Product and Catalog Management
- Oracle Fusion Product Hub

Product License	Features
Oracle Fusion Product Model All Oracle Fusion customers are licensed to use.	Define Basic Items
	Define Basic Catalogs
	Define Basic Product Structures
Oracle Fusion Product and Catalog Management	Define Advanced Items (also will get Define Basic Items by dependency in ADR)
	Define Change Orders
	Define Product Rules
	Define Advanced Product Structures (also will get Define Basic Product Structures by dependency in ADR)
	Manage Advanced Item Profile Options
	Define New Item Requests
Oracle Fusion Product Hub	Define Product Source System
	Define Advanced Catalogs (also get Define Basic Catalogs by dependency in ADR)
	Define Data Quality for Products
	Manage Advanced Item Profile Options

Define Basic Items

Managing Product Value Sets: Explained

Value sets are specific to the application in which they will be used. In the Oracle Product Information Management application, value sets are used primarily for

defining attributes where the values that an attribute can have is limited to a specific set of values.

Value sets can be edited or new value sets can be created from the **Manage Product Value Sets** page. The **Edit** icon launches the **Edit Value Sets** page, which redraws in the same region of the local area. The **Create** icon launches the **Create Value Sets** page, which redraws in the same region of the local area.

A value set is defined by the value set code and is specific to the module of an application in which the value set is to be used, such as Item Class.

The validation type determines how the value of field is validated for the assigned value set. The following are the seeded values:

- Format Only
- Independent
- Dependent
- Subset
- Table

The value data type determines the data type for the value set. The following are the seeded values:

- Character
- Number
- Date
- Date/Time

Managing Product Child Value Sets: Explained

The Manage Product Child Value Sets task uses the same page as the Manage Product Value Set task.

A child value set is used to define variants for stock-keeping units or SKUs. A SKU contains the common properties for an item. For example, a shirt can be produced with colors; white, red, yellow, and blue. The variant is used to represent the colors of the shirt.

You define child value sets as follows:

- Create a value set with validation type of independent, for example All Colors.
- Select the new value set in the **Manage Product Value Sets** results table, for example All Colors.
- Click **Manage Values**, create several values, for example Blue, Red, Green, Yellow, and Black.
- Create a value set with validation type of Subset and enter the first value set you created for the independent value set, for example: Summer Colors.

- Select the value set Summer Colors in the **Manage Product Value Set** result table.
- Click **Manage Values** and then click the **Add** icon. The dialog will show a list of values based on the value set named Summer colors. Select two of them.

The value set Summer Colors is a child of All Colors.

Managing Default Item Class: Explained

The Root Item Class is seeded and all item classes are created as children of the Root Item Class. For Oracle Fusion Product Model customers, only the Root Item Class is available. The Manage Default Item Class task enables Product Model customers to manage item class templates, descriptive flexfields, attachment categories and lifecycle phases. The Manage Default Item Class task launches an edit page for the Root Item Class.

The functionality for the Root Item Class is defined using three tabs:

- The Basic tab enables descriptive flexfields and attachment categories to be viewed and managed for the Root Item Class.
- The Lifecycle Phases tab enables one or more lifecycle phases of a lifecycle to be associated with an item class.
- The Templates tab is where you define and manage item templates for the item class.

Managing Item Statuses: Explained

In the Item Status table, select a status code to display the associated attribute groups and attributes as well as control information.

You can create or edit or delete item statuses on the Manage Item Statuses page. Inactive dates are used to specify the date after which the item status will no longer be active. Operational attribute groups and attributes corresponding to the selected item status are displayed in the Details section. Select a value for the status from choice list for the attribute. Whenever the status is applied to the item, the value of the attribute may change. If the status will have no value, select **No**.

Select the Usage value of **None** or **Defaulted** or **Inherited** in the choice list for the **Usage** field that corresponds to how the attribute value will change based on the item status value:

- Defaulted-Sets the values of the item status attributes when the status value changes, but allows the overriding of the value during import and update of item.
- Inherited-Sets the values of the item status attributes when the status value changes, but overrides cannot occur.
- None-The item status attribute values will not be changed.

Any change made to an item status is not applied automatically to existing items, but will be applied during the editing of an item when the item status value is changed.

Managing Item Types: Explained

Item types are managed on the **Manage Item Types** page.

There are 32 seeded item types and you can edit them or create additional item types.

Item types are date-enabled and are made active or inactive by adjusting the Start Date and End Date.

To benefit from the use of item types, you must enable them by selecting the **Enable** checkbox.

Managing Cross-Reference Types: Explained

Cross-References provide the functionality to map additional information about an item in the form of a value and cross-reference type. For example, the cross-reference can map between an item and an old part number, where the value is the value for the old part number and the type is Old Part Number. Cross-Reference Types are part of item relationships where the item relationship type is Cross-Reference. There are no values seeded for cross-reference types. You define the values using the **Manage Cross Reference Types** task. Cross-reference types are date-enabled and can be made active or inactive by adjusting the values of the Start Date and End Date. To benefit from using item relationship for cross-reference, you must enable cross-reference types by checking the **Enable** checkbox.

Importing Items: Explained

You can import items and item-related information using interface tables. This import data is loaded into the production tables using the Import Item task.

Import Item

The Import Item task creates an Enterprise Storage Server (ESS) process that takes the data that is loaded in the interface tables and uses the import process to move the data to the production tables. The import processes will perform all of the validations necessary to ensure the data imported is correct prior to moving the data into the production tables.

1. Access the Enterprise Storage Server and provide a process name (job definition) such as **Item Import Process**.
2. Select Setup and Maintenance from the Navigator.

Access the All Tasks tab on the Overview page, and search for the Import Item task with the name of your ESS process definition.

3. Click the **Go to Task** icon in the search results for that Import Item task.

The parameters for the item import process are

- **Batch ID:** Associate the interface table to an item batch definition.
 - **Organization:** Select an organization to be used for the import.
 - **Process Only:** Determines how the data is processed. The choices are:
 - **Create**
 - **Sync**
 - **Update**
 - **Process All Organizations:** Select **Yes** if the import contains items that will be imported to multiple organizations.
 - **Delete Processed Rows:** Select **Yes** to delete rows that are imported without errors
4. Click **Submit** and the Request Number will be displayed.

Monitoring Import Items

Select Setup and Maintenance from the Navigator, then access Monitor Item Imports to search for specific Enterprise Storage Server processes and monitor their status in the search results table.

Managing Related Item Subtypes: Explained

A related item is an item relationship between two existing items. How the two items are related is defined by a subtype. Multiple subtypes for related items are seeded, and you define additional subtypes on the **Manage Related Item Subtypes** page.

Managing Descriptive Flexfields for Items: Explained

You can use descriptive flexfields to capture additional information about items beyond what is provided by the predefined set of operational attributes in Oracle Fusion Product Model.

Item Descriptive Flexfields

If you are not using Oracle Fusion Product and Catalog Management, then you cannot create user-defined attribute groups and attributes. However you can use descriptive flexfields associated at Item level to create fields to capture information about items. Like other descriptive flexfields, item descriptive flexfields have context segments and context-sensitive segments whose values are validated on entry by value sets. You can define the value sets to control what values users can enter in a descriptive flexfield segment. Examples of information that you might capture are size and volumetric weight.

Manage this flexfield type by using the Manage Item Descriptive Flexfields task, which you can access by searching for flexfield tasks on the Setup and Maintenance Overview page.

Item Revision Descriptive Flexfields

Use descriptive flexfields associated at Item Revision level to capture item revision information whose values may differ between revisions of the same item.

Manage this flexfield type by using the Manage Item Revision Descriptive Flexfields task, which you can access by searching for flexfield tasks on the Setup and Maintenance Overview page.

Item Relationship Descriptive Flexfields

When defining descriptive flexfields associated with item relationships, you must use certain prefixes when naming the context segments, in order for the segments to be displayed for the respective relationships.

The prefixes required for naming the context segments are listed in the following table, with their corresponding item relationship types. For example, if you define an item relationship descriptive flexfield with a context segment named `RELATED_RELATIONSHIP_ATTRIBUTES`, then the value segments of this context will be displayed for Related Item Relationships when users conduct transactions in that context. For another example, when users navigate to a UI of a particular object, such as a Competitor Item, they see the contexts whose internal name has the prefix `COMP`.

Relationship Type	Prefix for Context Segment
Competitor Item Relationship	COMP
Customer Item Relationship	CUST
Item Cross-reference Relationship	XREF
GTIN Relationship	GTIN
Manufacturer Part Number Relationship	MFG
Related Item Relationship	RELATED
Source System Item Relationship	SYS

Manage this flexfield type by using the Manage Item Relationship Descriptive Flexfields task, which you can access by searching for flexfield tasks on the Setup and Maintenance Overview page.

Trading Partner Item Descriptive Flexfields

When defining descriptive flexfields associated with trading partner items, you must use certain prefixes when naming the context segments, in order for the segments to be displayed for the respective trading partner type.

The prefixes required for naming the context segments are listed in the following table, with their corresponding trading partner types. For example, if you define

a trading partner item descriptive flexfield with a context segment named `COMP_TPI_ATTRIBUTES`, then the value segments of this context will be displayed for Competitor Item when users conduct transactions in that context..

Trading Partner Type	Prefix for Context Segment
Competitor Item	COMP
Customer Item	CUST
Manufacturer Item	MFG

Manage this flexfield type by using the Manage Trading Partner Item Descriptive Flexfields task, which you can access by searching for flexfield tasks on the Setup and Maintenance Overview page.

FAQs for Define Basic Items

What's lifecycle validation?

Lifecycle validation enforces compatible lifecycle phases between parent and component items in an item structure, at the structure name level. For example, an item in the Design lifecycle phase can only have component items that are in the same lifecycle phase or the next phase. The only exception is for items in the Obsolete lifecycle phase, because this is considered the end of life for an item. Items in the Obsolete lifecycle phase cannot be added to a new structure.

The lifecycle phases for a computer component lifecycle might be:

- Concept
- Design
- Prototype
- Pre-Production
- Retirement (Obsolete)

What's the difference between lifecycle phase types and lifecycle phases?

Lifecycle phase types are seeded and describe the type of lifecycle phase. They are Design, Obsolete, Preproduction or Prototype, and Production.

Lifecycle phases must be created by the user by selecting one of the seeded lifecycle phase types.

Define Basic Product Structure

Managing Product Value Sets: Explained

Value sets are specific to the application in which they will be used. In the Oracle Product Information Management application, value sets are used primarily for

defining attributes where the values that an attribute can have is limited to a specific set of values.

Value sets can be edited or new value sets can be created from the **Manage Product Value Sets** page. The **Edit** icon launches the **Edit Value Sets** page, which redraws in the same region of the local area. The **Create** icon launches the **Create Value Sets** page, which redraws in the same region of the local area.

A value set is defined by the value set code and is specific to the module of an application in which the value set is to be used, such as Item Class.

The validation type determines how the value of field is validated for the assigned value set. The following are the seeded values:

- Format Only
- Independent
- Dependent
- Subset
- Table

The value data type determines the data type for the value set. The following are the seeded values:

- Character
- Number
- Date
- Date/Time

Managing Item Structure Type Details: Explained

Item structure type is a seeded value that enables you to define the composition of an item. You can add additional structure names and specify item attachment categories that need to be available when viewing or managing structures. Item structure types provide a common set of metadata to all structures defined under it.

Structure Type Details

A structure type enables you to classify and characterize item structures throughout the lifecycle of an item. You can define an unlimited number of structure names for a structure type, enabling you to create several different structures of the Item Structure Type that you can use for comparison.

A seeded structure name (Primary) is available. Only the description and lifecycle validation flag can be updated for this structure name. It will always be active.

You can associate item attachment categories with a structure type.

Define Basic Catalogs

Catalogs: How They Work Together

A catalog is a collection of categories that you use to classify items. You can organize the categories into a hierarchy that represents a taxonomy. You create new categories only in the context of a catalog. You can add existing categories to one or more catalogs, either from another catalog or as shared categories from a source catalog.

You can set the **Catalog Content** value to **Items at all levels** which allows items to be assigned to any level within the category hierarchy, not only to the leaf levels.

The following diagram shows the relationships of the catalog components.

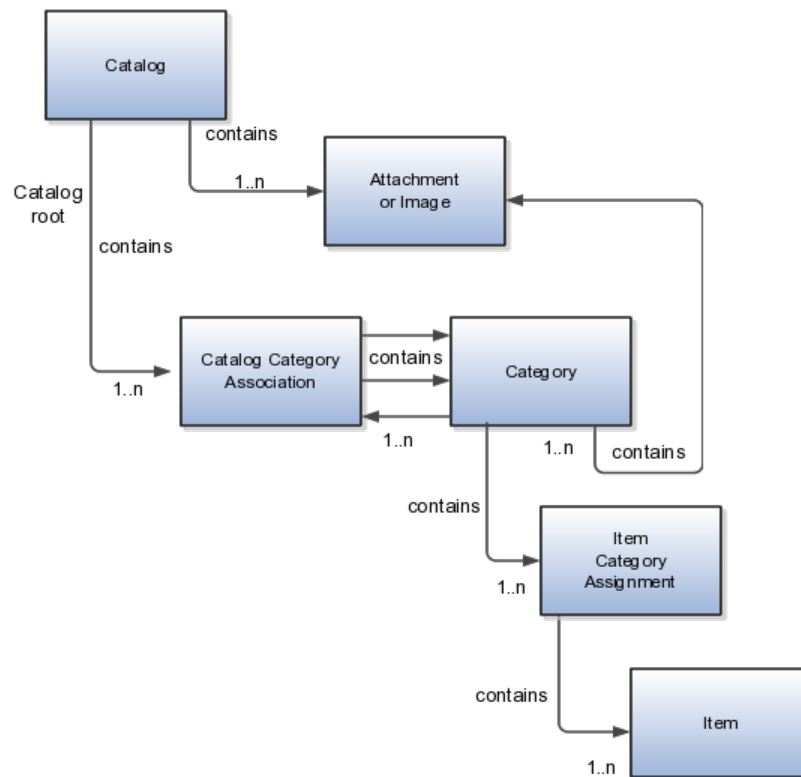

Catalog

A catalog is a collection of categories that are organized to define a classification of items. The top most level of a catalog is the catalog root. All categories for the first level in the category hierarchy are associated with the catalog root through the catalog category association component.

Category

A category is a component of a catalog that represents a portion of the classification defined by the categories and category hierarchy in the catalog. You can associate a category to a catalog through the catalog category association. Both the shared category and the native category are associated through the catalog category association.

Catalog Category Association

Catalog category association represents the relationship between a catalog and a category, or a parent category and a child category. Each catalog category association represents one relationship between the catalog and a category or one relationship between a parent category and a child category.

Item Category Assignment

Item category assignment represents the assignment of the item to a category in a catalog. Each item category assignment represents the relationship between a category and an item.

Item

An item represents objects such as a product, service or template. An item is assigned through the item category assignment component.

Attachment or Image

Information is associated to the catalog and/or category, or both, through the attachment framework. Multiple attachments are supported but you can associate only a single attachment or attachment type image with a catalog or category.

Formatting Catalogs: Explained

The format of a catalog is defined at the time the catalog is created and controls the behavior of the catalog at runtime.

When you format a catalog the layout controls three main areas and includes the following tasks, some fields are required, and others are optional.

- Catalog configuration
- Date enablement
- Category sharing

Catalog Configuration

You can configure the catalog, and this affects how the content behaves. The catalog configuration contains a set of attributes that define the catalog configuration. These attributes interact to define the runtime behavior of the catalog.

The configuration functions are:

- Catalog code: A unique identifier that is used.

- **Catalog structure:** The key flexfield structure used to define the catalog.
- **Controlled at:** Controls how items are assigned to categories and has two values. The first value is master level, which enables the automatic assignment of items to all child organizations associated with the master organization, if the current context is a master organization. The second value is organization level, which assigns the item only to the organization in the current context.
- **Default category:** Applies any time a new item is created. The newly created item is assigned to this category within the catalog automatically. The automatic assigned is controlled by the functional area.
- **Catalog content:** Controls what content can be added to the catalog and where the content can be added. This attribute has three values:
 - The Item at leaf levels allows items to be added only to the bottom level categories in the hierarchy.
 - The Items at all levels allows items to be assigned to any category in the hierarchy regardless of level.
 - Categories only allows categories to be added only to the catalog.
- **Allow multiple item category assignment:** When this option is selected, you can assign an item to one or more categories in the catalog. The default is deselected, which means that each item can be assigned to only one category in the catalog.
- **Enable hierarchies for categories:** When this option is selected, you can create a hierarchy for the catalog. The default is deselected, which means that the catalog cannot have a hierarchy and categories are associated with the catalog root.
- **Enable automatic assignment of categories:** When this option is selected, the catalog is built by automatically associating all categories, based on matching the catalog structure value to the category structure value.

Catalog Date Enablement

The date enablement function controls when the catalog is in an active state or inactive state by using the start date and end date attributes.

Category Sharing

The category sharing function enables sharing by reference to categories from a designated source catalog.

The sharing function has these attributes:

- **Source catalog:** A catalog that does not have sharing enabled from which categories, category hierarchies, and assigned items can be added to the catalog.
- **Sharing content:** Controls what content can be added from the source catalog. This attribute has three values:
 - **Categories only:** Only categories without assigned items can be shared.

- Items only: Only categories with assigned items can be shared.
- Items and categories: All categories can be shared.

Catalog Details: Explained

You can change a default category so that you can use it for item creation, or modify the inactive date so that the category is no longer used as you update a catalog. You can correct mistakes or reclassify the category due to shifting relationships within the category hierarchy.

You can view and edit a catalog on the Edit Catalog page when you have editing rights. For users that do not have rights to edit, the page is in read only mode.

The following aspects are important regarding managing and editing catalog details:

- Catalog header region
- Catalog detail tab
- Category hierarchy tab

Catalog Header Region

This region contains the catalog name and description, the selection of the default category and the start and end date for the catalog.

Catalog Detail Tab

The Detail tab contains:

- The configuration attributes for the catalog that controls the runtime behavior for the catalog.
- The sharing attributes for the catalog which controls the source catalog that will be used for sharing from and what content can be shared.
- The additional information which contains the descriptive flexfields defined for the catalog.

Category Hierarchy Tab

This contains the category hierarchy region in which the category hierarchy can be created and maintained. In addition, items can be assigned, and the usage of the category in other catalog can be viewed, and the attributes for the category and catalog category association can be edited.

Automatic Assignment Catalogs: Explained

The automatic assignment catalog feature enables you to reduce the cost of creating and maintaining a catalog. It is a simple way to create a nonhierarchical catalog because you do not have to add categories manually to the catalog.

All categories that have the same category structure value as the catalog are automatically assigned and associated to the catalog when you create a catalog category association for each category. Note that if you create a category in

another catalog with the same structure value as the automatic assignment catalog, the category is added to your catalog. The categories displayed for auto assignment catalogs are refreshed only at startup and after you save.

Automatic Assignments

The automatic assignment feature is enabled during catalog creation when you select the **Enable automatic assignment of category** check box. When you open a new catalog, any categories that have the same category structure value as the catalog structure value for the catalog are automatically assigned to the catalog.

For example, Purchasing may maintain a master catalog containing all categories that represent commodities. Each commodity team can create categories for their commodity in their own catalog.

- The master catalog for Purchasing is named Purchasing and is configured during creation to support the automatic assignment of categories.
- The Electronic commodity team creates a catalog named Electronics and proceeds to create categories that represent the classification of their commodity. The Electronic commodity team creates the categories televisions, computers, and home theaters.
- The other commodity teams create and maintain separate catalogs.
- Because you enabled automatic assignments for the Purchasing catalog, any categories created by the commodity teams are added to the catalog automatically. The Purchasing managers can view the collection of all commodities represented as categories in the Purchasing catalog.

Assigning Items to Categories: Explained

You can assign items to categories on the Edit Catalog page, category hierarchy tab, on the category detail item tab. You can assign items only to active categories and categories where the **Category Content** field value is **Items and Categories** or **Items Only**. In addition, you can configure catalogs to control item assignment to categories within the catalog by selecting the **Allow multiple item category assignment** check box, which allows items to be added to all levels of the category hierarchy.

You select items from a choice list and add them to the category. The choice list is filtered based on a set of rules:

- **Item data level security:** Displays only the items that the user has permission to view and assign.
- **Organization context:** Based on the organization context that is controlled by a choice list in the item table header, only the items assigned to organizations are displayed.

Controlling Item Assignment

You also control item assignment by selecting the value of the **Controlled at** check box. If you select the **Master Level** value and the organization context is a master organization, the items are automatically assigned to all child organizations that are associated with the master organization.

Publishing Catalogs: Explained

Other applications can use catalog data if you export the catalog content. For example, you may want to export catalog content to use as a monthly report of all items assigned to a specific catalog. You can use the default publish template provided in hyper text markup language (HTML). You can specify the content and layout of the catalog information. When the catalog is published, you select the format and initiate the creation of the content in the file.

The following aspects are important regarding catalog data to be published:

- Publish a catalog
- Type of catalog content that can be published

Publish a Catalog

You initiate a search for a catalog from the Manage Catalogs page, select the row corresponding to the catalog that you want to publish and select the **Publish** action. The application generates the report based on the default template in HTML format, and the locale prior to creation of the file. You can select a new template or format from the report window. The content displayed for items, categories, catalog categories, and catalog is based on the publish template.

Type of Catalog Content That Can Be Published

The default catalog publish template allows the publication of the catalog header details, category hierarchy, category details, and category item assignments. The order of a published report begins with the catalog header and the catalog category details. If the category has a child relationship then the catalog category association details for the child category follows. If the child category has a hierarchy, then the complete hierarchy under the category is published with the catalog category association details and categories details.

FAQs for Define Basic Catalogs

How can I share catalog content?

Categories can be shared across multiple catalogs allowing catalog content to be reused and saving the work needed to maintain multiple copies of the categories. In the case of category sharing, the category structure in the source catalog can be different than the native catalog.

Categories can be shared using two methods; the first method is directly associating the category to the catalog. The category is added to the catalog and can be edited in the catalog or any catalog the category is associated to. The items assigned to the category are not shared, but are assigned to the category in context with the catalog the category is associated. For example if the category name or description is changed in one catalog, the change will be reflected in all catalogs where the category is associated, but if items are assigned to a category, the assignment will be for that single catalog.

The second method of sharing categories is adding a category by reference into the catalog. During the creation of the catalog, sharing can be enabled by specifying a single source catalog that will be used for sharing by reference and setting the value of the sharing content to control what content will be shared from the source catalog. The advantage of using sharing by reference is source catalog content can be shared to multiple catalogs and maintained in a single place, the source catalog. In addition, the referenced content can be more than one category, for example a complete category hierarchy and any assigned items to categories in shared content can also be reference within the catalog.

How can I define category hierarchies?

Categories can be organized to represent classification taxonomies. The hierarchy organizations for categories have parent and child relationships that form a tree structure. The category hierarchy is created and maintained within the Edit Catalog page, category hierarchy tab. The category hierarchy is shown in true relationship to the way it is defined.

The category hierarchy can be created using two methods: the first is manually creating the hierarchy by adding referenced categories, duplicating categories or creating category for the catalog.

The second method for creating the hierarchy is by importing the category hierarchy through the spreadsheet interface. The category hierarchy can be exported from other catalog or other sources, edited and imported into a new catalog, additionally it can be added manually to the spreadsheet.

The category hierarchy can be edited using **Move Category**. The catalog category association cannot be deleted, but can be end dated to make the catalog category association inactive. The category hierarchy table provides a choice list filter that controls what catalog category associations and categories area displayed based on the date enablement. The category hierarchy can also be edited by exporting the complete hierarchy, editing it and importing the category hierarchy back into the catalog.

How can I duplicate categories?

You can select and duplicate a category as a quick way to create a similar category configuration. Selecting the **Duplicate** icon action launches a Create Category dialog that has attribute fields populated based on the selected category attribute values. The category name is prefixed with **Copy_** followed by the name of the selected category. You fill in the required field information in the key flexfield segment values which are blank. Once the category attributes are updated and the key flexfield segments values are entered, the **OK** button adds the newly created category into the category hierarchy of the selected category you have configured.

How can I add categories?

Categories are catalog components that are associated to a catalog for purpose of classification of items. You can add existing categories to the point of selection which can be a category in the hierarchy or the root of the catalog. If no category is selected, the default is the root of the catalog.

You can add categories by selecting the **Add Category** field and selecting the value **Add Category**. You can then search for existing categories based on the value of the catalog structure for the catalog. You can narrow the search for existing categories by using the **Advance Search** region in the dialog. You can add each selected category by selecting the **Apply** button and the add category region remains open. The **OK** button adds a category if a category is selected and then closes the dialog.

How can I add shared categories?

Adding a shared category is similar to adding an existing category except the category is selected from the catalog that has been designated as a source catalog. The sharing content attribute value determines what content is shared from the source catalog. A category within a source catalog that has been added to a native catalog is also known as a referenced category. You use the drop list menu from the Add Categories menu, and the Shared Category option will be disabled if the catalog has not been configured for category sharing.

How can I add images to a catalog or category?

You can attach an image from your desktop or from a configured repository to a catalog or a category, or both. The image is displayed in the catalog detail and the category detail section of the catalog page. Only one image can be associated with a catalog or category. To attach an image, select the green plus icon to launch the Manage Attachment dialog. The image attachment type can have values of **File** or **Repository File/Folder** and is selected in this dialog. The title you provide for the image attachment will appear under the image that is displayed in the catalog. The description you provide is not displayed. **Browse** will allow you to select the file to be used as the image for the catalog or category. After the information is entered in to the dialog, you click the **OK** button to load the image and the image attachment title will be displayed under the image. The image will not initially be displayed until the catalog is saved. The image can be replaced with another image by selecting the red X to delete the existing image and entering a new image.

Define Advanced Items

Managing Item Classes: Explained

When you are ready to create or edit an item class, you must decide whether to allow items to be created under the item class.

To create an item class, perform the following steps:

- Create a list of all items.
- Classify or categorize these items (Item classes).
- Define any parent child relationships (Item Class Hierarchy).
- Gather the unique types of specifications required for each type of classification at a high level (user-defined attribute groups).

- Gather the unique specifications required within the group (user-defined attributes).
- If there are specified values that must be used, define them (value sets and values).

Item classes can be used for classification purposes and in some case, item creation may not be allowed. By optionally setting the item creation allowed attribute to No, item creation under an item class can be prevented. However, a child item class of such a item class may be allowed for item creation. For example:

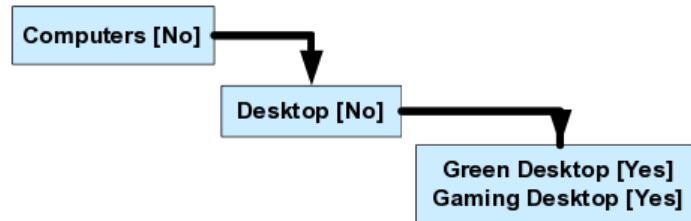

This will prevent items from being created in Computers and Desktop and allow items to be created for Green Desktops and Gaming Desktops. Optionally, specify a date on which the item class will become inactive. You cannot specify an inactive date that is later than the inactive date of an item class parent, nor can you specify an inactive date that has already passed. Also, all children of a parent item class with an inactive date should be made inactive at the same time or earlier.

Attachment categories enable you to categorize and classify attachments to an item. To classify item attachments, associate attachment categories with item catalog categories. Associated attachment categories are inherited down through the item class hierarchy.

Item classes can be set up for item numbers and descriptions so that they are automatically generated when net items are created. This ensures that new items created in item classes have a consistent numbering scheme. Versioning control allows new versions to be created for all items of item class. An integrated workflow definition allows creation of custom new item request definition for new items created. This definition workflow enables you to route the definition and approval of an item using various steps. When creating a new item, various aspects of an item like base operational attributes, user-defined attributes, structures, attachments, categories associated, organization assignments, are defined by various people in the organization using a workflow process.

You can control item creation, viewing and update access by assigning a role on the item class to a principal or group of users. Security allows a person or a group to have privileges on an item of item class in each organization. This is inherited and hence a person who has a privilege in a parent item class will automatically have the same privilege in the child item classes.

Transactional Attributes: Explained

Attributes that exist for each instance of an item and the values for the attributes can be different.

For example:

- The number of megabytes (MB) or gigabytes (GB) of e-mail storage on a digital subscriber line (DSL) account.
- The monogram text on a shirt pocket.
- The color of a music player.

These attributes are defined at the item class and their attribute value is captured at the time of a transaction by downstream applications. The metadata values of these attributes are maintained at the item class. Order orchestration and order capture systems are two examples of downstream use. All transactional attributes must be associated with a value set.

The following metadata values can be defined for an attribute.

- Required: Indicates whether the attribute value is required at the transaction.
- Default Value: Indicates the default value of the attribute.
- Value Set: Indicates the value set associated with the attribute.
- Read Only: Indicates whether the attribute value is read only.
- Hidden: Indicates whether the attribute is not shown.
- Active: Indicates whether the attribute is active or inactive.

Transactional attributes are inherited across the item class hierarchy. The metadata is data-effective. Changes in the metadata will be reflected immediately at the item level. For example:

- Any of the metadata of a transactional item attribute belonging to a specific domain, if modified in the child item class would break the inheritance. Any changes done at the parent item class for this transactional item attribute would not get inherited. Multiple records with same date range can exist if they belong to different domains. For example, the transactional item attribute **Memory** is associated with a **Domain** and order capture. Each of the domains may use a different set of metadata for its own purpose. Hence, for the same date range, two different records can exist. Only Start Dates for a transactional item attribute would be entered by a user. End date would be calculated automatically based on the next Date Effective record.
- Users can modify (either Start Date and metadata) of a future effective record. Records with Starting date as Past cannot be modify or edited.
- Only start dates can be set to permit updating by a user, and the end date of a record will automatically be pulled from the next record.
- Any changes performed in the parent item class would be inherited by the child item class. If the corresponding record is modified in the child, then these changes will not be inherited.

Item pages provide a mechanism with which to customize the user interface.

Pages and Attribute Groups

Pages and attribute groups enable you to structure your data.

Benefits include:

- You can combine and sequence attribute groups into pages.
- There is no limit on the number of attribute groups associated with a page
- Pages can be created at item class and are inherited down the item class hierarchy.
- Attribute groups can be added to pages sequentially and based on this sequence, these attribute groups are shown in items
- Attributes groups can be added for an inherited page at the child item class.

Functional Item pages are another type of special pages which are used to associate pages already created for use in the application. Application scope indicates the application which uses these pages and the usage indicates the specific use of the configured pages.

Data Quality

You can associate attributes for the purpose of standardization and matching, to be performed when items are created. You restrict the attributes to be processed for standardization or matching or both. Selecting Standardization allows the data quality engine to return the standardized values for these attributes. Matching allows the data quality engine to return any existing items which matches the value of these attributes and are potential duplicates.

Lifecycle Phases

Sequential lifecycles phases enable you to track and control the lifecycle phases of items. Each phase represents a set of tasks and deliverables that are required before promoting the item to the next phase. You can associate lifecycle phases to an item class which are created elsewhere. Lifecycle phases are inherited down the item class hierarchy and new lifecycle phases can be added to child item classes. For example, the lifecycle phases for a computer component item class might be: Concept, Prototype, Production, and Retirement.

Templates

Template is a defined set of attribute values used during item creation. When you apply a template to an item, you overlay or default-in the set of attribute values to the item definition. For example, every time users in a particular organization create new items, the attributes, as defined and approved by the organization appear in the appropriate fields. No user guesswork is required, and time is saved during the creation of items with a similar form, fit and function. Templates are created for each item class. Templates are specific to organization. Templates are inherited down the item class hierarchy. You can define both operational attributes and user defined attributes for each template.

Search and Display Format

Search formats provide a convenient way to save frequently used search criteria. Search formats created at item class will be available to all users. Search formats are always created in the context of item class. Display formats enable you to predefine search display views. You can use these views to look at different sets of item attributes that are returned by the search. Display formats created at

item class will be available to all users. Display formats are always created in the context of item class.

Import Format

An import format identifies the base and user-defined attributes in an item class that are imported into the application using a spreadsheet. Consequently, when you import item business entities from a spreadsheet, the items are all imported into the particular item class defined in the import format. These imported item business entities inherit all the attribute groups defined for the specific item class. You cannot edit the layout of an import format once it is created.

FAQs for Define Advanced Items

How can I create an item class?

To create an item class, select a parent item class on the **Item Class Search Results** page and select **Create**. Provide the required information, and optionally include additional details, such as attribute groups, pages, templates, and search and display formats.

How can I create item class templates?

Create a template for item class and then define the **Overview** and **Specification** tabs of the item class template.

What are item classes?

The item class hierarchy provides a logical classification and grouping of similar products, and also acts as a template for product definition by enabling the association and inheritance of data elements and policies that are shared by products.

Define Change Orders

Change Order Definitions: Explained

The following components are required for creating change orders:

Change Priorities and Change Reasons

Change priorities are used to identify the criticality of a change while change reasons are used to categorize and establish the cause or reason for a change.

Processes and rules can be defined around change priorities and change reasons so that change orders with a high priority or with safety related reasons get priority over other change orders or they get routed through different levels of approvals.

Predefined values for change priorities and change reasons:

- Priorities: **High**, **Medium**, and **Low**

- Reasons: **Cost**, **Quality**, and **Safety**

Additional values for change priorities and change reasons can be added by accessing the task's **Manage Change Reasons** and **Manage Change Priorities** in Functional Setup Manager.

Change Statuses and Status Types

Status indicates a stage in a change order's lifecycle. You can create new statuses within predefined status types.

Predefined values for status type:

- **Open**, **Interim Approval**, **Approval**, **Scheduled** and **Completed**

New statuses can be added and managed by accessing the **Manage Change Statuses** task in Functional Setup Manager.

Change Order Types

Each change order is created within a change order type.

Change order types contain the following information:

- Number generation method
- Workflow
- Propagation rules

Change Statuses and Status Types: Explained

Change statuses enable you to manage a change order through its life cycle. You can define statuses to indicate various states of a change.

Changes are managed through their statuses. Each status is associated with a set of predefined Business Process Execution Language (BPEL) processes. For example, the process for Open status is set to send request comment notifications to users while the Interim Approval and Approval statuses are tied to Approval Management extensions (AMX) and triggers approval rules.

Status Types

Status types are predefined statuses that determine the behavior of change order when it is in that status. For example, when a change order is in **Open** status, then change can be authored. A status type is used to categorize statuses.

Predefined statuses:

- **Open**: The change order can be updated. Item changes are typically authored while a change order is in this status.

Note

A predefined request comment notification is associated with the **Open** status. The change order cannot move to the next status until this notification has a

response. The notification is then sent automatically to the assignee and the requestor.

This automatic notification can be bypassed by removing the assignees. If the notification is bypassed and the BPEL process is set to automatically promote then the change order automatically moves to the next status. Otherwise, you need to manually move the change order to the next status.

Refer to Notifications for list of status types and their default notifications.

- **Interim Approval:** An intermediate approval on the item changes before the final approval. This status can be configured along with **Open** status to allow users to author item changes progressively.

There is an approval workflow associated with this status type which is based on AMX rules as shown in Status Types Sequence below.

- **Approval:** This status is used to track approvals. A change order cannot be updated while in this status. Once approval is granted, AMX rules automatically promote the change order to **Scheduled** status.
- **Scheduled:** The changes are ready to be pushed into production on the effective date given on a change order line. The change order cannot be updated in this status.
- **Completed:** All change lines are completed. A change cannot be reopened or canceled once in this status. All change order types are configured to end in the **Completed** status by default.

Promoting and Demoting Changes Automatically

You can explicitly promote or demote a change order to its different statuses. Change orders may also be promoted or demoted to the next status automatically after the completion of the workflow in a specific status.

The following table shows which of the status types require user configuration to enable automatic promotion, which status types have automatic promotion enabled by default, and which status types can be set for automatic demotion

Status Type	User configuration required during Setup for automatic promotion	Default automatic promotion	Change order can be set for automatic demotion
Open	Yes	No	No
Interim Approval	Yes	No	Yes
Approval	No	Yes	Yes
Scheduled	No	Yes	No
Completed	No	No	No

Status Types Sequence

The following list shows a typical status sequence on a change order type:

1. Draft
2. Open 1

3. Interim Approval 1
4. Open 2
5. Interim Approval 2
6. Approval
7. Scheduled
8. Completed

This status sequence would drive the lifecycle of a change order as follows:

- In the initial open status (Open 1), item changes to certain attributes can be authored which are then routed through an interim approval (Interim Approval 1).
- Once interim approval for those changes is granted, changes to additional attributes which might be tied to the attributes changed in the initial open status (Open 1) can now be authored in the subsequent open status (Open 2) which are then routed through a second interim approval (Interim Approval 2).
- All these changes then get routed for final approval during the Approval status. After approval the change order gets scheduled and is completed once the changes are pushed into production on the effective date specified at the change order line.

Creating Change Statuses

The predefined statuses are organized within status types and can also be used as change statuses.

You can also create new change statuses specific to your business processes on the Access the Manage Change Statuses page in Functional Setup Manager.

When you create a change status, select a status type and optionally, the date when the status will be disabled.

Note

You cannot add a status to a change order type once it is disabled.

Change Order Types: Explained

Change order types are the basis of new change orders. A change order type includes information on how a change order is generated, processed, and propagated

When you define or edit a change order type, you specify information for the following:

Number Generation Method

Specify a method for generating numbers for change orders that use this change order type.

Workflow

Each change order type contains lifecycle processes based on predefined and user-defined statuses. You can associate different statuses to the change order type and sequence them to define a workflow.

Propagation Rules

Specify the organizations from which a change order might be propagated. For each specified source organization, select one or more target organizations or organization hierarchies where the change order can be propagated.

Change Order Propagation Rules: Explained

Change order propagation rules determine how changes are propagated from one organization to one or more different organizations.

This allows you to implement changes in multiple organizations by propagating change orders to organizations (eliminating the need create change orders in each selected organization) while still having the flexibility to adapt implementation schedules based on individual organizations. Organization hierarchies can also be used to propagate changes to multiple organizations.

Associating Propagation Rules to Change Order Types

Propagation rules are associated with the change order type that you select for the new change order. You define propagation rules when you create a change order type or edit an existing one on the Propagation Rules tab.

Specify the organizations from which a change order might be propagated. For each specified source organization, select one or more target organizations or organization hierarchies where the change order can be propagated.

Each change order type can be configured to support propagation from different organizations and propagation to different organizations or organization hierarchies.

Using Change Order Status to Control Propagation

Change order statuses are used to determine when a change order gets propagated to different organizations.

For each organization or organization hierarchy that you add to the propagation rule:

- Select a change order status for propagation.
- Choose **auto-propagate** and the propagation rule will execute automatically when the change order enters the specified status.
- Select the status of the propagated change in the organizations selected for propagation. This is the status the propagated change is set to in the selected organizations.
- Set one of the specified organizations or organization hierarchies as default for the propagating organization.

Number Generation Methods: Explained

There are three number generation methods.

The three number generation methods are:

- Sequence Generated
- User-Defined
- Rules

Sequence Generated

If the new item request numbering method is sequence generated, then all item number requests will be automatically generated based on the sequence generation rules specified. You can specify a prefix, starting number, increment, and suffix. Enter a starting number and an increment value to determine the sequencing

User-Defined

You enter the new item request number at the time of creation.

Rules

New item request number is generated based on the rule set associated with it.

Change Order Approval Required Rules: Explained

Rules can require approval through a change order when certain changes are made to an item.

Approval required rules are triggered when you make these changes to an item and will add the changes to a new or existing change order.

Approval required rules are supported for the following areas

- Items
- Item revisions
- Item supplier

Changes to item attributes and structures fall under item and item revisions

Changes to item revision attributes and item supplier associations fall under item supplier

If an approval required rule is triggered on any item changes that fall into one of the three areas listed above, then all changes authored for that item that fall under that area will be added to a change order.

For example, a rule is defined that requires approval if a primary structure is created for any item.

During a single session directly editing an item, a user changes the value of an item level attribute and then creates a primary structure for that item.

On saving the data, the approval required rule will be triggered because of the new primary structure and the user is prompted to either create a new change order or add to an existing one.

When the new change order is created or an existing change order is updated, then the change to the value of the item attribute will also get added to the change order along with the primary structure change for required approval.

Approval Required Rules and User Groups

The approvals can be from individual users or from multiple users in a predefined user group. Because individual rules can be made for specific item revisions, attributes, or structures one rule can require approvals from one user group when an attribute is changed, while changes made to a different attribute will require approvals from a different user group.

For example, the new primary structure rule described above requires approvals from members of the TestApprovalGroup user group.

Another rule is defined that requires approval if the scheduled date when changes will be implemented for an item is later than the date 01/01/2012, then approvals are required from the COApprovalSAG approval group

This means that if the user n creates a primary structure for that item, and specifies a scheduled date for the item that is later than 01/01/2012, approval responses are required from both the COApprovalSAG and TestApprovalGroup approval groups.

Change order approval rules are defined and managed through BPM Worklist. For information on how approval rules are defined and managed, refer to the Oracle Fusion Middleware Developer's Guide for Oracle SOA Suite

Define Product Rules

Rules and Rule Sets: Explained

Rules define integrity constraints on the attributes of items and structures. Define integrity constraints on operational as well as on user-defined attributes. Integrity constraints often implement business rules and are created through use of the rules framework. For example, minimum speed must be less than maximum speed.

Rule sets gather multiple rules together and are assigned to an association type, such as attribute groups, item classes, change types, or structure types. They also list valid business entities. For example, item, item supplier, and item revision. This enables the expressions entered to be validated by checking for allowable entities.

If the rule set is assigned to an attribute group, then only the attributes in that group can be used in the rule.

If the rule set is assigned to an item class, then only the attribute groups valid for that item class will be used.

The status of a rule set can be identified as draft. Users can keep a rule set in draft status until the drafting of rules is complete. If so, the rule set is not triggered as regular transactions are completed. During this time, simulation analysis can be run to study the impact of the rule sets on a selected set of existing items, enabling users to make necessary changes. While performing the simulation, the draft rule sets along with other active rule sets are applied on the selected set of items, and the impact is captured; this is handled by an asynchronous scheduled process.

The rules for new item request and change order type associations are used to generate new item request and change order numbers.

There are three types of rule sets and rules:

- Validation
- Assignment
- Composite

Validation

Validation rule sets validate conditions based on attribute values defined for items. They are typically used to model predefined business rules on items.

Each attribute is referenced by its business entity and attribute group name followed by the attribute name. For example, `item.Physical_Attributes.NetWeight`. In this example, `item` indicates that it is an item attribute; `Physical_Attributes` is the internal name of the attribute group, and `NetWeight` is the internal name of the attribute.

Validation rules restrict items that can be added as related items to an item, and restrict the relationship types that can be allowed for items. This restriction could be based on item or item revision-level attributes which could be operational or EFF.

Test the validations by going to the Item Update screens and editing the appropriate attribute groups. Updated values are validated against the rules, and error messages appear on the screen.

Assignment

An assignment rule set determines the value of an item attribute based on the specified condition. Generally, rule sets for assignments should be executed before validations, since they permit you to write validation conditions ensuring that the result of the assignments are valid.

On the Edit Rule Set page, create a rule. For example, `Lead Percent is Total Lead Mass divided by Unit Weight`.

After you create a rule, validate and save it. This enters the first assignment rule into the rule set. Then, if necessary, enter subsequent rules. Rules are executed in the order of their sequence in the rule set. Therefore, if an attribute's expression

depends on a previously calculated value, you must ensure that the previous value appears ahead of the attribute and is therefore computed first.

Composite

Composite rules set can contain both validation and assignment rule sets. They can be used to aggregate rule sets that operate on different attribute groups and item classes.

You create a composite rule set on the Manage Rule Sets page. To define a composite rule set of mixed type, ensure it contains both validation and assignment rule sets. Set the type to Mixed, enabling the creation of a rule set that contains both assignment and validation rule sets. Then add assignment and validation rule sets to the composite rule set.

Defining Rules: Examples

There are many instances when you might need to configure a rule to cover a specific business requirement.

Defining Rules on Multiple Row Attributes

You can write rules that validate and assign information pertaining to all the rows of attribute values in a multiple row attribute group. Additionally, you can define rules that can have criteria for a validation condition that may reside outside the scope of a multiple row attribute group. These criteria could be an item status, lifecycle status, user item type, and more. For example, pricing information (specifically Sale Price) is held in a multiple row attribute group. You can write rules to calculate the sales price by looking at the cost price (which may be a held value or a calculated value) in another single or multiple row attribute group.

You can also write rules to sum up or roll up the value and assign the calculated value in another attribute. Additionally, you can write rules to validate and enforce the sum function of a multiple row attribute group, whereby the sum total of all values for an attribute in a multiple row attribute should add up to a value such as 100. In other words, in a multiple row attribute group, verify that the total in a certain column is not larger than a specified value.

Another example is when you enter an ingredients list and provide a percentage for each ingredient, the values cannot add up to more than 100 percent.

Note

You can achieve the above by using the functions `loop_sum` and `conditional_loop_sum`.

Automatic Assignment of Items to Organizations

You can define assignment rules that automatically assign items to one or more organizations based on item attributes and item revision-level attributes, on another organization assignment, or on a catalog assignment.

For example, you can write rules such as:

- If an item is an In-House item, it should be assigned to Boston Manufacturing and Detroit Manufacturing organizations.
- If an item is a Bought-Out item, it should be assigned to the Texas Distribution Center organization.

On the transaction side, when a user provides a specific value for a particular attribute while creating an item, the item is automatically assigned to a specified organization as defined in the rule.

Validate Organization Assignments

You can define validation rules to validate item organization assignments based on item and item revision-level attributes, or another organization assignment, or a catalog assignment

For example, you can write a rule to enforce the following validation: When the item class of the item is Exadata Servers, the assigned organization cannot be Seattle Distribution Center.

You can set the severity for the rule as Reject, Warning or Needs Approval.

Automatic Assignment of Items to Catalog and Categories

You can define assignment rules that automatically assign items to one or more catalog and categories based on attribute values, or organization assignment, or another catalog assignment. For example, you can write a rule such as: If an item is assigned to Seattle Manufacturing - M1 organization, assign the item to Catalog - Manufactured Products and Category - Eastern Region.

Validate Catalog and Category Assignments

Define validation rules to validate item-catalog and category assignments based on attributes, or an organization assignment, or another catalog assignment. For example: When the item class of an item is Cotton Products, the assigned catalog-category cannot be Winter Wear-Kids.

You can set the severity for the rule as Reject or Warning.

FAQs for Define Product Rules

What are item rules?

Item rules are used to define the integrity constraints of attributes of items and structures. Integrity constraints are defined on operational as well as user-defined attributes. Integrity constraints are often business rules, created using the rules framework. For example, Min Speed < Max Speed or Lead Time < 4 Days.

Item rules can also be used to derive values of certain attributes based on the state of the item.

What's a rule set?

A group of Product Information Management rules for items and related objects.

How can I promote a new item request?

Review your notifications, go to the **Manage New Item Requests** tab and select the row containing your new item request. From the Actions menu, select **Promote**. In the Promote dialog box, you can select from the available phases to promote the new item request. You also must enter a comment when promoting to the next phase.

What number generation methods are available?

There are three number generation methods available. Sequence Generated, User-Defined, and Rules.

What are return types?

Return type can be generic, in which case you specify the target attribute group and target attribute to which the value will be assigned. Otherwise, return type is an item description and item numbers.

What's rule set assigning?

Rules are not active until they are assigned to an appropriate business entity. You use the Setup Rule Set Assignments link to assign a rule set to either an item, item revision, or item supplier business entity.

What's a return type for?

Return type can be generic, in which case you can specify the target attribute group and target attribute for the value to be assigned to. Otherwise return type can be item description and item number to generate assignment rules.

What's a rule sequence?

Rule sequence dictates the order in which rules are executed. They are typically entered in 10s, but can be 1, 2, 3 or 100, 200, 300.

What's a rule-builder expression?

Rule-builder expressions enable you to specify the body of a rule. For example, an If Expression or a Validation Condition. Note that right-click functionality is enabled to assist in selecting attributes that participate in the rule expression.

What's a severity equals warning?

Severity can be warning, reject, or needs approval

In the case of warning, a message is displayed to the user but they are allowed to continue.

In the case of reject, a message is displayed and the user must fix the issue before proceeding.

In the case of needs approval, changes made by the user must be approved through a change order.

What's a validation condition?

A validation condition is evaluated when the result of an "If Expression" is "True." Only when the validation condition evaluates to "False" will a message be displayed. For example, if you created a rule where the width of an item is greater than its length and the validation condition is false, if a user tried to define an item where the width of the item is greater, a message will display saying the length must be greater than the width.

What's the difference between assignment rule sets and validation rule sets?

Assignment rule sets are used to determine the value of an item attribute based on a specified condition.

Validation rule sets specify the rules to determine the validity of an item.

What's the hierarchy of rules and rule sets?

Both assignment and validation type rule sets can be added to a composite rule set thus creating a hierarchy.

What's the user message and where does it display?

The user message is displayed when the validation condition evaluates to FALSE. They can be displayed by the module consuming the rules framework and also, be displayed as a dialog box.

Define New Item Requests

Number Generation Methods: Explained

There are three number generation methods.

The three number generation methods are:

- Sequence Generated
- User-Defined
- Rules

Sequence Generated

If the new item request numbering method is sequence generated, then all item number requests will be automatically generated based on the sequence generation rules specified. You can specify a prefix, starting number, increment,

and suffix. Enter a starting number and an increment value to determine the sequencing

User-Defined

You enter the new item request number at the time of creation.

Rules

New item request number is generated based on the rule set associated with it.

New Item Request Definition Phase: Explained

During the definition phase, definition notifications are routed to participants for them to complete the item's definition tasks.

Define an Item

From the **Manage New Item Requests** page, search for the New Item Request.

Launch the new item request from the **Search Results** table by clicking on a new item request link. That will take you to the New Item Request page.

Click on the Details sub tab and select the definition row. In the definition Workflow Details table, select Expand All from the Actions menu.

Click the Go to Task icon for the entity that needs definition. The item page appears where you enter the item information. The item definition page is rendered dynamically for each participant, where you can only enter the attributes or item entities for which you are responsible for.

New Item Requests Workflow Processes: Explained

There are four predefined New Item Request (NIR) workflow statuses which enable you to perform various tasks when a new item request is created. You cannot create new statuses or delete statuses.

The four statuses are:

- Open
- Definition
- Approval
- Completed

Open

New item request attributes and items are defined and updated when the workflow status is open. A seeded request comment notification is associated with this status and the new item request cannot move to the next status until this notification has been responded to. The notification will be sent to the assignee and the requester of the new item request. However, to bypass the notification, assignees can be removed through customization by a programmer.

Assignees would then need to promote the new item request to the next status manually or set it to automatically promote to the next status in the Business Process Execution Language (BPEL) process.

Definition

In the definition workflow status, you define the item information, such as specifications, structures, and packs. Additional items cannot be added in this workflow status. The definition workflow steps are defined at the item class level. Based on the definition steps, a notification is sent to those responsible for defining the item. Once the item is defined, you then promote the new item request to approval status manually or to be automatically approved in the BPEL process.

Approval

When approval is granted, the new item request cannot be modified. Approval notifications are sent to the approvers based on the rules set up in Approval Management Extensions (AMX). Once the new item request is approved, the status is automatically changed to completed.

Completed

During the completed phase, the NIR is in its final stage and its lifecycle is completed. It cannot be modified.

New Item Request Approval Phase: Explained

During the approval phase of a new item request, approval notifications are routed to the participants.

The approvals can be from individual users or from multiple users in a predefined user group. From the notification, you can approve or reject the new item request.

New item approval rules are defined and managed through the Approval Management Engine. For information on how approval rules are defined and managed, refer to the Oracle Fusion Middleware Developer's Guide for Oracle SOA Suite.

FAQs for New Item Requests and Change Orders

What number generation methods are available?

There are three number generation methods available. Sequence Generated, User-Defined, and Rules.

Can I mark item definitions as mandatory?

Yes. When setting up the definition steps for **New Item Requests** at the **Item Class**, you will be able to mark various item details as mandatory, at each step.

This ensures that item information required for a downstream step is defined and available for use.

Any item definition available to be set up for definition through new item requests can be marked as mandatory while creating the new item request definition steps at the item class. This includes entities such as:

- operational
- extensible flexfields
- structures and packs
- supplier associations
- organization assignments
- attachments
- catalog category assignments
- relationships

Can I enforce New Item Request mandatory steps on the user side?

Yes. Enforcing mandatory definition on the user side ensures that item definitions are completed as required by the item class. Any definitions marked as mandatory in the definition workflow at the item class level are enforced. Mandatory definitions will be identified in the **definitions page** and must be completed before allowing the workflow to proceed to the next step.

Missing definitions are listed during save and will cause an error message when clicking the done button on the definition notification.

Can new item requests be automatically promoted and demoted?

Yes. The seeded **New Item Request Type** provides promotion and demotion configuration. This enables you to set up automatic promotion and demotion rules at the new item request type level.

Can Request Comment notification be skipped in a new item request in open status?

Yes. When **Skip Request Comment** is enabled for open status, Request Comment notifications will not be sent for a New Item Request.

Can I make changes to item organization assignment and route it for approval through a change order?

Yes. You can enable an item in a child organization through a change order. By providing an effective date for the assignment, you can ensure that the item is available for transaction in the child organization from the specified date only. If approval routings are enabled for the change order, you can seek approvals on the item organization assignment before enabling the item in a child organization.

If approval routings are enabled for the change order, you can seek approvals on the item organization assignment before enabling the item in a child organization.

Can Request Comment notification be skipped in a change order in open status?

Yes. When **Skip Request Comment** is enabled for open status, **Request Comment** notifications will not be sent for a change order.

How can I view the mandatory definitions when defining an item, viewing notifications or from new item request details page?

When defining an item, below the header **View Required Definitions** link will open a window listing the required definition entities. From notification and **New Item Request Details** page click the **Details** icon in the **Required Definition Values** column which will open up the same listings.

What does All Values Required mean?

When checked definition of the entire entity is required and business entity is **Item Operational Attributes** and **All Values Required** is checked, all attributes within the selected attribute group are moved by default to selected list and the view is read-only

Can mandatory definitions be inherited?

If the association is inherited and **All Values Required** is not checked, then inherited-required attributes from parent will be displayed in read only format under selected list and you can move additional required attributes from available list to selected list.

If the association is inherited and **All Values Required** is checked in parent, then **All Values Required** is read only and inherited attributes will be placed under selected list also in read only format.

Define Product Source Systems

Managing Product Source Systems: Explained

Manage source system attributes for the import and data quality options of the data being consolidated and imported into Oracle Product Information Management Data Hub.

Source System Setup

The set up of a source system is accomplished by Oracle Trading Community Model.

Editing Source Systems

The task of managing source systems involves the editing of the additional attributes that you associate with a source system. These attributes control data quality and import options.

Data Quality and Import Options

Data quality and import options defined for a source system are defaulted for a batch, thus eliminating the need to redefine them when you are creating batches.

Define Customers for Product Management

Trading Community Model Data Import Objects: Explained

Import objects are business entities that can be imported into the trading community model registry, for example, competitors, partners or resource teams. When you create a data import batch you should choose which business entity, or object, you are importing from the batch into the trading community model registry. For example, if you are responsible for resource management, you might want to import objects such as employee resource and resource team.

The import process flow will change according to which object you have selected. There are two import process flows for the following sets of objects:

1. Customer, reference, competitor, and custom party.
2. Employee resource, resource team, partner, and partner contact.

Customer, Reference, Competitor, and Custom Party

When you select these objects you will receive the option to check for duplicates within the import batch before the import, and the option to check for duplicates between the import batch and the trading community model registry before import. You will also be able to choose to preview data before it is imported, specify if addresses will be cleansed before import, and set how many errors you will allow before the import is terminated.

Employee Resource, Resource Team, Partner, and Partner Contact

If you choose to import these objects you will not be able to deduplicate the batch or registry data. However, you will be able to choose to preview data before it is imported, specify if addresses will be cleansed before import, and set how many errors you will allow before the import is terminated.

Defining the Import Process for Customers and Consumers: Points to Consider

Oracle Fusion Applications provides two utilities to import data, File-Based Import and Data Import. File-based Import allows you to import data directly

from a CSV or XML file. Data Import imports data from interface tables once the tables are populated by an external process. Data Import cannot be used in a Cloud deployment, because you cannot populate interface tables using an external process in a Cloud deployment. In Cloud deployments, you can only use File-based import to import data. However, even if you are using File-based Import, you can use the Data Import dashboard to monitor the import job and view reports and statistics. You can choose to pause a File-Import batch, and use Data Import work area to configure data quality services, monitor import jobs, view errors, and view batch statistics. Import activities are paused if the **HZ_IMP_PAUSE_FILE_IMPORT** profile option is set to Yes in the Manage Import Profile Options page. If the profile option is set to Yes, all submitted import activities are sent for administrator review and appear in the Data Import Batches Overview page.

Before importing data into the registry, you need to decide if you want to use the data quality services and if so, how you want to configure the data quality services.

The data quality services are:

- Batch deduplication
- Registry deduplication
- Import to registry options

Batch Deduplication

Within the batch deduplication page you can decide if you want to identify and resolve duplicates within the batch that you are importing from the interface tables. If you want to check for duplicates you need to choose what match configuration rule you want to use to identify duplicates for each entity. Then you need to specify what action will be taken on the persons, organizations, and address duplicates found within the batch. Your specified actions will be performed on the batch before the data is imported into the registry.

Registry Deduplication

Similar to batch deduplication, registry deduplication identifies duplicates between the data in the batch and the data in the registry before the data is imported into the registry. If you want to check for duplicates you need to choose what match configuration rule you want to use to identify duplicates for each entity. Then you need to specify what action will be taken on the persons, organizations, and address duplicates found in the registry deduplication check. Your specified actions will be performed when you import the batch into the registry.

Import to Registry Options

When defining an import process you can decide whether to run the import process in preview mode, or you can choose to load the data directly into the registry without previewing the data. You can also choose to cleanse addresses prior to import, validate addresses in an import batch against geography data, and define an error limit for the batch.

Import Process Mode

You can choose to run the import batch in preview mode, or you can skip the preview and load the data directly into the registry.

If you select to run the batch in preview mode you will be able to review information about the level of duplicates or incorrect addresses in the batch data before the data is actually imported. You will also be able to preview how many records will be created and how many records will be updated for each entity. You can then continue to import the batch, or you can amend the match configuration rules and actions to be taken on the identified duplicates and then rerun the batch to review the data again.

If you do not want to review the batch data before it is imported into the registry, then you can choose to skip the preview and allow the data to be loaded into the registry as soon as preprocessing is complete. You may prefer not to preview the batch data if the data source is frequently used.

Note

The Define Import: Import to Registry page is the only place that you can specify if you want to run the batch in preview mode. Once the option to skip the preview mode is selected, and you submit the batch for processing, you will not be able to review the batch data before it is imported.

Cleanse Addresses

You can choose to validate the addresses in the interface tables before importing them into the registry. The addresses are validated using an integrated third party service that verifies addresses and corrects them if they are incorrect.

Geography Validation

You can choose to validate the addresses in an import batch against geography data before importing them into registry. The addresses are validated against the master reference geography data, according to the geography-based address validation settings for each country. The addresses with validation errors are not imported. However, Geography Name Referencing is run on all imported addresses regardless of this profile option setting.

Error Handling Limit

You can define how many process errors can be generated by the import batch process before the process terminates automatically. Error reports are generated by the application for you to review.

Performing What-If Analysis on Data Import Batches: Worked Example

This example demonstrates how to perform What-If analysis on a data import batch that has been processed and has completed with a status of pre-import completed. The match configuration is redefined and the import process is resubmitted. The batch deduplication actions are then amended, and the batch import is completed.

The following table summarizes key decisions for this scenario.

Decisions to Consider	In This Example
Do you want to redefine batch deduplication match configuration?	Yes, a different match configuration is selected for the organizations entity.
Do you want to redefine registry deduplication match configuration?	Yes, a different match configuration is selected for the persons entity.
What actions do you want to take on Persons, Organizations, and Addresses duplicates?	<ul style="list-style-type: none"> • Within registry deduplication, choose Do not import duplicate records for Persons and Organizations. • Within registry deduplication, choose Import duplicate records for Addresses.

Prerequisites

1. The data import batch has been created.
2. The data is uploaded into the interface tables.
3. The batch is imported and has completed with a status of pre-import completed.

Viewing the What-If Analysis

1. On the Data Import Batches Overview page, click on the batch ID URL.
2. On the Edit Data Import Batch page, review the summary and import process performance information. Click **Import Details** to open the What-If analysis page.
3. On the Import Process Details page, click the **Batch Deduplication** tab. Check that you are satisfied with the batch deduplication results.
4. On the Import Process Details page, click the **Registry Deduplication** tab. Check that you are satisfied with the registry deduplication results.
5. On the Import Process Details page, click the **Address Cleansing** tab. Check that you are satisfied with the address cleansing results.

Redefining the Match Configuration and Resubmitting the Import Process

The results of the batch and registry deduplication are not as expected and so the match configurations need to be redefined.

1. On the Import Process Details page, click **Cancel**.
2. On the Data Import Batches Overview page, click on the batch name. Click **Actions** and then click **Import**.
3. On the Define Import: Batch Deduplication page, choose a different match configuration for the organizations entity. Click **Next**.
4. On the Define Import: Registry Deduplication page, choose a different match configuration for the persons entity. Click **Next**.

5. On the Define Import: Import Registry page, click **Submit**

Changing the Action for Duplicates within the What-If Analysis

You want to view the What-If analysis for the new match configurations that you selected for the batch.

1. On the Data Import Batches Overview page, click on the batch ID URL.
2. On the Edit Data Import Batch page, review the summary and import process performance information. Click **Import Details** to open the What-If analysis page.
3. The new match configurations have produced satisfactory results, but you would like to change the actions that will be carried out on the duplicates. On the Import Process Details page, click the **Registry Deduplication** tab.
4. For the Persons and Organizations duplicates, choose **Do not import duplicate records** from the choice list.
5. For the possible duplicates for Addresses, choose **Import duplicate records** from the choice list.
6. Click **Complete Import**.

Defining the Import Process for Customers and Consumers: Worked Example

This example demonstrates how to create an import batch, and how to define the import process data quality services you want to use on the data prior to completing the import.

Note

Once an import is completed, the data is loaded into the Trading Community Model registry.

Create an import batch containing customer and consumer objects, load the import data into the interface tables, and configure the data import process so that you can view the batch in preview mode to check that all duplicate data are removed.

Creating an import batch

1. On the Data Import Batches Overview page, click on the **Create Data Import Batch** task located in the task pane.
2. On the Create Data Import Batch page, complete the fields as shown in this table:

Field	Value
Batch Name	Customer Import Batch

Source System	Comma separated values
Object	Customer and Consumer
Estimated Number of Records	300
Batch Description	Import of customer data

3. Click **Save and Close**
4. After creating the import batch, load your data into the interface tables using a standard ETL tool.

Defining the Data Import Process: Batch Deduplication

You want to check the batch for address, organization, and person duplicates; you also want to remove all of these duplicates from the batch.

1. On the Data Import Batches Overview page, highlight the Batch Name, but do not click on the Batch ID URL.
2. Click **Actions** and then click **Import**.
3. On the Define Import: Batch Deduplication page, select the **Check for duplicates within the batch before import**.
4. Complete the fields in the **Select match configuration to determine duplicates within the import batch** section, as shown in this table:

Field	Value
Addresses	Batch Location Basic Duplicate Identification
Organizations	Batch Organization Basic Duplicate Identification
Persons	Batch Person Basic Duplicate Identification

5. Complete the fields in the **Override Default Actions** section, as shown in this table:

Field	Value
Select Action for Persons and Organizations	Remove all duplicates
Select Action for Addresses	Remove all duplicates

6. Click **Next**.

Defining the Data Import Process: Registry Deduplication

You want to check for address, organization, and person duplicates between the import batch and the Trading Community Model registry; you also do not want to import duplicate records.

1. On the Define Import: Registry Deduplication page, select the **Check for duplicates between the import batch and the registry before import**.
2. Complete the fields in the **Select match configuration to determine duplicates within the import batch** section, as shown in this table:

Field	Value
Addresses	Batch Location Basic Duplicate Identification
Organizations	Batch Organization Basic Duplicate Identification
Persons	Batch Person Basic Duplicate Identification

3. Complete the fields in the Override Default Actions section, as shown in this table:

Field	Value
Select Action for Persons and Organizations	Do not import duplicate records
Select Action for Addresses	Do not import duplicate records

4. Click **Next**.

Defining the Data Import Process: Import to Registry

You want to configure the data import process so that you can view the batch in preview mode, enabling you to review the data after preprocessing. You want to cleanse addresses before they are imported, and specify an error limit for the batch. You also want to validate all addresses in the import batch against geography data. This validates all incoming addresses as per the geography structure and validation level setup in Manage Geographies task. The addresses that are reported as Error during validation are not imported.

1. On the Define Import: Import to Registry page, select **Run the batch in preview mode**.
2. Select **Cleanse addresses before import**.
3. Select **Validate address against geography**.
4. In the **Error Limit** field, enter 200.
5. Click **Submit**.

FAQs for Define Customers for Product Management

Can I redefine the data import process for an already imported batch and reimport it?

Yes. If the data is still available in the interface tables and the batch status is **Preimport Completed**, **Completed with Errors**, **Error**, or **Terminated when**

Error Limit Reached, then you can redefine the data import process and reimport the batch. However, once a batch has been successfully imported then you will not be able to reimport the batch, even if the data is present in the interface tables.

How can I view the errors that occurred during preimport processing?

You can view any errors that occurred after submitting the batch for import by selecting the batch in the data import batches Overview page, and then click **Report**.

What happens if I purge a data import batch?

You permanently remove all records in the batch from the import interface tables. You should purge batches after the batch has been imported successfully and you are sure that the data in the interface tables is no longer required.

Purging the interface tables improves import performance. To archive imported data, you should copy the data to a set of custom tables.

Why can't I purge a data import batch?

Data import batches cannot be purged when they have a status of **Processing**. Purging a batch purges the batch data in the interface tables and so cannot be carried out while the batch is importing the data from the interface tables into the registry.

Why did I receive a message that the data enrichment process was declined?

The Oracle Fusion Trading Community Data Quality service may be unavailable, or you may not have the necessary licenses for the Data Quality service.

Can I try and import a batch again?

Yes. You can reimport a batch to correct validation errors if the import process status is either **Preimport Completed**, **Completed With Errors**, **Error**, or **Terminated When Error Limit Reached**.

Why can't I view the import process details?

The import process details are only available when you have selected to run the batch in preview mode, and you have submitted the batch for import.

How can I create item relationships between items and customers?

When creating item relationships between items and customers, the customer's information must be imported into the system prior to creating a relationship. The **Define Customers for Product Management** task list contains tasks that support importing customers into the system. The data import batch process for customers is managed using the **Import Person and Organization** task.

Define Advanced Catalogs

What is catalog mapping?

You use **Catalog Category** mapping to map categories of different catalogs to the reporting categories in other catalogs. This feature allows one or more categories within a catalog to be mapped to category in a second catalog. For example, suppose that you want to roll up the costs associated with allow items assigned to a set of categories in catalog. Catalog mapping allows you to select a category in a catalog, and map all the categories in the set to that category. When you use this feature you are required to write code to do the roll up as identified in the example.

Define Data Quality for Products

Defining and Maintaining Data Lens for Product Data Quality: Explained

The quality of product data is enhanced by the ability to check data quality while creating, editing, or importing items. This ability is provided by the integration of Oracle Fusion Product Hub with Oracle Product Data Quality. Oracle Product Data Quality provides classification, standardization, and matching of items, which are services that refine item data and prevent duplicate items.

In order to provide the ability to check data quality, you must initially define and later maintain a data lens in Oracle Product Data Quality, using metadata extracted from item classes and catalogs. A data lens uses semantic technology and contextual knowledge to clarify and cleanse product data as it enters a data repository.

Classification, Standardization, and Matching

Classification, standardization, and matching are the features that perform data quality checking.

In Oracle Product Data Quality, after you have initially set up the semantic model, you define rules for the following:

- **Classification:** rules that classify data items as belonging to the appropriate item class based on the values of certain attributes. Classification also includes suggested assignments of items to one or more catalogs and to categories within those catalogs.
- **Standardization:** rules that make the values of specified item attributes consistent with desired norms.
- **Matching:** rules for detecting when an item that is being created or imported matches an item that already exists in the Oracle Fusion Product Hub repository.

Extract Metadata for the Semantic Model

Before end users can check data quality in Oracle Fusion Product Hub, you must initially set up the semantic model in Oracle Product Data Quality. The semantic model is a fully configured data lens, which contains detailed contextual information about your data, and which contains your definitions for classification, standardization, and matching.

The foundation for the classification service is the hierarchy of your item classes and item catalogs. Consequently, you must set up the hierarchies for item classes and item catalogs, in Oracle Fusion Product Hub, before you extract metadata for building the semantic model.

Data quality depends primarily on the values of attributes. While defining an item class, select the attributes to be used when checking data quality, in the order that you want them to be applied for data quality checking. All selected attributes are used for classification and standardization. You can also select attributes to be used for matching duplicate items. In Oracle Product Data Quality, you later define the detailed rules for the relationships between these data quality attributes.

When the item hierarchies are in place, select the relevant catalogs and item classes on the Manage Catalogs or Manage Item Classes page, then select **Actions - Extract Data Quality Metadata**. This action schedules the Data Quality Metadata Extract process, which extracts metadata from the item class and catalog tables of Oracle Fusion Product Hub into an external file. The extract process includes the child hierarchy of the catalog or item class, and all of its attribute information. You can examine the results of the process on the Manage Scheduled Processes page, where you can also directly schedule the Data Quality Metadata Extract process.

In Oracle Product Data Quality, the AutoBuild feature uses extracted metadata for item classes and catalogs to construct the semantic model required for data quality checking.

You can also provide the AutoBuild feature with sample item data by exporting the results of an item search into an external spreadsheet, then transferring that spreadsheet data into Oracle Product Data Quality. To export the data, perform a search on the Manage Items page, then in the Search Results section, select **Actions - Export to Excel**.

For more information on transferring the extracted metadata, setting up the semantic model, and using AutoBuild, see the documentation for Oracle Product Data Quality, especially the following:

- Oracle Product Data Quality PIM Connector User's Guide
- Oracle Product Data Quality AutoBuild Reference Guide

Maintaining the Data Lens

As your data store evolves, you can continue to adjust the semantic model, modifying the rules, and extracting item class and catalog metadata.

Profile Options

The following profile options must be set when working with Oracle Product Data Quality.

Display Name	Internal Name	Description
Oracle Product Data Quality DSA name	EGI_DSA_NAME	The name of the Oracle Product Data Quality DSA (Data Service Application) that is used to perform data quality checks on items. The default value is PRODUCT_HUB_DSA, which can be changed as needed.
Concurrent Requests for DSA	EGI_DSA_SERVER_THRESHOLD	The number of requests that the Oracle Product Data Quality DSA can support at a given time. This value is dependent on the server capacity on the user side.

Regional and Local Area Search

Regional Item Work Area Search

A regional search in the Item work area provides modes for general-item searches, including, Autosuggest, Key Word Search, and SQL searching.

The autosuggest option is enabled for the input field of the regional area.

Regional Item Search Parameters

The following are some of the parameters for Regional Item Search.

Autosuggest Search

Autosuggest is enabled for the item input text box in the Regional Area search. As you enter characters into the item input text box, suggested search topics are displayed in a drop-down list. Select a value from the drop-down list and click the **Go** icon to initiate your search.

SQL Search

SQL search is available only in the local area of the Item work area. To access it, click the **Advanced** link of the Item regional area search. For more details, see Local Area Item Search, below.

Keyword Search

Oracle Text technology provides keyword searching capabilities that uses data extracted from values in the items table and set up in an indexed file. The indexed data is set up by the administrator and is set up to run periodically. Additional indexes can be added by the administrator as needed. By default, regional search uses the following item attributes in the index:

- Item Number
- Description
- Item Class
- Long Description
- Organization Code
- Manufacturer

The Oracle Text search engine can be configured by the administrator to support features including:

- Word Stemming
- Wildcards
- Synonym Matches
- Fuzzy Searching
- Dictionary Matching
- Soundex Searching

Oracle Text is case insensitive.

Operators

The operators in the following table can be used with search expressions:

Operator	Operator	Operator
Operator Precedence	ABOUT	ACCUMulate (,)
AND (&)	Broader Term (BT, BTG, BTP, BTI)	EQUIvalence (=)
Fuzzy	HASPATH	INPATH
MDATA	MINUS (-)	Narrower Term (NT, NTG, NTP, NTI)
NEAR (;)	NOT (~)	OR ()
Preferred Term (PT)	Related Term (RT)	soundex (!)
stem (s)	Stored Query Expression (SQE)	SYNonym (SYN)
threshold (>)	Translation Term (TR)	Translation Term Synonym (TRSYN)
Top Term (TT)	weight (*)	wildcards (%_)
WITHIN		

You can use the following wildcards, which are features of Oracle Text search, to enhance your search:

- Percent sign (%) matches 0 or more characters
- Underscore (_) matches 0 or 1 character
- Backslash (\) escapes wildcard characters (%_, or \)

Word Stemming

Word stemming allows word stems such as run to match other parts of speech such as ran, running, and runs. Word stemming requires that a dictionary be installed by the administrator and word stemming enabled for search. The operator stem (\$), where \$ is the word you wish to search using stemming, is used for stemming in search criterion.

Fuzzy Operator

The fuzzy operator is used to expand a query to include words that are spelled similarly to the term entered in the search criterion. The fuzzy operator is helpful for finding accurate results when there is frequent misspelling.

Synonym Operator

The synonym operator SYN enables the query to be expanded to include terms that are defined in a thesaurus as synonyms for specified terms.

Soundex Operator

The soundex operator ! enables the query to be expanded to include words that have similar sounds. This function enables comparison of words that are spelled differently, but sound alike in English or a 7-bit character set. For examples search '!Smythe' might return 'Smith'.

Oracle Text allows users to join keywords such as AND or OR within a single search criterion. Additionally, quotes can be used to indicate that characters within the quotes are to be searched in exact order.

Within Operator

The within operator allows the narrowing of a query down into document sections. Document sections can be one of the following:

- Zone Sections
- Field Sections
- Attribute Sections
- Special Sections (sentence or paragraph)

ABOUT Operator

The ABOUT operator allows the return of documents that are related to a query term or phrase. In English and French, ABOUT enables you to query on concepts, even if a concept is not actually part of a query. For example, an ABOUT query on heat might return documents related to temperature, even though the term temperature is not part of the query.

AND and OR Operators

The AND operator allows searching where at least one occurrence of each of the query terms exists. The OR operator allows searching where at least one occurrence of any of the query terms exist.

Dictionary Matching

Dictionary matching of the search terms can be enabled and requires a dictionary to be set up for the search. The spelling of terms in the input fields is checked against the dictionary to provide corrections to term misspellings.

Local Item Search Parameters

A local area search in the Item work area provides modes for general-item searches, including, Autosuggest, Key Word Search, and SQL searching.

Local Area Item Search Parameters

Item local area search is available in the Manage Items page and provides a search region in which users can enter values in one or more search fields, add search fields, and trigger the search.

The Manage Items search region has a default saved search, which defines the search fields that are displayed when the Manage Items page is initially opened. You can define your personal saved searches consisting of search fields to be used in the search. The seeded saved searches and personal saved searches are selected in the saved search drop list.

The Manage Item SQL follows the standards for search, but there are minor differences between the regional area or local area search and are listed below.

Wildcards

Multicharacter Wildcards: "%" and "*" must be interpreted as a wildcard that matches any character string, including spaces and special characters.

Single-Character Wildcards: "_" must be interpreted as a wildcard that matches any single character.

Literals: Literal "_", "%", and "*" characters must be preceded by the escape character "\"

Note

Wildcards as such "%" are not allowed at the start of a value and are not allowed for Item Number in the item search (due to performance reasons).

Conditions for the Search Criteria

As you select conditions for a search, drop-down lists will display only values that are appropriate to the scope of your search.

Required Fields

Some search fields are required. A blue asterisk indicates a require field. Two green asterisks indicate that at least one in a set of search fields is required.

Keyword Search Field

The Keyword search field is added to the search region to allow the user to search both with SQL and with keyword search. The keyword search field uses the same features as the regional area search, except that the autosuggest feature is not available. When a user enters values for both the keyword search fields and other search fields, the keyword search and SQL search are performed separately. The results from both are displayed in the search result table.

Define Transactional Business Intelligence Configuration

Define Transactional Business Intelligence Configuration: Highlights

Configure Oracle Transactional Business Intelligence for ad hoc reporting, review certain setup objects to be used in Transactional Business Intelligence, and manage the presentation catalog and currency type display.

Defining Transactional Business Intelligence Configuration

- Review details about the Transactional Business Intelligence tasks. Refer to the Oracle Fusion Transactional Business Intelligence Administrator's Guide.

Access to Person Data

Assigning Security Profiles to Job Roles for Oracle Fusion Transactional Business Intelligence Users: Explained

Users of Oracle Fusion Transactional Business Intelligence (Transactional Business Intelligence) need access to some person data for reporting purposes. To provide this access, you assign a predefined security profile to relevant job or abstract roles using the Oracle Fusion Human Capital Management (HCM) setup task Manage Data Role and Security Profiles. On completion of this task, Oracle Fusion Data Security is updated automatically for roles being used to access Transactional Business Intelligence.

Job or Abstract Roles and Related Security Profiles

The following table identifies, by Oracle Fusion product, the job and abstract roles that need access to person data and the predefined security profile that you assign to each role.

Product	Job or Abstract Role	Security Profile
Oracle Fusion Assets	Asset Accountant	View All Workers

Oracle Fusion Assets	Asset Accounting Manager	View All Workers
Oracle Fusion Enterprise Planning and Budgeting	Budget Analyst	View All Workers
Oracle Fusion Enterprise Planning and Budgeting	Budget Manager	View All Workers
Oracle Fusion Financial Consolidation Hub	Consolidation Accountant	View All Workers
Oracle Fusion Financial Consolidation Hub	Consolidation Manager	View All Workers
Oracle Fusion Financials Common Module	Intercompany Accountant	View All Workers
Oracle Fusion General Ledger	Financial Analyst	View All Workers
Oracle Fusion General Ledger	General Accountant	View All Workers
Oracle Fusion General Ledger	General Accounting Manager	View All Workers
Oracle Fusion Incentive Compensation	Incentive Compensation Participant Manager	View Manager Hierarchy
Oracle Fusion Inventory Management	Warehouse Manager	View All Workers
Oracle Fusion Project Foundation	Project Accountant	View All Workers
Oracle Fusion Project Foundation	Project Administrator	View All Workers
Oracle Fusion Project Foundation	Project Billing Specialist	View All Workers
Oracle Fusion Purchasing	Buyer	View All Workers
Oracle Fusion Sourcing	Category Manager	View All Workers
Oracle Fusion Sourcing	Sourcing Project Collaborator	View All Workers

For example, as part of their Transactional Business Intelligence setup:

- Oracle Fusion Assets implementors must assign the predefined security profile View All Workers to the Asset Accountant and Asset Accounting Manager job roles.
- Oracle Fusion Incentive Compensation implementors must assign the predefined security profile View Manager Hierarchy to the abstract role Incentive Compensation Participant Manager.

The security profiles that HCM roles need to access Transactional Business Intelligence are assigned during the setup of HCM data security: no additional setup is required for Transactional Business Intelligence purposes.

Enabling an Oracle Fusion Transactional Business Intelligence User to Access Person Data: Worked Example

This example shows how to assign a security profile to a job or abstract role to enable users with that role to access person data. This task is required for users of Oracle Fusion Transactional Business Intelligence (Transactional Business Intelligence) who do not also use Oracle Fusion Human Capital Management (HCM).

The following table summarizes key decisions for this scenario. When performing this task, use the job or abstract role for your product and the name of the relevant predefined person security profile in place of those shown here.

Decisions to Consider	In This Example
What is the name of the Transactional Business Intelligence job or abstract role?	Warehouse Manager
What is the name of the person security profile?	View All Workers

To perform these tasks, you must have the role IT Security Manager.

1. Launch the task Manage Data Role and Security Profiles.
2. Search for the job or abstract role.
3. Assign the relevant predefined security profile to the job or abstract role.

Launching the Task Manage Data Role and Security Profiles

1. On the Overview page of the Setup and Maintenance work area, click the **All Tasks** tab.
2. In the Search region, complete the fields as shown in this table:

Field	Value
Search	Tasks
Name	Manage Data Role and Security Profiles

3. Click **Search**.
4. In the search results, click **Go to Task** for the Manage Data Role and Security Profiles task.

Searching for the Job or Abstract Role

1. On the Manage HCM Data Roles page, enter the job name Warehouse Manager in the **Role** field.
2. Click **Search**.
3. In the search results, highlight the entry for the Warehouse Manager job role.
4. Click **Assign**.

Assigning the Security Profile to the Job Role

1. In the **Person Security Profile** field on the Assign Data Role: Security Criteria page, select the security profile View All Workers.
2. Click **Review**.
3. On the Assign Data Role: Review page, click **Submit**.

Define Extensions: Define Custom Enterprise Scheduler Jobs

Managing Job Definitions: Highlights

Oracle Enterprise Scheduler jobs are run in Oracle Fusion Applications to process data and, in some cases, to provide report output. A job definition contains the metadata that determines what the job does and what options are available to users who run the job. You can create and maintain job definitions for use in Oracle Fusion Applications.

Managing job definitions is fully described in the Oracle Fusion Applications Administrator's Guide. As you read content from that guide, note that the guide describes managing Oracle Enterprise Scheduler, including job definitions, from Oracle Enterprise Manager Fusion Applications Control. You can also access job definitions by starting in the Setup and Maintenance Overview page and searching for the Enterprise Scheduler job tasks for your applications.

Selecting the Appropriate Implementation Task

Each Enterprise Scheduler job definition task uses one Java EE application, which is referenced in the task name. You must use the right task because, to access the product job definition that you want to view or work on, the view objects must be contained in the application. If you do not select the right task, then the job definition will not be displayed properly or function correctly. The application name is usually the same as the product that the job definition belongs to, but not always.

- For example, the Oracle Fusion Payables Java EE application contains the Oracle Fusion Expenses product view objects. To create or maintain a job definition for use in Expenses, you select the Manage Custom Enterprise Scheduler Jobs for Payables and Related Applications task.
- In another example, the Oracle Fusion Payments product view objects are contained in both Oracle Fusion Payables and Oracle Fusion Receivables Java EE applications. You need to select the task appropriate to the job definition for Payments. Use the Manage Custom Enterprise Scheduler Jobs for Receivables and Related Applications task if the job is for receivables functionality, or the Manage Custom Enterprise Scheduler Jobs for Payables and Related Applications task if the job is for payables functionality.

- Use the task description to see the products that correspond to the Java EE application specified in the task name. For example, the description for the Payables task lists Oracle Fusion Payables, Assets, Expenses, and Payments.
- You can view task descriptions in the help window for the task, if any, or in the generated setup task lists and tasks report from the Getting Started page.
- If you have access to the Manage Task Lists and Tasks page, you can also open the details for specific tasks to see the description.
- For general information about product and Java EE application relationships, use Oracle Enterprise Manager Fusion Applications Control (Fusion Applications Control).

See: Topology Section

Viewing and Creating Job Definitions

- You can access predefined and custom job definitions.

See: Viewing Job Definitions

- You can create jobs based on Java, PL/SQL, or any other supported technology.

See: Creating a Job Definition

- If you are using the Setup and Maintenance work area, then the Enable submission from Enterprise Manager check box is available for the job definition.
 - If you do not select this check box, then the job cannot be run from Enterprise Manager.
 - If you select this check box, then you can define parameters for this job definition only in Enterprise Manager. Save the rest of your work on the job definition, and then go to Enterprise Manager if you need to define parameters.

Managing List of Values Sources: Highlights

A list of values source for Oracle Enterprise Scheduler job definitions determines where a list of values comes from and what the specific values are. These lists of values are used in parameters and user properties of job definitions. For example, you can use a source of country values for a Country job parameter.

Managing list of values sources is fully described in the Oracle Fusion Applications Administrator's Guide. As you read content from that guide, note that the guide describes managing Oracle Enterprise Scheduler, including list of values sources, from Oracle Enterprise Manager Fusion Applications Control. You can also access list of values sources by starting in the Setup and Maintenance Overview page and searching for Enterprise Scheduler job tasks.

Registering and Searching for List of Values Sources

- Create list of values sources to register them for use in job definitions.

See: Registering Sources for Lists of Values

- Search for list of values sources to edit or delete, or to make sure a particular source does not already exist before you create it.

See: Searching for List of Value Sources

Customization and Sandboxes

Customizing Pages Using Oracle Composer: Highlights

You can customize dashboards and some work areas, where available, for all or some users based on a selected customization layer, for example only for users in a specific country or with a specific job role. When you select to customize a page from the **Administration** menu in the global area, you invoke Oracle Composer, which enables the customization. The Administration menu is only available if you have appropriate roles.

From the same menu, you can also:

- Customize the global area.
- Access the Customization Manager, which displays a list of components in the current page and details about the layers in which each component is customized.
- Access sandboxes from the Administration menu, to make customizations to a runtime use session before deploying your changes to the mainline.

Customizing pages using Oracle Composer, the Customization Manager, and sandboxes are described in the Oracle Fusion Applications Extensibility Guide.

Editing Pages

- Customizations that you can make to existing pages include adding content and changing layout.

See: Editing a Page in Oracle Composer

- You can also update display and other options for specific components within the page.

See: Editing Component Properties in Oracle Composer

Global Page Template

- Customize the global area at the site layer.

See: Editing the UI Shell Template Used by All Pages

Customization Manager

- Use Customization Manager to analyze and diagnose customization metadata, and to perform customization related tasks that cannot be done in the user interface, for example to revert customizations to a

previous version. You can also do direct customization by manipulating the metadata and uploading it back.

See: Using Customization Manager to Manage Runtime Customizations

Sandboxes

- Create or select an appropriate sandbox, and set it as active to capture your customizations using Oracle Composer. When you are ready, you publish the sandbox to make your changes available to users.

See: Using the Sandbox Manager

Sandboxes: Highlights

Use a sandbox to commit customizations to a runtime use session for validation before deploying changes to the mainline. Administrators create and manage sandboxes. An active sandbox isolates changes from the mainline and other users.

Sandboxes can contain the following types of customization changes.

- Metadata, such as non-flexfield UI page customizations
- Data security
- Generated flexfields business components

Metadata changes are captured in a metadata sandbox. Data security changes are additionally captured in a data security enabled sandbox. Changes to a flexfield are captured in a flexfield that is deployed as a single flexfield sandbox. Once you are ready to make sandbox changes available in the mainline, you either publish the metadata or data security sandbox, or deploy the flexfield. Only metadata and data security sandboxes can be downloaded as a sandbox file for import to another Oracle Fusion Applications instance.

The following table lists the differences among the types of sandboxes.

Type of Changes	Type of Sandbox	Method for Making Changes Available in Mainline	Downloadable?
Metadata	Sandbox	Publish sandbox	Yes
Data security	Sandbox enabled for data security changes	Publish sandbox	Yes
Flexfield	Flexfield deployed as a flexfield-enabled sandbox	Deploy flexfield	No

Only one sandbox can be active at a time. Changes made while a sandbox is active are captured in that sandbox.

For more information on using the Sandbox Manager, and customizing and securing pages, business objects, data, and custom objects in a sandbox, see the Oracle Fusion Applications Extensibility Guide.

Managing a Page Customization Sandbox

You can make metadata (MDS) type changes in a sandbox, including menu customizations, changes to the personalization menu, implicit ADF customizations, or changes made with Oracle Composer or CRM Application Composer.

- If you are entitled to do so, manage sandboxes in the Sandbox Manager.

See: Using the Sandbox Manager

- Implement customizations on an existing page to change the metadata of a sandbox before deploying the changes to the mainline.

See: Customizing Existing Pages

- Using CRM Application Composer, customize business objects in a sandbox before deploying the changes to the mainline.

See: Customizing Objects

Managing a Data Security Sandbox

You can create a sandbox for data security testing, or designate an existing sandbox to become enabled for data security testing.

- If you are entitled to do so, manage data security-enabled sandboxes in the Sandbox Manager.

See: Using the Sandbox Manager

- If you customize business objects in CRM Application Composer, you may need to define data security policies to make them accessible to users.

See: Defining Security Policies for Business Objects

- If you create new business objects, you need to secure them.

See: Customizing Security for Custom Business Objects

Managing a Flexfield Sandbox

You create a flexfield-enabled sandbox by deploying one flexfield to a sandbox using the Manage Flexfield task flow. The flexfield sandbox gets its name from the flexfield you deploy. You cannot test two flexfields in the same sandbox. Once you deploy a flexfield as a sandbox, you must sign out and back in to view how the sandbox runtime reflects the flexfield changes, such as new segments. You can redeploy the same flexfield to the same sandbox repeatedly as you make incremental changes to the flexfield setup.

- Since a flexfield sandbox cannot be published, any page customizations or data security in the flexfield sandbox cannot reach the mainline when the flexfield is deployed to the mainline. If you have entitlement to do so, see Deploying a Flexfield to a Sandbox: Points to Consider.
- If you are entitled to do so, manage flexfield-enabled sandboxes in the Sandbox Manager.

See: Using the Sandbox Manager

Moving Common Reference Objects

Moving Common Reference Objects: Overview

The common reference objects in Oracle Fusion Middleware Extensions for Applications are used by several setup tasks in the Setup and Maintenance work area. The common reference objects become a part of the configuration package that is created for an implementation project. While moving the application content, for example, from the test phase to the production phase of an implementation, you must pay special attention to the nuances of these common reference objects.

Parameters

The common reference objects are represented as business objects. A single object can be referenced in multiple setup tasks with different parameters. In the configuration package that is created for the implementation project, parameters passed to a setup task are also passed to the business objects being moved. As a result, the scope of the setup tasks is maintained intact during the movement.

Dependencies

Common reference objects may have internal references or dependencies among other common reference objects. Therefore, it is necessary that all the dependencies are noted before the movement of objects so that there are no broken references among the objects.

Business Objects for Moving Common Reference Objects: Points to Consider

Common reference objects in Oracle Fusion Functional Setup Manager are represented by business objects. These business objects are the agents that contain the application content and carry them across whenever the application setup is moved from one environment to another, for example, test environment to production environment.

Choice of Parameters

The following table lists the business objects, the corresponding movement details, and the effect of the setup task parameter on the scope of the movement.

Note

Only the translation in the current user language is moved.

Business Object Name	Moved Functional Item	Effect on the Scope of Movement
Application Menu Customization	Customizations to the navigator menu	Movement of navigator menu customizations requires manual effort. For details regarding the manual command, refer to the Oracle Fusion Applications Administrators Guide.
Application Message	Messages and associated tokens	No parameters: all messages are moved. moduleType/moduleKey: only messages belonging to the specified module and its descendant modules in the taxonomy hierarchy are moved. messageName/applicationId: only the specified message is moved.
Application Taxonomy	Application taxonomy modules and components	No parameters: all taxonomy modules and components are moved.
Application Attachment Entity	Attachment entities	No parameters: all attachment entities are moved. moduleType/moduleKey: only attachment entities belonging to the specified module and its descendant modules in the taxonomy hierarchy are moved.
Application Attachment Category	Attachment categories and category-to-entity mappings	No parameters: all attachment categories and category-to-entity mappings are moved. moduleType/moduleKey: only attachment categories belonging to the specified module and its descendant modules in the taxonomy hierarchy along with the respective category-to-entity mappings are moved.
Application Document Sequence Category	Document sequence categories	No parameters: all categories are moved. moduleType/moduleKey: only categories belonging to the specified module and its descendant modules in the taxonomy hierarchy are moved. code/applicationId: only the specified document sequence category code is moved.

Application Document Sequence	Document sequences and their assignments	<p>No parameters: all sequences are moved.</p> <p><code>moduleType/moduleKey</code>: only document sequences belonging to the specified module and its descendant modules in the taxonomy hierarchy are moved</p> <p><code>name</code>: only the specified document sequence is moved.</p>
Application Descriptive Flexfield	Descriptive flexfield registration data and setup data	<p>No parameters: all descriptive flexfields are moved.</p> <p><code>moduleType/moduleKey</code>: only descriptive flexfields belonging to the specified module and its descendant modules in the taxonomy hierarchy are moved.</p> <p><code>descriptiveFlexfieldCode/applicationId</code>: only the specified descriptive flexfield is moved.</p> <hr/> <p>Note</p> <p>Importing a flexfield's metadata can change its deployment status and therefore, the affected flexfields must be redeployed. The import process automatically submits affected flexfields for redeployment.</p> <hr/> <p>Note</p> <p>Only flexfields with a deployment status of Deployed or Deployed to Sandbox are eligible to be moved.</p>

Application Extensible Flexfield	Extensible flexfield registration data and setup data, including categories	<p>No parameters: all extensible flexfields are moved</p> <p><code>moduleType/moduleKey</code>: only extensible flexfields belonging to the specified module and its descendant modules in the taxonomy hierarchy are moved.</p> <p><code>extensibleFlexfieldCode/applicationId</code>: only the specified extensible flexfield is moved.</p> <hr/> <p>Note</p> <p>Importing a flexfield's metadata can change its deployment status and therefore, the affected flexfields must be redeployed. The import process automatically submits affected flexfields for redeployment.</p> <hr/> <p>Note</p> <p>Only flexfields with a deployment status of Deployed or Deployed to Sandbox are eligible to be moved.</p>
Application Key Flexfield	Key flexfield registration data and setup data	<p>No parameters: all key flexfields are moved.</p> <p><code>moduleType/moduleKey</code>: only key flexfields belonging to the specified module and its descendant modules in the taxonomy hierarchy are moved.</p> <p><code>keyFlexfieldCode/applicationId</code>: only the specified key flexfield is moved.</p> <hr/> <p>Note</p> <p>Importing a flexfield's metadata can change its deployment status and therefore, the affected flexfields must be redeployed. The import process automatically submits affected flexfields for redeployment.</p> <hr/> <p>Note</p> <p>Only flexfields with a deployment status of Deployed or Deployed to Sandbox are eligible to be moved.</p>

Application Flexfield Value Set	Value set setup data	<p>No parameters: all value sets are moved.</p> <p><code>moduleType/moduleKey</code>: only value sets belonging to the specified module and its descendant modules in the taxonomy hierarchy are moved.</p> <p><code>valueSetCode</code>: only the specified value set is moved.</p> <hr/> <p>Note</p> <p>Importing a value set's metadata can change the deployment status of flexfields that use the value set, and therefore the affected flexfields must be redeployed. The import process automatically submits affected flexfields for redeployment.</p>
Application Reference Currency	Currency data	No parameters: all currencies are moved.
Application Reference ISO Language	ISO language data	No parameters: all ISO languages are moved.
Application Reference Industry	Industry data including industries in territories data	No parameters: all industries are moved.
Application Reference Language	Language data	No parameters: all languages are moved.
Application Reference Natural Language	Natural language data	No parameters: all natural languages are moved.
Application Reference Territory	Territory data	No parameters: all territories are moved.
Application Reference Time zone	Time zone data	No parameters: all time zones are moved.
Application Standard Lookup	Standard lookup types and their lookup codes	<p>No parameters: all standard lookups are moved.</p> <p><code>moduleType/moduleKey</code>: only standard lookups belonging to the specified module and its descendant modules in the taxonomy hierarchy are moved.</p> <p><code>lookupType</code>: only the specified common lookup is moved.</p>

Application Common Lookup	Common lookup types and their lookup codes	<p>No parameters: all common lookups are moved.</p> <p><code>moduleType/moduleKey</code> - only common lookups belonging to the specified module and its descendant modules in the taxonomy hierarchy are moved.</p> <p><code>lookupType</code>: only the specified common lookup is moved.</p>
Application Set-Enabled Lookup	Set-enabled lookup types and their lookup codes	<p>No parameters: all set-enabled lookups are moved.</p> <p><code>moduleType/moduleKey</code>: only set-enabled lookups belonging to the specified module and its descendant modules in the taxonomy hierarchy are moved.</p> <p><code>lookupType</code>: only the specified set-enabled lookup is moved.</p>
Application Profile Category	Profile categories	<p>No parameters: all profile categories are moved.</p> <p><code>moduleType/moduleKey</code>: only categories belonging to the specified module and its descendant modules in the taxonomy hierarchy are moved.</p> <p><code>name/applicationId</code>: only the specified category is moved.</p>
Application Profile Option	Profile options and their values	<p>No parameters: all profile options and their values are moved.</p> <p><code>moduleType/moduleKey</code>: only profile options and their values belonging to the specified module are moved.</p> <p><code>profileOptionName</code>: only the specified profile option and its values are moved.</p>

Application Profile Value	Profile options and their values	<p>No parameters: all profiles and their values are moved.</p> <p><code>moduleType/moduleKey</code>: only profiles and their values belonging to the specified module are moved.</p> <p><code>categoryName/categoryApplicationId</code>: only profiles and their values belonging to the specified category are moved.</p> <p><code>profileOptionName</code>: only the specified profile and its values are moved.</p>
Application Reference Data Set	Reference data sets	No parameters: all sets are moved.
Application Reference Data Set Assignment	Reference data set assignments	<p><code>determinantType</code>: only assignments for the specified determinant type are moved.</p> <p><code>determinantType/referenceGroupName</code>: only assignments for the specified determinant type and reference group are moved.</p>
Application Tree Structure	Tree structures and any labels assigned to the tree structure	<p>No parameters: all tree structures (and their labels) are moved.</p> <p><code>moduleType/moduleKey</code>: only tree structures (and their labels) belonging to the specified module are moved.</p> <p><code>treeStructureCode</code>: only the specified tree structure (with its labels) is moved.</p>
Application Tree	Tree codes and versions	<p>No parameters: all trees are moved.</p> <p><code>moduleType/moduleKey</code>: only trees belonging to the specified module are moved.</p> <p><code>treeStructureCode</code>: only trees belonging to the specified tree structure are moved.</p> <p><code>TreeStructureCode/TreeCode</code>: only trees belonging to the specified tree structure and tree code are moved.</p>

Application Tree Label	Tree structures and any labels assigned to the tree structure	<p>No parameters: all tree structures (and their labels) are moved.</p> <p><code>moduleType/moduleKey</code>: only tree structures (and their labels) belonging to the specified module and its descendant modules in the taxonomy hierarchy are moved.</p> <p><code>treeStructureCode</code>: only the specified tree structure (with its labels) is moved.</p>
Application Data Security Policy	Database resources, actions, conditions, and data security policies	<p>No parameters: all database resources/actions/conditions/policies are moved.</p> <p><code>moduleType/moduleKey</code>: only database resources/actions/conditions/policies belonging to the specified module and its descendant modules in the taxonomy hierarchy are moved.</p> <p><code>objName</code>: only the specified database resource along with its actions/conditions/policies is moved.</p> <hr/> <p>Note</p> <ul style="list-style-type: none"> • If the policies being moved contain reference to newly created roles, move the roles before moving the policies. • If the source and target systems use different LDAPs, manually perform the GUID reconciliation after moving the data security policies.
Application Activity Stream Configuration	Activity stream options	No parameters: all activity stream options are moved.

Moving Related Common Reference Objects: Points to Consider

Certain common reference objects may use other common reference objects creating dependencies among the objects. During the movement of common reference objects, these dependencies or references need to be taken care of.

Dependencies

The dependencies among the common reference objects may be caused by any of the following conditions.

- Flexfield segments use value sets

- Value sets may make use of standard, common, or set-enabled lookups
- Key flexfields may have an associated tree structure and key flexfield segments may have an associated tree code
- Tree codes and versions may be defined over values of a value set
- Data security policies may be defined for value sets that have been enabled for data security

You may choose to move one, some, or all of the business objects by including the ones you want to move in your configuration package. For example, you may choose to move only value sets and not lookups, or you may choose to move both value sets and their lookups as part of the same package. Whatever be the combination, it is recommended that during the movement of objects, you follow an order that maintains the dependencies among the objects.

While moving the business objects, adhere to the guidelines and exactly follow the order as listed below.

1. Move created taxonomy modules before moving any objects that reference them, such as flexfields, lookups, profiles, attachments, reference data sets, document sequences, messages, and data security.
2. Move created currencies before moving any objects that reference them, such as territories.
3. Move created territories before moving any objects that reference them, such as languages and natural languages.
4. Move created ISO languages before moving any objects that reference them, such as languages, natural languages, and industries.
5. Move created tree structures before moving any objects that reference them, such as trees or tree labels.
6. Move created profile options before moving any objects that reference them, such as profile categories or profile values.
7. Move created attachment entities before moving any objects that reference them, such as attachment categories that reference them.

Note

In scenarios where there may be dependencies on other objects, you must move the dependencies before moving the referencing object. For example, if data security policies being moved have dependencies on newly created security roles, you must move the security roles before moving the security policies.

Using Seed Data Framework to Move Common Reference Objects: Points to Consider

To move the common reference objects, you can use the Seed Data Framework (SDF). You can also use the command line interface of SDF to move the object setup data. For more information about seed data loaders including common reference object loaders, see Oracle Fusion Applications Developer's Guide.

Movement Dependencies

The seed data interface moves only the setup metadata. For example, if you use SDF to import flexfield metadata, the flexfield setup metadata is imported into your database. However, you must invoke the flexfield deployment process separately after seed data import to regenerate the runtime flexfield artifacts in the target environment. Similarly, if you use SDF to import data security metadata, you must first move any new referenced roles and then manually run the GUID reconciliation where required.

To ensure that the reference data is not lost during the movement, certain guidelines are prescribed. It is recommended that you perform the movement of object data exactly in the order given below.

Note

Only the translation in the current user language is moved.

1. Move created taxonomy modules before moving any objects that reference them, such as flexfields, lookups, profiles, attachments, reference data sets, document sequences, messages, and data security.
2. Move created currencies before moving any objects that reference them, such as territories.
3. Move created territories before moving any objects that reference them, such as languages and natural languages.
4. Move created ISO languages before moving any objects that reference them, such as languages, natural languages, and industries.
5. Move created tree structures before moving any objects that reference them, such as trees or tree labels.
6. Move created profile options before moving any objects that reference them, such as profile categories or profile values.
7. Move created attachment entities before moving any objects that reference them, such as attachment categories that reference them.
8. Move created reference data sets before moving any objects that reference them, such as reference data set assignments and set-enabled lookups.
9. Move created document sequence categories before moving any objects that reference them, such as document sequences.
10. Move created tree labels before moving any objects that reference them, such as trees.
11. Move created data security objects and policies before moving any objects that reference them, such as value sets.
12. Move created value sets before moving any objects that reference them, such as flexfields.
13. Move created trees before moving any objects that reference them, such as key flexfields.

Glossary

abstract role

A description of a person's function in the enterprise that is unrelated to the person's job (position), such as employee, contingent worker, or line manager. A type of enterprise role.

accounting flexfield

The chart of accounts that determines the structure, such as the number and order of individual segments, as well as the corresponding values per segment.

accounting method

A set of journal entry rules which determine how a subledger journal entry is to be created for each event class or event type.

action

The kind of access named in a security policy, such as view or edit.

ADF

Acronym for Application Developer Framework. A set of programming principles and rules for developing software applications.

AMX

Abbreviation for Approval Management extensions.

application feature

A standardized functionality that is available to implemented.

application identity

Predefined application level user with elevated privileges. An application identity authorizes jobs and transactions for which other users are not authorized, such as a payroll run authorized to access a taxpayer ID while the user who initiated the job is not authorized to access such personally identifiable information.

application role

A role specific to applications and stored in the policy store.

Applications Core

Abbreviation for Oracle Fusion Middleware Extensions for Applications. The technical product code is FND.

assignment

A set of information, including job, position, pay, compensation, managers, working hours, and work location, that defines a worker's or nonworker's role in a legal employer.

attribute

A named entity whose value describes a product item. Attributes can be organized into attribute groups. You can search for items based on attribute values, by adding attribute fields when using Advanced Search (but you cannot search on transactional attributes). You can compare the attribute values of selected items returned by an item search.

automatic assignment catalog

A non-hierarchical catalog to which categories that match the catalog's Catalog Structure value are automatically added. Add categories and share categories actions are disabled for this catalog configuration.

balancing segment

A chart of accounts segment used to automatically balance all journal entries for each value of this segment.

beneficiary

A person or organization designated to receive benefits from a compensation plan on the death of the plan participant.

BPEL

Business Process Execution Language; a standard language for defining how to send XML messages to remote services, manipulate XML data structures, receive XML messages asynchronously from remote services, manage events and exceptions, define parallel sequences of execution, and undo parts of processes when exceptions occur.

business function

A business process, or an activity that can be performed by people working within a business unit and describes how a business unit is used.

business object

A resource in an enterprise database, such as an invoice or purchase order.

business unit

A unit of an enterprise that performs one or many business functions that can be rolled up in a management hierarchy.

calendar event

A period that signifies an event, such as a public holiday or a training course, that impacts worker availability.

catalog

A collection of categories used to classify items which can be organized into a hierarchy that represents a taxonomy.

category

Catalog component that is associated to a catalog to classify items.

chart of accounts

The account structure your organization uses to record transactions and maintain account balances.

clause adoption

Reusing a clause from the global business unit in local business units either by adopting the clause without change or by localizing it.

clause localization

A type of clause adoption where the adopted clause is edited to suit the local business unit needs.

competency

Any measurable behavior required by an organization, job, or position that a person may demonstrate in the work context. A competency can be a piece of knowledge, a skill, an attitude, or an attribute.

condition

An XML filter or SQL predicate WHERE clause in a data security policy that specifies what portions of a database resource are secured.

content item

An individual quality, skill, or qualification within a content type that you track in profiles.

content library

A repository of the content types and individual content items that can be associated with person profiles and profiles for workforce structures such as jobs and positions.

content type

An attribute such as a skill, quality, or qualification that is added to a profile.

context

A grouping of flexfield segments to store related information.

context segment

The flexfield segment used to store the context value. Each context value can have a different set of context-sensitive segments.

context-sensitive segment

A flexfield segment that may or may not appear depending upon a context such as other information that has been captured. Context-sensitive segments are custom attributes that apply to certain entity rows based on the value of the context segment.

contingent worker

A self-employed or agency-supplied worker. Contingent worker work relationships with legal employers are typically of a specified duration. Any person who has a contingent worker work relationship with a legal employer is a contingent worker.

contract deviations

Differences between the contract terms in a contract and those in the contract terms template applied to that contract and any deviations from company policies as determined by Contract Expert feature rules.

Contract Expert

A feature of the application that permits you to create business rules in the Contract Terms Library to enforce corporate policies and standards for contracts.

Contract Terms Library

A repository of standard clauses, contract terms templates, and business rules built using Contract Expert.

corporate rate type

Rate you define to standardize rates used in conversion of one currency to another over a period of time. This rate is generally a standard market rate determined by senior financial management for use throughout the organization.

cost center

A unit of activity or group of employees used to assign costs for accounting purposes.

cost organization

A grouping of inventory organizations that indicates legal and financial ownership of inventory, and which establishes common costing and accounting policies.

country holding company

A legal entity that acts on behalf of several divisions within an enterprise, and is the legal employer in a country.

data dimension

A stripe of data accessed by a data role, such as the data controlled by a business unit.

data instance set

The set of human capital management (HCM) data, such as one or more persons, organizations, or payrolls, identified by an HCM security profile.

data role

A role for a defined set of data describing the job a user does within that defined set of data. A data role inherits job or abstract roles and grants entitlement to access data within a specific dimension of data based on data security policies. A type of enterprise role.

data role template

A template used to generate data roles by specifying which base roles to combine with which dimension values for a set of data security policies.

data security

The control of access to data. Data security controls what action a user can taken against which data.

data security policy

A grant of entitlement to a role on an object or attribute group for a given condition.

database resource

An applications data object at the instance, instance set, or global level, which is secured by data security policies.

department

A division of a business enterprise dealing with a particular area of activity.

descriptive flexfield

Customizable expansion space, such as fields used to capture additional descriptive information or attributes about an entity, such as customer cases. Information collection and storage may be configured to vary based on conditions or context.

descriptive flexfield

An extendable field that captures additional information.

determinant

A value that determines which reference data set will be used in a specific business context.

determinant type

Designates the field within transactional columns that controls how data is shared across organizations such as business unit, asset book, cost organization or project unit. The type determines the reference data sets that would be used in a transaction.

determinant type

An additional and optional field within transactional columns (besides category and application) that is used to assign document sequences. The available determinant types are Business Unit, Ledger, Legal Entity, and Tax Registration.

determinant value

A value specific to the determinant type dimension of a document sequence. The determinant value is relevant in a document sequence assignment only if the document sequence has a determinant type. If Ledger is the determinant type for a document sequence, the determinant value is the specific ledger number whose documents are numbered by the document sequence.

division

A business-oriented subdivision within an enterprise. Each division is organized to deliver products and services or address different markets.

document sequence

A unique number that is automatically or manually assigned to a created and saved document.

duty role

A group of function and data privileges representing one duty of a job. Duty roles are specific to applications, stored in the policy store, and shared within an Oracle Fusion Applications instance.

educational establishment

A school, college, university, or other learning institution.

employment terms

A set of information about a nonworker's or employee's job, position, pay, compensation, working hours, and work location that all assignments associated with the employment terms inherit.

enterprise

An organization with one or more legal entities under common control.

enterprise role

Abstract, job, and data roles are shared across the enterprise. An enterprise role is an LDAP group. An enterprise role is propagated and synchronized across

Oracle Fusion Middleware, where it is considered to be an external role or role not specifically defined within applications.

entitlement

Grants of access to functions and data. Oracle Fusion Middleware term for privilege.

ESS

Acronym for Enterprise Storage Server. An application that optimizes data storage.

extensible flexfield

Customizable expansion space, as with descriptive flexfields, but able to capture multiple sets of information within a context and multiple contexts grouped to appear in a named region of a user interface page. Some extensible flexfields allow grouping contexts into categories.

feature choice

A selection you make when configuring offerings that modifies a setup task list, or a setup page, or both.

fixed rate type

Rate you set between two currencies that remains constant. For example, a rate set between the euro currency and each Economic and Monetary Union (EMU) currency during the conversion to the euro currency.

flexfield

Grouping of extensible data fields called segments, where each segment is an attribute added to an entity for capturing additional information.

flexfield segment

An extensible data field that represents an attribute on an entity and captures a single atomic value corresponding to a predefined, single extension column in the Oracle Fusion Applications database. A segment appears globally or based on a context of other captured information.

free-form content type

A content type that contains a code, name, and description only, and does not contain any properties until you add it to a profile type.

function security

The control of access to a page or a specific widget or functionality within a page. Function security controls what a user can do.

global area

The region across the top of the user interface. It provides access to features and tools that are relevant to any page you are on.

grade

A component of the employment model that defines the level of compensation for a worker.

GTIN

Abbreviation for Global Trade Identification Number

HCM

Abbreviation for Human Capital Management.

HCM data role

A job role, such as benefits administrator, associated with specified instances of Oracle Fusion Human Capital Management (HCM) data, such as one or more positions or all persons in a department.

identity

A person representing a worker, supplier, or customer.

instance qualifier set

A set of values that uniquely identifies multiple instances of the same profile item.

interface table

A database table used for transferring data between applications or from an external application or data file.

inventory organization

A logical or physical entity in the enterprise that is used to store definitions of items or store and transact items.

inventory organization

An organization that tracks inventory transactions and balances, and can manufacture or distribute products.

item master

A collection of data that describes items and their attributes recorded in a database file.

item organization

Item definition where inventory balances are not stored and movement of inventory is not tracked in the applications. Item attributes that carry financial and accounting information are hidden.

item subinventory

An association of an item with a subinventory that is created when you add an item to a subinventory.

Items

Entries within the Product master database. For example, items for a manufacturing company can include nuts, bolts, and screws.

job

A generic role that is independent of any single department or location. For example, the jobs Manager and Consultant can occur in many departments.

job role

A role for a specific job consisting of duties, such as an accounts payable manager or application implementation consultant. A type of enterprise role.

key flexfield

Configurable key consisting of multiple parts or segments, each of which may be meaningful individually or in combination with the others. Key flexfields are commonly implemented to represent part numbers and account numbers.

key flexfield segment instance

A single occurrence of a key flexfield segment in a key flexfield structure instance.

key flexfield structure

The arrangement of segments in a key flexfield. In some cases, multiple structures can be defined for a single key flexfield.

key flexfield structure instance

A single occurrence of a key flexfield structure that shares the same order of segments as every other instance of the key flexfield structure, but uses different value sets to validate the segments.

legal authority

A government or legal body that is charged with powers such as make laws, levy and collect fees and taxes, and remit financial appropriations for a given jurisdiction.

legal employer

A legal entity that employs people.

legal entity

An entity is identified and given rights and responsibilities under commercial law, through the registration with the country's appropriate authority.

legal jurisdiction

A physical territory, such as a group of countries, single country, state, county, parish, or city, which comes under the purview of a legal authority.

legal reporting unit

The lowest level component of a legal structure that requires registrations. Used to group workers for the purpose of tax and social insurance reporting or represent a part of your enterprise with a specific statutory or tax reporting obligation.

legislative data group

A means of partitioning payroll and related data. At least one legislative data group is required for each country where the enterprise operates. Each legislative data group is associated with one or more payroll statutory units.

line of business

Set of one or more highly related products which service a particular customer transaction or business need. Refers to an internal corporate business unit.

lookup code

A value available for lookup within a lookup type such as the code BLUE within the lookup type COLORS.

lookup type

A set of lookup codes to be used together as a list of values on a field in the user interface.

mainline

A branch of data that serves as a single source of truth.

manufacturing facilities

Employed in the making of goods for sale such as a factory or plant.

model profile

A collection of the work requirements and required skills and qualifications of a workforce structure, such as a job or position.

native catalog

A catalog that a user is managing.

natural account

Categorizes account segment values by account type, asset, liability, expense, revenue, or equity, and sets posting, budgeting, and other options.

natural account segment

A chart of accounts segment used to categorize your accounting transactions by account type: asset, liability, owner's equity, revenue, or expense.

offering

A comprehensive grouping of business functions, such as Sales or Product Management, that is delivered as a unit to support one or more business processes.

OWLCS

Abbreviation for Oracle WebLogic Communication Services. Offers the TPCC service to Fusion applications and sets up the calls via SIP integration with the telephony network.

party fiscal classification

A classification used by a tax authority to categorize a party for a tax.

payroll statutory unit

A legal entity registered to report payroll tax and social insurance. A legal employer can also be a payroll statutory unit, but a payroll statutory unit can represent multiple legal employers.

pending worker

A person who will be hired or start a contingent worker placement and for whom you create a person record that is effective before the hire or start date.

person type

A subcategory of a system person type, which the enterprise can define. Person type is specified for a person at the employment-terms or assignment level.

personally identifiable information

Any piece of information that can potentially be used to uniquely identify, contact, or locate a single person. Within the context of an enterprise, some PII data can be considered public, such as a person's name and work phone number, while other PII data is confidential, such as national identifier or passport number.

PL/SQL

Abbreviation for procedural structured queried language.

position

A specific occurrence of one job, fixed within one department, also often one location. For example, the position Finance Manager is an instance of the job Manager in the Finance Department.

primary ledger

Main record-keeping ledger.

privilege

A grant or entitlement of access to functions and data. A privilege is a single, real world action on a single business object.

profile option

User preferences and system configuration options consisting of a name and a value, that can be set at hierarchical levels of an enterprise. Also called a profile or user option.

profile option level

A level at which profile option values are defined. Site, product, and user are predefined levels.

profile option level hierarchy

The ordering of profile option levels. The order of the levels in the hierarchy determines which levels take precedence.

profile option value

The value portion of a profile option's name and value. A profile option may have multiple values set at different levels, such as site or user.

profile type

A template that defines the content sections of a profile, role access for each section, and whether the profile is for a person, or for a workforce structure such as a job or position.

project expenditure organization

An organization that can incur expenditures and hold financial plans for projects.

PSTN

Abbreviation for public switched telephone network which is the network of the world's public circuit-switched telephone networks.

rating model

A scale used to measure the performance and proficiency of workers.

reference data

Data in application tables that is not transactional and not high-volume such as sales methods, transaction types, or payment terms, and can be shared and used across organizational boundaries.

reference data set

Contains reference data that can be shared across a number of business units or other determinant types. A set supports common administration of that reference data.

reference group

A logical grouping of tables that correspond to logical entities such as payment terms defined across multiple tables or views. Grouping establishes common partitioning requirements across the entities causing them to share the same set assignments.

referenced category

A category within the native catalog that is shared from a designated source catalog. A reference category is not editable.

registration

The record of a party's identity related details with the appropriate government or legal authorities for the purpose of claiming and ensuring legal and or commercial rights and responsibilities.

role

Controls access to application functions and data.

role hierarchy

Structure of roles to reflect an organization's lines of authority and responsibility. In a role hierarchy, a parent role inherits all the entitlement of one or more child roles.

role mapping

A relationship between one or more job roles, abstract roles, and data roles and one or more conditions. Depending on role-mapping options, the role can be provisioned to or by users with at least one assignment that matches the conditions in the role mapping.

role provisioning

The automatic or manual allocation of an abstract role, a job role, or a data role to a user.

sandbox

A runtime session that commits changes out of reach of mainline users.

security profile

A set of criteria that identifies one or more human capital management (HCM) objects of a single type for the purposes of securing access to those objects. Security profiles can be defined for persons, organizations, positions, countries, LDGs, document types, payrolls, payroll flows, and workforce business processes.

security reference implementation

Predefined function and data security in Oracle Fusion Applications, including role based access control, and policies that protect functions, data, and segregation of duties. The reference implementation supports identity management, access provisioning, and security enforcement across the tools, data transformations, access methods, and the information life cycle of an enterprise.

segregation of duties

An internal control to prevent a single individual from performing two or more phases of a business transaction or operation that could result in fraud.

semantic model

A fully configured data lens constructed in Oracle Product Data Quality, which provides the basis for checking data quality. The semantic model contains your definitions for classification, standardization, and matching.

service provider model

A business unit that provides specific business functions for another business unit.

set

Reference data that is organized into groups appropriate to organizational entities, to enable reference data sharing.

set enabled

An entity, such as a lookup, customer, location, organization, or document attachment, that is allowed to participate in reference data sharing by drawing on the data of a reference data set.

shared category

A category within a source catalog that has been added to a native catalog as a referenced category. The category can be shared with one or more catalogs.

SOA

Abbreviation for service-oriented architecture.

spot rate type

Rate you enter to perform conversion based on this rate as of a specific date. This rate applies to the immediate delivery of a currency.

SQL predicate

A type of condition using SQL to constrain the data secured by a data security policy.

storage facilities

Commercial building for storage of goods such as a warehouse.

structure

A bill of materials. A structure contains information on the parent item, components, attachments, and descriptive elements.

system person type

A fixed name that the application uses to identify a group of people.

tax registration

The registration of a party with a tax authority that confers tax rights and imposes certain tax obligations.

territory

A legally distinct region that is used in the country field of an address.

tree

Information or data organized into a hierarchy with one or more root nodes connected to branches of nodes. A tree must have a structure where each node corresponds to data from one or more data sources.

tree structure

Characteristics applied to trees, such as what data to include or how the tree is versioned and accessed.

tree version

An instance of a tree. If a tree is associated with a reference data set, all versions belong to one set. Includes life cycle elements such as start and end date and a status indicator whether the tree is active or not.

user rate type

Rate you enter at journal entry time to convert foreign currency transactions to your functional currency.

value set

A set of valid values against which values entered by an end user are validated. The set may be tree structured (hierarchical).

work relationship

An association between a person and a legal employer, where the worker type determines whether the relationship is a nonworker, contingent worker, or employee work relationship.

workflow

An automated process in which tasks are passed from a user, a group of users, or the application to another for consideration or action. The tasks are routed in a logical sequence to achieve an end result.

XML filter

A type of condition using XML to constrain the data secured by a data security policy.