

SPARC T5-8 Server

Getting Started Guide

This guide describes how to install and power on Oracle's SPARC T5-8 server for the first time using the preinstalled Oracle Solaris OS.

Before performing the procedures in this guide, review the following documents at the Oracle documentation web site: <http://www.oracle.com/goto/t5-8/docs>.

- *SPARC T5-8 Server Product Notes* - For any late-breaking issues that impact installation requirements.
- *SPARC T5-8 Server Installation Guide* - For more detailed installation information.
- *SPARC T5-8 Server Safety and Compliance Manual* - For safety and regulatory compliance information.

For additional safety information, refer to the *Important Safety Information for Oracle's Sun Hardware Systems*, which is in the shipping kit.

Shipping Kit

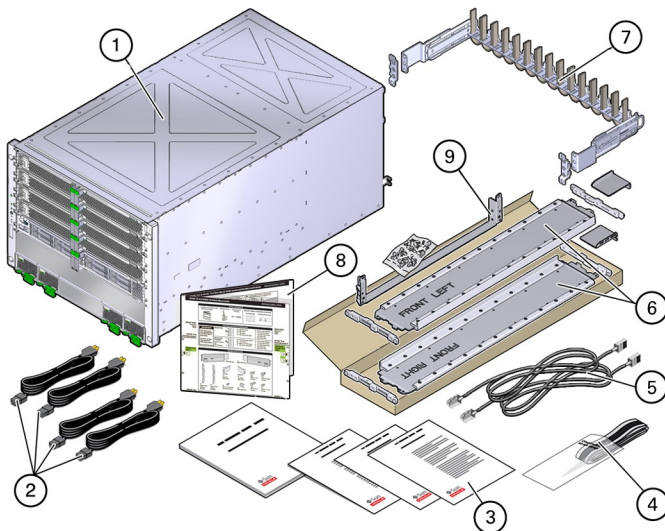

1	Server	6	Rackmounting kit
2	AC power cords (quantity 4)	7	Cable management assembly (CMA)
3	Printed documents	8	Rack card
4	Antistatic wrist strap	9	Shipping bracket
5	Ethernet cable (quantity 2)		

▼ Prepare the Server

1. **After you remove the server from the box, place it on a mechanical lift if one is available.**



Caution - Do not attempt to move the server alone without a lift. At a minimum, the main components must be removed, and two people are required to move the server without a lift.

2. **Remove all of the processor modules, the main module, the power supplies, the fans, and the PCIe carriers.**

For instructions on how to remove these components, refer to the *SPARC T5-8 Server Service Manual*.

3. **Install any PCIe adapters that need to be installed in the PCIe carriers.**

For instructions on how to install these components, refer to the *SPARC T5-8 Server Service Manual*.

4. **Install the installation brackets onto the rack.**

For instructions on how to install the brackets, refer to the *SPARC T5-8 Server Installation Guide*.

▼ Install the Server

For quick installation and configuration, follow these steps. For more detailed information, refer to the complete online product documentation set.



Caution - *Do not apply power until instructed to do so.* This server includes a service processor (SP) that configures and boots the host server. To properly configure the host server and view SP messages, do not apply AC power to the server until you make the SP and host networking connections, as described in this guide.

1. **Place the server in its intended location.**

For rackmounting and CMA instructions, refer to the *SPARC T5-8 Server Installation Guide*.

2. **Install all of the components that you removed, as well as any optional components you plan to use with the server that were not factory installed.**

For instructions on how to install these components, refer to the *SPARC T5-8 Server Service Manual*.

3. **Connect a serial cable between the server's SER MGT port and a terminal device.**

This connection provides the initial communication with the SP. Set up the server to communicate using 9600 baud, 8 bit, no parity, 1 stop bit. For DTE-to-DTE communication, use a RJ-45 crossover adapter with a standard RJ-45 cable to set up a null modem configuration, so that the transmit and receive signals are crossed over.

4. **(Optional) Connect an Ethernet cable between the server's NET MGT port and the network to which future connections to the SP and host will be made.**

Configure the server for the first time through the SER MGT port. After the initial configuration, you can set up communication between the SP and host through this Ethernet interface.

5. **Connect an Ethernet cable between one of the server's NET ports and the network to which the server will communicate.**
6. **Connect the power cords to the power supplies and to separate power sources.**

The server is equipped with two power supplies. Connect them to two separate circuits (200 to 240 VAC) to provide power redundancy.

When the power cords are connected, the SP initializes and the power supply LEDs light. After a few minutes, the SP login prompt displays on the terminal device. At this time, the host is not initialized or powered on.

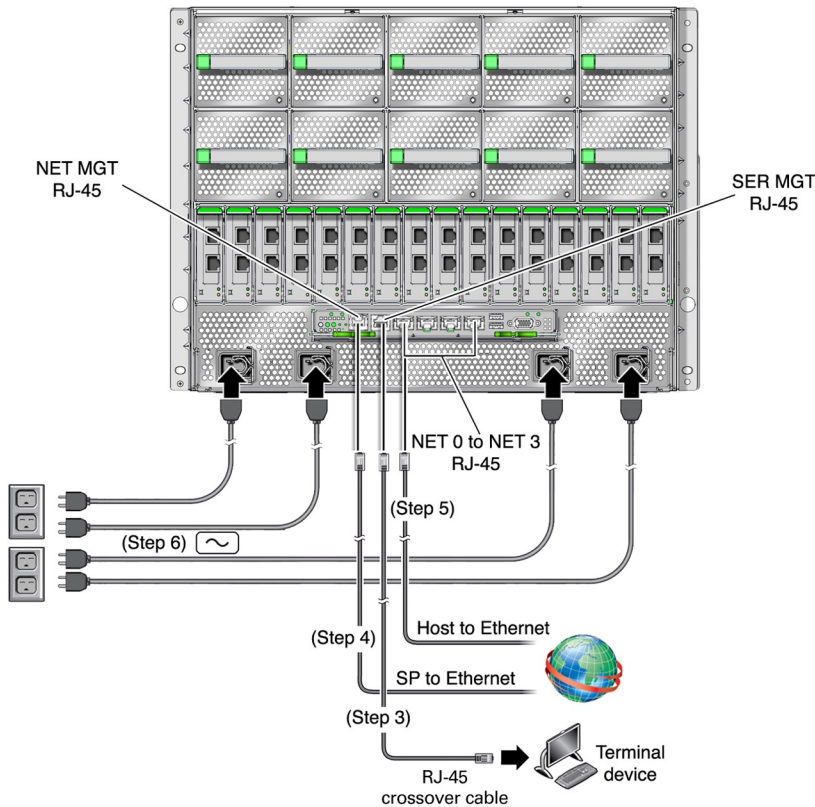

▼ Power On the Server

1. **At the terminal device, log in to the SP as root with a password of changeme.**

After a brief delay, the Oracle Integrated Lights Out Manager (Oracle ILOM) prompt (->) is displayed. For optimal security, change the root password. For more information about administration tasks such as changing passwords, adding accounts, and setting account privileges, refer to the *SPARC T5 Series Servers Administration Guide* and the Oracle ILOM documentation at: <http://www.oracle.com/goto/ilom/docs>

By default, the SP is configured to use DHCP to obtain an IP address. If you plan to assign a static IP address to the SP, refer to the *SPARC T5-8 Server Installation Guide* for instructions.

2. Power on the server and redirect the host output to display on the serial terminal device.

```
-> start /System
Are you sure you want to start /System (y/n)? y
-> start /HOST/console
Are you sure you want to start /HOST/console (y/n)? y
Serial console started.
```

. . .
Server initialization takes several minutes to complete.

To cancel the server initialization, press the #. (Hash+Dot) keys to return to the Oracle ILOM prompt. Then type: `stop /System`

Note - To use an OS other than the preinstalled version, refer to the *SPARC T5-8 Server Installation Guide*.

3. (Optional) Execute other Oracle ILOM commands while the server initialization continues in the background.

- a. **To display the Oracle ILOM prompt, press the #. (Hash+Dot) keys.**
- b. **To see information about available Oracle ILOM commands, type: `help`**
To see information about a specific command, type: `help command-name`
- c. **To return to displaying host output from the server initialization, type: `start /HOST/console`**

4. When prompted, follow the onscreen instructions and type the configuration information for your server.

If you are not sure how to respond, accept the default and make changes later when the Oracle Solaris OS is running. After you confirm the configuration information, the server reboots and displays the Oracle Solaris login prompt.

5. Log in to the server.

You now can enter Oracle Solaris OS commands at the prompt. For more details, refer to the Oracle Solaris 11 OS man pages and documentation at:

<http://www.oracle.com/goto/solaris11/docs>

6. Consider using Oracle virtualization and data center management software.

- **Oracle VM Server for SPARC** is a preinstalled system virtualization feature that gives you the ability to create discrete logical groupings or logical domains (LDoms), each with its own OS, resources, and identity within a single computer system. You can run a variety of applications in different logical domains and keep them independent for performance and security purposes. Go to:

<https://docs.oracle.com/en/virtualization/>

- **Oracle Enterprise Manager Ops Center** is a data center management tool that provides many features, including a comprehensive configuration solution for software provisioning, hardware fault analysis, and performance management. Go to:

<http://docs.oracle.com/en/enterprise-manager/>

▼ **Check for the Latest OS Updates, Patches, and Firmware**

Some server features are enabled only when certain versions of patches or firmware are installed. Install the latest available versions for the best performance, security, and stability.

- 1. Review the product notes for your server.**

This document describes important product dependencies and late-breaking information.

See “[Product Documentation Library](#)” on page 6.

- 2. Download the latest available versions from My Oracle Support at:**

<https://support.oracle.com>

Product Documentation Library

Documentation and resources for this product and related products are available at <http://www.oracle.com/goto/t5-8/docs>.

Feedback

Provide feedback on this document at <http://www.oracle.com/goto/docfeedback>.

Documentation Accessibility

For information about Oracle's commitment to accessibility, visit the Oracle Accessibility Program web site at <http://www.oracle.com/pls/topic/lookup?ctx=acc&id=docacc>.

Access to Oracle Support

Oracle customers that have purchased support have access to electronic support through My Oracle Support. For information, visit <http://www.oracle.com/pls/topic/lookup?ctx=acc&id=info> or visit <http://www.oracle.com/pls/topic/lookup?ctx=acc&id=trs> if you are hearing impaired.

Copyright © 2013, 2016, Oracle and/or its affiliates. All rights reserved.

Copyright © 2013, 2016, Oracle et/ou ses affiliés. Tous droits réservés.

ORACLE[®]

Part No: E35080-05

Mfg. No: 7078107

March 2016

