

Pillar Axiom™ 300



Advanced Hardware Installation Guide

Copyright Notice

Copyright © 2007 Pillar Data Systems, Inc. All rights reserved.

Pillar Data Systems, Inc.

2840 Junction Avenue

San Jose, CA 95134

Part Number: 4420-00090-0000

2007-January

Trademarks

Pillar Data Systems, Pillar Axiom, and the “green icon” logo are trademarks of Pillar Data Systems, Inc. All other trademarks are trademarks of their respective owners.

Important Note to Users

This guide contains CONFIDENTIAL INFORMATION of Pillar Data Systems and should not be disclosed or further distributed to third parties without the express prior written consent of Pillar Data Systems.

This guide and use of Pillar Axiom hardware and software to which this guide applies, is subject to the Pillar Data Systems End User License Agreement and Warranty Statement that accompanied the Pillar Axiom system and this guide. A copy of the Pillar Data Systems End User License Agreement and Warranty Statement is on the same CD with which this guide is provided (if you entered into a signed written agreement with Pillar Data Systems for the purchase/use of this Pillar Axiom system that supersedes the Pillar Data Systems End User License Agreement and Warranty Statement, then such signed written agreement will apply).

Pillar Data Systems reserves the right to change the specifications and content in this guide at any time.

Table of Contents

Chapter 1 Before You Begin

Audience	13
Pillar Axiom System Components	14
Customer-Supplied Materials	14
Safety Notice Conventions	16
Additional Documentation	16
Contact Information	17

Chapter 2 Set Up the Rack

Unpack the Components	18
Position the Rack	19
Connect Multiple Racks	20
Prepare the Racks	20
Attach the Connection Bracket	21
Attach the Baying Plates	22
Adjust the Leveling Legs	24
Stabilize the Rack	25
Install the Anti-Tip Brackets	25
Install a Stabilizer Plate	27
Component Placement	28
Install Slammer Rack Rails	31
Install Brick Rack Rails	34
Install Pilot Rack Rails	37

Chapter 3 Install Components

Install Power Distribution Units	41
Install a Pilot	43
Install a Slammer	45

Install a Brick	47
Install the Slammer Batteries	49

Chapter 4 Connect Data Cables

Cable Requirements	51
Slammer CU Interconnections	52
Brick CU Interconnections	52
Pilot CU Interconnections	53
Connections with One Slammer	53
Pilot-to-Slammer Connections	53
Brick-to-Slammer Connections	54
Connect SATA Bricks to One Slammer	54
Connections with Two Slammers	57
Pilot-to-Slammers Connections	57
Fibre Channel Slammer-to-Slammer Connections	59
Bricks-to-Slammers Connections	60
Connect SATA Bricks to Two Slammers	61
Combine FC and SATA Brick Strings	63
Add SATA Bricks to a FC RAID Brick System	63
Add FC RAID Bricks to a SATA System	66
Rules for Combining Bricks	67
Connect the Cables Between Two Racks	68
Connect to your Network	68

Chapter 5 Connect Power Cables

Cable Connection Procedure	70
Component Power Usage	71
PDU Outlet Amperage Limits	72
Power Cabling Examples	73
One Slammer and Three SATA Bricks	74
One Slammer and 16 SATA Bricks	75

Chapter 6 Complete the Installation

Power On the System	77
Verify Status LEDs	79
Attach the Bezels	82
Install HBA Drivers and Firmware (SAN Only)	84
Set Up Switch Zones for the HBA (SAN Only)	84

Attach the Rack Doors and Panels	84
--	----

Chapter 7 Initial Configuration

Pre-Configuration Checklist.	86
Start the Graphical User Interface (GUI).	87
Configure the System with the Configuration Wizard	89
Configure Global System Parameters	90
Configure NAS Storage Parameters	93
Configure SAN Storage	96
Configure Administrator Accounts	98
Install Axiom Path Manager (SAN Only)	99

Chapter 8 Expansion Planning

Add a New Brick	100
Add a New Slammer	102

Appendix A Slammer LED Startup Progress Codes

Introduction to LED Startup Codes	104
LED Startup Codes	105

Appendix B Safety Statements

Introduction to Safety Statements	110
Safety Statements	110
Warning Notices	110
Lightning Activity Warning	113
Power Supply Warning	114
Main Power Disconnect Warning	116
Installation Warning	116
Power Disconnect Warning	117
Warning Statement for Norway and Sweden	117
Restricted Access Area Warning	118
Product Disposal Warning	119
Jewelry Removal Warning	120
Qualified Personnel Warning	121
Warning Statement for Finland.	122
Warning Statement for Sweden	122
Power Cabling Warning	123
Supply Circuit Warning	123
Voltage Mismatch Warning.	124
SELV Circuit Warning.	125
Incorrect Connection Warning	127

Caution Notices	128
Appendix C Hardware Specifications	
Introduction to Hardware Specifications	130
Axiom Hardware Specifications.	130
System Power Requirements	131
System Environmentals	131
System Regulatory Agency Compliance	133
Regulatory Agency Compliances	133
FCC Warning Statement	135
European Union Compliance Statement	136
System Packaging and Transportation	137
System Warranty	137
Pilot Hardware Specifications	137
Pilot Dimensions and Weight	138
Pilot Power Characteristics	138
Pilot Regulatory Agency Compliance	138
Pilot Packaging and Transportation	139
Slammer Hardware Specification	140
Slammer Dimensions and Weight	140
Slammer Power Characteristics	140
Slammer Regulatory Agency Compliance	141
Slammer Packaging and Transportation	142
Brick Hardware Specification	143
Brick Dimensions and Weight	143
Brick Power Characteristics	143
Brick Regulatory Agency Compliance	144
Brick Packaging and Transportation	145
Axiom PDU Hardware Specification	146
Pillar Rack Hardware Specification	147
Index	150

List of Figures

Figure 1 Floor plan for rack installation 19

Figure 2 Sample 42U side panels 20

Figure 3 Location of frame corners 21

Figure 4 Connection bracket installation 21

Figure 5 Roof baying plate attachment 22

Figure 6 Adjacent anchor bolts at the front of the racks 23

Figure 7 Rack leveling leg locations 24

Figure 8 Leveling leg adjustment 24

Figure 9 Attach anchor bolts to rack 26

Figure 10 Position anti-tip brackets 26

Figure 11 Secure anti-tip brackets to the floor 27

Figure 12 Stabilizer plate attached to the rack base and floor 28

Figure 13 Hardware mapping in a fully loaded 42U rack 29

Figure 14 Hardware mapping for Bricks in additional racks 30

Figure 15 Scope hook attachment 32

Figure 16 Slammer rails installed in rack 33

Figure 17 Scope hook attachment 35

Figure 18 2U rack rails installed in rack 36

Figure 19 Scope hook attachment 38

Figure 20 Positioning spacer bar 39

Figure 21 Pilot rail front attachment 39

Figure 22 Snap-in cage nut 41

Figure 23 Securing a 1U PDU in the bottom of a rack 42

Figure 24 An installed PDU at the bottom of the rack 42

Figure 25 Inserting the upper Pilot server component 44

Figure 26 Inserting a Slammer	46
Figure 27 Inserting a Brick	47
Figure 28 Brick ears	48
Figure 29 Brick front	48
Figure 30 Slammer bezel removal	49
Figure 31 Slammer battery insertion	50
Figure 32 Cables interconnect control units	52
Figure 33 FC cables connect Brick RAID controllers for failover	52
Figure 34 Cat5e cables connect Pilot controllers for failover	53
Figure 35 Pilot cabled to one Slammer	54
Figure 36 Slammer cabled to five SATA Bricks	56
Figure 37 Pilot cabled to two Slammers	58
Figure 38 Fibre Channel Connections between Slammers	60
Figure 39 Slammer cabled to five SATA Bricks	62
Figure 40 FC cables to connect additional SATA bricks to FC RAID Bricks.	65
Figure 41 Mixed Brick system example.	66
Figure 42 Pilot management cables	68
Figure 43 Slammer network cables.	69
Figure 44 Pulizzi TPC2105-1 outlet amperage limits	72
Figure 45 Pulizzi TPC2104 outlet amperage limits	72
Figure 46 Pulizzi PC3365 outlet amperage limits	73
Figure 47 Sample power cabling scheme with 230V power	74
Figure 48 Sample power cabling scheme with 115V on a TCP2105-1 PDU	75
Figure 49 Sample power cabling scheme with 230V (one circuit shown)	76
Figure 50 Secure Slammer batteries.	77
Figure 51 Turn on Brick power	78
Figure 52 Turn on PDU power	78
Figure 53 Pilot bezel LEDs	79
Figure 54 Slammer bezel LEDs	79
Figure 55 Brick bezel LEDs.	80
Figure 56 Pilot connectivity LEDs	80
Figure 57 Pilot connectivity LEDs	81
Figure 58 Brick LEDs	82
Figure 59 Bezel hook on the right side of the bezel	83

Figure 60 Press ejector tabs to lock bezel	83
Figure 61 Configuration Tasks page	89
Figure 62 System Time page	90
Figure 63 Management and Data Path Interfaces page	91
Figure 64 Notification and Account Security Settings page	92
Figure 65 Storage Allocation and Quality of Service (QoS) page	93
Figure 66 Storage Capacity and Performance Settings page	94
Figure 67 Create New File Server page	95
Figure 68 Storage Allocation and Quality of Service (QoS) page for LUNs	97
Figure 69 Storage Capacity and Performance Settings page for a LUN.	97
Figure 70 Maximum tilt angles for stationary Pillar 42 U racks	149

List of Tables

Table 1 Pillar Axiom 300 Series components.	14
Table 2 Required tools	14
Table 3 Required equipment and supplies	15
Table 4 Additional resources.	17
Table 5 Contacts at Pillar Data Systems	17
Table 6 Slammer rail kit parts (not to scale)	31
Table 7 Brick rail kit parts (not to scale)	34
Table 8 Pilot rail kit parts (not to scale)	37
Table 9 FC patch cable purposes	51
Table 10 Cat 5e connections for internal management.	53
Table 11 SATA Brick / Slammer FC connections	55
Table 12 Cat 5e Pilot connections for internal management.	57
Table 13 Cat 5e Slammer connections for internal management.	57
Table 14 Fibre Channel Slammer-to-Slammer connections	59
Table 15 SATA Brick / Slammer FC connections	61
Table 16 Brick / Slammer cables.	63
Table 17 Pillar Axiom component electrical requirements	71
Table 18 Global system parameters	86
Table 19 Code translation for the Fault LED	105
Table 20 Code translation for the Activity LED	106
Table 21 Code translation for the Status LED.	106
Table 22 Slammer LED startup codes	108
Table 23 Electrical warning in other languages.	111
Table 24 Lightning warning in other languages.	114
Table 25 Power supply warning in other languages	114

Table 26 Power disconnect warning in other languages.	116
Table 27 Install instructions warning in other languages.	116
Table 28 Warnings for Norway and Sweden.	117
Table 29 Restricted access warning for other languages	118
Table 30 Product disposal warning for other languages	119
Table 31 Jewelry removal warning for other languages	120
Table 32 Qualified personnel warning for other languages.	122
Table 33 Warnings for Finland	122
Table 34 Warnings for Sweden.	122
Table 35 Power cabling warning for other languages	123
Table 36 Supply circuit warning for other languages	124
Table 37 Voltage mismatch warning for other languages	124
Table 38 SELV circuit warning for other languages	126
Table 39 Connection warning for other languages	127
Table 40 System altitude specifications	131
Table 42 System acoustics specification	132
Table 43 System random vibration specifications.	132
Table 44 Safety, quality, and environmental standards	133
Table 45 EM emissions and immunity.	135
Table 46 Pilot dimensions and weight (both control units)	138
Table 47 Pilot power characteristics (per control unit)	138
Table 48 Pilot safety and quality standards.	139
Table 49 Slammer dimensions and weight	140
Table 50 Slammer power characteristics	140
Table 51 Slammer safety and quality standards.	141
Table 52 Slammer EM emissions and immunity.	142
Table 53 Brick dimensions and weight	143
Table 54 Brick power characteristics	143
Table 55 Brick safety and quality standards	144
Table 56 Brick EM emissions and immunity	144
Table 57 PDU specifications.	146
Table 58 Rack specifications for an Axiom system.	147

CHAPTER 1

Before You Begin

Audience

This guide is for Data Center System Administrators and Professional Services Consultants who install Pillar Axiom storage systems. We assume that you understand how to:

- Assemble hardware components.
- Connect the components to the LAN and to power circuits.
- Use a graphical user interface (GUI) in a web browser.

This guide explains how to:

- Position and stabilize a populated rack in the data center.
- Create rack bays.
- Install hardware components.
- Connect the system to inlet power and to the networks.
- Turn on the system.
- Perform initial configuration.
- Add additional Slammers and Bricks.

Pillar Axiom System Components

This guide explains how to install the following Pillar Axiom 300 Series components in Pillar Data Systems or non-Pillar Data Systems racks:

Table 1 Pillar Axiom 300 Series components

Product name	Model
Bricks	<ul style="list-style-type: none"> BRX 500-160A7 BRX 500-250A7 BRX 500-400A7 BRX 500-500A7
Slammer (and batteries)	<ul style="list-style-type: none"> SLM 500
Pilot	<ul style="list-style-type: none"> Axiom Pilot
Power distribution units (PDU)	<ul style="list-style-type: none"> Pulizzi TPC2104/5 Pulizzi PC3365 Marway

Customer-Supplied Materials

You need the following tools to install a Pillar Axiom system:

Table 2 Required tools







Tool	Purpose	Illustration
1/4-in (7-mm) flat-tip screwdriver	Adjust leveling feet.	
Adjustable wrench, 6 in (15 cm)	Adjust leveling feet.	
#1 and #2 Phillips-head screwdrivers	Remove and secure Pillar Axiom hardware components.	
Socket wrench with a 1/2-in (13 mm) socket	Connect two racks.	

Table 2 Required tools (continued)

Tool	Purpose	Illustration
Torx® T20 screwdriver	Attach rail assemblies to the vertical channels and secure hardware components to the rails.	
Torx T30 screwdriver	Connect two racks.	
Wire cutters	Cut tie wraps.	

Note: Pillar Data Systems does not provide these tools.

To install a Pillar Axiom storage system you need to have the following equipment and supplies before you start:

Table 3 Required equipment and supplies

On hand?	Item	Purpose
<input type="checkbox"/>	At least two power sources on independent circuits with appropriate connectors for the voltage and amperage ratings	Provide power to the PDUs. Axiom systems require redundant power supplies from two PDUs on separate input circuits.
<input type="checkbox"/>	Copper Ethernet switch with two open 10/100 ports	Connect Pilot management ports to the Ethernet LAN.
<input type="checkbox"/>	Two Category 5 100BaseT cables	Connect Pilot management ports to the Ethernet switch.
<input type="checkbox"/>	For each NAS Slammer, two to four GbE-capable (copper or optical) cables	Connect NAS Slammer network data ports to the LAN.
<input type="checkbox"/>	For each NAS Slammer, a copper or optical Ethernet switch with at least two open GbE ports	Each NAS Slammer has four network data ports. At least one port per Slammer control unit (CU) must be connected.
<input type="checkbox"/>	For each SAN Slammer, two to four SAN Fiber-optic cables	Connect SAN Slammer data ports to the fabric.
<input type="checkbox"/>	For each SAN Slammer, two to four open ports on the SAN fabric	Each SAN Slammer has four data ports. At least one port per Slammer control unit (CU) must be connected.

Table 3 Required equipment and supplies (continued)

On hand?	Item	Purpose
<input type="checkbox"/>	Workstation on the same LAN as the Pilot and with a supported browser:	Connect to the AxiomONE Storage Services Manager to carry out the final installation tasks.

Safety Notice Conventions

Hazard signal words conform to the American National Standards Institute (ANSI) Z535.4-1998 meanings. This guide uses the following conventions for safety notices:



Indicates a potentially hazardous situation that, if not avoided, could result in death or serious injury.



Indicates a potentially hazardous situation that, if not avoided, may result in minor or moderate injury.

Important! To emphasize a point, to remind you of something, or to indicate potential problems in the outcome of the in-process task.

A set of important safety notices apply throughout this guide. Read them before working on a Pillar Axiom system. See Appendix B, [Safety Statements](#).

Additional Documentation

Before you install the Pillar Axiom system, refer to the following resources that you completed with the assistance of your Pillar Data Systems representative:

- *Site Preparation Survey*
- *Storage Requirements Survey*

Use the following resources as you work with an Axiom storage system.

Table 4 Additional resources

For information on...	Refer to this document...
Terms used within this document	<i>Pillar Glossary</i>
Axiom system hardware and software architecture	<i>System Architecture Overview</i>
How to configure, monitor, and administer a system	<i>Administrator's Guide</i>
How to develop scripts or set up batch processes	<i>CLI Reference Guide</i>
How to replace or upgrade hardware components	<i>Service Guide</i>

Contact Information

Table 5 Contacts at Pillar Data Systems

For help with...	Contact...
<ul style="list-style-type: none"> • Error messages • Usage questions 	<p>Context-sensitive help that is available in the graphical user interface (GUI).</p> <p>support@pillardata.com.</p> <p>USA: 1-877-4PILLAR (1-877-474-5527)—request Technical Support at the prompt.</p> <p>International: +1 408 518 4400.</p> <p>Web: http://support.pillardata.com/.</p> <p>Have your system serial number ready.</p>
<ul style="list-style-type: none"> • Implementation assistance • System information • Enhancement requests 	<p>sales@pillardata.com.</p> <p>USA: 1-877-4PILLAR (1-877-474-5527)—request Sales at the prompt.</p> <p>International: +1 408 503 4200.</p>
Documentation improvements and resources	<p>docs@pillardata.com.</p> <p>http://www.pillardata.com/techdocs/—log in with your username and password.</p>

CHAPTER 2

Set Up the Rack

Unpack the Components

Each Pillar Axiom storage system is built to a customer's specifications and shipped in a single shipment. Check the components you received against the packing slip (or bill of lading), which lists everything that was shipped. If any components are missing, call 1-877-4PILLAR (474-5527) and report what was not included in your shipment. Note how many pallets or containers you received, in case the missing components are in a container that simply has not yet arrived.



A Brick weighs up to 65 lb (29.5 kg). For safe handling, use two people to lift it.



A Slammer weighs 94 lb (42.6 kg). For safe handling, use two people to lift it.



Before you handle a component, make sure that you have taken electrostatic discharge precautions:

- The minimum requirement is an anti-static wrist strap connected to a hard ground. We recommend that you remove components from their packaging and place them on an ESD-qualified table equipped with ground points for wrist straps.
- Static charges can build up rapidly on rolling carts. If you transport a hardware component by cart, ground the cart with a drag chain on an ESD floor. If there is no ESD cart available or ESD floor, ground yourself before you touch a component that has been transported on a cart.

After you remove the components from their packaging, inspect them for any damage that may have occurred enroute. If there is any damage:

- 1 Check your Terms of Sale to see who notifies the carrier.
- 2 Notify the carrier or Pillar Data Systems, as appropriate, within 72 hours.
- 3 Record all damage.
- 4 Call Technical Support to open a service request for future insurance claims.

Tip: Check the packing materials to verify that you have retrieved all the small parts before recycling.

Important! Pillar Axiom components are compatible with racks that are compliant to the EIA-310-D standard. Pillar Axiom Slammers and Bricks may not install successfully into a rack that is not EIA-310-D compliant.

Illustrations show a Pillar Axiom 42U rack or parts of it. If you have a non-Pillar rack, it should be similar.

Position the Rack

The following figure illustrates a floor plan for new rack installations. The space around the rack (or bay, if you have multiple racks) is needed to perform the installation tasks safely.

Figure 1 Floor plan for rack installation

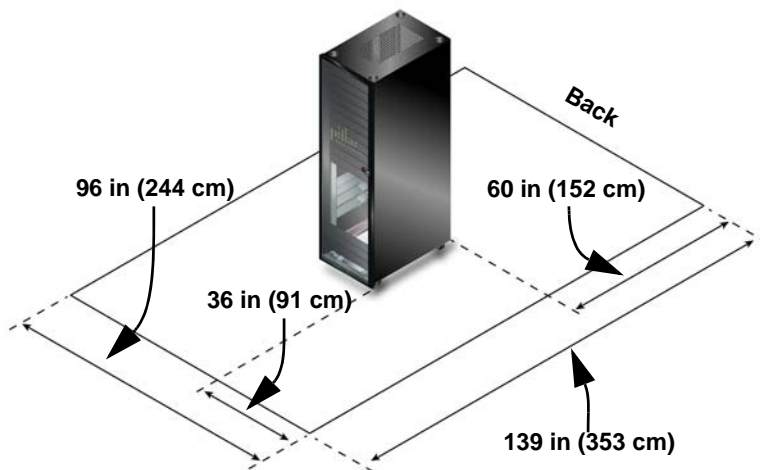

Connect Multiple Racks

If you are installing more than one rack, connect them together first. If you do not have multiple Pillar racks, skip to [Adjust the Leveling Legs](#).

Prepare the Racks

To create a bay of Pillar racks, first remove the adjacent (inner) side panels from each rack and move the racks into position. You will route the cables directly from one rack to the other through the open sides because the cables are not long enough to route through a raised floor.

Figure 2 Sample 42U side panels

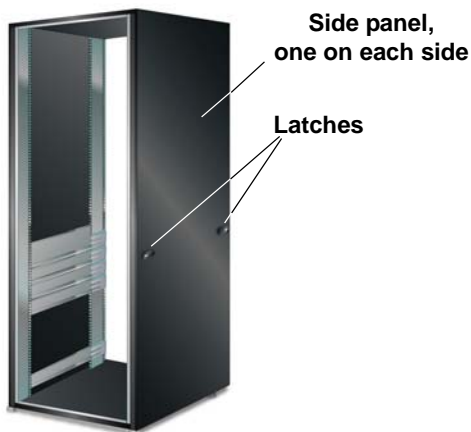

To remove a side panel from a rack:

- 1 If locked, unlock the side panel.
- 2 Unlatch the side panel by:
 - Pushing the release button, or
 - Lifting the release handle(s).
- 3 Remove the side panel and set it aside.
- 4 Position the racks so that their open sides abut and their front sides are flush.

Attach the Connection Bracket

The connection bracket provides extra rigidity to the bay.

Important! Make sure at least one of the racks is not anchored so you can adjust its position as you attach them together.

To attach the connection bracket:

- 1 Locate the two adjacent frame corners at the top and rear of two racks to be connected.

Figure 3 Location of frame corners

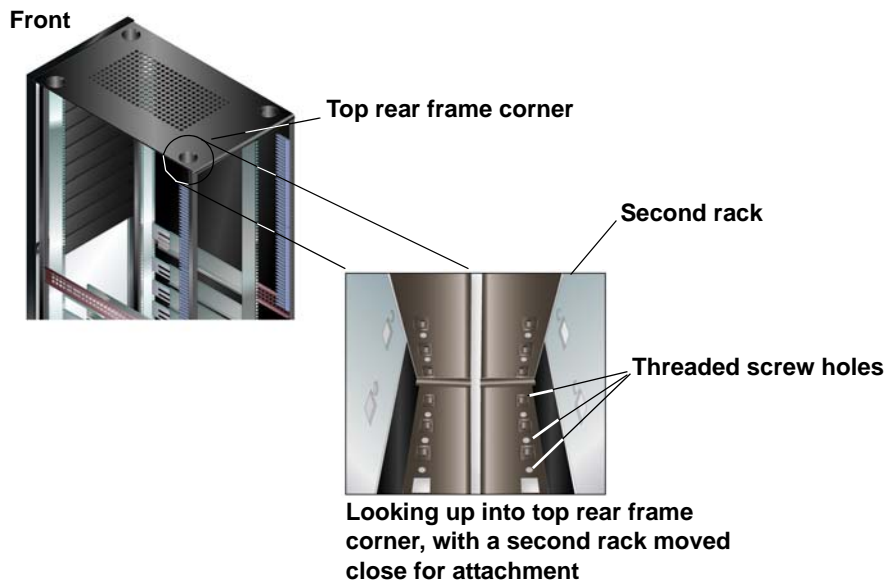

- 2 Place the connection bracket into the frame corner.
- 3 Insert an M8 hex screw through the hole in one of the bracket corners.
- 4 Loosely screw the M8 screw into the threaded hole in the frame.

Figure 4 Connection bracket installation

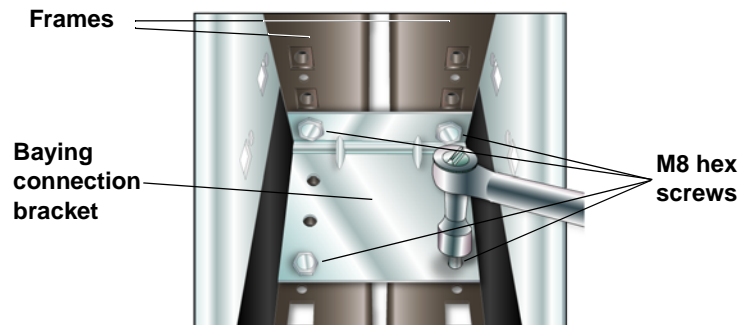

- 5 Insert an M8 hex screw through one of the other corner holes in the bracket and loosely screw it into the threaded hole in the frame.
- 6 Repeat Step 5 for the other two corner holes.

Note: You will tighten the screws after all the bay connections are in place.

Attach the Baying Plates

Baying plates bind two Pillar racks together at the roof and bottom of the rack.

Tip: Use the stabilizer plate described in [Install a Stabilizer Plate](#) in conjunction with the baying kit that comes with each rack.

To attach the baying plates at the top:

- 1 At the front of each rack roof, use a T30 Torx[®] screwdriver to remove the two adjacent Torx-head screws and set them aside.
- 2 Place a baying plate over the two holes.

Figure 5 Roof baying plate attachment

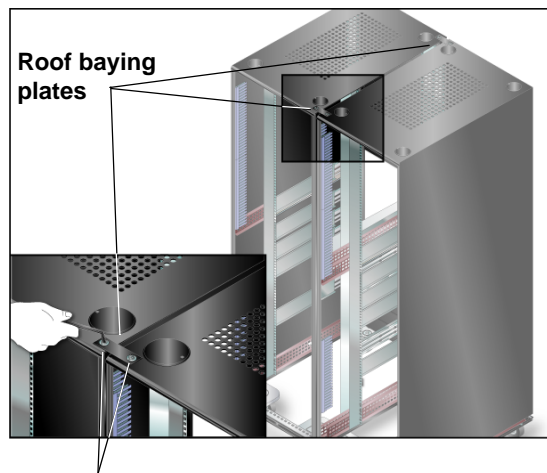

M12 Torx screws

- 3 Insert a Torx screw (from Step 1) into each plate hole.
- 4 Re-seat the Torx screws loosely.
- 5 Repeat Steps 1 through 4 for the two holes at the back of the roof.

- 6 At the bottom of the adjacent rack sides, remove the anti-tip brackets, if any, and unscrew the anchor bolts.

Figure 6 Adjacent anchor bolts at the front of the racks

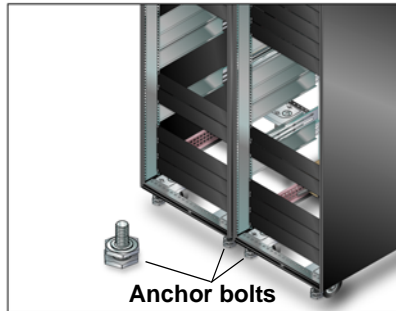

- 7 Hold the baying plate across the two anchor-bolt holes and loosely replace the anchor bolts.
- 8 Repeat Steps 6 and 7 in the back of the racks.
- 9 Use the socket wrench to tighten the connection bracket screws.
- 10 Use the T30 Torx-head screwdriver to tighten the top baying plate screws.
- 11 Use the 3/4-in (19-mm) open-end wrench to tighten the bottom baying plate anchor bolts.

Adjust the Leveling Legs

Racks have built-in leveling legs at each corner. Adjust these legs so they are in firm contact with the floor and the rack is level. If the rack connects to others, adjust the legs so the racks are at the same height and can be bolted together.

Figure 7 Rack leveling leg locations

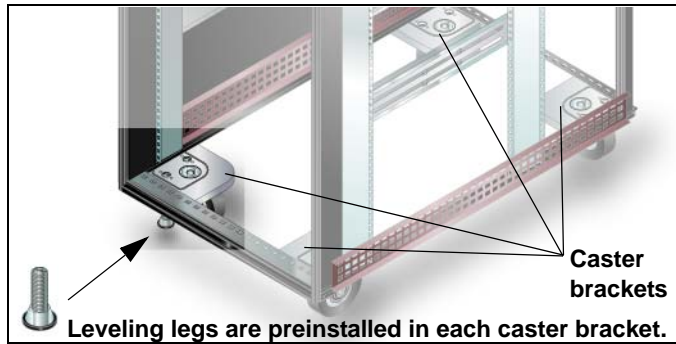

To adjust the legs:

- 1 Turn each leveling leg clockwise to lower the feet until they touch the floor. Use a 1/4-in (7-mm) flat-tip screwdriver in the slot at the top of the leg.

Figure 8 Leveling leg adjustment

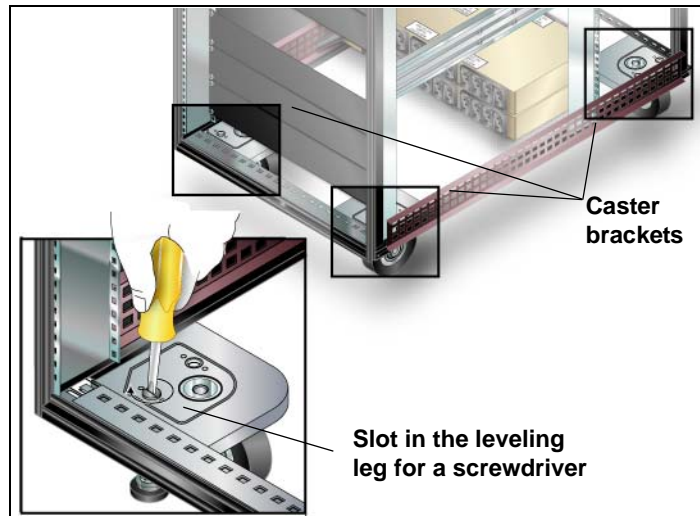

- 2 Use a 3/4-in (19-mm) open-end wrench on the bottom of the legs to jack up the rack. Raise the rack until level with all the casters off the floor.

If you connect racks in a bay it is more important that the racks be at the same height than level so that you can bolt them together.

Stabilize the Rack

After you move the rack to its final position and adjust the legs, you must stabilize it to keep it from shifting when you install the components.

You can take any one of the following actions to stabilize the rack:

- Attach anti-tip brackets and secure them to the floor.
- Attach a stabilizer plate and secure it to the floor.
- Install a seismic stabilization system.

Important! If the rack will be part of a bay of racks, attach the rack to the bay before you install stabilizer plates or some other stabilization system.

Install the Anti-Tip Brackets

One stabilization option is to install the anti-tip brackets that are included with the system. Before you install the anti-tip brackets, consider:

- If you intend to bay the rack with another Pillar rack, you must use baying plates on connecting corners. Baying plates prevent the use of anti-tip brackets so you must stabilize the bay with stabilization plates.
- Make sure that the rack is in its final position before you secure anti-tip brackets to the floor.
- Anti-tip brackets may require a sub-floor tie-down system if the floor has removable panels.
- For solid floors, drill holes into the floor and use appropriate anchor bolts to secure the anti-tip brackets.

Important! If you intend to install an optional stabilizer plate, do not install the front anti-tip brackets.

To install the anti-tip brackets:

- 1 Screw the anchor bolt into the bottom outside corner of the rack frame until the bolt is seated.

Figure 9 Attach anchor bolts to rack

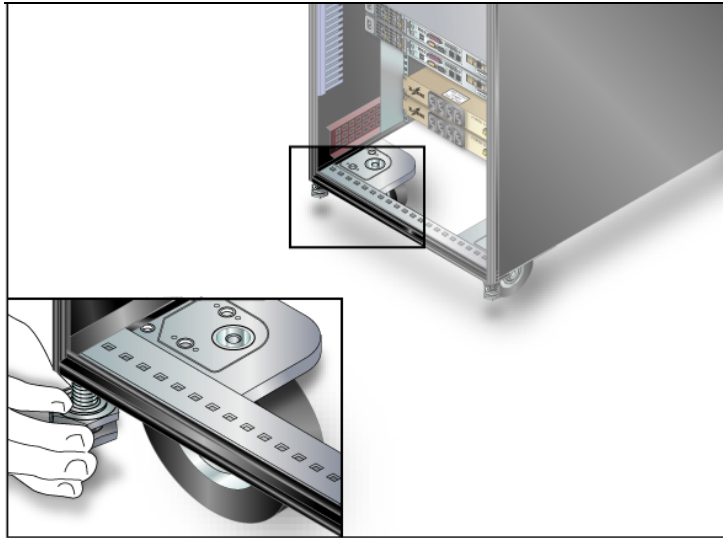

- 2 Slide the bracket fingers into the anchor bolt pocket.

Figure 10 Position anti-tip brackets

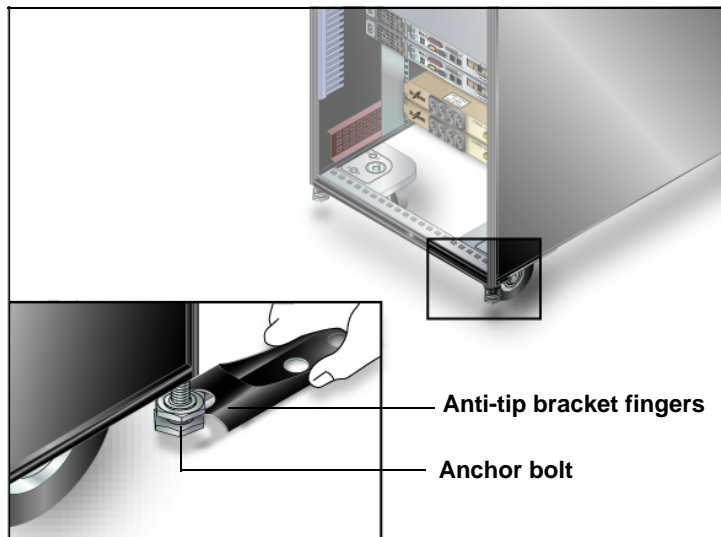

- 3 Position the anti-tip bracket so that it points away from the rack and is parallel to the sides.

- 4 Adjust the anchor bolt so that it is finger-tight against the anti-tip bracket, and secure the anti-tip bracket to the floor.

Figure 11 Secure anti-tip brackets to the floor

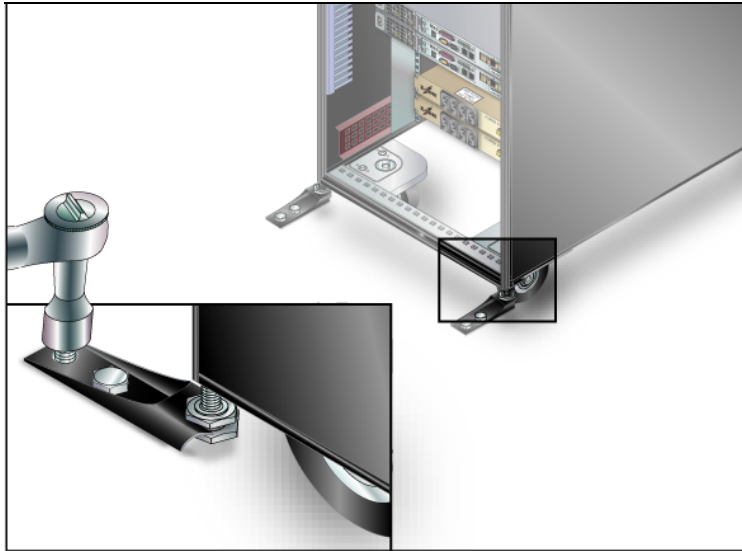

- 5 Repeat Step 1 through Step 4 for all four corners.

Install a Stabilizer Plate

At the front of the rack, you can install an optional stabilizer plate instead of anti-tip brackets. Stabilizer plates provide greater stability than anti-tip brackets, which must be removed in order to install a stabilizer plate. You cannot use anti-tip brackets in a bay because the anchor bolts are used to hold the baying plates in place. Therefore you should use stabilizer plates for racks in a bay.

Also note that if you have removable floor panels, you must bolt the stabilizer plates through to the solid sub-floor.

To install a stabilizer plate:

- 1 Place the stabilizer plate at the front of the rack with the short side up.
- 2 Align the holes in the short side with the holes in the rack frame. Adjust the leveling legs to raise or lower the rack to align the plate and rack holes.
- 3 Insert an M8 bolt into each hole in the short side of the stabilizer plate.

- 4 Use the hex wrench to tightly bolt the stabilizer plate to the rack.

Figure 12 Stabilizer plate attached to the rack base and floor

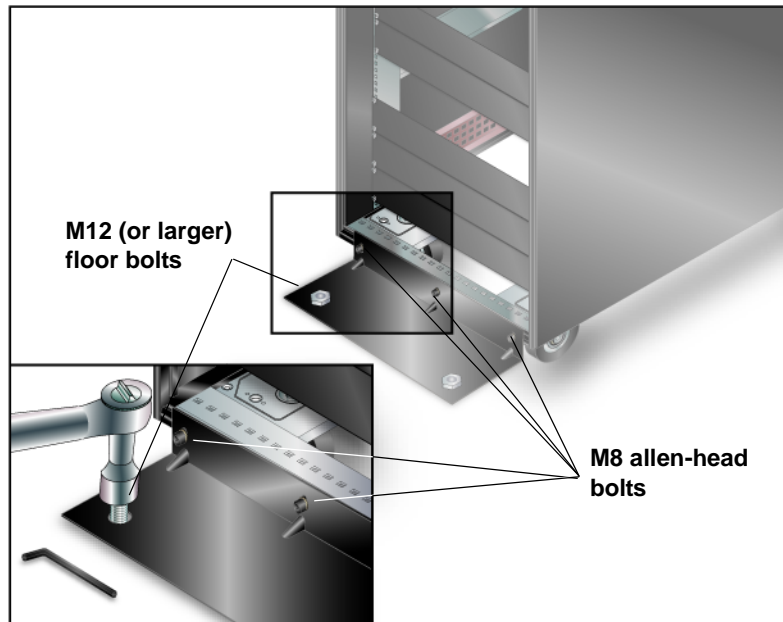

- 5 Secure the stabilizer plate to the floor with bolts and washers that are appropriate for the type of floor.

Important! The floor bolts must be no smaller than M12.

Component Placement

This section helps you locate Pillar Axiom components within a rack and gives you the rack unit (U) heights of these components.

The figure below illustrates how the Pillar Axiom storage system components are mapped into a fully loaded 42U rack. The first figure illustrates the mapping for a rack that contains the following maximum configurations:

- For a one-Slammer system:
 - 1 Pilot
 - 1 Slammer
 - 16 Bricks

- For a two-Slammer system:
 - 1 Pilot
 - 2 Slammers
 - 14 Bricks

Note: 2U of space is reserved above the PDUs for cable routing. The number and type of PDUs depends on the power supply. If more PDUs are needed, then everything has to move up to make room, keeping the 2U of reserved space, and moving any Bricks displaced at the top to the next rack.

Figure 13 Hardware mapping in a fully loaded 42U rack

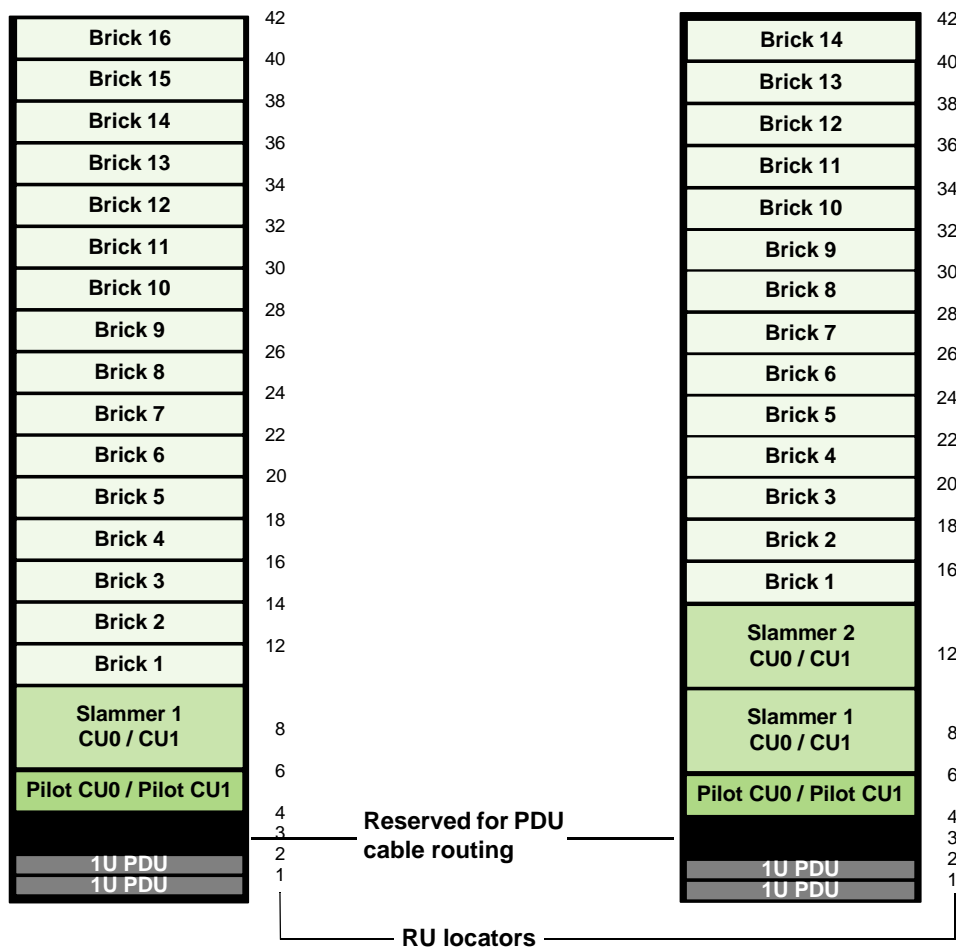

A Pillar Axiom storage system can contain a maximum of 32 Bricks. The additional Bricks must be placed in a second 42U rack. The figure below illustrates how these residual Bricks are mapped into a second 42U rack.

Note: In a system that is configured for the maximum number of Bricks, you should connect the additional racks to the first rack before you install and cable the hardware components. Start populating each subsequent rack at the top to facilitate cabling. A high center of gravity is not a problem because the racks are secured to each other and to the floor.

Figure 14 Hardware mapping for Bricks in additional racks

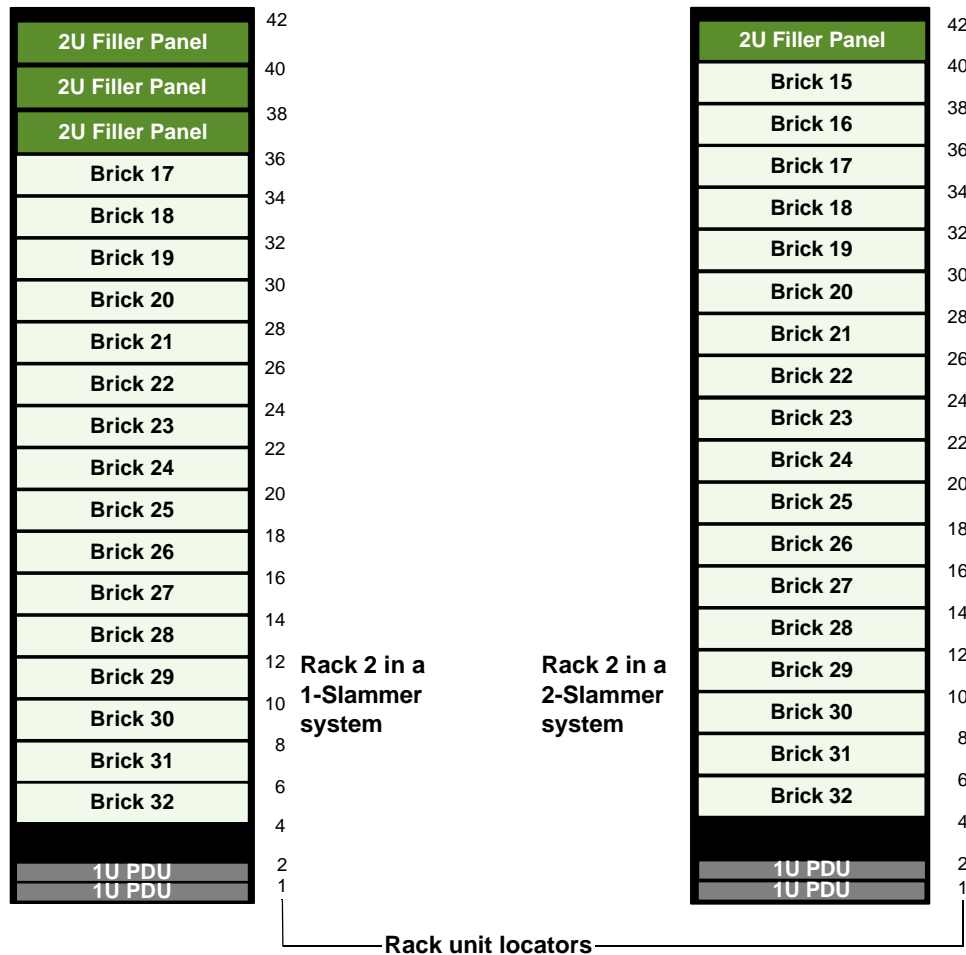





Note: Brick names are just for illustration; actual names, as seen in the AxiomONE Storage Services Manager, may be different.

Install Slammer Rack Rails

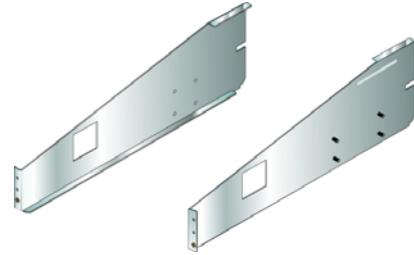
Slammer rails are 4U rack rail assemblies that contain the following parts:

Table 6 Slammer rail kit parts (not to scale)

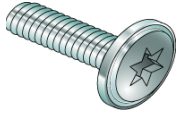
Component	Drawing	Quantity
Slammer rails 1475-00024-xx 1475-00025-xx		One left-right pair per kit.
Slammer rail scopes 2525-00093-xx 2525-00095-xx		One left-right pair per kit.
10-32 Hex nuts for attaching scopes to rails 2500-01051-xx		Eight per kit
Rack mount spacers 2500-01065-xx		Eight per kit
10-32 x 1/2 in Torx head (#20) screws 2500-01071-xx		Ten per kit

Verify that the rail kit contains all the parts listed in the table.

To install a pair of Slammer rails, you need:

- One Slammer rack rail kit with rails and scopes pre-attached
- #20 Torx wrench
- Socket wrench

To install a pair of Slammer mounting rails:

- 1 Hang the scope hook in the appropriate hole at the back of the rack, as shown below. These rail scopes are always used for components that take up at least two rack units.

Figure 15 Scope hook attachment

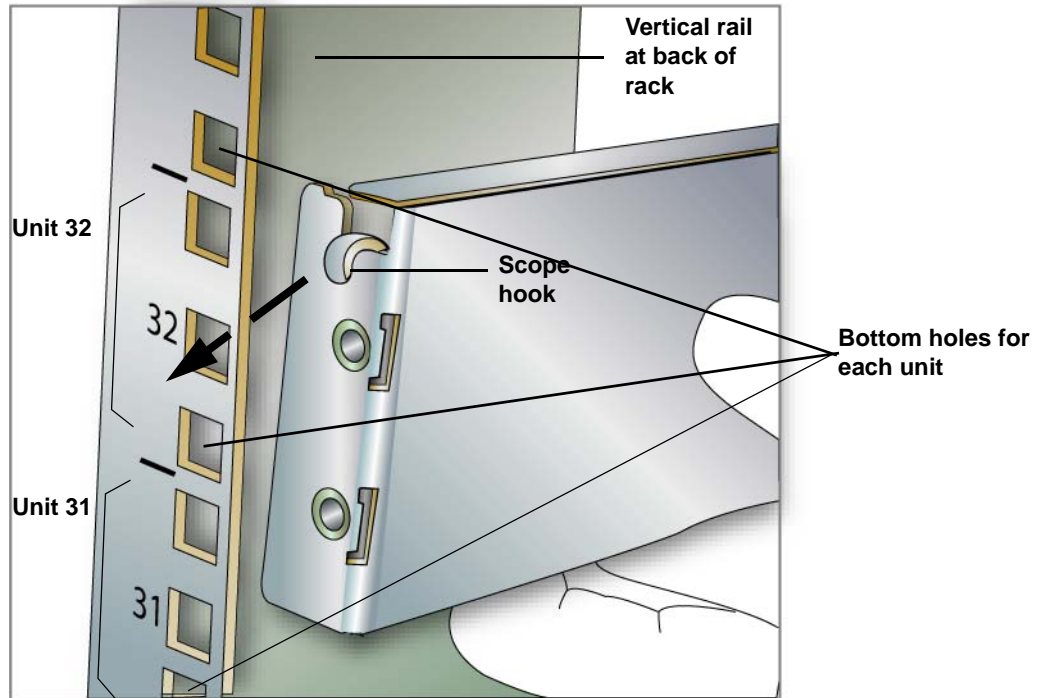

In the figure above, two labeled rack units, 31 and 32, are shown at the back of the rack.

- The bottom of unit 31 is just out of sight below its bottom hole.
 - The scope hook is one-and-a-half units above the bottom of the rail.
 - When you place the hook in the middle of unit 32, the bottom of the rail lines up with the bottom of unit 31.
 - A 4U Slammer rail would fill units 31-34 in the above illustration.
- 2 At the front of the rack, slide the rail scopes until the rail reaches the holes at the front.
 - 3 Making sure the rail is horizontal, place a spacer on a #20 Torx screw and screw it through the bottom hole in the front frame and into the rail, as shown in the next figure. Repeat this for the hole above it (but not the top hole, which is for securing the Slammer).
 - 4 Secure the screws at the back, under the scope hook.

- 5 Repeat steps 1-4 for the other side rail.

Figure 16 Slammer rails installed in rack

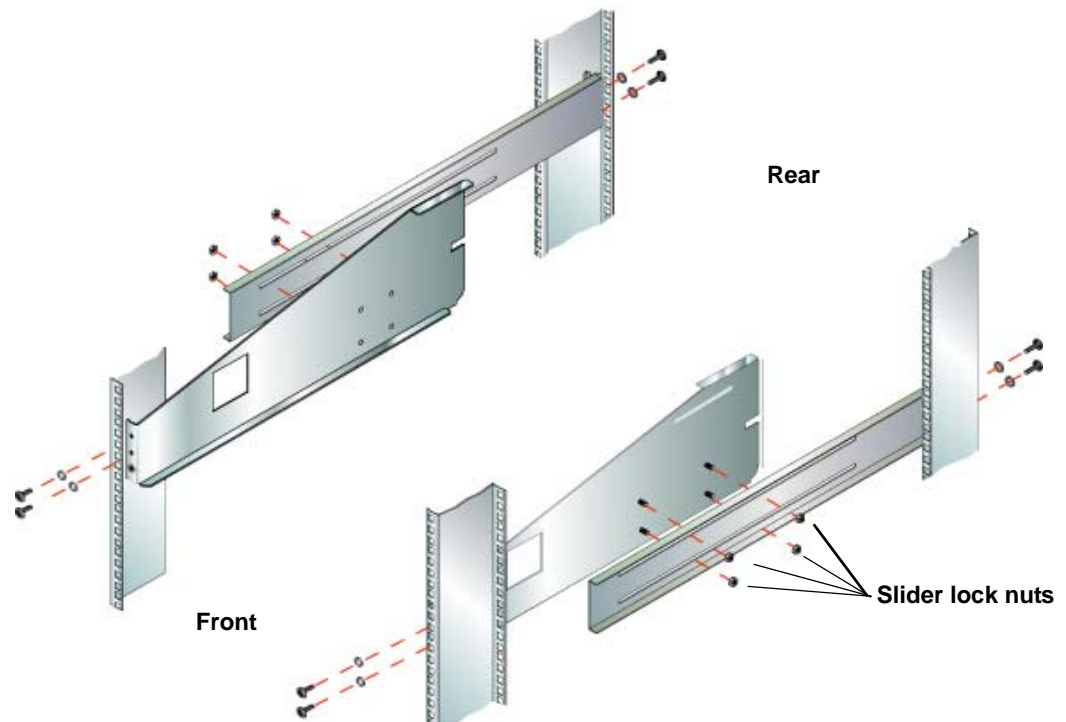





- 6 Tighten the four slider lock nuts that attach each rail scope to the rail.

Install Brick Rack Rails

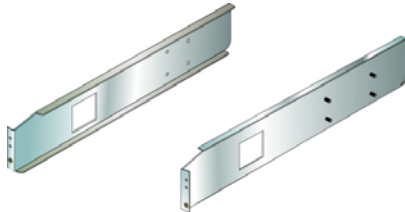
Brick rails are 2U rack rail assemblies that contain the following parts:

Table 7 Brick rail kit parts (not to scale)

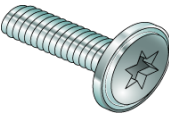
Component	Drawing	Quantity
Brick rails 1450-00022-xx 1450-00023-xx		One left-right pair per kit.
Brick rail scopes 2525-00093-xx 2525-00095-xx		One left-right pair per kit
10-32 Hex nuts for attaching scopes to rails 2500-01051-xx		Eight per kit
Rack mount spacers 2500-01065-xx		four per kit
10-32 x 1/2 in Torx head (#20) screws 2500-01071-xx		Ten per kit

Verify that the rail kit contains all the parts listed in the table.

To install a pair of 2U rack rails, you need:

- One Brick rail kit with rails and scopes pre-attached
- #20 torx wrench
- Socket wrench

To install a pair of Brick mounting rails:

- 1 Hang the scope hook in the appropriate hole at the back of the rack, as shown below. These rail scopes are always used for components that take up at least two rack units.

Figure 17 Scope hook attachment

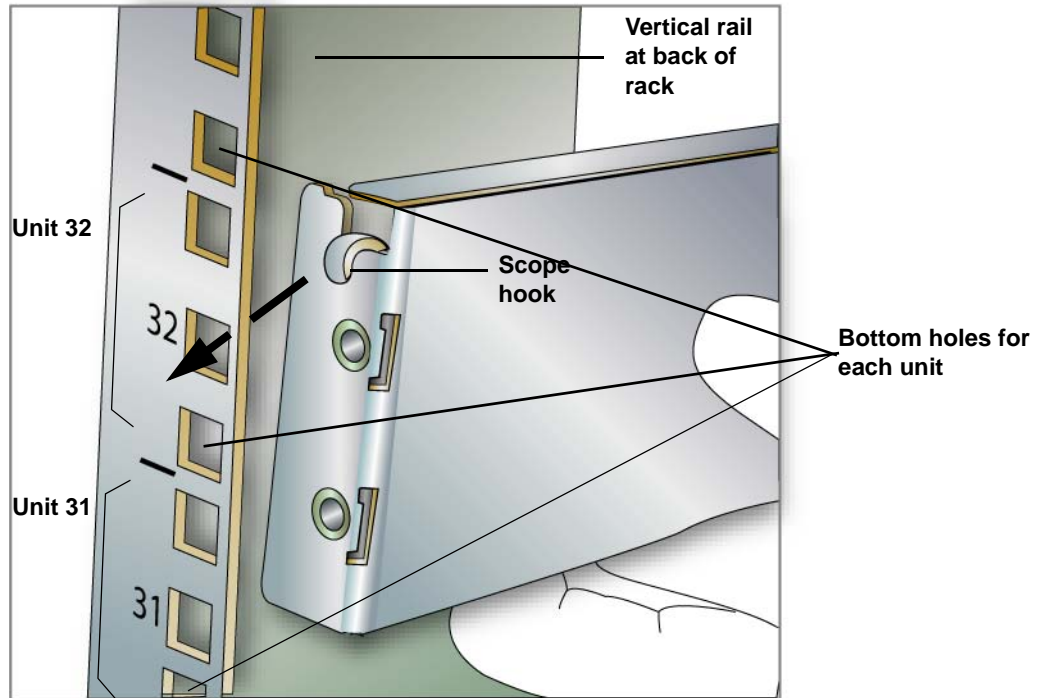

In the figure above, two labeled rack units, 31 and 32, are shown at the back of the rack.

- The bottom of unit 31 is just out of sight below its bottom hole.
 - The scope hook is one-and-a-half units above the bottom of the rail.
 - When you place the hook in the middle of unit 32, the bottom of the rail lines up with the bottom of unit 31.
 - A 2U Brick rail would fill units 31-32 in the above illustration.
- 2 At the front of the rack, slide the rail scopes until the rail reaches the holes at the front.

- 3 Making sure the rail is horizontal, place a spacer on a #20 Torx screw and screw it through the center hole in the front frame and into the rail, as shown in the next figure. Repeat this for the other center screw in the front and the screws at the back, under the scope hook.

The square hole in the front is at the top on the left side and at the bottom on the right side. These square holes are for securing the Brick. Use only the round holes to secure the rails into the rack.

Figure 18 2U rack rails installed in rack

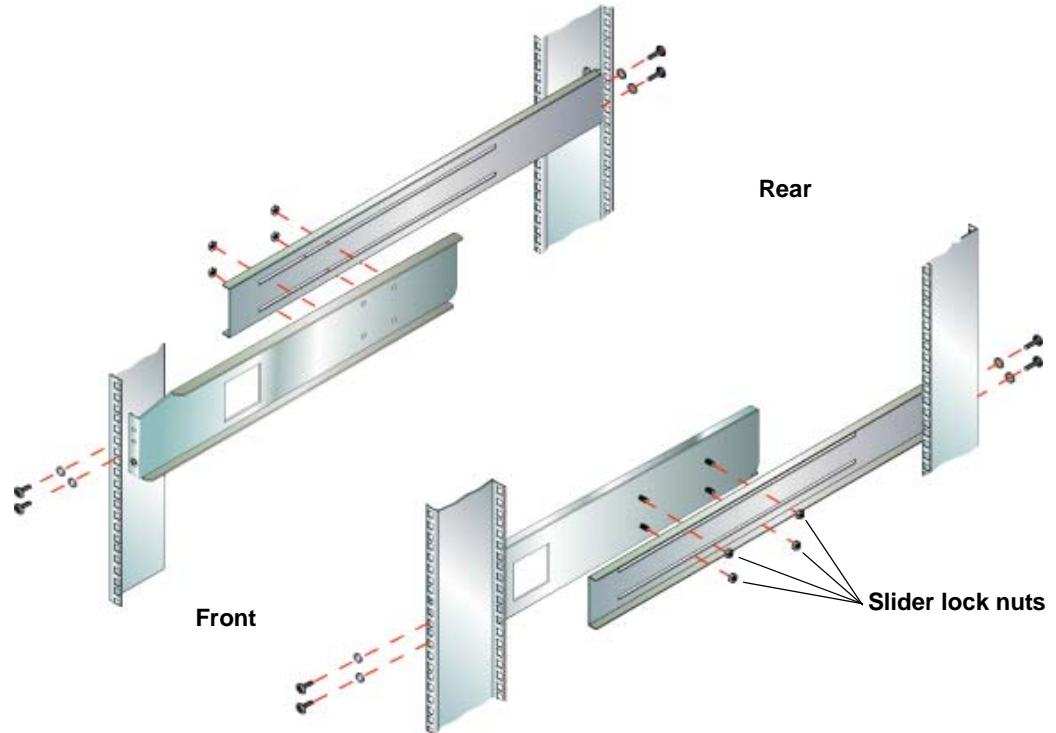

- 4 Repeat steps 1-3 for the other side rail.
- 5 Tighten the four slider lock nuts that attach each rail scope to the rail.

Install Pilot Rack Rails

Pilot rails are 2U rack rail assemblies that contain the following parts:

Table 8 Pilot rail kit parts (not to scale)

Component	Drawing	Quantity
Pilot rail kits 1475-00036-xx 1450-00037-xx		One left-right pair per kit.
Pilotrail scopes 2525-00093-xx 2525-00095-xx		One left-right pair per kit
10-32 Hex nuts for attaching scopes to rails 2500-01051-xx		Eight per kit
Rack mount spacers 2500-01065-xx		Four per kit
Rack mount nut bar 2526-00106-xx		Two per kit
10-32 x 1/2 in Torx head (#20) screws 2500-01071-xx		12 per kit

Verify that the rail kit contains all the parts listed in the table.

Before installing a pair of Pilot rack rails, make sure you have:

- One Brick rail kit with rails and scopes pre-attached
- #20 Torx wrench
- Socket wrench

To install a pair of Pilot mounting rails:

- 1 Hang the scope hook in the appropriate hole at the back of the rack, as shown below:

Figure 19 Scope hook attachment

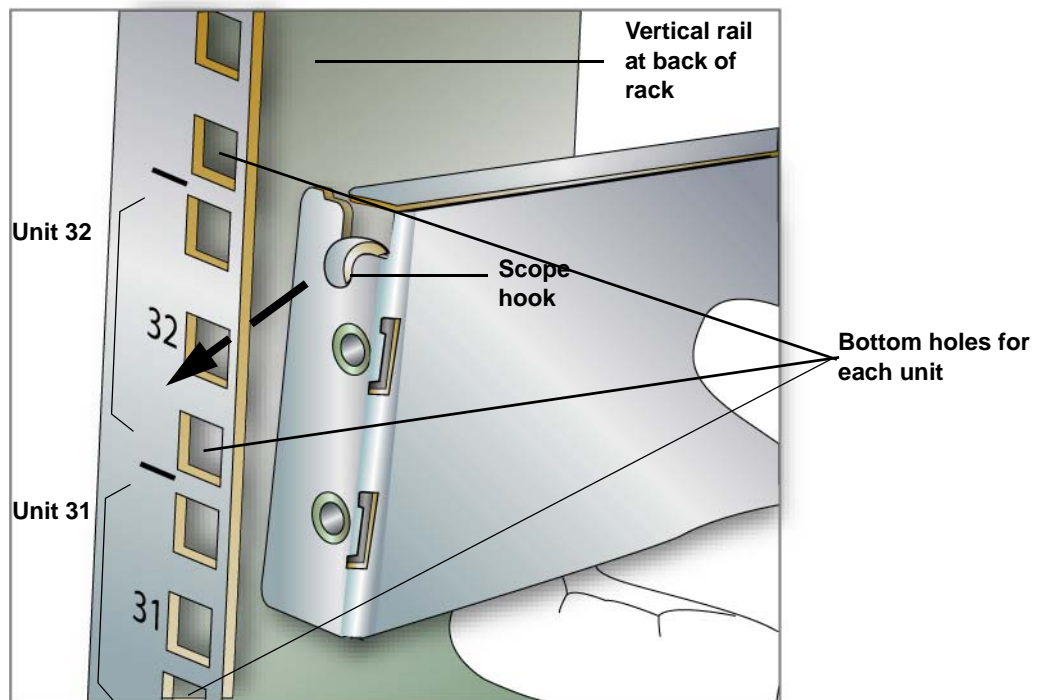

In the figure above, two labeled rack units, 31 and 32, are shown at the back of the rack.

- The bottom of unit 31 is just out of sight below its bottom hole.
 - The scope hook is one-and-a-half units above the bottom of the rail.
 - When you place the hook in the middle of unit 32, the bottom of the rail lines up with the bottom of unit 31.
 - A 2U Pilot rail would fill units 31-32 in the above illustration.
- 2 At the front of the rack, slide the rail scopes until the rail reaches the holes at the front. The rail flange goes in front of the rack mount holes, and the four-hole spacer bar goes behind, as shown below.

- 3 Making sure the rail is horizontal, fit the four-hole spacer bar into the four square rack holes that span the boundary between the two units this rail is to occupy. The figure below shows positioning a spacer for units 35 and 36.

Figure 20 Positioning spacer bar

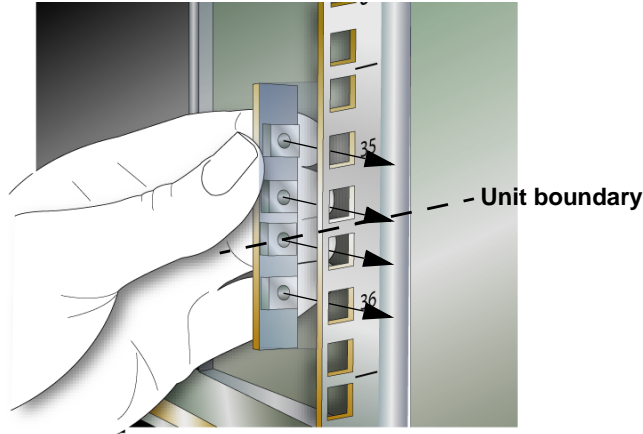
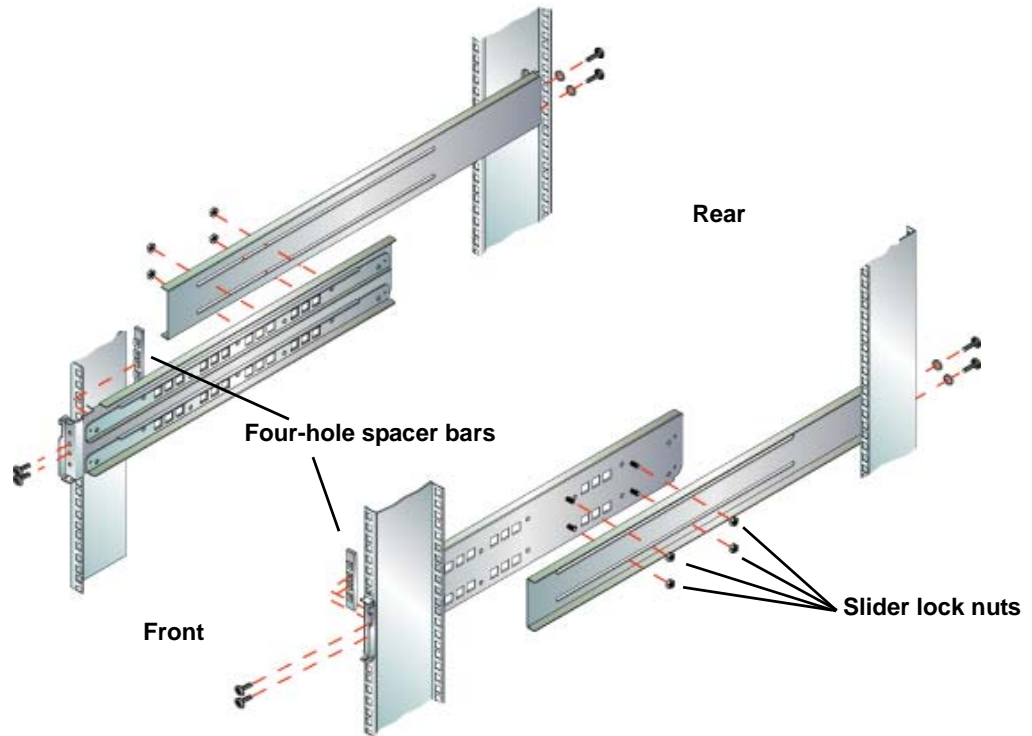

Figure 21 Pilot rail front attachment



- 4 Use two #20 torx screws to secure the rail, through the rack into the spacer bar. Repeat this for a second screw in the front, as shown above. Use the center holes. The top and bottom holes are for securing the Pilots to the rack.

- 5 At the back, place a spacer on a #20 Torx screw and screw it through the hole in the rear frame and into the rail under the scope hook. Install the second screw the same way.
- 6 Repeat steps 1-4 for the other side rail.
- 7 Tighten the four slider lock nuts that attach each rail scope to the rail.

Install Components

Install Power Distribution Units

Mount power distribution units (PDUs) in the bottom units of the rack. The default configuration places up to four 1U 220v/30a PDUs at the bottom of the rack.

To install a PDU, you need:

- A 1U or 3U PDU.
- #2 Phillips-head screwdriver.
- Four snap-in cage nuts (for square mounting holes) or four clip-on cage nuts (for round mounting holes).
- Four 10-32 x ½ in screws.

Important! We strongly recommend that you use PDUs from Pillar Data Systems. If you install non-Pillar PDUs, they must meet the Pillar Data Systems PDU specification, as described in the *Pillar Axiom System Site Planning Guide*.

To install a 1U PDU:

- 1 Choose one of the following options:
 - For square mounting holes, snap a 10-32 snap-in cage nut into the bottom and 3rd hole of each channel.

Figure 22 Snap-in cage nut

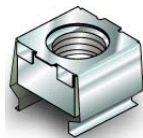

- For round mounting holes, clip one 10-32 clip-on cage nut into the bottom and 3rd holes of each channel in the pair. (Pillar Data Systems does not provide clip-on cage nuts.)
- 2 Insert the PDU into the rack, as shown below. There are no rails for a PDU.

Figure 23 Securing a 1U PDU in the bottom of a rack

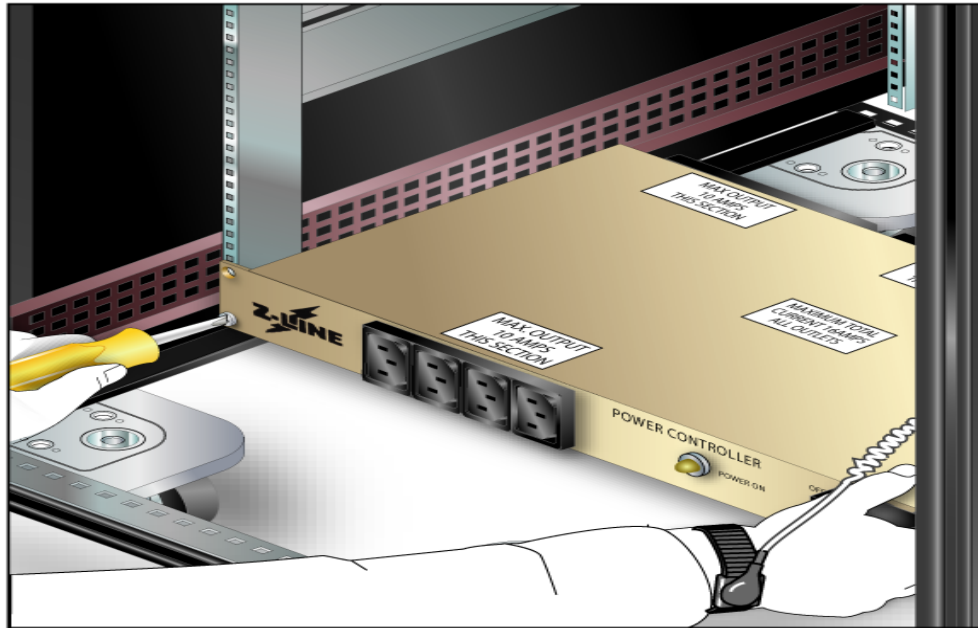

- 3 Align the ears of the PDU to the four cage nuts.
- 4 Insert a 10-32 x 1/2 in screw through the top and bottom holes in the right and left ears of the PDU and into the cage nuts. Secure both screws tightly.

Figure 24 An installed PDU at the bottom of the rack

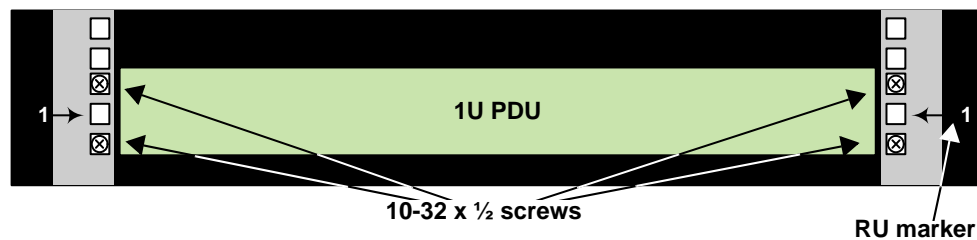

Important! Do not plug the PDU into a power supply until the rack is complete and ready for start-up.

Repeat the procedure to install any other PDUs.

To install a 3U PDU:

- 1 For square or round mounting holes:
 - Insert one 10-32 snap-in cage nut into the 3rd hole from the bottom of each channel in the pair.
 - Insert one 10-32 snap-in cage nut into the 7th hole from the bottom of each channel in the pair.
- 2 Align the slots in the PDU ears to the four cage nuts.
- 3 Insert a 10-32 x ½ in screw through the bottom hole in the right and left ears of the PDU and into the cage nuts. Secure both screws tightly.
- 4 Repeat Step 3 for the top holes in both ears.

Important! Until you are instructed to do so, do not plug the PDU into an inlet power supply.

Install a Pilot

Install the Pilot at the bottom of the rack, just above the PDUs. This placement makes installation and future expansion as efficient as possible.



Ensure that component distribution in the rack is balanced. Follow the hardware placement map to ensure this balance. Uneven distribution can cause hazardous instability. The rack must have stabilization plates or anti-tip brackets installed so the rack does not tip when you install a component.



Mounting rail assemblies must be used to support and secure a Pilot in the rack. The Pilot's mounting ears by themselves will not support the weight of the Pilot.

To install a Pilot:

- 1 Put on an antistatic wrist strap and attach the grounding wire to ground.
- 2 From the front of the rack, place the back side of the first Pilot server component on the bottom mounting rails and slide it into place.

Important! When sliding a Pilot CU into the rack, keep it level to avoid bending the rail supports.

- 3 Insert the other Pilot CU above it, as shown below.

Figure 25 Inserting the upper Pilot server component



- 4 Use a 10-32 Torx screw through the hole in each Pilot server component ear and screw it in securely with a #20 Torx wrench.

Important! Do not plug the chassis into a PDU until instructed to do so.



Never block the inlet and outlet holes in the chassis components. Sufficient air circulation is required for the components to operate properly and to avoid a fire hazard. Do not push objects of any kind into the ventilation holes. Such action could result in fire or electrical shock. Keep all liquids away from hardware components.

Install a Slammer

Install the Slammers above the Pilot.



A Slammer weighs 94 lb (42.6 kg). For safe handling, use two people to lift it.



Ensure that component distribution in the rack is balanced. Follow the hardware placement map to ensure this balance. Uneven distribution can cause hazardous instability. The rack must have stabilization plates or anti-tip brackets installed so the rack does not tip when you install a component.

To install a Slammer:

- 1 Put on an antistatic wrist strap and attach the grounding wire to ground.
- 2 From the front side of the rack, set the back of the Slammer onto the mounting rails and slide the Slammer into place. Leave about one inch (2.5 cm) of clearance between the Slammer's ears and the vertical channels.

Important! When sliding the Slammer into the rack, keep it level to avoid bending the rail supports, which would make it difficult to insert a component below.

Figure 26 Inserting a Slammer

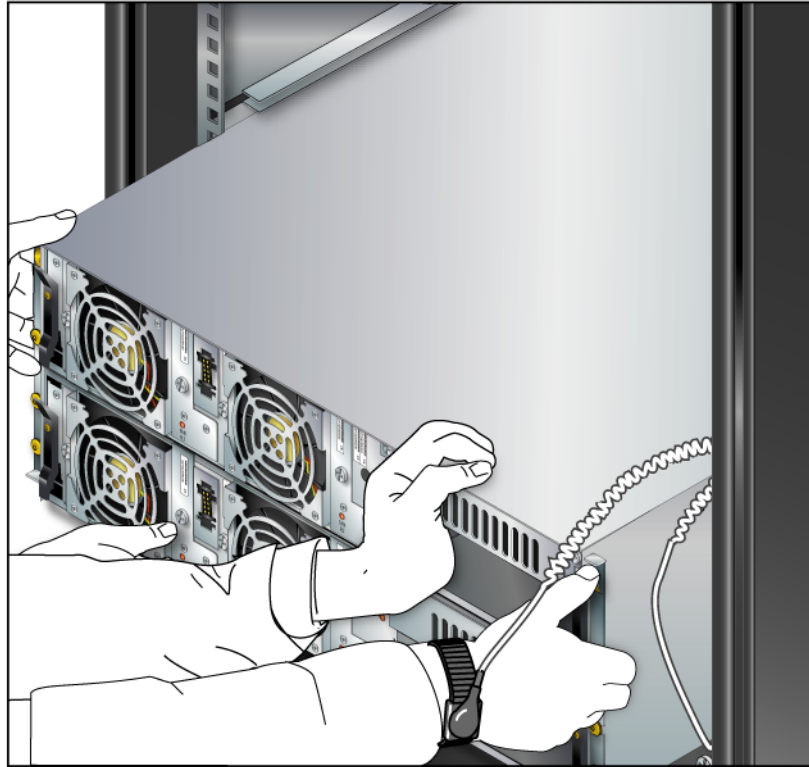

- 3 Put a spacer on a 10-32 x 1/2-in Torx screw, then insert the screw through the hole in the ear on the left side of the Slammer. This spacer helps to center the Torx screw in the hole.
- 4 Push the Slammer so that its ears and the spacers rest against the vertical channels and start the Torx screws with your fingers.
- 5 Use a #20 Torx wrench to secure the screws to the rack.
Note: This step only keeps the Slammer in place; the screws provide no other support.
- 6 Repeat Steps 3 -6 for the right side of the Slammer.

If you have a 2-Slammer system, install the second Slammer now.

Important! Do not apply power to the Slammer until instructed to do so.

Install a Brick

Pillar Data Systems packages and ships the Bricks separately from the system. As you install the Bricks, work from the bottom of the rack toward the top. If you have additional racks of Bricks, work from the top down.

- 1 Put on an antistatic wrist strap, ground strap, or heel strap, and attach the grounding wire to a ground.
- 2 At the front of the rack, insert the Brick onto the mounting rack rails and slide into place.

 **CAUTION** Bricks weigh up to 65 lb. (29.5 kg) each. For safe handling, use two people to lift it.

Important! When you slide the component into the rack, keep it level to avoid bending the rail supports, which would make it difficult to insert a component below.

Figure 27 Inserting a Brick

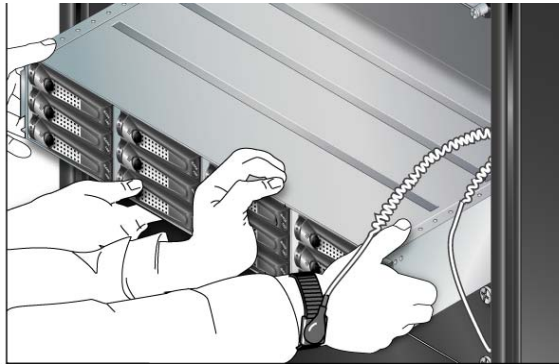

- 3 Use two, 10-32 Torx screws (two on each side) and a Torx T20 driver to secure the Brick ears to the rack.

Important! Use care as you install the screws on the right to avoid damaging the printed circuit, which provides power and signals to the Brick bezel.

Figure 28 Brick ears

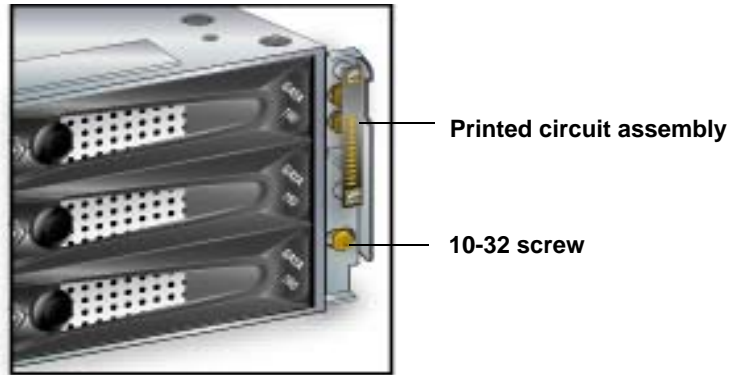

- 4 Inspect the disk drives to ensure each drive is flush and securely seated.

To seat an improperly seated disk drive:

- Fully open the cam latch on the disk drive carrier.
- Press the disk drive carrier into the Brick chassis until it stops.
- Close the cam latch until it snaps shut to engage the disk drive with the Brick midplane.

Figure 29 Brick front

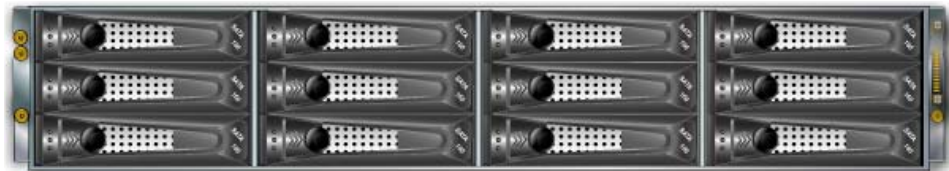

If you have multiple Bricks, install them all now, even those that require additional racks.

Install the Slammer Batteries

Slammer batteries are shipped separately. Use the following procedure to install them.

- 1 Ensure the installation dates on the Slammer batteries have not expired. If a battery has expired, contact Technical Support.
- 2 Slammer batteries install from the front of the Slammer, so you have to remove the front cover (bezel). If the bezel is not attached, skip to step 5.
- 3 Press the Slammer ejector tabs on the bezel to unlock them.
- 4 Lift both ejector tabs to disengage the bezel from the rack.

Figure 30 Slammer bezel removal

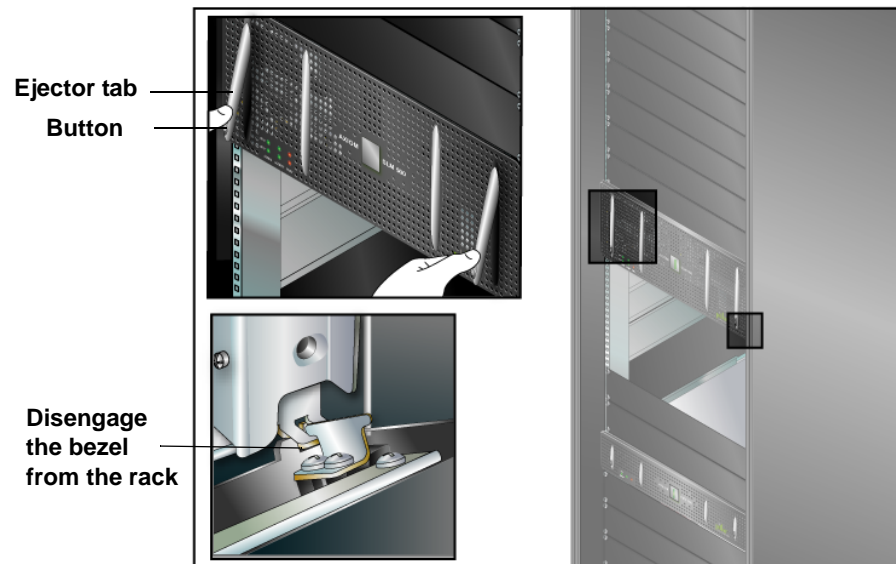

- 5 Insert the batteries into the Slammer, but do not secure them until you complete the installation. When you secure them, they start to discharge as they preserve data in memory. Since there is no data to preserve, you should wait until you are ready to power the system before securing the batteries.

Figure 31 Slammer battery insertion

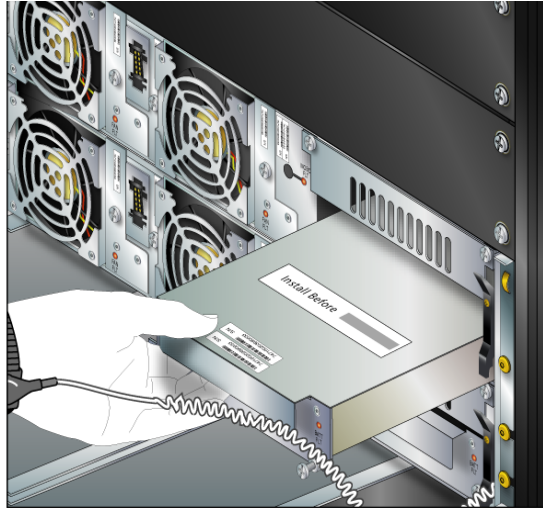

Connect Data Cables

Cable Requirements

Connections between the Pilot and a Slammer and between the Slammer's control units require a total of three Ethernet Cat 5e cables.

Fibre Channel patch cables that connect the Slammer and Bricks support the private management interface and the Storage System Fabric (SSF). These cables come in two lengths: 20 inches (0.5 m) and 6.5 feet (2 m). The purpose of these sizes is outlined in the following table.

Table 9 FC patch cable purposes

If the purpose is ...	Use this cable ...
To connect Slammer control units	20 in (50.8 cm)
To connect Slammers to Bricks	6.5 ft (2 m)
To connect Brick RAID controllers	20 in (50.8 cm)
To cascade Bricks	6.5 ft (2 m)

The Cat 5e and Fibre Channel cables that you need are included in your installation kit.

 When running a Fibre Channel cable, be sure not to bend it into a turn with a radius of less than two inches (5.1 cm). Also, do not tighten tie wraps or fasteners so tightly that they crimp the cable casing.

Note: The cables shown in the figures in this chapter are colored to make them easier to follow, but they are actually black. Attach matching labels to the ends of each cable to help you keep track of your connections.

Slammer CU Interconnections

The Slammer contains two control units (CUs) that must be connected together so that if one CU fails the other one can take over. Connect the control units as shown below. Note that port FC1 in each CU connects to port FC8 in the other CU. Use an Ethernet cable to connect the ETH1 ports together.

Figure 32 Cables interconnect control units

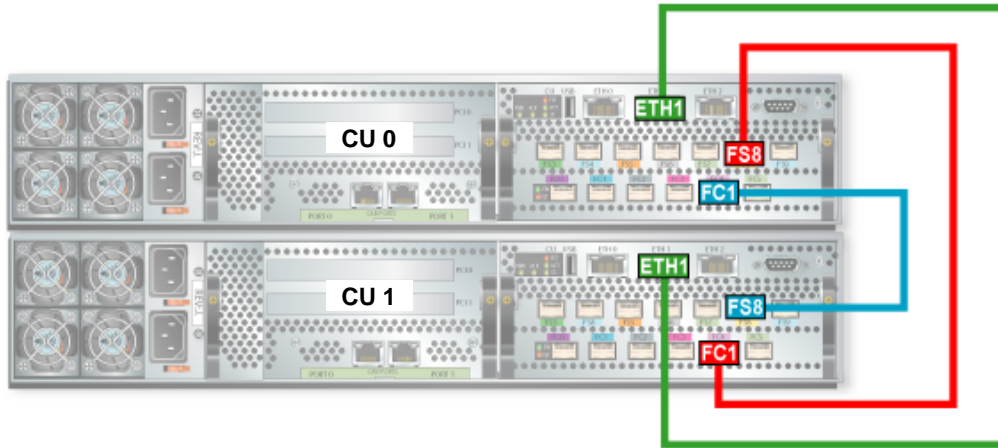

Brick CU Interconnections

Each RAID controller in a Brick manages six disk drives. If one of the controllers fails, the other takes control of all disk drives. To support the failover feature, connect the RAID controllers with the 20 in (0.5 m) Fibre Channel cable, as shown below. Port FC0 in each RAID controller connects to port FC3 in the other.

Figure 33 FC cables connect Brick RAID controllers for failover



Note:

Pilot CU Interconnections

Each control unit in a Pilot can take over if the other fails. To support the failover feature, connect the controllers with the Cat 5e cable between Ethernet port 0 on each CU.

Figure 34 Cat5e cables connect Pilot controllers for failover

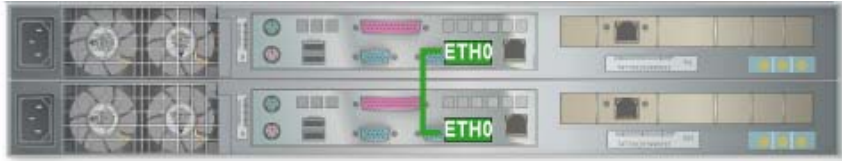

Connections with One Slammer

This topic describes connecting a Pilot to the Slammer with Ethernet cables and connecting Bricks to the Slammer with Fibre Channel cables through a Storage System Fabric (SSF).

Pilot-to-Slammer Connections

The Fast Ethernet connection between the Pilot and the Slammer control units provides the Pillar Axiom private management interface with a redundant data path in case of a Slammer control unit failover.

To cable the Pilot to one Slammer:

- 1 Make the Cat 5e Ethernet connections between the Pilot and Slammer ports. Use the information in the table below to guide you.

Table 10 Cat 5e connections for internal management

From	CU	Port	To	CU	Port
Pilot	0	ETH-1	Slammer-1	0	ETH-0
Pilot	1	ETH-1	Slammer-1	1	ETH-2

- 2 Verify your Cat 5e connections against the following figure.

Figure 35 Pilot cabled to one Slammer

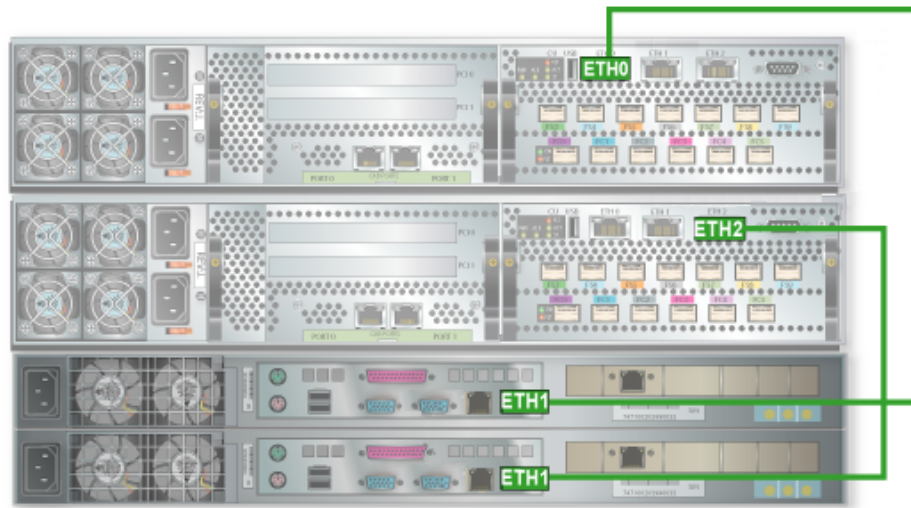

Run the data cables so that they do not obstruct component replacement. They should go down the rear corner of the rack opposite from the power cables, which can cause interference if they are run alongside data cables. Use the tie wraps and velcro straps provided to secure bundles of cables to the rack.

Ethernet cables are not labeled. Use the shortest cable you can. However, make sure that:

- They are properly dressed to the side, so that other components can be removed without unplugging the cable.
- The cable is not so taut that it puts a strain on the connectors.

Brick-to-Slammer Connections

Connect SATA Bricks to One Slammer

This section describes the cabling needs for connecting SATA Bricks to a single Slammer.

One Slammer can manage from 2 to 32 SATA Bricks. This section describes how to cable these SATA Bricks. It covers connecting the control units within each Brick as a failover capability and connecting Bricks to Slammers.

Brick and Slammers are connected by the Storage System Fabric (SSF). The example below shows how to connect five Bricks to a Slammer. Connect the Brick control units (CUs) to the Slammer with the 6.5 ft (2 m) Fibre Channel (FC) cables, as shown in the table below.

Table 11 SATA Brick / Slammer FC connections

From	CU	Port	To	CU	Port
Brick-1	1	FC2	Slammer-1	1	FS2
Brick-1	0	FC2	Slammer-1	0	FS0
Brick-2	1	FC2	Slammer-1	1	FS0
Brick-2	0	FC2	Slammer-1	0	FS2
Brick-3	1	FC2	Slammer-1	1	FS3
Brick-3	0	FC2	Slammer-1	0	FS1
Brick-4	1	FC2	Slammer-1	1	FS1
Brick-4	0	FC2	Slammer-1	0	FS3
Brick-5	1	FC2	Brick-1	1	FC1
Brick-5	0	FC2	Brick-1	0	FC1

Verify your SSF Fibre Channel connections against the following figure:

Figure 36 Slammer cabled to five SATA Bricks

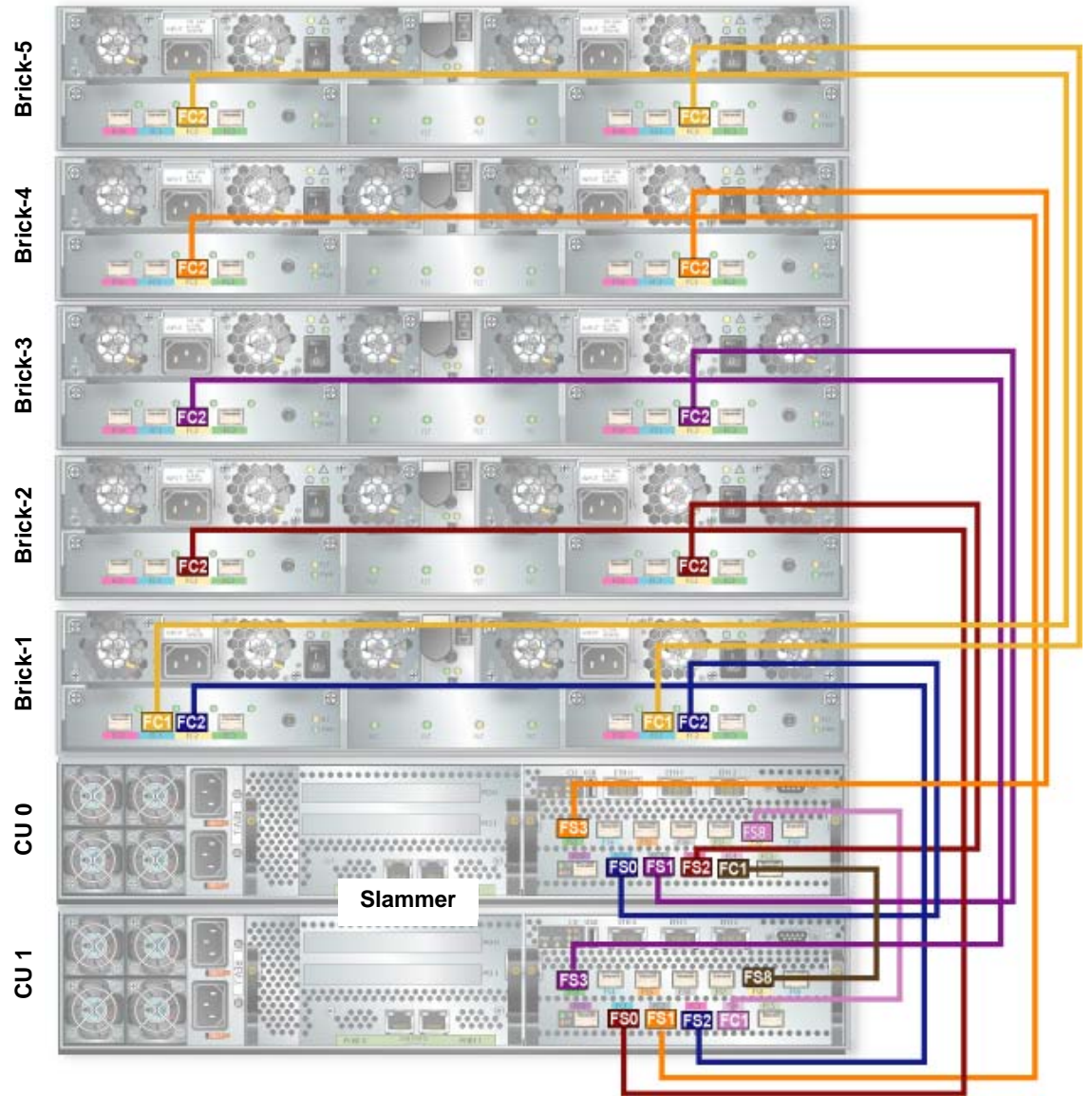

You can connect up to 32 Bricks in this way. Brick: 6 would connect to Brick 2 the same way Brick 5 connects to Brick 1; Brick 9 to Brick 5, and so on up to Brick 32 connecting to Brick 28.

Connections with Two Slammers

This topic describes connecting a Pilot to two Slammers with Ethernet cables and connecting Bricks to the Slammer with Fibre Channel cables through a Storage System Fabric (SSF). This section does not include power cables or the connection from the Axiom system to your local area network.

Pilot-to-Slammers Connections

The Ethernet connection between the Pilot and the Slammers and the Ethernet connections between the two Slammers provides the Pillar Axiom private management interface with a redundant data path if a Slammer CU should fail over.

To make the Ethernet connections among the Pilot and two Slammers:

- 1 Make the Cat 5e Ethernet connections between the Pilot and Slammers as follows:

Table 12 Cat 5e Pilot connections for internal management

From	CU	Port	To	CU	Port
Pilot	0	ETH1	Slammer-1	0	ETH0
Pilot	1	ETH1	Slammer-2	1	ETH2

- 2 Make the Cat 5e Ethernet connections between the Slammers as follows:

Table 13 Cat 5e Slammer connections for internal management

From	CU	Port	To	CU	Port
Slammer-1	0	ETH1	Slammer-1	1	ETH1
Slammer-1	0	ETH2	Slammer-2	0	ETH0
Slammer-1	1	ETH0	Slammer-2	0	ETH2
Slammer-1	1	ETH2	Slammer-2	1	ETH0
Slammer-2	0	ETH1	Slammer-2	1	ETH1

- 3 Verify your Cat 5e connections against the following figure.

Figure 37 Pilot cabled to two Slammers

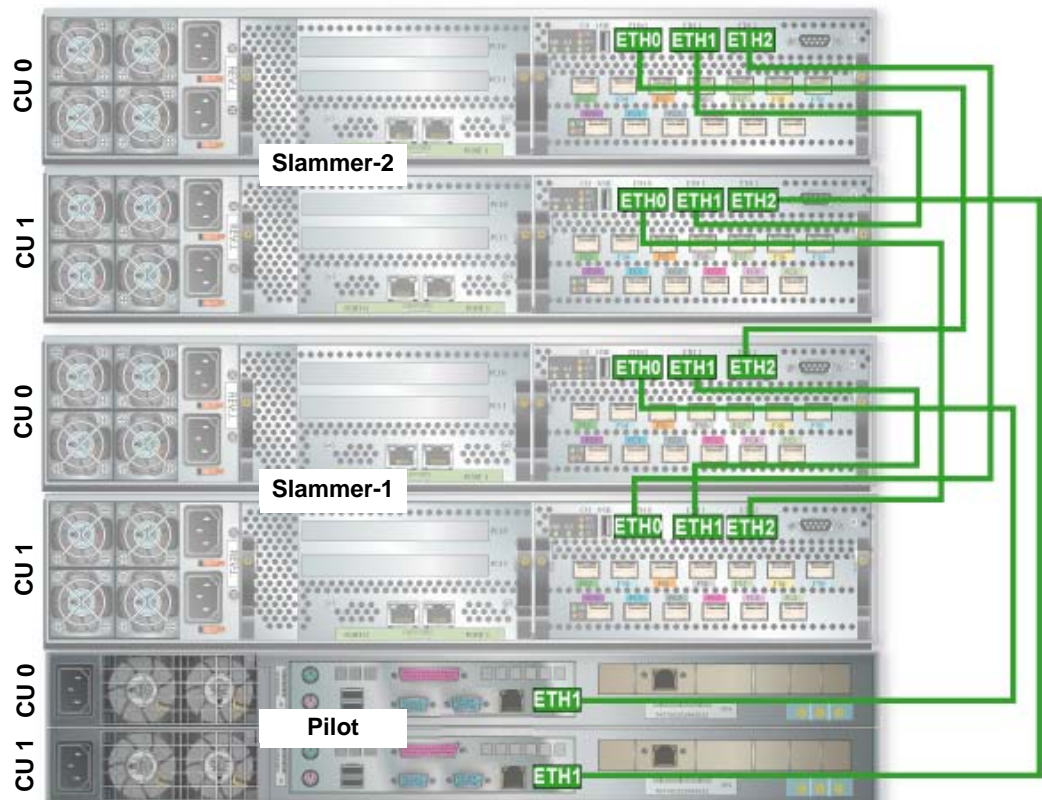

Run the data cables so that they do not obstruct component replacement. They should go down the rear corner of the rack opposite from the power cables, which can cause interference if they are run alongside data cables. Use the tie wraps and velcro straps provided to secure bundles of cables to the rack.

Ethernet cables are not labeled. Use the shortest cable you can while still making sure that they are properly dressed to the side, so that other components can be removed without unplugging any cable, and that it is not so taut that it puts a strain on the connector ends.

Fibre Channel Slammer-to-Slammer Connections

To cable for Fibre Channel cross-connect and failover in two Slammers:

- 1 Connect the Slammer control units (CUs) with Fibre Channel cable as described in the following table.

Table 14 Fibre Channel Slammer-to-Slammer connections

From	CU	Port	To	CU	Port
Slammer-1	0	FC0	Slammer-2	0	FS7
Slammer-1	0	FC1	Slammer-1	1	FS8
Slammer-1	0	FC2	Slammer-2	1	FS9
Slammer-1	1	FC0	Slammer-2	1	FS7
Slammer-1	1	FC1	Slammer-1	0	FS8
Slammer-1	1	FC2	Slammer-2	0	FS9
Slammer-2	0	FC0	Slammer-1	1	FS7
Slammer-2	0	FC1	Slammer-2	1	FS8
Slammer-2	0	FC2	Slammer-1	0	FS9
Slammer-2	1	FC0	Slammer-1	0	FS7
Slammer-2	1	FC1	Slammer-2	0	FS8
Slammer-2	1	FC2	Slammer-1	1	FS9

- 2 Verify your Slammer Fibre Channel connections against the following diagram:

Figure 38 Fibre Channel Connections between Slammers

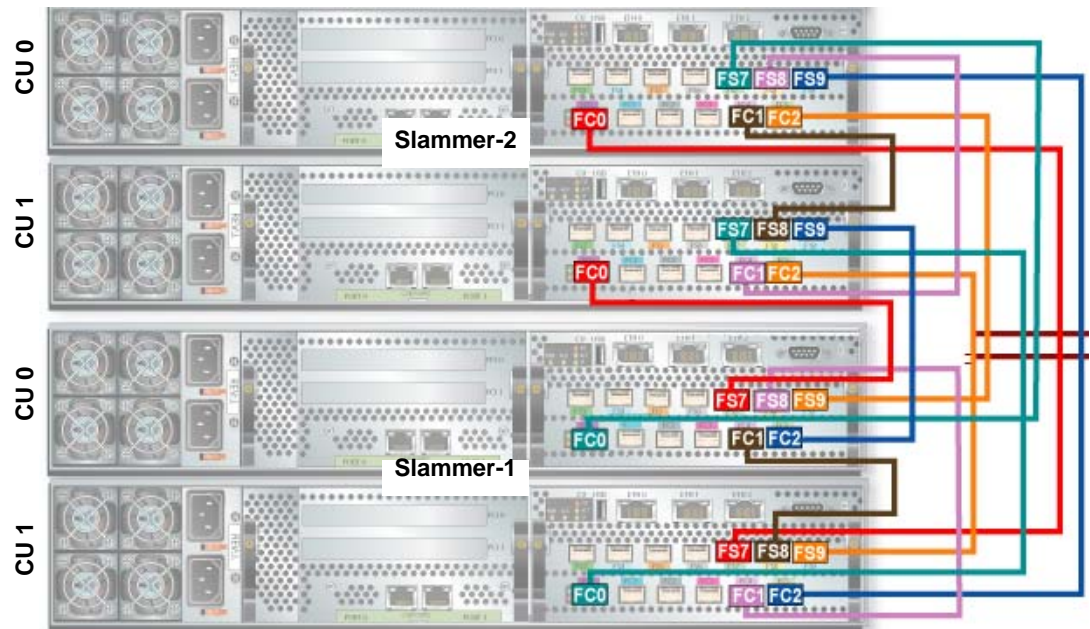

Bricks-to-Slammers Connections

The Storage System Fabric (SSF) subsystem provides the interconnects among the Bricks and Slammers supports all data and coordination traffic. This subsystem enables the Slammers and Bricks in a particular configuration to act as a single system, with scalability and high performance.

Connect SATA Bricks to Two Slammers

This section describes the cabling required to connect SATA Bricks to two Slammers.

Brick and Slammers are connected by the Storage System Fabric (SSF). The example below shows how to connect five Bricks to a Slammer. Connect the Brick control units (CUs) to the Slammer with the 6.5 ft (2 m) Fibre Channel (FC) cables, as shown in the table below.

Table 15 SATA Brick / Slammer FC connections

From	CU	Port	To	CU	Port
Brick-1	1	FC2	Slammer-1	1	FS2
Brick-1	0	FC2	Slammer-1	0	FS0
Brick-2	1	FC2	Slammer-1	1	FS0
Brick-2	0	FC2	Slammer-1	0	FS2
Brick-3	1	FC2	Slammer-1	1	FS3
Brick-3	0	FC2	Slammer-1	0	FS1
Brick-4	1	FC2	Slammer-1	1	FS1
Brick-4	0	FC2	Slammer-1	0	FS3
Brick-5	1	FC2	Brick-1	1	FC1
Brick-5	0	FC2	Brick-1	0	FC1

Verify your SSF Fibre Channel connections against the following figure:

Figure 39 Slammer cabled to five SATA Bricks

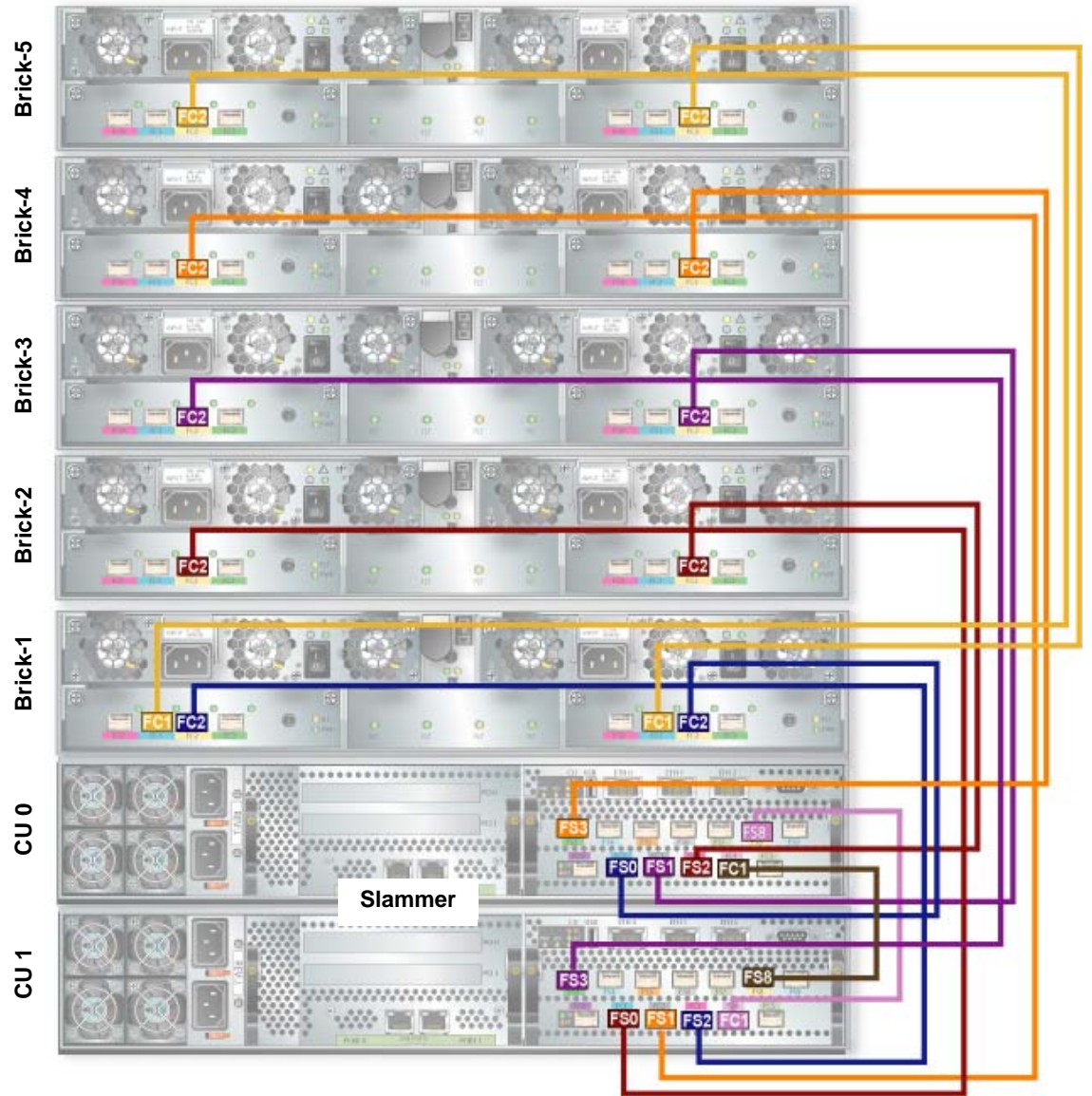

You can connect up to 32 Bricks in this way. Brick: 6 would connect to Brick 2 the same way Brick 5 connects to Brick 1; Brick 9 to Brick 5, and so on up to Brick 32 connecting to Brick 28.

Combine FC and SATA Brick Strings

A string is a collection of Bricks connected together and connected to two Slammer ports, with each Brick connected to the prior Brick or to the set of Slammers. Strings may be composed of combinations of FC RAID Bricks, FC Expansion Bricks and SATA Bricks.

Add SATA Bricks to a FC RAID Brick System

When you are populating a rack with a combination of FC RAID Bricks and FC Expansion Bricks pairs and additional SATA Bricks, the RAID Bricks should be positioned closest to the Slammer with the corresponding Expansion Brick positioned just behind each one. The SATA Bricks are added to the end of the string.

To combine FC RAID Bricks with SATA Bricks

- 1 Connect the FC RAID Bricks and Slammers as you would normally. You may use either the one Slammer or two Slammer configuration. The SATA Brick are added to the end of the FC RAID Bricks.
- 2 Connect your SATA Bricks to the FC RAID Bricks using the 6.5 ft (2 m) FC cables, based on the table below:

Table 16 Brick / Slammer cables

From port			To port		
Chassis	CU	Port	Chassis	CU	Port
FC RAID Brick 1	1	FC-1	SATA Brick 1	1	FC-2
FC RAID Brick 1	0	FC1	SATA Brick 1	0	FC-2
FC RAID Brick 2	1	FC-1	SATA Brick 2	1	FC-2
FC RAID Brick 2	0	FC1	SATA Brick 2	0	FC-2
FC RAID Brick 3	1	FC-1	SATA Brick 3	1	FC-2
FC RAID Brick 3	0	FC1	SATA Brick 3	0	FC-2

Table 16 Brick / Slammer cables (continued)

From port			To port		
Chassis	CU	Port	Chassis	CU	Port
FC RAID Brick 4	1	FC-1	SATA Brick 4	1	FC-2
FC RAID Brick 4	0	FC1	SATA Brick 4	0	FC-2
FC RAID Brick 5	1	FC-1	SATA Brick 5	1	FC-2
FC RAID Brick 5	0	FC1	SATA Brick 5	0	FC-2
FC RAID Brick 6	1	FC-1	SATA Brick 6	1	FC-2
FC RAID Brick 6	0	FC1	SATA Brick 6	0	FC-2
FC RAID Brick 7	1	FC-1	SATA Brick 7	1	FC-2
FC RAID Brick 7	0	FC1	SATA Brick 7	0	FC-2
FC RAID Brick 8	1	FC-1	SATA Brick 8	1	FC-2
FC RAID Brick 8	0	FC1	SATA Brick 8	0	FC-2

Note: The Expansion Bricks are not connected to the SATA Bricks.

- 3 Verify your SSF Fibre Channel connections against the following figure:

Figure 40 FC cables to connect additional SATA bricks to FC RAID Bricks

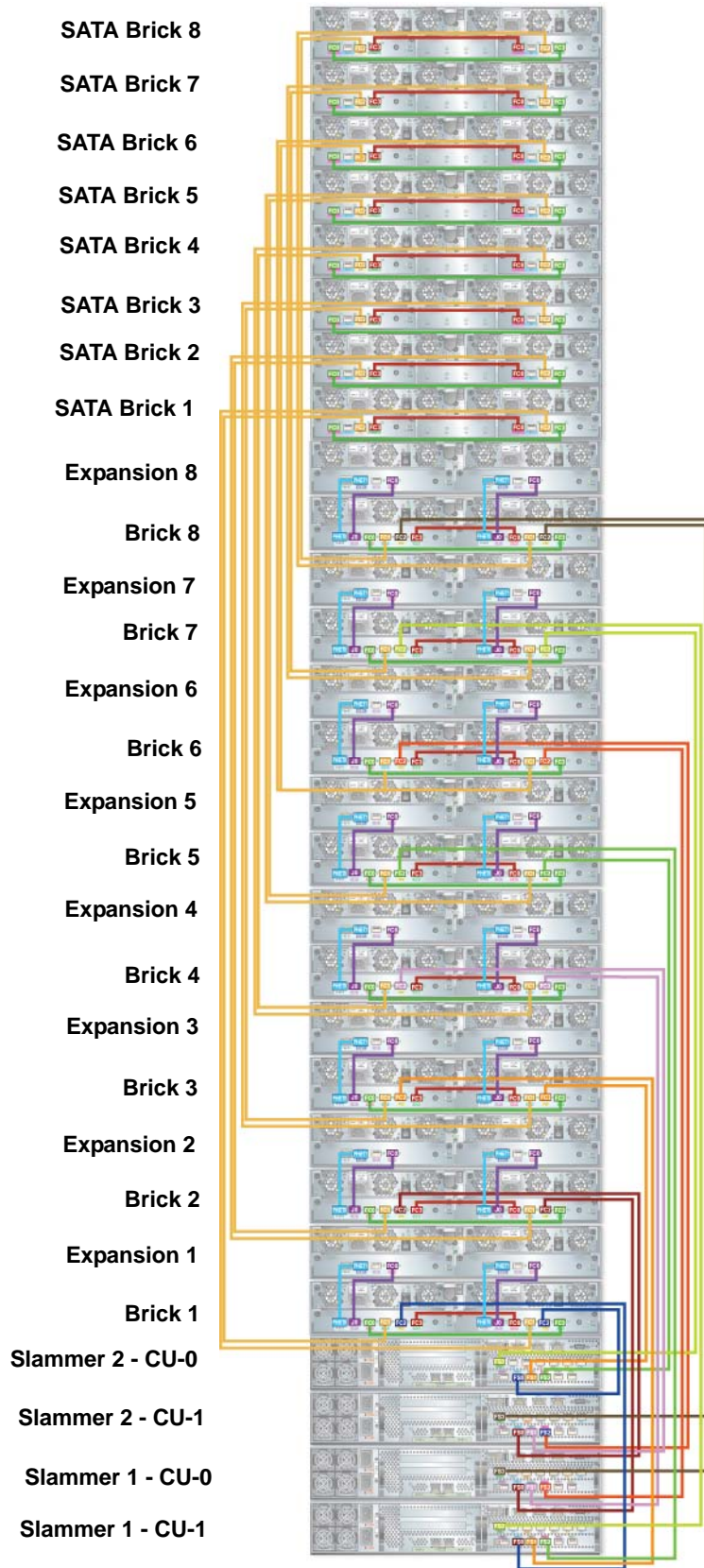

Add FC RAID Bricks to a SATA System

It is not always practical to configure a system with all of the FC Brick pairs closest to the Slammer. This section discusses adding a FC RAID Brick and FC Expansion Brick pair to an existing SATA System.

When adding bricks to systems, FC RAID Bricks may be added onto SATA Brick strings and SATA Bricks may be added onto the FC RAID Brick pairs. The figure below shows examples of how to cable both of these instances:

Figure 41 Mixed Brick system example

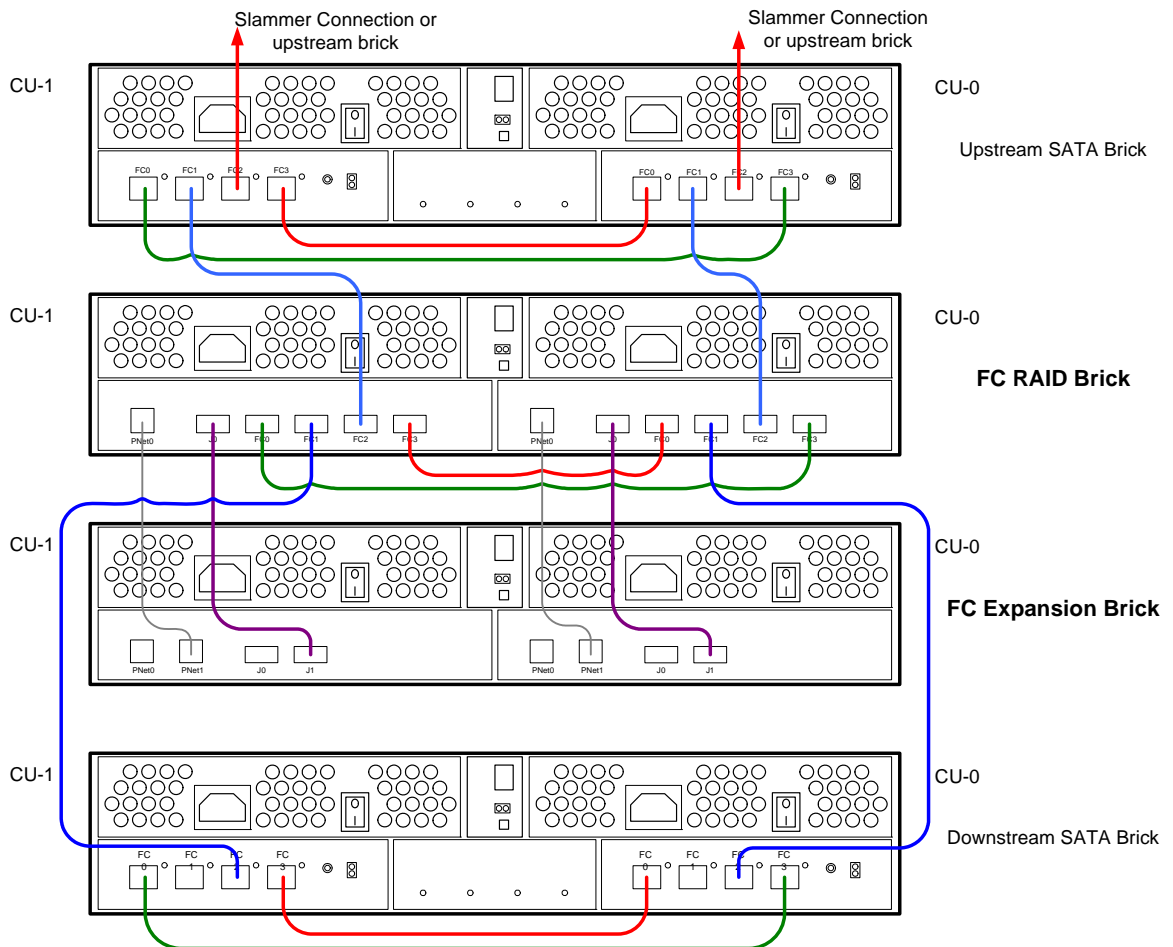

Rules for Combining Bricks

Showing every possible combination of FC and SATA Bricks is outside the scope of this document. However, if you follow these rules you should be successful.

These rules apply to both the Ax500 and Ax300 systems:

- 1 FC Bricks must always be configured in pairs of one FC RAID Brick and one FC Expansion Brick.
- 2 Slammer ports are used by FC RAID Bricks in the same order as the scheme for connecting SATA Bricks. This fosters balance among the strings while maintaining predictable assignment of Bricks to strings.
- 3 Bricks should be added to Strings so that the number of Bricks in any string differs by no more than 2 between the longest and the shortest String.
- 4 If additional SATA or FC RAID Bricks are added to a string, they attach to the last existing on that string. They should not be inserted into the middle of a string.
- 5 FC Brick pairs may be added to any configuration. These may be added to a running system as long as the new units are cabled up within the rack, are powered on, and have completed their initialization process prior to connecting them to the existing configuration.
- 6 Brick CU-0 upstream ports are connected to Slammer CU-0 ports or the CU-0 downstream ports of other Bricks; likewise, Brick CU-1 ports are connected to Slammer CU-1 ports or Brick CU-1 ports.
- 7 The Ax300 supports single FC RAID Brick configurations, but larger Ax300 FC Brick configurations must be composed of pairs of FC RAID Bricks and FC Expansion Bricks. Ax300 systems with a single FC RAID Brick can have a single FC Expansion Brick added to complete the pair with the previously installed FC RAID Brick.

Connect the Cables Between Two Racks

Be sure the two racks are bayed before you make connections between them. Route the Fibre Channel (FC) cables directly from one rack to the other through the open sides. Do not route cables from rack to rack through the raised floor. The cables supplied are not long enough.

When routing an FC cable from one rack to the other, route the cable through the plastic chase that is dedicated to FC cables on the right side of the rack (from the rear). The FC chase to use depends on which side the racks join.

Important! Make sure the Fibre Channel cables do not cross over or get too close to the power supply cords. Keep them separated to minimize EMI.

Connect to your Network

To connect the system to your network:

- 1 Connect the Pilot management (MGMT) ports to the Ethernet LAN on which the management console resides.

Figure 42 Pilot management cables

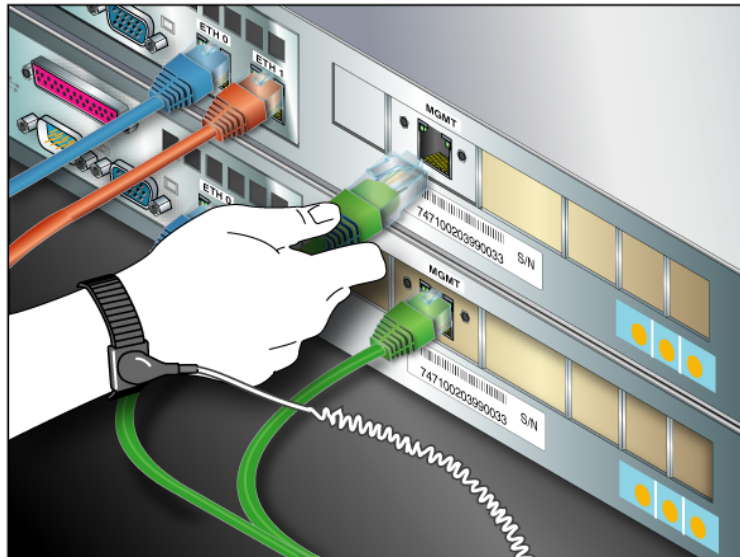

- 2 For NAS Slammers, connect two gigabit Ethernet (GbE) cables from the NIM interface ports on the Slammer to any open data port available on two separate gigabit Ethernet network switches.
For SAN Slammers, connect two Fibre Channel cables from the NIM interface ports on the Slammer to any open data port available on two separate FC network switches.

Figure 43 Slammer network cables

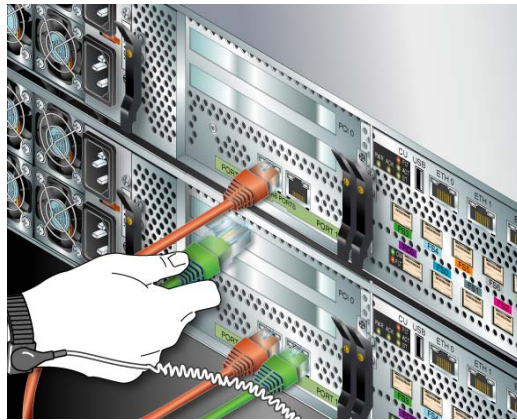

NAS Slammer

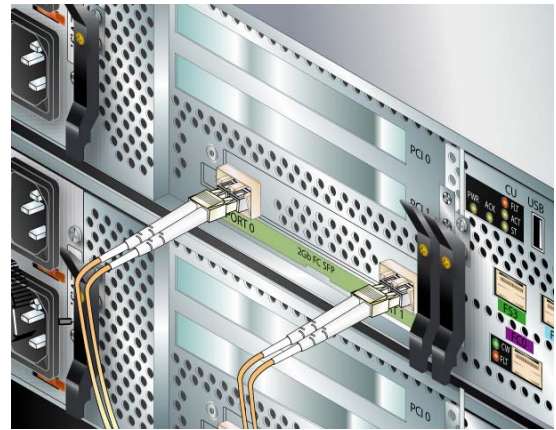

SAN Slammer

CHAPTER 5

Connect Power Cables

Cable Connection Procedure

If you are using Pillar Data Systems racks, the system comes with all the components and power supplies (power distribution units or PDUs) already installed in the rack. When you ordered the system you specified the type of power (voltage, amperage, and phases), which determines the type of electrical service outlets you have at your facility. The plugs on the PDUs you ordered have been installed to match these outlets.

Use the following procedure to connect the component's power cables and power cables that were not pre-installed:

- 1 Review the Pillar Axiom system [Component Power Usage](#).
- 2 Review the [PDU Outlet Amperage Limits](#).
- 3 Understand the [Power Cabling Examples](#).
- 4 Plug in your system components so that no PDU amperage limits are exceeded.
- 5 Dress all cables to the opposite side of the rack from any data cables.
- 6 Secure them to the rack such that they do not restrict the removal of any other component.

Note: You should not turn on any power circuits until the installation is complete and all network cables are in place. Powering on the system is described in Chapter 6, [Complete the Installation](#).

Component Power Usage

The Pillar Axiom storage system components must be plugged in to the PDUs such that they do not exceed the amperage rating of any outlet group. If you exceed the amperage rating, the circuit breakers trip.

Except where indicated, the maximum rated amperage of the outlet banks remains the same regardless of the electrical service voltage. Therefore, if you are using 230V service, components draw half the amperage as when powered by 115V and you can plug more components into each PDU.

This table lists the maximum electrical requirements of the basic Pillar Axiom components. Each component has redundant power cords plugged into different PDUs on separate circuits.

Table 17 Pillar Axiom component electrical requirements

Component	Amps at 115V	Amps at 230V	Power (watts)
Slammer	6.1 A	3.05 A	685 W
SATA Brick	2.54 A	1.17 A	254 W
Pilot	1.5 A	0.8 A	143 W

With redundant power supplies, the amperage draw for each power cord is rated for the case when one circuit fails, which increases the amperage draw on the other cord.

PDU Outlet Amperage Limits

The number of Axiom system components you can plug into each Pillar-supplied PDU varies. This section discusses each PDU.

The Pulizzi TPC2105, below, can use 115V or 230V, 30 A electrical service. The amperage limits are the same at either input voltage.

Figure 44 Pulizzi TPC2105-1 outlet amperage limits

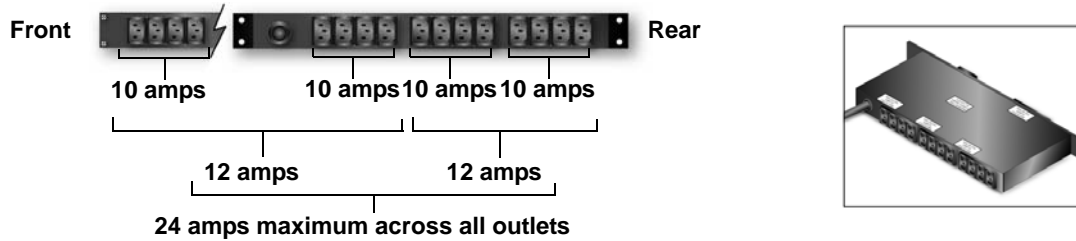

The Pulizzi TPC2104, below, can use 115V or 230V 20 A electrical service. The amperage limits per four-outlet group are different for 115 V and 230 V, but the overall amperage limit is 16 A regardless of the input voltage.

Figure 45 Pulizzi TPC2104 outlet amperage limits

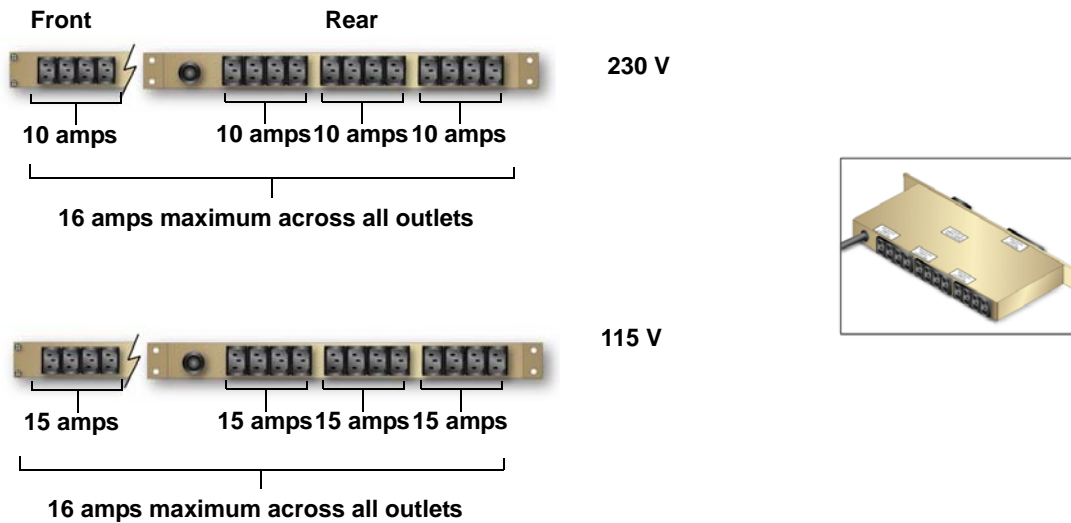

The Pulizzi PC3365 is shown below. It requires 230/400 VAC WYE three-phase input power. The output at each outlet is always 215V. This PDU is only available outside the United States.

Figure 46 Pulizzi PC3365 outlet amperage limits

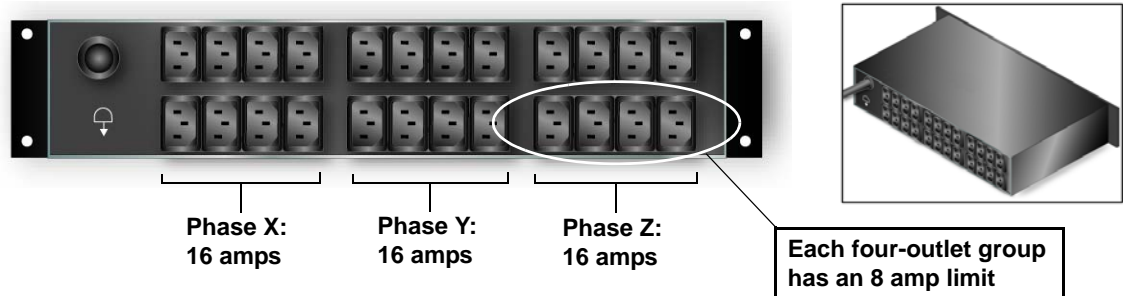

Power Cabling Examples

Here are some examples of where to plug components with various types of PDUs.

With a Pillar Data Systems rack, the Brick power cords are pre-installed in the rack with colored tie wraps, ready for you to plug into the back of each Brick. All cords of the same color connect to one set of power distribution units (PDUs), while the other cords connect to the other set of PDUs.

One Slammer and Three SATA Bricks

Also, there hasn't been enough time to create power diagrams specifically for FC Bricks, but I've made notes on the power differences.]

This example uses 230 V power and two Pulizzi TPC 2104 PDUs. The power cords on each component must go to separate PDUs, plugged in to separate circuits. A sample power cabling scheme such as the one below would distribute the load within the limits of each outlet bank.

Figure 47 Sample power cabling scheme with 230V power

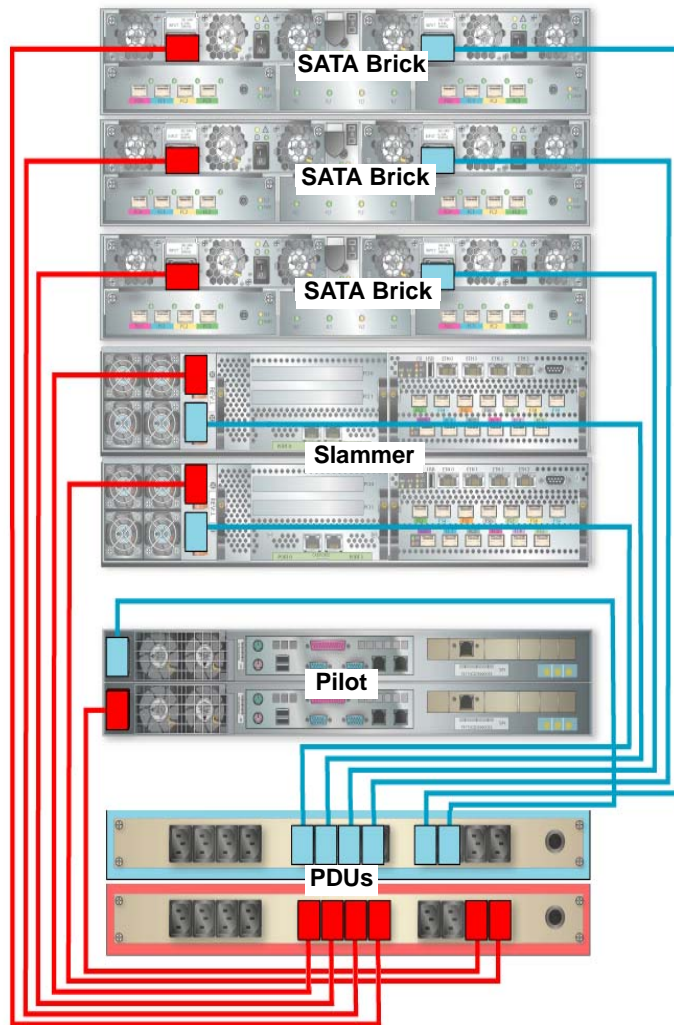

In the above example, the two Slammers and two SATA Bricks in the four-outlet bank require 1.525, 1.525, 1.17, and 1.17 A respectively, or 5.39 A. This is below the 10-A limit for a four-outlet bank.

If we modify the example to use 120V, the cable connections depend on which PDU you are using. The same two Slammers and two SATA Bricks draw 3.05, 3.05, 2.54, and 2.54 or 11.18 A. This load is acceptable for the Pulizzi TPC 2104 PDU because the amperage limit for a four-outlet bank is 15 A at 115 V.

For the TCP2105-1 PDU, at 115 V the maximum for four outlets is 10 A. Therefore, you would have to distribute the plugs differently than the 230 V system, as shown below:

Figure 48 Sample power cabling scheme with 115V on a TCP2105-1 PDU

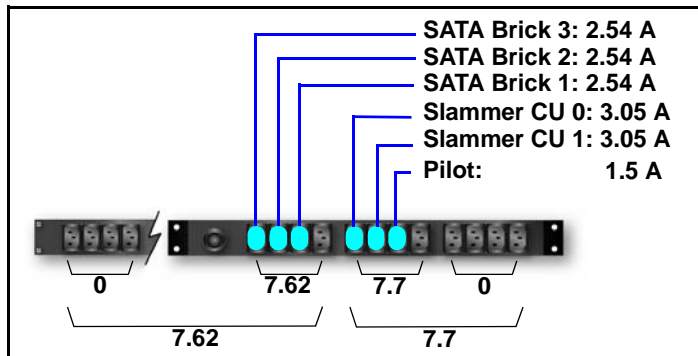

Other arrangements are possible. Make sure that you do not exceed the rating for a four-outlet bank or the rating for a set of two banks, which is 12 A for this PDU.

Another PDU is still needed for the power cords for the redundant circuit, which was left out of the above figures for simplicity. The redundant PDU should be cabled the same way.

Note: The amperage requirements for an FC Brick are higher than a SATA Brick at 115 Volts. The FC Bricks draw almost 1 full additional amp each. Configuring for FC Bricks may require upgrading your PDU specification. If you have any questions about your PDU configuration please contact Pillar Data Systems Technical Support.

One Slammer and 16 SATA Bricks

One Slammer and 16 SATA Bricks (and a Pilot) represents a full 42U rack. Split power cables (the plug end splits into two outlet ends) enable you to connect two components to a single outlet in the PDU and reduce the density of the cabling.

Note: The total amperage draw per outlet bank is more important than which Brick is plugged in to which outlet. The drawings below illustrate one way to distribute the load. Always try to balance the load among the outlet banks.

Figure 49 Sample power cabling scheme with 230V (one circuit shown)

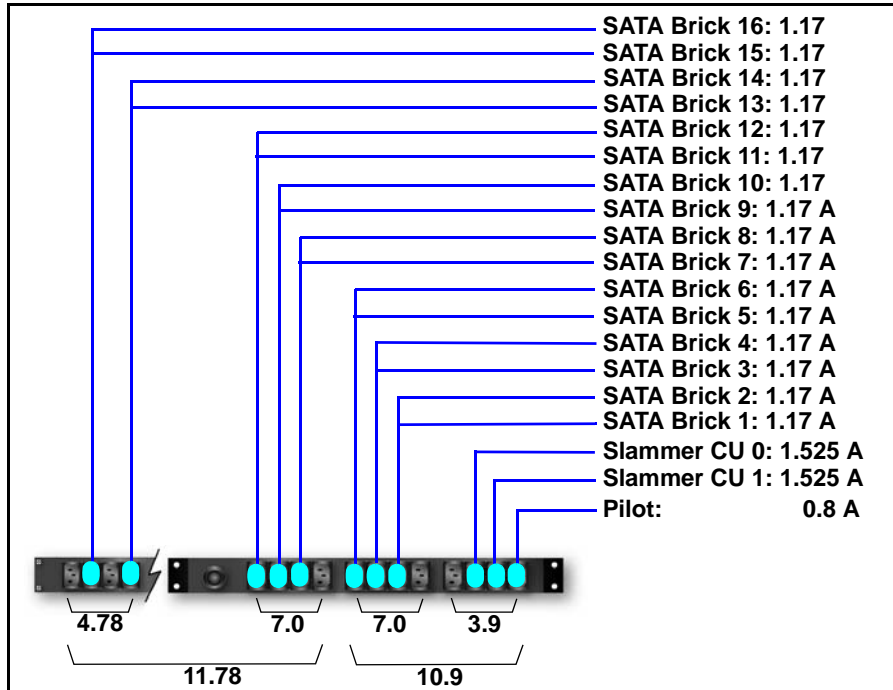

Important! If you use split power cables, as shown above, make sure they power separate components. Do not use a split power cable to power two sides of the same component. The two sides need to be on separate circuits, in case one fails.

Note: The amperage requirements for an FC Brick are higher than a SATA Brick at 115 Volts. The FC Bricks draw almost 1 full additional amp each. Configuring for FC Brick pairs may require upgrading your PDU specification. If you have any questions about your PDU configuration please contact Pillar Data Systems Technical Support.

CHAPTER 6

Complete the Installation

Power On the System

As part of your site planning, you set up a separate circuit and power outlet for each PDU. These outlets should be located within reach of the 15 ft. (4.572 m) PDU power input cables.

To supply power:

- 1 Ensure the PDU circuit breakers are in the Off position.
- 2 Connect the PDUs to a facility power source. If the facility's main circuit breakers are off, turn them on to supply power to the PDUs.
- 3 At the front of the system, use a #2 flathead or Phillips head screwdriver to secure the Slammer batteries in place with the two attached screws.

Figure 50 Secure Slammer batteries

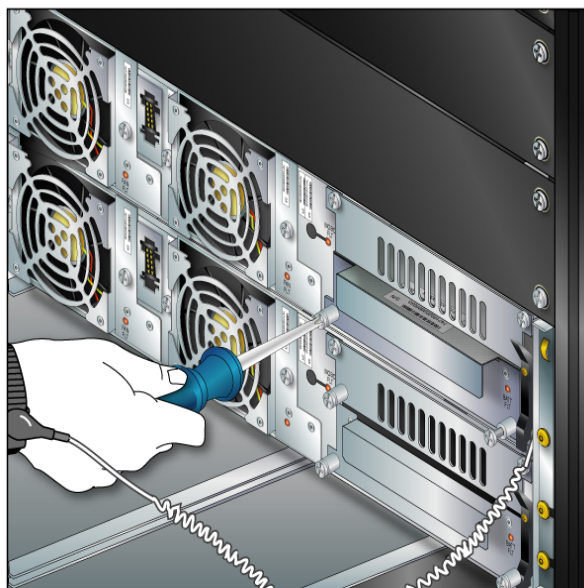

- 4 At the back of the system, turn on the power switches for each Brick.

Figure 51 Turn on Brick power

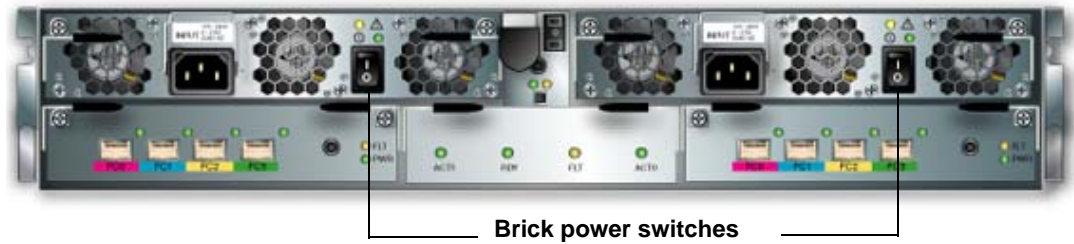

Note: Slammers and Pilots automatically power on when you apply power to the system in the next step.

- 5 At the front of the system, switch on the PDU circuit breakers to apply power to the hardware components. This lights the Power On LED, and starts the component cooling fans.

Figure 52 Turn on PDU power

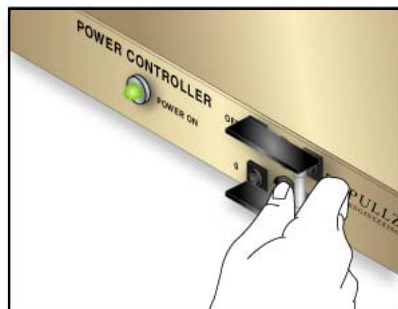

Important! You must turn on all of the PDUs within 10 sec of each other.

Verify Status LEDs

Check the component LEDs to verify hardware installation.

At the front of the system:

- 1 Verify the Pilot CU LEDs are green and not blinking.

If the LEDs are off, ensure there is power to the PDU circuit breakers and you have turned them on within 10 sec of each other.

Figure 53 Pilot bezel LEDs

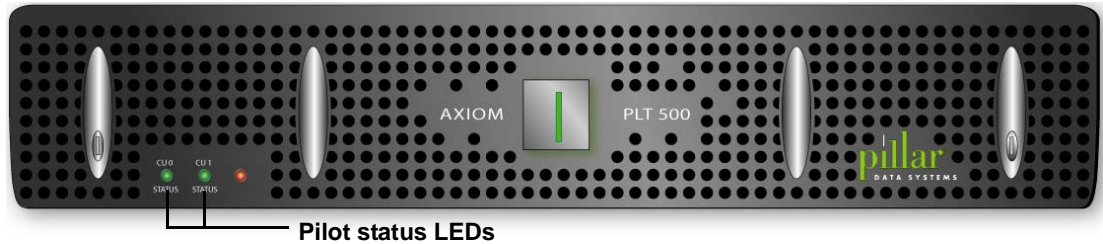

- 2 Verify that the Slammer Status LEDs are green and not blinking. They may be amber while the Slammer is booting and the software initializing, but should turn green when the Slammer is operational.

Figure 54 Slammer bezel LEDs

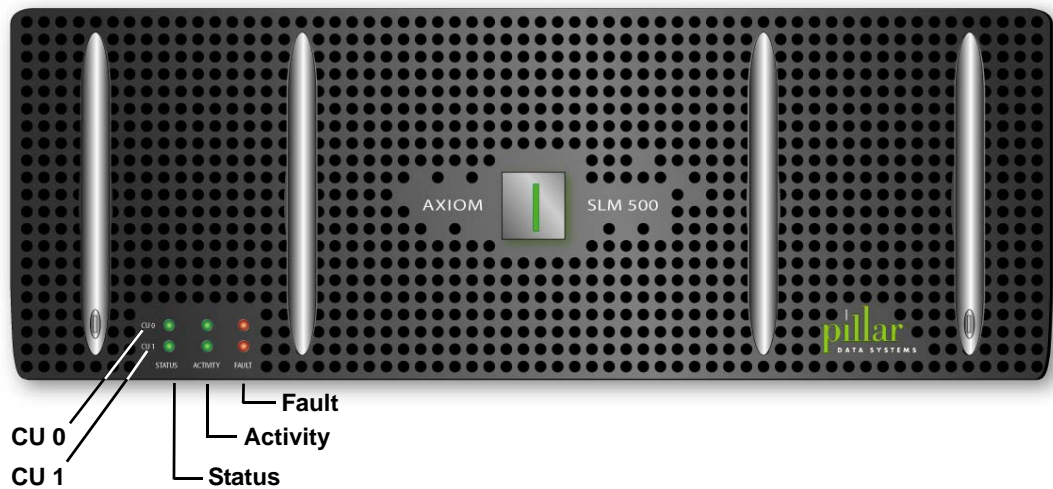

- 3 Verify that the Fault LEDs are off. If they are on at this stage, it is usually because the bezel is not fully seated.

- 4 For each Brick make sure that the CU 0 and CU 1 Status LEDs are green. Blinking means activity and is normal.

Figure 55 Brick bezel LEDs

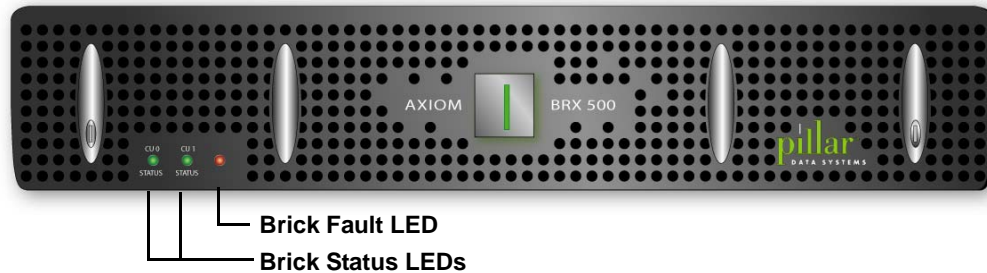

- 5 Verify that the Fault LED for each Brick is off. A lit Fault LED at this stage usually means the bezel is not fully seated.

For a detailed list of Slammer LED startup progress codes refer to Appendix A, [Slammer LED Startup Progress Codes](#).

At the back of the system:

- 1 Verify that the connectivity LEDs on each Pilot CU are green. Blinking indicates activity, which may be normal during bootup.

If the LEDs are off, check both Pilot management connections and both connections to your Ethernet LAN.

Figure 56 Pilot connectivity LEDs

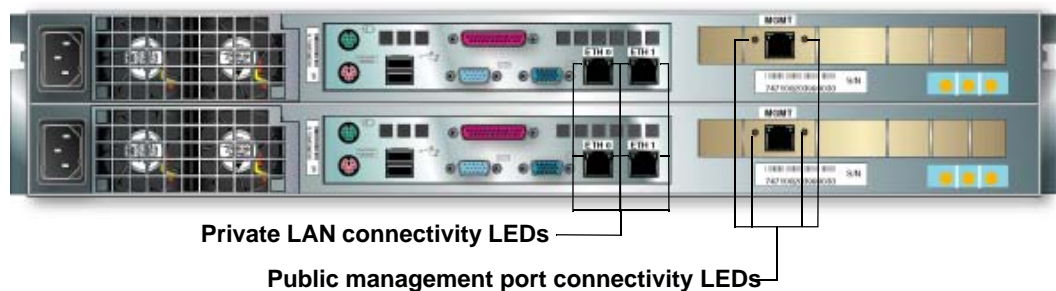

2 The Slammer has numerous status LEDs.

Figure 57 Pilot connectivity LEDs

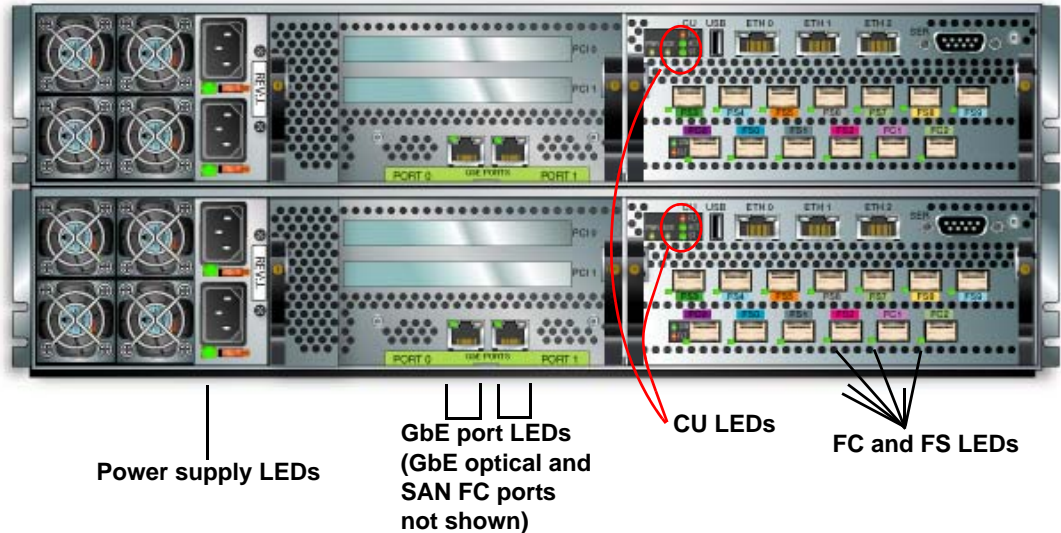

- The power supply LEDs are green and not blinking. If the power supply LEDs are off or are amber make sure the power cable is securely connected at both ends and the PDUs are powered on.
- On a NAS Slammer, for each GbE network port, the LED on the left is green and not blinking, and the one on the right is amber. If they are off, check the network connections.
- On a SAN Slammer, the Fibre Channel port LEDs are green and not blinking.
- For the control unit LEDs, the ST LED is green. The ACT LED might be on if the Slammer is configured and active, but is normally off at this stage of installation.
- All LEDs with an FC or FS cable port connection are green and not blinking. If they are amber or off, check the FC cabling.

- 3 On the Bricks, verify:
 - The power supply LEDs are green and not blinking.

Figure 58 Brick LEDs

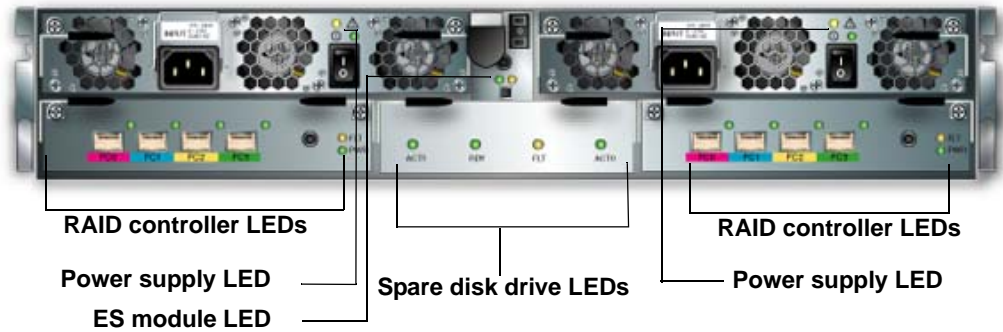

If either power supply LED is off or amber:

- Ensure the power cable on that side is securely connected at both ends.
- Ensure the PDU and Brick is powered on.
- Ensure you turned on the PDUs within 10 sec of each other.
- The enclosure services (ES) module LED is green and not blinking.

If the ES module LED is amber, ensure that both power cables are securely connected to both the Brick and the PDU.

- The connected RAID controller LEDs are green.

If the RAID controller LEDs are off or are blinking green, check the network connections.

- The spare disk drive LEDs are green and not blinking.

If the ES module, RAID controller, or spare disk drive has failed, contact Technical Support.

Attach the Bezels

At the front of the system, ensure all disk drives are fully seated by pressing each disk drive carrier into the Brick chassis to make sure they are fully seated.

You must attach all bezels or the system generates an error condition and lights amber LEDs.

To attach the bezels:

- 1 Insert the bottom two hooks on the bezel into the bottom rack rail tabs.

Figure 59 Bezel hook on the right side of the bezel

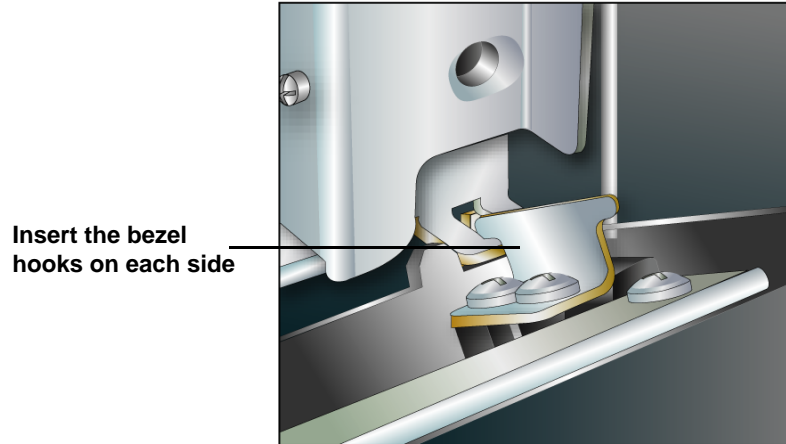

- 2 Press the top corners of the bezel to engage the top two bezel hooks with the top rail tabs.
- 3 Press both ejector tabs (if open) until they lock in place. The top hooks should latch with an audible click. If the bezel does not light when you apply power to the system, verify that the top and bottom hooks are all properly engaged.

Figure 60 Press ejector tabs to lock bezel

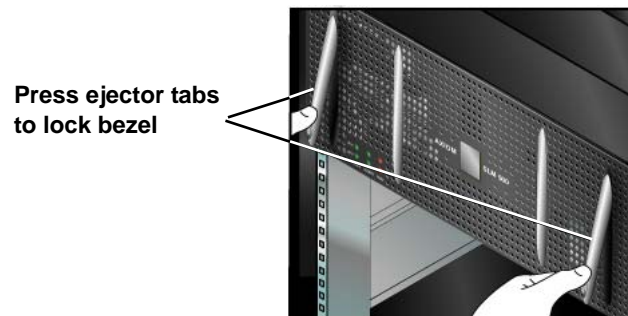

Install HBA Drivers and Firmware (SAN Only)

You must install Fibre Channel HBAs in the servers and their required software before you can access LUNs on a SAN system. Complete the instructions from your HBA vendor to:

- Install the HBAs in the servers.
- Download available drivers and firmware.
- Install or update the BIOS, if required.

Note: If you intend to install Axiom Path Manager software, refer to the appropriate *Pillar Axiom Path Manager Installation Guide*.

Set Up Switch Zones for the HBA (SAN Only)

If appropriate, follow the instructions from your switch vendor to set up zones to:

- Permit host HBA ports to access the Slammer ports.
- Segregate servers with different operating systems.
- Segregate servers with different security requirements.

Attach the Rack Doors and Panels

In this procedure, you reattach the front and back doors and both side panels to the rack. These steps help to ensure the security and proper cooling of Pillar Axiom components.

To reattach the doors on a rack:

- 1 Based on the type of door hinge, reassemble the hinges.
- 2 Reattach the doors.
- 3 Reattach the door grounding straps at the bottom of the doors.
- 4 Lock the front and back doors to the rack (optional).

To reattach the side panels on a rack:

- 1 Hang the top of the panel on the top of the rack frame and latch the panel to close it.

Important! Be sure not to pinch any cables that might have strayed from their proper moorings.

- 2 Secure the panel appropriately using one of the following options:
 - Engage the latch handle(s) and snap the panel into place.
 - Screw the panels to the rack frame at the top and bottom.
- 3 Lock both side panels (optional).

Initial Configuration

Pre-Configuration Checklist

This is a list of the information you need to know for configuration.

Table 18 Global system parameters

Done	Information
<input type="checkbox"/>	Check the <i>Pillar Axiom 500 Release Notes</i> and the Pillar Data Systems Support Portal to see if there any software updates available. Refer to the <i>Administrator's Guide</i> for instructions on installing software upgrades.
GUI access	
<input type="checkbox"/>	Get the IP address of the Pilot (the default is 10.0.0.2) and the user ID and password from the <i>Site Preparation Survey</i> or from Pillar Data Systems.
Global system parameters	
<input type="checkbox"/>	Get the IP address of your primary NTP server for synchronizing system time.
<input type="checkbox"/>	Decide on three IP addresses that are available to assign to the Pilot.
<input type="checkbox"/>	Know the management network submask and the IP address for the gateway.
<input type="checkbox"/>	Understand Link Aggregation and whether to use it for Slammer data paths.
<input type="checkbox"/>	To allow alerts to be e-mailed, you need the IP address of your e-mail server.
<input type="checkbox"/>	Get the Call-Home information from Pillar Data Systems.
NAS storage parameters	
<input type="checkbox"/>	If you saved a performance profile (from another Axiom system), you must know where it is so you can browse to it.

Table 18 Global system parameters (continued)

Done	Information
<input type="checkbox"/>	Decide on an IP address that is available in your network for the File Server.
<input type="checkbox"/>	Know the data network submask and the IP address for the gateway. This should be a different network than the management network.
<input type="checkbox"/>	Know your Virtual LAN ID, if you are using one.
<input type="checkbox"/>	Know the DNS domain name and DNS server IP addresses.
<input type="checkbox"/>	Understand enough about filesystems and storage to specify capacity, growth increment, type of redundancy, priority over other volumes, typical file size, random or sequential file access, and read or write I/O bias.
<input type="checkbox"/>	Understand file sharing for CIFS and NFS, including exporting, user accounts, and specifying allowed hosts or networks.
SAN storage parameters	
<input type="checkbox"/>	Understand enough about SANs to specify capacity, type of redundancy, priority over other volumes, random or sequential file access, read or write I/O bias, and Snap LUN space requirements.

Start the Graphical User Interface (GUI)

The AxiomONE Storage Services Manager provides a graphical user interface (GUI) to manage the Axiom system. Access the GUI by connecting to the Pilot's high-availability IP address, which is 10.0.0.2.

To connect to the GUI for the first time:

- 1 Through a Web browser, connect to the Pilot IP address 10.0.0.2 (network mask is 255.255.255.0).

Tip: Because this address is not routable, be sure that the browser host is on the local subnet.

- 2 Use the following values to log in:
 - Login Name: `administrator`
 - Password: `pillar`

- 3 When prompted, enter a new password.

Note: Get the password that is to be used from the *Site Preparation Survey*. Be sure that the Primary System Administrator also gets this password.



Do not lose this new password; otherwise, the system must be reset.

- 4 Click the OK button.

At this point, the system tests the cabling among the Slammers and Bricks. After the cable test, the system reports that all connections are OK or lists the connections that failed.

To troubleshoot a failed connection:

- 1 Ensure that the Fibre Channel cable is properly seated at both ends.
- 2 Run the system verification test manually by going to the Support > Verify System Operation page in the GUI. Click on the System Configuration link in the content pane.
- 3 If the connection still fails, swap the cable with one that works.
- 4 Repeat Step 2.

Note: This second test should determine whether the cable or one of the original ports is bad.

- 5 Contact Technical Support who will help you determine whether you have a bad cable or port and which one is bad:
 - Request a replacement Fibre Channel cable for a bad cable.
 - Request a replacement private interconnect module for a bad Slammer port or RAID controller for a bad Brick port.

After the cable test, the system asks if you want to run the Configuration Wizard.

Configure the System with the Configuration Wizard

The Configuration Wizard pages guide you through the manual steps to configure your system.

- 1 From the initial GUI screen, select Configuration Wizard.
- 2 From the Configuration Wizard initial page, click the Next button.
- 3 Select all three configuration tasks:

Figure 61 Configuration Tasks page

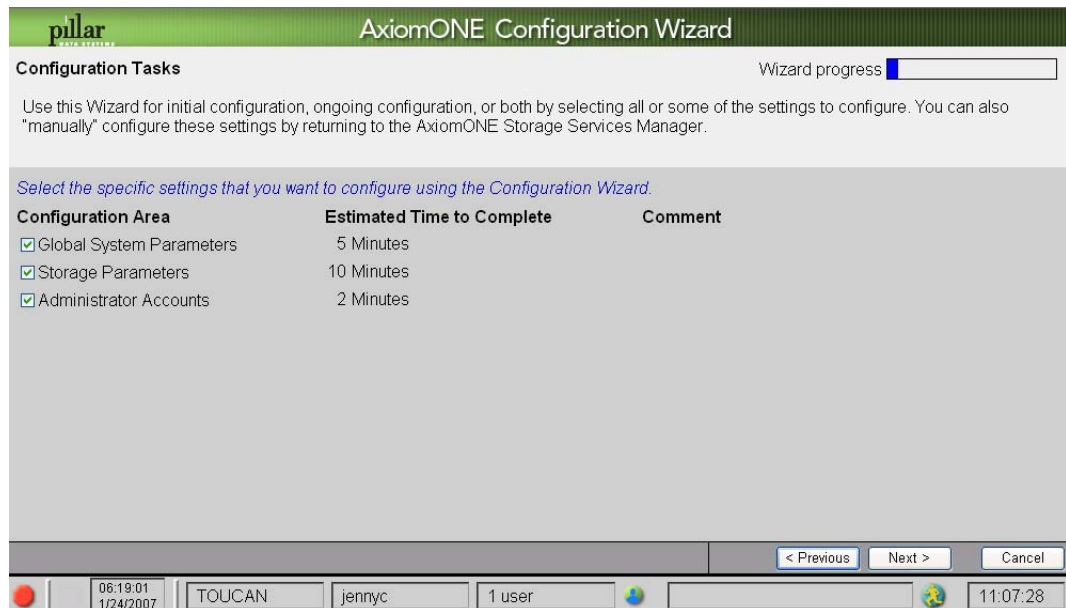

- 4 Click the Next button.

Note: If you intend to configure both NAS and SAN Slammers, run this wizard a second time, select only Storage Parameters, and specify a filesystem instead of a LUN (or the other way around).

Configure Global System Parameters

To configure the Global System parameters:

- 1 In the System Time page, enter the IP addresses of the primary Network Time Protocol (NTP) server and up to two secondary NTP servers (optional).

Note: If you do not set the system time, the Pillar Axiom system uses the default time set on the Pilot (Pacific Time).

- 2 Select the time zone that you want to define for the Pillar Axiom system, and click the Next button.

Figure 62 System Time page

The screenshot shows the 'Global System Parameters - System Time' page in the 'AxiomONE Configuration Wizard'. The page includes a progress bar, a description of system time synchronization, and fields for NTP server settings and time zone selection.

Global System Parameters - System Time Wizard progress

The system date and time settings synchronize the time across all Pillar Axiom components. The system time can be adjusted by navigating to the System area and choosing Summary.

Specify any NTP Servers. Select the appropriate time zone.

Current System Date/Time
08:50:09 October 24th, 2006

NTP Server Settings

Primary IP Address:

Alternate IP Address:

Alternate IP Address:

Time Zone:

< Previous Next > Cancel

- In the Management and Data Path Interfaces page, enter the System Name. This is the name of the management interface IP address and can be used with an external naming service to access the management interface by a host name rather than the IP address. This is not the host or NetBIOS name.

Figure 63 Management and Data Path Interfaces page

The screenshot shows the 'AxiomONE Configuration Wizard' interface. The main heading is 'Global System Parameters - Management and Data Path Interfaces'. Below this, there's a progress bar and a note: 'The management and data path interfaces are system-wide settings independent of the storage configuration.' A sub-heading reads: 'To assign a primary IP address select DHCP or enter a static address.' The 'System Name' field contains 'XYZ-data'. Under 'Management Interface Settings', 'Static IP Address' is selected. The IP address fields are: Default (192.1.1.10), Pilot CU 0 (192.1.1.11), and Pilot CU 1 (192.1.1.12). The Subnet mask is set to 255.255.255.0 and the Gateway is 192.1.1.1. Under 'Data Path Interface Settings', 'Enable Link Aggregation' is unchecked, with a tooltip that says 'Combines Ethernet ports on a Slammer for higher throughput.' Navigation buttons for '< Previous' and 'Next >' are at the bottom right.

- Select a Static IP Address.
- Enter a reachable management IP Default Address. (The default address of 10.0.0.2 cannot be routed.) If you only enter the default address, the system automatically assigns the next two IP addresses in sequence as Pilot CU 0 and Pilot CU 1 addresses. For example, if you enter 129.214.10.10 as the default address, the system automatically assigns IP address 129.214.10.11 to Pilot CU 0 and 129.214.10.12 to Pilot CU 1.

If those sequential addresses are not available, enter the desired values for the additional IP addresses in the fields for Pilot CU0 and Pilot CU1.

Important! All three addresses must be on the same subnet.

Note: Get the IP address that is to be used from the *Site Preparation Survey*. Be sure that the Primary System Administrator also gets this IP address.



Do not lose this IP address; otherwise, the system must be reset.

- 6 Enter the subnet mask for your network and the IP address of the default gateway for the management interfaces . If you do not want the management interfaces to be reachable from anywhere other than the local subnet, leave the default gateway blank. However, you must enter a valid netmask.
- 7 Select Enable Link Aggregation for the data interfaces if you are using it in your network and want to use it for Slammer data paths.
Important! If you select this option, only one port is available for configuration for each Slammer CU data path—the aggregated port.
- 8 Click the Next button. The Next button assigns the primary IP addresses and brings up the next dialog.

Figure 64 Notification and Account Security Settings page

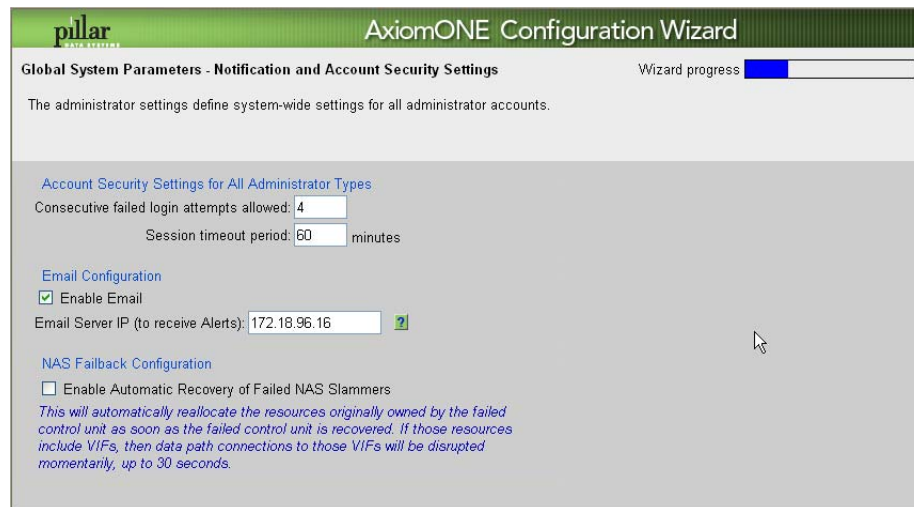

The screenshot displays the 'AxiomONE Configuration Wizard' interface. The title bar shows the 'pillar' logo and 'AxiomONE Configuration Wizard'. Below the title bar, the page is titled 'Global System Parameters - Notification and Account Security Settings' with a 'Wizard progress' indicator. The main content area is divided into sections: 'Account Security Settings for All Administrator Types' with input fields for 'Consecutive failed login attempts allowed' (set to 4) and 'Session timeout period' (set to 60 minutes); 'Email Configuration' with a checked 'Enable Email' checkbox and an 'Email Server IP (to receive Alerts)' field set to 172.18.96.16; and 'NAS Failback Configuration' with an unchecked 'Enable Automatic Recovery of Failed NAS Slammers' checkbox and a descriptive note about resource reallocation.

- 9 Enter the Account Security values for failed log-ins and session time-out period.
- 10 To receive alerts by email, check Enable Email and specify your Email server IP address.
- 11 To enable the Call-Home feature, choose whether to use the Pillar Server or the local host and enter the Call-Home information you got from Pillar Data Systems.
- 12 Check Enable Automatic Recovery of Failed NAS Slammers if you want NAS Slammers to automatically fail back when a failed control unit is restored. If you want to control when a recovery occurs, do not check this box. (SAN Slammers fail back automatically.)
- 13 Click the Next button to configure your storage.

Configure NAS Storage Parameters

If you do not have NAS storage, skip to [Configure SAN Storage](#).

To configure NAS Storage Parameters:

- 1 In the Storage Allocation and Quality of Service (QoS) page, select Filesystem from the Storage Type drop-down box.

Figure 65 Storage Allocation and Quality of Service (QoS) page

The screenshot shows the 'Storage Allocation and Quality of Service (QoS)' page in the AxiomONE Configuration Wizard. The page title is 'Storage Allocation and Quality of Service (QoS)' and the wizard progress is shown as a blue bar. The page contains the following elements:

- Header:** 'pillar DATA SYSTEMS' logo and 'AxiomONE Configuration Wizard' title.
- Section:** 'Storage Allocation and Quality of Service (QoS)' with a progress indicator.
- Description:** 'The QoS settings define the performance characteristics for a logical volume (filesystem or LUN) in your storage environment. You may create only one logical volume at a time using this wizard. To create additional volumes, you can run the Capacity Planner®, run this Configuration Wizard again, or create them "manually" from the Storage page.'
- Instructions:** 'Select the application category that best describes your storage use environment or you may choose a specific performance profile. Your selection will determine the quality of service for the filesystem. Note: Standard Performance Profiles* cannot be deleted.'
- Capacity:** 'Total System Capacity available for use: 3792 GB'
- Storage Type:** A dropdown menu set to 'Filesystem'.
- Performance Characteristics:**
 - Application Category: 'Hardware/Software Development' (dropdown)
 - Performance Profiles: 'Highest Throughput *' (dropdown)
- Buttons:** 'Import Profile(s)' and 'Delete Selected Profile' (disabled).
- Navigation:** '< Previous' and 'Next >' buttons at the bottom right.

- 2 Select an option on which to base the QoS settings. Choose one of:
 - Application Category to select the application category that best describes your storage use environment. Each category has certain default profile values that you can edit on the Capacity and Performance page.
 - If you have exported a performance profile from another filesystem to use here, select the Performance Profile option and Highest Throughput. If you select this option you get a chance to browse to the exported profile.
- 3 Click the Next button to configure this filesystem.
- 4 Enter the filesystem's name as well as the capacity values.

Figure 66 Storage Capacity and Performance Settings page

The screenshot shows the 'Storage Capacity and Performance Settings' page in the AxiomONE Configuration Wizard. The page is titled 'Storage Capacity and Performance Settings' and includes a 'Wizard progress' bar. Below the title, there is a note: 'The default performance settings displayed below are recommended based on the application category "Hardware/Software". You may modify them to best fit your application, but it is recommended that you use the default values.'

The page is divided into several sections:

- Filesystem:** Name: EngSW
- Capacity:** Capacity: 350 GB, Growth Increment: 35 GB (Set off at 90% capacity), Maximum Capacity: 500 GB, Redundancy: Double
- Retention Policy:**
 - Enable Retention Policy for SecureWORMfs
 - Standard:** Use to store reference data that is non-rewritable (protected). Data is retained on the filesystem for a fixed period of time that is specified by the retention period settings, however, you can delete data at anytime by deleting the entire filesystem.
 - Compliance:** Use to store key business data as stipulated by various regulations that require data to be retained for a fixed period of time. You cannot delete a compliant filesystem if there are protected files on the filesystem. You must enable the NTP Server to use this feature.
- Performance:**
 - Priority vs. other Volumes: High
 - Typical File Size: Small (<20KB)
 - Files are typically accessed: Random
 - I/O Bias: Read

A table indicates how much capacity (GB) is available based on priority and redundancy:

		Priority				
		Archive	Low	Medium	High	Premium
Redundancy	Standard	3791	3033	2274	756	0
	Double	1895	1516	1137	378	0
	Triple	1263	1011	758	252	0

At the bottom of the page, there are navigation buttons: '< Previous', 'Next >', and 'Cancel'.

- 5 The performance settings are based on the application category you selected, but you can change them to suit your needs.
- 6 To specify SecureWORMfs for this filesystem, check the retention policy box.
- 7 Click Next. If you check the Retention Policy box you go to the Retention Policy Settings page. Otherwise you go to the File Sharing page in [Step 10](#).
- 8 In the Retention Policy Settings page set the master retention period values.
- 9 Specify suitable scan times and click the Next button.

- 10 In the File Sharing page, select the type(s) of file sharing that you want for this filesystem, and click Next button.
- 11 On Shares page, specify a share name and use just a back-slash (\) for the path. A new filesystem is empty, so there is no other path to specify.
- 12 Check Enabled to share the filesystem to Windows (CIFS) users and click the Next button.
- 13 On the Exports page, enter a back-slash (\) for the path. The UID for anonymous is for a CIFS user with no matching user account. It is also for a root user on a client if the filesystem is not exported as root access. A common value to use for this is -2.
- 14 Specify the hosts to which you would like to export this filesystem and whether it should be exported as Read Only or Root Access.
- 15 Click Next to specify a File Server.

To create a File Server:

- 1 In the Choose a File Server page, select Create a New File Server, and click the Next button.

Figure 67 Create New File Server page

The screenshot shows the 'Create New File Server - Networking' page of the Axiom Configuration Wizard. The page title is 'AXIOM CONFIGURATION WIZARD' and the current step is 'Create New File Server - Networking'. A progress bar shows the wizard is approximately 75% complete. Below the title, there is a description: 'The Network parameters define the virtual interface (VIF) and Domain Name Server (DNS) for the File Server. The DNS domain specifies the domain to be searched.' The form contains several sections: 'File Server Name' with a text box containing 'FileServer1'; 'Virtual Interfaces' with fields for IP address, Netmask (255.255.255.0), VLAN_ID, Slammer (Tiger), Controller Unit (0), PORT Number (PORT0), and Jumbo Frame Size (1500); 'Route' with a Default Gateway field; and 'DNS Settings' with fields for DNS Domain, DNS Server1, DNS Server2, and DNS Server3. At the bottom, there are navigation buttons: '< Previous', 'Next >', and 'Cancel'.

- 2 Enter the File Server name, which becomes the name your clients use to access the File Server.

- 3 Specify an IP address that is available on the data network, the appropriate netmask, and the default gateway. This is not the same network you use for the management interface.
- 4 If you are using a virtual LAN in your network and want to use it for your NAS Slammer, specify it's ID here. Leave it blank or specify 0 for no VLAN.
- 5 Specify the name of the NAS Slammer, it's control unit (CU 0 or 1), and port (0 or 1). This is where the filesystem is connected.
- 6 Leave Jumbo Frame Size at 1500, which means do not use Jumbo Frames. If you use Jumbo Frames, all the hardware on the network has to support Jumbo Frames.
- 7 Specify the IP address for one or more Domain Name Servers.
- 8 Click the Next button to configure administrator accounts. then, if you need to configure SAN storage, restart the Wizard and go to the next section.

Configure SAN Storage

If you just configured NAS storage, run the Configuration Wizard a second time, and only specify Storage Parameters. You do not need to configure the global parameters or accounts again if they are already configured.

To configure SAN storage parameters:

- 1 In the Storage Allocation and Quality of Service (QoS) page, select LUN from the Storage Type drop-down box.

Figure 68 Storage Allocation and Quality of Service (QoS) page for LUNs

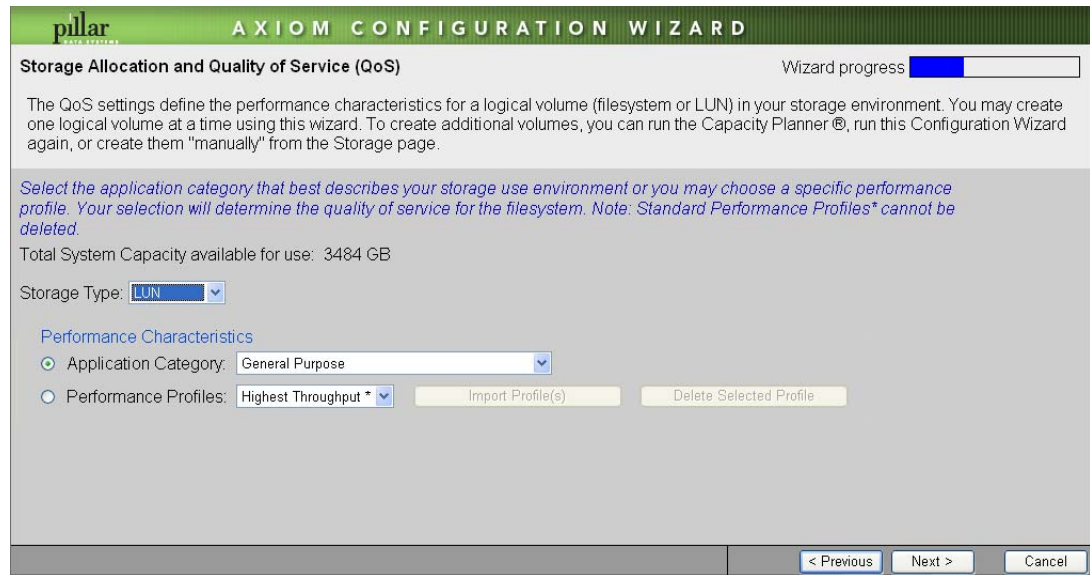

- 2 Select an option on which to base the QoS settings. Choose either:
 - Application Category to select the application category that best describes your storage use environment. Each category has certain default profile values that you can edit on the Capacity and Performance page.
 - If you have exported a performance profile from another filesystem to use here, select the Performance Profile option and Highest Throughput. If you select this option you get a chance to browse to the exported profile.
- 3 Click the Next button to configure this LUN.

Figure 69 Storage Capacity and Performance Settings page for a LUN

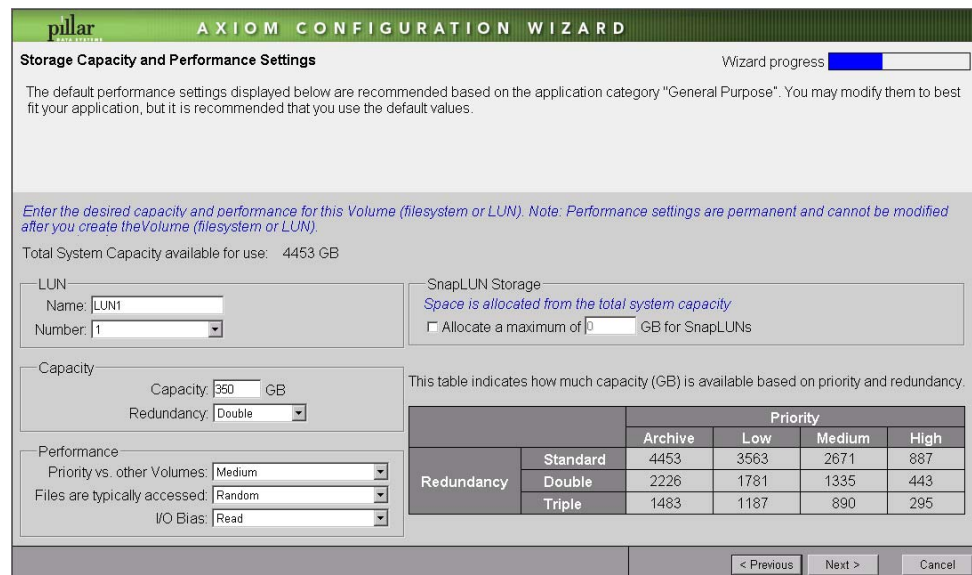

- 4 Enter a LUN name and LUN number.
- 5 Enter values to specify the LUN capacity, redundancy, and performance attributes, if you need to change the defaults for this application type.

Note: You can modify a LUN to update its capacity attributes at any time. You cannot change a LUN's redundancy and performance attributes after you create the LUN.
- 6 If you want to create a Snap LUN, enter the amount of space you would like to allocate.
- 7 Click the Next button to configure administrator accounts, unless you have already completed this step.

Configure Administrator Accounts

To create an administrator account:

- 1 Enter administrator account details, including Login name, Role, and Password. For Roles, choose from:
 - Administrator 1 to perform all configuration, management, and monitoring tasks.
 - Administrator 2 to perform all tasks except:
 - Create and manage File Servers and administrator accounts.
 - Modify global, SNMP, and NDMP settings.
 - Modify software or hardware configurations.
 - Shut down the system.
 - Monitor to display system information only. This administrator cannot modify the configuration but can modify administrator account attributes.
- 2 Click the Next button. The Configuration Wizard displays a configuration summary.
- 3 Click the Finish button to implement the configuration. You do not need to restart the system.

Install Axiom Path Manager (SAN Only)

To operate your SAN system, you may optionally install the Pillar Axiom Path Manager drivers and software, which:

- Ensure your operating system does not interpret multiple paths as multiple disk drives.
- Provide path failover.
- Streamline system management.

Important! Configure the LUNs before you install the Axiom Path Manager software.

Complete the procedures in the appropriate *Pillar Axiom Path Manager Installation Guide* to install the Pillar Axiom Path Manager driver and software.

Expansion Planning

Add a New Brick

When adding Bricks, use Guided Maintenance.

Use the following procedure to add new Bricks.

- 1 When you are ordering new Bricks, refer to Chapter 5, [Connect Power Cables](#), to determine if you need additional power distribution units (PDUs) and to devise a cabling plan that specifies to which PDU outlet each Brick power cable connects.
- 2 Before the Bricks arrive, work out where you will install each Brick and PDU. Add Bricks above the Slammer(s) until they reach the top rack unit, and then start at the top of the next rack and work down. PDUs go at the bottom of the rack.
- 3 Install any new PDUs as described in [Install Power Distribution Units](#).
- 4 Install the new Bricks as described in [Install a Brick](#).
- 5 Refer to Chapter 4, [Connect Data Cables](#) for information about how to cable bricks. You do not need to power the Axiom system down to cable additional Brick unless you are also adding a Slammer. Run all the cables so that you can remove any components without disconnecting a cable.
- 6 Make sure the power switches on the back of the new Bricks are off before connecting the power cables.
- 7 Run the power cables and plug them into the PDUs according to the cabling plan devised in step 1.
- 8 Verify seating on all disk drives by pressing on each one to make sure it is fully seated. They are seated correctly if they do not go in any further and none stick out more than the others.

- 9 Make sure the Pillar Axiom system is powered on and all the new cables are in place. It is important that the system be running when you power on a new Brick so that the system can detect and integrate the Brick.
- 10 Add power to one new Brick. You do not power on the next Brick until the current Brick is successfully integrated. Power on the Bricks connected directly to a Slammer first, then those that are connected to the first group of Bricks, and so on.
- 11 When prompted by an Administrator Action in the GUI, accept the new Brick.
- 12 Verify from the GUI that the new Brick's capacity is added to the total system capacity.
- 13 After you complete the Administrator action to accept this Brick and you have verified correct RAID Controller firmware version repeat [Step 10](#) through [Step 12](#) for each new Brick.
- 14 When all Bricks are powered on and RAID controller firmware version verified, check all LEDs for green indication. See [Verify Status LEDs](#).

Notes:

- Go to the Software Module page of the Support tab. There should be only one “Brick Firmware” entry, which is for the RAID controller. (It is OK to have more than one entry for “Brick Disk Drive Firmware.”)
- If the RAID controller firmware is not updated, perform a system restart and recheck with `PDSquery`.
- If the RAID controller firmware still did not update, power off and then power on the system and recheck with `PDSquery`.
- If the new Brick's capacity is not added to the total system capacity, there was an error adding the Brick. Disconnect the Brick from the system, accept the Administrator action to remove the Brick, and attempt the operation again.

Add a New Slammer

We do not recommend adding a Slammer to an Axiom system while the system is in normal running status.

If the existing racks are full, you need additional racks and may have to move some Bricks to accommodate a second Slammer. See the hardware map in [Component Placement](#) for more information.

To perform the pre-installation check:

- 1 Inventory the Slammer and installation components to make sure you have the correct cables and mounting hardware.
- 2 Before beginning the installation, check the status of the system to ensure that it is in proper status, as follows:
 - All Fibre Channel Status LEDs on Slammer and Brick ports with connectors inserted are steady green, not amber or flashing green.
 - The System Summary Status in the GUI is green for all components.
 - No background tasks are running.
 - There are no outstanding Administrator Actions.
 - No file systems or SAN LUNs are offline, degraded, or in conservative mode.
- 3 Perform a `PDSquery -v` and check the output for correct status of all components.
- 4 Collect a full System Information File and download it in the event it is needed by technical support if the upgrade fails to complete successfully. Optionally, clear the log files with `supporttool PerformClearLogs`.

To install the Slammer:

- 1 Place the Axiom system in Shutdown Status with the GUI or command line interface (CLI) and verify that the system has successfully shut down.
- 2 Physically add the new Slammer to the system, as described in [Install a Slammer](#).
- 3 Connect the Ethernet and Fibre Channel cables following the instructions in Chapter 4, [Connect Data Cables](#).
- 4 Attach the Slammer power connections to separate PDUs as shown in Chapter 5, [Connect Power Cables](#).

- 5 Restart the Pillar Axiom system. Carefully observe the System Health Status to ensure that the Slammers proceed through startup and achieve a normal status.
- 6 Check that the system recognizes the new Slammer. That is, the system adds it to the configuration and performs a successful startup to normal status, with any firmware updates to the Slammer CU completing successfully.
- 7 Perform a `PDSquery -v` to check the status and revisions of the Slammer and the Slammer and Brick Fibre Channel (FC) ports.
- 8 Check the Fibre Channel status LEDs on all ports on all Slammers and Bricks. If there is a FC cable connected, the associated port status LED should be solid green and not amber or blinking green.

Slammer LED Startup Progress Codes

Introduction to LED Startup Codes

When a Slammer is powered on, it goes through a sequence of actions. Generally, the time to finish these actions for a new installation is about 20 minutes.

Notes:

- The time to start up your system may be shorter or longer, depending the configuration of Slammers and Bricks and a number of other factors.
- Slammers cannot complete the startup sequence without the Pilot being powered on and functioning.
- While a Slammer performs startup diagnostics and then waits for its runtime image to download from the Pilot:
 - The Fault LED (FLT) is off.
 - The Activity LED (ACT) is green and blinks fast.
 - The Status LED (ST) is green and blinks slowly.

During the remainder of the startup, FLT and ACT are off while ST slowly blinks amber once each second. During this time, the GUI shows the Slammer to be in "booting 0xnnnn" status while the Pilot initializes the Slammer's data services components.

When the Slammer successfully completes the startup sequence, ST is steady green.

Tip: If the front bezel Fault (FLT) LED is on steady and no other fault indicators on the Slammer are lit, the bezel may not be properly seated. Slammers always light FLT when the bezel is off.

- If the Slammer halts during startup, the three LEDs on the back of the chassis (FLT, ACT, and ST) or the three LEDs on the bezel (Status, Activity, and Fault) help you identify where the Slammer halted in the startup sequence.

LED Startup Codes

The Slammer bezel has Fault, Status, and Activity LEDs that can display various colors and blink rates. These LEDs also appear on the private interface module at the back of the Slammer chassis, and are labeled FLT (Fault), ACT (Activity), and ST (Status).

These LEDs can:

- Be green or amber.
- Be on or off.
- Be steady, with no blinks.
- Blink rapidly—slightly more than two blinks per sec (2.375 hz).
- Blink slowly—one blink per 1.5 sec (0.67 hz).

The configuration of all three LEDs can be translated into a 3-digit progress code. Use this code to identify the cause of failure in the table at the end of this section.

The first digit of a startup progress code is determined by the color and blink rate of the FLT LED. Use the information in the following table to determine the first digit of this code.

Table 19 Code translation for the Fault LED

LED color	Blink rate	Code
None	Off	0
Amber	Steady	1
	Rapid	2
	Slow	3

The second digit of the startup progress code is determined by the color and blink rate of the Activity LED. Use the information in the following table to determine the second digit of this code.

Table 20 Code translation for the Activity LED

LED color	Blink rate	Code
None	Off	0
Amber	Steady	1
	Rapid	3
	Slow	4
Green	Steady	2
	Rapid	5
	Slow	6

The third digit of the startup progress code is determined by the color and blink rate of the Status LED. Use the information in the following table to determine the third digit of this code.

Table 21 Code translation for the Status LED

LED color	Blink rate	Code
None	Off	0
Amber	Steady	1
	Rapid	3
	Slow	4
Green	Steady	2
	Rapid	5
	Slow	6

For example, the following LED configuration represents a progress code of 111, which means that the simple memory test failed on the Slammer:

- FLT—steady amber
- ACT—steady amber
- ST—steady amber

The table below describes the meaning of the startup progress codes as indicated by the LEDs.

Note: The software modules in the table below are defined as follows:

- Boot Block is a software module that contains initialization routines, which include Preferred and Alternate Boot Page validation.
- MPOST is manufacturing POST and is for testing the motherboard.
- Preferred Boot Page is the preferred runtime start-up code.
- Alternate Boot Page is the safe (or backup) start-up code. Both the Preferred Boot Page and the Alternate Boot Page are alternately updateable in the field. The Alternate Boot Page should ensure that the Slammer can start up even when the Preferred Boot Page is corrupted.

Table 22 Slammer LED startup codes

Code			Software module	Meaning	
F	A	S			
0	0	0	Boot Block	CPU did not start to fetch code yet.	
0	5	6		The Slammer control unit (CU) PROM has completed startup diagnostics and is waiting for the software to be downloaded from the Pilot.	
1	0	2		Ready to initialize memory.	
1	1	0		Installed memory is unsupported.	
1	0	3		Ready to initialize DQS settings.	
1	1	1		Simple memory test failed.	
1	0	4		Ready to check preferred boot page CRC. If CRC is OK, control transfers to preferred boot page; otherwise, alternate boot page CRC is checked. If CRC is OK, control transfers to alternate boot page; otherwise, start-up will fail.	
1	1	2		Boot page CRC failed.	
1	6	3		Starting up from alternate boot page.	
1	6	2		Start-up failed - both boot pages failed their CRC checks.	
1	1	3		Shadow RAM failed.	
2	4	2		MPOST/Monitor	MPOST is ready to load.
2	3	6			Ready to start loader monitor.
2	4	0	Ready to continue starting up after loader monitor.		

Table 22 Slammer LED startup codes (continued)

Code			Software module	Meaning
F	A	S		
2	0	0	Preferred or Alternate Boot Page	Current boot page started to execute.
2	0	4		Ready to initialize IDT.
2	0	6		Ready to initialize NMI handler.
2	1	0		Ready to initialize COM1 serial port.
2	1	2		Ready to initialize CMS hardware.
2	1	4		Ready to initialize fan controller.
2	1	6		Ready to start CPU 2.
2	0	2		Prepare to reset CPU 1 to reconfigure CPU 2.
2	3	0		Ready to initialize PCI devices.
2	4	4		Ready to check memory configuration.
2	4	6		Current memory configuration does not match configuration in EEPROM.
2	5	0		Current memory configuration does not match initial configuration in CMOS.
2	5	2		Memory DIMMs are different.
2	5	4		Failed to read memory configuration from EEPROM.
2	5	6		Ready to do full memory test.
2	6	0		Full memory test failed.
3	6	6		Downloading and starting up application image.
3	X	X		LED startup progress code reserved for the OS (where X is not 6).

Once the Slammer reaches state 3XX, where the FLT LED is blinking slowly, all further control of the startup process is managed by the Pilot. When the Pilot assumes control of the Slammer, the status LED begins blinking slowly amber until the software components are all successfully brought online.

APPENDIX B

Safety Statements

Introduction to Safety Statements

For the Pillar Axiom storage system, this appendix lists safety statements to provide specific warning and cautionary notices about the electrical and weight properties that are associated with an Axiom system and its hardware components.

Safety Statements

The following safety statements include all hazard notices, in all pertinent languages.

Important! Procedures listed in the body of this document assume that the electrical characteristics of the power supply to which Axiom components are connected comply with the technical specifications for those components.

For electrical characteristics of Axiom components, see [Axiom Hardware Specifications](#) in [Appendix C](#).

Warning Notices



This hazard symbol means warning. You are in a situation that could cause bodily injury. Before you work on any equipment, be aware of the hazards that are involved with electrical circuitry and be familiar with standard practices for preventing accidents.

Table 23 Electrical warning in other languages

Waarschuwing	Dit waarschuwingssymbool betekent gevaar. U verkeert in een situatie die lichamelijk letsel kan veroorzaken. Voordat u aan enige apparatuur gaat werken, dient u zich bewust te zijn van de bij elektrische schakelingen betrokken risico's en dient u op de hoogte te zijn van standaard maatregelen om ongelukken te voorkomen.
Varoitus	Tämä varoitusmerkki merkitsee vaaraa. Olet tilanteessa, joka voi johtaa ruumiinvammaan. Ennen kuin työskentelet minkään laitteiston parissa, ota selvää sähkökytkentöihin liittyvistä vaaroista ja tavanomaisista onnettomuuksien ehkäisykeinoista.
Attention	Ce symbole d'avertissement indique un danger. Vous vous trouvez dans une situation pouvant causer des blessures ou des dommages corporels. Avant de travailler sur un équipement, soyez conscient des dangers posés par les circuits électriques et familiarisez-vous avec les procédures couramment utilisées pour éviter les accidents.
Warnung	Dieses Warnsymbol bedeutet Gefahr. Sie befinden sich in einer Situation, die zu einer Körperverletzung führen könnte. Bevor Sie mit der Arbeit an irgendeinem Gerät beginnen, seien Sie sich der mit elektrischen Stromkreisen verbundenen Gefahren und der Standardpraktiken zur Vermeidung von Unfällen bewusst.
Avvertenza	Questo simbolo di avvertenza indica un pericolo. La situazione potrebbe causare infortuni alle persone. Prima di lavorare su qualsiasi apparecchiatura, occorre conoscere i pericoli relativi ai circuiti elettrici ed essere al corrente delle pratiche standard per la prevenzione di incidenti.
Advarsel	Dette varselsymbolet betyr fare. Du befinner deg i en situasjon som kan føre til personskade. Før du utfører arbeid på utstyr, må du være oppmerksom på de faremomentene som elektriske kretser innebærer, samt gjøre deg kjent med vanlig praksis når det gjelder å unngå ulykker.
Aviso	Este símbolo de aviso indica perigo. Encontra-se numa situação que lhe poderá causar danos físicos. Antes de começar a trabalhar com qualquer equipamento, familiarize-se com os perigos relacionados com circuitos eléctricos, e com quaisquer práticas comuns que possam prevenir possíveis acidentes.
Advertencia	Este símbolo de aviso significa peligro. Existe riesgo para su integridad física. Antes de manipular cualquier equipo, considerar los riesgos que entraña la corriente eléctrica y familiarizarse con los procedimientos estándar de prevención de accidentes.

Table 23 Electrical warning in other languages (continued)

Varning	Denna varningssymbol signalerar fara. Du befinner dig i en situation som kan leda till personskada. Innan du utför arbete på någon utrustning måste du vara medveten om farorna med elkretsar och känna till vanligt förfarande för att förebygga skador.
---------	---



Do not work on the system or connect or disconnect cables during periods of lightning activity.



When removing a power supply, do not touch the power supply when the power cord is connected. For systems with a power switch, line voltages are present within the power supply even when the power switch is off and the power cord is connected. For systems without a power switch, line voltages are present within the power supply when the power cord is connected.



The power supply cord is used as the main disconnect device. Ensure that the socket outlet is located or installed near the equipment and is easily accessible.



When working on a chassis or near power supplies, use extreme caution because line voltages may be present within the chassis.



Ultimate disposal of this product should be handled according to all national laws and regulations.



Some equipment is connected to power lines. Before you work on this equipment, remove all jewelry that contains metal. Such jewelry includes rings, necklaces, and watches. Metal objects heat up when connected to power and ground. Hot metal objects can cause serious burns or weld the metal object to the terminals.



Only qualified personnel should install or replace this equipment.



Secure all power cabling when you install this unit to avoid disturbing field-wiring connections.



Do not overload the circuit when you connect components to the power supply.



A voltage mismatch can cause equipment damage and may pose a fire hazard. If the voltage indicated on the label differs from the power outlet voltage, *do not connect the chassis to that receptacle.*



To avoid electric shock, do not connect safety extra-low voltage (SELV) circuits to telephone-network voltage (TNV) circuits. LAN ports contain SELV circuits, and WAN ports contain TNV circuits. Some LAN and WAN ports both use RJ-45 connectors. Use caution when connecting cables.



Incorrect connection of this equipment to a general purpose outlet could result in a hazardous situation.



Bricks have two power supply cords and Slammers have four. To reduce the risk of electric shock, disconnect all power supply cords to these components before you open their top covers.



The Axiom storage system operates at high voltages. To protect against physical harm, power off the system whenever possible during installation.



Never block the inlet and outlet holes in the chassis components. Sufficient air circulation is required for the components to operate properly and to avoid a fire hazard. Do not push objects of any kind into the ventilation holes. Such action could result in fire or electrical shock. Keep all liquids away from hardware components.



Ensure that component distribution in the rack is balanced. Follow the hardware placement map to ensure this balance. Uneven distribution can cause hazardous instability. The rack must have stabilization plates or anti-tip brackets installed so the rack does not tip when you install a component.

Lightning Activity Warning



Do not work on the system or connect or disconnect cables during periods of lightning activity.

Table 24 Lightning warning in other languages

Waarschuwing	Tijdens onweer dat gepaard gaat met bliksem, dient u niet aan het systeem te werken of kabels aan te sluiten of te ontkoppelen.
Varoitus	Älä työskentele järjestelmän parissa äläkä yhdistä tai irrota kaapeleita ukkosilmalla.
Attention	Ne pas travailler sur le système ni brancher ou débrancher les câbles pendant un orage.
Warnung	Arbeiten Sie nicht am System und schließen Sie keine Kabel an bzw. trennen Sie keine ab, wenn es gewittert.
Avvertenza	Non lavorare sul sistema o collegare oppure scollegare i cavi durante un temporale con fulmini.
Advarsel	Utfør aldri arbeid på systemet, eller koble kabler til eller fra systemet når det tordner eller lyner.
Aviso	Não trabalhe no sistema ou ligue e desligue cabos durante períodos de mau tempo (trovoada).
Advertencia	No operar el sistema ni conectar o desconectar cables durante el transcurso de descargas eléctricas en la atmósfera.
Varning	Vid åska skall du aldrig utföra arbete på systemet eller ansluta eller koppla loss kablar.

Power Supply Warning



When removing a power supply, do not touch the power supply when the power cord is connected. For systems with a power switch, line voltages are present within the power supply even when the power switch is off and the power cord is connected. For systems without a power switch, line voltages are present within the power supply when the power cord is connected.

Table 25 Power supply warning in other languages

Waarschuwing	U dient de voeding niet aan te raken zolang het netsnoer aangesloten is. Bij systemen met een stroomschakelaar zijn er lijnspanningen aanwezig in de voeding, zelfs wanneer de stroomschakelaar uitgeschakeld is en het netsnoer aangesloten is. Bij systemen zonder een stroomschakelaar zijn er lijnspanningen aanwezig in de voeding wanneer het netsnoer aangesloten is.
--------------	--

Table 25 Power supply warning in other languages (continued)

Varoitus	Älä kosketa virtalähdettä virtajohdon ollessa kytkettynä. Virrankatkaisimella varustetuissa järjestelmissä on virtalähteen sisällä jäljellä verkkojännite, vaikka virrankatkaisin on katkaistu- asennossa virtajohdon ollessa kytkettynä. Järjestelmissä, joissa ei ole virrankatkaisinta, on virtalähteen sisällä verkkojännite, kun virtajohto on kytkettynä.
Attention	Ne pas toucher le bloc d'alimentation quand le cordon d'alimentation est branché. Avec les systèmes munis d'un commutateur marche-arrêt, des tensions de ligne sont présentes dans l'alimentation quand le cordon est branché, même si le commutateur est à l'arrêt. Avec les systèmes sans commutateur marche-arrêt, l'alimentation est sous tension quand le cordon d'alimentation est branché.
Warnung	Berühren Sie das Netzgerät nicht, wenn das Netzkabel angeschlossen ist. Bei Systemen mit Netzschalter liegen Leitungsspannungen im Netzgerät vor, wenn das Netzkabel angeschlossen ist, auch wenn das System ausgeschaltet ist. Bei Systemen ohne Netzschalter liegen Leitungsspannungen im Netzgerät vor, wenn das Netzkabel angeschlossen ist.
Avvertenza	Non toccare l'alimentatore se il cavo dell'alimentazione è collegato. Per i sistemi con un interruttore di alimentazione, tensioni di linea sono presenti all'interno dell'alimentatore anche quando l'interruttore di alimentazione è in posizione di disattivazione (off), se il cavo dell'alimentazione è collegato. Per i sistemi senza un interruttore, tensioni di linea sono presenti all'interno dell'alimentatore quando il cavo di alimentazione è collegato.
Advarsel	Berør ikke strømforsyningsenheden når strømledningen er tilkoblet. I systemer som har en strømbryter, er det spenning i strømforsyningsenheden selv om strømbryteren er slått av og strømledningen er tilkoblet. Når det gjelder systemer uten en strømbryter, er det spenning i strømforsyningsenheden når strømledningen er tilkoblet.
Aviso	Não toque na unidade abastecedora de energia quando o cabo de alimentação estiver ligado. Em sistemas com interruptor, a corrente eléctrica estará presente na unidade abastecedora, sempre que o cabo de alimentação de energia estiver ligado, mesmo quando o interruptor se encontrar desligado. Para sistemas sem interruptor, a tensão eléctrica dentro da unidade abastecedora só estará presente quando o cabo de alimentação estiver ligado.

Table 25 Power supply warning in other languages (continued)

Advertencia	No tocar la fuente de alimentación mientras el cable esté enchufado. En sistemas con interruptor de alimentación, hay voltajes de línea dentro de la fuente, incluso cuando el interruptor esté en Apagado (OFF) y el cable de alimentación enchufado. En sistemas sin interruptor de alimentación, hay voltajes de línea en la fuente cuando el cable está enchufado.
Varning	Vidrör inte strömförsörjningsenheten när nätsladden är ansluten. För system med strömbrytare finns det nätspänning i strömförsörjningsenheten även när strömmen har slagits av men nätsladden är ansluten. För system utan strömbrytare finns det nätspänning i strömförsörjningsenheten när nätsladden är ansluten.

Main Power Disconnect Warning



The power supply cord is used as the main disconnect device. Ensure that the socket outlet is located or installed near the equipment and is easily accessible.

Table 26 Power disconnect warning in other languages

Attention	Le cordon d'alimentation est utilisé comme interrupteur général. La prise de courant doit être située ou installée à proximité de l'équipement et être facile d'accès.
-----------	--

Installation Warning



Read the installation instructions before you connect the system to its power source.

Table 27 Install instructions warning in other languages

Waarschuwing	Raadpleeg de installatie-aanwijzingen voordat u het systeem met de voeding verbindt.
Varoitus	Lue asennusohjeet ennen järjestelmän yhdistämistä virtalähteeseen.
Attention	Avant de brancher le système sur la source d'alimentation, consulter les directives d'installation.

Table 27 Install instructions warning in other languages (continued)

Warnung	Lesen Sie die Installationsanweisungen, bevor Sie das System an die Stromquelle anschließen.
Avvertenza	Consultare le istruzioni di installazione prima di collegare il sistema all'alimentatore.
Advarsel	Les installasjonsinstruksjonene før systemet kobles til strømkilden.
Aviso	Leia as instruções de instalação antes de ligar o sistema à sua fonte de energia.
Advertencia	Ver las instrucciones de instalación antes de conectar el sistema a la red de alimentación.
Varning	Läs installationsanvisningarna innan du kopplar systemet till dess strömförsörjningsenhet.

Power Disconnect Warning

**WARNING**

When working on a chassis or near power supplies, follow the Guided Maintenance procedures in the AxiomONE Storage Services Manager for instructions on how to work with and around power supplies. Use extreme caution because line voltages may be present within the chassis.

Warning Statement for Norway and Sweden

Table 28 Warnings for Norway and Sweden

Advarsel	Apparatet skal kobles til en jordet stikkontakt.
Varning	Apparaten skall anslutas till jordat nätuttag.

Restricted Access Area Warning



This unit is intended for installation in restricted access areas. A restricted access area is where access can only be gained by service personnel through the use of a special tool, lock and key, or other means of security, and is controlled by the authority responsible for the location.

Table 29 Restricted access warning for other languages

Waarschuwing	Dit toestel is bedoeld voor installatie op plaatsen met beperkte toegang. Een plaats met beperkte toegang is een plaats waar toegang slechts door servicepersoneel verkregen kan worden door middel van een speciaal instrument, een slot en sleutel, of een ander veiligheidsmiddel, en welke beheerd wordt door de overheidsinstantie die verantwoordelijk is voor de locatie.
Varoitus	Tämä laite on tarkoitettu asennettavaksi paikkaan, johon pääsy on rajoitettua. Paikka, johon pääsy on rajoitettua, tarkoittaa paikkaa, johon vain huoltohenkilöstö pääsee jonkin erikoistyökalun, lukkoon sopivan avaimen tai jonkin muun turvalaitteen avulla ja joka on paikasta vastuussa olevien toimivaltaisten henkilöiden valvoma.
Attention	Cet appareil est à installer dans des zones d'accès réservé. Ces dernières sont des zones auxquelles seul le personnel de service peut accéder en utilisant un outil spécial, un mécanisme de verrouillage et une clé, ou tout autre moyen de sécurité. L'accès aux zones de sécurité est sous le contrôle de l'autorité responsable de l'emplacement.
Warnung	Diese Einheit ist zur Installation in Bereichen mit beschränktem Zutritt vorgesehen. Ein Bereich mit beschränktem Zutritt ist ein Bereich, zu dem nur Wartungspersonal mit einem Spezialwerkzeugs, Schloß und Schlüssel oder anderer Sicherheitsvorkehrungen Zugang hat, und der von dem für die Anlage zuständigen Gremium kontrolliert wird.
Avvertenza	Questa unità deve essere installata in un'area ad accesso limitato. Un'area ad accesso limitato è un'area accessibile solo a personale di assistenza tramite un'attrezzo speciale, lucchetto, o altri dispositivi di sicurezza, ed è controllata dall'autorità responsabile della zona.
Advarsel	Denne enheten er laget for installasjon i områder med begrenset adgang. Et område med begrenset adgang gir kun adgang til servicepersonale som bruker et spesielt verktøy, lås og nøkkel, eller en annen sikkerhetsanordning, og det kontrolleres av den autoriteten som er ansvarlig for området.

Table 29 Restricted access warning for other languages (continued)

Aviso	Esta unidade foi concebida para instalação em áreas de acesso restrito. Uma área de acesso restrito é uma área à qual apenas tem acesso o pessoal de serviço autorizado, que possua uma ferramenta, chave e fechadura especial, ou qualquer outra forma de segurança. Esta área é controlada pela autoridade responsável pelo local.
Advertencia	Esta unidad ha sido diseñada para instalarse en áreas de acceso restringido. Área de acceso restringido significa un área a la que solamente tiene acceso el personal de servicio mediante la utilización de una herramienta especial, cerradura con llave, o algún otro medio de seguridad, y que está bajo el control de la autoridad responsable del local.
Varning	Denna enhet är avsedd för installation i områden med begränsat tillträde. Ett område med begränsat tillträde får endast tillträdas av servicepersonal med ett speciellt verktyg, lås och nyckel, eller annan säkerhetsanordning, och kontrolleras av den auktoritet som ansvarar för området.

Product Disposal Warning



Ultimate disposal of this product should be handled according to all national laws and regulations.

Table 30 Product disposal warning for other languages

Waarschuwing	Dit produkt dient volgens alle landelijke wetten en voorschriften te worden afgedankt.
Varoitus	Tämän tuotteen lopullisesta hävittämisestä tulee huolehtia kaikkia valtakunnallisia lakeja ja säännöksiä noudattaen.
Attention	La mise au rebut définitive de ce produit doit être effectuée conformément à toutes les lois et réglementations en vigueur.
Warnung	Dieses Produkt muß den geltenden Gesetzen und Vorschriften entsprechend entsorgt werden.
Avvertenza	L'eliminazione finale di questo prodotto deve essere eseguita osservando le normative italiane vigenti in materia.
Advarsel	Endelig disponering av dette produktet må skje i henhold til nasjonale lover og forskrifter.

Table 30 Product disposal warning for other languages (continued)

Aviso	A descartagem final deste produto deverá ser efectuada de acordo com os regulamentos e a legislação nacional.
Advertencia	El desecho final de este producto debe realizarse según todas las leyes y regulaciones nacionales.
Varning	Slutlig kassering av denna produkt bör skötas i enlighet med landets alla lagar och föreskrifter.

Jewelry Removal Warning



Some equipment is connected to power lines. Before you work on this equipment, remove all jewelry that contains metal. Such jewelry includes rings, necklaces, and watches. Metal objects heat up when connected to power and ground. Hot metal objects can cause serious burns or weld the metal object to the terminals.

Table 31 Jewelry removal warning for other languages

Waarschuwing	Alvorens aan apparatuur te werken die met elektrische leidingen is verbonden, sieraden (inclusief ringen, kettingen en horloges) verwijderen. Metalen voorwerpen worden warm wanneer ze met stroom en aarde zijn verbonden, en kunnen ernstige brandwonden veroorzaken of het metalen voorwerp aan de aansluitklemmen lassen.
Varoitus	Ennen kuin työskentelet voimavirtajohtoihin kytkettyjen laitteiden parissa, ota pois kaikki korut (sormukset, kaulakorut ja kellot mukaan lukien). Metalliesineet kuumenevat, kun ne ovat yhteydessä sähkövirran ja maan kanssa, ja ne voivat aiheuttaa vakavia palovammoja tai hitsata metalliesineet kiinni liitäntänapoihin.
Attention	Avant d'accéder à cet équipement connecté aux lignes électriques, ôter tout bijou (anneaux, colliers et montres compris). Lorsqu'ils sont branchés à l'alimentation et reliés à la terre, les objets métalliques chauffent, ce qui peut provoquer des blessures graves ou souder l'objet métallique aux bornes.

Table 31 Jewelry removal warning for other languages (continued)

Warnung	Vor der Arbeit an Geräten, die an das Netz angeschlossen sind, jeglichen Schmuck (einschließlich Ringe, Ketten und Uhren) abnehmen. Metallgegenstände erhitzen sich, wenn sie an das Netz und die Erde angeschlossen werden, und können schwere Verbrennungen verursachen oder an die Anschlußklemmen angeschweißt werden.
Avvertenza	Prima di intervenire su apparecchiature collegate alle linee di alimentazione, togliersi qualsiasi monile (inclusi anelli, collane, braccialetti ed orologi). Gli oggetti metallici si riscaldano quando sono collegati tra punti di alimentazione e massa: possono causare ustioni gravi oppure il metallo può saldarsi ai terminali.
Advarsel	Fjern alle smykker (inkludert ringer, halskjeder og klokker) før du skal arbeide på utstyr som er koblet til kraftledninger. Metallgjenstander som er koblet til kraftledninger og jord blir svært varme og kan forårsake alvorlige brannskader eller smelte fast til polene.
Aviso	Antes de trabalhar em equipamento que esteja ligado a linhas de corrente, retire todas as jóias que estiver a usar (incluindo anéis, fios e relógios). Os objectos metálicos aquecerão em contacto com a corrente e em contacto com a ligação à terra, podendo causar queimaduras graves ou ficarem soldados aos terminais.
Advertencia	Antes de operar sobre equipos conectados a líneas de alimentación, quitarse las joyas (incluidos anillos, collares y relojes). Los objetos de metal se calientan cuando se conectan a la alimentación y a tierra, lo que puede ocasionar quemaduras graves o que los objetos metálicos queden soldados a los bornes.
Varning	Tag av alla smycken (inklusive ringar, halsband och armbandsur) innan du arbetar på utrustning som är kopplad till kraftledningar. Metallobjekt hettas upp när de kopplas ihop med ström och jord och kan förorsaka allvarliga brännskador; metallobjekt kan också sammansvetsas med kontakterna.

Qualified Personnel Warning



Only qualified personnel should install or replace this equipment.

Table 32 Qualified personnel warning for other languages

Waarschuwing	Installatie en reparaties mogen uitsluitend door getraind en bevoegd personeel uitgevoerd worden.
Varoitus	Ainoastaan koulutettu ja pätevä henkilökunta saa asentaa tai vaihtaa tämän laitteen.
Avertissement	Tout installation ou remplacement de l'appareil doit être réalisé par du personnel qualifié et compétent.
Achtung	Gerät nur von geschultem, qualifiziertem Personal installieren oder auswechseln lassen.
Avvertenza	Solo personale addestrato e qualificato deve essere autorizzato ad installare o sostituire questo apparecchio.
Advarsel	Kun kvalifisert personell med riktig opplæring bør montere eller bytte ut dette utstyret.
Aviso	Este equipamento deverá ser instalado ou substituído apenas por pessoal devidamente treinado e qualificado.
Atención	Estos equipos deben ser instalados y reemplazados exclusivamente por personal técnico adecuadamente preparado y capacitado.
Varning	Denna utrustning ska endast installeras och bytas ut av utbildad och kvalificerad personal.

Warning Statement for Finland

Table 33 Warnings for Finland

Varoitus	Alleviates ja suojalukitus ohitettaessa olet alttiina näkymättömälle lasersäteilylle. Äjã katso säteeseen.
----------	--

Warning Statement for Sweden

Table 34 Warnings for Sweden

Varning	Osynlig laserstrålning när denna del är öppen och förregleringen är urkopplad. Rikta inte blicken in mot strålen.
---------	---

Power Cabling Warning



Secure all power cabling when you install this unit to avoid disturbing field-wiring connections.

Table 35 Power cabling warning for other languages

Waarschuwing	Zet alle stroomkabels vast wanneer dit toestel wordt geïnstalleerd om te voorkomen dat de verbindingen van de veldbedrading worden verstoord.
Varoitus	Kiinnitä kaikki voimakaapelit tiukkaan tätä laitetta asentaessasi, jotta vältät kentän johdinkytkentöjen vioittumista.
Attention	Lors de l'installation de cet appareil, fixer tous les câbles d'alimentation pour éviter de provoquer des perturbations aux raccordements des câblages propres au site.
Warnung	Bei der Installation dieser Einheit die Netzverkabelung befestigen, um die Störung von Feldkabelanschlüssen zu vermeiden.
Avvertenza	In fase di installazione dell'unità, assicurare tutti i cablaggi di alimentazione per evitare di alterare i collegamenti degli avvolgimenti di campo.
Advarsel	Når denne enheten installeres, må alle kraftledninger sikres for å unngå at feltkabelkoblingene forstyrres.
Aviso	Para evitar problemas com as ligações de rede de campanha, prenda todos os cabos de corrente quando instalar esta unidade.
Advertencia	Sujetar todo el cableado de alimentación cuando se instale este equipo para evitar que se mezcle con las conexiones del cableado "in situ".
Varning	Fäst allt starkströmskablage vid installation av denna enhet så att fältkopplingen inte rubbas.

Supply Circuit Warning



Do not overload the circuit when you connect components to the power supply.

Table 36 Supply circuit warning for other languages

Waarschuwing	Let erop dat de toestellen op voedingscircuits worden aangesloten zonder het vermogen van de bedrading te overschrijden.
Varoitus	Laiteyksiköt on yhdistettävä huolellisesti syöttöpiiriin niin, että johdot eivät ole ylikuormitettuja.
Avertissement	Veillez à bien connecter les unités au circuit d'alimentation afin de ne pas surcharger les connections.
Achtung	Beim Anschließen der Geräte an das Stromnetz ist darauf zu achten, daß die Schaltverbindungen nicht überlastet werden.
Avvertenza	Fare attenzione quando si collegano le unità al circuito di alimentazione, per non sovraccaricare i cablaggi.
Advarsel	Vær nøye med å koble enheter til strømforsyningskretsen slik at ledningene ikke overbelastes.
Aviso	Deverá ter precaução ao ligar unidades ao circuito de fornecimento de energia, para não sobrecarregar a instalação.
Atención	Poner mucho cuidado al conectar los equipos al circuito de alimentación a fin de no sobrecargar el cableado.
Varning	Var noga vid anslutning av enheter till matarströmkretsen så att ledningarna inte överbelastas.

Voltage Mismatch Warning



A voltage mismatch can cause equipment damage and may pose a fire hazard. If the voltage indicated on the label differs from the power outlet voltage, *do not connect the chassis to that receptacle.*

Table 37 Voltage mismatch warning for other languages

Waarschuwing	Aansluiting op een verkeerd voedingsvoltage kan beschadiging van de apparatuur veroorzaken en tot brandgevaar leiden. Het chassis mag niet aangesloten worden als de spanning die op het label staat aangegeven, anders is dan de spanning van het stopcontact.
Varoitus	Erisuuruisten jännitteiden yhdistäminen voi aiheuttaa laitevaurion ja tulipalon vaaran. Jos tarraan merkitty jännite eroaa pistorasian jännitteestä, älä yhdistä asennuspohjaa pistorasiaan.

Table 37 Voltage mismatch warning for other languages (continued)

Avertissement	Une erreur de voltage risque d'endommager l'appareil et constitue un risque d'incendie. Si la tension indiquée sur l'étiquette est différente de la tension de l'alimentation, ne connectez en aucun cas le châssis à la prise.
Achtung	Bei nicht übereinstimmender Spannung kann es zu Geräteschäden und Feuergefahr kommen. Wenn die auf dem Etikett angegebene Spannung nicht mit der Steckdosenspannung übereinstimmt, schließen Sie das Gerät nicht an diese Steckdose an.
Avvertenza	Una tensione inadeguata può causare danni all'apparecchio e rischio di incendio. Se la tensione riportata sulla targhetta è diversa da quella della presa di alimentazione, non collegare lo chassis a tale presa.
Advarsel	Ulik spenning kan forårsake skade på utstyret og innebære brannfare. Dersom spenningen på merkelappen er forskjellig fra spenningen i stikkontakten, må du ikke koble kabinetet til den stikkontakten.
Aviso	Uma voltagem incorrecta poderá causar danos no equipamento e constituir um risco de incêndio. Se a voltagem indicada na etiqueta for diferente da voltagem de saída de corrente da parede, não ligue o chassis a esse receptáculo.
Atención	Las diferencias en el voltaje pueden causar daños a los equipos y presentar peligro de incendio. Si el voltaje indicado en la etiqueta es diferente al de la toma de alimentación, no conectar el chasis a dicha toma.
Varning	Inkompatibla spänningar kan resultera i materiella skador samt utgör brandfara. Om den spänning som anges på etiketten skiljer sig från strömuttagets spänning ska chassit inte anslutas till detta uttag.

SELV Circuit Warning



To avoid electric shock, do not connect safety extra-low voltage (SELV) circuits to telephone-network voltage (TNV) circuits. LAN ports contain SELV circuits, and WAN ports contain TNV circuits. Some LAN and WAN ports both use RJ-45 connectors. Use caution when connecting cables.

Table 38 SELV circuit warning for other languages

Waarschuwing	Om elektrische schokken te vermijden, mogen veiligheidscircuits met extra lage spanning (genaamd SELV = Safety Extra-Low Voltage) niet met telefoonnetwerkspanning (TNV) circuits verbonden worden. LAN (Lokaal netwerk) poorten bevatten SELV circuits en WAN (Regionaal netwerk) poorten bevatten TNV circuits. Sommige LAN en WAN poorten gebruiken allebei RJ-45 connectors. Ga voorzichtig te werk wanneer u kabels verbindt.
Varoitus	Jotta vältyt sähköiskulta, älä kytke pienjännitteisiä SELV-suojapiirejä puhelinverkkojännitettä (TNV) käyttäviin virtapiireihin. LAN-portit sisältävät SELV-piirejä ja WAN-portit puhelinverkkojännitettä käyttäviä piirejä. Osa sekä LAN- että WAN-porteista käyttää RJ-45-liittimiä. Ole varovainen kytkiessäsi kaapeleita.
Attention	Pour éviter une électrocution, ne raccordez pas les circuits de sécurité basse tension (Safety Extra-Low Voltage ou SELV) à des circuits de tension de réseau téléphonique (Telephone Network Voltage ou TNV). Les ports du réseau local (LAN) contiennent des circuits SELV et les ports du réseau longue distance (WAN) sont munis de circuits TNV. Certains ports LAN et WAN utilisent des connecteurs RJ-45. Raccordez les câbles en prenant toutes les précautions nécessaires.
Warnung	Zur Vermeidung von Elektroschock die Sicherheits-Kleinspannungs-Stromkreise (SELV-Kreise) nicht an Fernsprechnetzspannungs-Stromkreise (TNV-Kreise) anschließen. LAN-Ports enthalten SELV-Kreise, und WAN-Ports enthalten TNV-Kreise. Einige LAN- und WAN-Ports verwenden auch RJ-45-Steckverbinder. Vorsicht beim Anschließen von Kabeln.
Avvertenza	Per evitare scosse elettriche, non collegare circuiti di sicurezza a tensione molto bassa (SELV) ai circuiti a tensione di rete telefonica (TNV). Le porte LAN contengono circuiti SELV e le porte WAN contengono circuiti TNV. Alcune porte LAN e WAN fanno uso di connettori RJ-45. Fare attenzione quando si collegano cavi.
Advarsel	Unngå å koble lavspenningskretser (SELV) til kretser for telenettspenning (TNV), slik at du unngår elektrisk støt. LAN-utganger inneholder SELV-kretser og WAN-utganger inneholder TNV-kretser. Det finnes både LAN-utganger og WAN-utganger som bruker RJ-45-kontakter. Vær forsiktig når du kobler kabler.

Table 38 SELV circuit warning for other languages (continued)

Aviso	Para evitar choques eléctricos, não conecte os circuitos de segurança de baixa tensão (SELV) aos circuitos de tensão de rede telefónica (TNV). As portas LAN contêm circuitos SELV e as portas WAN contêm circuitos TNV. Algumas portas LAN e WAN usam conectores RJ-45. Tenha o devido cuidado ao conectar os cabos.
Advertencia	Para evitar la sacudida eléctrica, no conectar circuitos de seguridad de voltaje muy bajo (safety extra-low voltage = SELV) con circuitos de voltaje de red telefónica (telephone network voltage = TNV). Los puertos de redes de área local (local area network = LAN) contienen circuitos SELV, y los puertos de redes de área extendida (wide area network = WAN) contienen circuitos TNV. En algunos casos, tanto los puertos LAN como los WAN usan conectores RJ-45. Proceda con precaución al conectar los cables.
Varning	För att undvika elektriska stötar, koppla inte säkerhetskretsar med extra låg spänning (SELV-kretsar) till kretsar med telefontätspänning (TNV-kretsar). LAN-portar innehåller SELV-kretsar och WAN-portar innehåller TNV-kretsar. Vissa LAN- och WAN-portar är försedda med RJ-45-kontakter. Iaktta försiktighet vid anslutning av kablar.

Incorrect Connection Warning



Incorrect connection of this equipment to a general purpose outlet could result in a hazardous situation.

Table 39 Connection warning for other languages

Waarschuwing	Incorrecte aansluiting van deze of aangesloten apparatuur op een stopcontact voor algemene doeleinden kan een gevaarlijke situatie tot gevolg hebben.
Varoitus	Tämän laitteen tai siihen liitettyjen laitteiden virheellinen kytkentä yleispistorasiaan voi aiheuttaa vaaratilanteen.
Attention	Un branchement incorrect de cet équipement ou de l'équipement branché à une prise d'usage général peut créer une situation dangereuse.
Warnung	Inkorrektes Anschließen von diesem oder damit verbundenen Geräten an einer Allzwecksteckdose kann eine Gefahrensituation verursachen.

Table 39 Connection warning for other languages (continued)

Avvertenza	Un collegamento errato di questo apparecchio, o dell'apparecchiatura a esso collegato, a una presa di uso generale può causare una situazione pericolosa.
Advarsel	Feil kobling av dette utstyret eller tilhørende utstyr til et vanlig uttak kan føre til farlige situasjoner.
Aviso	Uma conexão incorrecta a uma ficha de alimentação eléctrica normal, deste ou de qualquer equipamento a este conectado, poderá resultar numa situação potencialmente perigosa.
Advertencia	La conexión incorrecta de este equipo, o del equipo conectado, a una toma o receptáculo de tipo general podría resultar en una situación peligrosa.
Varning	Felaktig koppling av denna eller ansluten utrustning till ett universaluttag kan orsaka riskfylld situation.

Caution Notices

**CAUTION**

It is required that, if interconnecting equipment resides within more than one equipment rack, these racks should be at the same ground potential.

**CAUTION**

When handling any electronic device, be sure to take electrostatic discharge (ESD) precautions. The minimum requirement is a properly grounded antistatic wrist strap and grounding wire.

**CAUTION**

If removal of a FRU or blanking plate leaves a hole, block the hole quickly with a blanking plate or by installing a replacement FRU. Failure to do this can disrupt airflow and seriously reduce cooling.

**CAUTION**

Ambient temperature within the rack may be greater than that of the room. With regard to the maximum rated ambient for Axiom components, do not reduce the amount of airflow that is required for safe operation.



Never block the ventilation holes in a chassis. Sufficient air circulation is required for the internal components to operate properly and to prevent the possibility of fire. Do not push objects of any kind into the ventilation holes. Such action could result in fire or electrical shock. Keep all liquids away from Axiom components.



Ensure that component weight distribution in the rack is balanced. Uneven weight distribution can cause hazardous instability. The rack should have stabilization feet or brackets installed, or have another means that does not allow the rack to tip when you service it. At a minimum, we recommend that you install stabilization brackets on the rear feet of the rack because the rack is front-heavy.



Slammers weigh 100 lb (45.4 kg). To handle them safely, use an appropriate number of persons.



Qualified personnel are advised to exercise great care at all times when they work on an Axiom system. Remember to:

- Remove rings, watches, or other jewelry and neckties before you begin any procedure.
- Use caution near fan assemblies; the moving parts can change speed unexpectedly.
- Use the correct tools for the job.
- Keep all paperwork up to date, complete, and accurate.



The sum of the ratings of the components that plug into the PDU must be less than 80% of the current and power ratings of the PDU. Similarly, the current rating of the PDU must be less than 80% of the rating for the building supply circuit.



A Brick weighs up to 65 lb (29.5 kg). For safe handling, use two people to lift it.

APPENDIX C

Hardware Specifications

Introduction to Hardware Specifications

Hardware specifications (sometimes called data sheets):

- Describe the system's operating environment.
- List the agency approvals.
- List physical attributes of the Axiom system and its hardware components.

Axiom Hardware Specifications

An Axiom storage system is an assembly of the following components, all of which are described in this appendix:

- One Pilot management controller.
For details, see [Pilot Hardware Specifications](#).
- One or two Slammer storage controllers.
For details, see [Slammer Hardware Specification](#).
- Two to 16 Brick storage enclosures.
For details, see [Brick Hardware Specification](#).

- One to four PDUs per rack, the number of which depends on power inlet characteristics and the number of components in each rack.

For details, see [Axiom PDU Hardware Specification](#).

- One or two racks, the number of which depends on the configuration of Slammers and Bricks.

For details, see [Pillar Rack Hardware Specification](#).

A Pillar Axiom storage system has the characteristics that are described on the following pages.

System Power Requirements

Axiom systems require one of the power inputs shown below. The voltage and frequency show minimum and maximum values.

- 100-120 V, 47-63 Hz, 20 A
- 200-240 V, 47-63 Hz, 20 A
- 100-120 V, 47-63 Hz, 30 A
- 200-240 V, 47-63 Hz, 30 A
- 230 V, 16 A or 32 A (Europe)
- Wye-connected 3-phase:
 - USA: 199-217 V, 47-63 Hz, 30 A
 - Europe: 380-415 V, 47-63 Hz, 16 A

The total power required by a rack depends on the number and type of hardware that is in the rack.

System Environmentals

Table 40 System altitude specifications

Mode	Elevation
operational	-200 to 10,000 ft (-61 to 3048 m)
nonoperational	-200 to 40,000 ft (-61 to 12,192 m)

Table 41 System temperature and humidity specifications

Mode	Temperature	Non-condensing Humidity	Max wet bulb temperature	Gradient
operational	+41 to 104° F (5 to 40° C) up to 7000 ft	10–85% 10%/hr gradient	86° F (30° C)	36° F/hr (20° C/hr)
nonoperational	-40 to 158° F (-40 to 70° C)	5–95% 10%/hr gradient	104° F (40° C)	54° F/hr (30° C/hr)

Note: For Bricks that have five-platter disk drives, the maximum ambient operational temperature from 7000 ft to 10,000 ft is 95° F (35° C).

Acoustics for an Axiom system that comprises the following components were tested to ISO 7779 by standard specifications:

- One Pilot
- One NAS Slammer
- Three Bricks

Such a system generates an acoustic level that is no greater than 70 dBA.

Table 42 System acoustics specification

Acoustic level (tested to ISO7779)
Does not exceed 6.5 Bels under normal conditions, which is: <ul style="list-style-type: none"> • 73.4° F (23° C) ambient • all fans operational • no fault conditions The acoustic level will increase under fault conditions.

Table 43 System random vibration specifications

Mode	Force	Frequency	Time
operational	0.1 G RMS	3–100 hz (X, Y, and Z axis)	15 min
nonoperational	Administered using the Telcordia GR-63 CORE test specifications. Tested with the rack inside a shipping crate.		

System Regulatory Agency Compliance

Agency approvals are based on a system that consists of:

- One Pilot.
- Two NAS Slammers.
- Twelve Bricks.

This section identifies:

- [Regulatory Agency Compliances](#)
- [FCC Warning Statement](#)
- [European Union Compliance Statement](#)

Regulatory Agency Compliances

The Axiom storage system complies with the following regulatory agency requirements.

Table 44 Safety, quality, and environmental standards



Logo	Standard
	FCC (United States). This device complies with FCC Rules Part 15. Operation is subject to the following two conditions: (1) This device may not cause harmful interference. (2) This device must accept any interference that may be received, including interference that may cause undesired operation.
	CB Scheme by IECIEE standard IEC 60950, First Edition
	Conformite Europeenne /DoC
	UL and CSA under UL (cUL)
	TUV/GS

Table 44 Safety, quality, and environmental standards (continued)



Logo	Standard
	<p>Pillar Data Systems offers customers a recycle program to properly dispose of surplus products and products that have reached their end of life. Equipment that is returned to Pillar through this program is disposed of in an environmentally safe manner using processes that comply with the WEEE (EU Directive on Waste Electrical and Electronic Equipment) regulations. Pillar provides (on request) documentation about product disposition when the recycling process is complete. Upon request, Pillar also provides a Certificate of Destruction, which releases the customer from further liability for the equipment returned through the Recycle program. Customers should contact Pillar customer service department for information on the logistics and location(s) of the approved recycle facilities.</p>
	<p>Pillar Data Systems objectives are to ensure that our high product quality and reliability standards are met through the processes that have been verified and approved. This is achieved through ISO 9001:2000 and the development and deployment of Pb-free solder qualification guidelines for components (RoHS), interconnects, and PCB, PCA reliability. Pillar will continue to work with industry consortia to define common qualification criteria. Pillar will apply Pb-free solder technologies to product designs as required by legislation.</p>
	<p>ISO 9001:2000 Registered manufacturing process</p>

Table 45 EM emissions and immunity

Standard
<ul style="list-style-type: none"> • CISPR 22-A • EN55022 Class A radiated and conducted emissions (100V/240V) • EN55024 Immunity: <ul style="list-style-type: none"> • EN 61000-3-2 • EN 61000-3-3 • EN 61000-4-2 ESD: ± 4 kV contact, ± 8 kV air touch • EN 61000-4-3 Radiated immunity (within the limits that are listed in our technical specifications) • EN 61000-4-4 Electrical fast transients/burst: ± 1 kV AC, ± 0.5 kV I/O • EN 61000-4-5 Surges ± 1 kV differential mode, ± 2 kV common mode • EN 61000-4-6 Conducted immunity: 3 V • EN 61000-4-8 • EN 61000-4-11 Supply dips and interruptions: 30% and 100% • VCCI (Japan): <div style="border: 1px solid black; padding: 10px; margin-top: 10px;"> <p style="text-align: center;">この装置は、クラスA情報技術装置です。この装置を家庭環境で使用すると電波妨害を引き起こすことがあります。この場合には使用者が適切な対策を講ずるよう要求されることがあります。</p> <p style="text-align: right;">VCCI -A</p> </div>

FCC Warning Statement

This equipment has been tested and found to comply with the limits for a Class A digital device, pursuant to part 15 of the FCC rules. These limits are designed to provide reasonable protection against harmful interference when the equipment is operated in a commercial environment.

This equipment generates, uses, and can radiate radio-frequency energy and, if not installed and used in accordance with the instruction manual, may cause harmful interference to radio communications. Operation of this equipment in a residential area is likely to cause harmful interference, in which case users will be required to correct the interference at their own expense.

You can determine if your equipment causes interference by turning it off. If the interference stops, it was probably caused by the equipment or one of its peripheral devices. If the equipment causes interference to radio or television reception, try to correct the interference by using one or more of the following measures:

- Turn the television or radio antenna until the interference stops.
- Move the equipment to one side or the other of the television or radio.
- Move the equipment farther away from the television or radio.
- Plug the equipment into an outlet that is on a different circuit from the television or radio. (That is, make certain the equipment and the television or radio are on circuits that are controlled by different circuit breakers or fuses.)



Changes or modifications that are not expressly approved by the party that is responsible for compliance could void the user's authority to operate the equipment.

European Union Compliance Statement

This product is in conformity with the protection requirements of EC Council Directive 89/336/EEC on the approximation of the laws of the Member States relating to electro-magnetic compatibility. The manufacturer cannot accept responsibility for any failure to satisfy the protection requirements that result from a non-recommended modification of the product.

This product has been tested and found to comply with the limits for Class A Information Technology Equipment according to CISPR 22/European Standard EN 55022. The Limits for Class A equipment were derived for residential environments to provide reasonable protection against interference with licensed communication equipment.

A Declaration of Conformity with the requirements of the Directive has been signed by Pillar Data Systems, 2840 Junction Avenue, San Jose, CA 95134.

The following standards were applied:

- 1 Emissions: EN55022 (Class A radiated and conducted, 110v/240v)
- 2 EMC: EN55024 (immunity):
 - EN 61000-3-2
 - EN 61000-3-3

- EN 61000-4-2 ESD: ± 4 kV contact, ± 8 kV air touch
- EN 61000-4-3 Radiated immunity (within the limits that are listed in our technical specifications)
- EN 61000-4-4 Electrical fast transients/burst: ± 1 kV AC, ± 0.5 kV I/O
- EN 61000-4-5 Surges ± 1 kV differential mode, ± 2 kV common mode
- EN 61000-4-6 Conducted immunity: 3 V
- EN 61000-4-11 Supply dips and interruptions: 30% and 100%

System Packaging and Transportation

Packaging meets the following requirements:

- For packages under 150 lb—International Safe Transit Association (ISTA 2A) Procedures 1 and 2.
- For packages over 150 lb—Network Equipment Building System (NEBS) core standards.

GR-63-CORE, Packaged Equipment Shock (4.3.1), Office Vibration (4.4.3) and Transportation Vibration (4.4.4).

System Warranty

Hardware components in an Axiom storage system are covered by a three-year warranty.

Pilot Hardware Specifications

A Pilot is an active management and provisioning front end as well as the administrator interface to an Axiom storage system.

Pilot Dimensions and Weight

Table 46 Pilot dimensions and weight (both control units)

Attribute	Value
Height	3.5 in (8.9 cm); 2U
Width	17.7 in (45.0 cm)
Depth	24 in (61.0 cm)
Weight	40 lb (18.1 kg)

Pilot Power Characteristics

Table 47 Pilot power characteristics (per control unit)

Power characteristic	Value
Frequency	47–63 Hz
AC voltage	100–240 V
Current draw	1.6 A at 115 V 0.8 A at 230 V
Max power consumption	150 VA
Max heat dissipation	750 BTU/hr
AC plug type	2 IEC 320 connection

Pilot Regulatory Agency Compliance

This equipment has been tested and found to comply with the limits for a class B digital device, pursuant to part 15 of the FCC rules. These limits are designed to provide reasonable protection against harmful interference when the equipment is operated in a commercial environment.

This equipment generates, uses, and can radiate radio frequency energy and, if not installed and used in accordance with the instruction guide, may cause harmful interference to radio communications. Operation of this equipment in a residential area is may cause harmful interference, in which case the user must correct the interference at his own expense.

Notice 1

The changes or modifications not expressly approved by the party responsible for compliance could void the user’s authority to operate the equipment.

Notice 2

Shielded interface cables and A.C. power cord, if any, must be used in order to comply with the emission limits.

VOIR LA NOTICE D’INSTALLATION AVANT DE RACCORDER AU RESEAU.



Table 48 Pilot safety and quality standards

Logo	Standard
	FCC (United States). This device complies with FCC Rules Part 15 for a class B digital device.
	Conformite Europeenne /DoC

Pilot Packaging and Transportation

Packaging meets the following requirements:

- For packages under 150 lb—International Safe Transit Association (ISTA 2A) Procedures 1 and 2.

- For packages over 150 lb—Network Equipment Building System (NEBS) core standards.

GR-63-CORE, Packaged Equipment Shock (4.3.1), Office Vibration (4.4.3) and Transportation Vibration (4.4.4).

Slammer Hardware Specification

Slammers are fully redundant controllers within an Axiom storage system. A Slammer can be ordered as either a SAN or a NAS front end.

Slammer Dimensions and Weight

Table 49 Slammer dimensions and weight

Attribute	Value
Height	7 in (17.78 cm); 4U
Width	17.72 in (45 cm)
Depth	26 in (66 cm)
Weight	100 lb (45.4 kg)

Slammer Power Characteristics

Table 50 Slammer power characteristics

Power characteristic	Value
Frequency	47–63 Hz
AC voltage	100–120V / 200–240V
Max power consumption	720 VA
Current draw (combined for both control units)	6.4 A at 115 V 3.2 A at 230 V

Table 50 Slammer power characteristics (continued)

Power characteristic	Value
Max heat dissipation	2220 BTU/hr
AC plug type	Four IEC 320 C13 connection

Slammer Regulatory Agency Compliance

Axiom Slammers comply with the following regulatory agency requirements.

Table 51 Slammer safety and quality standards



Logo	Standard
	FCC (United States). This device complies with FCC Rules Part 15. Operation is subject to the following two conditions: (1) This device may not cause harmful interference and (2) This device must accept any interference that maybe received, including interference that may cause undesired operation.
	CB Scheme by IECEE standard IEC 60950, Third Edition (1999)
	Conformite Europeenne /DoC
	UL and CSA under UL (cUL)
	TUV/GS
	ISO 9001:2000 Registered manufacturing process

Table 52 Slammer EM emissions and immunity

Standard
<ul style="list-style-type: none"> • CISPR 22-A • EN55022 Class A radiated and conducted emissions (110v/220v) • EN55024 Immunity: <ul style="list-style-type: none"> • EN 61000-3-2 • EN 61000-3-3 • EN 61000-4-2 ESD: ± 4 kV contact, ± 8 kV air • EN 61000-4-3 Radiated immunity (within the limits that are listed in our technical specifications) • EN 61000-4-4 Electrical fast transients/burst: ± 1 kV AC, ± 0.5 kV I/O • EN 61000-4-5 Surges ± 1 kV differential mode, ± 2 kV common mode • EN 61000-4-6 Conducted immunity: 3 V • EN 61000-4-8 • EN 61000-4-11 Supply dips and interruptions: 30% and 100%

Slammer Packaging and Transportation

Packaging meets the following requirements:

- For packages under 150 lb—International Safe Transit Association (ISTA 2A) Procedures 1 and 2.
- For packages over 150 lb—Network Equipment Building System (NEBS) core standards.

GR-63-CORE, Packaged Equipment Shock (4.3.1), Office Vibration (4.4.3) and Transportation Vibration (4.4.4).

Brick Hardware Specification

A Brick is a high-performance disk subsystem with an optimized, proprietary RAID controller.

Brick Dimensions and Weight

Table 53 Brick dimensions and weight

Attribute	Value
Height	3.5 in (8.89 cm); 2U
Width	17.72 in (45 cm)
Depth	22 in (55.88 cm)
Weight	65 lb (29.5 kg)

Brick Power Characteristics

Table 54 Brick power characteristics

Power characteristic	Value
Frequency	47–63 Hz
AC voltage	100–120V / 200–240V
Max power consumption	267 VA
Current draw	2.667 A at 115 V 1.233 A at 230 V
Max heat dissipation	1370 BTU/hr
AC plug type	Two IEC 320 connections

Brick Regulatory Agency Compliance

Axiom Bricks comply with the following regulatory agency requirements.

Table 55 Brick safety and quality standards



Logo	Standard
	FCC (United States). This device complies with FCC Rules Part 15. Operation is subject to the following two conditions: (1) This device may not cause harmful interference and (2) This device must accept any interference that maybe received, including interference that may cause undesired operation.
	CB Scheme by IECEE standard IEC 60950, Third Edition (1999)
	Conformite Europeenne /DoC
	UL and CSA under UL (cUL)
	TUV/GS
	ISO 9001:2000 Registered manufacturing process

Table 56 Brick EM emissions and immunity

Standard
<ul style="list-style-type: none"> • CISPR 22-A • EN55022 Class A radiated and conducted emissions (110v/220v) • EN55024 Immunity: <ul style="list-style-type: none"> • EN 61000-3-2 • EN 61000-3-3 • EN 61000-4-2 ESD: ±4 kV contact, ±8 kV air • EN 61000-4-3 Radiated immunity (within the limits that are listed in our technical specifications) • EN 61000-4-4 Electrical fast transients/burst: ±1 kV AC, ±0.5 kV I/O • EN 61000-4-5 Surges ±1 kV differential mode, ±2 kV common mode • EN 61000-4-6 Conducted immunity: 3 V • EN 61000-4-11 Supply dips and interruptions: 30% and 100%

Brick Packaging and Transportation

Packaging meets the following requirements:

- For packages under 150 lb—International Safe Transit Association (ISTA 2A) Procedures 1 and 2.
- For packages over 150 lb—Network Equipment Building System (NEBS) core standards.

GR-63-CORE, Packaged Equipment Shock (4.3.1), Office Vibration (4.4.3) and Transportation Vibration (4.4.4).

Axiom PDU Hardware Specification

If you install non-Pillar PDUs, they must meet the Pillar Data Systems PDU specification, as outlined below.

Table 57 PDU specifications

Criteria	20 amp	30 amp
Form factor	EIA Rack Mountable 1 U high (1.75 in, 4.45 cm) < 8 in (20.3 cm) deep	EIA Rack Mountable 1 U high (1.75 in, 4.45 cm) < 8 in (20.3 cm) deep
Receptacles	C13, 12 receptacles min. Mounted on rear of chassis (opposite circuit breakers).	C13, 12 receptacles min. Mounted on rear of chassis (opposite circuit breakers).
Inlet cable	15 ft (4.572 m) min Plug options: L6-20P, L5-20P	15 ft (4.572 m) min Plug options: L6-30P, L5-30P
Voltage input	100–240 VAC	100–240 VAC
Voltage output	100–240 VAC	100–240 VAC
Circuit breakers	Two, 10 A ea. Each circuit breaker controls half of the outlet receptacles.	Two, 15 A ea. Each circuit breaker controls half of the outlet receptacles.
Receptacle retention device	All receptacles have a plug retention device.	All receptacles have a plug retention device.
Inlet cable retention device	If a detachable inlet cable is provided, a cable retention device is included.	NA
EMI/RFI filter	Common Mode Insertion Loss 10 db @ 1 MHz, Differential Mode 30 db @ 1 MHz. MHz/db - .15/6, .50	Common Mode Insertion Loss 10 db @ 1 MHz, Differential Mode 30 db @ 1 MHz. MHz/db - .15/6, .50
Surge suppression	270 VAC	320 VAC

Pillar Rack Hardware Specification

A Pillar 42 U rack contains:

- One Pilot.
- One or two NAS or SAN Slammers.
- Two to 15 Bricks. The exact number of Bricks depends on the number of Slammers in the rack.
- Two to four power distribution units.

Table 58 Rack specifications for an Axiom system

Criteria	Pillar 42 U	Non-Pillar 42 U (minimum requirements)
Height (inside)	42 U 73.6 in (187 cm)	42 U 73.6 in (187 cm)
Width (inside)	17.7 in (45 cm)	<ul style="list-style-type: none"> • 19 in (48.26 cm) panel • 17.7 in (45 cm) rail-to-rail
Height (outside)	78.7 in (199.9 cm)	NA
Width	<ul style="list-style-type: none"> • 23.8 in (60.48 cm) overall • 17.7 in (45 cm) rail-to-rail • 19 in (48.26 cm) panel 	NA
Depth (inside)	<ul style="list-style-type: none"> • 35 in (88.9 cm) • 26–30 in (66–76.2 cm) rail-to-rail 	<ul style="list-style-type: none"> • 35 in (88.9 cm) overall • 26–30 in (66–76.2 cm) rail-to-rail
Front door	<ul style="list-style-type: none"> • Vented • Light-tint Plexiglas • 1.5 in (3.81 cm) deep • Lockable • Open left/right • 1 in (2.54 cm) clearance between front vertical channel and inside of frame 	<ul style="list-style-type: none"> • Vented • 1 in (2.54 cm) deep min. • 1 in (2.54 cm) clearance between front vertical channel and inside of frame
Rear door	<ul style="list-style-type: none"> • Vented • Lockable • Open left/right 	Vented
Sides	<ul style="list-style-type: none"> • Solid • Removable • Lockable • 1 in (2.54 cm) between side and frame 	NA

Table 58 Rack specifications for an Axiom system (continued)

Criteria	Pillar 42 U	Non-Pillar 42 U (minimum requirements)
Vertical channels	<ul style="list-style-type: none"> • Square- or round-hole unthreaded • 26 in (66 cm) apart 	<ul style="list-style-type: none"> • EIA spacing • Front-to-rear mounting • Cage nuts • Square or round EIA-standard mounting holes preferred
Vents	<ul style="list-style-type: none"> • Front and back doors • Top 	<ul style="list-style-type: none"> • Front and back doors • Top
PDU	<ul style="list-style-type: none"> • 4 PDUs • 90–240 VAC, 50-60 Hz • 20-30 A • 42 C13 outlets • Horizontal mount 	<ul style="list-style-type: none"> • Redundant power • 90–240 VAC, 50-60 Hz • 8350 watts
Heat dissipation	28,500 BTU/hr	28,500 BTU/hr
Frame gauge		12-14
Loaded weight	1505 lb (683 kg)	1505 lb (683 kg)
Topple angle when fully loaded and stationary	<ul style="list-style-type: none"> • 12° when front of rack faces downward • 24° when rear of rack faces downward 	NA

The center of gravity of a populated Pillar 42 U rack is toward the front. The threshold tilt angle depends on whether the front or rear of the rack faces down the slope:

- Front faces downward: 12° maximum slope.
- Rear faces downward: 24° maximum slope.

Figure 70 Maximum tilt angles for stationary Pillar 42 U racks

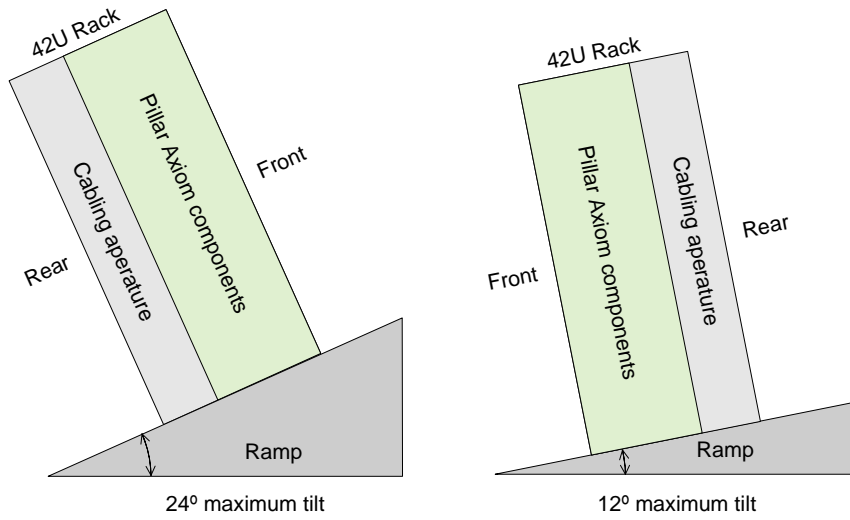

Index

Numerics

- 2U rack rails
 - install 35
- 4U rack rails 31
 - install 32

A

- acoustics specifications 132
- activity (ACT) LED, Slammer
 - startup progress code 106
- add
 - Bricks 100
 - Slammer 102
- administrator
 - account configuration 98
 - action to accept Brick 101
- alerts by email 93
- altitude specifications 131
- amperage
 - component draw 71
 - Pulizzi PC3365 73
 - Pulizzi TPC2104 72
 - Pulizzi TPC2105-1 72
- anti-tip brackets 26
- APM installation 99
- Axiom system
 - See Pillar Axiom hardware

B

- batteries, Slammer 49
- bay connections 20
- bays, rack
 - attach baying plates 22
 - interconnection bracket 21
- bezel attachment 82
- boot-up time, system 104
- bracket, rack connector 21

- Brick hardware components
 - hardware specifications 143
 - install 47
 - power on 78

Bricks

- add 100
- CU interconnection 52
- rack rails 34
- test SSF connections 88

C

- cables
 - fiber optic, test for failure 88
 - user supplied 15
- Call-Home feature 93
- casters 24
- cautions
 - defined 16
 - in English 128
- complete the installation
 - supply power 77
 - test SSF configuration 88
 - turn on the system 77
- components, Pillar Axiom hardware
 - placement in rack 29
 - supported hardware 14
 - technical specifications 130
- configuration, system
 - test 88
- connect to the GUI 87
- connection bracket 21

connection ports
 Brick failover 52, 53
 cross-connect
 one Slammer 52
 two Slammers 60
 private management interface
 one Slammer 54
 two Slammers 58
 Slammer failover
 one Slammer 54
 two Slammers 58
 Storage System Fabric 56, 62
 conservative mode 102
 contacts (Pillar Data Systems) 17
 copper switches 15
 cross-connect ports
 one Slammer system 52
 two Slammers 60
 customer-supplied material 15

D

data sheets. See hardware specifications.
 dimensions and weight
 Bricks 143
 Pilots 138
 Slammers 140
 documentation
 additional 17
 conventions 16

E

electrical safety issues
 list of hazards (translated) 110
 electromagnetic emissions and immunity
 Bricks 144
 Pillar Axiom systems 135
 Slammers 142
 electrostatic discharge (ESD) 18
 environment, data center
 Pillar Axiom system requirements 131
 equipment needed for installation 15
 Ethernet connections
 internal management
 one Slammer 54
 two Slammers 58
 message transport
 one Slammer 54
 two Slammers 58
 European Union Compliance Statement 136

F

fabric, test 88
 failed log-ins 93

failover connections
 Bricks 52
 Pilots 53
 failover ports
 Bricks 52
 one Slammer 54
 two Slammers 58
 fault (FLT) LED, Slammer
 startup progress code 105
 FC Expansion Brick 63
 FC RAID Brick 63
 FCC warning statement 135
 fiber optic cables
 test for failure 88
 Fibre Channel connections
 Brick failover 52
 Bricks 52
 cable bends 51
 cross-connect
 one Slammer system 52
 two Slammer system 57
 Pilot failover 53
 Pilots 53
 Storage System Fabric 56, 62
 one-rack systems 60
 Fibre Channel loop switches
 one Slammer 52
 two Slammers 59
 File Server name 95
 filesystem
 name 94
 frame size, jumbo 96
 FS ports
 Slammer cross-connect
 two Slammers 60

G

Gigabit Ethernet (GbE)
 switches 15
 Graphical User Interface (GUI), start 87
 ground straps, use of 18
 grounding straps
 door 84

H

halt, system
 evaluate LED startup codes 105
 LEDs identify problem 105

- hardware ports
 - Brick failover 52, 53
 - cross-connect
 - one Slammer 52
 - two Slammers 60
 - private management interface
 - one Slammer 54
 - two Slammers 58
 - Slammer failover
 - one Slammer 54
 - two Slammers 58
 - Storage System Fabric 56, 62
- hardware specifications
 - acoustics 132
 - altitude 131
 - dimensions and weight
 - Bricks 143
 - Pilots 138
 - Slammers 140
 - humidity 132
 - PDU 146
 - power characteristics
 - Bricks 143
 - Pilots 138
 - Slammers 140
 - rack 147
 - regulatory agency compliances
 - Bricks 144
 - Pillar Axiom system 133
 - Pilots 138
 - Slammers 141
 - temperature 132
 - vibration
 - random 132
- hardware, Pillar Axiom
 - LED boot-up codes 104
 - map 29
 - supported 14
 - technical specifications 130
- hazard signal words
 - translated 110
- help, online 17
- host bus adapters 84
- humidity specifications 132

I

- inserts, rack mount 31, 37
- installation
 - required tools 14

- installation procedures
 - cable Brick failover 52
 - cable Bricks
 - to one Slammer 54
 - to two Slammers 60
 - cable FC cross-connect
 - one Slammer 52
 - two Slammers 59
 - cable multiple racks 68
 - cable Pilot to one Slammer 53
 - cable Pilot to two Slammers 57
 - connect PDUs to power 70
 - create a rack bay
 - attach baying plates 22
 - attach interconnection bracket 21
 - install 2U rack rails 34
 - install 4U rack rails 31
 - install Bricks 47
 - install Pilots 43
 - install Slammer batteries 49
 - install Slammers 45
 - racks 18
 - supply power 77
 - test SSF cable 88
 - turn system on 77
- installation requirements
 - equipment and supplies 15
- internal management connections
 - one Slammer 54
 - two Slammers 58
- IP address
 - Domain Name Server 96
 - email server 93
 - management interface 91
 - primary 92
 - static 91

L

- LED startup progress codes
 - LED blink rates 105
 - meaning of 108
- leveling legs 24
- Link Aggregation 92
- login, first time
 - change password 87
 - connect to the GUI 87
 - test system configuration 88
- LUN configuration 97

M

- material supplied by customer 15

mounting rail kits

Brick 34

Pilot 37

Slammer 31

N

NAS storage configuration 93

network connection 68

Network Time Protocol (NTP) servers 90

NIM 69

notice conventions, safety 16

O

online help 17

P

panel removal, rack 20

password, Primary System Administrator 87

PDU's

hardware specifications 146

install 41, 43

power hardware components 77

Pulizzi PC3365 73

Pulizzi TPC2104 72

Pulizzi TPC2105-1 72

Pillar Data Systems Web site 17

Pilot hardware components

hardware specifications 137

Pilots

CU interconnection 53

install 43

IP address 87

power on 78

rack rails 37

where to install 43

placement of components in rack 29

ports, hardware

Brick failover 52, 53

cross-connect

one Slammer 52

two Slammers 60

private management interface

one Slammer 54

two Slammers 58

Slammer failover

one Slammer 54

two Slammers 58

Storage System Fabric 56, 62

position the Pillar Axiom rack

level the rack 24

stabilize the rack 25

power

cabling examples 73

circuits

customer-supplied 15

component usage 71

requirements, system 131

power characteristics, hardware

Bricks 143

Pilots 138

Slammers 140

power on

Bricks 78

Pilots 78

Slammers 78

private management interface ports

one Slammer 54

two Slammers 58

product support 17

progress codes, LED startup 105

Q

Quality of Service (QoS) settings

NAS 93

SAN 96

R

rack rails

install

2U rails 35

4U rails 32

racks

42U specifications 147

compatibility 19

doors and panels 84

install a Pilot 43

install a Slammer 45

level 24

multiple 20

power connection 70

set up 18

stabilization

anti-tip brackets 26

stabilizer plates 27

stabilize 25

test SSF configuration 88

- regulatory agency compliances
 - EM emissions and immunity
 - Bricks 144
 - Pillar Axiom systems 135
 - Slammers 142
 - safety and quality standards
 - Bricks 144
 - Pillar Axiom systems 133
 - Pilots 139
 - Slammers 141
 - system 133
- resources, additional 17
- RJ-45
 - network cables 15

S

- safety
 - statements
 - translated 110
- safety and quality standards
 - Bricks 144
 - Pillar Axiom systems 133
 - Pilots 139
 - Slammers 141
- safety notice conventions 16
- sales
 - contact information 17
- SAN storage configuration 96
- SATA Brick 63
- SATA Bricks 54, 61
- SecureWORMfs 94
- session time-out 93
- Slammer hardware components
 - hardware specifications 140
 - LED startup codes 105
- Slammers
 - add 102
 - automatic recovery 93
 - battery installation 49
 - CU interconnection 52
 - install 45
 - LED startup codes 105
 - power on 78
 - rack rails 31
 - test SSF connections 88
- spacers, rack mount 31, 37
- SSF 88
- stabilization systems
 - anti-tip brackets 26
 - anti-tip plates 25
 - stabilizer plates 27
- stabilizer plates 27

- startup
 - progress codes
 - for the ACT LED 106
 - for the FLT LED 105
 - for the ST LED 106
 - interpretation 108
 - time 104
- status (ST) LED, Slammer
 - startup progress code 106
- Storage System Fabric
 - connections 60
 - ports 56, 62
 - test configuration 88
- supplies needed for installation 15
- switches 15
 - zone setup 84
- system
 - configuration test 88
 - name 91

T

- technical support 17
- temperature specifications 132
- tests
 - evaluate LED startup codes 105
- time
 - startup 104
 - system 90
- tools, required 14
- turn on Pillar Axiom systems 77

V

- vibration specifications
 - random 132
- virtual LAN 96

W

- warnings
 - defined 16
 - in English 110
 - non-English translations 110
- Web browser, customer-supplied 16
- wizard, configuration 89