

# Pillar Axiom<sup>®</sup> 500



## Advanced Hardware Installation Guide

---

## Copyright Notice

© 2008 Pillar Data Systems, Inc. All rights reserved.

Pillar Data Systems, Inc.  
2840 Junction Avenue  
San Jose, CA 95134

Part Number: 4420-00082-0400

2008-February

## Trademarks

Pillar Data Systems, Pillar Axiom, and the “green icon” logo are registered trademarks of Pillar Data Systems, Inc. All other trademarks are trademarks of their respective owners.

## Important Note to Users

This guide contains CONFIDENTIAL INFORMATION of Pillar Data Systems and should not be disclosed or further distributed to third parties without the express prior written consent of Pillar Data Systems.

This guide and use of Pillar Axiom hardware and software to which this guide applies is subject to the Pillar Data Systems End User License Agreement and Warranty Statement that accompanied the Pillar Axiom system and this guide. A copy of the Pillar Data Systems End User License Agreement and Warranty Statement is on the same CD with which this guide is provided (if you entered into a signed written agreement with Pillar Data Systems for the purchase or use of this Pillar Axiom system that supersedes the Pillar Data Systems End User License Agreement and Warranty Statement, then such signed written agreement will apply).

Pillar Data Systems reserves the right to change the specifications and content in this guide at any time.

---

# Table of Contents

## Chapter 1 Before You Begin

Audience. . . . .	12
Contact Information. . . . .	13
Pillar Axiom System Components. . . . .	14
Customer-Supplied Materials. . . . .	15
Safety Notice Conventions. . . . .	16
Additional Documentation. . . . .	17

## Chapter 2 Set Up the Rack

About Component Inspection. . . . .	18
Rack Position. . . . .	20
About Multiple Rack Connections. . . . .	20
Adjust the Leveling Legs. . . . .	25
About Rack Stability. . . . .	27
About Component Placement. . . . .	31
About Component Placement for One Slammer and SATA Bricks. . . . .	31
About Component Placement for One Slammer and FC Bricks. . . . .	32
About Component Placement for Two or Three Slammers and FC Bricks. . . . .	34
About Component Placement for 4 Slammers and 64 Bricks. . . . .	35
Pilot Rail Kit Parts. . . . .	37
Install a Pair of Pilot Mounting Rails. . . . .	38
Slammer Rail Kit Parts. . . . .	41
Install a Pair of Slammer Mounting Rails. . . . .	42
Brick Rail Kit Parts. . . . .	44
Install a Pair of Brick Mounting Rails. . . . .	45

## Chapter 3 Install Components

About Power Distribution Unit Installation. . . . .	48
Install a 1U PDU. . . . .	49
Install a 2U PDU. . . . .	51

---

About Installation. . . . .	52
Install a Pilot. . . . .	53
About Slammer Installation. . . . .	55
Install a Slammer. . . . .	56
Install a Brick. . . . .	58
Install the Slammer Batteries. . . . .	61
<b>Chapter 4 Connect Data Cables</b>	
About Data Cabling the Pillar Axiom System. . . . .	63
Summary of Cabling Rules. . . . .	64
Connect the Pillar Axiom System to Your Network. . . . .	66
Pilot Network Requirements. . . . .	66
Slammer Network Requirements. . . . .	67
<b>Chapter 5 Connect Power Cables</b>	
Connect Power Cables. . . . .	68
About Component Power Usage. . . . .	69
PDU Outlet Amperage Limits. . . . .	70
About Power Cabling. . . . .	72
Sample Power Cabling for One Slammer and Three Bricks. . . . .	72
Sample Power Scheme for One Slammer and 16 SATA Bricks . . . . .	74
<b>Chapter 6 Complete the Installation</b>	
Power On the System. . . . .	77
Verify Status LEDs at the Front of the System. . . . .	79
Verify Status LEDs at the Back of the System. . . . .	82
Attach the Bezels. . . . .	85
About HBA Driver and Firmware Installation (SAN Only). . . . .	87
About Switch Zone for HBA Set Up (SAN Only). . . . .	88
Attach the Rack Doors and Panels. . . . .	89
Attach the Rack's Side Panels. . . . .	90
<b>Chapter 7 Initial Configuration</b>	
Pre-Configuration Checklist. . . . .	91
Start the Graphical User Interface (GUI). . . . .	93
Reset the Primary System Administrator Password. . . . .	94
Configure the System with the Configuration Wizard. . . . .	95
Configure Global System Parameters. . . . .	95
Configure NAS Storage Parameters. . . . .	99
Configure SAN Storage Parameters. . . . .	101
About AxiomONE Path Manager Installation (SAN Only). . . . .	104

---

## Chapter 8 Expansion Planning

About Additional Slammers. . . . .	105
Complete the Pre-Installation Checklist. . . . .	105
Install the Slammer. . . . .	105

## Appendix A Slammer LED Startup Progress Codes

About LED Startup Codes. . . . .	107
Slammer LED Codes. . . . .	108
LED Code Translation. . . . .	109
LED Halt Codes. . . . .	111

## Appendix B Safety Statements

Introduction to Safety Statements. . . . .	114
Safety Statements. . . . .	115
Warning Notices. . . . .	116
Electrical Warning in Other Languages. . . . .	116
Lightning Activity Warning. . . . .	119
Lightning Warning in Other Languages. . . . .	119
Power Supply Warning. . . . .	120
Power Supply Warning in Other Languages. . . . .	120
Main Power Disconnect Warning. . . . .	122
Power Disconnect Warning in Other Languages. . . . .	122
Installation Warning. . . . .	122
Power Disconnect Warning. . . . .	123
Warning Statement for Norway and Sweden. . . . .	123
Restricted Access Area Warning. . . . .	123
Restricted Access Warning in Other Languages. . . . .	124
Product Disposal Warning. . . . .	125
Product Disposal Warning in Other Languages. . . . .	125
Jewelry Removal Warning. . . . .	126
Jewelry Removal Warning in Other Languages. . . . .	126
Qualified Personnel Warning. . . . .	128
Warning Statement for Finland. . . . .	129
Warning Statement for Sweden. . . . .	129
Power Cabling Warning. . . . .	129
Power Cabling Warning in Other Languages. . . . .	129
Supply Circuit Warning. . . . .	130
Supply Circuit Warning in Other Languages. . . . .	130
Voltage Mismatch Warning. . . . .	131

---

Voltage Mismatch Warning in Other Languages. . . . .	131
SELV Circuit Warning. . . . .	133
SELV Circuit Warning in Other Languages. . . . .	133
Incorrect Connection Warning. . . . .	135
Incorrect Connection Warning in Other Languages. . . . .	135
Caution Notices. . . . .	136

**Appendix C Pillar Axiom Hardware Specifications**

About Hardware Specifications. . . . .	138
About Pillar Axiom Hardware Specifications. . . . .	139
System Power Requirements. . . . .	139
System Environmentals. . . . .	140
System Regulatory Agency Compliance. . . . .	141
System Packaging and Transportation. . . . .	144
System Warranty. . . . .	145
About Hardware Specifications. . . . .	146
Pilot Dimensions and Weight. . . . .	146
Pilot Power Characteristics. . . . .	146
Pilot Regulatory Agency Compliance. . . . .	147
Pilot Packaging and Transportation. . . . .	148
About Slammer Hardware Specification. . . . .	149
Slammer Dimensions and Weight. . . . .	149
Slammer Power Characteristics. . . . .	149
Slammer Regulatory Agency Compliance. . . . .	150
Slammer Packaging and Transportation. . . . .	151
About Brick Hardware Specification. . . . .	152
Brick Dimensions and Weight. . . . .	152
Brick Power Characteristics. . . . .	152
Brick Regulatory Agency Compliance. . . . .	153
Brick Packaging and Transportation. . . . .	154
Pillar Axiom PDU Hardware Specification. . . . .	155
Pillar Rack Hardware Specification. . . . .	157

<b>Index. . . . .</b>	<b>160</b>
-----------------------	------------

---

# List of Figures

Figure 1 Floor plan for rack installation. . . . .	20
Figure 2 Sample 42U side panels. . . . .	21
Figure 3 Location of frame corners. . . . .	22
Figure 4 Connection bracket installation. . . . .	23
Figure 5 Roof baying plate attachment. . . . .	24
Figure 6 Adjacent anchor bolts at the front of the racks. . . . .	25
Figure 7 Rack leveling leg locations. . . . .	26
Figure 8 Leveling leg adjustment. . . . .	26
Figure 9 Attach anchor bolts to rack. . . . .	27
Figure 10 Position anti-tip brackets. . . . .	28
Figure 11 Secure anti-tip brackets to the floor. . . . .	28
Figure 12 Stabilizer plate attached to the rack base and floor. . . . .	30
Figure 13 Fully loaded 42U racks for one Slammer and 32 SATA Bricks. . . . .	32
Figure 14 Fully loaded 42U rack for one Slammer and 16 FC Bricks. . . . .	33
Figure 15 Fully loaded 42U racks for three Slammers and 32 FC Bricks. . . . .	35
Figure 16 Fully loaded 42U racks for four Slammers and 64 Bricks. . . . .	36
Figure 17 Scope hook attachment. . . . .	39
Figure 18 Positioning spacer bar. . . . .	40
Figure 19 Pilot rail front attachment. . . . .	40
Figure 20 Scope hook attachment. . . . .	43
Figure 21 Slammer rails installed in rack. . . . .	44

---

Figure 22 Scope hook attachment. . . . .	46
Figure 23 2U rack rails installed in rack. . . . .	47
Figure 24 Snap-in cage nut. . . . .	49
Figure 25 Securing a 1U PDU in the bottom of a rack. . . . .	49
Figure 26 An installed PDU at the bottom of the rack. . . . .	50
Figure 27 Inserting the upper Pilot CU. . . . .	53
Figure 28 Inserting a Slammer. . . . .	56
Figure 29 Inserting a Brick. . . . .	59
Figure 30 Brick ears. . . . .	59
Figure 31 Brick front. . . . .	60
Figure 32 Slammer bezel removal. . . . .	61
Figure 33 Slammer battery insertion. . . . .	62
Figure 34 Pilot management cables. . . . .	66
Figure 35 Pulizzi TPC2105-1 outlet amperage limits. . . . .	70
Figure 36 Pulizzi TPC2104 outlet amperage limits. . . . .	71
Figure 37 Pulizzi PC3365 outlet amperage limits. . . . .	71
Figure 38 Sample power cabling scheme with 230 V power. . . . .	72
Figure 39 Sample power cabling scheme with 115 V on a TCP2105-1 PDU. . . . .	73
Figure 40 Sample power cabling scheme with 230 V (one circuit shown). . . . .	75
Figure 41 Secure Slammer batteries. . . . .	77
Figure 42 Turn on Brick power. . . . .	78
Figure 43 Turn on PDU power. . . . .	78
Figure 44 Pilot bezel LEDs. . . . .	79
Figure 45 Slammer bezel LEDs. . . . .	80
Figure 46 Brick bezel LEDs. . . . .	80
Figure 47 Pilot connectivity LEDs. . . . .	82
Figure 48 Slammer connectivity LEDs. . . . .	82
Figure 49 Brick LEDs. . . . .	83



---

Figure 50 Bezel hook on the right side of the bezel. . . . .	85
Figure 51 Press ejector tabs to lock bezel. . . . .	86
Figure 52 Configuration Tasks page. . . . .	95
Figure 53 System Time page. . . . .	96
Figure 54 Management and Data Path Interfaces page. . . . .	97
Figure 55 Notification and Account Security Settings page. . . . .	98
Figure 56 Storage Allocation and Quality of Service (QoS) page. . . . .	99
Figure 57 Storage Capacity and Performance Settings page. . . . .	100
Figure 58 Storage Allocation and Quality of Service (QoS) page for LUNs. . . . .	102
Figure 59 Storage Capacity and Performance Settings page for a LUN. . . . .	103
Figure 60 Maximum tilt angles for stationary Pillar 42 U racks. . . . .	159

---

# List of Tables

Table 1 Contacts at Pillar Data Systems. . . . .	13
Table 2 Pillar Axiom 500 Series components. . . . .	14
Table 3 Required tools. . . . .	15
Table 4 Additional resources. . . . .	17
Table 5 Pilot rail kit parts . . . . .	37
Table 6 Slammer rail kit parts . . . . .	41
Table 7 Brick rail kit parts . . . . .	45
Table 8 Pillar Axiom component electrical requirements. . . . .	69
Table 9 Global system parameters. . . . .	91
Table 10 Code translation for the Fault LED. . . . .	109
Table 11 Code translation for the Activity LED. . . . .	109
Table 12 Code translation for the Status LED. . . . .	110
Table 13 Slammer LED halt codes. . . . .	111
Table 14 Electrical warning in other languages . . . . .	116
Table 15 Lightning warning in other languages. . . . .	119
Table 16 Power supply warning in other languages. . . . .	120
Table 17 Power disconnect warning in other languages. . . . .	122
Table 18 Installation warning in other languages. . . . .	122
Table 19 Warnings for Norway and Sweden. . . . .	123
Table 20 Restricted access warning in other languages. . . . .	124
Table 21 Product disposal warning in other languages. . . . .	125

---

Table 22 Jewelry removal warning in other languages. . . . .	126
Table 23 Qualified personnel warning in other languages. . . . .	128
Table 24 Warning statement for Finland. . . . .	129
Table 25 Warning statement for Sweden. . . . .	129
Table 26 Power cabling warning in other languages. . . . .	129
Table 27 Supply circuit warning in other languages. . . . .	130
Table 28 Voltage mismatch warning in other languages. . . . .	131
Table 29 SELV circuit warning in other languages. . . . .	133
Table 30 Connection warning in other languages. . . . .	135
Table 31 System altitude specifications. . . . .	140
Table 32 System temperature and humidity specifications. . . . .	140
Table 33 System acoustics specification. . . . .	141
Table 34 System random vibration specifications. . . . .	141
Table 35 Safety, quality, and environmental standards. . . . .	142
Table 36 Pilot dimensions and weight (both control units). . . . .	146
Table 37 Pilot power characteristics (per control unit). . . . .	146
Table 38 Pilot safety and quality standards. . . . .	147
Table 39 Slammer dimensions and weight. . . . .	149
Table 40 Slammer power characteristics. . . . .	149
Table 41 Slammer safety and quality standards. . . . .	150
Table 42 Slammer EM emissions and immunity. . . . .	150
Table 43 Brick dimensions and weight. . . . .	152
Table 44 Brick power characteristics. . . . .	152
Table 45 Brick safety and quality standards. . . . .	153
Table 46 Pillar Axiom EM emissions and immunity. . . . .	153
Table 47 PDU specifications. . . . .	155
Table 48 Rack specifications for a Pillar Axiom system. . . . .	157

## CHAPTER 1

# Before You Begin

## Audience

This guide is for Data Center System Administrators and Professional Services Consultants who install Pillar Axiom storage systems that come with most components already installed in Pillar Data Systems racks. We assume that you understand how to:

- Assemble hardware components.
- Connect the components to the LAN and to power circuits.
- Use a graphical user interface (GUI) in a web browser.

This guide explains how to:

- Position and stabilize a populated rack in the data center.
- Create rack bays.
- Install hardware components.
- Connect the system to inlet power and to the networks.
- Turn on the system.
- Perform initial configuration.
- Add additional Slammers and Bricks.

## Contact Information

**Table 1 Contacts at Pillar Data Systems**

For help with...	Contact...
Error messages, usage questions, and other support issues	US and Canada: 877-4PILLAR (1-877-474-5527) Europe: +800 PILLAR FS (+800 74 44 27 37) Asia Pacific: +1-408-518-4515 South Africa: +0 800 980 400 Have your system serial number ready. Email <a href="mailto:support@pillardata.com">support@pillardata.com</a> Support portal: <a href="http://support.pillardata.com">support.pillardata.com</a>
Sales and general contact information	<a href="http://www.pillardata.com/company/contact/">www.pillardata.com/company/contact/</a>
Documentation improvements and resources	<a href="mailto:docs@pillardata.com">docs@pillardata.com</a> <a href="http://www.pillardata.com/techdocs/">www.pillardata.com/techdocs/</a> (log in with your username and password)

## Pillar Axiom System Components

The following Pillar Axiom 500 Series components are contained in Pillar Data Systems or non-Pillar Data Systems racks.

**Table 2 Pillar Axiom 500 Series components**









Product name	Model
Bricks	<ul style="list-style-type: none"> <li>• BRX 500-400A7—400 GB SATA disk drives, 4800 raw GB</li> <li>• BRX 500-500A7—500 GB SATA disk drives, 6000 raw GB</li> <li>• BRX 500-750A7—750 GB SATA disk drives, 9000 raw GB</li> <li>• BRX 500-1000A7—1 TB SATA disk drives, 12000 raw GB</li> <li>• BRX 500-73F15R—73 GB FC disk drives (RAID)</li> <li>• BRX 500-73F15E—73 GB FC disk drives (Expansion)</li> <li>• BRX 500-146F15R—146 GB FC disk drives (RAID)</li> <li>• BRX 500-146F15E—146 GB FC disk drives (Expansion)</li> <li>• BRX 500-300F15R—300 GB FC disk drives (RAID)</li> <li>• BRX 500-300F15E—300 GB FC disk drives (Expansion)</li> </ul>
Slammer (and batteries)	<ul style="list-style-type: none"> <li>• SLM 500-GEC—NAS, copper interface</li> <li>• SLM 500-GEO—NAS, optical interface</li> <li>• SLM 500-SAN—SAN, 2 GB optical interface</li> <li>• SLM 500-SAN-4G—SAN, 4 GB optical interface</li> <li>• SLM500-GEC8—NAS, copper interface</li> <li>• SLM500-GEO8—NAS optical interface</li> </ul>
Pilot	<ul style="list-style-type: none"> <li>• Pillar Axiom Pilot</li> </ul>
Power distribution units (PDU)	<ul style="list-style-type: none"> <li>• PDU 500-1P20A—115/230 V, 20 A, 1 <math>\phi</math></li> <li>• PDU 500-1P30A—f 115/230 V, 30 A, 1 <math>\phi</math></li> <li>• PDU 500-3P30A—f 208 V, 30 A, 3 <math>\phi</math></li> <li>• PDU 500-3P16A—230/400 V, 16 A, 3 <math>\phi</math> WYE</li> </ul>

**Note:** The BRX 500-160A7 and BRX 500-250A7 are no longer available for new systems.

## Customer-Supplied Materials

You need the following tools to install a Pillar Axiom system:



**Table 3 Required tools**

Tool	Purpose	Illustration
1/4-in (7-mm) flat-tip screwdriver	Adjust leveling feet.	
Adjustable wrench, 6 in (15 cm)	Adjust leveling feet.	
#1 and #2 Phillips-head screwdrivers	Remove and secure Pillar Axiom hardware components.	
Socket wrench with a 1/2-in (13 mm) socket	Connect two racks.	
Offset box wrench, 13/32 in (10 mm)	Work with adjustable mounting rail assemblies.	
Torx® T20 screwdriver	Attach rail assemblies to the vertical channels and secure hardware components to the rails.	
Torx® T30 screwdriver	Connect two racks.	
Wire cutters	Cut tie wraps.	

**Note:** These tools are not included with the Pillar Axiom system.

## Safety Notice Conventions

Hazard signal words conform to the American National Standards Institute (ANSI) Z535.4-1998 meanings. This guide uses the following conventions for safety notices:

- |  |  |
|--|--|
|  <b>CAUTION</b> | Indicates a potentially hazardous situation that, if not avoided, may result in minor or moderate injury.  |
|  <b>Warning</b> | Indicates a potentially hazardous situation that, if not avoided, could result in death or serious injury. |
|  <b>DANGER</b>  | Indicates an imminently hazardous situation that, if not avoided, will result in death or serious injury.  |

**Important!** To emphasize a point, to remind you of something, or to indicate potential problems in the outcome of the in-process task.

A set of important safety notices apply throughout this guide. Read them before working on a Pillar Axiom system. See [Safety Statements](#).



## Additional Documentation

Before you install the Pillar Axiom system, refer to the following resources that you completed with the assistance of your Pillar Data Systems representative:

- *Site Preparation Survey*
- *Storage Requirements Survey*

Use the following resources as you work with an Axiom storage system.

**Table 4 Additional resources**

For information on...	Refer to this document...
Terms used within this document	<i>Pillar Glossary</i>
Pillar Axiom system hardware and software architecture	<i>System Architecture Overview</i>
How to configure, monitor, and administer a system	<i>Administrator's Guide</i>
How to develop scripts or set up batch processes	<i>CLI Reference Guide</i>
How to replace or upgrade hardware components	<i>Pillar Axiom Service Guide</i>

## CHAPTER 2

# Set Up the Rack

## About Component Inspection

Each Pillar Axiom storage system is built to a customer's specifications and shipped in a single shipment. Check the components you received against the packing slip (or bill of lading), which lists everything that was shipped. If any components are missing, call 1-877-4PILLAR (474-5527) and report what was not included in your shipment. Note how many pallets or containers you received, in case the missing components are in a container that simply has not yet arrived.



**CAUTION**

A Brick weighs up to 65 lb (29.5 kg). For safe handling, use two people to lift it.



**CAUTION**

A Slammer weighs 94 lb (42.6 kg). For safe handling, use two people to lift it.



**CAUTION**

Before you handle a component, make sure that you have taken electrostatic discharge precautions:

- The minimum requirement is an anti-static wrist strap connected to a hard ground. We recommend that you remove components from their packaging and place them on an ESD-qualified table equipped with ground points for wrist straps.
- Static charges can build up rapidly on rolling carts. If you transport a hardware component by cart, ground the cart with a drag chain on an ESD floor. If there is no ESD cart available or ESD floor, ground yourself before you touch a component that has been transported on a cart.

After you remove the components from their packaging, inspect them for any damage that may have occurred enroute. If there is any damage:

- 1 Check your Terms of Sale to see who notifies the carrier.
- 2 Notify the carrier or Pillar Data Systems, as appropriate, within 72 hours.
- 3 Record all damage.
- 4 Call Technical Support to open a service request for future insurance claims.

**Tip:** Check the packing materials to verify that you have retrieved all the small parts before recycling.

**Important!**

Pillar Axiom components are compatible with racks that are compliant to the EIA-310-D standard. Pillar Axiom Slammers and Bricks may not install successfully into a rack that is not EIA-310-D compliant.

Illustrations show a Pillar Axiom 42U rack or parts of it. If you have a non-Pillar rack, it should be similar.

## Rack Position

The following figure illustrates a floor plan for new rack installations. The space around the rack (or bay, if you have multiple racks) is needed to perform the installation tasks safely.

Figure 1 Floor plan for rack installation

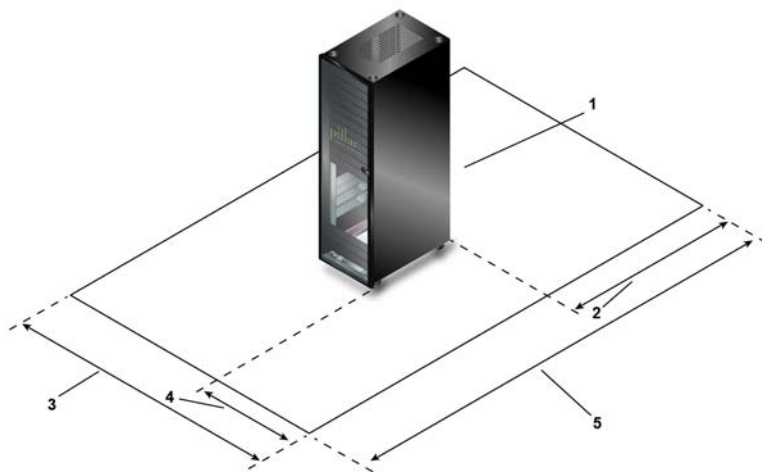

### Legend

1	Back of unit
2	60 in (152 cm)
3	96 in (244 cm)
4	36 in (91 cm)
5	139 in (353 cm)

## About Multiple Rack Connections

If you are installing more than one rack, connect them together first. If you do not have multiple Pillar racks, skip to [Adjust the Leveling Legs](#).

## Prepare the Racks

To create a bay of Pillar racks, first remove the adjacent (inner) side panels from each rack and move the racks into position. You will route the cables directly from

one rack to the other through the open sides because the cables are not long enough to route through a raised floor.

Figure 2 Sample 42U side panels

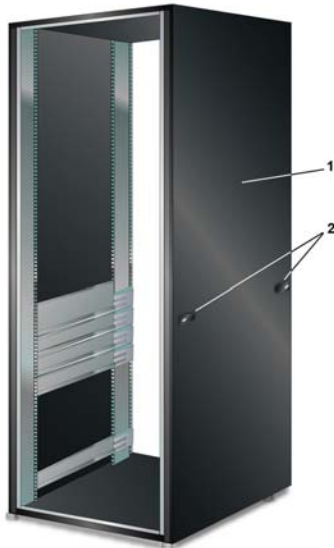

### Legend

1 Side panel, one on each side
2 Latches

- 1 If locked, unlock the side panel using the supplied keys.
- 2 Unlatch the side panel by:
  - Pushing the release button, or
  - Lifting the release handle(s).
- 3 Remove the side panel and set it aside.
- 4 Position the racks so that their open sides abut and their front sides are flush.

## Attach the Connection Bracket

The connection bracket provides extra rigidity to the bay.

**Important!** Make sure at least one of the racks is not anchored so you can adjust its position as you attach them together.

- 1 Locate the two adjacent frame corners at the top and rear of two racks to be connected.

Figure 3 Location of frame corners

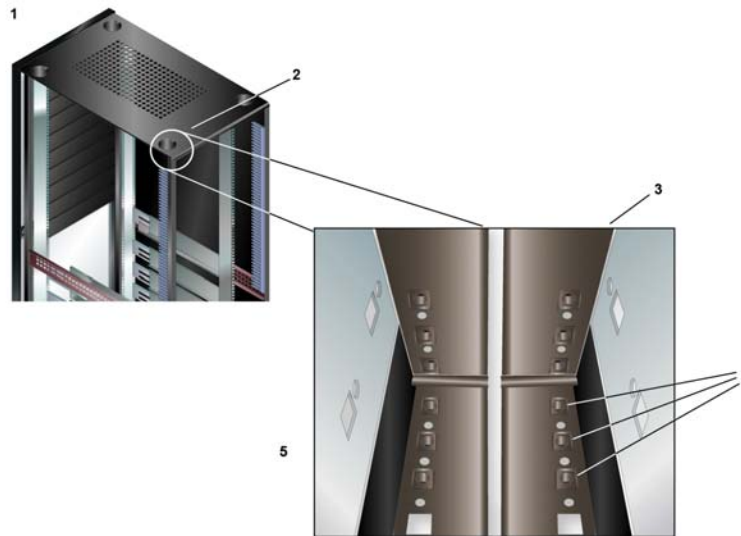

### Legend

1 Front
2 Top rear frame corner
3 Second rack
4 Threaded screw holes
5 Looking up into top rear frame corner, with a second rack moved close for attachment

- 2 Place the connection bracket into the frame corner.
- 3 Insert an M8 hex screw through the hole in one of the bracket corners.
- 4 Loosely screw the M8 screw into the threaded hole in the frame.

Figure 4 Connection bracket installation

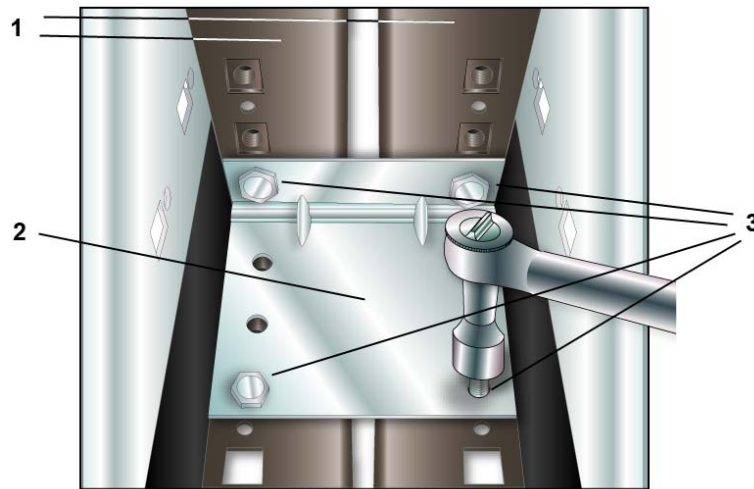

**Legend**

1 Frames
2 Baying connection bracket
3 M8 hex screws

- 5 Insert an M8 hex screw through one of the other corner holes in the bracket and loosely screw it into the threaded hole in the frame.
- 6 Repeat Step 5 for the other two corner holes.

**Note:** Tighten the screws after all the bay connections are in place.

### Attach the Baying Plates

Baying plates bind two Pillar racks together at the roof and bottom of the rack.

**Tip:** Use the stabilizer plate described in [Install a Stabilizer Plate](#) in conjunction with the baying kit that comes with each rack.

- 1 At the front of each rack roof, use a T30 Torx® screwdriver to remove the two adjacent Torx-head screws and set them aside.
- 2 Place a baying plate over the two holes.

**Figure 5 Roof baying plate attachment**

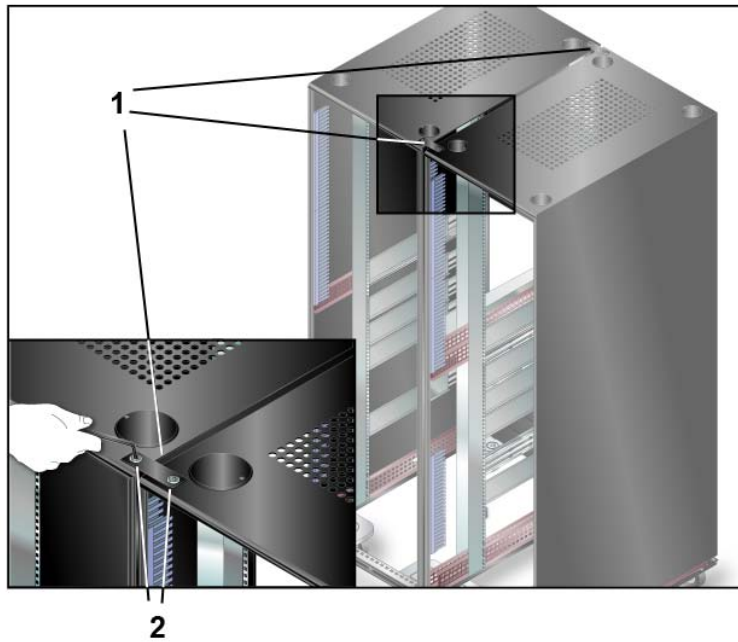

**Legend**

1 Roof baying plates
2 M12 Torx screws

- 3 Insert a Torx screw (from Step 1) into each plate hole.
- 4 Re-seat the Torx screws loosely.
- 5 Repeat Steps 1 through 4 for the two holes at the back of the roof.
- 6 At the bottom of the adjacent rack sides, remove the anti-tip brackets, if any, and unscrew the anchor bolts.



Figure 6 Adjacent anchor bolts at the front of the racks



### Legend

1 Anchor bolts
----------------

- 7 Hold the baying plate across the two anchor-bolt holes and loosely replace the anchor bolts.
- 8 Repeat Steps 6 and 7 in the back of the racks.
- 9 Use the socket wrench to tighten the connection bracket screws.
- 10 Use the T30 Torx-head screwdriver to tighten the top baying plate screws.
- 11 Use the 3/4-in (19-mm) open-end wrench to tighten the bottom baying plate anchor bolts.

## Adjust the Leveling Legs

Racks have built-in leveling legs at each corner. Adjust these legs so they are in firm contact with the floor and the rack is level. If the rack connects to others, adjust the legs so the racks are at the same height and can be bolted together.

- 1 Turn each leveling leg clockwise to lower the feet until they touch the floor. Use a 1/4-in (7-mm) flat-tip screwdriver in the slot at the top of the leg.

Figure 7 Rack leveling leg locations

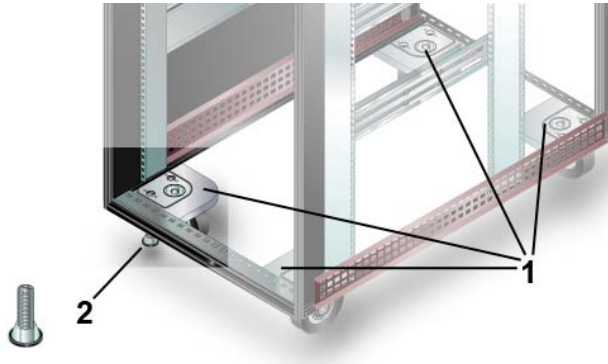

**Legend**

1 Caster brackets
2 Leveling legs are preinstalled in each caster bracket.

- 2 Use a 3/4-in (19-mm) open-end wrench on the bottom of the legs to jack up the rack. Raise the rack until level with all the casters off the floor.

Figure 8 Leveling leg adjustment

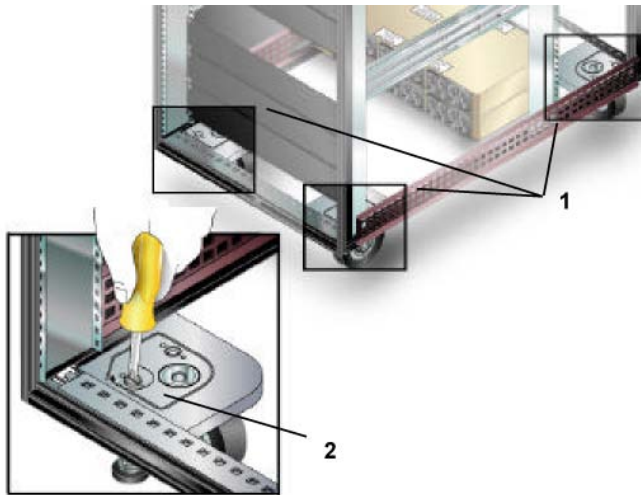

**Legend**

1 Caster brackets
2 Slot in the leveling leg for a screwdriver

**Note:** If you connect racks in a bay it is more important that the racks be at the same height than level so that you can bolt them together.

## About Rack Stability

After you move the rack to its final position and adjust the legs, you must stabilize it to keep it from shifting when you install the components.

You can use any combination of the following actions to stabilize the rack:

- Attach anti-tip brackets and secure them to the floor. Go to [Install the Anti-Tip Brackets](#).
- Attach a stabilizer plate and secure it to the floor. Go to [Install a Stabilizer Plate](#).
- Install a seismic stabilization system.

**Important!** If the rack will be part of a bay of racks, attach the rack to the bay before you install stabilizer plates or some other seismic stabilization system.

## Install the Anti-Tip Brackets

- 1 Screw the anchor bolt into the bottom outside corner of the rack frame until the bolt is seated.

Figure 9 Attach anchor bolts to rack

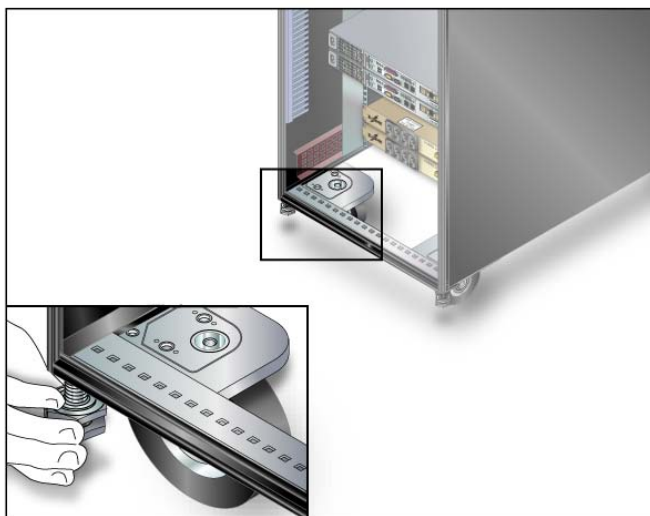

- 2 Slide the bracket fingers into the anchor bolt pocket as illustrated in the following figure.

Figure 10 Position anti-tip brackets

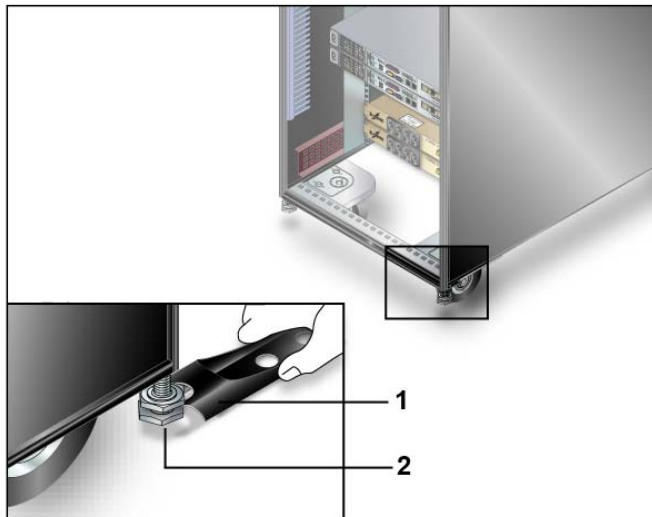

**Legend**

1 Anti-tip bracket fingers
2 Anchor bolt

- 3 Position the anti-tip bracket so that it points away from the rack and is parallel to the sides.
- 4 Adjust the anchor bolt so that it is finger-tight against the anti-tip bracket, and secure the anti-tip bracket to the floor.

Figure 11 Secure anti-tip brackets to the floor

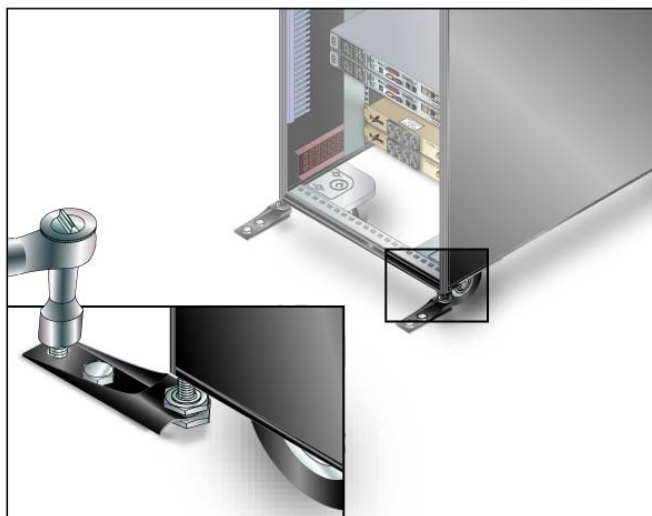

- 5 Repeat Step 1 through Step 4 for all four corners.

## About Stabilizer Plate Installation

At the front of the rack, you can install an optional stabilizer plate instead of anti-tip brackets. Stabilizer plates provide greater stability than anti-tip brackets, which must be removed in order to install a stabilizer plate. You cannot use anti-tip brackets in a bay because the anchor bolts are used to hold the baying plates in place. Therefore you should use stabilizer plates for racks in a bay.

Also note that if you have removable floor panels, you must bolt the stabilizer plates through to the solid sub-floor.

## Install a Stabilizer Plate

These are the steps for installing the optional stabilizer plate for the Pillar Axiom system.

- 1 Place the stabilizer plate at the front of the rack with the short side up.
- 2 Align the holes in the short side with the holes in the rack frame. Adjust the leveling legs to raise or lower the rack to align the plate and rack holes.
- 3 Insert an M8 bolt into each hole in the short side of the stabilizer plate.
- 4 Use the hex wrench to tightly bolt the stabilizer plate to the rack.

Figure 12 Stabilizer plate attached to the rack base and floor

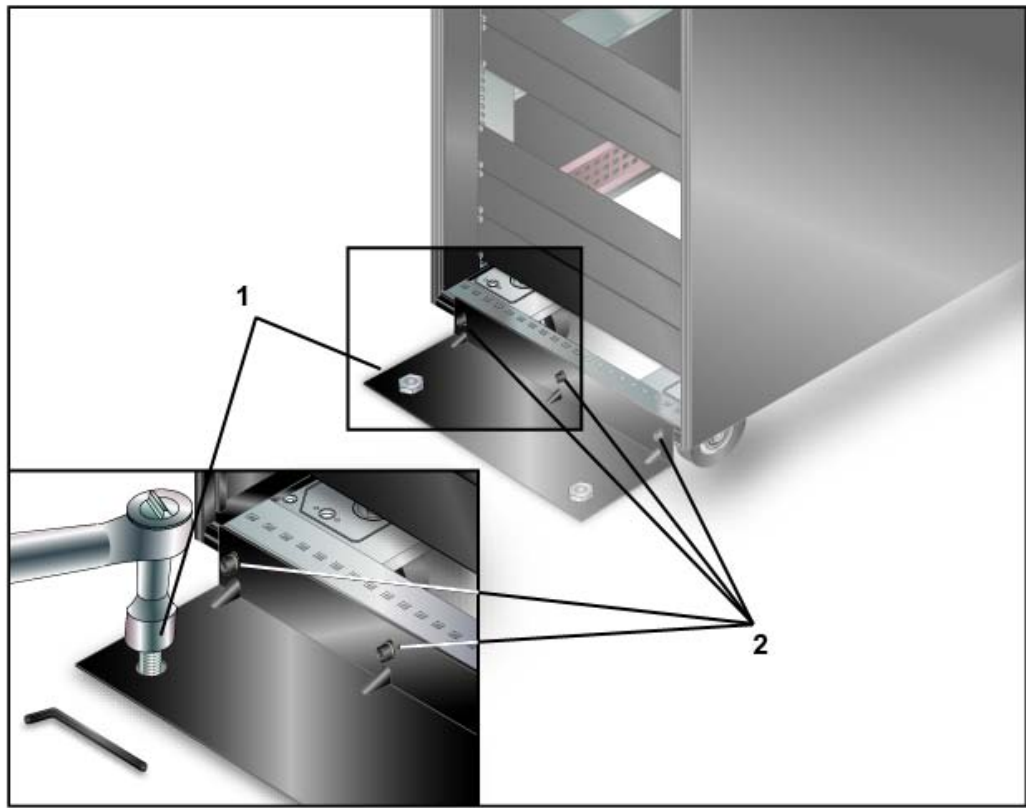

**Legend**

1 M12 (or larger) floor bolts
2 M8 allen-head bolts

- 5 Secure the stabilizer plate to the floor with bolts and washers that are appropriate for the type of floor.

**Important!** The floor bolts must be no smaller than M12.

## About Component Placement

For non-Pillar racks, all component rails must be installed before loading components into the racks.

Racks from Pillar Data Systems come with the component rails pre-installed. If you have Pillar racks, skip ahead to [Install Components](#).

Install the component rails according to the component placement diagrams for your system configuration. Install them in the order of:

- Pilot rails near the bottom of the rack, 2U above the PDUs.
- Slammer rails above the Pilot rails.
- Brick rails above the Slammer rails.



### CAUTION

Some Pillar Axiom components weigh over 65 pounds (29.5 kg). Make sure all rail components are tightly secured before loading the components to prevent damage and injury.

If you are building a rack that only contains Bricks, you should still start from the bottom. Go to these topics for complete information on component placement:

- [About Component Placement for One Slammer and SATA Bricks](#)
- [About Component Placement for One Slammer and FC Bricks](#)
- [About Component Placement for Two or Three Slammers and FC Bricks](#)
- [About Component Placement for 4 Slammers and 64 Bricks](#)

## About Component Placement for One Slammer and SATA Bricks

A Pillar Axiom system with one Slammer supports up to 32 SATA Bricks. Install the components in the rack as shown in the figure below. Any components that are not installed must be replaced with filler panels.

The figure below illustrates how the Pillar Axiom storage system components are mapped into fully loaded 42U racks for the following configuration:

- 1 Pilot
- 1 Slammer
- 32 SATA Bricks

**Note:** 2U of space is reserved above the PDUs for cable routing. The number and type of PDUs depends on the power supply. If more PDUs are needed, or when you need to add additional components into the rack (such as adding another Slammer), then everything has to move up to make room, keeping the 2U of reserved space, and moving any Bricks displaced at the top to the next rack.

Figure 13 Fully loaded 42U racks for one Slammer and 32 SATA Bricks

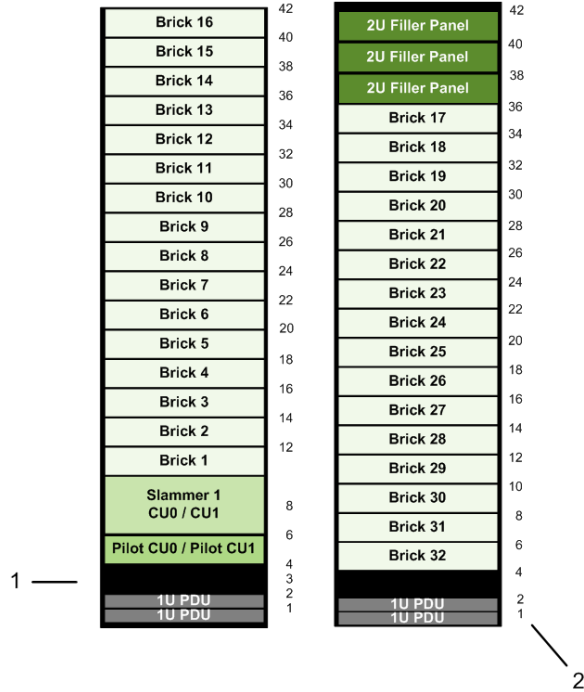

**Legend**

1	Reserved for PDU cable routing
2	RU locators

**Note:** Brick names are just for illustration; actual names, as seen in the AxiomONE Storage Services Manager, may be different.

**Note:** In a system that is configured for the maximum number of Bricks, connect the additional racks to the first rack before you install and cable the hardware components.

## About Component Placement for One Slammer and FC Bricks

A Pillar Axiom system with one Slammer supports up to 16 FC Bricks. Install the components in the rack as shown in the figure below. Any components that are not installed must be replaced with filler panels.



Figure 14 Fully loaded 42U rack for one Slammer and 16 FC Bricks

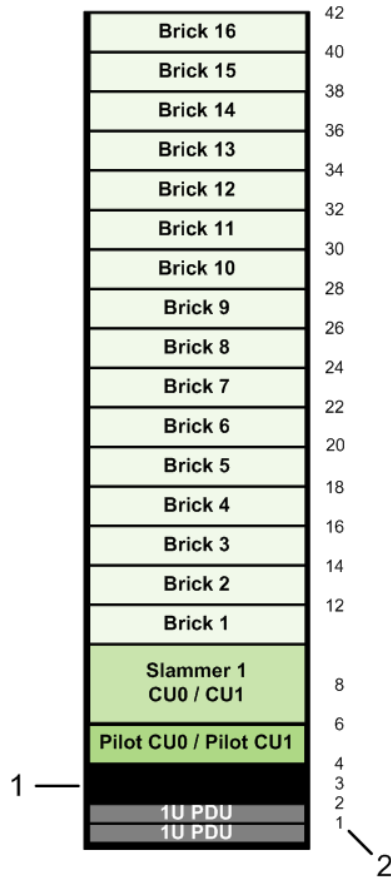

**Legend**

1	Reserved for PDU cable routing
2	RU locators

The figure above illustrates how the Pillar Axiom storage system components are mapped into a fully loaded 42U rack for the following configuration:

- 1 Pilot
- 1 Slammer
- 16 FC Bricks

**Note:** 2U of space is reserved above the PDUs for cable routing. The number and type of PDUs depends on the power supply. If more PDUs are needed, or when you need to add additional components into the rack (such as adding another Slammer), then everything has to move up to make room, keeping the 2U of reserved space, and moving any Bricks displaced at the top to the next rack.

**Note:** Brick names are just for illustration; actual names, as seen in the AxiomONE Storage Services Manager, may be different.

For information on larger FC configurations, go to [About Component Placement for Two or Three Slammers and FC Bricks](#) and [About Component Placement for 4 Slammers and 64 Bricks](#).

## About Component Placement for Two or Three Slammers and FC Bricks

A Pillar Axiom system with two or three Slammers supports up to 32 FC Bricks. Install the components in the rack as shown in the figure below. Any components that are not installed must be replaced with filler panels.

The figure below illustrates how the Pillar Axiom storage system components are mapped into fully loaded 42U racks for a configuration of:

- 1 Pilot
- 3 Slammers
- 32 FC Bricks

**Note:** 2U of space is reserved above the PDUs for cable routing. The number and type of PDUs depends on the power supply. If more PDUs are needed, or when you need to add additional components into the rack (such as adding another Slammer), then everything has to move up to make room, keeping the 2U of reserved space, and moving any Bricks displaced at the top to the next rack.

If only two Slammers are being installed, replace Slammer 3 with two filler panels.

Figure 15 Fully loaded 42U racks for three Slammers and 32 FC Bricks

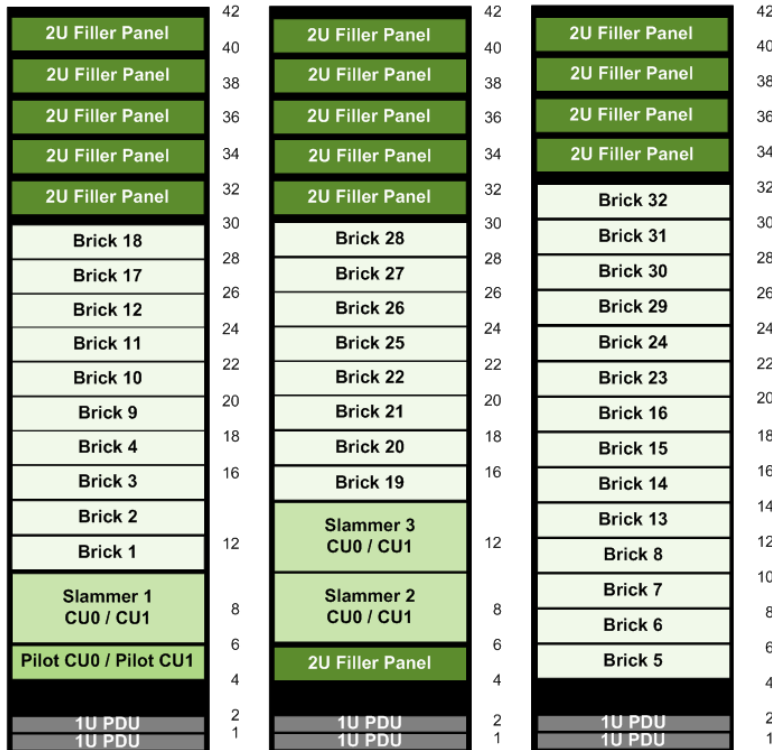

**Note:** Brick names are just for illustration; actual names, as seen in the AxiomONE Storage Services Manager, may be different.

**Note:** In a system that is configured for the maximum number of Bricks, connect the additional racks to the first rack before you install and cable the hardware components.

For information on 4-Slammer FC systems, go to [About Component Placement for 4 Slammers and 64 Bricks](#). For information on a 1-Slammer FC system, go to [Sample Power Scheme for One Slammer and 16 SATA Bricks](#).

## About Component Placement for 4 Slammers and 64 Bricks

A Pillar Axiom system with four Slammers supports up to 64 FC or SATA Bricks. Install the components in the rack as shown in the figure below. Any components that are not installed must be replaced with filler panels.

The figure below illustrates how the Pillar Axiom storage system components are mapped into a fully loaded 42U racks for the maximum configuration of:

- 1 Pilot

- 4 Slammers
- 64 FC or SATA Bricks

When using SATA Bricks, this configuration can use as few as two Slammers. Replace the empty spaces for the missing Slammers with filler panels. If less than four Slammers are being used with FC Bricks, go to [About Component Placement for Two or Three Slammers and FC Bricks](#) for more information.

**Note:** 2U of space is reserved above the PDUs for cable routing. The number and type of PDUs depends on the power supply. If more PDUs are needed, then everything has to move up to make room, keeping the 2U of reserved space, and moving any Bricks displaced at the top to the next rack.

Figure 16 Fully loaded 42U racks for four Slammers and 64 Bricks

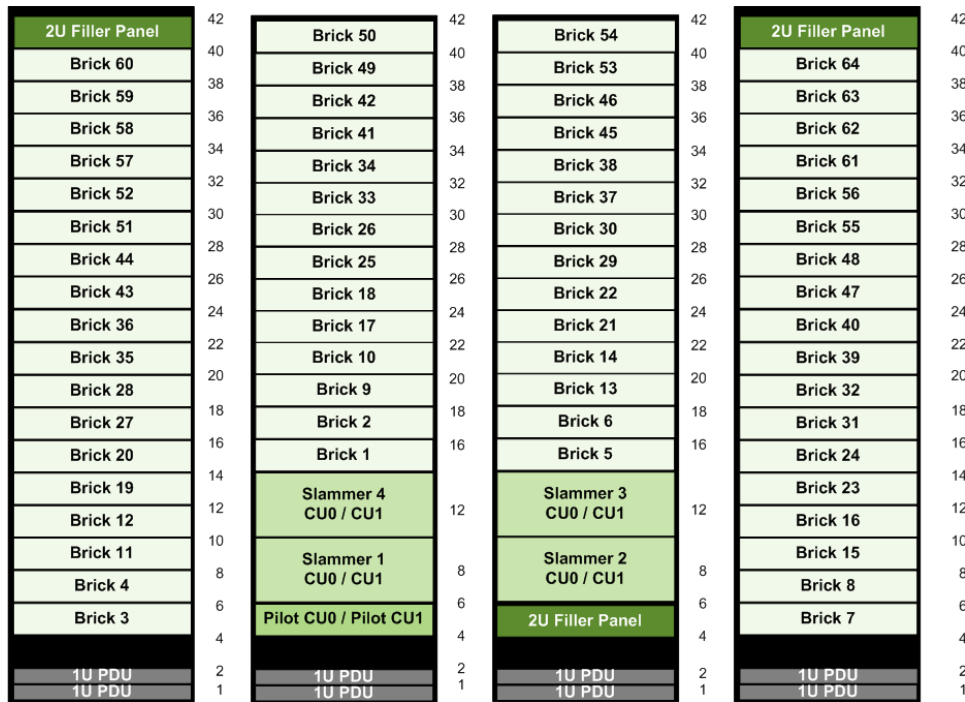

**Note:** Brick names are just for illustration; actual names, as seen in the AxiomONE Storage Services Manager, may be different.

**Note:** In a system that is configured for the maximum number of Bricks, connect the additional racks to the first rack before you install and cable the hardware components.

## Pilot Rail Kit Parts



Verify that the rail kit contains all the parts listed in the table.

Before installing a pair of Pilot rack rails, make sure you have:



- One Pilot rail kit with rails and scopes pre-attached
- #20 Torx wrench
- Socket wrench

Pilot rails are 2U rack rail assemblies that contain the following parts:

**Table 5 Pilot rail kit parts**

Component	Drawing (not to scale)	Quantity
Pilot rail kit s 1475-00036-xx 1450-00037-xx		One left-right pair per kit.
Pilot rail scopes 2525-00093-xx 2525-00095-xx		One left-right pair per kit.
10-32 Hex nuts for attaching scopes to rails 2500-01051-xx		Eight per kit.

**Table 5 Pilot rail kit parts (continued)**

Component	Drawing (not to scale)	Quantity
Rack mount spacers 2500-01065-xx		Four per kit.
Rack mount nut bar 2526-00106-xx		Two per kit.
10-32 x 1/2 in Torx head (#20) screws 2500-01071-xx		12 per kit.

## Install a Pair of Pilot Mounting Rails

- 1 Hang the scope hook in the appropriate hole at the back of the rack, as shown below:

Figure 17 Scope hook attachment

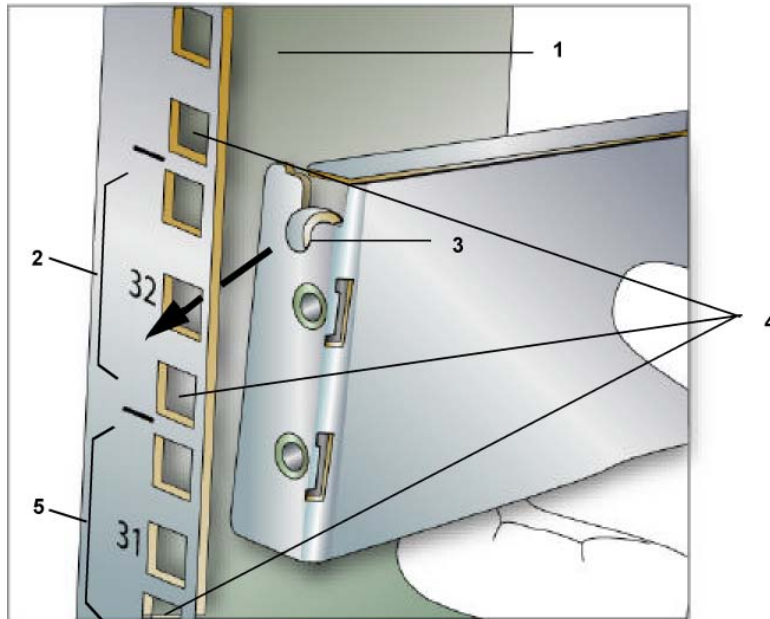

Legend

1	Vertical rail at back of rack
2	Unit 32
3	Scope hook
4	Bottom holes for each unit
5	Unit 31

In the figure above, two labeled rack units, 31 and 32, are shown at the back of the rack.

- The bottom of unit 31 is just out of sight below its bottom hole.
- The scope hook is one-and-a-half units above the bottom of the rail.
- When you place the hook in the middle of unit 32, the bottom of the rail lines up with the bottom of unit 31.
- A 2U Pilot rail would fill units 31-32 in the above illustration.

- 2 At the front of the rack, slide the rail scopes until the rail reaches the holes at the front. The rail flange goes in front of the rack mount holes, and the four-hole spacer bar goes behind, as shown below.
- 3 Making sure the rail is horizontal, fit the four-hole spacer bar into the four square rack holes that span the boundary between the two units this rail is to occupy. The figure below shows positioning a spacer for units 35 and 36.

Figure 18 Positioning spacer bar

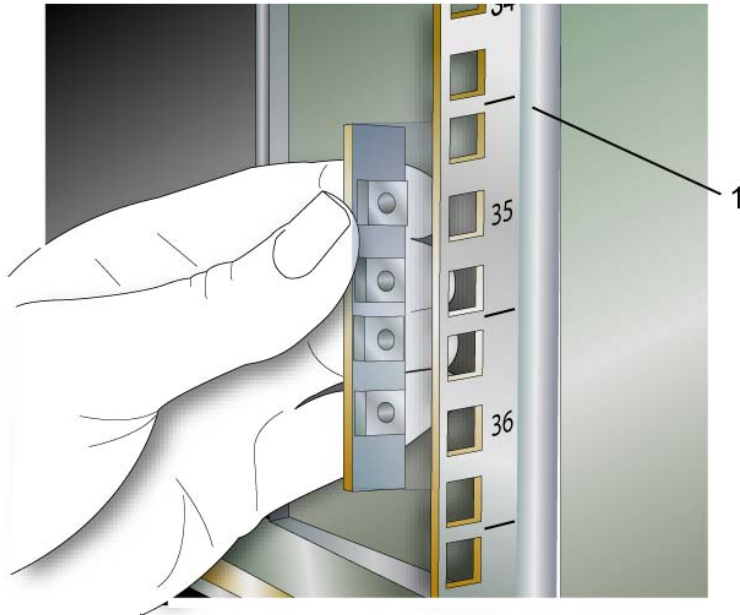

**Legend**

1 Unit boundary
-----------------

Figure 19 Pilot rail front attachment

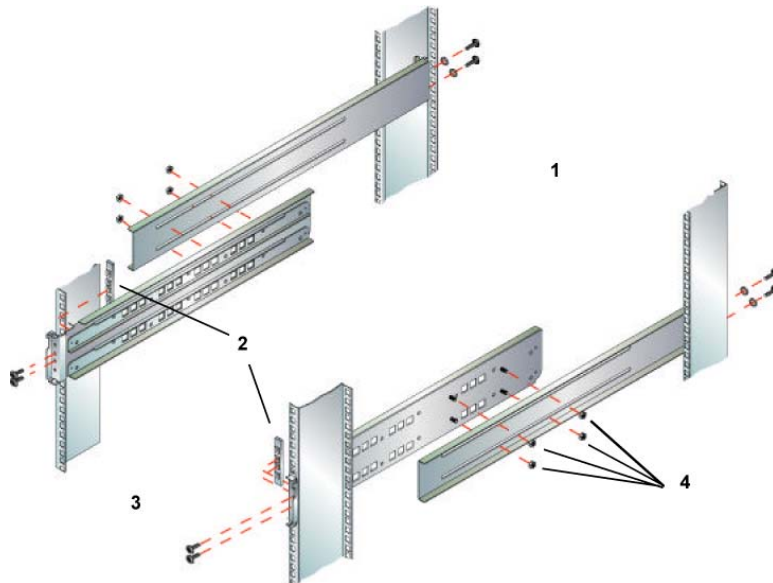

**Legend**

1 Rear
2 Four-hole spacer bars
3 Front
4 Slider lock nuts



- 4 Use two #20 Torx screws to secure the rail, through the rack into the spacer bar. Repeat this for a second screw in the front, as shown above. Use the center holes. The top and bottom holes are for securing the Pilots to the rack.
- 5 At the back, place a spacer on a #20 Torx screw and screw it through the hole in the rear frame and into the rail under the scope hook. Install the second screw the same way.
- 6 Repeat steps 1-4 for the other side rail.
- 7 Tighten the four slider lock nuts that attach each rail scope to the rail.

## Slammer Rail Kit Parts

Verify that the rail kit contains all the parts listed in the table.

To install a pair of Slammer rails, you need:

- One Slammer rack rail kit with rails and scopes pre-attached
- #20 Torx wrench
- Socket wrench

Slammer rails are 4U rack rail assemblies that contain the following parts:

**Table 6 Slammer rail kit parts**





Component	Drawing (not to scale)	Quantity
Slammer rails 1475-00024-xx 1475-00025-xx		One left-right pair per kit.
Slammer rail scopes 2525-00093-xx 2525-00095-xx		One left-right pair per kit.

Table 6 Slammer rail kit parts (continued)

Component	Drawing (not to scale)	Quantity
10-32 Hex nuts for attaching scopes to rails 2500-01051-xx		Eight per kit.
Rack mount spacers 2500-01065-xx		Eight per kit.
10-32 x 1/2 in Torx head (#20) screws 2500-01071-xx		Ten per kit.

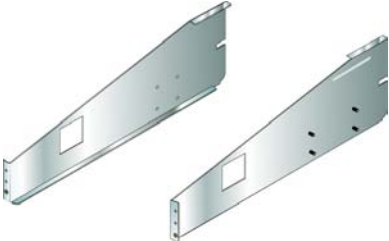
## Install a Pair of Slammer Mounting Rails

- 1 Hang the scope hook in the appropriate hole at the back of the rack, as shown below. These rail scopes are always used for components that take up at least two rack units.

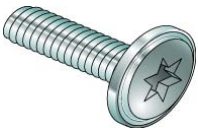
Figure 20 Scope hook attachment

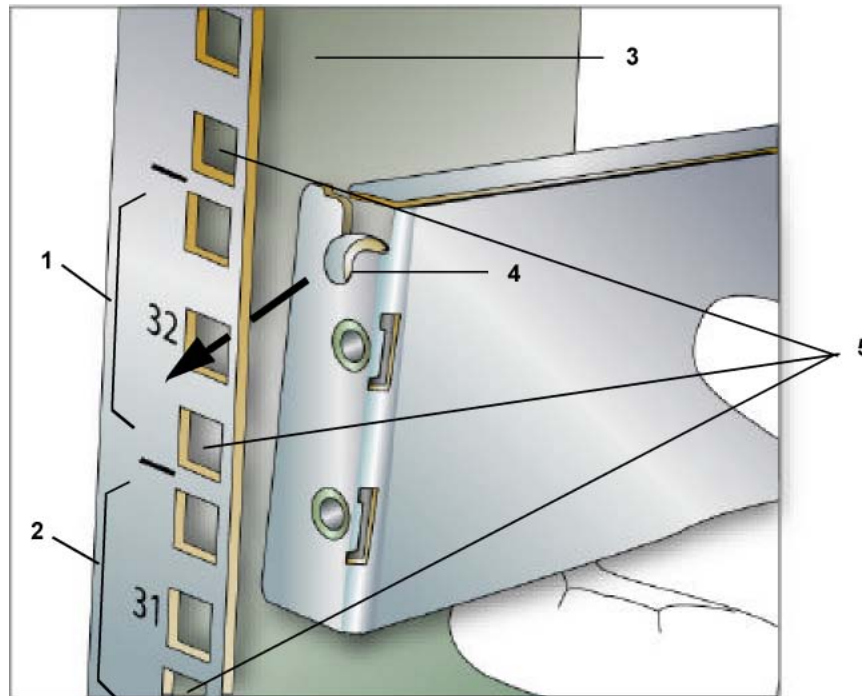

**Legend**

1 Unit 32
2 Unit 31
3 Vertical rail at back of rack
4 Scope hook
5 Bottom holes for each unit

In the figure above, two labeled rack units, 31 and 32, are shown at the back of the rack.

- The bottom of unit 31 is just out of sight below its bottom hole.
  - The scope hook is one-and-a-half units above the bottom of the rail.
  - When you place the hook in the middle of unit 32, the bottom of the rail lines up with the bottom of unit 31.
  - A 4U Slammer rail would fill units 31-34 in the above illustration.
- 2 At the front of the rack, slide the rail scopes until the rail reaches the holes at the front.
  - 3 Making sure the rail is horizontal, place a spacer on a #20 Torx screw and screw it through the bottom hole in the front frame and into the rail, as shown in the next figure. Repeat this for the hole above it (but not the top hole, which is for securing the Slammer).

- 4 Secure the screws at the back, under the scope hook.
- 5 Repeat steps 1-4 for the other side rail.

Figure 21 Slammer rails installed in rack

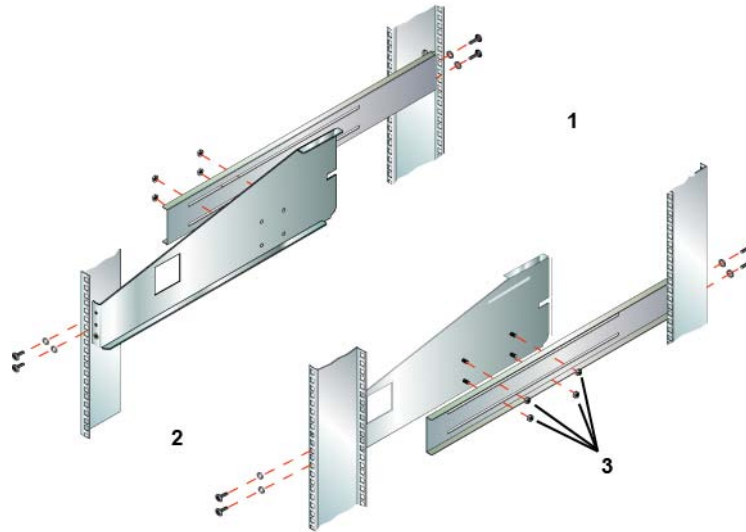

### Legend

1 Rear
2 Front
3 Slider lock nuts

- 6 Tighten the four slider lock nuts that attach each rail scope to the rail.

## Brick Rail Kit Parts



Verify that the rail kit contains all the parts listed in the table.

To install a pair of 2U rack rails, you need:

- One Brick rail kit with rails and scopes pre-attached
- #20 Torx wrench
- Socket wrench

Brick rails are 2U rack rail assemblies that contain the following parts:

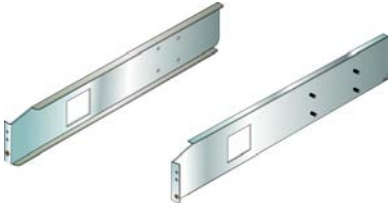
**Table 7 Brick rail kit parts**

Component	Drawing (not to scale)	Quantity
Brick rails 1450-00022-xx 1450-00023-xx		One left-right pair per kit.
Brick rail scopes 2525-00093-xx 2525-00095-xx		One left-right pair per kit.
10-32 Hex nuts for attaching scopes to rails 2500-01051-xx		Eight per kit.
Rack mount spacers 2500-01065-xx		Four per kit.
10-32 x 1/2 in Torx head (#20) screws 2500-01071-xx		Ten per kit.

## Install a Pair of Brick Mounting Rails

- 1 Hang the scope hook in the appropriate hole at the back of the rack, as shown below. These rail scopes are always used for components that take up at least two rack units.

Figure 22 Scope hook attachment

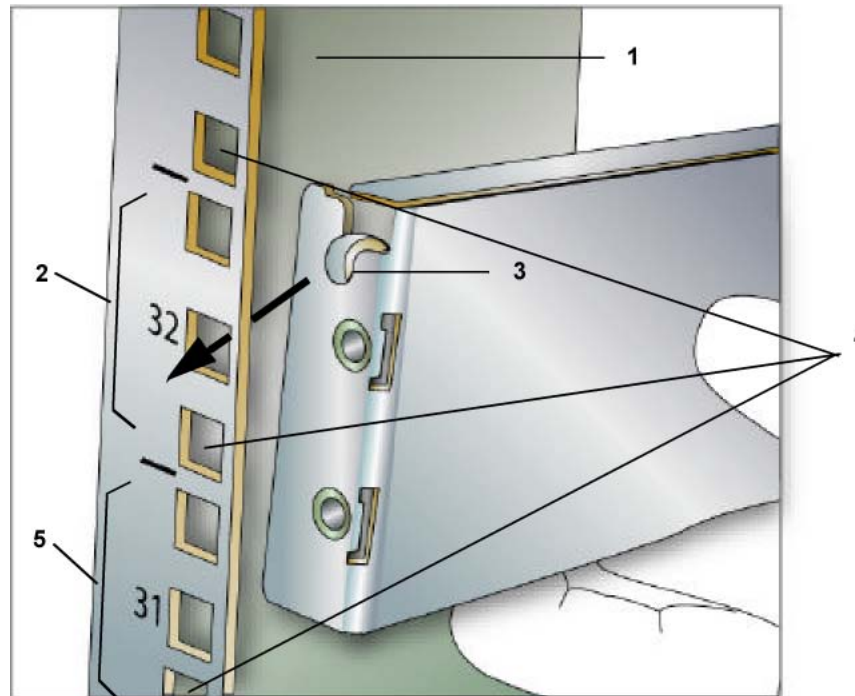

### Legend

1	Vertical rail at back of rack
2	Unit 32
3	Scope hook
4	Bottom holes for each unit
5	Unit 31

In the figure above, two labeled rack units, 31 and 32, are shown at the back of the rack.

- The bottom of unit 31 is just out of sight below its bottom hole.
  - The scope hook is one-and-a-half units above the bottom of the rail.
  - When you place the hook in the middle of unit 32, the bottom of the rail lines up with the bottom of unit 31.
  - A 2U Brick rail would fill units 31-32 in the above illustration.
- 2 At the front of the rack, slide the rail scopes until the rail reaches the holes at the front.
  - 3 Making sure the rail is horizontal, place a spacer on a #20 Torx screw and screw it through the center hole in the front frame and into the rail, as shown in the next figure. Repeat this for the other center screw in the front and the screws at the back, under the scope hook.

The square hole in the front is at the top on the left side and at the bottom on the right side. These square holes are for securing the Brick. Use only the round holes to secure the rails into the rack.

Figure 23 2U rack rails installed in rack

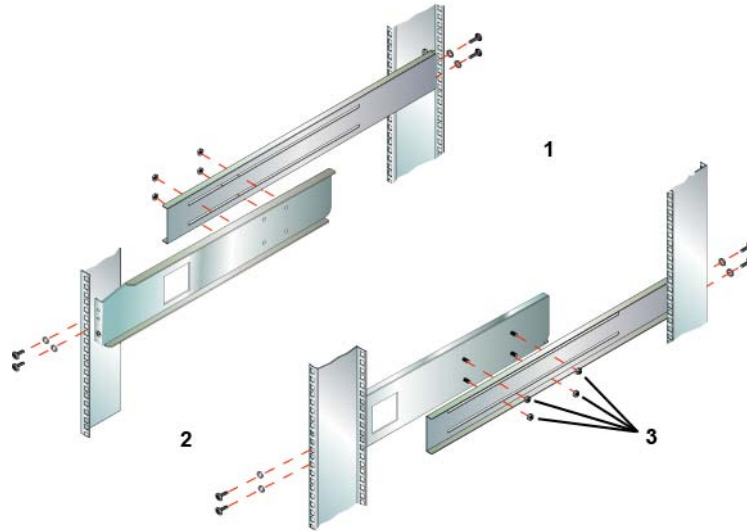

### Legend

1 Rear
2 Front
3 Slider lock nuts

- 4 Repeat steps 1-3 for the other side rail.
- 5 Tighten the four slider lock nuts that attach each rail scope to the rail.

## CHAPTER 3

# Install Components

## About Power Distribution Unit Installation

Mount power distribution units (PDUs) in the bottom units of the rack. The default configuration places up to four 1U 220 V/30 A PDUs at the bottom of the rack.

To install a PDU, you need:

- A 1U or 2U PDU.
- #2 Phillips-head screwdriver.
- Four snap-in cage nuts (for square mounting holes) or four clip-on cage nuts (for round mounting holes).
- Four 10-32 x ½ in screws.

**Important!** We strongly recommend that you use PDUs from Pillar Data Systems. If you install non-Pillar PDUs, they must meet the Pillar Data Systems PDU specification, as described in the *Pillar Axiom Site Preparation Survey*.



## Install a 1U PDU

- 1 Choose one of the following options:
  - For square mounting holes, snap a 10-32 snap-in cage nut into the bottom and 3rd hole of each channel.

Figure 24 Snap-in cage nut

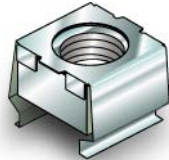

- For round mounting holes, clip one 10-32 clip-on cage nut into the bottom and 3rd holes of each channel in the pair. (Pillar Data Systems does not provide clip-on cage nuts.)
- 2 Insert the PDU into the rack, as shown below. There are no rails for a PDU.

Figure 25 Securing a 1U PDU in the bottom of a rack



- 3 Align the ears of the PDU to the four cage nuts.

- 4 Insert a 10-32 x 1/2 in screw through the top and bottom holes in the right and left ears of the PDU and into the cage nuts. Secure both screws tightly.

Figure 26 An installed PDU at the bottom of the rack

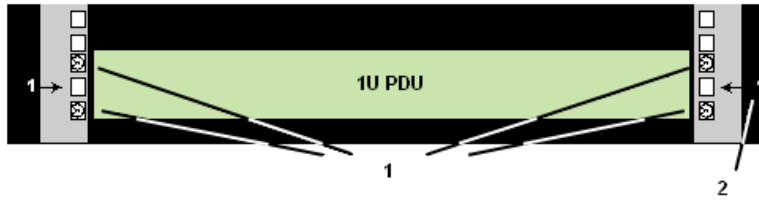

### Legend

1 10-32 x 1/2 screws
2 RU marker

**Important!** Do not plug the PDU into a power supply until the rack is complete and ready for startup.

- 5 Repeat this procedure to install any other PDUs.

## Install a 2U PDU

- 1 For square or round mounting holes:
  - Insert one 10-32 snap-in cage nut into the 3rd hole from the bottom of each channel in the pair.
  - Insert one 10-32 snap-in cage nut into the 7th hole from the bottom of each channel in the pair.
- 2 Align the slots in the PDU ears to the four cage nuts.
- 3 Insert a 10-32 x ½ in screw through the bottom hole in the right and left ears of the PDU and into the cage nuts. Secure both screws tightly.
- 4 Repeat Step 3 for the top holes in both ears.

**Important!** Until you are instructed to do so, do not plug the PDU into an inlet power supply.

## About Installation

Install the Pilot at the bottom of the rack, just above the PDUs. This placement makes installation and future expansion as efficient as possible.



Ensure that component distribution in the rack is balanced. Follow the hardware placement map to ensure this balance. Uneven distribution can cause hazardous instability. The rack must have stabilization plates or anti-tip brackets installed so the rack does not tip when you install a component.



Mounting rail assemblies must be used to support and secure a Pilot in the rack. The Pilot's mounting ears by themselves will not support the weight of the Pilot.

## Install a Pilot

- 1 Put on an antistatic wrist strap and attach the grounding wire to ground.
- 2 From the front of the rack, place the back side of the first Pilot server component on the bottom mounting rails and slide it into place.

**Important!** When sliding a Pilot CU into the rack, keep it level to avoid bending the rail supports.

- 3 Insert the other Pilot CU above it, as shown below.

Figure 27 Inserting the upper Pilot CU



- 4 Use a 10-32 Torx screw through the hole in each Pilot CU ear and screw it in securely with a #20 Torx wrench.

**Important!** Do not plug the chassis into a PDU until instructed to do so.



Never block the inlet and outlet holes in the chassis components. Sufficient air circulation is required for the components to operate properly and to avoid a fire hazard. Do not push objects of any kind into the ventilation holes. Such action could result in fire or electrical shock. Keep all liquids away from hardware components.

## About Slammer Installation

Install the Slammers above the Pilot.



A Slammer weighs 94 lb (42.6 kg). For safe handling, use two people to lift it.



Ensure that component distribution in the rack is balanced. Follow the hardware placement map to ensure this balance. Uneven distribution can cause hazardous instability. The rack must have stabilization plates or anti-tip brackets installed so the rack does not tip when you install a component.

## Install a Slammer

- 1 Put on an antistatic wrist strap and attach the grounding wire to ground.
- 2 From the front side of the rack, set the back of the Slammer onto the mounting rails and slide the Slammer into place. Leave about one inch (2.5 cm) of clearance between the Slammer's ears and the vertical channels.

**Important!** When sliding the Slammer into the rack, keep it level to avoid bending the rail supports, which would make it difficult to insert a component below.

Figure 28 Inserting a Slammer

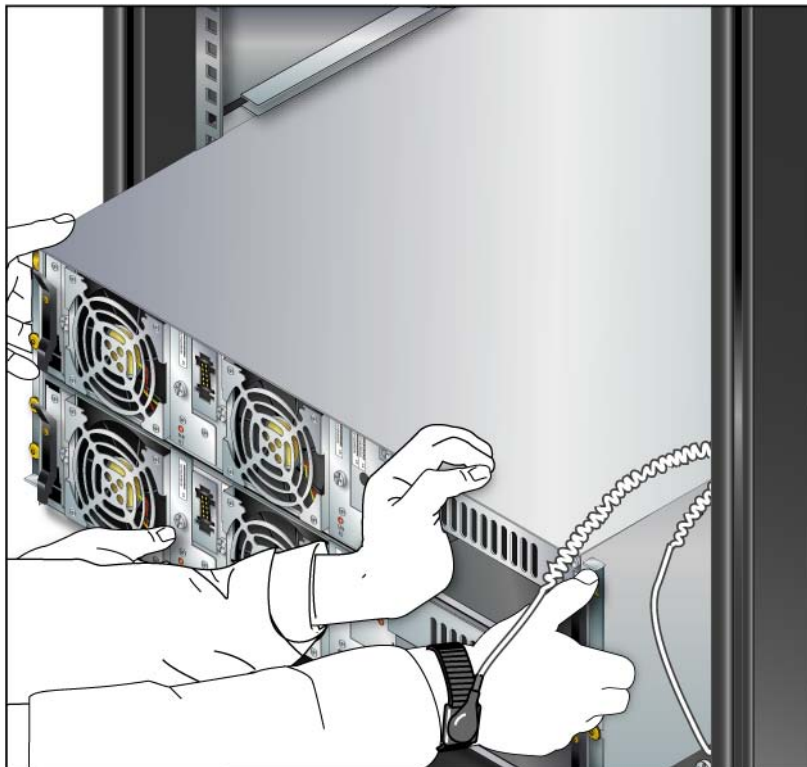

- 3 Put a spacer on a 10-32 x 1/2-in Torx screw, then insert the screw through the hole in the ear on the left side of the Slammer. This spacer helps to center the Torx screw in the hole.
- 4 Push the Slammer so that its ears and the spacers rest against the vertical channels and start the Torx screws with your fingers.
- 5 Use a #20 Torx wrench to secure the screws to the rack.

**Note:** This step only keeps the Slammer in place; the screws provide no other support.



- 6 Repeat Steps 3-6 for the right side of the Slammer.

If you have a two, three, or four Slammer system, install the remaining Slammers now.

**Important!** Do not apply power to the Slammer until instructed to do so.

## Install a Brick

Pillar Data Systems packages and ships the Bricks separately from the system. As you install the Bricks, work from the bottom of the rack toward the top. If you have additional racks of Bricks, work from the top down.

- 1 Put on an antistatic wrist strap, ground strap, or heel strap, and attach the grounding wire to a ground.
- 2 At the front of the rack, insert the Brick onto the mounting rack rails and slide into place.



Before you handle a component, make sure that you have taken electrostatic discharge precautions:

- The minimum requirement is an anti-static wrist strap connected to a hard ground. We recommend that you remove components from their packaging and place them on an ESD-qualified table equipped with ground points for wrist straps.
- Static charges can build up rapidly on rolling carts. If you transport a hardware component by cart, ground the cart with a drag chain on an ESD floor. If there is no ESD cart available or ESD floor, ground yourself before you touch a component that has been transported on a cart.

**Important!** When you slide the component into the rack, keep it level to avoid bending the rail supports, which would make it difficult to insert a component below.

Figure 29 Inserting a Brick

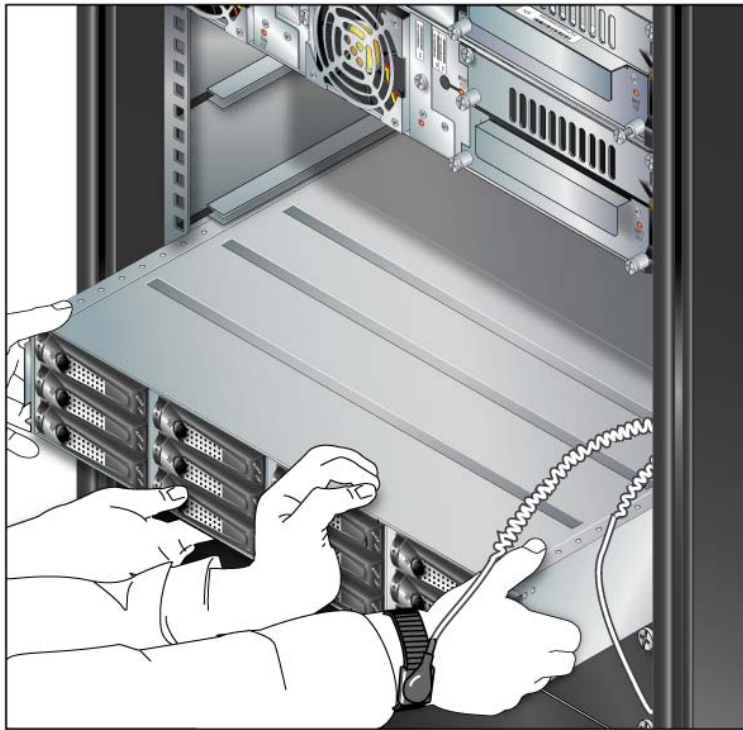

- 3 Use two, 10-32 Torx screws (two on each side) and a Torx T20 driver to secure the Brick ears to the rack.

**Important!** Use care as you install the screws on the right to avoid damaging the printed circuit, which provides power and signals to the Brick bezel.

Figure 30 Brick ears

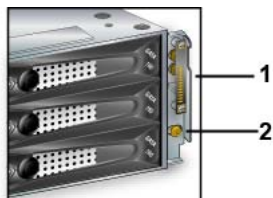

**Legend**

1 Printed circuit assembly
2 10-32 screw

- 4 Inspect the disk drives to ensure each drive is flush and securely seated.
  - Fully open the cam latch on the disk drive carrier.
  - Press the disk drive carrier into the Brick chassis until it stops.

- Close the cam latch until it snaps shut to engage the disk drive with the Brick midplane.

Figure 31 Brick front

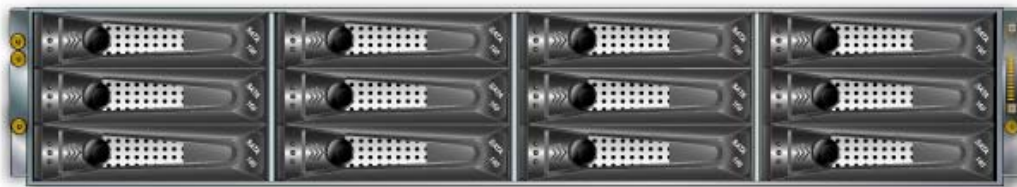

- 5 If you have multiple Bricks, install them all now, even those that require additional racks.

## Install the Slammer Batteries

Slammer batteries are shipped separately. Use the procedure below to install them.

- 1 Ensure the installation dates on the Slammer batteries have not expired.  
The expiration date is printed on the label on top of the battery. If a battery has expired, contact Technical Support.
- 2 Slammer batteries install from the front of the Slammer, so you have to remove the front cover (bezel).  
If the bezel is not attached, skip to step 5.
- 3 Press the Slammer ejector tabs on the bezel to unlock them.
- 4 Lift both ejector tabs to disengage the bezel from the rack.

Figure 32 Slammer bezel removal



### Legend

1 Ejector tab button
2 Disengage the bezel from the rack
3 Bezel hooks

- 5 Insert the batteries into the Slammer, but do not secure them until you complete the installation. When you secure them, they start to discharge as they preserve data in memory. Since there is no data to preserve, you should wait until you are ready to power the system before securing the batteries.

Figure 33 Slammer battery insertion

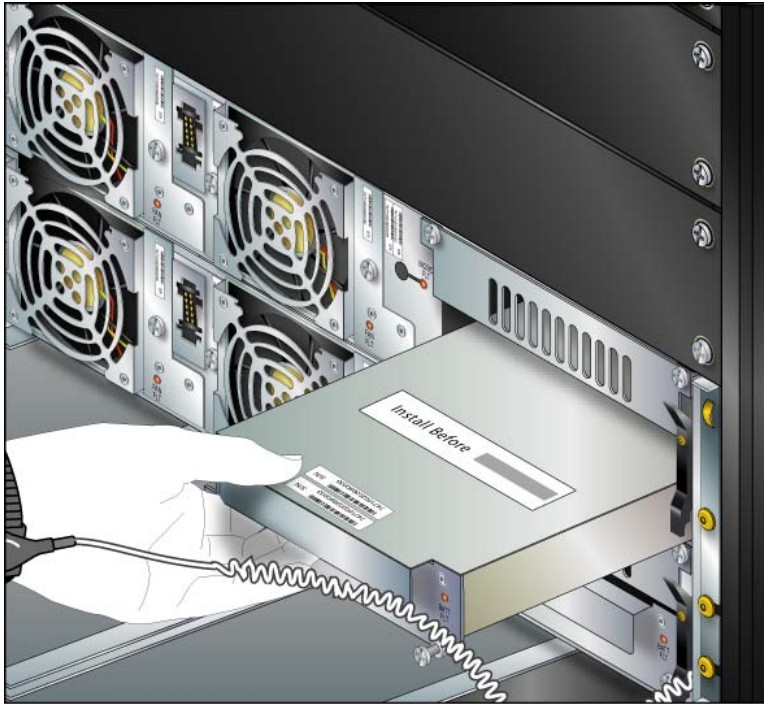

## CHAPTER 4

# Connect Data Cables

## About Data Cabling the Pillar Axiom System

The Pillar Axiom system transmits data between its components through the Storage System Fabric (SSF) and the Private Management Interface (PMI). The Pillar Axiom system can be any component combination of:

- One Pilot.
- One to four Slammers.
- One to 64 Bricks.

The SSF and PMI cables provide the data connections among the Bricks, Slammers, and Pilots to support all data and management traffic.

All of the possible PMI and SSF data cable combinations that can be installed in the Pillar Axiom system are fully detailed in the *Pillar Axiom 500 SSF Cabling Reference*. Use the information in that guide to install the data cables for your components.

Once you have completed cabling the SSF and PMI, go to [Connect the Pillar Axiom System to Your Network](#).

## Summary of Cabling Rules

These cabling rules describe fundamental principles that need to be applied when cabling Fibre Channel and SATA Bricks in a Pillar Axiom 500 system.

**Note:** Future releases of the Pillar Axiom storage system will change some of these rules.

- A string is a collection of Bricks connected together. The head of the string connects to two Slammer ports. Each of the other Bricks in the string are connected to the previous Brick in the string.
- Strings contain combinations of FC RAID Bricks, FC Expansion Bricks, and SATA Bricks.
- A string may contain up to eight Bricks.
- A string may contain up to four FC Bricks.
- FC RAID Bricks and SATA Bricks can be connected to Slammer ports. FC RAID Bricks and SATA Bricks can also be connected to other Bricks, which directly or indirectly connect to Slammer ports.
- 1-Slammer systems have at most four strings. Multi-Slammer systems have at most eight strings.
- Systems that have been upgraded by adding an additional Slammer can run with the number of strings appropriate to the prior configuration.
- Add Bricks to strings so that the number of Bricks in any string differs by no more than two between the longest and the shortest strings.
- When adding SATA or FC RAID Bricks to a string, attach them to the last SATA or FC RAID Brick on that string.
- When adding SATA Bricks to a Pillar Axiom system that previously had only FC Bricks, add all the SATA Bricks before you respond to the "Media Placement Recommendations" Administrator Action item.
- FC RAID Bricks use Slammer ports in the same order as the scheme for connecting SATA Bricks. This scheme fosters balance among the strings while maintaining predictable assignment of Bricks to strings. A given Brick will always be on a particular string with particular Slammer ports. The same cable labels are used for SATA and FC RAID Bricks.



- Brick CU-0 upstream ports are connected to Slammer CU-0 ports or the CU-0 downstream ports of another Brick; likewise, Brick CU-1 ports are connected to Slammer CU-1 ports or Brick CU-1 ports.
- FC Expansion Bricks are connected to FC RAID Bricks using the J0, J1, and Pnet ports. The current release restricts FC Brick deployment to zero or one FC Expansion Brick on each FC RAID Brick.
- FC RAID Bricks can be configured alone or in pairs of one FC RAID Brick and one FC Expansion Brick.
- Systems upgraded in the field may have a configuration different from those built in the factory.
- For systems built at the factory, strings that mix SATA Bricks and FC Bricks will have the FC RAID Bricks closest to the Slammer. Field upgrades may differ—newly added Bricks can be connected to the last FC RAID or SATA Brick at the end of existing strings.
- FC RAID Bricks and FC RAID + Expansion pairs may be added to a running system as long as they are cabled within the rack, powered on, and have completed initialization prior to connecting them to the existing configuration.

**Tip:** After RAID controllers finish initializing, scrubbing normally starts on the disk drives. Scrubbing causes all the disk drive LEDs to blink rapidly.

**Important!** When adding FC RAID + Expansion pairs, cable all the links between the new Bricks, power them up, allow them to initialize, and then add the links to the previously running system.

- In 3- and 4-Slammer configurations, each Brick must connect to the Slammers as follows:
  - 3-Slammer configuration: Connect to Slammer 1 or Slammer 3 *and* to Slammer 2.
  - 4-Slammer configuration: Connect to Slammer 1 or Slammer 2 *and* to Slammer 3 or Slammer 4.

**Tip:** To maximize performance and avoid having a Slammer control unit traverse an inter-switch link to get to the Brick, be sure the above conditions are met.

## Connect the Pillar Axiom System to Your Network

To connect the system to your network:

- 1 Connect the management (MGMT) ports to the Ethernet LAN on which the management console resides.

Figure 34 Pilot management cables

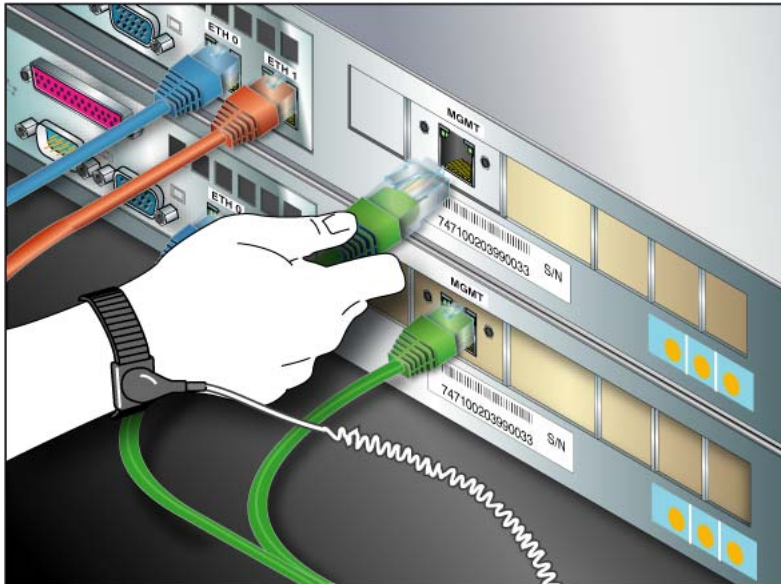

- 2 For 2-port NAS Slammers, connect gigabit Ethernet (GbE) cables from the network interface module (NIM) ports on the Slammer to any open data ports available on two separate gigabit Ethernet network switches. For 4-port GbE NAS Slammers, connect the NIM ports to four separate network switches.

For SAN Slammers, connect Fibre Channel cables from the NIM ports on the Slammer to any open data ports available on two separate FC network switches.

## Pilot Network Requirements

The Pilot requires:

- Two 100 BaseT ports for the public connection to the management network. For added redundancy, the two connections should be to separate switches. The Pillar Axiom system provides a standard Cat 5 RJ-45 jack on each Pilot control unit (CU) for this connection.

- The external switch ports must be set to auto-negotiation for the Pilot interfaces.
- Three IP addresses on the same subnet: one IP for each physical interface and one shared IP.

**Note:** VLAN tagging is not supported on the management interfaces.

The AxiomONE Path Manager (APM) communicates with the Pilot over secure, encrypted XML. If the APM is installed on a SAN host, that host will require an Ethernet interface for communication with the AxiomONE Storage Services Manager. The network configuration must allow the SAN host to reach the Pilot management IP Ethernet interfaces.

## Slammer Network Requirements

NAS data paths require gigabit Ethernet connections. Both fiber and copper are supported.

SAN data paths require 1 Gbps, 2 Gbps, or 4 Gbps Fibre Channel (optical) connections, which can be single- or multi-mode.

The type of connection should be specified when ordering your Pillar Axiom system. Contact your Account Representative if you need to change the type of physical connection for either Gigabit or Fibre Channel.

## CHAPTER 5

# Connect Power Cables

## Connect Power Cables

If you are using Pillar Data Systems racks, the system comes with all the components and power supplies (power distribution units or PDUs) already installed in the rack. When you ordered the system you specified the type of power (voltage, amperage, and phases), which determines the type of electrical service outlets you have at your facility. The plugs on the PDUs you ordered have been installed to match these outlets.

Use the following procedure to connect the component's power cables and power cables that were not pre-installed:

- 1 Review the Pillar Axiom power requirements in [About Component Power Usage](#) and in [PDU Outlet Amperage Limits](#).
- 2 Review the information in [About Power Cabling](#) and verify your PDUs meet the electrical requirements.
- 3 Plug in your system components so that no PDU amperage limits are exceeded.
- 4 Dress all cables to the opposite side of the rack from any data cables.
- 5 Secure the power cables to the rack such that they do not restrict the removal of any other component.

**Important!** You should not turn on any power circuits until the installation is complete and all network cables are in place. Powering on the system is described in [Complete the Installation](#).

## About Component Power Usage

The components must be plugged in to the PDUs such that they do not exceed the amperage rating of any outlet group. If you exceed the amperage rating, the circuit breakers trip.

Except where indicated, the maximum rated amperage of the outlet banks remains the same regardless of the electrical service voltage. Therefore, if you are using 230V service, components draw half the amperage as when powered by 115V and you can plug more components into each PDU.

This table lists the maximum electrical requirements of the basic Pillar Axiom components. Each component has redundant power cords plugged into different PDUs on separate circuits.

**Table 8 Pillar Axiom component electrical requirements**

Component	Amps at 115V	Amps at 208V	Amps at 230V	Power (watts)
Slammer	6.10 A	3.29 A	3.05 A	685 W
SATA Brick	2.55 A	1.22 A	1.17 A	255 W
FC Brick	3.35 A	1.59 A	1.49 A	330 W
Pilot	2.49 A	1.37 A	1.24 A	286 W

With redundant power supplies, the amperage draw for each power cord is rated for the case when one circuit fails, which increases the amperage draw on the other cord.

## PDU Outlet Amperage Limits

The number of Axiom system components you can plug into each Pillar-supplied PDU varies. This section discusses each PDU.

The Pulizzi TPC2105 (see the figure below) can use 115 V or 230 V, 30 A electrical service. The amperage limits are the same at either input voltage.

Figure 35 Pulizzi TPC2105-1 outlet amperage limits

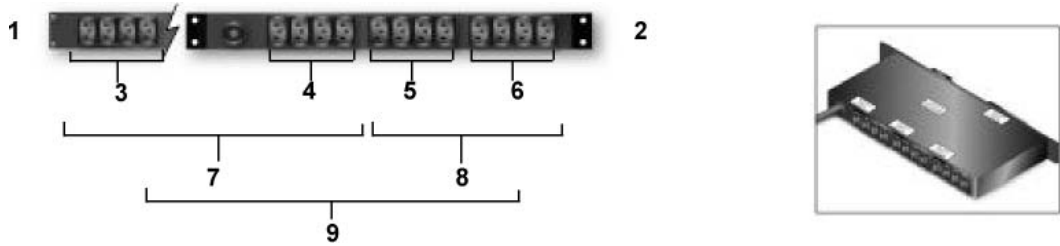

### Legend

1 Front	6 Supports 10 A
2 Rear	7 Supports 12 A
3 Supports 10 A	8 Supports 12 A
4 Supports 10 A	9 Supports 24 A maximum across all outlets
5 Supports 10 A	

The Pulizzi TPC2104 (see the figure below) can use 115 V or 230 V 20 A electrical service. The amperage limits per four-outlet group are different for 115 V and 230 V, but the overall amperage limit is 16 A regardless of the input voltage.

Figure 36 Pulizzi TPC2104 outlet amperage limits

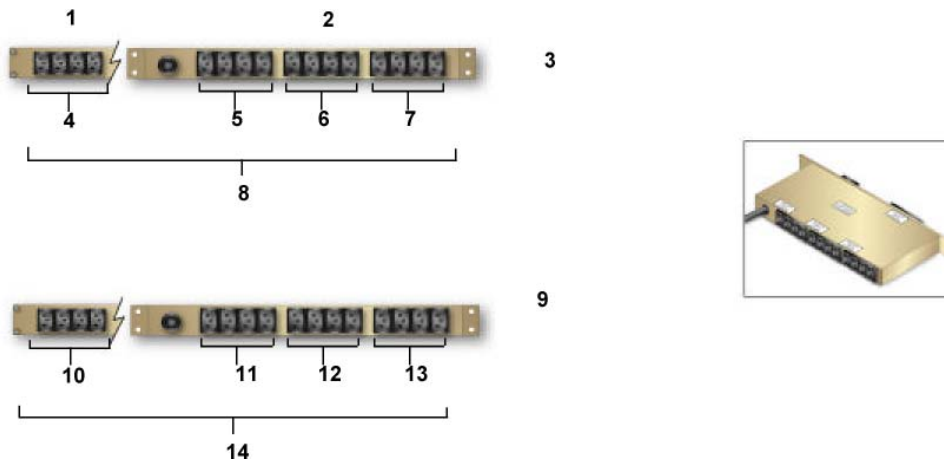

Legend

1 Front	8 Supports 16 A maximum across all outlets
2 Rear	9 Supports 115 V
3 Supports 230 V	10 Supports 15 A
4 Supports 10 A	11 Supports 15 A
5 Supports 10 A	12 Supports 15 A
6 Supports 10 A	13 Supports 15 A
7 Supports 10 A	14 Supports 16 A maximum across all outlets

The Pulizzi PC3365 is shown below. It requires 230/400 VAC WYE three-phase input power. The output at each outlet is always 215V. This PDU is only available outside the United States.

Figure 37 Pulizzi PC3365 outlet amperage limits

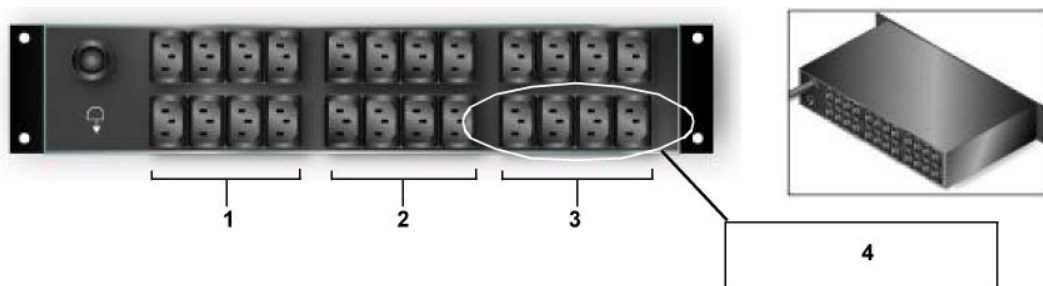

Legend

1 Phase X: 16 A
2 Phase Y: 16 A
3 Phase Z: 16 A
4 Each four-outlet group has an 8 A limit

## About Power Cabling

Here are some examples of where to plug components with various types of PDUs.

With a Pillar Data Systems rack, the Brick power cords are pre-installed in the rack with colored tie wraps, ready for you to plug into the back of each Brick. All cords of the same color connect to one set of power distribution units (PDUs), while the other cords connect to the other set of PDUs.

### Sample Power Cabling for One Slammer and Three Bricks

The Pillar Axiom storage system in the figure below uses 230 V power and two Pulizzi TPC 2104 PDUs. The power cords on each component must go to separate PDUs, plugged in to separate circuits. A sample power cabling scheme such as the one below would distribute the load within the limits of each outlet bank.

Figure 38 Sample power cabling scheme with 230 V power

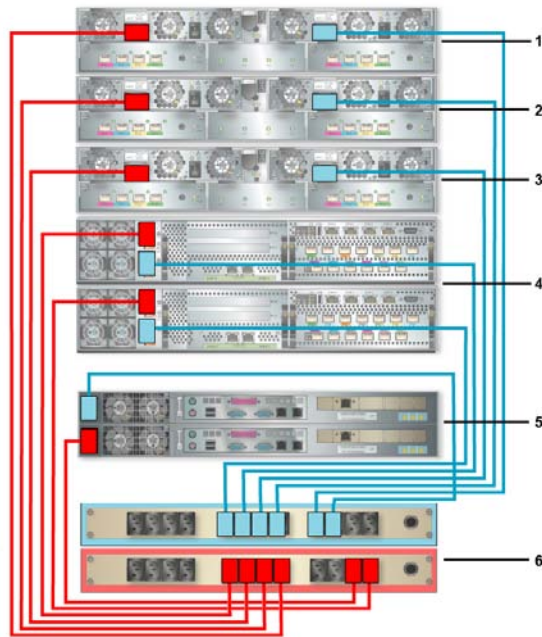

#### Legend

1 Brick 1	4 Slammer
2 Brick 2	5 Pilot
3 Brick 3	6 PDUs



In the above example, the Slammer's CU 0, the two SATA Bricks and the Pilot in the four-outlet bank require 1.525, 1.525, 1.24, 1.24, and 0.80 A respectively, or 6.33 A. This is below the 10-A limit for a four-outlet bank.

If we modify the example to use 120 V, the cable connection configuration depends on which PDU you are using. The same two Slammers and two SATA Bricks draw 3.05, 3.05, 2.54, 2.54, and 1.50 or 12.68 A. This load is acceptable for the Pulizzi TPC 2104 PDU because the amperage limit for a four-outlet bank is 15 A at 115 V.

However, for the TCP2105-1 PDU, at 115 V the maximum for four outlets is 10 A. Therefore, you would have to distribute the plugs differently than the 230 V system, as shown in the figure below:

Figure 39 Sample power cabling scheme with 115 V on a TCP2105-1 PDU

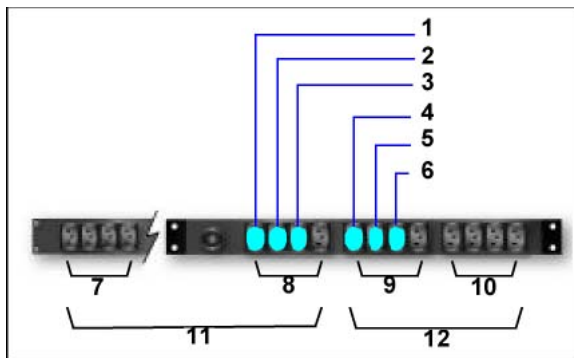

**Legend**

1 SATA Brick 3: 2.54 A drawn	7 No amps drawn for group
2 SATA Brick 2: 2.54 A drawn	8 Total of 7.62 amps drawn for group
3 SATA Brick 1: 2.54 A drawn	9 Total of 8.59 amps drawn for group
4 Slammer CU 0: 3.05 A drawn	10 No amps drawn for group
5 Slammer CU 1: 3.05 A drawn	11 Total of 7.62 total amps drawn for groups
6 Pilot: 2.49 A drawn	12 Total of 8.59 total amps drawn for groups

Other configurations are possible. Make sure that you do not exceed the rating for a four-outlet bank or the rating for a set of two banks, which is 12 A for this PDU.

**Note:** Another PDU is still needed for the power cords for the redundant circuit, which was left out of the above figures for simplicity. The redundant PDU should be cabled the same way.

**Note:** The amperage requirements for an FC Brick is higher than a SATA Brick at 115 Volts. The FC Bricks draw almost 1 full additional amp each. Configuring for FC Bricks may require upgrading your PDU specification. If you have any questions about your PDU configuration please contact Pillar Data Systems Technical Support.

## Sample Power Scheme for One Slammer and 16 SATA Bricks

One Slammer and 16 SATA Bricks (and a Pilot) represents a full 42U rack. Split power cables (the plug end splits into two outlet ends) enable you to connect two components to a single outlet in the PDU and reduce the density of the cabling.

**Note:** The total amperage draw per outlet bank is more important than which Brick is plugged in to which outlet. The drawings below illustrate one way to distribute the load. Always try to balance the load among the outlet banks.

Figure 40 Sample power cabling scheme with 230 V (one circuit shown)

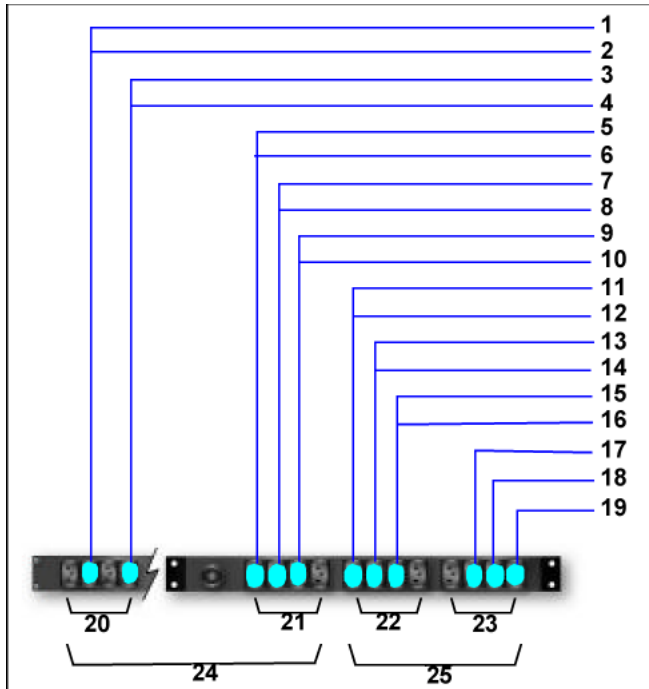

Legend

1 SATA Brick 16: 1.17 A drawn	14 SATA Brick 3: 1.17 A drawn
2 SATA Brick 15: 1.17 A drawn	15 SATA Brick 2: 1.17 A drawn
3 SATA Brick 14: 1.17 A drawn	16 SATA Brick 1: 1.17 A drawn
4 SATA Brick 13: 1.17 A drawn	17 Slammer CU 0: 1.525 A drawn
5 SATA Brick 12: 1.17 A drawn	18 Slammer CU 1: 1.525 A drawn
6 SATA Brick 11: 1.17 A drawn	19 Pilot: 0.8 A drawn
7 SATA Brick 10: 1.17 A drawn	20 Total 4.78 A drawn
8 SATA Brick 9: 1.17 A drawn	21 Total 7.0 A drawn
9 SATA Brick 8: 1.17 A drawn	22 Total 7.0 A drawn
10 SATA Brick 7: 1.17 A drawn	23 Total 3.9 A drawn
11 SATA Brick 6: 1.17 A drawn	24 Grand total 11.78 A drawn
12 SATA Brick 5: 1.17 A drawn	25 Grand total 10.9 A drawn
13 SATA Brick 4: 1.17 A drawn	

**Important!** If you use split power cables, as shown above, make sure they power separate components. Do not use a split power cable to power two sides of the same component. The two sides need to be on separate circuits, in case one fails.

**Note:** The amperage requirements for an FC Brick are higher than a SATA Brick at 115 Volts. The FC Bricks draw almost 1 full additional amp each. Configuring for FC Brick pairs may require upgrading your PDU specification. If you have any questions about your PDU configuration please contact Pillar Data Systems Technical Support.

CHAPTER 6

# Complete the Installation

## Power On the System

As part of your site planning, you set up a separate circuit and power outlet for each PDU. These outlets should be located within reach of the 15 ft. (4.572 m) PDU power input cables.

- 1 Ensure the PDU circuit breakers are in the Off position.
- 2 Connect the PDUs to a facility power source. If the facility's main circuit breakers are off, turn them on to supply power to the PDUs.
- 3 At the front of the system, use a #2 flathead or Phillips head screwdriver to secure the Slammer batteries in place with the two attached screws.

Figure 41 Secure Slammer batteries

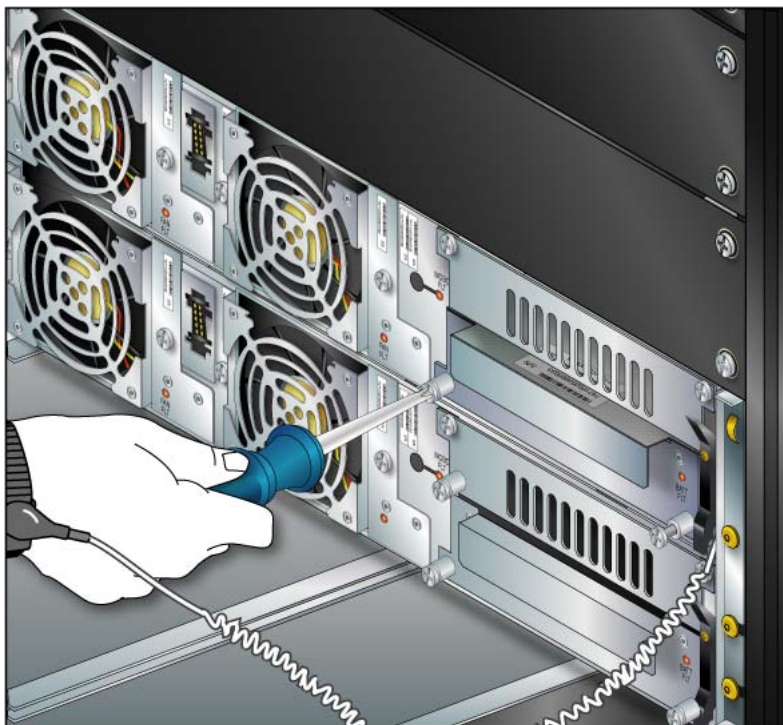

- 4 At the back of the system, turn on the power switches for each Brick.

Figure 42 Turn on Brick power



**Legend**

1 Brick power switches

**Note:** Slammers and Pilots automatically power on when you apply power to the system in the next step.

- 5 At the front of the system, switch on the PDU circuit breakers to apply power to the hardware components. This lights the Power On LED, and starts the component cooling fans.

Figure 43 Turn on PDU power

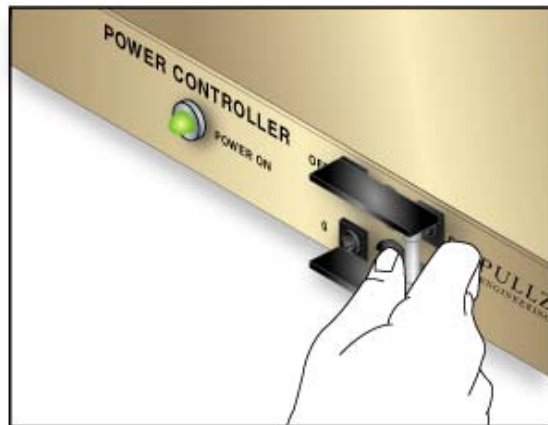

**Important!** You must turn on all of the PDUs within 10 sec of each other.

## Verify Status LEDs at the Front of the System

Check the component LEDs to verify hardware installation.

- 1 Verify the Pilot CU LEDs are green and not blinking.

If the LEDs are off, ensure there is power to the PDU circuit breakers and you have turned them on within 10 sec of each other.

Figure 44 Pilot bezel LEDs

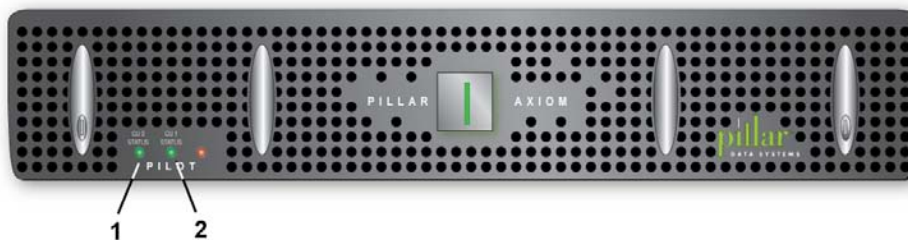

### Legend

1 CU 0 LED
2 CU 1 LED

- 2 Verify that the Slammer Status LEDs are green and not blinking. They may be amber while the Slammer is booting and the software initializing, but should turn green when the Slammer is operational.

Figure 45 Slammer bezel LEDs

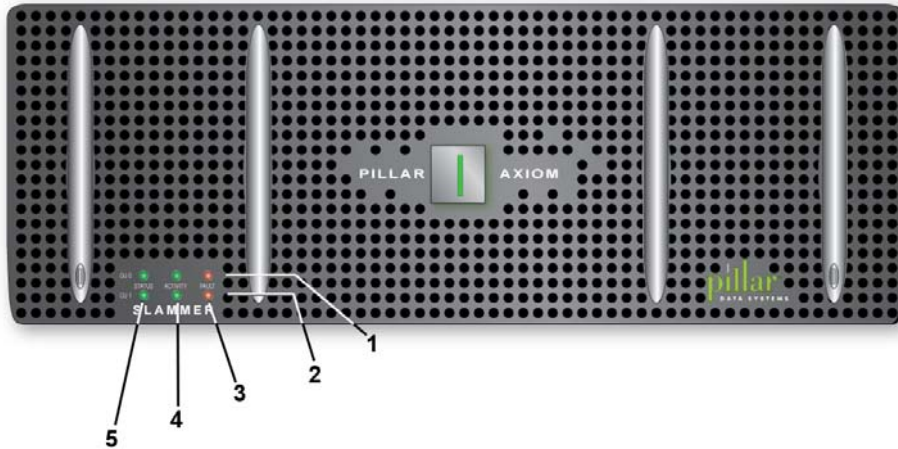

**Legend**

1 CU 0
2 CU 1
3 Fault LEDs
4 Activity LEDs
5 Status LEDs

- 3 Verify that the Fault LEDs are off. If they are on at this stage, it is usually because the bezel is not fully seated.
- 4 For each Brick make sure that the CU 0 and CU 1 Status LEDs are green. Blinking means activity and is normal.

Figure 46 Brick bezel LEDs

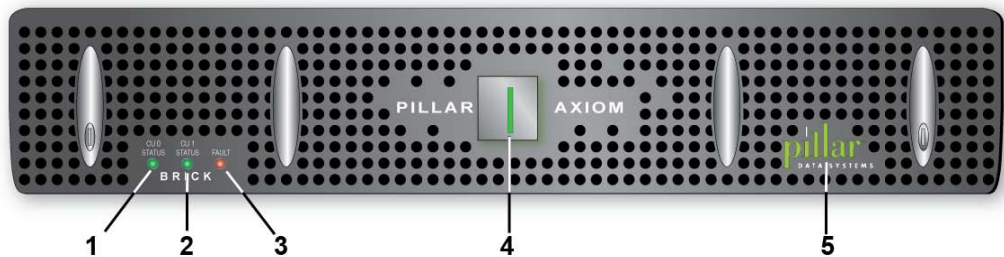

**Legend**

1 CU 0 Status light
2 CU 1 Status light
3 Fault LED
4 Power light
5 Pillar logo



- 5 Verify that the Fault LED for each Brick is off. A lit Fault LED at this stage usually means the bezel is not fully seated.

For a detailed list of Slammer LED startup progress codes refer to [Slammer LED Startup Progress Codes](#).

## Verify Status LEDs at the Back of the System

At the back of the system:

- 1 Verify that the connectivity LEDs on each Pilot CU are green. Blinking indicates activity, which may be normal during bootup.

If the LEDs are off, check both Pilot management connections and both connections to your Ethernet LAN.

Figure 47 Pilot connectivity LEDs

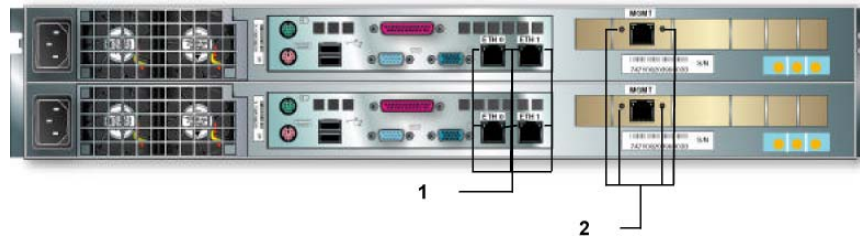

### Legend

1 Private LAN connectivity LEDs
2 Public management port connectivity LEDs

- 2 On the Slammers verify:
  - The power supply LEDs are green and not blinking.

Figure 48 Slammer connectivity LEDs



### Legend

1 Power supply LEDs
2 GbE network interface module (NIM) port LEDs (4-port NIM and SAN FC NIM not shown)
3 CU LEDs
4 FC and FS LEDs

If the power supply LEDs are off or are amber make sure the power cable is securely connected at both ends and the PDUs are powered on.

- On a NAS Slammer, for any 2-port or 4-port network interface module (NIM) GbE port, the LED on the left is green and not blinking, and the one on the right is amber. If they are off, check the network connections.
- On a SAN Slammer, the NIM port LEDs are green and not blinking.
- For the control unit LEDs, the ST LED is green. The ACT LED might be on if the Slammer is configured and active, but is normally off at this stage of installation.
- All LEDs with an FC or FS cable port connection are green and not blinking. If they are amber or off, check the FC cabling.

3 On the Bricks, verify:

- The power supply LEDs are green and not blinking.

Figure 49 Brick LEDs

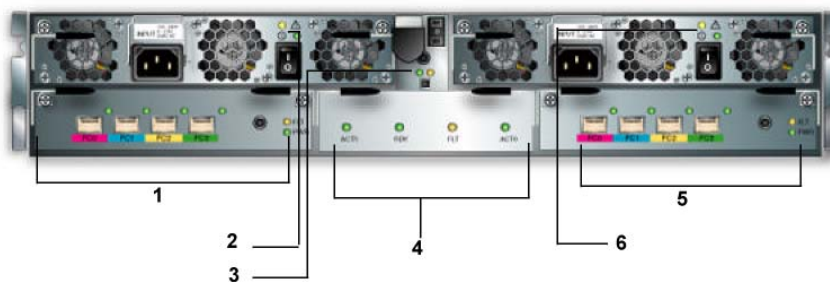

Legend

1 RAID controller LEDs	4 Spare disk drive LEDs
2 Power supply LED	5 RAID controller LEDs
3 ES module LED	6 Power supply LED

If either power supply LED is off or amber:

- Ensure the power cable on that side is securely connected at both ends.
- Ensure the PDU and Brick is powered on.
- Ensure you turned on the PDUs within 10 sec of each other.
- The enclosure services (ES) module LED is green and not blinking. If the ES module LED is amber, ensure that both power cables are securely connected to both the Brick and the PDU.
- The connected RAID controller LEDs are green. If the RAID controller LEDs are off or are blinking green, check the network connections.

- The spare disk drive LEDs are green and not blinking. If the ES module, RAID controller, or spare disk drive has failed, contact Technical Support.

## Attach the Bezels

At the front of the system, ensure all disk drives are fully seated by pressing each disk drive carrier into the chassis to make sure they are fully seated.

You must attach all bezels or the system generates an error condition and lights amber LEDs.

- 1 Insert the bottom two hooks on the bezel into the bottom rack rail tabs.

Figure 50 Bezel hook on the right side of the bezel

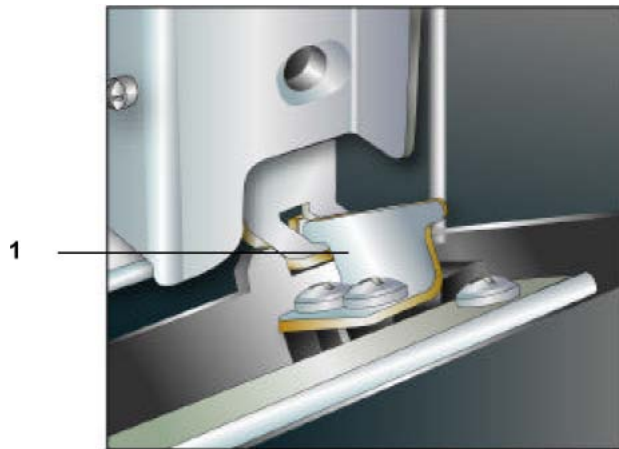

### Legend

1 Insert the bezel hooks on each side
---------------------------------------

- 2 Press the top corners of the bezel to engage the top two bezel hooks with the top rail tabs.
- 3 Press both ejector tabs (if open) until they lock in place. The top hooks should latch with an audible click. If the bezel does not light when you apply power to the system, verify that the top and bottom hooks are all properly engaged.

Figure 51 Press ejector tabs to lock bezel

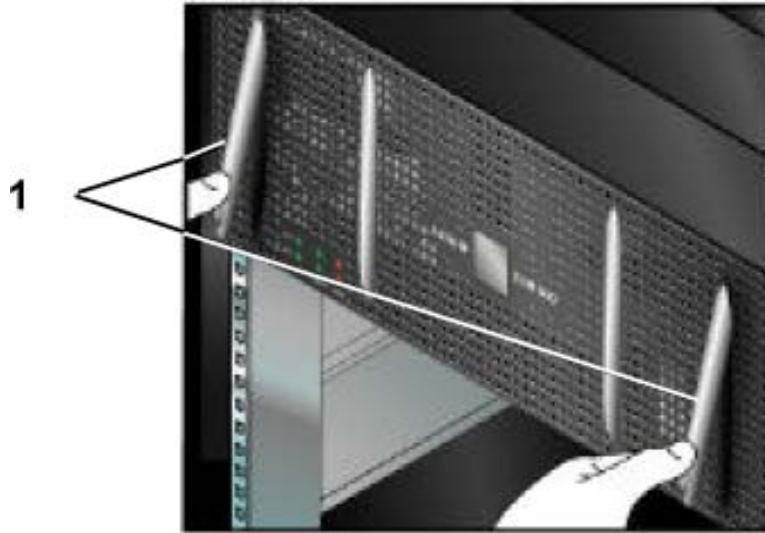

**Legend**

1 Press ejector tabs to lock bezel
------------------------------------

## About HBA Driver and Firmware Installation (SAN Only)

You must install Fibre Channel HBAs in the servers and their required software before you can access LUNs on a SAN system. Complete the instructions from your HBA vendor to:

- Install the HBAs in the servers.
- Download available drivers and firmware.
- Install or update the BIOS, if required.

**Note:** If you intend to install Axiom Path Manager software, refer to the appropriate *AxiomONE Path Manager Installation Guide and Release Notes*.

## About Switch Zone for HBA Set Up (SAN Only)

If appropriate, follow the instructions from your switch vendor to set up zones to:

- Permit host HBA ports to access the Slammer ports.
- Segregate servers with different operating systems.
- Segregate servers with different security requirements.



## Attach the Rack Doors and Panels

In this procedure, you reattach the front and back doors and both side panels to the rack. These steps help to ensure the security and proper cooling of Pillar Axiom components.

To reattach the doors on a rack:

- 1 Based on the type of door hinge, reassemble the hinges.
- 2 Reattach the doors.
- 3 Reattach the door grounding straps at the bottom of the doors.
- 4 Lock the front and back doors to the rack (optional).

## Attach the Rack's Side Panels

- 1 Hang the top of the panel on the top of the rack frame and latch the panel to close it.

**Important!** Be sure not to pinch any cables that might have strayed from their proper moorings.

- 2 Secure the panel appropriately using one of the following options:
  - Engage the latch handle(s) and snap the panel into place.
  - Screw the panels to the rack frame at the top and bottom.
- 3 Lock both side panels (optional).

## CHAPTER 7

# Initial Configuration

## Pre-Configuration Checklist

This is a list of the information you need to know for configuration. Print out this list and check off each item as it is completed.

**Table 9 Global system parameters**

Done	Information
	Check the <i>Pillar Axiom 500 Release Notes</i> and the Pillar Data Systems Support Portal to see if there are any software updates available. Refer to the <i>Pillar Axiom Administrator's Guide</i> for instructions on installing software updates.
GUI access	
	Get the IP address of the Pilot (the default is 10.0.0.2) and the user ID and password from the <i>Site Preparation Survey</i> or from Pillar Data Systems.
Global system parameters	
	Get the IP address of your primary NTP server for synchronizing system time.
	Decide on three IP addresses that are available to assign to the Pilot.
	Know the management network submask and the IP address for the gateway.
	Understand link aggregation and whether to use it for Slammer data paths.
	To allow alerts to be e-mailed, you need the IP address of your e-mail server.
	Get the Call-Home connection parameters and IP addresses from Pillar Data Systems.

Table 9 Global system parameters (continued)

Done	Information
NAS storage parameters	
	If you saved a performance profile (from another Pillar Axiom system), you must know where it is so you can browse to it.
	Decide on an IP address that is available in your network for the File Server.
	Know the data network submask and the IP address for the gateway. This should be a different network than the management network.
	Know your virtual LAN ID, if you are using one.
	Know the DNS domain name and DNS server IP addresses.
	Understand enough about filesystems and storage to specify capacity, growth increment, type of redundancy, priority over other volumes, typical file size, random or sequential file access, and read or write I/O bias.
	Understand file sharing for CIFS and NFS, including exporting, user accounts, and specifying allowed hosts or networks.
SAN storage parameters	
	Understand enough about SANs to specify capacity, type of redundancy, priority over other volumes, random or sequential file access, read or write I/O bias, and Clone LUN space requirements.

## Start the Graphical User Interface (GUI)

Because this address is not routable, be sure that the browser host is on the local subnet.

The AxiomONE Storage Services Manager provides a graphical user interface (GUI) to manage the Pillar Axiom system. Access the GUI by connecting to the Pilot's high-availability IP address, which is 10.0.0.2.

- 1 Through a Web browser, connect to the Pilot IP address 10.0.0.2 (network mask is 255.255.255.0).
- 2 Use the following values to log in:
  - a Login Name: administrator
  - b Password: pillar
- 3 When prompted, enter a new password.

**Note:** Get the password that is to be used from the *Site Preparation Survey*. Be sure that the Primary System Administrator also gets this password.



Do not lose this new password; otherwise, the system must be reset.

- 4 Click the OK button.

At this point, the system tests the cabling among the Slammers and Bricks. After the cable test, the system reports that all connections are OK or lists the connections that failed.

## Reset the Primary System Administrator Password

If you forget the Primary System Administrator password, you can reset it.

- 1 Use a Type 1 Administrator account, if one exists, to reset the password. A Support Administrator cannot reset the Primary Administrator password.
- 2 If no Type 1 Administrator account is available, contact Technical Support for the encrypted file (for resetting the password), which may be placed in a USB key. Use the USB key as instructed.

**Note:** It is strongly recommended that you set up an additional Type 1 Administrator account when you install the system. A Type 1 Administrator can modify account passwords without knowing the previous password for any accounts.

## Configure the System with the Configuration Wizard

The Configuration Wizard pages guide you through the manual steps to configure your system.

- 1 From the initial GUI screen, select Configuration Wizard.
- 2 From the Configuration Wizard initial page, click the Next button.
- 3 Select all three configuration tasks:

Figure 52 Configuration Tasks page

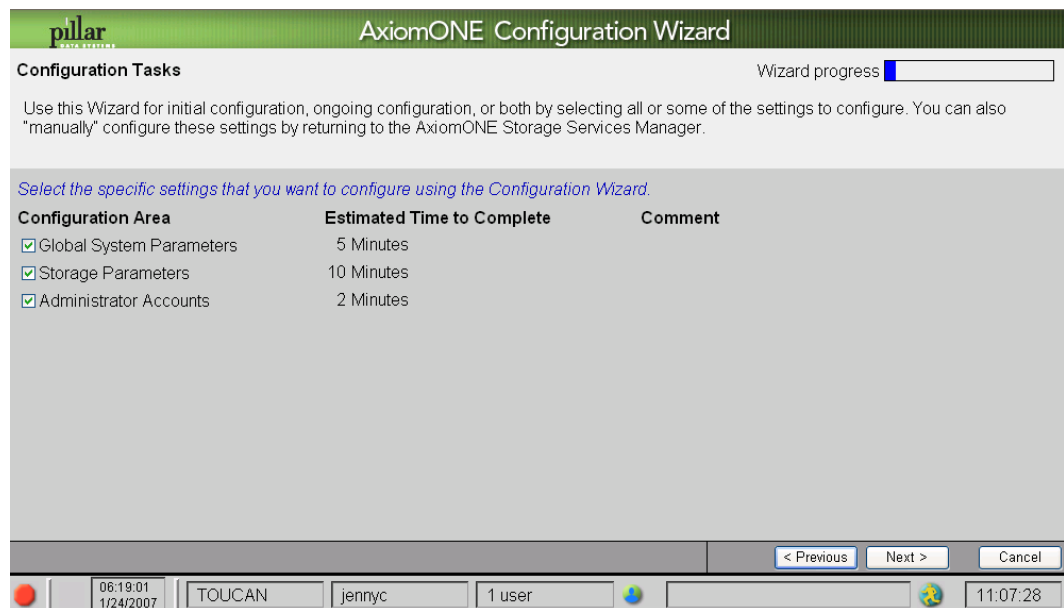

- 4 Click the Next button.

**Note:** If you intend to configure both NAS and SAN Slammers, run this wizard a second time, select only Storage Parameters, and specify a LUN instead of a filesystem (or the other way around).

## Configure Global System Parameters

- 1 In the System Time page, enter the IP addresses of the primary Network Time Protocol (NTP) server and up to two alternate NTP servers (optional).

**Note:** If the time on a Pillar Axiom system is being controlled by a time server, the date and time should only be changed on that time server.

**Note:** If you are not using an NTP server, we recommend not changing the date by means of the GUI or CLI once the initial installation is complete and the system is operational. If you change the date on a Pilot or Slammer by more than 15 minutes, the NTP daemon will mistrust the request and exit.

- 2 Select the time zone that you want to define for the Pillar Axiom system, and click the Next button.

**Note:** If you do not set the system time, the Pillar Axiom system uses the default time set on the Pilot (Pacific Time).

**Figure 53 System Time page**

**Global System Parameters - System Time** Wizard progress

The system date and time settings synchronize the time across all Pillar Axiom components. The system time can be adjusted by navigating to the System area and choosing Summary.

*Specify any NTP Servers. Select the appropriate time zone.*

Current System Date/Time  
08:50:09 October 24th, 2006

NTP Server Settings

Primary IP Address:

Alternate IP Address:

Alternate IP Address:

Time Zone:

- 3 In the Management and Data Path Interfaces page, enter the System Name. This is the name of the management interface IP address and can be used with an external naming service to access the management interface by a host name rather than the IP address. This is not the host or NetBIOS name.



Figure 54 Management and Data Path Interfaces page

**Global System Parameters - Management and Data Path Interfaces** Wizard progress

The management and data path interfaces are system-wide settings independent of the storage configuration.

*To assign a primary IP address select DHCP or enter a static address.*

System Name:

**Management Interface Settings**

Enable DHCP  Static IP Address

	Default	Pilot CU 0	Pilot CU 1
IP Address:	<input type="text" value="192.1.1.10"/>	<input type="text" value="192.1.1.11"/>	<input type="text" value="192.1.1.12"/>
Subnet mask:	<input type="text" value="255.255.255.0"/>		
Gateway:	<input type="text" value="192.1.1.1"/>		

**NAS Data Path Interface**

Slammer Link Aggregation  
*Combines Ethernet ports on a Slammer for higher throughput.*

< Previous    Next >    Cancel

- 4 Select the Static IP Address option.
- 5 Enter a reachable management Default IP Address. (The default address of 10.0.0.2 cannot be routed.)

If you only enter the default address, the system automatically assigns the next two IP addresses in sequence as Pilot CU 0 and Pilot CU 1 addresses. For example, if you enter 129.214.10.10 as the default address, the system automatically assigns IP address 129.214.10.11 to Pilot CU 0 and 129.214.10.12 to Pilot CU 1. If those sequential addresses are not available, enter the desired values for the additional IP addresses in the fields for Pilot CU 0 and Pilot CU 1.

**Important!** All three addresses must be on the same subnet as the dynamically assigned public IP address; otherwise, the private interfaces may not work.

In the current release, the DHCP feature has the following behavior characteristics:

- Dynamically assigns only the public IP address of the Pilot.
- Locks the two private IP addresses.
- Retains DHCP settings during a Pilot failover.
- Does not reflect the updated IP address or the status of the DHCP setting in the GUI until the Pilot restarts or fails over.

- Updates the values correctly without a need to restart when you change back to static addresses.

If DHCP is enabled on the Pilot and DNS lookup is available on the management console, you can log in to the Pillar Axiom system using the system name rather than its IP address.

**Note:** Get the IP address that is to be used from the *Site Preparation Survey*. Be sure that the Primary System Administrator also gets this IP address.

**CAUTION** Do not lose this IP address; otherwise, the system must be reset.

- 6 Enter the subnet mask for your network and the IP address of the default gateway for the management interfaces . If you do not want the management interfaces to be reachable from anywhere other than the local subnet, leave the default gateway blank. However, you must enter a valid netmask.
- 7 Click the Next button. The Next button assigns the primary IP addresses and brings up the next dialog.

Figure 55 Notification and Account Security Settings page

The screenshot shows the 'AxiomONE Configuration Wizard' interface. The title bar includes the 'pillar' logo and 'AxiomONE Configuration Wizard'. Below the title bar, the page is titled 'Global System Parameters - Notification and Account Security Settings' with a 'Wizard progress' indicator. The main content area contains the following sections:

- Account Security Settings for All Administrator Types:**
  - Consecutive failed login attempts allowed:
  - Session timeout period:  minutes
- Email Configuration:**
  - Enable Email
  - Email Server IP (to receive Alerts):  ?
- NAS Failback Configuration:**
  - Enable Automatic Recovery of Failed NAS Slammers
  - This will automatically reallocate the resources originally owned by the failed control unit as soon as the failed control unit is recovered. If those resources include VIFs, then data path connections to those VIFs will be disrupted momentarily, up to 30 seconds.*

- 8 Enter the Account Security values for session time-out period.
- 9 To receive alerts by email, check Enable Email and specify your Email server IP address.
- 10 Check Enable Automatic Recovery of Failed NAS Slammers if you want NAS Slammers to automatically fail back when a failed control unit is restored. If

you want to control when a recovery occurs, do not check this box. (SAN Slammers fail back automatically.)

## Configure NAS Storage Parameters

If you do not have NAS storage, skip to [Configure SAN Storage Parameters](#).

- 1 In the Storage Allocation and Quality of Service (QoS) page, select Filesystem from the Storage Type drop-down box.

**Figure 56 Storage Allocation and Quality of Service (QoS) page**

The screenshot shows the 'Storage Allocation and Quality of Service (QoS)' page in the AxiomONE Configuration Wizard. The page title is 'Storage Allocation and Quality of Service (QoS)' and the wizard progress is indicated by a blue bar. The page contains the following elements:

- Storage Type:** A dropdown menu set to 'Filesystem'.
- Performance Characteristics:**
  - Application Category:** A dropdown menu set to 'Hardware/Software Development'.
  - Performance Profiles:** A dropdown menu set to 'Highest Throughput \*'.
  - Buttons: 'Import Profile(s)' and 'Delete Selected Profile'.
- Total System Capacity available for use:** 3792 GB.
- Navigation:** '< Previous', 'Next >', and 'Cancel' buttons.

- 2 Choose one of the following options to determine QoS performance:
  - Select an Application Category that best describes your storage use environment. Each category has certain default profile values that you can edit on the Capacity and Performance page (which is the next page the Wizard presents).
  - Select the Performance Profile for Oracle Automatic Storage Management if this Pillar Axiom system is connected to an Oracle system.
- 3 Click the Next button to configure this filesystem.
- 4 Enter the filesystem's name as well as the capacity values.

Figure 57 Storage Capacity and Performance Settings page

The screenshot shows the 'Storage Capacity and Performance Settings' page in the AxiomONE Configuration Wizard. The wizard progress bar is at the top right. Below the title, there is a note about default settings. The main configuration area is divided into several sections:

- Filesystem:** Name: Eng5W
- Capacity:** Capacity: 350 GB, Maximum Capacity: 35 GB, Redundancy: Double
- CloneFS Storage:**  Allocate a maximum of 0 GB for CloneFSs. Space is allocated from the total system capacity.
- Retention Policy:**  Enable Retention Policy for SecureWORMfs.
  - Standard:** Use to store reference data that is non-rewritable (protected). Data is retained on the filesystem for a fixed period of time that is specified by the retention period settings, however, you can delete data at anytime by deleting the entire filesystem.
  - Compliance:** Use to store key business data as stipulated by various regulations that require data to be retained for a fixed period of time. You cannot delete a compliant filesystem if there are protected files on the filesystem. You must enable the NTP Server to use this feature.
- Performance:** Priority vs other Volumes: High, Typical File Size: Small (<20KB), Files are typically accessed: Random, I/O Bias: Read.

A table at the bottom indicates how much capacity (GB) is available based on priority and redundancy:

		Priority				
		Archive	Low	Medium	High	Premium
Redundancy	Standard	1846	1477	1107	369	0
	Double	923	738	554	185	0

- 5 To activate RAID 10 by setting file access to Random and the I/O Bias to Write.  
The system defaults to RAID 5 otherwise.
- 6 To activate CloneFS Storage for this filesystem, check the allocation box and specify a maximum number of gigabytes to be used for CloneFS.
- 7 To specify SecureWORMfs for this filesystem, check the Retention Policy box. Select either the Standard or Compliance option for SecureWORMfs.
- 8 Click Next. If you checked the Retention Policy box you go to the Retention Policy Settings page. Otherwise you go to the File Sharing page in [Step 11](#).
- 9 In the Retention Policy Settings page set the master retention period values.
- 10 Specify suitable scan times and click the Next button.
- 11 In the File Sharing page, select the type(s) of file sharing that you want for this filesystem, and click Next button.
- 12 If you are sharing to Windows (CIFS) users, the Shares page appears. Specify a share name and use just a back-slash (\) for the path. A new filesystem is empty, so there is no other path to specify. Check the Enabled option to activate the share.
- 13 If you are sharing with UNIX (NFS) users, the Exports page appears. Enter a back-slash (\) for the export path. The UID for anonymous is for a CIFS user with no matching user account. It is also for a root user on a client if the

filesystem is not exported as root access. A common value to use for this is -2.

- 14 Specify the Allowed Hosts as the destination for this filesystem export, and whether it should be exported as Read Only or Root Access.
- 15 Click Next to specify a NAS File Server.  
If you select this option, skip to Step 20.
- 16 To use an existing File Server, select it from the drop-down list and click Next. Use the View button to review details about the selected File Server.
- 17 To create a new File Server, select that option and click the Next button.
- 18 Enter a new File Server name and define the virtual interface (VIF) and Domain Name Server (DNS) for the File Server. The DNS domain specifies the domain to be searched.
- 19 Create an administrator account for the system. Set the Role to be Administrator 1 for this initial account. Additional accounts with lower privileges can be created later.
- 20 Review the parameter settings. If you want to make any changes, click the Previous button. When you are satisfied with the settings, click the Finish button to configure the Pillar Axiom system.

If there are any invalid settings in your parameters, the wizard will open the related page and highlight the fields in red.

## Configure SAN Storage Parameters

If you just configured NAS storage, run the Configuration Wizard a second time, and only specify Storage Parameters. You do not need to configure the global parameters or accounts again if they are already configured.

- 1 In the Storage Allocation and Quality of Service (QoS) page, select LUN from the Storage Type drop-down box.

Figure 58 Storage Allocation and Quality of Service (QoS) page for LUNs

The screenshot shows the 'Storage Allocation and Quality of Service (QoS)' page in the Pillar Axiom Configuration Wizard. The page title is 'Storage Allocation and Quality of Service (QoS)' and the wizard progress is indicated by a blue bar. The page contains the following elements:

- Header:** Pillar logo and 'AXIOM CONFIGURATION WIZARD'.
- Section:** 'Storage Allocation and Quality of Service (QoS)'.
- Text:** 'The QoS settings define the performance characteristics for a logical volume (filesystem or LUN) in your storage environment. You may create one logical volume at a time using this wizard. To create additional volumes, you can run the Capacity Planner, run this Configuration Wizard again, or create them "manually" from the Storage page.'
- Instructions:** 'Select the application category that best describes your storage use environment or you may choose a specific performance profile. Your selection will determine the quality of service for the filesystem. Note: Standard Performance Profiles\* cannot be deleted.'
- Capacity:** 'Total System Capacity available for use: 3484 GB'.
- Storage Type:** A dropdown menu set to 'LUN'.
- Performance Characteristics:**
  - Application Category: 'General Purpose' (dropdown menu).
  - Performance Profiles: 'Highest Throughput \*' (dropdown menu), with 'Import Profile(s)' and 'Delete Selected Profile' buttons.
- Navigation:** '< Previous', 'Next >', and 'Cancel' buttons.

- 2 Choose one of the following options to determine QoS performance:
  - Select an Application Category that best describes your storage use environment. Each category has certain default profile values that you can edit on the Capacity and Performance page (which is the next page the Wizard presents).
  - Select the Performance Profile for Oracle Automatic Storage Management if this Pillar Axiom system is connected to an Oracle system.
- 3 Click the Next button to configure this LUN.

Figure 59 Storage Capacity and Performance Settings page for a LUN

**Storage Capacity and Performance Settings** Wizard progress

The default performance settings displayed below are recommended based on the application category "General Purpose". You may modify them to best fit your application, but it is recommended that you use the default values.

*Enter the desired capacity and performance for this Volume (filesystem or LUN).*

Total System Capacity available for use: 2215 GB

**LUN**  
 Name: LUN1  
 Number: 1

**CloneLUN Storage**  
*Space is allocated from the total system capacity*  
 Allocate a maximum of 0 GB for CloneLUNs

**Capacity**  
 Capacity: 350 GB  
 Maximum Capacity: 500 GB  
 Redundancy: Double

**Access Protocol**  
 Fibre Channel  
 iSCSI

**Performance**  
 Priority vs. other Volumes: Medium  
 Files are typically accessed: Random  
 I/O Bias: Read

This table indicates how much capacity (GB) is available based on priority and redundancy.

		Priority				
		Archive	Low	Medium	High	Premium
Redundancy	Standard	1846	1477	1107	369	0
	Double	923	738	554	185	0

< Previous    Next >    Cancel

- 4 Enter a LUN name and LUN number.
- 5 Specify the LUN capacity, redundancy, and performance attributes.
 

**Note:** You can modify a LUN to update its capacity attributes at any time. You cannot change a LUN's redundancy and performance attributes after you create the LUN.
- 6 To activate the Clone LUN storage function, enter the amount of space to allocate.
- 7 Select your Access Protocols if you are using Fibre Channel, iSCSI, or both. If these protocols are not being used, leave these options blank.
- 8 Click the Next button to configure administrator accounts, unless you have already completed this step when configuring NAS parameters.
- 9 Create an administrator account for the system and set the Role to be Administrator 1 for this initial account.
 

Otherwise, continue with Step 10. Additional accounts with lower privileges can be created later.
- 10 Review the parameter settings. If you want to make any changes, click the Previous button. When you are satisfied with the settings, click the Finish button to configure the Pillar Axiom system.

If there are any invalid settings in your parameters, the wizard will open the related page and highlight the fields in red.

## About AxiomONE Path Manager Installation (SAN Only)

To operate your SAN system, you may optionally install Pillar's AxiomONE Path Manager (APM) drivers and software on your SAN host, which:

- Ensures your SAN host operating system does not interpret multiple paths as multiple disk drives.
- Provides path failover.
- Streamlines system management.

**Important!** Configure the LUNs on the Pillar Axiom before you install the AxiomONE Path Manager system software on the SAN host.

Complete the procedures in the appropriate *AxiomONE Path Manager Installation Guide and Release Notes* to install the AxiomONE Path Manager driver and software on the SAN host.



## CHAPTER 8

# Expansion Planning

## About Additional Slammers

We do not recommend adding a Slammer to an Pillar Axiom system while the system is in normal running status.

If the existing racks are full, you need additional racks and may have to move some Bricks to accommodate a second Slammer. See the hardware map in [About Component Placement for One Slammer and SATA Bricks](#) for more information.

## Complete the Pre-Installation Checklist

- 1 Inventory the Slammer and installation components to make sure you have the correct cables and mounting hardware.
- 2 Before beginning the installation, check the status of the system to ensure that it is in proper status, as follows:
  - a All Fibre Channel Status LEDs on Slammer and Brick ports with connectors inserted are steady green, not amber or flashing green.
  - b The System Summary Status in the GUI is green for all components.
  - c No background tasks are running.
  - d There are no outstanding Administrator Actions.
  - e No filesystems or SAN LUNs are offline, degraded, or in conservative mode.

## Install the Slammer

- 1 Place the Pillar Axiom system in Shutdown Status with the GUI or command line interface (CLI) and verify that the system has successfully shut down.
- 2 Physically add the new Slammer to the system, as described in [About Slammer Installation](#).

- 3 Connect the Ethernet and Fibre Channel cables following the instructions in the *Pillar Axiom 500 SSF Cabling Reference*.
- 4 Attach the Slammer power connections to separate PDUs as shown in [Connect Power Cables](#).
- 5 Restart the Pillar Axiom system. Carefully observe the System Health Status to ensure that the Slammers proceed through startup and achieve a normal status.
- 6 Check that the system recognizes the new Slammer. That is, the system adds it to the configuration and performs a successful startup to normal status, with any firmware updates to the Slammer CU completing successfully.
- 7 Check the Fibre Channel status LEDs on all ports on all Slammers and Bricks. If there is a FC cable connected, the associated port status LED should be solid green and not amber or blinking green.

## APPENDIX A

# Slammer LED Startup Progress Codes

## About LED Startup Codes

When a Slammer is powered on, it goes through a sequence of actions. Generally, the time to finish these actions for a new installation is about 12 minutes.

The time to start up your system may be shorter or longer, depending on the number of configured entities (filesystems, LUNs, Snap FSs, Snap LUNs, quotas, and so on) and, to some degree, on the configuration of Slammers and Bricks.

Slammers cannot complete the startup sequence without the Pilot being powered on and functioning.

While a Slammer performs startup diagnostics and then waits for its runtime image to download from the Pilot:

- The Fault LED (FLT) is off.
- The Activity LED (ACT) is green and blinks fast.
- The Status LED (ST) is green and blinks slowly.

During the remainder of the startup, FLT and ACT are off while ST slowly blinks amber once each second. During this time, the GUI shows the Slammer to be in "booting 0xnnnn" status while the Pilot initializes the Slammer's data services components.

When the Slammer successfully completes the startup sequence, ST is steady green.

**Tip:** If the front bezel Fault (FLT) LED is on steady and no other fault indicators on the Slammer are lit, the bezel may not be properly seated. Slammers always light FLT when the bezel is off.

If the Slammer halts during startup, the three LEDs on the back of the chassis (FLT, ACT, and ST) or the three LEDs on the bezel (Status, Activity, and Fault) help you identify where the Slammer halted in the startup sequence.

## Slammer LED Codes

The Slammer bezel has Fault, Status, and Activity LEDs that can display various colors and blink rates. These LEDs also appear on the private interface module at the back of the Slammer chassis, and are labeled FLT (Fault), ACT (Activity), and ST (Status).

These LEDs can:

- Be green or amber.
- Be on or off.
- Be steady, with no blinks.
- Blink rapidly—slightly more than two blinks per sec (2.375 hz).
- Blink slowly—one blink per 1.5 sec (0.67 hz).

The configuration of all three LEDs can be translated into a 3-digit progress code. Use this code to identify the cause of failure in the table in [LED Code Translation](#).

## LED Code Translation

The first digit of a startup progress code is determined by the color and blink rate of the FLT LED. Use the information in the following table to determine the first digit of this code.

**Table 10 Code translation for the Fault LED**

LED color	Blink rate	Code
None	Off	0
Amber	Steady	1
	Rapid	2
	Slow	3

The second digit of the startup progress code is determined by the color and blink rate of the Activity LED. Use the information in the following table to determine the second digit of this code.

**Table 11 Code translation for the Activity LED**

LED color	Blink rate	Code
None	Off	0
Amber	Steady	1
	Rapid	3
	Slow	4
Green	Steady	2
	Rapid	5
	Slow	6

The third digit of the startup progress code is determined by the color and blink rate of the Status LED. Use the information in the following table to determine the third digit of this code.

Table 12 Code translation for the Status LED

LED color	Blink rate	Code
None	Off	0
Amber	Steady	1
	Rapid	3
	Slow	4
Green	Steady	2
	Rapid	5
	Slow	6

For example, the following LED configuration represents a progress code of 111, which means that the simple memory test failed on the Slammer:

- FLT—steady amber
- ACT—steady amber
- ST—steady amber

## LED Halt Codes

The following table describes the meaning of the halt codes as indicated by the LEDs.

**Note:** The software modules in the following table are defined as follows:

- Boot Block is a software module that contains initialization routines, which include Preferred and Alternate Boot Page validation.
- MPOST is manufacturing POST and is for testing the motherboard.
- Preferred Boot Page is the preferred runtime start-up code.
- Alternate Boot Page is the safe (or backup) start-up code. Both the Preferred Boot Page and the Alternate Boot Page are alternately updateable in the field. The Alternate Boot Page should ensure that the Slammer can start up even when the Preferred Boot Page is corrupted.

**Table 13 Slammer LED halt codes**

Code			Software module	Meaning
F	A	S		
0	0	0	Boot Block	CPU did not start to fetch code yet.
0	5	6		The Slammer control unit (CU) PROM has completed startup diagnostics and is waiting for the software to be downloaded from the Pilot.
1	0	2		Ready to initialize memory.
1	1	0		Installed memory is unsupported.
1	0	3		Ready to initialize DQS settings.
1	1	1		Simple memory test failed.
1	0	4		Ready to check preferred boot page CRC. If CRC is OK, control transfers to preferred boot page; otherwise, alternate boot page CRC is checked. If CRC is OK, control transfers to alternate boot page; otherwise, start-up will fail.

**Table 13 Slammer LED halt codes (continued)**

Code			Software module	Meaning
F	A	S		
1	1	2		Boot page CRC failed.
1	6	3		Starting up from alternate boot page.
1	6	2		Start-up failed - both boot pages failed their CRC checks.
1	1	3		Shadow RAM failed.
2	4	2	MPOST/Monitor	MPOST is ready to load.
2	3	6		Ready to start loader monitor.
2	4	0		Ready to continue starting up after loader monitor.
2	0	0	Preferred or Alternate Boot Page	Current boot page started to execute.
2	0	4		Ready to initialize IDT.
2	0	6		Ready to initialize NMI handler.
2	1	0		Ready to initialize COM1 serial port.
2	1	2		Ready to initialize CMS hardware.
2	1	4		Ready to initialize fan controller.
2	1	6		Ready to start CPU 2.
2	0	2		Prepare to reset CPU 1 to reconfigure CPU 2.
2	3	0		Ready to initialize PCI devices.
2	4	4		Ready to check memory configuration.
2	4	6		Current memory configuration does not match configuration in EEPROM.
2	5	0		Current memory configuration does not match initial configuration in CMOS.



**Table 13 Slammer LED halt codes (continued)**

Code			Software module	Meaning
F	A	S		
2	5	2		Memory DIMMs are different.
2	5	4		Failed to read memory configuration from EEPROM.
2	5	6		Ready to do full memory test.
2	6	0		Full memory test failed.
3	6	6		Exiting Loader; entering netboot.
3	X	X		LED startup progress code reserved for the OS (where X is not 6).

Once the Slammer reaches state 3XX, where the FLT LED is blinking slowly, all further control of the startup process is managed by the Pilot. When the Pilot assumes control of the Slammer, the status LED begins blinking slowly amber until the software components are all successfully brought online.

## APPENDIX B

# Safety Statements

## Introduction to Safety Statements

For the Pillar Axiom storage system, this appendix lists safety statements to provide specific warning and cautionary notices about the electrical and weight properties that are associated with a Pillar Axiom system and its hardware components.

## Safety Statements

The following safety statements include all hazard notices, in all pertinent languages.

**Important!** Procedures listed in the body of this document assume that the electrical characteristics of the power supply to which Pillar Axiom components are connected comply with the technical specifications for those components.

For electrical characteristics of Pillar Axiom components, see [Pillar Axiom Hardware Specifications](#).

## Warning Notices



This hazard symbol means warning. You are in a situation that could cause bodily injury. Before you work on any equipment, be aware of the hazards that are involved with electrical circuitry and be familiar with standard practices for preventing accidents.

## Electrical Warning in Other Languages

Table 14 Electrical warning in other languages

Waarschuwing	Dit waarschuwingssymbool betekent gevaar. U verkeert in een situatie die lichamelijk letsel kan veroorzaken. Voordat u aan enige apparatuur gaat werken, dient u zich bewust te zijn van de bij elektrische schakelingen betrokken risico's en dient u op de hoogte te zijn van standaard maatregelen om ongelukken te voorkomen.
Varoitus	Tämä varoitusmerkki merkitsee vaaraa. Olet tilanteessa, joka voi johtaa ruumiinvammaan. Ennen kuin työskentelet minkään laitteiston parissa, ota selvää sähkökytkentöihin liittyvistä vaaroista ja tavanomaisista onnettomuuksien ehkäisykeinoista.
Attention	Ce symbole d'avertissement indique un danger. Vous vous trouvez dans une situation pouvant causer des blessures ou des dommages corporels. Avant de travailler sur un équipement, soyez conscient des dangers posés par les circuits électriques et familiarisez-vous avec les procédures couramment utilisées pour éviter les accidents.
Warnung	Dieses Warnsymbol bedeutet Gefahr. Sie befinden sich in einer Situation, die zu einer Körperverletzung führen könnte. Bevor Sie mit der Arbeit an irgendeinem Gerät beginnen, seien Sie sich der mit elektrischen Stromkreisen verbundenen Gefahren und der Standardpraktiken zur Vermeidung von Unfällen bewußt.
Avvertenza	Questo simbolo di avvertenza indica un pericolo. La situazione potrebbe causare infortuni alle persone. Prima di lavorare su qualsiasi apparecchiatura, occorre conoscere i pericoli relativi ai circuiti elettrici ed essere al corrente delle pratiche standard per la prevenzione di incidenti.

Table 14 Electrical warning in other languages (continued)

Advarsel	Dette varselsymbolet betyr fare. Du befinner deg i en situasjon som kan føre til personskade. Før du utfører arbeid på utstyr, må du være oppmerksom på de faremomentene som elektriske kretser innebærer, samt gjøre deg kjent med vanlig praksis når det gjelder å unngå ulykker.
Aviso	Este símbolo de aviso indica perigo. Encontra-se numa situação que lhe poderá causar danos físicos. Antes de começar a trabalhar com qualquer equipamento, familiarize-se com os perigos relacionados com circuitos eléctricos, e com quaisquer práticas comuns que possam prevenir possíveis acidentes.
Advertencia	Este símbolo de aviso significa peligro. Existe riesgo para su integridad física. Antes de manipular cualquier equipo, considerar los riesgos que entraña la corriente eléctrica y familiarizarse con los procedimientos estándar de prevención de accidentes.
Varning	Denna varningssymbol signalerar fara. Du befinner dig i en situation som kan leda till personskada. Innan du utför arbete på någon utrustning måste du vara medveten om farorna med elkretsar och känna till vanligt förfarande för att förebygga skador.

**Warning**

Do not work on the system or connect or disconnect cables during periods of lightning activity.

**Warning**











When removing a power supply, do not touch the power supply when the power cord is connected. For systems with a power switch, line voltages are present within the power supply even when the power switch is off and the power cord is connected. For systems without a power switch, line voltages are present within the power supply when the power cord is connected.

**Warning**

The power supply cord is used as the main disconnect device. Ensure that the socket outlet is located or installed near the equipment and is easily accessible.

**Warning**

When working on a chassis or near power supplies, use extreme caution because line voltages may be present within the chassis.

-  **Warning** Ultimate disposal of this product should be handled according to all national laws and regulations.
-  **Warning** Some equipment is connected to power lines. Before you work on this equipment, remove all jewelry that contains metal. Such jewelry includes rings, necklaces, and watches. Metal objects heat up when connected to power and ground. Hot metal objects can cause serious burns or weld the metal object to the terminals.
-  **Warning** Only qualified personnel should install or replace this equipment.
-  **Warning** Secure all power cabling when you install this unit to avoid disturbing field-wiring connections.
-  **Warning** Do not overload the circuit when you connect components to the power supply.
-  **Warning** A voltage mismatch can cause equipment damage and may pose a fire hazard. If the voltage indicated on the label differs from the power outlet voltage, *do not connect the chassis to that receptacle*.
-  **Warning** To avoid electric shock, do not connect safety extra-low voltage (SELV) circuits to telephone-network voltage (TNV) circuits. LAN ports contain SELV circuits, and WAN ports contain TNV circuits. Some LAN and WAN ports both use RJ-45 connectors. Use caution when connecting cables.
-  **Warning** Incorrect connection of this equipment to a general purpose outlet could result in a hazardous situation.
-  **Warning** The Pillar Axiom storage system operates at high voltages. To protect against physical harm, power off the system whenever possible during installation.
-  **Warning** Never block the inlet and outlet holes in the chassis components. Sufficient air circulation is required for the components to operate properly and to avoid a fire hazard. Do not push objects of any kind into the ventilation holes. Such action could result in fire or electrical shock. Keep all liquids away from hardware components.



Ensure that component distribution in the rack is balanced. Follow the hardware placement map to ensure this balance. Uneven distribution can cause hazardous instability. The rack must have stabilization plates or anti-tip brackets installed so the rack does not tip when you install a component.

## Lightning Activity Warning



Do not work on the system or connect or disconnect cables during periods of lightning activity.

## Lightning Warning in Other Languages

Table 15 Lightning warning in other languages

Waarschuwing	Tijdens onweer dat gepaard gaat met bliksem, dient u niet aan het systeem te werken of kabels aan te sluiten of te ontkoppelen.
Varoitus	Älä työskentele järjestelmän parissa äläkä yhdistä tai irrota kaapeleita ukkosilmalla.
Attention	Ne pas travailler sur le système ni brancher ou débrancher les câbles pendant un orage.
Warnung	Arbeiten Sie nicht am System und schließen Sie keine Kabel an bzw. trennen Sie keine ab, wenn es gewittert.
Avvertenza	Non lavorare sul sistema o collegare oppure scollegare i cavi durante un temporale con fulmini.
Advarsel	Utfør aldri arbeid på systemet, eller koble kabler til eller fra systemet når det tordner eller lyner.
Aviso	Não trabalhe no sistema ou ligue e desligue cabos durante períodos de mau tempo (trovoada).
Advertencia	No operar el sistema ni conectar o desconectar cables durante el transcurso de descargas eléctricas en la atmósfera.
Varning	Vid å ska skall du aldrig utföra arbete på systemet eller ansluta eller koppla loss kablar.

## Power Supply Warning



When removing a power supply, do not touch the power supply when the power cord is connected. For systems with a power switch, line voltages are present within the power supply even when the power switch is off and the power cord is connected. For systems without a power switch, line voltages are present within the power supply when the power cord is connected.

## Power Supply Warning in Other Languages

Table 16 Power supply warning in other languages

Waarschuwing	U dient de voeding niet aan te raken zolang het netsnoer aangesloten is. Bij systemen met een stroomschakelaar zijn er lijnspanningen aanwezig in de voeding, zelfs wanneer de stroomschakelaar uitgeschakeld is en het netsnoer aangesloten is. Bij systemen zonder een stroomschakelaar zijn er lijnspanningen aanwezig in de voeding wanneer het netsnoer aangesloten is.
Varoitus	Älä kosketa virtalä hdettä virtajohdon ollessa kytkettynä . Virrankatkaisimella varustetuissa jä rjestelmissä on virtalä hteen sisä llä jä llellä verkkojä nnite, vaikka virrankatkaisin on katkaistu-asennossa virtajohdon ollessa kytkettynä . Jä rjestelmissä , joissa ei ole virrankatkaisinta, on virtalä hteen sisä llä verkkojä nnite, kun virtajohto on kytkettynä .
Attention	Ne pas toucher le bloc d'alimentation quand le cordon d'alimentation est branché. Avec les systèmes munis d'un commutateur marche-arrêt, des tensions de ligne sont présentes dans l'alimentation quand le cordon est branché, même si le commutateur est ààl'arrêt. Avec les systèmes sans commutateur marche-arrêt, l'alimentation est sous tension quand le cordon d'alimentation est branché.
Warnung	Berü hren Sie das Netzgerä t nicht, wenn das Netzkabel angeschlossen ist. Bei Systemen mit Netzschalter liegen Leitungsspannungen im Netzgerä t vor, wenn das Netzkabel angeschlossen ist, auch wenn das System ausgeschaltet ist.



Table 16 Power supply warning in other languages (continued)

	Bei Systemen ohne Netzschalter liegen Leitungsspannungen im Netzgerät vor, wenn das Netzkabel angeschlossen ist.
Avvertenza	Non toccare l'alimentatore se il cavo dell'alimentazione è collegato. Per i sistemi con un interruttore di alimentazione, tensioni di linea sono presenti all'interno dell'alimentatore anche quando l'interruttore di alimentazione è in posizione di disattivazione (off), se il cavo dell'alimentazione è collegato. Per i sistemi senza un interruttore, tensioni di linea sono presenti all'interno dell'alimentatore quando il cavo di alimentazione è collegato.
Advarsel	BerØr ikke strØmforsyningsenheden når strØmledningen er tilkoblet. I systemer som har en strØmbryter, er det spenning i strØmforsyningsenheden selv om strØmbryteren er slått av og strØmledningen er tilkoblet. Når det gjelder systemer uten en strØmbryter, er det spenning i strØmforsyningsenheden når strØmledningen er tilkoblet.
Aviso	Não toque na unidade abastecedora de energia quando o cabo de alimentação estiver ligado. Em sistemas com interruptor, a corrente eléctrica estará presente na unidade abastecedora, sempre que o cabo de alimentação de energia estiver ligado, mesmo quando o interruptor se encontrar desligado. Para sistemas sem interruptor, a tensão eléctrica dentro da unidade abastecedora só estará presente quando o cabo de alimentação estiver ligado.
Advertencia	No tocar la fuente de alimentación mientras el cable esté enchufado. En sistemas con interruptor de alimentación, hay voltajes de línea dentro de la fuente, incluso cuando el interruptor esté en Apagado (OFF) y el cable de alimentación enchufado. En sistemas sin interruptor de alimentación, hay voltajes de línea en la fuente cuando el cable está enchufado.
Varning	Vidrör inte strömförsörjningsenheten när nätsladden är ansluten. För system med strömbrytare finns det nätspänning i strömförsörjningsenheten även när strömmen har slagits av men nätsladden är ansluten. För system utan strömbrytare finns det nätspänning i strömförsörjningsenheten när nätsladden är ansluten.

## Main Power Disconnect Warning



The power supply cord is used as the main disconnect device. Ensure that the socket outlet is located or installed near the equipment and is easily accessible.

## Power Disconnect Warning in Other Languages

Table 17 Power disconnect warning in other languages

Attention	Le cordon d'alimentation est utilisé comme interrupteur général. La prise de courant doit être située ou installée à proximité de l'équipement et être facile d'accès.
-----------	--

## Installation Warning



Read the installation instructions before you connect the system to its power source.

Table 18 Installation warning in other languages

Waarschuwing	Raadpleeg de installatie-aanwijzingen voordat u het systeem met de voeding verbindt.
Varoitus	Lue asennusohjeet ennen jä rjestelmä n yhdistä mistä virtalä hteeseen.
Attention	Avant de brancher le système sur la source d'alimentation, consulter les directives d'installation.
Warnung	Lesen Sie die Installationsanweisungen, bevor Sie das System an die Stromquelle anschließen.
Avvertenza	Consultare le istruzioni di installazione prima di collegare il sistema all'alimentatore.

Table 18 Installation warning in other languages (continued)

Advarsel	Les installasjonsinstruksjonene før systemet kobles til strømkilden.
Aviso	Leia as instruções de instalação antes de ligar o sistema à sua fonte de energia.
Advertencia	Ver las instrucciones de instalación antes de conectar el sistema a la red de alimentación.
Varning	Läs installationsanvisningarna innan du kopplar systemet till dess strömförsörjningsenhet.

## Power Disconnect Warning



When working on a chassis or near power supplies, follow the Guided Maintenance procedures in the AxiomONE Storage Services Manager for instructions on how to work with and around power supplies. Use extreme caution because line voltages may be present within the chassis.

## Warning Statement for Norway and Sweden

Table 19 Warnings for Norway and Sweden

Advarsel	Apparatet skal kobles til en jordet stikkontakt.
Varning	Apparaten skall anslutas till jordat nätuttag.

## Restricted Access Area Warning



This unit is intended for installation in restricted access areas. A restricted access area is where access can only be gained by service personnel through the use of a special tool, lock and key, or other means of security, and is controlled by the authority responsible for the location.

## Restricted Access Warning in Other Languages

Table 20 Restricted access warning in other languages

Waarschuwing	Dit toestel is bedoeld voor installatie op plaatsen met beperkte toegang. Een plaats met beperkte toegang is een plaats waar toegang slechts door servicepersoneel verkregen kan worden door middel van een speciaal instrument, een slot en sleutel, of een ander veiligheidsmiddel, en welke beheerd wordt door de overheidsinstantie die verantwoordelijk is voor de locatie.
Varoitus	Tä mä laite on tarkoitettu asennettavaksi paikkaan, johon pä ä sy on rajoitettua. Paikka, johon pä ä sy on rajoitettua, tarkoittaa paikkaa, johon vain huoltohenkilöstö pä ä see jonkin erikoistyökalun, lukkoon sopivan avaimen tai jonkin muun turvalaitteen avulla ja joka on paikasta vastuussa olevien toimivaltaisten henkilöiden valvoma.
Attention	Cet appareil est à installer dans des zones d'accès réservé. Ces dernières sont des zones auxquelles seul le personnel de service peut accéder en utilisant un outil spécial, un mécanisme de verrouillage et une clé, ou tout autre moyen de sécurité. L'accès aux zones de sécurité est sous le contrôle de l'autorité responsable de l'emplacement.
Warnung	Diese Einheit ist zur Installation in Bereichen mit beschränktem Zutritt vorgesehen. Ein Bereich mit beschränktem Zutritt ist ein Bereich, zu dem nur Wartungspersonal mit einem Spezialwerkzeugs, Schloß und Schlüssel oder anderer Sicherheitsvorkehrungen Zugang hat, und der von dem für die Anlage zuständigen Gremium kontrolliert wird.
Avvertenza	Questa unità deve essere installata in un'area ad accesso limitato. Un'area ad accesso limitato è un'area accessibile solo a personale di assistenza tramite un'attrezzo speciale, lucchetto, o altri dispositivi di sicurezza, ed è controllata dall'autorità responsabile della zona.
Advarsel	Denne enheten er laget for installasjon i områder med begrenset adgang. Et område med begrenset adgang gir kun adgang til servicepersonale som bruker et spesielt verktøy, lås og nøkkel, eller en annen sikkerhetsanordning, og det kontrolleres av den autoriteten som er ansvarlig for området.

Table 20 Restricted access warning in other languages (continued)

Aviso	Esta unidade foi concebida para instalação em áreas de acesso restrito. Uma área de acesso restrito é uma área à qual apenas tem acesso o pessoal de serviço autorizado, que possua uma ferramenta, chave e fechadura especial, ou qualquer outra forma de segurança. Esta área é controlada pela autoridade responsável pelo local.
Advertencia	Esta unidad ha sido diseñada para instalarse en áreas de acceso restringido. Área de acceso restringido significa un área a la que solamente tiene acceso el personal de servicio mediante la utilización de una herramienta especial, cerradura con llave, o algún otro medio de seguridad, y que está bajo el control de la autoridad responsable del local.
Varning	Denna enhet är avsedd för installation i områden med begränsat tillträde. Ett område med begränsat tillträde får endast tillträdas av servicepersonal med ett speciellt verktyg, lås och nyckel, eller annan säkerhetsanordning, och kontrolleras av den auktoritet som ansvarar för området.

## Product Disposal Warning



Ultimate disposal of this product should be handled according to all national laws and regulations.

## Product Disposal Warning in Other Languages

Table 21 Product disposal warning in other languages

Waarschuwing	Dit produkt dient volgens alle landelijke wetten en voorschriften te worden afgedankt.
Varoitus	Tämä tuotteen lopullisesta hävittämisestä tulee huolehtia kaikkia valtakunnallisia lakeja ja säädöksiä noudattaen.
Attention	La mise au rebut définitive de ce produit doit être effectuée conformément à toutes les lois et réglementations en vigueur.

Table 21 Product disposal warning in other languages (continued)

Warnung	Dieses Produkt muß den geltenden Gesetzen und Vorschriften entsprechend entsorgt werden.
Avvertenza	L'eliminazione finale di questo prodotto deve essere eseguita osservando le normative italiane vigenti in materia.
Advarsel	Endelig disponering av dette produktet må skje i henhold til nasjonale lover og forskrifter.
Aviso	A descartagem final deste produto deverá ser efectuada de acordo com os regulamentos e a legislação nacional.
Advertencia	El desecho final de este producto debe realizarse según todas las leyes y regulaciones nacionales.
Varning	Slutlig kassering av denna produkt bör skötas i enlighet med landets alla lagar och föreskrifter.

## Jewelry Removal Warning

**DANGER**

Some equipment is connected to power lines. Before you work on this equipment, remove all jewelry that contains metal. Such jewelry includes rings, necklaces, and watches. Metal objects heat up when connected to power and ground. Hot metal objects can cause serious burns or weld the metal object to the terminals.

## Jewelry Removal Warning in Other Languages

Table 22 Jewelry removal warning in other languages

Waarschuwing	Alvorens aan apparatuur te werken die met elektrische leidingen is verbonden, sieraden (inclusief ringen, kettingen en horloges) verwijderen. Metalen voorwerpen worden warm wanneer ze met stroom en aarde zijn verbonden, en kunnen ernstige brandwonden veroorzaken of het metalen voorwerp aan de aansluitklemmen lassen.
Varoitus	Ennen kuin työskentelet voimavirtajohtoihin kytkettyjen laitteiden parissa, ota pois kaikki korut (sormukset, kaulakorut

Table 22 Jewelry removal warning in other languages (continued)

	ja kellot mukaan lukien). Metalliesineet kuumenevat, kun ne ovat yhteydessä sähkövirran ja maan kanssa, ja ne voivat aiheuttaa vakavia palovammoja tai hitsata metalliesineet kiinni liitäntänapoihin.
Attention	Avant d'accéder à cet équipement connecté aux lignes électriques, ôtez tout bijou (anneaux, colliers et montres compris). Lorsqu'ils sont branchés à l'alimentation et reliés à la terre, les objets métalliques chauffent, ce qui peut provoquer des blessures graves ou souder l'objet métallique aux bornes.
Warnung	Vor der Arbeit an Geräten, die an das Netz angeschlossen sind, jeglichen Schmuck (einschließlich Ringe, Ketten und Uhren) abnehmen. Metallgegenstände erhitzen sich, wenn sie an das Netz und die Erde angeschlossen werden, und können schwere Verbrennungen verursachen oder an die Anschlußklemmen angeschweißt werden.
Avvertenza	Prima di intervenire su apparecchiature collegate alle linee di alimentazione, togliersi qualsiasi monile (inclusi anelli, collane, braccialetti ed orologi). Gli oggetti metallici si riscaldano quando sono collegati tra punti di alimentazione e massa: possono causare ustioni gravi oppure il metallo può saldarsi ai terminali.
Advarsel	Fjern alle smykker (inkludert ringer, halskjeder og klokker) før du skal arbeide på utstyr som er koblet til kraftledninger. Metallgjenstander som er koblet til kraftledninger og jord blir svært varme og kan forårsake alvorlige brannskader eller smelte fast til polene.
Aviso	Antes de trabalhar em equipamento que esteja ligado a linhas de corrente, retire todas as jóias que estiver a usar (incluindo anéis, fios e relógios). Os objectos metálicos aquecerão em contacto com a corrente e em contacto com a ligação à terra, podendo causar queimaduras graves ou ficarem soldados aos terminais.
Advertencia	Antes de operar sobre equipos conectados a líneas de alimentación, quitarse las joyas (incluidos anillos, collares y relojes). Los objetos de metal se calientan cuando se conectan a la alimentación y a tierra, lo que puede ocasionar quemaduras graves o que los objetos metálicos queden soldados a los bornes.
Varning	Tag av alla smycken (inklusive ringar, halsband och armbandsur) innan du arbetar på utrustning som är kopplad till kraftledningar. Metallobjekt hettas upp när de kopplas ihop med

Table 22 Jewelry removal warning in other languages (continued)

	ström och jord och kan förorsaka allvarliga brä nnskador; metallobjekt kan också sammansvetsas med kontakterna.
--	---

## Qualified Personnel Warning



Only qualified personnel should install or replace this equipment.

Table 23 Qualified personnel warning in other languages

Waarschuwing	Installatie en reparaties mogen uitsluitend door getraind en bevoegd personeel uitgevoerd worden.
Varoitus	Ainoastaan koulutettu ja pä tevä henkilökunta saa asentaa tai vaihtaa tä mä n laitteen.
Avertissement	Tout installation ou remplacement de l'appareil doit être réalisé par du personnel qualifié et compétent.
Achtung	Gerä t nur von geschultem, qualifiziertem Personal installieren oder auswechseln lassen.
Avvertenza	Solo personale addestrato e qualificato deve essere autorizzato ad installare o sostituire questo apparecchio.
Advarsel	Kun kvalifisert personell med riktig opplæring bØ r montere eller bytte ut dette utstyret.
Aviso	Este equipamento deverá ser instalado ou substituí do apenas por pessoal devidamente treinado e qualificado.
Atenció n	Estos equipos deben ser instalados y reemplazados exclusivamente por personal técnico adecuadamente preparado y capacitado.
Varning	Denna utrustning ska endast installeras och bytas ut av utbildad och kvalificerad personal.



## Warning Statement for Finland

Table 24 Warning statement for Finland

Varoitus	Alleviates ja suojalukitus ohitettaessa olet alttiina näkymättömälle lasersäteilylle. Äjã katso säteeseen.
----------	--

## Warning Statement for Sweden

Table 25 Warning statement for Sweden

Varning	Osynlig laserstrå lning nä r denna del ä r öppen och förregleringen ä r urkopplad. Rikta inte blicken in mot strå len.
---------	--

## Power Cabling Warning

**DANGER**

Secure all power cabling when you install this unit to avoid disturbing field-wiring connections.

## Power Cabling Warning in Other Languages

Table 26 Power cabling warning in other languages

Waarschuwing	Zet alle stroomkabels vast wanneer dit toestel wordt geïnstalleerd om te voorkomen dat de verbindingen van de veldbedrading worden verstoord.
Varoitus	Kiinnitä kaikki voimakaapelit tiukkaan tä tä laitetta asentaessasi, jotta vä ltä t kentä n johdinkytkentöjen vioittumista.
Attention	Lors de l'installation de cet appareil, fixer tous les câ bles d'alimentation pour éviter de provoquer des perturbations aux raccordements des câ blages propres au site.

Table 26 Power cabling warning in other languages (continued)

Warnung	Bei der Installation dieser Einheit die Netzverkabelung befestigen, um die Störung von Feldkabelanschlüssen zu vermeiden.
Avvertenza	In fase di installazione dell'unità, assicurare tutti i cablaggi di alimentazione per evitare di alterare i collegamenti degli avvolgimenti di campo.
Advarsel	Når denne enheten installeres, må alle kraftledninger sikres for å unngå at feltkabelkoblingene forstyrres.
Aviso	Para evitar problemas com as ligações de rede de campanha, prenda todos os cabos de corrente quando instalar esta unidade.
Advertencia	Sujetar todo el cableado de alimentación cuando se instale este equipo para evitar que se mezcle con las conexiones del cableado "in situ".
Varning	Fäst allt starkströmskablage vid installation av denna enhet så att fästkopplingen inte rubbas.

## Supply Circuit Warning

**DANGER**

Do not overload the circuit when you connect components to the power supply.

## Supply Circuit Warning in Other Languages

Table 27 Supply circuit warning in other languages

Waarschuwing	Let erop dat de toestellen op voedingscircuits worden aangesloten zonder het vermogen van de bedrading te overschrijden.
Varoitus	Laiteyksiköt on yhdistettävä huolellisesti syöttöpiiriin niin, että johdot eivät ole ylikuormitettuja.

Table 27 Supply circuit warning in other languages (continued)

Avertissement	Veillez à bien connecter les unités au circuit d'alimentation afin de ne pas surcharger les connexions.
Achtung	Beim Anschließen der Geräte an das Stromnetz ist darauf zu achten, daß die Schaltverbindungen nicht überlastet werden.
Avvertenza	Fare attenzione quando si collegano le unità al circuito di alimentazione, per non sovraccaricare i cablaggi.
Advarsel	Vær nøye med å koble enheter til strømforsyningskretsen slik at ledningene ikke overbelastes.
Aviso	Deverá ter precaução ao ligar unidades ao circuito de fornecimento de energia, para não sobrecarregar a instalação.
Atención	Poner mucho cuidado al conectar los equipos al circuito de alimentación a fin de no sobrecargar el cableado.
Varning	Var noga vid anslutning av enheter till matarströmkretsen så att ledningarna inte överbelastas.

## Voltage Mismatch Warning

**DANGER**

A voltage mismatch can cause equipment damage and may pose a fire hazard. If the voltage indicated on the label differs from the power outlet voltage, do not connect the chassis to that receptacle.

## Voltage Mismatch Warning in Other Languages

Table 28 Voltage mismatch warning in other languages

Waarschuwing	Aansluiting op een verkeerd voedingsvoltage kan beschadiging van de apparatuur veroorzaken en tot brandgevaar leiden. Het chassis mag niet aangesloten worden als de spanning die op het label staat aangegeven, anders is dan de spanning van het stopcontact.
Varoitus	Erisuuruisten ja nnitteiden yhdistäminen voi aiheuttaa laitevaurion ja tulipalon vaaran. Jos tarraan merkittyjä nnte

Table 28 Voltage mismatch warning in other languages (continued)

	eroaa pistorasian jä nnitteestä , ä lä yhdistä asennuspohjaa pistorasiaan.
Avertissement	Une erreur de voltage risque d'endommager l'appareil et constitue un risque d'incendie. Si la tension indiquée sur l'étiquette est différente de la tension de l'alimentation, ne connectez en aucun cas le châ ssis à la prise.
Achtung	Bei nicht ü bereinstimmender Spannung kann es zu Gerä teschä den und Feuergefahr kommen. Wenn die auf dem Etikett angegebene Spannung nicht mit der Steckdosenspannung ü bereinstimmt, schließ en Sie das Gerä t nicht an diese Steckdose an.
Avvertenza	Una tensione inadeguata puõcausare danni all'apparecchio e rischio di incendio. Se la tensione riportata sulla targhetta è diversa da quella della presa di alimentazione, non collegare lo chassis a tale presa.
Advarsel	Ulik spenning kan forå rsake skade på utstyret og inneb\xbe re brannfare. Dersom spenningen på merkelappen er forskjellig fra spenningen i stikkontakten, må du ikke koble kabinettet til den stikkontakten.
Aviso	Uma voltagem incorrecta poderá causar danos no equipamento e constituir um risco de incêndio. Se a voltagem indicada na etiqueta for diferente da voltagem de saí da de corrente da parede, não ligue o chassis a esse receptá culo.
Atenció n	Las diferencias en el voltaje pueden causar dañ os a los equipos y presentar peligro de incendio. Si el voltaje indicado en la etiqueta es diferente al de la toma de alimentació n, no conectar el chasis a dicha toma.
Varning	Inkompatibla spä nningar kan resultera i materiella skador samt utgör brandfara. Om den spä nning som anges på etiketten skiljer sig frå n strömuttagets spä nning ska chassit inte anslutas till detta uttag.

## SELV Circuit Warning



To avoid electric shock, do not connect safety extra-low voltage (SELV) circuits to telephone-network voltage (TNV) circuits. LAN ports contain SELV circuits, and WAN ports contain TNV circuits. Some LAN and WAN ports both use RJ-45 connectors. Use caution when connecting cables.

## SELV Circuit Warning in Other Languages

Table 29 SELV circuit warning in other languages

<p>Waarschuwing</p>	<p>Om elektrische schokken te vermijden, mogen veiligheidscircuits met extra lage spanning (genaamd SELV = Safety Extra-Low Voltage) niet met telefoonnetwerkspanning (TNV) circuits verbonden worden. LAN (Lokaal netwerk) poorten bevatten SELV circuits en WAN (Regionaal netwerk) poorten bevatten TNV circuits. Sommige LAN en WAN poorten gebruiken allebei RJ-45 connectors. Ga voorzichtig te werk wanneer u kabels verbindt.</p>
<p>Varoitus</p>	<p>Jotta vä ltyt sä hköiskulta, ä lä kytke pieniä nnitteisiä SELV-suojapiirejä puhelinverkkojä nnitettä (TNV) kä yttä viin virtapiireihin. LAN-portit sisä ltä vä t SELV-piirejä ja WAN-portit puhelinverkkojä nnitettä kä yttä viä piirejä . Osa sekä LAN- että WAN-porteista kä yttä ä RJ-45-liittimiä . Ole varovainen kytkiessä si kaapeleita.</p>
<p>Attention</p>	<p>Pour éviter une électrocution, ne raccordez pas les circuits de sécurité basse tension (Safety Extra-Low Voltage ou SELV) à des circuits de tension de réseau téléphonique (Telephone Network Voltage ou TNV). Les ports du réseau local (LAN) contiennent des circuits SELV et les ports du réseau longue distance (WAN) sont munis de circuits TNV. Certains ports LAN et WAN utilisent des connecteurs RJ-45. Raccordez les câ bles en prenant toutes les précautions nécessaires.</p>
<p>Warnung</p>	<p>Zur Vermeidung von Elektroschock die Sicherheits-Kleinspannungs-Stromkreise (SELV-Kreise) nicht an Fernsprechnetzspannungs-Stromkreise (TNV-Kreise) anschließen. LAN-Ports enthalten SELV-Kreise, und WAN-</p>

Table 29 SELV circuit warning in other languages (continued)

	Ports enthalten TNV-Kreise. Einige LAN- und WAN-Ports verwenden auch RJ-45-Steckverbinder. Vorsicht beim Anschließen von Kabeln.
Avvertenza	Per evitare scosse elettriche, non collegare circuiti di sicurezza a tensione molto bassa (SELV) ai circuiti a tensione di rete telefonica (TNV). Le porte LAN contengono circuiti SELV e le porte WAN contengono circuiti TNV. Alcune porte LAN e WAN fanno uso di connettori RJ-45. Fare attenzione quando si collegano cavi.
Advarsel	Unngå å koble lavspenningskretser (SELV) til kretser for telenettspenning (TNV), slik at du unngår elektrisk støt. LAN-utganger inneholder SELV-kretser og WAN-utganger inneholder TNV-kretser. Det finnes både LAN-utganger og WAN-utganger som bruker RJ-45-kontakter. Vår forsiktige når du kobler kabler.
Aviso	Para evitar choques eléctricos, não conecte os circuitos de segurança de baixa tensão (SELV) aos circuitos de tensão de rede telefónica (TNV). As portas LAN contêm circuitos SELV e as portas WAN contêm circuitos TNV. Algumas portas LAN e WAN usam conectores RJ-45. Tenha o devido cuidado ao conectar os cabos.
Advertencia	Para evitar la sacudida eléctrica, no conectar circuitos de seguridad de voltaje muy bajo (safety extra-low voltage = SELV) con circuitos de voltaje de red telefónica (telephone network voltage = TNV). Los puertos de redes de área local (local area network = LAN) contienen circuitos SELV, y los puertos de redes de área extendida (wide area network = WAN) contienen circuitos TNV. En algunos casos, tanto los puertos LAN como los WAN usan conectores RJ-45. Proceda con precaución al conectar los cables.
Varning	För att undvika elektriska stötar, koppla inte säkerhetskretsar med extra låg spänning (SELV-kretsar) till kretsar med telefonnätspänning (TNV-kretsar). LAN-portar innehåller SELV-kretsar och WAN-portar innehåller TNV-kretsar. Vissa LAN- och WAN-portar är försedda med RJ-45-kontakter. Iaktta försiktighet vid anslutning av kablar.

## Incorrect Connection Warning



Incorrect connection of this equipment to a general purpose outlet could result in a hazardous situation.

## Incorrect Connection Warning in Other Languages

Table 30 Connection warning in other languages

Waarschuwing	Incorrecte aansluiting van deze of aangesloten apparatuur op een stopcontact voor algemene doeleinden kan een gevaarlijke situatie tot gevolg hebben.
Varoitus	Tä mää n laitteen tai siihen liitettyjen laitteiden virheellinen kytkentä yleispistorasiaan voi aiheuttaa vaaratilanteen.
Attention	Un branchement incorrect de cet équipement ou de l'équipement branché à une prise d'usage général peut créer une situation dangereuse.
Warnung	Inkorrektes Anschließen von diesem oder damit verbundenen Geräten an einer Allzwecksteckdose kann eine Gefahrensituation verursachen.
Avvertenza	Un collegamento errato di questo apparecchio, o dell'apparecchiatura a esso collegato, a una presa di uso generale può causare una situazione pericolosa.
Advarsel	Feil kobling av dette utstyret eller tilhørende utstyr til et vanlig uttak kan føre til farlige situasjoner.
Aviso	Uma conexão incorrecta a uma ficha de alimentação eléctrica normal, deste ou de qualquer equipamento a este conectado, poderá resultar numa situação potencialmente perigosa.
Advertencia	La conexión incorrecta de este equipo, o del equipo conectado, a una toma o receptáculo de tipo general podrá resultar en una situación peligrosa.
Varning	Felaktig koppling av denna eller ansluten utrustning till ett universaluttag kan orsaka riskfylld situation.

## Caution Notices

 CAUTION

It is required that, if interconnecting equipment resides within more than one equipment rack, these racks should be at the same ground potential.

 CAUTION

When handling any electronic device, be sure to take electrostatic discharge (ESD) precautions. The minimum requirement is a properly grounded antistatic wrist strap and grounding wire.

 CAUTION

If removal of a FRU or blanking plate leaves a hole, block the hole quickly with a blanking plate or by installing a replacement FRU. Failure to do this can disrupt airflow and seriously reduce cooling.

 CAUTION

Ambient temperature within the rack may be greater than that of the room. With regard to the maximum rated ambient for Axiom components, do not reduce the amount of airflow that is required for safe operation.

 CAUTION

Never block the ventilation holes in a chassis. Sufficient air circulation is required for the internal components to operate properly and to prevent the possibility of fire. Do not push objects of any kind into the ventilation holes. Such action could result in fire or electrical shock. Keep all liquids away from Axiom components.

 CAUTION

Ensure that component weight distribution in the rack is balanced. Uneven weight distribution can cause hazardous instability. The rack should have stabilization feet or brackets installed, or have another means that does not allow the rack to tip when you service it. At a minimum, we recommend that you install stabilization brackets on the rear feet of the rack because the rack is front-heavy.

 CAUTION

Slammers weigh 100 lb (45.4 kg). To handle them safely, use an appropriate number of persons.



 **CAUTION**

Qualified personnel are advised to exercise great care at all times when they work on an Axiom system. Remember to:

- Remove rings, watches, or other jewelry and neckties before you begin any procedure.
- Use caution near fan assemblies; the moving parts can change speed unexpectedly.
- Use the correct tools for the job.
- Keep all paperwork up to date, complete, and accurate.

 **CAUTION**

The sum of the ratings of the components that plug into the PDU must be less than 80% of the current and power ratings of the PDU. Similarly, the current rating of the PDU must be less than 80% of the rating for the building supply circuit.

 **CAUTION**

A Brick weighs up to 65 lb (29.5 kg). For safe handling, use two people to lift it.

## APPENDIX C

# Pillar Axiom Hardware Specifications

## About Hardware Specifications

Hardware specifications (sometimes called data sheets):

- Describe the system's operating environment.
- List the agency approvals.
- List physical attributes of the Pillar Axiom storage system and its hardware components.

## About Pillar Axiom Hardware Specifications

A Pillar Axiom storage system is an assembly of the following components, all of which are described in this appendix:

- One Pilot management controller. See [About Hardware Specifications](#).
- One to four Slammer storage controllers. See [About Slammer Hardware Specification](#).
- One to 64 Brick storage enclosures. See [About Brick Hardware Specification](#).
- One to four PDUs per rack, the number of which depends on power inlet characteristics and the number of components in each rack. See [Pillar Axiom PDU Hardware Specification](#).
- One to four 42U racks, the number of which depends on the configuration of Slammers and Bricks. See [Pillar Rack Hardware Specification](#).

A Pillar Axiom storage system has the characteristics that are described on the following pages.

## System Power Requirements

Pillar Axiom storage systems require one of the power inputs shown below. The voltage and frequency show minimum and maximum values.

- 100-120 V, 47-63 Hz, 20 A
- 200-240 V, 47-63 Hz, 20 A
- 100-120 V, 47-63 Hz, 30 A
- 200-240 V, 47-63 Hz, 30 A
- 230 V, 16 A or 32 A (Europe)
- Wye-connected 3-phase:
  - USA: 199-217 V, 47-63 Hz, 30 A
  - Europe: 380-415 V, 47-63 Hz, 16 A

The total power required by a rack depends on the number and type of hardware that is in the rack.

## System Environmentals

Table 31 System altitude specifications

Mode	Elevation
Operational	-200 to 10,000 ft (-61 to 3048 m)
Non-operational	-200 to 40,000 ft (-61 to 12,192 m)

Table 32 System temperature and humidity specifications

Mode	Temperature	Non-condensing humidity	Max wet bulb temperature	Gradient
Operational	+41 to 104°F (5 to 40°C) up to 7000 ft	10–85% 10%/hr gradient	86°F (30°C)	36°F/hr (20°C/hr)
Non-operational	-40 to 158°F (-40 to 70°C)	5–95% 10%/hr gradient	104°F (40°C)	54°F/hr (30°C/hr)

**Note:** For Bricks that have five-platter disk drives, the maximum ambient operational temperature from 7000 ft to 10,000 ft is 95°F (35°C).

## Pillar Axiom Acoustics

Acoustics for a Pillar Axiom system that comprises the following components were tested to ISO 7779 by standard specifications:

- One Pilot
- One NAS Slammer
- Three Bricks

Such a system generates an acoustic level that is no greater than 70 dBA.

**Table 33 System acoustics specification**

Acoustic level (tested to ISO7779)
<p>Does not exceed 6.5 Bels under normal conditions, which is:</p> <ul style="list-style-type: none"> <li>• 73.4°F (23°C) ambient</li> <li>• All fans operational</li> <li>• No fault conditions</li> </ul> <p>The acoustic level will increase under fault conditions.</p>

## System Random Vibration Specifications

**Table 34 System random vibration specifications**

Mode	Force	Frequency	Time
Operational	0.1 G RMS	3–100 hz (X, Y, and Z axis)	15 min
Non-operational	Administered using the Telcordia GR-63 CORE test specifications. Tested with the rack inside a shipping crate.		

## System Regulatory Agency Compliance

Agency approvals are based on a Pillar Axiom system that consists of:

- One Pilot
- Two Slammers
- Twelve Bricks





This section identifies:

- [Regulatory Agency Compliances](#)
- [FCC Warning Statement](#)
- [European Union Compliance Statement](#)

## Regulatory Agency Compliances

The Pillar Axiom storage system complies with the following regulatory agency requirements.

**Table 35 Safety, quality, and environmental standards**

Logo	Standard
	FCC (United States). This device complies with FCC Rules Part 15. Operation is subject to the following two conditions: <ol style="list-style-type: none"> <li>1 This device may not cause harmful interference.</li> <li>2 This device must accept any interference that may be received, including interference that may cause undesired operation.</li> </ol>
	CB Scheme by IEC standard IEC 60950, First Edition
	Conformite Europeenne /DoC
	UL and CSA under UL (cUL)
	TUV/GS
	<p>Pillar Data Systems offers customers a recycle program to properly dispose of surplus products and products that have reached their end of life. Equipment that is returned to Pillar through this program is disposed of in an environmentally safe manner using processes that comply with the WEEE (EU Directive on Waste Electrical and Electronic Equipment) regulations.</p> <p>Pillar provides (on request) documentation about product disposition when the recycling process is complete. Upon request, Pillar also provides a Certificate of Destruction, which releases the customer from further liability for the equipment returned through the Recycle program.</p> <p>Customers should contact Pillar Customer Service for information on the logistics and location(s) of the approved recycle facilities.</p>

**Table 35 Safety, quality, and environmental standards (continued)**

Logo	Standard
	<p>Pillar Data Systems objectives are to ensure that our high product quality and reliability standards are met through the processes that have been verified and approved. This is achieved through ISO 9001:2000 and the development and deployment of Pb-free solder qualification guidelines for components (RoHS), interconnects, and PCB, PCA reliability. Pillar will continue to work with industry consortia to define common qualification criteria. Pillar will apply Pb-free solder technologies to product designs as required by legislation.</p>
	<p>ISO 9001:2000 Registered manufacturing process</p>

## FCC Warning Statement

This equipment has been tested and found to comply with the limits for a Class A digital device, pursuant to part 15 of the FCC rules. These limits are designed to provide reasonable protection against harmful interference when the equipment is operated in a commercial environment.

This equipment generates, uses, and can radiate radio-frequency energy and, if not installed and used in accordance with the instruction manual, may cause harmful interference to radio communications. Operation of this equipment in a residential area is likely to cause harmful interference, in which case users will be required to correct the interference at their own expense.

You can determine if your equipment causes interference by turning it off. If the interference stops, it was probably caused by the equipment or one of its peripheral devices. If the equipment causes interference to radio or television reception, try to correct the interference by using one or more of the following measures:

- Turn the television or radio antenna until the interference stops.
- Move the equipment to one side or the other of the television or radio.
- Move the equipment farther away from the television or radio.
- Plug the equipment into an outlet that is on a different circuit from the television or radio. (That is, make certain the equipment and the television or radio are on circuits that are controlled by different circuit breakers or fuses.)



Changes or modifications that are not expressly approved by the party that is responsible for compliance could void the user's authority to operate the equipment.

## European Union Compliance Statement

This product is in conformity with the protection requirements of EC Council Directive 89/336/EEC on the approximation of the laws of the Member States relating to electro-magnetic compatibility. The manufacturer cannot accept responsibility for any failure to satisfy the protection requirements that result from a non-recommended modification of the product.

This product has been tested and found to comply with the limits for Class A Information Technology Equipment according to CISPR 22/European Standard EN 55022. The Limits for Class A equipment were derived for residential environments to provide reasonable protection against interference with licensed communication equipment.

A Declaration of Conformity with the requirements of the Directive has been signed by Pillar Data Systems, 2840 Junction Avenue, San Jose, CA 95134.

The following standards were applied:

- 1 Emissions: EN55022 (Class A radiated and conducted, 110 V, 240 V)
- 2 EMC: EN55024 (immunity):
  - EN 61000-3-2
  - EN 61000-3-3
  - EN 61000-4-2 ESD:±4 kV contact,±8 kV air touch
  - EN 61000-4-3 Radiated immunity (within the limits that are listed in our technical specifications)
  - EN 61000-4-4 Electrical fast transients/burst:±1 kV AC,±0.5 kV I/O
  - EN 61000-4-5 Surges ±1 kV differential mode,±2 kV common mode
  - EN 61000-4-6 Conducted immunity: 3 V
  - EN 61000-4-11 Supply dips and interruptions: 30% and 100%

## System Packaging and Transportation

Packaging meets the following requirements:



- For packages under 150 lb—International Safe Transit Association (ISTA 2A) Procedures 1 and 2.
- For packages over 150 lb—Network Equipment Building System (NEBS) core standards.  
GR-63-CORE, Packaged Equipment Shock (4.3.1), Office Vibration (4.4.3) and Transportation Vibration (4.4.4).

## System Warranty

Hardware components in a Pillar Axiom storage system are covered by a three-year warranty.

## About Hardware Specifications

A is an active management and provisioning front end as well as the administrator interface to a .

### Pilot Dimensions and Weight

Table 36 Pilot dimensions and weight (both control units)

Attribute	Value
Height	3.5 in (8.9 cm); 2U
Width	17.7 in (45.0 cm)
Depth	20-26 in (50.8-66.0 cm)
Weight	40 lb (18.1 kg)

### Pilot Power Characteristics

Table 37 Pilot power characteristics (per control unit)

Power characteristic	Value
Frequency	47 to 63 Hz
AC voltage	100 to 240 V
Current draw	1.5 A at 115 V 0.8 A at 230 V
Max power consumption	143 VA
Max heat dissipation	750 BTU/hr
AC plug type	2 IEC 320 connection

## Pilot Regulatory Agency Compliance

This equipment has been tested and found to comply with the limits for a class B digital device, pursuant to part 15 of the FCC rules. These limits are designed to provide reasonable protection against harmful interference when the equipment is operated in a commercial environment.

This equipment generates, uses, and can radiate radio frequency energy and, if not installed and used in accordance with the instruction guide, may cause harmful interference to radio communications. Operation of this equipment in a residential area is may cause harmful interference, in which case the user must correct the interference at his own expense.

[other]                      The changes or modifications not expressly approved by the party responsible for compliance could void the user's authority to operate the equipment.

[other]                      Shielded interface cables and A.C. power cord, if any, must be used in order to comply with the emission limits.

VOIR LA NOTICE D'INSTALLATION AVANT DE RACCORDER AU RESEAU.

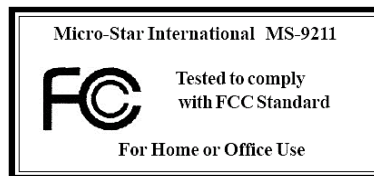

Table 38 Pilot safety and quality standards

Logo	Standard
	FCC (United States). This device complies with FCC Rules Part 15 for a class B digital device.
CE	Conformite Europeenne /DoC

## Pilot Packaging and Transportation

Pilot packaging meets the following requirements:

- For packages under 150 lb—International Safe Transit Association (ISTA 2A) Procedures 1 and 2.
- For packages over 150 lb—Network Equipment Building System (NEBS) core standards.

GR-63-CORE, Packaged Equipment Shock (4.3.1), Office Vibration (4.4.3) and Transportation Vibration (4.4.4).

## About Slammer Hardware Specification

Slammers are fully redundant controllers within a Pillar Axiom storage system. A Slammer can be ordered as either a SAN or a NAS front end.

## Slammer Dimensions and Weight

Table 39 Slammer dimensions and weight

Attribute	Value
Height	7 in (17.78 cm); 4U
Width	17.72 in (45 cm)
Depth	26 in (66 cm)
Weight	100 lb (45.4 kg)

## Slammer Power Characteristics



Table 40 Slammer power characteristics

Power characteristic	Value
Frequency	47 to 63 Hz
AC voltage	100–120 V to 200–240 V
Max power consumption	685 VA
Current draw (combined for both control units)	6.1 A at 115 V 3.2 A at 230 V
Max heat dissipation	2220 BTU/hr
AC plug type	Four IEC 320 C13 connection

## Slammer Regulatory Agency Compliance

Pillar Axiom Slammers comply with the following regulatory agency requirements.

**Table 41 Slammer safety and quality standards**

Logo	Standard
	FCC (United States). This device complies with FCC Rules Part 15. Operation is subject to the following two conditions: <ol style="list-style-type: none"> <li>1 This device may not cause harmful interference and</li> <li>2 This device must accept any interference that maybe received, including interference that may cause undesired operation.</li> </ol>
	CB Scheme by IECEE standard IEC 60950, Third Edition (1999)
	Conformite Europeenne /DoC
	UL and CSA under UL (cUL)
	TUV/GS
	ISO 9001:2000 Registered manufacturing process

**Table 42 Slammer EM emissions and immunity**

Standard
<ul style="list-style-type: none"> <li>• CISPR 22-A</li> <li>• EN55022 Class A radiated and conducted emissions (110 V, 220 V)</li> <li>• EN55024 Immunity:                             <ul style="list-style-type: none"> <li>• EN 61000-3-2</li> <li>• EN 61000-3-3</li> <li>• EN 61000-4-2 ESD: ±4 kV contact, ±8 kV air</li> <li>• EN 61000-4-3 Radiated immunity (within the limits that are listed in our technical specifications)</li> <li>• EN 61000-4-4 Electrical fast transients/burst: ±1 kV AC, ±0.5 kV I/O</li> <li>• EN 61000-4-5 Surges ±1 kV differential mode, ±2 kV common mode</li> </ul> </li> </ul>

**Table 42 Slammer EM emissions and immunity (continued)**

Standard
<ul style="list-style-type: none"> <li>• EN 61000-4-6 Conducted immunity: 3 V</li> <li>• EN 61000-4-8</li> <li>• EN 61000-4-11 Supply dips and interruptions: 30% and 100%</li> </ul>

## Slammer Packaging and Transportation

Packaging meets the following requirements:

- For packages under 150 lb—International Safe Transit Association (ISTA 2A) Procedures 1 and 2.
- For packages over 150 lb—Network Equipment Building System (NEBS) core standards.

GR-63-CORE, Packaged Equipment Shock (4.3.1), Office Vibration (4.4.3) and Transportation Vibration (4.4.4).

## About Brick Hardware Specification

A Brick is a high-performance disk subsystem with an optimized, proprietary RAID controller.

## Brick Dimensions and Weight

Table 43 Brick dimensions and weight

Attribute	Value
Height	3.5 in (8.89 cm); 2U
Width	17.72 in (45 cm)
Depth	22 in (55.88 cm)
Weight (SATA)	65 lb (29.5 kg)
Weight (FC)	70 lb (31.8kg)

## Brick Power Characteristics

Table 44 Brick power characteristics



Power characteristic	Value
Frequency	47 to 63 Hz
AC voltage	100–120 V to 200–240 V
Max power consumption (SATA)	267 VA
Max power consumption (FC)	330 VA
Current draw (SATA)	2.55 to 1.17 A at 115 or 230 V
Current draw (FC)	3.35 to 1.49 A at 115 or 230 V
Max heat dissipation	1370 BTU/hr
AC plug type	Two IEC 320 connections



## Brick Regulatory Agency Compliance

Pillar Axiom Bricks comply with the following regulatory agency requirements.

**Table 45 Brick safety and quality standards**

Logo	Standard
	FCC (United States). This device complies with FCC Rules Part 15. Operation is subject to the following two conditions: <ol style="list-style-type: none"> <li>1 This device may not cause harmful interference and</li> <li>2 This device must accept any interference that maybe received, including interference that may cause undesired operation.</li> </ol>
	CB Scheme by IECEE standard IEC 60950, Third Edition (1999)
	Conformite Europeenne /DoC
	UL and CSA under UL (cUL)
	TUV/GS
	ISO 9001:2000 Registered manufacturing process

**Table 46 Pillar Axiom EM emissions and immunity**

Standard
<ul style="list-style-type: none"> <li>• CISPR 22-A</li> <li>• EN55022 Class A radiated and conducted emissions (110 V, 220 V)</li> <li>• EN55024 Immunity:                             <ul style="list-style-type: none"> <li>• EN 61000-3-2</li> <li>• EN 61000-3-3</li> <li>• EN 61000-4-2 ESD: ±4 kV contact, ±8 kV air</li> <li>• EN 61000-4-3 Radiated immunity (within the limits that are listed in our technical specifications)</li> <li>• EN 61000-4-4 Electrical fast transients/burst: ±1 kV AC, ±0.5 kV I/O</li> </ul> </li> </ul>

**Table 46 Pillar Axiom EM emissions and immunity (continued)**

Standard
<ul style="list-style-type: none"> <li>• EN 61000-4-5 Surges <math>\pm 1</math> kV differential mode, <math>\pm 2</math> kV common mode</li> <li>• EN 61000-4-6 Conducted immunity: 3 V</li> <li>• EN 61000-4-11 Supply dips and interruptions: 30% and 100%</li> </ul>

## Brick Packaging and Transportation

Packaging meets the following requirements:

- For packages under 150 lb—International Safe Transit Association (ISTA 2A) Procedures 1 and 2.
- For packages over 150 lb—Network Equipment Building System (NEBS) core standards.

GR-63-CORE, Packaged Equipment Shock (4.3.1), Office Vibration (4.4.3) and Transportation Vibration (4.4.4)

## Pillar Axiom PDU Hardware Specification

If you install non-Pillar PDUs, they must meet the Pillar Data Systems PDU specification, as outlined below.

Table 47 PDU specifications

Criteria	20 amp single-phase	30 amp single-phase	3-phase
Form factor	EIA Rack Mountable  1 U high (1.75 in, 4.45 cm)  < 8 in (20.3 cm) deep	EIA Rack Mountable  1 U high (1.75 in, 4.45 cm)  < 8 in (20.3 cm) deep	EIA Rack Mountable  2 U high (3.5 in, 8.9 cm)  9.5 in (24.13 cm) deep
Receptacles IEC 60320	C13, 12 receptacles min. Mounted on rear of chassis (opposite circuit breakers).	C13, 12 receptacles min. Mounted on rear of chassis (opposite circuit breakers).	C13, 24 receptacles (8 per phase) min. Mounted on back of chassis (opposite circuit breakers).
Inlet cable	15 ft (4.572 m) min  Plug options: L6-20P, L5-20P	15 ft (4.572 m) min  Plug options: L6-30P, L5-30P	15 ft (4.572 m) min  NEMA L21-30P
Voltage input	100–240 VAC	100–240 VAC	120-208 VAC 3-phase
Voltage output	100–240 VAC	100–240 VAC	120 VAC 1-phase
Circuit breakers (CB)	Two, 10 A ea.  Each circuit breaker controls half of the outlet receptacles.	Two, 15 A ea.  Each circuit breaker controls half of the outlet receptacles.	One main, 30 A  Three secondary, 20 A each

**Table 47 PDU specifications (continued)**

Criteria	20 amp single-phase	30 amp single-phase	3-phase
Receptacle retention device	All receptacles have a plug retention device.	All receptacles have a plug retention device.	All receptacles have a plug retention device.
Inlet cable retention device	If a detachable inlet cable is provided, a cable retention device is included.	NA	NA
EMI/RFI filter	Common Mode Insertion Loss 10 db @ 1 MHz, Differential Mode 30 db @ 1 MHz. MHz/db - .15/6, .50	Common Mode Insertion Loss 10 db @ 1 MHz, Differential Mode 30 db @ 1 MHz. MHz/db - .15/6, .50	Common mode insertion loss 25 db @ 1 MHz. Differential mode insertion loss 22 db @ 1 MHz. MHz/db - .15/6, .50
Surge suppression	270 VAC	320 VAC	275 VAC

## Pillar Rack Hardware Specification

A Pillar Axiom 42 U rack contains:

- One Pilot.
- One or two NAS or SAN Slammers.
- One to 16 Bricks. The exact number of Bricks depends on the number of Slammers in the rack.
- One to four power distribution units.

Table 48 Rack specifications for a Pillar Axiom system

Criteria	Pillar rack	Non-Pillar rack (minimum requirements)
Height (inside)	42 U 73.6 in (187 cm)	42 U to hold one Pilot, one or two Slammers, and up to 15 Bricks  18 U to hold one Pilot, one Slammer, and up to four Bricks  73.6 in (187 cm)
Width (inside)	17.7 in (45 cm)	<ul style="list-style-type: none"> <li>• 19 in (48.26 cm) panel</li> <li>• 17.7 in (45 cm) rail-to-rail</li> </ul>
Height (outside)	78.7 in (199.9 cm)	NA
Width	<ul style="list-style-type: none"> <li>• 23.8 in (60.48 cm) overall</li> <li>• 17.7 in (45 cm) rail-to-rail</li> <li>• 19 in (48.26 cm) panel</li> </ul>	NA
Depth (inside)	<ul style="list-style-type: none"> <li>• 35 in (88.9 cm)</li> <li>• 26–30 in (66–76.2 cm) rail-to-rail</li> </ul>	<ul style="list-style-type: none"> <li>• 35 in (88.9 cm) overall</li> <li>• 26–30 in (66–76.2 cm) rail-to-rail</li> </ul>
Front door	<ul style="list-style-type: none"> <li>• Vented</li> <li>• Light-tint Plexiglas</li> <li>• 1.5 in (3.81 cm) deep</li> <li>• Lockable</li> <li>• Open left/right</li> </ul>	<ul style="list-style-type: none"> <li>• Vented</li> <li>• 1 in (2.54 cm) deep min.</li> <li>• 1 in (2.54 cm) clearance between front vertical channel and inside of frame</li> </ul>

**Table 48 Rack specifications for a Pillar Axiom system (continued)**

Criteria	Pillar rack	Non-Pillar rack (minimum requirements)
	<ul style="list-style-type: none"> <li>1 in (2.54 cm) clearance between front vertical channel and inside of frame</li> </ul>	
Rear door	<ul style="list-style-type: none"> <li>Vented</li> <li>Lockable</li> <li>Open left/right</li> </ul>	Vented
Sides	<ul style="list-style-type: none"> <li>Solid</li> <li>Removable</li> <li>Lockable</li> <li>1 in (2.54 cm) between side and frame</li> </ul>	NA
Vertical channels	<ul style="list-style-type: none"> <li>Square- or round-hole unthreaded</li> <li>26 in (66 cm) apart</li> </ul>	<ul style="list-style-type: none"> <li>EIA spacing</li> <li>Front-to-rear mounting</li> <li>Cage nuts</li> <li>Square or round EIA-standard mounting holes preferred</li> </ul>
Vents	<ul style="list-style-type: none"> <li>Front and back doors</li> <li>Top</li> </ul>	<ul style="list-style-type: none"> <li>Front and back doors</li> <li>Top</li> </ul>
PDU	<ul style="list-style-type: none"> <li>4 PDUs</li> <li>90–240 VAC, 50-60 Hz</li> <li>20-30 A</li> <li>42 C13 outlets</li> <li>Horizontal mount</li> </ul>	<ul style="list-style-type: none"> <li>Redundant power</li> <li>90–240 VAC, 50-60 Hz</li> <li>8350 watts/1991 watts</li> </ul>
Heat dissipation	28,500 BTU/hr/6793 BTU/hr	28,500 BTU/hr/6793 BTU/hr
Frame gauge		12-14
Loaded weight	1505 lb (683 kg)/730 lb (332 kg)	1505 lb (683 kg)/730 lb (332 kg)
Topple angle when fully loaded and stationary	12° when front of rack faces downward 24° when rear of rack faces downward 24° when rear of rack faces downward	NA

The center of gravity of a populated Pillar 42 U rack is toward the front. The threshold tilt angle depends on whether the front or rear of the rack faces down the slope:

- Front faces downward: 12° maximum slope.
- Rear faces downward: 24° maximum slope.

Figure 60 Maximum tilt angles for stationary Pillar 42 U racks

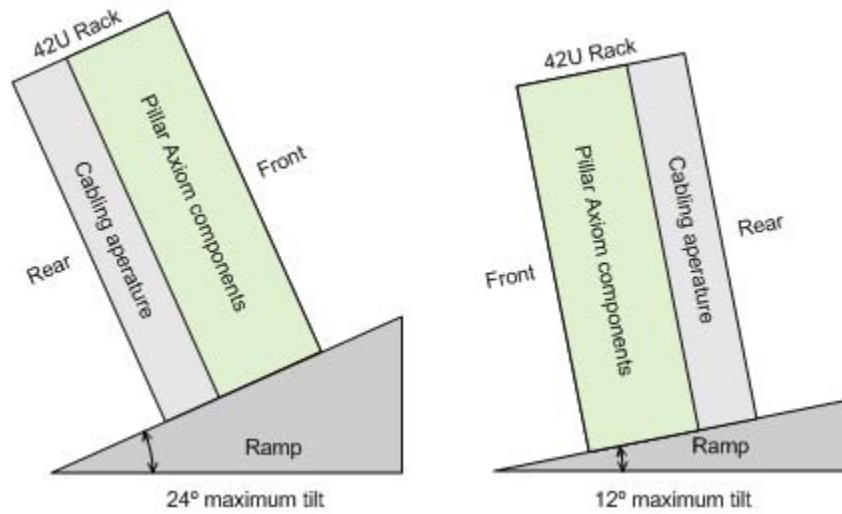

---

# Index

2-port *66*  
2U rack rails  
  install *45*  
3-Slammer system *34*  
4-port *66*  
4U rack rails *41*  
  install *42*

## A

acoustics specifications *140*  
activity (ACT) LED, Slammer  
  startup progress code *109*  
add  
  Slammer *105*  
alerts by email *95*  
altitude specifications *140*  
amperage  
  component draw *68*  
  Pulizzi PC3365 *70*  
  Pulizzi TPC2104 *70*  
  Pulizzi TPC2105-1 *70*  
anti-tip brackets *27*  
APM installation *104*  
AxiomONE Path Manager *104*

## B

batteries, Slammer *61*  
bay connections *20*  
bays, rack  
  attach baying plates *23*  
  interconnection bracket *21*  
bezel attachment *85*  
boot-up time, system *107*  
bracket, rack connector *21*  
Brick hardware components  
  hardware specifications *152*  
  install *58*  
  power on *77*  
Brick strings  
  rules for cabling *64*  
Bricks  
  rack rails *44*  
  test SSF connections *93*

Bricks, FC *32, 34*  
Bricks, SATA *31*

## C

cable connections (Fibre Channel)  
  FC Bricks rules *64*  
cabling rules *64*  
Call-Home feature *95*  
casters *25*  
cautions  
  defined *16*  
  in English *136*  
CloneFS *99*  
complete the installation  
  supply power *77*  
  test SSF configuration *93*  
  turn on the system *77*  
components, Pillar Axiom hardware  
  placement in rack *31, 32, 34, 35*  
  supported hardware *14*  
  technical specifications *139*  
configuration wizard *95*  
configuration, system  
  test *93*  
connect to the GUI *93*  
connection bracket *21*  
conservative mode *105*  
contacts (Pillar Data Systems) *13*

## D

data sheets. hardware specifications. *138*  
DHCP *95*  
dimensions and weight  
  Bricks *152*  
  Pilots *146*  
  Slammers *149*  
documentation  
  additional *17*  
  conventions *16*

## E

electrical safety issues  
  list of hazards (translated) *115*



electromagnetic emissions and immunity  
 Bricks *153*  
 Slammers *150*

electrostatic discharge (ESD) *18*

environment, data center  
 Pillar Axiom system requirements *140*

Ethernet LAN *66*

European Union Compliance Statement *144*

**F**

fabric, test *93*

failed log-ins *95*

fault (FLT) LED, Slammer  
 startup progress code *109*

FC & SATA Bricks  
 rules, cabling *64*

FC Bricks *32, 34*  
 rules, cabling *64*

FCC warning statement *143*

Fibre Channel switches *66*

filesystem  
 name *99*

**G**

gigabit Ethernet switches *66*

Graphical User Interface (GUI), start *93*

ground straps, use of *18*

grounding straps  
 door *89*

**H**

halt  
 codes interpretation *111*

halt, system  
 evaluate LED codes *108*  
 LEDs identify problem *107*

hardware specifications  
 acoustics *140*  
 altitude *140*  
 dimensions and weight Bricks *152*  
 dimensions and weight Pilots *146*  
 dimensions and weight Slammers *149*  
 humidity *140*  
 PDU *155*  
 power characteristics Bricks *152*  
 power characteristics Pilots *146*  
 power characteristics Slammers *149*  
 regulatory agency compliances Bricks *153*  
 regulatory agency compliances Pillar Axiom system *142*  
 regulatory agency compliances Pilots *147*  
 regulatory agency compliances Slammers *150*  
 temperature *140*  
 vibration random *141*

hardware, Pillar Axiom  
 LED boot-up codes *107*  
 map *31, 32, 34, 35*  
 supported *14*  
 technical specifications *139*

hazard signal words  
 translated *115*

help, online *13*

host bus adapters *87*

humidity specifications *140*

**I**

inserts, rack mount *37, 41*

installation  
 required tools *15*

installation procedures  
 connect PDUs to power *68*  
 create a rack bay attach baying plates *23*  
 create a rack bay attach interconnection bracket *21*  
 install 2U rack rails *44*  
 install 4U rack rails *41*  
 install Bricks *58*  
 install Pilots *52*  
 install Slammer batteries *61*  
 install Slammers *55*  
 racks *18*  
 supply power *77*  
 test SSF cable *93*  
 turn system on *77*

IP address  
 email server *95*  
 management interface *95*  
 primary *95*  
 static *95*

**L**

LED halt codes  
 meaning of *111*

LED progress codes  
 LED blink rates *108*

leveling legs *25*

Link Aggregation *95*

login, first time  
 change password *93*  
 connect to the GUI *93*  
 test system configuration *93*

LUN configuration *101*

**M**

MGMT ports *66*

mixed Brick types  
 connection rules *64*

mounting rail kits

Brick 44  
Pilot 37  
Slammer 41

## N

NAS storage configuration 99  
network connection 66  
Network Interface Module 66  
network requirements  
Pilot 66  
Slammer 67  
Network Time Protocol (NTP) servers 95  
NIM 66  
notice conventions, safety 16

## O

online help 13

## P

panel removal, rack 20  
password, Primary System Administrator 93  
password, reset Primary System Administrator 94  
PDUs  
hardware specifications 155  
install 49, 51  
power hardware components 77  
Pulizzi PC3365 70  
Pulizzi TPC2104 70  
Pulizzi TPC2105-1 70  
Pillar Axiom system Pillar Axiom hardware 139  
Pillar Data Systems Web site 13  
Pilot hardware components  
hardware specifications 146  
Pilots  
install 53  
IP address 93  
power on 77  
rack rails 37  
where to install 52  
placement of components in rack  
1-Slammer system 31, 32  
2-Slammer system 2-Slammer system 34  
3-Slammer system 34  
4-Slammer system 35  
position the Pillar Axiom rack  
level the rack 25  
stabilize the rack 27  
power  
cabling examples 72  
cabling examples, sixteen Bricks 74  
cabling examples, three Bricks 72  
component usage 68  
requirements, system 139  
power characteristics, hardware

Bricks 152  
Pilots 146  
Slammers 149

power on

Bricks 77  
Pilots 77  
Slammers 77

product support 13

progress codes, LED startup 108

## Q

Quality of Service (QoS) settings  
NAS 99  
SAN 101

## R

rack rails

install 2U rails 45  
install 4U rails 42

racks

compatibility 18  
doors and panels 89  
install a Pilot 53  
install a Slammer 56  
level 25  
multiple 20  
power connection 68  
set up 18  
stabilization anti-tip brackets 27  
stabilization stabilizer plates 29  
stabilize 27  
test SSF configuration 93

RAID 10 99

RAID 5 99

regulatory agency compliances

EM emissions and immunity Bricks 153  
EM emissions and immunity Slammers 150  
safety and quality standards Bricks 153  
safety and quality standards Pillar Axiom systems 142  
safety and quality standards Pilots 147  
safety and quality standards Slammers 150  
system 142

resources, additional 17

rules, cabling 64

## S

safety

statements translated 115

safety and quality standards

Bricks 153  
Pillar Axiom systems 142  
Pilots 147  
Slammers 150

---

safety notice conventions 16  
sales  
    contact information 13  
SAN storage configuration 101  
SATA Bricks 31  
SecureWORMfs 99  
session time-out 95  
Slammer hardware components  
    hardware specifications 149  
    LED codes 108  
Slammer, one  
    map 32  
    placement in rack 32  
Slammers  
    add 105  
    battery installation 61  
    install 56  
    LED codes 108  
    power on 77  
    rack rails 41  
    test SSF connections 93  
Slammers, four  
    map 35  
    placement in rack 35  
Slammers, one  
    map 31  
    placement in rack 31  
Slammers, three  
    map 34  
    placement in rack 34  
Slammers, two  
    map 34  
Slammers,two  
    placement in rack 34  
spacers, rack mount 37, 41  
SSF 93  
stabilization systems  
    anti-tip brackets 27  
    stabilizer plates 29  
stabilizer plates 29  
startup  
    progress codes for the ACT LED 109  
    progress codes for the FLT LED 109  
    progress codes for the ST LED 109  
    time 107  
status (ST) LED, Slammer  
    startup progress code 109  
Storage System Fabric  
    test configuration 93  
Storage System Fabric (SSF)  
    FC Brick cabling rules 64  
strings, Brick  
    cabling rules 64  
switches

gigabit Ethernet Fibre Channel 66  
    zone setup 88  
system  
    configuration test 93  
    name 95  
system configuration 95  
system warranty 145

**T**  
technical support 13  
temperature specifications 140  
tests  
    evaluate LED codes 108  
time  
    startup 107  
    system 95  
tools, required 15  
turn on Pillar Axiom systems 77

**V**  
vibration specifications  
    random 141

**W**  
warnings  
    defined 16  
    in English 116  
    non-English translations 115  
warranty information 145  
wizard, configuration 95