

# Oracle® ZFS Storage Appliance Cabling Guide

For ZS3-x, 7x20 Controllers, and DE2-24, Sun Disk Shelves

**ORACLE**

Part No: E53670-01  
June 2014

Copyright © 2009, 2014, Oracle and/or its affiliates. All rights reserved.

This software and related documentation are provided under a license agreement containing restrictions on use and disclosure and are protected by intellectual property laws. Except as expressly permitted in your license agreement or allowed by law, you may not use, copy, reproduce, translate, broadcast, modify, license, transmit, distribute, exhibit, perform, publish, or display any part, in any form, or by any means. Reverse engineering, disassembly, or decompilation of this software, unless required by law for interoperability, is prohibited.

The information contained herein is subject to change without notice and is not warranted to be error-free. If you find any errors, please report them to us in writing.

If this is software or related documentation that is delivered to the U.S. Government or anyone licensing it on behalf of the U.S. Government, the following notice is applicable:

U.S. GOVERNMENT END USERS. Oracle programs, including any operating system, integrated software, any programs installed on the hardware, and/or documentation, delivered to U.S. Government end users are "commercial computer software" pursuant to the applicable Federal Acquisition Regulation and agency-specific supplemental regulations. As such, use, duplication, disclosure, modification, and adaptation of the programs, including any operating system, integrated software, any programs installed on the hardware, and/or documentation, shall be subject to license terms and license restrictions applicable to the programs. No other rights are granted to the U.S. Government.

This software or hardware is developed for general use in a variety of information management applications. It is not developed or intended for use in any inherently dangerous applications, including applications that may create a risk of personal injury. If you use this software or hardware in dangerous applications, then you shall be responsible to take all appropriate fail-safe, backup, redundancy, and other measures to ensure its safe use. Oracle Corporation and its affiliates disclaim any liability for any damages caused by use of this software or hardware in dangerous applications.

Oracle and Java are registered trademarks of Oracle and/or its affiliates. Other names may be trademarks of their respective owners.

Intel and Intel Xeon are trademarks or registered trademarks of Intel Corporation. All SPARC trademarks are used under license and are trademarks or registered trademarks of SPARC International, Inc. AMD, Opteron, the AMD logo, and the AMD Opteron logo are trademarks or registered trademarks of Advanced Micro Devices. UNIX is a registered trademark of The Open Group.

This software or hardware and documentation may provide access to or information on content, products, and services from third parties. Oracle Corporation and its affiliates are not responsible for and expressly disclaim all warranties of any kind with respect to third-party content, products, and services. Oracle Corporation and its affiliates will not be responsible for any loss, costs, or damages incurred due to your access to or use of third-party content, products, or services.

Copyright © 2009, 2014, Oracle et/ou ses affiliés. Tous droits réservés.

Copyright © 2009, 2014, Oracle et/ou ses affiliés. Tous droits réservés.

Ce logiciel et la documentation qui l'accompagne sont protégés par les lois sur la propriété intellectuelle. Ils sont concédés sous licence et soumis à des restrictions d'utilisation et de divulgation. Sauf disposition de votre contrat de licence ou de la loi, vous ne pouvez pas copier, reproduire, traduire, diffuser, modifier, breveter, transmettre, distribuer, exposer, exécuter, publier ou afficher le logiciel, même partiellement, sous quelque forme et par quelque procédé que ce soit. Par ailleurs, il est interdit de procéder à toute ingénierie inverse du logiciel, de le désassembler ou de le décompiler, excepté à des fins d'interopérabilité avec des logiciels tiers ou tel que prescrit par la loi.

Les informations fournies dans ce document sont susceptibles de modification sans préavis. Par ailleurs, Oracle Corporation ne garantit pas qu'elles soient exemptes d'erreurs et vous invite, le cas échéant, à lui en faire part par écrit.

Si ce logiciel, ou la documentation qui l'accompagne, est concédé sous licence au Gouvernement des Etats-Unis, ou à toute entité qui délivre la licence de ce logiciel ou l'utilise pour le compte du Gouvernement des Etats-Unis, la notice suivante s'applique:

U.S. GOVERNMENT END USERS. Oracle programs, including any operating system, integrated software, any programs installed on the hardware, and/or documentation, delivered to U.S. Government end users are "commercial computer software" pursuant to the applicable Federal Acquisition Regulation and agency-specific supplemental regulations. As such, use, duplication, disclosure, modification, and adaptation of the programs, including any operating system, integrated software, any programs installed on the hardware, and/or documentation, shall be subject to license terms and license restrictions applicable to the programs. No other rights are granted to the U.S. Government.

Ce logiciel ou matériel a été développé pour un usage général dans le cadre d'applications de gestion des informations. Ce logiciel ou matériel n'est pas conçu ni n'est destiné à être utilisé dans des applications à risque, notamment dans des applications pouvant causer des dommages corporels. Si vous utilisez ce logiciel ou matériel dans le cadre d'applications dangereuses, il est de votre responsabilité de prendre toutes les mesures de secours, de sauvegarde, de redondance et autres mesures nécessaires à son utilisation dans des conditions optimales de sécurité. Oracle Corporation et ses affiliés déclinent toute responsabilité quant aux dommages causés par l'utilisation de ce logiciel ou matériel pour ce type d'applications.

Oracle et Java sont des marques déposées d'Oracle Corporation et/ou de ses affiliés. Tout autre nom mentionné peut correspondre à des marques appartenant à d'autres propriétaires qu'Oracle.

Intel et Intel Xeon sont des marques ou des marques déposées d'Intel Corporation. Toutes les marques SPARC sont utilisées sous licence et sont des marques ou des marques déposées de SPARC International, Inc. AMD, Opteron, le logo AMD et le logo AMD Opteron sont des marques ou des marques déposées d'Advanced Micro Devices. UNIX est une marque déposée d'The Open Group.

Ce logiciel ou matériel et la documentation qui l'accompagne peuvent fournir des informations ou des liens donnant accès à des contenus, des produits et des services émanant de tiers. Oracle Corporation et ses affiliés déclinent toute responsabilité ou garantie expresse quant aux contenus, produits ou services émanant de tiers. En aucun cas, Oracle Corporation et ses affiliés ne sauraient être tenus pour responsables des pertes subies, des coûts occasionnés ou des dommages causés par l'accès à des contenus, produits ou services tiers, ou à leur utilisation.

# Contents

---

<b>Using This Documentation .....</b>	<b>5</b>
<b>1 Cabling .....</b>	<b>7</b>
Cabling Guidelines .....	7
Cabinet Configuration .....	7
Load Distribution .....	7
Cable Lengths .....	8
Using DE2-24 and Sun Disk Shelves Together .....	8
Maximum Number of Disk Shelves per Controller Configuration .....	8
Connecting to Attached Storage .....	9
Next Steps .....	12
<b>2 Oracle DE2-24 Disk Shelf to 2X4 Port SAS-2 HBAs .....</b>	<b>13</b>
DE2-24 to 7120 .....	13
7120 Standalone to DE2-24 Disk Shelves .....	13
DE2-24 to 7320 .....	14
7320 Standalone to DE2-24 Disk Shelves .....	14
7320 Clustered to DE2-24 Disk Shelves .....	15
DE2-24 to 7420 .....	17
7420 Standalone to DE2-24 Disk Shelves .....	17
7420 Clustered to DE2-24 Disk Shelves .....	31
<b>3 Oracle DE2-24 Disk Shelf to 4X4 Port SAS-2 HBAs .....</b>	<b>47</b>
DE2-24 to 7320 .....	47
7320 Standalone to DE2-24 Disk Shelves .....	47
7320 Clustered to DE2-24 Disk Shelves .....	48
DE2-24 to 7420 .....	50
7420 Standalone to DE2-24 Disk Shelves .....	50
7420 Clustered to DE2-24 Disk Shelves .....	57
DE2-24 to ZS3-2 .....	67

ZS3-2 Standalone to DE2-24 Disk Shelves .....	67
ZS3-2 Clustered to DE2-24 Disk Shelves .....	71
DE2-24 to ZS3-4 .....	75
ZS3-4 Standalone to DE2-24 Disk Shelves .....	75
ZS3-4 Clustered to DE2-24 Disk Shelves .....	82
<b>4 Sun Disk Shelf .....</b>	<b>93</b>
Sun Disk Shelf to 7120 .....	93
7120 Standalone to Sun Disk Shelves .....	93
Sun Disk Shelf to 7320 .....	94
7320 Standalone to Sun Disk Shelves .....	94
7320 Clustered to Sun Disk Shelves .....	95
Sun Disk Shelf to 7420 .....	97
7420 Standalone to Sun Disk Shelves .....	97
7420 Clustered to Sun Disk Shelves .....	111
<b>5 Mixed DE2-24 and Sun Disk Shelves .....</b>	<b>127</b>
DE2-24 and Sun Disk Shelves to 7320 .....	127
7320 Standalone to Mixed Disk Shelves .....	127
7320 Clustered to Mixed Disk Shelves .....	128
DE2-24 and Sun Disk Shelves to 7420 .....	129
7420 Standalone to Mixed Disk Shelves .....	129
7420 Clustered to Mixed Disk Shelves .....	136
DE2-24 and Sun Disk Shelves to ZS3-2 .....	146
ZS3-2 Standalone to Mixed Disk Shelves .....	146
ZS3-2 Clustered to Mixed Disk Shelves .....	148
DE2-24 and Sun Disk Shelves to ZS3-4 .....	151
ZS3-4 Standalone to Mixed Disk Shelves .....	151
ZS3-4 Clustered to Mixed Disk Shelves .....	158

## Using This Documentation

---

- **Overview** – Describes how to cable the Oracle ZFS Storage Appliance
- **Audience** – Technicians, system administrators, and authorized service providers
- **Required knowledge** – Experience working with the Oracle ZFS Storage Appliance

## Product Documentation Library

Visit <http://www.oracle.com/goto/ZFSStorage/docs> for the Oracle ZFS Storage Appliance documentation library.

For related documentation, including white papers, visit <http://www.oracle.com/technetwork/server-storage/sun-unified-storage/overview/index.html> and click on the Documentation tab. For late-breaking information and known issues about this product, visit My Oracle Support at <http://support.oracle.com>.

## Access to Oracle Support

Oracle customers have access to electronic support through My Oracle Support. For information, visit <http://www.oracle.com/pls/topic/lookup?ctx=acc&id=info> or visit <http://www.oracle.com/pls/topic/lookup?ctx=acc&id=trs> if you are hearing impaired.

## Feedback

Provide feedback about this documentation at <http://www.oracle.com/goto/docfeedback>.



# ◆◆◆ CHAPTER 1

## Cabling

---

This section describes cabling between the Oracle ZFS Storage Appliance controller and the storage shelves.

### Cabling Guidelines

To cable the controller to the disk shelves, use the the following guidelines:

#### Cabinet Configuration

- Do not span disk chains across multiple cabinets.
- Mount the controller in the center of the cabinet.
- Do not remove cabinet panels to run cables between cabinets.
- Install disk shelves at the bottom of the cabinet, placing the heaviest disk shelves bottommost, such as the DE2-24C.

#### Load Distribution

- Balance the number of disk shelves across the disk chains in your system.
- The maximum number of disk shelves supported by each disk chain is six.
- Connect each disk chain to two HBAs if available.
- Do not mix disks with different capacities or rotation speeds within a single disk shelf.
- To maximize performance, use the maximum number of disk chains supported by the controller's SAS HBAs. For example, four SAS HBAs with eight chains and eight disk shelves will have better performance than two SAS HBAs with four chains and eight disk shelves.

## Cable Lengths

- The maximum cable length between DE2-24 disk shelves is two meters.
- The maximum cable length between Sun Disk Shelves is 0.5 meters.
- The maximum cable length between a controller and disk shelves is six meters.

## Using DE2-24 and Sun Disk Shelves Together

- To use DE2-24 and Sun Disk Shelves together, the controller must use 4X4 port SAS-2 HBAs.
- Do not use DE2-24 and Sun Disk Shelves in the same disk chain.

## Maximum Number of Disk Shelves per Controller Configuration

The following table shows the maximum supported controller configurations.

**NOTE:** Controllers cannot use 2X4 port SAS-2 HBAs and 4X4 port SAS-2 HBAs at the same time. To use DE2-24 and Sun Disk Shelves together, the controller must use 4X4 port SAS-2 HBAs, which are only supported with software version 2013.1.0 and later.

**TABLE 1-1** Maximum Number of Disk Shelves per Controller Configuration

Controller	Max. Shelves	Max. 2X4 Port SAS-2 HBA	Max. 4X4 Port SAS-2 HBA
ZS3-2	16	NA	2
ZS3-4	36	NA	4
7120	2	1	NA
7320	6	1	1
7420	36	6	6



## Connecting to Attached Storage



Disk shelves can be added to standalone or clustered storage controllers without powering down the appliance or loss of service to clients. Use the diagrams in this section to connect one or more disk shelves. After connecting expansion storage, verify that you have redundant paths to each disk shelf.



---

**Caution** - Improper orientation of mini-SAS HD cables during installation can damage the HBA connector and cause the HBA to malfunction. Position the blue release tab downward for horizontally mounted HBAs or to the right for vertically mounted HBAs. See MOS (<https://support.oracle.com>) Doc ID 1643673.1.

---

The following list provides links to cable diagrams for standalone and clustered controllers.

### Oracle DE2-24 Disk Shelf to 2X4 Port SAS-2 HBAs

- DE2-24 Disk Shelves to 7120
  - [“7120 Standalone to DE2-24 Disk Shelves” on page 13](#)
- DE2-24 Disk Shelves to 7320
  - [“7320 Standalone to DE2-24 Disk Shelves” on page 14](#)
  - [“7320 Clustered to DE2-24 Disk Shelves” on page 15](#)
- DE2-24 Disk Shelves to 7420 Standalone
  - [“7420 Standalone to DE2-24 Disk Shelves \(2 HBAs\)” on page 18](#)
  - [“7420 Standalone to DE2-24 Disk Shelves \(3 HBAs\)” on page 20](#)
  - [“7420 Standalone to DE2-24 Disk Shelves \(4 HBAs\)” on page 22](#)
  - [“7420 Standalone to DE2-24 Disk Shelves \(5 HBAs\)” on page 25](#)
  - [“7420 Standalone to DE2-24 Disk Shelves \(6 HBAs\)” on page 28](#)
- DE2-24 Disk Shelves to 7420 Clustered
  - [“7420 Clustered to DE2-24 Disk Shelves \(2 HBAs\)” on page 31](#)
  - [“7420 Clustered to DE2-24 Disk Shelves \(3 HBAs\)” on page 33](#)

- [“7420 Clustered to DE2-24 Disk Shelves \(4 HBAs\)” on page 36](#)
- [“7420 Clustered to DE2-24 Disk Shelves \(5 HBAs\)” on page 40](#)
- [“7420 Clustered to DE2-24 Disk Shelves \(6 HBAs\)” on page 43](#)

#### **Oracle DE2-24 Disk Shelf to 4X4 Port SAS-2 HBAs**

- DE2-24 Disk Shelves to 7320
  - [“7320 Standalone to DE2-24 Disk Shelves” on page 47](#)
  - [“7320 Clustered to DE2-24 Disk Shelves” on page 48](#)
- DE2-24 Disk Shelves to 7420 Standalone
  - [“7420 Standalone to DE2-24 Disk Shelves \(2 HBAs\)” on page 50](#)
  - [“7420 Standalone to DE2-24 Disk Shelves \(3 HBAs\)” on page 51](#)
  - [“7420 Standalone to DE2-24 Disk Shelves \(4 HBAs\)” on page 54](#)
- DE2-24 Disk Shelves to 7420 Clustered
  - [“7420 Clustered to DE2-24 Disk Shelves \(2 HBAs\)” on page 57](#)
  - [“7420 Clustered to DE2-24 Disk Shelves \(3 HBAs\)” on page 60](#)
  - [“7420 Clustered to DE2-24 Disk Shelves \(4 HBAs\)” on page 63](#)
- DE2-24 Disk Shelves to ZS3-2 Standalone
  - [“ZS3-2 Standalone to DE2-24 Disk Shelves \(1 HBA\)” on page 67](#)
  - [“ZS3-2 Standalone to DE2-24 Disk Shelves \(2 HBAs\)” on page 68](#)
- DE2-24 Disk Shelves to ZS3-2 Clustered
  - [“ZS3-2 Clustered to DE2-24 Disk Shelves \(1 HBA\)” on page 71](#)
  - [“ZS3-2 Clustered to DE2-24 Disk Shelves \(2 HBAs\)” on page 72](#)
- DE2-24 Disk Shelves to ZS3-4 Standalone
  - [“ZS3-4 Standalone to DE2-24 Disk Shelves \(2 HBAs\)” on page 75](#)
  - [“ZS3-4 Standalone to DE2-24 Disk Shelves \(3 HBAs\)” on page 76](#)
  - [“ZS3-4 Standalone to DE2-24 Disk Shelves \(4 HBAs\)” on page 79](#)
- DE2-24 Disk Shelves to ZS3-4 Clustered
  - [“ZS3-4 Clustered to DE2-24 Disk Shelves \(2 HBAs\)” on page 82](#)
  - [“ZS3-4 Clustered to DE2-24 Disk Shelves \(3 HBAs\)” on page 85](#)
  - [“ZS3-4 Clustered to DE2-24 Disk Shelves \(4 HBAs\)” on page 88](#)

#### **Sun Disk Shelf**

- Sun Disk Shelves to 7120
  - [“7120 Standalone to Sun Disk Shelves” on page 93](#)
- Sun Disk Shelves to 7320
  - [“7320 Standalone to Sun Disk Shelves” on page 94](#)
  - [“7320 Clustered to Sun Disk Shelves” on page 95](#)
- Sun Disk Shelves to 7420 Standalone

- “7420 Standalone to Sun Disk Shelves (2 HBAs)” on page 97
- “7420 Standalone to Sun Disk Shelves (3 HBAs)” on page 100
- “7420 Standalone to Sun Disk Shelves (4 HBAs)” on page 102
- “7420 Standalone to Sun Disk Shelves (5 HBAs)” on page 105
- “7420 Standalone to Sun Disk Shelves (6 HBAs)” on page 108
- Sun Disk Shelves to 7420 Clustered
  - “7420 Clustered to Sun Disk Shelves (2 HBAs)” on page 111
  - “7420 Clustered to Sun Disk Shelves (3 HBAs)” on page 113
  - “7420 Clustered to Sun Disk Shelves (4 HBAs)” on page 116
  - “7420 Clustered to Sun Disk Shelves (5 HBAs)” on page 120
  - “7420 Clustered to Sun Disk Shelves (6 HBAs)” on page 123

#### **Mixed DE2-24 and Sun Disk Shelves**

- DE2-24 and Sun Disk Shelves to 7320
  - “7320 Standalone to Mixed Disk Shelves” on page 127
  - “7320 Clustered to Mixed Disk Shelves” on page 128
- DE2-24 and Sun Disk Shelves to 7420 Standalone
  - “7420 Standalone to Mixed Disk Shelves (2 HBAs)” on page 129
  - “7420 Standalone to Mixed Disk Shelves (3 HBAs)” on page 131
  - “7420 Standalone to Mixed Disk Shelves (4 HBAs)” on page 133
- DE2-24 and Sun Disk Shelves to 7420 Clustered
  - “7420 Clustered to Mixed Disk Shelves (2 HBAs)” on page 136
  - “7420 Clustered to Mixed Disk Shelves (3 HBAs)” on page 138
  - “7420 Clustered to Mixed Disk Shelves (4 HBAs)” on page 141
- DE2-24 and Sun Disk Shelves to ZS3-2 Standalone
  - “ZS3-2 Standalone to Mixed Disk Shelves (1 HBA)” on page 146
  - “ZS3-2 Standalone to Mixed Disk Shelves (2 HBAs)” on page 147
- DE2-24 and Sun Disk Shelves to ZS3-2 Clustered
  - “ZS3-2 Clustered to Mixed Disk Shelves (1 HBA)” on page 148
  - “ZS3-2 Clustered to Mixed Disk Shelves (2 HBAs)” on page 149
- DE2-24 and Sun Disk Shelves to ZS3-4 Standalone
  - “ZS3-4 Standalone to Mixed Disk Shelves (2 HBAs)” on page 151
  - “ZS3-4 Standalone to Mixed Disk Shelves (3 HBAs)” on page 153
  - “ZS3-4 Standalone to Mixed Disk Shelves (4 HBAs)” on page 155
- DE2-24 and Sun Disk Shelves to ZS3-4 Clustered
  - “ZS3-4 Clustered to Mixed Disk Shelves (2 HBAs)” on page 158
  - “ZS3-4 Clustered to Mixed Disk Shelves (3 HBAs)” on page 160
  - “ZS3-4 Clustered to Mixed Disk Shelves (4 HBAs)” on page 163

## Next Steps

After connecting attached storage, apply power and configure the appliance.

- [Chapter 4, “Powering On and Configuring the System,” in “Oracle ZFS Storage Appliance Installation Guide ”](#)
- [“Initial Configuration” in “Oracle ZFS Storage Appliance Installation Guide ”](#)

Storage expansion may require adding or replacing HBAs in your configuration. For information, see the following sections:

- [ZS3-2 Maintenance Procedures: “PCIe Cards and Risers” in “Oracle ZFS Storage Appliance Customer Service Manual ”](#)
- [ZS3-4 Maintenance Procedures: “PCIe Cards and Risers” in “Oracle ZFS Storage Appliance Customer Service Manual ”](#)
- [7x20 Maintenance Procedures: “PCIe Cards and Risers” in “Oracle ZFS Storage Appliance Customer Service Manual ”](#)

# ◆◆◆ CHAPTER 2

## Oracle DE2-24 Disk Shelf to 2X4 Port SAS-2 HBAs

---

### DE2-24 to 7120

#### 7120 Standalone to DE2-24 Disk Shelves

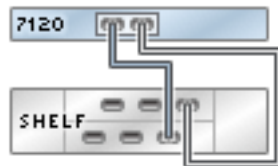
The following figures show the supported configurations for the Oracle ZFS Storage 7120 standalone controller. To cable the controller to the disk shelves, use the [“Cabling Guidelines” on page 7](#), which include the [“Maximum Number of Disk Shelves per Controller Configuration” on page 8](#).

---

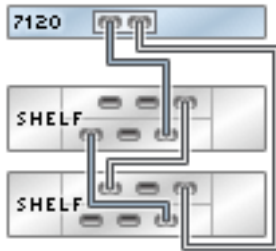
**Note** - For hardware port locations, see the PCIe Options section in the Hardware Maintenance Overview for your controller model.

---

**FIGURE 2-1** 7120 standalone controller with one HBA connected to one DE2-24 disk shelf in a single chain



**FIGURE 2-2** 7120 standalone controller with one HBA connected to two DE2-24 disk shelves in a single chain



## DE2-24 to 7320

### 7320 Standalone to DE2-24 Disk Shelves

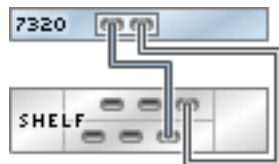
The following figures show a subset of the supported configurations for Oracle ZFS Storage 7320 standalone controllers with one HBA. To cable the controller to the disk shelves, use the [“Cabling Guidelines” on page 7](#), which include the [“Maximum Number of Disk Shelves per Controller Configuration” on page 8](#).

---

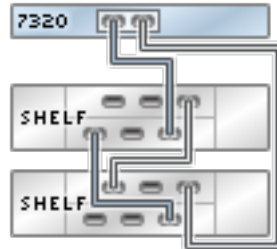
**Note** - For hardware port locations, see the PCIe Options section in the Hardware Maintenance Overview for your controller model.

---

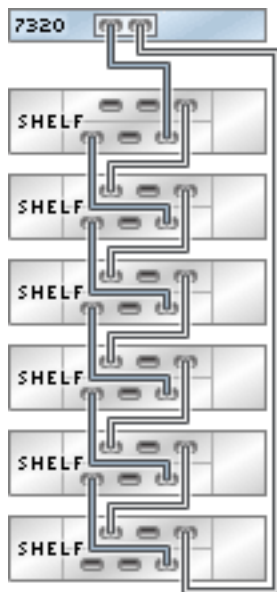
**FIGURE 2-3** 7320 standalone controller with one HBA connected to one DE2-24 disk shelf in a single chain



**FIGURE 2-4** 7320 standalone controller with one HBA connected to two DE2-24 disk shelves in a single chain



**FIGURE 2-5** 7320 standalone controller with one HBA connected to six DE2-24 disk shelves in a single chain



## 7320 Clustered to DE2-24 Disk Shelves

The following figures show a subset of the supported configurations for the Oracle ZFS Storage 7320 clustered controllers with one HBA. To cable the controller to the disk shelves, use the

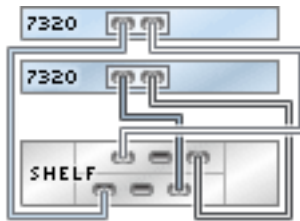
“Cabling Guidelines” on page 7, which include the “Maximum Number of Disk Shelves per Controller Configuration” on page 8.

---

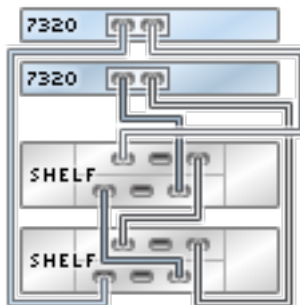
**Note** - For hardware port locations, see the PCIe Options section in the Hardware Maintenance Overview for your controller model.

---

**FIGURE 2-6** 7320 clustered controllers with one HBA connected to one DE2-24 disk shelf in a single chain

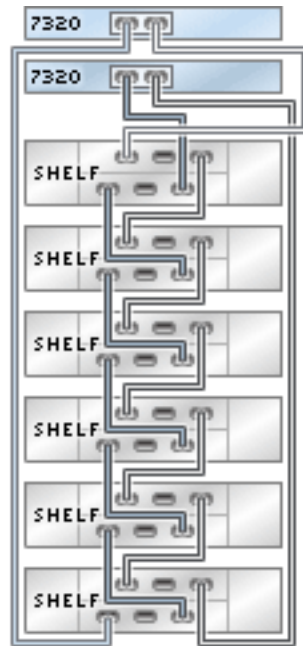


**FIGURE 2-7** 7320 clustered controllers with one HBA connected to two DE2-24 disk shelves in a single chain





**FIGURE 2-8** 7320 clustered controllers with one HBA connected to six DE2-24 disk shelves in a single chain



## DE2-24 to 7420

### 7420 Standalone to DE2-24 Disk Shelves

The following figures show a subset of the supported configurations for Oracle ZFS Storage 7420 standalone controllers with two HBAs. To cable the controller to the disk shelves, use the [“Cabling Guidelines” on page 7](#), which include the [“Maximum Number of Disk Shelves per Controller Configuration” on page 8](#).

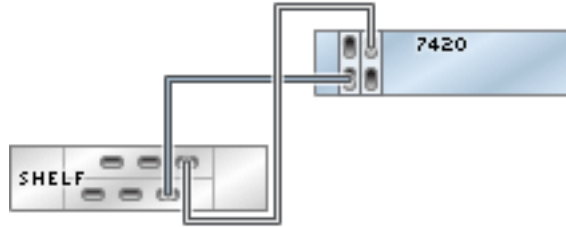
---

**Note** - For hardware port locations, see the PCIe Options section in the Hardware Maintenance Overview for your controller model.

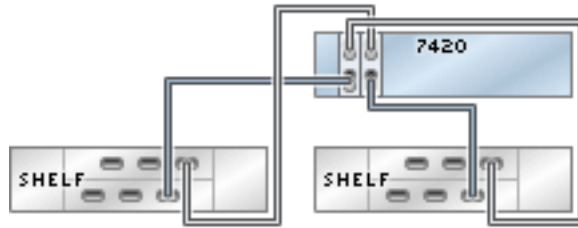
---

## 7420 Standalone to DE2-24 Disk Shelves (2 HBAs)

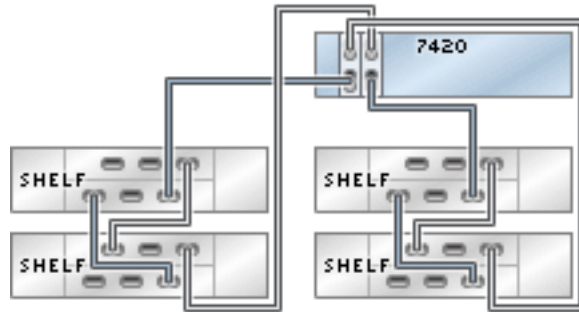
**FIGURE 2-9** 7420 standalone controller with two HBAs connected to one DE2-24 disk shelf in a single chain



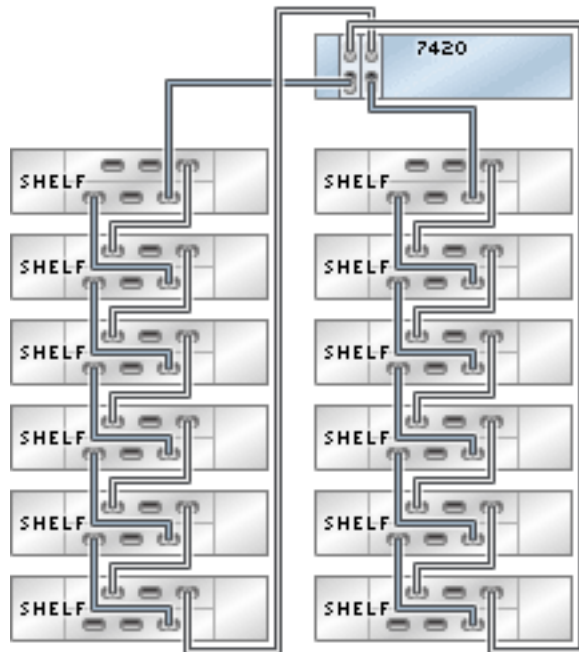
**FIGURE 2-10** 7420 standalone controller with two HBAs connected to two DE2-24 disk shelves in two chains



**FIGURE 2-11** 7420 standalone controller with two HBAs connected to four DE2-24 disk shelves in two chains



**FIGURE 2-12** 7420 standalone controller with two HBAs connected to 12 DE2-24 disk shelves in two chains



## 7420 Standalone to DE2-24 Disk Shelves (3 HBAs)

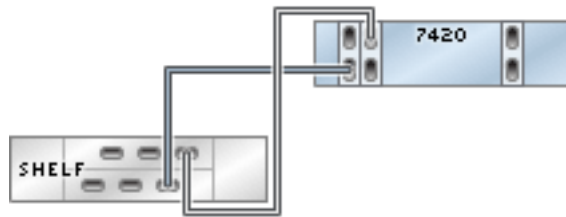
The following figures show a subset of the supported configurations for Oracle ZFS Storage 7420 standalone controllers with three HBAs. To cable the controller to the disk shelves, use the “[Cabling Guidelines](#)” on page 7, which include the “[Maximum Number of Disk Shelves per Controller Configuration](#)” on page 8.

---

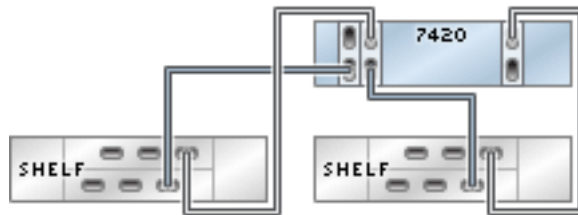
**Note** - For hardware port locations, see the PCIe Options section in the Hardware Maintenance Overview for your controller model.

---

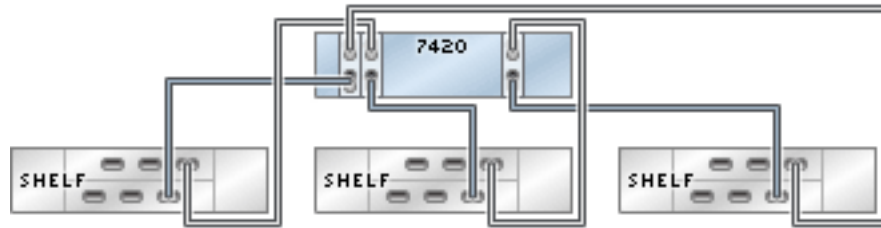
**FIGURE 2-13** 7420 standalone controller with three HBAs connected to one DE2-24 disk shelf in a single chain



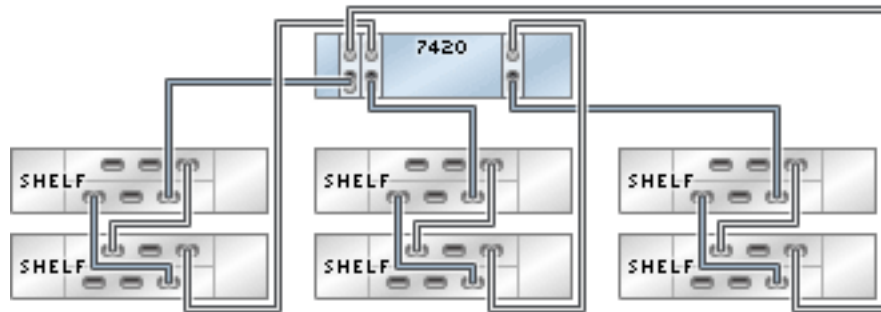
**FIGURE 2-14** 7420 standalone controller with three HBAs connected to two DE2-24 disk shelves in two chains



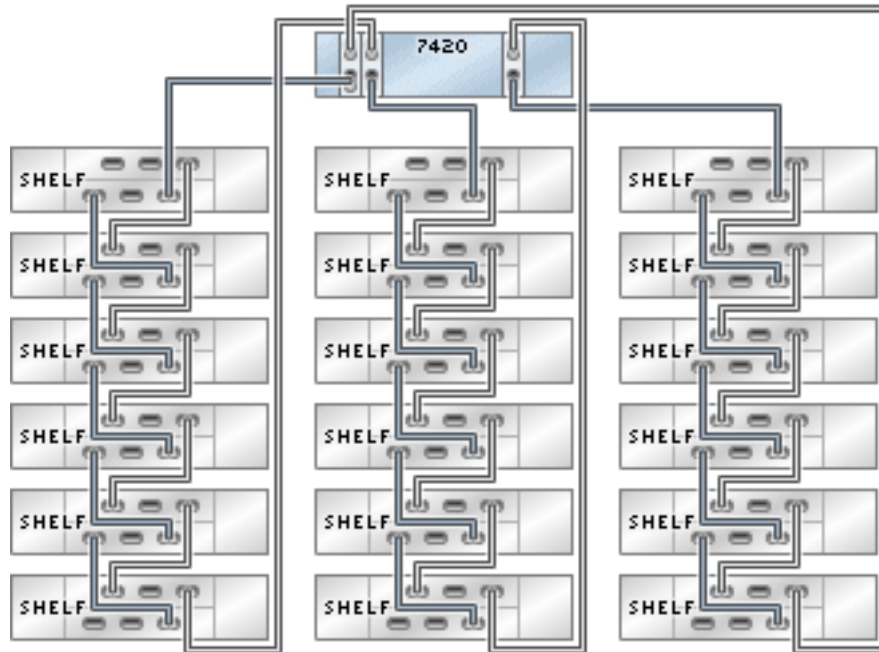
**FIGURE 2-15** 7420 standalone controller with three HBAs connected to three DE2-24 disk shelves in three chains



**FIGURE 2-16** 7420 standalone controller with three HBAs connected to six DE2-24 disk shelves in three chains



**FIGURE 2-17** 7420 standalone controller with three HBAs connected to 18 DE2-24 disk shelves in three chains



## 7420 Standalone to DE2-24 Disk Shelves (4 HBAs)

The following figures show a subset of the supported configurations for Oracle ZFS Storage 7420 standalone controllers with four HBAs. To cable the controller to the disk shelves, use the [“Cabling Guidelines” on page 7](#), which include the [“Maximum Number of Disk Shelves per Controller Configuration” on page 8](#).

---

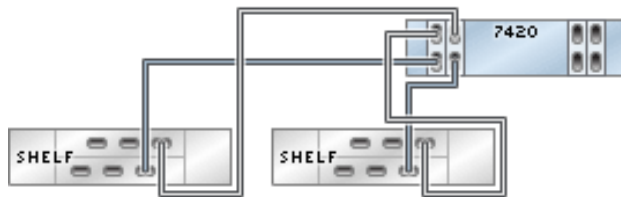
**Note** - For hardware port locations, see the PCIe Options section in the Hardware Maintenance Overview for your controller model.

---

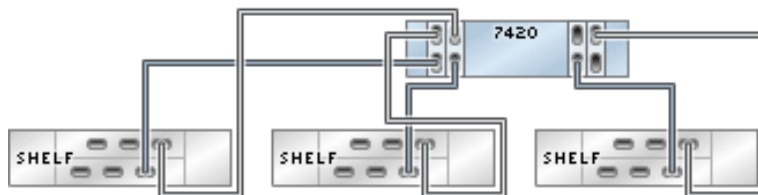
**FIGURE 2-18** 7420 standalone controller with four HBAs connected to one DE2-24 disk shelf in a single chain



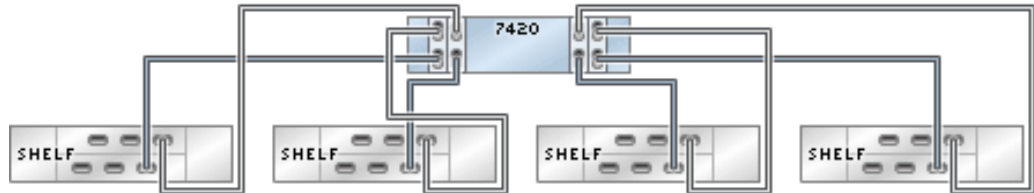
**FIGURE 2-19** 7420 standalone controller with four HBAs connected to two DE2-24 disk shelves in two chains



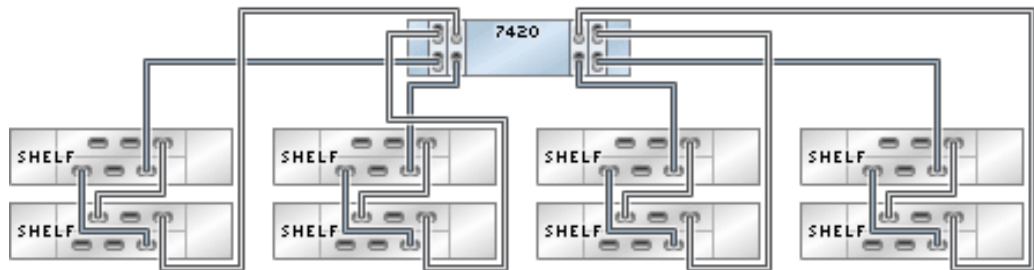
**FIGURE 2-20** 7420 standalone controller with four HBAs connected to three DE2-24 disk shelves in three chains



**FIGURE 2-21** 7420 standalone controller with four HBAs connected to four DE2-24 disk shelves in four chains

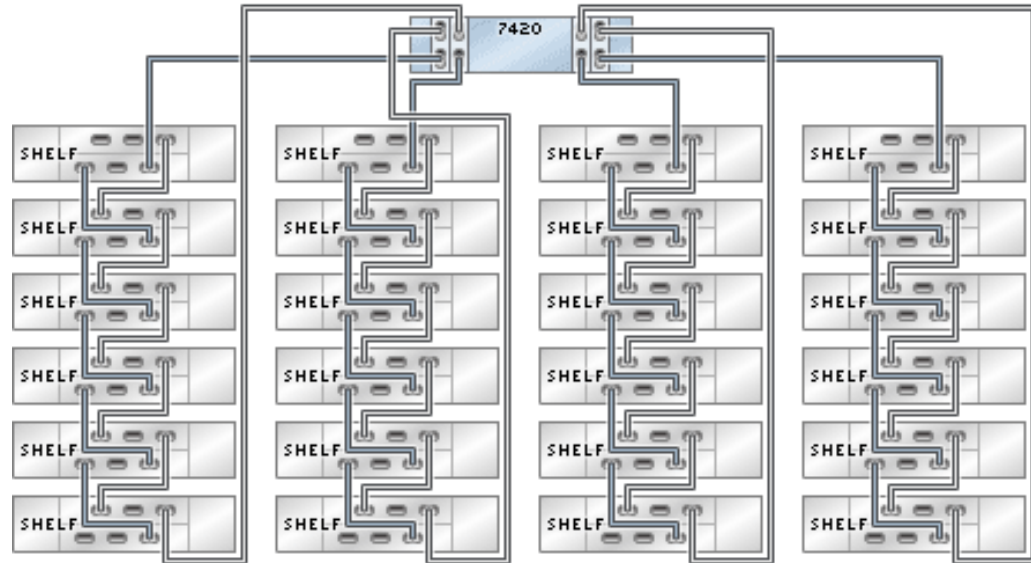


**FIGURE 2-22** 7420 standalone controller with four HBAs connected to eight DE2-24 disk shelves in four chains





**FIGURE 2-23** 7420 standalone controller with four HBAs connected to 24 DE2-24 disk shelves in four chains



## 7420 Standalone to DE2-24 Disk Shelves (5 HBAs)

The following figures show a subset of the supported configurations for Oracle ZFS Storage 7420 standalone controllers with five HBAs. To cable the controller to the disk shelves, use the [“Cabling Guidelines”](#) on page 7, which include the [“Maximum Number of Disk Shelves per Controller Configuration”](#) on page 8.

---

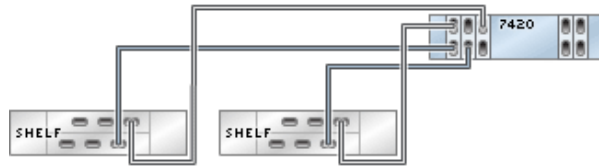
**Note** - For hardware port locations, see the PCIe Options section in the Hardware Maintenance Overview for your controller model.

---

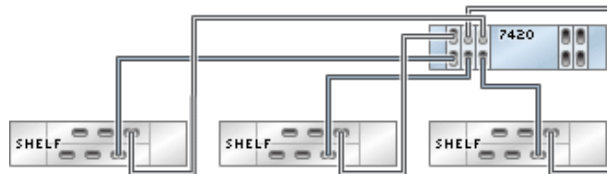
**FIGURE 2-24** 7420 standalone controller with five HBAs connected to one DE2-24 disk shelf in a single chain



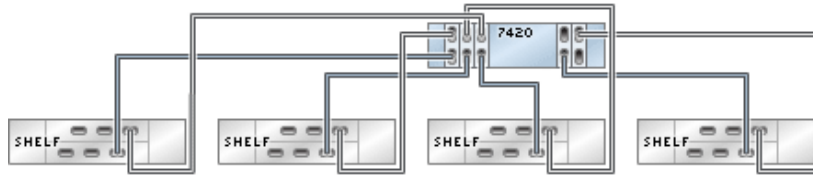
**FIGURE 2-25** 7420 standalone controller with five HBAs connected to two DE2-24 disk shelves in two chains



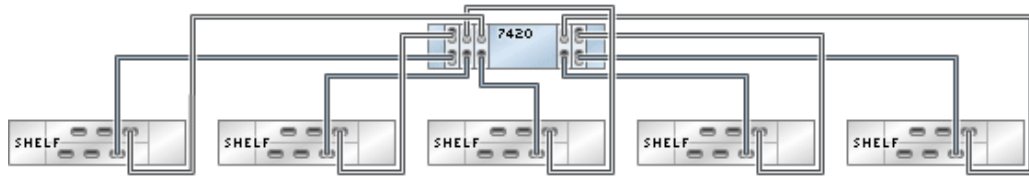
**FIGURE 2-26** 7420 standalone controller with five HBAs connected to three DE2-24 disk shelves in three chains



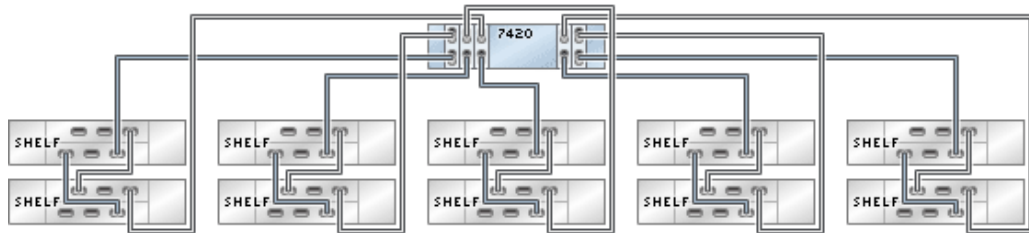
**FIGURE 2-27** 7420 standalone controller with five HBAs connected to four DE2-24 disk shelves in four chains



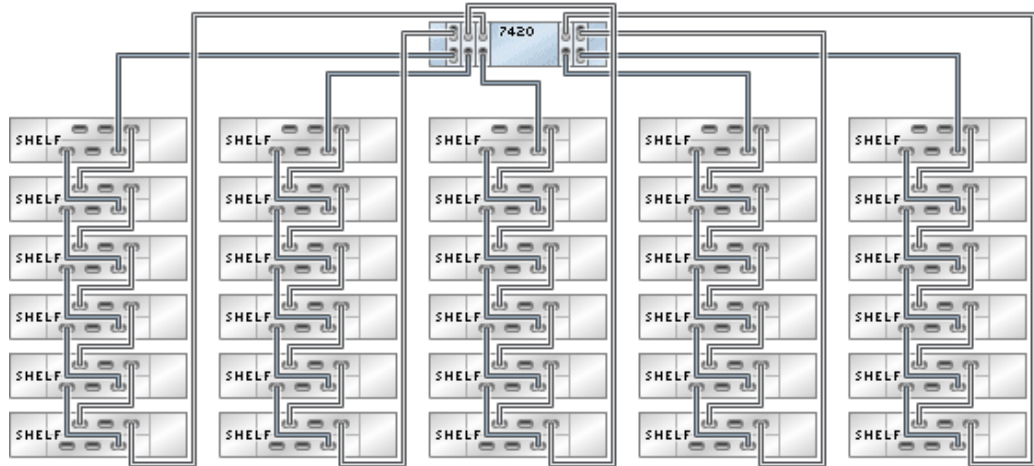
**FIGURE 2-28** 7420 standalone controller with five HBAs connected to five DE2-24 disk shelves in five chains



**FIGURE 2-29** 7420 standalone controller with five HBAs connected to ten DE2-24 disk shelves in five chains



**FIGURE 2-30** 7420 standalone controller with five HBAs connected to 30 DE2-24 disk shelves in five chains



## 7420 Standalone to DE2-24 Disk Shelves (6 HBAs)

The following figures show a subset of the supported configurations for Oracle ZFS Storage 7420 standalone controllers with six HBAs. To cable the controller to the disk shelves, use the [“Cabling Guidelines” on page 7](#), which include the [“Maximum Number of Disk Shelves per Controller Configuration” on page 8](#).

---

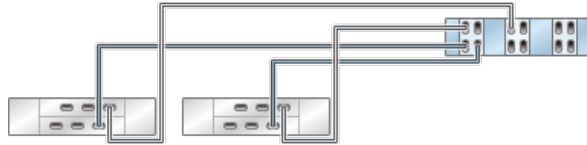
**Note** - For hardware port locations, see the PCIe Options section in the Hardware Maintenance Overview for your controller model.

---

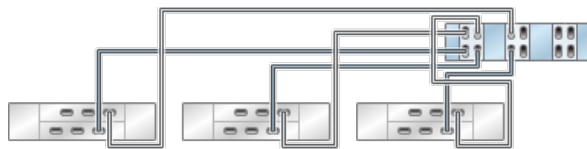
**FIGURE 2-31** 7420 standalone controller with six HBAs connected to one DE2-24 disk shelf in a single chain



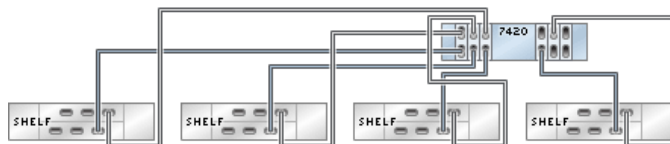
**FIGURE 2-32** 7420 standalone controller with six HBAs connected to two DE2-24 disk shelves in two chains



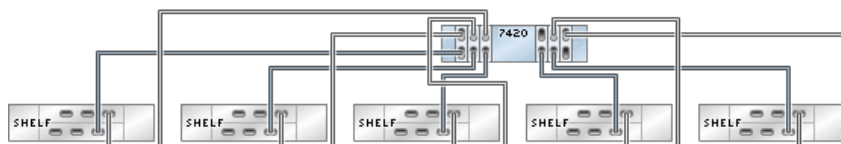
**FIGURE 2-33** 7420 standalone controller with six HBAs connected to three DE2-24 disk shelves in three chains



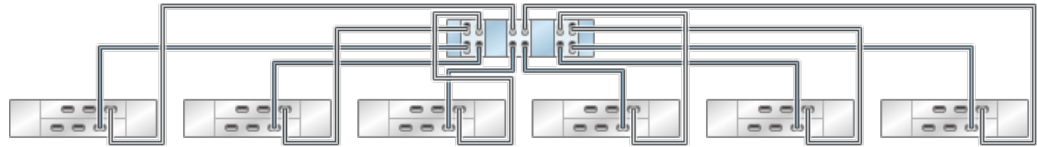
**FIGURE 2-34** 7420 standalone controller with six HBAs connected to four DE2-24 disk shelves in four chains



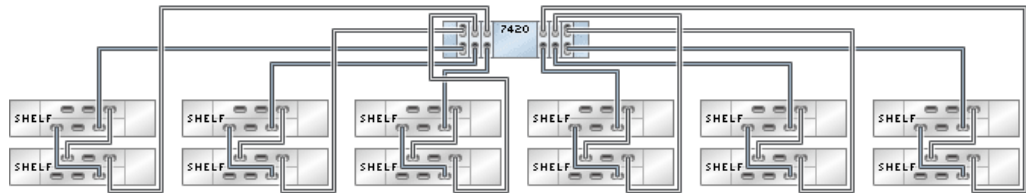
**FIGURE 2-35** 7420 standalone controller with six HBAs connected to five DE2-24 disk shelves in five chains



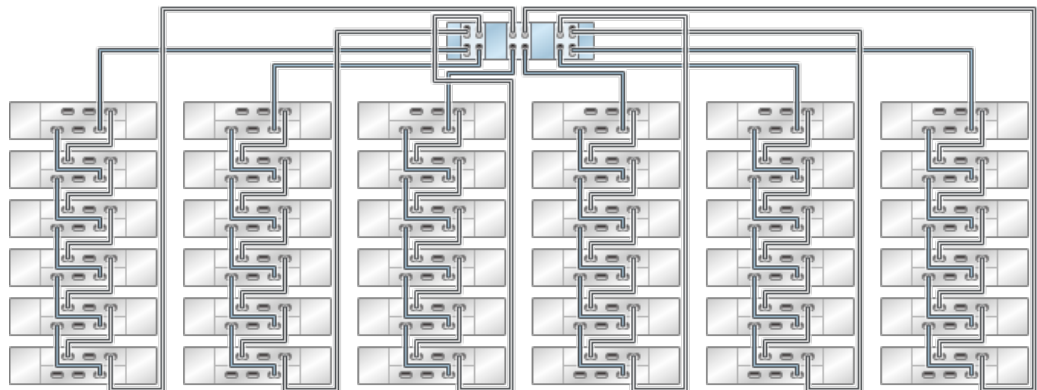
**FIGURE 2-36** 7420 standalone controller with six HBAs connected to six DE2-24 disk shelves in six chains



**FIGURE 2-37** 7420 standalone controller with six HBAs connected to 12 DE2-24 disk shelves in six chains



**FIGURE 2-38** 7420 standalone controller with six HBAs connected to 36 DE2-24 disk shelves in six chains



## 7420 Clustered to DE2-24 Disk Shelves

### 7420 Clustered to DE2-24 Disk Shelves (2 HBAs)

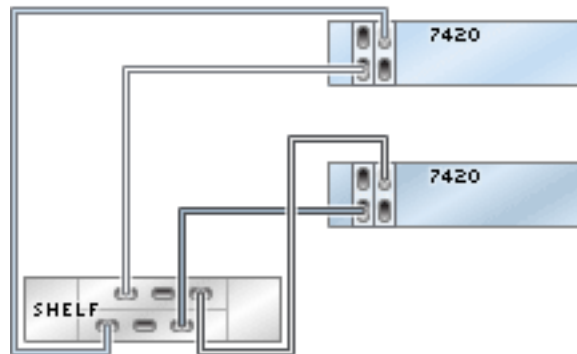
The following figures show a subset of the supported configurations for Oracle ZFS Storage 7420 clustered controllers with two HBAs. To cable the controller to the disk shelves, use the [“Cabling Guidelines” on page 7](#), which include the [“Maximum Number of Disk Shelves per Controller Configuration” on page 8](#).

---

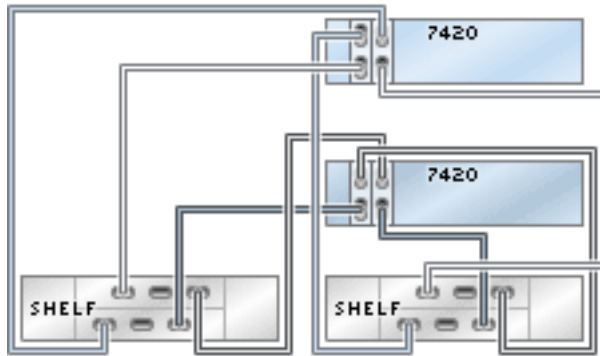
**Note** - For hardware port locations, see the PCIe Options section in the Hardware Maintenance Overview for your controller model.

---

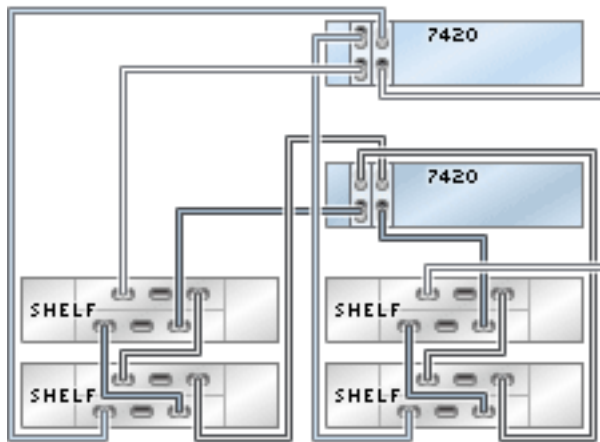
**FIGURE 2-39** 7420 clustered controllers with two HBAs connected to one DE2-24 disk shelf in a single chain



**FIGURE 2-40** 7420 clustered controllers with two HBAs connected to two DE2-24 disk shelves in two chains

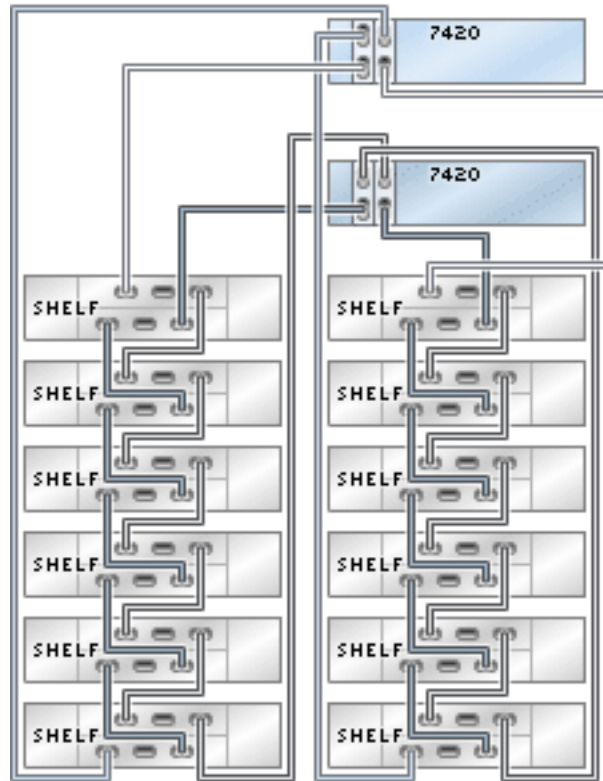


**FIGURE 2-41** 7420 clustered controllers with two HBAs connected to four DE2-24 disk shelves in two chains





**FIGURE 2-42** 7420 clustered controllers with two HBAs connected to 12 DE2-24 disk shelves in two chains



### 7420 Clustered to DE2-24 Disk Shelves (3 HBAs)

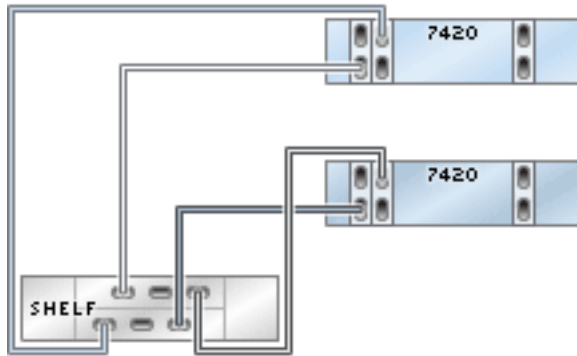
The following figures show a subset of the supported configurations for Oracle ZFS Storage 7420 clustered controllers with three HBAs. To cable the controller to the disk shelves, use the [“Cabling Guidelines” on page 7](#), which include the [“Maximum Number of Disk Shelves per Controller Configuration” on page 8](#).

---

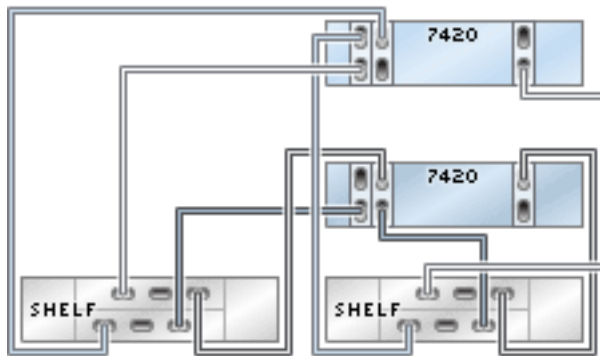
**Note** - For hardware port locations, see the PCIe Options section in the Hardware Maintenance Overview for your controller model.

---

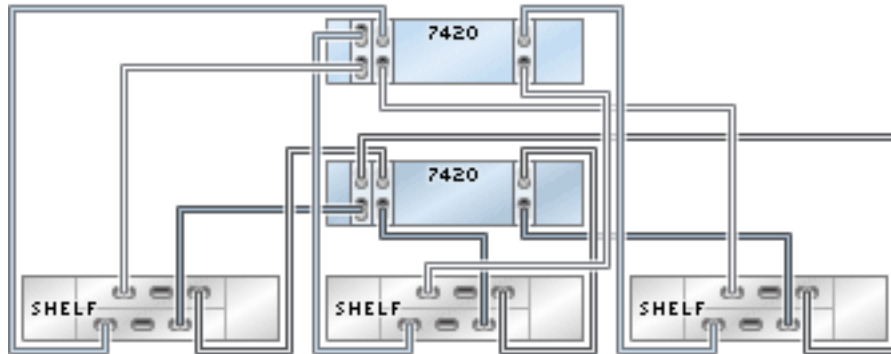
**FIGURE 2-43** 7420 clustered controllers with three HBAs connected to one DE2-24 disk shelf in a single chain



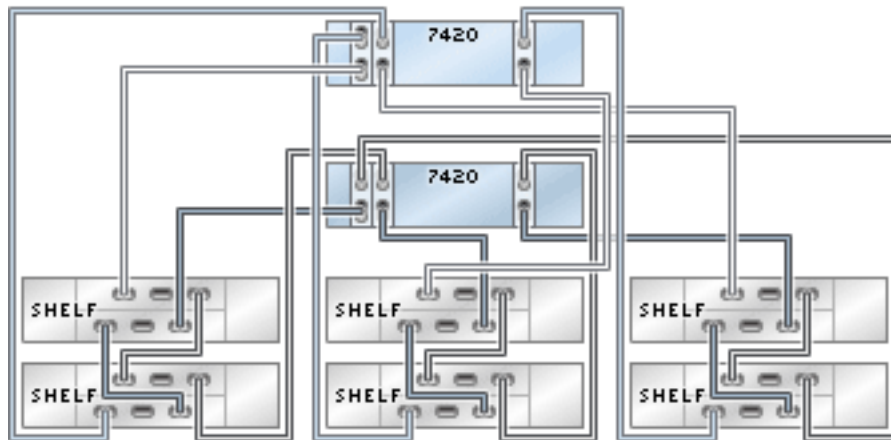
**FIGURE 2-44** 7420 clustered controllers with three HBAs connected to two DE2-24 disk shelves in two chains



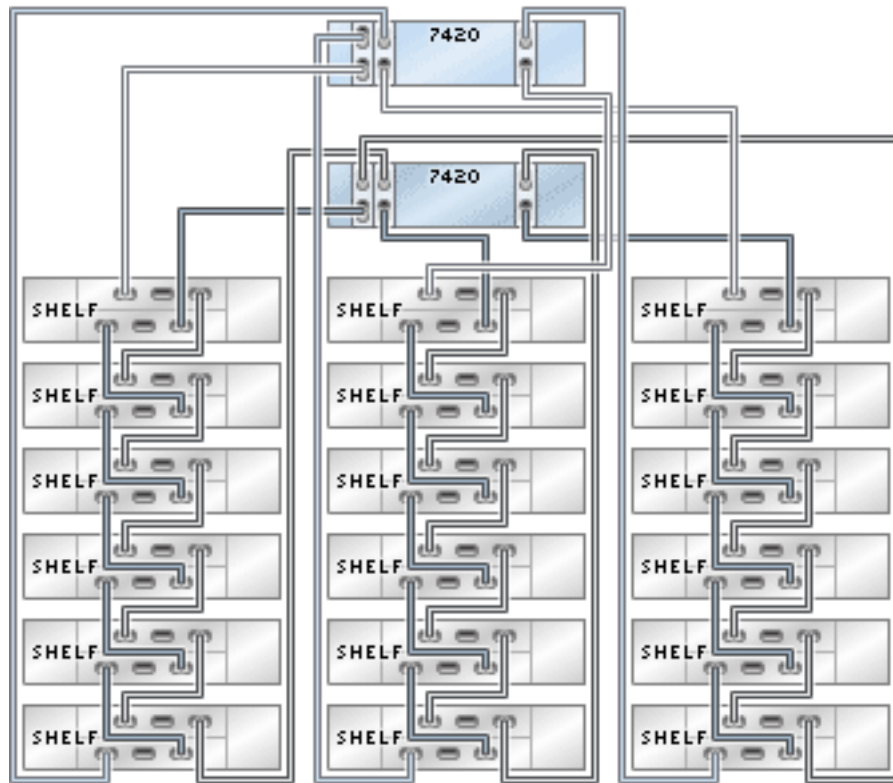
**FIGURE 2-45** 7420 clustered controllers with three HBAs connected to three DE2-24 disk shelves in three chains



**FIGURE 2-46** 7420 clustered controllers with three HBAs connected to six DE2-24 disk shelves in three chains



**FIGURE 2-47** 7420 clustered controllers with three HBAs connected to 18 DE2-24 disk shelves in three chains



### 7420 Clustered to DE2-24 Disk Shelves (4 HBAs)

The following figures show a subset of the supported configurations for Oracle ZFS Storage 7420 clustered controllers with four HBAs. To cable the controller to the disk shelves, use the [“Cabling Guidelines” on page 7](#), which include the [“Maximum Number of Disk Shelves per Controller Configuration” on page 8](#).

---

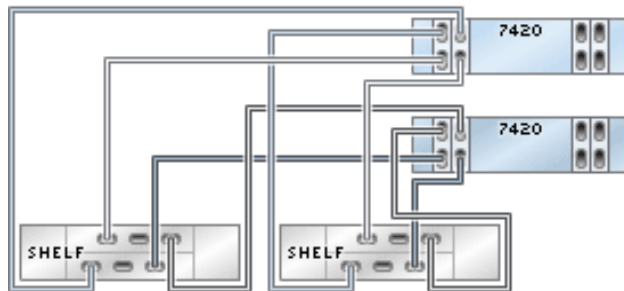
**Note** - For hardware port locations, see the PCIe Options section in the Hardware Maintenance Overview for your controller model.

---

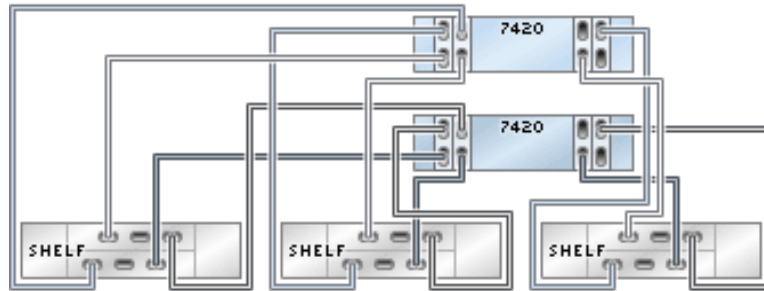
**FIGURE 2-48** 7420 clustered controllers with four HBAs connected to one DE2-24 disk shelf in a single chain



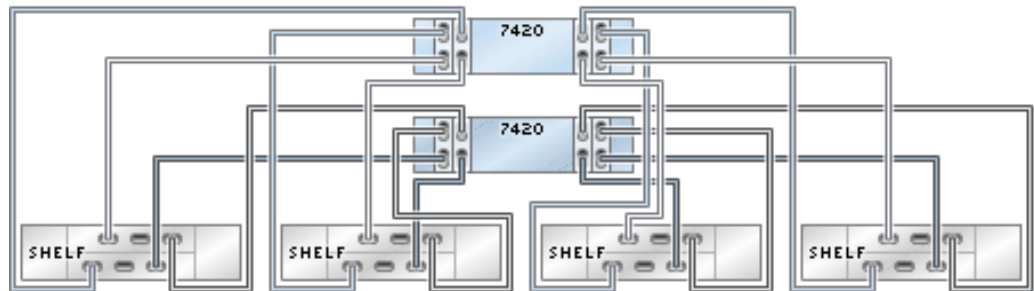
**FIGURE 2-49** 7420 clustered controllers with four HBAs connected to two DE2-24 disk shelves in two chains



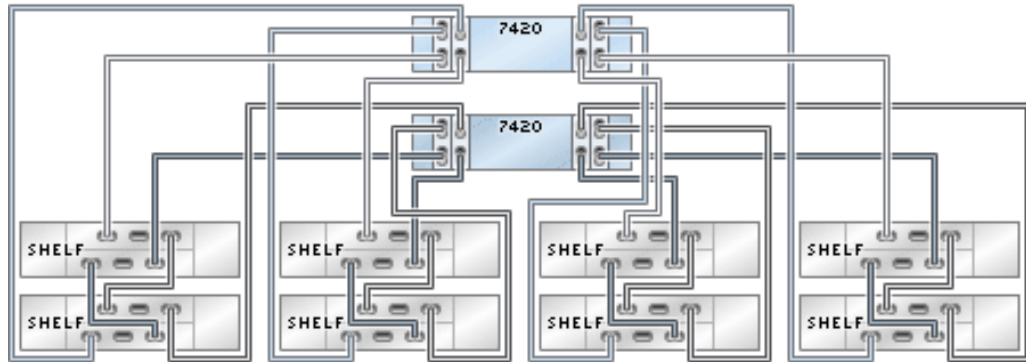
**FIGURE 2-50** 7420 clustered controllers with four HBAs connected to three DE2-24 disk shelves in three chains



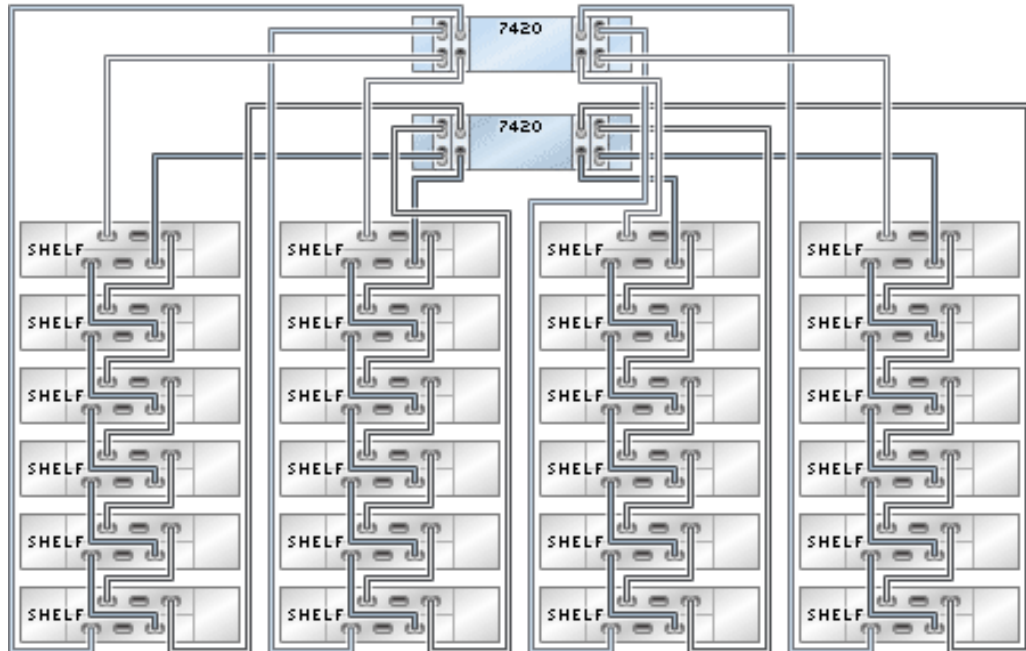
**FIGURE 2-51** 7420 clustered controllers with four HBAs connected to four DE2-24 disk shelves in four chains



**FIGURE 2-52** 7420 clustered controllers with four HBAs connected to eight DE2-24 disk shelves in four chains



**FIGURE 2-53** 7420 clustered controllers with four HBAs connected to 24 DE2-24 disk shelves in four chains



## 7420 Clustered to DE2-24 Disk Shelves (5 HBAs)

The following figures show a subset of the supported configurations for Oracle ZFS Storage 7420 clustered controllers with five HBAs. To cable the controller to the disk shelves, use the [“Cabling Guidelines” on page 7](#), which include the [“Maximum Number of Disk Shelves per Controller Configuration” on page 8](#).

---

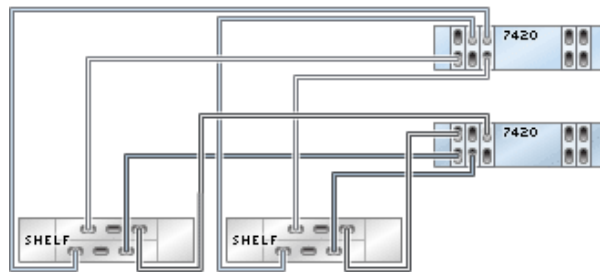
**Note** - For hardware port locations, see the PCIe Options section in the Hardware Maintenance Overview for your controller model.

---

**FIGURE 2-54** 7420 clustered controllers with five HBAs connected to one DE2-24 disk shelf in a single chain

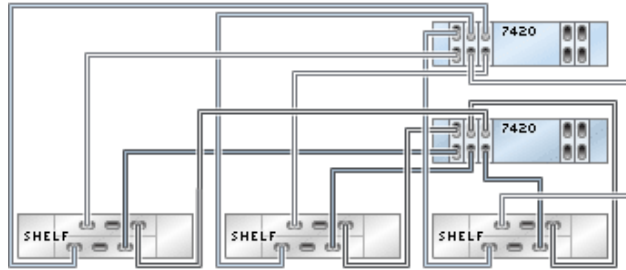


**FIGURE 2-55** 7420 clustered controllers with five HBAs connected to two DE2-24 disk shelves in two chains

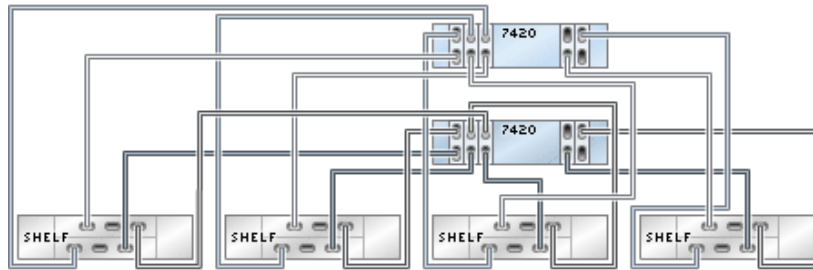




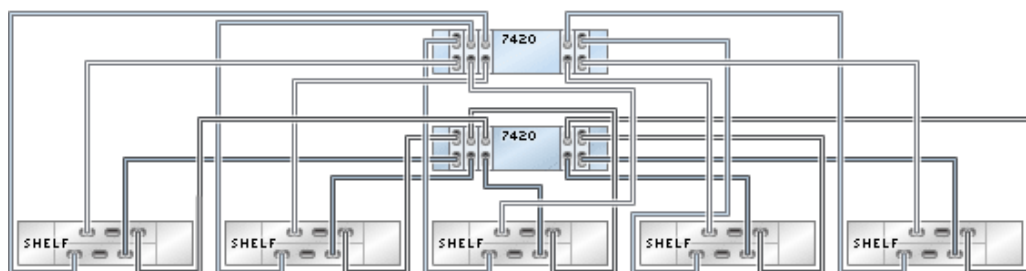
**FIGURE 2-56** 7420 clustered controllers with five HBAs connected to three DE2-24 disk shelves in three chains



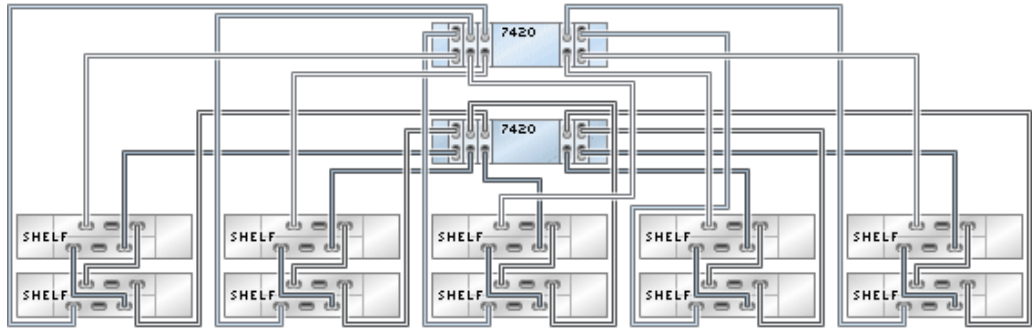
**FIGURE 2-57** 7420 clustered controllers with five HBAs connected to four DE2-24 disk shelves in four chains



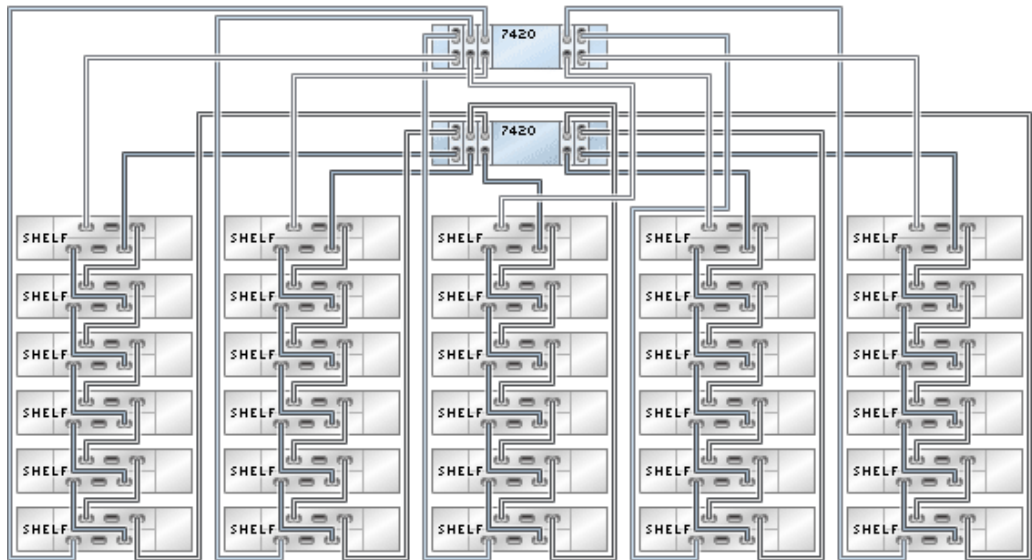
**FIGURE 2-58** 7420 clustered controllers with five HBAs connected to ten DE2-24 disk shelves in five chains



**FIGURE 2-59** 7420 clustered controllers with five HBAs connected to ten DE2-24 disk shelves in five chains



**FIGURE 2-60** 7420 clustered controllers with five HBAs connected to 30 DE2-24 disk shelves in five chains



## 7420 Clustered to DE2-24 Disk Shelves (6 HBAs)

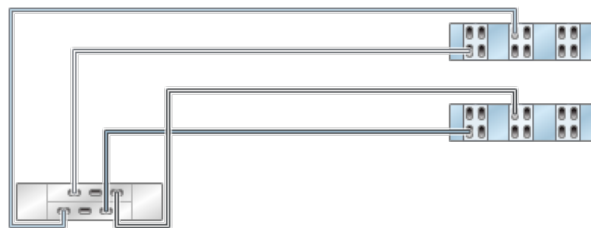
The following figures show a subset of the supported configurations for Oracle ZFS Storage 7420 clustered controllers with six HBAs. To cable the controller to the disk shelves, use the “Cabling Guidelines” on page 7, which include the “Maximum Number of Disk Shelves per Controller Configuration” on page 8.

---

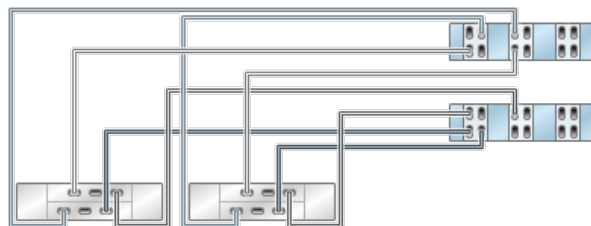
**Note** - For hardware port locations, see the PCIe Options section in the Hardware Maintenance Overview for your controller model.

---

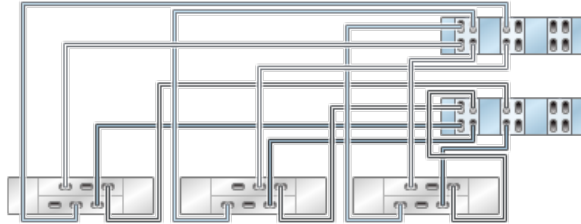
**FIGURE 2-61** 7420 clustered controllers with six HBAs connected to one DE2-24 disk shelf in a single chain



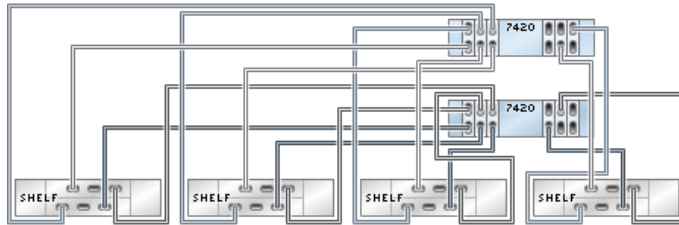
**FIGURE 2-62** 7420 clustered controllers with six HBAs connected to two DE2-24 disk shelves in two chains



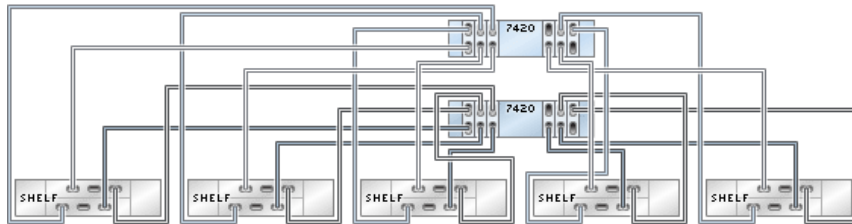
**FIGURE 2-63** 7420 clustered controllers with six HBAs connected to three DE2-24 disk shelves in three chains



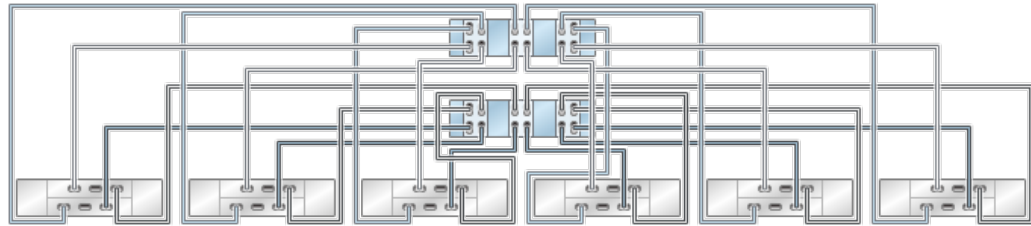
**FIGURE 2-64** 7420 clustered controllers with six HBAs connected to four DE2-24 disk shelves in four chains



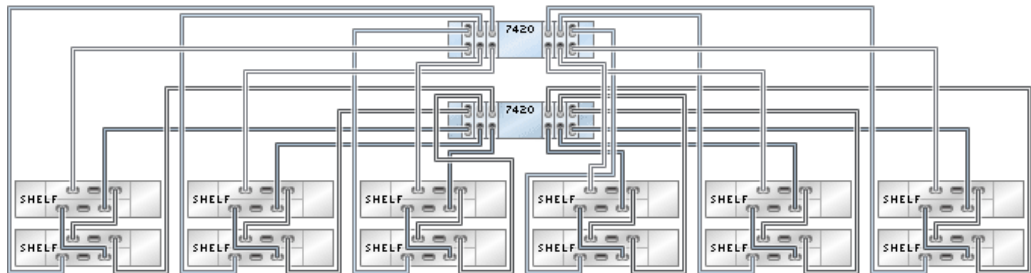
**FIGURE 2-65** 7420 clustered controllers with six HBAs connected to five DE2-24 disk shelves in five chains



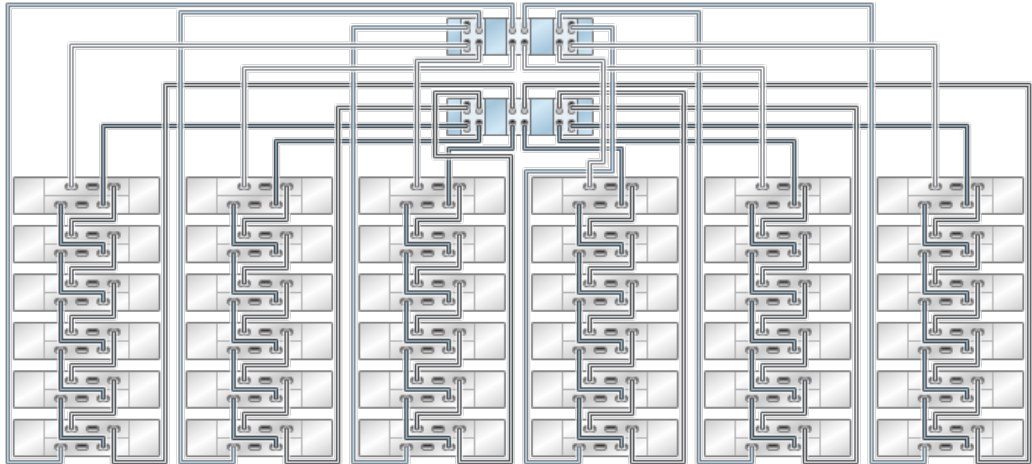
**FIGURE 2-66** 7420 clustered controllers with six HBAs connected to six DE2-24 disk shelves in six chains



**FIGURE 2-67** 7420 clustered controllers with six HBAs connected to 12 DE2-24 disk shelves in six chains



**FIGURE 2-68** 7420 clustered controllers with six HBAs connected to 36 DE2-24 disk shelves in six chains



# ◆◆◆ CHAPTER 3

## Oracle DE2-24 Disk Shelf to 4X4 Port SAS-2 HBAs

---

### DE2-24 to 7320

#### 7320 Standalone to DE2-24 Disk Shelves

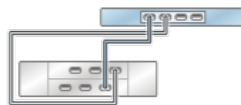
The following figures show a subset of the supported configurations for Oracle ZFS Storage 7320 standalone controllers with one HBAs. To cable the controller to the disk shelves, use the [“Cabling Guidelines” on page 7](#), which include the [“Maximum Number of Disk Shelves per Controller Configuration” on page 8](#).

---

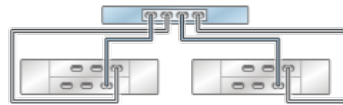
**Note** - For hardware port locations, see the PCIe Options section in the Hardware Maintenance Overview for your controller model.

---

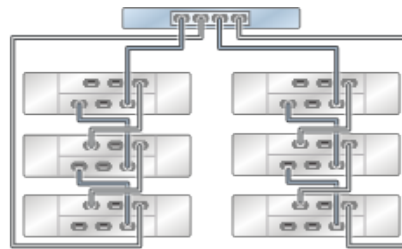
**FIGURE 3-1** 7320 standalone controller with one HBA connected to one DE2-24 disk shelf in a single chain



**FIGURE 3-2** 7320 standalone controller with one HBA connected to two DE2-24 disk shelves in two chains



**FIGURE 3-3** 7320 standalone controller with one HBA connected to six DE2-24 disk shelves in two chains



## 7320 Clustered to DE2-24 Disk Shelves

The following figures show a subset of the supported configurations for Oracle ZFS Storage 7320 clustered controllers with one HBA. To cable the controller to the disk shelves, use the [“Cabling Guidelines” on page 7](#), which include the [“Maximum Number of Disk Shelves per Controller Configuration” on page 8](#).

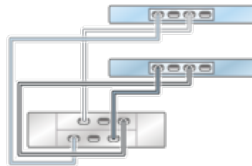
---

**Note** - For hardware port locations, see the PCIe Options section in the Hardware Maintenance Overview for your controller model.

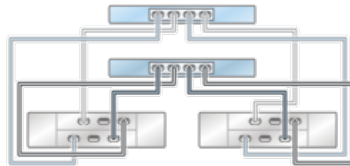
---



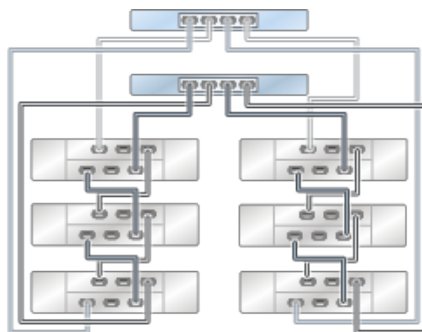
**FIGURE 3-4** 7320 clustered controllers with one HBA connected to one DE2-24 disk shelf in a single chain



**FIGURE 3-5** 7320 clustered controllers with one HBA connected to two DE2-24 disk shelves in two chains



**FIGURE 3-6** 7320 clustered controllers with one HBA connected to six DE2-24 disk shelves in two chains



## DE2-24 to 7420

### 7420 Standalone to DE2-24 Disk Shelves

#### 7420 Standalone to DE2-24 Disk Shelves (2 HBAs)

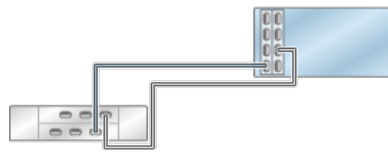
The following figures show a subset of the supported configurations for Oracle ZFS Storage 7420 standalone controllers with two HBAs. To cable the controller to the disk shelves, use the [“Cabling Guidelines” on page 7](#), which include the [“Maximum Number of Disk Shelves per Controller Configuration” on page 8](#).

---

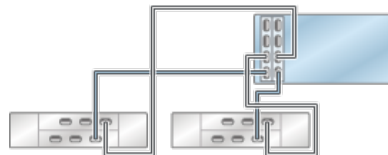
**Note** - For hardware port locations, see the PCIe Options section in the Hardware Maintenance Overview for your controller model.

---

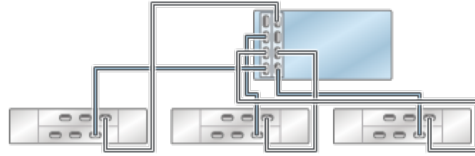
**FIGURE 3-7** 7420 standalone controller with two HBAs connected to one DE2-24 disk shelf in a single chain



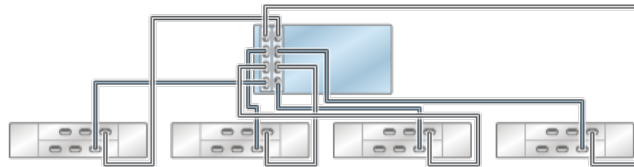
**FIGURE 3-8** 7420 standalone controller with two HBAs connected to two DE2-24 disk shelves in two chains



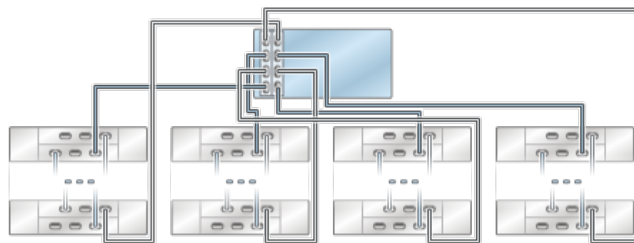
**FIGURE 3-9** 7420 standalone controller with two HBAs connected to three DE2-24 disk shelves in three chains



**FIGURE 3-10** 7420 standalone controller with two HBAs connected to four DE2-24 disk shelves in four chains



**FIGURE 3-11** 7420 standalone controller with two HBAs connected to multiple DE2-24 disk shelves in four chains



## 7420 Standalone to DE2-24 Disk Shelves (3 HBAs)

The following figures show a subset of the supported configurations for Oracle ZFS Storage 7420 standalone controllers with three HBAs. To cable the controller to the disk shelves, use

the “Cabling Guidelines” on page 7, which include the “Maximum Number of Disk Shelves per Controller Configuration” on page 8.

---

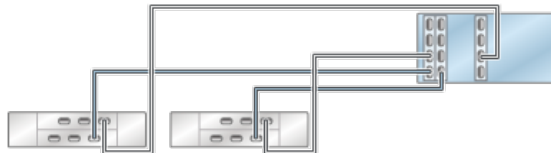
**Note** - For hardware port locations, see the PCIe Options section in the Hardware Maintenance Overview for your controller model.

---

**FIGURE 3-12** 7420 standalone controller with three HBAs connected to one DE2-24 disk shelf in a single chain



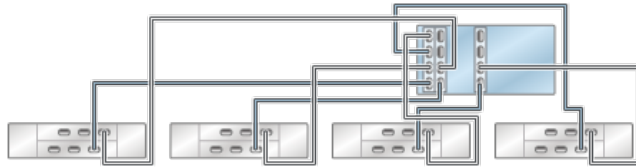
**FIGURE 3-13** 7420 standalone controller with three HBAs connected to two DE2-24 disk shelves in two chains



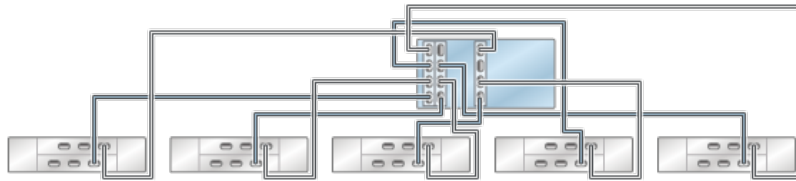
**FIGURE 3-14** 7420 standalone controller with three HBAs connected to three DE2-24 disk shelves in three chains



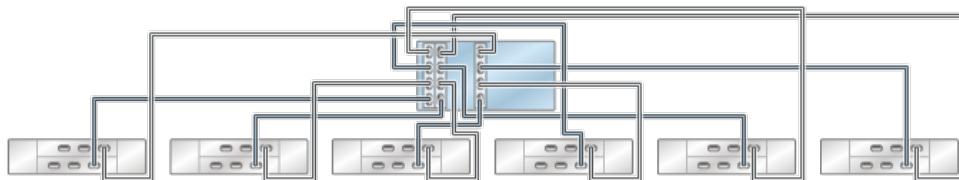
**FIGURE 3-15** 7420 standalone controller with three HBAs connected to four DE2-24 disk shelves in four chains



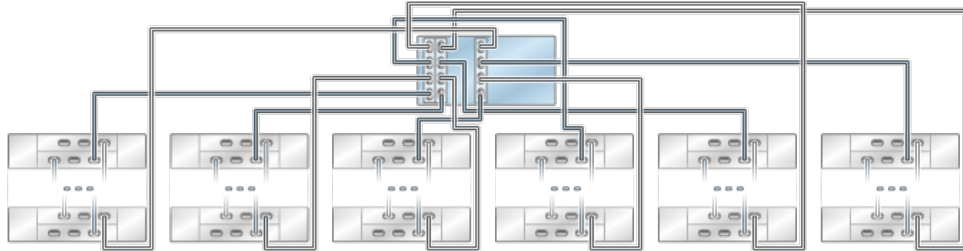
**FIGURE 3-16** 7420 standalone controller with three HBAs connected to five DE2-24 disk shelves in five chains



**FIGURE 3-17** 7420 standalone controller with three HBAs connected to six DE2-24 disk shelves in six chains



**FIGURE 3-18** 7420 standalone controller with three HBAs connected to multiple DE2-24 disk shelves in six chains



### 7420 Standalone to DE2-24 Disk Shelves (4 HBAs)

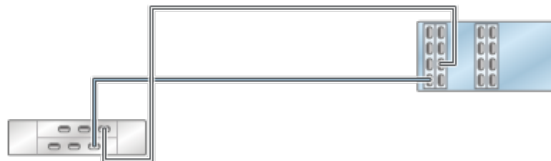
The following figures show a subset of the supported configurations for Oracle ZFS Storage 7420 standalone controllers with four HBAs. To cable the controller to the disk shelves, use the [“Cabling Guidelines” on page 7](#), which include the [“Maximum Number of Disk Shelves per Controller Configuration” on page 8](#).

---

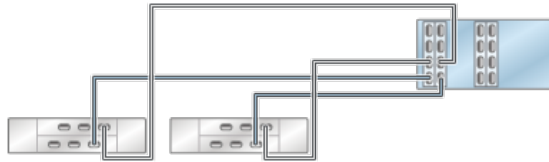
**Note** - For hardware port locations, see the PCIe Options section in the Hardware Maintenance Overview for your controller model.

---

**FIGURE 3-19** 7420 standalone controller with four HBAs connected to one DE2-24 disk shelf in a single chain



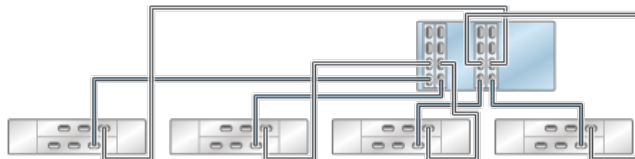
**FIGURE 3-20** 7420 standalone controller with four HBAs connected to two DE2-24 disk shelves in two chains



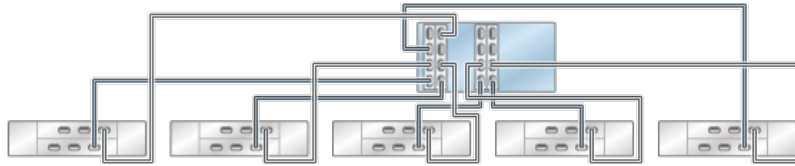
**FIGURE 3-21** 7420 standalone controller with four HBAs connected to three DE2-24 disk shelves in three chains



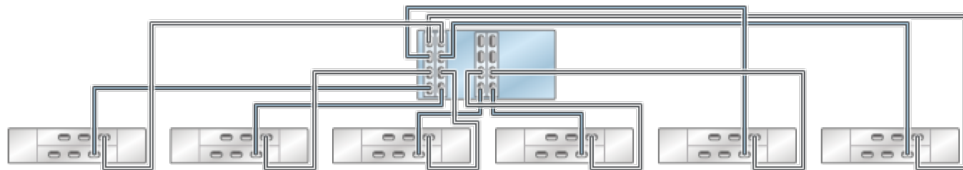
**FIGURE 3-22** 7420 standalone controller with four HBAs connected to four DE2-24 disk shelves in four chains



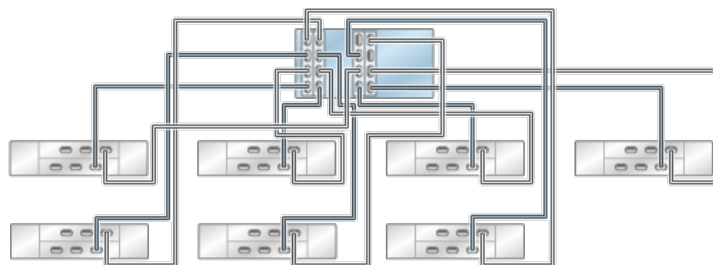
**FIGURE 3-23** 7420 standalone controller with four HBAs connected to five DE2-24 disk shelves in five chains



**FIGURE 3-24** 7420 standalone controller with four HBAs connected to six DE2-24 disk shelves in six chains

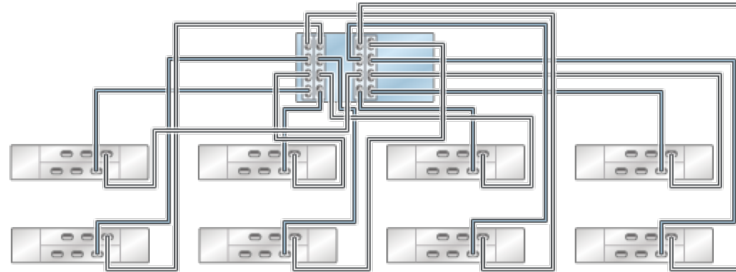


**FIGURE 3-25** 7420 standalone controller with four HBAs connected to seven DE2-24 disk shelves in seven chains

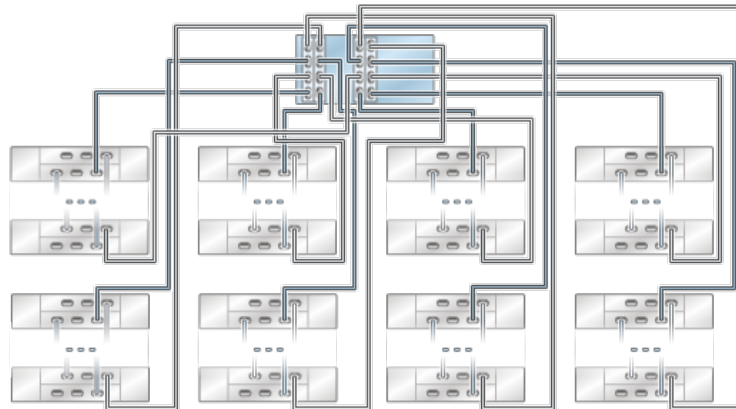




**FIGURE 3-26** 7420 standalone controller with four HBAs connected to eight DE2-24 disk shelves in eight chains



**FIGURE 3-27** 7420 standalone controller with four HBAs connected to multiple DE2-24 disk shelves in eight chains



## 7420 Clustered to DE2-24 Disk Shelves

### 7420 Clustered to DE2-24 Disk Shelves (2 HBAs)

The following figures show a subset of the supported configurations for Oracle ZFS Storage 7420 clustered controllers with two HBAs. To cable the controller to the disk shelves, use the

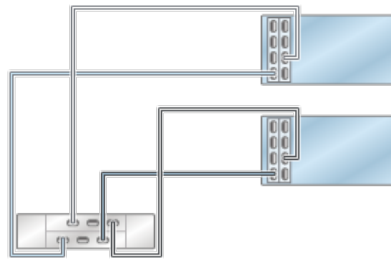
“Cabling Guidelines” on page 7, which include the “Maximum Number of Disk Shelves per Controller Configuration” on page 8.

---

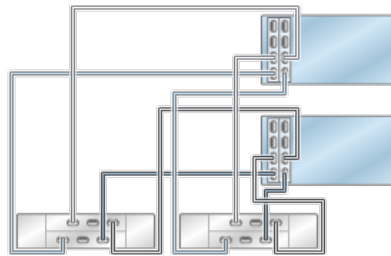
**Note** - For hardware port locations, see the PCIe Options section in the Hardware Maintenance Overview for your controller model.

---

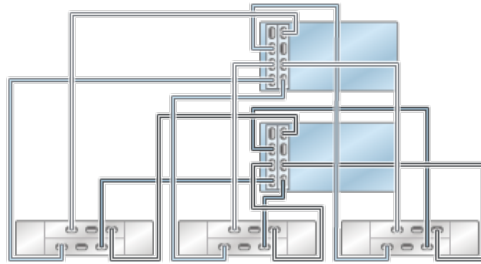
**FIGURE 3-28** 7420 clustered controllers with two HBAs connected to one DE2-24 disk shelf in a single chain



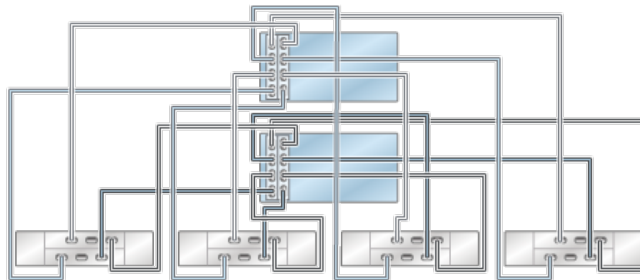
**FIGURE 3-29** 7420 clustered controllers with two HBAs connected to two DE2-24 disk shelves in two chains



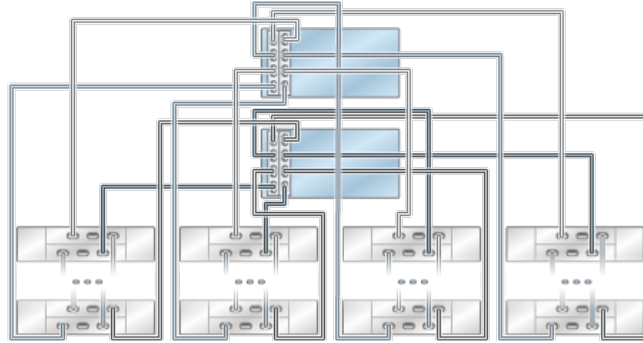
**FIGURE 3-30** 7420 clustered controllers with two HBAs connected to three DE2-24 disk shelves in three chains



**FIGURE 3-31** 7420 clustered controllers with two HBAs connected to four DE2-24 disk shelves in four chains



**FIGURE 3-32** 7420 clustered controllers with two HBAs connected to multiple DE2-24 disk shelves in four chains



### 7420 Clustered to DE2-24 Disk Shelves (3 HBAs)

The following figures show a subset of the supported configurations for Oracle ZFS Storage 7420 clustered controllers with three HBAs. To cable the controller to the disk shelves, use the [“Cabling Guidelines”](#) on page 7, which include the [“Maximum Number of Disk Shelves per Controller Configuration”](#) on page 8.

---

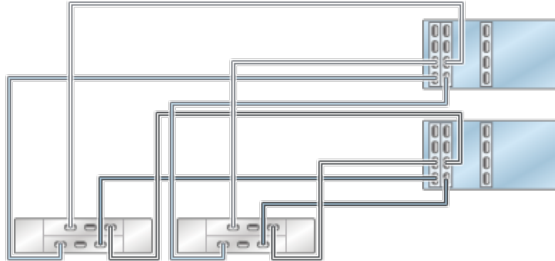
**Note** - For hardware port locations, see the PCIe Options section in the Hardware Maintenance Overview for your controller model.

---

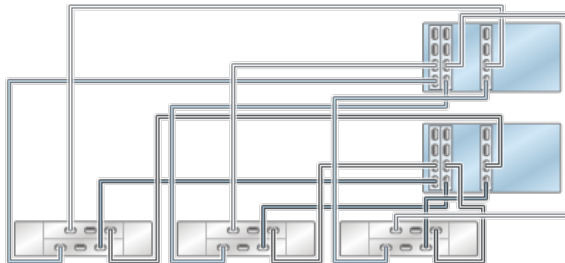
**FIGURE 3-33** 7420 clustered controllers with three HBAs connected to one DE2-24 disk shelf in a single chain



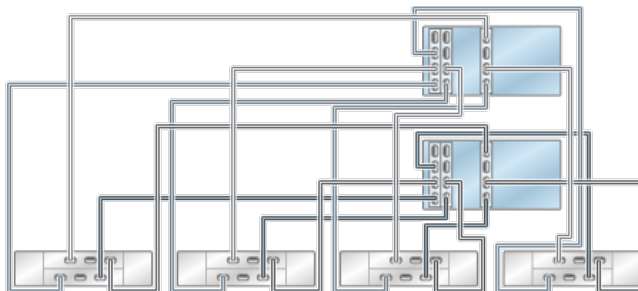
**FIGURE 3-34** 7420 clustered controllers with three HBAs connected to two DE2-24 disk shelves in two chains



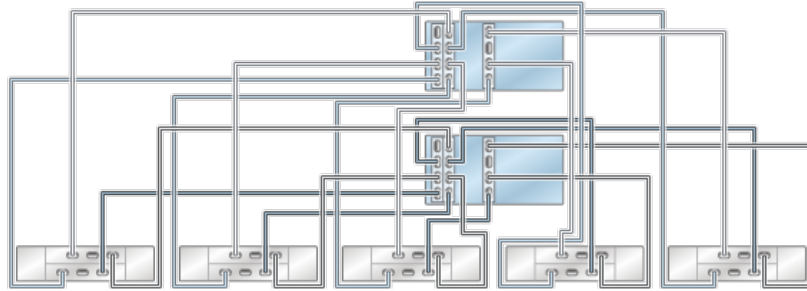
**FIGURE 3-35** 7420 clustered controllers with three HBAs connected to three DE2-24 disk shelves in three chains



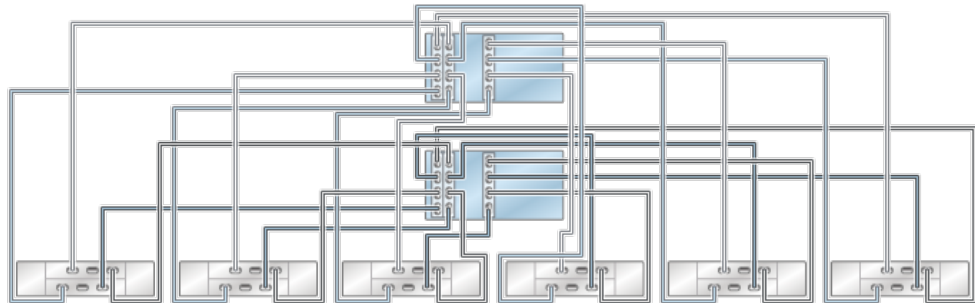
**FIGURE 3-36** 7420 clustered controllers with three HBAs connected to four DE2-24 disk shelves in four chains



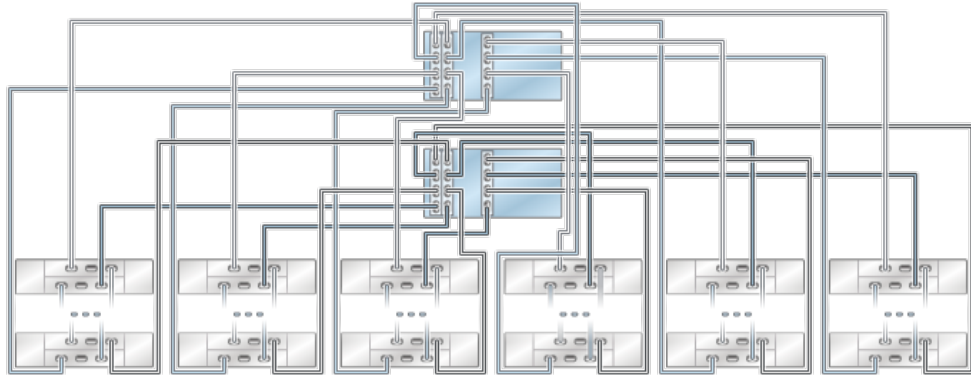
**FIGURE 3-37** 7420 clustered controllers with three HBAs connected to five DE2-24 disk shelves in five chains



**FIGURE 3-38** 7420 clustered controllers with three HBAs connected to six DE2-24 disk shelves in six chains



**FIGURE 3-39** 7420 clustered controllers with three HBAs connected to multiple DE2-24 disk shelves in six chains



### 7420 Clustered to DE2-24 Disk Shelves (4 HBAs)

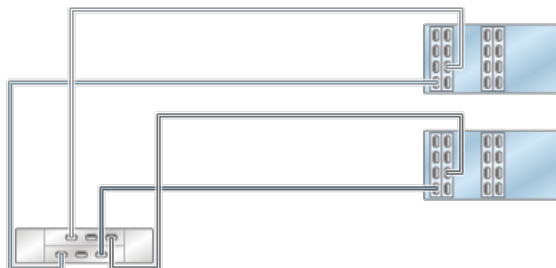
The following figures show a subset of the supported configurations for Oracle ZFS Storage 7420 clustered controllers with four HBAs. To cable the controller to the disk shelves, use the “Cabling Guidelines” on page 7, which include the “Maximum Number of Disk Shelves per Controller Configuration” on page 8.

---

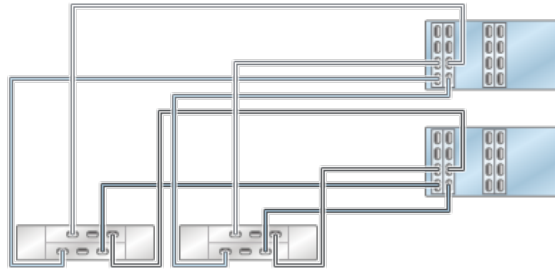
**Note** - For hardware port locations, see the PCIe Options section in the Hardware Maintenance Overview for your controller model.

---

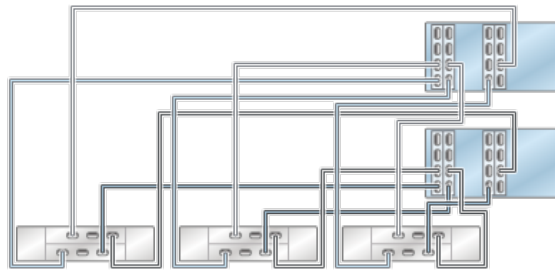
**FIGURE 3-40** 7420 clustered controllers with four HBAs connected to one DE2-24 disk shelf in a single chain



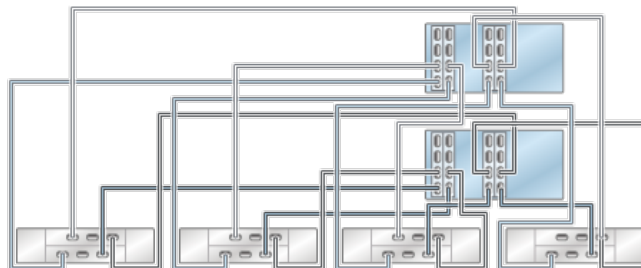
**FIGURE 3-41** 7420 clustered controllers with four HBAs connected to two DE2-24 disk shelves in two chains



**FIGURE 3-42** 7420 clustered controllers with four HBAs connected to three DE2-24 disk shelves in three chains

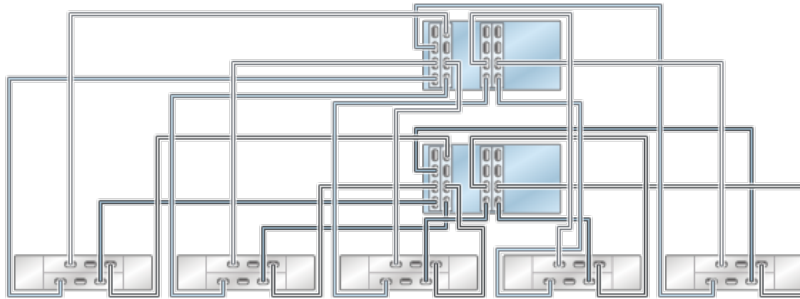


**FIGURE 3-43** 7420 clustered controllers with four HBAs connected to four DE2-24 disk shelves in four chains

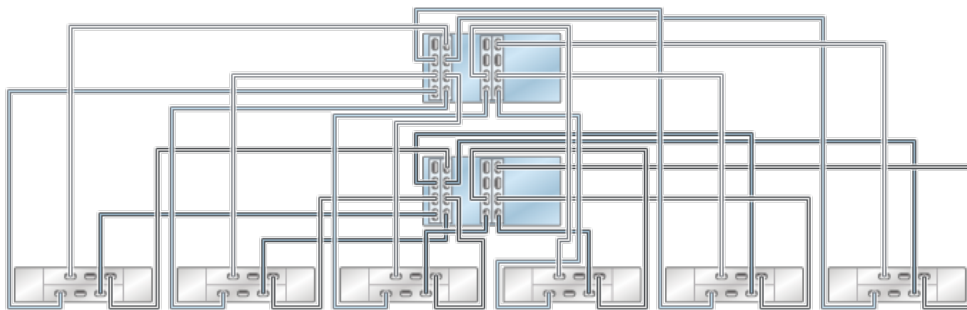




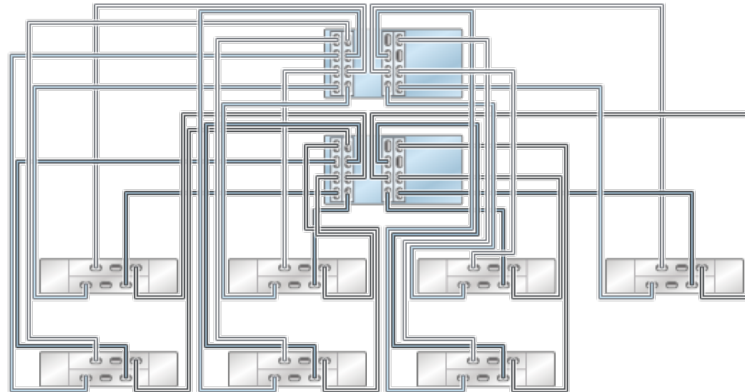
**FIGURE 3-44** 7420 clustered controllers with four HBAs connected to five DE2-24 disk shelves in five chains



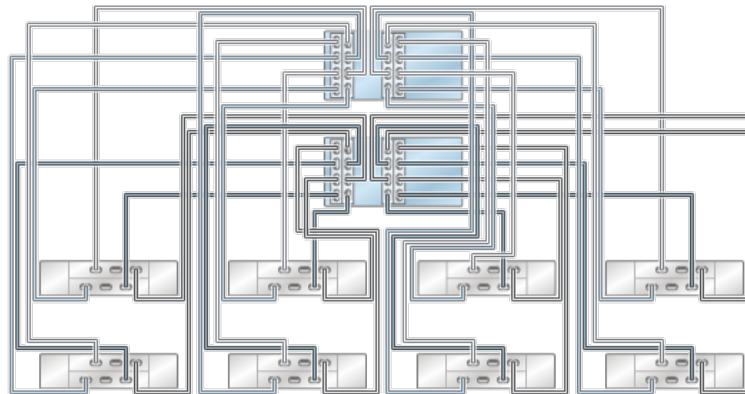
**FIGURE 3-45** 7420 clustered controllers with four HBAs connected to six DE2-24 disk shelves in six chains



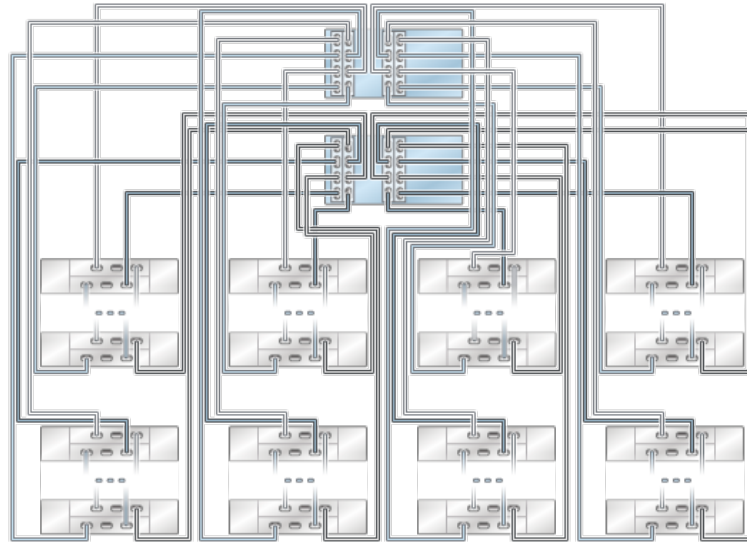
**FIGURE 3-46** 7420 clustered controllers with four HBAs connected to seven DE2-24 disk shelves in seven chains



**FIGURE 3-47** 7420 clustered controllers with four HBAs connected to eight DE2-24 disk shelves in eight chains



**FIGURE 3-48** 7420 clustered controllers with four HBAs connected to multiple DE2-24 disk shelves in eight chains



## DE2-24 to ZS3-2

### ZS3-2 Standalone to DE2-24 Disk Shelves

#### ZS3-2 Standalone to DE2-24 Disk Shelves (1 HBA)

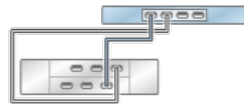
The following figures show a subset of the supported configurations for Oracle ZFS Storage ZS3-2 standalone controllers with one HBA. To cable the controller to the disk shelves, use the [“Cabling Guidelines” on page 7](#), which include the [“Maximum Number of Disk Shelves per Controller Configuration” on page 8](#).

---

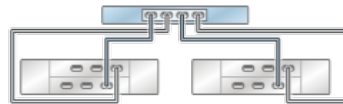
**Note** - For hardware port locations, see the PCIe Options section in the Hardware Maintenance Overview for your controller model.

---

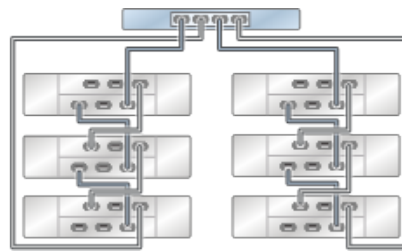
**FIGURE 3-49** ZS3-2 standalone controller with one HBA connected to one DE2-24 disk shelf in a single chain



**FIGURE 3-50** ZS3-2 standalone controller with one HBA connected to two DE2-24 disk shelves in two chains



**FIGURE 3-51** ZS3-2 standalone controller with one HBA connected to six DE2-24 disk shelves in two chains



## ZS3-2 Standalone to DE2-24 Disk Shelves (2 HBAs)

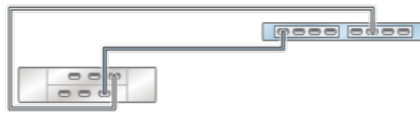
The following figures show a subset of the supported configurations for Oracle ZFS Storage ZS3-2 standalone controllers with two HBAs. To cable the controller to the disk shelves, use the [“Cabling Guidelines”](#) on page 7, which include the [“Maximum Number of Disk Shelves per Controller Configuration”](#) on page 8.

---

**Note** - For hardware port locations, see the PCIe Options section in the Hardware Maintenance Overview for your controller model.

---

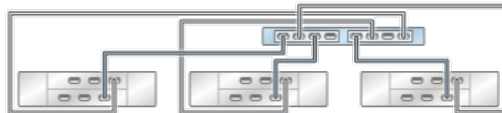
**FIGURE 3-52** ZS3-2 standalone controller with two HBAs connected to one DE2-24 disk shelf in one chain



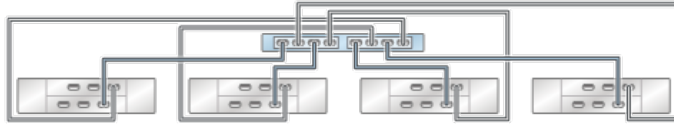
**FIGURE 3-53** ZS3-2 standalone controller with two HBAs connected to two DE2-24 disk shelves in two chains



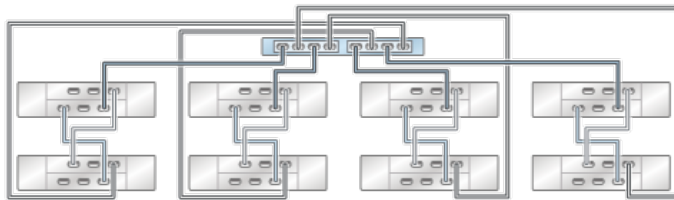
**FIGURE 3-54** ZS3-2 standalone controller with two HBAs connected to three DE2-24 disk shelves in three chains



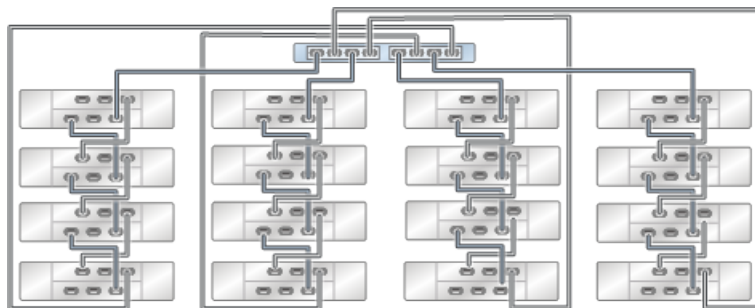
**FIGURE 3-55** ZS3-2 standalone controller with two HBAs connected to four DE2-24 disk shelves in four chains



**FIGURE 3-56** ZS3-2 standalone controller with two HBAs connected to eight DE2-24 disk shelves in four chains



**FIGURE 3-57** ZS3-2 standalone controller with two HBAs connected to sixteen DE2-24 disk shelves in four chains



## ZS3-2 Clustered to DE2-24 Disk Shelves

### ZS3-2 Clustered to DE2-24 Disk Shelves (1 HBA)

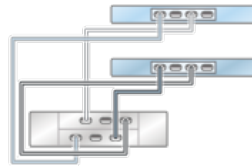
The following figures show a subset of the supported configurations for Oracle ZFS Storage ZS3-2 clustered controllers with one HBA. To cable the controller to the disk shelves, use the “Cabling Guidelines” on page 7, which include the “Maximum Number of Disk Shelves per Controller Configuration” on page 8.

---

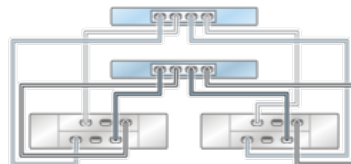
**Note** - For hardware port locations, see the PCIe Options section in the Hardware Maintenance Overview for your controller model.

---

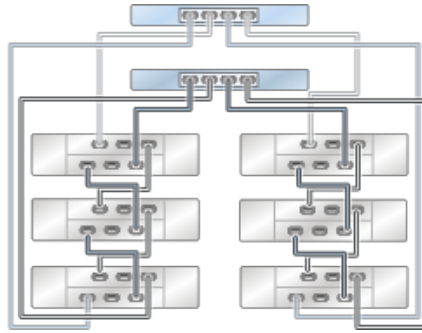
**FIGURE 3-58** ZS3-2 clustered controllers with one HBA connected to one DE2-24 disk shelf in a single chain



**FIGURE 3-59** ZS3-2 clustered controllers with one HBA connected to two DE2-24 disk shelves in two chains



**FIGURE 3-60** ZS3-2 clustered controllers with one HBA connected to six DE2-24 disk shelves in two chains



## ZS3-2 Clustered to DE2-24 Disk Shelves (2 HBAs)

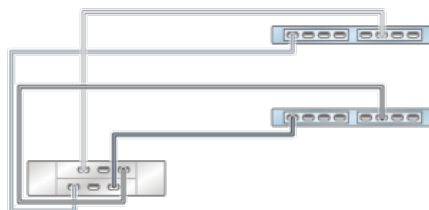
The following figures show a subset of the supported configurations for Oracle ZFS Storage ZS3-2 clustered controllers with two HBAs. To cable the controller to the disk shelves, use the [“Cabling Guidelines”](#) on page 7, which include the [“Maximum Number of Disk Shelves per Controller Configuration”](#) on page 8.

---

**Note** - For hardware port locations, see the PCIe Options section in the Hardware Maintenance Overview for your controller model.

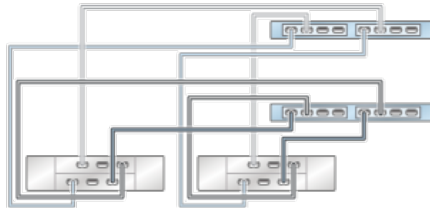
---

**FIGURE 3-61** ZS3-2 clustered controllers with two HBAs connected to one DE2-24 disk shelf in a single chain

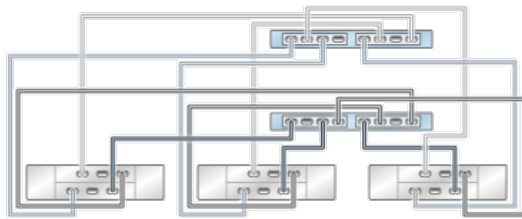




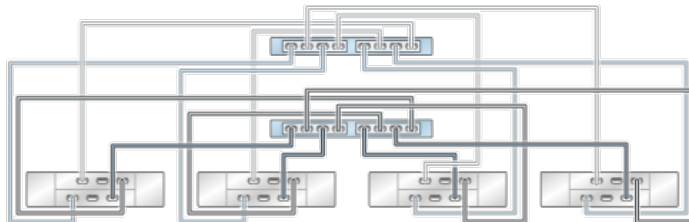
**FIGURE 3-62** ZS3-2 clustered controllers with two HBAs connected to two DE2-24 disk shelves in two chains



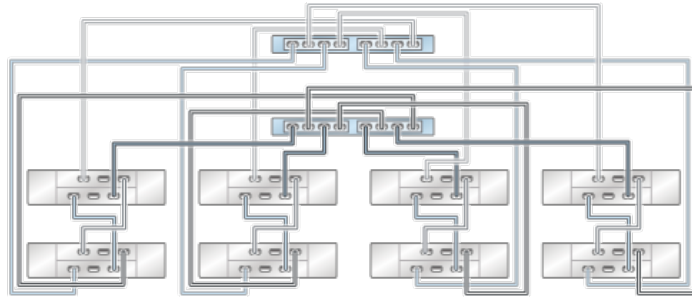
**FIGURE 3-63** ZS3-2 clustered controllers with two HBAs connected to three DE2-24 disk shelves in three chains



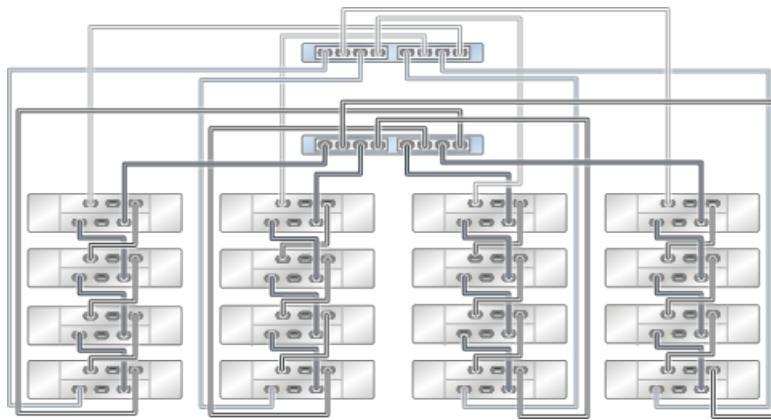
**FIGURE 3-64** ZS3-2 clustered controllers with two HBAs connected to four DE2-24 disk shelves in four chains



**FIGURE 3-65** ZS3-2 clustered controllers with two HBAs connected to eight DE2-24 disk shelves in four chains



**FIGURE 3-66** ZS3-2 clustered controllers with two HBAs connected to sixteen DE2-24 disk shelves in four chains



## DE2-24 to ZS3-4

### ZS3-4 Standalone to DE2-24 Disk Shelves

#### ZS3-4 Standalone to DE2-24 Disk Shelves (2 HBAs)

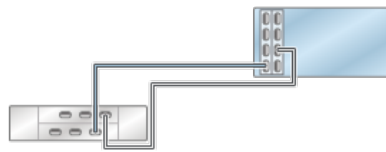
The following figures show a subset of the supported configurations for Oracle ZFS Storage ZS3-4 standalone controllers with two HBAs. To cable the controller to the disk shelves, use the “[Cabling Guidelines](#)” on page 7, which include the “[Maximum Number of Disk Shelves per Controller Configuration](#)” on page 8.

---

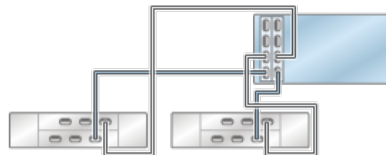
**Note** - For hardware port locations, see the PCIe Options section in the Hardware Maintenance Overview for your controller model.

---

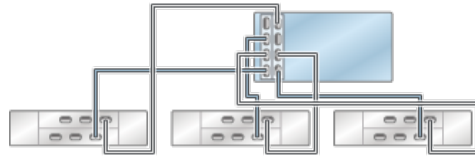
**FIGURE 3-67** ZS3-4 standalone controller with two HBAs connected to one DE2-24 disk shelf in a single chain



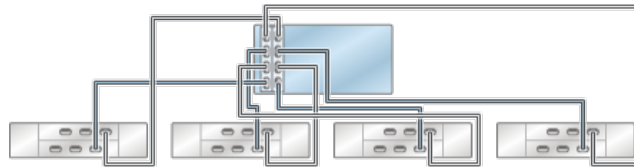
**FIGURE 3-68** ZS3-4 standalone controller with two HBAs connected to two DE2-24 disk shelves in two chains



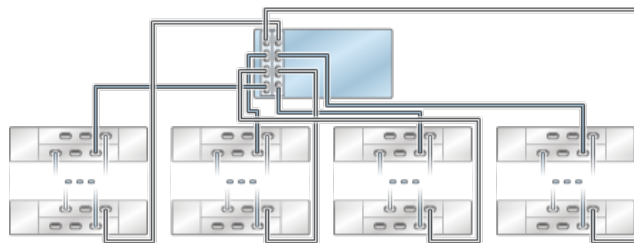
**FIGURE 3-69** ZS3-4 standalone controller with two HBAs connected to three DE2-24 disk shelves in three chains



**FIGURE 3-70** ZS3-4 standalone controller with two HBAs connected to four DE2-24 disk shelves in four chains



**FIGURE 3-71** ZS3-4 standalone controller with two HBAs connected to multiple DE2-24 disk shelves in four chains



### ZS3-4 Standalone to DE2-24 Disk Shelves (3 HBAs)

The following figures show a subset of the supported configurations for Oracle ZFS Storage ZS3-4 standalone controllers with three HBAs. To cable the controller to the disk shelves, use

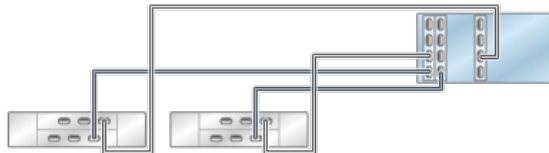
the “Cabling Guidelines” on page 7, which include the “Maximum Number of Disk Shelves per Controller Configuration” on page 8.

**Note** - For hardware port locations, see the PCIe Options section in the Hardware Maintenance Overview for your controller model.

**FIGURE 3-72** ZS3-4 standalone controller with three HBAs connected to one DE2-24 disk shelf in a single chain



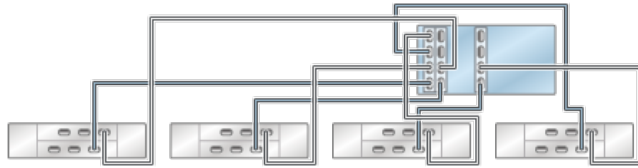
**FIGURE 3-73** ZS3-4 standalone controller with three HBAs connected to two DE2-24 disk shelves in two chains



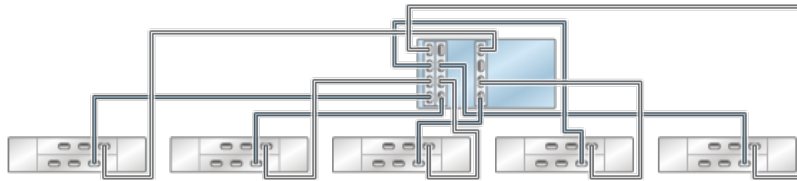
**FIGURE 3-74** ZS3-4 standalone controller with three HBAs connected to three DE2-24 disk shelves in three chains



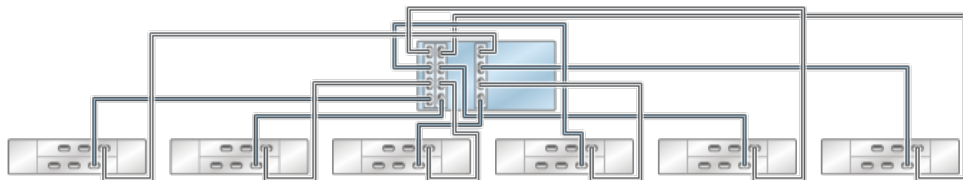
**FIGURE 3-75** ZS3-4 standalone controller with three HBAs connected to four DE2-24 disk shelves in four chains



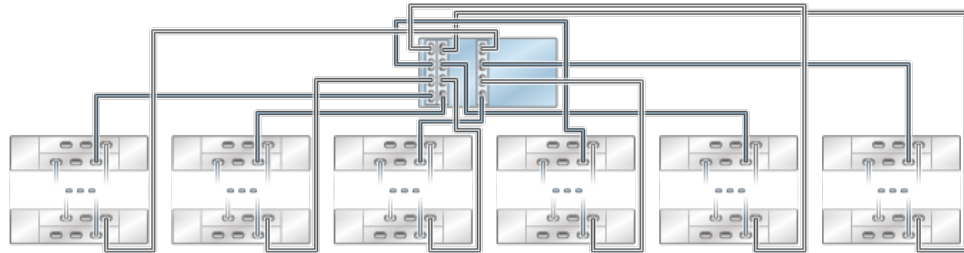
**FIGURE 3-76** ZS3-4 standalone controller with three HBAs connected to five DE2-24 disk shelves in five chains



**FIGURE 3-77** ZS3-4 standalone controller with three HBAs connected to six DE2-24 disk shelves in six chains



**FIGURE 3-78** ZS3-4 standalone controller with three HBAs connected to multiple DE2-24 disk shelves in six chains



### ZS3-4 Standalone to DE2-24 Disk Shelves (4 HBAs)

The following figures show a subset of the supported configurations for Oracle ZFS Storage ZS3-4 standalone controllers with four HBAs. To cable the controller to the disk shelves, use the “[Cabling Guidelines](#)” on page 7, which include the “[Maximum Number of Disk Shelves per Controller Configuration](#)” on page 8.

---

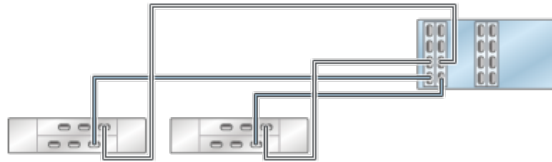
**Note** - For hardware port locations, see the PCIe Options section in the Hardware Maintenance Overview for your controller model.

---

**FIGURE 3-79** ZS3-4 standalone controller with four HBAs connected to one DE2-24 disk shelf in a single chain



**FIGURE 3-80** ZS3-4 standalone controller with four HBAs connected to two DE2-24 disk shelves in two chains



**FIGURE 3-81** ZS3-4 standalone controller with four HBAs connected to three DE2-24 disk shelves in three chains

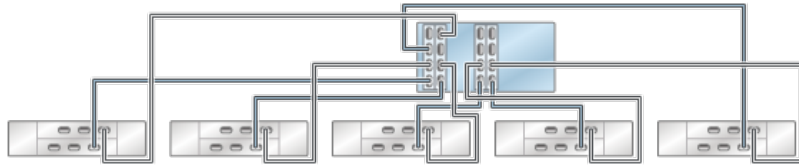


**FIGURE 3-82** ZS3-4 standalone controller with four HBAs connected to four DE2-24 disk shelves in four chains

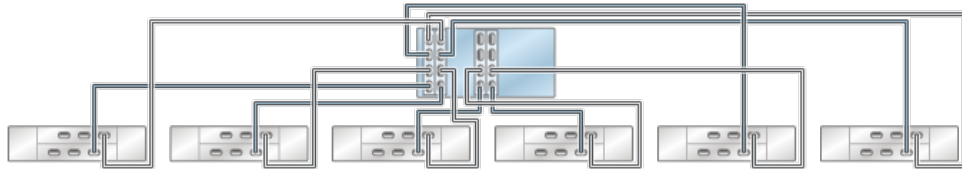




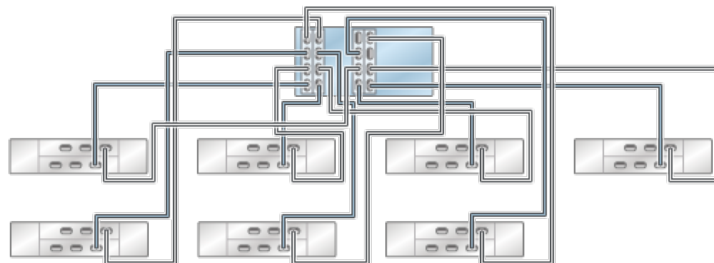
**FIGURE 3-83** ZS3-4 standalone controller with four HBAs connected to five DE2-24 disk shelves in five chains



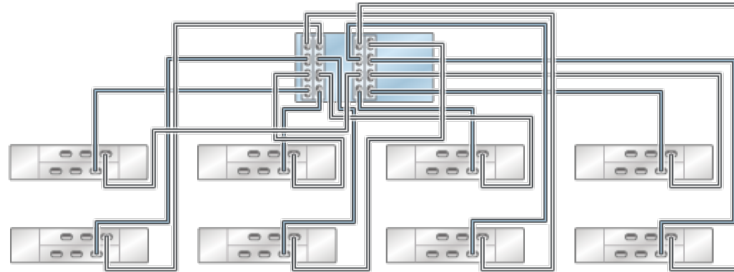
**FIGURE 3-84** ZS3-4 standalone controller with four HBAs connected to six DE2-24 disk shelves in six chains



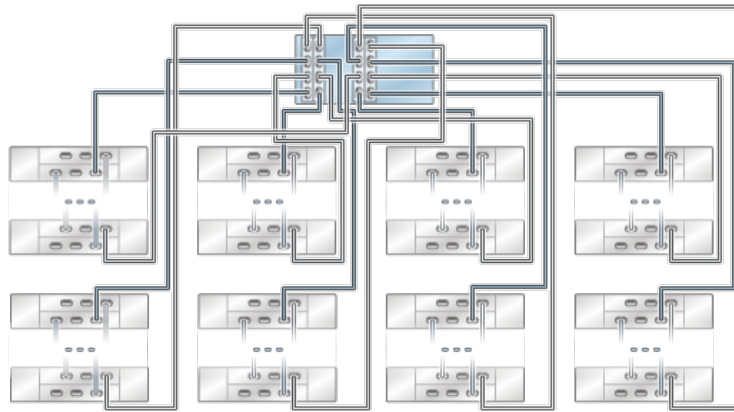
**FIGURE 3-85** ZS3-4 standalone controller with four HBAs connected to seven DE2-24 disk shelves in seven chains



**FIGURE 3-86** ZS3-4 standalone controller with four HBAs connected to eight DE2-24 disk shelves in eight chains



**FIGURE 3-87** ZS3-4 standalone controller with four HBAs connected to multiple DE2-24 disk shelves in eight chains



## ZS3-4 Clustered to DE2-24 Disk Shelves

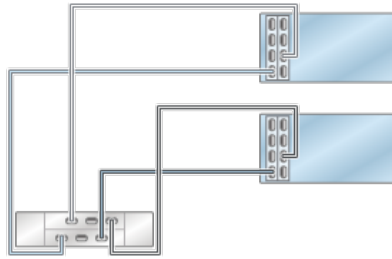
### ZS3-4 Clustered to DE2-24 Disk Shelves (2 HBAs)

The following figures show a subset of the supported configurations for Oracle ZFS Storage ZS3-4 clustered controllers with two HBAs. To cable the controller to the disk shelves, use the

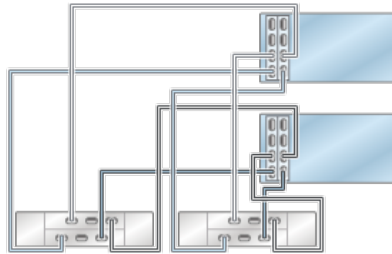
“Cabling Guidelines” on page 7, which include the “Maximum Number of Disk Shelves per Controller Configuration” on page 8.

**Note** - For hardware port locations, see the PCIe Options section in the Hardware Maintenance Overview for your controller model.

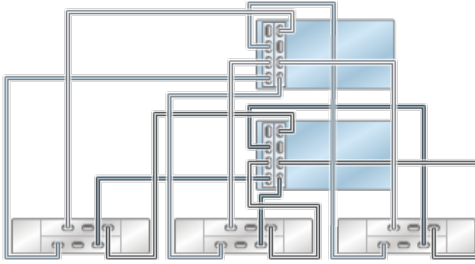
**FIGURE 3-88** ZS3-4 clustered controllers with two HBAs connected to one DE2-24 disk shelf in a single chain



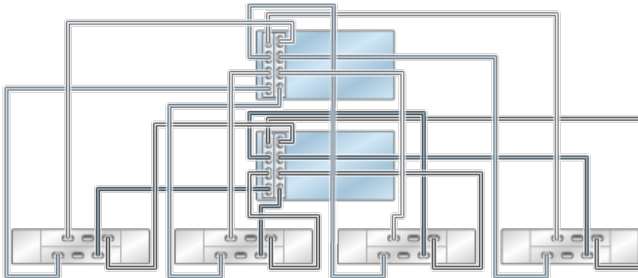
**FIGURE 3-89** ZS3-4 clustered controllers with two HBAs connected to two DE2-24 disk shelves in two chains



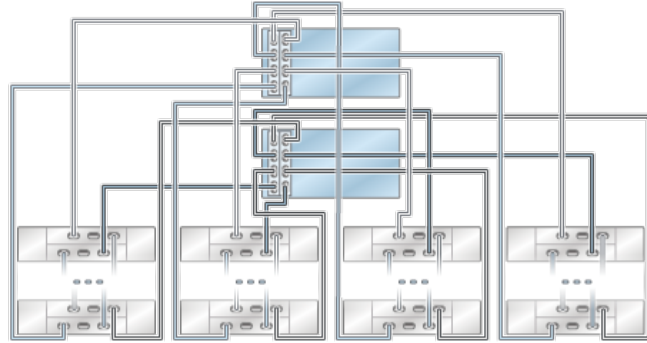
**FIGURE 3-90** ZS3-4 clustered controllers with two HBAs connected to three DE2-24 disk shelves in three chains



**FIGURE 3-91** ZS3-4 clustered controllers with two HBAs connected to four DE2-24 disk shelves in four chains



**FIGURE 3-92** ZS3-4 clustered controllers with two HBAs connected to multiple DE2-24 disk shelves in four chains



### ZS3-4 Clustered to DE2-24 Disk Shelves (3 HBAs)

The following figures show a subset of the supported configurations for Oracle ZFS Storage ZS3-4 clustered controllers with three HBAs. To cable the controller to the disk shelves, use the [“Cabling Guidelines”](#) on page 7, which include the [“Maximum Number of Disk Shelves per Controller Configuration”](#) on page 8.

---

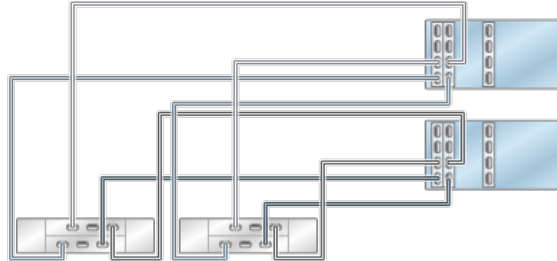
**Note** - For hardware port locations, see the PCIe Options section in the Hardware Maintenance Overview for your controller model.

---

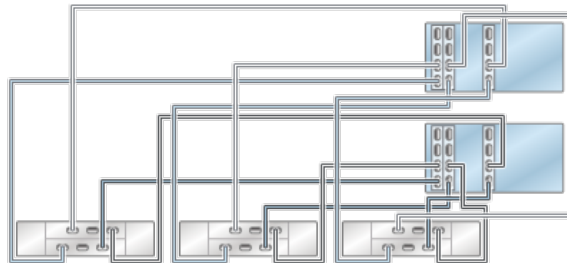
**FIGURE 3-93** ZS3-4 clustered controllers with three HBAs connected to one DE2-24 disk shelf in a single chain



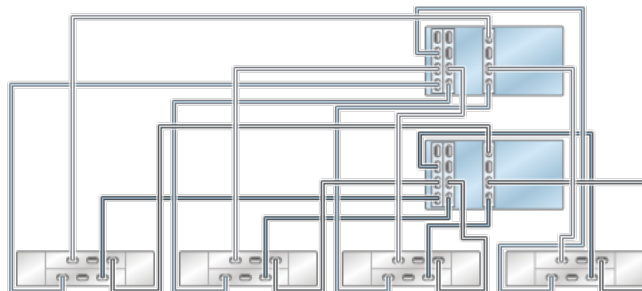
**FIGURE 3-94** ZS3-4 clustered controllers with three HBAs connected to two DE2-24 disk shelves in two chains



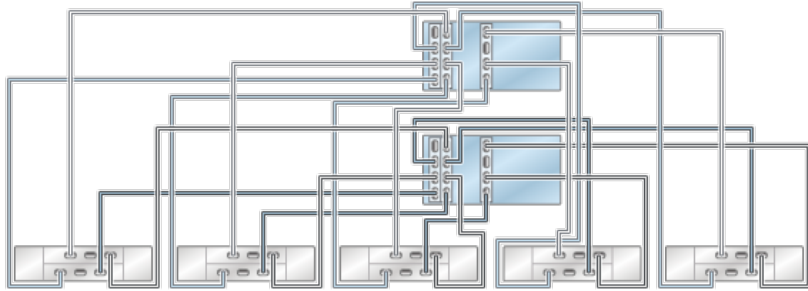
**FIGURE 3-95** ZS3-4 clustered controllers with three HBAs connected to three DE2-24 disk shelves in three chains



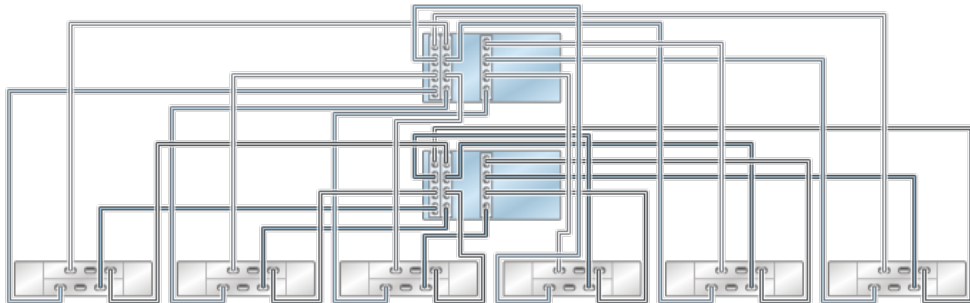
**FIGURE 3-96** ZS3-4 clustered controllers with three HBAs connected to four DE2-24 disk shelves in four chains



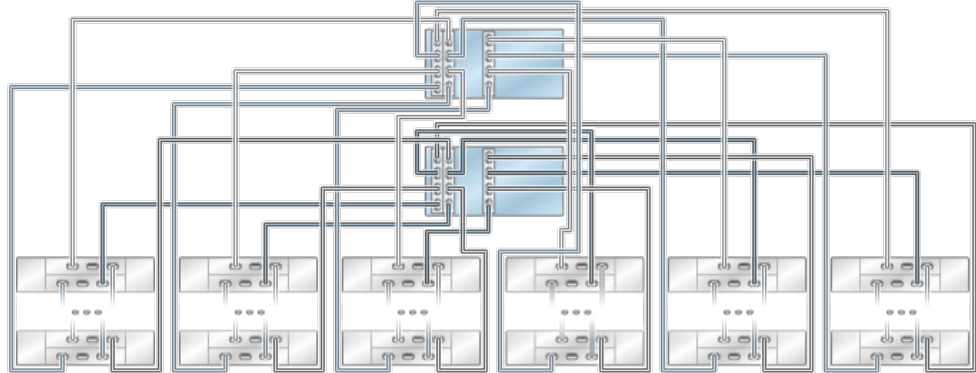
**FIGURE 3-97** ZS3-4 clustered controllers with three HBAs connected to five DE2-24 disk shelves in five chains



**FIGURE 3-98** ZS3-4 clustered controllers with three HBAs connected to six DE2-24 disk shelves in six chains



**FIGURE 3-99** ZS3-4 clustered controllers with three HBAs connected to multiple DE2-24 disk shelves in six chains



### ZS3-4 Clustered to DE2-24 Disk Shelves (4 HBAs)

The following figures show a subset of the supported configurations for Oracle ZFS Storage ZS3-4 clustered controllers with four HBAs. To cable the controller to the disk shelves, use the [“Cabling Guidelines” on page 7](#), which include the [“Maximum Number of Disk Shelves per Controller Configuration” on page 8](#).

---

**Note** - For hardware port locations, see the PCIe Options section in the Hardware Maintenance Overview for your controller model.

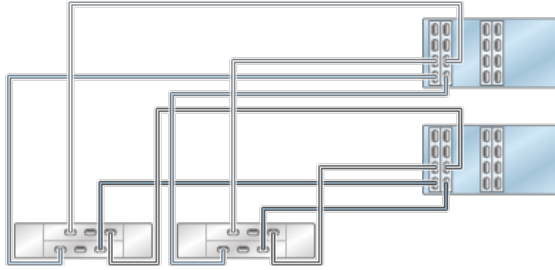
---

**FIGURE 3-100** ZS3-4 clustered controllers with four HBAs connected to one DE2-24 disk shelf in a single chain

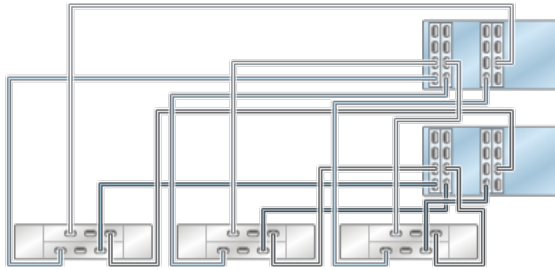




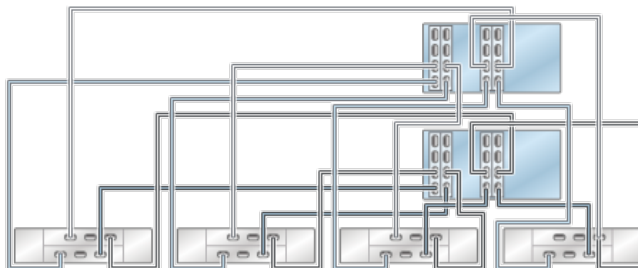
**FIGURE 3-101** ZS3-4 clustered controllers with four HBAs connected to two DE2-24 disk shelves in two chains



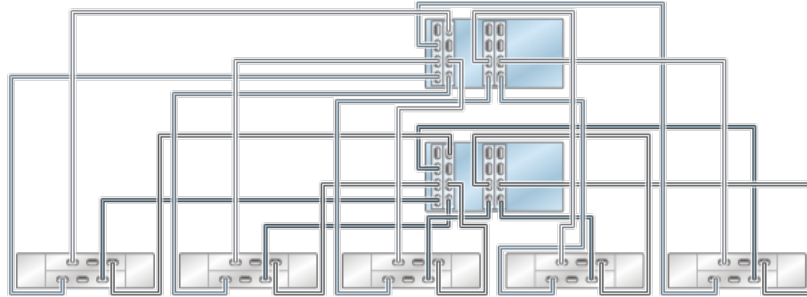
**FIGURE 3-102** ZS3-4 clustered controllers with four HBAs connected to three DE2-24 disk shelves in three chains



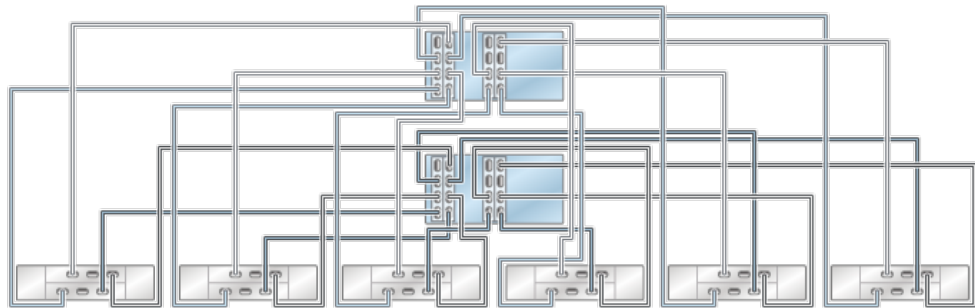
**FIGURE 3-103** ZS3-4 clustered controllers with four HBAs connected to four DE2-24 disk shelves in four chains



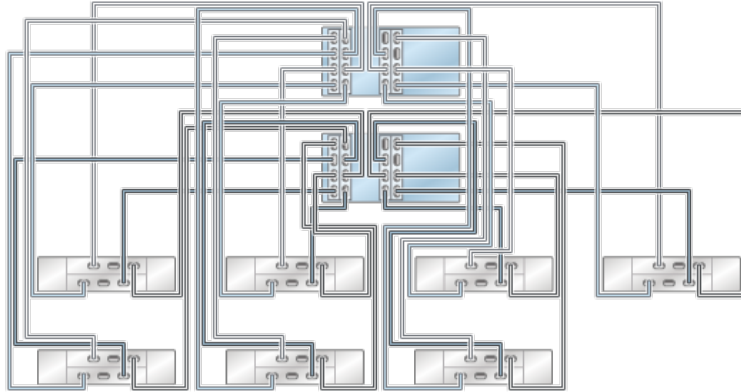
**FIGURE 3-104** ZS3-4 clustered controllers with four HBAs connected to five DE2-24 disk shelves in five chains



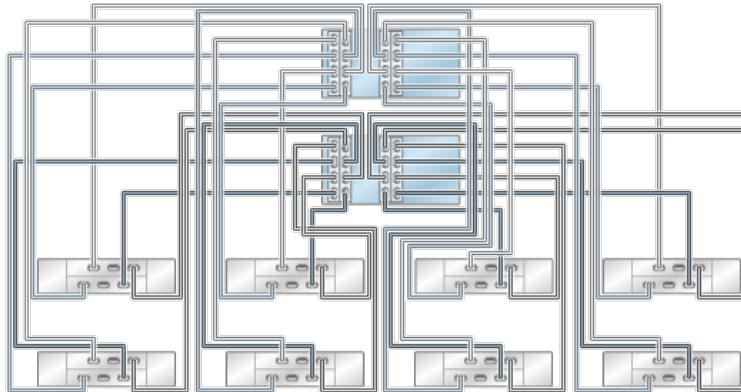
**FIGURE 3-105** ZS3-4 clustered controllers with four HBAs connected six DE2-24 disk shelves in six chains



**FIGURE 3-106** ZS3-4 clustered controllers with four HBAs connected to seven DE2-24 disk shelves in seven chains

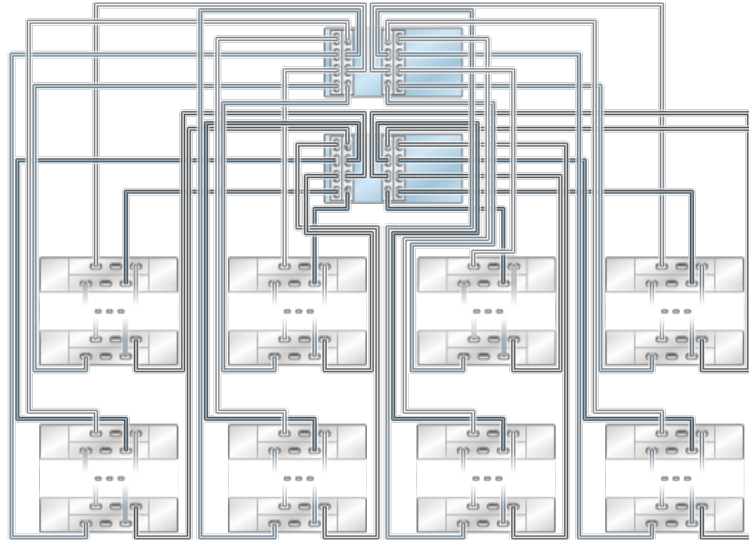


**FIGURE 3-107** ZS3-4 clustered controllers with four HBAs connected to eight DE2-24 disk shelves in eight chains



**FIGURE 3-108**

ZS3-4 clustered controllers with four HBAs connected to multiple DE2-24 disk shelves in eight chains



# ◆◆◆ CHAPTER 4

## Sun Disk Shelf

---

### Sun Disk Shelf to 7120

#### 7120 Standalone to Sun Disk Shelves

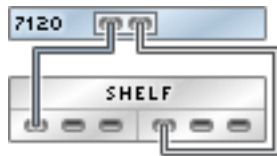
The following figures show a subset of the supported configurations for Oracle ZFS Storage 7120 standalone controllers with one HBA. To cable the controller to the disk shelves, use the [“Cabling Guidelines”](#) on page 7, which include the [“Maximum Number of Disk Shelves per Controller Configuration”](#) on page 8.

---

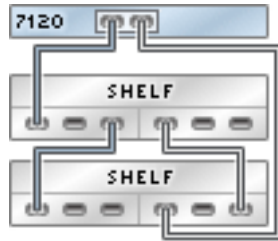
**Note** - For hardware port locations, see the PCIe Options section in the Hardware Maintenance Overview for your controller model.

---

**FIGURE 4-1** 7120 standalone controller with one HBA connected to one Sun Disk Shelf in a single chain



**FIGURE 4-2** 7120 standalone controller with one HBA connected to two Sun Disk Shelves in a single chain



## Sun Disk Shelf to 7320

### 7320 Standalone to Sun Disk Shelves

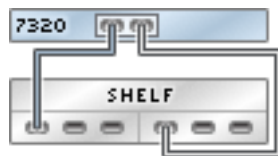
The following figures show a subset of the supported configurations for Oracle ZFS Storage 7320 standalone controllers with one HBA. To cable the controller to the disk shelves, use the [“Cabling Guidelines” on page 7](#), which include the [“Maximum Number of Disk Shelves per Controller Configuration” on page 8](#).

---

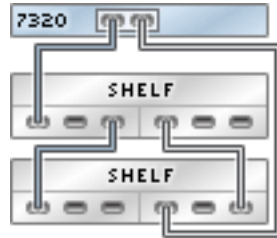
**Note** - For hardware port locations, see the PCIe Options section in the Hardware Maintenance Overview for your controller model.

---

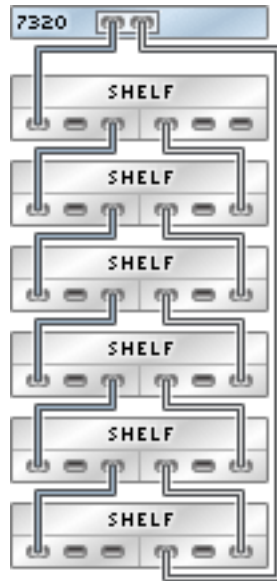
**FIGURE 4-3** 7320 standalone controller with one HBA connected to one Sun Disk Shelf in a single chain



**FIGURE 4-4** 7320 standalone controller with one HBA connected to two Sun Disk Shelves in a single chain



**FIGURE 4-5** 7320 standalone controller with one HBA connected to six Sun Disk Shelves in a single chain



## 7320 Clustered to Sun Disk Shelves

The following figures show a subset of the supported configurations for Oracle ZFS Storage 7320 clustered controllers with one HBA. To cable the controller to the disk shelves, use the

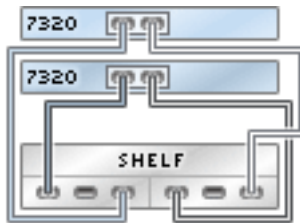
“Cabling Guidelines” on page 7, which include the “Maximum Number of Disk Shelves per Controller Configuration” on page 8.

---

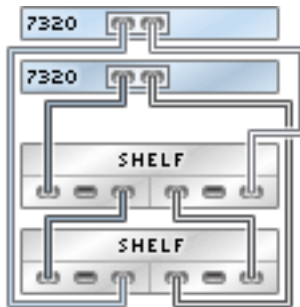
**Note** - For hardware port locations, see the PCIe Options section in the Hardware Maintenance Overview for your controller model.

---

**FIGURE 4-6** 7320 clustered controllers with one HBA connected to one Sun Disk Shelf in a single chain

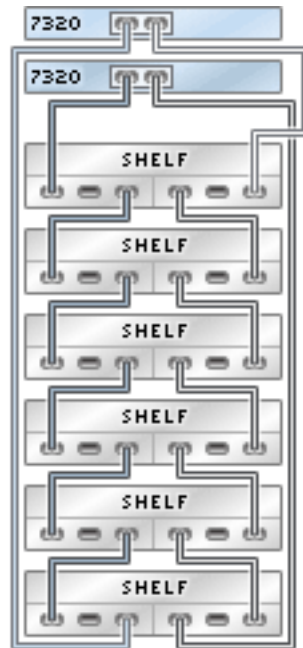


**FIGURE 4-7** 7320 clustered controllers with one HBA connected to two Sun Disk Shelves in a single chain





**FIGURE 4-8** 7320 clustered controllers with one HBA connected to six Sun Disk Shelves in a single chain



## Sun Disk Shelf to 7420

### 7420 Standalone to Sun Disk Shelves

#### 7420 Standalone to Sun Disk Shelves (2 HBAs)

The following figures show a subset of the supported configurations for Oracle ZFS Storage 7420 standalone controllers with two HBAs. To cable the controller to the disk shelves, use the [“Cabling Guidelines”](#) on page 7, which include the [“Maximum Number of Disk Shelves per Controller Configuration”](#) on page 8.

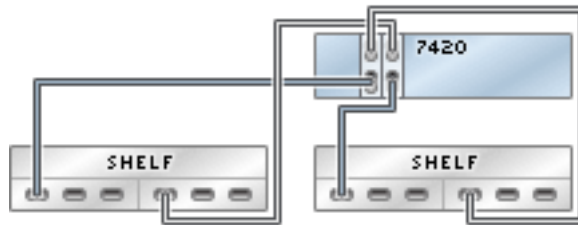
**Note** - For hardware port locations, see the PCIe Options section in the Hardware Maintenance Overview for your controller model.

---

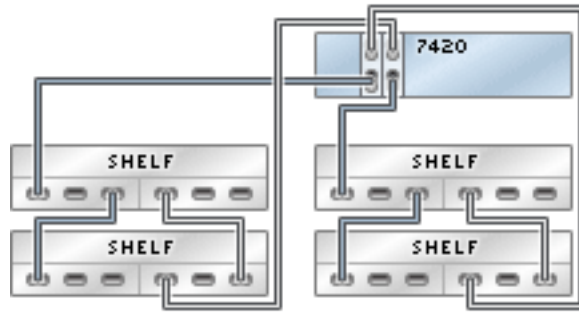
**FIGURE 4-9** 7420 standalone controller with two HBAs connected to one Sun Disk Shelf in a single chain



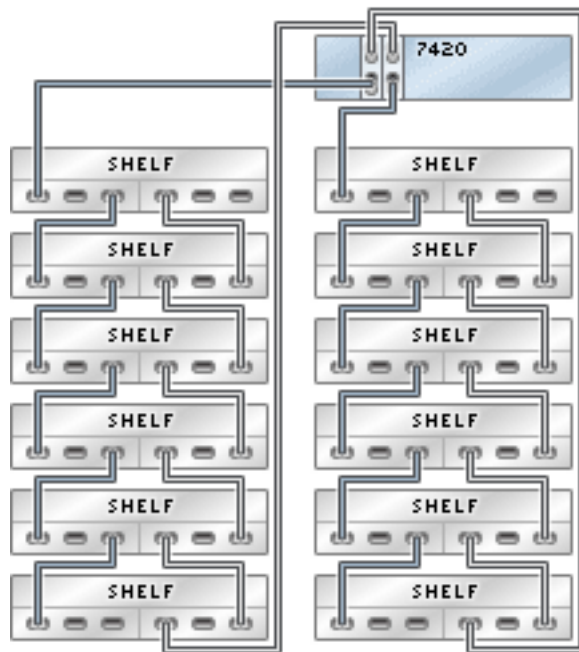
**FIGURE 4-10** 7420 standalone controller with two HBAs connected to two Sun Disk Shelves in two chains



**FIGURE 4-11** 7420 standalone controller with two HBAs connected to four Sun Disk Shelves in two chains



**FIGURE 4-12** 7420 standalone controller with two HBAs connected to 12 Sun Disk Shelves in two chains



## 7420 Standalone to Sun Disk Shelves (3 HBAs)

The following figures show a subset of the supported configurations for Oracle ZFS Storage 7420 standalone controllers with three HBAs. To cable the controller to the disk shelves, use the “[Cabling Guidelines](#)” on page 7, which include the “[Maximum Number of Disk Shelves per Controller Configuration](#)” on page 8.

---

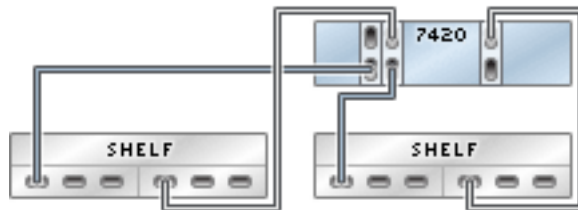
**Note** - For hardware port locations, see the PCIe Options section in the Hardware Maintenance Overview for your controller model.

---

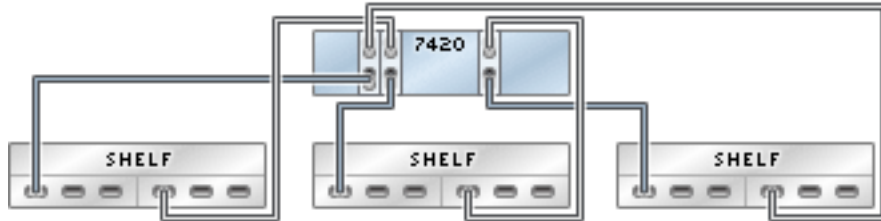
**FIGURE 4-13** 7420 standalone controller with three HBAs connected to one Sun Disk Shelf in a single chain



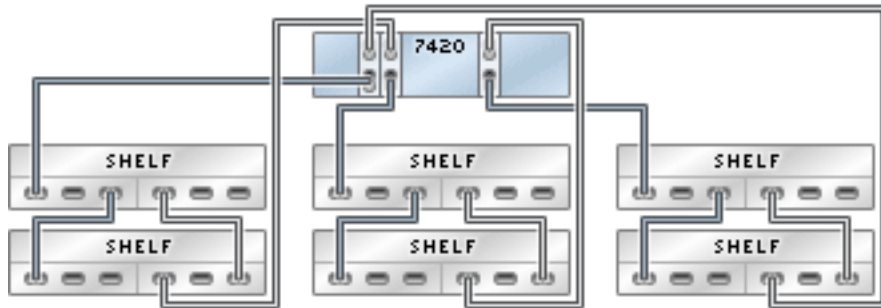
**FIGURE 4-14** 7420 standalone controller with three HBAs connected to two Sun Disk Shelves in two chains



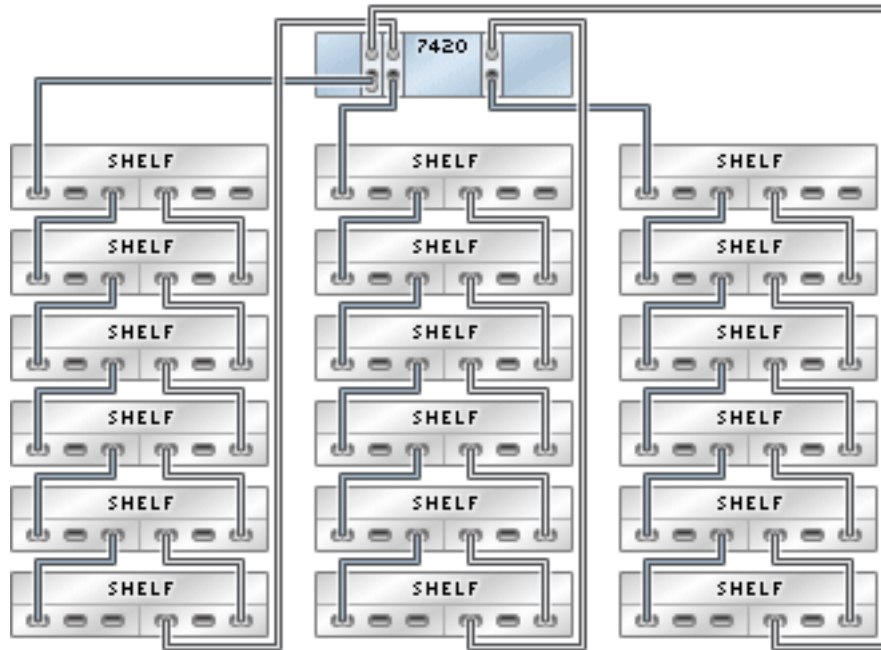
**FIGURE 4-15** 7420 standalone controller with three HBAs connected to three Sun Disk Shelves in three chains



**FIGURE 4-16** 7420 standalone controller with three HBAs connected to six Sun Disk Shelves in three chains



**FIGURE 4-17** 7420 standalone controller with three HBAs connected to 18 Sun Disk Shelves in three chains



### 7420 Standalone to Sun Disk Shelves (4 HBAs)

The following figures show a subset of the supported configurations for Oracle ZFS Storage 7420 standalone controllers with four HBAs. To cable the controller to the disk shelves, use the [“Cabling Guidelines” on page 7](#), which include the [“Maximum Number of Disk Shelves per Controller Configuration” on page 8](#).

---

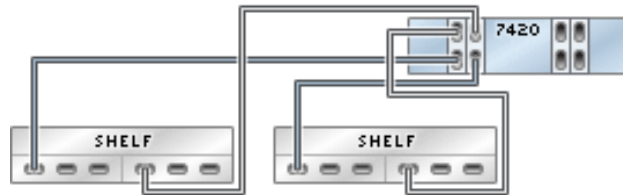
**Note** - For hardware port locations, see the PCIe Options section in the Hardware Maintenance Overview for your controller model.

---

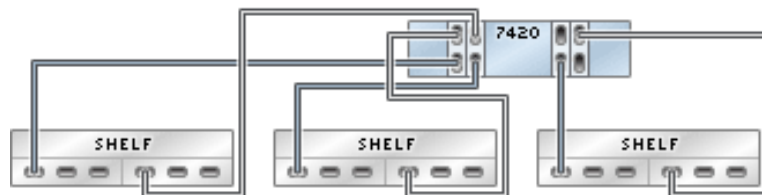
**FIGURE 4-18** 7420 standalone controller with four HBAs connected to one Sun Disk Shelf in a single chain



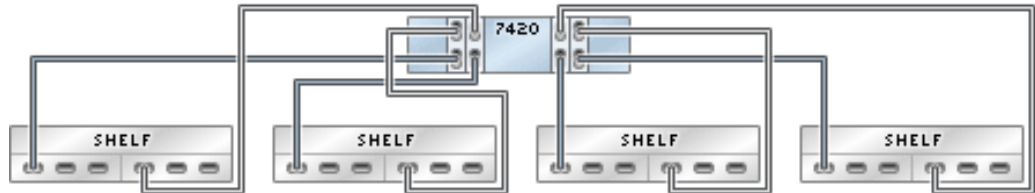
**FIGURE 4-19** 7420 standalone controller with four HBAs connected to two Sun Disk Shelves in two chains



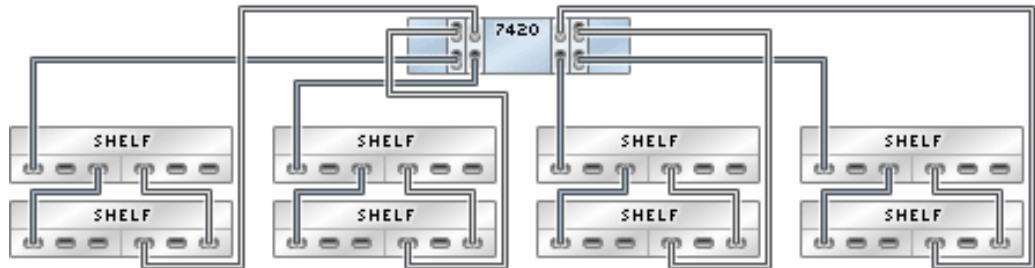
**FIGURE 4-20** 7420 standalone controller with four HBAs connected to three Sun Disk Shelves in three chains



**FIGURE 4-21** 7420 standalone controller with four HBAs connected to four Sun Disk Shelves in four chains

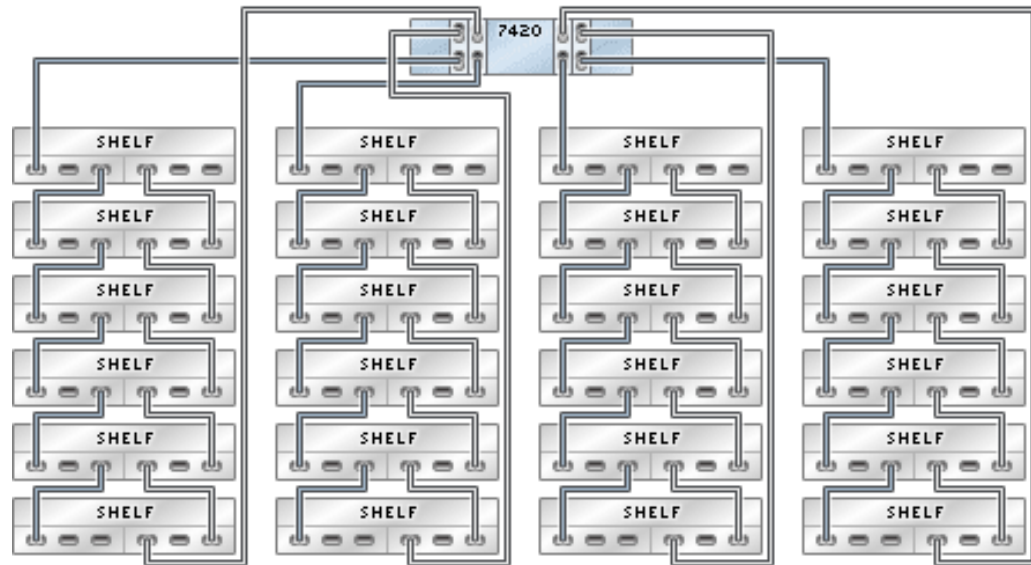


**FIGURE 4-22** 7420 standalone controller with four HBAs connected to eight Sun Disk Shelves in four chains





**FIGURE 4-23** 7420 standalone controller with four HBAs connected to 24 Sun Disk Shelves in four chains



### 7420 Standalone to Sun Disk Shelves (5 HBAs)

The following figures show a subset of the supported configurations for Oracle ZFS Storage 7420 standalone controllers with five HBAs. To cable the controller to the disk shelves, use the [“Cabling Guidelines”](#) on page 7, which include the [“Maximum Number of Disk Shelves per Controller Configuration”](#) on page 8.

---

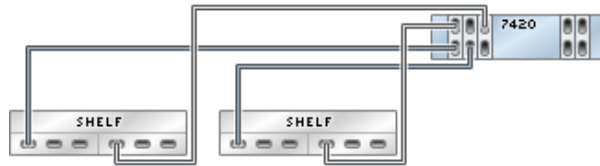
**Note** - For hardware port locations, see the PCIe Options section in the Hardware Maintenance Overview for your controller model.

---

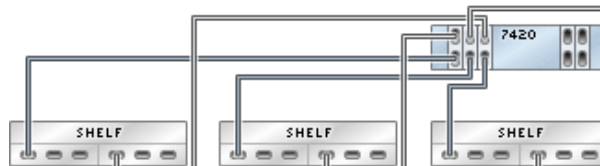
**FIGURE 4-24** 7420 standalone controller with five HBAs connected to one Sun Disk Shelf in a single chain



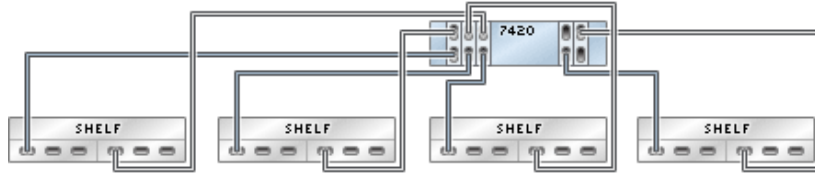
**FIGURE 4-25** 7420 standalone controller with five HBAs connected to two Sun Disk Shelves in two chains



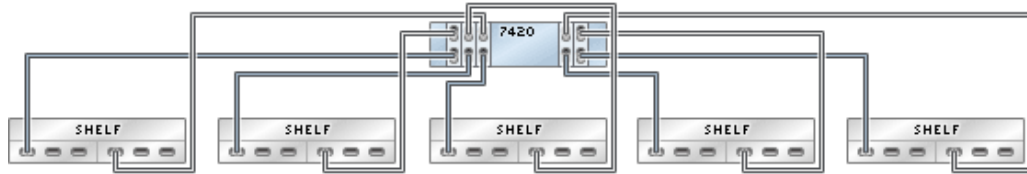
**FIGURE 4-26** 7420 standalone controller with five HBAs connected to three Sun Disk Shelves in three chains



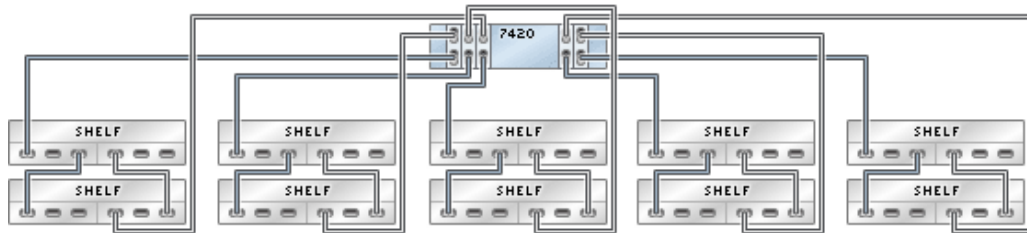
**FIGURE 4-27** 7420 standalone controller with five HBAs connected to four Sun Disk Shelves in four chains



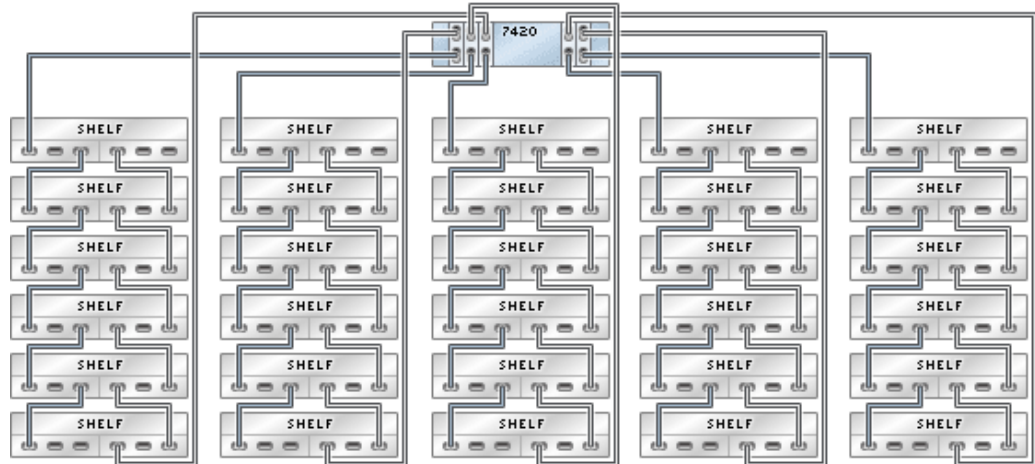
**FIGURE 4-28** 7420 standalone controller with five HBAs connected to five Sun Disk Shelves in five chains



**FIGURE 4-29** 7420 standalone controller with five HBAs connected to ten Sun Disk Shelves in five chains



**FIGURE 4-30** 7420 standalone controller with five HBAs connected to 30 Sun Disk Shelves in five chains



### 7420 Standalone to Sun Disk Shelves (6 HBAs)

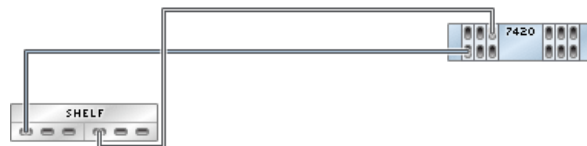
The following figures show a subset of the supported configurations for Oracle ZFS Storage 7420 standalone controllers with six HBAs. To cable the controller to the disk shelves, use the [“Cabling Guidelines” on page 7](#), which include the [“Maximum Number of Disk Shelves per Controller Configuration” on page 8](#).

---

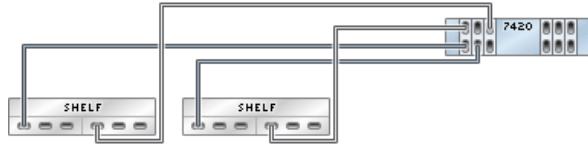
**Note** - For hardware port locations, see the PCIe Options section in the Hardware Maintenance Overview for your controller model.

---

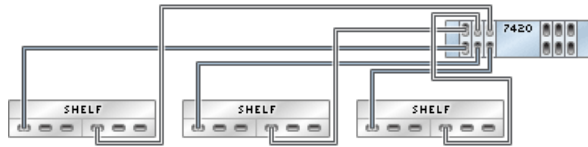
**FIGURE 4-31** 7420 standalone controller with six HBAs connected to one Sun Disk Shelf in a single chain



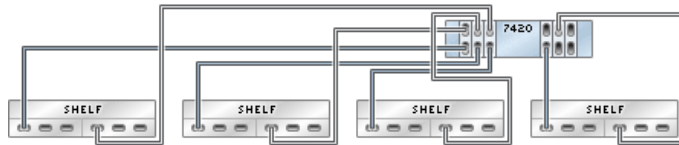
**FIGURE 4-32** 7420 standalone controller with six HBAs connected to two Sun Disk Shelves in two chains



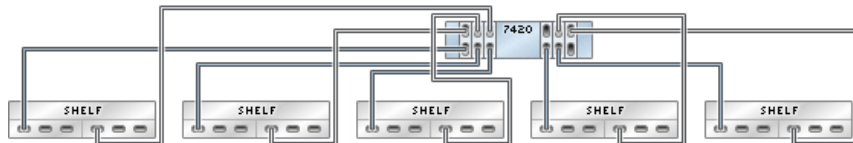
**FIGURE 4-33** 7420 standalone controller with six HBAs connected to three Sun Disk Shelves in three chains



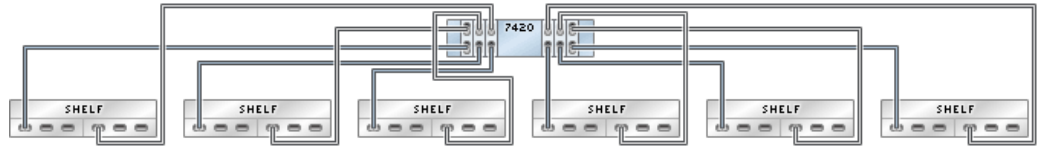
**FIGURE 4-34** 7420 standalone controller with six HBAs connected to four Sun Disk Shelves in four chains



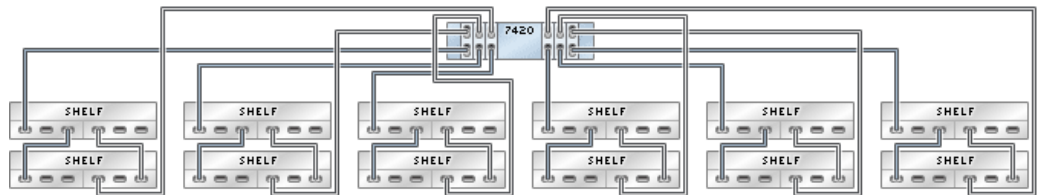
**FIGURE 4-35** 7420 standalone controller with six HBAs connected to five Sun Disk Shelves in five chains



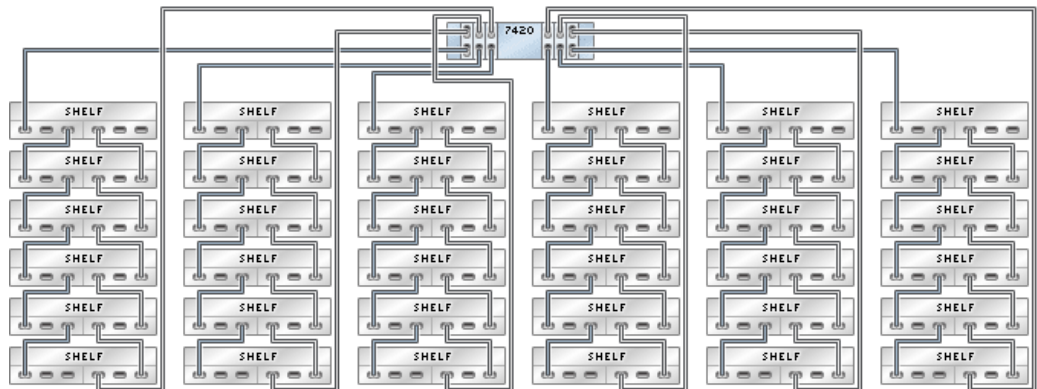
**FIGURE 4-36** 7420 standalone controller with six HBAs connected to six Sun Disk Shelves in six chains



**FIGURE 4-37** 7420 standalone controller with six HBAs connected to 12 Sun Disk Shelves in six chains



**FIGURE 4-38** 7420 standalone controller with six HBAs connected to 36 Sun Disk Shelves in six chains



## 7420 Clustered to Sun Disk Shelves

### 7420 Clustered to Sun Disk Shelves (2 HBAs)

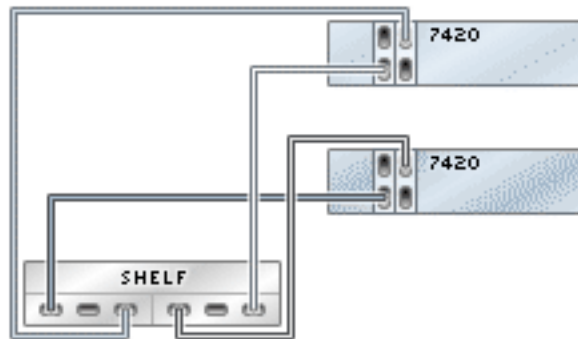
The following figures show a subset of the supported configurations for Oracle ZFS Storage 7420 clustered controllers with two HBAs. To cable the controller to the disk shelves, use the [“Cabling Guidelines” on page 7](#), which include the [“Maximum Number of Disk Shelves per Controller Configuration” on page 8](#).

---

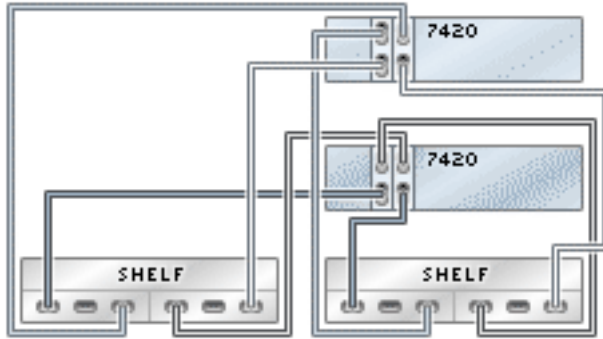
**Note** - For hardware port locations, see the PCIe Options section in the Hardware Maintenance Overview for your controller model.

---

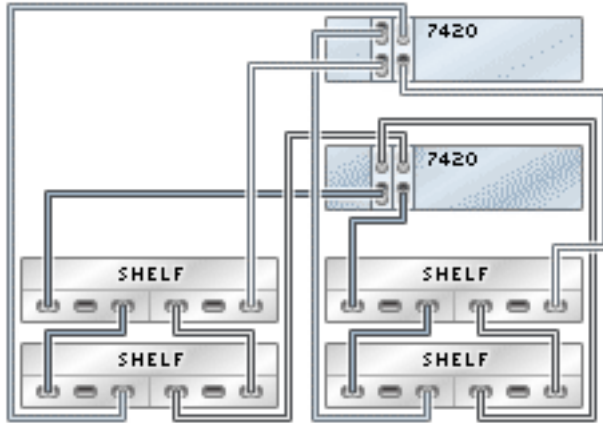
**FIGURE 4-39** 7420 clustered controllers with two HBAs connected to one Sun Disk Shelf in a single chain



**FIGURE 4-40** 7420 clustered controllers with two HBAs connected to two Sun Disk Shelves in two chains

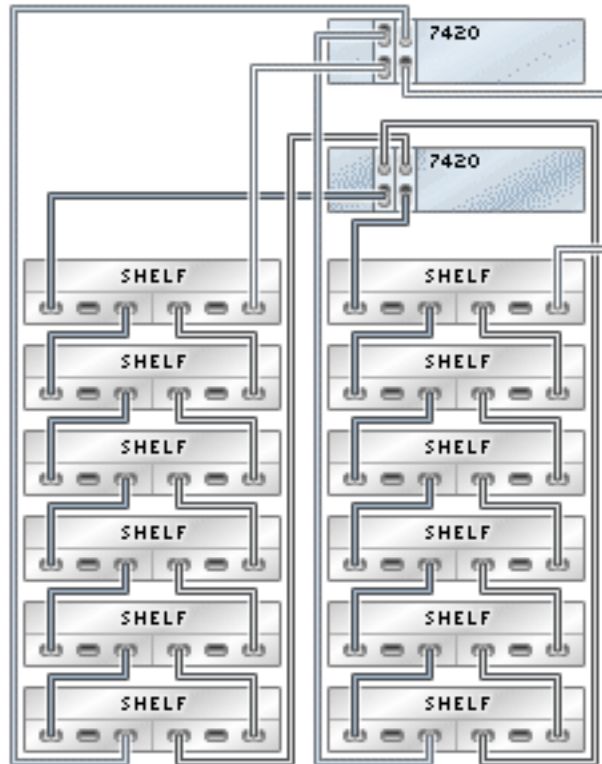


**FIGURE 4-41** 7420 clustered controllers with two HBAs connected to four Sun Disk Shelves in two chains





**FIGURE 4-42** 7420 clustered controllers with two HBAs connected to 12 Sun Disk Shelves in two chains



### 7420 Clustered to Sun Disk Shelves (3 HBAs)

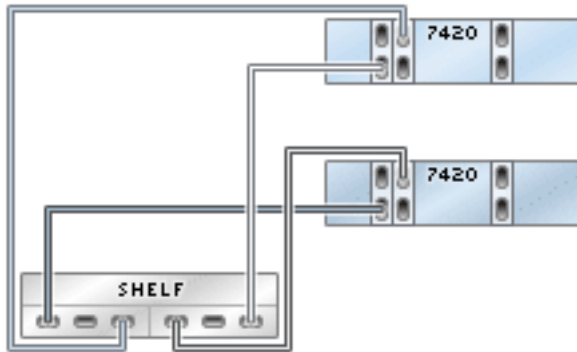
The following figures show a subset of the supported configurations for Oracle ZFS Storage 7420 clustered controllers with three HBAs. To cable the controller to the disk shelves, use the [“Cabling Guidelines” on page 7](#), which include the [“Maximum Number of Disk Shelves per Controller Configuration” on page 8](#).

---

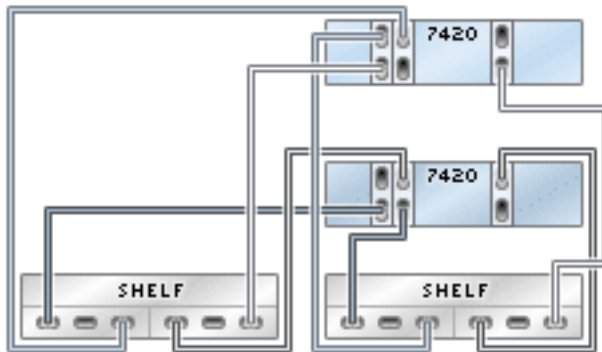
**Note** - For hardware port locations, see the PCIe Options section in the Hardware Maintenance Overview for your controller model.

---

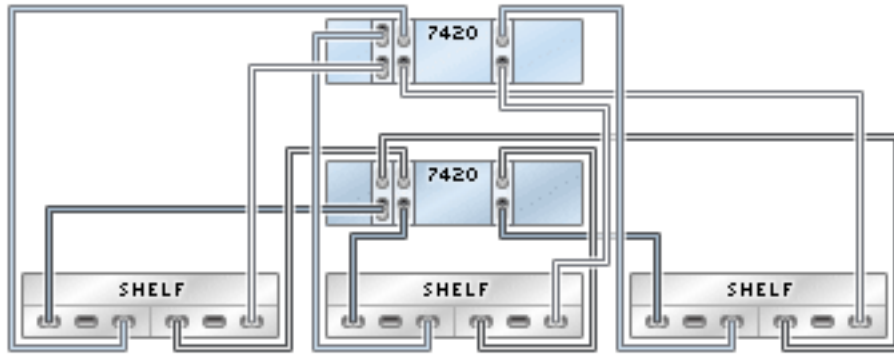
**FIGURE 4-43** 7420 clustered controllers with three HBAs connected to one Sun Disk Shelf in a single chain



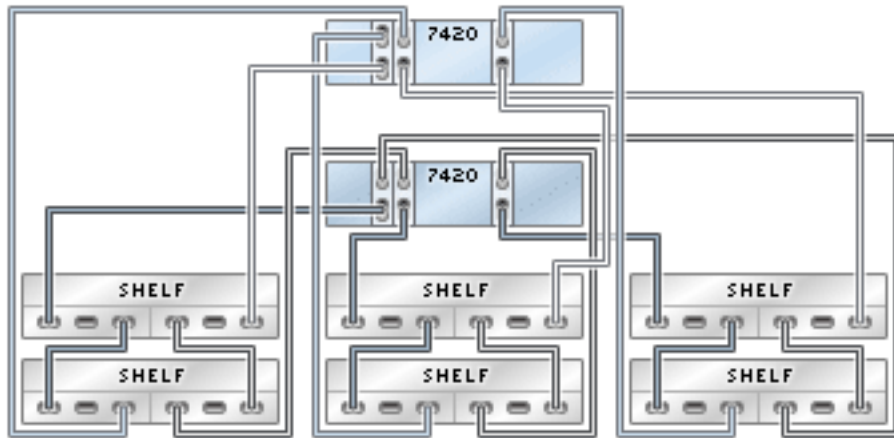
**FIGURE 4-44** 7420 clustered controllers with three HBAs connected to two Sun Disk Shelves in two chains



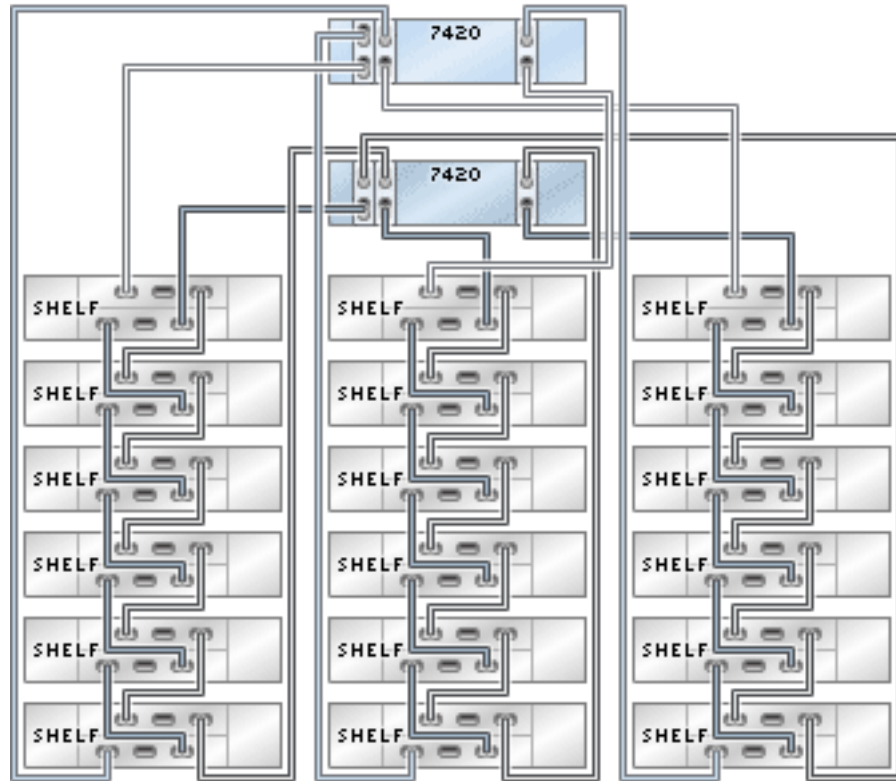
**FIGURE 4-45** 7420 clustered controllers with three HBAs connected to three Sun Disk Shelves in three chains



**FIGURE 4-46** 7420 clustered controllers with three HBAs connected to six Sun Disk Shelves in three chains



**FIGURE 4-47** 7420 clustered controllers with three HBAs connected to 18 Sun Disk Shelves in three chains



### 7420 Clustered to Sun Disk Shelves (4 HBAs)

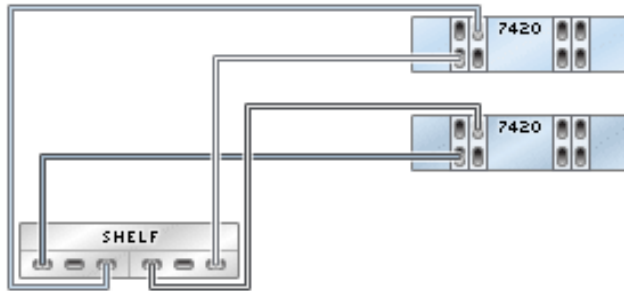
The following figures show a subset of the supported configurations for Oracle ZFS Storage 7420 clustered controllers with four HBAs. To cable the controller to the disk shelves, use the [“Cabling Guidelines” on page 7](#), which include the [“Maximum Number of Disk Shelves per Controller Configuration” on page 8](#).

---

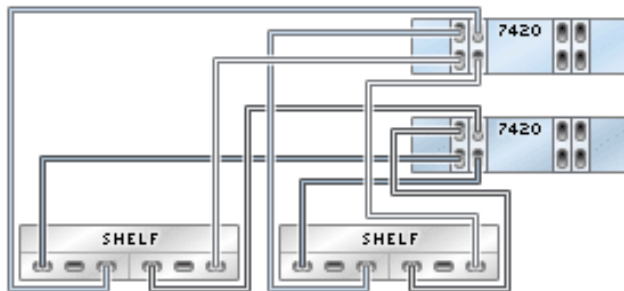
**Note** - For hardware port locations, see the PCIe Options section in the Hardware Maintenance Overview for your controller model.

---

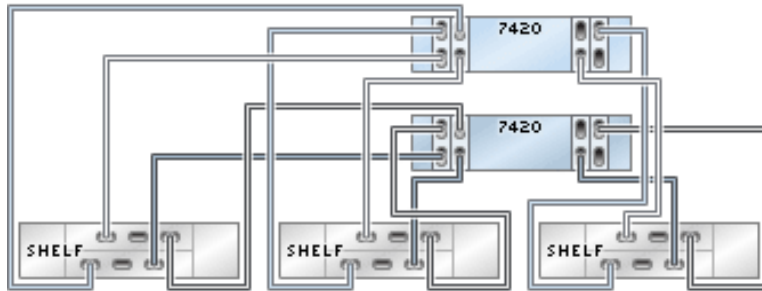
**FIGURE 4-48** 7420 clustered controllers with four HBAs connected to one Sun Disk Shelf in a single chain



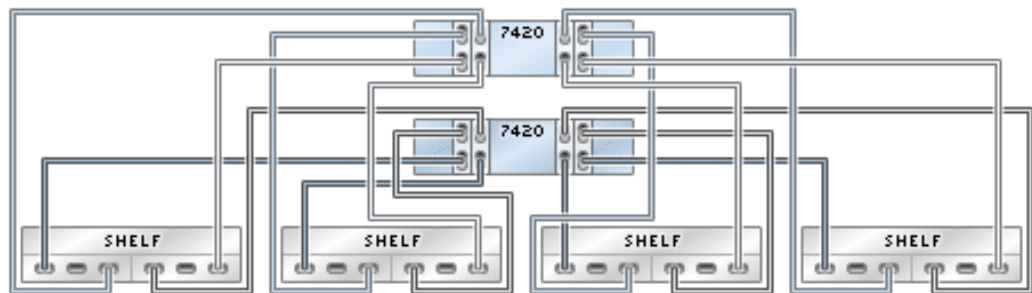
**FIGURE 4-49** 7420 clustered controllers with four HBAs connected to two Sun Disk Shelves in two chains



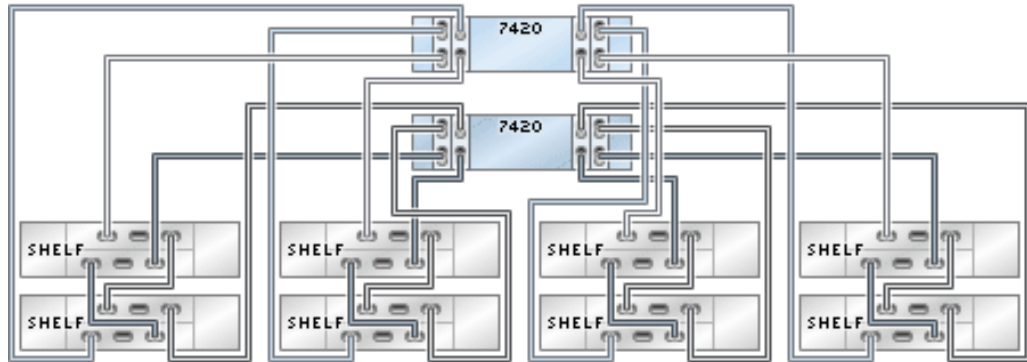
**FIGURE 4-50** 7420 clustered controllers with four HBAs connected to three Sun Disk Shelves in three chains



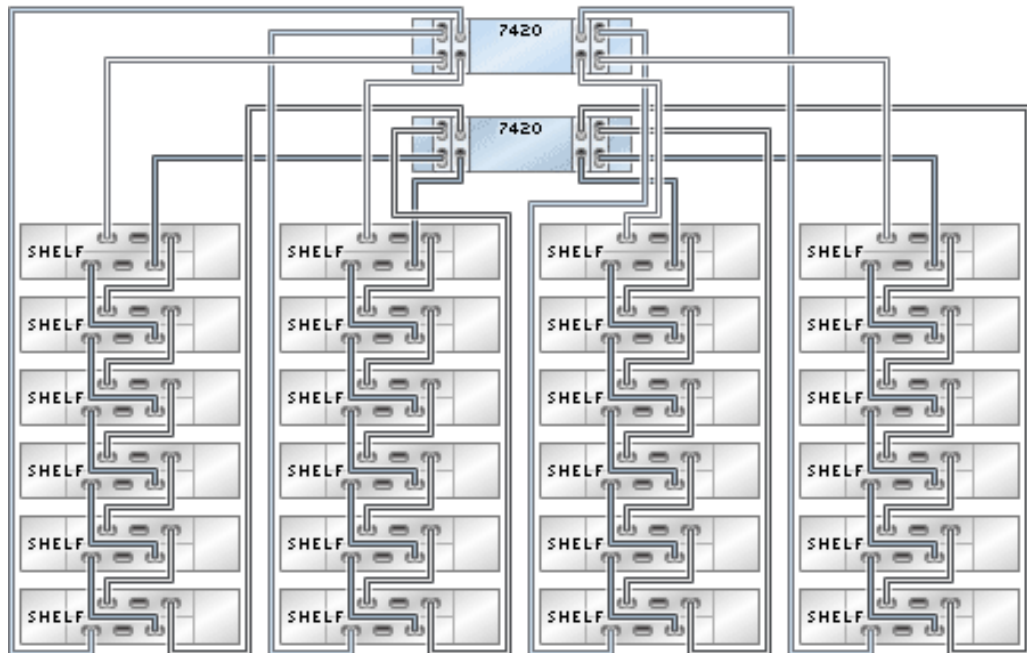
**FIGURE 4-51** 7420 clustered controllers with four HBAs connected to four Sun Disk Shelves in four chains



**FIGURE 4-52** 7420 clustered controllers with four HBAs connected to eight Sun Disk Shelves in four chains



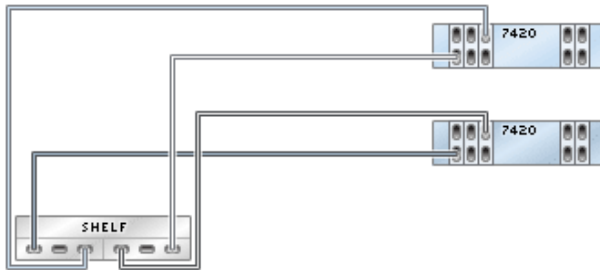
**FIGURE 4-53** 7420 clustered controllers with four HBAs connected to 24 Sun Disk Shelves in four chains



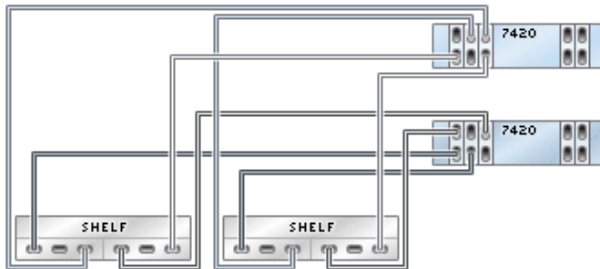
## 7420 Clustered to Sun Disk Shelves (5 HBAs)

The following figures show a subset of the supported configurations for Oracle ZFS Storage 7420 clustered controllers with five HBAs. To cable the controller to the disk shelves, use the [“Cabling Guidelines” on page 7](#), which include the [“Maximum Number of Disk Shelves per Controller Configuration” on page 8](#).

**FIGURE 4-54** 7420 clustered controllers with five HBAs connected to one Sun Disk Shelf in a single chain

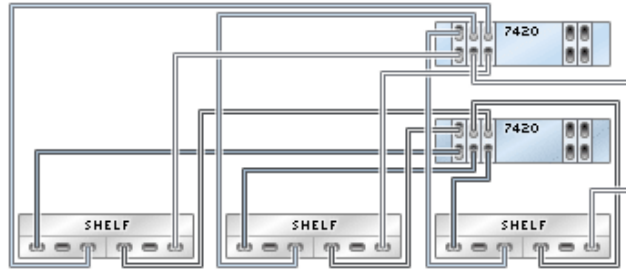


**FIGURE 4-55** 7420 clustered controllers with five HBAs connected to two Sun Disk Shelves in two chains

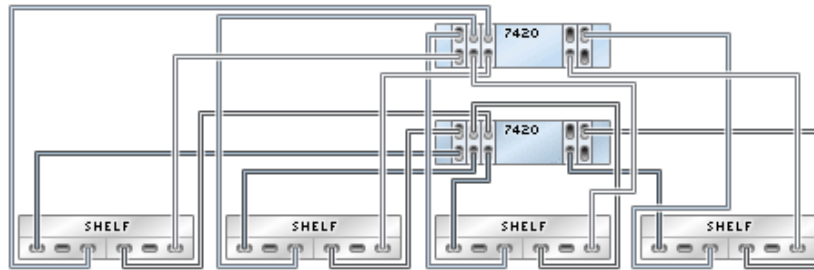




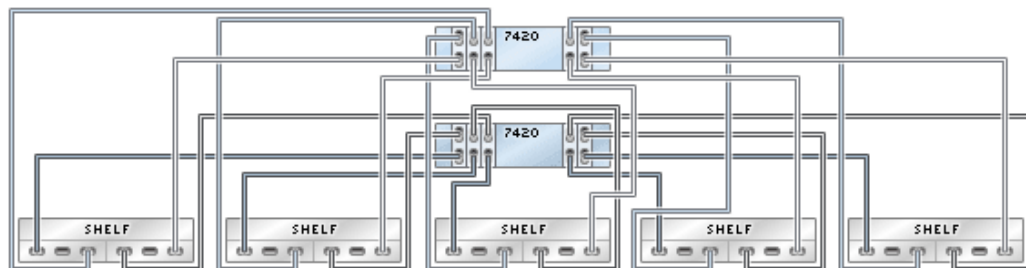
**FIGURE 4-56** 7420 clustered controllers with five HBAs connected to three Sun Disk Shelves in three chains



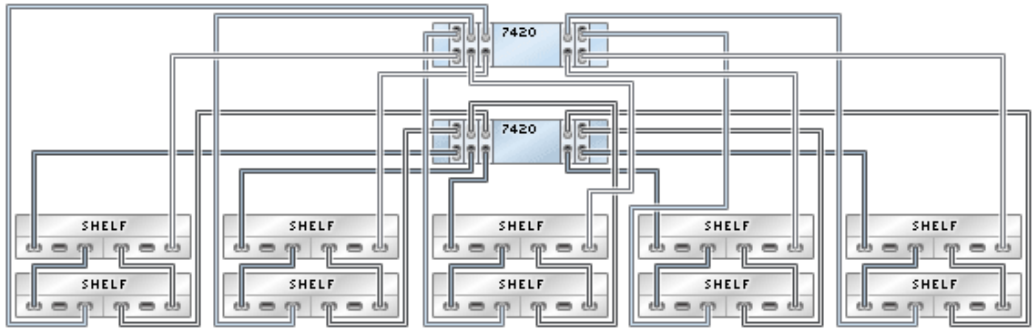
**FIGURE 4-57** 7420 clustered controllers with five HBAs connected to four Sun Disk Shelves in four chains



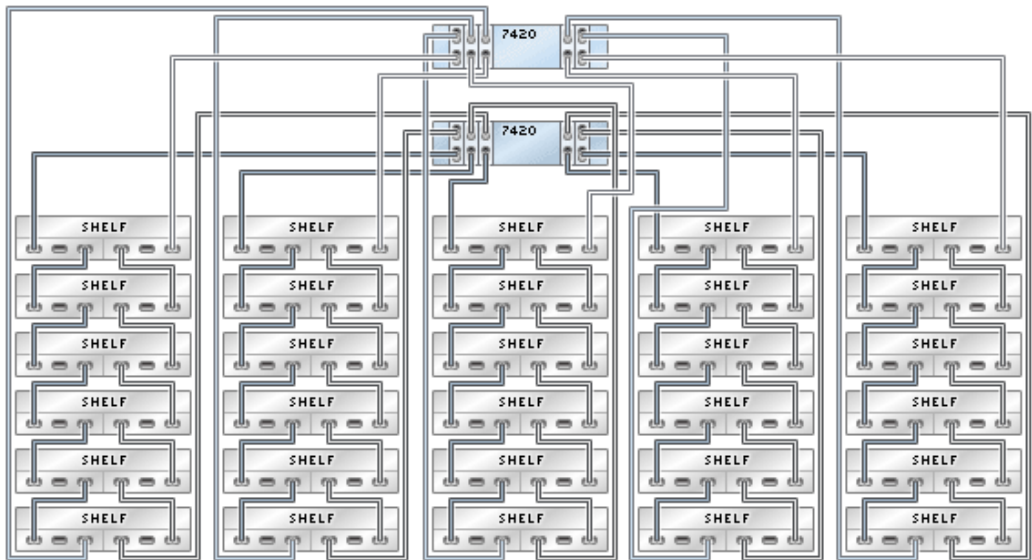
**FIGURE 4-58** 7420 clustered controllers with five HBAs connected to five Sun Disk Shelves in five chains



**FIGURE 4-59** 7420 clustered controllers with five HBAs connected to ten Sun Disk Shelves in five chains



**FIGURE 4-60** 7420 clustered controllers with five HBAs connected to 30 Sun Disk Shelves in five chains



## 7420 Clustered to Sun Disk Shelves (6 HBAs)

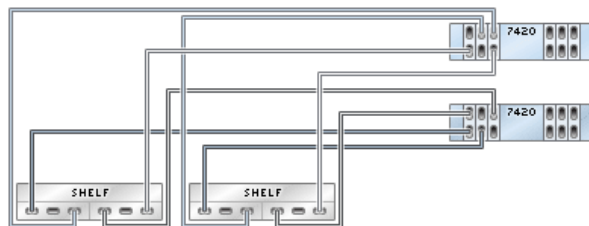
The following figures show a subset of the supported configurations for Oracle ZFS Storage 7420 clustered controllers with six HBAs. To cable the controller to the disk shelves, use the “Cabling Guidelines” on page 7, which include the “Maximum Number of Disk Shelves per Controller Configuration” on page 8.

**Note** - For hardware port locations, see the PCIe Options section in the Hardware Maintenance Overview for your controller model.

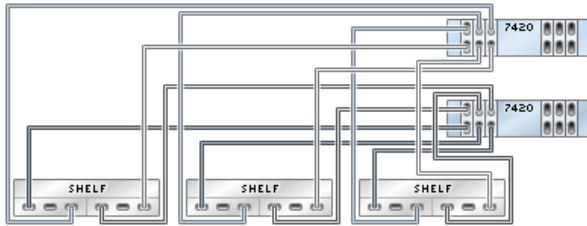
**FIGURE 4-61** 7420 clustered controllers with six HBAs connected to one Sun Disk Shelf in a single chain



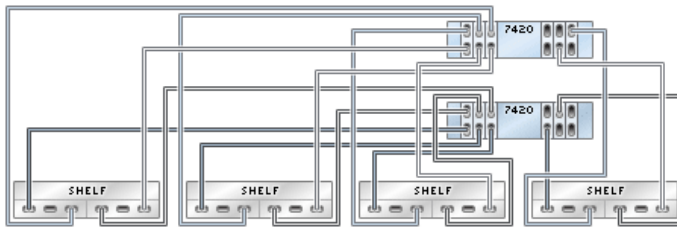
**FIGURE 4-62** 7420 clustered controllers with six HBAs connected to two Sun Disk Shelves in two chains



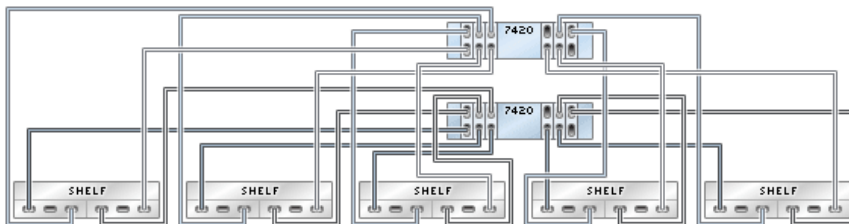
**FIGURE 4-63** 7420 clustered controllers with six HBAs connected to three Sun Disk Shelves in three chains



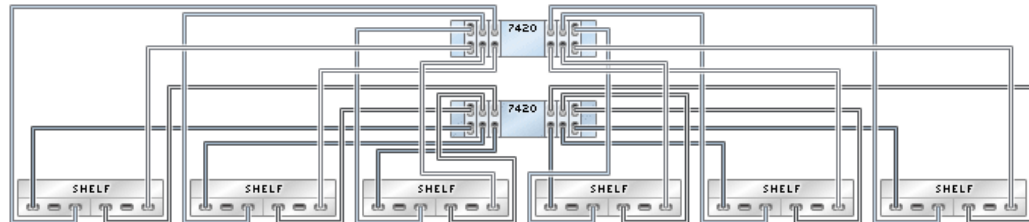
**FIGURE 4-64** 7420 clustered controllers with six HBAs connected to four Sun Disk Shelves in four chains



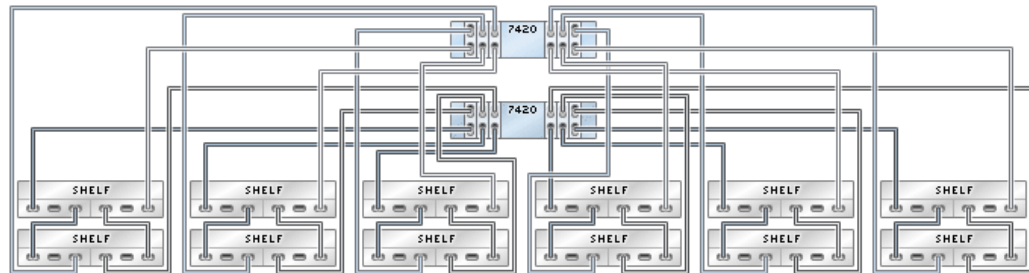
**FIGURE 4-65** 7420 clustered controllers with six HBAs connected to five Sun Disk Shelves in five chains



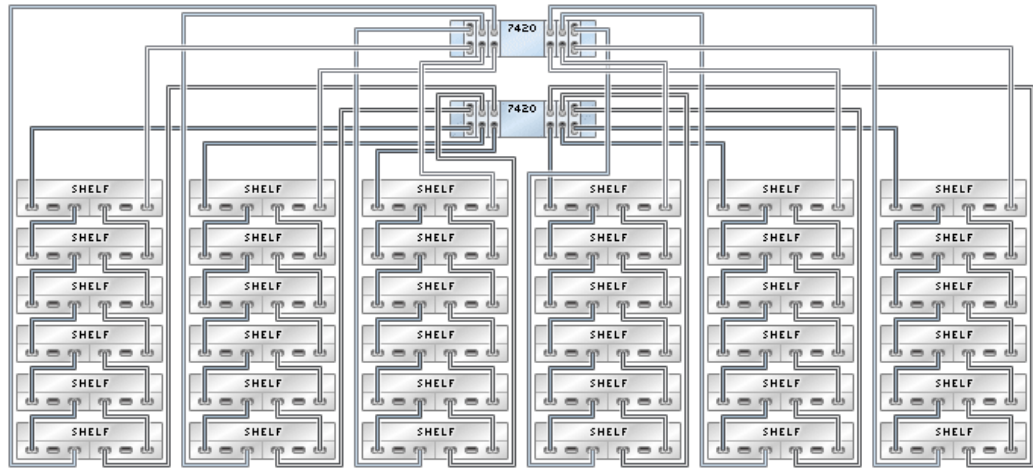
**FIGURE 4-66** 7420 clustered controllers with six HBAs connected to six Sun Disk Shelves in six chains



**FIGURE 4-67** 7420 clustered controllers with six HBAs connected to 12 Sun Disk Shelves in six chains



**FIGURE 4-68** 7420 clustered controllers with six HBAs connected to 36 Sun Disk Shelves in six chains



## Mixed DE2-24 and Sun Disk Shelves

---

### DE2-24 and Sun Disk Shelves to 7320

#### 7320 Standalone to Mixed Disk Shelves

The following figures show a subset of the supported configurations for Oracle ZFS Storage 7320 standalone controllers with one HBA. To cable the controller to the disk shelves, use the [“Cabling Guidelines” on page 7](#), which include the [“Maximum Number of Disk Shelves per Controller Configuration” on page 8](#).

Using mixed disk shelves on a controller requires the following:

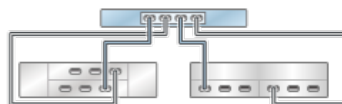
- The controller must use only 4X4 port SAS-2 HBAs
- Do not use mixed disk shelves in the same chain

---

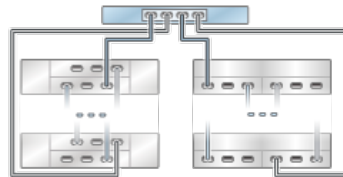
**Note** - For hardware port locations, see the PCIe Options section in the Hardware Maintenance Overview for your controller model. 4X4 port SAS-2 HBAs are only supported with software version 2013.1.0 and later.

---

**FIGURE 5-1** 7320 standalone controller with one HBA connected to two mixed disk shelves in two chains (DE2-24 shown on the left)



**FIGURE 5-2** 7320 standalone controller with one HBA connected to multiple mixed disk shelves in two chains (DE2-24 shown on the left)



## 7320 Clustered to Mixed Disk Shelves

The following figures show a subset of the supported configurations for Oracle ZFS Storage 7320 clustered controllers with one HBA. To cable the controller to the disk shelves, use the [“Cabling Guidelines” on page 7](#), which include the [“Maximum Number of Disk Shelves per Controller Configuration” on page 8](#).

Using mixed disk shelves on a controller, requires the following:

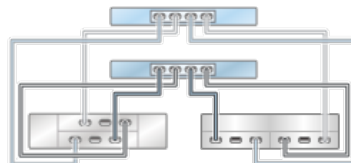
- The controller must use only 4X4 port SAS-2 HBAs
- Do not use mixed disk shelves in the same chain

---

**Note** - For hardware port locations, see the PCIe Options section in the Hardware Maintenance Overview for your controller model. 4X4 port SAS-2 HBAs are only supported with software version 2013.1.0 and later.

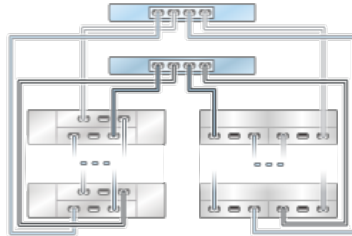
---

**FIGURE 5-3** 7320 clustered controllers with one HBA connected to two mixed disk shelves in two chains (DE2-24 shown on the left)





**FIGURE 5-4** 7320 clustered controllers with one HBA connected to multiple mixed disk shelves in two chains (DE2-24 shown on the left)



## DE2-24 and Sun Disk Shelves to 7420

### 7420 Standalone to Mixed Disk Shelves

#### 7420 Standalone to Mixed Disk Shelves (2 HBAs)

The following figures show a subset of the supported configurations for Oracle ZFS Storage 7420 standalone controllers with two HBAs. To cable the controller to the disk shelves, use the [“Cabling Guidelines” on page 7](#), which include the [“Maximum Number of Disk Shelves per Controller Configuration” on page 8](#).

Using mixed disk shelves on a controller, requires the following:

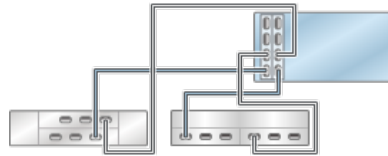
- The controller must use only 4X4 port SAS-2 HBAs
- Do not use mixed disk shelves in the same chain

---

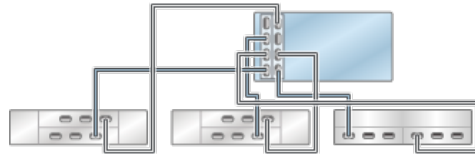
**Note** - For hardware port locations, see the PCIe Options section in the Hardware Maintenance Overview for your controller model. 4X4 port SAS-2 HBAs are only supported with software version 2013.1.0 and later.

---

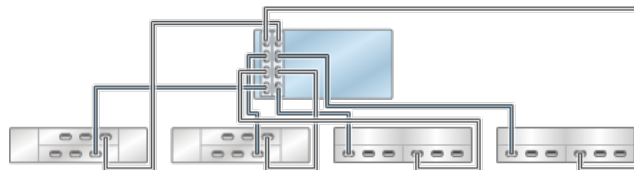
**FIGURE 5-5** 7420 standalone controllers with two HBAs connected to two mixed disk shelves in two chains (DE2-24 shown on the left)



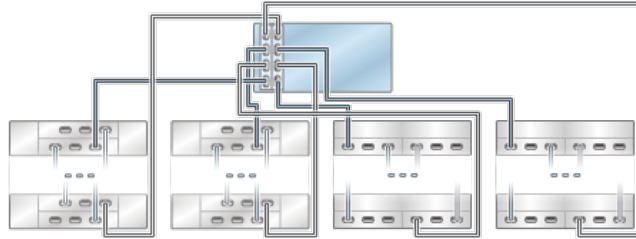
**FIGURE 5-6** 7420 standalone controllers with two HBAs connected to three mixed disk shelves in three chains (DE2-24 shown on the left)



**FIGURE 5-7** 7420 standalone controllers with two HBAs connected to four mixed disk shelves in four chains (DE2-24 shown on the left)



**FIGURE 5-8** 7420 standalone controllers with two HBAs connected to multiple mixed disk shelves in four chains (DE2-24 shown on the left)



### 7420 Standalone to Mixed Disk Shelves (3 HBAs)

The following figures show a subset of the supported configurations for Oracle ZFS Storage 7420 standalone controllers with three HBAs. To cable the controller to the disk shelves, use the “[Cabling Guidelines](#)” on page 7, which include the “[Maximum Number of Disk Shelves per Controller Configuration](#)” on page 8.

Using mixed disk shelves on a controller, requires the following:

- The controller must use only 4X4 port SAS-2 HBAs
- Do not use mixed disk shelves in the same chain

---

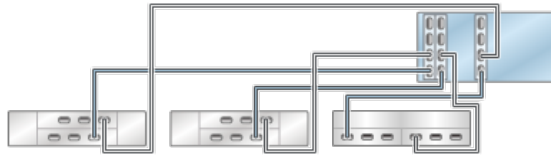
**Note** - For hardware port locations, see the PCIe Options section in the Hardware Maintenance Overview for your controller model. 4X4 port SAS-2 HBAs are only supported with software version 2013.1.0 and later.

---

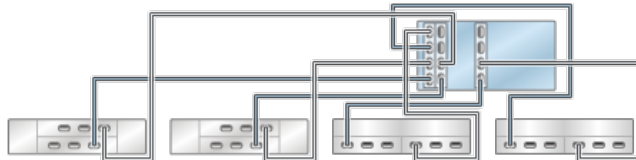
**FIGURE 5-9** 7420 standalone controllers with three HBAs connected to two mixed disk shelves in two chains (DE2-24 shown on the left)



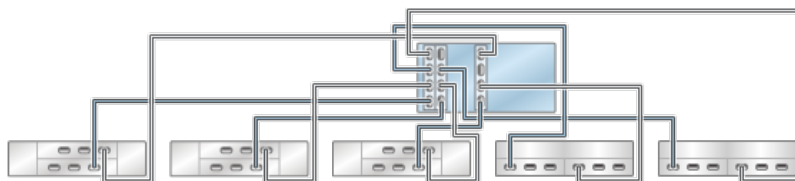
**FIGURE 5-10** 7420 standalone controllers with three HBAs connected to three mixed disk shelves in three chains (DE2-24 shown on the left)



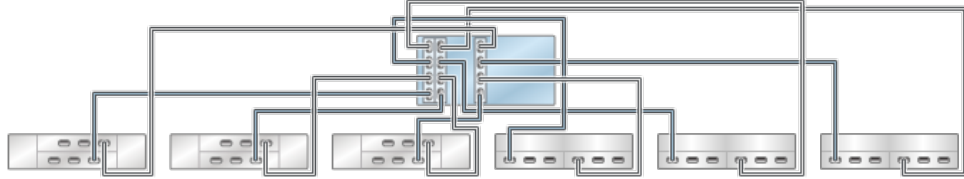
**FIGURE 5-11** 7420 standalone controllers with three HBAs connected to four mixed disk shelves in four chains (DE2-24 shown on the left)



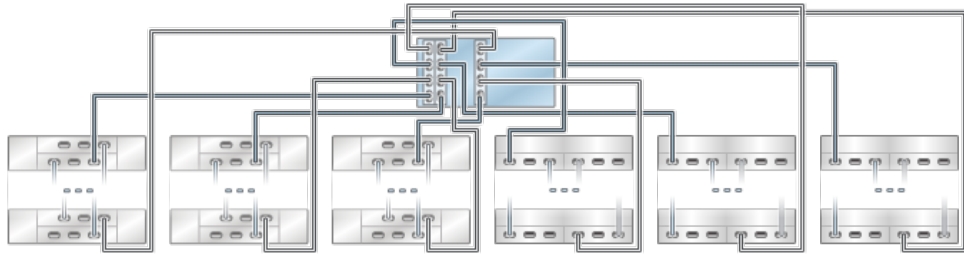
**FIGURE 5-12** 7420 standalone controllers with three HBAs connected to five mixed disk shelves in five chains (DE2-24 shown on the left)



**FIGURE 5-13** 7420 standalone controllers with three HBAs connected to six mixed disk shelves in six chains (DE2-24 shown on the left)



**FIGURE 5-14** 7420 standalone controllers with three HBAs connected to multiple mixed disk shelves in six chains (DE2-24 shown on the left)



## 7420 Standalone to Mixed Disk Shelves (4 HBAs)

The following figures show a subset of the supported configurations for Oracle ZFS Storage 7420 standalone controllers with four HBAs. To cable the controller to the disk shelves, use the [“Cabling Guidelines”](#) on page 7, which include the [“Maximum Number of Disk Shelves per Controller Configuration”](#) on page 8.

Using mixed disk shelves on a controller, requires the following:

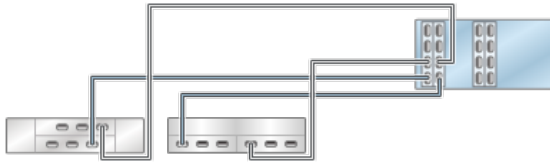
- The controller must use only 4X4 port SAS-2 HBAs
- Do not use mixed disk shelves in the same chain

---

**Note** - For hardware port locations, see the PCIe Options section in the Hardware Maintenance Overview for your controller model. 4X4 port SAS-2 HBAs are only supported with software version 2013.1.0 and later.

---

**FIGURE 5-15** 7420 standalone controllers with four HBAs connected to two mixed disk shelves in two chains (DE2-24 shown on the left)



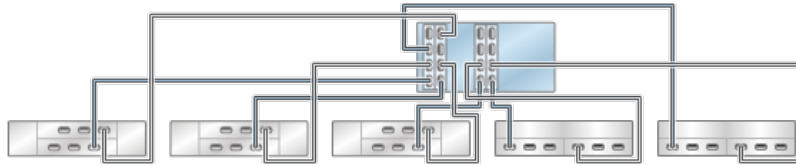
**FIGURE 5-16** 7420 standalone controllers with four HBAs connected to three mixed disk shelves in three chains (DE2-24 shown on the left)



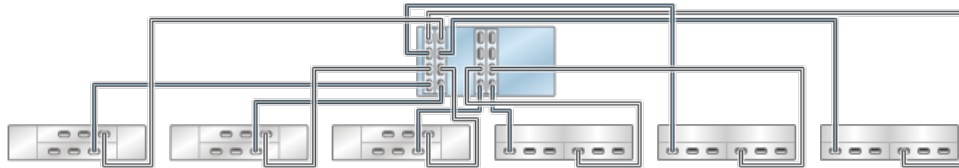
**FIGURE 5-17** 7420 standalone controllers with four HBAs connected to four mixed disk shelves in four chains (DE2-24 shown on the left)



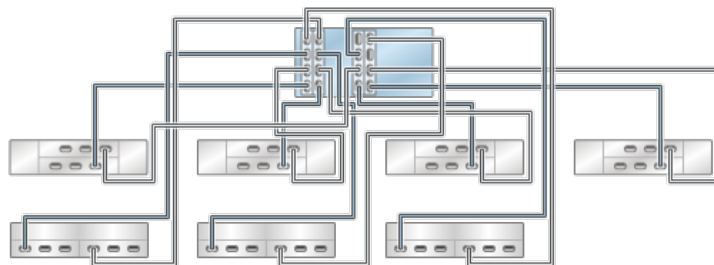
**FIGURE 5-18** 7420 standalone controllers with four HBAs connected to five mixed disk shelves in five chains (DE2-24 shown on the left)



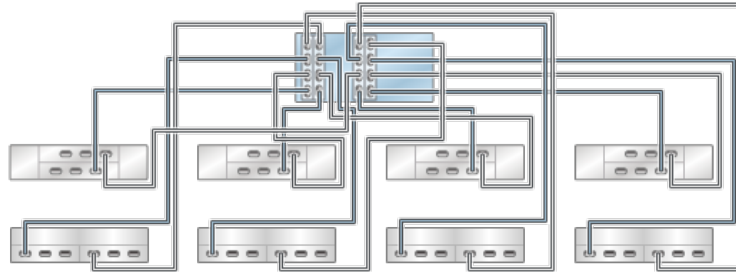
**FIGURE 5-19** 7420 standalone controllers with four HBAs connected to six mixed disk shelves in six chains (DE2-24 shown on the left)



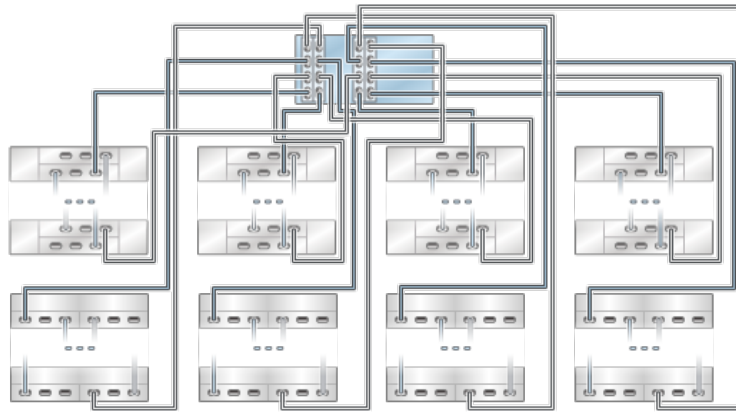
**FIGURE 5-20** 7420 standalone controllers with four HBAs connected to seven mixed disk shelves in seven chains (DE2-24 shown on the top)



**FIGURE 5-21** 7420 standalone controllers with four HBAs connected to eight mixed disk shelves in eight chains (DE2-24 shown on the top)



**FIGURE 5-22** 7420 standalone controllers with four HBAs connected to multiple mixed disk shelves in eight chains (DE2-24 shown on the top)



## 7420 Clustered to Mixed Disk Shelves

### 7420 Clustered to Mixed Disk Shelves (2 HBAs)

The following figures show a subset of the supported configurations for Oracle ZFS Storage 7420 clustered controllers with two HBAs. To cable the controller to the disk shelves, use the



“Cabling Guidelines” on page 7, which include the “Maximum Number of Disk Shelves per Controller Configuration” on page 8.

Using mixed disk shelves on a controller, requires the following:

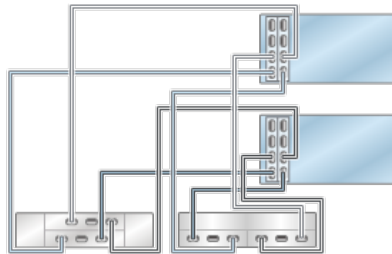
- The controller must use only 4X4 port SAS-2 HBAs
- Do not use mixed disk shelves in the same chain

---

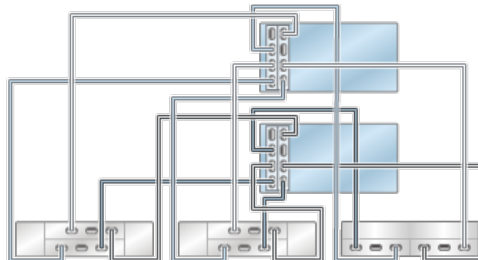
**Note** - For hardware port locations, see the PCIe Options section in the Hardware Maintenance Overview for your controller model. 4X4 port SAS-2 HBAs are only supported with software version 2013.1.0 and later.

---

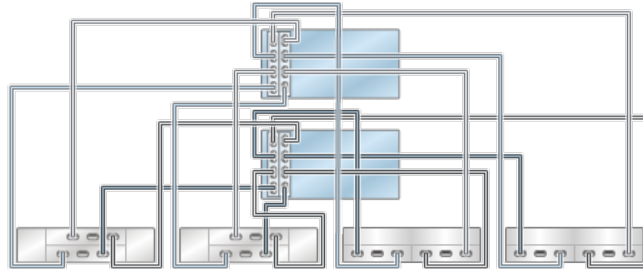
**FIGURE 5-23** 7420 clustered controllers with two HBAs connected to two mixed disk shelves in two chains (DE2-24 shown on the left)



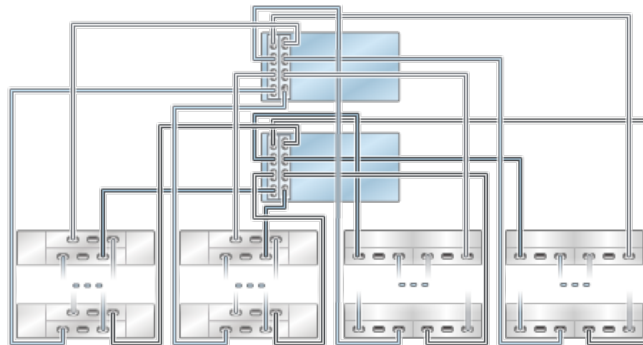
**FIGURE 5-24** 7420 clustered controllers with two HBAs connected to three mixed disk shelves in two chains (DE2-24 shown on the left)



**FIGURE 5-25** 7420 clustered controllers with two HBAs connected to four mixed disk shelves in four chains (DE2-24 shown on the left)



**FIGURE 5-26** 7420 clustered controllers with two HBAs connected to multiple mixed disk shelves in four chains (DE2-24 shown on the left)



### 7420 Clustered to Mixed Disk Shelves (3 HBAs)

The following figures show a subset of the supported configurations for Oracle ZFS Storage 7420 clustered controllers with three HBAs. To cable the controller to the disk shelves, use the [“Cabling Guidelines” on page 7](#), which include the [“Maximum Number of Disk Shelves per Controller Configuration” on page 8](#).

Using mixed disk shelves on a controller, requires the following:

- The controller must use only 4X4 port SAS-2 HBAs

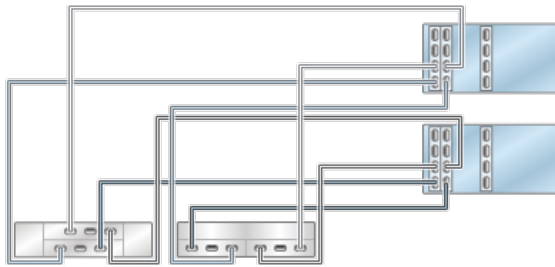
- Do not use mixed disk shelves in the same chain

---

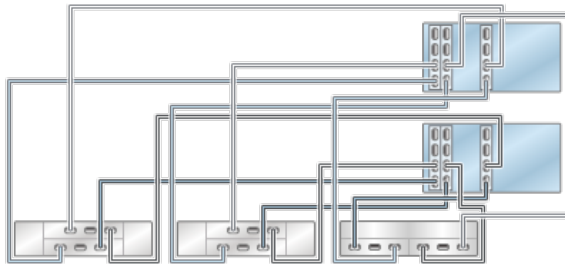
**Note** - For hardware port locations, see the PCIe Options section in the Hardware Maintenance Overview for your controller model. 4X4 port SAS-2 HBAs are only supported with software version 2013.1.0 and later.

---

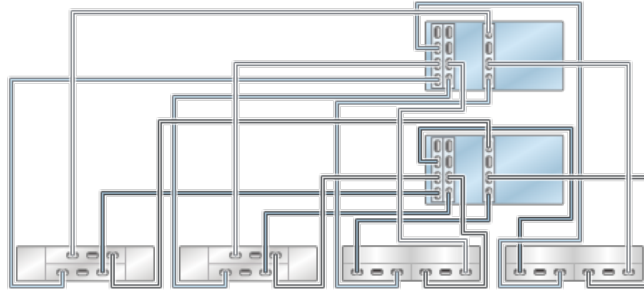
**FIGURE 5-27** 7420 clustered controllers with three HBAs connected to two mixed disk shelves in two chains (DE2-24 shown on the left)



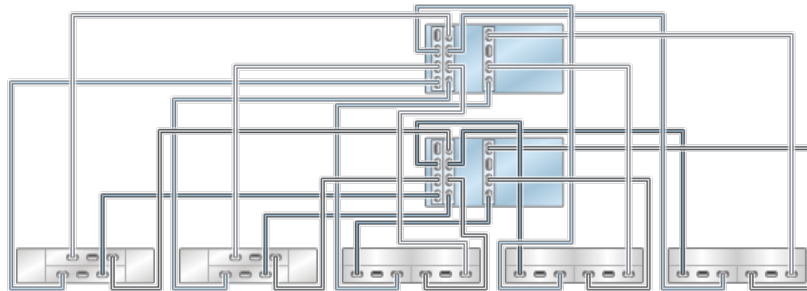
**FIGURE 5-28** 7420 clustered controllers with three HBAs connected to three mixed disk shelves in three chains (DE2-24 shown on the left)



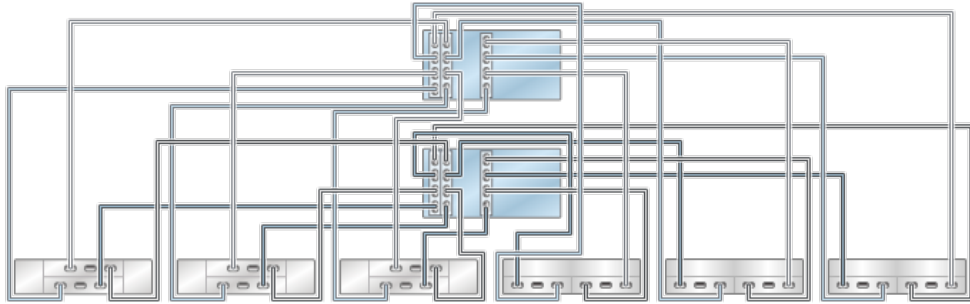
**FIGURE 5-29** 7420 clustered controllers with three HBAs connected to four mixed disk shelves in four chains (DE2-24 shown on the left)



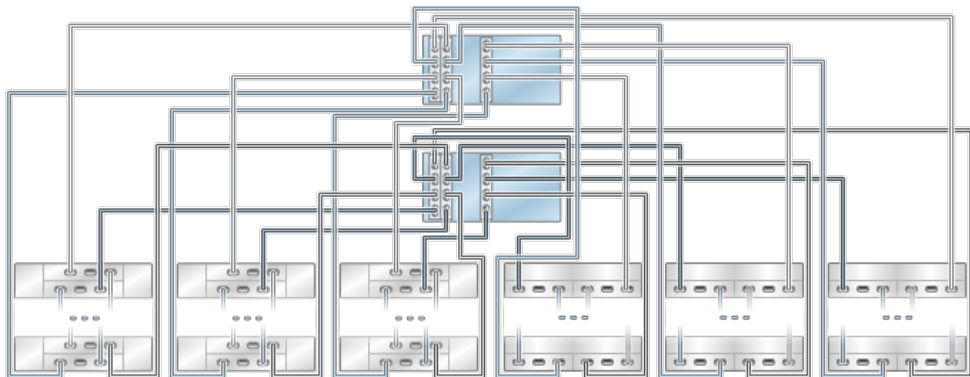
**FIGURE 5-30** 7420 clustered controllers with three HBAs connected to five mixed disk shelves in five chains (DE2-24 shown on the left)



**FIGURE 5-31** 7420 clustered controllers with three HBAs connected to six mixed disk shelves in six chains (DE2-24 shown on the left)



**FIGURE 5-32** 7420 clustered controllers with three HBAs connected to multiple mixed disk shelves in six chains (DE2-24 shown on the left)



## 7420 Clustered to Mixed Disk Shelves (4 HBAs)

The following figures show a subset of the supported configurations for Oracle ZFS Storage 7420 clustered controllers with four HBAs. To cable the controller to the disk shelves, use the [“Cabling Guidelines” on page 7](#), which include the [“Maximum Number of Disk Shelves per Controller Configuration” on page 8](#).

Using mixed disk shelves on a controller, requires the following:

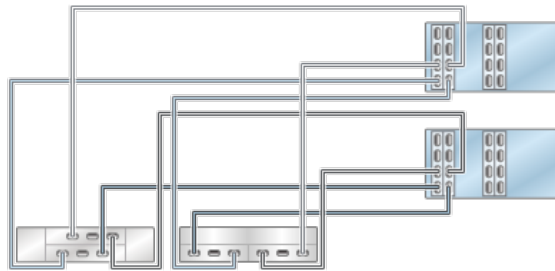
- The controller must use only 4X4 port SAS-2 HBAs
- Do not use mixed disk shelves in the same chain

---

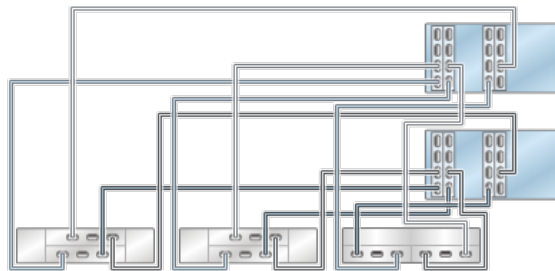
**Note** - For hardware port locations, see the PCIe Options section in the Hardware Maintenance Overview for your controller model. 4X4 port SAS-2 HBAs are only supported with software version 2013.1.0 and later.

---

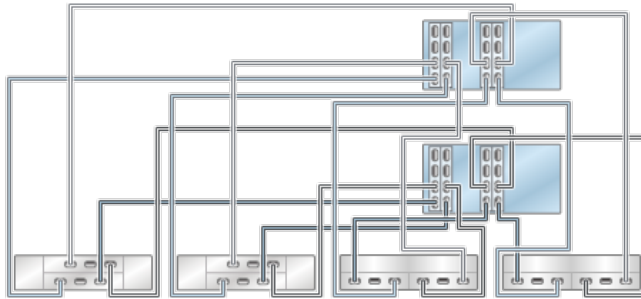
**FIGURE 5-33** 7420 clustered controllers with four HBAs connected to two mixed disk shelves in two chains (DE2-24 shown on the left)



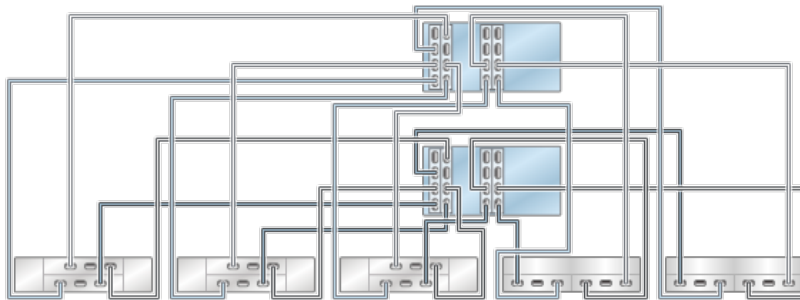
**FIGURE 5-34** 7420 clustered controllers with four HBAs connected to three mixed disk shelves in three chains (DE2-24 shown on the left)



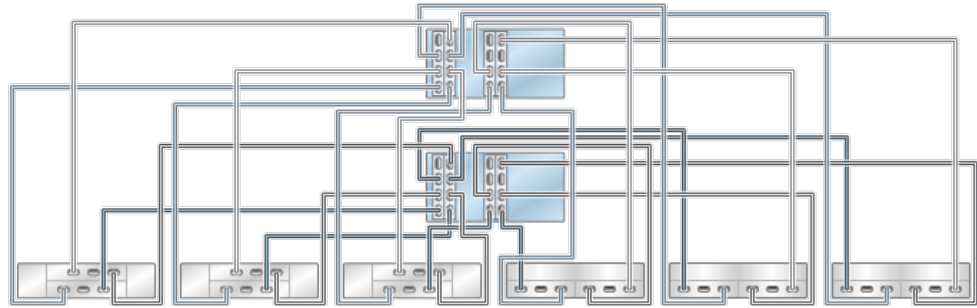
**FIGURE 5-35** 7420 clustered controllers with four HBAs connected to four mixed disk shelves in four chains (DE2-24 shown on the left)



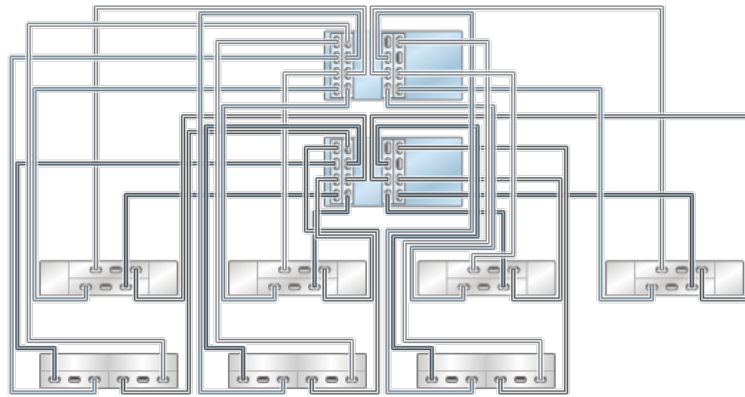
**FIGURE 5-36** 7420 clustered controllers with four HBAs connected to five mixed disk shelves in five chains (DE2-24 shown on the left)



**FIGURE 5-37** 7420 clustered controllers with four HBAs connected to six mixed disk shelves in six chains (DE2-24 shown on the left)

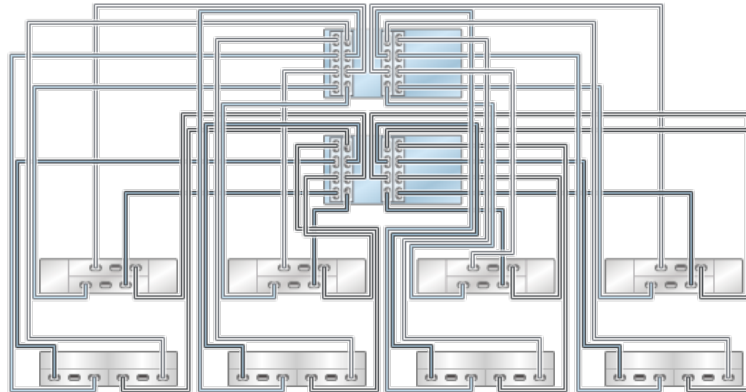


**FIGURE 5-38** 7420 clustered controllers with four HBAs connected to seven mixed disk shelves in seven chains (DE2-24 shown on the top)

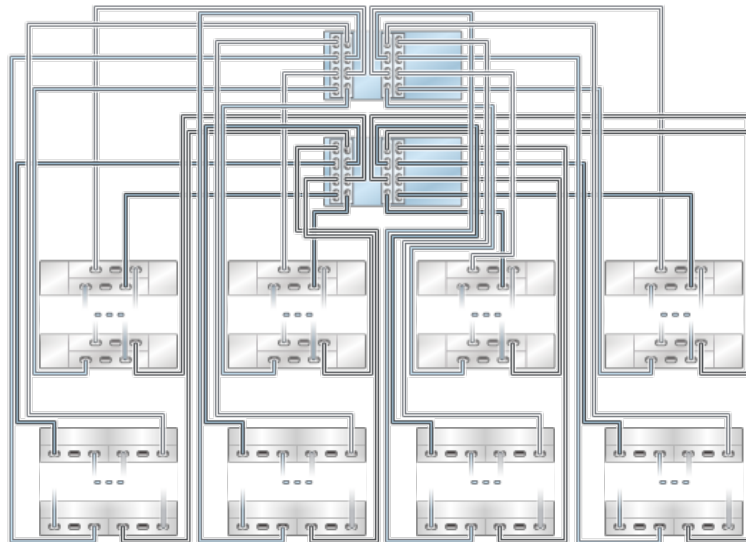




**FIGURE 5-39** 7420 clustered controllers with four HBAs connected to eight mixed disk shelves in eight chains (DE2-24 shown on the top)



**FIGURE 5-40** 7420 clustered controllers with four HBAs connected to multiple mixed disk shelves in eight chains (DE2-24 shown on the top)



## DE2-24 and Sun Disk Shelves to ZS3-2

### ZS3-2 Standalone to Mixed Disk Shelves

#### ZS3-2 Standalone to Mixed Disk Shelves (1 HBA)

The following figures show a subset of the supported configurations for Oracle ZFS Storage ZS3-2 standalone controllers with one HBA. To cable the controller to the disk shelves, use the [“Cabling Guidelines” on page 7](#), which include the [“Maximum Number of Disk Shelves per Controller Configuration” on page 8](#).

Using mixed disk shelves on a controller requires the following:

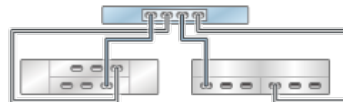
- The controller must use only 4X4 port SAS-2 HBAs
- Do not use mixed disk shelves in the same chain

---

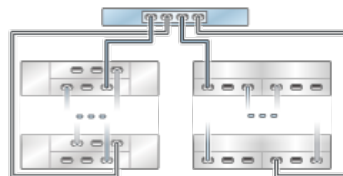
**Note** - For hardware port locations, see the PCIe Options section in the Hardware Maintenance Overview for your controller model. 4X4 port SAS-2 HBAs are only supported with software version 2013.1.0 and later.

---

**FIGURE 5-41** ZS3-2 standalone controller with one HBA connected to two mixed disk shelves in two chains (DE2-24 shown on the left)



**FIGURE 5-42** ZS3-2 standalone controller with one HBA connected to multiple mixed disk shelves in two chains (DE2-24 shown on the left)



## ZS3-2 Standalone to Mixed Disk Shelves (2 HBAs)

The following figures show a subset of the supported configurations for Oracle ZFS Storage ZS3-2 standalone controllers with two HBAs. To cable the controller to the disk shelves, use the “[Cabling Guidelines](#)” on page 7, which include the “[Maximum Number of Disk Shelves per Controller Configuration](#)” on page 8.

Using mixed disk shelves on a controller requires the following:

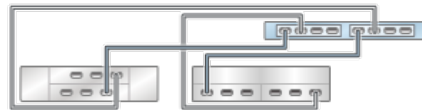
- The controller must use only 4X4 port SAS-2 HBAs
- Do not use mixed disk shelves in the same chain

---

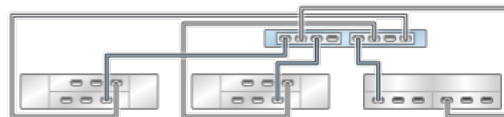
**Note** - For hardware port locations, see the PCIe Options section in the Hardware Maintenance Overview for your controller model. 4X4 port SAS-2 HBAs are only supported with software version 2013.1.0 and later.

---

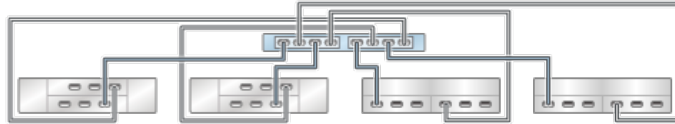
**FIGURE 5-43** ZS3-2 standalone controller with two HBAs connected to two mixed disk shelves in two chains (DE2-24 shown on the left)



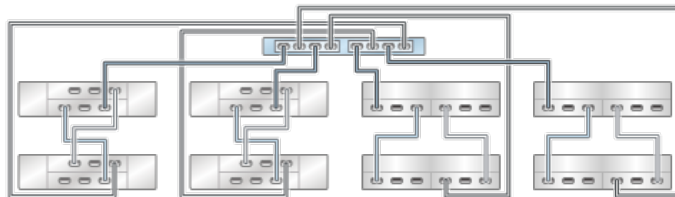
**FIGURE 5-44** ZS3-2 standalone controller with two HBAs connected to three mixed disk shelves in three chains (DE2-24 shown on the left)



**FIGURE 5-45** ZS3-2 standalone controller with two HBAs connected to four mixed disk shelves in four chains (DE2-24 shown on the left)



**FIGURE 5-46** ZS3-2 standalone controller with two HBAs connected to eight mixed disk shelves in four chains (DE2-24 shown on the left)



## ZS3-2 Clustered to Mixed Disk Shelves

### ZS3-2 Clustered to Mixed Disk Shelves (1 HBA)

The following figures show a subset of the supported configurations for Oracle ZFS Storage ZS3-2 clustered controllers with one HBA. To cable the controller to the disk shelves, use the [“Cabling Guidelines” on page 7](#), which include the [“Maximum Number of Disk Shelves per Controller Configuration” on page 8](#).

Using mixed disk shelves on a controller, requires the following:

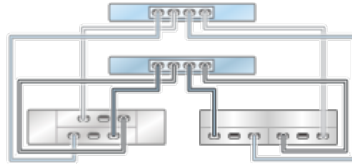
- The controller must use only 4X4 port SAS-2 HBAs
- Do not use mixed disk shelves in the same chain

---

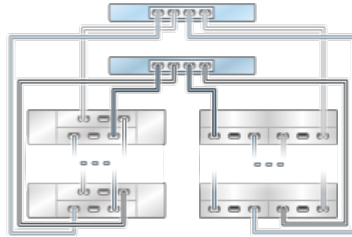
**Note** - For hardware port locations, see the PCIe Options section in the Hardware Maintenance Overview for your controller model. 4X4 port SAS-2 HBAs are only supported with software version 2013.1.0 and later.

---

**FIGURE 5-47** ZS3-2 clustered controllers with one HBA connected to two mixed disk shelves in two chains (DE2-24 shown on the left)



**FIGURE 5-48** ZS3-2 clustered controllers with one HBA connected to multiple mixed disk shelves in two chains (DE2-24 shown on the left)



## ZS3-2 Clustered to Mixed Disk Shelves (2 HBAs)

The following figures show a subset of the supported configurations for Oracle ZFS Storage ZS3-2 clustered controllers with two HBAs. To cable the controller to the disk shelves, use the [“Cabling Guidelines” on page 7](#), which include the [“Maximum Number of Disk Shelves per Controller Configuration” on page 8](#).

Using mixed disk shelves on a controller, requires the following:

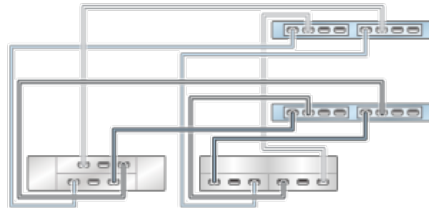
- The controller must use only 4X4 port SAS-2 HBAs
- Do not use mixed disk shelves in the same chain

---

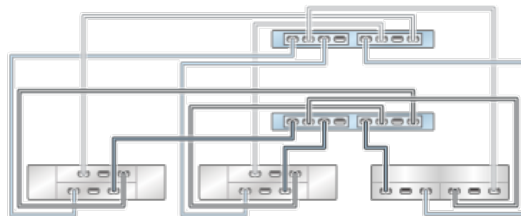
**Note** - For hardware port locations, see the PCIe Options section in the Hardware Maintenance Overview for your controller model. 4X4 port SAS-2 HBAs are only supported with software version 2013.1.0 and later.

---

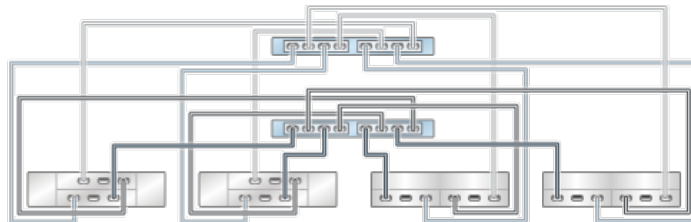
**FIGURE 5-49** ZS3-2 clustered controller with two HBAs connected to two mixed disk shelves in two chains (DE2-24 shown on the left)



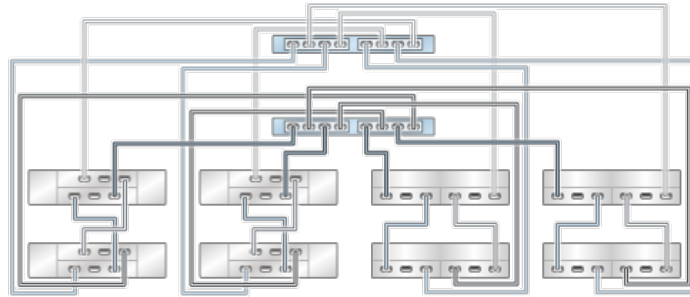
**FIGURE 5-50** ZS3-2 clustered controller with two HBAs connected to three mixed disk shelves in three chains (DE2-24 shown on the left)



**FIGURE 5-51** ZS3-2 clustered controller with two HBAs connected to four mixed disk shelves in four chains (DE2-24 shown on the left)



**FIGURE 5-52** ZS3-2 clustered controller with two HBAs connected to eight mixed disk shelves in four chains (DE2-24 shown on the left)



## DE2-24 and Sun Disk Shelves to ZS3-4

### ZS3-4 Standalone to Mixed Disk Shelves

#### ZS3-4 Standalone to Mixed Disk Shelves (2 HBAs)

The following figures show a subset of the supported configurations for Oracle ZFS Storage ZS3-4 standalone controllers with two HBAs. To cable the controller to the disk shelves, use the [“Cabling Guidelines” on page 7](#), which include the [“Maximum Number of Disk Shelves per Controller Configuration” on page 8](#).

Using mixed disk shelves on a controller, requires the following:

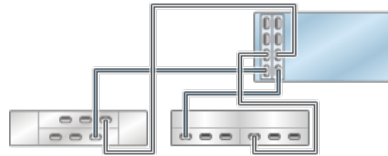
- The controller must use only 4X4 port SAS-2 HBAs
- Do not use mixed disk shelves in the same chain

---

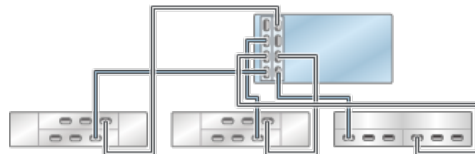
**Note** - For hardware port locations, see the PCIe Options section in the Hardware Maintenance Overview for your controller model. 4X4 port SAS-2 HBAs are only supported with software version 2013.1.0 and later.

---

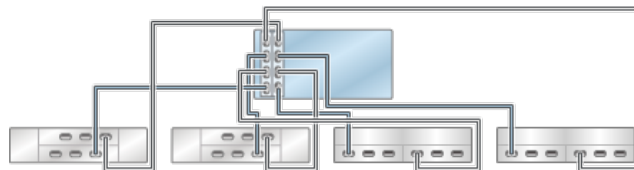
**FIGURE 5-53** ZS3-4 standalone controllers with two HBAs connected to two mixed disk shelves in two chains (DE2-24 shown on the left)



**FIGURE 5-54** ZS3-4 standalone controllers with two HBAs connected to three mixed disk shelves in three chains (DE2-24 shown on the left)

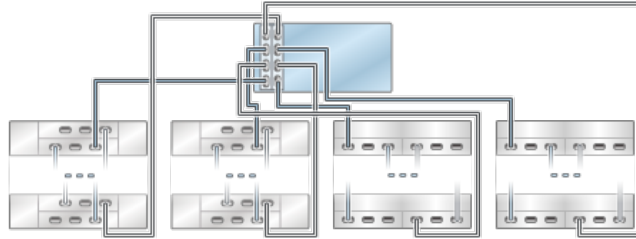


**FIGURE 5-55** ZS3-4 standalone controllers with two HBAs connected to four mixed disk shelves in four chains (DE2-24 shown on the left)





**FIGURE 5-56** ZS3-4 standalone controllers with two HBAs connected to multiple mixed disk shelves in four chains (DE2-24 shown on the left)



### ZS3-4 Standalone to Mixed Disk Shelves (3 HBAs)

The following figures show a subset of the supported configurations for Oracle ZFS Storage ZS3-4 standalone controllers with three HBAs. To cable the controller to the disk shelves, use the [“Cabling Guidelines”](#) on page 7, which include the [“Maximum Number of Disk Shelves per Controller Configuration”](#) on page 8.

Using mixed disk shelves on a controller, requires the following:

- The controller must use only 4X4 port SAS-2 HBAs
- Do not use mixed disk shelves in the same chain

---

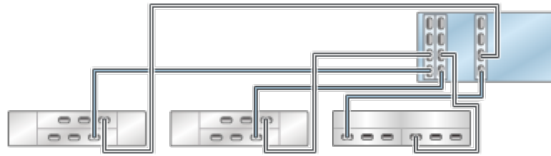
**Note** - For hardware port locations, see the PCIe Options section in the Hardware Maintenance Overview for your controller model. 4X4 port SAS-2 HBAs are only supported with software version 2013.1.0 and later.

---

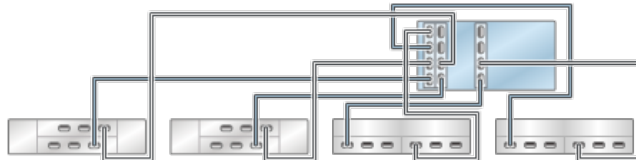
**FIGURE 5-57** ZS3-4 standalone controllers with three HBAs connected to two mixed disk shelves in two chains (DE2-24 shown on the left)



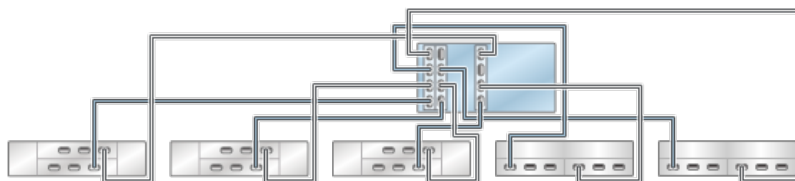
**FIGURE 5-58** ZS3-4 standalone controllers with three HBAs connected to three mixed disk shelves in three chains (DE2-24 shown on the left)



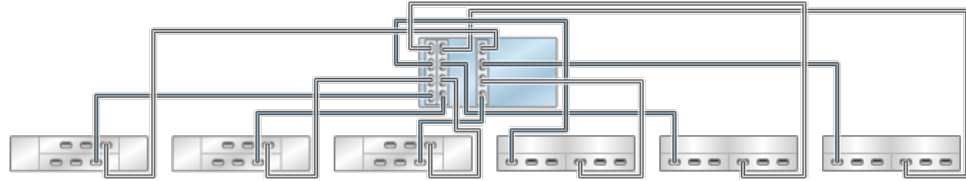
**FIGURE 5-59** ZS3-4 standalone controllers with three HBAs connected to four mixed disk shelves in four chains (DE2-24 shown on the left)



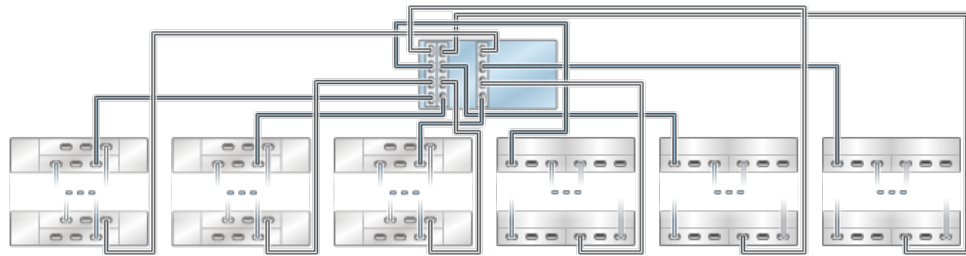
**FIGURE 5-60** ZS3-4 standalone controllers with three HBAs connected to five mixed disk shelves in five chains (DE2-24 shown on the left)



**FIGURE 5-61** ZS3-4 standalone controllers with three HBAs connected to six mixed disk shelves in six chains (DE2-24 shown on the left)



**FIGURE 5-62** ZS3-4 standalone controllers with three HBAs connected to multiple mixed disk shelves in six chains (DE2-24 shown on the left)



## ZS3-4 Standalone to Mixed Disk Shelves (4 HBAs)

The following figures show a subset of the supported configurations for Oracle ZFS Storage ZS3-4 standalone controllers with four HBAs. To cable the controller to the disk shelves, use the [“Cabling Guidelines” on page 7](#), which include the [“Maximum Number of Disk Shelves per Controller Configuration” on page 8](#).

Using mixed disk shelves on a controller, requires the following:

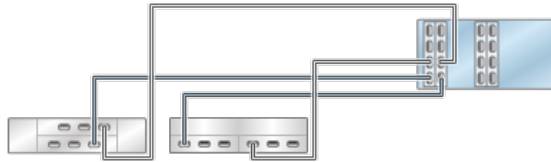
- The controller must use only 4X4 port SAS-2 HBAs
- Do not use mixed disk shelves in the same chain

---

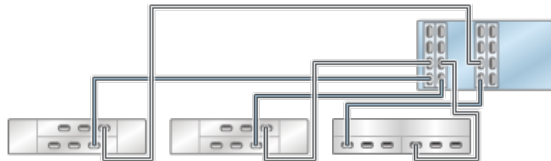
**Note** - For hardware port locations, see the PCIe Options section in the Hardware Maintenance Overview for your controller model. 4X4 port SAS-2 HBAs are only supported with software version 2013.1.0 and later.

---

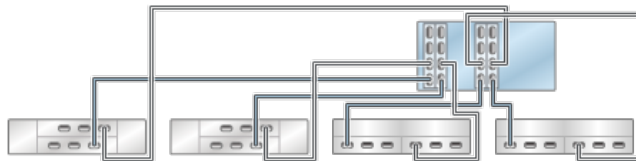
**FIGURE 5-63** ZS3-4 standalone controllers with four HBAs connected to two mixed disk shelves in two chains (DE2-24 shown on the left)



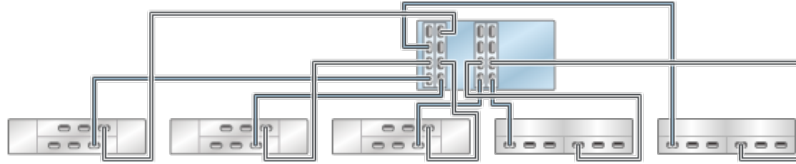
**FIGURE 5-64** ZS3-4 standalone controllers with four HBAs connected to three mixed disk shelves in three chains (DE2-24 shown on the left)



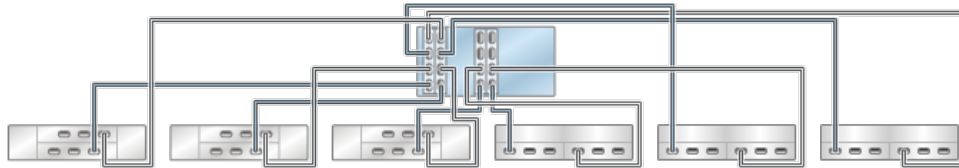
**FIGURE 5-65** ZS3-4 standalone controllers with four HBAs connected to four mixed disk shelves in four chains (DE2-24 shown on the left)



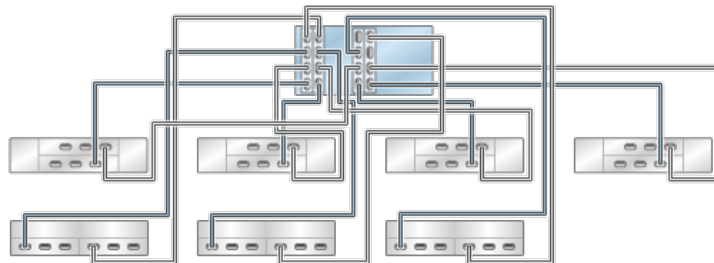
**FIGURE 5-66** ZS3-4 standalone controllers with four HBAs connected to five mixed disk shelves in five chains (DE2-24 shown on the left)



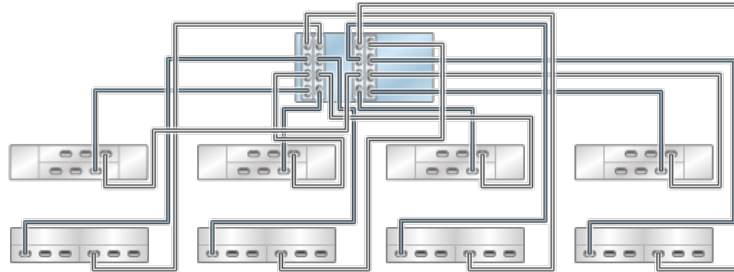
**FIGURE 5-67** ZS3-4 standalone controllers with four HBAs connected to six mixed disk shelves in six chains (DE2-24 shown on the left)



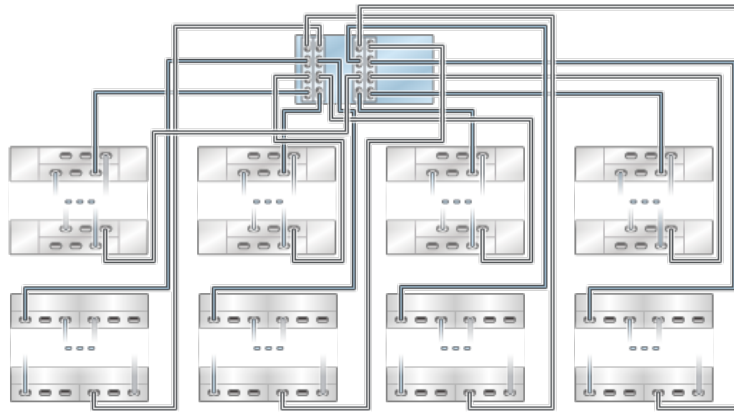
**FIGURE 5-68** ZS3-4 standalone controllers with four HBAs connected to seven mixed disk shelves in seven chains (DE2-24 shown on the top)



**FIGURE 5-69** ZS3-4 standalone controllers with four HBAs connected to eight mixed disk shelves in eight chains (DE2-24 shown on the top)



**FIGURE 5-70** ZS3-4 standalone controllers with four HBAs connected to multiple mixed disk shelves in eight chains (DE2-24 shown on the top)



## ZS3-4 Clustered to Mixed Disk Shelves

### ZS3-4 Clustered to Mixed Disk Shelves (2 HBAs)

The following figures show a subset of the supported configurations for Oracle ZFS Storage ZS3-4 clustered controllers with two HBAs. To cable the controller to the disk shelves, use the

“Cabling Guidelines” on page 7, which include the “Maximum Number of Disk Shelves per Controller Configuration” on page 8.

Using mixed disk shelves on a controller, requires the following:

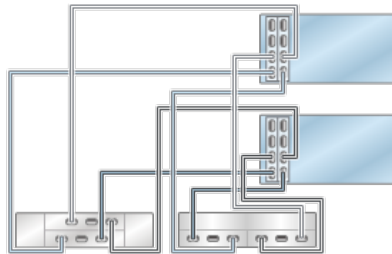
- The controller must use only 4X4 port SAS-2 HBAs
- Do not use mixed disk shelves in the same chain

---

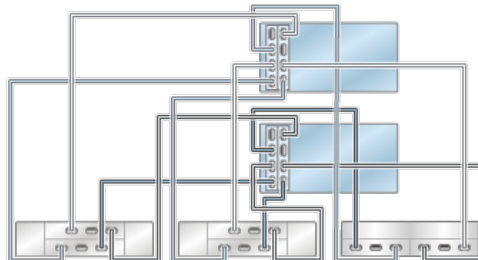
**Note** - For hardware port locations, see the PCIe Options section in the Hardware Maintenance Overview for your controller model. 4X4 port SAS-2 HBAs are only supported with software version 2013.1.0 and later.

---

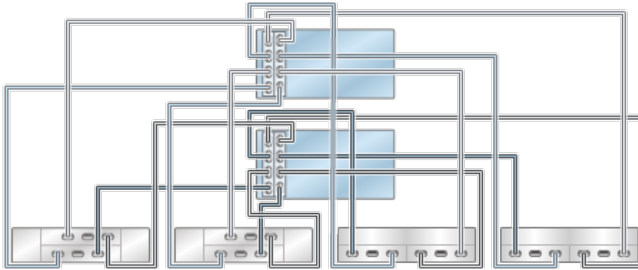
**FIGURE 5-71** ZS3-4 clustered controllers with two HBAs connected to two mixed disk shelves in two chains (DE2-24 shown on the left)



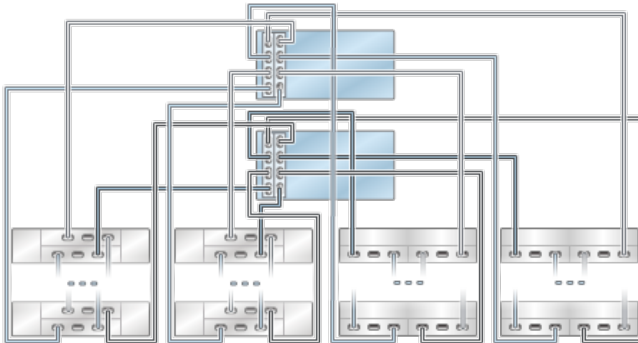
**FIGURE 5-72** ZS3-4 clustered controllers with two HBAs connected to three mixed disk shelves in two chains (DE2-24 shown on the left)



**FIGURE 5-73** ZS3-4 clustered controllers with two HBAs connected to four mixed disk shelves in four chains (DE2-24 shown on the left)



**FIGURE 5-74** ZS3-4 clustered controllers with two HBAs connected to multiple mixed disk shelves in four chains (DE2-24 shown on the left)



### ZS3-4 Clustered to Mixed Disk Shelves (3 HBAs)

The following figures show a subset of the supported configurations for Oracle ZFS Storage ZS3-4 clustered controllers with three HBAs. To cable the controller to the disk shelves, use the [“Cabling Guidelines” on page 7](#), which include the [“Maximum Number of Disk Shelves per Controller Configuration” on page 8](#).

Using mixed disk shelves on a controller, requires the following:

- The controller must use only 4X4 port SAS-2 HBAs



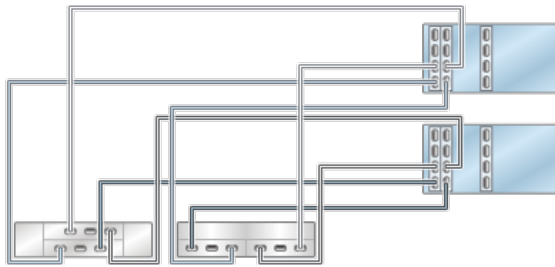
- Do not use mixed disk shelves in the same chain

---

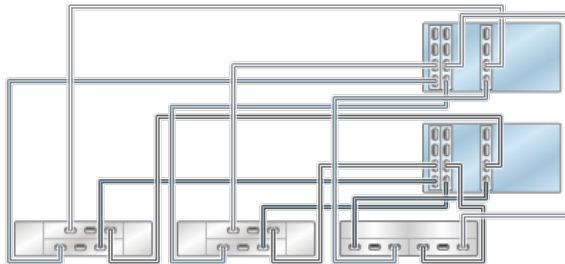
**Note** - For hardware port locations, see the PCIe Options section in the Hardware Maintenance Overview for your controller model. 4X4 port SAS-2 HBAs are only supported with software version 2013.1.0 and later.

---

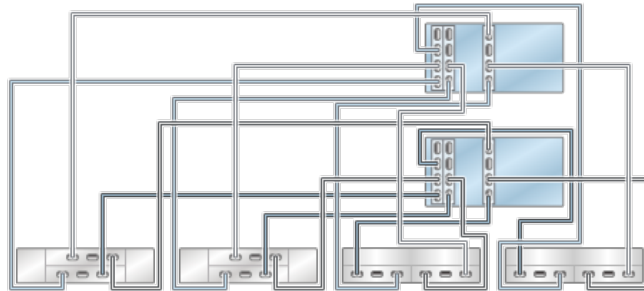
**FIGURE 5-75** ZS3-4 clustered controllers with three HBAs connected to two mixed disk shelves in two chains (DE2-24 shown on the left)



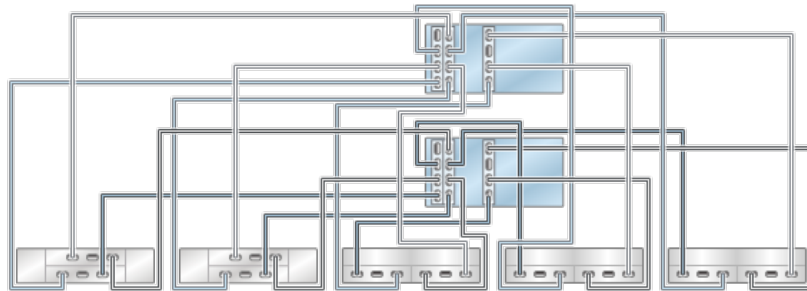
**FIGURE 5-76** ZS3-4 clustered controllers with three HBAs connected to three mixed disk shelves in three chains (DE2-24 shown on the left)



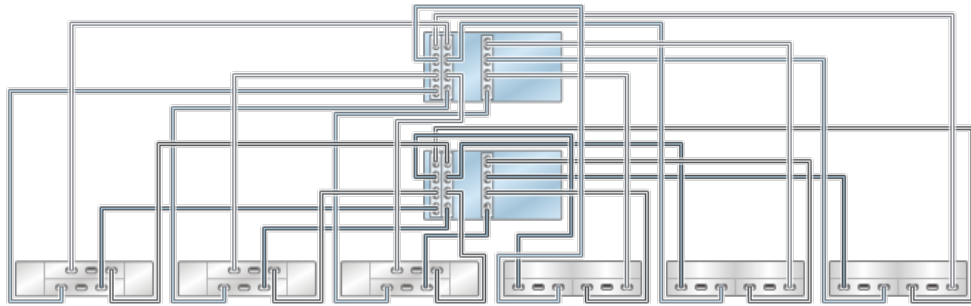
**FIGURE 5-77** ZS3-4 clustered controllers with three HBAs connected to four mixed disk shelves in four chains (DE2-24 shown on the left)



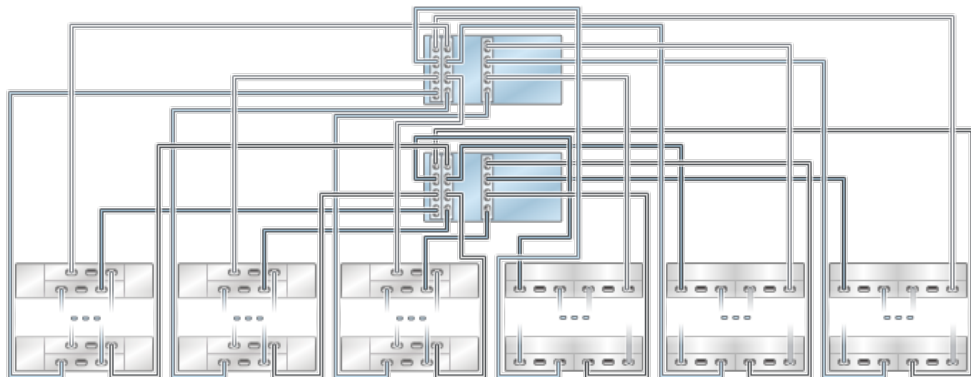
**FIGURE 5-78** ZS3-4 clustered controllers with three HBAs connected to five mixed disk shelves in five chains (DE2-24 shown on the left)



**FIGURE 5-79** ZS3-4 clustered controllers with three HBAs connected to six mixed disk shelves in six chains (DE2-24 shown on the left)



**FIGURE 5-80** ZS3-4 clustered controllers with three HBAs connected to multiple mixed disk shelves in six chains (DE2-24 shown on the left)



## ZS3-4 Clustered to Mixed Disk Shelves (4 HBAs)

The following figures show a subset of the supported configurations for Oracle ZFS Storage ZS3-4 clustered controllers with four HBAs. To cable the controller to the disk shelves, use the “Cabling Guidelines” on page 7, which include the “Maximum Number of Disk Shelves per Controller Configuration” on page 8.

Using mixed disk shelves on a controller, requires the following:

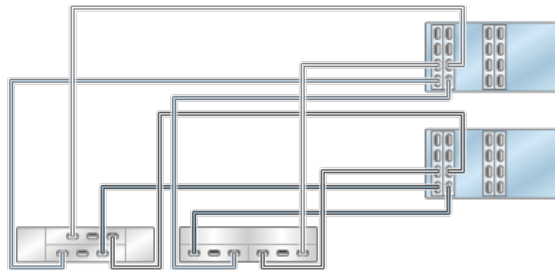
- The controller must use only 4X4 port SAS-2 HBAs
- Do not use mixed disk shelves in the same chain

---

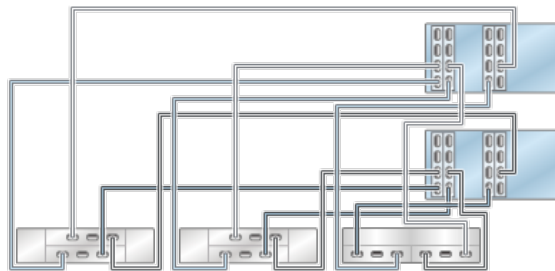
**Note** - For hardware port locations, see the PCIe Options section in the Hardware Maintenance Overview for your controller model. 4X4 port SAS-2 HBAs are only supported with software version 2013.1.0 and later.

---

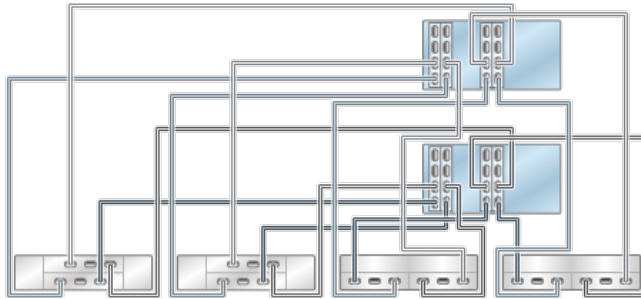
**FIGURE 5-81** ZS3-4 clustered controllers with four HBAs connected to two mixed disk shelves in two chains (DE2-24 shown on the left)



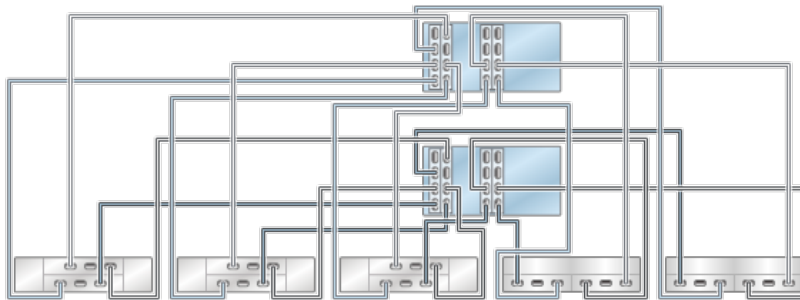
**FIGURE 5-82** ZS3-4 clustered controllers with four HBAs connected to three mixed disk shelves in three chains (DE2-24 shown on the left)



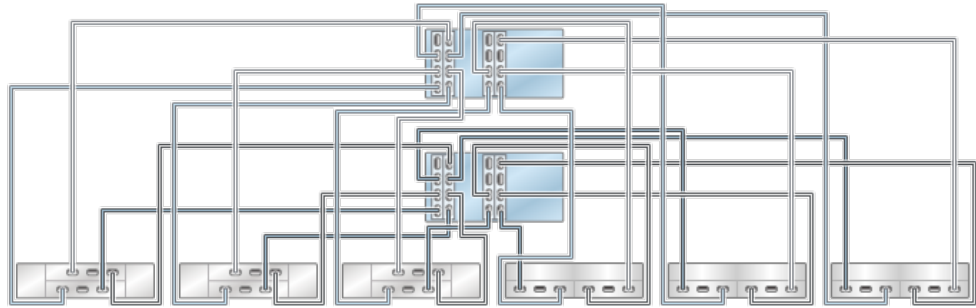
**FIGURE 5-83** ZS3-4 clustered controllers with four HBAs connected to four mixed disk shelves in four chains (DE2-24 shown on the left)



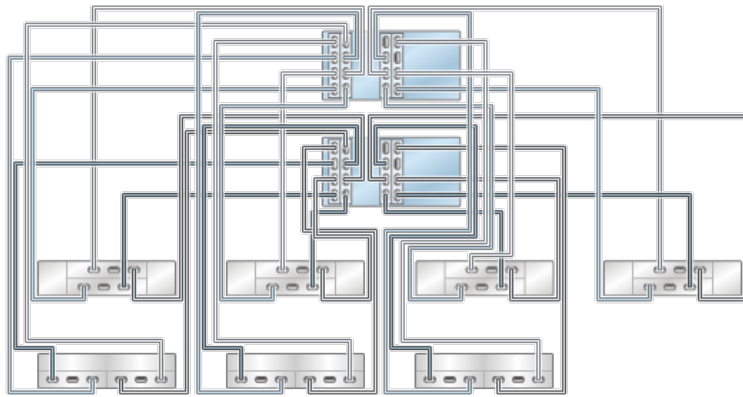
**FIGURE 5-84** ZS3-4 clustered controllers with four HBAs connected to five mixed disk shelves in five chains (DE2-24 shown on the left)



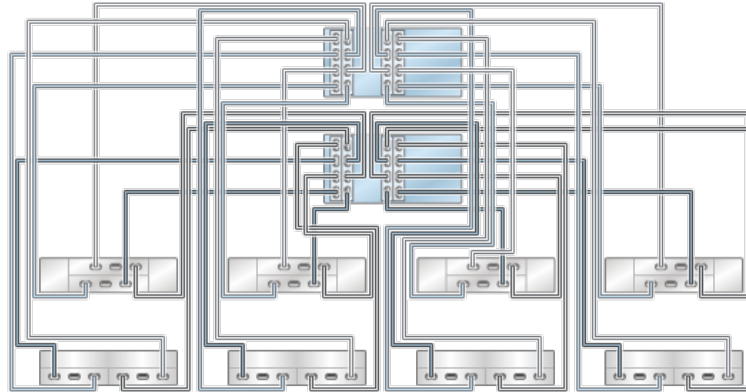
**FIGURE 5-85** ZS3-4 clustered controllers with four HBAs connected to six mixed disk shelves in six chains (DE2-24 shown on the left)



**FIGURE 5-86** ZS3-4 clustered controllers with four HBAs connected to seven mixed disk shelves in seven chains (DE2-24 shown on the top)



**FIGURE 5-87** ZS3-4 clustered controllers with four HBAs connected to eight mixed disk shelves in eight chains (DE2-24 shown on the top)



**FIGURE 5-88** ZS3-4 clustered controllers with four HBAs connected to multiple mixed disk shelves in eight chains (DE2-24 shown on the top)

