

StorageTek T10000

Tape Drive Systems Assurance Guide

E20715-11

September 2016

Copyright © 2006, 2016, Oracle and/or its affiliates. All rights reserved.

This software and related documentation are provided under a license agreement containing restrictions on use and disclosure and are protected by intellectual property laws. Except as expressly permitted in your license agreement or allowed by law, you may not use, copy, reproduce, translate, broadcast, modify, license, transmit, distribute, exhibit, perform, publish, or display any part, in any form, or by any means. Reverse engineering, disassembly, or decompilation of this software, unless required by law for interoperability, is prohibited.

The information contained herein is subject to change without notice and is not warranted to be error-free. If you find any errors, please report them to us in writing.

If this is software or related documentation that is delivered to the U.S. Government or anyone licensing it on behalf of the U.S. Government, then the following notice is applicable:

U.S. GOVERNMENT END USERS: Oracle programs, including any operating system, integrated software, any programs installed on the hardware, and/or documentation, delivered to U.S. Government end users are "commercial computer software" pursuant to the applicable Federal Acquisition Regulation and agency-specific supplemental regulations. As such, use, duplication, disclosure, modification, and adaptation of the programs, including any operating system, integrated software, any programs installed on the hardware, and/or documentation, shall be subject to license terms and license restrictions applicable to the programs. No other rights are granted to the U.S. Government.

This software or hardware is developed for general use in a variety of information management applications. It is not developed or intended for use in any inherently dangerous applications, including applications that may create a risk of personal injury. If you use this software or hardware in dangerous applications, then you shall be responsible to take all appropriate fail-safe, backup, redundancy, and other measures to ensure its safe use. Oracle Corporation and its affiliates disclaim any liability for any damages caused by use of this software or hardware in dangerous applications.

Oracle and Java are registered trademarks of Oracle and/or its affiliates. Other names may be trademarks of their respective owners.

Intel and Intel Xeon are trademarks or registered trademarks of Intel Corporation. All SPARC trademarks are used under license and are trademarks or registered trademarks of SPARC International, Inc. AMD, Opteron, the AMD logo, and the AMD Opteron logo are trademarks or registered trademarks of Advanced Micro Devices. UNIX is a registered trademark of The Open Group.

This software or hardware and documentation may provide access to or information about content, products, and services from third parties. Oracle Corporation and its affiliates are not responsible for and expressly disclaim all warranties of any kind with respect to third-party content, products, and services unless otherwise set forth in an applicable agreement between you and Oracle. Oracle Corporation and its affiliates will not be responsible for any loss, costs, or damages incurred due to your access to or use of third-party content, products, or services, except as set forth in an applicable agreement between you and Oracle.

Contents

Preface	ix
Audience.....	ix
Documentation Accessibility	ix
1 Introduction	
Description	1-1
Tape Drive Components	1-2
Small Form-factor Pluggable Modules	1-3
Power Supply Modules.....	1-3
Maintenance Port Use.....	1-4
Encryption.....	1-5
Tape Drive Features.....	1-5
StorageTek Data Integrity Validation	1-5
StorageTek Direct Copy	1-6
StorageTek File Access Accelerator.....	1-6
StorageTek Maximum Capacity	1-6
StorageTek File Sync Accelerator	1-6
StorageTek Tape Application Accelerator	1-7
StorageTek Search Accelerator	1-7
StorageTek MIR Assisted Search	1-7
StorageTek In-Drive Reclaim Accelerator	1-8
StorageTek Tape Tiering Accelerator	1-8
Specifications	1-8
Tape Drive Performance Specifications	1-8
Physical Specifications	1-10
Shipping Dimensions	1-11
Environmental Requirements	1-11
Airborne Contamination.....	1-12
Configurations	1-12
Library Configurations.....	1-12
Rack Mount Configurations	1-13
Virtual Operator Panel	1-13
Tape Cartridge	1-14
Cables and Connectors	1-15
Cable Guidelines	1-15

LC Connectors	1-16
Connectivity	1-16
Interop Tool.....	1-17
Network Considerations	1-17
Binding.....	1-17
Zoning.....	1-18
Comparisons	1-18

2 Site Preparation

Management Software Requirements	2-1
Library Installation Requirements	2-3
StorageTek SL3000 Modular Library System.....	2-3
StorageTek SL8500 Modular Library System.....	2-4
L-Series Libraries	2-5
Rack Mount Configurations	2-5
Tape Drive Configuration and Planning	2-6
Drive Parameters.....	2-6
Network Selections	2-8
Initial Drive Settings	2-8
FICON Configurations	2-9
Hardware Configuration Definition	2-9
Port Configuration	2-9
Cables and Connectors.....	2-10
StorageTek Tape Analytics	2-10
Remote Support	2-11
Preparing for Drive Installation and Service	2-11
Personnel	2-11

3 Ordering

Tape Drive Order Numbers	3-1
T10000D Order Numbers.....	3-2
T10000C Order Numbers	3-2
Encryption Order Number	3-3
Conversion Kits and Upgrades	3-3
Drive Port Kits	3-4
Library Tray Kits	3-4
Ordering Media and Cartridge Labels	3-5
Power Cords	3-5
Ethernet Cables	3-5
Interface Cables	3-6
Multimode Fiber-optic OM4 Cable Numbers (16Gb).....	3-6
Multimode Fiber-optic OM2 Cable Numbers	3-6
Single Mode Fiber-optic Cable Numbers	3-7
One Gigabit Fiber-optic Cable Numbers	3-8

A Tape Cartridges

Disclaimer	A-1
Tape Cartridges	A-2
Standard Cartridges	A-2
Sport Cartridges	A-2
VolSafe Cartridges	A-3
Cleaning Cartridges	A-3
Additional Cartridge Components	A-3
Radio Frequency Identification	A-3
Media Information	A-4
Statistical Counters	A-4
Data Pointers	A-4
Normal Processing	A-4
Cross-Density Cartridge Processing	A-5
Invalid Media Information Conditions	A-6
Cartridge Environmental Requirements	A-6
Tape Cartridge Specifications	A-7
Labels	A-8
Standard and Sport Cartridge Labels	A-9
Diagnostic Cartridge Labels	A-9
Cleaning Cartridge Labels	A-9
Tape Cartridge Care	A-10
New Cartridges	A-10
Handling	A-10
Cleaning	A-10
Storing	A-10
Shipping	A-11

B Controlling Contaminants

Environmental Contaminants	B-1
Required Air Quality Levels	B-1
Contaminant Properties and Sources	B-2
Operator Activity	B-2
Hardware Movement	B-3
Outside Air	B-3
Stored Items	B-3
Outside Influences	B-3
Cleaning Activity	B-3
Contaminant Effects	B-4
Physical Interference	B-4
Corrosive Failure	B-4
Shorts	B-4
Thermal Failure	B-4
Room Conditions	B-4
Exposure Points	B-6
Filtration	B-6

Positive Pressurization and Ventilation.....	B-7
Cleaning Procedures and Equipment	B-7
Daily Tasks.....	B-8
Weekly Tasks	B-8
Quarterly Tasks	B-9
Biennial Tasks	B-9
Activity and Processes.....	B-10

Glossary

Index

List of Figures

1-1	T10000 Tape Drive Configurations	1-1
1-2	T10000A Tape Path	1-3
1-3	Power Supply Modules	1-4
1-4	Virtual Operator Panel	1-14
1-5	Tape Cartridge Introduction	1-15
2-1	Rack Mount Configuration	2-6
2-2	VOP Configuration Settings (T10000C Tape Drive)	2-7
2-3	Network Configuration	2-8
A-1	Tape Cartridge Types	A-1
A-2	Data Cartridge Label Example	A-9
A-3	Diagnostic Cartridge Label Example	A-9
A-4	Cleaning Cartridge Label Example	A-10

Preface

This document provides information to assist with the systems assurance of Oracle's StorageTek T10000 tape drive.

Audience

This document is intended for:

- Account executives
- Marketing and sales personnel
- System engineers
- Technical personnel (such as service representatives, professional service, or technical support)

The term T10000 is used in the document to generically reflect all drive models. The specific model suffix is used whenever model differentiation is appropriate.

Documentation Accessibility

For information about Oracle's commitment to accessibility, visit the Oracle Accessibility Program website at <http://www.oracle.com/pls/topic/lookup?ctx=acc&id=docacc>.

Access to Oracle Support

Oracle customers that have purchased support have access to electronic support through My Oracle Support. For information, visit <http://www.oracle.com/pls/topic/lookup?ctx=acc&id=info> or visit <http://www.oracle.com/pls/topic/lookup?ctx=acc&id=trs> if you are hearing impaired.

Introduction

Oracle's StorageTek T10000 tape drive family provides a range of small, modular, high-performance units designed for high-capacity data storage. The tape drive is either rack mounted or used in various StorageTek libraries (see [Figure 1-1](#)). There are four models in the T10000 drive family: T10000A, T10000B, T10000C, and T10000D.

Note: The tape drives are also called T10000, tape drive, or just drive throughout this guide.

Figure 1-1 T10000 Tape Drive Configurations

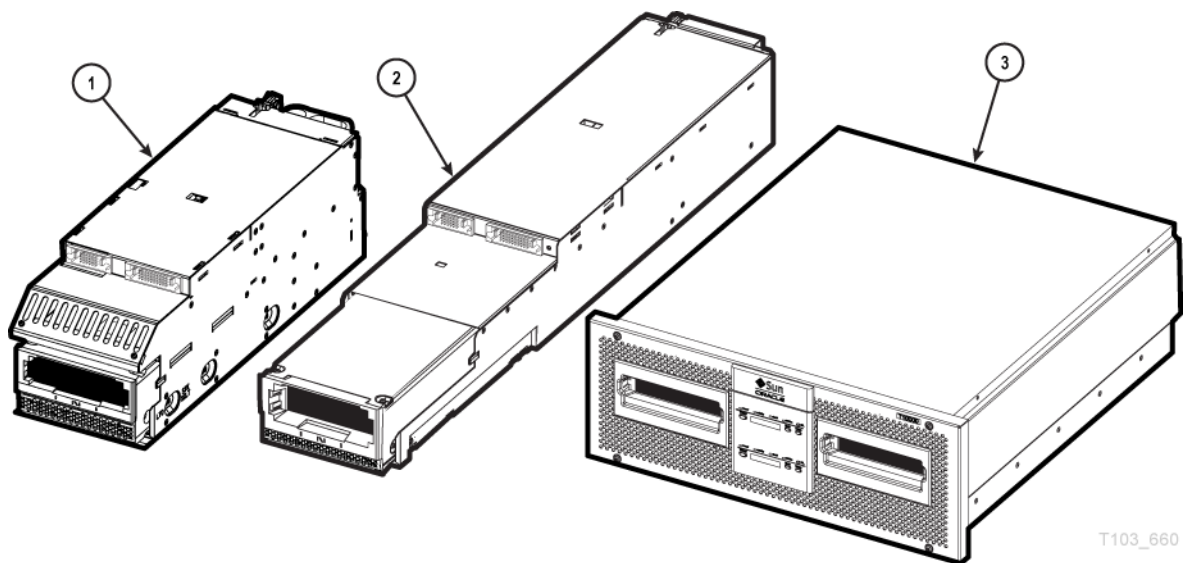

Illustration Legend:

- 1 - SL3000 configuration
- 2 - SL8500 configuration
- 3 - Rack tray

Description

The tape drive is 8.89 centimeters (3.5 inches) high, 14.6 centimeters (5.75 inches) wide, and 42.55 centimeters (16.75 inches) deep. The drive uses a single-reel tape cartridge and a technology called partial response, maximum likelihood (PRML) to provide the high-density data format that allows the:

- T10000A to record and store up to 500 gigabytes (GB) of uncompressed data
- T10000B to record and store up to 1 terabyte (TB) of uncompressed data
- T10000C to record and store up to 5.5 terabytes (TB) of uncompressed data
- T10000D to record and store up to 8.5 terabytes (TB) of uncompressed data

The host connections to the tape drive are fiber-optic, and provide a high rate of data transfer.

Tape Drive Components

The tape drive contains the following electrical and mechanical components:

- **Control processor:** Controls all drive functions and contains the embedded firmware.
- **ADC technology:** Performs data compression and decompression. ADC is an adaptive lossless data compression technique.
- **Specialized buffers:** Hold the data in a form written on tape and read back to the host.
- **Read and Write circuitry (Read/Write heads):** Uses PRML complemented by head technologies that write data to the tape and read it back. Dual head and 32-channel technology increases data integrity, promotes longer media life, and achieves high transfer rates.

Note: The T10000A or B drives use magneto-resistive (MR) heads while the T10000C or D drives use giant magneto-resistive (GMR) heads.

- **Encryption circuitry:** When enabled, encrypts and decrypts data.
- **Head cleaner:** Removes loose debris from the head during a cartridge unload.
- **Data buffer:** The T10000A or B drives have a 256 megabyte data buffer. The T10000C or D drive has a 2 gigabyte data buffer.
- **Variable speed servo system:** A variable speed servo system allows the tape drive to run at discrete speeds and tension.
- **Loader:** Loads the cartridge and engages it with the cartridge motor.
- **Threader:** Threads tape through the tape path to the take up reel during a load and returns the tape to the cartridge during an unload.
- **Tape path:** Guides the tape past the heads.
- **Ethernet port:** Provides a connection that supports items such as encryption keys, the virtual operator panel, or the Service Delivery Platform (SDP). The drives support IPv4 and IPv6 addresses (see "[Network Selections](#)").
- **Tape Transport Interface (TTI):** Transfers commands and status between the drive and the library.
- **RFID (Radio Frequency Identification) system:** Provides an interface to a memory chip in the tape cartridge.

Figure 1–2 shows elements of the tape path in the T10000A or B tape drive. The tape path of the T10000C or D is similar.

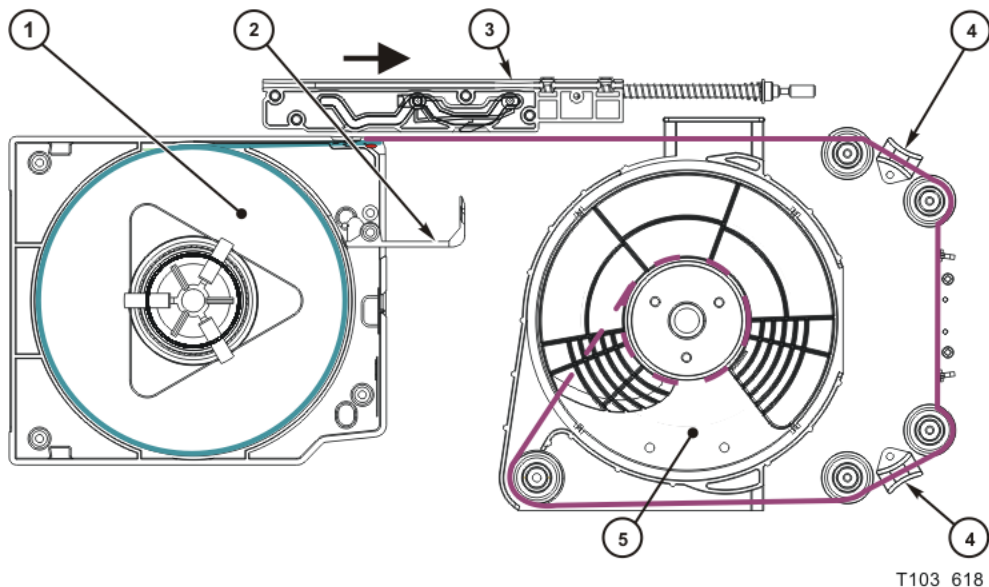
Figure 1–2 T10000A Tape Path**Illustration Legend:**

- 1 - Tape cartridge and loader (elevator)
- 2 - Tape cartridge door
- 3 - Buckler
- 4 - Tape path rollers and guides
- 5 - Take-up reel, motor, and hub assembly

Small Form-factor Pluggable Modules

There are different types of small form-factor pluggable (SFP) modules depending on the *wavelength* (mode) and type of cable:

- Short wavelength SFP module is used with 50-micron multimode cables.
- Long wavelength SFP module is used with 9-micron single mode cables.

Note: The T10000D uses a long wavelength SFP rated at 20km.

The tape drive is shipped with an SFP module in each of its two ports.

Tip: When planning the network, make sure the SFP module supports the specific network type and configuration including HBAs, switches, wavelength, and cable types.

Power Supply Modules

Figure 1–3 shows ways to provide power to the T10000 tape drives depending on the configuration:

- In an SL3000 or SL8500 configuration: a T10000 tape drive receives operating voltages from a DC power module located inside the drive tray.
- In a rack mount configuration: the drive receives operating voltages from an AC power supply module mounted inside the rack tray (chassis).

- In an L-Series library configuration: the T10000A or B drive receives operating voltages from an *external* AC power supply module installed on the library tray.
- In a 9741E cabinet configuration: the T10000A drive receives operating voltages from an *external* AC power supply module mounted inside the cabinet.

All versions of the power supply are field replaceable units (FRUs) with no other servicing requirements. If the power module fails, replace it with another module.

Note: Even though the power supplies look similar and have the same dimensions as other T-Series tape drive power supplies, *the T10000 power supplies are unique to the particular T10000 tape drive model.*

Figure 1–3 Power Supply Modules

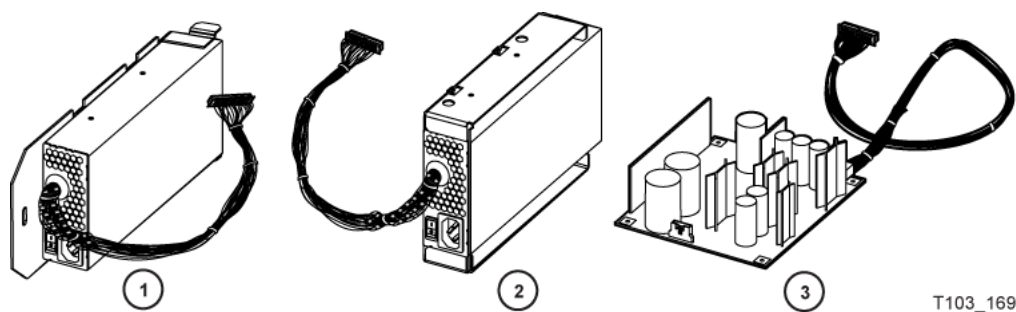

Illustration Legend:

- 1 - AC power supply for the 9741E drive cabinet (T10000A only)
- 2 - AC power supply for the rack chassis (all T10000 models) and L-Series libraries (T10000A or B only)
- 3 - DC power supply (SL8500 and SL3000 libraries)

Maintenance Port Use

All Oracle service calls to tape drives under warranty or maintenance contract require physical access and connection to the drive maintenance (Ethernet) port. If a customer has an Ethernet cable physically connected to the drive requiring service, the service representative must disconnect this cable to perform the required service action.

- T10000 non-encryption drives supported by the Service Delivery Platform (SDP) require 100% dedication of the drive's Ethernet port to the SDP site unit.
- T10000 encryption-enabled drives require 100% dedication of the drive's Ethernet port to the Encryption Service Network except during service activities by Oracle or Oracle-certified service partners.

Where Encryption and SDP coexist, the Ethernet port must be concurrently shared by using the Service Network.

Note: Oracle neither supports nor assumes any responsibility for drive functional failures that occur during the unauthorized use of the drive's maintenance port.

Unauthorized use applies to any use of the drive's Ethernet port for other than the following items:

- Encryption 1.x (not supported by the T10000C or T10000D drive)
- Encryption 2.x environments
- Virtual Operator Panel (VOP)
- Remote support platform (such as the Service Delivery Platform [SDP])
- Services Tape Health Check Tool
- StorageTek Diagnostic System (STDS)

Encryption

The tape drive has built-in encryption and works with the Oracle Key Manager (OKM) or Crypto Key Management System (KMS) to encrypt and decrypt data written by the T10000 tape drive. FIPS compliance:

- The T10000A drive with code level 1.40.108, 1.41.110, or 1.41.111 and KMS 2.1, or later, complies with FIPS 140-2 Level 1 security to data on magnetic tape.
- The T10000B drive with code level 1.40.208, 1.41.210, or 1.41.211 and KMS 2.1, or later, complies with FIPS 140-2 Level 2 security to data on magnetic tape.
- The T10000C drive with code level 1.51.318 or 1.57.308 and the OKM provides FIPS 140-2 Level 1 security to data on magnetic tape.
- The T10000D drive with code level 4.07.107 and the Oracle Key Manager provides FIPS 140-2 Level 1 security to data on magnetic tape.

Things to note about the tape drive are:

- The same drive either encrypts data or does not encrypt data, *not both*.
- The Ethernet port on the tape drive obtains encryption keys.
- Encryption cannot be turned off if it is activated in FIPS mode.

The data path key management (DPKM) subsystem is the third installment of encryption on StorageTek tape drives. DPKM uses the SCSI 4 commands `Security Protocol In` and `Security Protocol Out` to implement host-based key management on StorageTek encrypting tape drives. Encryption keys are delivered to the tape drive over the Fibre Channel interface (non-FIPS compliant). DPKM provides the ability to toggle the encryption state on or off on a per cartridge basis which allows the user to have a mix of encrypted and non-encrypted files on each tape cartridge. You use VOP to enable or disable the DPKM capability of the tape drive.

Tape Drive Features

The following features are available for the T10000C and T10000D tape drives. Some of the feature descriptions refer to white papers which are located at:

<http://www.oracle.com/technetwork/server-storage/sun-tape-storage/documentation/index.html>

StorageTek Data Integrity Validation

StorageTek Data Integrity Validation (DIV) ensures that a checksum, provided by an application or file system, is validated by the StorageTek T10000 for each record sent to the drive. The user-generated checksum is stored with each record on tape and can be

checked on any future read or verify operation (without the added overhead of sending data to the host). Information about how to use this feature is available in:

- *StorageTek T10000 Tape Drive Fibre Channel Reference Manual*
- *Redefining Tape Usage with StorageTek Tape Tiering Accelerator and StorageTek In-Drive Reclaim Accelerator* (white paper)

The DIV feature is available for the FC tape drive and requires application support.

StorageTek Direct Copy

Note: This feature is supported with the T10000D tape drive only.

Oracle's StorageTek Direct Copy feature enables migration of data in parallel with production processes. Copy data from any Fibre Channel tape device directly to StorageTek T10000D without burdening the host application or disk cache with CPU-intensive data migration activity. This feature is supported using Oracle Hierarchical Storage Manager 6.1. For more detailed information about this feature, contact your local sales representative to obtain a copy of the *StorageTek Direct Copy User Specification*.

StorageTek File Access Accelerator

Note: This feature is supported with the T10000D tape drive only.

Oracle's StorageTek File Access Accelerator feature enables applications to recall files from StorageTek T10000D using an optimized retrieval order that minimizes the time required for the tape drive to seek to each file. The tape drive receives a list of files from the application, optimizes the order of the list to minimize seek distances between files, and returns the re-ordered list to the application. And then the application sends read requests to the tape drive in the optimized file order using standard commands. For more detailed information about this feature, contact your local sales representative to obtain a copy of the *StorageTek T10000 Tape Drive Fibre Channel Interface Reference Manual*.

StorageTek Maximum Capacity

Maximum Capacity allows the use of tape capacity that is normally reserved to ensure tape-to-tape copy operations succeed. The *StorageTek T10000 Tape Drive Fibre Channel Interface Reference Manual* describes how to use this feature. This feature can increase the capacity of the T10000C to as much as 5.5 TB or the T10000D to as much as 8.5 TB.

Maximum capacity is off by default (enabled through VOP), available on FC drives and VSM, and no application support is needed.

StorageTek File Sync Accelerator

The StorageTek File Sync Accelerator (FSA) allows applications to reduce or eliminate back hitches that are normally caused by writing a tape mark or other sync operations.

The FSA feature is on by default (disabled through VOP), available on FC and FICON drives, and no application support is needed. Refer to the white paper *Maximizing Tape Performance with the StorageTek T10000 Tape Drives*.

StorageTek Tape Application Accelerator

The StorageTek Tape Application Accelerator (TAA) increases write throughput to tape despite an application inserting sync commands into the data stream. When TAA is enabled, the drive converts tape marks to buffered tape marks and syncs to NO-OPs. Data writes to tape faster because buffered tape marks and NO-OPs do not cause the tape drive to empty the contents of its buffer to tape and back hitch.

The TAA feature is off by default (enabled through VOP), available on FC and FICON drives, and no application support is needed.

Before enabling the TAA configuration, the user must determine how their particular application uses write tape marks and syncs. The terms File Sync and Write Tape Mark are defined differently in FICON and Fibre Channel environments.

- When TAA is enabled in a FICON drive, File Syncs are always converted to NO-OPs and tape marks are always treated as buffered tape marks.

Note: This feature must only be used in environments that handle deferred errors. When this feature is enabled, sending a tape mark does not ensure the data has successfully been written to the tape. A deferred error may be reported when buffered data is written to tape after command completion. In a FICON *only* environment, duplex write operations should use this feature.

- TAA operation in a Fibre Channel environment depends on whether the user's storage application automatically restarts a job following a power failure or reset condition.
 - For applications designed to restart a job following a failure event, Oracle highly recommends configuring TAA to convert File Syncs to NO-OPs but *without* treating tape marks as buffered tape marks.
 - For applications that are not designed to restart a job following a failure event, Oracle highly recommends duplexing output-type jobs to two tape drives.

Refer to the white paper *Maximizing Tape Performance with the StorageTek T10000 Tape Drives*.

StorageTek Search Accelerator

The StorageTek Search Accelerator (SSA) allows FICON applications to search for a string up to 1024 bytes in length. This feature can enhance Mainframe HSM Audit performance in FICON environments.

The SSA feature is available on FC and FICON drives, and application support is required (an API is available). Refer to the white paper *Using Oracle's StorageTek Search Accelerator*.

StorageTek MIR Assisted Search

The StorageTek T10000C and T10000D tape drives support access to the Media Information Region (MIR) of the cartridge. This command is implemented using a SCSI Read Buffer command similar to the StorageTek T10000B tape drive. MIR data provides location information for tape records and can be used by an application to order which records are read first from tape. The T10000 MAS N677 engineering document describes this feature.

The MAS feature is available for the FC tape drive, and application support is required.

StorageTek In-Drive Reclaim Accelerator

Note: This feature is supported with standard cartridges only.

The StorageTek In-Drive Reclaim Accelerator (IDR) allows applications to reclaim space on the tape without rewriting the entire tape. The application must save and manage a partition map to get the full benefit of this feature. The StorageTek Virtual Storage Manager (VSM) supports this feature with the StorageTek T10000B, T10000C, and T10000D drives. For more detailed information about this feature, contact your local sales representative to obtain a copy of the *ALP User's Guide*.

The IDR feature is available on FC and FICON drives, and application support is required (an API is available).

StorageTek Tape Tiering Accelerator

Note: This feature is supported with standard cartridges only.

The StorageTek T10000C and T10000D drives have the ability to partition tape. These partitions can be organized by an application to control where file sets are located on tape. Data sets located near the beginning of tape will have faster access characteristics than data written near the end-of-tape (EOT).

- Applications now have the ability to manage the location of data on the tape.
- StorageTek Tape Tiering Accelerator (TTA) allows partitions to be read only.
- TTA allows up to:
 - 480 logical volumes on a cartridge written by a T10000C drive
 - 600 logical volumes on a cartridge written by a T10000D drive

The TTA feature is available on FC and FICON drives, and application support is required (an API is available).

For more detailed information about this feature, contact your local sales representative to obtain a copy of the *ALP User's Guide*.

Specifications

This section lists the performance, physical, and environmental specifications for the T10000 tape drive.

Tape Drive Performance Specifications

Capacity and Performance:

- Capacity, native
 - T10000A: 500 gigabytes (5×10^{11} bytes)
 - T10000B: 1 terabyte (1×10^{12} bytes)
 - T10000C: 5 terabytes (5×10^{12} bytes)
 - T10000D: 8 terabytes (8×10^{12} bytes)

Note: When Max Capacity is enabled the capacity can be increased up to 5.5 terabytes for the T10000C or 8.5 terabytes for the T10000D.

- Capacity (Sport Cartridge)
 - T10000A: 120 gigabytes
 - T10000B: 240 gigabytes
 - T10000C: 1 terabyte (1×10^{12} bytes)
 - T10000D: 1.6 terabyte (1.6×10^{12} bytes)
- Data buffer size:
 - T10000A or B: 256 megabytes
 - T10000C or D: 2 gigabytes
- Tape speeds:
 - Read and Write
 - T10000A:** 2.0 and 4.95 meters/second
 - T10000B:**
 - * T10000B-formatted cartridges: 2.0 and 3.74 meters per second
 - * T10000A-formatted cartridges: 2.0 and 4.95 meters per second (read only)
 - T10000C:** 5.62 meters per second
 - T10000D:** 4.75 meters per second (additional speeds of 4.25, 3.75, 3.25, and 2.75 meters/second)
 - File search and locates:
 - T10000A or B: 8 to 12 meters per second (varying speeds)
 - T10000C or D: 10 to 13 meters per second (varying speeds)
 - High speed rewind:
 - T10000A or B: 8 to 12 meters per second (varying speeds)
 - T10000C or D: 10 to 13 meters per second (varying speeds)

Interfaces:

- Types:
 - T10000A: 2 gigabit or 4 gigabit Fibre Channel (FC) and FICON
 - T10000B/C: 4 gigabit FC and FICON
 - T10000D: 16 gigabit FC and 16 gigabit FICON

Note: The 16 gigabit tape drive interfaces are compatible with 8 gigabit and 4 gigabit environments.

- Data rate:
 - T10000A or B: 120 megabytes per second

- T10000C: 252 megabytes per second (native sustained) and 240 megabytes/second (full file host)
- T10000D: 252 megabytes per second (native sustained)

Note: The actual data rate achieved is a function of the complete system, including the processor, disk data rate, data block size, data compressibility, interface, I/O attachments, storage area network (SAN), and software used. Although the drives are capable of a 252 megabytes/second (T10000C or D) or 120 megabytes/second (T10000A or B) native data rate, other components may limit the actual effective data rate.

Access times:

- Tape load and thread to ready
 - T10000A or B: 16.5 seconds
 - T10000C: 13.1 seconds
 - T10000D: 13 seconds
- File access, average (includes loading)
 - T10000A or B: 62.5 seconds (30.5 seconds for Sport Cartridge)
 - T10000C: 70.1 seconds (30.6 seconds for Sport Cartridge)
 - T10000D: 62.5 seconds (28 seconds for Sport Cartridge)
- Rewind (maximum):
 - T10000A or B: 91 seconds (23 seconds for Sport Cartridge)
 - T10000C: 115 seconds (32.5 seconds for Sport Cartridge)
 - T10000D: 97 seconds (26 seconds for Sport Cartridge)

Unload time: 23 seconds

Reliability:

- Head life: 5 years
- Uncorrected bit error rate: 1×10^{-19}

Physical Specifications

- Width:
 - 146 millimeters (5.77 inches) drive [includes cartridge bezel]
 - 483 millimeters (19 inches) rackmount tray
- Depth:
 - Drive:
 - 433 millimeters (17 inches) T10000A or B [includes cartridge bezel and D connector]
 - 427 millimeters (16.8 inches) T10000C [includes cartridge bezel and SFP modules]
 - Rackmount tray: 640 millimeters (25 inches)

- Height: 81 millimeters (3.2 inches)
- Weight:
 - Rackmount tray: 18.6 kilograms (41 pounds) single drive or 25 kilograms (55 pounds) dual drive
 - SL8500 tray: 9.4 kilograms (20.75 pounds)
 - SL3000 tray: 10.1 kilograms (22.25 pounds)
 - L-series (T10000A or B only): 8.3 kilograms (18.3 pounds)
 - 9310 (T10000A only): 6.9 kilograms (15.25 pounds)

Shipping Dimensions

SL3000 library tray:

- Height: 340 millimeters (13.4 inches)
- Width: 310 millimeters (12.2 inches)
- Length: 660 millimeters (26 inches)
- Weight: 10.5 kilograms (23.1 pounds)

SL8500 library tray:

- Height: 310 millimeters (12 inches)
- Width: 330 millimeters (13 inches)
- Length: 1.02 meter (40 inches)
- Weight: 18 kilograms (26 pounds)

Environmental Requirements

Note: Although the T10000 tape drive will function over the full list of ranges as specified below, you will achieve *optimal reliability* by maintaining the environment within the recommended ranges.

Temperature:

- **Operating:**

Optimal: 22°C (72°F)

Recommended: 20° – 25°C (68° – 77°F)

Ranges: 15.6° to 32.2°C (60° to 90°F) - dry bulb

- **Shipping:**

Optimal: 22°C (72°F)

Recommended: 20° – 25°C (68° – 77°F)

Ranges: -40° to 60°C (-40° to 140°F)

- **Storing:**

Optimal: 22°C (72°F)

Recommended: 20° – 25°C (68° – 77°F)

Ranges: 10° to 40°C (50° to 104°F) - dry bulb

Relative Humidity:

■ **Operating:**

Optimal: 45%

Recommended: 40% – 50%

Ranges: 20% to 80%

■ **Shipping:**

Optimal: 45%

Recommended: 40% – 50%

Ranges: 10% to 95%

■ **Storing:**

Optimal: 45%

Recommended: 40% – 50%

Ranges: 10% to 95%

Wet bulb (non-condensing):

■ Operating: 29°C (84°F)

■ Shipping: 35°C (95°F)

■ Storing: 35°C (95°F)

Tip: Industry best practices recommend computer rooms maintain a relative humidity of 40% to 50% for best performance.

Airborne Contamination

Tape drives and media are subject to damage from airborne particulates. The operating environment must adhere to the requirements listed in [Appendix B, "Controlling Contaminants"](#).

Configurations

The T10000 tape drives are available in configurations for StorageTek libraries or for rack mounting.

Library Configurations

A drive tray for a library configuration contains a single tape drive (see [Figure 1-1](#)). The drive tray is designed specifically for the library model. Conversion kits are available to adapt from one library model to a different library model (see "[Library Tray Kits](#)").

- SL3000: Holds from 200 to 6,000 cartridges with up to 56 T10000 tape drives.
- SL8500: A single SL8500 holds up to 10,000 cartridges with up to 64 T10000 tape drives. A 10 module library complex can hold up to 100,000 cartridges and up to 640 tape drives.
- L-series:

Note: The T1000C and T1000D tape drive are not supported in the L-series libraries.

- L180: Holds from 84 to 174 cartridges with up to six T1000A or T1000B tape drives.
 - L700: Holds from 216 to 678 cartridges with up to 12 T1000A or T1000B tape drives.
 - L700e: Holds from 300 to 1,344 cartridges with up to 24 T1000A or T1000B tape drives when two libraries are connected with a pass-thru port (PTP).
 - L1400M: Holds from 300 to 1,344 cartridges with up to 24 T1000A or T1000B tape drives.
- 9310:

Note: The T1000B, T1000C, and T1000D tape drives are not supported in the 9310 library.

A single 9310 holds up to 6,000 cartridges with up to 80 T1000A tape drives on four drive walls with the 9741E drive cabinet.

See "[Library Installation Requirements](#)" for more information.

Rack Mount Configurations

A drive tray for a rack contains either one or two tape drives (see [Figure 1–1](#)).

A rack can hold either six manual-mount drives with *one* drive per tray (chassis), 12 manual-mount drives with *two* drives per tray, or a combination of *both* single-drive and dual-drive trays.

See "[Rack Mount Configurations](#)" for more information.

Virtual Operator Panel

The virtual operator panel allows operators and service representatives to monitor and perform tasks on a single tape drive. You can install the VOP software on a variety of platforms, such as Windows, Solaris, and Linux.

The VOP uses a standard RJ-45 Ethernet connection to the tape drive.

You can use VOP to perform drive operations, retrieve error information, and configure the tape drive.

[Figure 1–4](#) shows an example of the virtual operator panel (VOP) graphical user interface (GUI) for the T10000 tape drive with the Drive Operations menu expanded.

Figure 1–4 Virtual Operator Panel

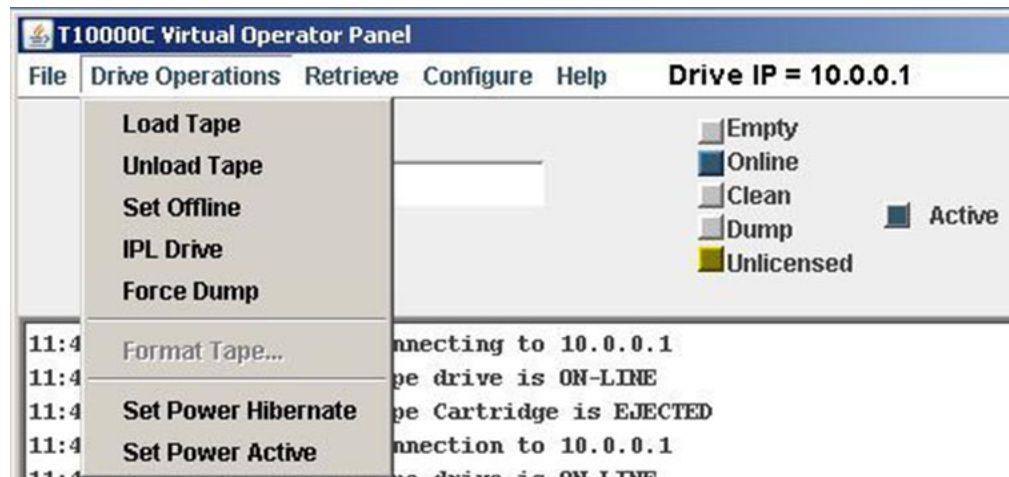

Tape Cartridge

The T10000 supports the following types of cartridges:

- StorageTek T10000 cartridge (T10000A or B drive):
 - Data: 500 gigabytes T10000A or 1 terabyte T10000B
 - Data, sport: 120 gigabytes T10000A or 240 gigabytes T10000B
 - VolSafe, capacity: 500 gigabytes T10000A or 1 terabyte T10000B
 - VolSafe, sport: 120 gigabytes T10000A or 240 gigabytes T10000B
 - Cleaning cartridge: 50 uses (CT or CL cartridge)
- StorageTek T10000 T2 cartridge (T10000C and T10000D tape drives):
 - Data, standard: 5 terabytes (T10000C) or 8 terabytes (T10000D)
 - Data, sport: 1 terabyte (T10000C) or 1.6 terabytes (T10000D)
 - VolSafe, sport: 1 terabyte (T10000C) or 1.6 terabytes (T10000D)
 - VolSafe, capacity: up to 5.5 terabytes (T10000C) or 8.5 terabytes (T10000D)
 - Cleaning cartridge: 50 uses (CL cartridge)

Included inside the cartridge is a Radio Frequency Identification (RFID) memory chip that stores information about the cartridge and its performance over time. A module in the drive retrieves information from the chip.

All cartridges include a cartridge label area, a cartridge door, and a write-protect switch. Figure 1–5 shows an example of the T10000 tape cartridge.

See [Appendix A, "Tape Cartridges"](#) for more information about the tape cartridges, examples of labels, and specifications.

Caution: *Servo track damage: Bulk-erase destroys pre-recorded servo tracks. Do not degauss StorageTek T10000 or T10000 T2 tape cartridges.*

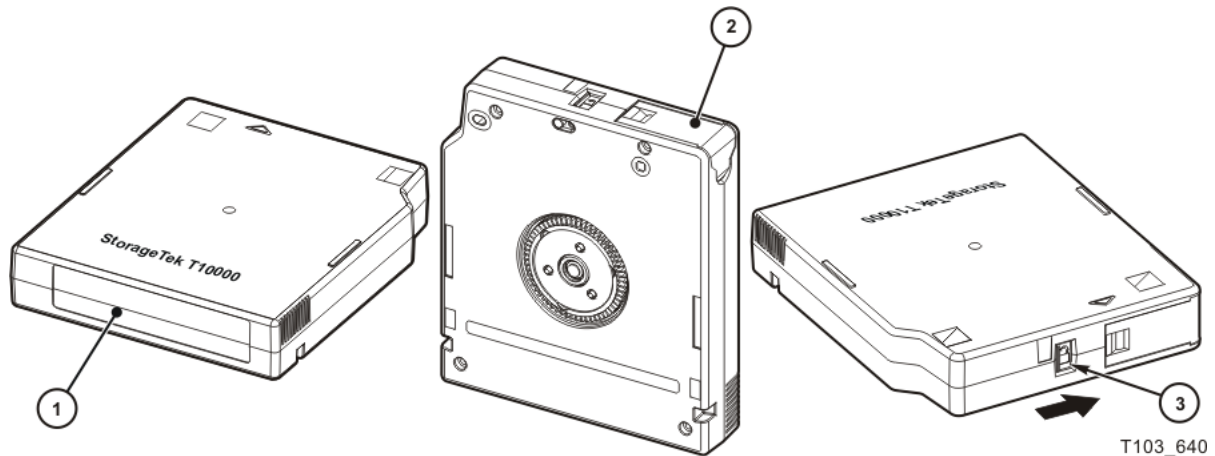
Figure 1–5 Tape Cartridge Introduction**Illustration Legend:**

- 1 - Label area
- 2 - Door (black = data, red = sport, white = cleaning, and yellow = VolSafe)
- 3 - Write protect switch

Cables and Connectors

The T10000 tape drive supports fiber-optic based host interfaces:

- Fibre Channel for open systems platforms
- FICON (IBM's Fibre Connection) for enterprise mainframes

Note: The drive supports 256 concurrent hosts.

The interfaces conform to standards:

- American National Standards Institute (ANSI)
- International Organization for Standardization (ISO)
- InterNational Committee for Information Technology Standards (INCITS)

Specific types of cables and connectors are used with the T10000 tape drive.

Cable Guidelines

Single mode:

- Transmission: Laser
- Core and cladding: 9/125
- Color: Yellow
- Interface speed: 1, 2, 4, or 16 gigabits per second
- Distance:
 - T10000A, B, or C: 2 m to 10 kilometers
 - T10000D: up to 20 kilometers with the T10000D long wavelength SFP

Multimode:

- Transmission: LED
 - Core and cladding: 50/125

Important: Multimode cables with a measurement of 62.5/125 are *not recommended*. If you encounter them at existing installations, replace them with multimode 50/125 interface cables.
 - OM2 cable:
 - Color: Orange
 - Interface speed and distance:
 - 1 gigabit per second, up to 500 meters
 - 2 gigabits per second, up to 300 meters
 - 4 gigabits per second, up to 150 meters
 - 8 gigabits per second, up to 50 meters
 - 16 gigabits per second, up to 35 meters
-
-
- Note:** Exceeding these lengths could introduce problems, exceed error thresholds, and inhibit performance.
-
-
- OM4 cable
 - Color: Aqua
 - Interface speed and distance:
 - 4 gigabits per second, up to 400 meters
 - 8 gigabits per second, up to 200 meters
 - 16 gigabits per second, up to 130 meters

LC Connectors

LC connectors are used on fiber-optic cables and connect to the SFP modules in the tape drive interface ports and with network switches and directors.

Connectivity

The T10000 tape drive supports connection of both ports in accordance with ANSI Fibre Channel specifications.

Refer to the InterNational Committee on Information Technology Standards (INCITS) documents:

SCSI Primary Commands -3 Section 5.6
Fibre Channel Protocol -3

Note: The drive can support two hosts if they honor the Reserve/Release or the Persistent Reserve/Release specifications.

A T10000 tape drive should not be connected to the same host port with another tape drive or disk subsystem. The stress on the HBA, due to the bandwidth needs, creates unacceptable error recovery issues between both solutions.

Interop Tool

The Interop Tool is a web-based tool designed with connectivity information on all supported products (StorageTek branded or third-party branded). The configurations listed on this website reflect the most current information reported from various sources, including internal testing labs and our technology partners.

The Interop Tool can be accessed by Oracle employees.

Network Considerations

Planning is foremost when building a storage area network (SAN). Here is a list of items to consider when designing and connecting to a network:

- Create a logical plan for connections.
- Use dual Fabrics and dual HBAs to attach servers.
- Separate vendor's and device types into zones.
- Use WWN zoning for flexibility and use Port zoning for security.
- Keep zone configurations the same on every switch in a single Fabric.
- Use unique names for aliases in a zone.
- Standardize vendors for switches and HBAs when possible.
- Use the same firmware and driver levels on similar devices.
- Use at least two links between switches for redundancy.
- Leave room for growth.
- Document and label everything; provide drawings when possible.
- Keep in mind that while large Fabrics are possible; it is best to limit the size and use multiple smaller Fabrics to reduce errors and confusion.

Binding

Some operating systems do not guarantee that devices will always have the same target ID or path after a restart. This can cause problems for applications that expect tape drives to have the same ID as before the restart.

Binding is a method that matches the World Wide Name (WWN) of a component (such as a tape drive, port, switch, or fabric) to a specific target ID in a Fibre Channel network. This capability is useful in environments that share devices.

Types of binding:

- Persistent binding secures an individual drive to an HBA.
- Port binding secures individual ports on a switch to a node.
- Switch binding secures individual switches in a fabric.
- Fabric binding secures the entire fabric in a network.

Zoning

Zoning is a method of grouping different ports and devices that connect to a switch or director. Zones:

- Enable or disable communications between devices and systems.
- Limit the access to confidential data on specific systems (security).
- Control the number of data paths between systems and devices.
- Separate different operating system types (such as Windows and UNIX).
- Restrict traffic from being re-directed.

Note: Zoning is highly recommended in mixed environments with different devices connected to the same switch or director.

Comparisons

Some comparisons between the T10000 tape drives and other drive-types, including StorageTek T-series and Linear Tape-Open are as follows:

Capacity:

- T10000 drives:
 - T10000A: 500 gigabytes standard cartridge and 120 gigabytes sport cartridge
 - T10000B: 1 terabytes standard cartridge and 240 gigabytes sport cartridge
 - T10000C: 5 terabytes standard cartridge and 1 terabyte sport cartridge
 - T10000D: 8 terabytes standard cartridge and 1.6 terabyte sport cartridge

Note: When Max Capacity is enabled the capacity can be increased up to 5.5 terabytes for the T10000C or 8.5 terabytes for the T10000D.

- T9940B: 200 gigabytes
- LTO6: 2.5 terabytes

Data rate:

- T10000 drives:

Note: The actual data rate achieved is a function of the complete system, including the processor, disk data rate, data block size, data compressibility, interface, I/O attachments, storage area network (SAN), and software used. Although the drives are capable of a 252 megabytes/second (T10000C or D) or 120 megabytes/second (T10000A or B) native data rate, other components may limit the actual effective data rate.

- T10000A or T10000B: 125 megabytes per second
- T10000C: native sustained of 252 megabytes per second and full file host of 240 megabytes per second
- T10000D: native sustained of 252 megabytes per second

- T9940B: 30 megabytes per second
- LTO6: 160 megabytes per second

Access time (average):

- T10000 drives:
 - T10000A or B: 62.5 seconds standard cartridge and 30.5 seconds sport cartridge
 - T10000C: 70.1 seconds standard cartridge and 30.6 seconds sport cartridge
 - T10000D: 62.5 seconds standard cartridge and 28 seconds sport cartridge
- T9940B: 59 seconds
- LTO6: 50 seconds

Read and write speed:

- T10000 drives:
 - T10000A 2.0 or 4.95 meters per second
 - T10000B: 2.0 or 3.74 meters per second
 - T10000C: 5.62 meters per second
 - T10000D: 4.75 meters per second (additional speeds of 4.25, 3.75, 3.23, and 2.75 meters per second)
- T9940B: 3.4 meters per second
- LTO6: 7.4 meters per second

Rewind time (maximum):

- T10000 drives:
 - T10000A or B: 91 seconds (23 seconds for the Sport Cartridge)
 - T10000C: 115 seconds (32.5 seconds for the Sport Cartridge)
 - T10000D: 97 seconds (26 seconds for the Sport Cartridge)
- T9940B: 90 seconds
- LTO6: 98 seconds

Media length (recordable):

- StorageTek T10000 tape cartridge: 855 meters (2805 feet)
- StorageTek T10000 T2 tape cartridge: 1107 meters (3632 feet)
- T9940 tape cartridge: 650 meters (2133 feet)
- LTO6 Ultrium data cartridge: 846 meters (2776 feet)

Tracks:

- T10000 drives:
 - T10000A: 768
 - T10000B: 1152
 - T10000C: 3584
 - T10000D: 4608
- T9940B: 576

- LTO6: 2176

Site Preparation

Use this chapter to prepare for the installation by reviewing:

- "Management Software Requirements"
- "Library Installation Requirements"
- "Rack Mount Configurations"
- "Tape Drive Configuration and Planning"
- "Cables and Connectors"
- "StorageTek Tape Analytics"
- "Remote Support"

Management Software Requirements

The minimum level software requirements to support the T10000 drives are listed.

Note: You should strive to use the latest available software level.

T10000D

- ACSLS 8.2
- ELS
 - 7.2: PTF L1H17HF plus VTCS PTF L1H17TC
 - 7.1: PTF L1H17HE plus VTCS PTF L1H17TB
 - 7.0: PTF L1H17HD plus VTCS PTF L1H17TA
- SAM-QFS 5.3-01 patch
- VTSS
 - VSM6: 6.0.7.xx
 - VSM4/5: D 02.18
- VM Client
 - 7.2: initial release
 - 7.1: PTF SM00019

T10000C

- ACSLS:

8.0 (Solaris/SPARC and Solaris/x86)

7.3.1 (Solaris/SPARC, Solaris/x86, and AIX))

- NCS/VTCS version 6.2
PTF L1A00SW - SMC
PTF L1C10AZ - MVS/CSC 6.2
PTF L1H15T2 - MVS/HSC
PTF L1H15T1 - VM/HSC
- VTCS:
PTFs: (non-StorageTek Tape Tiering Accelerator [TTA] and non-StorageTek In-Drive Reclaim [IDR])
 - L1H15I6
 - L1H15I4
- ELS version 7.0
PTFs:
 - VTCS 7.0: L1H15I7 (non-StorageTek Tape Tiering Accelerator [TTA] and non-StorageTek In-Drive Reclaim [IDR])
 - MVS/CSC: L1C10B0
 - HSC/SMC: L1H15T3
- ELS version 7.1
T10000C and T10000 T2 cleaning cartridge (CC) support
VTCS support is non-StorageTek Tape Tiering Accelerator [TTA]
PTF:
 - L1H15UX T10000 T2 cleaning cartridge (CL) support
- VTSS (VSM4/5)
D02.11.xxx (non-StorageTek Tape Tiering Accelerator [TTA] and non-StorageTek In-Drive Reclaim [IDR])
D02.12.xxx (StorageTek Tape Tiering Accelerator [TTA] and StorageTek In-Drive Reclaim [IDR])

T10000B

- ACSLS - 7.2 (PUT0702)
- NCS/VTCS:
NCS/VTCS 6.2
 - PTF L1H14EP - HSC 6.2 (MVS)
 - PTF L1A00OT - SMC 6.2
 - PTF L1H142C - VTCS 6.2
 - PTF L1C109N - MVS/CSC 6.2
 - PTF L1H14EO - HSC 6.2 (VM)
- NCS/VTCS 6.1

- PTF L1H14EN - HSC 6.1 (MVS)
- PTF L1A00OS - SMC 6.1
- PTF L1H1429 - VTCS 6.1
- PTF L1C109M - MVS/CSC 6.1
- PTF L1H14EM - HSC 6.1 (VM)
- VTSS
 - VSM4/5 (D02.03.00.00 and later releases)

T10000A

- ACSLS
 - 7.1 - PUT0601 or PUT0502
- NCS/VTCS:
 - NCS/VTCS 6.0:
 - PTF L1H12E3 - HSC 6.0 (MVS)
 - PTF L1A00D7 - SMC 6.0
 - PTF L1H12E1 - VTCS 6.0
 - PTF L1S1054 - LibraryStation 6.0
 - PTF L1C1074 - MVS/CSC 6.0
 - PTF L1H12E2 - HSC 6.0 (VM)
 - NCS/VTCS 6.1:
 - PTF L1H12FC - HSC 6.1 (MVS)
 - PTF L1A00DV - SMC 6.1
 - PTF L1H12FA - VTCS 6.1
 - PTF L1S1059 - LibraryStation 6.1
 - PTF L1C1075 - MVS/CSC 6.1
 - PTF L1H12FB - HSC 6.1 (VM)

Library Installation Requirements

If you are installing the T10000 tape drive in one of the StorageTek tape libraries, review the following information and requirements for that library:

- "StorageTek SL3000 Modular Library System"
- "StorageTek SL8500 Modular Library System"
- "L-Series Libraries"

Note: A library-specific T10000 drive tray and appropriate library firmware is required to support the T10000 drive.

StorageTek SL3000 Modular Library System

The SL3000 holds 200 to 6,000 cartridges and up to 56 tape drives.

The library microcode level (minimum) needed to support the drive model:

- T10000D:
FRS_4.0 (SLC 6.00) or later

Note: TS cartridge is not supported.

FRS_3.62 does not support 3590 mode

Note: The 4.0 SLC port speed display for 16 Gb link shows as invalid. This is a display issue only.

- T10000C: FRS_2.81, or later
FRS_2.81 supports the CL cleaning cartridge (T10000C), but an expired cleaning cartridge is not reported to HLI hosts. Compat 22 does not support the T10000C hibernation function.
- T10000A or B: FRS_2.00

The StorageTek Tape Library Site Survey Form is available to Oracle employees from the StorageTek Tape Storage section of the Systems website.

Note: The survey form is located in the *FAQs and Tools* link for a specific library model (Tape Libraries tab).

StorageTek SL8500 Modular Library System

The SL8500 library holds 1,448 to 10,000 cartridges and up to 64 tape drives. A *library complex* consists of two or more libraries and can store up to 100,000 tape cartridges with up to 640 tape drives.

The library microcode level (minimum) needed to support the drive model:

- T10000D
FRS_8.30 or later (full drive support)
FRS_8.07 (SLC 6.50) or later

Note: TS cartridge is not supported.

FRS_8.05

FRS_7.70 (does not support 3590 mode)

- T10000C: FRS_6.02, or later

Note: FRS_6.02 supports the CL cleaning cartridge (T10000C), but an expired cleaning cartridge is not reported to HLI hosts. Compat 22 does not support the T10000C hibernation function.

- T10000B: FRS_3.98 or later

- T10000A: FRS_3.00 or later

The StorageTek Tape Library Site Survey Form is available to Oracle employees from the StorageTek Tape Storage section of the Systems website.

Note: The survey form is located in the *FAQs and Tools* link for a specific library model (Tape Libraries tab).

L-Series Libraries

Note: The T10000C and T10000D tape drives are not supported by the L-Series libraries.

- The L180 library holds 84 to 174 cartridges and up to six T10000A/B drives.
- The L700 library holds 216 to 678 cartridges while L700e holds 300 to 1,344 cartridges. The library holds up to **12** T10000A/B drives (single frame) or up to **24** T10000 drives when two libraries are connected with a pass-thru port (PTP).
- The L1400M single frame library holds up to 678 cartridges while the L1400M dual frame holds up to 1,344 cartridges. The library holds up to **12** T10000A/B drives (single frame) or up to **24** T10000 drives (dual frame).

The library microcode level (minimum) is 3.11.02 or later (T10000A) or 3.17.03 or later (T10000B).

Rack Mount Configurations

A 42U rack can hold up to six drive trays (see [Figure 2-1](#)). A drive tray can have either one or two tape drives. The drive trays are installed between rack units U11 and U34.

Each drive tray provides a control panel with switches and indicators, a cartridge load and unload slot, and a 10-character display panel. The top operator panel works with the left hand drive, and the bottom panel works with the drive on the right.

Drive tray input power requirements for a drive tray with two tape drives are:

- T10000D: 240 watts (approximately 819 Btu/hr)
- T10000C: 229 watts (approximately 782 Btu/hr)
- T10000A/B: 172 watts (approximately 587 Btu/hr)

Note: The acceptable spacing between the cabinet front vertical rail and rear vertical rail is from 701 millimeters (28 inches) to 730 millimeters (28.75 inches). The horizontal separation between the front or rear set of vertical rails must be at least 438 millimeters (17.25 inches) but not greater than 442 millimeters (17.4 inches).

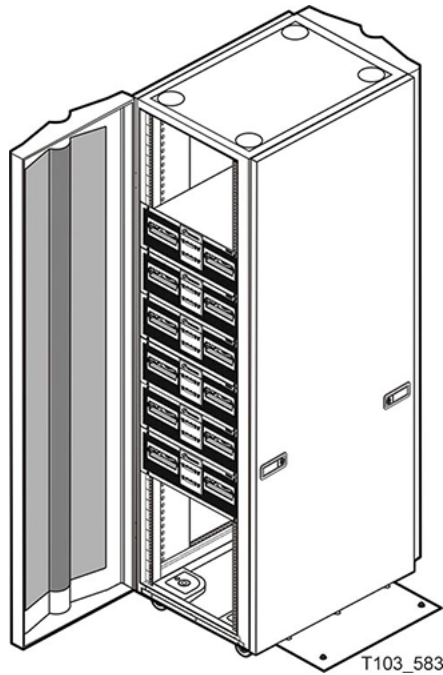
Figure 2–1 Rack Mount Configuration

Tape Drive Configuration and Planning

The following section provides information to help plan the configuration for the tape drives. Drives arrive with configuration parameters that were set during the manufacturing process. You can use Virtual Operator Panel (VOP) to change a parameter.

Drive Parameters

The Configure Drive Parameters dialog box lists the current settings for each parameter and provides options or lists for other parameters. The dialog box has a series of tabs (such as Encrypt, Fibre, and Network). The list of configuration parameters can vary by drive interface and drive model.

The following list provides an overview of typical parameters for a drive with a Fibre Channel interface:

- Drive emulation option (varies by drive interface)
- Data compression (No, Yes, or Off)
- Data security erase (No or Yes)
- Standard label protection (No or Yes)
- Tape completion display (No or Yes)
- Language of system messages (English is the default but four other options are available)
- Interface port attributes such as defining a hard address or speed negotiation.

Note: The SL3000 and SL8500 libraries do not support Arbitrated Loop addresses.

- T1000C/D additional parameters:

- File Sync Accelerator
- Tape App Accelerator
- Power tab in the dialog box

Used to enable or disable auto hibernation and specify the auto hibernation delay time.

Use the Encrypt tab to enable tape drive encryption and the Network tab to set various parameters (IPv4 address, IPv6 address, and network node name).

Figure 2–2 provides a *representative* example of the Fibre tab in the Sys Admin version of VOP. Actual parameter definitions and parameter values can differ by drive model (refer to the VOP documentation for additional details).

Figure 2–2 VOP Configuration Settings (T1000C Tape Drive)

Parameter Definition	Parameter Value	Update
FICON emulation option:	3592-FICON	<input type="checkbox"/>
Data compression:	<input type="radio"/> No <input checked="" type="radio"/> Yes <input type="radio"/> Off	<input type="checkbox"/>
Data security erase:	<input type="radio"/> No <input checked="" type="radio"/> Yes	<input type="checkbox"/>
Standard Label protect:	<input checked="" type="radio"/> No <input type="radio"/> Yes	<input type="checkbox"/>
Library address:	ff	<input type="checkbox"/>
Tape completion display:	<input checked="" type="radio"/> No <input type="radio"/> Yes	<input type="checkbox"/>
Language:	English	<input type="checkbox"/>
World Wide Name(default):	50:01:04:f0:00:b3:9d:7e	<input type="checkbox"/>
Pa hrd asgn phys addr:	<input checked="" type="radio"/> No <input type="radio"/> Yes	<input type="checkbox"/>
Pa arbtrtd loop addr:	0	<input type="checkbox"/>
Pa soft asgn phys addr:	<input type="radio"/> Hi <input checked="" type="radio"/> Lo	<input type="checkbox"/>
Pa max rcv size:	<input checked="" type="radio"/> 2112 <input type="radio"/> 2048	<input type="checkbox"/>
Pa WWN override(default):	50:01:04:f0:00:b3:9d:7f	<input type="checkbox"/>
Pa speed negotiation:	Auto	<input type="checkbox"/>
Pb hrd asgn phys addr:	<input checked="" type="radio"/> No <input type="radio"/> Yes	<input type="checkbox"/>
Pb arbtrtd loop addr:	1	<input type="checkbox"/>
Pb soft asgn phys addr:	<input type="radio"/> Hi <input checked="" type="radio"/> Lo	<input type="checkbox"/>
Pb max rcv size:	<input checked="" type="radio"/> 2112 <input type="radio"/> 2048	<input type="checkbox"/>
Pb WWN override(default):	50:01:04:f0:00:b3:9d:80	<input type="checkbox"/>
Pb speed negotiation:	Auto	<input type="checkbox"/>
FICON max block size:	<input checked="" type="radio"/> 256KB <input type="radio"/> 2MB	<input type="checkbox"/>
File Sync Accelerator:	<input type="radio"/> Enabled <input checked="" type="radio"/> Disabled	<input type="checkbox"/>
Tape App Accelerator:	<input checked="" type="radio"/> Disabled <input type="radio"/> Enabled	<input type="checkbox"/>

Buttons: Load Drive Config, Commit, Cancel

Network Selections

The network tab provides parameters to set a:

- Static IP address (IPv4 and IPv6)
- Gateway address
- Subnet mask

Figure 2–3 provides a *representative* example of the Network tab for VOP. Refer to the VOP documentation for additional details.

Figure 2–3 Network Configuration

Parameter Definition	Parameter Value	Update
IPv4 address:	010.000.000.001	<input type="checkbox"/>
Subnet mask:	255.255.255.000	<input type="checkbox"/>
Gateway:	255.255.255.000	<input type="checkbox"/>
IPv6 static address:		<input type="checkbox"/>
Network node name:	T10000-001000540	<input type="checkbox"/>

Buttons: Load Drive Config, Commit, Cancel

Initial Drive Settings

There are no default settings as such for the T10000. Before being shipped, manufacturing erases the configuration sector after internal testing.

The following registers are set to these initial settings:

- IP address: 10.0.0.1
- IP Mask: 255.255.255.0
- IP Gateway: 255.255.255.255
- IP NodeName: T10000-<last 9 digits of Serial Number>

FICON Configurations

Fibre Connection (FICON) is a proprietary IBM channel. The benefits of a FICON channel include greater bandwidth, more logical paths, more devices per channel, and greater distance.

- A total of 512 logical paths are possible. On dual-port tape drives, the 512 total logical paths can be unevenly split between Port A and Port B.
- Approximately *six* T-Series FICON tape drives, concurrently reading and writing large (64 KB) blocks, can be attached to a single channel.

Note: An 8Gb FICON channel supports attachment of up to three T10000D drives.

- Approximately 16 T-Series FICON tape drives, concurrently reading and writing small (16 KB) blocks, can be attached to a single channel.

Hardware Configuration Definition

After FICON drives are installed, you need to set the Hardware Configuration Definition (HCD) for each drive.

The *StorageTek T10000 Tape Drive FICON HCD Configuration* white paper is available to Oracle employees from the SE Support Tools section of the Systems website.

Port Configuration

Using standard Fibre Channel infrastructure and cables, the T10000 FICON tape drive configuration options are: 1) single-port (short or long wave), 2) dual-port (short or long wave), or 3) mixed-port (one short wave and one long wave port).

- Use multimode cables when connecting to short wave ports.
- Use single mode cables when connecting to long wave ports.

Notes:

1. Maximum total non-repeated channel distance for a short wave 850 nm small form-factor pluggable (SFP) using a 50 micron multimode cable on a 100 MB/s channel is 500 m (1640 feet).
2. Maximum total non-repeated channel distance for an 850 nm SFP using a 50 micron multimode cable on a 200 MB/s channel is 300 m (984 feet).
3. Maximum total non-repeated channel distance for an 850 nm SFP using a 50 micron multimode cable on a 400 MB/s channel is 150 m (492 feet).
4. The T10000D uses a long wavelength SFP rated at 20km (12.4 miles). An 8Gb FICON channel supports attachment of up to three T10000D drives.

5. Maximum total non-repeated channel distance for a T10000A, B, or C long wave 1310 nm SFP using a single mode cable is 10 kilometers (6.21 miles).
6. Single mode cable maximum distances can be extended through an amplifier-repeater unit up to 20 kilometers (12.4 mi) for a 100 MB/s channel or to 12 kilometers (7.46 miles) for a 200 MB/s channel.

Cables and Connectors

What are the fiber optic cabling requirements? Here are some considerations to help determine what is needed:

- Are there existing fiber optic cables at the customer site?
 - Should you consider reusing these cables rather than installing new ones?
 - Are these cables the correct type to use?
 - Are the cable connectors the correct type to use?

If the customer is upgrading their system to support LC connectors and SFP modules, no other modifications are required.
- Is there a link distance constraint?
- Are kits or adapters (LC to SC) included in the cable plan for a storage area network?
- Are cascaded directors or inter-switch links (ISLs) being used to extend distances?

StorageTek Tape Analytics

StorageTek Tape Analytics (STA) is an intelligent monitoring application, available exclusively for StorageTek modular tape libraries (including SL3000 and SL8500). It simplifies tape storage management and allows the customer to make informed decisions about future tape storage investments based on the current health of the tape storage environment.

STA allows the customer to monitor globally dispersed libraries from a single, browser-based user interface. The customer can manage open systems and mainframe, mixed-media, and mixed-drive environments across multiple library platforms.

STA allows the customer to increase the utilization and performance of tape investments by performing detailed performance trending analyses. These analyses are based on a regularly updated database of library operations. STA captures and retains data from your tape library environment and uses this data to calculate the health status of your library resources (drives and media). STA aggregates data according to a variety of criteria and displays it in tabular and graphical formats, allowing you to quickly assess environment activity, health, and capacity.

Minimum T10000 code levels for STA:

- T10000A:
 - 1.44.110 (low quality data, TTI 5.10)
 - 1.46.109 (higher quality data, TTI 5.20)
 - RQ48.48.105 or greater (highest quality data, TTI 5.30)
- T10000B:
 - 1.44.210 (low quality data, TTI 5.10)
 - 1.46.209 (higher quality data, TTI 5.20)

- RQ48.48.205 or greater (highest quality data, TTI 5.30)
- T10000C:
 - 1.51.320 (higher quality data, TTI 5.20)
 - 1.53.316 or greater (highest quality data, TTI 5.30)
- T10000D:
 - 4.06.xxx (FC interface)
 - 4.07.xxx (FICON)

Refer to the STA documentation library for additional information regarding the STA product and the dedicated STA server. Select the **StorageTek Tape Analytics documentation** link at the following URL:

<https://docs.oracle.com/en/storage#sw>

Remote Support

Service representatives are available to assist you and the customer with hardware and software problem resolution. During the initial order and installation planning, make sure to inform the customer about local and remote support options.

The Service Delivery Platform (SDP) is a support enhancement solution providing problem resolution, analysis and trending, and improved diagnostic capabilities. The SDP consists of a smart appliance placed at the customer site that connects to StorageTek tape drives. The SDP collects device events and alerts support analysts, providing remote diagnosis and auto service requests (ASR). For additional information on ASR see:

<http://www.oracle.com/technetwork/systems/asr/overview/index.html>

Preparing for Drive Installation and Service

Site preparation is important to ensure that no aspects of the installation and implementation are overlooked and to promote an error-free installation. Considerations that you and the customer must make before the equipment arrives includes:

- Unpacking and acclimating the tape drives before installing them
- Providing enough space to route cables and work comfortably
- Disposing of the shipping cartons and packaging material

Personnel

Installing a T10000 tape drive requires *one* or *two qualified installers* depending on the attachment, the number of drives, and the configuration.

Use this chapter to help order tape drives, cables, and media. If you have answers to the following questions, the task of locating the pertinent part number becomes easier.

1. What host interface is used (Fibre Channel or FICON)?
2. Type of interface transceiver (short wavelength, long wavelength, or short range)?

Note: Long wavelength transceivers require single-mode (9-micron fiber) cables while short wavelength and short range transceivers require multimode cables.

3. Is the drive installed in a library or a rack?

Note: Transceivers in a rack drive must be the same type (all LW or all SW).

This chapter provides the following information:

- "Tape Drive Order Numbers"
- "Conversion Kits and Upgrades"
- "Ordering Media and Cartridge Labels"
- "Power Cords" and "Ethernet Cables"
- "Interface Cables"

Tape Drive Order Numbers

See the appropriate section for the desired tape drive:

- "T10000D Order Numbers"
- "T10000C Order Numbers"

T10000D Order Numbers

Note: All StorageTek T10000D tape drives are dual port and are shipped with an SFP installed in each port.

- Fibre Channel (FC) tape drives are shipped with two short wave SFPs.
- FICON tape drives are shipped with two long wave SFPs.

The factory-installed SFPs may be changed to long wave or short wave by ordering a port conversion kit.

Library mounted drives:

- SL3000 library:
 - 7105799 - 1 T10000D 16 Gb FC for StorageTek SL3000, short wave
 - 7105800 - 1 T10000D 16 Gb FICON for StorageTek SL3000, long wave
- SL8500 library:
 - 7105797 - 1 T10000D 16 Gb FC for StorageTek SL8500, short wave
 - 7105798 - 1 T10000D 16 Gb FICON for StorageTek SL8500, long wave

StorageTek T10000D Tape Drive Port Conversions:

- 7105809 - 16 Gb FC or FICON conversion kit from short wave *to long wave*
- 7105810 - 16 Gb FC or FICON conversion kit from long wave *to short wave*

Note: Tape drive port conversion kits include a single SFP and a single cable. To convert two ports, you must order two conversion kits.

Rack mount:

- 7105801 - 1 T10000D 16 Gb FC with rackmount, short wave
- 7105802 - 1 T10000D 16 Gb FICON with rackmount, long wave

Adding a Second Drive to a Rack Mount:

- 7105803 - 1 T10000D 16 Gb FC second drive for rackmount, short wave
- 7105804 - 1 T10000D 16 Gb FICON second drive for rackmount, long wave

T10000C Order Numbers

Note: All StorageTek T10000C tape drives are dual port and are shipped with an SFP installed in each port.

- Fibre Channel (FC) tape drives are shipped with two short wave SFPs.
- FICON tape drives are shipped with two long wave SFPs.

The factory-installed SFPs may be changed to long wave or short wave by ordering a port conversion kit.

T10000A, T10000B, or T10000C Tape Drive Port Conversions:

- XT10K-4GB-LW-Z-N - 4 Gb FC or FICON conversion kit from short wave *to long wave*
- XT10K-4GB-SW-Z-N - 4 Gb FC or FICON conversion kit from long wave *to short wave*

Note: Tape drive port conversion kits include a single SFP and a single cable. To convert two ports, you must order two conversion kits.

Encryption Order Number

Before activating the encryption feature, an activation permit must be purchased using the following order number.

T10K-EKEY-A-N - Encryption for StorageTek T10000 tape drives (activation permit for one tape drive)

An encryption activation permit is required before enabling encryption on a T10000-series tape drive (regardless of generation). This requirement applies for both types of encryption key management:

- Keys are managed by the application using the data path (DPKM).
- Keys are managed by the Oracle Key Manager (OKM) or Key Management System (KMS) using an Ethernet connection that resides outside the data path.

If a customer has previously purchased one T10K-EKEY-A-N for each of their prior generation T10000-series tape drives, they may continue to use those activation permits for enabling encryption in the next generation T10000-series tape drives as long as the total number of T10000-series drives with encryption *does not* exceed the total number of encryption activation permits the customer has purchased.

An encryption activation permit may be ordered concurrently with a new StorageTek T10000-series tape drive or after the tape drive has already been installed.

Notes: For T10000A, T10000B, and T10000C (code level below 1.57.308), the license key that is included with the activation permit must be used by Oracle *service* to activate encryption in the tape drive.

For T10000C (code level 1.57.308 or later) and T10000D, a license key is not required to activate encryption in the tape drive. However, an activation permit is still required before Oracle *service* can activate encryption in the tape drive.

Conversion Kits and Upgrades

Conversion kits or upgrade kits are available for installation at the customer's site. See:

- ["Drive Port Kits"](#)
- ["Library Tray Kits"](#)

Tip: When planning the network, make sure the SFP module supports the specific network type and configuration (HBAs, switches, wavelength, and cable types).

Drive Port Kits

- **Port conversions:**

16 Gigabit port: see "[T10000D Order Numbers](#)" for part numbers

4 Gigabit port: see "[T10000C Order Numbers](#)" for part numbers

2 Gigabit port:

- **X984/T10K-2GB-LW-N** - T9840/T10K 2 Gbit LW SFP, cable kit
- **X984/T10K-2GB-SW-N** - T9840/T10K 2 Gbit SW SFP, cable kit

Note: Tape drive port conversion kits include a single SFP and a single cable. To convert two ports, you must order two conversion kits.

- **Fibre Channel to FICON conversion:**

- **T10C-FC/FI-CKITZ** - T10000C or T10000D Fibre Channel to FICON conversion

Note: No part number is necessary for a FICON to Fibre Channel conversion.

Library Tray Kits

Note: A conversion kit is not available for converting a StorageTek T10000 series tape drive:

- From a StorageTek 9310, L5500, L1400, L700, L180, or 9740 to a StorageTek SL3000 or SL8500 configuration
 - From a rackmount configuration to a StorageTek SL3000 or SL8500 configuration
 - From a StorageTek SL3000 or SL8500 configuration to a rackmount configuration
-
-

- **T10000D:**

7110131

StorageTek T10000D drive tray conversion kit from StorageTek SL3000 to StorageTek SL8500

7110136

StorageTek T10000D drive tray conversion kit from StorageTek SL8500 to StorageTek SL3000

- **T10000A or B or C:**

7110130

StorageTek T10000A, T10000B, or T10000C drive tray conversion kit from StorageTek SL3000 to SL8500

7110135

StorageTek T10000A, T10000B, or T10000C drive tray conversion kit from StorageTek SL8500 to SL3000

Ordering Media and Cartridge Labels

Ordering tape cartridges is easy.

- Call **1.877.STK.TAPE** to order media from your local reseller or to obtain media pre-sales support.
- E-mail addresses for local support questions: **tapemediaorders_ww@oracle.com**

See either [Appendix A, "Tape Cartridges"](#) for additional information or the tape media area on the corporate website.

<http://www.oracle.com/us/products/servers-storage/storage/tape-storage/t1000-data-cartridges/overview/index.html>

Power Cords

The following list provides the power cord requirements for the rack mount drive trays.

- **PWRCORD10187018-Z**
StorageTek Cord Set, 3X1MM2, 250Volt/10Amps, BELGIUM, HOLLAND, FRANCE, GERMANY, SWEDEN, NORWAY, FINLAND, Female/IEC320, 2.5 Meter, RoHS-5
- **PWRCORD10187019-Z**
StorageTek Cord Set, 3X18AWG, 125Volt/10Amps, USA, CANADA, Female/C13, 7.5FT, RoHS-5
- **PWRCORD10187045-Z**
StorageTek Power Cord, IEC320,3,SVT,18AWG, RoHS-5

Ethernet Cables

The tape drive uses Ethernet cables for virtual operator panel and maintenance port connections. The following cables are available.

- **CABLE10187033-Z** - CAT5E, 8 feet, 24 AWG, shielded
- **CABLE10187034-Z** - CAT5E, 35 feet, 24 AWG, shielded
- **CABLE10187035-Z** - CAT5E, 50 inches, 24 AWG, shielded

Plenum rated cables:

- **CABLE10187039-Z** - CAT5E, 35 feet, 24AWG, shielded, plenum
- **CABLE10187040-Z** - CAT5E, 55 feet, 24AWG, shielded, plenum
- **CABLE10187041-Z** - CAT5E, 100 feet, 24AWG, shielded, plenum

Note: Always use shielded Ethernet cables to connect to a drive installed in a library.

Interface Cables

The following sections provide information about the different interface cables.

- ["Multimode Fiber-optic OM2 Cable Numbers"](#)
- ["Single Mode Fiber-optic Cable Numbers"](#)
- ["One Gigabit Fiber-optic Cable Numbers"](#)

When you order cables, keep in mind:

- **Riser cable** materials are not classified according to flammability.
- **Plenum cables** meet UL standards for flammability.

Multimode Fiber-optic OM4 Cable Numbers (16Gb)

The following multimode (50-micron) fiber-optic cables connect Fibre Channel devices and FICON devices. These cables are aqua and have LC connectors.

Note: The tape drive supports LC connectors only.

OM4 cables support:

- 4 Gb/s transfer rate and a maximum channel length of 400 meters
- 8 Gb/s transfer rate and a maximum channel length of 200 meters
- 16 Gb/s transfer rate and a maximum channel length of 130 meters

Cables with LC connectors on both ends:

- **7106951:** OM4, 50 meters, 50/125, duplex, riser, LC-LC connectors (for factory installation)
- **7106952:** OM4, 50 meters, 50/125, duplex, riser, LC-LC connectors
- **7106953:** OM4, 50 meters, 50/125, duplex, plenum, LC-LC connectors (for factory installation)
- **7106954:** OM4, 50 meters, 50/125, duplex, plenum, LC-LC connectors

Multimode Fiber-optic OM2 Cable Numbers

The following multimode (50-micron) fiber-optic cables connect Fibre Channel devices and FICON devices. These cables are orange with tan LC connectors.

Note: The tape drive supports LC connectors only.

OM2 cables support:

- 4 Gb/s transfer rate and a maximum channel length of 150 meters
- 8 Gb/s transfer rate and a maximum channel length of 50 meters
- 16 Gb/s transfer rate and a maximum channel length of 35 meters

Cables with LC connectors on both ends:

- CABLE10800310-Z-A LC-LC, 50/125/ duplex, riser, 10 meter, RoHS-5 (for factory installation)
- CABLE10800310-Z-N LC-LC, 50/125/ duplex, riser, 10 meter, RoHS-5
- CABLE10800340-Z-A LC-LC, 50/125/ duplex, riser, 3 meter, RoHS-5 (for factory installation)
- CABLE10800340-Z-N LC-LC, 50/125/ duplex, riser, 3 meter, RoHS-5
- CABLE10800341-Z-A LC-LC, 50/125/ duplex, riser, 5 meter, RoHS-5 (for factory installation)
- CABLE10800341-Z-N LC-LC, 50/125/ duplex, riser, 5 meter, RoHS-5
- CABLE10800313-Z-A LC-LC, 50/125/ duplex, plenum, 10 meter, RoHS-5 (for factory installation)
- CABLE10800313-Z-N LC-LC, 50/125/ duplex, plenum, 10 meter, RoHS-5

Cables with an LC connectors on one end and an SC connector on the other end:

- CABLE10800317-Z - LC-SC, 50/125/ duplex, riser, 10 meter, RoHS-5
- CABLE10800318-Z - LC-SC, 50/125/ duplex, riser, 50 meter, RoHS-5
- CABLE10800319-Z - LC-SC, 50/125/ duplex, riser, 100 meter, RoHS-5
- CABLE10800320-Z - LC-SC, 50/125/ duplex, plenum, 10 meter, RoHS-5
- CABLE10800321-Z - LC-SC, 50/125/ duplex, plenum, 50 meter, RoHS-5
- CABLE10800322-Z - LC-SC, 50/125/ duplex, plenum, 100 meter, RoHS-5

Single Mode Fiber-optic Cable Numbers

The following single mode (9-micron) fiber optic cables are used with FICON devices configured with a long wave SFP. The cables are yellow and have blue LC connectors.

Note: The tape drive only supports LC connectors.

Cables with LC connectors on both ends:

- CABLE10800302-Z-A - LC-LC, 9/125/ duplex, riser, 3 meter, RoHS-5
- CABLE10800330-Z-A - LC-LC, 9/125/ duplex, plenum, 10 meter, RoHS-5
- CABLE10800331-Z-A - LC-LC, 9/125/ duplex, riser, 10 meter, RoHS-5
- CABLE10800332-Z-A - LC-LC, 9/125/ duplex, plenum, 50 meter, RoHS-5
- CABLE10800333-Z-A - LC-LC, 9/125/ duplex, riser, 50 meter, RoHS-5

Cables with an LC connectors on one end and an SC connector on the other end:

- CABLE10800334-Z - LC-SC, 9/125/ duplex, plenum, 10 meter, RoHS-5
- CABLE10800335-Z - LC-SC, 9/125/ duplex, riser, 10 meter, RoHS-5
- CABLE10800336-Z - LC-SC, 9/125/ duplex, plenum, 50 meter, RoHS-5
- CABLE10800337-Z - LC-SC, 9/125/ duplex, riser, 50 meter, RoHS-5

One Gigabit Fiber-optic Cable Numbers

SC connectors are the standard for 1 Gbps Fibre Channel devices such as the T9840A Tape Drive. You might see these connectors when replacing a T9x40 tape drive with a T10000 tape drive. The cables are orange and have SC connectors at both ends.

Cables with SC connectors on both ends.

- **CABLE10800294-Z** - SC-SC, 50/125/ Duplex, Plenum, 10 Meter, RoHS-5
- **CABLE10800295-Z** - SC-SC, 50/125/ Duplex, Plenum, 50 Meter, RoHS-5
- **CABLE10800297-Z** - SC-SC, 50/125/ Duplex, Riser, 10 Meter, RoHS-5
- **CABLE10800298-Z** - SC-SC, 50/125/ Duplex, Riser, 50 Meter, RoHS-5

Tip: When using cables with SC connectors, you must have an SC to LC adapter for each drive port (see "[Cables and Connectors](#)").

Tape Cartridges

Tape cartridges are not shipped as part of the T10000 tape drive; you must order them separately. See "Ordering Media and Cartridge Labels" for more information.

This appendix lists and describes the tape cartridges used with the StorageTek T10000 tape drives.

Figure A-1 Tape Cartridge Types

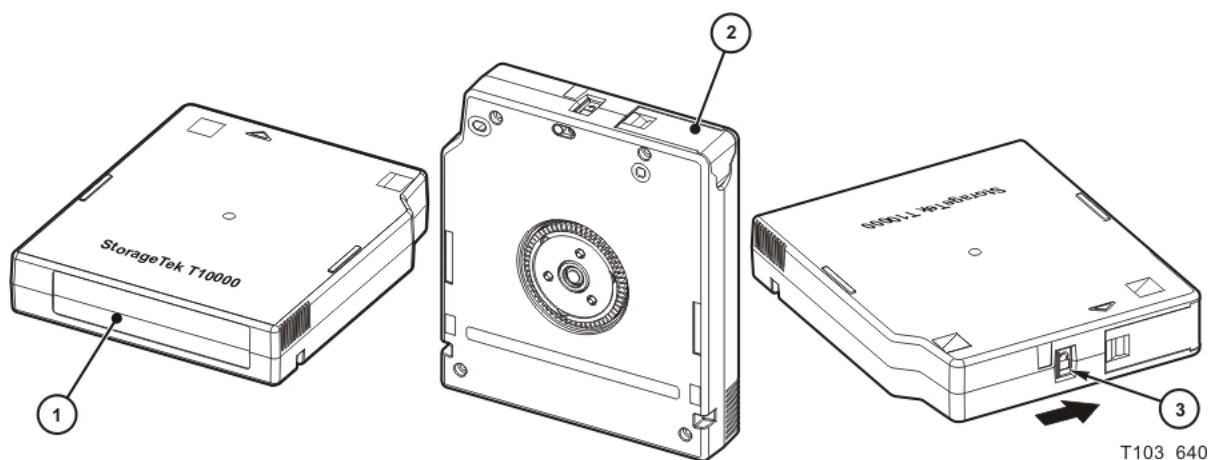

Illustration Legend:

- 1 - Label area
- 2 - Door (black = data, red = sport, white = cleaning, and yellow = VolSafe)
- 3 - Write protect switch

Disclaimer

Media Usage:

The storage media (tape cartridges) used in a library and tape drive can have a *significant* impact on the overall performance. The following is a policy regarding tape storage media:

- StorageTek-branded media has a warranty.
- The customer is responsible for all expenses and costs related to the repair or replacement of hardware damaged by non-StorageTek branded tape storage media.

Tape Cartridges

Optimized for high capacity, these cartridges use a single reel hub to maximize performance. The basic types of cartridges are:

- StorageTek T10000 (for the T10000A or B tape drives)
 - Standard
 - Sport
 - VolSafe (standard or sport)
 - Cleaning
- StorageTek T10000 T2 (for the T10000C or D tape drive)
 - Standard
 - Sport
 - VolSafe (standard or sport)
 - Cleaning

Standard Cartridges

Standard cartridges are the common read or write data cartridges. You can identify a standard cartridge by the *black* access door.

- Each *standard* data cartridge has a native capacity of:
 - StorageTek T10000: 500 GB (T10000A) or 1 TB (T10000B)
 - StorageTek T10000 T2: 5 TB (T10000C) or 8 TB (T10000D)

When Max Capacity is enabled, the capacity is 5.5 TB (T10000C) and 8.5 TB (T10000D).
- The StorageTek T10000 data cartridge specification supports 15,000 mounts. The StorageTek T10000 T2 data cartridge specification supports 25,000 mounts. The tape drive issues a warning message to the host when that number is exceeded.

Note: A mount is defined as the tape drive threading the tape onto the take-up reel and moving to the load point.

Sport Cartridges

Sport cartridges are a smaller version of the standard data cartridges. You can identify a sport cartridge by the *red* access door.

- Each *sport* data cartridge has a native capacity of:
 - StorageTek T10000: 120 GB (T10000A) or 240 GB (T10000B)
 - StorageTek T10000 T2: 1 TB (T10000C) or 1.6TB (T10000D)
- The StorageTek T10000 cartridge specification supports 15,000 mounts. The StorageTek T10000 T2 cartridge specification supports 25,000 mounts. The tape drive issues a warning message when that number is exceeded.

VolSafe Cartridges

VolSafe is an extension of the write protect function. Use VolSafe cartridges for write-once, read-many (WORM) applications. You cannot erase them without destroying the tape itself.

You can identify a VolSafe cartridge by the *yellow* access door.

- T10000 writes data to a VolSafe tape and then the drive can append a multitude of data sets onto the cartridge until the cartridge is full. In this way, VolSafe enables permanent archival of data on the tape without the possibility of data loss.
- VolSafe cartridges come in both standard and sport capacities.
- The StorageTek T10000 cartridge specification supports 15,000 mounts. The StorageTek T10000 T2 cartridge specification supports 25,000 mounts. The tape drive issues a warning message to the host when that number is exceeded.

VolSafe and WORM technologies are ideal for data storage, protection, and archive for a variety of applications such as the Sarbanes-Oxley Act.

The Sarbanes-Oxley Act was signed into law on July 30, 2002. This act introduced highly significant legislative changes to financial practice and corporate governance regulation. It introduced stringent new rules with the stated objective: “to protect investors by improving the accuracy and reliability of corporate disclosures made pursuant to the securities laws.”

Cleaning Cartridges

As the name implies, use a cleaning cartridge to clean a tape drive’s head and tape path.

Note: After the tape drive transports a predetermined length of tape or records a pre-determined number of errors, the drive automatically requests cleaning.

You can use a cleaning cartridge to clean a drive’s head up to the rated number of passes. An attempt to use a cleaning cartridge beyond that results in the tape drive rejecting the cartridge and posting an error message to the host.

You can identify these cartridges by a **white** leader access door.

Additional Cartridge Components

The T10000 tape cartridge has two additional components (“[Radio Frequency Identification](#)” and “[Media Information](#)”).

Radio Frequency Identification

The T10000 drive RFID circuitry reads the information in the RFID chip located in the cartridge when a tape is loaded. This information helps determine the type of tape and the state of the media information region (MIR).

- When the tape is loaded, the MIR is marked as invalid—or, subject to change—then updated with new information when it is unloaded.
- When the tape is released from the drive, the RFID chip is refreshed by the drive with the current MIR information, statistics, and status.

Media Information

The T10000 tape drives use information recorded on each tape cartridge to reduce access times and manage the useful life of the cartridge. This information is recorded in the cartridge's radio frequency identification (RFID) chip and at the beginning of tape in an area known as the media information region (MIR). The information stored in the RFID is a proper subset of the information stored in the MIR. The media information falls into two categories: statistical counters and data pointers.

Statistical Counters

Statistical counters reflect use of the cartridge and includes read or write activity, error activity, cumulative mounts, and other information about its use.

Data Pointers

The data pointer information is a directory (map) used to locate the customer (logical) data on the physical tape media. Because customer data is compressed and written in drive controlled blocks on the tape, a map is needed to efficiently locate the data after it is written. This map provides an index between customer data and the physical block on the tape media. After data is written, the drive accesses this map to optimize access to the customer data.

To locate or space to customer data, the logical object that identifies the block is translated to the physical location on the tape media, and the drive determines the quickest method to read the block. If the block is some physical distance from the current location, a calculation results in a high-speed locate to the block location and is followed by a normal speed read.

The existence of the media information is usually transparent to the customer unless it has a problem. This can occur if the information update fails during a dismount. The impact of invalid media information occurs in several areas. Because it enables high speed positioning, invalid media information forces all operations to a slow speed mode. This has no impact on a sequential read from the beginning of the tape. However, any operation using locate defaults to a sequential slow speed read to the requested block, which can result in longer processing time.

Note: Invalid media information might be suspected if you observe poor performance on a specific tape cartridge.

The following sections describe how media information is processed and some potential implications of problems with the information.

Normal Processing

Every time a tape cartridge is loaded, the media information is read from the tape media and saved in drive-resident memory. After being loaded in drive memory, a read-invalid state is written in the tape-resident RFID. The tape-resident media information is marked open, read-invalid because it does not reflect results of activity in the current mount session. All subsequent media information accesses during the current mount session are saved in the drive-resident information. If no writes are performed to the cartridge, the RFID remains in the read-invalid state meaning the MIR directory information is still completely valid. After a write takes place, the RFID is marked write-invalid meaning the MIR directory information on tape is invalid.

The T10000 drives use the drive-resident copy of the information to access customer data pointers for read-only functions. Statistical counters are continuously updated in the memory-resident information with any drive activity.

When the cartridge is unloaded as part of the unload routine, the drive-resident information is written to the cartridge's RFID and the tape-resident MIR with the closed state indication set.

Cross-Density Cartridge Processing

Whenever a data cartridge is loaded that was written in a data density format that is different from the one used when the drive writes, model-specific MIR processing occurs. In an environment with mixed T10000 drive models, a mandatory firmware update provides the capability for the lower-density drive to read the RFID of a higher-density drive.

For a standard data cartridge or Sport cartridge written by a *T10000A* drive, the:

- RFID can be read or updated by a T10000A, B, C, or D drive.
- MIR can be read by a T10000A, B, C, or D drive.
- MIR cannot be updated by a T10000B, C, or D drive.
- T10000A, B, C, or D drive counters can be updated after appropriate firmware updates are installed.
- Cartridge can be reclaimed by a T10000A or B drive.

For a standard data cartridge or Sport cartridge written by a *T10000B* drive, the:

- RFID can be:
 - Read by a T10000A, B, C, or D drive
 - Updated by a T10000B, C, or D drive
- MIR can be read by a T10000B, C, or D drive.
- MIR cannot be updated by a T10000A, C, or D drive.
- T10000B, C, or D drive counters can be updated after appropriate firmware updates are installed.
- Cartridge can be reclaimed by a T10000A or B drive.

Note: When the T10000A or B drive identifies the data cartridge as an unreadable-density data format, it displays 3215 on the Virtual Operator Panel (VOP) or the physical operator panel of the rack mount drive.

For a standard data cartridge or Sport cartridge written by a *T10000C* drive, the:

- RFID can be:
 - Read by a T10000A, B, C, or D drive
 - Updated by a T10000C or D drive
- MIR can be read by a T10000C or D drive.
- MIR cannot be updated by a T10000A or B drive.
- T10000C drive counters can be updated after appropriate firmware updates are installed.

- Cartridge can be reclaimed by a T10000C or D drive.

For a standard data cartridge or Sport cartridge written by a *T10000D* drive, the:

- RFID can be:
 - Read by a T10000A, B, C, or D drive
 - Updated by a T10000D drive
- MIR can be read by a T10000D drive.
- MIR cannot be updated by a T10000A, B, or C drive.
- T10000D drive counters can be updated after appropriate firmware updates are installed.
- Cartridge can be reclaimed by a T10000D drive.

Invalid Media Information Conditions

There are four media invalid conditions for the T10000 drives:

1. **Cartridge's RFID is unreadable.** The drive refuses to mount the cartridge (FSC of 403B). Return the cartridge to engineering to recover the customer data.
2. **Cartridge's RFID can be partially read.** The drive mounts the cartridge as read-only.
3. **RFID and MIR are out-of-sync.** None of the block information, coarse-grained in the RFID or fine-grained in the MIR, can be trusted. The cartridge is usable but the drive must rebuild the block information as it sequentially reads all of the data up to the desired customer data.

Note: This scenario can cause the drive to spend an hour or more rebuilding the block information, potentially causing the application running on the host to time out.

4. **MIR is corrupted or unreadable.** The fine-grained block location information on the cartridge cannot be used; the tape can be used with the coarse-grained block information on the RFID but with lower performance.

The drive posts a 4031 or 4032 informational FSC whenever it loads a cartridge with an *invalid* MIR. When a tape cartridge has an invalid media information, some action is required to correct it. Invalid media information can be corrected in several ways:

- Run the media correction utility through the VOP.
- The drive recovers the media information as it processes host commands, but very slowly.

Cartridge Environmental Requirements

Operating (tape path):

- Temperature: 10° to 45°C (50° to 113°F)
- Relative humidity (non-condensing): 20% to 80%
- Wet bulb (maximum): 26°C (79°F) with no condensation

Note: Conditioning time before use is 24 hours minimum but 72 hours preferred.

Storage (less than four weeks):

- Temperature: 10° to 32°C (50° to 90°F)
- Relative humidity (non-condensing): 5% to 80%
- Wet bulb (maximum): 26°C (79°F) with no condensation

Archival:

- Temperature: 15° to 26°C (59° to 79°F)
- Relative humidity (non-condensing): 15% to 50%
- Wet bulb (maximum): 26°C (79°F) with no condensation

Shipping (less than 10 days):

- Temperature: -23° to 49°C (-9° to 120°F)
- Relative humidity (non-condensing): 5% to 80%
- Wet bulb (maximum): 26°C (79°F) with no condensation

Note: The shipping environment must not exceed the limit of the storage environment, archive or non-archive, for longer than 10 days.

Tape Cartridge Specifications

Physical specifications:

- Height: 2.45 centimeters (0.964 inches)
- Length: 12.5 centimeters (4.92 inches)
- Depth (width): 10.9 centimeters (4.29 inches)
- Weight:
 - StorageTek T10000 cartridges (used with T10000A or B drives):
 - Standard data cartridge: 262.5 grams (9.26 ounces)
 - Sport data cartridge: 187 grams (6.60 ounces)
 - Cleaning cartridge: 196.3 grams (6.94 ounces)
 - StorageTek T10000 T2 cartridges (used with the T10000C or D drive):
 - Standard data cartridge: 270 grams (9.52 ounces)
 - Sport data cartridge: 191 grams (6.74 ounces)
 - Cleaning cartridge: 196.3 grams (6.94 ounces)
- Cartridge life:
 - StorageTek T10000 (used with T10000A or B drives): 15,000 mounts
 - StorageTek T10000 T2 (used with the T10000C or D drive): 25,000 mounts

Note: A mount is defined as the tape drive threading the tape onto the take-up reel and moving to the load point.

Tape media data:

- StorageTek T10000 cartridges (used with T10000A or B drives):
 - Standard data cartridge:
Capacity: 500 gigabytes (T10000A) or 1 terabyte (T10000B)
Media length: 917 meters (3,009 feet) [recordable 855 meters (2,805 feet)]
 - Sport data cartridge:
Capacity: 120 gigabytes (T10000A) or 240 gigabytes (T10000B)
Media length: 267 meters (876 feet) [recordable 205 meters (672.6 feet)]
 - Media thickness: 6.5 microns
 - Tracks:
T10000A: 768 (32 channels and 24 wraps)
T10000B: 1,152 (32 channels and 36 wraps)
- StorageTek T10000 T2 cartridges (used with the T10000C or D drive):
 - Standard data cartridge:
Capacity: 5 terabytes (T10000C) or 8 terabytes (T10000D)
Media length: 1,147 meters (3,763 feet) [recordable 1,107 meters (3,632 feet)]
 - Sport data cartridge:
Capacity: 1 terabyte
Media length: 334 meters (1,096 feet) [recordable 303 meters (994 feet)]
 - Media thickness: 5.2 microns
 - Tracks:
T10000C: 3,584 (32 channels and 112 wraps)
T10000D: 4,608 (32 channels and 144 wraps)

Caution: *Servo track damage:* Bulk-erase will destroy pre-recorded servo tracks. **Do not degauss T10000 tape cartridges.**

Labels

A cartridge label contains bar codes and visual characters. The visual characters do not need to line up with the bar code.

If you are using cartridges in rack mount tape drives, the cartridges may be labeled on the rear of the cartridge as desired.

If you are using the cartridges in a StorageTek library, see the *User's Guide* for that library regarding the label requirements.

The following specifications are pertinent to the label:

- AIM Uniform Symbology Specification USS-39

- ANSI MH10.8M-1993 ANSI Code 39 Barcode Specification

Standard and Sport Cartridge Labels

Data cartridge labels consist of eight characters and the associated barcode. These characters may consist of letters A–Z and numbers 0–9. No special characters (&,\$%#@# and so on) are allowed. The first six characters in the label are the customer volume ID or volume serial number (VOLSER). The last two characters are the media ID usually with a white background.

- T1 for the StorageTek T10000 cartridge
- TS for the StorageTek T10000 Sport cartridge
- T2 for StorageTek T10000 T2 cartridge
- TT for the StorageTek T10000 T2 Sport cartridge

Figure A–2 shows an example of a data cartridge label for the T10000A or B tape drive.

Figure A–2 Data Cartridge Label Example



Note: VolSafe cartridge labels are the same as data cartridge labels except that the background color of the media ID is usually yellow.

Diagnostic Cartridge Labels

The label must start with DG <space> so a library can recognize a diagnostic cartridge. The next three characters can be 000 to 999 while the last two characters indicate the media ID.

- T1 for a cartridge used with a T10000A or B tape drive
- T2 for a cartridge used with the T10000C or D tape drive

Figure A–3 shows an example of a diagnostic cartridge label for the T10000A or B tape drive.

Figure A–3 Diagnostic Cartridge Label Example



Cleaning Cartridge Labels

The cleaning label is “CLNxxx” where xxx is 00 to 99 to identify each individual cleaning tape. The library recognizes a cleaning cartridge by the label media identifier.

- CT for a T10000A or B drive
- CC for a cartridge used with a T10000C drive
- CL for a cartridge used with any model in the T10000 drive family

Figure A-4 shows an example of a cleaning cartridge label for the T10000A or B tape drive.

Figure A-4 Cleaning Cartridge Label Example



Tape Cartridge Care

T10000 cartridges require care to ensure proper operation and longevity.

New Cartridges

Unpack new tape cartridges in the area in which they will be used and allow them to acclimate for a period of at least 24 hours.

Handling

Caution: *Tape and cartridge damage:* Tape cartridges are easily damaged and you must handle them carefully. Follow these tape cartridge handling guidelines:

- Do not open a tape cartridge or touch the tape.
- Do not carry tape cartridges loosely in a container.
- Do not expose the tape or cartridge to direct sunlight or moisture.
- Do not expose a recorded tape cartridge to magnetic fields.
- Maintain clean operating, working, and storage environments.

Cleaning

Wipe all dust, dirt, and moisture from the cartridge case with a lint-free cloth.

Storing

Always store tape cartridges in an environment within the specified range of temperature and humidity. Follow these recommendations when you store cartridges:

- Do not take tape cartridges out of their protective wrapping until you need them. Use the tear string, not a sharp instrument, to remove wrapping.
- Store tape cartridges in a dirt-free environment that, if possible, duplicates the conditions of the data processing center.
- Before you use tape cartridges that have been in tape storage, acclimate them to the operating environment for at least 72 hours.

Shipping

Caution: *Tape and cartridge damage:* Tape cartridges are easily damaged. Proper packaging is required for shipping.

If you must ship cartridges, especially if they are for remote system backup, remote database duplication, or disaster recovery, follow these guidelines:

1. **Save the original factory packaging** when you receive new tape cartridges. Use this packaging material, or the equivalent, to package tape cartridges for shipment.
2. Wrap the tape cartridges in plastic to block moisture and contamination from entering the tape cartridges.
3. Pack the tape cartridges on edge, with the leader door on *top*. If you pack the tape cartridges flat, shipping vibration causes the clutches in the tape cartridges to disengage and slip.
4. Pad the tape cartridges on all six (6) sides.

If you are using factory packaging to ship fewer tape cartridges than the packaging originally held, or if you are using other packaging, fill voids in the packaging with foam padding equivalent to the original contents.

5. Label the outside of the shipping carton clearly with text or accepted symbols that indicate:
 - Do not expose to magnetic fields
 - Do not expose to moisture
 - Fragile
 - This end up

Controlling Contaminants

Control over contaminant levels in a computer room is extremely important because tape libraries, tape drives, and tape media are subject to damage from airborne particulates.

Environmental Contaminants

Most particles smaller than ten microns are not visible to the naked eye under most conditions, but these particles can be the most damaging. As a result, the operating environment must adhere to the following requirements:

- ISO 14644-1 Class 8 Environment
- The total mass of airborne particulates must be less than or equal to 200 micrograms per cubic meter
- Severity level G1 per ANSI/ISA 71.04-1985

Oracle currently requires the ISO 14644-1 standard approved in 1999, but will require any updated standards for ISO 14644-1 as they are approved by the ISO governing body. The ISO 14644-1 standard primarily focuses on the quantity and size of particulates and the proper measurement methodology, but does not address the overall mass of the particulates. As a result, the requirement for total mass limitations is also necessary as a computer room or data center could meet the ISO 14644-1 specification, but still damage equipment because of the specific type of particulates in the room. In addition, the ANSI/ISA 71.04-1985 specification addresses gaseous contaminations as some airborne chemicals are more hazardous. All three requirements are consistent with the requirements set by other major tape storage vendors.

Required Air Quality Levels

Particles, gasses and other contaminants may impact the sustained operations of computer hardware. Effects can range from intermittent interference to actual component failures. The computer room must be designed to achieve a high level of cleanliness. Airborne dusts, gasses and vapors must be maintained within defined limits to help minimize their potential impact on the hardware.

Airborne particulate levels must be maintained within the limits of *ISO 14644-1 Class 8 Environment*. This standard defines air quality classes for clean zones based on airborne particulate concentrations. This standard has an order of magnitude less particles than standard air in an office environment. Particles ten microns or smaller are harmful to most data processing hardware because they tend to exist in large numbers, and can easily circumvent many sensitive components' internal air filtration systems. When computer hardware is exposed to these submicron particles in great

numbers they endanger system reliability by posing a threat to moving parts, sensitive contacts and component corrosion.

Excessive concentrations of certain gasses can also accelerate corrosion and cause failure in electronic components. Gaseous contaminants are a particular concern in a computer room both because of the sensitivity of the hardware, and because a proper computer room environment is almost entirely recirculating. Any contaminant threat in the room is compounded by the cyclical nature of the airflow patterns. Levels of exposure that might not be concerning in a well ventilated site repeatedly attack the hardware in a room with recirculating air. The isolation that prevents exposure of the computer room environment to outside influences can also multiply any detrimental influences left unaddressed in the room.

Gasses that are particularly dangerous to electronic components include chlorine compounds, ammonia and its derivatives, oxides of sulfur and petrol hydrocarbons. In the absence of appropriate hardware exposure limits, health exposure limits must be used.

While the following sections will describe some best practices for maintaining an ISO 14644-1 Class 8 Environment in detail, there are some basic precautions that must be adhered to:

- Do not allow food or drink into the area
- Cardboard, wood, or packing materials must not be stored in the data center clean area
- Identify a separate area for unpacking new equipment from crates and boxes
- Do not allow construction or drilling in the data center without first isolating sensitive equipment and any air targeted specifically for the equipment. Construction generates a high level of particulates that exceed ISO 14644-1 Class 8 criteria in a localized area. Dry wall and gypsum are especially damaging to storage equipment.

Contaminant Properties and Sources

Contaminants in the room can take many forms, and can come from numerous sources. Any mechanical process in the room can produce dangerous contaminants or agitate settled contaminants. A particle must meet two basic criteria to be considered a contaminant:

- It must have the physical properties that could potentially cause damage to the hardware
- It must be able to migrate to areas where it can cause the physical damage

The only differences between a potential contaminant and an actual contaminant are time and location. Particulate matter is most likely to migrate to areas where it can do damage if it is airborne. For this reason, airborne particulate concentration is a useful measurement in determining the quality of the computer room environment.

Depending on local conditions, particles as big as 1,000 microns can become airborne, but their active life is very short, and they are arrested by most filtration devices. Submicron particulates are much more dangerous to sensitive computer hardware, because they remain airborne for a much longer time, and they are more apt to bypass filters.

Operator Activity

Human movement within the computer space is probably the single greatest source of contamination in an otherwise clean computer room. Normal movement can dislodge

tissue fragments, such as dander or hair, or fabric fibers from clothing. The opening and closing of drawers or hardware panels or any metal-on-metal activity can produce metal filings. Simply walking across the floor can agitate settled contamination making it airborne and potentially dangerous.

Hardware Movement

Hardware installation or reconfiguration involves a great deal of subfloor activity, and settled contaminants can very easily be disturbed, forcing them to become airborne in the supply air stream to the room's hardware. This is particularly dangerous if the subfloor deck is unsealed. Unsealed concrete sheds fine dust particles into the airstream, and is susceptible to efflorescence -- mineral salts brought to the surface of the deck through evaporation or hydrostatic pressure.

Outside Air

Inadequately filtered air from outside the controlled environment can introduce innumerable contaminants. Post-filtration contamination in duct work can be dislodged by air flow, and introduced into the hardware environment. This is particularly important in a downward-flow air conditioning system in which the sub-floor void is used as a supply air duct. If the structural deck is contaminated, or if the concrete slab is not sealed, fine particulate matter (such as concrete dust or efflorescence) can be carried directly to the room's hardware.

Stored Items

Storage and handling of unused hardware or supplies can also be a source of contamination. Corrugated cardboard boxes or wooden skids shed fibers when moved or handled. Stored items are not only contamination sources; their handling in the computer room controlled areas can agitate settled contamination already in the room.

Outside Influences

A negatively pressurized environment can allow contaminants from adjoining office areas or the exterior of the building to infiltrate the computer room environment through gaps in the doors or penetrations in the walls. Ammonia and phosphates are often associated with agricultural processes, and numerous chemical agents can be produced in manufacturing areas. If such industries are present near the data center facility, chemical filtration may be necessary. Potential impact from automobile emissions, dusts from local quarries or masonry fabrication facilities or sea mists should also be assessed if relevant.

Cleaning Activity

Inappropriate cleaning practices can also degrade the environment. Many chemicals used in normal or "office" cleaning applications can damage sensitive computer equipment. Potentially hazardous chemicals outlined in the "[Cleaning Procedures and Equipment](#)" section should be avoided. Out-gassing from these products or direct contact with hardware components can cause failure. Certain biocide treatments used in building air handlers are also inappropriate for use in computer rooms either because they contain chemicals, that can degrade components, or because they are not designed to be used in the airstream of a re-circulating air system. The use of push mops or inadequately filtered vacuums can also stimulate contamination.

It is essential that steps be taken to prevent air contaminants, such as metal particles, atmospheric dust, solvent vapors, corrosive gasses, soot, airborne fibers or salts from entering or being generated within the computer room environment. In the absence of

hardware exposure limits, use applicable human exposure limits from OSHA, NIOSH or the ACGIH.

Contaminant Effects

Destructive interactions between airborne particulate and electronic instrumentation can occur in numerous ways. The means of interference depends on the time and location of the critical incident, the physical properties of the contaminant and the environment in which the component is placed.

Physical Interference

Hard particles with a tensile strength at least 10% greater than that of the component material can remove material from the surface of the component by grinding action or embedding. Soft particles will not damage the surface of the component, but can collect in patches that can interfere with proper functioning. If these particles are tacky they can collect other particulate matter. Even very small particles can have an impact if they collect on a tacky surface, or agglomerate as the result of electrostatic charge build-up.

Corrosive Failure

Corrosive failure or contact intermittence due to the intrinsic composition of the particles or due to absorption of water vapor and gaseous contaminants by the particles can also cause failures. The chemical composition of the contaminant can be very important. Salts, for instance, can increase their size by absorbing water vapor from the air (nucleating). If a mineral salts deposit exists in a sensitive location, and the environment is sufficiently moist, it can grow to a size where it can physically interfere with a mechanism, or can cause damage by forming salt solutions.

Shorts

Conductive pathways can arise through the accumulation of particles on circuit boards or other components. Many types of particulate are not inherently conductive, but can absorb significant quantities of water in high-moisture environments. Problems caused by electrically conductive particles can range from intermittent malfunctioning to actual damage to components and operational failures.

Thermal Failure

Premature clogging of filtered devices will cause a restriction in air flow that could induce internal overheating and head crashes. Heavy layers of accumulated dust on hardware components can also form an insulative layer that can lead to heat-related failures.

Room Conditions

All surfaces within the controlled zone of the data center should be maintained at a high level of cleanliness. All surfaces should be periodically cleaned by trained professionals on a regular basis, as outlined in the "[Cleaning Procedures and Equipment](#)" section. Particular attention should be paid to the areas beneath the hardware, and the access floor grid. Contaminants near the air intakes of the hardware can more easily be transferred to areas where they can do damage. Particulate accumulations on the access floor grid can be forced airborne when floor tiles are lifted to gain access to the sub-floor.

The subfloor void in a downward-flow air conditioning system acts as the supply air plenum. This area is pressurized by the air conditioners, and the conditioned air is

then introduced into the hardware spaces through perforated floor panels. Thus, all air traveling from the air conditioners to the hardware must first pass through the subfloor void. Inappropriate conditions in the supply air plenum can have a dramatic effect on conditions in the hardware areas.

The subfloor void in a data center is often viewed solely as a convenient place to run cables and pipes. It is important to remember that this is also a duct, and that conditions below the false floor must be maintained at a high level of cleanliness. Contaminant sources can include degrading building materials, operator activity or infiltration from outside the controlled zone. Often particulate deposits are formed where cables or other subfloor items form air dams that allow particulate to settle and accumulate. When these items are moved, the particulate is re-introduced into the supply airstream, where it can be carried directly to hardware.

Damaged or inappropriately protected building materials are often sources of subfloor contamination. Unprotected concrete, masonry block, plaster or gypsum wall-board will deteriorate over time, shedding fine particulate into the air. Corrosion on post-filtration air conditioner surfaces or subfloor items can also be a concern. The subfloor void must be thoroughly and appropriately decontaminated on a regular basis to address these contaminants. Use vacuums equipped with High Efficiency Particulate Air (HEPA) filtration only in any decontamination procedure. Inadequately filtered vacuums will not arrest fine particles, passing them through the unit at high speeds, and forcing them airborne.

Unsealed concrete, masonry or other similar materials are subject to continued degradation. The sealants and hardeners normally used during construction are often designed to protect the deck against heavy traffic, or to prepare the deck for the application of flooring materials, and are not meant for the interior surfaces of a supply air plenum. While regular decontaminations will help address loose particulate, the surfaces will still be subject to deterioration over time, or as subfloor activity causes wear. Ideally all of the subfloor surfaces will be appropriately sealed at the time of construction. If this is not the case, special precautions will be necessary to address the surfaces in an on-line room.

It is extremely important that only appropriate materials and methodology are used in the encapsulation process. Inappropriate sealants or procedures can actually degrade the conditions they are meant to improve, impacting hardware operations and reliability. The following precautions should be taken when encapsulating the supply air plenum in an on-line room:

- Manually apply the encapsulant. Spray applications are totally inappropriate in an on-line data center. The spraying process forces the sealant airborne in the supply airstream, and is more likely to encapsulate cables to the deck.
- Use a pigmented encapsulant. The pigmentation makes the encapsulant visible in application, ensuring complete coverage, and helps in identifying areas that are damaged or exposed over time.
- It must have a high flexibility and low porosity to effectively cover the irregular textures of the subject area, and to minimize moisture migration and water damage.
- The encapsulant must not out-gas any harmful contaminants. Many encapsulants commonly used in industry are highly ammoniated or contain other chemicals that can be harmful to hardware. It is very unlikely that this out-gassing could cause immediate, catastrophic failure, but these chemicals will often contribute to corrosion of contacts, heads or other components.

Effectively encapsulating a subfloor deck in an on-line computer room is a very sensitive and difficult task, but it can be conducted safely if appropriate procedures

and materials are used. Avoid using the ceiling void as an open supply or return for the building air system. This area is typically very dirty and difficult to clean. Often the structural surfaces are coated with fibrous fire-proofing, and the ceiling tiles and insulation are also subject to shedding. Even before filtration, this is an unnecessary exposure that can adversely affect environmental conditions in the room. It is also important that the ceiling void does not become pressurized, as this will force dirty air into the computer room. Columns or cable chases with penetrations in both the subfloor and ceiling void can lead to ceiling void pressurization.

Exposure Points

All potential exposure points in the data center should be addressed to minimize potential influences from outside the controlled zone. Positive pressurization of the computer rooms will help limit contaminant infiltration, but it is also important to minimize any breaches in the room perimeter. To ensure the environment is maintained correctly, the following should be considered:

- Make sure all doors should fit snugly in their frames.
- Use gaskets and sweeps to address any gaps.
- Avoid using automatic doors in areas where they can be accidentally triggered. An alternate means of control would be to remotely locate a door trigger so that personnel pushing carts can open the doors easily. In highly sensitive areas, or where the data center is exposed to undesirable conditions, it may be advisable to design and install personnel traps. Double sets of doors with a buffer between can help limit direct exposure to outside conditions.
- Seal all penetrations between the data center and adjacent areas.
- Avoid sharing a computer room ceiling or subfloor plenum with loosely controlled adjacent areas.

Filtration

Filtration is an effective means of addressing airborne particulate in a controlled environment. It is important that all air handlers serving the data center are adequately filtered to ensure appropriate conditions are maintained within the room. In-room process cooling is the recommended method of controlling the room environment. The in-room process coolers re-circulate room air. Air from the hardware areas is passed through the units where it is filtered and cooled, and then introduced into the subfloor plenum. The plenum is pressurized, and the conditioned air is forced into the room, through perforated tiles, which then travels back to the air conditioner for reconditioning. The airflow patterns and design associated with a typical computer room air handler have a much higher rate of air change than typical comfort cooling air conditioners so air is filtered much more often than in an office environment. Proper filtration can capture a great deal of particulates. The filters installed in the in-room, re-circulating air conditioners should have a minimum efficiency of 40% (Atmospheric Dust-Spot Efficiency, ASHRAE Standard 52.1). Low-grade pre-filters should be installed to help prolong the life of the more expensive primary filters.

Any air being introduced into the computer room controlled zone, for ventilation or positive pressurization, should first pass through high efficiency filtration. Ideally, air from sources outside the building should be filtered using High Efficiency Particulate Air (HEPA) filtration rated at 99.97% efficiency (DOP Efficiency MILSTD-282) or greater. The expensive high efficiency filters should be protected by multiple layers of pre-filters that are changed on a more frequent basis. Low-grade pre-filters, 20% ASHRAE atmospheric dust-spot efficiency, should be the primary line of defense. The

next filter bank should consist of pleated or bag type filters with efficiencies between 60% and 80% ASHRAE atmospheric dust-spot efficiency.

ASHRAE 52-76 Dust spot efficiency Percent	Fractional Efficiencies Percent		
	3.0 micron	1.0 micron	0.3 micron
25-30	80	20	<5
60-65	93	50	20
80-85	99	90	50
90	>99	92	60
DOP 95	--	>99	95

Low efficiency filters are almost totally ineffective at removing sub-micron particulates from the air. It is also important that the filters used are properly sized for the air handlers. Gaps around the filter panels can allow air to bypass the filter as it passes through the air conditioner. Any gaps or openings should be filled using appropriate materials, such as stainless steel panels or custom filter assemblies.

Positive Pressurization and Ventilation

A designed introduction of air from outside the computer room system will be necessary to accommodate positive pressurization and ventilation requirements. The data center should be designed to achieve positive pressurization in relation to more loosely controlled surrounding areas. Positive pressurization of the more sensitive areas is an effective means of controlling contaminant infiltration through any minor breaches in the room perimeter. Positive pressure systems are designed to apply outward air forces to doorways and other access points within the data processing center to minimize contaminant infiltration of the computer room. Only a minimal amount of air should be introduced into the controlled environment. In data centers with multiple rooms, the most sensitive areas should be the most highly pressurized. It is, however, extremely important that the air being used to positively pressurize the room does not adversely affect the environmental conditions in the room. It is essential that any air introduction from outside the computer room is adequately filtered and conditioned to ensure that it is within acceptable parameters. These parameters can be looser than the goal conditions for the room since the air introduction should be minimal. A precise determination of acceptable limits should be based on the amount of air being introduced and the potential impact on the environment of the data center.

Because a closed-loop, re-circulating air conditioning system is used in most data centers, it will be necessary to introduce a minimal amount of air to meet the ventilation requirements of the room occupants. Data center areas normally have a very low human population density; thus the air required for ventilation will be minimal. In most cases, the air needed to achieve positive pressurization will likely exceed that needed to accommodate the room occupants. Normally, outside air quantities of less than 5% make-up air should be sufficient (ASHRAE Handbook: Applications, Chapter 17). A volume of 15 CFM outside air per occupant or workstation should sufficiently accommodate the ventilation needs of the room.

Cleaning Procedures and Equipment

Even a perfectly designed data center will require continued maintenance. Data centers containing design flaws or compromises may require extensive efforts to maintain conditions within desired limits. Hardware performance is an important factor contributing to the need for a high level of cleanliness in the data center.

Operator awareness is another consideration. Maintaining a fairly high level of cleanliness will raise the level of occupant awareness about special requirements and restrictions while in the data center. Occupants or visitors to the data center will hold the controlled environment in high regard and are more likely to act appropriately. Any environment that is maintained to a fairly high level of cleanliness and is kept in a neat and well organized fashion will also command respect from the room’s inhabitants and visitors. When potential clients visit the room they will interpret the overall appearance of the room as a reflection of an overall commitment to excellence and quality. An effective cleaning schedule must consist of specially designed short-term and long-term actions. These can be summarized as follows:

Frequency	Task
Daily Actions	Rubbish removal
Weekly Actions	Access floor maintenance (vacuum and damp mop)
Quarterly Actions	Hardware decontamination
	Room surface decontamination
Biennial Actions	Subfloor void decontamination
	Air conditioner decontamination (as necessary)

Daily Tasks

This statement of work focuses on the removal of each day’s discarded trash and rubbish from the room. In addition, daily floor vacuuming may be required in Print Rooms or rooms with a considerable amount of operator activity.

Weekly Tasks

This statement of work focuses on the maintenance of the access floor system. During the week, the access floor becomes soiled with dust accumulations and blemishes. The entire access floor should be vacuumed and damp mopped. All vacuums used in the data center, for any purpose, should be equipped with High Efficiency Particulate Air (HEPA) filtration. Inadequately filtered equipment cannot arrest smaller particles, but rather simply agitates them, degrading the environment they were meant to improve. It is also important that mop-heads and dust wipes are of appropriate non-shedding designs.

Cleaning solutions used within the data center must not pose a threat to the hardware. Solutions that could potentially damage hardware include products that are:

- Ammoniated
- Chlorine-based
- Phosphate-based
- Bleach enriched
- Petro-chemical based
- Floor strippers or re-conditioners.

It is also important that the recommended concentrations are used, as even an appropriate agent in an inappropriate concentration can be potentially damaging. The solution should be maintained in good condition throughout the project, and excessive applications should be avoided.

Quarterly Tasks

The quarterly statement of work involves a much more detailed and comprehensive decontamination schedule and should only be conducted by experienced computer room contamination-control professionals. These actions should be performed three to four times per year, based on the levels of activity and contamination present. All room surfaces should be thoroughly decontaminated including cupboards, ledges, racks, shelves and support equipment. High ledges and light fixtures and generally accessible areas should be treated or vacuumed as appropriate. Vertical surfaces including windows, glass partitions, doors, and so on should be thoroughly treated. Special dust cloths that are impregnated with a particle absorbent material are to be used in the surface decontamination process. Do not use generic dust rags or fabric cloths to perform these activities. Do not use any chemicals, waxes or solvents during these activities.

Settled contamination should be removed from all exterior hardware surfaces including horizontal and vertical surfaces. The unit's air inlet and outlet grilles should be treated as well. Do not wipe the unit's control surfaces as these areas can be decontaminated by the use of lightly compressed air. Special care should also be taken when cleaning keyboards and life-safety controls. Use specially treated dust wipes to treat all hardware surfaces. Monitors should be treated with optical cleansers and static-free cloths. Do not use Electro-Static Discharge (ESD) dissipative chemicals on the computer hardware, since these agents are caustic and harmful to most sensitive hardware. The computer hardware is sufficiently designed to permit electrostatic dissipation thus no further treatments are required. After all of the hardware and room surfaces have been thoroughly decontaminated, the access floor should be HEPA vacuumed and damp mopped as detailed in the Weekly Actions.

Biennial Tasks

The subfloor void should be decontaminated every 18 months to 24 months based on the conditions of the plenum surfaces and the degree of contaminant accumulation. Over the course of the year, the subfloor void undergoes a considerable amount of activity that creates new contamination accumulations. Although the weekly above floor cleaning activities will greatly reduce the subfloor dust accumulations, a certain amount of surface dirt will migrate into the subfloor void. It is important to maintain the subfloor to a high degree of cleanliness since this area acts as the hardware's supply air plenum. It is best to perform the subfloor decontamination treatment in a short time frame to reduce cross contamination. The personnel performing this operation should be fully trained to assess cable connectivity and priority. Each exposed area of the subfloor void should be individually inspected and assessed for possible cable handling and movement. All twist-in and plug-in connections should be checked and fully engaged before cable movement. All subfloor activities must be conducted with proper consideration for air distribution and floor loading. In an effort to maintain access floor integrity and proper psychrometric conditions, the number of floor tiles removed from the floor system should be carefully managed. In most cases, each work crew should have no more than 24 square feet (six tiles) of open access flooring at any one time. The access floor's supporting grid system should also be thoroughly decontaminated, first by vacuuming the loose debris and then by damp-sponging the accumulated residue. Rubber gaskets, if present, as the metal framework that makes up the grid system should be removed from the grid work and cleaned with a damp sponge as well. Any unusual conditions, such as damaged floor suspension, floor tiles, cables and surfaces, within the floor void should be noted and reported.

Activity and Processes

Isolation of the data center is an integral factor in maintaining appropriate conditions. All unnecessary activity should be avoided in the data center, and access should be limited to necessary personnel only. Periodic activity, such as tours, should be limited, and traffic should be restricted to away from the hardware to avoid accidental contact. All personnel working in the room, including temporary employees and janitorial personnel, should be trained in the most basic sensitivities of the hardware to avoid unnecessary exposure. The controlled areas of the data center should be thoroughly isolated from contaminant producing activities. Ideally, print rooms, check sorting rooms, command centers or other areas with high levels of mechanical or human activity should have no direct exposure to the data center. Paths to and from these areas should not necessitate traffic through the main data center areas.

Glossary

This glossary defines terms and abbreviations related to the T10000 tape drive.

Some of the definitions are taken from other glossaries. The letters in the parentheses that follow some definitions indicate the source of the definition:

(A) *The American National Standard Dictionary for Information Systems*, ANSI X3.172-1990, copyright 1990 by the American National Standards Institute (ANSI).

(E) The ANSI/Electronic Industries Association (EIA) Standard-440-A, *Fiber Optic Terminology*.

(I) *The Information Technology Vocabulary*, developed by Subcommittee 1, Joint Technical Committee 1, of the International Organization for Standardization and International Electro-technical Commission (ISO/IEC/JTC1/SC1).

(IBM) *The IBM Dictionary of Computing*, copyright 1994 by IBM.

(T) Draft international standards committee drafts, and working papers being developed by the ISO/IEC/JTC1/SC1.

access time

The time interval between the instant at which a call for data is initialized and the instant at which the delivery of data is completed. (T)

adapter

Any hardware that joins different connector types.

address

A character or group of characters that identifies a register, a particular part of storage, or some other data source or destination. (A)

AL_PA

See Arbitrated Loop Physical Address.

alphanumeric

A character or group of characters that identifies a register, a particular part of storage, or some other data source or destination. (A).

arbitrated loop

A Fibre Channel interconnect topology in which all parts are connected in a common loop. Before transmitting data, devices must participate in arbitration to gain control of the loop.

arbitrated loop physical address (AL_PA)

A one-byte value that identifies a port in an arbitrated loop topology.

arbitration

Any process by which a user of shared resources negotiates with other users for the right to use the resource. A port connected to a shared bus must win arbitration before it transmits data on the bus.

back hitch

A repositioning of the tape relative to the recording head. A back hitch includes the time required for the tape drive to decelerate to a stop, accelerate in the opposite direction, and decelerate to a stop again. Also commonly referred to as a *football* or *shoe shining*.

beginning-of-tape (BOT)

The location on a tape where written data begins.

block

A collection of contiguous records recorded as a unit. Interblock gaps separate blocks, and each block can contain one or more records.

buffer

A routine or storage that compensates for a difference in the rate of data flow, or the time of occurrence of events when transferring data from one device to another.

buffered write tape mark

A command that separates record data from standard labels or other record data. This command only adds the tape mark to the data buffer without data synchronization to the tape media.

burst

In data communication, a sequence of signals counted as one unit in accordance with a specific criterion or measure. (A)

capacity

Total amount of User Data stored on one data cartridge in 8-bit bytes. *Synonymous with "User Capacity" or "Native Capacity"*. This is the capacity that the user sees after the ECC/Format/ERP and other overhead has been assessed (no compression).

capacity, raw

Total amount of data stored on one data cartridge in 8-bit bytes before any ECC/Format/ERP and other overhead has been assessed (no compression).

capacity, user

Total amount of data stored on one data cartridge in 8-bit bytes that is sent by the host computer. This is the capacity that the user sees after the ECC/Format/ERP and other overhead has been assessed (no compression).

cartridge

A storage device that consists of magnetic tape on a supply reel in a protective housing.

channel

A functional unit, controlled by the processor (or host), that handles the transfer of data between processor storage and logical peripheral equipment.

cleaning cartridge

A data cartridge that contains special material to clean the tape path in a transport or drive.

compress

To save space by eliminating gaps, empty fields, redundancy, or unnecessary data to shorten the length of records or files. (IBM)

condition

One of a set of specified values that a data item can assume. (IBM)

conditioning time

The amount of time to prepare a tape cartridge for use in a T10000 Tape Drive.

configuration

The manner in which the hardware and software of an information processing system is organized and interconnected. (T)

connector

An electrical or optical part that joins two or more other parts.

coupler

Fiber-optic hardware that joins optical fiber connectors of the same type.

data error rate

The number of errors that occur per a measurable amount of data on a tape.

data path key management (DPKM)

The use of the SCSI 4 commands **Security Protocol In** and **Security Protocol Out** to implement host-based key management encryption on StorageTek tape drives.

data rate

The speed of a data transfer process, usually expressed in bits per second or bytes per second. (IBM)

data security erase (DSE)

A random binary pattern over-writing existing data from the point of an Erase command to the end-of-tape.

data tape

A data cartridge formatted for use as a regular data tape for the system in which it is used.

data tracks

The regions of recorded tape containing user data formed as discreet longitudinal "tracks" (similar to railroad tracks).

DHCP

See Dynamic Host Configuration Protocol.

diagnostics

Pertaining to the detection and isolation of errors in programs and faults in equipment.

DPKM

See data path key management.

drive

A drive controls the movement of the tape and records or reads the data on the tape as desired by the customer.

DSE

See data security erase.

dump

To copy the contents of all or part of storage to collect error information.

dynamic host configuration protocol (DHCP)

An IP protocol that a host uses to obtain all necessary configuration information, including an IP address.

dynamic world wide name (dWWN)

A feature that applies dynamic names to network devices rather than fixed names. When a dWWN-named device is replaced, it is assigned the same WWN as the one it replaced, preventing reconfiguration of the network.

emulation

The use of programming techniques and special machine features to permit a computing system to execute programs written for another system. (IBM)

encryption

The translation of data into a secret code. Encryption is one of the most effective ways to achieve data security. To read an encrypted file, you must have access to a special key or password that enables you to decipher it.

end of block (EOB)

A code that marks the end of a block of data. (IBM)

end of file (EOF)

A coded character recorded on a data medium to indicate the end of the medium. (IBM)

end-of-file label

1. An internal label indicating the end of a file and possibly containing data for file control. (T)
2. Synonymous with trailer label.

end-of-tape marker (EOT)

A marker on a magnetic tape to indicate the end of the permissible recording area. (IBM)

environmental requirement

Any of the physical conditions required for the protection and proper operation of a functional unit; the requirement is usually specified as a nominal value and a tolerance range. For a device, there may be more than one set of environmental requirements; for example, one set for transport, another for storage, and another for operation. (T) (A)

EOT

End of tape.

erase

To remove data from a data medium, leaving the medium available for recording new data. (I) (A)

error

A discrepancy between a computed, observed, or measured value or condition and the true, specified, or theoretically correct value or condition. (I) (A)

fault symptom code (FSC)

A four-character hexadecimal code generated in response to an error to help isolate failures within the device. Some FSCs are for information purposes only.

FC

See Fibre Channel.

fiber optics

The branch of optical technology concerned with the transmission of radiant power through fibers made of transparent materials such as glass, fused silica, and plastic. (E)

fiber-optic cable

A cable made of ultrathin glass or silica fibers which can transmit data using pulses of laser light. Fiber-optic cables have several advantages over copper cables: they have much less signal loss; they allow information to be transmitted at higher speeds and over longer distances; they are not affected by external electrical noise; and they are better for transmissions which require security.

Fibre Channel

The National Committee for Information Technology Standards standard that defines an ultrahigh-speed, content-independent, multilevel data transmission interface that supports multiple protocols simultaneously. Fibre Channel supports connectivity to millions of devices over copper or fiber-optic physical media and provides the best characteristics of both networks and channels over diverse topologies.

fibres connection (FICON)

An ESA/390 and zSeries computer peripheral interface. The I/O interface uses ESA/390 and zSeries FICON protocols (FC-FS and FC-SB-2) over a Fibre Channel serial interface that configures units attached to a FICON-supported Fibre Channel communications fabric.

FICON channel

A channel having a Fibre Channel connection (FICON) channel-to-control-unit I/O interface that uses optical cables as a transmission medium. May operate in either FC or FCV mode.

file-protect

To prevent the erasure or overwriting of data stored on data cartridges. *See also* write-protect switch.

file sync

A sync operation or command used to force data to tape.

- For FICON: the command protocol is a tape mark command without a count field.
- For Fibre Channel: the command protocol is not an actual sync command. It is a tape mark command that includes a count field. A count equal to zero indicates a file sync.

firmware

An ordered set of instructions and data stored in a way that is functionally independent of main storage; for example, microprograms stored in ROM. (T)

FRU

Field replaceable unit.

FSC

Fault symptom code.

FTP

File Transfer Protocol.

Gb

Gigabit, equal to 10^9 bits.

Gbps

Gigabits per second.

gigabyte (GB)

One billion (10^9) bytes. When referring to disk and tape capacity, one GB equals 1,000,000,000 bytes. When referring to memory capacity, one GB equals 1,073,741,824 in decimal notation or 2^{30} bytes.

hardware

All or part of the physical components of an information processing system, such as computers or peripheral devices. (T) (A)

HBA

See host bus adapter.

host

The primary computer on a network, with which other computers interact.

host bus adapter

A circuit installed in a multi-platform host or device that interfaces between the device and the bus.

host interface

Interface between a network and host computer. (T)

hub

A Fibre Channel Arbitrated Loop switching device that allows multiple servers and targets, such as storage systems, to connect at a central point. A single hub configuration appears as a single loop.

indicator

A device that provides a visual or other indication of the existence of a defined state. (T)

initial program load (IPL)

A process that activates a machine reset and loads system programs to prepare a computer system for operation. Processors having diagnostic programs activate these programs at initial program load execution. Devices running firmware usually reload the functional firmware from a diskette or disk drive at initial program load execution.

initialization

The operations required for setting a device to a starting state, before the use of a data medium, or before implementation of a process. (T)

interface

Hardware, software, or both, that links systems, programs, or devices. (IBM)

internet protocol (IP)

A protocol used to route data from its source to its destination in an Internet environment. (IBM)

internet protocol v4 (IPv4) address

A four-byte value that identifies a device and makes it accessible through a network. The format of an IP address is a 32-bit numeric address written as four numbers separated by periods. Each number can be from 0 to 255. For example, 129.80.145.23 could be an IP address.

internet protocol v6 (IPv6) address

The next generation internet protocol. It provides a much larger address space than IPv4. This is based upon the definition of a 128-bit address - IPv4 used a 32-bit address. The IPv6 address format is eight fields of four hexadecimal characters separated by colons (for example, 2001:0db8:85a3:0000:0000:8a2e:0370:7334)

IP

See internet protocol.

IPL

See initial program load.

laser

See light amplification by simulated emission of radiation.

LC connector

A standard connector for 2-Gbps Fibre Channel data transfer. This type of connector is used on fiber-optic cables.

library

A robotic system that stores, moves, mounts, and dismounts data cartridges that are used in data read or write operations.

light amplification by simulated emission of radiation (LASER)

Laser devices generate coherent radiation in the visible, ultraviolet, and infrared portions of the electromagnetic spectrum. Regarding Fibre Channel, lasers can transmit either short waves or long waves, depending on the composition of the arbitrated loop or fabric.

link

A physical connection (electrical or optical) between two nodes of a network.

logical path

A relationship between a channel and control unit that designates the physical path to be used for device-level communication between each entity, defined by a link address assigned to each entity.

magnetic tape

A tape with a magnetizable layer on which data can be stored. (T)

magnetic tape drive

A mechanism for moving magnetic tape and controlling its movement.

mainframe

A large computer with the ability to support hundreds or thousands of users simultaneously.

MB

Megabytes or 1,000,000 bytes for disk or tape storage but 1,048,576 (2^{20}) bytes of memory capacity.

menu

A list of options displayed to the user by a data processing system, from which the user can select an action to be initiated. (T)

microcode

A code, representing the instructions of an instruction set, that is implemented in a part of storage that is not program-addressable. (IBM)

multimode

A graded-index or step-index optical fiber that allows more than one bound mode to propagate. (E) Contrast with single mode.

multimode fiber

An optical fiber designed to carry multiple signals, distinguished by frequency or phase, at the same time.

net mask

A 32-bit, or 4-byte number, in dotted decimal format (typically written as four numbers separated by periods, such as 255.255.255.0) that is applied to an IP address to identify the network or node address of a host or router interface. (Synonymous with subnet mask.)

network

An arrangement of nodes and branches that connects data processing devices to one another through software and hardware links to facilitate information interchange.

nexus

A connection that exists between an initiator, a target, and a logical unit. This is where one initiator port talks to one target port, addressing one LUN and together they execute a task.

offline

Neither controlled by, nor communicating with, a computer. (IBM)

online

Pertaining to the operation of a functional unit when under the direct control of the computer. (T)

open systems

A system whose characteristics comply with standards made available throughout the industry and that can connect to other systems complying with the same standards.

operating system

Software that controls the execution of programs and that provides services such as resource allocation, scheduling, input and output control, and data management. Although operating systems are predominantly software, partial hardware implementations are possible.

operator control panel

A functional unit that contains switches used to control all or part of a computer and possibly the indicators giving information about its functioning. (T)

Partial Response Maximum Likelihood (PRML)

A method for converting a weak analog signal into a stronger digital signal to provide a higher recording density and contributes to faster data transfer rates.

performance

One of two major factors on which the total productivity of a system depends. Performance is largely determined by a combination of throughput, response time, and availability. (IBM)

plenum cable

A cable made of fire-resistant material that, when burned, generates little smoke. Plenum cables are used for installation in air ducts (plenums).

port

A specific communications end point within a host. A port is identified by a port number. (IBM) (2) In Fibre Channel, an access point in a device where a link attaches.

protocol

A set of semantic and syntactic rules that determines the behavior of functional units in achieving communication.

read/write head

The data sensing and recording unit of a tape drive. (IBM)

release

A distribution of a new product or new function and fixes for an existing product. (IBM)

rewind

To move tape from the take-up hub to the supply hub. (IBM)

R/W

Read/write

SCSI

Small Computer Serial Interface.

single mode

An optical fiber in which only the lowest-order bound mode can propagate at the wavelength of interest. (E)

small form-factor pluggable (SFP)

Technology with a 2-gigabit transfer speed over smaller connectors, cables, and transceivers for larger bandwidth capability.

submenu

A menu related to and reached from a main menu. (IBM)

subsystem

A system that is part of some larger system.

switch

In Fibre Channel technology, a device that connects Fibre Channel devices together in a fabric.

system

A combination of functionally interrelated interacting mechanical and electrical elements designed to work as a coherent entity.

tape

See magnetic tape.

tape cartridge

A container holding magnetic tape that can be processed without separating the tape from the container.

tape drive

A device for moving magnetic tape and controlling its movement. (T)

TB

See terabyte.

TCP/IP

Transmission Control Protocol/Internet Protocol.

terabyte (TB)

A unit of measure equal to one trillion (10^{12}) bytes of disk or tape storage capacity. When referring to memory capacity, one TB equals 1,099,511,627,776 in decimal notation or 2^{40} bytes.

transmission control protocol/internet protocol (TCP/IP)

A set of communication protocols that support peer-to-peer connectivity functions for both local and wide area networks. (IBM)

U

A standard unit of measure of vertical space inside a rack mount cabinet equal to 44.5 mm (1.75 in.).

vary offline

To change the status of a device from online to offline. When a device is offline, no data set may be opened on that device. (IBM)

vary online

To restore a device to a state where it is available for use by the system. (IBM)

virtual operator panel (VOP)

A software application that allows a user to monitor and perform some operations on one or more tape drives remotely.

VolSafe

VolSafe (volume safe) is a special feature that provides write once, read many (WORM) technology to VolSafe-designated tape cartridges. VolSafe permits new data to only append the tape media, while it prevents erasure or overwrite of previously written data.

VOLSER

1. VOLume SERial Number. It is usually six characters long and is both the paper label stuck on the back edge of the cartridge and in the VOLID label that is recorded, particularly by MVS systems, at the beginning of the media.
2. An alphanumeric label that the host software uses to identify a volume. It attaches to the spine of a cartridge and is both human- and machine-readable.

VOP

See virtual operator panel.

world wide name (WWN)

A 64-bit integer that identifies a Fibre Channel port.

world wide node name (WWNN)

A 64-bit network address that identifies the company (in IEEE format) with a vendor specific identifier.

world wide port name (WWPN)

A 64-bit network address that identifies the port name.

wrap

A single pass of tape from either BOT to EOT or EOT to BOT with the heads in a fixed transverse location.

write-enabled

A setting on a data cartridge that allows data to be written on the tape.

write once read many (WORM)

A storage classification for media that can be written only once but read many times.

write operation

An output operation that sends a processed record to an output device or output file. (IBM)

write-protected

A setting on data cartridges that prevents data from being written on the tape. Reading data is still possible.

write tape mark

A command that separates record data from standard labels or other record data. This command implies buffered data synchronization to tape media.

- For FICON: The command protocol is a tape mark command without a count field.
- For Fibre Channel: The command protocol includes a count field. A count field greater than zero indicates *count* number of physical tape marks must be written to tape.

Numerics

- 50-micron
 - cable OM2, 3-6
 - cable OM4, 3-6
- 9-micron
 - cable information, 2-9
 - cable part numbers, 3-7

A

- AC power cords, 3-5
- access time comparisons, 1-19
- address, Ethernet port, 1-2, 2-8
- air quality, B-1

B

- binding, target ID, 1-17

C

- cables
 - Ethernet, 3-5
 - Fibre Channel
 - multimode, 3-6
 - single mode, 3-7
- capacity comparisons, 1-18
- cartridge
 - capacity, 1-14
 - description, 1-14
 - environmental requirements, A-6
 - labels, A-8
 - media length comparisons, 1-19
 - physical specifications, A-7
 - VolSafe, A-3
- caution, cartridge degauss, 1-14
- cleaning the data center, B-7
- concurrent hosts, 1-15
- configurations, tape drive, 1-12
- connections, drive ports, 1-16
- connectivity matrix, 1-17
- contaminants, controlling, B-1

D

- data buffer, 1-2

- data center cleaning procedures, B-7
- data compression technology, 1-2
- data path key management (DPKM), 1-5
- data rate comparisons, 1-18
- degauss, caution about, 1-14
- description
 - tape cartridge, 1-14
 - tape drive, 1-1
- dimensions
 - shipping, 1-11
 - tape cartridge, A-7
 - tape drive, 1-1
- DIV, 1-5
- DPKM, 1-5
- drive
 - description, 1-1
 - port connections, 1-16
 - second for rack mount
 - T10000D part numbers, 3-2
- drive features
 - StorageTek Data Integrity Validation, 1-5
 - StorageTek Direct Copy, 1-6
 - StorageTek File Access Accelerator, 1-6
 - StorageTek File Sync Accelerator, 1-6
 - StorageTek In-Drive Reclaim Accelerator, 1-8
 - StorageTek Maximum Capacity, 1-6
 - StorageTek MIR Assisted Search, 1-7
 - StorageTek Search Accelerator, 1-7
 - StorageTek Tape Application Accelerator, 1-7
 - StorageTek Tape Tiering Accelerator, 1-8

E

- encryption, 1-5
- Ethernet port address, 1-2, 2-8
- external power supply module, 1-3

F

- features, drive
 - StorageTek Data Integrity Validation, 1-5
 - StorageTek Direct Copy, 1-6
 - StorageTek File Access Accelerator, 1-6
 - StorageTek File Sync Accelerator, 1-6
 - StorageTek In-Drive Reclaim Accelerator, 1-8
 - StorageTek Maximum Capacity, 1-6

- StorageTek MIR Assisted Search, 1-7
- StorageTek Search Accelerator, 1-7
- StorageTek Tape Application Accelerator, 1-7
- StorageTek Tape Tiering Accelerator, 1-8
- Fibre Channel
 - multimode cables, 3-6
 - single mode cables, 3-7
- FICON HCD Configuration white paper, 2-9
- filtration, B-6
- FIPS level, 1-5
- FSA, 1-6

G

gateway, 2-8

H

hosts, concurrent, 1-15

I

IDR, 1-8

installation requirements

- rack mount, 2-5
- SL3000, 2-3
- SL8500, 2-4

interface cable

- distance
 - OM2, 3-6
 - OM4, 3-6
 - single mode for FICON, 2-9
- part numbers, 3-6
- types, 3-6

interoperability tool, 1-17

IP address, 2-8

IPv6 address, 1-2, 2-8

L

labels, ordering of, 3-5

LC connector, 1-16

library installation requirements, 2-3

M

magneto-resistive (MR) head, 1-2

maintenance port, 1-4

management software requirements, 2-1

matrix, connectivity, 1-17

media length comparisons, 1-19

media ordering, 3-5

multimode

- cable OM2, 3-6
- cable OM4, 3-6

N

network settings, 2-8

O

options, tape drive, 3-1

overview

- tape cartridge, 1-14
- tape drive, 1-1

P

part numbers

- conversion bills, 3-3
- Ethernet cables, 3-5
- multimode cables, 3-6
- OM2 fiber optic cables, 3-6
- power cords, 3-5
- single mode cables, 3-7

performance specifications, T10000 Tape Drive, 1-8

physical specifications

- T10000 Tape Drive, 1-10
- tape cartridge, A-7

port connections, 1-16

port kit

- 16 gigabit, 3-2
- 2 gigabit, 3-4
- 4 gigabit, 3-3

power cord part numbers, 3-5

PRML technology, 1-1

R

rack mount installation requirements, 2-5

Radio Frequency Identification (RFID), 1-14

read/write comparisons, 1-19

relative humidity specification, 1-12

remote support, 2-11

requirements

- contaminants, controlling, B-1
- environmental, tape cartridge, A-6
- environmental, tape drive, 1-11

rewind time comparisons, 1-19

S

servo system, 1-2

SFP modules, 1-3

shipping dimensions, 1-11

single mode

- cable information, 2-9
- cable part numbers, 3-7

site preparation, 2-1

size of tape drive, 1-1

SL3000

- characteristics, 2-3
- drive part numbers
 - T10000D, 3-2
- installation requirements, 2-3
- tape drive power supply, 1-3

SL8500

- characteristics, 2-4
- drive part numbers
 - T10000D, 3-2

- installation requirements, 2-4
- tape drive power supply, 1-3
- small form-factor pluggable modules, 1-3
- software requirements, 2-1
- specifications
 - tape cartridge, A-7
 - tape drive, 1-8
- SSA, 1-7
- StorageTek Tape Analytics (STA), 2-10
- subnet mask, 2-8
- support, remote, 2-11

T

T10000 Tape Drive

- components, 1-2
- connectivity, 1-15
- description of, 1-1
- environmental requirements, 1-11
- features
 - StorageTek Data Integrity Validation, 1-5
 - StorageTek Direct Copy, 1-6
 - StorageTek File Access Accelerator, 1-6
 - StorageTek File Synch Accelerator, 1-6
 - StorageTek In-Drive Reclaim Accelerator, 1-8
 - StorageTek Maximum Capacity, 1-6
 - StorageTek MIR Assisted Search, 1-7
 - StorageTek Search Accelerator, 1-7
 - StorageTek Tape Application Accelerator, 1-7
 - StorageTek Tape Tiering Accelerator, 1-8
- interfaces, 1-15
- performance specifications, 1-8
- physical specifications, 1-10
- size, 1-1
- speed, 1-2

T10000D

- FICON channel, 2-9
- long wavelength SFP, 1-3, 2-9

tape cartridge

- degauss caution, 1-14
- ordering, 3-5
- overview, 1-14

tape path, 1-2

- target ID binding, 1-17
- temperature specifications, 1-11
- tracks, number of, 1-19

V

- VolSafe description, A-3

W

- white paper, link to, 1-5

Z

- zoning, 1-18

