PeopleSoft FSCM 9.2: Quality

December 2013

PeopleSoft FSCM 9.2: Quality
CDSKU fscm92pbr2
Copyright © 1992, 2013, Oracle and/or its affiliates. All rights reserved.

Trademark Notice

Oracle and Java are registered trademarks of Oracle and/or its affiliates. Other names may be trademarks of their respective owners.

Intel and Intel Xeon are trademarks or registered trademarks of Intel Corporation. All SPARC trademarks are used under license and are trademarks or registered trademarks of SPARC International, Inc. AMD, Opteron, the AMD logo, and the AMD Opteron logo are trademarks or registered trademarks of Advanced Micro Devices. UNIX is a registered trademark of The Open Group.

License Restrictions Warranty/Consequential Damages Disclaimer

This software and related documentation are provided under a license agreement containing restrictions on use and disclosure and are protected by intellectual property laws. Except as expressly permitted in your license agreement or allowed by law, you may not use, copy, reproduce, translate, broadcast, modify, license, transmit, distribute, exhibit, perform, publish, or display any part, in any form, or by any means. Reverse engineering, disassembly, or decompilation of this software, unless required by law for interoperability, is prohibited.

Warranty Disclaimer

The information contained herein is subject to change without notice and is not warranted to be error-free. If you find any errors, please report them to us in writing.

Restricted Rights Notice

If this is software or related documentation that is delivered to the U.S. Government or anyone licensing it on behalf of the U.S. Government, the following notice is applicable:

U.S. GOVERNMENT END USERS: Oracle programs, including any operating system, integrated software, any programs installed on the hardware, and/or documentation, delivered to U.S. Government end users are "commercial computer software" pursuant to the applicable Federal Acquisition Regulation and agency-specific supplemental regulations. As such, use, duplication, disclosure, modification, and adaptation of the programs, including any operating system, integrated software, any programs installed on the hardware, and/or documentation, shall be subject to license terms and license restrictions applicable to the programs. No other rights are granted to the U.S. Government.

Hazardous Applications Notice

This software or hardware is developed for general use in a variety of information management applications. It is not developed or intended for use in any inherently dangerous applications, including applications that may create a risk of personal injury. If you use this software or hardware in dangerous applications, then you shall be responsible to take all appropriate fail-safe, backup, redundancy, and other measures to ensure its safe use. Oracle Corporation and its affiliates disclaim any liability for any damages caused by use of this software or hardware in dangerous applications.

Third Party Content, Products, and Services Disclaimer

This software or hardware and documentation may provide access to or information on content, products, and services from third parties. Oracle Corporation and its affiliates are not responsible for and expressly disclaim all warranties of any kind with respect to third-party content, products, and services. Oracle Corporation and its affiliates will not be responsible for any loss, costs, or damages incurred due to your access to or use of third-party content, products, or services.

Alpha and Beta Draft Documentation Notice

If this document is in preproduction status:

This documentation is in preproduction status and is intended for demonstration and preliminary use only. It may not be specific to the hardware on which you are using the software. Oracle Corporation and its affiliates are not responsible for and expressly disclaim all warranties of any kind with respect to this documentation and will not be responsible for any loss, costs, or damages incurred due to the use of this documentation.

Contents

- Preface..... xi**
 - Understanding the PeopleSoft Online Help and PeopleBooks..... xi
 - PeopleSoft Hosted Documentation..... xi
 - Locally Installed Help..... xi
 - Downloadable PeopleBook PDF Files.....xi
 - Common Help Documentation.....xi
 - Field and Control Definitions..... xii
 - Typographical Conventions..... xii
 - ISO Country and Currency Codes..... xiii
 - Region and Industry Identifiers..... xiii
 - Access to Oracle Support..... xiii
 - Documentation Accessibility.....xiv
 - Using and Managing the PeopleSoft Online Help.....xiv
 - PeopleSoft FSCM Related Links.....xiv
 - Contact Us.....xiv
 - Follow Us.....xiv
- Chapter 1: Getting Started With PeopleSoft Quality..... 17**
 - PeopleSoft Quality Business Processes..... 17
 - PeopleSoft Quality Integrations..... 17
 - PeopleSoft Quality Implementation..... 18
 - Related Product Documentation..... 18
 - Common Elements Used in Quality..... 19
- Chapter 2: Understanding PeopleSoft Quality..... 23**
 - PeopleSoft Quality Architecture..... 23
 - PeopleSoft Quality Features..... 23
 - Understanding PeopleSoft Quality Features..... 24
 - Reducing Quality Costs..... 24
 - Meeting Quality Requirements..... 24
 - Creating a Continuous Improvement Environment..... 25
 - Simplifying Data Collection..... 26
 - Controlling and Analyzing Online Data..... 26
 - Maximizing System Flexibility..... 27
 - Using Interactive Analysis Tools..... 28
 - Integration With Other PeopleSoft Applications..... 29
 - Integration With Third-Party Systems..... 30
- Chapter 3: Defining Quality Methods and Procedures..... 31**
 - Understanding PeopleSoft Quality Methods..... 31
 - Control Charts..... 31
 - Control Tests..... 39
 - Control Procedures..... 41
 - Sampling Codes..... 42
 - Understanding Graph and Display Preferences..... 43
 - Defining Control Charts..... 45
 - Pages Used to Define Control Charts..... 45
 - Defining Control Chart Page..... 45
 - Copy Configuration Item Page..... 46
 - Defining Control Tests..... 46

Pages Used to Define Control Tests.....	47
Define Control Test Page.....	47
Defining Control Procedures.....	48
Pages Used to Define Control Procedures.....	48
Define Control Procedure Page.....	48
Defining Sampling Codes.....	50
Pages Used to Define Sampling Codes.....	51
Characteristic Class Types Page.....	51
Sampling Frequency Types Page.....	51
Maintaining Graph and Display Preferences.....	52
Pages Used to Maintain Graph and Display Preferences.....	52
Define Graph Preferences Page.....	52
Statistic Selections Page.....	53
Chapter 4: Defining Quality Functions.....	57
Understanding Quality Functions.....	57
Maintaining Quality Functions.....	57
Pages Used to Maintain Quality Functions.....	58
Quality Business Unit Page.....	58
Defining Quality Functions.....	58
Integration With Other PeopleSoft Applications.....	59
Chapter 5: Maintaining Measurement Plans.....	63
Understanding Measurement Plans.....	63
Common Elements Used.....	63
Characteristics.....	63
Defining Measurement Plans.....	63
Pages Used to Define Measurement Plans.....	64
Maintaining Characteristics.....	64
Creating Formula Definitions.....	67
Adding Operator Instructions.....	70
Reviewing Measurement Plan Configuration Information.....	70
Pages Used to Review Measurement Plan Configuration Information.....	70
Measurement Plan Review Page.....	71
Characteristics Specifications Page.....	71
Chapter 6: Establishing Control Plans.....	73
Understanding Control Plans.....	73
Prerequisites.....	75
Defining Attribute Groups.....	77
Pages Used to Define Attributes.....	77
Understanding Attribute Groups.....	77
Attribute Labels Page.....	78
Attribute Codes Page.....	79
Defining Traceability Sets.....	80
Page Used to Define Traceability Sets.....	80
Understanding Traceability Sets.....	80
Define Traceability Set Page.....	80
Maintaining Stations.....	81
Page Used to Maintain Stations.....	82
Define Stations Page.....	82
Defining Control Plans.....	82
Pages Used to Define Control Plans.....	82
Understanding Control Plans.....	83

Load Quality Control Plans Page.....	83
Maintain Quality Control Plans Page.....	84
Create Quality Control Plans Page.....	86
Stream Details Page.....	86
Reviewing Control Plan Configurations.....	90
Pages Used to View Control Plan Configuration Information.....	90
Common Elements Used in This Section.....	90
Characteristics/Where Applied Page.....	90
Stream Specifications Page.....	91
Control Limits Page.....	92
Chapter 7: Collecting Quality Data.....	93
Understanding the Quality Data Collection Process.....	93
Data-Entry Pages.....	93
Quality Data Entry.....	93
Pending Session Recall.....	97
Completed Session Edits.....	102
Common Elements Used in Collecting Quality Data.....	104
Defining Data-Entry Access Lists.....	105
Pages Used to Define Data-Entry Access Lists.....	106
Define Operator Access List Page.....	106
Control Plan Selections Page.....	106
Entering, Maintaining, and Editing Quality Data.....	107
Pages Used to Enter, Maintain, and Edit Quality Data.....	107
Understanding the Creation of a New Sampling.....	108
Data Entry From Access List Page.....	108
Data Entry By Control Plan Page.....	109
Recalling Pending Sessions From Access Lists.....	109
Recalling Sessions Using Hierarchy Fields.....	109
Select Pending Session Page.....	110
Using Subgroup and Sample Methods to Enter Data.....	110
Pages Used to Maintain Quality Data Using Subgroup and Sample Methods.....	111
Understanding Subgroup and Sample Methods.....	111
Using the Subgroup Method.....	112
Using the Sample Method.....	114
Recording Defects.....	114
Working With Control Plans.....	115
Pages Used to Work With Control Plans.....	116
Instructions Page.....	117
Review Page.....	118
Graph Display Page.....	119
Probable Causes Page.....	119
Corrective Actions Page.....	120
Chapter 8: Reviewing Process Performance Information.....	123
Understanding the Alarm Review Process.....	123
Common Elements Used in Reviewing Process Performance Information.....	124
Viewing Alarms.....	125
Pages Used to View Alarms.....	125
Understanding Alarm Access Profiles.....	126
Define Alarm Review Criteria Page.....	126
Review Alarms Page.....	127
Alarm Detail Page.....	128

Instructions Page.....	129
Sample Values / Traceability Detail Page.....	130
Viewing Alarms Using PeopleSoft Workflow.....	130
Pages Used to View Alarms Using Workflow.....	131
Start Alarm WorkFlow Page.....	131
Alarm Detail Page.....	131
Reviewing Control Plan Performance.....	132
Pages Used to Review Control Plan Performance.....	132
Understanding the Control Plan Performance Component.....	133
Selection Criteria Page.....	133
Stream Review Page.....	135
Subgroup Detail Page.....	136
Basic Statistics Page.....	136
Capability Indices Page.....	137
Attributes Statistics Page.....	138
Chapter 9: Using PeopleSoft Quality Graphics.....	141
Viewing PeopleSoft Quality Graphics.....	141
Pages Used to View PeopleSoft Quality Graphics.....	141
Control Chart Page.....	142
Histogram Page.....	145
Pareto Chart Page.....	148
Bar Graph Page.....	150
Defining Data Extractions and Loading Datasets.....	151
Pages Used to Define Data Extractions and Load Datasets.....	151
Understanding Datasets and Data Extractions.....	152
Prerequisites.....	153
Common Elements Used in This Section.....	153
Define Extraction Criteria — General Page.....	153
Define Extract Criteria — Selection Page.....	154
Perform Data Extraction Page.....	155
Chapter 10: Using the PeopleSoft Quality Application Client.....	157
Understanding PeopleSoft Quality Application Client Charts and Analysis Tools.....	157
Prerequisites.....	157
Using the PeopleSoft Quality Application Client Toolbar.....	157
Creating and Managing Datasets.....	159
Pages Used to Create and Manage Datasets.....	159
Spreadsheet and Selector Panels.....	160
Configuring Datasets.....	162
Column Detail Panel.....	164
Subset Detail Panel.....	165
Subset/Column Detail Panel.....	166
Using Control Charts.....	167
Pages Used to Use Control Charts.....	167
Control Chart Panel.....	167
Modifying Control Chart Graph Options.....	170
Running Tests Against Control Charts.....	171
Using Histograms.....	172
Pages Used to Use Histograms.....	172
Histogram Panel.....	172
Modifying Histogram Graph Options.....	174
Running Mean Tests from Histograms.....	175

Running Standard Deviation Tests from Histograms.....	176
Using Bar Graphs.....	176
Pages Used to Use Bar Graphs.....	177
Viewing and Manipulating Bar Graphs.....	177
Modifying Bar Graph Options.....	179
Using Line Graphs.....	181
Pages Used to Use Line Graphs.....	181
Line Graph Panel.....	182
Modifying Line Graph Options.....	183
Using Pareto Charts.....	184
Pages Used to Use Pareto Charts.....	184
Pareto Chart Panel.....	184
Modifying Pareto Chart Options.....	186
Using Box Plots.....	188
Pages Used to Use Box Plots.....	188
Box Plots Panel.....	188
Modifying Box Plot Graph Options.....	191
Using Spreadsheets.....	192
Page Used to Use Spreadsheets.....	193
Spreadsheet Panel.....	193
Using the Statistical Matrix.....	194
Page Used to Use the Statistical Matrix.....	194
Statistical Matrix Panel.....	194
Creating Graph-Display Templates.....	196
Understanding Graph-Display Templates.....	196
Creating Graph-Display Layouts.....	196
Applying Graphic Layouts.....	197
Saving Configuration Settings.....	197
Page Used to Save Configuration Settings.....	198
Understanding Configuration Settings.....	198
Saving Control Definitions.....	198
Printing Displays.....	198
Chapter 11: Integrating PeopleSoft Quality With Other PeopleSoft Applications.....	201
Understanding PeopleSoft Quality Integration With Other PeopleSoft Applications.....	201
Prerequisites.....	201
Integrating With PeopleSoft Purchasing.....	202
Pages Used to Integrate With PeopleSoft Purchasing.....	202
Understanding PeopleSoft Quality Integration With PeopleSoft Purchasing.....	202
Quality Functions Page.....	203
Defining Purchasing Information in PeopleSoft Quality.....	203
Passing Purchasing Receiving Information to PeopleSoft Quality.....	205
Integrating With PeopleSoft Inventory.....	206
Pages Used to Integrate With PeopleSoft Inventory.....	207
Understanding PeopleSoft Inventory Integration With PeopleSoft Quality.....	207
Quality Functions Page.....	207
Defining Inventory Information for PeopleSoft Quality.....	208
Passing Inventory Information to PeopleSoft Quality.....	209
Integrating With PeopleSoft Manufacturing.....	211
Pages Used to Integrate With PeopleSoft Manufacturing.....	211
Understanding PeopleSoft Manufacturing Integration With PeopleSoft Quality.....	211
Reviewing Predefined PeopleSoft Manufacturing Quality Functions.....	212

Defining Production Management Information for PeopleSoft Quality.....	214
Passing Production Management Information to PeopleSoft Quality.....	215
Chapter 12: Integrating With Third-Party Applications.....	219
Understanding the Integration of PeopleSoft Quality With Third-Party Applications.....	219
PeopleSoft Quality Configuration.....	219
Using the PeopleSoft Quality EIP.....	220
Using EIP Data Rules.....	221
Using EIP Data Scenarios.....	223
Troubleshooting EIPs.....	240
Using SQL.....	241
Using and Testing Application Engine Programs.....	244
Chapter 13: Using Quality Statistical Equations and Methods.....	251
Understanding Quality Equations and Methods.....	251
Using the Statistical Matrix.....	251
Understanding the Statistical Matrix.....	251
Using Basic Statistics.....	252
Using Quartiles.....	253
Using Skewness and Kurtosis.....	254
Using Process Capability.....	255
Testing for Normality.....	256
Using Pearson Best-Fit Criteria.....	257
Using Attribute Statistics.....	257
Using Distribution Analysis.....	258
Using Histogram Statistics.....	258
Using Test Statistics.....	259
Using Control Charts.....	259
Using Variable Data-Control Charts.....	260
Using Attribute Data-Control Charts.....	261
Using Pareto Charts.....	262
Using Bar Graphs.....	263
Using Box Plots.....	263
Using Line Graphs.....	263
References.....	263
Appendix A: Delivered Workflow for PeopleSoft Quality.....	265
Delivered Workflow for PeopleSoft Quality.....	265
Alarm Notification.....	265

Preface

Understanding the PeopleSoft Online Help and PeopleBooks

The PeopleSoft Online Help is a website that enables you to view all help content for PeopleSoft Applications and PeopleTools. The help provides standard navigation and full-text searching, as well as context-sensitive online help for PeopleSoft users.

PeopleSoft Hosted Documentation

You access the PeopleSoft Online Help on Oracle's PeopleSoft Hosted Documentation website, which enables you to access the full help website and context-sensitive help directly from an Oracle hosted server. The hosted documentation is updated on a regular schedule, ensuring that you have access to the most current documentation. This reduces the need to view separate documentation posts for application maintenance on My Oracle Support, because that documentation is now incorporated into the hosted website content. The Hosted Documentation website is available in English only.

Locally Installed Help

If your organization has firewall restrictions that prevent you from using the Hosted Documentation website, you can install the PeopleSoft Online Help locally. If you install the help locally, you have more control over which documents users can access and you can include links to your organization's custom documentation on help pages.

In addition, if you locally install the PeopleSoft Online Help, you can use any search engine for full-text searching. Your installation documentation includes instructions about how to set up Oracle Secure Enterprise Search for full-text searching.

See *PeopleTools 8.53 Installation* for your database platform, "Installing PeopleSoft Online Help." If you do not use Secure Enterprise Search, see the documentation for your chosen search engine.

Note: Before users can access the search engine on a locally installed help website, you must enable the Search portlet and link. Click the Help link on any page in the PeopleSoft Online Help for instructions.

Downloadable PeopleBook PDF Files

You can access downloadable PDF versions of the help content in the traditional PeopleBook format. The content in the PeopleBook PDFs is the same as the content in the PeopleSoft Online Help, but it has a different structure and it does not include the interactive navigation features that are available in the online help.

Common Help Documentation

Common help documentation contains information that applies to multiple applications. The two main types of common help are:

- Application Fundamentals

- Using PeopleSoft Applications

Most product lines provide a set of application fundamentals help topics that discuss essential information about the setup and design of your system. This information applies to many or all applications in the PeopleSoft product line. Whether you are implementing a single application, some combination of applications within the product line, or the entire product line, you should be familiar with the contents of the appropriate application fundamentals help. They provide the starting points for fundamental implementation tasks.

In addition, the *PeopleTools: PeopleSoft Applications User's Guide* introduces you to the various elements of the PeopleSoft Pure Internet Architecture. It also explains how to use the navigational hierarchy, components, and pages to perform basic functions as you navigate through the system. While your application or implementation may differ, the topics in this user's guide provide general information about using PeopleSoft Applications.

Field and Control Definitions

PeopleSoft documentation includes definitions for most fields and controls that appear on application pages. These definitions describe how to use a field or control, where populated values come from, the effects of selecting certain values, and so on. If a field or control is not defined, then it either requires no additional explanation or is documented in a common elements section earlier in the documentation. For example, the Date field rarely requires additional explanation and may not be defined in the documentation for some pages.

Typographical Conventions

The following table describes the typographical conventions that are used in the online help.

<i>Typographical Convention</i>	<i>Description</i>
Key+Key	Indicates a key combination action. For example, a plus sign (+) between keys means that you must hold down the first key while you press the second key. For Alt+W, hold down the Alt key while you press the W key.
... (ellipses)	Indicate that the preceding item or series can be repeated any number of times in PeopleCode syntax.
{ } (curly braces)	Indicate a choice between two options in PeopleCode syntax. Options are separated by a pipe ().
[] (square brackets)	Indicate optional items in PeopleCode syntax.
& (ampersand)	When placed before a parameter in PeopleCode syntax, an ampersand indicates that the parameter is an already instantiated object. Ampersands also precede all PeopleCode variables.
⇒	This continuation character has been inserted at the end of a line of code that has been wrapped at the page margin. The code should be viewed or entered as a single, continuous line of code without the continuation character.

ISO Country and Currency Codes

PeopleSoft Online Help topics use International Organization for Standardization (ISO) country and currency codes to identify country-specific information and monetary amounts.

ISO country codes may appear as country identifiers, and ISO currency codes may appear as currency identifiers in your PeopleSoft documentation. Reference to an ISO country code in your documentation does not imply that your application includes every ISO country code. The following example is a country-specific heading: "(FRA) Hiring an Employee."

The PeopleSoft Currency Code table (CURRENCY_CD_TBL) contains sample currency code data. The Currency Code table is based on ISO Standard 4217, "Codes for the representation of currencies," and also relies on ISO country codes in the Country table (COUNTRY_TBL). The navigation to the pages where you maintain currency code and country information depends on which PeopleSoft applications you are using. To access the pages for maintaining the Currency Code and Country tables, consult the online help for your applications for more information.

Region and Industry Identifiers

Information that applies only to a specific region or industry is preceded by a standard identifier in parentheses. This identifier typically appears at the beginning of a section heading, but it may also appear at the beginning of a note or other text.

Example of a region-specific heading: "(Latin America) Setting Up Depreciation"

Region Identifiers

Regions are identified by the region name. The following region identifiers may appear in the PeopleSoft Online Help:

- Asia Pacific
- Europe
- Latin America
- North America

Industry Identifiers

Industries are identified by the industry name or by an abbreviation for that industry. The following industry identifiers may appear in the PeopleSoft Online Help:

- USF (U.S. Federal)
- E&G (Education and Government)

Access to Oracle Support

Oracle customers have access to electronic support through My Oracle Support. For information, visit <http://www.oracle.com/pls/topic/lookup?ctx=acc&id=info> or visit <http://www.oracle.com/pls/topic/lookup?ctx=acc&id=trs> if you are hearing impaired.

Documentation Accessibility

For information about Oracle's commitment to accessibility, visit the Oracle Accessibility Program website at <http://www.oracle.com/pls/topic/lookup?ctx=acc&id=docacc>.

Using and Managing the PeopleSoft Online Help

Click the Help link in the universal navigation header of any page in the PeopleSoft Online Help to see information on the following topics:

- What's new in the PeopleSoft Online Help.
 - PeopleSoft Online Help accessibility.
 - Accessing, navigating, and searching the PeopleSoft Online Help.
 - Managing a locally installed PeopleSoft Online Help website.
-

PeopleSoft FSCM Related Links

Financial and Supply Chain Management information for Secure Enterprise Search (SES) can be found in PeopleSoft Application Fundamentals documentation. For application specific information, see the "Understanding Search Pages within Components (*PeopleSoft FSCM 9.2: Application Fundamentals*)" topic.

[My Oracle Support](#)

[PeopleSoft Information Portal on Oracle.com](#)

[PeopleSoft Training from Oracle University](#)

[PeopleSoft Video Feature Overviews on YouTube](#)

Contact Us

[Send us your suggestions](#) Please include release numbers for the PeopleTools and applications that you are using.

Follow Us



Get the latest PeopleSoft updates on [Facebook](#).



Follow PeopleSoft on [Twitter@PeopleSoft_Info](#).

Chapter 1

Getting Started With PeopleSoft Quality

PeopleSoft Quality Business Processes

The PeopleSoft Quality business processes are:

- Create quality business units.
- Create quality methods and procedures.
- Develop quality functions.
- Develop measurement plans.
- Develop control plans.
- Collect quality data.
- View and analyze quality data.
- (Optional) Use the PeopleSoft Quality Application Client.
- Integrate with third-party and other PeopleSoft applications.

Implementing PeopleSoft Quality for the organization involves designing the system's business structure, then putting that structure in place.

We discuss these business processes in the business process sections in this documentation.

PeopleSoft Quality Integrations

PeopleSoft Quality integrates with the following PeopleSoft applications and with third-party applications:

- PeopleSoft Purchasing.
- PeopleSoft Inventory.
- PeopleSoft Manufacturing.
- Third-Party applications.

PeopleSoft Purchasing

When you inspect material received against a purchase order, you can use PeopleSoft Purchasing to initiate a quality data-entry session automatically in PeopleSoft Quality.

See [Integrating With PeopleSoft Purchasing](#).

PeopleSoft Inventory

When material is returned on a return material authorization (RMA) in PeopleSoft Inventory, you can use PeopleSoft Quality to enter detailed quality information against the material received. After the material is received on an RMA, the system creates a quality data-entry session.

See [Integrating With PeopleSoft Inventory](#).

PeopleSoft Manufacturing

When recording operation completions and scrap information against a production ID or schedule for any production type (production, rework, or teardown) using PeopleSoft Manufacturing, you can immediately initiate a data-entry session in PeopleSoft Quality.

See [Integrating With PeopleSoft Manufacturing](#).

Third-Party Applications

Many companies implementing manufacturing systems use automated collection devices or systems to assist in quality inspection and control. Through the use of the PeopleSoft Integration Broker technology, you can pass quality information collected from these devices to PeopleSoft Quality.

The third-party system passes quality control information to PeopleSoft Quality using the `Quality_Data_Submit` service operation.

See [Understanding the Integration of PeopleSoft Quality With Third-Party Applications](#).

PeopleSoft Quality Implementation

PeopleSoft Setup Manager enables you to review a list of setup tasks for the organization for the products that you are implementing. The setup tasks include the components that you must set up, listed in the order in which you must enter data into the component tables, and links to the corresponding documentation.

Other Sources of Information

In the planning phase of the implementation, take advantage of all PeopleSoft sources of information, including the installation guides, table-loading sequences, data models, and business process maps. A complete list of these resources appears in the PeopleSoft Application Fundamentals documentation, with information about where to find the most current version of each.

PeopleTools: PeopleSoft Setup Manager

Related Product Documentation

The *PeopleSoft Quality 9.1* provides you with implementation and processing information for Oracle's PeopleSoft Quality system. However, additional, essential information describing the setup and design of the system resides in companion documentation. The companion documentation consists of important

topics that apply to many or all of Oracle's PeopleSoft applications across the Financials, Enterprise Service Automation, and Supply Chain Management product lines. You should be familiar with the contents of these documentations.

These companion documentations contain information that applies specifically to Oracle's PeopleSoft Quality.

- *PeopleSoft Application Fundamentals 9.1*
- *PeopleSoft Order to Cash Common Information 9.1*
- *PeopleSoft Source to Settle Common Information 9.1*
- *PeopleSoft Managing Items 9.1*
- *PeopleSoft Supply Chain Management Integration 9.1*

Common Elements Used in Quality

As of Date	The last date for which a report or process includes data.
Description	Freeflow text up to 30 characters.
Effective Date	Date on which a table row becomes effective; the date that an action begins. For example, if you want to close out a ledger on June 30, the effective date for the ledger closing would be July 1. This date also determines when you can view and change the information. Pages or panels and batch processes that use the information use the current row.
EmplID (employee ID)	Unique identification code for an individual associated with the organization.
Language or Language Code	The language in which you want the field labels and report headings of the reports to print. The field values appear as you enter them. Language also refers to the language spoken by an employee, applicant, or non-employee.
Process Frequency (group box)	Designates the appropriate frequency in the Process Frequency group box: <i>Once</i> : Executes the request the next time the batch process runs. After the batch process runs, the process frequency is automatically set to <i>Don't Run</i> . <i>Always</i> : Executes the request every time the batch process runs. <i>Don't Run</i> : Ignores the request when the batch process runs.
Report ID	The report identifier.

Report Manager

Accesses the Report List page, where you can view report content, check the status of a report, and see content detail messages that show you a description of the report and the distribution list.

Process Monitor

Accesses the Process List page, where you can view the status of submitted process requests.

Run

Accesses the Process Scheduler request page, where you can specify the location where a process or job runs and the process output format.

For more information about the Report List page, the Process List page, and the Process Scheduler, see Process Scheduler Basics.

Run Control ID

A request identification that represents a set of selection criteria for a report or process.

User ID

The system identifier for the individual who generates a transaction.

SetID

An identification code that represents a set of control table information or TableSets. A TableSet is a group of tables (records) necessary to define the company's structure and processing options.

Short Description

Freeflow text up to 15 characters.

Standard Unit of Measure (standard UOM)

A type of unit used for quantifying in PeopleSoft systems, and usually associated with items. Depending on the application, units of measure might describe dimensions, weights, volumes, or amounts of locations, containers, or business activities. Examples include inches, pounds, work hours, and standard cost dollars.

Unit (business unit)

Represents a high-level organization of business information. You can use a business unit to define regional or departmental units within a larger organization.



When you click the Copy From button, the Copy Configuration Item page appears. Click this button if you want to create a new PeopleSoft Quality element by copying information from an existing element. The button is only available when you are adding a new element.



Click the Move Down button to move a PeopleSoft Quality element down in the sequence order.



Click the Move Up button to move a PeopleSoft Quality element up in the sequence order.



Click the Enter Formula button to transfer to a Formula Definition page, where you can enter a formula for the characteristic.



Click the Clear All Rows button to clear all rows on the page and in the buffer. If you haven't saved a row, the changes to the row will be lost. You can only delete control plans that haven't been previously saved. Clicking the button removes the previously created control plan from the working area, but doesn't delete the plan.

Details

When you click the Details button, the Stream Details page appears.

Create Plans

Click the Create Plans (create control plans) button to create control plans with the criteria that you entered. The system generates a list of values determined by the settings in the Wildcard (optional) group box and applies the values in the configuration and hierarchy constants to each row in the list. This creates multiple new control plans; all having the same settings, except for the unique values generated by the wildcard you select.



Click the Reset Control Limit Promotions button to reset process control limits.

Quality

When you click the Quality link, a new session is created and one of the two Data Entry pages (Subgroup Method or Sample Method) appear depending on the Data Entry Method associated with the control plan. From there, you can enter readings for the characteristics.

Delete Session

Click the Delete Session button to delete pending sessions.

Date From

Represents the starting date for a query or list.

Date Modified

Displays the current date and time when after you save new or changed values.

Modified By

Identifies who saved PeopleSoft Quality values.

PeopleTools: PeopleSoft Applications User's Guide

PeopleTools: PeopleSoft Process Scheduler

Chapter 2

Understanding PeopleSoft Quality

PeopleSoft Quality Architecture

Quality is a comprehensive statistical process control (SPC) application. With Quality, you can enter, manage, display, and analyze quality data that you collect from a variety of sources within the supply chain.\

To perform additional analysis or process characterization, you can install the Quality application client. The Quality application client uses windows to create an interactive analysis environment. The Quality application client also provides tools to generate interactive charts, graphs, spreadsheets, and statistics. This diagram illustrates how the Quality application client can provide supplemental analysis of the quality data extracted from the PeopleSoft database:

Image: Transferring data from Quality to the Quality application client for advanced analysis

This image illustrates transfer of data from Quality to the Quality application client.

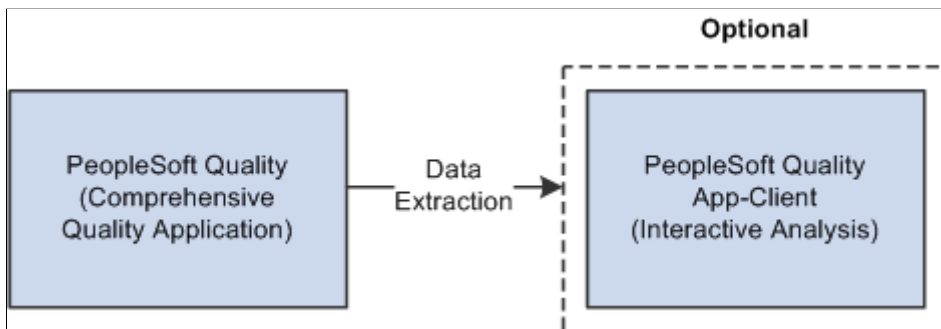

PeopleSoft Quality Features

This section provides an overview of Quality features and discusses how to:

- Reduce quality costs.
- Meet quality requirements.
- Create a continuous-improvement environment.
- Simplify data collection.
- Control and analyze online data.
- Maximize system flexibility.

- Use interactive analysis tools.

Understanding PeopleSoft Quality Features

Today, quality professionals deal with competitive pressures to reduce costs, implement international standards, continuously improve processes, and satisfy customers. Quality helps you effectively collect and interpret quality information, helping you reduce scrap, rework, and repairs. Using Quality, you can maintain control of processes, automate labor-intensive tasks, improve communication within the supply chain, and accelerate ISO 9000 family certification.

The application combines online SPC data collection with a relational database for quality analysis. Statistical Quality Control tools help you access and analyze critical quality characteristics. The tools provide an intuitive environment to create what-if scenarios without altering the original data.

Reducing Quality Costs

Billions of dollars a year are wasted due to poor quality. In less demanding organizations, the cost can be five percent of sales, while others incur up to forty percent of sales. Most costs can be attributed to excess variation in processes and products. But there is also a cost associated with reducing variation. These costs are distributed among four major categories:

- Detection
- Internal failure
- External failure
- Prevention

In general, these are the costs associated with producing, identifying, avoiding, or repairing products that don't meet requirements.

While Cost Management can help you capture and analyze the cost of quality, Quality can help you avoid these costs. Quality enables you to reduce process and product variation with advanced control charting methods, Pareto analysis, distribution assessment, and process capability evaluations.

Meeting Quality Requirements

The ISO 9000 global standard has created an enormous need to organize, structure, control, and communicate all facets of the quality system. Quality, combined with Manufacturing, Inventory, and Purchasing, facilitates the organization and maintenance of the quality information system (its structure, control plans, and key documentation) throughout the enterprise. Online access and review of these details improves communication, reduces procedural errors, and contributes to a successful audit of overall quality effort.

When integrating inspection procedures, operation instructions, and other controlled documents, Quality provides an environment for manufacturing consistency and continuous improvement by:

- Documenting statistically significant changes in the manufacturing process.
- Automatically assessing control violations with immediate notification to operators.

- Electronically distributing violations internally or to the extended enterprise (suppliers or customers) using intelligent Workflow agents.

When an out-of-control condition is determined, Quality provides the tools to view the condition, indicate probable causes, and take corrective actions. This information is then tied to the event and, specifically, to the point on the control chart. Additionally, each point (subgroup) on the control chart contains a complete history of traceability data, such as supplier ID or serial ID.

When you receive items on a purchase order or a Return Material Authorization (RMA), Quality provides integration with Purchasing and Inventory to assist in monitoring and inspecting the quality of the item being received or returned.

Throughout the environment, you use advanced security and audit tools to restrict user access and maintain database integrity. In addition to the network, database, and PeopleTools online security, Quality provides audit-trail information for critical areas of the quality management process, including control-plan modifications, data-entry events, control-test violations, specification limit changes, and control limit changes.

Creating a Continuous Improvement Environment

This diagram illustrates how the functions and features within Quality (characterize, stabilize, maintain, and improve) help you meet the requirements within a continuous improvement model:

Image: Continuous improvement model

This diagram illustrates how the functions and features within Quality.

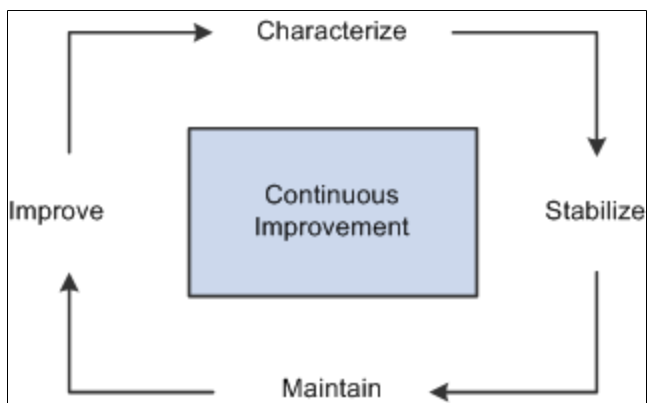

This model incorporates four main continuous activities. Each activity validates the previous activity.

Characterize

The starting point. In this phase, Quality provides tools for an initial set of data to determine what the process or product looks like, statistically and graphically. At this stage, you determine important characteristics, the distribution shape, the measurement system capability, the initial process capability indices, the starting process yield, and Pareto analysis of defects. In addition, you can design the control chart to determine the correct subgrouping, sample frequency, control test sensitivity, and chart type. Ultimately, you'll use Quality to establish a baseline and optimum method of control.

Stabilize

Once the baseline is established, you'll use Quality to help stabilize the process. A process is any set of conditions or system of causes that produce a given result, such as a manufactured product. You must control these conditions to minimize the variation within a process. With Quality, you can monitor this variation by using control charts, analyzing the data for significant changes, and taking immediate corrective action.

Maintain

When a process is first analyzed, it's usually out of control. You can initially monitor and control the process offline, while reducing any negative impact to the operation. After gaining stability, you use online activities to identify and contain less frequent out-of-control occurrences.

To maintain stabilized processes, you monitor for special causes that creep into the process before they cause nonconforming products. You use automatic control-limit assessment, control testing, and alarm notification to keep processes in check.

Improve

A process in statistical control doesn't guarantee quality output, only predictable output. A stable process may still not be capable of producing products that conform to specification. You can explore process data, find new ways to improve quality, and verify improvements using an analytical toolbox.

As you introduce new people, machinery, equipment, and methods into the process, the control charts are the first indicators of success. Quality helps you recharacterize and restabilize the process at new levels of performance.

Simplifying Data Collection

With Quality, you can manually gather any combination of variable and attribute data using point-and-click pick lists for traceability items. Characteristics can have different subgroup sizes, control charts, and control rules, all within the same data-entry session. During data entry, characteristics can also be derived. For example, you can enter measurements for two characteristics (width and length) while a third measurement (area) is automatically calculated using a predefined formula; for example, width * length.

Quality also offers an XML-based publish and subscribe architecture to automatically collect data from any measurement device or electronic data-collection system.

Controlling and Analyzing Online Data

As soon as you enter data, Quality evaluates it for specification and control-chart violations. You can instantly view the charts or graphics anytime during the data-collection process. Control violations can also be routed to offline personnel, who can review the data and chart information and determine if support action is necessary.

Identifying Causes and Taking Corrective Actions

With data-collection pages, users provide information on what may have caused an out-of-control problem and on the corrective action that they took. This information is also available to offline support personnel, who can review or add causes, actions, and comments. This information is associated with the subgroup and stored in the database for further analysis and review.

Managing Alarms

Each time a subgroup violates a statistical test or an individual measurement is out of specification, an alarm occurs. You can send alarms to a worklist or through electronic mail, using Workflow. You can view details for an alarm, add corrective action and comments, review representative charts, and close out the alarm.

Maximizing System Flexibility

You use Quality to configure the quality-control environment by identifying each process control and data-collection point. To configure what you want to control and how you want to control the process:

1. Define quality control requirements.

Quality functions determine which fields are available for data entry or query. They also provides parenting for related process hierarchies and their associated streams. When defining the quality function, you determine the trace and hierarchy fields that are common to that quality application or functional area. When recording inspection data against a sampling, hierarchy fields determine the data that you are entering sampling results against. You use trace fields to enter traceability information, such as the lot number associated with that sampling.

Measurement plans represent groups of characteristics that form measurement criteria for inspection and control. When defining characteristics for a measurement plan, you determine the properties of the characteristic being measured, the subgroup size, how to display the data on charts, and the quality control rules to apply for each characteristic.

Control plans bring together application, measurement, and control-and-response criteria for a specific product and process. Up until this point, all elements of configuration that you have established haven't been applied to a specific process. The control plan provides the remaining element of configuration, defining the process and applying methods of inspection and control to that process.

When defining a control plan, you reference a quality function that indicates the fields to display as hierarchy fields on the plan. Then, for each individual hierarchy field combination, you define the measurement plan that applies.

2. Construct control charts.

Quality includes standard control charts you use to define specialized charts with formulas, labels, and test zones. Each component of the chart can contain requirements. For example, the point on the chart can be subtracted from the nominal specification value before being plotted, or control limit formulas may contain a special constant to achieve 2.5 sigma control limits.

3. Create diverse control rules.

If the organization has unique or non-standard procedures for evaluating process control or limit calculations, you can define these same procedures within Quality.

You can create control tests from Shewhart prototypes and selectively apply the tests to mean or variance charts. The tests are evaluated when performing data-entry functions. You can control the sensitivity of each test by specifying the number of points to be evaluated and the number of points in the pattern required to trigger a violation.

You can also employ a three-level phased approach for establishing control limits by setting them to automatically calculate at 10, 20, and 30 subgroups. This gives the operation a moderate level of

control at 10 to 29 subgroups and fixed control at 30. You can also automatically recalculate at a specified point interval.

Using Interactive Analysis Tools

Using Quality, you can view control charts, histograms, Pareto charts, and more. In addition, you can assemble a variety of graphics, charts, and statistical tables for reports and documents. Use the extraction process to build reusable queries that produce a concise dataset automatically filled with the appropriate control limits, specifications, and other relevant quality information. Along with the sorting and filtering capabilities for defining an extraction, you can also use mechanisms built directly into the analysis tools to explore the dataset.

You can perform offline interactive analysis in the Quality application client. The Quality application client is an analytical software service module that enables you to display, manage, and analyze quality data. Using the application client, you can create datasets and export results directly into spreadsheets to further analyze process data.

You can use a dataset created by extracting data from the database, and you can add more data, modify existing data, or delete data in a what-if scenario. For example, to see results of a new sampling or control scheme, you can change information locally in a control chart and examine the results. Based on the results, you can put the new process into active production or discard the dataset. The results are never written to the database, but you can save them to a file.

These options are instantly available using buttons on the Quality application client toolbar:

- Control chart
 - Provides charts for variable and attribute data, including XB/R, XB/s, X/MR, p, u, c, and np. You can build additional control charts, such as precontrol or hybrid. Functions and display settings include selecting chart points, sweep points for details, display alarms, and change control limits.
- Histogram
 - View the distribution of the data, view key statistics, test for normality, and apply Pearson criteria for non-normal distributions. You can select cells, display box plots, sweep cells for boundaries, count, and percent, display curve fits, and overlay specifications.
- Pareto chart
 - View the top defects, probable causes, corrective actions, or control test violations. You can use filtering and redraw options to display cumulative percentages, display top *n* cells, order cells, and display cell totals.
- Bar graph
 - Compare statistical values among multiple characteristics. You can group the characteristics by machines, work centers, stations, or other components, for unique within-process comparisons. You can view the results in ascending or descending order and mark the minimum and maximum bars and set scales.
- Box plots

Compare several distributions simultaneously. You can view data by Box and Whisker plots, boxed capability graphs, or simple minimum/maximum plots. You can also display statistical summaries, overlay six sigma regions, and modify graphic scales.

- Line graph

Overlay up to six lines of data in one display. You can also connect lines, observe for trends, sweep points for details, and display symbols.

- Statistical Matrix

Displays information about the dataset. With the statistical matrix format, you can view tabular-formatted statistics related to one or more subsets of the dataset.

Integration With Other PeopleSoft Applications

Quality can be called directly from other selected Purchasing, Inventory, and Manufacturing components.

You can call Quality from these applications:

- Purchasing, for receiving inspection.
- Manufacturing, for completions and scrap of items on production IDs and schedules.
- Inventory, for inspecting returned material on an RMA.

You can always invoke sample data entry directly from Quality.

To call Quality from Purchasing and Manufacturing:

1. Use a direct page-to-page interface to begin a business activity using one application.
2. Initiate a transfer to Quality sample data entry, automatically passing common information, such as item, lot number, and supplier information.
3. Enter inspection observations required by the measurement plan and view the results and the alarm information from the data entered online.
4. Return control to the originating application upon completion of the quality analysis.

To call Quality from Inventory:

1. Initiate a Quality sample data-entry session, and pass the relevant information from a business activity.
2. Navigate to Quality and display the session that was originally created.
3. Enter inspection observations required by the measurement plan.
4. View results and alarm information from data entered online.

Related Links

[Understanding PeopleSoft Quality Integration With Other PeopleSoft Applications](#)

Integration With Third-Party Systems

Many companies implementing manufacturing systems use automated collection devices or systems to assist in quality inspection and control. Through the use of the Application Messaging technology, you can pass quality information collected from these devices to Quality.

The third-party system passes quality control information to Quality using application messages. Messages are posted to a queue. Quality then:

1. Retrieves the message from the queue.
2. Analyzes the data.
3. Updates the database with results.

Transaction messages coming from the third-party system can be marked as move-only. In this mode, the system doesn't process the messages, but the data associated with the message is moved immediately into the PeopleSoft database. Use this feature to create data-entry sessions that can be reviewed or completed later.

Related Links

[Understanding the Integration of PeopleSoft Quality With Third-Party Applications](#)

Chapter 3

Defining Quality Methods and Procedures

Understanding PeopleSoft Quality Methods

Quality provides industry-accepted methods for applying statistical process control (SPC) practices to manufacturing operations. These methods help you:

- Monitor several processes simultaneously, in real-time, to assess stability and identify out-of-control conditions.
- Generate alarms and dispatch them online by using electronic mail or Workflow.
- Characterize, stabilize, and improve the process by using advanced statistics and graphing techniques.

Note: The product is delivered with many industry-standard definitions for control charts, control tests, and control procedures. You can elect to use these defaults or create specific methods. If you use the system's standard definitions, you don't have to use this topic to get started.

All the configured methods are available for use by Quality during both online and offline data analysis (Quality application client).

Related Links

[Delivered Workflow for PeopleSoft Quality](#)

Control Charts

Control charts are graphical representations of data that is associated with a process, plotted over time.

Use these charts to:

- Monitor a process to determine stability.
- Visualize trends and variability.
- Note and track process adjustments.
- Investigate causes of unacceptable or marginal quality.

PeopleSoft provides you with seven industry-standard control charts. These charts are time-series charts for monitoring and controlling processes or equipment. Each control chart has a unique chart ID that represents a different display format.

Using the Control Chart component, you can define custom charts to reflect special control requirements or labeling conventions. The charts are based on industry-standard control charts and are applicable to a specific data type.

Note: Chart IDs 1 through 7 are supplied as industry-standard system defaults.

Chart ID	Description	Data Type
1	X and Moving Range.	Variables
2	Xbar and Range.	Variables
3	Xbar and Sigma.	Variables
4	c Chart.	Defects
5	u Chart.	Defects
6	p Chart.	Defectives
7	np Chart.	Defectives

These tables illustrate the structure of each control chart.

Note: Some control charts are comprised of two individual subcharts for plotting means and variances together. These subcharts are labeled as chart 1 or chart 2 in the tables.

Control Chart ID: 1

Image: Control Chart ID: 1

This graphic shows Control Chart ID 1

Control Chart ID: 1							
Panel	Control Chart ID	Control Chart Name	Charts	Zones	Data Type	Constant Subgroup Size	Observ
General	1	X and Moving Range	2	3	Variables	Yes	GVAL
Chart 1							
	PeopleSoft Quality Formula			Industry Formula			
Label	X						
Plot X	GVAL						
Vars V	ABS (GMEAN - PREVX[1])						
UCLA (2)	SMEANX+(2.66*SMEANV)			$\bar{X} + 2.66(\overline{MR})$			
CL (1)	SMEANX			\bar{X}			
LCL (3)	SMEANX-(2.66*SMEANV)			$\bar{X} - 2.66(\overline{MR})$			
Chart 2							
	PeopleSoft Quality Formula			Industry Formula			
Label	MRange						
Plot X	ABS(GMEAN - PREVX[1])						
Vars V	ABS (GMEAN - PREVX[1])						
UCLA (2)	(SMEANV*3.267)			$3.267(\overline{MR})$			
CL (1)	SMEANV			\overline{MR}			
LCL (3)	0.0			0			

Control Chart ID: 2

Image: Control Chart ID: 2

This graphic displays Control Chart ID 2

Control Chart ID: 2							
Panel	Control Chart ID	Control Chart Name	Charts	Zones	Data Type	Constant Subgroup Size	Observ
General	2	Xbar and Range	2	3	Variables	Yes	GVAL
Chart 1							
	PeopleSoft Quality Formula			Industry Formula			
Label	Xbar						
Plot X	GMEAN						
Vars V	GRANGE						
UCLA (2)	SMEANX+(LA2*SMEANV)			$\bar{\bar{X}} + A_2\bar{R}$			
CL (1)	SMEANX			$\bar{\bar{X}}$			
LCL (3)	SMEANX-(LA2*SMEANV)			$\bar{\bar{X}} - 2.66(\bar{MR})$			
Chart 2							
	PeopleSoft Quality Formula			Industry Formula			
Label	Range						
Plot X	GRANGE						
Vars V	GRANGE						
UCLA (2)	(SMEANV*LD4)			$D_4\bar{R}$			
CL (1)	SMEANV			\bar{R}			
LCL (3)	(SMEANV*LD3)			$D_3\bar{R}$			

Control Chart ID: 3**Image: Control Chart ID: 3**

This graphic displays Control Chart ID 3

Control Chart ID: 3							
Panel	Control Chart ID	Control Chart Name	Charts	Zones	Data Type	Constant Subgroup Size	Observ
General	3	Xbar and Sigma	2	3	Variables	Yes	GVAL
Chart 1							
	PeopleSoft Quality Formula			Industry Formula			
Label	Xbar						
Plot X	GMEAN						
Vars V	GSDEV						
UCLA (2)	SMEANX+(LA3*SMEANV)			$\bar{\bar{X}} + A_3\bar{s}$			
CL (1)	SMEANX			$\bar{\bar{X}}$			
LCL (3)	SMEANX-(LA3*SMEANV)			$\bar{\bar{X}} - A_3\bar{s}$			
Chart 2							
	PeopleSoft Quality Formula			Industry Formula			
Label	Sigma						
Plot X	GSDEV						
Vars V	GSDEV						
UCLA (2)	(SMEANV*LB4)			$B_4\bar{s}$			
CL (1)	SMEANV			\bar{s}			
LCL (3)	(SMEANV*LB3)			$B_3\bar{s}$			

Control Chart ID: 4

Image: Control Chart ID: 4

This graphic displays Control Chart ID 4

Control Chart ID: 4							
Panel	Control Chart ID	Control Chart Name	Charts	Zones	Data Type	Constant Subgroup Size	Observ
General	4	c Chart	1	3	Defects	Yes	GVAL
Chart 1							
	PeopleSoft Quality Formula			Industry Formula			
Label	C						
Plot X	GSUM						
Vars V							
UCLA (2)	SMEANX+3*(SQRT(SMEANX))			$\bar{c} + 3\sqrt{\bar{c}}$			
CL (1)	SMEANX			\bar{c}			
LCL (3)	SMEANX-3*(SQRT(SMEANX))			$\bar{c} - 3\sqrt{\bar{c}}$			

Control Chart ID: 5**Image: Control Chart ID: 5**

This graphic displays Control Chart ID 5

Control Chart ID: 5							
Panel	Control Chart ID	Control Chart Name	Charts	Zones	Data Type	Constant Subgroup Size	Observ
General	5	u Chart	1	3	Defects	No	GVAL
Chart 1							
	PeopleSoft Quality Formula			Industry Formula			
Label	u						
Plot X	(GVAL/GSIZE)						
Vars V							
UCLA (2)	CL2+3*(SQRT(CL2/SMEANZ))			$\bar{u} + 3\sqrt{\frac{\bar{u}}{n}}$			
CL (1)	(SSOBSV/SSUMZ)			\bar{u}			
LCL (3)	CL2-3*(SQRT(CL2/SMEANZ))			$\bar{u} - 3\sqrt{\frac{\bar{u}}{n}}$			

Control Chart ID: 6

Image: Control Chart ID: 6

This graphic displays Control Chart ID 6

Control Chart ID: 6							
Panel	Control Chart ID	Control Chart Name	Charts	Zones	Data Type	Constant Subgroup Size	Observ
General	6	p Chart	1	3	Defectives	No	GVAL
Chart 1							
	PeopleSoft Quality Formula			Industry Formula			
Label	p						
Plot X	(GVAL/GSIZE)						
Vars V							
UCLA (2)	CL2+3*(SQRT(CL2*((1-CL2)/SMEANZ)))			$\bar{p} + 3\sqrt{\frac{\bar{p}(1-\bar{p})}{\bar{n}}}$			
CL (1)	(SSOBSV/SSUMZ)			\bar{p}			
LCL (3)	CL2-3*SQRT(CL2*((1-CL2)/SMEANZ))			$\bar{p} - 3\sqrt{\frac{\bar{p}(1-\bar{p})}{\bar{n}}}$			

Control Chart ID: 7

Image: Control Chart ID: 7

This graphic displays Control Chart ID 7

Control Chart ID: 7							
Panel	Control Chart ID	Control Chart Name	Charts	Zones	Data Type	Constant Subgroup Size	Observ
General	7	np Chart	1	3	Defectives	Yes	GVAL
Chart 1							
	PeopleSoft Quality Formula			Industry Formula			
Label	np						
Plot X	GVAL						
Vars V							
UCLA (2)	CL2+3*(SQRT(CL2*(1-(SSOBSV/SSUMZ))))			$n\bar{p} + 3\sqrt{n\bar{p}\left(1 - \frac{n\bar{p}}{n}\right)}$			
CL (1)	(SSOBSV/SSIZE)			$n\bar{p}$			
LCL (3)	CL2-3*SQRT(CL2*(1-(SSOBSV/SSIZE)))			$n\bar{p} - 3\sqrt{n\bar{p}\left(1 - \frac{n\bar{p}}{n}\right)}$			

Related Links

[Defining Control Charts](#)

[Control Chart Page](#)

[Using Control Charts](#)

Control Tests

To assess ongoing control and stability, you test incoming sample data online against various statistical conditions. Each condition is represented by a control test that is applied to subgroups that are plotted on a control chart. Quality includes a set of 17 default control tests. Each test is based on a standard Shewhart pattern for identifying special causes of variability. Use the default test or create control tests from the industry-standard default prototypes.

You can selectively apply the tests to mean or variance charts, and control the sensitivity of each test by specifying the number of points to evaluate and the number of points in the pattern that are required for triggering a violation. If a data point (subgroup) violates one or more control tests, the system generates an alarm. The system identifies a test by a unique ID number and description.

Note: Control tests 1 through 17 are supplied as industry-standard system defaults. You can't change the prototype fields for these tests.

Test ID Number	Description	Prototype	Chart	k of K
1	Specification limit violation.	1	1	1 of 1.
2	Control limit violation (mean).	2	1	1 of 1.
3	Control limit violation (variance).	2	2	1 of 1.
4	Trend - 7 pts (mean).	4	1	7 of 7.
5	Shift - 2 of 3 pts (mean).	6	1	2 of 3.
6	Shift - 4 of 5 pts (mean).	7	1	4 of 5.
7	Shift - 8 of 8 pts (mean).	3	1	8 of 8.
8	Mixture - 8 pts (mean).	9	1	8 of 8.
9	Systematic variable - 14 pts (mean).	5	1	14 of 14.
10	Stratification - 15 pts (mean).	8	1	15 of 15.
11	Trend - 7 pts (variance).	4	2	7 of 7.
12	Shift - 2 of 3 pts (variance).	6	2	2 of 3.
13	Shift - 4 of 5 pts (variance).	7	2	4 of 5.
14	Shift - 8 of 8 pts (variance).	3	2	8 of 8.
15	Mixture - 8 pts (variance).	9	2	8 of 8.
16	Systematic variable - 14 pts (variance).	5	2	14 of 14.
17	Stratification - 15 pts (variance).	8	2	15 of 15.

The standard Control Test Prototypes are defaults that are shipped with Quality. The prototypes illustrate the basic pattern that is evaluated. Control tests that you create are variations that are based on specific prototypes.

Illustration	Description
$\text{Variance} = \frac{\sum (X_i - \bar{X})^2}{n - 1}$	Value < LSL or > USL.
s^2	Current point beyond zone A.
$\text{Std Error} = \frac{s}{\sqrt{n}}$	K consecutive points in zone C or beyond.
$\frac{s}{\bar{x}}$	K consecutive points steadily increasing or decreasing.
$\text{Coef Vars} = \left(\frac{s}{ \text{Mean} } \right) \times 100$	K consecutive points alternating up and down.
$\text{Lwr Z Score} = \frac{\bar{X} - \text{LSL}}{s}$	k of K consecutive points in zone A or beyond.
$\text{Upr Z Score} = \frac{\text{USL} - \bar{X}}{s}$	k of K consecutive points in zone B or beyond.
$\text{Median} = .50(n + 1)$	K consecutive points in zone C above and below the centerline.
$\text{Quartile 25\%} = .25(n + 1)$	K consecutive points beyond zone C.

Related Links

[Defining Control Tests](#)

Control Procedures

Control procedures are a convenience mechanism that you use to specify an overall testing and control scheme that is executed as process data is collected and analyzed. Each procedure is comprised of a list of control tests (listed in order of execution), and optionally, subgroup milestones indicating a progression for control limit calculations. You associate procedures with inspection characteristics to achieve the desired level of process control, feedback, and alarming.

PeopleSoft provides four predefined control procedures, each with a varying number of tests. You can use these predefined control procedures, modify them, or create a set of procedures:

Control Procedure ID #	Description	Control Tests
1	Level I	Specification limit violation.
1	Level I	Control limit violation (variance).
1	Level I	Control limit violation (mean).

Control Procedure ID #	Description	Control Tests
2	Level II	Level I +.
2	Level II	Trend - 7 pts (mean).
2	Level II	Shift - 2 of 3 pts (mean).
2	Level II	Shift - 4 of 5 pts (mean).
2	Level II	Shift - 8 of 8 pts (mean).
3	Level III	Level II +.
3	Level III	Trend - 7 pts (variance).
3	Level III	Shift - 2 of 3 pts (variance).
3	Level III	Shift - 4 of 5 pts (variance).
3	Level III	Shift - 8 of 8 pts (variance).
4	Level IV	Level III +.
4	Level IV	Mixture - 8 pts (mean).
4	Level IV	Systematic variable - 14 pts (mean).
4	Level IV	Stratification - 15 pts (mean).
4	Level IV	Mixture - 8 pts (variance).
4	Level IV	Systematic variable - 14 pts (variance).
4	Level IV	Stratification - 15 pts (variance).

Related Links

[Defining Control Procedures](#)

Sampling Codes

Sampling codes indicate inspection priorities among characteristics and specify the needed frequency of inspection sampling. The codes can also help meet customer or regulatory auditing, reporting, and certification requirements by enhancing inspection instructions and associated documentation. The system provides code libraries for characteristic and inspection frequency classifications.

Related Links

[Defining Sampling Codes](#)

Understanding Graph and Display Preferences

Graph and display preferences determine the statistical and visual content of quality charts and graphs when viewed from both the PeopleSoft Internet Architecture and when using the (optional) Quality application client. You use graph and display preferences to:

- Define the presentation and statistical content of Quality charts and graphs to meet particular business needs.
- Enunciate details by overlaying related information such as specification limits, summary statistics, or control chart alarms.
- Simplify the interpretation of data when viewed by operators or quality personnel.

Quality provides four predefined graph preferences that contain standard default options and settings for the available graph types. Use the Graph and Display Preferences component to add new preferences or change the settings of existing preferences to suit data analysis requirements. The following tables illustrate the predefined graph and display preferences.

Graph Preferences ID: 1 - Variable Data Entry Default

<i>Option</i>	<i>Setting</i>
Default Working Graph.	Control Chart.
Default Pareto Chart Item.	Control Test Violations.
Pareto Cell Display Limit.	25.
Bar Graph Display Limit.	10.
Display Control Chart Alarms.	Yes.
Indicate Specs on Histogram.	Yes.
Statistics List.	OBSRV.MEAN.MINIMUM.MAXIMUM.STDDEV. CP.CPK. CPL.CPU.PCLOWER.PCUPPER. PCTOTAL.LSL.USL.

Graph Preferences ID: 2 - Attribute Data Entry Default

<i>Option</i>	<i>Setting</i>
Default Working Graph.	Control Chart.
Default Pareto Chart Item.	Defects.
Pareto Cell Display Limit.	10.
Bar Graph Display Limit.	10.

Option	Setting
Display Control Chart Alarms.	Yes.
Indicate Specs on Histogram.	No.
Statistics List.	OBSRV.MEAN.MINIMUM.MAXIMUM.SUMDEF. DEFPH. DEFPT.DEFPM.DEFPU.

Graph Preferences ID: 3 - Analysis Default

Option	Setting
Default Working Graph.	Control Chart.
Default Pareto Chart Item.	Control Test Violations.
Pareto Cell Display Limit.	25.
Bar Graph Display Limit.	25.
Display Control Chart Alarms.	Yes.
Indicate Specs on Histogram.	Yes.
Statistics List.	OBSRV.MEAN.MINIMUM.MAXIMUM.STDDEV.CP. CPK. CPL.CPU.PCSPEC.PCLOWER.PCUPPER. PCTOTAL.LSL. USL.

Graph Preferences ID: 4 - Advanced Analysis Default

Option	Setting
Default Working Graph.	Control Chart.
Default Pareto Chart Item.	Control Test Violations.
Pareto Cell Display Limit.	25.
Bar Graph Display Limit.	25.
Display Control Chart Alarms.	Yes.
Indicate Specs on Histogram.	Yes.

Option	Setting
Statistics List.	OBSRV.MEAN.MINIMUM.MAXIMUM.STDDEV. RANGE. VARIANCE.STDERR.COEFVAR. SKEWNESS. KURTOSIS. ZLOWER.ZUPPER.LOWER3S.UPPER3S. DISTYPE.Q1. MEDIAN. Q3.AVEMEANS.AVEVARS. CP.CPK.CPL. CPU. PCSPEC.PCLOWER.PCUPPER. PCTOTAL. LSL.USL.

Defining Control Charts

To define control charts, use the Control Charts component (QS_CL_CHART). This section discusses how to:

- Define control charts.
- Copy configuration items.

Pages Used to Define Control Charts

Page Name	Definition Name	Navigation	Usage
Define Control Chart	QS_CL_CHART0	Quality, Define Methods and Procedures, Control Charts, Define Control Chart	Define the scope of the chart, such as chart prototype and testing zones. Use these charts for real-time or offline data analysis.
Copy Configuration Item	QS_COPY0_PNL	Click the Copy From button on multiple pages in Quality.	Creates a new chart by copying an existing chart.

Defining Control Chart Page

Use the Define Control Chart page (QS_CL_CHART0) to define the scope of the chart, such as chart prototype and testing zones.

Use these charts for real-time or offline data analysis.

Navigation

Quality, Define Methods and Procedures, Control Charts, Define Control Chart



Click the Copy From button to create the new control chart by copying from an existing control chart. When you click this button, the Copy Configuration Item page appears.

Chart Prototype

Select a chart prototype. Values are: *X & Moving Range*, *Xbar & Range*, *Xbar & Sigma*, *c Chart*, *np Chart*, *p Chart*, and *u Chart*.

The chart prototype that you select defines the standard formulas that are used to calculate subgroup values and control limits.

Test Zones

Enter the number of divisions between the upper control limit (UCL) and the mean (CL) limit lines that are used for control-test evaluations. Zones typically represent standard deviations.

Data Type

Select the type of data that is to be plotted on this chart. Values include:

Variables: Measurable characteristics, such as length, mass, or time, and for characteristics that are derived from measurable characteristics, such as volume, density, or area.

Defects: Characteristics that represent defect counts, which are counts of the number of defects observed per unit, such as scratches, blemished, or missing subcomponents.

Defectives: Characteristics that represent counts of defective units and counts of how many units are defective using a pass or fail criteria.

Related Links

[Understanding Measurement Plans](#)

Copy Configuration Item Page

Use the Copy Configuration Item page (QS_COPY0_PNL) to create a new chart by copying an existing chart.

Navigation

Click the Copy From button on multiple pages in Quality.

Create a new control chart by selecting an existing chart from the Copy From field.

Defining Control Tests

To define control tests, use the Control Tests component (QS_CL_TEST). This section discusses how to define control tests.

Pages Used to Define Control Tests

Page Name	Definition Name	Navigation	Usage
Define Control Test	QS_CL_TEST	Quality, Define Methods and Procedures, Control Tests, Define Control Test	Define tests for detecting loss of process control. Test violations are reported as alarms and noted on control charts.
Copy Configuration Item	QS_COPY0_PNL	Copy From	Creates a new control test by copying an existing control test.

Define Control Test Page

Use the Define Control Test page (QS_CL_TEST) to define tests for detecting loss of process control.

Test violations are reported as alarms and noted on control charts.

Navigation

Quality, Define Methods and Procedures, Control Tests, Define Control Test



Click the Copy From button to create the new control test by copying from an existing control test. When you click this button, the Copy Configuration Item page appears.

Test Prototype

Prototype

Select the pattern to use for performing tests for special causes of variation. This is also known as the Western Electric rule type.

Pattern Example

Displays a cursory illustration of the pattern that is tested.

Note: The prototype illustration is standardized and is not adjusted based on the number of tested or trigger points that are entered for a specific control test.

Apply To

Select which subchart (Chart 1 or Chart 2) within a control chart to apply the test to. This enables alarming distinction between means and variance tests.

Sensitivity

Trigger Points

Enter the number of points (subgroups) in violation that are necessary to trigger the alarm.

Tested Points

Enter the overall number of plotted points (subgroups) that are to be tested. For example, if the Trigger Points value is 3 and

Tested Points is 6, then it takes three subgroups out of six in violation of the pattern to trigger the alarm.

Defining Control Procedures

To define control procedures, use the Control Procedures component (QS_CL_PROC). This section discusses how to define control procedures.

Pages Used to Define Control Procedures

<i>Page Name</i>	<i>Definition Name</i>	<i>Navigation</i>	<i>Usage</i>
Define Control Procedure	QS_CL_PROC	Quality, Define Methods and Procedures, Control Procedures, Define Control Procedure	Define groups of control tests and control limit promotion milestones that are to be applied for online analysis.
Copy Configuration Item	QS_COPY0_PNL	Click the Copy From button on multiple pages in Quality.	Creates a new control procedure by copying an existing control procedure.

Define Control Procedure Page

Use the Define Control Procedure page (QS_CL_PROC) to define groups of control tests and control limit promotion milestones that are to be applied for online analysis.

Navigation

Quality, Define Methods and Procedures, Control Procedures, Define Control Procedure

Image: Define Control Procedure page

This example illustrates the fields and controls on the Define Control Procedure page. You can find definitions for the fields and controls later on this page.

Control Procedure 3

*Procedure Description

Date Modified 09/14/1998 12:00AM

Modified By PSOFT STANDARD

Limit Promotion Milestones

Preliminary

Monitoring

OnGoing

Recalculate

History Requirements

Limits Calculate Window

Graph Window

Control Test Evaluation Order Personalize | First 1-11 of 11 Last

		*Control Test		
▼	▲	Specification Limit Violation	▼	+ -
▼	▲	Control Limit Violation (variance)	▼	+ -
▼	▲	Control Limit Violation (mean)	▼	+ -
▼	▲	Trend - 7 pts (mean)	▼	+ -
▼	▲	Shift - 2 of 3 pts (mean)	▼	+ -
▼	▲	Shift - 4 of 5 pts (mean)	▼	+ -
▼	▲	Shift - 8 of 8 pts (mean)	▼	+ -
▼	▲	Trend - 7 pts (variance)	▼	+ -
▼	▲	Shift - 2 of 3 pts (variance)	▼	+ -
▼	▲	Shift - 4 of 5 pts (variance)	▼	+ -
▼	▲	Shift - 8 of 8 pts (variance)	▼	+ -

Click the Copy From button to create the new control procedure by copying from an existing control procedure. When you click this button, the Copy Configuration Item page appears.

Limit Promotion Milestones

Limit promotion milestones indicate the subgroup numbers at which an automatic recalculation of control limits take place. As data is collected over time and corrective action is taken, the process should become more stable, yielding tighter control limits for periodic recalculations and reflecting a natural reduction in process variation. In Quality, this concept is considered to be control limit promotion.

Note: These settings are optional. Leave all three fields blank if you want to disable automatic control limit promotion.

Preliminary

Enter the number of subgroups that the system will use for the first calculation point for a new or unstable process.

Monitoring

Enter the number of subgroups that the system will use for the second calculation point for a process reaching stabilization.

OnGoing

Enter the number of subgroups that the system will use for the third calculation point, which is assumed to be the point at which the process reaches maturity.

Copyright © 1992, 2013, Oracle and/or its affiliates. All rights reserved.

49

Recalculate

Enter the number of subgroups that the system will use at which limits are recalculated on a recurring basis after an ongoing status is achieved. This setting is optional and only applies to control limits that are calculated by using the promotion milestones.

History Requirements

The history settings represent the number of prior subgroups that are recalled from the database for the purpose of calculating control limits. This number includes the currently entered subgroup.

Limits Calculate Window

Enter the number of subgroups to recall from history to create a control limit calculation window. Values are 2 through 250.

Graph Window

Enter the number of subgroups that are used when producing a graphic display during online data entry and analysis. Values are 1 through 99.

Control Test Evaluation Order

Control tests are evaluated during time of analysis in the order that this list specifies. The prompt selections are comprised of the Quality product defaults and any tests that you create. The system flags and reports up to three test violations per subgroup: one against each subchart, such as violations against both the means and variance, and one against specification limit violations.

Related Links

[Stream Details Page](#)

[Defining Control Tests](#)

[Control Chart Page](#)

[Using Control Charts](#)

Defining Sampling Codes

To define sampling codes, use the Sampling Codes component (QS_MFDS_TYPES). This section discusses how to:

- Maintain characteristic class types.
- Maintain sampling frequency types.

Note: Characteristic class and sampling frequency types are for reference and documentation only. System and processing behavior are not affected by their settings.

Pages Used to Define Sampling Codes

Page Name	Definition Name	Navigation	Usage
Characteristic Class Types	QS_CLASS_TYPE	Quality, Define Methods and Procedures, Sampling Codes, Characteristic Class Types	Maintain characteristic class types that note differences in inspection criticality or function. You use characteristic class types when defining measurement plans.
Sampling Frequency Types	QS_FRQ_TYPE	Quality, Define Methods and Procedures, Sampling Codes, Sampling Frequency Types	Maintain sampling frequency types that note the frequency for taking inspection samplings. You use sampling frequency types when creating control plans.

Characteristic Class Types Page

Use the Characteristic Class Types page (QS_CLASS_TYPE) to maintain characteristic class types that note differences in inspection criticality or function.

You use characteristic class types when defining measurement plans.

Navigation

Quality, Define Methods and Procedures, Sampling Codes, Characteristic Class Types

Enter a class type code to qualify the quality control characteristics, either by criticality or function. Class types are associated with characteristics when you create measurement plans.

Related Links

[Understanding Measurement Plans](#)

Sampling Frequency Types Page

Use the Sampling Frequency Types page (QS_FRQ_TYPE) to maintain sampling frequency types that note the frequency for taking inspection samplings.

You use sampling frequency types when creating control plans.

Navigation

Quality, Define Methods and Procedures, Sampling Codes, Sampling Frequency Types

Enter a frequency code to specify the recommended frequency of inspection for a control plan.

Related Links

[Understanding Control Plans](#)

Maintaining Graph and Display Preferences

To define graph preferences, use the Graph Preferences component (GRAPH_PREF). This section discusses how to maintain graph and display preferences.

Pages Used to Maintain Graph and Display Preferences

<i>Page Name</i>	<i>Definition Name</i>	<i>Navigation</i>	<i>Usage</i>
Define Graph Preferences	QS_GRSET	Quality, Define Methods and Procedures, Graph Preferences, Define Graph Preferences	<p>Define the settings for calculations and the defaults for graphic displays for new graph preferences or change settings on predefined graph preferences. The online graphic displays and statistical content are determined by how you define these preferences. At run time these settings remain static and cannot be changed by the user.</p> <p>If you are using the Quality application client offline against an extracted or user-defined data set, the graph type is selectable and certain settings can be changed by using the Modify Graph menu option from the Quality application client toolbar.</p>
Statistic Selections	QS_STATSELECT_PNL	Click the Statistics List link on the Define Graph Preferences page.	Associate statistics with control charts, histograms, or Pareto charts.

Define Graph Preferences Page

Use the Define Graph Preferences page (QS_GRSET) to define the settings for calculations and the defaults for graphic displays for new graph preferences or change settings on predefined graph preferences.

The online graphic displays and statistical content are determined by how you define these preferences. At run time these settings remain static and cannot be changed by the user. If you are using the Quality application client offline against an extracted or user-defined data set, the graph type is selectable and certain settings can be changed by using the Modify Graph menu option from the Quality application client toolbar.

Navigation

Quality, Define Methods and Procedures, Graph Preferences, Define Graph Preferences

Graph Preference ID	A sequential ID that is automatically assigned to a graph by the system appears.
Graph Preference Name	Enter a user-defined name for the graph.
Default Working Graph	Select the default graph that you want to view when performing online operations, such as data entry and alarm review. Options are: <i>Control Chart</i> , <i>Histogram</i> , and <i>Pareto Chart</i> .
Default Pareto Chart Item	Select the attribute type that you want to plot on the Pareto Chart. Options are: <i>Control Test Violations</i> , <i>Corrective Actions</i> , <i>Defects</i> , and <i>Probable Causes</i> .
Pareto Cell Display Limit	Enter the number of cells to display based upon cell count and the graphing order that you select.
Bar Graph Display Limit	Enter the number of bars to display based on the statistics value and the graphing order that you select.
Display Control Chart Alarms	Select to activate alarm point enunciation on each chart. Alarms are indicated on a separate (stacked) bar graph located below the control chart. The charts are arranged so that alarms (bars) will line up for each plot point on the control chart. The absence of a bar indicates no alarms for that point, a bar extending above the x-axis indicates an alarm charged against the means chart, and a bar extending below the x-axis indicates an alarm against the variance chart. If this option is not selected then the bar graph will not appear.
Indicate Specs on Histogram	Select to overlay the current characteristic specification limits on the histogram. For online graphs, the specification limits are indicated in the cell listing area and not actually drawn on the graph.
Statistics List	Click this link to access the Statistic Selections page, where you can select the statistics that you want to associate with control charts, histograms, or Pareto charts and the order in which the statistics appear.

Statistic Selections Page

Use the Statistic Selections page (QS_STATSELECT_PNL) to associate statistics with control charts, histograms, or Pareto charts.

Navigation

Click the Statistics List link on the Define Graph Preferences page.

Image: Statistic Selections page

This example illustrates the fields and controls on the Statistic Selections page. You can find definitions for the fields and controls later on this page.

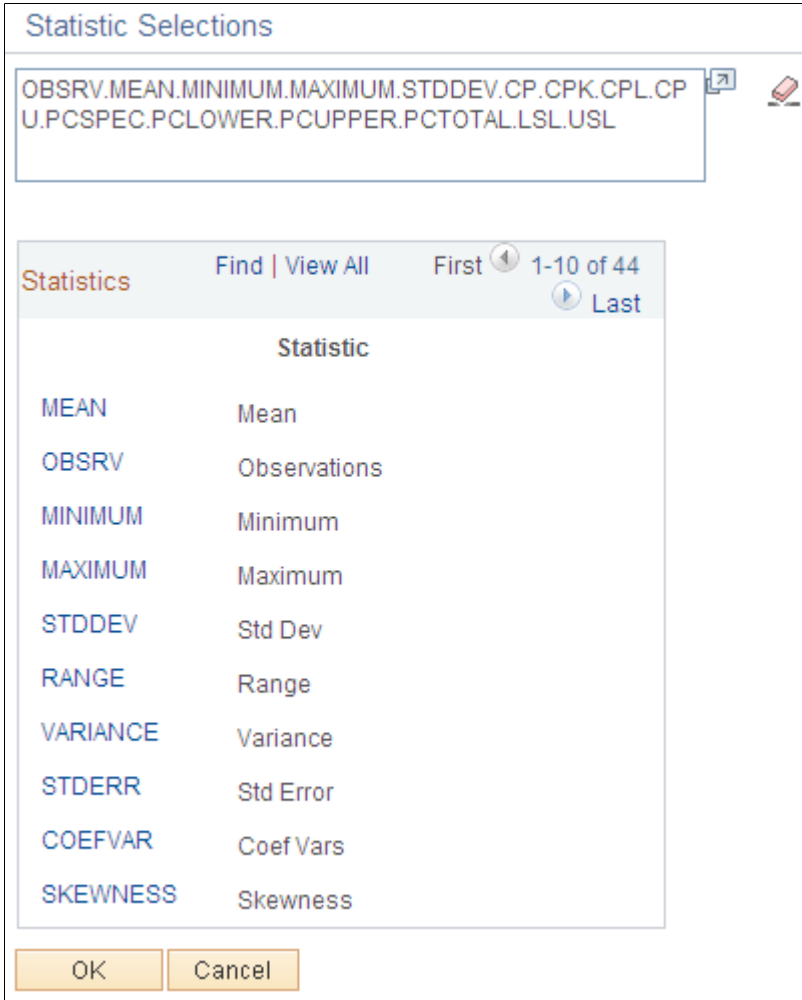

Use the scroll function to display all statistics and associated descriptions that are available in the Statistics Catalog. Click the different statistics links to select and place them into the list for the graphic or display. The following table shows the 44 statistics that are available on the Statistic Selections page.

Statistic	Statistic Description	Data Type Qualifier
MEAN	Mean.	Any
OBSRV	Observations.	Any
MINIMUM	Minimum.	Any
MAXIMUM	Maximum.	Any
STDDEV	Std Dev (standard deviation).	Any

Statistic	Statistic Description	Data Type Qualifier
RANGE	Range.	Any
VARIANCE	Variance.	Any
STDERR	Std Error (standard error).	Any
COEFVAR	Coef Vars (coefficient variables).	Any
SKEWNESS	Skewness.	Any
KURTOSIS	Kurtosis.	Any
ZLOWER	Lwr Z Score (lower Z score).	Any
ZUPPER	Upr Z Score (upper Z score).	Any
LOWER3S	Lwr 3 Sigma (lower 3 Sigma).	Any
UPPER3S	Upr 3 Sigma (upper 3 Sigma).	Any
DISTYPE	Dist Type (distribution type).	Any
SUMX	Sum.	Any
SUMX2	Sum of Squares.	Any
SUMZ	Sum Sgrp Sizes (sum of subgroup sizes).	Any
SIZEN	Subgroup Size.	Any
Q1	Quartile 25%.	Any
MEDIAN	Median.	Any
Q3	Quartile 75%.	Any
AVEMEANS	X Dbl Bar (X double bar).	Any
AVEVARS	R Bar.	Variables
CP	Cp.	Variables
CPK	Cpk.	Variables
CPL	Cpl.	Variables
CPU	Cpu.	Variables
CPK90	Cpk @ 90%.	Variables
PCSPEC	Cr.	Variables

Statistic	Statistic Description	Data Type Qualifier
PCLOWER	Est % Below Spec (estimated percent below specification).	Variables
PCUPPER	Est % Above Spec (estimated percent above specification).	Variables
PCTOTAL	Est % Total (estimated percent total).	Variables
SUMDEF	Sum Defects.	Defects
DEFPH	Defects/100.	Defects
DEFPT	Defects/1000.	Defects
DEFPM	Defects/Mil.	Defects
DEFPU	Defects/Unit.	Defects
LSL	LSL.	Any
USL	USL.	Any
FACT1	Factor 1.	Any
FACT2	Factor 2.	Any
TRANS	Transform.	Any

Defining Quality Functions

Understanding Quality Functions

Most production environments comprise several processing or data-collection areas. Each area can perform a different function and potentially yield unique process and traceability information. This makes it necessary to configure the quality control environment to ensure that it is capable of collecting information that is relevant to the business needs.

You can configure Quality to emulate these various data collection requirements through the use of quality functions. A quality function is a set of fields that identifies nonparametric information and maps process-specific field information into Quality for process identification, data tracking, and analysis.

Quality manages individual data-collection requirements simultaneously by not imposing a fixed-field hierarchy or traceability structure. Identifying key process information is essential to implementing effective quality control plans. You create a new configuration level (quality function) that defines the fields and attendant information that provides a base level for inspection plan creation and integration.

Maintaining Quality Functions

To define Quality Business Units, use the Quality Definition component (QUALITY_BU). To define quality functions, use the Quality Functions component (QS_APP_DEF). Use quality functions to specify hierarchy and trace field requirements inherent in a given process or family of processes. Quality functions enable interaction with Quality using native terms and eliminate the need for special placeholder fields.

Quality functions are defined at the system level to ensure continuity of access and analysis across multiple business units; therefore, you don't define quality functions by SetID or business unit. Quality also uses quality functions to determine which fields appear on pages when fields are available for data entry or data query on subsequent Quality pages.

This section discusses how to:

- Establish a Quality business unit.
- Define quality functions.

Pages Used to Maintain Quality Functions

<i>Page Name</i>	<i>Definition Name</i>	<i>Navigation</i>	<i>Usage</i>
Quality Bus Unit	BUS_UNIT_QS	Set Up Financials/Supply Chain, Business Unit Related, Quality, Quality Definition, Quality Bus Unit	Establish a Quality business unit. You can't create an independent Quality business unit.
Define Quality Function	QS_APP_DEF	Quality, Define Methods and Procedures, Quality Functions, Define Quality Function	Maintain application fields that are categorized as hierarchy or traceability to control data entry and analysis field input requirements.
Copy Configuration Item	QS_COPY0_PNL	Click the Copy From button on multiple pages in Quality.	Create a new quality function by copying an existing quality function.

Quality Business Unit Page

Use the Quality Bus Unit page (BUS_UNIT_QS) to establish a Quality business unit.

Navigation

Set Up Financials/Supply Chain, Business Unit Related, Quality, Quality Definition, Quality Bus Unit

Quality business units are derived from Inventory, Purchasing, or Manufacturing business units. You can change the description.

Defining Quality Functions

Use the Define Quality Function page (QS_APP_DEF) to maintain application fields that are categorized as hierarchy or traceability to control data entry and analysis field input requirements.

Navigation

Quality, Define Methods and Procedures, Quality Functions, Define Quality Function

Note: After you associate a control plan with a quality function, you cannot add or delete fields. You can specify up to 12 trace fields and 12 hierarchy fields for a quality function.

Graph Preference ID

Select the default graph preference for the system to apply in those instances where a summary analysis is performed across multiple process streams and bar charts or Pareto charts appear.

Data Persistence

Session Data Life Days

Specifies the number of days (1 to 120) to retain incomplete data-entry sessions for completion. This setting applies to all process streams that are created under the quality function.

Edit Data Limit Days

Specifies the number of days (1 to 365) that historical data is available for editing or correction. This setting applies to all process streams that are created under the quality function.

Application Fields

Select how you use a field when entering quality data against control plans in the Field Use field. Field selections must be unique within a quality function and are categorized as either stream hierarchy fields or traceability fields. The list of available fields is system-defined by PeopleSoft and may vary depending on which PeopleSoft applications you have installed.

Stream Hierarchy

The field becomes a stream component, and the system uses it to maintain control limits.

Traceability

Identifies trace information when collecting sampling data.

The field name (actual database object name) and default prompt table or view, which is used to populate drop-down lists if one exists for the field, appear when you select a field. You can override the prompt table or view on this page if you define a replacement or special-case view.

Related Links

[Select Pending Session Page](#)

[Understanding Control Plans](#)

Integration With Other PeopleSoft Applications

A quality function parents control plans with associated sample data and is the first point of integration between Quality and other PeopleSoft applications. The function provides awareness of the different fields that are common to an integrating application. Quality functions are created to synchronize fields with other PeopleSoft applications and eliminate the need to enter placeholders in unused fields.

To configure Quality to operate in a given data collection environment:

1. Define a quality function.
2. Identify the characteristics that you want to monitor on a measurement plan.
3. Create control plans that bring together a measurement plan and specific process identifiers.

Currently, Quality integrates with Purchasing, Inventory, and Production Management and delivers the following predefined quality functions to accommodate the integration between products:

PeopleSoft Application	Quality Function	Function Description	Hierarchy Fields	Trace Fields
Purchasing	RECV_INSPECT	Receiving inspection.	INV_ITEM_ID VENDOR_ID	DISTRIB_LINE_NUM DISTRIB_SEQ_NUM LOT_ID OPRID RECEIVER_ID RECV_LN_NBR SERIAL_ID TAG_NUMBER VENDOR_LOT_ID
Inventory	RMA	Inspect items on a returned material authorization.	INV_ITEM_ID	CONFIG_CODE CONTAINER_ID INV_LOT_ID QTY_INV_RECV RECEIPT_DTTM RECEIVER_ID RETURN_FROM_BU RETURN_FR_CUST_ID RMA_ID RMA_LN_NBR SERIAL_ID STORAGE_AREA
Production Management	COMPLETIONS	Record completions against a production ID or schedule.	COMPL_OP_SEQ INV_ITEM_ID MACHINE_CODE PRDN_AREA_CODE PRODUCTION_TYPE WORK_CENTER_CODE	BOM_CODE DT_TIMESTAMP INV_LOT_ID OPRID PRODUCTION_ID RTG_CODE

PeopleSoft Application	Quality Function	Function Description	Hierarchy Fields	Trace Fields
Production Management	COMPL_NO_MC	Same as COMPLETIONS, except no machine code field.	COMPL_OP_SEQ INV_ITEM_ID PRDN_AREA_CODE PRODUCTION_TYPE WORK_CENTER_CODE	BOM_CODE DT_TIMESTAMP INV_LOT_ID OPRID PRODUCTION_ID RTG_CODE
Production Management	COMPL_NO_OP	Same as COMPLETIONS, except no machine code, work center code, or compl op seq (completion operation sequence) fields.	INV_ITEM_ID PRDN_AREA_CODE PRODUCTION_TYPE	BOM_CODE DT_TIMESTAMP INV_LOT_ID OPRID PRODUCTION_ID RTG_CODE
Quality	QUALITY	Emulates the field structure that PeopleSoft 7.5 Quality uses. Use this if you upgrade from PeopleSoft 7.5 to PeopleSoft 8.	INV_ITEM_ID MACHINE_CODE QC_STEP_ID STATION_CODE WORK_CENTER_CODE	CREW_CODE DT_TIMESTAMP LOT_ID OPRID OP_SEQUENCE PRDN_AREA_CODE PRDN_DUE_SHIFT PRODUCTION_ID SERIAL_ID TASK_CODE TOOL_CODE

Related Links

[Reviewing Control Plan Configurations](#)

[Understanding the Quality Data Collection Process](#)

[Understanding PeopleSoft Quality Integration With Other PeopleSoft Applications](#)

Chapter 5

Maintaining Measurement Plans

Understanding Measurement Plans

Measurement plans identify and group the characteristics that you use as quality indicators for an operation, product, or process. The characteristics may be *quantitative* (directly measurable), such as dimensions or finish; or they may be *qualitative*, such as product desirability. For each characteristic, you can also define the procedures and methods that you use to monitor process stability.

This section lists common elements and discusses characteristics.

Common Elements Used

Measurement Plan	Displays an identifier for a set of characteristics and instructions.
Characteristic	Displays a specific characteristic name or identifier.

Characteristics

A Quality business unit and quality function must exist before you can define characteristics. When creating characteristics in a measurement plan, determine:

- Properties of the characteristics that you measure.
- Specification and acceptance limits.
- Sampling requirements.
- Testing and charting methods that you use to determine process stability.
- Operator instructions for data collection and alarm review.

Defining Measurement Plans

To define measurement plans, use the Measurement Plans component (QS_MFDS_PLAN). This section discusses how to:

- Maintain characteristics.
- (Optional) Create formula definitions.
- Add operator instructions.

Pages Used to Define Measurement Plans

Page Name	Definition Name	Navigation	Usage
Measurement Plans - Characteristics	QS_MFDS_PLAN	Quality, Establish Control Plans, Measurement Plans, Characteristics	Create and edit measurement plan characteristics. Define a group of characteristics for analyzing quality data. Specify the unit of measure, specification, acceptance limits, and the control procedures and charts for monitoring the characteristics. Define formulas to calculate sample values for characteristics that cannot be measured directly.
Formula Definition	QS_MFDS_CALC_PNL	Click the Enter Formula button on the Formula tab of the Measurement Plans - Characteristics page.	Create or edit characteristic formulas.
Measurement Plans - Instructions	QS_MFDS_PLAN_TXT	Quality, Establish Control Plans, Measurement Plans, Instructions	Add operator instructions.

Maintaining Characteristics

Use the Measurement Plans - Characteristics page (QS_MFDS_PLAN) to create and edit measurement plan characteristics.

Define a group of characteristics for analyzing quality data. Specify the unit of measure, specification, acceptance limits, and the control procedures and charts for monitoring the characteristics. Define formulas to calculate sample values for characteristics that cannot be measured directly.

Navigation

Quality, Establish Control Plans, Measurement Plans, Characteristics

Image: Measurement Plans - Characteristics page: General tab

This example illustrates the fields and controls on the Measurement Plans - Characteristics page: General tab. You can find definitions for the fields and controls later on this page.

*Characteristic	Class Type Code	*Data Type	Subgroup Size	*Incomplete Subgroup	Active	Return Results
NECK TORQUE	CRIT	Variables	3.00000	Do Not Accept	<input checked="" type="checkbox"/>	<input type="checkbox"/>
VISUAL	SPC	Defects	3.00000	Do Not Accept	<input checked="" type="checkbox"/>	<input type="checkbox"/>

Note: Do not use special characters, such as dashes and percent signs, in characteristic names.

Class Type Code (classification type code)	<p>Select the classification code that you want to use for inspection requirements.</p> <p>See Characteristic Class Types Page.</p>
Data Type	<p>Select the data type for this characteristic. Values are:</p> <p><i>Variables</i>: Quantitative or physically measurable (or derived) properties, such as size, mass, or time.</p> <p><i>Defects</i>: Qualitative or observed data on defect types—such as scratches and blemishes—and associated counts.</p> <p><i>Defectives</i>: Counts the number of units that are defective using a pass-or-fail criteria.</p>
Subgroup Size	<p>Enter the size of the sample taken during each inspection cycle. A 0 indicates that the subgroup size may vary, and the size is entered at the time of inspection. Size ranges are:</p> <ul style="list-style-type: none"> • Variables: 1 – 20 • Defects: 0 – 20 • Defectives: 0 – 500,000
Incomplete Subgroup	<p>Select to determine how the system responds when insufficient data exists to satisfy the subgroup size that is defined. This field is applicable to the variables data types only.</p> <p><i>Average</i>: The system completes incomplete subgroups using the average of the sample values that have been collected.</p> <p><i>Do Not Accept</i>: The system analyzes the subgroup only after the subgroup size is reached.</p>
Active	<p>Select to enable data collection for the characteristic.</p>
Return Results	<p>Select to have the system return subgroup results to integrated applications. This option also enables applications that call Quality data to capture information from the Quality session and use it for additional processing. In practice, the most significant results are usually pass-or-fail counts.</p> <p>Quality returns results for a single defectives type characteristic. Indicate the characteristic for which the system returns results.</p>
Controls	<p>Select the Controls tab.</p>
Control Chart	<p>Select the control chart that the system uses to monitor process variability. The standard system-supplied charts include:</p> <p><i>c Chart</i></p>

np Chart

p Chart

u Chart

X and Moving Range

Xbar and Range

Xbar and Sigma

Any custom charts that you define are also available for selection. Control chart selections depend on the characteristic data type.

Graphic Preferences

Select the default analysis content and graphic presentation for a characteristic during data entry or review. Graph preferences are configured using the Graph and Display Preferences component.

Control Procedure

Select the control procedure that the system uses to assess process control.

Specification Limits

Select the Specification Limits tab.

LSL (lower specification limit) and USL (upper specification limit)

Enter the limits for product or dimensional adherence. They are typically manufacturing and assembly tolerances or customer-specified targets. Leave either field blank to accommodate unilateral specifications.

LAL (lower acceptance level) and UAL (upper acceptance level)

Enter the absolute minimum and maximum values accepted during manual data entry operations. This reduces the entry of spurious data. You can leave either or both fields blank.

Formula

Select the Formula tab.

Factor 1 and Factor 2

Enter constant values that are imported into optional, derived characteristic formulas.

Formula

Specify a formula that the system uses to derive sample values for the characteristic. Enter the formula or click the Formula Definition button to access the Formula Definition page.

Note: During data entry, the system calculates sample values of characteristics with defined formulas. These cannot be edited.

Related Links

[Defining Control Charts](#)

[Define Graph Preferences Page](#)

[Defining Control Procedures](#)

Creating Formula Definitions

Use the Formula Definition page (QS_MFDS_CALC_PNL) to create or edit characteristic formulas.

Navigation

Click the Enter Formula button on the Formula tab of the Measurement Plans - Characteristics page.

Image: Formula Definition page

This example illustrates the fields and controls on the Formula Definition page. You can find definitions for the fields and controls later on this page.

The screenshot shows a web-based interface for defining a formula. The title bar reads "NECK TORQUE - Formula Definition". Below the title is a text input field labeled "Formula" which contains the text "STDDEV". To the right of the input field is a small icon. Below the input field is a keypad with several rows of buttons. The first row contains ABS(), SSIZE[], VAL[], ^, (,), C. The second row contains INT(), FACT1[], MEAN, 7, 8, 9, /. The third row contains NINT(), FACT2[], MINS, 4, 5, 6, *. The fourth row contains SQRT(), NOMSL, MAXS, 1, 2, 3, -. The fifth row contains LOG(), LSL[], RANGES, 0, ., +. The sixth row contains LOG10(), USL[], STDDEV. The seventh row contains EXP(). The eighth row contains PI. At the bottom of the keypad area are three buttons: OK, Cancel, and Refresh.

Equation component buttons are grouped according to these types of functions (from left to right):

- Basic or standard mathematical functions.
- Configuration parameters.
- Simple statistics.
- Sample value.

You can define a characteristic formula by entering values in the Formula field or by:

- Clicking an equation component button.
- Using the keypad area to insert numbers, mathematical operators, parentheses, and decimal points.

Examples of Characteristics

<i>Type of Calculation</i>	<i>Formula</i>
Multiply two characteristics.	(VAL[Length]*VAL[Width])
Calculate the deviation from the nominal of the specification.	(MEAN[Length]-NOMS[Length]) <hr/> Note: Requires bilateral specifications.
Round the value of length to hundredths.	(NINT(VAL[Length]*100)/100)
Calculate Cpk for the current subgroup of length.	(MINS((USL[Length]-MEAN[Length] / (3*STDEV[Length])) ((MEAN[Length]-LSL[Length]) / (3*STDEV[Length]))) <hr/> Note: Recommended usage should include the length characteristic with n>7 (at least 3) and an Xbar and sigma chart. <hr/> Cpk characteristic should be n=1 with an X and Moving Range chart.

Note: When defining formulas with algebraic calculations, enclose the formula in parentheses, for example, (VAL[Length] * VAL[Width]).

Equation Construction Functions

<i>Function</i>	<i>Description</i>	<i>Example</i>
ABS()	Absolute value of the quantity specified in parentheses.	ABS(VAL[Length]) <hr/> Note: Computes absolute value of the reading entered for length.
EXP()	Exponential function. Returns <i>e</i> raised to the power of the specified value.	EXP(2)
FACT1	Factor 1 from the Specifications page.	FACT[1]
FACT2	Factor 2 from the Specifications page.	FACT[2]
INT()	Integer portion.	INT(VAL[Length]) <hr/> Note: Computes integer portion of the reading entered for length.
LOG()	Natural log function.	LOG(Length)
LOG10()	Log based 10 function.	LOG10(Length)

Function	Description	Example
LSL	Lower specification limit of the current characteristic.	LSL
MAXS (maximum)	Maximum value in subgroup of readings entered for a characteristic.	MAXIMUM[Length] <hr/> Note: Computes maximum value in the subgroup of readings entered for length.
MEAN	Mean of subgroup of readings entered for a characteristic.	MEAN[Length] <hr/> Note: Computes mean of the subgroup of readings entered for length.
MINS (minimum)	Minimum value in subgroup of readings entered for a characteristic.	MINIMUM[Length] <hr/> Note: Computes minimum value in the subgroup of readings entered for length.
NINT()	Nearest integer.	NINT(VAL[Length]) <hr/> Note: Computes nearest integer to the reading entered for length.
NOMSL	The center point between the nominal specification lower limit and the nominal specification upper limit (LSL, USL).	NOMSL[Length]
PI	π (3.14159)	(VAL[Diameter]) * PI <hr/> Note: Multiplies the reading entered for diameter by 3.14159.
RANGES	Range of subgroup of readings entered for a characteristic.	RANGE[Length] <hr/> Note: Computes range of the subgroup of readings entered for length.
SQRT()	Square root.	SQRT(VAL[Length]) <hr/> Note: Computes square root of the reading entered for length.
SSIZE	Subgroup size of the current characteristic.	SSIZE

Function	Description	Example
STDDEV	Standard deviation of subgroup of readings entered for a characteristic.	STDDEV[Length] <hr/> Note: Computes standard deviation of the subgroup of readings entered for length. <hr/>
USL	Upper specification limit of the current characteristic.	USL
VAL	Reference to the current sample for the characteristic.	VAL[Length] * VAL[Width] <hr/> Note: The equation processor works from sample 1 to sample n within the current subgroup and attempts to reference the characteristics that make up the derived one. <hr/>

Adding Operator Instructions

Use the Measurement Plans - Instructions page (QS_MFDS_PLAN_TXT) to add operator instructions.

Navigation

Quality, Establish Control Plans, Measurement Plans, Instructions

Enter the text for the instructions. The text corresponds to the entire measurement plan.

Reviewing Measurement Plan Configuration Information

Use inquiries to view configuration data associated with the measurement plan. The inquiries provide an overview of characteristic specifications and their changes for all measurement plans associated with the Quality business unit and the quality function that you select.

This section discusses how to:

- Review measurement plans.
- Review characteristic specifications.

Pages Used to Review Measurement Plan Configuration Information

Page Name	Definition Name	Navigation	Usage
Measurement Plan Review	QS_MFDSLEVEL2_INQ	Quality, Review Quality Plans, Measurement Plans, Measurement Plan Review	Review current characteristic information or historical specification changes.

Page Name	Definition Name	Navigation	Usage
Characteristic Specifications	QS_MFDSSPEC_INQ	Quality, Review Quality Plans, Characteristic Specifications	Review current specifications and historical changes.

Measurement Plan Review Page

Use the Measurement Plan Review page (QS_MFDSLEVEL2_INQ) to review current characteristic information or historical specification changes.

Navigation

Quality, Review Quality Plans, Measurement Plans, Measurement Plan Review

Note: The specifications that appear may differ from the specifications on the process assignment. You can override the specifications when defining the control plan.

Related Links

[Understanding Measurement Plans](#)

[Viewing PeopleSoft Quality Graphics](#)

[Understanding PeopleSoft Quality Application Client Charts and Analysis Tools](#)

Characteristics Specifications Page

Use the Characteristic Specifications page (QS_MFDSSPEC_INQ) to review current specifications and historical changes.

Navigation

Quality, Review Quality Plans, Characteristic Specifications

Review specification limits for one or more measurement plans for a business unit and quality function.

Date From

Enter a starting date from when you want to review the full specification history. Select the Full History check box to enable the starting date.

Note: The system initially displays the current date minus one day.

Full History

Select to review the entire specification change history. Deselecting this check box disables the Date From field.

Active Only

Select to review only current characteristic specifications.

Graph Results

Click this button to launch a Pareto analysis of the original summary value for each inquiry.

See [Viewing PeopleSoft Quality Graphics](#).

Related Links

[Maintaining Characteristics](#)

Chapter 6

Establishing Control Plans

Understanding Control Plans

Control plans identify specific quality control points or processes and provide an overall structure for data collection, reaction, and analysis. Control plans comprise these features:

- Specific hierarchy field definitions that identify the process.
- Measurement plans containing the characteristics that you want to monitor.
- Attribute codes within categories to facilitate data annotation within reaction plans.
- Traceability information for use in tracking and identifying product variation.
- (Optional) Control limits that are used to maintain a predetermined level of process control.

Use the following steps to begin online quality data collection and control:

1. Establish a Quality business unit.
2. Create the quality function.
3. Define measurement plans.
4. Create the control plan.
5. Establish the relationship between each component so that you can record inspection data in the quality control environment.

PeopleSoft Quality Control Plan Configuration

This diagram illustrates the Quality control plan configuration using a quality function, measurement plan, and control plan:

Image: Quality control plan configuration

This diagram illustrates the Quality control plan configuration.

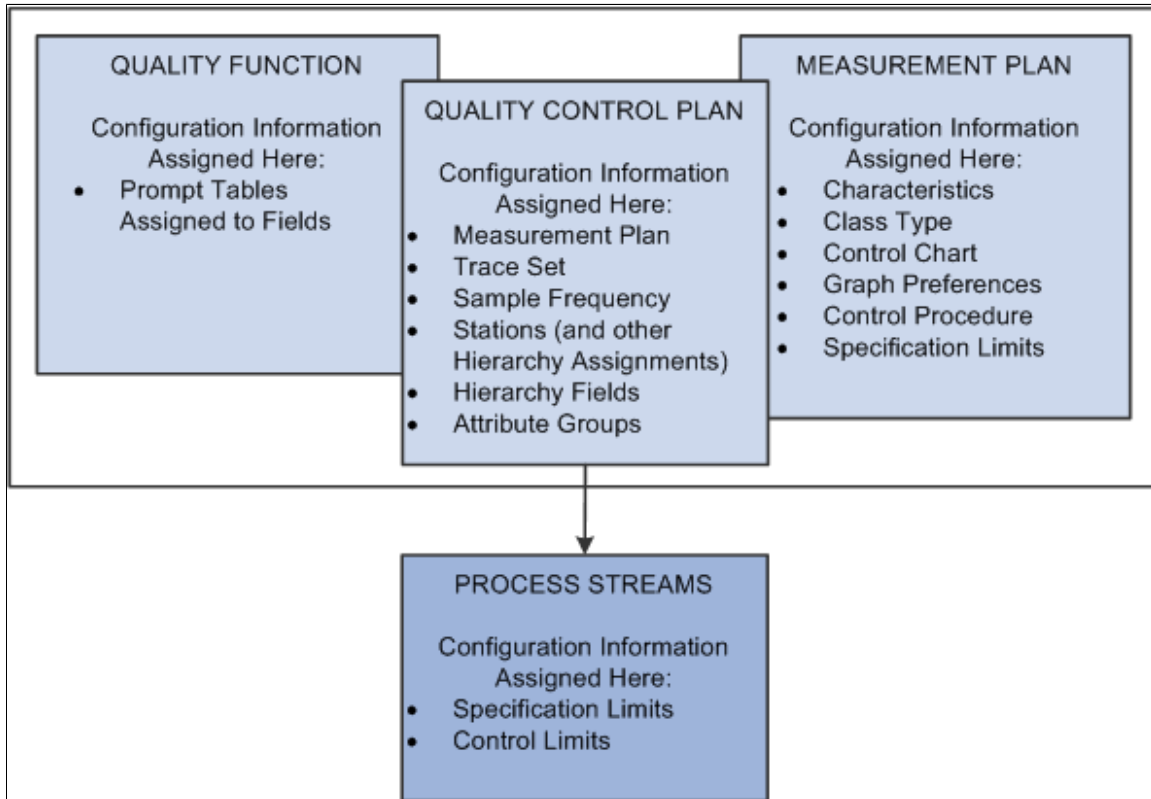

Quality Functions

A quality function is a set of fields that identify nonparametric information and map process-specific field information into Quality for process identification, data tracking, and analysis. Hierarchy fields define the actual process—stream—against which you collect and monitor data. Trace fields make it possible to collect associated information that is used for tracking purposes.

Measurement Plans

Measurement plans group characteristics that are used as quality indicators for a given process. Establish specific control methods, such as sampling, charting, and testing criteria, at this level.

Control Plans

The control plan brings together application, measurement, and control and response criteria for a specific product or process. PeopleSoft refers to a unique combination of hierarchy fields and a measurement plan as a control plan. The combination of fields and characteristics within the measurement plan is called a process stream. To this point, all elements of configuration that you establish are not yet applied to a specific process. The control plan provides the remaining element of configuration, defining the process and applying methods of inspection and control to that process.

When defining a control plan, you:

- Reference a quality function to enter specific hierarchy field definitions that identify the process.
- Assign a measurement plan to each individual hierarchy field combination.

Each characteristic that is associated with the plan then becomes a process stream with its own associated details.

- Determine the method for data entry for each individual characteristic.

You can record data by subgroup or by sample for each characteristic.

Relationship Example

Image: Example of Quality configuration

This diagram illustrates the relationship between a quality function, measurement plan, and control plan within a quality configuration.

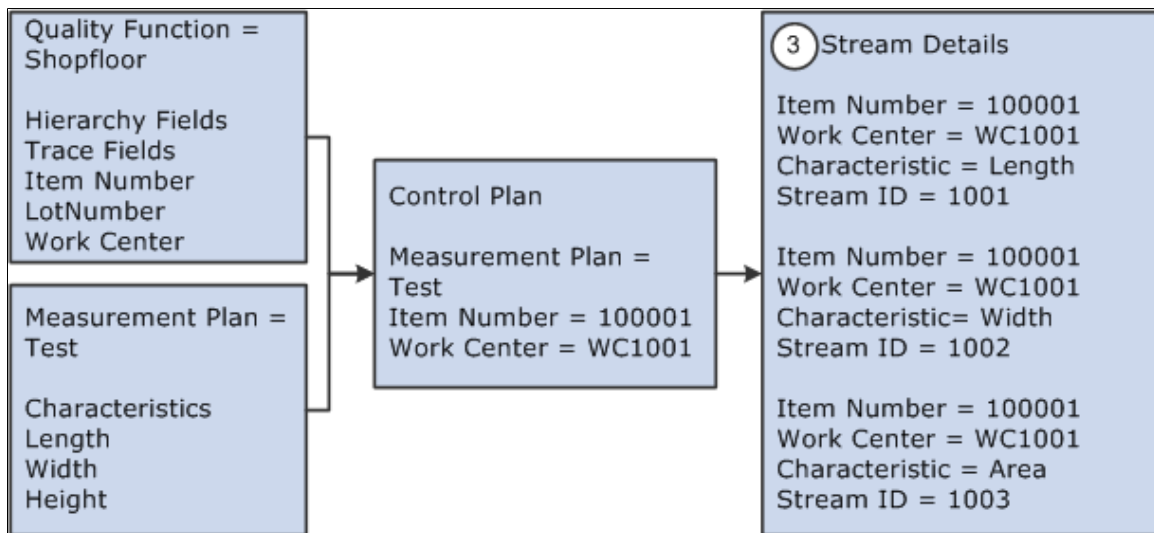

Related Links

[Understanding Quality Functions](#)

[Defining Measurement Plans](#)

[Defining Control Plans](#)

Prerequisites

Before you begin, consider the data tracking and collection requirements of areas where Quality is implemented. That is, how do you identify processes, what information is available or needed for tracking purposes, and how do you react to out-of-control conditions?

This table provides recommendations for configuring a quality plan either in combination with other PeopleSoft applications or as a standalone:

PeopleSoft Application	Use	Define Criteria in This Order
Inventory	Returned Material Authorization activity.	Define items by using the Item Definition and Item Attributes by Unit components in Inventory. When creating control plans, be sure to reference an item that already exists.
Purchasing	Purchase receiving activity.	<p>1. Define items by using the Item Definition and Item Attributes by Unit components in Inventory.</p> <p>2. Define suppliers by using the Maintain Suppliers component in Purchasing. When creating control plans, be sure to reference the purchasing supplier for the item.</p>
Production Management	Recording inspection data against production IDs or schedules in the manufacturing environment.	<p>1. Define items by using the Item Definition and Item Attributes by Unit components in Inventory.</p> <p>2. Define machines by using the Define Resources component in Manufacturing. You can use station codes to identify various machine parts or outputs as you create control plans. Defining machines or stations is optional.</p> <p>3. Define work centers by using the Define Work Centers and Tasks component in Manufacturing. When you record inspection samplings in Quality for manufacturing activity, reference the work center and machine where the sampling occurred.</p> <p>4. Define routings for the items by using the Structure Routings component in Manufacturing. When recording inspection samplings relating to manufacturing activity, you can specify at what operation the sampling is taken. Defining operation sequences is optional.</p> <p>5. Define the production area by using the Area Maintenance component in Manufacturing.</p> <p>6. Reference the product type for the order that you are recording information against. The system supplies this field for you. Options are: rework, production, or tear down.</p>

<i>PeopleSoft Application</i>	<i>Use</i>	<i>Define Criteria in This Order</i>
Quality	Standalone or with other applications.	<ol style="list-style-type: none"> 1. Define all the data that you associate with the hierarchy fields on the quality function. 2. Add the data to other applications in the correct sequence. 3. Establish the inspection criteria that is necessary for Quality.

Defining Attribute Groups

To define attribute groups, use the Attribute Groups component (QS_ATTRIB_SET). This section provides an overview of attribute groups and discusses how to:

- Define attribute labels.
- Maintain attribute codes.

Pages Used to Define Attributes

<i>Page Name</i>	<i>Definition Name</i>	<i>Navigation</i>	<i>Usage</i>
Attribute Labels	QS_ATTRIB_SET	Quality, Establish Control Plans, Attribute Groups, Attribute Labels	Define the attribute and the labels that are used for the defect, cause, and corrective action components.
Attribute Codes	QS_ATTRIB_DEFN	Quality, Establish Control Plans, Attribute Groups, Attribute Codes	Maintain attribute codes for their associated attribute categories for an attribute group.

Understanding Attribute Groups

Attribute groups are categorized lists of defect, cause, and action codes that you relate to one or more control plans. The system uses the lists as prompts during data entry and alarm review to assist in the classification of problems and corrective measures that are associated with a subgroup.

Using attribute codes, you can:

- Apply them to inspection samplings during quality data collection and alarm review activities.
- Provide qualitative annotation against a process.
- Present concise selection lists when noting product defects or indicating responses to out-of-control conditions.
- Enable detailed Pareto analysis of individual elements.

Attribute groups are made up of various categories: defects, probable causes, and corrective actions. Each category comprises one or more components that, when combined, form complete phrases. During data entry, the system builds attribute phrases as individual components are selected. You can analyze the resulting attribute phrases in their entirety or by individual components to investigate root problems or causes.

The following attribute categories are available:

- Defect components.
- Cause components.
- Corrective action components.

Defect Components

You can define up to three levels of defect components:

<i>Defect Component 1</i> <i>(Location)</i>	<i>Defect Component 2</i> <i>(Fault)</i>	<i>Defect Component 3</i> <i>(With)</i>
Top	Broken	Bolt
Bottom	Worn	Resistor

Cause Components

Cause components typically identify a problem that affects the process that you are monitoring. You can define up to two levels of cause components:

<i>Cause Component 1 (Problem)</i>	<i>Cause Component 2 (Affecting)</i>
Worn	Tool
Temperature Setting	To Low

Corrective Action Components

Action components describe what actions are taken in response to problems or out-of-control conditions. This is a single component.

Attribute Labels Page

Use the Attribute Labels page (QS_ATTRIB_SET) to define the attribute and the labels that are used for the defect, cause, and corrective action components.

Navigation

Quality, Establish Control Plans, Attribute Groups, Attribute Labels

Attribute Group	Enter a name for the group.
Defect Component 1, 2, and 3	Define a label for each of the defect components. Enter new labels for the components or use the defaults. Entering a blank label disables that component from entry and selection. That is, the system does not generate a pick list for that specific attribute component during data entry or alarm review.
Cause Component 1 and 2	Define a label for each cause component. Enter a blank label to disable a component.
Corrective Action	Define a label for the corrective action codes.

Note: You cannot blank out all labels, such as disable all components, for an attribute category. If all labels are blank, the system inserts default labels when it saves the group.

Attribute Codes Page

Use the Attribute Codes page (QS_ATTRIB_DEFN) to maintain attribute codes for their associated attribute categories for an attribute group.

Navigation

Quality, Establish Control Plans, Attribute Groups, Attribute Codes

When this page initially appears, all the attribute codes that are associated with all components of the attribute group appear. Select a particular type of attribute component to view its codes.

Attribute Component	Select the type of attribute that you want to view or define. Types include: <ul style="list-style-type: none"> • <i>List All Attribute Components</i>: Displays all the different attribute components. This selection is read-only. • <i>Action Component, Cause Component 1, Cause Component 2, Defect Component 1, Defect Component 2, or Defect Component 3</i>: Select the attribute component type that you want to add, delete, or modify the code list for.
Attribute Type	Displays the type of attribute, such as action, cause, or defect component. This field appears only when you select <i>List All Attribute Components</i> in the Attribute Component field.
Code	Enter a unique code for the attribute type.
Attribute Text	Enter the actual text that is used to build an attribute phrase.
Inactive	Select the check box if you want to deactivate the code. Inactive codes are not available for selection during processing.

Related Links

[Understanding the Quality Data Collection Process](#)

Defining Traceability Sets

To define traceability sets, use the Traceability sets component (QS_TRACE_SET). This section provides an overview of traceability sets and discusses how to create traceability sets.

Page Used to Define Traceability Sets

Page Name	Definition Name	Navigation	Usage
Define Traceability Set	QS_TRACE_SET	Quality, Establish Control Plans, Traceability Sets, Define Traceability Set	Create a traceability set.

Understanding Traceability Sets

A traceability set is a group of fields that specify the tagging or trace information that is collected during inspection. Each set comprises the trace fields that are defined within its parent quality function. Use traceability sets to:

- Assign to one or more control plans.
- Collect traceability item information at the time of inspection.
- Maintain process or product content and handling information, such as lot or serial ID.

This information is useful in determining causes of variation or in performance comparisons.

Define Traceability Set Page

Use the Define Traceability Set page (QS_TRACE_SET) to create a traceability set.

Navigation

Quality, Establish Control Plans, Traceability Sets, Define Traceability Set

Traceability fields are inherited from the parent quality function. You cannot add additional fields, but you can edit or inactivate field entries.

You can establish each field at the individual or subgroup level. If the field is set as *Individual*, the system prompts you for trace data for each sample in a subgroup. For example, if a subgroup size is five, and a traceability set has a Lot ID field set to *Individual*, then you are prompted for five lot numbers—one for each measured value in the subgroup. In the same example, if the field is set to *Subgroup*, then you are prompted for one lot number for the entire subgroup.

Active	Select to activate the trace field. The system prompts for and displays only active fields during data entry. You can activate up to 12 fields for a traceability set.
Field Name	The actual trace field (PeopleSoft object) name.
Level	Select the level at which you collect and store the trace field information:

Individual: A trace field value is entered for each individual sample of a subgroup.

Subgroup: A single trace value is entered for the entire subgroup regardless of subgroup size.

Input Type

Specify how data is entered in the trace field:

Auto Dflt (auto default): The default value is read from the input source or internal call-out routine and appears on the data-entry page. Override this entry by typing into the field or selecting from a prompt table list.

Fixed: A value is read from the input source or internal call-out routine and appears on the data-entry page. You can't override this entry.

User Input: Enter values directly into the field or select from a prompt table list.

Prompt Table or View

Specify the prompt table to associate with the trace field. This is the table or view that the system uses to populate drop-down lists during data entry. The default is inherited from the quality function, but you can override it here. Prompt tables are assumed to be Structured Query Language (SQL) tables or views that are created in a working database and are validated by using the Tools Record Definition table (QS_PSRECDEFN_VW). This field is not applicable for an input type of fixed.

Custom Field Format

Enter the name of an optional PeopleTools custom field-formatting object to use for display or input control.

Input Source

Set the source for populating default or fixed-trace values. The trace field value is read from this source at the time of data entry if either *Auto Dflt* or *Fixed* is specified for the Input Type field. This field is not applicable for an input type of user input. Options include:

%Datetime (datetime): Gets the current server date and time.

%OperatorId (operator ID): Gets the current user ID.

&G_TRACE_01 through &G_TRACE_12: Gets the value of a global PeopleCode variable that is defined prior to starting data entry.

Maintaining Stations

To define stations, use the Stations component (QS_STATIONS). This section discusses how to define stations.

Page Used to Maintain Stations

<i>Page Name</i>	<i>Definition Name</i>	<i>Navigation</i>	<i>Usage</i>
Define Stations	QS_STATIONS	Quality, Establish Control Plans, Stations, Define Stations	Use stations in combination with other hierarchy fields to differentiate or track multiple points of control. For example, stations can identify various machine parts or tooling facets, with each having a unique set of process-control limits.

Define Stations Page

Use the Define Stations page (QS_STATIONS) to use stations in combination with other hierarchy fields to differentiate or track multiple points of control.

For example, stations can identify various machine parts or tooling facets, with each having a unique set of process-control limits.

Navigation

Quality, Establish Control Plans, Stations, Define Stations

Enter a station code to associate with the Quality business unit.

Defining Control Plans

To define control plans use the Control Plans component (QS_CREATE_QCPLANS). This section provides an overview of control plans and discusses how to:

- Load control plans.
- Maintain control plans.
- Create multiple control plans at once.
- Maintain process streams.

Pages Used to Define Control Plans

<i>Page Name</i>	<i>Definition Name</i>	<i>Navigation</i>	<i>Usage</i>
Load QCPlans	QS_ROOT_FILTER	Quality, Establish Control Plans, Control Plans, Load QCPlans	Load a limited list of control plans with which to work.

Page Name	Definition Name	Navigation	Usage
Maintain QCPlans	QS_STREAM_ROOT	Quality, Establish Control Plans, Control Plans, Maintain QCPlans	Define and maintain control plans that bundle all associated inspection and control information into individual plans.
Create QCPlans	QS_QCPLAN_DEFINE	Quality, Establish Control Plans, Control Plans, Create QCPlans	Create multiple control plans at once. Enter the different fields on the page or use a wild card pertaining to a hierarchy field.
Stream Details	QS_STREAM_DETAIL	Click the Details button on the Maintain QCPlans page.	Maintain control limits for individual streams that are associated with each control plan.

Understanding Control Plans

The control plan is the combination of one set of characteristics with a specific instance of hierarchy values. The control plan:

- Brings together all areas of control into one single plan for data collection and analysis.
- Is required to collect data.
- Is the method by which you apply quality controls to specific hierarchy fields and the measurement plan.

Because a control plan contains a measurement plan (which can have more than one characteristic) when you save the control plan, the system creates a process stream beneath the control plan for each characteristic in the measurement plan. The process streams become the actual points of control.

A Quality business unit, quality function, and measurement plan must exist to create control plans. You can delete only those control plans that haven't been previously saved.

Load Quality Control Plans Page

Use the Load QCPlans page (QS_ROOT_FILTER) to load a limited list of control plans with which to work.

Navigation

Quality, Establish Control Plans, Control Plans, Load QCPlans

All fields are optional.

Configuration Settings

Select the fields by which you want to filter control plans.

Hierarchy Constant

Displays the hierarchy fields that are associated with the quality function. Select the hierarchy fields by which you want to filter the control plans.

Maintain Quality Control Plans Page

Use the Maintain QCPlans page (QS_STREAM_ROOT) to define and maintain control plans that bundle all associated inspection and control information into individual plans.

Navigation

Quality, Establish Control Plans, Control Plans, Maintain QCPlans

Image: Maintain QC Plans page

This example illustrates the fields and controls on the Maintain QC Plans page. You can find definitions for the fields and controls later on this page.

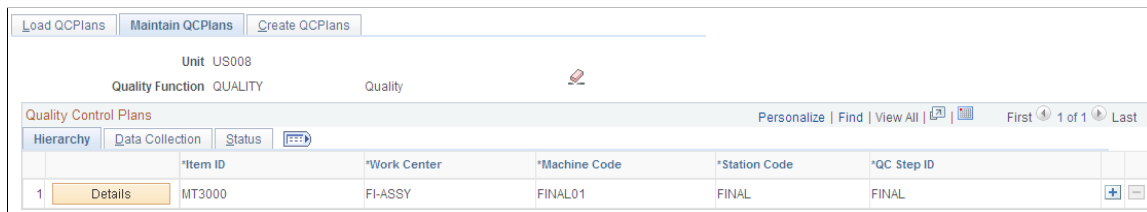

The first columns on the page vary depending on the quality function that you select. The columns are the individual hierarchy fields associated with the quality function. Enter the individual hierarchy fields for the control plan.

Data Collection Tab

Select the Data Collection tab.

Data Entry Method

Select the data-entry method: *By Sample* or *By Subgroup*.

Data Entry Name

Enter a name by which to group multiple control plans. By giving the same name to multiple rows, you can gather more than one set of streams for data entry and data extraction purposes.

Sequence

Enter a sequence number to define the order in which control plans with a common data-entry name appear in data entry.

Sample Frequency

Select the recommended sampling frequency for this control plan.

Trace Set

Select a trace set for the control plan. This field is active if you associate trace fields with the selected quality function.

Attribute Group

Select an attribute group to the control plan. This field is active if attribute groups are defined for the selected Quality business unit.

Examples of Data-Entry Methods

Using the by sample method for a control plan, you inspect all the characteristics for the first sample, then all the characteristics for the next sample, such as inspecting a large item that must be fixtured. You take all measurements of that item prior to fixturing the next item.

This diagram illustrates the by sample data-entry method where item 1 is inspected for characteristics A, B, and C, then item 2 is inspected for characteristics A, B, and C, and finally item 3 is inspected for characteristics A, B, and C:

Image: Example of the by sample data-entry method

This diagram illustrates the by sample data-entry method.

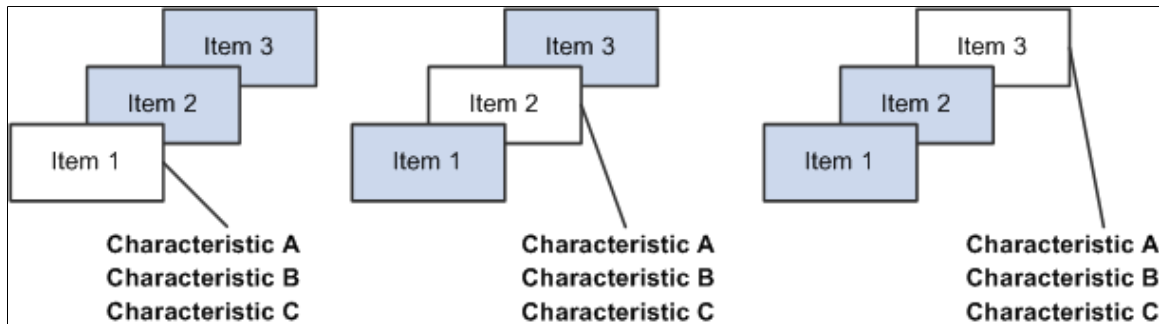

Using the by subgroup method, you inspect one characteristic for a group of items, then another characteristic for a group of items, such as inspecting several small items in succession with a specific gauge. You complete the sample for each characteristic prior to using the next gauge.

This diagram illustrates the by subgroup data-entry method where items 1, 2, and 3 are inspected for characteristic A, then items 1, 2, and 3 are inspected for characteristic B, and finally items 1, 2, and 3 are inspected for characteristic C:

Image: By subgroup data-entry method

This diagram illustrates the by subgroup data-entry method.

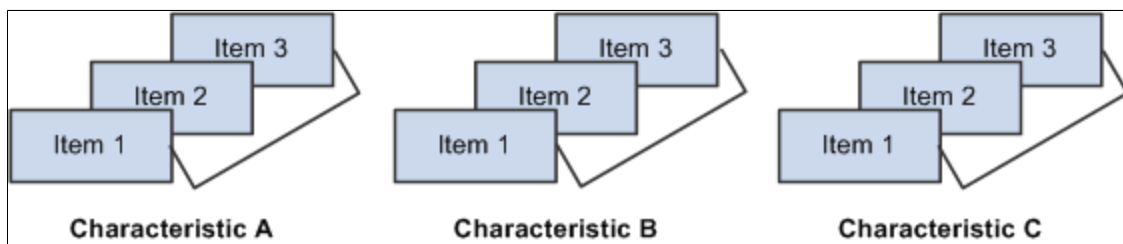

If you are collecting data against this control plan by using data entry by control plan, the system uses the method that you specify on this page. Otherwise, the system uses the data-entry method that you assign on the access list. The system uses the access list when setting up data entry for multiple control plans.

Status Tab

Select the Status tab.

The system displays the number of streams that exist under this control plan in the Stream Count field.

Related Links

[Stream Details Page](#)

[Understanding Quality Functions](#)

Create Quality Control Plans Page

Use the Create QCPlans page (QS_QCPLAN_DEFINE) to create multiple control plans at once.

Enter the different fields on the page or use a wild card pertaining to a hierarchy field.

Navigation

Quality, Establish Control Plans, Control Plans, Create QCPlans

Configuration Settings

Select or enter the values that you want to apply to the new control plans.

Wildcard (optional)

This group box affects the Hierarchy Constants group box.

Field	Select the field for which you want to use a wildcard.
String	Enter the wildcard using SQL-link syntax. For example, if you select <i>Item ID</i> as the field for the wildcard, and you want to create control plans for all items containing the letter A, enter <i>%A%</i> in the String field.
Source	Enter the prompt table that is assigned to this field in the quality function definition. You can override this entry with any valid table or view containing one column matching the wildcard field.

Hierarchy Constants

If you select a hierarchy field as a wild card, you can't enter data in that particular field in this group box.

The hierarchy fields in this group box are associated with the quality function. The fields vary depending on the quality function that you select.

Related Links

[Defining Control Plans](#)

Stream Details Page

Use the Stream Details page (QS_STREAM_DETAIL) to maintain control limits for individual streams that are associated with each control plan.

Navigation

Click the Details button on the Maintain QCPlans page.

Image: Stream Details page

This example illustrates the fields and controls on the Stream Details page. You can find definitions for the fields and controls later on this page.

Active	Stream ID	Characteristic	Sequence	UOM	LAL	UAL	Cascade Lock	LSL	USL	Factor 1	Factor 2
<input checked="" type="checkbox"/>		101 NECK TORQUE	1	KGF	400.00000	1200.00000	<input type="checkbox"/>	500.00000	900.00000		
<input checked="" type="checkbox"/>		102 VISUAL	2				<input type="checkbox"/>		3.00000		

Use this page to define stream-specific data-collection settings and specification limits.

Stream ID

A unique sequential ID that is assigned by the system to each stream appears. It cannot be changed.

Sequence

Enter the sequence of how the characteristics are ordered when performing data entry against the plan.

UOM (unit of measure), LAL (lower acceptance limit), and UAL (upper acceptance limit)

The system displays the values that are inherited from the measurement plan. The fields are display-only; you can't change them. The Cascade Lock field doesn't affect them.

Cascade Lock

With cascaded fields, the values that you assign at the characteristic level in the measurement plan cause the plan to act as a template. You can override the values that cascade to streams at any time at the stream level. You might want to change a specification limit in the characteristic instead of changing it on every stream, which is an advantage of cascading. However, if you don't want to overwrite the values for specific streams with values from the characteristic, protect those streams with the cascade lock.

Select the Cascade Lock check box if you want to lock the stream from being updated by changes that are made to the parent characteristic from the measurement plan. Changes in characteristics that are cascaded to streams are changes to the active setting, specification limits (lower specification limit and upper specification limit), and factors 1 and 2.

LSL (lower specification limit), USL (upper specification limit), Factor 1, and Factor 2

Enter stream-specific specification limits that you want to use. By default, the limits that are defined for the underlying characteristic are inherited. Select the Cascade Lock check box to protect these entries from changes that are made at the measurement plan level.

Control Limits Tab

Select the Control Limits tab to view or change working control limits for individual streams.

Clim Status (control limit status)process control limitsstatuses

Displays the control limit status for a particular stream:

None: Limits are not yet assigned or calculated for the stream.

Preliminary: First level of promotion.

Monitoring: Second level of promotion.

Ongoing: Third and final level of promotion.

Recalc (recalculate): Recalculated after ongoing.

Assigned: Limits are assigned manually.

Reset: Limits are reset manually to begin the promotion cycle that is defined by the control procedure that is assigned to this characteristic.

LCL (1) [lower control limit (graph 1)], CL (1) [control limit (1)], UCL (1) [upper control limit (1)], LCL (2), CL (2) , and UCL (2)

Display if control limits are established either by assignment or by calculation. The fields reflect the current control limit values and status of the stream.

Note: Quality assigns the statuses according to the limit promotion milestones information that you define by using the Control Procedures page.

Assigning Control Limits

Click the Assign Control Limits button to assign process control limits. The limit status changes to assigned, which means to ignore the promotional milestones that are associated with a control procedure that is associated with the measurement plan.

Enter the control limits that you want to assign to the stream in the control limit fields: LCL (1), CL (1), UCL (1), LCL (2), CL (2), or UCL (2).

Resetting Process Control Limits

Click the Reset Control Limit Promotions button to restart the limit calculation-promotion cycle. The Clim Status value changes to *Reset*.

Control Limit Promotion Method Example

In a typical control limit promotion method, the limits are assumed to be ever tightening over time as the process matures and process improvement methods take effect. This diagram illustrates process control limits where the subgroup milestones of 10, 20, and 30 are used as examples only and are not fixed:

Image: Understanding process control limits

This diagram illustrates process control limits.

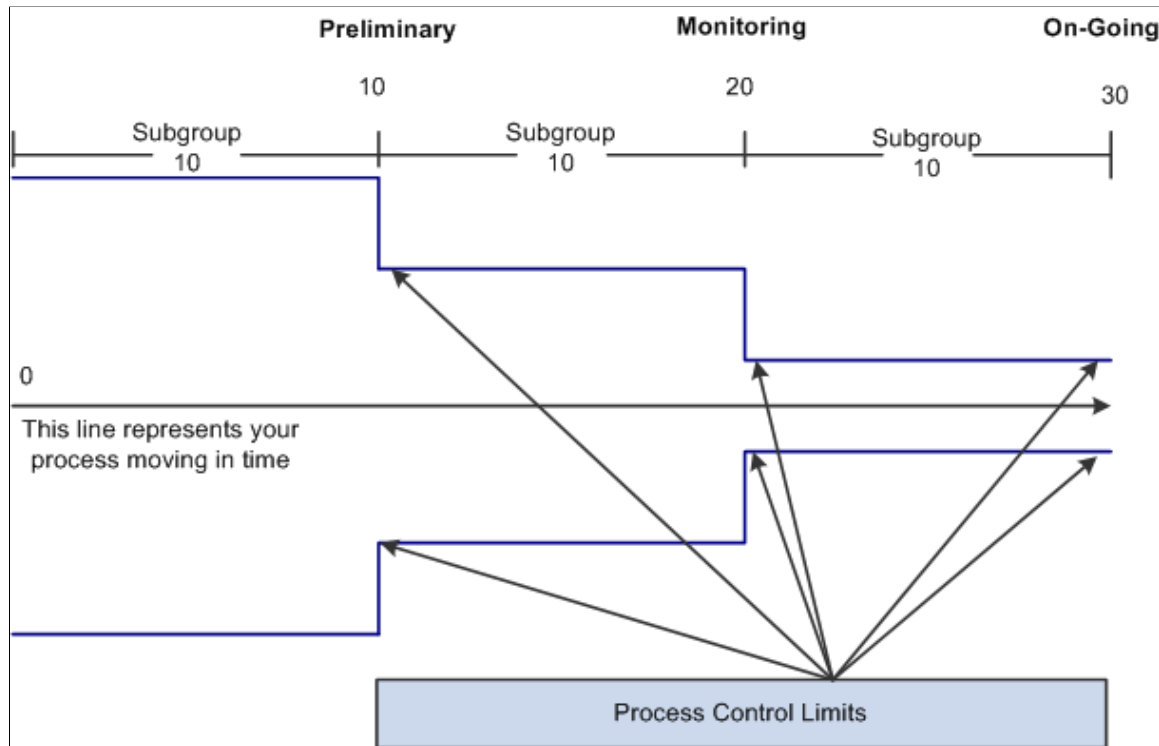

The following steps show how a control limit promotion cycle progresses:

1. For a new process with unknown capability, control limits are indeterminate and the system reflects a preliminary status.
2. As the process matures, the promotion cycle continues to collect data and makes improvements to the process through corrective actions. Control limits are recalculated at intervals, and the status progresses to monitoring and then to ongoing to reflect heightened stability and tighter control.
3. At any time during the different levels of promotion, you can reset control limits and restart the cycle. When you reset control limits, the system status is reset until it reaches the first promotion milestone (preliminary).
4. You can also assign specific control limits at any time. When you assign control limits, the system status is assigned and limit promotions are not performed.

Related Links

[Understanding Measurement Plans](#)

[Define Control Procedure Page](#)

Reviewing Control Plan Configurations

This section discusses how to:

- Review where-applied characteristics.
- View stream specifications.
- View control limit history.

Pages Used to View Control Plan Configuration Information

Page Name	Definition Name	Navigation	Usage
Characteristics-Where Applied	QS_MFDSCLASS_INQ	Quality, Review Quality Plans, Characteristics-Where Applied	View where and how often characteristics are applied to control plans.
Stream Specifications	QS_SPEC_LIM	Quality, Review Quality Plans, Stream Specifications	View stream specification change history for individual process streams.
Control Limits	QS_CONTROL_LIMIT	Quality, Review Quality Plans, Control Limits	View control-limit history for individual process streams.

Common Elements Used in This Section

Date From

Select the beginning date from which you want to view data. The system initially displays the current date (minus one day) in the field.

Active Only

Select this check box to indicate that you want to see only the active characteristics and streams.

Full History

Select this check box if you want to view the full specification or control limit history from a given date.

Graph Results

Click the Graph Results button to launch a Pareto analysis of the original summary value for each inquiry.

See [Viewing PeopleSoft Quality Graphics](#).

Characteristics/Where Applied Page

Use the Characteristics-Where Applied page (QS_MFDSCLASS_INQ) to view where and how often characteristics are applied to control plans.

Navigation

Quality, Review Quality Plans, Characteristics-Where Applied

The columns on this page vary depending on the quality function that you select. The columns are the hierarchy fields that are associated with the quality function.

Enter the filter fields to view specific data. The specification limits are the current limits applied to each stream and may be defined at the stream level or inherited from the underlying measurement plan characteristic.

Characteristic Details Tab

Access the Characteristic Details tab.

The system displays the characteristic, class type code, LSL, USL and UOM that is associated with each characteristic.

Related Links

[Understanding Quality Functions](#)

[Maintaining Characteristics](#)

[Viewing PeopleSoft Quality Graphics](#)

Stream Specifications Page

Use the Stream Specifications page (QS_SPEC_LIM) to view stream specification change history for individual process streams.

Navigation

Quality, Review Quality Plans, Stream Specifications

The system displays the process stream specifications and specification changes, such as changes that are applied to specifications at the characteristic and stream levels, for all control plans that are associated with the Quality business unit and quality function that is selected. View all characteristics that are defined for all control plans (process streams) for a quality function or select a specific set of characteristics by selecting the measurement plan.

The first columns on the page vary depending on the quality function that you select. These columns are the hierarchy fields that are associated with the quality function.

Specification Limit Details Tab

Select the Specification Limit Details tab.

Origin Code

The code appears, indicating where the specification limits are set or changed. Codes include:

- *MFDS*. The specifications are changed at the measurement plan level.
- *STRM*. The specifications are assigned at the control plan and stream level.

USL, LSL, Factor 1, and Factor 2

The systems displays the information that is associated with the process stream.

Related Links

[Understanding Quality Functions](#)

[Maintaining Characteristics](#)

Control Limits Page

Use the Control Limits page (QS_CONTROL_LIMIT) to view control-limit history for individual process streams.

Navigation

Quality, Review Quality Plans, Control Limits

You can further qualify the inquiry by selecting to see the full specification history. To do this, select the Full History check box. This option ignores the date from field.

If you want to see the current specifications, deselect the Full History check box and select the Active Only check box

The first columns on the page vary depending on the quality function that you select. These columns are the hierarchy fields that are associated with the quality function.

Control Limit Details (1) Tab

Select the Control Limit Details (1) tab.

Displays control limits for the first subchart that is assigned to the characteristic.

Control Limit Details (2) Tab

Select the Control Limit Details (2) tab.

Displays the control limits for the second subchart if you are using a control chart that is constructed of multiple subcharts.

Related Links

[Understanding Quality Functions](#)

[Stream Details Page](#)

Chapter 7

Collecting Quality Data

Understanding the Quality Data Collection Process

Operator interaction is part of the data-collection methodology. Quality provides you with a comprehensive data-collection environment that combines operator data entry with online analysis and immediate feedback. You record sample information against a control plan and then view analysis results to make improvements or corrections to the process.

You can enter, maintain, and edit quality data against variable, defect, or defective characteristics within a control plan. The system creates a data-entry session for each new sampling, based on the inspection frequency, as a container for the related measurement, cause, and action information that you entered.

Data-Entry Pages

To access data-entry pages:

1. Select a control plan from a list of often-used plans (access list).
2. Enter the specific hierarchy fields associated with the control plan.

Each method accesses the same set of pages that you use to create a new data-entry session or complete a pending session.

Related Links

[Defining Data-Entry Access Lists](#)

Quality Data Entry

This diagram illustrates the process flow when creating a new data-entry session against a control plan. Choose to access the control plans using the access list mode or the hierarch fields mode. For the new session, enter data using the subgroup method or the sample method and then the session ID is created.

Next, submit the readings for analysis. Review and diagnose any system-generated alarms and review the results in graphic form:

Image: Entering quality data business process flow (1 of 2)

This diagram illustrates the process flow.

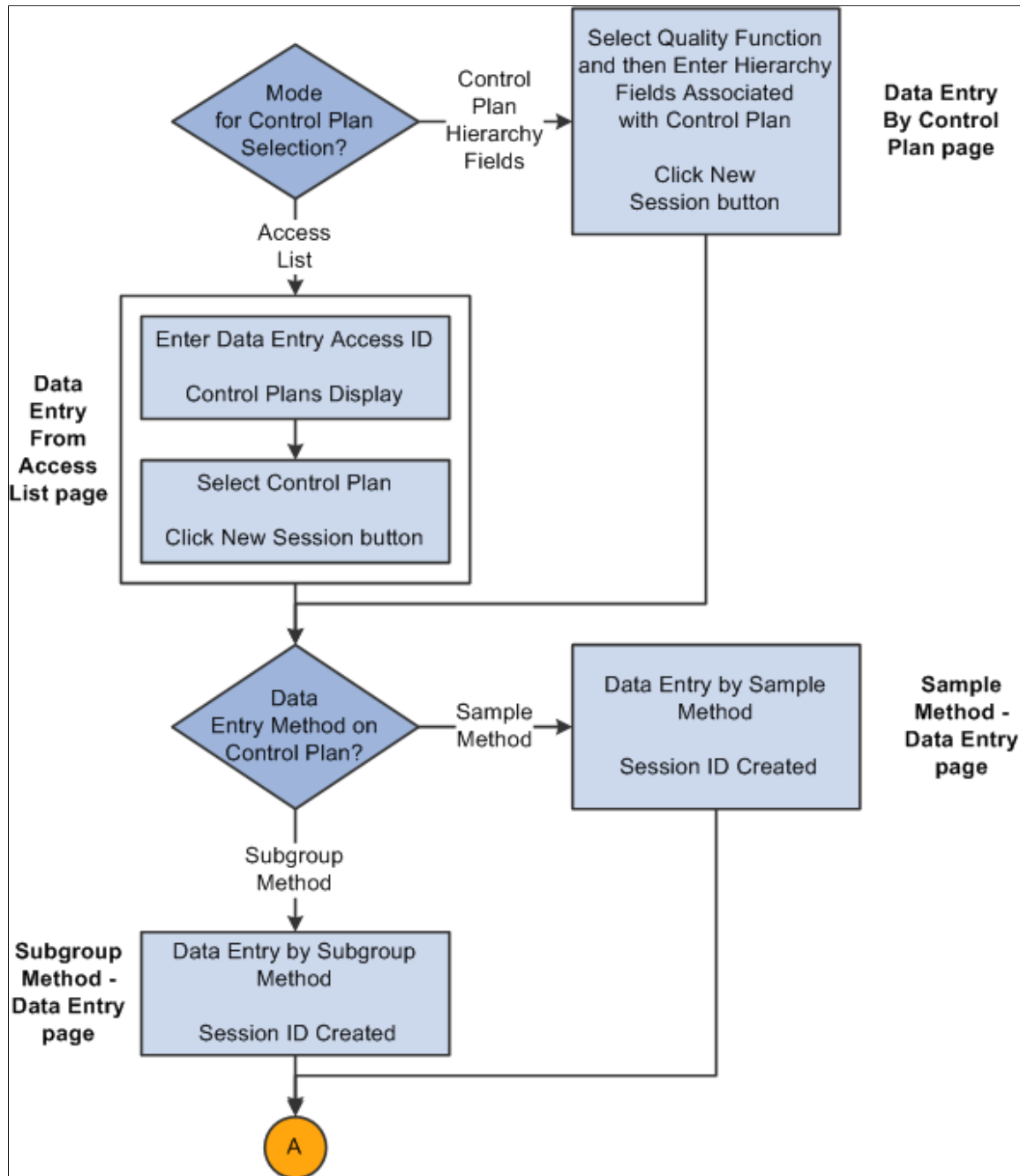
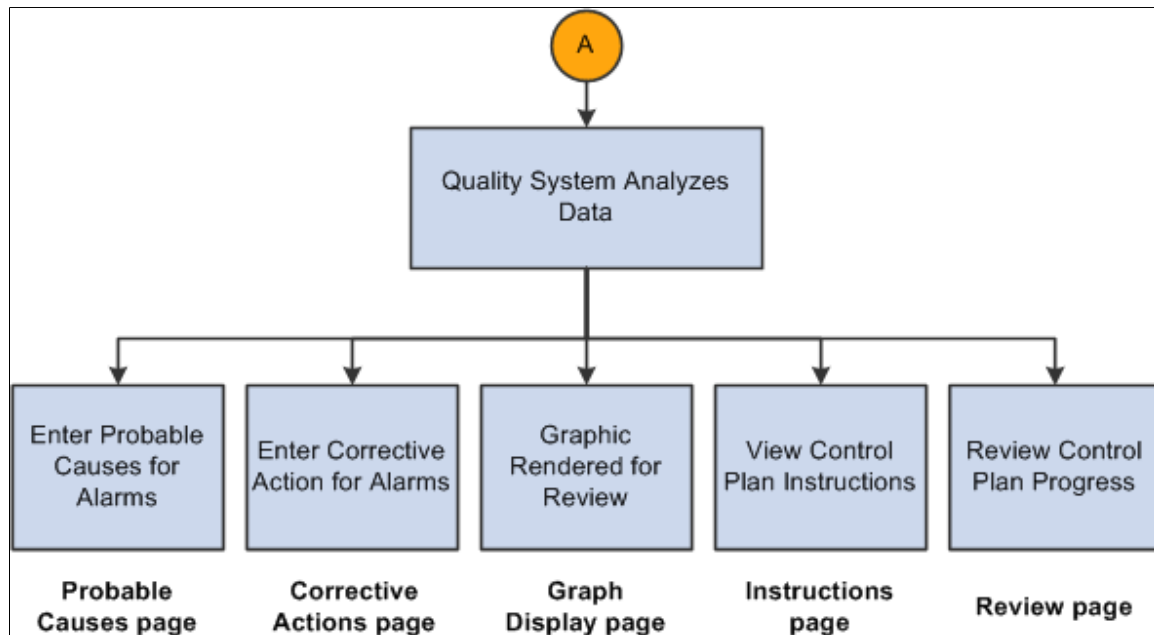

Image: Entering quality data business process flow (2 of 2)

This diagram illustrates the process flow.



Use the following procedures to initiate a quality session and record sampling data.

To enter quality data:

1. Determine how you want to access the control plans.
2. If you choose the access list mode, perform the steps in the "To choose the access list mode" procedure.
3. If you choose the hierarchy field mode, perform the steps in "To choose the hierarchy field mode" procedure.

To choose the access list mode:

1. Create an access list by using the Define Operator Access List page and associate control plans with the access list using the Control Plan Selections page.
2. Enter the data entry access ID and then select the control plan on the Data Entry From Access List page with which you want to work.
3. Click the New Session button.
4. Enter data associated with the characteristics on the control plan on the Subgroup Method - Data Entry page or the Sample Method - Data Entry page.

The system invokes the appropriate page depending on the data-entry method defined for the control plan. While entering data you can view:

- Instructions for the control plan on the Instructions page.
- Current results for a sampling on the Review page.

5. Submit the readings for analysis.
6. Review and diagnose the alarms that the system generated.

If the system generates alarms, you can:

- View the alarm notifications for each characteristic.
 - Enter the causes for the alarms on the Probable Causes page.
 - Enter the corrective actions taken to correct the alarm condition on the Corrective Actions page.
7. (Optional) Enter causes for potential problems and corrective actions on the Probable Causes and Corrective Actions pages even if the system does not generate alarms.
 8. View the results as a graphic.

The working control chart that you assigned to the characteristic appears on the Graph Display page.

See [Viewing PeopleSoft Quality Graphics](#).

To choose the hierarchy field mode:

1. Select the quality function and then enter the hierarchy fields associated with the control plan using the Data Entry By Control Plan page.
2. Click the New Session button on the Data Entry By Control Plan page.
3. Enter data associated with the characteristics for the control plan on the Subgroup Method - Data Entry page or the Sample Method - Data Entry page.

The system invokes the appropriate data-entry page depending on the data-entry method that you defined for the control plan.

While entering data you can:

- Complete the data-entry readings for one or more characteristics on the control plan.
 - View the instructions for the complete control plan on the Instructions page.
 - View the current results for a sampling on the Review page.
4. Submit the readings for analysis.
 5. Review and diagnose the alarms that the system generated.

If the system generates alarms, you can:

- View the alarm notifications for each characteristic.
- Enter the causes for the alarms on the Probable Causes page.
- Enter the corrective actions taken to correct the alarm condition on the Corrective Actions page.

6. (Optional) Enter causes for potential problems and corrective actions on the Probable Causes and Corrective Actions pages even if the system does not generate alarms.
7. View the results in a graphic.

The working control chart that you assigned to the characteristic appears on the Graph Display page.

See [Viewing PeopleSoft Quality Graphics](#).

Pending Session Recall

This graphic illustrates the process flow when recalling a pending data-entry session for completion. For the pending session that needs to be completed, choose to access the control plan using the access list mode or the hierarch fields mode. Select the data entry method of subgroup method or sample method and

then complete the session. Next, the Quality system analyzes the data to generate any alarms, and display the results in graphic form:

Image: Recalling a pending session business process flow (1 of 2)

This graphic illustrates the process flow.

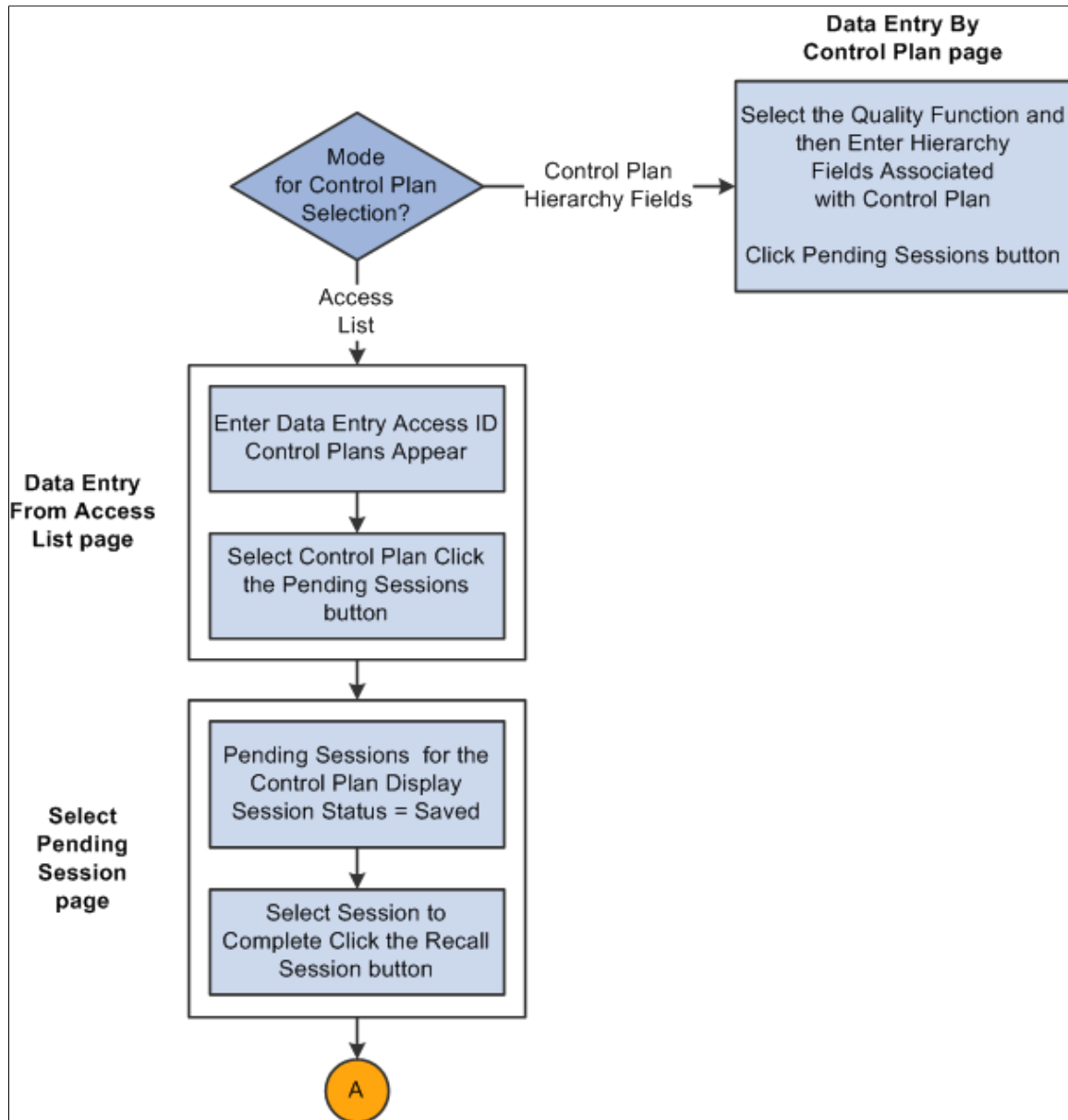
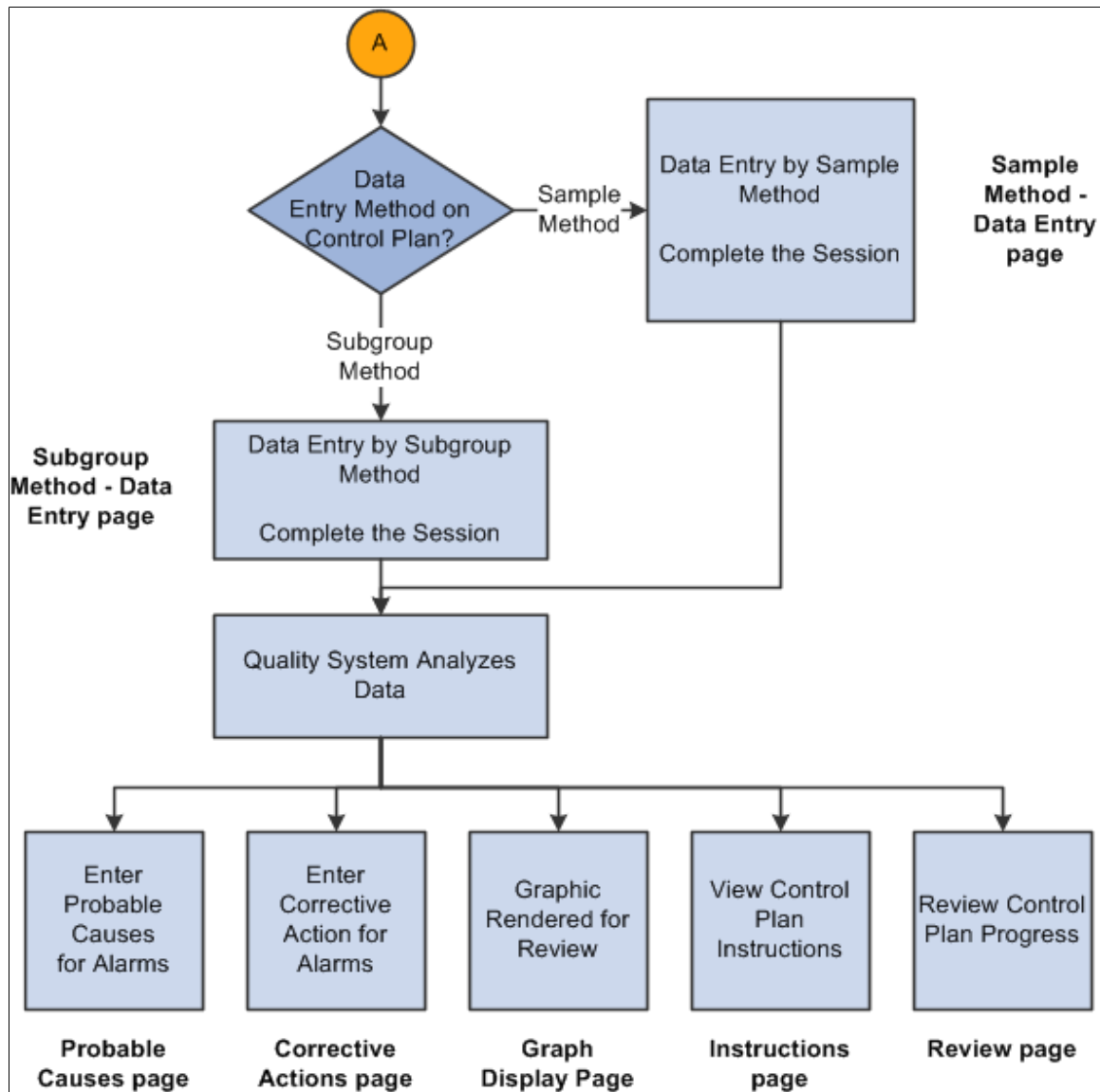

Image: Recalling a pending session business process flow (2 of 2)

This graphic illustrates the process flow.



To recall a pending session:

1. Determine whether you have pending sessions that need to be completed and how you want to access the control plans.
2. If you choose the access list mode, perform the steps in the "To choose the access list mode" procedure.
3. If you choose the hierarchy field mode, perform the steps in the "To choose the hierarchy field mode" procedure.

To choose the access list mode:

1. Enter the data entry access list ID and select the control plan with which you want to work on the Data Entry From Access List page.

2. Click the Pending Sessions button on the Data Entry From Access List page.
3. Select the pending session that you want to complete, by clicking the Recall Session button on the Select Pending Session page.
4. Enter data associated with the characteristics for the control plan on the Subgroup Method - Data Entry page or the Sample Method - Data Entry page.

The appropriate data-entry page appears depending on the data-entry method that you defined for the control plan.

As you enter data for a session, you can:

- Complete the data-entry readings for the incomplete characteristics.
 - View the instructions for the entire control plan on the Instructions page.
 - View the current results for a sampling on the Review page.
5. Submit the readings for analysis.
 6. Review and diagnose the alarms that the system generated.

If the system generates alarms, you can:

- View the alarm notifications for each characteristic.
 - Enter the causes for the alarms on the Probable Causes page.
 - Enter the corrective actions taken to correct the alarm condition on the Corrective Actions page.
7. (Optional) Enter causes for potential problems and corrective actions on the Probable Causes and Corrective Actions pages even if the system does not generate alarms.
 8. View the results in a graphic.

The working control chart that you assigned to the characteristic appears on the Graph Display page.

See [Viewing PeopleSoft Quality Graphics](#).

To choose the hierarchy field mode:

1. Select the quality function and then enter the hierarchy fields associated with the control plan, using the Data Entry by Control Plan page.
2. Click the Pending Sessions button on the Data Entry by Control Plan page.
3. Select the pending session that you want to complete, by clicking the Recall Session button on the Select Pending Session page.
4. Enter data associated with the characteristics for the control plan on either the Subgroup Method - Data Entry page or the Sample Method - Data Entry page.

The system invokes the appropriate data-entry page depending on the data-entry method that you defined for the control plan. While you enter data for a session you can:

- Complete the data-entry readings for the incomplete characteristics.
 - View the instructions for the entire control plan on the Instructions page.
 - View the current results for a sampling on the Review page.
5. Submit the readings for analysis.
 6. Review and diagnose the alarms that the system generated.

If the system generates alarms, you can:

- View the alarm notifications for each characteristic.
 - Enter the causes for the alarms on the Probable Causes page.
 - Enter the corrective actions taken to correct the alarm condition on the Corrective Actions page.
7. (Optional) Enter causes for potential problems and corrective actions on the Probable Causes and Corrective Actions pages even if the system does not generate alarms.
 8. View the results as a graphic.

The working control chart that you assigned to the characteristic appears on the Graph Display page.

Completed Session Edits

This graphic illustrates the process flow for editing a completed session. The steps are explained below the graphic:

Image: Editing a completed session business process flow (1 of 2)

This graphic illustrates the process flow.

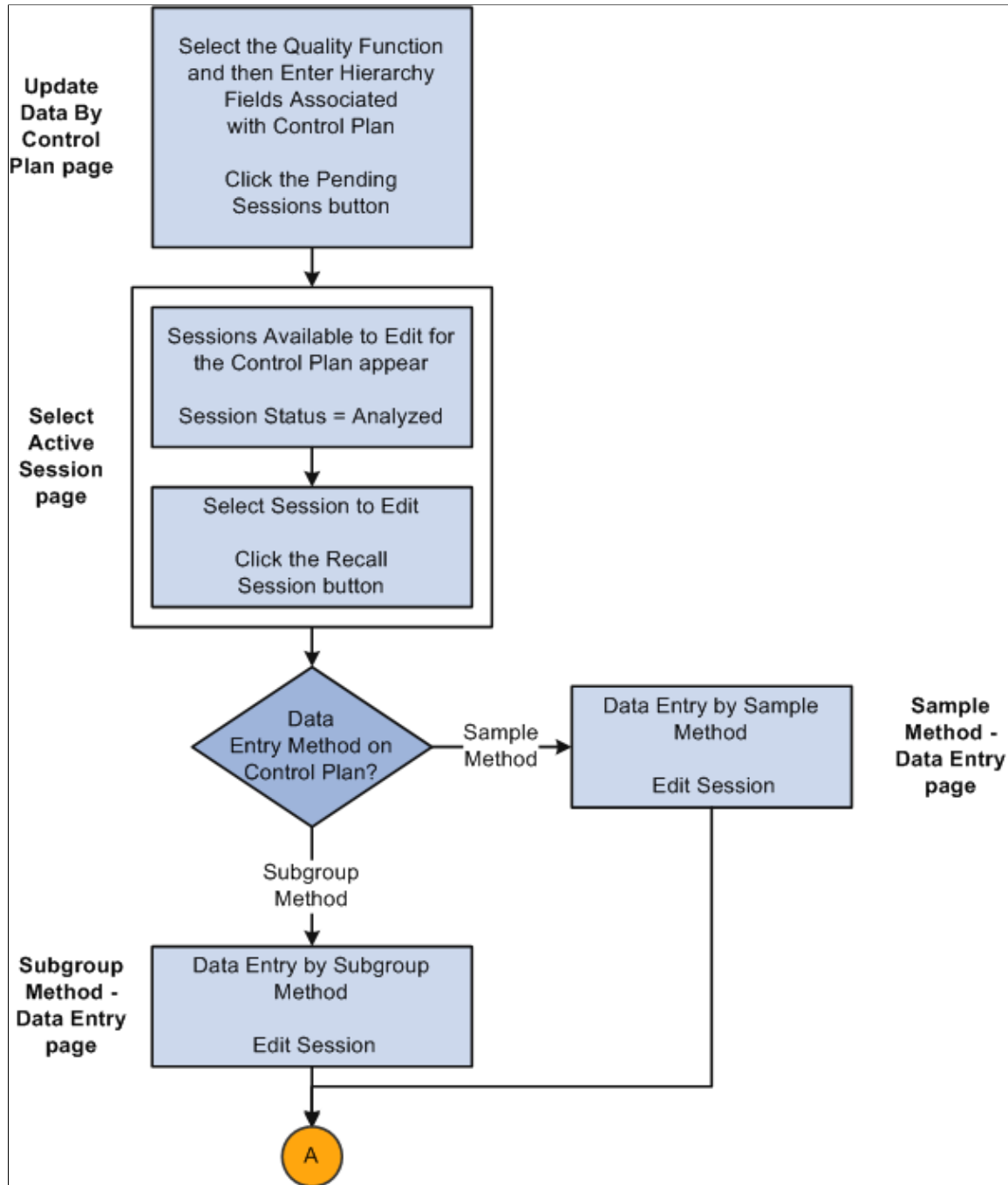
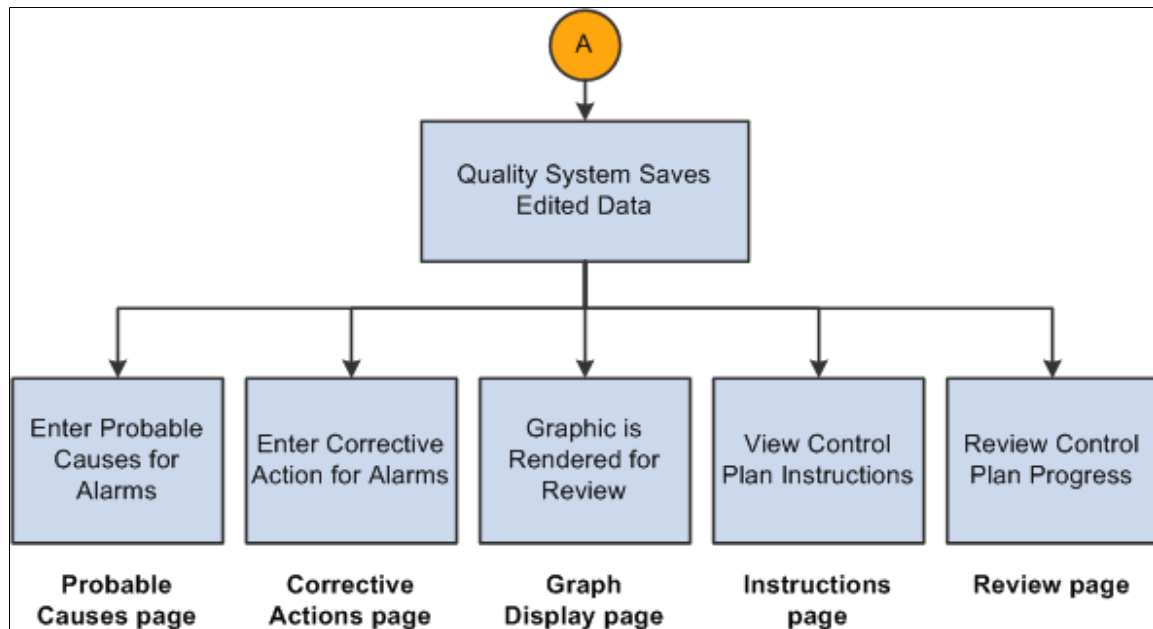

Image: Editing a completed session business process flow (2 of 2)

This graphic illustrates the process flow.



To edit data on a session that is completed:

1. Determine whether you have sessions that need to be edited, such as data that was entered incorrectly for the session.
2. Enter the hierarchy fields associated with the control plan on the Update Data By Control Plan page and click the Pending Sessions button.
3. Select the completed session that you want to edit, by clicking the Recall Session button on the Select Active Session page.
4. Edit data associated with the characteristics that are completed for the session by using the Subgroup Method - Data Entry page or the Sample Method - Data Entry page.

The system invokes the appropriate data-entry page depending on the data-entry method that you defined for the control plan. While editing data, you can:



- Edit the data-entry readings for completed characteristics.
 - View the instructions for the complete control plan on the Instructions page.
 - View the results for a sampling on the Review page.
5. Save the edited readings.

After you edit and save readings, the system does not generate new or cancel existing alarms; however, it does check acceptance limits (if defined). Plus, the system selects and displays the Subgroup Was Edited check box for each edited characteristic subgroup.

6. View the results as a graphic.

The working chart appears on the Graph Display page.

Common Elements Used in Collecting Quality Data

Data Entry Access ID	A user-specified ID providing access to a list of predefined and often used control plans.
Session	Denotes a data-entry instance. A session encapsulates all characteristics, readings, alarms, and actions that you enter for specific inspection samplings. The system automatically generates the unique session ID.
Pending Session	The session has been saved, but not all sample values have been entered or analyzed.
Completed Session	All sample values have been entered and each characteristic has been analyzed.
Date Created	Displays the date and time that the session was created.
Data Entry Name	A name given to a series of control plans to be run together. The number in parentheses next to the name displays the number of control plans associated with the data entry name. For example, <i>Assembly_1 (3)</i> means that you have three control plans associated with the data entry name of <i>Assembly_1</i> .
New Session	Click this button to create a new session using the subgroup or sample method depending on the data-entry method associated with the control plan. From there, you can enter readings for the characteristics.
Pending Sessions	Click this button to view the sessions that are pending or the sessions that are completed. When you click this button the Select Pending Session or Select Active Session pages appear.
	Click the Next button to scroll to the next quality object.
	Click the Previous button to scroll to the previous quality object.
Add To List	After you select an attribute, click the Add To List button to populate the list for a Quality page.
	Click the Enter Defects button to record defects observed for defects or defectives data types.
Calculate	Click this button to calculate and populate the Reading fields associated with a derived characteristic. This button is active only for derived-type characteristics. For example, suppose that you define three characteristics, such as length, width, and area and you define the area to equal the length times the width. If you have already entered readings for the length and

width characteristics, click the Calculate button to generate readings for the area characteristic. The system calculates and automatically enters the derived readings on the page.



Click the Next Control Plan in Sequence button to access the next control plan in sequence associated with the data entry name.

Complete

Click this button to populate the remaining reading fields with the average of the readings already entered for the characteristic.

You can use this button after you enter at least one reading.

In addition, you must have selected to average the data for an incomplete subgroup associated with a characteristic from the Measurement Plan page.

Repeat Sampling

Click this button to display the Data Entry page and create a new data-entry session. Use this feature to continue entering sample information without traversing the menu system. This button becomes active when you complete and save at least one characteristic for a control plan. The button is not active when editing a completed session.



Click the View Chart button to display the current working chart for the characteristic that you selected. The data appears with the graph preference that is associated with the control plan characteristic.



Click the Enter Probable Cause button to access the Probable Causes page and enter probable causes for alarms.



Click the Enter Corrective Action button to access the Corrective Actions page and log any corrective actions taken.



This button indicates an alarm associated with a subgroup of a characteristic. This button appears on various data entry, data analysis, and alarm review pages.

Defining Data-Entry Access Lists

To define data-entry access lists, use the Define Operator Access Lists component (QS_DE_ACCLIST8). This section discusses how to:

- Maintain access lists.
- Assign control plans to access lists.

Pages Used to Define Data-Entry Access Lists

Page Name	Definition Name	Navigation	Usage
Define Operator Access List	QS_DE_ACCLIST	Quality, Prepare Data Collection, Define Operator Access Lists	Define an access list. You create access lists and assign control plans to them. The lists present a concise list of frequently performed data-entry tasks to an operator. Multiple operators can use the same lists. The creation of an access list advances the security and flexibility in which administrators can assign specific data-entry obligations to operators.
Control Plan Selections	QS_DS_ACCLIST2	Click the Control Plan Selections link on the Define Operator Access List page.	Display all control plans associated with a quality function and select the plans that you want to associate with the access list.

Define Operator Access List Page

Use the Define Operator Access List page (QS_DE_ACCLIST) to define an access list.

You create access lists and assign control plans to them. The lists present a concise list of frequently performed data-entry tasks to an operator. Multiple operators can use the same lists. The creation of an access list advances the security and flexibility in which administrators can assign specific data-entry obligations to operators.

Navigation

Quality, Prepare Data Collection, Define Operator Access Lists

Control Plan Selections

Click this link to select control plans to associate with the access list.

Inactive

Select this check box if you do not want the system to display this control plan during data entry.

Default

Select this check box to launch this control plan automatically when performing data entry using an access list.

Control Plan Selections Page

Use the Control Plan Selections page (QS_DS_ACCLIST2) to display all control plans associated with a quality function and select the plans that you want to associate with the access list.

Navigation

Click the Control Plan Selections link on the Define Operator Access List page.

Select the Select check box next to each data entry name (control plan) that you want to assign to the access list. Control plans can be assigned to any number of access lists.

Note: Only control plans with a data entry name appears.

Related Links

[Understanding Control Plans](#)

Entering, Maintaining, and Editing Quality Data

This section provides an overview of how to create a new sampling and discusses how to:

- Select control plans from access lists.
- Select control plans using hierarchy fields.
- Recall pending sessions from access lists.
- Recall sessions using hierarchy fields.
- Use session list pages.

Pages Used to Enter, Maintain, and Edit Quality Data

<i>Page Name</i>	<i>Definition Name</i>	<i>Navigation</i>	<i>Usage</i>
Data Entry From Access List	QS_DE_ACLEEXEC	Quality, Enter Sampling Information, From Access List, Data Entry From Access List	<ul style="list-style-type: none"> • Select a control plan (by name) from a list. • Recall pending sessions from an access list. The mode is only available for pending sessions, not for completed sessions
Data Entry By Control Plan	QS_STRMROOT_SEL	Quality, Enter Sampling Information, By Control Plan, Data Entry By Control Plan	<ul style="list-style-type: none"> • Specify a control plan by entering its hierarchy fields. • Recall pending sessions using hierarchy fields.
Update Data By Control Plan	QS_STRMROOT_SEL	Quality, Enter Sampling Information, Update Completed Sessions, Update Data By Control Plan	Recall completed sessions using hierarchy fields.
Select Pending Session	QS_SESSN_SEL	Click the Pending Sessions button on the Data Entry From Access List page or the Data Entry By Control Plan page.	Select the pending session that you want to complete.

Page Name	Definition Name	Navigation	Usage
Select Active Session	QS_SESSN_SEL	Click the Pending Sessions button on the Update Data By Control Plan page.	Select the completed session that you want to edit.

Understanding the Creation of a New Sampling

To create a new sampling:

1. Select the control plan that you are working on from either the access list or by entering hierarchy fields associated with the control plan.

You can enter the readings for an inspection sampling for each characteristic through the Data Entry From Access List or Data Entry By Control Plan pages.

2. Enter inspection readings for the various characteristics associated with a control plan.

If you do not complete the plan, you can save the session and recall it at a later time for updates.

3. Submit the data for analysis to assess control and view the current working chart for each characteristic.
4. Enter probable causes for alarms or log corrective actions for any characteristic.
5. Review the control plan and current sample results.
6. View instructions on how to perform the inspection readings for all characteristics.

Data Entry From Access List Page

Use the Data Entry From Access List page (QS_DE_ACLEEXEC) to .

Navigation

Quality, Enter Sampling Information, From Access List, Data Entry From Access List

Select a control plan from an access list. This page simplifies the selection of repetitive control plans by inspection personnel.

Note: For security, the Access ID field does not provide a prompt list.

Launch Default Data Entry

Click this link to launch the control plan that you specified as the default for this access ID.

Related Links

[Define Operator Access List Page](#)

[Using Subgroup and Sample Methods to Enter Data](#)

Data Entry By Control Plan Page

Use the Data Entry By Control Plan page (QS_STRMROOT_SEL) to .

Navigation

Quality, Enter Sampling Information, By Control Plan, Data Entry By Control Plan

Enter the hierarchy fields associated with the plan. The fields that appear vary depending on the quality function. In the lower portion of the page, the hierarchy fields associated with the specific quality function appear.

Recalling Pending Sessions From Access Lists

To recall a pending session from an access list:

1. Access the Data Entry From Access List page.

Note: You can recall pending or incomplete sessions by using either the Data Entry From Access List or Data Entry By Control Plan pages.

You can recall completed sessions for editing only by using the Update By Control Plan page.

2. Click the Pending Sessions button next to a control plan to access the Select Pending Session page.
3. Select the pending session to complete.

Related Links

[Data Entry From Access List Page](#)

Recalling Sessions Using Hierarchy Fields

To maintain or complete a pending session:

1. Access the Data Entry By Control Plan page.
2. Enter the appropriate hierarchy fields for the target control plan.
3. Click the Pending Sessions button to access the Select Pending Session page.
4. Select the specific session that you want to complete from the list.

To edit a completed session:

1. Access the Update Data By Control Plan page.
2. Enter the appropriate hierarchy fields for the target control plan.
3. Click the Pending Sessions button to access the Select Active Session page.
4. Select the specific session that you want to edit from the list.

Related Links

[Data Entry By Control Plan Page](#)

Select Pending Session Page

Use the Select Pending Session page (QS_SESSN_SEL) to select the pending session that you want to complete.

Navigation

Click the Pending Sessions button on the Data Entry From Access List page or the Data Entry By Control Plan page.

Depending on the mode of entry to these pages, the system displays either a list of pending sessions to be completed or a list of completed sessions available to edit. Sessions are listed in descending order of creation date. In addition, the hierarchy fields associated with the quality function and control plan appear.

Session Displays the pending or completed sessions.

Status Displays the state of the session. Values include:

Saved: Pending sessions that you can maintain.

Analyzed: Completed sessions that you can edit.

The listed sessions are limited by the data persistence settings, the session data life days, and the edit data limit days that you defined for the quality function. This table lists the criteria that affects sessions:

Sessions	Session Status	Data Criteria
Pending	<i>Saved</i>	Current Date - Session Data Life Days
Completed	<i>Analyzed</i>	Current Date - Edit Data Limit Days

For example, suppose that you want to edit data for a completed session. The date is March 30, 2003, and the edit data limit days for the quality function is set to 20 days. The list of sessions that appear on this page are those sessions that you created between March 10, 2003 and March 30, 2003, with a session status of *Analyzed*.

Related Links

[Understanding Quality Functions](#)

[Entering, Maintaining, and Editing Quality Data](#)

Using Subgroup and Sample Methods to Enter Data

This section provides an overview of subgroup and sample methods and discusses how to:

- Use the subgroup method.
- Use the sample method.
- Record defects.

Pages Used to Maintain Quality Data Using Subgroup and Sample Methods

<i>Page Name</i>	<i>Definition Name</i>	<i>Navigation</i>	<i>Usage</i>
Data Entry (Subgroup Method)	QS_DE_GUI_S	<ul style="list-style-type: none"> Click the New Session button on the Data Entry page From Access List or Data Entry By Control Plan pages. Click the Recall Session button on the Select Pending Session or the Select Active Session pages. 	Enter readings for the inspection sampling for each characteristic subgroup according to subgroup.
Data Entry (Sample Method)	QS_DE_GUI_I	<ul style="list-style-type: none"> Click the New Session button on the Data Entry From Access List or Data Entry By Control Plan pages. Click the Recall Session button on the Select Pending Session or the Select Active Session pages. 	Enter readings for the characteristic by individual units, one by one.
Enter Defects	QS_DFCT8B_PNL	Click the Enter Defects button found on multiple pages.	Record defect information associated with a sample data type of defects or defectives.

Understanding Subgroup and Sample Methods

You enter, maintain, and edit quality data for characteristics by using either the subgroup or sample method. Use the subgroup method to enter readings for an entire subgroup at once. Use the sample method to enter individual readings for each characteristic on one unit.

The method that you select for data collection depends on the way that you physically measure and record readings for characteristics with which you are working. While the pages are functionally equivalent, each page is optimized to enhance field navigation and input based on the type of item handling or inspection taking place.

To use the subgroup method:

1. Enter readings for one characteristic on as many units as it takes to meet the subgroup size for the characteristic.
2. Enter readings for the next characteristic until its subgroup size is met, and so on, until you inspect all of the characteristics for the control plan.

To use the sample method:

1. Enter data readings for each characteristic on one unit.

2. Enter readings for each characteristic on another unit, and so on, until you have inspected enough units to meet the subgroup size that you defined.

Using the Subgroup Method

Use the Data Entry (Subgroup Method) page (QS_DE_GUI_S) to enter readings for the inspection sampling for each characteristic subgroup according to subgroup.

Navigation

- Click the New Session button on the Data Entry page From Access List or Data Entry By Control Plan pages.
- Click the Recall Session button on the Select Pending Session or the Select Active Session pages.

The Subgroup Method pages function basically the same, whether you are entering data for a new session, maintaining data for a pending session, or editing data for a completed session. The differences in the page behavior depend on the type of task that you are performing.

To enter data for a new session:

1. Enter data for all the characteristics for the control plan, including any defect classifications and tallies.
2. Enter causes and actions for the alarms after the characteristics have been analyzed.
3. Review the working chart for any characteristics.

To maintain data for a pending session:

1. Complete the readings for any unfinished characteristics or samples for the session.

The previously completed (analyzed) characteristics appear but cannot be changed.

2. Enter causes and alarms.
3. Review the working chart for any characteristic.

Note: A characteristic is considered complete after its sampling criteria has been fulfilled and analyzed. That is, subgroup results are calculated and alarm conditions evaluated. A data-entry session is considered complete after all the characteristics within the control plan have been analyzed.

To edit a completed session:

1. Make corrections to the data that you entered for that session.
2. Change trace fields, sample values, or defect information associated with the historical session.
3. Change or augment any of the probable causes and corrective actions.
4. Click the Apply button to resubmit the new readings.
5. Quality calculates and saves the results; however, it does not evaluate or generate new alarms.

Any prior alarm conditions remain in the database. Subgroups that are edited in this way are stamped in the database and annotated when they appear on control charts.

Characteristic

The system displays the number of characteristics associated with the control plan, such as 1 of 3 or 2 of 3.

The system uses the Control Plan field to display the number of control plans associated with a particular data entry name. For example, 1 of 1 means there is only 1 control plan associated with this data entry name.

User Input

Enter the row of data associated with the sample. The column titles that appear on the page correspond to the trace set fields associated with the control plan. If you previously defined the subgroup size, an equivalent number of detailed rows appear on the page. If you didn't define the subgroup size, which is possible for attributes-type characteristics using u, p, and np charts, enter the Sgrp size (subgroup size) on the page.

Enter the reading information for the different types of characteristics. Values are:

Value	Description
<i>Variable</i>	For variable data types, enter the value in the Reading field. The Enter Defects button does not appear for variable data-type characteristics.
<i>Defect</i>	For defect data type characteristics, select the actual defects and the number observed using the Enter Defects page. The attribute group associated with the control plan defines the defect selection lists. When you close the Enter Defects page, the defect tally is automatically placed in the Reading field. You can also enter the defect tally directly in the Reading field without accessing the Enter Defects page. What you enter on the Enter Defects page overrides what you enter directly in the Reading field on this page.
<i>Defective</i>	For defective data types, enter the observations in #Defectives. You also have the option of selecting any defect observations and counts on the Enter Defects page.

See [Recording Defects](#).

Characteristic - Other Information

As you submit samplings for analysis, Quality evaluates the process for control violations and displays any detected alarms. Up to three alarm conditions, one for mean, variance, and specification limit violations may appear in the center of the page. In addition, the appropriate control-chart labeling and associated subgroup calculations appear on the page.

Using the Sample Method

The Sample Method pages function basically the same, whether you are entering data for a new session, maintaining data for a pending session, or editing data for a completed session. The differences in the page behavior depend on the type of task that you are performing.

Note: A subgroup is considered complete after its sampling criteria is fulfilled and analyzed. That is, subgroup results are calculated and alarm conditions evaluated. A data-entry session is considered complete after all the characteristics within the control plan have been analyzed.

Control Plan Information

The system uses the Control Plan field to display the number of control plans associated with a particular data entry name. For example, 1 of 1 means there is only 1 control plan associated with this data entry name.

Traceability

Enter the traceability data associated with the sample.

The titles of the columns that appear on the page correspond to the trace set fields associated with the control plan. Depending on the definition of the trace set, there may be one or more fields that you can enter.

Sample Values

If you previously defined the subgroup size, an equivalent number of detailed rows appear on the page. If you didn't previously define the subgroup size, which is possible for attributes-type characteristics using u, p, and np charts, you can enter the Sgrp Size (subgroup size) on the page.

Enter the reading information for the different types of characteristics.

Note: The heading for the Reading field changes to represent the sample you are currently on. For example, Reading 1 lets you know you are entering data in the Reading field for the first sample.

Other Information

As you submit samplings for analysis, Quality evaluates the process for control violations and displays detected alarms. Up to three alarm conditions, one for means, variance, and specification limit violations may appear in the center of the page. In addition, the appropriate control-chart labeling and associated subgroup calculations appear on the page.

Related Links

[Recording Defects](#)

[Understanding Measurement Plans](#)

Recording Defects

Use the Enter Defects page (QS_DFCT8B_PNL) to record defect information associated with a sample data type of defects or defectives.

Navigation

Click the Enter Defects button found on multiple pages.

To enter a complete defect description:

1. Select each defect component required for a complete defect description using the defect category group boxes.

Select the Select One check box next to the correct component.

Note: The attribute group assigned to this control plan defines the list of entries that appear in the category group boxes.

2. Click the Add To List button.

After you click this button, use the List group box (Location, Fault and With) to view the predefined defect category selections applicable to this control plan. Select from each component to build a completed defect description corresponding to actual observations.

3. Enter the number of defects of this type observed in the Count field.

Note: A defect count of zero is not valid.

To change a defect description:

1. Select the List check box next to the defect description that you want to change that appears in the List group box.

2. Select the correct defect component or components.

Select the Select One check box next to the correct component.

3. Click the Add To List button.

When you click this button, the system overrides the values for the selected defect descriptions with the new values.

Related Links

[Defining Attribute Groups](#)

Working With Control Plans

This section discusses how to:

- View instructions.
- Review current session results.
- Display graphs.
- Record probable causes.

- Record corrective actions.

Pages Used to Work With Control Plans

<i>Page Name</i>	<i>Definition Name</i>	<i>Navigation</i>	<i>Usage</i>
Instructions	QS_DE_INSTRUCTIONS	<ul style="list-style-type: none"> • Quality, Enter Sampling Information, From Access List, Data Entry From Access List Click the New Session or Pending Session buttons on the Data Entry From Access List page. • Quality, Enter Sampling Information, By Control Plan, Data Entry By Control Plan Click the New Session or Pending Session buttons on the Data Entry By Control Plan page. • Quality, Enter Sampling Information, Update Completed Sessions, Update Data By Control Plan Click the Pending Session button on the Update Data By Control Plan page. 	Review instructions associated with the control plan while you enter data.

Page Name	Definition Name	Navigation	Usage
Review	QS_DE_REVIEW8	<ul style="list-style-type: none"> Quality, Enter Sampling Information, From Access List, Data Entry From Access List <p>Click the New Session or Pending Session buttons on the Data Entry From Access List page.</p> <ul style="list-style-type: none"> Quality, Enter Sampling Information, By Control Plan, Data Entry By Control Plan <p>Click the New Session or Pending Session buttons on the Data Entry By Control Plan page.</p> <ul style="list-style-type: none"> Quality, Enter Sampling Information, Update Completed Sessions, Update Data By Control Plan <p>Click the Pending Session button on the Update Data By Control Plan page.</p>	Review results and alarms for each characteristic on the control plan.
Graph Display	QS_CLCHART_RVW	<ul style="list-style-type: none"> Click the View Chart button on the Review page. Select the Display Graph option when performing alarm review. 	View the current working chart for a characteristic.
Probable Causes	QS_CAUSE8B_PNL	Click the Enter Probable Cause button on the Review page.	Record probable causes for alarms associated with the characteristic.
Corrective Actions	QS_ACTION8B_PNL	Click the Enter Corrective Action button on the Review page.	Record actions taken in response to an alarm condition or to log comments against the process.

Instructions Page

Use the Instructions page (QS_DE_INSTRUCTIONS) to review instructions associated with the control plan while you enter data.

Navigation

- Quality, Enter Sampling Information, From Access List, Data Entry From Access List
Click the New Session or Pending Session buttons on the Data Entry From Access List page.
- Quality, Enter Sampling Information, By Control Plan, Data Entry By Control Plan
Click the New Session or Pending Session buttons on the Data Entry By Control Plan page.
- Quality, Enter Sampling Information, Update Completed Sessions, Update Data By Control Plan
Click the Pending Session button on the Update Data By Control Plan page.

This page displays the instructions defined for the measurement plan. The instructions are the same, whether you are using a subgroup or sample method. In the upper-right portion of the page, a text box displays the hierarchy fields associated with the control plan.

Review Page

Use the Review page (QS_DE_REVIEW8) to review results and alarms for each characteristic on the control plan.

Navigation

- Quality, Enter Sampling Information, From Access List, Data Entry From Access List
Click the New Session or Pending Session buttons on the Data Entry From Access List page.
- Quality, Enter Sampling Information, By Control Plan, Data Entry By Control Plan
Click the New Session or Pending Session buttons on the Data Entry By Control Plan page.
- Quality, Enter Sampling Information, Update Completed Sessions, Update Data By Control Plan
Click the Pending Session button on the Update Data By Control Plan page.

Image: Review page: Results tab

This example illustrates the fields and controls on the Review page: Results tab. You can find definitions for the fields and controls later on this page.

The screenshot shows the 'Review' tab of the software interface. At the top, there are tabs for 'Data Entry', 'Instructions', and 'Review'. Below these, the control plan details are displayed: Unit US008, Quality Function QUALITY, Measurement Plan Bicycles Plan, and Session ID 20130305-125240-000-000000101. A 'Repeat Sampling' button is visible. On the right, a text box shows the hierarchy fields: Item ID: MIT3000, WC Code: FI-ASSY, Step Id: FINAL, Station: FINAL, and Machine: FINAL01. Below this, the 'Characteristic Review' section is shown with a 'Results' tab selected. A table displays the results for two characteristics: NECK TORQUE and VISUAL. The table includes columns for LSL, USL, UOM, Subgroup Size, Result 1, and Result 2.

Characteristic	LSL	USL	UOM	Subgroup Size	Result 1	Result 2
NECK TORQUE	500.00000	900.00000	KGF		3.00000	
VISUAL				3.00000	3.00000	

Control plans usually contain more than one characteristic. As you enter readings for a plan, you can review what has been analyzed. This page displays information and current subgroup results for each characteristic and is the same, whether you enter data for a new session, maintain a pending session, or edit a completed session.

In the upper-right portion of the page, a text box displays the hierarchy fields associated with the control plan. Each control plan characteristic appears in the Characteristic column.

LSL (lower specification limit) and USL (upper specification limit) Displays the lower and upper specification limits for the characteristic.

Subgroup Size Displays the subgroup size.

Result 1 and Result 2 Displays the subgroup results, based on the associated control chart calculated from the readings.

Alarms Tab

General Alarm, Chart 1 Alarm, and Chart 2 Alarm Displays alarm conditions for the characteristic.

Related Links

[Graph Display Page](#)

[Probable Causes Page](#)

Graph Display Page

Use the Graph Display page (QS_CLCHART_RVW) to view the current working chart for a characteristic.

Navigation

- Click the View Chart button on the Review page.
- Select the Display Graph option when performing alarm review.

The graph defined by the graph preference that is associated with the characteristics on the measurement plan appears. The graph is based upon the current N-point history for the process and may be a control chart, histogram, Pareto chart, or bar graph. In this mode, Quality generates the graph using the PeopleSoft Internet Architecture application server.

See [Viewing PeopleSoft Quality Graphics](#).

Related Links

[Understanding PeopleSoft Quality Application Client Charts and Analysis Tools](#)

Probable Causes Page

Use the Probable Causes page (QS_CAUSE8B_PNL) to record probable causes for alarms associated with the characteristic.

Navigation

Click the Enter Probable Cause button on the Review page.

Use this page to enter probable causes for an alarm or process behavior. You can post probable causes and corrective actions against any subgroup that has been analyzed, whether or not alarms have been detected.

To enter a probable cause definition:

1. Select each probable cause component required for a complete probable cause definition using the category group boxes.

Select the Select One check box next to the correct component.

Note: The attribute group assigned to this control plan defines the list of entries and actual labels that appear in the category group boxes.

2. Click the Add Probable Cause to List button.

After you click this button, use the List group box (Problem and Affecting) to view the predefined probable cause category selections applicable to this control plan. Select from each component to build a completed probable cause definition corresponding to actual observations.

To change a probable cause definition:

1. Select the List check box next to the probable cause definition that you want to change that appears in the List group box.

2. Select the correct probable cause component or components.

Select the Select One check box next to the correct component.

3. Click the Add Probable Cause to List button.

When you click this button the system overrides the values for the selected probable cause definition with the new values.

Related Links

[Defining Attribute Groups](#)

Corrective Actions Page

Use the Corrective Actions page (QS_ACTION8B_PNL) to record actions taken in response to an alarm condition or to log comments against the process.

Navigation

Click the Enter Corrective Action button on the Review page.

Use this page to enter corrective actions for an alarm or process behavior. You can post probable causes and corrective actions against subgroups that have been analyzed, whether or not alarms have been detected.

To enter a corrective action definition:

1. Select the action component required for a corrective action definition using the Category group box.

Select the Select One check box next to the correct component.

Note: The attribute group assigned to this control plan defines the list of entries and actual labels that appear in the category group box.

2. Click the Add Corrective Action to List button.

After you click this button, use the List group box (Action) to view the predefined corrective action category selections applicable to this control plan. Select the component to build a completed corrective action definition corresponding to actual observations.

To change a corrective action definition:

1. Select the List check box next to the corrective action definition that you want to change that appears in the List group box.
2. Select the correct corrective action component.

Click the Select One check box next to the correct component.

3. Click the Add Corrective Action to List button.

When you click this button, the system value overrides the value for the selected corrective action definition with the new value.

Related Links

[Defining Attribute Groups](#)

Reviewing Process Performance Information

Understanding the Alarm Review Process

When quality control violations occur, it is important to route the information to those responsible for assessing causes and taking corrective actions. The process of dispersing, recalling, and responding to these control violations is called alarm review.

Quality provides these alarm-review mechanisms:

- Operator viewing alarms.

As operators enter data against a control plan, Quality analyzes sample readings online and immediately displays alarm conditions on the same page. You can log probable causes and corrective actions during the same session.

- Receiving alarm notifications using Workflow.

Alarms generated by manual data entry and automated data collection through the Quality enterprise integration point (EIP) are directed as they occur to various worklists. The lists are populated and managed by Workflow on a role-user basis. From the worklist, the system provides a detail page that displays relevant process and subgroup information, as well as the working control chart for the data encapsulated by the alarm. You can note probable cause and corrective actions.

- Recalling alarms selectively.

You can query alarms by process, age, or type using alarm access profiles. The profiles serve as templates, allowing quick recall of alarms, regardless of the data-collection method, meeting extraction criteria that is specific to the job function or area of responsibility. The system recalls alarms and presents them in a summarized page. A detail page is linked to each alarm so that you can view relevant process and subgroup information and the working control chart for the data encapsulated by the alarm. You can note probable cause and corrective actions.

Related Links

[Entering, Maintaining, and Editing Quality Data](#)

[Viewing Alarms Using PeopleSoft Workflow](#)

[Alarm Detail Page](#)

[Viewing Alarms](#)

Common Elements Used in Reviewing Process Performance Information

Alarm Access ID

The identifier or name given to an alarm review profile.

Alarm Types

Defines which alarms the system displays for inquiries. Values include:

All Alarms: Displays all alarms regardless of probable cause or corrective action status.

Closed - Actions Logged: Displays only alarms with probable cause or corrective action logged against them.

Open - No Actions Logged: Displays only alarms with probable cause or corrective action not logged against them.

Return to Main Page

Click this link to display the originating (alarm listing) page.

View Instructions

Click this link to display the instructions associated with the measurement plan where the alarm occurred.

Display Graph

Select this option to display the default control chart associated with a characteristic.

Note: Data filling the graph is the N points (subgroups) leading up to the alarm condition, as defined by the control procedure assigned to this characteristic.



Click the Enter Probable Cause button to access the Probable Causes page where you can enter the probable causes against any subgroup selected.



Click the Log Actions button to access the Corrective Actions page where you log any corrective actions taken to correct the alarm condition.



This button indicates an alarm associated with a subgroup of a characteristic. This button appears on various data entry, data analysis, and alarm review pages.

Sample Detail

Click this link to access the Sample Detail page that contains individual sample values and trace field entries for the subgroup. You can apply causes and actions against any subgroup in the list not just the most current subgroup.

Viewing Alarms

To define alarm access profiles, use the Define Alarm Review Criteria component (QS_ALM_ACCLIST). This section provides an overview of alarm access profiles and discusses how to:

- Define alarm access profiles.
- View alarms using an access profile.
- View alarm details.
- View instructions.
- View sample details.

Pages Used to View Alarms

Page Name	Definition Name	Navigation	Usage
Define Alarm Review Criteria	QS_ALM_ACCLIST	Quality, Prepare Analysis, Define Alarm Review Criteria, Define Alarm Review Criteria	Define an alarm access ID that specifies the selection criteria for alarm review.
Review Alarms	QS_ALM_RVW_INQ	Quality, Analyze Quality Results, Review Alarm Conditions, Review Alarms, Review Alarms	View alarms that match the selection criteria that you specified on the alarm access profile.
Alarm Detail	QS_ALM_RVW_DET	Click a Characteristic (Display Detail) link on the Review Alarms page.	View the detailed information associated with the alarm. From this page you can access other pages, where you can review a chart, enter probable causes for the alarms, or log corrective actions.
Summarize Alarm Attributes	QS_ANLZ_ALMSUM_SPG	Click the Summary Analysis link on the Review Alarms page.	Select the attribute that you want to analyze and then have the system create a Pareto chart of that attribute.
Instructions	QS_INSTRUCT_PNL	Select the View Instruction option for the Go To Page field on the Alarm Detail page.	View the control plan instructions where an alarm occurred.
Sample Values / Traceability Detail	QS_TRCDET_PNL	Select the Sample Detail option for the Go To Page field on the Alarm Detail page.	View the actual sample values for the subgroup and trace fields that were entered for the subgroup.

Understanding Alarm Access Profiles

Quality analyzes data that you enter online and generates alarms if a control violation occurs for the process. When an alarm occurs, operators can take immediate action to correct the problem, or a quality analyst can review and monitor the alarms at a later date, enter causes for the alarms, and log corrective actions.

To facilitate alarm review and reduce review time for multiple alarms, create an alarm-access profile where you specify the processes or control plans that you want to view on an ongoing basis. You can also:

- View alarms of a relative age for which causes or corrective actions have not been taken.
- View only alarms where some action has been taken.
- View both types of alarms.

Define Alarm Review Criteria Page

Use the Define Alarm Review Criteria page (QS_ALM_ACCLIST) to define an alarm access ID that specifies the selection criteria for alarm review.

Navigation

Quality, Prepare Analysis, Define Alarm Review Criteria, Define Alarm Review Criteria

Recall Alarms of Type

Select a type of alarm to recall.

Review Period Days

Enter the relative age of alarms that you want to review. The system returns alarms based on the number of days specified subtracted from the current date.

Selection Criteria

These fields are the hierarchy fields associated with the quality function that you select. Select one of the following qualifiers next to each hierarchy field, and enter the appropriate data expression that goes with the qualifier.

<>	Select alarms where the hierarchy field is not equal to the value.
=	Select alarms where the hierarchy field is equal to the value.
ALL	All entries are returned. There is no qualification on this field.
BETWEEN	Select alarms between two hierarchy values that you enter.
LIKE	Select alarms where the field is like or similar to the value. The % sign is used as the wildcard.

For example, if you specify item ID as a hierarchy field, and you enter an item ID of *LIKE* and *30%*, then with this expression, the system retrieves all alarms associated with items starting with the number 30. The % character denotes the wildcard position and is used anywhere in the value string. The system uses the % character to form the search pattern for the item.

When using the *BETWEEN* qualifier, you must separate the expression by commas. For example, if you want to retrieve alarms associated with a particular set of work centers, you enter *BETWEEN WC10001, WC20001*. With this expression, the system retrieves alarms associated with the work centers between those two values.

Review Alarms Page

Use the Review Alarms page (QS_ALM_RVW_INQ) to view alarms that match the selection criteria that you specified on the alarm access profile.

Navigation

Quality, Analyze Quality Results, Review Alarm Conditions, Review Alarms, Review Alarms

Image: Review Alarms page: Stream Hierarchy tab

This example illustrates the fields and controls on the Review Alarms page: Stream Hierarchy tab. You can find definitions for the fields and controls later on this page.

Date Submitted	Characteristic	Item ID	Work Center	Machine Code	Station Code	QC Step ID	Measurement Plan
	Detail						

Make sure that an alarm access profile has been defined and alarms have been generated against control plans to populate the page.

Note: To enhance security, the Alarm Access ID field does not provide a prompt list.

The first columns to appear depend on the quality function that you select. The columns are the hierarchy fields associated with the quality function.

Date Submitted

Displays the date and time that the alarm occurred.

Characteristic

Displays the characteristic where the alarm was generated. Click the Characteristic (Display Detail) link to access the Alarm Detail page.

Summary Analysis

Click this link to view a Pareto chart of various alarm-related attributes.

Alarm Status Tab

Select the Alarm Status tab.

Test Violations

Displays the number of test violations that caused the alarm to trigger. The alarm is tagged to a specific subgroup, where up to three test violations can be detected for each subgroup: means and variance charts and specification violation.

Cause Count

Displays the number of probable causes previously entered against this alarm.

Action Count

Displays the number of corrective actions previously logged against this alarm.

Alarm Detail Page

Use the Alarm Detail page (QS_ALM_RVW_DET) to view the detailed information associated with the alarm.

From this page you can access other pages, where you can review a chart, enter probable causes for the alarms, or log corrective actions.

Navigation

Click a Characteristic (Display Detail) link on the Review Alarms page.

Image: Alarm Detail page

This example illustrates the fields and controls on the Alarm Detail page. You can find definitions for the fields and controls later on this page.

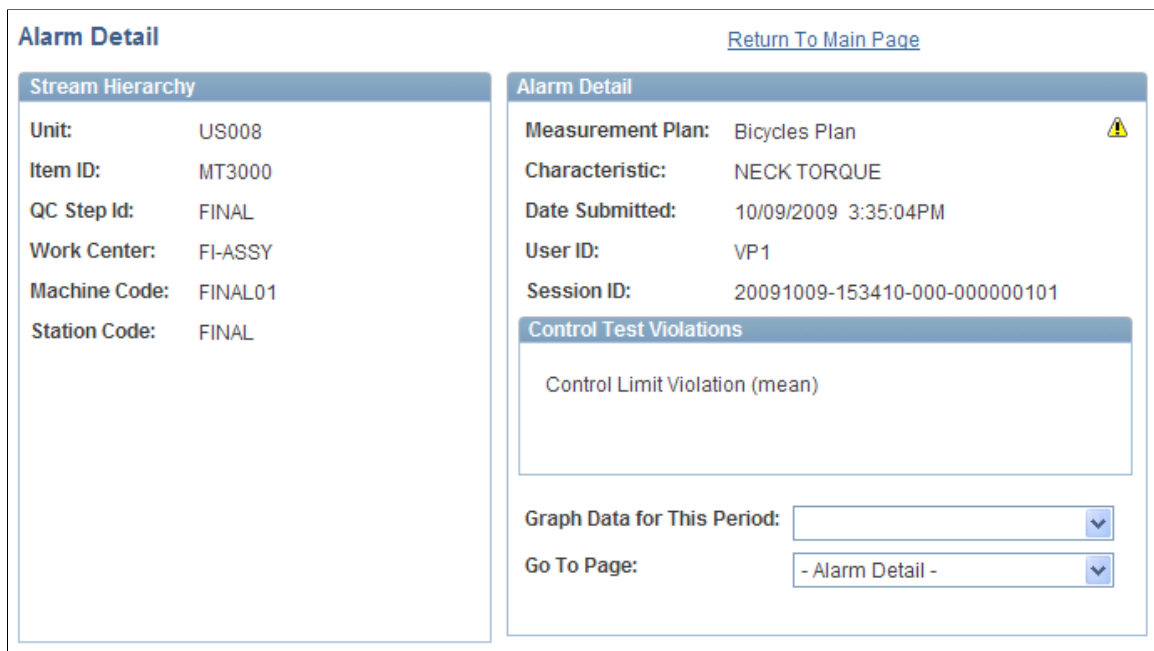

This page displays all the relevant subgroup information associated with a specific alarm.

Stream Hierarchy

The system displays the hierarchy fields associated with the quality function.

Alarm Detail

The system displays the basic information about the alarm, including the session ID associated with the alarm.

Graph Data for This Period

Select the type of graph that you want. Values are *Control Chart*, *Histogram*, *Pareto of Alarms*, *Pareto of Comments*, *Pareto of Corrective Actions*, *Pareto of Defects*, and *Pareto of Probable Causes*.

Control Test Violations

Displays the control-test violations associated with the alarm. There can be up to three test violations per alarm.

Additional Links

You can link to other pages using the Go To Page field to enter corrective and probable cause actions and sample details.

Instructions Page

Use the Instructions page (QS_INSTRUCT_PNL) to view the control plan instructions where an alarm occurred.

Navigation

Select the View Instruction option for the Go To Page field on the Alarm Detail page.

Image: Instructions page

This example illustrates the fields and controls on the Instructions page. You can find definitions for the fields and controls later on this page.

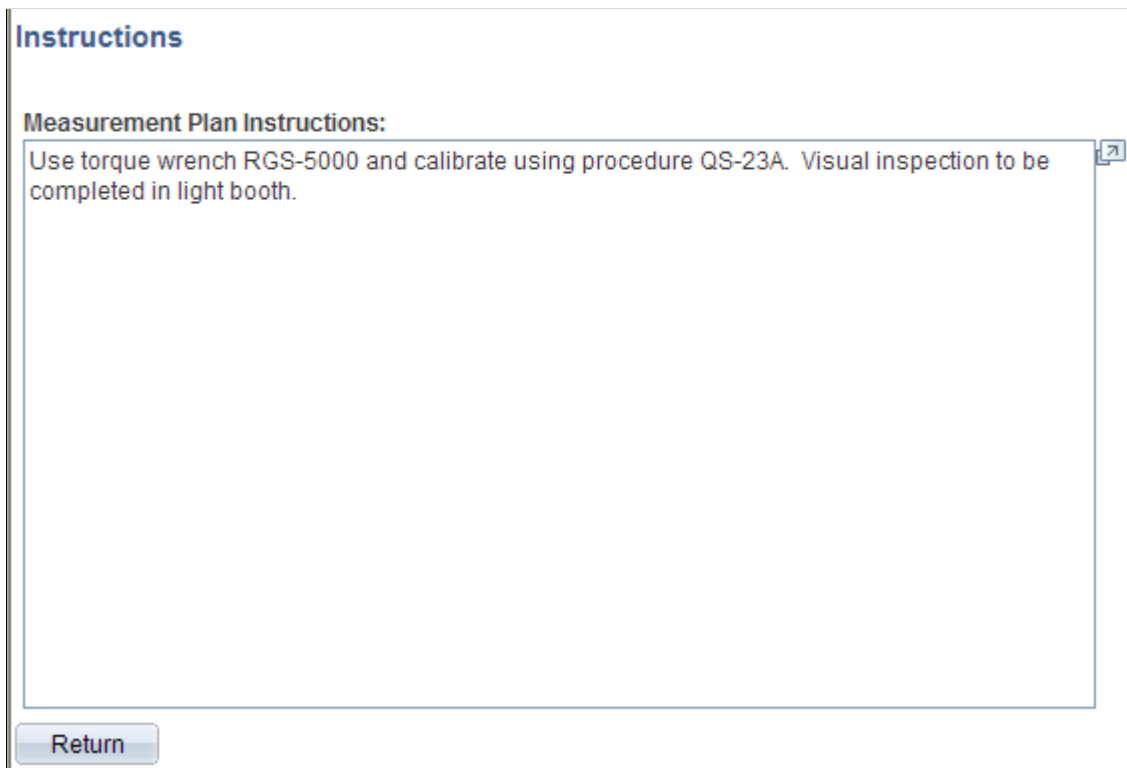

The system displays the measurement plan instructions that are associated with the control plan.

Sample Values / Traceability Detail Page

Use the Sample Values / Traceability Detail page (QS_TRCDET_PNL) to view the actual sample values for the subgroup and trace fields that were entered for the subgroup.

Navigation

Select the Sample Detail option for the Go To Page field on the Alarm Detail page.

Image: Sample Values / Traceability Detail page

This example illustrates the fields and controls on the Sample Values / Traceability Detail page. You can find definitions for the fields and controls later on this page.

Sample Values / Traceability Detail									
Traceability Values									
Sample	Reading	Task Code	Production Area	Crew Name	Tool ID	Date Timestamp	User ID	Operation Sequence	Prod
1	580.000000					10/09/2009 3:34:10.000000PM	VP1		
2	590.000000					10/09/2009 3:34:10.000000PM	VP1		
3	585.000000					10/09/2009 3:34:10.000000PM	VP1		

Return

The page displays the sample details and trace field information associated with the subgroup when the alarm occurred.

Sample	Displays the sample number.
Reading	Displays the sample or measurement value.
User ID	Displays the user ID of the operator who performed the data collection (applies only to manual data entry).
Any/all traceable fields	Displays the trace field values that are tagged to samples for this subgroup.

Viewing Alarms Using PeopleSoft Workflow

This section discusses how to:

- Start the Alarm Workflow process.
- View alarms from the worklist.

Pages Used to View Alarms Using Workflow

<i>Page Name</i>	<i>Definition Name</i>	<i>Navigation</i>	<i>Usage</i>
Start Alarm Workflow	QS_START_WF	Quality, Prepare Analysis, Start Alarm Workflow Process, Start Alarm WorkFlow	Initiate the Start Alarm Workflow Application Engine process (QS_ALM_WF) that takes generated alarms and posts alarm entries to the worklist or generates emails to notify appropriate individuals of the alarms.
Alarm Detail WF	QS_ALM_WF_DET	Quality, Analyze Quality Results, Review Alarm Workflow Detail, Alarm Detail WF	View alarms that were generated from the Start Alarm Workflow process.

Related Links

[Delivered Workflow for PeopleSoft Quality](#)

Start Alarm WorkFlow Page

Use the Start Alarm Workflow page (QS_START_WF) to initiate the Start Alarm Workflow Application Engine process (QS_ALM_WF) that takes generated alarms and posts alarm entries to the worklist or generates emails to notify appropriate individuals of the alarms.

Navigation

Quality, Prepare Analysis, Start Alarm Workflow Process, Start Alarm WorkFlow

You must have previously entered data against a subgroup and generated alarms before starting the process. The process takes previously generated alarms and posts them to appropriate individual worklists or notifies them using email.

Note: You should schedule this process as a recurring process to ensure uninterrupted dispatch of alarms to the worklists.

Alarm Detail Page

Use the Alarm Detail WF page (QS_ALM_WF_DET) to view alarms that were generated from the Start Alarm Workflow process.

Navigation

Quality, Analyze Quality Results, Review Alarm Workflow Detail, Alarm Detail WF

You must have previously entered data against a subgroup and generated alarms. You can use this page only if you incorporated Workflow into Quality. To review a session, click an alarm entry on the worklist.

This page is similar to the Review Alarms - Alarm Detail page.

Note: Access this page only through worklist.

Related Links

[Review Alarms Page](#)

Reviewing Control Plan Performance

This section provides an overview of the Control Plan Performance component and discusses how to:

- Select control plans.
- Review process streams.
- Review subgroup details.
- Review basic statistics.
- Review capability indices.
- Review attribute statistics.

Pages Used to Review Control Plan Performance

<i>Page Name</i>	<i>Definition Name</i>	<i>Navigation</i>	<i>Usage</i>
Selection Criteria	QS_STRMRVW_SEL	Quality, Analyze Quality Results, Review Ctrl Plan Performance, Selection Criteria	Select a control plan and specify the timeframe from which you want to extract information.
Stream Review	QS_STRMRVW_GEN	Quality, Analyze Quality Results, Review Ctrl Plan Performance, Stream Review	View summary information for all process streams in the control plan.
Compare Data Statistic	QS_ANLZ_STSSUM_SPG	Click the Comparative Analysis link on the Stream Review page.	Select the statistic for comparison.
Compare Dataset Statistics	QS_BARGRAPH_RVW	Click the Graph Results button on the Compare Dataset Statistics page.	View a bar graph comparing the selected statistics for all characteristics in the control plan.
Subgroup Detail	QS_SGRP_DET_PNL	Click the Characteristic (Display Detail) link on the Stream Review page.	View subgroup results associated with a selected process stream.
Basic Statistics	QS_STRMRVW_STS	Quality, Analyze Quality Results, Review Ctrl Plan Performance, Basic Statistics	View basic statistics by stream.
Capability Indices	QS_STRMRVW_STS2	Quality, Analyze Quality Results, Review Ctrl Plan Performance, Capability Indices	Display capability indices by stream.

Page Name	Definition Name	Navigation	Usage
Attributes Statistics	QS_STRMRVW_STS4	Quality, Analyze Quality Results, Review Ctrl Plan Performance, Attributes Statistics	View attribute statistics associated with the defects or defectives characteristics for the control plan.

Understanding the Control Plan Performance Component

You can monitor process performance using the Review Control Plan Performance component. For example, you can assess key statistics, perform graphical analysis, and, if needed, post probable causes and corrective actions. The inquiry is similar to creating a quality data extraction, but does not require the SQL-like qualification of plan hierarchy fields. Instead, you enter the specific hierarchy field values related to the control plan. These pages produce a quick snapshot of the process data over a specified period of time.

In addition, the process information on these pages can be downloaded in the form of a quality application client dataset and used for exploratory analysis off-line.

Note: This option is available if the Quality application client is installed.

Related Links

[Defining Data Extractions and Loading Datasets](#)

[Understanding PeopleSoft Quality Application Client Charts and Analysis Tools](#)

Selection Criteria Page

Use the Selection Criteria page (QS_STRMRVW_SEL) to select a control plan and specify the timeframe from which you want to extract information.

Navigation

Quality, Analyze Quality Results, Review Ctrl Plan Performance, Selection Criteria

Image: Selection Criteria page

This example illustrates the fields and controls on the Selection Criteria page. You can find definitions for the fields and controls later on this page.

The screenshot shows the 'Selection Criteria' page with the following fields and controls:

- Unit: US008
- Quality Function: QUALITY
- Measurement Plan: (empty)
- Item ID: (text input)
- QC Step ID: (text input)
- Work Center: (text input)
- Machine Code: (text input)
- Station Code: (text input)
- *Select Sessions By: Subgroup Window (dropdown menu)
- Number of Subgroups: 20 (text input)
- Review Period Days: 1 (text input)
- Date From: 03/04/2013 (calendar icon)
- From Time: 1:05PM (text input)
- Date To: 03/05/2013 (calendar icon)
- To Time: 1:05PM (text input)
- Search: (button)

Select the specific hierarchy fields in the upper portion of the page associated with the control plan for which you want to review performance. The hierarchy fields vary depending on the quality function that you select.

Select Sessions By

Select the time frame for which you want to view the control plan performance. Values include:

All Subgroups: Retrieves all subgroups for the process.

Note: Selecting *All Subgroups* against high-volume processes may cause longer processing times.

Daily Window: Retrieves data starting from a specified number of days from the current date and time. Enter the number of days to subtract from the current date in the Review Period Days field.

Specific Date Range: Selects data within a specific date range. Enter the date from and from time, as well as the date to and to time.

Subgroup Window: Selects the most current N subgroups completed. Enter the number of subgroups that you want in the Number of Subgroups field.

Stream Review Page

Use the Stream Review page (QS_STRMRVW_GEN) to view summary information for all process streams in the control plan.

Navigation

Quality, Analyze Quality Results, Review Ctrl Plan Performance, Stream Review

Image: Stream Review page

This example illustrates the fields and controls on the Stream Review page. You can find definitions for the fields and controls later on this page.

Characteristic	Stream ID	LSL	USL	Subgroups	Alarms	Display Graph
NECK TORQUE	101	500.00000	900.00000	7	2	<input type="text"/>
VISUAL	102		3.00000	7	2	<input type="text"/>

Comparative Analysis

Click this link to view a bar graph comparing selected statistics for all characteristics in the control plan.

Characteristic (Display Detail)

Click this link to access the Subgroup Detail page for that characteristic. The Subgroup Detail page lists the subgroup values that you selected and used to calculate the summary display.

Stream ID

Displays a unique process stream that was defined by the system.

LSL (lower specification limit)

Displays the current lower specification limit.

USL (upper specification limit)

Displays the current upper specification limit.

Subgroups

Displays the number of subgroups the system retrieves and uses for performance estimates.

Alarms

Displays the number of alarms occurring for the subgroup during the time period.

Display Graph

Select the type of graph that you would like to review for this characteristic. Values are *Control Chart*, *Histogram*, *Pareto of Alarms*, *Pareto of Comments*, *Pareto of Corrective Actions*, *Pareto of Defects*, and *Pareto of Probable Causes*.

Related Links

[Using the Subgroup Method](#)

Subgroup Detail Page

Use the Subgroup Detail page (QS_SGRP_DET_PNL) to view subgroup results associated with a selected process stream.

Navigation

Click the Characteristic (Display Detail) link on the Stream Review page.

Image: Subgroup Detail page

This example illustrates the fields and controls on the Subgroup Detail page. You can find definitions for the fields and controls later on this page.

Subgroup Detail							
Measurement Plan: Bicycles Plan				Return To Main Page			
Characteristic: NECK TORQUE				View Instructions			
Subgroup List							
Customize Find View All [Data Icon] [Grid Icon] First 1-7 of 7 Last							
		Date Submitted	Subgroup Size	Chart 1 Result	Chart 2 Result	Test Violations	Action Count
?	✖	10/09/2009 3:26:16PM	3.00000	661.66667	25.00000		
?	✖	10/09/2009 3:28:31PM	3.00000	674.33333	12.00000		
?	✖	10/09/2009 3:30:07PM	3.00000	665.00000	105.00000		
?	✖	10/09/2009 3:31:52PM	3.00000	695.00000	25.00000		
?	✖	10/09/2009 3:32:33PM	3.00000	694.00000	16.00000		
?	✖	10/09/2009 3:34:02PM	3.00000	693.33333	120.00000	1	
?	✖	10/09/2009 3:35:04PM	3.00000	585.00000	10.00000	1	

- Date Submitted** Displays the date and time that the subgroup was entered.
- Subgroup Size** Displays the subgroup sample size.
- Chart 1 Result** Displays the calculated subchart 1 plot value.
- Chart 2 Result** Displays the calculated subchart 2 plot value.
- Test Violations** Displays the number of test violations detected for this subgroup.
- Action Count** Displays the number of corrective actions logged against this subgroup.

Basic Statistics Page

Use the Basic Statistics page (QS_STRMRVW_STS) to view basic statistics by stream.

Navigation

Quality, Analyze Quality Results, Review Ctrl Plan Performance, Basic Statistics

Image: Basic Statistics page

This example illustrates the fields and controls on the Basic Statistics page. You can find definitions for the fields and controls later on this page.

Selection Criteria		Stream Review		Basic Statistics		Capability Indices		Attributes Statistics	
Unit:	US008								
Quality Function:	QUALITY								
Measurement Plan:	Bicycles Plan								
Basic Statistics		Customize		Find				First	
				1-2 of 2				Last	
Characteristic	Observations	Mean	Range	Sigma	Skewness	Kurtosis			
NECK TORQUE	21	666.90476	190.00000	46.53375	0.00000	-0.17333			
VISUAL	21	1.23809	4.00000	1.17918	0.60561	-0.64508			

- Observations** Displays the number of discrete observations used to in the statistical calculations.
- Mean** Displays the statistical mean.
- Range** Displays the range.
- Sigma** Displays the standard deviation.
- Skewness** Displays the skewness.
- Kurtosis** Displays the kurtosis.

Related Links

- [Using Basic Statistics](#)
- [Using Skewness and Kurtosis](#)

Capability Indices Page

Use the Capability Indices page (QS_STRMRVW_STS2) to display capability indices by stream.

Navigation

Quality, Analyze Quality Results, Review Ctrl Plan Performance, Capability Indices

Image: Capability Indices page

This example illustrates the fields and controls on the Capability Indices page. You can find definitions for the fields and controls later on this page.

Capability Indices								
Characteristic	Cp	Cpk	Cpl	Cpu	Cr	Est %Total	Est %Below	Est %Above
NECK TORQUE	1.43265	1.19558	1.19558	1.66972	69.80063	0.01676	0.01674	0.00002
VISUAL								

The system displays the process capabilities that are industry-accepted estimates calculated for each characteristic in the control plan.

Cp Process potential.

Cpk Process capability.

Cpl Lower process capability.

Cpu Upper process capability.

Cr Capability ratio.

Est % Total (estimated percent total), Est % Below (estimated percent below), and Est % Above (estimated percent above) Displays the estimated total percentage of units predicted to be out of specification.

Related Links

[Using Process Capability](#)

Attributes Statistics Page

Use the Attributes Statistics page (QS_STRMRVW_STS4) to view attribute statistics associated with the defects or defectives characteristics for the control plan.

Navigation

Quality, Analyze Quality Results, Review Ctrl Plan Performance, Attributes Statistics

Image: Attributes Statistics page

This example illustrates the fields and controls on the Attributes Statistics page. You can find definitions for the fields and controls later on this page.

Attributes Statistics						
Characteristic	Sum Subgroup Size	Sum Defects	Defects/Unit	Defects/100	Defects/1000	Defects/Million
NECK TORQUE	21	0	0.00000	0.00000	0.00000	0.00000
VISUAL	21	26	1.23809	123.80952	1238.09523	1238095.23809

Note: The statistics are only calculated for characteristics that have a data type of defects or defectives—count data.

Sum Subgroup Size (sum subgroup size) Displays a tally of all subgroup sizes entered for each subgroup retrieved by the inquiry.

Sum Defects Sum total of all defects.

Defects/Unit, Defects/100, Defects/1000, and Defects/Million Statistics include defects per unit, hundred, thousand, and million.

Related Links

[Using Attribute Statistics](#)

Chapter 9

Using PeopleSoft Quality Graphics

Viewing PeopleSoft Quality Graphics

This section discusses how to:

- View control charts.
- View histograms.
- View Pareto charts.
- View bar graphs.

Pages Used to View PeopleSoft Quality Graphics

Page Name	Definition Name	Navigation	Usage
Compare Dataset Statistics	QS_ANLZ_STSSUM_SPG	<ul style="list-style-type: none">• Select the View Chart button on the Data Entry From Access List - Review page: Results tab or on the Data Entry By Control Plan - Review page: Results tab.• Select the <i>Control Chart</i> in the Display Graph field on the Review Ctrl Plan Performance - Stream Review inquiry page.	View a control chart associated with the selected subgroups.
Histogram	QS_HISTOGRAM_RVW	Select <i>Histogram</i> in the Display Graph field on the Review Ctrl Plan Performance - Stream Review inquiry page.	View a histogram associated with the selected subgroups.
Pareto Chart	QS_PARETO_RVW	Select <i>Pareto of Alarms</i> , <i>Pareto of Comments</i> , <i>Pareto of Corrective Actions</i> , <i>Pareto of Defects</i> , or <i>Pareto of Probable Causes</i> in the Display Graph field on the Review Ctrl Plan Performance - Stream Review inquiry page.	View a Pareto chart of type comments, corrective actions, defects, or probable causes associated with the selected subgroups.
Bar Graph	QS_BARGRAPH_RVW	Click the Graph Results button on the Compare Data Statistics page.	View a bar graph associated with the selected subgroup.

Control Chart Page

Use the Compare Dataset Statistics page (QS_ANLZ_STSSUM_SPG) to view a control chart associated with the selected subgroups.

Navigation

- Select the View Chart button on the Data Entry From Access List - Review page: Results tab or on the Data Entry By Control Plan - Review page: Results tab.
- Select the *Control Chart* in the Display Graph field on the Review Ctrl Plan Performance - Stream Review inquiry page.

Image: Control Chart page 1 of 2

This example illustrates the fields and controls on the Control Chart page 1 of 2. You can find definitions for the fields and controls later on this page.

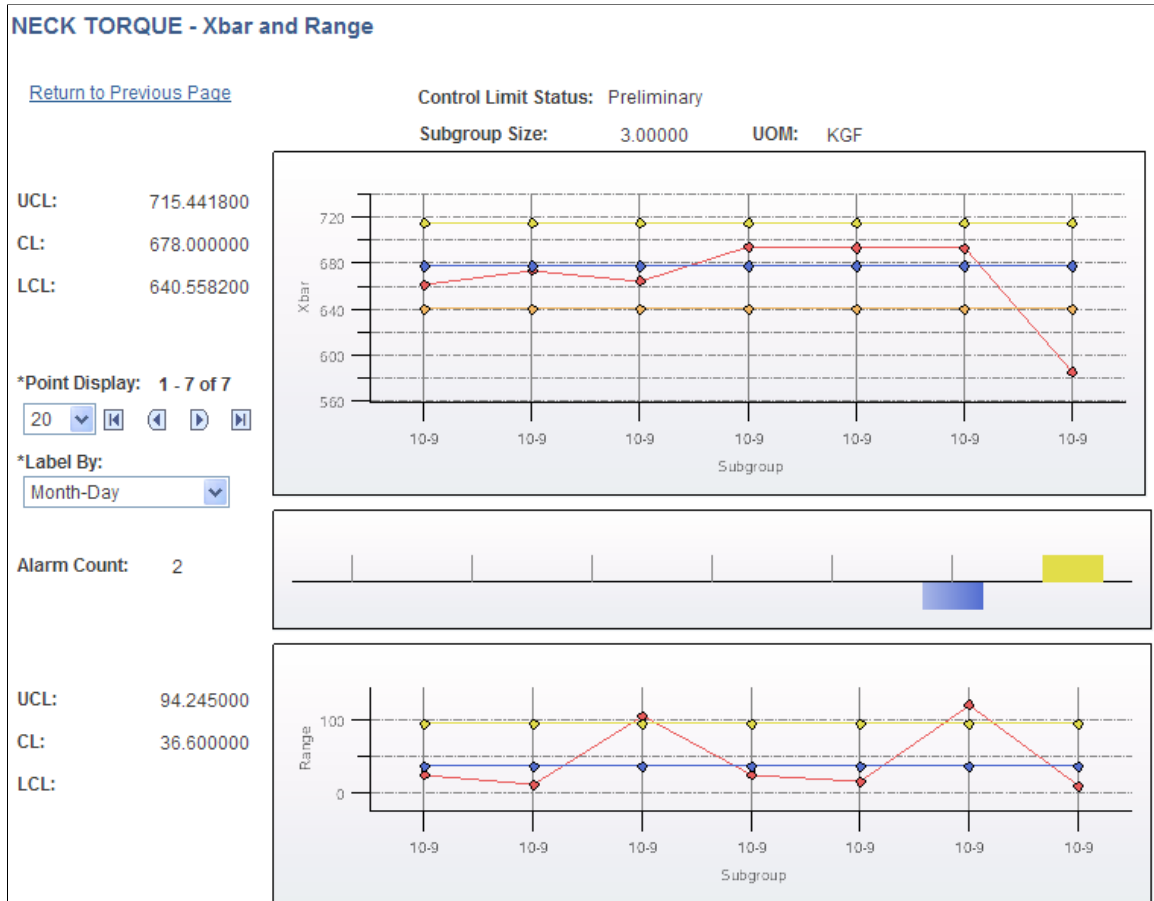

Image: Control Chart page 2 of 2

This example illustrates the fields and controls on the Control Chart page 2 of 2. You can find definitions for the fields and controls later on this page.

Subgroup Details						
Subgroup Results		Test Violations				
Sequence	Subgroup ID		Date/Time	Subgroup Size	Chart 1 Result	Chart 2 Result
1	1		10/09/09 3:26:16PM	3.00000	661.66667	25.00000
2	2		10/09/09 3:28:31PM	3.00000	674.33333	12.00000
3	3		10/09/09 3:30:07PM	3.00000	665.00000	105.00000
4	4		10/09/09 3:31:52PM	3.00000	695.00000	25.00000
5	5		10/09/09 3:32:33PM	3.00000	694.00000	16.00000
6	6	⚠	10/09/09 3:34:02PM	3.00000	693.33333	120.00000
7	7	⚠	10/09/09 3:35:04PM	3.00000	585.00000	10.00000

In the upper portion of the page, the control chart associated with the subgroups that you selected appears.

The control chart is rendered as two line graphs for plotting means and variance information. Each point on the control chart represents an individual subgroup.

To the left of each graph, the system displays the values and the appropriate labels for upper control limit (UCL), mean (CL), and lower control limit (LCL).

Note: Control limit labels are not set to scale; however, the control limit boundaries are overlaid to scale on each chart.

In the upper portion of the page, the system displays the control limit status, subgroup size, and unit of measure.

Point Display

Select the number of points to display for the control charts.
Values are: 05, 10, 15, 20, and 25.



Click this button to view the next group of control chart points.



Click this button to view the previous group of control chart points.

Label By

Select how to label the control charts. Values are:

- *Day:Hour*: Displays the day and hour under each individual subgroup point on the control chart.
- *Hour:Minute*: Displays the hour and minute under each individual subgroup point on the control chart.
- *Month-Day*: Displays the month and day under each individual subgroup point on the control chart.

- *Subgroup ID*: Displays the subgroup sequence ID under each individual subgroup point on the control chart.
- *Year-Month-Day*: Displays the year, month, and day under each individual subgroup point on the control chart.

Alarm Count

The alarm count represents the number of subgroups within the current chart that have an out-of-control condition. Next to this field, a bar graph represents the type of alarm that occurred for each subgroup. A red bar extending upward represents a specification violation, and a yellow bar extending upward represents a means (upper) control chart violation. A blue bar extending downward represents a variance (lower) control chart violation.

Additionally, the actual control test description appears when you hover over a subgroup point, enabling you to easily view the specific alarms corresponding to the bar graphs.

Subgroup Details

View details of the subgroup results and test violations for each subgroup.

Related Links

[Using Control Charts](#)

[Defining Control Plans](#)

[Review Page](#)

[Stream Review Page](#)

Histogram Page

Use the Histogram page (QS_HISTOGRAM_RVW) to view a histogram associated with the selected subgroups.

Navigation

Select *Histogram* in the Display Graph field on the Review Ctrl Plan Performance - Stream Review inquiry page.

Image: Histogram page 1 of 2

This example illustrates the fields and controls on the Histogram page 1 of 2. You can find definitions for the fields and controls later on this page.

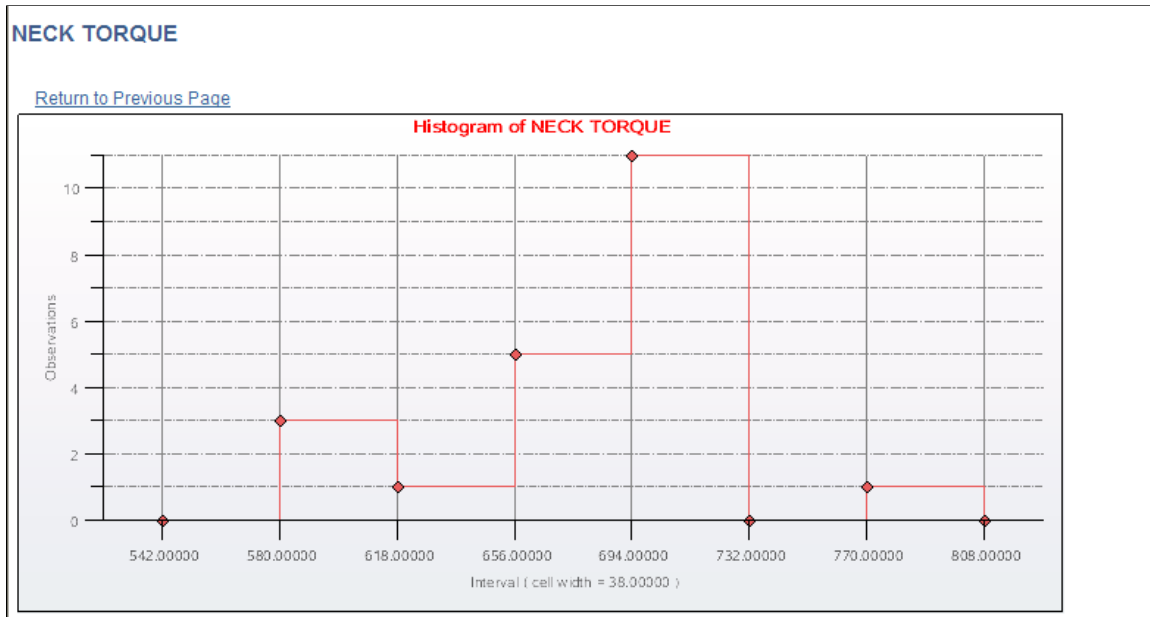

Image: Histogram page 2 of 2

This example illustrates the fields and controls on the Histogram page 2 of 2. You can find definitions for the fields and controls later on this page.

Cell Details					Statistics	
Cell	Cell Interval	Cell Midpoint	Cell Tally	% of Total	UOM	KGF
1	523.00000 / 561.00000	542.00000	0	0.00	Observations	21.00000
2	561.00000 / 599.00000	580.00000	3	14.29	Mean	666.90476
3	599.00000 / 637.00000	618.00000	1	4.76	Minimum	580.00000
4	637.00000 / 675.00000 { Mean	656.00000	5	23.81	Maximum	770.00000
5	675.00000 / 713.00000	694.00000	11	52.38	Sigma	46.53375
6	713.00000 / 751.00000	732.00000	0	0.00	Cp	1.43265
7	751.00000 / 789.00000	770.00000	1	4.76	Cpk	1.19558
8	789.00000 / 827.00000	808.00000	0	0.00	Cpl	1.19558
					Cpu	1.66972
					Cr	69.80063
					Est %Below	0.01674
					Est %Above	0.00002
					Est %Total	0.01676
					LSL	500.00000

In the upper portion of the page, the histogram associated with the subgroups that you selected appears. A histogram is used to display distribution analysis.

Cell Details**Cell Interval**

Displays the high and low boundaries that this cell represents. This field is derived by dividing the distribution range by the number of cells desired for display.

The left brace ({) character indicates in which cell the mean, lower specification limit, and upper specification values are contained.

Cell Midpoint

Displays the midpoint of the cell interval.

Cell Tally

Displays the total number of individual values in a cell.

% of Total (percent of total)

Displays the percent of individual values in a cell.

Statistics

Summary statistics are calculated based upon active values for this subset.

Related Links

[Using Histograms](#)

[Stream Review Page](#)

Pareto Chart Page

Use the Pareto Chart page (QS_PARETO_RVW) to view a Pareto chart of type comments, corrective actions, defects, or probable causes associated with the selected subgroups.

Navigation

Select *Pareto of Alarms*, *Pareto of Comments*, *Pareto of Corrective Actions*, *Pareto of Defects*, or *Pareto of Probable Causes* in the Display Graph field on the Review Ctrl Plan Performance - Stream Review inquiry page.

Image: Pareto Chart page

This example illustrates the fields and controls on the Pareto Chart page. You can find definitions for the fields and controls later on this page.

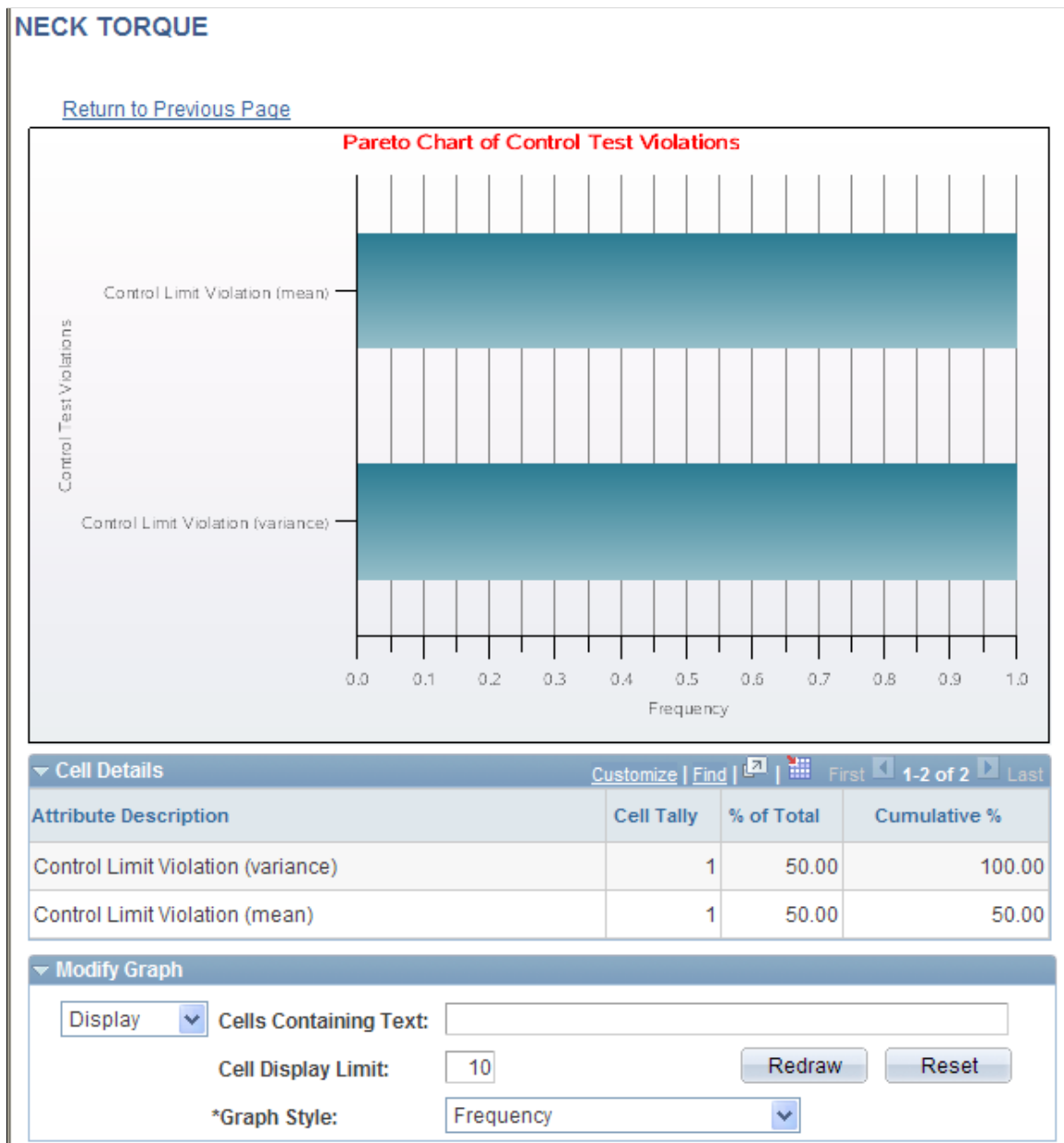

In the upper portion of the page, a Pareto chart associated with the selected subgroups and attribute type appears. You can create a Pareto chart of alarms, comments, corrective actions, defects, or probable causes. With Pareto charts, you can display attribute counts in a ranked-order format.

Cell Details

Attribute Description

Displays the attribute description. For example, for defects, defect attribute descriptions appear, and for alarms, alarm attribute descriptions appear.

Cell Tally

Displays the attribute count.

% of Total (percentage of total)

Displays the percentage of the number for that particular attribute type for which the attribute accounts. For example, for a Pareto chart of defects, this field represents the percentage of the number of defects for which that attribute accounts.

Cumulative % (cumulative percent)

Displays the cumulative percent value. If you were to plot this line on the Pareto chart, it would represent the cumulative percent line, also known as the Lorenze curve.

Modify Graph

Graph Style

Select the style of graph to display. Options are:

- *Frequency*: Displays the order of the attributes by frequency.
- *Cumulative Percent*: Displays the order of attributes by cumulative percent. This option redraws the chart using the cumulative percent on the X axis.

Redraw

Click this button to redraw the Pareto chart with the selected options (cells containing text, cell display limit, and graph style).

The complete list of cell statistics always appears, regardless of the modification options that you select.

Reset

Click this button to restore the number of cells that appear in the Pareto chart to the number of cells that appeared when the graph was first displayed.

The number of cells that appear in the Pareto chart can change when you use the Cells Containing Text and Cell Display Limit fields. When you click the Reset button, the cells that appear in the Pareto chart are redrawn to their original appearance. Reset does not effect the graph style.

Related Links

[Using Pareto Charts](#)

[Stream Review Page](#)

Bar Graph Page

Use the Bar Graph page (QS_BARGRAPH_RVW) to view a bar graph associated with the selected subgroup.

Navigation

Click the Graph Results button on the Compare Data Statistics page.

Image: Bar Graph page

This example illustrates the fields and controls on the Bar Graph page. You can find definitions for the fields and controls later on this page.

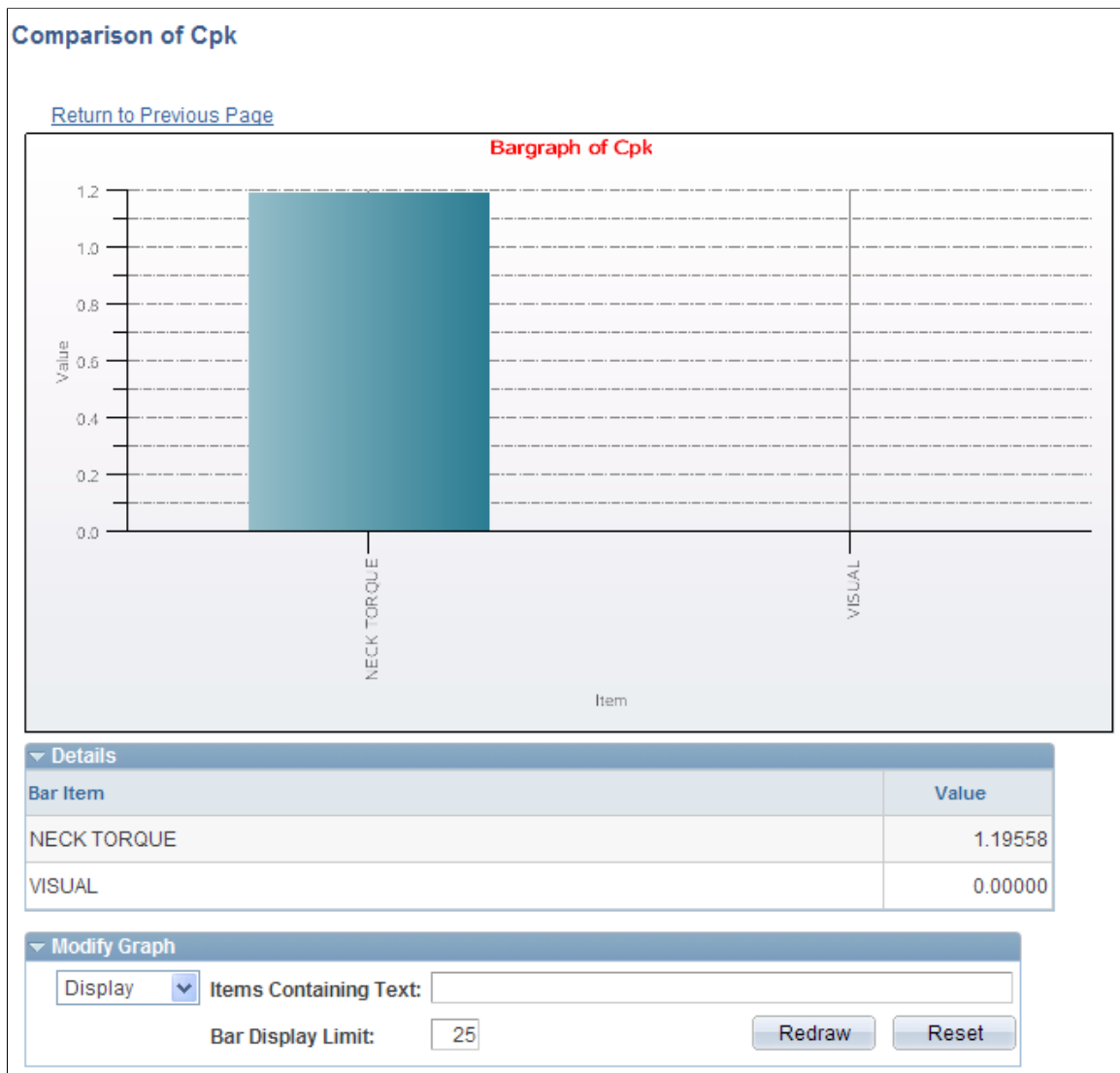

In the upper portion of the page, a bar graph associated with the selected subgroups appears. With bar graphs, you can compare a selected statistic between multiple subsets.

Details

The details (bar item and value) for the bar graph appear.

Modify Graph

Redraw

Click this button to redraw the bar graph with the options (items containing text and bar display limit) that you selected.

The complete list of details always appears, regardless of the modification options that you select.

Reset

Click this button to restore the number of items that appear in the bar graph to the number of items that appeared when the graph was first displayed.

The number of items in the bar graph can change when you use the Items Containing Text and Bar Display Limit fields. When you click the Reset button, the items that appear in the bar graph are redrawn to their original appearance.

Related Links

[Using Bar Graphs](#)

[Stream Review Page](#)

Defining Data Extractions and Loading Datasets

To define data extractions, use the Define Extraction Criteria component (QS_QSX_DEF). This section provides an overview of datasets and data extractions and discusses how to:

- Define extract settings.
- Define extract criteria.
- Perform data extractions.

Pages Used to Define Data Extractions and Load Datasets

<i>Page Name</i>	<i>Definition Name</i>	<i>Navigation</i>	<i>Usage</i>
Define Extraction Criteria - General	QS_QSX_DEF	Quality, Prepare Analysis, Define Extraction Criteria, General	Define general settings for the extraction.
Define Extraction Criteria - Selection Criteria	QS_QSX_FLDS	Quality, Prepare Analysis, Define Extraction Criteria, Selection Criteria	Define how to filter data for the extraction and select data-entry sessions.
Perform Data Extraction	QS_QSX_INQ	Quality, Analyze Quality Results, Perform Data Extraction	Execute the Data Extraction PeopleCode process.

Understanding Datasets and Data Extractions

Using the Quality application client, you can generate graphics and perform exploratory analysis of quality data while offline. The data managed by the PeopleSoft application client is called a dataset and contains the related measurement, traceability, attribute, and configuration information required for performing quality analysis. This information is formatted specifically for use by the Quality application client and resides outside the quality database.

Datasets are created as a result of defining and executing data extractions. The information taken from the Quality database fills a dataset based on selection and filtering criteria that you provide. Datasets are composed of spreadsheet-like elements, such as rows, columns, subsets (pages), and cell values. Datasets contain these options for column and row types:

- Common columns (traceability).

Common columns apply to all subsets in the dataset and usually represent traceability information, such as lot numbers and date stamps. Common columns help minimize redundant information when creating a standalone dataset.

- Data columns (reading, defects, violations).

Data columns are specific to an individual subset. Data columns typically include measurement values, subgroup counts, and attribute information, such as defects, causes, and actions.

Note: Datasets created from the database, such as performing data extractions, use data columns exclusively.

- Subset.

Subset columns are logical groupings of data, typically based on a process stream or characteristic. A subset encompasses the columns in the dataset much like a page does in a typical spreadsheet program. Subsets are configured similarly to measurement plan characteristics; you can assign a data type and control parameters to a subset. This enables the subset to be graphed and analyzed easily.

Note: Datasets created from the database populate the subset control configuration parameters with the current settings for the characteristic or stream. A dataset can contain up to 100 subsets. The tabs on the Quality application client spreadsheet represent subset names.

- Standard cell.

Standard cells contain a single value.

- Tall cell.

Tall cells contain multiple values. Attributes data, such as test violations, causes, and actions, can occur in multiples for a given cell, and thus may be displayed as multiple rows within the cell. Click the F2 button twice to enter multiple lines into a tall cell.

Datasets appear as a spreadsheet in the Quality application client. You create datasets using one of these methods:

- Define and run a data extraction.
- Access the Quality application client and create a dataset from scratch.

Extractions are reusable queries that retrieve data from the Quality database and can be shared by multiple users. The extraction functions (define and execute) are separated to facilitate access by users with different job functions, such as managers and analysts.

Use the Data Extraction PeopleCode process to select a set of inspection data from the PeopleSoft database and analyze it using the Quality application client tools. You define the data to extract and download it to the Quality application client for exploratory and ad-hoc analysis. Use the Quality application client to manipulate, add, change, or delete data to perform what-if analyses of processes and view graphics of the data.

Prerequisites

Before defining a dataset for use by the Quality application client, you must:

- Determine the processes to extract.
- Decide how to organize the dataset.
- Identify the categories of data to extract from the database.
- Determine the amount of data to include in the extraction.

You must also use the using the File Locations page to enter the location to store the datasets.

See "Defining Additional Common Information (*PeopleSoft FSCM 9.2: Application Fundamentals*)".

Common Elements Used in This Section

Extraction Name	Enter an extraction name. An extraction identifies data you select from the Quality database used to create a dataset. Extraction names must conform to Microsoft Windows NT file naming conventions, so avoid using special characters, such as dashes, periods, and apostrophes in names.
Description	Enter the description for the subset. The name must be unique within the dataset.
Graph Preference ID	Select the default graph preference to associate with an extraction.

Define Extraction Criteria — General Page

Use the Define Extraction Criteria - General page (QS_QSX_DEF) to define general settings for the extraction.

Navigation

Quality, Prepare Analysis, Define Extraction Criteria, General

Subset By Select how the system subsets data for the extraction. Options are:

All (Single Subset): All data is displayed as one subset.

Characteristic: The data is divided into subsets according to individual characteristics.

Stream: The data is divided into subsets according to process stream.

Display Options

Select if the system should include one or all other categories of information to display, in addition to session data information.

Select Sessions By

Select how sessions are selected by timeframe. Options are:

All Subgroups: Extract all the subgroups for each process.

Daily Window: Extract the sessions entered in the last *n* days based on the current date and time. Enter the number of days to subtract from the current date in the Number of Days field.

Specific Date Range: Extract the sessions entered between a certain date range. Enter the date from and from time, and enter the date to and to time.

Subgroup Window: Extract the most current *n* subgroups entered. You'll enter the number of subgroups in the Number of Subgroups field.

Lock Selections

Select this check box to protect the integrity of the expressions and the amount of data to be included in the extraction. If selections aren't locked here, you can modify them during execution.

Define Extract Criteria — Selection Page

Use the Define Extraction Criteria - Selection Criteria page (QS_QSX_FLDS) to define how to filter data for the extraction and select data-entry sessions.

Navigation

Quality, Prepare Analysis, Define Extraction Criteria, Selection Criteria

Specify the sessions from which you want to select data. You can limit the extraction to sessions entered for specific values of hierarchy data and trace data from the business unit and quality function, or you can limit data to sessions entered within a certain time period.

Hierarchy Field Selections and Trace Field Selections

The fields vary depending on the quality function. Use these fields to further limit the sessions that are retrieved. Set all operators to *ALL* if you do not want to qualify based on hierarchy or trace field values. Qualifier values for both fields include:

<>: Greater than or less than the value entered.

=: Equal to the value entered.

ALL: All entries are returned, and there is no qualification on the field.

BETWEEN: Select the field between the values you enter.

LIKE: Select the field where it is like or similar to the value. Use the % character to denote wildcard positions.

Perform Data Extraction Page

Use the Perform Data Extraction page (QS_QSX_INQ) to execute the Data Extraction PeopleCode process.

Navigation

Quality, Analyze Quality Results, Perform Data Extraction

The page displays the extraction criteria defined using the Define Extract Criteria component.

Session History

If you haven't locked the qualifier selections that specify the streams and data content to extract from the database, you can change the values associated with the statements and the history. The new settings are in effect for this run only and aren't saved.

Search

Click this button to run the Data Extraction PeopleCode process. When the process is complete, the system creates a dataset based on the extraction contents. Using the browser, you can display the dataset online if the Quality application client is installed on a local machine, or you can download the file to a local machine.

Dataset Location

Displays the location of where the dataset is created upon completion of the extraction process.

Note: The Data Extraction process creates one file, in the location you specified on the File Locations page. The name of the file is the extraction name with this extension: cld.

View Dataset

Click this button to view the dataset using the browser. You can either download the dataset file to a local machine or open the dataset remotely using the Quality application client. In either case, it is assumed that you have installed the application client software on the computer that you are using.

Related Links

[Understanding PeopleSoft Quality Application Client Charts and Analysis Tools](#)

Chapter 10

Using the PeopleSoft Quality Application Client

Understanding PeopleSoft Quality Application Client Charts and Analysis Tools

Quality provides industry-standard charts and graphs for you to assess process performance and optimize control to achieve continuous process improvement. Each chart possesses unique display and analysis traits that you can alter to enhance the interpretation of the data. Using the Quality application client, you can display individual graphs, multiple graphs, or overlay graphs simultaneously for ease of comparison or reporting.

The Quality application client displays are also referred to as graphing tools. Each tool is activated by clicking a button on the Quality application client main window toolbar. The system renders the requested chart in a separate window based upon the selections made from the Selector panel.

Note: Each graph is displayed, one at a time, in a separate window.

Related Links

[Spreadsheet and Selector Panels](#)

Prerequisites

Before you use the Quality application client, you must:

- Install the Quality application client.

See *PeopleSoft Supplemental Instructions for PeopleSoft 9.1 Supply Chain Management Installation*

- Create a dataset by extracting quality control information from the Quality database, if you want to use data that you have previously collected in the quality control environment.

See [Creating and Managing Datasets](#).

Using the PeopleSoft Quality Application Client Toolbar

The Quality application client toolbar is located at the top of the program's main window beneath the menu bar. The number of menus varies depending on if you have opened a dataset.

Except for standard Microsoft Windows buttons, such as Cut and Paste, buttons are unique to the Quality application client application and become active depending on the subset that you select and the graphic windows that are open. Because only one graphic window at a time is active, these options might become active or inactive dynamically as you display each graph.

You can also select each toolbar function from the View menu.



Click the New button to create a new dataset.



Click the Open button to open an existing dataset.



Click the Print button to print the active window.



Click the Copy button to copy selected text to the Clipboard.



Click the Selector Panel button to display the subset and column role selector window.



Click the Control Chart button to display a control chart based upon the currently selected subsets.



Click the Histogram button to display a histogram based upon the currently selected subsets.



Click the Bar Graph button to display a bar graph based upon the currently selected subsets.



Click the Line Graph button to display a line graph based upon the currently selected subsets.



Click the Pareto Chart button to display a Pareto chart based upon the currently selected subsets and attribute column.



Click the Box Plots button to display a box plot based upon the currently selected subsets.



Click the Spreadsheet button to display a spreadsheet of the open dataset.



Click the Statistical Matrix button to display a statistical matrix chart based upon the currently selected subsets.



Click the Previous Characteristic button to display the previous characteristic in the format of the active graphic window.
Available if multiple subsets have been selected for analysis.



Click the Next Characteristic button to display the next characteristic in the format of the active graphic window.
Available if multiple subsets have been selected for analysis.



Click the Redraw button to redraw the active window and apply any point or cell selections.



Click the Restore Dataset button to reload the original data for the active window.



Click the About button to display release and help information for the Quality application client.

Creating and Managing Datasets

Use Quality application client panels to create and modify dataset configurations and content. From these panels, you access additional detail panels for maintaining specific dataset elements.

This section discusses how to:

- Create and manage datasets.
- Configure datasets.
- Add columns.
- Add subsets.
- Define subset and column formulas.

Pages Used to Create and Manage Datasets

<i>Page Name</i>	<i>Definition Name</i>	<i>Navigation</i>	<i>Usage</i>
Selector	None	<ul style="list-style-type: none"> • Select File, New. • Select File, Open. 	Add or change columns and subsets for an existing dataset or for configuring a new dataset.
Spreadsheet	None	<ul style="list-style-type: none"> • Select File, New. • Select File, Open. 	Add or change cell values for a dataset.
Dataset Configuration	None	Click the Configure button on the Selector panel.	Configure dataset columns and subsets.
Column Detail	None	Click the Add button under Common Columns or Data Columns on the Dataset Configuration panel.	Add common columns or data columns to a dataset.
Subset Detail	None	Click the Add button under Subsets on the Dataset Configuration panel.	Add subsets to a dataset.
Subset/Column Detail	None	Click the Formula button on the Dataset Configuration panel.	Enter formulas to derive cell values for an entire column.

Spreadsheet and Selector Panels

Use the Spreadsheet page to add or change cell values for a dataset. Use the Selector page to add or change columns and subsets for an existing dataset or for configuring a new dataset.

Navigation

- Select File, New.
- Select File, Open.

Image: Spreadsheet and Selector panels

This example illustrates the fields and controls on the Spreadsheet and Selector panels. You can find definitions for the fields and controls later on this page.

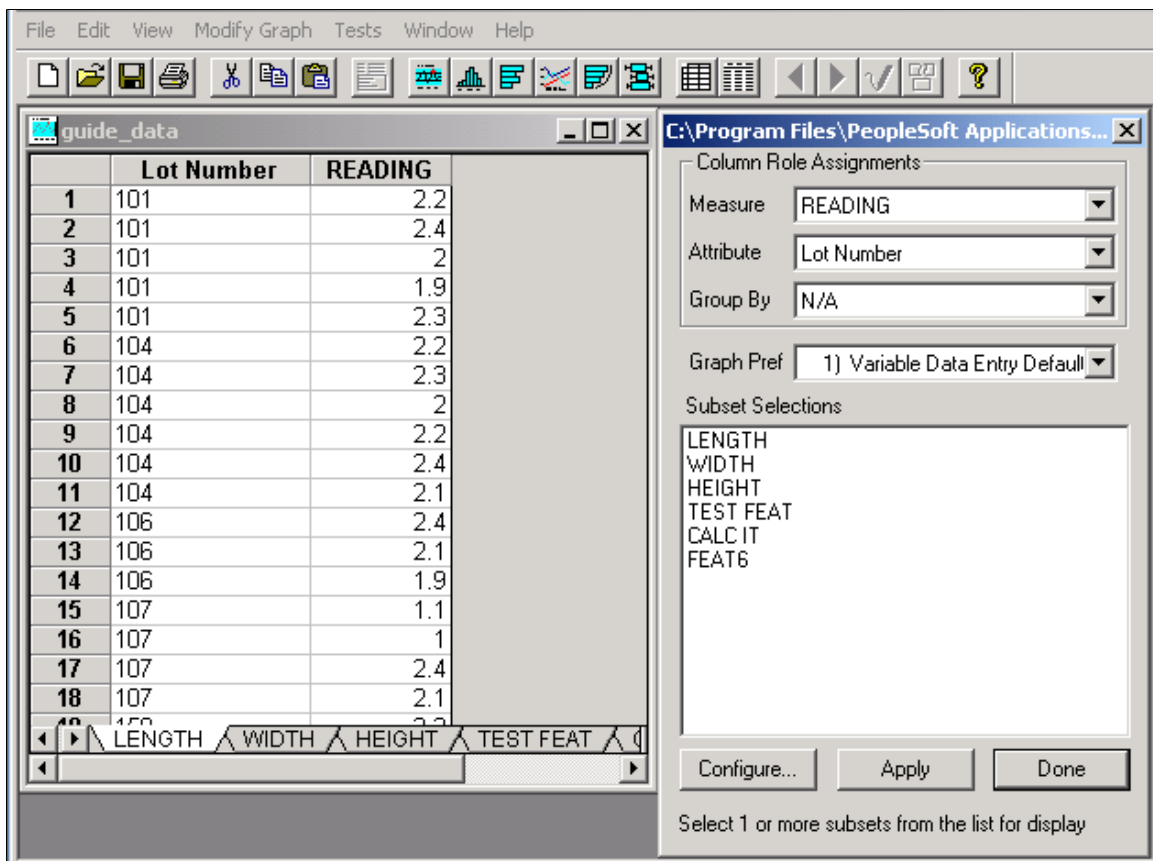

The Selector and Spreadsheet panels appear together when you initially launch the Quality application client from an extraction or when you open an existing dataset.

Using the Selector Panel

Use the Selector panel to manage dataset configurations, specify columns used for generating graphs, and to create or manipulate a dataset for analysis. You can:

- Define columns and subsets.
- Select the graph preference to use when performing analysis.

After you configure the dataset layout, enter the cell values that make up the dataset content in the columns and rows in the spreadsheet. The number of rows allowed is only limited by the available memory of a workstation.

After populating the dataset, you can select and manipulate information for analysis. For example, you can analyze one subset of data at a time or multiple subsets together and assign columns to roles for analysis. You can:

- Select different subsets of data to analyze and graph.
- Assign roles to columns for graphing and data-grouping purposes.
- Change the graph preferences.
- Add new common columns, data columns, and subsets to the dataset.

After configuring the dataset and entering data, you can access graphs using the Quality application client toolbar.

Measure, Attribute, and Group By	Select the columns used for producing graphs. If you are creating a new dataset, the system displays <i>N/A</i> (not applicable).
Graph Pref (graph preference)	Select the graph preference applied to this dataset.
Subset Selections	Select subsets to analyze and graph.
Configure	Click to access the Dataset Configuration panel.
Apply	Click to save changes you make to the settings.
Done	Click to exit the panel.

Using the Spreadsheet

Use the Spreadsheet panel to:

- Enter cell values for a new dataset.
- View, add, change, or delete cell data associated with an existing dataset.

The Spreadsheet panel operates basically the same, whether you are adding data for the first time or modifying existing data. The program displays the data associated with an existing dataset on the spreadsheet. The spreadsheet is empty when you add data for the first time.

To enter data into a cell, either click the cell or use the arrow keys to navigate to the cell. To enter multiple lines into a tall cell, press the F2 button twice. You can also cut and paste the different cells within the spreadsheet, similar to using Microsoft Windows Excel.

Using Graphics

To perform data analysis using graphs:

1. Access the Selector and Spreadsheet panels.

All graphs use the Measure field, except the Pareto chart, which displays attributes information.

2. Select the column values to plot on the different graph displays using the Measure field.

This is also the data column used for calculating any statistics and tests. Only numeric columns are available for selection.

3. Select the Attribute column for the Pareto chart.

Only character columns are available for selection.

4. (Optional) Select the column to group by.

You specify an alternate data grouping using another column.

As an example, you can create subgroups based upon a traceability field (lot number), as an alternative to viewing the natural subgroup size defined for the subset. All readings corresponding to a unique value are grouped together.

5. Select the graph preference to apply for analysis and graphing.
6. Select one or more subsets under Subset Selections to analyze or view using the graphing tools.

Depending on the graphing tool, multiple subsets either overlay or are segmented when displayed. Available subsets are based on the dataset.

Note: You must select at least one subset to view any of the Quality application client displays, except for the spreadsheet.

As you make selections using the Selector panel, tool buttons become active on the Quality application client toolbar, indicating which graphs you can select.

Related Links

[Define Graph Preferences Page](#)

Configuring Datasets

Use the Dataset Configuration dialog box to configure dataset columns and subsets.

Navigation

Click the Configure button on the Selector panel.

Image: Dataset Configuration dialog box

This example illustrates the fields and controls on the Dataset Configuration dialog box. You can find definitions for the fields and controls later on this page.

The panel operates similarly for entering new data or changing data.

Common Columns, Data Columns, and Subsets

Define the structure of the dataset. Click the Add button under each field to access panels for defining columns or subsets.

Note: Always add the different columns in the order in which they appear on the panel. Create common columns, then create data columns, and finally create subsets. You can't add common columns after adding data columns to a dataset.

Add

Click the buttons to access data-entry panels.

Note: The button under Common Columns won't be accessible if you created the dataset using the extraction process or if you defined data columns.

Formula

Click this button to access the Subset/Column Detail panel and enter the formula for a measurement data column.

Note: The Formula button becomes available when you select a measurement data column and a subset at the same time.

Related Links

[Column Detail Panel](#)

[Subset Detail Panel](#)

[Subset/Column Detail Panel](#)

Column Detail Panel

Use the Column Detail panel to add common columns or data columns to a dataset.

Navigation

Click the Add button under Common Columns or Data Columns on the Dataset Configuration panel.

Name

Identifies a dataset column. This name must be unique within the dataset.

Column

When you create columns in the dataset, they inherit properties from the selected column type, enabling the program to make assumptions about the new column and how to use it for analysis. The column type contains properties such as data type (character or numeric) and row type (single or multiple). This method minimizes the number of parameters required for defining columns in the dataset. Column type options include the following:

- 1) *APPLICATION FIELD*
- 2) *STREAM COMPONENT*
- 7) *DATE AND TIME*
- 8) *VALUE*
- 9) *SUBGROUP SIZE*
- 11) *SEQUENCE*
- 31) *SUBGROUP STATUS*
- 12) *HCLIM*
- 14) *TEST VIOLATION*

- 15) DEFECT
- 16) CAUSE
- 17) ACTION
- 20) COMMENT
- 28) SUBGROUP SEQUENCE
- 29) SAMPLE NO
- 30) SGRP STATUS
- 35) ATTRIBUTE TALLY

Subset Detail Panel

Use the Subset Detail panel to add subsets to a dataset.

Navigation

Click the Add button under Subsets on the Dataset Configuration panel.

Image: Subset Detail panel

This example illustrates the fields and controls on the Subset Detail panel. You can find definitions for the fields and controls later on this page.

The image shows a software window titled "Subset Detail" with a close button (X) in the top right corner. The window contains the following fields and controls:

- Name:** A text input field containing "Length".
- Data Type:** A dropdown menu with "Variables" selected.
- Subgroup Size:** A slider control ranging from 1 to 50, with a value of 20 displayed in a text box to the right.
- Control Chart:** A dropdown menu with "1) X and Moving Range" selected.
- Control Proc:** A dropdown menu with "1) Level I" selected.
- Spec Limits:** Two text input fields labeled "Lower" and "Upper", both currently empty.
- Factors:** Two text input fields labeled "1" and "2", both currently empty.
- Chart:** Three text input fields labeled "Lower", "Control", and "Upper", all currently empty. A "Clear" button is located to the right of these fields.

At the bottom of the window, there are "OK" and "Cancel" buttons. Below the window, the text "Select a datatype from the list" is visible.

Data Type

Select from:

Variables

*Defects**Defectives***Subgroup Size**

Enter the statistical process control subgroup size used for producing control charts and calculating subgroup statistics.

Control Chart

Select the control chart used for graphing the subset and evaluating process control.

Control Proc (control procedure)

Indicate the procedure used to evaluate process control.

Note: The actual charts and control procedures listed depend on the configuration of the database. Available combinations include the following types.

Data Type	Available Control Charts
Variables	X and moving range Xbar and range Xbar and sigma
Defects	c chart u chart
Defectives	p chart np chart

The current process control limits appear from the database if the dataset you are using was created using an extraction or inquiry.

Subset/Column Detail Panel

Use the Subset/Column Detail panel to enter formulas to derive cell values for an entire column.

Navigation

Click the Formula button on the Dataset Configuration panel.

The upper portion of the panel displays the subset and data column that you selected.

Formula

Enter a formula that applies to the measurement column and subset combination. The formula behaves similarly to the formula used to derive characteristics in measurement plans. For example, you use a formula when prototyping or characterizing a process that in actual use derives characteristics, or to derive costs from live data by appending a subset (characteristic) to a dataset that has been extracted from the database.

Related Links

[Maintaining Characteristics](#)

Using Control Charts

This section discusses how to:

- View and manipulate control chart data.
- Modify control chart graph options.
- Run tests from control charts.

Pages Used to Use Control Charts

<i>Page Name</i>	<i>Definition Name</i>	<i>Navigation</i>	<i>Usage</i>
Control Chart	None	<ul style="list-style-type: none"> • Click the Control Chart button. • Select View, Control Chart. 	View process performance trends over a specific time period or number of subgroups sampled. Control charts help you distinguish between natural and unnatural process variation and the effectiveness of corrective actions taken.
Modify Control Chart	None	Display a control chart. Select Modify Graph, Settings.	Change graph settings and display characteristics.
Control Procedures	None	Display a control chart. Select a different control procedure to run against current datasets. Select Tests, Apply Control Procedure.	Select a control procedure and apply it to the current control chart.

Control Chart Panel

Use the Control Chart panel to view process performance trends over a specific time period or number of subgroups sampled.

Control charts help you distinguish between natural and unnatural process variation and the effectiveness of corrective actions taken.

Navigation

- Click the Control Chart button.
- Select View, Control Chart.

Image: Control Chart panel

This example illustrates the fields and controls on the Control Chart panel. You can find definitions for the fields and controls later on this page.

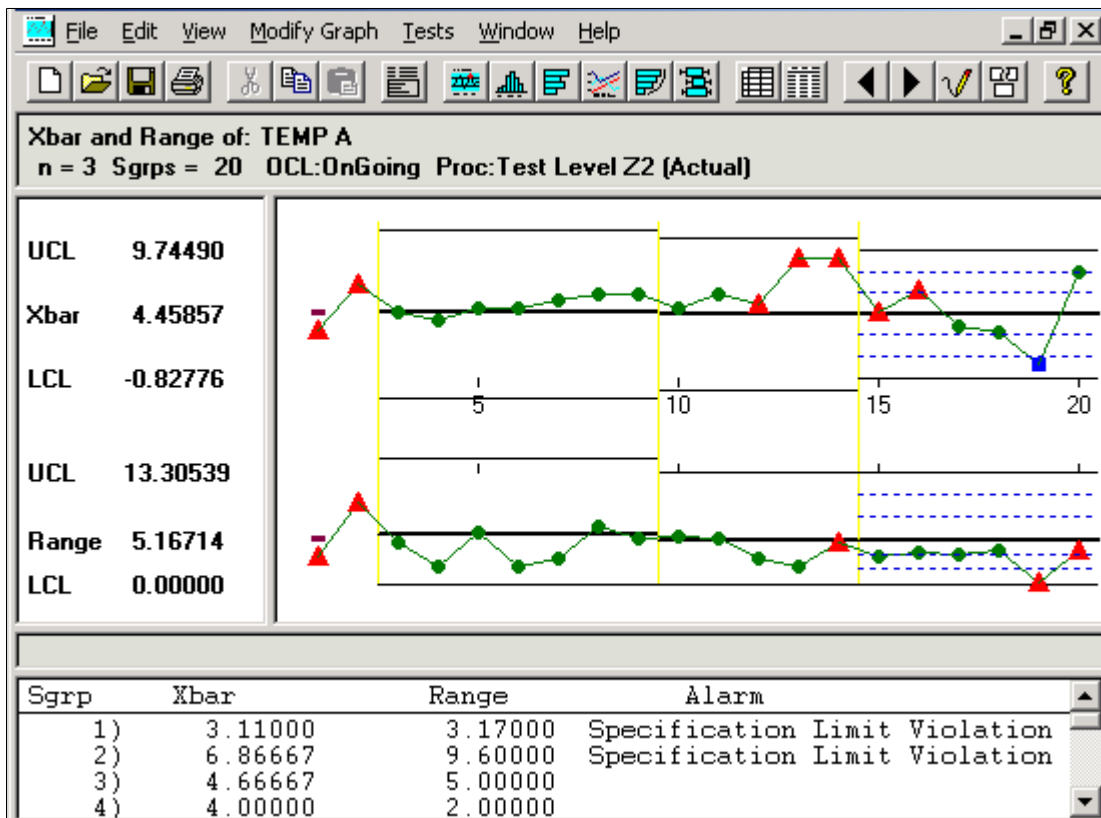

Control charts are comprised of multiple graph panes (sections) that display information about a subset. To resize the sections:

1. Place the cursor on the thick bar between the sections.
2. Drag the edge of the section to the new size.

You can also select an individual point and view the details, including subgroup calculations, trace data, and cause and corrective action information. When you click points in the chart section, a yellow vertical bar highlights the points, while corresponding values for the points appear in the detail section. To move this bar:

- Drag it.
- Use the Left Arrow and Right Arrow keys on the keyboard.

To remove the yellow highlight bar, drag it to the far left or far right of the chart.

To select multiple subgroup points:

1. Hold the Shift key down.
2. Drag the mouse over the points to remove or restore.
3. The points that you select are enclosed in red boxes in the chart section, and the summary list appears in the detail section.

To deselect the points, repeat steps 1 and 2, or use the Restore button. These subgroups are discounted from any local control limit recalculations or test violations when you click the Redraw button.

Note: When you use the control chart to apply tests, deselect points, or change control limits, the results are local to the active window; the dataset is not altered.

Title Section

This section displays the label of the chart being applied; for example, X-bar and Range charts. The title section also displays the subset for which the data is being displayed; for example, Temp A.

N	Displays the subgroup size used for this control chart.
Sgrps (subgroups)	Displays the number of subgroups or plotted points displayed in this chart.
OCL (operating control limit)	Displays the status of control limit promotion or calculation.
	<hr/> <p>Note: The status values correspond to the standard <i>None</i>, <i>Preliminary</i>, <i>Monitoring</i>, and <i>Ongoing</i> limit status values. <i>Modified</i> status indicates that the control limits were calculated dynamically for this graph window and not extracted from the database.</p> <hr/>
Proc (control procedure)	<p>Displays the control procedure in effect. It also indicates whether the alarms indicated on the chart were:</p> <p><i>(Tested)</i>: Tests and alarms were performed locally to this graph and not necessarily present in the database.</p> <p><i>(Actual)</i>: Alarms associated with the subgroups were extracted from the database.</p>

Chart Section

This section displays the main body of the graph. For example, if you selected the X-bar and range charts, you would see two graphs displayed on the control chart, one for the X-bar and one for the range chart. Each point on the graph represents an individual subgroup.

Alarms or out-of-control points are indicated by red triangles. Green circles represent all others. A blue square indicates that the subgroup readings were edited in the database using data-entry panels.

Note: Points with cause and action information associated with them are indicated by an over-bar.

You can see the subgroup values for each point on the chart by finding its number in the detail section of the control chart.

Control Limit Description Section

This section displays the values and appropriate labels for the upper control limit (UCL), mean (CL), and lower control limit (LCL) for each graph. These limits may have been extracted from the database, calculated, or set local to the graph.

Separator Section

This section is blank, unless you select a point in the graph section; then it displays detailed information about the point.

Detail Section

This section displays a list of subgroup summary information if a point has not been selected on the graph. This list includes the subgroup plot point values and alarm descriptions.

If you select an individual point on the graph, use this area to see detail information, such as traceability fields, probable causes, and corrective actions for that subgroup. If the dataset has been extracted from the Quality database, the Subgroup Status field also appears. The field indicates if a subgroup has been edited or changed in the database. A status of *800* indicates that one or more sample values have been changed for the subgroup, and this point is designated as a blue square on the chart. A status of *200* indicates that the subgroup has not been edited.

Related Links

[Understanding PeopleSoft Quality Methods](#)

[Modifying Control Chart Graph Options](#)

Modifying Control Chart Graph Options

Use the Modify Control Chart dialog box to change graph settings and display characteristics.

Navigation

Display a control chart.

Select Modify Graph, Settings.

You can change a chart by resizing the sections to adjust the amount of display information, by changing the control limits, and by choosing whether to display the control limit labels, alarm indicators, varying control limits, and test zones. Changes you make to the control chart affect only the active chart. If you open a second chart window, the changes are not in effect.

Fit Points to Window

Select to size the graph to fit inside the chart section of the window. Eliminates the horizontal scroll bar.

Display Ctl Limit Labels (display control limit labels)

Select to display labels in the description section of the control chart. This is useful if you have limited space and it is more important to display the graph than the labels.

Display Alarm Indicators

Select to display red triangle alarm indicators, representing subgroup points that are out of limits.

Display varying limits

Select to display historical control limits associated with a dataset in a step-wise fashion on the control chart. The system evaluates the chart based on the most current control limits. If the chart's time period includes prior limit calculations and you select this option, the system displays the limits as expanding or contracting segments against a fixed scale.

Note: This option applies only to datasets extracted from the Quality database.

Display test zones

Select to display positive and negative sigma lines in the main body of the control chart.

Control Limits

Select to reset limits for the UCL, CL, or LCL. There is a column to set limits for each graph in the active section of the control chart.

Maintain Current Limits

Select if you don't want the current control limits to be recalculated while you are working with this control chart.

Note: The limits are recalculated when you click the Redraw button.

Running Tests Against Control Charts

Use the Control Procedures dialog box to select a control procedure and apply it to the current control chart.

Navigation

Display a control chart.

Select a different control procedure to run against current datasets.

Select Tests, Apply Control Procedure.

You can select a control procedure from the list and apply it to the current chart. Each procedure contains one or more control tests that are executed against the chart to test alarm conditions. The procedures and tests were set up when you defined quality methods.

To run tests, select a control procedure. The tests run immediately, and the results appear in the lower portion of the panel. The first number represents the number of chart-based alarms, or alarms not generated from specification violations. The number in parentheses is the number of alarms generated from specification violations.

For example:

- 3 (3) Subgroups Alarmed on X Chart
- 6 (3) Subgroups Alarmed on MRange Chart

The example indicates that three alarms were generated from non-specification violations, and three alarms were generated from specification violations on the X-Bar graph of the control chart.

Because each subgroup on the chart can have more than one alarm condition, the total number of alarms can exceed the number of points on the chart. The number of specification-related alarms is the same for the second MRRange chart.

Use the configuration panels associated with the Selector panel in the Quality application client to change elements related to a subset, such as the subgroup size and default control procedure.

Related Links

[Understanding PeopleSoft Quality Methods](#)

[Control Chart Panel](#)

[Spreadsheet and Selector Panels](#)

Using Histograms

This section discusses how to:

- View and manipulate histograms.
- Modify histogram graph options.
- Run mean tests from histograms.
- Run standard deviation tests from histograms.

Pages Used to Use Histograms

<i>Page Name</i>	<i>Definition Name</i>	<i>Navigation</i>	<i>Usage</i>
Histogram	None	<ul style="list-style-type: none"> • Click the Histogram button. • Select View, Histogram. 	Display the distribution analysis.
Histogram Options	None	Open a histogram. Select Modify Graph, Settings.	Select options to modify the settings and display characteristics for histograms.
Mean Test	None	Open a histogram. Select Tests, Mean Test.	Run a means test against the histogram.
Stdev Test (standard deviation test)	None	Open a histogram. Select Tests, Stdev Test.	Run a standard deviation test against the histogram.

Histogram Panel

Use the Histogram panel to display the distribution analysis.

Navigation

- Click the Histogram button.
- Select View, Histogram.

Image: Histogram pane

This example illustrates the fields and controls on the Histogram pane. You can find definitions for the fields and controls later on this page.

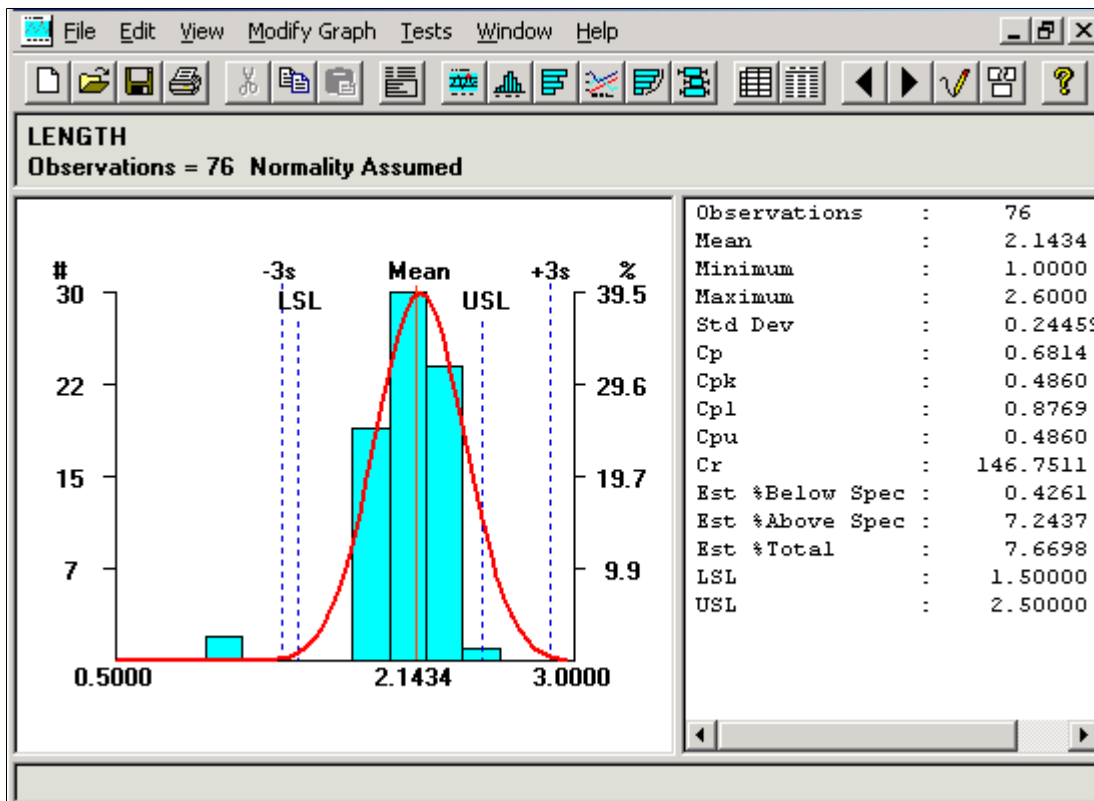

The histogram display comprises multiple panes (sections) that display information about a subset. To resize a section:

1. Place the cursor on the thick bar between the sections.
2. Drag the edge of the section to the new size.

Click a cell and it becomes crosshatched to highlight it. When you click the Redraw button, the histogram is redrawn with the crosshatched cells removed. This is useful to examine a smaller portion of the data. By deleting cells, you can temporarily exclude the data values associated with that cell and recalculate the histogram and statistics.

To select a cell, drag the cursor across the vertical bar. The cell is highlighted in yellow. You can see the details of the selected cell in the detail section of the histogram.

Note: Cell values excluded from the graph are local to the active window; the dataset is not altered.

Title Section

This section displays the subset being analyzed for example, TEMP A.

Observations	Displays the number of points used for the analysis.
Pearson Best-Fit, Tested for Normality, and Normality Assumed	Displays how the data distribution was assessed.

Chart Section

The section of the histogram displays the main body of the graph, with the following conditions:

- (Optional) Specifications and +/- 3 sigma regions appear as dashed lines.
- A thin, red, vertical line indicates the mean point.
- The histogram is scaled by frequency on the left and by percent on the right.
- (Optional) The distribution curve (indicated by a thick, red, curved line) overlays the chart.

List Section

This section displays summary statistics. You can change the statistics by changing graph preference settings. The statistics are calculated based upon the active data values for this subset.

Detail Section

This section is blank, unless you select a vertical bar (cell), in which case it displays detailed cell information. To select a cell, drag the cursor over the vertical bar, and it is highlighted in yellow.

Cell # (cell number)	Displays the order of the individual cell in the histogram. For example, <i>Cell #6</i> is the sixth cell in the sequence of cells displayed.
Width	Displays the dimension of the cell in the display.
Tally	Displays the total number of individual values in a cell.
% (percent)	Displays the percent of individual values in a cell.

Related Links

[Testing for Normality](#)

[Using Pearson Best-Fit Criteria](#)

[Define Graph Preferences Page](#)

Modifying Histogram Graph Options

Use the Histogram Options dialog box to select options to modify the settings and display characteristics for histograms.

Navigation

Open a histogram.

Select Modify Graph, Settings.

You can modify the histogram by resizing the sections to adjust the amount of display information in each section of the graph. You can choose whether to display the overlay curve, the overlay specifications, or to overlay a box plot. You can change the number of cells displayed and the upper and lower specification limits.

Note: Any changes you make to the histogram are in effect only for the active chart. If you open a second histogram window, the changes are not in effect.

Overlay Distribution Curve	Select to display a red bell curve line to overlay histogram cells.
Overlay Specs (overlay specifications)	Select to display blue, dashed, vertical lines for the upper specification limit (USL) and the lower specification limit (LSL).
Overlay Box and Whisker Plot	Select to display a box plot with the curve graph on the histogram.
Number of Cells	Indicate the number of cells displayed by the histogram. Move the slider or enter the number of cells in the settings box to the right to indicate how many cells you want between 4 and 30.
	<hr/> Note: The sample values are reordered to fit within the number of cells specified. <hr/>
Spec Limits (specification limits)	Enter the limits in the Upper and Lower fields.

Running Mean Tests from Histograms

Use the Mean Test dialog box to run a means test against the histogram.

Navigation

Open a histogram.

Select Tests, Mean Test.

Use mean tests to test the mean of the current sample versus a target mean and a confidence level.

To test for a mean:

1. Enter the target mean and confidence level, or use the defaults.
2. Click the Calculate button to see the results of the t Test calculation.
3. Click the Done button to update the graph on the histogram.

Running Standard Deviation Tests from Histograms

Use the Stdev Test (standard deviation test) dialog box to run a standard deviation test against the histogram.

Navigation

Open a histogram.

Select Tests, Stdev Test.

Use standard deviation tests to test the standard deviation of the current sample versus a target standard deviation and a confidence level.

To test for standard deviation:

1. Enter the target standard deviation, or use the default.

The standard deviation test has a limitation of $df = 100$. The sample size is display-only.

2. Select a confidence level.

Valid levels include:

- *0.995*
- *0.990*
- *0.975*
- *0.950*
- *0.050*
- *0.025*
- *0.010*
- *0.005*

3. Click the Calculate button to see the results of the chi-squared test calculation.
4. Click the Done button to update the graph on the histogram.

Related Links

[Using Test Statistics](#)

Using Bar Graphs

This section discusses how to:

- View and manipulate bar graphs.

- Modify bar graph options.

Pages Used to Use Bar Graphs

<i>Page Name</i>	<i>Definition Name</i>	<i>Navigation</i>	<i>Usage</i>
Bar Graph	None	<ul style="list-style-type: none"> • Click the Bar Graph button. • Select View, Bar Graph. 	Compare a selected statistic among subsets.
Modify Bar Graph	None	Open a bar graph. Select Modify Graph, Settings.	Modify settings and display characteristics for the active bar graph window.

Viewing and Manipulating Bar Graphs

Use the Bar Graph panel to compare a selected statistic among subsets.

Navigation

- Click the Bar Graph button.
- Select View, Bar Graph.

Image: Bar Graph panel

This example illustrates the fields and controls on the Bar Graph panel. You can find definitions for the fields and controls later on this page.

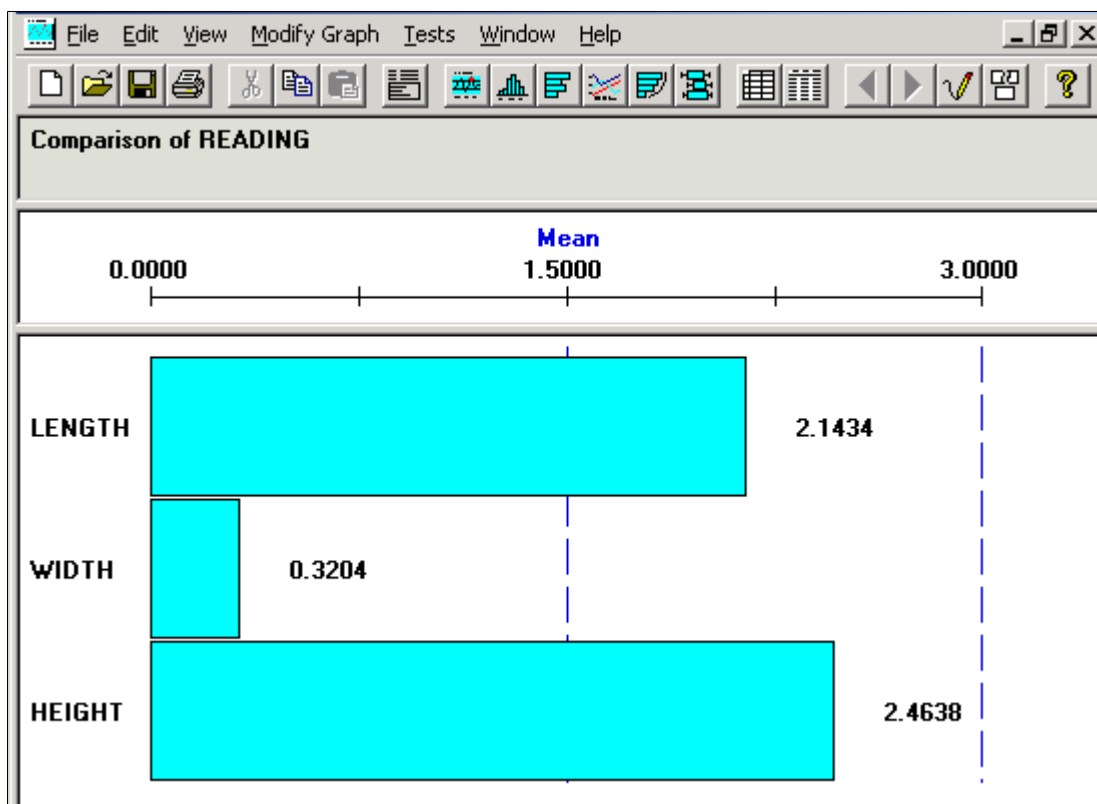

The bar graph is comprised of multiple panes (sections) that display information about the subset that you are examining. You resize sections the same as you do for a histogram. There is a bar on the graph for each subset you selected in the Selector panel.

Title Section

This section of the bar graph displays the statistics that you are comparing.

Pearson Best-Fit, Tested for Normality, and Normality Assumed Displays how the data distribution was assessed.

Scale Section

This section displays the name of the statistical item you are comparing

Name and Scale Displays upper and lower scale limits (based on the minimum and maximum statistical values). To select a different statistic, select Modify Graph, Settings.

Graph Section

This section displays a bar for each subset chosen from the Selector panel.

Modifying Bar Graph Options

Use the Modify Bar Graph dialog box to modify settings and display characteristics for the active bar graph window.

Navigation

Open a bar graph.

Select Modify Graph, Settings.

You can modify the size of the bar display, the bar values, reorder, and change the statistic on the bar graph. Any changes you make to the bar graph are in effect only for the active chart. If you open a second bar graph window, the changes are not in effect.

Fit Bars to Window	Select to expand the graph to fit the full size of the Bar Graph panel, eliminating the vertical scroll bar.
Display Bar Values	Select to display numeric values for each bar on the graph.
Indicate Min/Max (<>) Bars (indicate minimum/maximum bars)	Select to indicate which bars represent the minimum and maximum values. The bar that contains the lowest value displays <. The bar with the highest value displays >. This option is useful for distinguishing the highest and lowest value bars among bars of similar lengths.
Bar Display Limit (# bars) (number of bars)	Enter the number of bars to display on the graph. The limits for constraining the number of bars are from 2 to 1000. By default (or by entering 0 or 1), all the subsets that you selected in the Selector panel appear.
Graphing Order (Bars)	Select the order in which the bars (subsets) appear on the bar graph. Options are: <i>Selection:</i> Displays subsets in the order that they were selected on the Selector panel. <i>Ascending:</i> Displays bars in ascending order by statistical value. <i>Descending:</i> Displays bars in descending order by statistical value.
Statistic	Select an item from the list to compare. For example, you can compare machines to machines or compare multiple readings for cylinders of different diameters. Values include: <i>MEAN</i> <i>MINIMUM</i> <i>STDDEV</i>

VARIANCE

COEFVAR

KURTOSIS

ZUPPER

UPPER3S

SUMX

SUMZ

Q1

Q3

AVEVARS

CPK

CPU

PCSPEC

PCUPPER

SUMDEF

DEFPT

DEFPU

USL

FACT2

OBSRV

MAXIMUM

RANGE

STDERR

SKEWNESS

ZLOWER

LOWER3S

DISTYPE

SUMX2

SIZEN

*MEDIAN**AVEMEANS**CP**CPL**CPK90**PCLOWER**PCTOTAL**DEFPH**DEFFM**LSL**FACTI**TRANS***Scale Limits**

Enter values for the lower and upper display limits.

Related Links[Understanding Quality Equations and Methods](#)

Using Line Graphs

This section discusses how to:

- View line graphs.
- Modify line graph options.

Pages Used to Use Line Graphs

<i>Page Name</i>	<i>Definition Name</i>	<i>Navigation</i>	<i>Usage</i>
Line Graph	None	<ul style="list-style-type: none"> • Click the Line Graph button. • Select View, Line Graph. 	Display trends of individual measurement values.
Modify Line Graph	None	Open a line graph. Select Modify Graph, Settings.	Modify settings and display characteristics for the active line graph window.

Line Graph Panel

Use the Line Graph panel to display trends of individual measurement values.

Navigation

- Click the Line Graph button.
- Select View, Line Graph.

Image: Line Graph panel

This example illustrates the fields and controls on the Line Graph panel. You can find definitions for the fields and controls later on this page.

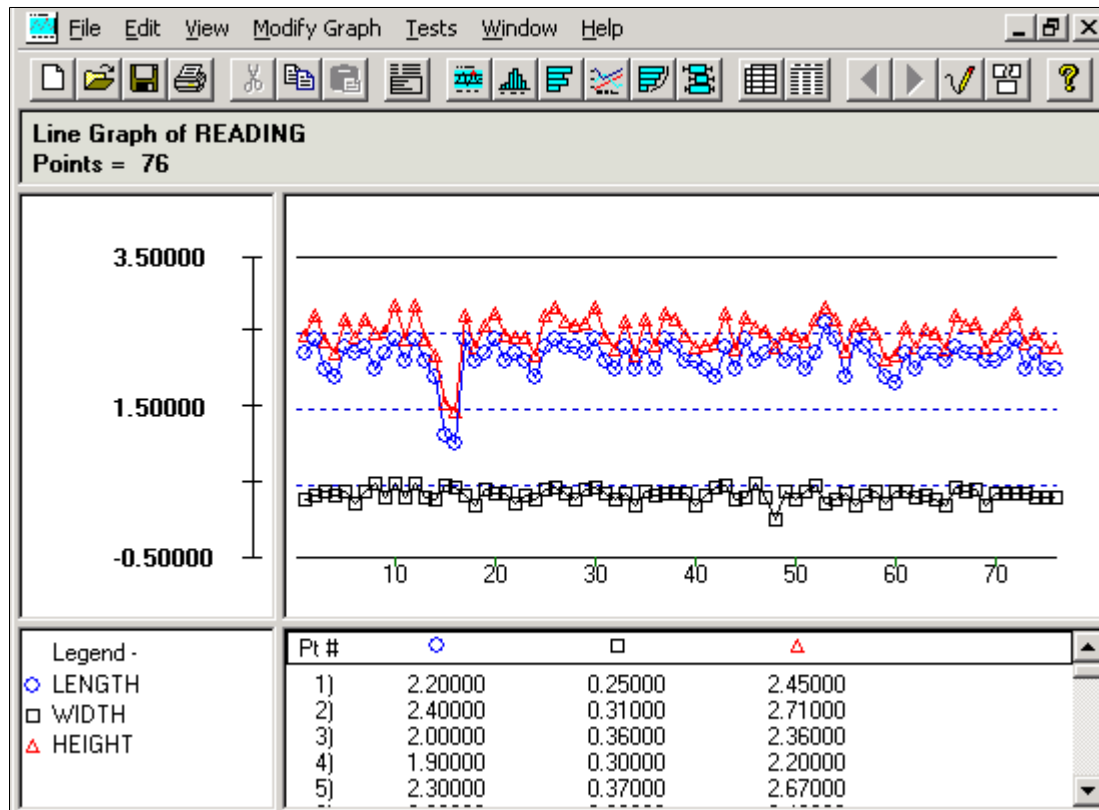

The line graph comprises multiple graph panes (sections) displaying information about the subset that you are examining. All subsets that you are comparing are overlaid on the same graph. You can select individual points on the line graph display to examine details.

When you click points on the graph section, a yellow vertical bar highlights the points. The corresponding values for the points are displayed in the detail section of the chart, with a single point for each subset. To move the yellow vertical bar:

- Drag it.
- Use the Left Arrow and Right Arrow keys on the keyboard.

To remove the yellow highlight bar, drag it to the far left or the far right of the chart.

Resize the sections the same as you resize histogram sections. All subsets are overlaid in the line graph, so you can view them at the same time. You can examine the graph with or without connecting lines or points.

Title Section

This section displays the label of the graph being displayed for a specific column, such as READING. The title section also displays the maximum number of points drawn on the graph.

Scale Section

This section indicates the numeric values for the scale used for the graph. Scales are usually calculated based upon the minimum/maximum observations for the subsets selected, but you can change the scale limits using the Modify Line Graph dialog box.

Graph Section

This section displays a line for each subset that you selected in the Selector panel. For example, if you selected three subsets, the system displays three lines on the line graph. Each line has a different geometric shape for its point indicator, and a different color.

Legend Section

This section displays the geometric shape and color that represent each subset on the line graph.

Detail Section

This section displays the individual data values for the points in each subset.

Related Links

[Define Graph Preferences Page](#)

Modifying Line Graph Options

Use the Modify Line Graph dialog box to modify settings and display characteristics for the active line graph window.

Navigation

Open a line graph.

Select Modify Graph, Settings.

You can modify the line graph by resizing the sections to adjust the amount of display information, changing the display lines and points, and changing the graph scale.

Any changes you make to the line graph are in effect only for the active chart. If you open a second line graph window, the changes are not in effect.

Fit Points to Window

Select to expand the graph to fit the full size of the Line Graph panel, eliminating the horizontal scroll bar.

Draw Connecting Lines

Select to display the lines that connect each point on the graph.

Draw Points

Select to display the points on each line in the graph.

Scale Limits

Enter values for the lower and upper scale limits.

Using Pareto Charts

This section discusses how to:

- View Pareto charts.
- Modify Pareto chart options.

Pages Used to Use Pareto Charts

<i>Page Name</i>	<i>Definition Name</i>	<i>Navigation</i>	<i>Usage</i>
Pareto Chart	None	<ul style="list-style-type: none"> • Click the Pareto button. • Select View, Pareto. 	View attribute data in descending order of frequency of occurrence.
Modify Pareto Chart	None	Open a Pareto chart. Select Modify Graph, Settings.	Modify settings or display characteristics for a Pareto chart.

Pareto Chart Panel

Use the Pareto Chart panel to view attribute data in descending order of frequency of occurrence.

Navigation

- Click the Pareto button.
- Select View, Pareto.

Image: Pareto Chart panel

This example illustrates the fields and controls on the Pareto Chart panel. You can find definitions for the fields and controls later on this page.

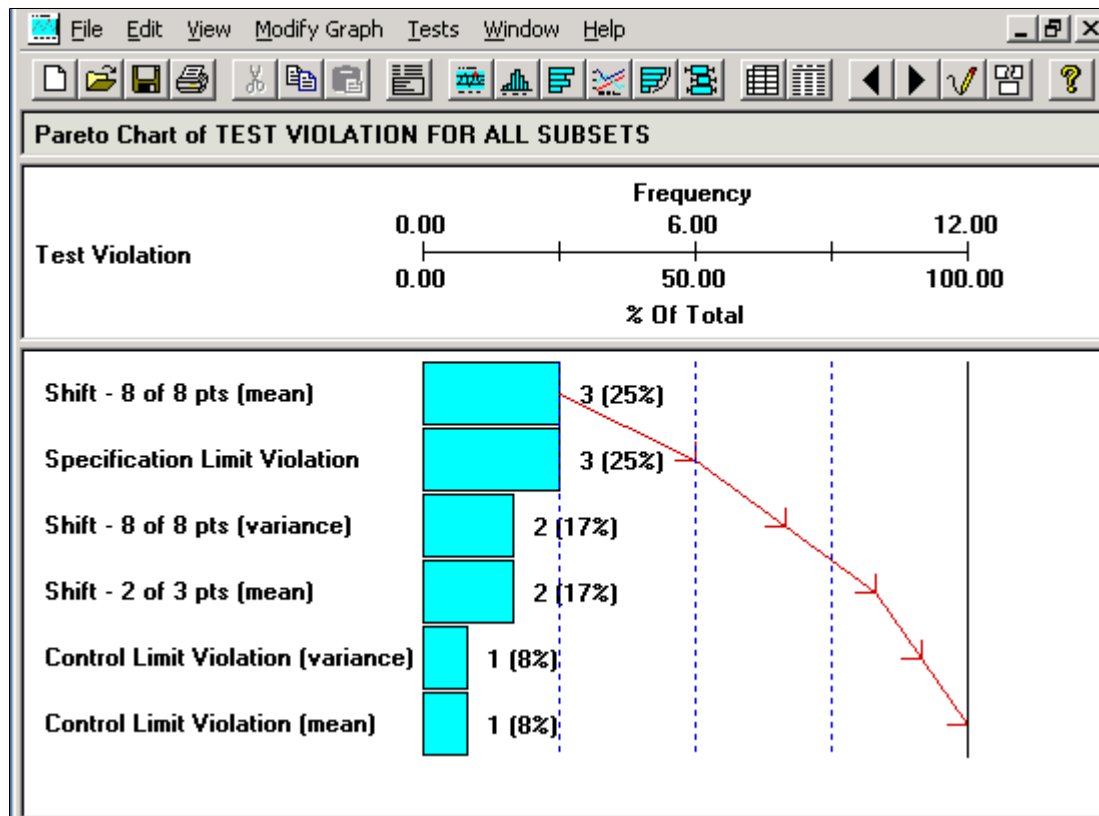

A Pareto chart is comprised of multiple graph panes (sections) and includes information about the subset that you are examining. You can resize the sections the same way that you resize histogram sections.

When you click a cell, it becomes crosshatched to highlight it. When you click the Redraw button, the Pareto chart is redrawn with the crosshatched cells removed. This is useful to examine a smaller portion of the data or compare certain attributes only. When you click the Restore button, the Pareto chart is redrawn in its original state. The redraw and restore functions only apply to the Pareto chart that you are currently manipulating and do not affect other Pareto charts.

When you select multiple subsets on the Selector panel and click the Pareto button, the chart that is initially displayed is a composite of all the subsets selected. From there, you can cycle and view the individual Pareto charts (layers) corresponding to each subset. For example, if you selected three subsets on the Selector panel, the system generates four Pareto charts. The first Pareto chart displays a composite of all the subsets, and there is also a Pareto chart for each individual subset.

Note: Each chart is displayed, one at a time, within the existing tool window.

Note: The Attribute column role assignment on the Selector panel determines which attribute appears on the Pareto chart.

Title Section

This section includes a heading that indicates which subset of data and attribute you are currently analyzing. In the previous illustration, the attribute being analyzed is Defects, and the Pareto chart being displayed is for all the subsets that you selected on the Selector panel.

If you filter the attributes, either by clicking a cell or by using the Modify Pareto Chart dialog box, you'll see (*Filtered*) in the title section.

Scale Section

This section displays the name of the data column that you are analyzing and a scale that exhibits the display limits for the Pareto chart. In the illustrated panel, the data column is Defects and the scale is Frequency.

Chart Section

This section contains the main body of the Pareto chart, including a description of each attribute, the attribute count, and the percentage of the number of defects for which that attribute accounts. The red line represents the cumulative percent line, also known as the Lorenz curve.

Note: Cell values excluded from the graph are local to the active window; the dataset is not altered.

Related Links

[Creating and Managing Datasets](#)

[Modifying Pareto Chart Options](#)

Modifying Pareto Chart Options

Use the Modify Pareto Chart dialog box to modify settings or display characteristics for a Pareto chart.

Navigation

Open a Pareto chart.

Select Modify Graph, Settings.

You can modify Pareto charts to display:

- Cells in one window.
- Cumulative lines.
- Graphing order of the cells.
- Specific numbers of cells.

You can also filtering the attribute components that are displayed. Any changes you make to the Pareto chart are in effect only for the active chart. If you open a second Pareto chart window, the changes are not in effect.

Fit Cells to Window

Select to expand the chart to fit the full size of the Pareto chart display panel, eliminating the vertical scroll bar.

Display Cumulative (%) Lines

Select to display a cumulative percent line across the graph.

Graphing Order (cells)

Select the order of display. Options are:

Ascending: Cells appear in ascending order by attribute count.

Descending: Cells appear in descending order by attribute count.

Top N Cells

Enter the number of cells you want in the Pareto chart. For example, if you enter *10*, 10 cells appear in the Pareto chart, if they are available. Leaving this field set to *0* or *1* displays all attribute cells.

Filter by Attribute Components

Specifies whether to display data based on components of the defect phrase or the cause/action phrase. The defect phrase includes *Location*, *Fault*, and *With*. The cause/action phrase includes *Problem*, *Affecting*, and *Action*.

Note: The Filter by Attribute Components section applies mainly to datasets extracted from the PeopleSoft database. The actual component meanings may vary, depending on how they were defined in the Attribute Categories pages.

Filter buttons refer to the first, second, and third phrase components, as follows:

The first component (Location or Problem).

The second component (Fault or Affecting).

The third component (With or Action).

For the first, second, and third components, select the filtering criteria and then the component attribute by which to filter.

Filtering criteria includes:

Expand: Includes all attributes for the component. This is the default setting for all three components.

Ignore: Excludes all attributes with the component.

Select: Displays a single component (by value).

Exclude: Displays everything, except for the selected component, by value.

You define component attributes in the Attribute Groups component.

When you are finished with selections, click the OK button. The Pareto chart is redrawn with the options you selected. The title section displays *Filtered*.

Related Links

[Defining Attribute Groups](#)

Using Box Plots

This section discusses how to:

- View box plots.
- Modify box plot graph options.

Pages Used to Use Box Plots

<i>Page Name</i>	<i>Definition Name</i>	<i>Navigation</i>	<i>Usage</i>
Box Plots	None	<ul style="list-style-type: none"> • Click the Box Plots button. • Select View, Box Plots. 	Display and compare process performance of multiple subsets.
Modify Box Plot	None	Open a box plot. Select Modify Graph, Settings.	Modify settings or display characteristics for active box plots window.

Box Plots Panel

Use the Box Plots panel to display and compare process performance of multiple subsets.

Navigation

- Click the Box Plots button.
- Select View, Box Plots.

Image: Box Plots panel

This example illustrates the fields and controls on the Box Plots panel. You can find definitions for the fields and controls later on this page.

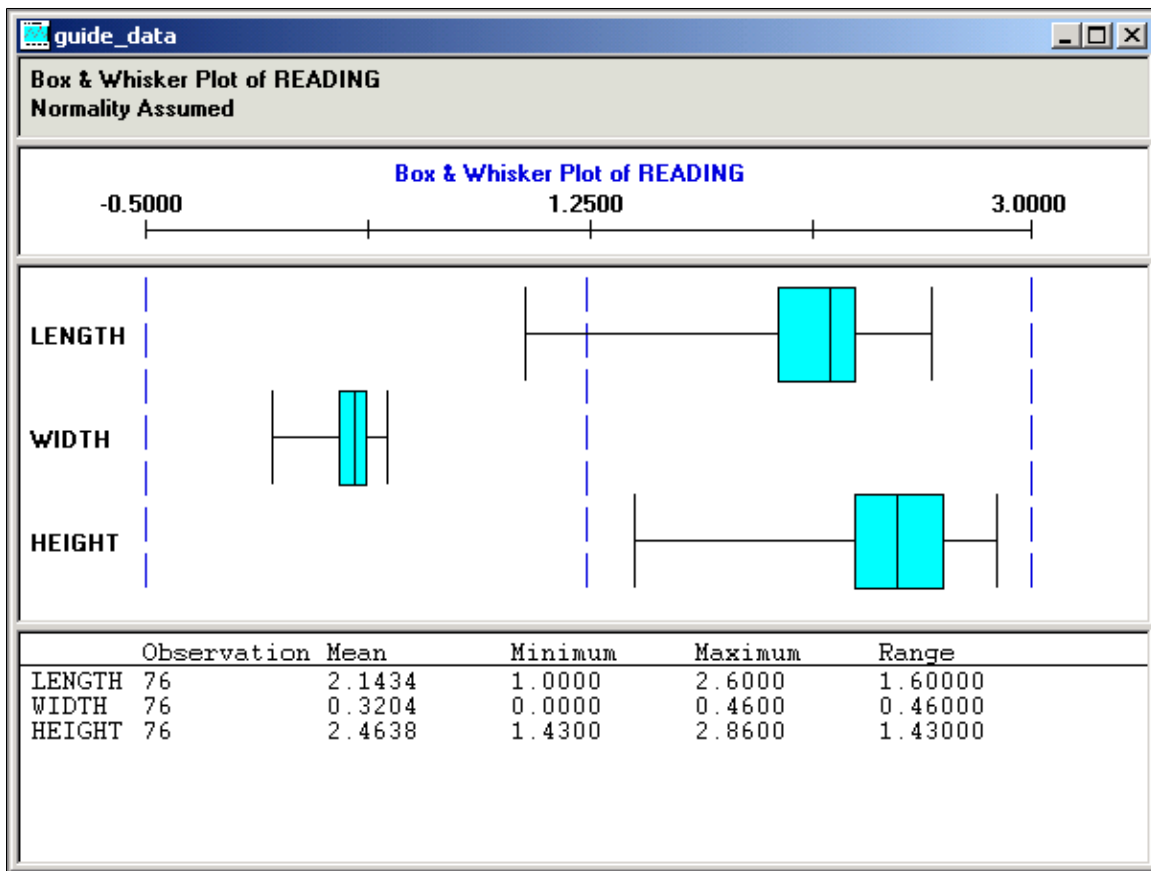

The box plots display is comprised of multiple graph panes (sections), with each section displaying information about the subset that you are examining. Box plots are also referred to as Box and Whisker plots, because of the vertical whisker lines at each end of the horizontal scale.

Box plots supports three styles of plots, including:

- Box and Whisker
- Capability
- Min/Max (minimum/maximum)

When you select multiple subsets on the Selector panel and click the Box Plots button, the displays represent the subsets you select. All selected subsets are overlaid together in the same box plots window.

You can select individual box plots by clicking the subset name. A red box appears around the subset that you selected. The detail section of the display changes from the collective summary of statistics for all box plots to individual summary statistics for the selected subset.

Deselect an individual box plot by clicking above the first box or below the last box in the label area. Click to the left of the boxes.

Title Section

This section includes a heading that indicates the plot type, the data column used as the basis for generating the box plots, and normality criteria for the calculations used to generate the box plots. In the previous illustration, the plot type is Box and Whisker, the data column is Reading, and the normality criteria is Pearson Best Fit.

The graph preference that you select on the Selector panel determines the normality criteria.

Scale Section

This section displays the name of the data column that you are analyzing and a scale, which exhibits the box plot's limits. In the previous illustration, the data column is Reading and the graph type is Box and Whisker.

Note: By default, the system calculates the scale based on the minimum/maximum values of the data to be graphed.

Chart Section

Section contents vary depending on the graph style.

The Box and Whisker chart section contains Box and Whisker displays. The ends of the whisker lines represent the minimum and maximum values, the left and right edges of the boxes represent the first quartile and third quartile values, and the centerlines represent the median value.

The individual boxes correspond to either the subsets that you selected or the data groupings established with the group by column role assignment on the Selector panel.

A capability graph appears in this section:

Image: Chart section - capability graph

This image displays the capability graph.

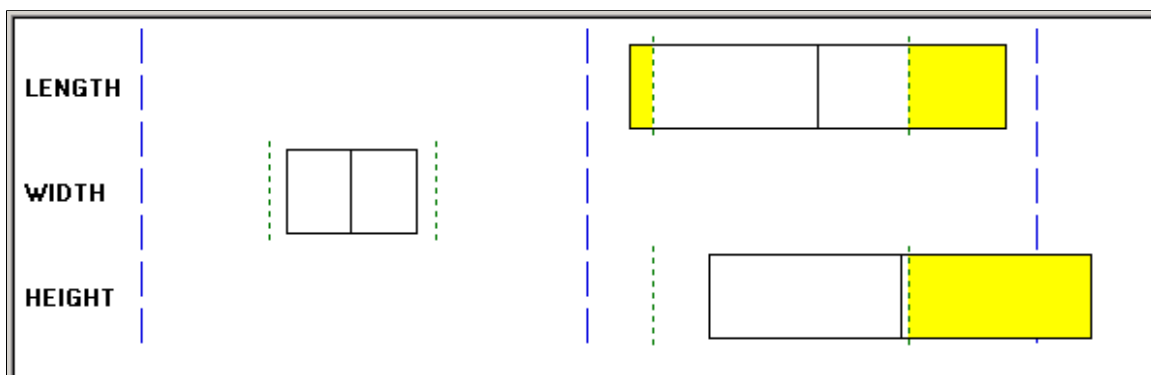

The left and right edges of the capability graph box represent the plus and minus 3 sigma values, and the centerline represents the mean value. In addition, green dashed lines represent the lower-and upper-specification limits, while yellow parts represent the areas out of specification based upon the distribution fitting (Normality, Pearson Best Fit) criteria in effect.

Individual boxes correspond to either the subsets that you selected or the data groupings established with the group by column role assignment on the Selector panel.

A min/max graph appears in the following section:

Image: Chart section - min/max graph

This image displays the min/max graph.

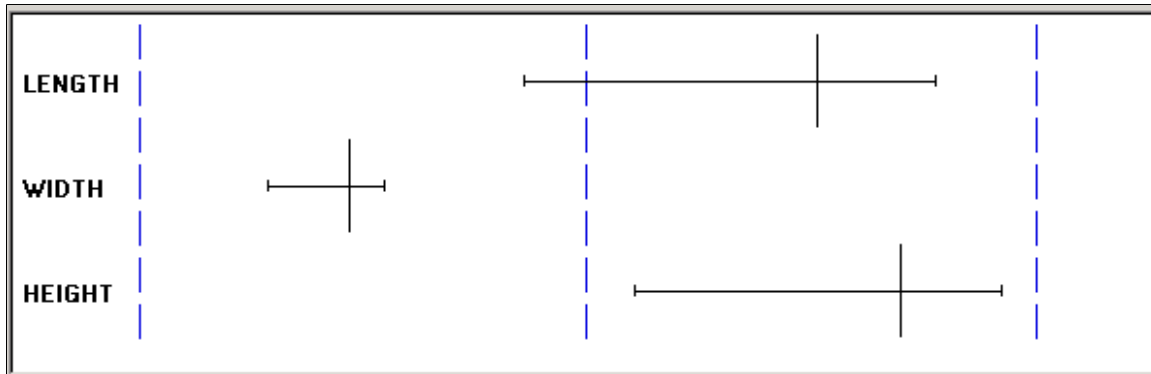

The left and right endpoints represent minimum and maximum values, and the centerline represents the mean.

The individual boxes correspond to either the subsets that you selected or the data groupings established with the group by column role assignment on the Selector panel.

Detail Section

This section of box plots includes the collective summary statistics for all box plots on the display. If you select an individual box plot, then the summary statistics for that individual box plot appear.

Related Links

[Define Graph Preferences Page](#)

[Modifying Box Plot Graph Options](#)

[Creating and Managing Datasets](#)

Modifying Box Plot Graph Options

Use the Modify Box Plot dialog box to modify settings or display characteristics for active box plots window.

Navigation

Open a box plot.

Select Modify Graph, Settings.

You can modify the box plots using the following:

Graph Style

Select a graph style for the chart section of the box plots display. Options are:

- *Box & Whisker*

- *Capability*
- *Min/Max*

Fit Plots to Window

Select to expand the chart to fit the full size of the box plot chart display, eliminating the vertical scroll bar.

Overlay +/- 3 Sigma Region

Select to overlay each capability box in the box plots window with a distribution curve. This option is only applicable when the graph style is set to *Capability*.

Graph Scale Limits

The system calculates and displays scales by adding and subtracting a percentage of the upper- and lower-plot values that are based on option and graph type selections. You can change the lower and upper graph scale limits, which change how the box plots appear in the window.

The scale section of the display changes to reflect the new graph scale limits. The scale that you enter stays in effect until you select another graph style or (sometimes) when you change the overlay 3 +/- Sigma Region check box. If you change any setting that could potentially alter the assessment of minimum/maximum plot values, the system recalculates the scales.

An example of a box plot with distribution curves overlaid appears in the following section:

Image: Overlaying distribution curves on box plots

This image displays the overlaying distribution curves.

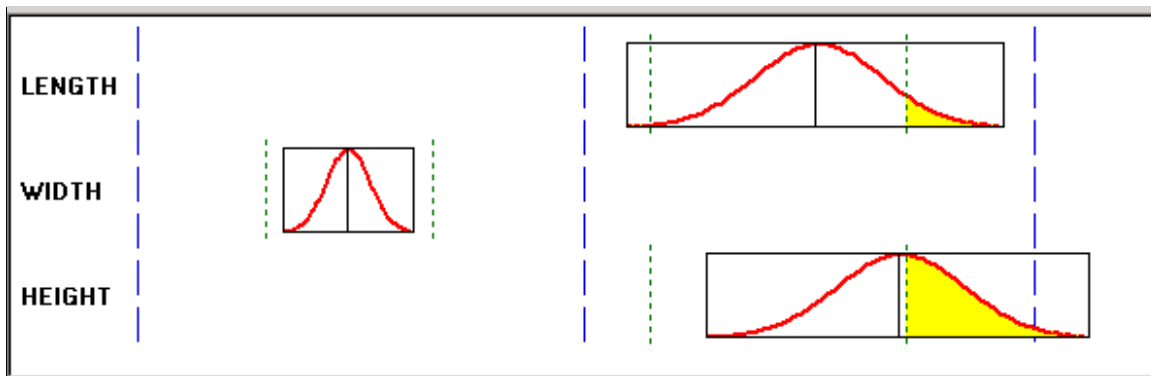

Note: The system calculates the distribution curve according to the normality/curve fitting criteria in effect by the graph preference ID that you selected.

Related Links

[Using Box Plots](#)

Using Spreadsheets

This section discusses how to view and manipulate spreadsheet data.

Page Used to Use Spreadsheets

Page Name	Definition Name	Navigation	Usage
Spreadsheet	None	<ul style="list-style-type: none"> Click the Spreadsheet button. Select View, Spreadsheet. 	View and manipulate data cell values and modify or add additional data.

Spreadsheet Panel

Use the Spreadsheet panel to view and manipulate data cell values and modify or add additional data.

Navigation

- Click the Spreadsheet button.
- Select View, Spreadsheet.

Image: Spreadsheet panel

This example illustrates the fields and controls on the Spreadsheet panel. You can find definitions for the fields and controls later on this page.

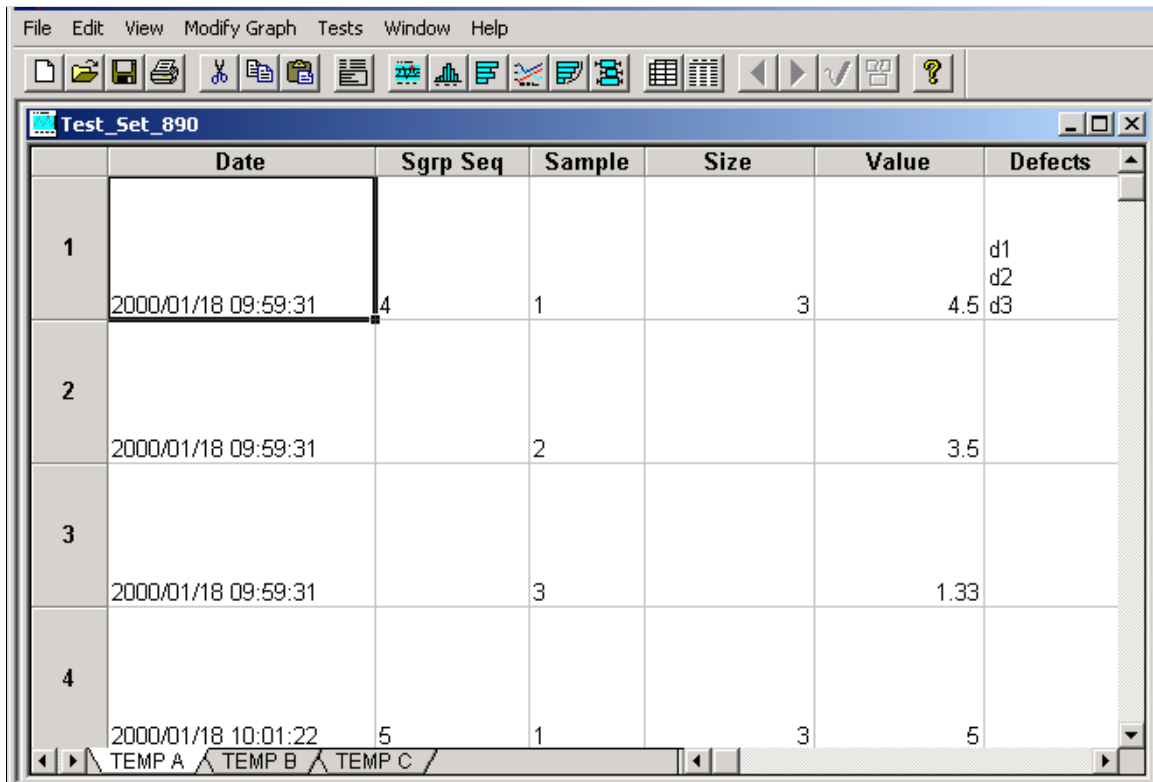

A spreadsheet displays the current dataset information in a grid format. Subsets within the dataset appear across the bottom of the spreadsheet. The spreadsheet functions much like a Microsoft Excel spreadsheet.

You can enter additional data in the cells or change existing data. You can copy, cut, and paste data within cells. Use the horizontal scroll bar at the bottom of the display to view additional data columns.

Click each subset at the bottom of the spreadsheet to see the data associated with that subset.

You can also export the data on the spreadsheet to a Microsoft Excel spreadsheet and other application types. To export the data, select File, Export, and the appropriate options.

Related Links

[Creating and Managing Datasets](#)

Using the Statistical Matrix

This section discusses how to view statistical matrix data.

Page Used to Use the Statistical Matrix

<i>Page Name</i>	<i>Definition Name</i>	<i>Navigation</i>	<i>Usage</i>
Statistical Matrix	None	<ul style="list-style-type: none"> Click the Statistical Matrix button. Select View, Statistical Matrix. 	Display statistics as columns or rows determined by settings in the graph preferences.

Statistical Matrix Panel

Use the Statistical Matrix panel to display statistics as columns or rows determined by settings in the graph preferences.

Navigation

- Click the Statistical Matrix button.
- Select View, Statistical Matrix.

Image: Statistical Matrix

This example illustrates the fields and controls on the Statistical Matrix. You can find definitions for the fields and controls later on this page.

	Statistic	LENGTH	WIDTH	HEIGHT
1	Observations	76	76	76
2	Mean	2.1434	0.3204	2.4638
3	Minimum	1.0000	0.0000	1.4300
4	Maximum	2.6000	0.4600	2.8600
5	Std Dev	0.24459	0.08439	0.24868
6	Cp	0.6814	1.2838	0.6702
7	Cpk	0.4860	1.2656	0.0485
8	Cpl	0.8769	1.2656	1.2919
9	Cpu	0.4860	1.3020	0.0485
10	Cr	146.7511	77.8951	149.2079
11	Est %Below Spec	0.4261	0.0073	0.0053
12	Est %Above Spec	7.2437	0.0047	44.2156
13	Est %Total	7.6698	0.0120	44.2210
14	LSL	1.50000	0.00000	1.50000
15	USL	2.50000	0.65000	2.50000

Subset Statistics: < >

The statistical matrix format is similar to a spreadsheet. You can view tabular formatted statistics related to one or more subsets of the dataset in the following categories:

- **General statistics**
Includes mean, observations, standard deviation, variance, covariance, range, minimum, maximum, skewness, kurtosis, Z scores, sum, upper and lower sigma, quartile, and median.
- **Capability indices**
Includes Cp, Cpk, Cpl, Cpu, Cr, Cpk at 90 percent, percent below specification, percent above specification, percent of total specification, and other associated statistics.
- **Defect statistics**
Includes defect sum, defects per unit, defects per hundred, defects per thousand, and defects per million.

The statistical matrix display uses the Measure column row assignments and the selected graph preferences from the Selector panel.

Related Links

[Creating and Managing Datasets](#)

Creating Graph-Display Templates

This section provides an overview of graph-display templates and discusses how to:

- Create graph-display layouts.
- Apply graphic layouts.

Understanding Graph-Display Templates

Templates are custom graphic layouts that you create, store, and reuse. Using the templates, you can simultaneously display one or more data-analysis tools in the Quality application client, making it possible to compare different graphs and charts for the same sets of data. For example, suppose you use a line graph, a bar graph, and a box plot to display a dataset. You can set up the Quality application client to display the three charts in the identical format for each dataset you examine.

You can also compare two datasets that are not identical, just similar. For example, if you create a layout using certain attributes or measurement columns, you can apply that layout to all similar datasets that have those columns defined. You can access data-analysis tools individually, using the Quality application client toolbar, or use the View menu.

Creating Graph-Display Layouts

To create graph-display layouts:

1. Open a dataset.
2. Select the dataset configuration using the Selector panel.
3. Select graphs using the buttons on the toolbar.
4. Size and position the graphs in the panel.
5. Select File, Save Layout.
6. Name the layout and select a place to save it.

The extension .tpl is automatically appended to the files.

The system saves the file to the same directory as dataset files on a workstation. Templates, like datasets, don't reside in the PeopleSoft database and should be considered workstation-specific.

Related Links

[Defining Data Extractions and Loading Datasets](#)

Applying Graphic Layouts

Access the Quality application client.

Image: Example of graph-display layout

This example illustrates the fields and controls on the Example of graph-display layout. You can find definitions for the fields and controls later on this page.

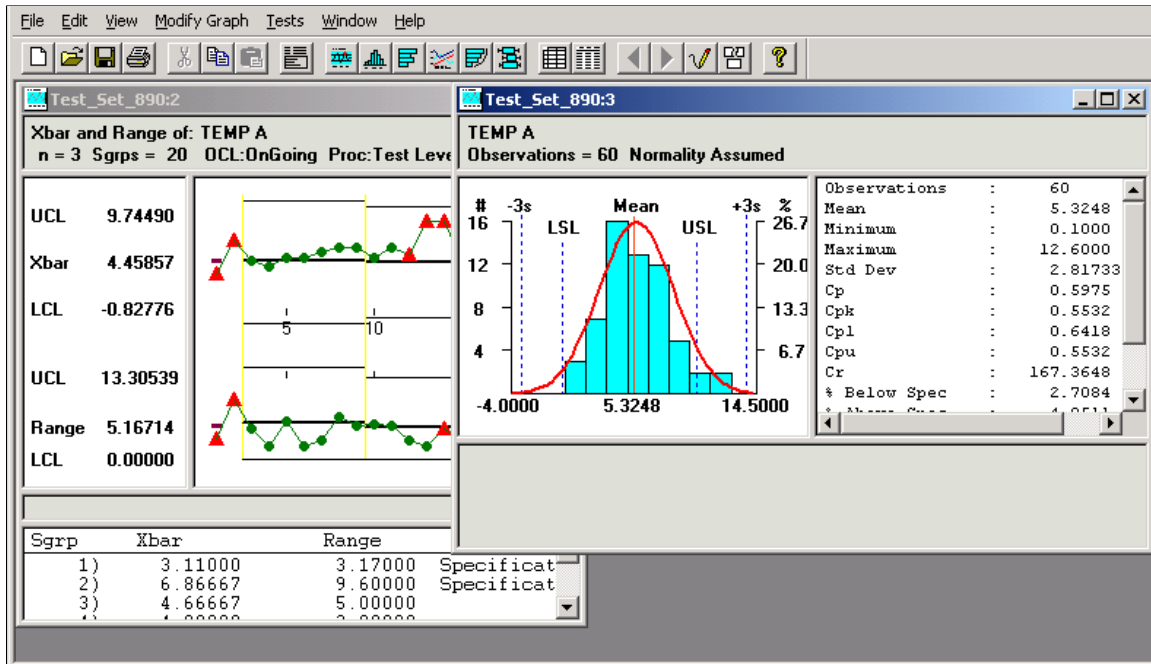

To apply a layout, select File, Apply Layout. Each time you apply a different layout to the same data, the new layout replaces the previous one. The panels on the layout display the data from the currently selected dataset. If you open a different dataset and apply the same layout, you see the new data displayed in the same arrangement of panels.

You can change any of the charts in the layout the same as when you display the chart individually. To display the original layout, apply it again.

Saving Configuration Settings

This section provides an overview of configuration settings and discusses how to save control definitions.

Page Used to Save Configuration Settings

<i>Page Name</i>	<i>Definition Name</i>	<i>Navigation</i>	<i>Usage</i>
Save Control Definitions	None	Select File, Save Control Definitions	Refresh local configuration file with the settings from any .cld file. Apply the latest database configurations (control tests, charts, and procedures) to new datasets created offline.

Understanding Configuration Settings

The control settings for each dataset are embedded in a .cld file. For data extractions or inquiries, where the output is written to a dataset file for downloading, current database configurations for control charts, control procedures, control tests, and graph and display preferences are appended to the file along with the actual data. This ensures a concise snapshot of the configuration, no matter when you view the dataset.

Saving Control Definitions

The save control definitions program updates the local QS_QSRV.CFG file with control definitions set in the database and embedded in an extraction or inquiry dataset file. With this selection, changes made using the Quality menu in PeopleSoft are copied to a client machine for offline analysis.

Using the option, you create and save a new control test using Quality. If you want the new test available for offline analysis in the Quality application client, the local configuration must be updated to include the test.

To update the configuration:

1. Perform an extraction or inquiry.
2. Download the associated dataset file.
3. Open the file in the Quality application client.
4. Select File, Save Control Definitions to update the local cache (configuration) file with the new test.

Printing Displays

Any of the Quality application client displays can be printed.

To print a Quality application client display:

1. Open the control chart, histogram, or Pareto chart to print.
2. Select File, Print.

Select Print Preview to view how the file will look before you print it.

Chapter 11

Integrating PeopleSoft Quality With Other PeopleSoft Applications

Understanding PeopleSoft Quality Integration With Other PeopleSoft Applications

The integration of Quality with Purchasing and Manufacturing enables you to:

1. Initiate a quality data-entry session.
2. Transfer to the Quality data-entry component.
3. Enter quality control data for the session.
4. View the results and alarm information online for the data that you entered against the session.
5. Return to the initiating application.

The integration with Inventory enables you to:

1. Initiate and save a quality data-entry session.
2. Retrieve and complete the quality sessions at a later date directly using Quality pages that were created by the RMA (Return Material Authorization) process.
3. View online the results and alarm information from the data that you entered against the session.

Related Links

"Installation Options - Inventory Page (*PeopleSoft FSCM 9.2: Application Fundamentals*)"

"Installation Options - Purchasing Page (*PeopleSoft FSCM 9.2: Application Fundamentals*)"

Prerequisites

Before other PeopleSoft applications can integrate with Quality, Quality must be installed in the environment. Verify the installation of Quality using the Installation Options - Installed Products page. If you are using Purchasing, Inventory, and Manufacturing, you do not have to use Quality.

Select the Quality check box on the Installation Options - Installed Products page to install Quality on the system.

Note: If you do not have Quality installed, the necessary links that you use to transfer to quality data entry from Purchasing or Manufacturing are not available.

Integrating With PeopleSoft Purchasing

This section provides an overview of the Quality integration with Purchasing and discusses how to:

- Review the purchasing predefined quality function.
- Define purchasing information in Quality.
- Pass purchasing receiving information to Quality.

Pages Used to Integrate With PeopleSoft Purchasing

<i>Page Name</i>	<i>Definition Name</i>	<i>Navigation</i>	<i>Usage</i>
Quality Functions	QS_APP_DEF	Quality, Define Methods and Procedures, Quality Functions	Control data-entry and analysis-field input requirements by maintaining application fields categorized as hierarchy or traceability.
Inspect Receipts - Select Receipt	PO_PICK_ORDERS	Purchasing, Receipts, Inspect Receipts, Select Receipt	Select the shipments that require inspection.
Inspect Receipts - Inspection	RECV_INSPECT	Purchasing, Receipts, Inspect Receipts, Inspection	Enter receipt line items through the inspection process.

Related Links

[Entering, Maintaining, and Editing Quality Data](#)

Understanding PeopleSoft Quality Integration With PeopleSoft Purchasing

When you inspect material received against a purchase order, you can use Purchasing to initiate a quality data-entry session automatically in Quality. Known information (hierarchy and trace fields) pass from Purchasing to Quality when you click the Transfer to Quality link on the Inspect Receipts - Inspection page.

After transferring to Quality, you can enter sample information specified by the control plan defined for this purchase receiving process. You can also view alarms generated against the control plan, enter probable causes and log corrective actions, and view data in a graphical format.

After you complete the quality data-entry session, click the OK button to return to Purchasing where you can continue to receive material or initiate the return to supplier setup process, using a defect quantity from Quality. The defect quantity is passed back to Purchasing from Quality.

Note: If you cannot enter all inspection data at this point, you can recall the quality data-entry session directly from Quality and complete it at any time.

Quality Functions Page

Use the Quality Functions page (QS_APP_DEF) to control data-entry and analysis-field input requirements by maintaining application fields categorized as hierarchy or traceability.

Navigation

Quality, Define Methods and Procedures, Quality Functions

PeopleSoft provides the RECV_INSPECT predefined quality function for integration between Purchasing and Quality. Use this function when you define the control plans and traceability sets for the purchase receiving process.

Stream Hierarchy Fields	Trace Fields
INV_ITEM_ID	DISTRIB_LINE_NUM
VENDOR_ID	DISTRIB_SEQ_NUM
	LOT_ID
	OPRID
	RECEIVER_ID
	RECV_LN_NBR
	SERIAL_ID
	TAG_NUMBER
	VENDOR_LOT_ID

Related Links

[Understanding Quality Functions](#)

Defining Purchasing Information in PeopleSoft Quality

Before you can integrate Purchasing with Quality through the receipt inspection process, define several types of information. Use pages described in other topics to define the following types of information in Quality.

Quality Business Unit

The following list describes the business unit:

- You must define a Quality business unit that matches the Purchasing Receiving business unit.
- You must define configuration information in Quality by using the SetID associated with the Purchasing Receiving business unit for the quality control tables.
- Traceability sets and attribute groups in Quality are associated with a SetID.

Measurement plans and control plans are associated with a Quality business unit. For integrating with Purchasing, the Purchasing Receiving business unit and the Quality business unit must have the same name.

Traceability Set

The quality function defines the hierarchy fields and trace fields that you can use for data collection. Trace fields must be grouped within a trace set and attached to a control plan before you use them to collect data.

When you define the trace set, the system displays the trace fields defined in the quality function. A comprehensive list of trace fields is provided; however, you can disable trace fields by marking one or more of them inactive. If you mark a trace field as inactive, that trace field is not a data-collection requirement in the Quality data-collection pages.

If you want to change the trace set values passed to Quality from Purchasing, Inventory, or Manufacturing, the Input Type field on the trace set should be set to *Auto Dflt* (auto default). If you do not want to change these fields in Quality, the Input Type field should be *Fixed*. To pass a trace field value from Purchasing to Quality, the input source value should be *External*.

Note: When defining the traceability set for Purchasing, reference the RECV_INSPECT predefined quality function.

Attribute Groups

Define attribute groups to produce concise and relevant selection lists for quality users. Define categories once, then future references to them appear in the selection criteria list.

Measurement Plan

Define measurement plans using the RECV_INSPECT predefined quality function. For purchase receiving:

- Define characteristics with a data type of defectives to track rejected or defective material.

The passing of data between Quality and Purchasing depends upon whether one characteristic is of attribute type (defectives).

- Set the subgroup size to zero, if you want the actual inspected subgroup size to be passed from Purchasing to Quality.

The quantity and inspection results are stored in Quality.

Control Plan

Create control plans using the RECV_INSPECT predefined quality function and the appropriate traceability set and measurement plan. For purchase receiving:

- Define control plans for the item and supplier combinations that you want to record quality control data against.
- Specify how you want to enter data against the control plan, by selecting the data-entry method (by subgroup or by sample).

The system uses the data-entry method to determine the pages that appear for data entry in Quality.

Related Links

[PeopleSoft Quality Business Processes](#)

[Defining Traceability Sets](#)

[Defining Attribute Groups](#)

[Defining Measurement Plans](#)

[Defining Control Plans](#)

Passing Purchasing Receiving Information to PeopleSoft Quality

To pass purchase receiving information to Quality:

1. Define the inspection sampling percent for the items that you are going to purchase and inspect.

Use the Purchasing Item Attributes - Purchasing Controls page to define the inspection sample percent and to select the Inspection Required check box for the items that you are going to purchase and inspect.

2. Create a purchase order that requires inspection.
3. Receive the purchase order using purchasing receiving.
4. Process the receipts with the batch Receiver Interface Push Application Engine process (PO_RECVPUSH) which ensure the receipts are ready for receipt inspection.

This process depends on the Interface Receipt check box that you select. You can select the Interface Receipt check box when you define Procurement - Receiver Setup information using the User Preferences component. It appears by default in the Receiving component. If you did not select the Interface Receipt check box when you defined the user preferences, you can select it on the Receipt Defaults page or you can use the Receipt Defaults page to override the selection that appears by default from the user preferences.

5. Display the received items that require inspection, using the Inspect Receipts component in Purchasing.
6. Click the Transfer to Quality link on the Inspect Receipts - Inspection page to initiate a quality data-entry session in Quality and transfer to either the Data Entry - Subgroup Method page or the Data Entry - Sample Method page, depending on the data-entry method that you specified when you created the quality control plan.

Purchasing passes the hierarchy and trace fields associated with the quality function to Quality. The system passes the inspection quantity as the SGRP (subgroup) size.

Inspection quantity = ((receipt quantity for line items) x (sample inspection percent for the item) – (current inspection quantity))

Note: For Purchasing to pass the inspection quantity of an item to Quality, define the subgroup size for the item as zero on the measurement plan and define the inspect sample percent for the item using the Item Definition component. This enables Quality to accept the subgroup size from Purchasing.

7. Enter the quality control information against the quality data-entry session using the Data Entry page in Quality.
8. View the results and perform analysis on the data that you entered for the data-entry session in Quality.

To view results, enter corrective actions or log probable causes, or view the data in graphical format, use the Subgroup Method or Sample Method component in Quality.

9. Click the OK button on one of the pages in the Subgroup Method or Sample Method component to transfer to the Inspect Receipts - Inspection page in Purchasing.

If Quality recorded a defect quantity, the defect quantity is passed back to Purchasing.

10. View the results of the inspection process.

After returning to receipt inspection and if Quality updated the SGRP Size, it is retrieved and added to the current inspection quantity value. If the inspection quantity is large enough to satisfy the inspection sample percent for the item, the inspection status changes to *Complete*. Also, on return to receipt inspection from Quality, the quality pass or fail count moves to the receipt inspections return quantity. If the pass or fail count is greater than zero, then the reject action changes to *Replacement*, and the reject reason changes to *Failed Inspection*. When you save the data, you can automatically generate a return to supplier for the quantity that was returned.

If Quality returns a defect quantity, you can initiate the return to vendor (RTV) setup. Click the RTV Setup link on the Inspect Receipts - Inspection page.

If Quality does not return a defect quantity, you can continue with the purchase receiving activities.

Related Links

"Defining Purchasing Item Attributes (*PeopleSoft FSCM 9.2: Purchasing*)"

"Understanding Purchase Order Approvals (*PeopleSoft FSCM 9.2: Purchasing*)"

"Understanding the Receiving Business Process (*PeopleSoft FSCM 9.2: Purchasing*)"

"Managing Receipts (*PeopleSoft FSCM 9.2: Purchasing*)"

"Using the Receiver Interface Push Application Engine Process (PO_RECVPUSH) (*PeopleSoft FSCM 9.2: Purchasing*)"

"Inspection Page (*PeopleSoft FSCM 9.2: Purchasing*)"

[Entering, Maintaining, and Editing Quality Data](#)

Integrating With PeopleSoft Inventory

This section provides an overview of Inventory integration with Quality and discusses how to:

- Review the predefined RMA and inventory quality function.
- Define inventory information for Quality.
- Pass inventory information to Quality.

Pages Used to Integrate With PeopleSoft Inventory

<i>Page Name</i>	<i>Definition Name</i>	<i>Navigation</i>	<i>Usage</i>
Quality Functions	QS_APP_DEF	Quality, Define Methods and Procedures, Quality Functions	Control data-entry and analysis-field input requirements by maintaining application fields categorized as hierarchy or traceability.
Interunit and RMA Receiving - Receipt Details	INV_RECV_SERIAL	Inventory, Putaway Stock, Interunit and RMA Receiving, Receipt Details	Enter serial IDs, lot IDs, and container information for the items to be received on an RMA.
Interunit and RMA Receiving - Putaway Details	INV_RECV_LN_PUTWY	Inventory, Putaway Stock, Interunit and RMA Receiving, Putaway Details	View receiving information and enter comments about the putaway item.

Understanding PeopleSoft Inventory Integration With PeopleSoft Quality

When material is returned on a return material authorization (RMA) in Inventory, you can use Quality to enter detailed quality information against the material received, if it has been previously configured for inspection in Quality. After the material is received on an RMA, the system creates a quality data-entry session. The system creates sessions only for items that have been configured in Quality. Otherwise, the system does not create a session.

When recording quality control information against a session, you can enter detailed defect information for the material being returned. Probable cause and corrective action information can also be collected as part of an investigative or troubleshooting process. Use Quality to view data collected against the session using control charts.

Quality Functions Page

Use the Quality Functions page (QS_APP_DEF) to control data-entry and analysis-field input requirements by maintaining application fields categorized as hierarchy or traceability.

Navigation

Quality, Define Methods and Procedures, Quality Functions

Use the Quality Functions page to provide the RMA predefined quality function for integration between Inventory and Quality. Reference this quality function when you define the control plans and traceability sets for the RMA process.

<i>Stream Hierarchy Fields</i>	<i>Trace Fields</i>
INV_ITEM_ID	CONFIG_CODE
	CONTAINER_ID
	INV_LOT_ID

Stream Hierarchy Fields	Trace Fields
	QTY_INV_RECV
	RECEIPT_DTTM
	RECEIVER_ID
	RETURN_FROM_BU
	RETURN_FR_CUST_ID
	RMA_ID
	RMA_LN_NBR
	SERIAL_ID
	STORAGE_AREA

Related Links

[Understanding Quality Functions](#)

Defining Inventory Information for PeopleSoft Quality

Before Inventory can integrate with Quality through the RMA process, you must define several types of information. Use pages described in other topics to define the following types of information in Quality.

PeopleSoft Quality Business Unit

The following list describes the business unit:

- You can define a Quality business unit that matches the Inventory business unit that you reference as the return to business unit on the individual RMA lines.
- You can define configuration information in Quality by using the SetID associated with this return to inventory business unit for the quality control tables.
- Traceability sets and attribute groups in Quality are associated with a SetID.

Measurement plans and control plans are associated with a Quality business unit. In the case of integrating with Inventory, the return to inventory business unit and the Quality business unit have the same name.

Traceability Set

When defining the traceability set for Inventory, reference the predefined quality function RMA.

Attribute Groups

Define attribute groups to produce concise and relevant selection lists for quality users. Define categories once, then future references to these categories appear in the selection criteria list.

Measurement Plan

Define measurement plans, using the RMA predefined quality function. For RMA receiving:

- Define characteristics with a data type of defectives to categorize the problems or reasons for returned material.

The passing of data between Quality and Inventory depends upon whether one characteristic is of attribute type (defectives).

- Set the subgroup size for the item or characteristic to zero to pass the sample size from Inventory to Quality.

Quality stores the sample size along with inspection results.

Control Plan

Create control plans, using the RMA predefined quality function and the appropriate traceability set, and the appropriate measurement plan. For the Inventory RMA process:

- Define control plans for items to be received on RMAs against which you want to record quality control data.
- Specify how you want to enter data against the control plan by specifying the data-entry method (by subgroup or by sample).

The system uses the data-entry method to determine which pages appear for data entry in Quality.

Related Links

[PeopleSoft Quality Business Processes](#)

"Defining PeopleSoft Inventory Business Unit Attributes (*PeopleSoft FSCM 9.2: Inventory*)"

[Defining Traceability Sets](#)

[Defining Attribute Groups](#)

[Defining Measurement Plans](#)

[Defining Control Plans](#)

Passing Inventory Information to PeopleSoft Quality

To pass RMA information to Quality:

1. Create an RMA that requires Inventory to record quality control information.
2. Receive the RMA using the InterUnit and RMA Receiving component.

Upon receipt of the RMA (receipt type of RMA, receipt line status of closed), the system creates a quality data-entry session for every putaway line on the RMA.

After you receive the items marked as quality item on the receipt line, the system passes the hierarchy field information and all possible trace fields from the RMA to Quality to associate the information with the quality data-entry session.

Note: If you are using the trace field, RETURN_FROM_BU, Inventory passes the RETURN_FROM_LOCATION value to this field. The location value may be truncated if it is passed to Quality.

On the Receipt Details page of the InterUnit and RMA Receiving component, enter the serial ID, lot ID, and container information. When you click the Copy Lines to Putaway Page button for each item, the entered lot and serial information automatically generates a putaway detail line and transfers this receipt data to the appropriate lines.

A serial-controlled item generates a quality data-entry session for each serial ID entered. However, multiple receipt lines with lot numbers only generate one quality data-entry session with only the lot number from the first row being transferred to Quality.

Note: If the quality item check box is not selected for the item on the RMA (the item has not been associated with a control plan in Quality) and the receipt line status is not set to *Closed* while it was saved from the receipt header, the system does not create a pending quality data-entry session.

3. Navigate to the Data Entry By Control Plan page and enter the item associated with the quality data-entry session that was created by receiving the RMA, and click the Pending Sessions button.

You can complete the session immediately or in the future. Complete it within the period (in days) determined by the session life days assigned to this quality function.

Note: If you cannot remember the item associated with the RMA, you can view all pending sessions by leaving the hierarchy fields blank on the Data Entry By Control Plan page and clicking the Pending Sessions button.

4. Select the quality data-entry session that the system created after receiving the RMA on the Select Pending Session page and click the Recall Session button.

The sessions created by the RMA process appear as the receiver ID number, the line number, and the sequence number.

5. Enter the quality control information against the quality data-entry session, using either the Data Entry - Subgroup Method page or the Data Entry - Sample Method page.

When you click the Recall Session button on the Select Pending Session page, either the Data Entry - Subgroup Method page or the Data Entry - Sample Method page appears. The page that appears depends on the data entry method (by subgroup or by sample) that you specified when you created the control plan in Quality for the RMA process.

6. View results and perform analysis on the data that you enter for the quality data-entry session.

To view results, enter corrective actions or log probable causes, or view the data in graphical format use the Subgroup Method or Sample Method component in Quality.

Related Links

"Interunit Transfer and RMA Item Receiving and Putaway (*PeopleSoft FSCM 9.2: Inventory*)"

[Entering, Maintaining, and Editing Quality Data](#)

[Using Subgroup and Sample Methods to Enter Data](#)

Integrating With PeopleSoft Manufacturing

This section provides an overview of Manufacturing integration with Quality and discusses how to:

- Review predefined Manufacturing quality functions.
- Define production management information for Quality.
- Pass production management information to Quality.

Pages Used to Integrate With PeopleSoft Manufacturing

<i>Page Name</i>	<i>Definition Name</i>	<i>Navigation</i>	<i>Usage</i>
Quality Functions	QS_APP_DEF	Quality, Define Methods and Procedures, Quality Functions	Control data-entry and analysis-field input requirements by maintaining application fields categorized as hierarchy or traceability.
Record Completions and Scrap - Production Selection	SF_COMP_SELECTION	Production Control, Process Production, Complete Production, Record Completions and Scrap, Production Selection	Select the production IDs or production schedules for which you want to record completion and scrap information.
Record Completions and Scrap - Record Completions/Scrap	SF_COMPL_ID	Production Control, Process Production, Complete Production, Record Completions and Scrap, Record Completions/Scrap	Enter completions and scrap data for production IDs and production schedules.

Understanding PeopleSoft Manufacturing Integration With PeopleSoft Quality

When you define a manufactured item, you will create a bill of material and routing for it. The bill of material can contain one output or multiple outputs. Using the routing, define manufacturing operations and if machine, labor, or both requirements are required at each operation on the routing.

Then determine how to manufacture the item. If you use a non-repetitive process, create production ID's for the items. If you use a repetitive process, create production schedules. In either case, determine at what operations to record completions for the item on the shop floor.

When recording operation completions and scrap information against a production ID or schedule for any production type (production, rework, or teardown) using Manufacturing, you can immediately initiate a data-entry session in Quality. When you click the Quality link on the Record Completions/Scrap page, the system starts a quality data-entry session, and it passes hierarchy and trace fields from the production ID or schedule to Quality.

After transferring to Quality, enter sample information for the manufactured item being completed. The quality control plan defines the sampling requirements. After entering data, return to Manufacturing to continue to work on the production ID or schedule.

PeopleSoft provides the following predefined quality functions for integration between Manufacturing and Quality:

- COMPLETIONS
- COMPL NO MC (completions no machine code)
- COMPL NO OP (completions with no operation sequence)

Reference the appropriate quality function when you define the control plans for the record completions and scrap process for a manufactured item.

COMPLETIONS

If you define manufactured items with routings, where the operations where you record completions are associated with a work center containing machines, then associate the completions process quality control plans with the COMPLETIONS predefined quality function. In this case, when recording completions against a production ID or schedule for the manufactured items, enter an operation sequence. That operation is associated with a work center containing one or more machines.

COMPL NO MC

If you define manufactured items with routings, where the operations where you record completions are associated with a work center that does not contain machines, then associate the completions process quality control plans with the COMPL NO MC quality function. In this case, when recording completions against a production ID or schedule for the manufactured items, enter an operation sequence. That operation is associated with a work center that does not contain a machine.

COMPL NO OP

If you do not create routings for manufactured items, associate the completions process quality control plans with the COMPL NO OP quality function. In this case, when you record completions against the production ID or schedule for the manufactured items, you do not enter an operation sequence, because you do not have a routing.

Also, if you define manufactured items that have routings, but you do not record an operation sequence, when recording completions against a production ID or schedule for the manufactured items, associate the completions process quality control plans with the COMPL NO OP quality function.

Reviewing Predefined PeopleSoft Manufacturing Quality Functions

Use the Quality Functions page (QS_APP_DEF) to control data-entry and analysis-field input requirements by maintaining application fields categorized as hierarchy or traceability.

Navigation

Quality, Define Methods and Procedures, Quality Functions

Select one of the three predefined quality functions for Manufacturing. This table lists the fields that are available for use with the specified function:

COMPLETIONS Quality Function

<i>Stream Hierarchy Fields</i>	<i>Trace Fields</i>
COMPL_OP_SEQ	BOM_CODE
INV_ITEM_ID	DT_TIMESTAMP
MACHINE_CODE	INV_LOT_ID
PRDN_AREA_CODE	OPRID
PRODUCTION_TYPE	PRODUCTION_ID
WORK_CENTER_CODE	RTG_CODE

COMPL NO MC Quality Function

<i>Stream Hierarchy Fields</i>	<i>Trace Fields</i>
COMPL_OP_SEQ	BOM_CODE
INV_ITEM_ID	DT_TIMESTAMP
PRDN_AREA_CODE	INV_LOT_ID
PRODUCTION_TYPE	OPRID
WORK_CENTER_CODE	PRODUCTION_ID
	RTG_CODE

COMPL NO OP Quality Function

<i>Stream Hierarchy Fields</i>	<i>Trace Fields</i>
INV_ITEM_ID	BOM_CODE
PRDN_AREA_CODE	DT_TIMESTAMP
PRODUCTION_TYPE	INV_LOT_ID
	OPRID
	PRODUCTION_ID
	RTG_CODE

Related Links

[Understanding Quality Functions](#)

Defining Production Management Information for PeopleSoft Quality

Before Manufacturing can integrate with Quality through the record completions and scrap process, define the following information in Quality.

PeopleSoft Quality Business Unit

The following list describes the business unit:

- You can define a Quality business unit that matches the Manufacturing business unit where you are recording completions and scrap information for the processes.
- You can define configuration information in Quality by using the SetID associated with this Manufacturing business unit for the quality control tables.
- Traceability sets and attribute groups in Quality are associated with a SetID.

Measurement plans and control plans are associated with a Quality business unit. In the case of integrating with Manufacturing, the Manufacturing business unit and the Quality business unit have the same name.

Traceability Set

The three Manufacturing quality functions define the hierarchy fields and trace fields that you use in the data-collection process.

Note: When defining the traceability set for Manufacturing, reference one of the predefined quality functions: COMPLETIONS, COMPL NO MC, or COMPL NO OP.

Attribute Groups

Define attribute groups to produce concise and relevant selection lists for quality users. Define categories once, then future references to them appear in the selection criteria list.

Measurement Plan

When defining the measurement plan, use one of the predefined quality functions: COMPLETIONS, COMPL NO MC, or COMPL NO OP. These plans include variables and attribute characteristics to capture real manufacturing quality results.

Control Plan

The control plan brings together application, measurement, and control and response criteria for a specific product and process. In the case of the manufacturing completions process, depending on the quality function that you use, define control plans for items that have different completions criteria, when the shop floor manufactures the item.

When defining control plans for the completions process, consider these questions:

- How do you record completions for the items you manufacture, if items have routings, do you specify an operation when recording completions against a production ID or schedule for those items?
- If you specify an operation while recording completions, is that operation related to a work center that contains one or more machines, or does it not contain any machines?
- Do you manufacture the item using a repetitive or non-repetitive process?

If the hierarchy fields in the control plan do not match the hierarchy fields associated with the production ID or schedule that you are completing, you receive a message when attempting to transfer from the Record Completions/Scrap page in Manufacturing to Quality. The message states: "Quality was not set up for this. Please review the Quality Control Plans." Some planning must be put into all the production combinations of item IDs, work centers, machine codes, and production areas when creating control plans for the environment.

In addition, when you create control plans, specify how you want to enter data against the control plan in Quality by specifying the data-entry method (by subgroup or by sample). The system uses the data-entry method to determine which pages appear for data entry in Quality.

Note: When defining the control plan, use one of the predefined quality functions (COMPLETIONS, COMPL NO MC, or COMPL NO OP), the appropriate traceability set, and the appropriate measurement plan.

Related Links

[PeopleSoft Quality Business Processes](#)

"Establishing Manufacturing Business Units (*PeopleSoft FSCM 9.2: Manufacturing*)"

[Defining Traceability Sets](#)

[Defining Attribute Groups](#)

[Defining Measurement Plans](#)

[Defining Control Plans](#)

Passing Production Management Information to PeopleSoft Quality

You can pass information to Quality and record quality control information against a quality data-entry session, using either a production ID or production schedule for a manufactured item in Manufacturing.

Passing Information to PeopleSoft Quality Using a Production ID

To pass production information to Quality using a production ID with a single output or multiple outputs:

1. Create a production ID.

You can create production IDs for items that produce single or multiple outputs. Regardless of whether or not an item has a single or multiple outputs, it can have one of the following criteria:

- No routing and no requirement for an operation sequence to be entered when recording completions while being manufactured.
- A routing and no requirement for an operation sequence to be entered when recording completions while being manufactured.
- A routing and a requirement for an operation sequence to be entered when recording completions.

The operation that you enter when recording completions is associated with a work center that does not contain any machines.

- A routing and a requirement for an operation sequence to be entered when recording completions.

The operation that you enter when recording completions is associated with a work center that does contain one or more machines.

2. Retrieve and display the different production ID's using the Record Completions and Scrap - Production Selection page.
3. Display one of the previously created production IDs from step 2.
4. Enter completions and scrap data for one of the different structured production IDs, using the Record Completions/Scrap page.
5. Click the Quality link on the Record Completions/Scrap page to initiate a data-entry session and to access either the Data Entry - Subgroup Method page or the Data Entry - Sample Method page in Quality, depending on the data-entry method that you specified when you created the quality control plan.

If you have a production ID related to a manufacturing item that produces a single output, the Quality link appears next to the Previous Operations group box.

If you have a production ID related to a manufacturing item that produces multiple outputs, the Quality link appears in the Output Details scroll area of the page. In this case, you are able to record quality control information and create a quality data-entry session for any of the different outputs that are produced from the production ID.

6. View results and perform analysis on the data that you enter for the quality data-entry session.

To view results, enter corrective actions or log probable causes, or view the data in graphical format, use the Subgroup Method or Sample Method component in Quality.

7. Click the OK button on one of the pages in the Subgroup Method or Sample Method component to transfer back to the Completions/Scrap page in Manufacturing.

Passing Information to PeopleSoft Quality Using Production Schedules

To pass production information to Quality using a production schedule with a single output or multiple outputs:

1. Create a production schedule.

See the previous setup steps for item criteria.

2. Retrieve and display the different production schedules, using the Record Completions and Scrap - Production Selection page.

Display one of the previously created production schedules from step 2.

3. Enter completions and scrap data for the different structured production schedules, using the Record Completions/Scrap page.

4. Click the Quality link on the Completions and Scrap page to initiate a data-entry session and to access either the Data Entry - Subgroup Method page or the Data Entry - Sample Method page in Quality, depending on the data-entry method that you specified when you created the quality control plan.
5. Enter the quality control information against the quality data-entry session.

If you have a production schedule related to a manufacturing item that produces a single output, the Quality link appears next to the Previous Operation group box.

If you have a production schedule related to a manufacturing item that produces multiple outputs, the Quality link appears in the Output Details scroll area of the page. In this case, you can record quality control information and create a quality data-entry session for any of the different outputs that are produced from the production ID.

6. View results and perform analysis on the data that you entered for the session.

To view results, enter corrective actions or log probable causes, or view the data in graphical format use the Subgroup Method or Sample Method component in Quality.

7. Click the OK button on one of the pages in the Subgroup Method or Sample Method component to transfer back to the Completions/Scrap page in Manufacturing.

Related Links

"Understanding Production IDs and Production Schedules (*PeopleSoft FSCM 9.2: Manufacturing*)"

"Understanding Recording Completions and Scrap (*PeopleSoft FSCM 9.2: Manufacturing*)"

[Entering, Maintaining, and Editing Quality Data](#)

Integrating With Third-Party Applications

Understanding the Integration of PeopleSoft Quality With Third-Party Applications

Most companies that are implementing manufacturing or distribution systems use automated collection devices or systems to assist in quality inspection and control. Using PeopleSoft Integration Broker technology, you can pass the quality information collected from those devices to Quality.

Before a third-party application can integrate with Quality through Integration Broker technology (PeopleSoft Quality EIPs), you must:

- Verify the installation of Quality.

Use the Installation Options - Installed Products page to verify that the application is installed.

See "Setting Up Cross-Application Installation Options (*PeopleSoft FSCM 9.2: Application Fundamentals*)".

- Define several pieces of configuration information in Quality.

PeopleSoft Quality Configuration

There are several pieces of information that you need to define in Quality before a third-party application can integrate with Quality.

Quality Function

The quality function determines which fields appear and are available for data collection or query on subsequent Quality pages and provides parenting for related process hierarchies and their associated streams. As part of the quality function, determine the trace and hierarchy fields that are common to the quality application or functional area, that is, what information is pertinent when collecting, storing, and reporting quality data.

When recording inspection data, hierarchy fields determine the process streams against which you collect sampling results, while trace fields track associated traceability information, such as the lot numbers. Hierarchy fields define the stream components that Quality uses to maintain control limits.

Traceability Set

Traceability sets identify trace field requirements during data collection against control plans. When you define a trace set, the system references the quality function to predefine the trace fields that are available for use. The system provides a comprehensive list of trace fields from which you can optionally select.

Attribute Groups

Use attribute groups to produce concise and relevant selection lists for quality users. Define the categories once, then future references to them appear in the selection criteria list.

Measurement Plan

Measurement plans define the characteristics and the sampling and charting criteria that you want to apply during data collection.

Control Plan

The control plan brings together measurement, traceability, control, and response activities for data collection.

Note: If Quality is not installed, you cannot view the buttons that transfer you to Quality data collection from Purchasing and Manufacturing.

Related Links

[Understanding Quality Functions](#)

[Understanding Measurement Plans](#)

[Defining Attribute Groups](#)

[Defining Traceability Sets](#)

[Defining Control Plans](#)

Using the PeopleSoft Quality EIP

Quality provides a single service operation that the system uses to collect quality control information from existing third-party systems. This service operation is `Quality_Data_Submit`.

PeopleSoft delivers the service operations in PeopleSoft Integration Broker with a default status of *Inactive*. You must activate each service operation before attempting to send or receive data from a third-party source or another PeopleSoft system, such as CRM.

To use the Quality EIP:

1. Setup the service operation within PeopleSoft Integration Broker and Enterprise Components:

Use the information in the table below and refer to the setup instructions in "Setting Up Service Operations (*PeopleSoft FSCM 9.2: Supply Chain Management Integration*)".

Service Operation	Direction and Type	Handlers	Chunking Available?	Integrates With
QUALITY_DATA_SUBMIT	Inbound Asynchronous	QualityDataSubmit	No	third-party system

2. Post service operations in the format required by the `Quality_Data_Submit` service operation into the `Quality_Data_Submit` message queue using PeopleSoft Integration Broker.

3. The Subscription PeopleCode then analyzes the data in the service operation—control testing and alarm notification—and updates the results in the PeopleSoft database.

The system marks subgroups that have encountered simple processing errors, such as an acceptance limit violation, as errors and holds them in a queue to prevent them from adversely affecting control calculations. To correct these problems, use the data editor.

If the system cannot process the service operation, it stops the service operation queue and all service operation processing for that channel cease until the situation is corrected. These types of errors should be found and corrected during integration and should not be part of a production system.

Note: Just as you should never have two or more operators simultaneously entering data into the same process stream, you should never have two or more EIP processes simultaneously submitting data to the same process stream. This almost always results in invalid analysis and alarming.

PeopleTools: PeopleSoft Integration Broker

Related Links

"Setting Up Service Operations (*PeopleSoft FSCM 9.2: Supply Chain Management Integration*)"

Using EIP Data Rules

Before you begin to configure and define the Quality EIPs, you should understand the data rules associated with the EIPs.

Every Sample Requires Its Own Traceability Entry

Except for defectives type characteristics (y defective out of n), every individual sample in the measurement plan requires its own traceability entry, even if all the entries are identical (the lot number is the same for all samples in the session). This means that the number of rows of traceability has to equal the maximum subgroup sample size of all the characteristics in the measurement plan that defines the session. Defectives type characteristics always count as one sample for traceability purposes regardless of the subgroup size.

In EIP terms, take the maximum of the QS_NVALUES for all the subgroups in the session, and that's the number of rows of traceability information that is required.

Examples

This table lists examples of measurement plans and the EIP requirements.

Characteristic	Data Type	Subgroup Size	Comments
Length	Variables	4	
Width	Variables	5	Largest subgroup size.
Bad units	Defectives	1000	Only counts as one row.

Characteristic	Data Type	Subgroup Size	Comments
Bad electrical	Defectives	0	Only counts as one row.
Defects	Defects	4	

Note: Defectives data types always count as one row regardless of subgroup size.

In this example, specify five rows of traceability for this session dataset, because the largest subgroup size is five.

Characteristic	Data Type	Subgroup Size	Comments
Length	Variables	4	
Width	Variables	5	Largest subgroup size.
Bad units	Defectives	1000	Only counts as one row.
Bad electrical	Defectives	0	Only counts as one row.
Defects	Defects	0	Variable subgroup size.

Note: Defectives data types always count as one row regardless of subgroup size.

The same rule applies in this example. The number of rows of traceability for the session dataset is still equal to the largest subgroup size. Because the defects subgroup size is variable, the dataset reflects this. Now the number of required traceability rows is five except for those datasets where the defects sample size is greater than five. As a result, the number of traceability rows equals the defects sample size.

Variable and Defects Data Types Have a Maximum Sample Size

Variable and defects have a maximum sample size of 20.

Subgroup Completion Only Applies to Variables Data Type

A subgroup completion only applies to variables type characteristics with accept incomplete option set to *Average*.

Order and Entry of Subgroup Values is Important

Subgroup values must start at the beginning and be contiguous (no holes in the values). Readings must start at 1 and continue until there are no others. You cannot specify the second and third values without specifying the first value.

This is a valid example:

```
<QS_NVALUES>3</QS_NVALUES>
<QS_VALUEREADING_1>1</QS_VALUEREADING_1>
<QS_VALUEREADING_2>2</QS_VALUEREADING_2>
<QS_VALUEREADING_3>3</QS_VALUEREADING_3>
<QS_VALUEREADING_4></QS_VALUEREADING_4>
```

```

      .
      .
      .
<QS_VALUEREADING_20></QS_VALUEREADING_20>

```

These are two invalid examples:

```

<QS_NVALUES>3</QS_NVALUES>
<QS_VALUEREADING_1>1</QS_VALUEREADING_1>
<QS_VALUEREADING_2>2</QS_VALUEREADING_2>
<QS_VALUEREADING_3>3</QS_VALUEREADING_3>
      .
      .
      .
<QS_VALUEREADING_20></QS_VALUEREADING_20>

```

Note: You cannot specify values 2 and 3 without specifying 1.

```

<QS_NVALUES>3</QS_NVALUES>
<QS_VALUEREADING_1>1</QS_VALUEREADING_1>
<QS_VALUEREADING_2></QS_VALUEREADING_2>
<QS_VALUEREADING_3>3</QS_VALUEREADING_3>
      .
      .
      .
<QS_VALUEREADING_20></QS_VALUEREADING_20>

```

Note: You cannot skip a value. In this example you cannot skip 2.

This is a valid averaging point example, however, QS_VALUEREADING_3 is to be interpreted as 0 that yields a different average:

```

<QS_NVALUES>3</QS_NVALUES>
<QS_VALUEREADING_1>1</QS_VALUEREADING_1>
<QS_VALUEREADING_2>2</QS_VALUEREADING_2>
<QS_VALUEREADING_3></QS_VALUEREADING_3>
      .
      .
      .
<QS_VALUEREADING_20></QS_VALUEREADING_20>

```

Be careful when it comes to averaging values associated with the subgroup. In this example, if you were calculating the average for a point calculation, it would be $(1+2+0) / 3 = 1$. QS_VALUEREADING_3 is interpreted as zero in this particular case.

If you change the QS_NVALUES to 2 and the subgroup size is still 3, with the accept incomplete option on, the average would be $(1+2)/2 = 1.5$. Therefore, the point calculation would be $(1+2+1.5)/3 = 1.5$. You can calculate a totally different outcome depending on how you enter the data for the EIP.

Related Links

[Using EIP Data Scenarios](#)

Using EIP Data Scenarios

How you define the Quality measurement plans determines how you should define and structure the Quality EIPs. The simpler the plans, the easier to define subgroups using EIPs.

Note: Complex measurement plans are inherently more difficult to integrate, test, and validate. Plans that may be appropriate for manual data entry might be cumbersome or impractical in an EIP configuration.

Sample	Traceability Item 1	Traceability Item 2	Characteristic 1	Characteristic 2
1	none	none	none	none
2	none	none	none	none
3	none	none	none	none

Image: EIP data scenario

This diagram illustrates the EIP data scenario

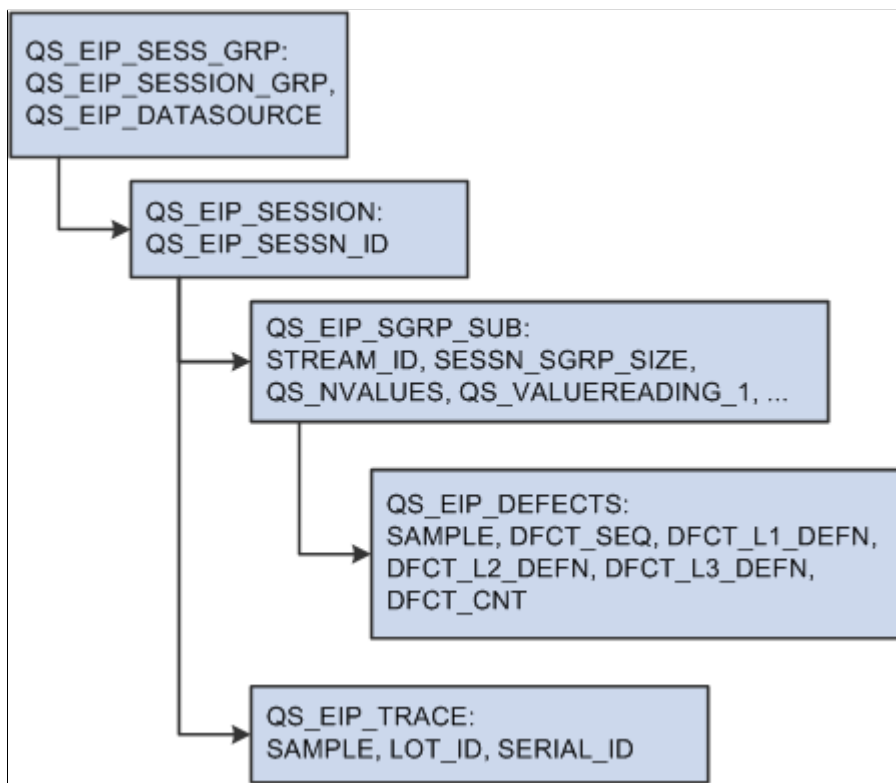

Scenario #1

A simple measurement plan with two variables type characteristics.

Sample	Lot Number	Serial Number	Length	Width
1	X02-00	SN-01	2.31	4.31
2	X02-00	SN-02	2.29	4.32

Sample	Lot Number	Serial Number	Length	Width
3	X02-00	SN-03	2.30	4.29

Image: Scenario #1

This diagram illustrates scenario #1 that has a simple measurement plan with two variables type characteristics.

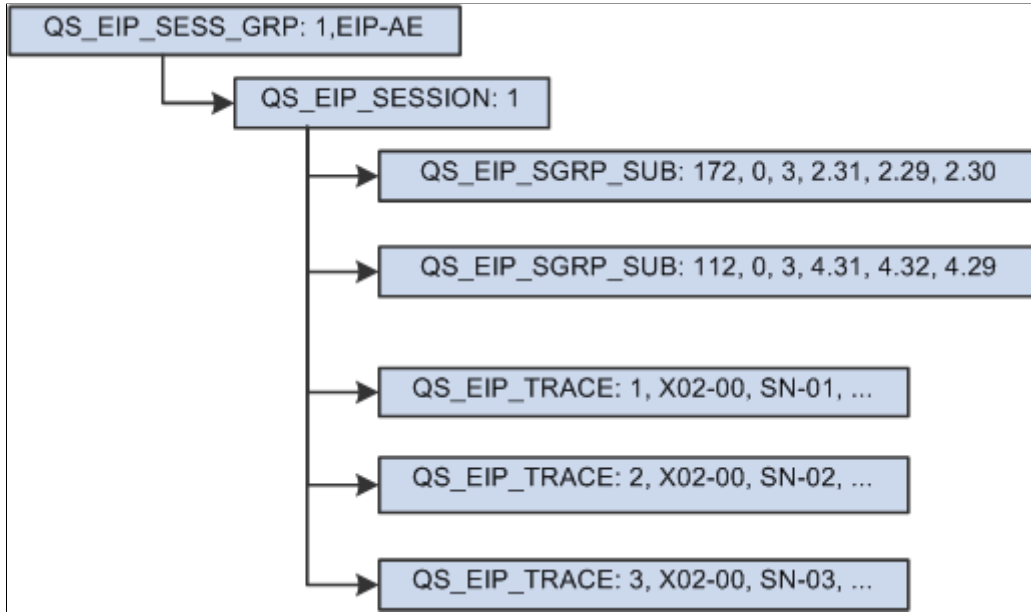

Scenario #2

A measurement plan containing variables type characteristics with one derived characteristic. In this scenario, the area characteristic is derived from the length and width characteristics.

Sample	Lot Number	Serial Number	Length	Width	Area +
1	X02-00	SN-01	2.31	4.31	none
2	X02-00	SN-02	2.29	4.32	none

Sample	Lot Number	Serial Number	Length	Width	Area +
3	X02-00	SN-03	2.30	4.29	none

Image: Scenario #2

This diagram illustrates scenario #2 that has a measurement plan containing variables type characteristics with one derived characteristic.

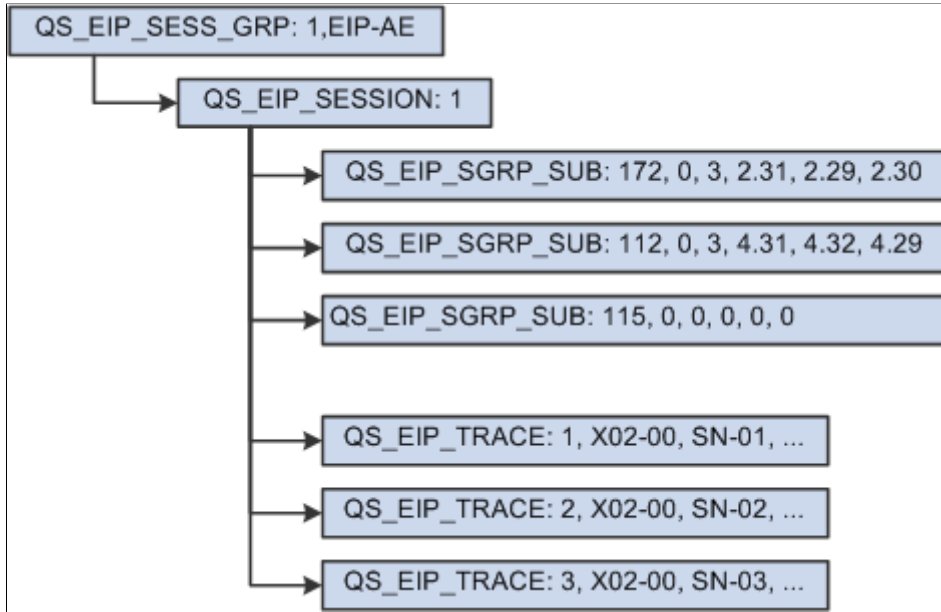

Note: You must submit a QS_EIP_SGRP_SUB record for the derived area characteristic, because the system knows nothing about measurement plans. It only knows and understands process streams. For the system to calculate the areas for this session, it must be asked to do so.

Scenario # 3

A measurement plan that contains variables type characteristics with non-uniform subgroup sample sizes.

Sample	Lot Number	Serial Number	Length	Width
1	X02-00	SN-01	2.31	4.31
2	X02-00	SN-02	2.29	4.32
3	X02-00	SN-03	2.30	4.29
4	X02-00	SN-04	none	4.30

Sample	Lot Number	Serial Number	Length	Width
5	X02-00	SN-05	none	4.31

Image: Scenario #3

This diagram illustrates scenario #3 that has a measurement plan containing variables type characteristics with non-uniform subgroup sample sizes.

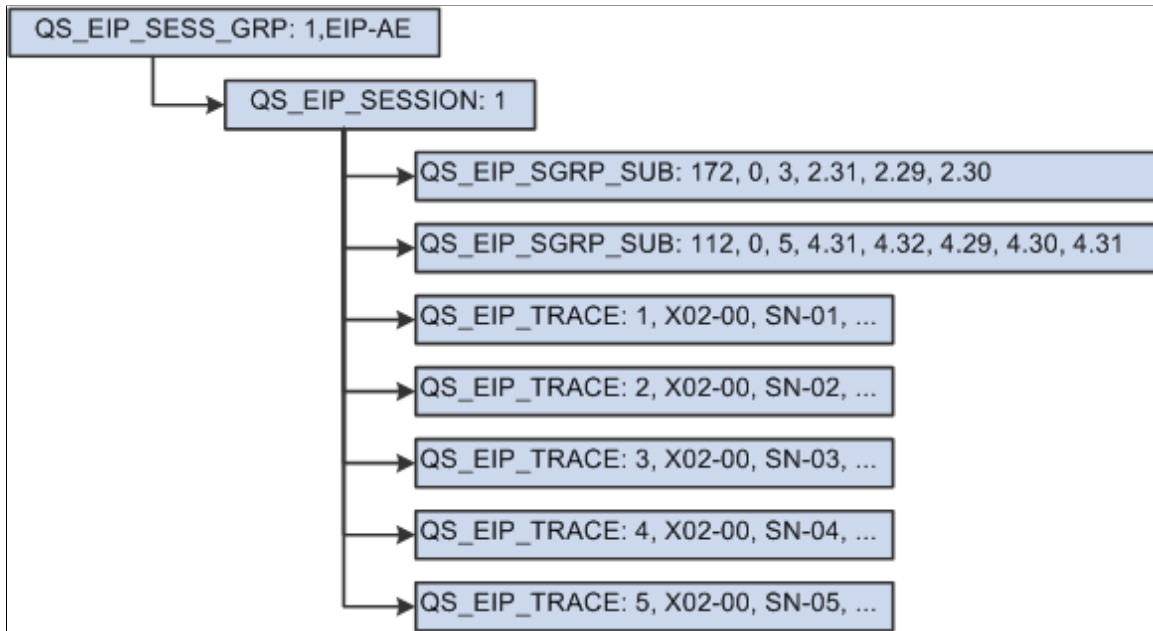

Scenario #4

A measurement plan with variables type characteristics with readings for one of the characteristics that is incomplete. In this scenario, length readings are incomplete.

Sample	Lot Number	Serial Number	Length	Width
1	X02-00	SN-01	2.31	4.31
2	X02-00	SN-02	2.29	4.32
3	X02-00	SN-03	2.30	4.29
4	X02-00	SN-04	-	4.30

Sample	Lot Number	Serial Number	Length	Width
5	X02-00	SN-05	-	4.31

Image: Scenario #4

This diagram illustrates scenario #4 that has a measurement plan containing variables type characteristics with readings for one of the characteristics that is incomplete.

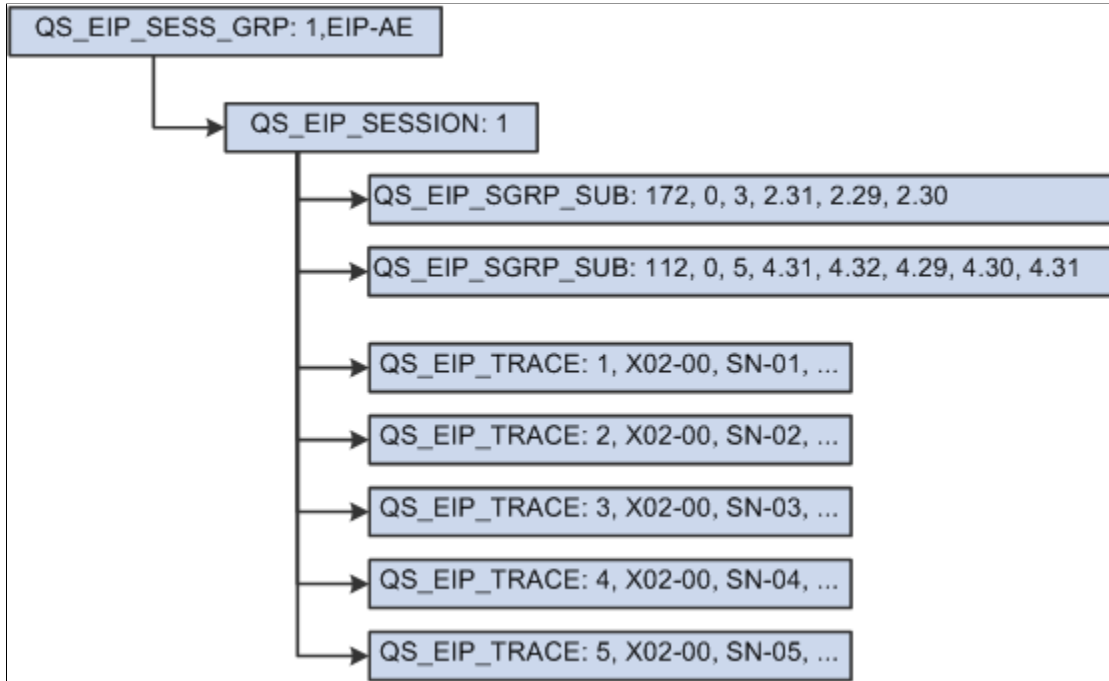

Scenario #5

A simple defectives type sample where the subgroup size is fixed.

<i>Sample</i>	<i>Lot Number</i>	<i>Bad Units</i>
1	X02-00	6.00

Image: Scenario #5

This diagram illustrates scenario #5 that has a simple defectives type sample where the subgroup size is fixed.

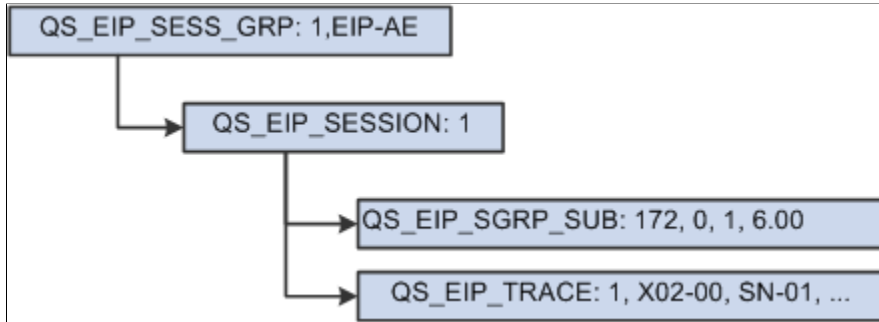

Scenario #6

A defectives type sample where the subgroup sample size is variable.

<i>Sample</i>	<i>Lot Number</i>	<i>Defective Units Subgroup Size</i>	<i>Defective Units Bad Units</i>
1	X02-00	1000	2.00

Image: Scenario #6

This diagram illustrates scenario #6 that has a defectives type sample where the subgroup sample size is variable.

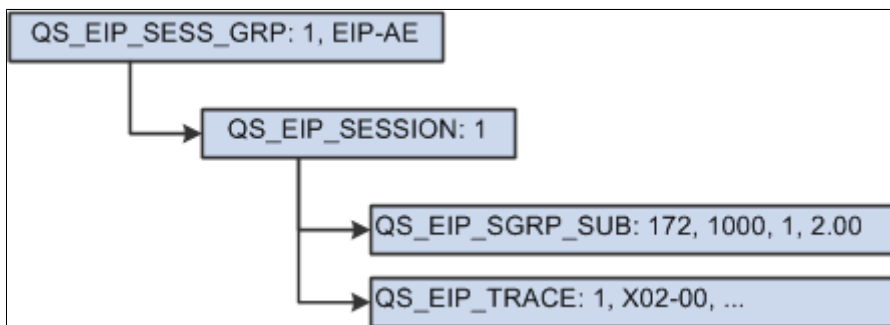

Scenario #7

A measurement plan with defectives categorized where the subgroup sample size is fixed at five. A sample might have one or more defects that qualify as making the item defective. In this scenario, there are five items, two of which are defective. In addition to noting the number of defective units, state the reason why they are defective.

Note: The data source determines whether the collection of defects constitutes a defective item.

<i>Sample</i>	<i>Lot Number</i>	<i>Serial Number</i>	<i>Defectives</i> <i>Defect</i>	<i>Defectives</i> <i>Bad Units</i>
1	X02-00	SN-01	3 Scratches, Top, Left 1 Broken, Contact Pin, P4	2
2	X02-00	SN-02	No defects	none
3	X02-00	SN-03	No defects	none
4	X02-00	SN-04	No defects	none
5	X02-00	SN-05	1 Paint Smear, Bottom, Left	none

Image: Scenario #7

This diagram illustrates scenario #7 that has a measurement plan with defectives categorized where the subgroup sample size is fixed at five.

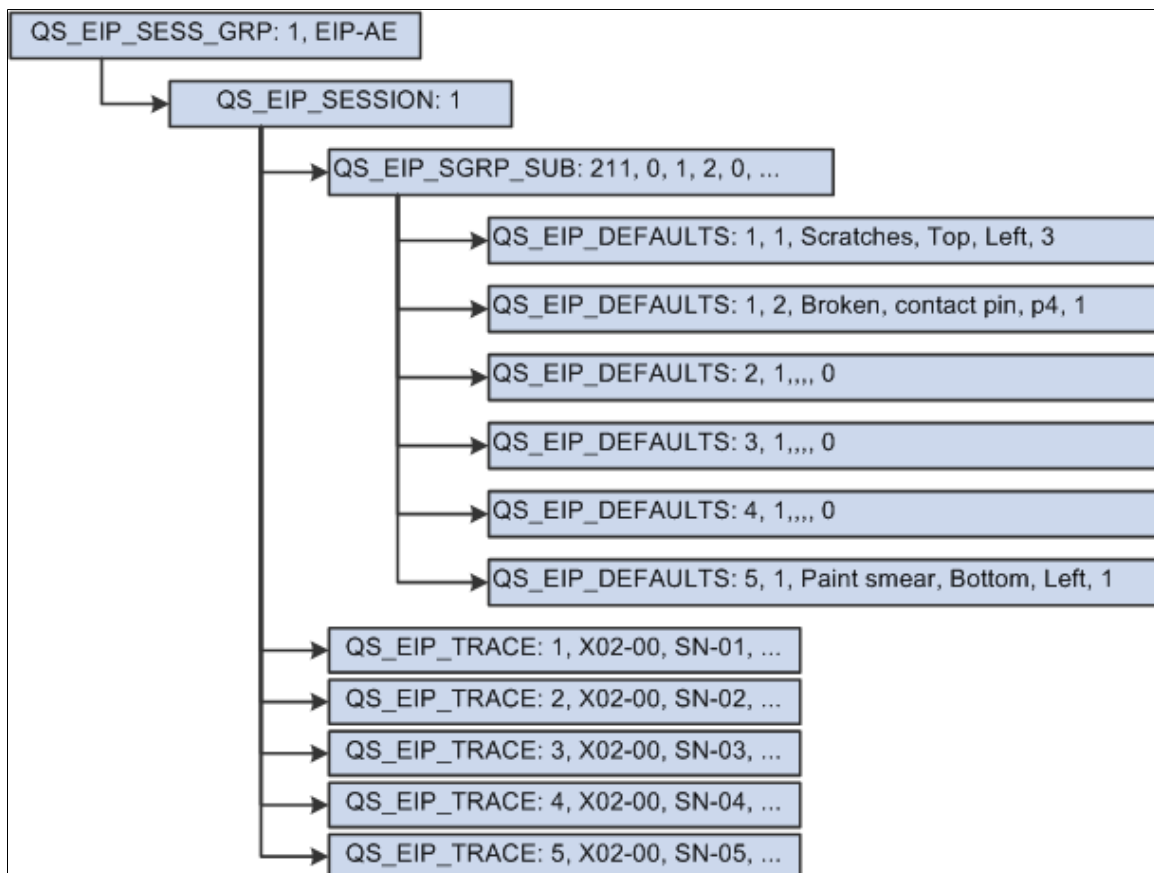

Scenario #8

A measurement plan with defects data type characteristics where the subgroup sample size is fixed or variable.

Sample	Lot Number	Serial Number	Physical Defects *
1	X02-00	SN-01	3 Scratches, Top, Left 1 Blemishes, Bottom, Right
2	X02-00	SN-02	1 Finish, Top, Right
3	X02-00	SN-03	2 Scratches, Top, Left 1 Scratches, Top, Right 2 Scratches, Bottom, Right
4	X02-00	SN-04	No defects
5	X02-00	SN-05	1 Paint smear, Bottom, Left

Note: * *Physical Defects* is a user-defined characteristic name and not a predefined type.

Image: Scenario #8

This diagram illustrates scenario #8 that has a measurement plan with defects data type characteristics where the subgroup sample size is fixed or variable.

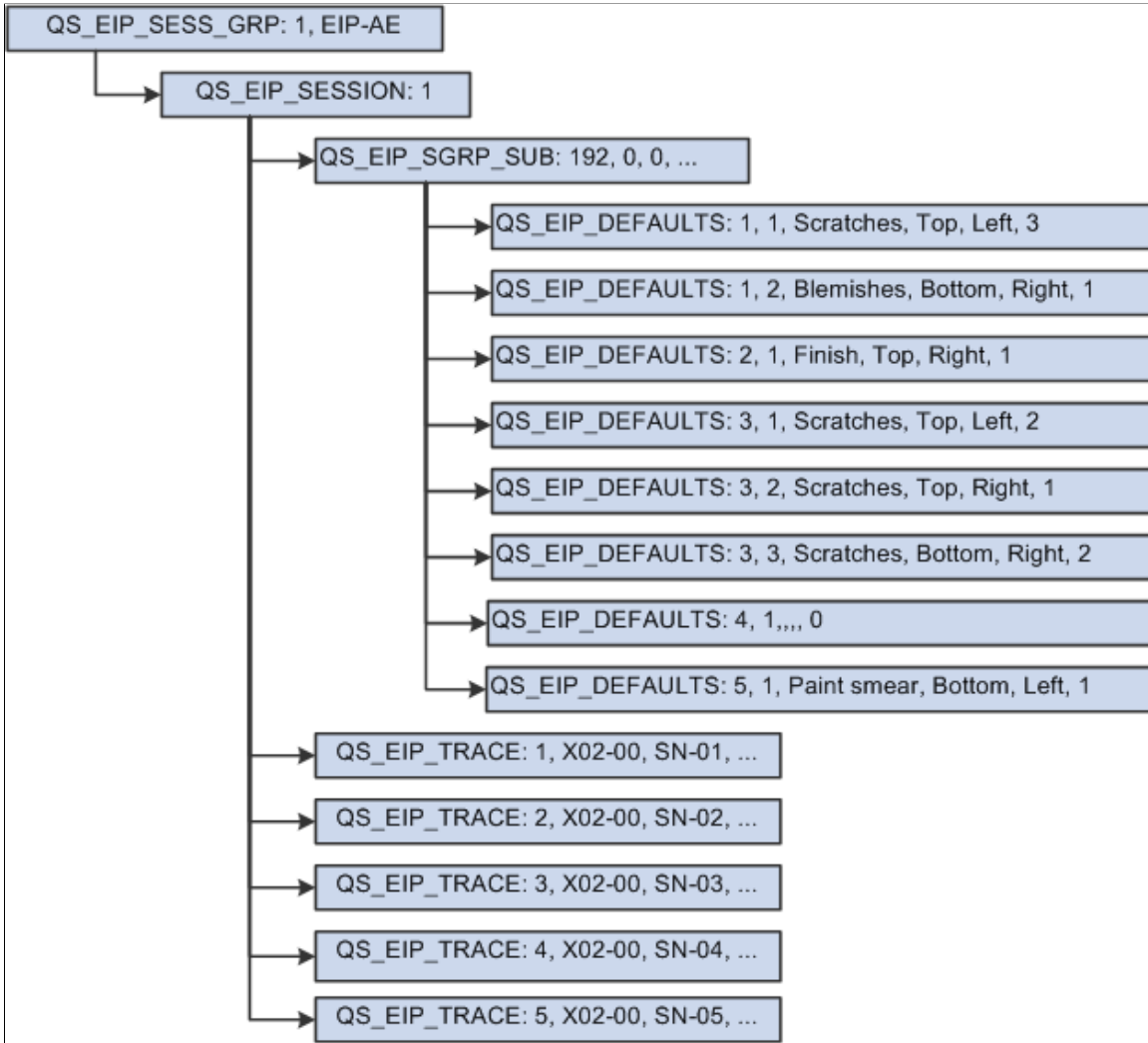

Scenario #9

A measurement plan with two defects data type characteristics where the subgroup sample size is uniform.

Sample	Lot Number	Serial Number	Physical Defects *	Electrical Defects *
1	X02-00	SN-01	3 Scratches, Top, Left 1 Blemishes, Bottom, Right	1 Inoperative connector, pin, 3
2	X02-00	SN-02	1 Finish, Top, Right	No defects

Sample	Lot Number	Serial Number	Physical Defects *	Electrical Defects *
3	X02-00	SN-03	2 Scratches, Top, Left 1 Scratches, Top, Right 2 Scratches, Bottom, Right	No defects
4	X02-00	SN-04	No defects	1 Inoperative chip, 741OpAmp, 2
5	X02-00	SN-05	1 Paint Smear, Bottom, Left	1 Incorrect jumper, Jmp 2, Pins 2-3

Note: * *Physical Defects* and *Electrical Defects* are user-defined characteristic names and not predefined types.

Image: Scenario #9

This diagram illustrates scenario #9 that has a measurement plan with two defects data type characteristics where the subgroup sample size is uniform.

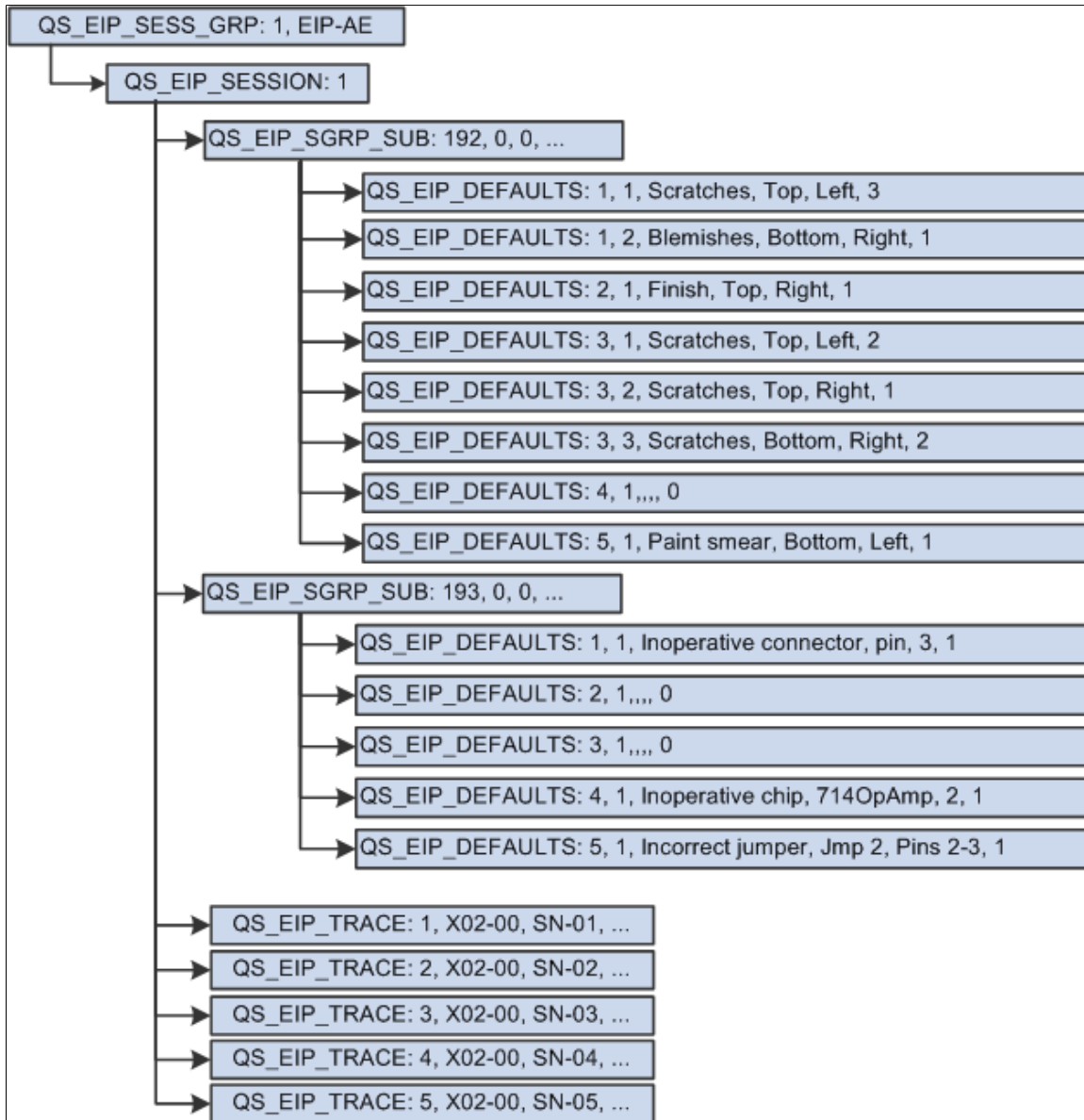

Scenario #10

A measurement plan with variables and defects data type characteristics with a uniform subgroup sample size of 5.

Sample	Lot Number	Serial Number	Physical Defects *	Length	Width
1	X02-00	SN-01	3 Scratches, Top, Left 1 Blemishes, Bottom, Right	2.31	4.31
2	X02-00	SN-02	1 Finish, Top, Right	2.29	4.32
3	X02-00	SN-03	2 Scratches, Top, Left 1 Scratches, Top, Right 2 Scratches, Bottom, Right	2.30	4.29
4	X02-00	SN-04	No defects	2.30	4.30
5	X02-00	SN-05	1 Paint smear, Bottom, Left	2.31	4.31

Note: * *Physical Defects* is a user-defined characteristic name and not a predefined type.

Image: Scenario #10

This diagram illustrates scenario #10 that has a measurement plan with variables and defects data type characteristics with a uniform subgroup sample size of 5.

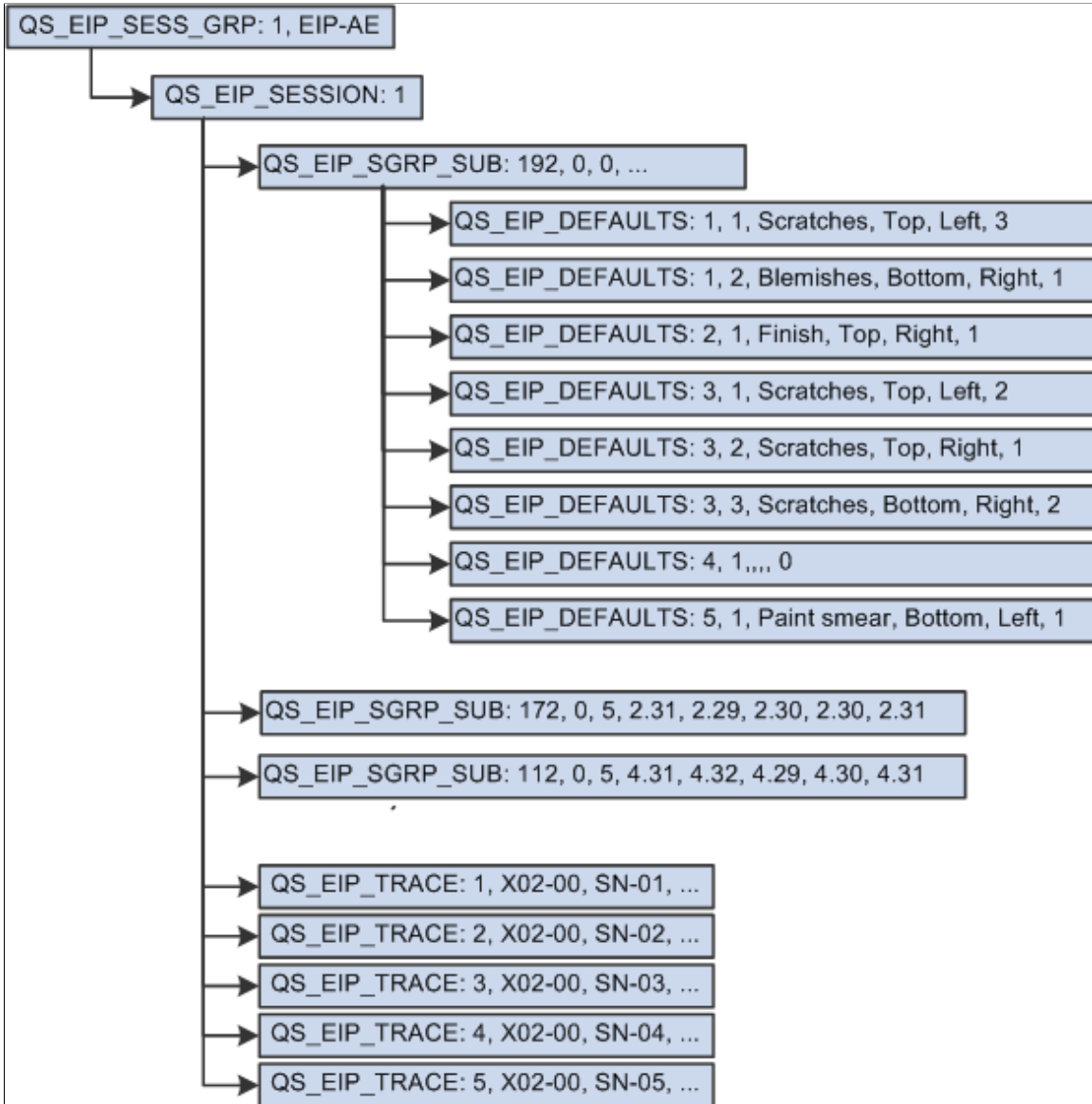

Scenario #11

A measurement plan with variables and defects data type characteristics and a non-uniform subgroup sample size.

Sample	Lot Number	Serial Number	Physical Defects *	Length	Width
1	X02-00	SN-01	3 Scratches, Top, Left 1 Blemishes, Bottom, Right	2.31	4.31
2	X02-00	SN-02	1 Finish, Top, Right	2.29	4.32
3	X02-00	SN-03	2 Scratches, Top, Left 1 Scratches, Top, Right 2 Scratches, Bottom, Right	none	4.29
4	X02-00	SN-04	none	none	4.30
5	X02-00	SN-05	none	none	4.31

Note: * *Physical Defects* is a user-defined characteristic name and not a predefined type.

Image: Scenario #11

This diagram illustrates scenario #11 that has a measurement plan with variables and defects data type characteristics and a non-uniform subgroup sample size.

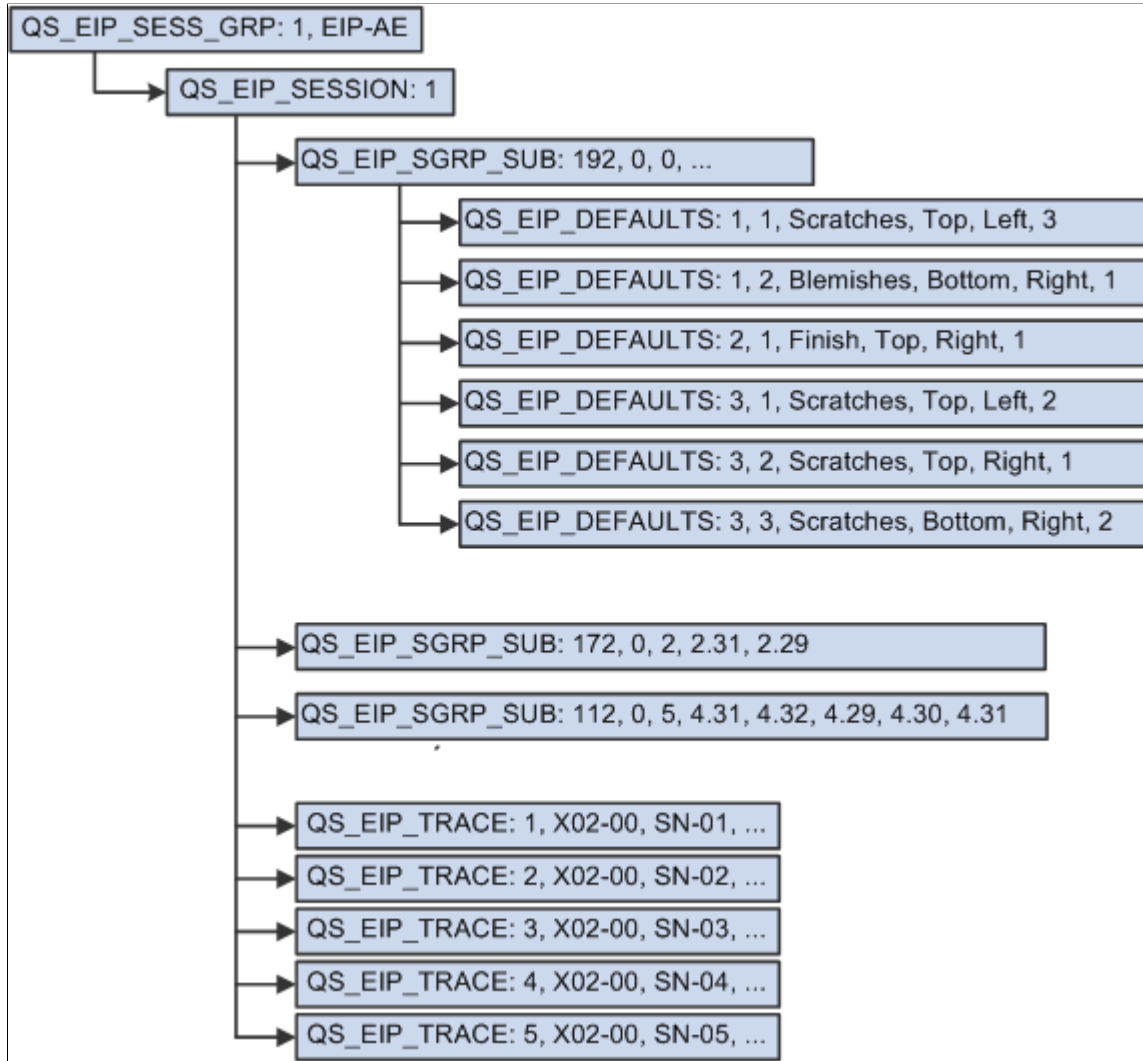

Scenario #12

A measurement plan with two defects and one defectives data type characteristics where the subgroup sample size is uniform.

Sample	Lot Number	Serial Number	Physical Defects *	Electrical Defects *	Bad Units
1	X02-00	SN-01	3 Scratches, Top, Left 1 Blemishes, Bottom, Right	1 Inoperative connector, pin, 3	3

Sample	Lot Number	Serial Number	Physical Defects *	Electrical Defects *	Bad Units
2	X02-00	SN-02	No defects	No defects	none
3	X02-00	SN-03	No defects	No defects	none
4	X02-00	SN-04	No defects	1 Inoperative chip, 741OpAmp, 2	none
5	X02-00	SN-05	1 Paint smear, Bottom, Left	1 Incorrect jumper, Jmp 2, Pins 2-3	none

Note: * *Physical Defects* and *Electrical Defects* are user-defined characteristic names and not predefined types.

Image: Scenario #12

This diagram illustrates scenario #12 that has a measurement plan with two defects and one defectives data type characteristics where the subgroup sample size is uniform.

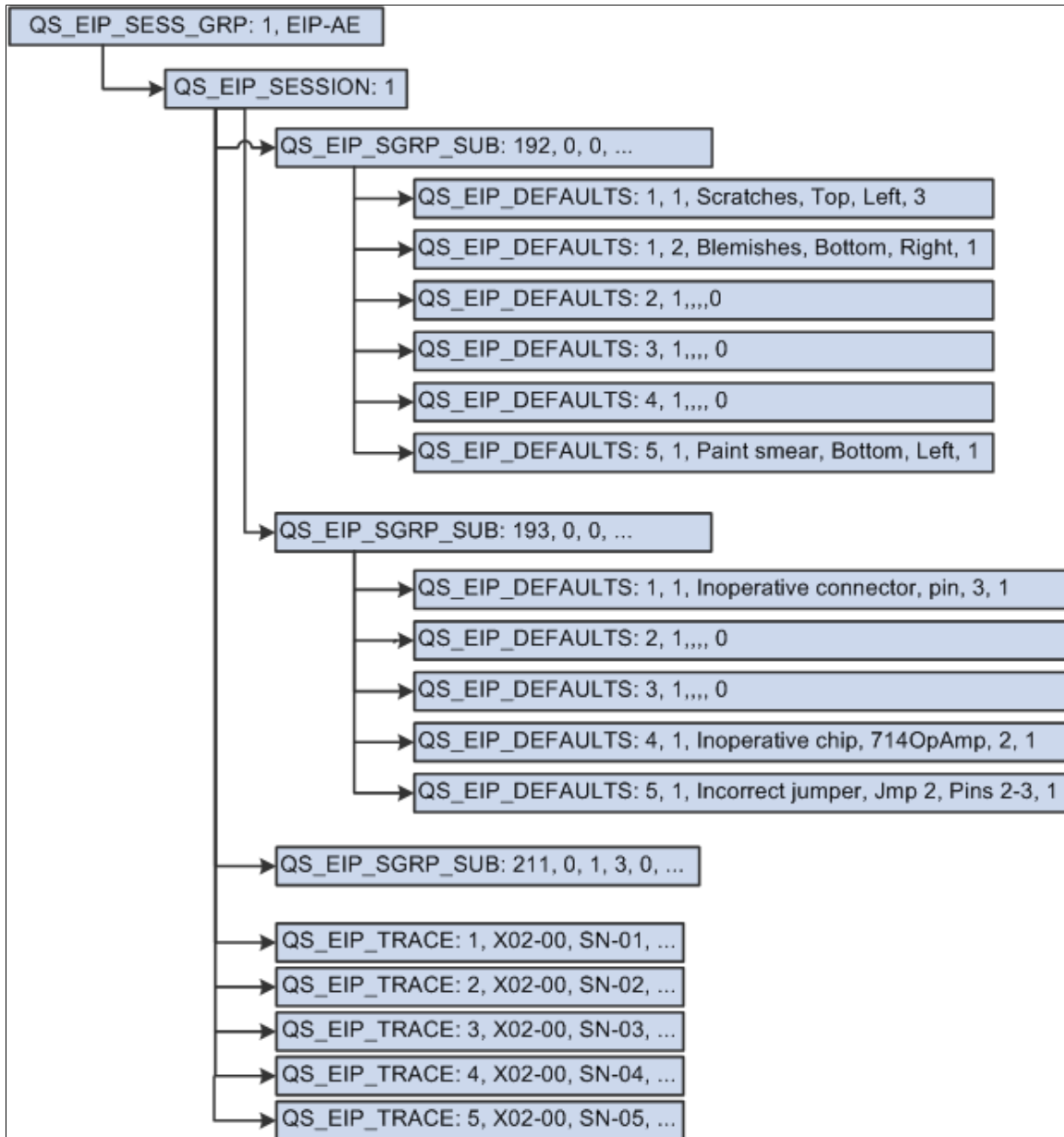

Troubleshooting EIPs

This section discusses how to:

- Use structured query language (SQL).

- Use and test PeopleSoft Application Engine programs.

Note: The stream IDs must be changed to reflect the configuration in the system. The stream ID sections that need to be changed are in *italics*.

Using SQL

Following are a series of sample SQL statements.

Validation SQL Statements

This sample code shows validation statements:

```
select
  PS_QS_STREAM8.STREAM_ID,
  PS_QS_STREAM8.QS_APP_CONTEXT
FROM PS_QS_STREAM8,PS_QS_STREAM_ROOT,PS_QS_APP_DEF
  WHERE PS_QS_STREAM8.STREAM_ID >= 164 AND PS_QS_STREAM8.STREAM_ID <= 164
    and PS_QS_STREAM8.STREAM_ROOT_ID = PS_QS_STREAM_ROOT.STREAM_ROOT_ID
    and PS_QS_APP_DEF.QS_APP_CONTEXT = PS_QS_STREAM_ROOT.QS_APP_CONTEXT
  ORDER BY STREAM_ID
```

```
select
  PS_QS_STREAM8.STREAM_ID
FROM PS_QS_STREAM8,PS_QS_STREAM_ROOT
  WHERE PS_QS_STREAM8.STREAM_ID >= 164 AND PS_QS_STREAM8.STREAM_ID <= 164
    and PS_QS_STREAM8.STREAM_ROOT_ID = PS_QS_STREAM_ROOT.STREAM_ROOT_ID
  ORDER BY STREAM_ID
```

```
select
  STREAM_ID,
  CLIM_STS_CD,
  CLIM_ID,
  STR_SGRP_CNT,
  STR_SGRP_SEQ,
  CUR_SGRP_SIZE,
  CUR_SPEC_VIO_CNT,
  CUR_PLOT_VALUE1,
  CUR_PLOT_VALUE2,
  RUN_MOMENT,
  TSWIN_BUFFER1,
  TSWIN_BUFFER2
FROM PS_QS_STREAM8
  WHERE STREAM_ID >= 164 AND STREAM_ID <= 164
```

```
select
  BUSINESS_UNIT,
  STREAM_ID,
  CLIM_ID,
  CLIM_STS_CD,
  CLIM_UPPER_X,
  CLIM_UX_IND,
  CLIM_MEAN_X,
  CLIM_MX_IND,
  CLIM_LOWER_X,
  CLIM_LX_IND,
  CLIM_UPPER_MRANGE,
  CLIM_UMRANGE_IND,
  CLIM_MEAN_RANGE,
  CLIM_MRANGE_IND,
  CLIM_LOWER_MRANGE,
  CLIM_LMRANGE_IND,
  CLIM_CRE_DTTM,
  CLIM_CRE_BY
from PS_QS_CNTL_LIM_HIS
  WHERE STREAM_ID >= 164 AND STREAM_ID <= 164
```

```

ORDER BY CLIM_ID

select
  BUSINESS_UNIT,
  SESSN_ID,
  STREAM_ID,
  SESSN_STREAM_SEQ,
  SESSN_SGRP_SEQ,
  SESSN_STRM_STS,
  SESSN_SGRP_SIZE,
  MFDS_DATA_TYPE_CD,
  SESSN_ANLZ_READY,
  CLIM_ID,
  SPEC_ID,
  SRSLT_P1,
  SRSLT_P1_IND,
  SRSLT_P2,
  SRSLT_P2_IND,
  CLIM_STS_CD,
  SPEC_VIO_SW,
  QS_ANALYZER_STATUS,
  QS_ALARM_CNT,
  QS_NVALUES,
  QS_VALUEREADING_1,
  QS_VALUEREADING_2,
  QS_VALUEREADING_3,
  QS_VALUEREADING_4,
  QS_VALUEREADING_5,
  DISPATCH_FLAG,
  SESSN_SUBMIT_DTTM,
  SRSLT_CRE_DTTM,
  QS_ACTION_CNT,
  QS_CAUSE_CNT,
  QS_COMM_CNT,
  OPERATOR,
  QS_UAID
from PS_QS_SUBGROUP
  WHERE STREAM_ID >= 164 AND STREAM_ID <= 164
  ORDER BY SESSN_ID

select
  BUSINESS_UNIT,
  SESSN_ID,
  STREAM_ID,
  SAMPLE,
  TEST_SEQ,
  TEST_ID
from PS_QS_SESSN_TEST8
  WHERE STREAM_ID >= 164 AND STREAM_ID <= 164
  ORDER BY SESSN_ID

```

Generic SQL Statements

This sample code shows generic statements:

```

select
  STREAM_ID,
  CLIM_STS_CD,
  CLIM_ID,
  STR_SGRP_CNT,
  STR_SGRP_SEQ,
  CUR_SGRP_SIZE,
  CUR_SPEC_VIO_CNT,
  CUR_PLOT_VALUE1,
  CUR_PLOT_VALUE2,
  RUN_MOMENT,
  TSWIN_BUFFER1,
  TSWIN_BUFFER2
FROM PS_QS_STREAM8
WHERE STREAM_ID >= 164 AND STREAM_ID <= 164

```

```

select * from PS_QS_CNTL_LIM_HIS WHERE STREAM_ID >= 164 AND STREAM_ID <= 164

select PS_QS_SESSN_HDR8.* from PS_QS_SUBGROUP,PS_QS_SESSN_HDR8
WHERE STREAM_ID >= 164 AND STREAM_ID <= 164
AND PS_QS_SESSN_HDR8.SESSN_ID = PS_QS_SUBGROUP.SESSN_ID
select PS_QS_SESSN_TRACE8.* from PS_QS_SUBGROUP,PS_QS_SESSN_TRACE8
WHERE STREAM_ID >= 164 AND STREAM_ID <= 164 AND PS_QS_SESSN_TRACE8.SESSN_ID = PS_QS_
SUBGROUP.SESSN_ID
select * from PS_QS_SUBGROUP WHERE STREAM_ID >= 164 AND STREAM_ID <= 164
select * from PS_QS_SESSN_DFCT8 WHERE STREAM_ID >= 164 AND STREAM_ID <= 164
select * from PS_QS_SESSN_TEST8 WHERE STREAM_ID >= 164 AND STREAM_ID <= 164

```

SQL to Reset Database Tables

This sample code shows statements to reset database tables:

```

update PS_QS_STREAM8 set
  CLIM_STS_CD = "NONE",
  CLIM_ID = "NONE",
  STR_SGRP_CNT = 0,
  STR_SGRP_SEQ = 0,
  CUR_SGRP_SIZE = 0,
  CUR_SPEC_VIO_CNT = 0,
  CUR_PLOT_VALUE1 = 0,
  CUR_PLOT_VALUE2 = 0,
  RUN_MOMENT = 0,
  TSWIN_BUFFER1 = "",
  TSWIN_BUFFER2 = ""
WHERE STREAM_ID >= 164 AND STREAM_ID <= 164

delete from PS_QS_SESSN_HDR8 WHERE SESSN_ID in (select SESSN_ID from PS_QS_SUBGROUP=>
where STREAM_ID >= 164 AND STREAM_ID <= 164)
delete from PS_QS_SESSN_TRACE8 WHERE SESSN_ID in (select SESSN_ID from PS_QS_SUBGRO=>
UP
where STREAM_ID >= 164 AND STREAM_ID <= 164)

delete from PS_QS_SESSN_DFCT8 WHERE STREAM_ID >= 164 AND STREAM_ID <= 164
delete from PS_QS_CNTL_LIM_HIS WHERE STREAM_ID >= 164 AND STREAM_ID <= 164
delete from PS_QS_SESSN_TEST8 WHERE STREAM_ID >= 164 AND STREAM_ID <= 164
delete from PS_QS_SUBGROUP WHERE STREAM_ID >= 164 AND STREAM_ID <= 164

```

SQL to Retrieve Stream Information

This sample code shows statements to retrieve information:

```

select
  STREAM_ID,
  MFDS_ID,
  CLIM_STS_CD,
  STR_SGRP_CNT,
  STR_SGRP_SEQ,
  CLIM_ID,
  CUR_SGRP_SIZE,
  CUR_SPEC_VIO_CNT,
  CUR_PLOT_VALUE1,
  CUR_PLOT_VALUE2,
  RUN_MOMENT,
  TSWIN_BUFFER1,
  TSWIN_BUFFER2,
  SPEC_ID,
  SPEC_LSL,
  SPEC_LSL_IND,
  SPEC_USL,
  SPEC_USL_IND,
  SPEC_FACTOR1,
  SPEC_FACTOR1_IND,

```

```

SPEC_FACTOR2,
SPEC_FACTOR2_IND,
MFDS_COLLECT_SW,
MFDS_NAME,
MFDS_SGRP_SIZE,
MFDS_DATA_TYPE_CD,
MFDS_LAL,
MFDS_LAL_IND,
MFDS_UAL,
MFDS_UAL_IND,
MFDS_INC_CD,
MFDS_FORMULA,
CHART_ID,
PROC_ID,
CLIM_UPPER_X,
CLIM_UX_IND,
CLIM_MEAN_X,
CLIM_MX_IND,
CLIM_LOWER_X,
CLIM_LX_IND,
CLIM_UPPER_MRANGE,
CLIM_UMRANGE_IND,
CLIM_MEAN_RANGE,
CLIM_MRANGE_IND,
CLIM_LOWER_MRANGE,
CLIM_LMRANGE_IND
FROM PS_QS_API_STR83_VW
WHERE STREAM_ID >= 164 AND STREAM_ID <= 164
ORDER BY STREAM_ID

```

Using and Testing Application Engine Programs

This is an example of a Application Engine program that reads an ASCII text file and posts a Quality EIP message. The following sample displays an input file for the Application Engine program:

```

/* Read source file and publish messages into EIP message queue. */

Local File &TestDataIn, &LogFileOut;
Local string &LineIn, &LogMsg, &FilenameIn, &LogFilename;
Local number &iRowSet, &WriteStatus, &nLinesIn, &nSessionGroups, &nSessions;
Local number &nSubgroups, &nDefects, &nTraceSets, &iValue;
Local number &iSession, &iSubgroup, &iDefect, &iTrace;

/* record keys */

Local number &SessionGroupId, &SessionId, &StreamId;
Local string &DataSource;

/* record fields */

Local string &Fieldname, &Fieldvalue;

Local Message &Message;
Local Rowset &SessionGroupRs, &SessionRs, &SubgroupRs, &DefectRs, &TraceRs;
Local Row &SessionGroupRow, &SessionRow, &SubgroupRow, &DefectRow, &TraceRow;
Local Record &SessionGroupRec, &SessionRec, &SubgroupRec, &DefectRec, &TraceRec;

Local datetime &SessionCreateDttm;

/* end of declarations *****/

&nLinesIn = 0;
&nSessionGroups = 0;
&nSessions = 0;
&nSubgroups = 0;
&nDefects = 0;
&nTraceSets = 0;

&FilenameIn = "EIPTestDataIn.txt";

```

```

&LogFilename = "EIPTestDataIn.log";

&LogFileOut = GetFile(&LogFilename, "W", "A", %FilePath_Absolute);

If (&LogFileOut.IsOpen = False) Then
    Return;
End-If;

&LogFileOut.WriteLine("Processing started " | %Datetime | ", [" | &FilenameIn | "]" =>
);
&LogFileOut.WriteLine("");

&TestDataIn = GetFile(&FilenameIn, "E", "A", %FilePath_Absolute);

If (&TestDataIn.IsOpen = False) Then
    &LogMsg = "Unable to open input file [" | &FilenameIn | "];
    &LogFileOut.WriteLine(&LogMsg);
    &LogFileOut.Close();
    Return;
End-If;

&Message = CreateMessage(Message.QUALITY_DATA_SUBMIT);

If (&Message = Null) Then
    &LogMsg = "Unable to create message";
    &LogFileOut.WriteLine(&LogMsg);
    &LogFileOut.Close();
    Return;
End-If;

If (&Message.IsActive = False) Then
    &LogMsg = "Message is inactive";
    &LogFileOut.WriteLine(&LogMsg);
    &LogFileOut.Close();
    Return;
End-If;

&SessionGroupRs = &Message.GetRowset();

While &TestDataIn.ReadLine(&LineIn)
    &nLinesIn = &nLinesIn + 1;
    &LogMsg = "Processing line " | &nLinesIn | ", [" | &LineIn | "];
    &LogFileOut.WriteLine(&LogMsg);

    /* We need to do publish messages here... */
    /* identify the record type */

    If (Substring(&LineIn, 1, 13) = "session group") Then

        /* check to make sure that we don't overrun our output message buffer */

        If ((&Message.Size + 100000) > %MaxMessageSize) Then
            &Message.Publish();
            &Message = CreateMessage(Message.QUALITY_DATA_SUBMIT);

            If (&Message = Null) Then
                &LogFileOut.WriteLine("Unable to create message");
                &LogFileOut.Close();
                Return;
            End-If;

            &SessionGroupRs = &Message.GetRowset();
        End-If;

        &nSessionGroups = &nSessionGroups + 1;
        &SessionGroupId = Value(LTrim(Substring(&LineIn, 15, 4)));
        &DataSource = Substring(&LineIn, 22, 12);

        If (&nSessionGroups > 1) Then
            &SessionGroupRs.InsertRow(&nSessionGroups - 1);
        End-If;
    End-While;

```

```

&SessionGroupRow = &SessionGroupRs.GetRow(&nSessionGroups);
&SessionGroupRec = &SessionGroupRow.GetRecord(Record.QS_EIP_SESS_GRP);

/* set keys */

&SessionGroupRec.QS_EIP_SESSION_GRP.Value = &SessionGroupId;
&SessionGroupRec.QS_EIP_DATASOURCE.Value = &DataSource;

&iSession = 0;
Else
  If (Substring(&LineIn, 1, 9) = " session") Then
    /* stop the last timer and start a new one */

    &nSessions = &nSessions + 1;
    &iSession = &iSession + 1;
    &SessionRs = &SessionGroupRow.GetRowset(1);

    /* original -> &SessionId = Value(LTrim(Substring(&LineIn, 14, 5))); */
    /* using statement below to autonumber */
    &SessionId = &iSession;

    If (&iSession > 1) Then
      &SessionRs.InsertRow(&iSession - 1);
    End-If;

    &SessionRow = &SessionRs.GetRow(&iSession);
    &SessionRec = &SessionRow.GetRecord(Record.QS_EIP_SESSION);

    /* set keys */

    &SessionRec.QS_EIP_SESSION_GRP.Value = &SessionGroupId;
    &SessionRec.QS_EIP_DATASOURCE.Value = &DataSource;
    &SessionRec.QS_EIP_SESSN_ID.Value = &SessionId;

    /* set fields */

    &SessionRec.BUSINESS_UNIT.Value = LTrim(Substring(&LineIn, 22, 10));
    &SessionCreateDttm = %Datetime;
    &SessionRec.SESSN_CRE_DTTM.Value = &SessionCreateDttm;

    /* Set session status to saved = 1, move = 2 */

    &SessionRec.QS_SESSION_STATUS.Value = 1;

    /* set traceset to locked = 2, not locked = 1 */

    &SessionRec.QS_EIP_TRACELOCK.Value = 2;

    &iSubgroup = 0;
    &iTrace = 0;
  Else
    If (Substring(&LineIn, 1, 12) = " subgroup") Then
      &nSubgroups = &nSubgroups + 1;
      &iSubgroup = &iSubgroup + 1;

      For &iRowSet = 1 To &SessionRow.ChildCount
        If (&SessionRow.GetRowset(&iRowSet).DBRecordName =
          "QS_EIP_SGRP_SUB") Then Break;
        End-If;
      End-For;

      &SubgroupRs = &SessionRow.GetRowset(&iRowSet);
      &StreamId = Value(LTrim(Substring(&LineIn, 14, 5)));

      If (&iSubgroup > 1) Then
        &SubgroupRs.InsertRow(&iSubgroup - 1);
      End-If;

      &SubgroupRow = &SubgroupRs.GetRow(&iSubgroup);
      &SubgroupRec = &SubgroupRow.GetRecord(Record.QS_EIP_SGRP_SUB);
    End-If;
  End-If;

```

```

/* set keys */

&SubgroupRec.QS_EIP_SESSION_GRP.Value = &SessionGroupId;
&SubgroupRec.QS_EIP_DATASOURCE.Value = &DataSource;
&SubgroupRec.QS_EIP_SESSN_ID.Value = &SessionId;
&SubgroupRec.STREAM_ID.Value = &StreamId;

/* set fields */
/* set subgroup status to submitted = 2, saved = 1 */

&SubgroupRec.QS_SUBGROUP_STATUS.Value = 2;

&SubgroupRec.SESSN_CRE_DTTM.Value = &SessionCreatedttm;
&SubgroupRec.SESSN_SUBMIT_DTTM.Value = %Datetime;
&SubgroupRec.OPERATOR.Value = %OperatorId;

&SubgroupRec.SESSN_SGRP_SIZE.Value =
    Value(LTrim(Substring(&LineIn, 20, 8)));
&SubgroupRec.QS_NVALUES.Value = Value(LTrim(Substring(&LineIn, 29, 8)))⇒
;

For &iValue = 1 To &SubgroupRec.QS_NVALUES.Value
    &Fieldname = "FIELD.QS VALUEREADING_" | &iValue;
    &SubgroupRec.GetField(@&Fieldname).Value =
        Value(RTrim(LTrim(Substring(&LineIn, 38 +
            (&iValue - 1) * 9), 8)))));
End-For;

&iDefect = 0;
Else
    If (Substring(&LineIn, 1, 12) = "    defect") Then
        &nDefects = &nDefects + 1;
        &iDefect = &iDefect + 1;

        For &iRowSet = 1 To &SubgroupRow.ChildCount
            If (&SubgroupRow.GetRowset(&iRowSet).
                DBRecordName = "QS_EIP_DEFECTS") Then
                Break;
            End-If;
        End-For;

        &DefectRs = &SubgroupRow.GetRowset(&iRowSet);

        If (&iDefect > 1) Then
            &DefectRs.InsertRow(&iDefect - 1);
        End-If;

        &DefectRow = &DefectRs.GetRow(&iDefect);
        &DefectRec = &DefectRow.GetRecord(Record.QS_EIP_DEFECTS);

        /* set keys */

        &DefectRec.QS_EIP_SESSION_GRP.Value = &SessionGroupId;
        &DefectRec.QS_EIP_DATASOURCE.Value = &DataSource;
        &DefectRec.QS_EIP_SESSN_ID.Value = &SessionId;
        &DefectRec.STREAM_ID.Value = &StreamId;
        &DefectRec.SAMPLE.Value = Value(LTrim(Substring(&LineIn, 16, 5)));
        &DefectRec.DFCT_SEQ.Value = Value(LTrim(Substring(&LineIn, 22, 3)));

        /* set fields */

        &DefectRec.DFCT_L1_DEFN.Value = RTrim(Substring(&LineIn, 28, 10));
        &DefectRec.DFCT_L2_DEFN.Value = RTrim(Substring(&LineIn, 39, 10));
        &DefectRec.DFCT_L3_DEFN.Value = RTrim(Substring(&LineIn, 50, 10));
        &DefectRec.DFCT_CNT.Value = Value(LTrim(Substring(&LineIn, 61, 5)));
    Else
        If (Substring(&LineIn, 1, 12) = "    traceset") Then
            &nTraceSets = &nTraceSets + 1;
            &iTrace = &iTrace + 1;

```

```

        For &iRowSet = 1 To &SessionRow.ChildCount
            If (&SessionRow.GetRowset(&iRowSet).DBRecordName =
                "QS_EIP_TRACE") Then
                Break;
            End-If;
        End-For;

        &TraceRs = &SessionRow.GetRowset(&iRowSet);

        If (&iTrace > 1) Then
            &TraceRs.InsertRow(&iTrace - 1);
        End-If;

        &TraceRow = &TraceRs.GetRow(&iTrace);
        &TraceRec = &TraceRow.GetRecord(Record.QS_EIP_TRACE);

        /* set keys */

        &TraceRec.QS_EIP_SESSION_GRP.Value = &SessionGroupId;
        &TraceRec.QS_EIP_DATASOURCE.Value = &DataSource;
        &TraceRec.QS_EIP_SESSN_ID.Value = &SessionId;
        &TraceRec.SAMPLE.Value = &iTrace;

        /* set operator and date/time stamp trace field defaults */

        &TraceRec.OPERATOR.Value = %OperatorId;
        &TraceRec.STAMP_DTTM.Value = %Datetime;
    Else
        /* set trace fields */

        If (Substring(&LineIn, 1, 11) = "        field") Then
            &Fieldname = "FIELD." | RTrim(Substring(&LineIn, 16, 14));
            &Fieldvalue = RTrim(LTrim(Substring(&LineIn, 30, 20)));
            &TraceRec.GetField(@&Fieldname).Value = &Fieldvalue;
        Else
            /* ignore comment lines */

            If ( Not ((Substring(&LineIn, 1, 2) = "//") Or
                (&LineIn = ""))) Then
                &LogMsg = "Invalid line [" | &LineIn | "];"
                &LogFileOut.WriteLine(&LogMsg);
            End-If;
        End-If;
    End-If;
End-If;
End-If;
End-If;
End-If;
End-While;

&LogFileOut.WriteLine("");
&LogMsg = "Message size = " | &Message.Size | ",
    maximum message size = " | %MaxMessageSize;
&LogFileOut.WriteLine(&LogMsg);

&Message.Publish();

/* cleanup */

&TestDataIn.Close();

&LogFileOut.WriteLine("");
&LogMsg = &nSessions | " sessions, " | &nSubgroups | " subgroups, " |
    &nDefects | " defects, " | &nTraceSets | " tracesets.";
&LogFileOut.WriteLine(&LogMsg);

&LogMsg = "Processing completed " | %Datetime | ", " | &nLinesIn |
    " lines processed, closing log file.";
&LogFileOut.WriteLine(&LogMsg);
&LogFileOut.Close();

```

Application Engine Sample Input Test File

This test file is only an example. For the file to be useful, you must change the information in the example to reflect the information in the configuration.

```
// Test set
//
session group      2    EIP-AE
  session          1    M04
    subgroup       140   3      3      13      11      12
    subgroup       141   3      3      24      23      23
    subgroup       142   3      3      34      33      33
  session          2    M04
    subgroup       140   3      3      12      12      13
    subgroup       141   3      3      22      22      22
    subgroup       142   3      3      32      32      32
  session          3    M04
    subgroup       140   3      3      11      12      13
    subgroup       141   3      3      21      22      23
    subgroup       142   3      3      31      32      33
  session          4    M04
    subgroup       140   3      3      13      11      13
    subgroup       141   3      3      13      11      13
    subgroup       142   3      3      13      11      13
  session          5    M04
    subgroup       140   3      3      12      11      13
    subgroup       141   3      3      12      11      13
    subgroup       142   3      3      12      11      13
  session          6    M04
    subgroup       140   3      3      14      11      13
    subgroup       141   3      3      14      11      13
    subgroup       142   3      3      14      11      13
  session          7    M04
    subgroup       140   3      3      12      12      12
    subgroup       141   3      3      22      22      22
    subgroup       142   3      3      22      22      22
  session          8    M04
    subgroup       140   3      3      13      12      13
    subgroup       141   3      3      13      12      13
    subgroup       142   3      3      13      12      13
  session          9    M04
    subgroup       140   3      3      14      13      11
    subgroup       141   3      3      14      13      11
    subgroup       142   3      3      14      13      11
  session          10   M04
    subgroup       140   3      3      14      13      12
    subgroup       141   3      3      13      11      11
    subgroup       142   3      3      13      11      11
  session          11   M04
    subgroup       140   3      3      13      11      11
    subgroup       141   3      3      12      11      12
    subgroup       142   3      3      12      11      12
  session          12   M04
    subgroup       140   3      3      12      11      12
    subgroup       141   3      3      13      11      13
    subgroup       142   3      3      13      11      13
  session          13   M04
    subgroup       140   3      3      13      11      13
    subgroup       141   3      3      12      12      13
    subgroup       142   3      3      12      12      13
  session          14   M04
    subgroup       140   3      3      12      12      13
    subgroup       141   3      3      13      12      11
    subgroup       142   3      3      13      12      11
  session          15   M04
    subgroup       140   3      3      13      12      11
    subgroup       141   3      3      11      13      13
    subgroup       142   3      3      11      13      13
  session          16   M04
    subgroup       140   3      3      11      13      13
```

subgroup	141		3	3	22	22	22
subgroup	142		3	3	22	22	22
session	17	M04					
subgroup	140		3	3	12	12	12
subgroup	141		3	3	13	12	11
subgroup	142		3	3	13	12	11
session	18	M04					
subgroup	140		3	3	13	12	11
subgroup	141		3	3	14	11	12
subgroup	142		3	3	11	12	14
session	19	M04					
subgroup	140		3	3	14	11	12
subgroup	141		3	3	11	12	14
subgroup	142		3	3	12	12	14
session	20	M04					
subgroup	140		3	3	11	12	14
subgroup	141		3	3	12	12	14
subgroup	142		3	3	14	11	12
session	21	M04					
subgroup	140		3	3	12	12	14
subgroup	141		3	3	13	11	11
subgroup	142		3	3	13	11	11
session	22	M04					
subgroup	140		3	3	13	11	11
subgroup	141		3	3	12	11	12
subgroup	142		3	3	12	11	12
session	23	M04					
subgroup	140		3	3	12	11	12
subgroup	141		3	3	12	11	11
subgroup	142		3	3	12	11	11
session	24	M04					
subgroup	140		3	3	11	12	11
subgroup	141		3	3	11	14	13
subgroup	142		3	3	11	14	13
session	25	M04					
subgroup	140		3	3	11	14	13
subgroup	141		3	3	13	11	12
subgroup	142		3	3	13	11	12

Using Quality Statistical Equations and Methods

Understanding Quality Equations and Methods

Quality integrates data collection and monitoring functions with comprehensive statistical analysis tools. The tools are a combination of standard industrial statistics and methods that enhance productivity and encourage exploratory analysis.

Text references are provided at the end of this document. As appropriate, statistics and descriptions are marked with the number that correlates to the references. Table values can be found with the associated text reference for those statistics that use these table values:

Image: Table Value

This example illustrates the Table Value.

$(Z, t \text{ and } \chi^2)$

Using the Statistical Matrix

This section provides an overview of the statistical matrix and discusses how to:

- Use basic statistics.
- Use quartiles.
- Use skewness and kurtosis.
- Use process capability.
- Test for normality.
- Use Pearson Best-Fit criteria.
- Use attribute statistics.

Understanding the Statistical Matrix

The statistical matrix is a spreadsheet view of various statistics that you can customize to include any statistic that Quality calculates. You can display the statistics in various formats.

Some statistics may be altered through the use of non-normal distribution assessment techniques. Quality incorporates the following methods to achieve an appropriate distribution fit. Both methods use the Pearson family of distributions.

- A test of normality, using the skewness and kurtosis of the distribution.

If the distribution is normal at a 95 percent confidence, then the data is evaluated based on the normal assumption. If the distribution isn't found to be normal at a 95 percent confidence, then the data is evaluated using the Pearson Best-Fit family of curves. This is the recommended method if you are unsure of the distribution type.

- Direct use of the Pearson Best-Fit family of curves.

The routines determine the best-fit and adjust the statistics appropriately.

Using Basic Statistics

The set of basic statistics includes measures of central tendencies, measures of dispersion, and the other descriptive statistics, as shown in the following table:

Equation	Statistic	Alternate Equation Forms
$\text{Mean} = \frac{\sum x_i}{n}$	The mean is the arithmetic mean (average) of a sample.	\bar{X} See References .
$\text{Stdev} = \sqrt{\frac{\sum (X_i - \bar{X})^2}{n - 1}}$	The standard deviation is the root-mean-square of a sample.	σ See References .
$\text{Observ} = n$	The observation is the total number of values in a sample.	None
$\text{Sum} = \sum X_i$	The summation is the total of all the values in a sample.	None
$\text{Min} = \text{Minimum}(X_i)$	The minimum is the smallest value in the sample.	None
$\text{Max} = \text{Maximum}(X_i)$	The maximum is the largest value in the sample.	None
$\text{Range} = \text{Max} - \text{Min}$	The range is the largest value minus the smallest value in the sample.	None
$\text{Variance} = \frac{\sum (X_i - \bar{X})^2}{n - 1}$	The variance is the square of the standard deviation.	σ^2 See References .
$\text{Std Error} = \frac{s}{\sqrt{n}}$	The standard error of the mean is the standard deviation of the mean. It measures the extent to which a sample mean can be expected to vary.	$\frac{\sigma}{\bar{x}}$ See References .

Equation	Statistic	Alternate Equation Forms
$\text{Coef Vars} = \left(\frac{s}{ \text{Mean} } \right) \times 100$	The coefficient of variation is the standard deviation of a sample expressed as a percentage of the mean. It is a measure of relative dispersion.	See References .
$\text{Lwr Z Score} = \frac{\bar{X} - \text{LSL}}{s}$	The lower Z-score is the number of standard deviations that the lower specification limit (LSL) is from the mean.	None
$\text{Upr Z Score} = \frac{\text{USL} - \bar{X}}{s}$	The upper Z-score is the number of standard deviations that the upper specification limit (USL) is from the mean.	None
Lwr 3 sigma = deviate at probability 0.00135	The lower 3 sigma represents three standard deviations from left of the mean.	None
Upr 3 sigma = deviate at probability 0.99865	The upper 3 sigma represents three standard deviations from right of the mean.	None

Using Quartiles

Quality calculates the twenty-fifth, fiftieth, (also referred to as the median), and seventy-fifth quartiles. The quartiles can be displayed as values and are used to graph the Box and Whisker plots.

To compute the quartiles, the system:

1. Arranges data in ascending order.
2. Ranks the data accordingly (1 to n).
3. Multiplies each quartile by $n+1$.
4. If the result is an integer, sets the quartile to the value of the calculated rank.

The following table shows quartile equations:

Equation	Statistic
$\text{Median} = .50(n + 1)$	The median is the center or middle of a sample. It is the value above which there are as many values as there are below it. It is also the fiftieth percentile of the sample (Quartile 50 percent). See References .
$\text{Quartile 25\%} = .25(n + 1)$	The twenty-fifth percent quartile is the point separating the lower 25 percent of the values from the upper 75 percent. See References .

Equation	Statistic
$\text{Quartile } 75\% = .75(n + 1)$	The seventy-fifth percent quartile is the point separating the upper 25 percent of the values from the lower 75 percent.
$\text{Quartile}_p = (1 - f)y_1 + (f)y_{I+1}$ where: p is the percentile, f is the fractional portion of the computed rank, I is the integer portion of the computed rank.	To resolve calculated values that are not integers (for example, if the percentage lies between two values), the value is interpolated by calculating the weighted average between the two ranks. See References .

Using Skewness and Kurtosis

The calculations for skewness and kurtosis use the following examples:

Equation	Statistic
$SK = \frac{\mu_3 - (3 \cdot \mu_1 \cdot \mu_2) + (2 \cdot \mu_1^3)}{s^3}$	Skewness measures the degree of asymmetry in a sample.
$KU = \left[\frac{\mu_4 - (4 \cdot \mu_1 \cdot \mu_3) + (6 \cdot \mu_1^2 \cdot \mu_2) - (3 \cdot \mu_1^4)}{s^4} \right] - 3$	Kurtosis measures the degree of peakedness in a sample.
$\mu_1 = \frac{\sum(X_i - A)}{n}$	N/A
$\mu_2 = \frac{\sum(X_i - A)^2}{n}$	N/A
$\mu_3 = \frac{\sum(X_i - A)^3}{n}$	N/A
$\mu_4 = \frac{\sum(X_i - A)^4}{n}$	N/A

Using Process Capability

Image: Process Capability

Process capability indices are industrial-accepted calculations for comparing the process output to defined specification limits. For a normal distribution, the process output is defined as :

$$\pm 3$$

standard deviations from the mean. For non-normal distributions, Quality determines the Best-Fit Pearson distribution and calculates equivalent 99.73 percent deviations (at 0.00135 and 0.99865).

The following table shows equations that relate to process capability:

Equation	Statistic
$C_p = \frac{USL - LSL}{Upr\ 3\ \text{sigma} - Lwr\ 3\ \text{sigma}}$	The process potential is the ratio of the process distribution to specification limits. It is the potential capability if the process was perfectly centered. This equation requires both upper and lower specifications.
$C_{pk} = \text{Min}(C_{pl}, C_{pu})$	This equation represents the actual process capability. These equations account for shifts in the process center. The C_{pk} is the lower of the C_{pl} or C_{pu} values, or worst-case capability. In the case of a unilateral specification, the C_{pk} is set to the calculated C_{pl} or C_{pu} value.
$C_{pl} = \frac{\bar{X} - LSL}{\bar{X} - Lwr\ 3\ \text{sigma}}$	The lower process capability represents the process's ability to perform at the LSL. This equation requires an LSL.
$C_{pu} = \frac{USL - \bar{X}}{Upr\ 3\ \text{sigma} - \bar{X}}$	The upper process capability represents the process's ability to perform at the USL. This equation requires a USL.

Equation	Statistic
$C_{pk @90\%} = C_{pk} \cdot \sqrt{\frac{\chi^2_{\alpha}}{n-1}}$ <p>where:</p> $\alpha = 0.90 \text{ with } (n - 1) \text{ degrees of freedom } (df).$	<p>The 90 percent confident C_{pk} is an adjusted C_{pk} based on a 90 percent confidence. The result is heavily affected by the sample size. The larger the sample size, the closer the computed value is to the actual C_{pk}.</p> <p>See References.</p>
$C_r = \left(\frac{\text{Upr 3 sigma} - \text{Lwr 3 sigma}}{\text{USL} - \text{LSL}} \right) \cdot 100$	<p>The capability ratio is the percentage that the process distribution consumes of the specification. This equation requires both upper and lower specifications.</p>
$\% \text{ Below Spec} = (.50 - \alpha_{\text{Lwr}}) \cdot 100$ <p>where:</p> α_{Lwr} <p>is the area under the curve from the mean to the LSL.</p>	<p>The percent below specification is the estimated area under the curve to the left of the LSL. This equation requires an LSL.</p>
$\% \text{ Above Spec} = (.50 - \alpha_{\text{Upr}}) \cdot 100$ <p>where:</p> α_{Upr} <p>is the area under the curve from the mean to the LSL.</p>	<p>The percent above specification is the estimated area under the curve to the right of the USL. This equation requires a USL.</p>
$\% \text{ Total} = \% \text{ Below Spec} + \% \text{ Above Spec}$	<p>The total percent out of specification is the total estimated area under the curve outside of the specification limits.</p>

Testing for Normality

Quality offers a test for normality based on the skewness and kurtosis of the distribution. The test compares the skewness and kurtosis to the expected sampling variation of these statistics at a 95 percent confidence interval. The following are the computations:

Equation	Statistic
$2 \cdot \sqrt{\frac{6}{n}}$	<p>This equation calculates skewness at a 95 percent confidence bound.</p>
$4 \cdot \sqrt{\frac{6}{n}}$	<p>This equation calculates kurtosis at a 95 percent confidence bound.</p>

Related Links

[References](#)

Using Pearson Best-Fit Criteria

Image: Pearson Best Fit Criteria

Quality uses Pearson criteria to determine the best-fit distribution for the sample. A K value, computed using the following equation, classifies the distribution as one of the following types:

$$K = \frac{SK(KU + 6)^2}{4(4KU - 3(SK)^2 + 12)(2KU - 3(SK)^2)}$$

Pearson Frequency Curves

The following table describes Pearson frequency curves.

<i>Type</i>	<i>Description</i>	<i>Criteria</i>
1	Beta	$K < 0$
2	Uniform	$K = 0, KU = 0, SK < 0$
3	Gamma	$2KU = 3(SK)^2$
4	Non Central t	$K > 0$ and $K < 1$
5	Inverse Gamma	$K = 1$
6	Inverse Beta	$K > 1$
7	Student t	$K = 0, SK = 0, KU > 0$
8	Normal	$K = 0, SK = 0, KU = 0$
10	Exponential	$2KU = 3(SK)^2, 2.25 > SK > 1.80$

Related Links

[References](#)

Using Attribute Statistics

Attribute statistics only apply to discrete data types, that is, count data. This type of data is typically associated with defect tallies.

The following table describes equations used with attribute statistics:

Equation	Statistic	Alternate Equation Forms
$\text{SUMDEF} = \sum \text{Defects}$	The sum of defects is the total count of all the defects in a sample.	None
$\text{DPU} = \frac{\sum \text{Defects}}{\sum \text{Samples}}$	This equation represents the average number of defects per unit.	\bar{d}
$\text{DPH} = \frac{\sum \text{Defects}}{100}$	This equation represents the number of defects per 100 units.	None
$\text{DPT} = \frac{\sum \text{Defects}}{1000}$	This equation represents the number of defects per 1000 units.	None
$\text{DPM} = \frac{\sum \text{Defects}}{1,000,000}$	This equation represents the number of defects per million units.	None

Using Distribution Analysis

Use the Quality application client to view and interact with histograms, box plots, Pearson distribution types, and basic statistics. Quality provides the following single sample statistical confidence tests:

- A t-test, to test the mean of the current population versus a target mean supplied by you.
- A chi-square test, to test the standard deviation of the current population versus a target standard deviation that you supply.

This section discusses how to:

- Use histogram statistics.
- Use test statistics.

Using Histogram Statistics

The following table lists equations that apply to histogram statistics:

Equation	Statistic
$k = n^{1/6} \cdot 3.25$ <p>k is the nearest integer ≥ 2 and ≤ 30.</p>	The number of cells is a calculated value that determines the number of bars to be displayed on a histogram.
$C_w = \frac{\text{Range}}{k}$	The cell width represents the size of each cell interval.

Equation	Statistic
$CLL_{i+1} = \text{Min} - \left(\frac{C_w}{2} \right)$ $CLL_i = CUL_{i-1}$	The cell lower limit is the lower class limit for each cell (i) within the histogram. The first cell (i=1) must be calculated, and then subsequent cell limits can be calculated using the second equation.
$CUL_i = CLL_{i+1} + CW$	The cell upper limit is the upper class limit for each cell within the histogram.
$CT_i = \text{\#of cell values}$	The cell tally is the total number of individual values in a cell.
$CP_i = \left(\frac{CT_i}{n} \right) \cdot 100$	The cell percentage is the percentage of individual values in a cell.

Using Test Statistics

The following table lists the two single sample statistical confidence tests: a mean test and a Stdev test (standard deviation test).

Equation	Statistic
$t = \frac{\bar{X} - \text{Target}_{\bar{x}}}{s / \sqrt{n}}$	<p>The mean test is a t-test that tests the mean of the current sample versus a target mean that you supply. Once the t value is calculated, it is compared to the t statistic (table value), which is determined by the confidence level selected for a one-sided test. The test assumes that the samples are normally distributed.</p> <p>See References.</p>
$\chi^2 = \frac{(n-1)(s)^2}{\text{Target}_s^2}$	<p>The standard deviation test is a chi-square test that tests the standard deviation of the current sample versus a target standard deviation that you supply. Once the chi-square value is calculated, it is compared to the chi-square statistic (table value), which is determined by the confidence level selected for the test. The standard deviation test has a limitation of</p> $df = 100.$ <p>See References.</p>

Using Control Charts

Control charts display standard and nonstandard statistical process control (SPC) control charts. The default control charts provided with the installation of Quality are the industrial-standard charts that are documented in most Quality references, and are categorized by variable and attribute type.

This section discusses how to:

- Use variable data control charts.

- Use attribute data control charts.

Using Variable Data-Control Charts

This table shows the use of variable data-control charts:

Equation	Statistic
$UCL_x = \bar{\bar{X}} + A_2 \bar{R} \quad UCL_R = D_4 \bar{R} \quad CL_x = \bar{\bar{X}}$ $CL_R = \bar{R} \quad LCL_x = \bar{\bar{X}} - A_2 \bar{R} \quad LCL_R = D_3 \bar{R}$ <p>where:</p> $\bar{\bar{X}} = \frac{\sum \bar{X}_i}{k} \quad \bar{R} = \frac{\sum R_i}{k}$	<p>The \bar{X}/R chart, or average and range chart, is the most commonly used chart in SPC. Each point (k) on the \bar{X} chart consists of an average of individual measurements within a subgroup of a constant sample size (n). The R chart represents the range (R), which is the maximum, individual measurement in the subgroup, minus the minimum.</p>

Equation	Statistic
$UCL_x = \bar{\bar{X}} + A_3\bar{s}$ $UCL_R = B_4\bar{s}$ $CL_x = \bar{\bar{X}}$ $CL_R = \bar{s}$ $LCL_x = \bar{\bar{X}} - A_3\bar{s}$ $LCL_R = B_3\bar{s}$ <p>where:</p> $\bar{\bar{X}} = \frac{\sum \bar{X}_i}{k}$ $\bar{s} = \frac{\sum s_i}{k}$	<p>The \bar{X} /s chart, or the average and standard deviation chart, is a variation of the \bar{X} / R chart typically used with subgroup sizes of greater than seven. Each point (k) on the \bar{X} chart consists of an average (\bar{X}) of individual (X) measurements within a subgroup of a constant sample size (n). The s chart represents the standard deviation (s) within the subgroup of individual measurement.</p>
$UCL_x = \bar{\bar{X}} + 2.66(\overline{MR})$ $UCL_{MR} = 3.267(\overline{MR})$ $CL_x = \bar{\bar{X}}$ $CL_{MR} = \overline{MR}$ $LCL_x = \bar{\bar{X}} - 2.66(\overline{MR})$ $LCL_{MR} = 0$ <p>where:</p> $\bar{\bar{X}} = \frac{\sum X_i}{k}$ $\overline{MR} = \frac{\sum MR_i}{k - 1}$	<p>The X/MR chart, or individual and moving range chart, is typically used when measurements can't easily be formed into subgroups. Measurements may be expensive or destructive, or time periods between samples may be excessive. Each point (s) on the \bar{X} chart consists of an individual (X) measurement. The MR chart represents the difference between the previous point and the current point (absolute value).</p>

Using Attribute Data-Control Charts

This table shows the use of attribute data-control charts:

Equation	Statistic
$\overline{X} \quad \boxed{CL_p = \bar{p}} \quad \boxed{LCL_p = \bar{p} - 3\sqrt{\frac{\bar{p}(1-\bar{p})}{\bar{n}}}}$ <p>where:</p> $\boxed{\bar{p} = \frac{\sum p_i}{\sum n_i}} \quad \boxed{\bar{n} = \frac{\sum n_i}{k}}$	<p>The p chart displays the proportion of nonconforming items in a group of items being inspected. The plotted point (p) is the fraction of defective items found for each sample (n). The sample size (n) need not be constant; however, sample sizes that vary more than 25 percent may provide misleading results (as documented in most SPC references).</p>
$\boxed{UCL_{np} = n\bar{p} + 3\sqrt{n\bar{p}\left(1 - \frac{n\bar{p}}{n}\right)}} \quad \boxed{CL_{np} = n\bar{p}}$ $\boxed{LCL_{np} = n\bar{p} - 3\sqrt{n\bar{p}\left(1 - \frac{n\bar{p}}{n}\right)}}$ <p>where:</p> $\boxed{n\bar{p} = \frac{\sum np_i}{k}}$	<p>The np chart displays the nonconforming items in a group of items being inspected. It is similar to the p chart, but requires a constant sample size (n). The plotted point (np) is the number of defective items found for each sample (n).</p>
$\boxed{UCL_c = \bar{c} + 3\sqrt{\bar{c}}} \quad \boxed{CL_c = \bar{c}} \quad \boxed{LCL_c = \bar{c} - 3\sqrt{\bar{c}}}$ <p>where:</p> $\boxed{\bar{c} = \frac{\sum c_i}{k}}$	<p>The c chart displays the number of defects found in a group of items being inspected. It requires a constant sample size (n). The plotted point (c) is the number of defects found for each sample (n).</p>
$\boxed{UCL_u = \bar{u} + 3\sqrt{\frac{\bar{u}}{\bar{n}}}} \quad \boxed{CL_u = \bar{u}} \quad \boxed{LCL_u = \bar{u} - 3\sqrt{\frac{\bar{u}}{\bar{n}}}}$ <p>where:</p> $\boxed{\bar{u} = \frac{\sum c_i}{\sum n_i}}$	<p>The u chart displays the number of defects found in a unit. Each unit is equal to the sample size, which may vary from group to group. This chart is similar to the c chart, but doesn't require a constant sample size (n). The plotted point (u) is the number of defects per unit (sometimes denoted as DPU).</p>

Using Pareto Charts

Use the Pareto chart to view a bar graph of discrete attributes, such as defects, causes, actions, or control test violations. The chart appears with horizontal bars in a descending order. The bars are accompanied with a cumulative percent curve (Lorenz curve) and bar statistics to the right of the chart.

You can remove bars by clicking them and redrawing them or by using filtering options provided under the Modify Graph menu.

Equation	Statistic
$\text{Bar Value} = \text{Category Tally}$	Each bar value is equal to the tally found for each attribute category.
$\text{Bar \%} = \left(\frac{\text{Bar Value}}{\sum \text{Bar Value}} \right) \cdot 100$	The bar percent is the percent that each bar represents for all displayed attribute categories.
$\text{Cum \%}_i = \text{Bar \%}_i + \text{Cum \%}_{i-1}$	The cumulative percent represents the cumulative bar percentages.

Using Bar Graphs

Use bar graphs to quickly compare statistics by subset in a horizontal bar layout. Use options to view the bars in subset and descending or ascending order. The bar value is the chosen subset and statistic that determine each bar length. The mean is the default value for each bar.

Related Links

[Using the Statistical Matrix](#)

Using Box Plots

Image: Box Plots

Use box plots to display Box and Whisker plots, capability graphs, or minimum/maximum plots for multisubset comparisons. The system provides a list of statistics at the bottom of each graphic, or you can select individual subsets for more detail. Use options, such as the display of statistics, overlay

± 3

sigma region, and graphic scaling, to modify the display.

Related Links

[Using the Statistical Matrix](#)

Using Line Graphs

Line graphs display up to six subsets of data (by individual values) on one chart. Interaction with the graph includes point selection.

References

Here are some references related to the contents of this topic.

1. Rippstein, Greg L. *Data Set Descriptions for Statistical Validation*. August 1996.
2. SAS Institute. *JMP version 2.0 Reference Guide for Macintosh*.
3. Ford Motor Company. *Continuing Process Control and Process Capability Improvement*. December 1987.
4. VSA, Inc. SQC release 7 for DOS software.
5. Montgomery, Douglas C. *Introduction to Statistical Quality Control*, 2nd ed. 1991.
6. Duncan, Acheson J. *Quality Control and Industrial Statistics*, 5th ed. 1986.
7. Rippstein, Greg L. *SPC Implementation Guide*, 1st ed. 1994.
8. Freund, John E., and Richard M. Smith. *Statistics: A First Course*, 4th ed. 1986.
9. Rippstein, Greg L. *Measurement Systems Analysis* (seminar guide). 1995.
10. Crocker, Douglas C. "Regression Analysis in Quality Control." 40th Annual Quality Congress, May 1986, Anaheim, CA. 42-49.
11. BBN Software Products. *RS/I Statistical Tools Reference Guide*. 1992.
12. Sanders, Murph, and Eng. *Statistics: A Fresh Approach*, 2d ed. 1980.
13. Gruska, Mirkhani, and Lamberson. *Non Normal Data Analysis*. Dearborn Heights, MI: Multifac Publishing Company, 1973.
14. *Biometrika* 50 (1968).
15. Western Electric Co., Inc. *Statistical Quality Control Handbook*. May 1985.
16. Hewlett-Packard Corporation. *Hewlett-Packard Applications Programs*. 1975.

Appendix A

Delivered Workflow for PeopleSoft Quality

Delivered Workflow for PeopleSoft Quality

This section discusses the Quality workflow.

Alarm Notification

This section discusses the Alarm Notification workflow.

Description

<i>Information Type</i>	<i>Description</i>
Event Description	The quality analyst records quality metrics and an out of tolerance situation is detected.
Action Description	When process control violations are detected, a work list notification is dispatched to quality control personnel such as, a QC Supervisor.
Notification Method	Worklist and Email

Workflow Objects

<i>Information Type</i>	<i>Description</i>
Approval Rule Set	N/A
Business Process	Alarm Notification
Activity	Alarm Notification
Role	QC Supervisor

