

Tekelec EAGLE[®] 5

Release 42.0

Feature Manual - ATINP

910-5904-001 Revision A

September 2010



Copyright 2010 Tekelec. All Rights Reserved. Printed in USA.

Legal Information can be accessed from the Main Menu of the optical disc or on the Tekelec Customer Support web site in the *Legal Information* folder of the *Product Support* tab.

Table of Contents

Chapter 1: Introduction.....	7
Introduction.....	8
Scope and Audience.....	8
Manual Organization.....	9
Related Publications.....	9
Documentation Availability, Packaging, and Updates.....	9
Documentation Admonishments.....	10
Customer Care Center.....	10
Emergency Response.....	13
Locate Product Documentation on the Customer Support Site.....	13
Chapter 2: Feature Description.....	14
ATINP Feature Overview.....	15
The ATINPQ Local Subsystem.....	15
ATINP Configuration Options.....	17
ATINP Protocol Handling of MSUs.....	26
ATINP Return Result Message.....	27
ATINP Error Response MSU Encoding.....	31
Hardware Requirements.....	32
MPS/EPAP Platform.....	32
EPAP/PDBA Overview.....	34
Subscriber Data Provisioning.....	35
EPAP (EAGLE Provisioning Application Processor).....	37
Service Module Cards.....	38
Network Connections.....	41
Chapter 3: EAGLE 5 ISS ATINP Commands.....	46
EAGLE 5 ISS Commands.....	47
Maintenance Commands.....	48
rept-stat-sccp.....	50
EAGLE 5 ISS Debug Commands.....	50
Chapter 4: ATINP Configuration.....	51
Introduction.....	52

EPAP Entity Provisioning.....	52
System Prerequisites.....	52
ATINP Feature Prerequisites.....	53
ATINP Configuration Procedure.....	54
Adding a Service Module Card.....	55
Enabling ATINP, Setting STP Options, and Turning On ATINP.....	59
Enabling the Service Portability Feature.....	60
Provisioning True Point Codes and Capability Point Codes.....	61
Provisioning the ATINPQ Local Subsystem.....	63
Adding the ATINPQ Local Subsystem Application.....	63
Removing a Local Subsystem Application.....	64
Provisioning the ATINP Service Selector.....	65
Adding an ATINP Service Selector.....	65
Removing a Service Selector.....	66
Changing an Existing Service Selector to an ATINP Service Selector.....	68
Provisioning the ATINP Options.....	70
Activating the ATINPQ Local Subsystem.....	71
Turning On the Service Portability Feature.....	72
Turning Off the Service Portability Feature.....	73
Changing the State of a Subsystem Application.....	74
Taking the Subsystem Application Offline.....	75
Taking the Subsystem Application Online.....	76
The 1100 TPS/DSM for ITU NP Feature.....	76
Enable the 1100 TPS/DSM for ITU NP Feature.....	79
Turn On the 1100 TPS/DSM for ITU NP Feature.....	79
Turn Off the 1100 TPS/DSM for ITU NP Feature.....	80
Activating the E5-SM4G Throughput Capacity Feature.....	81

Chapter 5: ATINP Measurements.....84

ATINP Measurements.....	85
-------------------------	----

Chapter 6: Maintenance.....87

ATINPQ Subsystem Alarms (UAMs).....	88
ATINPQ Subsystem UIMs.....	88
EPAP Status and Alarms.....	90
DSM Status Requests.....	90
EPAP System Status Reports.....	91
Code and Application Data Loading.....	92
DSM Code Loading.....	92
EPAP Application Data Loading.....	92

Glossary.....95

List of Figures

- Figure 1: MPS/EPAP Platform Architecture.....32
- Figure 2: Subscriber Data Provisioning Architecture (High Level).....35
- Figure 3: Database Administrative Architecture.....37
- Figure 4: Customer Provisioning Network.....42
- Figure 5: EPAP Sync Network.....43
- Figure 6: DSM Networks.....43
- Figure 7: Dial-Up PPP Network.....45
- Figure 8: Obit Message for Abort of Card Loading.....94

List of Tables

Table 1: Admonishments.....	10
Table 2: ATINP Options.....	17
Table 3: RTDB Lookup Success Determination.....	27
Table 4: Encoded Number Portability Status value.....	30
Table 5: Service Module Card Provisioning and Reload Settings.....	40
Table 6: EPAP IP Addresses in the DSM Network.....	44
Table 7: Commands used for ATINP.....	47
Table 8: Maintenance Commands.....	49
Table 9: System Prerequisites.....	52
Table 10: ATINP Feature Prerequisite.....	53
Table 11: Service Module Card Locations.....	56
Table 12: System Prerequisites for Adding a Service Module Card.....	56
Table 13: Prerequisite for Adding an E5-SM4G Service Module Card.....	57
Table 14: ATINPQ Local Subsystem Prerequisites.....	63
Table 15: Subsystem Allow/Inhibit.....	72
Table 16: System Prerequisites.....	77
Table 17: Feature Prerequisites.....	78
Table 18: Maximum E5-SM4G Card and System TPS Capacity.....	81
Table 19: System Prerequisites.....	82
Table 20: E5-SM4G Throughput Capacity Feature Prerequisite.....	82
Table 21: Pegs for Per System and Per SSP.....	85
Table 22: ATINPQ UAMs.....	88
Table 23: ATINPQ UIMs.....	89

Chapter 1

Introduction

Topics:

- *Introduction.....8*
- *Scope and Audience.....8*
- *Manual Organization.....9*
- *Related Publications.....9*
- *Documentation Availability, Packaging, and Updates.....9*
- *Documentation Admonishments.....10*
- *Customer Care Center.....10*
- *Emergency Response.....13*
- *Locate Product Documentation on the Customer Support Site.....13*

This chapter contains a brief description of the ATINP feature. The contents include sections about the manual scope, audience, and organization; how to find related publications; and how to contact Tekelec for assistance.

Introduction

Before number portability, SCPs and other querying nodes could easily determine which network the subscriber belonged to based on the digits dialed by the caller. With number portability, subscriber digits cannot be relied upon to determine the subscriber's network.

Anytime Interrogation Number Portability Query (ATINP) is an EAGLE 5 ISS feature that provides a method for querying entities to obtain number portability and routing information for subscribers directly from an EAGLE 5 ISS.

ATINP provides number portability functions for decoding the information in the incoming ATI query message, number conditioning before the RTDB lookup, determining the success or failure of the RTDB lookup, and formatting the Return Result or Error Response based on the result of the lookup. ATINP is fully compliant with the ATI standards for Global Number Portability in 3GPP TS 23.066 V7.0.0 (2007-06), *Support of Mobile Number Portability*.

ATINP supports the use of Additional Subscriber Data (ASD) in formatting response messages.

ATINP supports Service Portability functions that allow a subscriber to keep the same phone number when switching from one type of network or service technology to another within the same operator's network. With Service Portability, the subscriber remains with the same operator, but receives service from a different network technology supported by that operator or moves from one physical network to another, with both networks operated by the same service provider. The Service Portability (S-Port) feature allows RTDB GRN Entity digits to be used as Service Portability prefixes for own-network GSM and IS41 subscribers in response digit formats.

ATINP supports functions to cluster CNLs into groups referred to as ROPs, which can be used to simplify routing and simple billing analysis in cases where the number of supported CNLs is very large. The Generic Routing Number field is used to store ROP information.

The ATINPQ local subsystem in the EAGLE 5 ISS processes ITU-TCAP ATI messages with the requested information parameter "MNP Requested Info". The EAGLE 5 ISS responds with an ATI ACK message that contains number portability and routing information, or with an ATI NACK message if the requested information cannot be provided. The original ATI query is discarded.

ATINP is an EPAP-based feature that requires EPAP provisioning data from the Real Time Database (RTDB). Subscriber data is transferred from customer databases to the EPAP. The EPAP formats the RTDB and loads it to each Service Module card on the EAGLE 5 ISS. The RTDB data is used in obtaining number portability information and in determining how to correctly format the ATI ACK response message. See [MPS/EPAP Platform](#) for more information about EPAP.

Scope and Audience

This manual is intended for anyone responsible for installing, maintaining, and using the ATINP feature in the EAGLE 5 ISS. Users of this manual and the others in the EAGLE 5 ISS family of documents must have a working knowledge of telecommunications and network installations.

Manual Organization

This document is organized into the following chapters:

- [Introduction](#) contains general information about the ATINP documentation, the organization of this manual, and how to get technical assistance.
- [Feature Description](#) provides a functional description of the ATINP feature, including network perspectives, assumptions and limitations, a database overview, Service Module provisioning and reloading, ATINP user interface, and an audit overview.
- [EAGLE 5 ISS ATINP Commands](#) describes the commands that can be used for ATINP feature configuration and maintenance functions.
- [ATINP Configuration](#) provides procedures for configuring the ATINP feature for use in the EAGLE 5 ISS.
- [ATINP Measurements](#) describes ATINP-related measurements, measurements reports, and methods of collection.
- [Maintenance](#) describes ATINP-related UAMs and UIMs, EPAP status and alarm reporting, DSM status reporting to the EPAP, system hardware verification, system status reporting, and code and application data loading.

Related Publications

For information about additional publications that are related to this document, refer to the *Related Publications* document. The *Related Publications* document is published as a part of the *Release Documentation* and is also published as a separate document on the Tekelec Customer Support Site.

Documentation Availability, Packaging, and Updates

Tekelec provides documentation with each system and in accordance with contractual agreements. For General Availability (GA) releases, Tekelec publishes a complete EAGLE 5 ISS documentation set. For Limited Availability (LA) releases, Tekelec may publish a documentation subset tailored to specific feature content or hardware requirements. Documentation Bulletins announce a new or updated release.

The Tekelec EAGLE 5 ISS documentation set is released on an optical disc. This format allows for easy searches through all parts of the documentation set.

The electronic file of each manual is also available from the [Tekelec Customer Support](#) site. This site allows for 24-hour access to the most up-to-date documentation, including the latest versions of Feature Notices.

Printed documentation is available for GA releases on request only and with a lead time of six weeks. The printed documentation set includes pocket guides for commands and alarms. Pocket guides may also be ordered separately. Exceptions to printed documentation are:

- Hardware or Installation manuals are printed without the linked attachments found in the electronic version of the manuals.
- The Release Notice is available only on the Customer Support site.



Note: Customers may print a reasonable number of each manual for their own use.

Documentation is updated when significant changes are made that affect system operation. Updates resulting from Severity 1 and 2 Problem Reports (PRs) are made to existing manuals. Other changes are included in the documentation for the next scheduled release. Updates are made by re-issuing an electronic file to the customer support site. Customers with printed documentation should contact their Sales Representative for an addendum. Occasionally, changes are communicated first with a Documentation Bulletin to provide customers with an advanced notice of the issue until officially released in the documentation. Documentation Bulletins are posted on the Customer Support site and can be viewed per product and release.

Documentation Admonishments

Admonishments are icons and text throughout this manual that alert the reader to assure personal safety, to minimize possible service interruptions, and to warn of the potential for equipment damage.

Table 1: Admonishments

	<p>DANGER: (This icon and text indicate the possibility of <i>personal injury</i>.)</p>
	<p>WARNING: (This icon and text indicate the possibility of <i>equipment damage</i>.)</p>
	<p>CAUTION: (This icon and text indicate the possibility of <i>service interruption</i>.)</p>

Customer Care Center

The Tekelec Customer Care Center is your initial point of contact for all product support needs. A representative takes your call or email, creates a Customer Service Request (CSR) and directs your requests to the Tekelec Technical Assistance Center (TAC). Each CSR includes an individual tracking number. Together with TAC Engineers, the representative will help you resolve your request.

The Customer Care Center is available 24 hours a day, 7 days a week, 365 days a year, and is linked to TAC Engineers around the globe.

Tekelec TAC Engineers are available to provide solutions to your technical questions and issues 7 days a week, 24 hours a day. After a CSR is issued, the TAC Engineer determines the classification of

the trouble. If a critical problem exists, emergency procedures are initiated. If the problem is not critical, normal support procedures apply. A primary Technical Engineer is assigned to work on the CSR and provide a solution to the problem. The CSR is closed when the problem is resolved.

Tekelec Technical Assistance Centers are located around the globe in the following locations:

Tekelec - Global

Email (All Regions): support@tekelec.com

- **USA and Canada**

Phone:

1-888-FOR-TKLC or 1-888-367-8552 (toll-free, within continental USA and Canada)

1-919-460-2150 (outside continental USA and Canada)

TAC Regional Support Office Hours:

8:00 a.m. through 5:00 p.m. (GMT minus 5 hours), Monday through Friday, excluding holidays

- **Central and Latin America (CALA)**

Phone:

USA access code +1-800-658-5454, then 1-888-FOR-TKLC or 1-888-367-8552 (toll-free)

TAC Regional Support Office Hours (except Brazil):

10:00 a.m. through 7:00 p.m. (GMT minus 6 hours), Monday through Friday, excluding holidays

- **Argentina**

Phone:

0-800-555-5246 (toll-free)

- **Brazil**

Phone:

0-800-891-4341 (toll-free)

TAC Regional Support Office Hours:

8:30 a.m. through 6:30 p.m. (GMT minus 3 hours), Monday through Friday, excluding holidays

- **Chile**

Phone:

1230-020-555-5468

- **Colombia**

Phone:

01-800-912-0537

- **Dominican Republic**

Phone:

1-888-367-8552

- **Mexico**

Phone:

001-888-367-8552

• **Peru**Phone:

0800-53-087

• **Puerto Rico**Phone:

1-888-367-8552 (1-888-FOR-TKLC)

• **Venezuela**Phone:

0800-176-6497

• **Europe, Middle East, and Africa**Regional Office Hours:

8:30 a.m. through 5:00 p.m. (GMT), Monday through Friday, excluding holidays

• **Signaling**Phone:

+44 1784 467 804 (within UK)

• **Software Solutions**Phone:

+33 3 89 33 54 00

• **Asia**• **India**Phone:

+91 124 436 8552 or +91 124 436 8553

TAC Regional Support Office Hours:

10:00 a.m. through 7:00 p.m. (GMT plus 5 1/2 hours), Monday through Saturday, excluding holidays

• **Singapore**Phone:

+65 6796 2288

TAC Regional Support Office Hours:

9:00 a.m. through 6:00 p.m. (GMT plus 8 hours), Monday through Friday, excluding holidays

Emergency Response

In the event of a critical service situation, emergency response is offered by the Tekelec Customer Care Center 24 hours a day, 7 days a week. The emergency response provides immediate coverage, automatic escalation, and other features to ensure that the critical situation is resolved as rapidly as possible.

A critical situation is defined as a problem with an EAGLE 5 ISS that severely affects service, traffic, or maintenance capabilities, and requires immediate corrective action. Critical problems affect service and/or system operation resulting in:

- A total system failure that results in loss of all transaction processing capability
- Significant reduction in system capacity or traffic handling capability
- Loss of the system's ability to perform automatic system reconfiguration
- Inability to restart a processor or the system
- Corruption of system databases that requires service affecting corrective actions
- Loss of access for maintenance or recovery operations
- Loss of the system ability to provide any required critical or major trouble notification

Any other problem severely affecting service, capacity/traffic, billing, and maintenance capabilities may be defined as critical by prior discussion and agreement with the Tekelec Customer Care Center.

Locate Product Documentation on the Customer Support Site

Access to Tekelec's Customer Support site is restricted to current Tekelec customers only. This section describes how to log into the Tekelec Customer Support site and locate a document. Viewing the document requires Adobe Acrobat Reader, which can be downloaded at www.adobe.com.

1. Log into the [Tekelec Customer Support](#) site.

Note: If you have not registered for this new site, click the **Register Here** link. Have your customer number available. The response time for registration requests is 24 to 48 hours.

2. Click the **Product Support** tab.
3. Use the Search field to locate a document by its part number, release number, document name, or document type. The Search field accepts both full and partial entries.
4. Click a subject folder to browse through a list of related files.
5. To download a file to your location, right-click the file name and select **Save Target As**.

Feature Description

Topics:

- [ATINP Feature Overview.....15](#)
- [The ATINPQ Local Subsystem.....15](#)
- [ATINP Configuration Options.....17](#)
- [ATINP Protocol Handling of MSUs.....26](#)
- [ATINP Return Result Message.....27](#)
- [ATINP Error Response MSU Encoding.....31](#)
- [Hardware Requirements.....32](#)
- [MPS/EPAP Platform.....32](#)

This chapter describes the functions provided by the ATINP feature, including MSU protocol handling, ATI message decoding, and response message formatting.

The chapter includes an overview of the EAGLE Provisioning Application Processor (EPAP). EPAP provides the Realtime Database (RTDB) that is used in the database lookup functions.

ATINP Feature Overview

ATINP Functions

The ATINP feature provides number portability functions and Service Portability functions for decoding the incoming ATI message, conditioning the MSISDN to International format if needed, performing the RTDB lookup, and determining the result of the lookup.

ATINP configuration options affect the following functions and values:

- Number conditioning of the incoming MSISDN digits before RTDB lookup is performed
- Determination of a successful RTDB lookup
- Controlling whether the IMSI, MSISDN, and Routing Number parameters will be included or not included in the ATI ACK response message.
- Formatting of the IMSI, MSISDN, and Routing Number parameters in the ATI ACK response message, and the maximum number of digits to be used from the SRFISMSI or entity ID in the encoding format.
- Default routing number and outbound message digits delimiter to be used in outbound message formats
- Use of GRN digits as Routing Number digits in the ATI ACK response message for own-network subscribers. (One example is using GRN digits for ROP information; EPAP 13.0 or later is required)

Response message handling functions determine whether a success or failure response is needed (or no response), format the information in the response message, send the response, and issue any required UIMs and network management messages.

ATINP Considerations

The GTT feature must be on before the ATINP feature can be enabled.

The ATINP feature must be enabled before configuration options can be provisioned in the ATINPQOPTS table for ATINP. The Service Portability feature must be also enabled before the ATINPQOPTS SPORTTYPE configuration option can be provisioned to use Service Portability with ATINP.

The ATINP feature and the Service Portability feature must be turned on before Service Portability processing will occur for ATI Query messages.

Note: The Service Portability feature, the IDP A-party Blacklist feature, and support for ROP data all use GRN data for different purposes. The IDP A-party Blacklist feature is mutually exclusive with the Service Portability feature; the restriction is enforced in feature provisioning. There is no enforced restriction for the Service Portability feature and ROP data support to be mutually exclusive. It is expected that Support for ROP and Service Portability will be not be used in the same EAGLE 5 ISS system.

The ATINPQ Local Subsystem

Local subsystems in the EAGLE 5 ISS are maintainable entities for query and response that are used when the STP acts as an SCP. Specific point codes can be defined for routing to local subsystems

independently of the STP in the network. A local subsystem can be taken online and offline as needed in the system.

The ATINPQ local subsystem in the EAGLE 5 ISS processes ITU-TCAP ATI messages with the requested information parameter "MNP Requested Info". The EAGLE 5 ISS responds with an ATI ACK message that contains number portability and routing information, or with an ATI NACK message if the requested information cannot be provided. The original ATI query is discarded.

ATINP supports ANSI MTP/SCCP and ITU-TCAP ATI query or ITU MTP/SCCP and ITU-TCAP ATI query.

For ATINP, EAGLE 5 ISS supports ANSI, ITU-I, ITU-N, ITU-I Spare, and ITU-N Spare capability point code types. ITU-N24 point codes are not supported. Capability point codes for the ATINPQ local subsystem can be configured only after the ATINP feature is enabled.

The ATINPQ local subsystem can have a mate subsystem and a concerned point code group assigned to it. The ATINPQ local subsystem cannot be set to Load Shared mode (as end nodes do not perform load sharing), but can be set only to Dominant or Solitary mode. The ATINPQ local subsystem can be entered in MAP table if the ATINP feature is enabled.

The ATINPQ local subsystem can be taken online and offline using the procedures in [Changing the State of a Subsystem Application](#).

Messages for the ATINPQ Local Subsystem

Messages for the ATINPQ local subsystem can arrive Rt-on-SSN or Rt-on-GT. All MSUs must contain either the EAGLE 5 ISS true or secondary point code (TSPC), or the ATINPQ capability point code (CPC) in the DPC field of the message. Traditionally, messages for local subsystems were allowed to have the DPC as the EAGLE 5 ISS STP CPC. However, it is strongly recommended to use the ATINPQ CPC for ATI queries, and not the CPC of the STP for network management issues that can arise.

Rt-on-SSN Handling

If the message arrives Rt-on-SSN, it must contain the EAGLE 5 ISS ATINPQ subsystem number in the Called Party Subsystem field of the message.

If the ATINPQ local subsystem is online, the DPC field can contain either the EAGLE 5 ISS true or secondary point code or the ATINPQ capability point code. Any response message will use the true or secondary point code assigned to the EAGLE 5 ISS as the OPC. Because the EAGLE 5 ISS cannot generate an SSP when a message arrives Rt-on-SSN for the EAGLE 5 ISS CPC, nodes sending Rt-on-SSN traffic should use the true or secondary point code.

If the ATINPQ local subsystem is offline and the mated subsystem is available, the EAGLE 5 ISS will generate a network management message to force the network to transition traffic to the mate.

Rt-on-GT Handling

Rt-on-GT MSUs can arrive either with SCCP CdPA information that matches an EAGLE 5 ISS service selector, or with a GTA address that has been provisioned to translate to the ATINPQ local subsystem.

If the ATINPQ subsystem is online, the DPC field can contain either the EAGLE 5 ISS true or secondary point code or the ATINPQ capability point code. The query is directed to the local subsystem and processed. Any response message will use the true or secondary point code assigned to the EAGLE 5 ISS as the OPC.

If the ATINPQ local subsystem is offline and the mated subsystem is available, the EAGLE 5 ISS will act as both STP and SCP, and reroute the message to the mated subsystem. If a Rt-on-GT message arrives for the EAGLE 5 ISS true or secondary point code, the EAGLE 5 ISS cannot generate a TFP.

The EAGLE 5 ISS handles and reroutes these messages, instead of forcing the adjacent node to route to the mate. Therefore, nodes that send Rt-on-GT traffic to an EAGLE 5 ISS should use an ATINPQ CPC, not the EAGLE 5 ISS TSPC.

Network Management Responses

The EAGLE 5 ISS must reply to network management queries about the current state of the local subsystem. When the local subsystem changes state, network management messages are sent to the CSPC group.

Multiple Local Subsystems

The EAGLE 5 ISS supports provisioning Capability Point Codes for two or more local subsystems, allowing local subsystems for two or more EPAP-based features to operate at the same time in the system. For example, local subsystems for the ATINP feature and the EIR feature can coexist in the system.

Though queries meant for any local system will still be processed if they are sent with DPC = STP CPC, it is strongly recommended not to use the STP CPC for such queries. Instead, the CPC for the appropriate subsystem should be used as the DPC of the message. For instance, for LNP queries use the LNP CPC, not the STP CPC. For ATI queries, use the ATINPQ CPC, and so on.

ATINP Configuration Options

The ATINP configuration options described in [Table 2: ATINP Options](#) are used for the following functions:

- Specify the format of the IMSI, MSISDN, and Routing Number parameters in the ATI ACK response message, and the maximum number of digits to be used from the SRFIMSI or Entity ID in the encoding format.
- Determine whether the IMSI, MSISDN, or Routing Number parameter is included or not included in the ATI ACK response message.
- Specify the default routing number and outbound message digits delimiter to be used in outbound message formats.
- Specify the number conditioning to be performed on the MSISDN digits in the incoming ATI query message before RTDB lookup is performed, and indicate the determination of a successful RTDB lookup.
- Specify Service Portability processing that can be performed for ATI messages.

Table 2: ATINP Options

Option	Value	Action in the STP
ATINPTYPE - specifies when an RTDB lookup is successful	ANY	MSISDN lookup is considered successful when any match is found (RN, SP, and match with no entity, GRN with PT=0xFF). See ATINP Protocol Handling of MSUs for a description of determination of success. Note: This specifically excludes the case when MSISDN was not found in RTDB.

Option	Value	Action in the STP
	ALWAYS	The lookup is always considered to be successful whether or not MSISDN was found in RTDB match.
ATIDLM - specifies whether delimiter digits or no delimiter is to be used in encoding outbound digits in ATI ACK response	NONE	This option can be set to NONE at any time by the user. The default value is NONE.
	HEX (1-15 digits)	
ATIDFLTRN - Default Routing Number used in encoding outgoing formats in the ATI ACK response in cases where an RN is not returned from an RTDB lookup	NONE	The specific encoding is described further in other option value descriptions.
	HEX (1-15 digits)	This option can be set to NONE at any time. The default value is NONE.
SNAI - specifies either that the NAI of the incoming MSISDN digits is considered to be International or International regardless of the NAI value in the incoming MSISDN, or that the NAI value determines whether number conditioning to International format is needed before RTDB lookup.	INTL	The NAI of the incoming MSISDN digits will be considered to be International. No conditioning will be performed on the MSISDN before RTDB lookup.
	NAT	The NAI of the incoming MSISDN digits will be considered to be National. The MSISDN will be conditioned to international format before RTDB lookup by pre-pending the provisioned STPOPTS default country code (DEFCC) parameter value. Note: The STPOPTS DEFCC parameter must be provisioned to a value other than NONE before the ATINP feature can be turned ON. The DEFCC value cannot be set to NONE after the ATINP feature is turned ON.
	NAI	The NAI field of the MSISDN parameter will determine whether number conditioning is required before RTDB lookup . If NAI is INTL (0x01) or Network Specific Number (0x3), then the number will be considered to be International and no conditioning is performed before RTDB lookup. If NAI is not considered INTL, it will be considered to be National. The STPOPTS default country code (DEFCC) value will be pre-pended to the MSISDN to condition it to international format before RTDB lookup. This is the default value.

Option	Value	Action in the STP
ATIACKRN - specifies the formatting of the Routing Number digits in the ATI ACK response.	NONE	The Routing Number parameter will not be included in the response.
	RN	<p>This is the default value.</p> <p>Note: This option value is expected to be used when Service Portability is used with ATINP.</p> <p>If Entity type RN was found in RTDB lookup, the subscriber is generally considered to be a foreign subscriber.</p> <p>The exception is the case when Entity data is RN with PT=0, and either the IGM feature is on or the Service Portability feature is enabled; the subscriber is considered to be an own-network IS41 subscriber in this case. The Entity type is considered to be SP.</p> <p>Foreign Subscribers</p> <p>Encode Routing Number digits as the found Entity ID. (Not affected by Service Portability processing.)</p> <p>Own Subscriber</p> <p>If the Service Portability feature is ON, the Entity type is SP (GSM subscriber), the SPORTTYPE option value is GSM or ALL, and GRN is available, encode the Routing Number as GRN. If GRN is not available, a UIM is generated and the Routing Number is not included in the response.</p> <p>If the Service Portability feature is ON, the Entity type is SP (GSM subscriber), the SPORTTYPE option value is IS41 or NONE, the behavior is the same as when the Service Portability feature is OFF.</p> <p>If the Service Portability feature is ON, the Entity type is RN and PT = 0 (IS41 subscriber), the SPORTTYPE option value is IS41 or ALL, and GRN is available, encode the Routing Number as GRN. If GRN is not available, a UIM is generated and the Routing Number is not included in the response.</p> <p>If the Service Portability feature is ON, the Entity type is RN and PT = 0 (IS41 subscriber), the SPORTTYPE option value is GSM or NONE, the behavior is the same as when the Service Portability feature is OFF.</p>

Option	Value	Action in the STP
		<p>If the Service Portability feature is ON, and a DN is not found in the RTDB, the DN is found but no Entity is found, or the DN is found and the Entity type is not SP or RN with PT = 0, the behavior is the same as when the Service Portability feature is OFF</p> <p>When the Service Portability feature is OFF, the Routing Number digits will be encoded as the ATIDFLTRN option value instead of the Entity ID, if the ATIDFLTRN value is not NONE and one of the following conditions is true:</p> <ul style="list-style-type: none"> • MSISDN was found but No Entity found in RTDB. • MSISDN was not found in RTDB (only in the case of ATINPTYPE=ALWAYS; for ATINPTYPE=ANY, this will result in a lookup failure). • Entity was found with type SP or considered to be type SP. <p>In all other cases, the Routing Number parameter will not be included in the response.</p>
	RNSP	<p>If an Entity was found in RTDB lookup and Entity type was either SP or RN, encode Routing Number digits as the found Entity ID.</p> <p>The Routing Number digits will be encoded as the ATIDFLTRN option value if the ATIDFLTRN value is not NONE and one of the following conditions is true:</p> <ul style="list-style-type: none"> • MSISDN found but Entity was not found. • MSISDN was not found in RTDB (Only in case of ATINPTYPE=ALWAYS. For ATINPTYPE=ANY, this will result in a lookup failure). • Entity of type other than SP or RN was found. <p>In all other cases, the Routing Number parameter will not be included in the response.</p>
	ASDDLNRNSP	<p>Encode the Routing Number as ASD (If available from lookup Entity) + ATIDL (If not NONE) + RNSP.</p> <p>RNSP is encoded as described for the ATIACKRN=RNSP value.</p>

Option	Value	Action in the STP
		<p>If formatting results in 0 digits or only DLM digits, the Routing Number parameter will not be included in the response message.</p> <p>If ATIDL M is not NONE, and ASD digits are available, DLM will be included even if RN/SP does not have any digits (resulting in ASD+DLM).</p> <p>The ASD field is returned in the Entity lookup data (if Entity was found). If the ASD field is not provisioned in EPAP, it will not be included in any formats specifying ASD.</p>
	RNSPDLMASD	<p>Encode Routing Number digits as RN/SP + ATIDL M (If not NONE) + ASD (If available from lookup Entity).</p> <p>RN/SP is encoded as described for the ATIACKRN=RNSP option.</p> <p>If formatting results in 0 digits or only DLM digits, the Routing Number will not be included in the response message.</p> <p>If ATIDL M is not NONE, and ASD digits are available, DLM will be included even if RN/SP does not have any digits (resulting in DLM+ASD).</p>
	SRFIMSI	<p>Encode Routing Number digits as SRFIMSI configured in the entity data.</p> <p>If SRFIMSI was not found (MSISDN not found in RTDB, or MSISDN found but no Entity found, or Entity found but SRFIMSI not configured), then the Routing Number will not be included in the response message.</p>
	SRFIMSIDL MASD	<p>Encode Routing Number digits as SRFIMSI + ATIDL M (If not NONE) + ASD (If available from lookup Entity).</p> <p>SRFIMSI is encoded as described for the ATIACKRN=SRFIMSI option.</p> <p>If formatting results in 0 digits or only DLM digits, the Routing Number will not be included in the response message.</p> <p>If ATIDL M is not NONE and ASD digits are available, DLM will be included even if SRFIMSI does not have any digits (resulting in DLM+ASD).</p>

Option	Value	Action in the STP
	ASDDLMSRFIMSI	<p>Encode Routing Number as ASD (If available from lookup Entity) + ATIDL M (If not NONE) + SRFIMSI.</p> <p>SRFIMSI is encoded as described for the ATIACKRN=SRFIMSI option.</p> <p>If formatting results in 0 digits or only DLM digits, the Routing Number parameter will be not be included in the response message.</p> <p>If ATIDL M is not NONE, and ASD digits are available, DLM will be included even if SRFIMSI does not have any digits (resulting in ASD+DLM).</p> <p>The ASD field is returned in the Entity lookup data (if Entity was found). If the ASD field is not provisioned in EPAP, it will not be included in any formats specifying ASD.</p>
	GRNDLMRNSP	<p>Encode Routing Number as GRN (if supported and available from lookup Entity) + ATIDL M (if not NONE) + RNSP.</p> <p>RNSP is encoded as described for the ATIACKRN = RNSP option.</p> <p>If formatting results in 0 digits or only DLM digits, the Routing Number parameter will be not be included in the response message.</p> <p>If ATIDL M is not NONE, and GRN digits are available, DLM will be included even if RN/SP does not have any digits (resulting in GRN+DLM).</p> <p>The GRN field is returned in the Entity lookup data (if GRN Entity was found). If the GRN field is not provisioned in EPAP, it will not be included in any formats specifying GRN.</p>
	RNSPDLMGRN	<p>Encode Routing Number as RN/SP + ATIDL M (if not NONE) + GRN (if supported and available from lookup entity).</p> <p>RN/SP is encoded as described for the ATIACKRN = RNSP option.</p> <p>If formatting results in 0 digits or only DLM digits, the Routing Number parameter will be not be included in the response message.</p> <p>If ATIDL M is not NONE, and GRN digits are available, DLM will be included even if RN/SP</p>

Option	Value	Action in the STP
		<p>does not have any digits (resulting in DLM+GRN).</p> <p>The GRN field is returned in the Entity lookup data (if GRN Entity was found). If the GRN field is not provisioned in EPAP, it will not be included in any formats specifying GRN.</p>
	SRFIMSIDLMGRN	<p>Encode Routing Number as SRFIMSI + ATIDLM (if not NONE) + GRN (if supported and available from lookup entity).</p> <p>Note: SRFIMSI digits configured with RN or SP entity data will be used only to encode the Routing Number.</p> <p>SRFIMSI is encoded as described for the ATIACKRN = SRFIMSI option.</p> <p>If formatting results in 0 digits or only DLM digits, the Routing Number parameter will be not be included in the response message.</p> <p>If ATIDLM is not NONE, and GRN digits are available, DLM will be included even if SRFIMSI does not have any digits (resulting in DLM+GRN).</p> <p>The GRN field is returned in the Entity lookup data (if GRN Entity was found). If the GRN field is not provisioned in EPAP, it will not be included in any formats specifying GRN.</p>
	GRNDLMSRFIMSI	<p>Encode Routing Number as GRN (if supported and available from lookup entity) + ATIDLM (if not NONE) + SRFIMSI.</p> <p>Note: SRFIMSI digits configured with RN or SP entity data will be used only to encode the Routing Number.</p> <p>SRFIMSI is encoded as described for the ATIACKRN = SRFIMSI option.</p> <p>If formatting results in 0 digits or only DLM digits, the Routing Number parameter will be not be included in the response message.</p> <p>If ATIDLM is not NONE, and GRN digits are available, DLM will be included even if SRFIMSI does not have any digits (resulting in GRN+DLM).</p> <p>The GRN field is returned in the Entity lookup data (if GRN Entity was found). If the GRN field</p>

Option	Value	Action in the STP
		is not provisioned in EPAP, it will not be included in any formats specifying GRN.
ATIACKMSISDN - specifies the inclusion and formatting of the MSISDN in the ATI ACK response message.	NONE	MSISDN parameter is not included in the ATI ACK response.
	MSISDN	MSISDN digits in the ATI ACK response will be encoded as the MSISDN from the incoming ATI query. This is the default value. Note: If the RTDB lookup matched on odd number of digits, then the MSISDN will be encoded with what was matched in the RTDB (without the trailing 0).
	ASD	The MSISDN in the ATI ACK response will be encoded as the ASD (Additional Subscriber Data) if the MSISDN was found during RTDB lookup and ASD was provisioned in EPAP. If ASD is not available, the MSISDN parameter will not be included in the response message.
	ASDDLMSISDN	The MSISDN digits in the ATI ACK response message will be encoded as ASD (if available) + ATIDLM (if not NONE) + MSISDN from incoming message. Note: If the RTDB lookup matched an odd number of digits, then the encoded MSISDN will be what was matched in the RTDB (without the trailing 0).
	GRN	The MSISDN digits in the ATI ACK response message will be encoded as GRN if supported and found during RTDB lookup, and provisioned in the EPAP. Note: If GRN is not supported or not provisioned, the MSISDN parameter will not be encoded in the response message.
	GRNDLMSISDN	The MSISDN digits in the ATI ACK response message will be encoded as GRN (if supported and available) + ATIDLM (if not NONE) + MSISDN from incoming message. When GRN field is supported, it will be returned in the entity lookup data (if GRN entity was found). If GRN field is not supported

Option	Value	Action in the STP
		or not available by EPAP, it will not be included in any formats specifying GRN. Note: If the RTDB lookup matched an odd number of digits, then the encoded MSISDN will be what was matched in the RTDB (without the trailing 0).
ATIACKIMSI - used for IMSI parameter encoding in the ATI ACK message	NONE	The IMSI parameter will not be included in the ATI ACK response message. This is the default value.
	SRFIMSI	If an Entity was found during lookup and <ul style="list-style-type: none"> • If SRFIMSI is provisioned in the Entity, then encode the outgoing IMSI digits as the SRFIMSI. • If SRFIMSI is not provisioned in the Entity, then do not include the IMSI parameter in the ATI ACK response.
	ASD	The IMSI digits in the ATI ACK response will be encoded as the ASD (Additional Subscriber Data) if ASD is found during RTDB lookup and ASD was provisioned in the EPAP. If ASD is not available, the IMSI parameter will not be included in the response message.
	GRN	The IMSI digits in the ATI ACK response will be encoded as the GRN if GRN is supported and found during RTDB lookup and GRN was provisioned in the EPAP. If GRN is not supported or not provisioned, the IMSI parameter will not be included in the response message.
ENTITYLEN - maximum number of digits to be used from RTDB lookup data (SRFIMSI or Entity ID) to encode Routing Number digits in the encoding format specified by the ATIACKRN option. If Entity ID or SRFIMSI is not being used by the specified ATIACKRN format, this option does not apply.	NONE	The SRFIMSI or Entity ID will be used without modification in the ATIACKRN format specified. This is the default value.
	Decimal (1-15)	For example, if the SRFIMSIASDDL format is specified, and ENTITYLEN = 5, SRFIMSI from Entity is "1234567890" (10 digits), ASD = "123", and DLM="55", then a maximum of 5 digits will be used from SRFIMSI to encode the format as "12345" + "123" + "55".

Option	Value	Action in the STP
		If ENTITYLEN = "NONE" then all 10 digits from SRFIMSI would have been used. The same applies to formats that will encode an Entity ID.
SPORTTYPE - indicates the Service Portability processing that is requested for ATI queries for own-network subscribers. Can be provisioned when the Service Portability feature is enabled but not turned on. Impacts protocol processing only if the Service Portability feature is turned on.	NONE	No Service Portability processing is requested. This is the default value.
	GSM	Service Portability is requested for ATI queries for own-network GSM subscribers (Entity = SP).
	IS41	Service Portability is requested for ATI queries for own-network IS41 subscribers (Entity = RN, PT = 0.).
	ALL	GSM and IS41 Service Portability is requested for own-network subscribers (Entity = SP or Entity = RN, PT = 0.).

ATINP Protocol Handling of MSUs

ATINP supports SCCP UDT and non-segmented XUDT Class 0 and Class 1 messages.

The high-level ATINP message processing flow, after the MSU reaches the active local subsystem is:

1. Decode and verify the incoming ATI message.

The requestedInfo parameter must be MNPRequestedInfo.

The incoming MSISDN must have at least one digit.

The information in each MSU is decoded and verified on the LIM card. SCCP messages to the EAGLE 5 ISS (Service Indicator = 3) are forwarded to Service Module cards for processing.

Response messages and UIMs (see [ATINPQ Subsystem UIMs](#)) can be generated for various common decode errors and for some ATINP-specific decode errors. Some malformed messages do not generate any response.

2. Condition the incoming MSISDN to international format if it is not considered to be international already.

An MSISDN of 15 digits or less will be conditioned to International format if needed.

The MSISDN is considered to be in International format if either of the following conditions is true:

- The ATINP option SNAI=INTL is provisioned (see [ATINP Configuration Options](#)).
- The ATINP option SNAI=NAI is provisioned and the Nature of Address field in the MSISDN is INTL (0x1) or Network Specific Number (0x3).

An MSISDN of more than 15 digits is not conditioned for lookup. If the provisioned value of the ATINPTYPE option is ALWAYS, a response is sent for "MSISDN NOT Found in NPDB".

A trailing Stop Digit (0xF) in the MSISDN is treated as filler and will not be considered as part of the MSISDN during lookup.

3. Search the RTDB to locate the conditioned MSISDN.

If the conditioned MSISDN is not found in the individual entries, the range entries are searched (odd/even number lookups are supported).

4. Determine whether the lookup is considered successful, based on provisioned ATINP options.

The provisioned ATINPTYPE option value determines whether the lookup is considered to be successful. See [Table 3: RTDB Lookup Success Determination](#).

5. If the lookup is successful, use the lookup information and ATINP options to encode the ATI ACK response message, and route the response to the originator of the ATI query. See [ATINP Configuration Options](#).

Note: In a successful DN lookup, if ASD is part of one of the entities, Additional Subscriber Data will be considered in formatting of the outgoing response message.

6. If the lookup is not successful, send an ATI NACK response message with the appropriate error code.
7. Discard the original ATI message.

See [ATINP Configuration Options](#) for option descriptions and response formats.

Table 3: RTDB Lookup Success Determination

ATINPTYPE Option	DN found in RTDB	Entity Found	Entity Type	Portability Type	Lookup Success
ALWAYS	N/A	N/A	N/A	N/A	Success
ANY	No	N/A	N/A	N/A	Failure
	Yes	No	N/A	N/A	Success
		Yes	SP	N/A	Success
			RN	N/A	Success
			GRN	0xFF	Success
			VMS	0xFF	Success
			All other cases are considered lookup failure.		

ATINP Return Result Message

A Return Result message ("ATI ACK" message) is used to return the result of the ATINP Query when the RTDB lookup is considered to be successful.

The Return Result message includes Number Portability Status. Routing Number digits, MSISDN digits, and IMSI digits can be included, and ASD and GRN data can be used, depending on RTDB lookup results and ATINP configuration option values. [ATINP Configuration Options](#) describes the options and the encoding results for each option value.

Routing Number

If the ATIACKRN option value is not **none**, routing number information is included in the response message. The ATIACKRN option values determine the data from the RTDB lookup that is used in the outgoing RN. (See [ATINP Configuration Options](#).)

A default routing number can be provisioned using the ATIDFLTRN option, to be used in the outgoing message formats when an RN is not returned from the RTDB lookup.

Additional Subscriber Data is included in some of the formats of the return result information if it is available in the found Entity. The following formats consider Additional Subscriber Data (ASD) digits for encoding the outgoing RN parameter:

- ASD+DLM+RNSP
- RNSP+DLM+ASD
- SRFIMSI+DLM+ASD
- ASD+DLM+SRFIMSI

Generic Routing Number (GRN) digits included in an Entity can be used in formatting the outgoing RN. The Generic Routing Number can be used in identifying GSM or IS41 own-network subscribers for Service Portability, or for identifying members of ROPs (CNL clusters). The following formats consider Generic Routing Number (GRN) digits for encoding the outgoing RN parameter:

- GRN+DLM+RNSP
- RNSP+DLM+GRN
- SRFIMSI+DLM+GRN
- GRN+DLM+SRFIMSI

Note: If the RTDB Entity type is RN with PT=0 and either the IGM feature is On or the Service Portability feature is enabled, the subscriber is considered to be an own-network IS41 subscriber, and the Entity type is treated as SP. See the ATIACKRN=RN configuration option description in [ATINP Configuration Options](#).

A maximum of 40 digits will be encoded in the routeingNumber field. Though the specified length of routeingNumber is 1-5 bytes, ATINP allows encoding of up to 40 digits, based on the ATIACKRN ATINP option value. If the format results in more than 40 digits, the digits will be truncated to satisfy the 40-digit limit. If truncation of digits occurs, UIM 1403 "LSS: Dgts truncated in encd parms" will be generated.

An outbound message digits delimiter and a maximum number of digits to be used from Entity data can be provisioned for use in the encoding formats.

If an odd number of digits is encoded, a filler of 0xF is used as the last digit.

IMSI Digits

If the ATIACKIMSI option value is not **none**, IMSI digits are included in the response, as indicated by the following ATIACKIMSI values:

- SRFIMSI - If an Entity was found during lookup and SRFIMSI was provisioned in the Entity, then the IMSI digits are encoded as the SRFIMSI value.
- ASD - If an Entity was found during RTDB lookup and ASD (Additional Subscriber Data) was provisioned in the EPAP Entity, then IMSI digits are encoded as the ASD. If ASD is not available, the IMSI parameter will not be encoded in the response message.

- GRN - If an Entity was found during RTDB lookup and GRN (Generic Routing Number) was provisioned in the EPAP Entity, then IMSI digits are encoded as the GRN. If GRN is not available, the IMSI parameter will not be encoded in the response message.

The ASD format considers ASD digits for encoding the outgoing IMSI parameter.

The Generic Routing Number can be used in identifying GSM or IS41 own-network subscribers for Service Portability, or for identifying members of ROPs (CNL clusters). The GRN format considers GRN digits for encoding the outgoing IMSI parameter.

If an odd number of digits is encoded, a filler of 0xF is used as the last digit.

MSISDN

If the ATIACKMSISDN option value is not **none**, MSISDN digits are included in the response. The digits can be either the MSISDN from the incoming message, Additional Subscriber Data found in the EPAP Entity, Generic Routing Number found in the EPAP Entity, or a combination of MSISDN, ASD or GRN, and digits delimiter.

The following formats consider ASD digits for encoding the outgoing MSISDN parameter:

- ASD
- ASD+DLM+MSISDN

Generic Routing Number (GRN) digits included in an Entity can be used in formatting the outgoing MSISDN. The Generic Routing Number can be used in identifying GSM or IS41 own-network subscribers for Service Portability, or for identifying members of ROPs (CNL clusters). The following formats consider GRN digits for encoding the outgoing MSISDN parameter:

- GRN
- GRN+DLM+MSISDN

A maximum of 40 digits will be encoded in the MSISDN digits field. Though the specified length of MSISDN is 1-9 bytes – 1 byte for nature of address/numbering plan, eight bytes for digits, ATINP will allow encoding of up to 40 digits for this field, based on the ATIACKMSISDN ATINP option value. If the format results in more than 40 digits, the digits will be truncated to satisfy the 40 digit limit. UIM 1403: “LSS: Dgts truncated in encd parms” will be generated.

If an odd number of digits was encoded, a filler of 0xF is used as the last digit. The Nature of Address field will be copied from the incoming MSISDN.

Number Portability Status

The portability type of the MSISDN can represent the following types of numbers:

- An own number ported out
- An own number not ported out
- A foreign number ported in
- A foreign number ported to foreign network
- Foreign number not known to be ported

Because the existing EPAP portability does not support options for “Own number not ported out” and “Foreign number ported in”, this feature cannot distinguish between these two types of numbers that belong to own network. Using configured data, a best fit match will be made for returning number portability status (encoded value is in parentheses), as follows:

Table 4: Encoded Number Portability Status value

Encoded Number Portability Status value	Criterion
Not Known To Be Ported (0)	<ul style="list-style-type: none"> • MSISDN not found in the NPDB • MSISDN found with no entity and EPAP portability type (PT) provisioned as one of the following values: <ul style="list-style-type: none"> • 0 (NOT KNOWN TO BE PORTED) • 1 (OWN NUMBER PORTED OUT) • 2 (FOREIGN NUMBER PORTED TO FOREIGN NETWORK) • 36 (NOT IDENTIFIED TO BE PORTED) • 0xFF (none - NO STATUS) • MSISDN and Entity found in RTDB with Entity type = RN, PT = 0, S-Port is not enabled, and IGM feature is OFF. • MSISDN and Entity found in RTDB with Entity type = RN, and PT=0xFF (none - NO STATUS) or PT=36 (Not identified to be ported). <p>Note: This says that if a routing number was not found in RTDB (no Entity) then the MNP SRF cannot provide any useful information to the querying node about the network that owns this MSISDN. The querying node uses its available digits to route the call. PT=5 implies migrated customer (own network) and PT=3, 4, and 6-35 are prepaid servers that are also own subscribers.</p>
Own Number Ported Out (1)	MSISDN and Entity found in RTDB with Entity type=RN and PT=1 (OWN NUMBER PORTED OUT)
Foreign Number Ported To Foreign Network (2)	MSISDN and Entity found in RTDB with Entity type=RN and PT=2 (FOREIGN NUMBER PORTED TO FOREIGN NETWORK)
Own Number Not Ported Out (4)	<ul style="list-style-type: none"> • MSISDN and Entity found in RTDB with Entity type other than RN. (Non-RN Entity type in general implies own subscriber). <p>Note: The combinations of 1 RN and 1 VMS ID, and 1 RN and 1 GRN, are valid combinations for network entities. In this case, the Entity type is considered to be RN (presumably, our own network is providing voice mail support for a foreign number).</p>

Encoded Number Portability Status value	Criterion
	<ul style="list-style-type: none"> • MSISDN found in RTDB with no Entity and PT=Migrated (5) • MSISDN found in RTDB with no Entity but PT=Prepaid (3, 4, 6-35). • MSISDN and Entity found in RTDB with Entity type=RN, PT=0, and S-Port is enabled or IGM feature is turned ON (migrated subscriber is considered own subscriber). • MSISDN and Entity found in RTDB with Entity type=RN, and PT=5 (migrated) or PT=Prepaid (3,4,6-35).
Foreign Number Ported In (5)	Not Supported. (Imported) Numbers that meet criteria for "Own Number Not Ported Out" have portability status value of 4.

ATINP Error Response MSU Encoding

The EAGLE 5 ISS can return any of the following error messages after processing an ATI message:

- Return Error

A response message with a Return Error component is referred to as an ATI NACK message or Return Error message. A Return Error component is used for the receipt of an ATI message when the ATINP feature is turned off (ATINP must be enabled – if ATINP is disabled, the message will not reach the subsystem), for ATI lookup problems, and for some decoding issues.

Refer to 3GPP TS 29.002 version 6.15.0, ETSI TS 129 002 V6.15.0 (2005-12), *Digital Cellular Telecommunications System (Phase2+); Mobile Application Part (MAP) Specification* .

- Reject

Reject messages are used for decoding errors in the Component portion of the original MSU.

- U-Abort

U-Abort messages are used for decode errors in the Dialog or Component portion of the original MSU.

- P-Abort

P-Abort messages are used for certain errors detected during decode of the Transaction portion of the original MSU.

Reject, P-Abort, and U-Abort error codes are described in ITU-T Recommendation Q.773, *Transaction Capabilities Formats and Encoding*.

Hardware Requirements

EPAP-related features that perform an RTDB lookup require Service Module cards (DSM cards or E5-SM4G cards) running the VSCCP application. The EAGLE 5 ISS can be equipped with:

- Up to 25 (24+1) Service Module cards when EPAP is running in a T1000 AS
- Up to 32 (31+1) Service Module cards when EPAP is running in a T1200 AS

Features that do not perform an RTDB lookup require Service Module cards only for GTT processing that might be performed for the feature. These features can coexist in systems with EPAP, but do not require an EPAP connection.

MPS/EPAP Platform

Tekelec provides the Multi-Purpose Server (MPS) platform as a subsystem of the EAGLE 5 ISS. The MPS provides support for EPAP-related features that perform Real Time Database (RTDB) lookups.

The MPS is composed of hardware and software components that interact to create a secure and reliable platform. For details about the MPS hardware, refer to *Tekelec 1000 Application Server Hardware Manual* or *Tekelec 1200 Application Server Hardware Manual*. The MPS provides the means of connecting the customer provisioning application with the EAGLE 5 ISS and accepts the customer number portability data, while accommodating numbers of varying lengths.

The EAGLE Provisioning Application Processor (EPAP) is software that runs on the MPS hardware platform. It collects and organizes customer provisioning data, and forwards the data to the EAGLE 5 ISS Service Module cards. [Figure 1: MPS/EPAP Platform Architecture](#) shows the overall system architecture from customer provisioning through the MPS subsystem to the EAGLE 5 ISS Service Module card databases.

Note: In this manual, Service Module card refers to either a DSM card or an E5-SM4G card unless a specific card is required. For more information about the supported cards, refer to *EAGLE 5 ISS Hardware Manual*.

Figure 1: MPS/EPAP Platform Architecture

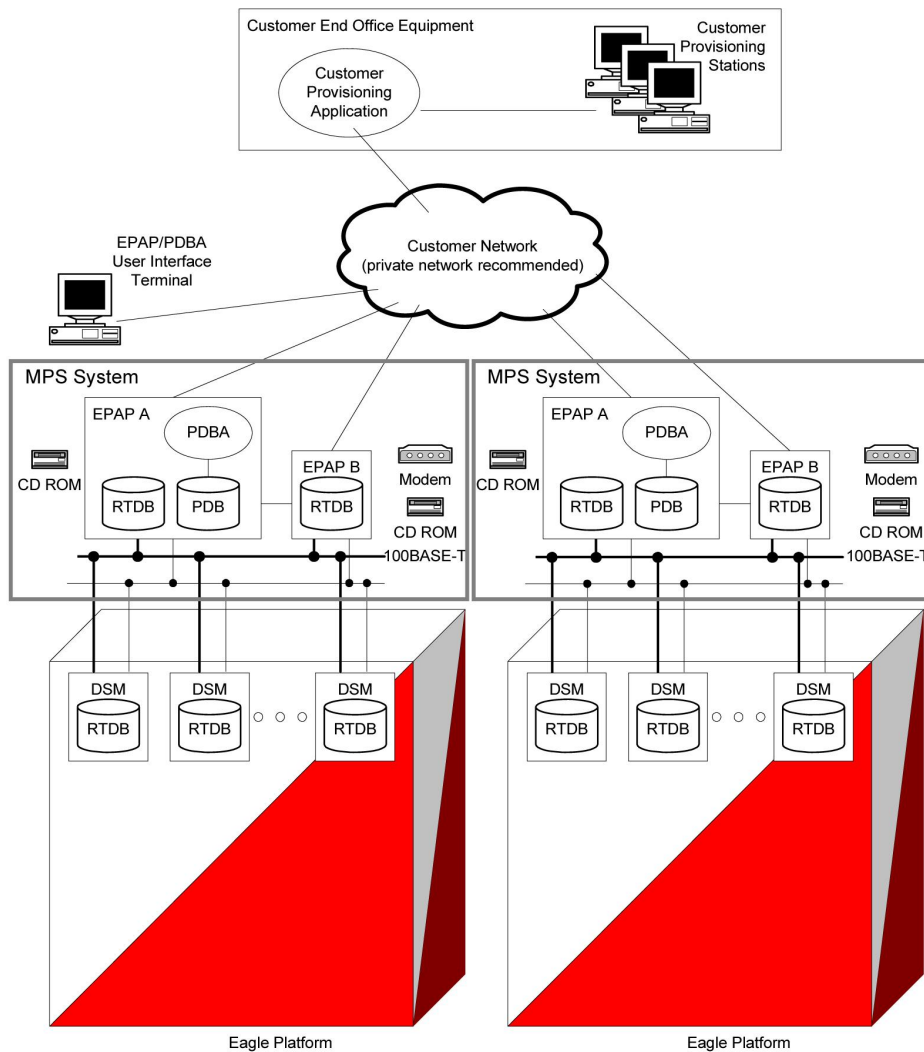

Design Overview and System Layout

Figure 1: MPS/EPAP Platform Architecture identifies the tasks, databases and interfaces which constitute the overall system architecture. The system consists of two mated MPS servers. Each MPS contains two EPAP platforms - EPAP A and EPAP B with each containing a Real Time Database (RTDB), Provisioning Database (PDB), servers, optical media, modems, and either network hubs when using a T1000 AS system or network switches when using a T1200 AS system. Each MPS and its associated EPAPs is an EPAP system; the EPAP system and the mated EAGLE 5 ISS are the mated EPAP system. Each EPAP system is either a T1000 AS or a T1200 AS system with a total of four Ethernet interfaces: one from each EPAP to the 100BASE-T Ethernet and one from each EPAP to either a 10BASE-T or a 100BASE-T Ethernet. Refer to [Table 5: Service Module Card Provisioning and Reload Settings](#) for the link speed.

On the EAGLE 5 ISS, a set of Service Module cards, which hold the RTDB, is part of the STP. Two high-speed Ethernet links connect the Service Module cards and the EPAPs. One of the links is a 100BASE-T Ethernet bus, and the other is either a 10BASE-T or a 100BASE-T Ethernet bus. Refer to [Table 5: Service Module Card Provisioning and Reload Settings](#) for the link speed.

The RTDB is provisioned and maintained through the EPAPs. EPAP A and EPAP B act as the active EPAP and the standby EPAP. One link serves as the active link, and the other link as the standby link. Only one EPAP and one link are active at a time. The database is provisioned through the active link by the active EPAP; the other EPAP provides redundancy.

If the active EPAP fails, the standby EPAP takes over the role of active EPAP and continues to provision the subscriber database. If the active link fails, the active EPAP switches to the standby link to continue provisioning the Service Module cards. The two Ethernet links are part of the DSM network.

Another 100BASE-T Ethernet link exists between the EPAPs; that link is called the EPAP Sync Network.

The major modules on the EPAP are:

- Service Module card provisioning module
- Maintenance module
- RTDB module
- PDB module

The Service Module card provisioning module is responsible for updating subscriber databases on the EAGLE 5 ISS Service Module cards using the Reliable Multicast Transport Protocol (RMTP) multicast. The maintenance module is responsible for the proper functioning of the EPAP platform. The PDB module is responsible for preparing and maintaining the Real Time Database, which is the *golden copy* of the subscriber database. The PDB module can run on one of the EPAPs of either mated EAGLE 5 ISS.

Functional Overview

The main function of the MPS/EPAP platform is to provision data from the customer network to the Service Module cards on the EAGLE 5 ISS. Subscriber database records are continuously updated from the customer network to the PDB. The PDB module communicates with the maintenance module and the RTDB task over a TCP/IP connection to provision the Service Module cards on the EAGLE 5 ISS. The maintenance module is responsible for the overall stability and performance of the system.

The RTDB on the EPAP contains a coherent, current copy of the subscriber database. If the current copy of the RTDB on the Service Module cards becomes *out-of-sync* because of missed provisioning or card rebooting, the EPAP Service Module card provisioning module sends database information through the provisioning link to the Service Module cards. The Service Module cards are reprovisioned with current subscriber information.

EPAP/PDBA Overview

The EAGLE Provisioning Application Processor (EPAP) platform and the Provisioning Database Application (PDBA), coupled with the Provisioning Database Interface (PDBI) facilitate the user database required for EAGLE 5 ISS EPAP-based features. The following functions are supported:

- Accept and store subscription data provisioned by the customer
- Update and reload subscriber databases on the Service Module cards

The PDBA operates on the master Provisioning Database (PDB). The EPAP and PDBA are both installed on the MPS hardware platform.

The EPAP platform performs the following:

- Maintains an exact copy of the real time database (RTDB) on the EPAP

- Distributes the subscription database to the Service Module cards
- Maintains a redundant copy of the RTDB database

The EPAP platform is a mated pair of processors (the upper processor, called EPAP A, and the lower processor, EPAP B) contained in one frame.

During normal operation, information flows through the EPAP/PDBA software with no intervention. Subscription data is generated at one or more operations centers and is delivered to the PDBA through a TCP socket interface (PDBI). The PDBA software stores and replicates data on EPAP A on the mated EPAP system. The data is then transmitted by the EPAPs across a private network to the Service Module cards located in the EAGLE 5 ISS frame.

The primary interface to the PDBA consists of machine-to-machine messages. The interface is defined by Tekelec and is described in the Provisioning Database Interface Manual. Provisioning software compatible with the EPAP socket interface can be created or updated using the interface described in that manual.

Additionally, a direct user interface is provided on each EPAP to allow for configuration, maintenance, debugging, and platform operations. A direct user interface is also provided by the PDBA for configuration and database maintenance.

The MPS/EPAP is an open-systems platform and easily accommodates the required high provisioning rates. Compared to the traditional OAM platform, the persistent database and provisioning in an open systems platform provides these benefits:

- Variety of hardware components and vendors
- Availability of third party communication and database tools
- Standard communication protocols
- Availability of personnel with related experience

Each EPAP server maintains a copy of the Real Time Database (RTDB) in order to provision the EAGLE 5 ISS Service Module cards. The EPAP server must comply with the hardware requirements in the *MPS Hardware Manual*. [Figure 1: MPS/EPAP Platform Architecture](#) illustrates the EPAP architecture contained in the MPS subsystem.

Each EPAP has a dedicated optical media drive. One EPAP per EAGLE 5 ISS platform has a modem capable of supporting remote diagnostics, configuration, and maintenance. These remote operations are performed through EPAP login sessions and are accessible across the customer network as well as through a direct terminal connection to the EPAP using an RS232 connection. Refer to *Tekelec 1000 Application Server Hardware Manual* or *Tekelec 1200 Application Server Hardware Manual* for details about the hardware devices and network connections.

Subscriber Data Provisioning

[Figure 2: Subscriber Data Provisioning Architecture \(High Level\)](#) shows a high-level view of the subscriber data provisioning architecture. Only those parts of the EAGLE 5 ISS platform that are relevant to subscriber data provisioning are shown. This section defines requirements for the Provisioning Database Interface (PDBI) between the EPAP and the operator's provisioning system (OPS). Provisioning clients connect to the EPAPs via the PDBI. This interface contains commands that allow all of the provisioning and retrieval of subscription data. The PDBI is used for real-time provisioning of subscriber and network entity data only. Refer to *Provisioning Database Interface Manual* for more details.

Figure 2: Subscriber Data Provisioning Architecture (High Level)

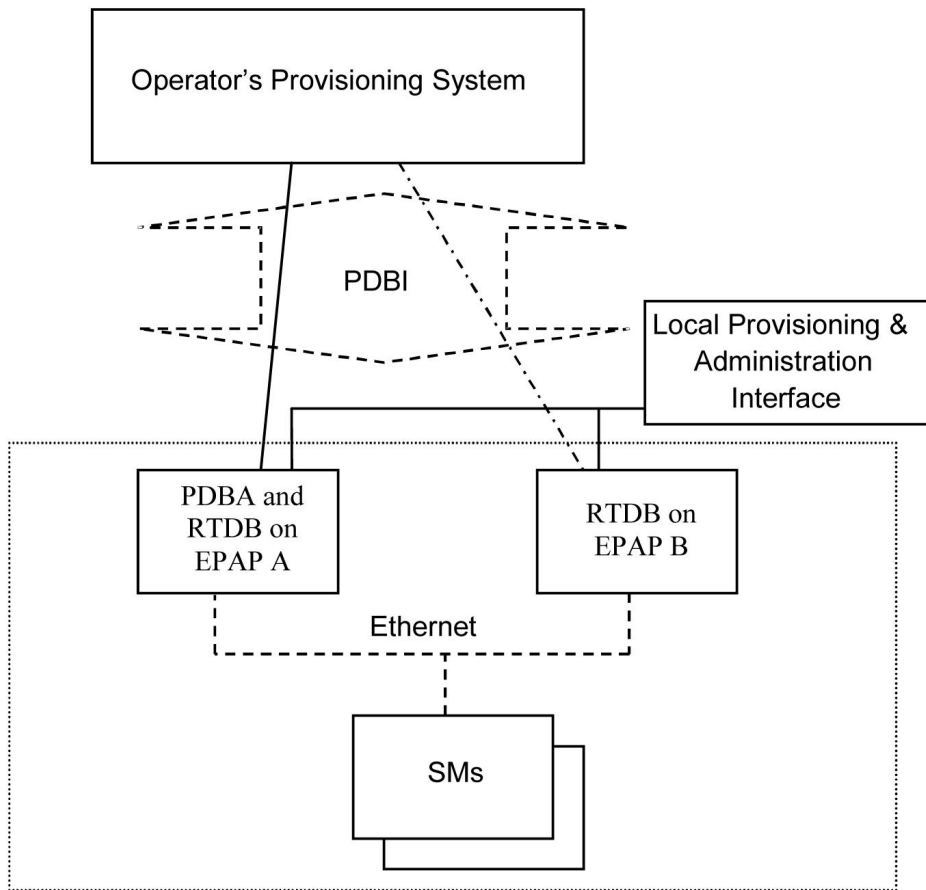

A pair of active/standby EPAP servers provides the interface between the Real Time Database (RTDB) of the EAGLE 5 ISS Service Module cards and the OPS. EPAP A is equipped with both the PDB (Provisioning Database) and the RTDB, and EPAP B has only the RTDB. An EPAP with only the RTDB must be updated by the EPAP that is equipped with the PDB.

For more information about the EPAP, refer to *EPAP Administration Manual*. For more information about the MPS hardware, refer to *Tekelec 1000 Application Server Hardware Manual* or *Tekelec 1200 Application Server Hardware Manual*.

Distributed Administrative Architecture

This section describes, at a high level, the distributed administrative architecture for the EAGLE 5 ISS, including the EPAP.

Databases requiring high update and retrieval rates, such as the EPAP RTDB, are populated using redundant Ethernet connections to Service Module cards from an EPAP MPS platform.

An EPAP consists of a combined Provisioning (MySQL) and Real Time Database (RTDB). The Provisioning Database (PDB) responds to requests for updates by the active and standby RTDBs on both mated EAGLE 5 ISSs. The active EPAP RTDB is responsible for initiating multi-cast updates of changed database records to the Service Module cards after the data has been committed to the EPAP disks. Furthermore, the PDB may accept and commit more database updates while the RTDBs are completing their previous updates.

It is this overlapping of database updates, coupled with an RTDB transactional database engine and fast download time, that allows larger amounts of data at a time to be transferred from the PDB. Committing larger amounts of data at a time to the RTDB (versus a single update at a time) allows faster overall transaction rates to be achieved. The boundaries of the transaction rates become more closely related to cache size and disk cache flush time than the disk access time of a single update. Thus, successful completion of EPAP database updates only guarantees that the PDB has been updated, but it does not mean the RTDB has completed the update and sent the new subscription data to the Service Module card.

The EPAP architecture contains a local provisioning terminal and a modem for remote access, as well as other functions. A backup device can be used to back up or restore the provisioning database. The local provisioning terminal is used to manually repair the standby EPAP RTDB or to turn the subscriber database audit on or off. For additional information, refer to *Tekelec 1000 Application Server Hardware Manual*, *Tekelec 1200 Application Server Hardware Manual*, and *EPAP Administration Manual*.

EPAP (EAGLE Provisioning Application Processor)

As shown in [Figure 1: MPS/EPAP Platform Architecture](#), a single MPS system contains two EAGLE Provisioning Application Processor (EPAP) servers. At any given time, only one EPAP actively communicates with the Service Module cards on the EAGLE 5 ISS. The other EPAP server is in standby mode. In addition, two MPS systems can be deployed in a mated pair configuration.

The primary purpose of the EPAP system is to maintain the Real Time Database (RTDB) and Provisioning Database (PDB), and to download copies of the RTDB to the Service Module cards.

The PDB on the active EPAP receives subscription data from the customer network through the Provisioning Database Interface (PDBI), the external source of provisioning information. The Provisioning Database Application (PDBA) continually updates the PDB of the active EPAP. The PDB uses MySQL database software. After an update is applied to the active PDB, the data is sent to the RTDBs on the active and standby EPAPs.

Both the active and standby EPAPs maintain copies of the RTDB. Periodically, the Service Module card polls the active EPAP RTDB for any new updates. The active EPAP downloads the updates to the Service Module card which stores a resident copy of the RTDB.

A mated pair configuration has two mated MPS Systems, as shown in [Figure 1: MPS/EPAP Platform Architecture](#). The PDB on the active EPAP automatically updates the PDB on the mate platform. The PDB on the mate platform then updates RTDBs on its EPAPs, which in turn update the RTDBs on the associated Service Module cards.

Provisioning of the EAGLE 5 ISS Service Module cards is performed through two interfaces using two different sets of commands. Provisioning is accomplished by the STP updates from EAGLE 5 ISS terminals and by updates from the customer's external provisioning system. This system of dual provisioning is illustrated in [Figure 3: Database Administrative Architecture](#).

Figure 3: Database Administrative Architecture

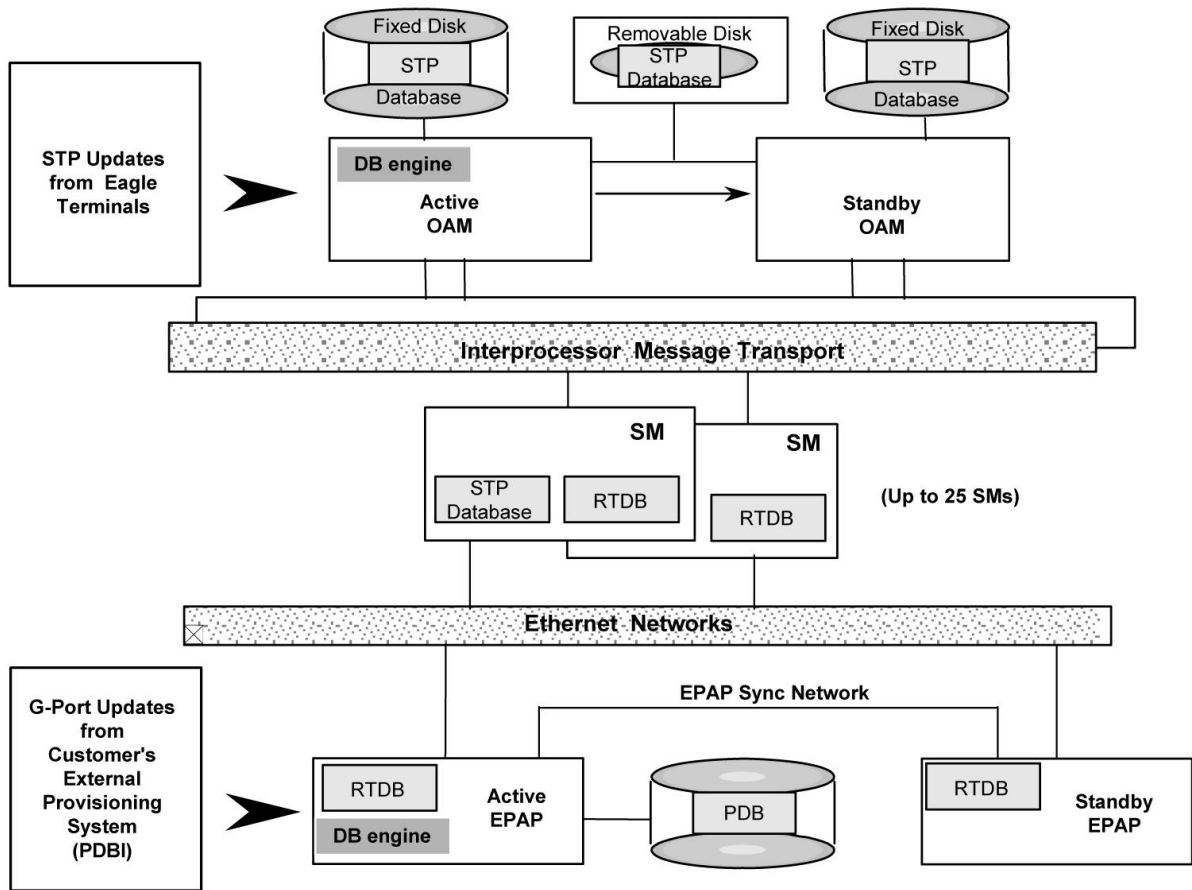

Service Module Cards

A maximum number of Service Module cards can be provisioned with one or more EPAP-related features enabled.

- Up to 25 cards (24+1) with EPAP running on a T1000 AS
- Up to 32 cards (31+1) with EPAP running on a T1200 AS

EPAP-related features require that all Service Module cards contain 4 GB of memory. [Figure 3: Database Administrative Architecture](#) illustrates each Service Module card having two Ethernet links, the main DSM network on the 100BASE-T link and the backup DSM network. Refer to [Table 5: Service Module Card Provisioning and Reload Settings](#) for the link speed. The Service Module cards run the VSCCP software application.

The Service Module card Ethernet ports are linked to the EPAP system to receive the downloaded Real Time Database (RTDB). Multiple Service Module cards provide a means of load balancing in high-traffic situations. The RTDB on the Service Module card is in a format that facilitates rapid lookups.

Though the Service Module card copies of the RTDB are intended to be identical, the various databases may not be identical at all times for the following reasons:

- When a Service Module card is initialized, the card downloads the current copy of the database from the EPAP. While that card is being loaded, it cannot receive new updates that have arrived at the EPAP since reload began.
- Card databases can become out-of-sync with the EPAP RTDB when the EPAP receives updates from its provisioning source, but it has not yet sent the updates down to the Service Module cards. Updates are applied to the Provisioning Database (PDB) as they are received.

Two possible scenarios contribute to a condition where a Service Module card may not have enough memory to hold the entire database:

- The database is downloaded successfully to the Service Module card, but subsequent updates eventually increase the size of the database beyond the capacity of the Service Module card memory. In this situation, it is desirable for EPAP-related features to continue processing transactions, even though the database might not be up-to-date.
- When a Service Module card is booted and it is determined then that the card does not have enough memory for the entire database, the database is not loaded on that card. Each Service Module card is responsible for recognizing and reporting its out-of-memory conditions by means of alarms.

Overview of EPAP to Service Module Card Communications

Before discussing Service Module card status reporting or EPAP status reporting, it is helpful to understand the communications between the Service Module cards and the EPAP in broad terms.

- UDP - sending Service Module card status messages

The Service Module cards and EPAPs create a UDP (User Datagram Protocol) socket which is used for status messages. One of the last things a Service Module card does when it is initialized is to send a status message to the EPAP, containing the Service Module ID, database level, and memory size. The EPAP maintains tables containing the last known status of each Service Module card. EPAP uses these to determine whether or not the Service Module card needs to download the database.

- IP - reporting EPAP maintenance data

The Service Module cards create a TCP socket when they are initialized, and listen for connection requests. During initialization or after a loss of connectivity, the active EPAP chooses one of the Service Module cards and issues a *Connect* to establish the TCP/IP connection with that Service Module card which is referred to as the primary Service Module card. The purpose of this link is to provide a path for reporting EPAP alarms and to forward maintenance blocks to the Service Module card.

- IP Multicast - downloading GSM database

Because of the large size of the database and the need to download it quickly on up to 32 Service Module cards, EPAP-related features use a technique known as IP multicasting. This technique is based on Reliable Multicast Transport Protocol-II (RMTP-II), a product of Globalcast Communications. IP multicasting downloads the RTDB and database updates to all of the Service Module cards simultaneously.

The administration of IP multicasting is based on the concept of a “tree”, or stream of data, which is constantly being broadcast by the EPAP. Service Module cards that need to download the real time database or to receive database updates “join the tree”. Service Module cards can also “leave the tree”, typically when the database fills their available memory.

Service Module Card Provisioning and Reload

One of the core functions of the EPAP is to provision the Service Module cards with the Real Time Database (RTDB) updates. In order to provide redundancy for this feature, separate RMTP channels are created on each interface from each EPAP:

Table 5: Service Module Card Provisioning and Reload Settings

RMTP Channel	T1000	T1200 Running Only DSM cards	T1200 Running Only E5-SM4G cards	T1200 Running both DSM and E5-SM4G cards
EPAP A, Link A (on the main DSM network)	100BASE-T	100BASE-T	100BASE-T	100BASE-T
EPAP A, Link B (on the backup DSM network)	10BASE-T	10BASE-T	100BASE-T	10BASE-T
EPAP B, Link A (on the main DSM network)	100BASE-T	100BASE-T	100BASE-T	100BASE-T
EPAP B, Link B (on the backup DSM network)	10BASE-T	10BASE-T	100BASE-T	10BASE-T
Note: Full duplex mode is supported only when running all E5-SM4G cards on the T1200. In all other cases, half duplex mode is supported.				

Provisioning and other data is broadcast on one of these channels to all of the Service Module cards. Provisioning is done by database level in order to leave tables coherent between updates.

The Service Module cards do the following:

- Detect the need for incremental updates and send a status message to the EPAP.
- Discriminate between the various streams according to the database level contained in each message and accept updates based on the Service Module card database level.

Service Module Card Reload Model

Service Module cards may require a complete database reload in the event of reboot or loss of connectivity for a significant amount of time. The EPAP provides a mechanism to quickly load a number of Service Module cards with the current database. The database on the EPAP is large and may be updated constantly. The database sent to the Service Module card or cards will likely be missing some of these updates making it corrupt, in addition to being "back level."

EPAP Continuous Reload

It is important to understand how the EPAP handles reloading of multiple Service Module cards from different starting points. Reload begins when the first Service Module card requires it. Records are read sequentially from the Real Time Database (RTDB) from an arbitrary starting point, wrapping back to the beginning. If another Service Module card requires reloading at this time, it uses the existing record stream and notifies the Service Module card provisioning task of the first record it read. This continues until all Service Module cards are satisfied.

Service Module Card Database Levels and Reloading

The current database level when the reload started is of special importance during reload. When a Service Module card detects that the last record has been received, it sends a status message back to the EPAP indicating the database level at the start of reload. This action starts incremental loading. The Service Module card continues to reload until it is completely caught up with the current level of the RTDB. As database records are sent to the Service Module cards during reload, normal provisioning can change those records. All records changed between the start and end of reloading must be incrementally loaded before the database is coherent and usable by the Service Module card.

The following terminology is used here for the stages of database reload for a given Service Module card.

- **Stage 1 loading:** The database is being copied record for record from the golden RTDB in the EPAP to the Service Module card RTDB. The database is incoherent during stage 1 loading.
- **Incremental update:** The database is receiving all of the updates missed during stage 1 loading or some other reason, such as network outage, processor limitation, or lost communication. The database is coherent, but back-level during incremental update.
- **Current:** The database is receiving current updates from the Service Module card provisioning task.
- **Coherent:** The database is at a whole database level which means not currently updating records belonging to a database level.

EPAP Status and Error Reporting via Maintenance Blocks

The EPAP forwards all status and error messages to the Service Module cards in maintenance blocks. Maintenance blocks are asynchronously sent whenever the EPAP has something to report. The maintenance blocks eventually update EPAP Device Control Blocks (DCBs) located on the EAGLE 5 ISS. The DCBs provide the status information that is received when a `rept-stat-mps` command is issued.

Network Connections

Several customer and Tekelec-installed private networks are required to support the provisioning of subscription data. These networks are:

- *Customer Provisioning Network*
- *EPAP Sync Network*
- *DSM Networks*
- *Dial-Up PPP Network*

The following discussion is an overview of these private networks. It expands on the networks in the architecture diagram shown in *Figure 4: Customer Provisioning Network*. (For details about configuring these networks, refer to the *EPAP Administration Manual*.)

Customer Provisioning Network

The customer network carries the following traffic:

- Customer queries and responses to the PDB via the PDBI from the customer provisioning network
- Updates between PDBs of a mated EAGLE 5 ISS pair
- Updates between a PDB on one EAGLE 5 ISS and RTDBs on a mated EAGLE 5 ISS
- PDBA import/export (file transfer) traffic
- Traffic from a PDBA reloading from its mate
- EPAP and PDBA user interface traffic.

A typical customer network is shown in *Figure 4: Customer Provisioning Network*.

Figure 4: Customer Provisioning Network

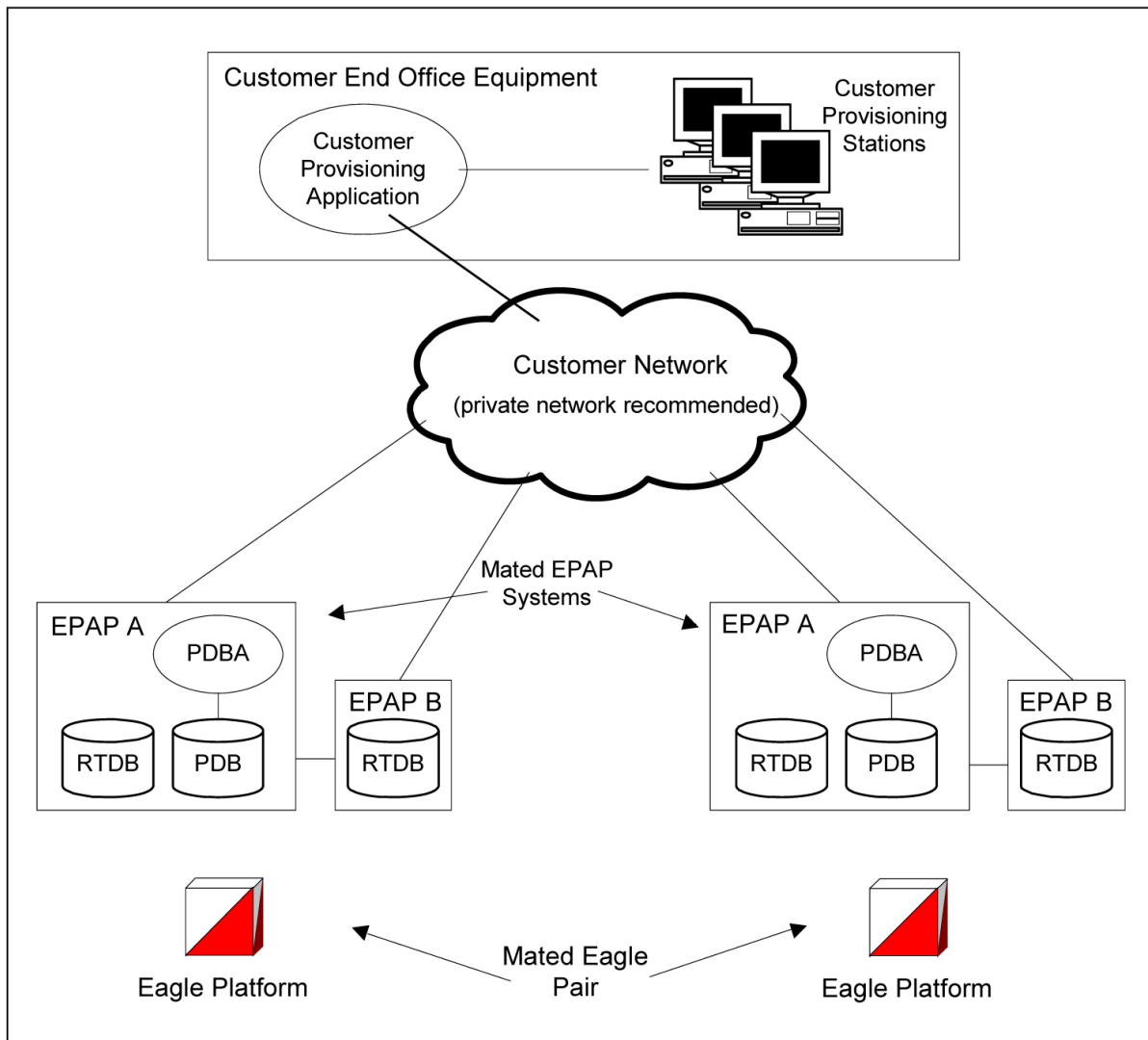

Although a dedicated network is recommended, it is possible that unrelated customer traffic can use the network as well. The determination, either to have a dedicated network or to allow other customer traffic, should be based on available external Ethernet bandwidth and network performance considerations.

EPAP Sync Network

The T1000 EPAP sync network carries RTDB and maintenance application traffic between active and standby EPAP servers on an MPS system. It synchronizes the contents of the RTDBs of both EPAP A and B. The EPAP Sync network is a single Ethernet connection between EPAP A and EPAP B running at 100BASE-T, as shown in [Figure 5: EPAP Sync Network](#). The T1200 EPAP Sync network is truncated with the EPAP back up DSM connection and communicates through the switch.

Figure 5: EPAP Sync Network

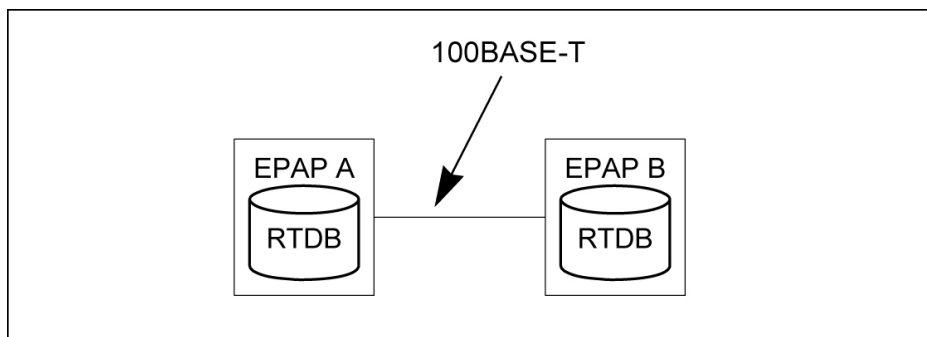

DSM Networks

The DSM networks are shown in [Figure 6: DSM Networks](#). They carry provisioning data from the active EPAP RTDB to the Service Module cards. They also carry reload and maintenance traffic to the Service Module cards.

The DSM networks consist of two Ethernet networks: the main DSM network running at 100BASE-T, and the backup DSM network running at either 10BASE-T or 100Base-T. Refer to [Table 6: EPAP IP Addresses in the DSM Network](#) for the link speed. Both Ethernet networks connect EPAP A and EPAP B with every Service Module card on a single EAGLE 5 ISS platform.

Figure 6: DSM Networks

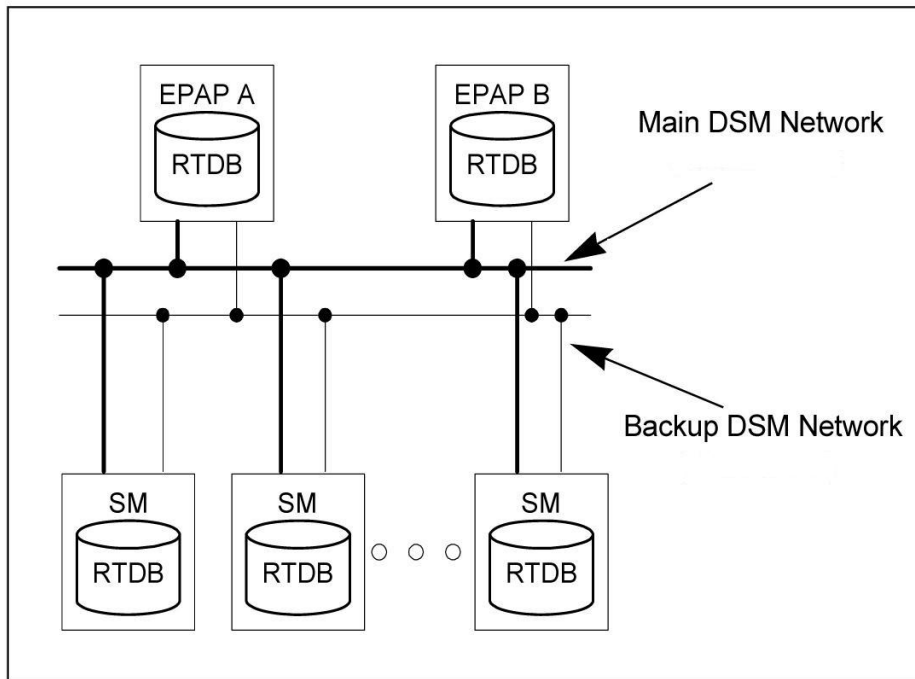

Maintenance information is sent from the active EPAP to an arbitrarily selected Service Module card. The selected Service Module card is known as the primary Service Module card. Static information is exchanged across this interface at initialization, and dynamic information is exchanged on occasion.

While much of the traditional OAM provisioning and database functionality is implemented on the EPAP, the maintenance reporting mechanism is still the OAM.

The first and second octets of the EPAP network addresses for this network are 192.168. (The first two octets for private class C networks are defined in RFC 1918.)

The third octet is customer specifiable for each DSM network. It is important to select values that do not interfere with the customer's network addressing scheme.

The fourth octet of the address is specified as follows:

- If the EPAP is configured as "EPAP A", the fourth octet has a value of 100.
- If the EPAP is configured as "EPAP B", the fourth octet has a value of 200.

Table 6: EPAP IP Addresses in the DSM Network summarizes the contents of each octet.

Table 6: EPAP IP Addresses in the DSM Network

Octet	Value
1	192
2	168
3	One customer-provisioned value for DSM network A and another for DSM network B
4	100 for EPAP A and 200 for EPAP B

Dial-Up PPP Network

The dial-up PPP network allows multiple user-interface sessions to be established with the EPAP. The network connects a remote EPAP/PDBA user interface terminal with the EPAP in the EAGLE 5 ISS's MPS subsystem. The dial-up PPP network is illustrated in *Figure 7: Dial-Up PPP Network*.

Figure 7: Dial-Up PPP Network

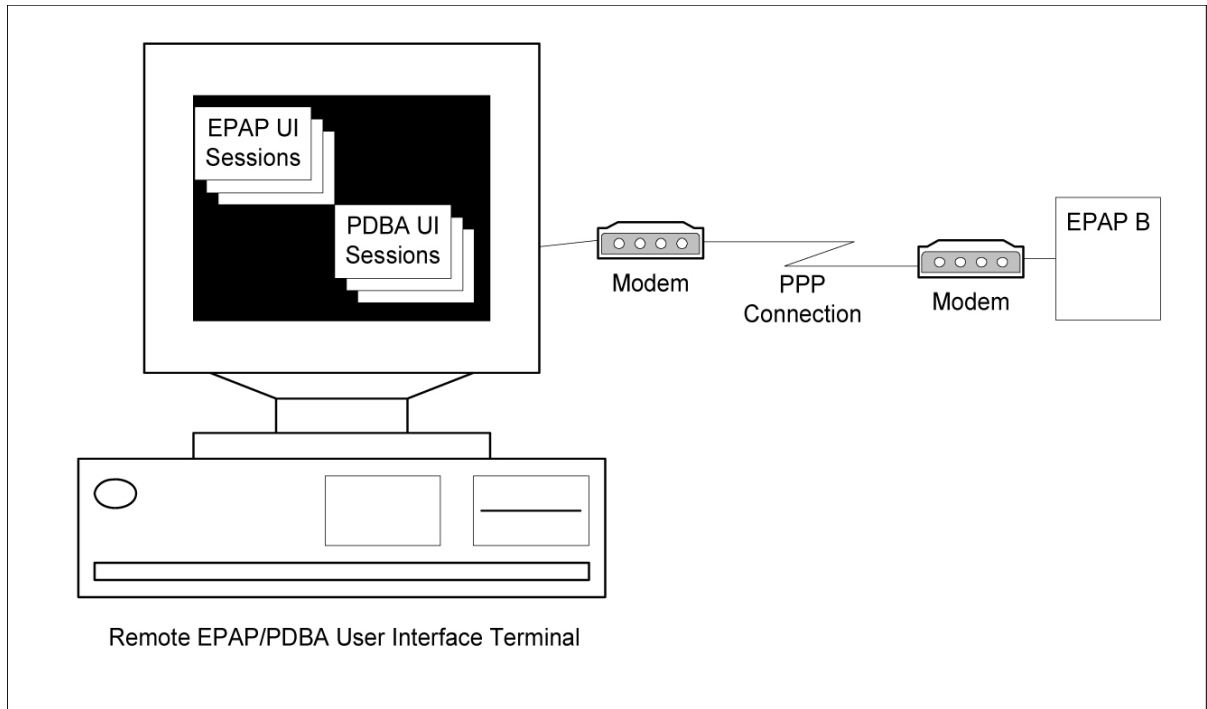

Chapter 3

EAGLE 5 ISS ATINP Commands

Topics:

- [EAGLE 5 ISS Commands.....47](#)
- [Maintenance Commands.....48](#)
- [EAGLE 5 ISS Debug Commands.....50](#)

This chapter contains brief descriptions of the EAGLE 5 ISS commands that are used for the configuration and maintenance for the ATINumber Portability Query (ATINP) feature.

EAGLE 5 ISS Commands

This chapter describes EAGLE 5 ISS commands that can be used for the configuration and maintenance of the ATI Number Portability Query (ATINP) feature.

Refer to the *Commands Manual* for complete descriptions of the following commands, including parameter names, valid values, and output examples for the commands.

Table 7: Commands used for ATINP

Type	Commands
System Serial Number	ent/rtrv-serial-num
Card	ent/dlt/rtrv/alw/inh/init/rept-stat-card
Feature Control	enable/chg/rtrv-ctrl-feat
STP Options	chg/rtrv-stpopts
EAGLE 5 ISS STP Self Identification	chg/rtrv-sid
Mated Application (MAP)	chg/dlt/ent/rtrv-map
Subsystem Application	chg/dlt/ent/rtrv-ss-appl
Service Selector	chg/dlt/ent/rtrv-srvsel
ATINP Options (and options for Service Portability)	chg/rtrv-atinpqopts
Local Subsystem Activation	alw/inh-map-ss
Retrieve, Report Status, and Maintenance	chg-th-alm, ent-trace, init-network, init-sys, rept-stat-alm, rept-stat-db, rept-stat-sys, rep-stat-trbl, rtrv-data, rtdb, rtrv-tbl-capacity

enable-ctrl-feat / chg-ctrl-feat / rtrv-ctrl-feat

These commands are used to enable, turn on, and display the on/off status of the ATINP feature and the Service Portability feature.

chg-stpopts / rtrv-stpopts

The STP Options commands are used to provision system options for the EAGLE 5 ISS. The options are used to control system-level processing. Features can check the option values to determine what processing to apply.

The Default Country Code (defcc) and DSM checksum audit (dsmaud) parameters are supported for ATINP.

chg/dlt/rtrv-ss-appl

The Local Subsystem Application commands are used to reserve a subsystem number for a local subsystem application, to delete the local subsystem application, to change the online/offline status of the subsystem application, and to display the local subsystem application status in the database.

The local subsystem application for the ATINP feature is ATINPQ.

ent-srvsel / dlt-srvsel / chg-srvsel / rtrv-srvsel

The service selector commands are used to provision and display service selector information for the atinp service.

chg-atinpqopts / rtrv-atinpqopts

The ATINP Options commands are used to provision the configuration options for the ATINP feature. The options control number portability and Service Portability processing for ATI messages and response message formatting.

The ATINP Options commands define and display ATINP options that are provisioned in the ATINPQOPTS table. The ATINP options are used for the following functions:

- Specify the format of the IMSI, MSISDN, and Routing Number parameters in the ATI ACK response message, and the maximum number of digits to be used from the SRFIMSI or Entity ID in the encoding format
- Determine whether the IMSI, MSISDN, or Routing Number parameter is included or not included in the ATI ACK response message
- Specify the default routing number and outbound message digits delimiter to be used in outbound message formats
- Specify the number conditioning to be performed on the MSISDN digits in the incoming ATI query message before RTDB lookup is performed, and indicate the determination of a successful RTDB lookup
- Specify Service Portability processing that can be performed for ATI messages

alw/inh / inh-map-ss

The alw/inh-map-ss commands allow and inhibit (or shut down) the operation of a mated application subsystem. The subsystem number for the local subsystem application must be specified in the command.

Allowing causes the subsystem to become operational in the system.

Inhibiting stops the operation of (shuts down) a mated application subsystem. The specified subsystem attempts a coordinated shutdown. If the coordinated shutdown fails, a UIM is issued indicating the shutdown failed. If the force parameter is specified in the command, the subsystem is forced to shut down, and a coordinated shutdown is not performed.

Maintenance Commands

The following commands can be used for maintenance when an EPAP-related feature is on.

Refer to the command descriptions in the *Commands Manual* for complete descriptions of the commands, including parameters, valid values, and output examples.

Table 8: Maintenance Commands

Command	Description
rept-stat-sys	Reports the status of system entities, including cards. The output includes the number of Service Module cards that are in service (IS-NR) and how many are in another state (IS-ANR, OOS-MT, OOS-MT-DSBLD).
rept-stat-sccp	Reports subsystem operating status, CPU usage, and Service Module card status. When the loc parameter is specified, the command displays detailed card traffic statistics. See the section in this manual for each feature that describes the use of the <code>rept-stat-sccp</code> command for that feature.
rept-stat-mps	Displays the overall status of the application running on the MPS (multi-purpose server). Command output for the various reports of this command include overall MPS alarm status and card status, and status for a specific Service Module card when a feature is on.
rept-stat-trbl	Includes a summary of any trouble notifications (UAMs) for local subsystems, cards, and linksets. The severity of each alarm is indicated in the output report.
rept-stat-alm	Displays the alarm counts and totals for local subsystems and DSM/EPAP IP links.
rept-stat-db	Displays the status information for the EAGLE 5 ISS databases. This includes the level information for each Service Module card, and for the active and standby EPAP databases. It reports database exception status such as corrupted, incoherent, or inconsistent, as well as providing the birth dates and levels. It shows the status of the PDB and RTDB databases when an EPAP-based feature is enabled.
rtrv-tbl capacity	Retrieves table use capacity summary information. For each table listed, the number of table entry elements in use and the total allowed number of table elements is presented, along with a percent (%) full value. Information is shown for some tables only if the feature that uses the table is enabled.
inh-card/alw-card	Used to change the operating state of the card from In-Service Normal (IS-NR) to Out-of-Service Maintenance-Disabled (OOS-MT-DSBLD). A craftsperson then can test the card or physically remove it from the shelf. The <code>alw-card</code> command is used to change the card from OOS-MT-DSBLD (Out-of-Service Maintenance-Disabled) to IS-NR (In-Service Normal) if card loading is successful.
inh-alm/unhb-alm	Used to allow and inhibit alarms on the Service Module card ports. The commands allow both Port A and Port B to be specified.
rtrv-data-rtdb	Retrieves Entity data, DN data, IMEI data, IMSI data, TN data, NPANXX data, and LRN data from the RTDB on an active Service Module card. If the loc parameter is specified and the target card is an active Service Module card, the RTDB data is retrieved from that card.

Command	Description
	<p>If the loc parameter is not specified, the RTDB data is retrieved on the active Service Module card that has the lowest IMT address.</p> <p>The RTDB status on the active Service Module card can be coherent or incoherent.</p>

rept-stat-sccp

This command reports local subsystem operating status, CPU usage related to the subsystem, and Service Module card status. When the loc parameter is specified, the command displays detailed card traffic statistics.

EAGLE 5 ISS Debug Commands

The *Commands Manual* contains descriptions of debug commands that can be used in assessing and modifying system status and operation. Most of the debug commands are used only under the direction of Tekelec support personnel.

The `ent-trace` command can be used to trace MSUs sent to Service Module cards that are running the VSCCP application. The EAGLE 5 ISS traps MSUs that meet the specified tracing criteria, which are the DN and ENTITYID parameters when the ATINP feature is enabled.

ATINP Configuration

Topics:

- *Introduction.....52*
- *ATINP Configuration Procedure.....54*
- *Adding a Service Module Card.....55*
- *Enabling ATINP, Setting STP Options, and Turning On ATINP.....59*
- *Enabling the Service Portability Feature.....60*
- *Provisioning True Point Codes and Capability Point Codes.....61*
- *Provisioning the ATINPQ Local Subsystem.....63*
- *Provisioning the ATINP Service Selector.....65*
- *Provisioning the ATINP Options.....70*
- *Activating the ATINPQ Local Subsystem.....71*
- *Turning On the Service Portability Feature.....72*
- *Turning Off the Service Portability Feature.....73*
- *Changing the State of a Subsystem Application.....74*
- *The 1100 TPS/DSM for ITU NP Feature.....76*
- *Activating the E5-SM4G Throughput Capacity Feature.....81*

This chapter provides procedures for configuring the ATINP feature for use in the EAGLE 5 ISS.

Introduction

The ATINP feature is configured on the EAGLE 5 ISS and on the EPAP. This chapter describes prerequisites and procedures for the EAGLE 5 ISS configuration only. The EPAP configuration is covered in the *EPAP Administration Manual*. This chapter also includes procedures for configuration of the Service Portability feature for use with ATINP, and for provisioning options to allow the use of the GRN for ROP information.

ATINP Configuration Procedure lists the steps for enabling and turning on the ATINP feature and the Service Portability feature, and for the provisioning required for the features. Each step contains a link or reference to information and procedures to use to complete the step. Feature provisioning can be performed after the features are enabled and before the features are turned on.

The ATINP feature and other related features are optional and must be purchased from Tekelec before they can be used in your system. If you are not sure whether you have purchased a specific feature, contact your Tekelec Sales or Account Representative.

Note: For an in-service environment, contact the *Customer Care Center* before continuing to configure the ATINP feature. For an environment that is not yet in-service, continue with the configuration.

EPAP Entity Provisioning

It is recommended that EPAP entity (SP or RN) administration not be done until after the point code and/or subsystem number has been entered into the EAGLE 5 ISS MAP table (see Step 5).

- EPAP-administered entity data can possibly become out-of-sync with the EAGLE 5 ISS MAP table when the creation of point codes and/or subsystem numbers in the MAP table is performed after EPAP database administration.
- If this mismatch is discovered in real-time operations, a UIM (such as SCCP did not route - DPC not in MAP tbl or SCCP did not route - SS not in MAP tbl) is sent to the EAGLE 5 ISS maintenance terminal.

System Prerequisites

Before any feature that is described in this manual can be enabled, the prerequisites listed in *Table 9: System Prerequisites* are required in the system.

Table 9: System Prerequisites

Prerequisite	Verification and Provisioning
<p>The system serial number must be correct and locked.</p> <p>For new installations, the system is shipped with an unlocked serial number. The serial number can be changed if necessary and must be locked after the system is on-site.</p> <p>For systems that are being upgraded, the serial number is usually already verified and locked.</p>	<p>Note: The serial number cannot be changed after it is entered and locked in the system.</p> <p>Locate the serial number for the system on a label affixed to the control shelf (1100).</p> <p>Enter the <code>rtrv-serial-num</code> command to display the serial number and its locked status.</p>

Prerequisite	Verification and Provisioning
	<p>Verify that the displayed serial number is correct for the system.</p> <p>If no serial number is displayed, enter the <code>ent-serial-num</code> command (without the lock parameter) to provision the serial number that appears on the control shelf label. Enter the <code>rtrv-serial-num</code> command and verify that the serial number was entered correctly.</p> <p>Enter the <code>ent-serial-num</code> command with the <code>lock=yes</code> parameter to lock the serial number in the system.</p>
<p>A sufficient number of Service Module cards must be equipped.</p> <p>Some features require only E5-SM4G cards and cannot use DSM cards. See specific feature prerequisites, if any, in this section.</p> <p>Refer to the <i>Dimensioning Guide for EPAP Advanced DB Features Technical Reference</i> for information on the dimensioning rules and the database capacity requirements for EPAP-related features.</p>	<p>Enter the <code>rept-stat-card:appl=vsccp</code> command to list the Service Module cards in the system.</p> <p>If more cards or cards of a different type are needed, refer to the procedures in the <i>Database Administration Manual - GTT</i> to add Service Module cards or remove DSM cards.</p>
<p>The GTT feature must be on in the system.</p> <p>Some features require an additional GTT-related feature such as EGTT. See the specific feature prerequisites in this section.</p>	<p>Enter the <code>rtrv-feat</code> command to display the GTT feature status.</p> <p>If the GTT feature is on, the <code>gtt=on</code> entry appears in the output.</p> <p>If the <code>gtt=off</code> entry appears in the output, use the procedures in the <i>Database Administration Manual - GTT</i> to turn on and provision the GTT feature and any other GTT-related features and functions that will be used in the system.</p>

ATINP Feature Prerequisites

Before the ATINP feature can be enabled, the following prerequisites are required in the system:

Table 10: ATINP Feature Prerequisite

Prerequisite	Verification and Provisioning
<p>The ANSIGFLEX system option cannot be set to Yes.</p>	<p>Enter the <code>rtrv-stpopts</code> command.</p> <p>Verify that the ANSIGFLEX entry does not appear in the command output or that the ANSI GFLEX entry shows a value of No.</p>

Prerequisite	Verification and Provisioning
The LNP feature cannot be on in the system.	<p data-bbox="854 310 1321 342">Enter the <code>rtrv-ctrl-feat</code> command.</p> <p data-bbox="854 363 1424 485">If the LNP feature is on, shown with a quantity greater than zero for the LNP ported TNs entry in the command output, the feature described in this manual cannot be enabled.</p>

ATINP Configuration Procedure

The EAGLE 5 ISS configuration of the ATINP feature consists of the following steps. The steps contain links and references to detailed procedures and information needed to complete each step.

1. Verify, and provision if needed, the system prerequisites. See [System Prerequisites](#).
2. Verify, and provision if needed, the feature prerequisites. See [ATINP Feature Prerequisites](#).
3. Enable the ATINP feature, set system STP options, and turn on the ATINP feature. See [Enabling ATINP, Setting STP Options, and Turning On ATINP](#).
4. Enable the Service Portability feature, if it will be used with ATINP. See [Enabling the Service Portability Feature](#).
5. Change the self identification of the EAGLE 5 ISS node to include true point codes and ATINP capability point codes. See [Provisioning True Point Codes and Capability Point Codes](#) and refer to the procedures in the *Database Administration Manual - SS7*.
6. Refer to the procedures in the *Database Administration Manual - Global Title Translation* to provision the following items:
 - Translation types and mappings
 - Mated Application table entries for the ATINP feature that contain the EAGLE 5 ISS true point codes, the ATINP capability point codes, and the ATINPQ subsystem number. Only solitary and dominant loadsharing are supported.

The ATINPQ subsystem can have a mate subsystem and a concerned point code group assigned to it in the MAP table.

If multiple point code types for ATINPQ are provisioned in the MAP table, then the point code type for the Subsystem Out-of-Service Request message (SOR) is determined using the following order:

1. ANSI
2. ITU-N
3. ITU-N Spare
4. ITU-I
5. ITU-I Spare
7. Provision state and subsystem number for the ATINPQ local subsystem application. See [Adding the ATINPQ Local Subsystem Application](#).
8. Provision the service selector mechanism to route MSUs to the ATINPQ subsystem. See [Adding an ATINP Service Selector](#).

The ATINP service is `atinp`.

The Translation Type and Subsystem Number are the values assigned for the ATINP local subsystem when the MAP table entries were defined. See Step 4 in this procedure.

ATINP supports ANSI, ITU-I, and ITU-N Global Title Indicators; ITU-N24 is not supported.

The Nature of Address Indicator and Numbering Plan are required when the GTI value is 4, and not allowed when the GTI value is 2.

ATINP does not support the Service Nature of Address or the Service Numbering Plan.

9. Provision ATINP options, including options for Service Portability and GRN data processing if required. See [Provisioning the ATINP Options](#).
10. Activate the ATINP local subsystem. See [Activating the ATINPQ Local Subsystem](#).
11. Turn on the Service Portability feature, if it will be used with ATINP. See [Turning On the Service Portability Feature](#).
12. Configure the Measurements Platform feature or the E5-OAM Integrated Measurements feature if measurements are to be collected for ATINPQ.

Refer to the procedures in the *Database Administration Manual - System Management* for configuring the Measurements Platform feature, the E5-OAM Integrated Measurements feature, and the EAGLE OA&M IP Security feature in the EAGLE 5 ISS. (OAM-based measurements reports are not available for ATINPQ).

Adding a Service Module Card

This procedure is used to add Service Module cards to the database to support GTT-related features and EPAP-related features.

EPAP-based features require Service Module cards running the VSCCP application. The following cards can be used as Service Module cards running the VSCCP application in the system:

- DSM 4G – a DSM card with 4 gigabytes of memory
- E5-SM4G - an EPM-based card with 4 gigabytes of memory

The system can contain a maximum number of Service Module cards for EPAP-related features:

- Up to 25 (24+1) Service Module cards if EPAP is running in a T1000 AS
- Up to 32 (31+1) Service Module cards if EPAP is running in a T1200 AS
 - The following Warning appears when more than 25 Service Module cards have been provisioned in the system and the `enable-ctrl-feat` command is entered to enable the first EPAP-related feature in the system:

```
Warning: The Eagle must be connected to an EPAP T1200 or higher
```

- The following Caution appears when the `ent-card` command is entered to add the 26th Service Module card to the database and any EPAP-related feature is enabled in the system:

```
CAUTION: Please ensure EPAP Application Server is running on
hardware supporting 32 SCCP cards e.g.: T1200.
Re-enter command within 30 seconds to confirm change.
```

Refer to *Dimensioning Guide for EPAP Advanced DB Features Technical Reference* for important information on the dimensioning rules and the Service Module card database capacity requirements.

A Service Module card occupies two card slots. A Service Module card can be inserted only in an odd/even numbered pair of empty card slots of an EAGLE 5 ISS shelf. The even-numbered card slot to the right of the odd-numbered slot where the Service Module card is to be inserted must be empty. A Service Module card cannot be inserted in slots 09 and 10 because slots 09 and 10 of each shelf contain HMUX cards, HIPR cards, or HIPR2 cards. The Service Module card is connected to the network through the odd-numbered card slot connector.

Note: Service Module cards can be inserted only in slots 01, 03, 05, 07, and 11 of the control shelf (1100).

Table 11: Service Module Card Locations

Location of the Service Module Card	Empty Card Location
Slot 01	Slot 02
Slot 03	Slot 04
Slot 05	Slot 06
Slot 07	Slot 08
Slot 11	Slot 12
Slot 13	Slot 14
Slot 15	Slot 16
Slot 17	Slot 18

Prerequisites

Before a Service Module card can be added, the prerequisites in [Table 12: System Prerequisites for Adding a Service Module Card](#) must be present in the system.

Table 12: System Prerequisites for Adding a Service Module Card

Prerequisite	Verification and Actions
The shelf to which the card is to be added must already be provisioned in the database.	Enter the <code>rtrv-shlf</code> command. If the shelf is not in the database, refer to the procedure for adding a shelf in the <i>Database Administration Manual – System Management</i> .
The odd/even slots in which the card will be inserted must not have a card already assigned in the database.	Enter the <code>rtrv-card</code> command. If a slot has a card assigned to it, use the <code>dlt-card</code> command to remove the card from the database.

Prerequisite	Verification and Actions
	Refer to the <code>dlt-card</code> command description in the <i>Commands Manual</i> .
The GTT feature must be on.	Enter the <code>rtrv-feat</code> command to display the GTT feature status. If the GTT feature is on, the <code>gtt=on</code> entry appears in the output. If the <code>gtt=off</code> entry appears in the output, use the procedures in the <i>Database Administration Manual - GTT</i> to turn on and provision the GTT feature and any other GTT-related features and functions that will be used in the system.
To add more than 25 Service Module cards to the database, the EPAP that is connected to the EAGLE 5 ISS must be running on a T1200 AS.	Use visual inspection or contact the Customer Care Center for assistance to determine the EPAP hardware type.

Before an E5-SM4G Service Module card can be added, the prerequisite in [Table 13: Prerequisite for Adding an E5-SM4G Service Module Card](#) must be present in the system.

Table 13: Prerequisite for Adding an E5-SM4G Service Module Card

Prerequisite	Verification and Actions
Slots 09 and 10 in the shelf to which the E5-SM4G card will be added must contain either HIPR cards or HIPR2 cards.	Enter the <code>rept-stat-gpl:gpl=hipr</code> command and the <code>rept-stat-gpl:gpl=hipr2</code> command to list the installed HIPR cards and HIPR2 cards in the system. If the shelf does not contain HIPR cards or HIPR2 cards, refer to procedures in the <i>Installation Manual - EAGLE 5 ISS</i> to install HIPR cards or HIPR2 cards in the shelf.

Refer to the *Commands Manual* for complete descriptions of the commands that are used in this procedure. The complete descriptions include all valid parameter values and output examples.

1. Display the cards in the system by entering the `rtrv-card` command. Odd-even pairs of card locations that do not contain cards (are not listed in the output) and do not contain HMUX, HIPR, or HIPR2 cards can be used for Service Module cards.

```

rlghncxa03w 08-03-15 16:34:56 EST EAGLE 39.2.0
CARD  TYPE      APPL      LSET NAME      LINK SLC LSET NAME      LINK SLC
1201  LIMDS0      SS7ANSI    LS1             A    0    LS1            B
1102  DSM          VSCCP      -----        A    --  -----        B    --
1113  GPSM         OAM
1114  TDM-A
1115  GPSM         OAM
1116  TDM-B
1117  MDAL
    
```

;

2. Verify that the Service Module card to be added has been physically installed in the correct card location.



CAUTION

CAUTION: If the version of the BPDCM GPL on the Service Module card does not match the BPDCM GPL version in the database when the Service Module card is inserted into the card slot, UAM 0002 is generated indicating that these GPL versions do not match. If UAM 0002 has been generated, perform the alarm clearing procedure for UAM 0002 in the *Unsolicited Alarm and Information Messages* manual before proceeding with this procedure.

3. Perform this step only if the card being added will be the 26th Service Module card in the system.

If the card is NOT the 26th Service Module card, continue to [Step 4](#).

Note: The same `ent-card` command must be entered twice within 30 seconds to complete the provisioning of the card.

- a) Enter the `ent-card` command the first time for the 26th card.

```
ent-card:loc=<card location>;type=dsm:appl=vsccp
```

When the command executes the first time and any EPAP-related feature is enabled, the following caution appears :

```
CAUTION: Please ensure EPAP Application Server is running on
          hardware supporting 32 SCCP cards e.g.: T1200.
          Re-enter command within 30 seconds to confirm change.
```

- b) Enter the same `ent-card` command the second time for the 26th card to complete the provisioning of the card.
- c) Go to [Step 5](#).

4. Add the Service Module card to the database, using the `ent-card` command.

```
ent-card:loc=<card location>;type=dsm:appl=vsccp
```

5. For an E5-SM4G card, verify the temperature threshold settings by performing the “Changing the High-Capacity Card Temperature Alarm Thresholds” procedure in *Database Administration Manual - SS7*.

6. Verify the change by entering the `rtrv-card` command with the card location specified.

```
rtrv-card:loc=<card location>
```

```
rlghncxa03w 08-03-15 16:34:56 EST EAGLE 39.2.0
CARD   TYPE      APPL      LSET NAME      LINK SLC LSET NAME      LINK SLC
1301   DSM        VS CCP    -----      A    --  -----      B
```

7. Change the IP Address to MPS for the added card.

```
chg-ip-lnk:port=<a/b>;submask=255.255.255.0:mcast=yes:speed=100:loc=<odd-numbered
card location>;ipaddr=<EPAP DSM IP address>;duplex=full
```

8. Allow the added card to begin operation in the system.

```
alw-card:loc=<odd-numbered card location>
```

9. Back up the database changes, by entering the following command.

```
chg-db:action=backup:dest=fixcd
```

The following messages should appear; the active Maintenance and Administration Subsystem Processor (MASP) appears first.

```
BACKUP (FIXED) : MASP A - Backup starts on active MASP.
BACKUP (FIXED) : MASP A - Backup on active MASP to fixed disk complete.
BACKUP (FIXED) : MASP A - Backup starts on standby MASP.
BACKUP (FIXED) : MASP A - Backup on standby MASP to fixed disk complete.
```

10. Repeat this procedure for each Service Module card that needs to be added to the system.

Enabling ATINP, Setting STP Options, and Turning On ATINP

This procedure is used to enable the ATINP feature, set the system STP options, and turn on the ATINP feature in the EAGLE 5 ISS.

- The ATINP feature must be enabled using the ATINP feature part number 893022101 and a feature access key.

Note: Controlled features must be purchased before you can receive the feature access key to use to enable the feature. If you are not sure if you have purchased a feature and received the feature access key, contact your Tekelec Sales Representative or Account Representative.

When the ATINP feature is enabled, it is permanently enabled. The ATINP feature cannot be temporarily enabled.

Note: Provisioning of ATINP options and other information can be done after the feature is enabled and before the feature is turned on.

- After the ATINP feature has been enabled, the STP option for the default country code must be changed from NONE to an appropriate value for ATINP.

The `chg-stpopts` and `rtrv-stpopts` commands support the `defcc` and `dsmaud` parameters for the ATINP feature.

In the `rtrv-stpopts` command output, the `defcc` parameter is displayed with value NONE when the ATINP feature is enabled.

- After the ATINP feature has been enabled, the STP options are set, and database provisioning is complete, the ATINP feature status must be set to on (the feature must be "turned on").

After the ATINP feature is enabled and turned on, the ATINP feature can be turned off again.

When the feature is turned on:

- The `defcc` parameter value cannot be set to NONE.
- The DSM audit running state (`dsmaud`) parameter of the `chg-stpopts` command can be provisioned for ATINP.
- The `dsmaud` parameter is displayed with value off when the ATINP feature is turned on.

1. Enable the ATINP feature, by entering the `enable-ctrl-feat` command.
`enable-ctrl-feat:partnum=893022101:fak=<feature access key>`

Note: The feature access key (the `fak` parameter) is provided by Tekelec. If you do not have the controlled feature part number or the feature access key for the feature, contact your Tekelec Sales Representative or Account Representative.

When the feature is enabled, the ATINP entry appears in the output of the `rtrv-ctrl-feat` command.

```
rlghncxa03w 08-08-29 16:40:40 EST EAGLE5 39.2.0
The following features have been permanently enabled:
Feature Name          Partnum    Status    Quantity
HC-MIM SLK Capacity  893012707 on         64
ATINP                 893022101 off        ----
;
```

2. Verify that the `defcc STP` option parameter value is not NONE. Enter the `rtrv-stpopts` command.

- If the value is not NONE, continue with [Step 3](#).
- If the `defcc` parameter value is NONE, use the `chg-stpopts` command to provision a new value. Then continue with [Step 3](#).

Note: Database provisioning of ATINP options can be done here, before the ATINP feature is turned on in the system.

3. Turn on the ATINP feature. Enter the `chg-ctrl-feat` command.

```
chg-ctrl-feat:partnum=893022101:status=on
```

When the feature is turned on, the status changes to on in the `rtrv-ctrl-feat` command output.

```
rlghncxa03w 09-06-29 16:40:40 EST EAGLE5 41.1.0
The following features have been permanently enabled:
Feature Name          Partnum    Status    Quantity
HC-MIM SLK Capacity  893012707 on         64
ATINP                 893022101 on        ----
;
```

4. Back up the database changes, by entering the following command.

```
chg-db:action=backup:dest=fixed
```

The following messages appear; the active Maintenance and Administration Subsystem Processor (MASP) appears first.

```
BACKUP (FIXED) : MASP A - Backup starts on active MASP.
BACKUP (FIXED) : MASP A - Backup on active MASP to fixed disk complete.
BACKUP (FIXED) : MASP A - Backup starts on standby MASP.
BACKUP (FIXED) : MASP A - Backup on standby MASP to fixed disk complete.
```

Enabling the Service Portability Feature

If Service Portability can be applied to the messages processed by a feature described in this manual, use this procedure to enable the Service Portability feature in the EAGLE 5 ISS.

The Service Portability feature must be enabled using the feature part number 893034301 and a feature access key.

Note: Controlled features must be purchased before you can receive the feature access key to use to enable the feature. If you are not sure if you have purchased a feature and received the feature access key, contact your Tekelec Sales Representative or Account Representative.

When the S-Port feature is enabled, it is permanently enabled. The S-Port feature cannot be temporarily enabled. After the S-Port feature is enabled and turned on, the S-Port feature can be turned off again.

Provisioning of S-Port options can be done after the feature is enabled and before the feature is turned on.

After the S-Port feature has been enabled and database provisioning is complete, the S-Port feature status must be set to on (the feature must be “turned on”) before S-Port processing will occur.

1. Display the status of the features that are controlled with feature access keys. Enter the `rtrv-ctrl-feat` command. The output lists the enabled features in the system and shows the on/off status for each feature.

```
rlghncxa03w 09-06-29 16:40:40 EST EAGLE5 41.1.0
The following features have been permanently enabled:
Feature Name          Partnum   Status   Quantity
HC-MIM SLK Capacity   893012707 on        64
;
```

If the Service Portability entry appears in the `rtrv-ctrl-feat` output, performing this procedure is not necessary.

2. Enable the S-Port feature, by entering the `enable-ctrl-feat` command.
`enable-ctrl-feat:partnum=893034301:fak=<feature access key>`

When the feature is enabled, the Service Portability entry appears in the output of the `rtrv-ctrl-feat` command.

```
rlghncxa03w 09-06-29 16:40:40 EST EAGLE5 41.1.0
The following features have been permanently enabled:
Feature Name          Partnum   Status   Quantity
HC-MIM SLK Capacity   893012707 on        64
Service Portability    893034301 off       ----
;
```

3. Back up the database changes, by entering the following command.
`chg-db:action=backup:dest=fixed`

The following messages appear; the active Maintenance and Administration Subsystem Processor (MASP) appears first.

```
BACKUP (FIXED) : MASP A - Backup starts on active MASP.
BACKUP (FIXED) : MASP A - Backup on active MASP to fixed disk complete.
BACKUP (FIXED) : MASP A - Backup starts on standby MASP.
BACKUP (FIXED) : MASP A - Backup on standby MASP to fixed disk complete.
```

Provisioning True Point Codes and Capability Point Codes

This procedure explains briefly how to provision EAGLE 5 ISS true point codes, and capability point codes for EPAP-based features. Refer to the detailed procedures in the *Database Administration Manual - SS7* for provisioning true and capability point codes, and the CLI if needed.

For the ATINPQ subsystem, the EAGLE 5 ISS supports ANSI, ITU-I, ITU-N, ITU-I Spare, and ITU-N Spare capability point code types. including group codes. ITU-N24 capability point codes are not supported.

This procedure explains how to provision EAGLE 5 ISS true point codes and ATINP capability point codes.

1. Display the true and capability point codes in the system. Enter the `rtrv-sid` command.

```
tekelecstp 08-07-22 15:07:48 EST EAGLE 39.2.0

      PCA              PCI              PCN              CLLI              PCTYPE
      -----              -              -              tekelecstp              ANSI
;

```

2. Verify that the desired EPAP-based feature is enabled and turned on, by entering the `rtrv-ctrl-feat` command.

```
rlghncxa03w 09-06-29 16:40:40 EST EAGLE5 41.1.0
The following features have been permanently enabled:
Feature Name              Partnum      Status      Quantity
HC-MIM SLK Capacity      893012701   on          64
ATINP                    893022101   on          ----
;

```

- If the feature entry appears in the command output, and the feature status is on, continue with [Step 3](#).
 - If the feature entry does not appear in the command output or if the feature status in the entry is off, go to the procedure in this manual to enable and turn on the EPAP-based feature. Continue with [Step 3](#).
3. Change the true point codes and capability point codes as needed, using the `chg-sid` command. Refer to the procedures in the *Database Administration Manual - SS7* for changing the Self-Identification of the EAGLE 5 ISS. The system might need to be initialized for the point code changes to take effect. This must be done carefully to minimize traffic loss.
 4. Verify the changes with the `rtrv-sid` command.

```
tekelecstp 08-08-22 15:07:48 EST EAGLE 39.2.0

      PCA              PCI              PCN              CLLI              PCTYPE
      001-001-001      2-002-2      01234          tekelecstp              ANSI

      CPCA (ATINP)
      004-004-004

      CPCI (ATINP)
      5-012-0

      CPCN (ATINP)
      12345
;

```

5. Back up the changes using the `chg-db:action=backup:dest=fixed` command.

The following messages appear, the active Maintenance and Administration Subsystem Processor (MASP) appears first.

```
BACKUP (FIXED): MASP A - Backup starts on active MASP.
BACKUP (FIXED): MASP A - Backup on active MASP to fixed disk complete.
BACKUP (FIXED): MASP A - Backup starts on standby MASP.
BACKUP (FIXED): MASP A - Backup on standby MASP to fixed disk complete.

```

Provisioning the ATINPQ Local Subsystem

The following procedures in this section are used to add or remove a local subsystem application:

- [Adding the ATINPQ Local Subsystem Application](#)
- [Removing a Local Subsystem Application](#)

See the procedures in [Changing the State of a Subsystem Application](#) to take the subsystem application online or offline.

Note: The EAGLE 5 ISS supports the operation of two or more local subsystems for EPAP-related features in the system at one time. For example, the local subsystems for INP and EIR can coexist in the system.

Adding the ATINPQ Local Subsystem Application

This procedure is used to define the ATINPQ subsystem application. The subsystem application can be taken online when it is defined or later in the configuration process (see [Changing the State of a Subsystem Application](#)).

Before the ATINPQ subsystem application can be added to the database, the following conditions must exist in the system:

Table 14: ATINPQ Local Subsystem Prerequisites

Prerequisite	Verification
The ATINP feature must be enabled and turned on	Enter the <code>rtrv-ctrl-feat</code> command. If the ATINP entry with Status of on does not appear in the output, see the Enabling ATINP, Setting STP Options, and Turning On ATINP procedure.
The application specified by the <code>appl</code> parameter (<code>atinpq</code>) cannot already be in the database.	Enter the <code>rtrv-ss-appl</code> command. If the ATINPQ entry appears in the output, this procedure cannot be performed.
EAGLE 5 ISS true point codes and ATINP capability point codes must be defined, and entered in the Mated Application table with a subsystem number to be used for the ATINPQ subsystem application.	Only one subsystem number for the application can be defined, and must be used for all point code types assigned to the local subsystem. Enter the <code>rtrv-sid</code> command, and verify that the true and capability point codes needed for the feature are correct. If changes are required, see Provisioning True Point Codes and Capability Point Codes Enter the <code>rtrv-map</code> command, and verify that the MAP table entries are correct for the ATINPQ

Prerequisite	Verification
	local subsystem. If changes are required, refer to the procedures in the <i>Database Administration Manual – Global Title Translation</i> for provisioning solitary and dominant mated applications.

The examples in this procedure reserve the subsystem number 100 for the ATINPQ subsystem application and set the ATINPQ subsystem application status to online.

1. Add the ATINPQ application and subsystem number, using the `ent-ss-appl` command.

If the `stat` parameter is not specified, the status defaults to offline.

```
ent-ss-appl:appl=atinpq:ssn=100:stat=online
```

2. Verify the changes, by entering the `rtrv-ss-appl` command.

```
tekelecstp 08-07-25 08:02:22 EST EAGLE 39.2.0
APPL  SSN  STAT
ATINPQ 100  online

SS-APPL TABLE IS 25% FULL (1 OF 4)
;
```

3. Back up the changes using the `chg-db:action=backup:dest=fixed` command. The following messages appear, the active Maintenance and Administration Subsystem Processor (MASP) appears first.

```
BACKUP (FIXED): MASP A - Backup starts on active MASP.
BACKUP (FIXED): MASP A - Backup on active MASP to fixed disk complete.
BACKUP (FIXED): MASP A - Backup starts on standby MASP.
BACKUP (FIXED): MASP A - Backup on standby MASP to fixed disk complete.
```

Removing a Local Subsystem Application

This procedure is used to remove a subsystem application from the database. The subsystem application to be removed must be in the database and the subsystem must be out of service.

1. Display the subsystem application number for the local subsystem application in the database, by entering the `rtrv-ss-appl` command.
2. Display the operating status of the local subsystem, by entering the `rept-stat-sccp` command. If the subsystem is out of service, shown by an entry containing OOS-MT-DSBLD for the subsystem in the `rept-stat-sccp` output, go to [Step 5](#).
3. Place the local subsystem application out of service. Enter the `inh-map-ss` command and specify the subsystem number displayed in [Step 1](#).

```
inh-map-ss:ssn=11
```

```
rlghncxa03w 08-06-28 14:42:38 GMT EAGLE 39.2.0
Inhibit map subsystem command sent to all SCCP cards.
Command Completed.
```

When this command has successfully completed, the following message appears. If the `force=yes` parameter is not specified, wait for a message that indicates the subsystem is inhibited.

```
rlghncxa03w 08-06-28 14:42:38 GMT EAGLE 39.2.0
Inhibit map subsystem command sent to all SCCP cards.
Command Completed.
```

4. Verify that the local subsystem is out of service (OOS-MT-DSBLD), by entering the `rept-stat-sccp` command. If the local subsystem is not out of service, return to [Step 3](#) and enter the `inh-map-ss` command with the `force=yes` parameter specified.
5. Remove the local subsystem application from the database, by entering the `dlt-ss-appl` command.
`dlt-ss-appl:appl=<subsystem>`
6. Verify the changes by entering the `rtrv-ss-appl` command. The deleted entry should not appear in the output.

```
tekelecstp 08-07-25 08:02:22 EST EAGLE 39.2.0
APPL  SSN  STAT

SS-APPL TABLE IS 0% FULL (0 OF 4)
;
```

7. Back up the changes using the `chg-db:action=backup:dest=fixed` command. The following messages appear, the active Maintenance and Administration Subsystem Processor (MASP) appears first.

```
BACKUP (FIXED): MASP A - Backup starts on active MASP.
BACKUP (FIXED): MASP A - Backup on active MASP to fixed disk complete.
BACKUP (FIXED): MASP A - Backup starts on standby MASP.
BACKUP (FIXED): MASP A - Backup on standby MASP to fixed disk complete.
```

Provisioning the ATINP Service Selector

The procedures in this section describe how to add, change, and remove a service selector. The information is indicated that is specific to ATINP.

Refer to the *Commands Manual* for complete descriptions of the commands used in these procedures, including parameter names, valid values, and output examples for the commands.

Adding an ATINP Service Selector

This procedure is used to add a service selector for the ATINP feature.

The ATINP feature must be enabled and turned on before an ATINP service selector can be added.

1. Verify that the ATINP feature is enabled and turned on, by entering the `rtrv-ctrl-feat` command.

If the ATINP feature is enabled and turned on, the status of the ATINP entry is on.

```
rlghncxa03w 09-06-29 16:40:40 EST EAGLE5 41.1.0
The following features have been permanently enabled:
Feature Name           Partnum   Status   Quantity
HC-MIM SLK Capacity    893012707 on        64
ATINP                   893024401 on        ----
;
```

- If the ATINP feature is enabled and turned on, continue with [Step 2](#).
- If the ATINP feature is not enabled or turned on, go to [Enabling ATINP, Setting STP Options, and Turning On ATINP](#) to enable and turn on the ATINP feature. Then continue with [Step 2](#).

2. Display any existing ATINP service selectors in the database, by entering the `rtrv-srvsel:serv=atinp` command.

```

rlghncxa03w 08-06-28 14:42:38 GMT EAGLE 41.1.0

GTII  TT  NP      NAI  SSN  SNP  SNAI  SERV
4     1   e164   intl 3    ---  ---   atinp
4     2   e164   intl *   ---  ---   atinp

GTIN  TT  NP      NAI  SSN  SNP  SNAI  SERV
4     4   e164   natl 4    ---  ---   atinp

SRV SELECTOR table is (3 of 20992) 1 % full
;

```

3. Add new ATINP service selectors, using the `ent-srvsel` command. For example, enter commands like these:

```

ent-srvsel:serv=atinp:tt=35:ssn=100:gtin=4:np=e214:nai=natl
ent-srvsel:serv=atinp:tt=57:ssn=75:gtin=2

```

4. Verify the changes by entering the `rtrv-srvsel` command with the parameters and values used in [Step 3](#).

```

rlghncxa03w 08-06-28 14:42:38 GMT EAGLE 41.1.0

GTII  TT  NP      NAI  SSN  SNP  SNAI  SERV
4     1   e164   intl 3    ---  ---   atinp
4     2   e164   intl *   ---  ---   atinp

GTIN  TT  NP      NAI  SSN  SNP  SNAI  SERV
4     4   e164   natl 4    ---  ---   atinp
4     35  e214   natl 100  ---  ---   atinp
2     57  ---    ---  75   ---  ---   atinp

SRV SELECTOR table is (5 of 20992) 1 % full
;

```

5. Back up the changes using the `chg-db:action=backup:dest=fixed` command. The following messages appear, the active Maintenance and Administration Subsystem Processor (MASP) appears first.

```

BACKUP (FIXED): MASP A - Backup starts on active MASP.
BACKUP (FIXED): MASP A - Backup on active MASP to fixed disk complete.
BACKUP (FIXED): MASP A - Backup starts on standby MASP.
BACKUP (FIXED): MASP A - Backup on standby MASP to fixed disk complete.

```

Removing a Service Selector

This procedure is used to remove a service selector from the database.

The GTI, GTII, GTIN, tt, and ssn parameter values can be used to limit the amount of information displayed with the `rtrv-srvsel` command.

1. Display the service selectors in the database, by entering the `rtrv-srvsel` command.

```

rlghncxa03w 08-06-28 14:42:38 GMT EAGLE 39.2.0
GTII TT NP NAI SSN SNP SNAI SERV

4 1 e214 intl 4 e164 intl gport

4 1 e214 intl 5 e164 intl smsmr

4 2 e214 intl 5 e164 intl mnpsms

4 2 e164 intl --- --- vflex

GTIN TT NP NAI SSN SNP SNAI SERV

4 4 e214 natl 75 e164 intl gflex

4 9 e214 natl 100 e164 intl gflex

4 35 e214 natl 100 --- --- atinp

2 57 e214 natl 75 --- --- vflex

SRV SELECTOR table is (8 of 20992) 1 % full

;

```

2. Remove the service selector from the database, using the `dlt-srvsel` command. For example, enter commands like these.

```
dlt-srvsel:serv=atinp:tt=35:ssn=100:gtin=4:np=e214:nai=natl
```

```
dlt-srvsel:serv=atinp:tt=57:ssn=75:gtin=2
```

To remove a service selector, the GTI, GTII, GTIN, tt, and ssn parameter values must be entered as shown in the `rtrv-srvsel` command output.

3. Verify the changes by entering the `rtrv-srvsel` command with the parameters and values used in [Step 2](#).

```
rtrv-srvsel:serv=atinp:tt=35:ssn=100:gtin=4:np=e214:nai=natl
```

```

rlghncxa03w 08-06-28 14:42:38 GMT EAGLE 39.2.0

GTIN TT NP NAI SSN SNP SNAI SERV

No SRV Selector found in range

;

```

```
rtrv-srvsel:serv=atinp:tt=57:ssn=75:gtin=2
```

```

tekelecstp 08-08-28 16:35:22 EST EAGLE 39.2.0
GTII TT NP NAI NPV NAIV SSN SNP SNAI SERV

No SRV Selector found in range

;

```

4. Back up the changes using the `chg-db:action=backup:dest=fixed` command.

The following messages appear, the active Maintenance and Administration Subsystem Processor (MASP) appears first.

```
BACKUP (FIXED): MASP A - Backup starts on active MASP.
BACKUP (FIXED): MASP A - Backup on active MASP to fixed disk complete.
BACKUP (FIXED): MASP A - Backup starts on standby MASP.
BACKUP (FIXED): MASP A - Backup on standby MASP to fixed disk complete.
```

Changing an Existing Service Selector to an ATINP Service Selector

This procedure is used to change an existing non-ATINP service selector to a ATINP service selector.

The only parameters that can be changed using this procedure are:

:nserv

New DSM service type, ATINP

:nsnp

An ATINP service selector cannot contain an SNP value; if the service selector being changed contains an SNP value, this value must be changed to **none** with this parameter.

:nsnai

An ATINP service selector cannot contain an SNAI value; if the service selector being changed contains an SNAI value, this value must be changed to **none** with this parameter.

The `chg-srvsel` command requires that the following parameters be specified with the values shown in the `rtrv-srvsel` output for the service selector that is being changed. If any of these parameter values need to be changed for a ATINP service selector, use the procedure in [Removing a Service Selector](#) to remove the existing service selector. Then use the procedure in [Adding an ATINP Service Selector](#) to add the new ATINP service selector with the new parameter information.

:gtii/gtin/gtin24

Global title indicator for ITU international (gtii), ITU national using 14-bit point codes (gtin), and ITU national using 24-bit point codes (gtin24).

:tt

Translation type

:ssn

Subsystem number

:nai

Nature of address indicator

:naiv

Nature of address indicator value

:np

Numbering plan

:npv

Numbering plan value

1. Display the service selectors in the database, using the `rtrv-srvsel` command.

```

rlghncxa03w 08-06-28 14:42:38 GMT EAGLE 39.2.0

GTII  TT  NP      NAI  SSN  SNP  SNAI  SERV
4      1  e214   intl  4    e164 intl  gport
4      1  e214   intl  5    e164 intl  smsmr
4      2  e214   intl  5    e164 intl  mnpsms
4      2  e164   intl  *    ---  ---  vflex

GTIN  TT  NP      NAI  SSN  SNP  SNAI  SERV
4      4  e214   natl  34   e164 intl  gflex
4      9  e214   natl  ---  e164 intl  gflex

SRV SELECTOR table is (6 of 20992) 1 % full
;

```

2. Verify that the ATINP feature is enabled and turned on, by entering the `rtrv-ctrl-feat` command. If the ATINP feature is enabled and turned on, the status of the ATINP entry is on.

```

rlghncxa03w 09-06-29 16:40:40 EST EAGLE5 41.1.0
The following features have been permanently enabled:
Feature Name          Partnum  Status  Quantity
HC-MIM SLK Capacity  893012707  on      64
ATINP                 893024401  on      ----
;

```

- If the ATINP feature is enabled and turned on, continue with [Step 3](#).
 - If the ATINP feature is not enabled or turned on, go to [Enabling ATINP, Setting STP Options, and Turning On ATINP](#) to enable and turn on the ATINP feature. Then continue with [Step 3](#).
3. Change the service selector, using a `chg-srvsel` command similar to the following example.
`chg-srvsel:gtin=4:tt=4:np=e214:nai=natl:ssn=34:nsnp=none:nsnai=none:nserv=atinp`

Note: If the SNP or SNAI parameter values are shown as dashes in the `rtrv-srvsel` output, these parameters cannot be specified with the `chg-srvsel` command. If the `gtii/gtin/gtin24` parameter value is 2, the `np`, `nai`, `npv`, and `naiv` parameters cannot be specified with the `chg-srvsel` command.

If the `gtii/gtin/gtin24` parameter value is 4, either the `np` and `nai`, or the `npv` and `naiv` parameters must be specified with the `chg-srvsel` command. The `np` and `nai` parameters can be specified in place of the `npv` and `naiv` parameters, and the `npv` and `naiv` parameters can be specified in place of the `np` and `naiv` parameters as long as parameter values be specified correspond to the values shown in the `rtrv-srvsel` output. Refer to the `chg-srvsel` command description in the *Commands Manual*.

- Verify the changes by entering the `rtrv-srvsel` command with the `serv=atinp` parameter and the values for the other parameter that were used in [Step 3](#).

```
rtrv-srvsel:gtin=4:tt=4:np=e214:nai=natl:ssn=34:serv=atinp
```

```
rlghncxa03w 08-06-28 14:42:38 GMT EAGLE 39.2.0

GTIN  TT  NP      NAI  SSN  SNP  SNAI  SERV
4      4    e214   natl  34   ---  ---   atinp

SRV SELECTOR table is (6 of 20992) 1 % full

;
```

- Back up the changes using the `chg-db:action=backup:dest=fixed` command.

The following messages appear, the active Maintenance and Administration Subsystem Processor (MASP) appears first.

```
BACKUP (FIXED): MASP A - Backup starts on active MASP.
BACKUP (FIXED): MASP A - Backup on active MASP to fixed disk complete.
BACKUP (FIXED): MASP A - Backup starts on standby MASP.
BACKUP (FIXED): MASP A - Backup on standby MASP to fixed disk complete.
```

Provisioning the ATINP Options

Refer to [ATINP Configuration Options](#) in this manual and to the `chg-atinpqopts` command description in the *Commands Manual* for valid parameter values, input examples, and rules for entering the command correctly.

- Verify that the ATINP feature is enabled, by entering the `rtrv-ctrl-feat` command.

If the ATINP feature has not been turned on, the status in the ATINP entry is off.

```
rlghncxa03w 09-06-29 16:40:40 EST EAGLE5 41.1.0
The following features have been permanently enabled:
Feature Name          Partnum  Status  Quantity
HC-MIM SLK Capacity   893012707 on       64
ATINP                  893022101 off      ----

;
```

- If the ATINP feature is not enabled (the ATINP entry does not appear in the output), go to [Enabling ATINP, Setting STP Options, and Turning On ATINP](#) to enable the ATINP feature. Then continue with [Step 3](#).
 - If the ATINP feature is enabled, continue with [Step 3](#).
- If the Service Portability feature will be used with ATINP, verify that the Service Portability entry appears in the output in [Step 1](#).
 - If the Service Portability entry appears in the output, continue with [Step 3](#).
 - If the Service Portability entry does not appear in the output, go to [Enabling the Service Portability Feature](#) to enable the feature. Then continue with [Step 3](#).
 - Display the current settings of the ATINP options, using the `rtrv-atinpqopts` command.

4. Change the ATINP options to the required settings, by entering the `chg-atinpopts` command with at least one of the ATINP option parameters specified. If Service Portability will be used with ATINP, change the ATINP options that apply to Service Portability to the required settings.

Refer to [ATINP Configuration Options](#) in this manual and to the `chg-atinpopts` command description in the *Commands Manual* for valid parameter values, input examples, and rules for entering the command correctly.

```
chg-atinpopts:atinptype=<type>:snai=<snai>:atidlm=<delimiter>
```

5. Verify the changes, by entering the `rtrv-atinpopts` command.
6. If the ATINP feature was not turned on (status is off in the output in [Step 1](#)), go to [Enabling ATINP, Setting STP Options, and Turning On ATINP](#) to turn on the feature.
7. Back up the changes, using the `chg-db:action=backup:dest=fixed` command.

These messages appear, the active Maintenance and Administration Subsystem Processor (MASP) appears first.

```
BACKUP (FIXED) : MASP A - Backup starts on active MASP.
BACKUP (FIXED) : MASP A - Backup on active MASP to fixed disk complete.
BACKUP (FIXED) : MASP A - Backup starts on standby MASP.
BACKUP (FIXED) : MASP A - Backup on standby MASP to fixed disk complete.
```

Activating the ATINPQ Local Subsystem

The procedure in this section explains how to activate the ATINPQ local subsystem.

When all feature configuration is complete, the ATINPQ subsystem application must be taken online and the local subsystem must be activated to allow it to begin operation.

When the local subsystem operating state is Inhibited, the `chg-ss-appl` command can be used to change the online or offline database state of the subsystem. The `rtrv-ss-appl` command displays the online or offline provisioned value.

When the first Service Module card is loaded, this state tells whether the subsystem should be considered allowed (online) or inhibited (offline). This is a database state. If the command is accepted, then the change is made to the tables and can be read after an `init-sys` command is entered to initialize the system.

When the Service Module cards are in-service and the subsystem application is online, the `alw/inh-map-ss` commands can be used to change the dynamic operating state of the local subsystem to allowed or inhibited. The `inh-map-ss` command does not necessarily force a state change, because it can fail if the mate does not send an SOG. The `force=yes` parameter must be specified to bypass the SOR/SOG exchange and inhibit immediately. (There is no `rtrv-map-ss` command.)

The procedures in [Changing the State of a Subsystem Application](#) explain how to take a local subsystem online and offline.

Table 15: Subsystem Allow/Inhibit

Command \ Subsystem State	Offline	Online
alw-map-ss	Command is rejected because the subsystem must be online to be in the Allowed state.	Attempts to make the local subsystem active.
inh-map-ss	Command accepted, but no action because offline implies inhibited.	Attempts to inhibit the local subsystem. Use of the force=yes parameter bypasses the SOR/SOG exchange and inhibits immediately.
chg-ss-appl:appl=atinpq:nstat=online	Changes local subsystem status to online.	No change to local subsystem status in the database.
chg-ss-appl:appl=atinpq:nstat=offline	Command is rejected because the subsystem must be inhibited to go offline.	Changes local subsystem database status to offline.

1. Display the online/offline status of the ATINPQ subsystem application, by entering the `rtrv-ss-appl` command.

```
tekelecstp 08-07-25 08:02:22 EST EAGLE 39.2.0
APPL  SSN  STAT
ATINPQ 11  offline

SS-APPL TABLE IS 25% FULL (1 OF 4)
;
```

2. Change the ATINPQ subsystem status to online.
`chg-ss-appl:appl=atinpq:nstat=online`
3. Enter the command to allow the ATINPQ subsystem to begin operation.
`alw-map-ss:ssn=<ATINPQ ssn>`

```
integrat40 08-05-24 10:37:22 EST EAGLE5 39.2.0
Allow map subsystem command sent to all SCCP cards.
Command Completed.
;
```

4. Display the operating status of the ATINPQ subsystem, by entering the `rept-stat-sccp` command.

Turning On the Service Portability Feature

This procedure is used to turn on the Service Portability feature in the EAGLE 5 ISS, using the feature part number 893034301.

Before the Service Portability (S-Port) feature can be turned on, the feature must be enabled in the EAGLE 5 ISS.

Provisioning of S-Port options can be done after the feature is enabled and before the feature is turned on.

After the S-Port feature has been enabled and database provisioning is complete, the Service Portability feature status must be set to on (the feature must be “turned on”). MSUs will not be processed by the Service Portability feature until the feature is turned on.

After the Service Portability feature is enabled and turned on, it can be turned off again. Service Portability processing can occur only when the Service Portability feature is on and a feature that uses S-Port is on.

1. Display the status of the features that are controlled with feature access keys. Enter the `rtrv-ctrl-feat` command. The output lists the enabled features in the system and shows the on/off status for each feature.
 - If the entry for the Service Portability feature appears in the `rtrv-ctrl-feat` output with status on, performing this procedure is not necessary.
 - If the status of the Service Portability feature in the output is off, continue with [Step 2](#).

2. Turn on the S-Port feature, by entering the `chg-ctrl-feat` command.

```
chg-ctrl-feat:partnum=893034301:status=on
```

When the feature is turned on, the feature status changes to on in the `rtrv-ctrl-feat` command output.

```
rlghncxa03w 09-08-29 16:40:40 EST EAGLE5 41.1.0
The following features have been permanently enabled:
Feature Name          Partnum  Status  Quantity
HC-MIM SLK Capacity   893012707 on      64
ATINP                 893022101 on      ----
Service Portability   893034301 on      ----
;
```

3. Back up the database changes, by entering the following command.

```
chg-db:action=backup:dest=fixed
```

The following messages appear; the active Maintenance and Administration Subsystem Processor (MASP) appears first.

```
BACKUP (FIXED) : MASP A - Backup starts on active MASP.
BACKUP (FIXED) : MASP A - Backup on active MASP to fixed disk complete.
BACKUP (FIXED) : MASP A - Backup starts on standby MASP.
BACKUP (FIXED) : MASP A - Backup on standby MASP to fixed disk complete.
```

Turning Off the Service Portability Feature

Before the Service Portability (S-Port) feature can be turned on and off, the feature must be enabled in the EAGLE 5 ISS.

This procedure is used to turn off the Service Portability feature, using its feature part number 8930343001.

Note: MSUs will not be processed by a feature when the feature is turned off in the system.

1. Display the status of the features that are controlled with feature access keys. Enter the `rtrv-ctrl-feat` command. The output lists the enabled features in the system and shows the on/off status for each feature.

```
rlghncxa03w 09-06-29 16:40:40 EST EAGLE5 41.1.0
The following features have been permanently enabled:
```

```

Feature Name      Partnum  Status  Quantity
HC-MIM SLK Capacity  893012707  on      64
TIF Number Portability  893018901  on      ----
Service Portability  893034301  on      ----
;

```

If the entry for the Service Portability feature appears in the `rtrv-ctrl-feat` output with status off, performing this procedure is not necessary.

If the status of the Service Portability feature in the output is on, continue with [Step 2](#).

- Turn off the S-Port feature, by entering the `chg-ctrl-feat` command.

```
chg-ctrl-feat:partnum=<893034301>:status=off
```

When the feature is turned off, the feature status changes to off in the `rtrv-ctrl-feat` command output.

```

rlghncxa03w 09-05-29 16:40:40 EST  EAGLE5 41.1.0
The following features have been permanently enabled:
Feature Name      Partnum  Status  Quantity
HC-MIM SLK Capacity  893012707  on      64
TIF Number Portability  893018901  on      ----
Service Portability  893034301  off     ----
;

```

- Back up the database changes, by entering the following command.

```
chg-db:action=backup:dest=fixed
```

The following messages appear; the active Maintenance and Administration Subsystem Processor (MASP) appears first.

```

BACKUP (FIXED) : MASP A - Backup starts on active MASP.
BACKUP (FIXED) : MASP A - Backup on active MASP to fixed disk complete.
BACKUP (FIXED) : MASP A - Backup starts on standby MASP.
BACKUP (FIXED) : MASP A - Backup on standby MASP to fixed disk complete.

```

Changing the State of a Subsystem Application

The procedures in this section are used to set the state of an existing subsystem application to either online or offline.

The online or offline status of the subsystem application is shown in the STAT field of the `rtrv-ss-appl` command output.

The `rept-stat-sccp` command displays the operating state (in or out of service) of the subsystem.

If the subsystem application is to be taken online, the subsystem application must be offline.

When the subsystem is taken online (regardless of how the subsystem was taken offline), the EAGLE 5 ISS sends SNR/SSA. A UAM is generated, indicating that the subsystem is ALLOWED.

If the subsystem application is to be taken offline, the subsystem application must be online. The subsystem must be taken out of service (OOS-MT-DSBLD) with the `inh-map-ss` command before it can be taken offline.

A subsystem application can be taken offline using coordinated state change, or forced offline without using coordinated state change.

When the `inh-map-ss` command is entered for the subsystem, a coordinated shutdown is attempted. If the coordinated shutdown fails, a UIM is generated, indicating that the shutdown failed. If the force parameter is specified, the subsystem is forced to shut down; a coordinated shutdown is not performed.

For coordinated state change, SCMG sends an SOR message to the mated subsystem and will start a T_{coord} timer (30 seconds). If SCMG receives an SOG message from the mated subsystem before the T_{coord} timer expires, SCMG will broadcast SSPs to the concerned point code group, send SBR/SSP, and take the subsystem offline. A UAM is generated, indicating that the subsystem is PROHIBITED. If the SOG is not received before T_{coord} expires, then the inhibit request is denied and a UIM is generated.

When the subsystem is taken offline without coordinated state change, the EAGLE 5 ISS sends SBR/SSPs. A UAM is generated, indicating that the subsystem is PROHIBITED.

When the EAGLE 5 ISS receives an SOR message from its mated subsystem, it will reply with an SOG message if both of the following conditions are met:

- The local subsystem is available
- The total load on the DSM subsystem is less than 45% of its capacity

If either of these conditions is not met, the EAGLE 5 ISS will not reply to the SOR message.

Taking the Subsystem Application Offline

Use the procedure in this section to take a subsystem application offline.

1. Verify the state of the subsystem application - online or offline, by entering the `rtrv-ss-appl` command.

```
tekelecstp 08-07-25 08:02:22 EST EAGLE 39.2.0
APPL  SSN  STAT
ATINPQ 11  online

SS-APPL TABLE IS 25% FULL (1 OF 4)
;
```

If the ATINPQ subsystem application is offline, this procedure does not need to be performed.

2. Display the operating status of the subsystem by entering the `rept-stat-sccp` command.
3. Place the subsystem out of service. Specify the subsystem number displayed in the output in [Step 1](#).

```
inh-map-ss:ssn=100
```

```
rlghncxa03w 08-06-28 14:42:38 GMT EAGLE 39.2.0
Inhibit map subsystem command sent to all SCCP cards.
Command Completed.
;
```

4. Verify that the subsystem is out of service, by entering the `rept-stat-sccp` command.
5. Take the subsystem offline. Enter the `chg-ss-appl` command with the `nstat=offline` parameter.
`chg-ss-appl:appl=atinpq:nstat=offline`
6. Verify the changes by entering the `rtrv-ss-appl` command.

```
tekelecstp 08-07-25 08:02:22 EST EAGLE 39.2.0
APPL  SSN  STAT
ATINPQ 11  offline

SS-APPL TABLE IS 25% FULL (1 OF 4)
;
```

7. Back up the new changes using the `chg-db:action=backup:dest=fixed` command.

The following messages appear, the active Maintenance and Administration Subsystem Processor (MASP) appears first.

```
BACKUP (FIXED): MASP A - Backup starts on active MASP.
BACKUP (FIXED): MASP A - Backup on active MASP to fixed disk complete.
BACKUP (FIXED): MASP A - Backup starts on standby MASP.
BACKUP (FIXED): MASP A - Backup on standby MASP to fixed disk complete.
```

Taking the Subsystem Application Online

Use the procedure in this section to take the subsystem application online.

1. Verify the state of the subsystem application - online or offline, by entering the `rtrv-ss-appl` command.

```
tekelecstp 08-07-25 08:02:22 EST EAGLE 39.2.0
APPL  SSN  STAT
ATINPQ 11  offline

SS-APPL TABLE IS 25% FULL (1 OF 4)
;
```

If the ATINPQ subsystem is online, this procedure does not need to be performed.

2. Display the operating status of the subsystem by entering the `rept-stat-sccp` command.
3. Take the subsystem application online. Enter the `chg-ss-appl` command with the `nstat=online` parameter.
`chg-ss-appl:appl=atinpq:nstat=online`
4. Verify the changes by entering the `rtrv-ss-appl` command.

```
tekelecstp 08-07-25 08:02:22 EST EAGLE 39.2.0
APPL  SSN  STAT
ATINPQ 11  online

SS-APPL TABLE IS 25% FULL (1 OF 4)
;
```

5. Back up the new changes using the `chg-db:action=backup:dest=fixed` command.

The following messages appear, the active Maintenance and Administration Subsystem Processor (MASP) appears first.

```
BACKUP (FIXED): MASP A - Backup starts on active MASP.
BACKUP (FIXED): MASP A - Backup on active MASP to fixed disk complete.
BACKUP (FIXED): MASP A - Backup starts on standby MASP.
BACKUP (FIXED): MASP A - Backup on standby MASP to fixed disk complete.
```

The 1100 TPS/DSM for ITU NP Feature

When only DSM cards or a mixture of DSM cards and E5-SM4G cards (Service Module cards) are equipped in the system, all of the cards are normally rated at 850 transactions per second (TPS). The 1100 TPS/DSM for ITU NP feature increases the TPS rate for a Service Module card from 850 TPS to 1100 TPS.

The feature can be enabled when the equipped Service Module cards include DSM cards and one or more of the EPAP-related features listed in [Table 17: Feature Prerequisites](#) are enabled and turned on.

When the maximum number of Service Module cards is installed in the EAGLE 5 ISS, the maximum processing capacity of SCCP traffic for an EAGLE 5 ISS processing traffic for EPAP-related features is increased to 34,100 TPS.

Note: The increased capacity to 1100 TPS per DSM card assumes incoming traffic consists of at least 30% of GTT routed traffic that does not require EPAP-based lookup. If more than 70% of incoming traffic requires EPAP-based lookup, Group Ticket Voucher (TVG) may shutdown and overall TVG capacity of 1100 for the card may not be met.

The 1100 TPS/DSM for ITU NP feature must be enabled using the feature part number 893018001 and a feature access key (FAK). Based on the feature part number and the serial number of the EAGLE 5 ISS, the feature access key is site-specific.

Note: The feature access key for the 1100 TPS/DSM for ITU NP feature is provided by Tekelec when the feature is purchased. Contact your Tekelec Sales Representative or Account Representative before beginning the feature configuration procedure if you do not have the feature access key for this feature. The 1100 TPS/DSM for ITU NP feature cannot be enabled with a temporary feature access key.

After the 1100 TPS/Service Module card for ITU NP feature has been enabled, the feature must be turned on to begin operation in the system. The feature is an On/Off feature, it can be turned off again after it has been turned on.

System Prerequisites

Before the 1100 TPS/DSM for ITU NP feature can be enabled, the prerequisites listed in [Table 16: System Prerequisites](#) are required in the system.

Table 16: System Prerequisites

Prerequisite	Verification and Provisioning
<p>For new installations, the system serial number must be verified and locked. The system is shipped with an unlocked serial number. The serial number can be changed if necessary and must be locked after the system is on-site.</p> <p>For systems that are being upgraded, the serial number has already been verified and locked.</p>	<p>Enter the <code>rtrv-serial-num</code> command to display the serial number and its lock status.</p> <p>Verify that the displayed serial number is correct for the system. The serial number is shown on a label affixed to the control shelf (shelf 1100).</p> <p>If no serial number is displayed, or if the displayed serial number is not locked, refer to the <code>ent-serial-num</code> command description in <i>Commands Manual</i> for instructions to enter and lock the serial number.</p>
<p>The GTT feature must on in the system.</p>	<p>Enter the <code>rtrv-feat</code> command.</p> <p>If the GTT feature is on, the <code>gtt=on</code> entry appears in the output.</p> <p>If the <code>gtt=off</code> entry appears in the output, use the procedures in <i>Database Administration Manual – Global Title Translation</i> to turn on and provision</p>

Prerequisite	Verification and Provisioning
	the GTT feature and any related features and functions.

Feature Prerequisites

Before the 1100 TPS/DSM for ITU NP feature can be enabled, the prerequisites shown in [Table 17: Feature Prerequisites](#) are required in the system.

Table 17: Feature Prerequisites

Prerequisite	Verification and Provisioning
Service Module cards running the VSCCP application must be equipped. The cards can be all DSM cards, or a mixture of DSM cards and E5-SM4G cards. There must be at least one DSM card.	Enter the <code>rept-stat-gpl:gpl=vsccp</code> command and the <code>rept-stat-gpl:gpl=scpcphc</code> command to list the Service Module cards in the system. If the number of cards is not sufficient, use the procedure Adding a Service Module Card to add Service Module cards.
The ANSIGFLEX system option cannot be set to Yes.	Enter the <code>rtrv-stpopts</code> command. Verify that the ANSIGFLEX entry does not appear in the command output or that the ANSI GFLEX entry shows a value of No.
The LNP feature cannot be on in the system.	Enter the <code>rtrv-ctrl-feat</code> command. If the LNP feature is on, shown with a quantity greater than zero for the LNP ported TNs entry in the command output, the 1100 TPS/DSM for ITU NP feature cannot be enabled
At least one of the following EPAP-related features must be enabled and turned on: <ul style="list-style-type: none"> • G-Port • A-Port • INP • AINPQ • IGM • EIR • IDP Relay • V-Flex • IAR (NP, ASD, GRN) • MO-based GSM SMS NP • MO-based IS41SMS NP • TIF (NP, ASD, GRN, Number Substitution) 	Enter the <code>rtrv-ctrl-feat</code> command and verify that an entry for at least one of the listed EPAP-related features with Status on is present in the output. If no listed EPAP-related features are on, use the procedures in this manual or another Feature Manual for an EPAP-related feature that you will use in the system, to enable and turn on the EPAP-related feature.

This section provides the following procedures for the 1100 TPS/DSM for ITU NP feature:

- [Enable the 1100 TPS/DSM for ITU NP Feature](#)
- [Turn On the 1100 TPS/DSM for ITU NP Feature](#)
- [Turn Off the 1100 TPS/DSM for ITU NP Feature](#)

Refer to the *Commands Manual* for descriptions of the commands used in the procedures, including parameter names and valid values, rules for using the command correctly, and output examples.

Enable the 1100 TPS/DSM for ITU NP Feature

This procedure is used to enable the 1100 TPS/DSM for ITU NP feature.

1. Enable the 1100 TPS/DSM for ITU NP feature with part number 893018001 and the feature access key.

```
enable-ctrl-feat:partnum=893018001:fak=<feature access key>
```

2. Verify the change by entering the `rtrv-ctrl-feat` command with the 1100 TPS/DSM for ITU NP feature part number 893018001.

```
rtrv-ctrl-feat:partnum=893018001
rlghncxa03w 09-08-24 21:15:37 EST EAGLE 40.1.0
The following features have been permanently enabled:
Feature Name          Partnum    Status    Quantity
HC-MIM SLK Capacity   893012707  on        64
Prepaid SMS Intercept Ph1 893006701  on        ----
1100 TPS/DSM for ITU NP 893018001  off       ----
;
```

3. Back up the changes using the `chg-db:action=backup:dest=fixed` command.

The following messages appear, the active Maintenance and Administration Subsystem Processor (MASP) appears first.

```
BACKUP (FIXED) : MASP A - Backup starts on active MASP.
BACKUP (FIXED) : MASP A - Backup on active MASP to fixed disk complete.
BACKUP (FIXED) : MASP A - Backup starts on standby MASP.
BACKUP (FIXED) : MASP A - Backup on standby MASP to fixed disk complete.
```

Turn On the 1100 TPS/DSM for ITU NP Feature

This procedure is used to turn on the 1100 TPS/DSM for ITU NP feature, after it has been enabled or turned off.

Note: If the EPAP-based traffic is higher than 70% of all traffic on the EAGLE 5 ISS, the DSM card performance may not reach 1100 TPS per DSM card.

1. Enter the `chg-ctrl-feat` command the first time and specify the 1100 TPS/DSM feature part number 893018001 and the `status=on` parameter value.

```
chg-ctrl-feat:partnum=893018001:status=on
```

The following message is displayed:

```
CAUTION: Rated TPS for this feature supports an engineered GTT
traffic mix of no more than 70 percent EPAP-based traffic.
Re-enter the command within 30 seconds to confirm change.
```

2. Re-enter the command the second time within 30 seconds to turn on the 1100 TPS/DSM for ITU NP feature.

```
chg-ctrl-feat:partnum=893018001:status=on
```

3. Verify the change by entering the `rtrv-ctrl-feat` command with the 1100 TPS/DSM for ITU NP feature part number.

```
rtrv-ctrl-feat:partnum=893018001
rlghncxa03w 09-08-24 21:15:37 EST EAGLE 40.1.0
The following features have been permanently enabled:
Feature Name          Partnum    Status    Quantity
HC-MIM SLK Capacity  893012707  on        64
Prepaid SMS Intercept Ph1 893006701  on        ----
1100 TPS/DSM for ITU NP 893018001  on        ----
;
```

4. Back up the database changes using the `chg-db:action=backup:dest=fixed` command. The following messages appear, the active Maintenance and Administration Subsystem Processor (MASP) appears first.

```
BACKUP (FIXED): MASP A - Backup starts on active MASP.
BACKUP (FIXED): MASP A - Backup on active MASP to fixed disk complete.
BACKUP (FIXED): MASP A - Backup starts on standby MASP.
BACKUP (FIXED): MASP A - Backup on standby MASP to fixed disk complete.
```

Turn Off the 1100 TPS/DSM for ITU NP Feature

This procedure is used to turn off the 1100 TPS/DSM for ITU NP feature, after it has been enabled and turned on.

1. Enter the `chg-ctrl-feat` command the first time and specify the 1100 TPS/DSM feature part number 893018001 and the `status=off` parameter value.

```
chg-ctrl-feat:partnum=893018001:status=off
```

The following message is displayed:

```
CAUTION: This command decreases the total TPS of the SCCP system from 1100 to
850 TPS for each DSM card.
```

2. Re-enter the command the second time within 30 seconds to turn off the 1100 TPS/DSM for ITU NP feature.
3. Back up the database changes using the `chg-db:action=backup:dest=fixed` command. The following messages appear, the active Maintenance and Administration Subsystem Processor (MASP) appears first.

```
BACKUP (FIXED): MASP A - Backup starts on active MASP.
BACKUP (FIXED): MASP A - Backup on active MASP to fixed disk complete.
BACKUP (FIXED): MASP A - Backup starts on standby MASP.
BACKUP (FIXED): MASP A - Backup on standby MASP to fixed disk complete.
```

Activating the E5-SM4G Throughput Capacity Feature

The E5-SM4G Throughput Capacity feature quantities are used to increase the processing capacity of the E5-SM4G card and of system SCCP traffic for an EAGLE 5 ISS that contains E5-SM4G cards only (no DSM cards). The achievable TPS maximums are shown in [Table 18: Maximum E5-SM4G Card and System TPS Capacity](#).

Table 18: Maximum E5-SM4G Card and System TPS Capacity

Feature Quantity Part Number	Maximum TPS Capacity per E5-SM4G Card	Maximum System TPS Capacity
893019101 - Feature Quantity 5000	3125	<ul style="list-style-type: none"> 75,000 TPS with one or more EPAP-related features and 24+1 cards 96,875 TPS with one or more EPAP-related features and 31+1 cards (EPAP running on T1200 AS)
	5000	<ul style="list-style-type: none"> 150,000 TPS with no EPAP-related or ELAP-related feature traffic and 31+1 cards 120,000 TPS with G-Flex and the ANSIGFLEX STP option and 24+1 cards 155,000 TPS with G-Flex and the ANSIGFLEX STP option and 31+1 cards (EPAP running on T1200 AS) 40,000 TPS with ELAP and 8+1 cards 85,000 TPS with ELAP and 17+1 cards
893019102 - Feature Quantity 6800	6800	<ul style="list-style-type: none"> 210,800 TPS with no EPAP-related or ELAP-related feature traffic and 31+1 cards 163,200 TPS with one or more EPAP-related features and 24+1 cards 210,800 TPS with one or more EPAP-related features and 31+1 cards (EPAP running on T1200 AS) 54,400 TPS with ELAP and 8+1 cards 115,600 TPS with ELAP and 17+1 cards

An E5-SM4G Throughput Capacity quantity feature must be enabled using an E5-SM4G Throughput Capacity feature part number (893019101 or 893019102) and a feature access key.

The feature access key is based on the feature part number and the serial number of the EAGLE 5 ISS, making the feature access key site-specific.

Note: The E5-SM4G Throughput Capacity quantity feature must be purchased to receive the feature access key used to enable the feature. Contact your Tekelec Sales Representative or Account Representative before beginning this procedure if you have purchased the E5-SM4G Throughput

Capacity quantity feature, but do not have the feature access key. A temporary feature access key is not available for this feature.

After an E5-SM4G Throughput Capacity feature is enabled and turned on, the E5-SM4G Throughput Capacity feature cannot be turned off. When the E5-SM4G Throughput Capacity feature is enabled, it is permanently enabled. The E5-SM4G Throughput Capacity feature cannot be temporarily enabled.

System Prerequisites

Before the E5-SM4G Throughput Capacity feature can be enabled, the prerequisites listed in [Table 19: System Prerequisites](#) are required in the system.

Table 19: System Prerequisites

Prerequisite	Verification and Provisioning
<p>For new installations, the system serial number must be verified and locked. The system is shipped with an unlocked serial number. The serial number can be changed if necessary and must be locked after the system is on-site.</p> <p>For systems that are being upgraded, the serial number has already been verified and locked.</p>	<p>Enter the <code>rtrv-serial-num</code> command to display the serial number and its lock status.</p> <p>Verify that the displayed serial number is correct for the system. The serial number is shown on a label affixed to the control shelf (shelf 1100).</p> <p>If no serial number is displayed, or if the displayed serial number is not locked, refer to the <code>ent-serial-num</code> command description in the <i>Commands Manual</i> for instructions to enter and lock the serial number.</p>
<p>The GTT feature must on in the system.</p>	<p>Enter the <code>rtrv-feat</code> command.</p> <p>If the GTT feature is on, the <code>gtt=on</code> entry appears in the output.</p> <p>If the <code>gtt=off</code> entry appears in the output, use the procedures in the <i>Database Administration Manual – Global Title Translation</i> to turn on and provision the GTT feature and any related features and functions.</p>

E5-SM4G Throughput Capacity Feature Prerequisite

Before the E5-SM4G Throughput Capacity feature can be enabled, the prerequisite shown in [Table 20: E5-SM4G Throughput Capacity Feature Prerequisite](#) is required in the system.

Table 20: E5-SM4G Throughput Capacity Feature Prerequisite

Prerequisite	Verification and Provisioning
<p>E5-SM4G cards running the VSCCP application must be equipped.</p> <p>The required number of cards depends on the desired total system TPS to be achieved by the</p>	<p>Enter the <code>rept-stat-gpl:gpl=sccphc</code> command to list the E5-SM4G cards in the system.</p> <p>If the number of cards is not sufficient, use the procedure in Adding a Service Module Card to add E5-SM4G cards.</p>

Prerequisite	Verification and Provisioning
cards. See Table 18: Maximum E5-SM4G Card and System TPS Capacity .	

The following procedure explains how to enable an E5-SM4G Throughput Capacity quantity feature.

Note: After a quantity feature has been enabled, a feature for a higher quantity can be enabled; a feature for a lower quantity cannot be enabled. Quantity features are automatically turned on when they are enabled.

Refer to the *Commands Manual* for descriptions of the commands used in the procedure, including parameter names and valid values, rules for using the command correctly, and output examples.

1. Display the status of the features that are controlled by feature access keys. Enter the `rtrv-ctrl-feat` command.

```
rlghncxa03w 09-07-29 16:40:40 EST EAGLE5 41.1.0
The following features have been permanently enabled:
Feature Name          Partnum  Status  Quantity
HC-MIM SLK Capacity  893012707  on      64
E5-SM4G Throughput Cap 893019101  on      5000
;
```

- If the `rtrv-ctrl-feat` output shows that the correct E5-SM4G Throughput Capacity quantity feature is enabled and its status is on, no further action is necessary.
 - If no E5-SM4G Throughput Capacity feature quantity is enabled or a higher quantity needs to be enabled, continue with step [Step 2](#).
2. Enable the E5-SM4G Throughput Capacity quantity feature by entering the `enable-ctrl-feat` command with the correct part number and FAK for the desired quantity.
 3. Verify the status of the E5-SM4G Throughput Capacity quantity feature by entering the `rtrv-ctrl-feat` command with the feature part number that was just enabled (893033501 or 893019102).

```
rtrv-ctrl-feat:partnum=893019102

rlghncxa03w 09-08-29 16:40:40 EST EAGLE5 41.1.0
The following features have been permanently enabled:
Feature Name          Partnum  Status  Quantity
HC-MIM SLK Capacity  893012707  on      64
E5-SM4G Throughput Cap 893019102  on      6800
;
```

4. Back up the changes using the `chg-db:action=backup:dest=fixed` command.

The following messages appear, the active Maintenance and Administration Subsystem Processor (MASP) appears first.

```
BACKUP (FIXED): MASP A - Backup starts on active MASP.
BACKUP (FIXED): MASP A - Backup on active MASP to fixed disk complete.
BACKUP (FIXED): MASP A - Backup starts on standby MASP.
BACKUP (FIXED): MASP A - Backup on standby MASP to fixed disk complete.
```

Chapter 5

ATINP Measurements

Topics:

- [ATINP Measurements.....85](#)

This chapter describes the measurements that can be collected and generated for the ATINP feature.

ATINP Measurements

The EAGLE 5 ISS Measurements subsystem supports the collection and retrieval of measurements related to the ATINP feature and the ATINPQ local subsystem. The ATINP measurements can be collected with either of the following collection methods:

- The Measurements Platform feature enabled and the Measurements Platform collection option on
- The E5-OAM Integrated Measurements feature enabled and on and the E5-OAM Integrated Measurements collection option on

OAM-based (UI) measurements are not available for ATINP.

Refer to the *Measurements* manual for descriptions of collection methods, measurements, and measurements reports.

Refer to the *Commands Manual* for descriptions of the commands used to enable and turn on features, turn on measurements collection options, and schedule and generate measurements reports.

Refer to the procedures in the *Database Administration Manual - System Management* for configuring the Measurements Platform feature or the EAGLE 5 Integrated Measurements feature and the EAGLE OA&M IP Security feature in the EAGLE 5 ISS.

The Per System totals and Per SSP totals shown in [Table 21: Pegs for Per System and Per SSP](#) are collected for ATINP. The totals are reported in the Hourly Maintenance Measurements (MTCHATINP) report and Daily Maintenance Measurements (MTCDATINP) report.

Note: If an MSU is received with CdPA Rt-on-GT, EAGLE 5 ISS replaces the OPC with its PC as a part of the GTT process. If the CgPA is Rt-on-GT and no CgPA PC is present, it is not possible to determine the originating SSP until GTT has been performed on the CgPA during the encode function. If a decode problem with the query is encountered, then processing will be aborted and Per-SSP measurements will not be updated. GTT of the CgPA will not be attempted on a suspect message. Normal UIM generation will occur (see [ATINPQ Subsystem UIMs](#)).

Table 21: Pegs for Per System and Per SSP

Peg	Description
ATINPQRCV	Total number of queries received for the ATINPQ service, when the incoming message opcode is ATI. Note: MSUs resulting in U-Abort and P-Abort messages typically are not successfully decoded to identify them as ATI messages. ATINPQRCV will not be incremented for these MSUs.
ATIPNQACK	Total number of ATI ACK messages sent by the ATINPQ service
ATIPNQERR	Total number of incoming ATI messages that did not result in either ATI ACK or ATI NACK with Error Code of either Unknown Subscriber or ATI

Peg	Description
	<p>Not Allowed. (The ATI NACK is considered to be a TC_END TCAP message with a Return Error component.)</p> <p>Note: MSUs resulting in U-Abort and P-Abort messages typically are not successfully decoded to identify them as ATI messages. ATINPQERR will not be incremented for these MSUs.</p>

Chapter 6

Maintenance

Topics:

- *ATINPQ Subsystem Alarms (UAMs).....88*
- *ATINPQ Subsystem UIMs.....88*
- *EPAP Status and Alarms.....90*
- *EPAP System Status Reports.....91*
- *Code and Application Data Loading.....92*

This chapter describes the EAGLE 5 ISS maintenance functions that can be used for the ATiNP feature. This chapter also provides an overview of the interaction between the EPAP in the MPS subsystem and the EAGLE 5 ISS.

ATINPQ Subsystem Alarms (UAMs)

This section contains a list of EAGLE 5 ISS UAMs that support the ATINPQ local subsystem. All ATINPQ-related UAMs are generated to the APSS Output Group.

Refer to the *Unsolicited Alarm and Information Messages* manual for descriptions and corrective procedures for EAGLE 5 ISS-related alarms.

Refer to *MPS Platform Software and Maintenance Manual - EAGLE 5 ISS with T1000 AS or EPAP Alarms on T1200 Platform Manual* for descriptions and corrective procedures for MPS-related alarms.

Table 22: ATINPQ UAMs

UAM	Severity	Message Text	Alarm Condition
0565	Critical	ATINPQ Subsystem is not available	No SCCP cards have an ATINPQ status of Active (all are OOS or loading)
0566	Critical	ATINPQ Subsystem is disabled	All IS-NR SCCP cards have ATINPQ status of offline (with at least 1 card IS-NR). An inh-map-ss command has been executed.
0567	Minor	ATINPQ Subsystem normal, cards(s) abnormal	1 SCCP card has ATINPQ status of Active and there are 1 or more cards with ATINPQ status other the Active (offline or loading)
0568	None	ATINPQ Subsystem is available	All SCCP cards are IS-NR and have an ATINPQ status of Active
0569	None	ATINPQ Subsystem is removed	Last SCCP card deleted

ATINPQ Subsystem UIMs

This section contains a list of EAGLE 5 ISS UIMs that support the ATINPQ local subsystem.

Refer to the *Unsolicited Alarm and Information Messages* manual for a complete description of all UIM text and formats.

Note: If both a decode and an encode error occur during ATINP processing, precedence will be given to the decode error and only one UIM will be generated.

Table 23: ATINPQ UIMs

UIM	Text	Description	Action
1395	Inh ATINPQ SS request alrdy outstanding	A second attempt to inhibit the ATINPQ subsystem has been made while the first is still being processed.	None - the second attempt will be ignored
1396	Failure Inhibiting ATINPQ SS	The attempted inhibit of the ATINPQ subsystem failed. A response SOG was not received from the mate.	No action necessary.
1397	LSS: Missing Mandatory Parameter	A required parameter was missing in the ATINP query.	Verify that the incoming ATINP query has Subscriber Identity and Requested Info parameters.
1398	ATINPQ: Badly formatted Subs Id	The Subscriber Identity parameter in the ATINP query was found to be mistyped.	Verify that the Subscriber Identity parameter length is at least 2 bytes (1 byte length field of MSISDN). If greater than 2 bytes, the Subscriber Identity length must be equal to 2 + the length of the MSISDN.
1399	ATINPQ: Subscriber Identity not MSISDN	The Choice for Subscriber Identity in the ATINP query is not the MSISDN.	
1400	LSS: Invalid MSISDN digits length	The MSISDN length in Subscriber Information was 0, or the MSISDN had only one 0xF (filler) digit.	
1402	ATINPQ: Invalid Requested Info	The Requested Info parameter in the incoming ATINP query was invalid. Either the length of the Requested Info parameter does not contain MNP Requested Info, or the parameter is badly formatted.	
1403	LSS: Dgts truncated in encl parms	One or more encoded digits parameter in the ATINP ACK response had to be truncated to fit maximum allowed encoded digits.	Verify the expected number of digits in routingNumber and MSISDN fields. These depend on the combination of requested formatting for routingNumber and MSISDN fields (ATINPQOPTS, ATINACKRN, and ATINACKMSISDN options), digits in incoming ATINP query, and the result of RTDB lookup.

UIM	Text	Description	Action
1426	S-Port: Missing GRN for srvc prtcd subs	Service Portability required use of RTDB GRN for encoding response; however GRN was not provisioned.	Verify EPAP provisioning for the subscriber.

EPAP Status and Alarms

Because EPAP has no direct means of accepting user input or displaying output messages on EAGLE 5 ISS terminals, maintenance, measurements, and status information are routed through a Service Module card. EPAP sends two types of messages to the Service Module card: *EPAP Maintenance Blocks* and *DSM Status Requests*. Each message type is discussed in the following sections.

EPAP Maintenance Blocks

The active EPAP generates and sends maintenance blocks to the primary Service Module card. One maintenance block is sent as soon as the IP link is established between the active EPAP and the primary Service Module card. Additional maintenance blocks are sent whenever the EPAP needs to report any change in status or error conditions. The information returned in maintenance blocks is included in the output of the `rept-stat-mps` and `rept-stat-sccp` commands.

The EPAP sends maintenance blocks that contain at least the following information:

- Status of EPAP 'A' - actual states are active, standby, and down (inoperative). Maintenance blocks include a field for this information so that it can be forwarded to the EPAP A Device Control Block (DCB), where it is available for the output of the `rept-stat-mps` command.
- Status of EPAP 'B' - actual states are active, standby, and down (inoperative). Maintenance blocks include a field for this information so that it can be forwarded to the EPAP B DCB, where it is available for the output of the `rept-stat-mps` command.
- Identification of Active EPAP - a field to identify the active EPAP.
- Congestion Indicator - an indicator showing provisioning link congestion. The link between the EPAPs and the external source of provisioning data can become congested in high-provisioning traffic situations. When this occurs and subsequently as the congestion clears, the EPAP sends maintenance blocks to the Service Module card. The EPAP must ensure that no more than one maintenance block per second is sent to the primary Service Module card if the only reason is to report a change in congestion status.
- Alarm Conditions - an error code field. If the EPAP needs to report an alarm condition, it puts an appropriate UAM identifier in this field.
- Current MPS Database Size - a field indicating the current RTDB size. The Service Module card uses this information to calculate the percentage of memory utilized by the RTDB.

DSM Status Requests

When the EPAP needs to know the status of a Service Module card, it sends a DSM status request to that Service Module card. Because status messages are sent over UDP, the EPAP broadcasts the DSM

status request (to all Service Module cards) and each Service Module card returns its status to the EPAP.

DSM Status Reporting to the EPAP

The sections that follow describe the DSM status reporting for the EPAP.

DSM Status Messages – When Sent

Service Module cards send a DSM status message to the EPAP when any the following events occur in the Service Module card:

- The Service Module card is booted.
- The Service Module card receives a DSM Status Request message from the EPAP
- The Service Module card determines that it needs to download the entire database, for example, if the Service Module card determines that the RTDB needs to be downloaded (for instance, if the database is totally corrupted), or if a craftsperson requests that the database be reloaded.
- The Service Module card starts receiving database downloads or database updates. When a Service Module card starts downloading the RTDB or accepting database updates, it sends a DSM Status Message informing the EPAP of the first record received. This helps the EPAP keep track of downloads in progress.

DSM Status Messages Fields

The DSM Status Message provides the following information to the EPAP:

- **DSM Memory Size.** When the Service Module card is initialized, it determines the amount of memory present. The EPAP uses the value to determine if the Service Module card has enough memory to hold the RTDB.

Refer to the *Dimensioning Guide for EPAP Advanced DB Features Technical Reference* for important information on the dimensioning rules and the Service Module card database capacity requirements.

- **Load Mode Status.** This indicator indicates whether or not 80% of the IS-NR (In-Service Normal) LIMs have access to SCCP services.

EPAP System Status Reports

This section describes the following EPAP status reporting:

- System status
- EPAP-based feature status
- DSM memory capacity status
- Loading mode support status

System Status Reporting

The `rept-stat-sys` command and the `rept-stat-sccp` command supports the Service Module cards running the VSCCP application. EPAP-based feature statistics are reported in the

`rept-stat-sccp` command. Refer to the *Commands Manual* for descriptions of the commands and their output .

MPS Status Reporting

The `rept-stat-mps` command reports the status of the MPS system, particularly the provisioning system. See [Maintenance Commands](#) for more details.

DSM Memory Capacity Status Reporting

As mentioned in the [DSM Status Reporting to the EPAP](#), the Service Module card sends a message to the EPAP containing the amount of memory on the Service Module board. The EPAP determines whether the DSM has enough memory to store the RTDB and sends an ack or nak back to the Service Module card indicating whether or not the Service Module card has an adequate amount of memory. Refer to the *Dimensioning Guide for EPAP Advanced DB Features Technical Reference* for important information on the dimensioning rules and the DSM database capacity requirements.

The `rept-stat-mps:loc=xxxx` command shows the amount of memory used by the RTDB as a percent of available Service Module card memory.

Loading Mode Support Status Reporting

The OAM application determines whether or not the system is in an unstable loading mode because it knows the state of all LIM and Service Module cards in the system. When the loading mode is unstable, the `rept-stat-sys` command reports the existence of the unstable loading mode and the specific conditions that caused it. See [EPAP Application Data Loading](#) for more details.

Code and Application Data Loading

In general, administrative updates can occur while a Service Module card is loading. The Service Module card should remain in an in-transition state if the STP portion of the database has completed loading and is waiting for the RTDB to download.

DSM Code Loading

The EAGLE 5 ISS OAM performs code loading of the Service Module card.

EPAP Application Data Loading

In order to support both RTDB and EAGLE 5 ISS data loading, the VSCCP GPL verifies its hardware configuration during initialization to determine if it has the capacity to support the RTDB.

The VSCCP GPL application data loader registers all tables for loading, independent of feature provisioning and main board and applique hardware configuration. As a result, load requests are always identical. During loading, multiple Service Module card load requests are combined into a single download, reducing the overall download time. The Service Module card stores or discards RTDB table data based on whether or not it has RTDB-capable hardware for EPAP-based features.

The OAM, on the other hand, downloads or sets memory boundaries for configuration options and service selector tables only for provisioned features. When a feature is not provisioned, the OAM does

not attempt to read its tables from disk. Instead, empty tables (tables without entries) are downloaded. All other tables requested for loading are read from disk and downloaded routinely.

80% Threshold of Support

Loading mode is based on the ability of the system to provide SCCP service to at least 80% of the LIMs.

VSCCP Capacity

An insufficient number of Service Module cards that are in an IS-NR or OOS-MT-DSBLD state relative to 80% of the number of provisioned LIMs is called a “failure to provide adequate SCCP capacity.”

Insufficient SCCP Service

It is possible for LIM cards or Service Module cards to be inhibited or to have problems that prevent them from operating normally. If enough Service Module cards are out of service, it may not be possible for the remaining IS-NR Service Module cards to service at least 80% of the number of IS-NR LIM cards. This is called “insufficient SCCP service.” When this occurs, some of the LIM cards are denied SCCP service. It is possible to inhibit LIMs to bring the ratio back to 16:1 or better.

Conditions That Create an Unstable Loading Mode

Current system implementation interrupts and stops card loading upon execution of an STP database `chg` command. Loading mode support denies the execution of EAGLE 5 ISS database `chg` commands when the system is in an unstable loading mode. An unstable loading mode exists when any of the following conditions are true:

- The system's maintenance baseline has not been established.
- Less than 80% of the number of LIMs provisioned are in an IS-NR or OOS-MT-DSBLD state.
- The number of IS-NR and OOS-MT-DSBLD Service Module cards is insufficient to service at least 80% of all provisioned LIMs.
- Insufficient SCCP service occurs when an insufficient number of IS-NR Service Module cards are available to service at least 80% of the number of IS-NR LIMs.
- LIM cards are being denied SCCP service and any Service Module cards are in an abnormal state (OOS-MT-DSBLD, IS-ANR).

Actions Taken When the System is in an Unstable Loading Mode

- No affect on RTDB downloads or updates.

Unstable loading mode has no impact on RTDB downloads or the stream of RTDB updates.

- The `rept-stat-sys` command reports unstable loading mode.

When the loading mode is unstable, the `rept-stat-sys` command reports the existence of the unstable loading mode and the specific trigger that caused it.

- No EAGLE 5 ISS database updates allowed.

When in an unstable loading mode, the EAGLE 5 ISS does not accept database updates. When updates are rejected, the reason is given as: E3112 Cmd Rej: Loading Mode unstable due to SCCP service is deficient.

The `inh-card` and `alw-card` commands can be used to alter SCCP service levels to achieve the 80% threshold. This can be repeated for each card until the system is able to supply SCCP services

to at least 80% of the IS-NR LIM cards. The remaining 20% LIM or supporting Service Module cards may remain out of service until the stream of database updates ceases. This stream of updates can be temporarily interrupted to allow the remaining 20% of the system to come in service.

Once an EAGLE 5 ISS database has been loaded, that database can be updated (as long as the system is not in an unstable loading mode). However, if an database update comes in during EAGLE 5 ISS database loading, the Service Module card stops the current loading, issues a class 01D7 obit, and reboots. The obit is shown in the following example.

Figure 8: Obit Message for Abort of Card Loading

```

tekelecstp 97-04-08 12:29:04 EAGLE 35.0.0
-----
Card 1317  Module RADB_MGR.C  Line  337  Class 01d7
Card 1317  Module RADB_MGR.C  Line  337  Class 01d7
Register Dump :
    EFL=00000246      CS =0058          EIP=0000808d      SS =0060
    EAX=000a6ff3      ECX=000a0005      EDX=00000000      EBX=000a6fa0
    ESP=00108828      EBP=0010882c      ESI=001f1e10      EDI=00000000
    DS =0060          ES =0060          FS =0060          GS =0060

Stack Dump :
[SP+1E]=001f      [SP+16]=0000      [SP+0E]=000a      [SP+06]=0010
[SP+1C]=1e10      [SP+14]=0004      [SP+0C]=6fa0      [SP+04]=8850
[SP+1A]=0010      [SP+12]=001f      [SP+0A]=0004      [SP+02]=0001
[SP+18]=886c      [SP+10]=4928      [SP+08]=7ec3      [SP+00]=504b

User Data Dump :

14 02 fa ed 01 01 1d 01 5a 01 00      .....Z..

Report Date:97-04-08  Time:12:29:04

```

Using the force Option

Use the force option to execute commands that would put the system in unstable loading mode. If executing the `ent-card` command or `inh-card` command would cause the system to enter an unstable loading mode, use the force option in the command.

Glossary

A

ACK	Data Acknowledgement
ASD	Additional Subscriber Data Additional data that is associated with a subscriber (DN) or a range of subscribers.
ATI	Any Time Interrogation An ATI message allows an external server to interrogate an HLR and obtain information about the location and/or state of a GSM subscriber.
ATINP	ATI Number Portability Query feature
ATINPQ	ATI Number Portability Query (Name of the local subsystem)

C

CNL	Small Geographic Area
CSPC	Concerned Signaling Point Code The point code that receives subsystem allowed and subsystem prohibited status messages about a particular global title translation node. These messages are broadcast from SCCP management.

D

Database	All data that can be administered by the user, including cards, destination point codes, gateway screening
----------	--

D

tables, global title translation tables, links, LNP services, LNP service providers, location routing numbers, routes, shelves, subsystem applications, and 10 digit telephone numbers.

DCB

Device Control Block

E

EPAP

EAGLE Provisioning Application Processor

EPAP-related features

Features that require EPAP connection and use the Real Time Database (RTDB) for lookup of subscriber information.

- ANSI Number Portability Query (AINPQ)
- ANSI-41 Analyzed Information Query – no EPAP/ELAP (ANSI41 AIQ)
- Anytime Interrogation Number Portability (ATI Number Portability, ATINP)
- AINPQ, INP, G-Port SRI Query for Prepaid, GSM MAP SRI Redirect, IGM, and ATINP Support for ROP
- A-Port Circular Route Prevention (A-Port CRP)
- Equipment Identity Register (EIR)
- G-Flex C7 Relay (G-Flex)
- G-Flex MAP Layer Routing (G-Flex MLR)
- G-Port SRI Query for Prepaid
- GSM MAP SRI Redirect to Serving HLR (GSM MAP SRI Redirect)
- GSM Number Portability (G-Port)
- IDP A-Party Blacklist
- IDP A-Party Routing

E

- IDP Relay Additional Subscriber Data (IDPR ASD)
- IDP Relay Generic Routing Number (IDPR GRN)
- IDP Service Key Routing (IDP SK Routing)
- IDP Screening for Prepaid
- INAP-based Number Portability (INP)
- Info Analyzed Relay Additional Subscriber Data (IAR ASD)
- Info Analyzed Relay Base (IAR Base)
- Info Analyzed Relay Generic Routing Number (IAR GRN)
- Info Analyzed Relay Number Portability (IAR NP)
- INP Circular Route Prevention (INP CRP)
- IS41 Mobile Number Portability (A-Port)
- IS41 GSM Migration (IGM)
- MNP Circular Route Prevention (MNPCRCP)
- MO-based GSM SMS NP
- MO-based IS41 SMS NP
- MO SMS Generic Routing Number (MO SMS GRN)
- MO- SMS B-Party Routing
- MO SMS IS41-to-GSM Migration
- MT-based GSM SMS NP
- MT-based GSM MMS NP
- MT-based IS41 SMS NP
- MTP Routed Messages for SCCP Applications (MTP Msgs for SCCP Apps)
- MTP Routed Gateway Screening Stop Action (MTPRTD GWS Stop Action)
- Portability Check for MO SMS
- Prepaid IDP Query Relay (IDP Relay, IDPR)
- Prepaid SMS Intercept Phase 1 (PPSMS)
- Service Portability (S-Port)

E

- S-Port Subscriber Differentiation
- Triggerless ISUP Framework Additional Subscriber Data (TIF ASD)
- Triggerless ISUP Framework Generic Routing Number (TIF GRN)
- Triggerless ISUP Number Portability (TIF NP)
- Triggerless ISUP Framework Number Substitution (TIF NS)
- Triggerless ISUP Framework SCS Forwarding (TIF SCS Forwarding)
- Triggerless ISUP Framework Simple Number Substitution (TIF SNS)
- Voice Mail Router (V-Flex)

G

GRN	Generic Routing Number
GSM	Global System for Mobile Communications

I

IGM	See IS41 GSM Migration
IMSI	International Mobile Subscriber Identity

IP	<p>Internet Protocol</p> <p>IP specifies the format of packets, also called datagrams, and the addressing scheme. The network layer for the TCP/IP protocol suite widely used on Ethernet networks, defined in STD 5, RFC 791. IP is a connectionless, best-effort packet switching protocol. It provides packet routing, fragmentation and</p>
----	---

I

re-assembly through the data link layer.

ISS

Integrated Signaling System

L

LIM

Link Interface Module

Provides access to remote SS7, IP and other network elements, such as a Signaling Control Point (SCP) through a variety of signaling interfaces (DS0, MPL, E1/T1 MIM, LIM-ATM, E1-ATM, IPLIMx, IPGWx). The LIMs consist of a main assembly and possibly, an interface appliqué board. These appliqués provide level one and some level two functionality on SS7 signaling links.

Link

Signaling Link

Signaling Link

Carries signaling within a Link Set using a specific Association. A Link can belong to only one Link Set and one Association. There is generally one Link per Association in a Link Set.

M

MPS

Multi-Purpose Server

The Multi-Purpose Server provides database/reload functionality and a variety of high capacity/high speed offboard database functions for applications. The MPS resides in the General Purpose Frame.

MSISDN

Mobile Station International
Subscriber Directory Number

M

The MSISDN is the network specific subscriber number of a mobile communications subscriber. This is normally the phone number that is used to reach the subscriber.

N

NAI

Nature of Address Indicator

Standard method of identifying users who request access to a network.

O

OAM

Operations, Administration, and Maintenance

The application that operates the Maintenance and Administration Subsystem which controls the operation of the EAGLE 5 ISS.

OPS

Operator Provisioning System

P

PDB

Provisioning Database

PDBA

Provisioning Database Application

There are two Provisioning Database Applications (PDBAs), one in EPAP A on each EAGLE 5 ISS. They follow an Active/Standby model. These processes are responsible for updating and maintaining the Provisioning Database (PDB).

PDBI

Provisioning Database Interface

The interface consists of the definition of provisioning messages only. The customer must write a client application that uses the PDBI request/response messages to communicate with the PDBA.

P

PPP Point-to-Point Protocol

R

RFC Request for Comment
RFCs are standards-track documents, which are official specifications of the Internet protocol suite defined by the Internet Engineering Task Force (IETF) and its steering group the IESG.

RMTP Reliable Multicast Transport Protocol

RN Routing Number

ROP Large Geographic Area (Groups of CNLs)

RTDB Real Time Database

S

SCP Service Control Point
Service Control Points (SCP) are network intelligence centers where databases or call processing information is stored. The primary function of SCPs is to respond to queries from other SPs by retrieving the requested information from the appropriate database, and sending it back to the originator of the request.

Secure Copy

Service Module card
DSM card or E5-SM4G card that contains the Real Time Database (RTDB) downloaded from an EPAP or ELAP system.

S

SNAI	<p>Service Nature of Address Indicator</p> <p>An internal G-Port parameter that allows a user to specify how to interpret the signaling connection control part (SCCP) called party address (CdPA) GTA of a LOCREQ/SMSREQ message.</p>
SOG	<p>Subsystem Out-of-Service Grant</p> <p>Service Order Gateway</p>
SOR	<p>Support of Optimal Routing</p> <p>System Out of Service Request</p>
SP	<p>Signaling Point</p> <p>A set of signaling equipment represented by a unique point code within an SS7 domain.</p>
SSN	<p>Subsystem Number</p> <p>The subsystem number of a given point code. The subsystem number identifies the SCP application that should receive the message, or the subsystem number of the destination point code to be assigned to the LNP subsystem of the EAGLE 5 ISS.</p> <p>A value of the routing indicator portion of the global title translation data commands indicating that no further global title translation is required for the specified entry.</p>
STP	<p>Signal Transfer Point</p> <p>STPs are ultra-reliable, high speed packet switches at the heart of SS7 networks, which terminate all link types except F-links. STPs are nearly always deployed in mated pairs for reliability reasons. Their primary</p>

S

functions are to provide access to SS7 networks and to provide routing of signaling messages within and among signaling networks.

T

TCP Transfer Control Protocol

TCP/IP Transmission Control Protocol/Internet Protocol

TFP TransFer Prohibited (Msg)
A procedure included in the signaling route management (functionality) used to inform a signaling point of the unavailability of a signaling route.

TSPC True or Secondary Point Code

U

UAM Unsolicited Alarm Message
A message sent to a user interface whenever there is a fault that is service-affecting or when a previous problem is corrected. Each message has a trouble code and text associated with the trouble condition.

UDP User Datagram Protocol

UIM Unsolicited Information Message
A message sent to a user interface whenever there is a fault that is not service-affecting or when a previous problem is corrected. Each message has a trouble code and text associated with the trouble condition.

V

VSCCP

VxWorks Signaling Connection
Control Part

The application used by the Service
Module card to support
EPAP-related features and LNP
features. If an EPAP-related or LNP
feature is not turned on, and a
Service Module card is present, the
VSCCP application processes normal
GTT traffic.