

Tekelec EAGLE[®] 5

Feature Manual - IS41 GSM Migration

910-6269-001 Revision A

January 2012



Copyright 2012 Tekelec. All Rights Reserved. Printed in USA.

Legal Information can be accessed from the Main Menu of the optical disc or on the Tekelec Customer Support web site in the *Legal Information* folder of the *Product Support* tab.

Table of Contents

Chapter 1: Introduction.....	6
Overview.....	7
Scope and Audience.....	7
Manual Organization.....	7
Documentation Admonishments.....	8
Customer Care Center.....	8
Emergency Response.....	10
Related Publications.....	11
Documentation Availability, Packaging, and Updates.....	11
Locate Product Documentation on the Customer Support Site.....	12
Chapter 2: Feature Description.....	13
Introduction.....	14
IS412GSM Migration Changes.....	18
IGM Protocol.....	18
LOCREQ Query Response.....	31
MTP Routed SCCP Traffic.....	36
IGM SRI-SM Relay to Default IS41 SMSC.....	38
General Numbering Requirements.....	39
Hardware Requirements.....	40
MPS/EPAP Platform.....	40
EPAP/PDBA Overview.....	42
Subscriber Data Provisioning.....	43
EPAP (EAGLE Provisioning Application Processor).....	45
Service Module Cards.....	46
Network Connections.....	49
Chapter 3: Commands.....	54
Introduction.....	55
EAGLE 5 ISS GSM System Options Commands.....	55
EAGLE 5 ISS GSM SMS Options Commands.....	58
EAGLE 5 ISS IS41 Options Commands.....	58
EAGLE 5 ISS Service Selector Commands.....	62
EAGLE 5 ISS Feature Control Commands.....	65

EAGLE 5 ISS SCCP Service Commands.....	66
Chapter 4: Feature Configuration.....	69
Introduction.....	70
EPAP Entity Provisioning.....	71
Prerequisites.....	71
EAGLE 5 ISS HLR Destinations Configuration.....	72
IGM Feature Activation Procedure.....	78
The 1100 TPS/DSM for ITU NP Feature.....	81
Enable the 1100 TPS/DSM for ITU NP Feature.....	84
Turn On the 1100 TPS/DSM for ITU NP Feature.....	85
Turn Off the 1100 TPS/DSM for ITU NP Feature.....	86
Activating the E5-SM4G Throughput Capacity Feature.....	86
Adding a Service Module Card.....	90
LOCREQ Query Response Activation Procedure.....	97
Service Portability Activation Procedure.....	100
MTP Routed Messages for SCCP Applications Activation Procedure.....	101
Chapter 5: Measurements.....	103
IGM Measurements.....	104
Chapter 6: Maintenance.....	107
IGM Related Alarms.....	108
IGM UIMs.....	110
Maintenance Commands.....	112
rept-stat-sccp.....	114
EAGLE 5 ISS Debug Commands.....	114
EPAP Status and Alarm Reporting.....	114
DSM Status Requests.....	115
IGM System Status Reports.....	116
Glossary.....	118

List of Figures

Figure 1: LOCREQ Query Reponse RN Determination.....	33
Figure 2: MPS/EPAP Platform Architecture.....	41
Figure 3: Subscriber Data Provisioning Architecture (High Level).....	44
Figure 4: Database Administrative Architecture.....	46
Figure 5: Customer Provisioning Network.....	50
Figure 6: EPAP Sync Network.....	51
Figure 7: DSM Networks.....	52
Figure 8: Dial-Up PPP Network.....	53

List of Tables

Table 1: Admonishments.....	8
Table 2: IGM Customer Message Processing.....	20
Table 3: IGM and G-Port Customer Message Processing.....	22
Table 4: IGM and A-Port Message Processing.....	23
Table 5: IGM, A-Port, and G-Port Customer Message Processing.....	24
Table 6: DigitAction Applications.....	26
Table 7: MNP SCCP Service Re-Route Capability Summary.....	30
Table 8: Service Portability vs Number Portability by Destination Subscriber Type.....	35
Table 9: Subscriber Portability Type.....	38
Table 10: Changes in SRI-SM Relayed to Default IS41 SMSC	39
Table 11: Service Module Card Provisioning and Reload Settings.....	48
Table 12: EPAP IP Addresses in the DSM Network.....	52
Table 13: chg-gsmopts Parameters.....	55
Table 14: chg-gsmsmsopts Parameters.....	58
Table 15: chg-is41opts Parameters - Class = DATABASE.....	59
Table 16: ent-srvsel Parameters.....	62
Table 17: chg-srvsel Parameters.....	63
Table 18: dlt-srvsel Parameters.....	64
Table 19: rtrv-srvsel Parameters.....	65
Table 20: chg-sccp-serv Parameters.....	66
Table 21: dlt-sccp-serv Parameters.....	67
Table 22: Feature Activation Summary.....	70
Table 23: System Prerequisites.....	82
Table 24: Feature Prerequisites.....	83
Table 25: Maximum E5-SM4G, E5-SM8G-B, and System TPS Capacity.....	86
Table 26: System Prerequisites.....	88
Table 27: E5-SM4G Throughput Capacity Feature Prerequisite.....	89
Table 28: Service Module Card Locations.....	91
Table 29: System Prerequisites for Adding a Service Module Card.....	91
Table 30: Prerequisite for Adding an E5-SM4G Service Module Card.....	92
Table 31: Prerequisites for Adding an E5-SM8G-B Service Module Card.....	92
Table 32: Pegs for Per System IGM Measurements.....	104
Table 33: Pegs for Per SSP IGM Measurements.....	105
Table 34: Pegs for Per System and Per SSP IGM Measurements.....	106
Table 35: IGM Related UAMs.....	108
Table 36: IGM Related UIMs.....	110
Table 37: Maintenance Commands.....	112

Chapter 1

Introduction

Topics:

- *Overview.....7*
- *Scope and Audience.....7*
- *Manual Organization.....7*
- *Documentation Admonishments.....8*
- *Customer Care Center.....8*
- *Emergency Response.....10*
- *Related Publications.....11*
- *Documentation Availability, Packaging, and Updates.....11*
- *Locate Product Documentation on the Customer Support Site.....12*

This chapter provides a brief description of the IS41GSM Migration (IGM) feature of the EAGLE 5 Integrated Signaling System. The chapter also includes the scope, audience, and organization of the manual; how to find related publications; and how to contact Tekelec for assistance.

Overview

This manual provides feature descriptions, commands, maintenance, measurements, and configuration details associated with the IS41 GSM Migration (IGM) feature deployed on an EAGLE 5 Integrated Signaling System (ISS) that is also performing the STP function. The IGM feature applies to ITU and ANSI networks.

The IGM feature provides the mobile wireless service provider a way to migrate subscribers from IS-41 to GSM and GSM to IS-41. After the subscriber is marked as *migrated*, the GSM handset is fully functional, and the migrated subscriber has the option whether to continue to receive calls on the IS-41 or GSM handset.

Number lengths vary between countries and may vary within a country. As a result, the database structure supports numbers of varying length in a flexible way without requiring software modifications. A maximum number length of 15 digits for ported numbers is supported.

IGM is an optional feature on the EAGLE 5 ISS, and can be enabled and turned on, but not off, via a feature access key. Note that the IGM feature requires the Global Title Translation (GTT) feature and that IGM and North American LNP (Local Number Portability) are mutually exclusive on an EAGLE 5 ISS node.

Scope and Audience

This manual is intended for anyone responsible for installing, maintaining, and using the IGM feature in the EAGLE 5 ISS. Users of this manual and the others in the EAGLE 5 ISS family of documents must have a working knowledge of telecommunications and network installations.

Manual Organization



This document is organized into the following chapters:

- *Introduction* contains general information about the IGM documentation, the organization of this manual, and how to request technical assistance.
- *Feature Description* provides a functional description of the IGM feature, including network perspectives, assumptions and limitations, database overview, Service Module card provisioning and reloading, and IGM user interface.
- *Commands* describes the commands that support the IGM feature and explanations of appropriate command usage.
- *Feature Configuration* describes how to activate the IGM feature.
- *Measurements* describes the measurements available for IGM.
- *Maintenance* describes IGM maintenance information, including EPAP status and alarms, hardware verification messages, system status reports and commands, code and application data loading, and alarms.

Documentation Admonishments

Admonishments are icons and text throughout this manual that alert the reader to assure personal safety, to minimize possible service interruptions, and to warn of the potential for equipment damage.

Table 1: Admonishments

	DANGER: (This icon and text indicate the possibility of <i>personal injury</i> .)
	WARNING: (This icon and text indicate the possibility of <i>equipment damage</i> .)
	CAUTION: (This icon and text indicate the possibility of <i>service interruption</i> .)

Customer Care Center

The Tekelec Customer Care Center is your initial point of contact for all product support needs. A representative takes your call or email, creates a Customer Service Request (CSR) and directs your requests to the Tekelec Technical Assistance Center (TAC). Each CSR includes an individual tracking number. Together with TAC Engineers, the representative will help you resolve your request.

The Customer Care Center is available 24 hours a day, 7 days a week, 365 days a year, and is linked to TAC Engineers around the globe.

Tekelec TAC Engineers are available to provide solutions to your technical questions and issues 7 days a week, 24 hours a day. After a CSR is issued, the TAC Engineer determines the classification of the trouble. If a critical problem exists, emergency procedures are initiated. If the problem is not critical, normal support procedures apply. A primary Technical Engineer is assigned to work on the CSR and provide a solution to the problem. The CSR is closed when the problem is resolved.

Tekelec Technical Assistance Centers are located around the globe in the following locations:

Tekelec - Global

Email (All Regions): support@tekelec.com

- **USA and Canada**

Phone:

1-888-FOR-TKLC or 1-888-367-8552 (toll-free, within continental USA and Canada)

1-919-460-2150 (outside continental USA and Canada)

TAC Regional Support Office Hours:

8:00 a.m. through 5:00 p.m. (GMT minus 5 hours), Monday through Friday, excluding holidays

- **Caribbean and Latin America (CALA)**

Phone:

USA access code +1-800-658-5454, then 1-888-FOR-TKLC or 1-888-367-8552 (toll-free)

TAC Regional Support Office Hours (except Brazil):

10:00 a.m. through 7:00 p.m. (GMT minus 6 hours), Monday through Friday, excluding holidays

- **Argentina**

Phone:

0-800-555-5246 (toll-free)

- **Brazil**

Phone:

0-800-891-4341 (toll-free)

TAC Regional Support Office Hours:

8:30 a.m. through 6:30 p.m. (GMT minus 3 hours), Monday through Friday, excluding holidays

- **Chile**

Phone:

1230-020-555-5468

- **Colombia**

Phone:

01-800-912-0537

- **Dominican Republic**

Phone:

1-888-367-8552

- **Mexico**

Phone:

001-888-367-8552

- **Peru**

Phone:

0800-53-087

- **Puerto Rico**

Phone:

1-888-367-8552 (1-888-FOR-TKLC)

- **Venezuela**

Phone:

0800-176-6497

- **Europe, Middle East, and Africa**

Regional Office Hours:

8:30 a.m. through 5:00 p.m. (GMT), Monday through Friday, excluding holidays

- **Signaling**

Phone:

+44 1784 467 804 (within UK)

- **Software Solutions**

Phone:

+33 3 89 33 54 00

- **Asia**

- **India**

Phone:

+91 124 436 8552 or +91 124 436 8553

TAC Regional Support Office Hours:

10:00 a.m. through 7:00 p.m. (GMT plus 5 1/2 hours), Monday through Saturday, excluding holidays

- **Singapore**

Phone:

+65 6796 2288

TAC Regional Support Office Hours:

9:00 a.m. through 6:00 p.m. (GMT plus 8 hours), Monday through Friday, excluding holidays

Emergency Response

In the event of a critical service situation, emergency response is offered by the Tekelec Customer Care Center 24 hours a day, 7 days a week. The emergency response provides immediate coverage, automatic escalation, and other features to ensure that the critical situation is resolved as rapidly as possible.

A critical situation is defined as a problem with the installed equipment that severely affects service, traffic, or maintenance capabilities, and requires immediate corrective action. Critical situations affect service and/or system operation resulting in one or several of these situations:

- A total system failure that results in loss of all transaction processing capability
- Significant reduction in system capacity or traffic handling capability
- Loss of the system's ability to perform automatic system reconfiguration
- Inability to restart a processor or the system

- Corruption of system databases that requires service affecting corrective actions
- Loss of access for maintenance or recovery operations
- Loss of the system ability to provide any required critical or major trouble notification

Any other problem severely affecting service, capacity /traffic, billing, and maintenance capabilities may be defined as critical by prior discussion and agreement with the Tekelec Customer Care Center.

Related Publications

For information about additional publications that are related to this document, refer to the *Related Publications* document. The *Related Publications* document is published as a part of the *Release Documentation* and is also published as a separate document on the Tekelec Customer Support Site.

Documentation Availability, Packaging, and Updates

Tekelec provides documentation with each system and in accordance with contractual agreements. For General Availability (GA) releases, Tekelec publishes a complete EAGLE 5 ISS documentation set. For Limited Availability (LA) releases, Tekelec may publish a documentation subset tailored to specific feature content or hardware requirements. Documentation Bulletins announce a new or updated release.

The Tekelec EAGLE 5 ISS documentation set is released on an optical disc. This format allows for easy searches through all parts of the documentation set.

The electronic file of each manual is also available from the [Tekelec Customer Support](#) site. This site allows for 24-hour access to the most up-to-date documentation, including the latest versions of Feature Notices.

Printed documentation is available for GA releases on request only and with a lead time of six weeks. The printed documentation set includes pocket guides for commands and alarms. Pocket guides may also be ordered separately. Exceptions to printed documentation are:

- Hardware or Installation manuals are printed without the linked attachments found in the electronic version of the manuals.
- The Release Notice is available only on the Customer Support site.

Note: Customers may print a reasonable number of each manual for their own use.

Documentation is updated when significant changes are made that affect system operation. Updates resulting from Severity 1 and 2 Problem Reports (PRs) are made to existing manuals. Other changes are included in the documentation for the next scheduled release. Updates are made by re-issuing an electronic file to the customer support site. Customers with printed documentation should contact their Sales Representative for an addendum. Occasionally, changes are communicated first with a Documentation Bulletin to provide customers with an advanced notice of the issue until officially released in the documentation. Documentation Bulletins are posted on the Customer Support site and can be viewed per product and release.

Locate Product Documentation on the Customer Support Site

Access to Tekelec's Customer Support site is restricted to current Tekelec customers only. This section describes how to log into the Tekelec Customer Support site and locate a document. Viewing the document requires Adobe Acrobat Reader, which can be downloaded at www.adobe.com.

1. Log into the [Tekelec Customer Support](#) site.

Note: If you have not registered for this new site, click the **Register Here** link. Have your customer number available. The response time for registration requests is 24 to 48 hours.

2. Click the **Product Support** tab.
3. Use the Search field to locate a document by its part number, release number, document name, or document type. The Search field accepts both full and partial entries.
4. Click a subject folder to browse through a list of related files.
5. To download a file to your location, right-click the file name and select **Save Target As**.

Chapter 2

Feature Description

Topics:

- *Introduction.....14*
- *IGM Protocol.....18*
- *General Numbering Requirements.....39*
- *Hardware Requirements.....40*
- *MPS/EPAP Platform.....40*

This chapter describes the IS41 GSM Migration (IGM) feature.

Introduction

The IS41 GSM Migration (IGM) feature supports call termination for customers to migrate from IS-41 to GSM and GSM to IS-41 wireless technology. This is referred to as Portability Type = 5 (PT = 5). This feature provides the mobile wireless service provider a way to migrate subscribers from IS-41 to GSM and GSM to IS-41. Once the subscriber is marked as migrated, the GSM handset is fully functional, and the migrated subscriber has the option whether to continue to receive calls on the IS-41 or GSM handset.

IGM provides the ability for subscribers to change service providers while retaining their Mobile Dialed Number (MDN). IGM uses the EPAP Real Time Database (RTDB) to maintain subscriber portability and migration information. Subscriber information in the EPAP RTDB is keyed by Mobile MDNs for ANSI-41 subscribers and Mobile Station International ISDN Number (MSISDNs) for GSM subscribers.

IGM treats only those DN entries assigned with SP/PT= 5, No NE/PT=5, or assigned with RN/PT= 0 as migrated subscribers. Any other types of NE/PT assignments are not considered as migrated or ported subscribers.

Two types of subscriber entries, migrated and non-migrated subscribers, are supported. For migrated subscribers, the subscriber entries are entered with No NE/PT=5, SP/PT=5, and RN/PT=0. All other entries are non-migrated subscribers. IGM also supports DN block entries.

The ETSI standards are defined so that GSM carriers can choose to implement either Signaling Relay Function (SRF)-based (using MAP protocol) MNP or IN-based (using INAP protocol) MNP. IGM supports only the SRF-based solution for MNP. (INAP-based MNP processing is similar to wireline networks; this function is supported by the INP feature.)

Message Interception

SRF-based MNP processing involves the “intercepting” of existing MAP messages to check for ported numbers. For call-related messages, IGM acts as an “NP HLR” in the case where the number has been exported, by responding to the switch with an SRI, SRI-SM, LOCREQ, and SMSREQ ack messages. For non-migrated calls, IGM performs message relay.

Routing Options

The ETSI standards for SRF-based MNP define two routing options, direct routing and indirect routing. IGM supports both options:

- With direct routing, the network where the call is originated is responsible for determining whether the called party has ported and routing the call to the new subscription network.
- With indirect routing, this is the responsibility of the network that originally owned the number.

Number Lengths

Number lengths vary among countries and may even vary within a country. As a result, IGM supports numbers of varying length in a flexible way without necessitating software modifications. A maximum number length of 15 digits for ported numbers is supported.

Supported Messages

IGM uses the EPAP RTDB to derive the portability status of a subscriber.

IGM supports LOCREQ messages as well as SMSREQ messages, if the option is selected, for number portability handling. LOCREQ messages generate a LOCREQ response if the mobile dialed number (MDN) is migrated and relays the LOCREQ if the MDN is not ported (non-porting or porting in are handled the same way).

SMSREQ messages generate a SMSREQ NAK if access is denied and relays the SMSREQ if SMSREQ BYPASS is set to false. SRI generates an ACK if the MSISDN is migrated, and relays the message if the dialed number is not migrated. SRI-SM generates an ACK if the dialed number is migrated, and relays the message if it is not.

MTP Routed SCCP Traffic

When the MTP Msgs for SCCP Apps feature is turned on, all MTP routed UDT/non-segmented XUDT SCCP messages are routed to Service Module cards. When the MTP Routed GWS Stop Action feature is turned on, messages are filtered based on the provisioned Gateway Screening rules on a per linkset basis. The MTP Routed GWS Stop Action feature forwards only UDT, UDTS, XUDT and XUDTS SCCP messages to the Service Module cards for processing. The Service Module cards then perform SCCP decode and verification on the MTP routed messages.

MNP Circular Route Prevention

The MNP Circular Route Prevention (MNPCR) feature detects circular routing caused by incorrect information in one or more of the network number portability databases. For example, a subscriber may have ported from network A to network B. Network A has the correct routing information, indicating the subscriber now belongs to network B. However, network B may have incorrect routing information, indicating that the subscriber still belongs to network A. In this case, network A routes the call to network B, based on its portability data, but network B routes the call back to network A, based on its incorrect data. The result is a circular route. The MNPCR feature provides logic to prevent the circular routing from occurring.

MNP Circular Route Prevention is not valid when only IS41 GSM Migration (IGM) is turned on. ANSI-41 Mobile Number Portability (A-Port) or GSM Mobile Number Portability (G-Port) must be turned on for MNP Circular Route Prevention processing to be valid. Circular route prevention for only ITU MAP messages is supported when only IGM is turned on.

The MNP Circular Route Prevention feature (MNPCR) allows Circular Route Prevention based on the Translation Type (TT) of the SCCP CdPA to be performed for SRI messages when a Home Routing Number (HomeRN) is not present. For the Circular Route Prevention on Translation Type processing to be performed, the `crptt` parameter of the `chg-gsmopts` command must be set to a value between 0 and 255. If the `crptt` parameter of the `chg-gsmopts` command is set to the default value of `none`, then no Circular Route Prevention on Translation Type processing is performed. The MNP Circular Route Prevention feature cannot be turned off if the `crptt` parameter is provisioned to any value other than `none`. If a message is processed for Circular Route Prevention based on HomeRN, then Circular Route Prevention on Translation Type processing does not occur.

SRI messages must meet these criteria to be eligible for Circular Route Prevention on Translation Type:

- The message is selected for G-Port or IS41 GSM Migration processing.
- The message is not identified as G-Port SRI Query for Prepaid.
- The message is not MTP-routed. (The CdPA is Route-on-GT.)

- The translation type of the SCCP CdPA matches the provisioned translation type (`crptt`).
- The ITU TCAP Package type is ITU Begin.
- The OpCode is an SRI (hexadecimal 16).
- The Optimal Routing Interrogation Parameter (Tag = 0x04) is not present.
- The MSISDN is not assigned to the subscriber's network provider.

DigitAction Expansion

The DigitAction Expansion feature provides more flexibility to formulate the SCCP Called Party Address (SCCP) Global Title Address (GTA) field of the MAP messages relayed by IGM.

DigitAction Expansion is provisioned via the PDBI Enter Network Entity or Update Network Entity commands. DigitAction Expansion can also be modified via the Add an NE and Update an NE GUI screens.

Digit Action DELCCPREFIX

The Digit Action to delete country code if present and prefix database entity feature allows the DELCCPREFIX Digit Action to be applied to the Called Party Global Title Address (CdPA GTA) when the GTA has a National format, as well as when the GTA has an International format. The DELCCPREFIX option in the SCCPOPTS table specifies how the DELCCPREFIX digit action is applied to a Called Party Global Title Address (CdPA GTA).

- When the SCCPOPTS:DELCCPREFIX option is set to PFXWCC, the DELCCPREFIX digit action is applied to the CdPA GTA only when the address has a International format. The Country Code is deleted and the GTA is prefixed with the Entity ID.
- When the SCCPOPTS:DELCCPREFIX option is set to PFX4ALL, the DELCCPREFIX digit action is applied to the CdPA GTA in all cases. For an International format, the Country Code is deleted and the GTA is prefixed with the Entity ID. For a National format, the GTA is prefixed with the Entity ID.

The `chg-sccpopts` command is used to specify the `delccprefix` parameter value to configure the DELCCPREFIX Digit Action functionality.

MNP SCCP Service Re-Route

The MNP SCCP Service Re-Route feature is used when the IGM subscriber database is incoherent with MPS data and the GTT data is valid. The MNP SCCP Service Re-Route feature provides the capability to re-route the traffic from the EAGLE 5 ISS to other IGM subscriber database nodes and inform the originating nodes to re-route the IGM service related traffic to other IGM service nodes.

The MNP SCCP Service Re-Route feature is designed to handle and control re-routing of IGM traffic from an affected node to alternate nodes within an operators network. This feature is an optional feature and does not affect the normal IGM function. This feature also provides the option to mark IGM offline to perform a controlled re-routing during this state.

ROP Support

The IS41 GSM Migration (IGM) feature allows Small Geographic Areas (CNLs) to be grouped into Large Geographic Areas (ROPs). This grouping simplifies the routing and allows a call to be delivered as close to the interconnection destination as possible. ROP information is stored in the generic routing

number (GRN) field. Both CNL and ROP information can be provisioned for a single subscriber entry; however, only one of the CNL or ROP fields can be selected for the outgoing message

The G-Port, G-Port SRI Query for Prepaid, GSM MAP SRI Redirect, AINPQ, INP, and ATINP features also support ROP.

Include Optional CUG Parameter in SRI Ack Messages

The Include Optional CUG Parameter in SRI Ack Messages functionality allows an existing Closed User Group-CheckInfo (CUG-CheckInfo) parameter in an incoming SRI message to be included in the outgoing SRI Ack message.

The Include Optional CUG Parameter in SRI Ack Messages functionality is controlled by the `encodecug` option of the `chg-gsmopts` command `off` and `on` parameters. The `encodecug` option of the `chg-gsmopts off/on` parameter can be changed only if the G-Port or IGM feature is enabled.

The CUG-CheckInfo parameter in an incoming SRI message is copied in the original sequence to the outgoing SRI Ack message when these conditions are met:

- The `encodecug` option of the `chg-gsmopts` command is set to `on`.
- The CUG-CheckInfo parameter is present in an incoming SRI message.
- The CUG-CheckInfo parameter in an incoming SRI message is encoded in definite length format that is less than or equal to 30 bytes.

If the three conditions described above are met, the original CUG-CheckInfo sequence from the incoming SRI message is copied into the SRI Ack message. If encoded in the SRI Ack message, the CUG-CheckInfo parameter is located after the MSRN (Tag = 0x04) and before the MSISDN (Tag = 0x8C) or NPS parameter (Tag = 0x8D), if either MSISDN or NPS parameter is present. The CUG-CheckInfo parameter in an SRI Ack message uses Tag = 0xA3.

If the CUG-CheckInfo parameter is greater than 30 bytes and all other conditions for encoding are met, then only the CUG-Interlock and CUG-OutgoingAccess parameters are copied from an incoming SIR message to the outgoing SRI Ack message. The ExtensionContainer is omitted.

When the `encodecug` option is set to `off`, the CUG-CheckInfo parameter is not encoded in the SRI Ack message.

If the `encodecug` option is set to `on` but the CUG-CheckInfo parameter in an incoming SRI message uses an indefinite length format, the CUG-CheckInfo parameter is not encoded in the SRI Ack message.

Route SRI_SM and ReportSMSDeliveryStatus for Non-local or Ported-out Subscribers using GTT

The Route SRI_SM and ReportSMSDeliveryStatus for Non-local or Ported-out Subscribers using GTT functionality modifies SRI_SM and ReportSMSDeliveryStatus messages to allow routing of the message to an alternate network using Global Title Translation (GTT). This functionality allows processing to occur when the Directory Number (DN) in the database is associated with both the Service Point (SP) and Generic Routing Number (GRN) network elements and the GRN is not present in the EAGLE 5 ISS HomeRN table, or when the subscriber is ported out and associated with the Routing Number (RN).

The message is altered by changing the SCCP Called Party Address (CdPA) to the Country Code (CC) + GRN + DN or to CC + RN + DN. This alteration allows GTT to redirect the query to an alternate network. If a CC is not located in the DN, then the SCCP CdPA is converted to a GRN + DN or RN + DN format.

This conversion is performed only on ITU TCAP Begin MSUs with Op Code of SRI_SM or ReportSMSDeliveryStatus delivered to the GPort or MNP service selector for processing. If the MT-Based GSM SMS NP or the IS41 GSM Migration (IGM) feature generates a response for the SRI_SM message, then this functionality is not applicable.

The Route SRI_SM and ReportSMSDeliveryStatus for Non-local or Ported-out subscribers using GTT functionality is controlled by the `srismgttrtg` option of the `chg-gsmopts` command `off` and `on` parameters. The `srismgttrtg` option of the `chg-gsmopts off/on` parameter can be changed only if the G-Port or IGM feature is enabled.

Option to Suppress NumberPortabilityStatusIndicator in SRI Ack

The Option to Suppress NumberPortabilityStatusIndicator in SRI Ack functionality allows the Number Portability Status Indicator (NPSI) to be omitted from all SRI Ack messages.

The Option to Suppress NumberPortabilityStatusIndicator in SRI Ack functionality is controlled by the `encodenps` option of the `chg-gsmopts` command `off` and `on` parameters. The `encodenps` option of the `chg-gsmopts off/on` parameter can be changed only if the G-Port or IGM feature is enabled.

The NumberPortabilityStatusIndicator parameter is encoded in an SRI Ack message when these conditions are met:

- The `encodenps` option of the `chg-gsmopts` command is set to `on`.
- SRI is considered MAP Phase 2+.
- DN Portability Type is 0, 1, 2, or 36. (Portability Type = 36 is encoded as Portability Type = 0.)

Note: MAP Phase is set based on either data in the dialog portion or `GSMOPTS:DEFMAPVR` if the dialog portion does identify.

The NumberPortabilityStatusIndicator parameter is not encoded in any SRI Ack message if the `encodenps` option of the `chg-gsmopts` command is set to `off`.

IS412GSM Migration Changes

For systems that are upgraded to the IGM feature, the upgrade process sets an SCCP option to `on` if the G-Port feature is turned on and the IS412GSM prefix is defined. If the G-Port feature is turned on and the IS412GSM prefix is not defined, the upgrade process sets the SCCP option to `off`. The default setting for new systems is `off` (disabled).

The EAGLE 5 ISS populates a new GSM2IS41 prefix following the same mechanism that is used for the existing IS412GSM prefix. The EAGLE 5 ISS returns a GSM2IS41 prefix in the SRI Ack message if a received SRI message is destined for a non-migrated IS41 or GSM migrated IS41 subscriber (a data entry is found with RN and PT=0).

IGM Protocol

IGM provides the following main functions:

Message Discrimination

Because IGM provides translation of migrated and non-migrated numbers, it provides a method to identify which messages need migration handling versus GTT. This task of identification is provided via a service selector table where the user defines the service for a combination of selectors.

Operation Code Discrimination

IGM handles ANSI Loc_Req, SMSREQ, GSM SRI, and SRI_SM differently than other ANSI/GSM operation codes. The Portability type field is only considered for these operation codes. Message relay is performed for all other operation codes based on IGM Translation data.

Number Conditioning

The RTDB stores International MSISDN only. IGM provides the capability to condition incoming numbers to be international MSISDN (Insert CC or/and NDC) for the database look up. IGM removes the GSM prefix from GSM SRI messages and then conditions the non-international numbers to international numbers, if needed, before performing any database lookup.

IS412GSM

IGM generates a Loc_Req Return Result Response, when the MDN in the Loc_Req is a *Migrated with one handset* subscriber. When formulating a Loc_Req response, IGM uses the IS412GSM prefix in GSMOPTS to build the Routing Digits. If the IS412GSM prefix is not provisioned, IGM issues UIM 1130 IS412GSM not provisioned and falls through to GTT.

GSM2IS41

The GSM2IS41 prefix is used in the SRI Ack message if the message received is SRI and DN lookup has RN and PT = 0 assigned. If MIGRPFX = MULTIPLE, then the RN from the RTDB is used as the prefix in the SRI Ack message. If MIGRPFX = SINGLE and GSM2IS41 prefix is NONE, then the SRI Ack message issues UIM 1341 SRI rcvd GSM2is41 prefix not provisioned and the message falls through to GTT.

Database Lookup

IGM performs the RTDB database lookup using the international MSISDN.

The individual number database is searched first:

- If the number is not found, the number range database is searched.
- If a match is not found in the individual and range-based database, the GTT is performed on the message.

In the event of the MSISDN numbers in the RTDB database being odd and CDPA GTI of the incoming message being '2', and the last digit of the number is 'zero':

- IGM first performs database lookup one time using the even number.
- If no match is found, IGM again performs the database lookup, using the odd number (without last digit).

Since a DN may be the target of the A-Port, G-Port, or IGM message processing in a hybrid network (where an operator owns both GSM and IS41 network), message processing call disposition is based

on what applications are in service. [Table 2: IGM Customer Message Processing](#) through [Table 5: IGM, A-Port, and G-Port Customer Message Processing](#) show call dispositions for the following configurations:

- IGM Only ([Table 2: IGM Customer Message Processing](#))
- IGM and G-Port ([Table 3: IGM and G-Port Customer Message Processing](#))
- IGM and A-Port ([Table 4: IGM and A-Port Message Processing](#))
- A-Port, G-Port, and IGM ([Table 5: IGM, A-Port, and G-Port Customer Message Processing](#))

The following notations apply to [Table 2: IGM Customer Message Processing](#) through [Table 5: IGM, A-Port, and G-Port Customer Message Processing](#).

PT = Portability Type for the DN

Values:

- 0 – Not known to be ported
- 1 – Own number ported out
- 2 – Foreign number ported to foreign network
- 3 – Prepaid 1 (used by PPSMS)
- 4 – Prepaid 2 (used by PPSMS)
- 5 – Migrated with one handset
- 6 – Prepaid 3 (used by PPSMS)

through

- 32 – Prepaid 35 (used by PPSMS)
- 36 – Not identified to be ported
- FF – No status, No Portability Type

NE = Network Entity

PPSMSPT = Prepaid1 through Prepaid 35 used by PPSMS

RN = Routing Number

SP = Signaling Point

SRI = Send Routing Information

SP* : This row refers to DN is assigned with SP, with or without PT. SP** : This row refers to DN is assigned with SP without PT. DN blocks are commonly assigned with SP and without PT.

Table 2: IGM Customer Message Processing

NE/PT	SRI	SRI_SM	Other GSM	LOCREQ	SMSREQ	Other IS41
RN and PT = 0	MIGRPFX = single: ACK, use GSM2IS41 prefix MIGRPFX = multiple: ACK, RN from RTDB	Based on provisioned option: a) SRI_SM_NACK with Return	Relay	Relay	Relay	Relay

NE/PT	SRI	SRI_SM	Other GSM	LOCREQ	SMSREQ	Other IS41
		Error Component b) Relay to configured default CDMA SMSC				
RN and PT ≠ 0	GTT	GTT	GTT	GTT	GTT	GTT
SP and PT = 5	Relay	Relay	Relay	ReturnResult with IS412GSM prefix	If SMSREQBYPASS = true, then Relay; else ReturnResult with SMS Access Denied Reason = 5	Relay
SP and PT ≠ 5	Relay	Relay	Relay	Relay	Relay	Relay
No NE and PT = 0	ACK (no NE)	GTT	GTT	GTT	GTT	GTT
No NE and PT=1, 2, 36, or No PT	GTT	GTT	GTT	GTT	GTT	GTT
No NE and PT = 5	GTT	GTT	GTT	ReturnResult with IS412GSM prefix	If SMSREQBYPASS = true, then GTT; else ReturnResult with SMS Access Denied Reason = 5	GTT
No NE and PT = PPSMSPT	GTT	GTT	GTT	GTT	GTT	GTT
No DN entry found	GTT	GTT	GTT	GTT	GTT	GTT

Table 3: IGM and G-Port Customer Message Processing

NE/PT	SRI	SRI_SM	Other GSM	LOCREQ	SMSREQ	Other IS41
RN and PT = 0	MIGRPFX = single: ACK, use GSM2IS41 prefix MIGRPFX = multiple: ACK, RN from RTDB	Based on provisioned option: a) SRI_SM_NACK with Return Error Component b) Relay to configured default CDMA SMSC	Relay	Relay	Relay	Relay
RN and PT ≠ 0 or No PT	ACK (RN from RTDB) for PT = 0, 1, 2: Existing Encode NPS for PT = 36: maps to 0	Relay	Relay	GTT	GTT	GTT
SP and PT = 5	Relay	Relay	Relay	ReturnResult with IS412GSM prefix	If SMSREQBYPASS = true, then Relay; else ReturnResult with SMS Access Denied Reason = 5	Relay
SP and PT ≠ 5	Relay	Relay	Relay	Relay	Relay	Relay
No NE and PT = 5	GTT	GTT	GTT	ReturnResult with IS412GSM prefix	If SMSREQBYPASS = true, then GTT; else ReturnResult with SMS Access Denied Reason = 5	GTT

NE/PT	SRI	SRI_SM	Other GSM	LOCREQ	SMSREQ	Other IS41
No NE and PT= 0, 1, 2, 36, or No PT	ACK (no NE) for PT = 0: Existing Encode NPS for PT = 36: maps to 0 if needed	GTT	GTT	GTT	GTT	GTT
No NE and PT = PPSMSPT	GTT	GTT	GTT	GTT	GTT	GTT
No DN entry found	GTT	GTT	GTT	GTT	GTT	GTT

Table 4: IGM and A-Port Message Processing

NE/PT	SRI	SRI_SM	Other GSM	LOCREQ	SMSREQ	Other IS41
RN and PT = 0	MIGRPFX = single: ACK, use GSM2IS41 prefix MIGRPFX= multiple: ACK, RN from RTDB	Based on provisioned option: a) SRI_SM_NACK with Return Error Component b) Relay to configured default CDMA SMSC	Relay	Relay	Relay	Relay
RN and PT≠ 0	GTT	GTT	GTT	ReturnResult with RN from RTDB	Relay	Relay
SP and PT= 5	Relay	Relay	Relay	ReturnResult with IS41GSM prefix	If SMSREQBYPASS = true, then Relay; else ReturnResult with SMS Access	Relay

NE/PT	SRI	SRI_SM	Other GSM	LOCREQ	SMSREQ	Other IS41
					Denied Reason = 5	
SP and PT ≠ 5	Relay	Relay	Relay	Relay	Relay	Relay
No NE and PT = 5	GTT	GTT	GTT	ReturnResult with IS412GSM prefix	If SMSREQBYPASS = true, then GTT; else ReturnResult with SMS Access Denied Reason = 5	GTT
No NE and PT = 0	ACK (no NE)	GTT	GTT	ReturnResult (no NE)	GTT	GTT
No NE and PT = 1, 2, 36, or No PT	GTT	GTT	GTT	ReturnResult (no NE)	GTT	GTT
No NE and PT = PPSMSPT	GTT	GTT	GTT	GTT	GTT	GTT
No DN entry found	GTT	GTT	GTT	GTT	GTT	GTT

Table 5: IGM, A-Port, and G-Port Customer Message Processing

NE/PT	SRI	SRI_SM	Other GSM	LOCREQ	SMSREQ	Other IS41
RN and PT = 0	MIGRPFX = single: ACK, use GSM2IS41 prefix MIGRPFX = multiple: ACK, RN from RTDB	Based on provisioned option: a) SRI_SM_NACK with Return Error Component	Relay	Relay	Relay	Relay

NE/PT	SRI	SRI_SM	Other GSM	LOCREQ	SMSREQ	Other IS41
		b) Relay to configured default CDMA SMSC				
RN and PT ≠ 0	ACK (RN from RTDB) for PT = 0, 1,2: Existing Encode NPS for PT = 36: mps to 0	Relay	Relay	ReturnResult with RN from RTDB	Relay	Relay
SP and PT = 5	Relay	Relay	Relay	ReturnResult with IS412GSM prefix	If SMSREQBYPASS = true, then Relay; else ReturnResult with SMS Access Denied Reason = 5	Relay
SP and PT ≠ 5	Relay	Relay	Relay	Relay	Relay	Relay
No NE and PT = 5	GTT	GTT	GTT	ReturnResult with IS412GSM prefix	If SMSREQBYPASS = true, then GTT; else ReturnResult with SMS Access Denied Reason = 5	GTT
No NE and PT = 0 or 36	ACK (no NE) for PT = 0: Existing Encode NPS for PT = 36: maps to 0	GTT	GTT	ReturnResult (no NE)	GTT	GTT
No NE and PT = 1, 2 or No PT	ACK (no NE)	GTT	GTT	ReturnResult (no NE)	GTT	GTT

NE/PT	SRI	SRI_SM	Other GSM	LOCREQ	SMSREQ	Other IS41
No NE and PT = PPSMSPT	GTT	GTT	GTT	GTT	GTT	GTT
No DN entry found	GTT	GTT	GTT	GTT	GTT	GTT

Database lookup results in the following:

1. Applying normal routing or
2. Relaying the message to the destination as noted in the database or
3. Returning an acknowledge message to the originating switch.

Message Relay

The rules for formatting the SCCP CdPA GTA field are based on the value specified in the DigitAction field. In the case where a received IS41 message is relayed, the EAGLE formulates the SCCP CdPA GTA field of the outgoing message according to DigitAction specified. If DigitAction = none, the EAGLE 5 ISS does not overwrite the SCCP CdPA GTA. For all other values, the EAGLE 5 ISS formats the SCCP CdPA GTA according to the value assigned to DigitAction. [Table 6: DigitAction Applications](#) identifies the required DigitAction options as well as the samples of how the SCCP CdPA GTA of an outgoing message is formatted for each of the options. The illustration assumes the RN/SP ID is 1404 and default country code is 886.

Table 6: DigitAction Applications

DigitAction	Value in Incoming CdPA GTA	Value in Outgoing CdPA GTA	Meaning
none	886944000213	886944000213	No change to the Called Party GTA (default)
prefix	886944000213	1404886944000213	Prefix Called Party GTA with the entity id
replace	886944000213	1404	Replace Called Party GTA with the entity id
insert	886944000213	8861404944000213	Insert entity id after country code. (CC + Entity Id + NDC + SN)

DigitAction	Value in Incoming CdPA GTA	Value in Outgoing CdPA GTA	Meaning
delccprefix	886944000213	1404944000213	Delete country code and add prefix (No action is taken if country code is not present.)
delcc	886944000213	944000213	Delete country code
spare1	886944000213	treated as none	No change to the Called Party GTA (default)
spare2	886944000213	treated as none	No change to the Called Party GTA (default)

Returning Acknowledgement

When a LOCREQ Ack is returned, the EAGLE 5 ISS follows the LOCREQ encoding rules along with the following enhancements for added flexibility:

1. Allow users to specify which TCAP LOCREQ parameter (TCAP Outgoing Called Party parameter) shall encode the RN (and/or DN) information
2. Allow users to specify the DigitType value to encode the TCAP Outgoing Called Party parameter
3. Allow users to specify the value to encode the Nature of Number field of the TCAP Outgoing Called Party parameter
4. Allow users to specify the value to encode the Numbering Plan field of the TCAP Outgoing Called Party parameter
5. Allow users to specify the digit encoding format of the locreq TCAP Outgoing Called Party parameter
6. Allow users to specify the MSCID values to be encoded in the locreq message
7. Allow users to specify the ESN values to be encoded in the locreq message
8. Allow users to specify how the digits of the locreq MIN parameter shall be encoded.

The following encoding rules are followed when an SRI Ack is returned:

1. When an SRI Ack is returned, the EAGLE 5 ISS follows the SRI Ack encoding rules along with the following enhancements for added flexibility
2. Allow users to specify which SRI parameter (the TCAP MSRN parameter) encodes the RN (and/or DN) information
3. Allow users to specify the value to encode the Nature of Address field of the TCAP MSRN parameter
4. Allow users to specify the value to encode the Numbering Plan field of the TCAP MSRN parameter.

MNP SCCP Service Re-Route Capability

This feature is designed to handle and control re-routing of MNP traffic from an affected node to alternate nodes within an operators network. This feature is an optional feature and does not affect the normal MNP functionality. This feature consists of the following main functions:

- *Service State*
- *MNP Re-Routing*
- *MNP Capability Point Codes*

Service State

Service state is part of the MNP SCCP Service Re-Route Capability. Service state is used to indicate the current state of MNP, either `ONLINE` or `OFFLINE`. Service state also gives the user the option to mark MNP as `OFFLINE` or `ONLINE` based on the current behavior. If a MNP problem is identified, MNP can be marked `OFFLINE` to initiate the re-routing procedure. When the Service Module cards need to be reloaded, MNP can be marked `OFFLINE` until enough cards are in-service and then bring MNP `ONLINE` in a controlled fashion. This feature also provides the option to mark MNP `OFFLINE` to perform a controlled re-routing during this state.

MNP Re-Routing

MNP Re-Routing is an optional feature and is enabled by defining a list of alternate PCs or by defining the GTT option. MNP re-routing is activated by marking MNP `OFFLINE`. When MNP is `OFFLINE` and alternate PCs are provisioned, any messages destined for MNP are re-routed to the available alternate PCs that are defined for MNP. If alternate PCs are not provisioned or none are available, then the GTT option is used. If the GTT option is set to `YES`, then messages destined for MNP will fall through to GTT as part of the re-routing procedure.

Re-Routing is applied to all MNP messages (based on `SRVSEL`). There is no distinction of DPC of the messages. The DPC of the message can be either `True`, `Secondary`, or `Capability Point code`.

MNP Capability Point Codes

Capability Point Codes (CPC) are also supported for MNP. The use of MNP capability point code aids the adjacent nodes in knowing about MNP outages. When MNP is brought down through administrative commands, all traffic destined to this MNP node will generate a Transfer Prohibited (TFP) message to the adjacent node about the MNP CPC. The TFP response to the adjacent node causes the traffic originating nodes to stop sending MNP traffic to this node. All MNP traffic coming into this node is sent to the alternate MNP nodes. Adjacent nodes will initiate route-set-test procedures after receipt of the TFP response.

If the messages are destined to the EAGLE 5 ISS true point code, then TFP messages are not generated when the MNP service is `OFFLINE`. The originator would not be aware of the outage.

Once MNP is back in service on the EAGLE 5 ISS, a Transfer Allowed (TFA) message is sent to the traffic adjacent nodes in response to route-set-test message. The traffic originating nodes will then start sending MNP traffic to the original MNP node.

MNP Capability point codes can be provisioned when the MNP feature is `ON`. There can be more than one Capability Point Code assigned to MNP `CPCType`.

When the MNP feature is turned `ON` and the MNP service state is set to `OFFLINE`, the user can change the service to `ONLINE` at any point. Once the feature is turned `ONLINE`, MNP will start processing messages if at least one Service Module card is `IS-NR`.

The MNP service can be set to OFFLINE at any point. This causes the EAGLE 5 ISS to stop processing MNP traffic and re-routing is performed.

The MNP service state is persistent. Booting the OAM or all the Service Module cards will not change the service state. Commands must be used to change the service state.

MNP supports up to seven alternate PCs per domain. All six domains (ANSI, ITU-I, ITU-N, ITU-N spare, ITU-I spare, and ITU-N24) are supported. An entire set of alternate PCs is considered as a re-route set. A GTT option is supported for MNP re-route. When the MNP service is OFFLINE, MNP messages fall through to GTT based on the GTT option. This option is set to YES by default.

MNP SCCP Service Re-Route Capability Summary

If the MNP service is not normal (because the RTDB is not in sync with MPS or if cards are misrouting MNP messages) then the MNP service state should be changed to OFFLINE.

Before changing MNP service to OFFLINE, it should be decided what kind of re-routing will be used during the outage. The EAGLE 5 ISS supports re-routing data to alternate point codes or falling through to GTT as two possible options. Re-routing to alternate point code has priority over falling through to GTT. Examples of the two options follow:

Option 1

Define alternate point codes to re-route MNP traffic. This is the recommended option. Up to 7 alternate MNP nodes can be provisioned to re-route all the incoming MNP traffic. Once provisioned, the MNP service can be changed to OFFLINE. This example has any incoming being MNP traffic being load-shared to point codes based on the relative cost.

```
chg-sccp-serv:serv=mnp:pci1=1-1-1:rc1=10:pci2=2-2-2:rc2=10:pci3=3-3-3:rc3=10:pci4=4-4-4:rc4=10
```

```
chg-sccp-serv:serv=mnp:pci1=1-1-1:rc1=10:pci2=2-2-2:rc2=10:pci3=3-3-3:rc3=10:pci4=4-4-4:rc4=10
```

```
chg-sccp-serv:serv=mnp:pci1=5-5-5:rc1=10:pci2=6-6-6:rc2=10:pci3=7-7-7:rc3=10:pci4=8-8-8:rc4=10
```

```
chg-sccp-serv:serv=mnp:state=offline
```

Option 2

With this option default GTT translations are provisioned for MNP service. Then the chg-sccp-serv command is used to provision GTT=YES. All MNP messages will fall through to GTT. An example command follows:

```
chg-sccp-serv:serv=mnp:gtt=yes (it is yes by default)
```

Once the MNP re-routing data is provisioned, MNP service can be changed to OFFLINE. At this point all MNP traffic will be re-routed. The user can take necessary steps to correct the MNP service on the node. Until all the cards or enough cards are in active state with valid MNP subscriber database, MNP service should not be changed to ONLINE.

Table 7: MNP SCCP Service Re-Route Capability Summary shows the actions taken when the MNP service is offline, a message arrives at the affected node requiring MNP service, and the Service Module cards are available.

Table 7: MNP SCCP Service Re-Route Capability Summary

Result of service selector	DPC	Alternate point code defined and available	GTT to be performed as fall through	Message Handling	Network Management
MNP	MNP Capability PC	Yes	N/A	Re-Route to alternate point code based on relative cost	TFP concerning CPC
MNP	MNP Capability PC	No [*]	Yes	Fall through to GTT and perform GTT	TFP concerning CPC
MNP	MNP Capability PC	No [*]	No	Generate UDTS (return cause = network failure)	TFP concerning CPC
MNP	MNP Capability PC	Not Defined	Yes	Fall through to GTT and perform GTT	TFP concerning CPC
MNP	MNP Capability PC	Not Defined	No	Generate UDTS (return cause = no xlation for this addr)	TFP concerning CPC
Not MNP	MNP Capability PC	N/A	N/A	Perform appropriate Service/GTT	None
MNP	True or Secondary PC or non-MNP CPC	Yes	N/A	Re-Route to alternate point code based on relative cost	None
MNP	True or Secondary PC or non-MNP CPC	No [*]	No	Generate UDTS (return cause = network failure)	None
MNP	True or Secondary PC or non-MNP CPC	No [*]	Yes	Fall through to GTT and perform GTT	None
MNP	True or Secondary PC or non-MNP CPC	Not Defined	Yes	Fall through to GTT and perform GTT	None

Result of service selector	DPC	Alternate point code defined and available	GTT to be performed as fall through	Message Handling	Network Management
MNP	True or Secondary PC or non-MNP CPC	Not Defined	No	Generate UDTS (return cause = no xlation for this addr)	None
Not MNP	True or Secondary PC or non-MNP CPC	N/A	N/A	Perform appropriate Service/GTT	None
*Alternate point codes are defined and unavailable (prohibited or congested).					

LOCREQ Query Response

The LOCREQ Query Response feature allows EAGLE 5 ISS to respond to LOCREQ query messages with a LOCREQ response message containing routing information for both ported and non-ported subscribers. Service Portability (S-Port) processing is used to control whether Generic Routing Number (GRN) or default Routing Number (RN) digits are used for the routing information in the LOCREQ response message.

The LOCREQ Query Response feature is applied to LOCREQ query messages received by EAGLE 5 ISS for local subsystem processing; however, EAGLE 5 ISS does not provide true subsystem support for these queries. Any LOCREQ query message to a True, Secondary, or Capability Point Code of the EAGLE 5 ISS is considered a potential candidate for LOCREQ Query Response feature. The query message is selected for LOCREQ Query Response processing if all of these conditions are met:

- The MTP DPC is a True, Secondary, or Capability Point Code of EAGLE 5 ISS.
- The message is a UDT or non-segmented XUDT message.
- The SCCP Called Party Address RI = SSN.
- The SCCP Called Party Address GTI is 0, 2, or 4. (GTI=4 is supported for only ITU SCCP messages.)
- The SCCP Calling Party Address RI = SSN.
- The TCAP variant is ANSI.
- The TCAP Operation Code is LocReq.

If all conditions are met and the MNP service state is `online`, then the LOCREQ query message is delivered to the MNP service handler for LOCREQ Query Response processing. If any of the conditions is not true, the LOCREQ query message is processed without LOCREQ Query Response processing.

If all conditions are met but the MNP service state is `offline`, then these actions occur:

- A UIM is issued.
- A TFP concerning the CPC is returned if the DPC in the original message was an MNP CPC.
- (X)UDTS:Subsystem Unavailable is returned, if Return on Error is set.
- The message is discarded.

LOCREQ Query Response Processing

For LOCREQ Query Response processing to occur, the LOCREQ Query Response feature must be enabled and turned on and the IS41OPTS option LOCREQRSPND must be set to on. The LOCREQ Query Response feature processes only ANSI TCAP Query with Permission messages with an Operation Code of LocReq.

LOCREQ Query Response processing functions include:

- The DN is retrieved from the TCAP portion.
- The NAI is determined based on the MTPLOCREQNAI value provisioned in the IS41OPTS table.
- A-Port or IGM number conditioning (for example, HomeRN Deletion and IEC/NEC Deletion) is applied to the DN.
- MNP Circular Route Prevention is not applied to LOCREQ query messages processed by the LOCREQ Query Response feature.
- Every LOCREQ query message processed by the LOCREQ Query Response feature is acknowledged with a response message.

Figure 1: LOCREQ Query Reponse RN Determination shows the logic to determine the RN digits used in the LOCREQ query response.

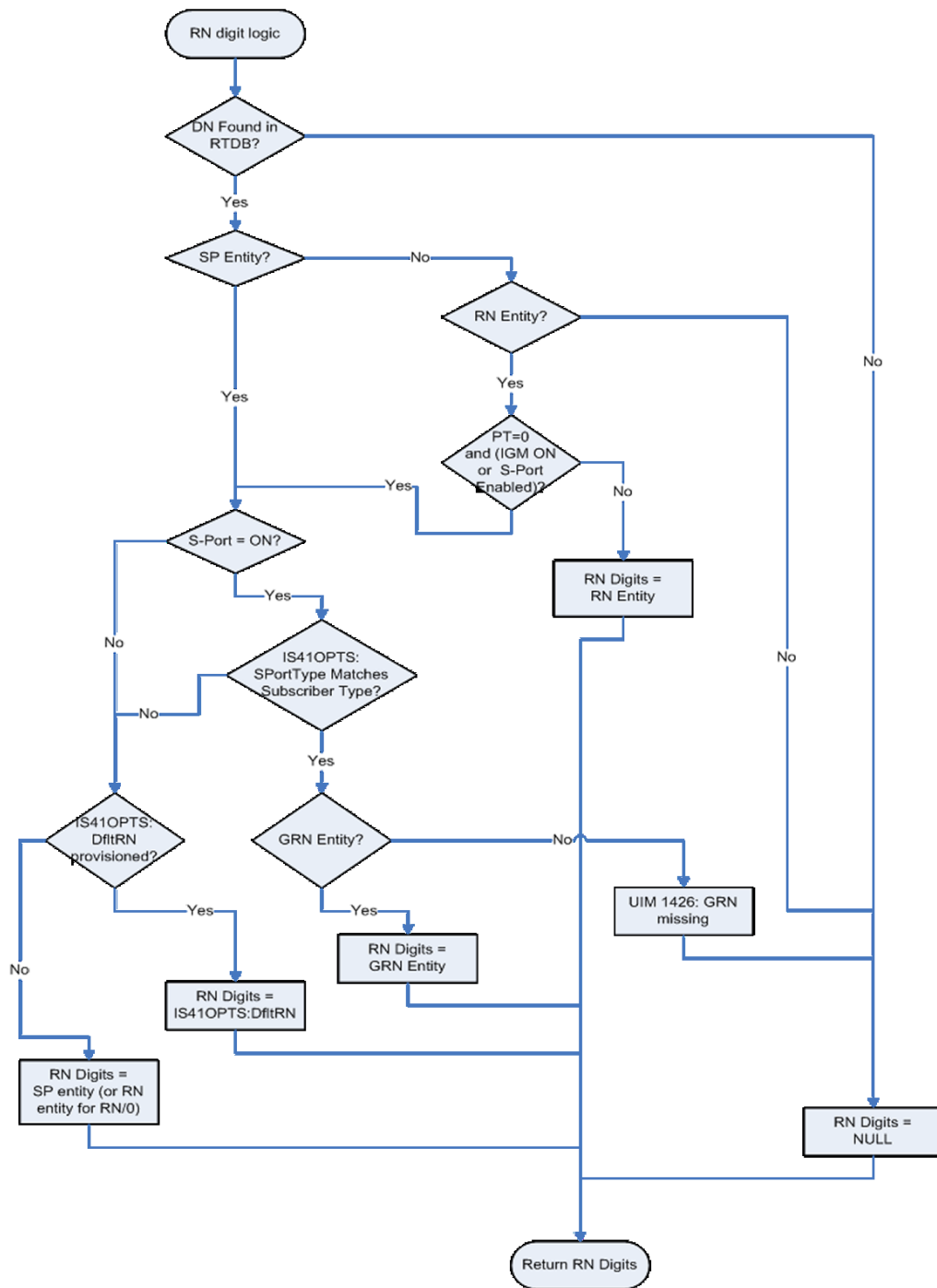

Figure 1: LOCREQ Query Reponse RN Determination

LOCREQ Query Response Errors

The LOCREQ Query Response feature responds to LOCREQ queries unless one of these errors occurs.

Decode Errors

Error result - (X)UDTS:Unqualified is generated; UIM is issued; MSU is discarded.

- The TCAP message is incorrectly formatted (invalid parameter tag or length).
- Called Party Number or Dialed Digits parameter does not exist.
- Digits parameter is less than 4 bytes.
- Number of digits is greater than 21.
- Encoding scheme is not BCD.
- Numbering Plan is not Telephony or ISDN.

Number Conditioning Errors

Error result - (X)UDTS:Unqualified is generated; UIM is issued; MSU is discarded.

- Default country code (DEFCC) parameter is required, but is not provisioned.
- Default Network Destination Code (DEFNDC) parameter is required, but is not provisioned.
- International (conditioned) digits are less than 5 or greater than 15.

Encode Errors

Error result - No response message is generated; UIM is issued; MSU is discarded.

- CgPA PC/OPC is not in the route table. CgPA PC is used if present in message,;otherwise OPC is used.
- CgPA PC/OPC is an Alias. No conversion is allowed.

LOCREQ Query Response Maintenance and Measurements

The LOCREQ Query Response feature increments counters against MNP service in the `rept-stat-sccp` output.

- *Failure* counter is incremented if a Return Result cannot be generated because of decode errors, number conditioning errors or encode errors.
- *Failure* counter is incremented if a message is received and MNP service state is `offline`.
- *Warning* counter is incremented if GRN was required but was missing, and the Return Result was sent.
- *Success* counter is incremented if a Return Result is generated, except if the Warning counter was incremented for missing GRN.

LOCREQ Query Response feature increments these Measurement registers, also used by A-Port and IGM features, if a LOCREQ query response message generates successfully:

- IS41LRMRCV
- IS41LRRTRN
- APLRACK (per SSP)

LOCREQ Query Response feature increments these Measurement registers, also used by A-Port and IGM features, if a LOCREQ query response message fails to be generated:

- IS41LRMRCV
- IS41LRERR

Service Portability for LOCREQ Query Response

Service Portability (S-Port) processing supports LOCREQ Query Response by controlling whether Generic Routing Number (GRN) or default Routing Number (RN) digits are used for the RN in the LOCREQ response message. Parameter SPORTTYPE (Service Portability Type) is provisioned in IS41OPTS table to specify the application of Service Portability that is to be applied to the associated feature. Parameter DFLTRN (Default Routing Number) is provisioned in IS41OPTS table to provide the RN digits if Service Portability is not turned on or the SPORTTYPE does not match the subscriber type.

Number Portability functions use the Network Entity Type (RN/SP) from the RTDB when formatting outgoing Called Party digits in the LOCREQ response message. The S-Port feature allows RTDB GRN Entity digits to be used for own-network GSM and IS41 subscribers in response digit formats. The GRN field in the RTDB is used to provision Service Portability prefixes on a per subscriber basis.

When Service Portability is applied, the LOCREQ response message is prefixed with the Generic Routing Number associated with the DN, instead of the Network Entity Type (RN/SP) that is used by number portability. The GRN digits can indicate the protocol (IS41 or GSM), calling area, and Operator network as defined by individual operators.

Table 8: Service Portability vs Number Portability by Destination Subscriber Type shows whether Service Portability or Number Portability is applied when Service Portability is turned on and RTDB lookup is successful based on the value of the IS41OPTS parameters SPORTTYPE and DFLTRN.

Table 8: Service Portability vs Number Portability by Destination Subscriber Type

SPORTTYPE	Own-Network GSM Entity Type = SP, any Portability Type	Own-Network IS41 Entity Type = RN, Portability Type = 0	Foreign (OLO) and others Entity Type = RN, Portability Type ≠ 0 -or- No Entity Type , any Portability Type
None	Apply Number Portability	Apply Number Portability	Apply Number Portability
GSM	Apply Service Portability - use GRN	Apply Number Portability	Apply Number Portability
IS41	Apply Number Portability	Apply Service Portability - use GRN	Apply Number Portability
ALL	Apply Service Portability - use GRN	Apply Service Portability - use GRN	Apply Number Portability

MTP Routed SCCP Traffic

The MTP Msgs for SCCP Apps and MTP Routed GWS Stop Action features forward MTP routed SCCP messages to the Service Module cards. The SCCP messages forwarded by either feature are processed in the same way on the Service Module cards. The difference between the two features is that the MTP Routed GWS Stop Action feature filters messages based on provisioned Gateway Screening rules on a per linkset basis and forwards only UDT, UDTS, XUDT and XUDTS SCCP messages to Service Module cards, while the MTP Msgs for SCCP Apps feature forwards all MTP routed SCCP messages to the Service Module card without filtering. Because the MTP Routed GWS Stop Action feature selectively forwards the messages to the Service Module card, the feature has less impact on SCCP performance than the MTP Msgs for SCCP Apps feature. The features can coexist, which means that both features can be turned on in the same system.

MTP Msgs for SCCP Apps

MTP routed SCCP messages are supported with the MTP Msgs for SCCP Apps feature. LOCREQ and SMSREQ messages are supported. A Feature Access Key (FAK) for part number 893-0174-01 is required to enable the MTP Msgs for SCCP Apps feature. This feature can be turned on and off, but cannot be enabled with a temporary FAK. GTT must be on to enable the MTP Msgs for SCCP Apps feature.

After the MTP Msgs for SCCP Apps feature is turned on, all SCCP messages are routed to Service Module cards. The Service Module card then performs SCCP decode/verification. Use of the MTP Msgs for SCCP Apps feature adversely affects the SCCP capacity because all of these messages are counted under SCCP capacity.

If the MTP routed messages have CdPA RI=GT or SSN and GTI \neq 0 (GTI = 2 or 4), then a service selection (SRVSEL) lookup is performed using the SCCP CdPA information. If the result of the lookup is MNP service, then the message is sent to MNP handling. If a service selector does not match or the service is OFFLINE, then MTP routing is performed on the messages. MNP SCCP Service re-route is not performed on MTP routed messages.

If the MTP routed messages have CdPA GTI=0, the TCAP portion of ANSI TCAP messages is decoded. SMSMR service is invoked for SMDPP messages; IAR Base feature is invoked for Analyzed messages. For all other messages, MNP service is invoked.

MNP handling checks whether the TCAP portion of the message is ITU or ANSI.

If the message has ANSI TCAP, then:

- General TCAP/MAP verification for A-Port is performed if the A-Port or IGM feature is turned on. Only LOCREQ and SMSREQ messages are handled by A-Port or IGM for MTP routed messages.
- When GTI \neq 0, message relay is performed on non-LOCREQ and non-SMSREQ ANSI TCAP messages based on the SCCP CdPA portion of the message.
- When GTI = 0, MTP routing is performed on non-LOCREQ ANSI TCAP messages.

If the message has ITU TCAP, the IGM feature is on, and GTI \neq 0, then:

- The message is considered for relaying based on the RTDB lookup results. General TCAP/MAP verification is not performed on the message.
- Message relay is performed based on the SCCP CdPA portion of the message with GTI = 2 or 4.

If the message has ITU TCAP, the IGM feature is on, and GTI = 0, then MTP routing of the message is performed.

ITUN-ANSI SMS Conversion is not affected by the MTP Msgs for SCCP Apps feature; ITUN-ANSI SMS Conversion handles only Registration Notification and SMS Notification messages.

MTP Routed GWS Stop Action

The MTP Routed GWS Stop Action feature provides a Gateway Screening (GWS) stop action: `sccp`. This stop action allows IS41-based features to process MTP routed traffic. GWS rules are used to filter MTP routed SCCP messages (UDT, UDTS, XUDT, and XUDTS) on a per linkset basis. The messages are then forwarded to Service Module cards for processing by features that support MTP routed messages based on Service Selection criteria. A Feature Access Key (FAK) for part number 893-0356-01 is required to enable the MTP Routed GWS Stop Action feature. This feature can be turned on and off, but cannot be enabled with a temporary FAK. GTT must be on to enable the MTP Routed GWS Stop Action feature. The MTP Routed GWS Stop Action feature must be enabled before the `sccp` stop action can be provisioned, and before message processing can occur. The `sccp` stop action must be the last stop action in the GWS action set.

If the MTP Msgs for SCCP Apps feature is turned on, all SCCP messages are forwarded to Service Module cards without the `sccp` GWS stop action being executed, regardless of whether the MTP Routed GWS Stop Action feature is turned on.

After provisioning, the `sccp` stop action can be used by these features:

- A-Port
- G-Flex
- Info Analyzed Relay ASD
- Info Analyzed Relay Base
- Info Analyzed Relay GRN
- Info Analyzed Relay NP
- IS41 GSM Migration (IGM)
- ITUN-ANSI SMS Conversion
- MNP Circular Route Prevention
- MO-Based IS41SMS NP
- MO SMS ASD
- MO SMS B-Party Routing
- MO SMS GRN
- MO SMS IS41 to GSM Migration
- MTP MAP Screening
- MT-Based IS41 SMS NP

Refer to *Database Administration Manual – Gateway Screening* for additional information and provisioning procedures for the MTP Routed GWS Stop Action feature.

SMSREQ Handling for Migrated or Ported Subscribers

The SMSREQ Handling for Migrated or Ported Subscribers enhancement allows MTP routed SMSREQ messages to be supported by A-Port, IGM, MNPCRP, and MT-Based IS41 SMS NP features. Service selection criteria for MTP routed SMSREQ messages is the same for MTP routed LOCREQ messages. The MNP service processing for MTP routed SMSREQ messages is the same for Global Title (GT)

routed SMSREQ messages. However, MTP routing is performed on MTP routed messages when these messages fall through from the MNP service. Feature precedence is applied for SMSREQ messages as shown:

1. MNPCRP - If a circular route condition is detected, a UIM is generated and MTP routing is performed on the message.
2. IGM - If the DN is own-network GSM subscriber (Portability Type = 5) and SMSREQBYPASS = No, then send an SMSREQ Error Response (Return Result message) to the originator with SMS Access Denied Reason = 5.
3. MT-Based IS41 SMS NP - If the DN matches the MT-Based IS41 SMS NP feature criteria (IS41SMSOPTS:MTSMSTYPE), the SMSREQ response is generated.
4. A-Port - A-Port relays the message based on the RTDB lookup result. If relay information is not present in the RTDB data associated with the DN, then the message is MTP routed.
5. If A-Port is not turned on, then IGM relays the SMSREQ message for only own-network subscribers if the SMSREQ response is not previously sent for subscribers not handled by IGM. If relay information is not present in the Network Entity Type (RN/SP) associated with the DN or if Network Entity Type indicates an Other Licensed Operator (OLO) subscriber, then the message is MTP routed.
6. If none of the feature processing in the previous items is performed, then the message is MTP routed.

If a feature in the precedence list is off, processing by that feature is not performed.

Table 9: Subscriber Portability Type

Network Entity Type (NE)	Portability Type (PT)	Subscriber Type
RN	0	Own-network subscriber, if IGM or Service Portability is on Otherwise, Other Licensed Operator (OLO) subscriber
RN	any value other than 0	OLO subscriber
SP	any	Own-network subscriber
No entity, or any entity other than RN or SP	0, 1, 2, 36, or none (255)	OLO subscriber
No entity, or any entity other than RN or SP	any value other than 0, 1, 2, 36, or none (255)	Own-network subscriber

IGM SRI-SM Relay to Default IS41 SMSC

The IGM SRI-SM Relay to Default IS41 SMSC enhancement supports relaying of SRI-SM messages to Default IS41 SMSC for Own Network subscribers (NE=RN, PT=0). The configurable option

GSMSMSOPTS:IGMSMSRELAY specifies whether the IGM responds with a Return Error message to the originator (option value = NO) or relays the SRI-SM message to the Default IS41 SMSC Own Network IS41 subscribers (option value = YES). The SRI-SM message is relayed to the Default IS41 SMSC based on GTT translation in the GTTSET defined in the GSMSMSOPTS:IS41SMSCGTTSN option. The Default IS41 SMSC address is a 15-digit hexadecimal character string specified in the GSMSMSOPTS:DEFIS41SMSC option.

Because the SRI-SM message is always GT-routed to the EAGLE 5 ISS, the MTP OPC of the message is always replaced by the True Point Code of the EAGLE 5 ISS.

Table 10: Changes in SRI-SM Relayed to Default IS41 SMSC

	RI=GT	RI=DPCSSN
MTP DPC	Translated PC	Translated PC
CdPA	Change only when PC conversion is required	Translated PC if present in incoming message
CdPA SSN	No change	Translated SSN
CdPA RI	GT	SSN
CdPA Digits	No change	No change
CgPA PC	Change only when PC conversion is required	Change only when PC conversion is required

General Numbering Requirements

Incoming called party numbers, from the SCCP portion, destined for IGM processing are conditioned to fit the GDB requirements where possible. The following factors are used to condition the SCCP numbers.

- Based on provisioning: If the GTT selectors available in the incoming message match an entry in the IGM selector table, then the service numbering plan from the selector table entry uses that number's numbering plan. Further conditioning is applied based on this new numbering plan.
- Based on configurable options: If the GTT selectors available in the incoming message match an entry in the IGM selector table, then the service nature of address from the selector table entry uses that number's nature of address. Further conditioning is applied based on this new nature of address.
- If the nature of address is Subscriber, the default CC + default NC (network code for E.164) are prepended to the number. The default codes to be used by the EAGLE 5 ISS must be previously provisioned by the EAGLE 5 ISS operator. If not, a UIM is issued, and the message falls through to GTT.

Numbers with fewer than five digits after the above conditioning are not used for IGM. In this case, a UIM is issued, and the message falls through to GTT.

Numbers with more than fifteen digits after the above conditioning are not used for IGM. In this case, a UIM is issued, and the message falls through to GTT.

Hardware Requirements

EPAP-related features that perform an RTDB lookup require Service Module cards (DSM cards, E5-SM4G cards, or E5-SM8G-B cards) running the VSCCP application. The EAGLE 5 ISS can be equipped with up to 32 (31+1) Service Module cards.

Features that do not perform an RTDB lookup require Service Module cards only for GTT processing that might be performed for the feature. These features can coexist in systems with EPAP, but do not require an EPAP connection.

MPS/EPAP Platform

Tekelec provides the Multi-Purpose Server (MPS) platform as a subsystem of the EAGLE 5 ISS. The MPS provides support for EPAP-related features that perform Real Time Database (RTDB) lookups.

The MPS is composed of hardware and software components that interact to create a secure and reliable platform. For details about the MPS hardware, refer to *Tekelec 1200 Application Server Hardware Manual*. The MPS provides the means of connecting the customer provisioning application with the EAGLE 5 ISS and accepts the customer number portability data, while accommodating numbers of varying lengths.

The EAGLE Provisioning Application Processor (EPAP) is software that runs on the MPS hardware platform. It collects and organizes customer provisioning data, and forwards the data to the EAGLE 5 ISS Service Module cards. [Figure 2: MPS/EPAP Platform Architecture](#) shows the overall system architecture from customer provisioning through the MPS subsystem to the EAGLE 5 ISS Service Module card databases.

In this manual, Service Module card refers to a DSM card, an E5-SM4G card, or an E5-SM8G-B card unless a specific card is required. For more information about the supported cards, refer to *EAGLE 5 ISS Hardware Manual*.

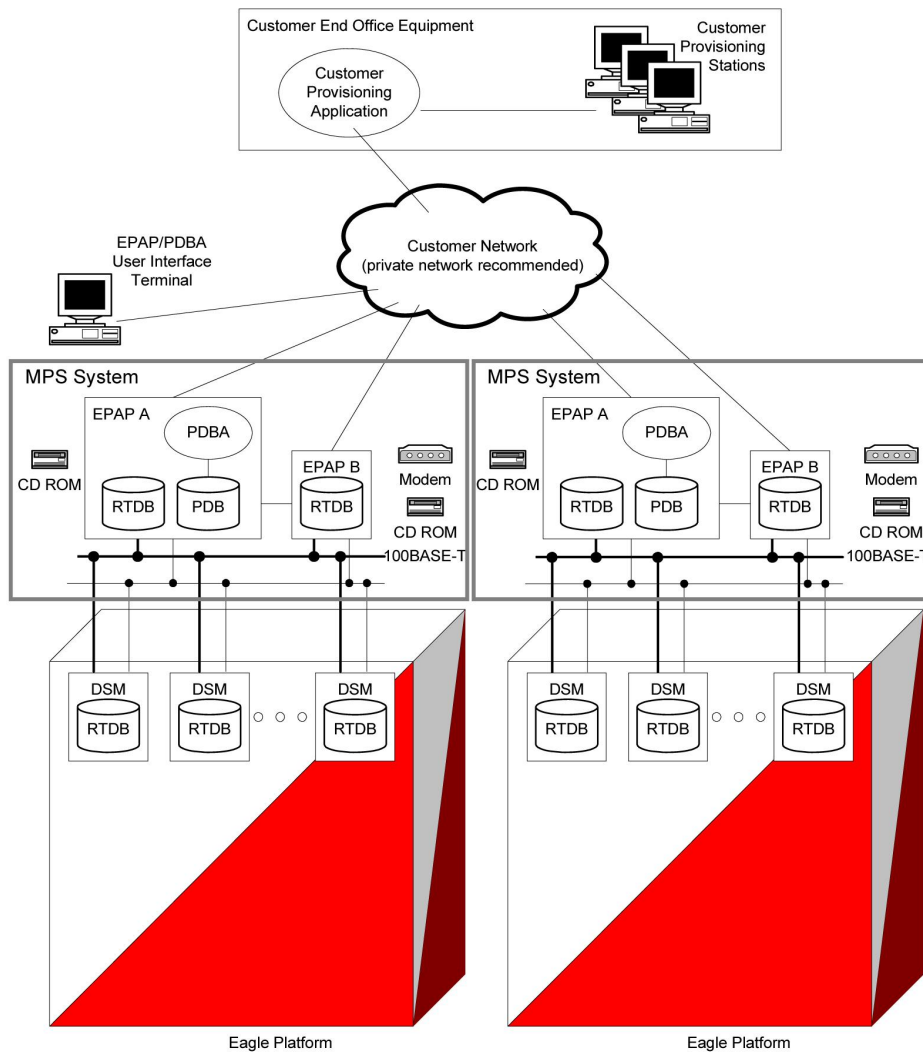

Figure 2: MPS/EPAP Platform Architecture

Design Overview and System Layout

Figure 2: *MPS/EPAP Platform Architecture* identifies the tasks, databases and interfaces which constitute the overall system architecture. The system consists of two mated MPS servers. Each MPS contains two EPAP platforms - EPAP A and EPAP B with each containing a Real Time Database (RTDB), Provisioning Database (PDB), servers, optical media, modems, and network switches when using a T1200 AS system. Each MPS and its associated EPAPs are an *EPAP system*; the EPAP system and the mated EAGLE 5 ISS are the *mated EPAP system*. Each EPAP system is a T1200 AS system with a total of four Ethernet interfaces: one from each EPAP to the 100BASE-T Ethernet and one from each EPAP to either a 10BASE-T or a 100BASE-T Ethernet. See [Table 11: Service Module Card Provisioning and Reload Settings](#) for the link speed.

On the EAGLE 5 ISS, a set of Service Module cards, which hold the RTDB, is part of the STP. Two high-speed Ethernet links connect the Service Module cards and the EPAPs. One of the links is a 100BASE-T Ethernet bus, and the other is either a 10BASE-T or a 100BASE-T Ethernet bus. See [Table 11: Service Module Card Provisioning and Reload Settings](#) for the link speed.

The RTDB is provisioned and maintained through the EPAPs. EPAP A and EPAP B act as the active EPAP and the standby EPAP. One link serves as the active link, and the other link as the standby link. Only one EPAP and one link are active at a time. The database is provisioned through the active link by the active EPAP; the other EPAP provides redundancy.

If the active EPAP fails, the standby EPAP takes over the role of active EPAP and continues to provision the subscriber database. If the active link fails, the active EPAP switches to the standby link to continue provisioning the Service Module cards. The two Ethernet links are part of the DSM network.

Another 100BASE-T Ethernet link exists between the EPAPs; that link is called the EPAP Sync Network.

The major modules on the EPAP are:

- Service Module card provisioning module
- Maintenance module
- RTDB module
- PDB module

The Service Module card provisioning module is responsible for updating subscriber databases on the EAGLE 5 ISS Service Module cards using the Reliable Multicast Transport Protocol (RMTP) multicast. The maintenance module is responsible for the proper functioning of the EPAP platform. The PDB module is responsible for preparing and maintaining the Real Time Database, which is the *golden copy* of the subscriber database. The PDB module can run on one of the EPAPs of either mated EAGLE 5 ISS.

Functional Overview

The main function of the MPS/EPAP platform is to provision data from the customer network to the Service Module cards on the EAGLE 5 ISS. Subscriber database records are continuously updated from the customer network to the PDB. The PDB module communicates with the maintenance module and the RTDB task over a TCP/IP connection to provision the Service Module cards on the EAGLE 5 ISS. The maintenance module is responsible for the overall stability and performance of the system.

The RTDB on the EPAP contains a coherent, current copy of the subscriber database. If the current copy of the RTDB on the Service Module cards becomes *out-of-sync* because of missed provisioning or card rebooting, the EPAP Service Module card provisioning module sends database information through the provisioning link to the Service Module cards. The Service Module cards are reprovisioned with current subscriber information.

EPAP/PDBA Overview

The EAGLE Provisioning Application Processor (EPAP) platform and the Provisioning Database Application (PDBA), coupled with the Provisioning Database Interface (PDBI) facilitate the user database required for EAGLE 5 ISS EPAP-related features. The following functions are supported:

- Accept and store subscription data provisioned by the customer
- Update and reload subscriber databases on the Service Module cards

The PDBA operates on the master Provisioning Database (PDB). The EPAP and PDBA are both installed on the MPS hardware platform.

The EPAP platform performs the following:

- Maintains an exact copy of the real time database (RTDB) on the EPAP

- Distributes the subscription database to the Service Module cards
- Maintains a redundant copy of the RTDB database

The EPAP platform is a mated pair of processors (the upper processor, called EPAP A, and the lower processor, EPAP B) contained in one frame.

During normal operation, information flows through the EPAP/PDBA software with no intervention. Subscription data is generated at one or more operations centers and is delivered to the PDBA through a TCP socket interface (PDBI). The PDBA software stores and replicates data on EPAP A on the mated EPAP system. The data is then transmitted by the EPAPs across a private network to the Service Module cards located in the EAGLE 5 ISS frame.

The primary interface to the PDBA consists of machine-to-machine messages. The interface is defined by Tekelec and is described in the *Provisioning Database Interface Manual*. Provisioning software compatible with the EPAP socket interface can be created or updated using the interface described in that manual.

Additionally, a direct user interface is provided on each EPAP to allow for configuration, maintenance, debugging, and platform operations. A direct user interface is also provided by the PDBA for configuration and database maintenance.

The MPS/EPAP is an open-systems platform and easily accommodates the required high provisioning rates. Compared to the traditional OAM platform, the persistent database and provisioning in an open systems platform provides these benefits:

- Variety of hardware components and vendors
- Availability of third party communication and database tools
- Standard communication protocols
- Availability of personnel with related experience

Each EPAP server maintains a copy of the Real Time Database (RTDB) in order to provision the EAGLE 5 ISS Service Module cards. The EPAP server must comply with the hardware requirements in the *Tekelec 1200 Application Server Hardware Manual*. [Figure 2: MPS/EPAP Platform Architecture](#) illustrates the EPAP architecture contained in the MPS subsystem.

Each EPAP has a dedicated optical media drive. One EPAP per EAGLE 5 ISS platform has a modem capable of supporting remote diagnostics, configuration, and maintenance. These remote operations are performed through EPAP login sessions and are accessible across the customer network as well as through a direct terminal connection to the EPAP using an RS232 connection. Refer to *Tekelec 1200 Application Server Hardware Manual* for details about the hardware devices and network connections.

Subscriber Data Provisioning

[Figure 3: Subscriber Data Provisioning Architecture \(High Level\)](#) shows a high-level view of the subscriber data provisioning architecture. Only those parts of the EAGLE 5 ISS platform that are relevant to subscriber data provisioning are shown. This section defines requirements for the Provisioning Database Interface (PDBI) between the EPAP and the operator's provisioning system (OPS). Provisioning clients connect to the EPAPs using the PDBI. This interface contains commands that allow all of the provisioning and retrieval of subscription data. The PDBI is used for real-time provisioning of subscriber and network entity data only. Refer to *Provisioning Database Interface Manual* for more details.

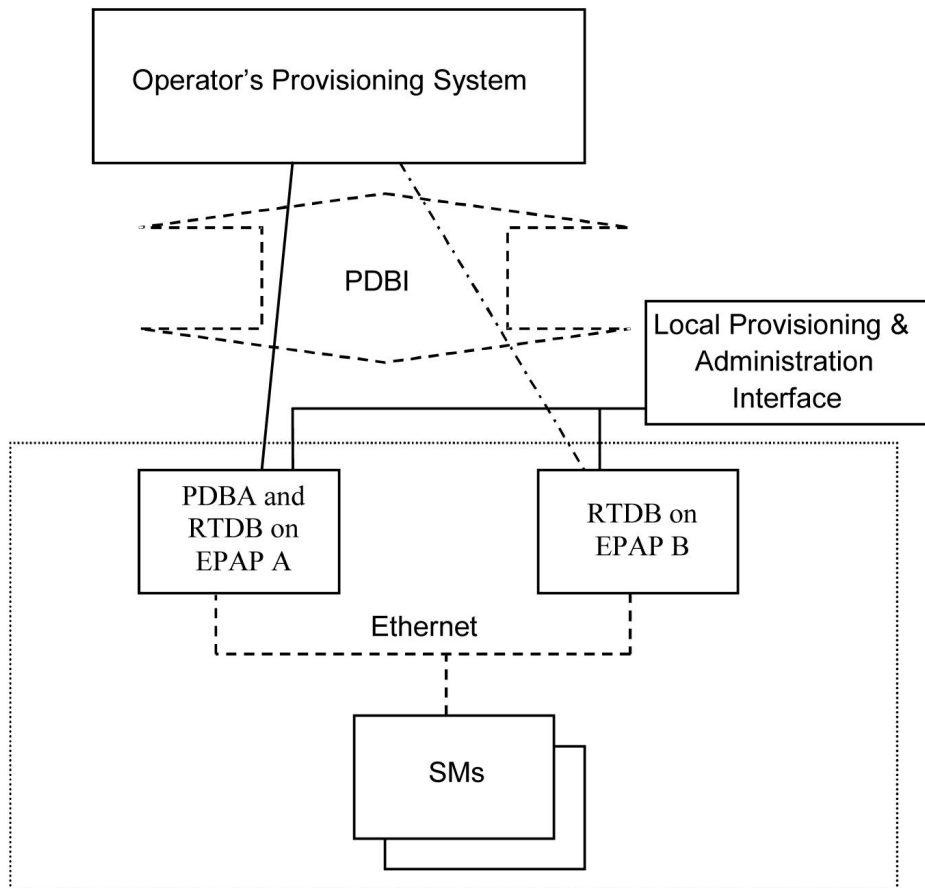

Figure 3: Subscriber Data Provisioning Architecture (High Level)

A pair of active/standby EPAP servers provides the interface between the Real Time Database (RTDB) of the EAGLE 5 ISS Service Module cards and the OPS. EPAP A is equipped with both the PDB (Provisioning Database) and the RTDB, and EPAP B has only the RTDB. An EPAP with only the RTDB must be updated by the EPAP that is equipped with the PDB.

For more information about the EPAP, refer to *EPAP Administration Manual*. For more information about the MPS hardware, refer to *Tekelec 1200 Application Server Hardware Manual*.

Distributed Administrative Architecture

This section describes, at a high level, the distributed administrative architecture for the EAGLE 5 ISS, including the EPAP.

Databases requiring high update and retrieval rates, such as the EPAP RTDB, are populated using redundant Ethernet connections to Service Module cards from an EPAP MPS platform.

An EPAP consists of a combined Provisioning (MySQL) and Real Time Database (RTDB). The Provisioning Database (PDB) responds to requests for updates by the active and standby RTDBs on both mated EAGLE 5 ISSs. The active EPAP RTDB is responsible for initiating multi-cast updates of changed database records to the Service Module cards after the data has been committed to the EPAP disks. Furthermore, the PDB may accept and commit more database updates while the RTDBs are completing their previous updates.

It is this overlapping of database updates, coupled with an RTDB transactional database engine and fast download time, that allows larger amounts of data at a time to be transferred from the PDB. Committing larger amounts of data at a time to the RTDB (versus a single update at a time) allows faster overall transaction rates to be achieved. The boundaries of the transaction rates become more closely related to cache size and disk cache flush time than the disk access time of a single update. Thus, successful completion of EPAP database updates only guarantees that the PDB has been updated, but it does not mean the RTDB has completed the update and sent the new subscription data to the Service Module card.

The EPAP architecture contains a local provisioning terminal and a modem for remote access, as well as other functions. A backup device can be used to back up or restore the provisioning database. The local provisioning terminal is used to manually repair the standby EPAP RTDB or to turn the subscriber database audit on or off. For additional information, refer to *Tekelec 1200 Application Server Hardware Manual* and the *EPAP Administration Manual*.

EPAP (EAGLE Provisioning Application Processor)

As shown in [Figure 2: MPS/EPAP Platform Architecture](#), a single MPS system contains two EAGLE Provisioning Application Processor (EPAP) servers. At any given time, only one EPAP actively communicates with the Service Module cards on the EAGLE 5 ISS. The other EPAP server is in standby mode. In addition, two MPS systems can be deployed in a mated pair configuration.

The primary purpose of the EPAP system is to maintain the Real Time Database (RTDB) and Provisioning Database (PDB), and to download copies of the RTDB to the Service Module cards.

The PDB on the active EPAP receives subscription data from the customer network through the Provisioning Database Interface (PDBI), the external source of provisioning information. The Provisioning Database Application (PDBA) continually updates the PDB of the active EPAP. The PDB uses MySQL database software. After an update is applied to the active PDB, the data is sent to the RTDBs on the active and standby EPAPs.

Both the active and standby EPAPs maintain copies of the RTDB. Periodically, the Service Module card polls the active EPAP RTDB for any new updates. The active EPAP downloads the updates to the Service Module card which stores a resident copy of the RTDB.

A mated pair configuration has two mated MPS Systems, as shown in [Figure 2: MPS/EPAP Platform Architecture](#). The PDB on the active EPAP automatically updates the PDB on the mate platform. The PDB on the mate platform then updates RTDBs on its EPAPs, which in turn update the RTDBs on the associated Service Module cards.

Provisioning of the EAGLE 5 ISS Service Module cards is performed through two interfaces using two different sets of commands. Provisioning is accomplished by the STP updates from EAGLE 5 ISS terminals and by updates from the customer's external provisioning system. This system of dual provisioning is illustrated in [Figure 4: Database Administrative Architecture](#).

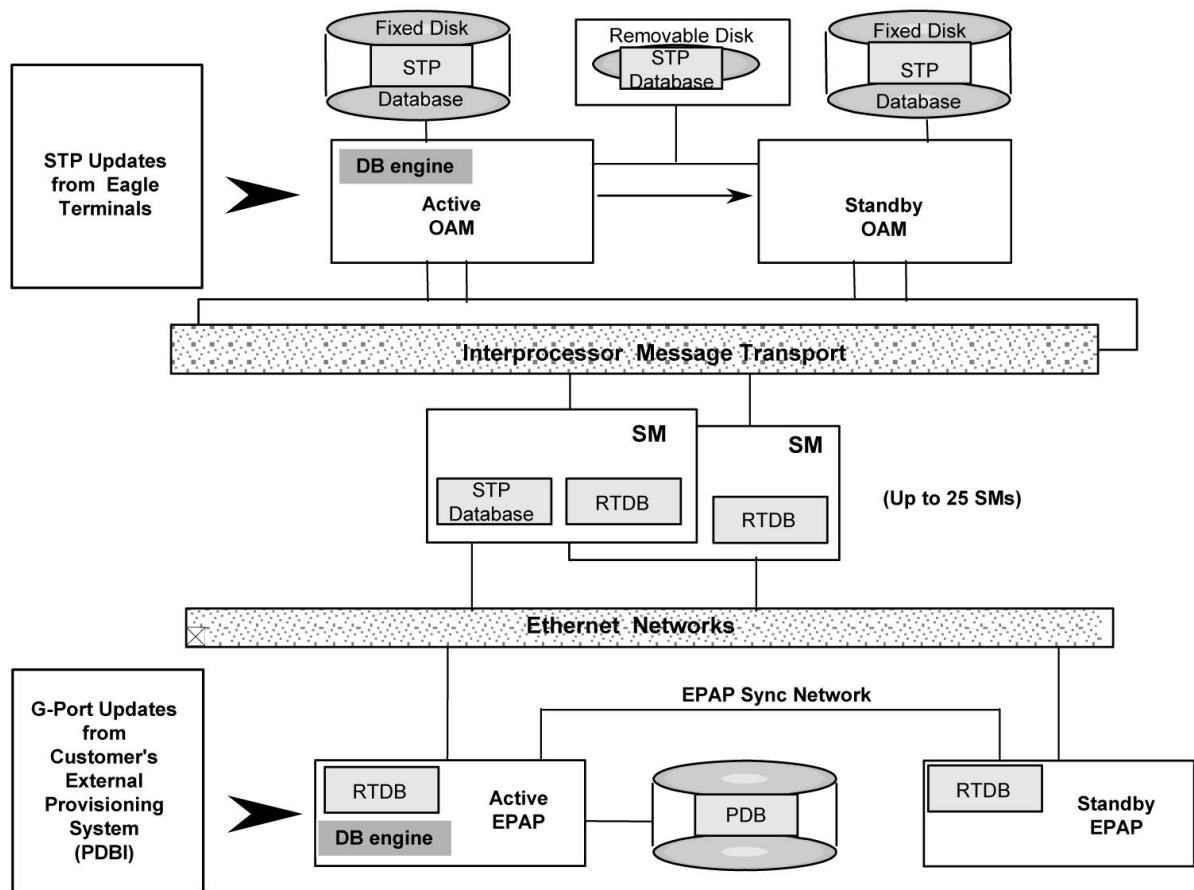

Figure 4: Database Administrative Architecture

Service Module Cards

Up to 32 cards (31+1) Service Module cards can be provisioned with one or more EPAP-related features enabled and EPAP running on a T1200 AS.

EPAP-related features require that all Service Module cards contain 4 GB of memory. *Figure 4: Database Administrative Architecture* illustrates each Service Module card having two Ethernet links, the main DSM network on the 100BASE-T link and the backup DSM network. See *Table 11: Service Module Card Provisioning and Reload Settings* for the link speed. The Service Module cards run the VSCCP software application.

The Service Module card Ethernet ports are linked to the EPAP system to receive the downloaded Real Time Database (RTDB). Multiple Service Module cards provide a means of load balancing in high-traffic situations. The RTDB on the Service Module card is in a format that facilitates rapid lookups.

Though the Service Module card copies of the RTDB are intended to be identical, the various databases may not be identical at all times for the following reasons:

- When a Service Module card is initialized, the card downloads the current copy of the database from the EPAP. While that card is being loaded, it cannot receive new updates that have arrived at the EPAP since reload began.

- Card databases can become out-of-sync with the EPAP RTDB when the EPAP receives updates from its provisioning source, but it has not yet sent the updates down to the Service Module cards. Updates are applied to the Provisioning Database (PDB) as they are received.

Two possible scenarios contribute to a condition where a Service Module card may not have enough memory to hold the entire database:

- The database is downloaded successfully to the Service Module card, but subsequent updates eventually increase the size of the database beyond the capacity of the Service Module card memory. In this situation, it is desirable for EPAP-related features to continue processing transactions, even though the database might not be up-to-date.
- When a Service Module card is booted and it is determined then that the card does not have enough memory for the entire database, the database is not loaded on that card. Each Service Module card is responsible for recognizing and reporting its out-of-memory conditions by means of alarms.

Overview of EPAP to Service Module Card Communications

Before discussing Service Module card status reporting or EPAP status reporting, it is helpful to understand the communications between the Service Module cards and the EPAP in broad terms.

- UDP - sending Service Module card status messages

The Service Module cards and EPAPs create a UDP (User Datagram Protocol) socket which is used for status messages. One of the last things a Service Module card does when it is initialized is to send a status message to the EPAP, containing the Service Module ID, database level, and memory size. The EPAP maintains tables containing the last known status of each Service Module card. EPAP uses these to determine whether or not the Service Module card needs to download the database.

- IP - reporting EPAP maintenance data

The Service Module cards create a TCP socket when they are initialized, and listen for connection requests. During initialization or after a loss of connectivity, the active EPAP chooses one of the Service Module cards and issues a *Connect* to establish the TCP/IP connection with that Service Module card which is referred to as the primary Service Module card. The purpose of this link is to provide a path for reporting EPAP alarms and to forward maintenance blocks to the Service Module card.

- IP Multicast - downloading GSM database

Because of the large size of the database and the need to download it quickly on up to 32 Service Module cards, EPAP-related features use a technique known as IP multicasting. This technique is based on Reliable Multicast Transport Protocol-II (RMTP-II), a product of Globalcast Communications. IP multicasting downloads the RTDB and database updates to all of the Service Module cards simultaneously.

The administration of IP multicasting is based on the concept of a “tree”, or stream of data, which is constantly being broadcast by the EPAP. Service Module cards that need to download the real time database or to receive database updates “join the tree”. Service Module cards can also “leave the tree”, typically when the database fills their available memory.

Service Module Card Provisioning and Reload

One of the core functions of the EPAP is to provision the Service Module cards with the Real Time Database (RTDB) updates. In order to provide redundancy for this feature, separate RMTP channels are created on each interface from each EPAP:

Table 11: Service Module Card Provisioning and Reload Settings

RMTP Channel	T1200 running only DSM cards	T1200 running any combination of E5-SM4G and E5-SM8G-B cards	T1200 running DSM cards with any combination of E5-SM4G and E5-SM8G-B cards
EPAP A, Link A (on the main DSM network)	100BASE-T	100BASE-T	100BASE-T
EPAP A, Link B (on the backup DSM network)	10BASE-T	100BASE-T	10BASE-T
EPAP B, Link A (on the main DSM network)	100BASE-T	100BASE-T	100BASE-T
EPAP B, Link B (on the backup DSM network)	10BASE-T	100BASE-T	10BASE-T
Note: Full duplex mode is supported only when running any combination of E5-SM4G and E5-SM8G-B cards on the T1200. In all other cases, half duplex mode is supported.			

Provisioning and other data is broadcast on one of these channels to all of the Service Module cards. Provisioning is done by database level to leave tables coherent between updates.

The Service Module cards perform the following:

- Detect the need for incremental updates and send a status message to the EPAP.
- Discriminate between the various streams according to the database level contained in each message and accept updates based on the Service Module card database level.

Service Module Card Reload Model

Service Module cards may require a complete database reload in the event of reboot or loss of connectivity for a significant amount of time. The EPAP provides a mechanism to quickly load a number of Service Module cards with the current database. The database on the EPAP is large and may be updated constantly. The database sent to the Service Module card or cards will likely be missing some of these updates making it corrupt, in addition to being "back level."

EPAP Continuous Reload

It is important to understand how the EPAP handles reloading of multiple Service Module cards from different starting points. Reload begins when the first Service Module card requires it. Records are read sequentially from the Real Time Database (RTDB) from an arbitrary starting point, wrapping back to the beginning. If another Service Module card requires reloading at this time, it uses the existing

record stream and notifies the Service Module card provisioning task of the first record it read. This continues until all Service Module cards are satisfied.

Service Module Card Database Levels and Reloading

The current database level when the reload started is of special importance during reload. When a Service Module card detects that the last record has been received, it sends a status message back to the EPAP indicating the database level at the start of reload. This action starts incremental loading. The Service Module card continues to reload until it is completely caught up with the current level of the RTDB. As database records are sent to the Service Module cards during reload, normal provisioning can change those records. All records changed between the start and end of reloading must be incrementally loaded before the database is coherent and usable by the Service Module card.

The following terminology is used here for the stages of database reload for a given Service Module card.

- **Stage 1 loading:** The database is being copied record for record from the golden RTDB in the EPAP to the Service Module card RTDB. The database is incoherent during stage 1 loading.
- **Incremental update:** The database is receiving all of the updates missed during stage 1 loading or some other reason, such as network outage, processor limitation, or lost communication. The database is coherent, but back-level during incremental update.
- **Current:** The database is receiving current updates from the Service Module card provisioning task.
- **Coherent:** The database is at a whole database level which means not currently updating records belonging to a database level.

EPAP Status and Error Reporting via Maintenance Blocks

The EPAP forwards all status and error messages to the Service Module cards in maintenance blocks. Maintenance blocks are asynchronously sent whenever the EPAP has something to report. The maintenance blocks eventually update EPAP Device Control Blocks (DCBs) located on the EAGLE 5 ISS. The DCBs provide the status information that is received when a `rept-stat-mps` command is issued.

Network Connections

Several customer and Tekelec-installed private networks are required to support the provisioning of subscription data. These networks are:

- *Customer Provisioning Network*
- *EPAP Sync Network*
- *DSM Networks*
- *Dial-Up PPP Network*

The following discussion is an overview of these private networks. It expands on the networks in the architecture diagram shown in *Figure 5: Customer Provisioning Network*. For details about configuring these networks, refer to *EPAP Administration Manual*.

Customer Provisioning Network

The customer network carries the following traffic:

- Customer queries and responses to the PDB via the PDBI from the customer provisioning network

- Updates between PDBs of a mated EAGLE 5 ISS pair
- Updates between a PDB on one EAGLE 5 ISS and RTDBs on a mated EAGLE 5 ISS
- PDBA import/export (file transfer) traffic
- Traffic from a PDBA reloading from its mate
- EPAP and PDBA user interface traffic.

A typical customer network is shown in *Figure 5: Customer Provisioning Network*.

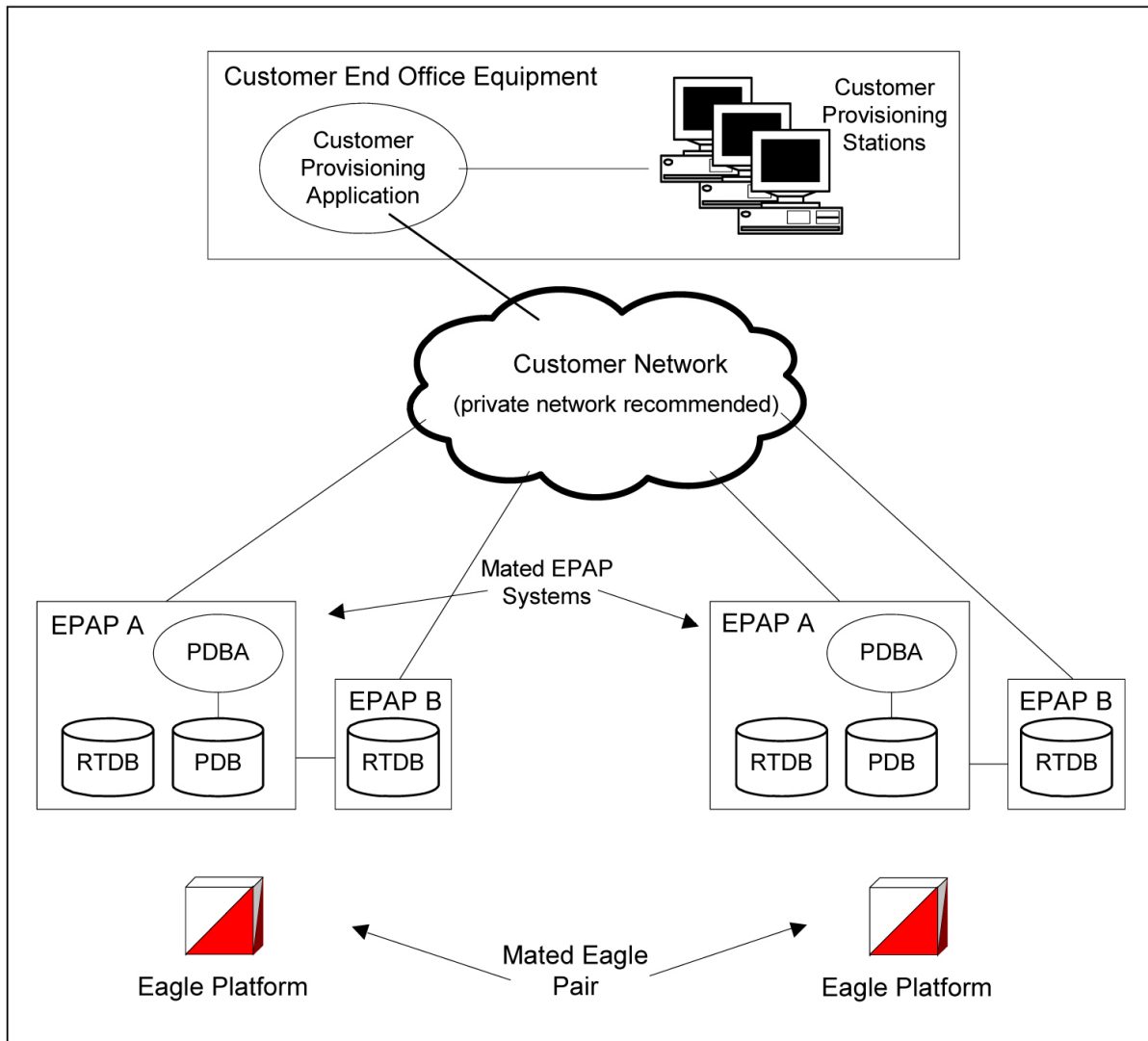

Figure 5: Customer Provisioning Network

Although a dedicated network is recommended, it is possible that unrelated customer traffic can use the network as well. The determination, either to have a dedicated network or to allow other customer traffic, should be based on available external Ethernet bandwidth and network performance considerations.

EPAP Sync Network

The EPAP sync network carries RTDB and maintenance application traffic between active and standby EPAP servers on an MPS system. It synchronizes the contents of the RTDBs of both EPAP A and B. The EPAP Sync network is a single Ethernet connection between EPAP A and EPAP B running at 100BASE-T, as shown in [Figure 6: EPAP Sync Network](#). The T1200 EPAP Sync network is truncated with the EPAP backup DSM connection and communicates through the switch.

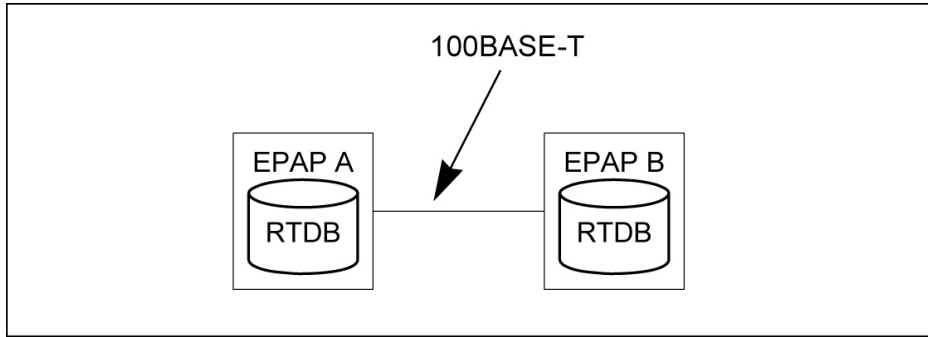

Figure 6: EPAP Sync Network

DSM Networks

The DSM networks are shown in [Figure 7: DSM Networks](#). They carry provisioning data from the active EPAP RTDB to the Service Module cards. They also carry reload and maintenance traffic to the Service Module cards.

The DSM networks consist of two Ethernet networks: the main DSM network running at 100BASE-T, and the backup DSM network running at either 10BASE-T or 100Base-T. See [Table 12: EPAP IP Addresses in the DSM Network](#) for the link speed. Both Ethernet networks connect EPAP A and EPAP B with every Service Module card on a single EAGLE 5 ISS platform.

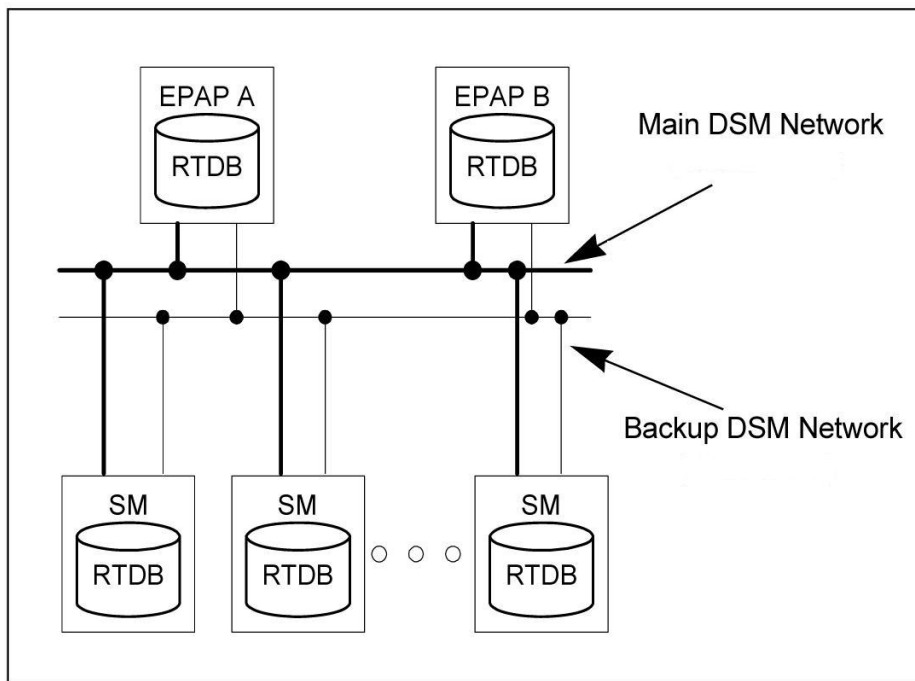

Figure 7: DSM Networks

Maintenance information is sent from the active EPAP to an arbitrarily selected Service Module card. The selected Service Module card is known as the primary Service Module card. Static information is exchanged across this interface at initialization, and dynamic information is exchanged on occasion.

While much of the traditional OAM provisioning and database functionality is implemented on the EPAP, the maintenance reporting mechanism is still the OAM.

The first and second octets of the EPAP network addresses for this network are 192.168. (The first two octets for private class C networks are defined in RFC 1918.)

The third octet is customer specifiable for each DSM network. It is important to select values that do not interfere with the customer's network addressing scheme.

The fourth octet of the address is specified as follows:

- If the EPAP is configured as "EPAP A", the fourth octet has a value of 100.
- If the EPAP is configured as "EPAP B", the fourth octet has a value of 200.

Table 12: EPAP IP Addresses in the DSM Network summarizes the contents of each octet.

Table 12: EPAP IP Addresses in the DSM Network

Octet	Value
1	192
2	168
3	One customer-provisioned value for DSM network A and another for DSM network B

Octet	Value
4	100 for EPAP A and 200 for EPAP B

Dial-Up PPP Network

The dial-up PPP network allows multiple user-interface sessions to be established with the EPAP. The network connects a remote EPAP/PDBA user interface terminal with the EPAP in the EAGLE 5 ISS's MPS subsystem. The dial-up PPP network is illustrated in *Figure 8: Dial-Up PPP Network*.

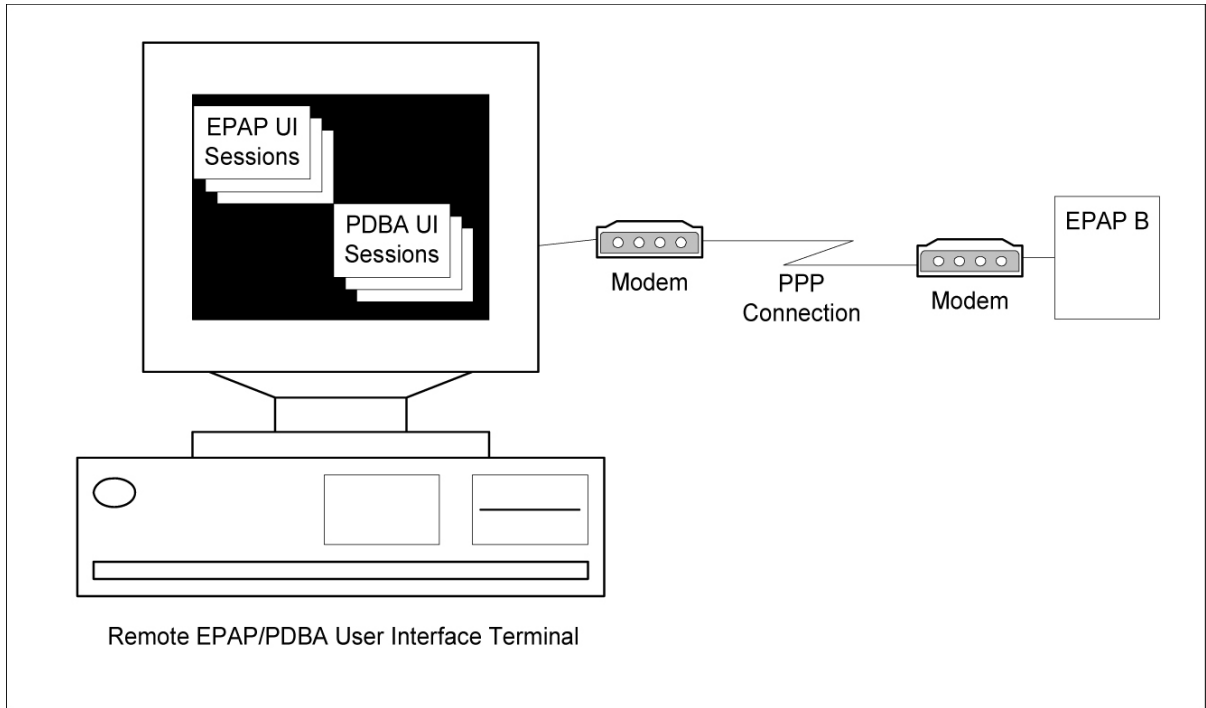

Figure 8: Dial-Up PPP Network

Chapter 3

Commands

Topics:

- *Introduction.....55*
- *EAGLE 5 ISS GSM System Options Commands.....55*
- *EAGLE 5 ISS GSM SMS Options Commands.....58*
- *EAGLE 5 ISS IS41 Options Commands.....58*
- *EAGLE 5 ISS Service Selector Commands.....62*
- *EAGLE 5 ISS Feature Control Commands.....65*
- *EAGLE 5 ISS SCCP Service Commands.....66*

This chapter provides brief descriptions of the EAGLE 5 ISS commands that are used for the configuration, control, maintenance, and measurements of the IS41 GSM Migration (IGM) feature.

Introduction

This chapter describes the EAGLE 5 ISS commands used to administer the IGM feature. The command descriptions include parameters that are used with the IGM feature. Refer to *Commands Manual* for complete command descriptions including parameter names, valid parameter values, examples, and dependencies.

EAGLE 5 ISS GSM System Options Commands

The GSM system options (`chg/rtrv-gsmopts`) commands change and display GSM system options in the EAGLE 5 ISS database.

Refer to *Commands Manual* for complete descriptions of the commands, including parameters, valid parameter values, rules for using the commands, and output examples.

- **chg-gsmopts: Change GSM System Options Command** – The `chg-gsmopts` command changes GSM system options in the GSMOPTS table. The default or currently provisioned parameter value is overwritten when a parameter is specified.

Table 13: chg-gsmopts Parameters

Parameter	Range	Description
crptt	0-255, none	Circular Route Prevention Translation Type The MNP Circular Route Prevention feature must be turned on before this parameter can be provisioned to any value other than none. The MNP Circular Route Prevention feature cannot be turned off if this parameter is provisioned to any value other than none. The default value is none.
defmapvr	1-3	Default MAP version
defmcc	1-3 digits, none	E212 default mobile country code
defmnc	1-4 digits, none	E212 default mobile network code
gsm2is41	1-15 digits, none	GSM to IS-41 migration prefix
is41gsm	1-15 digits, none	IS-41 to GSM migration prefix

Parameter	Range	Description
mccmnc	4-7 digits, none	E212 mobile country code and mobile network code
migrpfx	single, multiple	Migration prefix
msisdntrunc	1 digit (0-5)	MS ISDN Truncation digits
msrndig	rn, rndn, ccrndn, rnccdn, rnasd, asdrn, rnasddn, asdrndn, ccrnasddn, ccasdrndn, rnasdccd, asdrnccd, rngrn, grnrn, rngrndn, grnrndn, ccrngrndn, ccgrnrndn, rngrnccd, grnrnccd	RN used "as is" or with MSISDN
msrnnai	1-7	NAIV for the MSRN
msrnp	0-15	Numbering plan for the MSRN
multcc	1 to 3 digits (0-9, a-f, A-F)	Multiple Country Code
nmultcc	1 to 3 digits (0-9, a-f, A-F), none	New Multiple Country Code
off	encdnpsdnnotfound, encdnpsptnone, encodecug, encodenps, srismgttrtg	<p>This parameter turns off specified options. Up to 8 comma-separated unique options can be specified.</p> <ul style="list-style-type: none"> • encdnpsdnnotfound - NPSI for DN not found option This option specifies whether the NPSI is included in SRI Ack messages when the DN is not found. The default setting is <i>off</i>. • encdnpsptnone - NPSI for PT = none This option specifies whether the NPSI is included in SRI Ack messages when the Portability Type = none. The default setting is <i>off</i>. • encodecug - Closed User Group (CUG) option This option specifies whether the Closed User Group (CUG) Checkinfo from the SRI message is included in

Parameter	Range	Description
		<p>the SRI ack message. The default setting is <code>off</code>.</p> <ul style="list-style-type: none"> <code>encodenps</code> - Number Portability Status Indicator (NPSI) option <p>This option specifies whether the Number Portability Status Indicator (NPSI) is omitted from all SRI Ack messages. The default setting is <code>on</code>.</p> <ul style="list-style-type: none"> <code>srismgttrtg</code> - SRI_SM Routing option <p>This option specifies whether the SRI_SM routing feature is on. The default setting is <code>off</code>.</p>
<code>on</code>	<code>encdnpsdnotfound, encdnpsptnone, encodecug, encodenps, srismgttrtg</code>	This parameter turns on specified options. Up to 8 comma-separated unique options can be specified. Refer to <code>off</code> parameter for option descriptions.
<code>serverpfx</code>	1-4 digits, none	Server SRI prefix
<code>srfaddr</code>	1-15 digits	Entity address of MNP_SRF node
<code>srfnai</code>	0-127	NAIV of the MNP_SRF
<code>srfnp</code>	0-15	Numbering plan value of the MNP_SRF Network Code
<code>sridn</code>	<code>tcap, sccp</code>	Send Routing Information Dialed Number location
<code>sridnnotfound</code>	<code>gtt, srinack</code>	When G-Port encounters an RTDB query result that indicates that the given DN is not known, SRIDNNOTFOUND parameter value determines further processing.

- **rtrv-gsmopts: Retrieve GSM System Options Command** – The `rtrv-gsmopts` command displays the GSM option values that are provisioned in the GSMOPTS table.

EAGLE 5 ISS GSM SMS Options Commands

The GSM SMS options (`chg/rtrv-gsmsmsopts`) commands change and display specific SMS and MMS options in the EAGLE 5 ISS database. The `chg-gsmsmsopts` command parameters associated with IS41 GSM Migration feature are shown in *Table 14: chg-gsmsmsopts Parameters*.

Refer to the *Commands Manual* for complete descriptions of the commands, including parameters and valid values, rules for using the commands correctly, and output examples.

- **chg-gsmsmsopts: Change GSM SMS Options Command** – The `chg-gsmsmsopts` command changes GSM SMS and MMS system options in the database. This command updates the GSMSMSOPTS table. The default parameters are always overwritten when specified.

Table 14: chg-gsmsmsopts Parameters

Parameter	Range	Description
defis41smsc	1-15 digits, none	Default IS41 short message service center
igmsmsrelay	yes, no	IGM-based SMS relay
is41smscgtsn	ayyyyyyyy	IS41 SMSC GTT Set name

- **rtrv-gsmsmsopts: Retrieve GSM SMS Options Command** - The `rtrv-gsmsmsopts` command displays all GSM SMS and MMS options from the database.

EAGLE 5 ISS IS41 Options Commands

The IS41 options (`chg/rtrv-is41opts`) commands are used to change and display the values of one or more of the system-level processing option values maintained in the IS41OPTS table. All values are assigned initially to system defaults at STP installation. The values can be updated using the `chg-is41opts` command.

Refer to the *Commands Manual* for complete descriptions of the commands, including parameters and valid values, rules for using the commands correctly, and output examples.

- **chg-is41opts: Change IS41 Options** – The `chg-is41opts` command changes IS41-specific options in the database. This command updates the IS41OPTS table. The default or currently provisioned parameter values are overwritten when a parameter is specified.

Table 15: `chg-is41opts` Parameters - Class = DATABASE

Parameter	Range	Description
<code>dfltrn</code>	1-15 hexadecimal digits (0-9, a-f, A-F), none	Default Routing Number. This parameter specifies the routing digits when Service Portability is not applicable. This parameter can be modified only when the LOCREQ Query Response feature is enabled. Default value is none.
<code>esnmfg</code>	0-255	TCAP LOCREQ ESN Manufacturer code. This parameter specifies the value to be encoded in the TCAP LOCREQ ESN parameter in the manufacturer code section.
<code>esnsn</code>	0-16777215	TCAP LOCREQ ESN Serial Number. This parameter specifies the value to be encoded in the TCAP LOCREQ ESN parameter in the serial number section.
<code>iec</code>	digit string 1-5 digits, none	International Escape Code
<code>locreqdn</code>	<code>tcap</code> , <code>sccp</code>	LOCREQ DN. This parameter specifies whether to obtain the Called Party, used for database lookup, from the SCCP layer or the TCAP layer of a received LOCREQ message.
<code>locreqrmhrn</code>	<code>yes</code> , <code>no</code>	LOCREQ Remove HomeRN. This parameter specifies whether to remove the HomeRN from the TCAP Outgoing Called party for a relayed LOCREQ message. This parameter cannot be specified in the same command entry as the <code>on</code> and <code>off</code> parameters.
<code>mscmktid</code>	0-65535	LOCREQ MSCID Market ID. This parameter specifies the value to be encoded in LOCREQ MSCID parameter for Market ID.
<code>mscswitch</code>	0-255	LOCREQ MSCID Market ID Switch. This parameter specifies the value to be encoded in LOCREQ MSCID parameter in the market id switch section.
<code>mtplocreqnai</code>	<code>ccrndn</code> , <code>frmsg</code> , <code>intl</code> , <code>natl</code> , <code>rnidn</code> , <code>rnndn</code> , <code>rnsdn</code> , <code>sub</code> , <code>locreqlen</code>	Message Translation Part LOCREQ nature of address indicator. Used to define how Called Party obtained from the TCAP layer of a received MTP-routed LOCREQ message is interpreted.
<code>nec</code>	digit string 1-5 digits, none	National Escape Code

Parameter	Range	Description
off	locreqrmhrn, locreqrspnd, smsreqbypass	<p>This parameter turns off the specified options. Up to 8 comma-separated unique options can be specified.</p> <ul style="list-style-type: none"> locreqrmhrn - LOCREQ Remove HomeRN. This option specifies whether to remove the HomeRN from the TCAP Outgoing Called party for a relayed LOCREQ message. Option default is <code>off</code>. locreqrspnd - LOCREQ Query Response. This option specifies whether to always respond to a LOCREQ query. This option can be changed only if the LOCREQ Query Response feature is turned on. Option default is <code>off</code>. smsreqbypass - SMSREQ Bypass. This option specifies whether a received SMSREQ message that passes the MNP Service Selector (<code>serv=mnps</code> parameter of <code>chg-sccp-serv</code>) will undergo A-Port message processing. Option default is <code>off</code>. <p>This parameter cannot be specified in the same command entry as the <code>locreqrmhrn</code> and <code>smsreqbypass</code> parameters.</p>
on	locreqrmhrn, locreqrspnd, smsreqbypass	<p>This parameter turns on the specified options. Up to 8 comma-separated unique options can be specified. See <code>off</code> parameter for option descriptions. This parameter cannot be specified in the same command entry as the <code>locreqrmhrn</code> and <code>smsreqbypass</code> parameters.</p>
rspcdpari	frmsg, gt, ssn	<p>Response Called Party Routing Indicator. This parameter specifies the value of the Routing Indicator bit to encode the SCCP CdPA GTA of a returned LOCREQ message.</p>
rspcgpanai	0-127, none	<p>Response Calling Party Nature of Address Indicator (NAI). This parameter specifies a new NAI value to override the NAI value specified in the SCCP CdPA of a received LOCREQ/SMSREQ if the message is to be relayed after database lookup.</p>
rspcgpanp	0-15, none	<p>Response Calling Party Numbering Plan. This parameter specifies a new Numbering Plan value to override the Numbering Plan value specified in the SCCP CdPA of a received LOCREQ/SMSREQ if the message is to be relayed after database lookup.</p>
rspcgpapcp	frmsg, on, off	<p>Response Calling Party Point Code Present. This parameter specifies the value of the Point Code Present</p>

Parameter	Range	Description
		bit to encode the SCCP CgPA GTA of a returned LOCREQ message
rspcgpari	frmsg, gt, ssn	Response Calling Party Routing Indicator. This parameter specifies the value of the Routing Indicator bit to encode the SCCP CgPA GTA of a returned locreq message.
rspcgpatt	0-255, none	Response Calling Party Translation Type (TT). This parameter specifies a new TT value to override the TT value specified in the SCCP CdPA of a received LOCREQ/SMSREQ if the message is to be relayed after database lookup.
rspdig	ccrndn, hrnrndn, rn, rndn	Routing Number. This parameter specifies the digit encoding format of the TCAP Outgoing Called Party parameter for a LOCREQ response message on a per EAGLE 5 ISS node basis.
rspdigtype	0-255	Response Digit Type. This parameter specifies the value that will encode the DigitType field in the TCAP Outgoing Called Party parameter of a LOCREQ response message.
rspmin	homern, nothomern, tendelhomern, tenhomern, tenzero	Response LOCREQ MIN Parameter Encoding. This parameter specifies how the digits of the LOCREQ MIN parameter will be encoded.
rspnon	0-255, none	MSRN Nature of Number. This parameter specifies the Nature of Number value of the TCAP Outgoing Called Party parameter.
rspnp	0-15, none	MSRN Numbering Plan. This parameter specifies the Numbering Plan values of the TCAP Outgoing Called Party parameter.
rspparm	ddigit, rtdigit, tlist	Response Parameter. This parameter specifies which TCAP LOCREQ parameter (TCAP Outgoing Called Party) will encode the RN and/or DN information.
smsreqbypass	yes, no	SMSREQ Bypass. This parameter specifies whether a received SMSREQ message that passes the MNP Service Selector (<code>serv=mnp</code> parameter of <code>chg-sccp-serv</code>) will undergo IS41 GSM Migration (IGM) message processing. This parameter cannot be specified in the same command entry as the <code>on</code> and <code>off</code> parameters.

Parameter	Range	Description
		The MT-Based IS41 SMS NP feature does not consider the value of this parameter. If <code>smsreqbypass</code> has a value of <code>yes</code> , the IGM processing will not be applied but the message will be considered for MT-Based IS41 SMS NP processing.
<code>sporttype</code>	<code>none, gsm, is41, all</code>	Service Portability Type. This parameter specifies the application of Service Portability that is applied to the associated feature. This parameter can be modified only when the Service Portability and LOCREQ Query Response features are enabled. Default value is <code>none</code> .
<code>tcapsnai</code>	<code>ccrndn, frmsg, intl, natl, rnidn, rnndn, rnsdn, sub</code>	This parameter specifies how the Called Party from the TCAP layer of a received LOCREQ message is interpreted.

- **rtrv-is41opts: Retrieve IS41 Options** – The `rtrv-is41opts` command displays the IS41 option values that are provisioned in the IS41OPTS table.

EAGLE 5 ISS Service Selector Commands

The service selector (`ent / chg / dlt / rtrv-srvsel`) commands are used to provision, delete, change, and display the applicable service selectors required to change a service entry for SCCP services. .

Refer to the *Commands Manual* for complete descriptions of the ommands, including parameters and valid values, rules for using the commans correctly, and output examples.

- **ent-srvsel: Enter Service Selectors** – The parameters of the `ent-srvsel` command can be used to specify the applicable service selectors that indicate that IGM feature processing is required. The IGM feature must be enabled before entering this command.

Table 16: ent-srvsel Parameters

Parameter	Optional/ Mandatory	Range	Description
<code>gti, gtia, gtii, gtin, gtin24</code>	Mandatory	2, 4	Global Title Indicator
<code>serv</code>	Mandatory	<code>eir, gflex, gport, inpq, inpmr, smsmr, idps, idpr, mnp, vflex, atinp</code>	SCCP service
<code>ssn</code>	Mandatory	0-255, *	Subsystem number

Parameter	Optional/ Mandatory	Range	Description
tt	Mandatory	0-255	Translation Type
nai	Optional	1sub, rsvd, natl, intl	Nature Of Address Indicator
naiv	Optional	0-127	NAI Value
np	Optional	e164, generic, x121, f69, e210, e212, e214, private	Numbering Plan
npv	Optional	10-15	Numbering Plan Value
snai	Optional	1sub, natl, intl, rmidn, rrndn, rnsdn, ccrndn	Service Nature of Address Indicator
snp	Optional	1e164, e212, e214	Service Numbering Plan

- **chg-srvsel: Change Service Selector** – The `chg-srvsel` command can be used to specify the applicable selectors required to change an existing IGM selector entry.

Table 17: `chg-srvsel` Parameters

Parameter	Optional/ Mandatory	Range	Description
gti, gtia, gtii, gtin, gtin24	Mandatory	2, 4	Global Title Indicator
ssn	Mandatory	0-255, *	Subsystem number
tt	Mandatory	0-255	Translation Type
nai	Optional	sub, rsvd, natl, intl	Nature Of Address Indicator
naiv	Optional	0-127	NAI Value
np	Optional	e164, generic, x121, f69, e210, e212, e214, private	Numbering Plan
npv	Optional	0-15	Numbering Plan Value

Parameter	Optional/ Mandatory	Range	Description
nserv	Mandatory	eir, gflex, gport, inpq, inpmr, smsmr, idpr, idps, mnp, vflex, atinp	New SCCP service
nsnai	Optional	sub, natl, intl, rmidn, rnmndn, rnsdn, ccrndn, none	New Service Nature of Address Indicator
nsnp	Optional	e164, e212, e214, none	New Service Numbering Plan

- **dlt-srvsel: Delete Service Selector** – The `dlt-srvsel` command deletes a service selector entry..

Table 18: dlt-srvsel Parameters

Parameter	Optional/ Mandatory	Range	Description
gti, gtia, gtii, gtin, gtin24	Mandatory	2, 4	Global Title Indicator
ssn	Mandatory	0-255, *	Subsystem number
tt	Mandatory	0-255	Translation Type
nai	Optional	sub, rsvd, natl, intl	Nature Of Address Indicator
naiv	Optional	0-127	NAI Value
np	Optional	e164, generic, x121, f69, e210, e212, e214, private	Numbering Plan
npv	Optional	0-15	Numbering Plan Value

- **rtrv-srvsel: Retrieve Service Selector** – The `rtrv-srvsel` command displays a list of administered service selector combinations. Output is sorted first by service, then by global title domain (ANSI first, followed by ITU), GTI, translation type, numbering plan, and by the nature of address indicator. The output can be filtered by specifying any optional parameter.

Table 19: rtrv-srvsel Parameters

Parameter	Optional/ Mandatory	Range	Description
gti, gtia, gtii, gtin, gtin24	Optional	2, 4	Global Title Indicator
nai	Optional	sub, rsvd, natl, intl	Nature Of Address Indicator
naiv	Optional	0-127	NAI Value
np	Optional	e164, generic, x121, f69, e210, e212, e214, private	Numbering Plan
npv	Optional	0-15	Numbering Plan Value
serv	Optional	eir, gflex, gport, inpq, inpmr, smsmr, idpr, idps, mnp, vflex, atinp	SCCP service
snai	Optional	sub, natl, intl, rmidn, rnrndn, rnsdn, ccrndn	Service Nature of Address Indicator
snp	Optional	e164, e212, e214	Service Numbering Plan
ssn	Mandatory	0-255, *	Subsystem number
tt	Optional	0-255	Translation Type

EAGLE 5 ISS Feature Control Commands

The `ent/chg/rtrv-ctrl-feat` commands are used to enable, turn on, and display the feature status of the IS41 GSM Migration (IGM) feature. A Feature Access Key is used to enable the IGM feature. The feature must be purchased to receive a Feature Access Key for the feature.

No temporary key is associated with the IGM feature. After the feature is turned on, it cannot be turned off.

Additional verifications are performed to ensure the correct hardware is present in the system. T

The feature part number 893017301 is used to enable the IGM feature on the EAGLE 5 ISS.

Refer to the *Commands Manual* for a complete description of these commands.

- **enable-ctrl-feat: Enable Control Feature Command**

The `enable-ctrl-feat` command is used for the permanent enabling of the IGM feature.

```
enable-ctrl-feat:partnum=893017301:fak=<Feature Access Key>
```

- **chg-ctrl-feat: Change Control Feature Command**

The `chg-ctrl-feat` command is used to turn on the IGM feature. The IGM feature must be enabled before it can be turned on.

```
chg-ctrl-feat:partnum=893017301:status=on
```

- **rtrv-ctrl-feat: Retrieve Control Feature Command**

The `rtrv-ctrl-feat` command is used display the status of the feature.

EAGLE 5 ISS SCCP Service Commands

The `chg/dlt/rtrv-sccp-serv` commands allow for services to be taken online and offline, and for the service processing loads to be shifted to other designated nodes. These commands also support the assignment of PCs to PC groups used for MNP re-route assignment.

The `chg-sccp-serv` command is used to provision entries in the SCCP-SERV table. The provisioned entries are shown in the `rtrv-sccp-serv` command output. The maximum number of entries that the MRN table can contain is reduced by the number of entries shown in the `rtrv-sccp-serv` command output. For more information on provisioning MRN tables, refer to the *Database Administration Manual - Global Title Translations*.

Refer to the *Commands Manual* for complete descriptions of the commands, including parameters and valid values, rules for using the commands correctly, and output examples.

- **chg-sccp-serv: Change SCCP Service** – The `chg-sccp-serv` command is used to add point codes to an existing service group, or to change the Relative Cost (RC) of existing point codes in a group. SCCP Service groups are organized by service (G-Flex, G-Port, MNP) and point code network type (ANSI, ITU-I, ITU-I Spare, ITU-N, ITU-N Spare, or ITU-N24). Up to 7 PCs may be in a network type grouping for service re-route load sharing. This command allows for additions and modifications of up to 4 PCs at once. The point code parameters support the Spare Point Code subtype prefix *s-* for ITU-I and ITU-N point codes.

Table 20: chg-sccp-serv Parameters

Parameter	Optional/ Mandatory	Range	Description
serv	Mandatory	gport, gflex, mnp	Service
state	Optional	offline, online	Status
gtt	Optional	no, yes	Global Title Translation
pc1, pca1, pci1, pcn1, pcn241	Optional	Refer to <i>Commands Manual</i>	Post GTT-translated PC

Parameter	Optional/ Mandatory	Range	Description
rc1	Optional	00-99	Relative Cost
pc2, pca2, pci2, pcn2, pcn242	Optional	Refer to <i>Commands Manual</i>	Post GTT-translated PC
rc2	Optional	00-99	Relative Cost
pc3, pca3, pci3, pcn3, pcn243	Optional	Refer to <i>Commands Manual</i>	Post GTT-translated PC
rc3	Optional	00-99	Relative Cost
pc4, pca4, pci4, pcn4, pcn244	Optional	Refer to <i>Commands Manual</i>	Post GTT-translated PC
rc4	Optional	00-99	Relative Cost

- **dlt-sccp-serv: Delete SCCP Service** – The `dlt-sccp-serv` command is used remove entries from the SCCP-SERV table. A single command may remove either a PC from a group, or remove the entire group.

Table 21: dlt-sccp-serv Parameters

Parameter	Optional/ Mandatory	Range	Description
serv	Mandatory	gport, gflex, mnp	Service
pc1, pca1, pci1, pcn1, pcn241	Optional	Refer to <i>Commands Manual</i>	Post GTT-translated PC
pc2, pca2, pci2, pcn2, pcn242	Optional	Refer to <i>Commands Manual</i>	Post GTT-translated PC
pc3, pca3, pci3, pcn3, pcn243	Optional	Refer to <i>Commands Manual</i>	Post GTT-translated PC
pc4, pca4, pci4, pcn4, pcn244	Optional	Refer to <i>Commands Manual</i>	Post GTT-translated PC
all	Optional	No, Yes	Yes will delete the entire group

- **rtrv-sccp-serv: Retrieve SCCP Service** – The `rtrv-sccp-serv` command is used to display the SCCP Service application relationship information maintained by the EAGLE 5 ISS. Point codes are grouped by service.

Feature Configuration

Topics:

- *Introduction.....70*
- *EPAP Entity Provisioning.....71*
- *Prerequisites.....71*
- *EAGLE 5 ISS HLR Destinations Configuration.....72*
- *IGM Feature Activation Procedure.....78*
- *The 1100 TPS/DSM for ITU NP Feature.....81*
- *Activating the E5-SM4G Throughput Capacity Feature.....86*
- *Adding a Service Module Card.....90*
- *LOCREQ Query Response Activation Procedure.....97*
- *Service Portability Activation Procedure.....100*
- *MTP Routed Messages for SCCP Applications Activation Procedure.....101*

This chapter describes the prerequisites, considerations, and steps to activate the IS41 GSM Migration (IGM) feature. This chapter also includes feature activation procedures for these features:

- 1100 TPS/DSM for ITU NP
- E5-SM4G Throughput Capacity
- MTP Msgs for SCCP Apps

Introduction

This chapter identifies prerequisites for the IS41 GSM Migration (IGM) feature activation procedure and provides the feature activation procedures for these features:

- IS41 GSM Migration (IGM)
- 1100 TPS/DSM for ITU NP
- E5-SM4G Throughput Capacity
- Service Portability
- LOCREQ Query Response
- MTP Msgs for SCCP Apps

These feature activation procedures are performed at the EAGLE 5 ISS.

The IGM feature and other related features are optional and are purchased from Tekelec. Contact your Tekelec Sales or Account Representative to determine whether you have purchased a specific feature or for additional information. These features are related to the IGM feature:

- Global Title Translation (GTT)
- Enhanced Global Title Translation (EGTT)
- Variable-Length Global Title Translation (VGTT)
- Mobile Number Portability Circular Route Prevention (MNPCRCP)

Note: After a permanently-on feature has been turned on with the `enable-ctrl-feat` command, the feature cannot be turned off. Because this feature may affect other features or system databases, confirm that a feature license and technical support from Tekelec are available before turning on this feature. Contact your Tekelec Sales or Account Representative to verify whether the feature has been purchased.

Refer to *Dimensioning Guide for EPAP Advanced DB Features Technical Reference* for important information about the dimensioning rules and the Service Module database capacity requirements.

Summary of Feature Activation

This table summarizes the feature activation attributes for the features in this chapter.

Table 22: Feature Activation Summary

Feature Name	Part Number	Temporary FAK Available?	Permanently On?
IS41 GSM Migration (IGM)	893017301	No	Yes
MNP Circular Route Prevention (MNPCRCP)	893007001	Yes	No
1100 TPS/DSM for ITU NP	893018001	No	No
E5-SM4G Throughput Capacity	893019101	No	Yes

Feature Name	Part Number	Temporary FAK Available?	Permanently On?
	893019102		
Service Portability	893034301	No	No
LOCREQ Query Response	893038501	No	Yes
MTP Msgs for SCCP Apps	893017401	No	No

Feature Activation Considerations

- After a permanently-on feature has been enabled and turned on with the `enable-ctrl-feat` and `chg-ctrl-feat` commands, the feature cannot be turned off. Because this feature may affect other features or system databases, confirm that a feature license and technical support from Tekelec are available before turning on this feature. Contact your Tekelec Sales or Account Representative to verify whether the feature has been purchased.
- Refer to *Dimensioning Guide for EPAP Advanced DB Features Technical Reference* for important information about the dimensioning rules and the Service Module database capacity requirements.

EPAP Entity Provisioning

It is recommended that EPAP entity (SP or RN) administration not be done until after the point code and/or subsystem number has been entered into the EAGLE 5 ISS MAP table.

- EPAP-administered entity data can possibly become out-of-sync with the EAGLE 5 ISS MAP table when the creation of point codes and/or subsystem numbers in the MAP table is performed after EPAP database administration.
- If this mismatch is discovered in real-time operations, a UIM (such as `SCCP did not route - DPC not in MAP tbl` or `SCCP did not route - SS not in MAP tbl`) is sent to the EAGLE 5 ISS maintenance terminal.

Prerequisites

The IGM feature activation assumes that Global Title Translation (GTT), Enhanced Global Title Translation (EGTT), or Variable-Length Global Title Translation (VGTT) is already provisioned. Refer to *Database Administration Manual - Global Title Translation* for provisioning procedures.

The IGM feature activation assumes that the EPAP software is already configured; refer to EPAP Software Configuration in *EPAP Administration Manual*.

The NT serial number (`ent-serial-num`) must be entered and locked before IGM can be enabled and turned on.

The IGM feature requires a Service Module card running the VSCCP application prior to turning on the IGM feature. The IGM feature cannot be turned on if any of the Service Module cards have less than 4 GB of memory installed.

The IGM feature activation assumes that the Service Module cards to be installed are identified.

- Note installed Service Module card locations, if any.
- Note available odd-even card slots for Service Module card installation.
- Determine Service Module card IP addresses and have them available during the activation procedure.

For in-service systems, schedule Service Module card replacement in maintenance window that allows the reboot of Service Module cards (`init-card:loc=<Service Module card location>`) one at a time.

For in-service systems that already have another EPAP-related feature enabled, perform only [IGM Feature Activation Procedure](#) to turn on the IGM feature. With another EPAP-related feature enabled, the Service Module cards already contain the Real Time Database (RTDB).

For new systems, Service Module cards may be rebooted all at one time using the `init-card:appl=vscpp` command. For new systems, GTT, EGTT, or VGTT features must be turned on prior to the reboot of all Service Module cards.

EAGLE 5 ISS HLR Destinations Configuration

This procedure configures the EAGLE 5 ISS system for Home Location Register (HLR) destinations before activating the EPAP-related feature. This procedure assumes that the EAGLE 5 ISS is an existing system in which an EPAP-related feature is being activated. The route to the HLR database may already be configured. Perform this procedure to verify that all HLR destinations for the feature are provisioned and to configure changes, as needed.

Refer to *Commands Manual* for detailed descriptions of the commands used in this procedure.

Procedure Overview

- Display current PCs, CPCs, DPCs, routes, and linksets using [Step 1](#) through [Step 6](#).
- Change current PCs, CPCs, DPCs, routes, linksets, and LIM cards using [Step 7](#) through [Step 25](#).

For detailed information about specific configuration activities in this procedure, refer to these topics in *Database Administration Manual - SS7*:

- Point Code Formats
- Adding a Point Code to the Self-Identification of the EAGLE 5 ISS
- Changing the Self-Identification of the EAGLE 5 ISS
- Adding a Destination Point Code
- Adding an SS7 Linkset
- Adding an SS7 Signaling Link
- Adding a Route Containing an SS7 DPC

1. Display the current self-identification characteristics (PC and CPC) of the system using the `rtrv-sid` command.

The self-identification characteristics of the system displayed by the `rtrv-sid` command include the point code (PC) assigned to the system, the CLLI code of the system, the capability point code of the STP (CPC), and the type of point codes supported by the system.

If the ITUDUPPC (ITU national duplicate point code) feature is on, the ITU national point code also contains a group code. The group code is a two-character field from *aa* to *zz* that is entered as the last subfield of an ITU national point code, *nnnnn-gc* (for example, 2112-aa).

2. Display the current destination point codes (DPC) in the Destination point code table using the `rtrv-dstn` command.
3. Display the current route and linkset configuration using the `rtrv-rte` command.
4. If the system point code (`pci/pcn`) or capability point code to be configured in this procedure is shown in [Step 1](#), [Step 2](#), or [Step 3](#), choose another point code to configure with this procedure. If configuring an ITU-N network, continue to [Step 5](#). If configuring a mated application but not configuring an ITU-N network, proceed to [Step 6](#). Otherwise, proceed to [Step 7](#).
5. Use the `rtrv-stpopts` command to display the PC or CPC format when configuring the system point code or capability point code of an ITU-N network.

The ITU-N point code format option `npcfmt i` determines the format of the ITU-N point code in the database and how it is displayed in all system outputs. The defined value is shown in the `NPCFMTI` field displayed in the output of the `rtrv-stpopts` command.

To change the format of the ITU-N point code, refer to "Point Code Formats" in *EAGLE 5 ISS Database Administration Manual - SS7*.

Continue to [Step 6](#) to display mated applications in the database. Otherwise, proceed to [Step 7](#).

6. Display the mated applications in the database using the `rtrv-map` command.
 - a) If the point code of the system is displayed in the `rtrv-map` command output, remove the system point code from the mated application table. Refer to procedure "Removing a Mated Application" in *EAGLE 5 ISS Database Administration Manual - Features*.
 - b) If the point code of the system or capability point code is a destination point code of a route, select a point code that is not in the destination point code table (refer to output in [Step 2](#)) and not the destination point code of a route (refer to output in [Step 3](#)).
7. Change the point code of the system and capability point code by network type using procedures "Adding a Point Code to the Self-Identification of the EAGLE 5 ISS" and "Changing the Self-Identification of the EAGLE 5 ISS" in *Database Administration Manual - SS7*.
8. Enter a destination point code for the HLR location in the Destination table by network type using the `ent-dstn` command.

Command examples:

```
ent-dstn:dpci=2-100-2
```

```
ent-dstn:dpcn=21112
```

where:

:dpc/dpca/dpci/dpcn

Destination point code to add to the database

9. Verify the changes using the `rtrv-dstn` command and specifying the DPC entered in [Step 8](#).

Command examples:

```
rtrv-dstn:dpci=2-100-2
```

```
rtrv-dstn:dpcn=21112
```

Example of possible output for the **DPCI** command example:

```
tekelecstp51 09-08-24 21:16:37 GMT EAGLE 41.0.0
DPCI          CLLI          BEI  ELEI  ALIASA          ALIASN/N24  DMN
2-100-2      -----          no  ---  -----          -----  SS7
```

Example of possible output for the **DPCN** command example:

```
tekelecstp51 09-08-24 21:16:37 GMT EAGLE 41.0.0
DPCN          CLLI          BEI  ELEI  ALIASA          ALIASI  DMN
21112        -----          no  ---  -----          -----  SS7
```

10. Enter a linkset with the `ent-ls` command and assign the linkset to the destination point code by network type.

Command examples:

```
ent-ls:apci=2-200-2:lsn=ls400001:lst=a
```

```
ent-ls:apcn=21122:lsn=ls500001:lst=a
```

where:

:apc/apca/apci/apcn

Adjacent point code - the DPC of the adjacent signaling node at the far end of the linkset

:lsn

Linkset name

:lst

Linkset type

11. Verify the changes using the `rtrv-ls` command and specifying the linkset name.

Command example:

```
rtrv-ls:lsn=ls400001
```

```
rtrv-ls:lsn=ls500001
```

Example of possible output for **lsn400001** command example:

```
tekelecstp51 09-08-24 21:16:37 GMT EAGLE 41.0.0
LSN          APCI    (SS7)  SCRN  L3T  SLT          GWS  GWS  GWS
ls400001     2-200-2  scr1   1    2    no  a    0    on  off  off  no  on
CLLI        TFATCABMLQ  MTPRSE  ASL8
RLGHNCXA03W  1          no      no
LOC  PORT  SLC  TYPE  L2T  L1          PCR  PCR
SET  BPS  MODE  TSET  ECM  N1  N2
```

Example of possible output for **lsn500001** command example:

```
tekelecstp51 09-08-24 21:16:37 GMT EAGLE 41.0.0
LSN          APCN    (SS7)  SCRN  L3T  SLT          GWS  GWS  GWS
ls500001     21122  scr3   1    2    no  a    0    on  off  off  no  on
```

```

CLLI          TFATCABMLQ  MTPRSE  ASL8
RLGHNCXA03W  1          no         no
              L2T        L1          PCR PCR
LOC  PORT  SLC  TYPE    SET  BPS    MODE  TSET  ECM   N1  N2

```

12. Add the LIM cards to the database using the `ent-card` command.

Command examples:

```
ent-card:appl=ccs7itu:loc=1105:type=lime1
```

```
ent-card:appl=ccs7itu:loc=1106:type=lime1
```

where:

:appl

Specifies that the application is CCS7ITU.

:loc

Specifies the slot number for the card.

:type

Specifies that the card is a LIME1 card.

13. Enter the E1 interface using the `ent-e1` command.

Command examples:

```
ent-t1:loc=1105:e1port=1
```

```
ent-t1:loc=1106:e1port=1
```

where:

:loc

Card location or slot as stenciled on the shelf

:e1port

E1 card port number

14. Verify the changes using the `rtrv-card` command with the card location specified.

Command examples:

```
rtrv-card:loc=1105
```

```
rtrv-card:loc=1106
```

Example of possible output for command example:

```

tekelecstp51 09-08-24 21:16:37 GMT EAGLE 41.0.0

```

CARD	TYPE	APPL	LSET NAME	LINK	SLC	LSET NAME	LINK	SLC
1105	LIME1	CCS7ITU	ls400001	A	00	-----	B	--
1106	LIME1	CCS7ITU	ls500001	A	00	-----	B	--

15. Assign signaling links to the LIM cards using the `ent-slk` command.

Command example:

```
ent-slk:l2tset=1:link=a:loc=1105:lsn=ls400001:slc=0:e1port=1:ts=1
```

```
ent-slk:l2tset=1:link=a:loc=1106:lsn=ls500001:slc=0:e1port=1:ts=1
```

where:

:l2tset

Level 2 timer set. A signaling link can be assigned to any of the thirty timer sets.

:link

Signaling link assigned on the card specified in the `loc` parameter

:loc

Card location to which the signaling link is assigned

:lsn

Unique linkset name

:slc

Signaling link code. The `slc` must be unique within the linkset, and must be the same at both the system location and the distant node.

e1port

Port for E1 interface on the E1 card to which the signaling link and timeslot are being assigned

ts

E1 timeslot for the assigned signaling link

Signaling links are the only elements in the database supported directly by a hardware device. When a link is added to a linkset, the link remains in Out-of-Service-Maintenance-Disabled (OOS-MT-DSBLD) state until it is activated; see [Step 23](#).

16. Verify the changes using the `rtrv-slk` command, specifying the card location and ID of the signaling link entered in [Step 15](#).

Command examples:

```
rtrv-slk:loc=1105:link=a
```

```
rtrv-slk:loc=1106:link=a
```

17. Add a route for the new DPC by network type using the `ent-rte` command.

Command examples:

```
ent-rte:dpci=2-100-2:lsn=ls400001:rc=10
```

```
ent-rte:dpcn=21112:lsn=ls500001:rc=10
```

where:

:dpc/dpca/dpci/dpcn

Destination point code of the node to which the traffic is bound

:lsn

Linkset name associated with this route

:rc

Relative cost or priority of this route

18. Verify the changes using the `rtrv-rte` command and specifying the destination point code of the route.
19. Add a mated application by network type to the database using the `ent-map` command.

Command examples:

```
ent-map:grp=grp03:materc=99:mpci=3-200-1:mssn=50:pci=2-100-1:ssn=12:rc=20
```

```
ent-map:grp=grp07:materc=99:mpcn=11114:mssn=250:pcn=11112:ssn=12:rc=10
```

where:

:grp

Concerned point code broadcast list (CSPC) group name. This parameter specifies the name of a group of point codes that should be notified of the subsystem status. A different CSPC group can be assigned to each mated PC/SSN.

:materc

Mate relative cost

:mpc/mpca/mpci/mpcn

Mate remote point code.

:mssn

Mate subsystem number – the subsystem address of the backup point code that is to receive the message

:pci/pcn

ITU international/national point code

:rc

Relative cost

:ssn

Subsystem number – the subsystem address of the primary point code that is to receive the message

20. Verify the changes using the `rtrv-map` command.
21. Allow the LIM cards that were entered in [Step 12](#) using the `alw-card` command.

Command examples:

```
alw-card:loc=1105
```

```
alw-card:loc=1106
```

This message appears:

```
tekelecstp51 09-08-24 21:16:37 GMT EAGLE 41.0.0
Card has been allowed.
```

22. Verify In-Service-Normal (IS-NR) state of the cards using the `rept-stat-card` command.
23. Activate the signaling links entered in [Step 15](#) using the `act-slk` command.

Command examples:

```
act-slk:loc=1105:link=a
```

```
act-slk:loc=1106:link=a
```

The link changes state from Out-of-Service-Maintenance-Disabled (OOS-MT-DSBLD) to In-Service-Normal (IS-NR). The output confirms the activation.

```
tekelecstp51 09-08-24 21:16:37 GMT EAGLE 41.0.0
Activate Link message sent to card
```

24. Verify In-Service-Normal (IS-NR) state of the signaling link using the `rept-stat-slk` command.

Command examples:

```
rept-stat-slk:loc=1105
```

```
rept-stat-slk:loc=1106
```

25. Display the new LIM cards in the database using the `rtrv-card` command.

Example of a possible output:

```
tekelecstp51 09-08-24 21:16:37 GMT EAGLE 41.0.0
CARD  TYPE      APPL      LSET NAME      LINK SLC LSET NAME      LINK SLC
1105  LIME1      CCS7ITU    1s400001      A   00  -----      B   --
1106  LIME1      CCS7ITU    1s500001      A   00  -----      B   --
```

26. Back up the database changes using the `chg-db:action=backup:dest=fixed` command.

The following messages appear, the active Maintenance and Administration Subsystem Processor (MASP) appears first.

```
BACKUP (FIXED): MASP A - Backup starts on active MASP.
BACKUP (FIXED): MASP A - Backup on active MASP to fixed disk complete.
BACKUP (FIXED): MASP A - Backup starts on standby MASP.
BACKUP (FIXED): MASP A - Backup on standby MASP to fixed disk complete.
```

The HLR destinations are now configured and ready for activation of the EPAP-related feature.

IGM Feature Activation Procedure

Use this procedure to enable, turn on, and configure the IS41 GSM Migration (IGM) feature.

Refer to the *Commands Manual* for complete descriptions of the commands that are used in this procedure, including parameters and valid values, rules for using the commands correctly, and output examples.



CAUTION

CAUTION: Before starting this procedure, contact the [Customer Care Center](#) for assistance in performing the feature activation procedure. Do not proceed without consulting with Technical Services.

1. Enter the `enable-ctrl-feat` command to enable the IGM feature:
`enable-ctrl-feat:partnum=893017301:fak=<Feature Access Key>`
2. Enter the `chg-ctrl-feat` command to turn on the IGM feature:
`chg-ctrl-feat:partnum=893017301:status=on`
3. Enter the default country code and default network destination code to convert the nature of address indicator (NAI) of MSISDNs to the international format (`nai=intl`), by entering the `chg-stpopts` command.

For example:

```
chg-stpopts: defcc=1: defndc=38: dsmaud=on: npcfmti=2-9-2-1
```

where:

:defcc

Default country code

:defndc

Default network destination code

:dsmaud

Service Module card checksum audit running state (*on* or *off*)

:npcfmti

ITU National Point Code Format Identifier, which identifies how the ITU national point code is entered into the database and how it is displayed in all EAGLE 5 ISS outputs. The ITU national point code is a 14-bit integer.

4. Verify the new country code and network destination code, using the `rtrv-stpopts` command.
5. Change the GSM system options in the database, using the `chg-gsmopts` command.

For example:

```
chg-gsmopts: defmapvr=2: is412gsm=34: msrndig=ccrndn: srfaddr=23448: srfnai=7: srfnp=15
```

where:

:defmapvr

Default MAP version

is412gsm

IS41 to GSM migration prefix

:msrndig

Routing Number to be used as is or to be concatenated with the MSISDN

:srfaddr

Entity address of the MNP_SRF node

:srfnai

Nature of Address Indicator value of the MNP_SRF

:srfnp

Numbering Plan value of the MNP_SRF

6. Verify the changes, using the `rtrv-gsmopts` command to display all GSM system option values from the database.
7. Change the IS41 system options in the database, using the `chg-is41opts` command.
8. Verify the changes using the `rtrv-is41opts` command to display all IS41 system option values from the database.
9. Add Routing Number prefixes for the operating network, using the `ent-homern` command. Add Home RNs that are prefixed to DNs for incoming INP MR messages. Up to 100 Routing Number prefixes for the operating network can be added to the HOMERN table.

For example:

```
ent-homern:rn=34
```

where:

:rn

Home routing number prefix. Parameter value is 1 to 15 hex digits (0-F).

10. Verify the changes using the `rtrv-homern` command to retrieve a list of Routing Number prefixes that belong to the operating network.
11. Display the list of administered service selector combinations, using the `rtrv-srvsel` command. Avoid lengthy output by using various parameter combinations to filter the list. The Service Selector table can have over 1,000 entries.
12. Enter the IGM service selectors by network type, if necessary, using the `ent-srvsel` command. This command assigns applicable service selectors required to specify the service entry for Service Module card services.

For example:

```
ent-srvsel:gtii=4:nai=intl:np=e164:serv=mdp:snai=intl:snp=e164:ssn=9:tt=1
```

where:

:gtii

Global title indicator, ITU international

:nai

Nature of address indicator

:np

Numbering plan

:serv

Service feature

:snai

International Service Nature of Address Indicator

:snp

Service numbering plan

:ssn

Subsystem number

:tt

Translation type

13. Verify the changes, using the `rtrv-srvsel` command to retrieve the list of administered service selector combinations. Avoid lengthy output by using various parameter combinations to filter the list. The Service Selector table can have over 1,000 entries.

For example:

```
rtrv-srvsel:gtii=2
```

```
rtrv-srvsel:gtii=4
```

where:

gtii

Global title indicator, ITU international



CAUTION

CAUTION: GTT, EGTT, and VGTT traffic is routed based on the global titles in the OAM database while G-Flex, G-Port, A-Port, and INP traffic is routed based on the global title in the RTDB. Rebooting a Service Module card running the VSCCP application causes both the OAM databases and the RTDB on the Service Module card to reload.

14. Verify that the Service Module card returns to In-Service-Normal (IS-NR) state, using the `rept-stat-card` command.



WARNING

WARNING: Do not proceed until In-Service-Normal (IS-NR) state of the Service Module card is restored.

15. After In-Service-Normal (IS-NR) state of the Service Module card is restored and verified using the `rept-stat-card` command, repeat [Step 14](#) for each Service Module card in the system.

16. Set the IGM service state online using `chg-sccp-serv:serv=mdp:state=online`.

17. Confirm that the activation steps were successful by performing the following verifications:

- Verify that all Service Module cards are loaded and are in In-Service-Normal (IS-NR) state, using the `rept-stat-sccp` command.
- Verify that all Service Module cards and the EPAP are connected and operational, using the `rept-stat-mps` command.
- Verify that database levels are identical for the EPAP PDB and RTDB. Display the RTDBs on the Service Module cards, using `rept-stat-db:display=all`.

18. Back up the database changes using the `chg-db:action=backup:dest=fixed` command.

The following messages appear, the active Maintenance and Administration Subsystem Processor (MASP) appears first.

```
BACKUP (FIXED): MASP A - Backup starts on active MASP.
BACKUP (FIXED): MASP A - Backup on active MASP to fixed disk complete.
BACKUP (FIXED): MASP A - Backup starts on standby MASP.
BACKUP (FIXED): MASP A - Backup on standby MASP to fixed disk complete.
```

The IS41 GSM Migration (IGM) feature is now enabled, turned on, and operating in the system.

The 1100 TPS/DSM for ITU NP Feature

When only DSM cards or a mixture of DSM cards with E5-SM4G or E5-SM8G-B cards (Service Module cards) are equipped in the system, all of the cards are normally rated at 850 transactions per second

(TPS). The 1100 TPS/DSM for ITU NP feature increases the TPS rate for a Service Module card from 850 TPS to 1100 TPS.

The feature can be enabled when the equipped Service Module cards include DSM cards and at least one of the EPAP-related features listed in [Table 24: Feature Prerequisites](#) is enabled and turned on.

When the maximum number of Service Module cards is installed in the EAGLE 5 ISS, the maximum processing capacity of SCCP traffic for an EAGLE 5 ISS processing traffic for EPAP-related features is increased to 34,100 TPS.

The increased capacity to 1100 TPS per DSM card assumes incoming traffic consists of at least 30% of GTT routed traffic that does not require EPAP-based lookup. If more than 70% of incoming traffic requires EPAP-based lookup, Group Ticket Voucher (TVG) may shut down and overall TVG capacity of 1100 TPS for the card may not be met. E5-SM8G-B cards are inhibited if Group Ticket Voucher (TVG) is enabled.

The 1100 TPS/DSM for ITU NP feature must be enabled using the feature part number 893018001 and a feature access key (FAK). Based on the feature part number and the serial number of the EAGLE 5 ISS, the feature access key is site-specific. The 1100 TPS/DSM for ITU NP feature cannot be enabled with a temporary feature access key.

Note: The feature access key for the 1100 TPS/DSM for ITU NP feature is provided by Tekelec when the feature is purchased. Contact your Tekelec Sales Representative or Account Representative before beginning the feature configuration procedure if you do not have the feature access key for this feature.

After the 1100 TPS/DSM for ITU NP feature has been enabled, the feature must be turned on to begin operation in the system. The feature is an On/Off feature which means that the feature can be turned off after it has been turned on.

System Prerequisites

Before the 1100 TPS/DSM for ITU NP feature can be enabled, the prerequisites listed in [Table 23: System Prerequisites](#) are required in the system.

Table 23: System Prerequisites

Prerequisite	Verification and Provisioning
<p>For new installations, the system serial number must be verified and locked. The system is shipped with an unlocked serial number. The serial number can be changed if necessary and must be locked after the system is on-site.</p> <p>For systems that are being upgraded, the serial number has already been verified and locked.</p>	<p>Enter the <code>rtrv-serial-num</code> command to display the serial number and its lock status.</p> <p>If a serial number is displayed, verify that the serial number is correct for the system. The system serial number is shown on a label affixed to the control shelf (shelf 1100).</p> <p>If the displayed serial number is correct and locked, no action is necessary.</p> <p>If the displayed serial number is correct and not locked, enter the <code>ent-serial-num</code> command WITH the <code>lock=yes</code> parameter, and specify the serial number that is shown on the control shelf label.</p> <p>If no serial number is displayed,</p>

Prerequisite	Verification and Provisioning
	<ul style="list-style-type: none"> Enter the <code>ent-serial-num</code> command WITHOUT the lock parameter, and specify the serial number that is shown on the control shelf label. Enter the <code>rtrv-serial-num</code> command and verify that the correct serial number was entered. Enter the <code>ent-serial-num</code> command again WITH the correct serial number and the <code>lock=yes</code> parameter. <p>If a serial number is displayed or entered and locked that does not match the number on the control shelf, contact the Customer Care Center for assistance.</p>
The GTT feature must on in the system.	<p>Enter the <code>rtrv-feat</code> command.</p> <p>If the GTT feature is on, the <code>gtt=on</code> entry appears in the output.</p> <p>If the <code>gtt=off</code> entry appears in the output, use the procedures in <i>Database Administration Manual – Global Title Translation</i> to turn on and provision the GTT feature and any related features and functions.</p>

Feature Prerequisites

Before the 1100 TPS/DSM for ITU NP feature can be enabled, the prerequisites shown in [Table 24: Feature Prerequisites](#) are required in the system.

Table 24: Feature Prerequisites

Prerequisite	Verification and Provisioning
Service Module cards running the VSCCP application must be equipped. The cards can be all DSM cards, or a mixture of DSM cards with E5-SM4G or E5-SM8G-B cards. At least one DSM card must be installed.	<p>Enter the <code>rept-stat-gpl:gpl=vscpc</code> command and the <code>rept-stat-gpl:gpl=sccphc</code> command to list the Service Module cards in the system.</p> <p>If the number of cards is not sufficient, use the procedure Adding a Service Module Card to add Service Module cards.</p>
The ANSIGFLEX system option cannot be set to Yes.	<p>Enter the <code>rtrv-stpopts</code> command.</p> <p>Verify that the ANSIGFLEX entry does not appear in the command output or that the ANSIGFLEX entry shows a value of no.</p>

Prerequisite	Verification and Provisioning
The LNP feature cannot be on in the system.	Enter the <code>rtrv-ctrl-feat</code> command. If the LNP feature is on, shown with a quantity greater than zero for the <code>LNP ported TNs</code> entry in the command output, the 1100 TPS/DSM for ITU NP feature cannot be enabled.
<p>At least one of the following EPAP-related features must be enabled and turned on:</p> <ul style="list-style-type: none"> • G-Port • A-Port • INP • AINPQ • IGM • EIR • IDP Relay • V-Flex • IAR (NP, ASD, GRN) • MO-based GSM SMS NP • MO-based IS41SMS NP • TIF (NP, ASD, GRN, Number Substitution, TIF Subscr CgPN Blacklist) 	<p>Enter the <code>rtrv-ctrl-feat</code> command and verify that an entry for at least one of the listed EPAP-related features with Status on is present in the output.</p> <p>If none of the listed EPAP-related features are on, use the procedures in the Feature Manual of the EPAP-related feature to be used to enable and turn on the appropriate EPAP-related feature.</p>

This section provides the following procedures for the 1100 TPS/DSM for ITU NP feature:

- [Enable the 1100 TPS/DSM for ITU NP Feature](#)
- [Turn On the 1100 TPS/DSM for ITU NP Feature](#)
- [Turn Off the 1100 TPS/DSM for ITU NP Feature](#)

Refer to *Commands Manual* for descriptions of the commands used in the procedures including parameter names, valid parameter values, rules for using the commands, and output examples.

Enable the 1100 TPS/DSM for ITU NP Feature

This procedure is used to enable the 1100 TPS/DSM for ITU NP feature.

1. Enable the 1100 TPS/DSM for ITU NP feature with part number 893018001 and the feature access key.

```
enable-ctrl-feat:partnum=893018001:fak=<feature access key>
```

2. Verify the change by entering the `rtrv-ctrl-feat` command with the 1100 TPS/DSM for ITU NP feature part number 893018001.

```
rtrv-ctrl-feat:partnum=893018001
rlghncxa03w 09-08-24 21:15:37 EST EAGLE 40.1.0
The following features have been permanently enabled:
Feature Name          Partnum  Status  Quantity
HC-MIM SLK Capacity   893012707 on       64
Prepaid SMS Intercept Ph1 893006701 on       ----
```

```
1100 TPS/DSM for ITU NP 893018001 off ----
;
```

3. Back up the changes using the `chg-db:action=backup:dest=fixed` command.

The following messages appear, the active Maintenance and Administration Subsystem Processor (MASP) appears first.

```
BACKUP (FIXED) : MASP A - Backup starts on active MASP.
BACKUP (FIXED) : MASP A - Backup on active MASP to fixed disk complete.
BACKUP (FIXED) : MASP A - Backup starts on standby MASP.
BACKUP (FIXED) : MASP A - Backup on standby MASP to fixed disk complete.
```

Turn On the 1100 TPS/DSM for ITU NP Feature

This procedure is used to turn on the 1100 TPS/DSM for ITU NP feature, after it has been enabled or turned off.

Note: If the EPAP-based traffic is higher than 70% of all traffic on the EAGLE 5 ISS, the DSM card performance may not reach 1100 TPS per DSM card.

1. Enter the `chg-ctrl-feat` command the first time and specify the 1100 TPS/DSM for ITU NP feature part number 893018001 and the `status=on` parameter value.

```
chg-ctrl-feat:partnum=893018001:status=on
```

The following message is displayed:

```
CAUTION: Rated TPS for this feature supports an engineered GTT
traffic mix of no more than 70 percent EPAP-based traffic.
Re-enter the command within 30 seconds to confirm change.
```

2. Re-enter the command the second time within 30 seconds to turn on the 1100 TPS/DSM for ITU NP feature.

```
chg-ctrl-feat:partnum=893018001:status=on
```

3. Verify the change by entering the `rtrv-ctrl-feat` command with the 1100 TPS/DSM for ITU NP feature part number.

```
rtrv-ctrl-feat:partnum=893018001
rlghncxa03w 09-08-24 21:15:37 EST EAGLE 40.1.0
The following features have been permanently enabled:
Feature Name          Partnum    Status  Quantity
HC-MIM SLK Capacity   893012707  on      64
Prepaid SMS Intercept Ph1 893006701  on      ----
1100 TPS/DSM for ITU NP 893018001  on      ----
;
```

4. Back up the database changes using the `chg-db:action=backup:dest=fixed` command.

The following messages appear, the active Maintenance and Administration Subsystem Processor (MASP) appears first.

```
BACKUP (FIXED): MASP A - Backup starts on active MASP.
BACKUP (FIXED): MASP A - Backup on active MASP to fixed disk complete.
BACKUP (FIXED): MASP A - Backup starts on standby MASP.
BACKUP (FIXED): MASP A - Backup on standby MASP to fixed disk complete.
```

Turn Off the 1100 TPS/DSM for ITU NP Feature

This procedure is used to turn off the 1100 TPS/DSM for ITU NP feature, after it has been enabled and turned on.

1. Enter the `chg-ctrl-feat` command the first time and specify the 1100 TPS/DSM for ITU NP feature part number 893018001 and the `status=off` parameter value.

```
chg-ctrl-feat:partnum=893018001:status=off
```

The following message is displayed:

```
CAUTION: This command decreases the total TPS of the SCCP system from 1100 to 850 TPS for each DSM card.
```

2. Re-enter the command the second time within 30 seconds to turn off the 1100 TPS/DSM for ITU NP feature.
3. Back up the database changes using the `chg-db:action=backup:dest=fixed` command.

The following messages appear, the active Maintenance and Administration Subsystem Processor (MASP) appears first.

```
BACKUP (FIXED): MASP A - Backup starts on active MASP.
BACKUP (FIXED): MASP A - Backup on active MASP to fixed disk complete.
BACKUP (FIXED): MASP A - Backup starts on standby MASP.
BACKUP (FIXED): MASP A - Backup on standby MASP to fixed disk complete.
```

Activating the E5-SM4G Throughput Capacity Feature

The E5-SM4G Throughput Capacity feature quantities are used to increase the processing capacity of the E5-SM4G card, the E5-SM8G-B card, and the system SCCP traffic for an EAGLE 5 ISS that contains E5-SM4G or E5-SM8G-B cards only. DSM Service Module cards are not affected. The achievable TPS maximums are shown in [Table 25: Maximum E5-SM4G, E5-SM8G-B, and System TPS Capacity](#).

Table 25: Maximum E5-SM4G, E5-SM8G-B, and System TPS Capacity

Feature Quantity Part Number	Maximum TPS Capacity per E5-SM4G Card	Maximum TPS Capacity per E5-SM8G -B Card	Maximum System TPS Capacity
893019101 - Feature Quantity 5000	3125	3125	96,875 TPS with one or more EPAP-related features and 31+1 cards with EPAP running on T1200 AS
	5000	5000	<ul style="list-style-type: none"> • 150,000 TPS with no EPAP-related or ELAP-related feature traffic and 31+1 cards • 120,000 TPS with G-Flex and the ANSIGFLEX STP option and 24+1 cards

Feature Quantity Part Number	Maximum TPS Capacity per E5-SM4G Card	Maximum TPS Capacity per E5-SM8G -B Card	Maximum System TPS Capacity
			<ul style="list-style-type: none"> • 155,00 TPS with G-Flex and the ANSIGFLEX STP option and 31+1 cards with EPAP running on T1200 AS • 40,000 TPS with ELAP and 8+1 cards • 85,000 TPS with ELAP and 17+1 cards
893019102 - Feature Quantity 6800	6800	6800	<ul style="list-style-type: none"> • 210,800 TPS with no EPAP-related or ELAP-related feature traffic and 31+1 cards • 210,800 TPS with one or more EPAP-related features and 31+1 cards with EPAP running on T1200 AS • 54,400 TPS with ELAP and 8+1 cards • 115,600 TPS with ELAP and 17+1 cards
893019103 - Feature Quantity 10000	6800	10000	<p>For E5-SM4G:</p> <ul style="list-style-type: none"> • 210,800 TPS with no EPAP-related or ELAP-related feature traffic and 31+1 cards • 210,800 TPS with one or more EPAP-related features and 31+1 cards with EPAP running on T1200 AS • 54,400 TPS with ELAP and 8+1 cards • 115,600 TPS with ELAP and 17+1 cards <p>For E5-SM8G-B:</p> <ul style="list-style-type: none"> • 310,000 TPS with no EPAP-related or ELAP-related feature traffic and 31+1 cards • 310,000 TPS with one or more EPAP-related features and 31+1 cards with EPAP running on T1200 AS

Feature Quantity Part Number	Maximum TPS Capacity per E5-SM4G Card	Maximum TPS Capacity per E5-SM8G -B Card	Maximum System TPS Capacity
			<ul style="list-style-type: none"> 80,000 TPS with ELAP and 8+1 cards 170,000 TPS with ELAP and 17+1 cards

An E5-SM4G Throughput Capacity quantity feature must be enabled using an E5-SM4G Throughput Capacity feature part number (893019101, 893019102, or 893019102) and a feature access key.

The feature access key is based on the feature part number and the serial number of the EAGLE 5 ISS, making the feature access key site-specific.

Note: The E5-SM4G Throughput Capacity quantity feature must be purchased to receive the feature access key used to enable the feature. Contact your Tekelec Sales Representative or Account Representative before beginning this procedure if you have purchased the E5-SM4G Throughput Capacity quantity feature, but do not have the feature access key. A temporary feature access key is not available for this feature.

After an E5-SM4G Throughput Capacity feature is enabled and turned on, the E5-SM4G Throughput Capacity feature cannot be turned off. When the E5-SM4G Throughput Capacity feature is enabled, it is permanently enabled. The E5-SM4G Throughput Capacity feature cannot be temporarily enabled.

System Prerequisites

Before the E5-SM4G Throughput Capacity feature can be enabled, the prerequisites listed in [Table 26: System Prerequisites](#) are required in the system.

Table 26: System Prerequisites

Prerequisite	Verification and Provisioning
<p>For new installations, the system serial number must be verified and locked. The system is shipped with an unlocked serial number. The serial number can be changed if necessary and must be locked after the system is on-site.</p> <p>For systems that are being upgraded, the serial number has already been verified and locked.</p>	<p>Enter the <code>rtrv-serial-num</code> command to display the serial number and its lock status.</p> <p>Verify that the displayed serial number is correct for the system. The serial number is shown on a label affixed to the control shelf (shelf 1100).</p> <p>If no serial number is displayed, or if the displayed serial number is not locked, refer to the <code>ent-serial-num</code> command description in <i>Commands Manual</i> for instructions to enter and lock the serial number.</p>
<p>The GTT feature must on in the system.</p>	<p>Enter the <code>rtrv-feat</code> command.</p> <p>If the GTT feature is on, the <code>gtt=on</code> entry appears in the output.</p> <p>If the <code>gtt=off</code> entry appears in the output, use the procedures in <i>Database Administration Manual – Global Title Translation</i></p>

Prerequisite	Verification and Provisioning
	to turn on and provision the GTT feature and any related features and functions.

E5-SM4G Throughput Capacity Feature Prerequisite

Before the E5-SM4G Throughput Capacity feature can be enabled, the prerequisite shown in [Table 27: E5-SM4G Throughput Capacity Feature Prerequisite](#) is required in the system.

Table 27: E5-SM4G Throughput Capacity Feature Prerequisite

Prerequisite	Verification and Provisioning
<p>E5-SM4G cards or E5-SM8G-B cards running the VSCCP application must be equipped.</p> <p>The required number of cards depends on the desired total system TPS to be achieved by the cards. See Table 25: Maximum E5-SM4G, E5-SM8G-B, and System TPS Capacity.</p>	<p>Enter the <code>rept-stat-gpl:gpl=sccphc</code> command to list the E5-SM4G cards and E5-SM8G-B cards in the system.</p> <p>If the number of cards is not sufficient, use the procedure in Adding a Service Module Card to add E5-SM4G cards or E5-SM8G-B cards.</p>

The following procedure explains how to enable an E5-SM4G Throughput Capacity quantity feature.

Note: After a quantity feature has been enabled, a feature for a higher quantity can be enabled; a feature for a lower quantity cannot be enabled. Quantity features are automatically turned on when they are enabled.

Refer to *Commands Manual* for complete descriptions of the commands used in this procedure, including parameter names, valid parameter values, rules for using the commands, and output examples.

1. Display the status of the features that are controlled by feature access keys. Enter the `rtrv-ctrl-feat` command.

```
rlghncxa03w 09-07-29 16:40:40 EST EAGLE5 41.1.0
The following features have been permanently enabled:
Feature Name          Partnum    Status    Quantity
HC-MIM SLK Capacity   893012707  on        64
E5-SM4G Throughput Cap 893019101  on        5000
;
```

- If the `rtrv-ctrl-feat` output shows that the correct E5-SM4G Throughput Capacity quantity feature is enabled and its status is on, no further action is necessary.
 - If no E5-SM4G Throughput Capacity feature quantity is enabled or a higher quantity needs to be enabled, continue with [Step 2](#).
2. Enable the E5-SM4G Throughput Capacity quantity feature by entering the `enable-ctrl-feat` command with the correct part number and FAK for the desired quantity.
 3. Verify the status of the E5-SM4G Throughput Capacity quantity feature by entering the `rtrv-ctrl-feat` command with the feature part number that was enabled (893033501, 893019102, or 893019103) in [Step 2](#).

```
rtrv-ctrl-feat:partnum=893019102
rlghncxa03w 09-08-29 16:40:40 EST EAGLE5 41.1.0
The following features have been permanently enabled:
Feature Name          Partnum    Status    Quantity
```

```

HC-MIM SLK Capacity      893012707  on          64
E5-SM4G Throughput Cap  893019102  on          6800
;

```

4. Back up the changes using the `chg-db:action=backup:dest=fixed` command.

The following messages appear, the active Maintenance and Administration Subsystem Processor (MASP) appears first.

```

BACKUP (FIXED): MASP A - Backup starts on active MASP.
BACKUP (FIXED): MASP A - Backup on active MASP to fixed disk complete.
BACKUP (FIXED): MASP A - Backup starts on standby MASP.
BACKUP (FIXED): MASP A - Backup on standby MASP to fixed disk complete.

```

Adding a Service Module Card

This procedure is used to add Service Module cards to the database to support GTT-related features and EPAP-related features.

EPAP-related features require Service Module cards running the VSCCP application. The following cards can be used as Service Module cards running the VSCCP application in the system:

- DSM 4G – a Service Module card with 4 gigabytes of memory and supports Group Ticket Voucher (TVG) and Message Flow Control (MFC)
- E5-SM4G - a Service Module card with 4 gigabytes of memory and supports TVG and MFC
- E5-SM8G-B - a Service Module card with 8 gigabytes of memory and supports only MFC

The system can contain a maximum of 32 (31+1) Service Module cards for EPAP-related features with EPAP running on a T1200 AS:

- The following Warning appears when more than 25 Service Module cards have been provisioned in the system and the `enable-ctrl-feat` command is entered to enable the first EPAP-related feature in the system:

```
Warning: The Eagle must be connected to an EPAP T1200 or higher
```

- The following Caution appears when the `ent-card` command is entered to add the 26th Service Module card to the database and any EPAP-related feature is enabled in the system:

```
CAUTION: Please ensure EPAP Application Server is running on
          hardware supporting 32 SCCP cards e.g.: T1200.
          Re-enter command within 30 seconds to confirm change.
```

Refer to *Dimensioning Guide for EPAP Advanced DB Features* for important information on dimensioning rules and Service Module card database capacity requirements.

A Service Module card occupies two card slots. A Service Module card can be inserted in only an odd/even numbered pair of empty card slots of an EAGLE 5 ISS shelf. The even-numbered card slot to the right of the odd-numbered slot where the Service Module card is to be inserted must be empty. A Service Module card cannot be inserted in slots 09 and 10 because slots 09 and 10 of each shelf contain HMUX cards, HIPR cards, or HIPR2 cards. The Service Module card is connected to the network through the odd-numbered card slot connector.

Note: Service Module cards can be inserted only in slots 01, 03, 05, 07, and 11 of the control shelf (1100).

Table 28: Service Module Card Locations

Location of the Service Module Card	Empty Card Location
Slot 01	Slot 02
Slot 03	Slot 04
Slot 05	Slot 06
Slot 07	Slot 08
Slot 11	Slot 12
Slot 13	Slot 14
Slot 15	Slot 16
Slot 17	Slot 18

Prerequisites

Before a Service Module card can be added, the prerequisites in [Table 29: System Prerequisites for Adding a Service Module Card](#) must be present in the system.

Table 29: System Prerequisites for Adding a Service Module Card

Prerequisite	Verification and Actions
The shelf to which the card is to be added must already be provisioned in the database.	Enter the <code>rtrv-shlf</code> command. If the shelf is not in the database, refer to the procedure for adding a shelf in <i>Database Administration Manual – System Management</i> .
The odd/even slots in which the card will be inserted must not have a card already assigned in the database.	Enter the <code>rtrv-card</code> command. If a slot has a card assigned to it, use the <code>dlt-card</code> command to remove the card from the database. Refer to the <code>dlt-card</code> command description in <i>Commands Manual</i> .
The GTT feature must be on.	Enter the <code>rtrv-feat</code> command to display the GTT feature status. If the GTT feature is on, the <code>gtt=on</code> entry appears in the output. If the <code>gtt=off</code> entry appears in the output, use the procedures in <i>Database Administration Manual - GTT</i> to turn on and provision the GTT feature and any other GTT-related features and functions that will be used in the system.

Prerequisite	Verification and Actions
To add more than 25 Service Module cards to the database, the EPAP connected to the EAGLE 5 ISS must be running on a T1200 AS.	Use visual inspection or contact the for assistance to determine the EPAP hardware type.

Before an E5-SM4G Service Module card can be added, the prerequisite in [Table 30: Prerequisite for Adding an E5-SM4G Service Module Card](#) must be present in the system.

Table 30: Prerequisite for Adding an E5-SM4G Service Module Card

Prerequisite	Verification and Actions
Slots 09 and 10 in the shelf to which the E5-SM4G card will be added must contain either HIPR cards or HIPR2 cards.	Enter the <code>rept-stat-gp1:gp1=hipr</code> command and the <code>rept-stat-gp1:gp1=hipr2</code> command to list the installed HIPR cards and HIPR2 cards in the system. If the shelf does not contain HIPR cards or HIPR2 cards, refer to procedures in <i>Installation Manual - EAGLE 5 ISS</i> to install HIPR cards or HIPR2 cards in the shelf.

Before an E5-SM8G-B Service Module card can be added, the prerequisites in [Table 31: Prerequisites for Adding an E5-SM8G-B Service Module Card](#) must be present in the system.

Table 31: Prerequisites for Adding an E5-SM8G-B Service Module Card

Prerequisite	Verification and Actions
Slots 09 and 10 in the shelf to which the E5-SM8G-B card will be added must contain either HIPR cards or HIPR2 cards.	Enter the <code>rept-stat-gp1:gp1=hipr</code> command and the <code>rept-stat-gp1:gp1=hipr2</code> command to list the installed HIPR cards and HIPR2 cards in the system. If the shelf does not contain HIPR cards or HIPR2 cards, refer to procedures in <i>Installation Manual - EAGLE 5 ISS</i> to install HIPR cards or HIPR2 cards in the shelf.
Fan trays must be installed.	If fan trays are not installed, refer to <i>Installation Manual - EAGLE 5 ISS</i> for the fan installation procedure.
The Cooling Fan feature (FAN) must be on.	Enter the <code>rtrv-feat</code> command to display the status of the Cooling Fan feature (FAN). If <code>FAN = off</code> in the <code>rtrv-feat</code> output, refer to procedures in <i>Database Administration Manual -</i>

Prerequisite	Verification and Actions
	<i>System Management</i> to turn on the Cooling Fan feature (FAN).
The Message Flow Control (MFC) option must be on.	Enter the <code>rtrv-stpopts</code> command to display the status of the Message Flow Control (MFC) option. Refer to procedures in <i>Database Administration Manual - System Management</i> to turn on the Message Flow Control (MFC) option.

Refer to *Commands Manual* for complete descriptions of the commands used in this procedure. The complete descriptions include valid parameter values and output examples.

1. Display the cards in the system by entering the `rtrv-card` command. Odd-even pairs of card locations that do not contain cards (are not listed in the output) and do not contain HMUX, HIPR, or HIPR2 cards can be used for Service Module cards.

```
rlghncxa03w 08-03-15 16:34:56 EST EAGLE 39.2.0
CARD   TYPE      APPL      LSET NAME      LINK SLC LSET NAME      LINK SLC
1201   LIMDS0      SS7ANSI    LS1             A    0    LS1             B
1102   DSM          VSCCP      -----        A    --  -----        B    --
1113   GPSM         OAM
1114   TDM-A
1115   GPSM         OAM
1116   TDM-B
1117   MDAL
;
```

2. Verify that the Service Module card to be added has been physically installed in the correct card location and the required cabling is installed to connect the card to the EPAP.



CAUTION: If the version of the BPDCM GPL on the Service Module card does not match the BPDCM GPL version in the database when the Service Module card is inserted into the card slot, UAM 0002 is generated indicating that these GPL versions do not match. If UAM 0002 has been generated, perform the alarm clearing procedure for UAM 0002 in the *Unsolicited Alarm and Information Messages* manual before proceeding with this procedure.

3. Perform this step only if the card being added will be the 26th Service Module card in the system. If the card is NOT the 26th Service Module card, continue to [Step 4](#).

Note: The same `ent-card` command must be entered twice within 30 seconds to complete the provisioning of the card.

- a) Enter the `ent-card` command the first time for the 26th card.

```
ent-card:loc=<card location>;type=dsm;appl=vscpp
```

When the command executes the first time and any EPAP-related feature is enabled, the following caution appears :

```
CAUTION: Please ensure EPAP Application Server is running on
          hardware supporting 32 SCCP cards e.g.: T1200.
          Re-enter command within 30 seconds to confirm change.
```

- b) Enter the `ent-card` command a second time for the 26th card to complete the provisioning of the card.
- c) Go to [Step 5](#).
4. Add the Service Module card to the database, using the `ent-card` command.
`ent-card:loc=<card location>:type=dsm:appl=vsccp`
5. For an E5-SM4G or E5-SM8G-B card, verify the temperature threshold settings by performing the “Changing the High-Capacity Card Temperature Alarm Thresholds” procedure in *Database Administration Manual - SS7*.
6. Verify the change by entering the `rtrv-card` command with the card location specified.
`rtrv-card:loc=<card location>`

```

rlghncxa03w 08-03-15 16:34:56 EST EAGLE 39.2.0
CARD   TYPE      APPL      LSET NAME      LINK SLC LSET NAME      LINK SLC
1301   DSM         VSCCP     -----      A    --  -----      B
;

```

7. Display the current IP link parameters associated with the Service Module card in the database by entering the `rtrv-ip-lnk` command.

```

RLGHNCXA03W 09-08-24 21:14:37 GMT EAGLE 41.0.0
LOC PORT IPADDR  SUBMASK  DUPLEX  SPEED  MACTYPE  AUTO  MCAST
1107 A  -----  -----  HALF    10     DIX      NO    NO
1107 B  -----  -----  HALF    10     DIX      NO    NO

```

8. Enter the IP address and other parameter values associated with the Service Module card in the database using the `chg-ip-lnk` command.

For example, enter:

```
chg-ip-lnk:loc=1107:port=a:duplex=half:ipaddr=192.168.122.1:mactype=dix:speed=100:
mcast=yes:submask=255.255.255.0
```

```
chg-ip-lnk:loc=1107:port=b:duplex=half:ipaddr=192.168.123.1:mactype=dix:speed=10:
mcast=yes:submask=255.255.255.0
```

where:

:loc

Card location or slot number of the Service Module card in the EAGLE 5 ISS

:port

Ethernet interface Port ID - the physical interface of the Service Module card

:ipaddr

IP address for the specified port. This is a TCP/IP address expressed in standard dot notation. IP addresses consist of the network number of the system and the unique host number.

:submask

Subnet mask of the IP interface in the form of an IP address with a restricted range of values

:duplex

Mode of operation of the interface

:speed

Interface bandwidth in megabits per second. The speed is either 100 Mbps for main Service Module network or 10 Mbps for backup Service Module network.

:mactype

Media Access Control Type of the interface. Specify `dix` for the Digital/Inter/Xerox *de facto* standard for Ethernet 2.

:mcast

Multicast Control to enable or disable multicast support for the interface. This parameter value must be `yes` to establish the connection from the Service Module card to the MPS system.

- Verify the IP address and other parameter values associated with the Service Module card in the database by entering the `rtrv-ip-lnk` command.

```
RLGHNCXA03W 09-08-24 21:14:37 GMT EAGLE 41.0.0
LOC  PORT  IPADDR          SUBMASK          DUPLEX  SPEED  MACTYPE  AUTO  MCAST
1107 A    192.168.122.1  255.255.255.0  HALF    100    DIX      NO    YES
1107 B    192.168.123.1  255.255.255.0  HALF    10     DIX      NO    YES
```

- Display the current IP host information in the database by entering the `rtrv-ip-host` command.

```
RLGHNCXA03W 09-08-24 21:17:37 GMT EAGLE 41.0.0
IPADDR          HOST
192.1.1.32      KC_HLR2
192.1.1.50      DN_MSC1
192.1.1.52      DN_MSC2
```

- Add the host name and IP address for each VSCCP link, using the `ent-ip-host` command.

Command examples:

```
ent-ip-host:host=vsccp_1107_a:ipaddr=192.168.122.1
```

```
ent-ip-host:host=vsccp_1107_b:ipaddr=192.168.123.1
```

where:

:host

Host name. Each VSCCP link must be specified separately.

:ipaddr

IP network address for each EPAP. The first three octets of the IP address must be the same as MPS A and B ports, respectively. The fourth octet identifies the Service Module card and must have a unique octet identifier for the card IP address.

- Verify the new IP host information in the database by entering the `rtrv-ip-host` command.

```
RLGHNCXA03W 09-08-24 21:19:37 GMT EAGLE 41.0.0
IPADDR          HOST
192.1.1.32      KC_HLR2
192.1.1.50      DN_MSC1
192.1.1.52      DN_MSC2
192.168.122.1   VSCCP_1107_A
192.168.123.1   VSCCP_1107_B
```

- Enter local domain and IP router address for the Service Module card, using the `chg-ip-card` command.

Note: Most customer private networks do not require setting up a default router for the Service Module card. If your network configuration requires a default router to connect the Service Module

card communication to the EPAP, then only one default router is assignable to each Service Module card. Assign the default router address to each Service Module card as shown in this step.

For example:

```
chg-ip-card:defrouter=192.168.122.250:domain=nc.tekelec.com:loc=<card
location>
```

where:

:defrouter

Default router IP address. This is a TCP/IP address expressed in standard dot notation. IP addresses consist of the network number of the system and the unique host number.

:domain

Domain name of domain server

:loc

Card location or slot number of the Service Module card in the EAGLE 5 ISS

14. Verify the new TCP/IP parameters associated with the Service Module card in the database by entering the `rtrv-ip-card` command.

```
RLGHNCXA03W 09-08-24 21:21:37 GMT EAGLE 41.0.0
LOC 1107
SRCHORDR LOCAL
DNSA -----
DNSB -----
DEFROUTER 192.168.122.250
DOMAIN NC.TEKELEC.COM
```

15. Allow the Service Module card that was added to operate in the system, using the `alw-card` command.

```
alw-card:loc=<card location>
```

16. Verify the In-Service-Normal (IS-NR) status of the Service Module card, using the `rept-stat-card` command.

17. Test the presence of the EPAP hosts on the network using the `pass` command with the `ping` parameter. This command is invoked with a destination that is either a hostname or IP address.

Command examples:

```
pass:loc=1107:cmd="ping 192.168.122.100" .
```

```
pass:loc=1107:cmd="ping 192.168.122.200" .
```

```
pass:loc=1107:cmd="ping 192.168.123.100" .
```

```
pass:loc=1107:cmd="ping 192.168.123.200" .
```

where:

:loc

Card location or slot number in the EAGLE 5 ISS

:cmd

Command string passed to Service Module card for processing

After successful completion of each command, the system response is similar to the following output:

```
rlghncxa03w 09-08-24 08:30:44 GMT EAGLE 41.0.0
pass: loc=1107: cmd="ping 192.168.122.100"
Command entered at terminal #1.
;
rlghncxa03w 09-08-24 08:30:44 GMT EAGLE 41.0.0
PASS: Command sent to card
;
rlghncxa03w 09-08-24 08:30:44 GMT EAGLE 41.0.0
PING command in progress
;
rlghncxa03w 09-08-24 08:30:46 GMT EAGLE 41.0.0
PING 192.168.122.100: 56 data bytes
64 bytes from tekral.nc.tekelec.com (192.168.122.100):icmp_seq=0.time=5. ms
64 bytes from tekral.nc.tekelec.com (192.168.122.100):icmp_seq=1.time=0. ms
64 bytes from tekral.nc.tekelec.com (192.168.122.100):icmp_seq=2.time=0. ms
----192.168.100.3 PING Statistics----
3 packets transmitted, 3 packets received, 0% packet loss
round-trip (ms) min/avg/max = 0/1/5
PING command complete
```

If the pass commands with the ping parameter are not successful, verify the correct connection of the hardware cabling and repeat this step. If the command fails again, contact [Customer Care Center](#).

18. Back up the database changes, by entering the following command.

```
chg-db:action=backup:dest=fixed
```

The following messages should appear; the active Maintenance and Administration Subsystem Processor (MASP) appears first.

```
BACKUP (FIXED) : MASP A - Backup starts on active MASP.
BACKUP (FIXED) : MASP A - Backup on active MASP to fixed disk complete.
BACKUP (FIXED) : MASP A - Backup starts on standby MASP.
BACKUP (FIXED) : MASP A - Backup on standby MASP to fixed disk complete.
```

19. Repeat this procedure for each Service Module card that needs to be added to the system.

LOCREQ Query Response Activation Procedure

This procedure is used to enable and turn on the LOCREQ Query Response feature in the EAGLE 5 ISS.

Prerequisites

- A-Port or IS41 GSM Migration (IGM) must be enabled and turn on before the LOCREQ Query Response feature can be enabled.
- The LOCREQ Query Response feature is optional and must be purchased from Tekelec. The feature must be purchased to receive the Feature Access Key (FAK) that is required to enable the feature. Contact your Tekelec Sales Representative or Account Representative to determine whether the LOCREQ Query Response feature has been purchased and for additional information.

The LOCREQ Query Response feature is enabled using part number 893038501 and the Feature Access Key (FAK). The LOCREQ Query Response feature cannot be disabled after it is enabled and cannot

be enabled with a temporary FAK. After the LOCREQ Query Response feature is enabled and turned on, the LOCREQ Query Response feature cannot be turned off.

Some parameters and options used with the LOCREQ Query Response feature can be provisioned after the LOCREQ Query Response feature is enabled, but before the LOCREQ Query Response feature is turned on. The `locreqrspnd` option of the `chg-is41opts` command can be modified only if the LOCREQ Query Response feature is enabled and turned on. The `df1trn` parameter of the `chg-is41opts` command can be modified only if the LOCREQ Query Response feature is enabled. The `sporttype` parameter of the `chg-is41opts` command can be modified only if both the Service Portability feature and the LOCREQ Query Response feature are enabled.

LOCREQ Query Response processing cannot occur until:

- The LOCREQ Query Response feature is enabled and turned on.
- The `locreqrspnd` option of the `chg-is41opts` command is set to on.

For details about the commands used in this procedure, see *Commands Manual*.

1. Display the status of features controlled by Feature Access Keys (FAKs). The resulting output displays the features that are enabled in the system and the `on/off` status for each feature.

Command example:

```
rtrv-ctrl-feat
```

Output example:

```
rlghncxa03w 10-06-29 16:40:40 EST EAGLE5 42.0.0
The following features have been permanently enabled:
Feature Name          Partnum    Status    Quantity
HC-MIM SLK Capacity   893012707 on         64
APORT                 893016601 on         ----
Service Portability   893034301 on         ----
;
```

The output shows the enabled features and the `on/off` status for each enabled feature in the EAGLE 5 ISS.

- If the LOCREQ Query Response entry appears in the `rtrv-ctrl-feat` output with status = on, this procedure does not need to be performed.
 - If an entry for either APORT or IGM with a status of on does not appear in the `rtrv-ctrl-feat` output, then this procedure cannot be performed until either the A-Port or IS41 GSM Migration (IGM) feature is enabled and turned on.
 - If the LOCREQ Query Response entry appears in the `rtrv-ctrl-feat` output with status = off, go to [Step 4](#) to turn on the LOCREQ Query Response feature.
 - To enable and turn on the LOCREQ Query Response feature, continue to [Step 2](#).
2. Enable the LOCREQ Query Response feature.

Command example:

```
enable-ctrl-feat:partnum=893038501:fak=<Feature Access Key>
```

3. Verify that the LOCREQ Query Response feature is enabled.

Command example:

```
rtrv-ctrl-feat
```

```
rlghncxa03w 09-06-29 16:40:40 EST EAGLE5 41.1.0
The following features have been permanently enabled:
Feature Name          Partnum    Status    Quantity
```

```

HC-MIM SLK Capacity      893012707  on          64
APORT                    893016601  on          ----
Service Portability     893034301  on          ----
LOCREQ Query Response   893038501  off         ----
;

```

Some parameters and options can be provisioned after the feature is enabled but is turned off. LOCREQ Query Response processing cannot occur until the feature is enabled and turned on and the `locreqrspnd` option of the `chg-is41opts` command is set to `on`.

4. Turn on the LOCREQ Query Response feature.

Command example:

```
chg-ctrl-feat:partnum=893038501:status=on
```

5. Verify that the LOCREQ Query Response is enabled and turned on.

Command example:

```
rtrv-ctrl-feat
```

```

rlghncxa03w 09-06-29 16:40:40 EST  EAGLE5 41.1.0
The following features have been permanently enabled:
Feature Name          Partnum    Status    Quantity
HC-MIM SLK Capacity   893012707  on        64
APORT                  893016601  on        ----
Service Portability   893034301  on        ----
LOCREQ Query Response 893038501  on        ----
;

```

LOCREQ Query Response processing cannot occur until the `locreqrspnd` option of the `chg-is41opts` command is set to `on`.

6. Specify the parameters `dfltrn` and `sporttype` used with LOCREQ Query Response and .Service Portability features

Command example:

```
chg-is41opts:dfltrn=48607:sporttype=is41
```

7. Set the `locreqrspnd` option of the `chg-is41opts` command to `on`.

Command example:

```
chg-is41opts:on=locreqrspnd
```

8. Verify that the IS41OPTS parameter setting are correct.

Command example:

```
rtrv-is41opts
```

The LOCREQ Query Response feature is now enabled, turned on, and operating in the system. The feature cannot be disabled and cannot be turned off. LOCREQ Query Response processing can be halted by setting the `locreqrspnd` option of the `chg-is41opts` command to `off`.

9. Back up the database changes using the `chg-db:action=backup:dest=fixed` command.

The following messages appear, the active Maintenance and Administration Subsystem Processor (MASP) appears first.

```

BACKUP (FIXED): MASP A - Backup starts on active MASP.
BACKUP (FIXED): MASP A - Backup on active MASP to fixed disk complete.
BACKUP (FIXED): MASP A - Backup starts on standby MASP.
BACKUP (FIXED): MASP A - Backup on standby MASP to fixed disk complete.

```

Service Portability Activation Procedure

This procedure is used to enable and turn on the Service Portability (S-Port) feature in the EAGLE 5 ISS.

The Service Portability feature is optional and must be purchased from Tekelec. The feature must be purchased to receive the Feature Access Key (FAK) that is required to enable the feature. Contact your Tekelec Sales Representative or Account Representative to determine whether the Service Portability feature has been purchased and for additional information.

The Service Portability (S-Port) feature is enabled using part number 893034301 and the Feature Access Key (FAK). The S-Port feature cannot be disabled after it is enabled and cannot be enabled with a temporary FAK. After the S-Port feature is enabled and turned on, the S-Port feature can be turned off.

S-Port options can be provisioned after the S-Port feature is enabled and before the S-Port feature is turned on. After the S-Port feature is enabled and provisioning is complete, the S-Port feature must be turned on (status set to *on*), before S-Port processing will occur.

For details about the commands used in this procedure, refer to *Commands Manual*.

1. Display the status of the features that are controlled with Feature Access Keys (FAKs).

Command example:

```
rtrv-ctrl-feat
```

The output shows the enabled features and the on/off status for each enabled feature in the EAGLE 5 ISS. If the `rtrv-ctrl-feat` output shows an LNP ported TNs quantity entry, this procedure cannot be performed. If the Service Portability entry appears in the `rtrv-ctrl-feat` output with status = on, this procedure does not need to be performed. If the Service Portability entry appears in the `rtrv-ctrl-feat` output with status = off, go to [Step 4](#) to turn on the S-Port feature. To enable and turn on the S-Port feature, continue to [Step 2](#).

2. Enable the S-Port feature.

Command example:

```
enable-ctrl-feat:partnum=893034301:fak=<Feature Access Key>
```

3. Verify that the S-Port feature is enabled.

Command example:

```
rtrv-ctrl-feat
```

```
rlghncxa03w 09-06-29 16:40:40 EST EAGLE5 41.1.0
The following features have been permanently enabled:
Feature Name      Partnum  Status  Quantity
HC-MIM SLK Capacity  893012707  on      64
Service Portability  893034301  off     ----
;
```

S-Port options can be provisioned after the feature is enabled. S-Port processing will not occur until the feature is enabled and turned on.

4. Turn on the S-Port feature.

Command example:

```
chg-ctrl-feat:partnum=893034301:status=on
```

5. Verify that the S-Port feature is enabled and turned on.

Command example:

```
rtrv-ctrl-feat
```

```
rlghncxa03w 09-06-29 16:43:40 EST EAGLE5 41.1.0
The following features have been permanently enabled:
Feature Name          Partnum      Status  Quantity
HC-MIM SLK Capacity   893012707   on      64
Service Portability   893034301   on      ----
;
```

S-Port processing can occur after the feature is enabled and turned on.

6. Back up the database changes using the `chg-db:action=backup:dest=fixed` command.

The following messages appear, the active Maintenance and Administration Subsystem Processor (MASP) appears first.

```
BACKUP (FIXED): MASP A - Backup starts on active MASP.
BACKUP (FIXED): MASP A - Backup on active MASP to fixed disk complete.
BACKUP (FIXED): MASP A - Backup starts on standby MASP.
BACKUP (FIXED): MASP A - Backup on standby MASP to fixed disk complete.
```

The Service Portability (S-Port) feature is now enabled, turned on, and operating in the system. The feature can be turned off using the `chg-ctrl-feat` command, but cannot be disabled.

MTP Routed Messages for SCCP Applications Activation Procedure

This procedure is used to enable and turn on the MTP Routed Messages for SCCP Applications (MTP Msgs for SCCP Apps) feature in the EAGLE 5 ISS.

- Before the MTP Msgs for SCCP Apps feature can be enabled, GTT must be on.
- The MTP Msgs for SCCP Apps feature is optional and must be purchased from Tekelec. The feature must be purchased to receive the Feature Access Key (FAK) that is required to enable the feature. Contact your Tekelec Sales Representative or Account Representative to determine whether the MTP Msgs for SCCP Apps feature has been purchased and for additional information.

The MTP Msgs for SCCP Apps feature is enabled using part number 893017401 and the Feature Access Key (FAK). The MTP Msgs for SCCP Apps feature cannot be disabled after it is enabled and cannot be enabled with a temporary FAK. After the MTP Msgs for SCCP Apps feature is enabled and turned on, the feature can be turned off.

The MTP Msgs for SCCP Apps feature must be enabled and turned on (status set to *on*) before MTP Msgs for SCCP Apps processing will occur.

For details about the commands used in this procedure, see *Commands Manual*.

1. Display the status of the features that are controlled with Feature Access Keys (FAKs).

Command example:

```
rtrv-ctrl-feat
```

The output shows the enabled features and the on/off status for each enabled feature in the EAGLE 5 ISS.

- If the MTP Msgs for SCCP Apps entry appears in the `rtrv-ctrl-feat` output with status = on, this procedure does not need to be performed.
 - If the MTP Msgs for SCCP Apps entry appears in the `rtrv-ctrl-feat` output with status = off, go to [Step 4](#) to turn on the MTP Msgs for SCCP Apps feature.
 - If the MTP Msgs for SCCP Apps entry does not appear in the `rtrv-ctrl-feat` output, continue with [Step 2](#).
2. Enable the MTP Msgs for SCCP Apps feature.

Command example:

```
enable-ctrl-feat:partnum=893017401:fak=<Feature Access Key>
```

3. Verify that the MTP Msgs for SCCP Apps feature is enabled.

Command example:

```
rtrv-ctrl-feat
```

```
rlghncxa03w 09-06-29 16:40:40 EST EAGLE5 41.1.0
The following features have been permanently enabled:
Feature Name          Partnum   Status   Quantity
HC-MIM SLK Capacity   893012707 on        64
MO-based IS41 SMS NP   893019501 on         ----
MTP Msgs for SCCP Apps 893017401 off        ----
;
```

MTP Msgs for SCCP Apps processing will not occur until the feature is enabled and turned on.

4. Turn on the MTP Msgs for SCCP Apps feature.

Command example:

```
chg-ctrl-feat:partnum=893017401:status=on
```

5. Verify that the MTP Msgs for SCCP Apps feature is enabled and turned on.

Command example:

```
rtrv-ctrl-feat
```

```
rlghncxa03w 09-06-29 16:43:40 EST EAGLE5 41.1.0
The following features have been permanently enabled:
Feature Name          Partnum   Status   Quantity
HC-MIM SLK Capacity   893012707 on        64
MO-based IS41 SMS NP   893019501 on         ----
MTP Msgs for SCCP Apps 893017401 on         ----
;
```

MTP Msgs for SCCP Apps processing can occur after the feature is enabled and turned on.

6. Back up the database changes using the `chg-db:action=backup:dest=fixed` command.

The following messages appear, the active Maintenance and Administration Subsystem Processor (MASP) appears first.

```
BACKUP (FIXED): MASP A - Backup starts on active MASP.
BACKUP (FIXED): MASP A - Backup on active MASP to fixed disk complete.
BACKUP (FIXED): MASP A - Backup starts on standby MASP.
BACKUP (FIXED): MASP A - Backup on standby MASP to fixed disk complete.
```

The MTP Msgs for SCCP feature is now enabled, turned on, and operating in the system. The feature can be turned off using the `chg-ctrl-feat` command, but cannot be disabled.

Chapter 5

Measurements

Topics:

- [IGM Measurements.....104](#)

This chapter describes the measurements information available from the EAGLE 5 ISS for the IS41 GSM Migration (IGM) feature.

IGM Measurements

Refer to *EAGLE 5 ISS Measurements* for information about measurement systems and reporting.

Refer to *EAGLE 5 ISS Commands Manual* for descriptions of commands used to generate, schedule, and transfer measurements reports.

Refer to *Database Administration Manual - System Management* for provisioning information and procedures for these measurement systems:

- OAM-based Measurements - IGM measurements are available using the File Transfer Area (FTA) feature and not directly by EAGLE 5 ISS terminals.
- Measurements Platform
- E5-OAM Integrated Measurements

Table 32: Pegs for Per System IGM Measurements describes the peg counts of Message Signalling Units (MSUs) supported per-system for the A-Port featureIGM feature.

Table 32: Pegs for Per System IGM Measurements

Event Name	Description	Type	Unit
APSMSRCV	Number of SMS Request messages received <ul style="list-style-type: none"> • If the MT-Based IS41 SMS NP feature is not turned on and the <code>is41opts:smsreqbypass</code> option is set to yes, this count will not be updated. • If neither the MT-Based IS41 SMS NP feature nor the IGM feature is turned on, this count will not be updated. 	System	Peg count
APSMSREL	Number of SMS Request messages relayed <ul style="list-style-type: none"> • If the MT-Based IS41 SMS NP feature is not turned on and the <code>is41opts:smsreqbypass</code> option is set to yes, this count will not be updated. • If neither the MT-Based IS41 SMS NP feature nor the IGM feature is turned on, this count will not be updated. 	System	Peg count
APSMRQREP	Number of SMSREQ messages received that result in SMSREQ ACK or SMSREQ NACK responses This count will include any SMSREQ NACKs generated by the IGM feature.	System	Peg count

Event Name	Description	Type	Unit
APSMRQERR	Number of SMSREQ messages received that resulted in error This count is applicable only when the incoming message is SMSREQ . The peg count is incremented only when the MT-Based IS-41 SMS NP feature is turned on. If the IGM feature is also turned on and the IGM feature handles the message resulting in an error, this peg count is incremented.	System	Peg count
GPSRRCV	Number of call-related SRI messages received	System	Peg count
GPSRGTT	Number of call-related SRI messages that fell through to GTT	System	Peg count
GPSRREP	Number of call-related SRI messages that received A-Port service	System	Peg count
GPSRERR	Number of call-related messages that cause errors and SRI Negative ACK	System	Peg count
IS41LRERR	Number of IS-41 Location Request - Error response messages sent	System	Peg count
IS41LRMRCV	Number of IS-41 Location Request messages received.	System	Peg count
IS41LRRTRN	Number of IS-41 Location Request - Return Result messages sent	System	Peg count

Table 33: Pegs for Per SSP IGM Measurements describes the peg counts of Message Signalling Units (MSUs) supported per-SSP for the IGM feature.

Table 33: Pegs for Per SSP IGM Measurements

Event Name	Description	Type	Unit
APLRACK	Number of call related LOCREQ messages acknowledged	Point Code	Peg count
APLRRLY	Number of call related LOCREQ messages relayed	Point Code	Peg count

Event Name	Description	Type	Unit
APNOCL	Number of non-call non-LOCREQ related messages relayed	Point Code	Peg count
APNOCLGT	Number of non-call non-LOCREQ related messages that fell through to GTT	Point Code	Peg count
GPSRACK	Number of call-related SRI responses	Point Code	Peg count
GPSRRLY	Number of call-related SRI messages relayed	Point Code	Peg count

Table 34: Pegs for Per System and Per SSP IGM Measurements describes the peg counts of Message Signalling Units (MSUs) supported both per-system and per-SSP for the IGM feature.

Table 34: Pegs for Per System and Per SSP IGM Measurements

Event Name	Description	Type	Unit
GPNOCL	Number of non-call-related messages relayed by G-Port	System, Point Code	Peg count
GPNOCLGT	Number of non-call-related messages that fell through to GTT	System, Point Code	Peg count

Chapter 6

Maintenance

Topics:

- *IGM Related Alarms.....108*
- *IGM UIMs.....110*
- *Maintenance Commands.....112*
- *EAGLE 5 ISS Debug Commands.....114*
- *EPAP Status and Alarm Reporting.....114*
- *IGM System Status Reports.....116*

This chapter describes the maintenance information available from the EAGLE 5 ISS for the IS41 GSM Migration (IGM) feature. The information includes status, alarms (UAMs), and information messages (UIMs).

IGM Related Alarms

All IGM related UAMs are output to the Maintenance Output Group. *Unsolicited Alarm and Information Messages* contains a complete description of all UAMs. [Table 35: IGM Related UAMs](#) contains a listing of UAMs used to support the IGM feature.

Refer to *Unsolicited Alarm and Information Messages* for more information and corrective procedures for the EAGLE 5 ISS related alarms. Refer to *MPS Platform Software and Maintenance Manual* for information and corrective procedures for the MPS related alarms.

Table 35: IGM Related UAMs

UAM	Severity	Message Text	MPS or EAGLE 5 ISS
0013	Major	Card is isolated from system	EAGLE 5 ISS
0084	Major	IP Connection Unavailable	EAGLE 5 ISS
0085	None	IP Connection Available	EAGLE 5 ISS
0099	Major	Incompatible HW for provisioned slot	EAGLE 5 ISS
0250	None	MPS available	MPS
0261	Critical	MPS unavailable	MPS
0328	None	SCCP is available	EAGLE 5 ISS
0329	None	SCCP capacity normal, card(s) abnormal	EAGLE 5 ISS
0330	Major	SCCP TPS Threshold exceeded	EAGLE 5 ISS
0331	Critical	SCCP is not available	EAGLE 5 ISS
0335	None	SCCP is removed	EAGLE 5 ISS
0336	Major	LIMs have been denied SCCP service	EAGLE 5 ISS
0370	Critical	Critical Platform Failures	MPS
0371	Critical	Critical Application Failures	MPS
0372	Major	Major Platform Failures	MPS

UAM	Severity	Message Text	MPS or EAGLE 5 ISS
0373	Major	Major Application Failures	MPS
0374	Minor	Minor Platform Failures	MPS
0375	Minor	Minor Application Failures	MPS
0422	Major	Insufficient extended memory	EAGLE 5 ISS
0423	None	Card reload attempted	EAGLE 5 ISS
0441	Major	Incorrect MBD - CPU	EAGLE 5 ISS
0442	Critical	RTDB database capacity is 95% full	EAGLE 5 ISS
0443	Major	RTDB database is corrupted	EAGLE 5 ISS
0444	Minor	RTDB database is inconsistent	EAGLE 5 ISS
0445	None	RTDB database has been corrected	EAGLE 5 ISS
0446	Major	RTDB database capacity is 80% full	EAGLE 5 ISS
0447	None	RTDB database capacity alarm cleared	EAGLE 5 ISS
0448	Minor	RTDB database is incoherent	EAGLE 5 ISS
0449	Major	RTDB resynchronization in progress	EAGLE 5 ISS
0451	Major	RTDB reload is required	EAGLE 5 ISS
0526	None	Service is available	EAGLE 5 ISS
0527	Minor	Service abnormal	EAGLE 5 ISS
0528	Critical	Service is not available	EAGLE 5 ISS
0529	Critical	Service is disabled	EAGLE 5 ISS
0530	None	Service is removed	EAGLE 5 ISS

IGM UIMs

Unsolicited Alarm and Information Messages contains a complete description of all UIM text and formats. [Table 36: IGM Related UIMs](#) lists UIMs used to support the IGM feature.

Table 36: IGM Related UIMs

UIM	Text	Description	Action	Output Group (UI Output Direction)
1035	SCCP rsp did not route - invalid GTI	The SCCP response did not route due to an invalid GTI	Use a valid GTI in the CGPA part of the query	gtt
1036	SCCP rsp did not route - invalid TT	The SCCP response did not route due to an invalid TT	Provision the CGPA TT in the GTT TT table	gtt
1037	SCCP rsp did not route - bad Xlation	The SCCP response did not route due to a bad translation	Provision the CGPA GTA address in the GTT database	gtt
1038	SCCP rsp did not route - SSP not True PC	The SCCP response did not route due to SSP is not true point code	Use the true point code in the CGPA point code or OPC of the query	gtt
1039	SCCP rsp did not route - bad Selectors	The SCCP response did not route due to invalid selectors	Provision the CGPA GTI, TT, NP, and NAI in the EGTT selector table	gtt
1130	IS412GSM not provisioned	The IS-41 to GSM Migration prefix specified by the IS412GSM parameter is not provisioned on this system.	The IS412GSM prefix must be specified in the GSMOPTS table.	gtt
1131	Invalid digits in IS41 MAP Digits parms	The EAGLE 5 ISS encountered an error in decoding the digits parameter in the LocationRequest message.	Correct the digits parameter	gtt
1169	SCCP rcvd inv TCAP portion	This indicates that SCCP discarded a message because the TCAP provided in the	No action is necessary.	application subsystem

UIM	Text	Description	Action	Output Group (UI Output Direction)
		called party address is invalid in the EAGLE 5 ISS.		
1227	SCCP did not route - DPC not in MAP tbl	This message indicates that SCCP did not route a message because the destination point code was not in the mated application (MAP) table. The message was discarded.	If the DPC indicated in the message should not be routed to, no further action is necessary.	gtt
1230	SCCP did not route - SS not in MAP tbl	This message indicates that SCCP did not route a message because the destination subsystem was not in the Mated Application (MAP) table. The message was discarded.	No action is necessary.	gtt
1242	Conv to intl num - Dflt CC not found	Conversion to international number failed because default CC was not found	Define the default CC with <code>chg-stpopts :defcc=xxx</code>	application subsystem
1243	Conv to intl num - Dflt NC not found	Conversion to international number failed because default NC was not found	Define the default NDC with <code>chg-stpopts :defndc=xxxxx</code>	application subsystem
1246	Invalid length of conditioned digits	Invalid length of conditioned digits (length of conditioned international number is less than 5 or greater than 15)	Use an international number with length in the acceptable range	application subsystem
1256	MNP Circular Route Detected	This message indicates the network has incorrect number portability data for a subscriber.	Verify and update number portability data.	application subsystem
1294	Invalid digits in MAP MSISDN parameter	No digits found in MAP MSISDN parameter	Specify valid digits in the MSISDN	application subsystem

UIM	Text	Description	Action	Output Group (UI Output Direction)
1295	Translation PC is Eagle's	PC translation is invalid because it is one of EAGLE 5 ISS's PCs	Change the point code	application subsystem
1297	Invalid length of prefix/suffix digits	Attempted digit action of prefixing entity ID is invalid because combined length of entity ID and GT digits was greater than 21 digits	Change the attempted digit action or decrease the length of the entity ID and/or GT digits	application subsystem
1341	SRI rcvd - GSM2IS41 not provisioned	MIGRPFX=SINGLE and GSM2IS41 prefix is NONE. The GSM to IS-41 Migration prefix is not provisioned on this system.	The GSM2IS41 prefix must be specified in the GSMOPTS table.	gtt
1432	IGM Relay Failed - Bad IS41 SMSC Xlation	GTT translation lookup on DEFIS41SMSC digits failed. Message falls through to SCCP CDPA GTT.	The DEFIS41SMSC digits must be provisioned.	gtt

Maintenance Commands

The following commands can be used for maintenance when an EPAP-related feature is on.

Refer to *Commands Manual* for complete descriptions of the commands, including parameters, valid parameter values, rules for using the commands, and output examples.

Table 37: Maintenance Commands

Command	Description
rept-stat-sys	Reports the status of system entities, including cards. The output includes the number of Service Module cards that are in service (IS-NR) and how many are in another state (IS-ANR, OOS-MT, OOS-MT-DSBLD).
rept-stat-sccp	Reports operating status of services and subsystems, CPU usage, and Service Module card status. When the loc parameter is specified, the command displays detailed card traffic statistics, including cards that are denied SCCP service. See the section in this manual that describes the use of the <code>rept-stat-sccp</code> command.

Command	Description
rept-stat-mps	Displays the overall status of the EPAP application running on the MPS (multi-purpose server). Command output for the various reports of this command include overall MPS alarm status and card status, and status for a specific Service Module card when a feature is on.
rept-stat-trbl	Includes a summary of any trouble notifications (UAMs) for local subsystems, cards, and linksets. The severity of each alarm is indicated in the output report.
rept-stat-alm	Displays the alarm counts and totals for local subsystems and Service Module card/EPAP IP links.
rept-stat-db	Displays the status information for the EAGLE 5 ISS databases. This includes the level information for each Service Module card, and for the active and standby EPAP RTDB. The command reports database exception status such as corrupted, incoherent, or inconsistent, as well as providing the birth dates and levels. It shows the status of each PDB and RTDB when an EPAP-related feature is enabled.
rtrv-tbl capacity	Retrieves table use capacity summary information. For each table listed, the number of table entry elements in use and the total allowed number of table elements is presented, along with a percent (%) full value. Information is shown for some tables only if the feature that uses the table is enabled.
inh-card/alw-card	<p>The <code>inh-card</code> command is used to change the operating state of the card from In-Service Normal (IS-NR) to Out-of-Service Maintenance-Disabled (OOS-MT-DSBLD). A craftsperson then can test the card or physically remove it from the shelf.</p> <p>The <code>alw-card</code> command is used to change the card from OOS-MT-DSBLD (Out-of-Service Maintenance-Disabled) to IS-NR (In-Service Normal) if card loading is successful.</p>
inh-alm/unhb-alm	Used to allow and inhibit reporting of alarms for a given device, including the Service Module card ports. The commands allow both Port A and Port B to be specified. Inhibited alarms will not generate UAMs or cause alarm indicators to be turned on. All <code>rept-stat-xxx</code> commands continue to display the alarms with an indication that the device has its alarms inhibited.
rtrv-data-rtdb	<p>Retrieves Entity data, DN data, IMEI data, IMSI data, TN data, NPANXX data, and LRN data from the RTDB on an active Service Module card.</p> <p>If the <code>loc</code> parameter is specified and the target card is an active Service Module card, the RTDB data is retrieved from that card.</p> <p>If the <code>loc</code> parameter is not specified, the RTDB data is retrieved on the active Service Module card that has the lowest IMT address.</p> <p>The RTDB status on the active Service Module card can be coherent or incoherent.</p>

rept-stat-sccp

The `rept-stat-sccp` command displays the status of the Service Module cards and the statistics of the services running on the Service Module cards. The command also displays any cards that are denied SCCP service. An MSU is considered to be an A-Port MSU after service selection. Statistics are displayed under MNP Service Statistics for A-Port, G-Port, and IGM features.

EAGLE 5 ISS Debug Commands

Chapter 6 of the *Commands Manual* contains descriptions of commands that can be used in assessing and modifying system status and operation. The debug commands are used only under the direction of Tekelec support personnel.

The `ent-trace` command traps A-Port MSUs (Message Signaling Units) based on the point code of the switch that generated the MSU (SSP), a particular DN and entity ID. For MDN and entity ID, the comparison is based on the search key built from the CdPA GTAI (Global Title Address Information) after any conditioning. The existing GT SCCP trigger also applies to A-Port messages.

EPAP Status and Alarm Reporting

Because EPAP has no direct means of accepting user input or displaying output messages on EAGLE 5 ISS terminals, EPAP maintenance, measurements, and status information are routed through a Service Module card. EPAP sends two types of messages to the Service Module card: *EPAP Maintenance Blocks* and *DSM Status Requests and DSM Status Messages*. Each message type is discussed in the following sections.

EPAP Maintenance Blocks

The EPAP forwards all status and error messages to the Service Module cards in maintenance blocks. Maintenance blocks are asynchronously sent whenever the EPAP has something to report. The status information that is displayed when a `rept-stat-mps` command is issued includes information that came from the maintenance blocks.

The active EPAP generates and sends maintenance blocks to the primary Service Module card. One maintenance block is sent as soon as the IP link is established between the active EPAP and the primary Service Module card. Additional maintenance blocks are sent whenever the EPAP needs to report any change in status or error conditions. The information returned in maintenance blocks is included in the output of the `rept-stat-mps` and `rept-stat-sccp` commands.

The EPAP sends maintenance blocks that contain at least the following information:

- Status of EPAP 'A' - actual states are active, standby, and down (inoperative). Maintenance blocks include a field for this information so that it can be available for the output of the `rept-stat-mps` command.
- Status of EPAP 'B' - actual states are active, standby, and down (inoperative). Maintenance blocks include a field for this information so that it can be available for the output of the `rept-stat-mps` command.

- Identification of Active EPAP - a field to identify the active EPAP.
- Congestion Indicator - an indicator showing provisioning link congestion. The link between the EPAPs and the external source of provisioning data can become congested in high-provisioning traffic situations. When this occurs and subsequently as the congestion clears, the EPAP sends maintenance blocks to the Service Module card.
- Alarm Conditions - an error code field. If the EPAP needs to report an alarm condition, it puts an appropriate UAM identifier in this field.
- Current MPS Database Size - a field indicating the current RTDB size. The Service Module card uses this information to calculate the percentage of memory used by the RTDB.

DSM Status Requests and DSM Status Messages

When the EPAP needs to know the status of a Service Module card, it sends a DSM Status Request to all Service Module cards, and each Service Module card returns its status to the EPAP.

Service Module cards send a DSM Status Message to the EPAP when any the following events occur in the Service Module card:

- The Service Module card is booted.
- The Service Module card receives a DSM Status Request message from the EPAP
- The Service Module card determines that it needs to download the entire RTDB; for example, the Service Module card determines that the RTDB needs to be downloaded because it is totally corrupted, or a craftsperson requests that the RTDB be reloaded. The Service Module card sends a Full Download Request message to the EPAP
- The Service Module card starts receiving RTDB downloads or updates. When a Service Module card starts downloading the RTDB or accepting updates, it sends a DSM Status Message informing the EPAP of the first record received. This helps the EPAP keep track of downloads in progress.

The DSM Status Message provides the following information to the EPAP:

- **DSM Memory Size.** When the Service Module card is initialized, it determines the amount of memory present. The EPAP uses the value to determine if the Service Module card has enough memory to hold the RTDB.

Refer to the *Dimensioning Guide for EPAP Advanced DB Features* for important information on the dimensioning rules and the Service Module card database capacity requirements.

- **Load Mode Status.** This indicator indicates whether or not a sufficient number of the IS-NR (In-Service Normal) LIMs have access to SCCP services.

DSM Status Requests

When the EPAP needs to know the status of a Service Module card, it sends a DSM status request to that Service Module card. Because status messages are sent over UDP, the EPAP broadcasts the DSM status request (to all Service Module cards) and each Service Module card returns its status to the EPAP.

DSM Status Reporting to the EPAP

The sections that follow describe the DSM status reporting for the EPAP.

DSM Status Messages – When Sent

Service Module cards send a DSM status message to the EPAP when any the following events occur in the Service Module card:

- The Service Module card is booted.
- The Service Module card receives a DSM Status Request message from the EPAP
- The Service Module card determines that it needs to download the entire database, for example, if the Service Module card determines that the RTDB needs to be downloaded (for instance, if the database is totally corrupted), or if a craftsman requests that the database be reloaded.
- The Service Module card starts receiving database downloads or database updates. When a Service Module card starts downloading the RTDB or accepting database updates, it sends a DSM Status Message informing the EPAP of the first record received. This helps the EPAP keep track of downloads in progress.

DSM Status Messages Fields

The DSM Status Message provides the following information to the EPAP:

- **DSM Memory Size.** When the Service Module card is initialized, it determines the amount of memory present. The EPAP uses the value to determine if the Service Module card has enough memory to hold the RTDB.

Refer to the *Dimensioning Guide for EPAP Advanced DB Features* for important information on the dimensioning rules and the Service Module card database capacity requirements.
- **Load Mode Status.** This indicator indicates whether or not 80% of the IS-NR (In-Service Normal) LIMs have access to SCCP services.

IGM System Status Reports

Status reporting described here includes the following:

- System status
- IGM status
- Service Module card memory capacity status
- Loading mode support status

System Status Reporting

The `rept-stat-sys` command supports the Service Module cards running the VSCCP application.

The `rept-stat-sccp` command supports the Service Module cards running the VSCCP application and reports IGM statistics.

IGM Status Reporting

The `rept-stat-mps` command supports IGM system reporting. `rept-stat-mps` concentrates on reporting the status of the provisioning system. See "Maintenance and Measurements User Interface Commands", for more details. IGM statistics are placed in the `rept-stat-sccp` command.

Service Module card Memory Capacity Status Reporting

As described in the *DSM Status Messages Fields*, the Service Module card sends a message to the EPAP containing the amount of memory on the Service Module card. The EPAP determines whether the Service Module card has enough memory to store the RTDB and sends an ack or nak back to the Service Module card indicating whether or not the Service Module card has an adequate amount of memory. Refer to the *Dimensioning Guide for EPAP Advanced DB Features Technical Reference* for important information on the dimensioning rules and the Service Module card database capacity requirements.

When the EPAP sends database updates to the Service Module cards, the update messages include a field that contains the new database memory requirements. Each Service Module card monitors the DB size requirements, and issues a minor alarm if the size of the DB exceeds 80% of its memory. If a database increases to the point that there is insufficient Service Module card memory, a major alarm is issued.

The `rept-stat-mps:loc=xxxx` command shows the amount of memory used by the RTDB as a percent of available Service Module card memory.

Loading Mode Support Status Reporting

The OAM application determines whether or not the system is in an unstable loading mode since it knows the state of all LIM and Service Module cards in the system. When the loading mode is unstable, the `rept-stat-sys` command reports the existence of the unstable loading mode and the specific conditions that caused it.

Glossary

A

A-Port	ANSI-41 Mobile Number Portability A feature that enables IS-41 subscribers to change their service provider while retaining the same Mobile Dialed Number (MDN).
ACK	Data Acknowledgement
ANSI	American National Standards Institute An organization that administers and coordinates the U.S. voluntary standardization and conformity assessment system. ANSI develops and publishes standards. ANSI is a non-commercial, non-government organization which is funded by more than 1000 corporations, professional bodies, and enterprises.
ANSI-41 Mobile Number Portability	See A-Port.

C

CC	Country Code
CCS7ITU	The application for the ITU SS7 signaling links that is used with card types <code>limds0</code> , <code>limch</code> , <code>lime1</code> , and <code>limt1</code> .
CdPA	Called Party Address The field in the SCCP portion of the MSU that contains the additional addressing information of the destination of the MSU. Gateway screening uses this additional

C

information to determine if MSUs that contain the DPC in the routing label and the subsystem number in the called party address portion of the MSU are allowed in the network where the EAGLE 5 ISS is located.

Circular Route Prevention

See CRP.

CLLI

Common Language Location Identifier

The CLLI uniquely identifies the STP in terms of its physical location. It is usually comprised of a combination of identifiers for the STP's city (or locality), state (or province), building, and traffic unit identity. The format of the CLLI is:

The first four characters identify the city, town, or locality.

The first character of the CLLI must be an alphabetical character.

The fifth and sixth characters identify state or province.

The seventh and eighth characters identify the building.

The last three characters identify the traffic unit.

CNL

Small Geographic Area

CPC

Capability Point Code

A capability point code used by the SS7 protocol to identify a group of functionally related STPs in the signaling network.

CPU

Central Processing Unit

C

CUG Closed User Group

D

DB Database
Daughter Board
Documentation Bulletin

DCB Device Control Block

Destination The node to which the signaling link traffic is routed. This destination is identified by a point code, either a full point code or a cluster point code.

DN Directory number
A DN can refer to any mobile or wireline subscriber number, and can include MSISDN, MDN, MIN, or the wireline Dialed Number.

DPC Destination Point Code
DPC refers to the scheme in SS7 signaling to identify the receiving signaling point. In the SS7 network, the point codes are numeric addresses which uniquely identify each signaling point. This point code can be adjacent to the EAGLE 5 ISS, but does not have to be.

DPCI Destination Point Code International

DPCN Destination Point Code National

E

EGTT Enhanced Global Title Translation

E

A feature that is designed for the signaling connection control part (SCCP) of the SS7 protocol. The EAGLE 5 ISS uses this feature to determine to which service database to send the query message when a Message Signaling Unit (MSU) enters the system.

Enhanced Global Title Translation

See EGTT.

EPAP

EAGLE Provisioning Application Processor

EPAP-related features

Features that require EPAP connection and use the Real Time Database (RTDB) for lookup of subscriber information.

- ANSI Number Portability Query (AINPQ)
- ANSI-41 AnalyzedInformation Query – no EPAP/ELAP (ANSI41 AIQ)
- Anytime Interrogation Number Portability (ATI Number Portability, ATINP)
- AINPQ, INP, G-Port SRI Query for Prepaid, GSM MAP SRI Redirect, IGM, and ATINP Support for ROP
- A-Port Circular Route Prevention (A-Port CRP)
- Equipment Identity Register (EIR)
- G-Flex C7 Relay (G-Flex)
- G-Flex MAP Layer Routing (G-Flex MLR)
- G-Port SRI Query for Prepaid
- GSM MAP SRI Redirect to Serving HLR (GSM MAP SRI Redirect)
- GSM Number Portability (G-Port)
- IDP A-Party Blacklist

E

- IDP A-Party Routing
- IDP Relay Additional Subscriber Data (IDPR ASD)
- IDP Relay Generic Routing Number (IDPR GRN)
- IDP Service Key Routing (IDP SK Routing)
- IDP Screening for Prepaid
- INAP-based Number Portability (INP)
- Info Analyzed Relay Additional Subscriber Data (IAR ASD)
- Info Analyzed Relay Base (IAR Base)
- Info Analyzed Relay Generic Routing Number (IAR GRN)
- Info Analyzed Relay Number Portability (IAR NP)
- INP Circular Route Prevention (INP CRP)
- IS41 Mobile Number Portability (A-Port)
- IS41 GSM Migration (IGM)
- MNP Circular Route Prevention (MNPCR)
- MO-based GSM SMS NP
- MO-based IS41 SMS NP
- MO SMS Generic Routing Number (MO SMS GRN)
- MO- SMS B-Party Routing
- MO SMS IS41-to-GSM Migration
- MT-based GSM SMS NP
- MT-based GSM MMS NP
- MT-based IS41 SMS NP
- MTP Routed Messages for SCCP Applications (MTP Msgs for SCCP Apps)
- MTP Routed Gateway Screening Stop Action (MTPRTD GWS Stop Action)
- Portability Check for MO SMS
- Prepaid IDP Query Relay (IDP Relay, IDPR)
- Prepaid SMS Intercept Phase 1 (PPSMS)

E

- Service Portability (S-Port)
- S-Port Subscriber Differentiation
- Triggerless ISUP Framework Additional Subscriber Data (TIF ASD)
- Triggerless ISUP Framework Generic Routing Number (TIF GRN)
- Triggerless ISUP Number Portability (TIF NP)
- Triggerless ISUP Framework Number Substitution (TIF NS)
- Triggerless ISUP Framework SCS Forwarding (TIF SCS Forwarding)
- Triggerless ISUP Framework Simple Number Substitution (TIF SNS)
- Voice Mail Router (V-Flex)

ESN

Electronic Serial Number

ETSI

European Technical Standards Institute

F

FAK

Feature Access Key

The feature access key allows the user to enable a controlled feature in the system by entering either a permanent feature access key or a temporary feature access key. The feature access key is supplied by Tekelec.

FTA

File Transfer Area

A special area that exists on each OAM hard disk, used as a staging area to copy files to and from the EAGLE 5 ISS using the Kermit file-transfer protocol.

G

G

G-Flex	<p>GSM Flexible numbering</p> <p>A feature that allows the operator to flexibly assign individual subscribers across multiple HLRs and route signaling messages, based on subscriber numbering, accordingly.</p>
G-Port	<p>GSM Mobile Number Portability</p> <p>A feature that provides mobile subscribers the ability to change the GSM subscription network within a portability cluster, while retaining their original MSISDN(s).</p>
GRN	Generic Routing Number
GSM	Global System for Mobile Communications
GT	Global Title Routing Indicator
GTA	Global Title Address
GTI	Global Title Indicator
GTT	<p>Global Title Translation</p> <p>A feature of the signaling connection control part (SCCP) of the SS7 protocol that the EAGLE 5 ISS uses to determine which service database to send the query message when an MSU enters the EAGLE 5 ISS and more information is needed to route the MSU. These service databases also verify calling card numbers and credit card numbers. The service databases are identified in the SS7 network by a point code and a subsystem number.</p>

G

GUI	Graphical User Interface
	The term given to that set of items and facilities which provide the user with a graphic means for manipulating screen data rather than being limited to character based commands.

H

HLR	Home Location Register
HOMERN	Home Network Routing Number Prefix
HW	Hardware

I

ID	Identity, identifier
IGM	See IS41 GSM Migration
IN	Intelligent Network
	A network design that provides an open platform for developing, providing and managing services.
INAP	Intelligent Network Application Part
INP	INAP-based Number Portability
	Tekelec's INP can be deployed as a stand-alone or an integrated signal transfer point/number portability solution. With Tekelec's stand-alone NP server, no network reconfiguration is required to implement number portability. The NP server delivers a much greater signaling capability than the conventional SCP-based approach.

I

	Intelligent Network (IN) Portability
IP	<p>Internet Protocol</p> <p>IP specifies the format of packets, also called datagrams, and the addressing scheme. The network layer for the TCP/IP protocol suite widely used on Ethernet networks, defined in STD 5, RFC 791. IP is a connectionless, best-effort packet switching protocol. It provides packet routing, fragmentation and re-assembly through the data link layer.</p>
IS-41	<p>Interim Standard 41</p> <p>Same as and interchangeable with ANSI-41. A standard for identifying and authenticating users, and routing calls on mobile phone networks. The standard also defines how users are identified and calls are routed when roaming across different networks.</p>
IS41 GSM Migration	<p>A feature that adds GSM IS-41 migration functions to the existing IS-41 to GSM feature. This enhancement provides flexibility in the encoding and decoding of parameters of LOCREQ messages and responses to number migration from one mobile protocol to another.</p>
ISDN	Integrated Services Digital Network
IS-NR	In Service - Normal
ISDN	Integrated Services Digital Network

I

Integrates a number of services to form a transmission network. For example, the ISDN network integrates, telephony, facsimile, teletext, Datex-J, video telephony and data transfer services, providing users with various digital service over a single interface: voice, text, images, and other data.

ISS

Integrated Signaling System

ITU

International Telecommunications Union

ITUDUPPC

ITU National Duplicate Point Code

This feature applies only to 14-bit ITU national point codes. This feature allows an EAGLE 5 ISS mated pair to route traffic for two or more countries that may have overlapping point code values.

L

LIM

Link Interface Module

Provides access to remote SS7, IP and other network elements, such as a Signaling Control Point (SCP) through a variety of signaling interfaces (DS0, MPL, E1/T1 MIM, LIM-ATM, E1-ATM, IPLIMx, IPGWx). The LIMs consist of a main assembly and possibly, an interface appliqué board. These appliqués provide level one and some level two functionality on SS7 signaling links.

Link

Signaling Link

Signaling Link

L

Carries signaling within a Link Set using a specific Association. A Link can belong to only one Link Set and one Association. There is generally one Link per Association in a Link Set.

LNP

Local Number Portability

LOCREQ

Location Request Message

A TDMA/CDMA MSC query to an HLR for retrieving subscription/location information about a subscriber to terminate a voice call.

M

MAP

Mobile Application Part

Mated Application

The point codes and subsystem numbers of the service databases that messages are routed to for global title translation.

MDN

Mobile Dialed Number
Mobile Directory Number

MFC

Message Flow Control

MIN

Mobile Identification Number

MNP

Mobile Number Portability

MNP Circular Route Prevention

A G-Port MNP feature that detects instances of circular routing caused by incorrect information in one or more of the network number portability databases. If a circular route has been detected, a message

M

will be generated by the EAGLE 5 ISS and returned to the originator.

MPS

Multi-Purpose Server

The Multi-Purpose Server provides database/reload functionality and a variety of high capacity/high speed offboard database functions for applications. The MPS resides in the General Purpose Frame.

Messages Per Second

A measure of a message processor's performance capacity. A message is any Diameter message (Request or Answer) which is received and processed by a message processor.

MR

Message Relay

MRN

Message Reference Number

An unsolicited numbered message (alarm or information) that is displayed in response to an alarm condition detected by the system or in response to an event that has occurred in the system.

Mated Relay Node

A mated relay node (MRN) group is provisioned in the database to identify the nodes that the traffic is load shared with, and the type of routing, either dominant, load sharing, or combined dominant/load sharing.

MSISDN

Mobile Station International
Subscriber Directory Number

The MSISDN is the network specific subscriber number of a mobile communications subscriber. This is normally the phone number that is used to reach the subscriber.

M

MSRN	Mobile Station Roaming Number
MTP	Message Transfer Part The levels 1, 2, and 3 of the SS7 protocol that control all the functions necessary to route an SS7 MSU through the network
MTP Msgs for SCCP Apps	MTP Routed Messages for SCCP Applications feature A feature that supports MTP-routed SCCP message processing for features that normally do not MTP route messages. The feature supports both LOCREQ and SMSREQ messages.

N

NAI	Nature of Address Indicator Standard method of identifying users who request access to a network. Network Access Identifier
NAK	Negative Acknowledgment
NC	Network Cluster Network Code Not Compliant
NDC	Network destination code
NE	Network Element An independent and identifiable piece of equipment closely associated with at least one processor, and within a single location.

N

Network Entity

NP

Number Plan

O

OAM

Operations, Administration, and Maintenance

The application that operates the Maintenance and Administration Subsystem which controls the operation of many Tekelec products.

OOS-MT-DSBLD

Out of Service - Maintenance Disabled

The entity is out of service and the maintenance system is preventing the entity from performing its normal service function.

OPC

Originating Point Code

OPS

Operator Provisioning System

own-network

Belonging to or assigned to this operator.

P

PC

Point Code

The identifier of a signaling point or service control point in a network. The format of the point code can be one of the following types:

- ANSI point codes in the format network indicator-network cluster-network cluster member (**ni-nc-ncm**).
- Non-ANSI domestic point codes in the format network indicator-network

P

cluster-network cluster member (**ni-nc-ncm**).

- Cluster point codes in the format network indicator-network cluster-* or network indicator-*-*.
- ITU international point codes in the format **zone-area-id**.
- ITU national point codes in the format of a 5-digit number (**nnnnn**), or 2, 3, or 4 numbers (members) separated by dashes (**m1-m2-m3-m4**) as defined by the Flexible Point Code system option. A group code is required (**m1-m2-m3-m4-gc**) when the ITUDUPPC feature is turned on.
- 24-bit ITU national point codes in the format main signaling area-subsignaling area-service point (**msa-ssa-sp**).

PDB

Provisioning Database

PDBA

Provisioning Database Application

There are two Provisioning Database Applications (PDBAs), one in EPAP A on each EAGLE 5 ISS. They follow an Active/Standby model. These processes are responsible for updating and maintaining the Provisioning Database (PDB).

PDBI

Provisioning Database Interface

The interface consists of the definition of provisioning messages only. The customer must write a client application that uses the PDBI request/response messages to communicate with the PDBA.

PPP

Point-to-Point Protocol

P

PPSMS	Prepaid Short Message Service Prepaid Short Message Service Intercept
PT	Portability Type

R

RC	Relative Cost
RFC	Request for Comment RFCs are standards-track documents, which are official specifications of the Internet protocol suite defined by the Internet Engineering Task Force (IETF) and its steering group the IESG.
RMTP	Reliable Multicast Transport Protocol
RN	Routing Number
ROP	Large Geographic Area (Groups of CNLs)
Route	A signaling path from an LSP to an RSP using a specified Link Set
RTDB	Real Time Database

S

SCCP	Signaling Connection Control Part
Service Module card	DSM, E5-SM4G, or E5-SM8G-B card that contains the Real Time Database (RTDB) downloaded from an EPAP or ELAP system.

S

Service Nature of Address Indicator	See SNAI.
Service Portability	See S-Port.
SM	Short Message
SMS	Short Message Service
SMSREQ	SMS Request Message
S-Port	<p>Service Portability</p> <p>A number portability extension which allows a subscriber to retain the same subscriber number when moving from one network type or service technology to another within the network of a single operator. Service Portability provides different routing number digits for formats that require routing numbers. Service Portability does not affect message flows.</p>
SP	<p>Signaling Point</p> <p>A set of signaling equipment represented by a unique point code within an SS7 domain.</p>
Spare Point Code	<p>The EAGLE ITU International/National Spare Point Code feature allows a network operator to use the same Point Codes across two networks (either ITU-I or ITU-N). The feature also enables National and National Spare traffic to be routed over the same linkset. The EAGLE uses the MSU Network Indicator (NI) to differentiate the same point code of one network from the other. In accordance with the SS7 standard, unique Network</p>

S

Indicator values are defined for Point Code types ITU-I, ITU-N, ITU-I Spare, and ITU-N Spare.

SRF	Service Resource Function Provide resources to a call, such as announcements, voice prompting, and voice recognition. An example of a SRF is a Voice Recognition Unit (VRU).
SRI	Send_Route_Information Message
SS	Subsystem Supplementary Services
SSP	Subsystem Prohibited network management message. Subsystem Prohibited SCCP (SCMG) management message. (CER)
STP	Signal Transfer Point The STP is a special high-speed switch for signaling messages in SS7 networks. The STP routes core INAP communication between the Service Switching Point (SSP) and the Service Control Point (SCP) over the network.

T

TCAP	Transaction Capabilities Application Part
TCP	Transfer Control Protocol
TCP/IP	Transmission Control Protocol/Internet Protocol

T

TFA	TransFer Allowed (Msg)
TFP	TransFer Prohibited (Msg) A procedure included in the signaling route management (functionality) used to inform a signaling point of the unavailability of a signaling route.
TPS	Transactions Per Second
Translation Type	See TT.
TT	Translation Type. Resides in the Called Party Address (CdPA) field of the MSU and determines which service database is to receive query messages. The translation type indicates which Global Title Translation table determines the routing to a particular service database.
TVG	Group Ticket Voucher

U

UAM	Unsolicited Alarm Message A message sent to a user interface whenever there is a fault that is service-affecting or when a previous problem is corrected. Each message has a trouble code and text associated with the trouble condition.
UDP	User Datagram Protocol
UDT	Unitdata Transfer

U

UDTS	Unitdata Transfer Service An error response to a UDT message.
------	--

V

VGTT	Variable Length GTT A feature that provides the ability to provision global title entries of varying lengths to a single translation type or GTT set. Users are able to assign global title entries of up to 10 different lengths to a single translation type or GTT set.
------	---

VSCCP	VxWorks Signaling Connection Control Part The application used by the Service Module card to support EPAP-related features and LNP features. If an EPAP-related or LNP feature is not turned on, and a Service Module card is present, the VSCCP application processes normal GTT traffic.
-------	---

X

XUDT	Extended User Data
XUDTS	Extended Unitdata Service message An error response to an XUDT message.