

Tekelec EAGLE[®] 5

Release 44.0

Database Administration Manual - Features

910-6275-001 Revision A

January 2012



Copyright 2012 Tekelec. All Rights Reserved. Printed in USA.

Legal Information can be accessed from the Main Menu of the optical disc or on the Tekelec Customer Support web site in the *Legal Information* folder of the *Product Support* tab.

Table of Contents

Chapter 1: Introduction.....	7
Overview.....	8
Scope and Audience.....	9
Manual Organization.....	9
Documentation Admonishments.....	10
Customer Care Center.....	10
Emergency Response.....	12
Related Publications.....	13
Documentation Availability, Packaging, and Updates.....	13
Locate Product Documentation on the Customer Support Site.....	14
Maintenance and Administration Subsystem.....	14
EAGLE 5 ISS Database Partitions.....	16
Chapter 2: STPLAN Configuration.....	19
STPLAN Feature Overview.....	20
TCP/IP Router.....	23
Hardware Requirements	25
Node Requirements.....	25
Gateway Screening.....	26
STPLAN Provisioning.....	27
Understanding Firewall and Router Filtering.....	28
IP Addresses.....	29
Network Configuration Procedures.....	31
Adding an STPLAN Card.....	36
Removing an STPLAN Card.....	42
Adding a TCP/IP Data Link.....	45
Removing a TCP/IP Data Link.....	49
Adding a TCP/IP Node.....	51
Removing a TCP/IP Node.....	54
Configuring the Copy Original OPC for STPLAN Option.....	58
Configuring the Option for Including the Incoming and Outgoing Linkset Names in the STPLAN Message Format.....	59

Chapter 3: Database Transport Access (DTA)

Configuration.....	61
DTA Feature Overview.....	62
Functional Description.....	64
Summary of the Gateway Screening Redirect Table Commands	67
SCCP Subsystem Management.....	68
EAGLE 5 ISS Requirements	69
Configuring the EAGLE 5 ISS for the DTA Feature.....	69
Changing the Gateway Screening Redirect Parameters.....	78
Disabling the Gateway Screening Redirect Function.....	82

Chapter 4: GSM MAP Screening Configuration.....86

Introduction.....	87
GSM MAP Screening Overview.....	87
GSM MAP Screening Details.....	90
GSM MAP Screening Example.....	107
GSM MAP Screening Procedures.....	108
Activating the GSM MAP Screening Feature.....	112
Configuring the MTP MAP Screening Feature.....	118
Configuring a Linkset for the GSM MAP Screening Feature.....	121
Changing the System-Wide GSM MAP Screening Options.....	128
Adding a GSM Subsystem Number Screening Entry.....	130
Removing a GSM Subsystem Number Screening Entry.....	132
Adding a GSM MAP Screening Operation Code.....	133
Removing a GSM MAP Screening Operation Code.....	145
Changing a GSM MAP Screening Operation Code.....	148
Adding a GSM MAP Screening Entry.....	157
Removing a GSM MAP Screening Entry.....	180
Changing a GSM MAP Screening Entry.....	187
Changing the GSM MAP Screening TCAP Continue and End Message Processing Option.....	202

Chapter 5: EAGLE 5 Integrated Monitoring Support

Configuration.....	205
Introduction.....	206
TCP/IP Link Provisioning.....	208
Time Stamping.....	212
EAGLE 5 ISS Provisioning.....	212

Network Considerations.....	215
Enabling the Time Slot Counter Synchronization (TSCSYNC) and EAGLE 5 Integrated Monitoring Support (E5IS) Features.....	216
Configuring the EISCOPY Option for the EAGLE 5 Integrated Monitoring Support Feature.....	217
Configuring the FCMODE Option for the EAGLE 5 Integrated Monitoring Support Feature.....	221
Configuring the IP Addresses for the EAGLE 5 Integrated Monitoring Support Feature.....	227
Adding a Signaling Transport Card (STC).....	231
Removing a Signaling Transport Card (STC).....	237
Appendix A: Reference Information.....	240
Configuring the MFC Option.....	241
Glossary.....	243

List of Figures

Figure 1: EAGLE 5 ISS Database Partitions (Legacy Control Cards).....	16
Figure 2: EAGLE 5 ISS Database Partitions (E5-Based Control Cards).....	17
Figure 3: STPLAN Messages Embedded in TCP/IP Packets.....	22
Figure 4: STPLAN Network with a TCP/IP Router.....	23
Figure 5: STPLAN in a Large Network.....	24
Figure 6: STPLAN Network with Subnet Routing.....	24
Figure 7: IP Address Bit Categorization.....	30
Figure 8: STPLAN Database Relationships.....	32
Figure 9: STPLAN Configuration Example.....	36
Figure 10: Example of Configuration for the DTA Feature.....	63
Figure 11: DTA Encapsulation.....	65
Figure 12: Configuration of GTT for Routing Management.....	68
Figure 13: GSM MAP Screening Overview.....	89
Figure 14: GSM MAP Screening Details	93
Figure 15: GSM MAP Screening Database Relationships.....	111
Figure 16: Monitoring via Hardware Connection.....	206
Figure 17: EAGLE 5 Integrated Monitoring Support Network Connectivity.....	207
Figure 18: ESP/IMF/EAGLE 5 ISS Network.....	208
Figure 19: Ethernet Link Establishment - EMP Link Data.....	209
Figure 20: Ethernet Link Establishment - EMP Fast Copy Link PDU.....	210
Figure 21: Ethernet Link Establishment - EMP Fast Copy Link PDU Modified for the IPGHC GPL.....	211

List of Tables

Table 1: Admonishments.....	10
Table 2: Gateway Screening Action.....	27
Table 3: STPLAN External Ports and Their Use.....	28
Table 4: Values of IP Addresses.....	30
Table 5: Invalid IP Address Error Codes.....	31
Table 6: STPLAN Configuration Example Database.....	35
Table 7: STPLAN Card Part Numbers.....	37
Table 8: DCM Card Locations.....	37
Table 9: Maximum Encapsulation Length per DTA DPC Type.....	66
Table 10: Commands for the Gateway Screening Redirect Table.....	67
Table 11: Cards Required in Specific Situations.....	69
Table 12: Translation Type Parameters.....	76
Table 13: Translation Type Parameters.....	80
Table 14: Example GSM MAP Screening Table.....	107
Table 15: System-Wide Screening Table.....	108
Table 16: GSM MAP Screening Linkset Configuration Table.....	122
Table 17: Example GSM MAP Screening SSN Configuration Table.....	130
Table 18: Example GSM MAP Screening Operation Code Configuration Table.....	136
Table 19: Add GSM MAP Screening Entry Parameter Combinations.....	159
Table 20: Example CGPA GSM MAP Screening Configuration Table.....	164
Table 21: Example CDPA GSM MAP Screening Configuration Table.....	164
Table 22: Change GSM MAP Screening Entry Parameter Combinations.....	189
Table 23: Monitored Card Types.....	213
Table 24: STC Part Numbers.....	232
Table 25: Dual-Slot STC Locations.....	232

Chapter 1

Introduction

Topics:

- *Overview.....8*
- *Scope and Audience.....9*
- *Manual Organization.....9*
- *Documentation Admonishments.....10*
- *Customer Care Center.....10*
- *Emergency Response.....12*
- *Related Publications.....13*
- *Documentation Availability, Packaging, and Updates.....13*
- *Locate Product Documentation on the Customer Support Site.....14*
- *Maintenance and Administration Subsystem.....14*
- *EAGLE 5 ISS Database Partitions.....16*

Chapter 1, Introduction, contains an overview of the features described in this manual, general information about the database, and the organization of this manual.

Overview

The *Database Administration Manual – Features* describes the procedures used to configure the EAGLE 5 ISS and its database to implement these features:

- STPLAN
- Database Transport Access
- GSM MAP Screening
- Eagle 5 Integrated Monitoring Support

Note: Before enabling any one of these features, make sure you have purchased the feature to be turned on. If you are not sure whether you have purchased the feature to be turned on, contact your Tekelec Sales Representative or Account Representative.

Note: Database administration privileges are password restricted. Only those persons with access to the command class “Database Administration” can execute the administrative functions. Refer to the *Commands Manual* for more information on command classes and commands allowed by those classes.

It is possible for two or more users to make changes to the same database element at any time during their database administration sessions. It is strongly recommended that only one user at a time make any changes to the database.

Throughout this manual, these terms are used to refer to either the original card or the EPM-B version or other replacement version of the card unless one of the card types is specifically required.

- E5-ENET - the original E5-ENET or the E5-ENET-B card
- E5-ATM - the original E5-ATM or the E5-ATM-B card
- E5-IPSM - the original E5-IPSM or the E5-ENET-B card that is running the IPSHC GPL
- E5-SM4G - the original E5-SM4G or the E5-SM8G-B card (not an EPM-B card)
- MCPM - the original MCPM or the E5-MCPM-B card

STPLAN

The STPLAN feature provides a TCP/IP connection from any interface shelf to support external applications. Message signaling units (MSUs) that are processed by the EAGLE 5 ISS can be copied and directed through the LAN interface to an external server or microcomputer application such as a usage measurements system. The gateway screening feature must be available on the STP in order to use the STPLAN feature.

The feature requires an STPLAN card, either the DCM, SSEDCCM, or E5-SLAN card running the `stplan` application.

Database Transport Access

The Database Transport Access (DTA) feature provides a mechanism for the redirection of specific Message signaling units (MSUs) to a customized database. The EAGLE 5 ISS uses gateway screening to qualify incoming MSUs for redirection. Once gateway screening is passed, the original MSU is encapsulated into a new MSU and routed to its new destination.

GSM MAP Screening

The GSM MAP Screening feature examines the Mobile Application Part (MAP) level of incoming SCCP messages to against predefined criteria in the system database to determine whether or not to allow an external server to interrogate an HLR and obtain information about the location and/or state of a GSM subscriber. This feature also allows the user to control which external entities can request this information, and what information they can request before allowing the message to pass through to the HLR.

EAGLE 5 Integrated Monitoring Support

The Integrated Monitoring Support feature allows the network traffic on the EAGLE 5 ISS's signaling links to be monitored by an IMF (integrated message feeder) without additional intrusive cabling. Message Signaling Units (MSUs), alarms, and events are copied to the Sentinel/IMF to provide the network traffic monitoring. The monitored traffic is delivered to the Sentinel/IMF using the EAGLE 5 ISS's STCs (Signaling Transport Cards) which are connected to the ESP/IMF subsystem by Ethernet links. The ESP/IMF subsystem delivers the monitored traffic to the Sentinel/IMF. EAGLE 5 ESP (extended services platform)/

Scope and Audience

This manual is intended for database administration personnel or translations personnel responsible for configuring the EAGLE 5 ISS and its database to implement the features shown in the [Overview](#) section.

Manual Organization

Throughout this document, the terms database and system software are used. Database refers to all data that can be administered by the user, including shelves, cards, links, routes, global title translation tables, and gateway screening tables. System software refers to data that cannot be administered by the user, including generic program loads (GPLs).

This document is organized into the following sections.

[Introduction](#) contains an overview of the features described in this manual, general information about the database, and the organization of this manual.

[STPLAN Configuration](#) describes the STPLAN feature and the procedures necessary to configure the EAGLE 5 ISS to support this feature.

[Database Transport Access \(DTA\) Configuration](#) describes the Database Transport Access (DTA) feature and the procedures necessary to configure the EAGLE 5 ISS to support this feature.

[GSM MAP Screening Configuration](#) describes the GSM MAP Screening feature and the procedures necessary to configure the EAGLE 5 ISS to support this feature.



[EAGLE 5 Integrated Monitoring Support Configuration](#) describes the Eagle 5 Integrated Monitoring Support feature and the procedures necessary to configure the EAGLE 5 ISS to support this feature.

Reference Information describes the procedure for configuring the EAGLE 5 ISS to support the Message Flow Control (MFC) option.

Documentation Admonishments

Admonishments are icons and text throughout this manual that alert the reader to assure personal safety, to minimize possible service interruptions, and to warn of the potential for equipment damage.

Table 1: Admonishments

	<p>DANGER: (This icon and text indicate the possibility of <i>personal injury</i>.)</p>
	<p>WARNING: (This icon and text indicate the possibility of <i>equipment damage</i>.)</p>
	<p>CAUTION: (This icon and text indicate the possibility of <i>service interruption</i>.)</p>

Customer Care Center

The Tekelec Customer Care Center is your initial point of contact for all product support needs. A representative takes your call or email, creates a Customer Service Request (CSR) and directs your requests to the Tekelec Technical Assistance Center (TAC). Each CSR includes an individual tracking number. Together with TAC Engineers, the representative will help you resolve your request.

The Customer Care Center is available 24 hours a day, 7 days a week, 365 days a year, and is linked to TAC Engineers around the globe.

Tekelec TAC Engineers are available to provide solutions to your technical questions and issues 7 days a week, 24 hours a day. After a CSR is issued, the TAC Engineer determines the classification of the trouble. If a critical problem exists, emergency procedures are initiated. If the problem is not critical, normal support procedures apply. A primary Technical Engineer is assigned to work on the CSR and provide a solution to the problem. The CSR is closed when the problem is resolved.

Tekelec Technical Assistance Centers are located around the globe in the following locations:

Tekelec - Global

Email (All Regions): support@tekelec.com

- **USA and Canada**

Phone:

1-888-FOR-TKLC or 1-888-367-8552 (toll-free, within continental USA and Canada)

1-919-460-2150 (outside continental USA and Canada)

TAC Regional Support Office Hours:

8:00 a.m. through 5:00 p.m. (GMT minus 5 hours), Monday through Friday, excluding holidays

- **Caribbean and Latin America (CALA)**

Phone:

USA access code +1-800-658-5454, then 1-888-FOR-TKLC or 1-888-367-8552 (toll-free)

TAC Regional Support Office Hours (except Brazil):

10:00 a.m. through 7:00 p.m. (GMT minus 6 hours), Monday through Friday, excluding holidays

- **Argentina**

Phone:

0-800-555-5246 (toll-free)

- **Brazil**

Phone:

0-800-891-4341 (toll-free)

TAC Regional Support Office Hours:

8:30 a.m. through 6:30 p.m. (GMT minus 3 hours), Monday through Friday, excluding holidays

- **Chile**

Phone:

1230-020-555-5468

- **Colombia**

Phone:

01-800-912-0537

- **Dominican Republic**

Phone:

1-888-367-8552

- **Mexico**

Phone:

001-888-367-8552

- **Peru**

Phone:

0800-53-087

- **Puerto Rico**

Phone:

1-888-367-8552 (1-888-FOR-TKLC)

- **Venezuela**
Phone:
0800-176-6497
- **Europe, Middle East, and Africa**
Regional Office Hours:
8:30 a.m. through 5:00 p.m. (GMT), Monday through Friday, excluding holidays
- **Signaling**
Phone:
+44 1784 467 804 (within UK)
- **Software Solutions**
Phone:
+33 3 89 33 54 00
- **Asia**
 - **India**
Phone:
+91 124 436 8552 or +91 124 436 8553
TAC Regional Support Office Hours:
10:00 a.m. through 7:00 p.m. (GMT plus 5 1/2 hours), Monday through Saturday, excluding holidays
 - **Singapore**
Phone:
+65 6796 2288
TAC Regional Support Office Hours:
9:00 a.m. through 6:00 p.m. (GMT plus 8 hours), Monday through Friday, excluding holidays

Emergency Response

In the event of a critical service situation, emergency response is offered by the Tekelec Customer Care Center 24 hours a day, 7 days a week. The emergency response provides immediate coverage, automatic escalation, and other features to ensure that the critical situation is resolved as rapidly as possible.

A critical situation is defined as a problem with the installed equipment that severely affects service, traffic, or maintenance capabilities, and requires immediate corrective action. Critical situations affect service and/or system operation resulting in one or several of these situations:

- A total system failure that results in loss of all transaction processing capability
- Significant reduction in system capacity or traffic handling capability

- Loss of the system's ability to perform automatic system reconfiguration
- Inability to restart a processor or the system
- Corruption of system databases that requires service affecting corrective actions
- Loss of access for maintenance or recovery operations
- Loss of the system ability to provide any required critical or major trouble notification

Any other problem severely affecting service, capacity/traffic, billing, and maintenance capabilities may be defined as critical by prior discussion and agreement with the Tekelec Customer Care Center.

Related Publications

For information about additional publications that are related to this document, refer to the *Related Publications* document. The *Related Publications* document is published as a part of the *Release Documentation* and is also published as a separate document on the Tekelec Customer Support Site.

Documentation Availability, Packaging, and Updates

Tekelec provides documentation with each system and in accordance with contractual agreements. For General Availability (GA) releases, Tekelec publishes a complete EAGLE 5 ISS documentation set. For Limited Availability (LA) releases, Tekelec may publish a documentation subset tailored to specific feature content or hardware requirements. Documentation Bulletins announce a new or updated release.

The Tekelec EAGLE 5 ISS documentation set is released on an optical disc. This format allows for easy searches through all parts of the documentation set.

The electronic file of each manual is also available from the [Tekelec Customer Support](#) site. This site allows for 24-hour access to the most up-to-date documentation, including the latest versions of Feature Notices.

Printed documentation is available for GA releases on request only and with a lead time of six weeks. The printed documentation set includes pocket guides for commands and alarms. Pocket guides may also be ordered separately. Exceptions to printed documentation are:

- Hardware or Installation manuals are printed without the linked attachments found in the electronic version of the manuals.
- The Release Notice is available only on the Customer Support site.

Note: Customers may print a reasonable number of each manual for their own use.

Documentation is updated when significant changes are made that affect system operation. Updates resulting from Severity 1 and 2 Problem Reports (PRs) are made to existing manuals. Other changes are included in the documentation for the next scheduled release. Updates are made by re-issuing an electronic file to the customer support site. Customers with printed documentation should contact their Sales Representative for an addendum. Occasionally, changes are communicated first with a Documentation Bulletin to provide customers with an advanced notice of the issue until officially released in the documentation. Documentation Bulletins are posted on the Customer Support site and can be viewed per product and release.

Locate Product Documentation on the Customer Support Site

Access to Tekelec's Customer Support site is restricted to current Tekelec customers only. This section describes how to log into the Tekelec Customer Support site and locate a document. Viewing the document requires Adobe Acrobat Reader, which can be downloaded at www.adobe.com.

1. Log into the *Tekelec Customer Support* site.

Note: If you have not registered for this new site, click the **Register Here** link. Have your customer number available. The response time for registration requests is 24 to 48 hours.

2. Click the **Product Support** tab.
3. Use the Search field to locate a document by its part number, release number, document name, or document type. The Search field accepts both full and partial entries.
4. Click a subject folder to browse through a list of related files.
5. To download a file to your location, right-click the file name and select **Save Target As**.

Maintenance and Administration Subsystem

The Maintenance and Administration Subsystem (MAS) is the central management point for the EAGLE 5 ISS. The MAS provides user interface, maintenance communication, peripheral services, alarm processing, system disk interface, and measurements. Management and redundancy are provided by use of two separate subsystem processors.

The MAS resides on two separate sets of Maintenance and Administration Subsystem Processor (MASP) cards and a Maintenance Disk and Alarm card (collectively referred to as control cards). The control cards are located in slots 1113 through 1118 of the EAGLE 5 ISS control shelf. The control cards can be either E5-based cards or legacy cards.

Note: In normal operation, the E5-based control cards and the legacy control cards cannot be mixed in one EAGLE 5 ISS control shelf.

Legacy Control Cards

The legacy set of EAGLE 5 ISS control cards consists of the following cards:

- Two MASP card sets; each set contains the following two cards:
 - A General Purpose Service Module II (GPSM-II) card
 - A Terminal Disk Module (TDM) card
- One Maintenance Disk and Alarm (MDAL) card

General Purpose Service Module II (GPSM-II) Card

Each GPSM-II card contains the Communications Processor and the Applications Processor and provides connections to the IMT bus. The card controls the maintenance and database administration activity and performs both application and communication processing. GPSM-II cards are located in slots 1113 and 1115 of the control shelf.

Terminal Disk Module (TDM) Card

Each TDM card provides the Terminal Processor for the 16 I/O ports, and interfaces to the Maintenance Disk and Alarm (MDAL) card. The TDM card also distributes Composite Clocks and High Speed Master clocks throughout the EAGLE 5 ISS, and distributes Shelf ID to the EAGLE 5 ISS. Each TDM card contains one fixed disk drive that is used to store primary and backup system databases, measurements, and Generic Program Loads (GPLs). The TDM cards are located in slots 1114 and 1116 of the control shelf.

Maintenance Disk and Alarm (MDAL) Card

The MDAL card processes alarm requests and provides fan control. There is only one MDAL card in a control card set. Critical, major, and minor system alarms are provided for up to 6 individual frames. In addition to the 3 system alarms, the MDAL card provides the system audible alarm. The MDAL card provides control of fans on a per-frame basis and allows for each fan relay to be set individually. The MDAL card contains a removable cartridge drive; the removable cartridge is used for installing new software; backing up the system software, the application software, and the database; and for downloading data for off-line processing. The MDAL card is located in slots 1117 and 1118 of the control shelf.

E5-based Control Cards

The E5-based set of EAGLE 5 ISS control cards consists of the following cards:

- Two Maintenance and Administration Subsystem Processor cards (E5-MASP) cards. Each dual-slot E5-MASP card is made up of the following two modules:
 - Maintenance Communication Application Processor (E5-MCAP) card
 - Terminal Disk Module (E5-TDM) card
- One Maintenance Disk and Alarm card (E5-MDAL card)

Maintenance Communication Application Processor (E5-MCAP) Card

The E5-MCAP card contains the Communications Processor and Applications Processor and provides connections to the IMT bus. The card controls the maintenance and database administration activity and performs both application and communication processing. E5-MCAP cards are located in slots 1113 and 1115 of the control shelf.

Each E5-MCAP card contains two USB ports. One latched USB port is used with removable flash media (“thumb drives”), and one flush-mounted USB port is used with a plug-in “credit card” flash drive. The removable media drive is used to install and back up customer data. The credit card drive is used for upgrade and could be used for disaster recovery.

Terminal Disk Module (E5-TDM) Card

The E5-TDM card provides the Terminal Processor for the 16 I/O ports, and interfaces to the Maintenance Disk and Alarm (E5-MDAL) card and fixed disk storage. The E5-TDM card also distributes Composite Clocks and High Speed Master clocks throughout the EAGLE 5 ISS, and distributes Shelf ID to the EAGLE 5 ISS. Each E5-TDM card contains one fixed SATA drive that is used to store primary and backup system databases, measurements, and Generic Program Loads (GPLs). E5-TDM cards are located in slots 1114 and 1116 of the control shelf.

Maintenance Disk and Alarm (E5-MDAL) Card

The E5-MDAL card processes alarm requests and provides fan control. There is only one E5-MDAL card in a control card set. Critical, major, and minor system alarms are provided for up to 6 individual frames. In addition to the 3 system alarms, the E5-MDAL card provides the system audible alarm. The E5-MDAL card provides control of fans on a per-frame basis, and allows for each fan relay to be

set individually. The E5-MDAL card does not contain a removable cartridge drive; drives for removable media are located on the E5-MCAP card. The E5-MDAL card is located in slots 1117 and 1118 of the control shelf.

EAGLE 5 ISS Database Partitions

The data that the EAGLE 5 ISS uses to perform its functions are stored in two separate areas: the fixed disk drives, and the removable cartridge. The following sections describe these areas and data that is stored on them. These areas and their partitions are shown in *Figure 1: EAGLE 5 ISS Database Partitions (Legacy Control Cards)* and *Figure 2: EAGLE 5 ISS Database Partitions (E5-Based Control Cards)*.

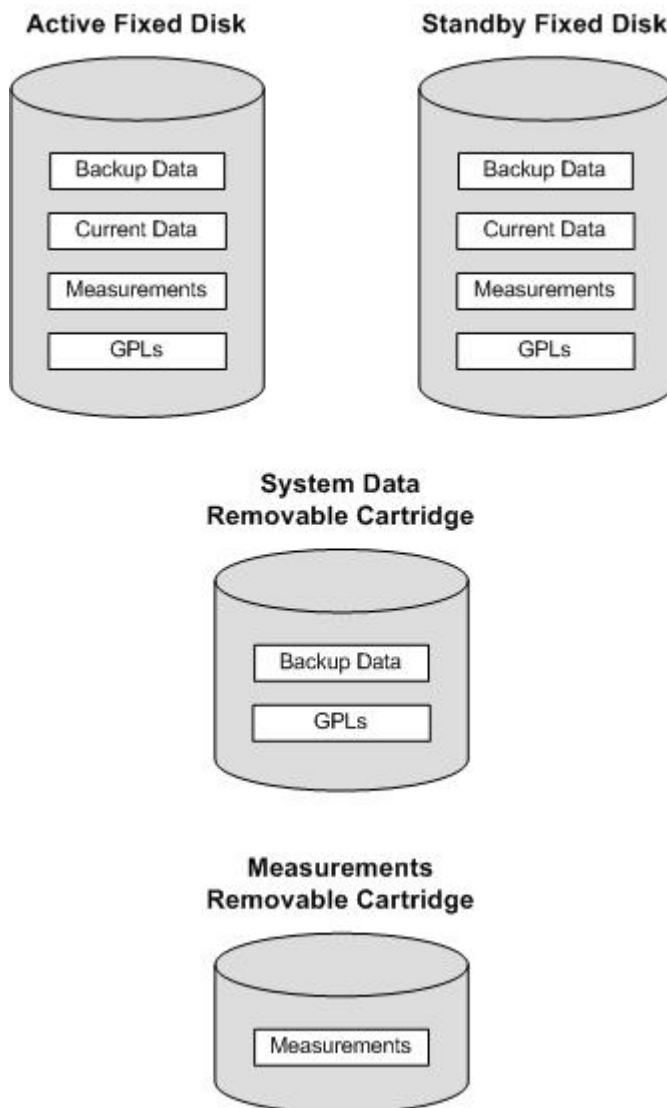

Figure 1: EAGLE 5 ISS Database Partitions (Legacy Control Cards)

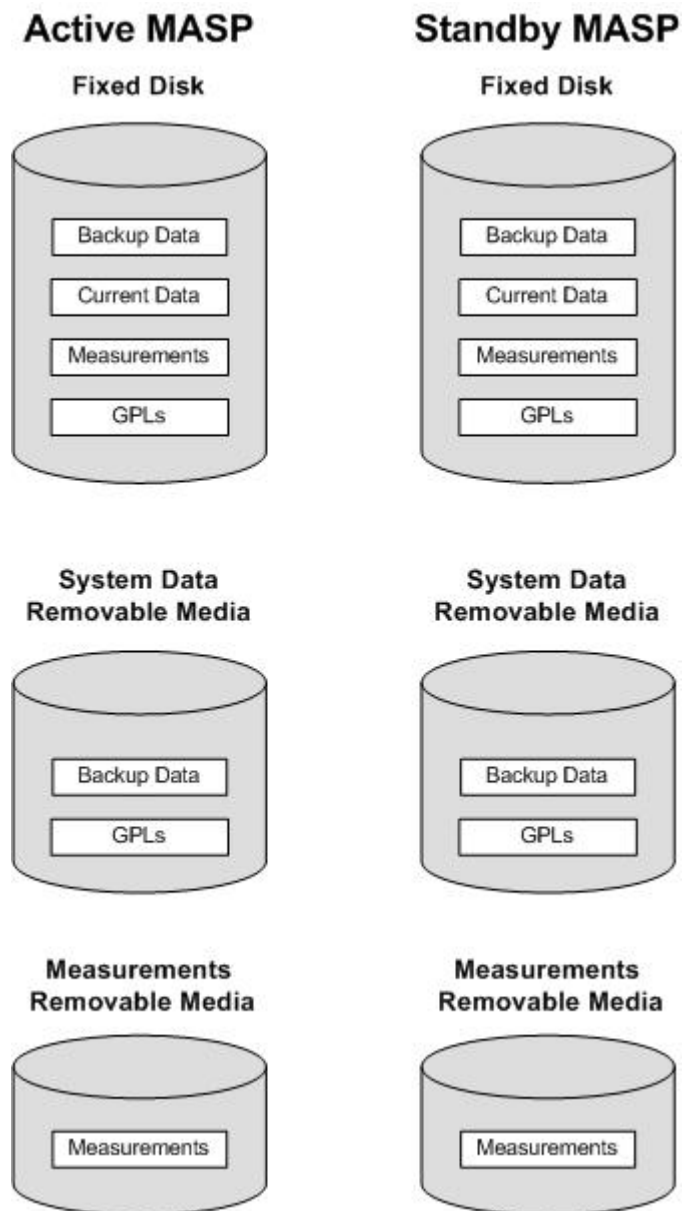

Figure 2: EAGLE 5 ISS Database Partitions (E5-Based Control Cards)

Fixed Disk Drive

There are two fixed disk drives on the EAGLE 5 ISS. The fixed disk drives contain the “master” set of data and programs for the EAGLE 5 ISS. The two fixed disk drives are located on the terminal disk modules (TDMs). Both disks have the same files. The data stored on the fixed disks is partially replicated on the various cards in the EAGLE 5 ISS. Changes made during database administration sessions are sent to the appropriate cards.

The data on the fixed disks can be viewed as four partitions.

- Current partition

- Backup partition
- Measurements partition
- Generic program loads (GPLs) partition

The data which can be administered by users is stored in two partitions on the fixed disk, a current database partition which has the tables which are changed by on-line administration, and a backup database partition which is a user-controlled copy of the current partition.

All of the on-line data administration commands affect the data in the current partition. The purpose of the backup partition is to provide the users with a means of rapidly restoring the database to a known good state if there has been a problem while changing the current partition.

A full set of GPLs is stored on the fixed disk, in the GPL partition. There is an approved GPL and a trial GPL for each type of GPL in this set and a utility GPL, which has only an approved version. Copies of these GPLs are downloaded to the EAGLE 5 ISS cards. The GPL provides each card with its functionality. For example, the `ss7ansi` GPL provides MTP functionality for link interface modules (LIMs).

Measurement tables are organized as a single partition on the fixed disk. These tables are used as holding areas for the measurement counts.

Removable Cartridge or Removable Media

The removable cartridge is used with the legacy MDAL control card in card location 1117. The removable media is used with the E5-MCAP card portion of the E5-MASP in card locations 1113 and 1115.

The removable cartridge or removable media is used for two purposes.

- To hold an off-line backup copy of the administered data and system GPLs
- To hold a copy of the measurement tables

Because of the size of the data stored on the fixed disk drives on the TDMs, a single removable cartridge or removable media cannot store all of the data in the database, GPL and measurements partitions.

To use a removable cartridge or removable media to hold the system data, it must be formatted for system data. To use a removable cartridge or removable media to hold measurements data, it must be formatted for measurements data. The EAGLE 5 ISS provides the user the ability to format a removable cartridge or removable media for either of these purposes. A removable cartridge or removable media can be formatted on the EAGLE 5 ISS by using the `format-disk` command. More information on the `format-disk` command can be found in the *Commands Manual*. More information on the removable cartridge or removable media drives can be found in the *Hardware Manual - EAGLE 5 ISS*.

Additional and preformatted removable cartridges or removable media are available from the [Customer Care Center](#).

STPLAN Configuration

Topics:

- *STPLAN Feature Overview.....20*
- *TCP/IP Router.....23*
- *Hardware Requirements25*
- *Node Requirements.....25*
- *Gateway Screening.....26*
- *STPLAN Provisioning.....27*
- *Understanding Firewall and Router Filtering....28*
- *IP Addresses.....29*
- *Network Configuration Procedures.....31*
- *Adding an STPLAN Card.....36*
- *Removing an STPLAN Card.....42*
- *Adding a TCP/IP Data Link.....45*
- *Removing a TCP/IP Data Link.....49*
- *Adding a TCP/IP Node.....51*
- *Removing a TCP/IP Node.....54*
- *Configuring the Copy Original OPC for STPLAN Option.....58*
- *Configuring the Option for Including the Incoming and Outgoing Linkset Names in the STPLAN Message Format.....59*

Chapter 2, STPLAN Configuration, describes the STPLAN feature and the procedures necessary to configure the EAGLE 5 ISS to support this feature.

STPLAN Feature Overview

The STPLAN feature provides a TCP/IP connection from any interface shelf to support external applications. Message signal units (MSUs) that are processed by the EAGLE 5 ISS can be copied and directed through the LAN interface to an external server or microcomputer application such as a usage measurements EAGLE 5 ISS. The gateway screening feature must be available on the STP in order to use the STPLAN feature.

The feature requires an STPLAN card, either the DCM, SSEDCCM, or E5-SLAN card running the `stpplan` application, which provides an ethernet interface at the backplane, as well as the processing power required to support TCP/IP message encapsulation.

The STPLAN card receives SS7 MSUs from the Interprocessor Message Transport (IMT) bus and copies the MSUs into memory resident on the STPLAN card. The EAGLE 5 ISS encapsulates the copied MSU into TCP/IP packets and sends the encapsulated message over the ethernet to the host computer or to a TCP/IP router. The host computer is responsible for assembling and processing the packets it receives. The TCP/IP router routes the messages to a host computer on another network.

Each STPLAN card uses one ethernet port. The Transmission Control Protocol (TCP) and User Datagram Protocol (UDP) are supported at the transport layer. Internet Protocol (IP), Internet Control Message Protocol (ICMP) and Address Resolution Protocol (ARP) are supported at the network layer.

If the DCM card or SSEDCCM card is used as the STPLAN card, either 10baseT ethernet or 100baseT ethernet is supported by the EAGLE 5 ISS. The ethernet connection is made directly to the EAGLE 5 ISS backplane and no external media access unit (MAU) is used. The MAU is incorporated in the DCM card. The DCM card capacity is 1200 TPS when configured to run on a 10baseT network, and 2500 TPS when configured for a 100baseT network.

If the E5-SLAN card is used as the STPLAN card, 10/100Mbps port data transfer rate is supported by the EAGLE 5 ISS. The ethernet interface supports 10/100 Mbps data rates, full/half duplex, fixed/auto-negotiate, DIX/802.3 MAC header modes. The capacity of the E5-SLAN card is 1200 TPS when configured to run on a 10baseT network, or on a 100baseT network at half duplex, and 12000 TPS when configured for a 100baseT network at full duplex.

This implementation does not support standard TCP/IP protocols such as TELNET and FTP. However, it supports EAGLE 5 ISS applications that are built on TCP/IP using the Socket Application Programming Interface (API). The protocol stack is not biased toward any particular application.

Message Sequencing

The STPLAN card adds a time stamp to the message before sending it to the LAN. The time stamp maintains a one second granularity and is synchronized with the host computer. This synchronization requires the host computer to be capable of responding to the time and date queries on the UDP port 37. The receiver can use the time stamp to provide sequencing within an application. The STPLAN application does not use sequence numbers for messages.

Message Format

Because TCP/IP is a stream-oriented protocol, the host computer can receive multiple messages in a single packet, or the message can be divided among different packets. [Figure 3: STPLAN Messages Embedded in TCP/IP Packets](#) shows an example of both. There are multiple MSUs in the first packet with one of the MSUs divided between the first packet and the second packet.

This list describes the fields used in these packets:

- STP/LAN Protocol Version (a 1-byte value) – The type of EAGLE 5 ISS message being carried from the LIMs to the STPLAN card. The only valid value for this field is 1.
- Time Stamp Type (a 1-byte value) – The type of timestamp that is being used in the message. The only valid value for this field is 1, indicating that the supported timestamp type is the UNIX style timestamp (a 32-bit number containing the time elapsed since 00:00:00 hour, January 1, 1970).
- MSU Count (a 1-byte value) – How many MSUs are actually contained in the packet.
- Total Length (a 2-byte value) – The total length, in bytes, of the data plus the MSU headers embedded inside the packet. This length should not be greater than 485 bytes.
- Port ID (a 2-byte value) – The ID of the port on the LIM which copied the data to the STPLAN card. The valid range for this field is 0–511.
- Timestamp (a 4-byte value) – The actual timestamp at which the message is sent out to the host.
- MSU Length (a 2-byte value) – The length of the actual MSU in bytes. The sum of the MSU lengths of all the MSUs in the packet plus the sum of the sizes of the single MSU headers should be equal to the number contained in the Total Length field.
- MSU – The MSU that is contained in the packet.

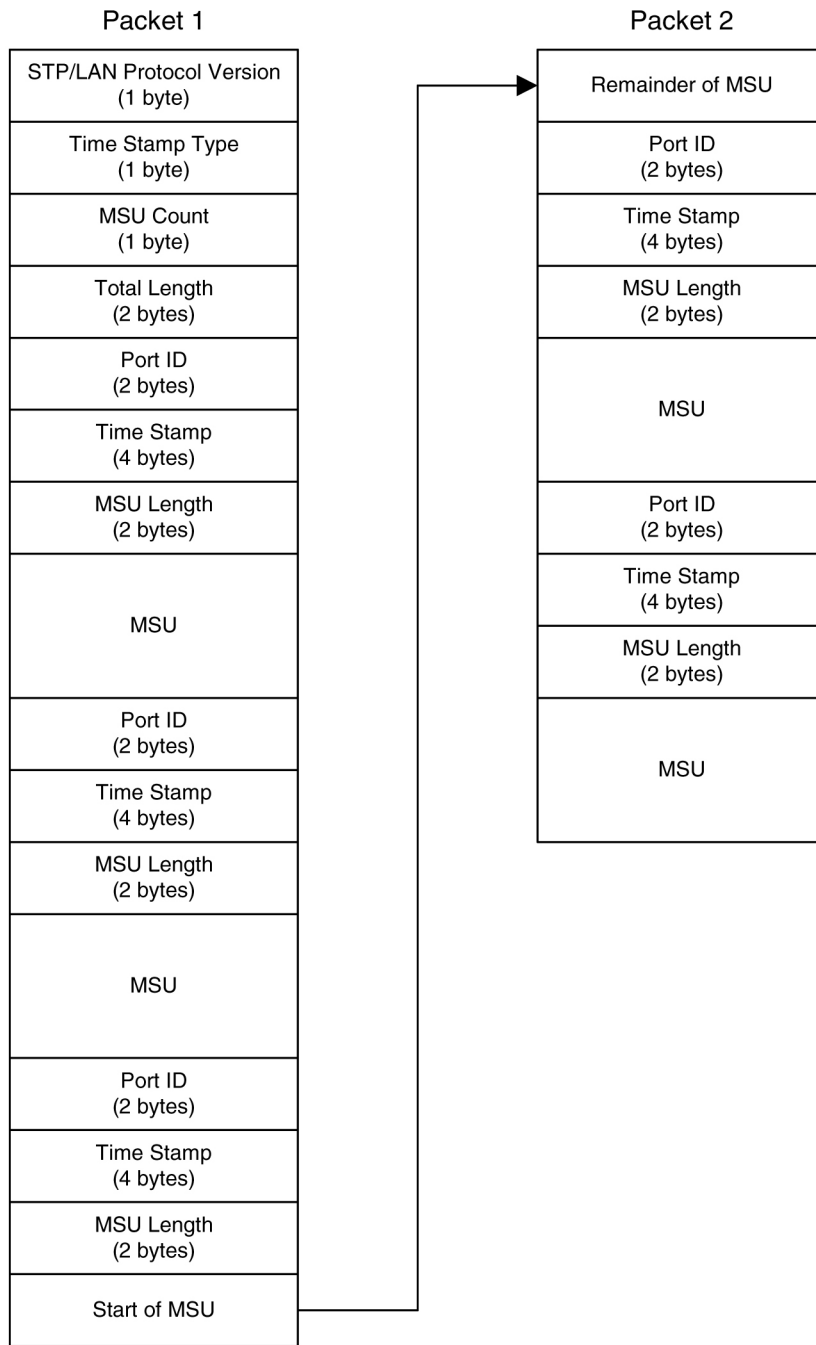

Figure 3: STPLAN Messages Embedded in TCP/IP Packets

TCP/IP Router

A TCP/IP router is used to route STPLAN messages from the EAGLE 5 ISS to a remote host in another network or subnetwork. [Figure 4: STPLAN Network with a TCP/IP Router](#) shows an example of the STPLAN feature using a TCP/IP router.

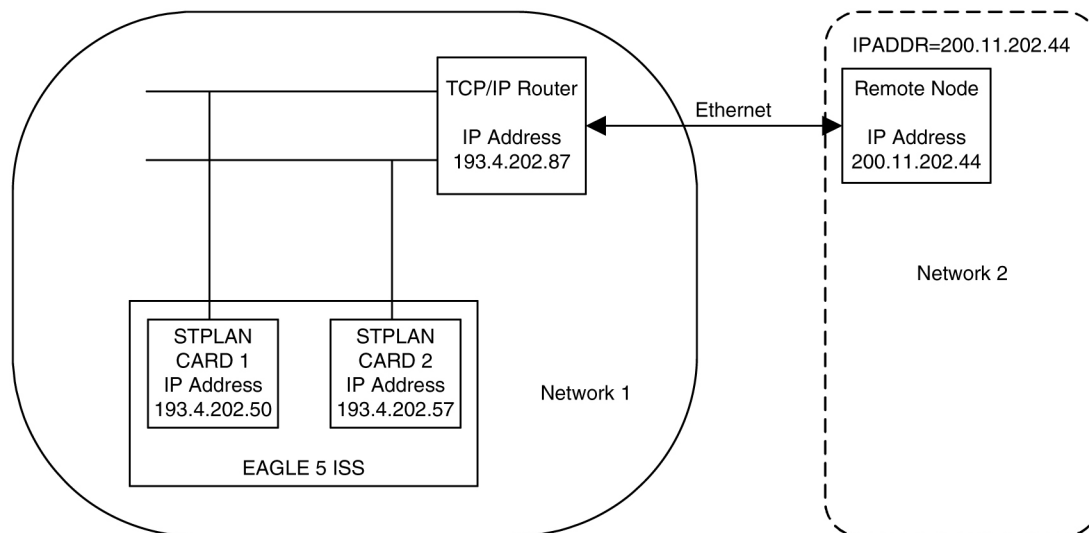

Figure 4: STPLAN Network with a TCP/IP Router

Note: The term “STPLAN Card” used in [Figure 4: STPLAN Network with a TCP/IP Router](#) refers to either a DCM, SSEDCCM, or E5-SLAN card running the `stplan` application.

In this example, STPLAN cards 1 and 2, with IP addresses 193.4.202.50 and 193.4.202.57, need to route their traffic to the remote host at IP address 200.11.202.44. The STPLAN cards and the remote host are in two different networks; the network ID of the STPLAN cards is 193.4.202.67 and the network ID of the remote host is 200.11.202.44. The EAGLE 5 ISS can connect only to TCP/IP nodes that are in the same network as the EAGLE 5 ISS. To permit communication between the STPLAN cards and an external network, a TCP/IP router is placed in between the EAGLE 5 ISS and the remote host. The TCP/IP router is located in the same network as the EAGLE 5 ISS, with the IP address of 193.4.202.87. The messages can now be sent to the remote host through the TCP/IP router.

A TCP/IP default router must be entered into the database when the class and network ID of the data link’s IP address and host’s IP address do not match or when subnet routing is used. The TCP/IP router is entered into the database with the `ent-ip-node` command. The EAGLE 5 ISS cannot distinguish between a large network and the use of subnet routing, and cannot detect the omission of a TCP/IP router. In a large network, no TCP/IP routers are required because all the nodes are directly connected to a single ethernet. See [Figure 5: STPLAN in a Large Network](#).

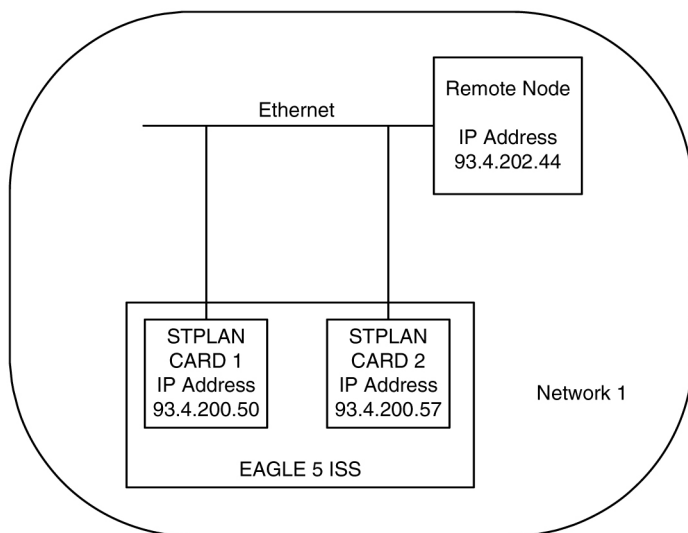

Figure 5: STPLAN in a Large Network

Note: The term “STPLAN Card” used in *Figure 5: STPLAN in a Large Network* refers to either a DCM, SSEDCM, or E5-SLAN card running the stplan application.

If a user is using subnet routing and as a result, multiple ethernets, TCP/IP routers are required and must be configured in the EAGLE 5 ISS. See *Figure 6: STPLAN Network with Subnet Routing*.

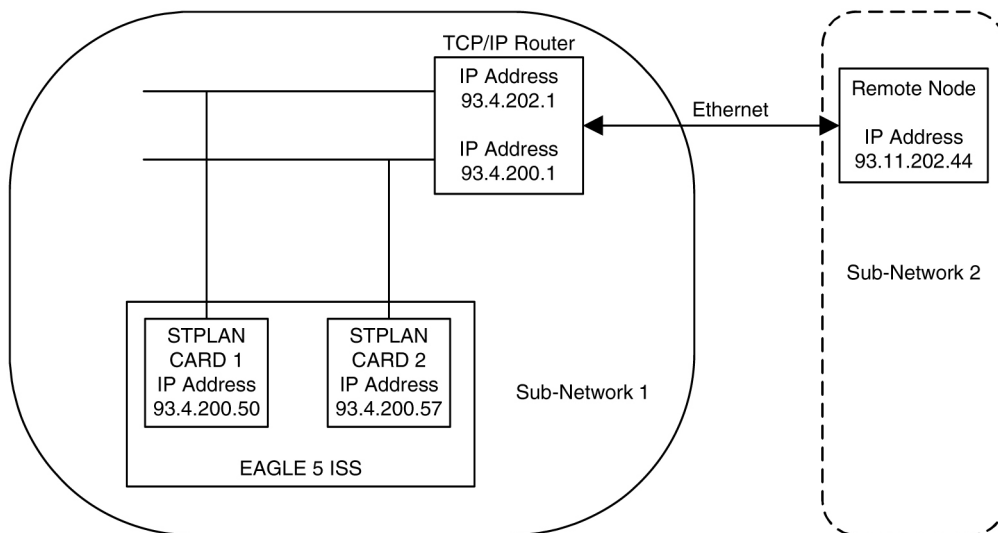

Figure 6: STPLAN Network with Subnet Routing

Note: The term “STPLAN Card” used in *Figure 6: STPLAN Network with Subnet Routing* refers to either a DCM, SSEDCM, or E5-SLAN card running the stplan application.

For the examples shown in *Figure 5: STPLAN in a Large Network* and *Figure 6: STPLAN Network with Subnet Routing*, the IP addresses of the TCP/IP data links and the remote node are the same. In *Figure 5: STPLAN in a Large Network*, the remote node is in the same network as the TCP/IP data links, so no TCP/IP router is needed. In *Figure 6: STPLAN Network with Subnet Routing*, the user is using subnet routing. The remote node is in one subnetwork, and the TCP/IP data links are in another subnetwork. Even though the network portion of the IP addresses of the TCP/IP data links and the remote node

are the same (93, a class A IP address), a TCP/IP router is required because the user is using subnet routing.

If, when configuring STPLAN according to the network in [Figure 6: STPLAN Network with Subnet Routing](#), the TCP/IP router is not configured with the `ent-ip-node` command, the EAGLE 5 ISS does not detect that the TCP/IP router has been omitted, and no warnings are given in this case. The EAGLE 5 ISS sees the remote node as a TCP/IP node in the same network as the TCP/IP data links, because of the class of the IP addresses, and does not require the user to specify the `iprte` parameter of the `ent-ip-node` command.

Hardware Requirements

The hardware requirements and configuration include these items:

- The EAGLE 5 ISS supports up to 32 DCM, SSEDCEM, or E5-SLAN cards.
- Multiple DCM, SSEDCEM, or E5-SLAN cards can connect to each each host on different ports. The assignment of the LIMs is done automatically by the EAGLE 5 ISS.
- The TSM and multiple LIM cards can also be used.
- For the DCM or SSEDCEM card, one of two cables can be used to connect the card to the node, a straight-thru cable or a transmit/receive cross-over cable. The cable from the node terminates directly to the backplane and does not use any adapters. The cable connects to port A (the top port) on the card.
- For the E5-SLAN card, one of the two cables can be used to connect the E5-SLAN card to the node, an existing cable used by SSEDCEM cards or a standard CAT-5 ethernet cable. The cable used by SSEDCEM cards requires a backplane cable adaptor (P/N 830-1103-02) to connect to the E5-SLAN card to the node. The CAT-5 ethernet cable requires a backplane cable adaptor (P/N 830-1102-02) to connect the E5-SLAN card to the node. The cable connects to port A0 on the PMC A ethernet card within the E5-SLAN card.

Refer to the *Hardware Manual - EAGLE 5 ISS* for more information about the DCM or E5-SLAN card.

Node Requirements

In order for a node to communicate with the DCM, SSEDCEM, or E5-SLAN card, you must configure the node system to perform or include these items:

- The node system must include an ethernet driver, TCP/IP protocol interface, and application software to process the incoming messages.
- The node TCP/IP protocol must be able to accept connections and supply an accurate time/date stamp over UDP port 37. (See RFC 868.)
- If multiple nodes are receiving data, the node application must be able to correlate related messages that are received on different nodes. Because of the load-balancing feature, the EAGLE 5 ISS cannot guarantee a constant LIM-to-node path.

Gateway Screening

Gateway screening tables can be configured to screen messages for certain attributes. The screening process results in a message being accepted or rejected into the network. The criteria for message screening depends on the type of message received by the EAGLE 5 ISS, and the contents of the gateway screening tables.

You can send a copy of the message that has passed all of the screening criteria to a node. To stop the screening process and, at the same time, send a copy of the message to the STPLAN application, the next screening function identifier (*NSFI*) of the screen where the gateway screening process stops must be set to *stop*, and a gateway screening stop action set containing the *copy* gateway screening stop action must be assigned to that screen. The linkset containing the SS7 messages copied to the STPLAN application must have a gateway screening screenset assigned to it and the *gwsa* or *gwsn* parameter must be set to *on*.



CAUTION:

When Gateway Screening is in the screen test mode, as defined by the linkset parameters *gwsa=off* and *gwsn=on*, the gateway screening action in the gateway screening stop action set specified by the *actname* parameter of the gateway screening screen set at the end of the gateway screening process will be performed.

Gateway screening functions are defined using screening tables or screensets which contain a set of rules. Each screenset is uniquely identified by a screenset name. A screenset is a collection of screening references or rules, each assigned a unique screening reference name. Each screening reference belongs to a specific category, which indicates the criteria that is used to either accept or reject an incoming MSU. For example, the category “*blkopc*” rejects all MSUs with the OPCs specified in the screening reference.

The screening parameters (point codes, routing indicator, subsystem number, and so forth) are used to match information in the SS7 message.

Each group of screening references is referred to as a screen set and is identified by a particular screen set name (*SCRN*). The screen set can then be applied to a particular linkset. This allows, for example, for specific OPCs with particular SIOs and DPCs to be allowed into the network.

There are two basic functions, *allow* and *block*. In an allowed screen (for example, allowed DPC), if a match is found and the next screening function identifier (*nsfi*) is equal to anything but *stop*, the next screening reference (*nsr*) is identified and the screening process continues. If the next screening function identifier is *stop*, the message is processed and no further screening takes place. If no match is found, the message is rejected. If the next screening function identifier is *stop* and a gateway screening stop action set that contains the *copy* gateway screening stop action is assigned to the screen, the EAGLE 5 ISS sends a copy of the message to the STPLAN application.

In a blocked screen (for example, blocked DPC):

Table 2: Gateway Screening Action

If...	then...
a match is found and the next screening function identifier is <code>fail</code> ,	the message is rejected and no further screening takes place.
no match is found and the next screening function identifier is equal to anything but <code>stop</code> ,	the next screening reference is identified and the screening process continues.
the next screening function identifier is equal to <code>stop</code> ,	the message is processed and no further screening takes place.
the next screening function identifier is equal to <code>stop</code> and a gateway screening stop action containing the copy gateway screening stop action is assigned to the screen	the message is processed and the EAGLE 5 ISS sends a copy of the message to the STPLAN application.

The allowed OPC and DPC screens are useful in the gateway screening process when specifying particular sets of point codes that are allowed to send or receive messages to or from another network. The blocked OPC and DPC screens are useful in the gateway screening process to specify particular sets of point codes that are not allowed to send or receive messages to or from another network.

Congestion Management

If a message reaches the outbound “stop and copy” phase of the gateway screening process, and the LIM that is designated to transmit a copy of the message to the node is congested, the copy of the message is not transmitted to the node. The STP disables the application only on the particular LIM that is experiencing congestion.

Conversely, a message may arrive on an inbound LIM that is in danger of congestion while the outbound LIM is not in danger of congestion. As the message was not screened on the inbound LIM, it is not marked to be copied to the STPLAN card.

Go to the *Database Administration Manual - Gateway Screening* for information on configuring gateway screening entities.

STPLAN Provisioning

The STPLAN application allows the user to selectively copy outbound messages to a remote node for further processing. The messages that are copied to the remote node are actually selected for copying on the inbound linkset by the Gateway Screening feature. The messages that pass the screening criteria set for that linkset are processed by the EAGLE 5 ISS, and are copied prior to being transmitted on the outbound link.

The external connection to the remote node consists of several E5-SLAN cards or DCM cards (STPLAN cards) equipped with Ethernet interfaces using the TCP/IP protocol to communicate to an external processing device running software that receives and processes the messages. Each STPLAN card

supports a single remote destination node. Each STPLAN card may also support a single default router.

On the EAGLE 5 ISS, the LAN interface is implemented through a pool of STPLAN cards. For reliability, STPLAN cards are provisioned on an “N+1” redundancy basis so that in case of failure of one such card, performance can be maintained during the time required to replace it. Performance calculations assume that a typical LIM card carries 0.8 Erlang worth of traffic, which would be the case if cards normally carry 0.4 Erlang and a failover situation occurs.

STPLAN cards are provisioned per site based on the total number of cards in the EAGLE 5 ISS which require STPLAN service.

To determine the number of STPLAN cards required in a particular site to accommodate the worst-case traffic situations, the following quantities must be determined first.

- LSL = the number of low-speed links in the system
- HSL = the number of high-speed LIM ATMs links in the system
- SE-HSL = the number of high-speed SE-HSL links in the system
- ST-HSL-A = the number of high-speed ST-HSL-A links in the system
- KTPS = the number of thousands of packets per second that IPLIM/IPGWY cards will handle, e.g.: 2 for 2,000 TPS, 4 for 4,000 TPS, etc.
- The estimated average size of MSUs flowing through the system (such as 80 octets per MSU).

Contact your Tekelec Sales Representative or Account Representative to determine the number of STPLAN cards that must be provisioned in your EAGLE 5 ISS, and to determine where in the EAGLE 5 ISS these STPLAN cards must be provisioned.

Understanding Firewall and Router Filtering

Firewall protocol filtering for the interface between the EAGLE 5 ISS DCM, SSEDCCM, or E5-SLAN card and the host computer is defined in [Table 3: STPLAN External Ports and Their Use](#).

Table 3: STPLAN External Ports and Their Use

Interface	TCP/IP Port	Use	Inbound	Outbound
10BASE-TX or 100BASE-TX	1024 to 5000 ¹	STPLAN Traffic	Yes	Yes
	7	UDP Echo (ping)	Yes	Yes
	37	Time/Date	Yes	Yes
	N/A	ARP (Address Resolution Protocol) ²	Yes	Yes

Interface	TCP/IP Port	Use	Inbound	Outbound
<p>1. The TCP/IP port is the port number configured with the <code>ipport</code> parameter of the <code>ent-ip-node</code> command. The value of the <code>ipport</code> parameter is shown in the <code>IPPORT</code> field of the <code>rtrv-ip-node</code> command output. The values for this parameter are in the range 1024–5000.</p> <p>2. ARP is used to provide TCP communication. The customer network will provide this information as appropriate.</p>				

The STPLAN application requires a data pipe of 10 or 100 Mb. The actual percentage of SLAN transactions that is used (the maximum) is defined by the `cap` parameter of the `ent-ip-node` command. There can be more than one connection from the EAGLE 5 ISS to the node defined by the `ipaddr` (the node's IP address) parameter of the `ent-ip-node` command.

IP Addresses

An IP address contains 32 bits grouped into four segments or octets. Each octet contains eight bits. The range of values for an octet is from 0 (all bits in the octet are 0) to 255 (all bits in the octet are 1). The four octets of an IP address are grouped into three different identifiers: the class ID, the network number and the host number. The value in the class ID determines how the rest of the bits in the ip address are categorized, mainly into the network number and the host number. The value of the class ID are in the first octet. If the first bit in the first octet is 0, the IP address is a class A IP address. If the first two bits in the first octet are 1 and 0, the IP address is a class B IP address. If the first three bits in the first octet are 1, 1, and 0, the IP address is a class C IP address. There are class D and E IP addresses, but these classes of IP addresses are not supported by the EAGLE 5 ISS. The loopback IP addresses (127.*.*) are supported by DCM, SSEDCCM, and E5-SLAN cards.

The network number of the IP address is the part of an IP address that identify the network that the host belongs to. The octets that make up the network number depend on the class of the IP address. For class A IP addresses, the network number is the bits in the first octet minus the class ID bits (the first bit of the first octet). For class B IP addresses, the network number is the bits in the first octet minus the class ID bits (the first two bits of the first octet) plus the bits in the second octet. For class C IP addresses, the network number is the bits in the first octet minus the class ID bits (the first three bits in the first octet) plus the bits in the second and third octets.

The host number of an IP address is the part of an IP address that identify a specific host on a network. The host number contains all the bits that do not belong to the class ID or the network number. For class A IP addresses, the host number contains all the bits in the second, third and fourth octets. For class B IP addresses, the host number contains all the bits in the third and fourth octets. For class C IP addresses, the host number contains all the bits in the fourth octet.

Table 4: Values of IP Addresses summarizes the IP address values for the classes of IP addresses. *Figure 7: IP Address Bit Categorization* illustrates the different parts of the IP addresses in each class of IP addresses.

Table 4: Values of IP Addresses

IP Address Class	IP Address Format	Class ID Bits	Range of IP Address Values
A	N.H.H.H	0	1.0.0.1 to 126.255.255.254
B	N.N.H.H	1, 0	128.1.0.1 to 191.254.255.254
C	N.N.N.H	1, 1, 0	192.0.1.1 to 223.255.254.254

N = Network Number, H = Host Number

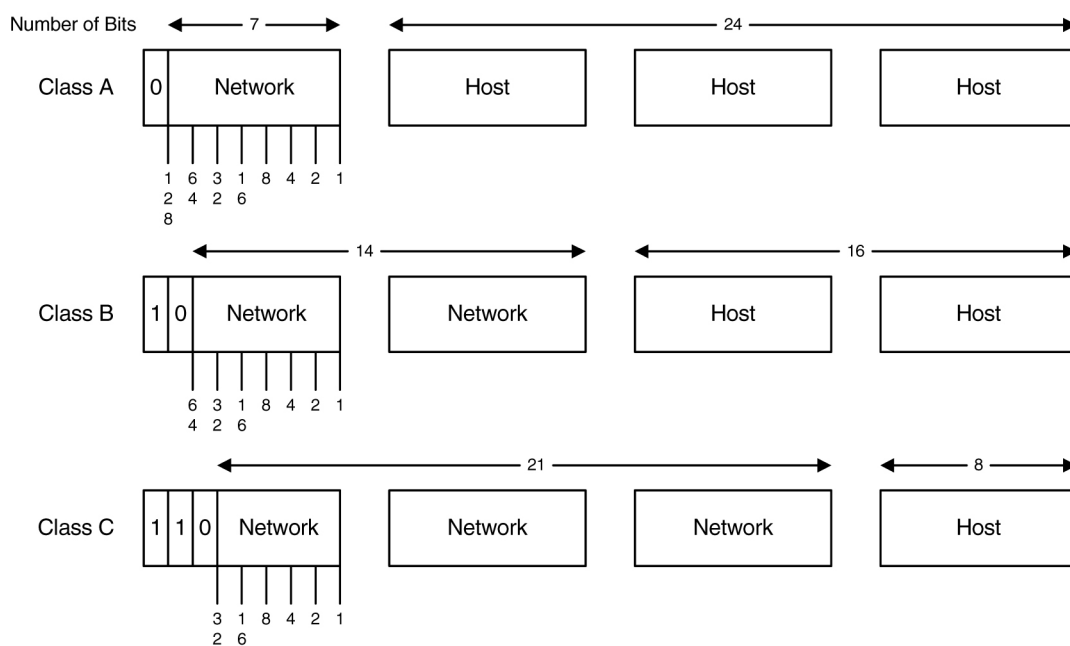

Figure 7: IP Address Bit Categorization

The EAGLE 5 ISS does not allow IP addresses to be entered that contain an invalid class ID, network number or host number. Valid class ID values are shown in [Table 4: Values of IP Addresses](#). Valid network numbers and host numbers cannot contain all 0 bits or all 1 bits. For example, the class A IP address 10.0.0.0 is invalid because it contains a host number of '0.0.0'. A class B IP address of 128.0.10.5 is also invalid because the network number is '0.0' (remember the network number for a class B address is the bits in the first octet minus the class ID bits). The class C IP address of 192.0.1.255 is also invalid because it contains a host number of '255' (all ones). One of the error codes shown in [Table 5: Invalid IP Address Error Codes](#) will be generated when an invalid IP address is entered.

Table 5: Invalid IP Address Error Codes

Error Code	Error Message
E2028	Octet 1 is out of range, 1..223
E2071	Network Number Invalid
E2072	Host Number Invalid
E2070	IP Address invalid for Address Class

Network Configuration Procedures

To support the STPLAN feature, you must configure these database elements that are specific to the STPLAN feature.

- DCM, SSEDCM, or E5-SLAN card
- TCP/IP Data Link
- IP Node

When the EAGLE 5 ISS is booted, each module gets the configuration information from the database. [Figure 8: STPLAN Database Relationships](#) shows the database elements that must be configured, and the order in which they should be configured.

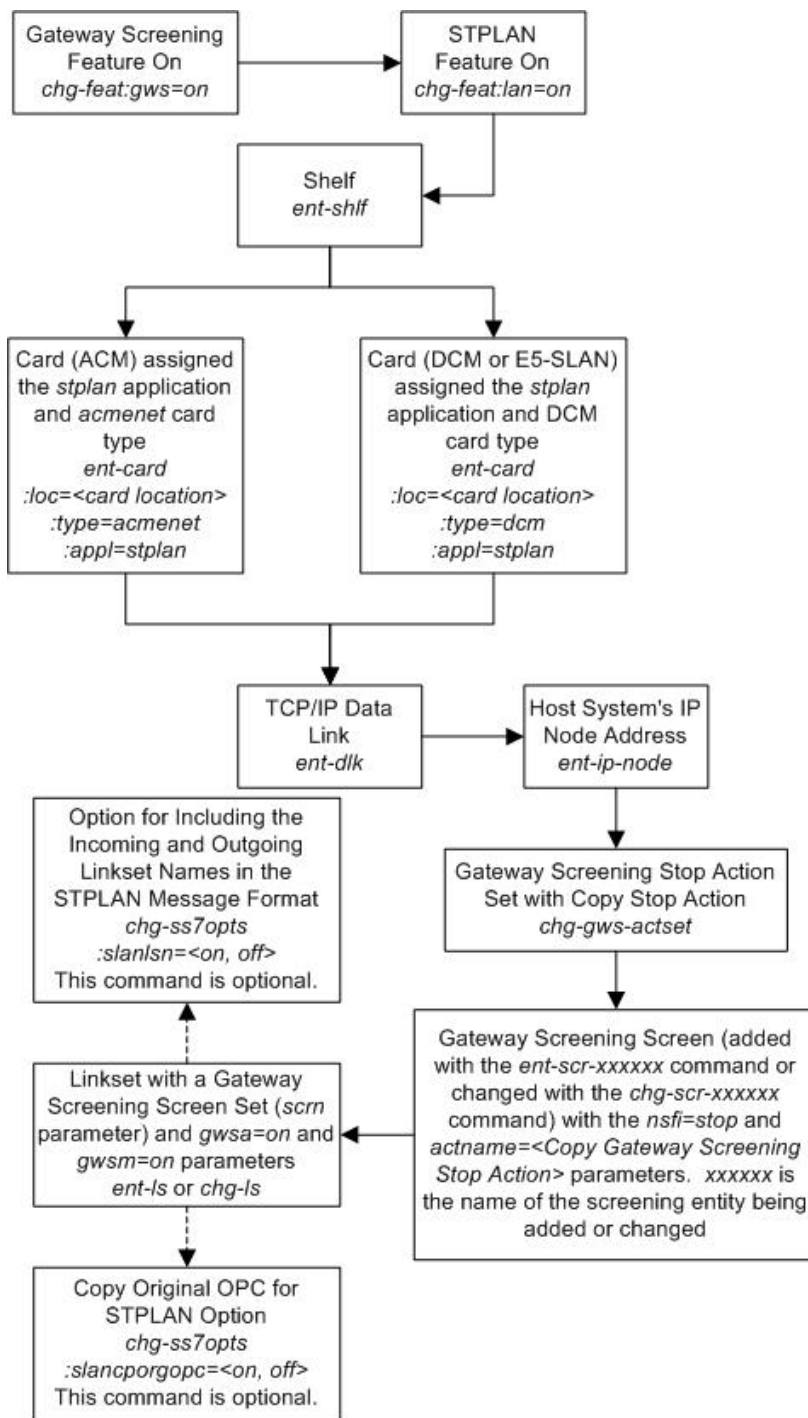

Figure 8: STPLAN Database Relationships

These procedures use a variety of commands. If you need more information on these commands, refer to the *Commands Manual* to find the required information.

This list describes the database entities (shown in [Figure 8: STPLAN Database Relationships](#)) that must be configured for the STPLAN feature.

1. The STPLAN and gateway screening features must be turned on. Verify that these features are turned on with the `rtrv-feat` command. If either of these the features are not on, shown with the entries `GWS = off` (if the gateway screening feature is off), and `LAN = off` (if the STPLAN feature is off), in the `rtrv-feat` command output, enter the `chg-feat:gws=on` command to turn on the gateway screening feature, and the `chg-feat:lan=on` command to turn on the STPLAN feature.

Note: Once the gateway screening and STPLAN features are turned on with the `chg-feat` command, they cannot be turned off.

2. Make sure that the required shelf is in the database with the `rtrv-shlf` command. If it is not in the database, add it with the `ent-shlf` command.
3. Make sure the cards that the TCP/IP data links will be assigned to are in the database with the `rtrv-card` command. These cards can be either DCM, SSED, or E5-SLAN cards (card type `dcm`). The DCM, SSED, or E5-SLAN card must have the `stplan` application assigned to it. If these cards are not in the database, add them with the `ent-card` command, a DCM, SSED, or E5-SLAN card with the `type=dcm` and `appl=stplan` parameters.
4. The TCP/IP data links needed by the STPLAN feature must be in the database. Verify this by entering the `rtrv-dlk` command. If the necessary TCP/IP data links are not in the database, add them with the `ent-dlk` command. Make sure that the card location specified in the `ent-dlk` command is an DCM, SSED, or E5-SLAN card shown in step 3. You must also select the speed of 10 (default) or 100.
5. The TCP/IP nodes used by the STPLAN feature must be in the database. Verify this by entering the `rtrv-ip-node` command. If the necessary TCP/IP nodes are not in the database, add them with the `ent-ip-node` command with a card location assigned to a TCP/IP data link shown in step 4.
6. The GLS card must be provisioned and installed to be able to load card's screen-set
7. The STPLAN feature uses gateway screening to select the messages that are copied and sent to the STPLAN application on a DCM, SSED, or E5-SLAN card. A gateway screening stop action set containing the `COPY` gateway screening stop action must be assigned to the gateway screening entity where the gateway screening process stops (the NSFI of the screen is `STOP`). Enter the `rtrv-gws-actset` command to display the gateway screening stop action sets in the database. The database contains at least two gateway screening stop actions sets that contain the `COPY` gateway screening stop action as shown in bold in the example output. These gateway screening stop actions are always in the database and cannot be changed or removed.

```
rlghncxa03w 06-10-20 21:16:37 GMT EAGLE5 36.0.0
ACT  ACT  ACT  ACT  ACT  ACT  ACT  ACT  ACT  ACT  ACT  ACT
ID   NAME  1    2    3    4    5    6    7    8    9    10
--   -
1    copy  copy
2    rdct  rdct
3    cr    copy rdct
GWS action set table is (3 of 16) 19% full
```

8. Verify that the necessary gateway screening entities have been configured with the required gateway screening stop action set, by entering the appropriate gateway screening retrieve command specifying the `actname` parameter with the gateway screening stop action name shown in the `rtrv-gws-actset` command output.

```
rtrv-scrset:actname=copy
rtrv-scr-opc:actname=copy
rtrv-scr-blkopc:actname=copy
```

```

rtrv-scr-sio:actname=copy
rtrv-scr-dpc:actname=copy
rtrv-scr-blkdpc:actname=copy
rtrv-scr-destfld:actname=copy
rtrv-scr-cgpa:actname=copy
rtrv-scr-tt:actname=copy
rtrv-scr-cdpa:actname=copy
rtrv-scr-aftpc:actname=copy
rtrv-scr-isup:actname=copy

```

If a gateway screening entity is configured to copy messages to an STPLAN application, the entry STOP appears in the NSFI field and the NSR/ACT field contains the name of the gateway screening stop action set specified in the gateway screening retrieve command (see the following example).

```

rlghncxa03w 06-10-20 21:17:37 GMT EAGLE5 36.0.0
SCREEN = ALLOWED OPC
SR   NI      NC      NCM      NSFI      NSR/ACT
opc1 010      010      010      STOP      COPY
opc1 010      010      012      STOP      COPY

```

If the desired gateway screening entity is not configured to copy messages to the STPLAN application, configure these entities to copy messages to the STPLAN application. Go to the *Database Administration Manual - Gateway Screening* for information on configuring gateway screening entities.

9. The linkset containing the messages copied for the STPLAN application must have a gateway screening assigned to it. Either the `gwsa` or `gwsn` parameters of the linkset must be set to `on`. Verify this with the `rtrv-ls` command. If the desired linkset does not have a gateway screening assigned to it, shown in the `SCRN` field of the `rtrv-ls` output, or the `GWSA` or `GWSM` field is set to `off`, refer to the Changing an SS7 Linkset procedure in the *Database Administration Manual - SS7* and change the `scrn`, `gwsa`, and `gwsn` parameters of the desired linkset.



CAUTION

CAUTION: When Gateway Screening is in the screen test mode, as defined by the linkset parameters `gwsa=off` and `gwsn=on`, the gateway screening action in the gateway screening stop action set specified by the `actname` parameter of the gateway screening screen set at the end of the gateway screening process will be performed.

10. The copy original OPC for STPLAN option can be configured for the STPLAN feature. Enter the `rtrv-ss7opts` command to verify the status of this option. This option is configured by performing the procedure [Configuring the Copy Original OPC for STPLAN Option](#). Configuring this option is not required for the STPLAN feature.
11. The option for including the incoming and outgoing linkset names in the STPLAN message format can be configured for the STPLAN feature. Enter the `rtrv-ss7opts` command to verify the status of this option. This option is configured by performing the procedure [Configuring the Option for Including the Incoming and Outgoing Linkset Names in the STPLAN Message Format](#). Configuring this option is not required for the STPLAN feature.

The STPLAN configuration procedures in this chapter use the sample network information shown in [Table 6: STPLAN Configuration Example Database](#). [Figure 9: STPLAN Configuration Example](#) shows a diagram of this sample network.

Table 6: STPLAN Configuration Example Database

Card Location	Interface Address	TCP/IP Router Address	STPLAN Node Address	STPLAN Port ID
1103	193.4.201.34	—	193.4.201.70	1024
1104	193.4.201.35	—	193.4.201.71	1024
1201	193.4.201.30	—	193.4.201.50	1024
1203	193.4.201.31	—	193.4.201.51	1024
1204	193.4.202.39	193.4.202.30	200.50.100.47	2000
1205	193.4.202.32	—	193.4.201.50	3000
1206	197.4.217.39	197.4.217.47	203.14.212.30	4000
1207	194.5.198.74	—	194.5.198.34	4000

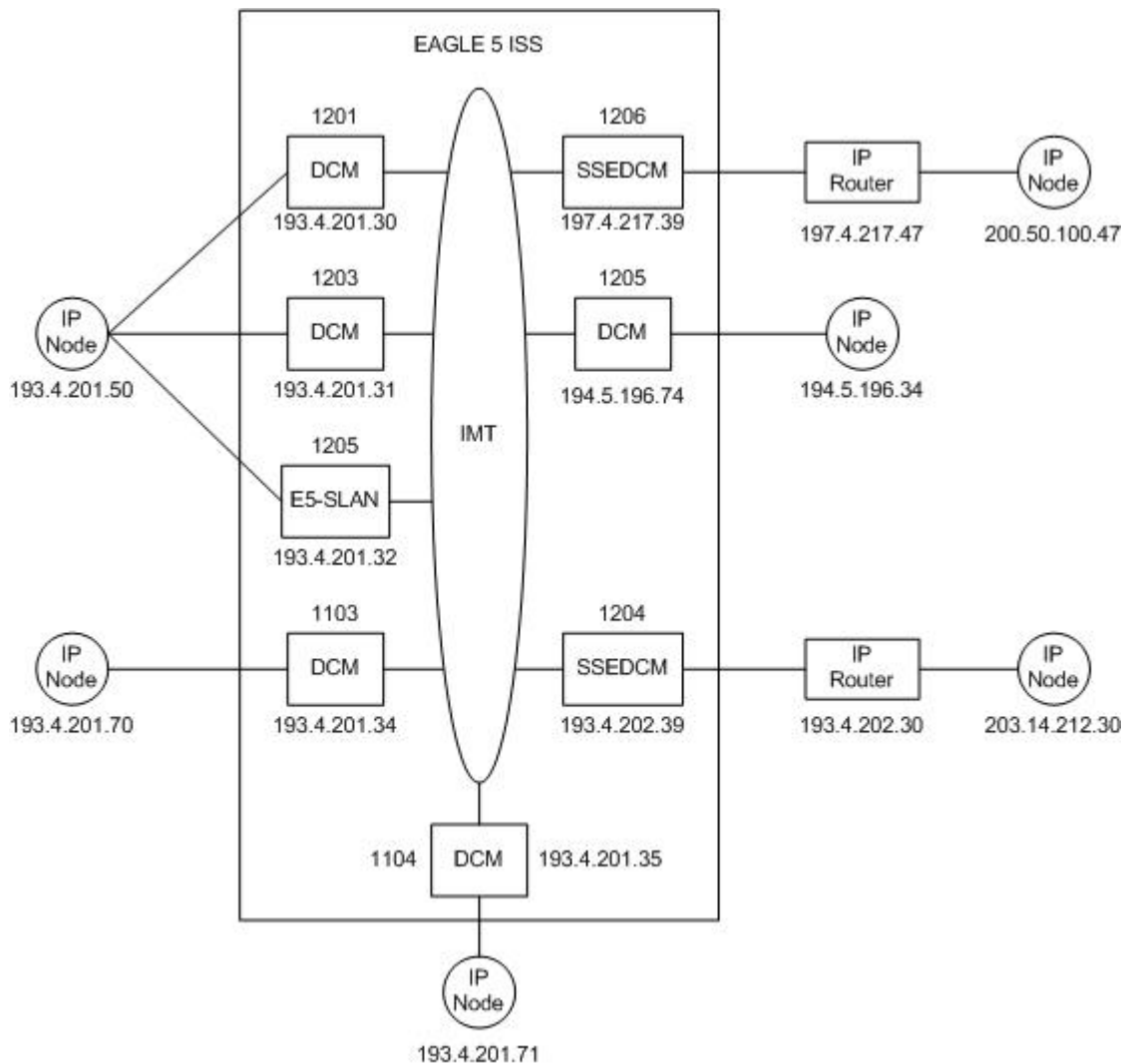

Figure 9: STPLAN Configuration Example

Adding an STPLAN Card

This procedure is used to add a card supporting the STPLAN feature, either a DCM, SSED, or E5-SLAN card running the `stplan` to the database using the `ent-card` command. The `ent-card` command uses these parameters:

- `:loc` – The location of the card being added to the database.
- `:type` – The type of card being added to the database. For this procedure, the value of this parameter is `dcm`.
- `:app1` – The application software that is assigned to the card. For this procedure, the value of this parameter is `stplan`.

The STPLAN card part numbers are shown in [Table 7: STPLAN Card Part Numbers](#).

Table 7: STPLAN Card Part Numbers

Card Type	Card Name (as shown on the card label)	TYPE Parameter Value	Part Number
Dual-Slot DCM	DCM	dcm	870-1945-XX 870-1984-01
	DCM	dcm	870-2372-01
Single-Slot EDCM	EDCM-A	dcm	870-2508-XX
	E5-SLAN Card	E5-ENET	870-2212-02
	E5-ENET-B	dcm	870-2971-XX

Note: If the STPLAN card will be sending traffic to the ECAP, the STPLAN card must be a single-slot EDCM or an E5-SLAN card.

The dual-slot DCM card can be inserted only in card slots 01, 03, 05, 07, 11, 13, 15, and 17 of the extension shelf. The dual-slot DCM card can be inserted in the control shelf, but only in slots 01, 03, 05, 07, and 11. The dual-slot DCM card occupies two card slots, so the even numbered card slot adjacent to the odd numbered slot where the dual-slot DCM card has been inserted must be empty, as shown in [Table 8: DCM Card Locations](#). The dual-slot DCM card is connected to the network through the odd numbered card slot connector.

Table 8: DCM Card Locations

Location of the DCM	Empty Card Location	Location of the DCM	Empty Card Location
Slot 01	Slot 02	Slot 11	Slot 12
Slot 03	Slot 04	Slot 13	Slot 14
Slot 05	Slot 06	Slot 15	Slot 16
Slot 07	Slot 08	Slot 17	Slot 18

Before the card can be configured in the database for the STPLAN feature, the STPLAN and Gateway Screening features must be turned on with the `chg-feat` command. The Gateway Screening feature must be on before the STPLAN feature can be turned on. The `rtv-feat` command can verify that the STPLAN and Gateway Screening features are on.

Note: After the Gateway Screening and STPLAN features are turned on with the `chg-feat` command, they cannot be turned off.

Note: Perform the “Changing the High-Capacity Card Temperature Alarm Thresholds” procedure in the *Database Administration Manual-SS7* to verify the temperature threshold settings for the E5-SLAN card.

The shelf to which the card is to be added must already be in the database. This can be verified with the `rtrv-shlf` command. If the shelf is not in the database, see the "Adding a Shelf" procedure in the *Database Administration Manual – System Management*.

The card cannot be added to the database if the specified card location already has a card assigned to it.

STPLAN Card Provisioning

Follow these rules to provision STPLAN cards:

- A minimum of two STPLAN cards must be provisioned in an EAGLE 5 ISS.
- A maximum of 32 STPLAN cards can be provisioned in an EAGLE 5 ISS.
- For shelves containing HMUX cards, the following rules apply to provisioning STPLAN cards.
 - If the shelf containing the STPLAN cards (only DCM or SSEDCCM cards, but not E5-SLAN cards) has HMUX cards installed in card slots 9 and 10, the shelf can contain a maximum of three STPLAN cards.
 - The STPLAN cards should be provisioned in shelves adjacent to the shelf containing the cards being monitored - half of the STPLAN cards should be provisioned in the next shelf and the other half of the STPLAN cards should be provisioned in the previous shelf. For example, if the shelf generating the STPLAN traffic is shelf 2100, half of the STPLAN cards should be provisioned in shelf 1300 and the other half of the STPLAN cards should be provisioned in shelf 2200.
- For shelves containing HIPR or HIPR2 cards, the STPLAN cards (DCM or SSEDCCM cards) should be provisioned in the same shelves that contain HIPR or HIPR2 cards. The shelf can contain more than three STPLAN cards.
- The E5-SLAN card requires that HIPR or HIPR2 cards are installed in the card locations 9 and 10 in the shelf that will contain the E5-SLAN card. If HIPR or HIPR2 cards are not installed in the shelf that the E5-SLAN card will occupy, the E5-SLAN card will be auto-inhibited when the E5-SLAN card is inserted into the shelf. Enter the `rept-stat-gpl:gpl=hipr` command to verify whether or not HIPR cards are installed in the same shelf as the E5-SLAN card being provisioned in this procedure. Enter the `rept-stat-gpl:gpl=hipr2` command to verify whether or not HIPR2 cards are installed in the same shelf as the E5-SLAN card being provisioned in this procedure. The shelf can contain more than three E5-SLAN cards.
- If the E5-SLAN card is an E5-ENET-B card, the FAN feature must be turned on and fans must be installed on the shelf that contains the E5-ENET-B card. Enter the `rtrv-feat` command to verify whether or not the FAN feature is turned on. Perform the procedures in the *Installation Manual* to install fans on the shelf that contains the E5-ENET-B card if fans must be installed. The MFC (message flow control) option must be on. Enter the `rtrv-stpopts` command to verify whether or not the MFC option is on. Perform the [Configuring the MFC Option](#) procedure to turn on the MFC option, if required.

Note: Contact your Tekelec Sales Representative or Account Representative to determine the number of STPLAN cards that must be provisioned in your EAGLE 5 ISS, and to determine where in the EAGLE 5 ISS these STPLAN cards must be provisioned before performing this procedure.

1. Enter the `rtrv-card` command to display the cards in the EAGLE 5 ISS.

Cards should be distributed throughout the EAGLE 5 ISS for proper power distribution. Refer to the *Installation Manual* for the shelf power distribution.

```
rlghncxa03w 09-05-25 09:58:31 GMT EAGLE5 41.0.0
```

CARD	TYPE	APPL	LSET NAME	LINK	SLC	LSET NAME	LINK	SLC
1102	TSM	GLS						
1103	DCM	STPLAN						
1104	DCM	STPLAN						
1113	GPSM	EOAM						
1114	TDM-A							
1115	GPSM	EOAM						
1116	TDM-B							
1117	MDAL							
1203	DCM	STPLAN						
1205	DCM	STPLAN						
1206	DCM	STPLAN						
1211	LIMDS0	SS7ANSI	lsn1	A	0	lsn2	B	1
1216	LIMDS0	SS7ANSI	sp2	A	0	sp1	B	0
1303	LIMDS0	SS7ANSI	sp3	A	0			
1304	LIMDS0	SS7ANSI	sp3	A	1			
1306	LIMDS0	SS7ANSI	nsp3	A	1	nsp4	B	1

If the APPL field of the `rtrv-card` command output shows cards assigned to the STPLAN application, continue the procedure with [Step 5](#).

2. Enter the `rtrv-feat` command to verify that the STPLAN and the Gateway Screening features are on.

If the STPLAN feature is on, the LAN field should be set to on. If the Gateway Screening feature is on, the GWS field should be set to on. For this example, the STPLAN and Gateway Screening features are off.

Note: The `rtrv-feat` command output contains other fields that are not used by this procedure. To view all fields displayed by the `rtrv-feat` command, see the `rtrv-feat` command description in the *Commands Manual*.

If the gateway screening and STPLAN features are on, continue the procedure with [Step 5](#). If the Gateway Screening feature is not on, continue the procedure with [Step 3](#). If the Gateway Screening feature is on, but the STPLAN feature is off, continue the procedure with [Step 4](#).

3. If the Gateway Screening feature is not on, turn the Gateway Screening feature on by entering this command.

```
chg-feat:gws=on
```

Note: After the Gateway Screening feature is turned on with the `chg-feat` command, it cannot be turned off.

4. Turn the STPLAN feature on by entering this command.

```
chg-feat:lan=on
```

Note: Once the STPLAN feature is turned on with the `chg-feat` command, it cannot be turned off.

5. Verify that the card has been physically installed into the proper location.

Note: If the STPLAN card will be sending traffic to the ECAP, the STPLAN card must be a single-slot EDCM or a E5-SLAN card.



CAUTION

CAUTION: If the versions of the flash GPLs on the STPLAN card does not match the flash GPL versions in the database when the STPLAN is inserted into the card slot, UAM 0002 is generated indicating that these GPL versions do not match. If UAM 0002 has been generated, perform the alarm clearing procedure for UAM 0002 in the

Unsolicited Alarm and Information Messages Manual before proceeding with this procedure.

If an E5-SLAN card is being added, continue the procedure with [Step 6](#), otherwise continue the procedure with [Step 12](#).

6. Enter the `rept-stat-gpl:gpl=hipr` command to verify whether HIPR cards are installed in the same shelf as the E5-SLAN card to be provisioned.

```
rlghncxa03w 07-02-01 11:40:26 GMT EAGLE5 37.0.0
GPL      CARD      RUNNING      APPROVED      TRIAL
HIPR     1109     126-002-000  126-002-000  126-003-000
HIPR     1110     126-002-000  126-002-000  126-003-000
HIPR     1209     126-002-000  126-002-000  126-003-000
HIPR     1210     126-002-000  126-002-000  126-003-000
HIPR     1309     126-002-000  126-002-000  126-003-000
HIPR     1310     126-002-000  126-002-000  126-003-000
HIPR     2109     126-002-000  126-002-000  126-003-000
HIPR     2110     126-002-000  126-002-000  126-003-000
Command Completed
```

If HIPR cards are installed in the shelf containing the E5-SLAN card, perform one of these steps to continue the procedure .

- If the card that is being added is an E5-ENET card, continue the procedure with [Step 12](#).
- If the card that is being added is an E5-ENET-B card, continue the procedure with [Step 8](#).

If HIPR cards are not installed at the card locations 9 and 10 on the shelf where the E5-SLAN card is to be installed, continue the procedure with [Step 7](#).

7. Verify that HIPR2 cards are installed at card locations 9 and 10 in the shelf where the E5-SLAN card will be installed. Enter this command.

```
rept-stat-gpl:gpl=hipr2
```

This is an example of the possible output.

```
rlghncxa03w 09-07-01 11:40:26 GMT EAGLE5 41.1.0
GPL      CARD      RUNNING      APPROVED      TRIAL
HIPR2    1109     126-002-000  126-002-000  126-003-000
HIPR2    1110     126-002-000  126-002-000  126-003-000
HIPR2    1209     126-002-000  126-002-000  126-003-000
HIPR2    1210     126-002-000  126-002-000  126-003-000
HIPR2    1309     126-002-000  126-002-000  126-003-000
HIPR2    1310     126-002-000  126-002-000  126-003-000
HIPR2    2109     126-002-000  126-002-000  126-003-000
HIPR2    2110     126-002-000  126-002-000  126-003-000
Command Completed
```

If HIPR or HIPR2 cards are not installed at the card locations 9 and 10 on the shelf where the E5-SLAN card is to be installed, refer to the *Installation Manual* to install the HIPR or HIPR2 cards.

After the procedures in the *Installation Manual* have been performed, or if HIPR2 cards are installed at the card locations 9 and 10 on the shelf where the E5-SLAN card is to be installed, continue the procedure by performing one of these steps.

- If the card that is being added is an E5-ENET card, continue the procedure with [Step 12](#).
- If the card that is being added is an E5-ENET-B card, continue the procedure with [Step 8](#).

8. Enter the `rtrv-stpopts` command to verify whether or not the MFC option is on.

This is an example of the possible output.

```
rlghncxa03w 11-10-17 16:02:05 GMT EAGLE5 44.0.0
STP OPTIONS
-----
MFC                               off
```

The `rtrv-stpopts` command output contains other fields that are not used by this procedure. To see all fields displayed by the `rtrv-stpopts` command, see the `rtrv-stpopts` command description in the *Commands Manual*.

If the MFC option is off, perform the [Configuring the MFC Option](#) procedure to turn on the MFC option.

If the MFC option is on or the [Configuring the MFC Option](#) procedure was performed in this step, continue the procedure with [Step 9](#).

9. The Fan feature must be turned on. If the `rtrv-feat` command in [Step 2](#) was not performed, enter the `rtrv-feat` command to verify that the Fan feature is on.

If the Fan feature is on, shown in either the `rtrv-feat` output in this step or in [Step 2](#) if [Step 2](#) was performed, the FAN field should be set to on.

The `rtrv-feat` command output contains other fields that are not used by this procedure. To see all fields displayed by the `rtrv-feat` command, see the `rtrv-feat` command description in the *Commands Manual*.

If the Fan feature is on, continue the procedure with [Step 11](#).

If the Fan feature is off, continue the procedure with [Step 10](#).

10. Turn the Fan feature on by entering this command.

```
chg-feat: fan=on
```

Note: Once the Fan feature is turned on with the `chg-feat` command, it cannot be turned off.

When the `chg-feat` has successfully completed, this message appears.

```
rlghncxa03w 11-10-28 11:43:04 GMT EAGLE5 44.0.0
CHG-FEAT: MASP A - COMPLTD
```

11. The shelf containing the E5-ENET-B card that is being added in this procedure must have fans installed. Verify whether or not fans are installed on the shelf.

If the fans are installed, continue the procedure with [Step 12](#).

If the fans are not installed on the shelf containing the E5-ENET-B card, go to the *Installation Manual* and install the fans. After the fans have been installed and tested, continue the procedure with [Step 12](#).

12. Add the card to the database using the `ent-card` command.

For this example, enter this command:

```
ent-card: loc=1201: type=dcn: appl=stplan
```

13. Verify the changes using the `rtrv-card` command with the card location specified.

For this example, enter these commands.

```
rtrv-card:loc=1201
```

```
rlghncxa03w 09-05-20 21:22:37 GMT EAGLE5 41.0.0
CARD  TYPE      APPL      LSET NAME      LINK SLC LSET NAME      LINK SLC
1201  DCM          STPLAN
```

14. Back up the new changes, using the `chg-db:action=backup:dest=fixed` command.

These messages should appear; the active Maintenance and Administration Subsystem Processor (MASP) appears first.

```
BACKUP (FIXED) : MASP A - Backup starts on active MASP.
BACKUP (FIXED) : MASP A - Backup on active MASP to fixed disk complete.
BACKUP (FIXED) : MASP A - Backup starts on standby MASP.
BACKUP (FIXED) : MASP A - Backup on standby MASP to fixed disk complete.
```

Removing an STPLAN Card

This procedure is used to remove a card supporting the STPLAN feature, either a DCM, SSED CM, or E5-SLAN card running the `stplan` application, from the database using the `dlr-card` command.

The card cannot be removed if it does not exist in the database.

No TCP/IP data links can be assigned to the card you wish to remove from the database.



CAUTION: If the card being removed from the database is the last in-service card supporting the STPLAN feature (either DCM, SSED CM, or E5-SLAN card), removing this card from the database will disable the STPLAN feature.

CAUTION

The examples in this procedure are used to remove the DCM card in card location 1201 from the database.

1. Display the cards in the database using the `rtrv-card` command.

This is an example of the possible output.

```
rlghncxa03w 09-05-25 09:58:31 GMT EAGLE5 41.0.0
CARD  TYPE      APPL      LSET NAME      LINK SLC LSET NAME      LINK SLC
1101  DSM          VS CCP
1102  TSM          GLS
1103  DCM          STPLAN
1104  DCM          STPLAN
1113  GP SM        EOAM
1114  TDM-A
1115  GP SM        EOAM
1116  TDM-B
1117  MDAL
1201  DCM          STPLAN
1203  DCM          STPLAN
1204  DCM          STPLAN
1205  DCM          STPLAN
1206  DCM          STPLAN
1207  DCM          STPLAN
1211  LIMDS0      SS7ANSI  lsn1          A      0      lsn2          B      1
1216  LIMDS0      SS7ANSI  sp2           A      0      sp1           B      0
1303  LIMDS0      SS7ANSI  sp3           A      0
```

1304	LIMDS0	SS7ANSI	sp3	A	1				
1306	LIMDS0	SS7ANSI	nsp3	A	1	nsp4	B	1	

If no STPLAN cards are shown in the `rtrv-card` output, this procedure cannot be performed. STPLAN cards are shown by the entry STPLAN in the APPL field.

2. Display the status of the TCP/IP data link assigned to the card you wish to remove by entering the `rept-stat-dlk` command with the card location of the STPLAN card being removed. For this example, enter this command.

```
rept-stat-dlk:loc=1201
```

This is an example of the possible output.

```
rlghncxa03w 10-07-20 21:20:37 GMT EAGLE5 42.0.0
DLK          PST          SST          AST
1201         IS-NR        Active     ----
Alarm Status = No Alarms.
Command Completed.
```

3. If the TCP/IP data link is not in an OOS-MT-DSBLD state, deactivate the TCP/IP data link assigned to the card using the `canc-dlk` command with the card location specified in [Step 2](#).

For this example, enter this command.

```
canc-dlk:loc=1201
```

When this command has successfully completed, this message should appear.

```
rlghncxa03w 06-10-20 21:18:37 GMT EAGLE5 36.0.0
Deactivate Link message sent to card.
```

4. Verify that the state of the TCP/IP data link is OOS-MT-DSBLD by entering the `rept-stat-dlk` command with the card location specified in [Step 3](#). For this example, enter this command.

```
rept-stat-dlk:loc=1201
```

This is an example of the possible output.

```
rlghncxa03w 10-07-20 21:20:37 GMT EAGLE5 42.0.0
DLK          PST          SST          AST
1201         OOS-MT-DSBLD Manual     ----
Alarm Status = * 0155 STPLAN connection unavailable
Command Completed.
```

5. Inhibit the card using the `rmv-card` command, specifying the card location specified in [Step 3](#). For this example, enter this command.

```
rmv-card:loc=1201
```

When this command has successfully completed, this message should appear.

```
rlghncxa03w 06-10-20 21:19:37 GMT EAGLE5 36.0.0
Card has been inhibited.
```

6. Display the TCP/IP nodes in the database by entering the `rtrv-ip-node` command with the card location specified in [Step 5](#). For this example, enter this command.

```
rtrv-ip-node=loc=1201
```

This is an example of the possible output.

```
rlghncxa03w 06-10-20 21:20:37 GMT EAGLE5 36.0.0
IPADDR          IPPORT  IPAPPL  LOC   CAP   IPRTE
193.4.201.50    1024   stplan  1201  10%  --
```

- Remove the TCP/IP node assigned to the card location containing the TCP/IP data link to be removed from the database using the `dlt-ip-node` command with the card location specified in [Step 6](#).

For this example, enter this command.

```
dlt-ip-node:ipaddr=193.4.201.50:loc=1201
```

When this command has successfully completed, this message should appear.

```
rlghncxa03w 06-10-20 21:21:37 GMT EAGLE5 36.0.0
DLT-IP-NODE: MASP A - COMPLTD
```

- Remove the data link from the specified card by using the `dlt-dlk` command with the card location specified in [Step 7](#).

For this example, enter this command.

```
dlt-dlk:loc=1201
```

When this command has successfully completed, this message should appear.

```
rlghncxa03w 06-10-20 21:22:37 GMT EAGLE5 36.0.0
DLT-DLK: MASP A - COMPLTD
```

- Remove the card using the `dlt-card` command with the card location of the card to be removed. The `dlt-card` command has only one parameter, `loc`, which is the location of the card. For this example, enter this command.

```
dlt-card:loc=1201
```

When this command has successfully completed, this message should appear.

```
rlghncxa03w 06-10-20 21:23:37 GMT EAGLE5 36.0.0
DLT-CARD: MASP A - COMPLTD
```

- Verify the changes using the `rtrv-card` command specifying the card that was removed in [Step 9](#).

For this example, enter this command.

```
rtrv-card:loc=1201
```

When this command has successfully completed, this message should appear.

```
E2144 Cmd Rej: Location invalid for hardware configuration
```

- Backup the new changes using the `chg-db:action=backup:dest=fixed` command.

These messages should appear; the active Maintenance and Administration Subsystem Processor (MASP) appears first.

```
BACKUP (FIXED) : MASP A - Backup starts on active MASP.
```

```

BACKUP (FIXED) : MASP A - Backup on active MASP to fixed disk complete.
BACKUP (FIXED) : MASP A - Backup starts on standby MASP.
BACKUP (FIXED) : MASP A - Backup on standby MASP to fixed disk complete.

```

Adding a TCP/IP Data Link

This procedure is used to add a TCP/IP data link to the database using the `ent-dlk` command.

The `ent-dlk` command uses these parameters:

`:loc` – The card location of the DCM, SSEDCEM, or E5-SLAN card that the TCP/IP data link will be assigned to.

`:ipaddr` – The TCP/IP data link's IP address

`:duplex` – The mode of operation of the interface. The value for this parameter is `half` or `full`. The default value is `half`. The value `half` indicates that the mode of operation of the interface is half duplex. The value `full` indicates that the mode of operation of the interface is full duplex.

`:speed` – The transmission rate of the TCP/IP data link, either 10 Mb/s (`speed=10`) or 100 Mb/s (`speed=100`). The default value for this optional parameter is 10. The `speed=100` parameter can be specified only if the application running on the STPLAN card is STPLAN. The application running on the card is shown in the `APPL` field of the `rtrv-card` command output.

`:auto` – This parameter specifies whether the hardware automatically determines duplex and speed. The value for this parameter is `yes` or `no`. The value `yes` indicates that the parameters `duplex` and `speed` are automatically determined. Dashes are displayed in the `LINK`, `SPEED` and `DUPLEX` columns in the `rtrv-dlk` output if the `auto` parameter value is `yes`. The value `no` indicates that the parameters `duplex` and `speed` are not determined automatically.

The default value for the `auto` parameter is `yes`, if the `speed` and `duplex` parameters are not specified.

The `speed` and `duplex` parameters can be specified with the `auto` parameter only if the `auto` parameter value is `no`.

If the `speed` and `duplex` parameters are specified and the `auto` parameter is not specified, the default value for the `auto` parameter is `no`.

If either the `duplex` or `speed` parameters are specified, then both the `duplex` and `speed` parameters must be specified.

The examples used in this procedure are based on the example network shown in [Figure 9: STPLAN Configuration Example](#) and [Table 6: STPLAN Configuration Example Database](#).

The STPLAN and Gateway Screening features must be turned on. Verify this by entering the `rtrv-feat` command. If either the STPLAN feature or Gateway Screening feature is off, they can be turned on by entering the `chg-feat :lan=on` command for the STPLAN feature and the `chg-feat :gws=on` command for the Gateway Screening feature.

Note: After the Gateway Screening and STPLAN features are turned on with the `chg-feat` command, they cannot be turned off.

The card that the TCP/IP data link is assigned to must be a DCM, SSEDCEM, or E5-SLAN card running the `stplan` application. This can be verified in step 2 with the `rtrv-card` command. The DCM, SSEDCEM, or E5-SLAN card is shown by the entries `DCM` in the `TYPE` field and `STPLAN` in the `APPL`

field of the `rtrv-card` command output. If the STPLAN card is not shown in the `rtrv-card` command output, go to [Adding an STPLAN Card](#) and add the required card to the database.

The specified card cannot have a TCP/IP data link assigned to it, nor can the TCP/IP data link be in the database. This can be verified in step 1.

The IP address to be assigned to the TCP/IP data link cannot be assigned to a TCP/IP node or to a TCP/IP router. Enter the `rtrv-ip-node` command to display the IP addresses of the TCP/IP nodes and the TCP/IP routers. This can be verified in step 2.

Refer to the *Commands Manual* for complete descriptions of the commands used in this procedure, including parameter descriptions and valid values, rules for correct use, and output examples.

1. Display the data links in the database by entering the `rtrv-dlk` command.

This is an example of the possible output.

```
rlghncxa03w 07-02-20 21:16:37 GMT EAGLE5 37.0.0
LOC      IPADDR          LINK SPEED  DUPLEX  AUTO
1103    193.4.201.70    10Mbit  HALF    NO
1104    193.4.201.71    10Mbit  HALF    NO
```

2. Display the TCP/IP nodes and TCP/IP routers by entering the `rtrv-ip-node` command.

This is an example of the possible output.

```
rlghncxa03w 06-10-20 21:16:37 GMT EAGLE5 36.0.0
IPADDR      IPPORT  IPAPPL  LOC   CAP  IP RTE
193.4.201.70  1024   stplan  1103  10%  --
193.4.201.71  1024   stplan  1104  10%  --
```

3. Display the cards in the database by entering the `rtrv-card` command.

This is an example of the possible output.

```
rlghncxa03w 09-05-25 09:58:31 GMT EAGLE5 41.0.0
CARD  TYPE  APPL      LSET NAME      LINK SLC  LSET NAME      LINK SLC
1102  TSM    GLS
1103  DCM    STPLAN
1104  DCM    STPLAN
1113  GPSM   EOAM
1114  TDM-A
1115  GPSM   EOAM
1116  TDM-B
1117  MDAL
1201  DCM    STPLAN
1203  DCM    STPLAN
1204  DCM    STPLAN
1205  DCM    STPLAN
1206  DCM    STPLAN
1207  DCM    STPLAN
1211  LIMDS0 SS7ANSI  lsn1          A    0    lsn2          B    1
1216  LIMDS0 SS7ANSI  sp2           A    0    sp1           B    0
1303  LIMDS0 SS7ANSI  sp3           A    0
1304  LIMDS0 SS7ANSI  sp3           A    1
1306  LIMDS0 SS7ANSI  nsp3          A    1    nsp4          B    1
```

The STPLAN card that will be specified in step 4 must be shown in the `rtrv-card` output in this step, but cannot be shown in the `loc` column of the `rtrv-dlk` output in step 1.

If the required STPLAN card is not shown in the `rtrv-card` output, perform [Adding an STPLAN Card](#) and add the STPLAN card to the database.

If the STPLAN card is shown in the `rtrv-dlk` output, either select an STPLAN card that is shown in the `rtrv-card` output, but not shown in the `rtrv-dlk` output, or perform [Adding an STPLAN Card](#) and add the STPLAN card to the database.

The `speed`, `duplex`, and `auto` parameters can be specified with the `ent-dlk` command.

4. Add the data link to the database by entering the `ent-dlk` command.

For this example, enter these commands.

```
ent-dlk:loc=1201:ipaddr=193.4.201.50:speed=100:auto=no
```

```
ent-dlk:loc=1203:ipaddr=193.4.201.51
```

```
ent-dlk:loc=1204:ipaddr=200.50.100.47
```

```
ent-dlk:loc=1205:ipaddr=193.4.201.50
```

```
ent-dlk:loc=1206:ipaddr=203.14.212.30
```

```
ent-dlk:loc=1207:ipaddr=203.14.212.39
```

The `ent-dlk` command assigns the IP address (`ipaddr`) to the STPLAN card. If the network is a private network (not on the Internet), you can assign any unique address. If the STPLAN card is on the Internet, you must obtain an IP address from the Internet Network Information Center (NIC). Refer to [IP Addresses](#) for information on the IP address values used in the `ent-dlk` command.

The default value for the `auto` parameter is `yes`, if the `speed` and `duplex` parameters are not specified.

The `speed` and `duplex` parameters can be specified with the `auto` parameter only if the `auto` parameter value is `no`.

If the `speed` and `duplex` parameters are specified and the `auto` parameter is not specified, the default value for the `auto` parameter is `no`.

If either the `duplex` or `speed` parameters are specified, then both the `duplex` and `speed` parameters must be specified.

5. Verify the changes using the `rtrv-dlk` command with the card location specified in step 4.

For this example, enter these commands.

```
rtrv-dlk:loc=1201
```

This is an example of the possible output.

```
rlghncxa03w 07-02-20 21:16:37 GMT EAGLE5 37.0.0
LOC  IPADDR          LINK SPEED  DUPLEX  AUTO
1201 193.4.201.50      100Mbit  HALF    NO
```

```
rtrv-dlk:loc=1203
```

This is an example of the possible output.

```
rlghncxa03w 07-02-20 21:16:37 GMT EAGLE5 37.0.0
LOC  IPADDR          LINK SPEED  DUPLEX  AUTO
1203 193.4.201.51      -----  ----    YES
```

```
rtrv-dlk:loc=1204
```

This is an example of the possible output.

```
rlghncxa03w 07-02-20 21:16:37 GMT EAGLE5 37.0.0
LOC   IPADDR           LINK SPEED  DUPLEX  AUTO
1204  200.50.100.47      10Mbit    HALF    NO
```

```
rtrv-dlk:loc=1205
```

This is an example of the possible output.

```
rlghncxa03w 07-02-20 21:16:37 GMT EAGLE5 37.0.0
LOC   IPADDR           LINK SPEED  DUPLEX  AUTO
1205  193.4.201.50      -----   ----    YES
```

```
rtrv-dlk:loc=1206
```

This is an example of the possible output.

```
rlghncxa03w 07-02-20 21:16:37 GMT EAGLE5 37.0.0
LOC   IPADDR           LINK SPEED  DUPLEX  AUTO
1206  203.14.212.30     -----   ----    YES
```

```
rtrv-dlk:loc=1207
```

This is an example of the possible output.

```
rlghncxa03w 07-02-20 21:16:37 GMT EAGLE5 37.0.0
LOC   IPADDR           LINK SPEED  DUPLEX  AUTO
1207  202.14.212.39     -----   ----    YES
```

- Place the cards into service by entering the `rst-card` command with the card location specified in step 4.

For this example, enter these commands.

```
rst-card:loc=1201
```

```
rst-card:loc=1203
```

```
rst-card:loc=1204
```

```
rst-card:loc=1205
```

```
rst-card:loc=1206
```

```
rst-card:loc=1207
```

This message should appear when each command has successfully completed.

```
rlghncxa03w 06-10-20 21:21:37 GMT EAGLE5 36.0.0
Card has been allowed.
```

- Place the data links into service by entering the `act-dlk` command with the card location specified in step 4.

For this example, enter these commands.

```
act-dlk:loc=1201
```

```
act-dlk:loc=1203
```

```
act-dlk:loc=1204
```



```
act-dlk:loc=1205
act-dlk:loc=1206
act-dlk:loc=1207
```

This message should appear when each command has successfully completed.

```
rlghncxa03w 06-10-20 21:22:37 GMT EAGLE5 36.0.0
Activate Link message sent to card
```

- Back up the new changes using the `chg-db:action=backup:dest=fixed` command. These messages should appear; the active Maintenance and Administration Subsystem Processor (MASP) appears first.

```
BACKUP (FIXED) : MASP A - Backup starts on active MASP.
BACKUP (FIXED) : MASP A - Backup on active MASP to fixed disk complete.
BACKUP (FIXED) : MASP A - Backup starts on standby MASP.
BACKUP (FIXED) : MASP A - Backup on standby MASP to fixed disk complete.
```

Removing a TCP/IP Data Link

This procedure is used to remove a TCP/IP data link from the database using the `dlt-dlk` command.

The examples used in this procedure are used to remove the TCP/IP data link on card 1204 from the database.

The card that the TCP/IP data link is assigned to must be a DCM, SSED CM, or E5-SLAN card running the `stplan` application. This can be verified with the `rtrv-card` command. The DCM, SSED CM, or E5-SLAN card is shown by the entries DCM in the `TYPE` field and `STPLAN` in the `APPL` field of the `rtrv-card` command output.

The specified card must have a TCP/IP data link assigned to it and the TCP/IP data link must be in the database. This can be verified in step 1.

- Display the data links in the database by entering the `rtrv-dlk` command.

```
rlghncxa03w 07-02-20 21:16:37 GMT EAGLE5 37.0.0
LOC      IPADDR          LINK SPEED  DUPLEX  AUTO
1103    193.4.201.70      10Mbit    HALF    NO
1104    193.4.201.71      10Mbit    HALF    NO
1201    193.4.201.50      100Mbit   HALF    NO
1203    193.4.201.51      -----   ----    YES
1204    200.50.100.47     10Mbit    HALF    NO
1205    193.4.201.50      -----   ----    YES
1206    203.14.212.30     -----   ----    YES
1207    202.14.212.39     -----   ----    YES
```

- Place the TCP/IP data link to be removed out of service using the `canc-dlk` command, using the output from step 1 to obtain the card location of the TCP/IP data link to be removed.

For this example, the TCP/IP data link to be removed is assigned to card 1204. Enter this command.

```
canc-dlk:loc=1204
```

When the command has successfully completed, this message should appear.

```
rlghncxa03w 06-10-20 21:17:37 GMT EAGLE5 36.0.0
Deactivate Link message sent to card.
```

3. Verify that the TCP/IP data link is out of service - maintenance disabled (OOS-MT-DSBLD) using the `rept-stat-dlk` command.

For this example, enter this command.

```
rept-stat-dlk:loc=1204
```

```
rlghncxa03w 06-10-20 21:18:37 GMT EAGLE5 36.0.0
DLK    PST      SST      AST
1204  OOS-MT-DSBLD Unavail  ---
      ALARM STATUS =
Command Completed.
```

4. Place the card specified in step 3 out of service by using the `rmv-card` command.

For this example, enter this command.

```
rmv-card:loc=1204
```

This message should appear.

```
rlghncxa03w 06-10-20 21:19:37 GMT EAGLE5 36.0.0
Card has been inhibited.
```

5. Display the TCP/IP nodes in the database by entering the `rtrv-ip-node` command with the card location specified in step 4. For this example enter this command

```
rtrv-ip-node:loc=1204
```

```
rlghncxa03w 07-02-20 21:20:37 GMT EAGLE5 37.0.0
IPADDR      IPPORT  IPAPPL  LOC   CAP   IP RTE
200.50.100.47 1024   stplan 1204  10%  --
```

6. Remove the TCP/IP node assigned to the card location containing the TCP/IP data link to be removed from the database using the `dlt-ip-node` command with the card location specified in step 5.

For this example, enter this command.

```
dlt-ip-node:ipaddr=200.50.100.47:loc=1204
```

7. Remove the data link from the database using the `dlt-dlk` command.

The `dlt-dlk` command has only one parameter, `loc`, which is the location of the STPLAN card containing the TCP/IP data link. For this example, enter this command.

```
dlt-dlk:loc=1204
```

8. Verify the changes using the `rtrv-dlk` command with the card location specified in step 7.

```
rtrv-dlk:loc=1204
```

When this command has successfully completed, this message should appear.

```
E2604 Cmd Rej: Card location not assigned a TCP/IP link
```

9. Back up the new changes using the `chg-db:action=backup:dest=fixed` command.

These messages should appear; the active Maintenance and Administration Subsystem Processor (MASP) appears first.

```
BACKUP (FIXED) : MASP A - Backup starts on active MASP.
BACKUP (FIXED) : MASP A - Backup on active MASP to fixed disk complete.
BACKUP (FIXED) : MASP A - Backup starts on standby MASP.
BACKUP (FIXED) : MASP A - Backup on standby MASP to fixed disk complete.
```

Adding a TCP/IP Node

This procedure is used to add a TCP/IP node to the database using the `ent-ip-node` command.

The `ent-ip-node` command uses these parameters:

`:ipaddr` – The node's IP address.

`:ipappl` – The IP application supported by the node.

`:ipport` – The logical IP port to address the application on the node.

`:loc` – The card location of the STPLAN card that contains the TCP/IP link that will be directly connected to the node.

`:cap` – The maximum percentage (1 to 100) of ethernet capacity for this node connection. This capacity is added to other connections to this node for the total capacity of the node. The total capacity of the node cannot exceed 100%. The value of the `cap` parameter can be used to calculate the throughput for DCMs or E5-ENET cards (the single-slot EDCM or E5-SLAN card types shown in [Table 7: STPLAN Card Part Numbers](#)) and to control the amount of traffic that is being sent to the ECAP. Refer to these sections of the `ent-ip-node` command description in the *Commands Manual* for more information.

- Determining the correct CAP value for ECAP
- Using the CAP Value to Calculate Throughput for DCM and E5-ENET Cards

`:iprte` – The IP address of the TCP/IP router.

This examples used in this procedure are based on the example network shown in [Figure 9: STPLAN Configuration Example](#) and [Table 6: STPLAN Configuration Example Database](#).

The TCP/IP node cannot already be in the database. This can be verified in step 1.

The specified card must have a TCP/IP data link assigned to it. This can be verified in step 2.

The IP address assigned to the TCP/IP node cannot be assigned to any other TCP/IP nodes, TCP/IP routers, or TCP/IP data links.

The class of the IP address (`ipaddr`) must match the class of the assigned TCP/IP data link's IP address only if the `iprte` parameter is not specified with the `ent-ip-node` command. The EAGLE 5 ISS supports three classes of IP addresses, class A, class B, and class C. Class A IP addresses can contain only the values 1 to 126 in the first field of the IP address. Class B IP addresses can contain only the values 128 to 191 in the first field of the IP address. Class C IP addresses can contain only the values 192 to 223 in the first field of the IP address. No IP address can contain the value 127 in the first field of the IP address. These IP addresses are reserved for loopback.

The network portion of the IP address (`ipaddr`) must match the network portion of the IP address assigned to the TCP/IP data link only if the `iprte` parameter is not specified with the `ent-ip-node` command. The network portion of the IP address is based on the class of the IP address. If the IP

address is a class A IP address, the first field is the network portion of the IP address. If the IP address is a class B IP address, the first two fields are the network portion of the IP address. If the IP address is a class C IP address, the first three fields are the network portion of the IP address. For example, if the IP address of the TCP/IP data link is 193.5.207.150, a class C IP address, the network portion of the IP address for the TCP/IP node must be 193.5.207.

Refer to the [TCP/IP Router](#) section for more information of the TCP/IP router.

If the `iprte` parameter is specified with the `ent-ip-node` command, the class and network portion of the TCP/IP router's IP address must match the class and network portion of the TCP/IP data link and cannot match the IP address of the TCP/IP node being added to the database. If subnet routing is being used, the `iprte` parameter must be specified with the `ent-ip-node` command. Refer to the [TCP/IP Router](#) section on for more information of the TCP/IP router.

The capacity of all connections to the IP address cannot be greater than 100%. This is shown in the `CAP` field of the `rtrv-ip-node` command output.

1. Display the TCP/IP nodes in the database by entering the `rtrv-ip-node` command.

This is an example of the possible output.

```
rlghncxa03w 06-10-20 21:16:37 GMT EAGLE5 36.0.0
IPADDR      IPPORT  IPAPPL  LOC   CAP  IPRTE
193.4.201.70 1024    stplan 1103  10%  --
193.4.201.71 1024    stplan 1104  10%  --
```

2. Display the TCP/IP data links in the database by entering the `rtrv-dlk` command.

This is an example of the possible output.

```
rlghncxa03w 07-02-20 21:16:37 GMT EAGLE5 37.0.0
LOC      IPADDR      LINK SPEED  DUPLEX  AUTO
1103     193.4.201.70 10Mbit  HALF    NO
1104     193.4.201.71 10Mbit  HALF    NO
1201     193.4.201.50 100Mbit HALF    NO
1203     193.4.201.51 ----- ----    YES
1204     200.50.100.47 10Mbit  HALF    NO
1205     193.4.201.50 ----- ----    YES
1206     203.14.212.30 ----- ----    YES
1207     202.14.212.39 ----- ----    YES
```

If the required TCP/IP data link is not shown in the `rtrv-dlk` output, perform the "Adding a TCP/IP Data Link" procedure on page 3-33 and add the required TCP/IP data link to the database.

3. Add the TCP/IP nodes to the database by entering the `ent-ip-node` command.

For this example, enter these commands.

```
ent-ip-node:loc=1201:ipaddr=193.4.201.65:ipappl=stplan:ippport=1024 :cap=10
```

```
ent-ip-node:loc=1203:ipaddr=193.4.201.78:ipappl=stplan:ippport=1024 :cap=10
```

```
ent-ip-node:loc=1204:ipaddr=200.50.115.101:ipappl=stplan:ippport=2000
:cap=40:iprte=193.4.202.30
```

```
ent-ip-node:loc=1205:ipaddr=193.4.201.56:ipappl=stplan:ippport=3000 :cap=40
```

```
ent-ip-node:loc=1206:ipaddr=203.24.212.30:ipappl=stplan:ippport=4000
:cap=40:iprte=197.4.217.47
```

```
ent-ip-node:loc=1207:ipaddr=205.37.12.63:ipappl=stplan:ippport=3963
:cap=40:iprte=198.10.186.53
```

When each of these commands has successfully completed, this message should appear.

```
rlghncxa03w 06-10-20 21:18:37 GMT EAGLE5 36.0.0
ENT-IP-NODE: MASP A - COMPLTD
```

4. Verify the changes using the `rtrv-ip-node` command with the IP address specified in step 3. For this example, enter these commands.

```
rtrv-ip-node:ipaddr=193.4.201.65
```

This is an example of the possible output.

```
rlghncxa03w 07-02-20 21:19:37 GMT EAGLE5 37.0.0
IPADDR      IPPORT  IPAPPL  LOC    CAP  IPRTE
193.4.201.65  1024   stplan  1201  10%  --
193.4.201.65  3000   stplan  1205  40%  --
```

```
rtrv-ip-node:ipaddr=193.4.201.78
```

This is an example of the possible output.

```
rlghncxa03w 07-02-20 21:19:37 GMT EAGLE5 37.0.0
IPADDR      IPPORT  IPAPPL  LOC    CAP  IPRTE
193.4.201.78  1024   stplan  1203  10%  --
```

```
rtrv-ip-node:ipaddr=200.50.115.101
```

This is an example of the possible output.

```
rlghncxa03w 07-02-20 21:19:37 GMT EAGLE5 37.0.0
IPADDR      IPPORT  IPAPPL  LOC    CAP  IPRTE
200.50.115.101  2000   stplan  1204  40%  193.4.202.30
```

```
rtrv-ip-node:ipaddr=203.24.212.30
```

This is an example of the possible output.

```
rlghncxa03w 07-02-20 21:19:37 GMT EAGLE5 37.0.0
IPADDR      IPPORT  IPAPPL  LOC    CAP  IPRTE
203.24.212.30  1024   stplan  1206  40%  197.4.217.47
```

```
rtrv-ip-node:ipaddr=205.37.12.63
```

This is an example of the possible output.

```
rlghncxa03w 07-02-20 21:19:37 GMT EAGLE5 37.0.0
IPADDR      IPPORT  IPAPPL  LOC    CAP  IPRTE
205.37.12.63  3963   stplan  1207  40%  198.10.186.53
```

5. Place the data links into service by entering the `act-dlk` command with the card location shown in step 4.

For this example, enter these commands.

```
act-dlk:loc=1201
```

```
act-dlk:loc=1203
```

```
act-dlk:loc=1204
```

```
act-dlk:loc=1205
```

```
act-dlk:loc=1206
```

```
act-dlk:loc=1207
```

This message should appear when each command has successfully completed.

```
rlghncxa03w 06-10-20 21:20:37 GMT EAGLE5 36.0.0
Activate Link message sent to card
```

6. Check the status of the data links using the `rept-stat-dlk` command, specifying the card locations of the data links entered in step 5.

The link should be in service-normal (IS-NR) after the link has been activated. This is an example of the possible output.

```
rlghncxa03w 06-10-20 21:21:37 GMT EAGLE5 36.0.0
DLK          PST          SST          AST
1103         IS-NR         Avail        ----
1104         IS-NR         Avail        ----
1201         IS-NR         Avail        ----
1203         IS-NR         Avail        ----
1204         IS-NR         Avail        ----
1205         IS-NR         Avail        ----
1206         IS-NR         Avail        ----
1207         IS-NR         Avail        ----
Command Completed.
```

7. Backup the new changes using the `chg-db:action=backup:dest=fixed` command.

These messages should appear; the active Maintenance and Administration Subsystem Processor (MASP) appears first.

```
BACKUP (FIXED) : MASP A - Backup starts on active MASP.
BACKUP (FIXED) : MASP A - Backup on active MASP to fixed disk complete.
BACKUP (FIXED) : MASP A - Backup starts on standby MASP.
BACKUP (FIXED) : MASP A - Backup on standby MASP to fixed disk complete.
```

Removing a TCP/IP Node

This procedure is used to remove a TCP/IP node from the database using the `dlt-ip-node` command.

The `dlt-ip-node` command uses these parameters:

`:ipaddr` – The node's IP address.

`:ipappl` – The IP application supported by the node.

`:ipport` – The logical IP port that addresses the application on the node.

`:loc` – The card location of the STPLAN card that contains the TCP/IP link that is directly connected to the node.

`:force` – Whether or not to remove all applications associated with the node, thus removing the entire node from the database.

The examples used in this procedure are used to remove the TCP/IP node with the IP address 193.4.201.71 from the database.

The TCP/IP node must be in the database. This can be verified in step 1.

The specified card must have a TCP/IP data link assigned to it. This can be verified in step 2.

The card that the TCP/IP data link is assigned to must be a DCM, SSED, or E5-SLAN card running the stplan application. This can be verified with the rtrv-card command. The DCM, SSED, or E5-SLAN card is shown by the entries DCM in the TYPE field and STPLAN in the APPL field of the rtrv-card command output.

If only the ipaddr parameter is specified with the dlt-ip-node command, all the connections to a TCP/IP node will be removed from the database. To remove all the connections to a TCP/IP node, the force=yes parameter must be specified with the ipaddr parameter.

The ipappl or ipport parameters can be specified with the dlt-ip-node command, but both parameters cannot be specified with the dlt-ip-node command at the same time.

1. Display the TCP/IP nodes in the database by entering the rtrv-ip-node command.

This is an example of the possible output.

```
rlghncxa03w 06-10-20 21:16:37 GMT EAGLE5 36.0.0
IPADDR      IPPORT  IPAPPL  LOC    CAP    IPRT
193.4.201.15  1024   stplan  1103  10%   --
193.4.201.23  1024   stplan  1104  10%   --
193.4.201.65  1024   stplan  1201  10%   --
193.4.201.65  3000   stplan  1205  40%   --
193.4.201.78  1024   stplan  1203  10%   --
200.50.115.101 2000   stplan  1204  40%   193.4.202.30
203.24.212.30 4000   stplan  1206  40%   197.4.217.47
205.37.12.63  3963   stplan  1207  40%   198.10.186.53
```

2. Display the TCP/IP data links in the database by entering the rtrv-dlk command.

This is an example of the possible output.

```
rlghncxa03w 07-02-20 21:16:37 GMT EAGLE5 37.0.0
LOC  IPADDR      LINK SPEED  DUPLEX  AUTO
1103 193.4.201.70  10Mbit  HALF    NO
1104 193.4.201.71  10Mbit  HALF    NO
1201 193.4.201.50  100Mbit HALF    NO
1203 193.4.201.51  ----- ----    YES
1204 200.50.100.47  10Mbit  HALF    NO
1205 193.4.201.50  ----- ----    YES
1206 203.14.212.30  ----- ----    YES
1207 202.14.212.39  ----- ----    YES
```

3. Verify the current state of the TCP/IP data link assigned to the TCP/IP node to be removed from the database using the rept-stat-dlk command. For this example, the TCP/IP data link to be placed out of service is assigned to card 1104. For this example, enter this command.

```
rept-stat-dlk:loc=1104
```

This is an example of the possible output.

```
rlghncxa03w 10-07-20 21:21:37 GMT EAGLE5 42.0.0
DLK  PST      SST      AST
1104  IS-NR    Active   ----
Alarm Status = No Alarms.
Command Completed.
```

Note: Skip step 4 and step 5 and go to step 6 if the status of the TCP/IP data link shown in the output of step 3 is OOS-MT-DSBLD.

- Place the TCP/IP data link using the `canc-dlk` command, using the outputs from steps 1 and 2 to obtain the card location (shown in the `LOC` field of both outputs) of the TCP/IP data link to be placed out of service.

For this example, the TCP/IP data link to be placed out of service is assigned to card 1104. Enter this command.

```
canc-dlk:loc=1104
```

When the command has successfully completed, this message should appear.

```
rlghncxa03w 06-10-20 21:18:37 GMT EAGLE5 36.0.0
Deactivate Link message sent to card.
```

- Verify that the TCP/IP data link is out of service - maintenance disabled (OOS-MT-DSBLD) using the `rept-stat-dlk` command.

For this example, enter this command.

```
rept-stat-dlk:loc=1104
```

This is an example of the possible output.

```
rlghncxa03w 10-07-20 21:19:37 GMT EAGLE5 42.0.0
DLK          PST          SST          AST
1104         OOS-MT-DSBLD Unavail  ----
  ALARM STATUS = * 0155 STPLAN connection unavailable
```

Command Completed.

- Verify the current state of the card assigned to the TCP/IP data link to be removed using the `rept-stat-card` command. For this example, enter this command.

```
rept-stat-card:loc=1104
```

This is an example of the possible output.

```
rlghncxa03w 07-02-20 21:19:37 GMT EAGLE5 37.0.0
CARD  VERSION      TYPE      GPL      PST      SST      AST
1104  126-003-002  DCM      STPLAN  IS-NR    Active  -----
  ALARM STATUS      = No Alarms.
  BPCM GPL version  = 126-002-000
  IMT BUS A         = Conn
  IMT BUS B         = Conn
  DLK A  PST        = OOS-MT-DSBLD    SST = Unavail  AST = -----
  SLAN % EAGLE CAPACITY = 0%
  SLAN % HOST CAPACITY  = 0%
```

Command Completed.

Note: Skip steps 7 and 8 and go to step 9 if the status of the card shown in the output of step 6 is OOS-MT-DSBLD.

- Place the card assigned to the TCP/IP node to be removed out of service by using the `rmv-card` command, specifying the card location used in step 3.

For this example, enter this command.

```
rmv-card:loc=1104
```

This message should appear.

```
rlghncxa03w 06-10-20 21:20:37 GMT EAGLE5 36.0.0
Card has been inhibited.
```

- Verify that the card is out-of service - maintenance disabled (OOS-MT-DSBLD) using the `rept-stat-card` command. For this example, enter this command.

```
rept-stat-card:loc=1104
```

This is an example of the possible output.

```
rlghncxa03w 07-02-20 21:19:37 GMT EAGLE5 37.0.0
CARD  VERSION      TYPE      GPL      PST      SST      AST
1104  126-003-002    DCM      STPLAN   OOS-MT-DSBLD  Manual  -----
ALARM STATUS      = ** 0013 Card is isolated from the system
BPDCM GPL version = 126-002-000
IMT BUS A         = Conn
IMT BUS B         = Conn
DLK A  PST        = OOS-MT-DSBLD      SST = Unavail  AST = -----
SLAN % EAGLE CAPACITY = 0%
SLAN % HOST CAPACITY  = 0%
Command Completed.
```

- Remove the TCP/IP node to the database using the `dlt-ip-node` command. For this example, enter this command.

```
dlt-ip-node:ipaddr=193.4.201.71:ipport=1024 :loc=1104
```

This message should appear.

```
rlghncxa03w 06-10-20 21:21:37 GMT EAGLE5 36.0.0
DLT-IP-NODE: MASP A - COMPLTD
```

If you wish to remove all the connections to a TCP/IP node, for example, all the connections to the node at IP address 193.4.201.65, enter the `dlt-ip-node` command with the IP address of the node and the `force=yes` parameter, or enter the `dlt-ip-node` command with the IP address of the node and the `ipappl=stplan` parameter. For this example, enter one of these commands.

```
dlt-ip-node:ipaddr=193.4.201.65:force=yes
```

```
dlt-ip-node:ipaddr=193.4.201.65:ipappl=stplan
```

- Verify the changes using the `rtrv-ip-node` command.

If a single connection to a TCP/IP node was removed in step 9, enter the `rtrv-ip-node` command with the card location specified in step 9. For this example, enter this command.

```
rtrv-ip-node:loc=1104
```

The following message is displayed.

```
rlghncxa03w 07-02-20 21:22:37 GMT EAGLE5 37.0.0
E2622 Cmd Rej: IPADDR not assigned to specified LOC
```

If all the connections to a TCP/IP node were removed in step 9, enter the `rtrv-ip-node` command with the IP address specified in step 9. For this example, enter this command

```
rtrv-ip-node:ipaddr=193.4.201.65
```

The following message is displayed.

```
rlghncxa03w 07-02-20 21:22:37 GMT EAGLE5 37.0.0
IPADDR          IPPORT  IPAPPL  LOC    CAP    IPRTE
```

```
IPADDR not connected to any TCP/IP Link.
```

11. Backup the new changes using the `chg-db:action=backup:dest=fixed` command.

These messages should appear; the active Maintenance and Administration Subsystem Processor (MASP) appears first.

```
BACKUP (FIXED) : MASP A - Backup starts on active MASP.
BACKUP (FIXED) : MASP A - Backup on active MASP to fixed disk complete.
BACKUP (FIXED) : MASP A - Backup starts on standby MASP.
BACKUP (FIXED) : MASP A - Backup on standby MASP to fixed disk complete.
```

Configuring the Copy Original OPC for STPLAN Option

This procedure is used to configure the copy original OPC for STPLAN option using the `chg-ss7opts` command with the `slanpcorgopc` parameter. The `slanpcorgopc` parameter has two values:

- `on` – After the MSU has been processed by other applications, but before the MSU is copied for the STPLAN application, the OPC of the MSU is replaced by the point code that was the OPC of the MSU when the MSU entered the EAGLE 5 ISS.
 - `off` – The OPC of the MSU is not replaced by the point code that was the OPC of the MSU when the MSU entered the EAGLE 5 ISS.
1. Display the existing value for the `slanpcorgopc` parameter by entering the `rtrv-ss7opts` command. This is an example of the possible output.

```
rlghncxa03w 08-10-17 16:02:05 GMT EAGLE5 39.2.0
SS7 OPTIONS
-----
SLANPCORGOPC          off
```

Note: The `rtrv-ss7opts` command output contains other fields that are not used by this procedure. If you wish to see all the fields displayed by the `rtrv-ss7opts` command, see the `rtrv-ss7opts` command description in the *Commands Manual*.

If the current `SLANPCORGOPC` value is `on`, continue the procedure with [Step 3](#).

If the current `SLANPCORGOPC` value is `off`, continue the procedure with [Step 2](#).

2. Verify that the STPLAN feature is on by entering the `rtrv-feat` command.

If the STPLAN feature is on, the `LAN` field should be set to `on`.

Note: The `rtrv-feat` command output contains other fields that are not used by this procedure. If you wish to see all the fields displayed by the `rtrv-feat` command, see the `rtrv-feat` command description in the *Commands Manual*.

If the STPLAN feature is on, continue the procedure with [Step 3](#).

If the STPLAN feature is not on, perform the procedure [Adding an STPLAN Card](#) to turn the STPLAN feature on and to add the required STPLAN cards. After the procedure [Adding an STPLAN Card](#) has been performed, continue the procedure with [Step 3](#).

3. Change the value of the `slanpcorgopc` parameter.

If the current value of the `slanpcorgopc` parameter is off, enter this command.

```
chg-ss7opts:slanpcorgopc=on
```

If the current value of the `slanpcorgopc` parameter is on, enter this command.

```
chg-ss7opts:slanpcorgopc=off
```

When this command has successfully completed, this message should appear.

```
rlghncxa03w 08-10-07 00:22:57 GMT EAGLE5 39.2.0
CHG-SS7OPTS: MASP A - COMPLTD
```

4. Verify the changes using the `rtrv-ss7opts` command. This is an example of the possible output.

```
rlghncxa03w 08-10-17 16:02:05 GMT EAGLE5 39.2.0

SS7 OPTIONS
-----
SLANPCORGPC          on
```

Note: The `rtrv-ss7opts` command output contains other fields that are not used by this procedure. If you wish to see all the fields displayed by the `rtrv-ss7opts` command, see the `rtrv-ss7opts` command description in the *Commands Manual*.

5. Back up the new changes using the `chg-db:action=backup:dest=fixed` command. These messages should appear, the active Maintenance and Administration Subsystem Processor (MASP) appears first.

```
BACKUP (FIXED) : MASP A - Backup starts on active MASP.
BACKUP (FIXED) : MASP A - Backup on active MASP to fixed disk complete.
BACKUP (FIXED) : MASP A - Backup starts on standby MASP.
BACKUP (FIXED) : MASP A - Backup on standby MASP to fixed disk complete.
```

Configuring the Option for Including the Incoming and Outgoing Linkset Names in the STPLAN Message Format

This procedure is used to configure the option that allows the incoming and outgoing linkset names to be included in the STPLAN message format using the `chg-ss7opts` command with the `slanlsln` parameter. The `slanlsln` parameter has two values:

- `on` – The incoming and outgoing linkset names are copied into the STPLAN message format.
 - `off` – The incoming and outgoing linkset names are not copied into the STPLAN message format.
1. Display the existing value for the `slanlsln` parameter by entering the `rtrv-ss7opts` command. This is an example of the possible output.

```
rlghncxa03w 09-03-17 16:02:05 GMT EAGLE5 40.1.0
```

```
SS7 OPTIONS
-----
SLANSL5                off
```

Note: The `rtrv-ss7opts` command output contains other fields that are not used by this procedure. If you wish to see all the fields displayed by the `rtrv-ss7opts` command, see the `rtrv-ss7opts` command description in the *Commands Manual*.

If the current `SLANSL5` value is on, continue the procedure with [Step 3](#).

If the current `SLANSL5` value is off, continue the procedure with [Step 2](#).

2. Verify that the STPLAN feature is on by entering the `rtrv-feat` command.

If the STPLAN feature is on, the `LAN` field should be set to on.

Note: The `rtrv-feat` command output contains other fields that are not used by this procedure. If you wish to see all the fields displayed by the `rtrv-feat` command, see the `rtrv-feat` command description in the *Commands Manual*.

If the STPLAN feature is on, continue the procedure with [Step 3](#).

If the STPLAN feature is not on, perform the procedure [Adding an STPLAN Card](#) to turn the STPLAN feature on and to add the required STPLAN cards. After the procedure [Adding an STPLAN Card](#) has been performed, continue the procedure with [Step 3](#).

3. Change the value of the `slanlsn` parameter.

If the current value of the `slanlsn` parameter is off, enter this command.

```
chg-ss7opts:slanlsn=on
```

If the current value of the `slanlsn` parameter is on, enter this command.

```
chg-ss7opts:slanlsn=off
```

When this command has successfully completed, this message should appear.

```
rlghncxa03w 09-03-07 00:22:57 GMT  EAGLE5 40.1.0
CHG-SS7OPTS: MASP A - COMPLTD
```

4. Verify the changes using the `rtrv-ss7opts` command. This is an example of the possible output.

```
rlghncxa03w 09-03-17 16:02:05 GMT  EAGLE5 40.1.0

SS7 OPTIONS
-----
SLANSL5                on
```

Note: The `rtrv-ss7opts` command output contains other fields that are not used by this procedure. If you wish to see all the fields displayed by the `rtrv-ss7opts` command, see the `rtrv-ss7opts` command description in the *Commands Manual*.

5. Back up the new changes using the `chg-db:action=backup:dest=fixed` command. These messages should appear, the active Maintenance and Administration Subsystem Processor (MASP) appears first.

```
BACKUP (FIXED) : MASP A - Backup starts on active MASP.
BACKUP (FIXED) : MASP A - Backup on active MASP to fixed disk complete.
BACKUP (FIXED) : MASP A - Backup starts on standby MASP.
BACKUP (FIXED) : MASP A - Backup on standby MASP to fixed disk complete.
```

Chapter 3

Database Transport Access (DTA) Configuration

Topics:

- *DTA Feature Overview.....62*
- *Functional Description.....64*
- *Summary of the Gateway Screening Redirect Table Commands67*
- *SCCP Subsystem Management.....68*
- *EAGLE 5 ISS Requirements69*
- *Configuring the EAGLE 5 ISS for the DTA Feature.....69*
- *Changing the Gateway Screening Redirect Parameters.....78*
- *Disabling the Gateway Screening Redirect Function.....82*

Chapter 3, Database Transport Access (DTA) Configuration, describes the Database Transport Access (DTA) feature and the procedures necessary to configure the EAGLE 5 ISS to support this feature.

DTA Feature Overview

This feature allows data to be routed through the SS7 network using the SCCP protocol without relying on TCAP as the upper level protocol.

In the case of specialized applications, MSUs containing SCCP and proprietary data must be sent through the network to customer-specific databases. However, these MSUs may need additional processing before being routed to their final destination.

The DTA feature provides a mechanism for the redirection of specific MSUs to a customized database. The EAGLE 5 ISS uses gateway screening to qualify incoming MSUs for redirection.

Once gateway screening is passed, the original MSU is encapsulated into a new MSU and routed to its new destination.

Figure 10: Example of Configuration for the DTA Feature shows a typical configuration for the DTA feature.

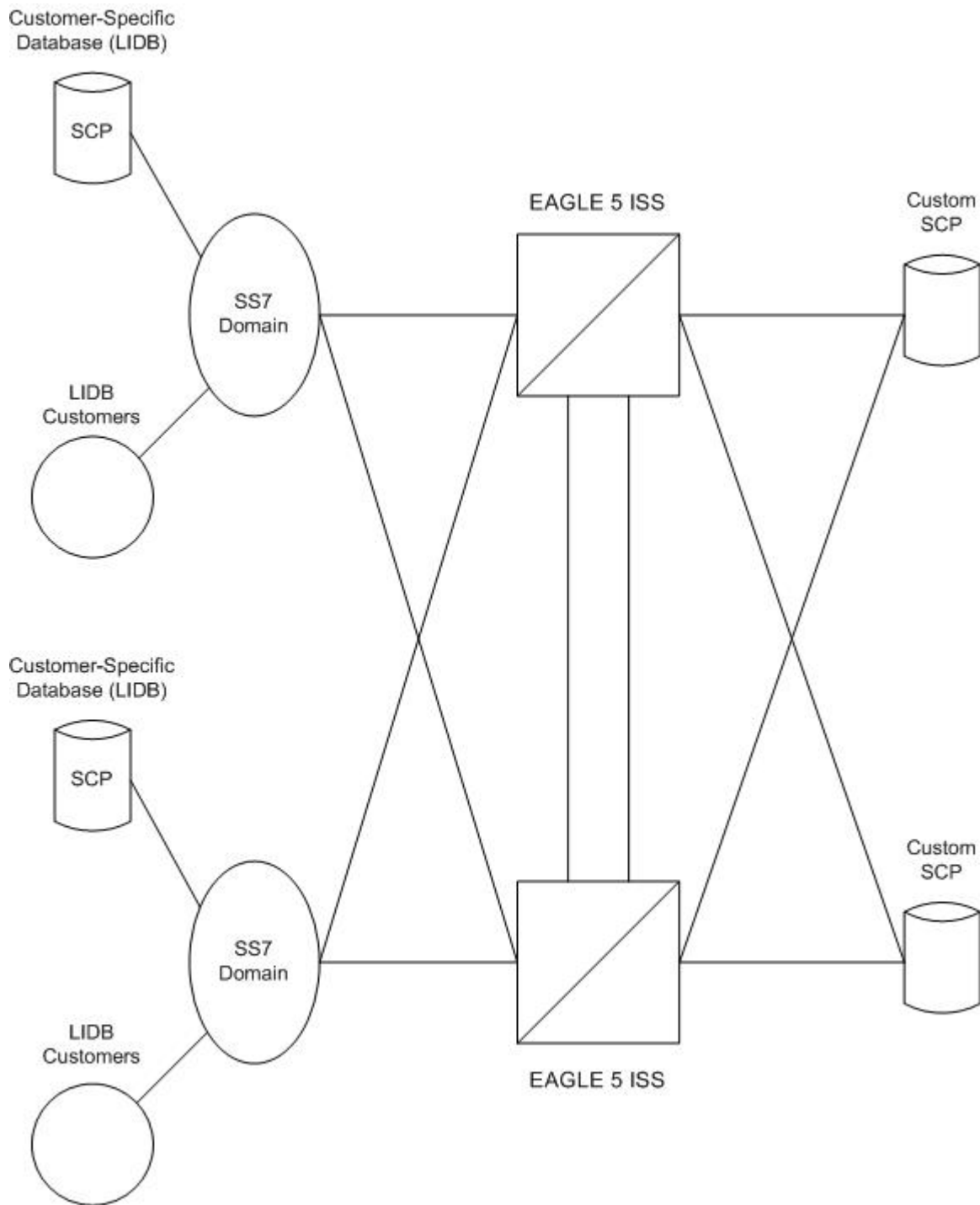

Figure 10: Example of Configuration for the DTA Feature

The new routing is specified by a redirection table that specifies the destination point code (DPC) and a new called party address. The routing indicator and the subsystem number are defined within the called party address.

The MSU is then passed to the SCP on the specified linkset where the application data is processed for a customized application.

Once the SCP has processed the user data, the SCP sends the MSU back to the EAGLE 5 ISS. At the EAGLE 5 ISS, the MSU is routed to its final destination in the SS7 network. The SCP determines the routing for the MSU, providing it in the routing label of the MTP portion of the MSU and in the SCCP called party address.

The SCP also provides new calling party address information to support billing applications. The SCP is considered as the originator (OPC) and the calling party.

As an optional feature, MSUs that are redirected to an SCP can also be copied using the STPLAN feature. This provides a copy of the redirected MSU to be routed over a TCP/IP interface to an adjunct processor. The copied MSU can then be processed for a variety of applications such as usage measurements.

The EAGLE 5 ISS does not provide any conversion of the copied MSU; it merely provides a copy of the redirected MSU after encapsulation of the original MSU. The copy is conducted by the LIM transmitting the redirected MSU.

If this feature is used, the DCM, SSEDCCM, or E5-SLAN card running the STPLAN application, is required. These cards provide an ethernet interface supporting TCP/IP applications. For more information regarding the STPLAN feature, see [STPLAN Configuration](#).

Functional Description

The principal function within the EAGLE 5 ISS for this feature is gateway screening. This feature allows the EAGLE 5 ISS to examine all incoming MSUs and determine whether or not they should be allowed into the network. Gateway screening looks at the routing label of the incoming MSU and matches this information with the EAGLE 5 ISS's gateway screening tables.

To support the DTA feature, a gateway screening stop action set containing the `rdct` (redirect) gateway screening stop action is assigned to the last screen in the screening process. The redirect gateway screening stop action selects the MSU that is redirected for the DTA feature. The screening table for the DTA feature examines the routing label (OPC, DPC) and the SIO fields of the MSU.

Once the MSU has been qualified for redirection by the gateway screening function, the original MSU is encapsulated into the data portion of SCCP within a new SS7 MSU, including all level two and level three headers. A redirect routing table identifies the DPC to be inserted into the routing label of the redirected MSU. In addition, the called party address in the SCCP portion of the MSU is modified according to the parameters set in the redirect routing table. [Figure 11: DTA Encapsulation](#) illustrates the encapsulation process.

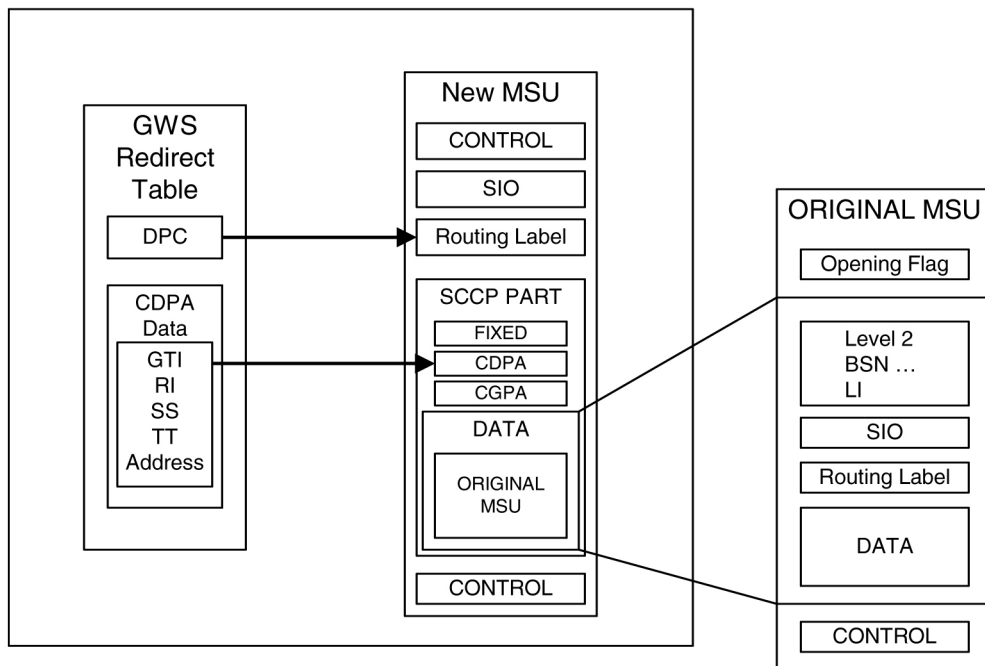

Figure 11: DTA Encapsulation

The global title function is used to determine which of the SCPs the MSU is routed to. In the event of subsystem failures, SCCP subsystem management determines which of the SCPs is available. The global title function provides the routing information and routes the MSU to the available SCP.

The global title function requires service modules which contain the global title translation tables.

Once the MSU has received its routing information, the MSU can be sent to the appropriate SCP (specified by the EAGLE 5 ISS's redirection table and global title). The SCP then processes the user data contained within the encapsulated MSU. Once processing has been completed, the MSU is sent back to the EAGLE 5 ISS for final routing.

The DTA feature will redirect MSUs to either ANSI or ITU nodes, depending on the value of the DPC in the redirect routing table, but the redirect routing table can contain only one DPC value. If the incoming message type is not the same as the DPC in the redirect routing table, the message is tunneled to the redirect DPC.

The subsystem number in the called party address determines whether the MSU is processed as an ANSI MSU or an ITU MSU. If the subsystem number is 0, the MSU is an ANSI MSU. If the subsystem number is 250, the MSU is an ITU MSU (an MSU containing either a ITU-I point code, 14-bit ITU-N point code, ITU-I Spare point code, or 14-bit ITU-N Spare point code). If the subsystem number is 251, the MSU is an ITU-N24 MSU (an MSU containing a 24-bit ITU-N point code).

Tunneling uses an MTP2/MTP3/SCCP header based on the network type of the DTA DPC to allow any incoming message to be routed to the DTA DPC. A wrapper is placed around the message (an ANSI wrapper around an ITU message, or an ITU wrapper around an ANSI message), and sends the message to the DTA DPC. The destination removes the wrapper and processes the original information.

Discarding MSUs

MSUs can be discarded for these reasons:

- Gateway screening is not available or the MSU does not pass gateway screening.
- The gateway screening redirect function is disabled.
- The MSU is too large to be encapsulated
- The DPC for the gateway screening redirect function is prohibited or congested.
- The EAGLE 5 ISS's SCCP subsystem is prohibited.

The discarding of MSUs is controlled by `gwsd` linkset parameter. If the `gwsd=on` parameter is specified for the linkset, and one or more of the conditions in the previous list are encountered, MSUs on the linkset are discarded. If the `gwsd=off` parameter is specified for the linkset, and one or more of the conditions in the previous list are encountered, MSUs on the linkset are routed to its original destination. Each of the MSU discard conditions are discussed in the following paragraphs.

If gateway screening is not available or the MSU does not pass gateway screening, the MSU is discarded. An unsolicited alarm message (UAM) is not generated. This condition is not dependent on the linkset `gwsd` parameter value. The `MSGWSDSLIM` measurement is pegged.

If the redirect mode is set to 'off' in the redirect function, either with the `chg-gws-redirect:enabled=off` or `dlt-gws-redirect` commands, and the linkset `gwsd=on` parameter is specified for the linkset, the MSU is discarded, UIM 1084 is generated, and the `DTAMSULOST` measurement is pegged. If the linkset `gwsd=off` parameter is specified for the linkset, the MSU is routed to its original destination, UIM 1084 is not generated, and the `DTAMSULOST` measurement is not pegged.

If an MSU is too large to be encapsulated, the MSU may be discarded, depending on the linkset's `gwsd` parameter value. The maximum length of the MSU is dependent on the number of digits contained in the global title address and on the network type of the DPC in the MSU, as shown in [Table 9: Maximum Encapsulation Length per DTA DPC Type](#).

Table 9: Maximum Encapsulation Length per DTA DPC Type

MSU DPC Type	GTA Length - 1 Digit	GTA Length - 21 Digits
ANSI	250 bytes	240 bytes
ITU-I	253 bytes	243 bytes
ITU-I Spare	253 bytes	243 bytes
ITU-N	253 bytes	243 bytes
ITU-N Spare	253 bytes	243 bytes
ITU-N24	250 bytes	240 bytes

MSUs that are too long are discarded based on the linkset `gwsd` parameter value. If the linkset `gwsd=on` parameter is specified for the linkset, the MSU is discarded, UIM 1084 is generated, and the `DTAMSULOST` measurement is pegged. If the linkset `gwsd=off` parameter is specified for the linkset, the MSU is routed to its original destination, UIM 1085 is generated, but the `DTAMSULOST` measurement is not pegged.

If the DPC of the gateway screening redirect function is the DPC of an external node, and if the route to this DPC is prohibited, or if this DPC is available, but the congestion level is above the priority of the MSU (for DTA, this priority is always 0), the MSU will not be encapsulated and will be discarded or routed according to the linkset's `gwsd` parameter value. If the linkset's `gwsd` value is `on`, the MSU

is discarded, UIM 1084 is generated, and the DTAMSULOST measurement is pegged. If the linkset's `gwsd` value is `off`, the MSU is routed to its original destination, UIM 1084 is not generated, and the DTAMSULOST measurement is not pegged.

If the DPC for the gateway screening redirect function is the EAGLE 5 ISS's point code, the MSU is sent to the EAGLE 5 ISS's SCCP subsystem for GTT processing. If the EAGLE 5 ISS's SCCP subsystem is prohibited, the MSU will not be encapsulated and will be discarded or routed according to the linkset's `gwsd` parameter value. If the linkset's `gwsd` value is `on`, the MSU is discarded, UIM 1084 is generated, and the DTAMSULOST measurement is pegged. If the linkset's `gwsd` value is `off`, the MSU is routed to its original destination, UIM 1084 is not generated, and the DTAMSULOST measurement is not pegged.

UIMs 1084 and 1085 are discussed in greater detail in the *Unsolicited Alarm and Information Messages Manual*.

Measurements

Two measurements are provided to indicate the number of MSUs discarded: DTAMSULOST and MSGWSDSLIM.

The DTAMSULOST measurement counts the number of MSUs discarded because gateway screening is not available. This can be caused by a number of events, including congestion in the EAGLE 5 ISS.

The MSGWSDSLIM counts the number of MSUs discarded because the received MSU was too large to be encapsulated or because the redirect function was disabled.

DTAMSULOST and MSGWSDSLIM are explained in greater detail in the *Measurements Manual*.

Summary of the Gateway Screening Redirect Table Commands

The following set of commands is used to administer the gateway screening redirect table.

Table 10: Commands for the Gateway Screening Redirect Table

Command	Explanation and action
<code>ent-gws-redirect</code>	The <code>ent-gws-redirect</code> command is used to enter the routing table for redirected MSUs.
<code>chg-gws-redirect</code>	The <code>chg-gws-redirect</code> command is used to modify the existing redirect routing table.
<code>dlt-gws-redirect</code>	The <code>dlt-gws-redirect</code> command is used to delete the redirect table from the database.
<code>rtrv-gws-redirect</code>	The <code>rtrv-gws-redirect</code> command is used to display the parameters of an existing redirect routing table.

SCCP Subsystem Management

The EAGLE 5 ISS provides SCCP subsystem management for all transactions sent to an SCP. In the case of the DTA feature, subsystem management is provided for the customized SCP. The customized SCP is deployed in a quad configuration adjacent to the EAGLE 5 ISS. The links connecting the EAGLE 5 ISS and the SCP must be configured in such a way to support SCCP subsystem management. The application supported by the dual SCPs is duplicated in both entities. The applications can be configured in one of the following two modes: dominant or load-shared.

When configured as dominant, one SCP is configured to receive all queries. This assignment is made in EAGLE 5 ISS routing tables. In the event the dominant SCP fails, traffic is diverted by SCCP subsystem management to the mate application.

If load sharing is configured, both SCPs will receive queries. SCCP ensures that all associated transactions are sent to the same SCP. Load sharing allows traffic to be distributed to both SCPs evenly, preventing congestion at one SCP.

If there is a failure in a load sharing configuration, all traffic is diverted by SCCP subsystem management to the mate SCP. When the failed SCP is restored, the EAGLE 5 ISS resumes load sharing.

Figure 12: Configuration of GTT for Routing Management shows an EAGLE 5 ISS configured with primary and backup SCPs.

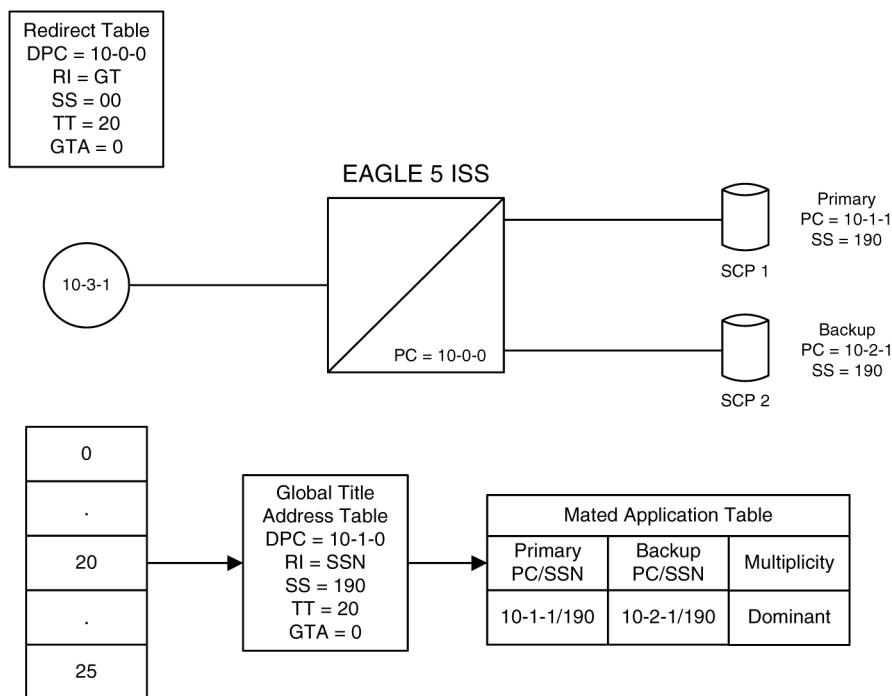

Figure 12: Configuration of GTT for Routing Management

EAGLE 5 ISS Requirements

There are no specific hardware requirements to support the DTA feature. However, if the following specific situations exist, the following cards are required.

Table 11: Cards Required in Specific Situations

If	Required Card
STPLAN feature is used	DCM, SSEDCCM, E5-SLAN
Subsystem management is used	DSM, E5-SM4G

Configuring the EAGLE 5 ISS for the DTA Feature

This procedure is used to add all the items to the EAGLE 5 ISS database that are necessary to implement the DTA feature.

The following features must be turned on:

- Gateway screening
- Global title translation

Verify that these features are turned on by entering the `rtrv-feat` command. If any of these features are turned off, they can be turned on by entering one of the following commands:

- `chg-feat:gws=on` – if the Gateway Screening feature is off (GWS = off in the `rtrv-feat` command output)
- `chg-feat:ggt=on` – if the Global Title Translation feature is off (GTT = off in the `rtrv-feat` command output)

Note: After the Gateway Screening and Global Title Translation features are turned on with the `chg-feat` command, they cannot be turned off.

The following items must be provisioned in the database before the EAGLE 5 ISS can be provisioned for the DTA feature:

- LIMs assigned to the `ss7ansi` application that are necessary to implement the DTA feature – "Adding an SS7 LIM" procedure in the *Database Administration Manual – System Management*. The LIMs can be verified by entering the `rtrv-card` command.
- Service Module cards assigned to the `vsccp` applications that are necessary to implement the DTA feature - Adding a Service Module procedure in the *Database Administration Manual – Global Title Translation*. The Service Module cards can be verified by entering the `rtrv-card` command.
- If you wish to redirect MSUs on IP cards (cards running the `iplim`, `iplimi`, `ss7ipgw`, `ipgwi`, or `ipsg` applications), then IP cards assigned to the `iplim`, `iplimi`, `ss7ipgw`, `ipgwi`, or `ipsg` applications must be in the database - see the Adding an IPLIMx Card, Adding an IPGWx Card, or Adding an IPSG Card procedures in the *Database Administration Manual - IP7 Secure Gateway*.

The IP cards can be verified by entering the `rtrv-card` command. If MSUs on IP cards are being redirected, the IP cards must be assigned to SCTP associations, and routing keys, if applicable, according to the application assigned to the IP card. The IP configuration can be verified by entering these commands, as appropriate: `rtrv-appl-rtkey`, `rtrv-as`, `rtrv-assoc`, `rtrv-ip-lnk`, `rtrv-ls`, `rtrv-slk`. Perform the procedures in the *Database Administration Manual - IP7 Secure Gateway* to update the IP7 Secure Gateway configuration as necessary.

- Linksets whose APCs are in the SS7 domain that are necessary to implement the DTA feature – see "Adding an SS7 Linkset" procedure in the *Database Administration Manual – SS7* . The APCs of SS7 linksets can be either ANSI, ITU-I, ITU-N, ITU-I Spare, ITU-N Spare, or ITU-N24 point codes. The linksets can be verified by entering the `rtrv-ls` command. The linksets whose traffic is to be redirected by the DTA feature, must have gateway screening allowed (specify the `gwsa=on` parameter) and must reference a gateway screening screen set. The name of the screen set is shown in the `SCRN` field of the `rtrv-ls` command output. The name of the screen set is specified by the `scrn` parameter in either the `ent-ls` or `chg-ls` commands. The screen set referenced by the linkset must be in the database. All gateway screening entities must be in the database before the necessary linkset can be added to the database or changed to reference the necessary screen set. See the "Gateway Screening Configuration" section to make sure that the necessary gateway screening entities are in the database for this feature. To enhance the reliability of the DTA feature, the gateway screening message discard function should be turned on with the `gwsd=on` parameter.
- Signaling links assigned to linksets containing SS7 APCs that are necessary to implement the DTA feature – "Adding an SS7 Signaling Link" procedure in the *Database Administration Manual – SS7* . The APCs of SS7 linksets can be either ANSI, ITU-I, ITU-N, ITU-I Spare, ITU-N Spare, or ITU-N24 point codes. The signaling links can be verified by entering the `rtrv-slk` command.
- Routes assigned to linksets containing SS7 APCs that are necessary to implement the DTA feature - "Adding a Route Containing an SS7 DPC" procedure in the *Database Administration Manual – SS7* . The DPCs of SS7 routes and APCs of SS7 linksets can be either ANSI, ITU-I, ITU-N, ITU-I Spare, ITU-N Spare, or ITU-N24 point codes. The routes can be verified by entering the `rtrv-rte` command.

Gateway Screening Configuration

The DTA feature uses gateway screening to select the messages that are redirected. A gateway screening stop action set containing the `rdct` (redirect) gateway screening stop action must be assigned to one of these gateway screening entities where the gateway screening process stops (the NSFI of the screen is STOP).

- Allowed OPC
- Blocked OPC
- Allowed SIO
- Allowed DPC
- Blocked DPC
- Allowed Destination Field
- Allowed ISUP Message Type

Enter the `rtrv-gws-actset` command to display the gateway screening stop action sets in the database. The database contains one gateway screening stop action set that contain the `rdct` gateway screening stop action as shown in bold in the example output. This gateway screening stop action is always in the database and cannot be changed or removed.

```
rlghncxa03w 06-10-07 00:17:31 GMT EAGLE5 36.0.0
ACT  ACT    ACT  ACT  ACT  ACT  ACT  ACT  ACT  ACT  ACT  ACT
ID   NAME    1    2    3    4    5    6    7    8    9    10
--   -----
```

```

1    copy    copy
2    rdct    rdct
3    cr      copy rdct

```

```
GWS action set table is (3 of 16) 19% full
```

For more information on configuring gateway screening stop action sets, see the “Configuring Gateway Screening Stop Action Sets” procedure in the *Database Administration Manual - Gateway Screening*.



CAUTION: Redirecting SLTA/SLTM messages prevents SLTA/SLTM messages from being returned to the EAGLE 5 ISS. The signaling link carrying these messages will fail if these messages are not returned to the EAGLE 5 ISS. To prevent SLTA/SLTM messages from being redirected, gateway screening stop action sets containing the redirect stop action should not be assigned to the following screens:

- Allowed OPC screens containing the adjacent point code of a linkset
- Allowed SIO screens containing the service indicator values 1 (SI=1) or 2 (SI=2)
- Allowed DPC screens containing the EAGLE 5 ISS’s point code.

To verify that the screen set being used with the gateway screening redirect function, enter the `rtrv-scrset:scrn=<screen set name assigned to the linkset being used>` command. If the last screen in the screen set is OPC, BLKOPC, SIO, DPC, BLKDPC, DESTFLD, or ISUP, enter the gateway screening retrieve command corresponding to the last screen in the screen set, with the screening reference name shown in the `rtrv-scrset` output. For example, if the last screen in the screen set is ISUP, enter the `rtrv-scr-isup` command with the `sr` parameter. If the NSR/ACT value shown in the retrieve output is a gateway screening stop action set name that contains the `rdct` stop action, shown in the `rtrv-gws-actset` output, this screen set can be used for the gateway screening redirect function. If you wish to use this screen set, but the `rdct` gateway screening stop action is not assigned to the last screen in the screen set, go to the *Database Administration Manual - Gateway Screening* and perform one of these procedures, as appropriate, to assign the `rdct` gateway screening stop action to the last screen in the screen set.

- “Changing an Allowed ISUP Message Type Screen”
- “Changing an Allowed Affected Destination Field Screen”
- “Changing a Blocked DPC Screen”
- “Changing an Allowed DPC Screen”
- “Changing an Allowed SIO Screen”
- “Changing a Blocked OPC Screen”
- “Changing an Allowed OPC Screen”

If the last screen in the screen set is CGPA, TT, CDPA, or AFTPC, it is recommended that either this screen set is changed so that the last screen in the screen set is OPC, BLKOPC, SIO, DPC, BLKDPC, DESTFLD, or ISUP with the `rdct` gateway screening stop action, or that another screen set with OPC, BLKOPC, SIO, DPC, BLKDPC, DESTFLD, or ISUP as the last screen in the screen set with the `rdct` gateway screening stop action be used. To find another screen set, enter the `rtrv-scrset` command, then enter the `rtrv-scrset` command again with one of the screen set names shown in the first `rtrv-scrset` output. If the last screen in the screen set is OPC, BLKOPC, SIO, DPC, BLKDPC, DESTFLD, or ISUP, enter the gateway screening retrieve command corresponding to the last screen in the screen set, with the screening reference name shown in the `rtrv-scrset` output. Repeat this entering the `rtrv-scrset` commands until a desirable screen set is found. If a desirable screen set cannot be found, either add a new screen set, or change the existing screen set. To add a new screen set, go to the *Database Administration Manual - Gateway Screening* and perform one of these procedures, as appropriate, and assign the `rdct` gateway screening stop action to the last screen in the screen set.

- “Adding an Allowed ISUP Message Type Screen”
- “Adding an Allowed Affected Destination Field Screen”
- “Adding a Blocked DPC Screen”
- “Adding an Allowed DPC Screen”
- “Adding an Allowed SIO Screen”
- “Adding a Blocked OPC Screen”
- “Adding an Allowed OPC Screen”

If you wish to change the existing screen set, go to the *Database Administration Manual - Gateway Screening* and perform one of these procedures, as appropriate. Make sure the last screen in the screen set has the rdct gateway screening stop action assigned.

- “Changing an Allowed ISUP Message Type Screen”
- “Changing an Allowed Affected Destination Field Screen”
- “Changing a Blocked DPC Screen”
- “Changing an Allowed DPC Screen”
- “Changing an Allowed SIO Screen”
- “Changing a Blocked OPC Screen”
- “Changing an Allowed OPC Screen”

Verify that the necessary gateway screening entities have been configured with the required gateway screening stop action set, by entering the appropriate gateway screening retrieve command specifying the actname parameter with the gateway screening stop action name shown in the rtrv-gws-actset command output.

- rtrv-scr-opc:actname=rdct – to display the allowed OPC screens
- rtrv-scr-blkopc:actname=rdct – to display the blocked OPC screens
- rtrv-scr-sio:actname=rdct – to display the allowed SIO screens
- rtrv-scr-dpc:actname=rdct – to display the allowed DPC screens
- rtrv-scr-blkdpc:actname=rdct – to display the blocked DPC screens
- rtrv-scr-destfld:actname=rdct – to display the allowed destination field screens
- rtrv-scr-isup:actname=rdct – to display the allowed ISUP message type screens

If a gateway screening entity is configured to redirect, the entry STOP appears in the NSF1 field, the NSR/ACT field contains the name of the gateway screening stop action set specified in the gateway screening retrieve command (see the following example).

```
rlghncxa03w 06-10-07 00:17:31 GMT EAGLE5 36.0.0
SCREEN = ALLOWED OPC
SR   NI      NC      NCM      NSF1     NSR/ACT
opc1 010      010      010      STOP     RDCT
opc1 010      010      012      STOP     RDCT
```

If the necessary gateway screening entities are not in the database, add them to the database using one of these procedures in the *Database Administration Manual - Gateway Screening*.

- “Adding an Allowed ISUP Message Type Screen”
- “Adding an Allowed Affected Destination Field Screen”
- “Adding a Blocked DPC Screen”
- “Adding an Allowed DPC Screen”
- “Adding an Allowed SIO Screen”
- “Adding a Blocked OPC Screen”

- “Adding an Allowed OPC Screen”

If the necessary gateway screening entities are in the database, use one these procedures in the *Database Administration Manual - Gateway Screening* to assign the redirect gateway screening stop action to them.

- “Changing an Allowed ISUP Message Type Screen”
- “Changing an Allowed Affected Destination Field Screen”
- “Changing a Blocked DPC Screen”
- “Changing an Allowed DPC Screen”
- “Changing an Allowed SIO Screen”
- “Changing a Blocked OPC Screen”
- “Changing an Allowed OPC Screen”



CAUTION: When Gateway Screening is in the screen test mode, as defined by the linkset parameters `gwsa=off` and `gws=on`, the gateway screening action in the gateway screening stop action set specified by the `actname` parameter of the gateway screening screen set at the end of the gateway screening process will be performed.

A screen set is required to start the screening process. Enter the `rtrv-scrset` command to verify that the necessary screen set is in the database. If the necessary screen set is not in the database, use the “Adding a Screen Set” in the in the *Database Administration Manual - Gateway Screening* and add the necessary screen set to the database. If the necessary screen set is in the database and the next screening function identifier (NSFI) needs to be changed, use the “Changing a Screen Set” in the in the *Database Administration Manual - Gateway Screening* to change the NSFI of the screen set.

Canceling the RTRV-GTT and RTRV-GTA Commands

Because the `rtrv-gtt` and `rtrv-gta` commands used in this procedure can output information for a long period of time, the `rtrv-gtt` and `rtrv-gta` commands can be canceled and the output to the terminal stopped. There are three ways that the `rtrv-gtt` and `rtrv-gta` commands can be canceled.

- Press the F9 function key on the keyboard at the terminal where the `rtrv-gtt` or `rtrv-gta` commands were entered.
- Enter the `canc-cmd` without the `trm` parameter at the terminal where the `rtrv-gtt` or `rtrv-gta` commands were entered.
- Enter the `canc-cmd:trm=<xx>`, where `<xx>` is the terminal where the `rtrv-gtt` or `rtrv-gta` commands were entered, from another terminal other than the terminal where the `rtrv-gtt` or `rtrv-gta` commands were entered. To enter the `canc-cmd:trm=<xx>` command, the terminal must allow Security Administration commands to be entered from it and the user must be allowed to enter Security Administration commands. The terminal’s permissions can be verified with the `rtrv-secu-trm` command. The user’s permissions can be verified with the `rtrv-user` or `rtrv-secu-user` commands.

For more information about the `canc-cmd` command, go to the *Commands Manual*.

1. Verify that the gateway screening redirect function is disabled by entering the `rtrv-gws-redirect` command.

The following is an example of the possible output.

```
rlghncxa03w 09-05-07 00:17:31 GMT EAGLE5 41.0.0
ENABLED      DPCA          RI      SSN  TT      GT
```

Redirect function data is not provisioned.

If the gateway screening redirect function is enabled, the `ent-gws-redirect` command in [Step 2](#) cannot be executed.

2. Provision the gateway screening redirect function by entering the following command.

This example is using the destination point code (`dpc`) 009-002-001, the routing indicator (`ri`) GT, the subsystem number (`ssn`) 15, the global title translation type (`tt`) 225, the global title address (`gta`) 9105551212, and the `enabled` parameter is equal to `on`.

```
ent-gws-redirect:dpc=009-002-001:ri=gt:ssn=15:tt=225
:gta=9105551212:enabled=on
```

- `:dpc/dpca/dpci/dpcn/dpcn24` – The destination point code, either an ANSI, ITU-I, ITU-N, ITU-I Spare, ITU-N Spare, or ITU-N24 point code, that the message is being redirected to. The point code used for this parameter must be in the database as a destination point code of a route, shown in the `rtrv-rte` output, or must be the STP's site point code, shown in the `rtrv-sid` output.

`:dpc/dpca` – an ANSI point code

`:dpci` – an ITU-I or ITU-I Spare point code

`:dpcn` – a 14-bit ITU-N or 14-bit ITU-N Spare point code

`:dpcn24` – a 24-bit ITU-N point code

If you wish to use a destination point code as a value for this parameter, verify that the destination point code has a route assigned to it by entering the `rtrv-rte` command with the point code value being assigned to the gateway screening redirect function. The `dpc` parameter specified with the `rtrv-rte` command must correspond to the parameter value being specified as shown in the list preceding this paragraph.

For this example, enter the `rtrv-rte:dpca=009-002-001` command. The following is an example of the possible output.

```
rlghncxa03w 06-10-07 00:19:31 GMT EAGLE5 36.0.0
DPCA          ALIASI          ALIASN/N24      LSN           RC          APCA
009-002-001  -----  -----  ls02         0          009-002-001
                                   RTX:No  CLLI=dtac11i
```

If you wish to use the STP's point code for the `dpc` parameter, enter the `rtrv-sid` command to find the STP's point code. The following is an example of the possible output.

```
rlghncxa03w 06-10-07 00:20:31 GMT EAGLE5 36.0.0
PCA          PCI          PCN           CLLI          PCTYPE
144-201-001  0-123-1      11211        rlghncxa03w  ANSI
              s-0-123-1    s-11211

CPCA
002-002-002      002-002-003      002-002-004      002-002-005
002-002-006      002-002-007      002-002-008      002-002-009
004-002-001      004-003-003      144-212-003

CPCA (LNP)
005-005-002      005-005-004      005-005-005

CPCI
1-001-1          1-001-2          1-001-3          1-001-4
1-002-1          1-002-2          1-002-3          1-002-4
2-001-1          7-222-7
```

CPCN			
02091	02092	02094	02097
02191	02192	11177	

The EAGLE 5 ISS's point code is shown in either the PCA, PCI, PCN, or PCN24 fields of the `rtrv-sid` command output. The `rtrv-sid` command will show either the PCN or PCN24 fields along with the PCA and PCI fields.

- `:ri` – The routing indicator for the redirected message.

If the routing indicator is `ssn`, the DPC and SSN shown in the output of the `rtrv-gws-redirect` command, is the final destination of the redirected message. If the routing indicator is `gt`, additional global title translation is required to determine the final destination of the redirected message.

- `:ssn` – The CDPA subsystem to which the redirected message is bound for
- `:tt` – The CDPA translation type of the global title translation
- `:gta` – The CDPA global title translation address. Hexadecimal digits cannot be specified for the `gta` parameter. Only decimal digits can be specified for the `gta` parameter,
- `:enabled` – Whether the messages that have passed GWS are to be redirected (on) or discarded based on the linkset's `gwsd` parameter value (off). If the `enabled` parameter is off and the linkset's `gwsd` value is on, the MSU is discarded, MRN 1084 is generated, and the DTAMSULOST measurement is pegged. If the `enabled` parameter is on and the linkset's `gwsd` value is off, the MSU is routed to its original destination, MRN 1084 is not generated, and the DTAMSULOST measurement is not pegged.

When the command has been completed successfully, the following message should appear.

```
rlghncxa03w 06-10-07 00:21:31 GMT EAGLE5 36.0.0
ENT-GWS-REDIRECT: MASP A - COMPLTD
```

3. Verify the changes by entering the `rtrv-gws-redirect` command.

The following is an example of the possible output.

```
rlghncxa03w 09-05-07 00:17:31 GMT EAGLE5 41.0.0
ENABLED  DPCA      RI  SSN  TT  GT
on       009-002-001  GT  15  225 9105551212
```

4. Verify if the enhanced global title translation feature is on or off by entering the `rtrv-feat` command.

If the enhanced global title translation feature is on, the `EGTT` field should be set to `on`.

Note: The `rtrv-feat` command output contains other fields that are not used by this procedure. If you wish to see all the fields displayed by the `rtrv-feat` command, see the `rtrv-feat` command description in the *Commands Manual*.

If the enhanced global title translation feature is on, the `rtrv-tt`, `ent-tt`, `rtrv-gtt`, and `ent-gtt` commands cannot be executed. Instead, the `rtrv-gttset`, `ent-gttset`, `rtrv-gttset`, `ent-gttset`, `rtrv-gta`, and `ent-gta` are used to verify and configure the global title translation data.

Note: If the enhanced global title translation is on, skip [Step 5](#), and [Step 6](#), and go to [Step 7](#).

- Verify the global title translation data in the database for the translation type specified in the output of [Step 3](#) by entering the `rtrv-gtt` command with the `type` and `gta` parameters, specifying the values shown in [Step 3](#) in the TT and GTA fields of the `rtrv-gws-redirect` command output.

For this example, enter this command.

```
rtrv-gtt:type=225:gta=9105551212
```

The following is an example of the possible output.

```
rlghncxa03w 06-10-07 00:24:31 GMT EAGLE5 36.0.0
TYPEA TTN      NDGT
225   DTA7     10
GTT TABLE IS 10% FULL.      (27000 of 269999)

START GTA          END GTA          XLAT  RI  PCA          SSN  NGT
9105551212        DPCSSN GT  009-002-001  15  ---
```

If the global title translation data is shown in the `rtrv-gtt` command output, no further action is necessary. Go to [Step 9](#).

- Verify that the global title translation type shown in the output of [Step 3](#), in the TT field, is in the database by entering the `rtrv-tt` command with the `type` parameter corresponding to the point code type shown in the `rtrv-gws-redirect` output and shown in [Table 12: Translation Type Parameters](#).

Table 12: Translation Type Parameters

Point Code Type	DPC Parameter shown in the <code>rtrv-gws-redirect</code> output	Translation Type Parameter
ANSI	DPC/DPCA	typea
ITU-I or ITU-I Spare	DPCI	typei
ITU-N or ITU-N Spare	DPCN	typen
ITU-N24	DPCN24	typen24

In this example, the global title translation type is 225 and the DPC value is an ANSI point code. The `typea` parameter should be specified with the `rtrv-tt` command. The translation type is shown in the `TYPEA` field. For this example, enter this command.

```
rtrv-tt:typea=225
```

The following is an example of the possible output.

```
rlghncxa03w 06-10-07 00:25:31 GMT EAGLE5 36.0.0
TYPEA TTN      NDGT
225   DTA7     10
```

If the translation type is shown in the `rtrv-tt` output, perform the “Adding a Global Title Translation” procedure in the *Database Administration Manual - Global Title Translation* and configure a global title translation entry that contains the values shown in the `rtrv-gws-redirect` output in [Step 3](#). This procedure is finished.

If the translation type is not shown in the `rtrv-tt` output, perform the “Adding a Translation Type” and “Adding a Global Title Translation” procedures in the *Database Administration Manual - Global Title Translation* and configure a global title translation entry that contains the values shown in the `rtrv-gws-redirect` output in [Step 3](#). This procedure is finished.

Note: If the enhanced global title translation is off, do not perform [Step 7](#), [Step 8](#), and [Step 9](#). This procedure is finished.

- Verify that the global title translation type specified in the output of [Step 3](#), in the TT field, is in the database by entering the `rtrv-gttset` command with the `tt` parameter.

For this example, enter the `rtrv-gttset:tt=225` command. The following is an example of the possible output.

```
rlghncxa03w 06-10-07 00:27:31 GMT EAGLE5 36.0.0
GTIA  TT  NP      NAI  GTTSN
2      225  --      ---  dta7
```

If the translation type is not in the database, this message is displayed in the scroll area of the terminal display.

```
No GTT Selectors matching the specified criteria were found.
```

If the translation type is shown in the `rtrv-gttset` command output, go to [Step 8](#) and verify that the global title address data is in the database.

If the translation type is not shown in the `rtrv-gttset` command output, perform the “Adding a GTT Set,” “Adding a GTT Selector,” and “Adding Global Title Address Information” procedures in the *Database Administration Manual - Global Title Translation* and configure a global title address entry that contains the values shown in the `rtrv-gws-redirect` output in [Step 3](#). This procedure is finished.

- The new global title address data must be in the database.

Verify the global title translation data in the database for the translation type specified in the output of [Step 7](#) by entering the `rtrv-gta` command with the GTTSN value shown in the output of [Step 7](#), and with the GTA, SSN, and DPC values shown in the output of [Step 3](#). For this example, enter this command.

```
rtrv-gta:gttsn=dta7:gta=9195551212:ssn=15:pca=009-002-001
```

The following is an example of the possible output.

```
rlghncxa03w 06-10-07 00:28:31 GMT EAGLE5 36.0.0
GTTSN      NETDOM  NDGT
dta7      ansi     10
GTA TABLE IS 1 % FULL (17 of 269999)

START GTA  END GTA  XLAT  RI  PCA          SSN CCGT NTT
```

If the required global title translation data is shown in the `rtrv-gta` command output, no further action is necessary. Go to [Step 9](#).

If the required global title translation data is not shown in the `rtrv-gta` command output, perform the “Adding Global Title Address Information” procedure in the *Database Administration Manual - Global Title Translation* and configure a global title address entry that contains the values shown in the `rtrv-gws-redirect` output in [Step 3](#). This procedure is finished.

- Backup the new changes using the `chg-db:action=backup:dest=fixed` command.

The following messages should appear, the active Maintenance and Administration Subsystem Processor (MASP) appears first.

```
BACKUP (FIXED) : MASP A - Backup starts on active MASP.  
BACKUP (FIXED) : MASP A - Backup on active MASP to fixed disk complete.  
BACKUP (FIXED) : MASP A - Backup starts on standby MASP.  
BACKUP (FIXED) : MASP A - Backup on standby MASP to fixed disk complete.
```

Changing the Gateway Screening Redirect Parameters

To change the configuration to support the DTA feature, one or more of the gateway screening redirect function's attributes can be changed using the `chg-gws-redirect` command. This procedure shows the steps necessary to change these attributes.

The gateway screening redirect function's data must be in the database and the gateway screening redirect function must be enabled, shown by the entry `on` in the `enabled` field of the `rtrv-gws-redirect` command output.

Any of the gateway screening redirect function's attributes can be changed. The new attributes, and any database entities required to support these attributes, must be in the database.

Canceling the `RTRV-GTT` and `RTRV-GTA` Commands

Because the `rtrv-gtt` and `rtrv-gta` commands used in this procedure can output information for a long period of time, the `rtrv-gtt` and `rtrv-gta` commands can be canceled and the output to the terminal stopped. There are three ways that the `rtrv-gtt` and `rtrv-gta` commands can be canceled.

- Press the `F9` function key on the keyboard at the terminal where the `rtrv-gtt` or `rtrv-gta` commands were entered.
- Enter the `canc-cmd` without the `trm` parameter at the terminal where the `rtrv-gtt` or `rtrv-gta` commands were entered.
- Enter the `canc-cmd:trm=<xx>`, where `<xx>` is the terminal where the `rtrv-gtt` or `rtrv-gta` commands were entered, from another terminal other than the terminal where the `rtrv-gtt` or `rtrv-gta` commands were entered. To enter the `canc-cmd:trm=<xx>` command, the terminal must allow Security Administration commands to be entered from it and the user must be allowed to enter Security Administration commands. The terminal's permissions can be verified with the `rtrv-secu-trm` command. The user's permissions can be verified with the `rtrv-user` or `rtrv-secu-user` commands.

For more information about the `canc-cmd` command, go to the *Commands Manual*.

The examples in this procedure are used to change the gateway screening redirect function's attributes to these values. The routing indicator is not being changed.

- `:dpc - 009-003-001`
- `:ssn - 45`
- `:tt - 175`
- `:gta - 3365841342`

1. Verify the gateway screening redirect function attributes by entering the `rtrv-gws-redirect` command.

```
rlghncxa03w 09-05-07 00:17:31 GMT EAGLE5 41.0.0
ENABLED      DPCA          RI      SSN  TT      GTA
on           003-175-010    GT      15   225    9105551212
```

If the DPC, shown in the DPC field, is not being changed, skip [Step 2](#), and [Step 3](#), and go to [Step 4](#).

2. Verify that the new DPC is in the database and has a route assigned to it.

Note: If the DPC is being changed to the EAGLE 5 ISS's point code, skip step 2 and go to step 3.

Verify this by entering the `rtrv-rte` command with the new DPC, in this example, 009-003-001.

```
rlghncxa03w 06-10-07 00:19:31 GMT EAGLE5 36.0.0
DPCA          ALIASI      ALIASN/N24  LSN      RC      APCA
009-003-001  -----  -----  ls02      0       009-001-001
RTX:No      CLLI=dtac11i
```

If the required route to the DPC is not shown in the `rtrv-rte` command output, go to the "Adding a Route Containing an SS7 DPC" procedure in the *Database Administration Manual - SS7* and add the route to the DPC to the database.

3. Display the EAGLE 5 ISS's point code by entering the `rtrv-sid` command.

Note: If the DPC is being changed to a point code in the routing table, shown in the output of step 2, skip step 3 and go to [Step 4](#).

```
rlghncxa03w 06-10-07 00:20:31 GMT EAGLE5 36.0.0
PCA          PCI          PCN          CLLI          PCTYPE
144-201-001  0-123-1      11211       rlghncxa03w  ANSI
              s-0-123-1    s-11211

CPCA
002-002-002  002-002-003  002-002-004  002-002-005
002-002-006  002-002-007  002-002-008  002-002-009
004-002-001  004-003-003  144-212-003

CPCA (LNP)
005-005-002  005-005-004  005-005-005

CPCI
1-001-1      1-001-2      1-001-3      1-001-4
1-002-1      1-002-2      1-002-3      1-002-4
2-001-1      7-222-7

CPCN
02091        02092        02094        02097
02191        02192        11177
```

The EAGLE 5 ISS's point code is shown in either the PCA, PCI, PCN, or PCN24 fields of the `rtrv-sid` command output. The `rtrv-sid` command will show either the PCN or PCN24 fields along with the PCA and PCI fields.

4. Change the parameters for the gateway screening redirect function by entering the `chg-gws-redirect` command with any of these parameters:

For this example, enter this command. In this example, the `ri` parameter is not being changed.

```
chg-gws-redirect:dpc=009-003-001:ssn=45:tt=175:gta=3365841342
```

- Verify the changes by entering the `rtrv-gws-redirect` command.

```
rlghncxa03w 09-05-07 00:17:31 GMT EAGLE5 41.0.0
ENABLED      DPCA          RI   SSN   TT   GTA
on           009-003-001  GT   45   175 3365841342
```

If only the DPC parameter was changed in [Step 4](#), skip [steps 6](#) through 10, go to [step 11](#).

- Verify if the enhanced global title translation feature is on or off by entering the `rtrv-feat` command.

If the enhanced global title translation feature is on, the `EGTT` field should be set to `on`.

For this example, the enhanced global title translation feature is on.

Note: The `rtrv-feat` command output contains other fields that are not used by this procedure. If you wish to see all the fields displayed by the `rtrv-feat` command, see the `rtrv-feat` command description in the *Commands Manual*.

If the enhanced global title translation feature is on, the `rtrv-tt`, `ent-tt`, `rtrv-gtt`, and `ent-gtt` commands cannot be executed. Instead, the `rtrv-gttset`, `ent-gttset`, `rtrv-gttsetl`, `ent-gttsetl`, `rtrv-gta`, and `ent-gta` are used to verify and configure the global title translation data.

- The new global title address data must be in the database.

Note: If the enhanced global title translation is on, skip [steps 7](#) and [8](#), and go to [step 9](#).

Verify the global title translation data in the database for the translation type specified in the output of [step 5](#) by entering the `rtrv-gtt` command with the `type` and `gta` parameters. For this example, enter this command.

```
rtrv-gtt:type=175:gta=3365841342
```

```
rlghncxa03w 06-10-07 00:24:31 GMT EAGLE5 36.0.0
TYPEA  TTN      NDGT
175    DTA7     10
GTT TABLE IS 10% FULL. (27000 of 269999)

START GTA          END GTA          XLAT  RI   PCA          SSN  NGT
3365841342        -----        DPCSSN GT  009-003-001  45  ---
```

If the global title translation data is shown in the `rtrv-gtt` command output, no further action is necessary. Go to [step 11](#).

- The new translation type must be in the database.

Verify that the global title translation type specified in the `rtrv-gws-redirect` output in [step 5](#) in the `TT` field, is in the database by entering the `rtrv-tt` command with the `type` parameter corresponding to the point code type shown in the `rtrv-gws-redirect` output in [step 5](#) and [Table 13: Translation Type Parameters](#).

Table 13: Translation Type Parameters

Point Code Type	DPC Parameter shown in the <code>rtrv-gws-redirect</code> output	Translation Type Parameter
ANSI	DPC/DPCA	typea

Point Code Type	DPC Parameter shown in the <code>rtrv-gws-redirect</code> output	Translation Type Parameter
ITU-I or ITU-I Spare	DPCI	typei
ITU-N or ITU-N Spare	DPCN	typen
ITU-N24	DPCN24	typen24

In this example, the new global title translation type is 175. The `typea` parameter should be specified with the `rtrv-tt` command. The translation type is shown in the `TYPEA` field. For this example, enter this command.

```
rtrv-tt:typea=175
```

```
rlghncxa03w 06-10-07 00:25:31 GMT EAGLE5 36.0.0
TYPEA  TTN      NDGT
175    DTA7      10
```

If the translation type is shown in the `rtrv-tt` output, perform the “Adding a Global Title Translation” procedure in the *Database Administration Manual - Global Title Translation* and configure a global title translation entry that contains the values shown in the `rtrv-gws-redirect` output in [step 5](#). This procedure is finished. If the translation type is not shown in the `rtrv-tt` output, perform the “Adding a Translation Type” and “Adding a Global Title Translation” procedures in the *Database Administration Manual - Global Title Translation* and configure a global title translation entry that contains the values shown in the `rtrv-gws-redirect` output in [step 5](#). This procedure is finished.

9. Verify that the global title translation type specified in the output of [step 5](#), in the `TT` field, is in the database by entering the `rtrv-gttset` command with the `tt` parameter.

Note: If the enhanced global title translation is off, do not perform steps 9, 10, and 11. This procedure is finished.

For this example, enter the `rtrv-gttset:tt=175` command.

```
rlghncxa03w 06-10-07 00:27:31 GMT EAGLE5 36.0.0
GTIA  TT  NP      NAI  GTTSN
2     175 --      ---  dta7
```

If the translation type is not in the database, this message is displayed in the scroll area of the terminal display.

```
No GTT Selectors matching the specified criteria were found.
```

If the translation type is shown in the `rtrv-gttset` command output, go to [step 10](#) and verify that the global title address data is in the database.

If the translation type is not shown in the `rtrv-gttset` command output, perform the “Adding a GTT Set,” “Adding a GTT Selector,” and “Adding Global Title Address Information” procedures in the *Database Administration Manual - Global Title Translation* and configure a global title address

entry that contains the values shown in the `rtrv-gws-redirect` output in step 3. This procedure is finished.

10. The new global title address must be in the database.

Verify the global title translation data in the database for the translation type specified in the output of [step 5](#) by entering the `rtrv-gta` command with the GTTSN value shown in the output of [step 9](#) and with the GTA, SSN, and DPC values shown in the output of [step 5](#). For this example, enter this command.

```
rtrv-gta:gttsn=dta7:gta=3365841342:pca=009-003-001:ssn=45
```

```
rlghncxa03w 06-10-07 00:28:31 GMT EAGLE5 36.0.0
GTTSN      NETDOM  NDGT
t800      ansi    10
GTA TABLE IS 1 % FULL (17 of 269999)

START GTA  END GTA    XLAT  RI  PCA          SSN CCGT NTT
```

If the required global title translation data is shown in the `rtrv-gta` command output, no further action is necessary. Go to [step 11](#).

If the required global title translation data is not shown in the `rtrv-gta` command output, perform the “Adding Global Title Address Information” procedure in the *Database Administration Manual - Global Title Translation* and configure a global title address entry that contains the values shown in the `rtrv-gws-redirect` output in [step 5](#). This procedure is finished.

11. Back up the new changes using the `chg-db:action=backup:dest=fixed` command.

The following messages should appear, the active Maintenance and Administration Subsystem Processor (MASP) appears first.

```
BACKUP (FIXED) : MASP A - Backup starts on active MASP.
BACKUP (FIXED) : MASP A - Backup on active MASP to fixed disk complete.
BACKUP (FIXED) : MASP A - Backup starts on standby MASP.
BACKUP (FIXED) : MASP A - Backup on standby MASP to fixed disk complete.
```

Disabling the Gateway Screening Redirect Function

This procedure is used to turn off the gateway screening redirect function using either the `dlt-gws-redirect` or `chg-gws-redirect` commands. Turning off the gateway screening redirect function also turns off the DTA feature.

1. Verify that the gateway screening redirect function is enabled by entering the `rtrv-gws-redirect` command.

```
rlghncxa03w 09-05-07 00:17:31 GMT EAGLE5 41.0.0
ENABLED  DPCA          RI  SSN  TT  GTA
on      009-002-001  GT  15  225 9105551212
```

2. Disable the gateway screening redirect function by entering the `dlt-gws-redirect` command or the `chg-gws-redirect:enabled=off` command.
3. Display the gateway screening stop action sets in the database by entering the `rtrv-gws-actset` command.

The entry rdct is displayed in the ACT1 through the ACT10 fields in any gateway screening stop action sets that have the redirect gateway screening stop action assigned to them.

```
rlghncxa03w 06-10-07 00:20:31 GMT EAGLE5 36.0.0
ACT ACT ACT ACT ACT ACT ACT ACT ACT ACT ACT ACT
ID NAME 1 2 3 4 5 6 7 8 9 10
--
1 copy copy
2 rdct rdct
3 cr copy rdct
GWS action set table is (3 of 16) 19% full
```

4. All gateway screening entities that have been assigned the redirect function must have the redirect function turned off.

Check the gateway screening entities for any screening references that have the redirect gateway screening stop action assigned to them.

Enter each of the following commands with the actname parameter specifying the name of the gateway screening stop action set shown in step 3 that contains the redirect gateway screening stop action. If a redirect gateway screening stop action has been assigned to a gateway screening entity, the name of the gateway screening stop action appears after the NSR/ACT field.

If a redirect gateway screening stop action has not been assigned to a gateway screening entity, the command is rejected with this message.

```
E3680 Cmd Rej: No match on ACTNAME parameter during retrieve
```

```
rtrv-scr-opc:actname=rdct
```

```
rlghncxa03w 06-10-07 00:21:31 GMT EAGLE5 36.0.0
SCREEN = ALLOWED OPC
SR NI NC NCM NSFI NSR/ACT
DTA1 240 001 010 STOP RDCT
```

```
rtrv-scr-blkopc:actname=rdct
```

```
rlghncxa03w 06-10-07 00:22:31 GMT EAGLE5 36.0.0
SCREEN = BLOCKED OPC
SR NI NC NCM NSFI NSR/ACT
DTA2 C C C STOP RDCT
```

```
rtrv-scr-sio:actname=rdct
```

```
rlghncxa03w 06-10-07 00:23:31 GMT EAGLE5 36.0.0
SCREEN = ALLOWED SIO
SR NIC PRI SI H0 H1 NSFI NSR/ACT
DTA3 1 3 4 -- -- STOP RDCT
```

```
rtrv-scr-dpc:actname=rdct
```

```
rlghncxa03w 06-10-07 00:24:31 GMT EAGLE5 36.0.0
SCREEN = ALLOWED DPC
SR NI NC NCM NSFI NSR/ACT
DTA4 243 015 001 STOP RDCT
```

```
rtrv-scr-blkdpc:actname=rdct
```

```
rlghncxa03w 06-10-07 00:25:31 GMT EAGLE5 36.0.0
SCREEN = BLOCKED DPC
```

SR	NI	NC	NCM	NSFI	NSR/ACT
DTA5	C	C	C	STOP	RDCT

```
rtrv-scr-destfld:actname=rdct
```

5. If any of the necessary gateway screening entities displayed in step 4 have been assigned a gateway screening stop action containing the redirect gateway screening stop action, change the gateway screening stop action for these entities to a gateway screening stop action displayed in step 3 that does not have the redirect gateway screening stop action assigned to it, or to have no gateway screening stop action set assigned to the gateway screening entity with the actname=none parameter.

These command examples are based on the example outputs shown in step 4.

```
chg-scr-opc:sr=dta1:ni=240:nc=001:ncm=010:actname=none
```

When this command has successfully completed, the following message should appear.

```
rlghncxa03w 06-10-07 00:27:31 GMT EAGLE5 36.0.0
CHG-SCR-OPC: SCREEN SET AFFECTED - DTA1 55% FULL
CHG-SCR-OPC: MASP A - COMPLTD
```

```
chg-scr-blkdpc:sr=dta2:nc=c:ni=c:ncm=c:actname=none
```

When this command has successfully completed, the following message should appear.

```
rlghncxa03w 06-10-07 00:28:31 GMT EAGLE5 36.0.0
CHG-SCR-BLKOPC: SCREEN SET AFFECTED - DTA2 55% FULL
CHG-SCR-OPC: MASP A - COMPLTD
```

```
chg-scr-sio:sr=dta3:nic=1:pri=3:si=4:actname=none
```

When this command has successfully completed, the following message should appear.

```
rlghncxa03w 06-10-07 00:29:31 GMT EAGLE5 36.0.0
CHG-SCR-SIO: SCREEN SET AFFECTED - DTA3 55% FULL
CHG-SCR-SIO: MASP A - COMPLTD
```

```
chg-scr-dpc:sr=dta4:ni=243:nc=015:ncm=001:actname=none
```

When this command has successfully completed, the following message should appear.

```
rlghncxa03w 06-10-07 00:30:31 GMT EAGLE5 36.0.0
CHG-SCR-DPC: SCREEN SET AFFECTED - DTA4 55% FULL
CHG-SCR-DPC: MASP A - COMPLTD
```

```
chg-scr-blkdpc:sr=dta5:nc=c:ni=c:ncm=c:actname=none
```

When this command has successfully completed, the following message should appear.

```
rlghncxa03w 06-10-07 00:31:31 GMT EAGLE5 36.0.0
CHG-SCR-BLKDPC: SCREEN SET AFFECTED - DTA5 55% FULL
CHG-SCR-BLKDPC: MASP A - COMPLTD
```

```
chg-scr-destfld:sr=dta6:ni=240:nc=001:ncm=010:actname=none
```

When this command has successfully completed, the following message should appear.

```
rlghncxa03w 06-10-07 00:32:31 GMT EAGLE5 36.0.0
CHG-SCR-DESTFLD: SCREEN SET AFFECTED - DTA6 55% FULL
CHG-SCR-DESTFLD: MASP A - COMPLTD
```

6. Verify that the changes have been made by entering any of the following commands with the `actname` parameter and the name of the gateway screening stop action set used in step 4.

```
rtrv-scr-opc:actname=rdct
rtrv-scr-blkopc:actname=rdct
rtrv-scr-sio:actname=rdct
rtrv-scr-dpc:actname=rdct
rtrv-scr-blkdpc:actname=rdct
rtrv-scr-destfld:actname=rdct
```

None of the screens should contain any entries assigned to the gateway screening redirect function. When each these commands are executed, this message should appear.

```
E3680 Cmd Rej: No match on ACTNAME parameter during retrieve
```

7. Back up the new changes using the `chg-db:action=backup:dest=fixed` command. The following messages should appear, the active Maintenance and Administration Subsystem Processor (MASP) appears first.

```
BACKUP (FIXED) : MASP A - Backup starts on active MASP.
BACKUP (FIXED) : MASP A - Backup on active MASP to fixed disk complete.
BACKUP (FIXED) : MASP A - Backup starts on standby MASP.
BACKUP (FIXED) : MASP A - Backup on standby MASP to fixed disk complete.
```

GSM MAP Screening Configuration

Topics:

- *Introduction.....87*
- *GSM MAP Screening Overview.....87*
- *GSM MAP Screening Details.....90*
- *GSM MAP Screening Example.....107*
- *GSM MAP Screening Procedures.....108*
- *Activating the GSM MAP Screening Feature.112*
- *Configuring the MTP MAP Screening Feature.....118*
- *Configuring a Linkset for the GSM MAP Screening Feature.....121*
- *Changing the System-Wide GSM MAP Screening Options.....128*
- *Adding a GSM Subsystem Number Screening Entry.....130*
- *Removing a GSM Subsystem Number Screening Entry.....132*
- *Adding a GSM MAP Screening Operation Code.....133*
- *Removing a GSM MAP Screening Operation Code.....145*
- *Changing a GSM MAP Screening Operation Code.....148*
- *Adding a GSM MAP Screening Entry.....157*
- *Removing a GSM MAP Screening Entry.....180*
- *Changing a GSM MAP Screening Entry.....187*
- *Changing the GSM MAP Screening TCAP Continue and End Message Processing Option.....202*

Chapter 4, GSM MAP Screening Configuration, describes the GSM MAP Screening feature and the procedures necessary to configure the EAGLE 5 ISS to support this feature.

Introduction

Traditionally, STP message screening has been limited to the MTP and SCCP levels; this has been sufficient to meet operators' needs. However, GSM mobile operators have an increasing need for screening at the Mobile Application Part (MAP) level. This need is driven by advanced network capabilities and proliferating roaming agreements.

New features that require this enhanced screening capability are Inter-operator Short Message Service (SMS) and Any Time Interrogation (ATI). The GSM MAP Screening feature focuses on solving the screening needs associated with ATI, which is defined in MAP version 3. An ATI message allows an external server to interrogate an HLR and obtain information about the location and/or state of a GSM subscriber. It may be desirable to control which external entities can request this information, and what information they can request before allowing the message to pass through to the HLR.

This feature allow the user to provision which MAP SSNs are affected, which MAP operations codes to screen, which origination points are allowed, and which error messages to use.

Note:

GSM MAP Screening can be used with linksets containing ITU international or ITU national adjacent point codes whether or not the Enhanced GSM MAP Screening feature is enabled and on. GSM MAP Screening can be used with linksets containing ANSI adjacent point codes only if the Enhanced GSM MAP screening feature is enabled and on.

GSM MAP Screening Overview

An SCCP MSU arrives at the EAGLE 5 ISS on a linkset with the `gsmscrn` parameter value set to `on`. If the DPC of the MSU is the EAGLE 5 ISS's point code, the MSU is processed by Global Title Translation and Gateway Screening on the called party address (CDPA). Any applicable SCCP/MTP conversions are also performed on the MSU. The MSU is passed on to GSM MAP Screening. GSM MAP screening is then performed on the MSU before forwarding it to the destination. If the `gsmscrn` parameter of the linkset is set to `off`, GSM MAP Screening is not performed on the MSU.

If the DPC of the MSU is not the EAGLE 5 ISS's point code, the message is routed to its destination using MTP routing. GSM MAP Screening is not performed on the MSU.

If the MTP MAP Screening feature is enabled and turned on, and the DPC of the MSU is not the EAGLE 5 ISS's point code, the MSU (SCCP message types 9 - UDT, or 10 - UDTs only) is sent to GSM MAP Screening without being processed by Global Title Translation and Gateway Screening on the called party address. GSM MAP screening is then performed on the MSU before forwarding the MSU to its destination.

When GSM MAP Screening on the message has completed, the EAGLE 5 ISS performs one of the following actions:

- Route the message to destination
- Discard the message
- Forward the message to a new destination

- Duplicate the message. Send the original message to the original destination, and send the duplicate message to a new destination.
- Duplicate the message and send the duplicate message to a new destination. Discard the original message.
- Return an error message to the originator.

GSM MAP screening first checks to see whether the calling party SSN and called party SSN are present and targeted to be screened or not.

If both SSNs are targeted, it then checks for the MAP operations code of the message to know whether it is targeted to be screened or not. If the MAP operations code is not targeted to be screened, then the EAGLE 5 ISS either discards or routes the message, defined by the `GSMDFLT` parameter of the `chg-stpopts` command. If the MAP operations code is targeted to be screened, GSM MAP screening checks the calling party address of the message to know whether it is targeted for screening or not.

If the CGPA (calling party address) of the message is not targeted for GSM MAP Screening, then the screening action defined in the MAP operations code table by the `df1tact` parameter of the `ent-gsms-opcode` command is performed on the message.

If the CGPA of the message is targeted for screening and the Enhanced GSM MAP Screening feature is enabled and on, GSM MAP Screening checks the CDPA (called party address) of the message to know whether or not it is targeted for screening. If the CDPA of the message is targeted for screening, GSM MAP screening checks to see if the ATI request contains the forbidden parameter value provisioned for the CDPA. If there is no forbidden parameter in the ATI request, the message is not an ATI request, or the provisioned forbidden parameter value for the CDPA is `none`, the message is routed to the destination. If the message is an ATI request and contains the forbidden parameter value provisioned for the CDPA, or the provisioned forbidden parameter value is `all`, GSM MAP screening performs the screening action defined in the CDPA screening table by the `action` parameter of the `ent-gsmmap-scrn` command.

If the CDPA of the message is not targeted for screening, GSM MAP screening checks to see if the ATI request contains the forbidden parameter value provisioned for the CGPA. If there is no forbidden parameter in the ATI request, the message is not an ATI request, or the provisioned forbidden parameter value for the CGPA is `none`, the message is routed to the destination. If the message is an ATI request and contains the forbidden parameter value provisioned for the CGPA, or the provisioned forbidden parameter value is `all`, GSM MAP screening performs the screening action defined in the CGPA screening table by the `action` parameter of the `ent-gsmmap-scrn` command.

If the CGPA of the message is targeted for screening and the Enhanced GSM MAP Screening feature is not enabled and off, GSM MAP Screening checks the CGPA (calling party address) of the message to know whether or not it is targeted for screening. If the CGPA of the message is targeted for screening, GSM MAP screening checks to see if the ATI request contains the forbidden parameter value provisioned for the CGPA. If there is no forbidden parameter in the ATI request, the message is not an ATI request, or the provisioned forbidden parameter value for the CGPA is `none`, the message is routed to the destination. If the message is an ATI request and contains the forbidden parameter value provisioned for the CGPA, or the provisioned forbidden parameter value is `all`, GSM MAP screening performs the screening action defined in the CGPA screening table by the `action` parameter of the `ent-gsmmap-scrn` command.

Figure 13: GSM MAP Screening Overview shows overview of GSM MAP screening functionality.

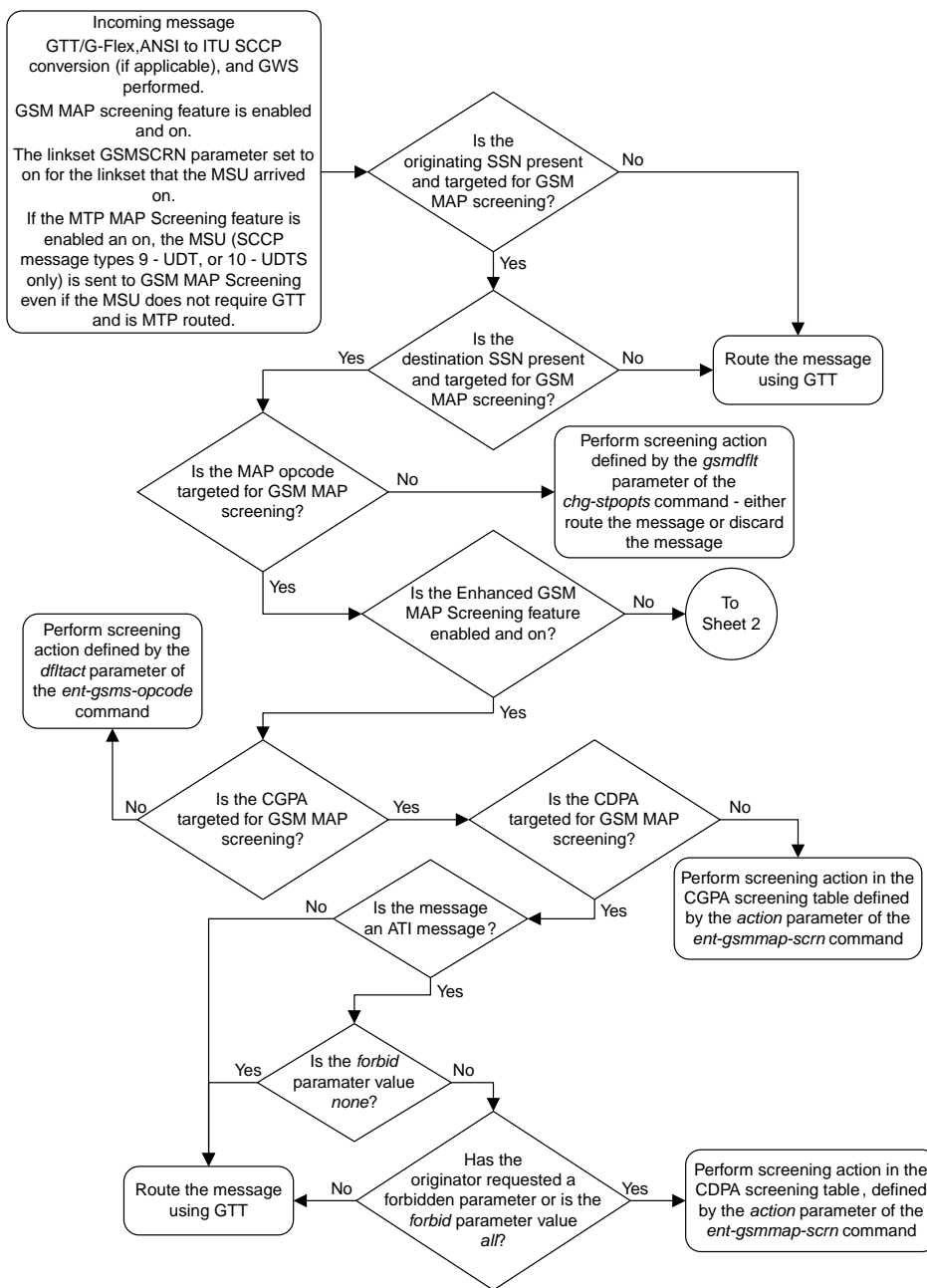

Sheet 1 of 2

Figure 13: GSM MAP Screening Overview

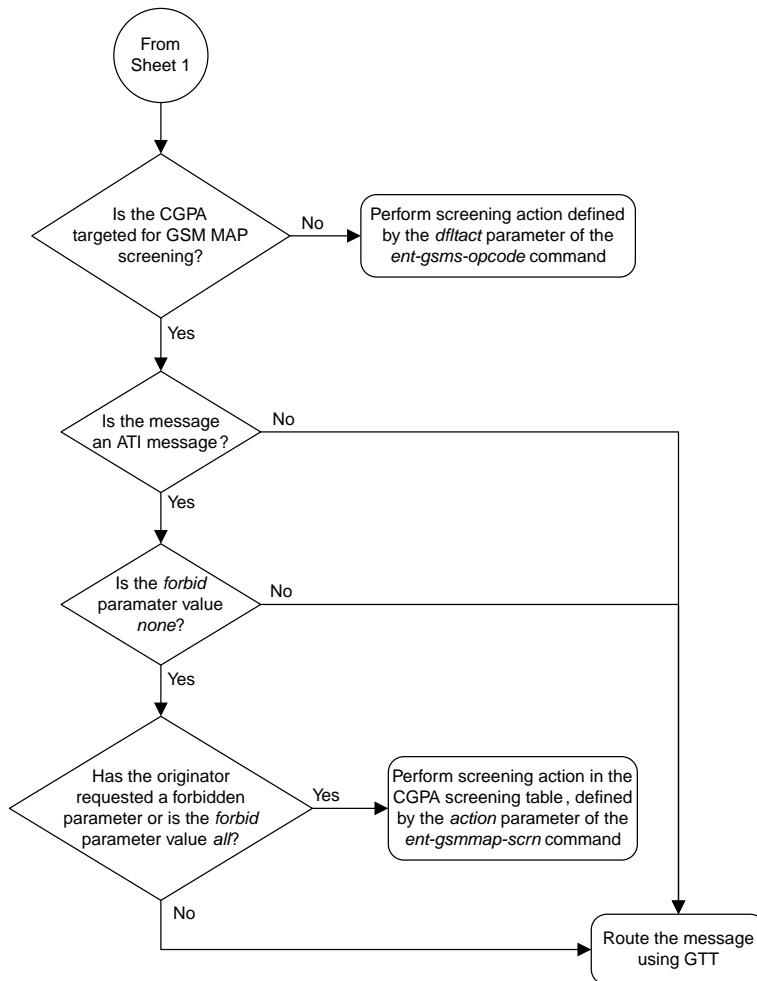

Sheet 2 of 2

GSM MAP Screening Details

GSM MAP screening verifies the MAP message format and performs screening before the message is routed to the destination. The following database tables are used in performing GSM MAP screening:

- SSN table
- MAP operations code table
- STP option table
- MAP screening table

GSM MAP Screening is performed in the following stages.

1. The following fields from SCCP message are decoded:
 - The SSN from the calling party address
 - The SSN from the called party address
 - The global title address from the calling party address
 - The global title address from the called party address (only if the Enhanced GSM MAP Screening feature is enabled and turned on).

Note: If the MTP MAP Screening is enabled and turned on, the MSU (SCCP message types 9 - UDT, or 10 - UDTS only) is sent to GSM MAP Screening even if the MSU does not require GTT and is MTP routed.

2. GSM MAP Screening performs a lookup in the origination SSN table for an entry with the SSN of calling party address. If an entry is not found, GSM MAP screening is stopped and the message is routed to its destination using global title translation.
3. GSM MAP Screening performs a lookup in the destination SSN table for an entry with the SSN of called party address. If an entry is not found, GSM MAP screening is stopped and the message is routed to its destination using global title translation.
4. GSM MAP Screening checks to see if the CGPA and CDPA GTI values are supported in the EAGLE 5 ISS. The EAGLE 5 ISS supports only these GTI values: for an ANSI message - GTI value of 2; for an ITU message - GTI values of 2 or 4. If the CGPA and CDPA GTI values are supported, the GTA values are decoded. If the GTI values are not supported in the EAGLE 5 ISS, the GTA, NAI, and NP values for the CGPA or CDPA are set to asterisk (*). The asterisk (*) values for the GTA, NAI, and NP parameters allows the action of the provisioned wildcard entries for the CGPA/CDPA MAP screening tables to be performed, or the action for the OPCODE table to be performed (if no wildcard entries are provisioned for the CGPA or CDPA in the GSM MAP screening table).
5. The MAP operations code and parameters are extracted from the MAP message. If the TCAP Package Type of the message is ITU TC-BEGIN, GSM MAP Screening continues.

If the GMSTCAPCE SCCP option is set to on and the TCAP Package Type is either ITU TC-CONTINUE or ITU TC-END, GSM MAP Screening continues. In order for GSM MAP Screening to be performed on these messages, the messages must meet the following requirements:

- ITU TC-CONTINUE messages must have an Invoke component type.
- ITU TC-END messages must have a Return-Result (Test) type.

If the TCAP Package Type of the message is not ITU TC-BEGIN, GSM MAP Screening is stopped and the message is routed to its destination using global title translation, as if the message passed GSM MAP screening.

If the GMSTCAPCE SCCP option is set to on, and the TCAP Package Type of the message is not ITU TC-CONTINUE or ITU TC-END, GSM MAP Screening is stopped and the message is routed to its destination using global title translation, as if the message passed GSM MAP screening.

If the TCAP portion is not in a valid format, the action defined by the GSM MAP screening decode error action from the STP option table (pass or discard) is performed and a UIM is generated indicating that an Invalid TCAP message received.

6. GSM MAP Screening performs a lookup in the MAP screening table for an entry with the MAP operations code of the MAP message. If an entry is not found, the default action from the STP option table is performed. If the default action parameter value is `pass`, the message is routed to its destination. If the default action parameter value is `discard`, the message is discarded.
7. GSM MAP Screening performs a lookup in the GSM MAP screening table for an entry containing the global title address of the calling party address. If an entry is not found in the GSM MAP

screening table, the screening action defined in the GSM MAP operations code table by the `df1tact` parameter of the `ent-gsms-opcode` command is performed.

8. If the Enhanced GSM MAP Screening feature is enabled and turned on, GSM MAP Screening performs a lookup for an entry for the called party address in the GSM MAP screening table.
9. If an entry is found in the MAP screening table, the forbidden parameter from the GSM MAP screening table is checked. If the forbidden parameter value is `none`, the message is routed to its destination. If the forbidden parameter value is `all`, the screening action defined in the GSM MAP screening table by the `action` parameter of the `ent-gsmmap-scrn` command is performed. For any other forbidden parameter, the parameter list of the message is examined. If the message is an ATI request and the forbidden parameter is found in the parameter list, then the screening action defined in the GSM MAP screening table by the `action` parameter of the `ent-gsmmap-scrn` command is performed.

The screening actions defined by the `df1tact` parameter of the `ent-gsms-opcode` command and the `action` parameter of the `ent-gsmmap-scrn` command are:

- **DISCARD** – do not route the MSU. The MSU is discarded (thrown away) and the appropriate UIM is issued. This is the default action value.
- **PASS** – route the message as normal to the destination and the appropriate UIM is issued.
- **ATIERR** – do not route the MSU and send a rejection message back to the originator.
- **ROUTE** – route the message as normal to the original destination node, defined by global title translation.
- **FORWARD** – route the original message to the forward node. The original message is not sent to the original node. If, however, the forwarded node is not available for routing then the MSU is routed to the original node, defined by global title translation.
- **DUPLICATE** – route the message as normal to the original destination, defined by global title translation, and route a copy of the original message to the duplicate node. If the MSU fails to route to the duplicate node, then a UIM is generated indicating the duplicate routing failure.
- **DUPLICATE AND DISCARD** – route the original message to the duplicate node. The original message is not sent to the original node. If, however, the duplicate node is not available for routing then the MSU is discarded.

Figure 14: GSM MAP Screening Details shows how GSM MAP screening is performed.

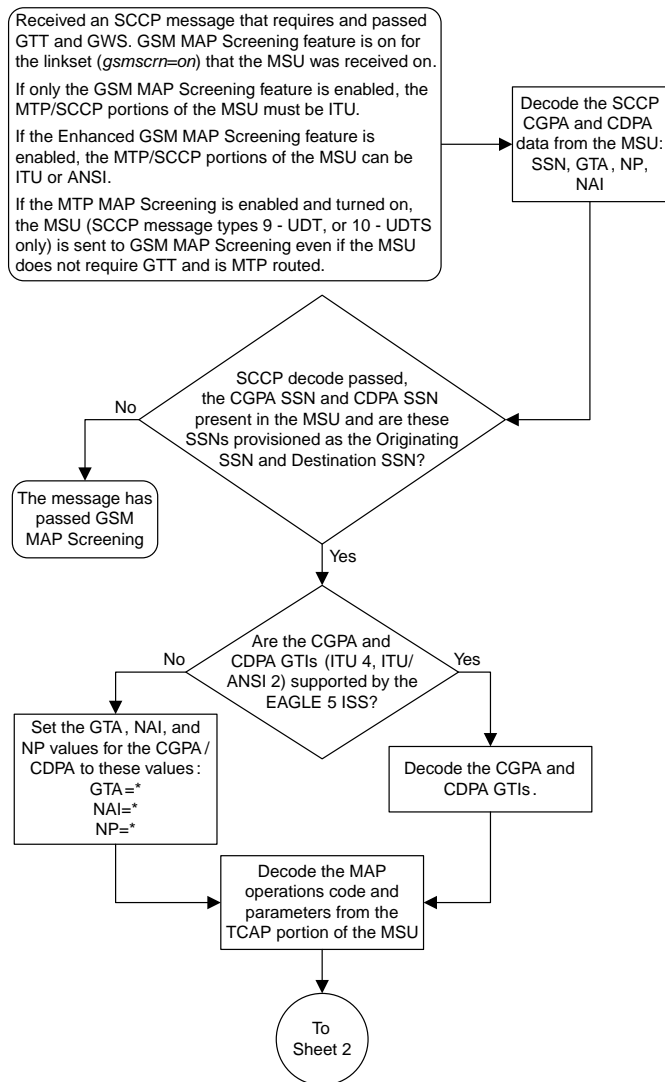

Sheet 1 of 15

Figure 14: GSM MAP Screening Details

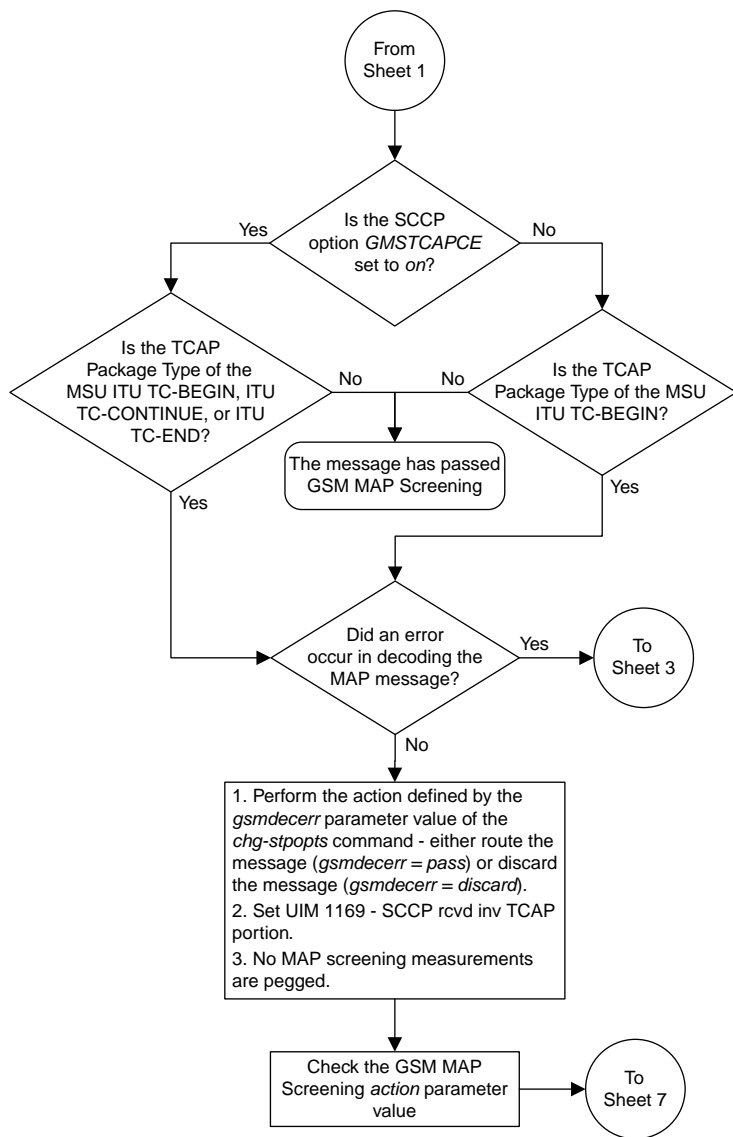

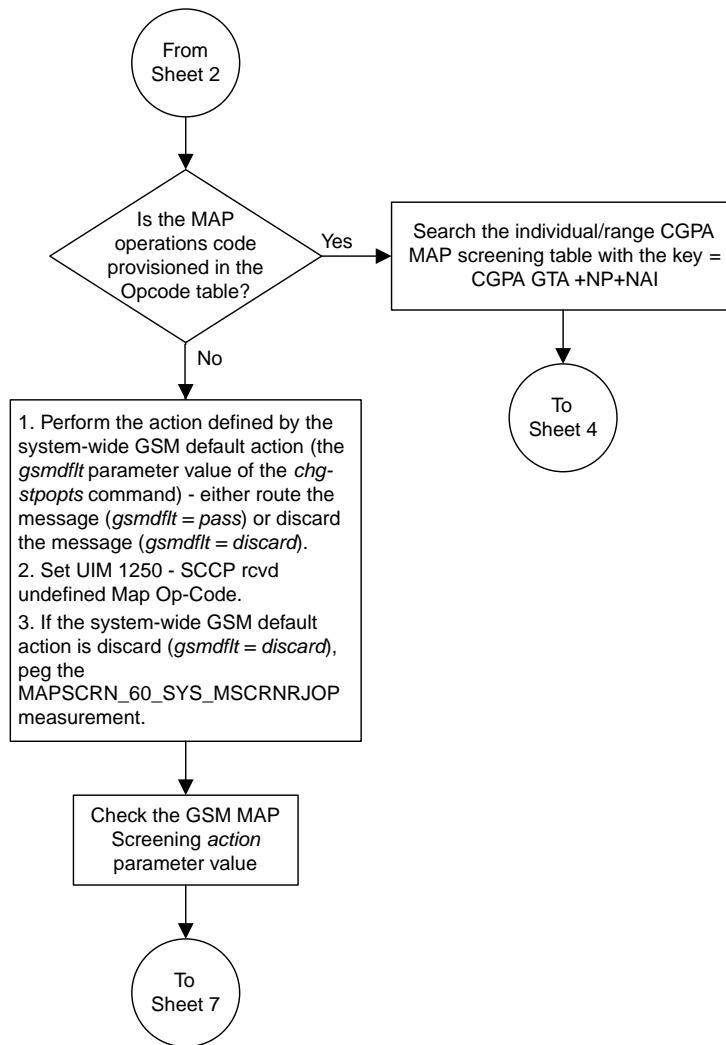

Sheet 3 of 15

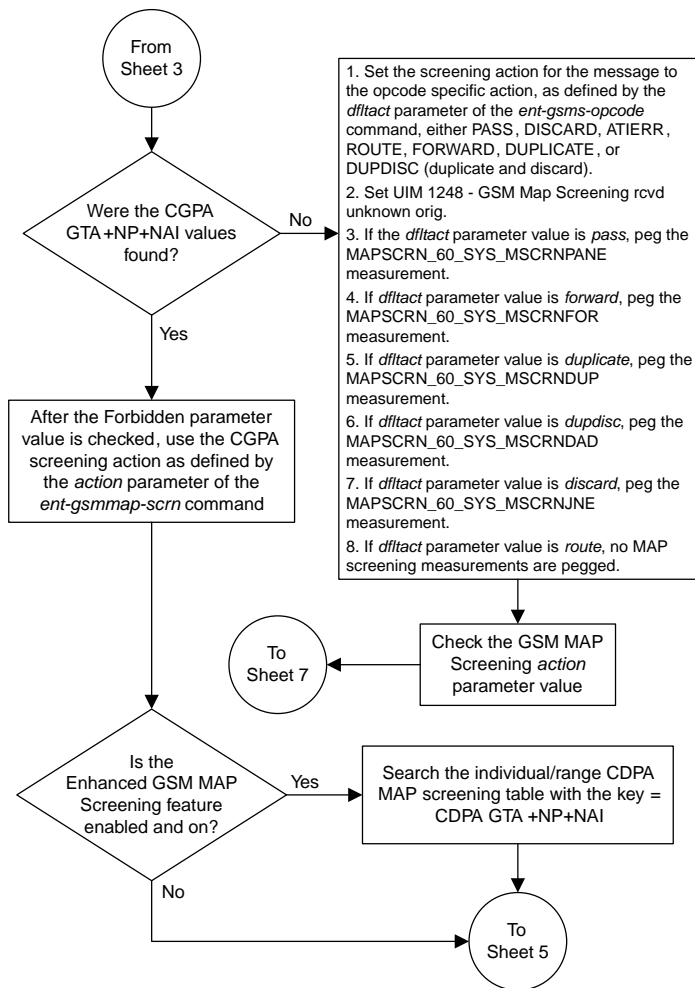

Sheet 4 of 15

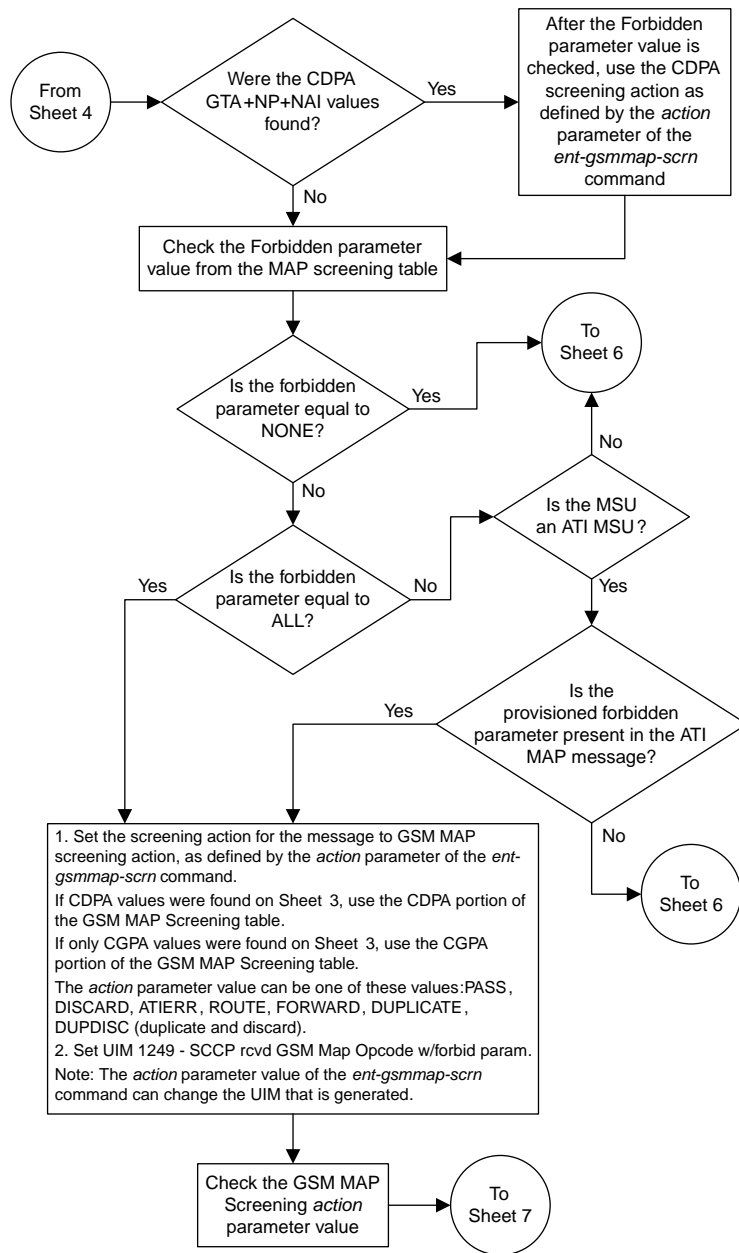

Sheet 5 of 15

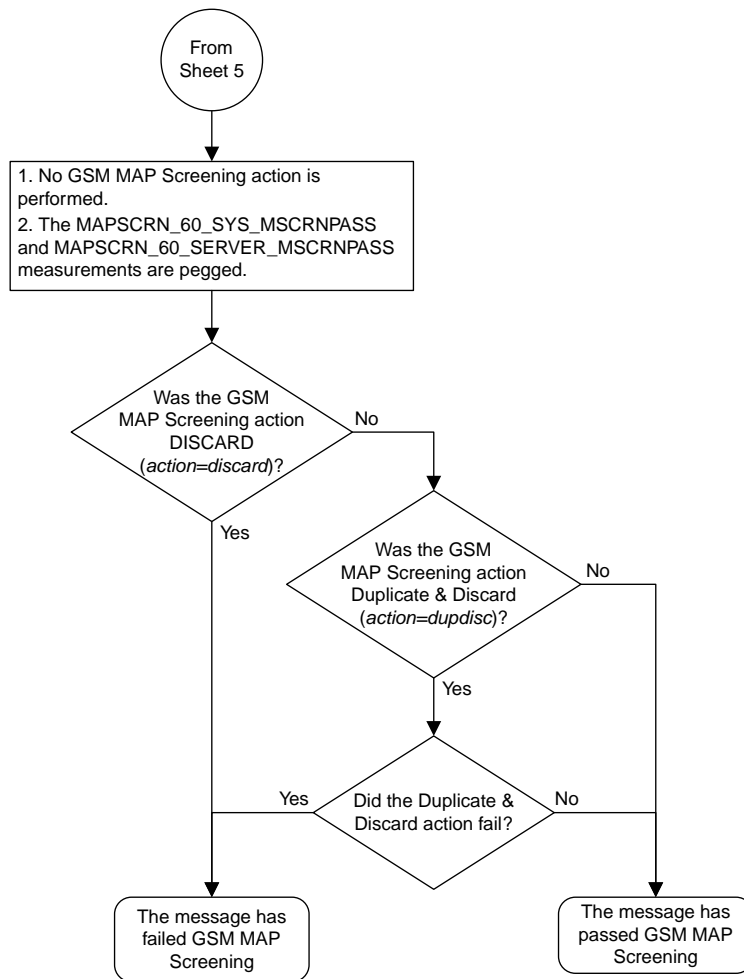

Sheet 6 of 15

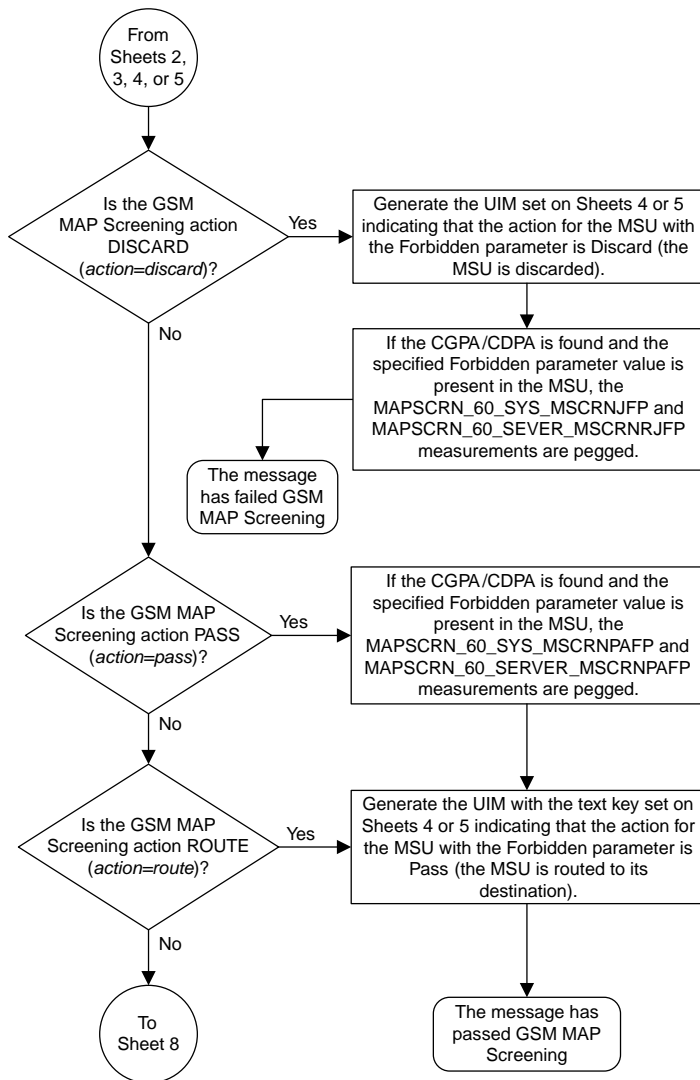

Sheet 7 of 15

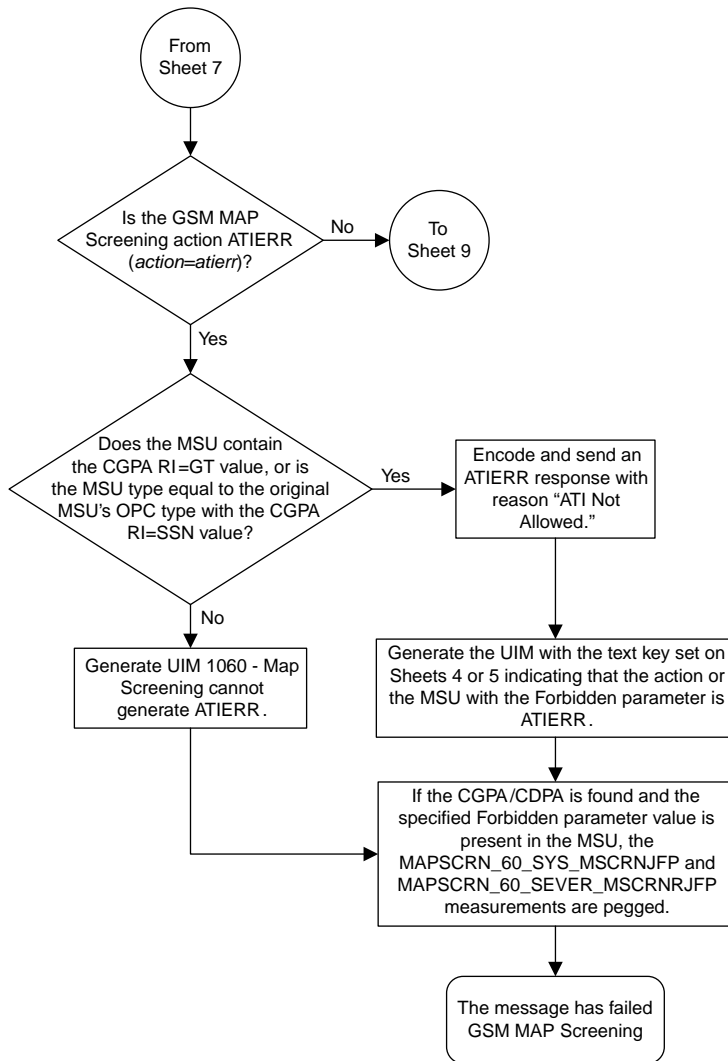

Sheet 8 of 15

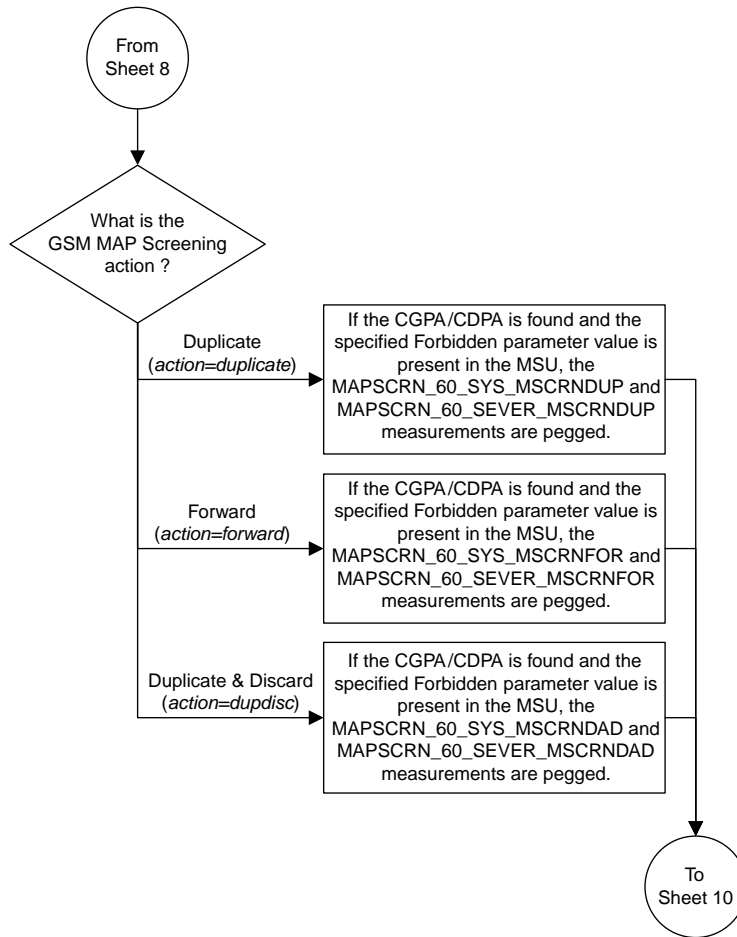

Sheet 9 of 15

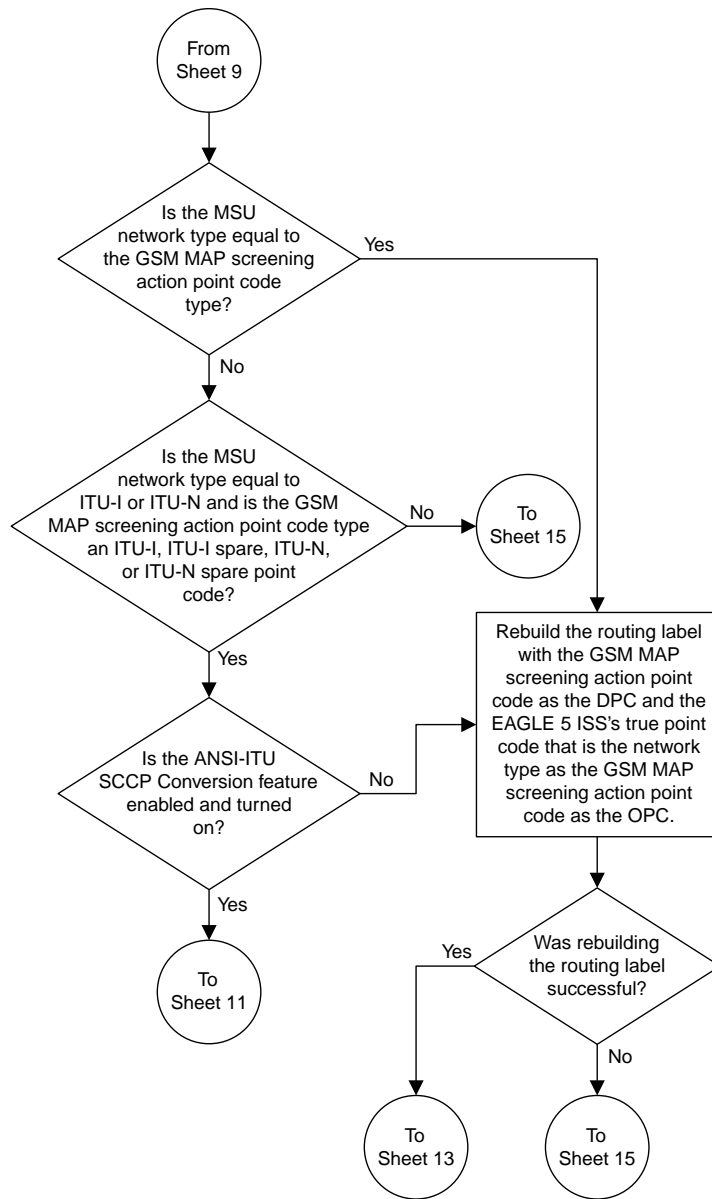

Sheet 10 of 15

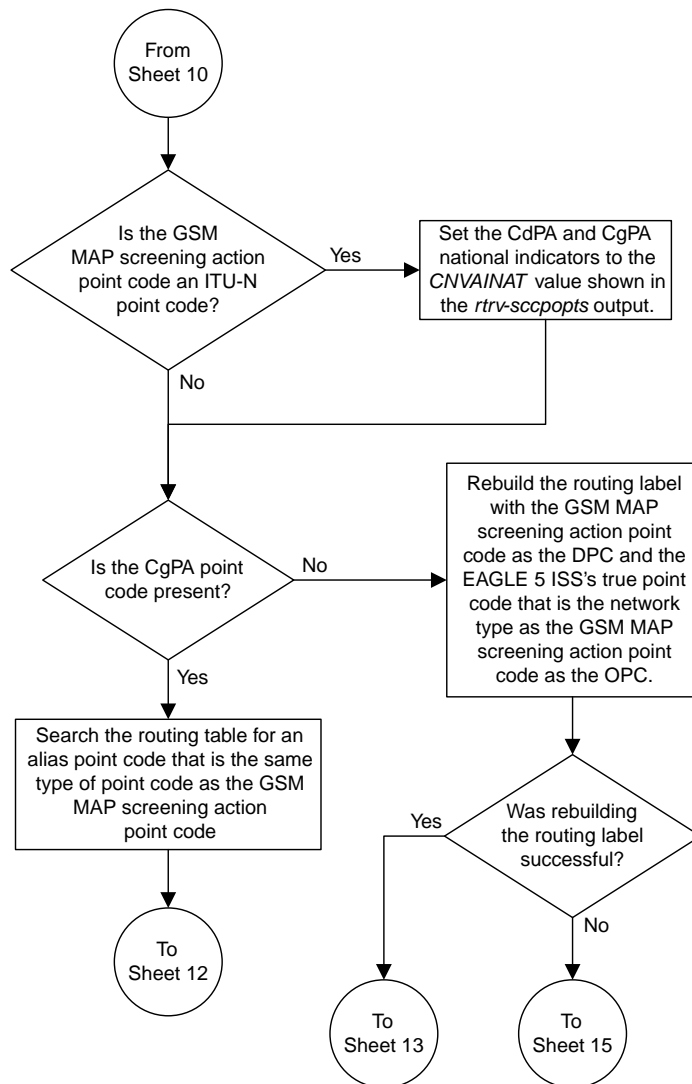

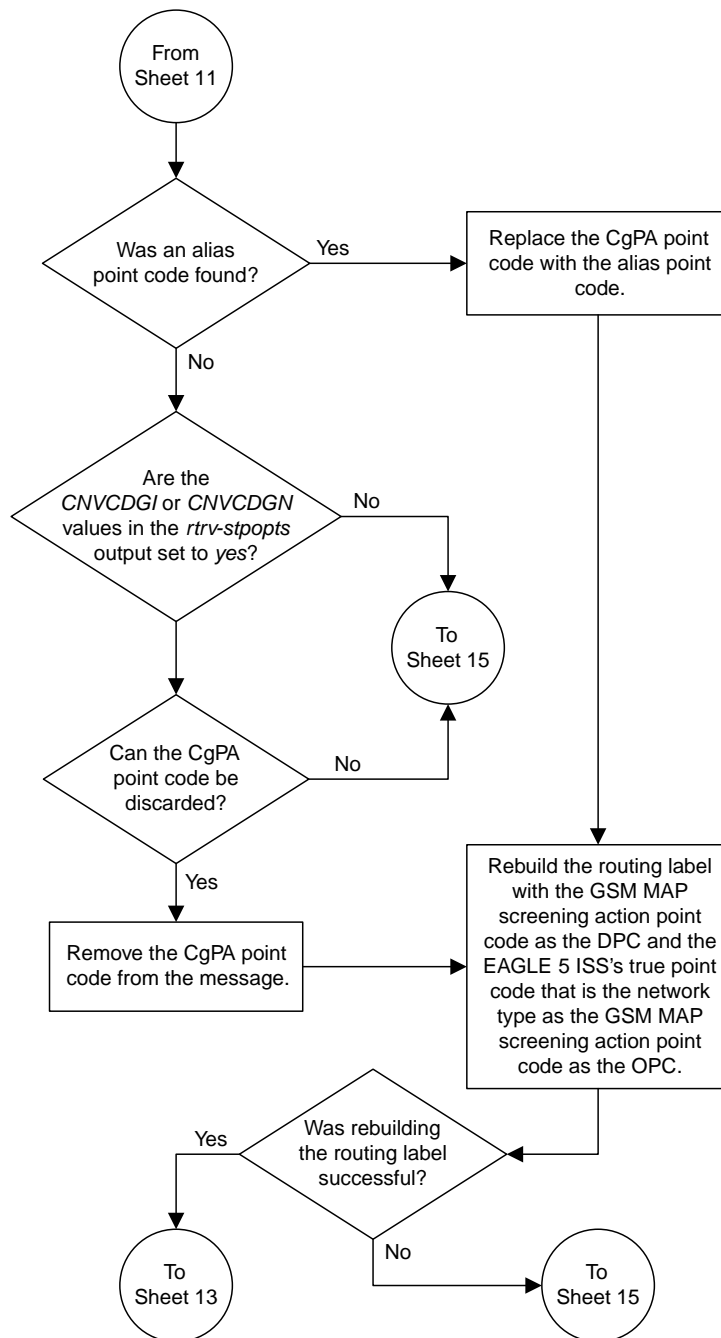

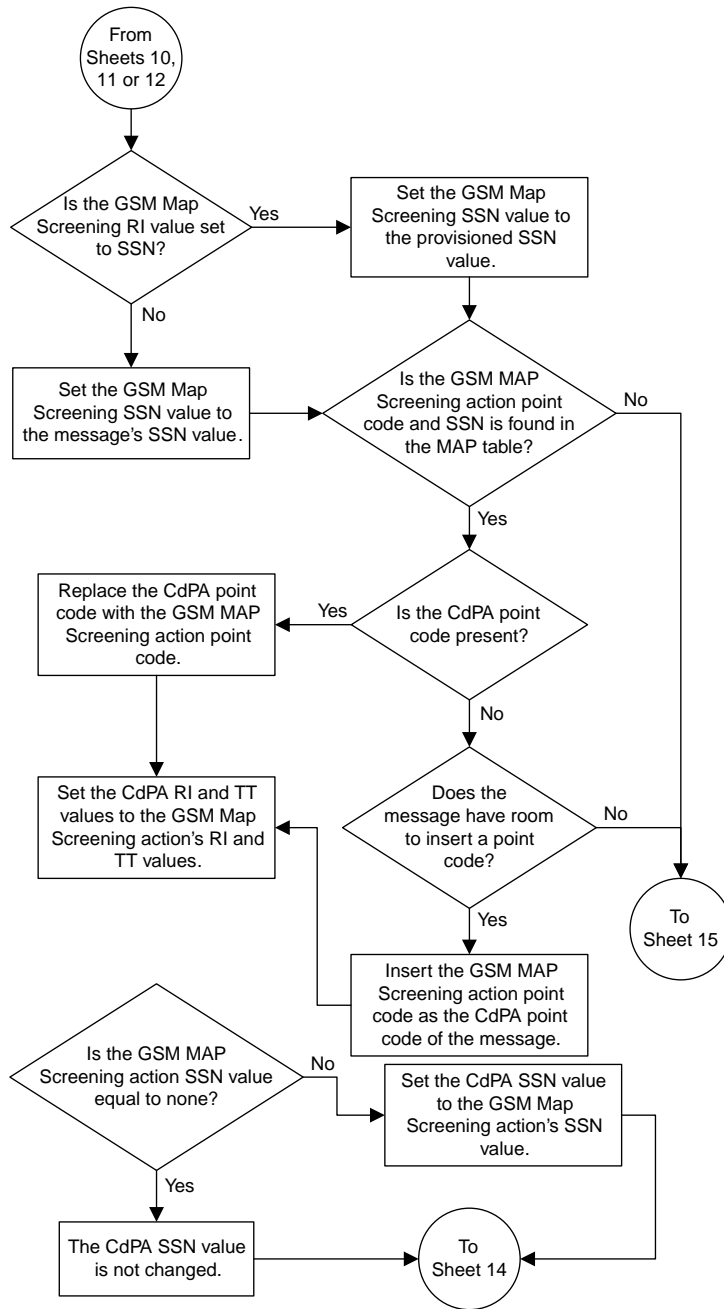

Sheet 13 of 15

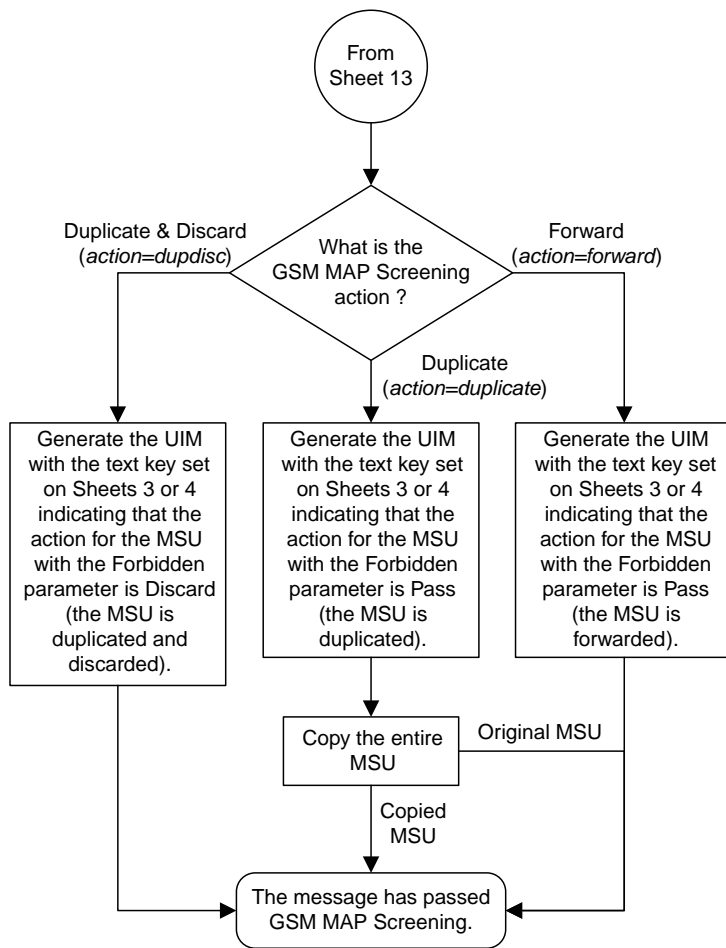

Sheet 14 of 15

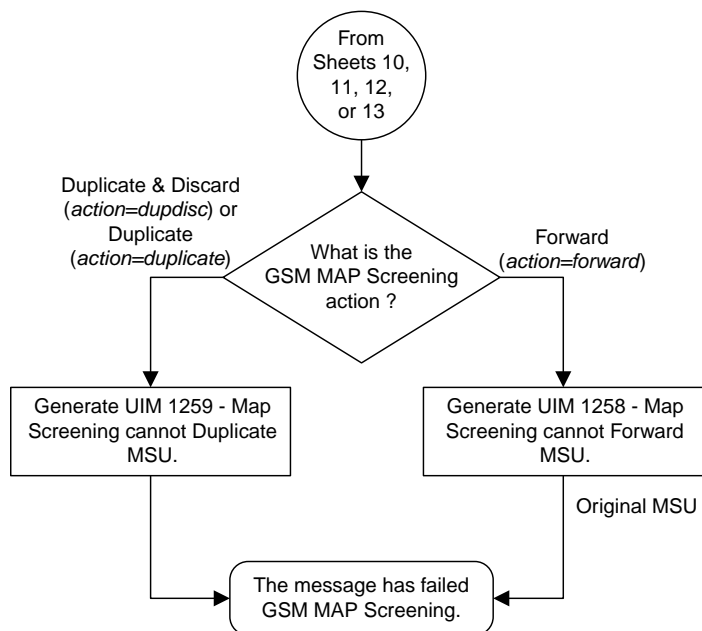

Sheet 15 of 15

GSM MAP Screening Example

Table 14: Example GSM MAP Screening Table shows an example of the GSM MAP screening table.

Table 14: Example GSM MAP Screening Table

Authorized Origination Point (E.164 address)	Numbering Plan	Nature of Address Indicator	MAP Operations Code	Forbidden Parameters	Screening Action
6611273888	1	4	ATI_Request	All	Discard
6611273444	1	4	SRI_for_SM	All	Discard
6611273444	1	4	ATI_Request	Subscriber state	ATI-error
5431111888	1	4	FW_SM	None	----

5431111777	1	4	ATI_Request	All	Pass
------------	---	---	-------------	-----	------

In this example,

- Any ATI_Request message from 6611273888 containing the numbering plan value of 1 and nature of address indicator value of 4 would be discarded.
- Any SRI_for_SM from 6611273444 containing the numbering plan value of 1 and nature of address indicator value of 4 would be discarded.
- An ATI_Request message from 6611273444 containing the numbering plan value of 1 and nature of address indicator value of 4 requesting the Location only would be routed. An ATI_Request message from 6611273444 requesting both the Location and Subscriber state would result in an ATI-error message being sent back to the originator. An ATI_Request message from 6611273444 requesting the Subscriber state only would result in an ATI-error message being sent back to the originator.
- A FW_SM message from 5431111888 containing the numbering plan value of 1 and nature of address indicator value of 4 would be routed successfully, because no parameters are forbidden.
- Any ATI_Request from 5431111777 containing the numbering plan value of 1 and nature of address indicator value of 4 would be routed successfully because of the "Pass" screening action. This could be used for testing purposes prior to screening.

Table 15: System-Wide Screening Table shows an example of the system-wide screening table. It specifies the action to be taken in the event that a MAP operations code was defined for MAP screening, but no specific entry was found in the MAP screening table.

Table 15: System-Wide Screening Table

MAP Operations Code	Operations Code Specific Screening Action
ATI	ATI-error
SRI_for_SM	Discard

GSM MAP Screening Procedures

The following procedures describe the steps needed to add, remove, or change GSM MAP Screening data in the database.

The items administered in this section are:

- Linkset with GSM MAP Screening enabled
- STP options for GSM MAP Screening
- GSM SSN
- GSM Opcodes
- GSM MAP Screening entries

- An option to enable or disable the processing of GSM MAP Screening TCAP Continue and TCAP End messages.

The procedures shown in this chapter use a variety of commands. For more information on these commands, refer to the *Commands Manual*.

Figure 15: GSM MAP Screening Database Relationships shows the relationships of the database elements that are configured in these procedures.

The following is a brief description of the GSM MAP Screening entities. These entities must be configured in the order that they are shown.

1. The Global Title Translation (GTT) feature must be turned on with the `chg-feat` command using the `gtt=on` parameter. The global title translation feature must be on before the GSM MAP Screening feature can be enabled and turned on. Verify that the GTT feature is on using the `rtrv-feat` command.

Note: Once the Global Title Translation (GTT) feature is turned on with the `chg-feat` command, it cannot be turned off.

The GTT feature must be purchased before turning on the GTT feature. If you are not sure whether you have purchased the GTT feature, contact your Tekelec Sales Representative or Account Representative.

2. The GSM MAP Screening feature must be enabled with the `enable-ctrl-feat` command, and turned on with the `chg-ctrl-feat` command. Verify the status of the GSM MAP Screening feature with the `rtrv-ctrl-feat` command.

Note: Once the GSM MAP Screening feature is enabled and turned on, it cannot be disabled or turned off.

3. GSM MAP Screening can process TCAP Continue and TCAP End messages in addition to TCAP Begin messages by setting the SCCP option parameter `GMSTCAPCE` to `on` with the `chg-sccpopts` command. Setting the SCCP option parameter `GMSTCAPCE` to `off` disables the processing of the TCAP Continue and TCAP End messages. The current value of the `GMSTCAPCE` parameter is shown in the `rtrv-sccpopts` output. For more information on setting the SCCP option parameter `GMSTCAPCE`, see the *Changing the GSM MAP Screening TCAP Continue and End Message Processing Option* procedure.

4. To use GSM MAP Screening on all types of linksets including ANSI linksets, or to provision CDPA entries in the GSM MAP Screening table, the Enhanced GSM MAP Screening feature must be enabled with the `enable-ctrl-feat` command, and turned on with the `chg-ctrl-feat` command. Verify the status of the Enhanced GSM MAP Screening features with the `rtrv-ctrl-feat` command.

Note: Once the Enhanced GSM MAP Screening feature is enabled and turned on, it cannot be disabled or turned off.

5. MSUs that do not require global title translation and are MTP routed can be sent to GSM MAP Screening only if the MTP MAP Screening feature is enabled with the `enable-ctrl-feat` command, and turned on with the `chg-ctrl-feat` command. The Enhanced GSM MAP Screening feature must be enabled and turned on to enable and turn on the MTP MAP Screening feature.
6. Linksets containing the `gsmscrn=on` parameter must be in the database. The `gsmscrn=on` parameter allows the messages on these linksets to be screened by the GSM MAP Screening feature. Verify this with the `rtrv-ls` command. If the necessary linksets are not in the database, add them with the `ent-ls` command, specifying the `gsmscrn=on` parameter. If the necessary linksets are in the database, but do not contain the `gsmscrn=on` parameter, change these linksets with the

`chg-ls` command, specifying the `gsmscrn=on` parameter. If the Enhanced GSM MAP screening feature is enabled and on, the adjacent point code of the linkset can be any type. If the Enhanced GSM MAP screening feature is not enabled and off, the adjacent point code of the linkset can be either an ITU international, ITU international spare, or 14 bit ITU national, 14-bit ITU national spare, or 24-bit ITU national point code. The EAGLE 5 ISS can contain either 14 bit or 24-bit ITU national point codes, but not both at the same time.

7. The GSM MAP screening options, `gsmdf1t` (GSM MAP screening default action) and `gsmdecerr` (GSM MAP screening decode error action), can be changed with the `chg-stpopts` command. The current values for these options can be verified with the `rtrv-stpopts` command. The `GSMDFLT` parameter allows the user to specify the default screening action (PASS or DISCARD) that occurs when a MAP operations code contained in the MSU is not found in the GSM MAP operations code table. The `gsmdecerr` parameter allows the user to specify the default screening action (PASS or DISCARD) that occurs when an error is detected in the TCAP layer of the MSU being screened. Such errors included an invalid value for a parameter, length error, missing data, and so on.
8. The origination and destination subsystem numbers that are being screened using the GSM MAP screening feature need to be provisioned in the database. These subsystem numbers are shown in the `rtrv-gsmssn-scrn` command and provisioned using the `ent-gsmssn-scrn` command.
9. The concerned GSM MAP screening operation codes and the default screening action for the operation code need to be provisioned in the database. These operation codes are shown in the `rtrv-gsms-opcode` command and provisioned using the `ent-gsms-opcode` command. The `ent-gsms-opcode` allows the user to provision a list of all operation codes that the EAGLE 5 ISS uses in performing GSM screening. If a point code and subsystem number is provisioned for the GSM MAP screening operation code, the point code and subsystem number must be shown in the `rtrv-map` output. If the flexible GTT Load Sharing feature is enabled, a MAP set containing the point code and subsystem number must be assigned to the GSM MAP screening operation code. For more information on provisioning GSM MAP screening operation codes, see the [Adding a GSM MAP Screening Operation Code](#) procedure.
10. The GSM MAP screening entries that filter or allow TCAP messages for certain MAP operation codes need to be provisioned in the database. The GSM MAP screening entries are shown in the `rtrv-gsmmap-scrn` command and provisioned using the `ent-gsmmap-scrn` command. The messages are filtered or allowed based on the origination addresses (`saddr/eaddr`), numbering plan value (`npv`), nature of address indicator value (`naiv`), MAP opnames (`opname`), and forbidden (`forbid`) parameters. If the Enhanced GSM MAP Screening feature is enabled and on, the CGPA and CDPA of the messages are checked by the GSM MAP Screening table. If the Enhanced GSM MAP Screening feature is not enabled and off, only the CGPA of the messages are checked by the GSM MAP Screening table. If a point code and subsystem number is provisioned for the GSM MAP screening entry, the point code and subsystem number must be shown in the `rtrv-map` output. If the Flexible GTT Load Sharing feature is enabled, a MAP set containing the point code and subsystem number must be assigned to the GSM MAP screening entry. For more information on provisioning GSM MAP screening operation entries, see the [Adding a GSM MAP Screening Entry](#) procedure.

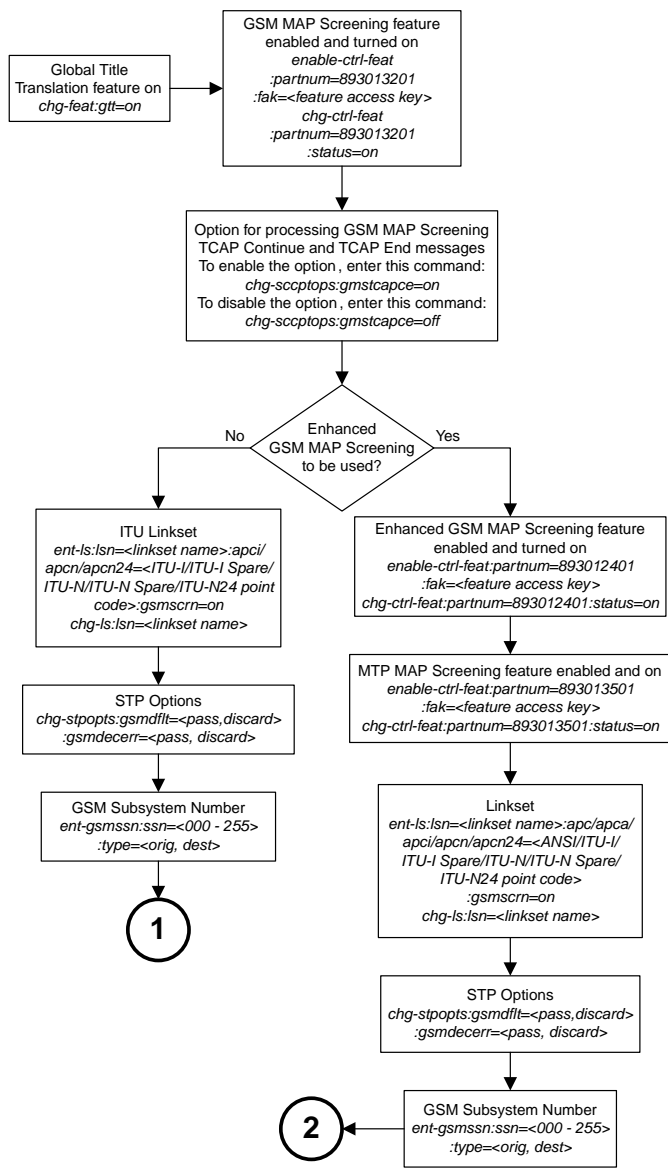

Sheet 1 of 2

Figure 15: GSM MAP Screening Database Relationships

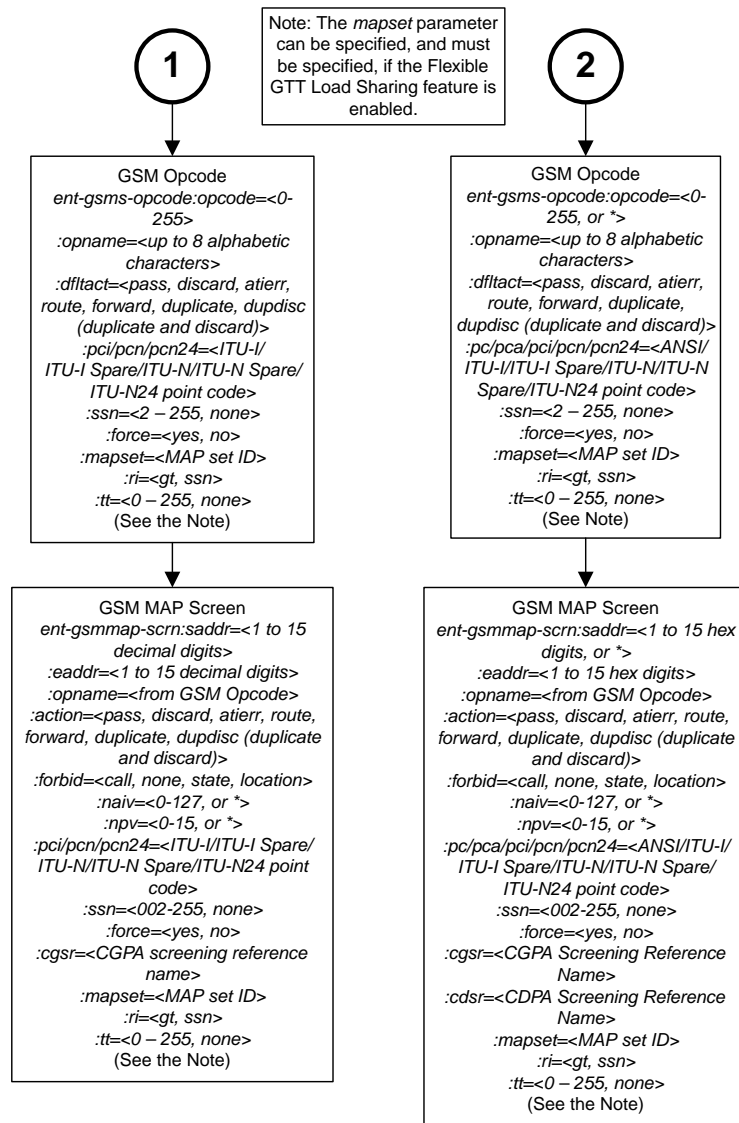

Sheet 2 of 2

Activating the GSM MAP Screening Feature

The GSM MAP screening feature is activated by enabling the GSM MAP Screening feature with the `enable-ctrl-feat` command, then by turning the feature on with the `chg-ctrl-feat` command. The status of the GSM MAP Screening feature can be verified with the `rtrv-ctrl-feat` command.

Before the GSM MAP Screening feature is activated, the global title translation feature must be on. This can be verified with the `rtrv-feat` command.

Note: Once the global title translation feature is turned on with the `chg-feat` command, it cannot be turned off.

The global title translation feature must be purchased before you turn the feature on with the `chg-feat` command. If you are not sure if you have purchased the global title translation feature, contact your Tekelec Sales Representative or Account Representative.

This procedure can also be used to enable and turn on the Enhanced GSM MAP Screening feature. The `enable-ctrl-feat` and `chg-ctrl-feat` commands are used to enable and turn on the Enhanced GSM MAP Screening feature. The GSM MAP Screening feature must be enabled and turned on before the Enhanced GSM MAP Screening feature is enabled and turned on.

The `enable-ctrl-feat` command enables the feature by inputting the feature's access key and the feature's part number with these parameters:

`:fak` – The feature access key supplied by Tekelec. The feature access key contains 13 alphanumeric characters and is not case sensitive.

`:partnum` – The Tekelec-issued part number of the GSM MAP Screening and Enhanced GSM MAP Screening features.

- The GSM MAP Screening feature, 893013201
- The Enhanced GSM MAP Screening feature, 893012401

The `enable-ctrl-feat` command requires that the database contain a valid serial number for the EAGLE 5 ISS, and that this serial number is locked. This can be verified with the `rtrv-serial-num` command. The EAGLE 5 ISS is shipped with a serial number in the database, but the serial number is not locked. The serial number can be changed, if necessary, and locked once the EAGLE 5 ISS is on-site, with the `ent-serial-num` command. The `ent-serial-num` command uses these parameters.

`:serial` – The serial number assigned to the EAGLE 5 ISS. The serial number is not case sensitive.

`:lock` – Specifies whether or not the serial number is locked. This parameter has only one value, `yes`, which locks the serial number. Once the serial number is locked, it cannot be changed.

Note: To enter and lock the EAGLE 5 ISS's serial number, the `ent-serial-num` command must be entered twice, once to add the correct serial number to the database with the `serial` parameter, then again with the `serial` and the `lock=yes` parameters to lock the serial number. You should verify that the serial number in the database is correct before locking the serial number. The serial number can be found on a label affixed to the control shelf (shelf 1100).

The GSM MAP Screening and Enhanced GSM MAP Screening features cannot be temporarily enabled (with the temporary feature access key).

Once these features have been enabled, the features must be turned on with the `chg-ctrl-feat` command. The `chg-ctrl-feat` command uses these parameters:

`:partnum` – The Tekelec-issued part number of the GSM MAP Screening and Enhanced GSM MAP Screening features.

- The GSM MAP Screening feature, 893013201
- The Enhanced GSM MAP Screening feature, 893012401

`:status=on` – used to turn on the features that customer has purchased and enabled.

Note: Once the GSM MAP Screening and Enhanced GSM MAP Screening features are turned on, they cannot be turned off.

The status of the features in the EAGLE 5 ISS is shown with the `rtrv-ctrl-feat` command.

The GSM MAP Screening feature requires that Service Module cards (DSM cards or E5-SM4G cards) are installed and provisioned in the EAGLE 5 ISS. The Enhanced GSM MAP Screening feature requires that Service Module cards (DSM cards or E5-SM4G cards) are installed and provisioned in the EAGLE 5 ISS. DSM and E5-SM4G cards are shown by the entry DSM in the TYPE column of the `rtrv-card` output and SCCP in the APPL column of the `rtrv-card` output.

1. Display the status of the controlled features by entering the `rtrv-ctrl-feat` command.

```
rlghncxa03w 06-10-28 21:15:37 GMT EAGLE5 36.0.0
The following features have been permanently enabled:

Feature Name           Partnum    Status    Quantity
HC-MIM SLK Capacity   893012707 on        64
Command Class Management 893005801 on        ----
LNP Short Message Service 893006601 on        ----
Intermed GTT Load Sharing 893006901 on        ----
XGTT Table Expansion   893006101 on       400000
XMAP Table Expansion   893007710 off       ----
Large System # Links   893005910 on       2000
Routesets              893006401 on       6000

The following features have been temporarily enabled:

Feature Name           Partnum    Status    Quantity    Trial Period Left
Zero entries found.

The following features have expired temporary keys:

Feature Name           Partnum
Zero entries found.
```

If the GSM MAP Screening feature (shown in the `rtrv-ctrl-feat` output as GSM Map Screening (GMS)) is enabled and on, no further action is necessary. This procedure does not need to be performed.

If you wish to use the Enhanced GSM MAP Screening feature, and the Enhanced GSM MAP Screening feature (shown in the `rtrv-ctrl-feat` output as Enhanced GMS (EGMS)) is enabled and on, no further action is necessary. This procedure does not need to be performed.

If the GSM MAP Screening feature is enabled and off, skip steps 2 through 7 and go to step 8.

If the Enhanced GSM MAP Screening feature is enabled and off, skip steps 2 through 10 and go to step 11.

2. Display the cards in the EAGLE 5 ISS using the `rtrv-card` command.

The GSM MAP Screening feature requires that Service Module cards are in the database. The Enhanced GSM MAP Screening feature requires that DSMs or E5-SM4G cards are in the database.

```
rlghncxa03w 09-05-25 09:58:31 GMT EAGLE5 41.0.0
CARD  TYPE      APPL      LSET NAME      LINK SLC  LSET NAME      LINK SLC
1113  GPSM        EOAM
1114  TDM-A
1115  GPSM        EOAM
1116  TDM-B
1117  MDAL
```

1201	LIMDS0	SS7ANSI	sp2	A	0	sp1	B	0
1203	LIMDS0	SS7ANSI	sp3	A	0			
1204	LIMDS0	SS7ANSI	sp3	A	1			
1206	LIMDS0	SS7ANSI	nsp3	A	1	nsp4	B	1
1216	DCM	STPLAN						
1308	LIMDS0	SS7ANSI	sp6	A	1	sp7	B	0
1314	LIMDS0	SS7ANSI	sp7	A	1	sp5	B	1
1317	DCM	STPLAN						

DSM and E5-SM4G cards are shown by the entry DSM in the TYPE column and VSCCP in the APPL column of the `rtrv-card` output.

If no Service Module cards are shown in the `rtrv-card` output, perform the “Adding a Service Module” procedure in the *Database Administration Manual - Global Title Translation* and add the required Service Module cards to the database.

If DSM or E5-SM4G cards are in the EAGLE 5 ISS, go to step 3.

Note: If the `rtrv-ctrl-feat` output in step 1 shows any controlled features, skip steps 3 through 6, and go to step 7. If the `rtrv-ctrl-feat` output shows only the HC-MIMSLK Capacity feature with a quantity of 64, steps 3 through 6 must be performed.

3. Display the serial number in the database with the `rtrv-serial-num` command.

This is an example of the possible output.

```
rlghncxa03w 06-10-28 21:15:37 GMT EAGLE5 36.0.0
System serial number = nt00001231

System serial number is not locked.

rlghncxa03w 06-10-28 21:15:37 GMT EAGLE5 36.0.0
Command Completed
```

Note: If the serial number is correct and locked, skip steps 4, 5, and 6, and go to step 7. If the serial number is correct but not locked, skip steps 4 and 5, and go to step 6. If the serial number is not correct, but is locked, the GSM MAP Screening and Enhanced GSM MAP Screening features cannot be enabled and the remainder of this procedure cannot be performed. Contact the Customer Care Center to get an incorrect and locked serial number changed. Refer to [Customer Care Center](#) for the contact information. The serial number can be found on a label affixed to the control shelf (shelf 1100).

4. Enter the correct serial number into the database using the `ent-serial-num` command with the `serial` parameter.

For this example, enter this command.

```
ent-serial-num:serial=<EAGLE 5 ISS's correct serial number>
```

5. Verify that the serial number entered into step 4 was entered correctly using the `rtrv-serial-num` command.

```
rlghncxa03w 06-10-28 21:15:37 GMT EAGLE5 36.0.0
System serial number = nt00001231

System serial number is not locked.
```

```
rlghncxa03w 06-10-28 21:15:37 GMT EAGLE5 36.0.0
Command Completed
```

If the serial number was not entered correctly, repeat steps 4 and 5 and re-enter the correct serial number.

- Lock the serial number in the database by entering the `ent-serial-num` command with the serial number shown in step 3, if the serial number shown in step 3 is correct, or with the serial number shown in step 5, if the serial number was changed in step 4, and with the `lock=yes` parameter.

For this example, enter this command.

```
ent-serial-num:serial=<EAGLE 5 ISS's serial number>:lock=yes
```

- Enable the GSM MAP Screening feature with the `enable-ctrl-feat` command specifying the part number for the GSM MAP Screening feature and the feature access key.

Enter this command.

```
enable-ctrl-feat:partnum=893013201:fak=<GSM MAP Screening feature access key>
```

Note: A temporary feature access key cannot be specified to enable this feature.

Note: The values for the feature access key (the `fak` parameter) are provided by Tekelec. If you do not have the feature access key for the GSM MAP Screening feature, contact your Tekelec Sales Representative or Account Representative.

- Turn the GSM MAP Screening feature on with the `chg-ctrl-feat` command specifying the part number for the GSM MAP Screening feature and the `status=on` parameter.

Enter this command.

```
chg-ctrl-feat:partnum=893013201:status=on
```

Note: Once the GSM MAP Screening feature is turned on, it cannot be turned off.

- Verify the changes by entering the `rtrv-ctrl-feat` command with the GSM MAP Screening feature part number.

Enter this command.

```
rtrv-ctrl-feat:partnum=893013201
```

```
rlghncxa03w 06-10-28 21:15:37 GMT EAGLE5 36.0.0
The following features have been permanently enabled:
```

Feature Name	Partnum	Status	Quantity
GSM Map Screening (GMS)	893013201	on	----

```
The following features have been temporarily enabled:
```

Feature Name	Partnum	Status	Quantity	Trial Period Left
Zero entries found.				

```
The following features have expired temporary keys:
```

Feature Name	Partnum
Zero entries found.	

- Enable the Enhanced GSM MAP Screening feature with the `enable-ctrl-feat` command specifying the part number for the Enhanced GSM MAP Screening feature and the feature access key.

Note: If you do not wish to enable and turn on the Enhanced GSM MAP Screening feature, skip steps 10, 11, and 12, and go to step 13.

Enter this command.
`enable-ctrl-feat:partnum=893012401:fak=<Enhanced GSM MAP Screening feature access key>`

Note: A temporary feature access key cannot be specified to enable this feature.

Note: The values for the feature access key (the `fak` parameter) are provided by Tekelec. If you do not have the feature access key for the Enhanced GSM MAP Screening feature, contact your Tekelec Sales Representative or Account Representative.

11. Turn the Enhanced GSM MAP Screening feature on with the `chg-ctrl-feat` command specifying the part number for the Enhanced GSM MAP Screening feature and the `status=on` parameter. Enter this command.

`chg-ctrl-feat:partnum=893012401:status=on`

Note: After the Enhanced GSM MAP Screening feature is turned on, it cannot be turned off.

12. Verify the changes by entering the `rtrv-ctrl-feat` command with the Enhanced GSM MAP Screening feature part number.

Enter this command.

`rtrv-ctrl-feat:partnum=893012401`

```
rlghncxa03w 06-10-28 21:15:37 GMT EAGLE5 36.0.0
The following features have been permanently enabled:

Feature Name          Partnum    Status    Quantity
Enhanced GMS (EGMS)  893012401  on       ----

The following features have been temporarily enabled:

Feature Name          Partnum    Status    Quantity    Trial Period Left
Zero entries found.

The following features have expired temporary keys:

Feature Name          Partnum
Zero entries found.
```

13. Back up the new changes using the `chg-db:action=backup:dest=fixed` command. These messages should appear, the active Maintenance and Administration Subsystem Processor (MASP) appears first.

```
BACKUP (FIXED): MASP A - Backup starts on active MASP.
BACKUP (FIXED): MASP A - Backup on active MASP to fixed disk complete.
BACKUP (FIXED): MASP A - Backup starts on standby MASP.
BACKUP (FIXED): MASP A - Backup on standby MASP to fixed disk complete.
```

Configuring the MTP MAP Screening Feature

The MTP MAP screening feature is enabled with the `enable-ctrl-feat` command. Once enabled, the feature can be turned on or off with the `chg-ctrl-feat` command. If the feature is already on, it can only be turned off. If the feature is off, it can only be turned on.

Before the MTP MAP Screening feature is enabled and turned on, the Enhanced GSM MAP Screening feature must be enabled and on. The Measurements Platform must also be enabled.

The status of the MTP MAP Screening and Enhanced GSM MAP Screening features can be verified with the `rtrv-ctrl-feat` command. The `rtrv-measopts` command shows whether the Measurements Platform is enabled or not.

The `enable-ctrl-feat` command enables the feature by inputting the feature's access key and the feature's part number with these parameters:

`:fak` – The feature access key supplied by Tekelec. The feature access key contains 13 alphanumeric characters and is not case sensitive.

`:partnum` – The Tekelec-issued part number of the MTP MAP Screening feature, 893013501

The MTP MAP Screening feature cannot be temporarily enabled (with a temporary feature access key).

The `chg-ctrl-feat` command uses these parameters:

`:partnum` – The Tekelec-issued part number of the MTP MAP Screening feature, 893013501.

`:status=on` – used to turn the MTP MAP Screening feature on.

`:status=off` – used to turn the MTP MAP Screening feature off.

Note: Turning the MTP MAP Screening feature on allows GSM MAP Screening to be performed on all SCCP messages, even if these messages do not require Global Title Translation and are MTP routed. The value of the `GSMSCRN` parameter of the linkset carrying these SCCP messages must be `YES`.

Note: Turning the MTP MAP Screening feature off allows GSM MAP Screening to be performed only on those SCCP messages, on linksets with the `GSMSCRN=YES` value, that have passed Global Title Translation and Gateway Screening.

1. Display the status of the controlled features by entering the `rtrv-ctrl-feat` command.

The following is an example of the possible output.

```
rlghncxa03w 06-10-28 21:15:37 GMT EAGLE5 36.0.0
The following features have been permanently enabled:

Feature Name           Partnum   Status   Quantity
HC-MIM SLK Capacity   893012707 on        64
Command Class Management 893005801 on        ----
LNP Short Message Service 893006601 on        ----
Intermed GTT Load Sharing 893006901 on        ----
XGTT Table Expansion   893006101 on       400000
XMAP Table Expansion   893007710 off        ----
Large System # Links   893005910 on        2000
Routesets              893006401 on        6000

The following features have been temporarily enabled:
```

```
Feature Name      Partnum    Status    Quantity    Trial Period Left
Zero entries found.
```

The following features have expired temporary keys:

```
Feature Name      Partnum
Zero entries found.
```

If the MTP MAP Screening feature (shown in the `rtrv-ctrl-feat` output as MTP Map Screening) is enabled and on, and you do not wish to turn the feature off, no further action is necessary. If you wish to turn this feature off, skip steps 2 through 4, and go to step 5.

If the MTP MAP Screening feature is enabled and off, skip steps 2 through 4 and go to step 5 to turn the feature on.

2. If the `rtrv-ctrl-feat` in step 1 shows that the Enhanced GSM MAP Screening feature is enabled and on, skip this step and go to step 3.

If the `rtrv-ctrl-feat` in step 1 shows that the Enhanced GSM MAP Screening feature is not enabled or off, perform the [Activating the GSM MAP Screening Feature](#) to enable and turn on the Enhanced GSM MAP Screening feature.

3. Verify whether or nor the Measurements Platform option is enabled (`PLATFORMENABLE = on`) using the `rtrv-measopts` command.

```
rlghncxa03w 06-10-01 16:02:05 GMT EAGLE5 36.0.0
```

```
PLATFORMENABLE = on
COLLECT15MIN   = off
CLLIBASEDNAME  = off
-----
SYSTOTSTP     = off
SYSTOTTT      = off
```

Note: The `rtrv-measopts` command output contains other fields that are not used by this procedure. If you wish to see all the fields displayed by the `rtrv-measopts` command, see the `rtrv-measopts` command description in the *Commands Manual*.

If the Measurements Platform is not enabled, perform the “Configuring the Measurements Platform Feature” procedure in the *Database Administration Manual - System Management* to enabled the Measurements Platform.

4. Enable the MTP MAP Screening feature with the `enable-ctrl-feat` command specifying the part number for the MTP MAP Screening feature and the feature access key.

Enter this command.

```
enable-ctrl-feat:partnum=893013501:fak=<MTP MAP Screening feature access key>
```

Note: A temporary feature access key cannot be specified to enable this feature.

Note: The values for the feature access key (the `fak` parameter) are provided by Tekelec. If you do not have the feature access key for the Enhanced GSM MAP Screening feature, contact your Tekelec Sales Representative or Account Representative.

5. Turn the MTP MAP Screening feature on or off with the `chg-ctrl-feat` command specifying the part number for the Enhanced GSM MAP Screening feature and either the `status=on` or `status=off` parameter.

To turn the MTP MAP Screening feature on, enter this command.

```
chg-ctrl-feat:partnum=893013501:status=on
```

To turn the MTP MAP Screening feature off, enter this command.

```
chg-ctrl-feat:partnum=893013501:status=off
```

- Verify the changes by entering the `rtrv-ctrl-feat` command with the MTP MAP Screening feature part number.

Enter this command.

```
rtrv-ctrl-feat:partnum=893013501
```

In the following example, the feature Status is on.

```
rlghncxa03w 06-10-28 21:15:37 GMT EAGLE5 36.0.0
The following features have been permanently enabled:

Feature Name          Partnum    Status    Quantity
MTP MAP Screening     893013501  on       ----

The following features have been temporarily enabled:

Feature Name          Partnum    Status    Quantity    Trial Period Left
Zero entries found.

The following features have expired temporary keys:

Feature Name          Partnum
Zero entries found.
```

In the following example, the feature Status is off

```
rlghncxa03w 06-10-28 21:15:37 GMT EAGLE5 36.0.0
The following features have been permanently enabled:

Feature Name          Partnum    Status    Quantity
MTP MAP Screening     893013501  off       ----

The following features have been temporarily enabled:

Feature Name          Partnum    Status    Quantity    Trial Period Left
Zero entries found.

The following features have expired temporary keys:

Feature Name          Partnum
Zero entries found.
```

- Back up the new changes using the `chg-db:action=backup:dest=fixed` command. These messages should appear, the active Maintenance and Administration Subsystem Processor (MASP) appears first.

```
BACKUP (FIXED): MASP A - Backup starts on active MASP.
BACKUP (FIXED): MASP A - Backup on active MASP to fixed disk complete.
BACKUP (FIXED): MASP A - Backup starts on standby MASP.
BACKUP (FIXED): MASP A - Backup on standby MASP to fixed disk complete.
```

Configuring a Linkset for the GSM MAP Screening Feature

This procedure is used to configure SS7 linksets for the GSM MAP Screening feature using the `gsmscrn` parameter of either the `ent-ls` or `chg-ls` command.

The `gsmscrn` parameter specifies whether or not GSM MAP screening is applied to messages arriving on the linkset. This parameter can be applied to all linksets, but this parameter can be specified for linksets with ANSI adjacent point codes only if the Enhanced GSM MAP Screening feature is enabled and on. The values for this parameter are `on` (GSM MAP screening is applied to the linkset) or `off` (GSM MAP screening is not applied to the linkset). GSM MAP screening is used to screen GSM MAP messages to control which external entities can request information about a GSM subscriber and the specific information these entities can request before allowing the GSM MAP message to pass through to the HLR.

Before the `gsmscrn` parameter can be specified for a specific linkset, the GSM MAP screening feature must be enabled and on. The status of the GSM MAP Screening feature, and if applicable the Enhanced GSM MAP screening feature, is shown in the `rtrv-ctrl-feat` command output with the entries `GSM Map Screening (GMS)` (for the GSM MAP Screening feature) and `Enhanced GMS (EGMS)` (for the Enhanced GSM MAP Screening feature). Perform the [Activating the GSM MAP Screening Feature](#) procedure to enable and turn on either of these features as required.

The value of the `gsmscrn` parameter is only displayed in the `rtrv-ls` command output when a specific linkset is being displayed with the `rtrv-ls:lsn=<linkset name>` command.

To configure a linkset for the GSM MAP Screening feature, the `ent-ls` or `chg-ls` commands uses these mandatory parameters in addition to the `gsmscrn` parameter.

`:lsn` – The name of the linkset. The linkset name can contain up to 10 characters, with the first character being a letter.

`:apc/apca/apci/apcn/apcn24` – Adjacent point code – the point code identifying the node that is next to the EAGLE 5 ISS. This parameter is only mandatory for the `ent-ls` command.

Note: See Chapter 2, Configuring Destination Tables in the *Database Administration Manual - SS7* for a definition of the point code types that are used on the EAGLE 5 ISS and for a definition of the different formats that can be used for ITU national point codes.

Note: The EAGLE 5 ISS can contain a 14-bit ITU-N point code (`apcn`) or a 24-bit ITU-N point code (`apcn24`), but not both at the same time.

`:lst` – The linkset type of the specified linkset This parameter is only mandatory for the `ent-ls` command.

The `ent-ls` and `chg-ls` commands contain other optional parameters that can be used to configure a linkset. These parameters are not shown here because they are not necessary for configuring a linkset for the GSM MAP Screening feature. These parameters are explained in more detail in the Adding an SS7 Linkset procedure or in the Changing an SS7 Linkset procedure in the *Database Administration Manual - SS7*, or in the `ent-ls` and `chg-ls` command descriptions in the *Commands Manual*.

The EAGLE 5 ISS can contain 1024 linksets, with a maximum of 255 of these linksets being gateway linksets. A gateway linkset is a linkset that contains routes to a different network.

This examples used in this procedure are based on the examples shown in [Table 16: GSM MAP Screening Linkset Configuration Table](#).

Table 16: GSM MAP Screening Linkset Configuration Table

Linkset Names	Linkset APC	LST	GSMSCRN
New Linksets Being Added			
lsn5	10685	a	on
lsi7	3-150-4	a	on
Existing Linkset Being Changed			
lsn4	N/A	N/A	on

The linkset to be added cannot be in the database. This can be verified in step 1 of this procedure.

Canceling the RTRV-LS and RTRV-DSTN Commands

Because the `rtrv-ls` and `rtrv-dstn` commands used in this procedure can output information for a long period of time, the `rtrv-ls` and `rtrv-dstn` commands can be canceled and the output to the terminal stopped. There are three ways that the `rtrv-ls` and `rtrv-dstn` commands can be canceled.

- Press the F9 function key on the keyboard at the terminal where the `rtrv-ls` or `rtrv-dstn` commands were entered.
- Enter the `canc-cmd` without the `trm` parameter at the terminal where the `rtrv-ls` or `rtrv-dstn` commands were entered.
- Enter the `canc-cmd:trm=<xx>`, where `<xx>` is the terminal where the `rtrv-ls` or `rtrv-dstn` commands were entered, from another terminal other than the terminal where the `rtrv-ls` or `rtrv-dstn` commands were entered. To enter the `canc-cmd:trm=<xx>` command, the terminal must allow Security Administration commands to be entered from it and the user must be allowed to enter Security Administration commands. The terminal's permissions can be verified with the `rtrv-secu-trm` command. The user's permissions can be verified with the `rtrv-user` or `rtrv-secu-user` commands.

For more information about the `canc-cmd` command, go to the *Commands Manual*.

1. Display the current linkset configuration using the `rtrv-ls` command.

This is an example of the possible output.

```
rlghncxa03w 09-05-10 11:43:04 GMT EAGLE5 41.0.0

LSN          APCA   (SS7)  SCRN   L3T  SLT          GWS  GWS  GWS
lsa1         240-020-000  scr1   1    1   yes a    1    off off off no   off
lsa2         240-030-000  scr2   1    2   no  c    3    on  on  on yes  off
lsa3         240-040-000  scr3   1    3   yes c    5    off off off yes  off
ls04         001-002-003  scr2   1    1   no  a    4    on  off on  yes  off

LSN          APCI   (SS7)  SCRN   L3T  SLT          GWS  GWS  GWS
lsi1         1-111-1     scr1   1    1   yes a    1    off off off ---  ---
```

```

lsi2      1-111-2      scr2  1  2  no  c  3   on  on  on  ---  ---
lsi3      1-111-3      scr3  1  3  yes c  5   off off off ---  ---

LSN      APCN      (SS7)  SCRN  SET  SET  BEI  LST  LNKS  ACT  MES  DIS  SLSCI  NIS
lsn1     11111      scr1  1  1  yes a  1   on  off off ---  off
lsn2     11112      scr2  1  2  no  c  3   on  on  on  ---  off
lsn3     11113      scr3  1  3  yes c  5   on  off off ---  off
lsn5     10685      scr1  1  3  yes a  4   on  off off ---  off

Link set table is ( 10 of 1024) 1% full

```

2. Display the point code and capability point code of the EAGLE 5 ISS by using the `rtrv-sid` command.

Note: If the APC of an existing linkset is not being changed, skip steps 2, 3, and 4, and go to step 5.

This is an example of the possible output.

```

rlghncxa03w 06-10-10 11:43:04 GMT EAGLE5 36.0.0
PCA          PCI          PCN          CLLI          PCTYPE
001-001-001  3-150-4          13482        rlghncxa03w  OTHER
              s-3-150-4          s-13482

CPCA
002-002-002      002-002-003      002-002-004      002-002-005
002-002-006      002-002-007      002-002-008      002-002-009
004-002-001      004-003-003      144-212-003

CPCA (LNP)
005-005-002      005-005-004      005-005-005

CPCI
1-001-1          1-001-2          1-001-3          1-001-4

CPCN
02091          02092          02094          02097
02191          02192          11177

```

If you wish to use ITU-I or ITU-N spare point codes with GSM MAP Screening, and the `rtrv-sid` output does not show any ITU-I or ITU-N spare point codes, add ITU-I and ITU-N spare point codes, as necessary, to the self identification of the EAGLE 5 ISS by performing the "Changing the Self-Identification of the EAGLE 5 ISS" procedure in the *Database Administration Manual - SS7*.

3. Display the point codes in the destination point code table by using the `rtrv-dstn` command with the linkset's adjacent point code.

For this example, enter these commands.

```
rtrv-dstn:dpci=3-150-4
```

This is an example of the possible output.

```

rlghncxa03w 10-12-10 11:43:04 GMT EAGLE5 43.0.0
DPCI          CLLI          BEI  ELEI  ALIASA          ALIASN/N24  DMN
3-150-4      lsi7clli     yes  ---  -----  -----  SS7

SPCI          NCAI          RCAUSE  NPRST  SPLITIAM  HMSMSC  HMSCP  SCCPMSCNV
-----  ----  none  off  none  no  no  none

Destination table is (28 of 2000) 1% full
Alias table is (5 of 8000) 1% full

rtrv-dstn:dpcn=10685

```

This is an example of the possible output.

```
rlghncxa03w 10-12-10 11:43:04 GMT EAGLE5 43.0.0
DPCN          CLLI          BEI  ELEI  ALIASA          ALIASI          DMN
10685         lsn5clli         yes  ---  -----          -----          SS7

SPCI          NCAI          RCAUSE NPRST SPLITIAM HMSMSC HMSCP SCCPMSGCNV
-----      ----          none  off  none         no         no         none

Destination table is (28 of 2000) 1% full
Alias table is (5 of 8000) 1% full
```

If the point code specified in the `rtrv-dstn` command in this step is not in the database, the following message is displayed.

```
rlghncxa03w 09-05-10 11:43:04 GMT EAGLE5 41.0.0

No destinations meeting the requested criteria were found

Destination table is (28 of 2000) 1% full
Alias table is (5 of 8000) 1% full
```

If a linkset is being added to the database, or the adjacent point code of the linkset is being changed, and the adjacent point code is not shown in the `rtrv-dstn` command output, go to the “Adding a Destination Point Code” procedure in the *Database Administration Manual - SS7* and add the adjacent point code to the destination point code table.

Note: An ANSI point code can be used as the APC of a linkset for GSM MAP Screening only if the Enhanced GSM MAP Screening feature is enabled and on.

- The adjacent point code of the linkset cannot be the DPC of any exception route.

Note: If the adjacent point code was added in step 3, skip step 4 and go to step 5.

Verify that the adjacent point code of the new linkset is not the DPC of any exception route by entering the `rtrv-rtx` command with the `dpc/dpca/dpci/dpcn/dpcn24` parameter. The `dpc/dpca/dpci/dpcn/dpcn24` parameter value is the adjacent point code value that will be specified for the new linkset. For this example, enter this command.

```
rtrv-rtx:dpci=3-150-4
```

This is an example of the possible output.

```
rlghncxa03w 06-10-10 11:43:04 GMT EAGLE5 36.0.0
  DPCI          RTX-CRITERIA          LSN          RC          APC
  3-150-4          OPCI
                    4-050-1          lsi2          20          1-111-2

DESTINATION ENTRIES ALLOCATED:    2000
  FULL DPC(s):                    13
  EXCEPTION DPC(s):                5
  NETWORK DPC(s):                  0
  CLUSTER DPC(s):                  1
  TOTAL DPC(s):                    19
  CAPACITY (% FULL):               1%
ALIASES ALLOCATED:                12000
  ALIASES USED:                    0
  CAPACITY (% FULL):               0%
X-LIST ENTRIES ALLOCATED:         500
```

If the adjacent point code of the linkset is not the DPC of a route exception table entry, no entries are displayed in the `rtrv-rtx` output, but a summary of the point code quantities is displayed, as shown in the following output example.

```
rlghncxa03w 06-10-10 11:43:04 GMT EAGLE5 36.0.0
  DESTINATION ENTRIES ALLOCATED:    2000
    FULL DPC(s):                    15
    EXCEPTION DPC(s):                5
    NETWORK DPC(s):                  0
    CLUSTER DPC(s):                  1
    TOTAL DPC(s):                    21
    CAPACITY (% FULL):                1%
  ALIASES ALLOCATED:                12000
    ALIASES USED:                    0
    CAPACITY (% FULL):                0%
  X-LIST ENTRIES ALLOCATED:         500
```

If the point code specified in this step is shown in the DPCA/DPCI/DPCN/ DPCN24 columns in this step, the point code value cannot be used as an adjacent point code unless one of two actions are taken:

- Choose another adjacent point code value and repeat steps 2, 3, and 4.
 - Remove all the entries displayed in this step by performing the “Removing a Route Exception Entry” procedure in the *Database Administration Manual - SS7*.
5. Verify that the GSM MAP Screening feature is enabled and on by entering the `rtrv-ctrl-feat` command with the part number of the GSM MAP Screening feature.

Enter this command.

```
rtrv-ctrl-feat:partnum=893013201
```

The following is an example of the possible output.

```
rlghncxa03w 06-10-28 21:15:37 GMT EAGLE5 36.0.0
The following features have been permanently enabled:

Feature Name           Partnum   Status   Quantity
GSM Map Screening (GMS) 893013201 on       ----

The following features have been temporarily enabled:

Feature Name           Partnum   Status   Quantity   Trial Period Left
Zero entries found.

The following features have expired temporary keys:

Feature Name           Partnum
Zero entries found.
```

If the GSM MAP screening feature is not enabled or off, go to the [Activating the GSM MAP Screening Feature](#) procedure to enable and turn on the GSM MAP screening feature.

6. Verify that the Enhanced GSM MAP Screening feature is enabled and on by entering the `rtrv-ctrl-feat` command with the part number of the Enhanced GSM MAP Screening feature.

Note: If ANSI point codes are not being used, skip step 6 and go to step 7.

Enter this command.

```
rtrv-ctrl-feat:partnum=893012401
```

The following is an example of the possible output.

```
rlghncxa03w 06-10-28 21:15:37 GMT EAGLE5 36.0.0
The following features have been permanently enabled:
```

Feature Name	Partnum	Status	Quantity
Enhanced GSM (EGMS)	893012401	on	----

The following features have been temporarily enabled:

Feature Name	Partnum	Status	Quantity	Trial Period Left
Zero entries found.				

The following features have expired temporary keys:

Feature Name	Partnum
Zero entries found.	

If the Enhanced GSM MAP screening feature is not enabled or off, go to the [Activating the GSM MAP Screening Feature](#) procedure to enable and turn on the Enhanced GSM MAP screening feature.

7. Display the current linkset configuration of the linkset to be changed using the `rtrv-ls` command with the linkset name.

Note: If no existing linksets are being changed, skip step 7 and go to step 8.

For this example, enter this command.

```
rtrv-ls:lsn=lsn4
```

This is an example of the possible output.

```
rlghncxa03w 09-07-17 11:43:04 GMT EAGLE5 41.1.0

LSN          APCN    (SS7)  SCRN  SET SET BEI LST LNKS ACT MES DIS SLSCI NIS
lsn4         09786          scr3  1  2  no  a  2   on off off no   on

          CLLI          TFATCABMLQ MTPRSE ASL8 SLRSRB ITUTFR GSMSCRN
lsn4clli    1          ---    ---  1     on    on

IPGWAPC MATELSN      IPTPS LSUSEALM SLKUSEALM GTTMODE
no      ----- ---    ---    ---          CdPA

          L2T          PCR PCR
LOC  LINK SLC TYPE      SET  BPS    ECM  N1  N2
1205 b    0  LIMDS0  1    56000 BASIC ---  ---
1211 a    2  LIMDS0  1    56000 BASIC ---  ---

Link set table is ( 21 of 1024) 2% full
```

8. Add the new linkset to the database using the `ent-ls` command.

Note: If you are not adding a new linkset to the database, skip step 8 and go to step 9.

For this example, enter these commands.

```
ent-ls:lsn=lsn5:apcn=10685:lst=a:gmscrn=on
```

```
ent-ls:lsn=lsi7:apci=3-150-4:lst=a:gmscrn=on
```

Note: An ANSI point code can be used as the APC of a linkset for GSM MAP Screening only if the Enhanced GSM MAP Screening feature is enabled and on.

The `apci` parameter value can be either an ITU-I point code or an ITU-I spare point code.

The `apcn` parameter value can be either an ITU-N point code or an ITU-N spare point code.

When each of these commands have successfully completed, this message should appear.

```
rlghncxa03w 06-10-17 16:23:21 GMT EAGLE5 36.0.0
Link set table is ( 21 of 1024) 2% full
ENT-LS: MASP A - COMPLTD
```

- Change the `gmscrn` parameter value in the existing linkset in the database using the `chg-ls` command.

Note: If you are not changing an existing linkset in the database, skip step 9 and go to step 10.

For this example, enter this command.

```
chg-ls:lsn=lsn4:gmscrn=on
```

Note: The `gmscrn` parameter can be specified for a linkset with an ANSI APC only if the Enhanced GSM MAP Screening feature is enabled and on.

When this commands has successfully completed, this message should appear.

```
rlghncxa03w 06-10-17 16:23:21 GMT EAGLE5 36.0.0
Link set table is ( 21 of 1024) 2% full
CHG-LS: MASP A - COMPLTD
```

- Verify the changes using the `rtrv-ls` command specifying the linkset name specified in either steps 8 or 9 with the `lsn` parameter.

For this example, enter these commands.

```
rtrv-ls:lsn=lsn4
```

This is an example of the possible output.

```
rlghncxa03w 09-07-17 11:43:04 GMT EAGLE5 41.1.0

LSN          APCN      (SS7)  SCRIN  SET SET BEI LST LNKS ACT MES DIS SLSCI NIS
lsn4         09786                scr3   1  2  no  a  2   on off off no   on

          CLLI          TFATCABMLQ MTPRSE ASL8  SLRSRB ITUTFR GSMSCRN
lsn4c11i    1             ---    ---  1     on    on

IPGWAPC MATELSN      IPTPS LSUSEALM SLKUSEALM GTTMODE
no      -----  ---    ---    ---    CdPA

          L2T          PCR  PCR
LOC  LINK SLC TYPE  SET  BPS  ECM  N1  N2
1205 b    0  LIMDS0  1   56000 BASIC ---  ---
1211 a    2  LIMDS0  1   56000 BASIC ---  ---

Link set table is ( 21 of 1024) 2% full
```

```
rtrv-ls:lsn=lsn5
```

This is an example of the possible output.

```
rlghncxa03w 06-10-17 11:43:04 GMT EAGLE5 36.0.0

LSN          APCN      (SS7)  SCRIN  SET SET BEI LST LNKS ACT MES DIS SLSCI NIS
lsn5         10685                none  1  2  no  a  0   off off off no  off

          CLLI          TFATCABMLQ MTPRSE ASL8  SLRSRB ITUTFR GSMSCRN
lsn5c11i    1             ---    ---  1     on    on

IPGWAPC MATELSN      IPTPS LSUSEALM SLKUSEALM GTTMODE
no      -----  ---    ---    ---    CdPA
```

```
Link set table is ( 21 of 1024) 2% full
```

```
rtrv-ls:lsn=lsi7
```

This is an example of the possible output.

```
rlghncxa03w 06-10-17 11:43:04 GMT EAGLE5 36.0.0
```

LSN	APCI	(SS7)	SCRN	SET	SET	L3T	SLT	BEI	LST	LNKS	ACT	MES	DIS	GWS	GWS	GWS	SLSCI	NIS
lsi7	3-150-4		none	1	2	no	a			0	off	off	off	no			no	off
	CLLI		TFATCABMLQ	MTPRSE	ASL8	SLRSRB	ITUTFR	GSMSCRN										
	lsn7clli		1	---	---	1	off	on										
	IPGWAPC	MATELSN	IPTPS	LSUSEALM	SLKUSEALM	GTTMODE												
	no	-----	---	---	---	CdPA												

```
Link set table is ( 21 of 1024) 2% full
```

11. Back up the new changes using the `chg-db:action=backup:dest=fixed` command.

```
BACKUP (FIXED) : MASP A - Backup starts on active MASP.
BACKUP (FIXED) : MASP A - Backup on active MASP to fixed disk complete.
BACKUP (FIXED) : MASP A - Backup starts on standby MASP.
BACKUP (FIXED) : MASP A - Backup on standby MASP to fixed disk complete.
```

Changing the System-Wide GSM MAP Screening Options

The GSM MAP screening options can be changed with the `chg-stpopts` command after the GSM MAP screening feature has been activated. The `chg-stpopts` command contains two options for GSM MAP screening.

- `GSMDFLT` – GSM MAP screening default action – Allows the user to specify the default screening action (PASS or DISCARD) that occurs when a MAP operations code contained in the MSU is not found in the GSM MAP operations code table.
- `gsmdecerr` – GSM MAP screening decode error action – Allows the user to specify the default screening action (PASS or DISCARD) that occurs when an error is detected in the TCAP layer of the MSU being screened. Such errors included an invalid value for a parameter, length error, missing data, and so on.

The GSM MAP Screening feature must be enabled and on before performing this procedure. Use the `rtrv-ctrl-feat` command to verify the status of the GSM MAP Screening feature. If the GSM MAP Screening feature is not enabled and off, go to the [Activating the GSM MAP Screening Feature](#) procedure to enable and turn on the GSM MAP screening feature.

When the GSM MAP screening feature is activated, the values for the `gsmdflt` and `gsmdecerr` parameters are set to `pass`. The current values for these options can be verified with the `rtrv-stpopts` command.

1. Verify that the GSM MAP Screening feature is enabled and on by entering the `rtrv-ctrl-feat` command with the part number of the GSM MAP Screening feature.

Enter this command.

```
rtrv-ctrl-feat:partnum=893013201
```

The following is an example of the possible output.

```
rlghncxa03w 06-10-28 21:15:37 GMT EAGLE5 36.0.0
The following features have been permanently enabled:
Feature Name          Partnum    Status    Quantity
GSM Map Screening (GMS) 893013201 on        ----

The following features have been temporarily enabled:
Feature Name          Partnum    Status    Quantity    Trial Period Left
Zero entries found.

The following features have expired temporary keys:
Feature Name          Partnum
Zero entries found.
```

If the GSM MAP screening feature is not enabled or off, go to the [Activating the GSM MAP Screening Feature](#) procedure to enable and turn on the GSM MAP screening feature.

2. Display the existing values for the `gsmdflt` and `gsmdecerr` parameters by entering the `rtrv-stpopts` command.

The value for the `gsmdflt` parameter is shown in the `GSMDFLT` field. The value for the `gsmdecerr` parameter is shown in the `GSMDECERR` field. This is an example of the possible output.

```
rlghncxa03w 06-10-17 16:02:05 GMT EAGLE5 36.0.0
STP OPTIONS
-----
GSMDFLT          PASS
GSMDECERR        PASS
```

Note:

The `rtrv-stpopts` command output contains other fields that are not used by this procedure. If you wish to see all the fields displayed by the `rtrv-stpopts` command, see the `rtrv-stpopts` command description in the *Commands Manual*.

3. Change either the GSM MAP screening default action (`gsmdflt`) and GSM MAP screening decode error action (`gsmdecerr`) options using the `chg-stpopts` command.

If you wish to change both options, enter the `chg-stpopts` command with the `gsmdflt` and `gsmdecerr` parameters as shown in this example.

```
chg-stpopts:gsmdflt=discard:gsmdecerr=discard
```

If you wish to change only one option, enter the `chg-stpopts` command with either the `gsmdflt` and `gsmdecerr` parameters as shown in these examples.

```
chg-stpopts:gsmdflt=discard
```

```
chg-stpopts:gsmdecerr=discard
```

For this example, the GSM MAP screening error code action is being changed.

When this command has successfully completed, this message should appear.

```
rlghncxa03w 06-10-07 00:22:57 GMT EAGLE5 36.0.0
CHG-STPOPTS: MASP A - COMPLTD
```

4. Verify the changes using the `rtrv-stpopts` command.

This is an example of the possible output.

```
rlghncxa03w 06-10-17 16:02:05 GMT EAGLE5 36.0.0
STP OPTIONS
-----
GSMDFLT          PASS
GSMDECERR        DISCARD
```

Note:

The `rtrv-stpopts` command output contains other fields that are not used by this procedure. If you wish to see all the fields displayed by the `rtrv-stpopts` command, see the `rtrv-stpopts` command description in the *Commands Manual*.

5. Backup the new changes using the `chg-db:action=backup:dest=fixed` command. These messages should appear, the active Maintenance and Administration Subsystem Processor (MASP) appears first.

```
BACKUP (FIXED): MASP A - Backup starts on active MASP.
BACKUP (FIXED): MASP A - Backup on active MASP to fixed disk complete.
BACKUP (FIXED): MASP A - Backup starts on standby MASP.
BACKUP (FIXED): MASP A - Backup on standby MASP to fixed disk complete.
```

Adding a GSM Subsystem Number Screening Entry

Use this procedure to provision the origination and destination SSNs (subsystem numbers) to be screened with the GSM MAP screening feature using the `ent-gsmssn-scrn` command.

The `ent-gsmssn-scrn` command uses these parameters.

`:ssn` – The subsystem number contained in either the calling party address (CGPA) or the called party address (CDPA) contained in the MAP message.

`:type` – The type of SSN, either an origination SSN (`orig`) or a destination SSN (`dest`). The origination SSN is found in the calling party address of the message. The destination SSN is found in the called party address of the message.

The GSM MAP Screening feature must be enabled and on before performing this procedure. Use the `rtrv-ctrl-feat` command to verify the status of the GSM MAP Screening feature. If the GSM MAP Screening feature is not enabled and off, go to the [Activating the GSM MAP Screening Feature](#) to enable and turn on the GSM MAP screening feature.

You cannot specify an `ssn` and `type` parameter combination that already exists in the database.

This examples used in this procedure are based on the examples shown in [Table 17: Example GSM MAP Screening SSN Configuration Table](#).

Table 17: Example GSM MAP Screening SSN Configuration Table

SSN	TYPE
250	orig

SSN	TYPE
251	dest

1. Verify that the GSM MAP Screening feature is enabled and on by entering the `rtrv-ctrl-feat` command with the part number of the GSM MAP Screening feature.

Enter this command.

```
rtrv-ctrl-feat:partnum=893013201
```

The following is an example of the possible output.

```
rlghncxa03w 06-10-28 21:15:37 GMT EAGLE5 36.0.0
The following features have been permanently enabled:

Feature Name          Partnum    Status    Quantity
GSM Map Screening (GMS) 893013201  on       ----

The following features have been temporarily enabled:

Feature Name          Partnum    Status    Quantity    Trial Period Left
Zero entries found.

The following features have expired temporary keys:

Feature Name          Partnum
Zero entries found.
```

If the GSM MAP screening feature is not enabled or off, go to the [Activating the GSM MAP Screening Feature](#) to enable and turn on the GSM MAP screening feature.

2. Display the GSM MAP Screening subsystem numbers in the database using the `rtrv-gsmssn-scrn` command.

This is an example of the possible output.

```
rlghncxa03w 06-10-07 00:28:31 GMT EAGLE5 36.0.0
SSN  ORIG  DEST
 2   Yes   No
10   Yes   Yes
GSM Map Screening table is (2 of 512) 1% full
RTRV-GSMSSN-SCRN: MASP A - COMPLTD
```

3. Add the new subsystem numbers to be screened to the database with the `ent-gsmssn-scrn` command.

For this example, enter these commands:

```
ent-gsmssn-scrn:ssn=250:type=orig
```

```
ent-gsmssn-scrn:ssn=251:type=dest
```

When each of these commands has successfully completed, this message appears.

```
rlghncxa03w 06-10-07 00:29:31 GMT EAGLE5 36.0.0
ENT-GSMSSN-SCRN: MASP A - COMPLTD
```

4. Verify the changes using the `rtrv-gsmssn-scrn` command.

This is an example of the possible output.

```
rlghncxa03w 06-10-07 00:28:31 GMT EAGLE5 36.0.0
SSN  ORIG  DEST
   2   Yes   No
  10   Yes   Yes
 250   Yes   No
 251   No    Yes
GSM Map Screening table is (4 of 512) 1% full
RTRV-GSMSSN-SCRN: MASP A - COMPLTD
```

5. Backup the new changes using the `chg-db:action=backup:dest=fixed` command. These messages should appear, the active Maintenance and Administration Subsystem Processor (MASP) appears first.

```
BACKUP (FIXED) : MASP A - Backup starts on active MASP.
BACKUP (FIXED) : MASP A - Backup on active MASP to fixed disk complete.
BACKUP (FIXED) : MASP A - Backup starts on standby MASP.
BACKUP (FIXED) : MASP A - Backup on standby MASP to fixed disk complete.
```

Removing a GSM Subsystem Number Screening Entry

Use this procedure to remove an SSN (subsystem number) from the GSM MAP SSN screening table using the `dlt-gsmssn-scrn` command.

The `dlt-gsmssn-scrn` command uses these parameters.

`:ssn` – The subsystem number contained in either the calling party address (CGPA) or the called party address (CDPA) contained in the MAP message.

`:type` – The type of SSN, either an origination SSN (`orig`) or a destination SSN (`dest`). The origination SSN is found in the calling party address of the message. The destination SSN is found in the called party address of the message.

The `ssn` and `type` parameter combination specified in the `dlt-gsmssn-scrn` command must be in the database.

1. Display the GSM MAP Screening subsystem numbers in the database using the `rtrv-gsmssn-scrn` command.

This is an example of the possible output.

```
rlghncxa03w 06-10-07 00:28:31 GMT EAGLE5 36.0.0
SSN  ORIG  DEST
   2   Yes   No
  10   Yes   Yes
 250   Yes   No
 251   No    Yes
GSM Map Screening table is (4 of 512) 1% full
RTRV-GSMSSN-SCRN: MASP A - COMPLTD
```

2. Remove the subsystem number from the database with the `dlt-gsmssn-scrn` command. For this example, enter this command.

```
dlt-gsmssn-scrn:ssn=010:type=orig
```

```
dlt-gsmssn-scrn:ssn=251:type=dest
```

When each of these commands has successfully completed, this message appears.

```
rlghncxa03w 06-10-07 00:29:31 GMT EAGLE5 36.0.0
DLT-GSMSSN-SCRN: MASP A - COMPLTD
```

3. Verify the changes using the `rtrv-gsmssn-scrn` command.

This is an example of the possible output.

```
rlghncxa03w 06-10-07 00:28:31 GMT EAGLE5 36.0.0
SSN  ORIG  DEST
  2   Yes   No
 10   No    Yes
 250  Yes   No
GSM Map Screening table is (3 of 512) 1% full
RTRV-GSMSSN-SCRN: MASP A - COMPLTD
```

4. Backup the new changes using the `chg-db:action=backup:dest=fixed` command.

These messages should appear, the active Maintenance and Administration Subsystem Processor (MASP) appears first.

```
BACKUP (FIXED) : MASP A - Backup starts on active MASP.
BACKUP (FIXED) : MASP A - Backup on active MASP to fixed disk complete.
BACKUP (FIXED) : MASP A - Backup starts on standby MASP.
BACKUP (FIXED) : MASP A - Backup on standby MASP to fixed disk complete.
```

Adding a GSM MAP Screening Operation Code

Use this procedure to provision the concerned GSM MAP screening operation codes and the default screening action for the operation code in the database using the `ent-gsms-opcode` command. This procedure allows the user to provision a list of all operation codes that the EAGLE 5 ISS uses in performing GSM screening.

The `ent-gsms-opcode` command uses these parameters.

`:opcode` – The MAP operation code. This parameter refers to the actual decimal value of the MAP operation codes from the TCAP layer of GSM MAP messages.

`:opname` – The name of operation code. This parameter lets the user give a meaningful name to the MAP operation code (`opcode`) entered. This name is used by subsequent commands such as `dlt-/chg-gsms-opcode` and `ent-/chg-/dlt-/rtrv-gsmmap-scrn`.

`:dfltact` – The default screening action. This parameter lets the user define a default screening action for the MAP operation code (`opcode`) entered. The default screening action is used when a matching CGPA (calling party) address is not found in the GSM MAP screening table or when a CGPA address is found but does not have the correct `npv` and `naiv` parameters as defined by the `ent-gsmmap-scrn` command. One of these actions can be assigned.

- `pass` – Route the message as normal to the destination.
- `discard` – The MSU is to be discarded.

- `atierr` – An ATI (Any Time Interrogation) reject message is generated. This option is only valid for ATI MAP operation codes.
- `route` – Route the message as normal to the original destination node.
- `forward` – Route the original message to the forward node. The original message is not sent to the original node. If, however, the forwarded node is not available for routing then the MSU is routed to the original node.
- `duplicate` – Route the message as normal to the original destination and route a copy of the original message to the duplicate node.
- `dupdisc` – Duplicate and discard – Route the original message to the duplicate node. The original message is not sent to the original node.

`:pc/pca/pci/pcn/pcn24` – The ANSI point code (`pc/pca`), ITU-I point code or ITU-I spare point code (`pci`), 14-bit ITU-N point code or 14-bit ITU-N spare point code (`pcn`), or 24-bit ITU-N point code (`pcn24`) of the node that the MSU is routed to by the `forward`, `duplicate`, or `dupdisc` screening actions. The EAGLE 5 ISS can contain 14-bit ITU-N point codes or 24-bit ITU-N point codes, but not both. To specify the `pc/pca` parameters, the Enhanced GSM MAP Screening feature must be enabled and on.

`:ssn` – The subsystem number of the node that the MSU is routed to by the `forward`, `duplicate`, or `dupdisc` screening actions. The values for this parameter are 2 to 255, or the value `none`. The default value for this parameter is `none`.

`:force` – The mated application override. Is the GSM MAP screening operation code to be entered without a mated application in the database (`yes` or `no`)?

`:mapset` – The MAP set ID, shown in the `rtrv-map` command. This parameter can be specified only if the Flexible GTT Load Sharing feature is enabled. The status of the Flexible GTT Load Sharing feature is shown in the `rtrv-ctrl-feat` output. To enable the Flexible GTT Load Sharing feature, perform the “Activating the Flexible GTT Load Sharing Feature” procedure in the *Database Administration Manual - Global Title Translation*.

If the Flexible GTT Load Sharing feature is not enabled:

- The `mapset` parameter cannot be used.
- The `pc/pca/pci/pcn/pcn24` and `ssn` values must be shown in the `rtrv-map` output, or else the `force=yes` parameter must be specified.

If the Flexible GTT Load Sharing feature is enabled:

- The `mapset` parameter can be specified only for GSM OPCODE entries that contain point code and subsystem entries. The `dfl tact` parameter value for these GSM OPCODE entries can be either `forward`, `duplicate`, or `dupdisc`.
- If the `dfl tact` parameter value for the GSM OPCODE entry will be `forward`, `duplicate`, or `dupdisc`, and the `pc/pca/pci/pcn/pcn24` and `ssn` parameters will be specified for the GSM OPCODE entry, the `mapset` parameter must be specified.
- The `force=yes` parameter can be used only if the MAP set assigned to the GSM OPCODE entry is the default MAP set.
- If the MAP set assigned to the GSM OPCODE entry is a MAP set other than the default MAP set, the `force=yes` parameter cannot be used. The point code and subsystem contained in the GSM OPCODE entry must be in the MAP set assigned to the GSM OPCODE entry.

- If the default MAP set is assigned to the GSM OPCODE entry and the `force=yes` parameter is not specified, the point code and subsystem contained in the GSM OPCODE entry must be in the default MAP set.

`:ri` - The routing indicator parameter. This parameter specifies whether a subsequent global title translation is required. This parameter has two values.

- `gt` - subsequent global title translation is required.
- `ssn` - subsequent global title translation is not required. This is the default value for the `ri` parameter.

`:tt` - the translation type that will be assigned to the GSM OPCODE entry. The values for this parameter are 0 to 255, or the value `none` which specifies that no translation type will be assigned to the GSM OPCODE entry.

The GSM MAP Screening feature must be enabled and on before performing this procedure. Use the `rtrv-ctrl-feat` command to verify the status of the GSM MAP Screening feature. If the GSM MAP Screening feature is not enabled and off, go to the [Activating the GSM MAP Screening Feature](#) to enable and turn on the GSM MAP screening feature.

The `opcode` parameter value must be a number between 0 and 255 or an asterisk (*). The `opcode=*` parameter can be specified only if the Enhanced GSM MAP Screening feature is enabled and on. Use the `rtrv-ctrl-feat` command to verify the status of the Enhanced GSM MAP Screening feature. If the Enhanced GSM MAP Screening feature is not enabled or off, go to the [Activating the GSM MAP Screening Feature](#) to enable and turn on the Enhanced GSM MAP screening feature.

The `opname` parameter value must be no more than 8 alphanumeric characters.

The word `none` cannot be used as a value for the `opname` parameter.

The `dfltact=atierr` parameter cannot be specified unless the value of the operation code (`opcode`) referenced by the `opname` parameter value is 71. The `atierr` option is only valid for ATI MAP operation codes; `opcode=71` signifies an ATI MAP operation code.

The value specified for the `opcode` parameter cannot already exist in the GSM MAP operation code table.

The value specified for the `opname` parameter cannot already be used in the GSM MAP operation code table.

The `pc/pca/pci/pcn/pcn24` and `ssn` values must be shown in the `rtrv-map` output, or else the `force=yes` parameter must be specified. If the `pc/pca/pci/pcn/pcn24` and `ssn` values are not shown in the `rtrv-map` output, and a new mated application is to be added, perform one of the "Provisioning a Mated Application" procedures in the *Database Administration Manual - Global Title Translation* and add the required mDatabaseated application with the `pc/pca/pci/pcn/pcn24` and `ssn` values:

The `force=yes` parameter can be specified only with the `pc/pca/pci/pcn/pcn24` and `ssn` parameters.

The `dfltact=forward`, `dfltact=duplicate`, or `dfltact=dupdisc` parameters can be specified only with the `pc/pca/pci/pcn/pcn24` and `ssn` parameters. If the `pc/pca/pci/pcn/pcn24` and `ssn` parameters are specified, the `dfltact=forward`, `dfltact=duplicate`, or `dfltact=dupdisc` parameters must be specified.

The `pc/pca/pci/pcn/pcn24` and `ssn` parameters must be specified together.

The `pc/pca/pci/pcn/pcn24` parameter values must be the DPC of a route and a proxy point code cannot be assigned to the point code. The `pc/pca` parameter value must be a full point code. The `pc/pca` parameter value can be a member of a cluster point code when that cluster point code is the DPC of a route. This can be verified with the `rtrv-rte` command. If the `pc/pca/pci/pcn/pcn24` value is not shown in the `rtrv-rte` as the DPC of a route, go to the "Adding a Route Containing an SS7 DPC" procedure in the *Database Administration Manual - SS7* and add a new route containing the `pc/pca/pci/pcn/pcn24` value. To verify whether or not a proxy point code is assigned to the `pc/pca/pci/pcn/pcn24` value, enter the `rtrv-dstn` command with the point code value. If a proxy point code is assigned to the point code, choose another point code.

This examples used in this procedure are based on the examples shown in [Table 18: Example GSM MAP Screening Operation Code Configuration Table](#).

Table 18: Example GSM MAP Screening Operation Code Configuration Table

OPCODE	OPNAME	DFLTACT	PC/PCA/PCI/ PCN/PCN24	SSN	MAPSET
100	pass100	pass	N/A	N/A	N/A
150	discard1	discard	N/A	N/A	N/A
71	ati	atierr	N/A	N/A	N/A
25	route25	route	N/A	N/A	N/A
139	fwd139	forward	3-159-7	128	dflt
187	dup187	duplicate	11519	79	10
93	dd93	dupdisc	5-25-3	200	20
36	for1	forward	002-002-002	10	25
*	star	pass	N/A	N/A	N/A

1. Verify that the GSM MAP Screening feature is enabled and on by entering the `rtrv-ctrl-feat` command with the part number of the GSM MAP Screening feature.

Enter this command.

```
rtrv-ctrl-feat:partnum=893013201
```

The following is an example of the possible output.

```
rlghncxa03w 06-10-28 21:15:37 GMT EAGLE5 36.0.0
The following features have been permanently enabled:

Feature Name          Partnum    Status   Quantity
GSM Map Screening (GMS) 893013201 on       ----
```

The following features have been temporarily enabled:

Feature Name	Partnum	Status	Quantity	Trial Period Left
Zero entries found.				

The following features have expired temporary keys:

Feature Name	Partnum
Zero entries found.	

If the GSM MAP screening feature is not enabled or off, go to the [Activating the GSM MAP Screening Feature](#) to enable and turn on the GSM MAP screening feature.

Note: If the opcode=* or the pc/pca parameters are not being used in this procedure, continue the procedure with [Step 3](#).

2. Verify that the Enhanced GSM MAP Screening feature is enabled and on by entering the `rtrv-ctrl-feat` command with the part number of the Enhanced GSM MAP Screening feature. Enter this command.

```
rtrv-ctrl-feat:partnum=893012401
```

The following is an example of the possible output.

```
rlghncxa03w 06-10-28 21:15:37 GMT EAGLE5 36.0.0
The following features have been permanently enabled:
Feature Name          Partnum    Status    Quantity
Enhanced GMS (EGMS)  893012401  on       ----

The following features have been temporarily enabled:
Feature Name          Partnum    Status    Quantity    Trial Period Left
Zero entries found.

The following features have expired temporary keys:
Feature Name          Partnum
Zero entries found.
```

If the Enhanced GSM MAP screening feature is not enabled or off, go to the [Activating the GSM MAP Screening Feature](#) to enable and turn on the Enhanced GSM MAP screening feature.

3. Display the GSM MAP screening operation codes in the database using the `rtrv-gsms-opcode` command.

This is an example of the possible output.

```
rlghncxa03w 08-09-10 11:43:04 GMT EAGLE5 39.2.0
OPCODE  OPNAME    DFLTACT    PCA          SSN  RI  TT
OPCODE  OPNAME    DFLTACT    PCI          SSN  RI  TT
OPCODE  OPNAME    DFLTACT    PCN          SSN  RI  TT
OPCODE  OPNAME    DFLTACT    PCN24       SSN  RI  TT
OPCODE  OPNAME    DFLTACT
 22     sri      disc
 50     pass50   pass
```

```
GSMMS OPCODE Table (2 of 257) is 1% full
```

If the Flexible GTTLoad Sharing feature is enabled, the MAPSET field is shown in the `rtrv-gsms-opcode` output. This is an example of the possible output

```
rlghncxa03w 08-09-10 11:43:04 GMT EAGLE5 39.2.0
```

```
OPCODE  OPNAME      DFLTACT    PCA          SSN  MAPSET RI  TT
OPCODE  OPNAME      DFLTACT    PCI          SSN  MAPSET RI  TT
OPCODE  OPNAME      DFLTACT    PCN          SSN  MAPSET RI  TT
OPCODE  OPNAME      DFLTACT    PCN24        SSN  MAPSET RI  TT

OPCODE  OPNAME      DFLTACT
22      sri         disc
50      pass50      pass
```

```
GSMMS OPCODE Table (2 of 257) is 1% full
```

4. Perform one of these actions.

- If the `dfiltact` parameter value will be either `pass`, `discard`, `route`, or `atierr`, continue the procedure with [Step 9](#).
- If the `dfiltact` parameter value will be either `forward`, `duplicate`, or `dupdisc`, perform one of these actions.
 - To use a point code and a MAP set from the mated application table, and MAP sets are not shown in the `rtrv-gsms-opcode` output in [Step 3](#), the Flexible GTT Load Sharing Feature must be enabled. Perform the “Activating the Flexible GTT Load Sharing Feature” procedure in the *Database Administration Manual - Global Title Translation* and enable the Flexible GTT Load Sharing feature. After enabling the Flexible GTT Load Sharing feature, continue the procedure with [Step 7](#).
 - To use a point code and a MAP set from the mated application table, and MAP sets are shown in the `rtrv-gsms-opcode` output in [Step 3](#), continue the procedure with [Step 7](#).
 - To use a point code in the mated application table, but without using a MAP set, and MAP sets are not shown in the `rtrv-gsms-opcode` output in [Step 3](#), skip continue the procedure with [Step 7](#).
 - To use a point code that is not in the mated application table, the `force=yes` parameter must be specified with the `ent-gsms-opcode` command. A proxy point code cannot be assigned to this point code. If the Flexible GTT Load Sharing feature is enabled, the `force=yes` parameter can be used only if the default MAP set is assigned to the GSM OPCODE entry. Continue the procedure with [Step 5](#).

5. Display the destination point codes in the database by entering the `rtrv-dstn` command. This is an example of the possible output.

```
rlghncxa03w 10-12-10 11:43:04 GMT EAGLE5 43.0.0
Extended Processing Time may be Required
```

DPCA	CLLI	BEI	ELEI	ALIASI	ALIASN/N24	DMN
001-207-000	-----	no	---	-----	-----	SS7
001-001-001	-----	no	---	-----	-----	SS7
001-001-002	-----	no	---	-----	-----	SS7
001-005-000	-----	no	---	-----	-----	SS7

```

001-007-000 ----- no --- ----- SS7
008-012-003 ----- no --- ----- SS7
003-002-004 ----- no --- ----- SS7
009-002-003 ----- no --- ----- SS7
010-020-005 ----- no --- ----- SS7

DPCI          CLLI          BEI  ELEI  ALIASA          ALIASN/N24  DMN
1-207-0       ----- no --- ----- SS7
0-015-0       ----- no --- ----- SS7
0-017-0       ----- no --- ----- SS7
1-011-1       ----- no --- ----- SS7
1-011-2       ----- no --- ----- SS7

Destination table is (14 of 2000) 1% full
Alias table is (0 of 12000) 0% full
PPC table is (1 of 20) 5% full

```

If the required point code is not shown in the `rtrv-dstn` output, perform the "Adding a Destination Point Code" procedure in the *Database Administration Manual - SS7* to add the required point code. A proxy point code cannot be assigned to the point code.

After the new point code has been added, perform the "Adding a Route Containing an SS7 DPC" procedure in the *Database Administration Manual - SS7* and add the required route to the database. After the route has been added, continue the procedure with [Step 9](#).

6. Display the point code that will be assigned to the mated application by using the `rtrv-dstn` command and specifying the point code. For this example, enter this command.

```
rtrv-dstn:dpca=010-020-005
```

This is an example of the possible output.

```

rlghncxa03w 10-12-10 11:43:04 GMT EAGLE5 43.0.0

DPCA          CLLI          BEI  ELEI  ALIASI          ALIASN/N24  DMN
010-020-005   ----- no --- ----- SS7

PPCA          NCAI PRX      RCAUSE NPRST SPLITIAM HMSMSC HMSCP SCCPMSGCNV
009-002-003   ---- no      50     on    20          no    no    none

Destination table is (14 of 2000) 1% full
Alias table is (0 of 12000) 0% full
PPC table is (1 of 20) 5% full

```

If the adjacent point code is not shown in the `rtrv-dstn` command output, the following output is displayed.

```

rlghncxa03w 09-05-10 11:43:04 GMT EAGLE5 41.0.0

No destinations meeting the requested criteria were found

Destination table is (14 of 2000) 1% full
Alias table is (0 of 12000) 0% full
PPC table is (1 of 20) 5% full

```

A proxy point code (a point code value is shown in the PPC column) cannot be assigned to the point code. If a proxy point code is shown in this step, choose another point code from the `rtrv-dstn` output in the previous step and repeat this step.

If the point code is not shown in the `rtrv-dstn` output, perform the "Adding a Destination Point Code" procedure in the *Database Administration Manual - SS7* and add the adjacent point code to the destination point code table.

After the new point code has been added, perform the "Adding a Route Containing an SS7 DPC" procedure in the *Database Administration Manual - SS7* and add the required route to the database. After the route has been added, continue the procedure with [Step 9](#).

- The point code and subsystem number being assigned to the GSM OPCODE must be in the mated application table.

Enter the `rtrv-map` command with the `pc/pca/pci/pcn/pcn24` and `ssn` values that will be specified with the `ent-gsms-opcode` command in [Step 9](#).

If the Flexible GTT Load Sharing feature is not enabled, for this example, enter these commands.

```
rtrv-map:pci=3-159-7:ssn=128
```

This is an example of the possible output.

```
rlghncxa03w 09-07-25 09:42:31 GMT EAGLE5 41.1.0
PCI          Mate PCI          SSN RC MULT SRM MRC GRP NAME SSO
3-159-7      128 10 SOL *N *N GRP01 OFF
MAP TABLE IS (20 of 1024) 2 % FULL
```

```
rtrv-map:pcn=11519:ssn=79
```

This is an example of the possible output.

```
rlghncxa03w 09-07-25 09:42:31 GMT EAGLE5 41.1.0
PCN          Mate PCN          SSN RC MULT SRM MRC GRP NAME SSO
11519        79 10 SOL *N *N GRP01 ON
MAP TABLE IS (20 of 1024) 2 % FULL
```

```
rtrv-map:pci=5-25-3:ssn=200
```

This is an example of the possible output.

```
rlghncxa03w 09-07-25 09:42:31 GMT EAGLE5 41.1.0
PCI          Mate PCI          SSN RC MULT SRM MRC GRP NAME SSO
5-025-3      200 10 SOL *N *N GRP01 ON
MAP TABLE IS (20 of 1024) 2 % FULL
```

```
rtrv-map:pca=002-002-002:ssn=10
```

This is an example of the possible output.

```
rlghncxa03w 06-10-25 09:42:31 GMT EAGLE5 36.0.0
E2452 Cmd Rej: Remote point code does not exist in MAP table
```

If the Flexible GTT Load Sharing feature is enabled:

- The `mapset` parameter must be specified with the `ent-gsms-opcode` command in [Step 9](#).
- The point code and subsystem contained in the GSM OPCODE entry must be in the MAP set assigned to the GSM OPCODE entry.

For this example, enter these commands.

```
rtrv-map:pci=3-159-7:ssn=128
```

This is an example of the possible output.

```
rlghncxa03w 09-07-25 09:42:31 GMT EAGLE5 41.1.0
MAPSET ID=DFLT
PCI          Mate PCI          SSN RC MULT SRM MRC GRP NAME SSO
3-159-7     128 10 SOL *N *N GRP01 OFF
MAP TABLE IS (20 of 36000) 1 % FULL
```

```
rtrv-map:pcn=11519:ssn=79
```

This is an example of the possible output.

```
rlghncxa03w 09-07-25 09:42:31 GMT EAGLE5 41.1.0
MAPSET ID=10
PCN          Mate PCN          SSN RC MULT SRM MRC GRP NAME SSO
11519       79 10 SOL *N *N GRP01 ON
MAP TABLE IS (20 of 36000) 1 % FULL
```

```
rtrv-map:pci=5-25-3:ssn=200
```

This is an example of the possible output.

```
rlghncxa03w 09-07-25 09:42:31 GMT EAGLE5 41.1.0
MAPSET ID=20
PCI          Mate PCI          SSN RC MULT SRM MRC GRP NAME SSO
5-025-3     200 10 SOL *N *N GRP01 ON
MAP TABLE IS (20 of 36000) 1 % FULL
```

```
rtrv-map:pca=002-002-002:ssn=10
```

This is an example of the possible output.

```
rlghncxa03w 06-10-25 09:42:31 GMT EAGLE5 36.0.0
E2452 Cmd Rej: Remote point code does not exist in MAP table
```

If the point code and subsystem number is not shown in the `rtrv-map` output, perform one of the "Provisioning a Mated Application" procedures in the *Database Administration Manual - Global Title Translation* and add the required point code and subsystem number to the mated application table.

- The point code specified with the `ent-gsms-opcode` command must be the DPC of a route.

If the point code specified with the `ent-gsms-opcode` command is an ANSI point code, the point code can be a member of a cluster point code when that cluster point code is the DPC of a route.

Enter the `rtrv-rte` command with the `dpci` parameter specifying the point code to be used with the `ent-gsms-opcode` command to verify whether or not the point code is the DPC of a route. For this example, enter these commands.

```
rtrv-rte:dpci=3-159-7
```

This is an example of the possible output.

```
rlghncxa03w 06-10-07 11:43:04 GMT EAGLE5 36.0.0
DPCI        ALIASN/N24        ALIASA        LSN        RC        APC
3-159-7     12111                240-111-111  1s100001  10        1-234-5
```

```

ls100002 10 1-234-6
ls100003 20 1-234-7
ls100004 30 1-234-1
ls100005 40 1-234-2
ls100006 50 1-234-3
RTX:No CLLI=idpl

```

```
rtrv-rte:dpcn=11519
```

This is an example of the possible output.

```

rlghncxa03w 06-10-07 11:43:04 GMT EAGLE5 36.0.0
DPCN          ALIASA          ALIASI  LSN          RC          APC
11519         011-222-111      0-001-1 ls200001     10         11111
              011-222-111      0-001-1 ls200002     10         11112
              011-222-111      0-001-1 ls200003     20         11113
              011-222-111      0-001-1 ls200004     30         11114
              011-222-111      0-001-1 ls200005     40         11115
              011-222-111      0-001-1 ls200006     50         11116
RTX:No CLLI=ndpl

```

```
rtrv-rte:dpci=5-25-3
```

This is an example of the possible output.

```

rlghncxa03w 06-10-07 11:43:04 GMT EAGLE5 36.0.0
DPCI          ALIASN/N24          ALIASA  LSN          RC          APC
5-25-3        07659              240-039-150 ls100001     10         5-25-3
              07659              240-039-150 ls100002     10         3-250-6
              07659              240-039-150 ls100003     20         7-34-7
              07659              240-039-150 ls100004     30         6-98-1
              07659              240-039-150 ls100005     40         3-142-2
              07659              240-039-150 ls100006     50         1-178-3
RTX:No CLLI=idpl

```

```
rtrv-rte:dPCA=002-002-002
```

```

rlghncxa03w 06-10-25 09:42:31 GMT EAGLE5 36.0.0
DPCA          ALIASI          ALIASN/N24  LSN          RC          APCA
002-002-002  -----          -----          lsn1         10         002-002-002
RTX:No CLLI=-----

```

If the point code is not shown in the `rtrv-rte` output, or, if the point code is an ANSI point code, the point code is not a member of a cluster point code when that cluster point code is the DPC of a route, go to the "Adding a Route Containing an SS7 DPC" procedure in the *Database Administration Manual - SS7* and add the required route to the database.

9. Add the new GSM MAP screening operation codes to the database with the `ent-gsms-opcode` command.

For this example, enter these commands:

```

ent-gsms-opcode:opcode=100:opname=pass100:dfltact=pass
ent-gsms-opcode:opcode=150:opname=discard1:dfltact=discard
ent-gsms-opcode:opcode=71:opname=ati:dfltact=atierr
ent-gsms-opcode:opcode=25:opname=route25:dfltact=route
ent-gsms-opcode:opcode=139:opname=fwd139:dfltact=forward
:pci=3-159-7:ssn=128:mapset=df1t

```

```
ent-gsms-opcode:opcode=187:opname=dup187:dfltact=duplicate
:pcn=11519:ssn=79:mapset=10

ent-gsms-opcode:opcode=93:opname=dd93:dfltact=dupdisc
:pci=5-25-3:ssn=200:mapset=20

ent-gsms-opcode:opcode=36:opname=for1:dfltact=forward
:pca=002-002-002:ssn=10:mapset=25

ent-gsms-opcode:opcode=*:opname=star1:dfltact=pass
```

When each of these commands has successfully completed, this message appears.

```
rlghncxa03w 06-10-10 11:43:04 GMT EAGLE5 36.0.0
ENT-GSMS-OPCODE: MASP A - COMPLTD
```

These are the rules that apply to adding a GSM MAP screening operation code.

1. The word "none" cannot be used as a value for the opname parameter.
 2. The pc/pca/pci/pcn/pcn24 value must be shown in the rtrv-rte output on [Step 8](#) as the DPC of a route. The pc/pca value must be a full point code value. The pc/pca value can be a member of a cluster point code when that cluster point code is the DPC of a route. A proxy point code cannot be assigned to the point code.
 3. The EAGLE 5 ISS can contain 14-bit ITU-N point codes or 24-bit ITU-N point codes, but not both.
 4. To specify the opcode=* or pc/pca parameters, the Enhanced GSM MAP Screening feature must be enabled and on.
 5. If the Flexible GTT Load Sharing feature is not enabled, shown on [Step 3](#), the mapset parameter cannot be used. The pc/pca/pci/pcn/pcn24 and ssn values must be shown in the rtrv-map output on [Step 7](#), otherwise, the force=yes parameter must be specified.
 6. If the Flexible GTT Load Sharing feature is enabled, shown on [Step 3](#), the mapset parameter must be used. The force=yes parameter can be used only if the MAP set assigned to the GSM OPCODE entry is the default MAP set. If the MAP set assigned to the GSM OPCODE entry is a MAP set other than the default MAP set, the force=yes parameter cannot be used. The point code and subsystem contained in the GSM OPCODE entry must be in the MAP set assigned to the GSM OPCODE entry. If the default MAP set is assigned to the GSM OPCODE entry and the force=yes parameter is not specified, the point code and subsystem contained in the GSM OPCODE entry must be in the default MAP set.
 7. If the ri or tt parameters are not specified, the default values for these parameters are assigned to the GSM OPCODE entry. The default values for these parameters are:
 - ri - ssn
 - tt - no value is specified. A dash is shown in the TT column of the rtrv-gsms-opcode output.
 8. If the ri=ssn parameter is specified, a numerical value must be specified for the ssn parameter.
10. Verify the changes using the rtrv-gsms-opcode command and specifying the opcode parameter value used in [Step 9](#).
- For this example, enter these commands.

```
rtrv-gsms-opcode:opcode=025
```

This is an example of the possible output.

```
rlghncxa03w 06-10-10 11:43:04 GMT EAGLE5 36.0.0
OPCODE  OPNAME      DFLTACT
 25      route25      route
```

GSMM5 OPCODE Table (11 of 257) is 4% full

rtrv-gsms-opcode:opcode=071

This is an example of the possible output.

```
rlghncxa03w 06-10-10 11:43:04 GMT EAGLE5 36.0.0
OPCODE  OPNAME      DFLTACT
 71      ati          atierr
```

GSMM5 OPCODE Table (11 of 257) is 4% full

rtrv-gsms-opcode:opcode=093

This is an example of the possible output.

```
rlghncxa03w 08-09-10 11:43:04 GMT EAGLE5 39.2.0
OPCODE  OPNAME      DFLTACT  PCI      SSN  MAPSET  RI  TT
 93      dd93        dupdc    5-25-3   200  20      ssn -
```

GSMM5 OPCODE Table (11 of 257) is 4% full

rtrv-gsms-opcode:opcode=100

This is an example of the possible output.

```
rlghncxa03w 06-10-10 11:43:04 GMT EAGLE5 36.0.0
OPCODE  OPNAME      DFLTACT
 100     pass100     pass
```

GSMM5 OPCODE Table (11 of 257) is 4% full

rtrv-gsms-opcode:opcode=139

This is an example of the possible output.

```
rlghncxa03w 08-09-10 11:43:04 GMT EAGLE5 39.2.0
OPCODE  OPNAME      DFLTACT  PCI      SSN  MAPSET  RI  TT
 139     fwd139      fwd       3-159-7  128  DFLT    ssn -
```

GSMM5 OPCODE Table (11 of 257) is 4% full

rtrv-gsms-opcode:opcode=150

This is an example of the possible output.

```
rlghncxa03w 06-10-10 11:43:04 GMT EAGLE5 36.0.0
OPCODE  OPNAME      DFLTACT
 150     discard1    disc
```

GSMM5 OPCODE Table (11 of 257) is 4% full

rtrv-gsms-opcode:opcode=187

This is an example of the possible output.

```
rlghncxa03w 08-09-10 11:43:04 GMT EAGLE5 39.2.0
OPCODE  OPNAME      DFLTACT   PCN          SSN  MAPSET RI  TT
 187    dup187        dup1      11519        79   10    ssn -

GSMMS OPCODE Table (11 of 257) is 4% full
```

```
rtrv-gsms-opcode:opcode=36
```

This is an example of the possible output.

```
rlghncxa03w 08-09-10 11:43:04 GMT EAGLE5 39.2.0
OPCODE  OPNAME      DFLTACT   PCA          SSN  MAPSET RI  TT
 36     for1        fwd       002-002-002  10   25    ssn -

GSMMS OPCODE Table (11 of 257) is 4% full
```

```
rtrv-gsms-opcode:opcode=*
```

This is an example of the possible output.

```
rlghncxa03w 06-10-10 11:43:04 GMT EAGLE5 36.0.0
OPCODE  OPNAME      DFLTACT
 *       star        pass

GSMMS OPCODE Table (11 of 257) is 4% full
```

11. Backup the new changes using the `chg-db:action=backup:dest=fixed` command.

These messages should appear, the active Maintenance and Administration Subsystem Processor (MASP) appears first.

```
BACKUP (FIXED) : MASP A - Backup starts on active MASP.
BACKUP (FIXED) : MASP A - Backup on active MASP to fixed disk complete.
BACKUP (FIXED) : MASP A - Backup starts on standby MASP.
BACKUP (FIXED) : MASP A - Backup on standby MASP to fixed disk complete.
```

Removing a GSM MAP Screening Operation Code

Use this procedure to remove GSM MAP screening operation codes and the default screening action for that operation code using the `dlt-gsms-opcode` command.

The `dlt-gsms-opcode` command uses only one parameter, `opname`. The value for the `opname` parameter is the user-defined name for the operation code shown in the `rtrv-gsms-opcode` command output.

The `opname` value being removed cannot be referenced by any GSM MAP screening entries (shown in the `rtrv-gsmmap-scrn` command output). Use the [Removing a GSM MAP Screening Entry](#) procedure to remove any GSM MAP screening entries that reference the `opname` name value being removed from the database.

1. Display the GSM MAP screening opcodes in the database using the `rtrv-gsms-opcode` command.

This is an example of the possible output.

```
rlghncxa03w 08-09-10 11:43:04 GMT EAGLE5 39.2.0

OPCODE  OPNAME    DFLTACT    PCA          SSN  RI  TT
 36     for1      fwd        002-002-002  10   gt  40

OPCODE  OPNAME    DFLTACT    PCI          SSN  RI  TT
 93     dd93     dupdc      5-25-3      200  ssn 10
139     fwd139   fwd        3-159-7     128  ssn -

OPCODE  OPNAME    DFLTACT    PCN          SSN  RI  TT
187     dup187   dupl       11519       79   gt  50

OPCODE  OPNAME    DFLTACT    PCN24        SSN  RI  TT

OPCODE  OPNAME    DFLTACT
 22     sri      disc
 25     route25 route
 50     pass50   pass
 71     ati      atierr
100     pass100 pass
150     discard1 disc
*      star    pass
```

GSMMS OPCODE Table (11 of 257) is 4% full

2. Display the GSM MAP screening entries that reference the opname value being removed from the database using the `rtrv-gsmmap-scrn` command specifying the opname parameter with the opname value being removed from the database. For this example, enter this command.

```
rtrv-gsmmap-scrn:opname=sri
```

This is an example of the possible output if the `rtrv-gsmmap-scrn` output contains no entries that reference the opname value being removed.

```
rlghncxa03w 08-09-20 09:07:58 GMT EAGLE5 39.2.0

Single CgPA Entries for OPNAME: sri
-----
SADDR          NP NAI FORBD ACT      PCA          SSN CGSR RI  TT
SADDR          NP NAI FORBD ACT      PCI          SSN CGSR RI  TT
SADDR          NP NAI FORBD ACT      PCN          SSN CGSR RI  TT
SADDR          NP NAI FORBD ACT      PCN24        SSN CGSR RI  TT
SADDR          NP NAI FORBD ACT  CGSR

Range CgPA Entries for OPNAME: sri
-----
SADDR          EADDR          NP NAI FORBD ACT      PCA          SSN CGSR
SADDR          EADDR          NP NAI FORBD ACT      PCI          SSN CGSR
SADDR          EADDR          NP NAI FORBD ACT      PCN          SSN CGSR
SADDR          EADDR          NP NAI FORBD ACT      PCN24        SSN CGSR
SADDR          EADDR          NP NAI FORBD ACT  CGSR
```

```
GSM Map Screening table is (1500 of 4000) 38% full
```

This is an example of the possible output if the `rtrv-gsmmap-scrn` output contains entries that reference the `opname` value being removed.

```
rtrv-gsmmap-scrn:opname=sri
```

```
rlghncxa03w 08-09-20 09:07:58 GMT EAGLE5 39.2.0
```

```
Single CgPA Entries for OPNAME: sri
```

```
-----
SADDR          NP NAI FORBD ACT      PCA          SSN CGSR RI  TT
SADDR          NP NAI FORBD ACT      PCI          SSN CGSR RI  TT
SADDR          NP NAI FORBD ACT      PCN          SSN CGSR RI  TT
SADDR          NP NAI FORBD ACT      PCN24        SSN CGSR RI  TT

SADDR          NP NAI FORBD ACT  CGSR
919462000000005 1 0  none  pass  sri1
```

```
Range CgPA Entries for OPNAME: sri
```

```
-----
SADDR          EADDR          NP NAI FORBD ACT      PCA          SSN CGSR
SADDR          EADDR          NP NAI FORBD ACT      PCI          SSN CGSR
SADDR          EADDR          NP NAI FORBD ACT      PCN          SSN CGSR
SADDR          EADDR          NP NAI FORBD ACT      PCN24        SSN CGSR

SADDR          EADDR          NP NAI FORBD ACT  CGSR
919461888888888 919461900000000 4 1  all  pass  sri2
919462000000000 919463000000000 * *  all  disc  sri3
```

```
GSM Map Screening table is (1500 of 4000) 38% full
```

If the GSM MAP screening entry in this step contains any CGPA entries, go to the [Removing a GSM MAP Screening Entry](#) procedure to remove the CGPA entries shown in this step.

3. Remove the GSM MAP `opname` value from the database using the `dlt-gsms-opcode` command. For this example, enter this command.

```
dlt-gsms-opcode:opname=sri
```

When this command has successfully completed, this message appears.

```
rlghncxa03w 06-10-07 00:29:31 GMT EAGLE5 36.0.0
DLT-GSMS-OPCODE: MASP A - COMPLTD
```

4. Verify the changes using the `rtrv-gsms-opcode` command with the `opname` parameter value specified in step 3. For this example, enter this command.

```
rtrv-gsms-opcode:opname=sri
```

This is an example of the possible output.

```
rlghncxa03w 06-10-10 11:43:04 GMT EAGLE5 36.0.0
E3892 Cmd Rej: OPNAME does not exist in the database
```

5. Backup the new changes using the `chg-db:action=backup:dest=fixed` command.

These messages should appear, the active Maintenance and Administration Subsystem Processor (MASP) appears first.

```
BACKUP (FIXED) : MASP A - Backup starts on active MASP.
BACKUP (FIXED) : MASP A - Backup on active MASP to fixed disk complete.
BACKUP (FIXED) : MASP A - Backup starts on standby MASP.
BACKUP (FIXED) : MASP A - Backup on standby MASP to fixed disk complete.
```

Changing a GSM MAP Screening Operation Code

Use this procedure to change the attributes of the GSM MAP screening operation codes using the `chg-gsms-opcode` command. The procedure allows you to change the default screening action and the operation-code name for a specific operation code. The `chg-gsms-opcode` command uses these parameters.

`:opname` – The user-defined name for the operation code shown in the `rttrv-gsms-opcode` command output.

`:nopname` – The new user-defined name for the operation code.

`:ndfltact` – The new default screening action.

- `pass` – Route the message as normal to the destination.
- `discard` – The MSU is to be discarded.
- `atierr` – An ATI (Any Time Interrogation) reject message is generated. This option is only valid for ATI MAP operation codes.
- `route` – Route the message as normal to the original destination node.
- `forward` – Route the original message to the forward node. The original message is not sent to the original node. If, however, the forwarded node is not available for routing then the MSU is routed to the original node.
- `duplicate` – Route the message as normal to the original destination and route a copy of the original message to the duplicate node.
- `dupdisc` – Duplicate and discard – Route the original message to the duplicate node. The original message is not sent to the original node.

`:npc/npca/npci/npcn/npcn24` – The new ANSI point code (`npc/npca`), new ITU-I point code or ITU-I spare point code (`npci`), new 14-bit ITU-N point code or 14-bit ITU-N spare point code (`npcn`), or new 24-bit ITU-N point code (`npcn24`) of the node that the MSU is routed to by the `forward`, `duplicate`, or `dupdisc` screening actions. The EAGLE 5 ISS can contain 14-bit ITU-N point codes or 24-bit ITU-N point codes, but not both. The `npc/npca` parameters can be specified only if the Enhanced GSM MAP Screening feature is enabled and on.

`:nssn` – The new subsystem number of the node that the MSU is routed to by the `forward`, `duplicate`, or `dupdisc` screening actions

`:force` – The mated application override. Is the GSM MAP screening operation code to be entered without a mated application in the database (yes or no)?

`:nmapset` – The new MAP set ID, shown in the `rtrv-map` command. This parameter can be specified only if the Flexible GTT Load Sharing feature is enabled. The status of the Flexible GTT Load Sharing feature is shown in the `rtrv-ctrl-feat` output. To enable the Flexible GTT Load Sharing feature, perform the “Activating the Flexible GTT Load Sharing Feature” procedure in the *Database Administration Manual - Global Title Translation*.

If the Flexible GTT Load Sharing feature is not enabled:

- The `nmapset` parameter cannot be used.
- The `npc/npca/npci/npcn/npcn24` and `nssn` values must be shown in the `rtrv-map` output, or else the `force=yes` parameter must be specified.

If the Flexible GTT Load Sharing feature is enabled:

- If the current `dfltact` parameter value is either `pass`, `route`, `discard`, or `atierr`, and the `dfltact` parameter value is changed to either `forward`, `duplicate`, or `dupdisc`, the GSM OPCODE entry must be assigned to a MAP set with the `nmapset=dflt` parameter (to assign the GSM OPCODE entry to the default MAP set), or with the `nmapset=<numbered MAP set ID>` parameter (to assign the GSM OPCODE entry to a MAP set other than the default MAP set).
- If the default MAP set will be assigned to the GSM OPCODE entry, the `npc/npca/npci/npcn/npcn24` and `nssn` values must be shown in the default MAP set in the `rtrv-map` output. If the `npc/npca/npci/npcn /npcn24` or `nssn` values are not shown in the default MAP set in the `rtrv-map` output, the `force=yes` parameter must be specified.
- If a MAP set other than the default MAP set will be assigned to the GSM OPCODE entry, the `npc/npca/npci/npcn/npcn24` and `nssn` values must be shown in that MAP set in the `rtrv-map` output. The `force=yes` parameter cannot be specified with the `chg-gsms-opcode` command.
- If the point code and subsystem values are not being changed, the `nmapset` parameter does not have to be specified unless the MAP set ID assigned to the GSM OPCODE entry is being changed. The new MAP set must contain the point code and subsystem values in the GSM OPCODE entry.

`:nri` - The new routing indicator parameter. This parameter specifies whether a subsequent global title translation is required. This parameter has two values.

- `gt` - subsequent global title translation is required.
- `ssn` - subsequent global title translation is not required.

`:ntt` - the new translation type that will be assigned to the GSM OPCODE entry. The values for this parameter are 0 to 255, or the value `none` which removes an existing translation type that is assigned to the GSM OPCODE entry.

The `nopname` parameter value must be no more than 8 alphanumeric characters.

The reserved word `none` cannot be used as a value for the `nopname` parameter.

The `ndfltact=atierr` parameter cannot be specified unless the value of the operation code (`opcode`) referenced by the `opname` parameter value is 71. The `atierr` option is only valid for ATI MAP operation codes; `opcode=71` signifies an ATI MAP operation code.

The `npc/npca/npci/npcn/npcn24` and `nssn` values must be shown in the `rtrv-map` output, or else the `force=yes` parameter must be specified. If the `npc/npca/npci/npcn/npcn24` and `nssn` values are not shown in the `rtrv-map` output, and a new mated application is to be added, perform one of the “Provisioning a Mated Application” procedures in the *Database Administration Manual - Global Title Translation* and add the required mated application with the `npc/npca/npci/npcn/npcn24` and `nssn` values.

The `force=yes` parameter can be specified only with the `npc/npca/npci/npcn/npcn24` and `nssn` parameters.

The `ndfltact=forward`, `ndfltact=duplicate`, or `ndfltact=dupdisc` parameters can be specified only with the `npc/npca/npci/npcn/npcn24` and `nssn` parameters. If the `npc/npca/npci/npcn/npcn24` and `nssn` parameters are specified, the `ndfltact=forward`, `ndfltact=duplicate`, or `ndfltact=dupdisc` parameters must be specified.

The `npc/npca/npci/npcn/npcn24` and `nssn` parameters must be specified together.

The `npc/npca/npci/npcn/npcn24` parameter values must be the DPC of a route or a member of a cluster route, and a proxy point code cannot be assigned to the point code. This can be verified with the `rtrv-rte` command. If the `npc/npca/npci/npcn/npcn24` value is not shown in the `rtrv-rte` as the DPC of a route, go to the "Adding a Route Containing an SS7 DPC" procedure in the *Database Administration Manual - SS7* and add a new route containing the `npc/npca/npci/npcn/npcn24` value. To verify whether or not a proxy point code is assigned to the `npc/npca/npci/npcn/npcn24` value, enter the `rtrv-dstn` command with the point code value. If a proxy point code is assigned to the point code, choose another point code.

1. Display the GSM MAP screening operation codes in the database using the `rtrv-gsms-opcode` command.

If the Flexible GTT Load Sharing feature is not enabled, this is an example of the possible output.

```
rlghncxa03w 08-09-10 11:43:04 GMT EAGLE5 39.2.0
OPCODE  OPNAME      DFLTACT  PCA          SSN  RI  TT
 36     for1        fwd      002-002-002  10   gt  10

OPCODE  OPNAME      DFLTACT  PCI          SSN  RI  TT
 93     dd93        dupdc    5-025-3     200  ssn 40
139     fwd139     fwd      3-159-7     128  ssn -

OPCODE  OPNAME      DFLTACT  PCN          SSN  RI  TT
187     dup187     dupl     11519       79   gt  50

OPCODE  OPNAME      DFLTACT  PCN24        SSN
 22     sri         disc
 25     route25    route
 50     pass50     pass
 71     ati        atierr
150     discard1   disc
*      star      pass
```

GSMMS OPCODE Table (10 of 257) is 4% full

If the Flexible GTT Load Sharing feature is enabled, this is an example of the possible output.

```
rlghncxa03w 08-09-10 11:43:04 GMT EAGLE5 39.2.0
OPCODE  OPNAME      DFLTACT  PCA          SSN  MAPSET RI  TT
 36     for1        fwd      002-002-002  10   25   gt  10

OPCODE  OPNAME      DFLTACT  PCI          SSN  MAPSET RI  TT
 93     dd93        dupdc    5-025-3     200  20   ssn 40
139     fwd139     fwd      3-159-7     128  DFLT ssn -

OPCODE  OPNAME      DFLTACT  PCN          SSN  MAPSET RI  TT
187     dup187     dupl     11519       79   10   gt  50
```

OPCODE	OPNAME	DFLTACT	PCN24	SSN	MAPSET	RI	TT
OPCODE	OPNAME	DFLTACT					
22	sri	disc					
25	route25	route					
50	pass50	pass					
71	ati	atierr					
150	discard1	disc					
*	star	pass					

GSMSMS OPCODE Table (10 of 257) is 4% full

Note: If the default action parameter value will be changed to either `pass`, `discard`, `route`, or `atierr`, or the `npc/npca/npci/npcn/npcn24` and `nssn` parameters are not to be specified, continue the procedure with [Step 8](#).

Note: If the `npc/npca` parameters are not being used in this procedure, or if the `rtrv-gsm-opcode` output in [Step 1](#) shows ANSI point code values (`pc/pca` parameter values) or the `opcode=*` parameter value, continue the procedure with [Step 3](#).

2. Verify that the Enhanced GSM MAP Screening feature is enabled and on by entering the `rtrv-ctrl-feat` command with the part number of the Enhanced GSM MAP Screening feature. Enter this command.

```
rtrv-ctrl-feat:partnum=893012401
```

The following is an example of the possible output.

```
rlghncxa03w 06-10-28 21:15:37 GMT EAGLE5 36.0.0
The following features have been permanently enabled:

Feature Name          Partnum    Status    Quantity
Enhanced GMS (EGMS)  893012401  on       ----

The following features have been temporarily enabled:

Feature Name          Partnum    Status    Quantity    Trial Period Left
Zero entries found.

The following features have expired temporary keys:

Feature Name          Partnum
Zero entries found.
```

If the Enhanced GSM MAP screening feature is not enabled or off, go to the [Activating the GSM MAP Screening Feature](#) to enable and turn on the Enhanced GSM MAP screening feature.

3. Perform one of these actions.
 - If the `ndfltact` parameter value will be either `pass`, `discard`, `route`, or `atierr`, continue the procedure with [Step 8](#).
 - If the point code is not being changed, continue the procedure with [Step 8](#). If the point code and subsystem values are not being changed, and the Flexible GTT Load Sharing feature is enabled, the `nmapset` parameter does not have to be specified unless the MAP set ID assigned to the GSM OPCODE entry is being changed. The new MAP set must contain the point code and subsystem values in the GSM OPCODE entry.
 - If the `ndfltact` parameter value will be either `forward`, `duplicate`, or `dupdisc`, perform one of these actions.

- To use a point code and a MAP set from the mated application table, and MAP sets are not shown in the `rtrv-gsms-opcode` output in [Step 1](#), the Flexible GTT Load Sharing Feature must be enabled. Perform the "Activating the Flexible GTT Load Sharing Feature" procedure in the *Database Administration Manual - Global Title Translation* and enable the Flexible GTT Load Sharing feature. After enabling the Flexible GTT Load Sharing feature, continue the procedure with [Step 6](#).
 - To use a point code and a MAP set from the mated application table, and MAP sets are shown in the `rtrv-gsms-opcode` output in [Step 1](#), skip steps 4 and 5 and continue the procedure with [Step 6](#).
 - To use a point code in the mated application table, but without using a MAP set, and MAP sets are not shown in the `rtrv-gsms-opcode` output in [Step 1](#), continue the procedure with [Step 6](#).
 - To use a point code that is not in the mated application table, the `force=yes` parameter must be specified with the `chg-gsms-opcode` command. A proxy point code cannot be assigned to this point code. If the Flexible GTT Load Sharing feature is enabled, the `force=yes` parameter can be used only if the default MAP set is assigned to the GSM OPCODE entry. Continue the procedure with [Step 4](#).
4. Display the destination point codes in the database by entering the `rtrv-dstn` command. This is an example of the possible output.

```

rlghncxa03w 10-12-10 11:43:04 GMT EAGLE5 43.0.0
Extended Processing Time may be Required

  DPCA          CLLI          BEI  ELEI    ALIASI          ALIASN/N24    DMN
001-207-000    ----- no  --- -----
001-001-001    ----- no  --- -----
001-001-002    ----- no  --- -----
001-005-000    ----- no  --- -----
001-007-000    ----- no  --- -----
008-012-003    ----- no  --- -----
003-002-004    ----- no  --- -----
009-002-003    ----- no  --- -----
010-020-005    ----- no  --- -----

  DPCI          CLLI          BEI  ELEI    ALIASA          ALIASN/N24    DMN
1-207-0        ----- no  --- -----
0-015-0        ----- no  --- -----
0-017-0        ----- no  --- -----
1-011-1        ----- no  --- -----
1-011-2        ----- no  --- -----

Destination table is (14 of 2000) 1% full
Alias table is (0 of 12000) 0% full
PPC table is (1 of 20) 5% full

```

If the required point code is not shown in the `rtrv-dstn` output, perform the "Adding a Destination Point Code" procedure in the *Database Administration Manual - SS7* to add the required point code. A proxy point code cannot be assigned to the point code.

After the new point code has been added, perform the "Adding a Route Containing an SS7 DPC" procedure in the *Database Administration Manual - SS7* and add the required route to the database. After the route has been added, continue the procedure with [Step 8](#).

5. Display the point code that will be assigned to the mated application by using the `rtrv-dstn` command and specifying the point code. For this example, enter this command.

```
rtrv-dstn:dpca=010-020-005
```

This is an example of the possible output.

```
rlghncxa03w 10-12-10 11:43:04 GMT EAGLE5 43.0.0

  DPCA          CLLI          BEI  ELEI    ALIASI          ALIASN/N24    DMN
  010-020-005  -----          no   ---  -----          -----          SS7

  PPCA          NCAI  PRX          RCAUSE NPRST  SPLITIAM  HMSMSC  HMSCP  SCCPMSGCNV
  009-002-003  ----  no          50      on    20        no     no     none

Destination table is (14 of 2000) 1% full
Alias table is (0 of 12000) 0% full
PPC table is (1 of 20) 5% full
```

If the adjacent point code is not shown in the `rtrv-dstn` command output, the following output is displayed.

```
rlghncxa03w 09-05-10 11:43:04 GMT EAGLE5 41.0.0

No destinations meeting the requested criteria were found

Destination table is (14 of 2000) 1% full
Alias table is (0 of 12000) 0% full
PPC table is (1 of 20) 5% full
```

A proxy point code (a point code value is shown in the PPC column) cannot be assigned to the point code. If a proxy point code is shown in this step, choose another point code from the `rtrv-dstn` output in the previous step and repeat this step.

If the point code is not shown in the `rtrv-dstn` output, perform the "Adding a Destination Point Code" procedure in the *Database Administration Manual - SS7* and add the adjacent point code to the destination point code table.

After the new point code has been added, perform the "Adding a Route Containing an SS7 DPC" procedure in the *Database Administration Manual - SS7* and add the required route to the database. After the route has been added, continue the procedure with [Step 8](#).

- The point code and subsystem number being assigned to the GSM operations code must be in the mated application table.

Enter the `rtrv-map` command with the `npc/npca/npci/npcn/npcn24` and `nssn` values that will be specified with the `chg-gsms-opcode` command in [Step 8](#).

If the Flexible GTT Load Sharing feature is not enabled, for this example, enter these commands.

For this example, enter this command.

```
rtrv-map:pci=4-038-1:ssn=50
```

This is an example of the possible output.

```
rlghncxa03w 09-07-25 09:42:31 GMT EAGLE5 41.1.0

PCI          Mate PCI          SSN RC MULT SRM  MRC  GRP  NAME  SSO
4-038-1          50 10 SOL *N *N  GRP01  ON
```

```
MAP TABLE IS (20 of 1024) 2 % FULL
```

Note: If the point code and subsystem number is not shown in the `rtrv-map` output, and is not added to the database in one of these procedures, the `force=yes` parameter must be specified with the `chg-gsms-opcode` command in [Step 8](#).

If the Flexible GTT Load Sharing feature is enabled and the current `dfltact` parameter value is either `pass`, `route`, `discard`, or `atierr`, and the `dfltact` parameter value is changed to either `forward`, `duplicate`, or `dupdisc`, the GSM OPCODE entry must be assigned to a MAP set with the `nmapset=dflt` parameter (to assign the GSM OPCODE entry to the default MAP set), or with the `nmapset=<numbered MAP set ID>` parameter (to assign the GSM OPCODE entry to a MAP set other the default MAP set).

- The point code specified with the `chg-gsms-opcode` command must be the DPC of a route.

If the point code specified with the `chg-gsms-opcode` command is an ANSI point code, the point code can be a member of a cluster point code when that cluster point code is the DPC of a route.

Enter the `rtrv-rte` command with the `dpc` parameter specifying the point code to be used with the `chg-gsms-opcode` command to verify whether or not the point code is the DPC of a route. For this example, enter these commands.

```
rtrv-rte:dpci=4-038-1
```

This is an example of the possible output.

```
rlghncxa03w 06-10-07 11:43:04 GMT EAGLE5 36.0.0
DPCI          ALIASN/N24          ALIASA          LSN          RC          APC
4-038-1      12111                      240-111-111  1s300001    10         4-038-1
                                           1s300002    10         2-066-7
                                           1s300003    20         5-087-4
                                           RTX:No     CLLI=idpl
```

If the point code is not shown in the `rtrv-rte` output, if the point code is an ANSI point code, the point code is not a member of a cluster point code when that cluster point code is the DPC of a route, go to the "Adding a Route Containing an SS7 DPC" procedure in the *Database Administration Manual - SS7* and add the required route to the database.

- Change the attributes of GSM MAP screening operation codes in the database with the `chg-gsms-opcode` command.

For this example, enter these commands:

```
chg-gsms-opcode:opname=pass100:ndfltact=discard
```

```
chg-gsms-opcode:opname=discard1:nopname=pass1:ndfltact=pass
```

```
chg-gsms-opcode:opname=sri:nopname=irs
```

```
chg-gsms-opcode:opname=fwd139:nopname=fwd1000:npci=4-038-1:nssn=50
:nmapset=18:nri=gt:ntt=60
```

When each of these commands has successfully completed, this message appears.

```
rlghncxa03w 06-10-10 11:43:04 GMT EAGLE5 36.0.0
GSM Map Op-Code Table is (8 of 256) 3% full
CHG-GSMS-OPCODE: MASP A - COMPLTD
```

These are the rules that apply to changing a GSM MAP screening operation code.

- The word "none" cannot be used as a value for the `opname` or `nopname` parameters.

2. The EAGLE 5 ISS can contain 14-bit ITU-N point codes or 24-bit ITU-N point codes, but not both.
3. If the point code and subsystem number values are not being changed, the `npc/npca/npci/npcn/npcn24` and `nssn` parameters must be specified with the current values for these parameters.
4. The `npc/npca/npci/npcn/npcn24` value must be shown in the `rtrv-rte` output on [Step 7](#) as the DPC of a route. The `npc/npca` value must be a full point code value. The `npc/npca` value can be a member of a cluster point code when that cluster point code is the DPC of a route. A proxy point code cannot be assigned to the point code.
5. If the Flexible GTT Load Sharing feature is not enabled, shown on [Step 1](#), the `npc/npca/npci/npcn/npcn24` and `nssn` values must be shown in the `rtrv-map` output on [Step 6](#). If the `npc/npca/npci/npcn/npcn24` or `nssn` values are not shown in the `rtrv-map` output, the `force=yes` parameter must be specified.
6. If the Flexible GTT Load Sharing feature is enabled, shown on [Step 1](#), and the current `dfltact` parameter value is either `pass`, `route`, `discard`, or `atierr`, and the `dfltact` parameter value is changed to either `forward`, `duplicate`, or `dupdisc`, the GSM OPCODE entry must be assigned to a MAP set with the `nmapset=dflt` parameter (to assign the GSM OPCODE entry to the default MAP set), or with the `nmapset=<numbered MAP set ID>` parameter (to assign the GSM OPCODE entry to a MAP set other the default MAP set).
7. If the Flexible GTT Load Sharing feature is enabled, shown on [Step 1](#), and the default MAP set will be assigned to the GSM OPCODE entry, the `npc/npca/npci/npcn/npcn24` and `nssn` values must be shown in the default MAP set in the `rtrv-map` output on [Step 6](#). If the `npc/npca/npci/npcn/npcn24` or `nssn` values are not shown in the default MAP set in the `rtrv-map` output, the `force=yes` parameter must be specified.
8. If the Flexible GTT Load Sharing feature is enabled, shown on [Step 1](#), and a MAP set other than the default MAP set will be assigned to the GSM OPCODE entry, the `npc/npca/npci/npcn/npcn24` and `nssn` values must be shown in that MAP set in the `rtrv-map` output on [Step 6](#).
9. To specify the `npc/npca` parameters, the Enhanced GSM MAP Screening feature must be enabled and turned on.
10. If only the point code or subsystem number value is being changed, the point code or subsystem number value being changed must be specified with the new value for the parameter being changed. The current value for the point code or subsystem number parameter not being changed must be specified. The `ndfltact` parameter does not have to be specified. For example, if the current point code is `pca=002-002-002` and the subsystem number is 50, and the point code is being changed to `pca=003-003-003` and the subsystem number is not changing, the `npca` parameter value would be the new point code value (003-003-003) and the `nssn` parameter value would be the current value (50).
11. If the Flexible GTT Load Sharing feature is enabled, shown on [Step 1](#), and the point code and subsystem values are not being changed, the `nmapset` parameter does not have to be specified unless the MAP set ID assigned to the GSM OPCODE entry is being changed. The new MAP set must contain the point code and subsystem values in the GSM OPCODE entry.
12. If an optional parameter is not specified, the value for that parameter is not changed.
13. The value `none` for the `tt` parameter removes the existing `tt` parameter value that is assigned to the GSM OPCODE entry. A dash is shown in the TT column of the `rtrv-gsms-opcode` output when the `tt` value is removed.
14. If, when the `chg-gsms-opcode` command is completed, the `ri` parameter value is `ssn`, then a numerical value must be assigned to the `ssn` parameter.

9. Verify the changes using the `rtrv-gsms-opcode` command with the `opname` parameter value specified in [Step 8](#).

If the `opname` parameter value was changed in [Step 8](#), the new `opname` parameter value should be specified with the `rtrv-gsms-opcode` command. For this example, enter these commands.

```
rtrv-gsms-opcode:opname=pass100
```

This is an example of the possible output.

```
rlghncxa03w 06-10-10 11:43:04 GMT EAGLE5 36.0.0
OPCODE  OPNAME      DFLTACT
100     pass100    discard
```

```
GSMMMS OPCODE Table (10 of 257) is 4% full
```

```
rtrv-gsms-opcode:opname=pass1
```

This is an example of the possible output.

```
rlghncxa03w 06-10-10 11:43:04 GMT EAGLE5 36.0.0
OPCODE  OPNAME      DFLTACT
150     pass1       pass
```

```
GSMMMS OPCODE Table (10 of 257) is 4% full
```

```
rtrv-gsms-opcode:opname=irs
```

This is an example of the possible output.

```
rlghncxa03w 06-10-10 11:43:04 GMT EAGLE5 36.0.0
OPCODE  OPNAME      DFLTACT
22      irs         disc
```

```
GSMMMS OPCODE Table (10 of 257) is 4% full
```

```
rtrv-gsms-opcode:opname=fwd1000
```

This is an example of the possible output.

```
rlghncxa03w 08-09-10 11:43:04 GMT EAGLE5 39.2.0
OPCODE  OPNAME      DFLTACT      PCI          SSN  MAPSET RI  TT
139     fwd1000    fwd          4-38-1       50   18   gt   60
```

```
GSMMMS OPCODE Table (10 of 257) is 4% full
```

10. Backup the new changes using the `chg-db:action=backup:dest=fixed` command.

These messages should appear, the active Maintenance and Administration Subsystem Processor (MASP) appears first.

```
BACKUP (FIXED) : MASP A - Backup starts on active MASP.
BACKUP (FIXED) : MASP A - Backup on active MASP to fixed disk complete.
BACKUP (FIXED) : MASP A - Backup starts on standby MASP.
BACKUP (FIXED) : MASP A - Backup on standby MASP to fixed disk complete.
```

Adding a GSM MAP Screening Entry

Use this procedure to provision the GSM MAP screening entries that filter or allow TCAP messages for certain MAP operation codes in the database using the `ent-gsmmap-scrn` command. The messages are filtered or allowed based on the origination addresses (`saddr/eaddr`), numbering plan value (`npv`), nature of address indicator value (`naiv`), MAP opnames (`opname`), and forbidden (`forbid`) parameters.

The `ent-gsmmap-scrn` command uses these parameters.

`:saddr` – The origination address (1 - 15 decimal digits, 1 - 15 hex digits, or *) for a single entry or the starting origination address for a range of entries of the CGPA/CDPA entry to be screened.

`:eaddr` – The ending origination address (1 - 15 decimal digits or 1 - 15 hex digits) for a range of entries of the CGPA/CDPA entry to be screened.

`:action` – The screening action to take if a message is forbidden as defined by the `forbid` parameter. One of these actions can be assigned.

- `pass` – Route the message as normal to the destination.
- `discard` – The MSU is to be discarded.
- `atierr` – An ATI (Any Time Interrogation) reject message is generated. This option is only valid for ATI MAP operation codes.
- `route` – Route the message as normal to the original destination node.
- `forward` – Route the original message to the forward node. The original message is not sent to the original node. If, however, the forwarded node is not available for routing then the MSU is routed to the original node.
- `duplicate` – Route the message as normal to the original destination and route a copy of the original message to the duplicate node.
- `dupdisc` – Duplicate and discard – Route the original message to the duplicate node. The original message is not sent to the original node.

`:pc/pca/pci/pcn/pcn24` – The ANSI point code (`pc/pca`), ITU-I point code or ITU-I spare point code (`pci`), 14-bit ITU-N point code or 14-bit ITU-N spare point code (`pcn`), or 24-bit ITU-N point code (`pcn24`) of the node that the MSU is routed to by the `forward`, `duplicate`, or `dupdisc` screening actions. The EAGLE 5 ISS can contain 14-bit ITU-N point codes or 24-bit ITU-N point codes, but not both. To specify the `pc/pca` parameters, the Enhanced GSM MAP Screening feature must be enabled and on.

`:ssn` – The subsystem number of the node that the MSU is routed to by the `forward`, `duplicate`, or `dupdisc` screening actions. The values for this parameter are 2 to 255, or the value `none`. The default value for this parameter is `none`.

`:force` – The mated application override. Is the GSM MAP screening operation code to be entered without a mated application in the database (`yes` or `no`)?

`:forbid` – The forbidden parameter value. If a forbidden parameter is detected, the message is rejected by the action defined by the `action` parameter. One of four forbidden parameter values can be specified.

- `all` – All parameters are forbidden. Take the specified screening action defined by the `action` parameter for incoming messages that contain the entered address and operation code combination.

- `none` – No parameters are forbidden. Take the specified screening action defined by the `action` parameter for incoming messages that contain the entered address and operation code combination.
- `state` – Take the specified screening action defined by the `action` parameter for incoming messages that contain `state` as the forbidden parameter for the entered address and operation code combination.
- `location` – Take the specified screening action defined by the `action` parameter for incoming messages that contain `location` as the forbidden parameter for the entered address and operation code combination.

Note: The `state` and `location` values are valid only for GSM ATI messages.

`:naiv` – The nature of address value (0 - 15 or *).

`:npv` – The numbering plan value (0 - 127 or *).

`:opname` – The user-defined name for the operation code. The `opname` value references the operation code (`opcode`) shown in the `rtrv-gsms-opcode` command. GSM MAP screening is performed on the specified address or addresses for the referenced operation code.

`:cgssr` – The CGPA screening reference name consisting of 1 alphabetic character and 3 optional alphanumeric characters.

`:cdsr` – The CDPA screening reference name consisting of 1 alphabetic character and 3 optional alphanumeric characters.

`:mapset` – The MAP set ID, shown in the `rtrv-map` command. This parameter can be specified only if the Flexible GTT Load Sharing feature is enabled. The status of the Flexible GTT Load Sharing feature is shown in the `rtrv-ctrl-feat` output. To enable the Flexible GTT Load Sharing feature, perform the “Activating the Flexible GTT Load Sharing Feature” procedure in the *Database Administration Manual - Global Title Translation*.

`:ri` – The routing indicator parameter. This parameter specifies whether a subsequent global title translation is required. This parameter has two values.

- `gt` - subsequent global title translation is required.
- `ssn` - subsequent global title translation is not required. This is the default value for the `ri` parameter.

`:tt` – the translation type that will be assigned to the GSM MAP screening entry. This parameter specifies the value that the translation type for the CdPA is set to as a result of GSM MAP screening. The values for this parameter are 0 to 255, or the value `none` which specifies that no translation type will be assigned to the GSM MAP screening entry.

Table 19: Add GSM MAP Screening Entry Parameter Combinations shows the parameter combinations that can be used in this procedure.

Table 19: Add GSM MAP Screening Entry Parameter Combinations

Entry Containing a Point Code and SSN (See Note 1) Enhanced GSM MAP Screening Feature Enabled and On	Entry Without a Point Code and SSN (See Note 1) Enhanced GSM MAP Screening Feature Enabled and On	Entry containing the Action ATIERR (See Note 1) Enhanced GSM MAP Screening Feature Enabled and On	Entry Containing a Point Code and SSN (See Note 1) GSM MAP Screening Feature Enabled and On Only	Entry Without a Point Code and SSN (See Note 1) GSM MAP Screening Feature Enabled and On Only	Entry containing the Action ATIERR (See Note 1) GSM MAP Screening Feature Enabled and On Only
Mandatory Parameters					
:opname = opname value (See Note 2)	:opname = opname value (See Note 2)	:opname = opname value containing opcode=71 (See Note 2)	:opname = opname value (See Note 2)	:opname = opname value (See Note 2)	:opname = opname value containing opcode=71 (See Note 2)
:cgsr = CGSR name (See Note 3)	:cgsr = CGSR name (See Note 3)	:cgsr = CGSR name (See Note 3)	:cgsr = CGSR name (See Note 3)	:cgsr = CGSR name (See Note 3)	:cgsr = CGSR name (See Note 3)
			saddr = 0 - 15 decimal digits (See Notes 4, 5, and 6)	saddr = 0 - 15 decimal digits (See Notes 4, 5, and 6)	saddr = 0 - 15 decimal digits (See Notes 4, 5, and 6)
Optional Parameters					
:saddr = 0 - 15 hex digits, or * (See Notes 4, 5, and 6)	:saddr = 0 - 15 hex digits, or * (See Notes 4, 5, and 6)	:saddr = 0 - 15 hex digits, or * (See Notes 4, 5, and 6)	:eaddr = 0 - 15 decimal digits (See Notes 4, 5, and 6)	:eaddr = 0 - 15 decimal digits (See Notes 4, 5, and 6)	:eaddr = 0 - 15 decimal digits (See Notes 4, 5, and 6)
:eaddr = 0 - 15 hex digits (See Notes 4, 5, 6, and 7)	:eaddr = 0 - 15 hex digits (See Notes 4, 5, 6, and 7)	:eaddr = 0 - 15 hex digits (See Notes 4, 5, 6, and 7)	:forbid = all	:forbid = all, none (See Note 15)	:forbid = state, location

Entry Containing a Point Code and SSN (See Note 1) Enhanced GSM MAP Screening Feature Enabled and On	Entry Without a Point Code and SSN (See Note 1) Enhanced GSM MAP Screening Feature Enabled and On	Entry containing the Action ATIERR (See Note 1) Enhanced GSM MAP Screening Feature Enabled and On	Entry Containing a Point Code and SSN (See Note 1) GSM MAP Screening Feature Enabled and On Only	Entry Without a Point Code and SSN (See Note 1) GSM MAP Screening Feature Enabled and On Only	Entry containing the Action ATIERR (See Note 1) GSM MAP Screening Feature Enabled and On Only
:cdsr = CDSR name (See Note 3)	:cdsr = CDSR name (See Note 3)	:cdsr = CDSR name (See Note 3)	:action = forward, duplicate, dupdisc (See Note 9)	:action = pass, discard, route (See Note 15)	:action = atierr
:forbid = all	:forbid = all, none (See Note 15)	:forbid = state, location	:npv = 0 - 15, or * (See Note 8)	:npv = 0 - 15, or * (See Note 8)	:npv = 0 - 15, or * (See Note 8)
:action = forward, duplicate, dupdisc (See Note 9)	:action = pass, discard, route (See Note 15)	:action = atierr	:naiv = 0 - 127, or * (See Note 8)	:naiv = 0 - 127, or * (See Note 8)	:naiv = 0 - 127, or * (See Note 8)
:npv = 0 - 15, or * (See Note 8)	:npv = 0 - 15, or * (See Note 8)	:npv = 0 - 15, or * (See Note 8)	:pci/pcn/pcn24 = point code value (See Notes 10, 11, 12, 13, and 14)		
:naiv = 0 - 127, or * (See Note 8)	:naiv = 0 - 127, or * (See Note 8)	:naiv = 0 - 127, or * (See Note 8)	:ssn = 0 - 255, none (See Notes 13, 14, and 16)		
pc/pca/pci/pcn/pcn24 = point code value (See Notes 10, 11, 12, 13, and 14)			:force=yes (See Notes 13 and 14) :mapset= dflt or numbered MAP set		

<p>Entry Containing a Point Code and SSN (See Note 1)</p> <p>Enhanced GSM MAP Screening Feature Enabled and On</p>	<p>Entry Without a Point Code and SSN (See Note 1)</p> <p>Enhanced GSM MAP Screening Feature Enabled and On</p>	<p>Entry containing the Action ATIERR (See Note 1)</p> <p>Enhanced GSM MAP Screening Feature Enabled and On</p>	<p>Entry Containing a Point Code and SSN (See Note 1)</p> <p>GSM MAP Screening Feature Enabled and On Only</p>	<p>Entry Without a Point Code and SSN (See Note 1)</p> <p>GSM MAP Screening Feature Enabled and On Only</p>	<p>Entry containing the Action ATIERR (See Note 1)</p> <p>GSM MAP Screening Feature Enabled and On Only</p>
			ID (See Notes 13 and 14)		
:ssn = 0 - 255, none (See Notes 13, 14, and 16)			:ri = gt, ssn (See Note 16)		
:force=yes (See Notes 13 and 14)			:tt = 0 - 255, none		
:mapset = dflt or numbered MAP set ID (See Notes 13 and 14)					
:ri = gt, ssn (See Note 16)					
:tt = 0 - 255, none					
<p>Notes:</p> <ol style="list-style-type: none"> 1. When a CGPA entry (<i>cgsr</i> parameter is specified without the <i>cdsr</i> parameter) is added to the GSM MAP Screening table, a default wild card entry is created for the CGPA entry, thus adding two entries to the GSM MAP Screening table. The default wild card CDPA entry is not shown in the <i>rtrv-gsmmap-scrn</i> output. As a result, the GSM MAP Screening table must have at least two free entries in order to provision a CGPA entry in the GSM MAP Screening table. When the first provisioned wildcard (*) CDPA entry is added to a CGPA entry, the number of entries in the GSM MAP Screening table, shown in the GSM MAP Screening command outputs, does not change. 2. The <i>opname</i> parameter value must be shown in either the <i>rtrv-gsms-opcode</i> or <i>rtrv-gsmmap-scrn</i> output. 3. The <i>cgsr</i> and <i>cdsr</i> parameter values consist of 1 alphabetic character and up to 3 optional alphanumeric characters. If the <i>cdsr</i> parameter is not specified, a CGPA entry with a default wild 					

Entry Containing a Point Code and SSN (See Note 1) Enhanced GSM MAP Screening Feature Enabled and On	Entry Without a Point Code and SSN (See Note 1) Enhanced GSM MAP Screening Feature Enabled and On	Entry containing the Action ATIERR (See Note 1) Enhanced GSM MAP Screening Feature Enabled and On	Entry Containing a Point Code and SSN (See Note 1) GSM MAP Screening Feature Enabled and On Only	Entry Without a Point Code and SSN (See Note 1) GSM MAP Screening Feature Enabled and On Only	Entry containing the Action ATIERR (See Note 1) GSM MAP Screening Feature Enabled and On Only
<p>card CDPA entry is created in the GSM MAP Screening table (see Note 1). If the <code>cdsr</code> parameter is specified, a CDPA entry is created in the GSM MAP Screening table.</p> <p>4. If a single entry is specified for the CGPA/CDPA (that is, the <code>eaddr</code> parameter is not specified) then the <code>saddr/npv/naiv/opname</code> parameter combination cannot exist in the GSM MAP Screening table.</p> <p>5. If a range of entries is specified for the CGPA/CDPA (that is, the <code>eaddr</code> parameter is specified) then the <code>saddr/eaddr/npv/naiv/opname</code> parameter combination cannot exist in the GSM MAP Screening table or overlap with another range entry in the GSM MAP Screening table.</p> <p>6. The <code>eaddr</code> parameter value must contain the same number of digits as the <code>saddr</code> parameter value. The <code>eaddr</code> parameter value must be greater than the <code>saddr</code> parameter value. The <code>saddr</code> parameter must be specified with the <code>eaddr</code> parameter.</p> <p>7. The <code>eaddr</code> parameter cannot be specified with the <code>saddr=*</code> parameter.</p> <p>8. If the Enhanced GSM MAP Screening feature is not enabled or off, and either the <code>npv</code> or <code>naiv</code> parameters are specified, both the <code>npv</code> and <code>naiv</code> parameters must be specified. If the asterisk (*) is specified for either the <code>npv</code> or <code>naiv</code> parameters, the asterisk must be specified for both the <code>npv</code> and <code>naiv</code> parameters. If numbers are specified for either the <code>npv</code> or <code>naiv</code> parameters, numbers must be specified for both the <code>npv</code> and <code>naiv</code> parameters.</p> <p>9. If the <code>action</code> parameter values are either <code>forward</code>, <code>duplicate</code>, or <code>dupdisc</code>, the point code and <code>ssn</code> parameters must be specified with the <code>ent-gsmmap-scrn</code> command. A proxy point code cannot be assigned to this point code.</p> <p>10. The point code value must be the DPC of a route or a member of a cluster route. The <code>pc/pca</code> value must be a full point code, The <code>pc/pca</code> value can be a member of a cluster point code when that cluster point code is the DPC of a route. This can be verified with the <code>rtrv-rte</code> command. If the point code value is not shown in the <code>rtrv-rte</code> output as the DPC of a route, go to the "Adding a Route Containing an SS7 DPC" procedure in the <i>Database Administration Manual - SS7</i> and add a new route containing the point code value.</p> <p>11. The EAGLE 5 ISS can contain 14-bit ITU-N point codes or 24-bit ITU-N point codes, but not both at the same time.</p> <p>12. If either the point code or <code>ssn</code> parameters are specified, then both the point code and <code>ssn</code> parameters must be specified.</p> <p>13. If the Flexible GTT Load Sharing feature is not enabled:</p> <ul style="list-style-type: none"> The <code>mapset</code> parameter cannot be specified. 					

Entry Containing a Point Code and SSN (See Note 1) Enhanced GSM MAP Screening Feature Enabled and On	Entry Without a Point Code and SSN (See Note 1) Enhanced GSM MAP Screening Feature Enabled and On	Entry containing the Action ATIERR (See Note 1) Enhanced GSM MAP Screening Feature Enabled and On	Entry Containing a Point Code and SSN (See Note 1) GSM MAP Screening Feature Enabled and On Only	Entry Without a Point Code and SSN (See Note 1) GSM MAP Screening Feature Enabled and On Only	Entry containing the Action ATIERR (See Note 1) GSM MAP Screening Feature Enabled and On Only
<ul style="list-style-type: none"> The point code and subsystem number values specified with the <code>ent-gsmmap-scrn</code> command must be shown in the <code>rtrv-map</code> output, or else the <code>force=yes</code> parameter must be specified. If the point code and subsystem number values are not shown in the <code>rtrv-map</code> output, and a new mated application is to be added, perform one of the "Provisioning a Mated Application" procedures in the <i>Database Administration Manual - Global Title Translation</i> and add the required mated application with the point code and subsystem number values. 					
<p>14. If the Flexible GTT Load Sharing feature is enabled:</p> <ul style="list-style-type: none"> The <code>mapset</code> parameter must be specified. • The <code>force=yes</code> parameter can be used only if the default MAP set assigned to the GSM MAP screening entry. If the MAP set assigned to the GSM MAP screening entry is a MAP set other than the default MAP set, the <code>force=yes</code> parameter cannot be used. The point code and subsystem contained in the GSM MAP screening entry must be in the MAP set assigned to the GSM MAP screening entry. If the default MAP set is assigned to the GSM MAP screening entry and the <code>force=yes</code> parameter is not specified, the point code and subsystem contained in the GSM MAP screening entry must be in the default MAP set. 					
<p>15. If the <code>forbid=none</code> parameter is specified, then the <code>action=pass</code> parameter must be specified.</p>					
<p>16. If the <code>ri=ssn</code> parameter is specified, a numerical value must be specified for the <code>ssn</code> parameter.</p>					

GSM screening entries can either be single entries or range entries. Single entries have precedence in screening over range entries. Thus the single entry table is searched first and if a match is found, the range table is never searched. Range entries may overlap single entries.

If a message is screened and does not contain matching GTA, NPV, and NAIV values, the message is rejected. The message is rejected with the default action defined by the `ent-gsms-opcode` command for the operation code (`opcode`) parameter entry referenced by the operation name (`opname`) parameter.

This examples used in this procedure are based on the examples shown in [Table 20: Example CGPA GSM MAP Screening Configuration Table](#) and [Table 21: Example CDPA GSM MAP Screening Configuration Table](#).

Table 20: Example CGPA GSM MAP Screening Configuration Table

CGSR	SADDR	EADDR	NPV	NAIV	OPNAME	FORBID
cg01	9194600000	---	5	75	pass50	none
cg02	252555100000	252700000000	12	37	discard1	all
cg03	8284540000	8284600000	---	---	ati	state
cg04	2416546464	---	0	127	route25	none
cg05	854000000	857000000	3	99	dd93	all
cg06	154363000000	155000000000	8	86	sri	all
cg07	368900000	369000000	9	111	dup187	none
CGSR	ACTION	PC/PCA/PCI/ PCN/PCN24	SSN	MAPSET		
cg01	pass	N/A	N/A	N/A		
cg02	discard	N/A	N/A	N/A		
cg03	atierr	N/A	N/A	N/A		
cg04	route	N/A	N/A	N/A		
cg05	forward	3-201-7	100	DFLT		
cg06	duplicate	9384	30	10		
cg07	dupdisc	4-102-6	150	20		

Table 21: Example CDPA GSM MAP Screening Configuration Table

CGSR	CDSR	SADDR	EADDR	OPNAME	NPV	NAIV	FORBID
cg01	cd01	---	---	pass50	6	15	all
cg02	cd15	---	---	discard1	10	15	all

CGSR	CDSR	SADDR	EADDR	OPNAME	NPV	NAIV	FORBID
cg07	cd10	---	---	dup187	11	57	all
CGSR	CDSR	ACTION	PC/PCA/ PCI/PCN/ PCN24	SSN	MAPSET		
cg01	cd01	pass	N/A	N/A	N/A		
cg02	cd15	discard	N/A	N/A	N/A		
cg07	cd10	dupdisc	5-97-2	135	30		

1. Display the GSM MAP screening operation codes in the database using the `rtrv-gsms-opcode` command.

If the Flexible GTT Load Sharing feature is not enabled, this is an example of the possible output.

```
rlghncxa03w 08-09-10 11:43:04 GMT EAGLE5 39.2.0
OPCODE  OPNAME    DFLTACT  PCA          SSN  RI  TT
 36     for1      fwd      002-002-002  10   gt  40

OPCODE  OPNAME    DFLTACT  PCI          SSN  RI  TT
 93     dd93     dupdc    5-25-3      200  ssn 10
139     fwd139   fwd      3-159-7     128  ssn -

OPCODE  OPNAME    DFLTACT  PCN          SSN  RI  TT
187     dup187   dupl     11519       79   gt  50

OPCODE  OPNAME    DFLTACT  PCN24        SSN  RI  TT

OPCODE  OPNAME    DFLTACT
 22     sri      disc
 25     route25 route
 50     pass50   pass
 71     ati      atierr
150     discard1 disc
*      star    pass
```

GSMMS OPCODE Table (10 of 257) is 4% full

If the Flexible GTT Load Sharing feature is enabled, this is an example of the possible output.

```
rlghncxa03w 08-09-10 11:43:04 GMT EAGLE5 39.2.0
OPCODE  OPNAME    DFLTACT  PCA          SSN  MAPSET RI  TT
 36     for1      fwd      002-002-002  10   25   gt  40

OPCODE  OPNAME    DFLTACT  PCI          SSN  MAPSET RI  TT
 93     dd93     dupdc    5-025-3     200  20   ssn 10
139     fwd139   fwd      3-159-7     128  DFLT ssn -

OPCODE  OPNAME    DFLTACT  PCN          SSN  MAPSET RI  TT
```

```

187   dup187   dupl   11519   79   10   gt   50
OPCODE OPNAME     DFLTACT PCN24     SSN   MAPSET RI   TT
OPCODE OPNAME     DFLTACT
22     sri      disc
25     route25 route
50     pass50   pass
71     ati      atierr
150    discard1 disc
*      star    pass

```

GSMMS OPCODE Table (10 of 257) is 4% full

Note:

If the desired GSM MAP screening operation code entry is not shown in the `rtrv-gsms-opcode` output, go to the [Adding a GSM MAP Screening Operation Code](#) and add the required entry. Skip step 2 and go to step 3.

If either the `forbid=state`, `forbid=location`, or `action=atierr` parameters are to be assigned to the GSM MAP screening entry, the GSM MAP screening operation code table must contain an entry containing the operation code value 71.

2. Enter the `rtrv-gsmmap-scrn` command with an `opname` value shown in the `rtrv-gsms-opcode` command output in step 1 to display the GSM MAP screening entries in the database.

For this example, enter these commands.

```
rtrv-gsmmap-scrn:opname=pass50
```

```

rlghncxa03w 08-09-20 09:07:58 GMT EAGLE5 39.2.0
Single CgPA Entries for OPNAME: pass50
-----
SADDR          NP NAI FORBD ACT      PCA          SSN CGSR RI   TT
SADDR          NP NAI FORBD ACT      PCI          SSN CGSR RI   TT
SADDR          NP NAI FORBD ACT      PCN          SSN CGSR RI   TT
SADDR          NP NAI FORBD ACT      PCN24        SSN CGSR RI   TT
SADDR          NP NAI FORBD ACT      CGSR
Range CgPA Entries for OPNAME: pass50
-----
SADDR          EADDR          NP NAI FORBD ACT      PCA          SSN CGSR
SADDR          EADDR          NP NAI FORBD ACT      PCI          SSN CGSR
SADDR          EADDR          NP NAI FORBD ACT      PCN          SSN CGSR
SADDR          EADDR          NP NAI FORBD ACT      PCN24        SSN CGSR
SADDR          EADDR          NP NAI FORBD ACT      CGSR
GSM Map Screening table is (1500 of 4000) 38% full

```

This is an example of the possible output.

```
rtrv-gsmmap-scrn:opname=discard1
```

This is an example of the possible output.

```

rlghncxa03w 08-09-20 09:07:58 GMT EAGLE5 39.2.0
Single CgPA Entries for OPNAME: discard1
-----
SADDR          NP NAI FORBD ACT      PCA          SSN CGSR RI  TT
SADDR          NP NAI FORBD ACT      PCI          SSN CGSR RI  TT
SADDR          NP NAI FORBD ACT      PCN          SSN CGSR RI  TT
SADDR          NP NAI FORBD ACT      PCN24        SSN CGSR RI  TT
SADDR          NP NAI FORBD ACT      CGSR

Range CgPA Entries for OPNAME: discard1
-----
SADDR          EADDR          NP NAI FORBD ACT      PCA
SSN CGSR

SADDR          EADDR          NP NAI FORBD ACT      PCI          SSN CGSR
SADDR          EADDR          NP NAI FORBD ACT      PCN          SSN CGSR
SADDR          EADDR          NP NAI FORBD ACT      PCN24        SSN CGSR
SADDR          EADDR          NP NAI FORBD ACT      CGSR

GSM Map Screening table is (1500 of 4000) 38% full
    
```

rtrv-gsmmap-scrn:opname=ati

This is an example of the possible output.

```

rlghncxa03w 08-09-20 09:07:58 GMT EAGLE5 39.2.0
Single CgPA Entries for OPNAME: ati
-----
SADDR          NP NAI FORBD ACT      PCA          SSN CGSR RI  TT
SADDR          NP NAI FORBD ACT      PCI          SSN CGSR RI  TT
SADDR          NP NAI FORBD ACT      PCN          SSN CGSR RI  TT
SADDR          NP NAI FORBD ACT      PCN24        SSN CGSR RI  TT
SADDR          NP NAI FORBD ACT      CGSR
919462000000005 1 0  locat atier atil

Range CgPA Entries for OPNAME: ati
-----
SADDR          EADDR          NP NAI FORBD ACT      PCA
SSN CGSR

SADDR          EADDR          NP NAI FORBD ACT      PCI          SSN CGSR
SADDR          EADDR          NP NAI FORBD ACT      PCN          SSN CGSR
SADDR          EADDR          NP NAI FORBD ACT      PCN24        SSN CGSR

SADDR          EADDR          NP NAI FORBD ACT      CGSR
919461888888888 919461900000000 4 1  locat atier ati2
919462000000000 919463000000000 * *  locat atier ati3
    
```

GSM Map Screening table is (1500 of 4000) 38% full

rtrv-gsmmap-scrn:opname=route25

This is an example of the possible output.

rtrv-gsmmap-scrn:opname=dd93

This is an example of the possible output.

rlghncxa03w 08-09-20 09:07:58 GMT EAGLE5 39.2.0

Single CgPA Entries for OPNAME: dd93

```
-----
SADDR          NP NAI FORBD ACT      PCA          SSN CGSR RI  TT
SADDR          NP NAI FORBD ACT      PCI          SSN CGSR RI  TT
SADDR          NP NAI FORBD ACT      PCN          SSN CGSR RI  TT
SADDR          NP NAI FORBD ACT      PCN24        SSN CGSR RI  TT
SADDR          NP NAI FORBD ACT  CGSR
```

Range CgPA Entries for OPNAME: dd93

```
-----
SADDR          EADDR          NP NAI FORBD ACT      PCA
SSN CGSR
SADDR          EADDR          NP NAI FORBD ACT      PCI          SSN CGSR
SADDR          EADDR          NP NAI FORBD ACT      PCN          SSN CGSR
SADDR          EADDR          NP NAI FORBD ACT      PCN24        SSN CGSR
SADDR          EADDR          NP NAI FORBD ACT  CGSR
```

GSM Map Screening table is (1500 of 4000) 38% full

rtrv-gsmmap-scrn:opname=sri

This is an example of the possible output.

rlghncxa03w 08-09-20 09:07:58 GMT EAGLE5 39.2.0

Single CgPA Entries for OPNAME: sri

```
-----
SADDR          NP NAI FORBD ACT      PCA          SSN CGSR RI  TT
SADDR          NP NAI FORBD ACT      PCI          SSN CGSR RI  TT
SADDR          NP NAI FORBD ACT      PCN          SSN CGSR RI  TT
SADDR          NP NAI FORBD ACT      PCN24        SSN CGSR RI  TT
SADDR          NP NAI FORBD ACT  CGSR
```

Range CgPA Entries for OPNAME: sri

```
-----
SADDR          EADDR          NP NAI FORBD ACT      PCA
SSN CGSR
SADDR          EADDR          NP NAI FORBD ACT      PCI          SSN CGSR
```



```
SADDR          EADDR          NP NAI FORBD ACT      PCN          SSN CGSR
SADDR          EADDR          NP NAI FORBD ACT      PCN24        SSN CGSR
SADDR          EADDR          NP NAI FORBD ACT      CGSR
```

GSM Map Screening table is (1500 of 4000) 38% full

rtrv-gsmmap-scrn:opname=dup187

This is an example of the possible output.

```
rlghncxa03w 08-09-20 09:07:58 GMT  EAGLE5 39.2.0
Single CgPA Entries for OPNAME: dup187
-----
SADDR          NP NAI FORBD ACT      PCA          SSN CGSR RI  TT
SADDR          NP NAI FORBD ACT      PCI          SSN CGSR RI  TT
SADDR          NP NAI FORBD ACT      PCN          SSN CGSR RI  TT
SADDR          NP NAI FORBD ACT      PCN24        SSN CGSR RI  TT
SADDR          NP NAI FORBD ACT      CGSR
```

```
Range CgPA Entries for OPNAME: dup187
-----
SADDR          EADDR          NP NAI FORBD ACT      PCA          SSN CGSR
SSN CGSR
SADDR          EADDR          NP NAI FORBD ACT      PCI          SSN CGSR
SADDR          EADDR          NP NAI FORBD ACT      PCN          SSN CGSR
SADDR          EADDR          NP NAI FORBD ACT      PCN24        SSN CGSR
SADDR          EADDR          NP NAI FORBD ACT      CGSR
```

GSM Map Screening table is (1500 of 4000) 38% full

If the Flexible GTT Load Sharing feature is enabled, the MAPSET field is shown in the rtrv-gsmmap-scrn output as shown in the following output example.

```
rlghncxa03w 08-09-20 09:07:58 GMT  EAGLE5 39.2.0
Single CgPA Entries for OPNAME: dup187
-----
SADDR          NP NAI FORBD ACT      PCA          SSN CGSR MAPSET RI  TT
SADDR          NP NAI FORBD ACT      PCI          SSN CGSR MAPSET RI  TT
SADDR          NP NAI FORBD ACT      PCN          SSN CGSR MAPSET RI  TT
SADDR          NP NAI FORBD ACT      PCN24        SSN CGSR MAPSET RI  TT
SADDR          NP NAI FORBD ACT      CGSR
Range CgPA Entries for OPNAME: dup187
-----
SADDR          EADDR          NP NAI FORBD ACT      PCA          SSN CGSR
SADDR          EADDR          NP NAI FORBD ACT      PCI          SSN CGSR
```

```

SADDR          EADDR          NP NAI FORBD ACT      PCN          SSN CGSR
SADDR          EADDR          NP NAI FORBD ACT      PCN24        SSN CGSR
SADDR          EADDR          NP NAI FORBD ACT      CGSR
GSM Map Screening table is (1500 of 4000) 38% full

```

Note:

If any of the following parameters or values are not being used in this procedure, skip step 3 and go to step 4.

- saddr=*
- cdsr
- pc/pca
- The saddr or eaddr parameter values containing hex digits.

If the `rtrv-gsmmap-scrn` output in this step shows any of the parameters or values listed above, skip step 3, and go to step 4.

3. Verify that the Enhanced GSM MAP Screening feature is enabled and on by entering the `rtrv-ctrl-feat` command with the part number of the Enhanced GSM MAP Screening feature. Enter this command.

```
rtrv-ctrl-feat:partnum=893012401
```

The following is an example of the possible output.

```

rlghncxa03w 06-10-28 21:15:37 GMT EAGLE5 36.0.0
The following features have been permanently enabled:
Feature Name          Partnum    Status    Quantity
Enhanced GMS (EGMS)  893012401  on       ----

The following features have been temporarily enabled:
Feature Name          Partnum    Status    Quantity    Trial Period Left
Zero entries found.

The following features have expired temporary keys:
Feature Name          Partnum
Zero entries found.

```

If the Enhanced GSM MAP screening feature is not enabled or off, go to the [Activating the GSM MAP Screening Feature](#) to enable and turn on the Enhanced GSM MAP screening feature.

4. Perform one of these actions.
 - If the action parameter value will be either `pass`, `discard`, `route`, or `atierr`, skip steps 4 through 8, and continue the procedure with step 9.
 - If the action parameter value will be either `forward`, `duplicate`, or `dupdisc`, perform one of these actions.
 - To use a point code and a MAP set from the mated application table, and MAP sets are not shown in the `rtrv-gsmmap-scrn` output in step 2, the Flexible GTT Load Sharing Feature must be enabled. Perform the “Activating the Flexible GTT Load Sharing Feature” procedure in the *Database Administration Manual - Global Title Translation* and enable the Flexible GTT

Load Sharing feature. After enabling the Flexible GTT Load Sharing feature, skip steps 5 and 6 and continue the procedure with step 7.

- To use a point code and a MAP set from the mated application table, and MAP sets are shown in the `rtrv-gsmmap-scrn` output in step 2, skip steps 5 and 6 and continue the procedure with step 7.
- To use a point code in the mated application table, but without using a MAP set, and MAP sets are not shown in the `rtrv-gsmmap-scrn` output in step 2, skip steps 5 and 6 and continue the procedure with step 7.
- To use a point code that is not in the mated application table, the `force=yes` parameter must be specified with the `ent-gsmmap-scrn` command. A proxy point code cannot be assigned to this point code. If the Flexible GTT Load Sharing feature is enabled, the `force=yes` parameter can be used only if the default MAP set is assigned to the GSM MAP screening entry. Continue the procedure with step 5.

5. Display the destination point codes in the database by entering the `rtrv-dstn` command. This is an example of the possible output.

```
rlghncxa03w 10-12-10 11:43:04 GMT EAGLE5 43.0.0
Extended Processing Time may be Required
```

DPCA	CLLI	BEI	ELEI	ALIASI	ALIASN/N24	DMN
001-207-000	-----	no	---	-----	-----	SS7
001-001-001	-----	no	---	-----	-----	SS7
001-001-002	-----	no	---	-----	-----	SS7
001-005-000	-----	no	---	-----	-----	SS7
001-007-000	-----	no	---	-----	-----	SS7
008-012-003	-----	no	---	-----	-----	SS7
003-002-004	-----	no	---	-----	-----	SS7
009-002-003	-----	no	---	-----	-----	SS7
010-020-005	-----	no	---	-----	-----	SS7

DPCI	CLLI	BEI	ELEI	ALIASA	ALIASN/N24	DMN
1-207-0	-----	no	---	-----	-----	SS7
0-015-0	-----	no	---	-----	-----	SS7
0-017-0	-----	no	---	-----	-----	SS7
1-011-1	-----	no	---	-----	-----	SS7
1-011-2	-----	no	---	-----	-----	SS7

```
Destination table is (14 of 2000) 1% full
Alias table is (0 of 12000) 0% full
PPC table is (1 of 20) 5% full
```

If the required point code is not shown in the `rtrv-dstn` output, perform the "Adding a Destination Point Code" procedure in the *Database Administration Manual - SS7* to add the required point code. A proxy point code cannot be assigned to the point code.

After the new point code has been added, skip steps 6 through 8 and perform the "Adding a Route Containing an SS7 DPC" procedure in the *Database Administration Manual - SS7* and add the required route to the database. After the route has been added, continue the procedure with step 9.

6. Display the point code that will be assigned to the mated application by using the `rtrv-dstn` command and specifying the point code. For this example, enter this command.

```
rtrv-dstn:dPCA=010-020-005
```

This is an example of the possible output.

```
rlghncxa03w 10-12-10 11:43:04 GMT EAGLE5 43.0.0

  DPCA          CLLI          BEI ELEI  ALIASI          ALIASN/N24  DMN
  010-020-005  ----- no  --- -----  -----  SS7

  PPCA          NCAI PRX  RCAUSE NPRST SPLITIAM HMSMSC HMSCP  SCCPMSGCNV
  009-002-003  ---- no   50      on   20          no   no   none

Destination table is (14 of 2000) 1% full
Alias table is (0 of 12000) 0% full
PPC table is (1 of 20) 5% full
```

If the adjacent point code is not shown in the `rtrv-dstn` command output, the following output is displayed.

```
rlghncxa03w 09-05-10 11:43:04 GMT EAGLE5 41.0.0

No destinations meeting the requested criteria were found

Destination table is (14 of 2000) 1% full
Alias table is (0 of 12000) 0% full
PPC table is (1 of 20) 5% full
```

A proxy point code (a point code value is shown in the PPC column) cannot be assigned to the point code. If a proxy point code is shown in this step, choose another point code from the `rtrv-dstn` output in the previous step and repeat this step.

If the point code is not shown in the `rtrv-dstn` output, perform the "Adding a Destination Point Code" procedure in the *Database Administration Manual - SS7* and add the adjacent point code to the destination point code table.

After the new point code has been added, skip steps 7 and 8 and perform the "Adding a Route Containing an SS7 DPC" procedure in the *Database Administration Manual - SS7* and add the required route to the database. After the route has been added, continue the procedure with step 9.

- The point code and subsystem number being assigned to the GSM MAP screening entry must be in the mated application table.

Enter the `rtrv-map` command with the `pci/pcn/pcn24` and `ssn` values that will be specified with the `ent-gsmmap-scrn` command in step 9.

If the Flexible GTT Load Sharing feature is not enabled, for this example, enter these commands.

```
rtrv-map:pci=3-201-7:ssn=100
```

This is an example of the possible output.

```
rlghncxa03w 09-07-25 09:42:31 GMT EAGLE5 41.1.0

PCI          Mate PCI          SSN RC MULT SRM MRC GRP NAME SSO
3-201-5          100 10 SOL *N *N GRP01  ON

MAP TABLE IS (20 of 1024) 2 % FULL
```

```
rtrv-map:pcn=9384:ssn=30
```

This is an example of the possible output.

```
rlghncxa03w 09-07-25 09:42:31 GMT EAGLE5 41.1.0
```

```
PCN          Mate PCN          SSN RC MULT SRM MRC GRP NAME SSO
9384                                     30 10 SOL *N *N GRP01 ON
```

```
MAP TABLE IS (20 of 1024) 2 % FULL
```

```
rtrv-map:pci=4-102-6:ssn=150
```

This is an example of the possible output.

```
rlghncxa03w 09-07-25 09:42:31 GMT EAGLE5 41.1.0
```

```
PCI          Mate PCI          SSN RC MULT SRM MRC GRP NAME SSO
4-102-6                                     150 10 SOL *N *N GRP01 ON
```

```
MAP TABLE IS (20 of 1024) 2 % FULL
```

If the Flexible GTT Load Sharing feature is enabled:

- The `mapset` parameter must be specified with the `ent-gsmmap-scrn` command in step 9.
- The point code and subsystem contained in the GSM MAP screening entry must be in the MAP set assigned to the GSM MAP screening entry.

For this example, enter these commands.

```
rtrv-map:pci=3-201-7:ssn=100
```

This is an example of the possible output.

```
rlghncxa03w 09-07-25 09:42:31 GMT EAGLE5 41.1.0
```

```
MAPSET ID=DFLT
```

```
PCI          Mate PCI          SSN RC MULT SRM MRC GRP NAME SSO
3-201-5                                     100 10 SOL *N *N GRP01 ON
```

```
MAP TABLE IS (20 of 1024) 2 % FULL
```

```
rtrv-map:pcn=9384:ssn=30
```

This is an example of the possible output.

```
rlghncxa03w 09-07-25 09:42:31 GMT EAGLE5 41.1.0
```

```
MAPSET ID=10
```

```
PCN          Mate PCN          SSN RC MULT SRM MRC GRP NAME SSO
9384                                     30 10 SOL *N *N GRP01 ON
```

```
MAP TABLE IS (20 of 1024) 2 % FULL
```

```
rtrv-map:pci=4-102-6:ssn=150
```

This is an example of the possible output.

```
rlghncxa03w 09-07-25 09:42:31 GMT EAGLE5 41.1.0
```

```
MAPSET ID=20
```

```
PCI          Mate PCI          SSN RC MULT SRM MRC GRP NAME SSO
4-102-6                                     150 10 SOL *N *N GRP01 ON
```

```
MAP TABLE IS (20 of 1024) 2 % FULL
```

If the point code and subsystem number is not shown in the `rtrv-map` output, perform one of the "Provisioning a Mated Application" procedures in the *Databa*

e Administration Manual - Global Title Translation and add the required point code and subsystem number to the mated application table.

8. The point code specified with the `ent-gsmmap-scrn` command must be the DPC of a route.

If the point code specified with the `ent-gsmmap-scrn` command is an ANSI point code, the point code can be a member of a cluster point code when that cluster point code is the DPC of a route. Enter the `rtrv-rte` command with the `dpc` parameter specifying the point code to be used with the `ent-gsmmap-scrn` command to verify whether or not the point code is the DPC of a route. For this example, enter these commands.

```
rtrv-rte:dpci=3-201-7
```

This is an example of the possible output.

```
rlghncxa03w 06-10-07 11:43:04 GMT EAGLE5 36.0.0
DPCI      ALIASN/N24      ALIASA      LSN      RC      APC
3-201-7   12111             240-111-111 ls100001  10     1-234-5
                    ls100002  10     1-234-6
                    ls100003  20     1-234-7
                    ls100004  30     1-234-1
                    ls100005  40     1-234-2
                    ls100006  50     1-234-3
                    RTX:No  CLLI=idpl
```

```
rtrv-rte:dpcn=9384
```

This is an example of the possible output.

```
rlghncxa03w 06-10-07 11:43:04 GMT EAGLE5 36.0.0
DPCN      ALIASA      ALIASI      LSN      RC      APC
9384      011-222-111 0-001-1    ls200001  10     11111
                    ls200002  10     11112
                    ls200003  20     11113
                    ls200004  30     11114
                    ls200005  40     11115
                    ls200006  50     11116
                    RTX:No  CLLI=ndpl
```

```
rtrv-rte:dpci=4-102-6
```

This is an example of the possible output.

```
DPCI      ALIASN/N24      ALIASA      LSN      RC      APC
4-102-6   7659           240-039-150 ls100001  10     5-25-3
                    ls100002  10     3-250-6
                    ls100003  20     7-34-7
                    ls100004  30     6-98-1
                    ls100005  40     3-142-2
                    ls100006  50     1-178-3
                    RTX:No  CLLI=idpl
```

If the point code is not shown in the `rtrv-rte` output, if the point code is an ANSI point code, the point code is not a member of a cluster point code when that cluster point code is the DPC of a route, go to the "Adding a Route Containing an SS7 DPC" procedure in the *Database Administration Manual* - SS7 and add the required route to the database.

9. Add the new CGPA GSM MAP screening entries to the database with the `ent-gsmmap-scrn` command.

Note: If a CDPA entry is being added to an existing CGPA entry, skip steps 9 and 10, and go to step 11.

See [Table 19: Add GSM MAP Screening Entry Parameter Combinations](#) for the parameter combinations that can be used with the `ent-gsmmap-scrn` command.

For this example, enter these commands:

```
ent-gsmmap-scrn:saddr=9194600000:npv=5:naiv=75:opname=pass50
:forbid=none:action=pass:cgsr=cg01

ent-gsmmap-scrn:saddr=252555100000:eaddr=252700000000:npv=12:naiv=37
:opname=discard1:forbid=all :action=discard:cgsr=cg02

ent-gsmmap-scrn:saddr=8284540000:eaddr=8284600000:opname=ati
:forbid=state:action=atierr:cgsr=cg03

ent-gsmmap-scrn:saddr=2416546464:opname=route25:forbid=all
:action=route:npv=0:naiv=127:cgsr=cg04

ent-gsmmap-scrn:saddr=854000000:eaddr=857000000:opname=dd93
:forbid=all:action=forward:npv=3:naiv=99:pci=3-201-7:ssn=100:cgsr=cg05
:mapset=dflt

ent-gsmmap-scrn:saddr=154363000000:eaddr=155000000000:opname=sri
:forbid=all:action=duplicate:npv=8:naiv=86:pcn=9384:ssn=30:cgsr=cg06
:mapset=10

ent-gsmmap-scrn:saddr=368900000:eaddr=369000000:opname=dupl87
:forbid=all:action=dupdisc:npv=9:naiv=111:pci=4-102-6:ssn=150:cgsr=cg07
:mapset=20
```

When each of these commands has successfully completed, this message appears.

```
rlghncxa03w 06-10-20 09:07:58 GMT EAGLE5 36.0.0
GSM Map Screening table is (1512 of 4000) 38% full
ENT-GSM MAP-SCRN: MASP A - COMPLTD
```

10. Verify the changes using the `rtrv-gsmmap-scrn` command and specifying the `opname` and `cgsr` parameter values specified in step 9.

For this example, enter these commands:

```
rtrv-gsmmap-scrn:opname=pass50
```

This is an example of the possible output.

```
rlghncxa03w 08-09-20 09:07:58 GMT EAGLE5 39.2.0

Single CgPA Entries for OPNAME: pass50
-----
SADDR          NP NAI FORBD ACT      PCA          SSN CGSR  MAPSET RI  TT
SADDR          NP NAI FORBD ACT      PCI          SSN CGSR  MAPSET RI  TT
SADDR          NP NAI FORBD ACT      PCN          SSN CGSR  MAPSET RI  TT
SADDR          NP NAI FORBD ACT      PCN24       SSN CGSR  MAPSET RI  TT
SADDR          NP NAI FORBD ACT  CGSR
9194600000     5  75  none  pass cg01

Range CgPA Entries for OPNAME: pass50
-----
SADDR          EADDR          NP NAI FORBD ACT      PCA
```

```
SSN CGSR
SADDR          EADDR          NP NAI FORBD ACT      PCI          SSN CGSR
SADDR          EADDR          NP NAI FORBD ACT      PCN          SSN CGSR
SADDR          EADDR          NP NAI FORBD ACT      PCN24        SSN CGSR
SADDR          EADDR          NP NAI FORBD ACT      CGSR
GSM Map Screening table is (1512 of 4000) 38% full
```

rtrv-gsmmap-scrn:opname=discard1

This is an example of the possible output.

```
rlghncxa03w 08-09-20 09:07:58 GMT EAGLE5 39.2.0
Single CgPA Entries for OPNAME: discard1
-----
SADDR          NP NAI FORBD ACT      PCA          SSN CGSR  MAPSET RI  TT
SADDR          NP NAI FORBD ACT      PCI          SSN CGSR  MAPSET RI  TT
SADDR          NP NAI FORBD ACT      PCN          SSN CGSR  MAPSET RI  TT
SADDR          NP NAI FORBD ACT      PCN24        SSN CGSR  MAPSET RI  TT
SADDR          NP NAI FORBD ACT      CGSR
Range CgPA Entries for OPNAME: discard1
-----
SADDR          EADDR          NP NAI FORBD ACT      PCA          SSN CGSR
SADDR          EADDR          NP NAI FORBD ACT      PCI          SSN CGSR
SADDR          EADDR          NP NAI FORBD ACT      PCN          SSN CGSR
SADDR          EADDR          NP NAI FORBD ACT      PCN24        SSN CGSR
SADDR          EADDR          NP NAI FORBD ACT      CGSR
252555100000  252700000000  12 37  all  disc  cg02
GSM Map Screening table is (1512 of 4000) 38% full
```

rtrv-gsmmap-scrn:opname=ati

This is an example of the possible output.

```
rlghncxa03w 08-09-20 09:07:58 GMT EAGLE5 39.2.0
Single CgPA Entries for OPNAME: ati
-----
SADDR          NP NAI FORBD ACT      PCA          SSN CGSR  MAPSET RI  TT
SADDR          NP NAI FORBD ACT      PCI          SSN CGSR  MAPSET RI  TT
SADDR          NP NAI FORBD ACT      PCN          SSN CGSR  MAPSET RI  TT
SADDR          NP NAI FORBD ACT      PCN24        SSN CGSR  MAPSET RI  TT
SADDR          NP NAI FORBD ACT      CGSR
Range CgPA Entries for OPNAME: ati
```



```
-----
SADDR          EADDR          NP NAI FORBD ACT      PCA          SSN CGSR
SADDR          EADDR          NP NAI FORBD ACT      PCI          SSN CGSR
SADDR          EADDR          NP NAI FORBD ACT      PCN          SSN CGSR
SADDR          EADDR          NP NAI FORBD ACT      PCN24        SSN CGSR
SADDR          EADDR          NP NAI FORBD ACT      CGSR
8284540000     8284600000     * * state atier cg03
GSM Map Screening table is (1512 of 4000) 38% full
```

rtrv-gsmmap-scrn:opname=route25

This is an example of the possible output.

```
rlghncxa03w 08-09-20 09:07:58 GMT EAGLE5 39.2.0
Single CgPA Entries for OPNAME: route25
-----
SADDR          NP NAI FORBD ACT      PCA          SSN CGSR  MAPSET RI  TT
SADDR          NP NAI FORBD ACT      PCI          SSN CGSR  MAPSET RI  TT
SADDR          NP NAI FORBD ACT      PCN          SSN CGSR  MAPSET RI  TT
SADDR          NP NAI FORBD ACT      PCN24        SSN CGSR  MAPSET RI  TT
SADDR          NP NAI FORBD ACT      CGSR
2416546464     0 127 all route cg04
Range CgPA Entries for OPNAME: ati
-----
SADDR          EADDR          NP NAI FORBD ACT      PCA          SSN CGSR
SADDR          EADDR          NP NAI FORBD ACT      PCI          SSN CGSR
SADDR          EADDR          NP NAI FORBD ACT      PCN          SSN CGSR
SADDR          EADDR          NP NAI FORBD ACT      PCN24        SSN CGSR
SADDR          EADDR          NP NAI FORBD ACT      CGSR
GSM Map Screening table is (1512 of 4000) 38% full
```

rtrv-gsmmap-scrn:opname=dd93

This is an example of the possible output.

```
rlghncxa03w 08-09-20 09:07:58 GMT EAGLE5 39.2.0
Single CgPA Entries for OPNAME: dd93
-----
SADDR          NP NAI FORBD ACT      PCA          SSN CGSR  MAPSET RI  TT
SADDR          NP NAI FORBD ACT      PCI          SSN CGSR  MAPSET RI  TT
SADDR          NP NAI FORBD ACT      PCN          SSN CGSR  MAPSET RI  TT
SADDR          NP NAI FORBD ACT      PCN24        SSN CGSR  MAPSET RI  TT
```

```

SADDR          NP NAI FORBD ACT  CGSR
Range CgPA Entries for OPNAME: dd93
-----
SADDR          EADDR              NP NAI FORBD ACT      PCA          SSN CGSR
SADDR          EADDR              NP NAI FORBD ACT      PCI          SSN CGSR
854000000      857000000      3 99 all fwd        3-201-7      100 cg05
MAPSET = DFLT RI=ssn TT=-
SADDR          EADDR              NP NAI FORBD ACT      PCN          SSN CGSR
SADDR          EADDR              NP NAI FORBD ACT      PCN24        SSN CGSR
SADDR          EADDR              NP NAI FORBD ACT      CGSR
GSM Map Screening table is (1512 of 4000) 38% full
    
```

rtrv-gsmmap-scrn:opname=sri

This is an example of the possible output.

```

rlghncxa03w 08-09-20 09:07:58 GMT  EAGLE5 39.2.0
Single CgPA Entries for OPNAME: sri
-----
SADDR          NP NAI FORBD ACT      PCA          SSN CGSR  MAPSET RI  TT
SADDR          NP NAI FORBD ACT      PCI          SSN CGSR  MAPSET RI  TT
SADDR          NP NAI FORBD ACT      PCN          SSN CGSR  MAPSET RI  TT
SADDR          NP NAI FORBD ACT      PCN24        SSN CGSR  MAPSET RI  TT
SADDR          NP NAI FORBD ACT  CGSR
Range CgPA Entries for OPNAME: sri
-----
SADDR          EADDR              NP NAI FORBD ACT      PCA          SSN CGSR
SADDR          EADDR              NP NAI FORBD ACT      PCI          SSN CGSR
SADDR          EADDR              NP NAI FORBD ACT      PCN          SSN CGSR
1534363000000  1550000000000  8 86 all dupl        9384          30 cg06
MAPSET = 10 RI=ssn TT=-
SADDR          EADDR              NP NAI FORBD ACT      PCN24        SSN CGSR
SADDR          EADDR              NP NAI FORBD ACT      CGSR
GSM Map Screening table is (1512 of 4000) 38% full
    
```

rtrv-gsmmap-scrn:opname=dup187

This is an example of the possible output.

```

rlghncxa03w 08-09-20 09:07:58 GMT  EAGLE5 39.2.0
Single CgPA Entries for OPNAME: dup187
-----
SADDR          NP NAI FORBD ACT      PCA          SSN CGSR  MAPSET RI  TT
SADDR          NP NAI FORBD ACT      PCI          SSN CGSR  MAPSET RI  TT
SADDR          NP NAI FORBD ACT      PCN          SSN CGSR  MAPSET RI  TT
    
```

```

SADDR          NP NAI FORBD ACT      PCN24          SSN CGSR  MAPSET RI  TT
SADDR          NP NAI FORBD ACT  CGSR
Range CgPA Entries for OPNAME: dup187
-----
SADDR          EADDR          NP NAI FORBD ACT      PCA          SSN CGSR
SADDR          EADDR          NP NAI FORBD ACT      PCI          SSN CGSR
368900000      369000000      9 111 all dupdc      4-102-6      150 cg07
MAPSET = 20 RI=ssn TT=-
SADDR          EADDR          NP NAI FORBD ACT      PCN          SSN CGSR
SADDR          EADDR          NP NAI FORBD ACT      PCN24        SSN CGSR
SADDR          EADDR          NP NAI FORBD ACT      CGSR
GSM Map Screening table is (1512 of 4000) 38% full

```

11. Add the new CDPA GSM MAP screening entries to the database with the `ent-gsmmap-scrn` command.

Note: If a CDPA entry is not being added, or if the Enhanced GSM MAP Screening feature is not enabled or off (see the `rtrv-ctrl-feat` output in step 3), skip steps 11 and 12, and go to step 13.

See [Table 19: Add GSM MAP Screening Entry Parameter Combinations](#) for the parameter combinations that can be used with the `ent-gsmmap-scrn` command.

For this example, enter these commands:

```
ent-gsmmap-scrn:opname=pass50:npv=6:naiv=15:forbid=all:action=pass
:cgsr=cg01:cdsr=cd01
```

```
ent-gsmmap-scrn:opname=discard1:npv=10:naiv=15:forbid=all:action=discard
:cgsr=cg02:cdsr=cd15
```

```
ent-gsmmap-scrn:opname=dup187:npv=11:naiv=57:forbid=all:pci=5-97-2
:ssn=135:action=dupdisc:cgsr=cg07:cdsr=cd10:mapset=30
```

When each of these commands has successfully completed, this message appears.

```

rlghncxa03w 06-10-20 09:07:58 GMT  EAGLE5 36.0.0
GSM Map Screening table is (1512 of 4000) 38% full
ENT-GSM MAP-SCRN: MASP A - COMPLTD

```

12. Verify the changes using the `rtrv-gsmmap-scrn` command and specifying the `opname`, `cgsr`, and `cdsr` parameter values specified in step 11.

For this example, enter these commands:

```
rtrv-gsmmap-scrn:opname=pass50:cgsr=cg01:cdsr=cd01
```

This is an example of the possible output.

```

rlghncxa03w 06-10-20 09:07:58 GMT  EAGLE5 36.0.0
SADDR          NP NAI FORBD ACT  CDSR
*              6 15  all  pass  cd01

```

```
GSM Map Screening table is (1512 of 4000) 38% full
```

```
rtrv-gsmmap-scrn:opname=discard1:cgsr=cg02:cdsr=cd15
```

This is an example of the possible output.

```
rlghncxa03w 06-10-20 09:07:58 GMT EAGLE5 36.0.0
```

```
SADDR      NP NAI FORBD ACT   CDSR
*          10 15  all  disc cd15
```

```
GSM Map Screening table is (1512 of 4000) 38% full
```

```
rtrv-gsmmap-scrn:opname=dup187:cgsr=cg07:cdsr=cd10
```

This is an example of the possible output.

```
rlghncxa03w 08-09-20 09:07:58 GMT EAGLE5 39.2.0
```

```
SADDR      NP NAI FORBD ACT   PCI      SSN CDSR  MAPSET RI
*          11 57  all  dupdc   5-97-2   135 cd10  30    ssn
TT=-
```

```
GSM Map Screening table is (1512 of 4000) 38% full
```

- Backup the new changes using the `chg-db:action=backup:dest=fixed` command.

These messages should appear, the active Maintenance and Administration Subsystem Processor (MASP) appears first.

```
BACKUP (FIXED) : MASP A - Backup starts on active MASP.
BACKUP (FIXED) : MASP A - Backup on active MASP to fixed disk complete.
BACKUP (FIXED) : MASP A - Backup starts on standby MASP.
BACKUP (FIXED) : MASP A - Backup on standby MASP to fixed disk complete.
```

Removing a GSM MAP Screening Entry

Use this procedure to remove the GSM MAP screening entries that filter or allow TCAP messages containing MAP operation codes, origination addresses, and forbidden parameters using the `dlt-gsmmap-scrn` command. The `dlt-gsmmap-scrn` command uses these parameters:

`:opname` – The user-defined name for the operation code. The `opname` value references the operation code (`opcode`) shown in the `rtrv-gsms-opcode` command output.

`:cgsr` – The CGPA screening reference name

`:cdsr` – The CDPA screening reference name

If the GSM MAP Screening entry contains CDPA entries, the individual CDPA entries can be removed without removing the CGPA entry. However, if you wish to remove the CGPA entry, all CDPA entries assigned to the CGPA entry must be removed before the CGPA entry can be removed.

To remove CDPA entries, the `opname`, `cgsr`, and `cdsr` parameters must be specified with the `dlt-gsmmap-scrn` command. To remove CGPA entries, the `opname` and `cgsr` parameters must be specified with the `dlt-gsmmap-scrn` command.

Unlike GTT (Global Title Translation) entries, the GSM MAP screening commands do not support splits of ranges during removing or changing entries.

1. Display the GSM MAP screening operation codes in the database using the `rtrv-gsms-opcode` command.

This is an example of the possible output.

```
rlghncxa03w 08-09-10 11:43:04 GMT EAGLE5 39.2.0
OPCODE  OPNAME      DFLTACT      PCA          SSN  RI  TT
 36      for1         fwd          002-002-002  10   gt  10

OPCODE  OPNAME      DFLTACT      PCI          SSN  RI  TT
 93      dd93        dupdc        5-25-3      200  ssn 30
139      fwd139     fwd          3-159-7     128  ssn -

OPCODE  OPNAME      DFLTACT      PCN          SSN  RT  TT
187      dup187     dupl         11519       79   gt  50

OPCODE  OPNAME      DFLTACT      PCN24        SSN

OPCODE  OPNAME      DFLTACT
 22      sri         disc
 25      route25    route
 50      pass50     pass
 71      ati         atierr
150      discard1   disc
*       star      pass
```

GSMSMS OPCODE Table (10 of 257) is 4% full

2. Enter the `rtrv-gsmmap-scrn` command with an `opname` value shown in the `rtrv-gsms-opcode` command output in step 1 to display the CGPA GSM MAP screening entries. For this example, enter these commands.

```
rtrv-gsmmap-scrn:opname=pass50
```

```
rlghncxa03w 08-09-20 09:07:58 GMT EAGLE5 39.2.0
Single CgPA Entries for OPNAME: pass50
-----
SADDR          NP NAI FORBD ACT      PCA          SSN CGSR RI  TT
SADDR          NP NAI FORBD ACT      PCI          SSN CGSR RI  TT
SADDR          NP NAI FORBD ACT      PCN          SSN CGSR RI  TT
SADDR          NP NAI FORBD ACT      PCN24        SSN CGSR RI  TT

SADDR          NP NAI FORBD ACT  CGSR
9194600000    5 75 none pass cg01

Range CgPA Entries for OPNAME: pass50
-----
SADDR          EADDR          NP NAI FORBD ACT      PCA          SSN CGSR
SADDR          EADDR          NP NAI FORBD ACT      PCI          SSN CGSR
SADDR          EADDR          NP NAI FORBD ACT      PCN          SSN CGSR
SADDR          EADDR          NP NAI FORBD ACT      PCN24        SSN CGSR
```

```
SADDR          EADDR          NP NAI FORBD ACT  CGSR
GSM Map Screening table is (1512 of 4000) 38% full
```

rtrv-gsmmap-scrn:opname=ati

This is an example of the possible output.

```
rlghncxa03w 08-09-20 09:07:58 GMT  EAGLE5 39.2.0
Single CgPA Entries for OPNAME: ati
-----
SADDR          NP NAI FORBD ACT  PCA          SSN CGSR RI  TT
SADDR          NP NAI FORBD ACT  PCI          SSN CGSR RI  TT
SADDR          NP NAI FORBD ACT  PCN          SSN CGSR RI  TT
SADDR          NP NAI FORBD ACT  PCN24        SSN CGSR RI  TT
SADDR          NP NAI FORBD ACT  CGSR
919462000000005 1  0  locat atier atil
Range CgPA Entries for OPNAME: ati
-----
SADDR          EADDR          NP NAI FORBD ACT  PCA          SSN CGSR
SADDR          EADDR          NP NAI FORBD ACT  PCI
SSN CGSR
SADDR          EADDR          NP NAI FORBD ACT  PCN
SSN CGSR
SADDR          EADDR          NP NAI FORBD ACT  PCN24        SSN CGSR
SADDR          EADDR          NP NAI FORBD ACT  CGSR
8284540000      8284600000      *  *  state atier cg03
919461888888888 919461900000000 4  1  locat atier ati2
919462000000000 919463000000000 *  *  locat atier ati3
GSM Map Screening table is (1512 of 4000) 38% full
```

rtrv-gsmmap-scrn:opname=sri

This is an example of the possible output.

```
rlghncxa03w 08-09-20 09:07:58 GMT  EAGLE5 39.2.0
Single CgPA Entries for OPNAME: sri
-----
SADDR          NP NAI FORBD ACT  PCA          SSN CGSR RI  TT
SADDR          NP NAI FORBD ACT  PCI          SSN CGSR RI  TT
SADDR          NP NAI FORBD ACT  PCN          SSN CGSR RI  TT
SADDR          NP NAI FORBD ACT  PCN24        SSN CGSR RI  TT
SADDR          NP NAI FORBD ACT  CGSR
Range CgPA Entries for OPNAME: sri
-----
SADDR          EADDR          NP NAI FORBD ACT  PCA          SSN CGSR
```

```

SADDR          EADDR          NP NAI FORBD ACT      PCI          SSN CGSR
SADDR          EADDR          NP NAI FORBD ACT      PCN          SSN CGSR
1534363000000 1550000000000      8 86 all dupl      9384         30 cg06
RI=ssn TT=-
SADDR          EADDR          NP NAI FORBD ACT      PCN24        SSN CGSR
SADDR          EADDR          NP NAI FORBD ACT      CGSR
GSM Map Screening table is (1512 of 4000) 38% full

```

Note: The `rtrv-gsmmap-scrn` output in step 2 shows only the CGPA entries in the MAP screening table for the specified OPNAME. The CGPA entries in step 2 could contain CDPA entries that would have to be removed before the CGPA entry could be removed. CDPA entries can be in the MAP screening table only if the Enhanced GSM MAP Screening feature is enabled and on.

If any of the following parameters or values are shown in the `rtrv-gsmmap-scrn` output in step 2, the Enhanced GSM MAP Screening feature is enabled and on. Skip step 3 and go to step 4.

- `saddr=*`
- `pc/pca`
- The `saddr` or `eaddr` parameter values containing hex digits.

If the `rtrv-gsmmap-scrn` output in step 2 does not show any of these parameters or values, it is possible that the Enhanced GSM MAP Screening feature is enabled and on. Perform step 3 to verify the status of the Enhanced GSM MAP Screening feature.

3. Enter the `rtrv-ctrl-feat` command with the part number of the Enhanced GSM MAP Screening feature.

Enter this command.

```
rtrv-ctrl-feat:partnum=893012401
```

The following is an example of the possible output.

```

rlghncxa03w 06-10-28 21:15:37 GMT EAGLE5 36.0.0
The following features have been permanently enabled:
Feature Name          Partnum    Status    Quantity
Enhanced GMS (EGMS)  893012401  on       ----
The following features have been temporarily enabled:
Feature Name          Partnum    Status    Quantity    Trial Period Left
Zero entries found.
The following features have expired temporary keys:
Feature Name          Partnum
Zero entries found.

```

Note: If step 3 shows that the Enhanced GSM MAP Screening feature is not enabled or off, CDPA entries cannot be in the MAP screening table. Skip step 4 and go to step 5.

4. To display the CDPA entries assigned to the CGPA entry shown in step 2, enter the `rtrv-gsmmap-scrn` command with the `opname` and `cgpr` parameter values specified shown in step 2.

For this example, enter these commands.

```
rtrv-gsmmap-scrn:opname=pass50:cgsr=cg01
```

```
rlghncxa03w 08-09-20 09:07:58 GMT EAGLE5 39.2.0
Single CdPA Entries for OPNAME: pass50 and CGSR: cg01
-----
SADDR          NP NAI FORBD ACT      PCA          SSN CDSR RI  TT
SADDR          NP NAI FORBD ACT      PCI          SSN CDSR RI  TT
SADDR          NP NAI FORBD ACT      PCN          SSN CDSR RI  TT
SADDR          NP NAI FORBD ACT      PCN24        SSN CDSR RI  TT
SADDR          NP NAI FORBD ACT      CDSR
*              6 15 all pass cd01
Range CdPA Entries for OPNAME: pass50 and CGSR: cg01
-----
SADDR          EADDR          NP NAI FORBD ACT      PCA          SSN CDSR
SADDR          EADDR          NP NAI FORBD ACT      PCI          SSN CDSR
SADDR          EADDR          NP NAI FORBD ACT      PCN          SSN CDSR
SADDR          EADDR          NP NAI FORBD ACT      PCN24        SSN CDSR
SADDR          EADDR          NP NAI FORBD ACT      CDSR
GSM Map Screening table is (1512 of 4000) 38% full
```

```
rtrv-gsmmap-scrn:opname=ati:cgsr=cg03
```

This is an example of the possible output.

```
rlghncxa03w 08-09-20 09:07:58 GMT EAGLE5 39.2.0
Single CdPA Entries for OPNAME: ati and CGSR: cg03
-----
SADDR          NP NAI FORBD ACT      PCA          SSN CDSR RI  TT
SADDR          NP NAI FORBD ACT      PCI          SSN CDSR RI  TT
SADDR          NP NAI FORBD ACT      PCN          SSN CDSR RI  TT
SADDR          NP NAI FORBD ACT      PCN24        SSN CDSR RI  TT
SADDR          NP NAI FORBD ACT      CDSR
919461000000130 2 16 locat atier ati5
Range CdPA Entries for OPNAME: ati and CGSR: cg03
-----
SADDR          EADDR          NP NAI FORBD ACT      PCA          SSN CDSR
SADDR          EADDR          NP NAI FORBD ACT      PCI          SSN CDSR
SADDR          EADDR          NP NAI FORBD ACT      PCN          SSN CDSR
SADDR          EADDR          NP NAI FORBD ACT      PCN24        SSN CDSR
SADDR          EADDR          NP NAI FORBD ACT      CDSR
```



```
4329290000      5450000000      * *   state atier cd15
9194630000000000 9194640000000000 11 95  locat atier ati7
8035490000000000 8036500000000000 * *   locat atier ati9
```

GSM Map Screening table is (1512 of 4000) 38% full

```
rtrv-gsmmap-scrn:opname=sri:cgsr=cg06
```

This is an example of the possible output.

```
rlghncxa03w 08-09-20 09:07:58 GMT EAGLE5 39.2.0
```

Single CgPA Entries for OPNAME: sri and CGSR: cg06

```
-----
SADDR          NP NAI FORBD ACT      PCA          SSN CDSR
SADDR          NP NAI FORBD ACT      PCI          SSN CDSR
SADDR          NP NAI FORBD ACT      PCN          SSN CDSR
SADDR          NP NAI FORBD ACT      PCN24        SSN CDSR
SADDR          NP NAI FORBD ACT      CDSR
```

Range CgPA Entries for OPNAME: sri and CGSR: cg06

```
-----
SADDR          EADDR          NP NAI FORBD ACT      PCA          SSN CDSR
SADDR          EADDR          NP NAI FORBD ACT      PCI          SSN CDSR
SADDR          EADDR          NP NAI FORBD ACT      PCN          SSN CDSR
SADDR          EADDR          NP NAI FORBD ACT      PCN24        SSN CDSR
SADDR          EADDR          NP NAI FORBD ACT      CDSR
```

GSM Map Screening table is (1512 of 4000) 38% full

5. Remove the GSM MAP screening entries from the database with the `dlt-gsmmap-scrn` command.

If CDPA entries are being removed, these parameters must be specified with the `dlt-gsmmap-scrn` command: `opname`, `cgsr`, and `cdsr`.

If the GSM MAP Screening entry contains CDPA entries, the individual CDPA entries can be removed without removing the CGPA entry. However, if you wish to remove the CGPA entry, all CDPA entries assigned to the CGPA entry must be removed before the CGPA entry can be removed.

To remove a CGPA entry, enter the `dlt-gsmmap-scrn` command with the `opname`, and `cgsr` parameter values.

For this example, enter these commands:

```
dlt-gsmmap-scrn:opname=pass50:cgsr=cg01:cdsr=cd01
```

```
dlt-gsmmap-scrn:opname=ati:cgsr=cg03:cdsr=cd15
```

```
dlt-gsmmap-scrn:opname=sri:cgsr=cg06
```

To remove the CGPA entry `cg01` from the `opname pass50` (now that CGPA entry `cg01` has no CDPA entries assigned), enter this command:

```
dlt-gsmmap-scrn:opname=pass50:cgsr=cg01
```

When each of these commands has successfully completed, this message appears.

```
rlghncxa03w 06-10-20 09:07:58 GMT EAGLE5 36.0.0
GSM Map Screening table is (1508 of 4000) 38% full
DLT-GSM MAP-SCRN: MASP A - COMPLTD
```

- Verify the changes using the `rtrv-gsmmap-scrn` command with the `opname` parameter value used in step 5.

If CDPA entries were removed from CGPA entries without removing the CGPA entry, specify the `opname` and `cgsr` parameter values used in step 5 with the `rtrv-gsmmap-scrn` command.

For this example, enter these commands:

```
rtrv-gsmmap-scrn:opname=pass50
```

This is an example of the possible output.

```
rlghncxa03w 08-09-20 09:07:58 GMT EAGLE5 39.2.0
Single CgPA Entries for OPNAME: pass50
-----
SADDR          NP NAI FORBD ACT      PCA          SSN CGSR RI  TT
SADDR          NP NAI FORBD ACT      PCI          SSN CGSR RI  TT
SADDR          NP NAI FORBD ACT      PCN          SSN CGSR RI  TT
SADDR          NP NAI FORBD ACT      PCN24        SSN CGSR RI  TT
SADDR          NP NAI FORBD ACT      CGSR
Range CgPA Entries for OPNAME: pass50
-----
SADDR          EADDR          NP NAI FORBD ACT      PCA          SSN CGSR
SADDR          EADDR          NP NAI FORBD ACT      PCI          SSN CGSR
SADDR          EADDR          NP NAI FORBD ACT      PCN          SSN CGSR
SADDR          EADDR          NP NAI FORBD ACT      PCN24        SSN CGSR
SADDR          EADDR          NP NAI FORBD ACT      CGSR
GSM Map Screening table is (1508 of 4000) 38% full
```

```
rtrv-gsmmap-scrn:opname=ati:cgsr=cg03
```

This is an example of the possible output.

```
rlghncxa03w 08-09-20 09:07:58 GMT EAGLE5 39.2.0
Single CdPA Entries for OPNAME: ati and CGSR: cg03
-----
SADDR          NP NAI FORBD ACT      PCA          SSN CDSR RI  TT
SADDR          NP NAI FORBD ACT      PCI          SSN CDSR RI  TT
SADDR          NP NAI FORBD ACT      PCN          SSN CDSR RI  TT
SADDR          NP NAI FORBD ACT      PCN24        SSN CDSR RI  TT
SADDR          NP NAI FORBD ACT      CDSR
```

```

919461000000130 2 16 locat atier ati5
Range CdPA Entries for OPNAME: ati and CGSR: cg03
-----
SADDR          EADDR          NP NAI FORBD ACT      PCA          SSN CDSR
SADDR          EADDR          NP NAI FORBD ACT      PCI          SSN CDSR
SADDR          EADDR          NP NAI FORBD ACT      PCN          SSN CDSR
SADDR          EADDR          NP NAI FORBD ACT      PCN24        SSN CDSR
SADDR          EADDR          NP NAI FORBD ACT      CDSR
919463000000000 919464000000000 11 95 locat atier ati7
803549000000000 803650000000000 * *   locat atier ati9
GSM Map Screening table is (1508 of 4000) 38% full

```

- Backup the new changes using the `chg-db:action=backup:dest=fixed` command. These messages should appear, the active Maintenance and Administration Subsystem Processor (MASP) appears first.

```

BACKUP (FIXED) : MASP A - Backup starts on active MASP.
BACKUP (FIXED) : MASP A - Backup on active MASP to fixed disk complete.
BACKUP (FIXED) : MASP A - Backup starts on standby MASP.
BACKUP (FIXED) : MASP A - Backup on standby MASP to fixed disk complete.

```

Changing a GSM MAP Screening Entry

Use this command to change the attributes of the GSM MAP screening entries that filter or allow TCAP messages for certain MAP operation codes using the `chg-gsmmap-scrn` command. The SCCP messages contain MAP operation codes, origination addresses, numbering plan values, nature of address indicator values, and forbidden parameters.

The `chg-gsmmap-scrn` command uses these parameters.

`:opname` – The user-defined name for the operation code. The `opname` value references the operation code (`opcode`) defined with the `ent-gsms-opcode` command. GSM MAP screening is performed on the specified address or addresses for the referenced operation code.

`:naction` – The new screening action to take if a message is forbidden as defined by the `forbid` parameter value. One of these actions can be assigned.

- `pass` – Route the message as normal to the destination.
- `discard` – The MSU is to be discarded.
- `atierr` – An ATI (Any Time Interrogation) reject message is generated. This option is only valid for ATI MAP operation codes.
- `route` – Route the message as normal to the original destination node.
- `forward` – Route the original message to the forward node. The original message is not sent to the original node. If, however, the forwarded node is not available for routing then the MSU is routed to the original node.
- `duplicate` – Route the message as normal to the original destination and route a copy of the original message to the duplicate node.

- `dupdisc` – Duplicate and discard – Route the original message to the duplicate node. The original message is not sent to the original node.

`:npc/npca/npci/npcn/npcn24` – The new ANSI point code (`npc/npca`), new ITU-I point code or ITU-I spare point code (`npci`), new 14-bit ITU-N point code or 14-bit ITU-N spare point code (`npcn`), or new 24-bit ITU-N point code (`npcn24`) of the node that the MSU is routed to by the `forward`, `duplicate`, or `dupdisc` screening actions. The EAGLE 5 ISS can contain 14-bit ITU-N point codes or 24-bit ITU-N point codes, but not both.

`:nssn` – The new subsystem number of the node that the MSU is routed to by the `forward`, `duplicate`, or `dupdisc` screening actions

`:force` – The mated application override. Is the GSM MAP screening operation code to be entered without a mated application in the database (`yes` or `no`)?

`:nforbid` – The new forbidden parameter value. If a forbidden parameter is detected, the message is rejected by the action defined by the `action` parameter value. One of four forbidden parameter values can be specified.

- `all` – All parameters are forbidden. Take the specified screening action defined by the `naction` parameter for incoming messages that contain the entered address and operation code combination.
- `none` – No parameters are forbidden. Take the specified screening action defined by the `naction` parameter for incoming messages that contain the entered address and operation code combination.
- `state` – Take the specified screening action defined by the `naction` parameter for incoming messages that contain `state` as the forbidden parameter for the entered address and operation code combination.
- `location` – Take the specified screening action defined by the `naction` parameter for incoming messages that contain `location` as the forbidden parameter for the entered address and operation code combination.

`:cgsr` – The current CGPA screening reference name.

`:cdsr` – The current CDPA screening reference name.

`:ncgsr` – The new CGPA screening reference name consisting of 1 alphabetic character and 3 optional alphanumeric characters.

`:ncdsr` – The new CDPA screening reference name consisting of 1 alphabetic character and 3 optional alphanumeric characters.

`:nmapset` – The new MAP set ID, shown in the `rtrv-map` command. This parameter can be specified only if the Flexible GTT Load Sharing feature is enabled. The status of the Flexible GTT Load Sharing feature is shown in the `rtrv-ctrl-feat` output. To enable the Flexible GTT Load Sharing feature, perform the “Activating the Flexible GTT Load Sharing Feature” procedure in the *Database Administration Manual - Global Title Translation* .

`:nri` - The new routing indicator parameter. This parameter specifies whether a subsequent global title translation is required. This parameter has two values.

- `gt` - subsequent global title translation is required.
- `ssn` - subsequent global title translation is not required.

`:ntt` - the new translation type that will be assigned to the GSM MAP screening entry. This parameter specifies the value that the translation type for the CdPA is set to as a result of GSM MAP screening. The values for this parameter are 0 to 255, or the value `none` which specifies removes the existing translation type from to the GSM MAP screening entry.

If a message is screened and does not contain matching npv and nai v values, the message is rejected. The message is rejected with the default action defined by the chg-gsms-opcode command for the operation code (opcode) parameter entry referenced by the operation name (opname) parameter.

Table 22: Change GSM MAP Screening Entry Parameter Combinations shows the parameter combinations that can be used in this procedure.

Table 22: Change GSM MAP Screening Entry Parameter Combinations

Entry Containing a Point Code and SSN Enhanced GSM MAP Screening Feature Enabled and On	Entry Without a Point Code and SSN Enhanced GSM MAP Screening Feature Enabled and On	Entry containing the Action ATIERR Enhanced GSM MAP Screening Feature Enabled and On	Entry Containing a Point Code and SSN GSM MAP Screening Feature Enabled and On Only	Entry Without a Point Code and SSN GSM MAP Screening Feature Enabled and On Only	Entry containing the Action ATIERR GSM MAP Screening Feature Enabled and On Only
Mandatory Parameters					
:opname = current opname value (See Note 2)	:opname = current opname value (See Note 2)	:opname = current opname value containing opcode=71 (See Note 2)	:opname = current opname value (See Note 2)	:opname = current opname value (See Note 2)	:opname = current opname value containing opcode=71 (See Note 2)
:cgsr = current CGSR value	:cgsr = current CGSR value	:cgsr = current CGSR value	:cgsr = current CGSR value	:cgsr = current CGSR value	:cgsr = current CGSR value
Optional Parameters (See Note 1)					
:cdsr = current CDSR value (See Notes 3 and 4)	:cdsr = current CDSR value (See Notes 3 and 4)	:cdsr = current CDSR value (See Notes 3 and 4)	:nforbid = all	:nforbid = all, none (See Note 13)	:nforbid = state, location
:nforbid = all	:nforbid = all, none (See Note 13)	:nforbid = state, location	:naction = forward, duplicate, dupdisc (See Note 6)	:naction = pass, discard, route (See Note 13)	:naction = atierr
:naction = forward, duplicate,	:naction = pass, discard, route (See Note 13)	:naction = atierr	:ncgsr = new CGSR value	:ncgsr = new CGSR value	:ncgsr = new CGSR value

<p>Entry Containing a Point Code and SSN</p> <p>Enhanced GSM MAP Screening Feature Enabled and On</p>	<p>Entry Without a Point Code and SSN</p> <p>Enhanced GSM MAP Screening Feature Enabled and On</p>	<p>Entry containing the Action ATIERR</p> <p>Enhanced GSM MAP Screening Feature Enabled and On</p>	<p>Entry Containing a Point Code and SSN</p> <p>GSM MAP Screening Feature Enabled and On Only</p>	<p>Entry Without a Point Code and SSN</p> <p>GSM MAP Screening Feature Enabled and On Only</p>	<p>Entry containing the Action ATIERR</p> <p>GSM MAP Screening Feature Enabled and On Only</p>
dupdisc (See Note 6)					
:ncgsr = new CGSR value (See Notes 4 and 5)	:ncgsr = new CGSR value (See Notes 4 and 5)	:ncgsr = new CGSR value (See Notes 4 and 5)	:npci/npcn/npcn24 =point code value (See Notes 7, 8, 9, 10, 11, and 12)		
:ncdsr = new CDSR value (See Notes 3 and 5)	:ncdsr = new CDSR value (See Notes 3 and 5)	:ncdsr = new CDSR value (See Notes 3 and 5)	:nssn = 0 - 255, none (See Notes 7, 8, 9, 10, 11, 12, and 14)		
:npc/npca/npci/npcn/npcn24 = point code value (See Notes 7, 8, 9, 10, 11, and 12)			:force=yes (See Notes 11 and 12)		
:nssn = 0 - 255, none (See Notes 7, 8, 9, 10, 11, 12, and 14)			:nmapset = dflt or numbered MAP set ID (See Notes 11 and 12)		
:force=yes (See Notes 11 and 12)			:nri = gt, ssn (See Note 14)		
			:ntt = 0 - 255, none (See Note 15)		

Entry Containing a Point Code and SSN Enhanced GSM MAP Screening Feature Enabled and On	Entry Without a Point Code and SSN Enhanced GSM MAP Screening Feature Enabled and On	Entry containing the Action ATIERR Enhanced GSM MAP Screening Feature Enabled and On	Entry Containing a Point Code and SSN GSM MAP Screening Feature Enabled and On Only	Entry Without a Point Code and SSN GSM MAP Screening Feature Enabled and On Only	Entry containing the Action ATIERR GSM MAP Screening Feature Enabled and On Only
:nmapset = dflt or numbered MAP set ID (See Notes 11 and 12)					
:nri = gt, ssn (See Note 14)					
:ntt = 0 - 255, none (See Note 15)					

Notes:

- At least one optional parameter must be specified with the `chg-gsmmap-scrn` command. If the `cdsr` parameter is specified, at least one other optional parameter must be specified with the `chg-gsmmap-scrn` command.
- The `opname` parameter value must be shown in the `rtrv-gsms-opcode` output.
- The `cdsr` parameter must be specified when the `ncdsr` parameter is specified.
- The `ncgsr` parameter should not be specified when the `cdsr` parameter is specified.
- The `ncgsr` and `ncdsr` parameters cannot be specified together.
- The point code value must be the DPC of a route or a member of a cluster route. The `npc/npca` value must be a full point code, The `npc/npca` value can be a member of a cluster point code when that cluster point code is the DPC of a route. This can be verified with the `rtrv-rte` command. If the point code value is not shown in the `rtrv-rte` output as the DPC of a route, go to the "Adding a Route Containing an SS7 DPC" procedure in the *Database Administration Manual - SS7* and add a new route containing the point code value. A proxy point code cannot be assigned to the point code.
- The EAGLE 5 ISS can contain 14-bit ITU-N point codes or 24-bit ITU-N point codes, but not both at the same time.
- If the new or current (if unchanged) `action` parameter values are either `forward`, `duplicate`, or `dupdisc`, the `point code` and `nssn` parameters must be specified with the `chg-gsmmap-scrn` command. If the `point code` or `subsystem number` values are not being changed, the `point code` and `subsystem number` parameters must be specified with the current values for these parameters.

Entry Containing a Point Code and SSN Enhanced GSM MAP Screening Feature Enabled and On	Entry Without a Point Code and SSN Enhanced GSM MAP Screening Feature Enabled and On	Entry containing the Action ATIERR Enhanced GSM MAP Screening Feature Enabled and On	Entry Containing a Point Code and SSN GSM MAP Screening Feature Enabled and On Only	Entry Without a Point Code and SSN GSM MAP Screening Feature Enabled and On Only	Entry containing the Action ATIERR GSM MAP Screening Feature Enabled and On Only
<p>9. If only the point code or subsystem number value is being changed, the point code or subsystem number value being changed must be specified with the new value for the parameter being changed. The current value for the point code or subsystem number parameter not being changed must be specified. The <code>naction</code> parameter does not have to be specified. For example, if the current point code is <code>pca=002-002-002</code> and the subsystem number is 50, and the point code is being changed to <code>pca=003-003-003</code> and the subsystem number is not changing, the <code>npca</code> parameter value would be the new point code value (003-003-003) and the <code>nssn</code> parameter value would be the current value (50).</p> <p>10. To specify the <code>npc/npca</code> parameters, the Enhanced GSM MAP Screening feature must be enabled and turned on.</p> <p>11. If the Flexible GTT Load Sharing feature is not enabled:</p> <ul style="list-style-type: none"> • The <code>nmapset</code> parameter cannot be specified. • The point code and subsystem number values specified with the <code>chg-gsmmap-scrn</code> command must be shown in the <code>rtrv-map</code> output, or else the <code>force=yes</code> parameter must be specified. If the point code and subsystem number values are not shown in the <code>rtrv-map</code> output, and a new mated application is to be added, perform one of the "Provisioning a Mated Application" procedures in the <i>Database Administration Manual - Global Title Translation</i> and add the required mated application with the point code and subsystem number values. <p>12. If the Flexible GTT Load Sharing feature is enabled:</p> <ul style="list-style-type: none"> • If the current <code>action</code> parameter value is either <code>pass</code>, <code>route</code>, <code>discard</code>, or <code>atierr</code>, and the <code>action</code> parameter value is changed to either <code>forward</code>, <code>duplicate</code>, or <code>dupdisc</code>, the GSM MAP screening entry must be assigned to a MAP set with the <code>nmapset=dflt</code> parameter (to assign the GSM MAP screening entry to the default MAP set), or with the <code>nmapset=<numbered MAP set ID></code> parameter (to assign the GSM MAP screening entry to a MAP set other the default MAP set). • If the default MAP set will be assigned to the GSM MAP screening entry, the <code>npc/npca/npci/npcn/npcn24</code> and <code>nssn</code> values must be shown in the default MAP set in the <code>rtrv-map</code> output. If the <code>npc/npca/npci/npcn/npcn24</code> or <code>nssn</code> values are not shown in the default MAP set in the <code>rtrv-map</code> output, the <code>force=yes</code> parameter must be specified. • If a MAP set other than the default MAP set will be assigned to the GSM MAP screening entry, the <code>npc/npca/npci/npcn/npcn24</code> and <code>nssn</code> values must be shown in that MAP set in the <code>rtrv-map</code> output. • If the point code and subsystem values are not being changed, the <code>nmapset</code> parameter does not have to be specified unless the MAP set ID assigned to the GSM MAP screening entry is being 					

Entry Containing a Point Code and SSN Enhanced GSM MAP Screening Feature Enabled and On	Entry Without a Point Code and SSN Enhanced GSM MAP Screening Feature Enabled and On	Entry containing the Action ATIERR Enhanced GSM MAP Screening Feature Enabled and On	Entry Containing a Point Code and SSN GSM MAP Screening Feature Enabled and On Only	Entry Without a Point Code and SSN GSM MAP Screening Feature Enabled and On Only	Entry containing the Action ATIERR GSM MAP Screening Feature Enabled and On Only
--------------------------------------------------------------------------------------------	-----------------------------------------------------------------------------------------	-----------------------------------------------------------------------------------------	----------------------------------------------------------------------------------------	-------------------------------------------------------------------------------------	-------------------------------------------------------------------------------------

changed. The new MAP set must contain the point code and subsystem values in the GSM MAP screening entry.

13. If the value of the `forbid` parameter is being changed to `none`, and the current value of the `action` parameter is `not pass`, the `naction=pass` parameter must be specified. If the current value of the `forbid` parameter is `none` and will not be changed, the value of the `action` parameter must be `pass` and cannot be changed.

14. If, when the `chg-gsmmap-scrn` command is completed, the `ri` parameter value is `ssn`, then a numerical value must be assigned to the `ssn` parameter.

15. The value `none` for the `tt` parameter removes the existing `tt` parameter value that is assigned to the GSM MAP screening entry. A dash is shown in the `TT` column of the `rtrv-gsmmap-scrn` output when the `tt` value is removed.

1. Display the GSM MAP screening operation codes in the database using the `rtrv-gsms-opcode` command.

If the Flexible GTT Load Sharing feature is not enabled, this is an example of the possible output.

```

rlghncxa03w 08-09-10 11:43:04 GMT EAGLE5 39.2.0
OPCODE  OPNAME      DFLTACT  PCA          SSN  RI  TT
 36      for1         fwd      002-002-002  10   gt  10

OPCODE  OPNAME      DFLTACT  PCI          SSN  RI  TT
 93      dd93         dupdc    5-025-3     200  ssn 40
139     fwd139      fwd      3-159-7     128  ssn -

OPCODE  OPNAME      DFLTACT  PCN          SSN  RI  TT
187     dup187     dupl     11519       79   gt  50

OPCODE  OPNAME      DFLTACT  PCN24        SSN

OPCODE  OPNAME      DFLTACT
 22     sri         disc
 25     route25    route
 50     pass50     pass
 71     ati        atierr
150     discard1   disc
*      star       pass
    
```

```
GSMMS OPCODE Table (10 of 257) is 4% full
```

If the Flexible GTT Load Sharing feature is enabled, this is an example of the possible output.

```
rlghncxa03w 08-09-10 11:43:04 GMT EAGLE5 39.2.0

OPCODE  OPNAME      DFLTACT      PCA          SSN  MAPSET RI  TT
 36      for1         fwd          002-002-002  10   25   gt  10

OPCODE  OPNAME      DFLTACT      PCI          SSN  MAPSET RI  TT
 93      dd93        dupdc        5-025-3     200  20   ssn 40
139     fwd139      fwd          3-159-7     128  DFLT  ssn -

OPCODE  OPNAME      DFLTACT      PCN          SSN  MAPSET RI  TT
187     dup187      dupl         11519        79   10   gt  50

OPCODE  OPNAME      DFLTACT      PCN24        SSN  MAPSET RI  TT

OPCODE  OPNAME      DFLTACT
 22     sri         disc
 25     route25    route
 50     pass50     pass
 71     ati        atierr
150     discard1   disc
*      star      pass
```

```
GSMMS OPCODE Table (10 of 257) is 4% full
```

If the default action for the GSM MAP screening entry will be `atierr`, or the `forbid` parameter value will be `location` or `state`, the `opname` value must contain an `opcode` value of 71.

2. Enter the `rtrv-gsmmap-scrn` command with an `opname` value shown in the `rtrv-gsmms-opcode` command output in step 1 to display the CGPA GSM MAP screening entries to change.

For this example, enter this command.

```
rtrv-gsmmap-scrn:opname=ati
```

This is an example of the possible output.

```
rlghncxa03w 08-09-20 09:07:58 GMT EAGLE5 39.2.0

Single CgPA Entries for OPNAME: ati
-----
SADDR          NP NAI FORBD ACT      PCA          SSN CGSR RI  TT
SADDR          NP NAI FORBD ACT      PCI          SSN CGSR RI  TT
SADDR          NP NAI FORBD ACT      PCN          SSN CGSR RI  TT
SADDR          NP NAI FORBD ACT      PCN24        SSN CGSR RI  TT

SADDR          NP NAI FORBD ACT  CGSR
919462000000005 1 0  locat atier atil

Range CgPA Entries for OPNAME: ati
-----
SADDR          EADDR          NP NAI FORBD ACT      PCA
SSN CGSR

SADDR          EADDR          NP NAI FORBD ACT      PCI          SSN CGSR
SADDR          EADDR          NP NAI FORBD ACT      PCN          SSN CGSR
```

```

SADDR          EADDR          NP NAI FORBD ACT      PCN24          SSN CGSR
SADDR          EADDR          NP NAI FORBD ACT      CGSR
8284540000     8284600000          * * state atier cg03
91946188888888 9194619000000000 4 1 locat atier ati2
91946200000000 9194630000000000 * * locat atier ati3
GSM Map Screening table is (1512 of 4000) 38% full
    
```

rtrv-gsmmap-scrn:opname=dd93

This is an example of the possible output.

```

rlghncxa03w 08-09-20 09:07:58 GMT EAGLE5 39.2.0
Single CgPA Entries for OPNAME: dd93
-----
SADDR          NP NAI FORBD ACT      PCA          SSN CGSR RI  TT
SADDR          NP NAI FORBD ACT      PCI          SSN CGSR RI  TT
SADDR          NP NAI FORBD ACT      PCN          SSN CGSR RI  TT
SADDR          NP NAI FORBD ACT      PCN24        SSN CGSR RI  TT
SADDR          NP NAI FORBD ACT      CGSR
Range CgPA Entries for OPNAME: dd93
-----
SADDR          EADDR          NP NAI FORBD ACT      PCA          SSN CGSR
SADDR          EADDR          NP NAI FORBD ACT      PCI          SSN CGSR
854000000     857000000     3 99 all fwd          3-201-7      100 cg05
RI=ssn TT=-
SADDR          EADDR          NP NAI FORBD ACT      PCN          SSN CGSR
SADDR          EADDR          NP NAI FORBD ACT      PCN24        SSN CGSR
SADDR          EADDR          NP NAI FORBD ACT      CGSR
GSM Map Screening table is (1512 of 4000) 38% full
    
```

If the Flexible GTTLoad Sharing feature is enabled, the MAPSET field is shown in the rtrv-gsmmap-scrn output as shown in the following output example.

```

rlghncxa03w 08-09-20 09:07:58 GMT EAGLE5 39.2.0
Single CgPA Entries for OPNAME: dd93
-----
SADDR          NP NAI FORBD ACT      PCA          SSN CGSR MAPSET RI
SADDR          NP NAI FORBD ACT      PCI          SSN CGSR MAPSET RI
SADDR          NP NAI FORBD ACT      PCN          SSN CGSR MAPSET RI
SADDR          NP NAI FORBD ACT      PCN24        SSN CGSR MAPSET RI
SADDR          NP NAI FORBD ACT      CGSR
Range CgPA Entries for OPNAME: dd93
-----
SADDR          EADDR          NP NAI FORBD ACT      PCA          SSN CGSR
    
```

```

SADDR          EADDR          NP NAI FORBD ACT      PCI
SSN CGSR
854000000      857000000      3 99 all fwd          3-201-7          100 cg05
MAPSET = DFLT RI=ssn TT=-

```

```

SADDR          EADDR          NP NAI FORBD ACT      PCN          SSN CGSR
SADDR          EADDR          NP NAI FORBD ACT      PCN24        SSN CGSR
SADDR          EADDR          NP NAI FORBD ACT      CGSR

```

GSM Map Screening table is (1512 of 4000) 38% full

Note: If the `npc/npca` or `ncdsr` parameters are being specified in this procedure, the Enhanced GSM MAP Screening feature must be enabled and on. If these parameters are not being specified in this procedure, skip step 3 and go to step 4.

If any of the following parameters or values are shown in the `rtrv-gsmmap-scrn` output in this step, the Enhanced GSM MAP Screening feature is enabled and on. Skip step 3 and go to step 4.

- `saddr=*`
- `pc/pca`
- The `saddr` or `eaddr` parameter values containing hex digits.

If the `rtrv-gsmmap-scrn` output in this step does not show any of these parameters or values, it is possible that the Enhanced GSM MAP Screening feature is enabled and on. If you wish to use the `npc/npca` or `ncdsr` parameters, perform step 3 to verify the status of the Enhanced GSM MAP Screening feature.

3. Verify that the Enhanced GSM MAP Screening feature is enabled and on by entering the `rtrv-ctrl-feat` command with the part number of the Enhanced GSM MAP Screening feature. Enter this command.

```
rtrv-ctrl-feat:partnum=893012401
```

The following is an example of the possible output.

```

rlghncxa03w 06-10-28 21:15:37 GMT EAGLE5 36.0.0
The following features have been permanently enabled:
Feature Name          Partnum    Status    Quantity
Enhanced GMS (EGMS)  893012401  on        ----

The following features have been temporarily enabled:
Feature Name          Partnum    Status    Quantity    Trial Period Left
Zero entries found.

The following features have expired temporary keys:
Feature Name          Partnum
Zero entries found.

```

- If the Enhanced GSM MAP screening feature is not enabled or is turned off, and you wish to use the `npc/npca` or `ncdsr` parameters, perform the [Activating the GSM MAP Screening Feature](#) procedure to enable and turn on the Enhanced GSM MAP Screening feature. After the Enhanced GSM MAP Screening feature has been enabled and turned on, continue the procedure with step 4.
- Skip step 4 and continue the procedure with step 5 if:

- The Enhanced GSM MAP Screening feature will not be enabled and turned on in this step.
 - The `npc/npc` or `ncdsr` parameters will not be specified in this procedure and the Enhanced GSM MAP Screening feature is enabled and turned on.
4. Enter the `rtrv-gsmmap-scrn` command with an `opname` and `cgsr` values shown in the `rtrv-gsmmap-scrn` command output in step 2 to display the CDPA GSM MAP screening entries to change.

For this example, enter this command.

```
rtrv-gsmmap-scrn:opname=ati:cgsr=cg03
```

This is an example of the possible output.

```
rlghncxa03w 08-09-20 09:07:58 GMT EAGLE5 39.2.0
Single CdPA Entries for OPNAME: ati and CGSR: cg03
-----
SADDR          NP NAI FORBD ACT      PCA          SSN CDSR RI  TT
SADDR          NP NAI FORBD ACT      PCI          SSN CDSR RI  TT
SADDR          NP NAI FORBD ACT      PCN          SSN CDSR RI  TT
SADDR          NP NAI FORBD ACT      PCN24        SSN CDSR RI  TT
SADDR          NP NAI FORBD ACT      CDSR
919461000000130 2 16 locat atier ati5
Range CdPA Entries for OPNAME: ati and CGSR: cg03
-----
SADDR          EADDR          NP NAI FORBD ACT      PCA          SSN CDSR
SADDR          EADDR          NP NAI FORBD ACT      PCI          SSN CDSR
SADDR          EADDR          NP NAI FORBD ACT      PCN          SSN CDSR
SADDR          EADDR          NP NAI FORBD ACT      PCN24        SSN CDSR
SADDR          EADDR          NP NAI FORBD ACT      CDSR
4329290000    5450000000    * * state atier cd15
91946300000000 91946400000000 11 95 locat atier ati7
80354900000000 80365000000000 * * locat atier ati9
GSM Map Screening table is (1512 of 4000) 38% full
```

```
rtrv-gsmmap-scrn:opname=dd93:cgsr=cg05
```

This is an example of the possible output.

```
rlghncxa03w 08-09-20 09:07:58 GMT EAGLE5 39.2.0
Single CdPA Entries for OPNAME: dd93 and CGSR: cg05
-----
SADDR          NP NAI FORBD ACT      PCA          SSN CDSR RI  TT
SADDR          NP NAI FORBD ACT      PCI          SSN CDSR RI  TT
SADDR          NP NAI FORBD ACT      PCN          SSN CDSR RI  TT
SADDR          NP NAI FORBD ACT      PCN24        SSN CDSR RI  TT
```

```

SADDR          NP NAI FORBD ACT    CDSR
Range CgPA Entries for OPNAME: dd93 and CGSR: cg05
-----
SADDR          EADDR          NP NAI FORBD ACT    PCA          SSN CDSR
SADDR          EADDR          NP NAI FORBD ACT    PCI          SSN CDSR
SADDR          EADDR          NP NAI FORBD ACT    PCN          SSN CDSR
SADDR          EADDR          NP NAI FORBD ACT    PCN24        SSN CDSR
SADDR          EADDR          NP NAI FORBD ACT    CDSR
GSM Map Screening table is (1512 of 4000) 38% full

```

Note: If the Flexible GTT Load Sharing feature is enabled, the MAPSET field is shown in the `rtrv-gsmmap-scrn` output if the `action` parameter value for the GSM MAP screening entry is either `forward`, `duplicate`, or `dupdisc`.

5. Perform one of these actions.

- If the `naction` parameter value will be either `pass`, `discard`, `route`, or `atierr`, skip steps 6 through 9, and continue the procedure with step 10.
- If the point code is not being changed, skip steps 6 through 9, and continue the procedure with step 10. If the point code and subsystem values are not being changed, and the Flexible GTT Load Sharing feature is enabled, the `nmapset` parameter does not have to be specified unless the MAP set ID assigned to the GSM MAP screening entry is being changed. The new MAP set must contain the point code and subsystem values in the GSM MAP screening entry.
- If the `naction` parameter value will be either `forward`, `duplicate`, or `dupdisc`, perform one of these actions.
 - To use a point code and a MAP set from the mated application table, and MAP sets are not shown in the `rtrv-gsmmap-scrn` output in step 4, the Flexible GTT Load Sharing Feature must be enabled. Perform the “Activating the Flexible GTT Load Sharing Feature” procedure in the *Database Administration Manual - Global Title Translation* and enable the Flexible GTT Load Sharing feature. After enabling the Flexible GTT Load Sharing feature, skip steps 6 and 7 and continue the procedure with step 8.
 - To use a point code and a MAP set from the mated application table, and MAP sets are shown in the `rtrv-gsmmap-scrn` output in step 4, skip steps 6 and 7 and continue the procedure with step 8.
 - To use a point code in the mated application table, but without using a MAP set, and MAP sets are not shown in the `rtrv-gsmmap-scrn` output in step 4, skip steps 6 and 7 and continue the procedure with step 8.
 - To use a point code that is not in the mated application table, the `force=yes` parameter must be specified with the `chg-gsmmap-scrn` command. A proxy point code cannot be assigned to this point code. If the Flexible GTT Load Sharing feature is enabled, the `force=yes` parameter can be used only if the default MAP set is assigned to the GSM OPCODE entry. Continue the procedure with step 6.

6. Display the destination point codes in the database by entering the `rtrv-dstn` command. This is an example of the possible output.

```
rlghncxa03w 10-12-10 11:43:04 GMT EAGLE5 43.0.0
```

```

Extended Processing Time may be Required

DPCA          CLLI          BEI  ELEI    ALIASI          ALIASN/N24    DMN
001-207-000  ----- no  --- -----
001-001-001  ----- no  --- -----
001-001-002  ----- no  --- -----
001-005-000  ----- no  --- -----
001-007-000  ----- no  --- -----
008-012-003  ----- no  --- -----
003-002-004  ----- no  --- -----
009-002-003  ----- no  --- -----
010-020-005  ----- no  --- -----

DPCI          CLLI          BEI  ELEI    ALIASA          ALIASN/N24    DMN
1-207-0      ----- no  --- -----
0-015-0      ----- no  --- -----
0-017-0      ----- no  --- -----
1-011-1      ----- no  --- -----
1-011-2      ----- no  --- -----

Destination table is (14 of 2000) 1% full
Alias table is (0 of 12000) 0% full
PPC table is (1 of 20) 5% full

```

If the required point code is not shown in the `rtrv-dstn` output, perform the "Adding a Destination Point Code" procedure in the *Database Administration Manual - SS7* to add the required point code. A proxy point code cannot be assigned to the point code.

After the new point code has been added, skip steps 7 through 9 and perform the "Adding a Route Containing an SS7 DPC" procedure in the *Database Administration Manual - SS7* and add the required route to the database. After the route has been added, continue the procedure with step 10.

7. Display the point code that will be assigned to the mated application by using the `rtrv-dstn` command and specifying the point code. For this example, enter this command.

```
rtrv-dstn:dpca=010-020-005
```

This is an example of the possible output.

```

rlghncxa03w 10-12-10 11:43:04 GMT EAGLE5 43.0.0

DPCA          CLLI          BEI  ELEI    ALIASI          ALIASN/N24    DMN
010-020-005  ----- no  --- -----

PPCA          NCAI PRX      RCAUSE NPRST  SPLITIAM  HMSMSC  HMSCP  SCCPMSGCNV
009-002-003  ---- no      50      on      20      no      no      none

Destination table is (14 of 2000) 1% full
Alias table is (0 of 12000) 0% full
PPC table is (1 of 20) 5% full

```

If the adjacent point code is not shown in the `rtrv-dstn` command output, the following output is displayed.

```

rlghncxa03w 09-05-10 11:43:04 GMT EAGLE5 41.0.0

No destinations meeting the requested criteria were found

Destination table is (14 of 2000) 1% full

```

```
Alias table is (0 of 12000) 0% full
PPC table is (1 of 20) 5% full
```

A proxy point code (a point code value is shown in the PPC column) cannot be assigned to the point code. If a proxy point code is shown in this step, choose another point code from the `rtrv-dstn` output in the previous step and repeat this step.

If the point code is not shown in the `rtrv-dstn` output, perform the "Adding a Destination Point Code" procedure in the *Database Administration Manual - SS7* and add the adjacent point code to the destination point code table.

After the new point code has been added, skip steps 8 and 9, and perform the "Adding a Route Containing an SS7 DPC" procedure in the *Database Administration Manual - SS7* and add the required route to the database. After the route has been added, continue the procedure with step 10.

8. The point code and subsystem number being assigned to the GSM MAP screening entry must be in the mated application table.

Enter the `rtrv-map` command with the `npc/npca/npci/npcn/npcn24` and `nssn` values that will be specified with the `chg-gsmmap-scrn` command in step 10.

If the Flexible GTT Load Sharing feature is not enabled, for this example, enter these commands.

```
rtrv-map:pci=5-79-2:ssn=89
```

This is an example of the possible output.

```
rlghncxa03w 09-07-25 09:42:31 GMT EAGLE5 41.1.0
PCI          Mate PCI          SSN RC MULT SRM MRC GRP NAME SSO
5-079-2      89 10 SOL *N *N GRP01 ON
MAP TABLE IS (20 of 1024) 2 % FULL
```

Note: If the point code and subsystem number is not shown in the `rtrv-map` output, and is not added to the database in one of these procedures, the `force=yes` parameter must be specified with the `chg-gsmmap-scrn` command in step 10.

If the Flexible GTT Load Sharing feature is enabled and the current `action` parameter value is either `pass`, `route`, `discard`, or `atierr`, and the `action` parameter value is changed to either `forward`, `duplicate`, or `dupdisc`, the GSM MAP screening entry must be assigned to a MAP set with the `nmapset=dflt` parameter (to assign the GSM MAP screening entry to the default MAP set), or with the `nmapset=<numbered MAP set ID>` parameter (to assign the GSM MAP screening entry to a MAP set other the default MAP set).

For this example, enter these commands.

```
rtrv-map:pci=5-79-2:ssn=89
```

This is an example of the possible output.

```
rlghncxa03w 09-07-25 09:42:31 GMT EAGLE5 41.1.0
MAPSET ID=DFLT
PCI          Mate PCI          SSN RC MULT SRM MRC GRP NAME SSO
5-079-2      89 10 SOL *N *N GRP01 ON
MAP TABLE IS (20 of 1024) 2 % FULL
```

If the point code and subsystem number is not shown in the `rtrv-map` output, perform one of the "Provisioning a Mated Application" procedures in the *Database Administration Manual - Global*

Title Translation and add the required point code and subsystem number to the mated application table.

- The point code specified with the `chg-gsmmap-scrn` command must be the DPC of a route. Enter the `rtrv-rte` command with the `dpc` parameter specifying the point code to be used with the `chg-gsmmap-scrn` command to verify whether or not the point code is the DPC of a route. For this example, enter these commands.

```
rtrv-rte:dpci=5-79-2
```

This is an example of the possible output.

```
rlghncxa03w 06-10-07 11:43:04 GMT EAGLE5 36.0.0
DPCI      ALIASN/N24      ALIASA      LSN      RC      APC
5-79-2    1501                230-101-191 ls100001  10     1-234-5
                               ls100002  10     3-65-4
                               RTX:No   CLLI=idp9
```

If the point code is not shown in the `rtrv-rte` output, go to the "Adding a Route Containing an SS7 DPC" procedure in the *Database Administration Manual - SS7* and add the required route to the database.

- Change the GSM MAP screening entry with the `chg-gsmmap-scrn` command.

[Table 22: Change GSM MAP Screening Entry Parameter Combinations](#) shows the parameter combinations that can be used with the `chg-gsmmap-scrn` command.

For this example, the Enhanced GSM MAP Screening feature is enabled and on. Enter these commands:

```
chg-gsmmap-scrn:opname=ati:cgsr=cg03:cdsr=cd15:nforbid=none :naction=pass
chg-gsmmap-scrn:opname=dd93:cgsr=cg05:nforbid=none:naction=pass
:npci=5-79-2:nssn=89:nmapset=20
```

When this command has successfully completed, this message appears.

```
rlghncxa03w 06-10-20 09:07:58 GMT EAGLE5 36.0.0
GSM Map Screening table is (1512 of 4000) 38% full
CHG-GSMMAP-SCRN: MASP A - COMPLTD
```

- Verify the changes using the `rtrv-gsmmap-scrn` command, specifying the `opname` parameter value used in step 10.

If the `cdsr` parameter was specified in step 10, specify the `cgsr`, and `cdsr` parameter values used in step 10 with the `opname` parameter value. For this example, the Enhanced GSM MAP Screening feature is enabled and on. Enter these commands:

```
rtrv-gsmmap-scrn:opname=ati:cgsr=cg03:cdsr=cd15
```

This is an example of the possible output.

```
rlghncxa03w 08-09-20 09:07:58 GMT EAGLE5 39.2.0
SADDR      EADDR      NP NAI FORBD ACT   CDSR  MAPSET RI
8284540000 8284600000 *  *   none pass  cd15  DFLT  ssn
TT=-
GSM Map Screening table is (1512 of 4000) 38% full
rtrv-gsmmap-scrn:opname=dd93
```

This is an example of the possible output.

```

rlghncxa03w 08-09-20 09:07:58 GMT EAGLE5 39.2.0
Single CgPA Entries for OPNAME: dd93
-----
SADDR          NP NAI FORBD ACT      PCA          SSN CGSR  MAPSET  RI
SADDR          NP NAI FORBD ACT      PCI          SSN CGSR  MAPSET  RI
SADDR          NP NAI FORBD ACT      PCN          SSN CGSR  MAPSET  RI
SADDR          NP NAI FORBD ACT      PCN24        SSN CGSR  MAPSET  RI
SADDR          NP NAI FORBD ACT      CGSR

Range CgPA Entries for OPNAME: dd93
-----
SADDR          EADDR          NP NAI FORBD ACT      PCA          SSN CGSR
SADDR          EADDR          NP NAI FORBD ACT      PCI          SSN CGSR
854000000      860000000      3 99 none pass        5-79-2      89 cg05
MAPSET = 20 RI=ssn TT=-
SADDR          EADDR          NP NAI FORBD ACT      PCN          SSN CGSR
SADDR          EADDR          NP NAI FORBD ACT      PCN24        SSN CGSR
SADDR          EADDR          NP NAI FORBD ACT      CGSR

GSM Map Screening table is (1512 of 4000) 38% full

```

- Backup the new changes using the `chg-db:action=backup:dest=fixed` command.

These messages should appear, the active Maintenance and Administration Subsystem Processor (MASP) appears first.

```

BACKUP (FIXED) : MASP A - Backup starts on active MASP.
BACKUP (FIXED) : MASP A - Backup on active MASP to fixed disk complete.
BACKUP (FIXED) : MASP A - Backup starts on standby MASP.
BACKUP (FIXED) : MASP A - Backup on standby MASP to fixed disk complete.

```

Changing the GSM MAP Screening TCAP Continue and End Message Processing Option

The option for enabling or disabling the processing of GSM MAP screening TCAP Continue and TCAP End messages can be changed with the `chg-sccpopts` command and with the following parameter:

`:gmstcapce` – This parameter has two values:

- `on` – enables the processing of TCAP Continue and TCAP End messages.
- `off` – disables the processing of TCAP Continue and TCAP End messages.

The system default value for this parameter is `off`.

The value of the `gsmtcapce` parameter is shown in the `GMSTCAPCE` field of the `rtrv-sccpopts` output. The `GMSTCAPCE` field of the `rtrv-sccpopts` output is shown only when the GSM MAP Screening feature is enabled and turned on. If the `GMSTCAPCE` field is not shown in the `rtrv-sccpopts` output, perform the [Activating the GSM MAP Screening Feature](#) to enable and turn on the GSM MAP screening feature.

1. Display the existing value for the `gsmtcapce` parameter by entering the `rtrv-sccpopts` command.

The value for the `gsmtcapce` parameter is shown in the `GSMTCAPCE` field. This is an example of the possible output.

```
rlghncxa03w 06-10-17 16:02:05 GMT  EAGLE5 36.0.0
SCCP OPTIONS
-----
GSMTCAPCE                          off
```

Note:

The `rtrv-sccpopts` command output contains other fields that are not used by this procedure. If you wish to see all the fields displayed by the `rtrv-sccpopts` command, see the `rtrv-sccpopts` command description in the *Commands Manual*.

If the `GSMTCAPCE` field is not shown in the `rtrv-sccpopts` output, perform the [Activating the GSM MAP Screening Feature](#) to enable and turn on the GSMMAP screening feature. After the GSMMAP Screening feature is enabled and turned on, go to step 2.

If the `GSMTCAPCE` field is shown in the `rtrv-sccpopts` output, go to step 2.

2. Change the `gsmtcapce` parameter value by entering on of the following commands.

If the current value of the `gsmtcapce` parameter is `off`, or if the GSM MAP Screening feature was enabled and turned on in step 1, enter the following command to enable the processing of TCAP Continue and TCAP End messages.

```
chg-sccpopts:gsmtcapce=on
```

If the current value of the `gsmtcapce` parameter is `on`, enter the following command to disable the processing of TCAP Continue and TCAP End messages.

```
chg-sccpopts:gsmtcapce=off
```

When this command has successfully completed, this message should appear.

```
rlghncxa03w 06-10-07 00:22:57 GMT  EAGLE5 36.0.0
CHG-SCCPOPTS: MASP A - COMPLTD
```

3. Verify the changes using the `rtrv-sccpopts` command.

This is an example of the possible output.

```
rlghncxa03w 06-10-17 16:02:05 GMT  EAGLE5 36.0.0
SCCP OPTIONS
-----
GSMTCAPCE                          on
```

Note:

The `rtrv-sccopts` command output contains other fields that are not used by this procedure. If you wish to see all the fields displayed by the `rtrv-sccopts` command, see the `rtrv-sccopts` command description in the *Commands Manual*.

4. Backup the new changes using the `chg-db:action=backup:dest=fixed` command. These messages should appear, the active Maintenance and Administration Subsystem Processor (MASP) appears first.

```
BACKUP (FIXED): MASP A - Backup starts on active MASP.  
BACKUP (FIXED): MASP A - Backup on active MASP to fixed disk complete.  
BACKUP (FIXED): MASP A - Backup starts on standby MASP.  
BACKUP (FIXED): MASP A - Backup on standby MASP to fixed disk complete.
```

Chapter 5

EAGLE 5 Integrated Monitoring Support Configuration

Topics:

- *Introduction.....206*
- *TCP/IP Link Provisioning.....208*
- *Time Stamping.....212*
- *EAGLE 5 ISS Provisioning.....212*
- *Network Considerations.....215*
- *Enabling the Time Slot Counter Synchronization (TSCSYNC) and EAGLE 5 Integrated Monitoring Support (E5IS) Features.....216*
- *Configuring the EISCOPY Option for the EAGLE 5 Integrated Monitoring Support Feature.....217*
- *Configuring the FCMODE Option for the EAGLE 5 Integrated Monitoring Support Feature.....221*
- *Configuring the IP Addresses for the EAGLE 5 Integrated Monitoring Support Feature.....227*
- *Adding a Signaling Transport Card (STC).....231*
- *Removing a Signaling Transport Card (STC)..237*

Chapter 5, EAGLE 5 Integrated Monitoring Support Configuration, describes the Eagle 5 Integrated Monitoring Support feature and the procedures necessary to configure the EAGLE 5 ISS to support this feature.

Introduction

The EAGLE 5 Integrated Monitoring Support feature allows the network traffic on the EAGLE 5 ISS's signaling links to be monitored by an ESP (extended services platform) or IMF (integrated message feeder) without additional intrusive cabling.

To monitor the network traffic on the EAGLE 5 ISS's signaling links without this feature requires physical, clamp-on connections to the EAGLE 5 ISS's SS7 signaling links (see [Figure 16: Monitoring via Hardware Connection](#)). This monitoring method involves costs for cable installation and maintenance for each SS7 link that is to be monitored.

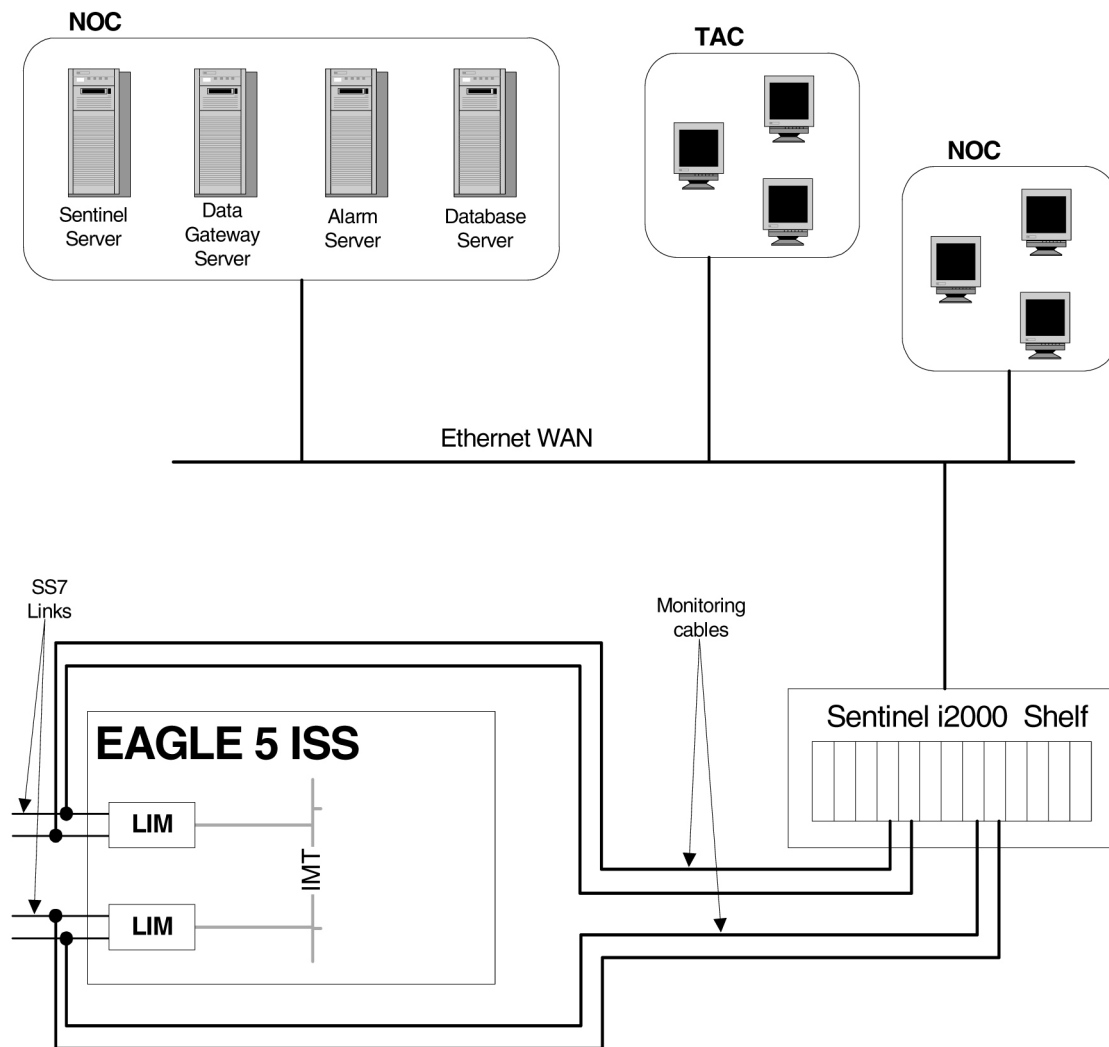

Figure 16: Monitoring via Hardware Connection

This feature eliminates the need to have intrusive hardware for each link that is to be monitored. The monitoring is performed by an Ethernet connection from an STC (Signaling Transport Card) or an FC-capable card to the ESP/IMF (see [Figure 17: EAGLE 5 Integrated Monitoring Support Network Connectivity](#)). An FC-capable card is a card that is configured to copy traffic directly to an IMF

subsystem over its Fast Copy interfaces. Currently, cards running the IPGHC and IPSG GPLs are the only supported FC-capable cards. Message Signaling Units (MSUs), alarms, and events may be copied to the ESP/IMF subsystem over the Ethernet link to provide the network traffic monitoring.

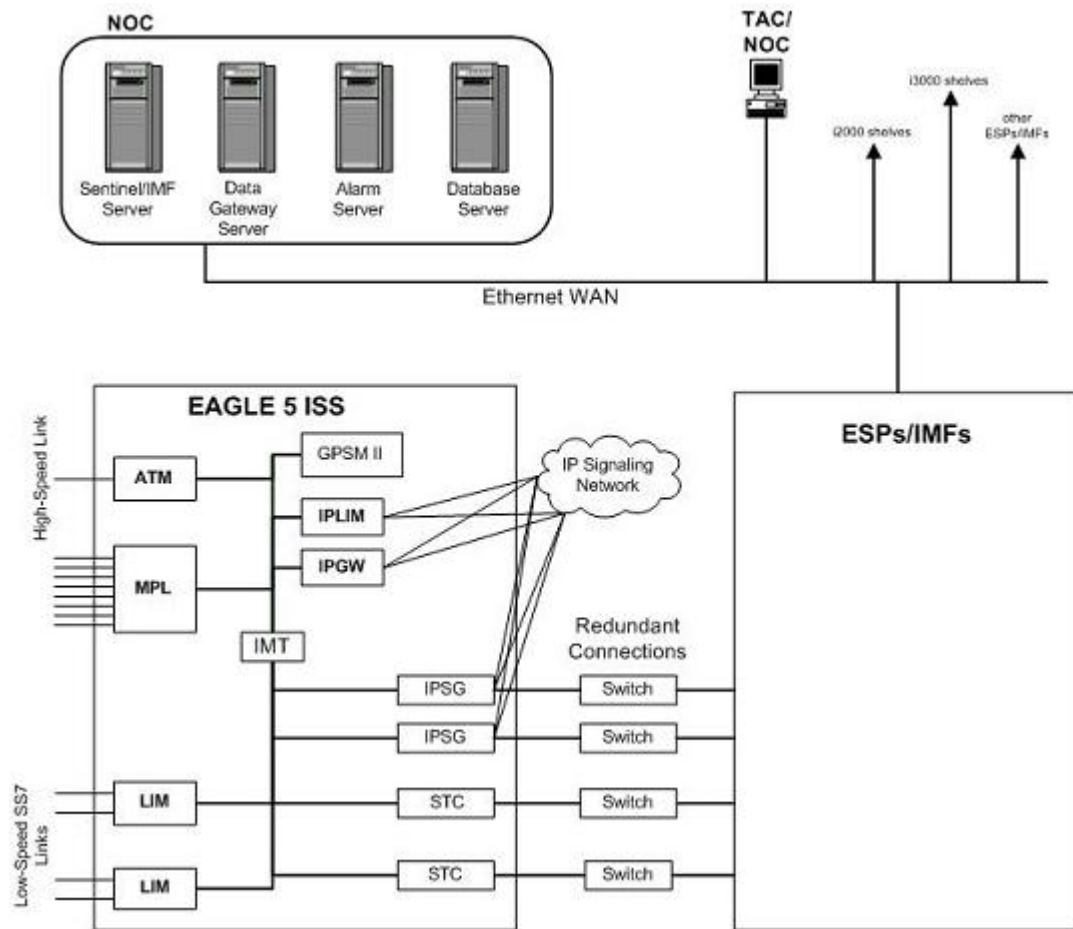

Figure 17: EAGLE 5 Integrated Monitoring Support Network Connectivity

As can be seen in [Figure 17: EAGLE 5 Integrated Monitoring Support Network Connectivity](#), this new method of connectivity removes the cabling and clamps from each monitored SS7 link. By incorporating a TCP/IP stack on each LIM and having the STCs or FC-capable cards serve as IP routers, the ESP/IMF subsystem may communicate directly with the SS7 LIMs. [Figure 18: ESP/IMF/EAGLE 5 ISS Network](#) shows the logical communications pathway.

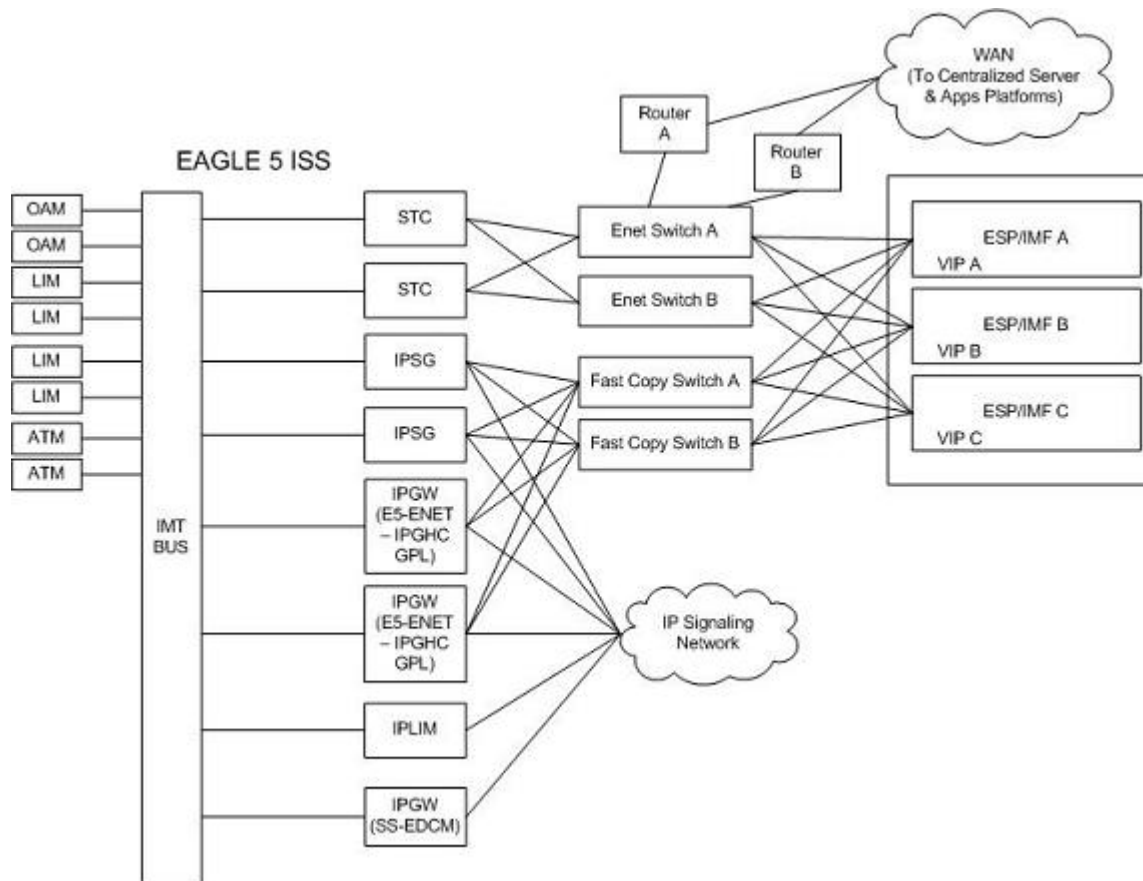

Figure 18: ESP/IMF/EAGLE 5 ISS Network

The STC communicates to the LIM by the IMT bus; the IP messages are simply encapsulated in an IMT wrapper between the cards. The STCs are provisioned in an $n+1$ configuration for redundancy. Each STC Ethernet port has a separate connection path to each Ethernet switch in order to provide an alternate path in the event of an Ethernet link failure. Note that the figure depicts a redundant network; this assures that a single network failure will not halt EAGLE 5 ISS or ESP/IMF operations. As shown in [Figure 18: ESP/IMF/EAGLE 5 ISS Network](#), one or more ESP/IMF may be connected to a single Ethernet switch. The number of STCs required corresponds to the number of SS7 links that are to be associated with the EAGLE 5 Integrated Monitoring Support feature, plus an additional STC for redundancy.

The LIMs are assigned private network addresses. The IP message origination address specified is that of the LIM. The IP message destination address is that of the VIP (virtual IP address) contained within the ESP/IMF server. The STC serves as a router from the LIM to the ESP/IMF servers.

TCP/IP Link Provisioning

The IP communications link, used to transmit copied MSUs between the EAGLE 5 ISS and the ESP/IMF subsystem, is dynamically configured by the Sentinel/IMF. This is performed automatically as part of the operations for coming into service. A special function, part of the card's application software,

is to establish communications with the ESP/IMF subsystem by sending a service request message (see *Figure 19: Ethernet Link Establishment - EMP Link Data*, *Figure 20: Ethernet Link Establishment - EMP Fast Copy Link PDU*, and *Figure 21: Ethernet Link Establishment - EMP Fast Copy Link PDU Modified for the IPGHC GPL*).

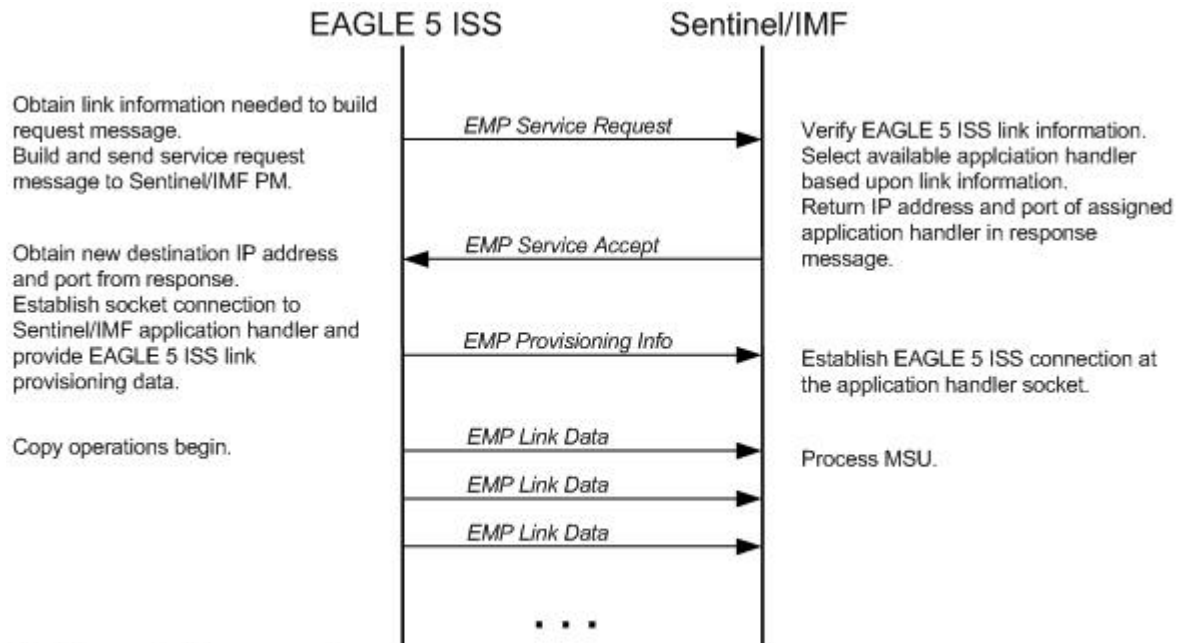

The diagram depicts an example of normal link data message flow.

Figure 19: Ethernet Link Establishment - EMP Link Data

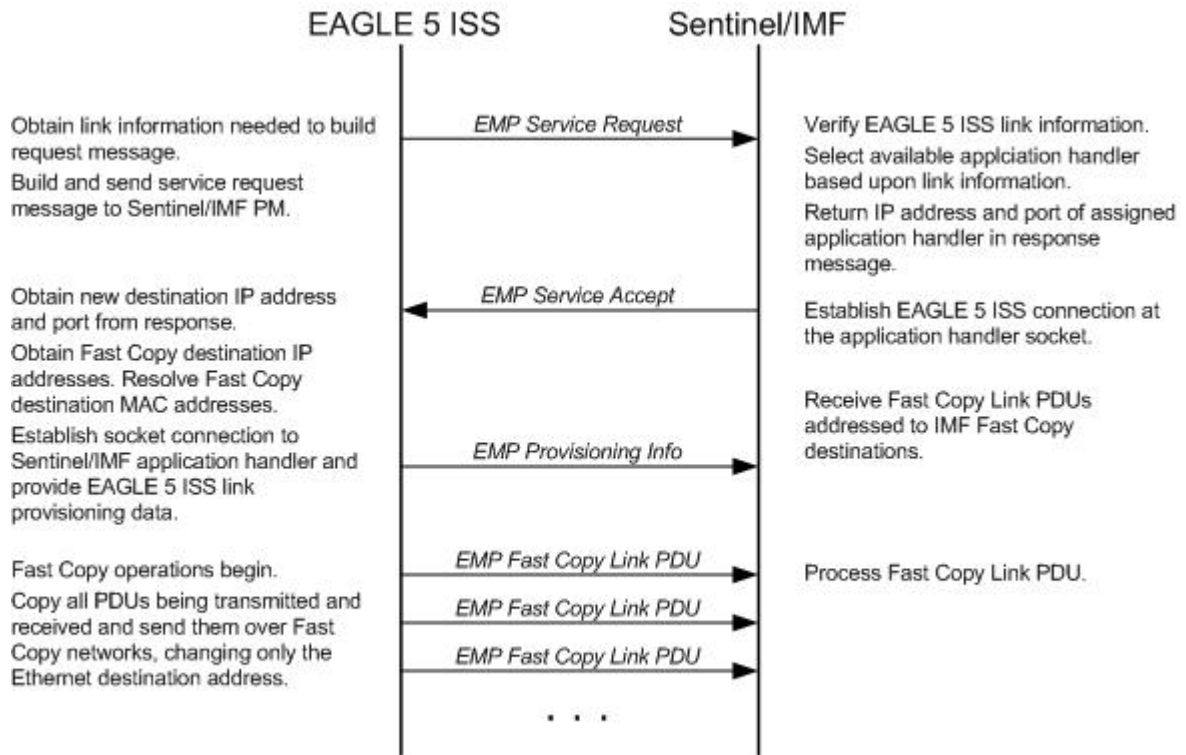

The diagram depicts an example of Fast Copy Link PDU message flow.

Figure 20: Ethernet Link Establishment - EMP Fast Copy Link PDU

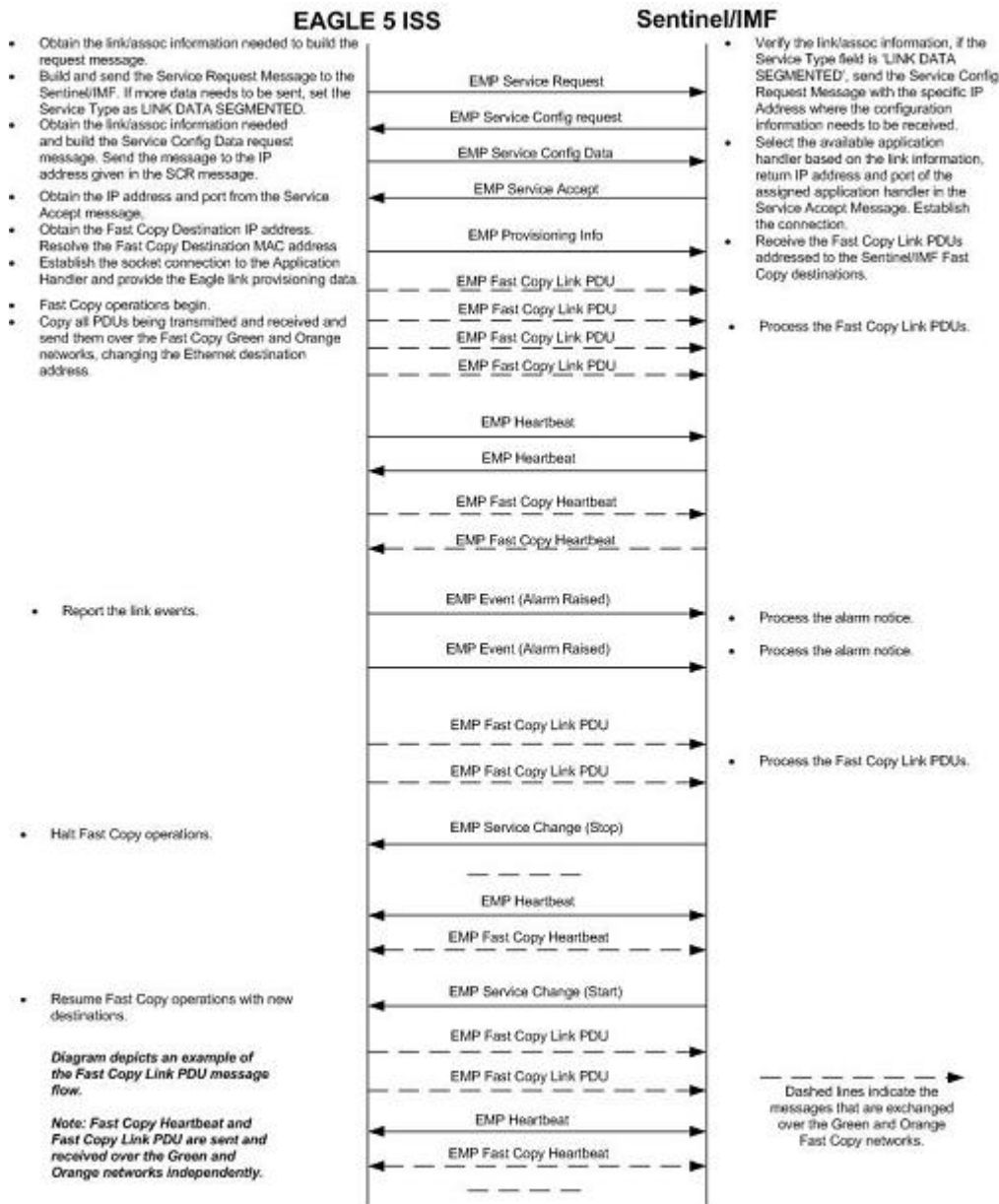

Figure 21: Ethernet Link Establishment - EMP Fast Copy Link PDU Modified for the IPGHC GPL

The LIM receiving the service accept response then opens a new socket using the specified IP address and port as the destination using standard TCP/IP socket messaging. The ESP /IMF server configured to service the port responds to the connect request and the socket is now available for normal operations. MSUs are copied from the LIM through the STC or FC-capable cards (if the Fast Copy function is being used) to the ESP/IMF server, then to the Sentinel/IMF.

The IPGHC GPL supports up to 50 associations per E5-ENET card. Each card hosts one SS7 signaling link. Sending information for 50 associations to the IMF requires a large UDP message. Network elements generally restrict broadcasting large UDP data. It is not guaranteed that the large Service Request Message (UDP broadcast) can reach the IMF in all networks. The Service Config Request Message and Service Config Data Message, shown in [Figure 21: Ethernet Link Establishment - EMP Fast](#)

Copy Link PDU Modified for the IPGHC GPL, are used to send the large configuration information to the IMF.

The Service Request Message message is sent with the "Service Type" field set to "LINK DATA SEGMENTED". The IMF responds with a Service Config Request Message querying the configuration data by specifying the IP address and UDP port where the large configuration data needs to be sent. The card running the IPGHC GPL sends (UDP unicast) the configuration data to the specific IP address and UDP port included in the Service Config Request Message.

If the LIM is unsuccessful with its initial link service request, it will reattempt link establishment with the ESP/IMF subsystem after delaying for a short period (that is, approximately 15 seconds). The LIM continuously repeats the link establishment procedure until it is successful. If the LIM ever loses its IP connection to the ESP server, the LIM will automatically begin reestablishment operations.

The STCs use Dynamic Host Configuration Protocol to provision themselves with IP addresses. The ESP/IMF subsystem contains a DHCP server and a DHCP client resides on the STC. The STC receives its IP address from the DHCP server in accordance with the DHCP standard.

The IP addresses of an FC-capable card is automatically assigned to the card as the card is brought into service. Each card is assigned two IP addresses, one for Fast Copy network A and the other for Fast Copy network B. The network portion of the IP addresses is determined from the FCNA and FCNAMASK (for the Fast Copy network A IP addresses) and the FCNB and FCNBMASK (for the Fast Copy network B IP addresses) values shown in the `rtrv-netopts` command output. The value of the host portion of the IP address for an FC-capable card is the IMT address of the card+1.

A custom routing protocol, TRP (Tekelec Routing Protocol) manages the multiple redundant links and provides a faster network convergence than is possible with standard routing protocols.

Time Stamping

The MSU information will be delivered to the ESP/IMF subsystem with an accurate time stamp (± 5 milliseconds). This allows the Sentinel/IMF to correlate a call's messages for CDR (Call Detail Record) operations.

EAGLE 5 ISS Provisioning

To provision this feature, these items are required:

- STC cards are installed in the EAGLE 5 ISS
- If the Fast Copy function is being used to copy traffic from IPSG cards (the `FCMODE=FCOPY` and `FCGPL=IPSG` values are shown in the `rtrv-eisopts` output), cards running the IPSG GPL must be installed in the EAGLE 5 ISS. The state of at least one of the cards running the IPSG GPL must be IS-NR.
- If the Fast Copy function is being used to copy traffic from cards running the IPGHC GPL (the `FCMODE=FCOPY` and `FCGPL=IPGHC` values are shown in the `rtrv-eisopts` output), cards running the IPGHC GPL must be installed in the EAGLE 5 ISS. The state of at least one of the cards running the IPGHC GPL must be IS-NR.
- The TSC (Time Slot Counter) Synchronization feature is enabled in the EAGLE 5 ISS. TSC synchronization is supplied by the GPSM-II or E5-MCAP cards in card locations 1113 and 1115.

- A timing source for the low-speed signaling links and for the TSC (Time Slot Counter) synchronization feature

If the EAGLE 5 ISS does not contain LIMDS0 cards, but contains TDM part numbers 870-0774-15 or later, the clock source for any low-speed links and for the TSC (Time Slot Counter) synchronization feature used by the Sentinel/IMF can be generated from the high-speed master clock source. An external BITS clock is not required.

If an external BITS clock is connected to an EAGLE 5 ISS without LIMDS0 cards, but with TDM part numbers 870-0774-15 or later, the external BITS clock must be used as the clock source for any low-speed links and for the TSC (Time Slot Counter) synchronization feature.

If LIMDS0 cards are present in the EAGLE 5 ISS, the external BITS clock is required for timing of the DS0 signaling links and for TSC (Time Slot Counter) synchronization used by the Sentinel/IMF. If the EAGLE 5 ISS also contains TDM part numbers 870-0774-15 or later along with the LIMDS0 cards, this procedure can be used to select the source of the high-speed master clock for the high-speed links using external timing. The high-speed master clock source cannot be used to generate the clock source for any low-speed links and for the TSC (Time Slot Counter) synchronization feature.

- A Network Time Protocol (NTP) timing source from the ESP/IMF server
- The EAGLE 5 ISS shelves can contain HMUX or HIPR or HIPR2 cards. Shelves containing IPLIMx, IPSG or IPGWx cards that are being monitored must contain HIPR or HIPR2 cards.

An “n + 1” STC configuration is required to provide redundancy for this feature.

The connection from the EAGLE 5 ISS to the ESP is an Ethernet connection with a minimum bandwidth of 10 Mbps. The dual-slot STC contains two 10 Mbps Ethernet ports. The single-slot STC contains two 100 Mbps Ethernet ports. FC-capable cards require a 100 Mbps/full duplex configuration for copying traffic to the ESP. If the IP port on the FC-Capable card is not able to auto-negotiate to this speed/duplex configuration, then the traffic will not be copied from this port to the ESP.

Refer to the *Hardware Manual* for more information about the E5-MCAP cards and STCs.

The $n+1$ STC configuration requires that a minimum of two STCs must be provisioned in the database. If single-slot STCs are being provisioned in the database, a minimum of two single-slot STCs must be provisioned.

[Table 23: Monitored Card Types](#) shows the signaling links on these cards can be monitored by this feature.

Table 23: Monitored Card Types

Card Application (APPL Value Used by the ent-card Command)	Card Type (TYPE Value Used by the ent-card Command)	Card Name
SS7ANSI	LIMDS0	MPL
SS7ANSI, CCS7ITU	LIME1	E1/T1 MIM, HC MIM, E5-E1T1 card
	LIMT1	E1/T1 MIM, HC MIM, E5-E1T1 card
	LIMCH	E1/T1 MIM
ATMANSI	LIMATM	LIM-ATM, E5-ATM, E5-ATM-B

Card Application (APPL Value Used by the ent-card Command)	Card Type (TYPE Value Used by the ent-card Command)	Card Name
ATMITU	LIME1ATM	E1-ATM, E5-ATM, E5-ATM-B
IPLIM	DCM	Single-Slot EDCM, E5-ENET, E5-ENET-B card
IPLIMI	DCM	Single-Slot EDCM, E5-ENET, E5-ENET-B card
SS7IPGW	DCM	Single-Slot EDCM, E5-ENET, E5-ENET-B card
IPGWI	DCM	Single-Slot EDCM, E5-ENET, E5-ENET-B card
IPSG	ENET	E5-ENET, E5-ENET-B card
<p>Notes:</p> <p>Only signaling links assigned to M2PA associations can be monitored on the cards running the IPLIM and IPLIMI applications. This can be verified by entering the <code>rtrv-assoc:adapter=m2pa</code> command.</p> <p>Signaling links assigned to M3UA associations can be monitored on the cards running the SS7IPGW and IPGWI applications. This can be verified by entering the <code>rtrv-assoc:adapter=m3ua</code> command. Signaling links assigned to SUA associations can be monitored only on cards that are running the IPGHC GPL in the STC and Fast Copy monitoring modes.</p> <p>Monitoring can be performed on single-slot EDCMs, E5-E1T1 cards, E5-ENET cards, and E5-ENET-B cards using only the IMF.</p> <p>Monitoring can be performed on channelized E1 signaling links and unchannelized E1 signaling links (assigned to the LIME1 card type). A channelized E1 signaling link is a signaling link that is assigned to a channelized E1 port, shown by the entry CHAN in the LINKCLASS field in the <code>rtrv-e1</code> output. An unchannelized E1 signaling link is a signaling link that is assigned to an unchannelized E1 port, shown by the entry UNCHAN in the LINKCLASS field in the <code>rtrv-e1</code> output.</p>		

The signaling links assigned to the cards running either the `ss7ansi` or `ccs7itu` applications are low-speed signaling links transmitting at either 56 kbps or 64 kbps. Signaling links assigned to the `atmansi` and `atmitu` applications are high-speed signaling links transmitting at 1.544 Mbps (`atmansi`) or 2.048 Mbps (`atmitu`). Signaling links assigned to the `iplim`, `iplimi`, `ss7ipgw`, `ipsg`, and `ipgwi` applications are IP signaling links.

Because the performance of a single-slot STC is higher than a dual-slot STC, a dual-slot STC cannot replace a single-slot STC. If a single-slot STC replaces a dual-slot STC, and it is the only single-slot STC in the EAGLE 5 ISS, another single-slot STC must be added to the EAGLE 5 ISS. To add the additional single-slot STC, go to [Adding a Signaling Transport Card \(STC\)](#).

In order to perform the necessary IP routing within the EAGLE 5 ISS switch, a private virtual network (PVN) is incorporated; the PVN represents the internal IP addressing scheme for every STC within the EAGLE 5 ISS switch. Each card has an auto-assigned, default, Class B private IP address (for example, 172.28.60.16).

Note: The EAGLE 5 ISS uses a default value of 172.20.48.0 for the PVN address. You may change the default value by specifying a new network portion of an IP address and a network mask; the host portion is auto-configured. The EAGLE 5 ISS requires use of the lower 8 bits of address space for auto-configuration of internal networking schemes. The entered mask value may be up to 255.255.255.0

Network Considerations

There are three networks used to connect the EAGLE 5 ISS to the ESP/IMF subsystem (see [Figure 18: ESP/IMF/EAGLE 5 ISS Network](#) :

- The EAGLE 5 ISS containing the STCs and FC-capable cards (if the Fast Copy function is being used).
- The two Ethernet switches
- The ESP/IMF servers

The monitored information is sent from the EAGLE 5 ISS to the ESP/IMF servers through the Ethernet switches, then forwarded to the Sentinel/IMF by the isolation routers. Each router will have one Ethernet port designated as the physical demarcation point between the customer network and the ESP/IMF subsystem.

IP Address Provisioning

The ESP/IMF subsystem requires IP addresses for these items:

- ESP/IMF external network:
 - Three IP addresses on the customer network for the ESP/IMF isolation routers, one IP address for HSRP, one IP address for each router (two total)
 - One netmask
 - One IP address for the default router.
- ESP/IMF internal network – Contiguous IP block routed within their network (last octet range 1-67 for 17 servers). The Sentinel/IMF considers each ESP/IMF server a separate processing element, therefore each ESP/IMF server needs its own IP address.
- Routes to their network to route to the VIP network already defined within ESP/IMF subsystem.



CAUTION: These IP addresses can be changed, as well as the PVN IP address in the EAGLE 5 ISS, contact the Customer Care Center (refer to [Customer Care Center](#) for the contact information) before changing these IP addresses.

Route Configuration

No explicit routing tables are provisioned in the ESP/IMF subsystem. Use of the single customer provided default router address is assumed for outgoing traffic. All incoming traffic will use the HSRP address provided by the isolation routers.

Network Limitations

The maximum length of the network cables between the ESP/IMF server frame and the STC cards is limited to 328 feet (100 meters). This limitation is the maximum length that any 10/100BaseT cable can be run.

Enabling the Time Slot Counter Synchronization (TSCSYNC) and EAGLE 5 Integrated Monitoring Support (E5IS) Features

The EAGLE 5 Integrated Monitoring Support feature requires that the Time Slot Counter Synchronization (TSCSYNC) and EAGLE 5 Integrated Monitoring Support (E5IS) features are enabled with the `chg-feat` command using the `tscsync` and `e5is` parameters. This procedure is used to enable these features.

Note: Once the Time Slot Counter Synchronization and EAGLE 5 Integrated Monitoring Support features are turned on with the `chg-feat` command, they cannot be turned off.

The Time Slot Counter Synchronization and EAGLE 5 Integrated Monitoring Support features must be purchased before turning on these features. If you are not sure whether you have purchased the Time Slot Counter Synchronization or EAGLE 5 Integrated Monitoring Support features, contact your Tekelec Sales Representative or Account Representative.

1. Verify that the EAGLE 5 Integrated Monitoring Support feature and Time Slot Counter Synchronization features are on, by entering the `rtrv-feat` command.

If the EAGLE 5 Integrated Monitoring Support feature is on, the `E5IS` field should be set to `on`. If the Time Slot Counter Synchronization feature is on, the `TSCSYNC` field should be set to `on`.

Note: The `rtrv-feat` command output contains other fields that are not used by this procedure. If you wish to see all the fields displayed by the `rtrv-feat` command, see the `rtrv-feat` command description in the *Commands Manual*.

If the Time Slot Counter Synchronization and the EAGLE 5 Integrated Monitoring Support features are not turned on, or just the Time Slot Counter Synchronization feature is turned on, continue the procedure with [Step 2](#).

If both the EAGLE 5 Integrated Monitoring Support feature and Time Slot Counter Synchronization features are on, then no further action is necessary. If you wish to change the `EISCOPY` and `FCMODE` values in the `rtrv-eisopts` output, the `PVN`, `PVNMASK`, `FCNA`, and `FCNB` values in the `rtrv-netopts` output, or add STC cards, perform the following procedures.

- `EISCOPY` value - [Configuring the EISCOPY Option for the EAGLE 5 Integrated Monitoring Support Feature](#)
- `FCMODE` value - [Configuring the FCMODE Option for the EAGLE 5 Integrated Monitoring Support Feature](#)
- `PVN`, `PVNMASK`, `FCNA`, `FCNB` values - [Configuring the IP Addresses for the EAGLE 5 Integrated Monitoring Support Feature](#)
- Add STC cards - [Adding a Signaling Transport Card \(STC\)](#)

2. Turn the Time Slot Counter Synchronization and EAGLE 5 Integrated Monitoring Support features on by entering one of these commands, depending on whether or not the `rtrv-feat` output in [Step 1](#) shows that the Time Slot Counter Synchronization feature is on.

If the Time Slot Counter Synchronization feature is not on, enter this command.

```
chg-feat:tscsync=on:e5is=on
```

If the Time Slot Counter Synchronization feature is on, enter this command.

```
chg-feat:e5is=on
```

Note: Once the Time Slot Counter Synchronization and EAGLE 5 Integrated Monitoring Support features are turned on with the `chg-feat` command, they cannot be turned off.

The Time Slot Counter Synchronization and EAGLE 5 Integrated Monitoring Support features must be purchased before turning on these features. If you are not sure whether you have purchased the Time Slot Counter Synchronization or EAGLE 5 Integrated Monitoring Support features, contact your Tekelec Sales Representative or Account Representative.

When the `chg-feat` has successfully completed, this message should appear.

```
rlghncxa03w 06-10-20 21:18:37 GMT EAGLE5 36.0.0
CHG-FEAT: MASP A - COMPLTD
```

3. Verify the changes by entering the `rtrv-feat` command.

If the EAGLE 5 Integrated Monitoring Support feature is on, the `E5IS` field should be set to `on`. If the Time Slot Counter Synchronization feature is on, the `TSCSYNC` field should be set to `on`.

4. Back up the new changes using the `chg-db:action=backup:dest=fixed` command.

These messages should appear, the active Maintenance and Administration Subsystem Processor (MASP) appears first.

```
BACKUP (FIXED) : MASP A - Backup starts on active MASP.
BACKUP (FIXED) : MASP A - Backup on active MASP to fixed disk complete.
BACKUP (FIXED) : MASP A - Backup starts on standby MASP.
BACKUP (FIXED) : MASP A - Backup on standby MASP to fixed disk complete.
```

5. When the EAGLE 5 Integrated Monitoring Support feature is turned on, the values for the `EISCOPY` and `FCMODE` values in the `rtrv-eisopts` output, and the `PVN`, `PVNMASK`, `FCNA`, and `FCNB` values in the `rtrv-netopts` output are set to their default values. If you wish to change any of these values or add STC cards, perform the following procedures.
 - `EISCOPY` value - [Configuring the EISCOPY Option for the EAGLE 5 Integrated Monitoring Support Feature](#)
 - `FCMODE` value - [Configuring the FCMODE Option for the EAGLE 5 Integrated Monitoring Support Feature](#)
 - `PVN`, `PVNMASK`, `FCNA`, `FCNB` values - [Configuring the IP Addresses for the EAGLE 5 Integrated Monitoring Support Feature](#)
 - Add STC cards - [Adding a Signaling Transport Card \(STC\)](#)

Configuring the EISCOPY Option for the EAGLE 5 Integrated Monitoring Support Feature

This procedure is used to configure the `EISCOPY` option for the EAGLE 5 Integrated Monitoring Support feature using the `chg-eisopts` command with the `eiscopy` parameter.

The `chg-eisopts` command can also be used to configure the `FCMODE` option. Perform [Configuring the FCMODE Option for the EAGLE 5 Integrated Monitoring Support Feature](#) to configure the `FCMODE` option.

The `eiscopy` parameter contains two values, `on` and `off`. The `eiscopy=on` parameter enables the EISCOPY function for the EAGLE 5 Integrated Monitoring Support feature. The `eiscopy=off` parameter turns off the EISCOPY function for the EAGLE 5 Integrated Monitoring Support feature. The EISCOPY function allows the EAGLE 5 ISS to copy MSUs to the ESP/IMF subsystem. The default value for the `eiscopy` parameter is `off`.

To change the EISCOPY option, the EAGLE 5 Integrated Monitoring Support feature (E5IS) must be turned on.

1. Verify that the EAGLE 5 Integrated Monitoring Support feature is on, by entering the `rtrv-feat` command.

If the EAGLE 5 Integrated Monitoring Support feature is on, the `E5IS` field should be set to `on`.

Note: The `rtrv-feat` command output contains other fields that are not used by this procedure. If you wish to see all the fields displayed by the `rtrv-feat` command, see the `rtrv-feat` command description in the *Commands Manual*.

If the EAGLE 5 Integrated Monitoring Support feature is not on, perform [Enabling the Time Slot Counter Synchronization \(TSCSYNC\) and EAGLE 5 Integrated Monitoring Support \(E5IS\) Features](#) to turn on the EAGLE 5 Integrated Monitoring Support feature. After the EAGLE 5 Integrated Monitoring Support feature is turned on, the `EISCOPY` and `FCMODE` values, shown in the `rtrv-eisopts` output, are `off`. After the EAGLE 5 Integrated Monitoring Support feature is turned on, continue the procedure with [Step 3](#).

If the EAGLE 5 Integrated Monitoring Support feature is on, continue the procedure with [Step 2](#).

2. Display the EISCOPY option by entering the `rtrv-eisopts` command.

This is an example of the possible output.

```
rlghncxa03w 10-07-07 11:43:04 GMT EAGLE5 42.0.0
EIS OPTIONS
-----
EISCOPY = OFF

FAST COPY OPTIONS
-----
FCGPL = IPSG          FCMODE = OFF
FCGPL = IPGHC         FCMODE = OFF
-----
```

If the `EISCOPY` value is `OFF`, continue the procedure with [Step 3](#).

If the `EISCOPY` value is `ON`, continue the procedure with [Step 9](#).

3. Display the STC cards in the database using the `rept-stat-mon` command.

This is an example of the possible output.

```
rlghncxa03w 10-07-01 09:12:36 GMT EAGLE5 42.0.0
```

CARD	VERSION	PST	SST	AST	TVG USAGE	CPU USAGE
1105	126-002-000	IS-NR	Active	-----	35%	52%
1205	126-002-000	IS-NR	Active	-----	35%	52%

1211	126-002-000	IS-NR	Active	-----	35%	52%
1303	126-002-000	IS-NR	Active	-----	35%	52%
1311	126-002-000	IS-NR	Active	-----	35%	52%
1313	126-002-000	IS-NR	Active	-----	35%	52%
2211	126-002-000	IS-NR	Active	-----	35%	52%
2213	126-002-000	IS-NR	Active	-----	35%	52%

Note: The `rept-stat-mon` command output contains other fields that are not used by this procedure. If you wish to see all the fields displayed by the `rept-stat-mon` command, see the `rept-stat-mon` command description in the *Commands Manual*.

At least two STCs must be shown in the `rept-stat-mon` output. The primary state (PST value) of at least two STCs must be IS-NR. If two or more STCs are shown in the `rept-stat-mon` output and the primary state of at least two of these STCs is IS-NR, continue the procedure with [Step 5](#).

If there are less than two STCs shown in the `rept-stat-mon` output, add the necessary STCs by performing [Adding a Signaling Transport Card \(STC\)](#). After the STCs have been added, continue the procedure with [Step 5](#).

If two or more STCs are shown in the `rept-stat-mon` output and the primary state of only one STC is IS-NR, or primary state of all of the STCs is not IS-NR, continue the procedure with [Step 4](#).

4. Enter the `rst-card` command as necessary so that the primary state of at least two of the STCs shown in [Step 3](#) is IS-NR. Specify the card location of the STC that is not IS-NR, shown in [Step 3](#), with the `rst-card` command.

For this example, enter these commands.

```
rst-card:loc=1205
```

```
rst-card:loc=1211
```

When this command has successfully completed, this message should appear.

```
rlghncxa03w 09-02-28 09:12:36 GMT EAGLE5 40.1.0
Card has been allowed.
```

5. Display the IP addresses and the PVN subnet mask by entering the `rtrv-netopts` command.

This is an example of the possible output.

```
rlghncxa03w 10-07-28 09:12:36 GMT EAGLE5 42.0.0
NETWORK OPTIONS
-----
PVN      = 172.20.48.0
PVNMASK  = 255.255.252.0
FCNA     = 172.21.48.0
FCNAMASK = 255.255.254.0
FCNB     = 172.22.48.0
FCNBMASK = 255.255.254.0
```

6. Display the current link parameters associated with the IP card in the database by entering the `rtrv-ip-lnk` command.

The following is an example of the possible output.

```
rlghncxa03w 10-07-28 21:14:37 GMT EAGLE5 42.0.0
LOC  PORT  IPADDR          SUBMASK          DUPLEX  SPEED  MACTYPE  AUTO  MCAST
1201  A      192.1.1.1      255.255.255.128  HALF   10     802.3    NO    NO
```

1203	A	192.1.1.12	255.255.255.0	----	---	DIX	YES	NO
1205	A	192.1.1.14	255.255.255.0	FULL	100	DIX	NO	NO

7. Display the IP routes in the database with the `rtrv-ip-rte` command.

This is an example of the possible output.

```
rlghncxa03w 10-07-28 09:12:36 GMT EAGLE5 42.0.0
LOC  DEST          SUBMASK          GTWY
1301 128.252.10.5     255.255.255.255 140.188.13.33
1301 128.252.0.0      255.255.0.0      140.188.13.34
1301 150.10.1.1       255.255.255.255 140.190.15.3
1303 192.168.10.1     255.255.255.255 150.190.15.23
1303 192.168.0.0      255.255.255.0    150.190.15.24

IP Route table is (5 of 1024) 1% full
```

8. The EISCOPY option cannot be turned on if any of these conditions are present.

The subnet address that results from the PVN and PVNMASK, FCNA and FCNAMASK, or FCNB and FCNBMASK values in the `rtrv-netopts` output are the same as the subnet address resulting from the IPADDR and SUBMASK values in the `rtrv-ip-lnk` command, or the DEST and SUBMASK values of the `rtrv-ip-rte` command.

The subnet address that results from the PVN and PVNMASK values in the `rtrv-netopts` output cannot be the same as the subnet addresses that result from the FCNA and FCNAMASK, or FCNB and FCNBMASK values in the `rtrv-netopts` output.

The host portion of the subnet address that results from the PVN and PVNMASK value in the `rtrv-netopts` output is not 0 (zero).

The PVNMASK value in the `rtrv-netopts` outputs not one of these values.

255.255.0.0	255.255.128.0	255.255.192.0
255.255.224.0	255.255.240.0	255.255.248.0
255.255.252.0	255.255.254.0	255.255.255.0

If any of these conditions are present, perform the [Configuring the IP Addresses for the EAGLE 5 Integrated Monitoring Support Feature](#) procedure to change the required IP addresses before proceeding to [Step 9](#).

9. Change the EISCOPY option by performing one of these substeps.

- a) To turn the EISCOPY option on, enter this command.

```
chg-eisopts:eiscopy=on
```

If you wish to change the FCMODE values, perform the [Configuring the FCMODE Option for the EAGLE 5 Integrated Monitoring Support Feature](#). This procedure is finished.

- b) To turn the EISCOPY option off and the FCMODE values of all the GPLS shown in the `rtrv-eisopts` output in [Step 2](#) is OFF, enter this command.

```
chg-eisopts:eiscopy=off
```



CAUTION: The EAGLE 5 Integrated Monitoring Support feature will be disabled if the EISCOPY option is turned off.

- c) To turn the EISCOPY option off and the FCMODE values of any of the GPLS shown in the `rtrv-eisopts` output in [Step 2](#) is either `STC` or `FCOPY`, enter this command.

```
chg-eisopts:eiscopy=of:fcgpl=all:fcmode=off
```



CAUTION: The EAGLE 5 Integrated Monitoring Support feature will be disabled if the EISCOPY option is turned off.

CAUTION

When the `chg-eisopts` has successfully completed, this message should appear.

```
rlghncxa03w 09-02-20 21:18:37 GMT EAGLE5 40.1.0
CHG-EISOPTS: MASP A - COMPLTD
```

10. Verify the changes to the EISCOPY option by entering the `rtrv-eisopts` command.

This is an example of the possible output.

```
rlghncxa03w 10-07-07 11:43:04 GMT EAGLE5 42.0.0
EIS OPTIONS
-----
EISCOPY = ON

FAST COPY OPTIONS
-----
FCGPL = IPSG          FCMODE = OFF
FCGPL = IPGHC        FCMODE = OFF
-----
```

11. Back up the new changes using the `chg-db:action=backup:dest=fixed` command.

These messages should appear, the active Maintenance and Administration Subsystem Processor (MASP) appears first.

```
BACKUP (FIXED) : MASP A - Backup starts on active MASP.
BACKUP (FIXED) : MASP A - Backup on active MASP to fixed disk complete.
BACKUP (FIXED) : MASP A - Backup starts on standby MASP.
BACKUP (FIXED) : MASP A - Backup on standby MASP to fixed disk complete.
```

Configuring the FCMODE Option for the EAGLE 5 Integrated Monitoring Support Feature

This procedure is used to configure the FCMODE option for the EAGLE 5 Integrated Monitoring Support feature with the `chg-eisopts` command and these parameters.

The `fcmode` parameter specifies a system-wide control to enable or disable monitoring on FC-capable cards. A card that can run the Fast Copy interface is referred to as an FC-capable card. Currently, E5-ENET cards running the IPSG and IPGHC GPLs are the only supported FC-capable cards. The `fcmode` parameter has three values.

- `off` - Monitoring is not performed on FC-capable cards.
- `stc` - STC monitoring is performed on FC-capable cards
- `fcopy` - FC monitoring is performed on FC-capable cards

The system default value for the `fcmode` parameter is `off`.

The `fcgpl` parameter specifies the type of cards that the monitoring specified by the `FCMODE` value will be applied to. The `fcgpl` parameter has three values.

- `ipsg` - monitoring is performed on E5-ENET cards running the IP SG GPL (IP SG cards).
- `ipghc` - monitoring is performed on E5-ENET cards running the IP GH C GPL.
- `all` - monitoring is performed on E5-ENET cards running the IP SG and IP GH C GPLs.

The system default value for the `fcgpl` parameter is `all`.

To change the `FCMODE` values, the `EISCOPY` value, shown in the `rtrv-eisopts` output, must be on. See the [Configuring the EISCOPY Option for the EAGLE 5 Integrated Monitoring Support Feature](#) procedure for information about changing the `EISCOPY` value.

1. Verify that the EAGLE 5 Integrated Monitoring Support feature is on, by entering the `rtrv-feat` command.

If the EAGLE 5 Integrated Monitoring Support feature is on, the `E5IS` field should be set to `on`.

Note: The `rtrv-feat` command output contains other fields that are not used by this procedure. If you wish to see all the fields displayed by the `rtrv-feat` command, see the `rtrv-feat` command description in the *Commands Manual*.

If the EAGLE 5 Integrated Monitoring Support feature is off, perform [Enabling the Time Slot Counter Synchronization \(TCSYNC\) and EAGLE 5 Integrated Monitoring Support \(E5IS\) Features](#) to turn on the EAGLE 5 Integrated Monitoring Support feature. After the EAGLE 5 Integrated Monitoring Support feature is turned on, the `EISCOPY` and `FCMODE` values for all the GPLs, shown in the `rtrv-eisopts` output, are `off`.

After the EAGLE 5 Integrated Monitoring Support feature is turned on, perform [Configuring the EISCOPY Option for the EAGLE 5 Integrated Monitoring Support Feature](#) to change the `EISCOPY` value to `ON`. When the `EISCOPY` value is changed to `ON`, the `FCMODE` values for all the GPLs are changed to `STC`.

- If the `FCMODE` values for all the GPLs will remain `STC`, this procedure is finished.
- If the `FCMODE` values for any of the GPLs will be changed, continue the procedure with by performing one of these steps.
 - If the `fcgpl=all` or `fcgpl=ipghc` parameters will be specified with the `fcmode=fcopy` parameter, continue the procedure with [Step 3](#).
 - If the `fcgpl=ipsg` parameter will be specified with the `fcmode=fcopy` parameter, continue the procedure with [Step 6](#).

If the EAGLE 5 Integrated Monitoring Support feature is on, continue the procedure with [Step 2](#).

2. Display the `EISCOPY` option by entering the `rtrv-eisopts` command.

This is an example of the possible output.

```
rlghncxa03w 10-07-07 11:43:04 GMT EAGLE5 42.0.0
EIS OPTIONS
-----
EISCOPY = OFF

FAST COPY OPTIONS
-----
FCGPL = IP SG          FCMODE = OFF
```

```
FCGPL = IPGHC      FCMODE = OFF
-----
```

Continue the procedure by performing one of these steps.

- If the EISCOPY value is OFF, perform [Configuring the EISCOPY Option for the EAGLE 5 Integrated Monitoring Support Feature](#) to change the EISCOPY to ON. When the EISCOPY value is changed to ON, the FCMODE values for all the GPLs are changed to STC.
 - If the FCMODE values for all the GPLs will remain STC, this procedure is finished.
 - If the FCMODE values for any of the GPLs will be changed, continue the procedure by performing one of these steps.
 - If the fcgpl=all or fcgpl=ipghc parameters will be specified with the fcmode=fcopy parameter, continue the procedure with [Step 3](#).
 - If the fcgpl=ipsg parameter will be specified with the fcmode=fcopy parameter, continue the procedure with [Step 6](#).
- If the EISCOPY value is ON, continue the procedure by performing one of these steps.
 - If the fcgpl=all or fcgpl=ipghc parameters will be specified with the fcmode=fcopy parameter, continue the procedure with [Step 3](#).
 - If the fcgpl=ipsg parameter will be specified with the fcmode=fcopy parameter, continue the procedure with [Step 6](#).

3. Display the IPGWx cards and their status by entering these commands.

```
rept-stat-card:appl=ss7ipgw
```

This is an example of the possible output.

```
rlghncxa03w 10-07-24 11:13:29 GMT EAGLE5 42.0.0
CARD  VERSION      TYPE      GPL      PST      SST      AST
1205  133-008-000    DCM      IPGHC    IS-NR    Active  -----
```

Command Completed.

```
rept-stat-card:appl=ipgwi
```

This is an example of the possible output.

```
rlghncxa03w 10-07-24 11:13:29 GMT EAGLE5 42.0.0
CARD  VERSION      TYPE      GPL      PST      SST      AST
1207  133-008-000    DCM      IPGHC    IS-NR    Active  -----
```

Command Completed.

If no cards that are running the IPGHC GPL are shown in the `rept-stat-card` outputs, perform the "Adding an IPGWx Card" procedure in the *Database Administration Manual - IP7 Secure Gateway* to provision the necessary IPGWx cards that run the IPGHC GPL. The required IPGWx linksets, signaling links, and associations must also be provisioned.

After the required cards, linksets, signaling links, and associations have been provisioned, or if cards that are running the IPGHC GPL are shown in the `rept-stat-card` outputs, and the status of at least one of the cards is IS-NR, continue the procedure by performing one of these steps.

- If the fcgpl=all parameter will be specified with the fcmode=fcopy parameter, continue the procedure with [Step 6](#).

- If the `fcgpl=all` parameter will not be specified with the `fcmode=fcopy` parameter, continue the procedure with [Step 9](#).

If cards that are running the IPGHC GPL are shown in the `rept-stat-card` outputs, and the status of all the cards is not IS-NR, continue the procedure with [Step 4](#).

4. Display the signaling links that are assigned to the cards displayed in [Step 3](#) by entering this command.

```
rtrv-slk:type=ipgw
```

This is an example of the possible output.

```
rlghncxa03w 10-07-24 11:13:29 GMT EAGLE5 42.0.0
LOC LINK LSN          SLC TYPE      ANAME          SLKTPS
1205 A  lsngtwy      0  SS7IPGW
1207 A  lsngtwyl    0  IPGWI
SLK table is (5 of 1200) 1% full.
```

If signaling links are not shown in this output, perform the "Adding an IPGWx Signaling Link" procedure in the *Database Administration Manual - IP7 Secure Gateway* to add the signaling links to the cards that are running the IPGHC GPL. After the IPGWx signaling links have been added, continue the procedure by performing one of these steps.

- If the `fcgpl=all` parameter will be specified with the `fcmode=fcopy` parameter, continue the procedure with [Step 6](#).
- If the `fcgpl=all` parameter will not be specified with the `fcmode=fcopy` parameter, continue the procedure with [Step 9](#).

If signaling links are shown in this output, continue the procedure with [Step 5](#).

5. Put into service the card shown in [Step 3](#) whose state is not IS-NR by entering the `rst-card` command with the location of the card. For this example, enter this command.

```
rst-card:loc=1205
```

When the command has successfully completed, this message should appear.

```
rlghncxa03w 10-07-24 11:13:29 GMT EAGLE5 42.0.0
Card has been allowed.
```

After the card has been placed into service, continue the procedure by performing one of these steps.

- If the `fcgpl=all` parameter will be specified with the `fcmode=fcopy` parameter, continue the procedure with [Step 6](#).
- If the `fcgpl=all` parameter will not be specified with the `fcmode=fcopy` parameter, continue the procedure with [Step 9](#).

6. Display the IPSP cards and their status by entering this command.

```
rept-stat-card:appl=ipsg
```

This is an example of the possible output.

```
rlghncxa03w 10-07-24 11:13:29 GMT EAGLE5 42.0.0
CARD  VERSION      TYPE      GPL      PST      SST      AST
1201  133-008-000  ENET      IPSP      IS-NR    Active  -----
```



```
1202 133-008-000 ENET IPSPG IS-NR Active -----
Command Completed.
```

If no cards that are running the IPSPG GPL (an IPSPG card) are shown in the `rept-stat-card` output, perform the "Adding an IPSPG Card" procedure in the *Database Administration Manual - IP7 Secure Gateway* to provision the necessary IPSPG cards. The required IPSPG linksets, signaling links, and associations must also be provisioned. After the required cards, linksets, signaling links, and associations have been provisioned, continue the procedure with [Step 9](#).

If IPSPG cards are shown in the `rept-stat-card` output, and the status of at least one of the cards is IS-NR, continue the procedure with [Step 9](#).

If IPSPG cards are shown in the `rept-stat-card` outputs, and the status of all the cards is not IS-NR, continue the procedure with [Step 7](#).

7. Display the signaling links that are assigned to the cards displayed in [Step 6](#) by entering this command.

```
rtrv-slk:type=ipsg
```

This is an example of the possible output.

```
rlghncxa03w 10-07-24 11:13:29 GMT EAGLE5 42.0.0
LOC LINK LSN          SLC TYPE      ANAME          SLKTPS/
1201 A  lsnipsg          0  IPSPG      assoc1         RSVDSLKTPS
1202 A  lsnipsg1         0  IPSPG      assoc2         10
                                                10
SLK table is (5 of 1200) 1% full.
```

If signaling links are not shown in this output, perform either the "Adding an IPSPG M2PA Signaling Link" procedure or "Adding an IPSPG M3UA Signaling Link" procedure in the *Database Administration Manual - IP7 Secure Gateway* to add the signaling links to the IPSPG cards. After the IPSPG signaling links have been added, continue the procedure with [Step 9](#).

If signaling links are shown in this output, continue the procedure with [Step 8](#).

8. Put into service the card shown in [Step 6](#) whose state is not IS-NR by entering the `rst-card` command with the location of the card. For this example, enter this command.

```
rst-card:loc=1201
```

When the command has successfully completed, this message should appear.

```
rlghncxa03w 10-07-24 11:13:29 GMT EAGLE5 42.0.0
Card has been allowed.
```

After the card has been placed into service, continue the procedure with [Step 9](#).

9. Change the `FCMODE` value by entering the `chg-eisopts` command with these parameters.

The `fcmode` parameter with one of these values.

- `off` - Monitoring is not performed on FC-capable cards.
- `stc` - STC monitoring is performed on FC-capable cards
- `fcopy` - FC monitoring is performed on FC-capable cards

The `fcgpl` parameter with one of these values.

- `ipsg` - monitoring is performed on E5-ENET cards running the IPSPG GPL (IPSPG cards).

- `ipghc` - monitoring is performed on E5-ENET cards running the IPGHC GPL.
- `all` - monitoring is performed on E5-ENET cards running the IPGHC and IPGHC GPLs. This is the default value for the `fcgpl` parameter if the `fcgpl` parameter is not specified.

If the `fcgpl` parameter is specified with the `chg-eisopts` command, the `fcmode` parameter must be specified.

For this example, enter one of these commands.

- a) To change the `FCMODE` value for IPGHC cards to off, enter this command.

```
chg-eisopts:fcmode=off:fcgpl=ipsg
```

- b) To change the `FCMODE` value for E5-ENET cards running the IPGHC GPL to `STC`, enter this command.

```
chg-eisopts:fcmode=stc:fcgpl=ipghc
```

- c) To change the `FCMODE` value for IPGHC cards and E5-ENET cards running the IPGHC GPL to `FCOPY`, enter one of these commands.

```
chg-eisopts:fcmode=fcopy:fcgpl=all
```

```
chg-eisopts:fcmode=fcopy
```

When the `chg-eisopts` has successfully completed, this message should appear.

```
rlghncxa03w 09-02-20 21:18:37 GMT EAGLE5 40.1.0
CHG-EISOPTS: MASP A - COMPLTD
```

10. Verify the changes to the `FCMODE` option by entering the `rtrv-eisopts` command.

For substep a in [Step 9](#), this is an example of the output.

```
rlghncxa03w 10-07-07 11:43:04 GMT EAGLE5 42.0.0
EIS OPTIONS
-----
EISCOPY = ON

FAST COPY OPTIONS
-----
FCGPL = IPGHC      FCMODE = OFF
FCGPL = IPGHC      FCMODE = STC
-----
```

For substep b in [Step 9](#), this is an example of the output.

```
rlghncxa03w 10-07-07 11:43:04 GMT EAGLE5 42.0.0
EIS OPTIONS
-----
EISCOPY = ON

FAST COPY OPTIONS
-----
FCGPL = IPGHC      FCMODE = FCOPY
FCGPL = IPGHC      FCMODE = STC
-----
```

For substep c in [Step 9](#), this is an example of the output.

```
rlghncxa03w 10-07-07 11:43:04 GMT EAGLE5 42.0.0
EIS OPTIONS
-----
```

```

EISCOPY = ON

FAST COPY OPTIONS
-----
FCGPL = IPSEG          FCMODE = FCOPY
FCGPL = IPGHC          FCMODE = FCOPY
-----

```

11. Back up the new changes using the `chg-db:action=backup:dest=fixed` command.

These messages should appear, the active Maintenance and Administration Subsystem Processor (MASP) appears first.

```

BACKUP (FIXED) : MASP A - Backup starts on active MASP.
BACKUP (FIXED) : MASP A - Backup on active MASP to fixed disk complete.
BACKUP (FIXED) : MASP A - Backup starts on standby MASP.
BACKUP (FIXED) : MASP A - Backup on standby MASP to fixed disk complete.

```

Configuring the IP Addresses for the EAGLE 5 Integrated Monitoring Support Feature

This procedure is used to configure the IP addresses and the `PVNMASK` value used for the EAGLE 5 Integrated Monitoring Support feature using the `chg-netopts` command with the `pvn`, `pvnmask`, `fcna`, and `fcnb` parameters.

The `pvn` and `pvnmask` parameters define the network used by the STCs to transmit copied MSUs between the EAGLE 5 ISS and the ESP/IMF subsystem. The IP communications link to the ESP/IMF subsystem is dynamically configured by the Sentinel/IMF. The LIMs are assigned Class B private network IP addresses (for example, 172.28.60.0), creating a PVN). The IP message origination address is the address of the LIM. The IP message destination address is that of the VIP (virtual IP address) contained within the ESP/IMF server.

The EAGLE 5 ISS uses a default value of 172.20.48.0 for the PVN address (`pvn` parameter). The default value may be changed by specifying a new network portion of an IP address and a network mask. The host portion of these PVN addresses are configured automatically. The default value for the `pvnmask` parameter is 255.255.252.0.

To change the network portion of the PVN address and the PVN submask used by the PVN addresses within the EAGLE 5 ISS, enter the `chg-netopts` command with the `pvn` and `pvnmask` parameters. The `EISCOPY` function must be disabled (`eiscopy=off`) in order to make these changes. For the `EISCOPY` value to be OFF, the `FCMODE` values for all the GPLs must be OFF. If the `FCMODE` values for all the GPLs are OFF, the `FCNA` and `FCNB` values can also be changed.

The `fcna` and `fcnb` parameters define, along with the `FCNAMASK` and `FCNBMASK` values shown in the `rtrv-netopts` output, the network used by the Fast Copy networks A and B. The IP address is assigned to the FC-capable cards dynamically based on the `fcna` and `fcnb` parameter values. A card that can run the Fast Copy interface is referred to as an FC-capable card. Currently, cards running the IPGHC and IPSEG GPLs are the only supported FC-capable cards. The default value for the `fcna` parameter is 172.21.48.0. The default value for the `fcnb` parameter is 172.22.48.0. The `FCNAMASK` and `FCNBMASK` values are 255.255.254.0 and cannot be changed. To change the `fcna` and `fcnb` parameter values, the `FCMODE` values for all the GPLs shown in the `rtrv-eisopts` output must be either `off` or `stc`. The `fcna` and `fcnb` parameter values can be a Class A, B, or C IP address. The third segment

of the IP address can only contain an even number. The value of the fourth segment of the IP address must be 0 (zero).

The subnet address that results from the PVN and PVNMASK, FCNA and FCNAMASK, or FCNB and FCNBMASK values cannot be the same as the subnet address resulting from the `ipaddr` and `submask` parameter values of the `chg-ip-lnk` command, or the `dest` and `submask` parameter values of the `ent-ip-rte` command.

This interaction applies to the PVN and PVNMASK values only if the `ipaddr` or `dest` parameter values are Class B IP addresses.

The `ipaddr`, `dest`, and `submask` parameter values can be verified by entering the `rtrv-ip-lnk` and `rtrv-ip-rte` commands. Choose `pvn` and `pvnmask`, `fcna`, or `fcnb` parameter values whose resulting subnet address is not be the same as the subnet address resulting from the `ipaddr` and `submask` parameter values of the `chg-ip-lnk` command, or the `dest` and `submask` parameter values of the `ent-ip-rte` command.

**CAUTION**

CAUTION: When configuring the IP addresses, make sure that the IP addresses do not conflict with the DHCP IP addresses that are leased to the STC cards. Any conflicting IP addresses can adversely affect the EAGLE 5 Integrated Monitoring Support feature.

To change the IP addresses and the PVNMASK value, the EAGLE 5 Integrated Monitoring Support feature (E5IS) must be turned on.

1. Verify that the EAGLE 5 Integrated Monitoring Support feature is on, by entering the `rtrv-feat` command.

If the EAGLE 5 Integrated Monitoring Support feature is on, the E5IS field should be set to on.

Note: The `rtrv-feat` command output contains other fields that are not used by this procedure. If you wish to see all the fields displayed by the `rtrv-feat` command, see the `rtrv-feat` command description in the *Commands Manual*.

If the EAGLE 5 Integrated Monitoring Support feature is not on, perform [Enabling the Time Slot Counter Synchronization \(TSCSYNC\) and EAGLE 5 Integrated Monitoring Support \(E5IS\) Features](#) to turn on the EAGLE 5 Integrated Monitoring Support feature. After the EAGLE 5 Integrated Monitoring Support feature is turned on, the EISCOPY value and the FCMODE values for all the GPLs, shown in the `rtrv-eisopts` output, are off. After the EAGLE 5 Integrated Monitoring Support feature is turned on, continue the procedure with [Step 3](#).

If the EAGLE 5 Integrated Monitoring Support feature is on, continue the procedure with [Step 2](#).

2. Display the EISCOPY and FCMODE values by entering the `rtrv-eisopts` command.

This is an example of the possible output.

```
rlghncxa03w 10-07-28 09:12:36 GMT EAGLE5 42.0.0
EIS OPTIONS
-----
EISCOPY = ON

FAST COPY OPTIONS
-----
FCGPL = IPSG          FCMODE = FCOPY
FCGPL = IPGHC        FCMODE = FCOPY
-----
```

Continue the procedure by performing one of these actions.

- If the PVN and PVNMASK values are being changed and the EISCOPY value is ON, perform the [Configuring the EISCOPY Option for the EAGLE 5 Integrated Monitoring Support Feature](#) procedure to change the EISCOPY value to OFF. After the [Configuring the EISCOPY Option for the EAGLE 5 Integrated Monitoring Support Feature](#) procedure has been performed, continue the procedure with [Step 3](#). For the EISCOPY value to be OFF, the FCMODE values for all the GPLs shown in the `rtrv-eisopts` output must be OFF. If the FCMODE values for all the GPLs shown in the `rtrv-eisopts` output are OFF, the FCNA and FCNB values can also be changed.

If the EISCOPY value is OFF, continue the procedure with [Step 3](#).

- If only the FCNA or FCNB values are being changed and the FCMODE value is FCOPY, perform the [Configuring the FCMODE Option for the EAGLE 5 Integrated Monitoring Support Feature](#) procedure to change the FCMODE values for all the GPLs shown in the `rtrv-eisopts` output to OFF or STC. After the [Configuring the FCMODE Option for the EAGLE 5 Integrated Monitoring Support Feature](#) procedure has been performed, continue the procedure with [Step 3](#).

If the FCMODE values for all the GPLs shown in the `rtrv-eisopts` output is OFF or STC, continue the procedure with [Step 3](#).

3. Display the IP addresses and the PVN subnet mask by entering the `rtrv-netopts` command.

This is an example of the possible output.

```
rlghncxa03w 09-02-28 09:12:36 GMT EAGLE5 40.1.0
NETWORK OPTIONS
-----
PVN      = 172.20.48.0
PVNMASK  = 255.255.252.0
FCNA     = 172.21.48.0
FCNAMASK = 255.255.254.0
FCNB     = 172.22.48.0
FCNBMASK = 255.255.254.0
```

4. Display the current link parameters associated with the IP card in the database by entering the `rtrv-ip-lnk` command.

The following is an example of the possible output.

```
rlghncxa03w 09-02-28 21:14:37 GMT EAGLE5 40.1.0
LOC  PORT  IPADDR          SUBMASK          DUPLEX  SPEED  MACTYPE  AUTO  MCAST
1201 A    192.1.1.1      255.255.255.128 HALF      10     802.3    NO    NO
1203 A    192.1.1.12    255.255.255.0   ----     ---    DIX      YES   NO
1205 A    192.1.1.14    255.255.255.0   FULL     100    DIX      NO    NO
```

5. Display the IP routes in the database with the `rtrv-ip-rte` command.

This is an example of the possible output.

```
rlghncxa03w 09-02-28 09:12:36 GMT EAGLE5 40.1.0
LOC  DEST          SUBMASK          GTWY
1301 128.252.10.5  255.255.255.255 140.188.13.33
1301 128.252.0.0   255.255.0.0     140.188.13.34
1301 150.10.1.1    255.255.255.255 140.190.15.3
1303 192.168.10.1  255.255.255.255 150.190.15.23
1303 192.168.0.0   255.255.255.0   150.190.15.24

IP Route table is (5 of 1024) 1% full
```

6. The subnet address that results from the `pv`n and `pv`nmask, `fc`na and `fc`namask, or `fc`nb and `fc`nbmask parameter values cannot be the same as the subnet address resulting from the `ip`addr and `sub`mask parameter values of the `chg-ip-lnk` command, or the `dest` and `sub`mask parameter values of the `ent-ip-rte` command.

This interaction applies to the `PVN` and `PVNMASK` values only if the `ip`addr or `dest` parameter values are Class B IP addresses. The `ip`addr, `dest`, and `sub`mask parameter values can be verified by entering the `rtrv-ip-lnk` and `rtrv-ip-rte` commands in [Step 4](#) and [Step 5](#).

Choose `pv`n and `pv`nmask, `fc`na, or `fc`nb parameter values for the `chg-netopts` command whose resulting subnet address is not be the same as the subnet address resulting from the `ip`addr and `sub`mask values shown in the `rtrv-ip-lnk` command in [Step 4](#), or the `dest` and `sub`mask values of the `rtrv-ip-rte` command in [Step 5](#). Continue the procedure with [Step 7](#).

7. Change the `PVN` and `PVNMASK`, `FCNA`, or `FCNB` values by entering the `chg-netopts` command.

To change the `PVN` and `PVNMASK` values, for this example, enter this command.

```
chg-netopts:pv=158.30.0.0:pvmask=255.255.252.0
```

To change either the `FCNA`, `FCNB`, or both the `FCNA` and `FCNB` values, for this example, enter one of these commands.

```
chg-netopts:fcna=180.37.56.0
```

```
chg-netopts:fcnb=181.37.56.0
```

```
chg-netopts:fcna=180.37.56.0:fcnb=181.37.56.0
```

To change the `PVN`, `PVNMASK`, `FCNA`, and `FCNB` values, for this example, enter this command.

```
chg-netopts:pv=158.30.0.0:pvmask=255.255.252.0:fcna=180.37.56.0:fcnb=181.37.56.0
```

Notes:

- At least one of the `pv`n and `pv`nmask, `fc`na, or `fc`nb parameters must be specified with the `chg-netopts` command.
- The `pv`n parameter value must be a Class B IP address. The host portion of the subnet address that results from the `pv`n and `pv`nmask parameter values must be 0 (zero).
- If either the `pv`n or `pv`nmask parameters are specified with the `chg-netopts` command, both parameters must be specified.
- The third segment of the IP address specified for the `fc`na and `fc`nb parameters can only contain an even number. The value of the fourth segment of the IP address must be 0 (zero).
- The `FCNAMASK` and `FCNBMASK` values shown in the `rtrv-netopts` output in [Step 3](#) cannot be changed.
- The `PVNMASK` value must be one of these values.

255.255.0.0	255.255.128.0	255.255.192.0
255.255.224.0	255.255.240.0	255.255.248.0
255.255.252.0	255.255.254.0	255.255.255.0

When the `chg-netopts` has successfully completed, this message should appear.

```
rlghncxa03w 11-03-20 21:18:37 GMT EAGLE5 43.0.0
Caution: Ensure that configured PVN/FCNA/FCNB addresses do not conflict
```

```
with the DHCP IP addresses leased to STC cards.
```

```
CHG-NETOPTS: MASP A - COMPLTD
```

8. Verify the changes using the `rtrv-netopts` command.

This is an example of the possible output.

```
rlghncxa03w 10-07-28 09:12:36 GMT EAGLE5 42.0.0
NETWORK OPTIONS
-----
PVN          = 158.30.0.0
PVMASK      = 255.255.252.0
FCNA        = 180.37.56.0
FCNAMASK    = 255.255.254.0
FCNB        = 181.37.56.0
FCNBMASK    = 255.255.254.0
```

9. Back up the new changes using the `chg-db:action=backup:dest=fixed` command.

These messages should appear, the active Maintenance and Administration Subsystem Processor (MASP) appears first.

```
BACKUP (FIXED) : MASP A - Backup starts on active MASP.
BACKUP (FIXED) : MASP A - Backup on active MASP to fixed disk complete.
BACKUP (FIXED) : MASP A - Backup starts on standby MASP.
BACKUP (FIXED) : MASP A - Backup on standby MASP to fixed disk complete.
```

If you do not wish to change the `EISCOPY` value or change the `FCMODE` values, this procedure is finished.

If you wish to change the `EISCOPY` value, perform [Configuring the EISCOPY Option for the EAGLE 5 Integrated Monitoring Support Feature](#).

If you wish to change the `FCMODE` values, perform [Configuring the FCMODE Option for the EAGLE 5 Integrated Monitoring Support Feature](#).

Adding a Signaling Transport Card (STC)

This procedure is used to add an STC (Signaling Transport Card) to the database using the `ent-card` command. The STC provides an interface between the EAGLE 5 ISS and the ESP (EAGLE 5 Integrated Monitoring Support feature). The STC allows the ESP subsystem to monitor the EAGLE 5 ISS's signaling links without additional intrusive cabling.

The `ent-card` command uses these parameters.

`:loc` – The location of the card being added to the database.

`:type` – The type of card being added to the database. For this procedure, the value of this parameter is `stc`.

`:appl` – The application software that is assigned to the card. For this procedure, the value of this parameter is `eroute`.

`:force` – Allow the LIM to be added to the database even if there are not enough service modules to support the number of LIMs in the EAGLE 5 ISS. This parameter is obsolete and is no longer used.

The STC can be either a single-slot STC, a dual-slot STC, or an E5-STC card as shown in [Table 24: STC Part Numbers](#).

Table 24: STC Part Numbers

Card Type	Card Name (as shown on the card Label)	Part Number
Dual-Slot STC	DCM	870-1945-XX 870-1984-01
	DCM	870-2372-01
Single-Slot STC	EDCM-A	870-2508-XX
	E5-ENET	870-2212-02
E5-STC	E5-ENET-B	870-2971-XX

The dual-slot STC can be inserted only in card slots 01, 03, 05, 07, 11, 13, 15, and 17 of the extension shelf. The dual-slot STC can be inserted in the control shelf, but only in slots 01, 03, 05, 07, and 11. The dual-slot STC occupies two card slots, so the even numbered card slot must be empty and not provisioned in the database, as shown in [Table 25: Dual-Slot STC Locations](#). The dual-slot STC is connected to the network through the odd numbered card slot connector.

Table 25: Dual-Slot STC Locations

Location of the STC	Empty Card Location	Location of the STC	Empty Card Location
Slot 01	Slot 02	Slot 11	Slot 12
Slot 03	Slot 04	Slot 13	Slot 14
Slot 05	Slot 06	Slot 15	Slot 16
Slot 07	Slot 08	Slot 17	Slot 18

The single-slot STC can be inserted into any card slot, except an even numbered card slot adjacent to a dual-slot card, shown in [Table 25: Dual-Slot STC Locations](#), slots 9 and 10 in each shelf, and slots 1113 through 1118.

The shelf to which the card is to be added, must already be in the database. This can be verified with the `rtrv-shlf` command. If the shelf is not in the database, see the "Adding a Shelf" procedure in the *Database Administration Manual - System Management*.

In order to enable the EISCOPY option, with the `chg-eisopts` command, and to comply with the $n+1$ STC configuration requirement, a minimum of two STCs must be provisioned in the database. A minimum of two STCs must be provisioned.

The number of SS7 signaling links that can be monitored by an STC varies depending the following criteria:

- Whether the STC is a dual-slot STC or single-slot STC
- The type of signaling link (defined by the application running on the card the signaling link is assigned to)

- The amount of traffic and the size of the MSUs being handled by the EAGLE 5 ISS

Note: Perform the “Changing the High-Capacity Card Temperature Alarm Thresholds” procedure in the *Database Administration Manual-SS7* to verify the temperature threshold settings for the E5-STC card.

STC Provisioning

The following rules apply to provisioning STCs.

- A minimum of two STCs must be provisioned in the EAGLE 5 ISS.
- The maximum number of STCs that can be provisioned in the EAGLE 5 ISS is 32.
- Only single-slot STCs can be installed and provisioned in the EAGLE 5 ISS if IP signaling links are being monitored. Dual-slot STCs cannot be installed or provisioned.
- HIPR or HIPR2 cards must be installed in the shelf that contains E5-STCs.
- For shelves containing HMUX cards, these rules apply to provisioning STCs.
 - If the shelf containing the STCs (only single/double slot STCs, but not E5-STCs) has HMUX cards installed in card slots 9 and 10, the shelf can contain a maximum of three STCs.
 - The STCs should be provisioned in shelves adjacent to the shelf containing the cards being monitored - half of the STCs should be provisioned in the next shelf and the other half of the STCs should be provisioned in the previous shelf. For example, if the shelf containing the cards being monitored is shelf 2100, half of the STCs monitoring shelf 2100 should be provisioned in shelf 1300 and the other half of the STCs monitoring shelf 2100 should be provisioned in shelf 2200.
- For shelves containing HIPR or HIPR2 cards in card slots 9 and 10, these rules apply to provisioning STCs.
 - STCs should be provisioned in the same shelf that contains the cards being monitored.
 - More than three STCs can be provisioned in the shelf depending on the number of empty cards slots the shelf has.
- To monitor signaling links on these cards, HIPR or HIPR2 cards must be installed in slots 9 and 10 of the shelf that contains these cards.
 - Single-slot EDCMs or E5-ENET cards that contain IP signaling links.
 - HC MIMs or E5-E1T1 cards that contain E1 or T1 signaling links.
- If the E5-STC card is an E5-ENET-B card, the FAN feature must be turned on and fans must be installed on the shelf that contains the E5-ENET-B card. Enter the `rtrv-feat` command to verify whether or not the FAN feature is turned on. Perform the procedures in the *Installation Manual* to install fans on the shelf that contains the E5-ENET-B card if fans must be installed. The MFC (message flow control) option must be on. Enter the `rtrv-stpopts` command to verify whether or not the MFC option is on. Perform the [Configuring the MFC Option](#) procedure to turn the MFC option on, if required.

Note: Contact your Tekelec Sales Representative or Account Representative to determine the number of STCs that must be provisioned in your EAGLE 5 ISS, and to determine where in the EAGLE 5 ISS these STC cards must be provisioned before performing this procedure.

The examples in this procedure are used to add an STC card in these card locations: 1303, 2101, and 2102.

1. Display the cards in the database using the `rtrv-card` command.

```
rlghncxa03w 09-05-28 09:12:36 GMT EAGLE5 41.0.0
CARD   TYPE     APPL      LSET NAME      LINK SLC LSET NAME      LINK SLC
1102   TSM        GLS
1113   GPDM       EOAM
1114   TDM-A
1115   GPDM       EOAM
1116   TDM-B
1117   MDAL
1201   LIMDS0    SS7ANSI   sp2             A      0      sp1            B      0
1203   LIMDS0    SS7ANSI   sp3             A      0
1204   LIMDS0    SS7ANSI   sp3             A      1
1206   LIMDS0    SS7ANSI   nsp3            A      1      nsp4           B      1
1216   DCM       STPLAN
1301   DSM       VSCCP
1308   LIMDS0    SS7ANSI   sp6             A      1      sp7            B      0
1314   LIMDS0    SS7ANSI   sp7             A      1      sp5            B      1
1317   DCM       STPLAN
```

The cards should be distributed throughout the EAGLE 5 ISS for proper power distribution. Refer to the *Installation Manual* for the shelf power distribution.

2. Verify that the EAGLE 5 Integrated Monitoring Support feature is on, by entering the `rtrv-feat` command. If the EAGLE 5 Integrated Monitoring Support feature is on, the `E5IS` field should be set to on.

Note: The `rtrv-feat` command output contains other fields that are not used by this procedure. To see all fields displayed by the `rtrv-feat` command, see the `rtrv-feat` command description in the *Commands Manual*.

Note: If the EAGLE 5 Integrated Monitoring Support feature is not on, go to the [Enabling the Time Slot Counter Synchronization \(TSCSYNC\) and EAGLE 5 Integrated Monitoring Support \(E5IS\) Features](#) procedure and enable the EAGLE 5 Integrated Monitoring Support feature.

If HIPR or HIPR2 cards are not required for provisioning STC cards, refer to [STC Provisioning](#) to determine if HIPR or HIPR2 cards are required, continue the procedure with [Step 9](#).

If HIPR or HIPR2 cards are required for provisioning STC cards, continue the procedure with [Step 3](#).

3. Verify that the HIPR cards are installed in card locations 9 and 10 in the shelf before adding the STC cards in this procedure. Enter this command.

```
rept-stat-gpl:gpl=hipr
rlghncxa03w 07-02-01 11:40:26 GMT EAGLE5 37.0.0
GPL     CARD     RUNNING      APPROVED      TRIAL
HIPR    1109      126-002-000 126-002-000 126-003-000
HIPR    1110      126-002-000 126-002-000 126-003-000
HIPR    1209      126-002-000 126-002-000 126-003-000
HIPR    1210      126-002-000 126-002-000 126-003-000
HIPR    1309      126-002-000 126-002-000 126-003-000
HIPR    1310      126-002-000 126-002-000 126-003-000
HIPR    2109      126-002-000 126-002-000 126-003-000
HIPR    2110      126-002-000 126-002-000 126-003-000
Command Completed
```

If HIPR cards are installed in the shelf containing the STC cards, continue the procedure by performing one of these steps.

- If the card that is being added is an E5-ENET card, continue the procedure with [Step 9](#).

- If the card that is being added is an E5-ENET-B card, continue the procedure with [Step 5](#).

If HIPR cards are not installed in the shelf containing the STC cards, continue the procedure with [Step 4](#).

4. Verify that the HIPR2 cards are installed in card locations 9 and 10 in the shelf before adding the STC cards in this procedure. Enter this command.

```
rept-stat-gpl:gpl=hipr2
```

This is an example of the possible output.

```
rlghncxa03w 09-07-01 11:40:26 GMT EAGLE5 41.1.0
GPL          CARD      RUNNING      APPROVED     TRIAL
HIPR2       1109      126-002-000 126-002-000 126-003-000
HIPR2       1110      126-002-000 126-002-000 126-003-000
HIPR2       1209      126-002-000 126-002-000 126-003-000
HIPR2       1210      126-002-000 126-002-000 126-003-000
HIPR2       1309      126-002-000 126-002-000 126-003-000
HIPR2       1310      126-002-000 126-002-000 126-003-000
HIPR2       2109      126-002-000 126-002-000 126-003-000
HIPR2       2110      126-002-000 126-002-000 126-003-000
Command Completed
```

If HIPR or HIPR2 cards are not installed in the shelf containing the STC cards, refer to the *Installation Manual* to install the HIPR or HIPR2 cards.

After the procedures in the *Installation Manual* have been performed, or if HIPR2 cards are installed at the card locations 9 and 10 on the shelf where the E5-STC card is to be installed, continue the procedure by performing one of these steps.

- If the card that is being added is an E5-ENET card, continue the procedure with [Step 9](#).
- If the card that is being added is an E5-ENET-B card, continue the procedure with [Step 5](#).

5. Verify whether or not the MFC option is on by entering the `rtrv-stpopts` command.

This is an example of the possible output.

```
rlghncxa03w 11-10-17 16:02:05 GMT EAGLE5 44.0.0
STP OPTIONS
-----
MFC                      off
```

The `rtrv-stpopts` command output contains other fields that are not used by this procedure. If you wish to see all the fields displayed by the `rtrv-stpopts` command, see the `rtrv-stpopts` command description in the *Commands Manual*.

If the MFC option is off, perform the [Configuring the MFC Option](#) procedure to turn on the MFC option.

If the MFC option is on, or the [Configuring the MFC Option](#) procedure was performed in this step, continue the procedure with [Step 6](#).

6. Fans must be installed on the shelves that contain the E5-ENET-B cards. The Fan feature must be turned on. If the Fan feature is on, shown in the `rtrv-feat` output in [Step 2](#), the FAN field should be set to on.

If the Fan feature is on, continue the procedure with [Step 8](#).

If the Fan feature is off, continue the procedure with [Step 7](#).

- Turn the Fan feature on by entering this command.

```
chg-feat:fan=on
```

Note: Once the Fan feature is turned on with the `chg-feat` command, it cannot be turned off.

The Fan feature must be purchased before you turn this feature on with the `chg-feat` command. If you are not sure if you have purchased the Fan feature, contact your Tekelec Sales Representative or Account Representative.

When the `chg-feat` has successfully completed, this message appears.

```
rlghncxa03w 11-10-28 11:43:04 GMT EAGLE5 44.0.0
CHG-FEAT: MASP A - COMPLTD
```

- The shelf containing the E5-ENET-B card that is being added in this procedure must have fans installed. Verify whether or not fans are installed on the shelf.

If the fans are installed, continue the procedure with [Step 9](#).

If the fans are not installed on the shelf containing the E5-ENET-B card, go to the *Installation Manual* and install the fans. After the fans have been installed and tested, continue the procedure with [Step 9](#).

- Add the STC card using the `ent-card` command. Refer to [STC Provisioning](#) for the rules for provisioning STC cards. A dual-slot STC card can be inserted only in an odd numbered slot and the adjacent even card slot must be empty, as shown in [Table 25: Dual-Slot STC Locations](#). A single-slot STC card can be inserted into any card slot except an even numbered card slot adjacent to a dual-slot card, slots 09 and 10 in each shelf, and slots 1113 through 1118. For this example, enter these commands.

```
ent-card:loc=1303:type=stc:appl=eroute
```

```
ent-card:loc=2101:type=stc:appl=eroute
```

```
ent-card:loc=2102:type=stc:appl=eroute
```

- Verify the changes using the `rtrv-card` command with the card location specified in [Step 9](#). For this example, enter these commands.

```
rtrv-card:loc=1303
```

```
rlghncxa03w 06-10-28 09:12:36 GMT EAGLE5 36.0.0
CARD  TYPE      APPL      LSET NAME      LINK SLC  LSET NAME      LINK SLC
1303  STC          EROUTE
```

```
rtrv-card:loc=2101
```

```
rlghncxa03w 06-10-28 09:12:36 GMT EAGLE5 36.0.0
CARD  TYPE      APPL      LSET NAME      LINK SLC  LSET NAME      LINK SLC
2101  STC          EROUTE
```

```
rtrv-card:loc=2102
```

```
rlghncxa03w 06-10-28 09:12:36 GMT EAGLE5 36.0.0
CARD  TYPE      APPL      LSET NAME      LINK SLC  LSET NAME      LINK SLC
2102  STC          EROUTE
```

- Verify that the card to be entered has been physically installed into the card location specified in [Step 9](#).



CAUTION

CAUTION: If the version of the flash GPLs on the STC does not match the flash GPL versions in the database when the STC is inserted into the card slot, UAM 0002 is generated indicating that these GPL versions do not match. If UAM 0002 has been generated, perform the alarm clearing procedure for UAM 0002 in the *Unsolicited Alarm and Information Messages* manual before proceeding with this procedure.

12. Put the STC card added in [Step 9](#) into service using the `alw-card` command specifying the card location specified in [Step 9](#). For this example, enter these commands.

```
alw-card:loc=1303
```

```
alw-card:loc=2101
```

```
alw-card:loc=2102
```

When the `alw-card` command has successfully completed, this message should appear.

```
rlghncxa03w 06-10-28 09:12:36 GMT EAGLE5 36.0.0
Card has been allowed.
```

13. Back up the new changes using the `chg-db:action=backup:dest=fixed` command. These messages should appear, the active Maintenance and Administration Subsystem Processor (MASP) appears first.

```
BACKUP (FIXED) : MASP A - Backup starts on active MASP.
BACKUP (FIXED) : MASP A - Backup on active MASP to fixed disk complete.
BACKUP (FIXED) : MASP A - Backup starts on standby MASP.
BACKUP (FIXED) : MASP A - Backup on standby MASP to fixed disk complete.
```

Removing a Signaling Transport Card (STC)

This procedure is used to remove an STC from the database using the `dlt-card` command.



CAUTION

CAUTION: If the STC is the last STC in service, removing this card from the database will disable the EAGLE 5 Integrated Monitoring Support feature.



CAUTION

CAUTION: If removing the STC reduces the quantity of STCs in the EAGLE 5 ISS below number of STCs required by the ESP subsystem, the performance of the EAGLE 5 Integrated Monitoring Support feature will be degraded.

The examples in this procedure are used to remove the STC in card location 1303.

Canceling the REPT-STAT-CARD Command

Because the `rept-stat-card` command used in this procedure can output information for a long period of time, the `rept-stat-card` command can be canceled and the output to the terminal stopped. There are three ways that the `rept-stat-card` command can be canceled.

- Press the F9 function key on the keyboard at the terminal where the `rept-stat-card` command was entered.
- Enter the `canc-cmd` without the `trm` parameter at the terminal where the `rept-stat-card` command was entered.

- Enter the `canc-cmd:trm=<xx>`, where `<xx>` is the terminal where the `rept-stat-card` command was entered, from another terminal other than the terminal where the `rept-stat-card` command was entered. To enter the `canc-cmd:trm=<xx>` command, the terminal must allow Security Administration commands to be entered from it and the user must be allowed to enter Security Administration commands. The terminal's permissions can be verified with the `rtrv-secu-trm` command. The user's permissions can be verified with the `rtrv-user` or `rtrv-secu-user` commands.

For more information about the `canc-cmd` command, go to the *Commands Manual*.

1. Display the cards in the database using the `rtrv-card` command. This is an example of the possible output.

```
rlghncxa03w 09-05-28 09:12:36 GMT EAGLE5 41.0.0
CARD  TYPE      APPL      LSET NAME      LINK SLC LSET NAME      LINK SLC
1101  DSM          VSCCP
1103  DCM          STPLAN
1113  GPSM        EOAM
1114  TDM-A
1115  GPSM        EOAM
1116  TDM-B
1117  MDAL
1201  LIMDS0      SS7ANSI   sp2            A    0    sp1            B    0
1202  LIMDS0      SS7ANSI   sp2            A    1    nsp3           B    0
1203  LIMDS0      SS7ANSI   sp3            A    0
1204  LIMDS0      SS7ANSI   sp3            A    1
1206  LIMDS0      SS7ANSI   nsp3           A    1    nsp4           B    0
1212  DSM          VSCCP
1214  TSM          GLS
1215  DCM          STPLAN
1301  LIMATM      ATMANSI   lsnatm1       A    0
1303  STC         EROUTE
1305  DCM          STPLAN
1308  LIMDS0      SS7ANSI   sp6            A    0    sp7            B    0
1311  LIMDS0      SS7ANSI   sp2            A    2    sp1            B    1
          sp7            A1   1    sp3            B1   2
1315  LIMDS0      SS7ANSI   sp7            A    2    sp5            B    0
1318  LIMATM      ATMANSI   lsnatm1       A    1
2101  STC         EROUTE
2102  STC         EROUTE
2105  STC         EROUTE
```

An STC is identified by the entries STC in the TYPE field and EROUTE in the APPL field.

2. Display the status of the STC being removed with the `rept-stat-card` command with the location of the STC. For this example, enter this command.

```
rept-stat-card:loc=1303
```

This is an example of the possible output.

```
rlghncxa03w 10-07-27 16:43:42 GMT EAGLE5 42.0.0
CARD  VERSION      TYPE      GPL      PST      SST      AST
1303  133-003-000  STC      EROUTE   IS-NR    Active   -----
ALARM STATUS      = No Alarms.
BPDCM GPL version = 133-108-000
IMT BUS A         = Conn
IMT BUS B         = Conn
CLOCK A          = Active
CLOCK B          = Idle
CLOCK I          = Idle
```

```

MBD BIP STATUS      = Valid
MOTHER BOARD ID    = Valid
DBD STATUS         = Valid
DBD TYPE           = Valid
DBD MEMORY SIZE    = 512M
HW VERIFICATION CODE = ----
EROUTE % OCCUP     = 50%
NTP broadcast      = VALID
Command Completed.

```

- Inhibit the card using the `rmv-card` command, specifying the card location. For this example, enter this command.

```
rmv-card:loc=1303
```

When this command has successfully completed, this message should appear.

```

rlghncxa03w 06-08-12 09:12:36 GMT EAGLE5 37.0.0
Card has been inhibited.

```

- Remove the card using the `dlt-card` command. The `dlt-card` command has only one parameter, `loc`, which is the location of the card. For this example, enter this command.

```
dlt-card:loc=1303
```

When this command has successfully completed, this message should appear.

```

rlghncxa03w 06-08-12 09:12:36 GMT EAGLE5 37.0.0
DLT-CARD: MASP A - COMPLTD

```

- Verify the changes using the `rtrv-card` command specifying the card that was removed in step 4. For this example, enter this command.

```
rtrv-card:loc=1303
```

When this command has successfully completed, this message should appear.

```
E2144 Cmd Rej: Location invalid for hardware configuration
```

- Back up the new changes using the `chg-db:action=backup:dest=fixed` command. These messages should appear, the active Maintenance and Administration Subsystem Processor (MASP) appears first.

```

BACKUP (FIXED) : MASP A - Backup starts on active MASP.
BACKUP (FIXED) : MASP A - Backup on active MASP to fixed disk complete.
BACKUP (FIXED) : MASP A - Backup starts on standby MASP.
BACKUP (FIXED) : MASP A - Backup on standby MASP to fixed disk complete.

```

Appendix

A

Reference Information

Topics:

- [Configuring the MFC Option.....241](#)

This appendix contains information that is used by more than one procedure in this manual.

Configuring the MFC Option

This procedure is used to configure the option for the EAGLE 5 ISS to use Message Flow Control (MFC) to control the traffic in the EAGLE 5 ISS instead of Group Ticket Voucher (TVG). This option is configured with `chg-stpopts` command using these parameters.

- `on=mfc` - turns the MFC option on. When the MFC option is turned on, Message Flow Control controls the traffic in the EAGLE 5 ISS.
 - `off=mfc` - turns the MFC option off. When the MFC option is turned off, Group Ticket Voucher controls the traffic in the EAGLE 5 ISS. The MFC option cannot be turned off using this procedure. Contact the Customer Care Center before attempting to turn off the MFC option. Refer to [Customer Care Center](#) for the contact information.
1. Display the existing value for the MFC option by entering the `rtrv-stpopts` command. The value for the MFC option is shown in the MFC field. This is an example of the possible output.

```
rlghncxa03w 10-12-17 16:02:05 GMT EAGLE5 43.0.0
STP OPTIONS
-----
MFC                               off
Command Completed.
```

The `rtrv-stpopts` command output contains other fields that are not used by this procedure. If you wish to see all the fields displayed by the `rtrv-stpopts` command, see the `rtrv-stpopts` command description in the *Commands Manual*.

If the MFC option is off, continue the procedure with [Step 2](#).

If the MFC option is on and you wish to turn the option off, this procedure cannot be performed. Contact the Customer Care Center before attempting to turn off the MFC option. Refer to [Customer Care Center](#) for the contact information.

If the MFC option is on and you do not wish to turn the option off, no further action is necessary.

2. Turn the MFC option on by entering this command.

```
chg-stpopts: on=mfc
```

When this command has successfully completed, this message should appear.

```
rlghncxa03w 10-12-07 00:22:57 GMT EAGLE5 43.0.0
CHG-STPOPTS: MASP A - COMPLTD
```

3. Verify the changes using the `rtrv-stpopts` command. This is an example of the possible output.

```
rlghncxa03w 10-12-17 16:02:05 GMT EAGLE5 43.0.0
STP OPTIONS
-----
MFC                               on
```

```
Command Completed.
```

The `rtrv-stpopts` command output contains other fields that are not used by this procedure. If you wish to see all the fields displayed by the `rtrv-stpopts` command, see the `rtrv-stpopts` command description in the *Commands Manual*.

4. Back up the new changes using the `chg-db:action=backup:dest=fixed` command. These messages should appear, the active Maintenance and Administration Subsystem Processor (MASP) appears first.

```
BACKUP (FIXED) : MASP A - Backup starts on active MASP.  
BACKUP (FIXED) : MASP A - Backup on active MASP to fixed disk complete.  
BACKUP (FIXED) : MASP A - Backup starts on standby MASP.  
BACKUP (FIXED) : MASP A - Backup on standby MASP to fixed disk complete.
```

Glossary

A

ACT	Activate
AFTPC	Affected Point Code The point code in subsystem-prohibited (SSP), subsystem-status-test (SST), and subsystem-allowed (SSA) SCCP management messages used by gateway screening to determine if the messages containing these point codes are allowed in to the network. This point code is in the SCMG Data (SCCP Management) portion of the signaling information field in the MSU.
Allowed Affected Destination Field	The gateway screening entity that identifies the point code in the affected destination field (the concerned signaling point code) of incoming MTP network management messages from another network that are allowed into the EAGLE 5 ISS. Messages containing the specified point code are allowed into the network.
Allowed DPC	The gateway screening entity that identifies the destination point codes that are allowed to receive SS7 messages from the EAGLE 5 ISS. Messages containing the specified destination point codes go on to the next step in the gateway screening process, or are allowed into the network if the gateway screening process stops with this entity.
Allowed ISUP	The gateway screening entity that identifies the ISUP or TUP message

A

types that are allowed into the network.

Allowed OPC

The gateway screening entity that identifies the originating point codes that are allowed to send SS7 messages into the network. Messages containing the specified originating point codes go on to the next step in the gateway screening process, or are allowed into the network if the gateway screening process stops with this entity.

Allowed SIO

The gateway screening entity that identifies the type of MSUs (ISUP, TUP, TCAP, and so forth) that are allowed into the network. The message type is determined by the network indicator code (NIC), priority (PRI), and service indicator (SI) fields of the signaling information octet (SIO) field in the MSU, and the H0 and H1 heading codes of the signaling information field of the MSU. Messages containing the specified message type go on to the next step in the gateway screening process, or are allowed into the network if the gateway screening process stops with this entity.

ANSI

American National Standards Institute

An organization that administers and coordinates the U.S. voluntary standardization and conformity assessment system. ANSI develops and publishes standards. ANSI is a non-commercial, non-government organization which is funded by more than 1000 corporations, professional bodies, and enterprises.

A

APC	<p>Adjacent Point Code</p> <p>The point code that identifies a node adjacent to the EAGLE 5 ISS. This term is used in link sets and routes.</p>
API	<p>Application Interface</p>
ARP	<p>Address Resolution Protocol</p> <p>ARP monitoring uses the Address Resolution Protocol to determine whether a remote interface is reachable.</p> <p>Auto Reply service</p> <p>Personalized SMS auto reply service. This service is provided by the Mobile Messaging XS-ARP component.</p>
ATI	<p>Any Time Interrogation</p> <p>An ATI message allows an external server to interrogate an HLR and obtain information about the location and/or state of a GSM subscriber.</p> <p>Incoming application-terminated</p>
ATMANSI	<p>The application used for high-speed ANSI ATM signaling links.</p>
ATMITU	<p>The application used for high-speed E1 ATM signaling links.</p>

B

BITS	<p>Building Integrated Timing System</p> <p>The Building Integrated Timing System (BITS) clocks come directly from the central office BITS clock source or indirectly from an optional holdover clock installed in the system.</p>
------	------------------------------------------------------------------------------------------------------------------------------------------------------------------------------------------------------------------------------------

B

BLKDPC

Blocked Destination Point Code

The point code that the gateway screening uses to keep MSUs bound for a specific point code out of the network where the EAGLE 5 ISS is located. This point code is in the routing label portion of the signaling information field in the MSU.

Messages that do not contain the specified destination point code go on to the next step in the gateway screening process, or are allowed into the network if the gateway screening process stops with this entity.

BLKOPC

Blocked Originating Point Code

The point code that gateway screening uses to keep MSUs coming from a specific point code out of the network where the EAGLE 5 ISS is located. This point code is in the routing label portion of the signaling information field in the MSU.

Messages that do not contain the specified originating point code go on to the next step in the gateway screening process, or are allowed into the network if the gateway screening process stops with this entity.

C

CCS7ITU

The application for the ITU SS7 signaling links that is used with card types `limds0`, `limch`, `lime1`, and `limt1`.

CDR

Call Detail Record

This refers to the recording of all connections in a database to permit activities such as billing connection charges or network analysis. CDR files are used in public switched

C

	networks, IP networks, for IP telephony, and mobile communications networks.
control cards	Cards that occupy slots 1113 through 1118 of the control shelf on an EAGLE 5 ISS and perform OAM, TDM, and database functions for the EAGLE 5 ISS. The legacy set consists of the single-slot GPSPM-II card running the OAM application and EOAM GPL, the single-slot TDM card, and the dual-slot MDAL card. The E5-based set consists of the dual-slot E5-MASP card (the E5-MCAP module and the E5-TDM module) and the dual-slot E5-MDAL card.
credit card drive	Flash memory credit card-shaped drive used in the flush-mounted USB port on an E5-MCAP card for upgrade; it could be used for disaster recovery.

D

DCM	Database Communication Module The DCM provides IP connectivity for applications. Connection to a host is achieved through an ethernet LAN using the TCP/IP protocol.
DESTFLD	The point code in the affected destination field (the concerned signaling point code) of incoming MTP network management messages from another network that are allowed into the EAGLE 5 ISS.
Destination	The node to which the signaling link traffic is routed. This destination is identified by a point code, either a

D

	full point code or a cluster point code.
DHCP	Dynamic Host Configuration Protocol
DPC	Destination Point Code DPC refers to the scheme in SS7 signaling to identify the receiving signaling point. In the SS7 network, the point codes are numeric addresses which uniquely identify each signaling point. This point code can be adjacent to the EAGLE 5 ISS, but does not have to be.
DPCA	Destination Point Code ANSI
DPCI	Destination Point Code International
DPCN	Destination Point Code National
DS0	Digital Signal Level-0 (64 Kbits/sec or 56 Kbits/sec) A basic digital signaling rate of 64 Kbits/sec, corresponding to the capacity of one voice-frequency-equivalent channel.
DSM	Database Service Module. The DSM provides large capacity SCCP/database functionality. The DSM is an application card that supports network specific functions such as EAGLE Provisioning Application Processor (EPAP), Global System for Mobile Communications (GSM), EAGLE Local Number Portability (ELAP),

D

and interface to Local Service Management System (LSMS).

DTA

Database Transport Access

A feature in the EAGLE 5 ISS that encapsulates specific MSUs into the data portion of SCCP within a new SS7 MSU and sends the new MSU to the destination using global title translation. The EAGLE 5 ISS uses gateway screening to determine which MSUs are used by the DTA feature.

E

E5-E1T1

EPM-based E1/T1 Multi-Channel Interface Module

An EPM-based card that provides E1 and T1 connectivity. The E5 indicates the card is for existing EAGLE 5 control and extension shelves. E1T1 is an abbreviation for the ITU E1 and ANSI T1 interfaces. Thus the nomenclature defines the shelves where the card can be used and the physical interface that it provides.

E5IS

EAGLE 5 Integrated Monitoring Support

The EAGLE 5 Integrated Monitoring Support feature allows the network traffic on the EAGLE 5 ISS's signaling links to be monitored by an ESP (extended services platform) or IMP (integrated message feeder) without additional intrusive cabling. Message Signaling Units (MSUs), alarms, and events are copied to the Sentinel/IMF to provide the network traffic monitoring. The monitored traffic is delivered to the Sentinel/IMF using the EAGLE'S STCs (Signaling Transport Cards)

E

which are connected to the ESP/IMF subsystem by Ethernet links. The ESP/IMF subsystem delivers the monitored traffic to the Sentinel/IMF.

E5-MASP card

E5-based dual-slot card that consists of the E5-MCAP module (occupies slot 1113 and slot 1115) and the E5-TDM module (occupies slot 1114 and slot 1116) in an EAGLE 5 ISS control shelf. Used when the E5-MDAL card is used.

E5-MCAP card

The module contains the Communications Processor and Applications Processor and provides connections to the IMT bus. Controls the maintenance and database administration activity and performs both application and communication processing. Runs the OAM application and OAMHC GPL. Occupies slot 1113 and slot 1115 in an EAGLE 5 ISS control shelf. Used when the E5-MDAL card is used. Contains two USB ports.

E5-MDAL card

The E5 MDAL card processes alarm requests, provides general purpose relays, and provides fan control. Occupies slots 1117 and 1118 in an EAGLE 5 ISS Control Shelf. Used with E5-MASP cards. Does NOT contain a drive for removable cartridges.

E5-SLAN

E5-ENET card used to support the STP LAN application.

E5-TDM card

The E5-TDM card provides the EAGLE 5 ISS with 16 ports for user

E

terminals, contains fixed disk storage and distributes Composite Clocks and High Speed Master clocks throughout the EAGLE 5 ISS. Occupies slot 1114 and slot 1116 in an EAGLE 5 ISS Control Shelf. Used when the E5-MDAL card is used.

ECAP

EAGLE Collector Application Processor

A dedicated standalone platform for the collection of EAGLE 5 ISS traffic statistical data.

ECAP provides the information and data needed to apply the charging rules to an external billing and charging application, called the Aggregator. ECAP depends on the Eagle SLAN card for this information.

EDCM

Enhanced Database Communication Module

ESP

Expanded Services Platform

The Sentinel system with the hardware and software platform that provides the interface to the Integrated EAGLE and Sentinel monitoring system. The ESP hardware and software platform runs on the model 120 server.

F**fixed disk drive**

Hard drive on the TDM card and the E5-TDM card.

flush-mounted USB port

USB port on the E5-MCAP card; used with credit card flash memory drives for upgrades and could be used for disaster recovery.

F

FTP

File Transfer Protocol

A client-server protocol that allows a user on one computer to transfer files to and from another computer over a TCP/IP network.

G

GLS

Generic Loading Services

An application that is used by the TSM cards for downloading gateway screening to LIM cards.

GPL

Generic Program Load

Software that allows the various features in the system to work. GPLs and applications are not the same software.

GPSM-II card

General Purpose Service Module II

Contains the communications processor and applications processor and provides connections to the Interprocessor Message Transport (IMT) bus. The GPSM-II card can run on the OAM, IPS, or MCP applications.

This card runs various GPLs and applications in the EAGLE 5 ISS. As a control card, it runs the OAM application and EOAM GPL. Used when the legacy TDM card and MDAL card are used.

GSM

Global System for Mobile Communications

GSMSCRN

GSM MAP Screening.

A feature that allows the user to provision which MAP subsystem numbers are affected, which MAP operations codes to screen, which

G

origination points are allowed, and which error messages to use.

GT Global Title Routing Indicator

GTA Global Title Address

GTI Global Title Indicator

GTT Global Title Translation

A feature of the signaling connection control part (SCCP) of the SS7 protocol that the EAGLE 5 ISS uses to determine which service database to send the query message when an MSU enters the EAGLE 5 ISS and more information is needed to route the MSU. These service databases also verify calling card numbers and credit card numbers. The service databases are identified in the SS7 network by a point code and a subsystem number.

GWS Gateway Screening

Used at gateway STPs to limit access into the network to authorized users. A gateway STP performs inter-network routing and gateway screening functions. GWS controls access to nonhome SS7 networks. Only an MSU that matches predefined criteria in the EAGLE 5 ISS's database is allowed to enter the EAGLE 5 ISS.

H

HC-MIM High Capacity Multi-Channel Interface Module

A card that provides access to eight E1/T1 ports residing on backplane

H

connectors A and B. Each data stream consists of 24 T1 or 31 E1 DS0 signaling links assigned in a time-division multiplex (TDM) manner. Each channel occupies a unique timeslot in the data stream and can be selected as a local signaling link on the interface card. Each card has 8 E1 or 8 T1 port interfaces with a maximum of 64 signaling links provisioned among the 8 E1/T1 ports.

HIPR

High-Speed IMT Packet Router

A card that provides increased system throughput and traffic capacity. HIPR moves EAGLE from an intra-shelf ring topology to an intra-shelf switch topology. HIPR acts as a gateway between the intra-shelf IMT BUS, running at 125Mbps, and the inter-shelf operating at 1.0625Gbps. The HIPR card will seat in the same slot as an HMUX card (slots xx09 & xx10 of each shelf).

HIPR2

High-Speed IMT Packet Router 2

A card that provides increased system throughput and traffic capacity on the existing Fibre-Channel ring. A high rate Fibre-Channel option of 2.5 Gbps is available when an EAGLE is provisioned with all HIPR2 cards. In a mixed topology where a HIPR2 is used in an EAGLE along with HMUX and HIPR, the Fibre-Channel ring runs at the lower rate of 1.0625 Gbps.

HLR

Home Location Register

HMUX

High-Speed Multiplexer

H

A card that supports the requirements for up to 1500 links, allowing communication on IMT buses between cards, shelves and frames. HMUX cards interface to 16 serial links, creating a ring from a series of point to point links. Each HMUX card provides a bypass multiplexer to maintain the ring's integrity as cards are removed and inserted into an operational shelf.

High-Speed IMT Multiplexer, a replacement card for the IPMX.

HSL High-Speed Link

I

ICMP Internet Control Message Protocol

ID Identity, identifier

IMF Integrated Message Feeder

The IMF sits on the EAGLE and replicates the signaling data that is processed through the EAGLE to send to an off-board processor (the IXP in the case of IAS). Because it replicates the data (and doesn't introduce a new element in the path) it does not introduce any delay to the signaling and it does not create a separate footprint for a "probe" system.

IMT Inter-Module-Transport

The communication software that operates the inter-module-transport bus on all cards except the LIMATM, DCM, DSM, and HMUX.

Internet Protocol See IP.

I

IP	<p>Internet Protocol</p> <p>IP specifies the format of packets, also called datagrams, and the addressing scheme. The network layer for the TCP/IP protocol suite widely used on Ethernet networks, defined in STD 5, RFC 791. IP is a connectionless, best-effort packet switching protocol. It provides packet routing, fragmentation and re-assembly through the data link layer.</p>
IP Address	<p>The location of a device on a TCP/IP network. The IP Address is either a number in dotted decimal notation which looks something like (IPv4), or a 128-bit hexadecimal string such as (IPv6).</p>
IPGWI	<p>An application that is used by the SSED/CM/E5-ENET card for IP point-to-multi-point connectivity within an ITU-I or ITU-N network. The system allows a maximum of 64 cards to be assigned the IPGWI application.</p>
IPGWx	<p>Point-to-multipoint MTP-User signaling (e.g. ISUP, TCAP) over IP capability. Typically used for A link connectivity which require routing keys. Far End not required to support MTP3. The IPGWx GPLs (IPGWI, SS7IPGW) run on the SSED/CM/E5-ENET cards.</p>
IPLIM	<p>The application used by the SSED/CM/E5-ENET card for IP point-to-point connectivity for ANSI point codes.</p>
IPLIMI	<p>The application used by the SSED/CM/E5-ENET card for IP</p>

I

point-to-point connectivity for ITU point codes.

IPLIMx Point-to-point MTP3 and MTP3-User signaling over IP capability. Typically used for B-C-D links but can be used for A links but does not have routing key functionality. Far End required to support MTP3. The IPLIMx GPLs (IPLIMI, IPLIM) run on the SSEDCEM/E5-ENET cards.

IS-NR In Service - Normal

ISS Integrated Signaling System

ISUP ISDN User Part

ITU International Telecommunications Union

L

LAN Local Area Network
A private data network in which serial transmission is used for direct data communication among data stations located in the same proximate location. LAN uses coax cable, twisted pair, or multimode fiber.

See also STP LAN.

latched USB port On the E5-MCAP card, a USB port with a lockable latch. Used with removable media (flash memory "thumb" drives) to install and back up customer data.

LIM Link Interface Module

L

Provides access to remote SS7, IP and other network elements, such as a Signaling Control Point (SCP) through a variety of signaling interfaces (DS0, MPL, E1/T1 MIM, LIM-ATM, E1-ATM, IPLIMx, IPGWx). The LIMs consist of a main assembly and possibly, an interface appliqué board. These appliqués provide level one and some level two functionality on SS7 signaling links.

Link

Signaling Link

Signaling Link

Carries signaling within a Link Set using a specific Association. A Link can belong to only one Link Set and one Association. There is generally one Link per Association in a Link Set.

Load Sharing

A type of routing used by global title translation to route MSUs. This type of routing is used when a second point code and subsystem is defined for the primary point code and subsystem. Traffic is shared equally between the replicated point codes and subsystems.

LSL

Low-speed Link

LST

Link Set Type

M

M2PA

SS7 MTP2-User Peer-to-Peer Adaptation Layer

M3UA

SS7 MTP3-User Adaptation Layer

M

	M3UA enables an MTP3 User Part to be connected to a remote MTP3 via a reliable IP transport.
MAP	Mobile Application Part
MAS	Maintenance and Administration Subsystem A set of cards located in the Control Shelf, used to provide a central management point for the EAGLE 5 ISS. The MAS provides user interface, maintenance communication, peripheral services, alarm processing, system disk interface, and measurements using the following three subassemblies: GPSM-II, TDM, and MDAL.
MASP	Maintenance and Administration Subsystem Processor The Maintenance and Administration Subsystem Processor (MASP) function is a logical pairing of the GPSM-II card and the TDM card. The GPSM-II card is connected to the TDM card by means of an Extended Bus Interface (EBI) local bus. The MDAL card contains the removable cartridge drive and alarm logic. There is only one MDAL card in the Maintenance and Administration Subsystem (MAS) and it is shared between the two MASPs.
Mated Application	The point codes and subsystem numbers of the service databases that messages are routed to for global title translation.
MAU	Media Access Unit

M

	<p>An industry standard single port Ethernet transceiver that connects the E5-ENET to the Ethernet.</p>
MFC	<p>Message Flow Control</p>
MPL	<p>Multi-port LIM</p>
MRN	<p>Message Reference Number</p> <p>An unsolicited numbered message (alarm or information) that is displayed in response to an alarm condition detected by the system or in response to an event that has occurred in the system.</p> <p>Mated Relay Node</p> <p>A mated relay node (MRN) group is provisioned in the database to identify the nodes that the traffic is load shared with, and the type of routing, either dominant, load sharing, or combined dominant/load sharing.</p>
MSU	<p>Message Signal Unit</p> <p>The SS7 message that is sent between signaling points in the SS7 network with the necessary information to get the message to its destination and allow the signaling points in the network to set up either a voice or data connection between themselves. The message contains the following information:</p> <ul style="list-style-type: none">• The forward and backward sequence numbers assigned to the message which indicate the position of the message in the traffic stream in relation to the other messages.

M

- The length indicator which indicates the number of bytes the message contains.
- The type of message and the priority of the message in the signaling information octet of the message.
- The routing information for the message, shown in the routing label of the message, with the identification of the node that sent message (originating point code), the identification of the node receiving the message (destination point code), and the signaling link selector which the EAGLE 5 ISS uses to pick which link set and signaling link to use to route the message.

MTP Message Transfer Part
The levels 1, 2, and 3 of the SS7 protocol that control all the functions necessary to route an SS7 MSU through the network

MTP2 Message Transfer Part, Level 2

MTP3 Message Transfer Part, Level 3

N

NAI Nature of Address Indicator
Standard method of identifying users who request access to a network.

Network Access Identifier

NAIV NAI Value

NIC Network Identifier Code

N

Network Information Center

Network Interface Card

Computer hardware that enables computers to communicate with one another over a computer network. Also called a network card or a network adapter.

NP

Number Plan

NPV

Numbering Plan Value

NSR

Next Screening Reference

NTP

Network Time Protocol

O

OOS-MT

Out of Service - Maintenance

The entity is out of service and is not available to perform its normal service function. The maintenance system is actively working to restore the entity to service.

OOS-MT-DSBLD

Out of Service - Maintenance Disabled

The entity is out of service and the maintenance system is preventing the entity from performing its normal service function.

OPC

Originating Point Code

P

PC

Point Code

The identifier of a signaling point or service control point in a network.

P

The format of the point code can be one of the following types:

- ANSI point codes in the format network indicator-network cluster-network cluster member (**ni-nc-ncm**).
- Non-ANSI domestic point codes in the format network indicator-network cluster-network cluster member (**ni-nc-ncm**).
- Cluster point codes in the format network indicator-network cluster-* or network indicator-*-*.
- ITU international point codes in the format **zone-area-id**.
- ITU national point codes in the format of a 5-digit number (**nnnnn**), or 2, 3, or 4 numbers (members) separated by dashes (**m1-m2-m3-m4**) as defined by the Flexible Point Code system option. A group code is required (**m1-m2-m3-m4-gc**) when the ITUDUPPC feature is turned on.
- 24-bit ITU national point codes in the format main signaling area-subsignaling area-service point (**msa-ssa-sp**).

PCA

Point Code ANSI

PCI

Peripheral Component Interface

Point Code International

Protocol Control Information

Peripheral Component Interconnect

PCN

Point Code National

Product Change Notice

P

PVN	Private Virtual Network Private Virtual Network represents the internal IP addressing scheme for every card within the EAGLE 5 ISS switch. Each card has an auto-assigned, default, Class B private IP address.
-----	--------------------------------------------------------------------------------------------------------------------------------------------------------------------------------------------------------------------

R

removable cartridge	MO cartridge used in the drive on the legacy MDAL card.
removable cartridge drive	Media drive for removable MO cartridges on the legacy MDAL card.
removable media	Flash memory or “thumb” drives used in the latched USB port on an E5-MCAP card for installation and backup of customer data.
RFC	Request for Comment RFCs are standards-track documents, which are official specifications of the Internet protocol suite defined by the Internet Engineering Task Force (IETF) and its steering group the IESG.
Route	A signaling path from an LSP to an RSP using a specified Link Set

S

SCCP	Signaling Connection Control Part
SCP	Service Control Point Service Control Points (SCP) are network intelligence centers where databases or call processing information is stored. The primary

S

function of SCPs is to respond to queries from other SPs by retrieving the requested information from the appropriate database, and sending it back to the originator of the request.

Secure Copy

Screen Set

A gateway screening table containing a list of rules, or screening references. The screening references indicate the screening action that is to be performed on a message in a specific linkset.

SE-HSL

Synchronous E1 High Speed Link

Format for E1 high-speed signaling links where time-slot 0 is used for framing and error control. The remainder of bandwidth, equivalent to 31 channels of 64Kbps data, is used as a single data link yielding a total capacity of 1.984 Mbps. Also known as Unchannelized E1.

SI

Service Indicator

SIO

Service Information Octet.

The network indicator code (NIC), priority (PRI), and service indicator (SI) in the SIO field in the message signaling unit (MSU). This information identifies the type of MSU (ISUP, TCAP, and so forth) that is allowed in the network where the EAGLE 5 ISS is located.

SLAN

Signaling Transfer Point Local Area Network

A feature in the EAGLE 5 ISS that copies MSUs selected through the gateway screening process and

S

sends these MSUs over the Ethernet to an external host computer for further processing.

SLTA

Signaling Link Test
Acknowledgment

SLTM

Signal Link Test Message

SMS

Short Message Service

SRI

Send_Route_Information Message

SS7

Signaling System #7

SS7ANSI

SS7 ANSI

An application used by the LIM cards and the E1/T1 MIM card for the MTP functionality.

SS7IPGW

SS7 IP Gateway

An application used by the DCM/SSEDCM card for IP point-to-multipoint capability within an ANSI network.

SSEDCM

Single Slot Enhanced Data
Communications Module

SSN

Subsystem Number

The subsystem number of a given point code. The subsystem number identifies the SCP application that should receive the message, or the subsystem number of the destination point code to be assigned to the LNP subsystem of the EAGLE 5 ISS.

S

A value of the routing indicator portion of the global title translation data commands indicating that no further global title translation is required for the specified entry.

Subsystem Number

Used to update the CdPA.

ST-HSL-A

Synchronous T1 High Speed Link

The 192 data bits of a framed T1 are combined to form a single unchannelized high-speed data stream that uses the SS7 protocol for messaging. Also known as Unchannelized T1.

STC

Signaling Transport Card

The Signaling Transport Card (STC) is a member of the DCM card family with an "eroute" generic program load (GPL) installed. The STCs provide the IP interface between the LIM cards on the IMT bus and the Signaling Extended Services Platform (ESP) subassembly. The STC is used for sending MSU data to the ESP/IMF.

STP

Signal Transfer Point

The STP is a special high-speed switch for signaling messages in SS7 networks. The STP routes core INAP communication between the Service Switching Point (SSP) and the Service Control Point (SCP) over the network.

STPLAN

Signaling Transfer Point Local Area Network

The application used by the SLAN card and E5-SLAN card to support the STP LAN feature. This

S

application does not support 24-bit ITU-N point codes.

T

TC	Table Copy Transaction Capabilities
TCAP	Transaction Capabilities Application Part
TCP	Transfer Control Protocol
TCP/IP	Transmission Control Protocol/Internet Protocol
TDM	Terminal Disk Module Time Division Multiplexing
TPS	Transactions Per Second
Translation Type	See TT.
TSC	Time Slot Counter
TSCSYNC	Time Slot Counter Synchronization The Time Slot Counter (TSC) Synchronization feature allows the system's A (Active) and B (Standby) internal clocks to be synchronized by the standby OAM GPSM-II card.
TSM	Translation Services Module Provides translation capability and Global Title Translation (GTT) implementation for the Local Number Portability (LNP) function and is used for downloading

T

gateway screening tables to link interface modules (LIMs).

TT

Translation Type.

Resides in the Called Party Address (CdPA) field of the MSU and determines which service database is to receive query messages. The translation type indicates which Global Title Translation table determines the routing to a particular service database.

TVG

Group Ticket Voucher

TX

Transmit

U

UAM

Unsolicited Alarm Message

A message sent to a user interface whenever there is a fault that is service-affecting or when a previous problem is corrected. Each message has a trouble code and text associated with the trouble condition.

UDP

User Datagram Protocol

UDT

Unitdata Transfer

UDTS

Unitdata Transfer Service

An error response to a UDT message.

UIM

Unsolicited Information Message

A message sent to a user interface whenever there is a fault that is not service-affecting or when a previous

U

problem is corrected. Each message has a trouble code and text associated with the trouble condition.

USB port

Receptacle for flash memory drives on personal computers. On the E5-MDAL card, a flush-mounted USB port used with credit card flash memory drives for upgrade. On the E5-MCAP card, a latched USB port for use with flash memory "thumb" drives for installation and backup of customer data.

V

VIP

Virtual IP Address

Virtual IP is a layer-3 concept employed to provide HA at a host level. A VIP enables two or more IP hosts to operate in an active/standby HA manner. From the perspective of the IP network, these IP hosts appear as a single host.