

NOTES: UNLESS OTHERWISE SPECIFIED

- 1) INSTALL ALL CABLE ASSEMBLIES WITH DRESSED BEND RADII IN ACCORDANCE WITH TEKELEC CABLE BEND RADII SPECIFICATION 906-0020-01.
- 2) ALL INTERCONNECTION POINTS SHALL BE STRAIN RELIEVED BY POSITIVE MECHANICAL FEATURES OR FASTENERS FOR LENGTH CONFIGURATIONS.
- 3) THIS DIAGRAM AND ALL PART NUMBERS SHOWN ARE FOR REFERENCE ONLY. REFERENCE CABLE PART NUMBERS WITH XX FOR THE DASH NUMBER ARE LENGTHS THAT ARE SITE SPECIFIC.
- 4) NO ADDITIONS, DELETIONS, SUBSTITUTIONS OR MODIFICATIONS WITHOUT PRIOR WRITTEN TEKELEC APPROVAL.
- 5) SEE TEKELEC P/N 820-2410-01 FOR CURRENT LIST HARDWARE.
- 6) ALL POWER CABLES ARE CONNECTED WITH THE RED LEAD TO -48VDC TERMINAL AND THE BLACK LEAD TO RETURN TERMINAL.
- 7) -48 VDC, RTN, AND GND PRIMARY CABLING EXITING THE FRAME SHALL BE 6 AWG. SEE TABLES C, D AND E FOR LENGTH CONFIGURATIONS.
- 8) 4-PORT SERIAL CABLE, SUPPLIED WITH PCI SERIAL CARD. PORT NUMBERS 1 THRU 4 ARE LOCATED ON THE FOUR DB-9 CONNECTORS. PORT 0 IS THE DB-44 CONNECTOR THAT INTERFACES WITH THE PCI SERIAL CARD.
- 9) USE LABEL PN 617-0009-01 TO MAKE LABEL SET FOR FROM AND TO ON CABLES INDICATED IN TABLE A AND TABLE C EACH CABLE INDICATED WILL REQUIRE 2 LABELS ONE AS SHOWN IN THE TABLES AND ONE WITH FROM AND TWO REVERSED AS SHOWN IN DETAIL K. PERMANENTLY PRINT LABELS WITH .09 HIGH BLACK CHARACTERS. CENTER TEXT APPROXIMATELY AS SHOWN. MAX 23 CHARACTERS PER LINE. SEE DETAIL L FOR PLACEMENT OF LABELS ON CABLES.
- 10) USE LABEL PN 617-0009-01 TO MAKE THE FOLLOWING LABELS. PERMANENTLY PRINT LABELS WITH .09 HIGH BLACK CHARACTERS. CENTER TEXT APPROXIMATELY AS SHOWN. MAX 23 CHARACTERS PER LINE.
 LABEL FOR SERVER A PCI 2 Serial Port 0: SERVER A PCI2 P0
 LABEL FOR SERVER A PCI 2 Serial Port 1: CUSTOMER MMI
 LABEL FOR SERVER A PCI 2 Serial Port 3: RESERVED
 LABEL FOR SERVER A PCI 2 Serial Port 4: CUSTOMER TERMINAL
 LABEL FOR SERVER A PCI 8 Serial Port 0: SERVER A PCI8 P0
 LABEL FOR SERVER B PCI 8 Serial Port 0: SERVER B PCI8 P0

REVISIONS			
REV	DESCRIPTION	DATE	APPROVED
A	RELEASE PER ECO #13025	9/5/03	D. GRIFFITH
B	REVISED PER ECN# 13351	1/27/04	D.GRIFFITH
C	REVISED PER ECN# 13400	3/17/04	M. BRYAN
D	REVISED PER ECN# 14228	XXX	M. BRYAN

DOCUMENT CONTROL
PRODUCTION RELEASED

FORM NO. 892-0053-01 1 1 0

DOCUMENT CONTROL
PRODUCTION RELEASE

DATA CONNECTIONS AND CABLES

UNLESS OTHERWISE SPECIFIED: DO NOT SCALE DRAWING. DIMENSIONS ARE IN INCHES. INTERPRET DIMENSIONS IN ACCORDANCE WITH ASME Y14.5M-1994. DRAWING TO CONFORM TO TEKELEC SPECIFICATION 907-0168-01. DEBURR AND BREAK SHARP EDGES AND CORNERS .005-.015. MACHINED SURFACE FINISH ¹²⁵ ✓ DECIMAL TOLERANCES: .XX = ±.02 .XXX = ±.005 ANGLE TOLERANCE: ± 1°		THIS DOCUMENT AND THE DATA DISCLOSED HEREIN OR HEREWITH IS PROPRIETARY AND IS NOT TO BE REPRODUCED, USED OR DISCLOSED IN WHOLE OR PART TO ANYONE WITHOUT THE WRITTEN PERMISSION OF TEKELEC. COPYRIGHT TEKELEC 2001.		TEKELEC 26580 W. Agoura Road, Calabasas, California 91302	
APPROVALS DRAWN BY: J. MYERS CHECKED: S. LYTLE APPROVED: D. GRIFFITH		DATE 7/29/03 7/31/03 7/31/03		INTERCONNECT DIAGRAM TEKWARE NETWORK ELEMENT	
APPLICATION FINISH MATERIAL		NEXT ASSY USED ON		SIZE: D DIVISION: NSD DRAWING NO.: 892-0053-01 SCALE: NONE FILE NAME: 892-0053-01_D.DWG	
THIRD ANGLE PROJECTION		REVISIONS		SHEET 1 OF 6	

D
C
B
A

D
C
B
A

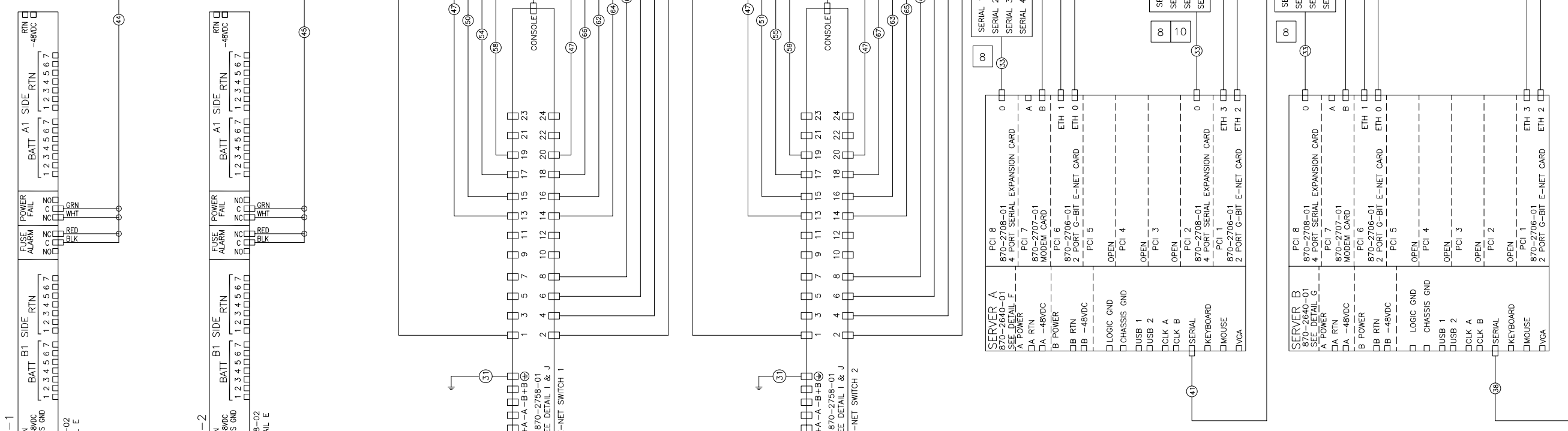

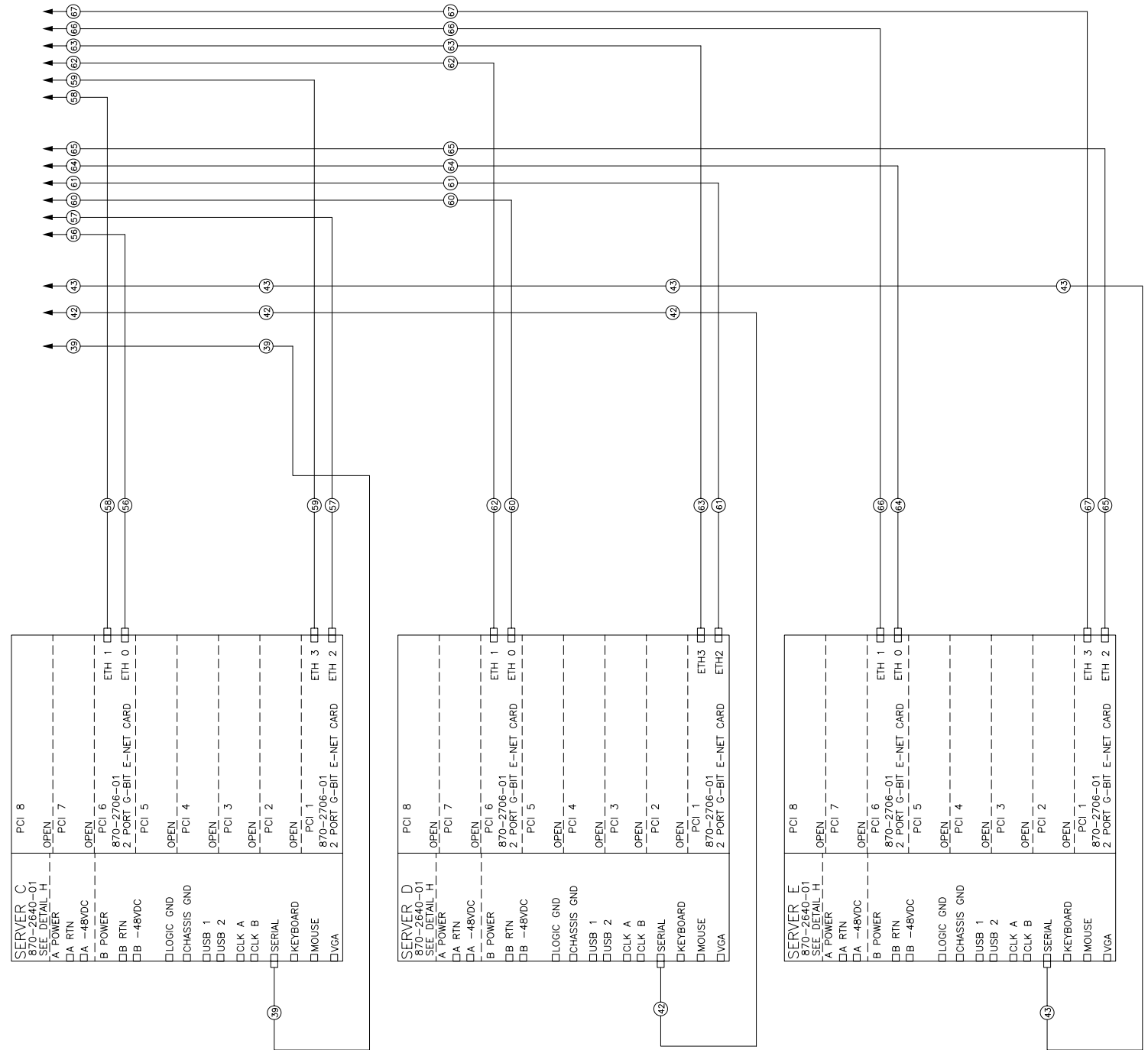

DATA CONNECTIONS AND CABLES

<small>THIS DOCUMENT AND THE DATA DISCLOSED HEREIN OR HEREWITH IS PROPRIETARY AND IS NOT TO BE REPRODUCED, USED OR DISCLOSED IN WHOLE OR PART TO ANYONE WITHOUT THE WRITTEN PERMISSION OF TEKELC. COPYRIGHT TEKELC. 2001.</small>	SIZE	DIVISION	DRAWING NO.	REV.
	D	NSD	892-0053-01	D
SCALE: NONE	FILE NAME: 892-0053-01_D.DWG	SHEET 2		

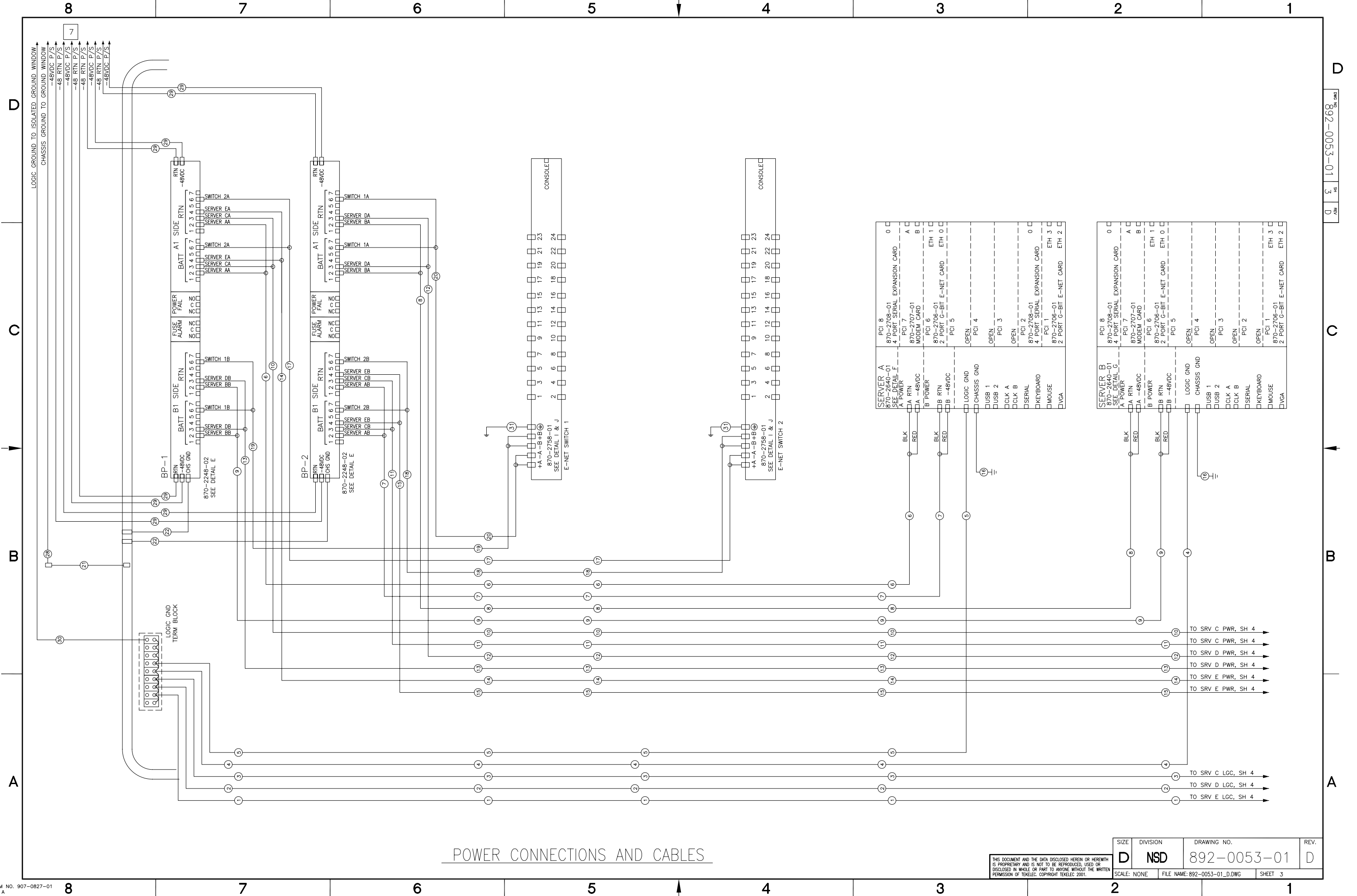

POWER CONNECTIONS AND CABLES

SIZE	DIVISION	DRAWING NO.	REV.
D	NSD	892-0053-01	D
SCALE: NONE	FILE NAME: 892-0053-01_D.DWG	SHEET 3	

D

C

B

A

D

C

B

A

FORM NO. 892-0053-01 4 D

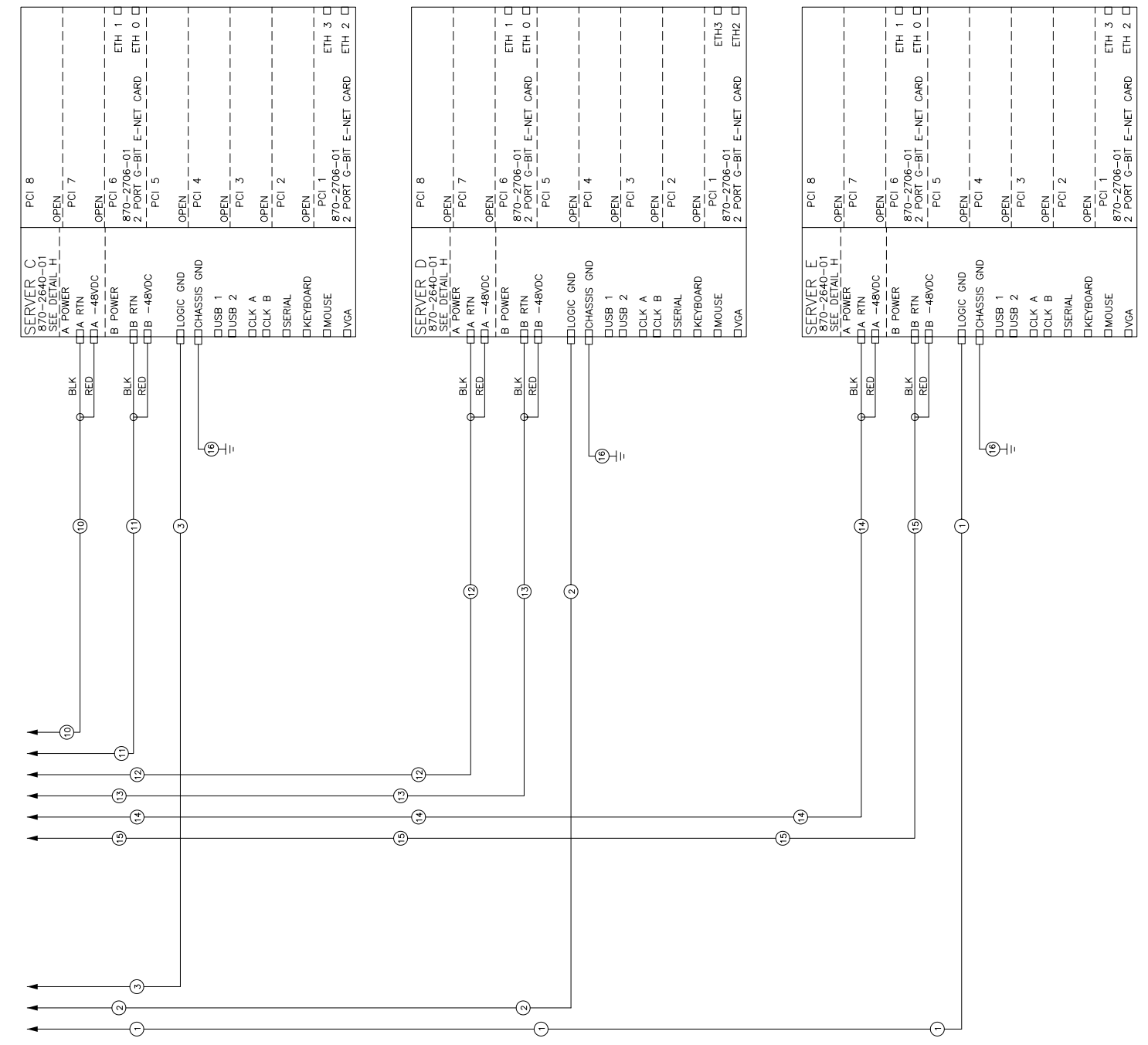

POWER CONNECTIONS AND CABLES

<small>THIS DOCUMENT AND THE DATA DISCLOSED HEREIN OR HEREWITH IS PROPRIETARY AND IS NOT TO BE REPRODUCED, USED OR DISCLOSED IN WHOLE OR PART TO ANYONE WITHOUT THE WRITTEN PERMISSION OF TEKELEC. COPYRIGHT TEKELEC 2001.</small>	SIZE	DIVISION	DRAWING NO.	REV.
	D	NSD	892-0053-01	D
SCALE: NONE	FILE NAME: 892-0053-01_D.DWG	SHEET 4		

TABLE A - POWER CABLE PART NUMBERS

ITEM NO.	TEKELEC P/N	QUANTITY	LENGTH	COMMENT	LABEL
1	830-0989-05	1	105.00 INCHES	FROM SERVER E TO LOGIC GROUND	YES
2	830-0989-04	1	95.00 INCHES	FROM SERVER D TO LOGIC GROUND	YES
3	830-0989-03	1	87.00 INCHES	FROM SERVER C TO LOGIC GROUND	YES
4	830-0989-02	1	79.00 INCHES	FROM SERVER B TO LOGIC GROUND	YES
5	830-0989-01	1	67.00 INCHES	FROM SERVER A TO LOGIC GROUND	YES
6	830-0988-01	1	64.00 INCHES	FROM SERVER A-A PWR TO BP1-2A	YES
7	830-0988-02	1	55.00 INCHES	FROM SERVER A-B PWR TO BP2-2B	YES
8	830-0988-03	1	72.00 INCHES	FROM SERVER B-A PWR TO BP2-2A	YES
9	830-0988-04	1	70.00 INCHES	FROM SERVER B-B PWR TO BP1-2B	YES
10	830-0988-05	1	81.00 INCHES	FROM SERVER C-A PWR TO BP1-3A	YES
11	830-0988-06	1	71.00 INCHES	FROM SERVER C-B PWR TO BP2-3B	YES
12	830-0988-07	1	88.00 INCHES	FROM SERVER D-A PWR TO BP2-3A	YES
13	830-0988-08	1	86.00 INCHES	FROM SERVER D-B PWR TO BP1-3B	YES
14	830-0988-09	1	98.00 INCHES	FROM SERVER E-A PWR TO BP1-4A	YES
15	830-0988-10	1	89.00 INCHES	FROM SERVER E-B PWR TO BP2-4B	YES
16	830-0927-01	5	31.00 INCHES	FROM SERVER CHASSIS TO FRAME GROUND	NO
17	830-1013-05	1	34.00 INCHES	FROM SWITCH 2A PWR TO BP1-6A	YES
18	830-1013-06	1	26.50 INCHES	FROM SWITCH 2B PWR TO BP2-6B	YES
19	830-1013-07	1	30.00 INCHES	FROM SWITCH 1B PWR TO BP1-6B	YES
20	830-1013-08	1	32.50 INCHES	FROM SWITCH 1A PWR TO BP2-6A	YES
21	830-0715-03	1	38.00 INCHES	CHASSIS GROUND TO GROUND WINDOW	NO
22	830-0830-01	2	N/A	CIRCUIT BREAKER TO FRAME GND	NO
28	CHASSIS GND (FIELD ROUTED)	1	SITE SPECIFIC	SEE TABLE F	FIELD
29	-48VDC AND 48V RTN (FIELD ROUTED)	8	SITE SPECIFIC	SEE TABLE E	FIELD
30	LOGIC GROUND	1	SITE SPECIFIC	SEE TABLE D	FIELD
31	830-1015-01	2	N/A	FROM SWITCH TO FRAME GND	NO

TABLE B - DATA CABLE PART NUMBERS

ITEM NO.	TEKELEC P/N	QUANTITY	LENGTH	COMMENT	LABEL
32	830-1012-01	2	NA	DB9M TO RJ45 ADAPTER FOR SERVER CONSOLE	NO
33	870-2708-01	3	NA	4 PORT SERIAL CABLE SUPPLIED WITH PCI CARD. LABEL INFO PER NOTE 10	YES
34	830-1005-04	1	48.00 INCHES	SERIAL: FROM SERVER A PCI8 P1 TO SWITCH 1 CONSOLE	YES
35	830-1005-04	1	48.00 INCHES	SERIAL: FROM SERVER A PCI8 P2 TO SWITCH 2 CONSOLE	YES
36	830-0963-XX	1	NA	SERIAL: FROM SERVER A PCI2 P1 TO CUSTOMER MMI	FIELD
37	830-0680-01	2	25 FT	RJ11 TO RJ11 PHONE LINE	NO
38	830-0970-01	1	60.00 INCHES	SERIAL: FROM SERVER A PCI2 P2 TO SERVER B SERIAL	YES
39	830-0970-01	1	60.00 INCHES	SERIAL: FROM SERVER B PCI8 P2 TO SERVER C SERIAL	YES
40	830-0964-XX	1	NA	SERIAL: FROM SERVER A PCI2 P4 TO CUSTOMER TERMINAL	FIELD
41	830-0970-01	1	60.00 INCHES	SERIAL: FROM SERVER B PCI8 P1 TO SERVER A SERIAL	YES
42	830-0970-01	1	60.00 INCHES	SERIAL: FROM SERVER B PCI8 P3 TO SERVER D SERIAL	YES
43	830-0970-01	1	60.00 INCHES	SERIAL: FROM SERVER B PCI8 P4 TO SERVER E SERIAL	YES
44	830-0961-05	1	60.00 INCHES	SERIAL: FROM SERVER A PCI8 P3 TO BP1 ALARMS	YES
45	830-0961-05	1	60.00 INCHES	SERIAL: FROM SERVER A PCI8 P4 TO BP2 ALARMS	YES
46	830-0978-XX	2	SITE SPECIFIC	DB26 - RJ45 SITE SPECIFIC STRAIGHT THROUGH CABLE	FIELD
47	830-0723-XX	AR	SITE SPECIFIC	CROSSOVER RJ45 TO RJ45: FROM SWITCHES TO CUSTOMER NETWORKS	FIELD
48	830-0724-06	1	6.0 FT	STRAIGHT THRU RJ45 TO RJ45: FROM SERVER A ETH0 TO SWITCH 1 PORT 2	YES
49	830-0724-06	1	6.0 FT	STRAIGHT THRU RJ45 TO RJ45: FROM SERVER A ETH2 TO SWITCH 2 PORT 2	YES
50	830-0724-06	1	6.0 FT	STRAIGHT THRU RJ45 TO RJ45: FROM SERVER A ETH1 TO SWITCH 1 PORT 15	YES
51	830-0724-06	1	6.0 FT	STRAIGHT THRU RJ45 TO RJ45: FROM SERVER A ETH3 TO SWITCH 2 PORT 15	YES
52	830-0724-06	1	6.0 FT	STRAIGHT THRU RJ45 TO RJ45: FROM SERVER B ETH0 TO SWITCH 1 PORT 4	YES
53	830-0724-06	1	6.0 FT	STRAIGHT THRU RJ45 TO RJ45: FROM SERVER B ETH2 TO SWITCH 2 PORT 4	YES
54	830-0724-06	1	6.0 FT	STRAIGHT THRU RJ45 TO RJ45: FROM SERVER B ETH1 TO SWITCH 1 PORT 17	YES
55	830-0724-06	1	6.0 FT	STRAIGHT THRU RJ45 TO RJ45: FROM SERVER B ETH3 TO SWITCH 2 PORT 17	YES
56	830-0724-07	1	7.0 FT	STRAIGHT THRU RJ45 TO RJ45: FROM SERVER C ETH0 TO SWITCH 1 PORT 6	YES
57	830-0724-07	1	7.0 FT	STRAIGHT THRU RJ45 TO RJ45: FROM SERVER C ETH2 TO SWITCH 2 PORT 6	YES
58	830-0724-07	1	7.0 FT	STRAIGHT THRU RJ45 TO RJ45: FROM SERVER C ETH1 TO SWITCH 1 PORT 19	YES
59	830-0724-07	1	7.0 FT	STRAIGHT THRU RJ45 TO RJ45: FROM SERVER C ETH3 TO SWITCH 2 PORT 19	YES
60	830-0724-67	1	8.0 FT	STRAIGHT THRU RJ45 TO RJ45: FROM SERVER D ETH0 TO SWITCH 1 PORT 8	YES
61	830-0724-67	1	8.0 FT	STRAIGHT THRU RJ45 TO RJ45: FROM SERVER D ETH2 TO SWITCH 2 PORT 8	YES
62	830-0724-67	1	8.0 FT	STRAIGHT THRU RJ45 TO RJ45: FROM SERVER D ETH1 TO SWITCH 1 PORT 16	YES
63	830-0724-67	1	8.0 FT	STRAIGHT THRU RJ45 TO RJ45: FROM SERVER D ETH3 TO SWITCH 2 PORT 16	YES
64	830-0724-67	1	8.0 FT	STRAIGHT THRU RJ45 TO RJ45: FROM SERVER E ETH0 TO SWITCH 1 PORT 14	YES
65	830-0724-67	1	8.0 FT	STRAIGHT THRU RJ45 TO RJ45: FROM SERVER E ETH2 TO SWITCH 2 PORT 14	YES
66	830-0724-67	1	8.0 FT	STRAIGHT THRU RJ45 TO RJ45: FROM SERVER E ETH1 TO SWITCH 1 PORT 18	YES
67	830-0724-67	1	8.0 FT	STRAIGHT THRU RJ45 TO RJ45: FROM SERVER E ETH3 TO SWITCH 2 PORT 18	YES

TABLE C - LOGIC GROUND CABLING

DISTANCE	PRIMARY CABLE PART NUMBER	CABLE AWG	TERMINAL LUG P/N	HEAT SHRINK PART NUMBER	COMMENT	REF. DETAIL
0'-40'	690-0131-01	6	502-0085-01	804-0228-01	CABLE LENGTH IS SITE-SPECIFIC	C
40'-160'	690-0108-07	1/0	804-0977-01	804-0229-01	CABLE LENGTH IS SITE-SPECIFIC	A

TABLE D - 48VDC & 48VRTN CABLING COMPONENTS

DISTANCE	ITEM A		ITEM B		ITEM C		HALF TAP SPLICE P/N	HTAP SOFT COVER P/N	COMMENT	REF. DETAIL	
	CABLE P/N	CABLE AWG	TERMINAL LUG P/N	HEAT SHRINK P/N	CABLE P/N	CABLE AWG					CABLE CONSTRUCTION
0' - 40'	690-0108-01	6	502-0085-01	804-0228-01	N/A	--	N/A	NONE REQUIRED	NONE REQUIRED	CABLE LENGTH IS SITE-SPECIFIC	C
40' - 65'	690-0108-01	6	502-0085-01	804-0228-01	690-0108-04	4	SITE SPECIFIC	T&B 63125	T&B HTC40	CABLE LENGTH IS SITE-SPECIFIC	B
65' - 100'	690-0108-01	6	502-0085-01	804-0228-01	690-0108-06	2	SITE SPECIFIC	T&B 63125	T&B HTC40	CABLE LENGTH IS SITE-SPECIFIC, HTAPPED STUBS <= 10' EACH END	B
100' - 160'	690-0108-01	6	502-0085-01	804-0228-01	690-0108-03	1/0	SITE SPECIFIC	T&B 63125	T&B HTC40	CABLE LENGTH IS SITE-SPECIFIC, HTAPPED STUBS <= 10' EACH END	B

TABLE E - SYSTEM FRAME GROUND CABLING

DISTANCE	CABLE P/N	CABLE AWG	ITEM A (830-0715-01 SUPPLIED WITH FRAME)		ITEM B		HTAP (A TO B CONNECTION)		COMMENT	REF. DETAIL
			TERMINAL LUG P/N	HEAT SHRINK P/N	CABLE P/N	CABLE AWG	H TAP P/N			
0' - 40'	690-0131-01	6	502-0085-01	804-0228-01	690-0131-01	6	804-0865-01	804-0865-01	CABLE LENGTH IS SITE-SPECIFIC	D
40' - 160'	690-0108-01	6	502-0085-01	804-0228-01	690-0108-07	1/0	804-0865-01	804-0865-01	CABLE LENGTH IS SITE-SPECIFIC	D

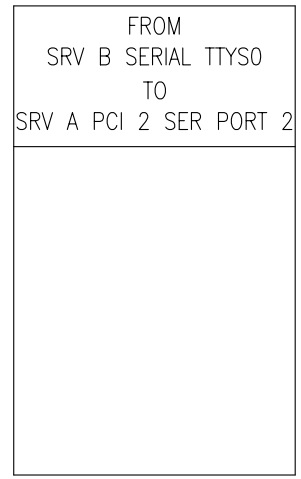
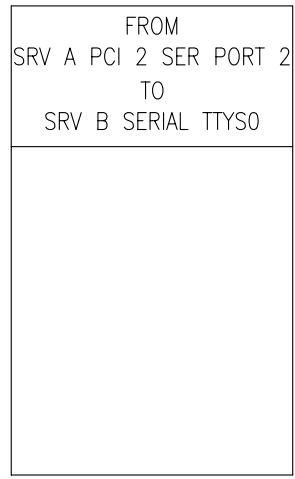

EXAMPLE OF TEXT SHOWN IN TABLES

EXAMPLE WITH TEXT REVERSED FROM FIRST LABEL

DETAIL K 9

CABLE LABEL EXAMPLE USING CABLE ITEM NO. 38

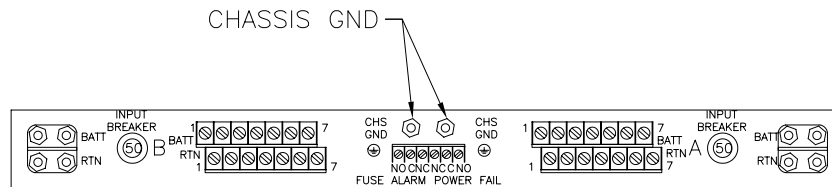

DETAIL "E"

CIRCUIT BREAKER (REAR VIEW) 870-2248-02

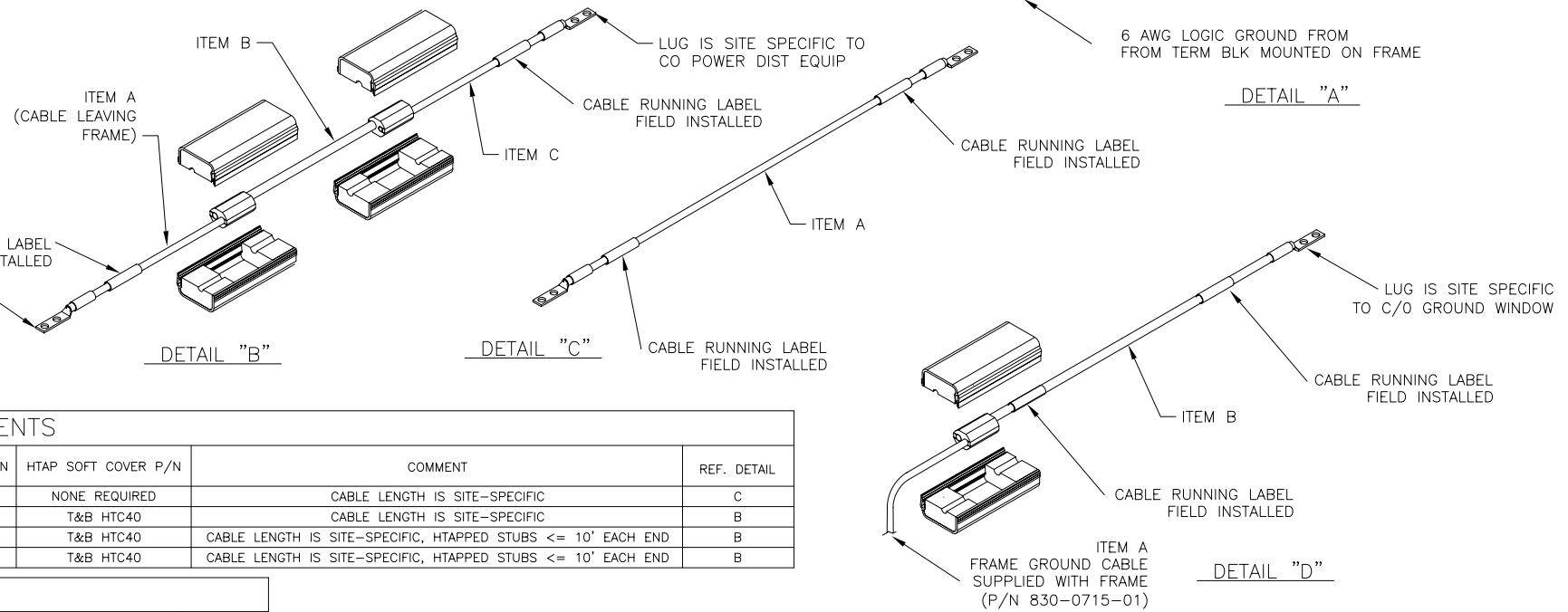

THIS DOCUMENT AND THE DATA DISCLOSED HEREIN OR HEREWITH IS PROPRIETARY AND IS NOT TO BE REPRODUCED, USED OR DISCLOSED IN WHOLE OR PART TO ANYONE WITHOUT THE WRITTEN PERMISSION OF TEKELEC. COPYRIGHT TEKELEC 2001.

SIZE	DIVISION	DRAWING NO.	REV.
D	NSD	892-0053-01	D
SCALE: NONE	FILE NAME: 892-0053-01.DWG	SHEET 5	

8

7

6

5

4

3

2

1

D

C

B

A

D

C

B

A

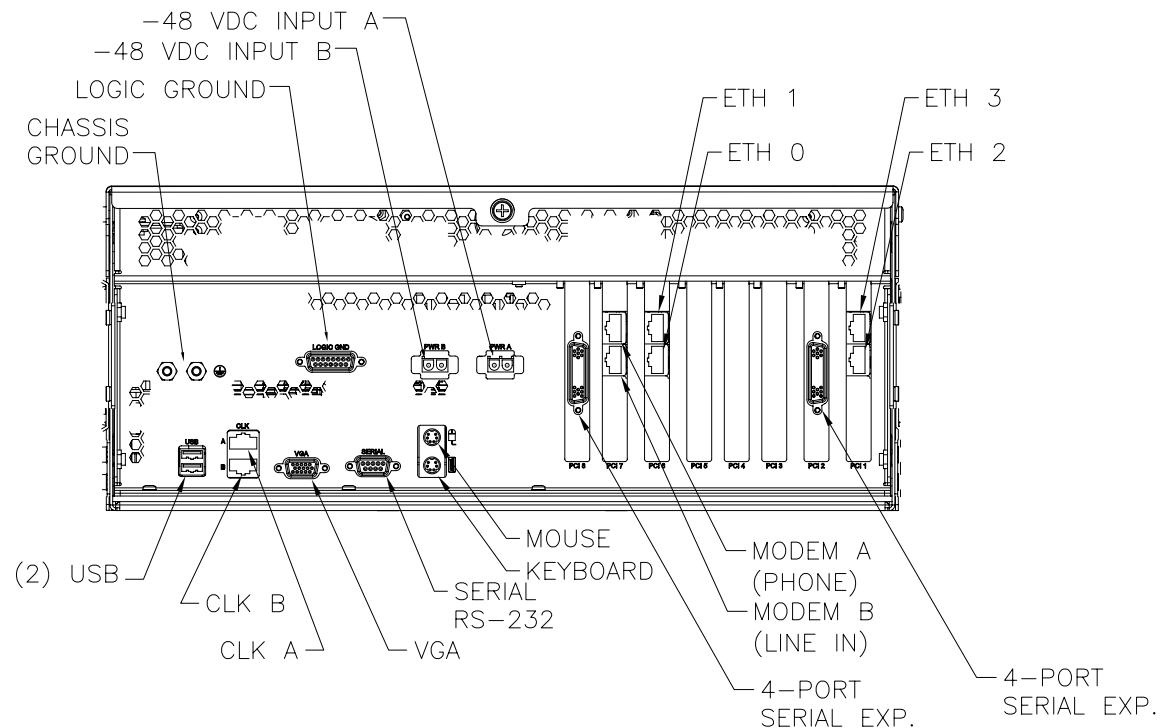

DETAIL "F"

SERVER A (REAR VIEW)
 870-2640-01 W/ PCI CARDS:
 SLOT 1 - 870-2706-01
 SLOT 2 - 870-2708-01
 SLOT 6 - 870-2706-01
 SLOT 7 - 870-2707-01
 SLOT 8 - 870-2708-01

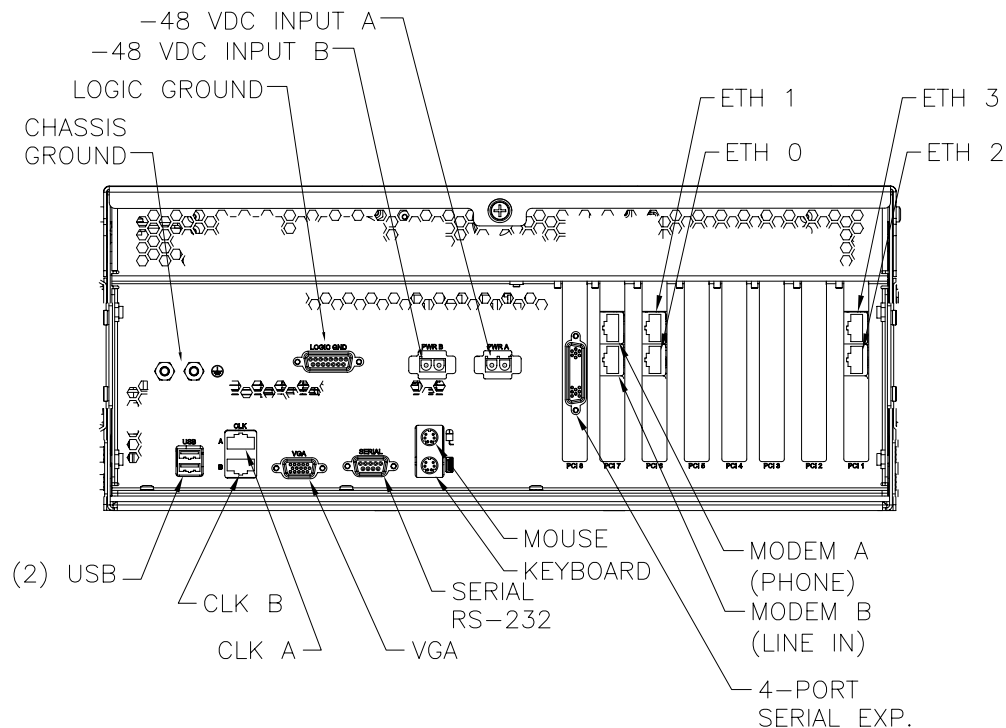

DETAIL "G"

SERVER B (REAR VIEW)
 870-2640-01 W/ PCI CARDS:
 SLOT 1 - 870-2706-01
 SLOT 6 - 870-2706-01
 SLOT 7 - 870-2707-01
 SLOT 8 - 870-2708-01

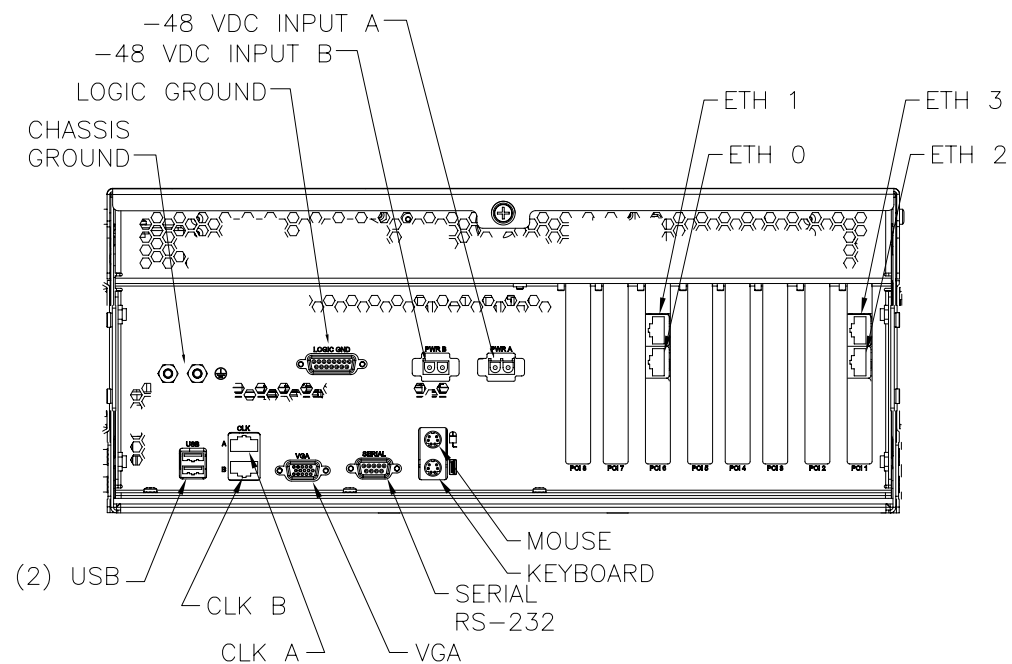

DETAIL "H"

SERVER C-5 (REAR VIEW)
 870-2640-01 W/ PCI CARDS:
 SLOT 1 - 870-2706-01
 SLOT 6 - 870-2706-01

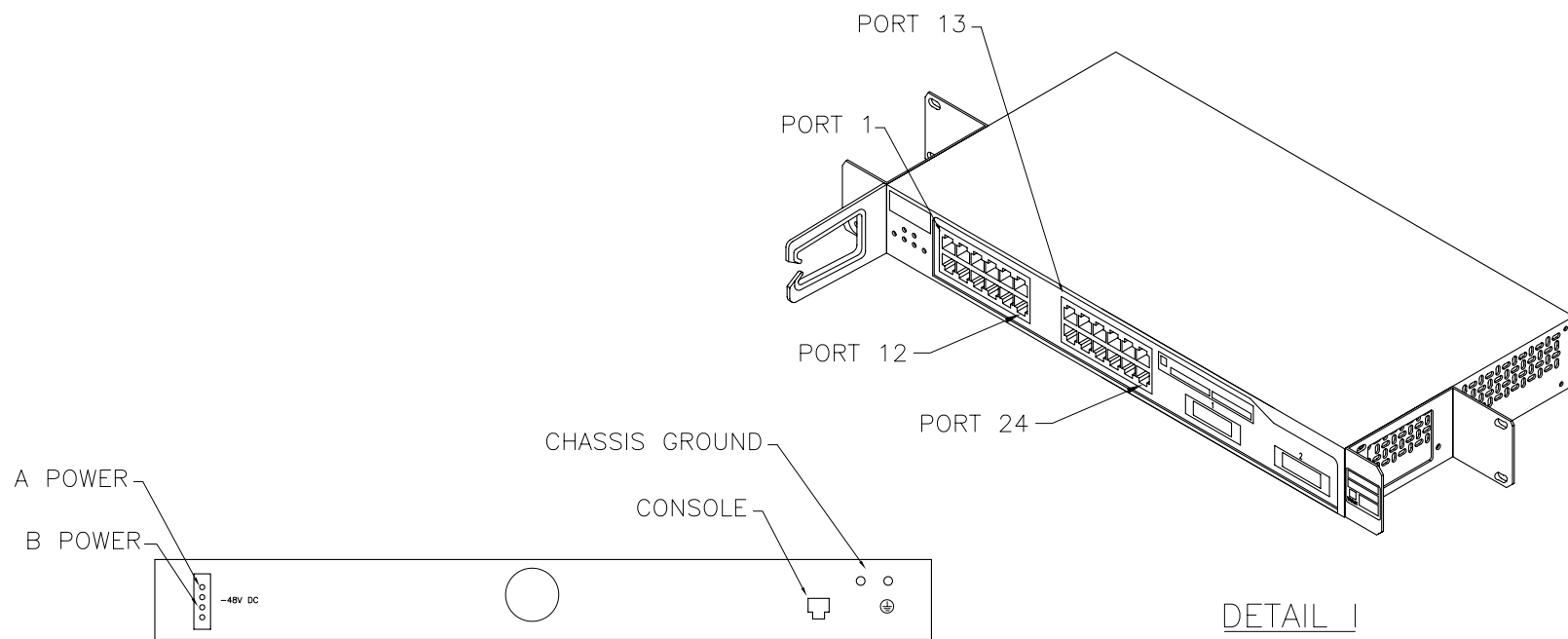

DETAIL J
 REAR VIEW-SWITCH
 870-2758-01

DETAIL I
 ISO VIEW OF THE FRONT-SWITCH
 870-2758-01

SIZE	DIVISION	DRAWING NO.	REV.
D	NSD	892-0053-01	D
SCALE: NONE		FILE NAME: 892-0053-01_D.DWG	SHEET 6

8

7

6

5

4

3

2

1