

8 7 6 5 4 3 2 1  
 8 7 6 5 4 3 2 1

NOTES: UNLESS OTHERWISE SPECIFIED

- 1) INSTALL ALL CABLE ASSEMBLIES WITH DRESSED BEND RADI IN ACCORDANCE WITH TEKELEC CABLE BEND RADIUS SPECIFICATION 906-0020-01.
- 2) ALL INTERCONNECTION POINTS SHALL BE STRAIN RELIEVED BY POSITIVE MECHANICAL FEATURES OR FASTENERS FOR LENGTH CONFIGURATIONS.
- 3) THIS DIAGRAM AND ALL PART NUMBERS SHOWN ARE FOR REFERENCE ONLY. REFERENCE CABLE PART NUMBERS WITH XX FOR THE DASH NUMBER ARE LENGTHS THAT ARE SITE SPECIFIC.
- 4) NO ADDITIONS, DELETIONS, SUBSTITUTIONS OR MODIFICATIONS WITHOUT PRIOR WRITTEN TEKELEC APPROVAL.

- 5) SEE TEKELEC P/N 820-5695-01 FOR CURRENT HARDWARE LIST.
- 6) USE LABEL PN 617-0009-01 TO MAKE LABEL SET FOR FROM AND TO ON CABLES INDICATED IN TABLE A. EACH CABLE INDICATED WILL REQUIRE 2 LABELS ONE AS SHOWN IN THE TABLES AND ONE WITH FROM AND TWO REVERSED AS SHOWN IN DETAIL K. PERMANENTLY PRINT LABELS WITH .09 HIGH BLACK CHARACTERS. CENTER TEXT APPROXIMATELY AS SHOWN. MAX 23 CHARACTERS PER LINE.

- 7) THREE LABELS REQUIRED FOR THE CABLES INDICATED THEY ARE Y CABLES.
- 8) CIRCUIT BREAKER IS SUPPLIED WITH JUMPERS BETWEEN POWER INPUTS TO CONNECT 4 CIRCUIT BREAKERS PER POWER INPUT. FUSE POSITIONS 1-4, 5-8 AND 9-12.

DOCUMENT CONTROL  
 PRODUCTION RELEASED

REVISIONS			
LTR	DESCRIPTION	DATE	APPROVED
A	RELEASED PER ECO # 14634	5/26/05	ARMSTRONG
B	REVISED PER ECO# 14814	06/20/05	ARMSTRONG
C	REVISED PER ECO# 14845	06/29/05	ARMSTRONG
D	REVISED PER ECO# 14932	08/04/05	ARMSTRONG

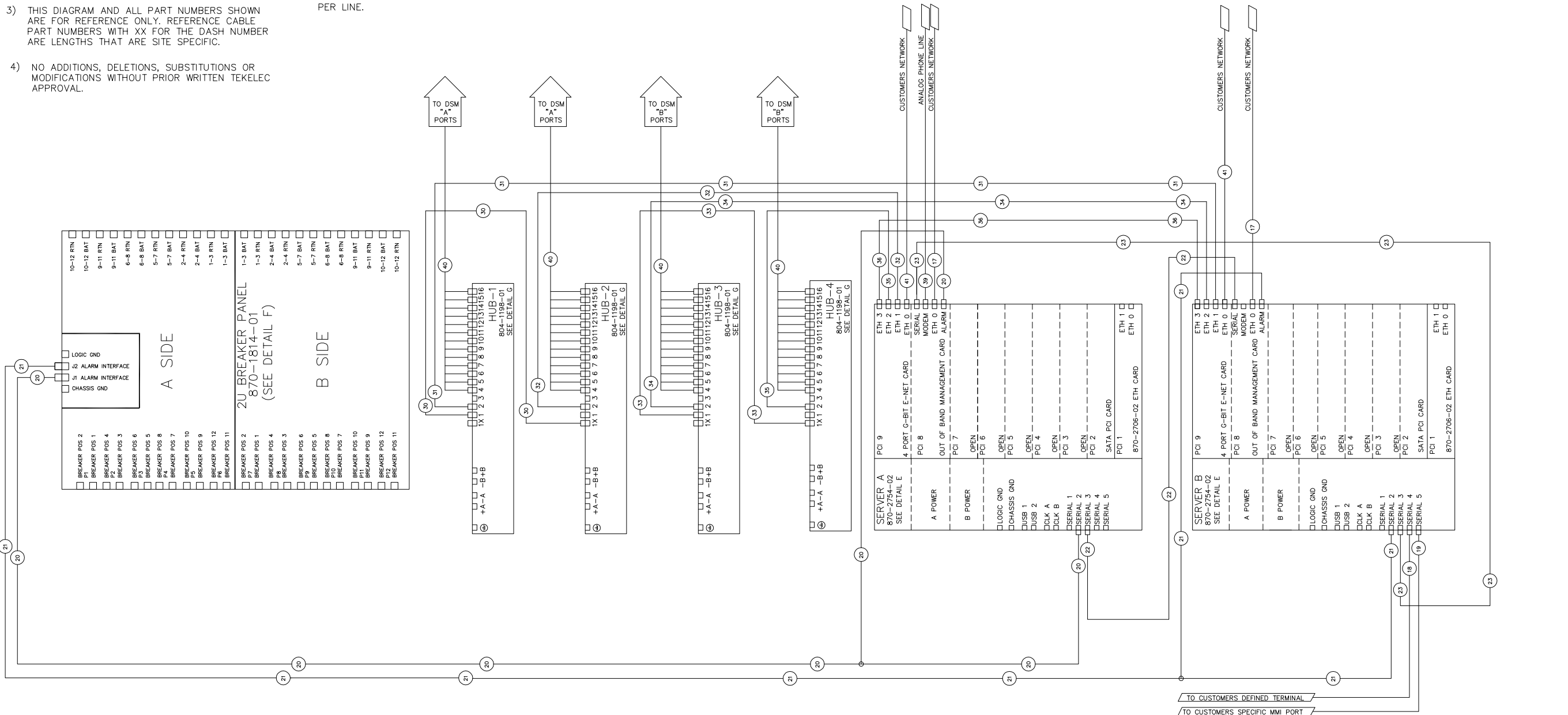

A B C D

DATA CONNECTIONS AND CABLES

STANDARD HOLE TOLERANCES:	
HOLE DIA	TOLERANCES
.013 THRU .125	+0.004 -0.001
.126 THRU .250	+0.006 -0.001
.251 THRU .500	+0.006 -0.001
.501 THRU .750	+0.008 -0.001
.751 THRU 1.000	+0.010 -0.001
1.001 THRU 2.000	+0.012 -0.001

CONTRACT NO.	
APPROVALS	DATE
DRAWN M.BRYAN	4/18/05
CHECKED BEAUCHAMP	XXXXX
APPROVED ARMSTRONG	5/26/05
APPROVED	
APPLICATION	
FINISH	
MATERIAL	

**TEKELEC** 26580 W. Agoura Road, Calabasas, California 91302

INTERCONNECT DIAGRAM  
 SYSTEM\_MPS\_TEKSERVER  
 DC FRAME ASSY

SIZE D	CAGE CODE	DRAWING NO. 892-0066-01	REV. D
--------	-----------	-------------------------	--------

SCALE: NONE FILE NAME: 892-0066-01\_D.dwg SHEET 1 OF 4

8 7 6 5 4 3 2 1

REVISIONS			
LTR	DESCRIPTION	DATE	APPROVED

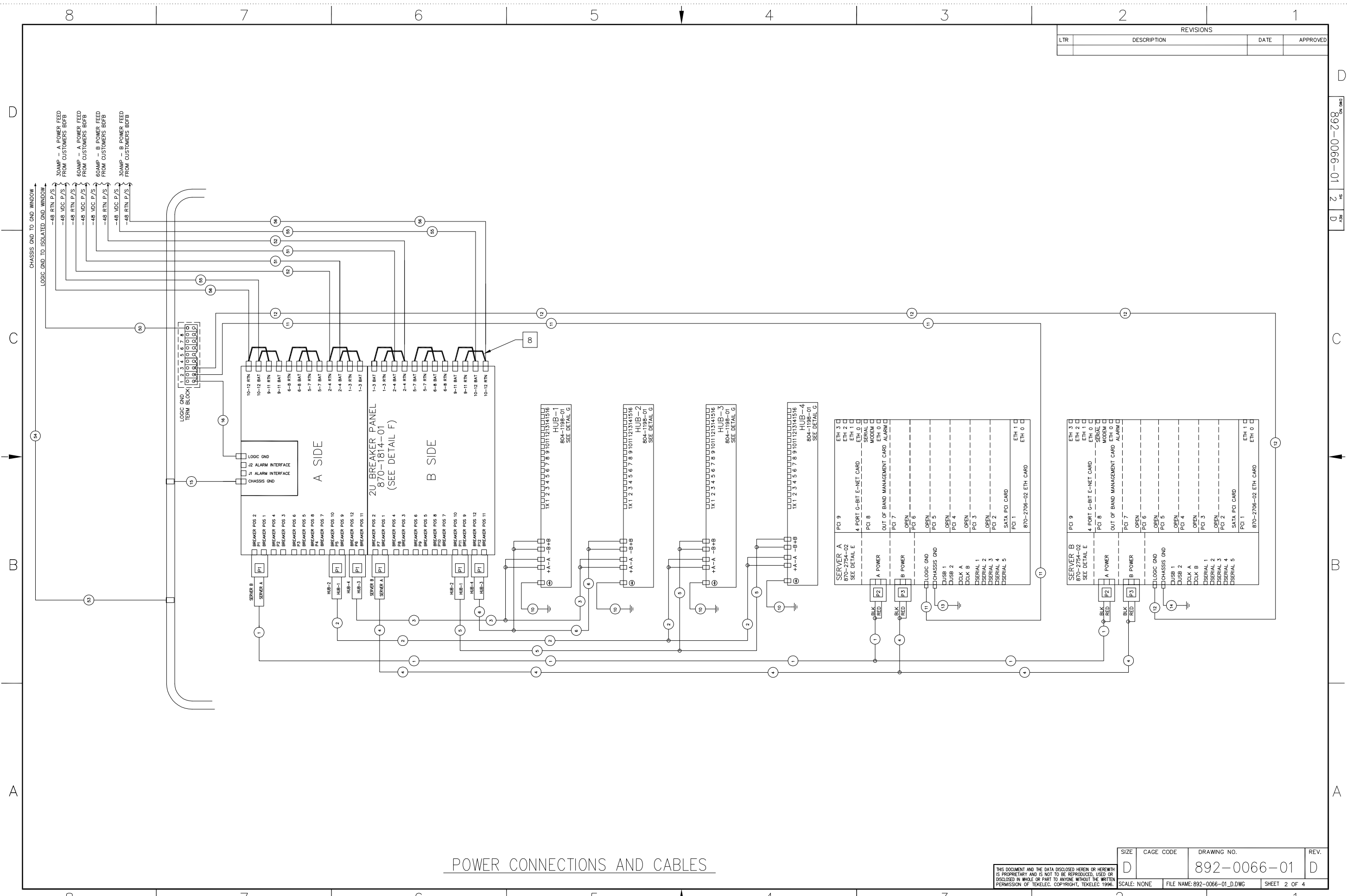

POWER CONNECTIONS AND CABLES

THIS DOCUMENT AND THE DATA DISCLOSED HEREIN OR HEREWIT  
 IS PROPRIETARY AND IS NOT TO BE REPRODUCED, USED OR  
 DISCLOSED IN WHOLE OR PART TO ANYONE WITHOUT THE WRITTEN  
 PERMISSION OF TEKELEC. COPYRIGHT, TEKELEC 1996.

SIZE D	CAGE CODE	DRAWING NO. 892-0066-01	REV. D
SCALE: NONE	FILE NAME: 892-0066-01_D.DWG	SHEET 2 OF 4	

D  
892-0066-01 2 D

A

ITEM NO.	TEKELEC P/N	QTY	LENGTH	RUN LIST AND LABEL INFORMATION FOR FROM AND TO	LABEL REQUIRED
1	830-0014-01	1	81.00 INCHES	FROM: SERVER A AND B - A POWER / TO: BP1 P1	NO
2	830-0016-01	1	48.00 INCHES	FROM: HUBS 3 AND 4 - A POWER / TO: BP1 P6	NO
3	830-0017-01	1	44.00 INCHES	FROM: HUBS 1 AND 2 - A POWER / TO: BP1 P5	NO
4	830-0015-01	1	81.00 INCHES	FROM: SERVER A AND B - B POWER / TO: BP1 P7	NO
5	830-0017-02	1	38.00 INCHES	FROM: HUBS 3 AND 4 - B POWER / TO: BP1 P12	NO
6	830-0016-02	1	36.00 INCHES	FROM: HUBS 1 AND 2 - B POWER / TO: BP1 P11	NO
7					
8					
9					
10	830-0822-01	4	14.00 INCHES	FROM: HUB CHASSIS GND / TO: FRAME	NO
11	830-1071-01	1	60.00 INCHES	FROM: SERVER A LOGIC GND / TO: LOGIC GND TERM BLK POS 2	YES
12	830-1071-02	1	67.00 INCHES	FROM: SERVER B LOGIC GND / TO: LOGIC GND TERM BLK POS 3	YES
13	830-0927-01	1	14.00 INCHES	FROM: SERVER A CHASSIS GND / TO: FRAME	NO
14	830-0927-01	1	14.00 INCHES	FROM: SERVER B CHASSIS GND / TO: FRAME	NO
15	830-0830-01	1	14.00 INCHES	FROM: BP1 FRAME GND / TO: FRAME	NO
16	830-1003-01	1	18.00 INCHES	FROM: BP1 LOGIC GND / TO: LOGIC GND TERM BLK POS 1	YES
17	CUSTOMER PROVIDED	2	SITE SPECIFIC	TO CUSTOMER NETWORK	FIELD LABEL
18	830-0058-XX	AR	SITE SPECIFIC	FROM: SERVER B SERIAL PORT 4 / TO: CUSTOMER SUPPLIED TERMINAL	FIELD LABEL
19	830-0059-XX	AR	SITE SPECIFIC	FROM: SERVER B SERIAL PORT 5 / TO: CUSTOMER SPECIFIC MMI PORT	FIELD LABEL
20	830-0020-01	1	72.00 INCHES	FROM: BP1 ALARM INT J1 / TO: SERVER A SERIAL PORT 2 TO: SERV A SLOT 8 ALM PORT	YES 7
21	830-0020-02	1	80.00 INCHES	FROM: BP1 ALARM INT J2 / TO: SERVER B SERIAL PORT 2 TO: SERV B SLOT 8 ALM PORT	YES 7
22	830-1074-06	1	72.00 INCHES	FROM: SERVER A SERIAL PORT 3 / TO: SERVER B SLOT 8 OOBM SERIAL	YES
23	830-1074-06	1	72.00 INCHES	FROM: SERVER B SERIAL PORT 3 / TO: SERVER A SLOT 8 OOBM SERIAL	YES
24					
25					
26					
27					
28					
29					
30	830-0724-05	1	12.00 INCHES	FROM: HUB-1 PORT 1 / TO: HUB-2 PORT 1X	YES
31	830-0724-07	1	84.00 INCHES	FROM: HUB-1 PORT 2 / TO: SERVER B SLOT 9 ETH 1	YES
32	830-0724-06	1	72.00 INCHES	FROM: HUB-2 PORT 2 / TO: SERVER A SLOT 9 ETH 1	YES
33	830-0724-05	1	12.00 INCHES	FROM: HUB-3 PORT 1 / TO: HUB-4 PORT 1X	YES
34	830-0724-06	1	72.00 INCHES	FROM: HUB-3 PORT 2 / TO: SERVER B SLOT 9 ETH 2	YES
35	830-0724-06	1	72.00 INCHES	FROM: HUB-4 PORT 2 / TO: SERVER A SLOT 9 ETH 2	YES
36	830-0723-67	1	60.00 INCHES	FROM: SERVER A SLOT 9 ETH 3 / TO: SERVER B SLOT 9 ETH 3	YES
37					
38					
39	830-0680-01	1	25.00 FEET	FROM: SERVER A SLOT 8 MODEM / TO: CUSTOMER PROVIDED PHONE LINE	FIELD LABEL
40	830-0788-XX	AR	SITE SPECIFIC	RJ45-DB26 STRAIGHT THROUGH - SHIELDED	FIELD LABEL
	830-0789-XX	AR	SITE SPECIFIC	RJ45-DB26 CROSSOVER - SHIELDED	FIELD LABEL
	830-0978-XX	AR	SITE SPECIFIC	RJ45-DB26 STRAIGHT THROUGH - UNSHIELDED	FIELD LABEL
	830-0979-XX	AR	SITE SPECIFIC	RJ45-DB26 CROSSOVER - UNSHIELDED	FIELD LABEL
41	CUSTOMER PROVIDED	2	SITE SPECIFIC	TO CUSTOMER NETWORK	FIELD LABEL
42					
43					
44					
45					
46					
47					
48					
49					
50	LOGIC GROUND	1	SEE TABLE D		FIELD LABEL
51	-48VDC (BAT)	2	SEE TABLE B		FIELD LABEL
52	-48 RTN	2	SEE TABLE B		FIELD LABEL
53	830-0715-03	1	84.00 INCHES		FIELD LABEL
54	CHASSIS GROUND	1	SEE TABLE F		FIELD LABEL
55	-48VDC (BAT)	2	SEE TABLE E		FIELD LABEL
56	-48 RTN	2	SEE TABLE E		FIELD LABEL

DISTANCE	PRIMARY CABLE PART NUMBER	CABLE AWG	TERMINAL LUG P/N	HEAT SHRINK PART NUMBER	COMMENT	REF. DETAIL
0'-40'	690-0131-01	6	502-0085-01	804-0228-01	CABLE LENGTH IS SITE-SPECIFIC	C
40'-160'	690-0108-07	1/0	804-0977-01	804-0229-01	CABLE LENGTH IS SITE-SPECIFIC	A

REVISIONS			
LTR	DESCRIPTION	DATE	APPROVED

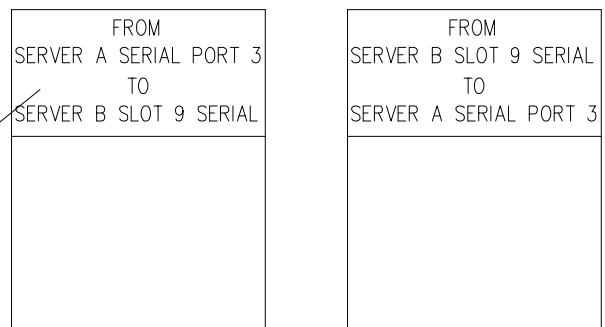

EXAMPLE OF TEXT SHOWN IN TABLES      EXAMPLE WITH TEXT REVERSED FROM FIRST LABEL

DETAIL E 6  
CABLE LABEL EXAMPLE USING CABLE ITEM NO. 22

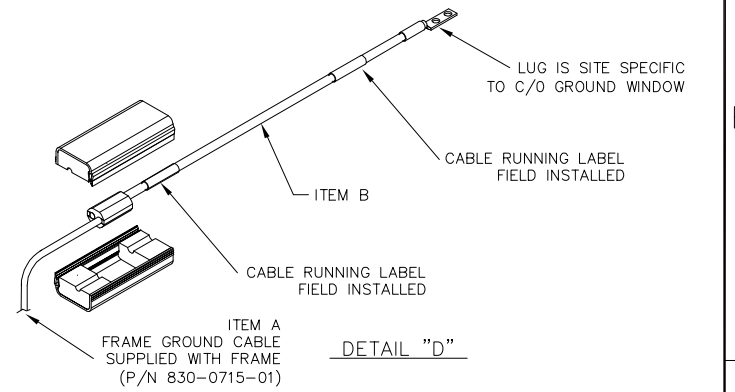
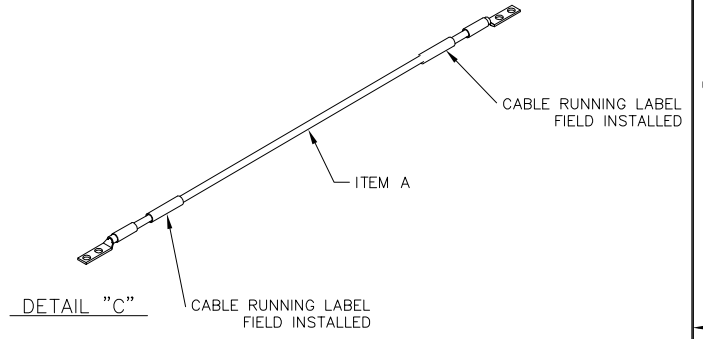
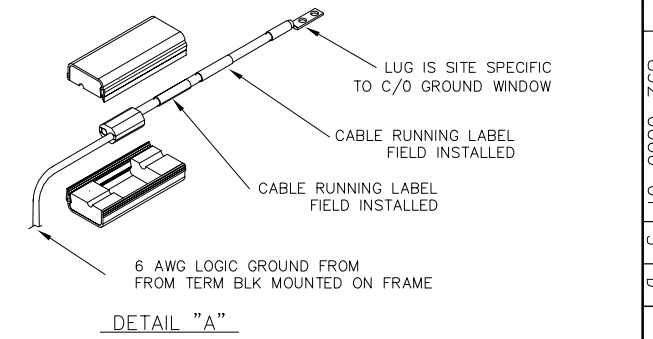
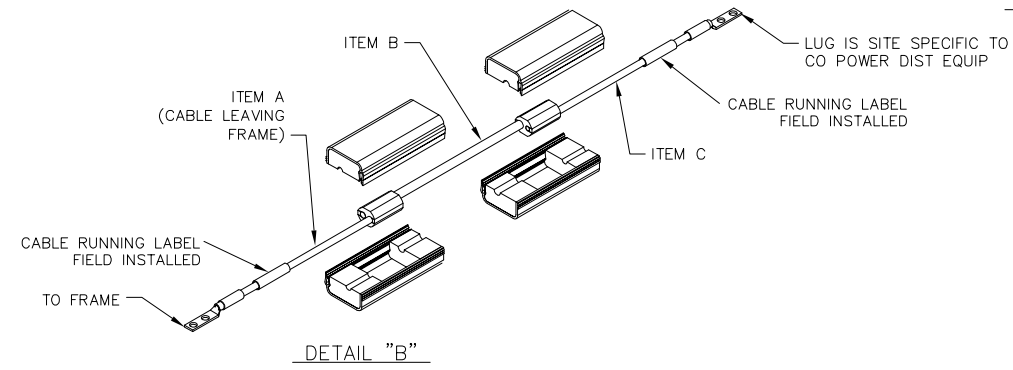

DISTANCE	ITEM A				ITEM B		ITEM C	HALF TAP SPICE P/N	HTAP SOFT COVER P/N	COMMENT	REF. DETAIL
	CABLE P/N	CABLE AWG	TERMINAL LUG P/N	HEAT SHRINK P/N	CABLE P/N	CABLE AWG					
0' - 40'	690-0108-01	6	502-0085-01	804-0228-01	690-0108-08	2	N/A	NONE REQUIRED	NONE REQUIRED	CABLE LENGTH IS SITE-SPECIFIC	C
40' - 70'	690-0108-01	6	502-0085-01	804-0228-01	690-0108-03	1/0	SITE SPECIFIC	T&B 63125	T&B HTC40	CABLE LENGTH IS SITE-SPECIFIC	B
70' - 110'	690-0108-01	6	502-0085-01	804-0228-01	690-0108-14	2/0	SITE SPECIFIC	T&B 63125	T&B HTC40	CABLE LENGTH IS SITE-SPECIFIC, HTAPPED STUBS <= 10' EACH END	B
110' - 170'	690-0108-01	6	502-0085-01	804-0228-01	690-0108-13	4/0	SITE SPECIFIC	T&B 63125	T&B HTC40	CABLE LENGTH IS SITE-SPECIFIC, HTAPPED STUBS <= 10' EACH END	B
170' - 200'	690-0108-01	6	502-0085-01	804-0228-01	690-0108-TBD	350 MCM	SITE SPECIFIC	T&B 63125	T&B HTC40	CABLE LENGTH IS SITE-SPECIFIC, HTAPPED STUBS <= 10' EACH END	B
200' - 220'	690-0108-01	6	502-0085-01	804-0228-01	690-0108-TBD	500 MCM	SITE SPECIFIC	T&B 63125	T&B HTC40	CABLE LENGTH IS SITE-SPECIFIC, HTAPPED STUBS <= 10' EACH END	B

DISTANCE	ITEM A				ITEM B		ITEM C	HALF TAP SPICE P/N	HTAP SOFT COVER P/N	COMMENT	REF. DETAIL
	CABLE P/N	CABLE AWG	TERMINAL LUG P/N	HEAT SHRINK P/N	CABLE P/N	CABLE AWG					
0' - 40'	690-0108-01	6	502-0085-01	804-0228-01	N/A	--	N/A	NONE REQUIRED	NONE REQUIRED	CABLE LENGTH IS SITE-SPECIFIC	C
40' - 65'	690-0108-01	6	502-0085-01	804-0228-01	690-0108-04	4	SITE SPECIFIC	T&B 63125	T&B HTC40	CABLE LENGTH IS SITE-SPECIFIC	B
65' - 100'	690-0108-01	6	502-0085-01	804-0228-01	690-0108-06	2	SITE SPECIFIC	T&B 63125	T&B HTC40	CABLE LENGTH IS SITE-SPECIFIC, HTAPPED STUBS <= 10' EACH END	B
100' - 160'	690-0108-01	6	502-0085-01	804-0228-01	690-0108-03	1/0	SITE SPECIFIC	T&B 63125	T&B HTC40	CABLE LENGTH IS SITE-SPECIFIC, HTAPPED STUBS <= 10' EACH END	B

DISTANCE	CABLE P/N	CABLE AWG	ITEM A (830-0715-01 SUPPLIED WITH FRAME)		ITEM B		HTAP (A TO B CONNECTION) H TAP P/N	COMMENT	REF. DETAIL
			TERMINAL LUG P/N	HEAT SHRINK P/N	CABLE P/N	CABLE AWG			
0' - 40'	690-0131-01	6	502-0085-01	804-0228-01	690-0131-01	6	804-0865-01	CABLE LENGTH IS SITE-SPECIFIC	D
40' - 160'	690-0108-01	6	502-0085-01	804-0228-01	690-0108-07	1/0	804-0865-01	CABLE LENGTH IS SITE-SPECIFIC	D

THIS DOCUMENT AND THE DATA DISCLOSED HEREIN OR HEREWITH IS PROPRIETARY AND IS NOT TO BE REPRODUCED, USED OR DISCLOSED IN WHOLE OR PART TO ANYONE WITHOUT THE WRITTEN PERMISSION OF TEKELEC. COPYRIGHT, TEKELEC 1996.

SIZE	CAGE CODE	DRAWING NO.	REV.
D		892-0066-01	D
SCALE: NONE		FILE NAME: 892-0066-01_D.DWG	SHEET 3 OF 4

REVISIONS			
LTR	DESCRIPTION	DATE	APPROVED

REVISIONS			
LTR	DESCRIPTION	DATE	APPROVED

892-0066-01  
 4  
 D

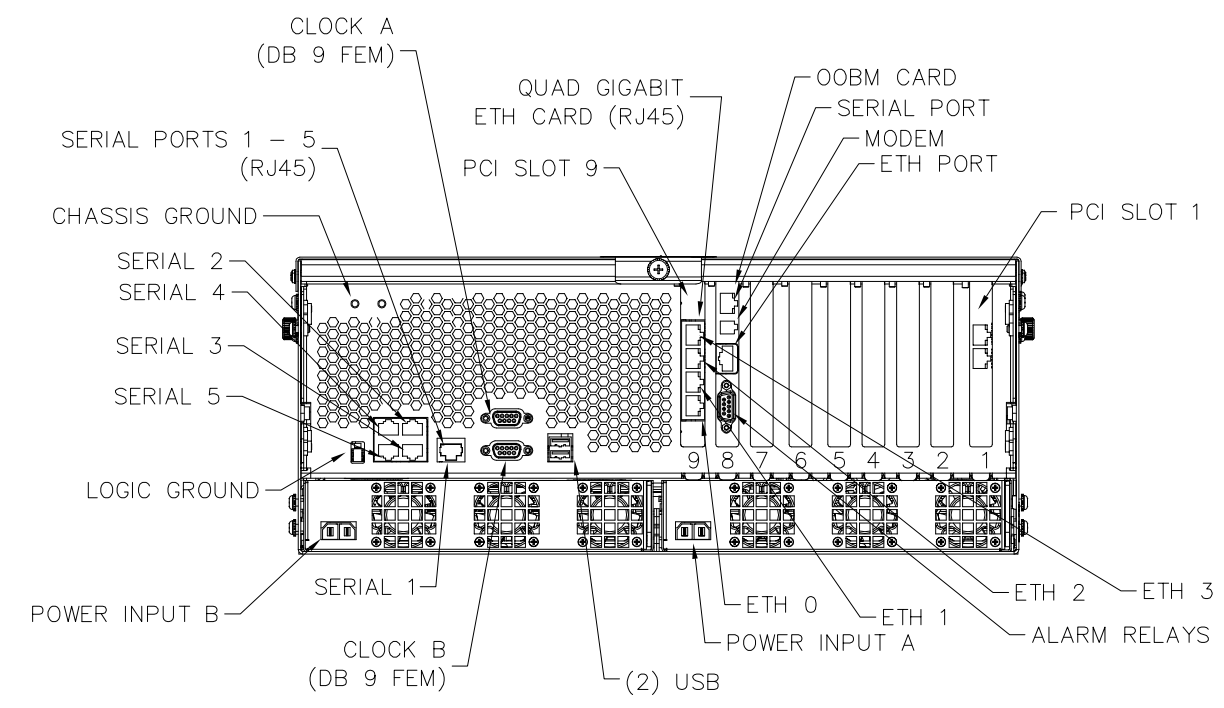

**DETAIL E**  
 SERVER A AND B (REAR VIEW)  
 870-2754-01 W/ PCI CARDS:  
 SLOT 1 -870-2706-02  
 SLOT 8 -870-2798-XX  
 SLOT 9 -870-2799-XX

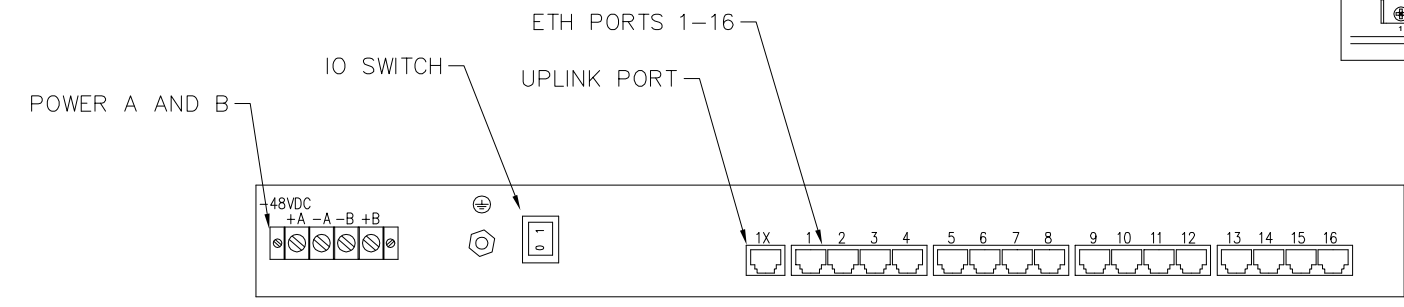

**DETAIL G**  
REAR VIEW-HUB

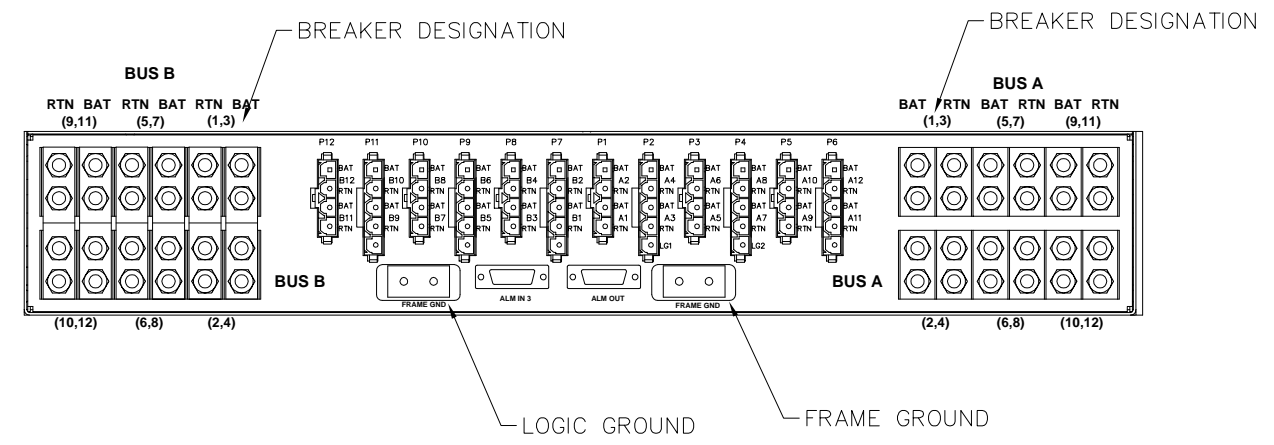

**DETAIL F**  
REAR VIEW-CIRCUIT BREAKER

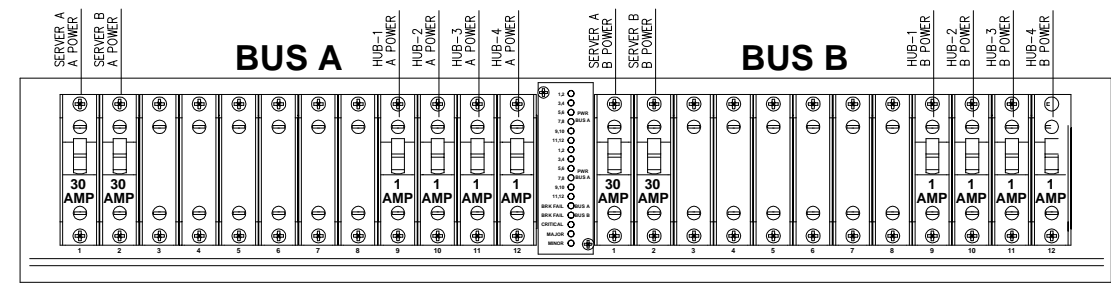

**DETAIL H**  
FRONT VIEW-CIRCUIT BREAKER

THIS DOCUMENT AND THE DATA DISCLOSED HEREIN OR HEREWITH IS PROPRIETARY AND IS NOT TO BE REPRODUCED, USED OR DISCLOSED IN WHOLE OR PART TO ANYONE WITHOUT THE WRITTEN PERMISSION OF TEKELEC. COPYRIGHT, TEKELEC 1996.

SIZE	CAGE CODE	DRAWING NO.	REV.
D		892-0066-01	D
SCALE: NONE	FILE NAME: 892-0066-01_D.DWG	SHEET 4 OF 4	

8 7 6 5 4 3 2 1

D  
 C  
 B  
 A