

NOTES: UNLESS OTHERWISE SPECIFIED

\*\*SEE PAGE 3 FOR NOTES\*\*

DOCUMENT CONTROL  
PRODUCTION RELEASED

REVISIONS			
REV	DESCRIPTION	DATE	APPROVED
A	RELEASE PER ECO #15315	10/28/05	BRYAN
B	REVISED PER ECN # 15494	12/08/05	M.BRYAN
C	REVISED PER ECN # 15793	03/20/06	M.BRYAN

# POWER CONNECTIONS AND CABLES

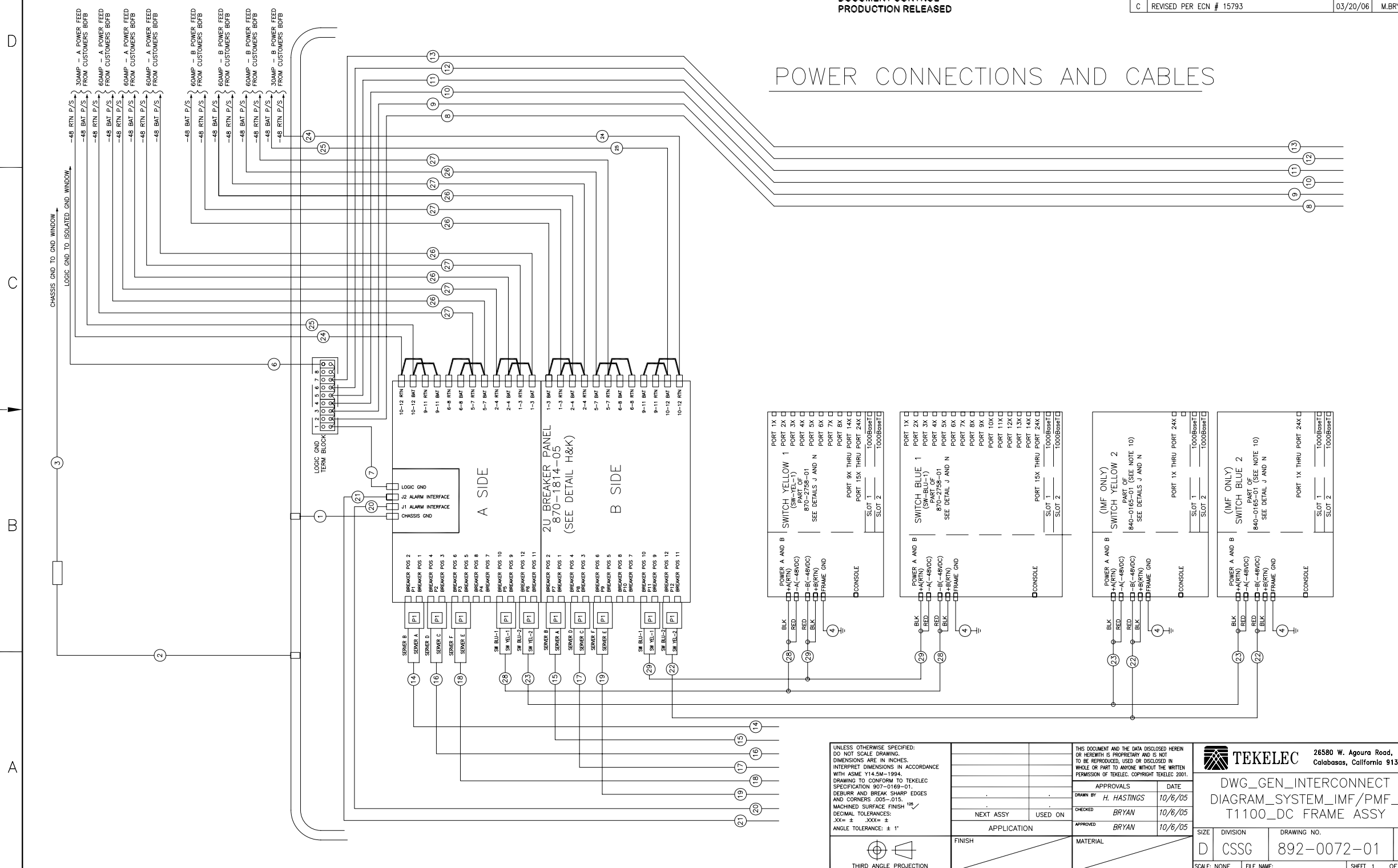

UNLESS OTHERWISE SPECIFIED: DO NOT SCALE DRAWING. DIMENSIONS ARE IN INCHES. INTERPRET DIMENSIONS IN ACCORDANCE WITH ASME Y14.5M-1994. DRAWING TO CONFORM TO TEKELEC SPECIFICATION 907-0169-01. DEBURR AND BREAK SHARP EDGES AND CORNERS .005-.015. MACHINED SURFACE FINISH $\sqrt{\text{R}}$ DECIMAL TOLERANCES: .XX = ± .XX0 ANGLE TOLERANCE: ± 1°		THIS DOCUMENT AND THE DATA DISCLOSED HEREIN OR HEREWITH IS PROPRIETARY AND IS NOT TO BE REPRODUCED, USED OR DISCLOSED IN WHOLE OR PART TO ANYONE WITHOUT THE WRITTEN PERMISSION OF TEKELEC. COPYRIGHT TEKELEC 2001.	
APPROVALS		DATE	
DRAWN BY H. HASTINGS		10/6/05	
CHECKED BRYAN		10/6/05	
APPROVED BRYAN		10/6/05	
MATERIAL			
FINISH			
NEXT ASSY USED ON			
APPLICATION			

**TEKELEC** 26580 W. Agoura Road, Calabasas, California 91302

DWG\_GEN\_INTERCONNECT  
DIAGRAM\_SYSTEM\_IMF/PMF\_  
T1100\_DC\_FRAME\_ASSY

SIZE	DIVISION	DRAWING NO.	REV.
D	CSSG	892-0072-01	C

SCALE: NONE FILE NAME: SHEET 1 OF 7

# POWER CONNECTIONS AND CABLES

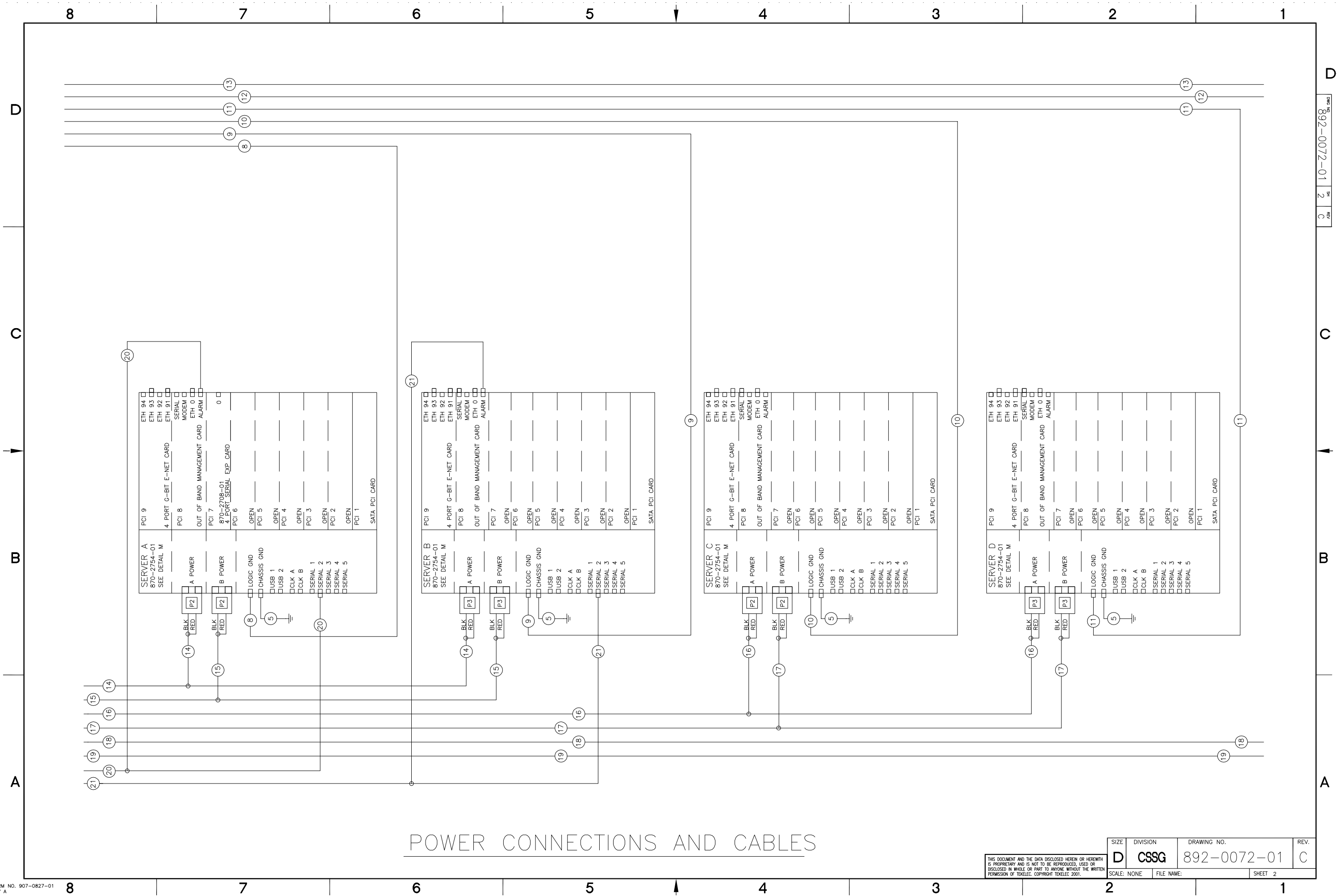

SIZE	DIVISION	DRAWING NO.	REV.
D	CSSG	892-0072-01	C
SCALE: NONE	FILE NAME:	SHEET 2	

- 1) INSTALL ALL CABLE ASSEMBLIES WITH DRESSED BEND RADII IN ACCORDANCE WITH TEKELEC CABLE BEND RADIUS SPECIFICATION 906-0020-01.
- 2) ALL INTERCONNECTION POINTS SHALL BE STRAIN RELIEVED BY POSITIVE MECHANICAL FEATURES OR FASTENERS FOR LENGTH CONFIGURATIONS.
- 3) THIS DIAGRAM AND ALL PART NUMBERS SHOWN ARE FOR REFERENCE ONLY. REFERENCE CABLE PART NUMBERS WITH XX FOR THE DASH NUMBER ARE LENGTHS THAT ARE SITE SPECIFIC.
- 4) NO ADDITIONS, DELETIONS, SUBSTITUTIONS OR MODIFICATIONS WITHOUT PRIOR WRITTEN TEKELEC APPROVAL.
- 5) SEE TEKELEC P/N 820-4844-01 FOR CURRENT LIST HARDWARE.
- 6) ALL POWER CABLES ARE CONNECTED WITH THE RED LEAD TO -48VDC TERMINAL AND THE BLACK LEAD TO RETURN TERMINAL.
- 7) -48 VDC, RTN, AND GND PRIMARY CABLING EXITING THE FRAME SHALL BE 6 AWG. SEE TABLES C, D, E, AND F FOR LENGTH CONFIGURATIONS.
- 8) USE LABEL PN 617-0009-01 TO MAKE LABEL SET FOR FROM AND TO ON CABLES AS INDICATED IN THE CABLE TABLES AND/OR THE APPLICATION TR. EACH CABLE INDICATED WILL REQUIRE A MIN OF 2 LABELS AS SHOWN IN DETAIL E. PERMANENTLY PRINT LABELS WITH .09 HIGH BLACK CHARACTERS. CENTER TEXT APPROXIMATELY AS SHOWN. MAX 23 CHARACTERS PER LINE. SEE DETAIL F FOR PLACEMENT OF LABELS ON CABLES.
- 9) THIS IS A CONFIGURABLE SYSTEM. THE SALES ORDER WILL SPECIFY THE PART NUMBERS AND QUANTITIES. THIS DIAGRAM SHOWS THE MAXIMUM CONFIGURATION.
- 10 (FROM SHEET 4) PART OF EXPANSION SWITCH KIT 840-0166-01. (BASE FRAME ONLY HAS 2 SWITCHES).
- 11 (FROM SHEET 4) NEXT FRAME REQUIRES 840-0165-01 SECOND FRAME KIT. (SEE DIAGRAM "A").
- 12 USE 3 LABELS P/N 617-0009-01 TO LABEL CABLE ITEMS 20 AND 21. (SEE EXAMPLES BELOW).

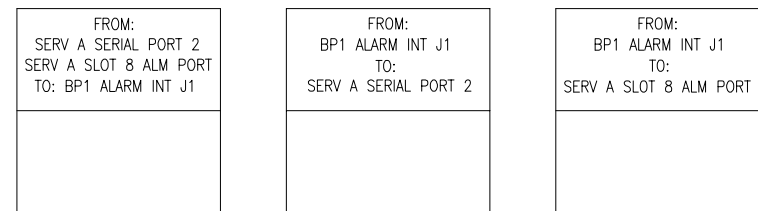

EXAMPLE OF LABELS FOR ITEM 20

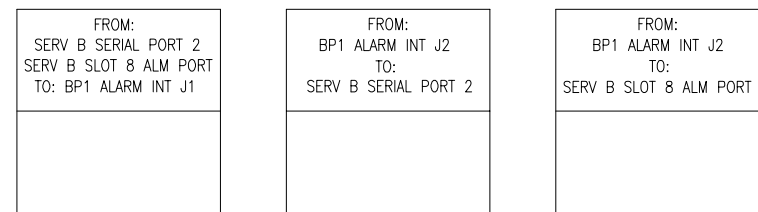

EXAMPLE OF LABELS FOR ITEM 21

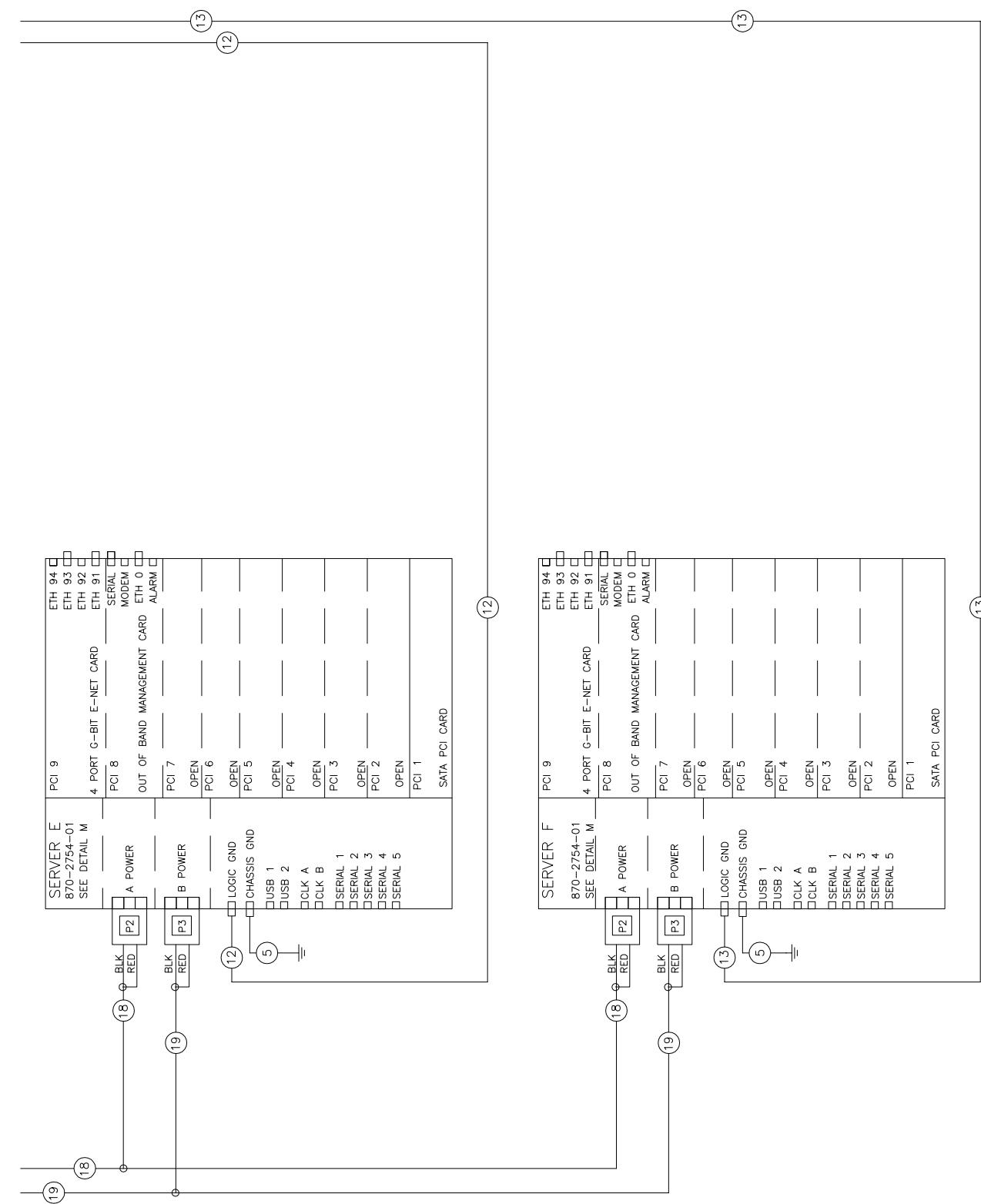

POWER CONNECTIONS AND CABLES

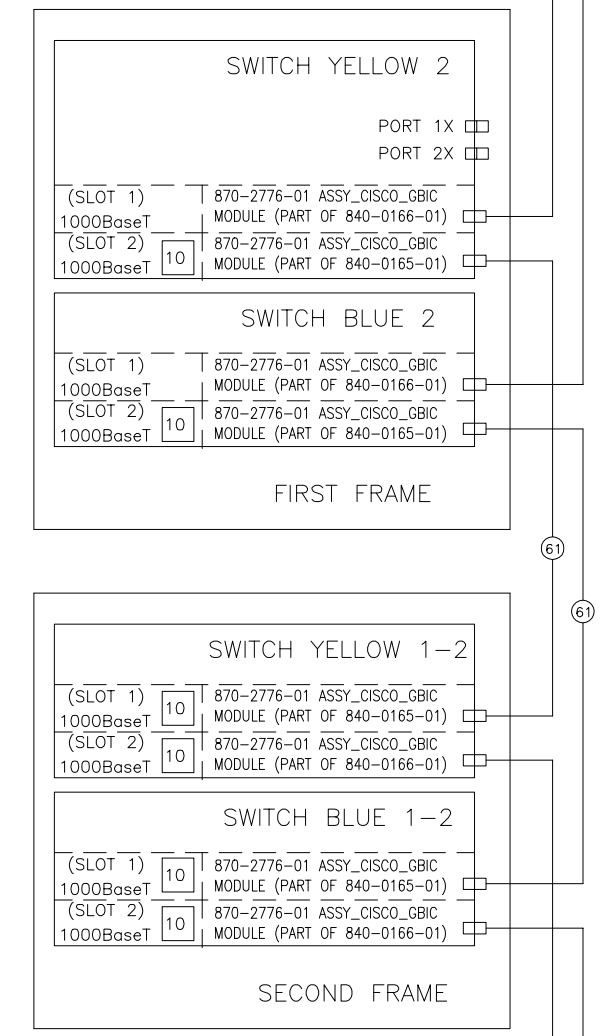

DIAGRAM "A"  
IMF LINK INTERCONNECTION

SIZE	DIVISION	DRAWING NO.	REV.
D	CSSG	892-0072-01	C
SCALE: NONE	FILE NAME:	SHEET 3	

# DATA CONNECTIONS AND CABLES

THIS DOCUMENT AND THE DATA DISCLOSED HEREIN OR HEREWITH IS PROPRIETARY AND IS NOT TO BE REPRODUCED, USED OR DISCLOSED IN WHOLE OR PART TO ANYONE WITHOUT THE WRITTEN PERMISSION OF TEXEL, INC. COPYRIGHT TEXEL, 2001.

SIZE <b>D</b>	DIVISION <b>CSSG</b>	DRAWING NO. <b>892-0072-01</b>	REV. <b>C</b>
SCALE: NONE	FILE NAME:	SHEET 4	

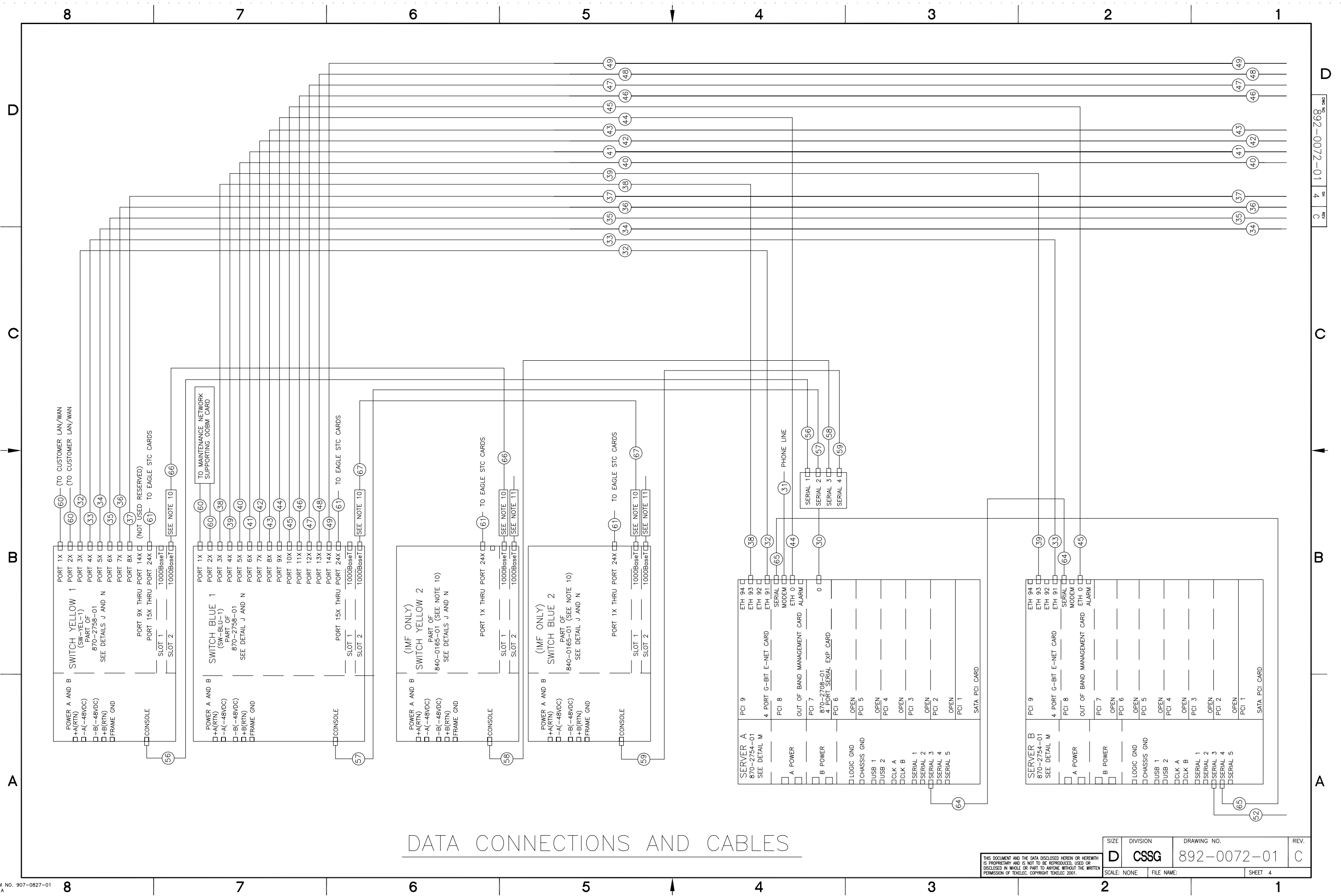

# DATA CONNECTIONS AND CABLES

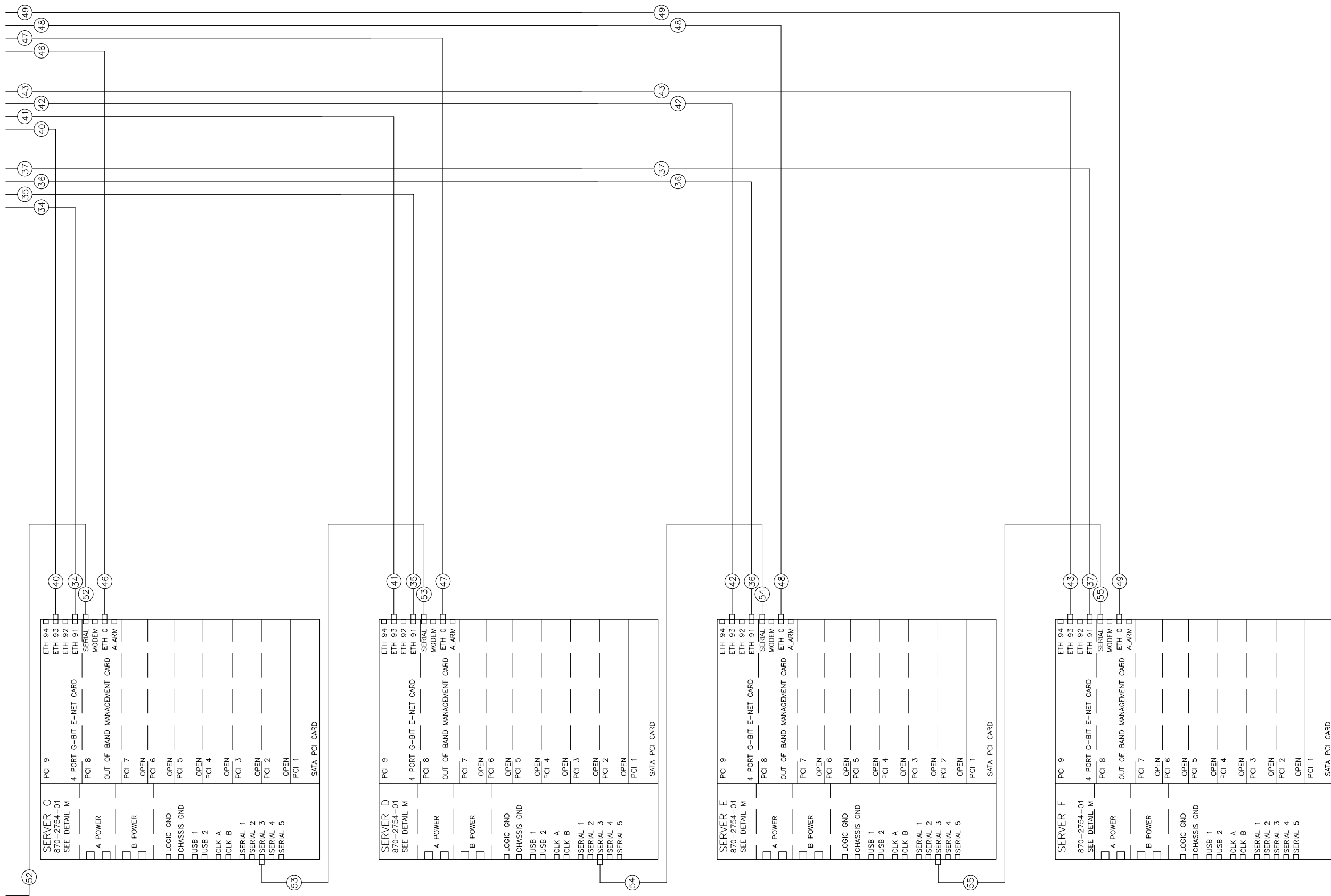

SIZE	DIVISION	DRAWING NO.	REV.
D	CSSG	892-0072-01	C
SCALE: NONE	FILE NAME:	SHEET 5	

TABLE A - POWER CABLE PART NUMBERS

ITEM NO.	TEKELEC P/N	QTY	LENGTH (INCHES)	RUN LIST AND LABEL INFORMATION FOR FROM AND TO	LABEL REQUIRED
1	830-0830-01	1	11.00	FROM: BP1 GND / TO: FRAME	YES
2	830-0715-03	1	84.00	FROM: FRAME / TO: CHASSIS GND	FIELD LABEL
3	CHASSIS GROUND	1	SEE TABLE F		FIELD LABEL
4	830-1015-01	4	22.00	FROM: SWITCH / TO: FRAME GND	NO
5	830-0927-01	6	14.00	FROM: SERVER CHASSIS GND / TO: FRAME	NO
6	LOGIC GROUND	1	SEE TABLE D	FROM: LOGIC GND TERMINAL BLOCK / TO: LOGIC GND	FIELD LABEL
7	830-1003-01	1	18.00	FROM: BP1 LOGIC GND / TO: LOGIC GND TERM BLK POS 1	NO
8	830-1071-01	1	64.00	FROM: SERVER A LOGIC GND / TO: LOGIC GND TERM BLK POS 2	NO
9	830-1071-02	1	76.00	FROM: SERVER B LOGIC GND / TO: LOGIC GND TERM BLK POS 3	NO
10	830-1071-03	1	84.00	FROM: SERVER C LOGIC GND / TO: LOGIC GND TERM BLK POS 4	NO
11	830-1071-04	1	92.00	FROM: SERVER D LOGIC GND / TO: LOGIC GND TERM BLK POS 5	NO
12	830-1071-05	1	102.00	FROM: SERVER E LOGIC GND / TO: LOGIC GND TERM BLK POS 6	NO
13	830-1071-06	1	116.00	FROM: SERVER F LOGIC GND / TO: LOGIC GND TERM BLK POS 7	NO
14	830-1085-01	1	81.00	FROM: SERVER A AND B - A POWER / TO: BP1 P1	NO
15	830-1086-01	1	81.00	FROM: SERVER A AND B - B POWER / TO: BP1 P7	NO
16	830-1086-02	1	97.00	FROM: SERVER C AND D - A POWER / TO: BP1 P2	NO
17	830-1085-02	1	93.00	FROM: SERVER C AND D - B POWER / TO: BP1 P8	NO
18	830-1085-03	1	113.00	FROM: SERVER E AND F - A POWER / TO: BP1 P3	NO
19	830-1086-03	1	106.00	FROM: SERVER E AND F - B POWER / TO: BP1 P9	NO
20	830-0020-01	1	72.00	FROM: BP1 ALARM INT J1 / TO: SERVER A SERIAL PORT 2	YES
21	830-0020-02	1	80.00	FROM: BP1 ALARM INT J2 / TO: SERVER B SERIAL PORT 2	YES
22	830-1087-02	1	37.00 36.00	FROM: BP1-P12 / TO: SW YEL 2-1 B POWER	NO
23	830-1088-02	1	50.00 49.00	FROM: BP1-P6 / TO: SW YEL 2-1 A POWER	NO
24	-48 RTN	2	SEE TABLE E		FIELD LABEL
25	-48 VDC (BAT)	2	SEE TABLE E		FIELD LABEL
26	-48 RTN	2	SEE TABLE C		FIELD LABEL
27	-48 VDC (BAT)	2	SEE TABLE C		FIELD LABEL
28	830-1087-03	1	47.00 46.00	FROM: BP1-P5 / TO: SW YEL 1-1 A POWER	NO
29	830-1088-03	1	37.00 36.00	FROM: BP1-P11 / TO: SW YEL 1-1 B POWER	NO

TABLE B - DATA CABLE PART NUMBERS

ITEM NO.	TEKELEC P/N	QUANTITY	LENGTH (FT)	RUN LIST AND LABEL INFORMATION FOR FROM AND TO	LABEL REQUIRED
30	870-2708-01	1	NA	4 PORT SERIAL CABLE SUPPLIED WITH PCI CARD.	NO
31	830-0680-01	1	25.00	RJ11 TO RJ11 PHONE LINE.	NO
32	830-0888-03	1	6.00	FROM SERVER 1A SLOT 9 ETH 91/TO SW YEL PORT 3X	YES
33	830-0888-05	1	7.00	FROM SERVER 1B SLOT 9 ETH 91/TO SW YEL PORT 4X	YES
34	830-0888-06	1	8.00	FROM SERVER 1C SLOT 9 ETH 93/TO SW YEL PORT 5X	YES
35	830-0888-06	1	8.00	FROM SERVER 1D SLOT 9 ETH 91/TO SW YEL PORT 6X	YES
36	830-0888-07	1	10.00	FROM SERVER 1E SLOT 9 ETH 91/TO SW YEL PORT 7X	YES
37	830-0888-07	1	10.00	FROM SERVER 1F SLOT 9 ETH 91/TO SW YEL PORT 8X	YES
38	830-0889-03	1	6.00	FROM SERVER 1A SLOT 9 ETH 93/TO SW BLU PORT 3X	YES
39	830-0889-05	1	7.00	FROM SERVER 1B SLOT 9 ETH 93/TO SW BLU PORT 4X	YES
40	830-0889-06	1	6.00	FROM SERVER 1C SLOT 9 ETH 93/TO SW BLU PORT 5X	YES
41	830-0889-06	1	6.00	FROM SERVER 1D SLOT 9 ETH 93/TO SW BLU PORT 6X	YES
42	830-0889-07	1	10.00	FROM SERVER 1E SLOT 9 ETH 93/TO SW BLU PORT 7X	YES
43	830-0889-07	1	10.00	FROM SERVER 1F SLOT 9 ETH 93/TO SW BLU PORT 8X	YES
44	830-0724-06	1	6.00	FROM SERVER 1A SLOT 8 ETH 0/TO SW BLU PORT 9X	YES
45	830-0724-07	1	7.00	FROM SERVER 1B SLOT 8 ETH 0/TO SW BLU PORT 10X	YES
46	830-0724-67	1	8.00	FROM SERVER 1C SLOT 8 ETH 0/TO SW BLU PORT 11X	YES
47	830-0724-67	1	8.00	FROM SERVER 1D SLOT 8 ETH 0/TO SW BLU PORT 12X	YES
48	830-0724-02	1	10.00	FROM SERVER 1E SLOT 8 ETH 0/TO SW BLU PORT 13X	YES
49	830-0724-02	1	10.00	FROM SERVER 1F SLOT 8 ETH 0/TO SW BLU PORT 14X	YES
50	NOT USED				
51	NOT USED				
52	830-1074-06	1	6.00	FROM SERVER 1B SERIAL 3 / TO SERVER 1C OOBM SERIAL	YES
53	830-1074-06	1	6.00	FROM SERVER 1C SERIAL 3 / TO SERVER 1D OOBM SERIAL	YES
54	830-1074-06	1	6.00	FROM SERVER 1D SERIAL 3 / TO SERVER 1E OOBM SERIAL	YES
55	830-1074-06	1	6.00	FROM SERVER 1E SERIAL 3 / TO SERVER 1F OOBM SERIAL	YES
56	830-1092-01	1	3.00	FROM SWITCH YEL 1-1 CONSOLE / TO SERVER 1A SLOT 7 SERIAL PORT 1	YES
57	830-1092-01	1	3.00	FROM SWITCH BLU 1-1 CONSOLE / TO SERVER 1A SLOT 7 SERIAL PORT 2	YES
58	830-1092-01	1	3.00	FROM SWITCH YEL 2-1 CONSOLE / TO SERVER 1A SLOT 7 SERIAL PORT 3	YES
59	830-1092-01	1	3.00	FROM SWITCH BLU 2-1 CONSOLE / TO SERVER 1A SLOT 7 SERIAL PORT 4	YES
60	CUSTOMER SUPPLIED	4	SITE SPECIFIC	TO CUSTOMER NETWORK-RJ45 STRAIGHT THRU OR CROSS-OVER	FIELD LABEL
61	830-0788-XX	AR	SITE SPECIFIC	YELLOW AND BLUE SWITCHES PORTS 15X-24X TO EAGLE	FIELD LABEL
62	830-0724-XX	2	SITE SPECIFIC	YELLOW AND BLUE SWITCHES EXTENSION FRAME 1000 BASE T	FIELD LABEL
63	CUSTOMER SUPPLIED	1	SITE SPECIFIC	TO CUSTOMER SUPPLIED TERMINAL	FIELD LABEL
64	830-1074-06	1	6.00	FROM SERVER 1A SERIAL 3 / TO SERVER 1B OOBM SERIAL	YES
65	830-1074-06	1	6.00	FROM SERVER 1B SERIAL 4 / TO SERVER 1A OOBM SERIAL	YES
66	830-0724-05	1	1.00	FROM SW YEL 1 SLOT 2 GIG MOD / TO SW YEL 2 SLOT 1 GIG MOD (NOTE 10)	YES
67	830-0724-05	1	1.00	FROM SW BLU 1 SLOT 2 GIG MOD / TO SW BLU 2 SLOT 1 GIG MOD (NOTE 10)	YES

TABLE C - 60 AMP POWER FEED CABLE CHART FOR -48VDC & 48VRTN CABLING COMPONENTS

DISTANCE	ITEM A				ITEM B		ITEM C	HALF TAP SPLICE P/N	HTAP SOFT COVER P/N	COMMENT	REF. DETAIL
	CABLE P/N	CABLE AWG	TERMINAL LUG P/N	HEAT SHRINK P/N	CABLE P/N	CABLE AWG	CABLE CONSTRUCTION				
0' - 40'	690-0108-01	6	502-0085-01	804-0228-01	690-0108-08	2	N/A	NONE REQUIRED	NONE REQUIRED	CABLE LENGTH IS SITE-SPECIFIC	B
40' - 70'	690-0108-01	6	502-0085-01	804-0228-01	690-0108-03	1/0	SITE SPECIFIC	T&B 63125	T&B HTC40	CABLE LENGTH IS SITE-SPECIFIC	B
70' - 110'	690-0108-01	6	502-0085-01	804-0228-01	690-0108-14	2/0	SITE SPECIFIC	T&B 63125	T&B HTC40	CABLE LENGTH IS SITE-SPECIFIC, HTAPPED STUBS <= 10' EACH END	B
110' - 170'	690-0108-01	6	502-0085-01	804-0228-01	690-0108-13	4/0	SITE SPECIFIC	T&B 63125	T&B HTC40	CABLE LENGTH IS SITE-SPECIFIC, HTAPPED STUBS <= 10' EACH END	B
170' - 200'	690-0108-01	6	502-0085-01	804-0228-01	690-0108-TBD	350 MCM	SITE SPECIFIC	T&B 63125	T&B HTC40	CABLE LENGTH IS SITE-SPECIFIC, HTAPPED STUBS <= 10' EACH END	B
200' - 220'	690-0108-01	6	502-0085-01	804-0228-01	690-0108-TBD	500 MCM	SITE SPECIFIC	T&B 63125	T&B HTC40	CABLE LENGTH IS SITE-SPECIFIC, HTAPPED STUBS <= 10' EACH END	B

TABLE D - LOGIC GROUND CABLING

DISTANCE	PRIMARY CABLE PART NUMBER	CABLE AWG	TERMINAL LUG P/N	HEAT SHRINK PART NUMBER	COMMENT	REF. DETAIL
0'-40'	690-0131-01	6	502-0085-01	804-0228-01	CABLE LENGTH IS SITE-SPECIFIC	C
40'-160'	690-0108-07	1/0	804-0977-01	804-0229-01	CABLE LENGTH IS SITE-SPECIFIC	A

FROM SERVER 1A  
SLOT 9 ETH 91  
TO  
SW YEL PORT 3X

FROM  
SW YEL PORT 3X  
TO SERVER 1A  
SLOT 9 ETH 91

EXAMPLE OF TEXT SHOWN IN TABLES      EXAMPLE WITH TEXT REVERSED FROM FIRST LABEL

DETAIL "E"      8  
CABLE LABEL EXAMPLE USING CABLE ITEM NO. 32

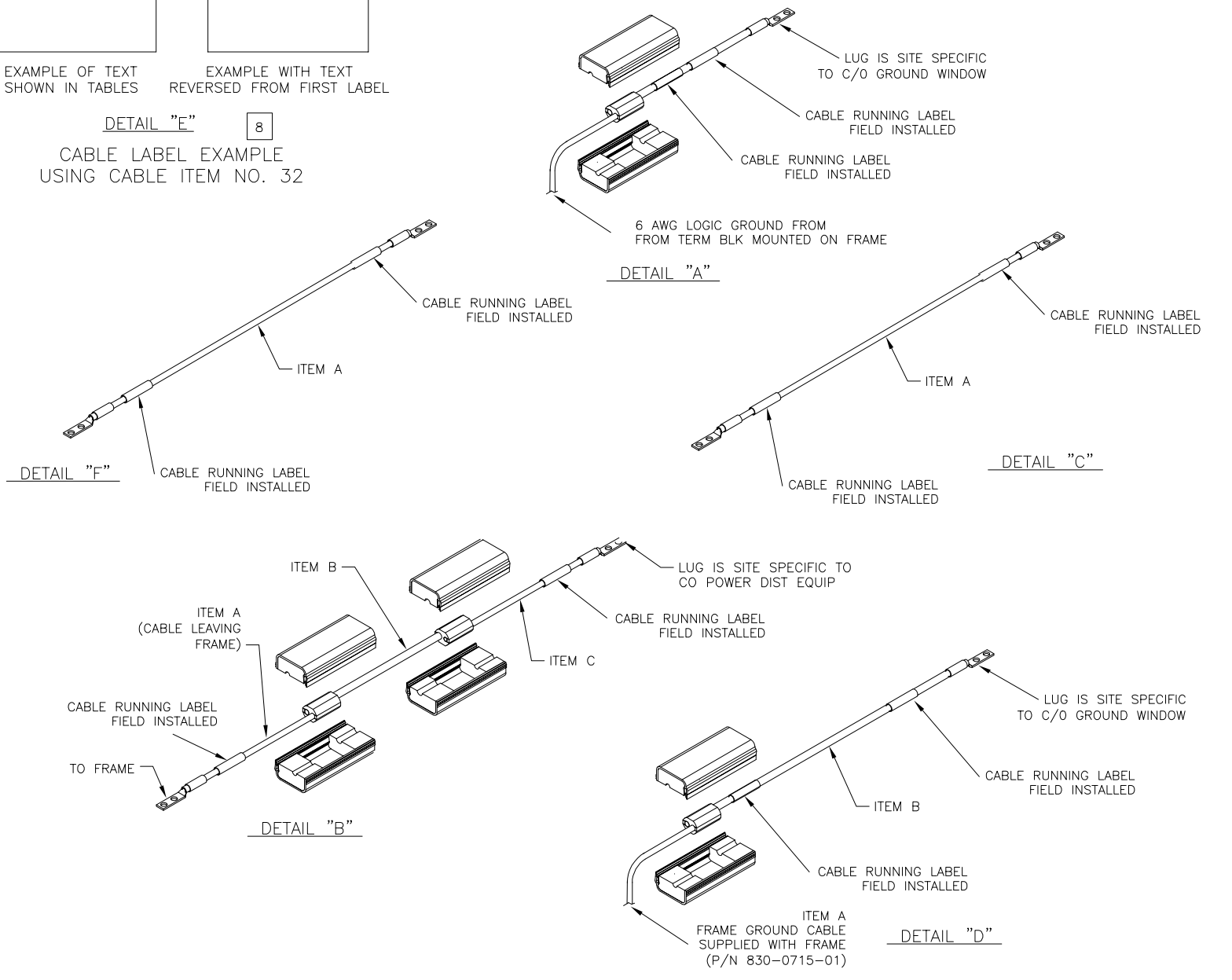

TABLE F - SYSTEM FRAME GROUND CABLING

DISTANCE	CABLE P/N	CABLE AWG	ITEM A (830-0715-01 SUPPLIED WITH FRAME)		ITEM B		HTAP (A TO B CONNECT) H TAP P/N	COMMENT	REF. DETAIL
			TERMINAL LUG P/N	HEAT SHRINK P/N	CABLE P/N	CABLE AWG			
0' - 40'	690-0131-01	6	502-0085-01	804-0228-01	690-0131-01	6	804-0865-01	CABLE LENGTH IS SITE-SPECIFIC	D
40' - 160'	690-0108-01	6	502-0085-01	804-0228-01	690-0108-07	1/0	804-0865-01	CABLE LENGTH IS SITE-SPECIFIC	D

SEE TABLE E - SHEET 7

THIS DOCUMENT AND THE DATA DISCLOSED HEREIN OR HEREWITH IS PROPRIETARY AND IS NOT TO BE REPRODUCED, USED OR DISCLOSED IN WHOLE OR PART TO ANYONE WITHOUT THE WRITTEN PERMISSION OF TEKELEC. COPYRIGHT TEKELEC 2001.

**TABLE E - 30 AMP POWER FEED CABLE CHART FOR -48VDC & 48VRTN CABLING COMPONENTS**

DISTANCE	ITEM A				ITEM B		ITEM C	HALF TAP SPLICE P/N	HTAP SOFT COVER P/N	COMMENT	REF. DETAIL
	CABLE P/N	CABLE AWG	TERMINAL LUG P/N	HEAT SHRINK P/N	CABLE P/N	CABLE AWG	CABLE CONSTRUCTION				
0' - 40'	690-0108-01	6	502-0085-01	804-0228-01	N/A	--	N/A	NONE REQUIRED	NONE REQUIRED	CABLE LENGTH IS SITE-SPECIFIC	C
40' - 65'	690-0108-01	6	502-0085-01	804-0228-01	690-0108-04	4	SITE SPECIFIC	T&B 63125	T&B HTC40	CABLE LENGTH IS SITE-SPECIFIC	B
65' - 100'	690-0108-01	6	502-0085-01	804-0228-01	690-0108-06	2	SITE SPECIFIC	T&B 63125	T&B HTC40	CABLE LENGTH IS SITE-SPECIFIC, HTAPPED STUBS <= 10' EACH END	B
100' - 160'	690-0108-01	6	502-0085-01	804-0228-01	690-0108-03	1/0	SITE SPECIFIC	T&B 63125	T&B HTC40	CABLE LENGTH IS SITE-SPECIFIC, HTAPPED STUBS <= 10' EACH END	B

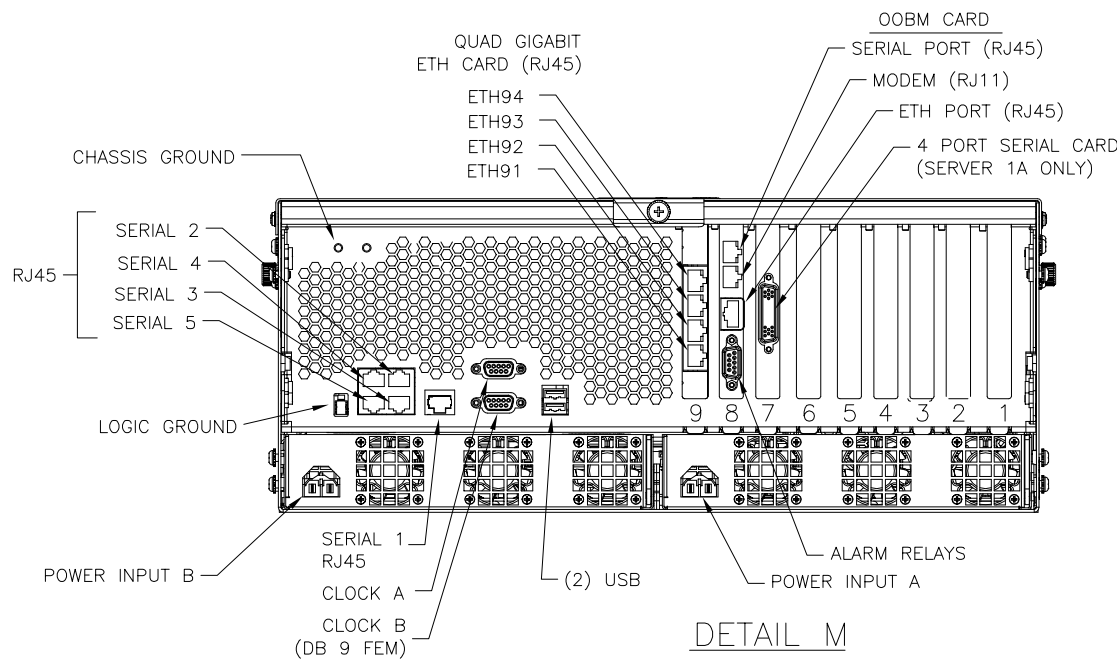

**DETAIL M**

SERVER (REAR VIEW) 870-2754-02 W/ PCI CARDS:  
(SEE TABLE H FOR CARD/SLOT INFORMATION)

**TABLE H**

PCI SLOT	BIT	MHZ	CARD
1	64	133	SATA
2	64	66	PROBE (SEE DETAIL P)
3	64	66	PROBE (SEE DETAIL P)
4	64	66	PROBE (SEE DETAIL P)
5	64	66	PROBE (SEE DETAIL P)
6	64	66	PROBE (SEE DETAIL P)
7	32	33	4 PORT SERIAL (SERVER A ONLY)
8	32	33	OOBM
9	8	4000	4 PORT ETHERNET

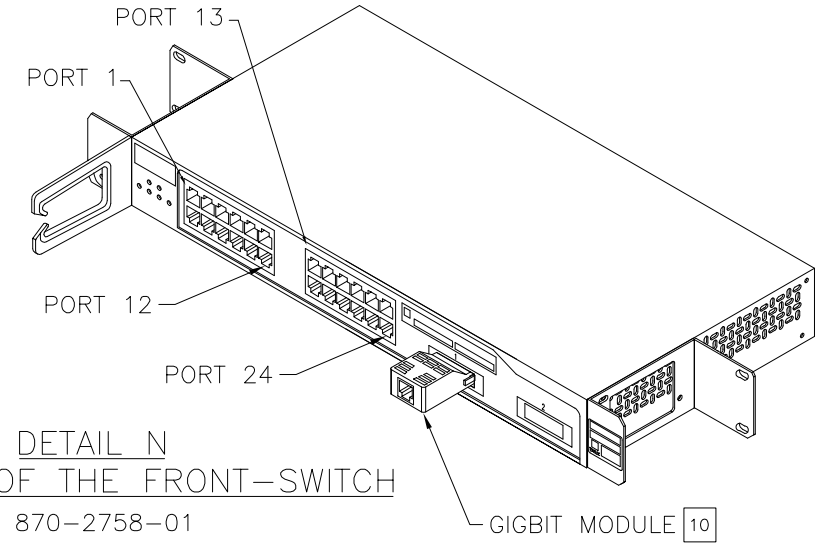

**DETAIL N**  
ISO VIEW OF THE FRONT-SWITCH  
870-2758-01

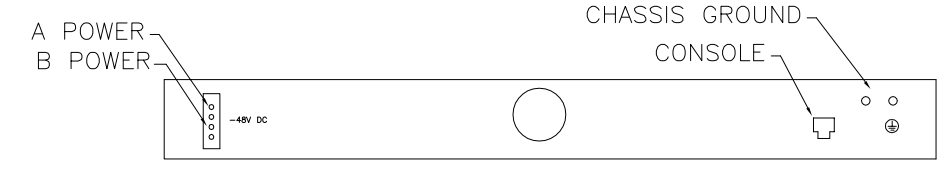

**DETAIL J**  
REAR VIEW-SWITCH

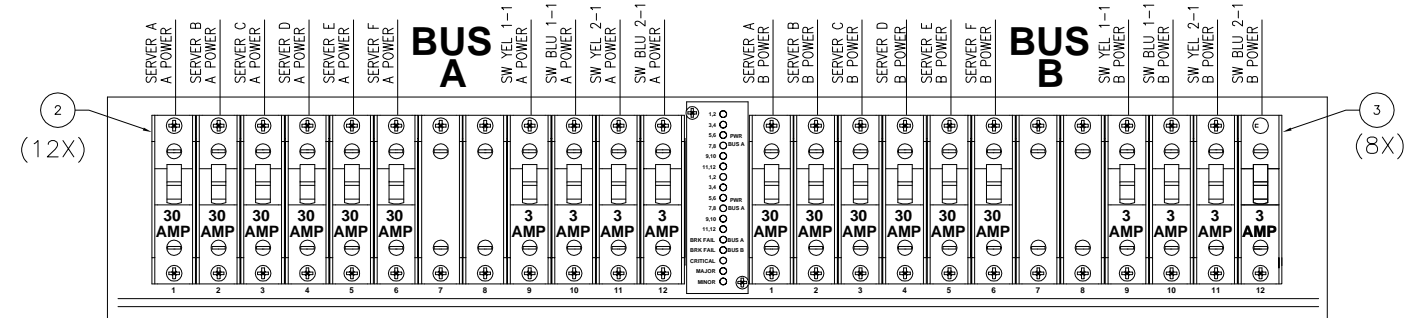

**DETAIL H - FRONT VIEW-CIRCUIT BREAKER**

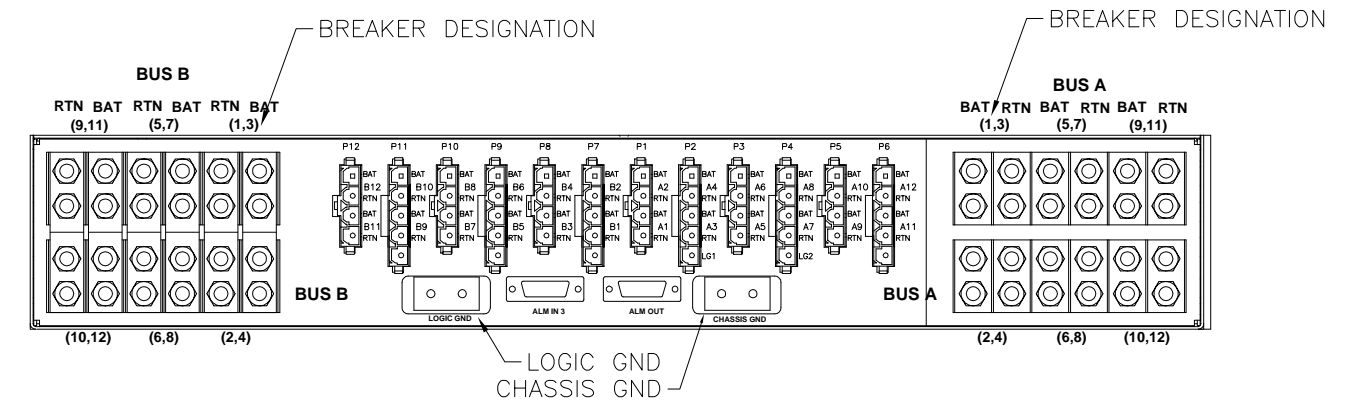

**DETAIL K-REAR VIEW - CIRCUIT BREAKER**

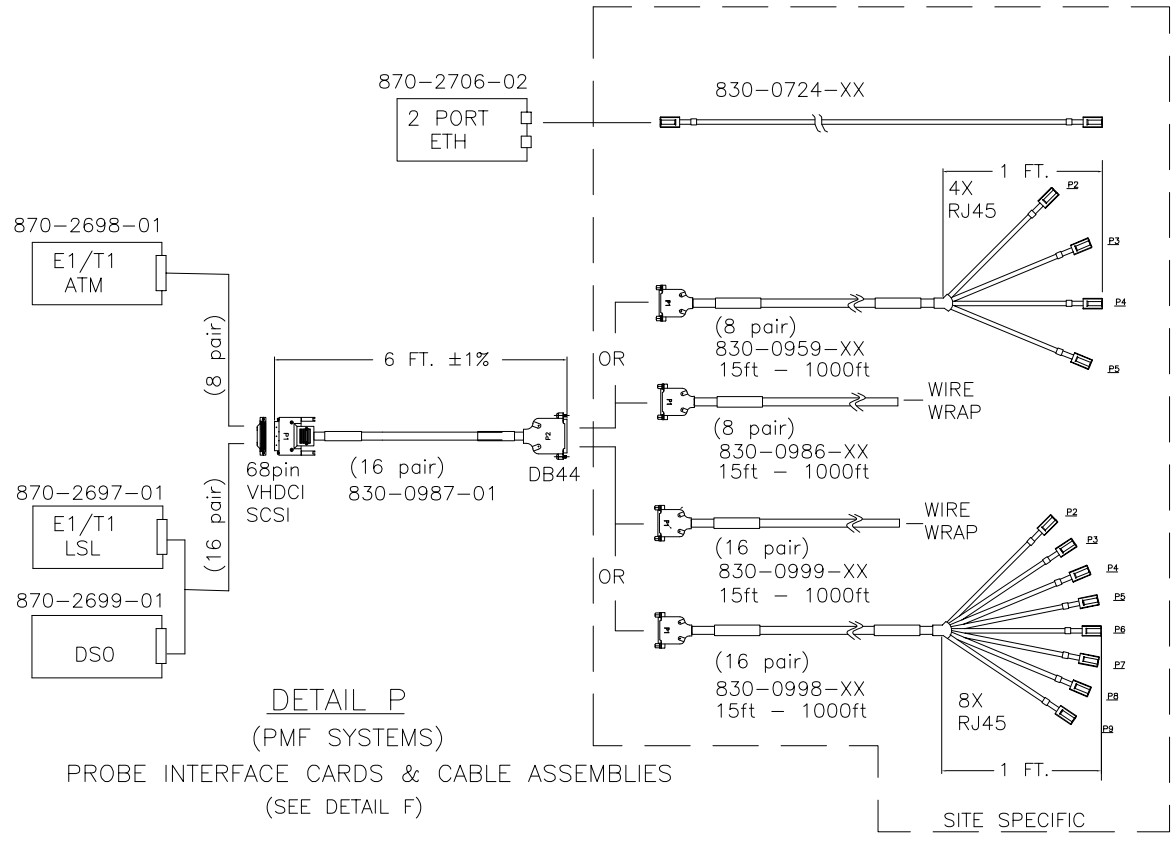

**DETAIL P**  
(PMF SYSTEMS)

PROBE INTERFACE CARDS & CABLE ASSEMBLIES  
(SEE DETAIL F)

SITE SPECIFIC

SIZE	DIVISION	DRAWING NO.	REV.
D	CSSG	892-0072-01	C
SCALE: NONE	FILE NAME:	SHEET 7	