

Tekelec EAGLE[®] 5
Integrated Signaling System

Feature Manual - G-Flex[®] C7 Relay

910-0188-001 Revision E

August 2006



TEKELEC

Copyright© 2005, 2006 Tekelec.
All Rights Reserved
Printed in U.S.A.

Notice

Information in this documentation is subject to change without notice. Unauthorized use or copying of this documentation can result in civil or criminal penalties.

Any export of Tekelec products is subject to the export controls of the United States and the other countries where Tekelec has operations.

No part of this documentation may be reproduced or transmitted in any form or by any means, electronic or mechanical, including photocopying or recording, for any purpose without the express written permission of an authorized representative of Tekelec.

Other product names used herein are for identification purposes only, and may be trademarks of their respective companies.

RoHS 5/6 - As of July 1, 2006, all products that comprise new installations shipped to European Union member countries will comply with the EU Directive 2002/95/EC "RoHS" (Restriction of Hazardous Substances). The exemption for lead-based solder described in the Annex will be exercised. RoHS 5/6 compliant components will have unique part numbers as reflected in the associated hardware and installation manuals.

WEEE - All products shipped to European Union member countries comply with the EU Directive 2002/96/EC, Waste Electronic and Electrical Equipment. All components that are WEEE compliant will be appropriately marked. For more information regarding Tekelec's WEEE program, contact your sales representative.

Trademarks

The Tekelec logo, EAGLE, G-Flex, G-Port, IP⁷, IP⁷Edge, IP⁷ Secure Gateway, and TALI are registered trademarks of Tekelec. TekServer is a trademark of Tekelec. All other trademarks are the property of their respective owners.

Patents

This product is covered by one or more of the following U.S. and foreign patents:

U.S. Patent Numbers:

5,008,929, 5,953,404, 6,167,129, 6,324,183, 6,327,350, 6,456,845, 6,606,379, 6,639,981, 6,647,113, 6,662,017, 6,735,441, 6,745,041, 6,765,990, 6,795,546, 6,819,932, 6,836,477, 6,839,423, 6,885,872, 6,901,262, 6,914,973, 6,940,866, 6,944,184, 6,954,526, 6,954,794, 6,959,076, 6,965,592, 6,967,956, 6,968,048, 6,970,542

Ordering Information

For additional copies of this document, contact your sales representative.

Table of Contents

Chapter 1. Introduction

Overview	1-1
Scope and Audience	1-2
Manual Organization	1-2
Related Publications	1-2
Documentation Packaging, Delivery, and Updates	1-7
Documentation Admonishments	1-8
Customer Assistance	1-9
Customer Care Center	1-9
Emergency Response	1-10
Acronyms	1-10

Chapter 2. Feature Description

G-Flex C7 Relay Overview	2-2
Product Description	2-3
EPAP (EAGLE Provisioning Application Processor)	2-9
DSM (Database Service Module) Cards	2-11
Network Connections	2-13
Network Perspectives	2-17
Serviceability Hints	2-19
Commands	2-20
Database Overview	2-21
Assumptions/Limitations	2-22
General Requirements	2-23
DSM Provisioning and Reload	2-27
DSM Reloading Model	2-27
DSM Reload Requirements	2-28
Provisioning Database Interface	2-29
EPAP Provisioning Blacklist	2-29
G-Flex Relay Function	2-30
Conversion of National/Local Numbers to International Numbers	2-33
Conversion of E.214 MGT to E.212 IMSI	2-34
Database Lookup	2-34
Message Forwarding	2-35

Error handling	2-37
G-Flex SCCP Service Re-Route Capability	2-37
Chapter 3. EAGLE 5 ISS G-Flex Commands	
Introduction	3-1
System Debug Services (SDS) Commands	3-1
MSU Trap and Trace Command	3-1
Provisioning Hierarchy for the G-Flex Database	3-2
EAGLE 5 ISS Terminal Database Commands	3-3
Maintenance and Measurements Commands	3-10
Commands	3-10
Chapter 4. G-Flex Feature Activation	
Introduction	4-1
Prerequisites	4-2
Feature Activation Overview	4-3
Feature Activation Procedure	4-9
Chapter 5. Maintenance and Measurements	
Hardware Requirements	5-1
EPAP Status and Alarms	5-1
EPAP Maintenance Blocks	5-2
DSM Status Requests	5-2
DSM Status Reporting to the EPAP	5-2
Hourly Maintenance Report	5-3
G-Flex System Status Reports	5-4
System Status Reporting	5-4
G-Flex Status Reporting	5-4
DSM Memory Capacity Status Reporting	5-4
Loading Mode Support Status Reporting	5-5
Code and Application Data Loading	5-5
DSM Code Loading	5-5
EPAP Application Data Loading	5-5
EPAP-DSM Loading Interface	5-6
Loading Mode Support	5-6
State Transitions during Start-Up	5-8
G-FLEX Related Alarms	5-11
EPAP - DSM Connection Status	5-12
EPAP UAMs	5-12

Table of Contents

DSM Failure	5-12
DSM-EPAP Link	5-12
DSM Hardware-Related Alarms	5-12
DSM Database Audit Alarm	5-13
DSM Database Alarms	5-14
G-Flex Subsystem Alarms	5-14
G-Flex Related UIMs	5-15
G-Flex Measurements	5-16
OAM Based Measurements	5-16
Measurements Platform	5-16
Measurement Reports	5-18

Index

List of Figures

Figure 2-1. E.214 (E.212) Routing Example - Location Updating2-5
Figure 2-2. Mobile Terminated Call2-6
Figure 2-3. Subscriber Data Provisioning Architecture (High Level)2-7
Figure 2-4. MPS/EPAP Platforms for Provisioning G-Flex2-10
Figure 2-5. Administrative Architecture2-11
Figure 2-6. Customer Provisioning Network2-15
Figure 2-7. EPAP Sync Network2-15
Figure 2-8. DSM Networks2-16
Figure 2-9. Dial-up PPP Network2-17
Figure 2-10. Location of an Integrated EAGLE 5 ISS/G-Flex Node in Wireless Network2-18
Figure 2-11. Location of a G-Flex Node in Wireless Network2-19
Figure 2-12. Functional Diagram – G-Flex in SCCP2-31
Figure 2-13. Functional Diagram – G-Flex SCCP Service Re-Route (OFFLINE)2-38
Figure 3-1. Provisioning Hierarchy3-3
Figure 4-1. Push in Inject/Eject Clamps4-21
Figure 4-2. Push Inject/Eject Clamps Outward4-29
Figure 4-3. Push in Inject/Eject Clamps4-30
Figure 5-1. Obit Message for Card Loading Abort5-8
Figure 5-2. G-Flex Not Enabled, DSM Running in TSM Emulation5-9
Figure 5-3. G-Flex Enabled, Normal Operating Sequence5-9
Figure 5-4. G-Flex Enabled, but DSM Memory Less Than 1 GB5-9
Figure 5-5. G-Flex Enabled, but DSM Not Connected to EPAP5-9
Figure 5-6. G-Flex Enabled, but DSM Memory Insufficient for Database5-10
Figure 5-7. G-Flex Enabled, but Database Exceeds DSM Memory5-10
Figure 5-8. G-Flex Not Enabled at First, but then Activated on DSM5-11
Figure 5-9. G-Flex Activation Unsuccessful due to Insufficient Database5-11

List of Tables

Table 2-1. DigitAction Applications	2-8
Table 2-2. EPAP IP Addresses in the DSM Network	2-17
Table 2-3. G-Flex Relay Data Combinations	2-32
Table 2-4. National/Local Numbers to International Numbers Conversion Logic	2-33
Table 2-5. GREF Forwarding Message: MTP Portion	2-35
Table 2-6. GFRF Forwarding Message: SCCP Portion	2-36
Table 2-7. G-Flex SCCP Re-route Summary	2-41
Table 2-8. G-Flex LIM Re-route Message Handling Summary	2-42
Table 5-1. G-Flex Subsystem Alarms	5-14
Table 5-2. G-Flex UIMs	5-15
Table 5-3. Pegs for G-Flex	5-17

Introduction

Overview	1-1
Scope and Audience	1-2
Manual Organization	1-2
Related Publications	1-2
Documentation Packaging, Delivery, and Updates.....	1-7
Documentation Admonishments	1-8
Customer Assistance	1-9
Acronyms.....	1-10

Overview

This manual provides an overview of the G-Flex[®] C7 Relay feature of the EAGLE 5 ISS (Integrated Signaling System). The G-Flex feature enables efficient Home Location Register (HLR) management in International Telecommunications Union (ITU), American National Standards Institute (ANSI), Global System for Mobile communications (GSM) networks, and IS-41 networks. The G-Flex C7 Relay node is located in the operator's C7/SS7 network between the Mobile Switching Centers (MSCs) and Home Location Registers (HLRs). G-Flex optimizes the use of subscriber numbers and number ranges by providing a logical link between any MSISDN number and any IMSI. This arrangement allows subscribers to be moved easily from one HLR to another.

The G-Flex feature is optional on the EAGLE 5 ISS, and can be turned on, but not off, via a feature bit. Note that G-Flex and North American LNP (Local Number Portability) are mutually exclusive on an EAGLE 5 ISS node. The global title translations (GTT) feature is required for operation of the G-Flex feature.

Scope and Audience

This manual is intended for anyone responsible for installing, maintaining, and using the G-Flex feature in the EAGLE 5 ISS. Users of this manual and the others in the EAGLE 5 ISS family of documents must have a working knowledge of telecommunications and network installations.

Manual Organization

This document is organized into the following chapters:

- Chapter 1, *Introduction*, contains general information about the G-Flex documentation, the organization of this manual, and how to get technical assistance.
- Chapter 2, *Feature Description*, provides a functional description of G-Flex, including network perspectives, assumptions and limitations, a database overview, DSM provisioning and reloading, G-Flex user interface, SDS commands, and the G-Flex relay function.
- Chapter 3, *EAGLE 5 ISS G-Flex Commands*, describes the user interface in detail.
- Chapter 4, *G-Flex Feature Activation*, describes how to activate the G-Flex feature.
- Chapter 5, *Maintenance and Measurements*, describes maintenance and measurements in detail, including EPAP status and alarms, hardware verification messages, TSM emulation mode, G-Flex system status reports and commands, code and application data loading, and alarms.

Related Publications

The *Feature Manual – G-Flex C7 Relay* is part of the EAGLE 5 ISS documentation and may refer to one or more of the following manuals:

- The *Commands Manual* contains procedures for logging into or out of the EAGLE 5 ISS, a general description of the terminals, printers, the disk drive used on the system, and a description of all the commands used in the system.
- The *Commands Pocket Guide* is an abridged version of the *Commands Manual*. It contains all commands and parameters, and it shows the command-parameter syntax.
- The *Commands Quick Reference Guide* contains an alphabetical listing of the commands and parameters. The guide is sized to fit a shirt-pocket.

Introduction

- The *Commands Error Recovery Manual* contains the procedures to resolve error message conditions generated by the commands in the *Commands Manual*. These error messages are presented in numerical order.
- The *Database Administration Manual – Features* contains procedural information required to configure the EAGLE 5 ISS to implement these features:
 - X.25 Gateway
 - STPLAN
 - Database Transport Access
 - GSM MAP Screening
 - EAGLE 5 ISS Support for Integrated Sentinel
- The *Database Administration Manual - Gateway Screening* contains a description of the Gateway Screening (GWS) feature and the procedures necessary to configure the EAGLE 5 ISS to implement this feature.
- The *Database Administration Manual – Global Title Translation* contains procedural information required to configure an EAGLE 5 ISS to implement these features:
 - Global Title Translation
 - Enhanced Global Title Translation
 - Variable Length Global Title Translation
 - Interim Global Title Modification
 - Intermediate GTT Load Sharing
 - ANSI-ITU-China SCCP Conversion
- The *Database Administration Manual - IP7 Secure Gateway* contains procedural information required to configure the EAGLE 5 ISS to implement the SS7-IP Gateway.
- The *Database Administration Manual – SEAS* contains the EAGLE 5 ISS configuration procedures that can be performed from the Signaling Engineering and Administration Center (SEAC) or a Signaling Network Control Center (SNCC). Each procedure includes a brief description of the procedure, a flowchart showing the steps required, a list of any EAGLE 5 ISS commands that may be required for the procedure but that are not supported by SEAS, and a reference to optional procedure-related information, which can be found in one of these manuals:
 - Database Administration Manual – Gateway Screening
 - Database Administration Manual – Global Title Translation

— Database Administration Manual – SS7

- The *Database Administration Manual – SS7* contains procedural information required to configure an EAGLE 5 ISS to implement the SS7 protocol.
- The *Database Administration Manual – System Management* contains procedural information required to manage the EAGLE 5 ISS database and GPLs, and to configure basic system requirements such as user names and passwords, system-wide security requirements, and terminal configurations.
- The *Dimensioning Guide for EPAP Advanced DB Features* is used to provide EAGLE Provisioning Application Processor (EPAP) planning and dimensioning information. This manual is used by Tekelec personnel and EAGLE 5 ISS customers to aid in the sale, planning, implementation, deployment, and upgrade of EAGLE 5 ISS systems equipped with one of the EAGLE 5 ISS EPAP Advanced Database (EADB) Features.
- The *ELAP Administration Manual* defines the user interface to the EAGLE LNP Application Processor (ELAP) on the MPS/ELAP platform. The manual defines the methods for accessing the user interface, menus, screens available to the user and describes their impact. It provides the syntax and semantics of user input, and defines the output the user receives, including information and error messages, alarms, and status.
- The *EPAP Administration Manual* describes how to administer the EAGLE 5 ISS Provisioning Application Processor on the Multi-Purpose Server (MPS)/EPAP platform. The manual defines the methods for accessing the user interface, menus, and screens available to the user and describes their impact. It provides the syntax and semantics of user input and defines the output the user receives, including messages, alarms, and status.
- The *Feature Manual - EIR* provides instructions and information on how to install, use, and maintain the EIR feature on the MPS/EPAP platform of the EAGLE 5 ISS. The feature provides network operators with the capability to prevent stolen or disallowed GSM mobile handsets from accessing the network.
- The *Feature Manual - G-Flex C7 Relay* provides an overview of a feature supporting the efficient management of Home Location Registers in various networks. This manual gives the instructions and information on how to install, use, and maintain G-Flex features on the MPS/EPAP platform of the EAGLE 5 ISS.
- The *Feature Manual - G-Port* provides an overview of a feature providing the capability for mobile subscribers to change the GSM subscription network within a portability cluster while retaining their original MSISDNs. This manual gives the instructions and information on how to install, use, and maintain G-Port features on the MPS/EPAP platform of the EAGLE 5 ISS.

Introduction

- The *Feature Manual - INP* provides the user with information and instructions on how to implement, utilize, and maintain INAP-based Number Portability (INP) features on the MPS/EPAP platform of the EAGLE 5 ISS.
- The *FTP-Based Table Retrieve Application (FTRA) User Guide* describes how to set up and use a PC to serve as the offline application for the EAGLE 5 ISS FTP Retrieve and Replace feature.
- The *Hardware Manual - EAGLE 5 ISS* contains hardware descriptions and specifications of Tekelec's signaling products. These include the EAGLE 5 ISS, OEM-based products such as the ASi 4000 Service Control Point (SCP), the Netra-based Multi-Purpose Server (MPS), and the Integrated Sentinel with Extended Services Platform (ESP) subassembly.

The Hardware Manual provides an overview of each system and its subsystems, details of standard and optional hardware components in each system, and basic site engineering. Refer to this manual to obtain a basic understanding of each type of system and its related hardware, to locate detailed information about hardware components used in a particular release, and to help configure a site for use with the system hardware.

- The *Hardware Manual - Tekelec 1000 Application Server* provides general specifications and a description of the Tekelec 1000 Applications Server (T1000 AS). This manual also includes site preparation, environmental and other requirements, procedures to physically install the T1000 AS, and troubleshooting and repair of Field Replaceable Units (FRUs).
- The *Hardware Manual - Tekelec 1100 Application Server* provides general specifications and a description of the Tekelec 1100 Applications Server (T1100 AS). This manual also includes site preparation, environmental and other requirements, procedures to physically install the T1100 AS, and troubleshooting and repair of Field Replaceable Units (FRUs).
- The *Installation Manual - EAGLE 5 ISS* contains cabling requirements, schematics, and procedures for installing the EAGLE 5 ISS along with LEDs, Connectors, Cables, and Power Cords to Peripherals. Refer to this manual to install components or the complete systems.
- The *Installation Manual - Integrated Applications* provides the installation information for integrated applications such as EPAP 4.0 or earlier (Netra-based Multi-Purpose Server (MPS) platform) and Sentinel. The manual includes information about frame floors and shelves, LEDs, connectors, cables, and power cords to peripherals. Refer to this manual to install components or the complete systems.

- The *LNP Database Synchronization Manual - LSMS with EAGLE 5 ISS* describes how to keep the LNP databases at the LSMS and at the network element (the EAGLE 5 ISS is a network element) synchronized through the use of resynchronization, audits and reconciles, and bulk loads. This manual is contained in both the LSMS documentation set and in the EAGLE 5 ISS documentation set.
- The *LNP Feature Activation Guide* contains procedural information required to configure the EAGLE 5 ISS for the LNP feature and to implement these parts of the LNP feature on the EAGLE 5 ISS:
 - LNP services
 - LNP options
 - LNP subsystem application
 - Automatic call gapping
 - Triggerless LNP feature
 - Increasing the LRN and NPANXX Quantities on the EAGLE 5 ISS
 - Activating and Deactivating the LNP Short Message Service (SMS) feature
- The *Maintenance Manual* contains procedural information required for maintaining the EAGLE 5 ISS and the card removal and replacement procedures. The *Maintenance Manual* provides preventive and corrective maintenance procedures used in maintaining the different systems.
- The *Maintenance Pocket Guide* is an abridged version of the Maintenance Manual and contains all the corrective maintenance procedures used in maintaining the EAGLE 5 ISS.
- The *Maintenance Emergency Recovery Pocket Guide* is an abridged version of the Maintenance Manual and contains the corrective maintenance procedures for critical and major alarms generated on the EAGLE 5 ISS.
- The *MPS Platform Software and Maintenance Manual - EAGLE 5 ISS with Tekelec 1000 Application Server* describes the platform software for the Multi-Purpose Server (MPS) based on the Tekelec 1000 Application Server (T1000 AS) and describes how to perform preventive and corrective maintenance for the T1000 AS-based MPS. This manual should be used with the EPAP-based applications (EIR, G-Port, G-Flex, and INP).
- The *MPS Platform Software and Maintenance Manual - EAGLE 5 ISS with Tekelec 1100 Application Server* describes the platform software for the Multi-Purpose Server (MPS) based on the Tekelec 1100 Application Server (T1100 AS) and describes how to perform preventive and corrective maintenance for the T1100 AS-based MPS. This manual should be used with the ELAP-based application (LNP).

Introduction

- The *Provisioning Database Interface Manual* defines the programming interface that populates the Provisioning Database (PDB) for the EAGLE 5 ISS features supported on the MPS/EPAP platform. The manual defines the provisioning messages, usage rules, and informational and error messages of the interface. The customer uses the PDBI interface information to write his own client application to communicate with the MPS/EPAP platform.
- The *Previously Released Features Manual* summarizes the features of previous EAGLE, EAGLE 5 ISS, and IP⁷ Secure Gateway releases, and it identifies the release number of their introduction.
- The *Release Documentation* contains the following documents for a specific release of the system:
 - *Feature Notice* - Describes the features contained in the specified release. The Feature Notice also provides the hardware baseline for the specified release, describes the customer documentation set, provides information about customer training, and explains how to access the Customer Support website.
 - *Release Notice* - Describes the changes made to the system during the lifecycle of a release. The Release Notice includes Generic Program Loads (GPLs), a list of PRs resolved in a build, and all known PRs.
NOTE: The *Release Notice* is maintained solely on Tekelec's Customer Support site to provide you with instant access to the most up-to-date release information.
 - *System Overview* - Provides high-level information on SS7, the IP7 Secure Gateway, system architecture, LNP, and EOAP.
 - *Master Glossary* - Contains an alphabetical listing of terms, acronyms, and abbreviations relevant to the system.
 - *Master Index* - Lists all index entries used throughout the documentation set.
- The *System Manual – EOAP* describes the Embedded Operations Support System Application Processor (EOAP) and provides the user with procedures on how to implement the EOAP, replace EOAP-related hardware, device testing, and basic troubleshooting information.

Documentation Packaging, Delivery, and Updates

Customer documentation is provided with each system in accordance with the contract agreements. It is updated whenever significant changes that affect system operation or configuration are made. Updates may be issued as an addendum, or a reissue of the affected documentation.

The document part number appears on the title page along with the current revision of the document, the date of publication, and the software release that the document covers. The bottom of each page contains the document part number and date of publication.



Two types of releases are major software releases and maintenance releases. Maintenance releases are issued as addenda with a title page and change bars. On changed pages, the date and document part number are changed; on unchanged pages that accompany the changed pages, the date and document part number are unchanged.

When the software release has a minimum affect on documentation, an addendum is provided. The addendum contains an instruction page, a new title page, a change history page, and replacement chapters with the date of publication, the document part number, and change bars.

If a new release has a major impact on documentation, such as a new feature, the entire documentation set is reissued with a new part number and a new release number.

Documentation Admonishments

Admonishments are icons and text throughout this manual that alert the reader to assure personal safety, to minimize possible service interruptions, and to warn of the potential for equipment damage. This manual has three admonishments, listed in descending order of priority.

	<p>DANGER: (This icon and text indicate the possibility of <i>personal injury</i>.)</p>
	<p>WARNING: (This icon and text indicate the possibility of <i>equipment damage</i>.)</p>
	<p>CAUTION: (This icon and text indicate the possibility of <i>service interruption</i>.)</p>

Customer Assistance

The Tekelec Customer Care Center offers a point of contact through which customers can receive support for problems. The Tekelec Customer Care Center is staffed with highly-trained engineers to provide solutions to technical questions and issues seven days a week, twenty-four hours a day. A variety of service programs are available through the Tekelec Customer Care Center to maximize the performance of Tekelec products that meet and exceed customer needs.

Customer Care Center

To receive technical assistance, call the Tekelec Customer Care Center at one of the following locations by one of the following methods:

- Tekelec, UK

Phone: +44 1784 467804

Fax: +44 1784 477120

Email: *ecsc@tekelec.com*

- Tekelec, USA

Phone (within continental US): (888) 367-8552

(outside continental US): +1 919-460-2150

Email: *support@tekelec.com*

When the call is received, a Customer Service Report (CSR) is issued to record the request for service. Each CSR includes an individual tracking number.

Once a CSR is issued, Technical Services determines the classification of the trouble. If a critical problem exists, emergency procedures are initiated. If the problem is not critical, information regarding the serial number of the system, COMMON Language Location Identifier (CLLI), initial problem symptoms (includes outputs and messages) is recorded. A primary Technical Services engineer is also assigned to work on the CSR and provide a solution to the problem. The CSR is closed when the problem is resolved.

Emergency Response

In the event of a critical service situation, emergency response is offered by Tekelec Technical Services twenty-four hours a day, seven days a week. The emergency response provides immediate coverage, automatic escalation, and other features to ensure that the critical situation is resolved as rapidly as possible.

A critical situation is defined as a problem with an EAGLE 5 ISS that severely affects service, traffic, or maintenance capabilities, and requires immediate corrective action. Critical problems affect service and/or system operation resulting in:

- A total system failure that results in loss of all transaction processing capability
- Significant reduction in system capacity or traffic handling capability
- Loss of the system's ability to perform automatic system reconfiguration
- Inability to restart a processor or the system
- Corruption of system databases that requires service affecting corrective actions
- Loss of access for maintenance or recovery operations
- Loss of the system ability to provide any required critical or major trouble notification

Any other problem severely affecting service, capacity/traffic, billing, and maintenance capabilities may be defined as critical by prior discussion and agreement with Tekelec Technical Services.

Acronyms

ADL.....Application Data Loader

AuC.....Authentication Center

CC.....E.164 Country Code

CdPA.....Called Party Address

CgPA.....Calling Party Address

CPC.....Service Capability Point Code

DCM.....Data Communications Module

DSM.....Database Services Module

EPAP.....EAGLE Provisioning Application Processor

ES.....Encoding Scheme

Introduction

FTR.....	File Transfer Region
GDB	G-Flex/G-Port/INP Database
G-Flex	GSM Flexible Numbering
GFDB	G-Flex Database
GMSC	Gateway Mobile Switching Center
G-Port	GSM Mobile Number Portability
GPL	Generic Program Load
GSM	Global System for Mobile communications
GTA.....	Global Title Address
GTAI	Global Title Address Information
GTI	Global Title Indicator
GTT	Global Title Translation
HLR.....	Home Location Register
IAM.....	Initial Address Message
IMSI	International Mobile Station Identifier
IN	Intelligent Network
INAP	Intelligent Network Application Protocol
INP	INAP-Based Number Portability
IP	Internet Protocol
IS-41	Interim Standard-41
IS-NR	In-Service Normal
ISDN	Integrated Services Digital Network
ITU	International Telecommunications Union
LIM	Link Interface Module
LNP	Local Number Portability
LSS	Local Subsystem
MAP	(1) Mobile Application Part (2) Mated APplication
MAS	Maintenance and Administration Subsystem
MCAP	MAS Communication Application Processor Card

MEA	Mismatch of Equipment and Attributes
MDN	Mobile Directory Number
MGT	Mobile Global Title
MIN	Mobile Identification Number
MMI	Man-Machine Interface
MNP	Mobile Number Portability
MPS	Multi-Purpose Server (Multi-Platform Server)
MSRN	Mobile Station Roaming Number
MSC.....	Mobile Switching Center
MSISDN.....	Mobile Station international ISDN number
MSU	Message Signaling Unit
MTP.....	Message Transfer Part
NC	E.214 Network Code
NDC	E.164 National Destination Code
NP.....	(1) Number Portability (2) Numbering Plan
NPA.....	Numbering Plan Area
NPDB	Numbering Plan Database
NPV.....	Numbering Plan Value
NSD.....	Network Systems Division, Tekelec
OAI.....	Object Access Interface
OAM	Operation Administration & Maintenance
OAP.....	Operations Support System/ Application Processor
OPS.....	Operator Provisioning System
PDB	Provisioning Database
PDBA	Provisioning Database Application
PDBI.....	Provisioning Database Interface
PFS.....	Product Functional Specification
PLMN	Public Land Mobile Network
PMTC.....	Peripheral Maintenance Control

Introduction

PPSMS	Prepaid Short Message Service
RMTP	Reliable Multicast Transport Protocol
RTDB.....	Real-Time Database
SCCP	Signaling Connection Control Part
SCP	Service Control Point
SDS.....	System Debug Services
SIM.....	Subscriber Identity Module
SMS	Short Message Service
SNP	Service Numbering Plan
SP.....	Signaling Point
SPC.....	Secondary Point Code
SS7.....	Signaling System 7
SSN.....	Subsystem Number
SSP	Service Switching Point
STP	Signal Transfer Point
TCAP	Transaction Capabilities Application Part
TCP	Transmission Control Protocol
TFA.....	Transfer Allowed
TFC.....	Transfer Congested
TFP	Transfer Prohibited
TSM.....	Translation Service Module
TT	Translation Type
UAM	Unsolicited Alarm Message
UDP	User Datagram Protocol
UDTS	Unit Data Transfer Service
UIM.....	Unsolicited Information Message
VGTT	Variable-Length Global Title Translation
VLR.....	Visitor Location Register
VMSC	Voice Mail Service Center
VSCCP	VxWorks Signaling Connection Control Part

Feature Description

G-Flex C7 Relay Overview	2-2
Product Description.....	2-3
EPAP (EAGLE Provisioning Application Processor).....	2-9
DSM (Database Service Module) Cards	2-11
Network Connections	2-13
Network Perspectives	2-17
Serviceability Hints.....	2-19
Commands.....	2-20
Database Overview.....	2-21
Assumptions/Limitations	2-22
General Requirements.....	2-23
DSM Provisioning and Reload	2-27
DSM Reloading Model.....	2-27
DSM Reload Requirements	2-28
Provisioning Database Interface	2-29
EPAP Provisioning Blacklist	2-29
G-Flex Relay Function.....	2-30
Conversion of National/Local Numbers to International Numbers.....	2-33
Conversion of E.214 MGT to E.212 IMSI	2-34
Database Lookup	2-34

Message Forwarding	2-35
G-Flex SCCP Service Re-Route Capability	2-37

G-Flex C7 Relay Overview

In today's mobile networks, subscribers are assigned to Home Location Registers (HLRs) and AuCs (Authentication Centers) via blocks or ranges of subscriber numbers. These ranges are used by MSCs (Mobile Switching Centers) to route many types of signalling messages to HLRs/AuCs. There are several types of numbers that identify subscribers, both of which are assigned by MSCs to HLR/AuCs via this range mechanism.

- MSISDN (Mobile Station International Integrated Services Digital Network) numbers, which use numbering plan E.164
- IMSI (International Mobile Subscriber Identity) numbers, which use numbering plan E.212
- MIN (Mobile Identification Number), which uses the E.164 numbering plan
- MDN (Mobile Directory Number), which uses the E.164 numbering plan

Problems arose in areas such as network load balancing and efficient use of HLR capacity. G-Flex is a feature designed to alleviate some of these problems by allowing the operator to flexibly assign individual subscribers to HLRs and route signaling messages, based on subscriber numbering, accordingly. The current phase of development applies to routing to HLRs only. In the future, this capability may be expanded to include routing to other intelligent devices such as SCPs (Service Control Points) and VMSCs (Voice Mail Service Centers), depending on market needs.

NOTE: For purposes of this discussion, the term HLR is used to include AuC, as applicable.

Today's rigid scheme for assigning subscribers to HLRs leads to several inefficiencies for network operators. Below are a few examples:

- When IMSI numbers, which identify the SIM (Subscriber Identity Module), get lost or are otherwise out of service, "holes" sometimes open in the IMSI ranges. These holes result in HLR capacity that cannot be used because switches will not be routing messages using those lost numbers anymore.
- In many cases, subscribers are "split" across multiple HLRs, as their IMSI range can point to a different HLR than their MSISDN range. Operators must take special steps to ensure that calls are not mishandled.
- With the advent of MNP (Mobile Number Portability), the MSISDN no longer indicates the subscription network. This leads to holes in the MSISDN ranges that address HLRs. As in the case with IMSIs, these MSISDN holes result in HLR capacity that cannot be used by existing MSC routing schemes.

Feature Description

- With the advent of MNP, operators need to handle message routing based on MSISDNs that are imported to the network from another operator, and so do not fit into the existing range mechanism at all.
- Prepaid service may result in the allocation of a large block of IMSIs to an HLR, many of which may not be put in service for a while.
- Corporate clients may reserve a large block of numbers that must be assigned to an HLR. Many of these may not be used for a while, if ever.

Product Description

The G-Flex C7 Relay node is located in the operator's C7/SS7 network between the MSCs and HLRs. It can also serve as the direct interface to other networks. G-Flex can be deployed as an integrated part of the STP (Signal Transfer Point) function or as a stand-alone node.

G-Flex optimizes the use of subscriber numbers and number ranges by providing a logical link between any MSISDN number or IMSI, and an HLR. This allows subscribers to easily be moved from one HLR to another.

It also allows each HLR to be filled to 100% of its capacity by allowing subscriber number ranges to be split over different HLRs and individual subscriber numbers to be assigned to any HLR. Another benefit is that subscriber number routing data is not required to be maintained in all MSCs in the network.

G-Flex is optional on the EAGLE 5 ISS, and can be turned on (but not turned off) via a feature bit. G-Flex and North American LNP (Local Number Portability) are mutually exclusive on an EAGLE 5 ISS node.

Call Flows

As stated in the preceding sections, several types of subscriber numbers can be used as a basis for routing messages to HLRs: IMSI, MSISDN, MIN, and MDN. In actuality, there are two flavors of IMSI routing: one that uses the actual IMSI, which is an E.212 number, and one that uses the Mobile Global Title (MGT), which is an E.214 number derived from the IMSI. G-Flex handles both of these cases in addition to the MSISDN/MIN/MDN cases, which use the E.164 numbering plan. The following subsections address these three cases.

In GSM networks, each network entity (for example, MSC, HLR, VLR [Visitor Location Register]) is identified by an E.164 entity address. Note that GSM networks also route messages based on E.164 entity addresses when those addresses are known by the sender. While the routing of these messages must also be handled by the G-Flex C7 Relay, this functionality is not considered to be a core part of the G-Flex functionality. These numbers are not expected to be populated in the G-Flex database and so messages routed using these addresses should fall through to normal (or enhanced) GTT (Global Title Translation). Therefore, call flows for this type of routing are not described here.

The call flows in this section show only one possible scenario for how messages are routed in the network and where various stages of GTT are performed. The G-Flex C7 Relay may perform intermediate or final GTT and/or replace the SCCP (Signaling Connection Control Part) CdPA (Called Party Address) with the HLR entity address, depending on the message received and provisioned data. All call flows here assume the G-Flex C7 Relay is integrated with the EAGLE 5 ISS.

MGT (E.214) Routing

The partial Location Update procedure, detailed in Figure 2-1, is an example of E.214 mobile global title routing. This routing is employed in situations where the E.164 address of the receiving node (HLRB) is not yet known by the sending node (VLRA).

In order to update information about the subscriber's location, VLRA sends a MAP (Mobile Application Part) Update_Location message to the G-Flex Relay (possibly via a Gateway MSC [Mobile Switching Center]).

The steps in Figure 2-1 are cross-referenced in the following procedure.

1. The message is received at the G-Flex Relay. Global title information triggers G-Flex processing. Since the SCCP CdPA contains an E.214 number, G-Flex first converts the E.214 number to an international E.212 number before searching the G-Flex database (GFDB) with the E.212 number (Step 1). G-Flex also handles the case where an E.212 number is received in the SCCP CdPA. In this case, the database is searched directly using the E.212 number.
2. G-Flex finds a match with HLR GT information and routes the message to the designated DPC (HLRB) (Step 2).
3. HLRB responds to VLRA with an Update_Location **ack**. This message has the E.164 address of VLRA in the SCCP CdPA and is routed by normal (or enhanced) GTT, not G-Flex (Step 3).
4. The message is relayed to VLRA (Step 4).

Feature Description

Figure 2-1. E.214 (E.212) Routing Example - Location Updating

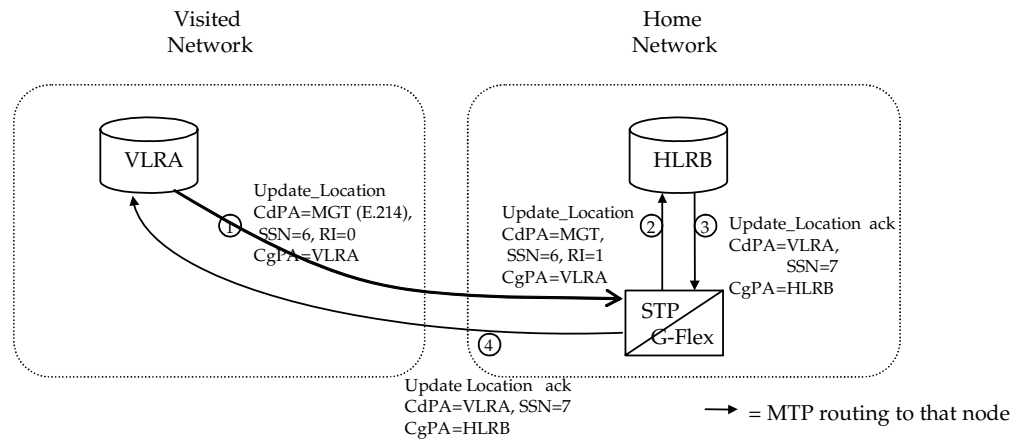

There are other MAP messages from VLR (Visitor Location Register) to HLR that also fall into this category of requiring E.214 global title routing. All of these messages are handled the same way by G-Flex, using the process described above.

IMSI (E.212) Routing

G-Flex processing, when it receives a message routed with an E.212 number in the SCCP CdPA GTA (Global Title Address), is essentially the same as when an E.214 number is received. The only difference is that the number does not have to be converted to E.212 (since it is already E.212) before doing the database lookup. Therefore, those call flows are not shown here.

MSISDN/MIN/MDN (E.164) Routing

A mobile terminated call results in the GMSC (Gateway Mobile Switching Center) querying the HLR through the use of the called number as a GTA. G-Flex is used to locate the appropriate HLR. The partial mobile terminated call procedure detailed in Figure 2-2 is an example of MSISDN global title SCCP addressing. This applies to MIN and MDN routing numbers as well.

The steps in Figure 2-2 are cross-referenced in the following procedure.

1. A call is originated and an IAM (Initial Address Message) is sent from the originating network to the subscription network (Step 1).
2. Digit analysis at GMSCB detects a mobile terminated call to a mobile station and generates a MAP Send_Routing_Info (SRI) message to the G-Flex Relay (Step 2).
3. The EAGLE 5 ISS receives the message. Global title information triggers G-Flex processing. Since the SCCP CdPA contains an E.164 number, G-Flex searches the GFDB with the E.164 number, which must be converted to an international number if it is not one already. The G-Flex finds a match with

- HLR GT information and routes the message to the designated DPC (HLRB) (Step 3).
4. HLRB responds to GMSCB with an SRI **ack**. This message has the E.164 address of GMSCB in the SCCP CdPA, and is routed by normal (or enhanced) GTT, not G-Flex (Step 4).
 5. The message is relayed to GMSCB (Step 5).
 6. GMSCB sends an IAM containing the MSRN (Mobile Station Roaming Number) to the visited network (Step 6).

Figure 2-2. Mobile Terminated Call

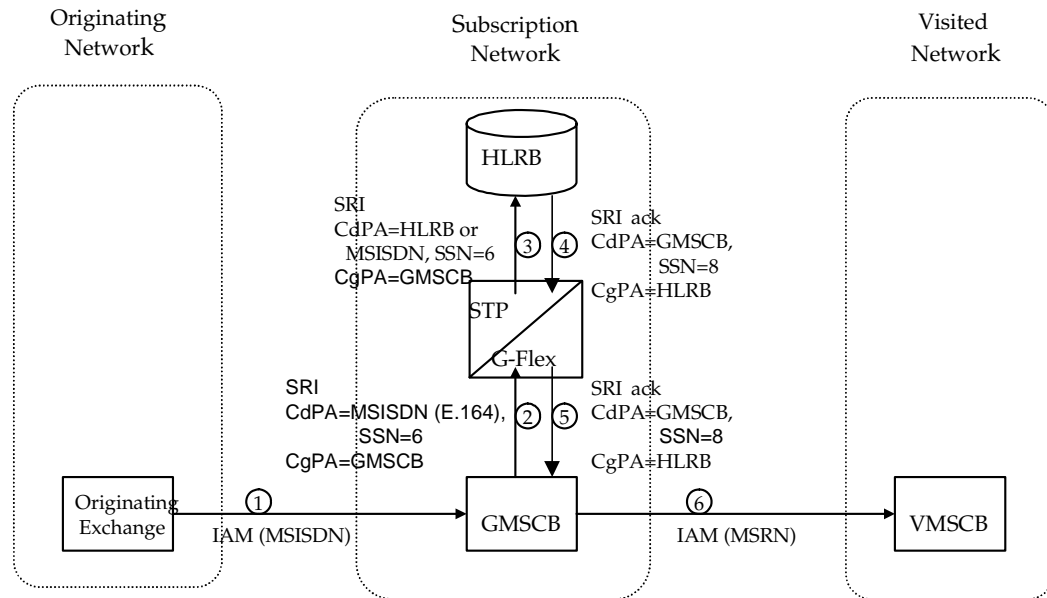

Other MAP messages that are routed using MSISDN/MIN/MDN global title routing to an HLR are handled the same way by G-Flex. This includes mobile terminated short messages, for example.

Subscriber Data Provisioning

Figure 2-3 shows the current high-level view of the subscriber data provisioning architecture that will be used for G-Flex. Only those parts of the EAGLE 5 ISS platform that are relevant to subscriber data provisioning are shown. This section defines requirements for the PDBI (Provisioning Database Interface) between the G-Flex C7 Relay and the operator's provisioning system (OPS). The PDBI is used only for real-time provisioning of subscriber and network entity data. Refer to the *PDBI Manual* for more details about the G-Flex PDBI.

Figure 2-3. Subscriber Data Provisioning Architecture (High Level)

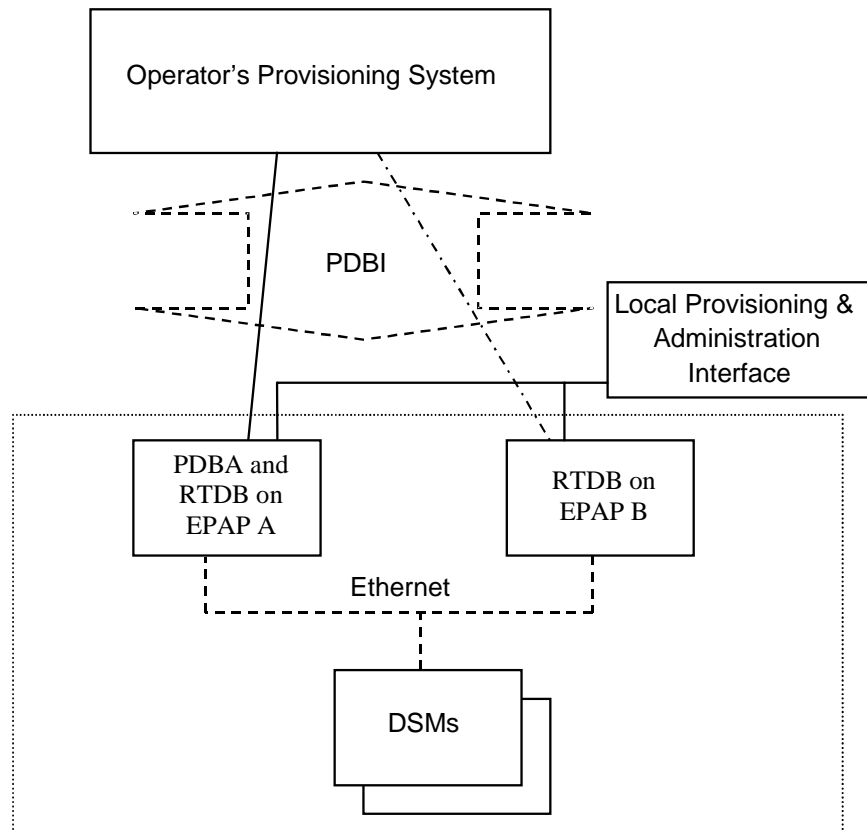

A pair of active/standby EPAP (EAGLE Provisioning Application Processors) servers provides the interface between the Realtime Database (RTDB) of the EAGLE 5 ISS DSMs (Database Service Modules) and the OPS. EPAP A is equipped with both the PDB (Provisioning Database) and the RTDB database, and EPAP B has just the RTDB. An EPAP with just the RTDB must be updated by the EPAP that has the PDB. The EPAP uses the Multi-Purpose Server (MPS) hardware.

For more information about the EPAP, refer to the *EPAP Administration Manual*. For more information about the MPS hardware, refer to the *Hardware Manual - Tekelec 1000 Application Server*.

DigitAction Expansion

The DigitAction Expansion provides more flexibility to formulate the SCCP Called Party Address (SCCP) Global Title Address (GTA) field of the MAP messages relayed by G-Flex.

Without DigitAction Expansion, G-Flex supports four options (none, insert, prefix, and replace) to overwrite the SCCP CdPA GTA field. With DigitAction Expansion, four additional options (delcc, delccprefix, spare1, and spare2) are included to overwrite the SCCP CdPA GTA field.

The rules for formatting the SCCP CdPA GTA field are based on the value specified in the DigitAction field. If DigitAction = none, the EAGLE 5 ISS does not overwrite the SCCP CdPA GTA. For all other values, the EAGLE 5 ISS formats the SCCP CdPA GTA according to the value assigned to DigitAction. Refer to Table 2-1 for examples of DigitAction Expansion on the SCCP CdPA GTA of an outgoing message when the Entity ID = 1404 and the default country code = 886..

Table 2-1. DigitAction Applications

DigitAction	Value in Incoming CdPA GTA	Value in Outgoing CdPA GTA	Meaning
none	886944000213	886944000213	No change to the Called Party GTA (default)
prefix	886944000213	1404886944000213	Prefix Called Party GTA with the entity id
replace	886944000213	1404	Replace Called Party GTA with the entity id
insert	886944000213	8861404944000213	Insert entity id after country code. (CC + Entity Id + NDC + SN)
delccprefix	886944000213	1404944000213	Delete country code and add prefix
delcc	886944000213	944000213	Delete country code
spare1	886944000213	treated as none	No change to the Called Party GTA (default)
spare2	886944000213	treated as none	No change to the Called Party GTA (default)

DigitAction Expansion is provisioned via the PDBI Enter Network Entity or Update Network Entity commands. DigitAction Expansion can also be modified via the Add an NE and Update an NE GUI screens.

G-Flex SCCP Service Re-Route Capability

This feature is used when the G-Flex database is incoherent with MPS data and the GTT data is valid. G-Flex SCCP Service Re-Route provides the capability to re-route the traffic from the EAGLE 5 ISS to other G-Flex database nodes and inform the originating nodes to re-route the G-Flex service related traffic to other G-Flex service nodes.

This feature is designed to handle and control re-routing of G-Flex traffic from an affected node to alternate nodes within an operators network. This feature is an optional feature and doesn't affect the normal G-Flex functionality. This feature also provides the option to mark G-Flex *OFFLINE* to perform a controlled re-routing during this state.

Feature Description

EPAP Provisioning Blacklist

This feature provides checks to prevent the inadvertent provisioning of protected address strings into the EPAP database. If a protected address string is provisioned into the PDB as a DN, DN Block or IMSI, the EAGLE 5 ISS may incorrectly route messages. This feature allows the user to define a list of prohibited address strings that are not allowed as DN, DN Block, or IMSI address strings. The E.164 addresses of all HLRs should be provisioned in the provisioning blacklist.

EPAP (EAGLE Provisioning Application Processor)

As shown in Figure 2-4, the G-Flex system contains two EPAP (EAGLE Provisioning Application Processors) servers. At any given time, only one actively communicates with the DSM (Database Service Module) boards. The other EPAP server is in standby mode.

Figure 2-4. MPS/EPAP Platforms for Provisioning G-Flex

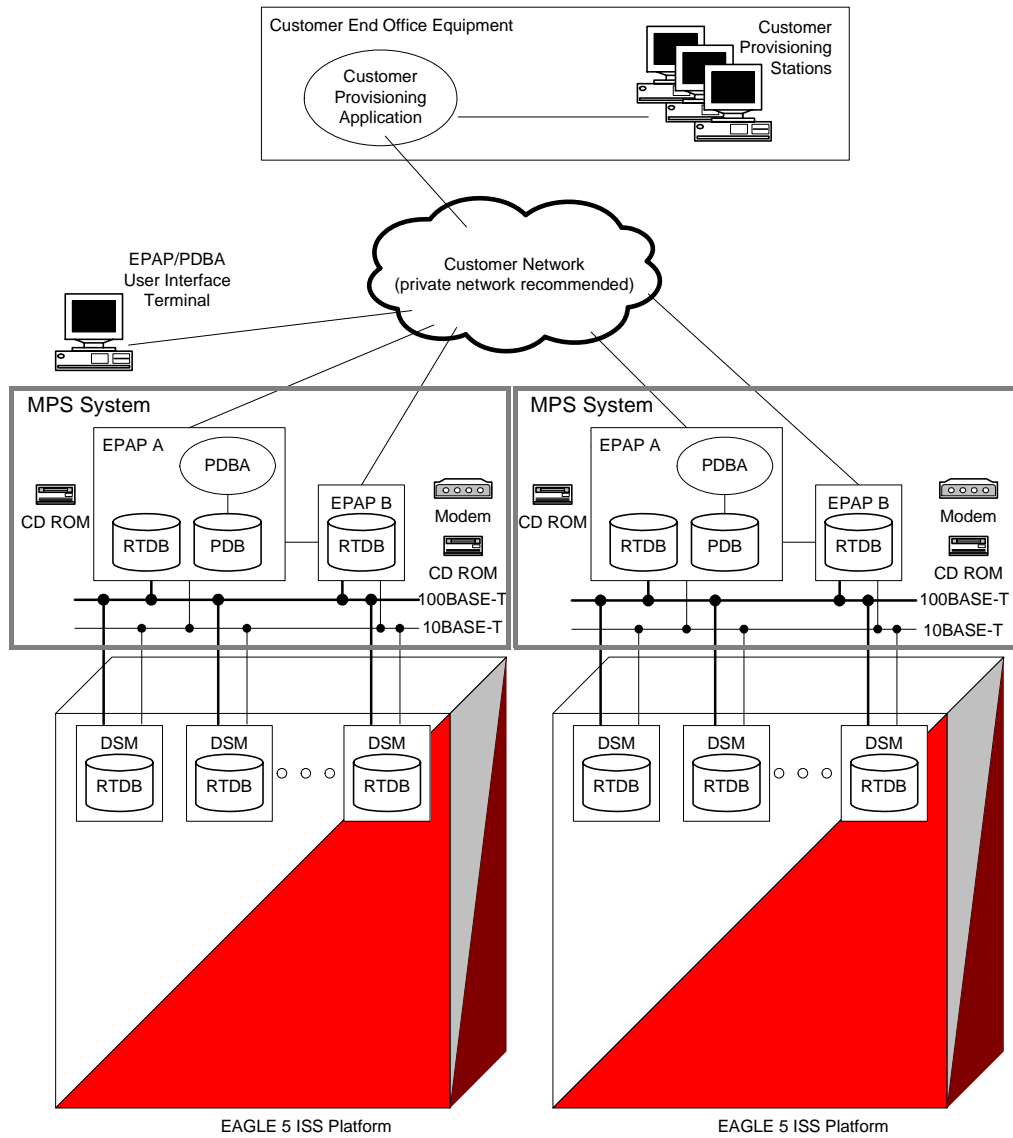

The primary purpose of the EPAP systems is to maintain the RTDB and PDB and to download copies of the RTDB to the DSM cards on the EAGLE 5 ISS.

The EPAP receives G-Flex data from the customer network through the PDBI, the external source of G-Flex provisioning information. The PDBI continually updates the active EPAP's PDB. (The PDB uses Versant database software.) Once an update is applied to the active PDB, it is sent to the RTDBs on the active and standby EPAPs.

Feature Description

Both the active and standby EPAPs maintain copies of the RTDB. Periodically, the DSM card polls the active EPAP RTDB for any new updates. The active EPAP downloads the updates to the DSM for its own resident copy of the RTDB database.

In a mated pair configuration, there are mated EPAP servers that provide two G-Flex platforms, as shown in Figure 2-4. The PDB on the active EPAP automatically updates the PDB on the mate platform. The PDB on the mate platform then updates its RTDBs.

As the OPS submits G-Flex provisioning requests, the EPAP updates the PDB and both copies of the RTDB. The EPAP maintains a file of database updates to be sent to the DSMs. This file contains the changes necessary to keep the DSMs copies up-to-date relative to the EPAP database, as shown in Figure 2-5.

Figure 2-5. Administrative Architecture

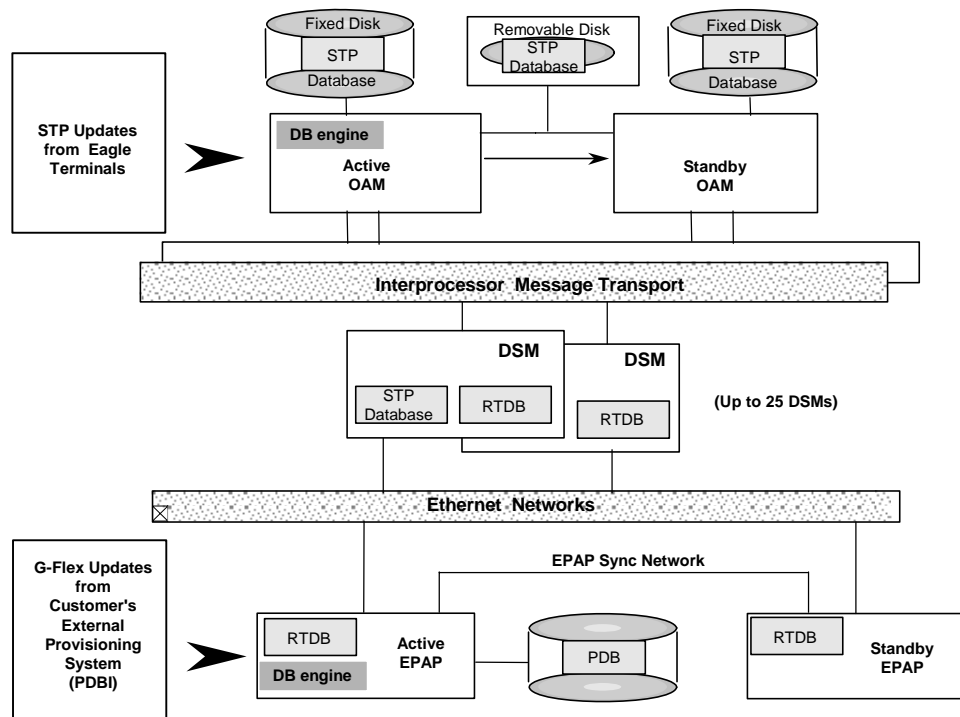

DSM (Database Service Module) Cards

The G-Flex feature can provision from 1 to 25 DSM cards. DSM cards have an AMD K-6 processor, from 1 to 4 GB of memory on an applique board, and two Ethernet ports. Figure 2-4 indicates each DSM card with two Ethernet links, the main DSM network on the 100BASE-T link and the backup DSM network on the 10BASE-T link.

The DSMs run a version of the SCCP software application that has been ported to the VxWorks OS. The DSM version is named 'VSCCP'. The extra memory holds a copy of the RTDB. The DSM Ethernet ports are linked to the EPAP systems to receive the downloaded RTDBs.

Multiple DSMs provide a means of load balancing in high-traffic situations. The DSM database is in a format that facilitates rapid lookups. Each DSM contains an identical database. Furthermore, all DSM G-Flex databases are identical to the RTDB maintained by the EPAPs.

However, the various databases may not be identical at all times for several reasons. First of all, when a DSM card is initialized, it downloads the current copy of the database from the EPAP. While that card is being downloaded, it cannot provide VSCCP services. Another condition that can result in databases being out-of-sync occurs when the EPAP receives updates from its provisioning source, but it has not yet sent them down to the DSM cards. Updates are applied to the provisioning database as they are received.

Two possible scenarios contribute to a condition where a DSM may not have enough memory to hold the entire database. In the first case, the database is downloaded successfully to the DSM, but subsequent updates eventually increase the size of the database beyond the capacity of the DSM memory. In this situation, it is desirable to continue processing G-Flex transactions, even though the database may not be as up-to-date as it could be.

The other case occurs when a DSM card is booted. If it is determined then that the card does not have enough memory for the entire database, the database is not loaded on that card. Each DSM is responsible for recognizing and reporting its out-of-memory conditions by means of alarms.

Overview of EPAP to DSM Communications

Before discussing DSM status reporting or EPAP status reporting, it is helpful to understand the communications between the DSMs and the EPAP in broad terms.

- UDP - sending DSM status messages

The DSMs and EPAPs create a UDP (User Datagram Protocol) socket, which is used for status messages. One of the last things a DSM does when it is initialized is to send a status message to the EPAP, containing the DSM ID, database level, and memory size. The EPAP maintains tables containing the last known status of each DSM. EPAP uses these to determine whether or not the DSM needs to download the database.

- IP - reporting EPAP maintenance data

The DSMs create an TCP/IP socket when they are initialized, and listen for connection requests. During initialization or after a loss of connectivity, the active EPAP chooses one of the DSMs and issues a *Connect* to establish the TCP/IP

Feature Description

connection with that DSM (referred to as the primary DSM). The purpose of this link is to provide a path for reporting EPAP alarms and to forward maintenance blocks to the DSM.

- IP Multicast - downloading GSM database

Because of the large size of the database and the need to download it quickly on up to 25 DSM cards, G-Flex uses a technique known as IP multicasting. This technique is based on Reliable Multicast Transport Protocol-II (RMTP-II), a product of Globalcast Communications. IP multicasting downloads the RTDB and database updates to the DSMs.

The administration of IP multicasting is based on the concept of a “tree”, or stream of data, which is constantly being broadcast by the EPAP. DSMs that need to download the real time database or to receive database updates “join the tree”. DSMs can also “leave the tree”, typically when the database fills their available memory.

Incremental Downloading

To take maximum advantage of the IP multicasting, a technique has been developed to download the RTDB database to the DSMs. In essence, this technique treats the file as a series of records. The file is sent starting with the first record and continuing sequentially until the last record has been sent.

Once a download is in progress, it is possible for another DSM to determine that it also needs to download the file. The new DSM can “jump in” and join the download in progress and begin its download with whatever record is currently being sent. When the last record in the file has been sent, the EPAP restarts the download from the beginning. The EPAP then sends the records that the new DSM needs to complete its database.

EPAP Status and Error Reporting via Maintenance Blocks

The EPAPs forward all status and error messages to the DSMs in maintenance blocks. Maintenance blocks are asynchronously sent whenever the EPAP has something to report. The maintenance blocks eventually update EPAP DCBs located on the EAGLE 5 ISS.

Network Connections

Several customer- and Tekelec-installed private networks are required to support the G-Flex feature. These networks are:

- Customer provisioning network
- EPAP sync network
- DSM networks
- Dial-up network

The following discussion is an overview of these private networks. It expands on the networks in the G-Flex architecture diagram shown in Figure 2-4, on page 2-10. (For details about configuring these networks, refer to the *EPAP User Interface Manual*.)

Customer Provisioning Network

The customer network carries the following traffic:

- Customer queries and responses to the PDB via the PDBI from the customer provisioning network
- Updates between PDBs if a mated EAGLE 5 ISS pair
- Updates between a PDB on one EAGLE 5 ISS and RTDBs on a mated EAGLE 5 ISS
- RTDB reload traffic if the active PDBA is not collocated on the same EPAP
- PDBA import/export (file transfer) traffic
- Traffic from a PDBA reloading from its mate
- EPAP and PDBA user interface traffic.

A typical customer network is shown in Figure 2-6.

Although a dedicated network is recommended, it is possible that unrelated customer traffic can use the network as well. The determination you make, either to have a dedicated network or to allow other customer traffic, should be based on available external Ethernet bandwidth and network performance considerations.

EPAP Sync Network

The EPAP sync network carries RTDB and maintenance application traffic between active and standby EPAP servers on an EPAP system. It synchronizes the contents of the RTDBs of both EPAP A and B. The EPAP network is a single Ethernet cable between EPAP A and EPAP B running at 100BASE-T, as shown in Figure 2-7.

Figure 2-6. Customer Provisioning Network

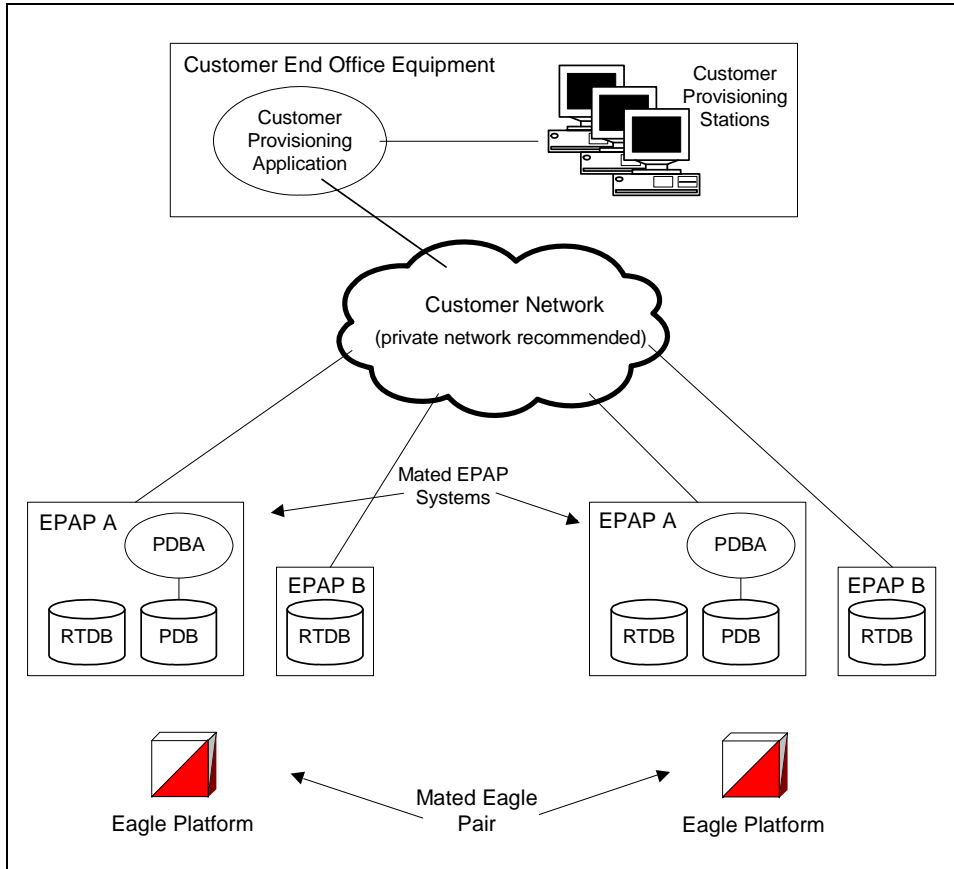
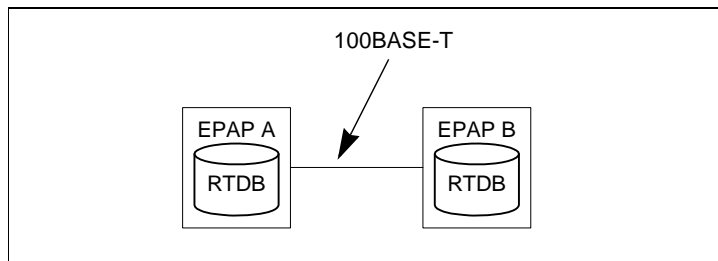

Figure 2-7. EPAP Sync Network



DSM Networks

The DSM networks are shown in Figure 2-8. They carry provisioning data from the Real Time Data Bases (RTDBs) from the active EPAP to the DSM cards. They also carry reload and maintenance traffic to the DSMs.

The DSM networks consist of two Ethernet networks, which are the main DSM network running at 100BASE-T and the backup DSM network running at 10BASE-T. Both Ethernet networks connect EPAP A and EPAP B with every DSM card on a single EAGLE 5 ISS platform.

Figure 2-8. DSM Networks

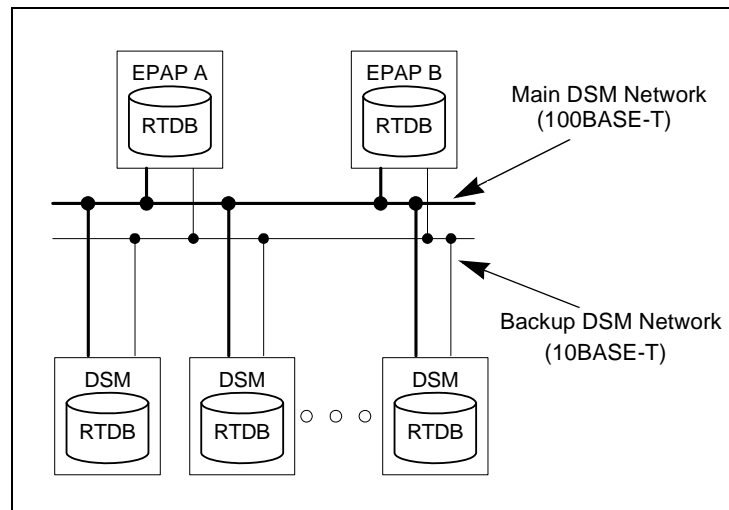

Maintenance information is sent from the active EPAP to an arbitrarily selected DSM card. The selected DSM is known as the primary DSM. Static information is exchanged across this interface at initialization, and dynamic information is exchanged on occasion.

While much of the traditional OAM provisioning and database functionality is implemented on the EPAP, the maintenance reporting mechanism is still the OAM.

The first and second octets of the EPAP network addresses for this network are 192.168. (The first two octets for private class C networks are defined in RFC 1597.)

The third octet is a customer specifiable for each DSM network. Be sure to select values that do not interfere with the customer's network addressing scheme.

The fourth octet of the address is specified as follows:

- If the EPAP is configured as "EPAP A", the fourth octet has a value of 100.
- If the EPAP is configured as "EPAP B", the fourth octet has a value of 200.

Feature Description

Table 2-2 summarizes the contents of each octet.

Table 2-2. EPAP IP Addresses in the DSM Network

Octet	Value
1	'192'
2	'168'
3	One customer-provisioned value for DSM network A, and another for DSM network B
4	'100' for EPAP A '200' for EPAP B

Dial-Up PPP Network

The dial-up PPP network, which is not illustrated in Figure 2-1 on page 2-5, allows multiple user interface sessions to be established with the EPAP. The network connects a remote EPAP/PDBA user interface terminal with the EPAP in the EAGLE 5 ISS's MPS subsystem. The dial-up PPP network is illustrated in Figure 2-9.

Figure 2-9. Dial-up PPP Network

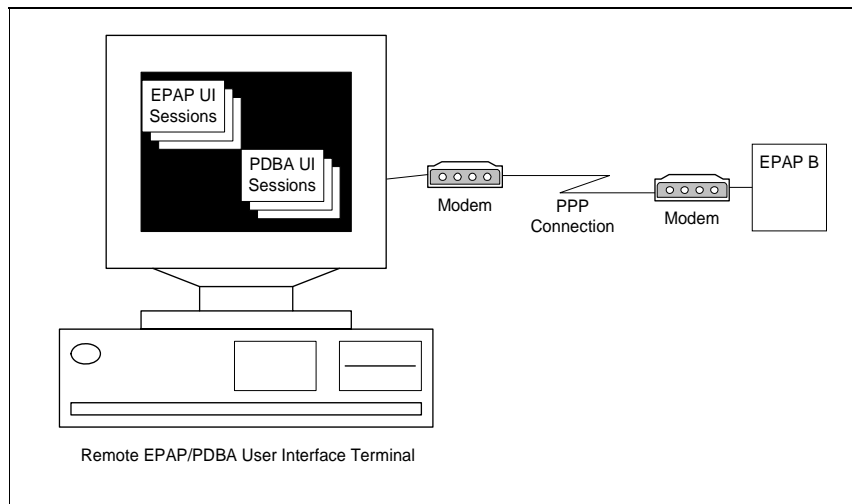

Network Perspectives

The EAGLE 5 ISS solution for G-Flex can be deployed in the network in two ways:

- as an integrated EAGLE 5 ISS/G-Flex node
- As a stand-alone EAGLE 5 ISS G-Flex relay function

Integrated EAGLE 5 ISS/G-Flex Node

Figure 2-10 shows the location of the Integrated EAGLE 5 ISS/G-Flex in a mobile network. This uses the Integrated EAGLE 5 ISS/G-Flex relay function solution to do HLR translations along with final GTT and routing functions.

Figure 2-10. Location of an Integrated EAGLE 5 ISS/G-Flex Node in Wireless Network

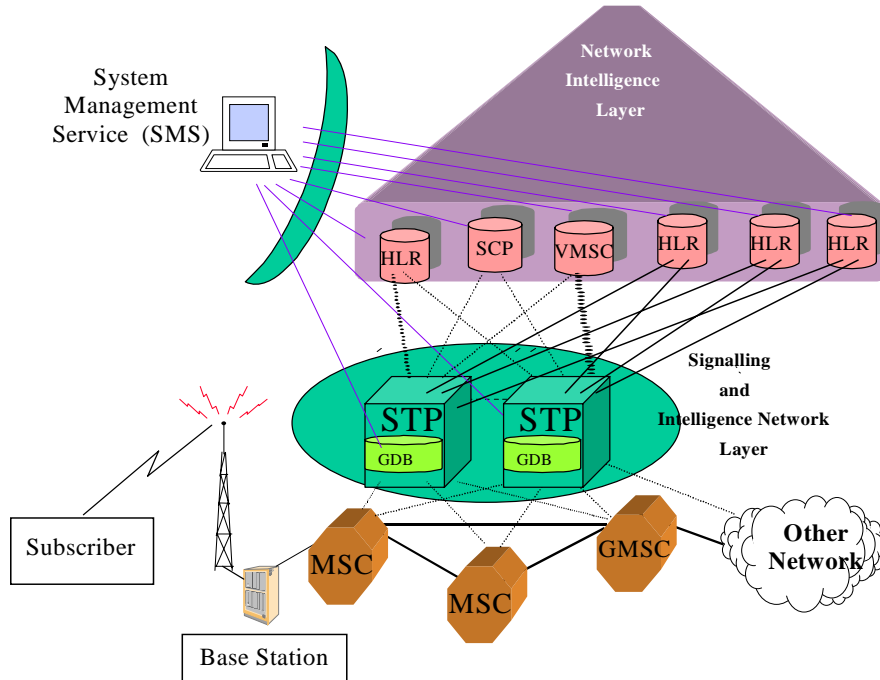

Stand-Alone EAGLE 5 ISS G-Flex Relay Function

Figure 2-11 shows the location of G-Flex in a wireless network. This performs only the G-Flex relay function, while the EAGLE 5 ISS performs the STP functions. One advantage of such a setup is that the impact on the network due to the introduction of this new node is minimal. The originating nodes continue to route messages to the same EAGLE 5 ISS. The existing EAGLE 5 ISS forwards only HLR-destined (or AuC-destined messages if the HLR is integrated) to the G-Flex relay function based on the DN and IMSI/MGT number ranges. All HLR-provisioned subscriber numbers must be provisioned in the GDB (G-Flex database) before the G-Flex relay function is brought into service.

Once in service, the G-Flex relay function performs the HLR translations on incoming messages and then either MTP routes the message through the EAGLE 5 ISS directly to the end node or forwards the translated message back to the EAGLE 5 ISS. If the EAGLE 5 ISS is capable of broadcasting SCCP subsystem management messages (that is, SSPs and SSAs) to the G-Flex node, then G-Flex could directly route the messages to the HLR entity numbers. It could then

Feature Description

forward the message to the EAGLE 5 ISS so that the forwarded messages could be easily translated to derive a HLR address. Note that the GTT (global title translation) data must be carefully set up to prevent looping between EAGLE 5 ISS and the G-Flex node.

Figure 2-11. Location of a G-Flex Node in Wireless Network

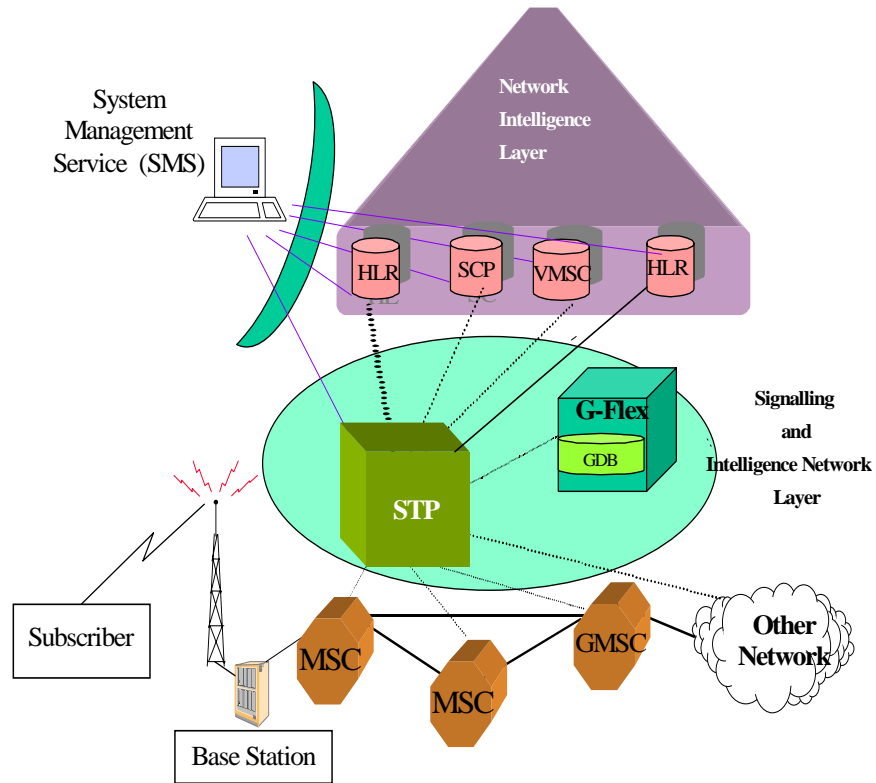

Serviceability Hints

Mated Application Considerations

An EPAP-administered entity data can possibly become out-of-sync with the EAGLE 5 ISS mated application table because the creation of entity point codes (and/or subsystem numbers) in the mated application table is not performed at database administration time.

If this mismatch is discovered at real time, a UIM message (such as "SCCP did not route - DPC not in MAP tbl" or "SCCP did not route - SS not in MAP tbl") is sent to the EAGLE 5 ISS maintenance terminal. This message means the MSU was discarded.

For this reason, it is recommended that the entity (SP or RN) not be administered until the entity PC (and/or SSN) has been entered into the EAGLE 5 ISS mated application (MAP) table.

Entity Point Codes and Routes

Verification that an entity point code exists in the route table and has a route is not performed at database administration time. Therefore, it is possible for the EPAP entity data to be out-of-sync with the EAGLE 5 ISS route table.

If an out-of-sync condition is discovered at real time, a UIM is sent to the EAGLE 5 ISS maintenance terminal, indicating one of these conditions:

- Destination point code is not in the route table.
- Destination point code exists in the route table but is not assigned a route.
- Destination point code exists in the route table and has been assigned a route, but it is out of service.

Commands

This section lists the maintenance and measurements user interface commands for the G-Flex feature. These commands allow provisioning, operations, and maintenance activities for DSM cards. For details, refer to Chapter 3, *Maintenance and Measurements Commands*, page 3-10.

Commands listed here include:

- rept-stat-sys
- rept-stat-sccp
- rept-stat-mps
- rept-meas
- rept-stat-trbl
- rept-stat-alm
- rept-stat-db
- inh-card / alw-card
- ent-card / rtrv-card / dlt-card
- chg-gpl / act-gpl / rtrv-gpl / rept-stat-gpl / copy-gpl
- ent-bp / dlt-bp / disp-bp / disp-mem / set-mem
- inh-alm / unhb-alm

Feature Description

- pass, including the following commands:
 - pass:cmd='ping'
 - pass:cmd='netstat'
 - pass:cmd='nslookup'
 - pass:cmd='arp'
 - pass:cmd='help'

The complete functionality of the commands is described in detail in the *Commands Manual*. That document also provides the actual parameter names, valid values, and output for the commands.

Database Overview

This section describes, at a high level, the distributed administrative architecture for the EAGLE 5 ISS, which includes the G-Flex administrative solution.

In general, EAGLE 5 ISS database updates are sent via an EAGLE 5 ISS terminal across an RS232 serial port to the active OAM (Operation Administration and Maintenance). The active OAM commits the update to TDM fixed disk and then sends the update control information to the standby OAM and to the rest of the network cards. When all databases are updated, the active OAM responds with a *Command Completed* indication to the user terminal. EAGLE 5 ISS database updates are generally considered to be EAGLE 5 ISS link, linkset, route, destination, mated application, gateway screening, and global title types of information.

Typically, large databases requiring much faster update and retrieval rates (compared to the rates provided by the OAM) are not administered via EAGLE 5 ISS terminals. These databases, such as G-Flex, are populated using redundant Ethernet connections to DSM cards from an EPAP MPS platform.

An EPAP consists of a combined Provisioning (Versant) and RTDB database. The Provisioning Database responds to requests for updates by the active and standby RTDB databases on both mated EAGLE 5 ISSs. The active EPAP RTDB database process is responsible for initiating multicast updates of changed database records to the DSM cards after the data has been committed to the EPAP disks. Furthermore, the Provisioning database may accept and commit more database updates while the RTDB databases are completing their previous updates.

It is this overlapping of database updates, coupled with an RTDB transactional database engine and fast download time, that allows larger amounts of data at a time from the provisioning database. Committing larger amounts of data at a time to be committed in the RTDB (versus a single update at a time) allows faster overall transaction rates to be achieved. The boundaries of the transaction rates become more closely related to cache size and disk cache flush time than the disk access time of a single update. Thus, successful completion of EPAP database updates only guarantees that the provisioning database has been updated, but it does *not* mean the RTDB has completed the update and sent it to the DSM card yet.

The EPAP architecture contains a local provisioning terminal and a modem for remote access, as well as other functions. A backup device is made available to backup or restore the Provisioning database. The local provisioning terminal is used to manually repair the standby EPAP RTDB database or to turn the G-Flex database audit on or off. For additional information, refer to the *EPAP Administration Manual*.

Assumptions/Limitations

The following assumptions and limitations are present.

1. The EAGLE 5 ISS does not perform any conversion in the SCCP portion of the message to support message routing across the domain boundary (ANSI to ITU and visa versa).
2. The EAGLE 5 ISS supports message routing across network boundaries (ITU-N to ITU-I) and visa versa. However, GTT and/or enhanced GTT (EGTT) neither modify the National Indicator bit in the CdPA AI nor convert the CdPA PC (Point Code) to match the network type.
3. For messages with E.214 numbers in the SCCP CdPA, a simple conversion can form an E.212 number. The E.212 number formed in this way is the full IMSI of the subscriber, that is, it is assumed that no truncation occurs when the E.214 number is originally formed from the E.212 number. Such truncation is allowed by the E.214 recommendation.
4. This feature allows for up to eight MSISDN numbers per subscriber (that is, per IMSI) to be related. It is assumed that operators do not need to support more than eight MSISDN numbers per subscriber. (Expansion to eight MSISDN numbers is anticipated in the near future.)
5. No overload controls are required beyond the existing EAGLE 5 ISS lower level mechanisms (for example, for MTP congestion, etc.)

Feature Description

6. Using combinations of GTT selectors (GTI [Global Title Indicator], TT [Translation Type], NP [Number Portability], and NAI) as triggers for G-Flex processing plus SSN discrimination will provide the ability to limit G-Flex processing to only the messages for which it is appropriate.
7. G-Flex C7 Relay supports message routing to a single network node for a particular subscriber. For example, an individual subscriber cannot have some messages routed to his HLR and other messages routed to a separate AuC. In this example, G-Flex does not support the AuC being collocated with the HLR. The G-Flex design allows for expansion to include routing to multiple network elements (corresponding to multiple services) for the same subscriber.
8. For performance estimates, EAGLE 5 ISS-generated UDTs messages will count as two processed messages.

General Requirements

Numbering

1. Incoming called party numbers (from the SCCP portion) destined for G-Flex processing are conditioned to fit the GDB requirements where possible:
 - If the GTT selectors available in the incoming message match an entry in the G-Flex selector table, then the service numbering plan from the selector table entry uses that number's numbering plan. Further conditioning is applied based on this new numbering plan.
 - If the GTT selectors available in the incoming message match an entry in the G-Flex selector table, then the service nature of address from the selector table entry uses that number's nature of address. Further conditioning is applied based on this new nature of address.
 - If the nature of address is National (Significant), the default CC (country code for E.164 or E.214) or default MCC (for E.212) is prepended to the number for GDB look up. The default code to be used by the EAGLE 5 ISS must be previously provisioned by the EAGLE 5 ISS operator. If not, a UIM (Unsolicited Information Message) is issued, and the message falls through to GTT.
 - If the nature of address is Subscriber, the default CC + default NC (network code for E.164 or E.214) or default MCC + default MNC (for E.212) are prepended to the number. The default codes to be used by the EAGLE 5 ISS must be previously provisioned by the EAGLE 5 ISS operator. If not, a UIM is issued, and the message falls through to GTT.

- If the numbering plan is E.214, the CC + NC part of the number is replaced with its corresponding MCC + MNC from the provisioned conversion data. If no matching CC + NC has been provisioned, a UIM is issued, and the message falls through to GTT.
- 2. Numbers with fewer than five digits after the above conditioning are not used for G-Flex. In this case, a UIM is issued, and the message falls through to GTT.
- 3. Numbers with more than 15 digits after the above conditioning are not used for G-Flex. In this case, a UIM is issued, and the message falls through to GTT.

Maintenance

Validation of G-Flex Hardware Configuration

DSM card loading has been modified to verify the validity of the hardware configuration for the DSM cards. Hardware verification includes the following.

- **DSM Main Board Verification**

An AMD-K6 (or better) main board is required to support the G-Flex VSCCP application on the DSM card. EAGLE 5 ISS maintenance stores the validity status of the VSCCP card's main board configuration.

NOTE: The system does not allow the G-Flex feature to be enabled if the hardware configuration is invalid.

When the VSCCP application is initializing, it determines the main board type. The SCCP maintenance block is the mechanism used to relay the main board information to OAM. This requires that the application software be loaded to the VSCCP card and then the main board information received in the SCCP maintenance block must be verified. If the main board is determined to be invalid for the G-Flex application, loading of the VSCCP card is automatically inhibited.

- **DSM Applique Memory Verification**

The VSCCP application performs two types of memory validation to determine whether or not a DSM has sufficient memory to run G-Flex:

- *Local Memory Validation.* When the G-Flex feature bit is first enabled, or any time the G-Flex feature is enabled and the DSM is initializing, VSCCP checks to see if the DSM has at least one D1G applique.

NOTE: The G-Flex feature bit cannot be enabled if any of the DSMs have less than 1 GB of memory installed.

Feature Description

- *Real-Time Memory Validation (during card initialization)*. Once communications between the DSM and EPAP have been established, and the DSM has joined the RMTP Tree, the EPAP starts downloading the RTDB to the DSM card. After the DSM card has downloaded the RTDB, it continues to receive database updates as necessary. The EPAP includes the size of the current RTDB in all records sent to the DSM. The DSM card compares the size required to the amount of memory installed, and issues a minor alarm once the database exceeds 80% of the DSM memory. If the database completely fills the DSM memory, a major alarm is issued, the DSM leaves the RMTP tree, and the DSM's status changes to IS-ANR/Restricted. The DSM continues to carry traffic.

- **Actions Taken When Hardware Determined to be Invalid**

When the hardware configuration for a DSM card is determined to be invalid for the G-Flex application, SCM automatically inhibits loading for that specific DSM card. A major alarm is generated indicating that card loading for that DSM card has failed and has been automatically inhibited (that is, prevented from reloading again). Refer to Chapter 5, *G-FLEX Related Alarms*, page 5-11, for the specific alarm that is generated. When card loading has been inhibited, the primary state of the card is set to `oos-mt-dsblld`, and the secondary state of the card is set to **MEA** (Mismatch of Equipment and Attributes).

The following actions apply to a DSM card determined to be invalid:

- The DSM will not download the EAGLE 5 ISS databases.
- The DSM will not download the real-time RTDB from the EPAP.
- The DSM will not accept RTDB updates (that is, add, change, delete) from the EPAP, nor will it accept EAGLE 5 ISS database updates.

- **Unstable Loading Mode**

At some point, having a number of invalid DSM cards results in some of the LIMs (Link Interface Module) being denied SCCP services. There is a threshold that needs to be monitored: if the number of valid DSMs is insufficient to provide service to at least 80% of the IS-NR LIMs, the system is said to be in an unstable loading mode. For other reasons why an EAGLE 5 ISS might be in an unstable loading mode, refer to Chapter 5, *Loading Mode Support*, page 5-6.

Maintenance Commands

The following commands are used for G-Flex maintenance.

- The debug command **ent-trace** traps G-Flex MSUs (Message Signaling Unit) based on the point code of the switch that generated the MSU (SSP), a particular DN, or IMSI. Note that a MSU is considered to be a G-Flex MSU after its CdPA SSN is determined to be a HLR SSN. For MSISDN and IMSI, the comparison is based on the search key built from the CdPA GTAI (Global Title Address Information) after any conditioning. The existing GT SCCP trigger also applies to G-Flex messages.
- The command **rept-stat-mps** reports current G-Flex statistics. A MSU is considered to be a G-Flex MSU after its CdPA SSN is determined to be a HLR SSN. This command reports G-Flex statistics on a single SCCP card basis or on a G-Flex system basis.

For more information, refer to Chapter 5, *Maintenance and Measurements*, page 5-1.

G-Flex Loading Mode Support

Loading mode support is not applicable for RTDB updates, since DSM cards use incremental loading from the EPAP. EAGLE 5 ISS Administrative updates are allowed while a DSM card is loading and the system is above the 80% card stability threshold. If it is below the 80% threshold, loading mode support allows EAGLE 5 ISS administrative updates to be rejected while cards finish loading and cross the 80% or better threshold.

For G-Flex, loading mode support is applicable for database updates originating from the EAGLE 5 ISS MCAP's (Maintenance and Administration Communication Application Processor card) destined for the DSM cards.

Audit Requirements

The G-Flex audit does not change EAGLE 5 ISS's compliance to STP audit requirements, to which it currently adheres. New G-Flex database tables residing on the EAGLE 5 ISS TDM fixed disks are audited by the existing EAGLE 5 ISS audit, which only verifies tables on the EAGLE 5 ISS active and standby TDMs. There are new audit mechanisms for new G-Flex tables residing on the EPAP platform that are downloaded to the DSM cards. The new audit mechanisms consist of the following.

- On each DSM card and on the standby EPAP, a background audit calculates checksums for each G-Flex RTDB table record and compares the calculated checksum against the checksum value stored in each record. If they are not the same, then a *database corrupt* alarm is issued.
- A process that runs periodically on the active EPAP (approximately every five seconds or less) sends the latest RTDB database level to all the DSM cards and the standby EPAP. If the database levels do not match, the standby EPAP or DSM card issues a *diff level* alarm.

Feature Description

For more information on the new audit mechanisms, refer to the EPAP Administration Manual.

DSM Provisioning and Reload

One of the core functions of the EPAP is to provision the DSM cards with the G-Flex database updates. In order to provide redundancy for this feature, separate RMTP channels are created on each interface from each EPAP:

- EPAP A, Link A (on the main DSM network, 100BASE-T)
- EPAP A, Link B (on the backup DSM network, 10BASE-T)
- EPAP B, Link A (on the main DSM network, 100BASE-T)
- EPAP B, Link B (on the backup DSM network, 10BASE-T)

Provisioning and other data is broadcast on one of these channels to all of the DSM cards. Provisioning is done by database level in order to leave DSM tables coherent between updates.

The DSM cards do the following:

- Detect the need for incremental updates and send a status message to the EPAP.
- Discriminate between the various streams by the database level contained in each message and accept updates according to the DSMs current database level.

DSM Reloading Model

EPAP Continuous Reload

It is important to understand how the EPAP handles reloading of multiple DSMs from different starting points. Reload begins when the first DSM requires it. Records are read sequentially from the real-time database from an arbitrary starting point, wrapping back to the beginning. If another DSM requires reloading at this time, it uses the existing record stream and notifies the DSM provisioning task of the first record it read. This continues until all DSMs are satisfied.

DSM Database Levels and Reloading

The current database level when the reload started is of special importance during reload. When a DSM detects that the last record has been received, it sends a status message back to the EPAP indicating the database level at the start of reload. This action starts incremental loading. The DSM continues to reload until it is completely caught up with the current level of the RTDB. As database records are sent to the DSMs during reload, normal provisioning can *change* those records. All records changed between the start and end of reloading must be incrementally loaded before the database is coherent and usable by the DSM.

The following terminology is used here for the stages of database reload for a given DSM.

- **Stage 1 loading:** The database is being copied record for record from the golden RTDB to the DSM RTDB. The database is incoherent during stage 1 loading.
- **Incremental update:** The database is receiving all of the updates missed during stage 1 loading or some other reason (e.g., network outage, processor limitation, lost communication, etc.). The database is coherent but back level during incremental update.
- **Current:** The database is receiving current updates from the DSM provisioning task.
- **Coherent:** The database is at a whole database level, that is, not currently updating records belonging to a database level.

DSM Reload Requirements

DSM cards may require a complete database reload if there is a reboot or loss of connectivity for a significant amount of time. The EPAP provides a mechanism to quickly load a number of DSM cards with the current database. The RTDB on the EPAP is large and can be updated constantly from the customer's provisioning network. As the RTDB is sent to the DSM cards, it can possibly miss some updates, making it inconsistent as well as back level.

The upload process is divided into two stages, one to sequentially send the initial database records and another to send any updates missed since the beginning of the first stage. The DSM reload stream uses a separate RMTP channel from the provisioning and incremental update streams. This allows DSM multicast hardware to filter out the high volume of reload traffic from DSM cards that do not require it.

DSM cards do the following:

- Detect the need for stage 1 loading and send a status message to the EPAP.
- Identify the first record DSM was able to read in the above status message if a record stream is already in progress.

Feature Description

- Handle the record stream regardless of the starting point (that is, records starting with the middle record of the middle table).
- Expect tables to be sent in a particular order and therefore detect any gap in the record stream.
- Send a status message if a gap is detected. Stage1 loading is essentially reset to the last update received.
- Handle wrapping from the last record from the last table to the first record of the first table.
- Know when they have received all the required records to proceed to stage 2 loading.
- Send a status message when stage 1 loading is complete, indicating the database level at the beginning of stage 1.
- Detect when the master RTDB crosses a memory boundary during stage 1 loading; the card automatically reboots and then auto-inhibits.

Provisioning Database Interface

Provisioning clients connect to the EPAPs via the Provisioning Database Interface (PDBI). This interface contains commands that allow all of the provisioning and retrieving of G-Flex data. For more information, refer to the *PDBI Manual*.

EPAP Provisioning Blacklist

This feature provides blacklist functionality for protected E.164 addresses of network elements, such as HLR's. All G-Flex provisioning data is checked against this blacklist to prevent inadvertent population of protected E.164 addresses into the G-Flex database as MSISDNs.

The G-Flex blacklist ranges are stored in the PDB database. G-Flex blacklist ranges are not sent to or stored in the RTDB.

The customer is responsible for determining the ranges of address strings that should be considered, protected, and entered into the blacklist. Reliability of this feature depends on the completeness of the blacklist.



CAUTION: If the G-Flex blacklist does not include all protected address strings in the customer network and one of those protected address strings is provisioned as a DN, DN Block, or IMSI, there will be unintended message routing, possibly causing network outages.

Provisioning of the E.164 addresses for this feature is only made via the EPAP GUI. The EPAP GUI is used to retrieve, view, and delete entries in the blacklist. EPAP GUI menus to add and delete G-Flex blacklist ranges are only accessible to PDBA group and the User Administration (uiadmin) user.

A maximum of 150 blacklist ranges are supported by the EPAP. A valid G-Flex blacklist range is defined by two address strings of 5-15 hexadecimal digits, where the ending address is greater than or equal to the beginning address. Address strings must be of the same length. G-Flex blacklist ranges cannot overlap. A valid G-Flex blacklist range cannot conflict with DN, DN block, or IMSI values in the PDB. If a conflict is determined, the blacklist range will be rejected.

When provisioning a valid G-Flex blacklist range, this feature also verifies that Network Entity address strings do not conflict with DN, DN Block or IMSI address strings within the same EPAP PDB.

This feature also verifies that Network Entity address strings do not conflict with DN, DN Block or IMSI address strings within the same EPAP PDB. The command is rejected if a conflict is found.

This feature also provides for PDBI checks against the blacklist ranges when the PDBI is used for the provisioning of DNs, DN blocks, and IMSIs. The command is rejected if a conflict is found.

This feature also provides for PDBI checks against the Network Entity table in memory when the PDBI is used for the provisioning of DNs, DN blocks, and IMSIs. The command is rejected if a conflict is found.

The provisioning of blacklist ranges do not cause PDB database levels to increment.

G-Flex Relay Function

G-Flex Relay Function (GFRF) is, in a way, an enhancement to GTT functionality. GFRF involves the following main enhancements to EAGLE 5 ISS's GTT.

- **Increased number of translations** – The GTT limit is 270,000 total translations. With GFRF, the number is millions. However, the GFRF translations are only from international MSISDNs and IMSIs to HLRs.
- **Number conditioning** – Since the GDB stores MSISDNs and IMSIs as international numbers and does not store MGTs, G-Flex provides the capability to condition incoming numbers to be international MSISDNs or IMSIs for the database look up.
- **Provides discrimination of messages that need its functionality** – Since G-Flex is currently only used for translating to HLRs, it provides a method to identify which messages should receive G-Flex Relay *vs.* GTT. This is provided via a G-Flex service selector table that defaults back to the GTT Selector table if a match is not found, and by providing SSN-based discrimination.

Feature Description

- **Variable number of digits** – There is no fixed number of digits for MSISDNs or IMSIs. For example, a 12-digit MSISDN can coexist with a 15-digit one. However, the number of digits of the stored numbers must be between 5 and 15.
- **Replacement of GT with entity address** – The ability to set the outgoing CdPA GT (NP, NAI, ES, GTAI) to the HLR's international entity number is provided.

Figure 2-12 shows the basic functional diagram for SCCP, with the new parts for G-Flex in bold.

Figure 2-12. Functional Diagram – G-Flex in SCCP

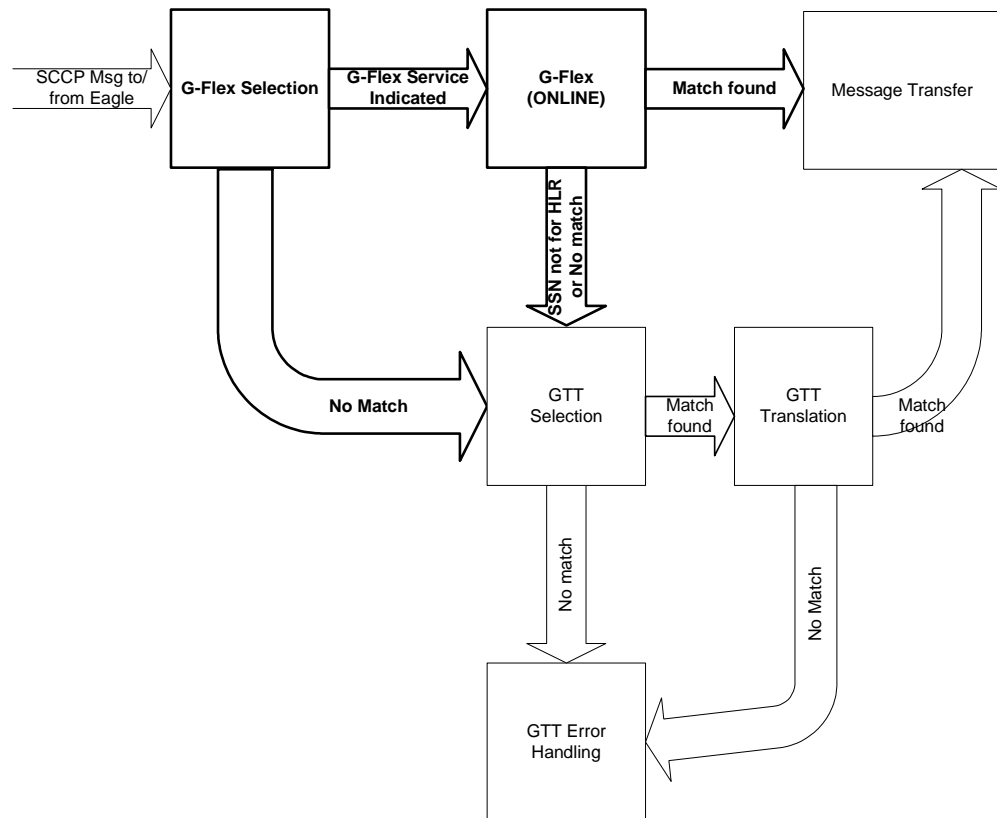

In order to keep the diagram simple, the only error conditions shown are the no-match cases for G-Flex and GTT selectors and translations. G-Flex has its own error handling for some cases that issues UIMs and peg measurements appropriately before letting the MSU fall through to GTT translation. Also, there are error conditions in GTT selection, GTT translation, and message transfer that are handled by GTT error handling.

G-Flex Relay is performed in the following stages.

1. The message arrives at EAGLE 5 ISS **route-on-gt**. The EAGLE 5 ISS decodes the SCCP portion and uses the data to perform G-Flex selection based on the CdPA GT fields other than the ES and GTAI. The result of this selection provides two pieces of data, identification of the **np** and **nai** for G-Flex and a G-Flex service indicator. The service indicator is G-Flex if GFRF is required. If a G-Flex selector does not match the incoming GT fields, then GTT selection is attempted. It is possible that G-Flex and GTT selectors will not match the incoming GT fields. In this case, GTT error handling is used.
2. If stage 1 indicates that G-Flex Relay is required and if the message is not a UDTS-generated by the EAGLE 5 ISS, the EAGLE 5 ISS performs SSN-based discrimination. If the G-Flex state is ONLINE then Step 3 is performed. Otherwise, G-Flex SCCP Service Re-Route is performed.
3. The conditioned number is looked up in the GDB.
4. If the number is found, the translation data for the number is used to alter and route the message.
5. If G-Flex Relay is not required, or the number is not found in the GDB, the set of GTT translations is used for translation.

Table 2-3 lists possible combinations for G-Flex selector and G-Flex data provisioning, and the resulting action of G-Flex relay.

Table 2-3. G-Flex Relay Data Combinations

G-Flex Selector Matches Incoming GT	Number in GDB	EAGLE 5 ISS Action
No	N/A	GTT used
Yes	No	Fall-through to GTT
Yes	Yes	G-Flex translation

GFRF is divided into the following subtasks. Each is described in the sections that follow.

- Conversion of national/local numbers to international numbers
- Conversion of E.214 MGT to E.212 international IMSI
- Database lookup
- Message forwarding
- Error handling

Conversion of National/Local Numbers to International Numbers

G-Flex stores international DNs and IMSIs in its database. SCCP CdPA numbers may need to be converted to international numbers in order to do a database lookup. When a message needs GFRF and has either a national (significant) number or *Subscriber Number* as the Service NAI, then the national/local to international number conversion is triggered. G-Flex uses the SCCP CdPA GTAI number and its SNAI to convert to an international number based on the numbering plan. Refer to Table 2-4.

Table 2-4. National/Local Numbers to International Numbers Conversion Logic

Service Numbering Plan	Service Nature of Address	Action
E.164	National (Significant) number	Prepend GTAI digits with the default E.164 country code (CC).
E.164	Subscriber number	Prepend GTAI digits with the default E.164 country code (CC) and network code (NC).
E.212	National (Significant) number	Prepend GTAI digits with the default mobile country code (MCC).
E.212	Subscriber number	Prepend GTAI digits with the default mobile country code (MCC) and mobile network code (MNC).
E.214	National (Significant) number	Prepend GTAI digits with the default E.164 country code (CC).
E.214	Subscriber number	Prepend GTAI digits with the default E.164 country code (CC) and network code (NC).
Other	N/A	Assume the default to be E.164 International number

Notes:

- If any of the default CC, NC, MCC, or MNC are required for conversion and are not provisioned in the database, GFRF issues a UIM and falls through to GTT.
- If the converted number is fewer than five digits, GFRF falls through and performs GTT on the message. GFRF issues a UIM when a converted number is fewer than five digits.
- If the converted number is more than 15 digits, then GFRF issues a UIM when the number exceeds 15 digits and falls through to GTT.
- GFRF uses the conditioned number for database lookup purposes only and does not modify the CdPA GTAI in the message unless **rcgta=yes** or **ccgt=yes**.

- For the G-Flex selector-specified service numbering plan (IMSI, DN, or MGT), the numbering plan in the incoming message is replaced with the G-Flex Selector service numbering plan (E.164, E.212, or E.214, respectively). This is for G-Flex database lookup purposes only.

Conversion of E.214 MGT to E.212 IMSI

Since the GDB does not store MGTs, the messages with E.214 MGT in the CdPA GTAI are converted to an E.212 International IMSI in order to perform the GDB lookup. G-Flex maintains a logical MGT2IMSI conversion table to perform this conversion. The MGT2IMSI conversion table contains up to ten entries of E.164 part (CC + NC digits) and its corresponding E.212 part (MCC + MNC). If a G-Flex message has E.214 as the CdPA numbering plan, GFRF performs the following steps to derive the E.212 International IMSI:

1. GFRF uses MGT as the key and does a lookup in the MGT2IMSI conversion table to find a match on E.164 part (CC + NC digits).
2. If a match is found, GFRF replaces the matched digits of the MGT with the corresponding E.212 part (MCC + MNC digits). If a match is not found, a UIM is issued and the GFRF falls through to GTT.
3. GFRF uses this complete E.212 International IMSI number to do the database lookup.

NOTE: If the IMSI for a particular country/network is the complete 15 digits and the E.164 CC + NC for that country is more than five digits, the MGT generated could contain a truncated MSIN. This is possible because the converted MGT is more than 15 digits and the maximum number of digits allowed in the MGT is 15 digits. (Refer to E.214 for more details on conversion.) Under these circumstances, the MGT is truncated at 15 digits. Therefore, the MGT-to-IMSI reconversion would not regenerate a complete IMSI and would lead to incorrect results and errors.

Database Lookup

GFRF performs the G-Flex database lookup using either the complete international DN or IMSI. If the DN or IMSI number is found in the database and it has a HLR translation, GFRF extracts the HLR translation data and generates a forwarding message. GFRF falls through and performs GTT for the following error cases:

- The DN number is not present in the database.
- The IMSI number is not present in the database.

The preceding error cases do not generate any UIM or UAM (Unsolicited Alarm Message), but fall through to GTT processing.

Feature Description

If the G-Flex database lookup is for GTI=2 and is an even number of digits ending in 0, then the G-Flex database performs a less than or equal to lookup for the odd number of digits (digit length minus 1). If a match is found, G-Flex saves the record and record index. It then tries to continue to find an exact match on the even number of digits. If the exact match is found in the G-Flex database, then the HLR translation data corresponding to the even number of digits record is used. Otherwise the HLR translation data corresponding to the found odd number of digits record is used. If the even and odd translation is not found, then the GFRF falls through and performs GTT.

The important issue is that the less than or equal to search re-enters the search where the comparison left off. This minimizes any impact on performance for this special case.

Message Forwarding

GFRF Forwarding Message: MTP Portion

G-Flex modifies the MTP routing label to include HLR PC as the DPC and EAGLE 5 ISS's own PC as the OPC. G-Flex modifies the MTP Level 2 length based on the size of the forwarding message. Table 2-5 lists the fields modified by GFRF.

Table 2-5. GREF Forwarding Message: MTP Portion

Fields	Values
MTP Level 2 length	Number of octets in response MSU starting from MTP3 SIO field. If number of octets is greater than 63, Level 2 length is set to 63
MTP Level3 DPC	Point code obtained from the HLR GT information in G-Flex database
MTP Level3 OPC	EAGLE 5 ISS's true PC

GFRF Forwarding Message: SCCP Portion

Replacing the CdPA GTAI digits with the HLR entity number. When a MSISDN or IMSI number is found in the database and the Replace GT flag is set for this entry, GFRF replaces the CdPA GTAI digits with the provisioned HLR entity number. G-Flex also modifies the numbering plan (E.164), nature of address (international), and encoding scheme to match the HLR entity number.

GFRF does not replace the Global Title Indicator format (GTI) element of the GT.

Replacing of SSN in the CdPA. When the HLR translation data includes a SSN, GFRF replaces the SSN in the called party address of the message with the new SSN. If the SSN is not present in the incoming message, then GFRF updates the Subsystem Number Indicator and includes the new SSN in the called party address of the message before it forwards the message to the next node.

Inclusion of OPC in the CgPA. When the routing indicator of the calling party address is set to *Route on SSN*, and no SPC is present in it, the OPC from the received message is taken and inserted into the CgPA before the message is forwarded to the next node.

Deleting the CdPA GT Digits

When G-Flex performs Final-GTT, the routing indicator of the called party address is set to **Route on SSN**. G-Flex provides an option to delete the global title present in the called party address. If the **Delete GT** option is set, G-Flex modifies the GTI to zero and deletes the GT information from the SCCP CdPA before the message is forwarded to the end node. Table 2-6 summarizes the possible changes by GFRF to the SCCP fields.

Table 2-6. GFRF Forwarding Message: SCCP Portion

Field	Value
SCCP CdPA Length	New CdPA length after the possible modifications
SCCP CdPA Routing indicator	Routing indicator obtained from the G-Flex database. (GT or DPCSSN)
SCCP CdPA Global Title Indicator	Same as incoming message or zero
SCCP CdPA Subsystem Number Indicator	Same as incoming message or replaced/inserted with the subsystem number indicator based on the existence of the SSN provisioned in the HLR translation
SCCP CdPA SSN	Same as incoming message or replaced/inserted with the SSN provisioned in the HLR translation
SCCP CdPA GT	Same as incoming message or replaced or deleted with HLR entity address provisioned in the database
SCCP CgPA Length	New CgPA length after the possible modifications
SCCP CgPA Point Code Indicator	Same as incoming message <i>or</i> if CgPA RI is "Route on SSN" and PCI is not 1, then set PCI to 1
SCCP CgPA SPC	If the CgPA RI is "Route on SSN" and no point code is present in the CgPA SPC, then the OCP is included as the SPC (Secondary Point Code)

Feature Description

Table 2-6. GFRF Forwarding Message: SCCP Portion (Continued)

Field	Value
SCCP CdPA Subsystem Number Indicator	Same as incoming message or replaced/inserted with the Subsystem Number indicator based on the existence of the SSN provisioned in the HLR translation

Error handling

The purpose of the Error handling is to discard or return messages that encounter routing and database failures and cannot be delivered to the HLR. When GFRF is unable to transfer a message and the return on error is *set*, then GFRF follows the same error handle procedures followed by GTT. The *data* field of the UDT message and the reason cause for return are included in UDTS message.

GFRF follows the same error handling procedures as GTT for the following error cases:

- Routing failures.
- Network Congestion.

Forwarding message after replace GT and/or Insertion of OPC or SSN is greater than the CCS7 message limit (272 bytes).

An exception to GTT error handling is when the GFRF database entry cannot be found. In this case, it is not considered an error and the GFRF capability will forward the message to GTT processing.

G-Flex SCCP Service Re-Route Capability

This feature is designed to handle and control re-routing of G-Flex traffic from an affected node to alternate nodes within an operators network. This feature is an optional feature and doesn't affect the normal G-Flex functionality. This feature consists to the following main functions:

- Service State
- G-Flex Re-routing
- G-Flex Capability Point Codes

Figure 2-13 shows the basic functional diagram for the G-Flex SCCP Service Re-Route feature, with the new parts for specific for this feature in bold.

Figure 2-13. Functional Diagram – G-Flex SCCP Service Re-Route (OFFLINE)

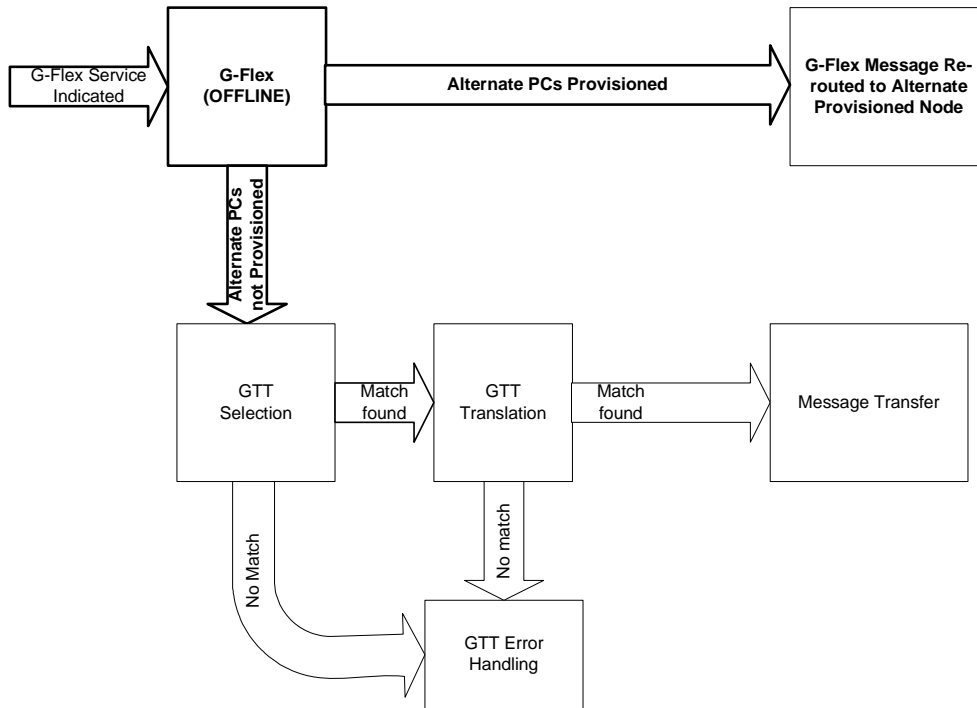

Service State

Service state is part of the G-Flex SCCP Service Re-Route capability. Service state is used to indicate the current state of G-Flex, either *ONLINE* or *OFFLINE*. Service state also gives the user the option to mark G-Flex as *OFFLINE* or *ONLINE* based on the current behavior. If a G-Flex problem is identified, G-Flex can be marked *OFFLINE* to initiate the re-routing procedure. In the case when SCCP cards need to be reloaded for some reason, G-Flex can be marked *OFFLINE* until enough cards are in-service and then bring G-Flex *ONLINE* in a controlled fashion. This feature also provides the option to mark G-Flex *OFFLINE* to perform a controlled re-routing during this state.

G-Flex Re-routing

G-Flex re-routing is an optional feature and is enabled by defining a list of alternate PCs or by defining the GTT option. G-Flex re-routing is activated by marking G-Flex *OFFLINE*. When G-Flex is *OFFLINE* and alternate PCs are provisioned, any messages destined for G-Flex are re-routed to the available alternate PCs that are defined for G-Flex. If alternate PCs are not provisioned or none are available, then the GTT option is used. If the GTT option is set to *YES*, then messages destined for G-Flex will fall through to GTT as part of the re-routing procedure.

Re-routing is applied to all G-Flex messages (based on *SRVSEL*). There is no distinction of *DPC* of the messages. The *DPC* of the message can be either *True*, *Secondary*, or *Capability Point* code.

G-Flex Capability Point Codes

Capability Point Codes (*CPC*) are also supported for G-Flex. The use of G-Flex capability point code aids the adjacent nodes in knowing about G-Flex outages. When G-Flex is brought down through administrative commands, all traffic destined to this G-Flex node will generate a *Transfer Prohibited (TFP)* message to the adjacent node about the G-Flex *CPC*. The *TFP* response to the adjacent node causes the traffic originating nodes to stop sending G-Flex traffic to this node. All G-Flex traffic coming into this node is sent to the alternate G-Flex nodes. Adjacent nodes will initiate *route-set-test* procedures after receipt of the *TFP* response.

If the messages are destined to the *EAGLE 5 ISS* true point code, then *TFP* messages are not generated when the G-Flex service is *OFFLINE*. The originator would not be aware of the outage.

Once G-Flex is back in service on the *EAGLE 5 ISS*, a *Transfer Allowed (TFA)* message is sent to the traffic originating adjacent nodes in response to *route-set-test* message. The traffic originating nodes will then start sending G-Flex traffic to the original G-Flex node.

G-Flex Capability point codes can be provisioned when the G-Flex feature is *ON*. There can be more than one *Capability Point Code* assigned to G-Flex *CPCType*.

When the G-Flex feature is turned *ON* and the G-Flex service state is set to *OFFLINE*, the user can change the service to *ONLINE* at any point. Once the feature is turned *ONLINE*, G-Flex will start processing messages if at least one *SCCP* card is *IS-NR*.

The G-Flex service can be set to *OFFLINE* at any point. This causes the *EAGLE 5 ISS* to stop processing G-Flex traffic and re-routing is performed.

The G-Flex service state is persistent. Booting the *OAM* or all the *SCCP* cards will not change the service state. Commands must be used to change the service state.

G-Flex supports up to 7 alternate PCs per domain. All 6 domains (ANSI, ITU-I, ITUN14, ITUN14 spare, ITU-I spare and ITUN24) are supported. An entire set of alternate PCs are considered as a re-route set. A GTT option is supported for G-Flex SCCP Service Re-Route. When the G-Flex service is *OFFLINE*, G-Flex messages fall through to GTT based on the GTT option. This option is set to *YES* by default.

G-Flex SCCP Service Re-Route Summary

If the G-Flex service is not normal (because the RTDB is not in sync with MPS or if cards are misrouting G-Flex messages) then the G-Flex service state should be changed to *OFFLINE*.

Before changing G-Flex service to *OFFLINE*, it should be decided what kind of re-routing will be used during the outage. The EAGLE 5 ISS supports re-routing data to alternate point codes or falling through to GTT as two possible options. Re-routing to alternate point codes has priority over falling through to GTT. Examples of the two options follow:

Option 1

Define alternate point codes to re-route G-Flex traffic. This is the recommended option. Up to 7 alternate G-Flex nodes can be provisioned to re-route all the incoming G-Flex traffic. Once provisioned, the G-Flex service can be changed to *OFFLINE*. This example has any incoming being G-Flex traffic being load-shared to point codes based on the relative cost.

```
chg-sccp-serv:serv=GFLEX:pci1=1-1-1:rc1=10:pci2=2-2-2:rc2=10:p
ci3=3-3-3:rc3=10:pci4=4-4-4:rc4=10

chg-sccp-serv:serv=GFLEX:pci1=5-5-5:rc1=10:pci2=6-6-6:rc2=10:p
ci3=7-7-7:rc3=10:pci4=8-8-8:rc4=10

chg-sccp-serv:serv=GFLEX:state=offline
```

Option 2

With this option default GTT translations are provisioned for G-Flex service. Then the **chg-sccp-serv** command is used to provision GTT=YES. All G-Flex messages will fall through to GTT. An example command follows:

```
chg-sccp-serv:serv=GFLEX:GTT=YES (it is YES by default)
```

Once the G-Flex re-routing data is provisioned, G-Flex service can be changed to *OFFLINE*. At this point all G-Flex traffic will be re-routed. The user can take necessary steps to correct the G-Flex service on the node. Until all the cards or enough cards are in active state with valid G-Flex database, G-Flex service should not be changed to *ONLINE*.

Table 2-7 shows the actions taken when the G-Flex service is offline, a message arrives at the affected node requiring G-Flex service, and SCCP cards are available.

Feature Description

Table 2-7. G-Flex SCCP Re-route Summary

Result of service selector	DPC	Alternate point code defined and available	GTT to be performed as fall through	Message Handling	Network Management
G-Flex	G-Flex Capability PC	Yes	N/A	Re-route to alternate point code based on relative cost	TFP concerning CPC
G-Flex	G-Flex Capability PC	No*	Yes	Fall through to GTT and perform GTT	TFP concerning CPC
G-Flex	G-Flex Capability PC	No*	No	Generate UDTS (return cause = network failure)	TFP concerning CPC
G-Flex	G-Flex Capability PC	Not Defined	Yes	Fall through to GTT and perform GTT	TFP concerning CPC
G-Flex	G-Flex Capability PC	Not Defined	No	Generate UDTS (return cause = no relation for this addr)	TFP concerning CPC
Not G-Flex	G-Flex Capability PC	N/A	N/A	Perform appropriate Service/GTT	None
G-Flex	True or Secondary PC or non-G-Flex CPC	Yes	N/A	Re-route to alternate point code based on relative cost	None
G-Flex	True or Secondary PC or non-G-Flex CPC	No*	No	Generate UDTS (return cause = network failure)	None
G-Flex	True or Secondary PC or non-G-Flex CPC	No*	Yes	Fall through to GTT and perform GTT	None
G-Flex	True or Secondary PC or non-G-Flex CPC	Not Defined	Yes	Fall through to GTT and perform GTT	None
G-Flex	True or Secondary PC or non-G-Flex CPC	Not Defined	No	Generate UDTS (return cause = no relation for this addr)	None
Not G-Flex	True or Secondary PC or non-G-Flex CPC	N/A	N/A	Perform appropriate Service/GTT	None

* Alternate point codes are defined and unavailable (prohibited or congested).

Table 2-8 shows the actions of LIM re-route functionality when SCCP cards are unavailable or down..

Table 2-8. G-Flex LIM Re-route Message Handling Summary

Routing Indicator in Incoming Message	DPC	Full or Partial Failure	G-Flex Service Status	Message Handling	Network Management
rt-on-gt	G-Flex Capability PC	Full	N/A	Generate UDTS	TFP concerning CPC, UPU
rt-on-gt	Non G-Flex Capability PC	Full	N/A	Generate UDTS	TFP concerning CPC, UPU
rt-on-gt	True PC	Full	N/A	Generate UDTS	UPU
rt-on-gt	G-Flex Capability PC	Partial*	ONLINE	Generate UDTS	None
rt-on-gt	True PC or non G-Flex Capability PC	Partial*	ONLINE	Generate UDTS	None
rt-on-gt	G-Flex CPC	Partial*	OFFLINE	Generate UDTS	TFP concerning CPC, UPU
rt-on-gt	True PC or non-G-Flex CPC	Partial*	OFFLINE	Generate UDTS	None

* It is considered a partial failure if some SCCP cards are available but overloaded.

EAGLE 5 ISS G-Flex Commands

Introduction.....	3-1
System Debug Services (SDS) Commands.....	3-1
Provisioning Hierarchy for the G-Flex Database	3-2
Maintenance and Measurements Commands	3-10

Introduction

This section describes the user interface and provides command examples needed to administer the G-Flex feature. The exact command syntax, specifications, and command classes are provided in the *Commands Manual*. The command examples are provided to convey the intention of the user interface requirements.

System Debug Services (SDS) Commands

The following section describes SDS command `ent-trace` used with G-Flex.

MSU Trap and Trace Command

The G-Flex Relay Function uses the existing `ent-trace` command functionality to provide a trap-and-trace feature for MSUs on the SCCP card. The G-Flex Relay Function introduces two new triggers so the user can trigger on DN and IMSI.

The user can create a MSU trigger on the SCCP card on any one or more of the criteria (both old and new) defined in the following using the `ent-trace` command. When multiple trigger criteria are entered, the MSU is trapped when any of the criteria are satisfied.



CAUTION: As with other debug commands, this command can cause OAM to reset if too many MSUs are trapped.

- **E.164 MSISDN number (MSISDN)** – Use this criterion to trap messages immediately before performing a G-Flex search based on the MSISDN numbers defined in the G-Flex database. This parameter allows a variable number of digits (from 5 to 15). The number specified must be an International E.164 number (MSISDN or Entity Number).
- **E.212 IMSI number (IMSI)** – Use this criterion to trap messages immediately before performing a G-Flex search based on the IMSI numbers defined in the G-Flex database. This parameter allows a variable number of digits (from 5 to 15). The number specified must be an international E.212 IMSI. This parameter cannot be used to trap on E.214 MGT.
- **Global Title digits (GT)** – Use this criterion to trap messages based on CdPA Global Title Address (that is, either E.164, E.214 MGT, or E.212 number) present in the SCCP part of the message.
- **SSP point code (MSC or VLR PC, for example)** – After the SSN has been determined to belong to a G-Flex entity object, use this criterion to trap messages based on CgPA (Calling Party Address) SPC present in the SCCP part of the message. If no point code is present in CgPA SPC, the criteria is matched with the OPC present in the MTP part of the message.

A trace must still be set on all SCCP cards (**card=sccp-a11**). Use a repetition parameter (**rep**) to control the number of MSUs that are trapped.

MSUs that satisfy any of the trigger criteria are trapped on the SCCP card, are forwarded to OAM, and are displayed. Refer to *Commands Manual* for a complete description of the **ent-trace** command.

Provisioning Hierarchy for the G-Flex Database

Part of the database is administered from the EPAP to the DSM cards, and part is administered from the EAGLE 5 ISS MCAPs to the DSM cards. In general, the EAGLE 5 ISS terminal interfaces use the **ent** commands to enter new data into the database, **chg** commands to change existing data in the database, and **dlc** commands to delete data in the database. The provisioning hierarchy in Figure 3-1 indicates where each subset of the G-Flex database is provisioned and stored.

Figure 3-1. Provisioning Hierarchy

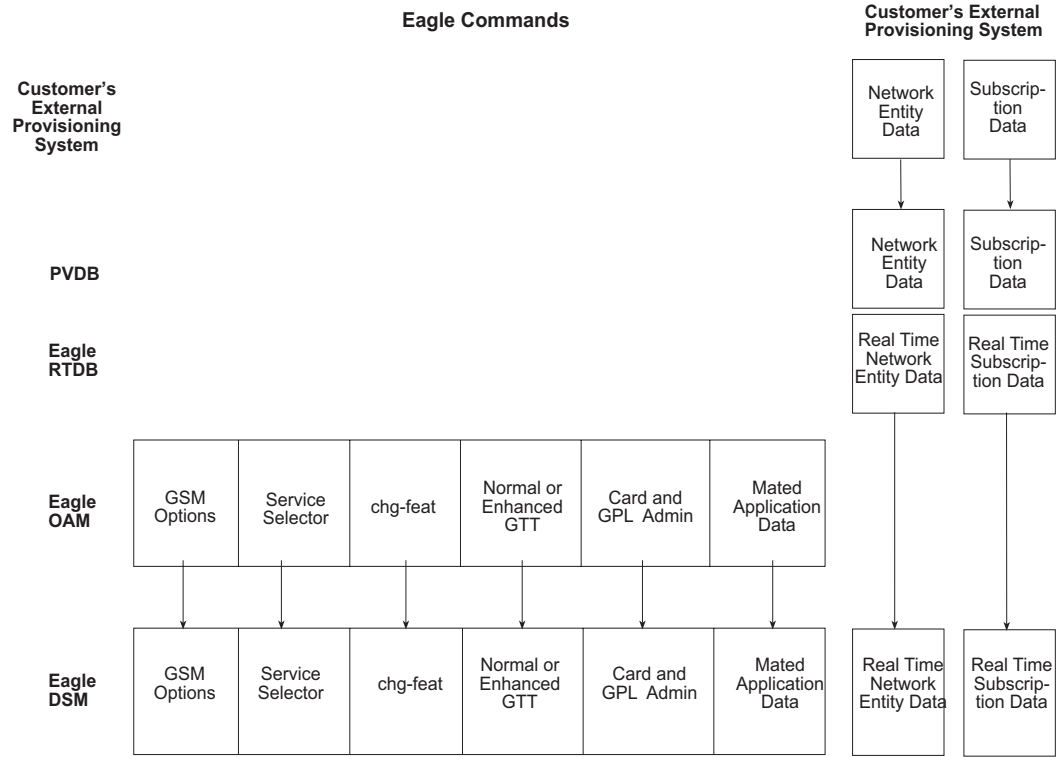

EAGLE 5 ISS Terminal Database Commands

EAGLE 5 ISS chg-feat Commands

The **chg-feat** command administers the G-Flex feature. It has two variations, each of which is described in the following: **chg-feat** and **rtrv-feat**. For further details on these commands, please refer to the *Commands Manual*.

- **chg-feat: Change Feature Status Command** – The **chg-feat** command activates optional features available for the system. Features can only be turned on. Once the feature is activated, it cannot be turned off. The **chg-feat** command turns on the G-Flex numbering capability and provides mutual exclusion between LNP and G-Flex. The GTT feature is a prerequisite for G-Flex. The **chg-feat** command also provides the processor, DRAM, and disk capacity validation required to support the G-Flex feature. This command updates the MAS configuration table. A command example follows.

```
chg-feat: gflex=on
gflex= {on,off}
```

EAGLE 5 ISS G-Flex Commands

Parameter	Optional/ Mandatory	Range	Description
PPSMSGTA	Optional	1-15 digits	Entity address of PPSMS Phase 1
PPSMSPCI1	Optional	zone, area, id, none	ITU PC of IN platform 1 for PPSMS Phase 1
PPSMSPCI2	Optional	zone, area, id, none	ITU PC of IN platform 2 for PPSMS Phase 1
PPSMSPCN1	Optional	nnnn, gc, m1, m2, m3, m4, none	ITU PC of IN platform 1 for PPSMS Phase 1
PPSMSPCN2	Optional	nnnn, gc, m1, m2, m3, m4, none	ITU PC of IN platform 2 for PPSMS Phase 1
PPSMSRI1	Optional	gt, ssn	RI of IN platform 1 for PPSMS Phase 1
PPSMSRI2	Optional	gt, ssn	RI of IN platform 2 for PPSMS Phase 1
SRIDN	Optional	tcap, sccp	SRIDN location

Command examples follow.

```
chg-gsmopts:defmcc=214:defmnc=34
chg-gsmopts:ccnc=33322123:mccmnc=21434
chg-gsmopts:ccnc=334:mccmnc=22435
chg-gsmopts:ccnc=334:mccmnc=none
```

- **rtrv-gsmopts: Retrieve G-Flex System Options Command** – The **rtrv-gsmopts** command retrieves all G-Flex-specific system options from the database.

The following G-Flex options are displayed.

```
rlghncxa03w 00-08-20 09:04:14 EST EAGLE 35.0.0

DEFMCC=214
DEFMNC=34
CCNC=33322123 MCCMNC=21434
```

;

EAGLE 5 ISS G-Flex Service Selector Commands

The G-Flex service selector (**srvsel**) commands are a new set of commands that provision new selectors for the G-Flex service, providing greater flexibility when provisioning the type of messages that require G-Flex processing. There are four variants, each of which is described in the following sections: **ent-srvsel**, **chg-srvsel**, **dlt-srvsel**, and **rtrv-srvsel**. For further details on the EAGLE 5 ISS G-Flex service selector commands (such as command rules and output format), refer to the *Commands Manual*.

- **ent-srvsel: Enter G-Flex Service Selectors Command** – The **ent-srvsel** command specifies that the applicable G-Flex service selectors indicating G-Flex processing is required. The available parameters follow:

Command : ent-srvsel

Class = DATABASE

Parameter	Optional/ Mandatory	Range	Description
GTI, GTIA, GTII, GTIN, GTIN24	Mandatory	1-4	Global Title Indicator
SERV	Mandatory	gport, gflex, inpq, inpmr	GSM service
SSN	Mandatory	0-255, *	Subsystem Number
TT	Mandatory	0-255	Translation Type
NAI	Optional	sub, rsvd, natl, intl	Nature Of Address Indicator
NAIV	Optional	0-127	NAI Value
NP	Optional	e164, generic, x121, f69, e210, e212, e214, private	Numbering Plan
NPV	Optional	0-15	Numbering Plan Value
SNAI	Optional	sub, natl, intl	Service Nature Of Address Indicator
SNP	Optional	e164, e212, e214	Service Numbering Plan

- **chg-srvsel: Change G-Flex Service Selector Command** – The **chg-srvsel** command specifies the applicable G-Flex selectors required to change an existing G-Flex selector entry. The available parameters follow:

Command : chg-srvsel

Class = DATABASE

Parameter	Optional/ Mandatory	Range	Description
GTI, GTIA, GTII, GTIN,GTIN24	Mandatory	1-4	Global Title Indicator
SSN	Mandatory	0-255, *	Subsystem Number
TT	Mandatory	0-255	Translation Type
NAI	Optional	sub, rsvd, natl, intl	Nature Of Address Indicator
NAIV	Optional	0-127	NAI Value
NP	Optional	e164, generic, x121, f69, e210, e212, e214, private	Numbering Plan
NPV	Optional	0-15	Numbering Plan Value
NSERV	Optional	gport, gflex, inpq, inpmr, smsmr, mmpsms, eir	New GSM service
NSNAI	Optional	sub, natl, intl, rnidn, none	New Service Nature Of Address Indicator
NSNP	Optional	e164, e212, e214, none	New Service Numbering Plan

- **dlt-srvsel: Delete G-Flex Service Selector Command** – The **dlt-srvsel** command deletes a G-Flex service selector. The available parameters follow:

EAGLE 5 ISS G-Flex Commands

Command : dlt-srvsel Class = DATABASE

Parameter	Optional/ Mandatory	Range	Description
GTI, GTIA, GTII, GTIN,GTIN24	Mandatory	1-4	Global Title Indicator
SSN	Mandatory	0-255, *	Subsystem Number
TT	Mandatory	0-255	Translation Type
NAI	Optional	sub, rsvd, natl, intl	Nature Of Address Indicator
NAIV	Optional	0-127	NAI Value
NP	Optional	e164, generic, x121, f69, e210, e212, e214, private	Numbering Plan
NPV	Optional	0-15	Numbering Plan Value

- rtrv-srvsel: Retrieve G-Flex Service Selector Command** – The **rtrv-srvsel** command displays a list of administered G-Flex service selector combinations. All output is sorted first by service, then by global title domain (ANSI first, followed by ITU), GTI, translation type, numbering plan, and by the nature of address indicator. The output can be filtered by specifying any optional parameter. The available parameters follow:

Command : rtrv-srvsel Class = DATABASE

Parameter	Optional/ Mandatory	Range	Description
GTI, GTIA, GTII, GTIN,GTIN24	Optional	1-4	Global Title Indicator
NAI	Optional	sub, rsvd, natl, intl	Nature Of Address Indicator
NAIV	Optional	0-127	NAI Value
NP	Optional	e164, generic, x121, f69, e210, e212, e214, private	Numbering Plan
NPV	Optional	0-15	Numbering Plan Value
SERV	Optional	gport, gflex, inpq, inpmr	GSM service
SNAI	Optional	sub, natl, intl, rnidn, rnnidn, rnsdn,ccrindn	Service Nature Of Address Indicator
SNP	Optional	e164, e212, e214	Service Numbering Plan
TT	Optional	0-255	Translation Type

EAGLE 5 ISS G-FLEX SCCP Service Commands

The **sccp-serv** commands allow for services to be taken ON and OFF line and their processing load to be shifted to other designated nodes. These commands also support the assignment of PCs to PC groups used for G-Flex SCCP Service Re-Route assignment. There are three variants, each of which is described in the following sections: **chg-sccp-serv**, **dlt-sccp-serv**, and **rtrv-sccp-serv**.

Entries (using the **chg-sccp-serv** command) are provisioned in the SCCP-SERV table, and are shown by the **rtrv-sccp-serv** command output. This reduces the maximum number of entries that the MRN table can contain by the number of entries shown in the **rtrv-sccp-serv** command output. For more information on provisioning MRN tables, refer to the *Database Administration Manual - Global Title Translations* manual.

For further details on the EAGLE 5 ISS G-Flex SCCP service commands (such as command rules and output format), refer to the *Commands Manual*.

- chg-sccp-serv: Change G-Flex SCCP Service Command** – The **chg-sccp-serv** command is used to add point codes to an existing service group, or to change the Relative Cost (RC) of existing point codes in a group. SCCP Service groups are organized by service (G-Flex or G-Port) and point code network type (ANSI, ITU-I, Spare ITU-I, ITU-N, Spare ITU-N, or ITUN-24). Up to seven PCs may be in a network type grouping for service re-route load sharing. This command allows for additions/modifications of up to 4 PCs at once. The point code parameters support the Spare Point Code subtype prefix **s-** for ITU-I and ITU-N point codes. The available parameters follow:

Command : **chg-sccp-serv** Class = DATABASE

Parameter	Optional/ Mandatory	Range	Description
SERV	Mandatory	gport, gflex	Service
STATE	Optional	offline, online	Status
GTT	Optional	no, yes	Global Title Translation
PC1, PCA1, PCI1, PCN1, PCN241	Optional	Refer to Commands Manual	Post GTT-translated PC
RC1	Optional	00-99	Relative Cost
PC2, PCA2, PCI2, PCN2, PCN242	Optional	Refer to Commands Manual	Post GTT-translated PC
RC2	Optional	00-99	Relative Cost
PC3, PCA3, PCI3, PCN3, PCN243	Optional	Refer to Commands Manual	Post GTT-translated PC
RC3	Optional	00-99	Relative Cost
PC4, PCA4, PCI4, PCN4, PCN244	Optional	Refer to Commands Manual	Post GTT-translated PC
RC4	Optional	00-99	Relative Cost

- **dlt-sccp-serv: Delete G-Flex SCCP Service Command** – The `dlt-sccp-serv` command is used to remove entries from the SCCP Service table. A single command may either remove a PC from a group, or remove the entire group. The available parameters follow:

Command : `dlt-sccp-serv Class = DATABASE`

Parameter	Optional/ Mandatory	Range	Description
SERV	Mandatory	gport, gflex	Service
PC1, PCA1, PCI1, PCN1, PCN241	Optional	Refer to Commands Manual	Post GTT-translated PC
PC2, PCA2, PCI2, PCN2, PCN242	Optional	Refer to Commands Manual	Post GTT-translated PC
PC3, PCA3, PCI3, PCN3, PCN243	Optional	Refer to Commands Manual	Post GTT-translated PC
PC4, PCA4, PCI4, PCN4, PCN244	Optional	Refer to Commands Manual	Post GTT-translated PC
ALL	Optional	No, Yes	Yes will delete the entire group

- **rtrv-sccp-serv: Retrieve G-Flex SCCP Service Command** – The `rtrv-sccp-serv` command is used to display the SCCP Service application relationship information maintained by the EAGLE 5 ISS. Point codes are grouped by service. The sample output that follows indicates that the G-Port and G-Flex features are turned on and the SCCP Service table is empty.

```
tekelecstp 05-12-20 08:32:58 EST 33.1.0-55.43.0
rtrv-sccp-serv
Command entered at terminal #4.
```

```
-----
Service      : GFLEX
State       : Offline
GTT Option  : Yes
-----
```

```
-----
Service      : GPORT
State       : Offline
GTT Option  : Yes
-----
```

;

EAGLE 5 ISS chg-db: Change Database Commands

The `chg-db` commands copy the EAGLE 5 ISS TDM resident G-Flex database tables during database backup, restore, and repair.

EAGLE 5 ISS `rept-stat-db`: Report Database Status

The `rept-stat-db` command displays both the EAGLE 5 ISS and the G-Flex database status and level information for each DSM network card, and for the active and standby EPAP databases.

Maintenance and Measurements Commands

This section provides a description of the maintenance and measurements commands for the G-Flex features. The commands that follow allow provisioning, operations, and maintenance activities for DSM cards.

Commands

The command examples shown illustrate the requirements and provide suggestions for suitable names and output. The complete functionality of the commands is described in detail in the *Commands Manual*, and the actual parameter names, valid values, and output for the commands are provided.

Commands described here include:

- `rept-stat-sys`
- `rept-stat-sccp`
- `rept-stat-mps`
- `rept-meas`
- `rept-stat-trbl`
- `rept-stat-alm`
- `rept-stat-db`
- `inh-card / alw-card`
- `ent-card / rtrv-card / dlt-card`
- `chg-sid / dlt-sid`
- `chg-gpl / act-gpl / rtrv-gpl / rept-stat-gpl / copy-gpl`
- `ent-bp / dlt-bp / displ-bp / disp-mem / set-mem`
- `inh-alm / unhb-alm`
- pass, including ping, netstat, nslookup, arp, and help commands

`rept-stat-sys`

The `rept-stat-sys` command syntax is not modified, but the report output now displays the status of the DSM cards. The remainder of the report is unchanged.

rept-stat-sccp

The command handling and scroll area output for the **rept-stat-sccp** command includes the DSM card. The **loc** parameter displays detailed card traffic statistics.

Samples of the reports produced by these commands are shown in the following two examples.

- **rept-stat-sccp**

```

Command entered at terminal #3.
;

tekelecstp 00-06-23 13:34:22 EST EAGLE 35.0.0-30.10.0
SCCP SUBSYSTEM REPORT IS-NR      Active      -----
GSM  SUBSYSTEM REPORT IS-NR      Active      -----

SCCP Cards Configured= 4  Cards IS-NR= 2  Capacity Threshold = 100%
CARD  VERSION      PST          SST          AST          MSU USAGE  CPU USAGE
-----
1212  101-001-000  IS-NR      Active      ALMINH      45%        30%
1301  101-001-000  IS-NR      Active      -----      35%        20%
1305  -----      OOS-MT      Isolated    -----      0%         0%
2112  -----      OOS-MT-DSBLD Manual      -----      0%         0%
-----

SCCP Service Average MSU Capacity = 40%      Average CPU Capacity = 25%

AVERAGE MSU USAGE PER SERVICE:
GTT   = 15%  GFLEX = 5%

TOTAL SERVICE STATISTICS:
SERVICE  SUCCESS  ERRORS  WARNINGS  FORWARD TO GTT  TOTAL
GTT:      1995    5       -          -              2000
GFLEX:    500     1       4          10             515

Command Completed.
;

```

- **rept-stat-sccp:loc=1106**

```

Command entered at terminal #4.
;

tekelecstp 00-06-23 13:34:22 EST EAGLE 35.0.0-30.10.0
CARD VERSION      TYPE  PST          SST          AST
1106 101-010-000  DSM   IS-NR      Active      -----
ALARM STATUS      = No Alarms.
GTT:  STATUS = ACT  MSU USAGE = 10%
GFLEX: STATUS = ACT  MSU USAGE = 10%
CPU USAGE = 15%

CARD SERVICE STATISTICS:
SERVICE  SUCCESS  ERRORS  WARNINGS  FORWARD TO GTT  TOTAL
GTT:      1995    5       -          -              2000
GFLEX:    500     1       4          10             515

```

Command Completed.

;

rept-stat-mps

There are two variants of this new command.

- **rept-stat-mps** - produces a summary report showing the overall status of the G-Flex provisioning system and a moderate level of information for each DSM card.
- **rept-stat-mps:loc=xxxx** - produces a more detailed report showing the G-Flex status of a specific DSM card. Note that this version of the command displays the percent utilization of a particular DSM memory.

Samples of the reports produced by these commands are shown in the following two examples.

- **rept-stat-mps**

Command entered at terminal #4.

;

Integrat40 00-06-24 10:37:22 EST EAGLE 35.0.0-30.10.0

	VERSION	PST	SST	AST
EPAP A	026-015-000	IS-NR	Active	-----
	ALARM STATUS = No Alarms			
EPAP B	026-015-000	IS-NR	Active	-----
	ALARM STATUS = No Alarms			

CARD	PST	SST	GSM STAT	G-Flex STAT
1106	IS-NR	Active	ACT	ACT
1201	IS-ANR	Active	SWDL	SWDL
1205	OOS-MT-DSBLD	Manual	-----	-----
1302	OOS-MT	Fault	-----	-----
1310	IS-ANR	Standby	SWDL	SWDL

CARD 1106 ALARM STATUS = No Alarms
 CARD 1201 ALARM STATUS = No Alarms
 CARD 1205 ALARM STATUS = No Alarms
 CARD 1302 ALARM STATUS = No Alarms
 CARD 1310 ALARM STATUS = No Alarms

Command Completed.

;

- **rept-stat-mps:loc=1106**

Command entered at terminal #4.

;

integrat40 99-09-24 10:37:22 EST EAGLE 35.0.0

CARD	VERSION	TYPE	PST	SST	AST
1106	101-9-000	DSM	IS-NR	Active	-----
	DSM PORT A		IS-NR	Active	-----
	DSM PORT B		IS-NR	Active	-----
	GTT STATUS	=	ACT		
	GSM STATUS	=	ACT		

EAGLE 5 ISS G-Flex Commands

```
ALARM STATUS          = No Alarms.  
DSM MEMORY USAGE     = xxx%
```

```
Command Completed.
```

```
;
```

rept-meas

This command includes G-Flex measurements in the output sent to the EAGLE 5 ISS Terminal. Refer to the *Commands Manual* for details of the command.

rept-stat-trbl

This command includes the G-Flex subsystem and DSM/EPAP IP link alarms. Refer to the *Commands Manual* for details of this command.

rept-stat-alm

This command includes the alarm totals of the G-Flex subsystem and DSM/EPAP IP links. Refer to the *Commands Manual* for details of this command.

rept-stat-db

This command displays both EAGLE 5 ISS and G-Flex database status and level information for each DSM network card, and for the active and standby EPAP databases. It reports database exception status such as corrupted, incoherent, or inconsistent, as well as providing the birthdates and levels. For details about this command, refer to the *Commands Manual*.

Hourly Maintenance Report

The Hourly Maintenance Report, generated automatically, includes the alarm totals of the G-Flex subsystem and DSM/EPAP IP links. A sample follows.

```
eagle10506 99-10-10 16:00:01 EST EAGLE 35.0.0  
5072.0000 REPT COND GSM SS  
"GSM SS :0440,MTCEINT-0,SA,99-10-10,16:00:01,,,,*C"  
;  
eagle10506 99-10-10 16:00:01 EST EAGLE 35.0.0  
5077.0000 REPT COND EPAPDSM  
"EPAPDSM :0084,MTCEINT-0,SA,99-10-10,16:00:01,,,,**"  
;  
eagle10506 99-10-10 16:00:01 EST EAGLE 35.0.0  
5007.0000 REPT COND CARD  
"CARD 1102:0422,SCMMA,SA,99-10-10,16:00:01,,,,**"  
;  
eagle10506 99-09-13 16:00:01 EST EAGLE 35.0.0  
3561.0000 REPT COND ALARM STATUS  
"ALARMS:PERM. INHIBITED,0,0,0"  
"ALARMS:TEMP. INHIBITED,0,0,0"  
"ALARMS:ACTIVE,10,14,3"  
"ALARMS:TOTAL,10,14,3"
```

;

inh-card / alw-card

The command-handling and scroll area output for these commands includes the DSM card. Refer to the *Commands Manual* for details of these commands.

- **inh-card** is not inhibited unless it is an ASM, TSM, DCM, DSM, ACM, or LIM card.
- If the specified card is the only in-service VSCCP card, the **force=yes** parameter is required.
- If inhibiting this VSCCP card would cause less than 80% of the IS-NR LIMs to have VSCCP service (that is, cause the system to enter an unstable loading mode), the **force=yes** parameter is required.

ent-card / rtrv-card / dlt-card

The command-handling and scroll area output for these commands includes the DSM card. For the **ent-card** command, the **APPL=VSCCP** is supported. Refer to the *Commands Manual* for details of this command.

- If the addition of a LIM card exceeds the system's VSCCP service capabilities, the **force=yes** parameter is required.

A sample of the reports produced by these commands is shown in the following example.

```
ent-card:loc=1201:type=dsm:appl=VSCCP
Command entered at terminal #3.
;
    Command Completed.
;
```

chg-gpl / act-gpl / rtrv-gpl / rept-stat-gpl / copy-gpl

The command-handling and scroll area output for these commands include the VSCCP GPL. Refer to the *Commands Manual* for details of these commands.

Samples of the reports produced by these commands are shown in this example.

```
act-gpl:appl=VSCCP:ver=26-1-0
Command entered at terminal #3.
;
tekelecstp 99-10-24 06:54:39 EST EAGLE 35.0.0
VSCCP activate on 1114 completed
VSCCP activate on 1116 completed
;
rtrv-gpl:appl= VSCCP
Command entered at terminal #3.
;
tekelecstp 99-10-04 07:01:08 EST EAGLE 35.0.0
```

EAGLE 5 ISS G-Flex Commands

```
GPL Auditing ON

APPL CARD RELEASE APPROVED TRIAL REMOVE TRIAL
VSCCP 1114 026-001-000 026-001-000 026-001-000 026-001-000
VSCCP 1116 026-001-000 026-001-000 026-001-000 -----

rept-stat-gpl:appl= VSCCP
Command entered at terminal #3.
;
tekelecstp 99-10-04 12:55:50 EST EAGLE 35.0.0
APPL CARD RUNNING APPROVED TRIAL
VSCCP 1205 026-001-000 ALM 026-001-000 026-001-000
VSCCP 1211 026-001-000 ALM+ 026-001-000 -----
Command Completed.
;
```

ent-bp / dlt-bp / disp-bp / disp-mem / set-mem

The command-handling and scroll area output for these commands includes the DSM card. (These commands recognize the DSM boards.)

- The **CARD=<GPL><Subsystem>** is supported for the VSCCP GPL.

A sample of the reports produced by these commands is shown in the following example.

```
disp-bp:card=vscpp-all:
Command Accepted - Processing

tekelecstp 99-01-20 19:21:10 EST EAGLE 35.0.0
disp-bp:card=vscpp-all
Command entered at terminal #1.
;

tekelecstp 99-12-04 01:38:29 EST EAGLE 35.0.0
SDS Installed Breakpoint Report from IMT Address H'0005
BP Address Memory-Dump Address Conditions Rpt Ct Ind
-----
H'0000a974 1- ANY 1 0
Code Breakpoint 2- ANY
;
```

chg-sid / dlt-sid

These commands are used to change and report on the self-identification of the EAGLE 5 ISS. The self-identification identifies the EAGLE 5 ISS to other signaling points in the network. This command includes a CPC type for G-Flex.

The CPC parameter is used to support incoming messages routed via Intermediate GTT (rt-gt) to the EAGLE 5 ISS (with DPC = CPC) for G-Flex. Refer to the *Commands Manual* for details of this command.

inh-alm / unhb-alm

These commands allow both Port A and Port B to be specified for the **dev=d1k**. This allows alarms to be inhibited on the DSM ports. Refer to the *Commands Manual* for details of these commands.

chg-ip-card / rtrv-ip-card

These commands allow you to provision and report on the Internet Protocol networking parameters for any given DSM card. Use the **loc** parameter to specify a DSM card, and the **dnsa** and **dnstb** parameters to specify a default router. Refer to the *Commands Manual* for details of these commands.

chg-ip-lnk / rtrv-ip-lnk

These commands allow you to provision and report on the Internet Protocol link table. Use the **loc** parameter to specify a DSM card. Refer to the *Commands Manual* for details of these commands.

ent-ip-host / dlt-ip-host / rtrv-ip-host

These commands allow you to provision, remove, and report on the entries in the Internet Protocol host table. The IP host table defines local and remote host names for IP addresses. Use the **host** parameter to specify the logical name for the device associated with the IP address in the **ipaddr** parameter. Refer to the *Commands Manual* for details of these commands.

pass

The **pass** command allows remote execution of a selected command by the targeted card. (These commands recognize the DSM boards.) Selected commands are allowed as follows.

- **pass:cmd="ping"**
- **pass:cmd="netstat"**
- **pass:cmd="nslookup"**
- **pass:cmd="arp"**
- **pass:cmd="help"**

For this feature, the **loc** parameter must be a VSCCP card location. For other details of the **pass** command, refer to *Commands Manual*.

pass:cmd="Ping"

The '**ping**' **pass** command supports troubleshooting of the private EPAP/DSM IP network. The following example demonstrates typical usage.

EAGLE 5 ISS G-Flex Commands

```
eagle10506 99-08-11 08:43:45 EST EAGLE 35.0.0

pass:loc=1215:cmd="ping -h"
Command entered at terminal #2.
;

eagle10506 99-08-11 08:43:45 EST EAGLE 35.0.0
PASS: Command sent to card
;

eagle10506 99-08-11 08:43:45 EST EAGLE 35.0.0

Usage: ping <hostname | ipaddr> [-h] [-i size] [-n count]
Options:
-h           Displays this message
-i count    Number of pings to send. Range=1..5. Default=3.
-n size     Sets size of ICMP echo packet. Range=12..2048. Default=64.
hostname    Name of machine to ping
ipaddr      IP Address of machine to ping (d.d.d.d)
;

```

pass:cmd="netstat"

The **'netstat'** **pass** command supports troubleshooting of network interface and routing configuration problems within the private EPAP/DSM IP network.

The following examples demonstrate typical usage.

```
eagle10506 99-08-11 08:43:00 EST EAGLE 35.0.0

pass:loc=1215:cmd="netstat -h"

Command entered at terminal #2.
;

eagle10506 99-08-11 08:43:00 EST EAGLE 35.0.0

PASS: Command sent to card
;

eagle10506 99-08-11 08:43:00 EST EAGLE 35.0.0

Usage: netstat [-a] [-i] [-h] [-m data|sys|dd] [-p icmp|ip|tcp|udp] [-r]
Options:
-a           display socket information for all protocols
-h           Displays this message
-i           display interface information for all interfaces
-m           display buffer pool information for 1 of the system pools
-p           display socket information for 1 of the protocols
-r           display the route table information
;

```

pass:cmd="nslookup"

The '**nslookup**' **pass** command supports debugging of domain name server (DNS) to IP addressing tables. DNS is not supported for EPAP cards for the initial release.

The following examples demonstrate typical usage.

```
eagle10506 99-08-11 08:45:57 EST EAGLE 35.0.0

pass:loc=1215:cmd="nslookup"
Command entered at terminal #2.
;

eagle10506 99-08-11 08:45:57 EST EAGLE 35.0.0
PASS: Command sent to card
;

eagle10506 99-08-11 08:45:57 EST EAGLE 35.0.0

Usage: nslookup [hostname|ipaddr]

Options:
    hostname  String name
    ipaddr    d.d.d.d
;
```

pass:cmd="arp"

The '**arp**' **pass** command supports the verification of and correction of IP stack ARP tables. In general, this command is not required for normal operation.

The following examples demonstrates typical usage.

```
eagle10506 99-08-11 08:43:23 EST EAGLE 35.0.0
pass:loc=1215:cmd="arp    -h"
Command entered at terminal #2.
;

eagle10506 99-08-11 08:43:23 EST EAGLE 35.0.0
PASS: Command sent to card
;

eagle10506 99-08-11 08:43:23 EST EAGLE 35.0.0

Usage: arp [-a] [-d ipaddr] [-f] [-h] [-s ipaddr enetaddr]

Options:
    -a          Display All entries in ARP table
    -d          Delete specified entry (ipaddr) from ARP table
    -f          Flush all entries from ARP table
    -h          Displays this message
    -s          Set ARP table entry to associate ipaddr with enetaddr
    enetaddr   x:x:x:x:x:x
    ipaddr     d.d.d.d
;
```

EAGLE 5 ISS G-Flex Commands

```
eagle10506 99-08-11 08:43:25 EST EAGLE 35.0.0  
ARP command complete  
;
```

pass:cmd="help"

The '**help**' **pass** command provides a list of supported **pass** commands for the target location.

The following examples demonstrates typical usage.

```
eagle10506 99-08-11 08:42:18 EST EAGLE 35.0.0  
pass:loc=1215:cmd="help"  
Command entered at terminal #2.  
;  
  
eagle10506 99-08-11 08:42:18 EST EAGLE 35.0.0  
PASS: Command sent to card  
;  
  
eagle10506 99-08-11 08:42:18 EST EAGLE 35.0.0  
List of commands supported is:  
nslookup  
netstat  
arp  
ping  
help  
  
END of LIST  
;
```

G-Flex Feature Activation

Introduction.....	4-1
Prerequisites	4-2
Feature Activation Overview.....	4-3
Feature Activation Procedure	4-9



CAUTION: For an in-service environment, contact Tekelec Technical Services (see “Customer Assistance” on page 1-9) before continuing to activate G-Flex. For an environment that is not yet in-service, you may continue with this procedure.

The G-Flex feature bit cannot be enabled if any of the DSMs have less than 1 GB of memory installed. Refer to the *Dimensioning Guide for EPAP Advanced DB Features Technical Reference* for important information on the dimensioning rules and the DSM database capacity requirements.

Introduction

This chapter identifies prerequisites for the G-Flex feature activation procedure, an overview of the activation steps, and a matching number of detailed step descriptions to turn on the G-Flex feature. The G-Flex feature activation is performed at the EAGLE 5 ISS.

The G-Flex features optimizes the use of subscriber numbers and number ranges in a GSM Mobile Network by providing a logical link between any Mobile Station international ISDN (MSISDN) number and any International Mobile Station Identifier (IMSI). This feature allows subscribers to be moved easily from one Home Location Register (HLR) to another. The G-Flex feature applies to ANSI, ITU-I (international), and ITU-N (national) networks.

The G-Flex feature, and other related features, are optional and can be purchased from Tekelec. If you are not sure whether you have purchased a specific feature, contact your Tekelec Sales or Account Representative.



CAUTION: Once a feature has been turned on with the `chg-feat` command, it cannot be turned off. Since features may overwrite other features or create changes in the database, assure that you have a license and full technical support from Tekelec before turning on this or any feature.

The G-Flex feature requires a DSM card running the VSCCP application. Systems with TSM cards running the SCCP application need to be upgraded to DSM cards prior to turning on the G-Flex feature.

Refer to the *Dimensioning Guide for EPAP Advanced DB Features Technical Reference* for important information on the dimensioning rules and the DSM database capacity requirements.

Procedures described in the remainder of this manual apply only to the G-Flex feature and can only be performed if the G-Flex feature is turned on.

The following features are related to the G-Flex feature (see your Tekelec Sales or Account Representative for additional information):

- Global Title Translation (GTT)
- Enhanced Global Title Translation (EGTT)
- Variable-Length Global Title Translation (VGTT)
- EAGLE Provisioning Application Processor (EPAP)

Prerequisites

The G-Flex feature activation assumes that the features Global Title Translation (GTT), Enhanced Global Title Translation (EGTT), and Variable-Length Global Title Translation (VGTT) are already provisioned. Refer to the *Database Administration Manual - Features* for provisioning procedures.

The G-Flex feature activation assumes that the EPAP software is already configured; refer to *EPAP Administration Manual*, [EPAP Software Configuration](#).

The G-Flex feature activation assumes that DSM cards to be installed and TSM cards to be removed are identified:

- Note installed DSM card locations if any
- Note available odd-even card slots for DSM card installation
- Note installed TSM card locations;

G-Flex Feature Activation

- Note adjacent odd-even TSM card slot number positions for DSM card replacement

NOTE: TSM cards use one card slot; DSM cards require two card slots, odd-even.

NOTE: The G-Flex feature cannot be turned on until TSM cards running the SCCP application are removed from the system.

- Determine DSM card IP addresses and have them available during the activation procedure.

For in-service systems, schedule DSM card replacement in maintenance window that allows the reboot of DSM cards (`init-card:loc=<DSM card location>`) one at a time.



CAUTION: In an in-service environment and when replacing TSM cards with DSM cards, initialize one DSM card at a time. Verify its return to IS-NR state before initializing another DSM card. This precaution keeps cards in service and precludes an interruption of SCCP services.

For in-service systems with TSM cards running SCCP traffic, one DSM card must be installed in an available double-slot odd-even location and provisioned for VSCCP prior to inhibiting the SCCP card. The DSM card running the VSCCP application will take over the SCCP traffic (`alw-card`) once the SCCP card becomes inhibited.



CAUTION: SCCP traffic redundancy will be lost if inhibiting two SCCP cards at a time with only one VSCCP card available in their place. Redundancy will be re-established once the two SCCP cards are replaced with a second VSCCP card.

For in-service systems that already have the G-Port and/or INP feature enabled, only perform steps 70 through 82 to turn on the G-Flex feature. With the G-Port and/or INP feature enabled, the DSM cards already contain the RTDB database.

For new systems, DSM cards may be rebooted all at one time using the `init-card:appl=vsccp` command.

For new systems, GTT, EGTT, and VGTT features may be turned on prior to or immediately following the reboot of all DSM cards.

Feature Activation Overview

This section provides an overview of the G-Flex feature activation procedure. The procedure is described in detail in section “Feature Activation Procedure” on page 4-9.

The feature activation consists of these sections:

- Configure system for HLR destinations in steps 1 through 28.

- Install DSM cards in available slots and configure for VSCCP in steps 29 through 44.
- Replace TSM cards configured for SCCP with DSM cards configured for VSCCP and inhibit/remove any remaining SCCP cards in steps 45 through 69.
- Turn on the G-Flex feature in steps 70 through 82.

Steps 1 through 28 configure the system to be able to communicate with the system of the HLR database. The route to this database may already be configured. Perform these steps to verify that you have entered all HLR destinations for G-Flex and make configuration changes as needed.

1. Display and note current system settings for point codes (PCs) and capability point codes (CPCs), destination point codes (DPCs), routes, and linksets using steps 1 through 7.
2. Use `rtrv-sid` command to display current PCs and CPCs.
3. Use `rtrv-dstn` command to display current DPCs.
4. Use `rtrv-rte` command to display current route configurations.
5. Identify PCs and CPCs; determine new PC and CPC to be entered in step 9.
6. Use `rtrv-stpopts` command to display PC or CPC format if ITU-N network.
7. Use `rtrv-map` command to display PCs of mated applications in database; remove system PC from table if necessary (refer to *Database Administration Manual - Features, Removing A Mated Application*)



CAUTION: Changing a system's point code requires a system reboot using the `init-sys` command to fully implement the changes. The `init-sys` command causes a complete system reload and should be used only in an environment that is not in service. Using this command ensures the updated self identification information is loaded onto all cards, but does interrupt service.

8. Change PC, CPC, DPC, route, linkset, and LIM card configurations for the HLR database using steps 9 through 28.
9. Use `chg-sid` command to configure PC and CPC by network type.
10. Use `init-sys` command to initialize system if changes were made in step 9 to any `pca/pci/pcn` parameter.



CAUTION: The `init-sys` command causes a complete system reload and should be used only in an environment that is not in service. Using this command ensures the updated self identification information is loaded onto all cards, but does interrupt service.



CAUTION: When the `init-sys` command executes, the system does not retain the manually initiated state (for example, OOS-MT-DSBLD) for the signaling link, card, or terminal. After the command executes, the system attempts to bring all provisioned links, cards, and terminals on line, including those that were previously out of service. You will need to manually put each device back into its previous state after the system is back on line. Print or electronically capture the output of the `rept-stat-slk`, `rept-stat-card`, and `rept-stat-trm` commands for reference prior to issuing the `init-sys` command. To restore a device to its previous state, issue the appropriate inhibit/deactivate command listed in the *Commands Manual* in the Related Commands section for each of the above `rept-stat` commands.

11. Use `rtrv-sid` command to display new PC and CPC.
12. Use `ent-dstn` command to enter DPC for HLR destinations.
13. Use `rtrv-dstn` command to display new HLR DPC.
14. Use `ent-ls` command to enter linkset and assign DPC for HLR destinations.
15. Use `rtrv-ls` command to display new linkset and assigned DPC for HLR destinations.
16. Use `ent-card` command to enter LIM card(s) into database.
17. Use `rtrv-card` command to display new LIM card(s) in database.
18. Use `ent-slk` command to assign signaling link(s) to LIM card(s).
19. Use `rtrv-slk` command to display new signaling link(s) assigned to LIM card(s).
20. Use `ent-rte` command to assign route to new DPC.
21. Use `rtrv-rte` command to display route assigned to new DPC.
22. Use `ent-map` command to enter mated application into database.
23. Use `rtrv-map` command to display new mated application in database.
24. Use `alw-card` command to allow LIM card(s).
25. Use `rept-stat-card` command to display status of new LIM card(s) in database.
26. Use `act-slk` command to activate new signaling link(s) for LIM card(s).
27. Use `rept-stat-slk` command to display IS-NR status of signaling link(s).
28. Use `rtrv-card` command to confirm the new LIM card(s) and identify VSCCP cards (DSM cards running VSCCP application) and SCCP cards (TSM cards running SCCP application).



CAUTION: When adding DSM cards in an in-service environment, you must take care not to interrupt traffic. Before replacing SCCP cards with DSMs, first install a VSCCP card in an available odd-even double-slot prior to removing SCCP cards to make additional room for other DSM cards.

29. Install and configure DSM card(s) in available odd-even slots as needed using steps 30 through 44.
30. Install DSM card(s) in available odd-even slots and verify green IMT bus LEDs.
31. Use **ent-card** command to enter DSM card(s) as VSCCP card(s) into database.
32. Use **rtrv-card** command to display new VSCCP card(s) in database.
33. Use **rtrv-ip-host** command to display current IP host information in database.
34. Use **ent-ip-host** command to add host name and IP address for each VSCCP link.
35. Use **rtrv-ip-host** command to display changed IP host information.
36. Use **chg-ip-card** command to set local domain and IP router address if necessary.
37. Use **rtrv-ip-card** command to display changed VSCCP card information.
38. Use **rtrv-ip-lnk** command to display current link parameters associated with the VSCCP card.
39. Use **chg-ip-lnk** command to set the IP address port and speed associated with the VSCCP card.
40. Use **rtrv-ip-lnk** command to display changed link parameters.
41. Use **alw-card** command to boot DSM card in TSM emulation mode.
42. Use **rept-stat-card** command to display IS-NR status of VSCCP card.
43. Use **pass** command to test presence of EPAP hosts on network.
44. Repeat steps 30 through 43 to add all DSM cards (N+1) to be installed in available slots. Go to the next step to start replacing TSM cards.
45. Replace TSM card(s) with DSM cards if applicable, and add DSM card(s) to database using steps 46 through 68.
46. Use **rtrv-card** command to display TSM cards running the SCCP application (SCCP cards) in database.
47. Use **rept-stat-card** command to display SCCP cards in IS-NR status.
48. Use **inh-card** command to inhibit SCCP card(s)

G-Flex Feature Activation

49. Use `rept-stat-card` command to display OOS-MT-DSBLD status of SCCP card(s).
50. Use `dlt-card` command to delete SCCP card(s) from database.
51. Use `rtrv-card` command to verify removal of SCCP cards from database.
52. Remove first TSM card from shelf.
53. Remove second TSM card from shelf.
54. Install DSM card in shelf and verify green IMT bus LEDs.
55. Use `ent-card` command to enter DSM card as VSCCP card into database.
56. Use `rtrv-card` command to display new VSCCP card in database.
57. Use `rtrv-ip-host` command to display IP host information in database.
58. Use `ent-ip-host` command to add host name and IP address for VSCCP link.
59. Use `rtrv-ip-host` command to display changed IP host information in database.
60. Use `chg-ip-card` command to set local domain and IP router address if necessary.
61. Use `rtrv-ip-card` command to display changed VSCCP card information.
62. Use `rtrv-ip-lnk` command to display current link parameters associated with VSCCP card.
63. Use `chg-ip-lnk` command to set the IP address port and speed associated with VSCCP card.
64. Use `rtrv-ip-lnk` command to display changed link parameters associated with the VSCCP card.
65. Use `alw-card` command to boot DSM card in TSM emulation mode.
66. Use `rept-stat-card` command to display IS-NR status of VSCCP card.
67. Use `pass` command to test presence of EPAP hosts on network.
68. Repeat steps 46 through 67 to replace all adjacent TSM cards identified in the prerequisites and to be replaced with DSM cards.
69. Repeat steps 48 through 52 to inhibit any remaining TSM cards running the SCCP application and remove them from database and shelf.

NOTE: The G-Flex feature cannot be turned on until TSM cards running the SCCP application are removed from the system.



CAUTION: Contact Tekelec Technical Services at this point for assistance in completing this G-Flex activation procedure (see "Customer Assistance" on page 1-9). Do not proceed without consulting with Tekelec Technical Services.

70. Turn on and configure G-Flex feature using steps 71 through 82.
71. Use `chg-feat` command to turn on G-Flex feature.
72. Use `chg-stpopts` command to enter default country code (CC) and default network destination code (NDC) to convert nature of address indicator (NAI) of MSISDNs to international format (`nai=intl`).
73. Use `rtrv-stpopts` command to verify changes of CC and NDC.
74. Use `chg-gsmopts` command to change GSM options.
75. Use `rtrv-gsmopts` command to verify changes to GSM options.
76. Use `ent-srvsel` command to enter G-Flex service selectors.
77. Use `rtrv-srvsel` command to verify changes to G-Flex service selectors.



CAUTION: When you have an in-service environment and you are replacing TSM cards with DSM cards, initialize one DSM card at a time. Verify its return to IS-NR state before initializing another card. This precaution keeps cards in service and precludes an interruption of SCCP services.

78. Use `init-card:loc=<DSM card>` command to load RTDB, OAM, GPL, and GTT data to VSCCP card.
79. Use `rept-stat-card` command to display IS-NR status of VSCCP card.
80. Repeat steps 78 and 79 to reboot each DSM card.

NOTE: Once the G-Flex feature is turned on, always boot the DSM cards with the `init-card :loc=<DSM card location>` command.

81. Use `chg-sccp-serv:serv=gflex:state=online` to set the G-Flex service to online.
82. Confirm success of activation procedure with `rept-stat-sccp`, `rept-stat-mps`, and `rept-stat-db:display=all` commands.

EPAP can now administer G-Flex entity objects and G-Flex subscribers. For details about performing these actions, refer to the *EPAP Administration Manual*.

The detailed G-Flex activation procedure is described next.

Feature Activation Procedure

Procedure

1. Before changing a true point code (PC) and adding a capability point code (CPC) for the G-Flex feature, display the current values of the self-identification configuration (shown in step 2), the destination point codes (DPCs) (shown in step 3), and the routes and linksets assigned to the DPCs (shown in step 4). The G-Flex feature applies to ANSI, ITU-I (international), and ITU-N (national) networks.

2. Display the current self identification of the system (PC and CPC) using the **rtrv-sid** command. This is an example of the possible output:

```

rlghncxa03w 01-10-07 00:57:31 GMT EAGLE 35.0.0
PCA          PCI          PCN          CLLI          PCTYPE
001-001-001 1-100-1          11111        rlghncxa03w  OTHER

CPCA
001-002-001 001-002-002      001-002-003  001-002-004

CPCI
1-101-1      1-101-2          1-101-3      1-101-4

CPCN
11121        11122            11123        11124

```

If the ITUDUPPC (ITU national duplicate point code) feature is on, the ITU national point code also contains a group code. The group code is a two-character field from aa to zz that is entered as the last subfield of an ITU national point code, nnnnn-gc (for example, 2112-aa)

3. Display the current destination point codes in the destination point code table (**dpca/dpci/dpcn**) using the **rtrv-dstn** command. This is an example of the possible output:

```

rlghncxa03w 01-10-10 11:43:04 GMT EAGLE 35.0.0
DPCA        CLLI        BEI ELEI    ALIASI    ALIASN    DOMAIN
201-001-001 rlghncxa03w no  ---    - - - - -  - - - - -  SS7

DPCI        CLLI        BEI ELEI    ALIASA    ALIASN    DOMAIN
2-100-1     rlghncxa03w no  ---    222-210-000 12001    SS7

DPCN        CLLI        BEI ELEI    ALIASA    ALIASI    DOMAIN
21111      rlghncxa03w no  ---    222-200-200 2-121-1  SS7

DESTINATION ENTRIES ALLOCATED:      2000
FULL DPC(s) :                        3
NETWORK DPC(s) :                      0
CLUSTER DPC(s) :                      0
TOTAL DPC(s) :                        3
CAPACITY (% FULL) :                   1%
X-LIST ENTRIES ALLOCATED:            500

```

4. Display the current route configuration using the `rtrv-rte` command. This is an example of the possible output:

```

rlghncxa03w 01-10-07 11:43:04 GMT EAGLE 35.0.0
DPCA          ALIASI          ALIASN          CLLI          LSN          RC APCA
201-001-001   1-111-1          11121          adp1          ls000001    10 240-012-002
               ls000002    10 240-012-002
               ls000003    20 240-012-002
               ls000004    30 240-012-002
               ls000005    40 240-012-002
               ls000006    50 240-012-002

DPCI          ALIASN          ALIASA          CLLI          LSN          RC APCI
2-100-1       121111         240-111-111   idp1          ls100001    10 1-234-5
               ls100002    10 1-234-6
               ls100003    20 1-234-7
               ls100004    30 1-234-1
               ls100005    40 1-234-2
               ls100006    50 1-234-3

DPCN          ALIASA          ALIASI          CLLI          LSN          RC APCN
21111         011-222-111   0-001-1       ndp1          ls200001    10 11111
               ls200002    10 11112
               ls200003    20 11113
               ls200004    30 11114
               ls200005    40 11115
               ls200006    50 11116

```

5. If the system's point code (`pca/pci/pcn`) or capability point code (`cpca/cpci/cpcn`) to be configured in this procedure is shown in steps 2, 3, or 4, choose another point code to configure with this procedure (step 9).
6. If configuring the system point code or capability point code (`pcn` or `cpcn`) of an ITU-N network, view the current value of the ITU-N point code format. Otherwise continue with step 7.

Enter the `rtrv-stpopts` command and specify the ITU-N point code format option `npcfmti`. The `npcfmti` option identifies how the ITU-N point code is entered into the database and how it is displayed in any outputs. The value is shown in the `NPCFMTI` field. This is an example of the possible output:

```

rlghncxa03w 01-10-17 16:02:05 GMT EAGLE 35.0.0
STP OPTIONS
-----
MTPT31CTL          1
MTPLTI             yes
MTPLTCTDPCQ        3
MTPLTST           10000
MTPXLQ             500
MTPXLET            0100
MTPXLOT            90%
MTPDPCQ            1750
TFATFRPR           1000
MTPRSI             yes
MTPRSIT            5000
MTPLPRST           yes
MTP10ALT           30000
SLSCNV             perlS
UIMRD              yes
CRITALMINH         no
DISPACTALMS        no
NPCFMTI            4-4-4-2
DEFCC               49
DEFNDC             177
DSMAUD             on

```

If you wish to change the format of the ITU-N point code, go to section “ITU National Point Code Formats” in the *Database Administration Manual - SS7*. Then continue with step 7.

7. Display the mated applications in the database using the `rtrv-map` command. These are examples of possible output:

```
rlghncxa03w 01-10-07 11:43:04 GMT EAGLE 35.0.0
PCA          SSN  RC  MPCA          MSSN MATERC SRM MRC GRP NAME
001-001-001      5  10                ---  ---
```

```
rlghncxa03w 01-10-07 11:43:04 GMT EAGLE 35.0.0
PCN          SSN  RC  MPCN          MSSN MATERC SRM MRC GRP NAME
11111        5  10  12347         5    20
```

```
rlghncxa03w 01-10-07 11:43:04 GMT EAGLE 35.0.0
PCI          SSN  RC  MPCN          MSSN MATERC SRM MRC GRP NAME
2-100-1      5  20  3-200-1       250   99 ---  --- abcdefgh
```

If the system’s point code is shown in the `rtrv-map` command output (in the **PCA**, **PCI**, **PCN**, **MPCA**, **MPCI**, or **MPCN** fields), remove the system’s point code from the mated application table. Refer to procedure “Removing a Mated Application” in the *Eagle STP Database Administration Manual - Features*.

If the system’s point code or capability point code is a destination point code of a route, select a point code that is not the destination point code of a route (see output of the `rtrv-rte` command in step 4) and not in the destination point code table (see output of the `rtrv-dstn` command in step 3).

8. Change PC, CPC, DPC, route, linkset, and LIM card configurations for the HLR database using steps 9 through 28.



CAUTION: Changing a system’s point code requires a system reboot using the `init-sys` command to fully implement the changes. The `init-sys` command causes a complete system reload and should be used only in an environment that is not in service. Using this command ensures the updated self identification information is loaded onto all cards but does interrupt service.

9. Configure the system’s point code (**pca/pci/pcn**) and capability point code (**cpca/cpci/cpcn**) by network type using the `chg-sid` command. For example, enter one of these commands:

```
chg-sid:pca=003-001-001:cpca=003-002-001
```

```
chg-sid:pci=1-100-2:cpci=1-102-1
```

```
chg-sid:pcn=11112:cpcn=11125
```

where:

:**pca/pci/pcn** – The point code used to uniquely identify the system.

:**cpca/cpci/cpcn** – The point code used by the SS7 protocol to identify a group of functionally related EAGLE 5 ISSs in the signaling network to which the EAGLE 5 ISS belongs.

After successful completion of this command, the system returns the following output:

```
rlghncxa03w 01-10-07 00:57:31 GMT EAGLE 35.0.0
CHG-SID: MASP A - COMPLTD
```

When any of the **pca/pci/pcn** parameters have changed, the system needs to be reinitialized. The following caution message is displayed:

```
CAUTION: SYSTEM SITE ID HAS BEEN CHANGED, MANUAL RE-INITIALIZATION IS NEEDED
```



CAUTION: The **init-sys** command causes a complete system reload and should be used only in an environment that is not in service. Using this command ensures the updated self identification information is loaded onto all cards, but does interrupt service.

When the **init-sys** command executes, the system does not retain the manually initiated state (for example, OOS-MT-DSBLD) for the signaling link, card, or terminal. After the command executes, the system attempts to bring all provisioned links, cards, and terminals on line, including those that were previously out of service. You will need to manually put each device back into its previous state after the system is back on line. Print or electronically capture the output of the **rept-stat-slk**, **rept-stat-card**, and **rept-stat-trm** commands for reference prior to issuing the **init-sys** command. To restore a device to its previous state, issue the appropriate inhibit/deactivate command listed in the *Commands Manual* in the Related Commands section for each of the above **rept-stat** commands.

10. Reinitialize the system by entering the **init-sys** command if changes were made in step 9 to any **pca/pci/pcn** parameter.

NOTE: The **init-sys** command must be entered twice within 30 seconds for the system to re-initialize. If the **init-sys** command is not executed twice within 30 seconds, the attempt to re-initialize the system is aborted.

When the **init-sys** command is first entered, this message should appear.

```
rlghncxa03w 01-10-07 00:57:31 GMT EAGLE 35.0.0
CAUTION: This command causes a complete system reload, and
will result in traffic loss.
Re-enter command within 30 seconds to confirm.
```

When the **init-sys** command is re-entered within the 30 second time limit, this message should appear.

```
rlghncxa03w 01-10-07 00:57:31 GMT EAGLE 35.0.0
Init System command issued at terminal #3
```

G-Flex Feature Activation

From the time that the **init-sys** command is accepted, you must wait approximately two minutes before you can perform step 11 (logging into the system). If the terminal is in the VT-100/VT-320 mode, the terminal display will be refreshed with non-zero alarm counts. During this two-minute interval, an intermediate screen refresh occurs, which is caused by the MASP's role change from active to standby and from standby to active. This screen refresh is typically a partial refresh and the alarm indicators are set to zero.

If you are logged into the system in the KSR mode, the only response you will receive of being able to log into the system is the message 'UAM 0009, MASP became active'. UAM 0009 could be issued twice due to a possible transient MASP role change (switching from active to standby). Following the execution of the **init-sys** command, the MASP that was active before the **init-sys** command was entered will be the active MASP again when the system has finished reinitializing.

-
11. Verify the SID changes using the **rtrv-sid** command. This is an example of the possible output:

```
durhncxa03w 01-10-07 00:57:31 GMT EAGLE 35.0.0
PCA
001-001-001      PCI      1-100-2      PCN      11112      CLLI      rlghncxa03w      PCTYPE
003-001-001      OTHER

CPCA
001-002-001      001-002-002      001-002-003      001-002-004
003-002-001

CPCI
1-101-1      1-101-2      1-101-3      1-101-4
1-102-1

CPCN
11121      11122      11123      11124
11125
```

-
12. Enter a destination point code for the HLR location in the Destination Point Code table by network type using the **ent-dstn** command. For example, enter one of these commands:

```
ent-dstn:dpca=301-100-100
```

```
ent-dstn:dpci=2-100-2
```

```
ent-dstn:dpcn=21112
```

where:

:dpc/dpca/dpci/dpcn – The destination point code being added to the database

The system returns this message:

```
rlghncxa03w 01-10-17 15:35:05 GMT EAGLE 35.0.0
Destination table is (40 of 4000) 1% full
ENT-DSTN: MASP A - COMPLTD
```

13. Verify the changes using the `rtrv-dstn` command and specifying the DPC that was entered in step 12. For example, enter one of these commands:

```
rtrv-dstn:dpca=301-100-100
```

```
rtrv-dstn:dpci=2-100-2
```

```
rtrv-dstn:dpcn=21112
```

This is an example of the possible output for DPCAs.

```
rtrv-dstn:dpca=301-100-100

RLGHNCXA03W 01-10-30 21:16:37 GMT EAGLE 35.0.0
DPCA        CLLI        BEI ELEI  ALIASI  ALIASN  DOMAIN
301-100-100 -----   no  ---   2-100-2    21112    SS7

                SPC            NCAI
                -----      no

Destination table is (20 of 2000) 1% full
```

This is an example of the possible output for DPCIs.

```
rtrv-dstn:dpci=2-100-2

RLGHNCXA03W 01-10-30 21:16:37 GMT EAGLE 35.0.0
DPCI        CLLI        BEI ELEI  ALIASA  ALIASN  DOMAIN
2-100-2     -----   no  ---   301-100-100  21112    SS7

                SPC            NCAI
                -----      no

Destination table is (20 of 2000) 1% full
```

This is an example of the possible output for DPCNs.

```
rtrv-dstn:dpcn=21112

RLGHNCXA03W 01-10-30 21:16:37 GMT EAGLE 35.0.0
DPCN        CLLI        BEI ELEI  ALIASA  ALIASI  DOMAIN
21112      -----   no  ---   301-100-100  2-100-2  SS7

                SPC            NCAI
                -----      no

Destination table is (20 of 2000) 1% full
```

14. Enter a linkset with the `ent-1s` command, and assign it to the destination point code by network type. For example, enter one of these commands:

```
ent-1s:lsn=1s300001:apca=240-020-001:lst=c
```

```
ent-1s:lsn=1s400001:apci=2-200-2:lst=c
```

```
ent-1s:lsn=1s500001:apcn=21122:lst=c
```

where:

:lsn – The name of the linkset

:apc/apca/apci/apcn – Adjacent point code – the point code identifying the node that is next to the system

:lst – The linkset type of the specified linkset

G-Flex Feature Activation

After successful completion of this command, the system returns the following message:

```
RLGHNCXA03W 01-10-17 16:23:21 GMT EAGLE 35.0.0
Link set table is ( 114 of 1024) 12% full
ENT-LS: MASP A - COMPLTD
```

15. Verify the changes using the **rtrv-ls** command and specifying the linkset name. For example, enter one of these commands:

```
rtrv-ls:lsn=ls300001
```

```
rtrv-ls:lsn=ls400001
```

```
rtrv-ls:lsn=ls500001
```

For lsn300001, the system returns output similar to the following:

```

                L3T  SLT
LSN          APCA (SS7)  SCRNL  SET  SET BEI LST LNKS GWSA GWSM GWSD SLSCI NIS
ls300001  240-020-001 scr1  1    2  no  a  0    on  off  off  no    on
CLLI        TFATCABMLQ  MTPRSE ASL8
RLGHNCXA03W 1          no    no
                L2T    L1
LOC  PORT SLC TYPE  SET BPS  MODE TSET ECM  PCR PCR
                N1  N2
Link set table is (114 of 1024) 12% full
```

For lsn400001, the system returns output similar to the following:

```

                L3T  SLT
LSN          APCI (SS7)  SCRNL  SET  SET BEI LST LNKS GWSA GWSM GWSD SLSCI
NIS
ls400001  2-200-2      scr1  1    2  no  a  0    on  off  off  no    on
CLLI        TFATCABMLQ  MTPRSE ASL8
RLGHNCXA03W 1          no    no
                L2T    L1
LOC  PORT SLC TYPE  SET BPS  MODE TSET ECM  PCR PCR
                N1  N2
Link set table is (114 of 1024) 12% full
```

For lsn500001, the system returns output similar to the following:

```

                L3T  SLT
LSN          APCN (SS7)  SCRNL  SET  SET BEI LST LNKS GWSA GWSM GWSD SLSCI
NIS
ls500001  21122       scr3  1    2  no  a  0    on  off  off  no    on
CLLI        TFATCABMLQ  MTPRSE ASL8
RLGHNCXA03W 1          no    no
                L2T    L1
LOC  PORT SLC TYPE  SET BPS  MODE TSET ECM  PCR PCR
                N1  N2
Link set table is (114 of 1024) 12% full
```

16. Add the LIM cards to the database using the **ent-card** command. For this example, enter these commands:

```
ent-card:loc=1105:type=limocu:appl=ccs7itu
```

```
ent-card:loc=1106:type=limocu:appl=ccs7itu
```

where:

:loc - specifies the slot number for the card.

:type - specifies that the card is a LIMOCU card.

:appl - specifies that the application is CCS7ITU.

After successful completion of this command, the system returns the following message:

```
RLGHNCXA03W 01-10-12 09:12:36 GMT EAGLE 35.0.0
ENT-CARD: MASP A - COMPLTD
```

17. Verify the changes using the **rtrv-card** command with the card location specified. For this example, enter these commands:

```
rtrv-card:loc=1105
```

```
rtrv-card:loc=1106
```

These are examples of the possible output:

```
RLGHNCXA03W 01-10-30 09:12:36 GMT EAGLE 35.0.0
CARD  TYPE      APPL      PORT A LSET (SLC)  PORT B LSET (SLC)
1105  LIMOCU      CCS7ITU  -----  (--)  -----  (--)
```

```
RLGHNCXA03W 01-10-30 09:12:36 GMT EAGLE 35.0.0
CARD  TYPE      APPL      PORT A LSET (SLC)  PORT B LSET (SLC)
1106  LIMOCU      CCS7ITU  -----  (--)  -----  (--)
```

18. Assign signaling links to the LIM cards using the **ent-slk** command. For example, enter these commands:

```
ent-slk:loc=1105:port=a:lsn=ls400001:slc=0:l2tset=1
```

```
ent-slk:loc=1106:port=a:lsn=ls500001:slc=0:l2tset=1
```

where:

:loc – The card location of the LIM that the SS7 signaling link will be assigned to.

:port – The port on the card specified in the **loc** parameter.

:lsn – The name of the linkset that will contain the signaling link.

:slc – The signaling link code. The **slc** must be unique within the linkset. It must be the same at both the system location and the distant node.

:l2tset – The level 2 timer set table. A signaling link may be assigned to any of the twenty tables.

After successful completion of this command, the system returns the following message:

```
RLGHNCXA03W 01-10-07 08:29:03 GMT EAGLE 35.0.0
ENT-SLK: MASP A - COMPLTD
```

G-Flex Feature Activation

Signaling links are the only elements in the database directly supported by a hardware device. When a link is added to a linkset, the link remains in the state OOS-MT-DSBLD (out of service maintenance disabled) until it is activated; see step 26.

-
19. Verify the changes using the **rtrv-slk** command, specifying the card location and port of the signaling link entered in step 18.

```
rtrv-slk:loc=1105:port=a
```

```
rtrv-slk:loc=1106:port=a
```

This is an example of the possible output.

```
RLGHNCXA03W 01-10-19 21:16:37 GMT EAGLE 35.0.0
LOC  PORT LSN      SLC TYPE      L2T  BPS  L1  MODE TSET  ECM  PCR  PCR
1105  A    1s400001  0  LIMOCU      1   56000  ---  ---  BASIC ---  -----
```

```
RLGHNCXA03W 01-10-19 21:16:37 GMT EAGLE 35.0.0
LOC  PORT LSN      SLC TYPE      L2T  BPS  L1  MODE TSET  ECM  PCR  PCR
1106  A    1s500001  0  LIMOCU      1   56000  ---  ---  BASIC ---  -----
```

20. Add a route for the new DPC by network type using the **ent-rte** command. For example, enter one of these commands:

```
ent-rte:dpca=301-100-100:lsn=1s300001:rc=10
```

```
ent-rte:dpci=2-100-2:lsn=1s400001:rc=10
```

```
ent-rte:dpcn=21112:lsn=1s500001:rc=10
```

where:

:dpc/dpca/dpci/dpcn – Destination point code of the node that the traffic is bound for

:lsn – The name of the linkset that will carry the traffic bound for the node specified by the destination point code.

:rc – The relative cost (priority) for this route.

After successful completion of this command, the system returns the following message:

```
RLGHNCXA03W 01-10-07 08:28:30 GMT EAGLE 35.0.0
ENT-RTE: MASP A - COMPLTD
```

21. Verify the changes using the **rtrv-rte** command and specifying the destination point code of the route. This is an example of the possible output:

```

rlghncxa03w 01-10-07 11:43:04 GMT EAGLE 35.0.0
DPCA          ALIASI          ALIASN      CLLI        LSN          RC  APCA
201-001-001  1-111-1            11121      adp1        ls000001    10  240-012-002
                1-111-1            11121      adp1        ls000002    10  240-012-002
                1-111-1            11121      adp1        ls000003    20  240-012-002
                1-111-1            11121      adp1        ls000004    30  240-012-002
                1-111-1            11121      adp1        ls000005    40  240-012-002
                1-111-1            11121      adp1        ls000006    50  240-012-002
301-001-001  1-111-1            11121      adp1        ls300001    10  240-020-001

DPCI          ALIASN          ALIASA      CLLI        LSN          RC  APCI
2-100-1       121111         240-111-111 idp1        ls100001    10  1-234-5
                121111         240-111-111 idp1        ls100002    10  1-234-6
                121111         240-111-111 idp1        ls100003    20  1-234-7
                121111         240-111-111 idp1        ls100004    30  1-234-1
                121111         240-111-111 idp1        ls100005    40  1-234-2
                121111         240-111-111 idp1        ls100006    50  1-234-3
2-100-2       121111         240-111-111 idp1        ls400001    10  1-200-2

DPCN          ALIASA          ALIASI      CLLI        LSN          RC  APCN
21111         011-222-111  0-001-1     ndp1        ls200001    10  11111
                011-222-111  0-001-1     ndp1        ls200002    10  11112
                011-222-111  0-001-1     ndp1        ls200003    20  11113
                011-222-111  0-001-1     ndp1        ls200004    30  11114
                011-222-111  0-001-1     ndp1        ls200005    40  11115
                011-222-111  0-001-1     ndp1        ls200006    50  11116
21112         011-222-111  0-001-1     ndp1        ls500001    10  11122

```

22. Add a mated application to the database by network type using the **ent-map** command. For this example, enter this command:

```
ent-map:pca=003-001-001:ssn=12:rc=0:mpca=004-004-004:mssn=250
:materc=99 :grp=grp10
```

```
ent-map:pci=2-100-1:ssn=12:rc=20:mpci=3-200-1:mssn=50
:materc=99:grp=grp03
```

```
ent-map:pcn=11112:ssn=12:rc=10:mpcn=11114:mssn=250:materc=99
:grp=grp07
```

where:

:pc/pca/pci/pcn – The point code of the primary signaling point that is to receive the message.

:ssn – Subsystem number – the subsystem address of the primary point code that is to receive the message.

:rc – The relative cost

:mpc/mpca/mpci/mpcn – The point code of the backup signaling point that is to receive the message.

:mssn – Mate subsystem number – the subsystem address of the backup point code that is to receive the message.

:materc – Mate relative cost.

:grp – The name of the concerned signaling point code group that contains the point codes that should be notified of the subsystem status. This parameter applies to both RPCs/SSNs.

G-Flex Feature Activation

When each of these commands have successfully completed, this message should appear.

```
RLGHNCXA03W 01-10-07 00:28:31 GMT EAGLE 35.0.0
ENT-MAP: MASP A - COMPLTD
```

23. Verify the changes using the **rtrv-map** command. These are examples of possible output.

```
rlghncxa03w 01-10-07 11:43:04 GMT EAGLE 35.0.0
PCA          SSN RC MPCA          MSSN MATERC SRM MRC GRP NAME
001-001-001   5 20 004-004-004   250      99 --- --- GRP10
003-001-001  12  0 004-004-004   250      99 --- --- GRP10

rlghncxa03w 01-10-07 11:43:04 GMT EAGLE 35.0.0
PCN          SSN RC MPCN          MSSN MATERC SRM MRC GRP NAME
11111        5 20 12347          250      99 --- --- GRP07
11112        12  0 12347          250      99 --- --- GRP07

rlghncxa03w 01-10-07 11:43:04 GMT EAGLE 35.0.0
PCI          SSN RC MPCI          MSSN MATERC SRM MRC GRP NAME
1-100-1      5  0 3-200-1        250      99 --- --- GRP03
2-100-1      12 20 3-200-1        50       99 --- --- GRP03
```

24. Allow the LIM cards that were entered in step 16 by using the **alw-card** command. For example, enter these commands:

```
alw-card:loc=1105
```

```
alw-card:loc=1106
```

This message appears:

```
RLGHNCXA03W 01-10-30 21:20:37 GMT EAGLE 35.0.0
Card has been allowed.
```

25. Verify the in-service normal (IS-NR) status of the cards using the **rept-stat-card** command. This is an example of the possible output:

```
RLGHNCXA03W 01-10-27 16:43:42 GMT EAGLE 35.0.0
CARD  VERSION          TYPE      APPL      PST          SST          AST
1101  100-000-00003-000  ASM      SCCP      IS-NR        Active       ---
1102  100-000-00003-000  ASM      SCCP      IS-NR        Active       ---
1103  100-000-00003-000  ACMENET  STPLAN   IS-NR        Active       ---
1104  100-000-00003-000  ACMENET  GLS      IS-NR        Active       ---
1105  100-000-00003-000  LIMOCU   CCS7ITU  IS-NR        Active       ---
1106  100-000-00003-000  LIMOCU   CCS7ITU  IS-NR        Active       ---
1113  100-000-00002-000  MCAP     OAM      IS-NR        Active       ---
1114  100-000-00002-000  TDM      IS-NR    IS-NR        Active       ---
1115  100-000-00002-000  MCAP     OAM      IS-NR        Active       ---
1116  100-000-00002-000  TDM      IS-NR    IS-NR        Active       ---
1117  100-000-00002-000  MDAL     IS-NR    IS-NR        Active       ---
1201  100-000-00003-000  LIMDS0   SS7ANSI  IS-NR        Active       ---
1202  100-000-00002-000  LIMV35   SS7GX25  IS-NR        Active       ---
1203  100-000-00003-000  LIMV35   SS7ANSI  IS-NR        Active       ---
1204  100-000-00003-000  LIMATM   ATMANSI  IS-NR        Active       ---
1205  100-000-00001-000  DCM      IPLIM    IS-NR        Active       ---
1207  100-000-00001-000  DCM      SS7IPGW  IS-NR        Active       ---
1303  100-000-00001-000  DCM      IPLIM    IS-NR        Active       ---
1305  100-000-00001-000  DCM      SS7IPGW  IS-NR        Active       ---
```

26. Activate the signaling links entered in step 18 using the **act-slk** command. For example, enter these commands

```
act-slk:loc=1105:port=a
```

```
act-slk:loc=1106:port=a
```

The link changes its state from *OOS-MT-DSBLD* (out-of-service maintenance-disabled) to *IS-NR* (in-service normal).

The output confirms the activation.

```
RLGHNCXA03W 01-10-07 11:11:28 GMT EAGLE 35.0.0
Activate Link message sent to card
```

27. Verify the in-service normal (IS-NR) status of the signaling link using the **rept-stat-slk** command. For example, enter these commands:

```
rept-stat-slk:loc=1105
```

```
rept-stat-slk:loc=1106
```

This message should appear.

```
RLGHNCXA03W 01-10-30 21:16:37 GMT EAGLE 35.0.0
SLK      LSN      CLLI      PST      SST      AST
1105,A  1s400001  -----  IS-NR    Avail    ----
Command Completed.
```

```
RLGHNCXA03W 01-10-30 21:16:37 GMT EAGLE 35.0.0
SLK      LSN      CLLI      PST      SST      AST
1106,A  1s500001  -----  IS-NR    Avail    ----
Command Completed.
```

28. Display the new LIM cards in the database using the **rtrv-card** command. This is an example of the possible output:

```
RLGHNCXA03W 01-10-15 16:34:56 GMT EAGLE 35.0.0
CARD  TYPE      APPL      PORT A LSET (SLC)  PORT B LSET (SLC)
1101  ASM        SCCP      -----  (--)  -----  (--)
1102  ASM        SCCP      -----  (--)  -----  (--)
1103  ACMENET    STPLAN    -----  (--)  -----  (--)
1104  ACMENET    GLS       -----  (--)  -----  (--)
1105  LIMOCU     CCS7ITU   1s400001  (00)  -----  (--)
1106  LIMOCU     CCS7ITU   1s500001  (00)  -----  (--)
1113  MCAP       OAM
1114  TDM
1115  MCAP       OAM
1116  TDM
1117  MDAL
1201  LIMDS0     SS7ANSI   lsn1      (00)   lsn2      (01)
1202  LIMV35     SS7GX25   lsngwy    (00)   -----  (--)
1203  LIMV35     SS7ANSI   lsn2      (00)   lsn1      (01)
1204  LIMATM     ATMANSI   atmgwy    (00)   -----  (--)
1205  DCM        IPLIM     ipgwy1    (00)   ipgwy3    (01)
1207  DCM        SS7IPGW   ipgwy2    (00)   -----  (--)
1303  DCM        IPLIM     ipgwy1    (00)   ipgwy3    (01)
1305  DCM        SS7IPGW   ipgwy4    (00)   -----  (--)
```

Determine a location where the double-slot DSM card can be inserted. The output shows slots 1107 and 1108 are not occupied. Also determine adjacent (odd-even slots) SCCP cards for later TSM card replacements.

G-Flex Feature Activation

29. Install and configure DSM card(s) as needed in available odd-even slots using steps 30 through 44. For our example, install a DSM card in slots 1107 and 1108.
-

30. Install the DSM card in slots 1107 and 1108. The DSM card requires two slots and must be installed in an odd slot with an adjacent empty even slot on its right side.
 - a. Open the eject levers on the DSM card. Carefully align the card's edges with the top and bottom card guides. Then push the card along the length of the card guides until the rear connectors on the card engage the mating connectors on the target shelf backplane.
 - b. Press the left edge of the card's faceplate using constant pressure until you feel the card's progress cease.



WARNING: Do not impact the faceplate in order to mate the connectors. Any impact to the card's faceplate can damage the faceplate, the pins, or the connectors.

- c. Push in the top and bottom inject/eject clamps. This locks the card in place and ensures a strong connection with the pins on the target shelf backplane.

Figure 4-1. Push in Inject/Eject Clamps



Push in the inject/eject clamps to lock the card in place.

- d. Verify that both IMT bus LEDs are green.
 - e. Install the cabling required to connect the DSM card to the MPS. Refer to the *Installation Manual* for details.
-

31. Add the DSM card to the database and configure it as VSCCP card using the **ent-card** command. For this example, enter this command.

```
ent-card:loc=1107:type=dsm:appl=vsccp
```

where:

:loc - specifies the slot number for the card. The slot number must be an odd number.

:type - specifies that the card is a DSM card.

:appl - specifies that the application is VSCCP.

After successful completion of this command, the system returns the following message:

```
RLGHNCXA03W 01-10-12 09:12:36 GMT EAGLE 35.0.0
ENT-CARD: MASP A - COMPLTD
```

32. Verify the VSCCP card using the **rtrv-card** command with the card location specified. For this example, enter this command:

```
rtrv-card:loc=1107
```

This is an example of the possible output:

```
RLGHNCXA03W 01-10-30 09:12:36 GMT EAGLE 35.0.0
CARD  TYPE      APPL      PORT A LSET (SLC)  PORT B LSET (SLC)
1107  DSM         VSCCP      -----  (--)  -----  (--)
```

33. Display the current IP host information in the database by entering the **rtrv-ip-host** command. This is an example of the possible output:

```
RLGHNCXA03W 01-10-30 21:17:37 GMT EAGLE 35.0.0

IPADDR      HOST
192.1.1.32  KC_HLR2
192.1.1.50  DN_MSC1
192.1.1.52  DN_MSC2
```

34. Add the host name and IP address for each VSCCP link using the **ent-ip-host** command. For example, enter these commands:

```
ent-ip-host:host=vsccp_1107_a:ipaddr=192.168.122.1
```

```
ent-ip-host:host=vsccp_1107_b:ipaddr=192.168.123.1
```

where:

:host - specifies the host name. Each VSCCP link must be specified separately.

G-Flex Feature Activation

:ipaddr - specifies the IP network address for each EPAP. The first three octets of the IP address must be the same as MPS A and B ports, respectively. The fourth octet identifies the DSM card and must have a unique octet identifier for the card's IP address; we recommend numbering the DSM cards sequentially, using values 1 to 25. (This example shows the assignment of the first DSM card.)

After successful completion of this command, the system returns the following message:

```
RLGHNCXA03W 01-10-30 21:18:37 GMT EAGLE 35.0.0
ENT-IP-HOST: MASP A - COMPLTD
```

35. Verify the new IP host information in the database by entering the **rtrv-ip-host** command. The following is an example of the possible output.

```
RLGHNCXA03W 01-10-30 21:19:37 GMT EAGLE 35.0.0

IPADDR          HOST
192.1.1.32      KC_HLR2
192.1.1.50      DN_MSC1
192.1.1.52      DN_MSC2
192.168.122.1   VSCCP_1107_A
192.168.123.1   VSCCP_1107_B
```

NOTE: Most G-Flex customer private networks do not require setting up a default router for the DSM card. However, if your network configuration does require a default router to connect the DSM card communication to the EPAP, then only one default router is assignable to each DSM card. Assign the default router address to each DSM card as shown in this step.

36. Change the TCP/IP information for the VSCCP card in the database using the **chg-ip-card** command. For this example, enter this command:

```
chg-ip-card:loc=1107:domain=nc.tekelec.com
:defrouter=192.168.122.250
```

where

:loc – The location of the VSCCP card within the EAGLE 5 ISS.

:domain – The domain name of domain server.

:defrouter – Default router address. The IP address for default router. This is a TCP/IP address expressed in standard "dot notation". IP addresses consist of the system's network number and the machine's unique host number.

After successful completion of this command, the system returns the following message:

```
RLGHNCXA03W 01-10-30 21:20:37 GMT EAGLE 35.0.0
CHG-IP-CARD: MASP A - COMPLTD
```

37. Verify the new TCP/IP parameters associated with the VSCCP card in the database by entering the `rtrv-ip-card` command. This is an example of the possible output:

```

RLGHNCXA03W 01-10-30 21:21:37 GMT EAGLE 35.0.0
  LOC 1107
    SRCHORDR LOCAL
    DNSA -----
    DNSB -----
    DEFROUTER 192.168.122.250
    DOMAIN NC.TEKELEC.COM

```

38. Display the current link parameters associated with the VSCCP card in the database by entering the `rtrv-ip-lnk` command. This is an example of the possible output:

```

RLGHNCXA03W 01-10-30 21:14:37 GMT EAGLE 35.0.0
LOC  PORT  IPADDR          SUBMASK          DUPLEX  SPEED  MACTYPE  AUTO  MCAST
1107  A      -----          -----          HALF    10     DIX      NO    NO
1107  B      -----          -----          HALF    10     DIX      NO    NO

```

39. Enter the IP address port and speed associated with the VSCCP card in the database using the `chg-ip-lnk` command. For this example, enter these commands:

```

chg-ip-lnk:loc=1107:port=a:duplex=half:ipaddr=192.168.122.1
:mactype=dix:speed=100:mcast=yes:submask=255.255.255.0
chg-ip-lnk:loc=1107:port=b:duplex=half:ipaddr=192.168.123.1
:mactype=dix:speed=10:mcast=yes:submask=255.255.255.0

```

where:

- :loc** – The card location of the VSCCP card within the EAGLE 5 ISS.
- :port** – The port ID. The `port` parameter of the `chg-ip-lnk` command specifies the physical interface of the DSM card.
- :ipaddr** – IP address assigned to the port. This is a TCP/IP address expressed in standard “dot notation.” IP addresses consist of the system’s network number and the machine’s unique host number.
- :duplex** – This is the mode of operation of the interface.
- :speed** – This is interface bandwidth in megabits per second. The speed is either 100 Mbps for main DSM network or 10 Mbps for backup DSM network.
- :mactype** – This is the Media Access Control Type of the interface. Specify `dix` for the Digital/Inter/Xerox *de facto* standard for the Ethernet.
- :mcast** – This is the Multicast Control of the interface.
- :submask** – The subnet mask of the IP interface, in the form of an IP address with a restricted range of values.

G-Flex Feature Activation

When this command has successfully completed, the following message appears:

```
RLGHNCXA03W 01-10-30 21:18:37 GMT EAGLE 35.0.0
CHG-IP-LNK: MASP A - COMPLTD
```

40. Verify the new link parameters associated with the VSCCP card in the database by entering the **rtrv-ip-lnk** command. This is an example of the possible output:

```
RLGHNCXA03W 01-10-30 21:14:37 GMT EAGLE 35.0.0
LOC  PORT IPADDR          SUBMASK          DUPLEX  SPEED  MACTYPE  AUTO  MCAST
1107  A    192.168.122.1        255.255.255.0    HALF    100    DIX      NO    YES
1107  B    192.168.123.1        255.255.255.0    HALF    10     DIX      NO    YES
```

41. Boot the DSM card that was added in step 31 in TSM emulation mode by using the **alw-card** command. For example, enter this command:

```
alw-card:loc=1107
```

This message appears:

```
RLGHNCXA03W 01-10-30 21:20:37 GMT EAGLE 35.0.0
Card has been allowed.
```

42. Verify the in-service normal (IS-NR) status of the VSCCP card using the **rept-stat-card** command. This is an example of the possible output.

```
RLGHNCXA03W 01-10-27 16:43:42 GMT EAGLE 35.0.0
CARD  VERSION          TYPE  APPL  PST          SST  AST
1101  100-000-00003-000  ASM   SCCP  IS-NR        Active ---
1102  100-000-00003-000  ASM   SCCP  IS-NR        Active ---
1103  100-000-00002-000  ACMENET STPLAN IS-NR        Active ---
1104  100-000-00003-000  ASM   GLS   IS-NR        Active ---
1105  100-000-00003-000  LIMOCU CCS7ITU IS-NR        Active ---
1106  100-000-00003-000  LIMOCU CCS7ITU IS-NR        Active ---
1107  100-000-00003-000  DSM   VSCCP IS-NR        Active ---
1113  100-000-00002-000  MCAP  OAM    IS-NR        Active ---
1114  100-000-00002-000  TDM   IS-NR        Active ---
1115  100-000-00002-000  MCAP  OAM    IS-NR        Active ---
1116  100-000-00002-000  TDM   IS-NR        Active ---
1117  100-000-00002-000  MDAL  IS-NR        Active ---
1201  100-000-00003-000  LIMDS0 SS7ANSI IS-NR        Active ---
1202  100-000-00002-000  LIMV35 SS7GX25 IS-NR        Active ---
1203  100-000-00003-000  LIMV35 SS7ANSI IS-NR        Active ---
1204  100-000-00003-000  LIMATM ATMANSI IS-NR        Active ---
1205  100-000-00001-000  DCM   IPLIM  IS-NR        Active ---
1207  100-000-00001-000  DCM   SS7IPGW IS-NR        Active ---
1303  100-000-00001-000  DCM   IPLIM  IS-NR        Active ---
1305  100-000-00001-000  DCM   SS7IPGW IS-NR        Active ---
```

43. Test the presence of the EPAP hosts on the network using the **pass** command with the **ping** parameter. This command is invoked with a destination (either a hostname or IP address). For example, enter the following command:

```
pass:loc=1107:cmd="ping 192.168.122.100".
pass:loc=1107:cmd="ping 192.168.122.200".
pass:loc=1107:cmd="ping 192.168.123.100".
pass:loc=1107:cmd="ping 192.168.123.200".
```

After successful completion of each command, the system returns output similar to the following:

```
rlghncxa03w 00-06-27 08:30:44 GMT EAGLE 35.0.0
pass: loc=1107: cmd="ping 192.168.122.100"
Command entered at terminal #1.
;
rlghncxa03w 00-06-27 08:30:44 GMT EAGLE 35.0.0
PASS: Command sent to card
;
rlghncxa03w 00-06-27 08:30:44 GMT EAGLE 35.0.0
PING command in progress
;
rlghncxa03w 00-06-27 08:30:46 GMT EAGLE 35.0.0
PING 192.168.122.100: 56 data bytes
64 bytes from tekral.nc.tekelec.com (192.168.122.100):icmp_seq=0.time=5. ms
64 bytes from tekral.nc.tekelec.com (192.168.122.100):icmp_seq=1.time=0. ms
64 bytes from tekral.nc.tekelec.com (192.168.122.100):icmp_seq=2.time=0. ms
----192.168.100.3 PING Statistics----
3 packets transmitted, 3 packets received, 0% packet loss
round-trip (ms) min/avg/max = 0/1/5
PING command complete
```

If the **pass** commands with the **ping** parameter is not successful, verify the the correct connection of the hardware cabling and try again. If the command fails again, contact Technical Services (see "Customer Assistance" on page 1-9).

44. Repeat steps 30 through 43 to add all DSM cards (N+1) to be installed in available slots. Go to the next step to start replacing TSM cards with DSM cards.

45. Replace TSM card(s) with DSM cards if applicable and add DSM card(s) to the database using steps 46 through 68. In this procedure, we are removing two existing adjacent TSM cards and replace them with a double-slot DSM card in slots 1101 and 1102.

NOTE: When adding DSM cards in an in-service environment, you must take care not to interrupt traffic. Before replacing SCCP cards with DSMs, first install a VSCCP card in an available double-slot.

46. Display the TSM cards running the SCCP application in the database using the `rtrv-card` command. This is an example of the possible output:

```

RLGHNCXA03W 01-10-15 16:34:56 GMT EAGLE 35.0.0
CARD   TYPE      APPL      PORT A LSET (SLC)   PORT B LSET (SLC)
1101   ASM        SCCP      -----  (--)   -----  (--)
1102   ASM        SCCP      -----  (--)   -----  (--)
1103   ACMENET    STPLAN   -----  (--)   -----  (--)
1104   ACMENET    GLS      -----  (--)   -----  (--)
1105   LIMOCU     CCS7ITU  1s300001 (00)   -----  (--)
1106   LIMOCU     CCS7ITU  1s400001 (00)   -----  (--)
1107   DSM        VSCCP    1s300001 (00)   -----  (--)
1113   MCAP       OAM
1114   TDM
1115   MCAP       OAM
1116   TDM
1117   MDAL
1201   LIMDS0     SS7ANSI  1sn1      (00)   1sn2      (01)
1202   LIMV35     SS7GX25  1sngwy    (00)   -----  (--)
1203   LIMV35     SS7ANSI  1sn2      (00)   1sn1      (01)
1204   LIMATM     ATMANSI  atmgyw    (00)   -----  (--)
1205   DCM        IPLIM    ipgwy1    (00)   ipgwy3    (01)
1207   DCM        SS7IPGW  ipgwy2    (00)   -----  (--)
1303   DCM        IPLIM    ipgwy1    (00)   ipgwy3    (01)
1305   DCM        SS7IPGW  ipgwy4    (00)   -----  (--)

```

Determine the cards to be removed from the database. In this procedure, we will remove the SCCP cards in card locations **1101 and 1102**.

47. Display the SCCP cards that are in service with the `rept-stat-card:stat=nr` command. For this example, enter the following command:

```
rept-stat-card:stat=nr
```

This is an example of the possible output:

```

RLGHNCXA03W 01-10-27 16:43:42 GMT EAGLE 35.0.0
CARD  VERSION      TYPE      APPL      PST      SST      AST
1101  100-000-00003-000  ASM      SCCP      IS-NR    Active  ---
1102  100-000-00003-000  ASM      SCCP      IS-NR    Active  ---
1103  100-000-00003-000  ACMENET  STPLAN   IS-NR    Active  ---
1104  100-000-00003-000  ACMENET  GLS      IS-NR    Active  ---
1105  100-000-00003-000  LIMOCU   CCS7ITU  IS-NR    Active  ---
1106  100-000-00003-000  LIMOCU   CCS7ITU  IS-NR    Active  ---
1107  100-000-00003-000  DSM      VSCCP    IS-NR    Active  ---
1113  100-000-00002-000  MCAP     OAM      IS-NR    Active  ---
1114  100-000-00002-000  TDM
1115  100-000-00002-000  MCAP     OAM      IS-NR    Active  ---
1116  100-000-00002-000  TDM
1117  100-000-00002-000  MDAL
1201  100-000-00003-000  LIMDS0   SS7ANSI  IS-NR    Active  ---
1202  100-000-00002-000  LIMV35   SS7GX25  IS-NR    Active  ---
1203  100-000-00003-000  LIMV35   SS7ANSI  IS-NR    Active  ---
1204  100-000-00003-000  LIMATM   ATMANSI  IS-NR    Active  ---
1205  100-000-00001-000  DCM      IPLIM    IS-NR    Active  ---
1207  100-000-00001-000  DCM      SS7IPGW  IS-NR    Active  ---
1303  100-000-00001-000  DCM      IPLIM    IS-NR    Active  ---
1305  100-000-00001-000  DCM      SS7IPGW  IS-NR    Active  ---

```

48. Inhibit the SCCP cards using the **inh-card** command and specifying the card locations.

```
inh-card:loc=1101
```

```
inh-card:loc=1102
```

When each command has successfully completed, this message appears:

```
RLGHNCXA03W 01-10-12 09:12:36 GMT EAGLE 35.0.0
Card has been inhibited.
```

49. Verify that the SCCP cards are in the Out-of-Service Maintenance-Disabled (OOS-MT-DSBLD) state with the **rept-stat-card** command. This is an example of the possible output:

```
RLGHNCXA03W 01-10-27 16:43:42 GMT EAGLE 35.0.0
CARD  VERSION          TYPE  APPL  PST          SST          AST
1101  100-000-00003-000  ASM   SCCP   OOS-MT-DSBLD Isolated    ---
1102  100-000-00003-000  ASM   SCCP   OOS-MT-DSBLD Isolated    ---
1103  100-000-00002-000  ACMENET STPLAN  IS-NR      Active      ---
1104  100-000-00002-000  ACMENET STPLAN  IS-NR      Active      ---
1105  100-000-00003-000  LIMOCU  CCS7ITU IS-NR      Active      ---
1106  100-000-00003-000  LIMOCU  CCS7ITU IS-NR      Active      ---
1107  100-000-00003-000  DSM     VSCCP   IS-NR      Active      ---
1113  100-000-00002-000  MCAP    OAM     IS-NR      Active      ---
1114  100-000-00002-000  TDM     IS-NR      Active      ---
1115  100-000-00002-000  MCAP    OAM     IS-NR      Active      ---
1116  100-000-00002-000  TDM     IS-NR      Active      ---
1117  100-000-00002-000  MDAL    IS-NR      Active      ---
1201  100-000-00003-000  LIMDS0  SS7ANSI IS-NR      Active      ---
1202  100-000-00002-000  LIMV35  SS7GX25 IS-NR      Active      ---
1203  100-000-00003-000  LIMV35  SS7ANSI IS-NR      Active      ---
1204  100-000-00003-000  LIMATM  ATMANSI IS-NR      Active      ---
1205  100-000-00001-000  DCM     IPLIM   IS-NR      Active      ---
1207  100-000-00001-000  DCM     SS7IPGW IS-NR      Active      ---
1303  100-000-00001-000  DCM     IPLIM   IS-NR      Active      ---
1305  100-000-00001-000  DCM     SS7IPGW IS-NR      Active      ---
```

50. Remove the SCCP cards from the database using the **dlt-card** command. The **dlt-card** command has only one parameter, **loc**, which is the location of the card. For this example, enter these commands:

```
dlt-card:loc=1101
```

```
dlt-card:loc=1102
```

After successful completion of this command, the system returns the following message:

```
RLGHNCXA03W 01-10-12 09:12:36 GMT EAGLE 35.0.0
DLT-CARD: MASP A - COMPLTD
```

51. Verify that the SCCP cards are removed from the database using the **rtrv-card** command and specifying the cards that were removed in step 50. For this example, enter these commands:

```
rtrv-card:loc=1101
```

```
rtrv-card:loc=1102
```

G-Flex Feature Activation

After successful completion of this command, the system returns the following message:

```
E2144 Cmd Rej: Location invalid for hardware configuration
```

52. Locate the TSM card to be removed from the shelf.

Because the TSM card takes just one slot and the DSM card requires two slots, the DSM card must be installed in an odd slot that is adjacent to an even slot on its right side. In this procedure, we will remove two TSM cards from slots 1101 and 1102 to make space for one DSM card.

- a. Push the inject/eject clamps outward from the card's faceplate (top clamp in the "UP" position, bottom clamp in the "DOWN" position). Pull the levers away from the shelf until they are parallel to the floor. Gently pull the card towards you until the card clears the shelf.

Figure 4-2. Push Inject/Eject Clamps Outward



- b. Place the card you have removed in an electrostatic discharge (ESD) protective container, or place the card in the spare card storage shelf.
-

53. Repeat step 52 to remove the second TSM card.

54. Install the DSM card in slots 1101 and 1102.

- a. Open the ejector levers on the DSM card. Carefully align the card's edges with the top and bottom card guides. Then push the card along the length of the card guides until the rear connectors on the card engage the mating connectors on the target shelf backplane.
- b. Press the left edge of the card's faceplate using constant pressure until you feel the card's progress cease.



WARNING: Do not impact the faceplate in order to mate the connectors. Any impact to the card's faceplate can damage the faceplate, the pins, or the connectors.

- c. Push in the top and bottom inject/eject clamps. This locks the card in place and ensures a strong connection with the pins on the target shelf backplane.

Figure 4-3. Push in Inject/Eject Clamps



Push in the inject/eject clamps to lock the card in place.

- d. Verify that both IMT bus LEDs are green.
- e. Install the cabling required to connect the DSM card to the MPS. Refer to the *Installation Manual* for details.

-
55. Add the DSM card to the database and assign the VSCCP application using the `ent-card` command. For this example, enter this command:

```
ent-card:loc=1101:type=dsm:appl=vsccp
```

where:

`:loc` - specifies the slot number for the card. The slot number must be an odd number.

`:type` - specifies that the card is a DSM card.

`:appl` - specifies that the application is VSCCP.

After successful completion of this command, the system returns the following message:

```
RLGHNCXA03W 01-10-12 09:12:36 GMT EAGLE 35.0.0
ENT-CARD: MASP A - COMPLTD
```

56. Display the new VSCCP card using the **rtrv-card** command with the card location specified. For this example, enter this command:

```
rtrv-card:loc=1101
```

This is an example of the possible output:

```
RLGHNCXA03W 01-10-30 09:12:36 GMT EAGLE 35.0.0
CARD   TYPE           APPL      PORT A LSET (SLC)   PORT B LSET (SLC)
1101 DSM              VSCCP    -----  (--)  -----  (--)
```

57. Display the current IP host information in the database by entering the **rtrv-ip-host** command. The following is an example of the possible output.

```
RLGHNCXA03W 01-10-30 21:17:37 GMT EAGLE 35.0.0
```

```
IPADDR      HOST
192.1.1.32  KC_HLR2
192.1.1.50  DN_MSC1
192.1.1.52  DN_MSC2
192.168.122.1 VSCCP_1107_A
192.168.123.1 VSCCP_1107_B
```

58. Add the host name and IP address for each VSCCP link using the **ent-ip-host** command. For example, enter these commands:

```
ent-ip-host:host=vsccp_1101_a:ipaddr=192.168.122.2
```

```
ent-ip-host:host=vsccp_1101_b:ipaddr=192.168.123.2
```

where:

:host - specifies the host name. Each VSCCP link must be specified separately.

:ipaddr - specifies the IP network address for each EPAP. The first three octets of the IP address must be the same as MPS A and B ports, respectively. The fourth octet identifies the DSM card and must have a unique octet identifier for the card's IP address; we recommend numbering the DSM cards sequentially, using values 1 to 25. (This example shows the assignment of the second DSM card.)

After successful completion of this command, the system returns the following message:

```
RLGHNCXA03W 01-10-30 21:18:37 GMT EAGLE 35.0.0
ENT-IP-HOST: MASP A - COMPLTD
```

59. Verify the new IP host information in the database by entering the **rtrv-ip-host** command. This is an example of the possible output:

```

RLGHNCXA03W 01-10-30 21:19:37 GMT EAGLE 35.0.0

IPADDR          HOST
192.1.1.32      KC_HLR2
192.1.1.50      DN_MSC1
192.1.1.52      DN_MSC2
192.168.122.1   VSCCP_1107_A
192.168.123.1   VSCCP_1107_B
192.168.122.2   VSCCP_1101_A
192.168.123.2   VSCCP_1101_B

```

NOTE: Most G-Flex customer private networks do not require setting up a default router for the DSM card. However, if your network configuration does require a default router to connect the DSM card communication to the EPAP, then only one default router is assignable to each DSM card. Assign the default router address to each DSM card as shown in this step.

60. Enter local domain and IP router address for the VSCCP card using the **chg-ip-card** command. For this example, enter this command:

```

chg-ip-card:loc=1107:domain=nc.tekelec.com
:defrouter=192.168.122.250

```

where

:loc – The card location of the card within the EAGLE 5 ISS.

:domain – The domain name of domain server.

:defrouter – Default router address. The IP address for default router. This is a TCP/IP address expressed in standard “dot notation”. IP addresses consist of the system’s network number and the machine’s unique host number.

After successful completion of this command, the system returns the following message:

```

RLGHNCXA03W 01-10-30 21:20:37 GMT EAGLE 35.0.0
CHG-IP-CARD: MASP A - COMPLTD

```

61. Verify the local domain and IP router address associated with the VSCCP card in the database by entering the **rtrv-ip-card** command. This is an example of the possible output:

```

RLGHNCXA03W 01-10-30 21:21:37 GMT EAGLE 35.0.0
LOC 1101
  SRCHORDR  LOCAL
  DNSA      -----
  DNSB      -----
  DEFROUTER 192.168.122.250
  DOMAIN    NC.TEKELEC.COM

```

62. Display the current link parameters associated with the VSCCP card in the database by entering the `rtrv-ip-lnk` command. This is an example of the possible output:

```

RLGHNCXA03W 01-10-30 21:14:37 GMT EAGLE 35.0.0
LOC  PORT IPADDR          SUBMASK          DUPLEX  SPEED  MACTYPE  AUTO  MCAST
1101  A  -----  -----  HALF    10    DIX      NO   NO
1101  B  -----  -----  HALF    10    DIX      NO   NO
1107  A  -----  -----  HALF    10    DIX      NO   NO
1107  B  -----  -----  HALF    10    DIX      NO   NO

```

63. Change the link parameters associated with the VSCCP card in the database using the `chg-ip-lnk` command. For this example, enter these commands:

```

chg-ip-lnk:loc=1101:port=a:duplex=half:ipaddr=192.168.122.2
:mactype=dix:speed=100:mcast=yes:submask=255.255.255.0

```

```

chg-ip-lnk:loc=1101:port=b:duplex=half:ipaddr=192.168.123.2
:mactype=dix:speed=10:mcast=yes:submask=255.255.255.0

```

where:

:loc – The card location of the card within the EAGLE 5 ISS.

:port – The port ID. The `port` parameter of the `chg-ip-lnk` command specifies the physical interface of the DSM card.

:ipaddr – IP address assigned to the port. This is a TCP/IP address expressed in standard “dot notation.” IP addresses consist of the system’s network number and the machine’s unique host number.

:duplex – This is the mode of operation of the interface.

:speed – This is interface bandwidth in megabits per second. The speed is either 100 Mbps for main DSM network or 10 Mbps for backup DSM network.

:mactype – This is the Media Access Control Type of the interface. Specify `dix` for the Digital/Inter/Xerox *de facto* standard for the Ethernet.

:mcast – This is the Multicast Control of the interface.

:submask – The subnet mask of the IP interface, in the form of an IP address with a restricted range of values.

When this command has successfully completed, the following message should appear.

```

RLGHNCXA03W 01-10-30 21:18:37 GMT EAGLE 35.0.0
CHG-IP-LNK: MASP A - COMPLTD

```

64. Verify the new link parameters associated with the VSCCP card in the database by entering the `rtrv-ip-lnk` command. The following is an example of the possible output.

```
RLGHNCXA03W 01-10-30 21:14:37 GMT EAGLE 35.0.0
LOC  PORT  IPADDR          SUBMASK          DUPLEX  SPEED  MACTYPE  AUTO  MCAST
1101  A     192.168.122.2     255.255.255.0   HALF    100    DIX      NO    YES
1101  B     192.168.123.2     255.255.255.0   HALF    10     DIX      NO    YES
1107  A     192.168.122.1     255.255.255.0   HALF    100    DIX      NO    YES
1107  B     192.168.123.1     255.255.255.0   HALF    10     DIX      NO    YES
```

65. Boot the DSM card that was inhibited in step 48 in TSM emulation mode by using the `alw-card` command. For example, enter this command:

```
alw-card:loc=1101
```

This message appears:

```
RLGHNCXA03W 01-10-30 21:20:37 GMT EAGLE 35.0.0
Card has been allowed.
```

66. Verify the in-service normal (IS-NR) status of the VSCCP card using the `rept-stat-card` command. This is an example of the possible output:

```
RLGHNCXA03W 01-10-27 16:43:42 GMT EAGLE 35.0.0
CARD  VERSION          TYPE  APPL  PST          SST  AST
1101  100-000-00003-000  DSM   VSCCP  IS-NR       Active ---
1103  100-000-00002-000  ACMENET STPLAN  IS-NR       Active ---
1104  100-000-00003-000  ASM    GLS     IS-NR       Active ---
1105  100-000-00003-000  LIMOCU CCS7ITU  IS-NR       Active ---
1106  100-000-00003-000  LIMOCU CCS7ITU  IS-NR       Active ---
1107  100-000-00003-000  DSM    VSCCP  IS-NR       Active ---
1113  100-000-00002-000  MCAP   OAM     IS-NR       Active ---
1114  100-000-00002-000  TDM    IS-NR    Active ---
1115  100-000-00002-000  MCAP   OAM     IS-NR       Active ---
1116  100-000-00002-000  TDM    IS-NR    Active ---
1117  100-000-00002-000  MDAL   IS-NR    Active ---
1201  100-000-00003-000  LIMDS0 SS7ANSI  IS-NR       Active ---
1202  100-000-00002-000  LIMV35 SS7GX25  IS-NR       Active ---
1203  100-000-00003-000  LIMV35 SS7ANSI  IS-NR       Active ---
1204  100-000-00003-000  LIMATM ATMANSI  IS-NR       Active ---
1205  100-000-00001-000  DCM    IPLIM   IS-NR       Active ---
1207  100-000-00001-000  DCM    SS7IPGW IS-NR       Active ---
1303  100-000-00001-000  DCM    IPLIM   IS-NR       Active ---
1305  100-000-00001-000  DCM    SS7IPGW IS-NR       Active ---
```

67. Test the presence of the EPAP hosts on the network using the `pass` command with the `ping` parameter. This command is invoked with a destination (either a hostname or IP address). For example, enter the following command:

```
pass:loc=1101:cmd="ping 192.168.122.100".
```

```
pass:loc=1101:cmd="ping 192.168.122.200".
```

```
pass:loc=1101:cmd="ping 192.168.123.100".
```

```
pass:loc=1101:cmd="ping 192.168.123.200".
```

G-Flex Feature Activation

After successful completion of each command, the system returns output similar to the following:

```
rlghncxa03w 00-06-27 08:30:44 GMT EAGLE 35.0.0
pass: loc=1101: cmd="ping 192.168.122.100"
Command entered at terminal #1.
;
rlghncxa03w 00-06-27 08:30:44 GMT EAGLE 35.0.0
PASS: Command sent to card
;
rlghncxa03w 00-06-27 08:30:44 GMT EAGLE 35.0.0
PING command in progress
;
rlghncxa03w 00-06-27 08:30:46 GMT EAGLE 35.0.0
PING 192.168.122.100: 56 data bytes
64 bytes from tekral.nc.tekelec.com (192.168.122.100):icmp_seq=0.time=5. ms
64 bytes from tekral.nc.tekelec.com (192.168.122.100):icmp_seq=1.time=0. ms
64 bytes from tekral.nc.tekelec.com (192.168.122.100):icmp_seq=2.time=0. ms
----192.168.100.3 PING Statistics----
3 packets transmitted, 3 packets received, 0% packet loss
round-trip (ms) min/avg/max = 0/1/5
PING command complete
```

If the **pass** command with the **ping** parameter is not successful, verify the the correct connection of the hardware cabling and try again. If the command fails again, contact Technical Services (see “Customer Assistance” on page 1-9).

-
68. Repeat steps 46 through 67 to replace all adjacent TSM cards identified in the prerequisites and to be replaced with DSM cards.

-
69. Repeat steps 48 through 52 to inhibit any remaining TSM cards running the SCCP application and remove them from database and shelf.

NOTE: The G-Flex feature cannot be turned on until TSM cards running the SCCP application are removed from the system.



CAUTION: At this point in the procedure, contact Tekelec Technical Services for assistance in completing this G-Flex activation procedure (see “Customer Assistance” on page 1-9).

Do not proceed without consulting with Technical Services.

-
70. Turn on the G-Flex feature using steps 71 through 82.

-
71. Enable the G-Flex feature using the following command:

```
chg-feat:gflex=on
```

The system returns the following output:

```
rlghncxa03w 01-10-11 11:34:04 GMT EAGLE 35.0.0
CHG-FEAT: MASP A - COMPLD
```

72. Enter the default country code (CC) and default network destination code (NDC) to convert the nature of address indicator (NAI) of MSISDNs to the international format (**nai=int1**) with the **chg-stpopts** command. Enter the command by network type.

For an ANSI network, for example, enter the following command:

```
chg-stpopts: defcc=1: defndc=972
```

For an ITU-I or ITU-N network, for example, enter the following command:

```
chg-stpopts: defcc=1: defndc=38: dsmaud=on: npcfmt1=2-9-2-1
```

where:

:defcc – The default country code.

:defndc – The default network destination code.

:dsmaud – The DSM audit running state (*on* or *off*).

:npcfmt1 – The ITU National Point Code Format Identifier, which identifies how the ITU-N point code is entered into the database and how it is displayed in all EAGLE 5 ISS outputs. This code is a 14-bit integer.

After successful completion of this command, the system returns the following output:

```
rlghncxa03w 01-10-07 00:57:31 GMT EAGLE 35.0.0
CHG-STPOPTS: MASP A - COMPLTD
```

73. Verify the new country code and network destination code using the **rtrv-stpopts** command. This is an example of the possible output in an ANSI network:

```
rlghncxa03w 01-10-07 00:57:31 GMT EAGLE 35.0.0
STP OPTIONS
-----
DEFCC                1
DEFNDC                972
```

This is an example of the possible output in an ITU-I or ITU-N network:

```
rlghncxa03w 01-10-07 00:57:31 GMT EAGLE 35.0.0
STP OPTIONS
-----
NPCFMTI              2-9-2-1
DEFCC                1
DEFNDC                38
DSMAUD                on
```

74. Change the default mobile country code (MCC) and default mobile network destination code (MNDC) to convert the nature of address indicator (NAI) of IMSIs to the international format (**nai=intl**). Enter the **chg-gsmopts** command by network type.

For an ANSI network, for example, enter the following command:

```
chg-gsmopts:ccnc=1972:defmcc=919:defmnc=6666:mccmnc=9196666
```

For an ITU/N network, for example, enter the following command:

```
chg-gsmopts:defmcc=214:defmnc=34:ccnc=334:mccmnc=22435
```

where:

:**ccnc** defines the E214 country code and network code.

:**defmcc** defines the default GSM mobile country code.

:**defmnc** defines the default GSM mobile network code.

:**mccmnc** defines the E212 mobile country code and mobile network code.

The system returns the following message:

```
rlghncxa03w 00-08-20 09:04:14 GMT EAGLE 35.0.0  
CHG-GSMOPTS: MASP A - COMPLTD
```

75. Verify the changes using the **rtrv-gsmopts** command. This command displays all GSM (Global System for Mobile Telecommunication) system options from the database. This is an example of the possible output in an ANSI network:

```
rlghncxa03w 00-08-20 09:04:14 GMT EAGLE 35.0.0  
GSMOPT OPTIONS  
-----  
DEFMCC=919  
DEFMNC=6666  
CCNC=1977  
MCCMNC=9196666
```

This is an example of the possible output in an ITU-I or ITU-N network:

```
rlghncxa03w 00-08-20 09:04:14 GMT EAGLE 35.0.0  
GSMOPT OPTIONS  
-----  
DEFMCC=214  
DEFMNC=34  
CCNC=334  
MCCMNC=22435
```

76. Use the **ent-srvsel** command to enter the G-Flex service selectors by network type. This command assigns applicable service selectors required to specify the service entry for DSM services.

For an ANSI network, for example, the following commands show how to set up service selector combinations for G-Flex services:

```
ent-srvsel:gtia=2:tt=10:snp=e164:snai=intl:serv:gflex
ent-srvsel:gtia=2:tt=11:snp=e164:snai=natl:serv:gflex
ent-srvsel:gtia=2:tt=12:snp=e164:snai=sub:serv:gflex
```

For an ITU-I network, for example, enter the following command:

```
ent-srvsel:gtii=4:tt=1:snp=e164:snai=intl:serv:gflex:nai=intl
:np=e164
```

where:

:gti/gtia/gtii/gtin - specifies the global title translation indicator (2 = ANSI, ITU; 4 = ITU).

:tt - specifies the translation type.

:snp - defines the service numbering plan (e164, e212, or e214).

:snai - specifies the international Service Nature of Address Indicator.

:serv - specifies the service feature.

:nai - specifies the nature of address indicator.

:np - specifies the numbering plan.

The system returns the following message:

```
rlghncxa03w 01-10-07 00:28:31 GMT EAGLE 35.0.0
Service Selector table is (114 of 1024) 11% full
ENT-SRVSEL: MASP A - COMPLTD
```

77. Verify the changes using the **rtrv-srvsel** command. This command retrieves a list of administered service selector combinations. Avoid lengthy output by filtering the list using various parameter combinations. (The selector table can have over 1,000 entries.) For example, enter this command:

```
rtrv-srvsel:gtia=2
rtrv-srvsel:gtii=2
rtrv-srvsel:gtii=4
```

After successful completion of this command, the system returns output similar to the following:

```
rlghncxa03w 01-10-28 00:29:31 GMT EAGLE 35.0.0
GTIA TT NP NAI NPV NAIV SNP SNAI SERV
2 10 --- --- --- --- e164 intl gflex
2 11 --- --- --- --- e164 natl gflex
2 12 --- --- --- --- e164 sub gflex

rlghncxa03w 01-10-28 00:29:31 GMT EAGLE 35.0.0
GTII TT NP NAI NPV NAIV SNP SNAI SERV
2 0 e164 intl --- --- e164 intl gflex
2 1 e164 intl --- --- e164 intl gflex
```

G-Flex Feature Activation

```
rlghncxa03w 01-10-28 00:29:31 GMT EAGLE 35.0.0
GTII TT NP NAI NPV NAIV SNP SNAI SERV
4 1 e164 intl --- --- e164 intl gflex
4 2 e164 intl --- --- e164 intl gflex
```



CAUTION: When you have an in-service environment and you are replacing TSM cards with DSM cards, initialize one DSM card at a time. Verify its return to IS-NR state before initializing another DSM card. This precaution keeps cards in service and precludes an interruption of SCCP services.

NOTE: GTT, EGTT, and VGTT traffic are routed based on the global titles in the OAM database while G-Flex, G-Port, and INP traffic is routed based on the global title in the RTDB. Rebooting a DSM card running the VSCCP application causes both the OAM and RTDB databases on the DSM card to reload.

78. Reload a DSM card using the `init-card` command. For example, enter this command:

```
init-card:loc=1101
```

The system returns the following message:

```
rlghncxa03w 01-10-07 00:28:31 GMT EAGLE 35.0.0
Command entered at terminal #3.
Init Card command issued to card 1101
```

79. Verify its return to IS-NR state with the `rept-stat-card` command. (Wait until in-service state is restored.) This is an example of the possible output:

```
RLGHNCXA03W 01-10-07 00:30:42 GMT EAGLE 35.0.0
CARD VERSION TYPE APPL PST SST AST
1101 100-000-00003-000 DSM VSCCP IS-NR Active ---
1103 100-000-00002-000 ACMENET STPLAN IS-NR Active ---
1104 100-000-00003-000 ASM GLS IS-NR Active ---
1105 100-000-00003-000 LIMOCU CCS7ITU IS-NR Active ---
1106 100-000-00003-000 LIMOCU CCS7ITU IS-NR Active ---
1107 100-000-00003-000 DSM VSCCP IS-NR Active ---
1113 100-000-00002-000 MCAP OAM IS-NR Active ---
1114 100-000-00002-000 TDM IS-NR Active ---
1115 100-000-00002-000 MCAP OAM IS-NR Active ---
1116 100-000-00002-000 TDM IS-NR Active ---
1117 100-000-00002-000 MDAL IS-NR Active ---
1201 100-000-00003-000 LIMDS0 SS7ANSI IS-NR Active ---
1202 100-000-00002-000 LIMV35 SS7GX25 IS-NR Active ---
1203 100-000-00003-000 LIMV35 SS7ANSI IS-NR Active ---
1204 100-000-00003-000 LIMATM ATMANSI IS-NR Active ---
1205 100-000-00001-000 DCM IPLIM IS-NR Active ---
1207 100-000-00001-000 DCM SS7IPGW IS-NR Active ---
1303 100-000-00001-000 DCM IPLIM IS-NR Active ---
1305 100-000-00001-000 DCM SS7IPGW IS-NR Active ---
```

80. After the `init-card` and the `rept-stat-card` commands show that service is successfully restored, repeat steps 78 and 79 for each DSM card in your system.
-

81. Enter the **chg-sccp-serv:serv=gflex:state=online** command to set the G-Flex service state online.

82. Confirm that essential activation procedures are successful.

- Use **rept-stat-sccp** to verify all your DSM cards are loaded and are IS-NR (in-service normal) status.
 - Use **rept-stat-mps** to verify all your DSM cards and the EPAP are connected and operational.
 - Use **rept-stat-db:display=all** to verify database levels are identical for the EPAP PDB and RTDB and the RTDBs on the DSM cards.
-

The G-Flex feature is now installed, activated, and ready for operations.

Maintenance and Measurements

Hardware Requirements	5-1
EPAP Status and Alarms	5-1
G-Flex System Status Reports	5-4
Code and Application Data Loading	5-5
G-FLEX Related Alarms	5-11
G-Flex Related UIMs	5-15
G-Flex Measurements	5-16

Hardware Requirements

The G-Flex feature requires DSM-based boards to run the VSCCP GPL. The EAGLE 5 ISS may be equipped with from 1 to 25 DSM boards to support G-Flex.



CAUTION: Having a mix of SCCP and VSCCP card types is not permitted with the G-Flex feature enabled, that is, VSCCP cards and SCCP cards cannot coexist in a system operating the G-Flex feature.

Refer to the *Dimensioning Guide for EPAP Advanced DB Features Technical Reference* for important information on the dimensioning rules and the DSM database capacity requirements.

EPAP Status and Alarms

EPAP has no direct means of accepting user input or displaying output messages on EAGLE 5 ISS terminals, so maintenance, measurements, and status information are routed through a DSM. EPAP sends two types of messages to the DSM: EPAP maintenance blocks and DSM status requests. Each is discussed in the following sections.

EPAP Maintenance Blocks

The active EPAP generates and sends maintenance blocks to the primary DSM. One maintenance block is sent as soon as the IP link is established between the active EPAP and the primary DSM. Additional maintenance blocks are sent whenever the EPAP needs to report any change in status or error conditions. The information returned in maintenance blocks is included in the output of the **rept-stat-mps** and **rept-stat-sccp** commands.

The EPAP sends maintenance blocks that contain (at least) the following information.

- Status of EPAP 'A' - actual states are active, standby, and down (inoperative). Maintenance blocks include a field so this information can be forwarded to the EPAP A DCB, where it is available for the output of the **rept-stat-mps** command.
- Status of EPAP 'B' - actual states are active, standby, and down (inoperative). Maintenance blocks include a field so this information can be forwarded to the EPAP B DCB, where it is available for the output of the **rept-stat-mps** command.
- Identification of active EPAP - a field to identify the active EPAP.
- Congestion indicator - an indicator showing provisioning link congestion. The link between the EPAPs and the external source of provisioning data can become congested in high provisioning traffic situations. When this occurs and subsequently as the congestion clears, the EPAP sends maintenance blocks to the DSM. The EPAP must ensure that no more than one maintenance block per second is sent to the primary DSM if the only reason is to report a change in congestion status.
- Alarm conditions - an error code field. If the EPAP needs to report an alarm condition, it puts an appropriate UAM identifier in this field.
- Current MPS database size - a field indicating the current RTDB size. The DSM uses this information to calculate the percentage of memory utilized by the RTDB.

DSM Status Requests

When the EPAP needs to know the status of a DSM, it can send a DSM Status Request to that DSM. Since status messages are sent over UDP, the EPAP broadcasts the DSM Status Request and all DSMs return their status to the EPAP.

DSM Status Reporting to the EPAP

The sections that follow describe the DSM status reporting for the EPAP.

DSM Status Messages – When Sent

The EPAP needs to know the current status of various aspects of the DSMs. Accordingly, the DSM sends a DSM status message to the EPAP when the following events occur:

- When the DSM is booted.
- When the DSM receives a DSM Status Request message from the EPAP.
- When the DSM determines that it needs to download the entire database, for example, if the DSM determines that the RTDB needs to be downloaded (for instance, if the database is totally corrupted), or if a craftsman requests that the database be reloaded.
- When the DSM starts receiving DB downloads or DB updates. When the DSM card(s) starts downloading the RTDB, or if the DSM starts accepting database updates, it needs to send a status message informing the EPAP of the first record received. This helps the EPAP keep track of downloads in progress.

DSM Status Message Fields

The DSM status message provides the following information to the EPAP:

- **DSM Memory Size.** When the DSM is initialized, it determines the amount of applique memory present. The EPAP uses this value to determine if the DSM has enough memory to hold the RTDB.
Refer to the *Dimensioning Guide for EPAP Advanced DB Features Technical Reference* for important information on the dimensioning rules and the DSM database capacity requirements.
- **Load Mode Status.** This is a flag indicating whether or not 80% of the IS-NR LIMs have access to SCCP services.

Hourly Maintenance Report

The Hourly Maintenance Report, generated automatically, includes the alarm totals of the G-Flex subsystem and DSM/EPAP IP links. A sample follows.

```
eagle10506 99-10-10 16:00:01 EST EAGLE 35.0.0
5072.0000 REPT COND GSM SS
"GSM SS :0440,MTCEINT-0,SA,99-10-10,16:00:01,,,,*C"
;
eagle10506 99-10-10 16:00:01 EST EAGLE 35.0.0
5073.0000 REPT COND INP SS
"INP SS :0440,MTCEINT-0,SA,99-10-10,16:20:01,,,,*C"
;
eagle10506 99-10-10 16:00:01 EST EAGLE 35.0.0
5077.0000 REPT COND EPAPDSM
"EPAPDSM :0084,MTCEINT-0,SA,99-10-10,16:00:01,,,,**"
;
eagle10506 99-10-10 16:00:01 EST EAGLE 35.0.0
5007.0000 REPT COND CARD
"CARD 1102:0422,SCMMA,SA,99-10-10,16:00:01,,,,**"
;
```

```
eagle10506 99-09-13 16:00:01 EST EAGLE 35.0.0
3561.0000 REPT COND ALARM STATUS
"ALARMS:PERM. INHIBITED,0,0,0"
"ALARMS:TEMP. INHIBITED,0,0,0"
"ALARMS:ACTIVE,10,14,3"
"ALARMS:TOTAL,10,14,3"
```

;

G-Flex System Status Reports

Status reporting described here includes the following:

- System status
- G-Flex status
- DSM memory capacity status
- Loading mode support status

System Status Reporting

The `rept-stat-sys` command supports the DSM cards running the VSCCP application.

The `rept-stat-sccp` command supports the DSM cards running the VSCCP application and reports G-Flex statistics.

G-Flex Status Reporting

The `rept-stat-mps` command is a new command that supports G-Flex system reporting. `rept-stat-mps` concentrates on reporting the status of the G-Flex provisioning system. See Chapter 3, *Maintenance and Measurements Commands*, page 3-10, for more details. G-Flex statistics are placed in the `rept-stat-sccp` command.

DSM Memory Capacity Status Reporting

As mentioned in the “DSM Status Reporting to the EPAP” section, page 5-2, the DSM sends a message to the EPAP containing the amount of memory on the DSM board. The EPAP determine whether the DSM has enough memory to store the RTDB and send an `ack` or `nak` back to the DSM indicating whether or not the DSM has an adequate amount of memory. Refer to the *Dimensioning Guide for EPAP Advanced DB Features Technical Reference* for important information on the dimensioning rules and the DSM database capacity requirements.

Maintenance and Measurements

When the EPAP sends database updates to the DSMs, the update messages include a field that contains the new database memory requirements. Each DSM monitors the DB size requirements, and issues a minor alarm if the size of the DB exceeds 80% of its memory. If a database increases to the point that there is insufficient DSM memory, a major alarm is issued.

The `rept-stat-mps:loc=xxxx` command shows the amount of memory used by the RTDB as a percent of available DSM memory.

Loading Mode Support Status Reporting

The OAM application determines whether or not the system is in an unstable loading mode since it knows the state of all LIM, SCCP, and DSM cards in the system. When the loading mode is unstable, the `rept-stat-sys` command reports the existence of the unstable loading mode and the specific conditions that caused it. Refer to the "Loading Mode Support" section, page 5-6, for more details.

Code and Application Data Loading

DSM Code Loading

The EAGLE 5 ISS OAM code loads the DSM card.

EPAP Application Data Loading

The G-Flex feature requires that (new) TDM-resident data tables be loaded in addition to those currently supported by EAGLE 5 ISS. The GPL and data loading support this additional table loading while maintaining support for loading the existing EAGLE 5 ISS tables.

In order to support both RTDB and STP data loading, the VSCCP GPL verifies its hardware configuration during initialization to determine if it has the capacity to support the RTDB.

The VSCCP GPL application data loader registers all tables for loading, independent of the G-Flex feature provisioning and main board / applique hardware configuration. As a result, load requests are always identical. During loading, multiple DSM load requests can then be combined into a single download, reducing the overall download time. The DSM card stores or discards RTDB table data based on whether or not it has RTDB-capable hardware for features like G-Flex, G-Port, and INP.

The OAM, on the other hand, downloads or sets memory boundaries for the G-Flex options, entity, and service selector tables only if the G-Flex feature is provisioned. When the G-Flex feature is not provisioned, the OAM does not attempt to read these tables from disk. Instead, empty tables (that is, tables without entries) are downloaded. All other tables requested for loading are read from disk and downloaded routinely.

Non-G-Flex Data Initialization

If the DSM card's hardware configuration cannot support the RTDB, the G-Flex tables are marked as absent during Service Management System initialization. Memory is not reserved for the G-Flex table data. Additionally, the G-Flex tables are registered with the application data loader (ADL) specifying a data discard function. G-Flex table data is discarded during loading by the ADL discard function, rather than storing it in memory.

G-Flex Data Initialization

If the DSM card detects G-Flex-capable hardware, the G-Flex tables are registered with ADL specifying a data load function. Any G-Flex table data downloaded are stored in memory during loading.

EPAP-DSM Loading Interface

The DSM must convey to the EPAP that it needs to download the RTDB. This is done when the DSM sends a Full Download Request message to the EPAP.

Loading Mode Support

No more than 16 LIMs can be serviced by each SCCP (or VSCCP) card.

80% Threshold of Support

Loading mode is based on the ability of the system to provide SCCP service to at least 80% of the LIMs.

VSCCP Capacity

An insufficient number of VSCCP cards that are `is-nr` or `oos-mt-dsbl'd` relative to 80% of the number of provisioned LIMs is called a "failure to provide adequate SCCP capacity."

Insufficient SCCP Service

It is also possible for LIMs or VSCCP cards to be inhibited or to have problems that prevent them from operating normally. If enough VSCCP cards are out of service, it may not be possible for the remaining `is-nr` VSCCP cards to service at least 80% of the number of `is-nr` LIMs. This is called "insufficient SCCP service." When this occurs, some of the LIMs are denied SCCP service. It is possible to inhibit LIMs to bring the ratio back to 16:1 (or better).

Conditions That Create an Unstable Loading Mode

Current system implementation interrupts and aborts card loading upon execution of an STP database **chg** command. Loading mode support denies the execution of STP database **chg** commands when the system is in an unstable loading mode. An unstable loading mode exists when any of the following conditions are true:

- The system's maintenance baseline has not been established.
- Less than 80% of the number of LIMs provisioned are **is-nr** or **oos-mt-dsblld**.
- The number of **is-nr** and **oos-mt-dsblld sccp** cards is insufficient to service at least 80% of all provisioned LIMs.
- Insufficient SCCP service occurs when an insufficient number of **is-nr** VSCCP cards are available to service at least 80% of the number of **is-nr** LIMs.
- LIM cards are being denied SCCP service and any VSCCP cards are in an abnormal state (**oos-mt, is-anr**).

Actions Taken When the System is in an Unstable Loading Mode

- No affect on RTDB downloads or updates.

Unstable loading mode has no impact on RTDB downloads or the stream of RTDB updates.

- **rept-stat-sys** reports unstable loading mode.

When the loading mode is unstable, the **rept-stat-sys** command reports the existence of the unstable loading mode and the specific trigger that caused it.

- No STP database updates allowed.

When in an unstable loading mode, the EAGLE 5 ISS does not accept STP database updates. When updates are rejected, the reason is given as **E3112 Cmd Rej: Loading Mode unstable due to SCCP service is deficient.**

The **inh-card** and **alw-card** commands can be used to alter SCCP service levels to achieve the 80% threshold. This can be repeated for each card until the system is able to supply SCCP services to at least 80% of the **is-nr** LIMs. The remaining 20% LIM or supporting VSCCP cards may remain out of service until the stream of STP database updates ceases. This stream of updates can be temporarily interrupted to allow the remaining 20% of the system to come in service.

Once an STP database has been loaded, that database can be updated (as long as the system is not in an unstable loading mode). However, if an STP update comes in during STP database loading, the DSM aborts the current loading, issues a class 01D7 obit, and reboots. Figure 5-1 shows an example.

Figure 5-1. Obit Message for Card Loading Abort

```

tekelecstp 97-04-08 12:29:04 EST EAGLE 35.0.0
-----
STH: Received a BOOT Appl-obituary reply for restart
Card 1317 Module RADB_MGR.C Line 337 Class 01d7
Register Dump :
  EFL=00000246      CS =0058      EIP=0000808d      SS =0060
  EAX=000a6ff3     ECX=000a0005     EDX=00000000     EBX=000a6fa0
  ESP=00108828     EBP=0010882c     ESI=001f1e10     EDI=00000000
  DS =0060         ES =0060         FS =0060         GS =0060

Stack Dump :
[SP+1E]=001f      [SP+16]=0000      [SP+0E]=000a      [SP+06]=0010
[SP+1C]=1e10      [SP+14]=0004      [SP+0C]=6fa0      [SP+04]=8850
[SP+1A]=0010      [SP+12]=001f      [SP+0A]=0004      [SP+02]=0001
[SP+18]=886c      [SP+10]=4928      [SP+08]=7ec3      [SP+00]=504b

User Data Dump :
14 02 fa ed 01 01 1d 01 5a 01 00      .....Z..

Report Date:97-04-08 Time:12:29:04

```

Using the force Option

Use the **force** option to execute commands that would put the system in unstable loading mode. If executing the **ent-card** or **inh-card** commands would cause the system to enter an unstable loading mode, use the **force** option on the command.

State Transitions during Start-Up

Figures 5-2 through 5-9 show the transitions that a DSM card goes through as it boots, loads code and data, and runs various VSCCP services. These figures do not illustrate every possible situation, but they do include the most common scenarios involving the G-Flex feature.

In Figure 5-2, the G-Flex feature is not enabled, and the DSM card can operate in TSM emulation mode, although it does not provide G-Flex operation.

Figure 5-2. G-Flex Not Enabled, DSM Running in TSM Emulation

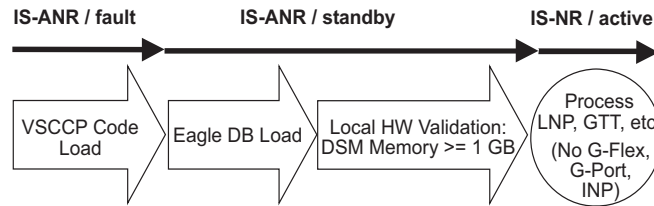

In Figure 5-3, the G-Flex feature is enabled, and the DSM card memory is at least 1 GB and is connected to the EPAP. A normal DSM card operating sequence occurs, providing G-Flex service.

Figure 5-3. G-Flex Enabled, Normal Operating Sequence

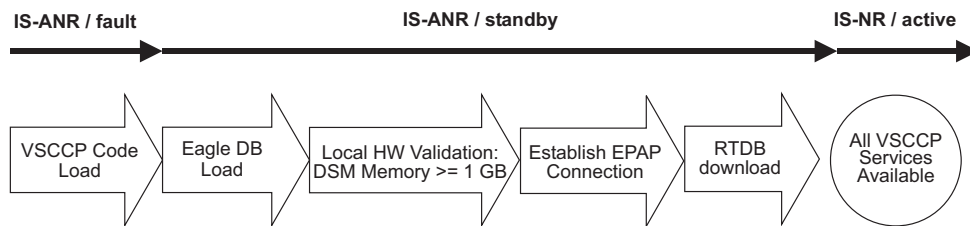

In Figure 5-4, the G-Flex feature is enabled, but the DSM card memory is less than 1 GB. The G-Flex feature cannot begin operation. Refer to the *Dimensioning Guide for EPAP Advanced DB Features Technical Reference* for important information on the dimensioning rules and the DSM database capacity requirements.

Figure 5-4. G-Flex Enabled, but DSM Memory Less Than 1 GB

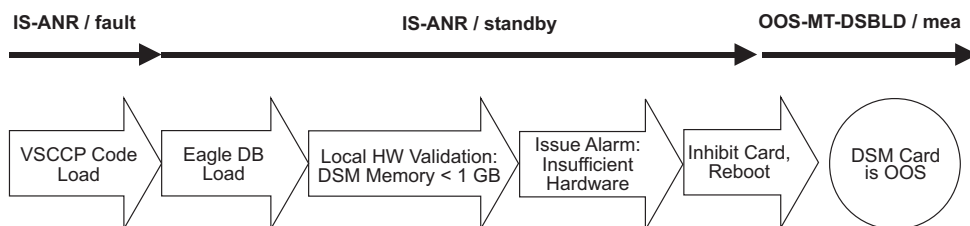

In Figure 5-5, the G-Flex feature is enabled, the DSM card memory has at least 1 GB, but the DSM card is unable to connect EPAP; the G-Flex cannot begin operation.

Figure 5-5. G-Flex Enabled, but DSM Not Connected to EPAP

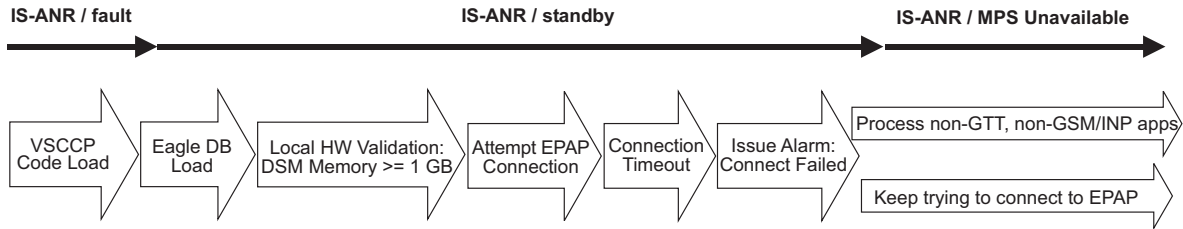

In Figure 5-6, the G-Flex feature is enabled, the DSM card has the required 1 GB memory and is connected to the EPAP, but the DSM card is too small for the required database; the G-Flex cannot begin operation. Refer to the *Dimensioning Guide for EPAP Advanced DB Features Technical Reference* for important information on the dimensioning rules and the DSM database capacity requirements.

Figure 5-6. G-Flex Enabled, but DSM Memory Insufficient for Database

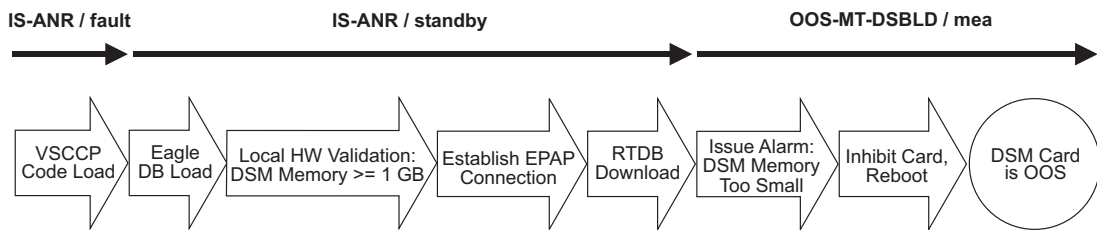

In Figure 5-7, the G-Flex feature is enabled, the DSM card is connected to the EPAP, but the RTDB grows eventually to exceed the capacity of the DSM card memory, despite its memory size of at least 1 GB (an alarm is issued when the DSM memory becomes full from the RTDB update). The G-Flex cannot begin operation. Refer to the *Dimensioning Guide for EPAP Advanced DB Features Technical Reference* for important information on the dimensioning rules and the DSM database capacity requirements.

Figure 5-7. G-Flex Enabled, but Database Exceeds DSM Memory

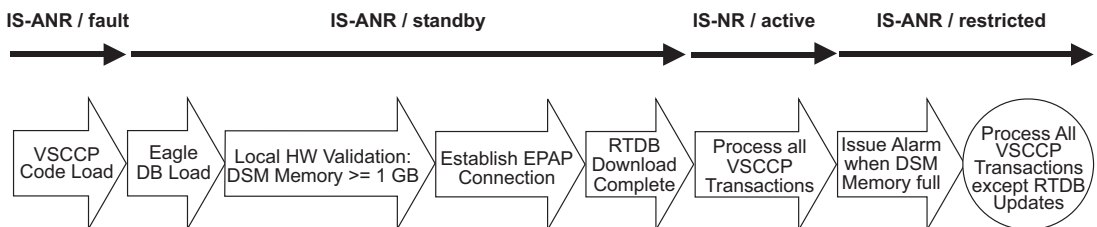

Maintenance and Measurements

In Figure 5-8, the G-Flex feature is not initially enabled; the DSM card memory has at least 1 GB but no EPAP connection; the DSM card is running other applications when the G-Flex feature is turned on; the DSM has sufficient memory to provide G-Flex service.

Figure 5-8. G-Flex Not Enabled at First, but then Activated on DSM

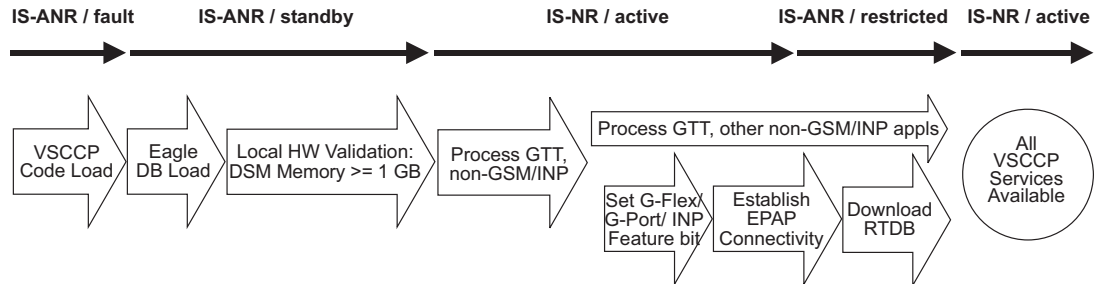

In Figure 5-9, the G-Flex feature is not initially enabled; the DSM card memory has at least 1 GB but no EPAP connection, and is running other applications when the G-Flex feature is turned on. However, the DSM card memory is insufficient for the needed database, and the cannot provide G-Flex operation. Refer to the *Dimensioning Guide for EPAP Advanced DB Features Technical Reference* for important information on the dimensioning rules and the DSM database capacity requirements.

Figure 5-9. G-Flex Activation Unsuccessful due to Insufficient Database

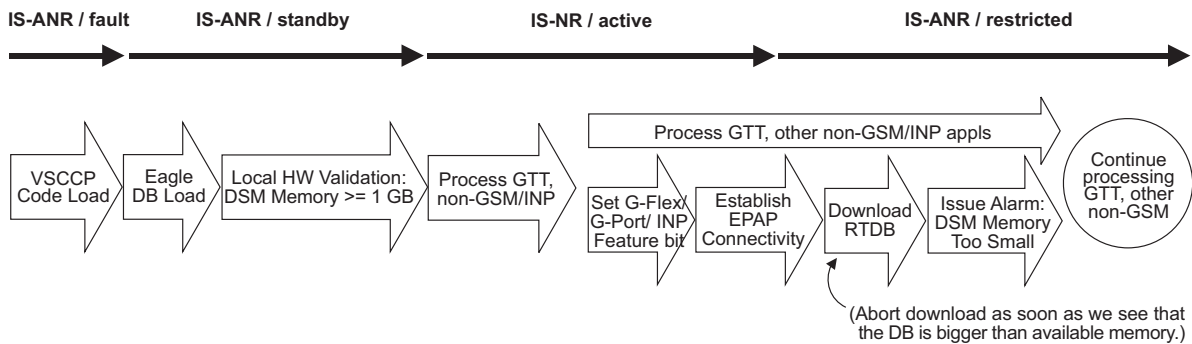

G-FLEX Related Alarms

Refer to the *Maintenance Manual* for a complete description and the associated corrective procedure for all G-Flex related UAMs.

EPAP - DSM Connection Status

The EPAP and the DSM are connected over a 100-Mbit Ethernet link and use TCP/IP. If this connection is inoperative, the DSM generates an appropriate UAM. Loss of connectivity or inability of the EPAP to communicate (for example, hardware or software failure) is detected and reported within 10 seconds.

EPAP UAMs

The maintenance blocks from the EPAP have a field used to identify error message requests. The DSM processes the incoming maintenance blocks and generates the requested UAM. The actual EPAP UAMs are defined in the *Maintenance Manual*; the DSM only acts as a delivery agent.

DSM Failure

No new alarms have been created to report DSM failure. The existing card alarm UAM 013, *Card is isolated from the system*, indicates a DSM card failure. The DSM failure alarm is output to the Card Output Group.

DSM-EPAP Link

Two alarms are used to indicate the DSM-to-EPAP link status:

- 0084, *IP Connection Unavailable* (Major)
- 0085, *IP Connection Available* (Normal/Clearing)

The DSM-EPAP Link alarms are output to the Link Maintenance Output Group. See the *Maintenance Manual* for details on these UAM formats.

Example:

```

1           2           3           4           5           6           7           8
1234567890123456789012345678901234567890123456789012345678901234567890
station1234 00-04-30 16:28:08 EST EAGLE 35.0.0
** 3582.0084 ** VSCCP PORT B 1217 IP Connection Unavailable
```

DSM Hardware-Related Alarms

A major alarm appears when a DSM card does not have the hardware configuration required for the G-Flex application. Loading the DSM card is automatically inhibited. Card alarms can be inhibited and uninhibited with the **inh-alm** and **unhb-alm** commands. The DSM Hardware-Related alarms are output to the Card Output Group.

Example:

```

1           2           3           4           5           6           7           8
1234567890123456789012345678901234567890123456789012345678901234567890
station1234 00-04-30 16:28:08 EST EAGLE 35.0.0
** 0012.0441 ** CARD 1108 VSCCP Incorrect main board - CPU
```

Maintenance and Measurements

A major alarm is displayed when a DSM card detects that its applique memory is at least 80% full. The actual memory usage can be displayed by entering the **rept-stat-mps:loc=xxxx** command.

Example:

```
1 2 3 4 5 6 7 8
1234567890123456789012345678901234567890123456789012345678901234567890
station1234 00-04-30 16:28:08 EST EAGLE 35.0.0
** 0012.0446 ** CARD 1108 VSCCP RTDB database capacity is 80% full
```

A critical alarm is generated when a DSM card detects that its applique memory is 95% full. Loading of the DSM card is automatically inhibited when it reaches 100% of capacity. The actual memory usage can be displayed by entering the **rept-stat-mps:loc=xxxx** command.

Example:

```
1 2 3 4 5 6 7 8
1234567890123456789012345678901234567890123456789012345678901234567890
station1234 00-04-30 16:28:08 EST EAGLE 35.0.0
*C 0012.0442 *C CARD 1108 VSCCP RTDB database capacity is 95% full
```

A major alarm is displayed when a DSM card does not have an applique with at least 1 GB of memory or does not have enough capacity for the RTDB. This alarm is generated whenever the DSM detects that its memory cannot contain the RTDB.

Example:

```
1 2 3 4 5 6 7 8
1234567890123456789012345678901234567890123456789012345678901234567890
station1234 00-04-30 16:28:08 EST EAGLE 35.0.0
** 0012.0422 ** CARD 1108 VSCCP Insufficient extended memory
```

When the **alw-card** command is executed, loading of the DSM card is attempted. The following message appears, indicating that card loading is no longer inhibited.

Example:

```
1 2 3 4 5 6 7 8
1234567890123456789012345678901234567890123456789012345678901234567890
station1234 00-04-30 16:28:08 EST EAGLE 35.0.0
0012.0423 CARD 1108 VSCCP Card reload attempted
```

DSM Database Audit Alarm

During an audit of the DSM cards, the status of the RTDB is examined and an alarm is raised when a corrupted database is found.

When any RTDB database becomes corrupted, a major alarm is raised. The DSM Database Audit alarm is output to the Card Output Group.

Example:

```
1 2 3 4 5 6 7 8
1234567890123456789012345678901234567890123456789012345678901234567890
```

```
station1234 00-04-30 16:28:08 EST EAGLE 35.0.0
** 0012.0443 ** CARD 1108 VSCCP          RTDB Database is corrupted
```

DSM Database Alarms

During the operation of DSM cards, the status of databases is examined and alarms can be raised. When a DSM card's RTDB is inconsistent (that is, DSM card's birthdate and level do not match the active EPAP RTDB birthdate and level), a minor alarm is raised. The DSM Database alarms are output to the Card Output Group.

Example:

```

1           2           3           4           5           6           7           8
1234567890123456789012345678901234567890123456789012345678901234567890
station1234 00-04-30 16:28:08 EST EAGLE 35.0.0
* 0012.0444 * CARD 1108 VSCCP          RTDB Database is inconsistent
```

While the EPAP RTDB database is being downloaded to a DSM card, it is in an incoherent state. An alarm is raised.

Example:

```

1           2           3           4           5           6           7           8
1234567890123456789012345678901234567890123456789012345678901234567890
station1234 99-09-30 16:28:08 EST EAGLE 35.0.0
* 0012.0448 * CARD 1108 VSCCP          RTDB Database is incoherent
```

When an inconsistent, incoherent, or corrupted DSM RTDB has been fixed (that is, repaired) when the DSM card is in an **is-nr** condition, an alarm is raised.

Example:

```

1           2           3           4           5           6           7           8
1234567890123456789012345678901234567890123456789012345678901234567890
station1234 00-04-30 16:28:08 EST EAGLE 35.0.0
0012.0445 CARD 1108 VSCCP          RTDB Database has been corrected
```

G-Flex Subsystem Alarms

The same alarms that are output for an SCCP subsystem are output for the G-Flex subsystem (including G-Flex traffic). See Table 5-1.

Table 5-1. G-Flex Subsystem Alarms

UAM #	Severity	Message Text	Output Group (UI Output Direction)
0328	None	SCCP is available	gtt
0329	None	SCCP capacity normal, card(s) abnormal	gtt
0330	Major	SCCP TPS Threshold exceeded	gtt

Table 5-1. G-Flex Subsystem Alarms (Continued)

UAM #	Severity	Message Text	Output Group (UI Output Direction)
0331	Critical	SCCP is not available	gtt
0335	None	SCCP is removed	gtt
0336	Major	LIM(s) have been denied SCCP service	gtt
0526	None	Service is available	sys_maint
0527	Minor	Service abnormal	sys_maint
0528	Critical	Service is not available	sys_maint
0529	Critical	Service is disabled	sys_maint
0530	None	Service is removed	sys_maint

G-Flex Related UIMs

UIM formats for the EGTT feature support the new GTT requirements. The *EAGLE5 ISS Maintenance Manual* contains a complete description of all UIM text and formats. See Table 5-2 for the G-Flex UIMs. All of the the G-Flex related UIMs are output to the Application Subsystem Output Group..

Table 5-2. G-Flex UIMs

UIM #	Text	Description	Action
1242	Conv to intl num - Dflt CC not found	Default CC is not defined	Define the default CC by chg-stpopts: defcc=xxxx
1243	Conv to intl num - Dflt NC not found	Conversion to international number failed because default NC was not found	Define the default NDC by chg-stpopts: defndc=xxxx
1244	Conv to intl num - Dflt MCC not found	Default MCC is not defined	Define the default MCC by chg-gsmopts: defmcc=xxxx
1245	Conv to intl num - Dflt MNC not found	Default MNC is not defined	Define the default MNC by chg-gsmopts: defmnc=xxxx
1246	Invalid length of conditioned digits	Length of the conditioned international number is <5 or >15	Use an international number with length within this range.

Table 5-2. G-Flex UIMs

1247	Conversion of MGT to IMSI not possible	The E.212 part for the E.214 MGT digit not found in the database	Enter the E.212 part (MCC + MNC) for the E.214 MGT part (CC + NDC) in the database using chg-gsmopts:ccndc=xxxxx x:mccmnc=YYYYYY
------	--	--	--

G-Flex Measurements

Refer to the *Maintenance Manual* for detailed measurement usage information.

OAM Based Measurements

The collection of measurements is a separate task from reporting. Measurements collection is activated automatically upon system power-up, or through administrative commands. Collection is organized by ENTTYPE and reporting period. Collection occurs per link every 5 minutes, and separately every 30 minutes. Measurements are generated on the application cards and periodically collected by the OAM and stored for later retrieval on the TDMs. The command related to measurements collection is *chg-meas*.

Reports can be scheduled or printed on-demand. Scheduled and on-demand reports are accessible by the following administrative commands:

- *chg-meas* - Turns collection on/off and schedules automatic report generation.
- *rtrv-meas-sched* - Verifies collection state and automatic report schedules.
- *rept-meas* - Generates individual measurement reports for schedule-enttype-entid combinations.

Before a report is printed, measurement collection must be activated. Refer to the *Commands Manual* for more information on how to use measurement commands.

Measurements Platform

The Measurements Platform (MP) is required for an EAGLE 5 ISS with more than 700 links. It provides a dedicated processor for collecting and reporting STP, LNP, INP, G-FLEX, and G-PORT measurements data. The interface to the customer's network supports the FTP transfer of Measurements reports to an FTP server. Following collection, scheduled reports are automatically generated and transferred to the customer's FTP server via the FTP interface.

NOTE: Existing FTP file server reports are overwritten by subsequent requests that produce the identical file name.

Reports can be scheduled or printed on-demand. Scheduled and on-demand reports are accessible by the following administrative commands:

Maintenance and Measurements

- *chg-measopts* - Used to enable or disable the automatic generation and FTP transfer of scheduled measurement reports to the FTP server.
- *rept-stat-meas* - Reports the status of the measurements subsystem including card location and state, Alarm level, and Subsystem State.
- *rept-ftp-meas* - Manually initiates generation and FTP transfer of a measurements report from the MCPM to the FTP server.
- *rtrv-measopts* - Generates a user interface display showing the enabled/disabled status of all FTP scheduled reports.

The following G-Flex MSU measurements are supported for the G-Flex feature.

Table 5-3. Pegs for G-Flex

Event Name	Description	Unit
gfgtmatch	G-Flex GTTs with Match – The total number of G-Flex Global Title Translation successfully completed.	Peg count
gfgtnomch	G-Flex GTTs No Match – The total number of G-Flex Global Title Translations completed that did not match an entry in the G-Flex database.	Peg count
gfgtnolkup	G-Flex GTTs No Look-up – The total number of G-Flex Global Title Translations that could not be looked up in the G-Flex database because of some error. NOTE: This counter is not available via rept-meas by TT.	Peg count

The following measurement events are included on the STP Daily Maintenance (MTCDD) and STP Day-to-Hour (MTCDDH) measurement reports and include peg counts for G-FLEX MSUs. These reports are similar to those used for GTT. The existing GTT/SCCP measurements are used for both GTT and G-Flex and appear in the same reports.

- **MSSCCPFL** MSUs discarded due to SCCP routing failure
Also includes G-Flex MSUs that got a match from either the G-Flex or GTT database, but cannot be routed because of PC (Point Code) or SS (SubSystem) congestion, PC or SS unavailable, SS unequipped, or an unqualified error.
- **GTTUN0NS** GTT unable to perform; no such type
Also includes G-Flex GTT MSUs that did not match on new selectors (GTI, NP, NAI) in addition to ones not matching on TT.
- **GTTUN1NT** GTT unable to perform: no translation on this address
Also includes G-Flex MSUs that fell through to GTT, obtained a selector match but still did not get a match on the GTA.

- **GTTPERFD** Number of GTT performed

Also includes G-Flex MSUs that got a match in either the G-Flex or GTT database.

These measurements can also be used to determine the following:

- Total number of G-Flex MSUs:
 $X = \text{gfgtmatch} + \text{gfgtnomch} + \text{gfgtnolkup}$
- Number of non-G-Flex GTT MSUs:
 $(\text{gttperfd} + \text{gttun1nt} + \text{gttun0ns}) - (X)$

This implementation does not discriminate between the MSSCCPFL, GTTUN0NS, GTTUN1NT, or GTTPERFD pegs for G-Flex or GTT applications. For example, a search failure could result from a problem in either the G-Flex or GTT database.

Measurement Reports

Measurements are available with these report commands. Refer to the *Commands Manual* for detailed usage information. :

OAM Based

- Per STP system, 24-hour total `rept-meas:type=systot:enttype=stp`
- Per STP system, by TT `rept-meas:type=systot:enttype=tt:tt=xxx`
- Per system, daily `rept-meas:type=mtcd:enttype=stp`
- Per system, day-to-hour `rept-meas:type=mtcdth:enttype=stp`

MP Based

- Per STP system, 24-hour total `rept-ftp-meas:type=systot:enttype=stp`
- Per STP system, by TT `rept-ftp-meas:type=systot:enttype=tt`
- Per system, daily `rept-ftp-meas:type=mtcd:enttype=stp`
- Per system, day-to-hour `rept-ftp-meas:type=mtcdth:enttype=stp`

Index

Numerics

20% LIM cards, 5-7
80% card stability threshold, 2-26
80% full applique memory, 5-13
80% of IS-NR LIMs, 2-25, 5-7
80% Threshold of Support, 5-6

A

Acronyms, 1-10
act-gpl, 3-14
Actions Taken When Hardware Determined to be Invalid, 2-25
Actions Taken When System is in Unstable Loading Mode, 5-7
activate optional features, 3-3
activate signaling link, 4-19, 4-20, 4-35
activate signaling link, act-slk
SS7IPGW, 4-19, 4-20, 4-35
active and standby EPAP servers, 2-15
active EPAP, 5-2
active EPAP RTDB database process, 2-21
active/standby EPAP servers, 2-7
act-slk, 4-5, 4-20
add capability PC, 4-9
add mated application, 4-18
add route for new DPC, 4-17
add signaling link, 4-16
addresses for network, 2-16
ADL, 1-10, 5-6
Administrative Architecture, 2-11
administrative updates, 2-26
alarm conditions, 5-2
Alarms, 5-11
allow DSM card, 4-39
allow inhibited card, 4-19, 4-25, 4-34
alw-card, 3-14, 4-5, 4-6, 4-7, 4-19, 4-25, 4-34, 5-7, 5-13
AMD K-6 processor, 2-11
American National Standards Institute, 1-1
amount of applique memory present, 5-3
ANSI, 1-1
appl=vsccp, 4-16, 4-22, 4-30
APPL=VSCCP parameter, 3-14
application data loader, 5-6

applique board, 2-11
applique hardware configuration, 5-5
applique memory, 5-13
applique memory present, 5-3
assign individual subscribers to HLRs, 2-2
assign routes and linksets, 4-9
Assumptions/Limitations, 2-22
AuC, 1-10, 2-2
Audit Requirements, 2-26
Authentication Center, 2-2

B

background audit, 2-26
Blacklist Ranges, 2-30

C

C7 network, 1-1
calculates checksums, 2-26
Call Flows, 2-3
capability point code, 4-9, 4-10, 4-12
caution
changing point code, 4-4, 4-11
init-sys command, 4-4, 4-12
Caution icon, 1-8
CC, 1-10
CCNC, 3-4
CCNC/MCCMNC numbering plan
conversion, 3-4
ccnc=, 4-37
CdPA, 1-10
CgPA, 1-10
change G-Flex-specific system options, 3-4
change GSM system options, 4-8, 4-37
change link parameters, 4-24, 4-33
change TCP/IP information for DSM, 4-23, 4-32
change true PC, 4-9
changing point code
caution, 4-4, 4-11
checksum value stored, 2-26
chg-feat, 3-3, 4-8, 4-35
Change Feature Status Command, 3-3
gflex=on, 4-8, 4-35
chg-gpl, 3-14

- chg-gsmopts, 4-8, 4-37
 - Change G-Flex System Options
 - Command, 3-4
- chg-ip-card, 3-16, 4-6, 4-7, 4-23, 4-32
- chg-ip-lnk, 3-16, 4-6, 4-7, 4-24, 4-33
- chg-sccp-serv
 - Change G-Flex SCCP Service
 - Command, 3-8
- chg-sid, 3-15, 4-4, 4-11
- chg-srvsel
 - Change G-Flex Service Selector
 - Command, 3-6
- chg-stpopts, 4-8, 4-36
- Code and Application Data Loading, 5-5
- Coherent, 2-28
- command
 - chg-sid, 4-4, 4-11
 - init-sys, 4-4, 4-12
- Commands, 2-20, 3-10
 - chg-sid, 3-15
 - dlt-sid, 3-15
- complete database reload, 2-28
- Conditions That Create Unstable Loading
 - Mode, 5-7
- configure EAGLE 5 ISS point code, 4-4, 4-11
- congestion indicator, 5-2
- connectivity, 2-28
- control number of trapped MSUs, 3-2
- Conversion of E.214 MGT to E.212
 - IMSI, 2-34
- Conversion of National/Local Numbers to
 - International Numbers, 2-33
- conversion parameter combinations, 3-4
- converted number sizes, 2-33
- copies TDM resident database tables, 3-9
- copy-gpl, 3-14
- corrupt alarm, 2-26
- corrupted database, 5-3, 5-13
- CPC, 4-9
- Current, 2-28
- current G-Flex statistics, 2-26
- Customer Assistance, 1-9
- Customer Contact Center, 1-9
- customer network, 2-10
- Customer Provisioning Network, 2-14
- Customer Support Center, 1-9
- Customer Support Centers, 1-9

D

- Danger icon, 1-8
- database corrupt alarm, 2-26
- database corrupted, 5-3
- database download, 2-12
- Database Lookup, 2-34
- Database Overview, 2-21
- database reload, 2-28
- Database Service Module, 2-7
- DCM, 1-10
- debug command ent-trace, 2-26
- debug DNS to IP addressing tables, 3-18
- dedicated network, 2-14
- defmcc=, 4-37
- defmnc=, 4-37
- delete G-Flex service selectors, 3-6
- Delete GT option, 2-36
- Deleting the CdPA GT Digits, 2-36
- delivery agent, 5-12
- destination point code, 2-20
- destination point codes, 4-4, 4-9
- Dial-Up PPP Network, 2-17
- direct interface to networks, 2-3
- disp-bp, 3-15
- display current IP host information, 4-22, 4-31
- display current link parameters, 4-24, 4-33
- display feature status, 3-4
- display G-Flex service selectors, 3-7
- display signaling link status, rept-stat-slk
 - SS7IPGW, 4-20
- display STP and G-Flex DB status and level
 - per DSM, 3-10
- disp-mem, 3-15
- dlt-bp, 3-15
- dlt-card, 3-14, 4-7, 4-28
- dlt-ip-host, 3-16
- dlt-sccp-serv
 - Delete G-Flex SCCP Service
 - Command, 3-9
- dlt-sid, 3-15
- dlt-srvsel
 - Delete G-Flex Service Selector
 - Command, 3-6
- Documentation Admonishments, 1-8
- Documentation Packaging, Delivery, and
 - Updates, 1-7
- downloads in progress, 5-3

Index

- DPC, 4-4, 4-9
 - dpci, dpcn parameters, 4-9
 - DSM, 1-10, 2-7
 - DSM (Database Service Module)
 - Cards, 2-11
 - DSM accepts DB updates, 5-3
 - DSM Applique Memory Verification, 2-24
 - DSM card failure, 5-12
 - DSM card polls, 2-11
 - DSM Code Loading, 5-5
 - DSM Database Alarms, 5-14
 - DSM Database Audit Alarm, 5-13
 - DSM Database Levels and Reloading, 2-28
 - DSM Failure, 5-12
 - DSM Hardware-Related Alarms, 5-12
 - DSM insufficient memory, 5-11
 - DSM Main Board Verification, 2-24
 - DSM Memory Capacity Status
 - Reporting, 5-4
 - DSM Memory Size, 5-3
 - DSM multicast hardware, 2-28
 - DSM Networks, 2-16
 - DSM Provisioning and Reload, 2-27
 - DSM Reload Requirements, 2-28
 - DSM Reloading Model, 2-27
 - DSM status, 5-3
 - DSM Status Message Fields, 5-3
 - DSM Status Messages – When Sent, 5-3
 - DSM Status Request message, 5-3
 - DSM-based boards, 5-1
 - DSM-EPAP Link, 5-12
 - DSM-EPAP link status, 5-12
 - DSM-VxWorks-SCCP application, 2-12
- E**
- E.164, 2-2, 2-5, 2-23, 2-34
 - E.164 entity address, 2-3
 - E.164 MSISDN number (MSISDN), 3-2
 - E.164 number, 3-2
 - E.212, 2-2, 2-34
 - E.212 IMSI, 3-2
 - E.212 IMSI number (IMSI), 3-2
 - E.212 International IMSI, 2-34
 - E.212 number, 2-5
 - E.212 numbers, 2-22
 - E.214, 2-23, 2-34
 - E.214 (E.212) Routing Example - Location
 - Updating, 2-5
 - E.214 MGT, 2-34
 - E.214 numbers, 2-22
 - EAGLE 5 ISS chg-db
 - Change Database Commands, 3-9
 - EAGLE 5 ISS chg-feat Commands, 3-3
 - EAGLE 5 ISS G-Flex Commands, 3-1
 - EAGLE 5 ISS G-FLEX SCCP Service
 - Commands, 3-8
 - EAGLE 5 ISS G-Flex Service Selector
 - Commands, 3-5
 - EAGLE 5 ISS G-Flex System Options
 - Commands, 3-4
 - EAGLE 5 ISS mated application table, 2-19
 - EAGLE 5 ISS rept-stat-db
 - Report Database Status, 3-10
 - EAGLE 5 ISS Terminal Database
 - Commands, 3-3
 - EAGLE 5 ISS terminal interfaces, 3-2
 - EAGLE Provisioning Application
 - Processors, 2-7
 - EDSM Status Requests, 5-2
 - enable G-Flex feature, 4-35
 - ent-bp, 3-15
 - ent-card, 3-14, 4-5, 4-6, 4-7, 4-15, 4-22, 4-30, 5-8
 - ent-dstn, 4-5, 4-13
 - enter destination PC, 4-13
 - enter DPC, 4-13
 - enter G-Flex service selectors, 4-8, 4-37
 - enter linkset, 4-14
 - entering
 - init-sys command, 4-4, 4-12
 - ent-ip-host, 3-16, 4-6, 4-7, 4-22, 4-31
 - Entity Number, 3-2
 - entity number, 2-31
 - entity PC, 2-20
 - entity point codes, 2-19
 - Entity Point Codes and Routes, 2-20
 - ent-ls, 4-5, 4-14
 - ent-map, 4-5, 4-18
 - ent-rte, 4-5, 4-17
 - ent-slk, 4-5, 4-16
 - ent-srvsel, 4-8, 4-37
 - Enter G-Flex Service Selectors
 - Command, 3-5
 - ent-trace, 2-26, 3-1

EPAP, 1-10, 2-7
 maintains database updates, 2-11
 updates PDB, 2-11
 EPAP - DSM Connection Status, 5-12
 EPAP (EAGLE Provisioning Application Processor), 2-9
 EPAP A, 2-7, 2-16
 status, 5-2
 EPAP A, Link A, 2-27
 EPAP A, Link B, 2-27
 EPAP Application Data Loading, 5-5
 EPAP architecture, 2-22
 EPAP B, 2-7, 2-16
 status, 5-2
 EPAP B, Link A, 2-27
 EPAP B, Link B, 2-27
 EPAP Continuous Reload, 2-27
 EPAP DCBs, 2-13
 EPAP IP Addresses in the DSM Network, 2-17
 EPAP Maintenance Blocks, 5-2
 EPAP network addresses, 2-16
 EPAP Provisioning Blacklist, 2-29
 EPAP RTDB incoherent, 5-14
 EPAP Status and Alarms, 5-1
 EPAP Status and Error Reporting via Maintenance Blocks, 2-13
 EPAP Sync Network, 2-15
 EPAP tracks downloads in progress, 5-3
 EPAP UAMs, 5-12
 EPAP/PDBA user interface terminal, 2-17
 EPAP-DSM Loading Interface, 5-6
 equipment damage, 1-8
 ES, 1-10
 Ethernet bandwidth, 2-14
 Ethernet links, 2-11
 Ethernet ports, 2-11
 execute selected command remotely by the targeted card, 3-16

F

feat commands, 3-3
 Feature Activation Overview, 4-3
 force option, 5-8
 force=yes parameter, 3-14
 fourth octet, 2-16
 FTR, 1-11

Full Download Request message, 5-6
 functional description, 1-2
 Functional Diagram – G-Flex in SCCP, 2-31, 2-38

G

GDB, 1-11
 general information, 1-2
 General Procedure for G-Flex Activation, 4-3
 General Requirements, 2-23
 GFDB, 1-11
 G-Flex, 1-11
 G-Flex Activation Unsuccessful due to Insufficient Database, 5-11
 G-Flex Blacklist, 2-29
 G-Flex blacklist range, 2-30
 G-Flex C7 Relay
 description, 2-2
 G-Flex C7 Relay feature, 1-1
 G-Flex C7 Relay Overview, 2-2
 G-Flex Capability point Codes, 2-39
 G-Flex Data Initialization, 5-6
 G-Flex Enabled, but Database Exceeds DSM Memory, 5-10
 G-Flex Enabled, but DSM Memory Insufficient for Database, 5-10
 G-Flex Enabled, but DSM Memory Less Than 1 GB, 5-9
 G-Flex Enabled, but DSM Not Connected to EPAP, 5-9
 G-Flex Enabled, Normal Operating Sequence, 5-9
 G-Flex Feature Activation, 4-1
 G-Flex Loading Mode Support, 2-26
 G-Flex Measurements, 5-16
 G-Flex MSU measurements, 5-17
 G-Flex MSUs, 2-26
 G-Flex Not Enabled at First, but then Activated on DSM, 5-11
 G-Flex Not Enabled, DSM Running in TSM Emulation, 5-9
 G-Flex pegs, 5-17
 G-Flex platforms, 2-11
 G-Flex provisioning requests, 2-11
 G-Flex Relay Data Combinations, 2-32
 G-Flex Relay Function, 2-30

Index

- G-Flex relay function, 2-18
- G-Flex Reroute Capability, 2-8, 2-37
- G-Flex Re-Route Summary, 2-40
- G-Flex Re-routing, 2-39
- G-Flex selector-specified service numbering plan, 2-34
- G-Flex statistics, 2-26
- G-Flex Status Reporting, 5-4
- G-Flex Subsystem Alarms, 5-14
- G-Flex System Status Reports, 5-4
- G-Flex UIMs, 5-15
- G-Flex VSCCP application, 2-24
- GFRF, 2-30
- GFRF Forwarding Message
 - SCCP Portion, 2-36
- GFRF forwarding message
 - SCCP portion, 2-35
- GFRF Forwarding Message - MTP Portion, 2-35
- Global System for Mobile communications, 1-1
- Global Title digits (GT), 3-2
- Global Title Indicator, 2-23
- Global Title Translation, 2-3
- GMSC, 1-11
- GPL, 1-11
- G-Port, 1-11
- group code, 4-9
- GSM, 1-1, 1-11
- gsmopts commands, 3-4
- GTA, 1-11
- GTAI, 1-11
- GTI, 1-11, 2-23
- GTT, 1-11, 2-3
- GTT/SCCP measurements, 5-17

H

- hardware configuration, 5-5
- Hardware Requirements, 5-1
- high-traffic situations, 2-12
- HLR, 1-1, 1-11, 2-2
- Home Location Register, 1-1, 2-2
- host=epap-a, 4-22, 4-31
- Hourly Maintenance Report, 3-13, 5-3
- how to activate G-Flex, 1-2

I

- IAM, 1-11
- IMSI, 1-1, 1-11, 2-2
- IMSI (E.212) Routing, 2-5
- IMSI incomplete, 2-34
- IMSI number, 4-1
- IMSI numbers, 3-2
- IN, 1-11
- INAP, 1-11
- incoherent EPAP RTDB, 5-14
- incomplete IMSI, 2-34
- inconsistent RTDB, 5-14
- incorrect results and errors, 2-34
- Increased number of translations, 2-30
- Incremental Downloading, 2-13
- incremental loading, 2-28
- incremental loading from EPAP, 2-26
- Incremental update, 2-28
- incremental updates, 2-27
- inh-alm, 3-16
- inh-card, 3-14, 4-6, 4-28, 5-7, 5-8
- inhibit loading DSM card, 5-12
- init-card, 4-8, 4-39
- init-sys, 4-4, 4-12
- init-sys command
 - caution, 4-4, 4-12
 - re-entering, 4-4, 4-12
- inoperative Ethernet connection, 5-12
- INP, 1-11
- Install, 4-29
- Installation Support, 1-7
- insufficient DSM memory, 5-11
- insufficient SCCP service, 5-6
- Integrated EAGLE 5 ISS/G-Flex Node, 2-18
- Integrated Signaling System, 1-1
- international DNs and IMSIs, 2-33
- international entity number, 2-31
- International Mobile Subscriber Identity, 2-2
- international numbers, 2-33
- International Telecommunications Union, 1-1
- Introduction, 1-1
- IP, 1-11
- IP - reporting EPAP maintenance data, 2-12
- IP Multicast - downloading GSM database, 2-13

IP multicasting, 2-13
 ipaddr=192.168.122.nnn, 4-23, 4-31
 IS-41, 1-1, 1-11
 ISDN, 1-11
 IS-NR, 1-11
 ITU, 1-1, 1-11
 ITU national duplicate PC, 4-9
 ITU national point code, 4-9
 ITUDUPPC, 4-9
 ITU-I, 2-22
 ITU-N, 2-22

L

LIM, 1-11
 LIMs, 2-25
 Link Interface Module, 2-25
 linksets assigned, 4-9
 list pass commands for target location, 3-19
 LNP, 1-11, 2-3
 load balancing high-traffic situations, 2-12
 Load Mode Status, 5-3
 loading DSM card, 5-12
 Loading Mode Support, 5-6
 loading mode support, 2-26
 Loading Mode Support Status
 Reporting, 5-5
 loc parameter, 4-16
 loc=1103, 4-16, 4-22, 4-30
 Local Memory Validation, 2-24
 Local Number Portability, 2-3
 local provisioning terminal, 2-22
 Location of G-Flex Node in Wireless
 Network, 2-19
 Location of Integrated STP/G-Flex Node in
 Wireless Network, 2-18
 logical link between MSISDN number and
 IMSI, 4-1
 loss of connectivity, 2-12, 2-28
 LSS, 1-11

M

main board, 5-5
 main board configuration, 2-24
 Maintenance, 2-24
 Maintenance and Administration
 Communication Application Processor
 card, 2-26

maintenance and measurement
 interface, 3-10
 Maintenance and Measurements, 5-1
 maintenance and measurements, 1-2
 maintenance application traffic, 2-15
 maintenance baseline, 5-7
 maintenance blocks, 2-13, 5-2
 Maintenance Commands, 2-26
 maintenance releases, 1-8
 maintenance reporting mechanism, 2-16
 major software releases, 1-8
 Manual Organization, 1-2
 MAP, 1-11, 2-4
 MAS, 1-11
 mate platform, 2-11
 Mated Application Considerations, 2-19
 mated application table, 2-19
 mated EPAP servers, 2-11
 mated pair configuration, 2-11
 maximum number of digits allowed in
 MGT, 2-34
 MCAP, 1-11, 2-26
 MCCMNC, 3-4
 mccmnc=, 4-37
 MDN, 1-12, 2-2
 MEA, 1-12, 2-25
 Measurement Reports, 5-18
 Measurements
 OAM Based, 5-16
 measurements, 5-17
 memory boundaries, 5-5
 memory insufficient, 5-11
 Message Forwarding, 2-35
 Message Signaling Unit, 2-26
 MGT, 1-12
 MGT (E.214) Routing, 2-4
 MGT2IMSI conversion table, 2-34
 MGT-to-IMSI reconversion, 2-34
 MIN, 1-12, 2-2
 Mismatch of Equipment and
 Attributes, 2-25
 MMI, 1-12
 MNP, 1-12, 2-2
 Mobile Application Part, 2-4
 Mobile Directory Number, 2-2
 Mobile Identification Number, 2-2
 Mobile Number Portability, 2-2

Index

Mobile Station International Integrated Services Digital Network, 2-2
Mobile Switching Center, 2-2
Mobile Switching Centers, 1-1
Mobile Terminated Call, 2-6
modem for remote access, 2-22
MPS, 1-12, 2-7
MPS database size, 5-2
MPS/EPAP Platforms for Provisioning G-Flex, 2-10
MSC, 1-1, 1-12, 2-2
MSIN truncated, 2-34
MSISDN, 1-12, 2-2
MSISDN number, 1-1, 4-1
MSISDN numbers, 3-2
MSISDN/MIN/MDN (E.164) Routing, 2-5
MSISDN/MIN/MDN global title routing, 2-6
MSRN, 1-12
MSU, 1-12
MSU measurements, 5-17
MSU Trap and Trace Command, 3-1
MSU trapped, 3-1
MSUs, 2-26
MTP, 1-12
multicast updates, 2-21
multiple DSMs, 2-27
multiple trigger criteria, 3-1
Multi-Purpose Server (MPS) hardware, 2-7

N

NAI, 2-23
National Indicator bit, 2-22
national number, 2-33
National/Local Numbers to International Numbers Conversion Logic, 2-33
NC, 1-12
NDC, 1-12
network addresses, 2-16
Network Connections, 2-13
Network Perspectives, 2-17
Non-G-Flex Data Initialization, 5-6
NP, 1-12, 2-23
NPA, 1-12
npcfmti option, 4-10
NPDB, 1-12
NPV, 1-12

NSD, 1-12
ninstall, 4-21
Number conditioning, 2-30
number conversion triggered, 2-33
Number Portability, 2-23
Numbering, 2-23
numbering plan, 2-2, 2-33, 2-34

O

OAI, 1-12
OAM, 1-12
OAM application, 5-5
OAM code, 5-5
OAM provisioning, 2-16
OAP, 1-12
Obit Message for Card Loading Abort, 5-8
octets, 2-16
OPS, 1-12, 2-7
out-of-memory condition, 2-12
out-of-sync, 2-19
out-of-sync condition, 2-20
overlapping database updates, 2-22
overload controls, 2-22
Overview, 1-1
Overview of EPAP to DSM Communications, 2-12

P

parameter
PCI
 chg-sid, 4-12
PCN
 chg-sid, 4-11, 4-12
pass, 3-16, 4-6, 4-7, 4-26, 4-34
 cmd="arp", 3-18
 cmd="help", 3-19
 cmd="netstat", 3-17
 cmd="nslookup", 3-18
 cmd="Ping", 3-16
PCI parameter
 chg-sid, 4-12
PCN parameter
 chg-sid, 4-11, 4-12
PDB, 1-12, 2-7
PDBA, 1-12
PDBI, 1-12, 2-6, 2-29
PDBI checks, 2-30

Pegs for G-Flex, 5-17
 personal safety, 1-8
 PFS, 1-12
 ping parameter, 4-26, 4-34
 PLMN, 1-12
 PMTC, 1-12
 point code, 4-12
 primary DSM, 2-16, 5-2
 private networks, 2-14
 Product Description, 2-3
 protected E.164 address, 2-29
 Provides discrimination of messages that
 need its functionality, 2-30
 provision new selectors for G-Flex, 3-5
 Provisioning Database, 2-7, 2-21
 Provisioning Database Interface, 2-6, 2-29
 Provisioning Hierarchy, 3-3
 Provisioning Hierarchy for the G-Flex
 Database, 3-2
 provisioning link congestion, 5-2

R

Realtime Database, 2-7
 Real-Time Memory Validation, 2-25
 re-entering init-sys command, 4-4, 4-12
 reinitialize system, 4-12
 Related Publications, 1-2
 Reliable Multicast Transport
 Protocol-II, 2-13
 reload traffic, 2-28
 reloading multiple DSMs, 2-27
 remote EPAP/PDBA user interface
 terminal, 2-17
 rep parameter, 3-2
 repetition parameter, 3-2
 replace TSM card with DSM card, 4-21,
 4-29
 Replacement of GT with entity
 address, 2-31
 report DSM failure, 5-12
 rept-meas, 3-13
 rept-stat-alm, 3-13
 rept-stat-card, 4-5, 4-6, 4-7, 4-8, 4-19, 4-25,
 4-28, 4-34, 4-39
 stat=nr, 4-27
 rept-stat-db, 3-13
 rept-stat-epap, 2-26, 3-12, 5-2, 5-4

rept-stat-gpl, 3-14
 rept-stat-sccp, 3-11, 5-2, 5-4
 rept-stat-slk, 4-5, 4-20
 rept-stat-sys, 3-10, 5-4, 5-5
 rept-stat-trbl, 3-13
 retrieve G-Flex-specific system options, 3-5
 RMTP, 1-13
 RMTP channel, 2-28
 RMTP-II, 2-13
 Route on SSN, 2-36
 route signaling messages, 2-2
 route table, 2-20
 route-on-gt, 2-32
 routes and linksets assigned to the
 DPCs, 4-9
 RS232 serial port, 2-21
 RTDB, 1-13, 2-7
 RTDB database, 2-21
 RTDB inconsistent, 5-14
 rtrv-card, 3-14, 4-5, 4-6, 4-7, 4-16, 4-20, 4-22,
 4-27, 4-28, 4-31
 rtrv-dstn, 4-4, 4-5, 4-9, 4-11, 4-14
 rtrv-feat
 Retrieve Feature Status Command, 3-4
 rtrv-gpl, 3-14
 rtrv-gsmopts
 Retrieve G-Flex System Options
 Command, 3-5
 rtrv-ip-card, 3-16, 4-6, 4-7, 4-24, 4-32
 rtrv-ip-host, 3-16, 4-6, 4-7, 4-22, 4-23, 4-31,
 4-32
 rtrv-ip-lnk, 3-16, 4-6, 4-7, 4-24, 4-25, 4-33,
 4-34
 rtrv-ls, 4-5, 4-15
 rtrv-map, 4-5, 4-11, 4-19
 rtrv-rte, 4-4, 4-5, 4-10, 4-11, 4-18
 rtrv-sccp-serv
 Retrieve G-Flex SCCP Service
 Command, 3-9
 rtrv-sid, 4-4, 4-5, 4-9, 4-13
 rtrv-slk, 4-5, 4-17
 rtrv-srvsel, 4-8, 4-38
 Retrieve G-Flex Service Selector
 Command, 3-7
 rtrv-stpopts, 4-4, 4-10, 4-36

S

SCCP, 1-13
 SCCP maintenance block, 2-24
 SCCP services, 2-25
 Scope and Audience, 1-2
 SCP, 1-13
 SDS, 1-13
 SDS command ent-trace, 3-1
 selector-specified service numbering
 plan, 2-34
 self identification of system, 4-9
 send status message, 2-27
 sequential steps to activate G-Flex, 4-1
 service interruptions, 1-8
 service numbering plan, 2-34
 service selector table, 5-5
 Service State, 2-38
 Serviceability Hints, 2-19
 set-mem, 3-15
 Signal Transfer Point, 2-3
 SIM, 1-13, 2-2
 sizes of converted numbers, 2-33
 SMS, 1-13
 SNP, 1-13
 software releases, 1-8
 SP, 1-13
 SPC, 1-13
 specifies G-Flex service selectors, 3-5
 specify G-Flex selectors, 3-6
 specify ITU national PC format, 4-10
 speed=10, 4-24, 4-33
 srvsel commands, 3-5
 SS7, 1-13
 SS7IPGW
 activate signaling link, act-slk, 4-19,
 4-20, 4-35
 display signaling link status,
 rept-stat-slk, 4-20
 SSN, 1-13
 SSN discrimination, 2-23
 SSP, 1-13
 SSP point code, 3-2
 Stage 1 loading, 2-28
 Stand-Alone EAGLE 5 ISS G-Flex Relay
 Function, 2-18
 standby mode, 2-9
 State Transitions during Start-Up, 5-8
 statistics, 2-26

status messages, 2-12
 status of DSMs, 5-3
 steps to activate G-Flex, 4-1
 STP, 1-13, 2-3
 STP administrative updates, 2-26
 STP audit requirement, 2-26
 STP database updates, 5-7
 STP database updates sent, 2-21
 STP functions, 2-18
 Subscriber Data Provisioning, 2-6
 Subscriber Data Provisioning
 Architecture, 2-7
 Subscriber Identity Module, 2-2
 subsystem alarms, 5-14
 subsystem numbers, 2-19
 sufficient memory, 5-11
 synchronizes the RTDBs, 2-15
 System Debug Services (SDS)
 Commands, 3-1
 system point code, 4-10
 system self-identification, 4-9
 System Status Reporting, 5-4

T

TCAP, 1-13
 TCP, 1-13
 TCP/IP socket, 2-12
 TDM fixed disk, 2-21
 TDM-resident data tables, 5-5
 Technical Assistance Centers, 1-9
 terminal interfaces, 3-2
 threshold monitoring, 2-25
 trace set on SCCP cards, 3-2
 track downloads in progress, 5-3
 traffic situations, 2-12
 Translation Type, 2-23
 trap on CdPA GTA, 3-2
 trap on CgPA SPC, 3-2
 trap on E.214 MGT, 3-2
 trap-and-trace MSUs on SCCP card, 3-1
 trigger criteria, 3-1, 3-2
 trigger on DN and IMSI, 3-1
 troubleshoot network interface and routing
 configuration, 3-17
 troubleshoot private EPAP/DSM IP
 network, 3-16
 true point code, 4-9

truncated MSIN, 2-34
 TSM, 1-13
 TT, 1-13, 2-23
 type=dsm, 4-16, 4-22, 4-30
 types of subscriber numbers, 2-3

U

UAM, 1-13
 UAM formats, 5-12
 UAM identifier, 5-2
 UAMs from EPAP, 5-12
 UDB, 1-13
 UDP, 2-12
 UDP - sending DSM status messages, 2-12
 UDTS messages, 2-23
 UIM, 1-13
 UIM issued, 2-34
 UIM message, 2-19
 UIM messages, 5-15
 unhb-alm, 3-16
 Unstable Loading Mode, 2-25
 User Datagram Protocol, 2-12
 user interface, 1-2
 user interface terminal, 2-17
 Using force Option, 5-8

V

valid G-Flex blacklist range, 2-30
 Validation of G-Flex Hardware
 Configuration, 2-24
 validity status, 2-24
 Variable number of digits, 2-31
 variable number of digits, 3-2
 verify and correct IP stack ARP tables, 3-18
 verify IS-NR card status, 4-19, 4-25, 4-34
 verify new link parameters, 4-25, 4-34
 Versant, 2-21
 Versant database, 2-10
 Visitor Location Register, 2-3
 VLR, 1-13, 2-3
 VLRA, 2-4
 VMSC, 1-13
 VSCCP, 1-13, 2-12
 VSCCP application, 2-24
 VSCCP Capacity, 5-6
 VSCCP GPL, 5-1, 5-5
 VSCCP services, 5-8

VxWorks, 1-13
 VxWorks OS, 2-12

W

Warning icon, 1-8
 wireless network, 2-18