

# *Tekelec 1100 Application Server*

---

## **Hardware Manual**

910-2969-001 Revision F

August 2006



**TEKELEC**

**Copyright 2006 Tekelec.  
All Rights Reserved  
Printed in U.S.A.**

### **Notice**

Information in this documentation is subject to change without notice. Unauthorized use or copying of this documentation can result in civil or criminal penalties.

Any export of Tekelec products is subject to the export controls of the United States and the other countries where Tekelec has operations.

No part of this documentation may be reproduced or transmitted in any form or by any means, electronic or mechanical, including photocopying or recording, for any purpose without the express written permission of an authorized representative of Tekelec.

Other product names used herein are for identification purposes only, and may be trademarks of their respective companies.

RoHS 5/6 - As of July 1, 2006, all products that comprise new installations shipped to European Union member countries will comply with the EU Directive 2002/95/EC "RoHS" (Restriction of Hazardous Substances). The exemption for lead-based solder described in the Annex will be exercised. RoHS 5/6 compliant components will have unique part numbers as reflected in the associated hardware and installation manuals.

WEEE - All products shipped to European Union member countries comply with the EU Directive 2002/96/EC, Waste Electronic and Electrical Equipment. All components that are WEEE compliant will be appropriately marked. For more information regarding Tekelec's WEEE program, contact your sales representative.

### **Trademarks**

The Tekelec logo, EAGLE, G-Flex, G-Port, IP<sup>7</sup>, IP<sup>7</sup>Edge, IP<sup>7</sup> Secure Gateway, and TALI are registered trademarks of Tekelec. TekServer is a trademark of Tekelec. All other trademarks are the property of their respective owners.

### **Patents**

This product is covered by one or more of the following U.S. and foreign patents:

#### U.S. Patent Numbers:

5,008,929, 5,953,404, 6,167,129, 6,324,183, 6,327,350, 6,456,845, 6,606,379, 6,639,981, 6,647,113, 6,662,017, 6,735,441, 6,745,041, 6,765,990, 6,795,546, 6,819,932, 6,836,477, 6,839,423, 6,885,872, 6,901,262, 6,914,973, 6,940,866, 6,944,184, 6,954,526, 6,954,794, 6,959,076, 6,965,592, 6,967,956, 6,968,048, 6,970,542

### **Ordering Information**

| For additional copies of this document, contact your sales representative.

# Table of Contents

## Chapter 1. About This Manual

Introduction .....	1-1
Where to Find Information in This Manual .....	1-2
Where to Find Other Information .....	1-3
Programs Needed to View Linked Documents .....	1-4
Documents That Show How to Perform a Procedure.....	1-4
Installation Documents.....	1-5
Applications Documents .....	1-5
Documentation Packaging and Updates .....	1-6
Documentation Admonishments .....	1-6
Customer Assistance .....	1-7

## Chapter 2. Safety and Pre-Installation Requirements

Introduction .....	2-1
Safety Information .....	2-1
Regulatory Compliance and Certification.....	2-4
Pre-Installation Site Requirements .....	2-5
Generic Site Requirements .....	2-5
Grounding and Power Requirements .....	2-8

## Chapter 3. T1100 AS Hardware System Overview

Introduction .....	3-2
T1100 AS Hardware System.....	3-2
T1100 AS Hardware Features.....	3-4
T1100 AS Rear I/O Panel .....	3-6
T1100 AS Status Indicators.....	3-7
T1100 AS Chassis Installation and Replacement .....	3-8
Cable Management Arms.....	3-9
Breaker Panel .....	3-10
Breaker Panel LEDs.....	3-11
Breaker Panel Power .....	3-12
Breaker Panel Settings .....	3-13
Power Distribution Units.....	3-13

## Table of Contents

Ethernet Switches or Hubs.....	3-14
Console Servers.....	3-14
<b>Chapter 4. How to Install a T1100 AS Frame</b>	
Introduction.....	4-1
How to Unpack the T1100 AS Frame and Conduct Inventory .....	4-2
How to Install a T1100 AS Frame.....	4-2
Recommended Tools .....	4-3
How to Prepare the Floor for Heavy Duty Frames.....	4-3
How to Anchor the HD Frame to the Floor .....	4-6
How to Anchor to Overhead Rack of HD Frame .....	4-18
How to Cable a T1100 AS Frame.....	4-20
<b>Chapter 5. How to Install Hardware in an Existing Frame</b>	
Introduction.....	5-1
How to Unpack and Conduct Inventory .....	5-1
How to Unpack a T1100 AS Unit and Conduct Inventory .....	5-1
How to Install an Individual T1100 AS Unit .....	5-3
How to Cable Components Added to Existing Frames.....	5-14
How to Cable a T1100 AS Unit Added to an Existing Heavy Duty Frame.....	5-14
How to Cable a T1100 AS Installed in Customer-Provided Frame .....	5-15
<b>Chapter 6. Post Installation Procedures</b>	
Introduction.....	6-1
How to Connect Frame Ground and Logic Ground .....	6-2
Recommended Tools .....	6-2
How to Ground in a DC Environment .....	6-3
How to Ground the Logic Connector in a AC Environment....	6-11
Post-Installation Checklist.....	6-13
How to Power Up.....	6-15
How to Power Up a Heavy Duty Frame .....	6-15
How to Power Up Added T1100 AS Unit in DC Environment.....	6-15
How to Power Up a T1100 AS Unit in an AC Environment.....	6-16
How to Change Passwords .....	6-16
<b>Chapter 7. Field Replaceable Units</b>	
Introduction.....	7-2

Safety Information.....	7-2
T1100 AS Hardware System FRUs and Part Numbers.....	7-4
T1100 AS FRUs.....	7-5
Tools Required .....	7-6
How to Replace a Console Server, Ethernet Switch, or Hub .....	7-7
How to Access T1100 AS FRUs.....	7-9
How to Slide T1100 AS Chassis Out from Frame .....	7-9
How to Slide T1100 AS Chassis Back into Frame .....	7-11
How to Remove T1100 AS Chassis from a Frame .....	7-12
How to Return a T1100 AS Chassis to the Frame .....	7-15
How to Replace T1100 AS FRUs.....	7-19
How to Replace the Air Filters .....	7-19
How to Replace the Rectangular Fan Assembly.....	7-21
How to Replace the Square Fan Assembly.....	7-23
How to Replace Hard Disk Drive Assemblies .....	7-26
How to Replace Removable Media Disk Drives (CD/DVD).....	7-32
How to Replace a Power Supply Module.....	7-38
How to Replace PCI Cards.....	7-40
How to Replace a T1100 AS Chassis FRU.....	7-46

## **Appendix A. T1100 AS Hardware Feature Information**

Introduction .....	A-1
Hardware Components.....	A-1
Interfaces .....	A-2
Out of Band Management Card.....	A-3
Electrical Features .....	A-3
Mechanical Design.....	A-4
Mechanical Maintenance Features.....	A-4
Component Access front fascia .....	A-5
Fans, Fan Assemblies, and Air Filters .....	A-5
Tekelec 1100 AS Main Board .....	A-5
T1100 AS Diagnostics .....	A-5

## **Appendix B. Hardware Repair and Return**

Introduction .....	B-1
How to Obtain a Return Material Authorization.....	B-1
How to Locate T1100 AS Part Numbers.....	B-2
Air Filter Part Number Information .....	B-3

## Table of Contents

Fan Assembly Part Number Information.....	B-3
Removable Media Disk Drive Assembly Part Number Information .....	B-6
Hard Disk Drive Assembly Part Number Information.....	B-9
PCI Card Part Number Information .....	B-12
T1100 AS Chassis Part Number Information.....	B-14
How to Arrange Return Shipping.....	B-19
Specifically Targeted PCBs .....	B-19
General Instructions .....	B-20
Returning a Crate.....	B-20

### **Appendix C. ELAP or EPAP**

#### **Network Integration**

Introduction.....	C-2
Network Overview.....	C-2
Customer-Supplied Information.....	C-4
IP Address Assignment .....	C-4
Netmask and Broadcast.....	C-6
Network Interface Functions .....	C-6
Network Assumptions.....	C-8
Network Configuration .....	C-8
Firewall and Router Filtering Considerations.....	C-8
Serial Communication .....	C-10
Modems .....	C-10
Printers.....	C-12
Tip Utility (EAGLE Only .....	C-12
VT100 Ports.....	C-12
Platform Security.....	C-12

#### **Glossary**

#### **Index**

# List of Figures

Figure 2-1. European Directives CE Mark .....	2-4
Figure 2-2. Combined UL and GS Mark .....	2-4
Figure 2-3. UL-Demko Mark .....	2-4
Figure 2-4. Combined UL Mark for the United States and Canada .....	2-5
Figure 2-5. Door Grounding Strap Placement .....	2-9
Figure 3-1. T1100 AS Hardware System in DC Environment .....	3-4
Figure 3-2. Tekelec 1100 AS Chassis .....	3-5
Figure 3-3. Interior View of T1100 AS Chassis .....	3-6
Figure 3-4. Rear I/O Panel .....	3-7
Figure 3-5. T1100 AS Status Indicators .....	3-8
Figure 3-6. T1100 AS with Side Cable Management Arms .....	3-10
Figure 3-7. Front of Breaker Panel .....	3-10
Figure 3-8. Breaker Panel LEDs .....	3-11
Figure 3-9. Front and rear of AC power distribution unit .....	3-14
Figure 4-1. Floor Marking Template for HD Frame .....	4-4
Figure 4-2. Anchor Assembly for Slab Floors .....	4-7
Figure 4-3. Anchor Installation of HD Frame into Slab Floor .....	4-9
Figure 4-4. Anchor Assembly for Raised Floor Over Concrete .....	4-10
Figure 4-5. Anchoring on Raised Floor Over Concrete Slab .....	4-12
Figure 4-6. Anchor Assembly for Use with Support Channel .....	4-14
Figure 4-7. Anchoring Frame to Raised Floor with Support Channel .....	4-15
Figure 4-8. Anchor Assembly for Support Channel with Spring Nut .....	4-17
Figure 4-9. Anchoring Frame Using Support Channel/Spring Nut .....	4-18
Figure 4-10. HD Frame with Overhead Rack .....	4-19
Figure 5-1. Slide Assembly .....	5-3
Figure 5-2. Slide Assembly Extended View .....	5-5
Figure 5-3. Slide Assembly Inner Member Roller Side View .....	5-5
Figure 5-4. Frame Adapter Bracket Expanded .....	5-6
Figure 5-5. Frame Adapter Brackets and Slide Assemblies .....	5-7
Figure 5-6. Slide Assembly Outer Member .....	5-8

## List of Figures

Figure 5-7. Slide Assembly Detail Left Side From Rear .....	5-9
Figure 5-8. Slide Assembly Inner Member Mounting .....	5-10
Figure 5-9. Detail of a Side Cable Management Arm .....	5-11
Figure 5-10. Side Cable Management Arm Installation (T1000 AS shown) .....	5-12
Figure 5-11. T1100 AS Rear Detail .....	5-13
Figure 5-12. Frame Mounting Detail .....	5-13
Figure 6-1. Frame Ground Cable Routes in DC Environment .....	6-5
Figure 6-2. Frame Ground Cable Attachment Locations in DC Environment .....	6-6
Figure 6-3. Chassis Ground Cable Attachment Location in DC Environment .....	6-7
Figure 6-4. Logic Ground Cable Routes in DC Environment .....	6-9
Figure 6-5. Frame and Logic Ground Cable Attachment Locations .....	6-10
Figure 6-6. Logic Ground Cable Route in AC Environment .....	6-12
Figure 7-1. T1100 AS Chassis Front View .....	7-10
Figure 7-2. Chassis Retention Hardware .....	7-14
Figure 7-3. Right Slide Assembly Mounting and Retention Bracket .....	7-17
Figure 7-4. T1100 AS Chassis Rear View .....	7-18
Figure 7-5. Inside view of T1100 showing fan filters .....	7-20
Figure 7-6. Front Top Cover Removal - Screw Locations .....	7-22
Figure 7-7. Inside view of T1100 showing square fan assembly .....	7-25
Figure 7-8. Inside view of T1100 showing hard drive locations .....	7-28
Figure 7-9. Hard drive removal .....	7-29
Figure 7-10. T1100 AS Chassis Label Locations .....	7-30
Figure 7-11. Hard Disk Drive Label on T1100 AS Chassis .....	7-30
Figure 7-12. Disk Drive label locations (fans removed) .....	7-30
Figure 7-13. Inside view of T1100 showing CD/DVD drive location .....	7-34
Figure 7-14. Front Top Cover Removal - Screw Locations .....	7-34
Figure 7-15. Removable Media Disk Drive Cables (drives removed) .....	7-35
Figure 7-16. CD/DVD inside bracket screw location .....	7-36
Figure 7-17. CD/DVD chassis screws .....	7-37
Figure 7-18. Rotate lock ring down to disengage power supply module. ....	7-39
Figure 7-19. PCI Card Part Label .....	7-40
Figure 7-20. PCI Slots Label .....	7-41



Figure 7-21. Chassis Rear Top Cover Views. ....	7-43
Figure 7-22. PCI Cards and Slot Assignments .....	7-44
Figure 7-23. Left Slide Member Mounting .....	7-47
Figure B-1. T1100 AS Chassis Front View .....	B-3
Figure B-2. T1100 AS Front Top Cover screws .....	B-4
Figure B-3. Fan Part number labels .....	B-5
Figure B-4. Removable Media Disk Drive Assembly Part Label .....	B-6
Figure B-5. T1100 AS Chassis Front View .....	B-7
Figure B-6. T1100 AS Front Top Cover screws .....	B-8
Figure B-7. CD/DVD label location .....	B-8
Figure B-8. T1100 AS Chassis Label Locations .....	B-9
Figure B-9. Base Unit/Hard Disk Label on T1100 AS Chassis .....	B-10
Figure B-10. T1100 AS front fascia open with hard drive locations .....	B-11
Figure B-11. Hard disk label locations .....	B-11
Figure B-12. T1100 AS Chassis Label Locations .....	B-12
Figure B-13. PCI Slots Label on T1100 AS Chassis .....	B-12
Figure B-14. T1100 AS Chassis Front View .....	B-13
Figure B-15. Frame Identification Label .....	B-15
Figure B-16. T1100 AS Chassis Front View .....	B-16
Figure B-17. Base Unit/Hard Disk Label on T1100 AS Chassis .....	B-17
Figure B-18. Memory Label on T1100 AS Chassis .....	B-18
Figure B-19. PCI Card Label on T1100 AS Chassis .....	B-18
Figure C-1. MPS Network Connections, Netra .....	C-3
Figure C-2. MPS Network Connections, T1000 AS, T1100 AS .....	C-3
Figure C-2. MPS Network Connections, T1000 AS, T1100 AS .....	C-3

# List of Tables

Table 1-1. Manual Organization .....	1-2
Table 2-1. Space Requirements .....	2-7
Table 3-1. Tekelec 1100 AS Chassis Dimensions and Weight .....	3-9
Table 3-2. Breaker Panel LED Settings .....	3-12
Table 6-1. Post-Installation Checklist .....	6-14
Table 7-1. T1100 AS Field Replaceable Units and Part Numbers .....	7-5
Table A-1. Basic Interfaces .....	A-2
Table A-2. Optional Interfaces (on PCI Cards) .....	A-3
Table C-1. IP Address for the DSM Network .....	C-4
Table C-2. IP Address for the Sync Network .....	C-5
Table C-3. EAGLE 5 ISS IP Addresses .....	C-5
Table C-4. Interface Functions Required for MPS .....	C-7
Table C-5. Interface Functions Required for MPS .....	C-9
Table C-6. Serial Port Assignments for MPS Servers A and B .....	C-10

# List of Procedures

Procedure 4-1. How to Unpack Frame and Conduct Inventory.....	4-2
Procedure 4-2. Mark Floor Layout.....	4-4
Procedure 4-3. Create Cable and Anchor Holes for Raised Floors .....	4-5
Procedure 4-4. Anchor a HD Frame into a Slab Floor.....	4-7
Procedure 4-5. Anchor the Frame to the Slab Beneath the Raised Floor .....	4-11
Procedure 4-6. Anchor Frame to Raised Floor with Support Channel.....	4-14
Procedure 4-7. Anchor Frame with Support Channel/Spring Nut .....	4-16
Procedure 4-8. Attach Overhead Rack Support .....	4-19
Procedure 5-1. Unpack a T1100 AS Chassis.....	5-2
Procedure 5-2. Installing a T1100 AS Chassis.....	5-4
Procedure 6-1. Prepare the Ground Cables .....	6-3
Procedure 6-2. Connect Ground Cable: Frame to Ground Window.....	6-4
Procedure 6-3. Connect T1100 AS Chassis Ground: T1100 AS Chassis to Frame.....	6-7
Procedure 6-4. Connect Logic Ground from Logic Ground Terminal Strip to Ground Window .....	6-8
Procedure 6-5. Connect Logic Ground: T1100 AS Logic Ground Port to Logic Ground Terminal Strip .....	6-11
Procedure 6-6. Connect Logic Ground Between Logic Ground Ports...	6-12
Procedure 6-7. Verify AC ground .....	6-13
Procedure 6-8. Power Up T1100 AS Unit in an AC Environment.....	6-16
Procedure 7-1. Replace an Ethernet Switch, Hub, or Console Server.....	7-7
Procedure 7-2. Slide T1100 AS Chassis Out from Frame.....	7-10
Procedure 7-3. Slide T1100 AS Chassis Back into Frame.....	7-11
Procedure 7-4. Remove a T1100 AS Chassis from Frame .....	7-12
Procedure 7-5. Return a T1100 AS Chassis to the Frame.....	7-16
Procedure 7-6. Replace Rectangular and Square Air Filters .....	7-19
Procedure 7-7. Replace a Rectangular Fan Assembly .....	7-21
Procedure 7-8. Replace a Square Fan Assembly .....	7-23
Procedure 7-9. Replace a Hard Disk Drive Assembly.....	7-26
Procedure 7-10. Replace a Removable Media Disk Drive Assembly.....	7-32

## List of Procedures

Procedure 7-11. Replace a power supply module.....	7-38
Procedure 7-12. Replace a PCI Card.....	7-40
Procedure 7-13. Replace a T1100 AS Chassis FRU .....	7-46
Procedure B-1. Obtaining an RMA.....	B-2
Procedure B-2. How to Locate serial numbers for Fan Assembly .....	B-3
Procedure B-3. How to Locate serial numbers for Removable Media Disk Drive Assembly .....	B-7
Procedure B-4. How to Locate serial numbers for Hard Disk Drive Assembly.....	B-10
Procedure B-5. How to Locate serial numbers for PCI Cards .....	B-13
Procedure B-6. How to Locate serial numbers for a T1100 AS Chassis .....	B-15
Procedure B-7. Preparing Crate and Dolly for Return to Tekelec.....	B-20
Procedure C-1. Configure Modem with Script .....	C-11
Procedure B-7. Preparing Crate and Dolly for Return to Tekelec.....	B-20

## About This Manual

Introduction.....	1-1
Where to Find Information in This Manual.....	1-2
Where to Find Other Information .....	1-3
Programs Needed to View Linked Documents .....	1-4
Documents That Show How to Perform a Procedure .....	1-4
Installation Documents .....	1-5
Applications Documents.....	1-5
Documentation Packaging and Updates.....	1-6
Documentation Admonishments .....	1-6
Customer Assistance .....	1-7

### Introduction

This manual is a generic manual that describes common components of Tekelec 1100 Application Server (AS) hardware systems and describes how to install and replace them. A T1100 AS hardware system consists of one or more T1100 AS (with applications loaded) and any additional hardware (such as hubs, switches, or power distribution equipment) needed to support the applications.

**NOTE:** This manual includes links to documents that are specific to a given product, depending on which product CD this manual is viewed. Although the manual is the same on CDs for various products, the linked documents are different on different product CDs. For more information about linked documents, see “Where to Find Other Information” on page 1-3.

T1100 AS hardware systems are delivered with applications already loaded.

For more information about T1100 AS hardware systems in AC and DC environments, see Chapter 3, “T1100 AS Hardware System Overview.”

Each time this manual is published, the revision level is changed. For example, the first time this manual is published, it uses Revision A; the second time it is published, it uses Revision B.

## Where to Find Information in This Manual

Table 1-1 shows how this manual is organized.

**Table 1-1.** Manual Organization

Chapter Number and Title	Description
Chapter 1, "About This Manual"	Describes how to use the manual, where to find other information, and how to contact Technical Services.
Chapter 2, "Safety and Pre-Installation Requirements"	Lists general safety instructions that readers should be familiar with, and lists site requirements that should be verified before installing T1100 AS hardware systems.
Chapter 3, "T1100 AS Hardware System Overview"	Presents an overview of the various hardware components that can be included in T1100 AS hardware systems.
Chapter 4, "How to Install a T1100 AS Frame"	Describes how to install a heavy duty frame which is delivered from manufacturing with T1100 AS units mounted in a heavy-duty frame for use in a DC environment.
Chapter 5, "How to Install Hardware in an Existing Frame"	Describes how to install an individual T1100 AS unit into a frame that has already been installed. This chapter covers both: <ul style="list-style-type: none"> <li>• Adding a T1100 AS unit into a heavy duty frame that already contains from 1 to 4 T1100 AS units in a DC environment</li> <li>• Installing a single T1100 AS unit into a customer's frame in an AC environment.</li> </ul>
Chapter 6, "Post Installation Procedures"	Presents a post-installation checklist and instructions on how to verify voltage and to power-up the system.
Chapter 7, "Field Replaceable Units"	Describes the components of a T1100 AS hardware system that can be replaced in the field, and includes procedures for replacing each type of field-replaceable unit (FRU).

**Table 1-1.** Manual Organization

Chapter Number and Title	Description
Appendix A, "T1100 AS Hardware Feature Information,"	Describes in greater detail some of the hardware features of the T1100 AS chassis.
Appendix B, "Hardware Repair and Return,"	Describes how to obtain a Return Material Authorization, find part numbers on labels, and ship returned equipment.

## Where to Find Other Information

This manual is delivered on a compact disk (CD) that also contains the following documentation (these documents can also be accessed from the introductory page of the documentation CD):

- The CD contains linked documents shown in the following sections. To display one of these documents from within this document, click anywhere in the highlighted area. For information about software needed to open these links, see "Programs Needed to View Linked Documents" on page 1-4.
- Optionally, the CD may also contain application documentation, which describes the environment in which the T1100 AS hardware system runs as well as provides information about the application.

**NOTE: Documentation about T1100 AS hardware components (such as breaker panels or Ethernet switches) that are supplied by other companies is shipped with the T1100 AS hardware system. When unpacking a frame or individual components, be sure to obtain this documentation and store it where it can be accessed later.**

The following related publications are also included with the LSMS documentation set

- The Tekelec EAGLE 5 Integrated Signaling System *Commands Error Recovery Manual* contains detailed information about the command-rejected error messages generated by the commands used on the EAGLE 5 ISS as well as error recovery procedures. This information can be helpful for the LSMS user when viewing certain exception logs.
- The Tekelec EAGLE 5 ISS *ELAP Administration Manual* provides a definition of the user interface to the EAGLE<sup>®</sup> 5 ISS LNP Application Processor on the MPS/ELAP platform. The manual defines the methods for accessing the interface, menus, screens available to the user and describes their impact. It provides the syntax and semantics of user input and defines the output the user receives, including information and error messages.
- The Tekelec EAGLE 5 ISS *Maintenance Manual* contains procedural information required for maintaining the EAGLE 5 ISS and the card removal and replacement procedures. The Tekelec EAGLE 5 ISS *Maintenance Manual* provides preventive and corrective maintenance procedures used in maintaining the different systems.

- The *Tekelec EAGLE 5 ISS LNP Feature Activation Guide* contains the procedures necessary to activate the LNP feature using telephone number quantities from 24 million to 120 million telephone numbers.
- The *Tekelec 1100 Application Server MPS Platform Software and Maintenance Manual* describes the platform software for the Multi-Purpose Server (MPS) based on the Tekelec 1100 Application Server (T1100 AS) and describes how to perform preventive and corrective maintenance for the T1100 AS-based MPS. This manual should be used with the ELAP-based application (LNP).

### Programs Needed to View Linked Documents

To view the linked documents, the workstation on which this manual is being viewed needs to have the following programs:

- Most of the linked documents are in Portable Document Format (PDF), which has a file type of `.pdf`. PDF is also the format of this manual. When a PDF link is clicked, the linked document is opened in the same window as this manual. To return to this manual, click the Back button on the PDF display window.
- A document with a `.doc` file type can be viewed with Microsoft® Word. The linked document may open in a minimized window.
- A document with an `.mpg` file type can be viewed with a variety of video programs. Two commonly used programs are:
  - Microsoft Windows® Media Player (this program is usually included with Microsoft Internet Explorer)
  - RealOne™ Player

### Documents That Show How to Perform a Procedure

The following documents illustrate how to perform procedures. The first document uses a Word format; the others are videos with sound that can be opened with most video programs.

- [822-0094-02.doc](#), WORK INSTRUCTIONS, UNPACKING, VERTICAL SHIPPING CRATE, HEAVY DUTY, EAGLE
- [fru-filter.mpg](#), video that shows how to replace a filter (also see Procedure 7-6, "Replace Rectangular and Square Air Filters," on page 7-19)
- [fru-rect-fan.mpg](#), video that shows how to replace a fan assembly (also see Procedure 7-7, "Replace a Rectangular Fan Assembly," on page 7-21)
- [fru-square-fan.mpg](#), video that shows how to replace a fan assembly (also see Procedure 7-8, "Replace a Square Fan Assembly," on page 7-23)
- [fru-hdd.mpg](#), video that shows how to replace a hard disk drive assembly (also see Procedure 7-9, "Replace a Hard Disk Drive Assembly," on page 7-26)



- [fru-dvd.mpg](#), video that shows how to replace a fan assembly (also see Procedure 7-10, “Replace a Removable Media Disk Drive Assembly,” on page 7-32)
- [fru-pwr-sup.mpg](#), video that shows how to replace a fan assembly (also see Procedure 7-11, “Replace a power supply module,” on page 7-38)
- [replace\\_main\\_unit.mpg](#), video that shows how to replace a Tekelec 1000 chassis (also see Procedure 7-13, “Replace a T1100 AS Chassis FRU,” on page 7-46)

## Installation Documents

This section contains links to assembly drawings, interconnect diagrams, and related installation documents.

**NOTE:** A given application or set of applications might support only a DC environment or only an AC environment. For information about which environment is supported, refer to the application documentation. If the environment is not supported by the application, the link in this hardware manual will open a document that states that the drawing is not available.

### Linked Documents

The following documents provide information about T1100 AS hardware systems:

- [AssemblyDrawingT1100.pdf](#), a drawing of the maximum configuration possible in a frame for AC and DC environments.
- [InterconnectDiagramT1100.pdf](#), a diagram that shows how the elements in a frame should be connected.
- [CableListT1100.pdf](#), a list of the cables shown in the system interconnect drawing. The list contains links to drawings of each cable used in the InterconnectDiagram.
- [BreakerSettingsT1100.pdf](#), information that shows mapping of breakers to hardware components.
- [PowerReqmtsT1100.pdf](#), information that shows the amount of power required by each of the components in a T1100 frame.

## Applications Documents

Tekelec 1100 Application Server units support a variety of applications. For more information, refer to application documentation.

**NOTE:** Application documentation may also contain information about additional hardware.

## Documentation Packaging and Updates

Customer documentation is upgraded whenever significant changes are made that affect system operation or configuration are made.

The document part number is shown on the title page along with the current revision of the document, the date of publication, and, if applicable, the software release that the document covers. The bottom of each page contains the document part number and the date of the publication.

## Documentation Admonishments

Admonishments are icons and text that may appear in this and other Tekelec manuals. Admonishments alert the reader to assure personal safety, to minimize possible service interruptions, and to warn of the potential for equipment damage.

The following admonishments, listed in descending order of priority, are used in Tekelec manuals.



**TOPPLE:** This icon and text indicate the possibility of equipment damage and personal injury from toppling.



**DANGER:** This icon and text indicate the possibility of *personnel injury*.



**WARNING:** This icon and text indicate the possibility of *equipment damage*.



**CAUTION:** This icon and text indicate the possibility of *service interruption*.

## Customer Assistance

The Customer Care Center offers a point of contact through which customers can receive support for problems that may be encountered during the use of Tekelec's products. The Customer Care Center is staffed with highly trained engineers to provide solutions to your technical questions and issues seven days a week, twenty-four hours a day. A variety of service programs are available through the Customer Care Center to maximize the performance of Tekelec products that meet and exceed customer's needs.

To receive technical assistance, call the Customer Care Center at one of the following locations:

- Tekelec, USA  
Phone (US and Canada) +1 888-FOR-TKLC  
Phone (international) +1 919-460-2150  
Fax +1-919-460-0877  
Email: support@tekelec.com
- Tekelec, Europe and UK  
Phone +44 1784 467 804  
Fax +44 1784 477 120  
Email: ecsc@tekelec.com



## Safety and Pre-Installation Requirements

Introduction.....	2-1
Safety Information .....	2-1
Regulatory Compliance and Certification .....	2-4
Pre-Installation Site Requirements.....	2-5
Generic Site Requirements.....	2-5
Grounding and Power Requirements .....	2-8

### Introduction

This chapter presents:

- General safety considerations that should always be kept in mind when Tekelec products are installed or replaced
- Listing of regulatory compliances and certifications that Tekelec products support
- Site requirements that should exist before Tekelec products are installed

### Safety Information

Safety icons and text are used throughout Tekelec manuals to warn the reader of the potential of personal injury, service interruption, and equipment damage. For information about what each of the icons mean, see [“Documentation Admonishments”](#) on page 1-6.

Before beginning any procedure described in this manual, ensure that you are familiar with each of the following safety admonishments. Additional safety admonishments may be included, or repeated, for specific procedures.



**TOPPLE:** Always read and understand instructions completely before working on, moving, raising or lowering the frame, any portion of the frame, or attachments to the frame or equipment.



**TOPPLE:** Never try to unpack any frame from the shipping container without at least two people to steady any movement of the frame and related components. At least two people are required to safely move and position any frame.



**TOPPLE:** Never pull out the shelf of any frame that is not anchored properly. Some frames are required to be attached to overhead ladder racks before shelves are extended.



**DANGER:** No commercially AC powered equipment may be used or placed within 7 ft. of -48V equipment. AC powered equipment within 7 ft. of -48V equipment may create a shock or current loop that can be severely hazardous to personnel and equipment.



**DANGER:** Do not wear metal, chains, rings, watches, or jewelry or carry exposed metal, keys or tools in pockets when working on system equipment or other related electrostatic-sensitive components. Always wear a wrist strap or other electrostatic protection when handling printed circuit boards and other electrostatic-sensitive devices.



**WARNING:** Do not leave or allow unused metal objects, such as screws or washers, to remain anywhere within the equipment. Remove all unused material from the equipment



**WARNING:** Do not allow any metal shavings to remain in the equipment area. Metal Shavings may result from over tightened screws or bolts. These small metal particles are hazardous to electronic equipment. Be careful not to over tighten screws or bolts.



**WARNING:** Do not use tie wraps on or above the top traverse arms on a frame. Always trim tie wrap flush and turn the trimmed tie wrap to the rear of the cable.



**CAUTION:** All personnel associated with the installation of these systems must adhere to all safety precautions and use required protection equipment, to avoid the possibility of injury to personnel, service degradation, and/or service interruption.



**CAUTION:** These systems have redundant power supplies to allow service during normal maintenance. When repairs require a total power disconnect, both input supply sources must be disconnected. This causes service interruption and takes down the systems.



**CAUTION:** This equipment has a connection between the earthed conductor of the DC supply circuit and the earthing conductor.



**CAUTION:** The Branch Circuit Overcurrent Protection shall be rated minimum -48V, maximum 40A.



**CAUTION:** Equipment is to be installed in restricted access areas in accordance with articles 110-16, 110-17, and 110-18 of the National Electric Code, ANSI/NFPA 70.



**CAUTION:** A readily accessible disconnect device that is suitable, approved, and rated shall be incorporated in the field wiring.



**CAUTION:** Connect to a reliably grounded SELV source which is reliably earthed and electrically isolated from the AC source.



**CAUTION:** Use only listed closed loop connectors for connection to the supply.



**CAUTION:** When some CPCI cards arrive from the manufacturer, they may have a small plastic cover over the screws and/or the alignment ejector pins. Remove and discard these plastic covers. If inserting the cards takes an excessive amount of force, check for obstructions. Forcing the card into a slot may damage the ejector handle or pin.

## Regulatory Compliance and Certification

Tekelec products are tested to meet the following regulatory standards:

- Network Equipment Building System (NEBS) level 3 as listed in Telcordia SR-3580 Issue 1, November 1995.
- Applicable Telcordia Electromagnetic Compatibility and Electrical Safety requirements in GR-1089-CORE; Issue 2, with Revision 1, February 1999.
- Applicable Physical Protection requirements in GR-63-CORE, Issue 2, April 2002.
- Relevant directives and harmonized standards in support of the products Compliance European (CE) mark required in Europe. Figure 2-1 shows the mark used to indicate this compliance.

**Figure 2-1.** European Directives CE Mark



- Requirements of RTTE Directive 1999/5/EC, Radio Telecommunications Terminal Equipment, as tested to the relevant standards identified in the Official Journal of the European Communities. Figure 2-2 and Figure 2-3 show the marks used to indicate this compliance.

**Figure 2-2.** Combined UL and GS Mark



**Figure 2-3.** UL-Demko Mark



- Relevant standards in ElectroMagnetic Compatibility (EMC) directive 89/336/EEC.



- Relevant standards in Safety directive 73/23/EEC, supported by Certified Body (CB) Test Certificates US/5923/UL or US/5451/UL issued by the National Certification Body as tested to IEC 60950 with national differences for European countries
- Underwriters Laboratories (UL) listed under UL File E200146 for USA and c-UL for Canada. Figure 2-4 shows the mark used to indicate this compliance.

**Figure 2-4.** Combined UL Mark for the United States and Canada



## Pre-Installation Site Requirements

Before installing any T1100 AS hardware system, ensure that the requirements described in both of the following sections have been met.

- “Generic Site Requirements” on page 2-5
- “Grounding and Power Requirements” on page 2-8

### Generic Site Requirements

Ensure that the site where the product will be installed conforms to the specifications listed in the following sections. These specifications are standard telephony industry requirements for equipment installation.

#### Fire Protection

Local fire protection codes must be satisfied in the equipment room where the system is to be located.

#### Environmental Requirements

Tekelec products are designed for environments that have temperature and humidity controls. Temperature and humidity controls must be activated as quickly as possible for equipment to operate at an optimum level.

When temperature and humidity controls fail, the equipment has been tested to operate within the following ranges:

- Temperature
  - 5° C to 40° C (41° F to 104° F) for normal operation
  - -5° C to 50° C (23° F to 122° F) for no more than 96 hours in duration and at elevations less than 1800 meters
  - -5° C to 50° C (23° F to 122° F) for storing the product
- Humidity
  - 5% to 85% non-condensing for normal operation
  - 5% to 90% non-condensing (but not to exceed 0.024 kilograms of water per kilogram of dry air) for no more than 96 hours in duration and at elevations less than 1800 meters

Tekelec products are tested to operate at an elevations within the following range:

- Minimum: 60 meters below sea level at ambient temperature of 30° C (86° F)
- Maximum: 4000 meters above sea level at ambient temperature of 40° C (104° F)

### HVAC Requirements

Tekelec products are designed to bring cool air in from the bottom front and exit heated air out the top rear of the installed equipment.

The required HVAC (Heating, Ventilation, and Air Conditioning) capacity depends on the installed equipment. To calculate needed HVAC capacity, determine the total wattage of the installed equipment and use the following formula:

$$\text{BTUs/hr.} = \text{watts} \times 3.413$$

The amount of power required by frame components is found at:

[PowerReqmts.pdf](#).

### Lighting

Adequate lighting should be provided in the room where the equipment is to be located. Lighting fixtures must be far enough from the equipment and cables to prevent heat damage and to allow safe access to equipment and cables.

### Earthquake Resistance

All Tekelec system configurations are designed to assure that the system remains operational during and after an earthquake, even when the system is located on the upper floors of a zone 4 central office.

**Space Requirements**

Provide space as described in Table 2-1. These space requirements provide for Tekelec equipment installed in a 23-inch heavy-duty frame, which measures 7 feet high. Separator panels and end panels add to the width of multiple frame systems.

**Table 2-1.** Space Requirements

Building Area	Dimensions	Notes
Halls	4.5 feet wide by 8 feet tall (1.4 meters wide by 2.4 meters tall)	To provide a clear, uncluttered route for moving equipment between the loading/receiving dock and the planned system location
Frame location	30 inches wide by 24 inches deep (76.2 cm wide by 60.96 cm deep)	Floor area recommended for one Tekelec frame (multiply by the number of frames listed on the Initial Sales Order) Total area per frame = 720 square inches (5.0 square feet) (0.465 square meters)
Side aisles	4 feet (1.2 meters)	To allow maneuvering frames into place and provide ample work space around the equipment
Front and rear access	3 feet 6 inches (107 cm)	From walls or other frames
Side access	12 inches (31 cm)	From walls or other frames

In addition, when planning the installation, be sure to take into account spare hardware storage, modems, terminals, printers, cross connect panels, and all other items that might require space in a system.

**Floor Loading**

Tekelec products installed in heavy-duty frames are designed for installation on raised or solid floors, which are recommended to have a distributed load capacity of no less than 100 pounds per square foot (504 kg/m<sup>2</sup>). Following are the maximum weights of Tekelec frames:

- Maximum weight of EAGLE 5 ISS Control or Extension frames: 850 lbs (386 kg).
- Maximum weight of a two T1000/T1100 server frame (for example, the MPS frame), including AC and DC LSMS frames: 600 lbs (273 kg).

- Maximum weight of the EOAP frame: 450 lbs (205 kg).
- Maximum weight of an application frame with up to six T1000/T1100 servers: 925 lbs (421 kg).

Use the following equation to calculate the floor loading:

Distributed floor capacity = Total equipment weight/floor area

## Grounding and Power Requirements

Before installing a T1100 AS hardware system, refer to the application documentation to determine whether it is to be installed in an Alternating Current (AC) or Direct Current (DC) environment. Then, ensure that the grounding and power requirements in the appropriate following sections have been met.

- “Grounding Requirements” on page 2-8 (this section describes requirements both for AC and DC environments)
- “Power Requirements in a DC Environment” on page 2-10
- “Power Requirements in an AC Environment” on page 2-10

## Grounding Requirements

Tekelec systems operate as digital isolated ground plane systems in a central office environment and require a single connection to the central office ground window. The system’s ground cables must provide the sole grounding connection between the entire system and the central office grounding.



**WARNING:** Always install an isolator pad between the frame and ground. Tekelec frames are shipped with isolator pads to completely isolate the frames from ground. If a non-Tekelec frame is used, an isolator pad must be provided.

The system can use three types of grounding paths:

- Battery return

The battery return grounding path is the return path for all –48VDC loads in the system. This path is isolated from other system grounds and connects to the rest of the central office through the –48VDC return connections located on the breaker panels of each frame.

- Logic Ground

Some system types require connection to a logic ground. The logic ground path provides a common voltage reference point between all circuit boards of a system. Each connection terminates to the system ground. The logic ground path is shown on your system’s interconnect drawing. The logic ground path does not carry current.

**NOTE:** If the AC-powered T1100 AS unit uses serial RS232 connections, the grounding in a standard serial cable will provide the logic ground necessary for the data transmission.

**NOTE:** AC-powered T1100 AS units should not be used for RS485, DS0, V.35, or other network connections unless specified by Tekelec.

- Frame/chassis ground

The frame/chassis ground path provides a low impedance connection for all metal parts of the entire system, including the frame, doors, shelves, and end panels. Each frame/chassis connection within the system lineup terminates to the frame and connects to the main ground by way of Htaps, #6 American Wire Gauge (AWG) to 1/0 cable.

**NOTE:** The frame/chassis ground path does not carry current.

For products installed in a frame, the doors installed are grounded to the frame through a two-hole lug ground wire and through a screw-down latch. Figure 2-5 shows a cutaway view example of an open frame door showing the door ground strap.

**Figure 2-5.** Door Grounding Strap Placement

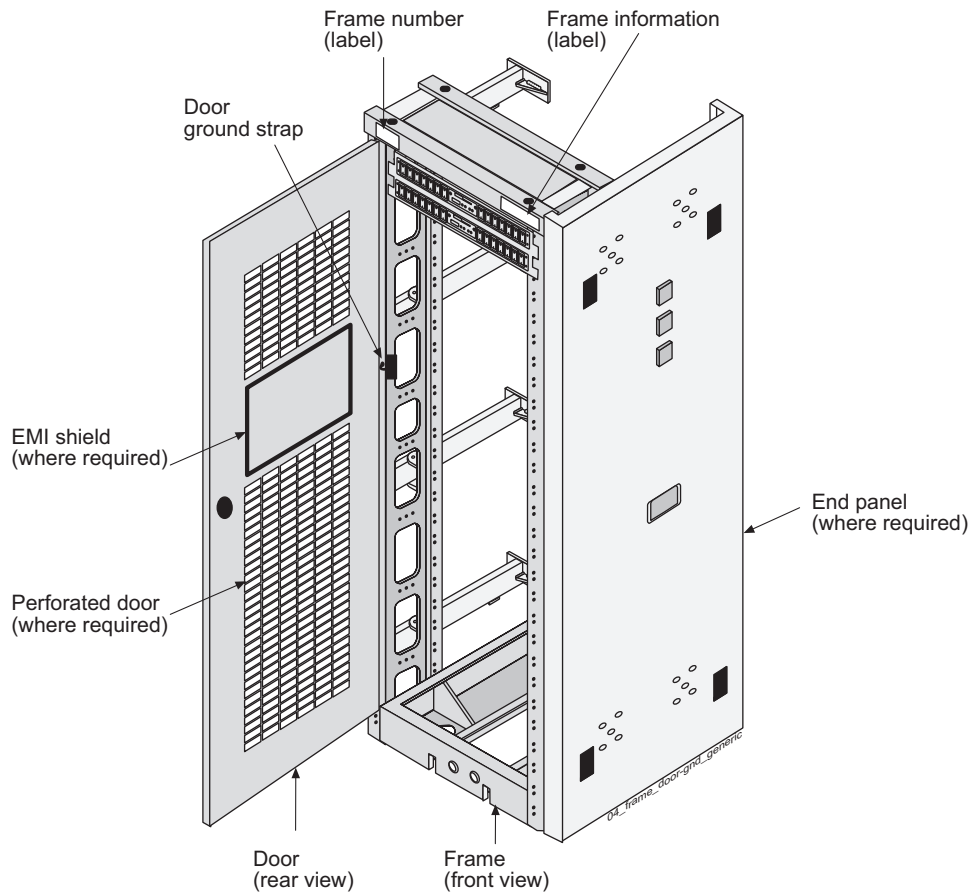

### Power Requirements in a DC Environment

A Direct Current environment must supply four feeds from the customer's power source. Each frame containing Tekelec products requires that power be provided from one to four breakers at -48VDC.

Each frame is divided into A and B power buses. In the event of loss of power on one of the buses, the other bus must be able to supply current for the entire frame. Therefore, each bus requires wiring sized to handle up to the maximum amps at -48VDC, with a maximum voltage drop of 0.6 volts. This requirement is met automatically when power is supplied by breakers.

**NOTE: If breakers are tripped by an overload, they must be switched completely OFF and then ON to reset.**

The following table contains detailed information on T1100 AS power requirements in a DC environment: [PowerReqmts.pdf](#),

### Power Requirements in an AC Environment

An Alternating Current environment must supply two feeds from separate circuits.

The following table contains detailed information on T1100 AS power requirements in a AC environment: [PowerReqmts.pdf](#),

# 3

## T1100 AS Hardware System Overview

T1100 AS Hardware System.....	3-2
T1100 AS Hardware Features.....	3-4
T1100 AS Rear I/O Panel .....	3-6
T1100 AS Status Indicators .....	3-7
T1100 AS Chassis Installation and Replacement.....	3-8
Breaker Panel.....	3-10
Breaker Panel LEDs .....	3-11
Breaker Panel Power.....	3-12
Breaker Panel Settings .....	3-13
Ethernet Switches or Hubs .....	3-14

## Introduction

Depending on the applications that run on them, T1100 AS hardware systems are delivered in one of the following ways:

- **Integrated applications**

Most applications that run on T1100 AS systems are designed to be integrated with features that run on a Signal Transfer Point (STP). T1100 AS systems for these applications run in a Direct Current (DC) environment and are delivered in one of the following ways:

- For most applications, the initial installation of the T1100 AS hardware system consists of one or more T1100 AS units, along with breaker panels and Ethernet communication equipment, already installed by Tekelec manufacturing in a heavy duty frame.
- Some applications allow a single T1100 AS unit to be added to a heavy duty frame that has been previously installed and already contains one to four T1100 AS units. To view the maximum configuration allowed, refer to the [Assembly drawings](#).

For more information about these T1100 AS hardware systems, see “T1100 AS Hardware System” on page 3-2.

- **Non-integrated applications**

Applications (such as provisioning applications or network management applications) that do not need to integrate with STP features may not require a DC environment.

To determine which environments are supported by the applications that run on the T1100 AS systems, refer to the applications documentation.

This chapter provides an overview of T1100 AS hardware systems in each of the possible environments and an overview of each of the components that can be part of a T1100 AS hardware system.

## T1100 AS Hardware System

A T1100 AS hardware system consists of the following hardware components, which are assembled in a heavy-duty frame by Tekelec and delivered as one unit when first ordered (some applications allow additional T1100 AS units, to a maximum of six, to be added later):

- Depending on the applications loaded, from one to six T1100 AS units, identified as A through E, starting with the topmost server identified as A. Each server consists of T1100 AS hardware that is loaded at the factory with platform software and application software. Some applications allow each



server to be installed with different application software. (The minimum and maximum number of servers in the frame depends on which applications are loaded. For an overview of the T1100 AS units, see “T1100 AS Hardware Features” on page 3-4.

**NOTE: Some applications allow individual T1100 AS units (to a maximum of six per frame) to be added later.**

- Breaker Panels (BPs) for DC systems. For an overview, see “Breaker Panel” on page 3-10; for more information, refer to the documentation delivered with the product.
- Power Distribution Units for AC systems. For more information, refer to the documentation delivered with the product
- Additional equipment, such as consoles, storage, and communications switches and hubs. For more information on these components, refer to the documentation delivered with the product.

Figure 3-1 shows an example T1100 AS hardware system.

**NOTE: This figure shows a DC system. For more complete information about the configuration used by your application, refer to the [Assembly drawings](#).** |

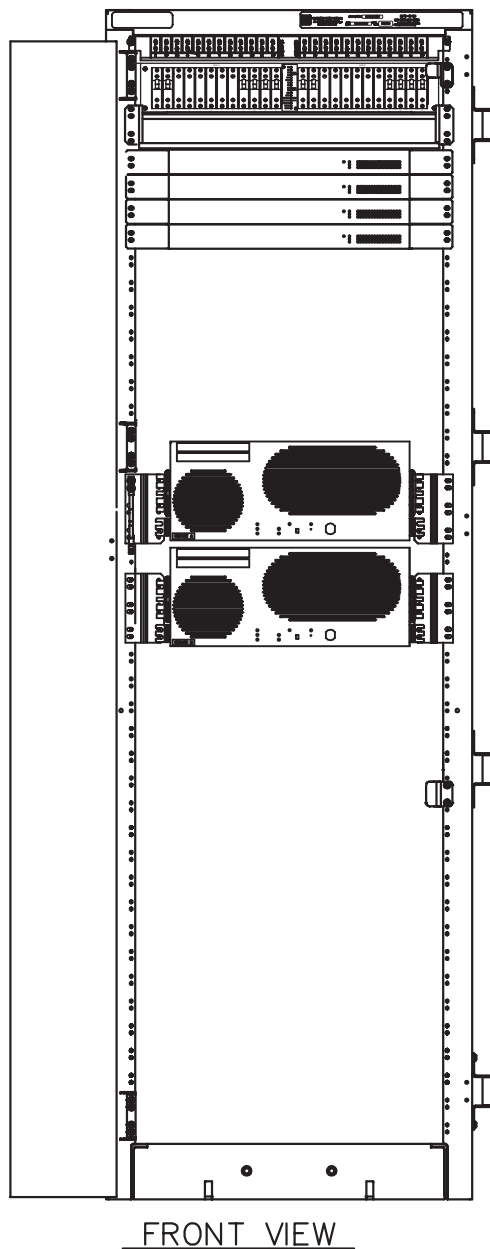
**Figure 3-1.** T1100 AS Hardware System in DC Environment

## T1100 AS Hardware Features

The Tekelec 1100 AS is a general-purpose application engine (AE) that offers high transaction rates with low latency. It supports a variety of application solutions for the wireless and wireline telecommunications infrastructure to provide the building blocks for next-generation signaling systems.

The Tekelec 1100 AS is a scalable computing platform constructed with state-of-the-art components packaged in a compact-size, stand-alone enclosure. The Tekelec 1100 AS chassis utilizes dual processors, and has eight PCI slots, four internally mounted media devices, redundant hot-swappable power supplies, and expandable memory.

Figure 3-2 shows a single Tekelec 1100 AS Services Platform. For clarity, it is shown not mounted in a frame.

**Figure 3-2.** Tekelec 1100 AS Chassis

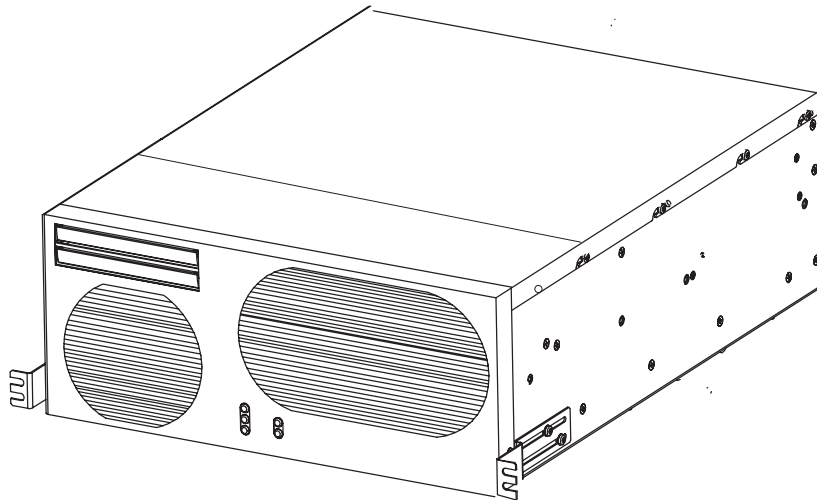
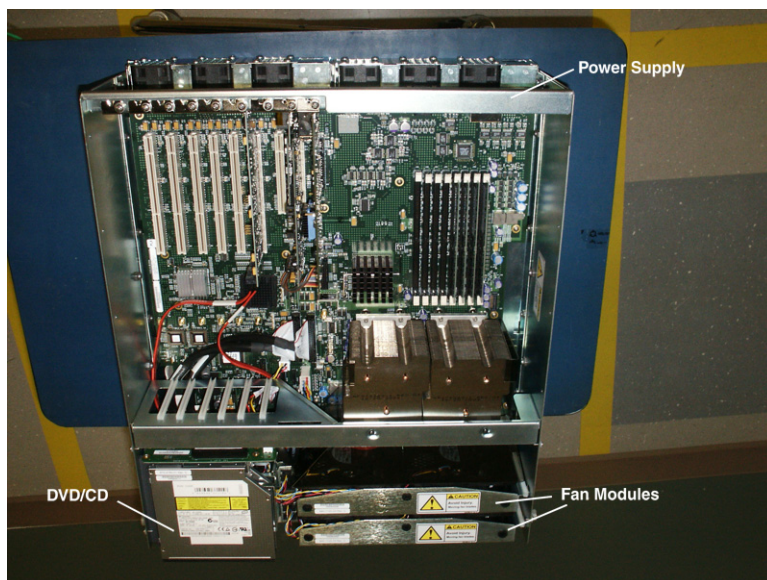

Figure 3-3 shows an exploded view of the T1100 AS chassis. This view shows where the various hardware components, especially the Field Replaceable Units (FRUs), are located.

**Figure 3-3.** Interior View of T1100 AS Chassis

The following are the Field Replaceable Units:

1. Air filters (two)
2. Fan modules (three)
3. Hard disks (two)
4. Removable media disk drive assembly (CD/DVD)
5. Peripheral Component Interconnect (PCI) cards/PCI Express card
6. Power Supplies
7. Entire T1100 AS chassis

For more information about FRUs, see [Chapter 7, "Field Replaceable Units."](#)

For more information about the hardware components, see Appendix A, "T1100 AS Hardware Feature Information."

### T1100 AS Rear I/O Panel

The rear input/output (I/O) panel is perforated to facilitate airflow and forms the back wall of the Tekelec 1100 AS enclosure. It has openings for:

- Eight peripheral component interface (PCI) cards' I/O panels
- One PCI Express card

- The I/O connectors on the rear edge of the main board (serial port, E1 or T1 clock inputs, and two USB ports)
- The power board I/O (logic ground connection)
- Five Serial ports

Power entry is at the rear of the Tekelec 1100 AS. There are two power supply modules. The A and B power supply modules are hot-swappable.

Logic ground is carried on a connector on the power board. The connector is bulkhead-mounted to the rear I/O panel. There are also two chassis ground connector studs on the rear I/O panel. See Figure 3-4 for a detailed view of the rear I/O panel.

**NOTE:** Figure 3-4 shows T1100 AS base configuration with empty PCI slots

**Figure 3-4.** Rear I/O Panel

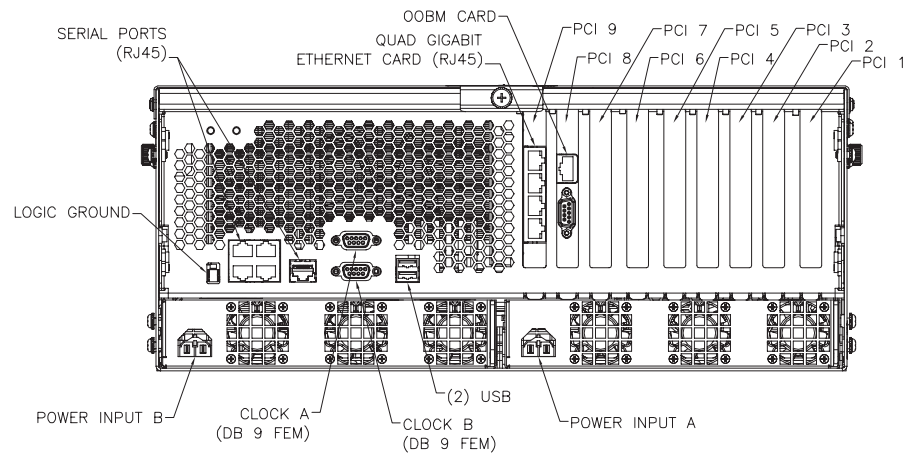

### T1100 AS Status Indicators

The T1100 AS platform provides the following light-emitting diode (LED) status indicators on the front fascia of the Tekelec 1100 AS platform (see Figure 3-5):

- Critical, Major, and Minor visual alarm indicators indicate operational condition of the Tekelec 1100 AS platform, including status of the major subsystems: processors, volatile memory, non-volatile memory (disk drives, etc.), and interfaces.
- Indicators for A and B power inputs.

Figure 3-5. T1100 AS Status Indicators



For more information about the diagnostics that manage these alarm and status indicators, see [“T1100 AS Diagnostics” on page A-5](#).

### T1100 AS Chassis Installation and Replacement

The T1100 AS chassis is installed in the frame using slides that have inner and outer rails. The outer slide rail is attached to the frame and the inner slide rail is attached to the T1100 AS chassis (see Figure 5-1 on page 5-3). The chassis is installed by sliding the inner rails into the outer rails.



**DANGER:** Moving a T1100 AS chassis requires two people. Each T1100 AS chassis weighs approximately 30 kg (65 lbs) and may cause personnel injury or damage to the internal components due to shock and vibration if not handled properly.

The Tekelec 1100 AS chassis is also field replaceable. Tekelec 1100 AS replacement, including disconnecting cables, mounting a replacement system (of identical configuration), and reconnecting cables requires no more than 30 minutes.

**NOTE:** All I/O connections are at the rear of the Tekelec 1100 AS chassis.

Table 3-1 lists the dimensions of the Tekelec 1100 AS chassis.

**Table 3-1.** Tekelec 1100 AS Chassis Dimensions and Weight

Dimension	Value	Notes for Rack-Mounting
Depth	21.6 inches from front surface to rear bulkhead	Allows over 2.5 inches of depth for cable management in a Tekelec Heavy Duty Frame. Chassis slide lock brackets are used to anchor the Tekelec 1100 AS chassis in position during normal operation.
Height	6.9 inch high (4U) form factor	Allows for multiple Tekelec 1100 AS chassis and associated Ethernet switches to be mounted in a Tekelec Heavy Duty frame
Width	17.6 inches wide, with slides	Allows for a Tekelec 1100 AS chassis to be installed in 19 inch racks. Adapter plates are required to mount a Tekelec 1100 AS chassis with slide rails in 23 inch frames.
Weight	65 Pounds	Moving the chassis requires two people.
<p><b>1. Tekelec makes no warranties for servers that are installed without proper clearances or that are removed from Tekelec-standard frames.</b></p> <p><b>2. The Tekelec 1100 AS enclosures should be free to slide only during installation, service, or repair; they should be locked down at all other times.</b></p>		

### Cable Management Arms

The T1100 AS is installed on slides for easy access. When the chassis is slid in or out, strain on the cables is relieved by side cable management arms. These cable management arms are attached to the sides of the frame and fold inward towards the back of the T1100 AS it is slid out from the frame (see Figure 3-6 on page 3-10). A T1100 AS chassis that is shipped with these cable management arms also includes tension bars that are mounted on the rear of the server to further reduce strain on the cables.

**Figure 3-6.** T1100 AS with Side Cable Management Arms



## Breaker Panel

Breaker panels are used to provide redundant power paths to T1100 AS units and other equipment in a heavy duty frame in a DC environment.

Figure 3-7 shows a breaker panel.

The breaker panel has two sides: side A and side B. Each side has twelve breakers, although only certain breakers on each side are active (closed). The open position of each breaker is marked by “O” and “I” marks the closed position.

**Figure 3-7.** Front of Breaker Panel

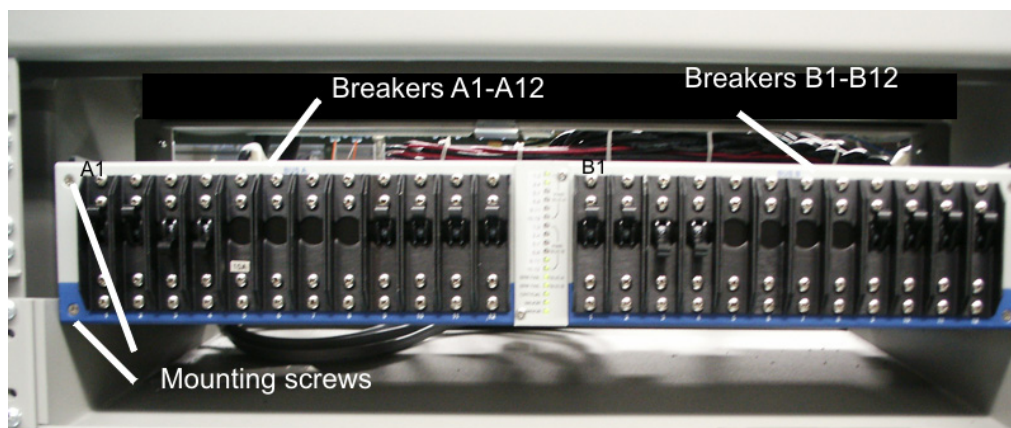



**Breaker Panel LEDs**

Figure 3-8 shows a close-up of the Indicator Panel in the center of the front of each breaker panel. Table 3-2 shows the possible LED settings and what each setting indicates.

**Figure 3-8.** Breaker Panel LEDs

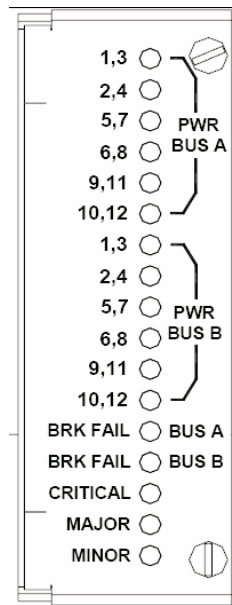

Table 3-2. Breaker Panel LED Settings

LED Position (from top)	Label on left side:	Label on right side:	Color	Indicates:
Top 6 LEDs	1,3 through 10,12	PWR BUS A	Green	Power is supplied from source A to breakers indicated by numbers on left
			Red	No power is supplied from source A to breakers indicated by numbers on left
			Off	Breakers indicated by numbers on left are not used
Next 6 LEDs	1,3 through 10,12	PWR BUS B	Green	Power is supplied from source B to breakers indicated by numbers on left
			Red	No power is supplied from source B to breakers indicated by numbers on left
			Off	Breakers indicated by numbers on left are not used
13th LED	BRK FAIL	BUS A	Green	No breakers on side A have tripped
			Red	One or more breakers on side A have tripped
14th LED	BRK FAIL	BUS B	Green	No breakers on side B have tripped
			Red	One or more breakers on side B have tripped
15th LED	CRITICAL	No label	Green	No critical platform alarms are reported <sup>1</sup>
			Red	One or more critical platform alarms are reported <sup>1</sup>
16th LED	MAJOR	No label	Green	No major platform alarms are reported <sup>1</sup>
			Red	One or major platform alarms are reported <sup>1</sup>
17th LED	MINOR	No label	Green	No minor platform alarms are reported <sup>1</sup>
			Red	One or minor platform alarms are reported <sup>1</sup>
<sup>1</sup> Both servers may send alarm information to the breaker panel for critical, major, or minor platform alarms. A <b>CRITICAL</b> , <b>MAJOR</b> , or <b>MINOR</b> LED is illuminated when one or more alarm of that type is reported from either or both servers.				

### Breaker Panel Power

The breakers receive power from the input circuit on their respective side. Each breaker controls the power to its corresponding power feed on the back of the breaker panel. The power feeds connect to the individual hardware devices in the frame.

Power comes into each breaker panel on side A and on side B. Each input power line connects to the input power feeds in the rear of the breaker panel. Each input power feed has an input circuit breaker beside it that ensures that the power is within an acceptable range.

### Breaker Panel Settings

To view a graphic that shows the mapping of breakers to the devices, see [BreakerSettings.pdf](#). When a server is installed and powered up, the associated breakers should be closed. Inactive breakers are not required to be in the closed position.

**NOTE:** The breaker mapping table shows only end-to-end connectivity from the breaker panel breakers to the servers. For detailed information on wiring, see the [interconnect diagram](#).

### Power Distribution Units

The AC Power Distribution Unit (PDU) is connected to a 240 V AC power source and distributes power to the components of the LSMS frame. Power is distributed to A side and B side feeds. There is one ON/OFF breaker switch for four A side power outlets and one ON/OFF breaker switch for four B side power outlets. For more information about the PDU, refer to the documentation that was delivered with the product.

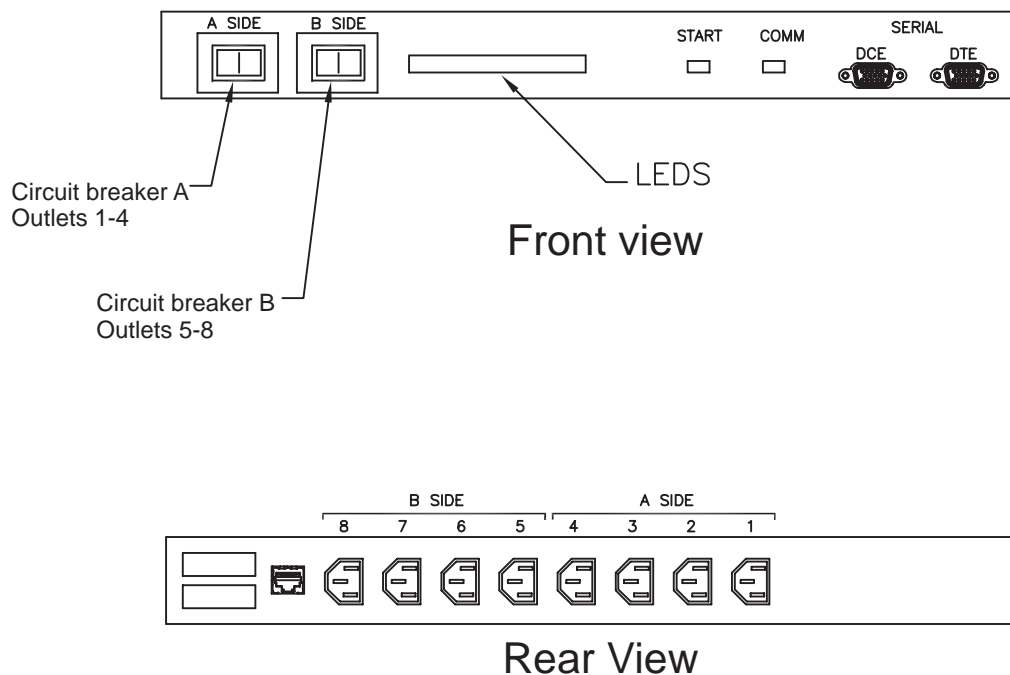
**Figure 3-9.** Front and rear of AC power distribution unit

## Ethernet Switches or Hubs

Ethernet switches or hubs cross-connect all the components in a heavy duty frame. To determine which type of Ethernet switch or hub is used, see the [assembly drawing](#). For more information about the Ethernet switches or hubs, refer to the documentation that was delivered with the product.

## Console Servers

Some T1100 AS hardware systems contain a console server, which provides access to the console ports of the T1100 AS units and allows Tekelec Customer Care Center to access remotely the T1100 AS units. A console server is used only during maintenance and failure conditions. The T1100 AS OOBM card (see “Out of Band Management Card” on page A-3) provides functions similar to a console server. To determine whether a console server is used, see the [assembly drawing](#).

For more information about the console server hardware, refer to the documentation that was delivered with the product. For information about how to configure the console server, contact Customer Care Center (see “Customer Assistance” on page 1-7).

# 4

## How to Install a T1100 AS Frame

Introduction.....	4-1
How to Unpack the T1100 AS Frame and Conduct Inventory .....	4-2
How to Install a T1100 AS Frame .....	4-2
Recommended Tools.....	4-3
How to Prepare the Floor for Heavy Duty Frames.....	4-3
How to Anchor the HD Frame to the Floor .....	4-6
How to Anchor to Overhead Rack of HD Frame .....	4-18
How to Cable a T1100 AS Frame .....	4-20

### Introduction

This chapter describes how to unpack and install in a DC environment a heavy-duty frame that contains from one or more T1100 AS units and associated equipment.

**NOTE:** Some of the figures in this section show the Tekelec T1000. The T1000 is identical in size to the T1100, and the frame installation instructions are the same for both chassis.

For information about installing a T1100 AS unit in an AC environment and about installing an additional T1100 AS unit into a heavy-duty frame that already contains from one to four T1100 AS units, see Chapter 5, “How to Install Hardware in an Existing Frame.”

**NOTE:** The total number of T1100 AS units allowed in a frame depends on the application. For more complete information about the maximum configuration allowed by the application, refer to the [assembly drawing](#).

## How to Unpack the T1100 AS Frame and Conduct Inventory

When the T1100 AS hardware system frame arrives, perform the following procedure:

### **Procedure 4-1. How to Unpack Frame and Conduct Inventory**

---

1. Unpack the heavy-duty frame, using the procedure described in [822-0094-02](#).
2. Ensure that all the parts listed on the packing list have been received.
3. Ensure that the part numbers on the labels on the left and right sides of each T1100 AS unit match the sales order for each of the following categories:
  - Base configuration for hard disk
  - Installed memory information
  - PCI card configuration

For information about the fields on a label, see “T1100 AS Chassis Part Number Information” on page B-14.

---

4. Be sure to return the frame’s shipping container, as described in [822-0094-02](#).
  5. This procedure is complete.
- 

## How to Install a T1100 AS Frame

A Heavy Duty (HD) frame is a specific Tekelec frame that has a specific footprint. It should not be confused with other 19- or 23-inch standard frames.

To install and anchor a heavy duty frame, perform the following tasks:

- Prepare the floor. See page 4-3.
- Anchor the frame to the floor. See page 4-6.

**NOTE: The anchoring procedure and the anchor assembly to use depend on the type of floor on which the frame is to be installed.**

- Anchor the frame to the ceiling using an overhead rack. See page 4-18.

### Recommended Tools

All Tekelec tools should be labeled "Property of TEKELEC" with either a press-on Field Tool Identification label (P/N 658-0941-01) or Field Tool Identification wrap (P/N 658-0941-02).

- Safety glasses
- Ear protectors
- Mounting hardware kit (P/N 840-0092-01)
- Isolator pad (in mounting hardware kit), also used as template
- Chalk (or chalk line)
- Fiberglass tape measure
- Felt tipped marking pen
- Rotary impact drill
- 18 mm (11/16 inch) masonry drill-bit
- 1 inch (25.4 mm) masonry drill-bit
- Extension cord
- High Efficiency Particulate Air (HEPA) vacuum cleaner
- Masking tape
- File
- 3/4 inch (19mm) box-end wrench
- 3/4 inch (19mm) socket wrench
- Carbide-toothed hole saw
- Sub-floor marking tool (star bit)
- Hammer

### How to Prepare the Floor for Heavy Duty Frames

Frame layout is site specific; Figure 4-1 on page 4-4 shows the most typical frame layout. The recommended minimum aisle spacing is 3 ft. (91.5 cm) front and rear. The following subsections provide instructions on marking the floor layout and preparing raised floors.

#### How to Mark the Floor Layout

Use the following procedure to mark the floor layout.

### Procedure 4-2. Mark Floor Layout

---

1. Verify with a customer representative that the required area dimensions and equipment location correspond with the marked floor plan.

---

2. Use the floor plan provided with the engineering site file specifications to mark the front base line and the borders of the first frame with the chalk line.

---

3. Align the frame template (isolator pad) with either of the two sides marked "This side front" along the front chalk line. Using a felt tip pen, mark Anchor locations in the middle of each oval anchor slot. Mark the corners of the first frame as shown in Figure 4-1.

**Figure 4-1.** Floor Marking Template for HD Frame

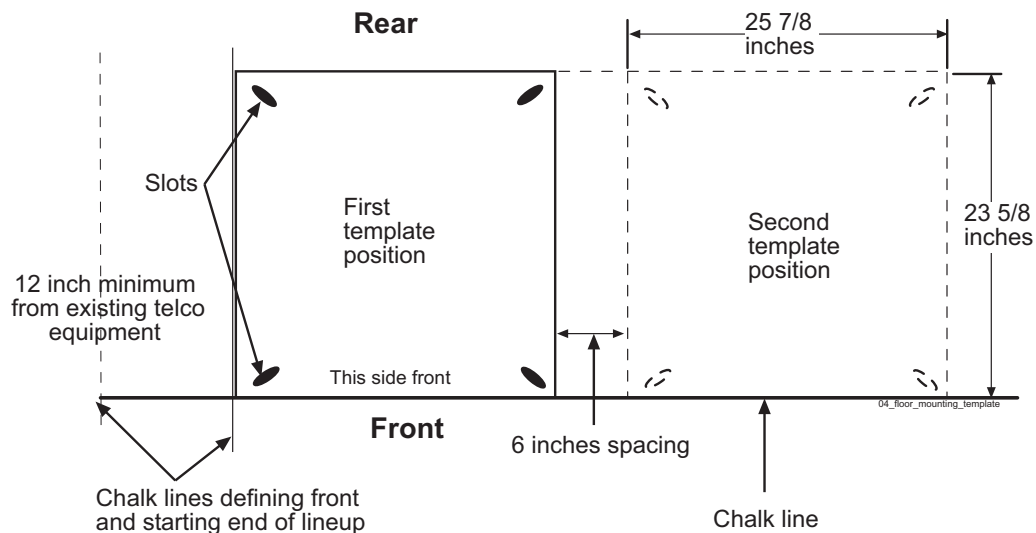

4. Create another chalk line that allows 6 inches between each frame for correct spacing.

Align the template (isolator pad) again against the front chalk line and continue the process of aligning, marking, and moving the template (isolator pad) until the site specific number of frame spaces has been laid out.

---

5. This procedure is complete.
-



Next, do one of the following:

- If you are installing the frame on a slab floor, see Procedure 4-4, "Anchor a HD Frame into a Slab Floor," on page 4-7.
- If you are installing the frame on a raised floor, see Procedure 4-3, "Create Cable and Anchor Holes for Raised Floors," on page 4-5.

### **Additional Preparations for Raised Floors**

Use the procedures in this section to prepare floors for anchoring frames on raised floors. For raised floors, you must create cable and anchor holes in the raised floor tiles.

#### **Procedure 4-3. Create Cable and Anchor Holes for Raised Floors**

---

1. Mark the spots where the cable holes are to be drilled. (The spots where the anchor holes are to be drilled were marked in Procedure 4-2, "Mark Floor Layout," on page 4-4.)

---
2. Mark the corners of the raised floor tiles to ensure the same tiles will be returned to the same place when the procedure is complete.

---
3. Remove the tiles from the equipment area.

---
4. Use a HEPA vacuum cleaner to collect the shavings while drilling. Using a carbide-toothed hole saw of the appropriate diameter, drill the cable holes required in the raised floor tiles. For the anchor holes, drill 1 inch (2.54 cm) diameter holes in the tiles corresponding to the marked anchor locations. Use a file to remove any sharp edges from the drilled tiles.

---
5. Return to the equipment area with the drilled tiles and replace the tiles, making sure the holes match where the frame anchors will be installed.

---
6. You have completed this procedure.

---

Next, perform one of the following procedures, depending on the anchoring method you choose:

- Procedure 4-5, "Anchor the Frame to the Slab Beneath the Raised Floor," on page 4-11
- Procedure 4-6, "Anchor Frame to Raised Floor with Support Channel," on page 4-14
- Procedure 4-7, "Anchor Frame with Support Channel/Spring Nut," on page 4-16

### How to Anchor the HD Frame to the Floor

See the following sections for instructions on anchoring heavy duty frames to the floor. These procedures are for typical installation sites with slab (concrete) floors and raised floors. You might have to accommodate these procedures to the unique features of your site. Depending upon your floor, use the procedure in one of the following sections:

- Anchoring directly to a slab floor (see “How to Anchor Frame to Slab Floor” on page 4-6)
- Anchoring to a slab floor beneath a raised floor (see “How to Anchor to Concrete Floor Under a Raised Floor” on page 4-10)
- Anchoring to a raised floor using washer and nut (see “How to Anchor on Raised Floor Using Support Channel” on page 4-13)
- Anchoring to a raised floor using a unistrut (see “How to Anchor on Raised Floor Using Support Channel with Spring Nut” on page 4-16)



**WARNING:** Before drilling holes in any flooring, verify with facilities personnel that the area is free of gas or water pipes, ventilation plenum, and electrical wiring conduits.

#### How to Anchor Frame to Slab Floor

Use the procedure in this section to anchor the frame directly to a concrete slab floor. If you are anchoring to a raised floor above a slab floor, see “How to Anchor to Concrete Floor Under a Raised Floor” on page 4-10. Always get permission from facility personnel before drilling any holes for HD frame installation.

Figure 4-2 shows the components of the Anchor Assembly used for a slab floor.

Figure 4-2. Anchor Assembly for Slab Floors

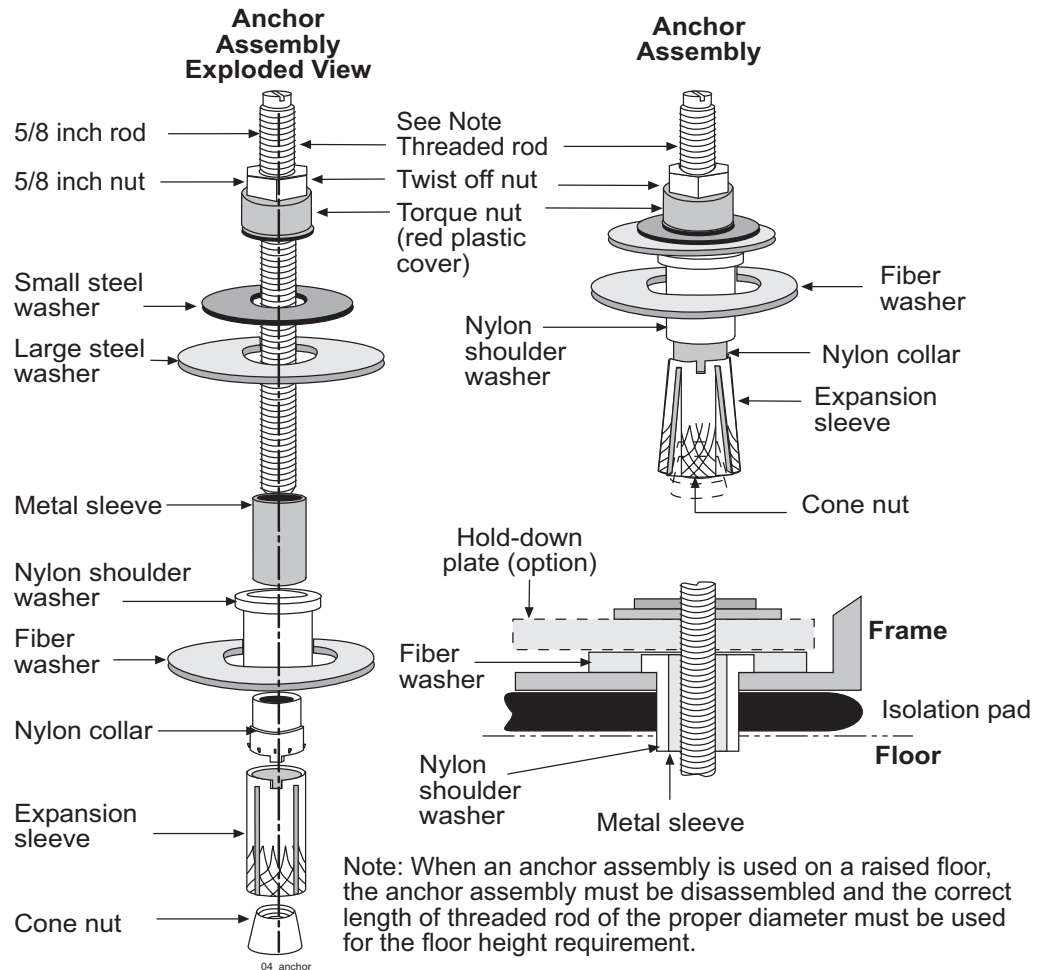

**Procedure 4-4. Anchor a HD Frame into a Slab Floor**

1. Use the HEPA vacuum cleaner to collect the dust while drilling holes. At each anchor location marked on the concrete floor, drill a hole that is 11/16 inches (18 mm) in diameter to a depth of 3 inches (7.7 cm). The anchor and frame will not come together properly if the hole is drilled at an angle other than 90°.

**NOTE:** If any obstruction is encountered while drilling the hole, fill the unusable hole with liquid concrete. After allowing sufficient time for the liquid concrete to set, drill the hole at another spot within the marked area. Clean out each hole after drilling is completed.

2. Set a fully assembled anchor into each drilled hole.

3. From each anchor remove all pieces above the metal sleeve. Retain the pieces for use in step 7.

---
4. Lay the isolator pad on the floor with the holes in the isolator pad aligned over the anchor assemblies.

---
5. Roll the frame (still on the dolly) into position above the isolator pad.

---
6. Lower the frame onto the floor with the holes in the frame aligned over the anchor assemblies. For instructions about how to lower the frame, refer to 822-0094-02.

---
7. Install the three square washers, the round fiberglass washer, the large steel washer, and the torque nut (with red plastic cover) in the order shown in Figure 4-3. (The large steel washer, nylon shoulder washer, and round fiber washer are found in the mounting hardware kit.)

When reassembling the anchor assembly, the bottom of the threaded rod must be flush with the bottom of the cone nut and the torque nut must be near the top of the threaded rod.

**NOTE: When reassembling any anchor bolt assembly, lightly finger tighten only.**

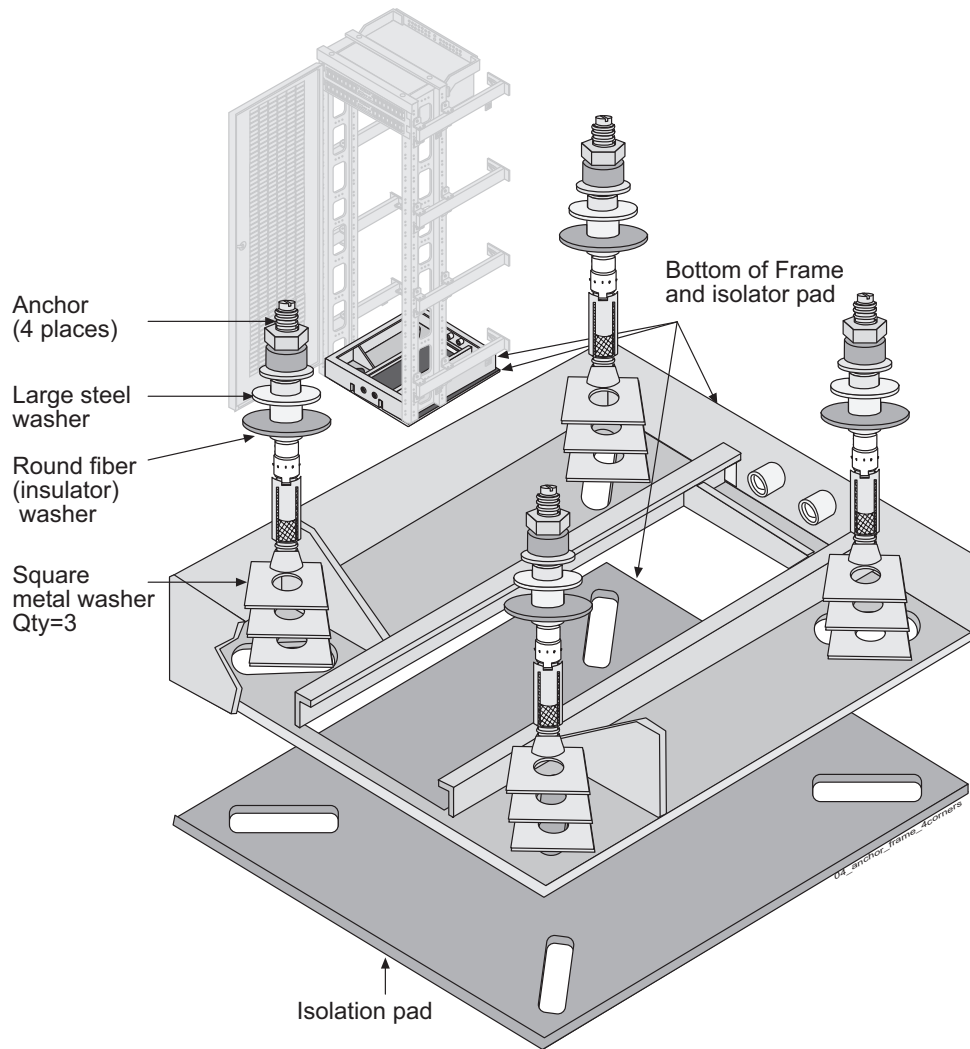
**Figure 4-3.** Anchor Installation of HD Frame into Slab Floor

- 
8. Tighten the top nut of the anchor assembly with a socket wrench until the twist off nut above the plastic red cover breaks free. Leave the twist off nut on the threaded rod to indicate that the torque on the nut beneath has been set properly.
- 
9. This procedure is complete.
- 

Next, go to Procedure 4-8, "Attach Overhead Rack Support," on page 4-19.

**How to Anchor on Raised Floors**

To anchor a frame on a raised floor, use the procedure in one of the following sections :

- “How to Anchor to Concrete Floor Under a Raised Floor” on page 4-10
- “How to Anchor on Raised Floor Using Support Channel” on page 4-13
- “How to Anchor on Raised Floor Using Support Channel with Spring Nut” on page 4-16

**How to Anchor to Concrete Floor Under a Raised Floor**

Use the following procedure to anchor a frame on a raised floor to the concrete slab beneath the raised floor. Figure 4-4 shows the components of the anchor assembly used for a concrete floor beneath a raised floor.

**Figure 4-4.** Anchor Assembly for Raised Floor Over Concrete

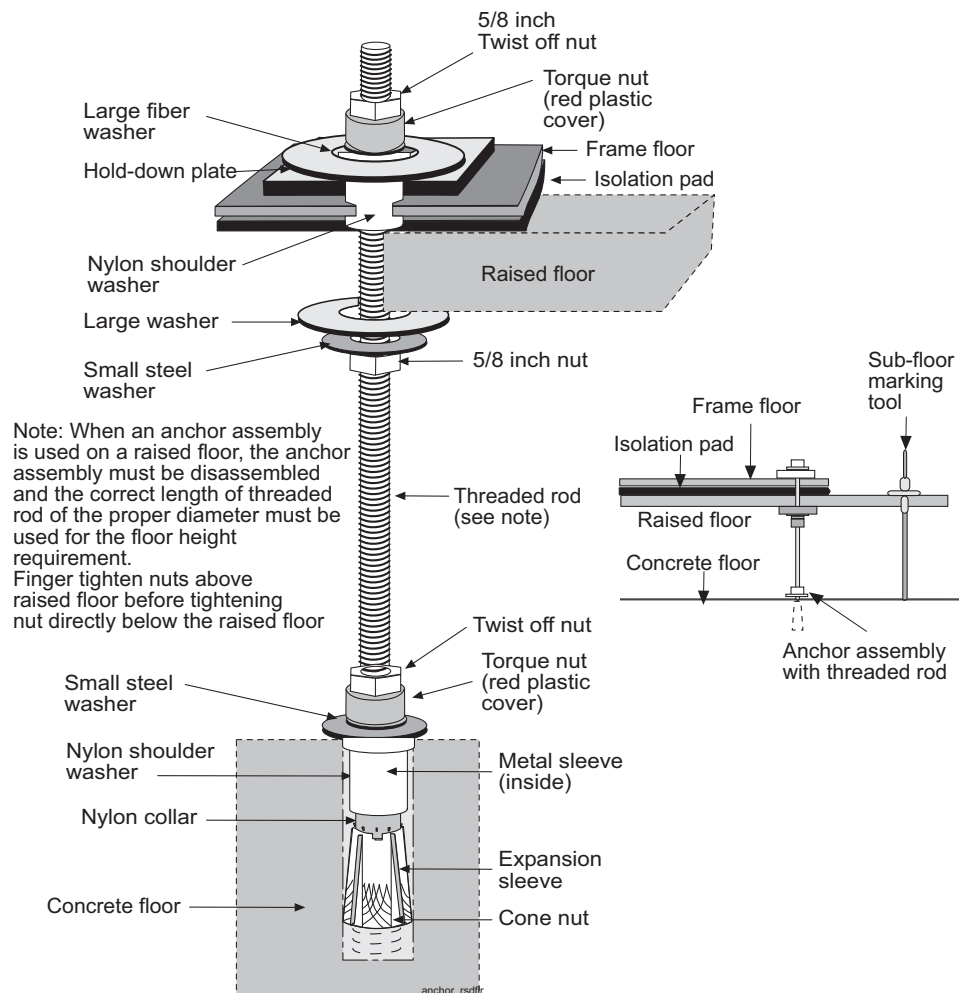

**Procedure 4-5. Anchor the Frame to the Slab Beneath the Raised Floor**

---

1. Ensure that Procedure 4-3, "Create Cable and Anchor Holes for Raised Floors," on page 4-5 has already been performed.

---

2. Perform the following substeps for each hole associated with each frame to be installed on the raised floor:

**NOTE: The threaded rod must be absolutely perpendicular to the floor. Using a level is recommended.**

- a. Insert the threaded rod into the anchor holes in the tiles, making sure that the threaded rod is perpendicular to the hole.
  - b. Strike the top of the threaded rod with a hammer using enough force to mark the concrete floor.
- 

3. Remove the floor tiles for access to the concrete floor.

---

4. Use a HEPA vacuum cleaner to collect the dust while drilling. Drill an 18 mm diameter hole in the concrete floor to a depth of 3 inches (7.7 cm).

**NOTE: The hole must be drilled perpendicular to the floor so the anchor and frame will come together properly.**

---

5. Ensure that each hole is clean after the drilling is complete.

---

6. For each threaded rod, thread the following components in the order shown onto one end of the rod (these components are threaded on the rod while the rod is upside down; see Figure 4-4 on page 4-10 to identify the components and their orientation):
  - a. Torque nut
  - b. Small steel washer
  - c. Metal sleeve
  - d. Nylon collar
  - e. Expansion sleeve
  - f. Cone nut (thread onto the rod until the end of the threaded rod is flush with the bottom of the cone nut)

**NOTE: These components should be in contact with each other, but do not tighten the assembly because doing so could prematurely expand the expansion sleeve.**

---

7. Insert each threaded rod/anchor assembly into its hole, with the cone nut at the bottom, and tighten with a 3/4 inch (19mm) wrench until the top nut of the torque nut breaks free (this nut is called the twist-off nut in Figure 4-4 on page 4-10).

**Figure 4-5.** Anchoring on Raised Floor Over Concrete Slab

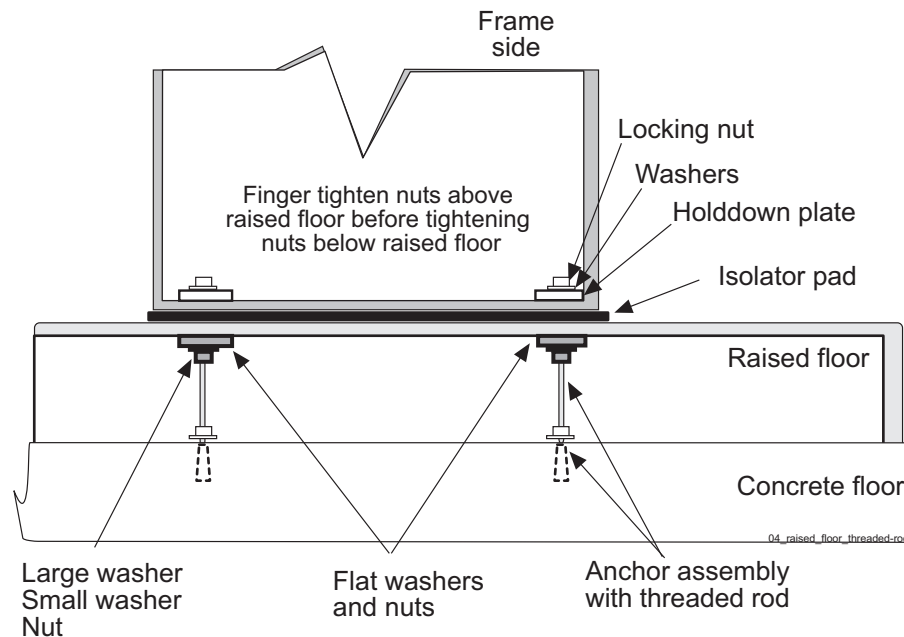

8. At the top end of each threaded rod, thread on a 5/8 inch nut until it is below the level where the floor tile will meet the threaded rod.
9. On top of the 5/8 inch nut, drop a small steel washer and then a large steel washer.
10. Return tiles to their original positions, fitting the anchor holes in the tiles over the threaded rod assemblies.
11. Lay the isolator pad on the raised floor with the holes in the isolator pad aligned over the threaded rod assemblies.
12. Roll the frame (still on the dolly) into position above the isolator pad.



13. Lower the frame onto the floor with the holes in the frame aligned over the threaded rod assemblies. For instructions about how to lower the frame, refer to 822-0094-02.
- 

14. Over each threaded rod, install the following components in the order shown (see Figure 4-4 on page 4-10):

- a. Nylon shoulder washer (through the holes in the frame and isolator pad and into the raised floor)
  - b. Fiber washer (around the nylon shoulder washer)
  - c. Square holddown plate
  - d. Large steel washer
  - e. Small steel washer
  - f. Torque nut
- 

15. For each threaded rod, finger-tighten the torque nut inside the frame.



**WARNING:** Finger-tighten nuts on threaded rods inside the frames above the raised floor before finger tightening the nuts below the raised floor.

---

16. For each threaded rod, finger-tighten the 5/8 inch nut and washers against the bottom of the floor tile (see Figure 4-5 on page 4-12).

**NOTE:** Tighten only until the washers and nuts are flush with the bottom of the floor tile. DO NOT over tighten, causing the tile or frame to tilt.

---

17. With a 3/4 inch (19mm) socket wrench, tighten each torque nut inside the frame until the twist off nut above the plastic red cover breaks free. Leave the twist off nut on the threaded rod to indicate that the torque on the nut beneath has been set properly.
- 

18. If any tiles were removed to access the underside of the raised floor, replace them.
- 

19. This procedure is complete.
- 

Next, go to Procedure 4-8, "Attach Overhead Rack Support," on page 4-19.

### How to Anchor on Raised Floor Using Support Channel

Use the following procedure to anchor the HD frame to the raised floor tiles using the anchor assembly shown in Figure 4-6.

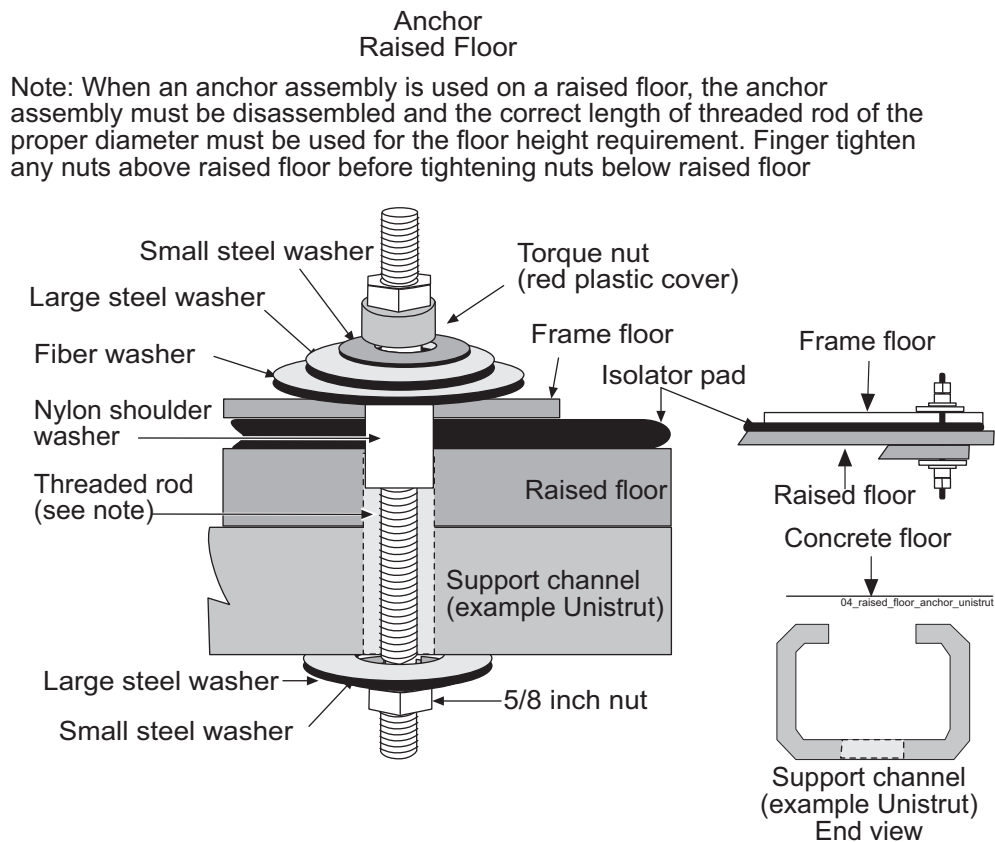
**Figure 4-6.** Anchor Assembly for Use with Support Channel**Procedure 4-6. Anchor Frame to Raised Floor with Support Channel**

1. Ensure that Procedure 4-3, "Create Cable and Anchor Holes for Raised Floors," on page 4-5 has already been performed.
2. For each threaded rod, thread the following components in the order shown onto one end of the rod (these components are threaded on the rod while the rod is upside down; see Figure 4-6 on page 4-14 to identify the components and their orientation):
  - a. 5/8 inch nut
  - b. Small steel washer
  - c. Large steel washer
3. From underneath the raised floor, insert the threaded rod/anchor assembly through the support channel, the raised floor, the isolator pad, and the frame floor.

**Figure 4-7.** Anchoring Frame to Raised Floor with Support Channel

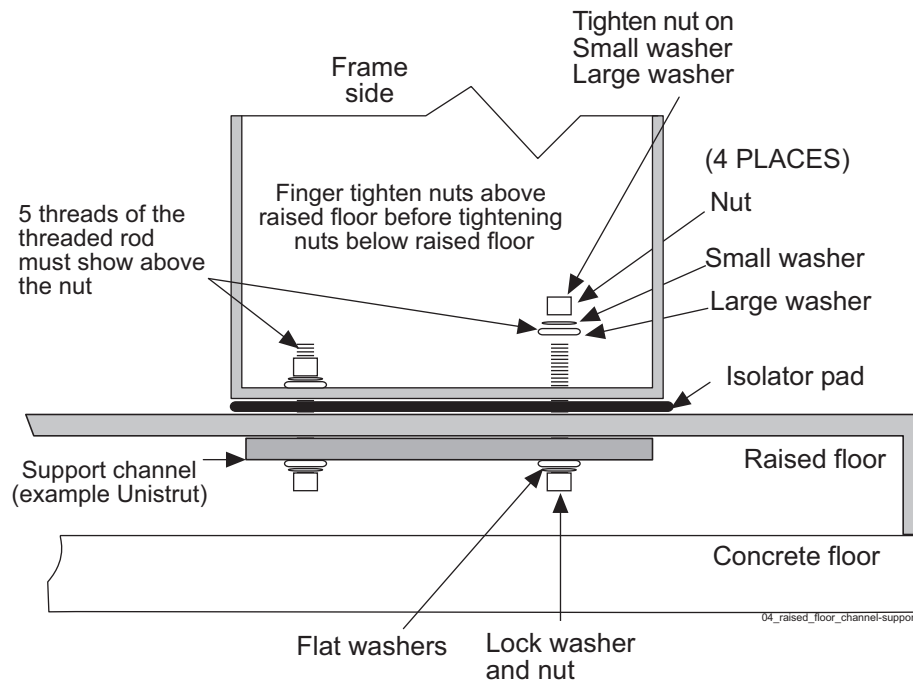

4. From inside the frame, drop onto each threaded rod the following components in the order shown (see Figure 4-7):
  - a. Metal sleeve inside a nylon shoulder washer
  - b. Fiber washer (around the nylon shoulder washer)
  - c. Large steel washer
  - d. Small steel washer
  - e. Torque nut

Be sure to leave at least 5 threads of the threaded rod exposed inside the frame.

---

5. Finger tighten the nut above the raised floor before finger tightening the nuts below the raised floor.

---

6. Finger tighten the nut below the raised floor.

---

7. Securely tighten all the nuts above the raised floor with a socket wrench.

**NOTE: Tighten only until the washer and nuts are flush with the bottom of the floor tile. DO NOT over tighten.**

---

8. Replace tiles if necessary.

---

9. This procedure is complete.

---

Next, go to Procedure 4-8 on page 4-19.

### **How to Anchor on Raised Floor Using Support Channel with Spring Nut**

Use the following procedure to anchor the HD frame to the raised floor tiles using the a support channel with spring nut.

#### **Procedure 4-7. Anchor Frame with Support Channel/Spring Nut**

---

1. Ensure that Procedure 4-3, "Create Cable and Anchor Holes for Raised Floors," on page 4-5 has already been performed.

---

2. Insert threaded rods through the frame and the raised floor and into the spring nut in the support channel as shown in see Figure 4-8.

**Figure 4-8.** Anchor Assembly for Support Channel with Spring Nut

Anchor  
Raised Floor

Note: When an anchor assembly is used on a raised floor, the anchor assembly must be disassembled and the correct length of threaded rod of the proper diameter must be used for the floor height requirement. Finger tighten any nuts above raised floor before tightening nuts below raised floor

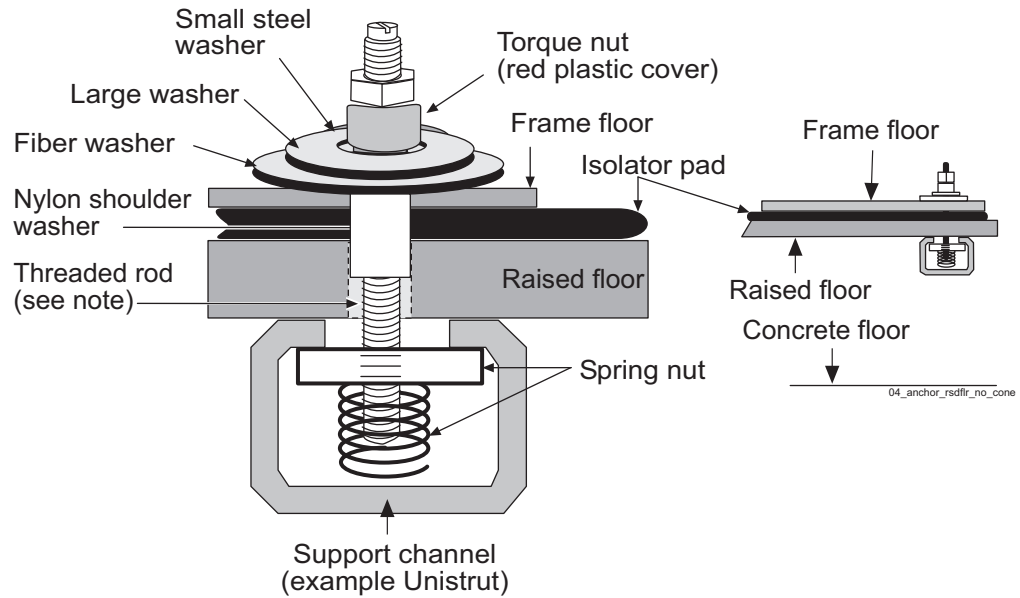

3. Finger tighten the rods into the spring nut in the support channels (see Figure 4-9).

**Figure 4-9.** Anchoring Frame Using Support Channel/Spring Nut

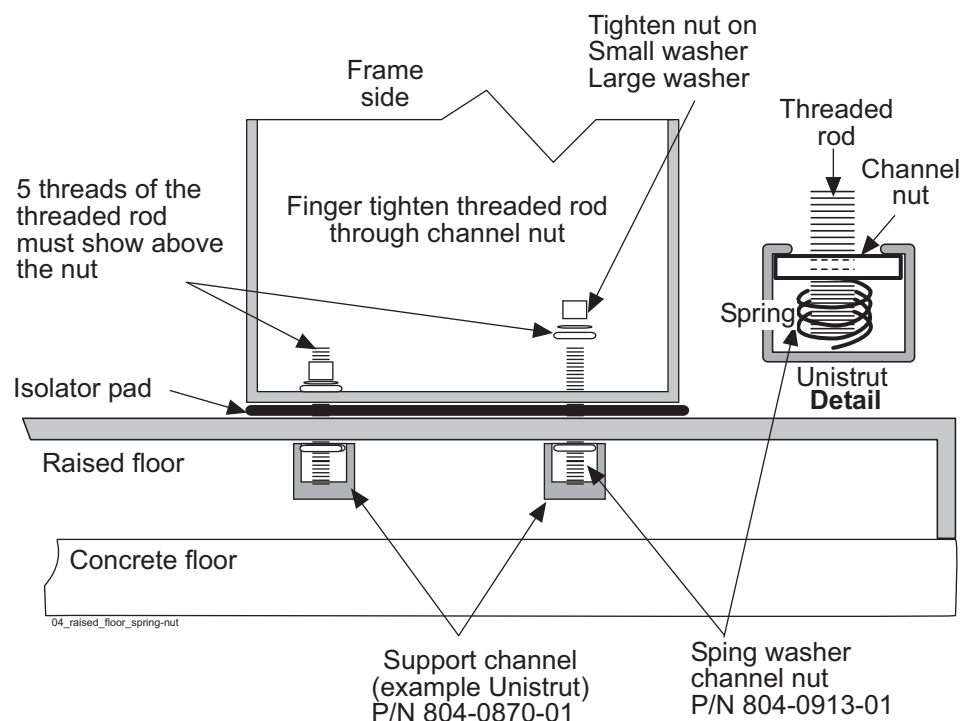

- 
4. Insert the large washer, small washer, and torque nut onto the threaded rod on the inside of the frame. Be sure to leave at least 5 threads of threaded rod exposed on the inside of the frame. Tighten the nuts above the raised floor.

**NOTE: DO NOT over tighten, causing the tile or frame to tilt.**

---

5. This procedure is complete.
- 

Next, go to Procedure 4-8, "Attach Overhead Rack Support," on page 4-19.

### How to Anchor to Overhead Rack of HD Frame

Frames with shelves that extend must be attached to overhead racks to prevent toppling.

### Procedure 4-8. Attach Overhead Rack Support

---

1. Using the Cable Rack Mounting kit with ladder hooks, threaded rods, and insulators, place the assembly directly above the frame for overhead support.
2. Secure the top of the frame to the overhead racks using threaded rods with hardware as shown in Figure 4-10 on page 4-19.

**Figure 4-10.** HD Frame with Overhead Rack

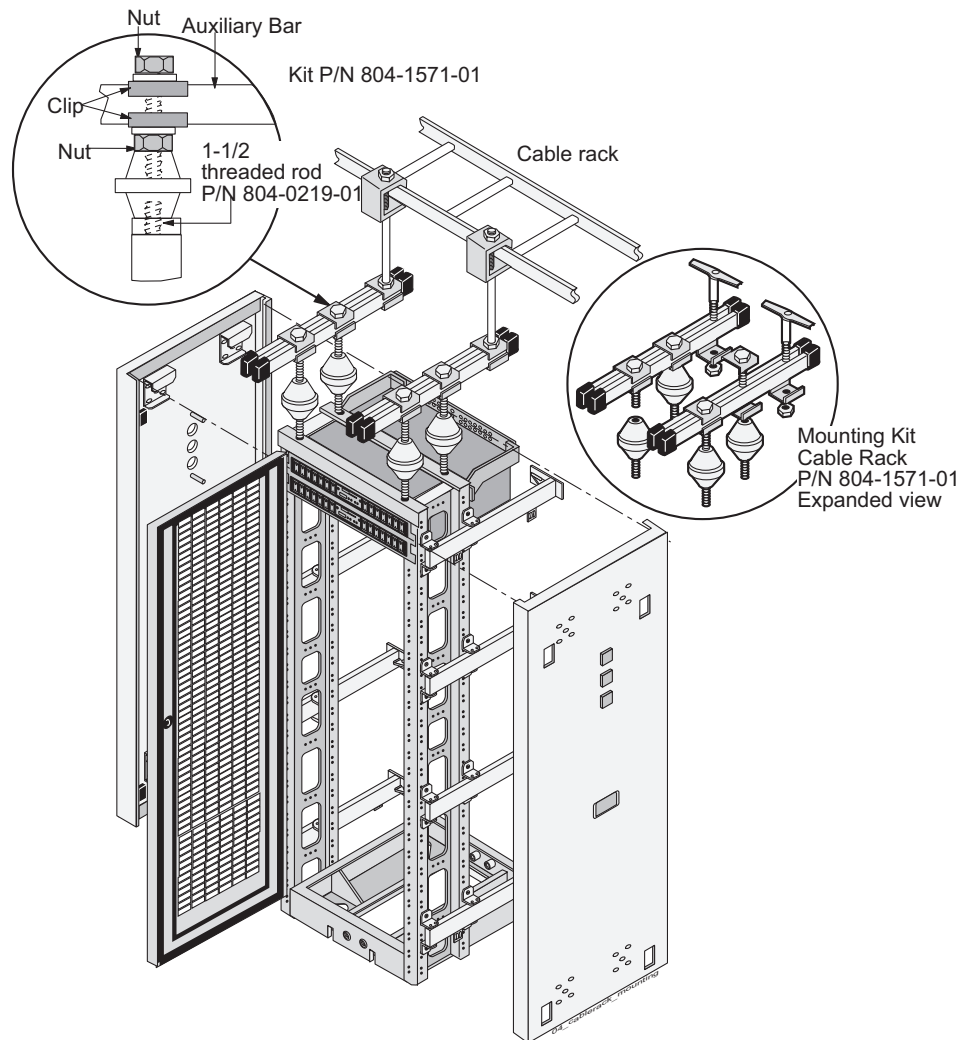

3. This procedure is complete.
-

## How to Cable a T1100 AS Frame



**WARNING:** Verify that all breakers are set to the OFF (O) position, and that all Power distribution panel circuit breakers are set to OFF. Be sure the T1100 AS chassis power switch is set to OFF.

Verify that the cables already attached are connected correctly. (The T1100 AS hardware system frame is shipped with most of the cables already attached.) Complete any other required cable connections.

To determine the cables used and how to connect them, refer to the [interconnect diagram](#), which lists each cable, its quantity, length, how it is used, and a diagram of how to connect it.

**NOTE:** Some of the listed cables are used only as required. Actual cables used may vary by application.

To view a drawing of a cable, refer to the [Cable List document](#), which lists all the cables that appear in the system interconnect diagram with a link from each part number to the drawing for that part number.



# How to Install Hardware in an Existing Frame

Introduction.....	5-1
How to Unpack and Conduct Inventory .....	5-1
How to Unpack a T1100 AS Unit and Conduct Inventory .....	5-1
How to Install an Individual T1100 AS Unit .....	5-3
How to Cable Components Added to Existing Frames.....	5-14

## Introduction

This chapter describes how to unpack install individual T1100 AS hardware system components and install them in frames that are already installed at customer sites.

**NOTE:** Some of the figures in this section show the T1000 AS. The T1000 is identical in size to the T1100, and the frame installation instructions are the same for both chassis.

For information about installing a T1100 AS hardware system that is delivered in a frame, see Chapter 4, “How to Install a T1100 AS Frame.”

## How to Unpack and Conduct Inventory

To unpack and conduct inventory, see one of the following sections:

- “How to Unpack a T1100 AS Unit and Conduct Inventory” on page 5-1

## How to Unpack a T1100 AS Unit and Conduct Inventory

When the individual T1100 AS unit arrives, perform the following procedure:

### Procedure 5-1.    Unpack a T1100 AS Chassis

---

1. Inspect the shipping container for indication of damage. If damage is noted, go to step 7.



**DANGER:** Moving a T1100 AS chassis requires two people. Each T1100 AS chassis weighs approximately 30 kg (65 lbs) and may cause personnel injury or damage to the internal components due to shock and vibration if not handled properly.

---

2. Inventory the material in the shipping container. If any discrepancies are noted, go to step 7.
- 



**WARNING:** Observe proper ESD procedures when handling the T1100 AS chassis. Always wear an ESD wrist strap connected to a grounded bench or frame.

3. Unpack the T1100 AS chassis from the shipping container and place the unit on a secure workbench that is grounded for ESD protection. Discard the container and packing material.
- 
4. Inspect the T1100 AS chassis for indication of damage. If damage is noted, go to step 7.
- 
5. Remove the slide assemblies from the shipping container. The slide assemblies (see Figure 5-1) consist of three sections that will be attached to the T1100 AS chassis and frame.

Figure 5-1. Slide Assembly

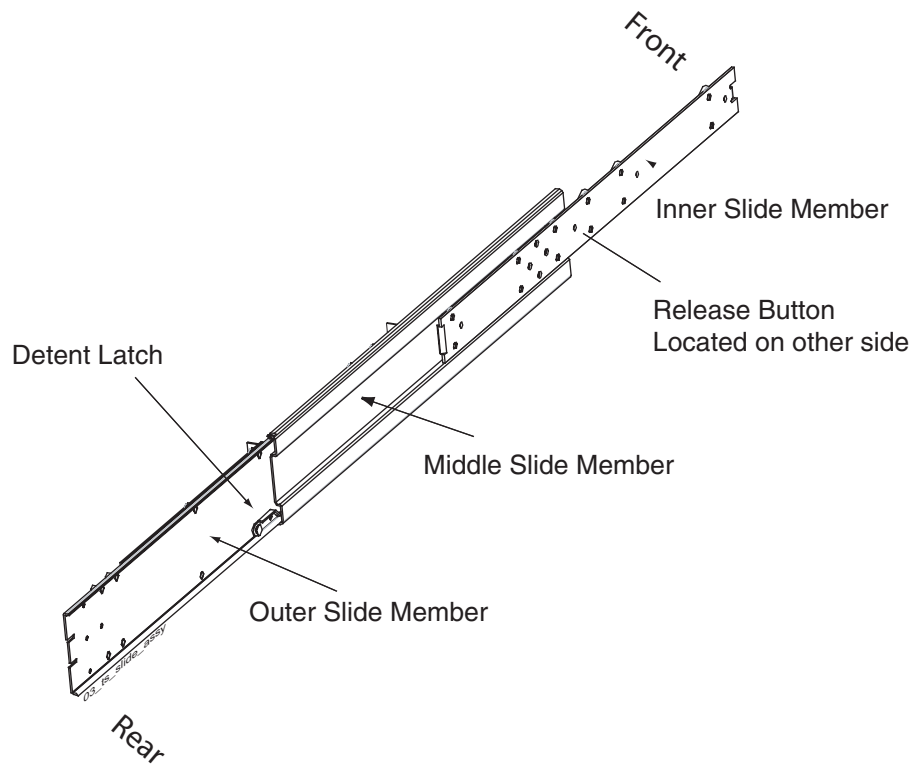

- 
6. Inspect the slide assemblies for indication of damage. If damage is noted, go to step 7.
- 
7. If any damage is noted or parts are missing, contact the Customer Care Center (see ["Customer Assistance" on page 1-7](#)).
- 

## How to Install an Individual T1100 AS Unit

Use the following procedure to install an individual T1100 AS unit into an existing frame. (For more information about the situations in which an individual T1100 AS unit can be installed, see "Introduction" on page 5-1.)

Tools Required:

- #3 Phillips screwdriver
- 3/8 inch nutdriver
- Volt Ohm Meter (VOM)

### Procedure 5-2. Installing a T1100 AS Chassis

---



**TOPPLE:** Before beginning this procedure, ensure the frame is properly secured to the floor and cable racks to prevent the frame from tipping over when the slide assembly and T1100 AS chassis is extended.



**DANGER:** Moving a T1100 AS chassis requires two people. Each T1100 AS chassis weighs approximately 30 kg (65 lbs) and may cause personnel injury or damage to the internal components due to shock and vibration if not handled properly.

1. Turn OFF the breakers that supply power to the position the T1100 AS chassis is being installed in. Consult the system interconnect or wiring tables for the frame or system type the T1100 AS chassis is installed in.



**WARNING:** A T1100 AS chassis is redundantly powered from both A and B -48 VDC buses. Ensure that both the circuit breaker supplying A power to a chassis and the circuit breaker supplying B power to a T1100 AS chassis are turned OFF by measuring the voltage with a VOM on the cable that connects the T1100 AS chassis to its breakers. Both A and B power LEDs on the front fascia of the T1100 AS chassis should be OFF.

---

2. Remove the front door and any plastic panels from the rear of the frame where the T1100 AS chassis is to be installed. Using an erasable marker indicate the location of the mounting screw holes on the frame rails reserved for the frame brackets. T1100 AS chassis are mounted to slide assemblies attached to the frame brackets for ease of installation and servicing.

**NOTE:** Each T1100 AS chassis is 4 U (7 inches) in height and can be mounted immediately above or below existing components (zero clearance). Limits to positioning the T1100 AS in a frame are data cable lengths, lengths of power cables to the breakers, and location of interconnected components.

---

3. Locate the slide assemblies, which consist of three sections that will be attached to the T1100 AS chassis and frame (see Figure 5-2).

---

4. Separate the inner slide members (with attached rollers) from the other sections by pulling the inner and outer members apart. When a slide assembly is approximately halfway extended, a large circular release button, located on the side of the inner slide member, will pop into a hole in the middle slide member. Press the release button and continue pulling the slide members apart until the inner slide member is completely separated. See Figure 5-2 and Figure 5-3 for details.

**NOTE:** Only the inner slide member will separate completely; the middle and outer slide members are permanently connected.

**Figure 5-2.** Slide Assembly Extended View

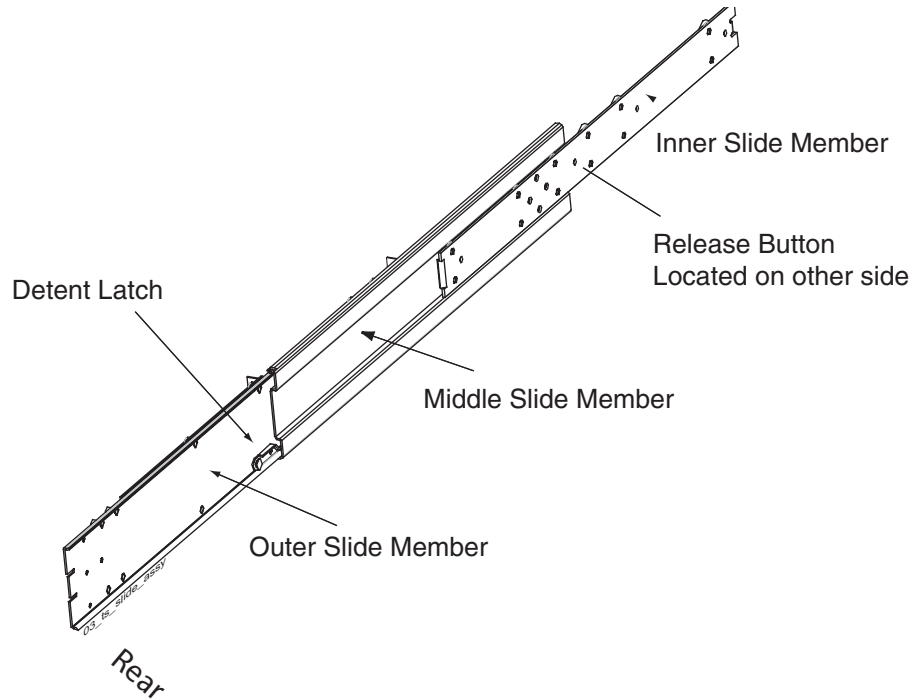

**Figure 5-3.** Slide Assembly Inner Member Roller Side View

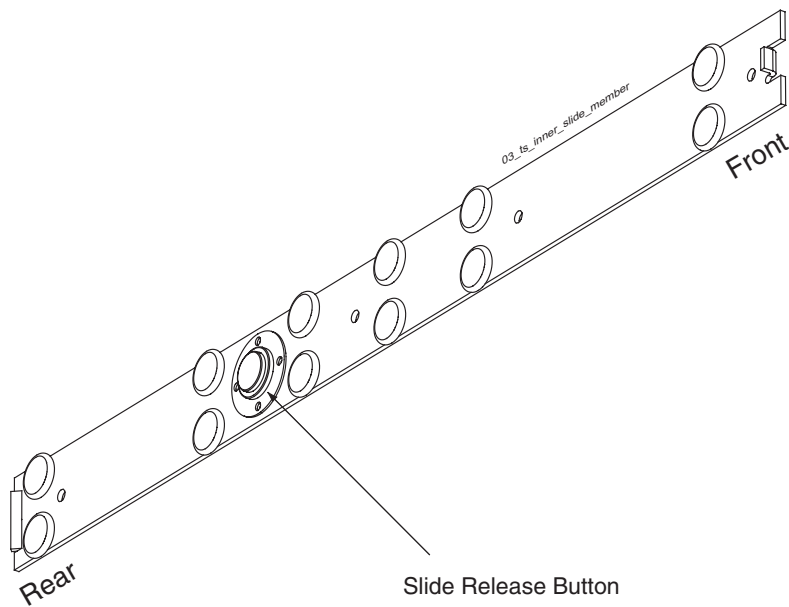

5. Set the slide members aside for use later in this procedure.
- 
6. Attach the four frame adapter brackets to the frame (23-inch frame only) using two each of the #12-24 Phillips screws. Orientation is important; see Figure 5-4 and Figure 5-5 for views of the frame adapter brackets with correct positioning. The small jog in the brackets is directed toward the rear of the frame.
- NOTE:** If the frame is 19-inch, do not use the frame adapter brackets. In 19-inch frames, the slide assembly brackets that are attached to the outside members are attached directly to the frame.

Figure 5-4. Frame Adapter Bracket Expanded

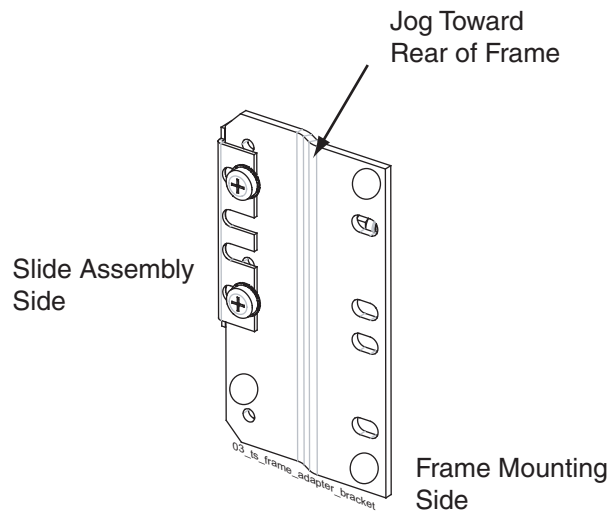
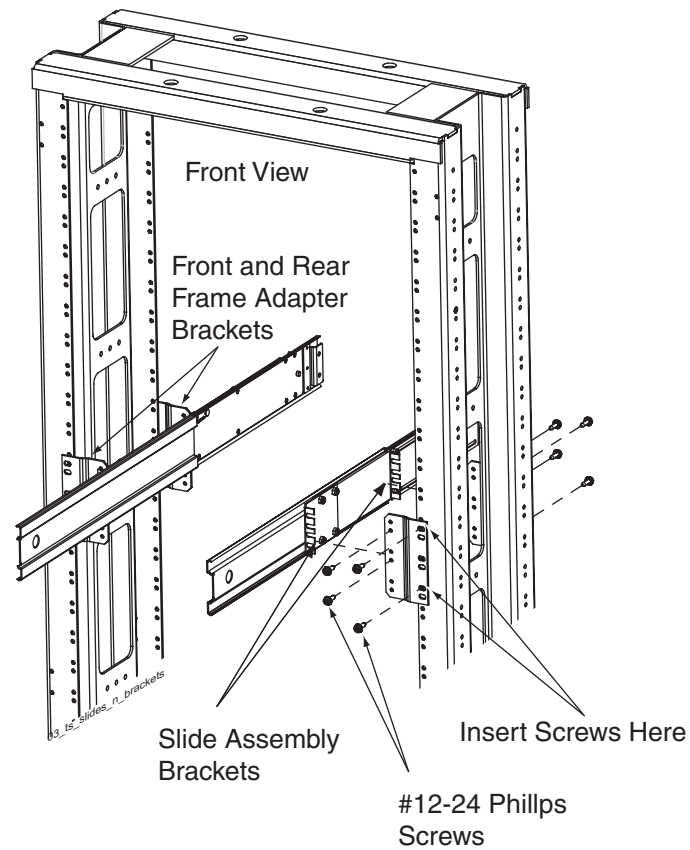
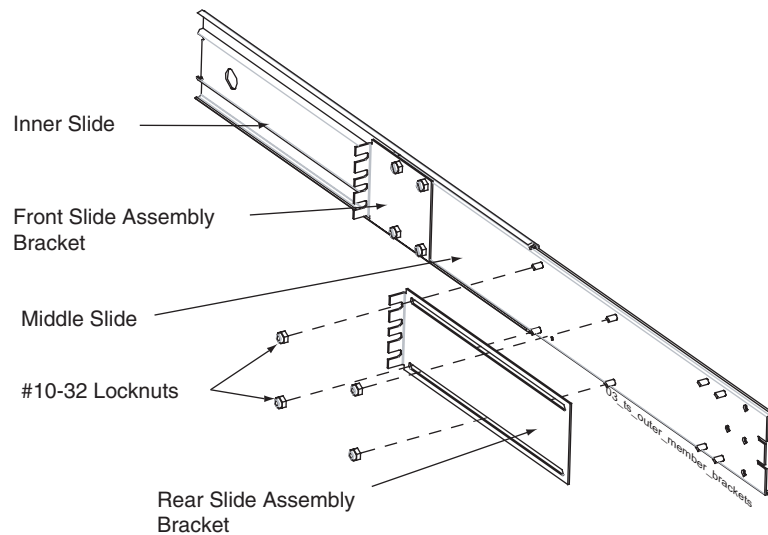

Figure 5-5. Frame Adapter Brackets and Slide Assemblies



7. Loosely attach the rear slide assembly brackets with four #10-32 locknuts to the outer slide members. This makes it easier when attaching the brackets to the frame adapters or frames. See Figure 5-6. The front slide assembly brackets are mounted at the factory.

**Figure 5-6.** Slide Assembly Outer Member

8. Attach the front and back slide assembly brackets on each slide assembly with four #12-24 Phillips screws to the four frame adapters installed in step 6. Both slide assemblies are identical. Viewed from the rear of the frame, orient the slide assemblies with the rear detent latches at the bottom on the left slide assembly and at the top on the right slide assembly. See Figure 5-7 on page 5-9 for positioning.

**NOTE:** The inner slide members are shown inserted into the middle slide member in this view for clarity only. In the following steps the inner slide members will be attached to the T1100 AS chassis and inserted into the middle slide members.

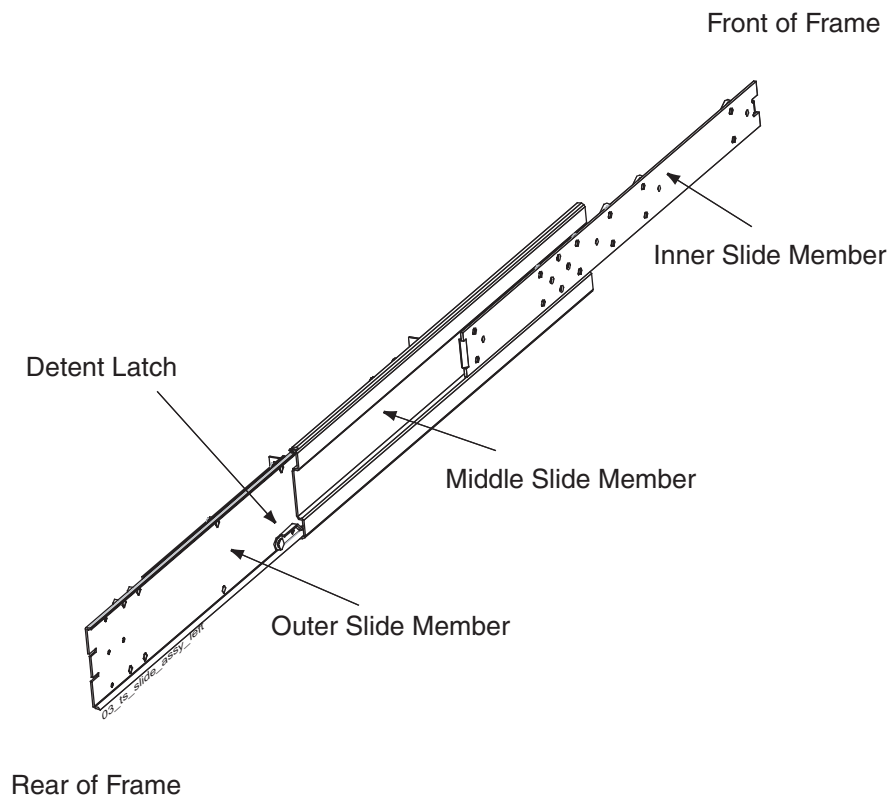

**Figure 5-7.** Slide Assembly Detail Left Side From Rear

- 
9. Tighten the four #10-32 locknuts on each of the rear slide assembly brackets.
- 
10. Pull the middle slide members from the outer slide members until the rear detents latch. This allows access to the release buttons when inserting the chassis with attached inner slide members.
- 
11. At the workbench, attach the inner slide members that were separated in step 4 on page 5-4, to both sides of the T1100 AS chassis with four #10-32 Phillips screws each. Orient the inner slide members with the roller bearings outward and the center tabs toward the front of the chassis. See Figure 5-8 for a view of the inner member on the left side of the T1100 AS chassis. The inner slide member orientation on the right side of the chassis is similar.

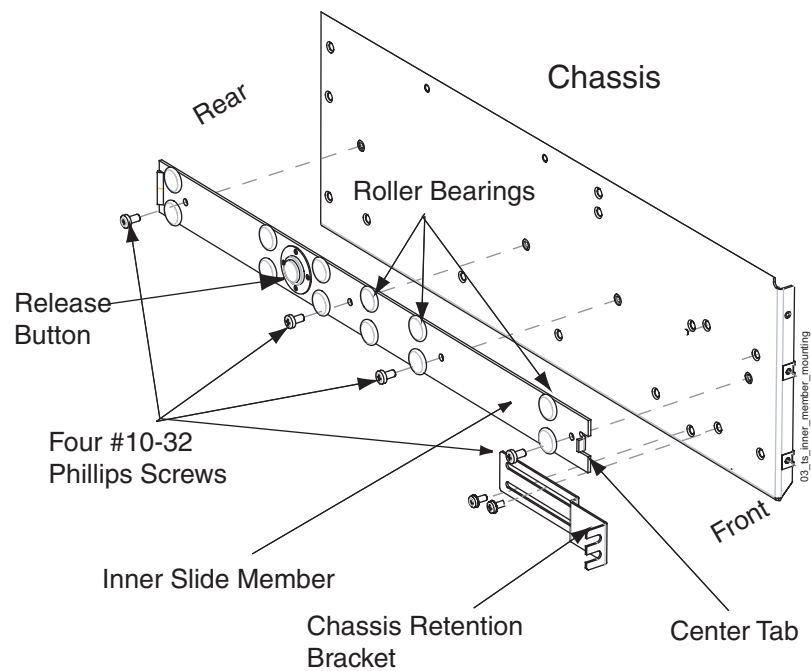
**Figure 5-8.** Slide Assembly Inner Member Mounting

- 
12. Lift the T1100 AS chassis with the attached inner slide members and carefully insert the inner slide member rollers into the middle slide members that were previously mounted on the frame.
- 
13. Simultaneously press the release buttons on the inner slide members once when the buttons encounter the middle slide members.

**NOTE:** The inner slide members will travel approximately two more inches and the release buttons will detent into the round cutouts of the middle slide members. This is the standard open position of the slides.

---

**14.** Attach the Cable Management System. Do one of the following:

- For Side Cable Management Systems, attach the cable management arms to the rear of the frame using the bolts included with the system. Be sure that the arms can slide in toward the T1100 AS.

**Figure 5-9.** Detail of a Side Cable Management Arm

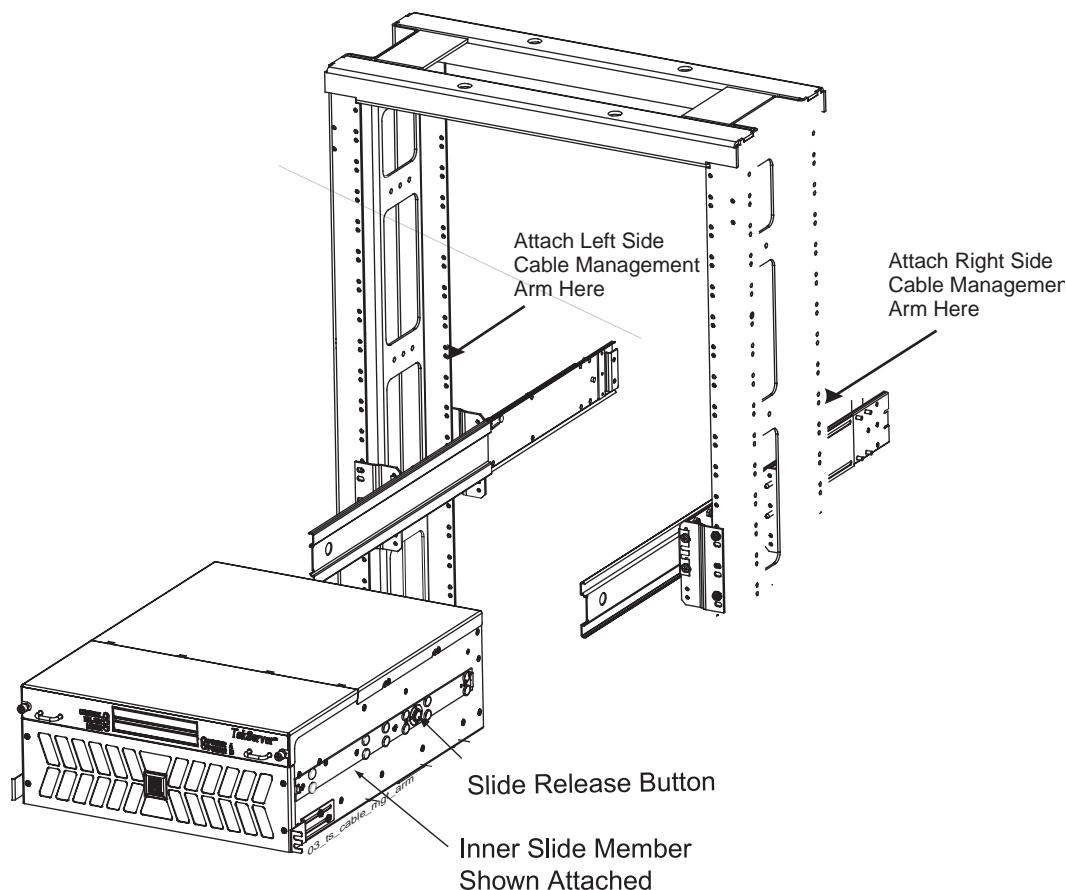
**Figure 5-10.** Side Cable Management Arm Installation (T1000 AS shown)

**NOTE:** The mounting position for the additional server may vary. The position shown in Figure 5-10 is for example only. T1000 shown, but mounting is the same for the T1100.

15. Route and connect the power and data cables through the cable management arm to the T1100 AS chassis. Check the labels on the cables and attach them to the appropriate connectors on the rear of the T1100 AS chassis (see Figure 5-11). For information about cables used, see “How to Cable Components Added to Existing Frames” on page 5-14.

Figure 5-11. T1100 AS Rear Detail

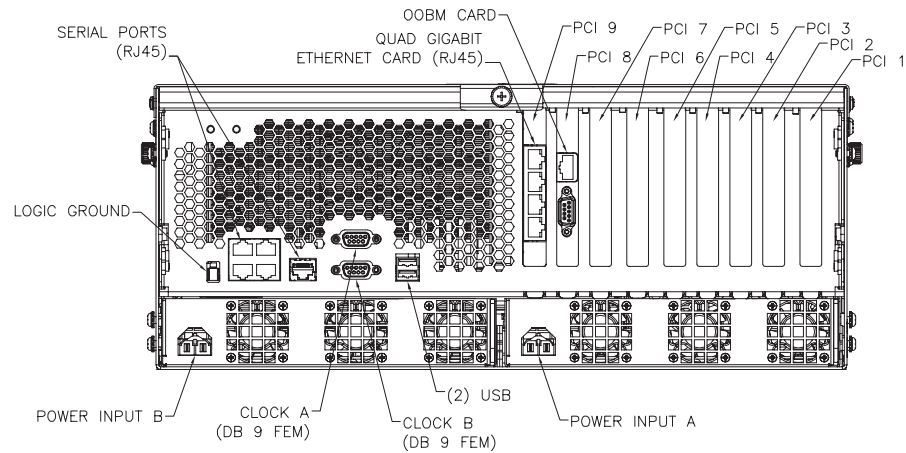

16. From the front of the frame, press the round release buttons and slowly push the T1100 AS into the frame while observing the cables to avoid binding or stretching (see Figure 5-12).

Figure 5-12. Frame Mounting Detail

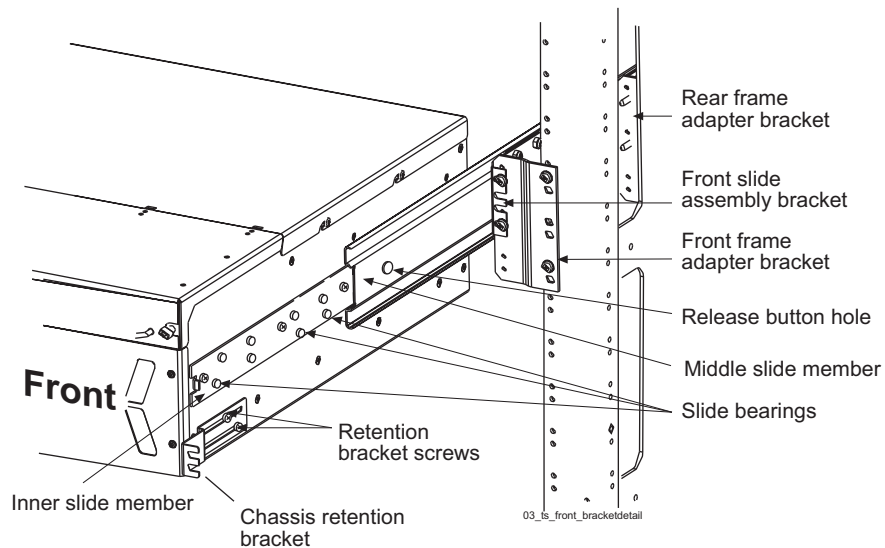

The chassis retention brackets on the front of the T1100 AS will contact the frame adapters when the chassis is positioned correctly in the frame.

17. Secure the chassis with one #10-32 screw on each side in the chassis retention brackets.

18. You must perform the procedures in “Post Installation Procedures” on page 6-1 before powering up the unit.



**WARNING:** Do not power up the unit at this time.

---

19. Replace any plastic panels and doors that were removed.
- 

20. This procedure is complete.
- 

Next, perform the procedures described in Chapter 6, “Post Installation Procedures.”

## How to Cable Components Added to Existing Frames

To cable equipment added to an existing frame, follow the directions in one of the following sections:

- “How to Cable a T1100 AS Unit Added to an Existing Heavy Duty Frame” on page 5-14
- “How to Cable a T1100 AS Installed in Customer-Provided Frame” on page 5-15

### How to Cable a T1100 AS Unit Added to an Existing Heavy Duty Frame



**WARNING:** Verify that all breakers are set to the OFF (O) position.

In a Direct Current (DC) environment, after an additional T1100 AS unit has been installed, attach cables.

To determine the cables used and how to connect them, refer to the [interconnect diagram](#), which lists each cable, its quantity, length, how it is used, and a diagram of how to connect it.

**NOTE:** Some of the listed cables are used only as required. Actual cables used may vary by application.

To view a drawing of a cable, refer to the [Cable List document](#), which lists all the cables that appear in the system interconnect diagram with a link from each part number to the drawing for that part number.

## How to Cable a T1100 AS Installed in Customer-Provided Frame



**WARNING:** Verify that all breakers are set to the OFF (O) position, and that all power distribution unit switches are in the OFF position.

In an Alternating Current (AC) environment, after the T1100 AS unit has been installed, attach cables.

To determine the cables used and how to connect them, refer to the [interconnect diagram](#), which lists each cable, its quantity, length, how it is used, and a diagram of how to connect it.

**NOTE:** Some of the listed cables are used only as required. Actual cables used may vary by application.

To view a drawing of a cable, click on the [Cable List document](#), which lists all the cables that appear in the system interconnect diagram with a link from each part number to the drawing for that part number.





# 6

## Post Installation Procedures

Introduction.....	6-1
How to Connect Frame Ground and Logic Ground .....	6-2
Recommended Tools.....	6-2
How to Prepare the Cables .....	6-3
How to Ground in a DC Environment.....	6-3
How to Verify the Ground in a DC Environment .....	6-11
How to Ground the Logic Connector in a AC Environment.....	6-11
How to Verify the Ground in an AC Environment .....	6-13
Post-Installation Checklist.....	6-13
How to Power Up.....	6-15
How to Power Up a Heavy Duty Frame .....	6-15
How to Power Up Added T1100 AS Unit in DC Environment.....	6-15
How to Power Up a T1100 AS Unit in an AC Environment.....	6-16
How to Change Passwords .....	6-16

### Introduction

This chapter describes the activities that should be performed after either of the following types of installation:

- A heavy duty frame that contains T1100 AS hardware has been installed
- T1100 AS hardware has been installed in an existing frame

**NOTE: Some of the figures in this section show the Tekelec T1000. The T1000 is identical in size to the T1100, and the frame installation instructions are the same for both chassis.**

## How to Connect Frame Ground and Logic Ground

The procedures in this section must be performed before turning on the power to the frame. To ground a T1100 AS hardware system, the following tasks must be performed:

- Prepare the ground cables (required only in a DC environment); see “How to Prepare the Cables” on page 6-3
- Ground the frame (required only in a DC environment); see “How to Ground the Frame in a DC Environment” on page 6-4.

**NOTE: Grounding for AC systems is provided through the AC electrical circuit; however, the T1100 AS frame can be grounded with an isolated frame ground. Customers are responsible for providing the connection from the LSMS frame to the customer frame grounding point.**

- Ground the chassis; see either of the following:
  - “How to Connect T1100 AS Chassis Ground from T1100 AS Chassis to Frame in DC Environment” on page 6-7
  - “How to Verify the Ground in an AC Environment” on page 6-13
- Ground the logic for the T1100 AS unit; see “How to Ground the Logic Connector in a DC Environment” on page 6-8 or “How to Ground the Logic Connector in a AC Environment” on page 6-11.
- Verify the grounding; see one of the following:
  - “How to Verify the Ground in a DC Environment” on page 6-11
  - “How to Verify the Ground in an AC Environment” on page 6-13



**DANGER: Strictly observe all grounding requirements to reduce the risk of electric shock.**

### Recommended Tools

The following tools are recommended for procedures in this chapter:

- Safety glasses
- Multi-meter
- Cable cutters
- Cable stripper
- Socket wrench set with 1/4-inch or 3/8-inch drive or open end wrenches
- Heat-shrink gun (hot air blower)
- Torque wrench
- Fiber paper

- Power knife
- Flush cutters
- Crimping tool with embossing dies (test before using)
- Non-oxidizing grease
- Lacing cord and nylon cable ties
- P-touch label maker

## How to Ground in a DC Environment

In a Direct Current (DC) environment, a T1100 AS hardware system operates as a digital isolated ground plane in a central ground environment and requires a single connection to the central ground window. The frame's ground cables must provide the sole grounding connection between the entire frame and the central office grounding.

Perform the procedures in the following sections:

- "How to Prepare the Cables" on page 6-3
- "How to Ground the Frame in a DC Environment" on page 6-4
- For each server in the heavy duty frame, use the procedure in "How to Connect T1100 AS Chassis Ground from T1100 AS Chassis to Frame in DC Environment" on page 6-7
- "How to Ground the Logic Connector in a DC Environment" on page 6-8
- "How to Verify the Ground in a DC Environment" on page 6-11

### How to Prepare the Cables

Use this procedure to prepare each frame and logic ground cable.

#### **Procedure 6-1. Prepare the Ground Cables**

---

1. Butt and strip the ends of the green ground cable (P/N 690-0108-07 for the frame ground and P/N 690-0131-01 for the logic ground).

---
2. Slide a piece of clear heat-shrink (P/N 804-0229-01 for the frame ground and P/N 804-0228-R01 for the logic ground) on the butted end of the cable below the stripped end. Move the heat-shrink past the stripped portion of the cable to allow access to the uncovered wire.

---
3. Apply a thin layer of non-oxidizing grease to the uncovered wires.

---

4. Slide the cable lug (P/N 804-0977-R01 for the frame ground and P/N 804-0817-R02 for the logic ground) over the stripped cable. Crimp the lug on the cable, using an embossing crimper. The stripped cable must fill the lug completely to the end of the barrel and be visible in the end window of the lug.

---
5. This procedure is complete.

---

Next, go to “How to Ground the Frame in a DC Environment” on page 6-4

### How to Ground the Frame in a DC Environment

This section describes how to ground the frame in a DC environment.

#### Procedure 6-2. Connect Ground Cable: Frame to Ground Window

---

1. Ensure that Procedure 6-1 on page 6-3 to prepare the frame ground cable (P/N 690-0108-07) has already been performed.

---
2. Attach the continuous aisle ground conductor 1/0 to the Ground Window. Run the conductor to the equipment (see Figure 6-1).



**WARNING:** Be sure that there is no connection between Tekelec equipment frame ground and the frame ground of any other telecommunications equipment.

---

3. Install the branch ground conductor to the frame using screws and washers. The continuous aisle ground conductor will be H-tapped to the branch (see Figure 6-1). The separate #6 American Wire Gauge (AWG) cable ground that runs to the frame will allow removal of a frame from a lineup without interrupting the grounding of any other frames in the lineup. Torque screws to 45 inch-pounds.

**Figure 6-1.** Frame Ground Cable Routes in DC Environment

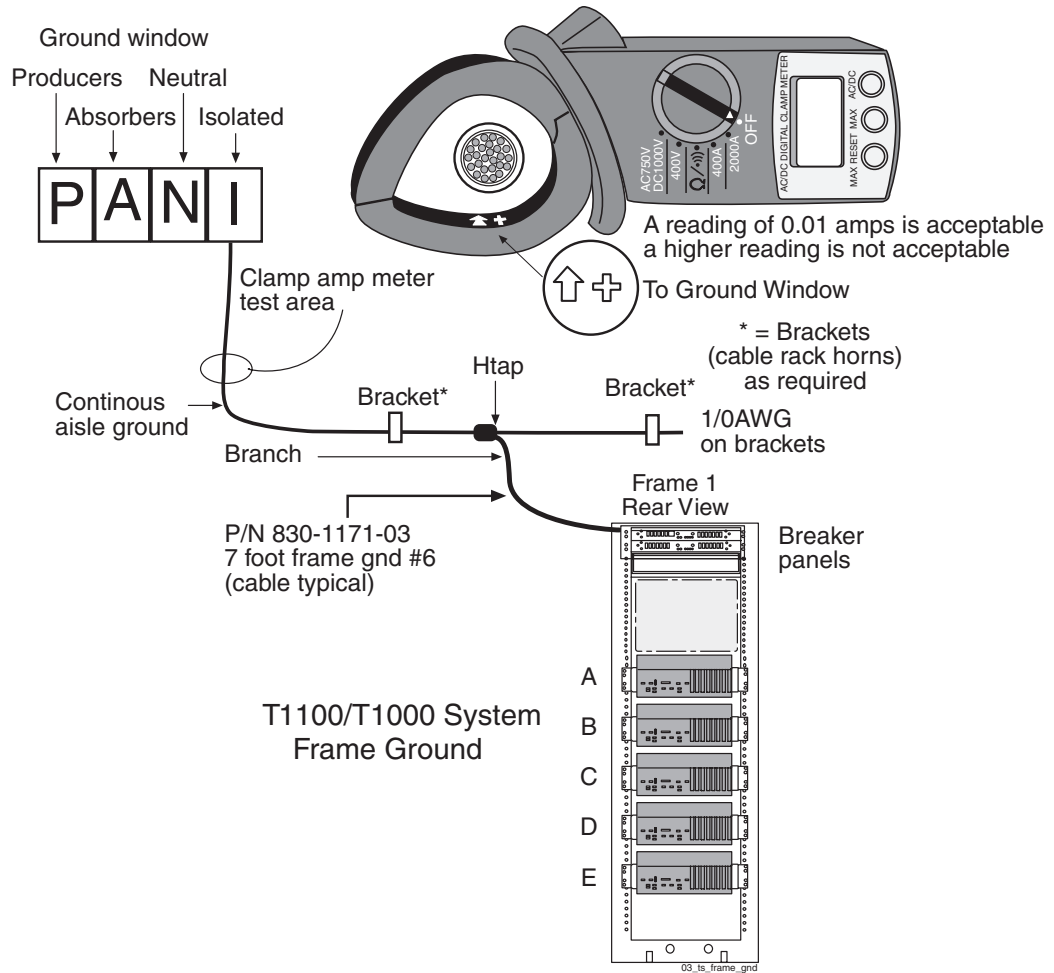

**NOTE:** This figure shows five servers in the frame. For more complete information about the configuration used by the application, refer to the [assembly drawing](#).

4. Label all cables with "TO" and "FROM" location information.  
Example: FROM T1100 AS frame ground, TO isolated main ground.
5. Ensure that a bolt through any nut must show at least two threads beyond the nut, but no more than four threads should be showing.
6. Use the lacing cord to secure a "DO NOT DISCONNECT LEAD" tag at each end of the cable, just beyond the lug. Apply the 145C cable tags to both ends of the frame ground cable.

**Figure 6-2.** Frame Ground Cable Attachment Locations in DC Environment

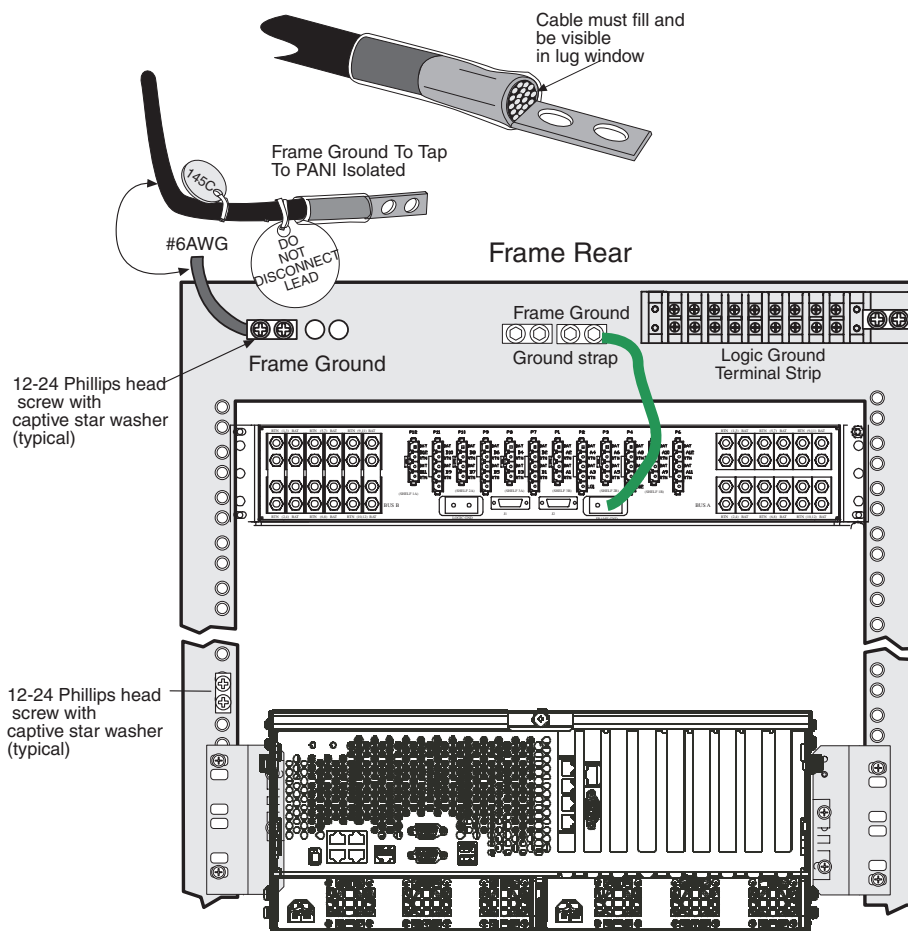

**NOTE 1:** Main Ground: 1/0 cable from the frame ground to the PANI "I" (isolated) section of the ground window.

**NOTE 2:** Frame Ground: A cable #6 AWG from a frame is H-tapped into a 1/0 cable and terminates on the "I" section of the ground window. If no ground window exists, the customer will designate the termination point.

**NOTE 3:** The size of the cable is determined by the overall length of the cable run. Refer to the Site File Book.

7. This procedure is complete.

Next, go to Procedure 6-3, "Connect T1100 AS Chassis Ground: T1100 AS Chassis to Frame," on page 6-7.

**How to Connect T1100 AS Chassis Ground from T1100 AS Chassis to Frame in DC Environment**

In a DC environment, use this procedure for each T1100 AS unit in the heavy duty frame.

**Procedure 6-3. Connect T1100 AS Chassis Ground: T1100 AS Chassis to Frame**

1. Remove the nuts on the T1100 AS chassis ground lugs on the back of the server (see Figure 6-3 on page 6-7).

**Figure 6-3. Chassis Ground Cable Attachment Location in DC Environment**

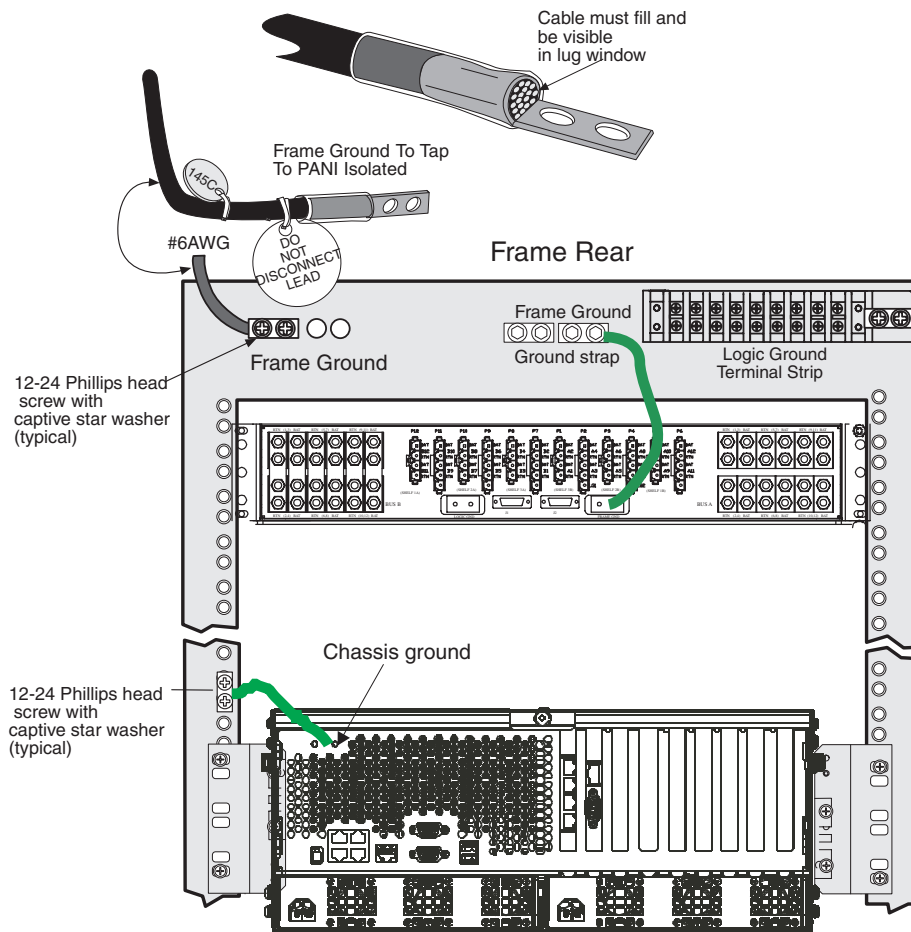

2. Attach the ground cable (P/N 830-0977-01) to the server. The ground cable has a different lug at each end and will terminate only one way.

3. Tighten the nuts to secure the cable to the rear of the T1100 AS.

---
4. Connect the other end of the cable to the side of the frame nearest the T1100 AS chassis (see Figure 6-2 on page 6-6). Be sure that the T1100 AS can slide in and out on its rails without binding this cable.

---
5. This procedure is complete.

---

Next, go to Procedure 6-4, "Connect Logic Ground from Logic Ground Terminal Strip to Ground Window," on page 6-8.

### How to Ground the Logic Connector in a DC Environment

This section describes how to attach the logic ground cables to the logic connector at the back of the server.

The logic ground cables are a part of the internal power distribution. They provide a ground connection between each server and the main ground. The logic ground is connected from each server to the terminal strip and from the terminal strip to the system bar or to the ground window by the consolidated power cables, cable #6 AWG (P/N 690-0131-01), terminal lug (P/N 804-0817-R02), and heat-shrink (P/N 804-0228-R01).

To complete the logic ground, both of the following procedures must be performed:

- Attach the logic ground from the logic ground terminal block to the system bar (EF00) or to the isolated ground of the Ground Window (Procedure 6-4 on page 6-8).



**WARNING:** Be sure that there is no connection between Tekelec equipment logic ground and the logic ground of any other telecommunications equipment.

- Attach the logic ground cable from the logic ground port on the T1100 AS to the logic ground screws on the logic ground terminal block (Procedure 6-5 on page 6-11).

#### Procedure 6-4. Connect Logic Ground from Logic Ground Terminal Strip to Ground Window

---

1. Use Procedure 6-1 on page 6-3 to prepare the logic ground cable (P/N 690-0131-01).

**NOTE:** It may be necessary to drill the central office ground window bar to accept the 3/8-inch bolts on one-inch centers.

---



2. Attach one of the ground cables to the logic ground terminal strip and the other end to the system ground bar (EF00) or the isolated ground of the ground window (see Figure 6-4 on page 6-9).

**Figure 6-4.** Logic Ground Cable Routes in DC Environment

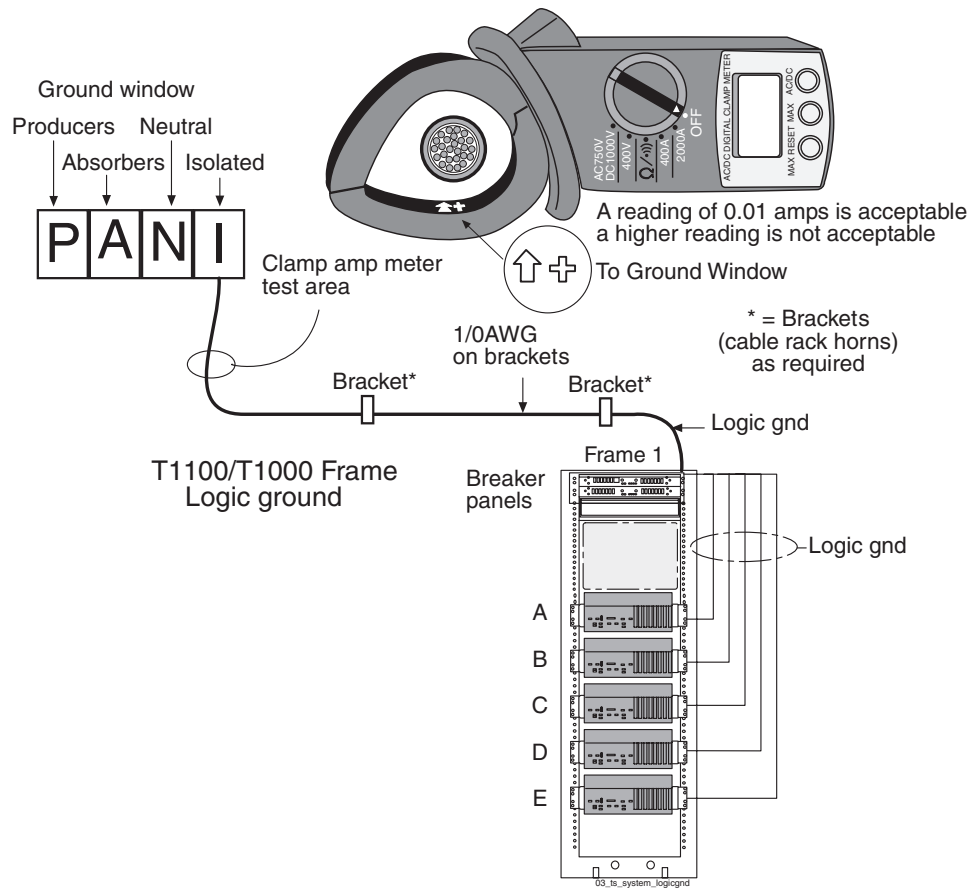

**NOTE:** This figure shows five servers in the frame. For more complete information about the configuration used by the application, refer to the [assembly drawing](#).

3. Apply the 145C cable tag (see Figure 6-5 on page 6-10) to both ends of the logic ground cable. Also, apply the "Do Not Disconnect" tag to both ends of the logic ground cable.

**Figure 6-5.** Frame and Logic Ground Cable Attachment Locations

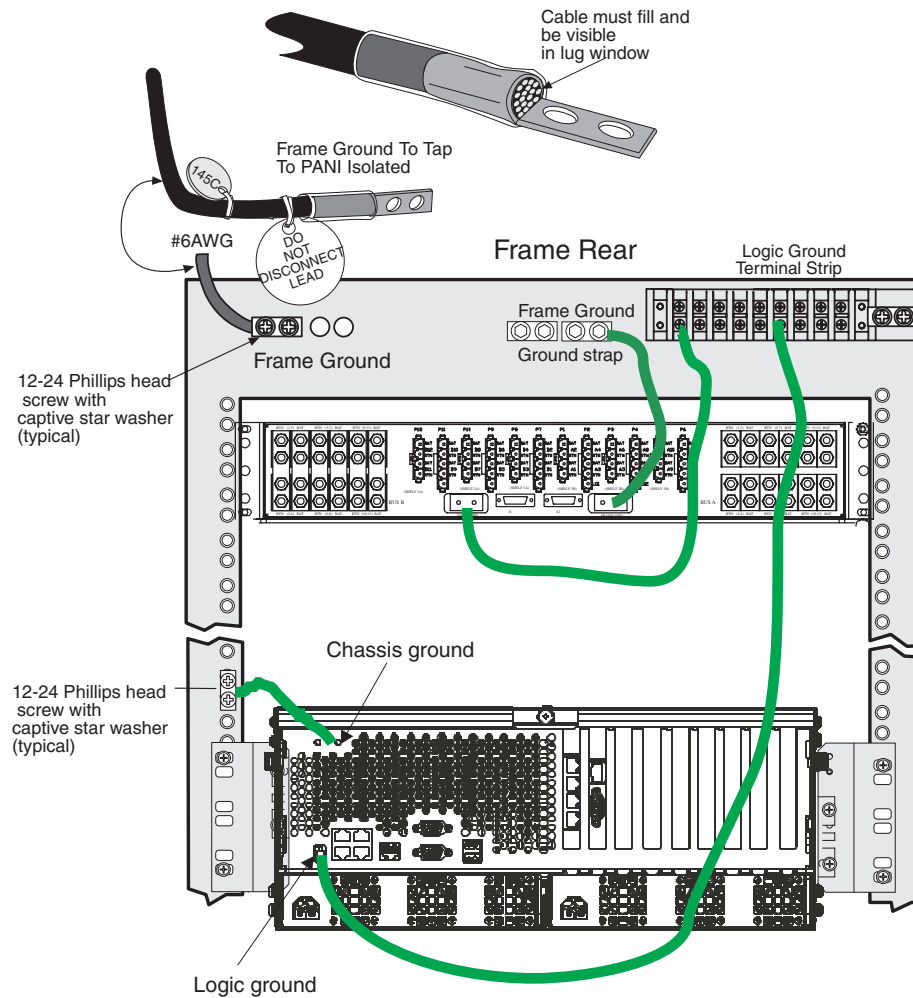

**NOTE 1:** DO NOT run Logic Ground or Power Cables on the cable horns in the top middle of a frame.

**NOTE 2:** The number of inter-frame Logic Ground connections may vary from the example shown in Figure 6-5. (One logic ground connection per T1100 AS.)

- 
4. This procedure is complete.
- 

Next, go to Procedure 6-5, "Connect Logic Ground: T1100 AS Logic Ground Port to Logic Ground Terminal Strip," on page 6-11.

### Procedure 6-5. Connect Logic Ground: T1100 AS Logic Ground Port to Logic Ground Terminal Strip

---

1. Connect one end of the logic ground cable with the 15-pin connector to the port labeled "Logic Ground" at the rear of the T1100 AS chassis. This cable does not need any special preparation and can be used as delivered with the server.

---
2. Connect the other end of the cable to one of the screws on the logic ground terminal strip at the top right side of the frame. Do this for each server. See Figure 6-5 on page 6-10.

---
3. This procedure is complete.

---

Next, go to "How to Verify the Ground in a DC Environment" on page 6-11.

### How to Verify the Ground in a DC Environment

After all frame components and all frame and logic ground cables are installed, the hardware tester must verify the frame and logic grounds. Power-up the frame using the procedure described in "How to Power Up" on page 6-15. Then, use the multi-meter to test the isolated continuous aisle ground at the position show in Figure 6-1 on page 6-5. The meter reading with the frame powered-up must be less than 0.01 Amps.

### How to Ground the Logic Connector in a AC Environment

This section describes how to attach the logic ground cable to the logic connector at the back of the server.



**WARNING:** Be sure that there is no connection between Tekelec equipment logic ground and the logic ground of any other telecommunications equipment.

**NOTE:** Grounding for AC systems is provided through the AC electrical circuit; however, the T1100 AS frame can be grounded with an isolated frame ground. Customers are responsible for providing the connection from the LSMS frame to the customer frame grounding point.

**Procedure 6-6. Connect Logic Ground Between Logic Ground Ports**

---

**NOTE:** This logic grounding procedure applies only when you have exactly two T1100 AS servers in an AC cabinet. If you have only one server, or more than two servers, contact Tekelec Customer Care Center for assistance.

1. Attach one end of the logic ground cable to the logic ground port at the back of one of the T1100 AS servers. Next, attach the other end of the logic ground cable to the logic ground port of the other server as shown in Figure 6-6 on page 6-12.

**Figure 6-6.** Logic Ground Cable Route in AC Environment

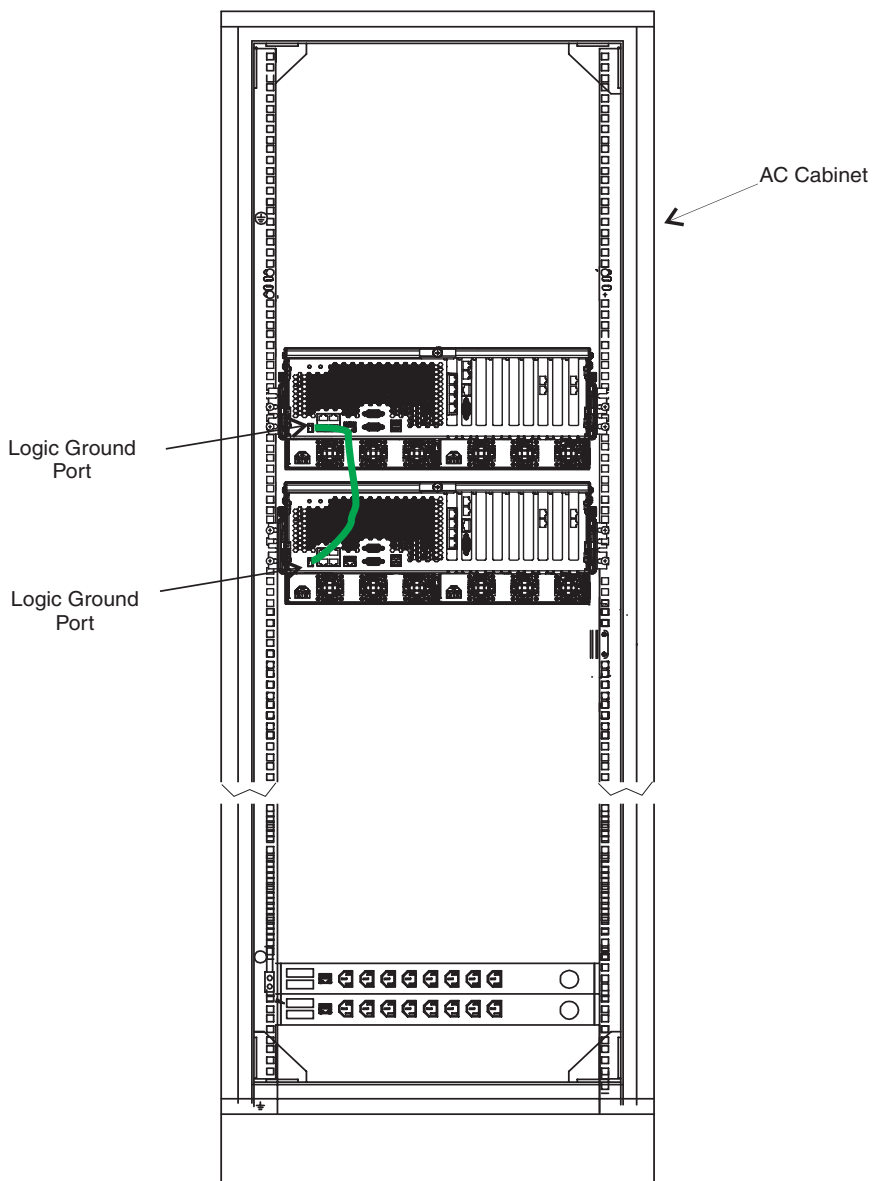

- 
2. Apply the 145C cable tag to both ends of the logic ground cable. Also, apply the “Do Not Disconnect” tag to both ends of the logic ground cable.

**NOTE 1: DO NOT run Logic Ground or Power Cables on the cable horns in the top middle of a frame.**

**NOTE 2: The number of inter-frame Logic Ground connections may vary from the example shown in Figure 6-6.**

---

3. This procedure is complete.
- 

Next, go to “How to Verify the Ground in an AC Environment” on page 6-13.

### How to Verify the Ground in an AC Environment

Use the following procedure to o verify ground in an AC environment.

#### Procedure 6-7. Verify AC ground

---

1. Take the black lead of a VOM and insert it into the ground post on the AC source plug/outlet being tested.

---
2. Take the red lead of the VOM and insert it into one of the hot sides of the plug/outlet. The meter should now read 208 VDC.

---
3. While keeping the black lead in place, remove the red lead from the branch it was inserted into in step 2 and insert it into the other branch of the outlet/plug. Again the meter should read 208 VDC.

---
4. This procedure is complete.

---

## Post-Installation Checklist

After you have performed installation procedures in this manual, fill out the checklist shown in Table 6-1.

**Table 6-1.** Post-Installation Checklist

<b>Check When Done</b>	<b>Verify that:</b>
	All items listed in the Equipment Specification have been installed.
	Shipping container is properly packed with ramp and frame dollies and shipped to Tekelec. <b>NOTE: This check applies only after a heavy duty frame has been installed.</b>
	The site is clean.
	Systems are neat, clean, and level.
	All cable connections are checked to ensure a tight and complete connection.
	Cabling is neatly installed and the labels are correct and easily readable.
	Power cabling does not run through a cable rack.
	Power cabling is not routed together with any other cables and has at least six inches of clearance.
	Racks have protective paper between the rack and any cables that would otherwise touch the rack.
	The main ground cable is correctly labeled and is marked "TO and "FROM" with the "Do Not Remove" tag installed on both ends of the cable at the grounding.
	The -48 VDC power feeds are correctly labeled at the site power distribution panel. There should be an A feed and a B feed for each breaker panel. <b>NOTE: This check applies only in a DC environment.</b>
	The T1100 AS power supply module is plugged in to the AC power source. <b>NOTE: This check applies only in an AC environment.</b>
	Any -48 VDC BATT and RTN cables are correctly labeled.
	Earthquake bracing, if any, is properly installed.
	Adequate floor clearances have been maintained.
	Panels, if any, are correctly installed.
	Cable sheets are properly filled out.
	Documentation has been received and is properly stored.
	OOBM Modems are operational.

**Table 6-1.** Post-Installation Checklist

Check When Done	Verify that:
	Customer site survey book is signed off.
	Check that power coming into the frame is -48V +/- 6V before powering up the frame.

## How to Power Up



**WARNING:** Only a certified Tekelec test engineer should power up a system after installation.

To power up, set the appropriate breakers to the ON position as described in one of the following sections.

- “How to Power Up a Heavy Duty Frame” on page 6-15
- “How to Power Up Added T1100 AS Unit in DC Environment” on page 6-15
- “How to Power Up a T1100 AS Unit in an AC Environment” on page 6-16

Turn the switch on the front of the T1100 AS to ON. When the breakers that supply power to the T1100 AS unit are switched ON, and the chassis switch is turned ON, the unit will execute a power up sequence which includes a Power On Self Test (POST). For information about initializing the software that runs on T1100 AS chassis, refer to the application manuals included with your documentation.

### How to Power Up a Heavy Duty Frame

In a Direct Current (DC) environment, to power up the equipment installed in the heavy duty frame, turn ON (flip the switch toward the | indicator) all the breakers that correspond to servers in the frame, as shown in [BreakerSettings.pdf](#). Next, turn ON the power switch on the front of the T1100 chassis.

### How to Power Up Added T1100 AS Unit in DC Environment



**WARNING:** Before powering up a server that has been added to an existing frame in a DC environment, verify that the breakers that correspond to the position where the server has been added are set to the OFF (O) position. Then, be sure that the chassis switch is set to the OFF position.

To power up an added server, turn ON (flip the switch toward the | indicator) the breakers that correspond to the position where the server was added, as shown in [BreakerSettings.pdf](#). Next, turn ON the power switch on the front of the T1100 chassis.

### How to Power Up a T1100 AS Unit in an AC Environment

Use the following procedure to power up a T1100 AS unit in an AC environment.



**WARNING:** Before powering up, verify that all output breakers or power distribution unit switches are set to the OFF (O) position. Be sure the chassis power switch is set to the OFF position.

#### Procedure 6-8. Power Up T1100 AS Unit in an AC Environment

---

1. Ensure that all AC and DC connections have been secured and checked.

---
2. Verify the ground at the AC outlet. See “How to Verify the Ground in an AC Environment” on page 6-13.

---
3. Set the output breakers to “ON” to send power to the T1100 AS unit.

---
4. Turn the T1100 AS chassis switch to “ON”.

---
5. This procedure is complete.

---

### How to Change Passwords

For security purposes, Tekelec recommends that all default passwords be changed to your own passwords. The new passwords should be kept in a secure location.

- To change the passwords for the T1100 AS platforms, refer to the application manual for the application loaded on each server.
- To change the passwords for the Ethernet switches, refer to the application manual for the application loaded on each server.

**NOTE:** There should always be a person on-site who knows the new passwords. If there is a need to contact the Customer Care Center, please provide the passwords on request.



# Field Replaceable Units

Introduction.....	7-2
Safety Information .....	7-2
T1100 AS Hardware System FRUs and Part Numbers.....	7-4
T1100 AS FRUs .....	7-5
Tools Required .....	7-6
How to Replace a Console Server, Ethernet Switch, or Hub.....	7-7
How to Access T1100 AS FRUs.....	7-9
How to Slide T1100 AS Chassis Out from Frame .....	7-9
How to Slide T1100 AS Chassis Back into Frame.....	7-11
How to Remove T1100 AS Chassis from a Frame .....	7-12
How to Return a T1100 AS Chassis to the Frame.....	7-15
How to Replace T1100 AS FRUs.....	7-19
How to Replace the Air Filters.....	7-19
How to Replace the Rectangular Fan Assembly .....	7-21
How to Replace the Square Fan Assembly.....	7-23
How to Replace Hard Disk Drive Assemblies.....	7-26
How to Replace Removable Media Disk Drives (CD/DVD) .....	7-32
How to Replace a Power Supply Module .....	7-38
How to Replace PCI Cards .....	7-40
How to Replace a T1100 AS Chassis FRU .....	7-46

## Introduction

T1100 AS Application Server hardware systems are designed for the high-availability environments required by telephony networks. They use redundant power supplies and many of the components within a single T1100 AS chassis are redundant.

Even with the advanced reliability of the T1100 AS design, hardware failures may still occur. The T1100 AS hardware is designed for easy maintenance when replacements are needed.



**CAUTION:** Always contact the Customer Care Center before performing any troubleshooting or replacing components.

This chapter describes which T1100 AS hardware system components are field-replaceable units (FRUs) and provides procedures for replacing them.

**NOTE:** This chapter does not describe how to diagnose which FRU may need to be replaced. For diagnostic information, refer to the applications documentation.



**CAUTION:** Many of the procedures in this chapter require you to lower the front fascia. Be sure you do not unplug the cable from the printed circuit board behind the front fascia while opening the front fascia. Removing this cable from its connections will cause the server to shut down.

## Safety Information

Safety icons and text are used throughout Tekelec manuals to warn the reader of the potential of personal injury, service interruption, and equipment damage. For information about what each of the icons mean, see [“Documentation Admonishments” on page 1-6](#).

Before beginning any procedure described in this manual, ensure that you are familiar with each of the following safety admonishments. Additional safety admonishments may be included, or repeated, for specific procedures.



**TOPPLE:** Always read and understand instructions completely before working on, moving, raising or lowering the frame, any portion of the frame, or attachments to the frame or equipment.



**TOPPLE:** Never try to unpack any frame from the shipping container without at least two people to steady any movement of the frame and related components. At least two people are required to safely move and position any frame.



**TOPPLE:** Never pull out the shelf of any frame that is not anchored properly. Some frames are required to be attached to overhead ladder racks before shelves are extended.



**DANGER:** No commercially AC powered equipment may be used or placed within 7 ft. of -48V equipment. AC powered equipment within 7 ft. of -48V equipment may create a shock or current loop that can be severely hazardous to personnel and equipment.



**DANGER:** Do not wear metal, chains, rings, watches, or jewelry or carry exposed metal, keys or tools in pockets when working on system equipment or other related electrostatic-sensitive components. Always wear a wrist strap or other electrostatic protection when handling printed circuit boards and other electrostatic-sensitive devices.



**WARNING:** Do not leave or allow unused metal objects, such as screws or washers, to remain anywhere within the equipment. Remove all unused material from the equipment



**WARNING:** Do not allow any metal shavings to remain in the equipment area. Metal Shavings may result from over tightened screws or bolts. These small metal particles are hazardous to electronic equipment. Be careful not to over tighten screws or bolts.



**WARNING:** Do not use tie wraps on or above the top traverse arms on a frame. Always trim tie wrap flush and turn the trimmed tie wrap to the rear of the cable.



**CAUTION:** All personnel associated with the installation of these systems must adhere to all safety precautions and use required protection equipment, to avoid the possibility of injury to personnel, service degradation, and/or service interruption.



**CAUTION:** These systems have redundant power supplies to allow service during normal maintenance. When repairs require a total power disconnect, both input supply sources must be disconnected. This causes service interruption and takes down the systems.



**CAUTION:** This equipment has a connection between the earthed conductor of the DC supply circuit and the earthing conductor.



**CAUTION:** The Branch Circuit Overcurrent Protection shall be rated minimum -48V, maximum 40A.



**CAUTION:** Equipment is to be installed in restricted access areas in accordance with articles 110-16, 110-17, and 110-18 of the National Electric Code, ANSI/NFPA 70.



**CAUTION:** A readily accessible disconnect device that is suitable, approved, and rated shall be incorporated in the field wiring.



**CAUTION:** Connect to a reliably grounded SELV source which is reliably earthed and electrically isolated from the AC source.



**CAUTION:** Use only listed closed loop connectors for connection to the supply.



**CAUTION:** When some CPCI cards arrive from the manufacturer, they may have a small plastic cover over the screws and/or the alignment ejector pins. Remove and discard these plastic covers. If inserting the cards takes an excessive amount of force, check for obstructions. Forcing the card into a slot may damage the ejector handle or pin.

### T1100 AS Hardware System FRUs and Part Numbers

The following T1100 AS hardware system components can be replaced in the field:

- Air filters (rectangular filter P/N 551-0022-03 and square filter P/N 551-0022-02)
- Fan assemblies (rectangular fan P/N 840-1125-03 and square fan P/N 840-1133-01).
- SATA hard drives (P/N 870-2787-02)
- Removable media drives assembly (P/N 870-2785-02)

- Power supply module (AC P/N 870-2795-04 and DC P/N 870-2795-03)
- Peripheral Component Interface (PCI) cards
  - PCI Ethernet dual port 10/100/1000 (P/N 870-2706-04)
  - Modem (P/N 870-2707-02)
  - Quad serial (P/N 870-2708-02)
  - PCI express interface/quad Gb ethernet (P/N 870-2790-02, slot 9)
  - Out of band management card (P/N 870-2798-02, slot 8)
  - Assy serial ATA interface card (P/N 870-2799-01, slot 2)
- T1100 AS chassis (DC P/N 870-2754-01 AC P/N 870-2754-02). Note: hard drive assemblies and PCI cards from the failed chassis can be moved to the replacement chassis.
- Ethernet switch or hub (see “How to Replace a Console Server, Ethernet Switch, or Hub” on page 7-7)

### T1100 AS FRUs

Table 7-1 shows the T1100 AS components that have been designed to be replaceable in the field. Most of these components are located for easy access; they can be replaced without completely removing them from the frame. In addition, some of them can even be replaced without needing to shut off power to the T1100 AS chassis.



**WARNING:** When you need to replace a FRU for which the power must be shut off, always first attempt to perform a soft shutdown of the application systems (refer to the application manual).

**Table 7-1.** T1100 AS Field Replaceable Units and Part Numbers

FRU	Part Number	T1100 AS Power State Required before Replacement	T1100 AS Location	Access
Rectangular air filters	551-0022-03	ON or OFF	Behind front fascia	lower front fascia while chassis in frame
Square air filter	551-0022-02	ON or OFF	Behind front fascia	lower front fascia while chassis in frame
* When a T1100 AS chassis needs to be replaced, the hard drive assemblies and the PCI cards can be moved from the failed chassis to the replacement chassis. Moving the hard drive assemblies from the failed server to the replacement server allows data to be preserved.				

**Table 7-1.** T1100 AS Field Replaceable Units and Part Numbers

FRU	Part Number	T1100 AS Power State Required before Replacement	T1100 AS Location	Access
Rectangular fan assemblies	840-1125-03	ON or OFF	Under front top cover and behind front fascia	Open front top cover after either: <ul style="list-style-type: none"> <li>• Sliding chassis out</li> <li>• Removing chassis from frame</li> </ul>
Square fan assemblies	840-1133-01	ON or OFF	Under front top cover and behind front fascia	
Hard drive assemblies	870-2787-02	ON or OFF	Under front top cover and behind front fascia	
Removable media drives assembly	870-2785-02	OFF	Under front top cover and behind front fascia	
PCI cards	Depend on system configuration	OFF	Under rear top cover	Open rear top cover after sliding chassis from frame
Power Supplies	DC 870-2795-03 AC 870-2795-04	ON or OFF	Rear of Unit	Depress locking ring cam at rear of unit.
T1100 AS chassis*	DC 870-2754-01 AC 870-2754-02	OFF	Entire unit	Remove chassis from frame
* When a T1100 AS chassis needs to be replaced, the hard drive assemblies and the PCI cards can be moved from the failed chassis to the replacement chassis. Moving the hard drive assemblies from the failed server to the replacement server allows data to be preserved.				

## Tools Required

The following tools are required for performing procedures in this chapter:

- Safety glasses
- # 0 Phillips screwdriver
- # 1 Phillips screwdriver
- # 2 Phillips screwdriver
- # 3 Phillips screwdriver

- 3/8 inch nutdriver
- Volt Ohm Meter (VOM)
- P-touch label tool

## How to Replace a Console Server, Ethernet Switch, or Hub

Perform the following procedure to replace miscellaneous equipment (such as a console server or an Ethernet switch or hub) in a heavy duty frame.

### Procedure 7-1. Replace an Ethernet Switch, Hub, or Console Server

---

1. Ensure that the following have been done:
    - a. An RMA has been obtained (see [“How to Obtain a Return Material Authorization” on page B-1](#))
    - b. A spare unit is available
- 



**DANGER:** Do not wear metal, chains, rings, watches, or jewelry or carry exposed metal, keys or tools in pockets when working on system equipment or other related electrostatic-sensitive components. Always wear a properly grounded ESD wrist strap or other electrostatic protection when handling printed circuit boards and other electrostatic-sensitive devices.

2. Inventory to ensure that the replacement equipment including cables are on site.

---
3. If the switch or console server is still operational, backup the configuration files.

---
4. If the unit to be replaced has a power switch, switch it OFF. Next, at the breaker panel or power distribution unit, turn off all breakers supplying power to the unit.

---
5. Use a VOM to verify that there is no power going to the unit.

---
6. Before removing any cables, make note of each cable location and make sure that all cables are labeled. If they are not labeled, make a label.

---
7. Remove all cables from the unit to be replaced. First remove the ethernet cables. Then remove the logic ground. Finally, remove the power cables.

---

8. While supporting the failed unit, use the #2 phillips screwdriver to remove the screws holding the mounting bracket of the unit to the frame.

---
9. Pull failed unit out of the frame. Remove the mounting brackets from the old unit.

---
10. Secure the mounting brackets to the replacement unit.

---
11. While holding the replacement unit in place, start the available screws 0.5 inch (P/N 601-0010-01) into the hole of the mounting bracket on either side of the unit. Still supporting the unit, install two screws into the hole through the bracket into the frame and tighten.

---
12. First attach the power cables. Then attach the logic ground. Be sure to attach cables to the same locations they were attached to at the start of the procedure.

---
13. Attach the ethernet cables to the same locations they were attached to at the start of this procedure.

---
14. If the unit has a power switch, switch it ON. Turn on the circuit breakers to supply power to the unit.

---
15. Using a VOM meter, check that there is adequate power (-48V) going to the unit. Verify that the power LED on the unit is lit.

---
16. If this procedure has been performed to replace console server or an Ethernet switch, contact the Customer Care Center (see "Customer Assistance" on page 1-7) to determine whether additional steps need to be performed.

---
17. This procedure is complete.

---



## How to Access T1100 AS FRUs

A T1100 AS FRU can be accessed in one of the following ways:



**WARNING:** Always wear an ESD wrist strap grounded to the bench or frame when working on electronic components.

- Without moving the chassis from its position in the frame. The air filters and power supply modules can be accessed this way; see “How to Replace the Air Filters” on page 7-19 and “How to Replace a Power Supply Module” on page 7-38.
- By sliding the chassis partway out of the frame (see “How to Slide T1100 AS Chassis Out from Frame” on page 7-9). This method can be used to access one or more of the following:
  - Fan assembly
  - Hard drive assembly
  - Removable media drives assembly
  - PCI cards
- By removing the chassis from the frame and placing it on a workbench (see “How to Remove T1100 AS Chassis from a Frame” on page 7-12)
  - This method must be used to access the T1100 AS chassis for replacement
  - This method may be used to access one or more of the following:
    - Fan assembly
    - Hard drive assembly
    - Removable media drives assembly
    - PCI cards

### How to Slide T1100 AS Chassis Out from Frame

The following FRUs can be replaced without removing the T1100 AS chassis entirely out of the frame:

- Fan assemblies
- Fan filters
- Hard disk drive assemblies
- Removable media disk drives assembly
- PCI cards
- Power Supply Modules



**SHOW ME:** To view a video (with sound) that shows some steps of the following procedure, [click here](#). For personnel safety and to protect equipment and data, be sure to read all the steps in the following procedure. For more information about how to view this video, see “Programs Needed to View Linked Documents” on page 1-4.

#### Procedure 7-2. Slide T1100 AS Chassis Out from Frame

---



**WARNING:** Always wear an ESD wrist strap grounded to the bench or frame when working on electronic components.

1. From the front of the frame, remove the # 12-24 Phillips screw from each chassis retention bracket (see Figure 7-1). Do not remove the screws in the frame adapter brackets.

**Figure 7-1.** T1100 AS Chassis Front View

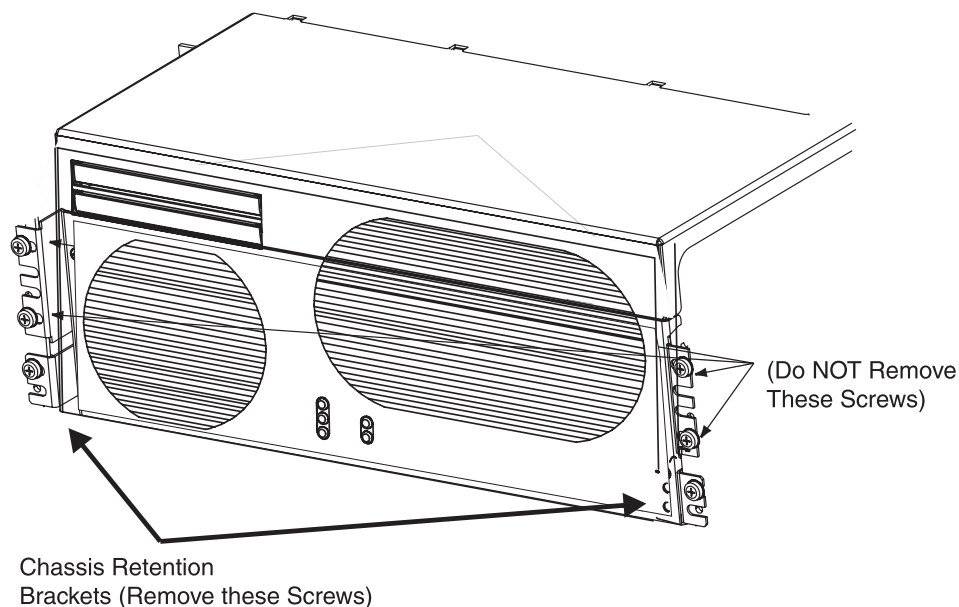

2. From the front of the frame, using the handles (T1000) or the knurled screws on the side of the chassis (T1100), pull forward until the release buttons on the inner arms of the slide assemblies pop into the holes on each side. While gently sliding the chassis, observe the cables to avoid binding, stretching, or disconnecting.



**DANGER:** If the T1100 AS chassis is pulled too far out after the release buttons are disengaged, the inner slide members (attached to the chassis) could come out of the middle slide members (attached to the frame).

---

3. This procedure is complete.
- 

Next, replace the desired FRU using one of the following procedures:

- Procedure 7-8, "Replace a Square Fan Assembly," on page 7-23
- Procedure 7-9, "Replace a Hard Disk Drive Assembly," on page 7-26
- Procedure 7-10, "Replace a Removable Media Disk Drive Assembly," on page 7-32
- "Replace a power supply module" on page 7-38
- Procedure 7-12, "Replace a PCI Card," on page 7-40

When the desired FRU has been replaced, perform Procedure 7-3, "Slide T1100 AS Chassis Back into Frame," on page 7-11.

### How to Slide T1100 AS Chassis Back into Frame

Perform the procedure in this section to slide the T1100 AS chassis back into the frame if one of the following FRUs was accessed by sliding the T1100 AS chassis out of the frame:

- Fan assemblies
- Fan filters
- Hard disk drive assemblies
- Removable media disk drive assemblies
- PCI cards

#### Procedure 7-3. Slide T1100 AS Chassis Back into Frame

---



**WARNING:** Always wear an ESD wrist strap grounded to the bench or frame when working on electronic components.

1. From the front of the frame, simultaneously press the round release buttons and slowly push the chassis into the frame while observing the cables to avoid binding or stretching.
- 

**NOTE:** When the chassis stops moving, the front of the T1100 AS should be slightly recessed to allow clearance behind the frame door when closed.

2. Adjust the chassis retention brackets on the front of the T1100 AS chassis to contact the frame adapter brackets when the chassis is positioned correctly in the frame.

---
3. Secure the chassis with one # 12-24 screw in the chassis retention brackets on each side.

---
4. This procedure is complete.

---

### How to Remove T1100 AS Chassis from a Frame

It may be necessary to remove a T1100 AS chassis from its frame for either of the following reasons:

- To move the chassis to a workbench where one or more of the following FRUs can be replaced (be sure that a replacement FRU is on hand):
  - Fan assemblies
  - Hard disk drive assemblies
  - Removable media disk drives assembly
  - PCI cards

**NOTE:** Alternatively, these FRUs can be replaced by sliding the T1100 AS chassis partway out of the frame, using Procedure 7-2, "Slide T1100 AS Chassis Out from Frame," on page 7-10.

- To remove and replace a failed T1100 AS chassis.

**NOTE:** If the hard disk drives and PCI cards in the failed chassis do not need to be replaced, they can be removed from the failed T1100 AS chassis and placed in the replacement chassis. Moving the disk drives in this way allows data to be preserved.

Use the following procedure to remove a T1100 AS chassis from the frame.

#### Procedure 7-4. Remove a T1100 AS Chassis from Frame

---



**WARNING:** This procedure CANNOT be performed while the T1100 AS chassis is powered on. Never power OFF a T1100 AS chassis until the application software and platform operating system (OS) are shut down. If possible, use the procedures in the application manual for a "soft shutdown." If the application interface is not operating or is not accessible, a hard shutdown (turning OFF the breakers) is sometimes required. Contact the Customer Care Center before doing a hard shutdown.



**WARNING:** Always wear an ESD wrist strap grounded to the bench or frame when working on electronic components.

1. Turn OFF the power switch on the front to the Chassis. Next, turn OFF the circuit breakers that supply power to the T1100 AS chassis to be removed.

To locate the circuit breakers supplying power to the T1100 AS chassis, refer to the system interconnect diagram for the system type and/or read the labels on the breakers. To access the circuit breakers on some frames, it may be necessary to remove the plastic covers on the front of the breakers. If the covers are removed, to maintain NEBS compliance, make sure they are replaced when the FRU replacement has been completed.



**WARNING:** A T1100 AS chassis is redundantly powered from both A and B -48 VDC buses. Ensure that both the circuit breaker supplying A power to a chassis and the circuit breaker supplying B power to a T1100 AS chassis are turned OFF by measuring the voltage with a VOM on the cable that connects the T1100 AS chassis to its breakers. Both A and B power LEDs on the front fascia of the T1100 AS chassis should be OFF.

---

2. Remove the front door and any plastic panels from the rear of the frame.

---
3. From the rear of the frame, check all cables attached to the chassis for correct labeling. If any labels are missing or damaged, create a label that indicates what connection it is attached to and where the other end is connected.

---
4. Disconnect all cables from the rear of the chassis.

---
5. From the front of the frame, remove the # 12-24 Phillips screw from each of the chassis retention brackets (see Figure 7-2). Do not remove the screws in the frame adapter brackets.

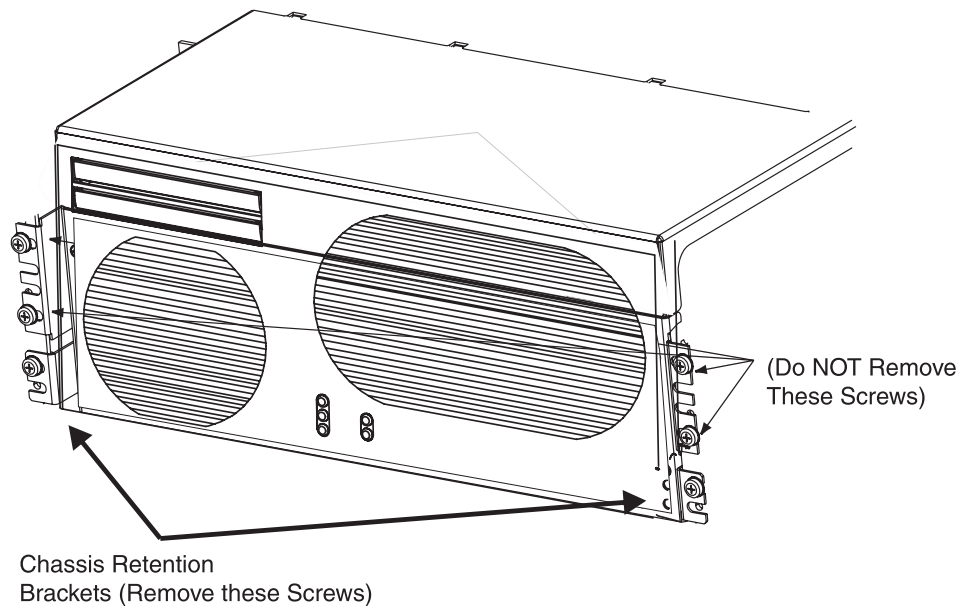
**Figure 7-2.** Chassis Retention Hardware

- 
6. From the front of the frame, using the handles on the front top cover or the knurled screws on the sides of the chassis, pull the T1100 AS chassis forward until the release buttons on the inner arms of the slide assemblies pop into the holes on each side.
- 



**DANGER:** Moving a T1100 AS chassis requires two people. Each T1100 AS chassis weighs approximately 30 kg (65 lbs) and may cause personnel injury or damage to the internal components due to shock and vibration if not handled properly.

7. Simultaneously depress the chassis release buttons on each side and slowly pull the chassis forward until the chassis and attached inner slide members are completely free of the slide assemblies. See Figure 7-3 on page 7-17 for locations of the release buttons.
- 
8. Place the chassis on a grounded bench and attach the ground wrist strap to the bench.
- 
9. This procedure is complete.
-

Continue with one of the following procedures:

- If the chassis has been removed from the frame to a workbench in order to replace one of the following FRUs, go the procedure shown:
  - Procedure 7-8, "Replace a Square Fan Assembly," on page 7-23
  - Procedure 7-9, "Replace a Hard Disk Drive Assembly," on page 7-26
  - Procedure 7-10, "Replace a Removable Media Disk Drive Assembly," on page 7-32
  - Procedure 7-12, "Replace a PCI Card," on page 7-40
- If the T1100 AS chassis is being replaced, but the hard drives and/or the PCI cards from the failed chassis are to be used in the replacement chassis, go to:
  - Procedure 7-13, "Replace a T1100 AS Chassis FRU," on page 7-46
  - Then go to either of both of the following procedures:
    - Procedure 7-9, "Replace a Hard Disk Drive Assembly," on page 7-26
    - Procedure 7-12, "Replace a PCI Card," on page 7-40
- If the T1100 AS chassis is being replaced, and it was ordered with replacements for the hard drives and PCI cards, go to Procedure 7-13, "Replace a T1100 AS Chassis FRU," on page 7-46.

When these procedures have been finished, return the chassis to the frame, using Procedure 7-5, "Return a T1100 AS Chassis to the Frame," on page 7-16.

### How to Return a T1100 AS Chassis to the Frame

Perform the procedure in this section when it is time to return the T1100 AS chassis to the frame for one of the following reasons:

- A T1100 AS chassis FRU is being replaced and the following procedures have been performed:
  - Procedure 7-4, "Remove a T1100 AS Chassis from Frame," on page 7-12
  - Procedure 7-13, "Replace a T1100 AS Chassis FRU," on page 7-46. One of the following procedures may also have been performed:
    - Procedure 7-9, "Replace a Hard Disk Drive Assembly," on page 7-26
    - Procedure 7-12, "Replace a PCI Card," on page 7-40
- An internal FRU is being replaced and the following procedures have been performed:
  - Procedure 7-4, "Remove a T1100 AS Chassis from Frame," on page 7-12
  - One or more of the following procedures:
    - Procedure 7-8, "Replace a Square Fan Assembly," on page 7-23
    - Procedure 7-9, "Replace a Hard Disk Drive Assembly," on page 7-26

–Procedure 7-10, “Replace a Removable Media Disk Drive Assembly,” on page 7-32

–Procedure 7-12, “Replace a PCI Card,” on page 7-40

#### **Procedure 7-5. Return a T1100 AS Chassis to the Frame**

---

1. Ensure that the circuit breakers that will be connected to the replaced T1100 AS chassis are still turned OFF.

To locate the circuit breakers supplying power to the T1100 AS chassis, refer to the system interconnect diagram for the system type and/or read the labels on the breakers. To access the circuit breakers on some frames, it may be necessary to remove the plastic covers on the front of the breakers. If the covers are removed, to maintain NEBS compliance, make sure they are replaced when the FRU replacement has been completed.



**WARNING:** A T1100 AS chassis is redundantly powered from both A and B -48 VDC buses. Ensure that both the circuit breaker supplying A power to a chassis and the circuit breaker supplying B power to a T1100 AS chassis are turned OFF by measuring the voltage with a VOM on the cable that connects the T1100 AS chassis to its breakers.

---



**WARNING:** Always wear an ESD wrist strap grounded to the bench or frame when working on electronic components.

2. Remove the front door and any plastic panels from the rear of the frame.

---
3. From the front of the frame, extend the slide assemblies approximately 10 to 14 inches until the detent latches on the rear of the slides engage.

---



**DANGER:** Moving a T1100 AS chassis requires two people. Each T1100 AS chassis weighs approximately 30 kg (65 lbs) and may cause personnel injury or damage to the internal components due to shock and vibration if not handled properly.

4. Lift the T1100 AS chassis and carefully insert the inner slide members into the middle slide members in the frame. See Figure 7-3.



Figure 7-3. Right Slide Assembly Mounting and Retention Bracket

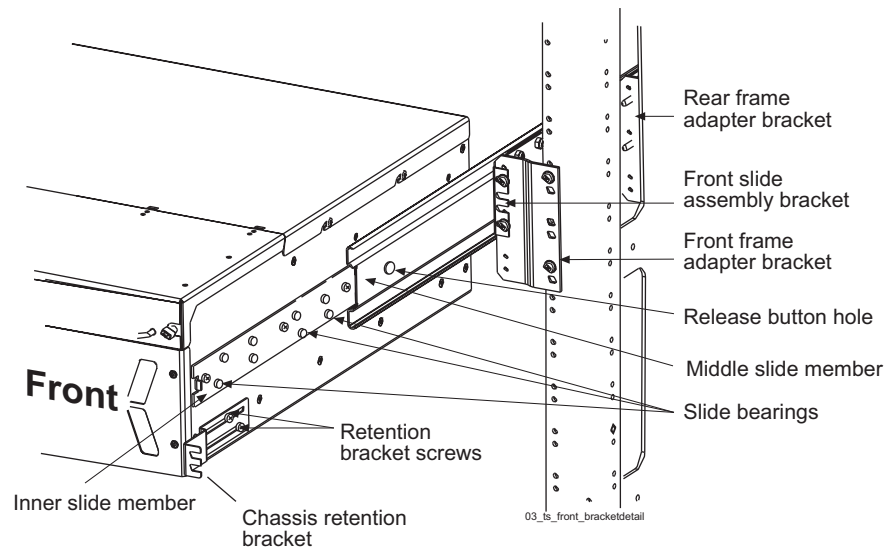

- 
5. Push the T1100 AS chassis toward the frame. When the buttons encounter the middle slide members, simultaneously press the release buttons on the inner slide members on both the left and right sides.

**NOTE:** The inner slide members will continue to travel until the release buttons pop into the round holes of the middle slide members.

---

6. At the rear of the frame, do one of the following:
  - For Side Cable Management Arm Systems attach the side cable management arms to the rear of the frame above the rails using the bolts provided (see Figure 5-9 on page 5-11).

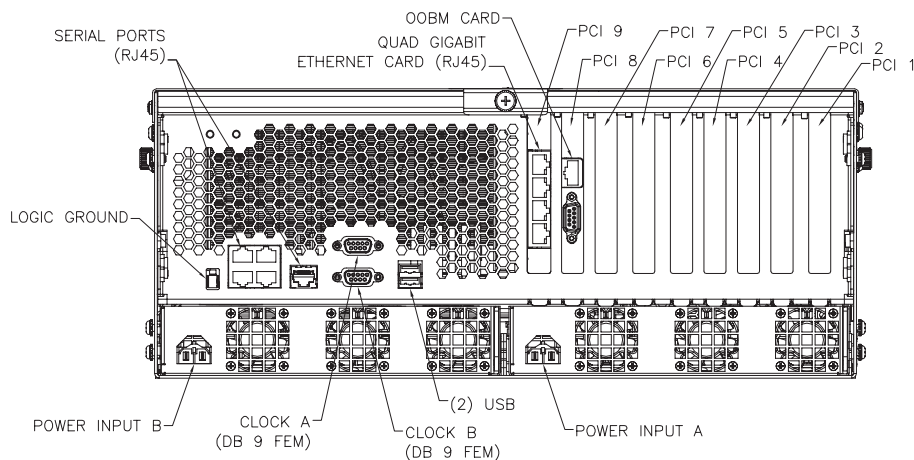
**Figure 7-4.** T1100 AS Chassis Rear View

- 
7. Route and connect the power and data cables through the cable management system to the T1100 AS chassis. Check the labels on the cables and attach them to the appropriate connectors on the rear of the T1100 AS chassis. Consult the cable running list, labels on the cables, and PCI configuration labels on the right of the chassis as seen from the rear. See Figure 7-4.
- 
8. Loosen the screws that attach the chassis retention brackets to the T1100 AS chassis. The chassis retention brackets are adjusted in step 11. See Figure 7-3 on page 7-17 for screw locations.
- 
9. From the front of the frame, simultaneously press the round release buttons and slowly push the chassis into the frame while observing the cables to avoid binding or stretching.
- 
- NOTE:** When the chassis stops moving, the front of the T1100 AS should be slightly recessed to allow clearance behind the frame door when closed.
10. Adjust the chassis retention brackets on the front of the T1100 AS chassis to contact the frame adapter brackets when the chassis is positioned correctly in the frame.
- 
11. Tighten the screws that attach the chassis retention brackets to the T1100 AS chassis.
- 
12. Secure the chassis with one # 12-24 screw in the chassis retention brackets on each side.
-

13. Replace any plastic panels and doors that were removed.

---

14. This procedure is complete.

---

Next, turn the power back on as described in "How to Power Up" on page 6-15.

## How to Replace T1100 AS FRUs

Use one of the following procedures in this section to replace a T1100 AS FRU:

- Procedure 7-6, "Replace Rectangular and Square Air Filters," on page 7-19
- Procedure 7-8, "Replace a Square Fan Assembly," on page 7-23
- Procedure 7-9, "Replace a Hard Disk Drive Assembly," on page 7-26
- Procedure 7-10, "Replace a Removable Media Disk Drive Assembly," on page 7-32
- Procedure 7-12, "Replace a PCI Card," on page 7-40
- Procedure 7-13, "Replace a T1100 AS Chassis FRU," on page 7-46

### How to Replace the Air Filters

There are two air filters on the T1100 AS: the rectangular air filter and the square air filter. It is recommended that the air filters on the T1100 AS chassis be replaced at least once a month. Before beginning these procedures, ensure that spare filters are on hand. If the number of spare filters is running low, order additional filters.

**NOTE:** It is not necessary to slide out or remove the T1100 AS chassis from its frame in order to replace the filter.



**SHOW ME:** To view a video (with sound) that shows some steps of the following procedure, [click here](#). For personnel safety and to protect equipment and data, be sure to read all the steps in the following procedure. For more information about how to view this video, see "Programs Needed to View Linked Documents" on page 1-4.

### Procedure 7-6. Replace Rectangular and Square Air Filters

---



**WARNING:** Always wear an ESD wrist strap grounded to the bench or frame when working on electronic components.

**NOTE:** Fan filters can be removed from the chassis without turning off the power. A finger-safe perforated panel separates the moving fans from the filters. The T1100 AS chassis does not have to be extended from the frame for this procedure.

1. Open the front fascia by unscrewing the knurled screws on either side of the chassis, and unlocking the front fascia. Then, carefully lower the front fascia. See "Inside view of T1100 showing fan filters" on page 7-20. The rectangular and square fan filters are attached to the inside of the front fascia.



**CAUTION:** Be sure you do not unplug the cable from the printed circuit board behind the front fascia while opening the front fascia. Removing this cable from its connections will cause the server to shut down.

**Figure 7-5.** Inside view of T1100 showing fan filters

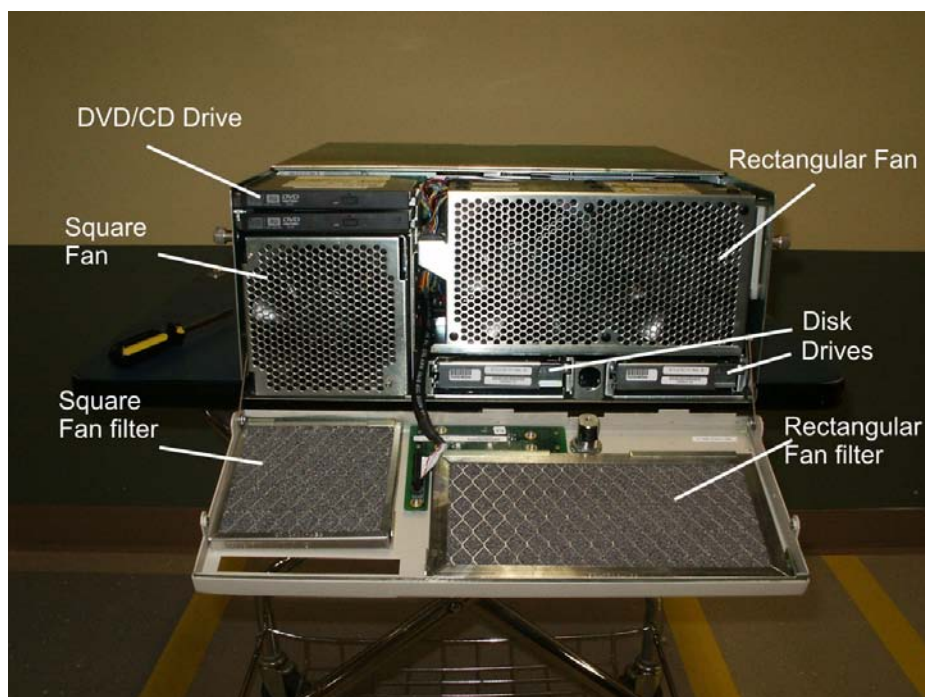

2. Use a flat bladed screwdriver to pry the old filters from their holders.
3. Insert the new filters into the metal retainers on the inside of the face plate.

**NOTE:** The wire mesh should be facing up when you insert the new filter and facing the inside of the chassis when the front fascia is closed.

---

4. This procedure is complete.
- 

### How to Replace the Rectangular Fan Assembly

Perform the following procedures to replace either of the two rectangular fan assemblies. This procedure can be performed while the T1100 AS chassis remains powered.



**SHOW ME:** To view a video (with sound) that shows some steps of the following procedure, [click here](#). For personnel safety and to protect equipment and data, be sure to read all the steps in the following procedure. For more information about how to view this video, see "Programs Needed to View Linked Documents" on page 1-4.

#### Procedure 7-7. Replace a Rectangular Fan Assembly

---

1. Ensure that the following have been done:
  - a. An RMA has been obtained (see Procedure B-1, "Obtaining an RMA," on page B-2); for information about the part number to be supplied, see "Fan Assembly Part Number Information" on page B-3.
  - b. A spare part is available



**WARNING:** The T1100 AS chassis performance requires all three fan assemblies (the two rectangular fan assemblies and the square fan assembly) be installed and operational for optimum performance. The procedure in this section can be done while the chassis remains powered. The T1100 AS chassis can operate with one fan assembly for brief periods. Perform ALL of this procedure without delay. If the replacement fan assembly is not available, DO NOT begin this procedure.

---

2. Prepare the T1100 AS chassis for access to the FRU using one of the following procedures:



**WARNING:** Always wear an ESD wrist strap grounded to the bench or frame when working on electronic components.

- Procedure 7-2, "Slide T1100 AS Chassis Out from Frame," on page 7-10
- Procedure 7-4, "Remove a T1100 AS Chassis from Frame," on page 7-12 (do not use this procedure when the fan assembly is replaced while the chassis remains powered)

3. Using a Phillips screwdriver, loosen the two screws on each side of the front top cover. See Figure 7-6 for locations.

**Figure 7-6.** Front Top Cover Removal - Screw Locations

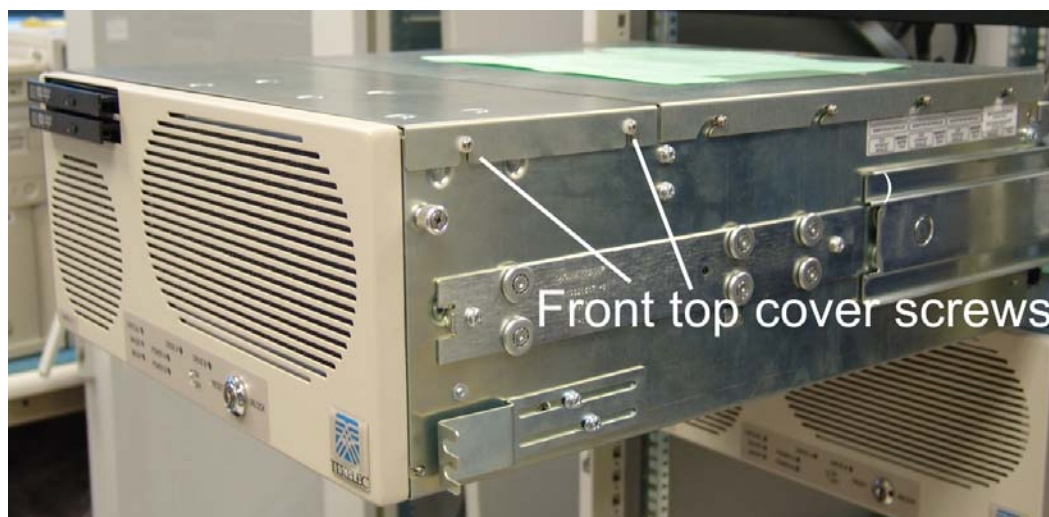

4. Grasp the edge of the front top cover of the chassis and lift up to remove the cover.
5. There are two rectangular fan assemblies on the right of the chassis. The replacement instructions are the same for each assembly. Grasp the top of each fan assembly with your index finger underneath the left and right edges of the top of the fan assembly. Lift the fan assembly straight up and out of the chassis to disengage the mating power connector and remove the fan assembly. Take care to ensure you do not insert your finger into the fan blades.
6. Set the rectangular fan assembly aside.

7. Lower the new fan assembly into the chassis. Be sure to align the pins on the bottom of the fan assemblies with the grommets on the chassis, and align the fan assembly with the plastic fan assembly guide on the right inside wall of the chassis. Press the fan assembly down to ensure the fan connector is in place.

---
8. Close the chassis front top cover and tighten the two screws on each side that fasten the cover to the chassis.

---
9. Depending on how the fan assembly was accessed in step 2, return the T1100 AS chassis to its original position using one of the following procedures:
  - Procedure 7-3, "Slide T1100 AS Chassis Back into Frame," on page 7-11
  - Procedure 7-5, "Return a T1100 AS Chassis to the Frame," on page 7-16

---
10. If requested, return the failed fan assembly to Tekelec. Arrange the return shipment by using the procedures in "How to Arrange Return Shipping" on page B-19.

---
11. This procedure is complete.

---

### How to Replace the Square Fan Assembly

Perform the following procedures to replace the square fan assembly. This procedure can be performed while the T1100 AS chassis remains powered.

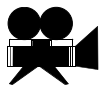

**SHOW ME:** To view a video (with sound) that shows some steps of the following procedure, [click here](#). For personnel safety and to protect equipment and data, be sure to read all the steps in the following procedure. For more information about how to view this video, see "Programs Needed to View Linked Documents" on page 1-4.

#### Procedure 7-8. Replace a Square Fan Assembly

---

1. Ensure that the following have been done:
  - a. An RMA has been obtained (see Procedure B-1, "Obtaining an RMA," on page B-2); for information about the part number to be supplied, see "Fan Assembly Part Number Information" on page B-3.
  - b. A spare part is available



**WARNING:** The T1100 AS chassis performance requires all three fan assemblies (the two rectangular fan assemblies and the square fan assembly) be installed and operational for optimum performance. The procedure in this section can be done while the chassis remains powered. The T1100 AS chassis can operate with one fan assembly for brief periods. Perform ALL of this procedure without delay. If the replacement fan assembly is not available, DO NOT begin this procedure.

---

2. Prepare the T1100 AS chassis for access to the FRU using one of the following procedures:



**WARNING:** Always wear an ESD wrist strap grounded to the bench or frame when working on electronic components.

- Procedure 7-2, "Slide T1100 AS Chassis Out from Frame," on page 7-10
  - Procedure 7-4, "Remove a T1100 AS Chassis from Frame," on page 7-12 (do not use this procedure when the fan assembly is replaced while the chassis remains powered)
- 

3. To replace the square fan assembly, first open the front fascia by unscrewing the knurled screws on either side of the chassis. Next, unlatch or use key to unlock the latch of the front fascia. Once unlocked, gently swing open the front fascia from the top of the chassis. The square fan is on the left side of the chassis. There are two fans inside the square fan assembly; however, the fans are replaced as a unit. See Figure 7-7 for square fan assembly location.



**CAUTION:** Be sure you do not unplug the cable from the printed circuit board behind the front fascia while opening the front fascia. Removing this cable from its connections will cause the server to shut down.



**Figure 7-7.** Inside view of T1100 showing square fan assembly

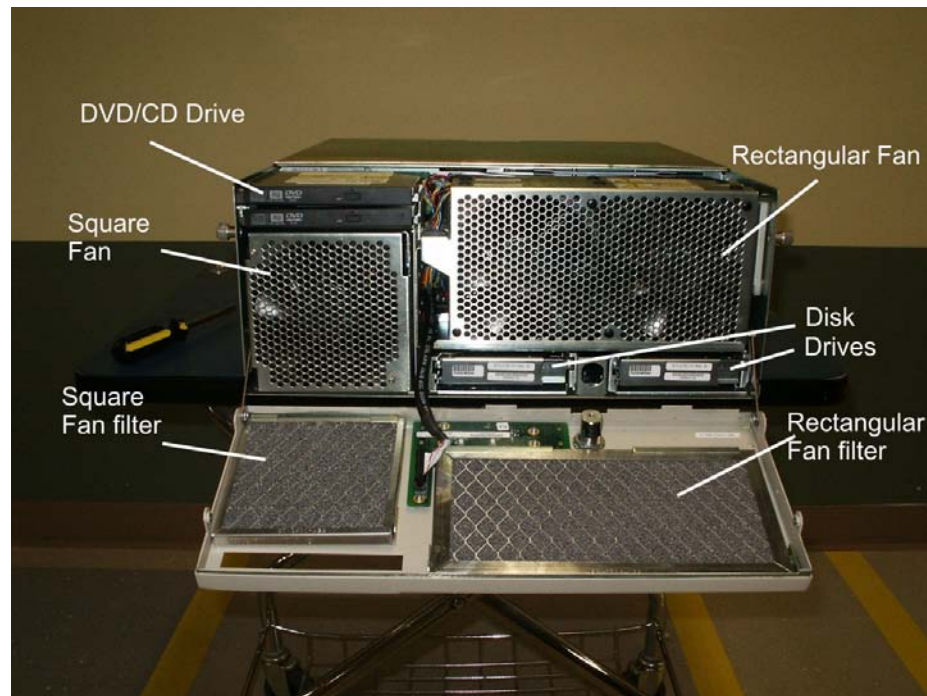

- 
4. With the thumb and forefinger of each hand, grasp the pins at the upper left corner and lower right corner of the square fan assembly. Then, while still holding the pins, pull the square fan assembly out of the chassis.
- 
5. Insert the new square fan assembly. Be sure to align the pins on the bottom of the assembly with the grommets in the chassis. Push the fan assembly in until it is flush with the front edge of the chassis.
- 
6. Swing the front fascia up and lock it. Tighten the knurled screws on either side of the front fascia. Check to ensure the CD/DVD drive can still eject.
- 
7. Close the chassis front top cover and tighten the two screws on each side that fasten the cover to the chassis.
- 
8. Depending on how the fan assembly was accessed in step 2, return the T1100 AS chassis to its original position using one of the following procedures:
    - Procedure 7-3, "Slide T1100 AS Chassis Back into Frame," on page 7-11
    - Procedure 7-5, "Return a T1100 AS Chassis to the Frame," on page 7-16
-

9. If requested, return the failed fan assembly to Tekelec. Arrange the return shipment by using the procedures in "How to Arrange Return Shipping" on page B-19.
- 
10. This procedure is complete.
- 

## How to Replace Hard Disk Drive Assemblies

Use the procedure in this section for either of the following purposes:

- To replace a failed hard disk drive
- To remove both hard disk drive assemblies from a failed T1100 AS chassis and place them in a replacement T1100 AS chassis



**SHOW ME:** To view a video (with sound) that shows some steps of the following procedure, [click here](#). For personnel safety and to protect equipment and data, be sure to read all the steps in the following procedure. For more information about how to view this video, see "Programs Needed to View Linked Documents" on page 1-4.

### Procedure 7-9. Replace a Hard Disk Drive Assembly

---

1. Do one of the following:
    - If this procedure is being performed to move hard disk drive assemblies from a failed T1100 AS chassis to the replacement T1100 AS chassis, skip to the next step.
    - If this procedure is being performed to replace a failed hard disk drive, ensure that the following have been done:
      - An RMA has been obtained (see Procedure B-1, "Obtaining an RMA," on page B-2); for information about part number information to be supplied, see "Hard Disk Drive Assembly Part Number Information" on page B-9.
      - A spare hard disk drive assembly is available. Ensure that the contents in the shipping container are complete; notify the project manager or the Customer Care Center of any discrepancies. In particular, verify that the contents include:
        - A part number label on the replacement hard disk drive assembly
        - "A" and "B" labels to be attached to the replacement hard disk drive assembly (see step 8 on page 7-29)
        - A label to attach to the base unit/hard disk label at the front of the left side of the T1100 AS chassis (see step 13 on page 7-31)
-



**CAUTION:** This procedure to replace the hard drives can be performed while the T1100 AS is powered on. However, do not remove both hard drives simultaneously.

2. Check the LEDs on the front fascia for an indication of which drive needs to be replaced. Refer to the application manual to perform any procedures recommended to limit data loss or corruption. For example, the application manual may require:
    - Prepare the failed drive for replacement
    - Data mirroring before replacing a failed hard disk drive
    - Application shutdown before powering off a T1100 AS chassis
- 

3. Prepare the T1100 AS chassis for access to the FRU using one of the following procedures:



**WARNING:** Always wear an ESD wrist strap grounded to the bench or frame when working on electronic components.

- Procedure 7-2, "Slide T1100 AS Chassis Out from Frame," on page 7-10
- Procedure 7-4, "Remove a T1100 AS Chassis from Frame," on page 7-12

**NOTE:** If this procedure is being performed to move hard disk drives from a failed T1100 AS chassis to a replacement T1100 AS chassis, Procedure 7-4, "Remove a T1100 AS Chassis from Frame," on page 7-12 is recommended.

---

4. To replace the hard drives, first open the front fascia by unscrewing the knurled screws on either side of the chassis, and use the key to unlock the front fascia. Once unlocked, carefully swing the front fascia open from the top of the chassis. The two hard drives are located below the rectangular fans. See Figure 7-8 for hard drive locations.



**CAUTION:** Be sure you do not unplug the cable from the printed circuit board behind the front fascia while opening the front fascia. Removing this cable from its connections will cause the server to shut down.

**Figure 7-8.** Inside view of T1100 showing hard drive locations

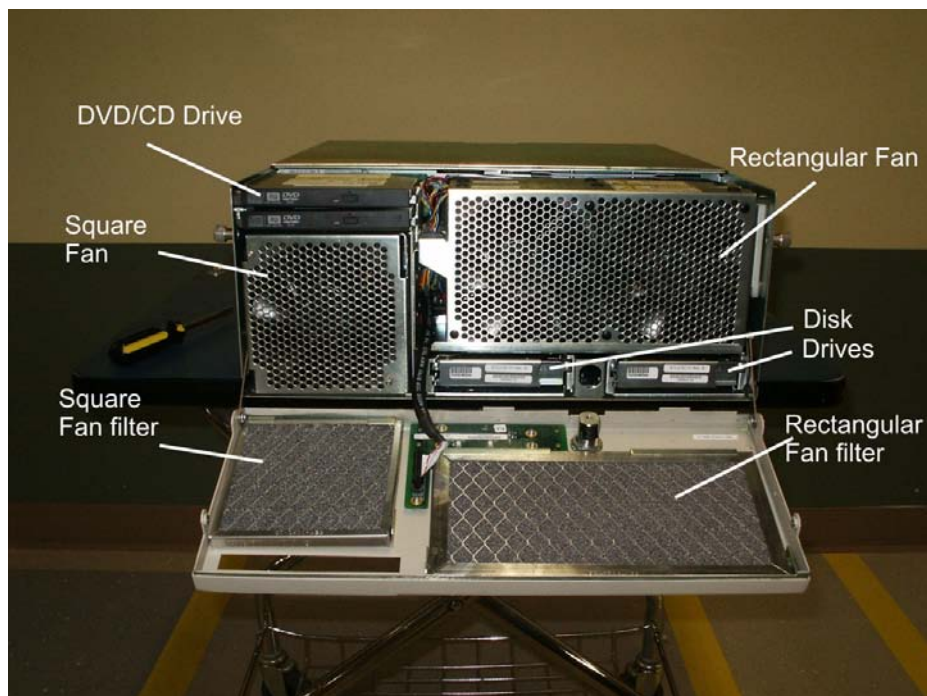

5. Do one of the following:
  - If this procedure is being performed to replace a failed hard disk drive, skip to the next step.
  - If this procedure is being performed to move hard disk drive assemblies from a failed T1100 AS chassis to the replacement T1100 AS chassis, note the position of the hard disk drive assembly that is about to be removed. The brackets on which the hard disk drives are mounted have position location labels. From the front of the chassis, the "A" drive is on the left and the "B" drive is on the right. It is recommended that this entire procedure be performed to remove the "A" hard disk drive assembly from the failed T1100 AS chassis and replace it into the "A" position in the replacement chassis, and then the procedure be repeated to remove the "B" hard disk drive assembly from the failed chassis and replace it into the "B" position of the replacement chassis.



**WARNING:** When replacing both drives in a failed T1100 AS chassis always place the drives in the locations they were removed from. Failure to replace the drives in the correct locations will cause data corruption and render the unit inoperable.

6. Insert your index finger into the right side of the drive release latch. Pull the latch towards you to disengage the drive and pull the drive out of the chassis.

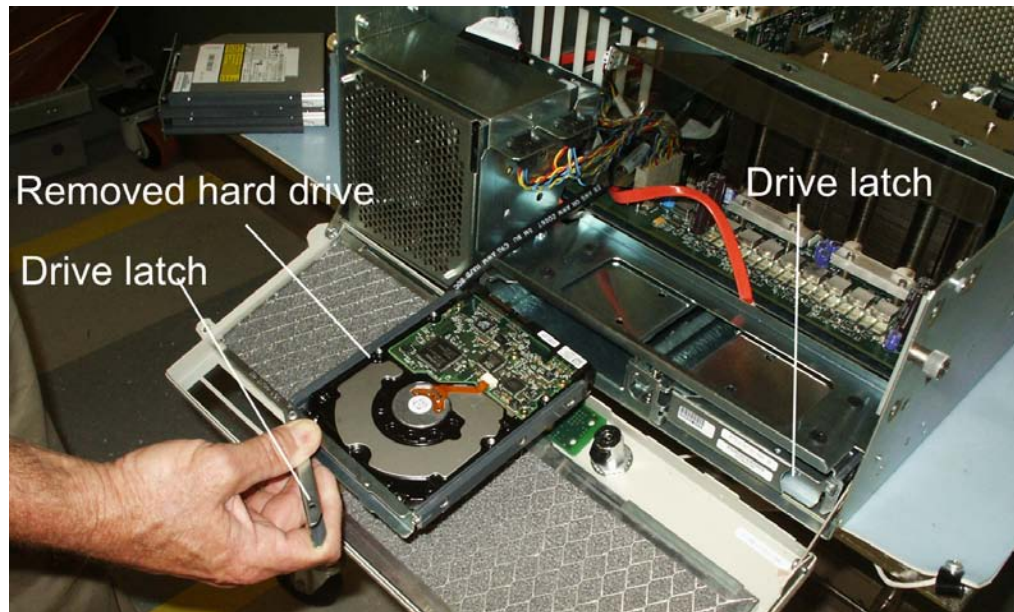
**Figure 7-9.** Hard drive removal

- 
7. Remove the hard disk drive and store in an approved ESD package or place on a grounded bench.
- 
8. Do one of the following:
    - If this procedure is being performed to replace a failed hard disk drive, note the position label attached to the failed hard disk drive assembly. Select the matching label ("A" or "B") from the contents of the shipping container in which the replacement hard disk drive assembly was received, and apply it to the hard disk drive. Figure 7-12 shows where the labels should be applied
    - If this procedure is being performed to move hard disk drive assemblies from a failed T1100 AS chassis to the replacement T1100 AS chassis, locate the part numbers on each of the hard disk drive assemblies (see Figure 7-12).

Ensure that the part numbers on hard disk drive assemblies to be moved match the part numbers for both the A and B positions on the base unit/hard disk label on the front of the left side of the replacement T1100 AS chassis (see Figure 7-10 and Figure 7-11). If the part numbers do not match, contact the Customer Care Center.

Figure 7-10. T1100 AS Chassis Label Locations

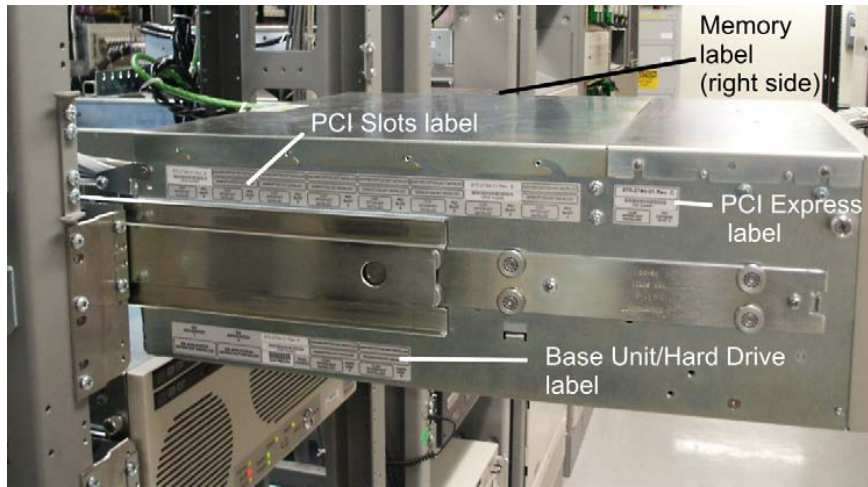

Figure 7-11. Hard Disk Drive Label on T1100 AS Chassis

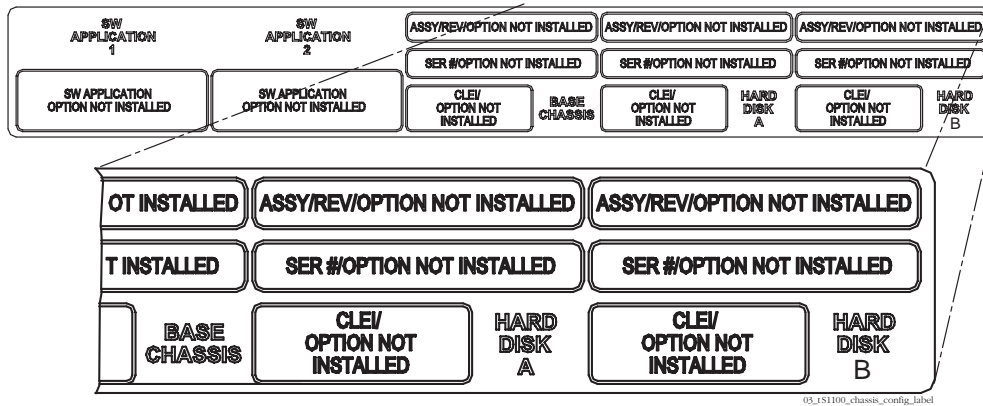
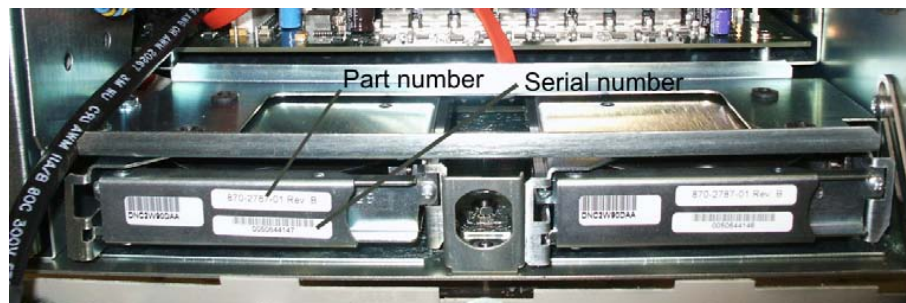

Figure 7-12. Disk Drive label locations (fans removed)





**WARNING:** When replacing both drives in a failed T1100 AS chassis always place the drives in the locations they were removed from. Failure to replace the drives in the correct locations will cause data corruption and render the unit inoperable.

---

9. Insert the new drive. As the drive engages the connectors push the latch closed to lock the drive in position.

---
10. Do one of the following:
  - If this procedure is being performed to replace a failed hard disk drive, skip to the next step.
  - If this procedure is being performed to move hard disk drive assemblies from a failed T1100 AS chassis to the replacement T1100 AS chassis, repeat step 5 through step 9 to move the other drive.

---
11. Close the front fascia.

---
12. Lock the front fascia and tighten the captive screws to secure the front fascia.

---
13. Do one of the following:
  - If this procedure is being performed to move hard disk drive assemblies from a failed T1100 AS chassis to the replacement T1100 AS chassis, skip to the next step.
  - If this procedure is being performed to replace a failed hard disk drive, do the following:
    - Attach the label that was received with the replacement hard disk drive assembly on the base unit/hard disk label located on the front of the left side of the T1100 AS chassis (for label placement, see Figure 7-10 on page 7-30).
    - Return the failed hard disk drive assembly to Tekelec, using the shipping contained in which the replacement hard disk drive assembly was received. Arrange the return shipment by using the procedures described in “How to Arrange Return Shipping” on page B-19.

---
14. Depending on how the hard disk drive assembly was accessed in step 3, return the T1100 AS chassis to its original position using one of the following procedures:
  - Procedure 7-3, “Slide T1100 AS Chassis Back into Frame,” on page 7-11
  - Procedure 7-5, “Return a T1100 AS Chassis to the Frame,” on page 7-16

---

15. Refer to applications documentation to determine additional required steps.
16. This procedure is complete.

### How to Replace Removable Media Disk Drives (CD/DVD)

Use the procedure in this section to replace the assembly that contains two removable media disk drives (also called CD/DVD drives). This assembly is located on the left side of the chassis beneath the front top cover.



**SHOW ME:** To view a video (with sound) that shows some steps of the following procedure, [click here](#). For personnel safety and to protect equipment and data, be sure to read all the steps in the following procedure. For more information about how to view this video, see “Programs Needed to View Linked Documents” on page 1-4.

#### Procedure 7-10. Replace a Removable Media Disk Drive Assembly

1. Ensure that the following have been done:
  - An RMA has been obtained (see Procedure B-1, “Obtaining an RMA,” on page B-2)
  - A spare removable media disk drive assembly is available. Inspect the replacement unit and its shipping container for indications of damage. If damage is noted, contact the project manager or report damage to the carrier. Ensure that the contents in the shipping container are complete; notify the project manager or the Customer Care Center of any discrepancies.

**NOTE:** T1100 AS removable media drives and adapter are considered one FRU. Remove and replace the entire adapter assembly including both removable media drives.



**WARNING:** This procedure CANNOT be performed while the T1100 AS chassis is powered on. Never power OFF a T1100 AS chassis until the application software and platform operating system (OS) are shut down. If possible, use the procedures in the application manual for a “soft shutdown.” If the application interface is not operating or is not accessible, a hard shutdown (turning OFF the breakers) is sometimes required. Contact the Customer Care Center before doing a hard shutdown.

2. Turn OFF the power switch on the T1100 AS chassis. Next, turn OFF the circuit breakers or power distribution units that supply power to the T1100 AS chassis containing the removable media disk drive assembly to be removed.



To locate the circuit breakers supplying power to the T1100 AS chassis, refer to the system interconnect diagram for the system type and/or read the labels on the breakers. To access the circuit breakers on some frames, it may be necessary to remove the plastic covers on the front of the breakers. If the covers are removed, to maintain NEBS compliance, make sure they are replaced when the FRU replacement has been completed.



**WARNING:** A T1100 AS chassis is redundantly powered from both A and B -48 VDC buses. Ensure that both the circuit breaker supplying A power to a chassis and the circuit breaker supplying B power to a T1100 AS chassis are turned OFF by measuring the voltage with a VOM on the cables that connects the T1100 AS chassis to its breakers. Both A and B power LEDs on the front fascia of the T1100 AS chassis should be OFF.

---

3. Prepare the T1100 AS chassis for access to the FRU using one of the following procedures:



**WARNING:** Always wear an ESD wrist strap grounded to the bench or frame when working on electronic components.

- Procedure 7-2, "Slide T1100 AS Chassis Out from Frame," on page 7-10
  - Procedure 7-4, "Remove a T1100 AS Chassis from Frame," on page 7-12
- 

4. To replace the CD/DVD drives, first open the front fascia by unscrewing the knurled screws on either side of the chassis, and use the key to unlock the front fascia. Once unlocked, the front fascia swings open from the top of the chassis. The CD/DVD drives are above the square fan on the left side of the chassis.

**Figure 7-13.** Inside view of T1100 showing CD/DVD drive location

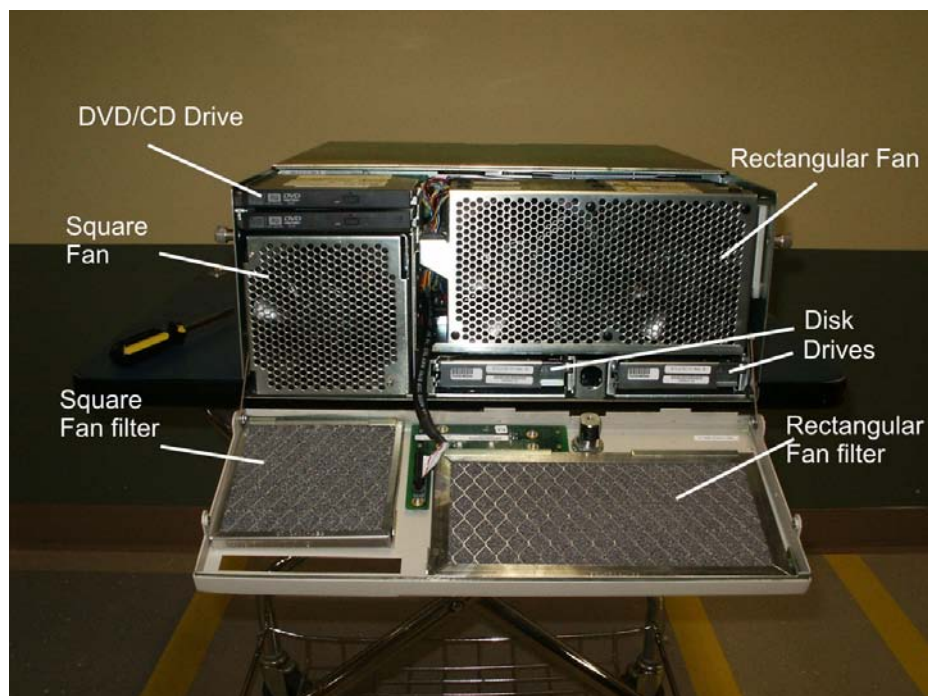

5. Using a Phillips screwdriver, loosen the two screws on each side of the front top cover. See Figure 7-14 for locations.

**Figure 7-14.** Front Top Cover Removal - Screw Locations

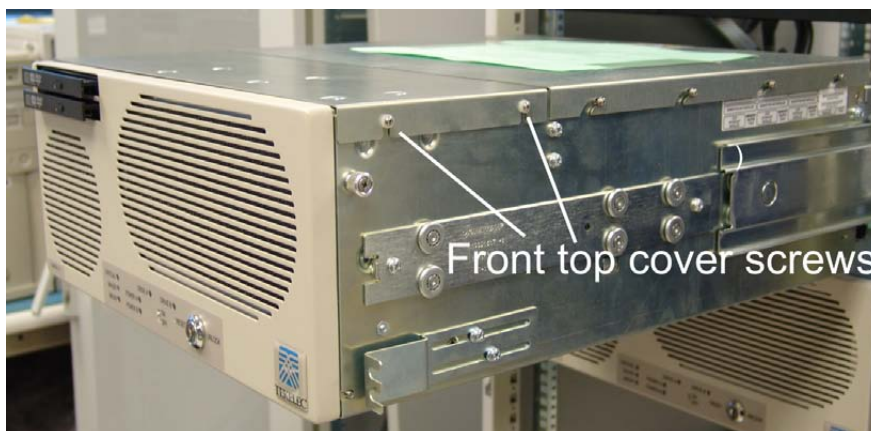

6. Grasp the edge of the front top cover of the chassis and lift up to remove the cover.

7. To access the IDE cables of the drives, remove the top rear cover. Unscrew the knurled screw at the back of the chassis. Slide the cover towards the rear of the chassis and lift the cover off of the chassis.

---

8. You must remove both rectangular fans to access the CD/DVD drive bracket screw. There are two rectangular fan assemblies on the right of the chassis. The removal instructions are the same for each assembly. Grasp the top of each fan assembly with your index finger underneath the left and right edges of the top of the fan assembly. Lift the fan assembly straight up and out of the chassis to remove it.

---

9. Set the rectangular fan assemblies aside.

---

10. Unplug the two flat 40-position IDE data cables and the single power cable from the drive adapter board. With a permanent marker, mark the IDE cable that is attached to the top IDE connector on the board.

**Figure 7-15.** Removable Media Disk Drive Cables (drives removed)

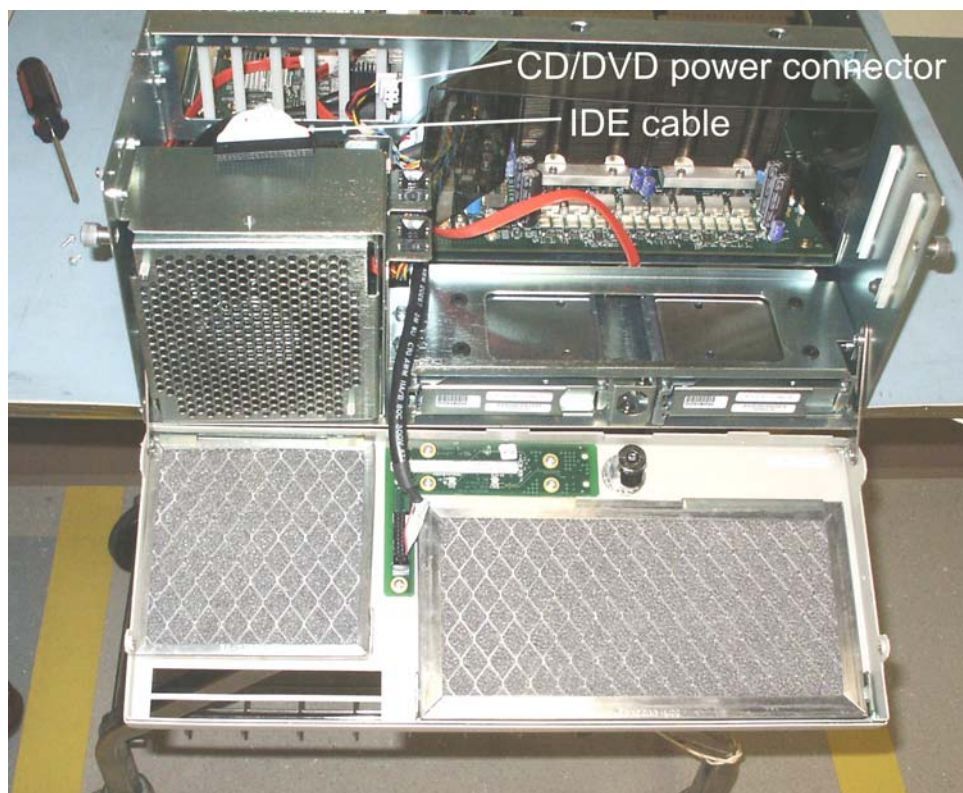

**NOTE:** T1100 AS removable media drives and adapter are considered one FRU. Remove and replace the entire adapter assembly including both removable media drives.

11. Unscrew the CD/DVD drive right side bracket screw. See “CD/DVD inside bracket screw location” on page 7-36

**Figure 7-16.** CD/DVD inside bracket screw location

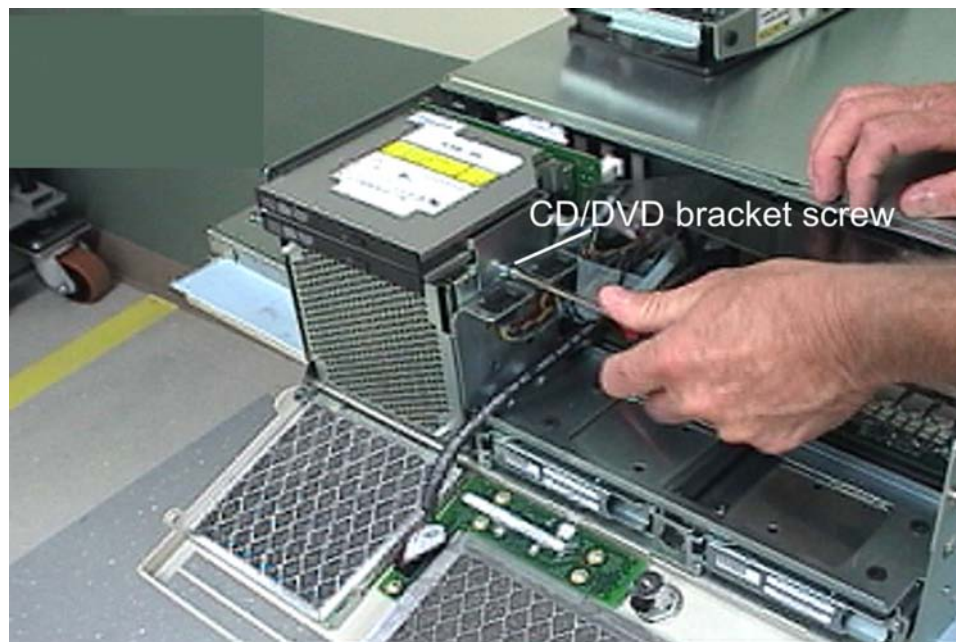

- 
12. Unscrew the CD/DVD drive left side chassis screws. See “CD/DVD chassis screws” on page 7-37. Lift the CD/DVD drive up to remove it.

Figure 7-17. CD/DVD chassis screws



- 
13. Place the CD/DVD drive assembly in an ESD container. If requested return the drive to Tekelec using the procedures described in Appendix B, "Hardware Repair and Return."
- 
14. Insert the new CD/DVD drive assembly. Attach the data and power cables on the back of the removable media disk drives. See Figure 7-15.  
**NOTE: The location of the top cable was marked in step 10 on page 7-35.**
- 
15. Tighten the CD/DVD drive chassis screws on the left side of the chassis.
- 
16. Tighten the CD/DVD bracket screw on the right side of the drive assembly.
- 
17. Close the chassis top rear cover and tighten the knurled screw at the rear of the chassis.
- 
18. Close the front top cover and tighten the screws to secure the top cover.
-

19. Swing the front fascia closed, lock the front fascia, and tighten the knurled screws on the sides of the chassis to secure the front fascia. Be sure the CD/DVD drive can eject.

---
20. Depending on how the removable media disk drive assembly was accessed in step 3, return the T1100 AS chassis to its original position using one of the following procedures:
  - Procedure 7-3, "Slide T1100 AS Chassis Back into Frame," on page 7-11
  - Procedure 7-5, "Return a T1100 AS Chassis to the Frame," on page 7-16

---
21. This procedure is complete.

---

### How to Replace a Power Supply Module

The T1100 AS can be configured with either two AC power supply modules or two DC power supply modules. **Do not** mix AC and DC power supply modules. Power supply modules are hot-swappable. Do not remove both power supply modules at the same time.



**WARNING:** Do not mix AC and DC power supply modules in the same chassis.



**SHOW ME:** To view a video (with sound) that shows some steps of the following procedure, [click here](#). For personnel safety and to protect equipment and data, be sure to read all the steps in the following procedure. For more information about how to view this video, see "Programs Needed to View Linked Documents" on page 1-4.

#### Procedure 7-11. Replace a power supply module

---

1. Engage a plane blade screwdriver into the notch on the edge of the locking ring. The ring is on the right side of the power supply module.

---
2. Rotate the ring down to disengage the power supply module. As the ring is rotated, the power supply module is cammed out of its connector.

**Figure 7-18.** Rotate lock ring down to disengage power supply module.

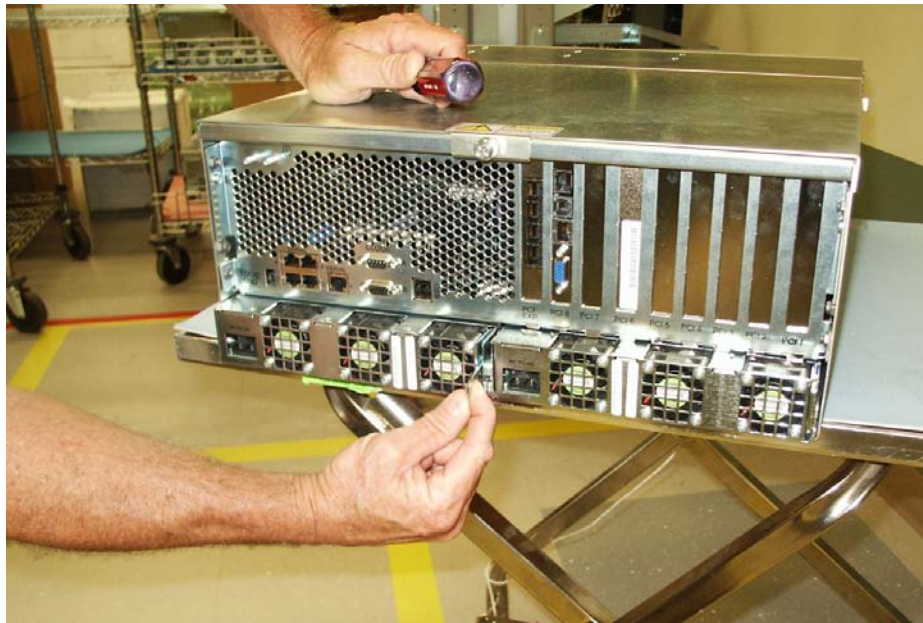

- 
3. Insert your index finger into the ring and pull the module out of the unit. Be sure to support the unit with your hands as it is pulled completely out of the chassis.



**CAUTION:** Be sure to use two hands when you are supporting the power supply modules.

---

4. Insert the new power supply module. As the module engages the connector, the locking ring will cam and rotate upward slightly.
  5. While pushing the new module in, rotate the locking ring upward until the unit is fully engaged with the chassis and the locking ring is flush with the edge of the power supply module.
  6. If requested, return the failed fan assembly to Tekelec. Arrange the return shipment by using the procedures in "How to Arrange Return Shipping" on page B-19.
  7. This procedure is complete.
-

## How to Replace PCI Cards

Use the procedure in this section for either of the following purposes:

- To replace a failed PCI card
- To remove PCI cards from a failed T1100 AS chassis and place them in a replacement T1100 AS chassis

### Procedure 7-12. Replace a PCI Card

---

1. Do one of the following:

- If this procedure is being performed to move PCI cards from a failed T1100 AS chassis to the replacement T1100 AS chassis, skip to the next step.
- If this procedure is being performed to replace a failed PCI card, ensure that the following have been done:
  - An RMA has been obtained (see Procedure B-1, “Obtaining an RMA,” on page B-2)
  - A spare PCI card is available. Inspect the replacement card and shipping container for indications of damage. If damage is noted, contact the project manager or report damage to the carrier. Ensure that the contents in the shipping container are complete; notify the project manager or the Customer Care Center of any discrepancies. In particular, verify that the contents include:
    - A part number label on the replacement PCI card (see Figure 7-19)

**Figure 7-19.** PCI Card Part Label

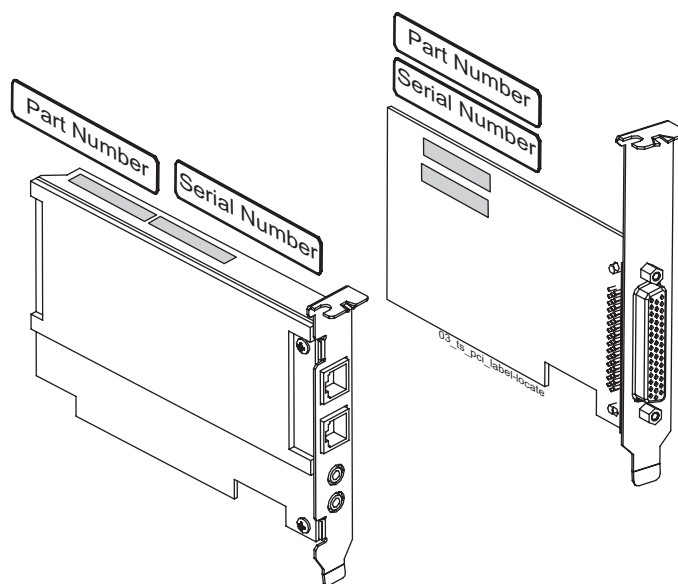



- A label (see Figure 7-20) to attach to the PCI card label on the left side of the T1100 AS chassis (see Figure B-8 on page B-9)

Figure 7-20. PCI Slots Label

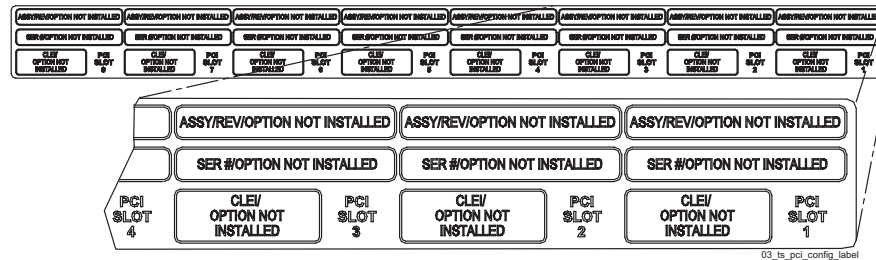

**WARNING:** This procedure CANNOT be performed while the T1100 AS chassis is powered on. Never power OFF a T1100 AS chassis until the application software and platform operating system (OS) are shut down.

2. Shut down the application and operating system. If possible, use the procedures in the application manual for a “soft shutdown.” If the application interface is not operating or is not accessible, a hard shutdown (turning OFF the breakers) is sometimes required. Contact the Customer Care Center before doing a hard shutdown.
3. Turn OFF the power switch on the chassis. Next, turn OFF the circuit breakers that supply power to the T1100 AS chassis containing the PCI card to be removed.

To locate the circuit breakers supplying power to the T1100 AS chassis, refer to the system interconnect diagram for the system type and/or read the labels on the breakers. To access the circuit breakers on some frames, it may be necessary to remove the plastic covers on the front of the breakers. If the covers are removed, to maintain NEBS compliance, make sure they are replaced when the FRU replacement has been completed.



**WARNING:** A T1100 AS chassis is redundantly powered from both A and B -48 VDC buses. Ensure that both the circuit breaker supplying A power to a chassis and the circuit breaker supplying B power to a T1100 AS chassis are turned OFF by measuring the voltage with a VOM on the cable that connects the T1100 AS chassis to its breakers. Both A and B power LEDs on the front fascia of the T1100 AS chassis should be OFF.

4. Prepare the T1100 AS chassis for access to the FRU using one of the following procedures:



**WARNING:** Always wear an ESD wrist strap grounded to the bench or frame when working on electronic components.

- Procedure 7-2, "Slide T1100 AS Chassis Out from Frame," on page 7-10
- Procedure 7-4, "Remove a T1100 AS Chassis from Frame," on page 7-12

**NOTE:** If this procedure is being performed to move PCI cards from a failed T1100 AS chassis to a replacement T1100 AS chassis, Procedure 7-4, "Remove a T1100 AS Chassis from Frame," on page 7-12 is recommended.

---

5. Determine the slot location of the PCI card to be removed using the T1100 AS PCI slots label located on the left rear of the of the chassis. See Figure 7-21 on page 7-43.

**NOTE:** Each T1100 AS chassis has a unique PCI configuration label listing card types and slot arrangements.

---

6. Ensure that all cables are labeled. Label any that are not labeled.

---

7. From the rear of the frame remove any cables attached to the PCI card to be removed.

---

8. From the rear of the chassis remove the rear top cover.
  - a. First loosen the four screws in the guide slots on both sides of the rear top cover.
  - b. Unscrew the captive fastener at the rear of the rear top cover until it releases.
  - c. Pull the cover toward the rear until the screws are clear of the guide slots then lift up. See Figure 7-21.

Figure 7-21. Chassis Rear Top Cover Views.

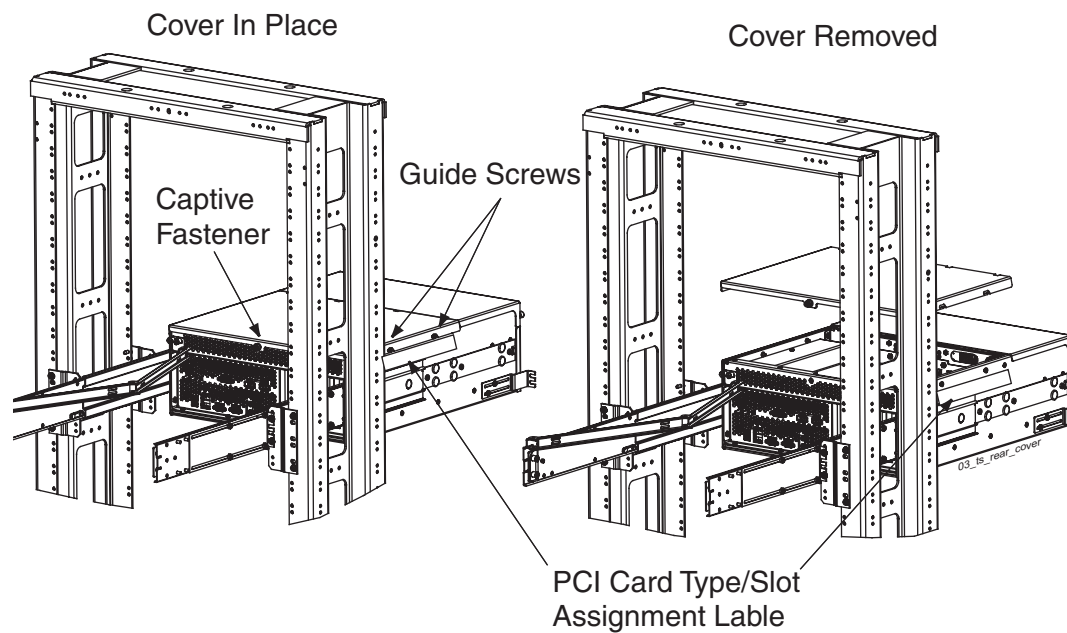

9. Using a #1 Phillips screwdriver remove the retention screw located at the top of the PCI faceplate.

**NOTE:** If a PCI card is being added, remove the PCI filler plate. When adding or removing cards apply the correct label to the PCI configuration label. Labels are shipped with PCI cards indicating card type and CLEI code.

10. Remove the PCI card by grasping with both hands and lifting until the card is disconnected from the card connector. See Figure 7-22.

Figure 7-22. PCI Cards and Slot Assignments

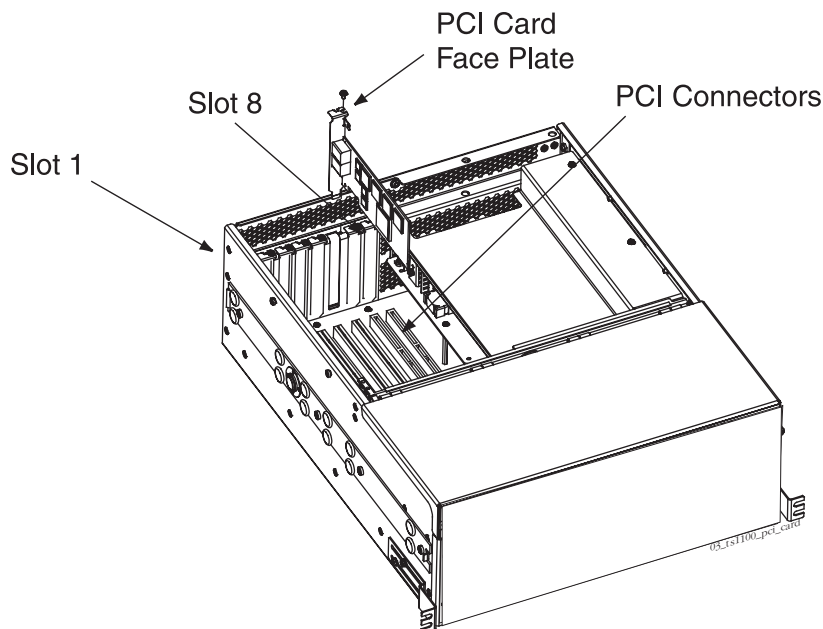

- 
11. Place the card in an approved ESD storage bag or container.
- 
12. Store the card for later return or other disposition.  
**NOTE: If PCI cards are to be discarded they must be scrapped in accordance with accepted environmental recycling procedures.**
- 
13. Remove the replacement PCI card from the ESD container.
- 
14. Inspect the replacement PCI card for damage and correct card type. Make sure the replacement card has the same information on the inventory label as the card that was removed. Card labels are located on the side of the card (see Figure 7-19 on page 7-40).
- 
15. Insert the replacement PCI card into the correct card connector by grasping with both hands and pressing firmly down while maintaining alignment with the connector.  
**NOTE: When inserting full-length PCI cards align with the correct slot guide on the bulkhead toward the front of the chassis.**
- 
16. Using a #1 Phillips screwdriver replace the retention screw located at the top of the PCI faceplate.
-

17. From the rear of the frame attach the cable to the PCI card.
- 
18. Do one of the following:
- If this procedure is being performed to replace a failed PCI card, skip to the next step.
  - If this procedure is being performed to move PCI cards from a failed T1100 AS chassis to the replacement T1100 AS chassis, repeat step 5 through step 17 for each PCI card to be moved.
- 
19. Replace the top rear cover on the T1100 AS chassis. Slide the guide slots over and past the screws loosened in step 8 on page 7-42.
- 
20. Tighten the four guide screws attaching the rear top cover to the T1100 AS chassis.
- 
21. Tighten the captive fastener at the rear of the cover.
- 
22. Close the chassis rear top cover.
- 
23. Do one of the following:
- If this procedure is being performed to move PCI cards from a failed T1100 AS chassis to the replacement T1100 AS chassis, skip to the next step.
  - If this procedure is being performed to replace a failed PCI card, do the following:
    - Attach the label that was received with the replacement PCI card on the appropriate section of the PCI card label located on the left side of the T1100 AS chassis (for a diagram of the label, see Figure 7-20 on page 7-41; for placement of this label on the T1100 AS chassis, see Figure B-8 on page B-9).
    - Return the failed PCI card to Tekelec, using the shipping contained in which the replacement PCI card was received. Arrange the return shipment by using the procedures described in Appendix B, "Hardware Repair and Return."
- 
24. This procedure is complete.
-

## How to Replace a T1100 AS Chassis FRU

Replacing a T1100 AS chassis requires that the slide assemblies be removed from the failed chassis and attached to the replacement chassis. A replacement chassis always contains fan assemblies and a removable media disk drive assembly. However, it does not contain replacement PCI cards or hard disk drives unless those parts are specified to be replaced when the Return Material Authorization (RMA) is obtained.

Usually, when a T1100 AS chassis needs to be replaced, the PCI cards and hard disk drive assemblies are removed from the failed T1100 AS chassis and placed in the replacement chassis. It is recommended that the slide assemblies be attached to the replacement chassis, using the procedure in this section, before moving the PCI cards and hard disk drive assemblies.

Use the following procedure when the Customer Care Center has determined that the T1100 AS chassis needs to be replaced.

### Procedure 7-13. Replace a T1100 AS Chassis FRU

---

1. Ensure that the following have been done:
    - a. An RMA has been obtained (see Procedure B-1, "Obtaining an RMA," on page B-2); for information about the part numbers to be supplied, see "T1100 AS Chassis Part Number Information" on page B-14.
    - b. A spare part is available
  2. Inspect the unit and shipping container for indications of damage. If damage is noted, contact the project manager or report damage to the carrier.
  3. Inventory the material in the shipping container and notify the project manager or Tekelec Production Control of any discrepancies.
- 



**WARNING:** Observe proper ESD procedures when handling the T1100 AS chassis. Always wear an ESD wrist strap connected to a grounded bench or frame.

4. Unpack the T1100 AS chassis from the shipping container and place the unit on a secure workbench that is grounded for ESD protection. Save the container and packing material for use in step 10.
-



**WARNING:** This procedure CANNOT be performed while the T1100 AS chassis is powered on. Never power OFF a T1100 AS chassis until the application software and platform operating system (OS) are shut down. If possible, use the procedures in the application manual for a “soft shutdown.” If the application interface is not operating or is not accessible, a hard shutdown (turning OFF the breakers) is sometimes required. Contact the Customer Care Center before doing a hard shutdown.

5. Shut down the server.

---

6. Remove the failed T1100 AS chassis from the frame using Procedure 7-4, “Remove a T1100 AS Chassis from Frame,” on page 7-12.

---

7. Using a # 3 Phillips screwdriver, remove the four # 10-32 screws that attach each inner slide member to the chassis and set the slide members aside.

**NOTE:** Observe the orientation of the inner slide members with the roller bearings outward and the center tabs toward the front of the chassis. The inner slide members are attached to the replacement T1100 AS chassis in step 8.

Figure 7-23. Left Slide Member Mounting

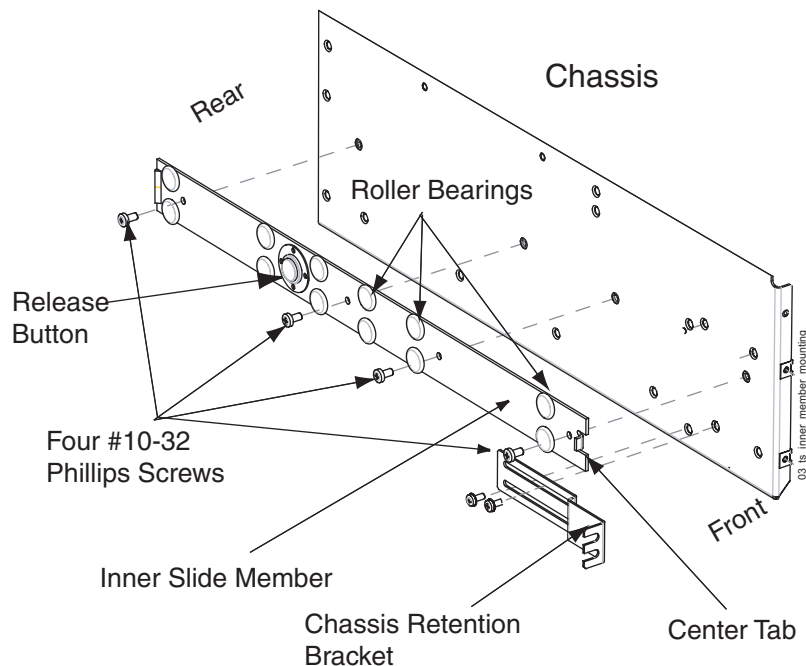

8. Attach inner slide members on both sides of the replacement T1100 AS chassis with four # 10-32 Phillips screws each. Orient the inner slide members with the roller bearings outward and the center tabs toward the front of the T1100 AS chassis. See Figure 7-23.

---
9. If the hard disk drives and/or PCI cards from the failed T1100 AS chassis need to be moved to the replacement chassis, perform either or both of the following procedures:
  - Procedure 7-9, "Replace a Hard Disk Drive Assembly," on page 7-26
  - Procedure 7-12, "Replace a PCI Card," on page 7-40

---
10. If requested, return the failed T1100 AS chassis to Tekelec. Arrange the return shipment by using the procedures in Appendix B, "Hardware Repair and Return."

---
11. This procedure is complete.

---

Next, perform Procedure 7-5, "Return a T1100 AS Chassis to the Frame," on page 7-16.





# T1100 AS Hardware Feature Information

Introduction.....	A-1
Hardware Components .....	A-1
Interfaces.....	A-2
Electrical Features.....	A-3
Mechanical Design .....	A-4
T1100 AS Diagnostics.....	A-5

## Introduction

This appendix provides additional information about T1100 AS base configuration hardware features. The specific application loaded on the hardware might require alterations to the base configuration. For an overview of T1100 AS hardware features, see Chapter 3, “T1100 AS Hardware System Overview.”

## Hardware Components

The Tekelec 1100 AS platform offers the following standard hardware components:

- Dual 3.2 GHz 32/64-bit processors
- Redundant hot swappable power modules (AC or DC available)
- Redundant BIOS architecture
- 800 megahertz (MHz) processor front side bus speed
- Up to 16 GB RAM

- Out-of-Band Management Card (OOBM) w/integrated Modem
- Light Emitting Diode (LED) diagnostic display
- Battery-backed real-time clock
- Hardware monitors that read and report:
  - Supply, battery, and core voltages
  - Fan speed inputs
  - Ambient and processor temperatures
- E1/T1 composite clock signal distribution
- Eight PCI Card Slots (six available - use Tekelec approved cards only)
- Four Integrated 10/100/1000 Base T ports
- Five Serial Ports (RJ45)
- Two warm-swappable SATA drives
- Two CD-RW/DVD-RW for internally supporting persistent storage
- NEBS Compliant

In addition, the Tekelec 1100 AS platform has a variety of internal and external interfaces, as described in “Interfaces” on page A-2.

## Interfaces

The Tekelec 1100 AS platform includes interfaces for accommodating expansion, control and configuration, network connectivity, and peripheral support.

- Table A-1 shows the basic interfaces supplied to all implementations that use the T1100 AS platform.
- Table A-2 on page A-3 shows additional interface types that can be added, using PCI cards, depending on product application.

**Table A-1.** Basic Interfaces

Interface	Description
PCI Slots	Eight Peripheral Computing Interface (PCI) expansion slots can accommodate Tekelec-designed or commercial-off-the-shelf (COTS) expansion modules (seven available).
Serial interfaces	A standard RS-232D serial interface is usually used for connecting to other equipment. Additional serial interfaces can be added optionally (see Table A-2).
USB ports	Two Universal Serial Bus (USB) ports to support direct connectivity to peripherals. The USB ports are accessible from the rear.

**Table A-1.** Basic Interfaces (Continued)

Interface	Description
External timing interface	External timing interface for synchronizing operations with network timing standards, as required for specific configurations. This timing interface may be implemented on Signaling Link modules as applicable.
Ethernet	The Tekelec 1100 AS has four Ethernet ports of 10Mbps, 100Mbps, or 1Gb operation as needed for specific product configurations.

**Table A-2.** Optional Interfaces (on PCI Cards)

Interface	Description
Ethernet	The Tekelec 1100 AS platform can support Ethernet ports of 10Mbps, 100Mbps, or 1Gb operation as needed for specific product configurations. Each PCI slot can support a qualified Ethernet card that can support two Ethernet ports (although it is not typical that all PCI slots contain Ethernet cards).
Serial	PCI cards that supply additional serial interfaces can be added to the T1100 AS platform. These serial interfaces are used to connect to other servers located in the same frame.

## Out of Band Management Card

The out of band management (OOBM) card provides "lights-out" management capabilities for the T1100 AS. The card provides multiple methods to connect to the T1100 AS serial console port, both locally and remotely. The card also provides a basic management interface that can be used to debug and control the host. The primary function of the OOBM is provide connectivity to a host system to remote users. While the card is located on the T1100 AS PCI bus, the card relies only on that bus for power, and thus is largely independent of the software running on the T1100 AS. Therefore, the card can be used to control and debug the host at times when the host is experiencing difficulty, or is locked up, and other means of connecting directly to the host do not work.

## Electrical Features

The Tekelec 1100 AS platform offers the following standard electrical features:

- Operates from -48 VDC +/- 5% power input according to Network Equipment Building System (NEBS) requirements in accordance with typical telecommunications applications
- Includes short-circuit protections and safety precautions in accordance with common standards

## Mechanical Design

The Tekelec 1100 AS mechanical design meets all applicable NEBS requirements and is designed to protect all of the active components. The design has efficient component cooling using low-impedance air paths, and its compact size allows multiple units to be configured in a frame with zero top and bottom clearance when stacked.

### Mechanical Maintenance Features

The Tekelec 1100 AS hardware has been designed for easy maintenance. The following components are field-replaceable units (FRUs):

- Fans
- Fan filters
- Disk drives
- CD/DVD drive assembly
- Peripheral Component Interconnect (PCI) cards
- PCI express card
- Power Supply Modules
- Complete T1100 AS Chassis
- LEDs to indicate which drive needs attention in case of drive failure

The fans, filters, power modules, and disk drives have lower mean time between failures (MTBF) and can be easily replaced, so they have been grouped together. The fans and fan filters are grouped behind the front fascia (for more information, see “Fans, Fan Assemblies, and Air Filters” on page A-5). The disk drives are accessible from the front of the unit (for more information, see “Component Access front fascia” on page A-5). The PCI cards are located at the rear of the T1100 AS chassis and plug into the main board.

All other components, which are less likely to fail, are located in the Tekelec 1100 AS main unit. If one of the components in the main unit fails, the hard disk drive assemblies (preserving the data which is stored on the hard disk drives) can be removed from the failed chassis and installed in the replacement chassis.

**NOTE: Use the procedures in Chapter 7, “Field Replaceable Units” when removing or replacing FRUs. Always perform a soft shutdown of the T1100 AS chassis before switching OFF all circuit breakers or power distribution units supplying redundant power. For more information about troubleshooting systems and performing soft shutdowns, see the appropriate maintenance manual for the application.**

### Component Access front fascia

The Tekelec 1100 AS platform has a hinged front fascia that is locked in place by captive screws during normal operation. This lid allows access to the fan assemblies and hard drives. The front lid also has the following features:

- Light emitting diode (LED) alarm indicators, mounted to the front surface of the lid.
- LED indicators to indicate which drive to replace in case of failure.

### Fans, Fan Assemblies, and Air Filters

The Tekelec 1100 AS platform has three fan assemblies to provide a redundant air source. This enables the system to run with a single fan failure and allows for replacement of a fan assembly while the Tekelec 1100 AS platform is operational. The fan assemblies are mounted in the Tekelec 1100 AS chassis to enable easy replacement.

The fans have a tachometer output that is monitored by the platform software. If a fan fails, the platform software generates an alarm. All Tekelec 1100 AS internal cables are routed for minimal impact to airflow.

The front fascia attaches to the front of the Tekelec 1100 AS platform. It is the air inlet cover and also serves to retain the square and rectangular air filters. The fascia can be lowered for air filter replacement while the chassis is still mounted in the frame. Finger guards between the filter and the fan assemblies located behind it allow removal of the filter while the T1100 AS chassis is in operation.

The air filter is a disposable assembly and one of the field replaceable units (FRUs). The filter material is held in an aluminum frame for ease of handling. Recommended replacement interval for the filters is monthly or more frequently depending on the operating environment.

### Tekelec 1100 AS Main Board

The main board has eight PCI card slots and one PCI express slot. PCI cards are plugged directly into the main board, and the PCI cards bulkhead panels are fixed to the Rear I/O Panel with screws. Slots one through six support full length (12.283 inch) PCI cards, slots seven and eight support cards 6.875 inches long, or less.

### T1100 AS Diagnostics

All components that comprise the Tekelec 1100 AS platform are designed for testability to ensure that operational status can be accurately determined and that appropriate levels of fault detection and isolation are possible with a minimum of effort.

The following levels of diagnostics are provided:

1. Power-On Self Test (POST) diagnostics run once at start-up to determine whether all required devices are installed and functional. POST can also be run by the Customer Care Center to verify that the Tekelec 1100 AS platform is operational.
2. Online diagnostics actively monitor the health of a running Tekelec 1100 AS platform. When online diagnostics encounter a problem, an alarm is raised and front fascia light-emitting diodes (LEDs) are illuminated to indicate a problem. Online diagnostics can be run while maintaining in-service operation of node.
3. Offline diagnostics can be used by the Customer Care Center to detect system hardware problems that POST cannot detect. Offline diagnostics can also provide load simulation and stress testing.

Diagnostics enable troubleshooting of installed systems by verifying:

- Operational capability of Field Replaceable Units (FRU).
- Operational status of peripheral system components (such as cables and connectors) through automated testing initiated by FRU components. Examples are loop-back and link tests.

# B

## Hardware Repair and Return

Introduction.....	B-1
How to Obtain a Return Material Authorization .....	B-1
How to Locate T1100 AS Part Numbers.....	B-2
Air Filter Part Number Information.....	B-3
Fan Assembly Part Number Information.....	B-3
Removable Media Disk Drive Assembly Part Number Information .....	B-6
Hard Disk Drive Assembly Part Number Information.....	B-9
PCI Card Part Number Information.....	B-12
T1100 AS Chassis Part Number Information .....	B-14
How to Arrange Return Shipping.....	B-19
Specifically Targeted PCBs.....	B-19
General Instructions .....	B-20
Returning a Crate.....	B-20

### Introduction

Any system components being returned for repair or replacement must be processed through the Tekelec Return Material Authorization (RMA) procedures. A hardware repair is defined as an item returned to Tekelec due to a failure, with the returned item being repaired and returned to the customer or replaced with a functionally identical item.

### How to Obtain a Return Material Authorization

Use the following procedure to obtain an Return Material Authorization (RMA).  
910-2969-001 Revision F, August 2006 B-1

### Procedure B-1. Obtaining an RMA

---

1. Contact the Customer Care Center (see “Customer Assistance” on page 1-7) and obtain a Return Material Authorization (RMA) number. Verify the:
    - Shipping and billing address in North Carolina
    - Individual who is to receive the item at the address
    - Prime customer contact

---
  2. Provide any part number information requested by the Customer Care Center representative. To locate the part number information, use the indicated procedure below:
    - Fan assembly, use Procedure B-2 on page B-3
    - Removable Media Disk Drive assembly, use Procedure B-3 on page B-7
    - Hard Disk Drive assembly, use Procedure B-4 on page B-10
    - PCI cards, use Procedure B-5 on page B-13
    - T1100 AS chassis, use Procedure B-6 on page B-15

---
  3. Provide a detailed description of the problem and failure symptoms:
    - Dead On Arrival 1 (DOA1) refers to a component that has failed in the initial powering up process or early testing procedures.
    - DOA2 refers to a component that has been returned from Repair and Maintenance Support (RMS) and fails.

---
  4. This procedure is complete.
- 

## How to Locate T1100 AS Part Numbers

Each T1100 AS FRU (except for air filters) has labels that contain the following information that may be needed for the RMA:

- Part number (to identify the type of FRU)
- Serial number (to provide more information about the specific FRU)
- CLEI (Common Language Equipment Identifier, a label that identifies the manufacturer and the part)

In addition to part numbers on each FRU, the T1100 AS chassis has several labels that contain part number information for FRUs that are internal to the chassis. These labels allow part number information to be gathered without needing to open the chassis.



### Air Filter Part Number Information

Air filters do not have labels to identify the part numbers. To order replacement air filters, contact a sales representative.

### Fan Assembly Part Number Information

The part number information for fan assemblies is located only on the labels on the fan assemblies. Procedure B-2 on page B-3 provides instructions about how to access these labels.

#### Procedure B-2. How to Locate serial numbers for Fan Assembly

---



**WARNING:** Always wear an ESD wrist strap grounded to the bench or frame when working on electronic components.

1. From the front of the frame, remove the # 12-24 Phillips screw from each chassis retention bracket (see Figure B-1). Do not remove the screws in the frame adapter brackets.

**Figure B-1.** T1100 AS Chassis Front View

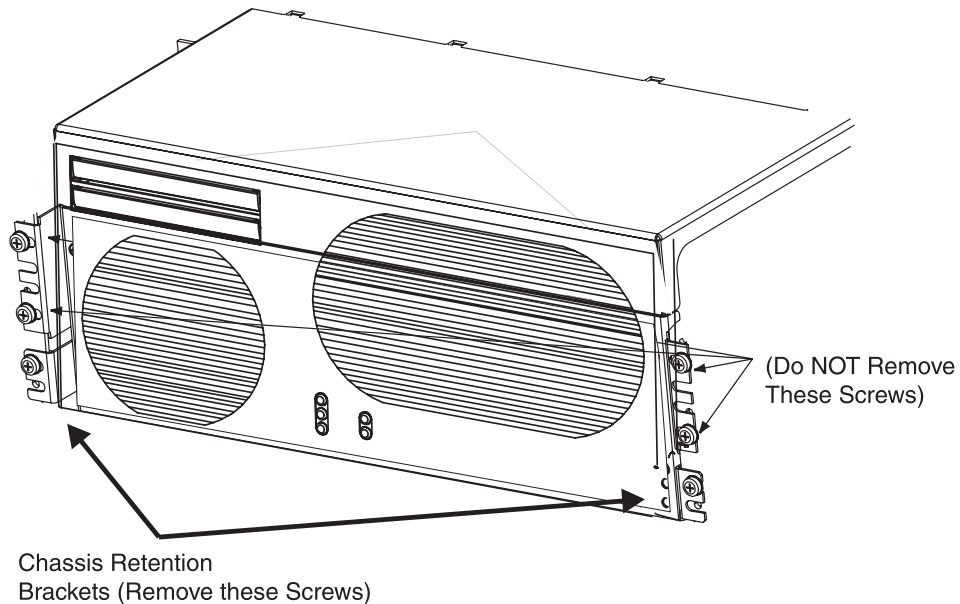

2. From the front of the frame, using the handles on the front top cover or knurled screws on the side of the chassis, pull forward until the release buttons on the inner arms of the slide assemblies pop into the holes on each side. Be careful to not disconnect, bind, or pinch any cables.



**DANGER:** If the T1100 AS chassis is pulled too far out after the release buttons are disengaged, the inner slide members (attached to the chassis) could come out of the middle slide members (attached to the frame).

---

3. Using a Phillips screwdriver, loosen the screws on the T1100 AS chassis front top cover until they are free. See Figure B-6 for locations.

**Figure B-2.** T1100 AS Front Top Cover screws

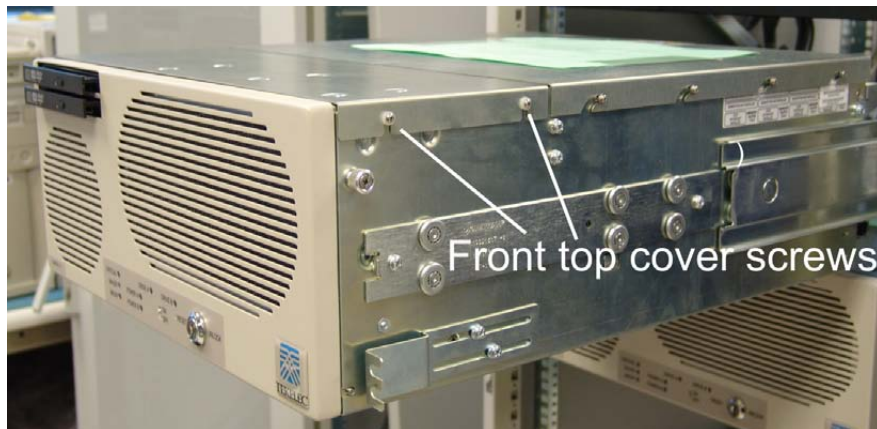

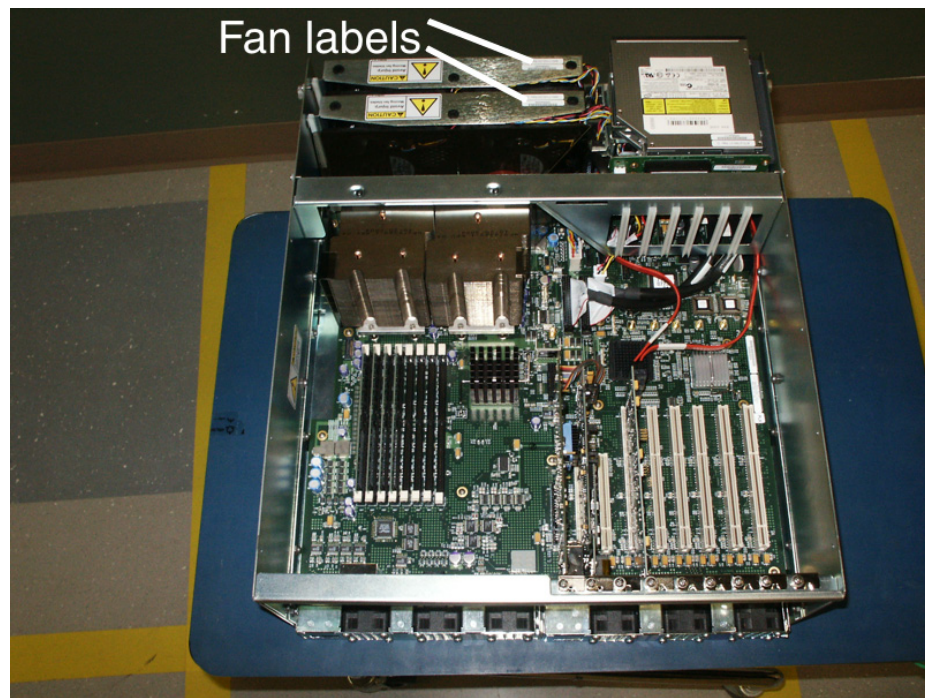
**Figure B-3.** Fan Part number labels

- 
4. Figure B-3 on page B-5 shows the location of the fan assembly part label.
- 
5. Close the chassis front top cover.
- 
6. Tighten the screws to secure the top cover.
- 
7. From the front of the frame, simultaneously press the round release buttons and slowly push the chassis into the frame while observing the cables to avoid binding or stretching.
- 

**NOTE:** When the chassis stops moving, the front of the T1100 AS should be slightly recessed to allow clearance behind the frame door when closed.

8. Adjust the chassis retention brackets on the front of the T1100 AS chassis to contact the frame adapter brackets when the chassis is positioned correctly in the frame.
- 
9. Secure the chassis with one # 12-24 screw in the chassis retention brackets on each side.
- 
10. This procedure is complete.
-

### Removable Media Disk Drive Assembly Part Number Information

The part number information for removable media disk drive assemblies is located only on the labels on the those assemblies. Figure B-4 on page B-6 shows where the removable media disk drive assembly part label is located. Procedure B-3 on page B-7 provides instructions about how to access this label.

**Figure B-4.** Removable Media Disk Drive Assembly Part Label

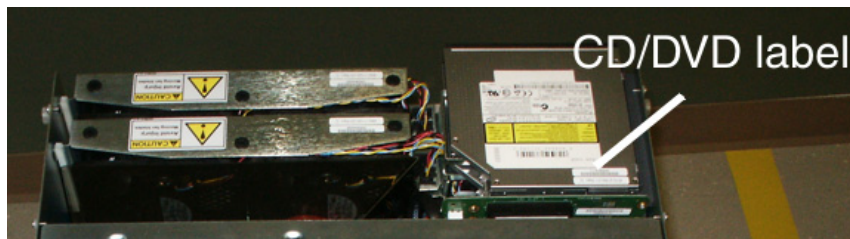

### Procedure B-3. How to Locate serial numbers for Removable Media Disk Drive Assembly

---



**WARNING:** Always wear an ESD wrist strap grounded to the bench or frame when working on electronic components.

1. From the front of the frame, remove the # 12-24 Phillips screw from each chassis retention bracket (see Figure B-1). Do not remove the screws in the frame adapter brackets.

**Figure B-5.** T1100 AS Chassis Front View

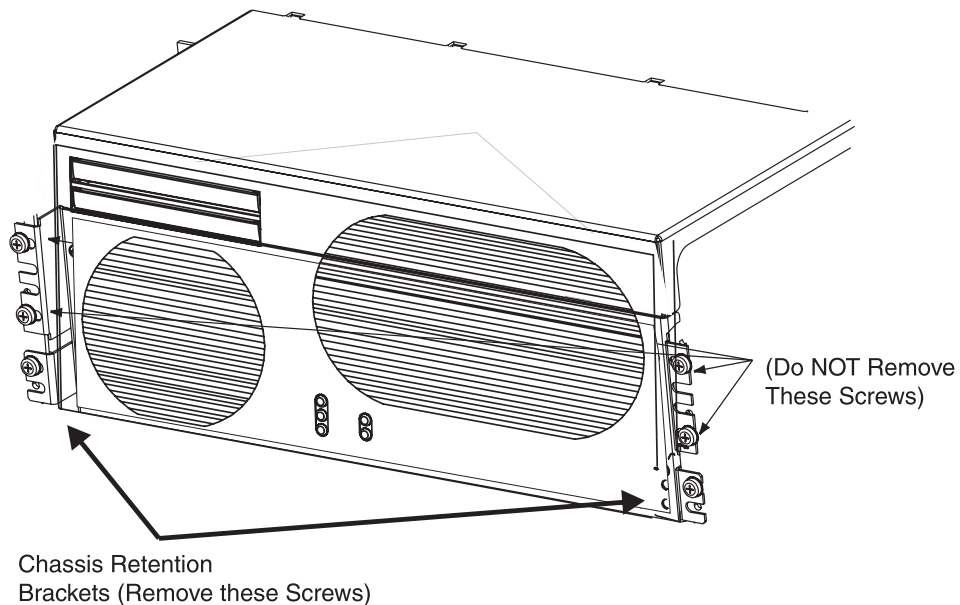

- 
2. From the front of the frame, using the knurled screws on the sides of the chassis, pull forward until the release buttons on the inner arms of the slide assemblies pop into the holes on each side. Be careful to not disconnect, bind, or pinch any cables.



**DANGER:** If the T1100 AS chassis is pulled too far out after the release buttons are disengaged, the inner slide members (attached to the chassis) could come out of the middle slide members (attached to the frame).

---

3. Using a Phillips screwdriver, loosen screws on the T1100 AS chassis front top cover until they are free. See Figure B-6 for locations.

Figure B-6. T1100 AS Front Top Cover screws

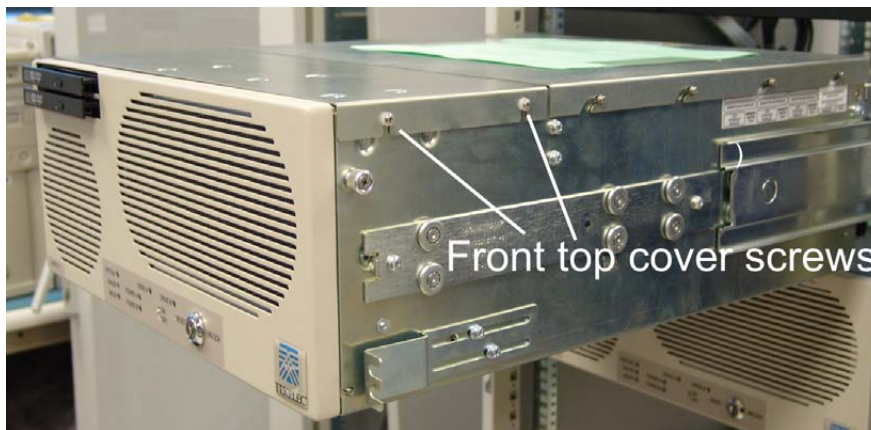

- 
4. Lift the cover off of the chassis.
- 
5. Figure B-7 shows the location of the removable media disk drive assembly part label.

Figure B-7. CD/DVD label location

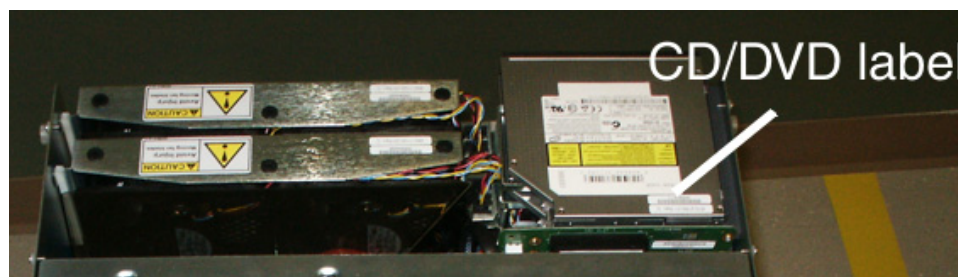

- 
6. Close the chassis front top cover.
- 
7. Tighten the screws to secure the front top cover.
- 
8. From the front of the frame, simultaneously press the round release buttons and slowly push the chassis into the frame while observing the cables to avoid binding or stretching.
- 

**NOTE:** When the chassis stops moving, the front of the T1100 AS should be slightly recessed to allow clearance behind the frame door when closed.

9. Adjust the chassis retention brackets on the front of the T1100 AS chassis to contact the frame adapter brackets when the chassis is positioned correctly in the frame.

---

10. Secure the chassis with one # 12-24 screw in the chassis retention brackets on each side.

---

11. This procedure is complete.

---

### Hard Disk Drive Assembly Part Number Information

The part number information for hard disk drive assemblies is located on both of the following labels:

- Label on the hard disk drive assembly (see Figure 7-11 on page 7-30).  
Use this label during replacement of the part to verify that the correct part number was ordered (see Procedure 7-9, "Replace a Hard Disk Drive Assembly," on page 7-26).
- The Base Unit/Hard Disk Drive Label on the outside of the T1100 AS chassis. Figure B-8 shows where this label is located and Figure B-9 shows a closeup view of a label. Use this label when requesting an RMA. Procedure B-4 on page B-10 provides instructions about how to access view this label.

**Figure B-8.** T1100 AS Chassis Label Locations

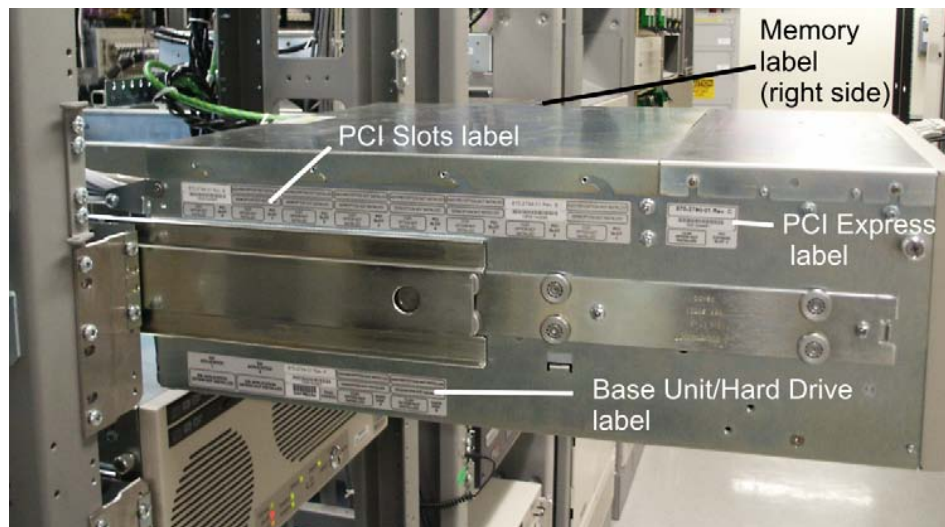
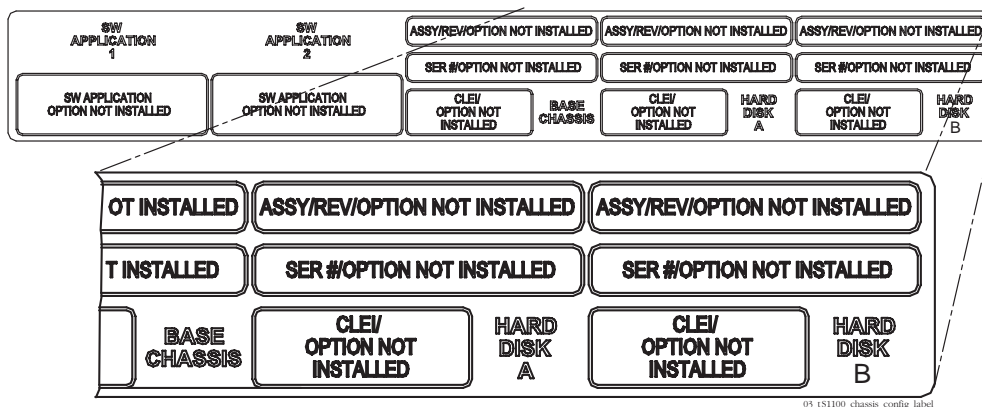

Figure B-9. Base Unit/Hard Disk Label on T1100 AS Chassis



**Procedure B-4. How to Locate serial numbers for Hard Disk Drive Assembly**

1. Request that the Customer Care Center assist you in determining whether the hard disk drive assembly that needs to be replaced is in position “A” or position “B”.

---

2. Determine whether the required Hard Disk area (A or B) of the base unit/hard disk label on the front of the left side of the T1100 AS chassis can be viewed from the side of the frame without sliding the chassis out from the frame. See Figure B-8 for the placement of the label on the chassis and Figure B-9 for the location of the Hard Disk information on the label.

---

3. If the necessary Hard Disk area of the base unit/hard disk label shown in Figure B-9 on page B-10 can be viewed, report the requested information from the label, and skip to step 7. Otherwise, perform the remaining steps.

---

**WARNING:** Always wear an ESD wrist strap grounded to the bench or frame when working on electronic components.



4. You do not need to slide the chassis from the frame to examine the hard drive labels. From the front of the frame, unscrew the knurled screws on the sides of the chassis and unlock the front pane (see Figure B-1).

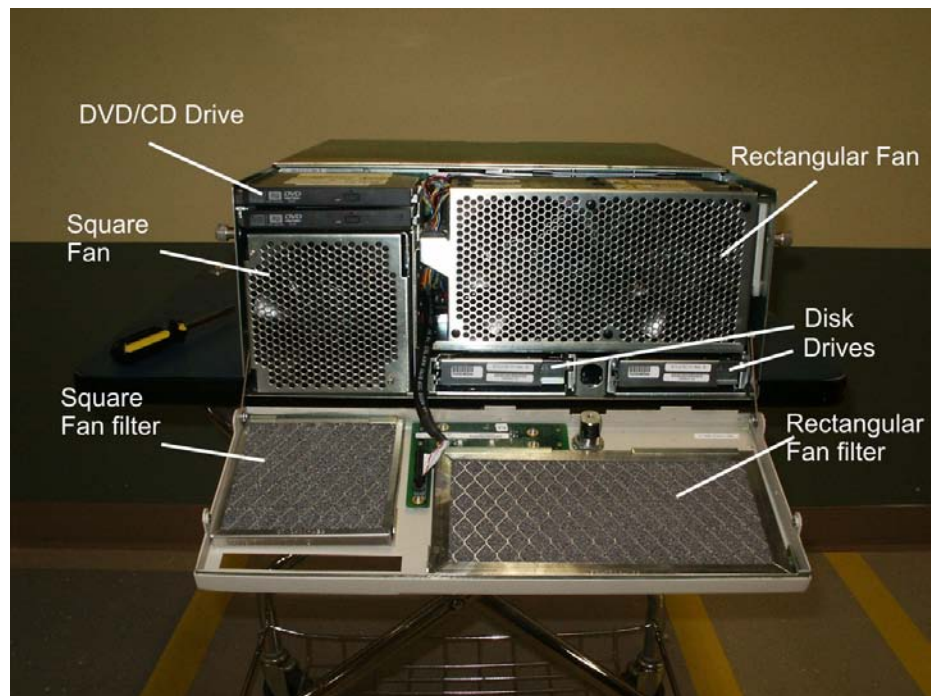
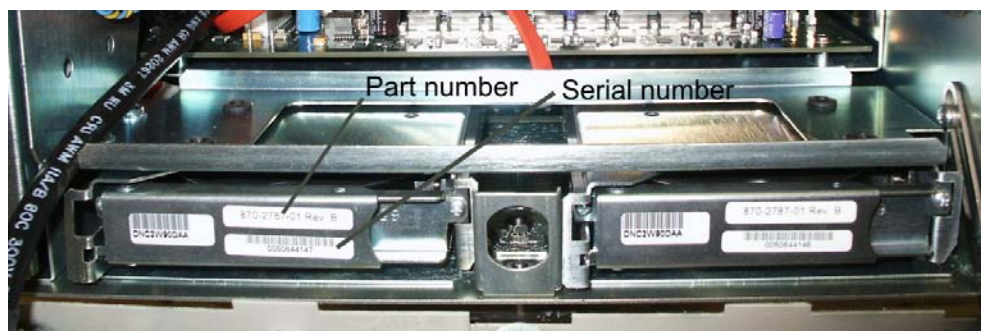

**Figure B-10.** T1100 AS front fascia open with hard drive locations**Figure B-11.** Hard disk label locations

- 
5. Report the requested part number information on the base unit/hard disk label.
- 
6. Close the front fascia. Be sure the CD/DVD can eject.
- 
7. This procedure is complete.
-

PCI Card Part Number Information

The part number information for PCI cards is located on both of the following labels:

- Label on each PCI card (see Figure 7-19 on page 7-40).  
Use this label during replacement of the part to verify that the correct part number was ordered (see Procedure 7-12, "Replace a PCI Card," on page 7-40).
- The PCI slots label on the outside of the T1100 AS chassis. Figure B-12 shows where this label is located and Figure B-13 shows a closeup view of a blank label. Use this label when requesting an RMA. Procedure B-5 on page B-13 provides instructions about how to view this label.

Figure B-12. T1100 AS Chassis Label Locations

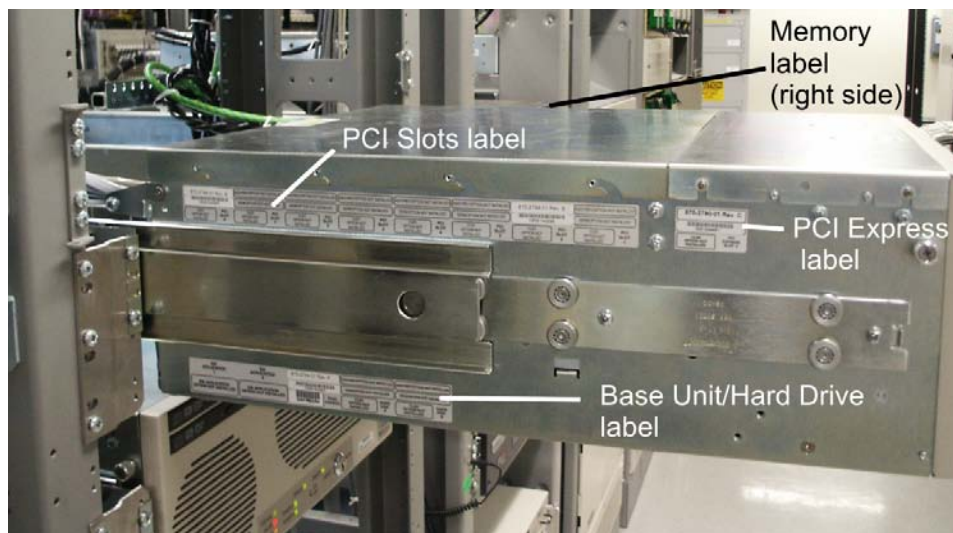
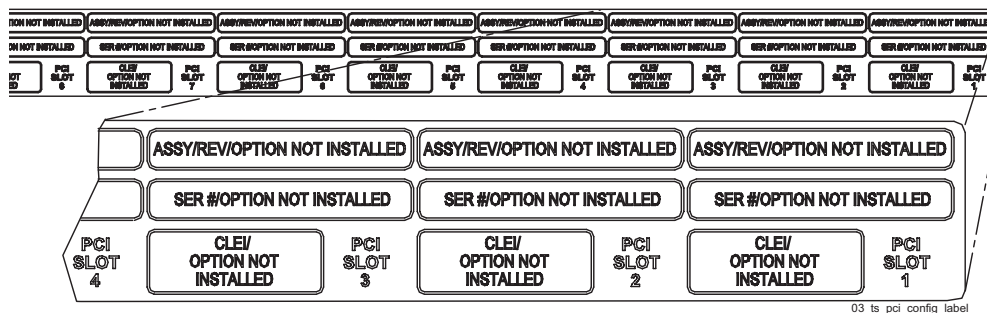

Figure B-13. PCI Slots Label on T1100 AS Chassis



**Procedure B-5. How to Locate serial numbers for PCI Cards**

---

1. Request that the Customer Care Center assist you in determining the which slot (1 through 8) contains the PCI card that needs to be replaced.

---
2. Determine whether the required PCI slot area of the PCI slots label on the rear of the left side of the T1100 AS chassis can be viewed from the side of the frame without sliding the chassis out from the frame. See Figure B-12 for the placement of the label on the chassis and Figure B-13 for the location of each PCI slot information on the label.

---
3. If the necessary PCI slot area of the PCI slots label shown in Figure B-12 can be viewed, report the requested information from the label, and skip to step 7. Otherwise, perform the remaining steps.

---



**WARNING:** Always wear an ESD wrist strap grounded to the bench or frame when working on electronic components.

4. From the front of the frame, remove the # 12-24 Phillips screw from each chassis retention bracket (see Figure B-1). Do not remove the screws in the frame adapter brackets.

**Figure B-14.** T1100 AS Chassis Front View

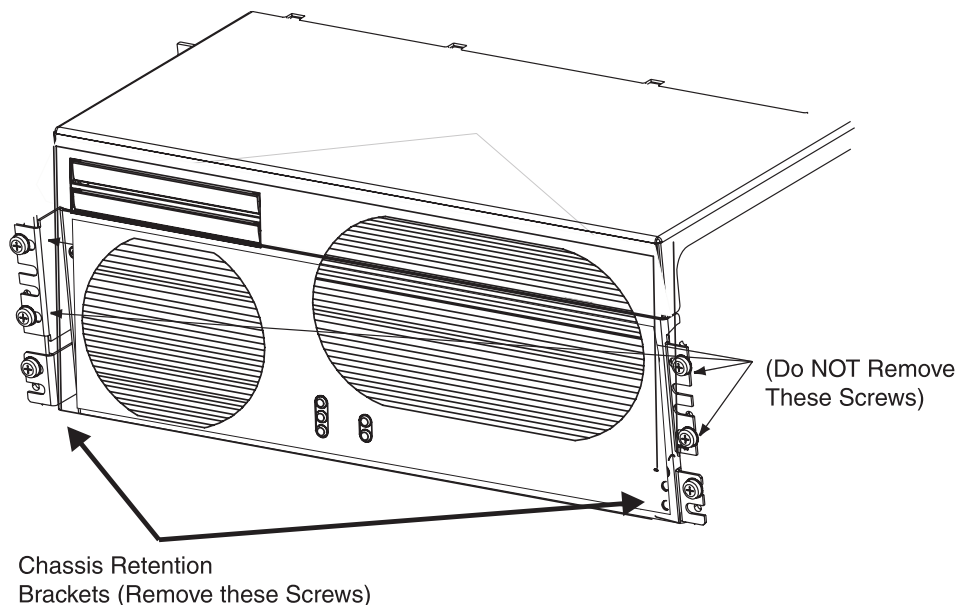

- 
- From the front of the frame, using the knurled screws on the sides of the chassis, pull forward until the release buttons on the inner arms of the slide assemblies pop into the holes on each side. Be careful you do not disconnect, bind, or pinch any cables.



**DANGER:** If the T1100 AS chassis is pulled too far out after the release buttons are disengaged, the inner slide members (attached to the chassis) could come out of the middle slide members (attached to the frame).

---

- Report the requested part number information from the PCI slots label.
- 

- From the front of the frame, simultaneously press the round release buttons and slowly push the chassis into the frame while observing the cables to avoid binding or stretching.
- 

**NOTE:** When the chassis stops moving, the front of the T1100 AS should be slightly recessed to allow clearance of the handles behind the frame door when closed.

- Adjust the chassis retention brackets on the front of the T1100 AS chassis to contact the frame adapter brackets when the chassis is positioned correctly in the frame.
- 
- Secure the chassis with one # 12-24 screw in the chassis retention brackets on each side.
- 
- This procedure is complete.
- 

### T1100 AS Chassis Part Number Information

When a T1100 AS chassis needs to be replaced, part number information from all of the following labels needs to be supplied:

- Frame identification from a label on the frame
- Server identification from a label on the front of the T1100 AS chassis
- Base unit and hard disk information from the base unit/hard disk label on the left side of the T1100 AS chassis
- Memory information from a label on the right side of the T1100 AS chassis
- PCI card information from a label on the left side of the T1100 AS chassis

Use the following procedure to locate the necessary part information:

**Procedure B-6. How to Locate serial numbers for a T1100 AS Chassis**

---

1. Supply the frame number for the frame in which the failed T1100 AS chassis is located (this label is located at the top left of the frame; see Figure B-15).

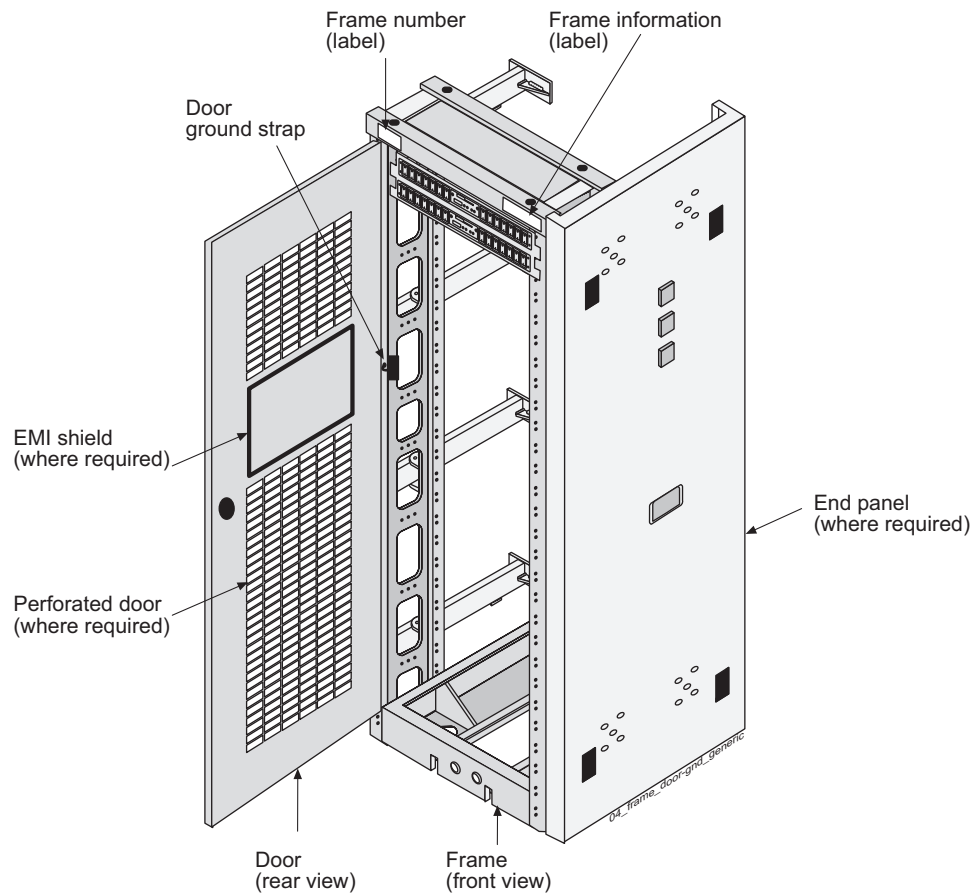
**Figure B-15. Frame Identification Label**

2. Supply the server identification letter (A through E) from the top left corner of the front of the chassis.
-

3. Determine whether the base unit/hard disk label, PCI slots label, and memory label on the sides of the T1100 AS chassis can be viewed from the sides of the frame without moving the chassis:
    - If all labels can be viewed, go to step 6 on page B-17.
    - If one or more labels cannot be viewed, go to the next step.
- 



**WARNING:** Always wear an ESD wrist strap grounded to the bench or frame when working on electronic components.

4. From the front of the frame, remove the # 12-24 Phillips screw from each chassis retention bracket (see Figure B-1). Do not remove the screws in the frame adapter brackets.

**Figure B-16.** T1100 AS Chassis Front View

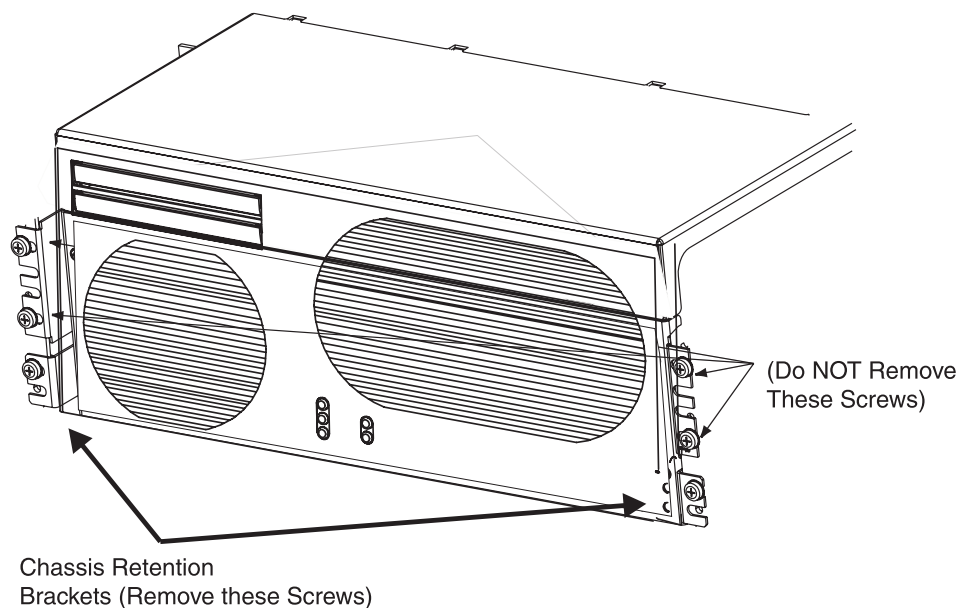

5. From the front of the frame, using the knurled screws on the sides of the chassis, pull forward until the release buttons on the inner arms of the slide assemblies pop into the holes on each side.



**DANGER:** If the T1100 AS chassis is pulled too far out after the release buttons are disengaged, the inner slide members (attached to the chassis) could come out of the middle slide members (attached to the frame).

---

6. Supply the requested part number information from the following areas of the base unit/hard disk label (Figure B-17 shows an expanded view of the label):

**Figure B-17.** Base Unit/Hard Disk Label on T1100 AS Chassis

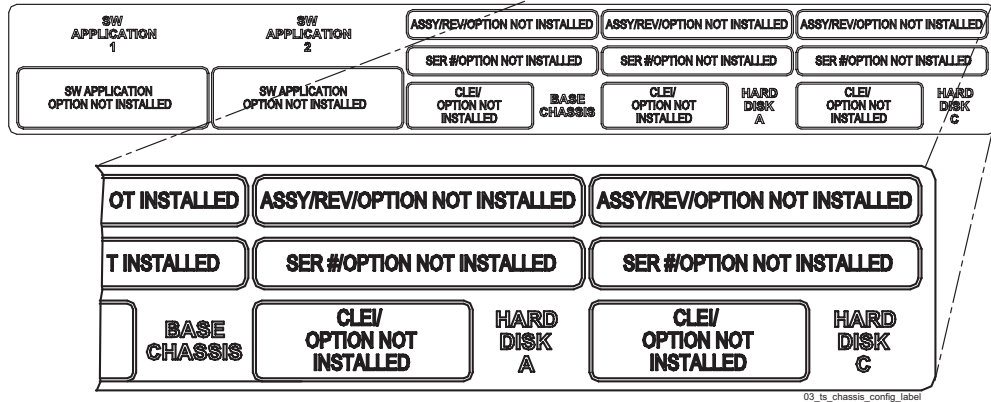

- Base chassis part number, serial number, and CLEI (in the middle of label)
  - Software applications (at the left side of label)
  - Part number, serial number, and CLEI for both Hard Disk A and Hard Disk B (at the right side of label). Report whether the replacement chassis is to also contain replacement hard drives. These numbers are needed in either case:
    - If the replacement chassis does not need to contain replacement hard disk drives, Tekelec manufacturing will use these numbers to create the new base unit/hard disk label and apply it to the replacement chassis
    - If the replacement chassis does need to contain replacement hard disk drives, Tekelec manufacturing will use these numbers both to install replacement hard disk drive assemblies in the chassis and also to create the new base unit/hard disk label and apply it to the replacement chassis
- 
7. To ensure that the replacement chassis has the same memory configuration as the failed chassis, supply all the requested information from the stickers on the memory label (see Figure B-18).

Figure B-18. Memory Label on T1100 AS Chassis

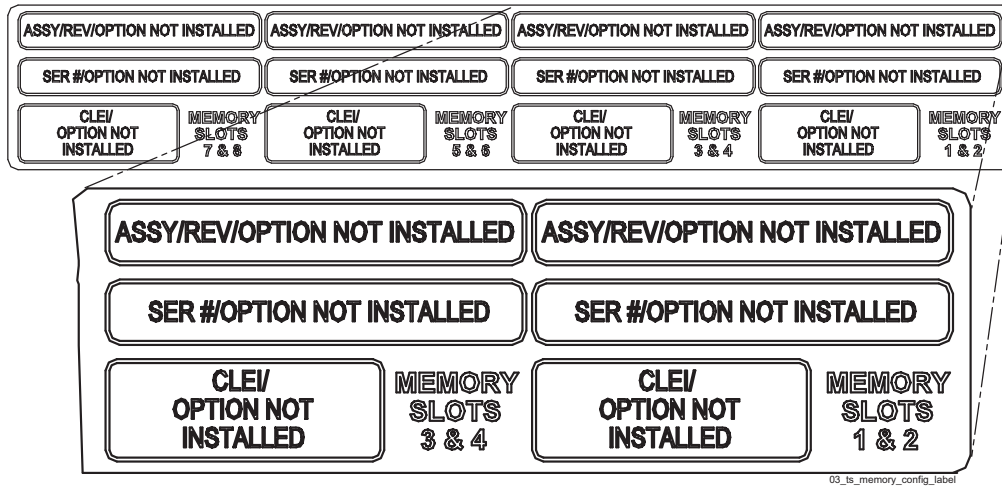

8. Supply all the information from the PCI slots label (see Figure B-19) and report whether the replacement chassis is to also contain replacement PCI cards. The information for all slots is needed in either case:
  - If the replacement chassis is to contain replacement PCI cards as well, Tekelec manufacturing will use the information to install the replacement PCI cards and also to create the new PCI slots label and apply it to the replacement chassis
  - If the replacement chassis does not need to contain replacement PCI cards, Tekelec manufacturing will use the information to create a new PCI slots label and apply it to the replacement chassis

Figure B-19. PCI Card Label on T1100 AS Chassis

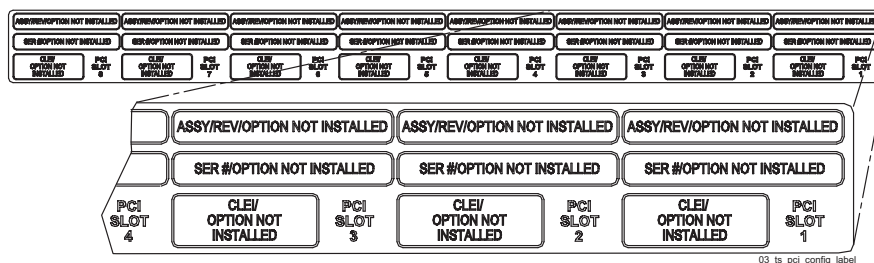



9. If the chassis was not slid out, skip to step 13. Otherwise, complete the remaining steps.

---
  10. From the front of the frame, simultaneously press the round release buttons and slowly push the chassis into the frame while observing the cables to avoid binding or stretching.

---
- NOTE: When the chassis stops moving, the front of the T1100 AS should be slightly recessed to allow clearance of the handles behind the frame door when closed.**
11. Adjust the chassis retention brackets on the front of the T1100 AS chassis to contact the frame adapter brackets when the chassis is positioned correctly in the frame.

---
  12. Secure the chassis with one # 12-24 screw in the chassis retention brackets on each side.

---
  13. This procedure is complete.

---

## How to Arrange Return Shipping

See one of the following:

- If the equipment to be returned is a Specifically Targeted Printed Circuit Board, see "Specifically Targeted PCBs" on page B-19
- For all other equipment types, see "General Instructions" on page B-20

### Specifically Targeted PCBs

For any reason the Director of Quality Assurance (QA), with input from other groups such as Customer Service, Hardware Systems, Repair and Maintenance Support (RMS) and/or Manufacturing, can authorize a board type to be "captured" and sent to the North Carolina facility for evaluation and analysis. NSD QA receives the board(s), records board information, such as part number and serial number and problem description on the appropriate forms and sends the PCB to a Hardware Systems representative who initiates the design engineering evaluation. Once the evaluation and repair, if applicable, is complete, the results are documented and the PCB returned to NSD QA.

Manufacturing may be involved in the investigations. In certain unique circumstances the capture of an individual PCB, for evaluation, can be initiated through a customer request.

## General Instructions

Returned equipment, assemblies, or subassemblies that are not Specifically Targeted PCBs must be shipped to the Tekelec Repair and Return Facility specified by the Technical Services engineer. Ensure that the following requirements are met:

- A returned item must be shipped in the original carton or equivalent container, assuring proper static handling procedures and with the freight charges prepaid.
- The assigned serial number must be printed clearly on the "Attn:" line of the shipping label on the outside of the shipping package.
- A returned item must also be tagged with the reason it is being returned. If the serial number is not placed on the label, the return could be delayed.

Ship to:

Tekelec  
Attn: RMA ####  
5200 Paramount Parkway  
Morrisville, NC 27560

## Returning a Crate

Use the following procedure to return a shipping crate and dollies to Tekelec.

### **Procedure B-7. Preparing Crate and Dolly for Return to Tekelec**

---

1. Replace the retaining brace.

---
2. Replace the shipping container front fascia using the bolts saved previously and arrange the return shipment by contacting:  

Shipping Manager  
Tekelec  
5200 Paramount Parkway  
Morrisville, NC 27560

---
3. After the frame is positioned and the dollies are removed from the frame, the dollies are returned to the same address as the shipping container listed above. Ship the dollies in **either** the crate **or** the box supplied with the crate, as described below:
  - If the equipment is being immediately installed, ship the dollies back to Tekelec in the crate after use. After installing the equipment, bolt the dollies securely in the crate and return to Tekelec.

- If the equipment is not being immediately installed, ship the dollies back to Tekelec in the box supplied with the crate. After unpacking the equipment, return the crate to Tekelec and retain the box to return the dollies. After installing the equipment, return the dollies to Tekelec in the supplied box.

**NOTE: It is the project manager's responsibility to assure the crate and dollies are returned to Tekelec.**

---



# C

## ELAP or EPAP Network Integration

Introduction.....	C-2
Network Overview.....	C-2
Customer-Supplied Information.....	C-4
IP Address Assignment.....	C-4
Netmask and Broadcast.....	C-6
Network Interface Functions.....	C-6
Network Assumptions.....	C-8
Network Interface Functions.....	C-6
Network Assumptions.....	C-8
Network Configuration.....	C-8
Firewall and Router Filtering Considerations.....	C-8
Serial Communication.....	C-10
Modems.....	C-10
Printers.....	C-12
Tip Utility (EAGLE Only).....	C-12
VT100 Ports.....	C-12
Platform Security.....	C-12

## Introduction

This chapter provides network integration information for the Multi-Purpose Server (MPS) systems. The MPS platform can be configured as an EAGLE Local Number Portability (ELAP) or EAGLE Provisioning Application Processor (EPAP) server. The MPS platform can be a Netra-based ELAP system or an ELAP/EPAP system based on the Tekelec 1000 Application Server (T1000 AS) or the Tekelec 1100 Application Server (T1100 AS).

The MPS provides an interface between the customer provisioning network and the EAGLE 5 ISS Database Service Module (DSM) cards. As the customer's data is updated, the MPS stores the data and updates the DSM cards. An MPS is usually co-located with an EAGLE 5 ISS. If you need to install an MPS at a distance from the EAGLE 5 ISS, contact your Customer Care Center for assistance.

## Network Overview

ELAP and EPAP provide network connections to allow interaction with DSMs, other MPS Servers, and the remote provisioning system. There are four network connections. Figure C-1, "MPS Network Connections, Netra," on page C-3 and Figure C-2, "MPS Network Connections, T1000 AS, T1100 AS," on page C-3 illustrate the networks and how they are connected.

All networks, except the provisioning network, use internal connections in the MPS. Only the provisioning network connects to the customer's network. The Ethernet interfaces are -10/100BaseT for Netra-based systems and Gigabit for T1000 AS or T1100 AS-based systems. All networks use TCP/IP and UDP/IP as the transport protocol.

- The provisioning network uses the Ethernet interface that typically connects to an external wide area network (WAN). This interface provides connectivity to the remote MPS system, an LSMS, or to a customer-provided provisioning system.
- The main DSM Network uses the Ethernet interface that connects to the primary network port on all DSM cards. This network has sufficient capacity to support up to 25 DSMs. The primary port on all DSM cards runs at 100BaseT.
- The backup DSM Network uses the Ethernet interface that connects to the backup network port on all DSM cards. This network has sufficient capacity to support up to 25 DSMs. The backup port on all DSM cards runs at 10BaseT.
- The Synchronization Network uses the Ethernet interface that is on private LAN segment. This interface provides direct connectivity between MPS A and MPS B. IP addresses on this network are also used to provide remote dial up Point-to-Point Protocol (PPP) access (two IP addresses are reserved for the upper MPS and two IP addresses are reserved for the lower MPS.). Both systems are configured for PPP access.

Figure C-1. MPS Network Connections, Netra

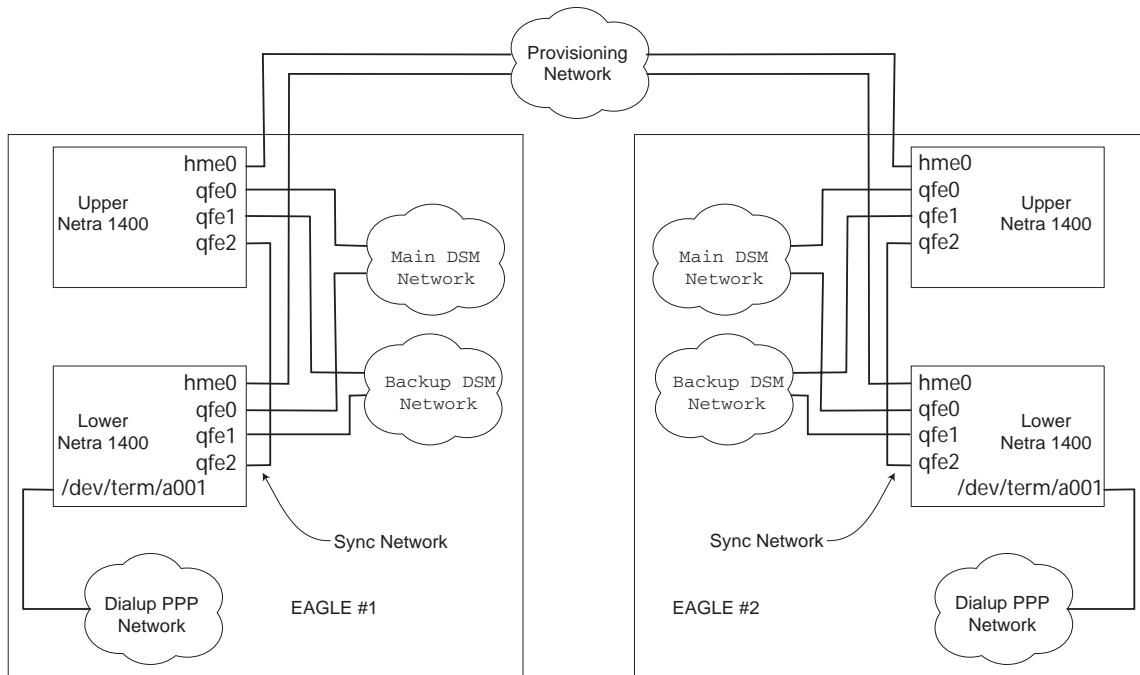
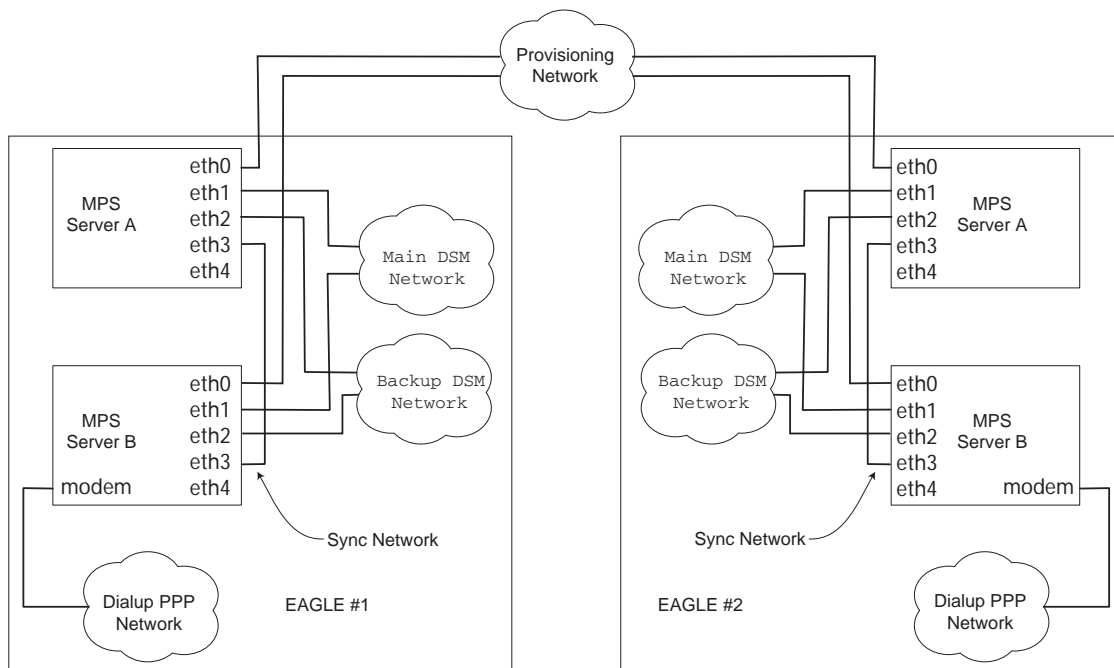

Figure C-2. MPS Network Connections, T1000 AS, T1100 AS



## Customer-Supplied Information

The customer's network administrator provides the following information:

1. Two IP addresses on the provisioning network
2. Netmask of the provisioning network
3. Default router on the provisioning network

## IP Address Assignment

The provisioning network requires two IP addresses, one for each MPS Server. The IP addresses are provided by the customer network administrator.

The main DSM Network, the backup DSM Network and the Synchronization Network addresses are pre-set prior to customer delivery. If there is a conflict in the customer's numbering plan with the pre-set addresses, the pre-set addresses can be changed.

The addresses require private class "C" network addresses as defined in RFC 1597 and RFC 1918. These networks are not routed (not visible to any external networks).

The third octet for each ELAP or EPAP Sync network address is set to .2 as the default. It can be changed if necessary. If you change this octet value, follow the instructions in "Configure ELAP or EPAP Sync Network" in the ELAP Administration Manual or the EPAP Administration Manual.

The fourth octet of the address is selected as follows:

- If the ELAP or EPAP is configured as ELAP A or EPAP A, the fourth octet has a value of 100.
- If the ELAP or EPAP is configured as ELAP B or EPAP B, the fourth octet has a value of 200.

Tekelec recommends that the addresses range between 192.168.1.0 and 192.168.255.0. The netmask of these networks must be 255.255.255.0. Table C-1 depicts the IP address allocation for the DSM Network.

**Table C-1.** IP Address for the DSM Network

IP Range	Function
xxx.xxx.xxx.1 - xxx.xxx.xxx.25	DSM Interfaces (One IP address per card)
xxx.xxx.xxx.100	MPS Server A IP Address
xxx.xxx.xxx.200	MPS Server B IP Address
xxx.xxx.xxx.210 - xxx.xxx.xxx.215	Local Access IP address (on Backup DMS network)



The same network address range selected for the MPS interfaces must be used when configuring the DSM cards within the EAGLE 5 ISS. Table C-2 depicts the IP address allocation for the Sync Network.

**Table C-2.** IP Address for the Sync Network

IP Range	Function
zzz.zzz.zzz.100	MPS Server A Ethernet IP Address
zzz.zzz.zzz.101	MPS Server A PPP Modem Address
zzz.zzz.zzz.102	MPS Server A PPP Dial-up Address
zzz.zzz.zzz.201	MPS Server B PPP Modem Address
zzz.zzz.zzz.202	MPS Server B PPP Dial-up Address
zzz.zzz.zzz.200	MPS Server B Ethernet IP Address

The Dialup Point-to-Point Protocol (PPP) Network allows multiple user interface sessions to be established to the ELAP or EPAP from a remote workstation.

The MPS servers are configured for the use of a modem on port a001 on the serial expansion board. The modem connection supports PPP (TCP/IP). With this capability, multiple networked applications can be run across the PPP link at the same time. The remote dial-in serial port configuration is described in "Modems" on page C-10.

PPP requires two IP addresses to be registered, one to the serial port on the server, and one to the client dialing into the server. These IP addresses are allocated on the Sync network, and will be different for each system.

If the IP address of the Sync network is changed using the ELAP or EPAP user interface menu item, the PPP IP addresses will be updated by the user interface operation at the same time.

Table C-4 depicts valid sample IP addresses as an example. This example shows three DSM cards in the EAGLE 5 ISS.

**Table C-3.** EAGLE 5 ISS IP Addresses

IP Range	Function
192.168.2.100	MPS Server A Sync IP Address
192.168.2.101	MPS Server A PPP Modem Address
192.168.2.102	MPS Server A PPP Dial-up Address
192.168.2.201	MPS Server B PPP Modem Address
192.168.2.202	MPS Server B PPP Dial-up Address

**Table C-3.** EAGLE 5 ISS IP Addresses (Continued)

<b>IP Range</b>	<b>Function</b>
192.168.2.200	MPS Server B Sync IP Address
192.168.122.1	DSM #1 Main DSM Network IP Address
192.168.122.2	DSM #2 Main DSM Network IP Address
192.168.122.3	DSM #3 Main DSM Network IP Address
192.168.122.100	MPS Server A Main DSM Network IP Address
192.168.122.200	MPS Server B Main DSM Network IP Address
192.168.123.1	DSM #1 Backup DSM Network IP Address
192.168.123.2	DSM #2 Backup DSM Network IP Address
192.168.123.3	DSM #3 Backup DSM Network IP Address
192.168.123.100	MPS Server A Backup DSM Network IP Address
192.168.123.200	MPS Server B Backup DSM Network IP Address
192.9.200.22 a	MPS Server A Provisioning DSM Network IP Address
192.9.200.66 a	MPS Server B Provisioning DSM Network IP Address
192.9.200.1 a	Provisioning Network Router (default router)
255.255.255.0 a	Provisioning Network Netmask

<sup>a</sup> These addresses are provided by the customer’s network administrator.

## Netmask and Broadcast

The MPS netmask defaults to that matching the address assigned to each interface. In the event of a class "C" network, the default broadcast address is the interface address ORed with a mask of x000000FF. For example, an IP address of 192.168.89.40 would have a broadcast address of 192.168.89.255. Only the netmask on the Provisioning network can be changed.

## Network Interface Functions

Table C-4 shows the interface functions required for MPS and the assignment to interfaces.

**Table C-4.** Interface Functions Required for MPS

<b>Interface Function</b>	<b>Protocol</b>	<b>Speed Netra Tekserver</b>	<b>Assigned to (Netra/Tekserver)</b>	<b>Assigned to (Netra/Tekserver)</b>
Connection to Provisioning Network *	TCP/IP	10/100BaseT Gigabit	MPS Server A (hme0 port/interface eth0)	MPS Server A (hme0 port/interface eth0)
Connection to Provisioning Network *	TCP/IP	10/100BaseT Gigabit	MPS Server B (hme0 port/interface eth0)	MPS Server B (hme0 port/interface eth0)
Dial-up PPP server on Sync Network	TCP/IP	PPP modem	MPS Server A PPP serial port (ipdptp0)	MPS Server A PPP serial port (ipdptp0)
Dial-up PPP server on Sync Network	TCP/IP	PPP modem	MPS Server A Client PPP serial port	MPS Server A Client PPP serial port
Dial-up PPP server on Sync Network	TCP/IP	PPP modem	MPS Server B PPP serial port (ipdptp0)	MPS Server B PPP serial port (ipdptp0)
Dial-up PPP server on Sync Network	TCP/IP	PPP modem	MPS Server B Client PPP serial port	MPS Server B Client PPP serial port
Main DSM Network	TCP/IP	10/100BaseT Gigabit	MPS Server A (qfe0 port/interface eth1)	MPS Server A (qfe0 port/interface eth1)
Main DSM Network	TCP/IP	10/100BaseT Gigabit	MPS Server B (qfe0 port/interface eth1)	MPS Server B (qfe0 port/interface eth1)
Backup DSM Network	TCP/IP	10/100BaseT Gigabit	MPS Server A (qfe1 port/interface eth2)	MPS Server A (qfe1 port/interface eth2)
Backup DSM Network	TCP/IP	10/100BaseT Gigabit	MPS Server B (qfe1 port/interface eth2)	MPS Server B (qfe1 port/interface eth2)
Sync Network	TCP/IP	10/100BaseT Gigabit	MPS Server A (qfe2 port/interface eth3)	MPS Server A (qfe2 port/interface eth3)
Sync Network	TCP/IP	10/100BaseT Gigabit	MPS Server B (qfe2 port/interface eth3)	MPS Server B (qfe2 port/interface eth3)

\* These are generally visible outside of the immediate MPS area and they will pass through routers and firewalls

## Network Assumptions

The MPS network route and gateway implementation conforms to the following:

- Four individual networks are required. Three of these networks are internal to the MPS system and should not need to be changed.
- MPS is configured to listen for Routing Information Protocol (RIP) broadcasts but does not send out any routing updates.
- Individual interfaces are configured with default IP addresses at the time of EPAP or ELAP initialization. IP addresses are assigned as part of the manufacturing procedure and can be changed at initialization if required. See “Network Configuration” on page C-8 to implement a change.
- No use of virtual LANs, custom subnets, or other routing parameters are used that could conflict with the customer network.
- Matching of the interfaces to the external destinations is implemented using a default route.

## Network Configuration

DSM and Sync Network addresses are configured to default values at EPAP or ELAP initialization and should not need to be changed. If they need to be changed for any reason, refer to sections “Network Connection” and “Configuration Menu” in the *ELAP Administration Manual* or *EPAP Administration Manual* included in your current Documentation Suite.

The provisioning network addresses are configured using the ELAP or EPAP user interface configuration menu; refer to “Configuration Menu” in the *ELAP Administration Manual* or *EPAP Administration Manual*.

## Firewall and Router Filtering Considerations

If a firewall is installed in the provisioning network between the MPS systems or between the MPS system(s) and the provisioning system, it must be configured to allow selected traffic to pass.

Firewall protocol filtering for the various interfaces is defined in Table C-5 from the perspective of each MPS

.

**Table C-5.** Interface Functions Required for MPS

Interface	IP Port	Use	In bound	Out bound	MPS Application
To Provisioning Network Netra: 10/BaseT (hme0) Tekserver: Gigabit (eth0)	20	ftp-data <sup>1</sup> - The customer may need to transfer provisioning data for bulk loading into PDB	yes <sup>1</sup>	yes	EPAP and ELAP
	21	ftp <sup>1</sup> - Tekelec Customer Service may need to ftp software to MPS in recovery situations	yes <sup>1</sup>	yes	EPAP and ELAP
	22	TCP (ssh) - ssh connections use TCP	yes <sup>2</sup>	yes	EPAP and ELAP
	23	telnet - needed by customer or Tekelec customer service	Yes	Yes	EPAP and ELAP
	123	NTP - needed for time-sync	Yes	Yes	EPAP and ELAP
	80	Apache - needed for ExAP Web-based GUI	Yes	No	EPAP and ELAP
	8001 <sup>3</sup>	SuEXEC - needed by ExAP Web-based GUI	Yes	No	EPAP and ELAP
	8473 <sup>3</sup>	GUI server - needed by ExAP Web-based GUI	Yes	Yes	EPAP and ELAP
	5871-5873 <sup>3</sup>	Provisioning data to the EPAP	Yes	No	EPAP only
	5874	Provisioning data to the EPAP	Yes	Yes	EPAP only
	5019	Versant Fault Tolerant Server - EPAP database mgmt system	Yes	Yes	EPAP only
	9696	PDBA - PDB application messages the provisioning data	Yes	Yes	EPAP only
	1030 <sup>3</sup>	LSMS Bulk Download and High Speed Audit	Yes	Yes	ELAP only
	7483 <sup>3</sup>	LSMS Provisioning Data	Yes	Yes	ELAP only
9691	Watcher Port (diagnostics)	Yes	Yes	ELAP only	

1. FTP data is normally received from the customer's Provisioning System. This assumes the firewall automatically opens the high numbered return port (the

default behavior of firewalls like Firewall-1). If using a basic packet filtering router, contact the Customer Care Center.

2. The two-way TCP communication channel endpoints are the port number 22 and the Server spawned random port value.
3. These ports are configurable via the configuration menus of the ELAP and EPAP software. See *"Configuration Menu" in the ELAP Administration Manual or EPAP Administration Manual* for more information.

## Serial Communication

Each MPS server has two onboard serial ports. Serial port A is the Console port and serial port B is connected by a null-modem cable to serial port A on the mate MPS server. The lower ELAP or EPAP server is configured with an additional 8 serial ports in a multiport PCI serial port card.

Table C-6 depicts the Serial Port assignments for MPS Servers A and B

**Table C-6.** Serial Port Assignments for MPS Servers A and B

MPS Server	Serial Port Name	Serial Port Use
A	ttya	Console
	ttyb	MPS Server B Console monitor
B	ttya	Console
	ttyb	MPS
	term/a000	Server A Console monitor
	term/a001	Connection for local provisioning terminal
	term/a002	Dial in modem connection
	term/a003	Connection to EAGLE for EAGLE testing/configuration
	term/a004	Used to monitor upper power distribution panel
	term/a005	Used to monitor lower power distribution panel
	term/a006	Reserved, currently configured for local provisioning terminal
term/a007	Reserved, currently configured for local provisioning terminal	

## Modems

### Dial-in Capability

MPS Server B is configured for a modem on port a001 on the 8-Port Connector Box and supports PPP (TCP/IP). With this capability, multiple networked applications can run across the PPP link simultaneously. PPP also requires two IP addresses to be registered, one to the serial port on the server, and one to be assigned to the client dialing into the server. These IP addresses are allocated on the synchronization network.

The remote dial-in serial port will be configured as follows:

- Hardware flow control (RTS/CTS)
- 38400 bps port speed
- 8-bit data
- No parity

If the remote dial-in serial port is not functional at one EAGLE 5 ISS site, dialing into the remote EAGLE 5 ISS site and connecting back to the functional MPS at the failed EAGLE 5 ISS site will allow remote recovery.

### Modem Configuration

To simplify configuring the modem to the setting described in the previous section “*Dial-in Capability*,” use the script

```
/opt/TKLCplat/bin/modem_setup. (also can be executed from  
Application GUI)
```

This script supports five modems:

- Motorola V.3600
- US Robotics X2 Sportster External
- US Robotics V.90 Sportster External
- Multitech MT5634ZBA (no long supported)
- 3Com US Robotics Courier 56k V-Everything

**NOTE: This script does NOT support any other modems.**

Set up the modem using this script with the following procedure.

#### Procedure C-1. Configure Modem with Script

---

1. Attach the modem to MPS server B, port a001 of the serial expansion board using an appropriate cable. (This cable must be wired straight through, all 25 pins wired.)

---
2. Apply power to the modem.

---

3. Run the script from a user shell account on MPS server B, such as epapdev or elapdev. Here is a sample execution of the script:

```
$ /opt/TKLCplat/bin/modem_setup tmodem  
connected  
Setting up Motorola V.3600 modem.  
Done setting up Motorola modem.
```

---

## Printers

Printers are not supported on the MPS systems.

## Tip Utility (EAGLE Only)

On MPS Server B, the UNIX tip utility is also used to connect an MPS Server to the EAGLE 5 ISS attached to serial port a002. A tip utility can be opened using the Connect to EAGLE MMI Port menu item in the debug menu of the ELAP or EPAP user interface. Use the tip command, "Return ~." to drop the connection and exit.

## VT100 Ports

On MPS Server B, serial ports a000 and a005-a007 are configured as VT100 login ports for use with a standard EAGLE 5 ISS VT520 terminal. The configuration is 9600 baud, 8-bit data, and no parity. Ports a005-a007 are reserved for future use.

## Platform Security

The EPAP and ELAP platform uses Secure Shell (ssh) for platform security. The Ssh protocol uses public-key encryption and does not pass passwords in clear text



# Glossary

<b>BIOS</b>	Basic Input Output System.
<b>CD</b>	Compact Disk.
<b>CD-RW</b>	Compact Disk-Read/Write.
<b>CLEI</b>	Common Language Equipment Identifier, a code used by some telephony companies to identify manufacturer, part number, and customer.
<b>CPU</b>	Central Processing Unit, the computing part of a computer.
<b>E1</b>	European Digital Signal Level-1 (2.048 Mbits/sec).
<b>ECC</b>	Error Correction Coded.
<b>FRU</b>	Field Replaceable Unit, any unit of hardware that can be replaced in the field by the customer.
<b>HD</b>	Heavy Duty.
<b>IDE</b>	Integrated Drive Electronics, an interface standard for connecting hard drives to PCs.
<b>I/O</b>	Input/Output.
<b>LED</b>	Light Emitting Diode.
<b>MHz</b>	Megahertz (1,000,000 Hertz).
<b>NE</b>	Network Element.
<b>NEBS</b>	Network Equipment Building System.
<b>PCI</b>	Peripheral Component Interconnect, a peripheral bus commonly used in PCs, Macintoshes and workstations that provides a high-speed data path between the CPU and peripheral devices (such as video, disk, and network).
<b>RAM</b>	Random Access Memory.
<b>RMA</b>	Return Material Authorization.
<b>ROM</b>	Read-only memory.
<b>RTTE</b>	Radio & Telecommunication Terminal Equipment.

- T1** The North American telecommunications standard defining a circuit that multiplexes and switches 24 channels and operates at speeds of 1.544 Mbps.
- UL** Underwriters Laboratories.
- USB** Universal Serial Bus, a hardware interface for low-speed peripherals such as the keyboard, mouse, joystick, scanner, printer and telephony devices. It also supports MPEG-1 and MPEG-2 digital video.
- VDC** Volts Direct Current.
- VGA** Videographic array.
- VOM** Volt Ohm Meter.

# Index

870-2785-02 7-4  
8-Port Connector C-11

## A

AC power  
    Power distribution unit 3-13  
addresses, network IP C-4  
administrator requirements, customer  
    (provisioning) network C-4  
air filter  
    part number B-3  
    replace 7-19  
Air filters 7-4  
anchor assembly  
    for raised floor with support channel 4-14  
    for raised floor with support channel and  
        spring nut 4-17  
    raised floor over concrete 4-10  
    slab floor 4-7  
anchor frame  
    for raised floor with support channel 4-13  
    for raised floor with support channel and  
        spring nut 4-16  
    to concrete under raised floor 4-10  
    to slab floor 4-6  
anchor holes, in raised floor 4-5  
assignments  
    MPS Server serial port C-10  
    network IP address C-4

## C

cable holes, in raised floor 4-5  
cable management arms 3-9  
cabling  
    additional NE server 5-14  
    frame 4-20  
CD/DVD 7-4

central office ground 6-8  
chalk line 4-4  
changing passwords 6-16  
Chassis Dimensions and weight 3-9  
checklist, post-installation 6-13  
compliance, regulatory 2-4  
configuration, Dialup PPP network serial  
    port C-11  
configuring the modem C-11  
Connect to Eagle MMI Port menu item C-12  
connections  
    DSM network C-2  
    EPAP or ELAP Sync network C-2  
    provisioning (customer) network C-2  
connections, ELAP and EPAP network C-2  
crimping tool 6-3  
customer (provisioning) network  
    administrator requirements C-4  
    interface C-8  
    IP addresses C-4  
Customer Assistance 1-7

## D

default  
    EPAP or ELAP Sync network IP  
        addresses C-4  
Dial-in Capability C-11  
Dialup PPP network  
    description C-5  
    IP addresses C-2, C-5  
    modem C-5  
    remote dial-in port C-5  
    serial port configuration C-11  
documentation  
    admonishments 1-6  
    delivery 1-6  
    packaging 1-6  
    updates 1-6  
drill bit, masonry 4-3  
DSM networks  
    connections C-2

## Index

IP addresses C-4

## E

Eagle

tip utility C-12

VT100 terminal ports C-12

VT520 terminal C-12

ear protectors 4-3

earthquake resistance 2-6

ELAP

Connect to Eagle MMI Port menu item C-12

network connections C-2

Sync network connection C-2

Sync network IP addresses C-4

electric shock 6-2

elevation requirements 2-6

environmental requirements 2-5

EPAP

Connect to Eagle MMI Port menu item C-12

network connections C-2

Sync network IP addresses C-4

Ethernet switch

replace 7-7

## F

Fan assemblies 7-4

fan assembly

part number label B-3, B-6

replace 7-21, 7-23

filtering

firewall protocol C-8

router C-8

fire protection requirements 2-5

firewall protocol filtering C-8

floor

loading 2-7

mark layout 4-4

plan 4-4

preparation

additional for raised floors 4-5

for heavy duty frame 4-3

raised

additional preparations 4-5

anchoring frame to concrete under raised floor 4-10

anchoring frame using support channel and spring nut 4-16

anchoring with support channel 4-13

slab

anchor assembly 4-7

slab, anchoring frame 4-6

frame

anchoring

to concrete under raised floor 4-10

to raised floor using support channel 4-13

to raised floor with support channel and spring nut 4-16

to slab floor 4-6

floor preparation 4-3

layout 4-4

template 4-4

unpacking 4-2

FRU

replacement

tools required 7-6

## G

ground

main 6-5

plane 6-3

window 6-4

Grounding 2-8

## H

hard disk drive

label B-9, B-11, B-12, B-14, B-17

part number B-9, B-11, B-12, B-14, B-17

replace 7-26

hard drive 7-4

hard drives 7-4

heavy duty frame

anchoring to concrete under raised floor 4-10

anchoring to raised floor with support channel and spring nut 4-16

anchoring to slab floor 4-6

floor preparation 4-3

installing, recommended tools 4-3

Htapped 6-4

HVAC requirements 2-6

## I

inspection, post-installation 6-13

installing

heavy duty frame 4-2

Tekelec 1000 chassis in a frame 5-4

interface

customer (provisioning) network C-8

firewall protocol filtering C-8

functions, network C-6

inventory

additional server 5-1

frame 4-2

IP addresses

default for EPAP or ELAP Sync network  
C-4

Dialup PPP network C-5

network assignments C-4

RFC 1597 standard C-4

RFC 1918 standard C-4

isolator pad 4-4

## L

label

fan assembly B-3, B-6

hard disk drive

on part B-9, B-11, B-12, B-14, B-17

PCI card

on card B-12

layout, frame 4-4

Lighting 2-6

lighting 2-6

## M

main ground 6-5

marking

cable holes 4-5

frame layout 4-4

masking tape 4-3

masonry drill-bit 4-3

Maximum weight 2-7

menu item, ELAP user interface

Connect to Eagle MMI Port C-12

menu item, EPAP user interface

Connect to Eagle MMI Port C-12

Modem C-10

Modem Configuration C-11

modem for PPP connection C-5

modems supported C-11

MPS Server

serial port assignments C-10

VT100 terminal ports C-12

Multi-Purpose Server C-2

## N

network

connections, ELAP and EPAP C-2

customer (provisioning) C-2, C-4, C-8

Dialup PPP C-5, C-11

DSM main and backup C-2

EPAP or ELAP Sync C-2

interface functions C-6

IP address assignments C-4

network, Dialup PPP C-5

## O

one-inch diameter hole 4-5

OOBM A-3

Out of band management A-3

Out of Band Management Card A-3

overhead rack support, attaching 4-19

## P

P/N 551-0022-02 7-4

P/N 551-0022-03 7-4

P/N 690-0131-01 6-8

P/N 804-0228-R01 6-3, 6-8

P/N 804-0817-R02 6-8

P/N 840-1125-03 7-4

P/N 840-1133-01 7-4

P/N 870-2706-04 7-5

P/N 870-2707-02 7-5

P/N 870-2708-02 7-5

P/N 870-2754-01 7-5

P/N 870-2754-02 7-5

P/N 870-2787-02 7-4

P/N 870-2790-02 7-5

P/N 870-2795-03 7-5

P/N 870-2795-04 7-5

P/N 870-2798-02 7-5

P/N 870-2799-01 7-5

## Index

- part number
  - air filter B-3
  - fan assembly B-3, B-6
  - hard disk drive B-9, B-11, B-12, B-14, B-17
  - locating B-2
  - PCI card B-12
- Part numbers
  - air filters 7-4
  - fan assemblies 7-4
  - Hard drives 7-4
- passwords, changing 6-16
- PCI card
  - label B-12
  - part number B-12
  - replace 7-40
- PDU 3-13
- Point-to-Point Protocol (PPP)
  - for Dialup PPP network C-5
  - modem for C-5
- port speed C-11
- port, remote dial-in C-5, C-11
- ports
  - assignments, MPS Server serial C-10
  - configuration for Dialup PPP serial C-11
  - firewall protocol filtering C-8
  - VT100 for Eagle VT520 terminal C-12
- post-installation inspection 6-13
- Power distribution unit 3-13
- power requirements 2-10
- pre-installation requirements 2-5
- preparing
  - floor for heavy duty frame 4-3
- Printers C-12
- protocol
  - filtering, firewall C-8
- Protocol, Point-to-Point (PPP) C-5
- provisioning (customer) network
  - <Italics>see also customer (provisioning) network
  - connection C-2
  - interface C-8
  - IP addresses C-4
- R**
  - rack, overhead 4-19
  - raised floor
    - additional preparations 4-5
    - anchor assembly
      - for anchoring to slab 4-10
      - for use with support channel 4-14
    - anchor assembly for use with support channel and spring nut 4-17
    - anchor with support channel 4-13
    - anchor with support channel and spring nut 4-16
    - create cable and anchor holes 4-5
  - recommended tools
    - installing heavy duty frame 4-3
  - regulatory compliance 2-4
  - relative humidity 2-6
  - remote dial-in port C-5, C-11
  - remote dial-in serial port C-11
  - Removable media drives assembly 7-4
  - replace
    - air filter 7-19
    - Ethernet switch 7-7
    - fan assembly 7-21, 7-23
    - hard disk drive 7-26
    - PCI card 7-40
  - requirements
    - customer network administrator C-4
    - pre-installation 2-5
  - Return Material Authorization B-1
  - return shipment 7-23, 7-26, 7-39, B-20
  - return shipping instructions B-19
  - RFC 1597 network address standard C-4
  - RFC 1918 network address standard C-4
  - risk of electric shock 6-2
  - RMA, obtaining B-1
  - rotary impact drill 4-3
  - router filtering C-8
- S**
  - safety 2-1, 7-2
  - safety glasses 4-3
  - SATA hard drives 7-4
  - script to configure modems C-11
  - serial ports
    - Dialup PPP network configuration C-11
    - Eagle VT520 terminal C-12
    - MPS Server assignments C-10
  - shipping, return instructions B-19
  - slab floor

- anchor assembly 4-7
- slab floor, anchoring frame 4-6
- space requirements 2-7
- standard, RFC 1597 address C-4
- standard, RFC 1918 address C-4
- supported modems C-11
- switch
  - replace 7-7
- Sync network, EPAP or ELAP
  - connection C-2
  - IP addresses C-4
- synchronization network C-11

## T

- T1100
  - specifications 3-9
- temperature requirements 2-6
- template, frame 4-4
- terminal
  - for Dialup PPP network C-11
  - VT100 ports for Eagle VT520 terminal C-12
- tip utility, Eagle C-12
- tools required for FRU replacement 7-6
- tools, recommended
  - installing heavy duty frame 4-3
  - to install heavy duty frame 4-3

## U

- unpacking frame 4-2
- utility, Eagle tip C-12

## V

- vacuum cleaner 4-3
- VT100 Ports C-12
- VT100 ports for Eagle VT520 terminal C-12
- VT520 Eagle terminal C-12

## W

- weight 3-9

## Index