

EAGLE[®] 5

Integrated Signaling System

Systems Overview

910-5566-001 Revision A
March 2009



**Copyright 2009 Tekelec
All Rights Reserved
Printed in USA**

Notice

Information in this documentation is subject to change without notice. Unauthorized use, copying, or translation of this documentation can result in civil or criminal penalties.

Any export of Tekelec products is subject to the export controls of the United States and the other countries where Tekelec has operations.

No part of this documentation may be reproduced, translated, or transmitted in any form or by any means, electronic or mechanical, including photocopying or recording, for any purpose without the express written permission of an authorized representative of Tekelec.

Other product names used herein are for identification purposes only, and may be trademarks of their respective companies.

RoHS 5/6 - As of July 1, 2006, all products that comprise new installations shipped to European Union member countries will comply with the EU Directive 2002/95/EC "RoHS" (Restriction of Hazardous Substances). The exemption for lead-based solder described in the Annex will be exercised. RoHS 5/6 compliant components will have unique part numbers as reflected in the associated hardware and installation manuals.

WEEE - All products shipped to European Union member countries comply with the EU Directive 2002/96/EC, Waste Electronic and Electrical Equipment. All components that are WEEE compliant will be appropriately marked. For more information regarding Tekelec's WEEE program, contact your sales representative.

Trademarks

The Tekelec logo, EAGLE, G-Flex, G-Port, IP7, IP7 Edge, and IP7 Secure Gateway are registered trademarks of Tekelec. TekServer, A-Port, EAGLE 5 ISS, and V-Flex are trademarks of Tekelec. All other trademarks are the property of their respective owners.

Patents

This product is covered by one or more of the following U.S. and foreign patents:

U.S. Patent Numbers:

5,732,213; 5,953,404; 6,115,746; 6,167,129; 6,324,183; 6,327,350; 6,456,845; 6,606,379; 6,639,981; 6,647,113; 6,662,017; 6,735,441; 6,745,041; 6,765,990; 6,795,546; 6,819,932; 6,836,477; 6,839,423; 6,885,872; 6,901,262; 6,914,973; 6,940,866; 6,944,184; 6,954,526; 6,954,794; 6,959,076; 6,965,592; 6,967,956; 6,968,048; 6,970,542; 6,987,781; 6,987,849; 6,990,089; 6,990,347; 6,993,038; 7,002,988; 7,020,707; 7,031,340; 7,035,239; 7,035,387; 7,043,000; 7,043,001; 7,043,002; 7,046,667; 7,050,456; 7,050,562; 7,054,422; 7,068,773; 7,072,678; 7,075,331; 7,079,524; 7,088,728; 7,092,505; 7,108,468; 7,110,780; 7,113,581; 7,113,781; 7,117,411; 7,123,710; 7,127,057; 7,133,420; 7,136,477; 7,139,388; 7,145,875; 7,146,181; 7,155,206; 7,155,243; 7,155,505; 7,155,512; 7,181,194; 7,190,702; 7,190,772; 7,190,959; 7,197,036; 7,206,394; 7,215,748; 7,219,264; 7,222,192; 7,227,927; 7,231,024; 7,242,695; 7,254,391; 7,260,086; 7,260,207; 7,283,969; 7,286,516; 7,286,647; 7,286,839; 7,295,579; 7,299,050; 7,301,910; 7,304,957; 7,318,091; 7,319,857; 7,327,670

Foreign Patent Numbers:

EP1062792; EP1308054; EP1247378; EP1303994; EP1252788; EP1161819; EP1177660; EP1169829; EP1135905; EP1364520; EP1192758; EP1240772; EP1173969; CA2352246

Ordering Information

Your Tekelec Sales Representative can provide you with information about how to order additional discs.

Table of Contents

Chapter 1: Introduction.....	1
Introduction.....	2
Scope and Audience.....	2
Manual Organization.....	2
Related Publications.....	2
Documentation Availability, Packaging, and Updates.....	3
Documentation Admonishments.....	3
Customer Care Center.....	4
Emergency Response.....	6
Locate Product Documentation on the Customer Support Site.....	7
Chapter 2: SS7 Networks.....	9
Common Channel Signaling Networks.....	10
SS7 Link and Message Types.....	10
Role of SSPs, STPs, and SCPs in SS7 Networks.....	12
STP System Link Administration.....	14
Chapter 3: Tekelec Signaling Systems.....	15
EAGLE 5 Integrated Signaling System (ISS).....	16
Theory of Operation.....	17
Maintenance and Administration Subsystem.....	19
Communication Subsystem.....	21
Application Subsystem.....	21
Generic Program Loads.....	21
Local Service Management System (LSMS).....	22
EAGLE 5 ISS Integrated Data Feed and IAS.....	24
Multi-purpose Server (MPS).....	25
Layered Design.....	28
Tekelec 1000 and Tekelec 1100 Application Server.....	28
Embedded OSS Application Processor (EOAP).....	30
Glossary.....	31

List of Figures

- Figure 1: SS7 Common Channel Signaling Networks.....10
- Figure 2: EAGLE 5 ISS System Functional Diagram.....17
- Figure 3: Example EAGLE 5 ISS Message Flow.....18
- Figure 4: LNP Hardware Overview.....23
- Figure 5: EAGLE-IAS Interfacing.....24
- Figure 6: MPS on T1000 AS/EAGLE 5 ISS Overview.....26
- Figure 7: Layered Design for MPS and Applications.....28
- Figure 8: EOAP Communication.....30

List of Tables

Table 1: Admonishments.....	3
-----------------------------	---

Chapter 1

Introduction

Topics:

- [Introduction Page 2](#)
- [Scope and Audience Page 2](#)
- [Manual Organization Page 2](#)
- [Related Publications Page 2](#)
- [Documentation Availability, Packaging, and Updates Page 3](#)
- [Documentation Admonishments Page 3](#)
- [Customer Care Center Page 4](#)
- [Emergency Response Page 6](#)
- [Locate Product Documentation on the Customer Support Site Page 7](#)

This manual provides a basic understanding of Tekelec Signaling systems and subsystems, including the EAGLE 5 ISS. This chapter includes sections about the manual scope, audience, and organization; how to find related publications; and how to contact Tekelec for assistance.

Introduction

This manual provides customers and system planners with a basic understanding of Tekelec Signaling systems and subsystems. This manual provides a high-level overview of how the EAGLE 5 Integrated Signaling System (EAGLE 5 ISS) works with Tekelec Signaling systems and subsystems in a network. Descriptions include the main features of each system, its functions, and its basic hardware requirements.

Scope and Audience

This manual provides customers and system planners with a basic understanding of Tekelec Signaling systems and subsystems and the EAGLE 5 ISS in a network. Users of this manual and the others in the EAGLE 5 ISS family of documents must have a working knowledge of telecommunications and network installations.

This manual does not describe how to install or replace hardware.

- For installation information, refer to the *Installation Manual - EAGLE 5 ISS* included in your current documentation set.
- For replacement procedures of existing hardware components, refer to the *Maintenance* manual included in your current documentation set.

Manual Organization

This document is organized into the following chapters:

- *Introduction* on page 1 contains sections about the manual scope, audience, and organization; how to find related publications, and how to contact Tekelec for assistance.
- *SS7 Networks* on page 9 provides an overview of Common Channel Signaling networks, the role of STPs in those networks, the connectivity of STPs with other network elements, and the administration of STPs within a signaling network.
- *Tekelec Signaling Systems* on page 15 describes the components of the EAGLE 5 ISS and provides a high-level theory of its operation.

Related Publications

For information about additional publications that are related to this document, refer to the *Related Publications* document. The *Related Publications* document is published as a part of the *Release Documentation* and is also published as a separate document on the Tekelec Customer Support Site.

Documentation Availability, Packaging, and Updates

Tekelec provides documentation with each system and in accordance with contractual agreements. For General Availability (GA) releases, Tekelec publishes a complete EAGLE 5 ISS documentation set. For Limited Availability (LA) releases, Tekelec may publish a documentation subset tailored to specific feature content or hardware requirements. Documentation Bulletins announce a new or updated release.

The Tekelec EAGLE 5 ISS documentation set is released on an optical disc. This format allows for easy searches through all parts of the documentation set.

The electronic file of each manual is also available from the Tekelec Customer Support site (support.tekelec.com). This site allows for 24-hour access to the most up-to-date documentation, including the latest versions of Feature Notices.

Printed documentation is available for GA releases on request only and with a lead time of six weeks. The printed documentation set includes pocket guides for commands and alarms. Pocket guides may also be ordered separately. Exceptions to printed documentation are:

- Hardware or Installation manuals are printed without the linked attachments found in the electronic version of the manuals.
- The Release Notice is available only on the Customer Support site.

Note:

Customers may print a reasonable number of each manual for their own use.



Documentation is updated when significant changes are made that affect system operation. Updates resulting from Severity 1 and 2 PRs are made to existing manuals. Other changes are included in the documentation for the next scheduled release. Updates are made by re-issuing an electronic file to the customer support site. Customers with printed documentation should contact their Sales Representative for an addendum. Occasionally, changes are communicated first with a Documentation Bulletin to provide customers with an advanced notice of the issue until officially released in the documentation. Documentation Bulletins are posted on the Customer Support site and can be viewed per product and release.

Documentation Admonishments

Admonishments are icons and text throughout this manual that alert the reader to assure personal safety, to minimize possible service interruptions, and to warn of the potential for equipment damage.

Table 1: Admonishments

	<p>DANGER: (This icon and text indicate the possibility of <i>personal injury</i>.)</p>
---	--

	<p>WARNING: (This icon and text indicate the possibility of <i>equipment damage</i>.)</p>
	<p>CAUTION: (This icon and text indicate the possibility of <i>service interruption</i>.)</p>

Customer Care Center

The Tekelec Customer Care Center is your initial point of contact for all product support needs. A representative takes your call or email, creates a Customer Service Request (CSR) and directs your requests to the Tekelec Technical Assistance Center (TAC). Each CSR includes an individual tracking number. Together with TAC Engineers, the representative will help you resolve your request.

The Customer Care Center is available 24 hours a day, 7 days a week, 365 days a year, and is linked to TAC Engineers around the globe.

Tekelec TAC Engineers are available to provide solutions to your technical questions and issues 7 days a week, 24 hours a day. After a CSR is issued, the TAC Engineer determines the classification of the trouble. If a critical problem exists, emergency procedures are initiated. If the problem is not critical, normal support procedures apply. A primary Technical Engineer is assigned to work on the CSR and provide a solution to the problem. The CSR is closed when the problem is resolved.

Tekelec Technical Assistance Centers are located around the globe in the following locations:

Tekelec - Global

Email (All Regions): support@tekelec.com

- **USA and Canada**

Phone:

1-888-FOR-TKLC or 1-888-367-8552 (toll-free, within continental USA and Canada)

1-919-460-2150 (outside continental USA and Canada)

TAC Regional Support Office Hours:

8:00 a.m. through 5:00 p.m. (GMT minus 5 hours), Monday through Friday, excluding holidays

- **Central and Latin America (CALA)**

Phone:

USA access code +1-800-658-5454, then 1-888-FOR-TKLC or 1-888-367-8552 (toll-free)

TAC Regional Support Office Hours (except Brazil):

10:00 a.m. through 7:00 p.m. (GMT minus 6 hours), Monday through Friday, excluding holidays

- **Argentina**

Phone:

0-800-555-5246 (toll-free)

- **Brazil**

Phone:

0-800-891-4341 (toll-free)

TAC Regional Support Office Hours:

8:30 a.m. through 6:30 p.m. (GMT minus 3 hours), Monday through Friday, excluding holidays

- **Chile**

Phone:

1230-020-555-5468

- **Columbia**

Phone:

01-800-912-0537

- **Dominican Republic**

Phone:

1-888-367-8552

- **Mexico**

Phone:

001-888-367-8552

- **Peru**

Phone:

0800-53-087

- **Puerto Rico**

Phone:

1-888-367-8552 (1-888-FOR-TKLC)

- **Venezuela**

Phone:

0800-176-6497

- **Europe, Middle East, and Africa**

- **Signaling**

Phone:

+44 1784 467 804 (within UK)

TAC Regional Support Office Hours:

8:00 a.m. through 7:00 p.m. (GMT), Monday through Friday, excluding holidays

- **Software Solutions**

Phone:

+33 3 89 33 54 00

TAC Regional Support Office Hours:

8:00 a.m. through 7:00 p.m. (GMT), Monday through Friday, excluding holidays

- **Asia**

- **India**

Phone:

+91 124 436 8552 or +91 124 436 8553

TAC Regional Support Office Hours:

10:00 a.m. through 7:00 p.m. (GMT plus 5 1/2 hours), Monday through Saturday, excluding holidays

- **Singapore**

Phone:

+65 6796 2288

TAC Regional Support Office Hours:

9:00 a.m. through 6:00 p.m. (GMT plus 8 hours), Monday through Friday, excluding holidays

Emergency Response

In the event of a critical service situation, emergency response is offered by the Tekelec Customer Care Center 24 hours a day, 7 days a week. The emergency response provides immediate coverage, automatic escalation, and other features to ensure that the critical situation is resolved as rapidly as possible.

A critical situation is defined as a problem with an EAGLE 5 ISS that severely affects service, traffic, or maintenance capabilities, and requires immediate corrective action. Critical problems affect service and/or system operation resulting in:

- A total system failure that results in loss of all transaction processing capability
- Significant reduction in system capacity or traffic handling capability
- Loss of the system's ability to perform automatic system reconfiguration
- Inability to restart a processor or the system
- Corruption of system databases that requires service affecting corrective actions
- Loss of access for maintenance or recovery operations
- Loss of the system ability to provide any required critical or major trouble notification

Any other problem severely affecting service, capacity/traffic, billing, and maintenance capabilities may be defined as critical by prior discussion and agreement with the Tekelec Customer Care Center.

Locate Product Documentation on the Customer Support Site

Access to Tekelec's Customer Support site is restricted to current Tekelec customers only. This section describes how to log into the Tekelec Customer Support site and locate a document. Viewing the document requires Adobe Acrobat Reader, which can be downloaded at www.adobe.com.

1. Log into the Tekelec **new** Customer Support site at support.tekelec.com.
Note: If you have not registered for this new site, click the **Register Here** link. Have your customer number available. The response time for registration requests is 24 to 48 hours.
2. Click the **Product Support** tab.
3. Use the Search field to locate a document by its part number, release number, document name, or document type. The Search field accepts both full and partial entries.
4. Click a subject folder to browse through a list of related files.
5. To download a file to your location, right-click the file name and select **Save Target As**.

Chapter 2

SS7 Networks

Topics:

- *Common Channel Signaling Networks Page 10*
- *SS7 Link and Message Types Page 10*
- *Role of SSPs, STPs, and SCPs in SS7 Networks Page 12*
- *STP System Link Administration Page 14*

This chapter provides an overview of Common Channel Signaling networks, the role of STPs in those networks, the connectivity of STPs with other network elements, and the administration of STPs within a signaling network.

Common Channel Signaling Networks

Signaling System No. 7 (SS7) is a signaling protocol that has become a worldwide standard for modern telecommunications networks. The U.S. implementation is based on the International Telecommunications Union-Telecommunications Section (ITU-TS) and TIX I Committee of the Exchange Carriers Standards Association (ECSA). SS7 is a layered protocol following the OSI reference model. It offers all of the same call setup advantages as CCS6, but also enables network elements to share more than just basic call-control information through the many services provided by the SS7 Integrated Services Digital Network-User Part (ISUP), and the Transaction Capabilities Application Part (TCAP).

The functions of the TCAP and ISUP layers correspond to the Application Layer of the OSI reference model, and allow for new services such as User-to-User signaling, Closed-User Group, Calling Line Identification, various options on Call Forwarding, and the rendering of services based on a centralized database (such as 800 and 910 service). All of these services may be offered between any two network subscribers, not just to subscribers served by the same telephone switch.

SS7 Link and Message Types

An SS7 Network consists of a flat non-hierarchical configuration enabling peer-to-peer communication. [Figure 1: SS7 Common Channel Signaling Networks](#) on page 10 depicts the makeup and connectivity of SS7 Common Channel Signaling networks currently installed and in use.

Figure 1: SS7 Common Channel Signaling Networks

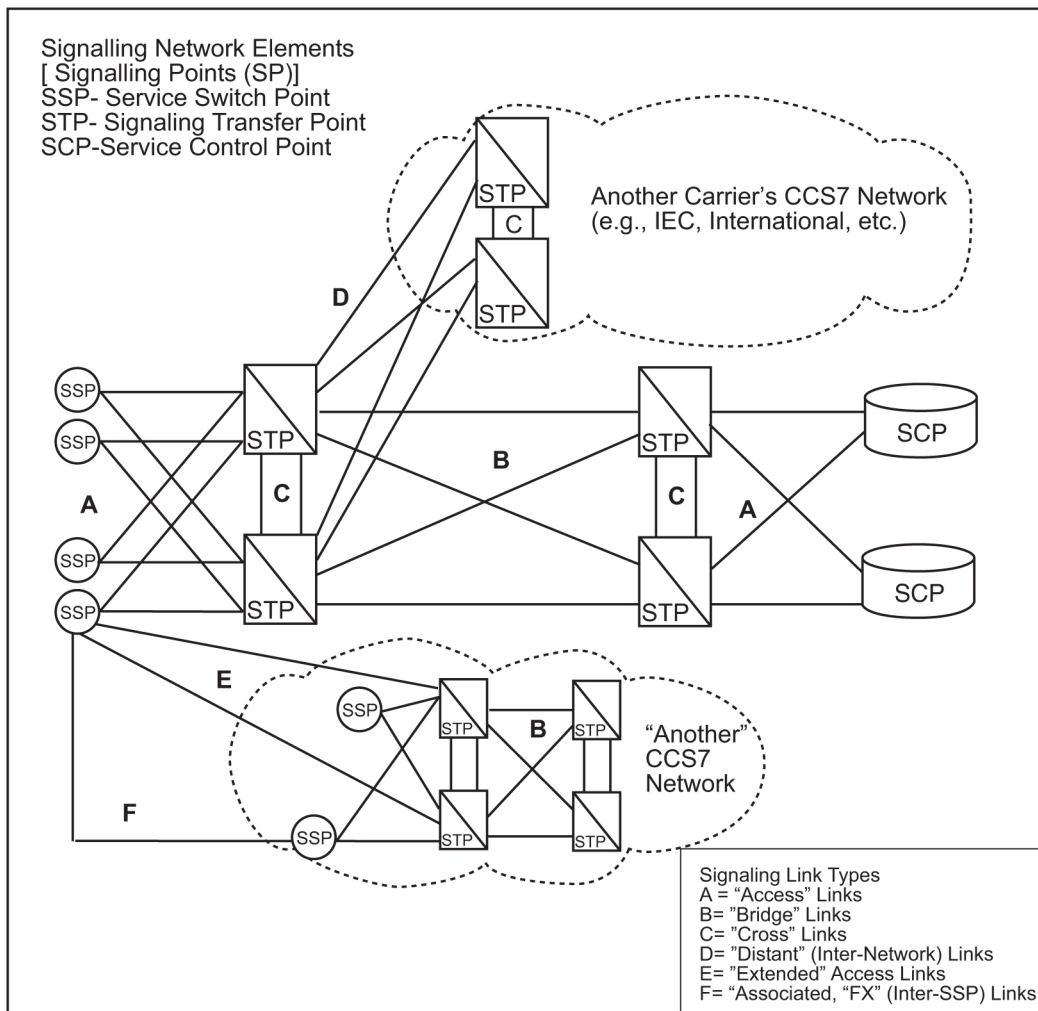

Figure 1: SS7 Common Channel Signaling Networks on page 10 shows the three principal network elements of SS7 Common Channel Signaling networks, interconnected by the six standard types of signaling links currently in use. Signaling links are data transmission links that ordinarily operate on digital carrier facilities at 56,000 bits per second in North America, and at 64,000 bits per second in most other regions of the world. High Speed Links (HSLs) at 1.54 Mbps are used in North America.

Signaling links between any two signaling network elements are deployed in groups called "link sets," dimensioned to carry the estimated signaling traffic between two STPs. Because STPs like the EAGLE 5 ISS are deployed in pairs, as shown in *Figure 1: SS7 Common Channel Signaling Networks* on page 10, an alternate route always exists between any two STPs.

One combination of the link sets interconnecting an SSP or SCP with both members of the STP pair is called a "combined link set." The traffic carried between any two signaling network elements is load-shared across links in a link set, rotating through all links available according to the rules of the SS7 protocol.

Traffic destined for any network element through the STP pair is further load-shared over the combined link set, unless restricted by network management rules also established by the SS7 protocol.

Role of SSPs, STPs, and SCPs in SS7 Networks

Service Switching Points (SSPs)

In conventional telephone networks, Service Switching Points (SSPs) are usually telephone central offices, also known as “End-Offices,” or “Access Tandems.” In the cellular mobile or “wireless” communications environment, an SSP is frequently located at the Mobile Switching Center (MSC). In either case, the SSPs perform circuit switching functions, and are capable of using the SS7 protocol to signal other SSPs for call setup, or to query the centralized databases that are stored in Service Control Points (SCPs).

Signaling Transfer Points (STPs)

STPs like the EAGLE 5 ISS are ultra-reliable, high speed packet switches at the heart of SS7 networks, which terminate all link types except “F” links. For reliability reasons, they are nearly always deployed in mated pairs.

The primary functions of STPs are to provide access to SS7 networks and routing of signaling messages. The SS7 protocol itself defines destination routing for both circuit-related signaling (inter-SSP) and non-circuit-related database inquiries to Service Control Points (SCPs). Many STPs contain additional routing information concerning the exact location of specific databases stored at different SCPs, so that an SSP can request information without knowing in which specific SCP it is stored.

STPs operate using the Message Transfer Part and Signaling Connection Control Part (MTP and SCCP) of the SS7 protocol. MTP provides basic message handling and network management procedures, and SCCP adds the capability to transmit database queries and other non-circuit-related signaling messages across the network. SCCP also provides a non-SS7-specific addressing interface (Global Title).

In SS7 networks, STPs perform the following three basic functions:

- **Message routing** - by using the originating and destination point codes (OPC and DPC) contained in the MTP “routing label”, in a “datagram” environment where a separate route may be chosen for each message packet. Routing tables, which are structured to allow message transport between any given pair of SSPs over different routes, are stored and maintained within STPs. The STP signaling Network Management functions control message routing during periods of link congestion or failure.
- **Specialized routing (Global Title Translation)** - by using the SCCP to translate addresses (Global Titles) from signaling messages that *do not contain* explicit information allowing MTP to route the message. For example, an STP translates a dialed “1+800” number to the DPC of an SCP for MTP routing, and gives a subsystem number (SSN) for delivery to the “800” database application at the SCP. In case of congestion or failures, the SCCP management at the STP takes responsibility for rerouting signaling traffic, based on information received through MTP concerning the point code routing status, and allowed or prohibited SSNs.
- **Carrier signaling access (Gateway Screening)** - by using MTP and SCCP to allow or deny access to the “Home” SS7 network for transport of signaling messages from another network.

To establish and maintain trunk connections between two SSPs, and to notify both when the connection is to be released, a pre-defined sequence of SS7 messages is exchanged between the

two SSPs. Except where "F" links have been installed between the concerned SSPs, these messages are routed to one of a pair of STPs in the local ("Home") SS7 network over an "A" link" or to one of a pair of STPs in another SS7 network over an "F" link. The following cases illustrate the STP function:

- For an ordinary customer-dialed call to a 7- or 10-digit domestic station address (I±NPA+NXX+XXXX), the STP, after consulting its routing tables, will route its received SS7 messages towards the designated SSP over the appropriate "A", "B", or "D" link.

Note: A message will be rerouted through a "C" link only in cases of where the use of the other "B" or "D" link sets are restricted or unavailable

- For calls to be given special billing or routing treatment, as indicated by other dialed prefix digits (such as I+NOO+..., IOXX +..., or 0+...), an intermediate step requires the STP to retrieve routing information from a non-resident routing table or database. This retrieval process ordinarily involves translation of the signaling address and a completely separate message transaction with an SCP.

As shown in [Figure 1: SS7 Common Channel Signaling Networks](#) on page 10, STPs are the hub of the signaling network infrastructure. A less efficient, and more expensive, signaling network might have each SSP connected to every other SSP by an "F" type signaling link. This approach would be much more costly than the hubbed network shown in [Figure 1: SS7 Common Channel Signaling Networks](#) on page 10, due to the total number of links that would be required. For example, a fully-connected, ten node network would require 45 "F" links, or 90 "F" links if each link was redundant. The alternative hubbed network approach for ten SSPs utilizing STPs (deployed in pairs for increased availability) requires only 20 links, one link to each member of the STP pair.

Service Control Points (SCPs)

Service Control Points (SCPs) are network intelligence centers where databases of call processing information is stored. The primary function of SCPs is to respond to queries from other SCPs, by retrieving the requested information from the appropriate database within the SCP node, and sending it back to the originator of the request.

SCPs currently serve as centralized databases to translate logical numbers (such as 1+N00 numbers) into network physical addresses, or to verify credit card data and status. Future plans call for expanding the centralized resource responsibilities of the SCP to include greater interaction in call processing. This expansion of responsibilities will be attained through newly defined "call models" implemented in SSPs that may invoke assistance from SCPs more than once for the same call.

The information managed by an SCP can be modified or updated without affecting any other node in the SS7 network. This ease of data administration is a major appeal of SS7 implementation. Applications of SCPs for 1+800 calls and credit card verifications could be implemented by storing the respective databases at each network switching node. This approach creates an unmanageable task of administering multiple decentralized databases.

To appreciate the expediency and economy of centralized databases, consider adding a new service to a 100 node network by updating 100 databases. The ease of administration and greater control of new service offerings are obvious when one compares the two alternatives.

STP System Link Administration

After an STP is installed, system administration consists primarily of the following:

- Addition of signaling link hardware and software
- Creation and maintenance of database tables for links, link sets, and routes
- Addition of hardware and software required for global title translation
- Creation and maintenance of global title translation (GTT) tables
- Addition of hardware and software for gateway screening
- Creation and maintenance of gateway screening tables
- Updating software

When required, hardware must always be installed at the affected STP site. However, there are three methods that can be employed to load software and administer data tables:

1. Local administration through user interfaces and portable storage media (disks or tapes).
2. Remote administration through a modem using vendor-proprietary methods and commands to load and update data.
3. Centralized, remote administration through a modem or dedicated digital data link, using an industry or network operator standard operations support system such as SCCS or SEAS.

Chapter 3

Tekelec Signaling Systems

Topics:

- *EAGLE 5 Integrated Signaling System (ISS)*
Page 16
- *Local Service Management System (LSMS)* Page 22
- *EAGLE 5 ISS Integrated Data Feed and IAS*
Page 24
- *Multi-purpose Server (MPS)* Page 25
- *Tekelec 1000 and Tekelec 1100 Application Server*
Page 28
- *Embedded OSS Application Processor (EOAP)*
Page 30

Tekelec uses different systems to support its processor and feature applications that include the following:

- EAGLE 5 Integrated Signaling System (ISS)
- Local Service Management System (LSMS)
- Integrated Data Acquisition
- Multi-purpose Server (MPS)
- Tekelec 1000 and Tekelec 1100 Application Server
- Embedded OSS Applications Processor (EOAP)

EAGLE 5 Integrated Signaling System (ISS)

The EAGLE 5 ISS is a large-capacity, multi-functional, fully scalable Signaling Transfer Point (STP). High capacity and scalability allow this system to grow from a single-shelf, 80-link STP to a multi-frame, 2000-link STP.

The EAGLE 5 ISS can handle increasing voice and data traffic loads and all of the signaling routing within a core network for signaling applications and services. The EAGLE 5 ISS performs key functions such as signal transfer, signaling gateway, and number portability. Integrated applications, dramatic database size, signaling capacity, and transaction speed coupled with next-generation IP connectivity provide the transition to the converged network model.

EAGLE 5 ISS-based products are NEBS-compliant (GR-63-CORE, Network Equipment-Building Systems). These products are configured in standard equipment frames to provide services to SS7 telephony networks.

Because of the distributed processor design, the EAGLE 5 ISS does not have a separate central processing unit to bottleneck traffic throughput. Application and interface cards provide plug-and-play functions that facilitate future growth. These cards generally do not have specific shelf or frame limitations, and allow full customization and definition of STP configuration. The EAGLE 5 ISS supports a variety of interface cards to support connectivity to a wide range of network elements. EAGLE 5 ISS provides connectivity interfaces for IP, ATM, DS0A, V.35, OCU, T1, and E1 protocols.

Features

- **Exceptional Capacity.** The system supports up to 2,000 links, one million global title translation (GTT) table entries and 384 million subscriber records.
- **High Performance.** Transaction speeds of up to 640,000 message signaling units (MSUs) per second.
- **Flexible Interconnection.** Supports multiple link interface types, including: 100 Base-T, DS0A, V.35, OCU, E1/T1 ATM HSL, channelized E1 and T1, and synchronous E1 HSL (SE-HSL).
- **Network Security.** Because signaling connectivity to other service providers is centralized at the EAGLE 5 ISS, gateway screening is centralized and not required at multiple switches.

IP Connectivity

The EAGLE 5 ISS provides connectivity between SS7 and IP networks, enabling messages to pass between the SS7 network domain and the IP network domain. It receives and sends Switched Circuit Network (SCN) native signaling at the edge of the IP network. This signaling gateway function can relay, translate, or terminate SS7 signaling in an SS7-Internet gateway. The signaling gateway function can also be co-resident with the media gateway function to process SCN signaling associated with line or trunk terminations controlled by the media gateway.

LNP

Local Number Portability (LNP) functions allow a subscriber to change location, service provider, or service while keeping the same directory number. LNP ensures that subscribers receive the same freedom of choice for local service as they do with long-distance service providers. LNP requires the Local Service Management System (LSMS), which provides the interface between the

Number Portability Administration Center (NPAC) service management system and the EAGLE 5 ISS. LSMS is composed of hardware and software components that interact to create a secure and reliable LNP system.

The EAGLE 5 ISS with LNP solution provides fully scalable transaction rates from 1,700 to 40,800 TPS. Tekelec simplifies number portability by integrating advanced database management and signaling functions directly into the EAGLE 5 ISS platform. Using a memory-based approach, LNP functions are combined with EAGLE 5 ISS capabilities in a single network node.

Theory of Operation

The EAGLE 5 ISS implements SS7 MTP function, level 2 and level 3, through software contained entirely within the Link Interface Modules (LIMs). No separate central processing unit exists within the EAGLE 5 ISS. All message processing logic, including the links, link sets, and routes associated with each origination point code and destination point code in the signaling network are included within the MTP Routing feature module. The STP offers full point code routing. (For rapid recovery from processor faults, copies of this software are also stored on the hard disk.) The LIMs can handle a 100% traffic load on each link, assuming a small MSU size.

The EAGLE 5 ISS consists of the following subsystems:

- Maintenance and Administration Subsystem (MAS)
- Communication Subsystem (Gigabit backbone)
- Application Subsystem

Figure 2: EAGLE 5 ISS System Functional Diagram on page 17 provides a high-level overview of the EAGLE 5 ISS subsystems and functions.

Figure 2: EAGLE 5 ISS System Functional Diagram

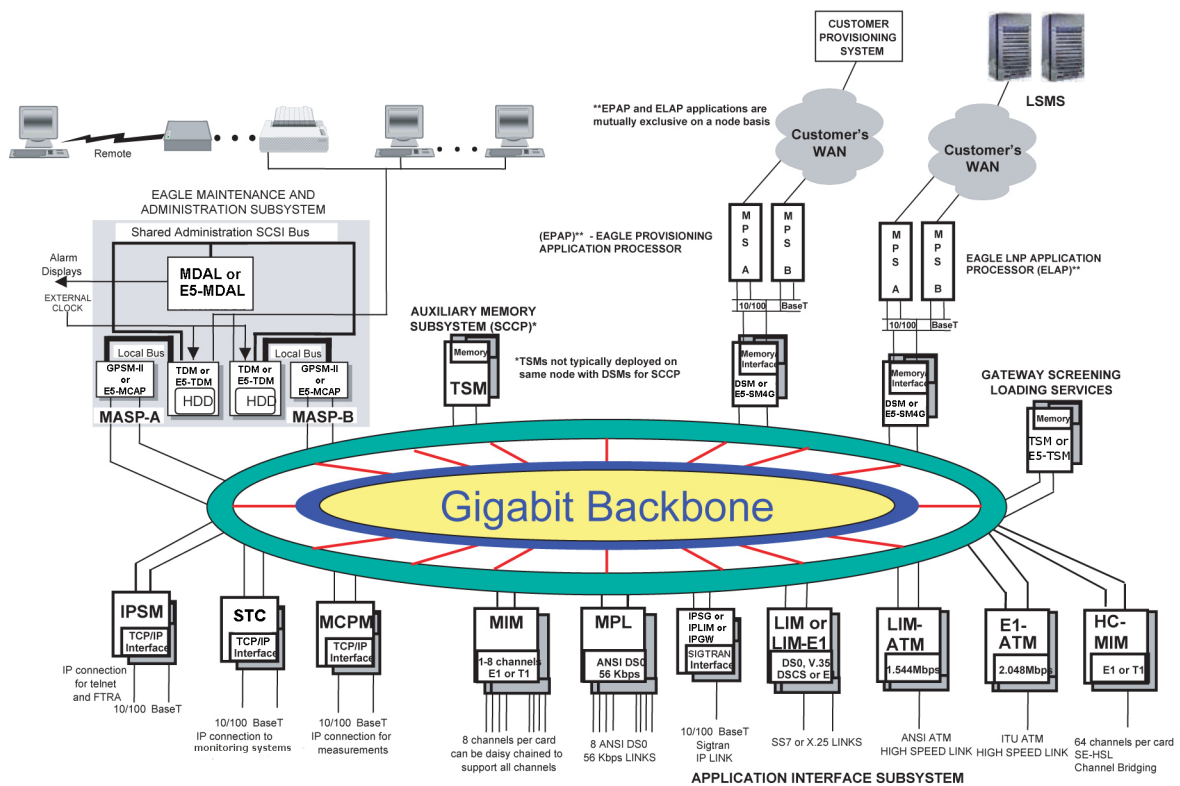

If gateway screening is on, incoming messages are screened before they are examined for further processing. The message discrimination function determines whether the message can be routed based solely on the MTP routing label. If so, the outgoing link is identified with its equipment address (LIM), and the message is transferred through an Inter-processor Message Transport (IMT) bus to that LIM card for transmission to the designated destination point code (DPC).

If the discrimination function determines that global title translation (GTT) is required, the message is sent, through the message distribution function, to SCCP routing that routes the message.

After the message arrives at the designated module, the DPC and subsystem number (SSN) for the message are determined by global title translation, and the message is transferred through an IMT bus to the appropriate LIM card for transmission to the designated DPC. See [Figure 3: Example EAGLE 5 ISS Message Flow](#) on page 18.

Figure 3: Example EAGLE 5 ISS Message Flow

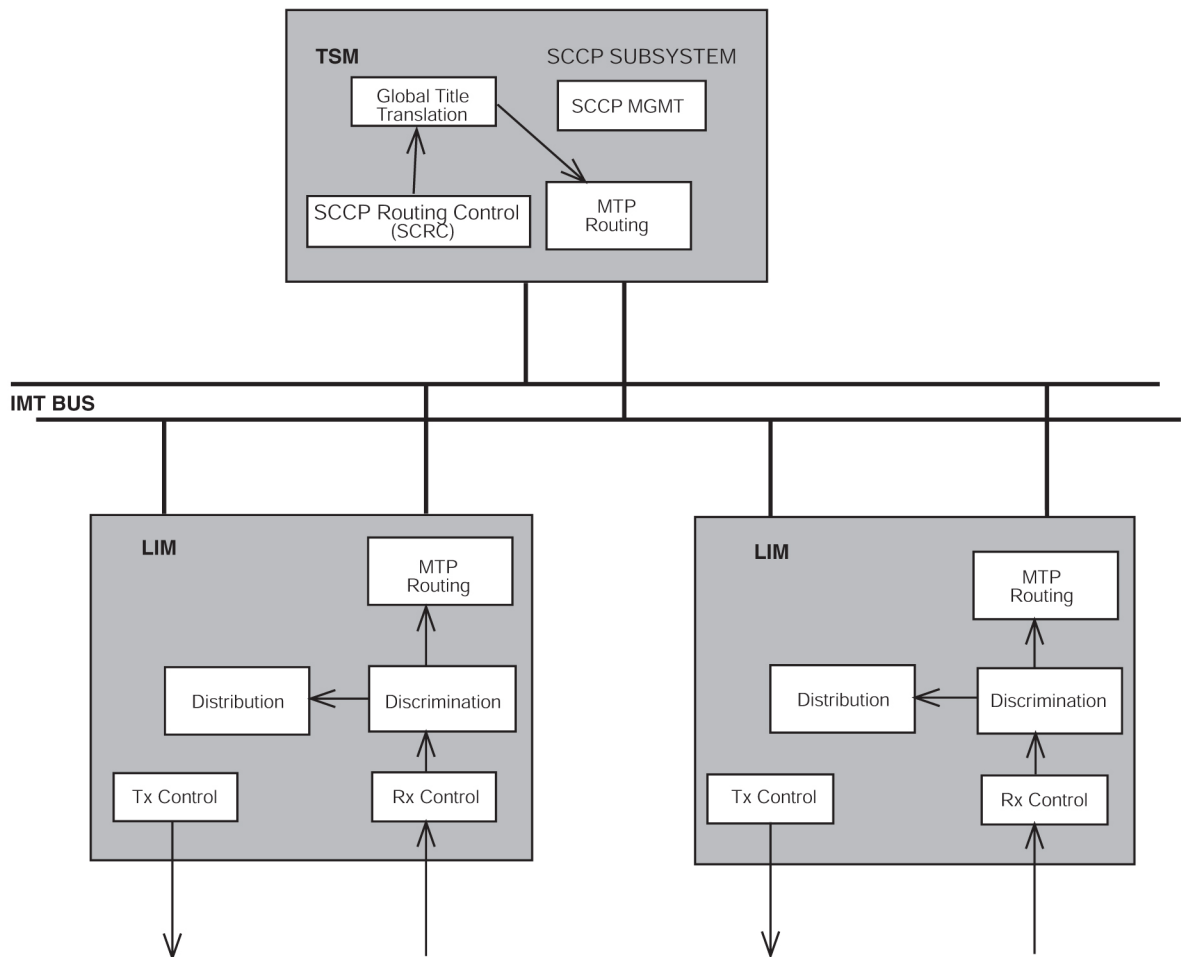

Maintenance and Administration Subsystem

The Maintenance and Administration Subsystem (MAS) is the central management point for the EAGLE 5 ISS. The MAS provides user interface, maintenance communication, peripheral services, alarm processing, system disk interface, and measurements. Management and redundancy are provided by use of two separate subsystem processors.

The MAS resides on two separate sets of Maintenance and Administration Subsystem Processor (MASP) cards and a Maintenance Disk and Alarm card (collectively referred to as control cards). The control cards are located in slots 1113 through 1118 of the EAGLE 5 ISS control shelf. The control cards can be either E5-based cards or legacy cards.

Note: In normal operation, the E5-based control cards and the legacy control cards cannot be mixed in one EAGLE 5 ISS control shelf.

Legacy Control Cards

The legacy set of EAGLE 5 ISS control cards consists of the following cards:

- Two MASP card sets; each set contains the following two cards:
 - A General Purpose Service Module II (GPSM-II) card

- A Terminal Disk Module (TDM) card
- One Maintenance Disk and Alarm (MDAL) card

General Purpose Service Module II (GPSM-II) Card

Each GPSM-II card contains the Communications Processor and the Applications Processor and provides connections to the IMT bus. The card controls the maintenance and database administration activity and performs both application and communication processing. GPSM-II cards are located in slots 1113 and 1115 of the control shelf.

Terminal Disk Module (TDM) Card

Each TDM card provides the Terminal Processor for the 16 I/O ports, and interfaces to the Maintenance Disk and Alarm (MDAL) card. The TDM card also distributes Composite Clocks and High Speed Master clocks throughout the EAGLE 5 ISS, and distributes Shelf ID to the EAGLE 5 ISS. Each TDM card contains one fixed disk drive that is used to store primary and backup system databases, measurements, and Generic Program Loads (GPLs). The TDM cards are located in slots 1114 and 1116 of the control shelf.

Maintenance Disk and Alarm (MDAL) Card

The MDAL card processes alarm requests and provides fan control. There is only one MDAL card in a control card set. Critical, major, and minor system alarms are provided for up to 6 individual frames. In addition to the 3 system alarms, the MDAL card provides the system audible alarm. The MDAL card provides control of fans on a per-frame basis and allows for each fan relay to be set individually. The MDAL card contains a removable cartridge drive; the removable cartridge is used for installing new software; backing up the system software, the application software, and the database; and for downloading data for off-line processing. The MDAL card is located in slots 1117 and 1118 of the control shelf.

E5-based Control Cards

The E5-based set of EAGLE 5 ISS control cards consists of the following cards:

- Two Maintenance and Administration Subsystem Processor cards (E5-MASP) cards. Each dual-slot E5-MASP card is made up of the following two modules:
 - Maintenance Communication Application Processor (E5-MCAP) card
 - Terminal Disk Module (E5-TDM) card
- One Maintenance Disk and Alarm card (E5-MDAL card)

Maintenance Communication Application Processor (E5-MCAP) Card

The E5-MCAP card contains the Communications Processor and Applications Processor and provides connections to the IMT bus. The card controls the maintenance and database administration activity and performs both application and communication processing. E5-MCAP cards are located in slots 1113 and 1115 of the control shelf.

Each E5-MCAP card contains two USB ports. One latched USB port is used with removable flash media ("thumb drives"), and one flush-mounted USB port is used with a plug-in "credit card" flash drive. The removable media drive is used to install and back up customer data. The credit card drive is used for upgrade and could be used for disaster recovery.

Terminal Disk Module (E5-TDM) Card

The E5-TDM card provides the Terminal Processor for the 16 I/O ports, and interfaces to the Maintenance Disk and Alarm (E5-MDAL) card and fixed disk storage. The E5-TDM card also distributes Composite Clocks and High Speed Master clocks throughout the EAGLE 5 ISS, and distributes Shelf ID to the EAGLE 5 ISS. Each E5-TDM card contains one fixed SATA drive that is used to store primary and backup system databases, measurements, and Generic Program Loads (GPLs). E5-TDM cards are located in slots 1114 and 1116 of the control shelf.

Maintenance Disk and Alarm (E5-MDAL) Card

The E5-MDAL card processes alarm requests and provides fan control. There is only one E5-MDAL card in a control card set. Critical, major, and minor system alarms are provided for up to 6 individual frames. In addition to the 3 system alarms, the E5-MDAL card provides the system audible alarm. The E5-MDAL card provides control of fans on a per-frame basis, and allows for each fan relay to be set individually. The E5-MDAL card does not contain a removable cartridge drive; drives for removable media are located on the E5-MCAP card. The E5-MDAL card is located in slots 1117 and 1118 of the control shelf.

Communication Subsystem

The Communication Subsystem consists of buses that provide communication between the control cards and between subsystems in the system.

Redundant IMT buses load share messages from the subsystems, and can each carry all messages if the other one fails. The IMT buses can function as a private LAN assigning an internal IP address to LIM cards. The internal addressing allows monitoring of SS7 links by the EAGLE 5 Integrated Monitoring Support feature without external connections. Signaling Transport Cards collect SS7 link information from LIM cards and transfer the information to an Integrated Acquisition System such a Tekelec Integrated Message Feeder.

Application Subsystem

The Application Subsystem consists of application cards. Application cards are capable of communicating with other cards through the redundant IMT buses. A Communications Processor (CP) on each application board provides control of communications from the cards to the IMT buses.

Software is downloaded to application cards on initial power-up from the Maintenance and Administration Subsystem Processors (MASP). After the EAGLE 5 ISS is loaded, software is downloaded to cards by the Generic Loader Services (GLS) and Operation Administration and Maintenance (OAM) functions.

Generic Program Loads

Application software is downloaded to individual application cards by means of Generic Program Loads (GPLs). A GPL is a specific instance of an application for a specific piece of hardware. Hardware is defined to EAGLE 5 ISS by means of a series of administration commands. Software is then loaded from the fixed disk over the IMT bus directly to the cards. The type of the GPL loaded depends on the card and card function that is chosen.

Local Service Management System (LSMS)

The Local Service Management System (LSMS) supports the administration of the Tekelec North American LNP solution. LSMS provides the interface between the Number Portability Administration Center (NPAC) Service Management System (SMS) and the EAGLE 5 ISS Element Management System (EMS). LSMS supports provisioning of the EAGLE 5 ISS with NPAC data as well as locally administered service provider-specific data.

LSMS is composed of hardware and software components that interact to create a secure and reliable LNP system. LSMS is equipped with a graphical user interface to administer subscription, service provider, and network data.

Features

LSMS features include:

- Eight industry standard Q.3 NPAC interfaces
- Support for administration of override data internal to the service provider's network
- Support of up to eight EAGLE 5 ISS pairs
- Ability to partition databases according to Area of Portability Service (AOPS), eliminating the need for database replication on all nodes
- Data auditing and reconciliation between EAGLE 5 ISS and LSMS
- Connection management for communications links, including automatic error detection and failure recovery
- Enhanced security, including key management and firewall

Functions

LSMS functions include:

- Receiving LNP data from the NPAC SMS
- Distributing data to the EAGLE 5 ISS and LNP
- Administering internal service provider LNP data to support the final global title translation for various services (such as LIDB, CNAM, CLASS, ISVM, and WSMSC)
- Storing NPAC LNP data and service provider LNP data in a persistent local database
- Supporting data audit function between the NPAC SMS and LSMS; The audit is initiated by the NPAC SMS
- Initiating audits and reconciliation between LSMS and EAGLE 5 ISS LNP
- Supporting connection management for NPAC and EAGLE 5 ISS LNP communication
- Handling local failures, NPAC communication failures, and EAGLE 5 ISS LNP communication failures and recovery
- Event Logging
- Providing internal data security using one-way encrypted passwords
- Providing a secure interface to the NPAC SMS using key list management

- Reporting event notifications and alarms

Figure 4: LNP Hardware Overview on page 23 provides an overview of the hardware components needed to support LNP. ELAP servers transmit data from the EAGLE 5 ISS to LSMS servers. ELAP servers use the Tekelec Multi-purpose Server (MPS) platform.

Figure 4: LNP Hardware Overview

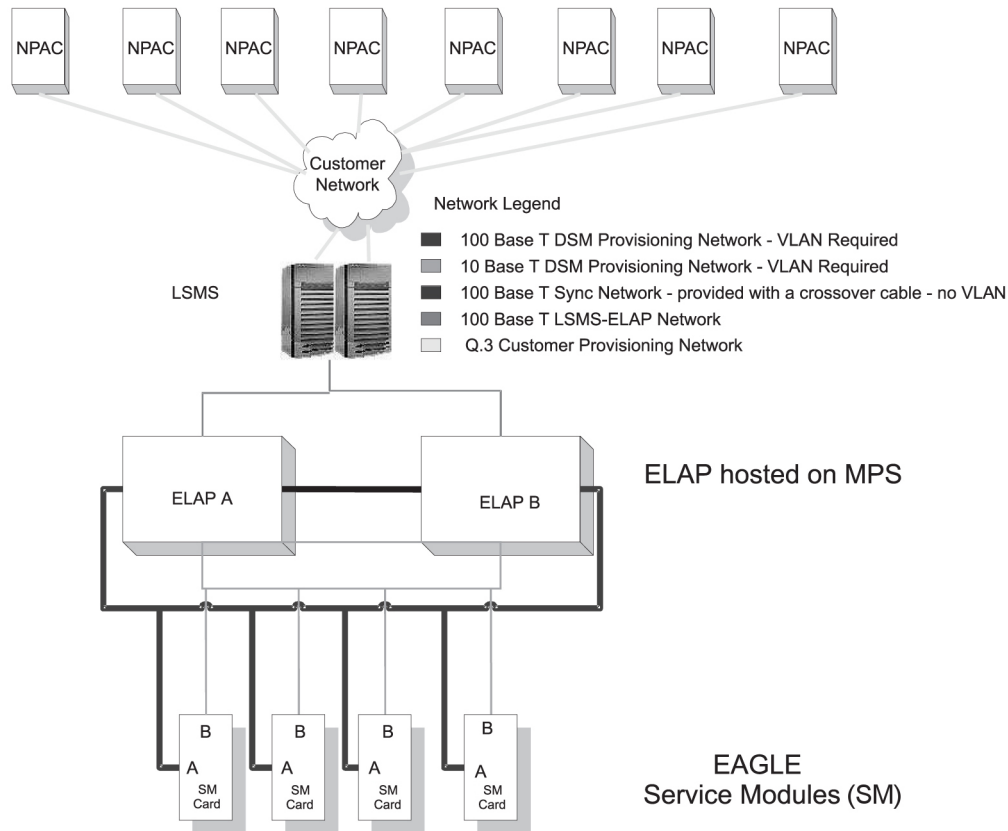

LSMS operates on an MPS server system in an active and hot standby configuration for high availability. Each Tekelec LSMS is configured with dual processors for fail-over conditions and shares a disk array capable of storing 96 million LNP data entries.

Theory of Operation

Normal updates are sent from LSMS to the active EAGLE LNP Application Processor (ELAP) at a rate of 25 TNs per second over a connection that uses the proprietary High Speed Operations Protocol (HSOP) over TCP/IP protocol. The ELAP forwards the messages to all the Service Module cards (DSM cards and E5-SM4G cards) using an IP multicast protocol (for more information, refer to the *ELAP Administration Manual*). No user action is required at the network element.

EAGLE 5 ISS Integrated Data Feed and IAS

The EAGLE 5 ISS platform supports an integrated data feed interface to the integrated data acquisition functions of the Tekelec Integrated Applications System (IAS).

Integrated data feed enables data mining of signaling information sent to the EAGLE 5 ISS platform. The SS7 signaling information is from high speed links (IP or ATM) and low speed links connected to the EAGLE 5 ISS.

Integrated data feed and acquisition enable Tekelec to provide an integrated monitoring system hosting business intelligence applications and mission-critical next-generation services for Performance Management and Revenue Assurance. For example, integrated data acquisition supports business intelligence applications including fraud detection, billing verification analysis, quality of service, sophisticated trouble shooting, and network monitoring.

Figure 5: EAGLE-IAS Interfacing on page 24 represents the interfacing of EAGLE 5 ISS to the IAS. The following numbered paragraphs correspond to numbered areas of the diagram.

Figure 5: EAGLE-IAS Interfacing

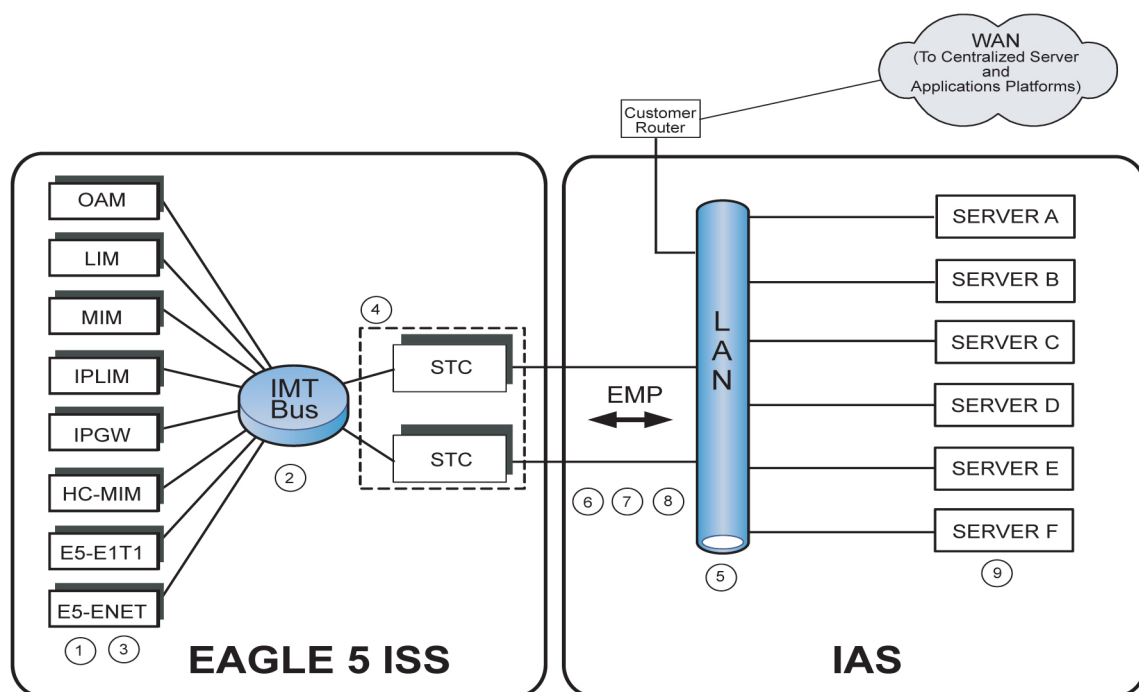

Note: SSEDCEM and E5-ENET card types are supported.

1. Probeless Data Collection

Integrated data feed supports a powerful, probe-less data collection system by eliminating external taps and the need for probes, which significantly saves central office space. Any or all links on EAGLE 5 ISS LIM cards can be selected for monitoring, relieving the burden of applying taps and cable changes typically associated with probe-based systems.

2. Intra/Inter Shelf Data Processing

Signaling Transport Cards (STC cards) are allocated per EAGLE 5 ISS shelf to maximize the effectiveness of the integrated monitoring by capturing and sending signaling data intra-shelf. Where necessary, signaling data may be sent over the IMT to an STC inter-shelf. STC cards are inserted into the EAGLE 5 ISS shelves as additional link monitoring capacity is required.

3. Message Time Stamping

Accurate time stamping is done using the Time Counter Synchronization (TSCSYNC) functions of the TDM card and the Network Timing Protocol (NTP) to provide a time stamp accuracy of +/- 5 ms. STC cards NTP synchronize to the T1100 Application Servers, which NTP synchronize to a network NTP server.

4. Transport Redundancy

Redundant STC cards provide a scalable and reliable transport for sending captured signaling information to the IAS. STC cards utilize the ticket voucher group (TVG) selection mechanism to grant data sending requests from EAGLE 5 ISS LIM cards that copy signaling information in real time. The TVG provides load shared STC cards when LIM cards send captured signaling data to the IAS.

5. Redundant LAN

Monitoring support for integrated data feed is provided over a redundant LAN connection to the IAS. Each STC card has two Ethernet ports for connecting to the redundant LAN that is realized by Ethernet switches in the IAS frame.

6. Monitoring Interface

EAGLE 5 ISS integrated data feed is provided using the EAGLE Monitoring Protocol (EMP) over a reliable TCP/IP transport.

7. Automatic Provisioning Updates

Integrated data feed provides automatic updates to the IAS when new links are provisioned on the EAGLE 5 ISS. These recent changes are sent to the IAS through the EMP interface.

8. Alarm Event Reporting

Integrated data feed sends alarm events to the IAS. EAGLE 5 ISS alarms associated with monitored links and status are sent to the alarm management subsystem of monitoring system through the EMP interface.

9. Highly Reliable Servers

Integrated data feed and acquisition are based on the highly reliable, carrier-grade EAGLE 5 ISS equipment that connects to T1100 Application Servers that store, process, filter, and forward signaling data to downstream correlation and application servers. The T1100 Application Servers provide mirrored drives for storage of captured signaling data.

Multi-purpose Server (MPS)

The Tekelec Multi-purpose Server (MPS) is a hardware and software platform that can be configured to support the EAGLE 5 ISS Local Number Portability Application Processor (ELAP) or the EAGLE 5 ISS Provisioning Application Processor (EPAP).

MPS on the Tekelec 1000 Application Server (T1000 AS) supports EPAP. Additional third-party software might be required to support the application. For hardware information, see the *Tekelec 1000 Application Server Hardware Manual*.

MPS on the Tekelec 1100 Application Server (T1100 AS) supports the ELAP. The ELAP application includes support for Local Number Portability (LNP) features. For hardware information, see the *Tekelec 1100 Application Server Hardware Manual*.

This section provides an overview of the hardware and software that comprises the MPS on the T1000 Application Server. For information about the EPAP application and how it interacts with the EAGLE 5 ISS, refer to the *EPAP Administration Manual*. For information about the ELAP application and how it interacts with the EAGLE 5 ISS, refer to the *ELAP Administration Manual*.

Figure 6: MPS on T1000 AS/EAGLE 5 ISS Overview on page 26 shows an overview of how the MPS on the T1000 AS is used with the EAGLE 5 ISS.

The MPS provides an interface between the customer provisioning network and the EAGLE 5 ISS Service Module cards (DSM cards and E5-SM4G cards). As the customer data is updated, the MPS stores the data and updates the Service Module cards. An MPS is usually co-located with an EAGLE 5 ISS.

Figure 6: MPS on T1000 AS/EAGLE 5 ISS Overview

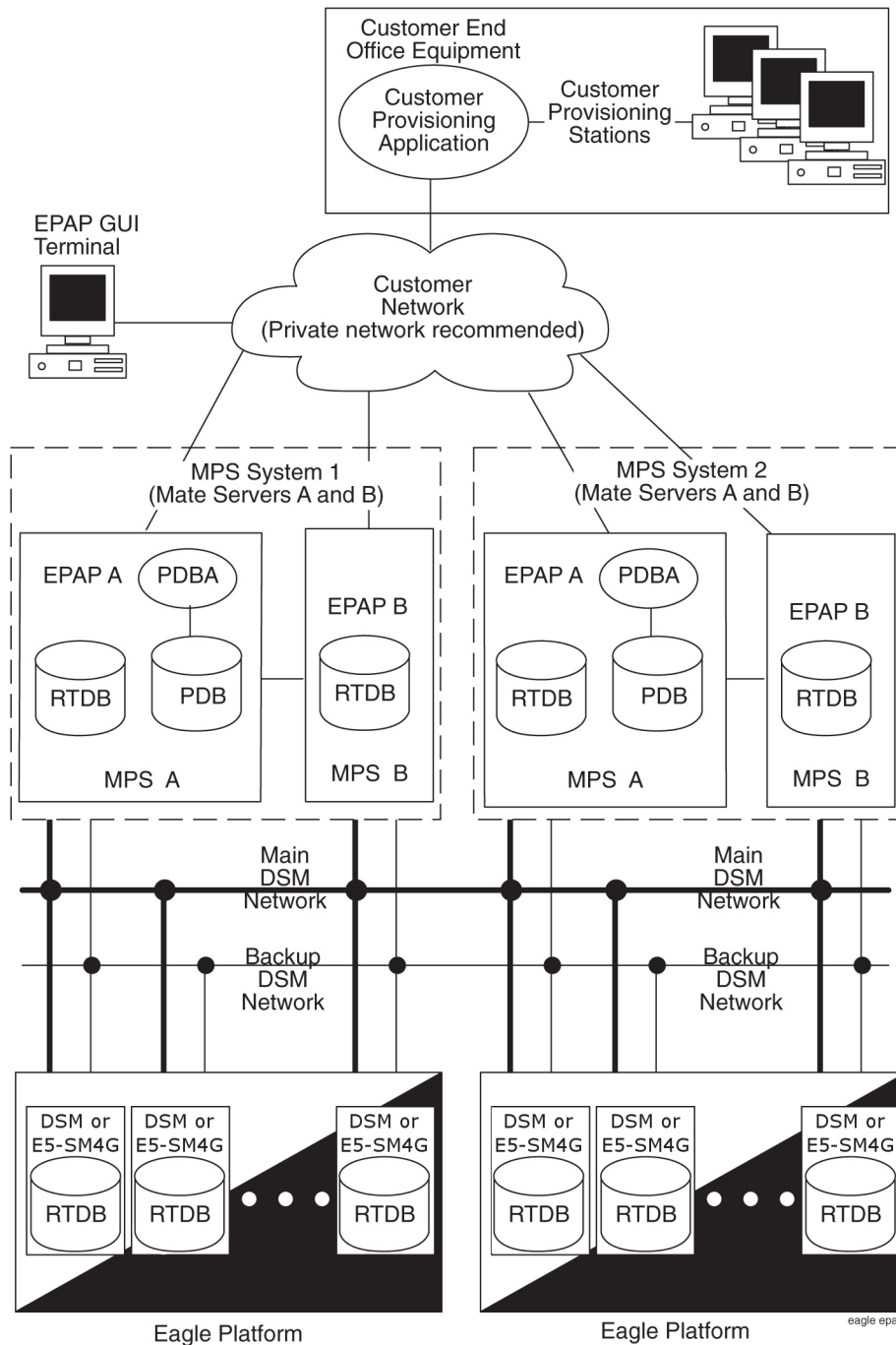

Features

MPS running the EAGLE Provisioning Application Processor (EPAP) software supports EPAP-based EAGLE 5 ISS features that allow a subscriber to change location, service provider, or service while keeping the same directory number, and that ensure that subscribers receive the same freedom of choice for local service as they do with long-distance service providers. The supported features include:

- A-Port, IS41 GSM Migration, MTP Messages for SCCP Applications
- ATI Number Portability Query (ATINP)
- Equipment Identity Register (EIR)
- G-Flex
- G-Port, G-Port SRI Query for Prepaid
- INP/AINPQ
- MO-based GSM SMS NP, MO-based IS41 SMS NP, MO SMS IS41-to-GSM Migration, MO SMS Additional Subscriber Data, MO SMS Generic Routing Number
- MT-based GSM SMS NP, MT-based IS41 SMS NP
- Portability Check for MO SMS
- Prepaid IDP Query Relay (IDP Relay), IDPR Additional Subscriber Data, IDPR Generic Routing Number
- Prepaid SMS Intercept Phase 1 (PPSMS)
- TIF Number Portability, TIF SCS Forwarding, TIF Simple Number Substitution, TIF Additional Subscriber Data, TIF Generic Routing Number
- V-Flex

MPS running the EAGLE LNP Application Processor (ELAP) software supports LNP quantity features for up to 384 million numbers.

Layered Design

The MPS is based on the T1000 AS and uses a layered design (see [Figure 7: Layered Design for MPS and Applications](#) on page 28) with defined interfaces to enable application and platform changes to be made independently. This design provides an environment in which changes made to platform components need not cause changes in applications.

Figure 7: Layered Design for MPS and Applications

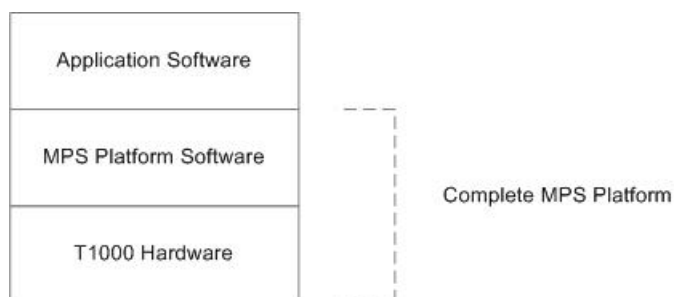

Tekelec 1000 and Tekelec 1100 Application Server

The Tekelec 1000 and 1100 Application Servers (T1000 AS and T1100 AS) use a multi-processing architecture based on the latest and the most powerful Intel server-class processors, enabling operators to transition between legacy systems and next-generation networks. At the same time, the servers improve cost-revenue ratios for the deployment of new services by combining and provisioning multiple applications from the most efficient location in the network—the Signal Transfer Point (STP). The T1000 AS and T1100 AS are fully integrated with the Tekelec EAGLE 5

Integrated Signaling System (ISS), providing the ability to implement and direct various network applications directly from the STP platform.

Key Benefits

The T1000 AS and T1100 AS provide an application hosting environment fully integrated with the Tekelec EAGLE 5 ISS. The benefits of this architecture include:

- **Low latency, high-speed processing.** Processing time for enhanced services and applications is dramatically reduced as service-related signaling is efficiently routed directly to the server platform instead of across the network.
- **High-bandwidth connectivity.** A typical deployment of external databases or application platforms requires long-haul transport of signaling traffic over relatively slow 56 or 64 Kbps links. Network latency introduced by this transport delay has a direct effect on the utilization of network resources, which are tied up during the transaction. Full utilization of T1000 AS and T1100 AS processing power translates directly into cost savings as fewer applications platforms are required.
- **Reduced transport and maintenance costs.** The T1000 AS and T1100 AS are fully integrated with the Tekelec EAGLE 5 ISS, alleviating the need for transport links and the associated costs.
- **Application rich.** The T1000 AS and T1100 AS are high performance, server-class computing platforms designed to host powerful applications requiring high reliability and throughput.

Features and Capabilities

The EAGLE 5 ISS handles all of the signaling routing within the core network.

- The EAGLE 5 ISS can be upgraded with the T1000 AS and T1100 AS integrated application server capabilities at any time, without forklifts.
- Large memory space for complex applications and large databases: 32-bit (T1000 AS) and 64-bit (T1100 AS) architectures for hosting high-performance applications that require direct addressing of up to 16 GB of memory.
- The T1100 AS hosts a variety of Tekelec applications requiring large in-memory databases, including:
 - Local Service Management System (LSMS) to support number portability
 - Integrated Applications Solutions (IAS) - such as Traffic Management, Roaming Management, Fraud Management, Billing Management, Market Intelligence, and Troubleshooting
 - Short Message Gateway (SMG)
 - Session Initiation Protocol (SIP)-SS7 Gateway
 - IP Multimedia Subsystem (IMS) solutions
- Protocol support: AIN, IN, INAP, CAMEL, WIN, SIP
- NEBS and ITU compliant

Embedded OSS Application Processor (EOAP)

The Embedded Operations Support System Application Processor (EOAP) is a general purpose interface module that provides the EAGLE 5 ISS system with a generic platform to develop and run software for feature-specific interfaces to the EAGLE 5 ISS. These interfaces, for example, include the optional Signaling and Engineering Administration System (SEAS).

The EOAP translates and converts higher layer protocols into asynchronous serial communication. It communicates with the EAGLE 5 ISS through a serial interface port. For the SEAS interface, EOAP provides translation and asynchronous-to-X.25 communication conversion. See [Figure 8: EOAP Communication](#) on page 30.

Figure 8: EOAP Communication

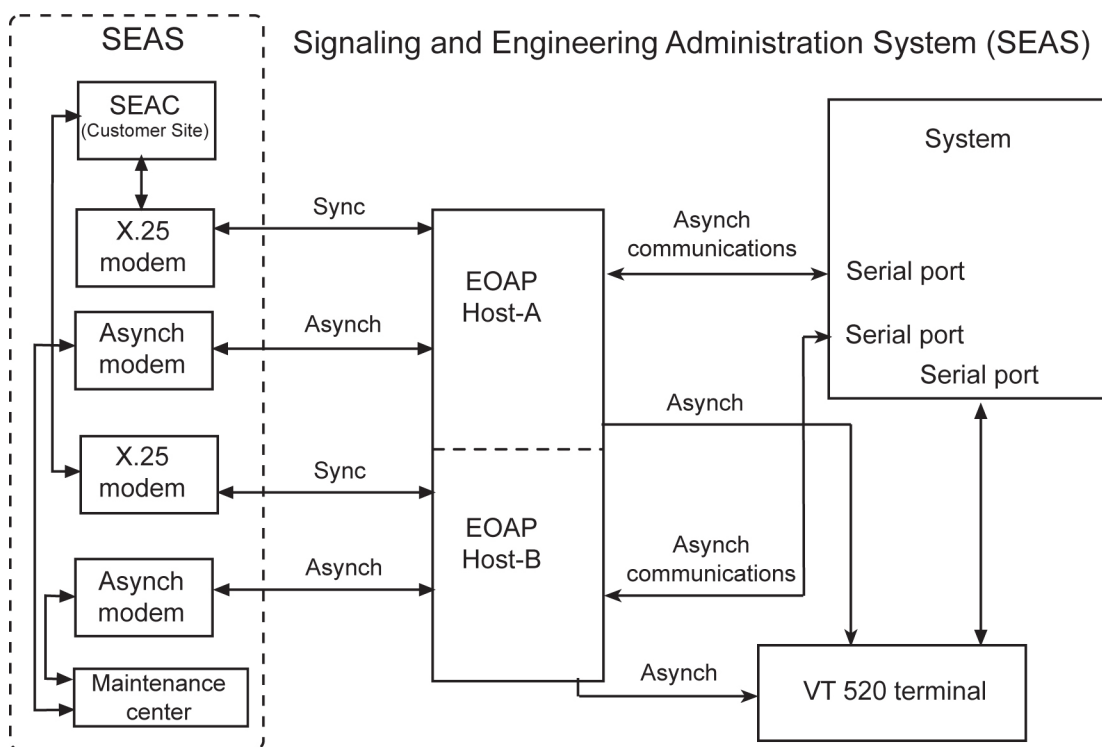

Each EOAP reports to the EAGLE 5 ISS its general status as well as the status of its User Application Layer (UAL), X.25 links, PVCs on those links, and Q.3 associations. The EAGLE 5 ISS can then report the status of the EOAP and its components to the user through the EAGLE 5 ISS Human-to-Machine Interface HMI.

Most aspects of the EOAP can be configured through an EAGLE 5 ISS terminal. For upgrade, debug, and maintenance functions, a VT-520 terminal directly connected to the EOAP is used.

The EOAP is a modular unit with field-replaceable components. For upgrade purposes, the EOAP can replace an existing Texas Micro OAP.

The EOAP shelf is designed for a split system consisting of an EOAP-A and an EOAP-B. Each EOAP system in the dual configuration consists of a processor card, a serial interface card, a power supply card, a removable hard drive, and a removable CD-ROM drive.

Glossary

A

AIN	<p>Advanced Intelligent Network</p> <p>A dynamic database used in Signaling System 7. It supports advanced features by dynamically processing the call based upon trigger points throughout the call handling process and feature components defined for the originating or terminating number.</p>
AOPS	<p>Area of Portability Service</p>
ATM	<p>Asynchronous Transfer Mode</p> <p>A packet-oriented transfer mode that uses an asynchronous time division multiplexing technique to multiplex information flow in fixed blocks, called cells.</p> <p>A high-bandwidth, low-delay switching, and multiplexing technology to support applications that include high-speed data, local area network interconnection, multimedia application and imaging, and residential applications such as video telephony and other information-based services.</p>

C

CAMEL	<p>Customized Applications for Mobile networks Enhanced Logic</p>
CCS6	<p>Common Channel Signaling System #6</p>

C

CD-ROM	Compact Disc - Read-Only Memory
CLASS	Custom Local Area Signaling Service Custom Local Area Subscriber Services
CNAM	Calling Name Delivery Service
control cards	Cards that occupy slots 1113 through 1118 of the control shelf on an EAGLE 5 ISS and perform OAM, TDM, and database functions for the EAGLE 5 ISS. The legacy set consists of the single-slot GPSM-II card running the OAM application and EOAM GPL, the single-slot TDM card, and the dual-slot MDAL card. The E5-based set consists of the dual-slot E5-MASP card (the E5-MCAP module and the E5-TDM module) and the dual-slot E5-MDAL card.
CP	Communications Processor
credit card drive	Flash memory credit card-shaped drive used in the flush-mounted USB port on an E5-MCAP card for upgrade; it could be used for disaster recovery.

D

DPC	Destination Point Code DPC refers to the scheme in SS7 signaling to identify the receiving signaling point. In the SS7 network, the point codes are numeric addresses which uniquely identify
-----	--

D

each signaling point. This point code can be adjacent to the EAGLE 5 ISS, but does not have to be.

DS0A

Digital Signal Level - 0

The interface used with the LIMDS0 card.

E

E1

The European equivalent of T1 that transmits digital data over a telephone network at 2.048 Mbps.

E5-MASP card

E5-based dual-slot card that consists of the E5-MCAP module (occupies slot 1113 and slot 1115) and the E5-TDM module (occupies slot 1114 and slot 1116) in an EAGLE 5 ISS control shelf. Used when the E5-MDAL card is used.

E5-MCAP card

The module contains the Communications Processor and Applications Processor and provides connections to the IMT bus. Controls the maintenance and database administration activity and performs both application and communication processing. Runs the OAM application and OAMHC GPL. Occupies slot 1113 and slot 1115 in an EAGLE 5 ISS control shelf. Used when the E5-MDAL card is used. Contains two USB ports.

E5-MDAL card

The E5 MDAL card processes alarm requests, provides general purpose relays, and provides fan control. Occupies slots 1117 and 1118 in an EAGLE 5 ISS Control Shelf. Used with E5-MASP cards.

E

Does NOT contain a drive for removable cartridges.

E5-ENET

EPM-based Ethernet card

A high capacity single-slot IP signaling card (EPM card plus Gig Ethernet PMC cards).

E5-TDM card

The E5-TDM card provides the EAGLE 5 ISS with 16 ports for user terminals, contains fixed disk storage and distributes Composite Clocks and High Speed Master clocks throughout the EAGLE 5 ISS. Occupies slot 1114 and slot 1116 in an EAGLE 5 ISS Control Shelf. Used when the E5-MDAL card is used.

ECSA

Exchange Carrier Standards Association

ELAP

EAGLE Local Number Portability Application Processor

EMP

EAGLE Monitoring Protocol

EMS

Element Management System

The EMS feature consolidates real-time element management at a single point in the signaling network to reduce ongoing operational expenses and network downtime and provide a higher quality of customer service.

EOAP

Embedded Operation Support System Applications Processor

Also, Enhanced OSS Application Process.

	E	
EPAP		EAGLE Provisioning Application Processor
	F	
fixed disk drive		Hard drive on the TDM card and the E5-TDM card.
flush-mounted USB port		USB port on the E5-MCAP card; used with credit card flash memory drives for installation and backup of customer data.
	G	
GB		Gigabyte — 1,073,741,824 bytes
GLS		Generic Loading Services An application that is used by the TSM cards for downloading gateway screening to LIM cards.
GPL		Generic Program Load Software that allows the various features in the system to work. GPLs and applications are not the same software.
GPSM-II card		General Purpose Service Module II Contains the communications processor and applications processor and provides connections to the Interprocessor Message Transport (IMT) bus. The GPSM-II card can run on the OAM, IPS, or MCP applications. This card runs various GPLs and applications in the EAGLE 5 ISS. As a control card, it runs the OAM application and EOAM GPL. Used when the legacy TDM cad and MDAL card are used.

G

GTT

Global Title Translation

A feature of the signaling connection control part (SCCP) of the SS7 protocol that the EAGLE 5 ISS uses to determine which service database to send the query message when an MSU enters the EAGLE 5 ISS and more information is needed to route the MSU. These service databases also verify calling card numbers and credit card numbers. The service databases are identified in the SS7 network by a point code and a subsystem number.

H

HMI

Human-to-Machine Interface

HSL

High-Speed Link

I

IAS

Integrated Application Solution

Provides an in-depth understanding of the network and equips wireline and wireless operators with the tools required to make informed business investment and cost reduction decisions. Service providers use the solutions to manage interconnection agreements, increase roaming revenue, ensure end-to-end QoS across the network, detect fraud, analyze subscriber behavior, examine service usage, as well as support existing applications such as fraud management, billing, service level agreement in their TDM, wireless, and VoIP networks.

Integration Application Server

I

IMS	<p>IP Multimedia Subsystem</p> <p>These are central integration platforms for controlling mobile communications services, customer management and accounting for mobile communications services based on IP. The IMS concept is supported by 3GPP and the UMTS Forum and is designed to provide a wide range of application scenarios for individual and group communication</p>
IMT	<p>Inter-Module-Transport</p> <p>The communication software that operates the inter-module-transport bus on all cards except the LIMATM, DCM, DSM, and HMUX.</p>
IN	<p>Intelligent Network</p> <p>A network design that provides an open platform for developing, providing and managing services.</p>
INAP	<p>Intelligent Network Application Protocol</p>
Integrated Services Digital Network	<p>The network services that provide end-to-end digital connections to which users have access to a wide range of services through a limited set of standard user to network interfaces.</p>
IP	<p>Internet Protocol</p> <p>IP specifies the format of packets, also called datagrams, and the addressing scheme. The network layer for the TCP/IP protocol suite</p>

I

widely used on Ethernet networks, defined in STD 5, RFC 791. IP is a connectionless, best-effort packet switching protocol. It provides packet routing, fragmentation and re-assembly through the data link layer.

ISS Integrated Signaling System

ISUP ISDN User Part

ITU-TS ITU Telecommunications Standardization Sector

K

Kbps Kilobits per second

L

latched USB port On the E5-MCAP card, a USB port with a lockable latch. Used with removable media (flash memory "thumb" drives) to install and back up customer data.

LIDB Line Information Database

LNP Local Number Portability

LSMS Local Service Management System

M

MAS Maintenance and Administration Subsystem

A set of cards located in the Control Shelf, used to provide a central management point for the EAGLE 5 ISS. The MAS provides

M

user interface, maintenance communication, peripheral services, alarm processing, system disk interface, and measurements using the following three subassemblies: GPSM-II, TDM, and MDAL.

MASP

Maintenance and Administration Subsystem Processor

The Maintenance and Administration Subsystem Processor (MASP) function is a logical pairing of the GPSM-II card and the TDM card. The GPSM-II card is connected to the TDM card by means of an Extended Bus Interface (EBI) local bus.

The MDAL card contains the removable cartridge drive and alarm logic. There is only one MDAL card in the Maintenance and Administration Subsystem (MAS) and it is shared between the two MASPs.

Mbps

Megabytes Per Second

MPS

Multi-Purpose Server

The Multi-Purpose Server provides database/reload functionality and a variety of high capacity/high speed offboard database functions for applications. The MPS resides in the General Purpose Frame.

MSC

Mobile Switching Center

MSU

Message Signaling Unit

The SS7 message that is sent between signaling points in the SS7 network with the necessary

M

information to get the message to its destination and allow the signaling points in the network to set up either a voice or data connection between themselves. The message contains the following information:

- The forward and backward sequence numbers assigned to the message which indicate the position of the message in the traffic stream in relation to the other messages.
- The length indicator which indicates the number of bytes the message contains.
- The type of message and the priority of the message in the signaling information octet of the message.
- The routing information for the message, shown in the routing label of the message, with the identification of the node that sent message (originating point code), the identification of the node receiving the message (destination point code), and the signaling link selector which the EAGLE 5 ISS uses to pick which link set and signaling link to use to route the message.

MTP

The levels 1, 2, and 3 of the SS7 protocol that control all the functions necessary to route an SS7 MSU through the network.

N

NEBS

Network Equipment Building Systems

O

5. Session layer
6. Presentation layer
7. Application layer

P

PVC

Permanent Virtual Circuit

A direct connection to an X.25 node that is configured in the EAGLE 5 ISS's database and can only be changed through database administration.

R

removable cartridge

MO cartridge used in the drive on the legacy MDAL card.

removable cartridge drive

Media drive for removable MO cartridges on the legacy MDAL card.

removable media

Flash memory or "thumb" drives used in the latched USB port on an E5-MCAP card for installation and backup of customer data.

S

SCCP

Signaling Connection Control Part

SCN

Switched Circuit Network

SCP

Service Control Point

Service Control Points (SCP) are network intelligence centers where databases or call processing information is stored. The primary function of SCPs is to respond to queries from other SPs by retrieving the requested information from the appropriate

S

database, and sending it back to the originator of the request.

Secure Copy

SE-HSL

Synchronous E1 High Speed Link

Format for E1 high-speed signaling links where time-slot 0 is used for framing and error control. The remainder of bandwidth, equivalent to 31 channels of 64Kbps data, is used as a single data link yielding a total capacity of 1.984 Mbps. Also known as Unchannelized E1.

SEAS

Signaling Engineering and Administration System

An interface defined by Bellcore and used by the Regional Bell Operating Companies (RBOCs), as well as other Bellcore Client Companies (BCCs), to remotely administer and monitor the signaling points in their network from a central location.

SIP

Session Initiation Protocol

SMG

Short Message Gateway

SMS

Short Message Service

SS7

Signaling System #7

SSEDCM

Single Slot Enhanced Data Communications Module

SSN

Subsystem Number

S

The subsystem number of a given point code. The subsystem number identifies the SCP application that should receive the message or the subsystem number of the destination point code to be assigned to an X.25 address or the LNP subsystem of the EAGLE 5 ISS.

A value of the routing indicator portion of the global title translation data commands indicating that no further global title translation is required for the specified entry.

SSP

Subsystem Prohibited network management message.

Subsystem Prohibited SCCP (SCMG) management message. (CER)

T

T1

Transmission Level 1

A T1 interface terminates or distributes T1 facility signals for the purpose of processing the SS7 signaling links carried by the E1 carrier.

A leased-line connection capable of carrying data at 1,544,000 bits-per-second.

TCAP

Transaction Capabilities Application Part

TCP/IP

Transmission Control Protocol/Internet Protocol

TDM

Terminal Disk Module
Time Division Multiplexing

T

TN	Telephone Number A 10 digit ported telephone number.
TPS	Transactions Per Second
TSCSYNC	Time Slot Counter Synchronization The Time Slot Counter (TSC) Synchronization feature allows the system's A (Active) and B (Standby) internal clocks to be synchronized by the standby OAM GPSM-II card.
TVG	Group Ticket Voucher

U

UAL	User Application Layer
USB port	Receptacle for flash memory drives on personal computers. On the E5-MDAL card, a flush-mounted USB port used with credit card flash memory drives for upgrade. On the E5-MCAP card, a latched USB port for use with flash memory "thumb" drives for installation and backup of customer data.

V

V.35	ITU Interface Recommendation, V.35 The interface used with the LIMV35 card.
------	--

W

WIN	Wireless Intelligent Network
-----	------------------------------

W

WIN's objective is to transport the resources of an intelligent network to a wireless network, utilizing the interim standard IS-41 which was adopted because its facilitates roaming.

WSMSC

Wireless Short Message Service Center

Systems Overview

Index

A

admonishments, documentation 3
availability, documentation 3

C

card
 E5-MCAP 20
 E5-MDAL 21
 E5-TDM 21
 General Purpose Service Module II (GPSM-II) 20
 MDAL 20
 TDM 20
 Terminal Disk Module (TDM) 20
cards
 control 19
 E5-MASP 20
 MASP 19
cartridge, removable 20
CAUTION admonishment 3
control cards
 E5-based 20
 EAGLE 5 ISS 19
 legacy 19
credit card flash drive 20
CSR, See Customer Service Request (CSR)
Customer Care Center
 contact information 4
 emergency response 6
Customer Service Request (CSR) 4
Customer Support site
 how to access 7

D

DANGER admonishment 3
documentation 2, 3, 7
 availability, packaging, and updates 3
 Documentation Bulletins 3
 electronic files 3
 locate on Customer Support site 7
 printed 3
 Related Publications 2
 Release Notice 3
drive
 credit card flash 20
 E5-TDM fixed SATA 21
 removable media flash 20
 TDM fixed 20

E

E5-based control cards 20
E5-MASP cards 20
E5-MCAP card 20
 USB ports 20
E5-MDAL card 21
E5-TDM card 21
electronic files, documentation 3
emergency response, Customer Care Center 6

F

fixed drive
 E5-TDM 21
 TDM 20

G

General Purpose Service Module II 20
GPSM-II card 20

H

High Speed Operations Protocol (HSOP) 23

I

IAS 24
Integrated Applications System (IAS) 24
Integrated data acquisition 24
Integrated data feed 24

L

legacy control cards 19
Local Service Management System (LSMS) 22
locate documentation on Customer Support site 7
LSMS 22

M

Maintenance and Administration Subsystem (MAS) 19
Maintenance and Administration Subsystem Processor (MASP) 19
Maintenance Communication Application Processor (MCAP) 20
Maintenance Disk and Alarm (MDAL) 20, 21
MAS 19

MASP 19
MASP cards 19
MDAL card 20

P

packaging, documentation 3
printed documentation 3

R

Related Publications 2
Release Notice 3
removable cartridge 20
removable media 20

S

SATA fixed drive, E5-TDM 21

T

TAC Regional Support Office 4
TDM card 20
Terminal Disk Module (TDM) 21
TOPPLE admonishment 3

U

updates, documentation 3
USB port
 flush-mounted 20
 latched 20

W

WARNING admonishment 3