

NOTES: UNLESS OTHERWISE SPECIFIED

- 1) INSTALL ALL CABLE ASSEMBLIES WITH DRESSED BEND RADII IN ACCORDANCE WITH TEKELEC CABLE BEND RADIUS SPECIFICATION 906-0020-01.
- 2) ALL INTERCONNECTION POINTS SHALL BE STRAIN RELIEVED BY POSITIVE MECHANICAL FEATURES OR FASTENERS FOR LENGTH CONFIGURATIONS.
- 3) THIS DIAGRAM AND ALL PART NUMBERS SHOWN ARE FOR REFERENCE ONLY. REFERENCE CABLE PART NUMBERS WITH XX FOR THE DASH NUMBER ARE LENGTHS THAT ARE SITE SPECIFIC.
- 4) NO ADDITIONS, DELETIONS, SUBSTITUTIONS OR MODIFICATIONS WITHOUT PRIOR WRITTEN TEKELEC APPROVAL.

- 5) SEE TEKELEC P/N 820-5695-01 FOR CURRENT HARDWARE LIST.
- 6) USE LABEL PN 617-0009-01 TO MAKE LABEL SET FOR FROM AND TO ON CABLES INDICATED IN TABLE A. EACH CABLE INDICATED WILL REQUIRE 2 LABELS ONE AS SHOWN IN THE TABLES AND ONE WITH FROM AND TWO REVERSED AS SHOWN IN DETAIL K. PERMANENTLY PRINT LABELS WITH .09 HIGH BLACK CHARACTERS. CENTER TEXT APPROXIMATELY AS SHOWN. MAX 23 CHARACTERS PER LINE.
- 7) THREE LABELS REQUIRED FOR THE CABLES INDICATED THEY ARE Y CABLES.
- 8) CIRCUIT BREAKER IS SUPPLIED WITH JUMPERS BETWEEN POWER INPUTS TO CONNECT 4 CIRCUIT BREAKERS PER POWER INPUT. FUSE POSITIONS 1-4, 5-8 AND 9-12.

DOCUMENT CONTROL  
PRODUCTION RELEASED

REVISIONS			
LTR	DESCRIPTION	DATE	APPROVED
A	RELEASED PER ECN # 14634	5/26/05	ARMSTRONG
B	REVISED PER ECN# 14814	06/20/05	ARMSTRONG
C	REVISED PER ECN# 14845	06/29/05	ARMSTRONG

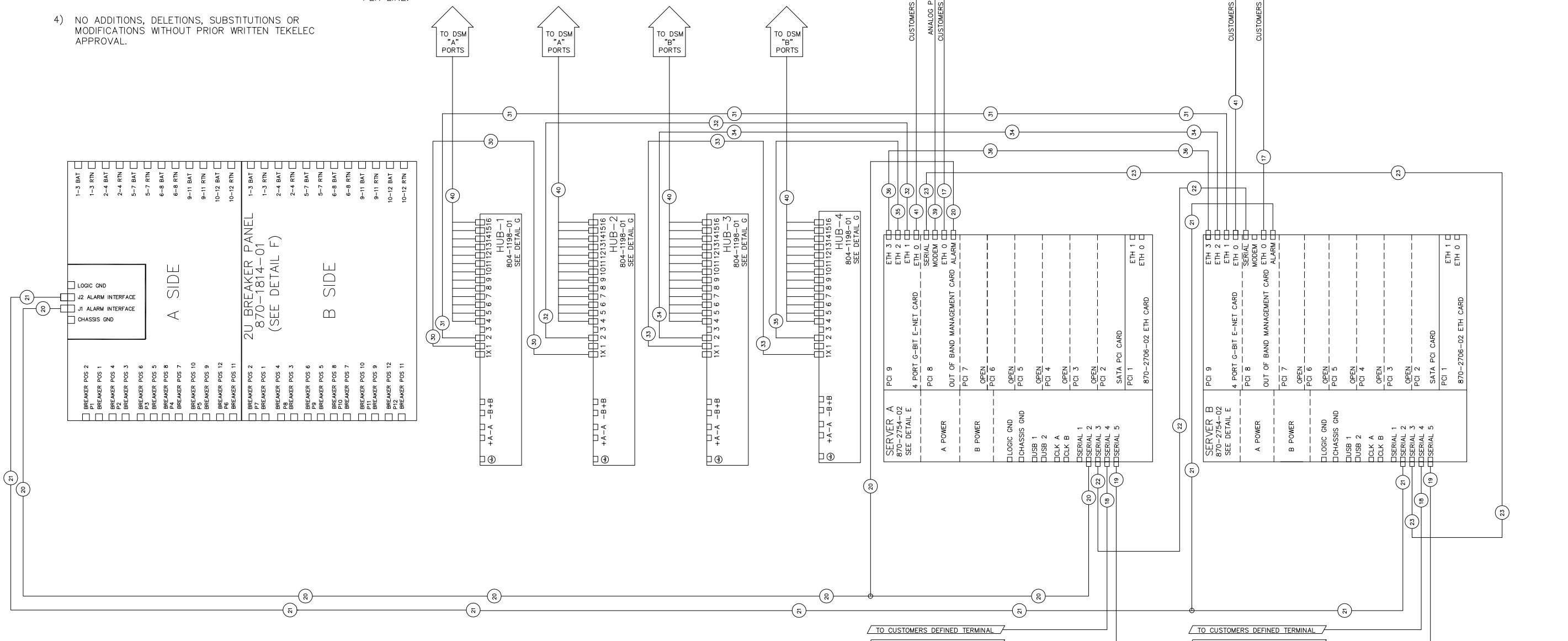

DATA CONNECTIONS AND CABLES

UNLESS OTHERWISE SPECIFIED, DO NOT SCALE DRAWING. DIMENSIONS ARE IN INCHES. INTERPRET DIMENSIONS IN ACCORDANCE WITH ANS I14.5M-82. DEBURR AND BREAK SHARP EDGES .005-.015. MACHINED SURFACE FINISH $\sqrt{R}$ . TOLERANCES: .XXX = ±010.		CONTRACT NO.		TEKELEC 26580 W. Agoura Road, Calabasas, California 91302	
STANDARD HOLE TOLERANCES:		APPROVALS		DATE	
HOLE DIA	TOLERANCES	DRAWN	M.BRYAN	4/18/05	
.013 THRU .125	+ .004 -.001	CHECKED	BEAUCHAMP	XXXXX	
.126 THRU .250	+ .005 -.001	APPROVED	ARMSTRONG	5/26/05	
.251 THRU .500	+ .006 -.001	APPLICATION		APPROVED	
.501 THRU .750	+ .008 -.001	NEXT ASSY		USED ON	
.751 THRU 1.000	+ .010 -.001	FINISH		MATERIAL	
1.001 THRU 2.000	+ .012 -.001	DRAWING NO.		REV.	
		892-0066-01		C	
SCALE: NONE		FILE NAME: 892-0066-01_REV_C.dwg		SHEET 1 OF 4	

THIS DOCUMENT AND THE DATA DISCLOSED HEREIN OR HEREWITH IS PROPRIETARY AND IS NOT TO BE REPRODUCED, USED OR DISCLOSED IN WHOLE OR PART TO ANYONE WITHOUT THE WRITTEN PERMISSION OF TEKELEC. COPYRIGHT, TEKELEC 1996.

10-9900-01

D

A

REVISIONS			
LTR	DESCRIPTION	DATE	APPROVED

892-0066-01 2 C  
 REV. SHEET NO.

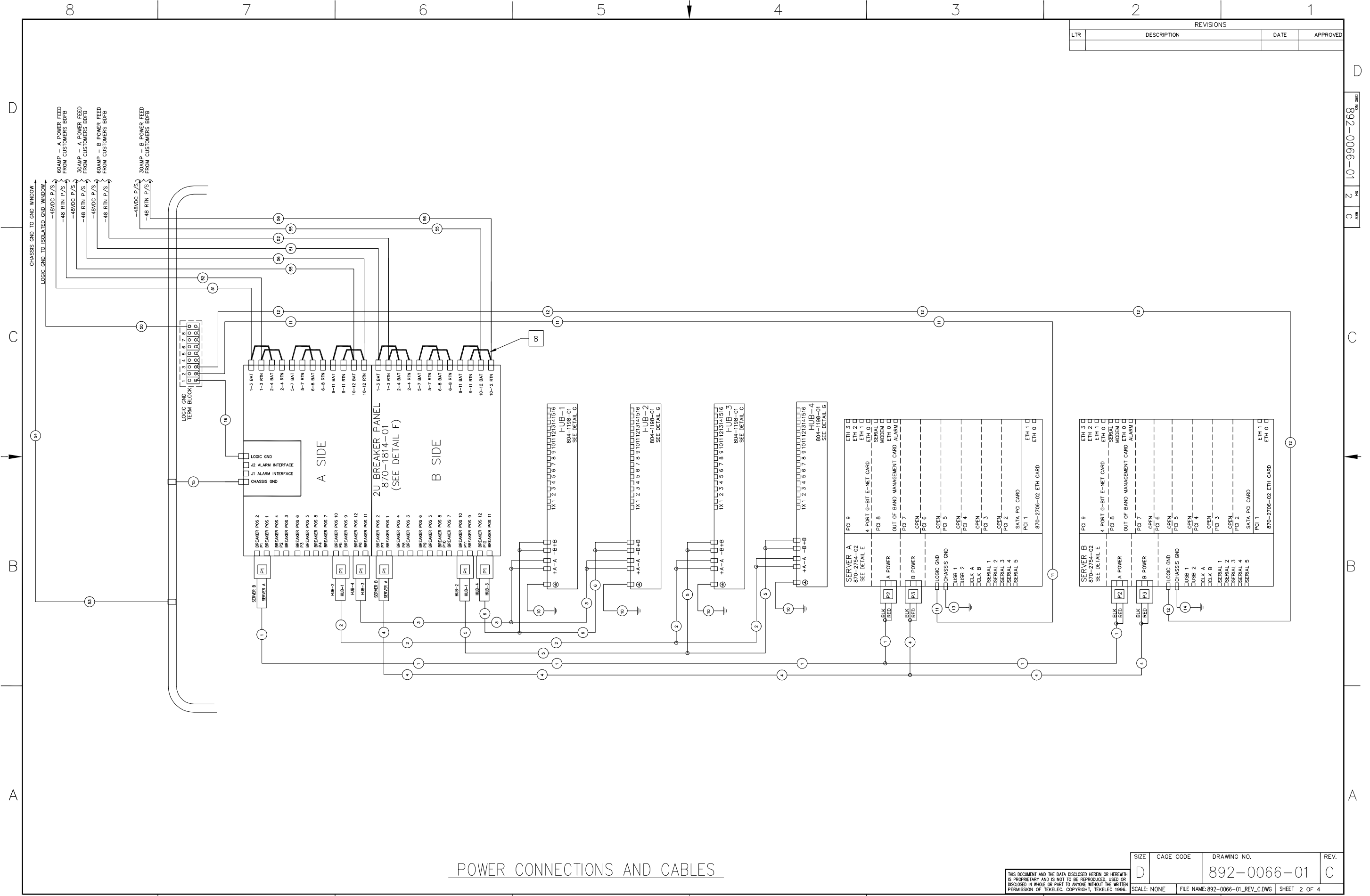

POWER CONNECTIONS AND CABLES

THIS DOCUMENT AND THE DATA DISCLOSED HEREIN OR HEREWITH IS PROPRIETARY AND IS NOT TO BE REPRODUCED, USED OR DISCLOSED IN WHOLE OR PART TO ANYONE WITHOUT THE WRITTEN PERMISSION OF TEKELEC. COPYRIGHT, TEKELEC 1996.

SIZE	CAGE CODE	DRAWING NO.	REV.
D		892-0066-01	C
SCALE: NONE		FILE NAME: 892-0066-01_REV_C.DWG	SHEET 2 OF 4

ITEM NO.	TEKELEC P/N	QTY	LENGTH	RUN LIST AND LABEL INFORMATION FOR FROM AND TO	LABEL REQUIRED
1	830-0014-01	1	81.00 INCHES	FROM: SERVER A AND B - A POWER / TO: BP1 P1	NO
2	830-0016-01	1	48.00 INCHES	FROM: HUBS 3 AND 4 - A POWER / TO: BP1 P6	NO
3	830-0017-01	1	44.00 INCHES	FROM: HUBS 1 AND 2 - A POWER / TO: BP1 P5	NO
4	830-0015-01	1	81.00 INCHES	FROM: SERVER A AND B - B POWER / TO: BP1 P7	NO
5	830-0017-02	1	38.00 INCHES	FROM: HUBS 3 AND 4 - B POWER / TO: BP1 P12	NO
6	830-0016-02	1	36.00 INCHES	FROM: HUBS 1 AND 2 - B POWER / TO: BP1 P11	NO
7					
8					
9					
10	830-0822-01	4	14.00 INCHES	FROM: HUB CHASSIS GND / TO: FRAME	NO
11	830-1071-01	1	60.00 INCHES	FROM: SERVER A LOGIC GND / TO: LOGIC GND TERM BLK POS 2	YES
12	830-1071-02	1	67.00 INCHES	FROM: SERVER B LOGIC GND / TO: LOGIC GND TERM BLK POS 3	YES
13	830-0927-01	1	14.00 INCHES	FROM: SERVER A CHASSIS GND / TO: FRAME	NO
14	830-0927-01	1	14.00 INCHES	FROM: SERVER B CHASSIS GND / TO: FRAME	NO
15	830-0830-01	1	14.00 INCHES	FROM: BP1 FRAME GND / TO: FRAME	NO
16	830-1003-01	1	18.00 INCHES	FROM: BP1 LOGIC GND / TO: LOGIC GND TERM BLK POS 1	YES
17	CUSTOMER PROVIDED	2	SITE SPECIFIC	TO CUSTOMER NETWORK	FIELD LABEL
18	830-0058-XX	AR	SITE SPECIFIC	FROM: SERVER A SERIAL PORT 4 / TO: CUSTOMER SUPPLIED TERMINAL FROM: SERVER B SERIAL PORT 4 / TO: CUSTOMER SUPPLIED TERMINAL	FIELD LABEL
19	830-0059-XX	AR	SITE SPECIFIC	FROM: SERVER A SERIAL PORT 5 / TO: CUSTOMER SPECIFIC MMI PORT FROM: SERVER B SERIAL PORT 5 / TO: CUSTOMER SPECIFIC MMI PORT	FIELD LABEL
20	830-0020-01	1	72.00 INCHES	FROM: BP1 ALARM INT J1 / TO: SERVER A SERIAL PORT 2 TO: SERV A SLOT 8 ALM PORT	YES
21	830-0020-02	1	80.00 INCHES	FROM: BP1 ALARM INT J2 / TO: SERVER B SERIAL PORT 2 TO: SERV B SLOT 8 ALM PORT	YES
22	830-1074-06	1	72.00 INCHES	FROM: SERVER A SERIAL PORT 3 / TO: SERVER B SLOT 8 OOB SERIAL	YES
23	830-1074-06	1	72.00 INCHES	FROM: SERVER B SERIAL PORT 3 / TO: SERVER A SLOT 8 OOB SERIAL	YES
24					
25					
26					
27					
28					
29					
30	830-0724-05	1	12.00 INCHES	FROM: HUB-1 PORT 1 / TO: HUB-2 PORT 1X	YES
31	830-0724-07	1	84.00 INCHES	FROM: HUB-1 PORT 2 / TO: SERVER B SLOT 9 ETH 1	YES
32	830-0724-06	1	72.00 INCHES	FROM: HUB-2 PORT 2 / TO: SERVER A SLOT 9 ETH 1	YES
33	830-0724-05	1	12.00 INCHES	FROM: HUB-3 PORT 1 / TO: HUB-4 PORT 1X	YES
34	830-0724-06	1	72.00 INCHES	FROM: HUB-3 PORT 2 / TO: SERVER B SLOT 9 ETH 2	YES
35	830-0724-06	1	72.00 INCHES	FROM: HUB-4 PORT 2 / TO: SERVER A SLOT 9 ETH 2	YES
36	830-0723-67	1	60.00 INCHES	FROM: SERVER A SLOT 9 ETH 3 / TO: SERVER B SLOT 9 ETH 3	YES
37					
38					
39	830-0680-01	1	25.00 FEET	FROM: SERVER A SLOT 8 MODEM / TO: CUSTOMER PROVIDED PHONE LINE	FIELD LABEL
40	830-0788-XX	AR	SITE SPECIFIC	RJ45-DB26 STRAIGHT THROUGH - SHIELDED	FIELD LABEL
	830-0789-XX	AR	SITE SPECIFIC	RJ45-DB26 CROSSOVER - SHIELDED	FIELD LABEL
	830-0978-XX	AR	SITE SPECIFIC	RJ45-DB26 STRAIGHT THROUGH - UNSHIELDED	FIELD LABEL
	830-0979-XX	AR	SITE SPECIFIC	RJ45-DB26 CROSSOVER - UNSHIELDED	FIELD LABEL
41	CUSTOMER PROVIDED	2	SITE SPECIFIC	TO CUSTOMER NETWORK	FIELD LABEL
42					
43					
44					
45					
46					
47					
48					
49					
50	LOGIC GROUND	1	SEE TABLE D		FIELD LABEL
51	-48VDC (BAT)	2	SEE TABLE B		FIELD LABEL
52	-48 RTN	2	SEE TABLE B		FIELD LABEL
53	830-0715-03	1	84.00 INCHES		FIELD LABEL
54	CHASSIS GROUND	1	SEE TABLE F		FIELD LABEL
55	-48VDC (BAT)	2	SEE TABLE E		FIELD LABEL
56	-48 RTN	2	SEE TABLE E		FIELD LABEL

DISTANCE	PRIMARY CABLE PART NUMBER	CABLE AWG	TERMINAL LUG P/N	HEAT SHRINK PART NUMBER	COMMENT	REF. DETAIL
0' - 40'	690-0131-01	6	502-0085-01	804-0228-01	CABLE LENGTH IS SITE-SPECIFIC	C
40' - 160'	690-0108-07	1/0	804-0977-01	804-0229-01	CABLE LENGTH IS SITE-SPECIFIC	A

REVISIONS			
LTR	DESCRIPTION	DATE	APPROVED

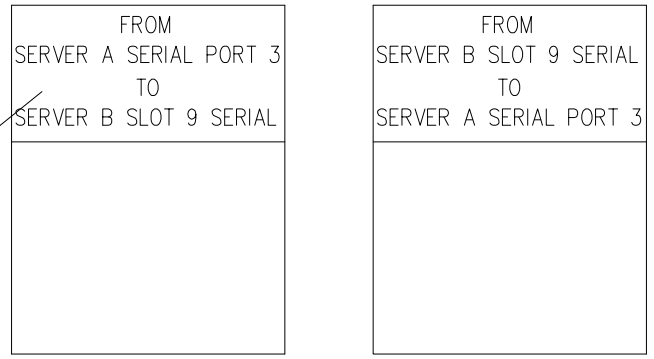

EXAMPLE OF TEXT SHOWN IN TABLES      EXAMPLE WITH TEXT REVERSED FROM FIRST LABEL

DETAIL E [6]  
CABLE LABEL EXAMPLE USING CABLE ITEM NO. 22

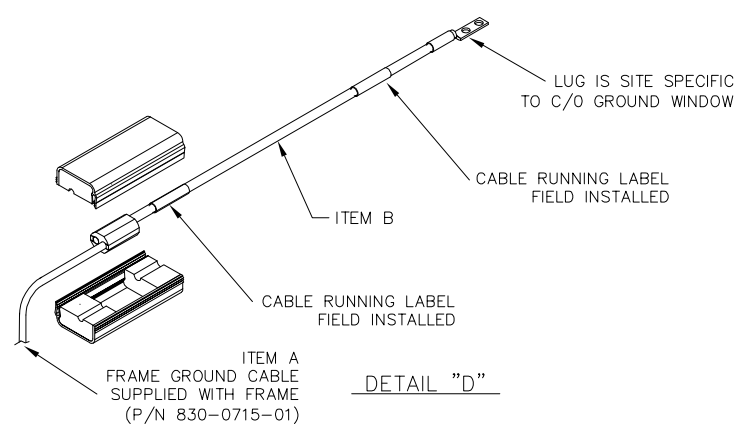
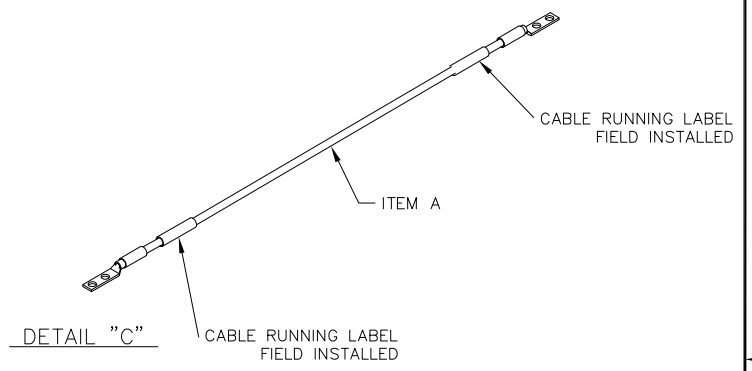
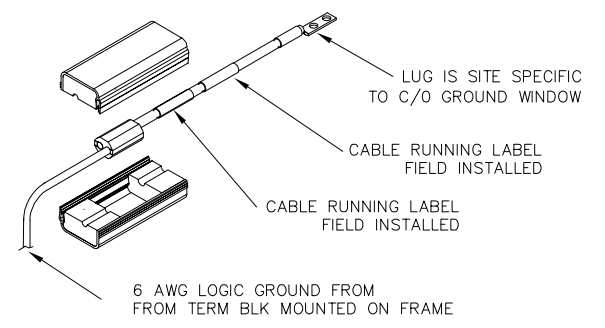
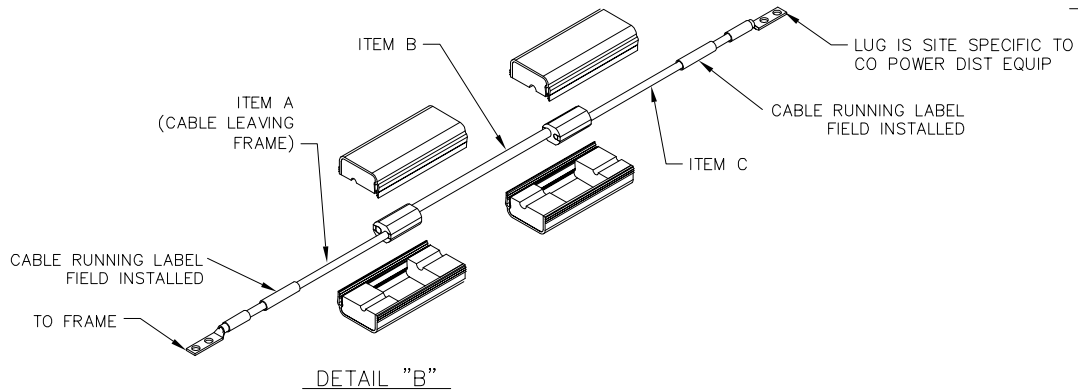

DISTANCE	ITEM A		ITEM B		ITEM C		HALF TAP SPLICE P/N	HTAP SOFT COVER P/N	COMMENT	REF. DETAIL	
	CABLE P/N	CABLE AWG	TERMINAL LUG P/N	HEAT SHRINK P/N	CABLE P/N	CABLE AWG					CABLE CONSTRUCTION
0' - 40'	690-0108-01	6	502-0085-01	804-0228-01	690-0108-08	2	N/A	NONE REQUIRED	NONE REQUIRED	CABLE LENGTH IS SITE-SPECIFIC	C
40' - 70'	690-0108-01	6	502-0085-01	804-0228-01	690-0108-03	1/0	SITE SPECIFIC	T&B 63125	T&B HTC40	CABLE LENGTH IS SITE-SPECIFIC	B
70' - 110'	690-0108-01	6	502-0085-01	804-0228-01	690-0108-14	2/0	SITE SPECIFIC	T&B 63125	T&B HTC40	CABLE LENGTH IS SITE-SPECIFIC, HTAPPED STUBS <= 10' EACH END	B
110' - 170'	690-0108-01	6	502-0085-01	804-0228-01	690-0108-13	4/0	SITE SPECIFIC	T&B 63125	T&B HTC40	CABLE LENGTH IS SITE-SPECIFIC, HTAPPED STUBS <= 10' EACH END	B
170' - 200'	690-0108-01	6	502-0085-01	804-0228-01	690-0108-TBD	350 MCM	SITE SPECIFIC	T&B 63125	T&B HTC40	CABLE LENGTH IS SITE-SPECIFIC, HTAPPED STUBS <= 10' EACH END	B
200' - 220'	690-0108-01	6	502-0085-01	804-0228-01	690-0108-TBD	500 MCM	SITE SPECIFIC	T&B 63125	T&B HTC40	CABLE LENGTH IS SITE-SPECIFIC, HTAPPED STUBS <= 10' EACH END	B

DISTANCE	ITEM A		ITEM B		ITEM C		HALF TAP SPLICE P/N	HTAP SOFT COVER P/N	COMMENT	REF. DETAIL	
	CABLE P/N	CABLE AWG	TERMINAL LUG P/N	HEAT SHRINK P/N	CABLE P/N	CABLE AWG					CABLE CONSTRUCTION
0' - 40'	690-0108-01	6	502-0085-01	804-0228-01	N/A	--	N/A	NONE REQUIRED	NONE REQUIRED	CABLE LENGTH IS SITE-SPECIFIC	C
40' - 65'	690-0108-01	6	502-0085-01	804-0228-01	690-0108-04	4	SITE SPECIFIC	T&B 63125	T&B HTC40	CABLE LENGTH IS SITE-SPECIFIC	B
65' - 100'	690-0108-01	6	502-0085-01	804-0228-01	690-0108-06	2	SITE SPECIFIC	T&B 63125	T&B HTC40	CABLE LENGTH IS SITE-SPECIFIC, HTAPPED STUBS <= 10' EACH END	B
100' - 160'	690-0108-01	6	502-0085-01	804-0228-01	690-0108-03	1/0	SITE SPECIFIC	T&B 63125	T&B HTC40	CABLE LENGTH IS SITE-SPECIFIC, HTAPPED STUBS <= 10' EACH END	B

DISTANCE	CABLE P/N	CABLE AWG	ITEM A (830-0715-01 SUPPLIED WITH FRAME)		ITEM B		HTAP (A TO B CONNECTION) H TAP P/N	COMMENT	REF. DETAIL
			TERMINAL LUG P/N	HEAT SHRINK P/N	CABLE P/N	CABLE AWG			
0' - 40'	690-0131-01	6	502-0085-01	804-0228-01	690-0131-01	6	804-0865-01	CABLE LENGTH IS SITE-SPECIFIC	D
40' - 160'	690-0108-01	6	502-0085-01	804-0228-01	690-0108-07	1/0	804-0865-01	CABLE LENGTH IS SITE-SPECIFIC	D

REVISIONS			
LTR	DESCRIPTION	DATE	APPROVED

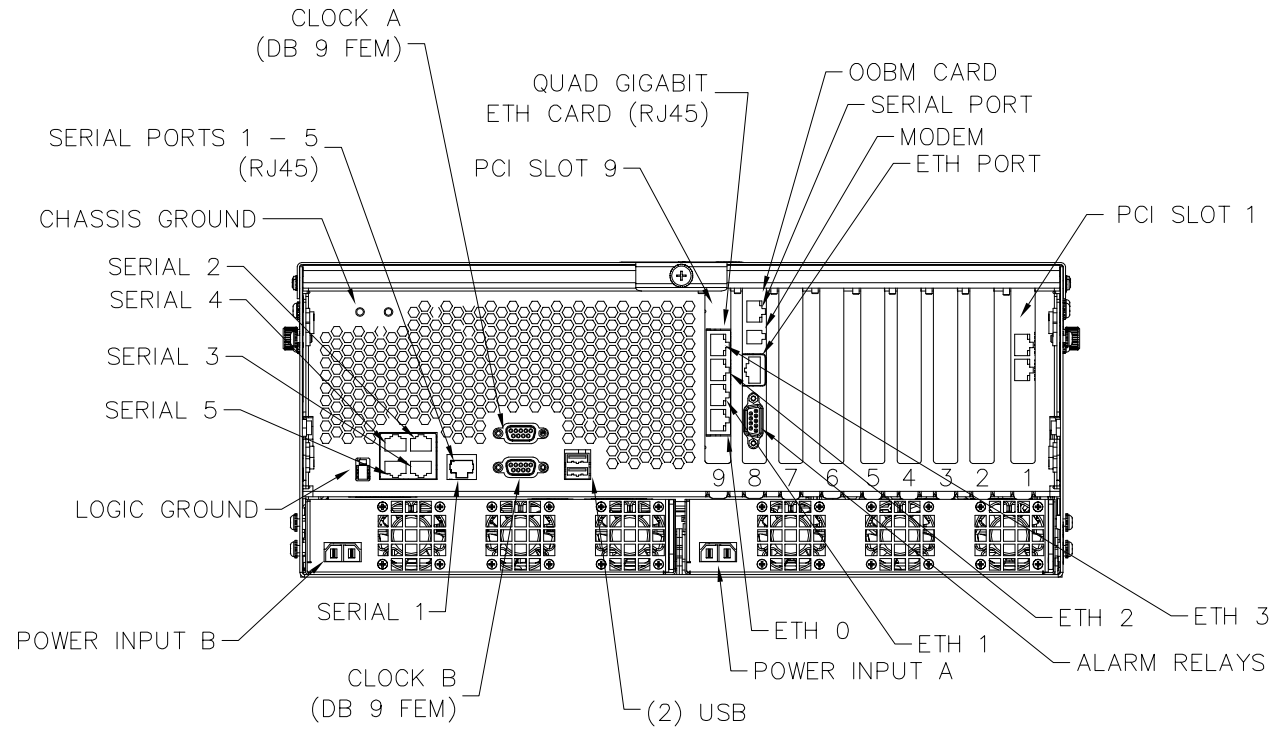

**DETAIL E**  
 SERVER A AND B (REAR VIEW)  
 870-2754-01 W/ PCI CARDS:  
 SLOT 1 -870-2706-02  
 SLOT 8 -870-2798-XX  
 SLOT 9 -870-2799-XX

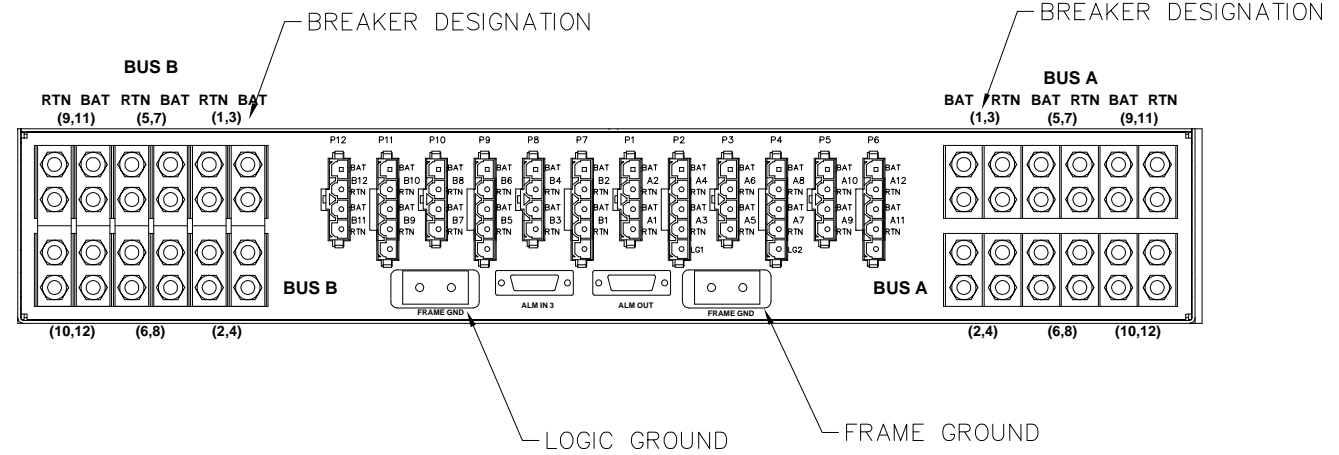

**DETAIL F**  
 REAR VIEW-CIRCUIT BREAKER

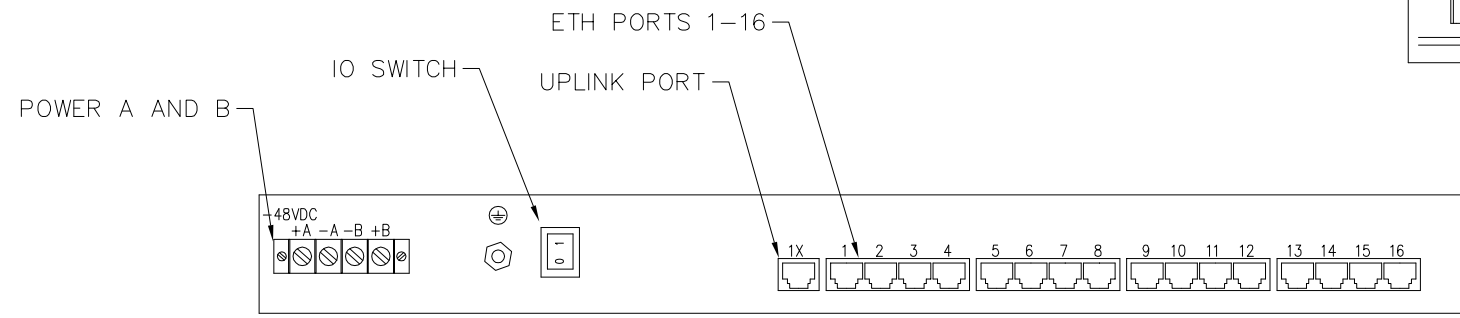

**DETAIL G**  
 REAR VIEW-HUB

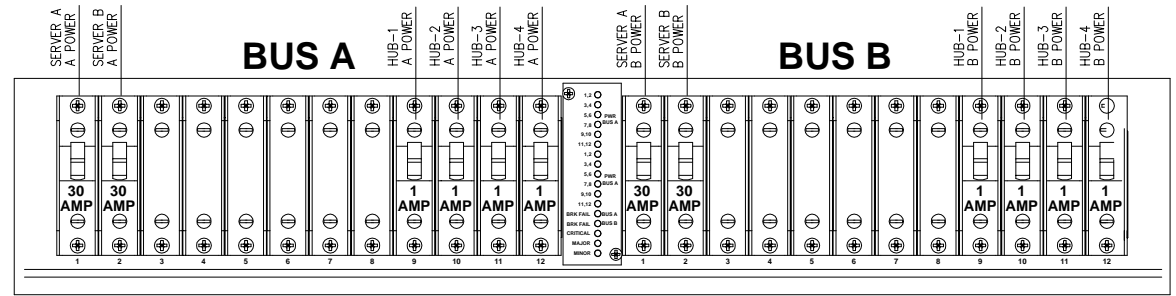

**DETAIL H**  
 FRONT VIEW-CIRCUIT BREAKER

SIZE	CAGE CODE	DRAWING NO.	REV.
D		892-0066-01	C
<small>THIS DOCUMENT AND THE DATA DISCLOSED HEREIN OR HEREWITH IS PROPRIETARY AND IS NOT TO BE REPRODUCED, USED OR DISCLOSED IN WHOLE OR PART TO ANYONE WITHOUT THE WRITTEN PERMISSION OF TEKELEC. COPYRIGHT, TEKELEC 1996.</small>			
SCALE: NONE	FILE NAME: 892-0066-01_REV_C.DWG	SHEET 4 OF 4	