

NOTES: UNLESS OTHERWISE SPECIFIED

REVISIONS			
REV	DESCRIPTION	DATE	APPROVED
B	REVISED PER ECO #12973	8/20/03	D. GRIFFITH
C	REVISED PER ECO #13150	10/24/03	D. GRIFFITH
D	REVISED PER ECO #13263	12/18/03	D. GRIFFITH
E	REVISED PER ECO #13404	2/24/04	D. GRIFFITH

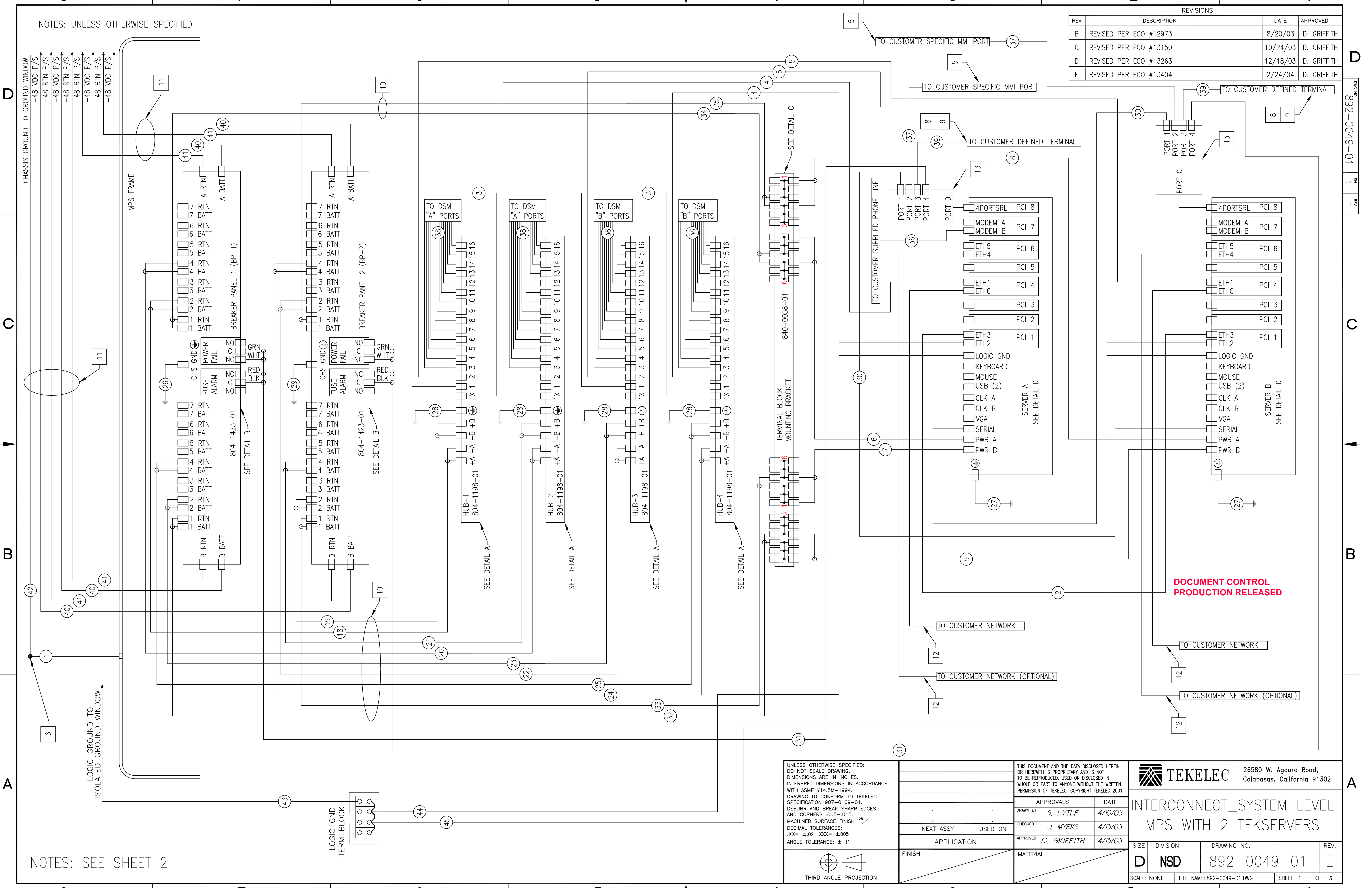

DOCUMENT CONTROL  
PRODUCTION RELEASED

NOTES: SEE SHEET 2

UNLESS OTHERWISE SPECIFIED:  
DO NOT SCALE DRAWING.  
DIMENSIONS ARE IN INCHES.  
INTERPRET DIMENSIONS IN ACCORDANCE WITH ASME Y14.5M-1994.  
DRAWING TO CONFORM TO TEKELEC SPECIFICATION 907-0169-01.  
DEBURR AND BREAK SHARP EDGES AND CORNERS .005-.015.  
MACHINED SURFACE FINISH 125  
DECIMAL TOLERANCES:  
XX= ±.02 XXX= ±.005  
ANGLE TOLERANCE: ± 1°

APPROVALS	DATE
DRAWN BY S. LYTLE	4/10/03
CHECKED J. MYERS	4/15/03
APPROVED D. GRIFFITH	4/15/03
NEXT ASSY	USED ON
APPLICATION	MATERIAL

**TEKELEC** 26580 W. Agoura Road, Calabasas, California 91302

INTERCONNECT\_SYSTEM LEVEL  
MPS WITH 2 TEKSERVERS

SIZE	DIVISION	DRAWING NO.	REV.
D	NSD	892-0049-01	E
SCALE: NONE	FILE NAME: 892-0049-01.DWG	SHEET 1	OF 3

NOTES: UNLESS OTHERWISE SPECIFIED

- 1) INSTALL ALL CABLE ASSEMBLIES WITH DRESSED BEND RADII IN ACCORDANCE WITH TEKELEC CABLE BEND RADIUS SPECIFICATION 906-0020-01.
- 2) ALL INTERCONNECTION POINTS SHALL BE STRAIN RELIEVED BY POSITIVE MECHANICAL FEATURES OR FASTENERS.
- 3) THIS DIAGRAM AND ALL PART NUMBERS SHOWN ARE FOR REFERENCE ONLY. REFERENCE CABLE PART NUMBERS WITH XX FOR THE DASH NUMBER ARE LENGTHS THAT ARE SITE SPECIFIC. SEE APPROPRIATE BILLS OF MATERIAL FOR SPECIFIC PART NUMBERS AND QUANTITIES.
- 4) NO ADDITIONS, DELETIONS, SUBSTITUTIONS OR MODIFICATIONS WITHOUT PRIOR WRITTEN TEKELEC APPROVAL.
- 5) CABLE SHOWN INTERCONNECTING TO CUSTOMER SPECIFIC MMI-X PORT MAY BE INSTALLED TO ANY OPEN MMI PORT.
- 6) CONNECT THE FRAME GROUND CABLE (ITEM 1) FROM THE MPS FRAME TO THE SYSTEM FRAME GROUND CABLE PER THE INSTRUCTIONS IN TABLE B.
- 7) (NOTE REMOVED)
- 8) TEKELEC P/N 804-0076-01 PROVIDES AN OPTIONAL CUSTOMER TERMINAL AND KEYBOARD (VT520).
- 9) SEE TEKELEC P/N 820-2410-01 FOR CURRENT LIST OF OPTIONAL CUSTOMER OEM HARDWARE
- 10) ALL POWER CABLES (SEE ITEMS 6-9, 18-25, AND 32-35 FROM THE CABLE LEGEND) ARE CONNECTED WITH THE RED LEAD TO THE NEGATIVE (OR -48VDC) TERMINAL AND THE BLACK LEAD TO THE POSITIVE (OR RETURN) TERMINAL.
- 11) -48 VDC, RTN, AND GND PRIMARY CABLING EXITING THE FRAME SHALL BE 6 AWG. SEE TABLES A AND B FOR LENGTH DEPENDENT CONFIGURATIONS.
- 12) SITE SPECIFIC CUSTOMER PROVIDED CABLE (STRAIGHT THROUGH HUB-HOST CONNECTION)
- 13) 4-PORT SERIAL CABLE, SUPPLIED WITH PCI SERIAL CARD (SLOT 8). PORT NUMBERS 1 THRU 4 ARE LOCATED ON THE DB-9 CONNECTOR HOUSINGS. PORT 0 IS A DB-44 CONNECTOR THAT INTERFACES WITH THE PCI SERIAL CARD. REPLACEMENT CABLE IS TEKELEC P/N 830-0972-01.
- 14) NOTE DELETED.
- 15) CABLE TO BE CHOSEN BASED ON SITE SURVEY.

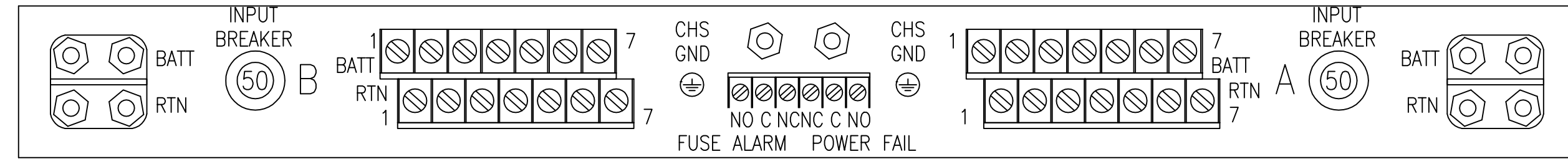
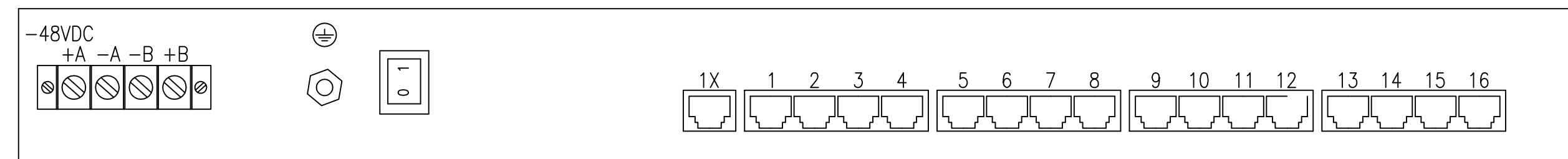

CABLE LEGEND				
ITEM NO.	TEKELEC PN	QUANTITY	LENGTH	COMMENT
1	830-0715-01	1	3'	FRAME GROUND
2	830-0723-03	1	4.5'	CAT 5 RJ45 TO RJ45 CROSSOVER CABLE
3	830-0724-05	2	1'	CAT 5 RJ45-RJ45 STRAIGHT THROUGH CABLE
4	830-0724-06	2	6'	CAT 5 RJ45-RJ45 STRAIGHT THROUGH CABLE
5	830-0724-07	2	7'	CAT 5 RJ45-RJ45 STRAIGHT THROUGH CABLE
6	830-0965-01	1	60.0"	TB 3, POS 1 & 4 TO SERVER A, PWR A
7	830-0965-02	1	60.0"	TB 2, POS 1 & 4 TO SERVER A, PWR B
8	830-0965-03	1	72.0"	TB 4, POS 1 & 4 TO SERVER B, PWR A
9	830-0965-04	1	72.0"	TB 1, POS 1 & 4 TO SERVER B, PWR B
18	830-0868-05	1	32.5"	BP-1, POS 2A TO HUB 1A
19	830-0868-06	1	25.0"	BP-2, POS 2B TO HUB 1B
20	830-0868-07	1	34.0"	BP-1, POS 4A TO HUB 2A
21	830-0868-08	1	26.5"	BP-2, POS 4B TO HUB 2B
22	830-0868-09	1	31.0"	BP-2, POS 2A TO HUB 3A
23	830-0868-10	1	29.5"	BP-1, POS 2B TO HUB 3B
24	830-0868-11	1	32.5"	BP-2, POS 4A TO HUB 4A
25	830-0868-12	1	31.0"	BP-1, POS 4B TO HUB 4B
27	830-0927-01	2	48"	GROUND, TEKSERVER TO FRAME
28	830-0822-01	4	14"	GROUND, HUB TO FRAME
29	830-0830-01	2	11"	BREAKER PANEL TO FRAME GROUND
30	830-0970-01	2	60"	NULL MODEM, SERIAL TO SERIAL
31	830-0961-01	2	144"	SERIAL ALARM CABLE
32	830-0866-01	1	48.5"	BP-1, POS 1B TO TB 1, POS 3 & 4
33	830-0866-02	1	51.5"	BP-2, POS 1B TO TB 2, POS 3 & 4
34	830-0866-03	1	53.5"	BP-1, POS 1A TO TB 3, POS 3 & 4
35	830-0866-04	1	46.5"	BP-2, POS 1A TO TB 4, POS 3 & 4
36	830-0680-01	1	25 FT	MODULAR RJ11-RJ11 CABLE
44	830-0989-02	1	92"	LOGIC GROUND FROM SERVER A
45	830-0989-03	1	99"	LOGIC GROUND FROM SERVER B
ITEMS BELOW ARE SITE SPECIFIC AND ARE NOT INCLUDED IN THE BOM				
37	830-0963-XX	AR	NA	OPTIONAL DB9F/DB25M SERIAL WITH FLOW CONTROL
38	830-0788-XX	AR	NA	DB26-RJ45 STRAIGHT THROUGH CABLE, SHIELDED
	830-0789-XX	AR	NA	DB26-RJ45 CROSSOVER CABLE, SHIELDED
	830-0978-XX	AR	NA	DB26-RJ45 STRAIGHT THROUGH CABLE, NON-SHIELDED
	830-0979-XX	AR	NA	DB26-RJ45 CROSSOVER CABLE, NON-SHIELDED
39	830-0964-XX	AR	NA	D9/D25 M/M SITE SPECIFIC NULL MODEM SERIAL CABLE
40	-48 VDC	4	NA	FIELD Routed- SEE TABLE A
41	-48 RTN	4	NA	FIELD Routed- SEE TABLE A
42	CHASSIS GND	1	NA	FIELD Routed -SEE TABLE B
43	LOGIC GND	1	NA	FIELD Routed -SEE TABLE C
R	FOR REFERENCE ONLY	NA	NA	

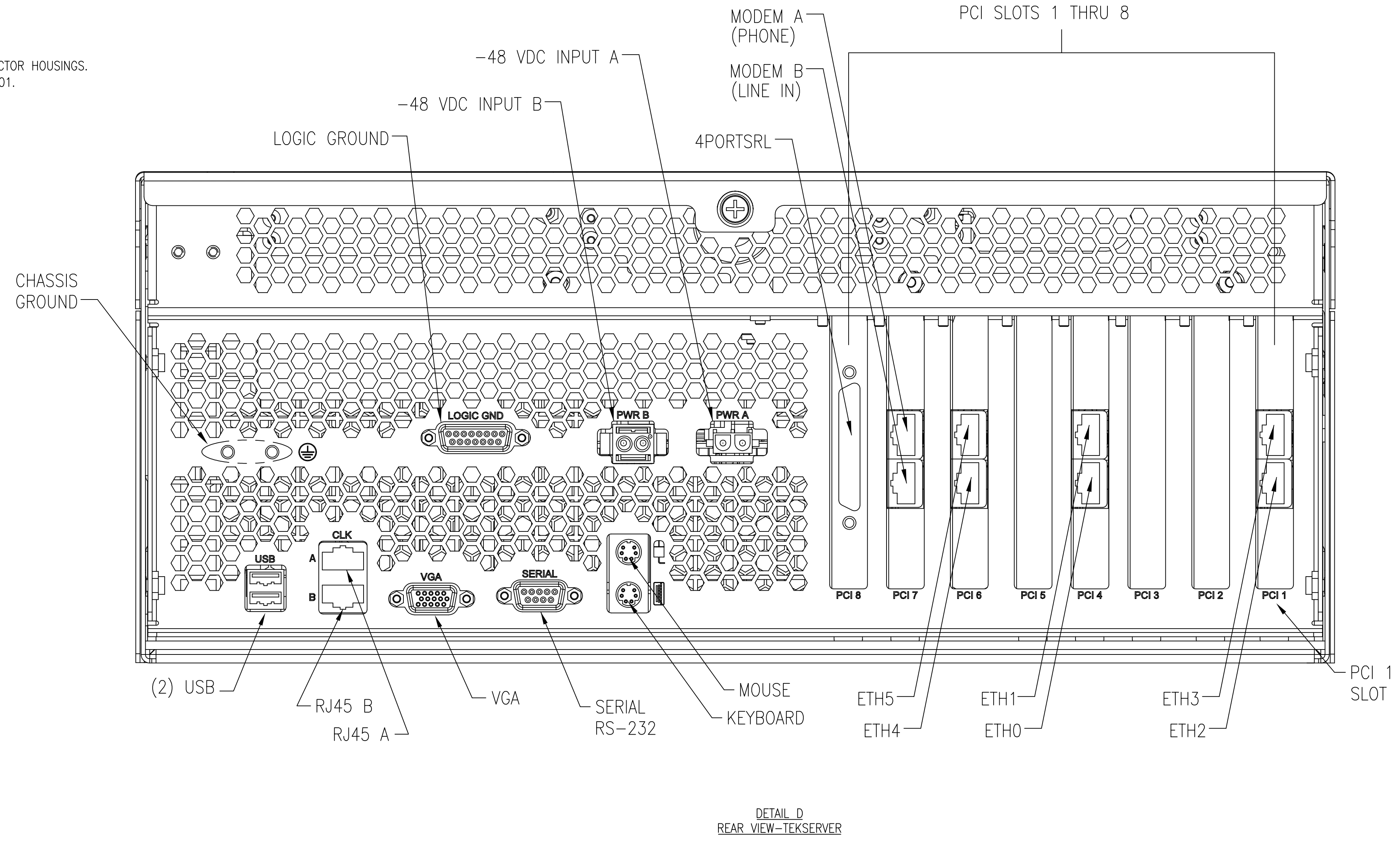

D  
 892-0049-01  
 2  
 E  
 C  
 B  
 A

SIZE	DIVISION	DRAWING NO.	REV.
D	NSD	892-0049-01	E
SCALE: NONE	FILE NAME: 892-0049-01.DWG	SHEET 2	

THIS DOCUMENT AND THE DATA DISCLOSED HEREIN OR HEREWITH IS PROPRIETARY AND IS NOT TO BE REPRODUCED, USED OR DISCLOSED IN WHOLE OR PART TO ANYONE WITHOUT THE WRITTEN PERMISSION OF TEKELEC. COPYRIGHT TEKELEC 2001.

D

D

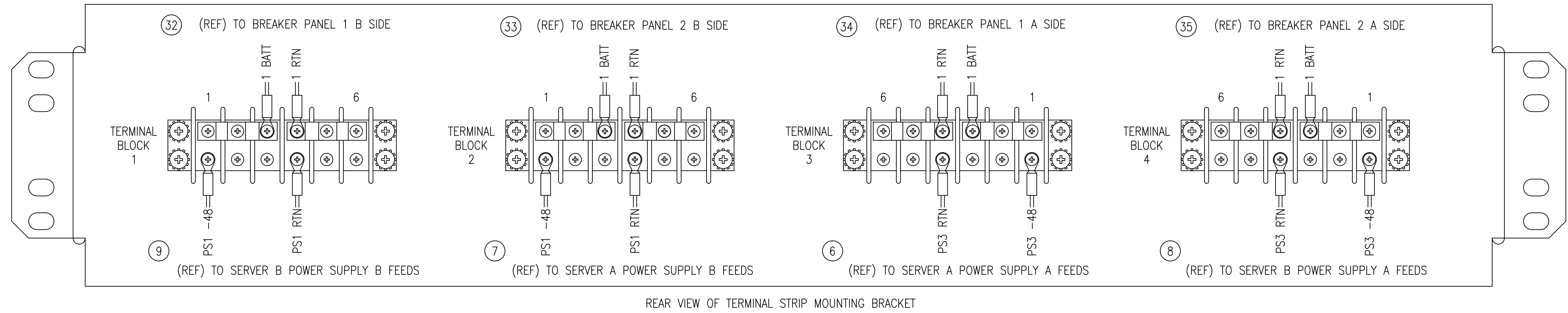

REAR VIEW OF TERMINAL STRIP MOUNTING BRACKET

DETAIL C  
REAR VIEW-TERMINAL STRIPS

TABLE A - 48VDC & 48VRTN CABLING COMPONENTS

DISTANCE	ITEM A				ITEM B		HTAP INFO (FOR ITEM A TO B CONNECTION)		ITEM C				COMMENTS	REF. DETAIL
	CABLE P/N	AWG	TERMINAL LUG P/N	HEAT SHRINK P/N	CABLE P/N	AWG	HALF TAP SPLICE P/N	HTAP SOFT COVER P/N	P/N	AWG	TERMINAL LUG P/N	HEAT SHRINK P/N		
0'-40'	690-0108-01	6	502-0085-01	804-0228-01	NOT APPLICABLE	----	NOT APPLICABLE	NOT APPLICABLE	NOT APPLICABLE				CABLE LENGTH IS SITE-SPECIFIC	E
40'-65'	690-0108-01	6	502-0085-01	804-0228-01	690-0108-04	4	T&B 63125	T&B HTC40	ALL SITE SPECIFIC				CABLE LENGTH IS SITE-SPECIFIC, HTAPPED STUDS <=10' EACH END	F
65'-100'	690-0108-01	6	502-0085-01	804-0228-01	690-0108-06	2	T&B 63125	T&B HTC40	ALL SITE SPECIFIC				CABLE LENGTH IS SITE-SPECIFIC, HTAPPED STUDS <=10' EACH END	F
100'-160'	690-0108-01	6	502-0085-01	804-0228-01	690-0108-03	1/0	T&B 63125	T&B HTC40	ALL SITE SPECIFIC				CABLE LENGTH IS SITE-SPECIFIC, HTAPPED STUDS <=10' EACH END	F

TABLE B - SYSTEM FRAME GROUND CABLING

DISTANCE	ITEM A (830-0715-01)				ITEM B		HTAP INFO (FOR ITEM A TO B CONNECTION)		ITEM B COMMENTS	REF. DETAIL
	P/N	AWG	TERMINAL LUG P/N	HEAT SHRINK P/N	P/N	AWG	HALF TAP SPLICE P/N	HTAP SOFT COVER P/N		
0'-40'	690-0131-01	6	502-0085-01	804-0228-01	690-0131-01	6	804-0865-01	NONE REQUIRED	CABLE LENGTH IS SITE-SPECIFIC, HTAPPED STUDS <=10'	G
40'-65'	690-0131-01	6	502-0085-01	804-0228-01	690-0108-07	1/0	804-0865-01	NONE REQ'D	CABLE LENGTH IS SITE-SPECIFIC, HTAPPED STUDS <=10'	G

TABLE C - LOGIC GROUND CABLING

DISTANCE	PRIMARY CABLE PART NUMBER	CABLE AWG	TERMINAL LUG P/N	HEAT SHRINK PART NUMBER	COMMENT	REF. DETAIL
0'-40'	690-0131-01	6	502-0085-01	804-0228-01	CABLE LENGTH IS SITE-SPECIFIC	E
40'-160'	690-0108-07	1/0	804-0977-01	804-0229-01	CABLE LENGTH IS SITE-SPECIFIC	H

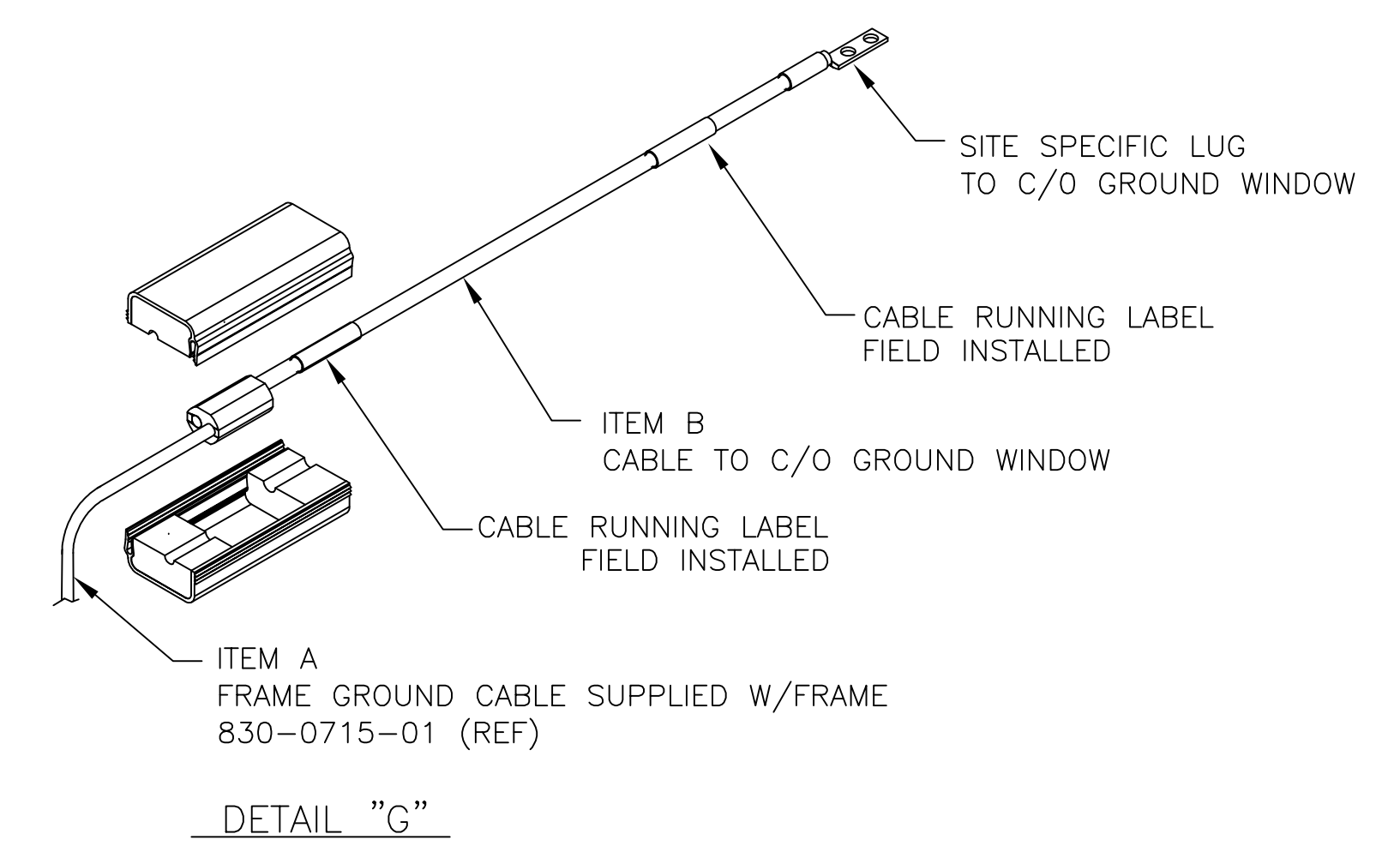
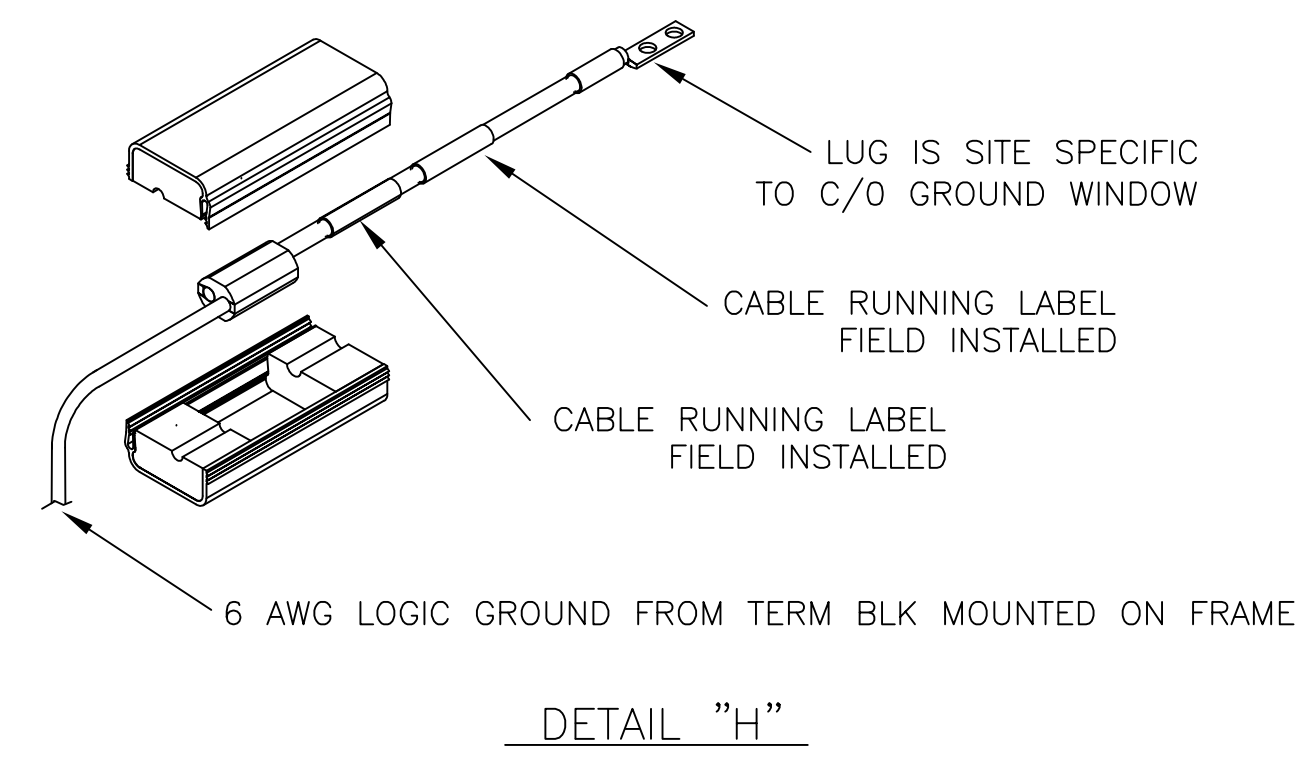
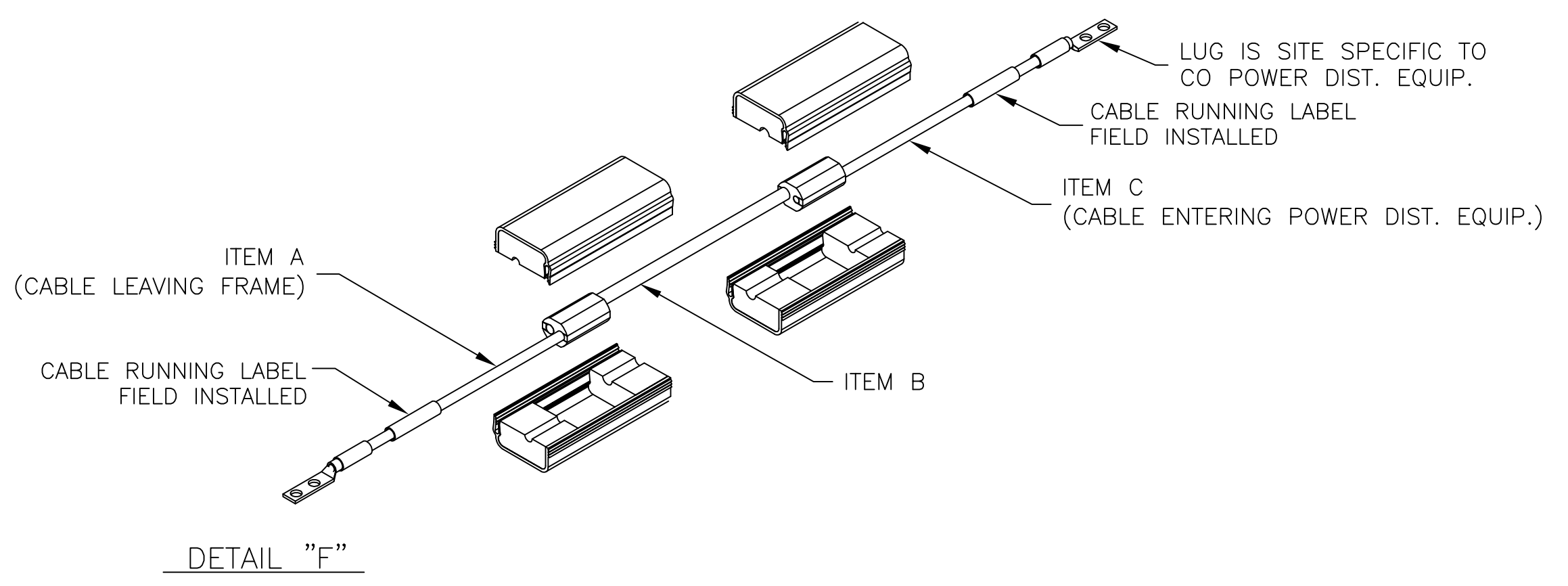
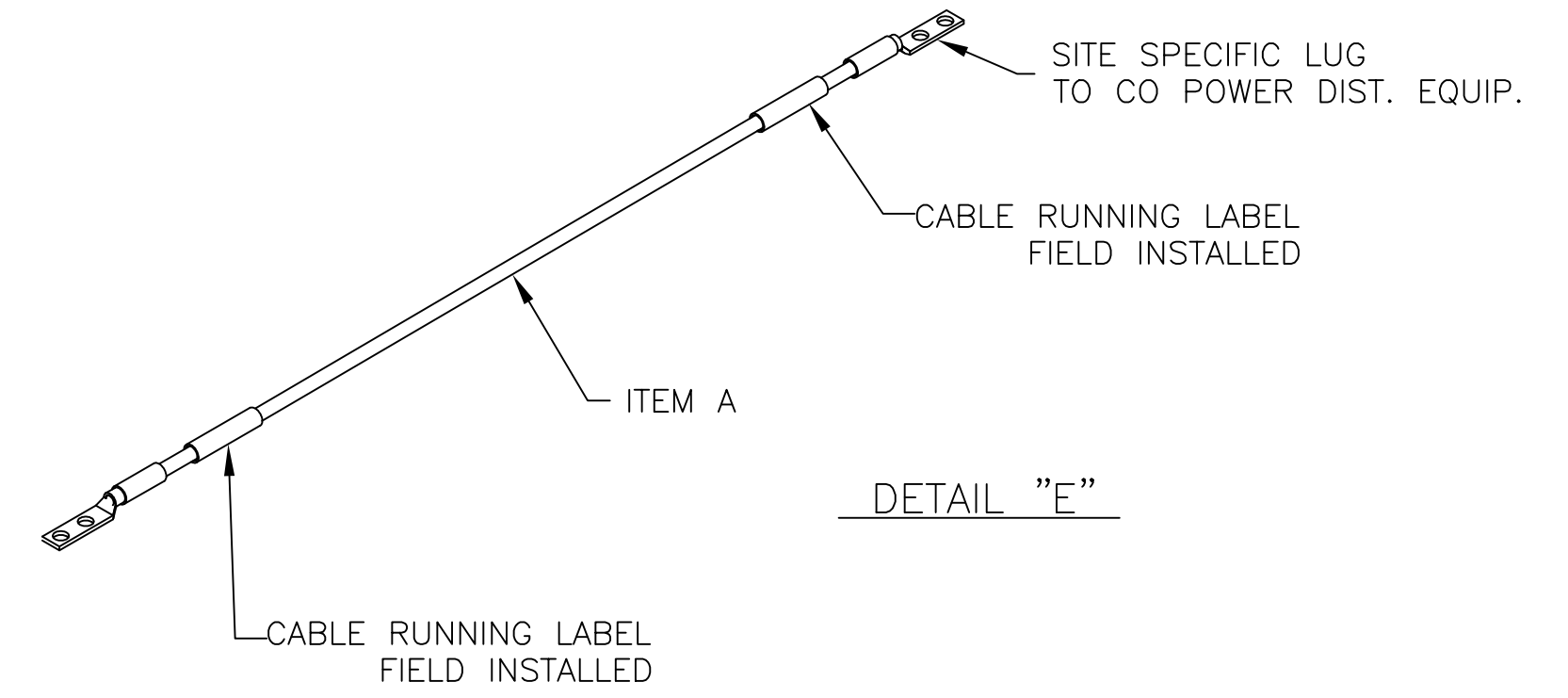

B

B

A

A

SIZE	DIVISION	DRAWING NO.	REV.
D	NSD	892-0049-01	E
SCALE: NONE	FILE NAME: 892-0049-01.DWG	SHEET 3	