

*Tekelec EAGLE<sup>®</sup> 5*  
*Integrated Signaling System*

---

**System Manual - EOAP**

910-2970-001 Revision D

February 2007



**TEKELEC**

**Copyright 2007 Tekelec.  
All Rights Reserved  
Printed in U.S.A.**

### **Notice**

Information in this documentation is subject to change without notice. Unauthorized use or copying of this documentation can result in civil or criminal penalties.

Any export of Tekelec products is subject to the export controls of the United States and the other countries where Tekelec has operations.

No part of this documentation may be reproduced or transmitted in any form or by any means, electronic or mechanical, including photocopying or recording, for any purpose without the express written permission of an authorized representative of Tekelec.

Other product names used herein are for identification purposes only, and may be trademarks of their respective companies.

RoHS 5/6 - As of July 1, 2006, all products that comprise new installations shipped to European Union member countries will comply with the EU Directive 2002/95/EC "RoHS" (Restriction of Hazardous Substances). The exemption for lead-based solder described in the Annex will be exercised. RoHS 5/6 compliant components will have unique part numbers as reflected in the associated hardware and installation manuals.

WEEE - All products shipped to European Union member countries comply with the EU Directive 2002/96/EC, Waste Electronic and Electrical Equipment. All components that are WEEE compliant will be appropriately marked. For more information regarding Tekelec's WEEE program, contact your sales representative.

### **Trademarks**

The Tekelec logo, EAGLE, G-Flex, G-Port, IP<sup>7</sup>, IP<sup>7</sup>Edge, IP<sup>7</sup> Secure Gateway, and TALI are registered trademarks of Tekelec. TekServer is a trademark of Tekelec. All other trademarks are the property of their respective owners.

### **Patents**

This product is covered by one or more of the following U.S. and foreign patents:

#### U.S. Patent Numbers:

5,008,929, 5,953,404, 6,167,129, 6,324,183, 6,327,350, 6,456,845, 6,606,379, 6,639,981, 6,647,113, 6,662,017, 6,735,441, 6,745,041, 6,765,990, 6,795,546, 6,819,932, 6,836,477, 6,839,423, 6,885,872, 6,901,262, 6,914,973, 6,940,866, 6,944,184, 6,954,526, 6,954,794, 6,959,076, 6,965,592, 6,967,956, 6,968,048, 6,970,542

### **Ordering Information**

For additional copies of this document, contact your sales representative.

# Table of Contents

<b>Chapter 1. Introduction .....</b>	<b>1-1</b>
Overview .....	1-2
Purpose .....	1-2
Scope .....	1-2
Related Publications .....	1-2
Regulatory Compliance and Certification .....	1-8
Customer Care Center .....	1-10
Problem – Critical .....	1-10
Problem – Major .....	1-11
Problem – Minor .....	1-11
Response .....	1-12
Emergency Response .....	1-12
Hardware Repair and Return .....	1-13
Repair and Return Shipping Instructions .....	1-14
Returning a Crate .....	1-16
Site Requirements .....	1-18
About this Document .....	1-19
Conventions .....	1-19
References .....	1-19
Acronyms .....	1-20
<b>Chapter 2. Functional Description .....</b>	<b>2-1</b>
Overview .....	2-2
Hardware .....	2-4
Shelf .....	2-4
Fan Assembly .....	2-5
Components .....	2-5
EOAP Port Labels and Functions .....	2-6
Asynchronous Maintenance Modem (Optional) .....	2-8
Terminal .....	2-9
Software .....	2-10
EOAP Applications .....	2-10
User Application Layer (UAL) Software .....	2-11
Other Software Packages .....	2-11
Interfaces .....	2-13
EOAP-to-STP .....	2-13
EOAP-to-SEAS .....	2-15
Administration .....	2-18
EAGLE 5 ISS Provisioning .....	2-18
EOAP Retransmission Delay .....	2-19

Maintenance .....	2-19
Hardware .....	2-19
Software .....	2-20
Upgrade Considerations .....	2-20
<b>Chapter 3. Installation Procedures .....</b>	<b>3-1</b>
Safety Information .....	3-2
Introduction .....	3-5
Procedures .....	3-5
EOAP Fan Assembly .....	3-11
EOAP Shelf .....	3-18
EOAP Cabling .....	3-23
EOAP Power-Up .....	3-70
Fan Operation Testing .....	3-71
Maintenance Modem Setup .....	3-74
<b>Chapter 4. EOAP Provisioning Procedures .....</b>	<b>4-1</b>
Overview .....	4-2
Initial Implementation .....	4-4
Configuring the OAP Port at the EAGLE 5 ISS .....	4-4
Configuring the OAP from the EAGLE 5 ISS Terminal .....	4-11
Reprovisioning .....	4-27
Changing the OAP Configuration from the EAGLE 5 ISS Terminal .....	4-27
VI Editor Quick Reference .....	4-39
<b>Chapter 5. Test Procedures .....</b>	<b>5-1</b>
Overview .....	5-2
Test Setup .....	5-3
EOAP Tests .....	5-5
Verify Aurora Serial Port Devices .....	5-5
Verify EOAP OSI and X25 Processes .....	5-5
Verify Hosts IP Address .....	5-6
Verify All Processes are Running .....	5-6
Verify AURORA Serial Connections to EAGLE 5 ISS (Single) .....	5-7
Verify AURORA Serial Connections to EAGLE 5 ISS (Dual) .....	5-9
Enter the EOAP Configuration .....	5-11
LoopbackTest of the Test X.25 Interface .....	5-14
Verify LEDs Report No Errors on the EOAP .....	5-17
Test Modem (Logical) .....	5-18
Identify EOAP GPL .....	5-18
Verify EOAP-to-SEAS Connection Status .....	5-20
<b>Chapter 6. Replacement Procedures .....</b>	<b>6-1</b>
Overview .....	6-2
Air Management Card .....	6-3
Card Cage/Shelf .....	6-8

## Table of Contents

Power Down the EOAP/Fan Assembly .....	6-10
Remove Cables .....	6-14
Remove Cards .....	6-17
Remove Card Cage .....	6-18
Install Cards .....	6-22
Reconnect Cables .....	6-24
Power Up EOAP/Fan Assembly .....	6-31
CD-ROM Drive Card .....	6-34
Fan Assembly .....	6-41
Remove Fan Assembly .....	6-42
Install Replacement Fan Assembly .....	6-44
Test Fan Operation and Fan Alarm .....	6-48
Hard Drive Card .....	6-51
Replace Hard Drive Card .....	6-52
Reprovision Hard Drive .....	6-59
Power Supply Card .....	6-66
Processor Card .....	6-73
Serial Card .....	6-85
<b>Chapter 7. Basic Troubleshooting .....</b>	<b>7-1</b>
Power .....	7-3
No System Power .....	7-3
No Fan Power .....	7-4
No cPCI Card Power .....	7-4
No CD-ROM Drive Power .....	7-5
No Hard Drive Power .....	7-5
SCSI/Drives .....	7-6
System Has Power But Will Not Boot .....	7-6
CD-ROM Not Responding .....	7-8
Drives Detected But System Will Not Boot .....	7-10
Connect/Disconnect SCSI Devices .....	7-11
Console Devices .....	7-12
Connect/Disconnect Console Devices .....	7-12
Maintenance Modem .....	7-15
LEDs .....	7-17
Power Supply Card .....	7-17
Processor Card .....	7-19
Serial Card .....	7-22
Hard Disk .....	7-25
File System Errors .....	7-25
Full Partition Check .....	7-26
IP .....	7-27
Error: syslog: s match_netconf: setnetconfig failed .....	7-27
EOAP Internal Software .....	7-28
msDI Controlled Software .....	7-28

Trace Inter-Process Messages (Except emsAgent) ..... 7-34  
Required Daemons ..... 7-42  
External Connectivity ..... 7-46  
    No External EOAP Connectivity ..... 7-46  
External Interfaces ..... 7-47  
    EOAP-to-EAGLE 5 ISS Interface ..... 7-47  
    EOAP-to-SEAS Interface ..... 7-51

**Index**

# List of Figures

Figure 1-1. European Directives CE Mark .....	1-8
Figure 1-2. Combined UL Mark for the United States and Canada .....	1-8
Figure 1-3. Hazardous Substances .....	1-9
Figure 2-1. EOAP Communication .....	2-3
Figure 2-2. EOAP Shelf .....	2-4
Figure 2-3. User Application Layer .....	2-11
Figure 2-4. Operating Context of EOAP .....	2-13
Figure 2-5. EOAP-to-EAGLE 5 ISS Interface .....	2-14
Figure 2-6. EAGLE 5 ISS-to-SEAS Interface .....	2-16
Figure 3-1. Removing a Card .....	3-3
Figure 3-2. EOAP Front .....	3-10
Figure 3-3. Fan Baffle to be Removed .....	3-13
Figure 3-4. Remove Grill and Filter from Fan Assembly .....	3-14
Figure 3-5. Insert Fan Assembly Below EOAP Shelf .....	3-15
Figure 3-6. Attach Fan Assembly to Front of Frame Rail .....	3-15
Figure 3-7. Position Cooling Duct on Fan Assembly .....	3-17
Figure 3-8. EOAP Shelf with Cooling Duct and Fan Assembly .....	3-18
Figure 3-9. EOAP Installed in OAP Frame .....	3-20
Figure 3-10. Fans and EOAP Showing Mounting Brackets .....	3-21
Figure 3-11. Fan Assembly Under EOAP .....	3-22
Figure 3-12. EOAP Backplane Cable Connections (Dual Configuration) .....	3-25
Figure 3-13. EOAP Cable Connections Diagram (Dual Configuration) .....	3-26
Figure 3-14. EOAP Backplane Cable Connections (Single Configuration) .....	3-27
Figure 3-15. EOAP Cable Connections Diagram (Single Configuration) .....	3-28
Figure 3-16. FAP Rear View (P/N 870-2320-03) .....	3-33
Figure 3-17. Route Clock Connection Cable .....	3-34
Figure 3-18. Install EOAP Power Cables (P/N 830-0699-xx) .....	3-36
Figure 3-19. Route Power Cables on EOAP Shelf .....	3-37
Figure 3-20. Route Power Cables to FAP .....	3-38
Figure 3-21. Install EOAP Fan Cables (P/N 830-0609-xx) .....	3-39

Figure 3-22. Install EOAP Clock In/Out Cable (P/N 830-0609-xx) .....	3-40
Figure 3-23. Install EOAP Clock Connection Cable .....	3-41
Figure 3-24. Route Clock Connection Cable, EOAP Shelf .....	3-42
Figure 3-25. Route Clock Connection Cable to Cable Rack .....	3-43
Figure 3-26. Route Clock Connection Cable .....	3-44
Figure 3-27. Install EOAP Terminal Cables .....	3-45
Figure 3-28. Route Terminal Cables on EOAP Shelf Backplane .....	3-46
Figure 3-29. Route EOAP Terminal Cables to Cable Rack .....	3-47
Figure 3-30. Locate Cables on EOAP Backplane .....	3-50
Figure 3-31. Secure Cables from EOAP to Cable Rack .....	3-52
Figure 3-32. FAP Rear View (P/N 870-2320-03) .....	3-54
Figure 3-33. Locating Processor Card .....	3-55
Figure 3-34. Dual EOAP Overview .....	3-57
Figure 3-35. Dual EOAP Card Slots and Drive Bays .....	3-58
Figure 3-36. Top Handle and Air Management Card .....	3-59
Figure 3-37. Freeing the Card from the EOAP Card Cage .....	3-59
Figure 3-38. Hard Drive and CD-ROM Drive Faceplates .....	3-60
Figure 3-39. EOAP Backplane Connector Pins .....	3-60
Figure 3-40. Card Handles .....	3-63
Figure 3-41. Inserting the Card .....	3-63
Figure 3-42. Locking the Inject/Eject Handles .....	3-64
Figure 3-43. Tightening Captive Screws .....	3-64
Figure 3-44. Installing a Drive Assembly .....	3-65
Figure 3-45. Pressing the Faceplate .....	3-65
Figure 3-46. Set Fan Switch to OFF .....	3-66
Figure 3-47. Fuse and Alarm Panel P/N 870-2320-03, Rear View .....	3-68
Figure 3-48. Fan Switch Set to ON. ....	3-70
Figure 3-49. Set Fan Switch to OFF .....	3-72
Figure 5-1. EOAP Connection Diagram .....	5-4
Figure 5-2. Verify LED on EOAP Is Green .....	5-17
Figure 6-1. Top Handle and Captive Screw of Air Management Card .....	6-4
Figure 6-2. Freeing the Card from the EOAP Card Cage .....	6-4
Figure 6-3. Air Management Card (P/N 870-1524-01) .....	6-5
Figure 6-4. Air Management Card Handles .....	6-5
Figure 6-5. Inserting the Replacement Air Management Card .....	6-6
Figure 6-6. Lock the Inject/Eject Handles .....	6-6
Figure 6-7. Tighten Captive Screws .....	6-7



## List of Figures

Figure 6-8. EOAP Card Cage .....	6-9
Figure 6-9. Cables Secured on EOAP Shelf Backplane (Single Configuration) .....	6-14
Figure 6-10. Cables Secured on EOAP Shelf Backplane (Dual Configuration) .....	6-15
Figure 6-11. Location of Side Panel Supports and Traverse Arms .....	6-16
Figure 6-12. Remove Screws and Washers from Frame Rail .....	6-18
Figure 6-13. Locate Mounting Brackets for EOAP Card Cage .....	6-19
Figure 6-14. Attach Mounting Bracket to EOAP Card Cage .....	6-20
Figure 6-15. Attach Card Cage to Rear of Frame Rail .....	6-21
Figure 6-16. Cable Connections on EOAP Backplane (Single Configuration) .....	6-24
Figure 6-17. Cable Connections on EOAP Backplane (Dual Configuration) .....	6-25
Figure 6-18. Locate Processor Card .....	6-26
Figure 6-19. Locate Cables on EOAP Backplane (Single Configuration) .....	6-27
Figure 6-20. Locate Cables on EOAP Backplane (Dual Configuration) .....	6-27
Figure 6-21. Cables Secured on EOAP Shelf Backplane (Single Configuration) .....	6-28
Figure 6-22. Cables Secured on EOAP Shelf Backplane (Dual Configuration) .....	6-28
Figure 6-23. Secure Cables from EOAP to Cable Rack .....	6-30
Figure 6-24. Fan Switch Set to ON .....	6-31
Figure 6-25. EOAP-A and EOAP-B Drive Assemblies .....	6-34
Figure 6-26. CD-ROM Drive Card Captive Screws .....	6-37
Figure 6-27. Support the CD-ROM Drive Card With Both Hands .....	6-38
Figure 6-28. CD-ROM Drive Card (P/N 870-1515-03) .....	6-39
Figure 6-29. Install the CD-ROM Drive Card .....	6-39
Figure 6-30. Press the Faceplate .....	6-40
Figure 6-31. Set Fan Switch to OFF .....	6-42
Figure 6-32. Remove Fan Assembly .....	6-43
Figure 6-33. Remove Grill and Filter from Fan Assembly .....	6-44
Figure 6-34. Insert Fan Assembly Below EOAP Shelf .....	6-45
Figure 6-35. Attach Fan Assembly to Front of Frame Rail .....	6-45
Figure 6-36. Replace Fan Filter and Grill .....	6-46
Figure 6-37. Fan Switch Set to ON .....	6-47
Figure 6-38. Set Fan Switch to OFF .....	6-49

Figure 6-39. EOAP-A and EOAP-B Drive Assemblies .....	6-52
Figure 6-40. Loosen Hard Drive Card Captive Screws .....	6-56
Figure 6-41. Free Hard Drive Card from the EOAP Card Cage .....	6-57
Figure 6-42. Support the Hard Drive Card With Both Hands .....	6-57
Figure 6-43. Examine EOAP Backplane Connector Pins .....	6-58
Figure 6-44. Hard Drive Card (P/N 870-1514-03) .....	6-58
Figure 6-45. Installing the Hard Drive Card .....	6-58
Figure 6-46. Pressing the Faceplate .....	6-59
Figure 6-47. Locate Power Supply Card .....	6-67
Figure 6-48. Loosening Captive Screws of Power Supply Card .....	6-68
Figure 6-49. Free the Card from the EOAP Card Cage .....	6-68
Figure 6-50. EOAP Backplane Connector Pins .....	6-69
Figure 6-51. Power Supply Card (P/N 870-1521-01) .....	6-69
Figure 6-52. Power Supply Card Handles .....	6-70
Figure 6-53. Inserting the Power Supply Card .....	6-70
Figure 6-54. Handles in Locked Position .....	6-71
Figure 6-55. Tighten Captive Screws .....	6-71
Figure 6-56. Locate Processor Card .....	6-77
Figure 6-57. Processor Card Captive Screws .....	6-78
Figure 6-58. Freeing the Processor Card from the EOAP Card Cage .....	6-79
Figure 6-59. EOAP Backplane Connector Pins .....	6-79
Figure 6-60. Processor Card (P/N 870-1523-01) .....	6-80
Figure 6-61. Processor Card Handles .....	6-80
Figure 6-62. Inserting the Replacement Processor Card .....	6-81
Figure 6-63. Locking the Inject/Eject Handles .....	6-82
Figure 6-64. Tightening Captive Screws .....	6-82
Figure 6-65. EOAP Serial and Ethernet Connections .....	6-83
Figure 6-66. Location of Serial Card .....	6-86
Figure 6-67. Top Handle and Captive Screw of Serial Card .....	6-87
Figure 6-68. Freeing the Card from the EOAP Card Cage .....	6-87
Figure 6-69. EOAP Backplane Connector Pins .....	6-88
Figure 6-70. Serial Card (870-1522-01) .....	6-88
Figure 6-71. Serial I/O Card Handles .....	6-89
Figure 6-72. Inserting the Replacement Serial Card .....	6-89
Figure 6-73. Locking the Inject/Eject Handles .....	6-90
Figure 6-74. Tighten Captive Screws .....	6-91
Figure 7-1. CD-ROM SCSI Jumper Settings .....	7-7

## List of Figures

Figure 7-2. Hard Drive SCSI Jumper Settings .....	7-7
---	-----

# List of Tables

Table 1-1. Basic RMA Types .....	1-13
Table 1-2. RMA Reasons for Return .....	1-13
Table 2-1. Status LEDs of the EOAP System .....	2-5
Table 2-2. EOAP Port Labels and Functions .....	2-7
Table 2-3. SCSI Addresses .....	2-8
Table 2-4. EOAP Processes .....	2-10
Table 3-1. EOAP Installation Order .....	3-6
Table 3-2. EOAP Installation Equipment Required .....	3-8
Table 3-3. Fan Assembly - Installation Order .....	3-11
Table 3-4. Fan Assembly - Tools and Equipment .....	3-12
Table 3-5. Tools and Equipment - EOAP Shelf .....	3-19
Table 3-6. Dual EOAP Cable Legend .....	3-24
Table 3-7. EOAP Port Labels and Functions .....	3-29
Table 3-8. External Interfaces System A .....	3-30
Table 3-9. External Interfaces System B .....	3-31
Table 3-10. Installation Order for Single-to-Dual EOAP Configuration .....	3-56
Table 3-11. Tools and Equipment - EOAP Cards and Drives .....	3-57
Table 3-12. EOAP Cards and Drives .....	3-61
Table 3-13. Tools and Equipment - EOAP Cards and Drives .....	3-62
Table 3-14. Fuse Panel Items and Description .....	3-68
Table 4-1. Performance Impact of <b>act-oap-config</b> Parameters .....	4-13
Table 4-2. Fields Displayed for the <b>RTRV-OAP-CONFIG</b> Command .....	4-14
Table 4-3. Example OAP Initial Configuration .....	4-15
Table 4-4. Example OAP Initial Configuration .....	4-27
Table 6-1. Slot and Bay Assignment for EOAP Cards .....	6-22
Table 7-1. Power Supply Card LEDs .....	7-17
Table 7-2. msDI Processes .....	7-28
Table 7-3. License, OSI, X.25 and Alarm Daemons .....	7-42

# 1

## Introduction

Overview .....	1-2
Purpose .....	1-2
Scope.....	1-2
Related Publications.....	1-2
Regulatory Compliance and Certification .....	1-8
Customer Care Center .....	1-10
Emergency Response .....	1-12
Site Requirements .....	1-18
About this Document.....	1-19
Conventions.....	1-19
References .....	1-19
Acronyms.....	1-20

## Overview

The Embedded Operations Support System Application Processor (EOAP) is a general purpose interface module that provides the STP system with a generic platform to develop and run software for feature-specific interfaces to the STP. These interfaces, for example, include the optional Signaling and Engineering Administration System (SEAS).

The EOAP translates and converts higher layer protocols into asynchronous serial communication. It communicates with the STP system through a serial interface port. For the SEAS interface, the EOAP provides translation and asynchronous-to-X.25 communication conversion.

The EOAP is a modular unit with field replaceable components. For upgrade purposes, the EOAP can replace an existing Texas Micro OAP.

The EOAP shelf is designed for a split system consisting of an EOAP-A and an EOAP-B. Each EOAP system in the dual configuration consists of a processor card, an interface card, a power supply card, a removable hard drive, and a removable CD-ROM drive.

## Purpose

The purpose of this document is to provide the user with information and instructions on how to implement and maintain the EOAP.

## Scope

The system manual describes the EOAP and provides procedures for initial implementation, the replacement of EOAP-related hardware, and basic troubleshooting.

## Related Publications

The *System Manual – EOAP* is part of the EAGLE 5 ISS documentation set and may refer to one or more of the following manuals:

- The *Commands Manual* contains procedures for logging into or out of the EAGLE 5 ISS, a general description of the terminals, printers, the disk drive used on the system, and a description of all the commands used in the system.
- The *Commands Pocket Guide* is an abridged version of the *Commands Manual*. It contains all commands and parameters, and it shows the command-parameter syntax.
- The *Commands Quick Reference Guide* contains an alphabetical listing of the commands and parameters. The guide is sized to fit a shirt-pocket.

## Introduction

- The *Commands Error Recovery Manual* contains the procedures to resolve error message conditions generated by the commands in the *Commands Manual*. These error messages are presented in numerical order.
- The *Database Administration Manual – Features* contains procedural information required to configure the EAGLE 5 ISS to implement these features:
  - X.25 Gateway
  - STP LAN
  - Database Transport Access
  - GSM MAP Screening
  - EAGLE 5 ISS Support for Integrated Sentinel
- The *Database Administration Manual - Gateway Screening* contains a description of the Gateway Screening (GWS) feature and the procedures necessary to configure the EAGLE 5 ISS to implement this feature.
- The *Database Administration Manual – Global Title Translation* contains procedural information required to configure an EAGLE 5 ISS to implement these features:
  - Global Title Translation
  - Enhanced Global Title Translation
  - Variable Length Global Title Translation
  - Interim Global Title Modification
  - Intermediate GTT Load Sharing
  - ANSI-ITU-China SCCP Conversion
- The *Database Administration Manual - IP7 Secure Gateway* contains procedural information required to configure the EAGLE 5 ISS to implement the SS7-IP Gateway.
- The *Database Administration Manual – SEAS* contains the EAGLE 5 ISS configuration procedures that can be performed from the Signaling Engineering and Administration Center (SEAC) or a Signaling Network Control Center (SNCC). Each procedure includes a brief description of the procedure, a flowchart showing the steps required, a list of any EAGLE 5 ISS commands that may be required for the procedure but that are not supported by SEAS, and a reference to optional procedure-related information, which can be found in one of these manuals:
  - Database Administration Manual – Gateway Screening
  - Database Administration Manual – Global Title Translation

## — Database Administration Manual – SS7

- The *Database Administration Manual – SS7* contains procedural information required to configure an EAGLE 5 ISS to implement the SS7 protocol.
- The *Database Administration Manual – System Management* contains procedural information required to manage the EAGLE 5 ISS database and GPLs, and to configure basic system requirements such as user names and passwords, system-wide security requirements, and terminal configurations.
- The *Dimensioning Guide for EPAP Advanced DB Features* is used to provide EPAP planning and dimensioning information. This manual is used by Tekelec personnel and EAGLE 5 ISS customers to aid in the sale, planning, implementation, deployment, and upgrade of EAGLE 5 ISS systems equipped with one of the EAGLE 5 ISS EPAP Advanced Database (EADB) Features.
- The *ELAP Administration Manual* defines the user interface to the EAGLE 5 ISS LNP Application Processor on the MPS/ELAP platform. The manual defines the methods for accessing the user interface, menus, screens available to the user and describes their impact. It provides the syntax and semantics of user input, and defines the output the user receives, including information and error messages, alarms, and status.
- The *EPAP Administration Manual* describes how to administer the EAGLE 5 ISS Provisioning Application Processor on the MPS/EPAP platform. The manual defines the methods for accessing the user interface, menus, and screens available to the user and describes their impact. It provides the syntax and semantics of user input and defines the output the user receives, including messages, alarms, and status.
- The *Feature Manual - EIR* provides instructions and information on how to install, use, and maintain the EIR feature on the Multi-Purpose Server (MPS) platform of the EAGLE 5 ISS. The feature provides network operators with the capability to prevent stolen or disallowed GSM mobile handsets from accessing the network.
- The *Feature Manual - G-Flex C7 Relay* provides an overview of a feature supporting the efficient management of Home Location Registers in various networks. This manual gives the instructions and information on how to install, use, and maintain the G-Flex feature on the Multi-Purpose Server (MPS) platform of the EAGLE 5 ISS.
- The *Feature Manual - G-Port* provides an overview of a feature providing the capability for mobile subscribers to change the GSM subscription network within a portability cluster while retaining their original MSISDNs. This manual gives the instructions and information on how to install, use, and maintain the G-Port feature on the Multi-Purpose Server (MPS) platform of the EAGLE 5 ISS.



## Introduction

- The *Feature Manual - INP* provides the user with information and instructions on how to implement, utilize, and maintain the INAP-based Number Portability (INP) feature on the Multi-Purpose Server (MPS) platform of the EAGLE 5 ISS.
- The *FTP-Based Table Retrieve Application (FTRA) User Guide* describes how to set up and use a PC to serve as the offline application for the EAGLE 5 ISS FTP Retrieve and Replace feature.
- The *Hardware Manual - EAGLE 5 ISS* contains hardware descriptions and specifications of Tekelec's signaling products. These include the EAGLE 5 ISS, OEM-based products such as the ASi 4000 Service Control Point (SCP), the Netra-based Multi-Purpose Server (MPS), and the Integrated Sentinel with Extended Services Platform (ESP) subassembly.

The Hardware Manual provides an overview of each system and its subsystems, details of standard and optional hardware components in each system, and basic site engineering. Refer to this manual to obtain a basic understanding of each type of system and its related hardware, to locate detailed information about hardware components used in a particular release, and to help configure a site for use with the system hardware.

- The *Hardware Manual - Tekelec 1000 Application Server* provides general specifications and a description of the Tekelec 1000 Applications Server (T1000 AS). This manual also includes site preparation, environmental and other requirements, procedures to physically install the T1000 AS, and troubleshooting and repair of Field Replaceable Units (FRUs).
- The *Hardware Manual - Tekelec 1100 Application Server* provides general specifications and a description of the Tekelec 1100 Applications Server (T1100 AS). This manual also includes site preparation, environmental and other requirements, procedures to physically install the T1100 AS, and troubleshooting and repair of Field Replaceable Units (FRUs).
- The *Installation Manual - EAGLE 5 ISS* contains cabling requirements, schematics, and procedures for installing the EAGLE 5 ISS along with LEDs, Connectors, Cables, and Power Cords to Peripherals. Refer to this manual to install components or the complete systems.
- The *Installation Manual - Integrated Applications* provides the installation information for integrated applications such as EPAP 4.0 or earlier (Netra-based Multi-Purpose Server (MPS) platform) and Sentinel. The manual includes information about frame floors and shelves, LEDs, connectors, cables, and power cords to peripherals. Refer to this manual to install components or the complete systems.

- The *LNP Database Synchronization Manual - LSMS with EAGLE 5 ISS* describes how to keep the LNP databases at the LSMS and at the network element (the EAGLE 5 ISS is a network element) synchronized through the use of resynchronization, audits and reconciles, and bulk loads. This manual is contained in both the LSMS documentation set and in the EAGLE 5 ISS documentation set.
- The *LNP Feature Activation Guide* contains procedural information required to configure the EAGLE 5 ISS for the LNP feature and to implement these parts of the LNP feature on the EAGLE 5 ISS:
  - LNP services
  - LNP options
  - LNP subsystem application
  - Automatic call gapping
  - Triggerless LNP feature
  - Increasing the LRN and NPANXX Quantities on the EAGLE 5 ISS
  - Activating and Deactivating the LNP Short Message Service (SMS) feature
- The *Maintenance Manual* contains procedural information required for maintaining the EAGLE 5 ISS and the card removal and replacement procedures. The *Maintenance Manual* provides preventive and corrective maintenance procedures used in maintaining the different systems.
- The *Maintenance Pocket Guide* is an abridged version of the Maintenance Manual and contains all the corrective maintenance procedures used in maintaining the EAGLE 5 ISS.
- The *Maintenance Emergency Recovery Pocket Guide* is an abridged version of the Maintenance Manual and contains the corrective maintenance procedures for critical and major alarms generated on the EAGLE 5 ISS.
- The *MPS Platform Software and Maintenance Manual - EAGLE 5 ISS with Tekelec 1000 Application Server* describes the platform software for the Multi-Purpose Server (MPS) based on the Tekelec 1000 Application Server (T1000 AS) and describes how to perform preventive and corrective maintenance for the T1000 AS-based MPS. This manual should be used with the EPAP-based applications (EIR, G-Port, G-Flex, and INP).
- The *MPS Platform Software and Maintenance Manual - EAGLE 5 ISS with Tekelec 1100 Application Server* describes the platform software for the Multi-Purpose Server (MPS) based on the Tekelec 1100 Application Server (T1100 AS) and describes how to perform preventive and corrective maintenance for the T1100 AS-based MPS. This manual should be used with the ELAP-based application (LNP).

## Introduction

- The *Provisioning Database Interface Manual* defines the programming interface that populates the Provisioning Database (PDB) for the EAGLE 5 ISS features supported on the MPS/EPAP platform. The manual defines the provisioning messages, usage rules, and informational and error messages of the interface. The customer uses the PDBI interface information to write his own client application to communicate with the MPS/EPAP platform.
- The *Previously Released Features Manual* summarizes the features of previous EAGLE, EAGLE 5 ISS, and IP<sup>7</sup> Secure Gateway releases, and it identifies the release number of their introduction.
- The *Release Documentation* contains the following documents for a specific release of the system:
  - *Feature Notice* - Describes the features contained in the specified release. The Feature Notice also provides the hardware baseline for the specified release, describes the customer documentation set, provides information about customer training, and explains how to access the Customer Support website.
  - *Release Notice* - Describes the changes made to the system during the lifecycle of a release. The Release Notice includes Generic Program Loads (GPLs), a list of PRs resolved in a build, and all known PRs.  
**NOTE: The *Release Notice* is maintained solely on Tekelec's Customer Support site to provide you with instant access to the most up-to-date release information.**
  - *System Overview* - Provides high-level information on SS7, the IP<sup>7</sup> Secure Gateway, system architecture, LNP, and EOAP.
  - *Master Glossary* - Contains an alphabetical listing of terms, acronyms, and abbreviations relevant to the system.
  - *Master Index* - Lists all index entries used throughout the documentation set.
- The *System Manual – EOAP* describes the Embedded Operations Support System Application Processor (EOAP) and provides the user with procedures on how to implement the EOAP, replace EOAP-related hardware, device testing, and basic troubleshooting information.

## Regulatory Compliance and Certification

Tekelec products are tested to meet the following regulatory standards:

- Network Equipment Building System (NEBS) level 3 as listed in Telcordia SR-3580.
- Applicable Telcordia Electromagnetic Compatibility and Electrical Safety requirements in GR-1089-CORE.
- Applicable Physical Protection requirements in GR-63-CORE.
- Relevant directives and harmonized standards in support of the products Compliance European (CE) mark required in Europe. Figure 1-1 shows the mark used to indicate this compliance.

**Figure 1-1.** European Directives CE Mark



- Relevant standards in ElectroMagnetic Compatibility (EMC) directive 89/336/EEC.
- Relevant standards in Safety directive 73/23/EEC, supported by Certified Body (CB) Test Certificates US/5923/UL or US/5451/UL issued by the National Certification Body as tested to IEC 60950 with national differences for European countries
- Underwriters Laboratories (UL) listed under UL File E200146 for USA and c-UL for Canada. Figure 1-2 shows the mark used to indicate this compliance.

**Figure 1-2.** Combined UL Mark for the United States and Canada



- Relevant standards in SJ/T 11363-2006 for limits of certain hazardous substances.

**Figure 1-3. Hazardous Substances**

部件名称 (Parts)	有毒有害物质或元素 (Hazardous Substance)					
	铅 (Pb)	汞 (Hg)	镉 (Cd)	六价铬 (Cr <sup>6+</sup> )	多溴联苯 (PBB)	多溴二苯醚 (PBDE)
金属部件 (Metal Parts)	○	○	○	○	○	○
电路模块 (Circuit Modules)	×	○	○	○	○	○
电缆及电缆组件 (Cables & Cable Assemblies)	×	○	○	○	○	○
塑料和聚合物部件 (Plastic and Polymeric parts)	○	○	○	○	○	○

- : 表示该有毒有害物质在该部件所有均质材料中的含量均在SJ/Txxxx-xxxx标准规定的限量要求以下。  
Indicates that the concentration of the hazardous substance in all homogeneous materials in the parts is below the relevant threshold of the SJ/T 11363-2006 standard.
- ×: 表示该有毒有害物质至少在该部件的某一均质材料中的含量超出SJ/Txxxx-xxxx标准规定的限量要求。  
Indicates that the concentration of the hazardous substance of at least one of all homogeneous materials in the parts is above the relevant threshold of the SJ/T 11363-2006 standard.

## Customer Care Center

Customer Care Center provides a point of contact through which support can be provided for problems that may be encountered during normal operation of the system.

To receive technical assistance, call the Customer Care Center at one of the following locations:

- Tekelec, UK
  - Phone+44 1784 467 804
  - Fax:+44 1784 477 120
  - Email:ecsc@tekelec.com
- Tekelec, USA
  - Phone (within the continental US) (888) FOR-TKLC
  - Phone(outside the continental US) +1 919-460-2150
  - Fax 919-460-2126
  - Email:support@tekelec.com

Once a Customer Service Request (CSR) is issued, the Customer Care Center, along with the customer, determines the classification of the trouble.

Problems are reported using problem criteria, as defined in the following sections and “TL-9000 Quality System Metrics (Book Two, Release 3.0)” .

### Problem – Critical

Critical problems severely affect service, capacity/traffic, billing, and maintenance capabilities and requires immediate corrective action, regardless of time of day or day of the week, as viewed by a customer upon discussion with the supplier. For example:

A loss of service that is comparable to the total loss of effective functional capacity of an entire switching or transport system.

A reduction in capacity or traffic handling capacity such that expected loads cannot be handled.

loss of ability to provide safety or emergency capability (for example, 911 calls).

## Introduction

### Problem – Major

Major problems cause conditions that seriously affect system operations, or maintenance and administration, and require immediate attention as viewed by the customer upon discussion with the supplier. Because of a lesser immediate or impending effect on system performance, the urgency is less than in a critical situation. A list of possible examples follows:

Reduction in any capacity/traffic measurement function

Any loss of functional visibility and/or diagnostic capability

Short outage equivalent to system or subsystem outages with accumulated duration of greater than two minutes in any 24-hour period or that continue to repeat during longer periods

Repeated degradation of DS1 or higher rate spans or connections

Prevention of access for routine administrative activity

Degradation of access for maintenance or recovery operations

Degradation of the system's ability to provide any required critical or major trouble notification

Any significant increase in product-related customer trouble reports

Billing error rates that exceed specifications

Corruption of system or billing databases

### Problem – Minor

Other problems that a customer does not view as critical or major are considered minor. Minor problems do not significantly impair the functioning of the system and do not significantly affect service to customers. These problems are tolerable during system use.

Engineering complaints are classified as minor unless otherwise negotiated between the customer and supplier.

## Response

If a critical problem exists, emergency procedures are initiated (see “Emergency Response”). If the problem is not critical, information regarding the serial number of the system, Common Language Location Identifier (CLLI), and initial problem symptoms and messages is recorded and a primary Customer Care Center specialist is assigned to work the Customer Service Request (CSR) and provide a solution to the problem. The CSR is closed when the problem has been resolved.

### Emergency Response

In the event of a critical service situation, emergency response is offered by the Customer Care Center.

Call 24 hours a day, 7 days a week

Tekelec, UK

- Phone +44 1784 467 804
- Fax: +44 1784 477 120
- Email: [ecsc@tekelec.com](mailto:ecsc@tekelec.com)

Tekelec, USA

- Phone (within the continental US) (888) FOR-TKLC
- Phone (outside the continental US) +1 919-460-2150
- Email: [support@tekelec.com](mailto:support@tekelec.com)

Emergency response provides immediate coverage, automatic escalation, and other features to ensure a rapid resolution to the problem.



## Hardware Repair and Return

Any system components being returned for repair or replacement must be processed through the Tekelec Return Material Authorization (RMA) procedures. A hardware repair is defined as an item returned to Tekelec due to a failure, with the returned item being repaired and returned to the customer. It is essential that serial numbers are recorded correctly. RMAs cannot be created without a valid serial number. All repair and quality information is tracked by serial number. Table 1-1 lists the basic RMA types. Table 1-2 lists the RMA return reasons.

**Table 1-1.** Basic RMA Types

Replacement Type	Description	Turnaround
Priority Advance Replacement	Customer requests the URGENT replacement of a damaged product	Same Day Shipment
Advance Replacement	Customer request the replacement of a damaged product	Shipment Within 3 Business Days
Repair/Return	Customer will return a damaged product for repair	Shipment Within 5 Days After Receipt
Expendable	A damaged part, such as a cable, is replaced, but the Customer does not return the damaged product	Depends on Urgency - Shipment Within 3 Business Days

**Table 1-2.** RMA Reasons for Return

Reason for Return	Description
Damaged by Environment	Product damaged by environmental phenomena such as water damage or earthquake
Damaged in Shipment	Damaged between shipment from Tekelec and receipt at the Customer's installation site.
DOA – Dead on Arrival	Product is not functional when it is first installed at the Customer's location.
Lab Return	Products returned from lab sites.
Product Capture	Defect to be captured by Quality or Engineering (not Product Recall).
Product Deficiency	Anything wrong with the part that doesn't fall into another category.
Product Recall	Products recalled by divisions for the repair of a defect or replacement of defective products.
Return – No Product Deficiency	Anything returned without the product being defective.

## Repair and Return Shipping Instructions

All returned equipment, assemblies, or subassemblies must be shipped to the Tekelec Repair and Return Facility specified by the Customer Care Center specialist. The item being returned must be shipped in the original carton or in an equivalent container assuring proper static handling procedures and with the freight charges prepaid.

The assigned RMA number must be clearly printed on the "RMA#:" line of the shipping label on the outside of the shipping package. If the RMA number is not placed on the label, the return could be delayed.

### Procedure- RMA

---

- 1 Obtain and confirm the following information before contacting the Tekelec Customer Contact Center:
  - Your name:
  - Company name:
  - Call-back number:
  - Email address:
  - Which product you are calling about?
  - Site location:
  - CLLI number
  - System serial number (NT, CE, LM, DS, etc...):
  - Complete software release (e.g., 28.0.1-41.53.0):
  - Upgrade forms  
WI005153  
WI005154  
WI005218

## Introduction

WI005219  
WI005220

- Tekelec card type: (e.g., ILA, MPL, DSM, etc):
- Tekelec card part number (870-####-##):
- Associated serial number (102#####):
- Reason for return or replacement (isolated from system):
- Full name of person the replacement card is being shipped to:
- Shipping address:

**NOTE: If possible, include associated alarms (UAMs) and a copy of the associated output (capture file).**

---

- 2 Contact the Customer Care Center and request a Return of Material Authorization (RMA).

Reference: "*Customer Care Center*" on page 10.

---

- 3 If the item is a like-for-like advance replacement, the Customer Care Center specialist arranges for shipment of the replacement item to the customer.
  - a Wait for the replacement component to arrive.
  - b Package the defective component in the box of materials you received with your replacement. Use proper static handling procedures.
  - c Label the outside and inside of the box with your RMA number clearly visible. Place the packing slip from the received replacements on the inside of your box.
  - d Ship the defective component to the return address listed on the packing slip.
- 4 If the item is a repair/return, the Customer Care Center specialist arranges for shipment of the replacement item to the customer.
  - a Package the defective component in a suitable package for shipping. Use proper static handling procedures.
  - b Label the outside and inside of the box with your RMA number clearly visible. Include a packing slip with all the information from Step 1 along with the RMA number.

- c Ship the defective component to the following address:  
TEKELEC  
Attn: RMA Department  
5200 Paramount Parkway  
Morrisville, NC 27560  
RMA#: <assigned by Tekelec>
  - d Wait for the repaired component to arrive.
- 

### Specifically Targeted PCBs

Manufacturing may be involved in the investigations. In certain unique circumstances the capture of an individual PCB, for evaluation, can be initiated through a customer request.

For any reason the Director of Quality (QA), with input from other groups such as NSG Customer Service, Hardware Systems, Repair and Maintenance Support (RMS) and/or Manufacturing, can authorize a board type to be "captured" and sent to the North Carolina facility for evaluation and analysis. NSG QA receives the board(s), records board information such as part number, serial number, and problem description on the appropriate forms. Next, NSG sends the PCB to a Hardware Systems representative who initiates the design engineering evaluation. Once the evaluation and repair, if applicable, is complete, the results are documented and the PCB returned to NSG QA.

### Returning a Crate

Use the following procedure to return a shipping crate and dollies to Tekelec.

## Procedure — Preparing Crate and Dolly for Return to Tekelec

---

1. Replace the retaining brace.
2. Replace the shipping container front panel using the bolts saved previously and arrange the return shipment by contacting:

Shipping Manager  
TEKELEC

Attn: RMA Department  
5200 Paramount Parkway  
Morrisville, NC 27560

RMA#: <assigned by Tekelec>

---

3. After the frame is positioned and the dollies are removed from the frame, the dollies are returned to the same address as the shipping container listed above.

If the equipment is being immediately installed, ship the dollies back to Tekelec in the crate after use. After installing the equipment, bolt the dollies securely in the crate and return to Tekelec.

OR

If the equipment is not being immediately installed, ship the dollies back to Tekelec in the box supplied with the crate. After unpacking the equipment, return the crate to Tekelec and retain the box to return the dollies. After installing the equipment, remove the dollies and return to Tekelec in the supplied box.

It is the site supervisor's responsibility to assure the crate and dollies are returned to Tekelec.

## Site Requirements

Implementation of the EOAP requires the following software and hardware baselines:

- EAGLE 5 ISS software release 25.0 or later.

If your site does not have release 25.0 or later installed, contact your Customer Care Center for an upgrade.

- Fuse and Alarm panel P/N 870-0243-09 or P/N 870-1606-01
- One fan per EOAP P/N 890-1038-01

## About this Document

### Conventions

The following icons are used throughout this document:



**DANGER:**

This icon and text indicate the possibility of *personal injury*.



**WARNING:**

This icon and text indicate the possibility of *equipment damage*.



**CAUTION:**

This icon and text indicate the possibility of *service interruption*.

The following typefaces are used throughout this document:

`This type indicates output from the machine.`

**This type indicates input by the user or a section of output that demonstrates a point to the user.**

**NOTE: EOAP commands in this document are CASE SENSITIVE.**

The following UNIX prompts appear throughout this document:

- # - you are logged in as root
- % - you are logged in as ccspj
- ok - the operating system is halted

### References

The following documents are referenced in this manual:

- *ESD Protection Procedure (907-0404-01)*
- *Mechanical Assembly Torque Specification (906-0008-01)*

## Acronyms

The following acronyms are used in this document:

AE.....	Application Entity
ANSI .....	American Standards Institute
BPDCM.....	The application software for flash memory management on the DCM card.
CDPA .....	Called Party Address
CLLI .....	Common Language Location Identifier
CMIP.....	Common Management Information Protocol
cPCI.....	CompactPCI
DCM.....	Database Communications Module
DTE .....	Data Terminal Equipment
DCE.....	Data Communications Equipment
EMAP.....	EAGLE 5 ISS Measurements Application Processor
EMDC .....	Element Measurement and Data Collection
EMS .....	Element Management Service
EOAP .....	Embedded OAP
ESD.....	Electro-static discharge
FAP.....	Fuse and Alarm Panel
GPF.....	General purpose frame
GPL .....	Generic Program Load
GTA.....	Global Title Address
GTI .....	Global Title Indicator
GTT .....	Global Title Translation
HMI.....	Human-Machine Interface
IMT.....	Interprocessor Message Transfer
IP .....	Internet Protocol
ITU .....	International Telecommunications Union
LIM.....	Link Interface Module
LNP .....	Local Number Portability
MAS .....	Maintenance and administration subsystem
MASP .....	MAS processor
MIB.....	Management Information Base



## Introduction

MR.....	Message Relay
MMI .....	Man-Machine Interface
MSU .....	Message Signaling Unit
NDC.....	Network Data Collection
NE .....	Network Element
NMD.....	Network Management Data
NSD.....	Network Switching Division
OAM .....	Operations, Administration, and Maintenance
OAP .....	Operations Support System Application Processor
OAPF .....	OAP Frame
OID .....	Object ID
OSI .....	Open System Interface
QAF.....	Q Adapter Function
OS.....	Operating System
OSS.....	Operation Support System
Q.3.....	Q.3 protocol
SCCP .....	Signaling Connection Control Part
SCMG .....	SCCP Management
SCSI.....	Small Computer System Interface
SEAC.....	Signaling Engineering and Administration Center
SEAS .....	Signaling Engineering and Administration System
SSN.....	SS7 Subsystem Number
STP .....	Signal Transfer Point
TCAP .....	Transaction Capabilities Application Part
TDM.....	Terminal Disk Module
TT .....	Translation Type
UDT .....	Unit Data Transfer
UDTS .....	Unit Data Transfer Service
UAL .....	User Application Layer
X.25 .....	An ITU-T standard protocol
PVC.....	Permanent Virtual Circuit



# Functional Description

Overview .....	2-2
Hardware .....	2-4
Shelf.....	2-4
Fan Assembly .....	2-5
Components.....	2-5
EOAP Port Labels and Functions .....	2-6
Asynchronous Maintenance Modem (Optional).....	2-8
Terminal.....	2-9
Software .....	2-10
EOAP Applications.....	2-10
User Application Layer (UAL) Software .....	2-11
Other Software Packages .....	2-11
Interfaces.....	2-13
EOAP-to-STP .....	2-13
EOAP-to-SEAS .....	2-15
Administration.....	2-18
EAGLE 5 ISS Provisioning.....	2-18
EOAP Retransmission Delay .....	2-19
EOAP Retransmission Delay.....	2-19

Maintenance .....2-19

    Hardware.....2-19

    Software.....2-20

Upgrade Considerations.....2-20

## Overview

The Embedded Operations Support System Application Processor (EOAP) is a general purpose interface module that provides the STP system with a generic platform to develop and run software for feature-specific interfaces to the STP. These interfaces, for example, include the optional Signaling and Engineering Administration System (SEAS).

The EOAP translates and converts higher layer protocols into asynchronous serial communication. It communicates with the STP system through a serial interface port. For the SEAS interface, the EOAP provides translation and asynchronous-to-X.25 communication conversion.

Each EOAP reports to the STP its general status as well as the status of its User Application Layer (UAL), X.25 links, PVCs on those links, and Q.3 associations. The STP can then report the status of the EOAP and its components to the user through the STP's Human-Machine Interface (HMI).

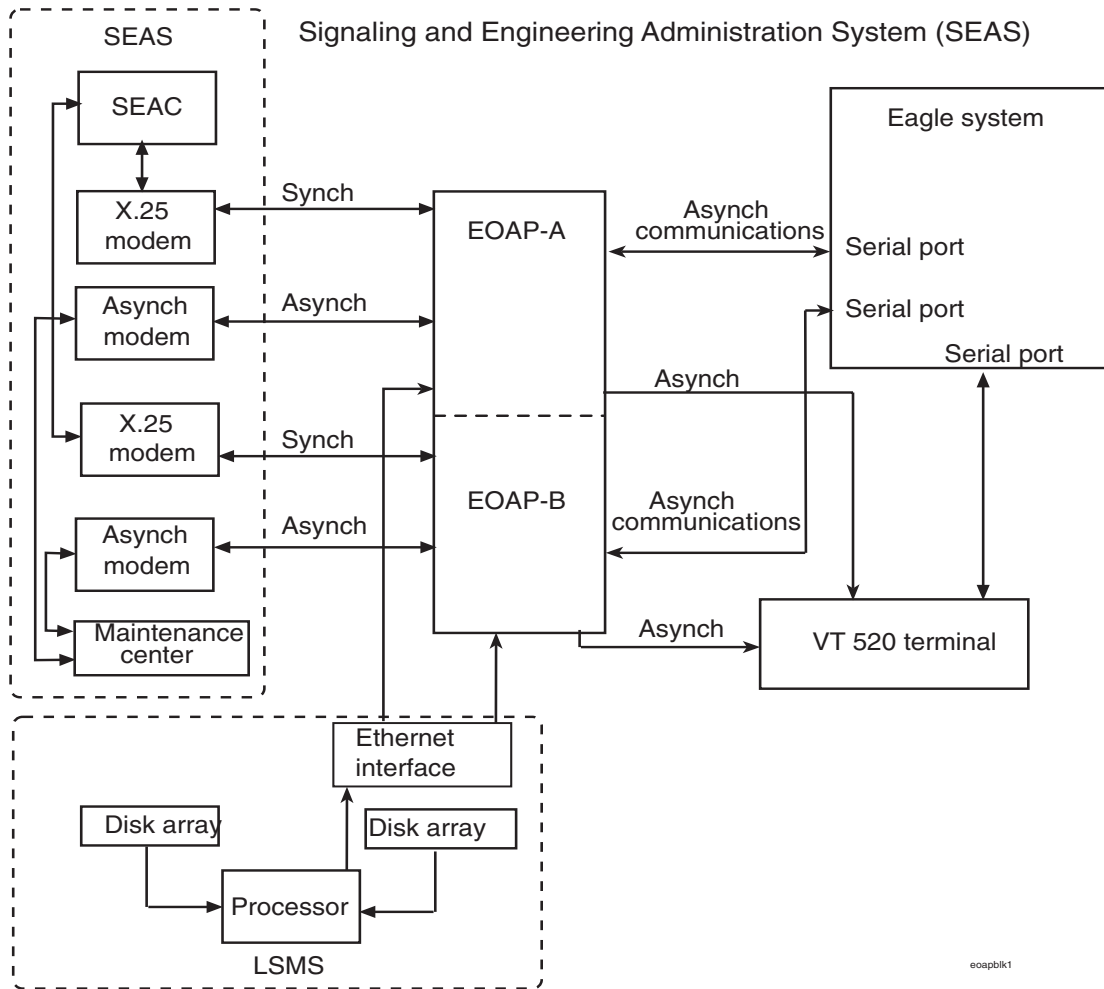
You can configure most aspects of the EOAP through the STP terminal. For upgrade, debug, and maintenance functions, use a VT-520 terminal directly connected to the EOAP.

The EOAP is a modular unit with field-replaceable components. For upgrade purposes, the EOAP can replace an existing Texas Micro OAP.

The EOAP shelf is designed for a split system consisting of an EOAP-A and an EOAP-B. Each EOAP system in the dual configuration consists of a processor card, a serial interface card, a power supply card, a removable hard drive, and a removable CD-ROM drive.

# Functional Description

Figure 2-1. EOAP Communication



## Hardware

### Shelf

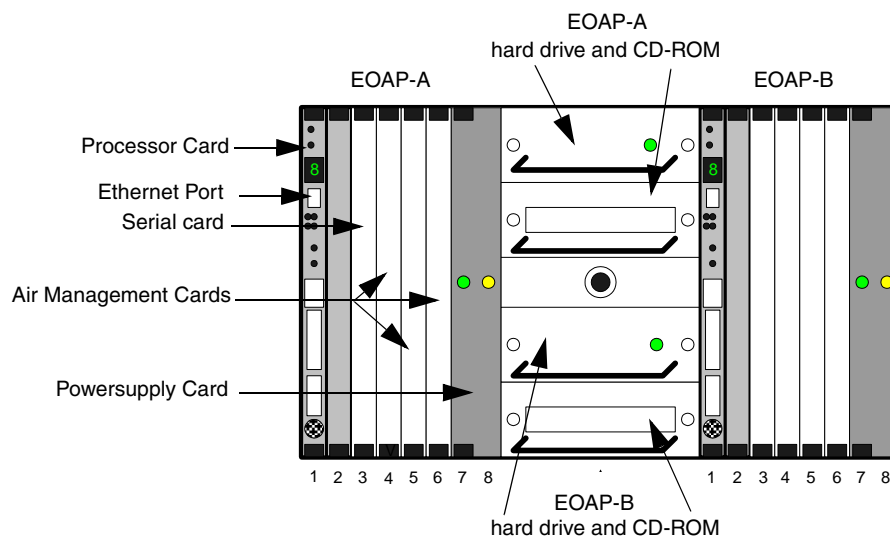
The EOAP shelf is designed for a split system consisting of an EOAP-A and an EOAP-B. Each EOAP in the dual configuration consists of the following components:

- Air management card (P/N 870-1524-01)
- CD-ROM drive card (P/N 870-1515-03)
- Hard drive card (P/N 870-1514-03)
- Power supply card (P/N 870-1521-01)
- Processor card (P/N 870-1523-01)
- Serial card (P/N 870-1522-01)

Figure 2 illustrates the layout of the system.

The center section of the dual EOAP system (both EOAP-A and EOAP-B) contains four individual drive bays. The top two drive bays are hard wired to EOAP-A and the bottom two drive bays are hard wired to EOAP-B. The top drive bay for each EOAP is occupied by the hard drive for that unit. The hard drive must be a SCSI II device, set to SCSI ID#0, with a minimum capacity of 9 GB. The factory pre-loaded hard drive is a field replaceable unit. If the hard drive card is replaced, the platform followed by all site-specific information must be reloaded on the EOAP.

**Figure 2-2.** EOAP Shelf



## Functional Description

### Fan Assembly

The EOAP requires a fan assembly for operation. Fan support also requires a new fan alarm cable (B clock cable P/N 830-0404-xx). Perform the replacement of a fan during a maintenance window and complete it within one hour.



**WARNING:** The EOAP unit can operate without failure or component damage for up to one hour without the fan tray providing cooling. Complete the replacement within this time frame to avoid having to shut down the entire EOAP unit.

### Components

#### Processor Card

The processor card occupies slots 1 and 2 of the EOAP. This card is a 300 MHz or faster CompactPCI card with 64 MB on-board RAM (expandable to 1 GB). The processor card is the main computational component of the EOAP system. On the front of the card are system status LEDs (see Table 2-1) and an Ethernet port. The card also provides abort and reset capabilities through both manual and software intervention.

**Table 2-1.** Status LEDs of the EOAP System

Value	Meaning
0	Normal Operation
1	Halted

The processor card is a field-replaceable unit. It provides two serial ports, which are accessible through the EOAP backplane, for connecting to a VT-520 terminal and an asynchronous maintenance modem. An RJ-45 Ethernet port on the front of the card provides negotiated 10/100BaseT network access for Local Number Portability (LNP) support.

The card provides the following usable front panel fixtures: abort and reset switches, a rotary mode switch, microphone and headphone jacks, a SCSI connector, and a keyboard connector.

Serial port A is used for direct console connection (vt100, PC, etc.) and port B is used for the maintenance modem connection (when required).

The processor card provides one 10/100 Mbits/s Ethernet port. It is routed to the front panel where it can be accessed via a TPE-RJ45 interface. The processor card incorporates an auto-negotiate feature to auto-detect 10Mbits/s or 100 Mbits/s. The bit rate auto-configures itself during operation.

### Serial Card

The serial card occupies slot 3 of the EOAP. This card is a CompactPCI with four serial ports accessible from the EOAP backplane. These ports support full RS-232C capabilities in both synchronous and asynchronous modes. The first two ports are used for EOAP-to-STP connections. The other two ports are used for connecting the EOAP with SEAS. The serial card is a field-replaceable unit.

### Power Supply Card

The power supply card occupies slots 7 and 8 of the EOAP. This card is a 48V input CompactPCI card. When powered by 48V central office power, the card provides +5, +12 and -12V outputs used by various components of the EOAP system. Two LEDs are located on the front of the card. The green LED indicates that the input voltage falls within the allowable range of 48 to 72 VDC, 12A max. The red LED indicates that an internal fault has occurred. These faults include over-voltage, input DC fail warning, loss of output power, and temperature exceeding set limits. The power supply card is a field-replaceable unit. Each EOAP I/O backplane contains a single input power connector.

### Hard Drive Card

The center section of the dual EOAP system (both EOAP-A and EOAP-B) contains four individual drive bays. The top two drive bays are hard wired to EOAP-A and the bottom two drive bays are hard wired to EOAP-B. The top drive bay for each EOAP is occupied by the hard drive for that unit. The hard drive must be a SCSI II device, set to SCSI ID#0, with a minimum capacity of 9 GB. The factory pre-loaded hard drive is a field-replaceable unit. If the hard drive card is replaced, the platform followed by all site-specific information must be reloaded on the EOAP from the EAGLE 5 ISS.

### CD-ROM Drive Card

The center section of the dual EOAP system (both EOAP-A and EOAP-B) contains four individual drive bays. The top two drive bays are hard wired to EOAP-A and the bottom two drive bays are hard wired to EOAP-B. The bottom drive bay for each EOAP is occupied by the CD-ROM drive card for that unit. The CD-ROM drive card must be a Solaris-compatible SCSI device and is currently configured as a 32X CD-ROM drive. The CD-ROM drive card is a field-replaceable unit.

## EOAP Port Labels and Functions

Connector types and locations for the connection of peripherals and peer systems to the EOAP are detailed in Table 2-2.



## Functional Description

**Table 2-2.** EOAP Port Labels and Functions

Port Label	Function	Location	Connector Type
BCLKIN-A	Clock connection cable P/N 830-0657-xx to last extension shelf in control frame	EOAP backplane	DB-9
BCLKIN-B	Clock in/out cable P/N 830-0609-xx to BCLKOUT-A	EOAP backplane	DB-9
BCLKOUT-A	Clock in/out cable P/N 830-0609-xx to BCLKIN-B	EOAP backplane	DB-9
BCLKOUT-B	Unused	EOAP backplane	DB-9
Ethernet port	EOAP-to-customer network Ethernet cable P/N 830-0710-xx	EOAP A and B processor cards (face plate, upper port)	RJ-45
FAN A PWR-A	Fan power cable P/N 830-0609-xx to fan tray A	EOAP backplane	DB-9
FAN A PWR-B	Unused	EOAP backplane	DB-9
FAN B PWR-A	Fan power cable P/N 830-0609-xx to fan tray B (single configuration)	EOAP backplane	DB-9
FAN B PWR-B	Fan power cable P/N 830-0609-xx to fan tray B (dual configuration)	EOAP backplane	DB-9
OAP RST A	Unused	EOAP backplane	---
OAP RST B	Unused	EOAP backplane	---
PORT 1A	Terminal cable P/N 830-0709-xx/ converter P/N 804-0176-01/ terminal cable P/N 830-0528-xx to display unit	EOAP backplane	DB-25
PORT 1B	Terminal cable P/N 830-0709-xx/ converter P/N 804-0176-01/ terminal cable P/N 830-0528-xx to display unit	EOAP backplane	DB-25
PORT 2A	Modem cable P/N 830-0709-xx to Modem A	EOAP backplane	DB-25
PORT 2B	Modem cable P/N 830-0709-xx to Modem B	EOAP backplane	DB-25
PORT 3A	MMI cable P/N 830-0708-xx to MMI-x-A port	Control shelf backplane, left side	DB-25
PORT 3B	MMI cable to MMI-x-B port P/N 830-0708-xx	Control shelf backplane, right side	DB-25
PORT 4A	Unused	EOAP backplane	---
PORT 4B	Unused	EOAP backplane	---
PORT 5A	Modem cable P/N 830-0709-xx to X.25 Modem A	EOAP backplane	DB-25
PORT 5B	Modem cable P/N 830-0709-xx to X.25 Modem B	EOAP backplane	DB-25
PORT 6A to PORT 10A	Unused	EOAP backplane	---
PORT 6B to PORT 10B	Unused	EOAP backplane	---
Power IN-A	Power cable A P/N 830-0699-xx to PORT 2A of EOAP-A	EOAP backplane	Mate-N-Lock 3 Pin
Power IN-B	Power cable B P/N 830-0699-xx to PORT 2A of EOAP-B	EOAP backplane	Mate-N-Lock 3 Pin

## Asynchronous Maintenance Modem (Optional)



**CAUTION:** The EOAP's open system architecture allows access to the operating system. Any undocumented changes to the files may cause the system to become corrupted and unusable. Making any undocumented changes on the EOAP, including changes to the hardware, operating system and/or the components found therein will void the warranty.



**WARNING:** EOAP hardware components, including disk drives, may be removed and (re)inserted with the power on, but they are NOT HOT SWAPPABLE at the operating system level.

Before any hardware component is removed from the EOAP, the operating system **MUST BE HALTED**. To halt the system, log in as `root`, then at the command line, type: `/usr/sbin/init 0`. When the `ok` prompt appears, it is safe to remove the component.

After a component is (re)inserted, the system must be reset for Solaris to successfully detect the component. To reset the system, at the `ok` prompt type: `reset-all`. The system should boot up. If the system returns to the `ok` prompt after the `reset-all` command has executed, type: `setenv auto-boot? true`. Then type: `reset-all`.

Although not provided with the EOAP, you can connect a Hayes-compatible modem to the EOAP to provide connectivity for remote monitoring and maintenance. This allows access to the EOAP as required by Customer Care Center. If used, the modem is connected to the EOAP through the processor card's second serial port. The modem must be configured for 9600 bps, 7 bits, Even parity, and 1 stop bit (7-E-1). Refer to Table 2-2 for the appropriate backplane port label for each EOAP.

## SCSI Addresses

Certain SCSI addresses have been reserved for devices that must be connected permanently to the EOAP. These addresses should not be used by any other devices. Refer to Table 2-3 for those reserved IDs.

**Table 2-3.** SCSI Addresses

Device	ID #
Hard Drive Card	0
Removable Media Drive Card	6
Golden Disk (Used only during software installation)	1

## Functional Description

### Terminal

The user console for the EOAP is a Digital Equipment Corporation VT-520 terminal. The VT-520 is connected to the EOAP through an RS232C terminal cable attached to the first serial connector of the processor card through the EOAP backplane. Refer to Table 2-2 for the appropriate backplane port label for each EOAP. The terminal allows monitoring and direct interfacing capabilities to the EOAP. To ensure that the terminal and EOAP interact correctly, the terminal must be setup for vt100 emulation.

## Software

### EOAP Applications

The EOAP application consists of a number of individual processes and commands. Together, these processes perform the SEAS function of the EOAP. Table 2-4 lists the processes in case application troubleshooting is required. For application troubleshooting procedures, refer to section *EOAP Internal Software* on page 7-28.



**CAUTION:** The EOAP's open system architecture allows access to the operating system. Any undocumented changes to the files may cause the system to become corrupted and unusable. Making any undocumented changes on the EOAP, including changes to the hardware, operating system and/or the components found therein will void the warranty.

**Table 2-4.** EOAP Processes

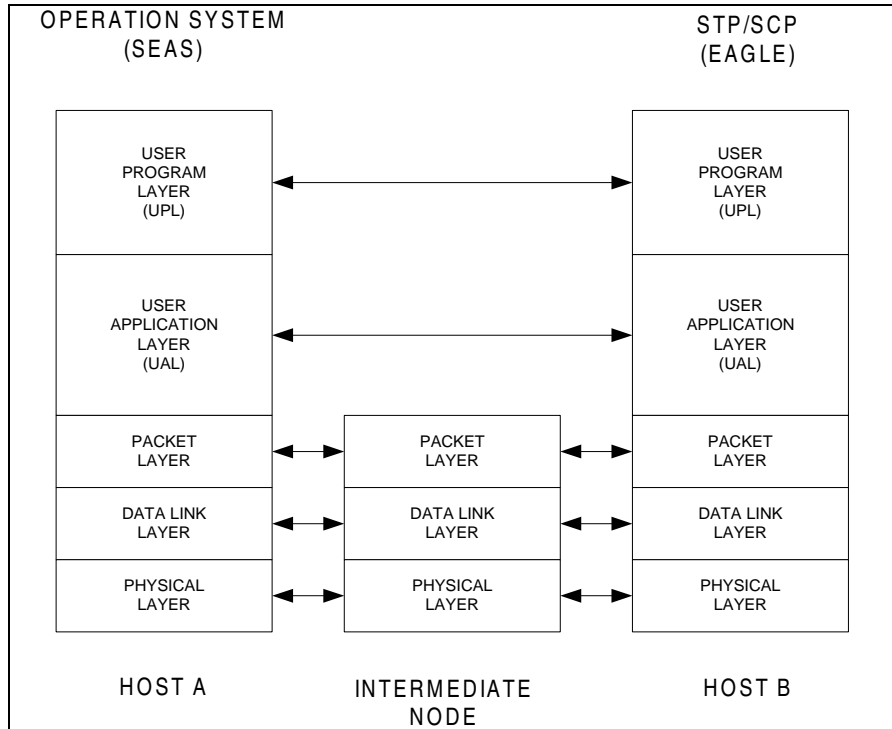
Component	Main Executables
EMS Agent	emsagent
RS232 Asynchronous Send / Receive daemon	ysTTY
EAGLE 5 ISS MNT-request receive and response daemon	ysT1mnt
EAGLE 5 ISS REPT-UIM autonomous event report daemon	ysT2uim
UAL/X25/Disk status refresh and notification daemon	ysT3status
Installation utilities	
Process registration and control daemon	msDI
UAL logical channel over X.25 daemon	ysA1ual
UAL time-out and status daemon	ysA2uim
UAL multiple-segments re-assembly daemon	ysA3mseg
UAL segment time-out resent daemon	ysA4Rsend
UPL TEST-SEAS-UPL message echo support daemon	ysADriver
UAL/X.25 status and Node event report daemon	ysAStat
Outbound UPL message segmentation and routing daemon	ysAOsNe

## Functional Description

### User Application Layer (UAL) Software

The EOAP uses UAL software to communicate with SEAS. The UAL supports level 4 of the OSS protocol stack (see Figure 2-3.)

**Figure 2-3.** User Application Layer



### Other Software Packages

#### Solaris 2.5.1

Solaris 2.5.1 is the operating system for the EOAP. This operating system is a UNIX-based platform, capable of supporting multi-processing and multi-threaded applications.

#### Solstice X.25 9.1 (Formerly Sunlink X.25 9.1)

The Solstice X.25 driver provides the protocol used for communications between the EOAP and the SEAC. This connection-oriented network-layer protocol is supported over the high-speed cPCI interface and provides the interface between the UAL and the Performance Technology COMLINK Driver. It supports levels 1, 2 and 3 of X.25 and allows activation/deactivation of the link and connection of the PVCs.

### **Aurora Driver Packages**

The Aurora driver packages provide connectivity between the processor card and the serial card. The ports configured by the driver packages provide a standard Solaris 2.5.1 interface that supports the Solstice X.25 product.

### **FORCE Driver**

The FORCE driver controls the seven-segment LED on the front panel of the processor card.

### **EOAP Reset from EAGLE 5 ISS**

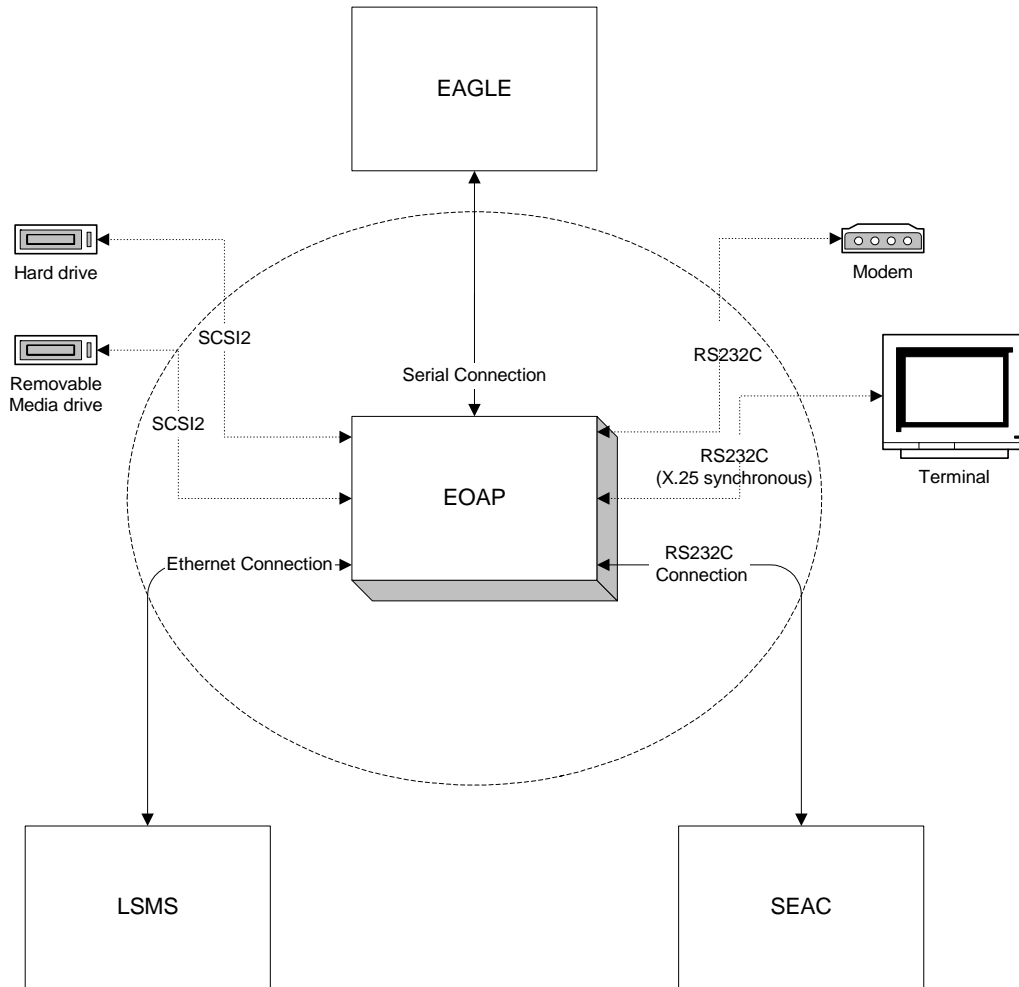
The EAGLE 5 ISS does not have the ability to reset the EOAP.

## Functional Description

### Interfaces

The EOAP is a general purpose interface module that provides the STP system with a generic platform to develop and run software for feature-specific interfaces to the STP. These interfaces include the optional Signaling and Engineering Administration System (SEAS). Figure 2-4 shows the EOAP's operation context.

**Figure 2-4. Operating Context of EOAP**



### EOAP-to-STP

#### Function

Each EOAP reports to the STP its general status as well as the status of its User Application Layer (UAL), X.25 links, PVCs on those links, and Q.3 associations. The STP can then report the status of the EOAP and its components to the user through the STP's HMI.

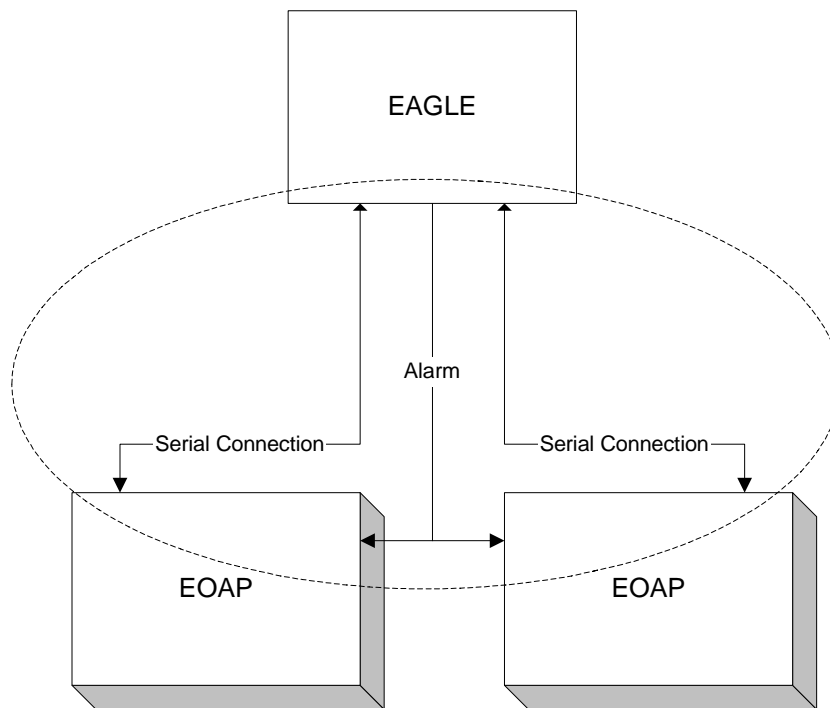
You can configure most aspects of the EOAP through the STP terminal. For upgrade, debug, and maintenance functions, use a VT-520 terminal directly connected to the EOAP.

The STP cannot perform a reset of the EOAP with the `init-oap` command from the STP terminal as it does with the OAP.

**Interface**

This section details the overall connections and setup required for the EOAP to STP interface. This includes the physical connection and a brief look at the messaging that occurs between the two.

**Figure 2-5.** EOAP-to-EAGLE 5 ISS Interface





## Functional Description

### Physical Connection

The EOAP is connected to the STP through the EOAP backplane using one of the two serial ports assigned to the processor card (only one port for each EOAP is used in a dual EOAP configuration). On the STP backplane, the cables are connected to any two of the MMI ports (MMI 0-MMI 15). By convention, if there are two EOAPs connected to the EAGLE 5 ISS (dual configuration), EOAP-A is connected to the lower numbered MMI port and EOAP-B is connected to the higher numbered MMI port. Regardless of their configuration, at any given moment, the EOAP connected to the lowest port is reported as OAP A by the STP. Any STP port connected to an EOAP must be configured as type "OAP" from the STP terminal.

### Testing the Connection

Once the EOAP has been connected to any external device, it must be tested to ensure the connection was made correctly and is working as designed. For the EOAP-to-STP connection, this involves testing the ability for the EOAP to send maintenance information to the STP and have that information reported, verifying that the EOAP can communicate with the EOAP backplane serial ports, and test the ability of the EAGLE 5 ISS to perform a restart of the EOAP from the STP terminal.

## EOAP-to-SEAS

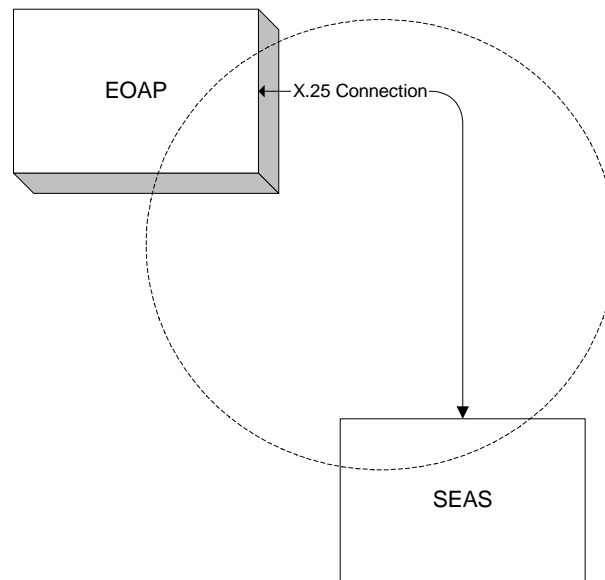
### Function

The EOAP provides connectivity between the Signaling Engineering and Administration Center (SEAC) and the STP by implementing the UAL and X.25 layers of the SEAS protocol.

Each EOAP is configured according to customer specifications. Configurations for the EOAP support for SEAS include X.25 and UAL parameters.

This section details the overall connections and setup required for the EOAP to SEAS interface. This includes the physical connection and a brief look at the messaging that occurs between the two. It will also include a list of the components (hardware and software) necessary for its implementation, which will also include the EOAP-to-EAGLE 5 ISS connections.

**Figure 2-6.** EAGLE 5 ISS-to-SEAS Interface



### Physical Connection

The EOAP is connected to the SEAS through the serial card. Port 3A/B and port 4A/B are reserved for SEAS communication. From these port(s), an RS232C cable is connected to a 9600 bps synchronous modem or other equivalent device necessary to connect to the SEAS system. If the configuration is for a single EOAP, the connection is made from both ports to two separate modems or other equivalent devices (X.25 connection). If the configuration is for a dual EOAP configuration, only one of the two serial ports is used per EOAP. Refer to Table 2-2 for the connector nomenclature for both EOAP-A and EOAP-B.

### Testing the Connection

Once the EOAP has been connected to any external device, it must be tested to ensure the connection was made correctly and is working as designed. For the EOAP-to-SEAS connection, this involves editing the configuration files manually and performing an X.25 loop-back test. There are no additional SEAS tests that can be performed at this time other than connecting to a live system. When connected to a live system, enter the **rept-stat-seas** command from the STP terminal.

## Functional Description

### Messaging

Communication between the EOAP and the SEAS involves three message types:

- SEAS commands
- STP responses
- STP autonomous messages

These messages may involve one-way or two way communication between the SEAS and the EOAP. The actual messages are from the SEAC to the STP, however, the EOAP receives and transmits these messages between the two in a format that each can understand.

### *SEAS Commands*

SEAS commands are messages originating from the SEAC that request the STP to perform a specific action. A response to this messages is returned by the STP within a required amount of time. These commands may specify when the command is to take place: either immediately upon receipt, upon receipt of a subsequent SEAS order-activation command, or automatically at a specified date and time. The default activation time for a SEAS command is immediately unless otherwise specified. At this time, the EOAP does not support time-delayed commands.

### *STP Responses*

STP responses are messages sent from the STP to the SEAC in response to a SEAS command. The three basic types of STP responses are: completion responses, acceptance acknowledgments without completion, and exception responses.

### *STP Autonomous Messages*

STP autonomous messages are messages sent from the STP automatically to the SEAC. These messages contain either scheduled measurement reports or on-occurrence event reports. Although these messages are logged by the SEAC, no acknowledgment is sent back to the STP confirming receipt.

## Administration

The EAGLE 5 ISS administration supports the EOAP by providing the means to

- provision the EOAP at the EAGLE 5 ISS

### EAGLE 5 ISS Provisioning

Administration provides support for the EOAP as follows:

- **chg-oap-config** command

This command allows the configuration of the host name, IP address, netmasks, SEAC CLLI, X.25 mode and packet size, and EOAP configuration.

- **act-oap-config** command

This command allows the update of the EOAP configuration.

- **rtrv-oap-config** command

This command displays the IP address, netmasks, default router, SEAC CLLI, X.25 configuration, and X.25 packet size and DTE/DCE.

## Functional Description

### EOAP Retransmission Delay

Performance of this feature is affected by the requirement that the EOAP buffer an EAGLE 5 ISS message before transmission. It is a SEAS requirement that the STP knows the total length of a message before transmission of the message to SEAS. The EAGLE 5 ISS currently is not aware of message length before transmission. This requires the EOAP to buffer the entire message before it retransmits the message to the SEAS.

**NOTE: For releases prior to EAGLE 5 ISS release 34.0, do not send TEST-SEAS-UPL messages with a quoted string greater than 256 characters to the EOAP/OAP.**

The STP/EOAP interface baud rate is 19200. The X.25 EOAP SEAS interface baud rate is 9600. To transfer a 12,000-character report (approximately 150 lines) from the STP to the EOAP, for example, takes approximately 5 seconds. The EOAP must buffer all 12,000 characters before retransmission. The EOAP would require another 10 seconds to retransmit the message. Total transmission time is 15 seconds.

The SEAS computers do not receive any response from the STP until EOAP retransmission begins. In the example above, SEAS does not receive any response for 5 seconds. This response delay increases for longer reports, assuming that SEAS will not time-out during the delay.

## Maintenance

### Hardware

Hardware maintenance for the EOAP consists of the replacement of any defective EOAP field-replaceable component. These components are the processor card, the the serial card, the power supply card, the hard drive card, and the CD-ROM drive card.

You must halt the Solaris operating system and remove power from the chassis before executing any hardware replacement procedures. You may have to power down one or both sides depending on what is replaced. For more information on halting the system and removing the power from the chassis, refer to *Power Down the EOAP/Fan Assembly* on page 6-10.



**CAUTION: The EOAP's open system architecture allows access to the operating system. Any undocumented changes to the files may cause the system to become corrupted and unusable. Making any undocumented changes on the EOAP, including changes to the hardware, operating system and/or the components found therein will void the warranty.**

If the hard drive is replaced, all site-specific information must be reloaded on the EOAP from the EAGLE 5 ISS. If other hardware items are replaced, no software changes will be required as long as they are replaced with identical items.

For more information about the replacement of these components, refer to Chapter 6, *Replacement Procedures*.

### Software

Software maintenance is not required. The EAGLE 5 ISS performs all required configuration. Should a failure occur that cannot be corrected through the EAGLE 5 ISS, Customer Care Center has the ability to access the EOAP through a modem or a direct terminal connection. To set up the modem connection for maintenance access, refer to *Maintenance Modem Setup* on page 3-74. If the operating system has been corrupted beyond the ability for your Customer Care Center to perform a recovery, the hard drive will be replaced in the field.

Although the capability does exist for an on-site full re-install of all software packages found on the EOAP, this maintenance must only be performed under close supervision of Tekelec Customer Services (see *Customer Care Center* on page 1-10).



**CAUTION:** The EOAP's open system architecture allows access to the operating system. Any undocumented changes to the files may cause the system to become corrupted and unusable. Making any undocumented changes on the EOAP, including changes to the hardware, operating system and/or the components found therein will void the warranty.

### Alarm Interface

The EOAP provides a programmable seven-segment display on the front panel of the processor card. Additionally, the power supply card provides "Input OK" and Fault LEDs.

### Upgrade Considerations

A detailed procedure for configuring the STP when upgrading from OAPs to EOAPs is described in the *Eagle Installation Manual*. The entire upgrade is performed either by a terminal connected directly to the EOAP or by an external connection through a modem.





# 3

## Installation Procedures

Safety Information .....	3-2
Introduction.....	3-5
Procedures .....	3-5
EOAP Fan Assembly .....	3-11
EOAP Shelf.....	3-18
EOAP Cabling .....	3-23
EOAP Power-Up .....	3-70
Fan Operation Testing .....	3-71
Maintenance Modem Setup.....	3-74

## Safety Information

Tekelec uses these icons and text throughout this manual to alert the reader to assure personal safety, to minimize possible service interruptions, and to warn of the potential for equipment damage.

	<b>TOPPLE:</b> (This icon and text indicate the possibility of <i>personal injury and equipment damage</i> .)
	<b>DANGER:</b> (This icon and text indicate the possibility of <i>personal injury</i> .)
	<b>CAUTION:</b> (This icon and text indicate the possibility of <i>service interruption</i> .)
	<b>WARNING:</b> (This icon and text indicate the possibility of <i>equipment damage</i> .)



**TOPPLE:** Always read and understand instructions thoroughly and completely before working on, moving, raising or lowering the frame, any portion of the frame or attachments to the frame or equipment.



**TOPPLE:** Never try to unpack any frame from the shipping container without at least two people to steady any movement of the frame and related components. At least two people are required to safely move and position any frame.



**TOPPLE:** Never pull out the shelf of any frame that is not anchored properly. Some frames are required to be attached to over head ladder racks before shelves are extended.



**DANGER:** At least two people are required to safely move and position the frame.



**DANGER:** No commercially AC powered equipment may be used or placed within 7 ft. of -48V equipment. This may create a shock or current loop that can be severely hazardous to personnel and equipment.



**DANGER:** Do not wear metal rings, watches, or jewelry or carry exposed metal keys or tools in pockets when working on system equipment or other related electrostatic-sensitive components. Always wear a wrist strap or other electrostatic protection when handling printed circuit cards and other electrostatic-sensitive devices.





**CAUTION:** All personnel associated with the installation of these systems must adhere to all safety precautions and use required protection equipment, to avoid the possibility of injury to personnel, service degradation, and/or service interruption.



**CAUTION:** These are redundant systems to allow service during normal maintenance. When repairs require a total power disconnect, both input supply sources must be disconnected. This will cause service interruption and takes down the systems.



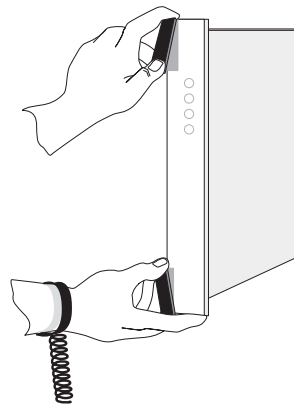
**CAUTION:** This equipment has a connection between the earthed conductor of the DC supply circuit and the earthing conductor.



**CAUTION:** After the frame has been shipped, or moved remove all cards prior to applying power. Reseat all cards carefully to avoid possible indiscriminate faulty connections.

To remove or install a card, use the injector/ejector module locking tabs at the top and bottom of the card faceplate. Refer to Figure 3-1.

Figure 3-1. Removing a Card



**CAUTION:** The EOAP's open system architecture allows access to the operating system. Any undocumented changes to the files may cause the system to become corrupted and unusable. Making any undocumented changes on the EOAP, including changes to the hardware, operating system and/or the components found therein will void the warranty.



**WARNING:** *Do not* use tie wraps on or above the top traverse arms on a frame. *Always* trim tie wrap flush and turn the trimmed tie wrap to the rear of the cable. Contact Site Supervisor for site specific customer information.



**WARNING:** *Do not* leave or allow unused metal objects, such as screws or washers, to remain anywhere within the equipment. Remove all unused material from the equipment



**WARNING:** *Do not* allow any metal shavings to remain in the equipment area. This may occur from over tightened screws or bolts. These small metal particles are hazardous to electronic equipment. Be careful not to over tighten screws or bolts.



**WARNING:** EOAP hardware components, including disk drives, may be removed and (re)inserted with the power on, but they are **NOT HOT SWAPPABLE** at the operating system level.

Before any hardware component is removed from the EOAP, the operating system **MUST BE HALTED**. To halt the system, log in as `root`, then at the command line, type: `/usr/sbin/init 0`. When the `ok` prompt appears, it is safe to remove the component.

After a component is (re)inserted, the system must be reset for Solaris to successfully detect the component. To reset the system, at the `ok` prompt type: `reset-all`. The system should boot up. If the system returns to the `ok` prompt after the `reset-all` command has executed, type: `setenv auto-boot? true`. Then type: `reset-all`.

### Introduction

This chapter describes the installation, cabling, and provisioning procedures for the EAGLE 5 ISS, Embedded Operations Support System Application Processor (EOAP). The procedures include the installation of the EOAP shelf, fan assembly, and cabling as well as the upgrade from a single-configuration EOAP to a dual-configuration EOAP. Any personnel using these procedures must have a thorough knowledge of standard telecommunication installation specifications and procedures.

### Procedures

The EOAP shelf is pre-assembled as a single or dual configuration with the required EOAP components (cards) installed.

The EOAP shelf is delivered either:

- Preassembled for single or dual configuration

and

- Packed with a fan assembly and cooling duct to be installed in an OAP Frame (OAPF)

or

- Preinstalled in a frame and partially cabled

Table 3-1, "EOAP Installation Order," on page 3-6 lists the installation procedures in the typical order of installation. Perform the installation in the order indicated to ensure that proper prerequisites are established. Skip any procedure that does not apply.

The EOAP consists of field-replaceable CompactPCI cards and drive bays that may be swapped out in the event of a hardware failure. EOAP hardware components, including disk drives, may be removed and (re)inserted with the power on, but they are NOT HOT SWAPPABLE at the operating system level. Before any hardware component is removed from the EOAP, the operating system MUST BE HALTED. To halt the system, log in as `root`, then at the command line, type: `/usr/sbin/init 0`. When the `ok` prompt appears, it is safe to remove the component

For replacement procedures (for example, the replacement of a processor card or card cage), refer to Chapter 6, *Replacement Procedures*.

Table 3-1. EOAP Installation Order

If your EOAP was delivered with...	...complete the installation in this order
<ul style="list-style-type: none"> <li>• Single configuration</li> <li>• Packed shelf and fan assembly</li> <li>• P/N 830-0404-xx B clock cable in system</li> </ul>	<ol style="list-style-type: none"> <li>1. <i>Install B Clock Cable</i></li> <li>2. <i>Install EOAP Fan Assembly</i> on page 3-13</li> <li>3. <i>Install Cooling Duct</i> on page 3-17</li> <li>4. <i>Install EOAP Fan Assembly</i> on page 3-13</li> <li>5. <i>Install EOAP Shelf</i> on page 3-20</li> <li>6. <i>Cable Single-Configuration EOAP</i> on page 3-32</li> <li>7. <i>Power Up EOAP</i> on page 3-70</li> <li>8. Provision the system from the EAGLE 5 ISS</li> <li>9. <i>Test Fan Operation</i> on page 3-71</li> <li>10. <i>Set Up Maintenance Modem</i> on page 3-74</li> </ol>
<ul style="list-style-type: none"> <li>• Dual configuration</li> <li>• Packed shelf and fan assembly</li> <li>• P/N 830-0404-xx B clock cable in system</li> </ul>	<ol style="list-style-type: none"> <li>1. <i>Install B Clock Cable</i></li> <li>2. <i>Install EOAP Fan Assembly</i> on page 3-13</li> <li>3. <i>Install Cooling Duct</i> on page 3-17</li> <li>4. <i>Install EOAP Shelf</i> on page 3-20</li> <li>5. <i>Dual-Configuration Cabling</i> on page 3-35</li> <li>6. <i>Power Up EOAP</i> on page 3-70</li> <li>7. Provision the system from the EAGLE 5 ISS</li> <li>8. <i>Test Fan Operation</i> on page 3-71</li> <li>9. <i>Set Up Maintenance Modem</i> on page 3-74</li> </ol>
<ul style="list-style-type: none"> <li>• Single configuration</li> <li>• Preinstalled shelf and fan assembly</li> <li>• P/N 830-0404-xx B clock cable in system</li> </ul>	<ol style="list-style-type: none"> <li>1. <i>Install B Clock Cable</i></li> <li>2. <i>Cable Single-Configuration EOAP</i> on page 3-32</li> <li>3. <i>Power Up EOAP</i> on page 3-70</li> <li>4. Provision the system from the EAGLE 5 ISS</li> <li>5. <i>Test Fan Operation</i> on page 3-71</li> <li>6. <i>Set Up Maintenance Modem</i> on page 3-74</li> </ol>
<ul style="list-style-type: none"> <li>• Dual configuration</li> <li>• Preinstalled shelf and fan assembly</li> <li>• P/N 830-0404-xx B clock cable in system</li> </ul>	<ol style="list-style-type: none"> <li>1. <i>Install B Clock Cable</i></li> <li>2. <i>Dual-Configuration Cabling</i> on page 3-35</li> <li>3. <i>Power Up EOAP</i> on page 3-70</li> <li>4. Provision the system from the EAGLE 5 ISS</li> <li>5. <i>Test Fan Operation</i> on page 3-71</li> <li>6. <i>Set Up Maintenance Modem</i> on page 3-74</li> </ol>

**Table 3-1.** EOAP Installation Order (Continued)

<b>If your EOAP was delivered with...</b>	<b>...complete the installation in this order</b>
<ul style="list-style-type: none"> <li>• Single configuration</li> <li>• Packed shelf and fan assembly</li> <li>• P/N 830-0404-xx B clock cable in system</li> </ul>	<ol style="list-style-type: none"> <li>1. <i>Install EOAP Fan Assembly</i> on page 3-13</li> <li>2. <i>Install Cooling Duct</i> on page 3-17</li> <li>3. <i>Install EOAP Shelf</i> on page 3-20</li> <li>4. <i>Cable Single-Configuration EOAP</i> on page 3-32</li> <li>5. <i>Power Up EOAP</i> on page 3-70</li> <li>6. Provision the system from the EAGLE 5 ISS</li> <li>7. <i>Test Fan Operation</i> on page 3-71</li> <li>8. <i>Set Up Maintenance Modem</i> on page 3-74</li> </ol>
<ul style="list-style-type: none"> <li>• Dual configuration</li> <li>• Packed shelf and fan assembly</li> <li>• P/N 830-0404-xx B clock cable in system</li> </ul>	<ol style="list-style-type: none"> <li>1. <i>Install EOAP Fan Assembly</i> on page 3-13</li> <li>2. <i>Install Cooling Duct</i> on page 3-17</li> <li>3. <i>Install EOAP Shelf</i> on page 3-20</li> <li>4. <i>Dual-Configuration Cabling</i> on page 3-35</li> <li>5. <i>Power Up EOAP</i> on page 3-70</li> <li>6. Provision the system from the EAGLE 5 ISS</li> <li>7. <i>Test Fan Operation</i> on page 3-71</li> <li>8. <i>Set Up Maintenance Modem</i> on page 3-74</li> </ol>
<ul style="list-style-type: none"> <li>• Single configuration</li> <li>• Preinstalled shelf and fan assembly</li> <li>• P/N 830-0404-xx B clock cable in system</li> </ul>	<ol style="list-style-type: none"> <li>1. <i>Cable Single-Configuration EOAP</i> on page 3-32</li> <li>2. <i>Power Up EOAP</i> on page 3-70</li> <li>3. Provision the system from the EAGLE 5 ISS</li> <li>4. <i>Test Fan Operation</i> on page 3-71</li> <li>5. <i>Set Up Maintenance Modem</i> on page 3-74</li> </ol>
<ul style="list-style-type: none"> <li>• Dual configuration</li> <li>• Preinstalled shelf and fan assembly</li> <li>• P/N 830-0404-xx B clock cable in system</li> </ul>	<ol style="list-style-type: none"> <li>1. <i>Dual-Configuration Cabling</i> on page 3-35</li> <li>2. <i>Power Up EOAP</i> on page 3-70</li> <li>3. Provision the system from the EAGLE 5 ISS</li> <li>4. <i>Test Fan Operation</i> on page 3-71</li> <li>5. <i>Set Up Maintenance Modem</i> on page 3-74</li> </ol>
<b>If You Are Cabling Single to Dual...</b>	<b>...complete the installation in this order</b>
<ul style="list-style-type: none"> <li>• For existing single-configuration EOAP</li> </ul>	<ol style="list-style-type: none"> <li>1. <i>Change Cabling to Dual Configuration</i> on page 3-66</li> <li>2. <i>Power Up EOAP</i> on page 3-70</li> <li>3. Provision the system from the EAGLE 5 ISS</li> <li>4. <i>Test Fan Operation</i> on page 3-71</li> <li>5. <i>Set Up Maintenance Modem</i> on page 3-74</li> </ol>

**Table 3-2.** EOAP Installation Equipment Required

Check	#	Name	P/N
	1	OAP frame (OAPF)	
	1	Fan assembly per EOAP shelf	890-1038-01
	1	EOAP shelf in single configuration EOAP dual configuration <ul style="list-style-type: none"> <li>• all cards are installed</li> <li>• hard drive card preloaded with EOAP configuration software</li> </ul>	890-1050-03 890-1050-01
Cables (single configuration)			
	x	B clock cables (quantity site-dependent)	830-0404-xx
	1	Clock connection cable	830-0657-xx
	1	Clock in/out cable	830-0609-xx
	2	Fan power cables	830-0609-xx
	1	EOAP power cable	830-0699-xx
	1	EOAP-to-customer network Ethernet cable	830-0710-xx
	1	Converter (for terminal cables	804-0176-01
	2	Terminal cables (one each)	830-0528-xx 830-0709-xx
	2	X.25 modem cables	830-0709-xx
	1	Dial-up modem cables	830-0709-xx
	2	MMI cables	830-0708-xx
Cables (dual configuration)			
	x	B clock cables (quantity site-dependent)	830-0404-xx
	1	Clock connection cable	830-0657-xx
	1	Clock in/out cable	830-0609-xx
	2	Fan power cables	830-0609-xx
	2	EOAP power cable	830-0699-xx
	1	EOAP-to-customer network Ethernet cable	830-0710-xx
	2	Converters (for terminal cables	804-0176-01
	4	Terminal cables (two each)	830-0528-xx 830-0709-xx
	4	X.25 modem cables	830-0709-xx
	2	Dial-up modem cables	830-0709-xx

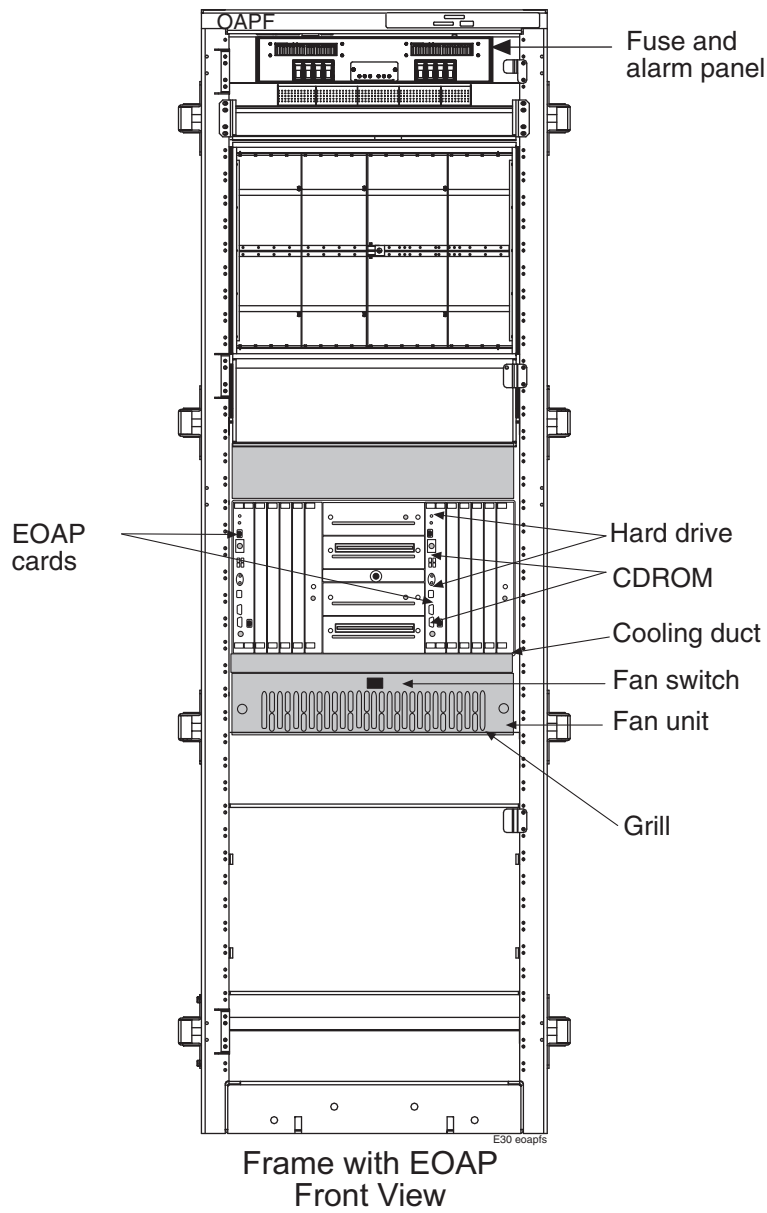
## Installation Procedures

**Table 3-2.** EOAP Installation Equipment Required (Continued)

Check	#	Name	P/N
	2	X.25 modem cables	830-0709-xx
Individual components necessary for dual configuration of EOAP Cards and Drives			
	1	Air management card	870-1524-01
	1	CD-ROM drive	870-1515-03
	1	Hard drive	870-1514-03
	1	Power supply card	870-1521-01
	1	Processor card	870-1523-01
	1	Serial card	870-1522-01

Table 3-2 list the equipment required for an initial installation of the EOAP. For a detailed list of tools and equipment required for individual procedures, refer to the beginning of each procedure. Refer to Figure 3-2 for component location in the OAP frame.

Figure 3-2. EOAP Front



**NOTE:** EOAP is fused at 10As (red), providing power to both the EOAP unit and the fan.



## Installation Procedures

### EOAP Fan Assembly

Refer to this section if your fan assembly did not come preinstalled. This section describes how to install a fan and cooling duct in the location below the EOAP shelf. If the EOAP shelf was not preinstalled, **install fan assemblies prior to installing the EOAP shelf.**

The EOAP shelf requires fan support for operation. Each fan uses fan alarm cable (B clock cable) P/N 830-0404-xx. This cable also provides control signals from the control shelf to the corresponding extension shelves. Verify that your system uses B clock cables P/N 830-0404-xx throughout the system that will include the fan assembly to be installed. If necessary, replace all B clock cables. Perform the replacement during a maintenance window and **prior to any fan assembly installation.**

After replacing the B clock cables, install the fan assembly (see "EOAP Fan Assembly" on page 3-11).

Install the fan assemblies in the order listed in Table 3-3; skip any procedure that does not apply:

**Table 3-3.** Fan Assembly - Installation Order

#	Procedure Name and Location
1.	<i>Install B Clock Cable</i>
2.	<i>EOAP Fan Assembly on page 3-11</i>
3.	<i>Install Cooling Duct on page 3-17</i>

Table 3-4 list tools and equipment required for the fan assembly installation.

**Table 3-4.** Fan Assembly - Tools and Equipment

Check	Tools and Equipment	P/N
	Safety glasses	
	Tie wraps	
	Flushcutter (to cut cable ties)	
	Phillips screw driver	
	Straight screw driver	
	B clock cable	830-0404-xx
	2 fan power cables	830-0609-xx
	1 fan assembly, each includes	890-1038-01
	— mounting brackets	652-0954-01
	— tooth washers	606-0062-01
	— screws	600-0934-01
	— air filters	551-0011-01
	Cooling duct for EOAP shelf	652-0860-01



**DANGER:** Exercise extreme care and strict adherence to safety precautions when working on or near electrical equipment.



**WARNING:** All tools must be insulated and/or taped.

All equipment that is below the shelf being worked on must be protected.

All jewelry must be removed before starting work.



**WARNING:** The EOAP unit can operate without failure or component damage for up to one hour without the fan tray providing cooling. Complete the replacement within this time frame to avoid having to shut down the entire EOAP unit.

**Procedure — Install EOAP Fan Assembly**

---

1. Determine where the fan assembly will be installed (see Figure 3-2, “EOAP Front,” on page 3-10) and be aware of hardware that needs to be retained or installed in a specific way. If an air baffle is installed in place of the fan assembly:
  - a. The fan unit may be secured with the same screws that are removed from the frame holding the baffle in place.
  - b. The brackets (P/N 652-0954-01) are installed from the rear of the frame using the screws provided with the brackets.
  - c. When the brackets are attached, secure them to the frame using external tooth washers (P/N 606-0062-01) and four screws (P/N 600-0193-01) (12x24 .500 cs zinc).

---

2. Place a piece of fiber paper on the top of the shelf below where the fan is to be installed to ensure that nothing will drop into the area and equipment below.

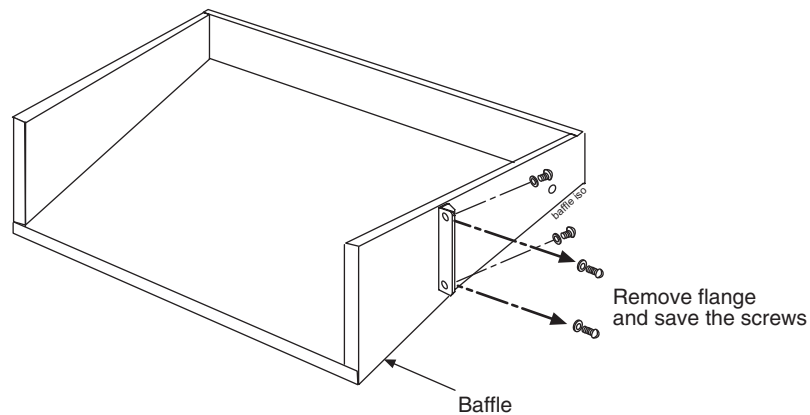
---

3. Remove the four screws, two on each side, from the mounting brackets on the frame that hold the baffle in place, on both sides. Place the screws in a safe place because they are used later in this procedure.

---

4. Loosen the four screws, two on either side, that hold the mounting brackets to the frame. This will allow the removal of the bracket.

**Figure 3-3. Fan Baffle to be Removed**

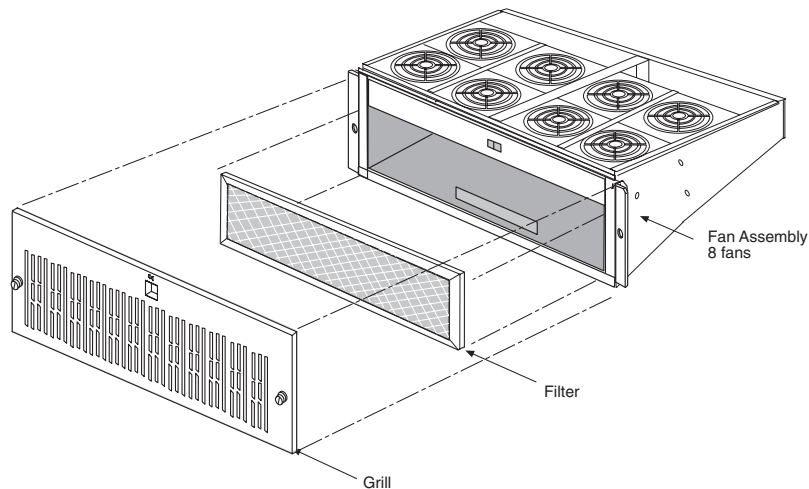


- 
5. Remove the baffle through the front of the frame.
-

6. Remove the fan assembly from the shipping container. The fan is shipped with the side flange not attached.

7. Remove the grill and filter from the fan assembly by loosening the two thumb screws on the grill faceplate. Temporarily store all in a safe place.

**Figure 3-4.** Remove Grill and Filter from Fan Assembly



8. From the front of the frame, slide the fan assembly into the shelf. Figures 3-5 shows a fan assembly inserted into an OAP frame.

On each side of the assembly, attach it with two screws (P/N 600-0193-01) and external tooth washers (P/N 606-0062-01) to the front frame rail. Tighten the screws. Refer to Figure 3-6, Step 6.



**WARNING:** Do not overtighten the screws as the heads could snap off.

**NOTE:** Spare rear bracket shipped with fan assembly.

Figure 3-5. Insert Fan Assembly Below EOAP Shelf

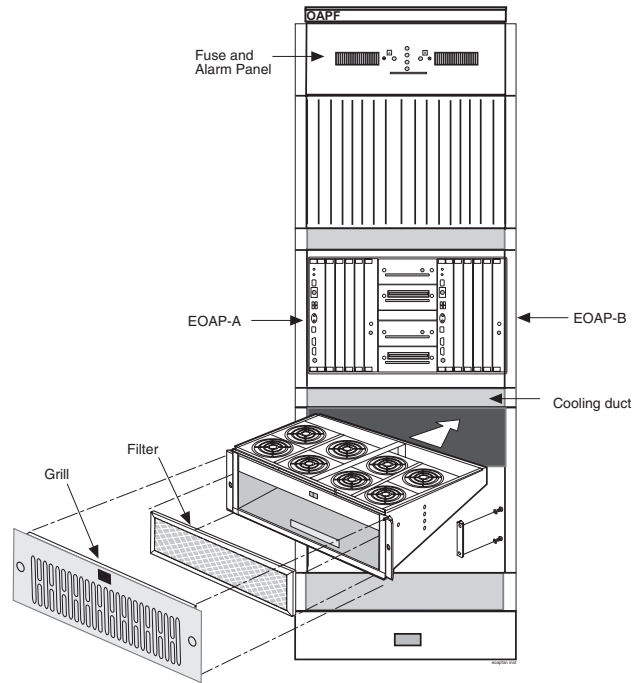
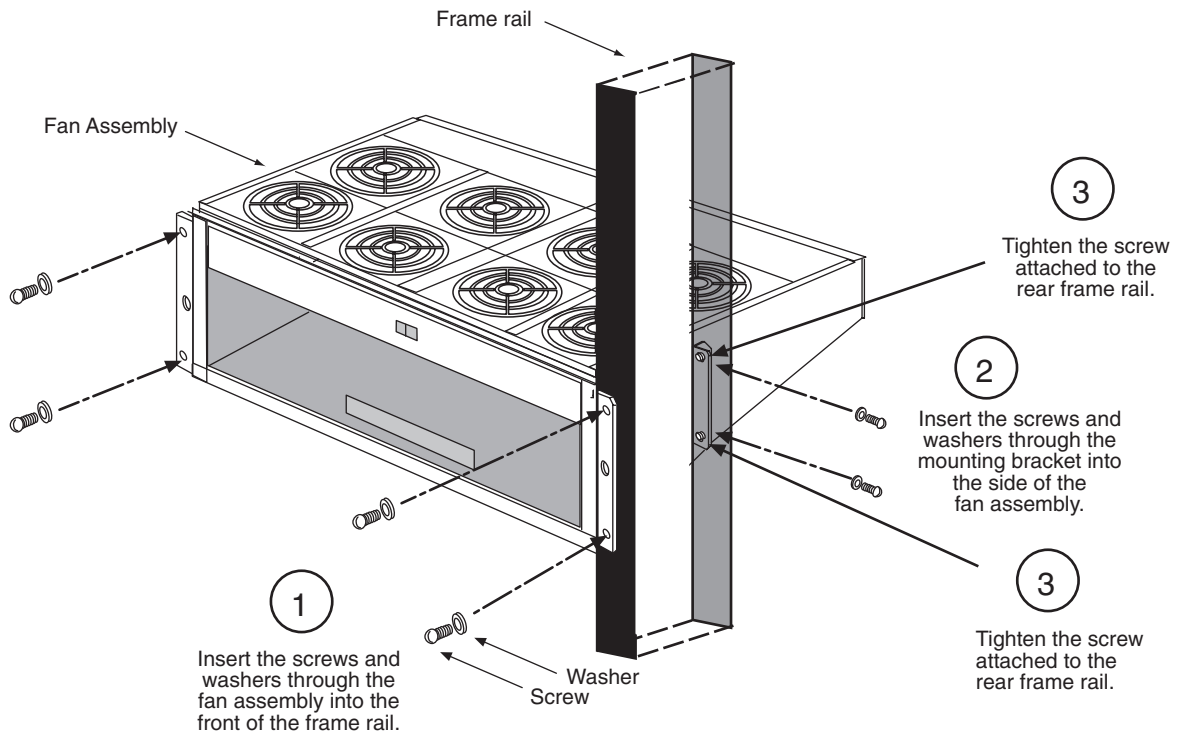


Figure 3-6. Attach Fan Assembly to Front of Frame Rail



9. From the rear of the frame and on each side of the fan assembly, insert two screws through the mounting bracket and into the side of the fan assembly. Refer to Figure 3-6, Step 2.
- 

10. Align the fan assembly with the sides of the shelf and tighten the two screws that secure the mounting brackets to the frame rails. Refer to Figure 3-6, Step 3.
- 

11. Replace the fan filter by setting it against the front of the fan assembly. Refer to Figure 3-4.

**NOTE: Point the air flow arrows stamped on top and bottom edge of filter towards the fan assembly.**

---

12. Replace the fan grill by placing it back over the filter on the front of the assembly. Hand-tighten the thumb screws. Refer to Figures 3-4.
- 

You have installed the fan assembly for the EOAP shelf. Install the cooling duct next.

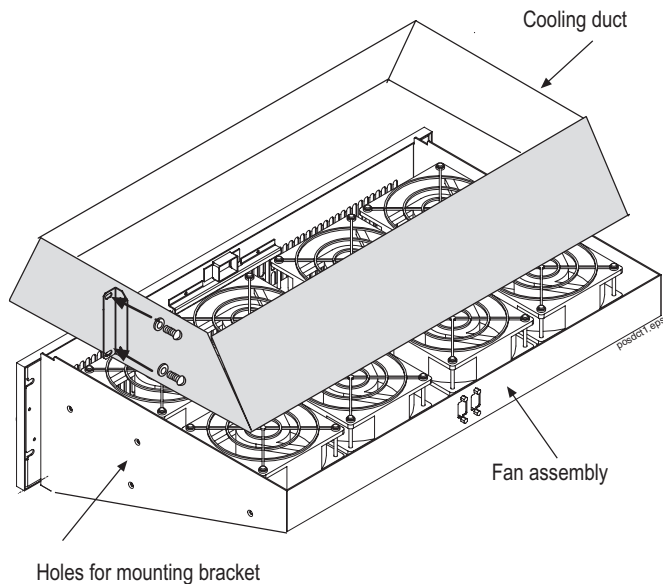
## Install Cooling Duct

### Procedure — Install Cooling Duct

---

1. Remove the cooling duct from the shipping container.
2. Determine the location for the cooling duct to be installed.
3. From the rear of the frame, place the cooling duct on top of the fan assembly.

Figure 3-7. Position Cooling Duct on Fan Assembly



4. A mounting bracket is attached to each side of the cooling duct. Insert two screws through the mounting bracket and into the frame rail. Tighten the screws.



**WARNING:** Do not overtighten the screws as the heads could snap off.

---

You have now installed the cooling duct. This procedure completes the installation of the fan assembly for the EOAP shelf. Cable, power up, and test the fan assembly after the EOAP shelf is installed. These procedures are described in sections *EOAP Shelf* on page 3-18, *EOAP Cabling* on page 3-23, *EOAP Power-Up* on page 3-70, and *Fan Operation Testing* on page 3-71.

## EOAP Shelf

The EOAP shelf contains EOAP cards for a single or dual EOAP configuration. At delivery, the EOAP shelf comes premounted in an OAP frame with all EOAP cards preinstalled. The EOAP shelf is always installed above the cooling duct of the fan assembly. Figure 3-8 shows an EOAP (dual configuration) in relationship to fan assembly and cooling duct.

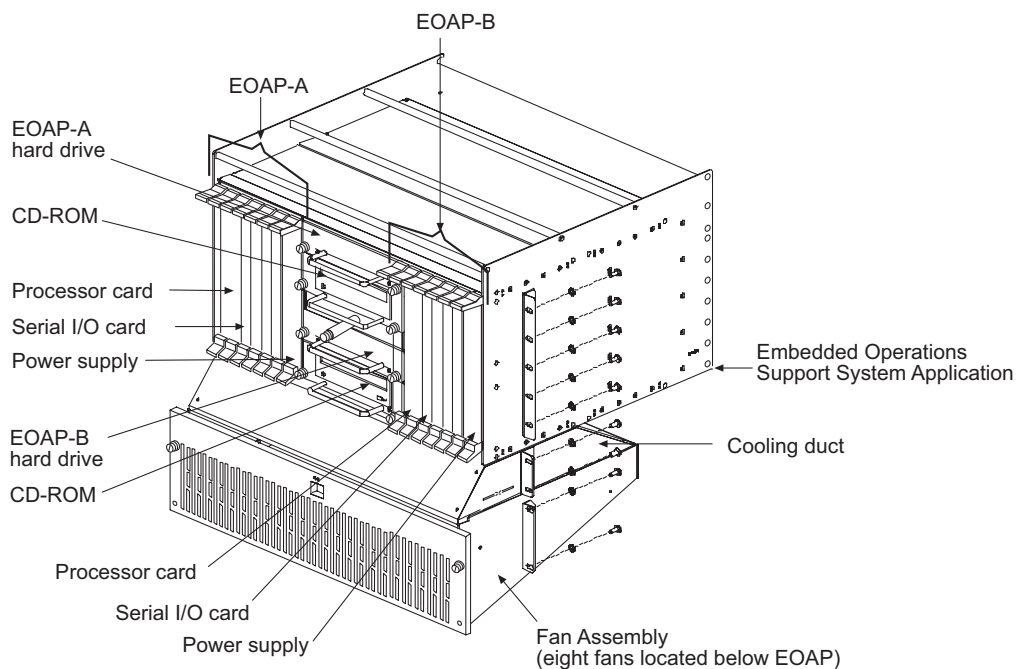
Use this procedure if your EOAP shelf was delivered together with a fan assembly and cooling duct to be installed in an OAP frame (OAPF). If your EOAP shelf came preinstalled in a frame, go to *Change Cabling to Dual Configuration* on page 3-66 to finish the cabling.

Two EOAP shelves can be mounted in each frame. This procedure describes how to mount a fully assembled EOAP shelf or an empty card cage to the frame. Installation of the fan assembly and cooling duct are described in *EOAP Fan Assembly* on page 3-11.



**WARNING: Do not overtighten the screws as the heads could snap off.**

**Figure 3-8.** EOAP Shelf with Cooling Duct and Fan Assembly





## Installation Procedures

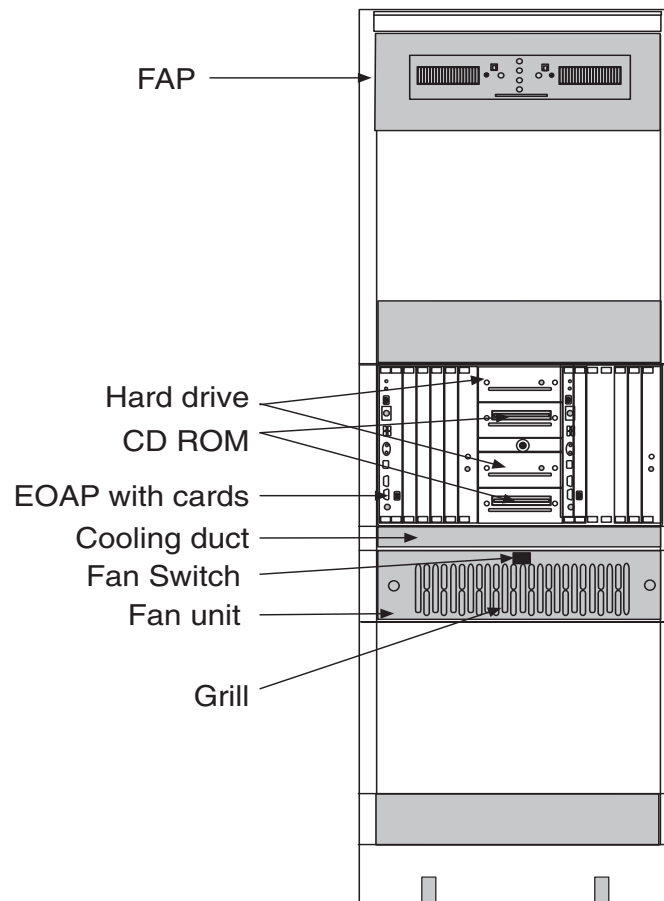
**Table 3-5.** Tools and Equipment - EOAP Shelf

Check	Tools and Equipment	
	Doors (P/N)	840-0016-02
	EOAP Shelf: <ul style="list-style-type: none"><li>• Single configuration</li><li>• Dual configuration</li></ul>	890-1050-03 890-1050-01
	Mounting brackets to attach to shelf (P/N 652-0841-01)	
	Mounting bracket screws (P/N 600-0154-01)	
	Flushcutter (to cut cable ties)	
	Phillips screw driver	
	Safety glasses	
	Tie wrap tool	

**Procedure — Install EOAP Shelf**

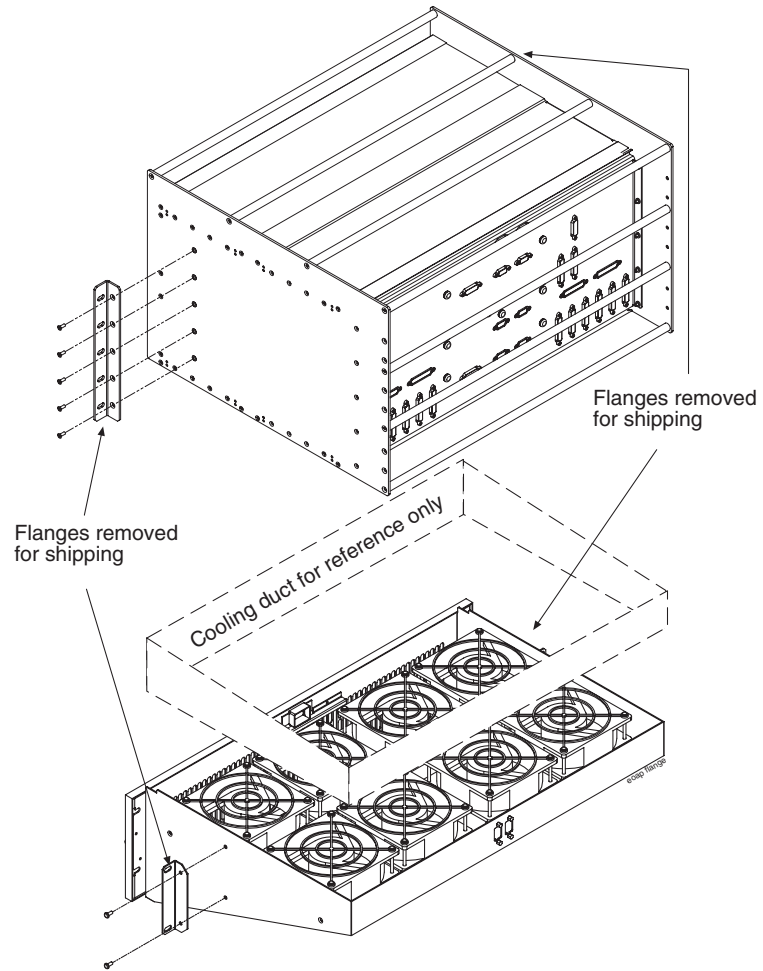
---

1. Examine the frame designated for the EOAP shelf. The shelf has to be installed above the cooling duct. Mark the space for the EOAP shelf.

**Figure 3-9.** EOAP Installed in OAP Frame

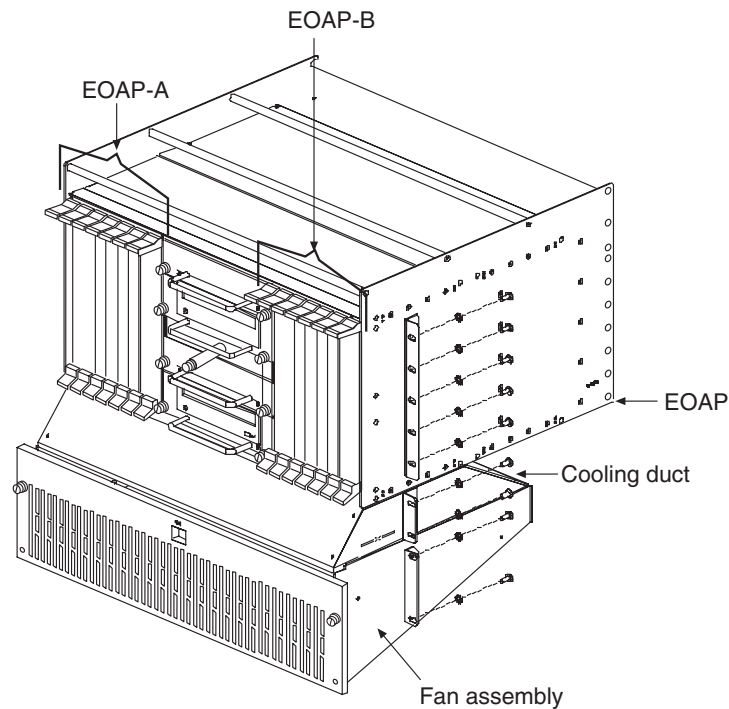
- 
2. Unpack the EOAP assembly.
- 
3. Install the mounting brackets (P/N 652-0841-01) with screws provided (P/N 600-0154-01) on the side of the assembly, refer to Figures 3-10.

Figure 3-10. Fans and EOAP Showing Mounting Brackets



4. Install the EOAP unit from the rear of the frame above the cooling duct.  
Secure the EOAP using screws and external tooth washers P/N 601-0010-01.

**Figure 3-11.** Fan Assembly Under EOAP



- 
5. Doors are shipped with the EOAP. Mount the doors on the front of the frame and ensure that the doors will close securely and fasten.
- 

The EOAP shelf is mounted. If you are upgrading from a single to a dual configuration, install the cards into the shelf next. Otherwise continue with installing the cables. Refer to the procedures in section *Maintenance Modem Setup* on page 3-74.

### EOAP Cabling

This section describes how to cable the EOAP for a single configuration, dual configuration, or change the cables from a single to a dual configuration. Refer to these sections:

- *EOAP Cabling Overview* on page 3-23
- *Single-Configuration Cabling* on page 3-32
- *Dual-Configuration Cabling* on page 3-35
- *Single-to-Dual Configuration Cabling* on page 3-56

### EOAP Cabling Overview

This section provides cable legends, port functions, EOAP backplane connections, and wiring diagrams for single, dual, or single-to-dual EOAP configurations.

#### *Cable Legend and Port Functions*

Use this cable legend to locate the cables on the EOAP backplane (Figure 3-14 or Figure 3-12) or the connection diagram (Figure 3-15 or Figure 3-13). Refer to Table 3-7 for EOAP backplane labels and port functions.

Table 3-6. Dual EOAP Cable Legend

**Note:**  
 On items 3, 4, and 5-  
 If using the FAP  
 (P/N 870-2320-03), use  
 terminal ring  
 (P/N 502-0040-01)

	Part Number	Quantity Required/ System	Length (units)	Comments
②	830-0257-01	2	1.5 ft. .457 m	Logic ground
③	Part of 830-0699-01 blue conductor	2	10 ft. 3.05 m	RTN Dress from OAP to fuse panel Strip and terminate
④	Part of 830-0699-01 Brown Conductor	2	10 ft. 3.05 m	-48 VDC Dress from OAP to fuse panel Strip and terminate
⑤	Part of 830-0699-01 green /yellow conductor	2	10 ft. 3.05 m	CGND Dress from OAP to fuse panel Strip and terminate
⑥	830-0638-xx	1	site specific	Alarm cable
⑦	Supplied w/ modem	2	vendor specific	Pwr cable
⑧	Supplied w/ modem	2	vendor specific	Pwr cable
⑨	830-0710-xx	2	site specific	Network cable
⑩	830-0657-xx	1	site specific	Clock cable
⑪	804-0176-01	2	N/A	Converter
⑫	830-0528-01	2	2 ft. .609 m	Terminal/convert cable
⑬	830-0708-xx	2	site specific	MMI port cable
⑭	830-0709-xx	6	site specific	Modem/terminal
⑮	830-0609-01	3	6 ft. 1.829 m	Clock in/out fan pwr cable
⑯	850-0496-01	2		Force transition card
⑰	830-0651-01	2	10 in. 254 mm	48V power cable From OAP backplane to CPCI power backplane
⑱	830-0224-02	4	3.5 in. 88.9 mm	Drive power cable
⑲	830-0656-01	2	5.3 in. 134.6mm	50 pos signal cable Hard drive cable in/out
⑳	830-0421-02	2	2.5 in. 63.5 mm	CD ROM cable
㉑	850-0514-01	4		Serial I/O transition card
Ⓐ	850-0763-01 for install only	2	N/A	DB loopback plug
Ⓑ	For reference only	N/A	N/A	

Cable legend

# Installation Procedures

**Figure 3-12. EOAP Backplane Cable Connections (Dual Configuration)**

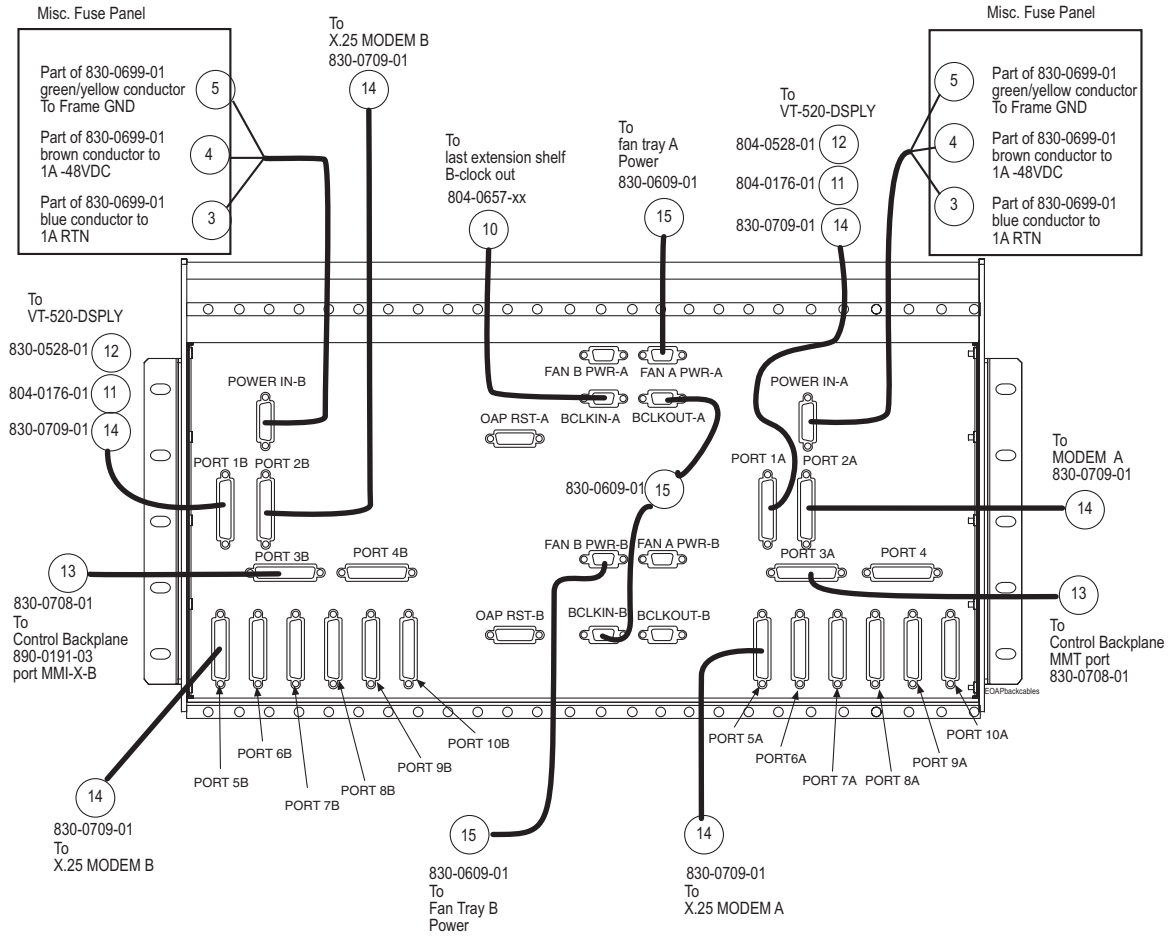
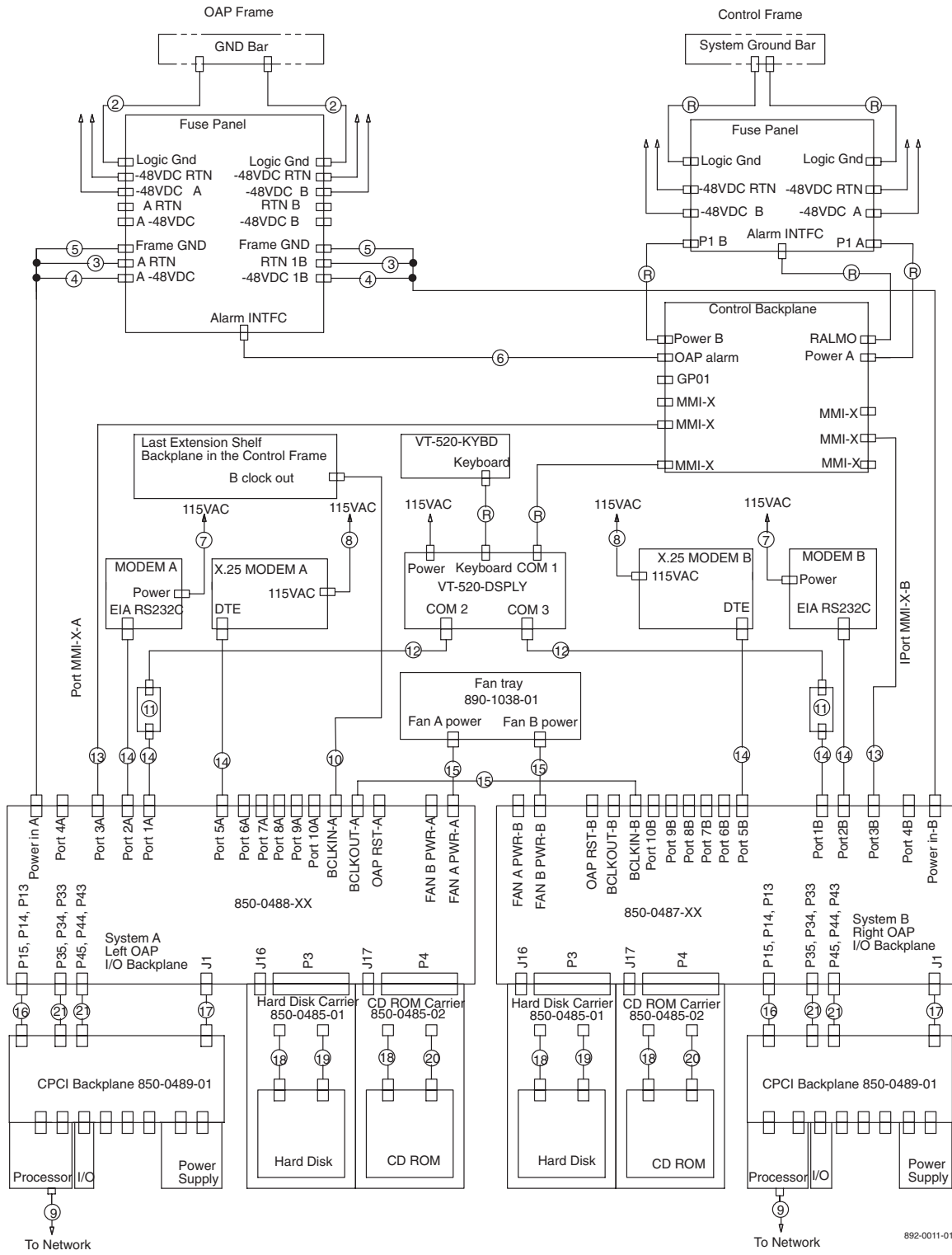


Figure 3-13. EOAP Cable Connections Diagram (Dual Configuration)



892-0011-01



# Installation Procedures

**Figure 3-14.** EOAP Backplane Cable Connections (Single Configuration)

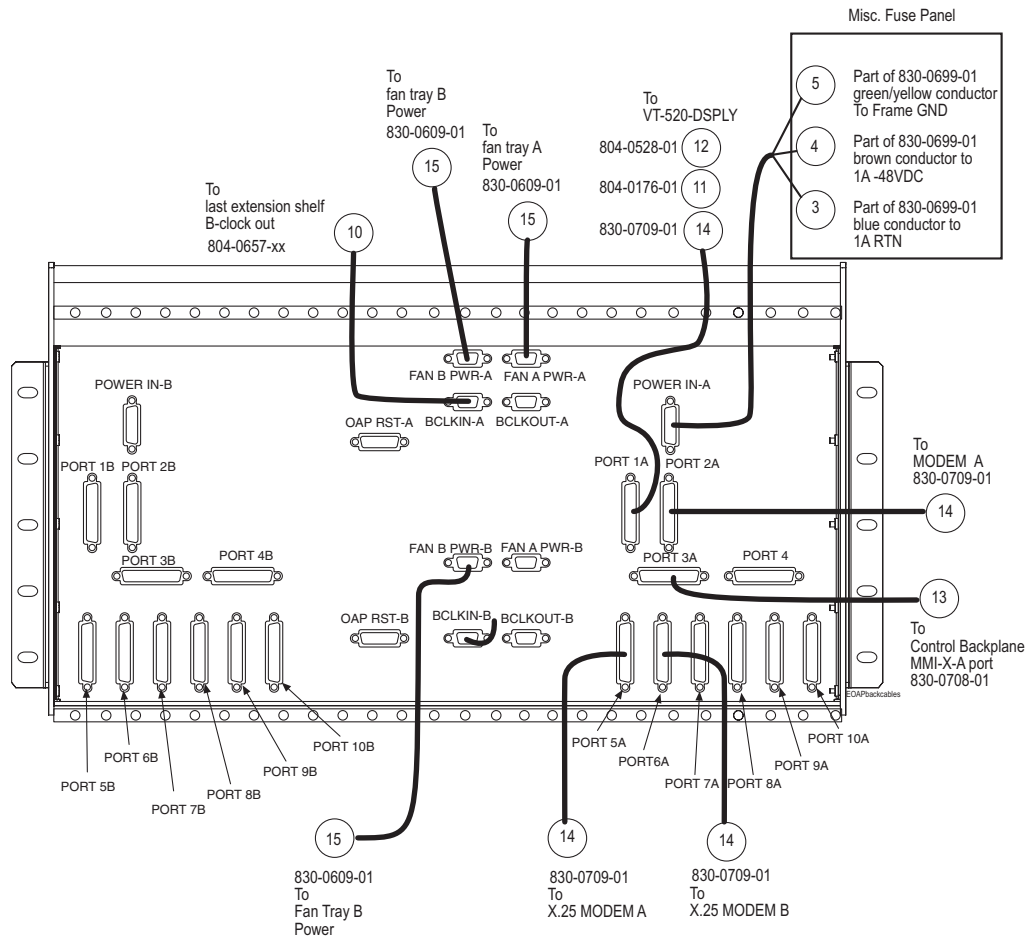
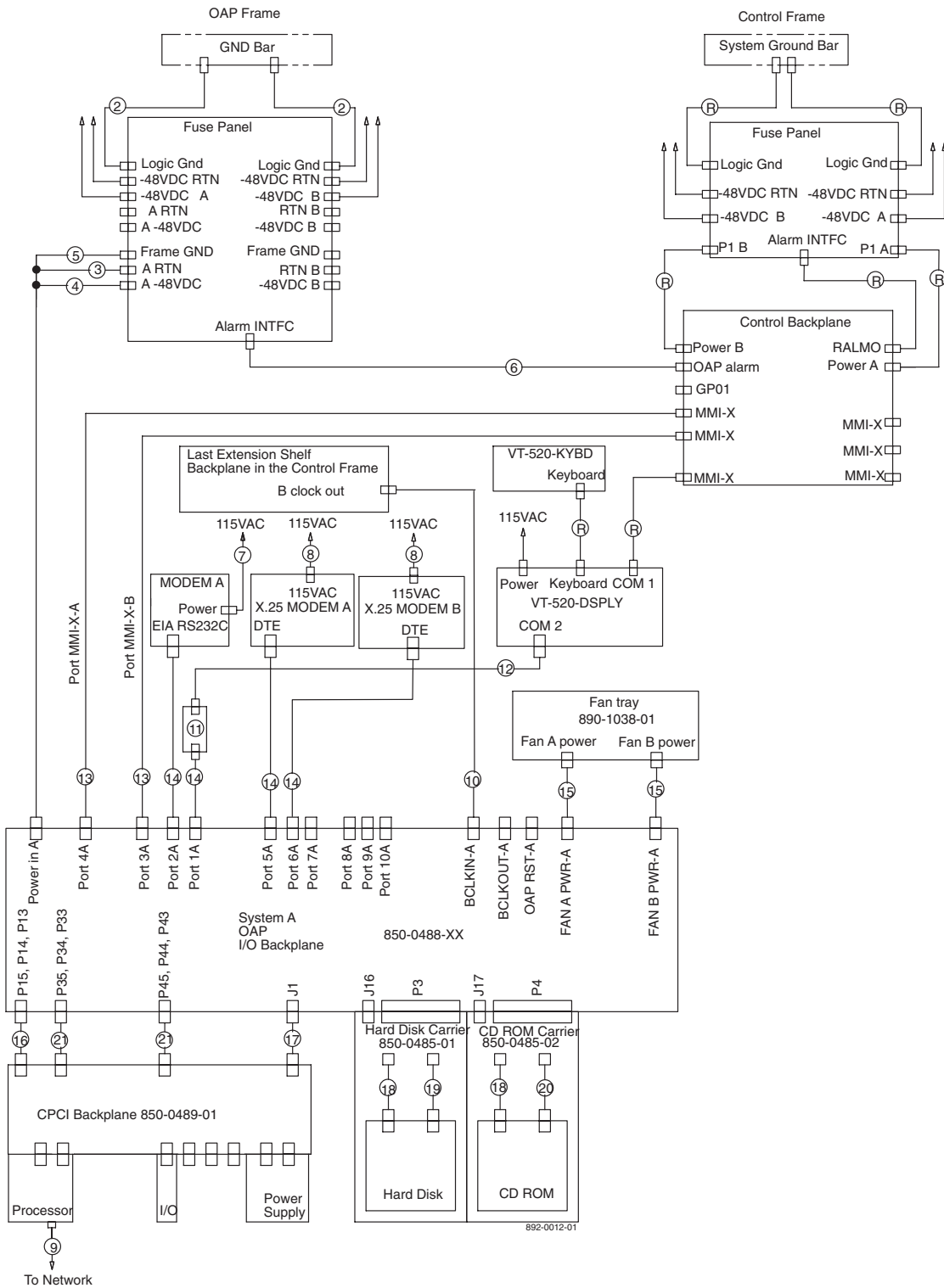


Figure 3-15. EOAP Cable Connections Diagram (Single Configuration)



## Installation Procedures

**Table 3-7.** EOAP Port Labels and Functions

Port Label	Function	Location	Connector Type
BCLKIN-A	Clock connection cable P/N 830-0657-xx to last extension shelf in control frame	EOAP backplane	DB-9
BCLKIN-B	Clock in/out cable P/N 830-0609-xx to BCLKOUT-A	EOAP backplane	DB-9
BCLKOUT-A	Clock in/out cable P/N 830-0609-xx to BCLKIN-B	EOAP backplane	DB-9
BCLKOUT-B	Unused	EOAP backplane	DB-9
Ethernet port	EOAP-to-customer network Ethernet cable P/N 830-0710-xx	EOAP A and B processor cards (face plate, upper port)	RJ-45
FAN A PWR-A	Fan power cable P/N 830-0609-xx to fan tray A	EOAP backplane	DB-9
FAN A PWR-B	Unused	EOAP backplane	DB-9
FAN B PWR-A	Fan power cable P/N 830-0609-xx to fan tray B (single configuration)	EOAP backplane	DB-9
FAN B PWR-B	Fan power cable P/N 830-0609-xx to fan tray B (dual configuration)	EOAP backplane	DB-9
EOAP RST A	Unused	EOAP backplane	---
EOAP RST B	Unused	EOAP backplane	---
PORT 1A	Terminal cable P/N 830-0709-xx/ converter P/N 804-0176-01/ terminal cable P/N 830-0528-xx to display unit	EOAP backplane	DB-25
PORT 1B	Terminal cable P/N 830-0709-xx/ converter P/N 804-0176-01/ terminal cable P/N 830-0528-xx to display unit	EOAP backplane	DB-25
PORT 2A	Modem cable to Modem A P/N 830-0709-xx	EOAP backplane	DB-25
PORT 2B	Modem cable to Modem B P/N 830-0709-xx	EOAP backplane	DB-25
PORT 3A	MMI cable to MMI-x-A port P/N 830-0708-xx	Control shelf backplane, left side	DB-25
PORT 3B	MMI cable to MMI-x-B port P/N 830-0708-xx	Control shelf backplane, right side	DB-25
PORT 4A	Unused	EOAP backplane	---
PORT 4B	Unused	EOAP backplane	---
PORT 5A	Modem cable to X.25 Modem A P/N 830-0709-xx	EOAP backplane	DB-25
PORT 5B	Modem cable to X.25 Modem B P/N 830-0709-xx	EOAP backplane	DB-25
PORT 6A to PORT 10A	Unused	EOAP backplane	---
PORT 6B to PORT 10B	Unused	EOAP backplane	---
Power IN-A	Power cable A P/N 830-0699-xx to PORT 2A of EOAP-A	EOAP backplane	Mate-N-Lock 3 Pin
Power IN-B	Power cable B P/N 830-0699-xx to PORT 2A of EOAP-B	EOAP backplane	Mate-N-Lock 3 Pin

**Table 3-8.** External Interfaces System A

Connector	Signal	Description (software name in parentheses)	Type	Usage/Destination
Power in-A	System power	-48VDC, chassis gnd, -48VDCRTN	N/A	From fuse panel
Fan A-PWR-A	Fan A power	Fan power, alarm control	N/A	To fan assembly
Fan B-PWR-A	Fan B power	Fan power, alarm control	N/A	To fan assembly
BCLKIN-A	B clock input	Provides fan alarm/control to fan A	N/A	From last extension shelf backplane
BCLKOUT-A	B clock output	Provides fan alarm/control to FAP B	N/A	To system B BCLKIN
1A	RS-232	Processor-Slot 1 (/dev/term/a)	Asynchronous	VT-520 Terminal
2A	RS-232	Processor-Slot 1 (/dev/term/b)	Asynchronous	Maintenance Modem
3A	RS-232	Serial I/O- Slot 3 (/dev/cua/0)	Asynchronous	System's Terminal Port
4A	RS-232	Serial I/O- Slot 3 (/dev/cua/1)	Asynchronous	System's Terminal Port
5A	RS-232	Serial I/O -Slot 3 (/dev/term/2)	Synchronous	X.25 port
6A	RS-232	Serial I/O -Slot 3 (/dev/term/3)	Synchronous	X.25 port
7A	RS-232	Reserved for future expansion through Slot 4	Asynchronous or synchronous	Currently unused
8A	RS-232	Reserved for future expansion through Slot 4	Asynchronous or synchronous	Currently unused
9A	RS-232	Reserved for future expansion through Slot 4	Asynchronous or synchronous	Currently unused
10A	RS-232	Reserved for future expansion through Slot 4	Asynchronous or synchronous	Currently unused
Front ethernet Port (RJ-45)	100BsT	LAN connection	10/100BaseT	Connection via LAN

## Installation Procedures

**Table 3-9.** External Interfaces System B

Connector	Signal	Description (software name in parentheses)	Type	Usage/Destination
Power in-A	System power	-48VDC, chassis gnd, -48VDCRTN	N/A	From fuse panel
Fan A-PWR-A	Fan A power	Fan power, alarm control	N/A	To fan assembly
Fan B-PWR-A	Fan B power	Fan power, alarm control	N/A	To fan assembly
BCLKIN-A	B clock input	Provides fan alarm/control to fan A	N/A	From last extension shelf backplane
BCLKOUT-A	B clock output	Provides fan alarm/control to FAP B	N/A	To system B BCLKIN
1B	RS-232	Processor-Slot 1 (/dev/term/a)	Asynchronous	VT-520 Terminal
2B	RS-232	Processor-Slot 1 (/dev/term/b)	Asynchronous	Maintenance Modem
3B	RS-232	Serial I/O- Slot 3 (/dev/cua/0)	Asynchronous	System's Terminal Port
4B	RS-232	Serial I/O- Slot 3 (/dev/cua/1)	Asynchronous	System's Terminal Port
5B	RS-232	Serial I/O -Slot 3 (/dev/term/2)	Synchronous	X.25 port
6B	RS-232	Serial I/O -Slot 3 (/dev/term/3)	Synchronous	X.25 port
7B	RS-232	Reserved for future expansion through Slot 4	Asynchronous or synchronous	Currently unused
8B	RS-232	Reserved for future expansion through Slot 4	Asynchronous or synchronous	Currently unused
9B	RS-232	Reserved for future expansion through Slot 4	Asynchronous or synchronous	Currently unused
10B	RS-232	Reserved for future expansion through Slot 4	Asynchronous or synchronous	Currently unused
Frontethernet Port (RJ-45)	100BsT	LAN connection	10/100BaseT	Connection via LAN

## Single-Configuration Cabling

Use this procedure to cable the shelf for a single-configuration EOAP. Cable Shelf for Single Configuration

### Procedure — Cable Single-Configuration EOAP

---

1. Attach power cable A P/N 830-0699-xx to the EOAP backplane:
  - a. Connect one end to port POWER IN-A.
  - b. Loosely route the power cable A from connector POWER IN-A down and across the second tie-down rod. Route the cable to the **right** side of the shelf.
  - c. Route the cable around the side of the shelf along the outside of a traverse arm extender but on the inside of the traverse arm and then to the frame rail. Route the cable up the frame rail to the FAP. Secure the cable with a cable tie near the FAP.

---
2. Finish power cable A at the FAP. Butt the cable at 1 and 1/2 inch beyond the frame rail. The butted cable exposes three wires, blue, brown, and green with a yellow tracer. Fan out the wires and attach them to the FAP as described next.
 

---
3. With P/N 870-2320-03 FAP prepare the wires and terminate them on each side of the FAP as follows:
  - a. Place a terminal ring P/N 502-0040-01 over each wire end and fasten it with a crimping tool.
  - b. Use a small straight or Phillips screw driver and remove the terminal screw from the RETURN (RTN) terminal strip. Center the terminal ring of the **blue wire** over the screw hole in the terminal strip. Reinsert the screw and tighten it.
  - c. Remove the terminal screw from the -48V terminal strip. Center the terminal ring of the **brown wire** over the screw hole in the terminal strip. Reinsert the screw and tighten it.
  - d. Remove the terminal screw from the CHASSIS GROUND terminal strip. Center the terminal ring of the **green wire** over the screw hole in the terminal strip. Reinsert the screw and tighten it.

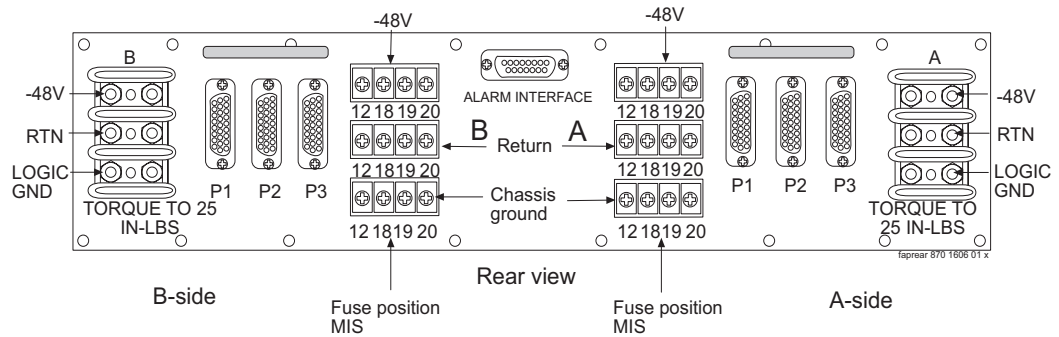
**WARNING:** Do not overtighten the screws as the heads could snap off.



Figure 3-32 shows the rear layout of the FAP (P/N 870-2320-03).

**NOTE: Form the wires together to their proper location and then break them out of the form.**

**Figure 3-16.** FAP Rear View (P/N 870-2320-03)



4. Connect fan power cable A to port FAN A PWR A and to the Fan B port on the back of the fan assembly.
5. Connect fan power cable B to port FAN B PWR A and to the Fan A port on the back of the fan assembly. Secure all fan connectors.
6. Connect the clock in/out cable to ports BCLKOUT-A and BCLKIN-B.
7. Connect the clock connection cable P/N 830-0657-xx to port BCLKIN-A of the EOAP backplane and to port BCLKOUT (J42) located at the lower right side of the last extension shelf backplane in the control frame. Tighten the cable connectors.

**NOTE: If no extension shelf is present, cable to connector B CLK 5 (J70) on control shelf backplane P/N 850-0330-03/04 or connector B CLK 7 (J17) on control shelf backplane P/N 850-0330-06.**





11. Route all new cables down to the bottom tie down rod and across the rod to the right side of the EOAP backplane. Use cable ties to secure the cables to the tie down rod every three to four inches.

---
12. Wrap the cables with fiber paper at the point they are routed around the edge of the EOAP shelf toward the frame rails.

---
13. Route the cables up the frame rail onto the cable rack and from there to each of their destinations. Form and dress the cables using cable ties to secure the cables to the frame rail and the traverse arms every three to four inches.

---
14. Tighten all connectors at their destination.

---
15. At the front of the EOAP, locate the Ethernet port on the processor card. Insert the Ethernet cable.

---
16. Verify your cable connections using Figure 3-14, "EOAP Backplane Cable Connections (Single Configuration)," on page 3-27 or Figure 3-15, "EOAP Cable Connections Diagram (Single Configuration)," on page 3-28.

---

You have completed the cabling for the single configuration. Power up EOAP-B next. Refer to Procedure *Power Up EOAP* on page 3-70.

### Dual-Configuration Cabling

Use this procedure to cable the shelf for a dual-configuration EOAP. This section describes complete cabling for the EOAP backplane. If the EOAP shelf is delivered preinstalled in a frame, the frame includes a Fuse and Alarm panel (FAP) and the shelf is partially cabled: power cables (P/N 830-0699-xx), fan cables (P/N 830-0609-xx), and the clock in/out cable (P/N 830-0609-xx) are connected, routed, and finished on the EOAP backplane and the frame. In this case, skip the first three cabling procedures and begin with procedure *Install EOAP Terminal Cables* on page 3-45.

For backplane cabling, connect each cable to its proper connector and loosely route it from the EOAP backplane down or up the frame rail, and where applicable, across the cable rack, and down to the destination shelf before forming it with other cables and securing it with cable ties. Forming and securing cables is described in *Finish Backplane Cables* on page 3-50. The following cables are installed:

- *Install EOAP Power Cables* on page 3-36
- *Install Fan Power Cables* on page 3-39
- *Install Clock In/Out Cable* on page 3-40

- Install EOAP Clock Connection Cable on page 3-41
- Install EOAP Terminal Cables on page 3-45
- Install EOAP Asynchronous Modem Cables on page 3-48
- Install EOAP X.25 Modem Cables on page 3-48
- Install EOAP MMI-X Cables on page 3-49
- Finish Backplane Cables on page 3-50
- Install EOAP-to-Customer Network Cable on page 3-55

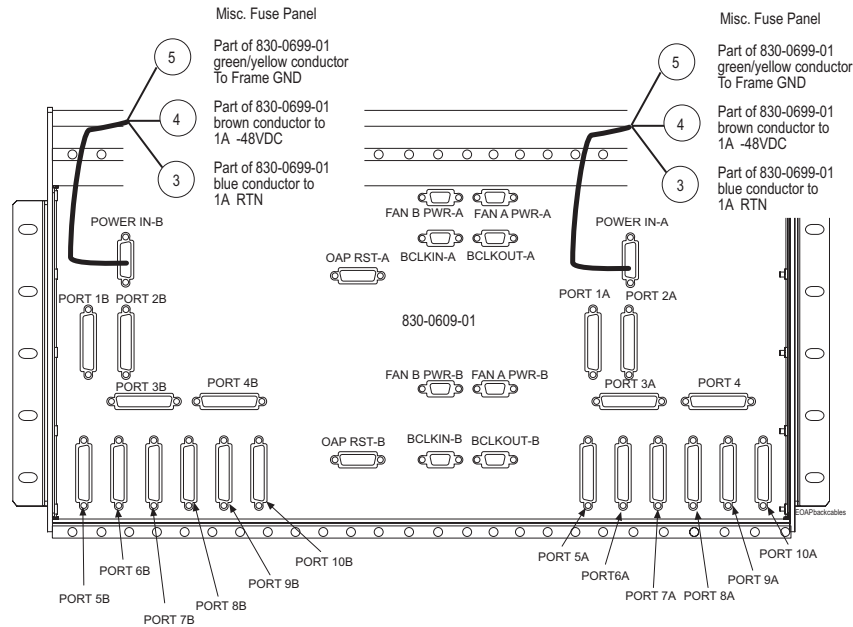
**Install EOAP Power Cables**

Use two EOAP power cables P/N 830-0699-xx to connect the EOAP shelf (backplane P/N 850-0488-xx) to the Fuse and Alarm Panel (FAP) (P/N 870-2320-03).

**Procedure — Install Power Cables**

1. Take the first power cable P/N 830-0699-xx and plug one end onto the EOAP backplane connector marked POWER IN-A. Refer to Figure 3-18.

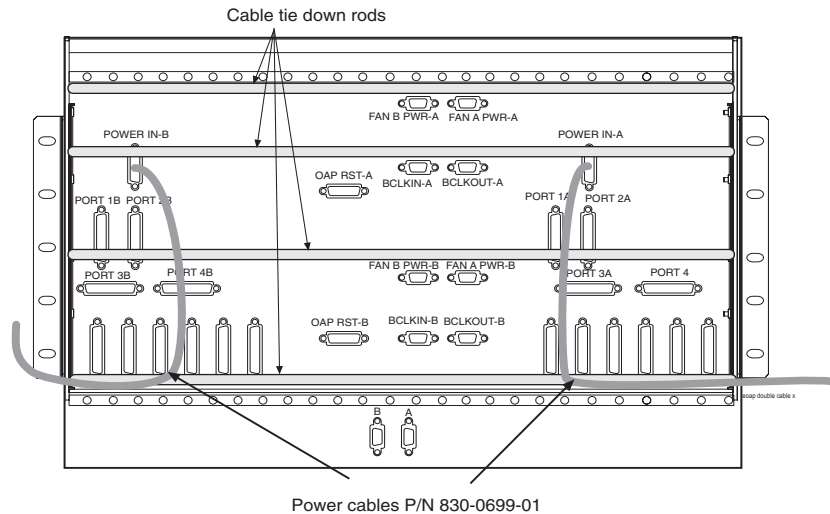
**Figure 3-18.** Install EOAP Power Cables (P/N 830-0699-xx)



## Installation Procedures

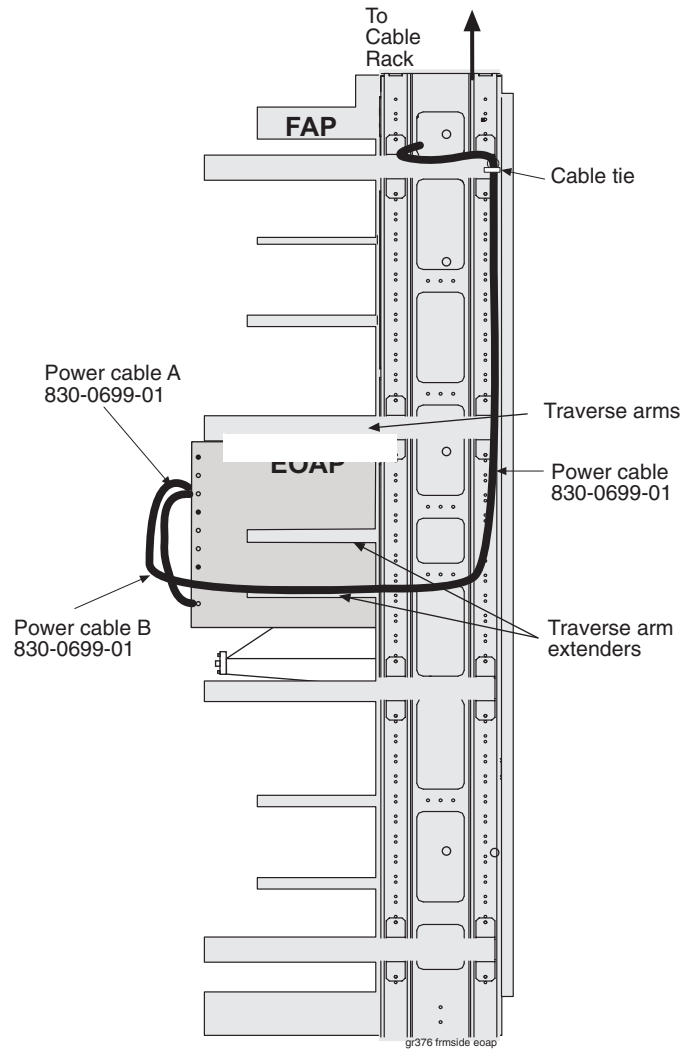
2. Take the second power cable and plug one end onto the EOAP backplane connector marked POWER IN-B. Figure 3-18 shows both power cables connected to the POWER IN ports on one end and the three wires fanned for the FAP on the other end.
3. Loosely route the first power cable (A power cable) from the connector POWER IN-A down and across the bottom cable tie-down rod, to the **right** side of the frame. Refer to Figure 3-19.

**Figure 3-19.** Route Power Cables on EOAP Shelf



4. Loosely route the second power cable (B power cable) from connector POWER IN-B down and across the second tie-down rod. Route the B power cable to the **left** side of the shelf. Refer to Figure 3-19.
5. On each side of the frame, route the respective power cable around the side of the shelf along the outside of a traverse arm extender but on the inside of the traverse arm and then to the frame rail. Route the cables up the frame rail to the FAP. Secure the cables on each side with a cable tie near the FAP. Refer to Figure 3-20.

Figure 3-20. Route Power Cables to FAP



You have now connected both power cables P/N 830-0699-xx to the EOAP and routed them near the FAP. Finish these cables as described in *Finish Backplane Cables* on page 3-50.

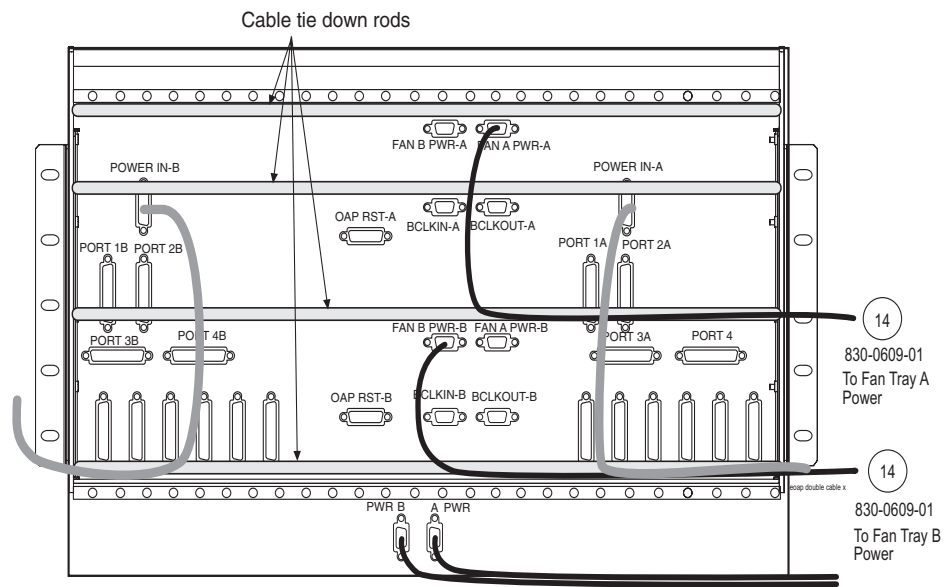
**Install Fan Power Cables**

Use two fan power cables P/N 830-0609-xx to connect the fan assembly (P/N 890-1038-01) to the EOAP shelf (backplane P/N 850-0488-xx).

**Procedure — Install Fan Power Cables**

1. Take the first fan cable (P/N 830-0609-xx) and plug one end onto the connector designated FAN A, PWR A located at the top center of the EOAP backplane. Refer to Figure 3-21 for connector location.

**Figure 3-21.** Install EOAP Fan Cables (P/N 830-0609-xx)



2. Plug the other end of the first fan cable (A fan power cable) onto the FAN A PWR connector on the back of the fan assembly. Refer to Figure 3-21 for connector location. Tighten the connectors.
3. Take the second fan cable and plug one end onto the backplane connector marked FAN B, PWR B located at the bottom center of the EOAP backplane. Refer to Figure 3-21 for connector location.
4. Plug the other end of the second fan cable (B fan power cable) cable onto the FAN B PWR connector on the back of the fan assembly. Refer to Figure 3-21 for connector location. Tighten the connectors.

You have now connected both fan cables P/N 830-0609-xx to the EOAP and fan assembly. Finish these cables as described in *Finish Backplane Cables* on page 3-50.

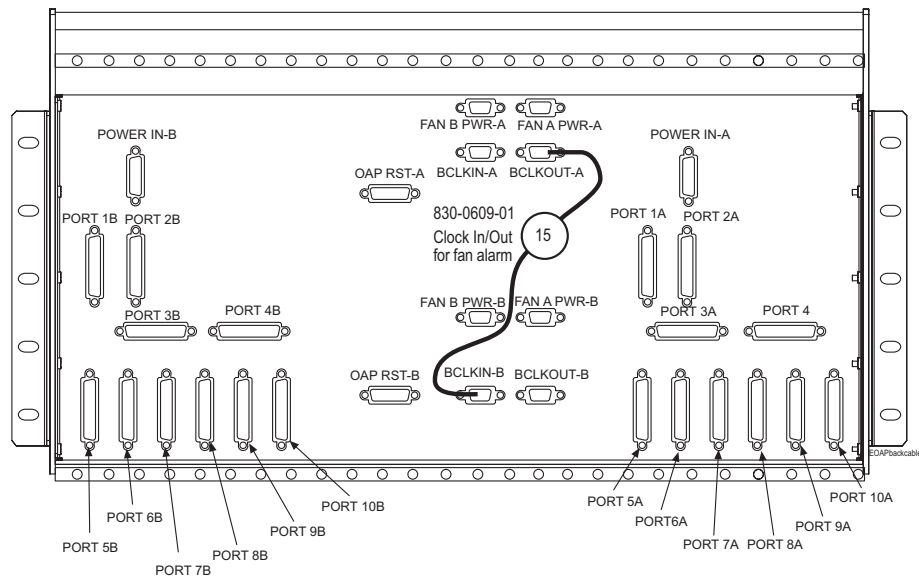
**Install Clock In/Out Cable**

Use the EOAP clock in/out cable P/N 830-0609-xx to connect ports BCLKOUT-A and BCLKIN-B on the EOAP shelf backplane. This cable provides the system with the fan alarm.

**Procedure — Install Clock In/Out Cable**

1. Take the EOAP clock in/out cable P/N 830-0609-xx and plug one end onto the backplane connector marked BCLKOUT-A located at the top center of the EOAP backplane.
2. Plug the other end of the clock in/out cable onto the BCLKIN-B connector at the bottom center of the EOAP backplane. Tighten the connectors. Figure 3-22 shows the clock in/out cable connected to the EOAP backplane.

**Figure 3-22.** Install EOAP Clock In/Out Cable (P/N 830-0609-xx)



You have now connected the BCLKOUT-A and BCLKIN-B ports on the back of the EOAP with the clock in/out cable P/N 830-0609-xx. Finish this cable with the other cables as described in *Finish Backplane Cables* on page 3-50.

*Install EOAP Clock Connection Cable*

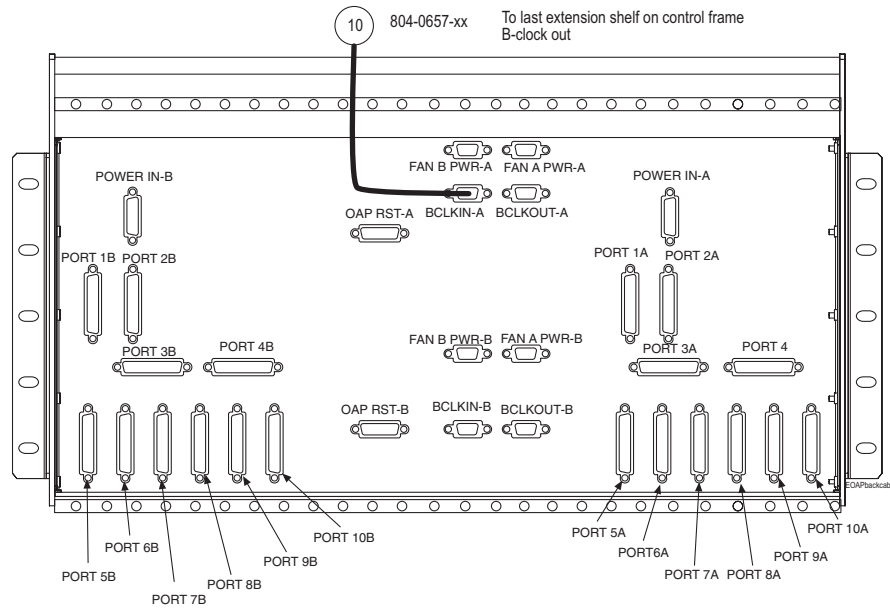
Use one EOAP clock connection cable P/N 830-0657-xx to connect the EOAP shelf (backplane P/N 850-0488-xx) to the last EAGLE 5 ISS extension shelf backplane in the control frame.

**Procedure — Install Clock Connection Cable**

---

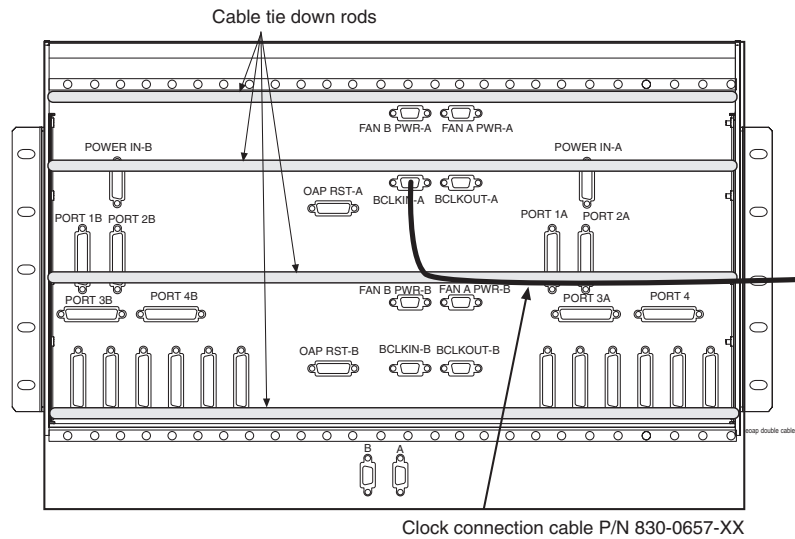
1. Plug one end of the P/N 830-0657-xx clock connection cable onto the connector marked BCLKIN-A located at the upper middle of the EOAP backplane. Refer to Figure 3-23. Tighten the cable connectors.

**Figure 3-23.** Install EOAP Clock Connection Cable



- From the connector, loosely route the clock connection cable down to the second tie-down rod and across the rod toward the right side of the EOAP backplane.

**Figure 3-24.** Route Clock Connection Cable, EOAP Shelf



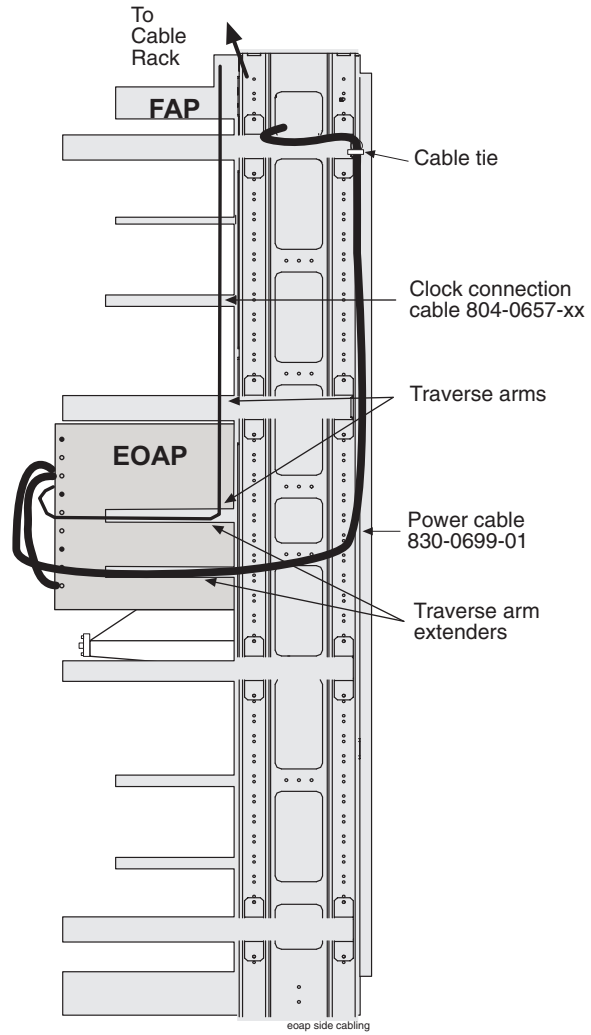
- Loosely route the clock connection cable around the right side of the shelf to the center of the next traverse arm extender. Refer to Figure 3-25. Then route the cable up to the top of the EOAP frame, across the cable rack, to the right side of the control frame, and down to the last extension shelf in the control frame.



**CAUTION:** Do Not connect this P/N 830-0657-xx cable to the EAGLE 5 ISS until both sides of the EOAP have been integrated into the system.



Figure 3-25. Route Clock Connection Cable to Cable Rack



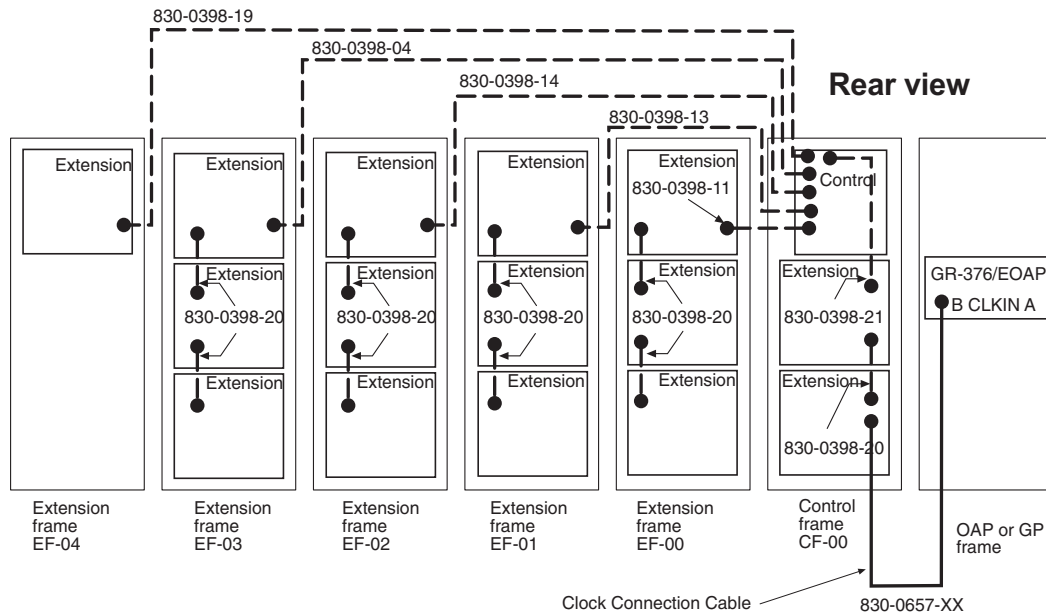
- After both EOAPs have been integrated into the system, plug the other end of the clock connection cable P/N 830-0657-xx onto the connector marked BCLKOUT (J42) located at the lower right side of the last extension shelf backplane in the control frame. Refer to Figure 3-26. Tighten the connector screws.



**CAUTION:** Do Not connect this P/N 830-0657-xx cable to the EAGLE 5 ISS until both sides of the EOAP have been integrated into the system.

**NOTE:** If no extension shelf is present, cable to connector B CLK 5 (J70) on control shelf backplane P/N 850-0330-03 or connector B CLK 7 (J17) on control shelf backplane P/N 850-0330-06.

Figure 3-26. Route Clock Connection Cable



You have now routed the clock connection cable P/N 830-0657-xx from the EOAP to the last extension shelf in the control frame. Finish this cable as described in *Finish Backplane Cables* on page 3-50.

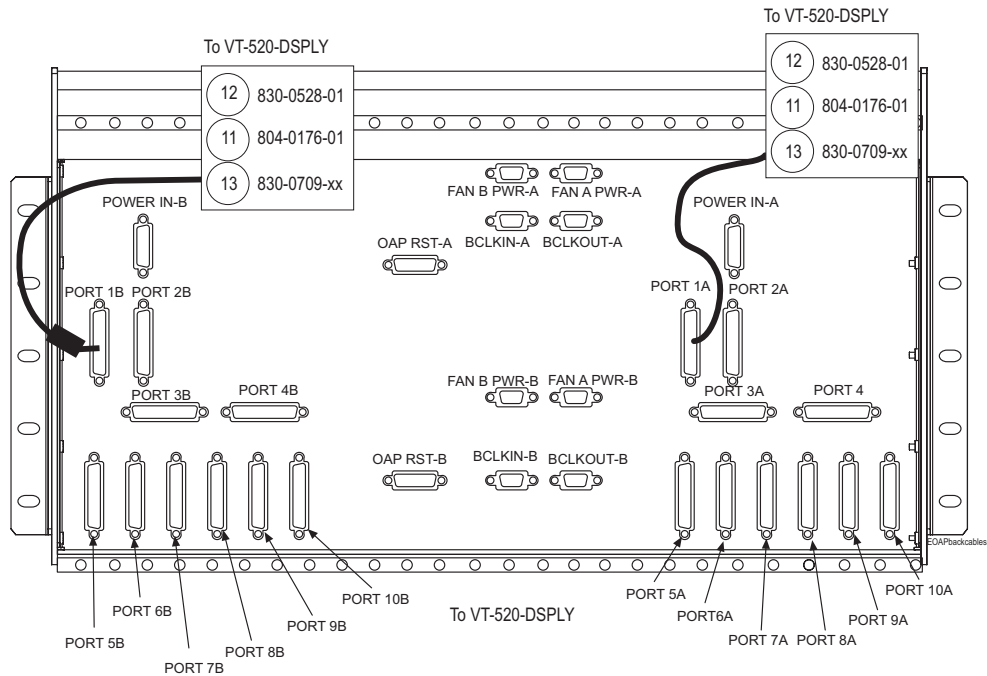
*Install EOAP Terminal Cables*

Use two EOAP terminal cables P/N 830-0528-xx, two converters P/N 804-0176-01, and two terminal cables P/N 830-0709-xx to attach a VT-520 terminal to the EOAP.

**Procedure — Install EOAP Terminal Cables**

1. Take the first terminal cable P/N 830-0528-xx. Plug the ferrite end onto the connector marked PORT 1A located at the center right of the EOAP backplane. Refer to Figure 3-27. Tighten the cable connector.

**Figure 3-27.** Install EOAP Terminal Cables



2. Attach a cable converter P/N 804-0176-01 to the other end of the first terminal cable P/N 830-0528-xx and tighten the connector screws. Label the converter as EOAP PORT 1A.
3. Take the second terminal cable P/N 830-0528-xx. Plug the ferrite end onto the connector marked PORT 1B located at the center left of the EOAP backplane. Refer to Figure 3-27. Tighten the cable connector.

4. Attach a cable converter P/N 804-0176-01 to the other end of the second terminal cable P/N 830-0528-xx and tighten the connector screws. Label the converter as EOAP port 1B.

---

5. Take the first terminal cable of P/N 830-0709-xx:
  - a. Plug one end onto the cable converter P/N 804-0176-01 labeled EOAP PORT 1A. Tighten the connector screws.
  - b. Label the other cable end as EOAP port 1A.

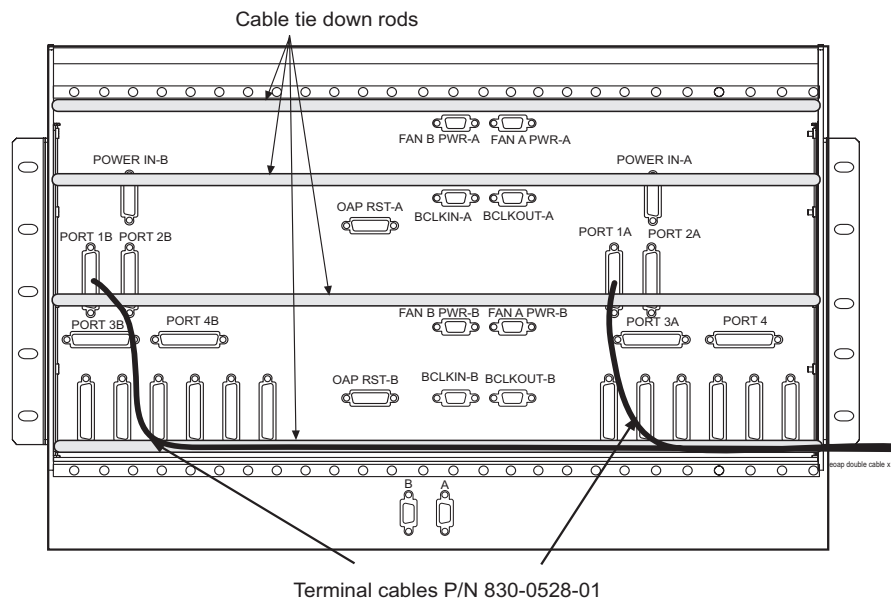
---

6. Take the second terminal cable P/N 830-0709-xx:
  - a. Plug one end onto the cable converter P/N 804-0176-01 labeled EOAP PORT 1B. Tighten the connector screws.
  - b. Label the other cable end as EOAP PORT 1B.

---

7. Loosely route these two extended terminal cables from each connector down to the third tie rod and across the rod toward the right side of the EOAP backplane.

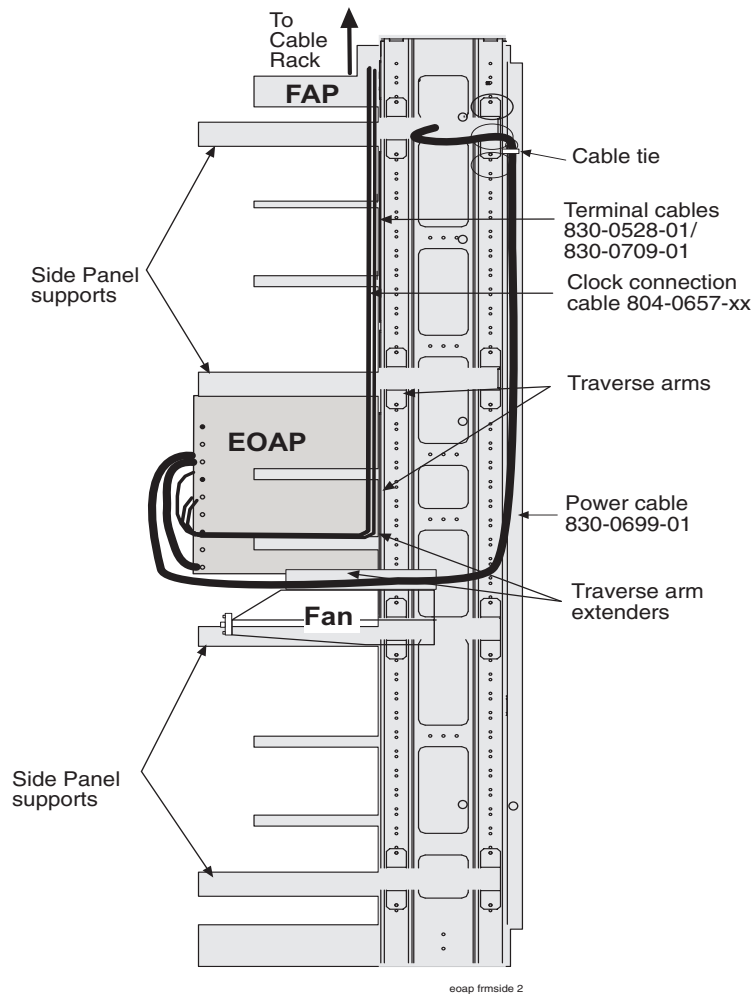
Figure 3-28. Route Terminal Cables on EOAP Shelf Backplane



## Installation Procedures

8. Route the two extended terminal cables around the right side of the shelf to the center of the next traverse arm extender. Refer to Figure 3-29. Then route the cable up to the top of the EOAP frame, across the cable rack, and down to the VT-520 terminal.

**Figure 3-29.** Route EOAP Terminal Cables to Cable Rack



- 
9. Take the cable end marked EOAP PORT 1A and plug it into port COM2 on the back of the VT-520 terminal.
- 
10. Take the cable end marked EOAP PORT 1B and plug it into port COM3 on the back of the VT-520 terminal.
-

You have now connected the four terminal cables P/Ns 830-0528-xx/830-0709-xx between the EOAP and the VT-520 terminal. Finish these cables as described in *Finish Backplane Cables* on page 3-50.

### ***Install EOAP Asynchronous Modem Cables***

Use two EOAP modem cables P/N 830-0709-xx to connect to asynchronous modems A and B.

#### **Procedure — Install EOAP Asynchronous Modem Cables**

---

1. Take the first modem cable P/N 830-0709-xx and connect it to PORT 2A located at the center right of the EOAP backplane. Connect the other end to Modem A. Tighten the cable connectors.

---
2. Take the second modem cable P/N 830-0709-xx and connect it to PORT 2B located at the center left of the EOAP backplane. Connect the other end to Modem B. Tighten the cable connectors.

---
3. Loosely route these two cables from each connector down to the third tie rod and across the rod toward the right side of the EOAP backplane.

---
4. Route the two cables around the right side of the shelf to the center of the next traverse arm extender. Then route the cable up to the top of the EOAP frame, across the cable rack, and down to the modem A connector.

---

You have now connected the two asynchronous modem cables P/N 830-0709-xx between the EOAP and the modems. Finish these cables as described in *Finish Backplane Cables* on page 3-50.

### ***Install EOAP X.25 Modem Cables***

Use two EOAP modem cables P/N 830-0709-xx to connect to the X.25 modems A and B.

#### **Procedure — Install EOAP X.25 Modem Cables**

---

1. Take the first modem cable P/N 830-0709-xx and connect it to PORT 5A located at the bottom right of the EOAP backplane. Connect the other end to X.25 modem A. Tighten the cable connectors.

---

## Installation Procedures

2. Take the second modem cable P/N 830-0709-xx and connect it to PORT 5B located at the bottom left of the EOAP backplane. Connect the other end to X.25 modem B. Tighten the cable connectors.

---
3. Loosely route these two cables along the third tie rod and across the rod toward the right side of the EOAP backplane.

---
4. Route the two cables around the right side of the shelf to the center of the next traverse arm extender. Then route the cable up to the top of the EOAP frame, across the cable rack, and down to the X.25 modem A and B connectors.

---

You have now connected the two X.25 modem cables P/N 830-0709-xx between the EOAP and the modems. Finish these cables as described in *Finish Backplane Cables* on page 3-50.

### *Install EOAP MMI-X Cables*

Use two EOAP MMI cables P/N 830-0708-xx to connect to the control shelf backplane.

#### **Procedure — Install EOAP MMI-X Cables**

---

1. Take the first MMI cable P/N 830-0708-xx and connect it to PORT 3A located at the center right of the EOAP backplane. Connect the other end to the control shelf backplane MMI-X A port. Tighten the cable connectors.

---
2. Take the second MMI cable P/N 830-0708-xx and connect it to PORT 3B located at the center left of the EOAP backplane. Connect the other end to the control shelf backplane MMI-X B port. Tighten the cable connectors.

---
3. Loosely route these two cables along the third tie rod and across the rod toward the right side of the EOAP backplane.

---
4. Route the two cables around the right side of the shelf to the center of the next traverse arm extender. Then route the cable up to the top of the EOAP frame, across the cable rack, and down to the control shelf backplane.

---

You have now connected the two MMI-X cables P/N 830-0708-xx between the EOAP and the control shelf backplane. Finish these cables as described in *Finish Backplane Cables* on page 3-50.

**Finish Backplane Cables**

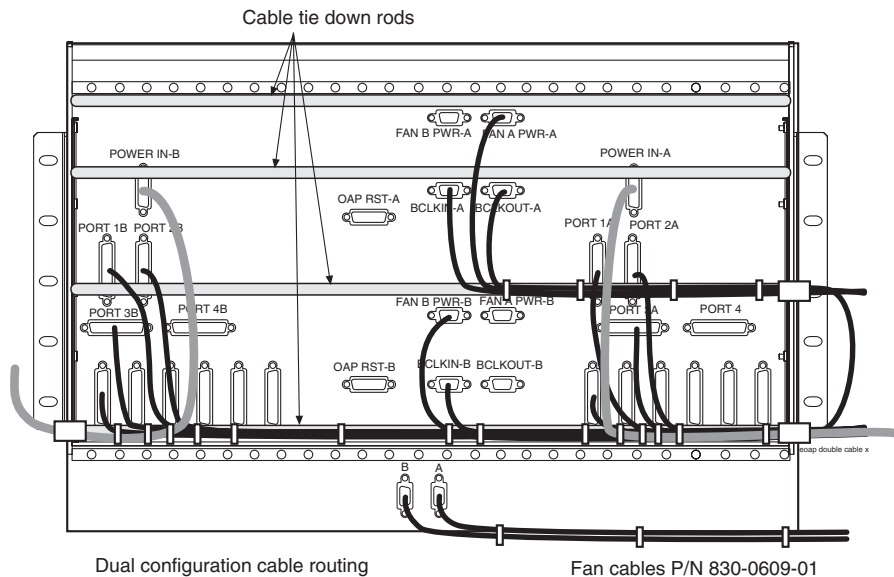
This section describes how to finish the cabling on the backplanes of the EOAP shelf. Finishing the cables includes the forming, final routing, tie down, and connection (if applicable) for each cable.

**NOTE:** Install all cable assemblies with dressed bend radii in accordance with *Tekelec Cable Bend Radius Specification (906-0020-01)*.

**Procedure — Finish Backplane Cables**

1. Go to the backplane of the EOAP to finish the cables from the EOAP top center backplane.
- 
2. Locate the Fan A power cable P/N 830-0609-xx (port FAN A PWR-A), the clock connection cable P/N 830-0657-xx (port BCLKIN-A), and the clock in/out cable P/N 830-0609-xx (port BCLKOUT-A) on the top center of the EOAP shelf backplane. Refer to Figure 3-30.

**Figure 3-30.** Locate Cables on EOAP Backplane



3. Use a cable tie and secure the cables to the third tie-down rod without obstructing any ports. Form these cables along the rod and secure them with cable ties every three or four inches until they reach the frame rail.
- 
4. Wrap the cables with fiber paper at the point where they are routed around the edge of the EOAP shelf toward the frame rail.



## Installation Procedures

5. Locate terminal cable P/N 830-0709-xx (PORT 1B) on the B side of the EOAP. Refer to Figure 3-30.
- 

6. Secure both cables to the bottom tie-down rod without obstructing any ports.
- 

7. Form the cables and secure them along the rod every three or four inches stopping short of the EOAP RST B port. Refer to Figure 3-30.

Continue now with the EOAP-A power cable.

---

8. Locate the power cable P/N 830-0699-xx (POWER-IN B) on the B side of the EOAP. Refer to Figure 3-30.
- 

9. Secure the B power cable with cable ties to the bottom tie-down rod of the backplane without obstructing any of the ports. Continue securing the cable every three or four inches until it reaches the frame rail.
- 

10. Wrap the B power cable with fiber paper at the point where it is routed around the edge of the EOAP shelf toward the frame rail. Refer to Figure 3-30.
- 

11. Route the B power cable up the frame rail to the FAP. Temporarily secure the cable to the cable rack until the A power cable is ready for wiring.

**NOTE: Do not form power cables on traverse arms.**

---

12. On the bottom center of the EOAP shelf backplane, locate the Fan B power cable P/N 830-0609-xx (FAN B PWR B) and the clock in/out cable P/N 830-0609-xx (BCLKIN-B). Refer to Figure 3-30.
- 

13. Secure the cables to the bottom tie-down rod without obstructing any ports.
- 

14. Form these cables along the rod with the cables coming from the B side of the EOAP. Secure the cables with cable ties every three or four inches stopping short of the A ports on the A side of the EOAP backplane.
- 

15. Locate the A power cable P/N 830-0699-xx (POWER IN-A) and the terminal cable P/N 830-0709-xx (PORT 1A) on the A side of the EOAP. Refer to Figure 3-30.
-

16. Use a cable tie and secure all three cables to the bottom tie-down rod without obstructing any ports.

17. Form the cables along the rod and secure them with cable ties every three or four inches. Refer to Figure 3-30.

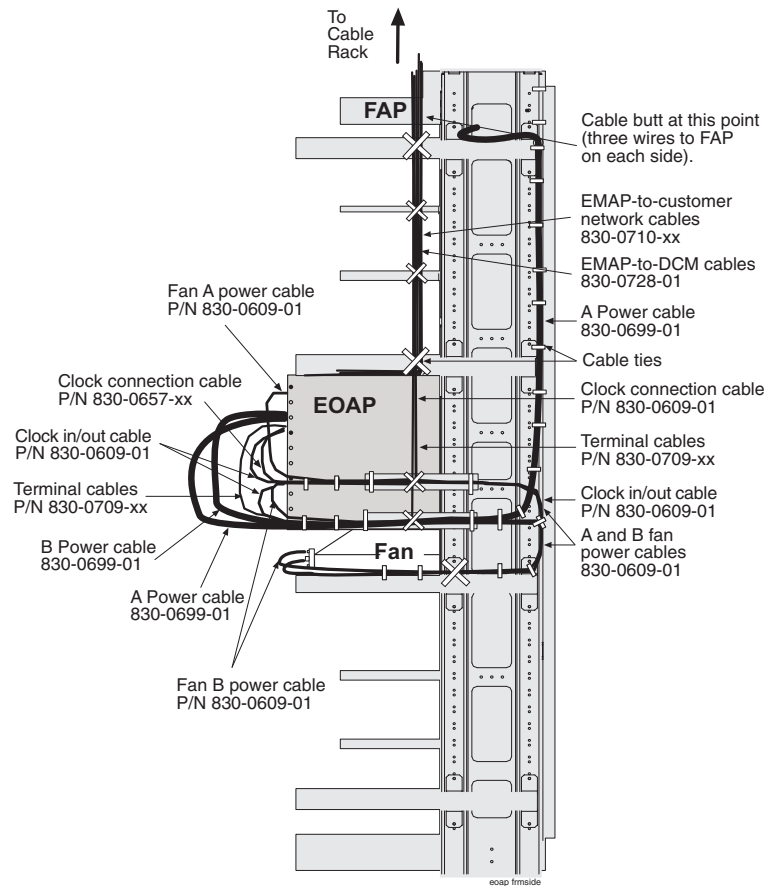
**NOTE:** Notice that the clock in/out cable (BCLKOUT-A to BCLKIN-B) is routed along the third tie-down rod and then looped back along the bottom tie-down rod to take away the slack from the cable.

18. Wrap the cables with fiber paper at the point they are routed around the edge of the EOAP shelf toward the frame rail. Refer to Figure 3-30.

19. Secure all cables routed along traverse arm extender to frame rail first.

20. At the frame rail, break out the fan cables and secure them every three or four inches down the frame rail across the traverse arm to the back of the fan assembly. Refer to Figure 3-31.

**Figure 3-31.** Secure Cables from EOAP to Cable Rack



21. On the back of the fan assembly, secure the two fan cables to the closest tie-down rod. Pull any unnecessary slack in the fan cables toward the frame rail or traverse arm.

---
22. At the frame rail, secure the remaining power cable with cable ties along its route up the frame rail. Refer to Figure 3-31.

---
23. Near the FAP, break out the A power cable and retrieve its FAP end from the cable rack, where it was stored earlier.

---
24. On the other side of the FAP, retrieve the FAP end of the B power cable from the cable rack, where it was stored earlier.

---
25. For each power cable, butt the cable at one and one half (1 ½) inches beyond the frame rail. Refer to Figure 3-31. The butted cable exposes three (3) wires, blue, brown, and green with a yellow tracer. Fan out the wires and attach them to the FAP as described next.

---
26. With P/N 870-2320-03 FAP, prepare the wires and terminate them on each side of the FAP as follows:
  - a. Place a terminal ring P/N 502-0040-01 over each wire end and fasten it with a crimping tool.
  - b. Use a small straight or Phillips screw driver and remove the terminal screw from the RETURN (RTN) terminal strip. Center the terminal ring of the **blue wire** over the screw hole in the terminal strip. Reinsert the screw and tighten it.
  - c. Remove the terminal screw from the -48V terminal strip. Center the terminal ring of the **brown wire** over the screw hole in the terminal strip. Reinsert the screw and tighten it.
  - d. Remove the terminal screw from the CHASSIS GROUND terminal strip. Center the terminal ring of the **green wire** over the screw hole in the terminal strip. Reinsert the screw and tighten it.

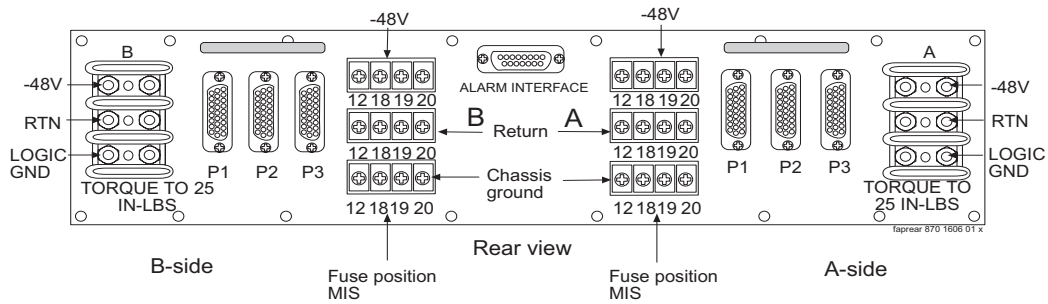


**WARNING:** Do not overtighten the screws as the heads could snap off.

Figure 3-32 shows the rear layout of the FAP (P/N 870-2320-03).

**NOTE:** Form the wires together to their proper location and then break them out of the form.

**Figure 3-32.** FAP Rear View (P/N 870-2320-03)



27. Connect the 1/0 American Wire Gauge (AWG) cable from the control frame system ground bar to the "I" (Isolated) section of the ground window, by way of Htaps if needed.

**NOTE:** If the miscellaneous frame is intended to house terminals, printers, and modems or other equipment that require commercial AC, this frame must have a separate frame ground to the ground window in the customer location.

**NOTE:** If no ground window exists, it is the responsibility of the customer to inform the installer where to terminate the ground and sign a waiver for the responsibility of that connection.

28. Frame ground #6 AWG cable from the frame and Htapped with another #6 AWG cable or with a 1/0 cable will also be terminated at the "I" section of the ground window. The difference in the wire size is determined by the distance to be covered by the length of the wire run.

**NOTE:** The reason for the separate #6 AWG cable to separate frame grounds is to allow removal of a frame from the lineup without interrupting the rest of the system grounds.

**NOTE:** The only grounds that are to be terminated on the system ground bar are the logic grounds from the fuse and alarm panel.

29. Go to the BCLOCKOUT port of the last extension shelf backplane in the control frame. Secure the clock connection cable (P/N 830-0657-xx) down to the next tie-down rod of the extension shelf and across the rod to the left side of the frame.

30. Go to the VT-520 terminal. Secure the terminal cables connected to the COM2 and COM3 port so that the cables will not interfere with safety or proper terminal use.

31. Continue forming and securing the cables from the customer network end.
- 

32. Recheck the cable slacks. Adjust if necessary and keep all unnecessary cable slack on the cable rack.
- 

You have installed and finished the cables from the EOAP backplane. Install the EOAP-to-Customer Network Ethernet cables that are connected to the front panel of each EOAP processor card next.

#### *Install EOAP-to-Customer Network Cable*

Use two EOAP-to-customer network Ethernet cables P/N 830-0710-xx to connect each side of the EOAP (EOAP-A and EOAP-B) to the customer IP network.

#### **Procedure — Install EOAP-to-Customer Network Cable**

---

1. Go to the front of the EOAP and locate the Ethernet port on the front panel of the EOAP-A processor card.

**Figure 3-33.** Locating Processor Card



2. Take the first Ethernet cable P/N 830-0710-xx and insert the end labeled "EOAP-A" into the Ethernet port of EOAP-A.
- 
3. Take the second Ethernet cable P/N 830-0710-xx and insert the end labeled EOAP-B into the Ethernet port of EOAP-B.
- 
4. Loosely route both Ethernet cables straight up to the top of the EOAP shelf and back to the third tie-down rod. Route both cables to the right side of the frame and up the frame rail onto the cable rack.
-

5. Route the cables across the cable rack to the customer network equipment and down the frame rail.
- 
6. Connect each cable to the respective Ethernet port of the customer network equipment.
- 

You have now connected the customer network to EOAP-A and EOAP-B using the two Ethernet cables P/N 830-0710-xx.

### Single-to-Dual Configuration Cabling

The cards of a single-configuration EOAP (EOAP-A) occupy the left side of the shelf and the two top drive bays in the center of the EOAP shelf. The right side of the shelf (EOAP-B) contains filler cards, also called Air Management cards. The two bottom drive bays in the center of the EOAP shelf are empty and covered with face plates. For a dual configuration EOAP, remove the filler cards and the face plate covers to install a second set of EOAP cards. Upgrade to a dual configuration by following these procedures:

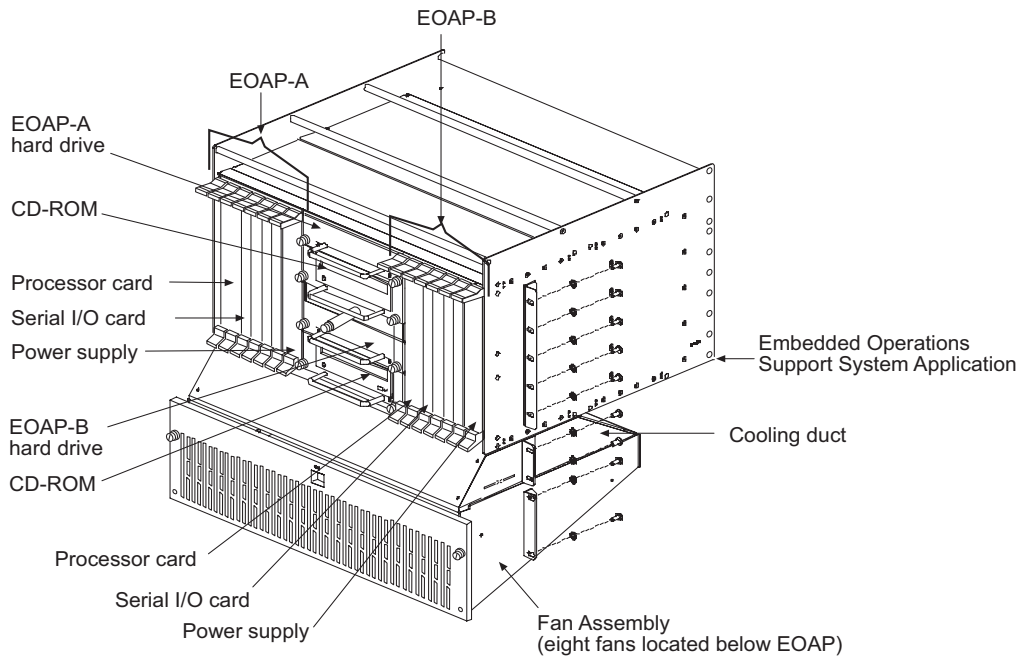
#### *Installation Order for Single-to-Dual EOAP Configuration*

Table 3-10 lists the recommended order for changing from single-configuration cabling to dual-configuration cabling.

**Table 3-10.** Installation Order for Single-to-Dual EOAP Configuration

#	Procedure Name and Location
1.	<i>Remove Filler Cards and Hard Drive Slot Covers on page 3-57,</i>
2.	<i>Install EOAP Cards and Drives on page 3-62</i>
3.	<i>Change Cabling to Dual Configuration on page 3-66</i>
4.	<i>Power Up EOAP on page 3-70</i>
5.	<i>Test Fan Operation on page 3-71</i>

Figure 3-34. Dual EOAP Overview



**Remove Filler Cards and Drive Slot Covers from EOAP-B**

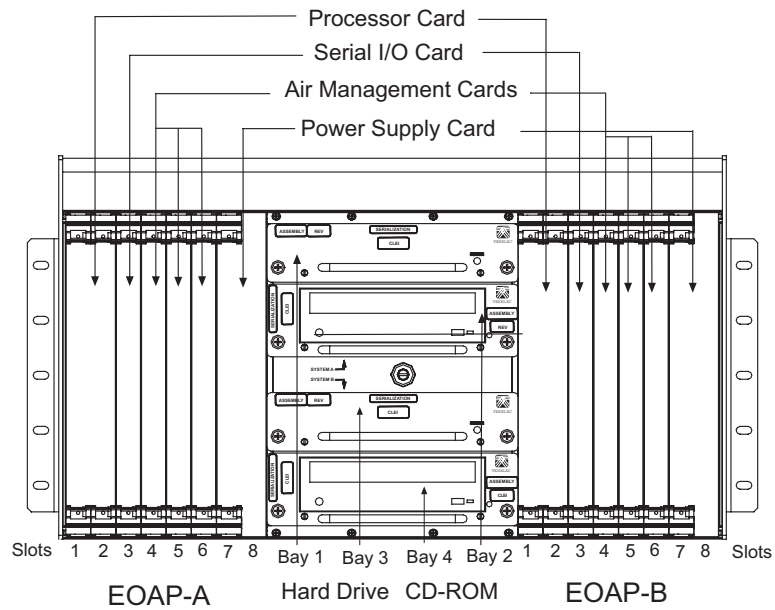
Table 3-11. Tools and Equipment - EOAP Cards and Drives

Check	Tools and Equipment
	Small Phillips head screwdriver
	Flashlight (to view back panel interior)

**Procedure — Remove Filler Cards and Hard Drive Slot Covers**

1. Locate EOAP-B on the right side of the EOAP shelf. Refer to Figure 3-35.
2. Identify slots for processor card (slots 1 and 2), serial card (slot 3), and power supply card (slots 7 and 8). Slots 1 to 8 are initially occupied by air management cards (filler cards). **Do not remove the air management cards in slots 4, 5, and 6.** Also locate the drive bays for the hard drive (bay 3) and CD-ROM drive (bay 4). Drive bays 3 and 4 are covered by faceplates. Remove the necessary filler cards and face plates next.

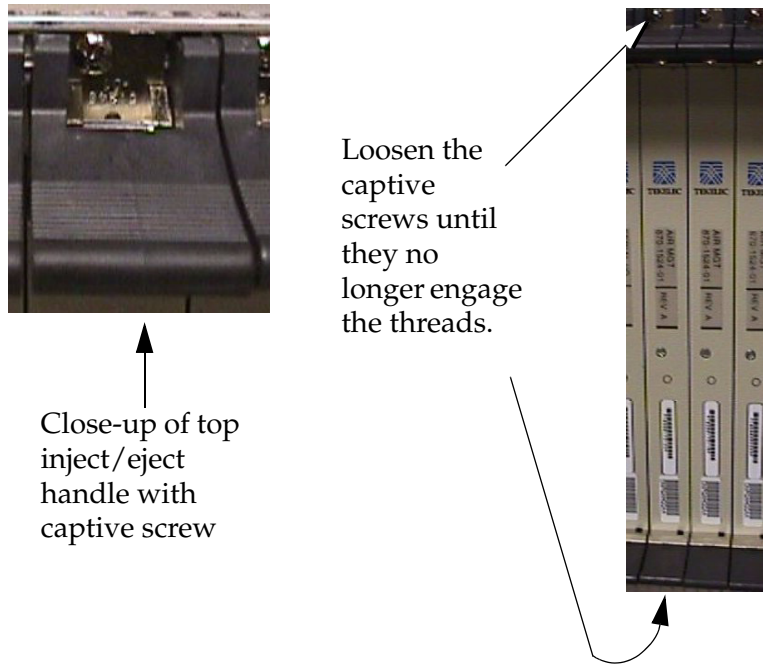
Figure 3-35. Dual EOAP Card Slots and Drive Bays



- 
3. While facing the filler card to be removed, locate the two captive screws attached to the top and bottom inject/eject handle brackets on the faceplate.
- 
4. Using a small Phillips head screwdriver, loosen the captive screws until they no longer engage the threads. **Do not remove the screws** from the ejector handle brackets.

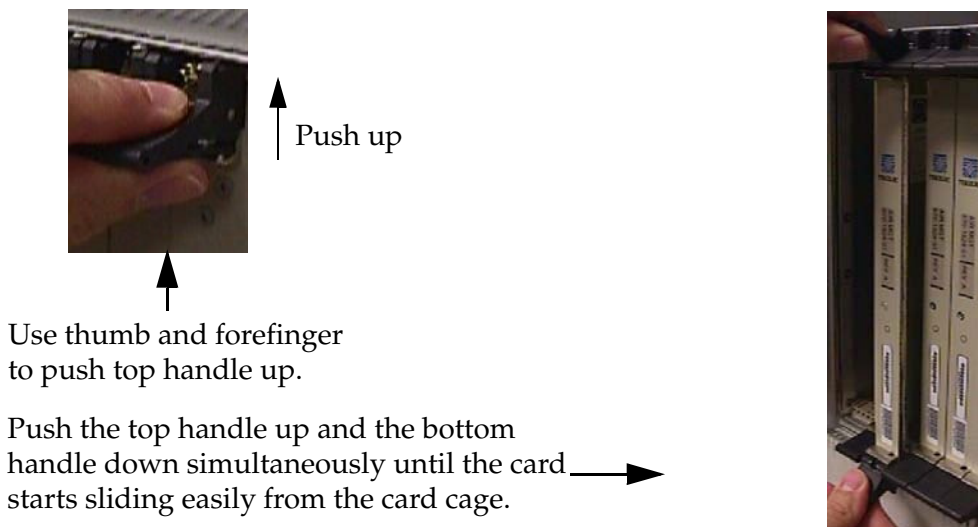


Figure 3-36. Top Handle and Air Management Card



- 
5. Using the thumb and forefinger, push the top handle up and the bottom handle down simultaneously until the card starts sliding easily from the card cage.

Figure 3-37. Freeing the Card from the EOAP Card Cage



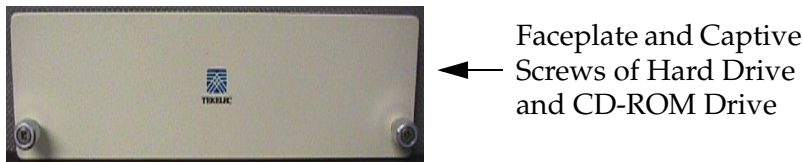
- 
6. Pull the card directly towards you until it clears the card guides and guide rails.
-

7. Repeat Steps 2 to 6 for each filler card to be removed (slots 1, 2, 3, 7, and 8).

8. Remove faceplates from hard drive and CD-ROM drive bays 3 and 4 by loosening the captive screws by hand until they no longer engage the threads in the floating fasteners on the drive bay faceplates.

**NOTE: The heads on the captive fasteners should spring outward when freed.**

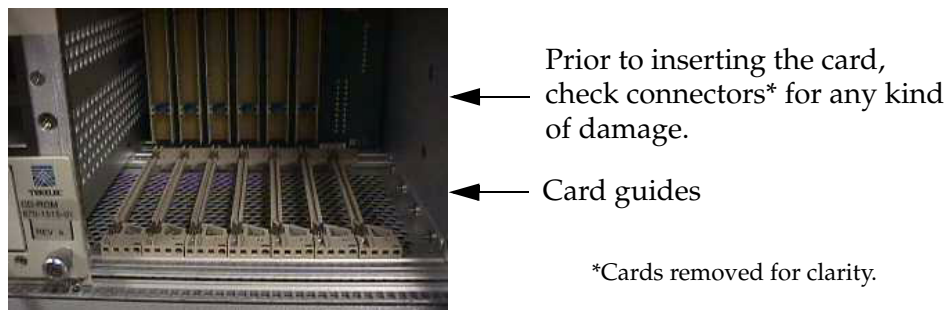
**Figure 3-38.** Hard Drive and CD-ROM Drive Faceplates



9. Examine Interior Backplane Connectors for each card to be installed.

Use your flashlight to examine the pins of the EOAP backplane connectors for any misalignment, evidence of shorts, or other signs of damage.

**Figure 3-39.** EOAP Backplane Connector Pins



If any of the connectors on the backplane show any damage, discontinue with the upgrade to the dual configuration and contact your Customer Care Center for assistance ( *Customer Care Center* on page 1-10).

You have removed the necessary filler cards and faceplates and examined the interior backplane connectors. Start installing the cards next.

### *Install EOAP Cards and Drives*







Use this procedure to install the EOAP cards required for the dual configuration. Refer to Table 3-12 for a picture of each card to be installed and to Table 3-13 for a list of tools and equipment.

Installation Procedures



**WARNING:** Prior to working on or around live equipment, follow proper ESD grounding procedures to prevent damage to the equipment; reference *ESD Protection Procedure (907-0404-01)*.

Table 3-12. EOAP Cards and Drives

Air Management Card (P/N 870-1524-01)	Power Supply Card (P/N 870-1521-01)	Processor Card (P/N 870-1523-01)	Serial Card (870-1522-01)
			
<p>CD-ROM Drive Card (P/N 870-1515-03)</p>		<p>Hard Drive Card (P/N 870-1514-03)</p>	
			

**Table 3-13.** Tools and Equipment - EOAP Cards and Drives

Check	Tools and Equipment	P/N
	Air Management Card	870-1524-01
	CD-ROM Drive	870-1515-03
	Hard Drive	870-1514-03
	Power supply card	870-1521-01
	Processor card	870-1523-01
	Serial Card	870-1522-01
	Small Phillips head screwdriver	

**Procedure — Install EOAP Cards and Drives**

- 
1. On the right side of the EOAP, locate the installation position of the card to be installed. Refer to Figure 3-35, “Dual EOAP Card Slots and Drive Bays,” on page 3-58 for slot locations. (slots 1 and 2 in EOAP-B).

- 
2. Remove the card from the shipping container. Refer to Table 3-12 for a picture of each card and drive to be installed.

Examine the card including the pins of the rear connector for any signs of damage.

If the card is damaged, discontinue with the installation of this card and contact your Customer Care Center for a replacement (see *Customer Care Center* on page 1-10).

- 
3. Make sure that the four captive screws located in the inject/eject handle brackets are partially backed out so they do not interfere with insertion.
- 
4. Push all handles outward from the replacement card's faceplate (top handle in the “UP” position, bottom handle in the “DOWN” position.)

Figure 3-40. Card Handles



Top handle in the "UP" position

Bottom handle in the "DOWN" position

\* Photo does not represent actual customer configuration. Components for EOAP-B are installed on the right side of the card cage.

- 
5. Carefully align the card's edges with the channels in the top and bottom card guides. Refer to Figure 3-41. Then push the card along the length of card guides until the rear connector on the card begins engaging the mating connector on the backplane.

Figure 3-41. Inserting the Card



Push the card along the length of the card guides until the rear connector on the card begins engaging the mating connector on the backplane.

\* Photo does not represent actual customer configuration. Components for EOAP-B are installed on the right side of the card cage.

- 
6. Press the faceplate of the card using constant pressure until you feel the card's progress cease.

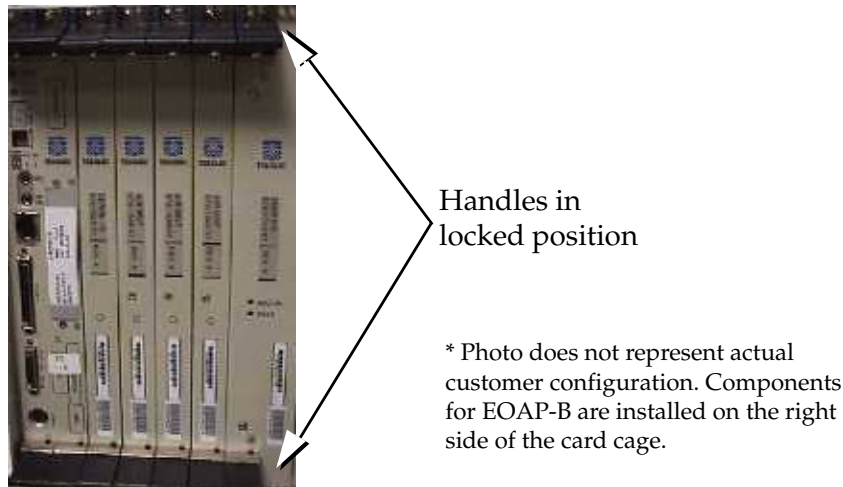


**WARNING:** Do not impact the faceplate in order to mate the two connectors. Any impact to the card's faceplate can damage the faceplate, the pins in the backplane, or the backplane itself.

---

7. Using the thumb and forefinger together, push the top inject/eject handle down and the bottom handle up until both handles are in the locked position. Figures 3-42 shows a close-up of a top inject/eject handle in the locked position.

**Figure 3-42.** Locking the Inject/Eject Handles

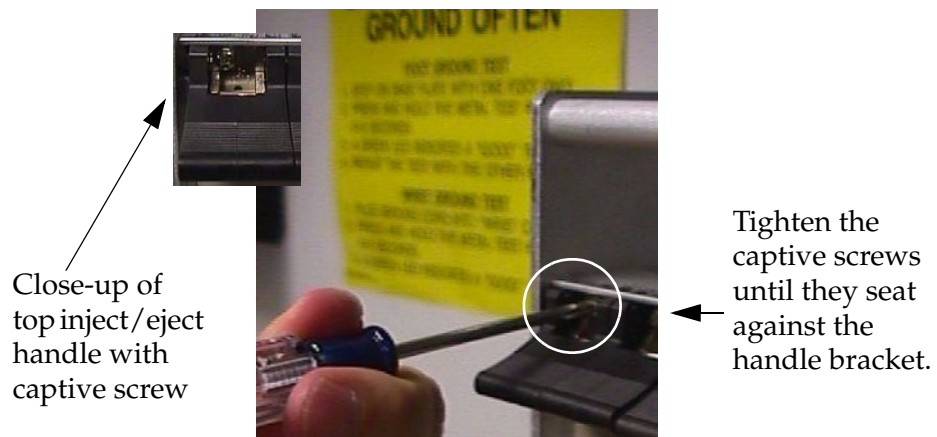


8. Using a small Phillips head screwdriver, tighten all captive screws in the handle brackets until they seat against the handle bracket.



**WARNING:** Do not overtighten the screws as the heads could snap off.

**Figure 3-43.** Tightening Captive Screws



9. Repeat Figures 1 through 8 to install the remaining cards

10. Locate the installation position of the drive to be installed.



## Installation Procedures

11. Remove the drive assembly from the shipping container. Refer to Table 3-12 for a picture of each drive to be installed.

---

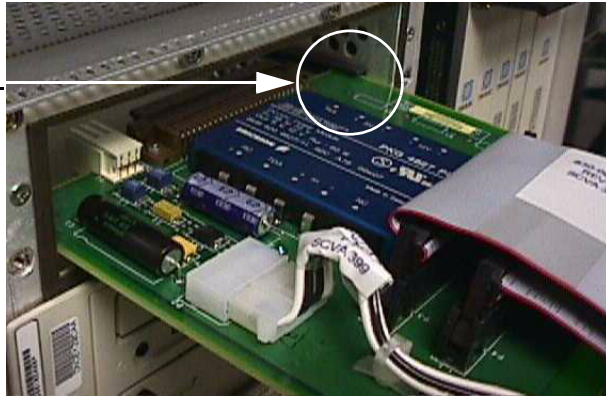
12. Use one hand to support the drive from underneath and the other hand to grasp the faceplate handle.

---

13. While facing the front of the drive bay, carefully insert the card through the proper opening. Align the edges of the card with the channels in the card guides. Then push the assembly until the rear connectors on the drive begin engaging the mated connectors on the backplane. Figures 3-44 shows the insertion of the hard drive.

**Figure 3-44.** Installing a Drive Assembly

Align the edges of the card with the card guides.



14. Press faceplate of assembly using constant pressure until connections are fully seated. Figures 3-45 shows the faceplate of the hard drive.

**Figure 3-45.** Pressing the Faceplate



Press the faceplate near the areas where the handle is in contact with the faceplate.

- Push in each head of the left and right captive screws on the faceplate until the threads make contact with the floating fasteners in the drive bay faceplate. Use your fingers to firmly tighten each screw.



**WARNING:** Do not overtighten the screws as the heads could snap off.

You have now installed the EOAP cards and drives. The hard drive is preloaded with software but must be provisioned at the EAGLE 5 ISS after the EOAP installation is completed. Change the EOAP cabling to a dual configuration next.

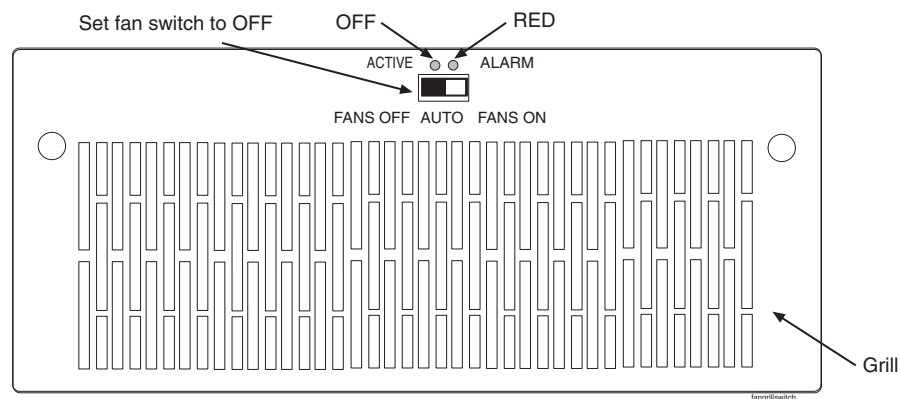
### *Change Cabling from Single to Dual Configuration*

Use this procedure to change the cabling to a dual configuration.

### **Procedure — Change Cabling to Dual Configuration**

- At the EOAP backplane, cut the tie wraps from all cables on the EOAP backplane.
- At the fan assembly, toggle the fan switch on the grill panel to the OFF position. The fan assembly stops running. The Active LED is off and the Alarm LED is red. The Minor LED at the FAP is lit. Other fan assemblies (if installed) are not affected.

**Figure 3-46.** Set Fan Switch to OFF



- At the EAGLE 5 ISS terminal, type in this command:

```
rept-stat-trbl
```

The EAGLE 5 ISS reports the following alarm: 302 COOLING FAN FAILURE.



## Installation Procedures

4. At the rear of the frame, remove the fan B power cable from port FAN B PWR A of the EOAP backplane and connect it to port FAN B PWR B. Secure the connector.
- 

5. At the fan assembly, turn the switch back to the ON position (refer to Figure 3-48). The Active and Alarm LEDs are green. The Minor LED at the FAP goes out. The fan assembly starts running.
- 

6. At the EAGLE 5 ISS terminal, type in this command:

```
rept-stat-trbl
```

The EAGLE 5 ISS reports the following alarm: 303 COOLING FAN NORMAL.

---

7. Connect the clock in/out cable to ports BCLKOUT-A and BCLKIN-B.
- 

8. Attach power cable B P/N 830-0699-xx:

- a. Connect one end to port POWER IN-B.
  - b. Loosely route power cable B from connector POWER IN-B down and across the second tie-down rod. Route the cable to the **left** side of the shelf.
  - c. Route the cable around the side of the shelf along the outside of a traverse arm extender but on the inside of the traverse arm and then to the frame rail. Route the cable up the frame rail to the FAP. Secure the cable with a cable tie near the FAP.
- 

9. Finish power cable B at the FAP. Butt the cable at 1 and 1/2 inch beyond the frame rail. The butted cable exposes three wires, blue, brown, and green with a yellow tracer. Fan out the wires and attach them to the FAP as described next.
- 

10. With P/N 870-2320-03 FAP, prepare the wires and terminate them on each side of the FAP as follows:

- a. Place a terminal ring P/N 502-0040-01 over each wire end and fasten it with a crimping tool.
- b. Use a small straight or Phillips screw driver and remove the terminal screw from the RETURN (RTN) terminal strip. Center the terminal ring of the **blue wire** over the screw hole in the terminal strip. Reinsert the screw and tighten it.
- c. Remove the terminal screw from the -48V terminal strip. Center the terminal ring of the **brown wire** over the screw hole in the terminal strip. Reinsert the screw and tighten it.

- d. Remove the terminal screw from the CHASSIS GROUND terminal strip. Center the terminal ring of the **green wire** over the screw hole in the terminal strip. Reinsert the screw and tighten it.

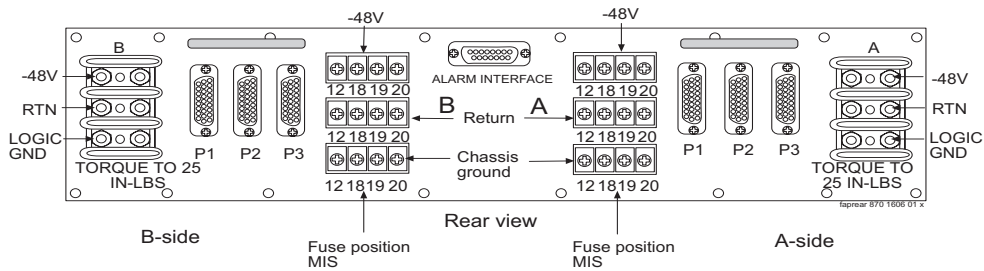


**WARNING: Do not overtighten the screws as the heads could snap off.**

Figure 3-47 shows the rear layout of the FAP P/N 870-2320-03.

**NOTE: Form the wires together to their proper location and then break them out of the form.**

**Figure 3-47. Fuse and Alarm Panel P/N 870-2320-03, Rear View**



**Table 3-14. Fuse Panel Items and Description**

Fuse Panel Item	Description
Input Terminal Block A	Input for power source A
Input Terminal Block B	Input for power source B
-48VDC and Return Outputs A	26-pin "D" connectors, P1, P2, and P3 for A-side outputs.
-48VDC and Return Outputs B	26-pin "D" connectors, P1, P2, and P3 for B-side outputs.
Alarm Panel	15-pin "D" connector for external alarms

11. Remove the existing MMI-X cables P/N 830-0708-xx:
    - a. Remove the B cable from port 3A and reconnect it to port 3B.
    - b. Remove the A cable from port 4A and reconnect it to port 3A.
- 
12. Connect the modem/terminal cables to the EOAP-B backplane:
    - a. Connect one end of terminal cable P/N 830-0709-xx to port 1B on the EOAP backplane; attach the converter P/N 804-0176-01 to the other end of this cable, and then attach terminal cable P/N 830-0528-xx to the converter. This extended cable will attach to the COM 3 port of the VT-520 display unit connected to the EOAP.

## Installation Procedures

- b. Connect one end of the dial-up modem B cable P/N 830-0709-xx to port 2B.
  - c. Remove the existing X.25 modem B cable from port 6A and reconnect it to port 5B.
- 

**13.** Tighten all modem/terminal cable connectors to the EOAP.

---

**14.** Route all new cables (except power cable B) down to the bottom tie down rod and across the rod to the right side of the EOAP backplane. Use cable ties to secure the cables to the tie down rod every three to four inches.

---

**15.** Wrap the cables with fiber paper at the point they are routed around the edge of the EOAP shelf toward the frame rails.

---

**16.** Route the cables up the frame rail onto the cable rack and from there to each of their destinations. Form and dress the cables using cable ties to secure the cables to the frame rail and the traverse arms every three to four inches.

---

**17.** Tighten all connectors at their destination.

---

**18.** At the front of the EOAP, locate the Ethernet port on the processor card. Insert the Ethernet cable.

---

You have completed the cabling for the dual configuration. Power up EOAP-B next. Refer to Procedure *Power Up EOAP* on page 3-70.

EOAP Power-Up



**WARNING:** The EOAP and the same-side fan tray use the same fuse. When the EOAP is powered up, the same-side fan tray also receives power. Take proper care to avoid injury or equipment damage near the fan blades.



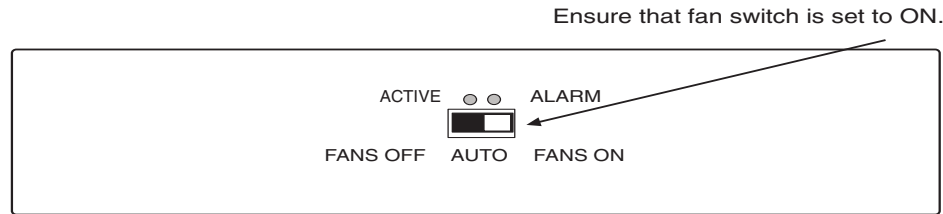
**WARNING:** The EOAP can operate without failure or component damage for up to one hour without the fan tray providing cooling. After powering up the EOAP, complete fan testing within this time frame.

Procedure — Power Up EOAP

---

1. Make sure the switch on the front of the fan assembly is set to ON.

Figure 3-48. Fan Switch Set to ON.



2. At the FAP, insert one EOAP/fan assembly fuse for the B side of the EOAP.



**WARNING:** Make sure you know exactly which fuses to insert. Reference the fuse card on the front of the FAP.

FAP (P/N 870-2320-03) offers four fuse positions on each side: 17A through 20A and 17B through 20B.

The EOAP requires 10A fuses (P/N 517-0012-01) in the FAP for both A and B feeds of the EOAP.

3. At the EAGLE 5 ISS terminal, the following message displays: powered up and the machine boots. The fans start running.

---

EOAP-B and the fan assembly are now powered up. Test the fan operation next. Refer to procedure *Fan Operation Testing* on page 3-71

## Fan Operation Testing

Use this procedure to test the fan operation at the EAGLE 5 ISS terminal and to ensure that the fan alarm is functioning.

**NOTE:** For more information on the commands used in this procedure, refer to the *Eagle Commands Manual*.

### Procedure — Test Fan Operation

---

1. At the EAGLE 5 ISS terminal, retrieve the feature options to ensure that the fan feature is turned on.

**rtrv-feat**

**NOTE:** Once you have turned on the feature, you cannot turn it off. The feature applies to any and all fans installed within the system. When replacing a fan assembly, the feature should already be turned on.

The output displays a list of optional features and their status on the system:

```
rlghncxa03w 00-06-07 00:57:31 EST Rel 26.0.0
EAGLE FEATURE LIST

GTT      = on      GWS      = on      NRT      = off
X25G     = on      LAN      = on      CRMD     = off
SEAS     = on      LFS      = off    MTPRS    = off
LNP      = on      FAN    = on    DSTN4000 = off
WNP      = off    CNCF     = on      LNP12MIL = off
TLNP     = off    SCCPCNV  = off    TCAPCNV  = off
X252000  = off    PLNP     = off    NCR      = off
ITUMTPRS = off    SLSOCB   = on      EGTT     = off
```

---

2. Enable the feature if necessary by entering the following command:

**chg-feat:fan=on**

where: **fan** is the parameter for turning on the fan feature.

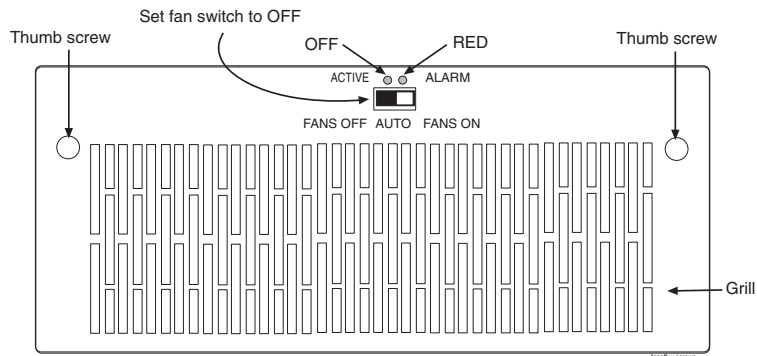
After the program updates, the system returns output similar to the following:

```
RLGHNCXA03W 00-06-11 11:34:04 EST Rel 26.0.0
CHG-FEAT: MASP A - COMPLD
```

---

- At the fan assembly, toggle the fan switch on the grill panel to the OFF position. The fan assembly stops running. The Active LED is off and the Alarm LED is red. The Minor LED at the FAP is lit. Other fan assemblies (if installed) are not affected.

**Figure 3-49.** Set Fan Switch to OFF



- At the EAGLE 5 ISS terminal, type in this command:

```
rept-stat-trbl
```

The EAGLE 5 ISS reports the following alarm: 302 COOLING FAN FAILURE.

- At the fan assembly, turn the switch back to the ON position (refer to Figure 3-48). The Active and Alarm LEDs are green. The Minor LED at the FAP goes out. The fan assembly starts running.
- At the EAGLE 5 ISS terminal, type in this command:
 

```
rept-stat-trbl
```

 The EAGLE 5 ISS reports the following alarm: 303 COOLING FAN NORMAL.
- With a flashlight, check that all fans are running. Remove the grill and filter from the fan assembly by removing the two thumb screws from the grill faceplate (see Figure 3-49). Temporarily store all in a safe place. Visually check the movement of the fans.
- Replace the fan filter by setting it against the front of the fan assembly.
 

**NOTE: Point the air flow arrows stamped on top and bottom edge of the filter towards the fan assembly.**
- Replace the fan grill by placing it back over the filter on the front of the assembly. Hand-tighten the thumb screws.

10. At the rear of the frame, remove the A power cable from the A fan assembly. Both fan LEDs are off. The Minor LED at the FAP is lit. The fans for EOAP-A stop running. Other fan assemblies (if installed) are not affected.
- 

11. At the EAGLE 5 ISS terminal, type in this command:

```
rept-stat-trbl
```

The EAGLE 5 ISS reports the following alarm: 302 COOLING FAN FAILURE.

---

12. Replace the A power cable on the rear of the fan assembly and secure the connector. The Active and Alarm LEDs are green. The Minor LED at the FAP goes out. The A fans start running.
- 

13. At the EAGLE 5 ISS terminal, type in this command:

```
rept-stat-trbl
```

The EAGLE 5 ISS reports the following alarm: 303 COOLING FAN NORMAL.

For a single-configuration EOAP, this procedure is completed.

For a dual-configuration EOAP, continue with Step 14.

---

14. At the rear of the frame, remove the B power cable from the B fan assembly. Both fan LEDs are off. The Minor LED at the FAP is lit. The fans for EOAP-B stop running. Other fan assemblies (if installed) are not affected.
- 

15. At the EAGLE 5 ISS terminal, type in this command:

```
rept-stat-trbl
```

The EAGLE 5 ISS reports the following alarm: 302 COOLING FAN FAILURE.

---

16. Replace the B power cable on the rear of the fan assembly and secure the connector. The Active and Alarm LEDs are green. The Minor LED at the FAP goes out. The B fans start running.
- 

17. At the EAGLE 5 ISS terminal, type in this command:

```
rept-stat-trbl
```

The EAGLE 5 ISS reports the following alarm: 303 COOLING FAN NORMAL.

---

You have tested the operation of the fan assembly and the fan alarm.

## Maintenance Modem Setup

Use the following procedure to set up the maintenance modem.



### WARNING: Solaris Console Port Break Issue

A terminal or modem connected to the EOAP serial port and acting as the system console can halt the operating system (bring it to the `ok` prompt) if you turn off or unplug the terminal, or unplug the modem or drop the connection. When the system is halted in this manner, it must be manually booted from the `ok` prompt to resume operation.

This problem affects all EOAPs running Solaris 2.5.1. The problem is most often encountered when Tekelec support personnel use a modem to dial into the customer's system.

### Solution

After the modem connection has been dropped or the terminal has been disconnected, use the EAGLE 5 ISS console to issue a reboot command to the EOAP.

## Procedure — Set Up Maintenance Modem

---



**CAUTION:** The EOAP's open system architecture allows access to the operating system. Any undocumented changes to the files may cause the system to become corrupted and unusable. Making any undocumented changes on the EOAP, including changes to the hardware, operating system and/or the components found therein will void the warranty.

1. Verify that the modem port is configured correctly:

Console login: **root**

Password: **xxxxxx**

**NOTE:** See Customer Care Center for the password for your equipment.

```
# pmadm -l
```

The system returns output similar to the following; the last line (**bold**) indicates the port to be used with the maintenance modem:

```
ttymon0      ttymon      0          ux  root      /dev/term/0 - -
/usr/bin/login - 9600 - login: - - - #/dev/term/0
ttymon0      ttymon      1          ux  root      /dev/term/1 - -
/usr/bin/login - 9600 - login: - - - #/dev/term/1
ttymon0      ttymon      2          ux  root      /dev/term/2 - -
/usr/bin/login - 9600 - login: - - - #/dev/term/2
ttymon0      ttymon      4          ux  root      /dev/term/4 - -
/usr/bin/login - 9600 - login: - - - #/dev/term/4
zsmon       ttymon      ttya       u   root      /dev/term/a I -
/usr/bin/login - 9600 ldterm,ttcompat ttya login: - tvi925 y #
zsmon       ttymon      ttyb       u   root      /dev/term/b I -
/usr/bin/login - 9600 ldterm,ttcompat ttyb login: - tvi925 y #
```



## Installation Procedures

```
zsmon          ttymon          3          u    root    /dev/term/3 - -  
/usr/bin/login - 9600E ldterm,ttcompat login: - 3 n #
```

**NOTE:** The command output shows this format if the line wrap option is set. You can set the line wrap option through the Setup menu.

If no login prompt appears, try each of the following:

- a. Press return several times.
- b. Switch the maintenance modem from Artecon port 3 to 2 or vice-versa.
- c. Cycle power on the maintenance modem.

If the login prompt appears in all CAPITAL letters, press <CTRL-D> at the prompt.

- 
2. Verify that both the calling and receiving modems are turned on and plugged into a working telephone jack.
- 
3. Configure the calling modem and the communication software for 9600 baud, 7 data bits, even parity, and 1 stop bit (7-E-1).
- 
4. Verify that the maintenance modem is capable of supporting the communication parameters shown in Step 3.
- 
5. Set the maintenance modem to "Auto Answer"
- 
6. Plug the maintenance modem into Artecon port 3.
- 
7. Verify that the maintenance modem answers the call and the modems attempt to establish communication.
-



# 4

## EOAP Provisioning Procedures

Overview .....	4-2
Initial Implementation .....	4-4
Configuring the OAP Port at the EAGLE 5 ISS .....	4-4
Configuring the OAP from the EAGLE 5 ISS Terminal.....	4-11
Reprovisioning.....	4-27
Changing the OAP Configuration from the EAGLE 5 SAS Terminal.....	4-27
VI Editor Quick Reference.....	4-39

## Overview

This chapter describes initial implementation of the Embedded Operations System Support Applications Processor (EOAP) and the configuration of the EAGLE 5 ISS to support either the EOAP or the Texas Micro OAP. Perform these procedures after the EOAP shelf or the Texas Micro OAP has been powered up.

**NOTE 1:** Throughout this appendix, the term EOAP is used only when referring to the specific EOAP hardware platform. The term OAP is used when referring to the functions performed by either the EOAP hardware or the Texas Micro OAP or when referring to either type of OAP.

**NOTE 2:** Perform all procedures logged in as “root” unless specified otherwise.

**NOTE 3:** In the event of a failure, repeat the section in which the failure occurred. If the failure re-occurs, contact technical services for assistance.

**NOTE 4:** Some of the following steps require use of function keys. To press function keys on a VT-520 terminal, type <Esc> plus the number or use the corresponding PF key. For example, to press function key F2, type <Esc>-2 or press the PF2 key. A quick reference guide to *vi* text editor commands is provided on page 4-39.

OAPs are named and addressed according to their MMI port number on the EAGLE 5 ISS backplane. OAP-A can use any MMI port, as long as OAP-B is assigned to a higher-numbered MMI port. The **act-oap-config** command will send the configuration information to the corresponding OAP. Depending on the differences in configuration, outages are possible.

On the EOAP hardware platform, when facing the front of the EOAP chassis, OAP-A is on the left side and OAP-B the right side. For the Texas Micro OAP, the designation of OAP A and OAP-B is solely dependent of the MMI port they are connected to.

If the host name, IP address, or net mask of the OAPs needs to be modified, configure the OAPs one by one. Always modify EOAP-A first. When these parameters are modified, the OAP needs to be rebooted to utilize the new data. Rebooting might take up to 10 minutes and the connection to SEAS will be lost during this time.

If for any reason, the EAGLE 5 ISS fails to deliver the OAP configuration to an OAP, or an OAP fails to utilize it, the OAP may be configured incorrectly or the OAP might be receiving bad data. This condition will be detected but not automatically corrected. The EAGLE 5 ISS will generate an alarm within 10 seconds of any mismatch in EAGLE 5 ISS and OAP databases. When the databases are back in synchronization, the EAGLE 5 ISS will clear the alarm within 5 seconds. Note that there can be two alarms raised, one for each OAP.

## EOAP Provisioning Procedures

### Tools and Equipment

The following tools and equipment are required for provisioning the EOAP for the first time:

- VT-520 display unit(s) or equivalent:
  - connected to EOAP-A and EOAP-B
  - connected to EAGLE 5 ISS.
- System information sheet for each EOAP containing:
  - system's hostname
  - customer's network IP address.
- Any of the following general information that is applicable to the customer's system:
  - customer's subnet netmask
  - customer's network default router IP address
  - number of configured EOAPs (single or dual)
  - SEAC common language location identifier (SEACCLLI)
  - X.25 packet size (7 or 8)
  - X.25 mode (DCE or DTE).

## Initial Implementation

To configure the EOAP, perform these procedures:

1. The OAP Upgrade procedure to perform initial EOAP configuration.
2. “Configuring the OAP Port at the EAGLE 5 ISS” procedure on page 4-4
3. “Configuring the OAP from the EAGLE 5 ISS Terminal” procedure on page 4-11.

### Configuring the OAP Port at the EAGLE 5 ISS

Use this procedure to configure the ports on the Terminal Disk Module (TDM) that are used to provide the links to the Embedded Operations System Support Applications Processor (EOAP) or the Texas Micro OAP for the SEAS feature using the **chg-trm** command.

The **chg-trm** command uses these parameters:

**:trm** – Serial port number

**:type** – The type of device being connected (**type=oap**).

To configure the OAP port, the SEAS feature must be on. If the SEAS feature is on, the entry **SEAS = on** is shown in the **rtrv-feat** command output. If the SEAS feature is off, enter the **chg-feat:seas=on** command to turn the SEAS feature on.

**NOTE:** Once the SEAS feature is turned on with the **chg-feat** command, it cannot be turned off.

**Before executing this procedure, make sure you have purchased the SEAS feature. If you are not sure if you have purchased the SEAS feature, contact your Tekelec Sales Representative or Account Representative.**

Only one OAP is required for the SEAS feature, but two OAPs can be configured for the SEAS feature. The EAGLE 5 ISS can have a maximum of two OAPs.

When the **type=oap** parameter is specified with the **chg-trm** command, none of the communication attribute parameters, **baud** (the baud rate of the terminal port), **prty** (the parity of the terminal port), **sb** (the number of stop bits for the terminal port’s RS-232 connection), and **fc** (the type of flow control for the terminal port’s RS-232 connection), can be specified. These parameters are defaulted to these values:

```

baud = 19200      sb = 1
prty = even      fc = sw

```

The **chg-trm** command contains other optional parameters that can be used when configuring an OAP port. These parameters are not shown here because they are not required for configuring an OAP port. These parameters are explained in more detail in the **chg-trm** command descriptions in the *Commands Manual*.

The total value of the terminals' baud rate cannot be greater than 172,032. If the total baud rate of the terminals (including the two OAP ports) exceeds 172,032, go to the **chg-trm** command descriptions in the *Commands Manual* and change the baud rates of the other terminals so that the total baud rate is not greater than 172,032.

The EAGLE 5 ISS requires at least two terminals assigned to the Security Administration command class. The terminal type of a terminal assigned to the Security Administration command class cannot be changed to the OAP terminal type (**type=oap**), if the change would leave the EAGLE 5 ISS with only one terminal assigned to the Security Administration command class. The command class assignments of the terminal are shown with the **rtrv-secu-trm** command. If the terminal type is being changed to **oap**, go to the **chg-trm** command descriptions in the *Commands Manual* and make sure that the command class assignment for the terminal port being changed does not have the Security Administration command class assigned to it, or change the command class assignment of another terminal to include the Security Administration command class.

### Procedure

---

1. Verify that the SEAS feature is on (**SEAS=on**) using the **rtrv-feat** command.

**NOTE:** The **rtrv-feat** command output contains other fields that are not used by this procedure. If you wish to see all the fields displayed by the **rtrv-feat** command, see the **rtrv-feat** command description in the *Commands Manual*.

---

2. Turn the SEAS feature on by entering this command.

**chg-feat:seas=on**

**NOTE:** Once the SEAS feature is turned on with the **chg-feat** command, it cannot be turned off.

**The SEAS feature must be purchased before you turn the feature on with the **chg-feat** command. If you are not sure if you have purchased the SEAS feature, contact your Tekelec Sales Representative or Account Representative.**

When this command has successfully completed, this message should appear.

```
rlghncxa03w 05-09-01 15:08:45 GMT EAGLE5 34.0.0
```

CHG-FEAT: MASP A - COMPLD

3. Display the values of all terminals using the **rtrv-trm** command. This is an example of the possible output:

```
rlghncxa03w 05-09-01 00:57:31 GMT EAGLE5 34.0.0
TRM  TYPE      COMM          FC      TMOUT  MXINV  DURAL
1    VT320     9600-7-E-1 SW      60      5      99:59:59
2    KSR       9600-7-E-1 HW      30      5      INDEF
3    KSR       9600-7-E-1 SW      60      0      00:00:00
4    VT320     2400-7-E-1 BOTH    60      5      00:30:00
5    VT320     9600-7-O-1 NONE    30      5      00:00:30
6    VT320     9600-7-E-2 SW      30      9      INDEF
7    PRINTER   9600-7-N-2 HW      30      5      00:30:00
8    KSR       19200-7-E-2 BOTH   30      5      00:30:00
9    VT320     9600-7-E-1 SW      30      7      00:30:00
10   VT320     9600-7-E-1 HW      30      5      00:30:00
11   VT320     4800-7-E-1 HW      30      5      00:30:00
12   PRINTER   9600-7-E-1 HW      30      4      00:30:00
13   VT320     9600-7-O-1 NONE    30      5      00:30:00
14   VT320     4800-7-E-2 SW      30      8      00:30:00
15   VT320     9600-7-N-2 HW      30      5      00:30:00
16   VT320     9600-7-E-2 BOTH    30      3      00:30:00
```

```
TRM  TRAF LINK SA  SYS PU  DB  UIMRD
1    NO  YES  NO  YES NO  YES YES
2    NO  NO  NO  NO  NO  NO  NO
3    YES YES  YES YES YES YES YES
4    YES NO  NO  NO  NO  NO  NO
5    NO  YES NO  NO  NO  NO  YES
6    NO  NO  YES NO  NO  NO  NO
7    YES YES  YES YES YES YES YES
8    NO  NO  NO  NO  YES NO  NO
9    NO  YES NO  NO  NO  YES YES
10   NO  NO  NO  NO  NO  YES NO
11   YES YES  YES YES YES YES YES
12   YES YES  YES YES YES YES NO
13   NO  YES NO  NO  NO  NO  YES
14   NO  NO  YES NO  NO  NO  NO
15   YES YES  YES NO  YES YES YES
16   NO  NO  NO  NO  YES NO  NO
```

```
APP  APP
TRM  SERV SS  CARD CLK DBG GTT GWS MEAS MON MPS SEAS SLAN
1    YES YES YES YES YES YES YES YES YES YES YES NO  NO
2    YES YES YES YES YES YES YES YES YES YES YES NO  NO
3    YES YES YES YES YES YES YES YES YES YES YES NO  NO
4    YES YES YES YES YES NO  YES YES YES YES YES NO  NO
5    YES YES YES YES YES YES YES YES YES YES YES NO  NO
6    YES YES YES YES YES YES YES YES YES YES YES NO  NO
7    NO  YES YES YES YES YES YES YES YES YES YES YES NO  NO
8    YES YES YES YES YES YES YES YES YES YES YES YES YES
9    YES YES YES YES YES YES YES YES YES YES YES YES YES
10   YES YES YES YES YES YES YES YES YES YES YES YES YES
11   NO  NO  NO  NO  NO  NO  NO  NO  NO  NO  NO  NO  NO
12   NO  NO  NO  NO  NO  NO  NO  NO  NO  NO  NO  NO  NO
13   NO  NO  NO  NO  NO  NO  NO  NO  NO  NO  NO  NO  NO
14   NO  NO  NO  NO  NO  NO  NO  NO  NO  NO  NO  NO  NO
15   NO  NO  NO  NO  NO  NO  NO  NO  NO  NO  NO  NO  NO
16   NO  NO  NO  NO  NO  NO  NO  NO  NO  NO  NO  NO  NO
```



The first part of the output displays the communication security attributes of the terminal port. The communication attributes of the terminal port, **BAUD**, **PRTY** (parity), **SB** (stop bits), and **DBTS** (data bits), are displayed in the **COMM** field of the **rtrv-trm** output and are displayed in this format: **BAUD-DBTS-PRTY-SB**. The second part of the **rtrv-trm** command output displays the types of unsolicited messages the terminal port may receive.

---

4. Place the terminal you wish to change out of service using the **rmv-trm** command and specifying the ports you wish to place out of service. For the configuration example of this procedure, enter these commands:

```
rmv-trm:trm=4  
rmv-trm:trm=10
```

After successful completion of each command, the EAGLE 5 ISS returns the following output:

```
rlghncxa03w 05-09-01 00:57:31 GMT EAGLE5 34.0.0  
Inhibit message sent to terminal  
  
rlghncxa03w 05-09-01 00:57:31 GMT EAGLE5 34.0.0  
Command Completed.
```

---

5. Verify that the terminal that was placed out of service in step 4 is in the **OOS-MT-DSBLD** state by entering the **rept-stat-trm** command. This is an example of the possible output:

```
rlghncxa03w 05-09-01 00:57:31 GMT EAGLE5 34.0.0  
TRM   PST           SST           AST  
1     IS-NR          Active       -----  
2     IS-NR          Active       -----  
3     IS-NR          Active       -----  
4     OOS-MT-DSBLD  Manual      -----  
5     IS-NR          Active       -----  
6     IS-NR          Active       -----  
7     IS-NR          Active       -----  
8     IS-NR          Active       -----  
9     IS-NR          Active       -----  
10    OOS-MT-DSBLD  Manual      -----  
11    IS-NR          Active       -----  
12    IS-NR          Active       -----  
13    IS-NR          Active       -----  
14    IS-NR          Active       -----  
15    IS-NR          Active       -----  
16    IS-NR          Active       -----  
Command Completed.
```

---

6. Display the command class values of all terminals using the **rtrv-secu-trm** command. This is an example of the possible output.

```
rlghncxa03w 05-09-01 12:31:04 GMT EAGLE5 34.0.0
TRM    LINK SA  SYS  PU   DB   DBG
1      NO  NO  YES  NO   YES  NO
2      NO  NO  NO   NO   YES  NO
3      YES ***  YES  YES  YES  YES
4      NO  YES NO   NO   NO   NO
5      YES NO  NO   NO   YES  YES
6      NO  YES NO   NO   NO   NO
7      NO  ***  YES  NO   YES  NO
8      NO  NO  NO   NO   NO   NO
9      YES YES  YES  YES  YES  YES
10     NO  NO  NO   NO   NO   NO
11     YES NO  YES  NO   YES  YES
12     NO  ***  NO   NO   NO   NO
13     NO  NO  NO   NO   YES  YES
14     NO  YES NO   NO   YES  YES
15     NO  NO  NO   NO   YES  YES
16     NO  NO  NO   NO   YES  YES
```

**NOTE:** If the terminal type is being changed to either **printer** or **none**, make sure the EAGLE 5 ISS has at least two terminals assigned to the Security Administration command class (shown in the SA column in the **rtrv-secu-trm** output). If the terminal being changed in this procedure is being removed from the Security Administration command class, and if this change would leave the EAGLE 5 ISS with only one terminal assigned to the Security Administration command class, go to the **chg-secu-trm** command description in the *Commands Manual* and change the command class assignment of another terminal to include the Security Administration command class.

7. Change the terminal characteristics using the **chg-trm** command. For this example enter these commands:

```
chg-trm:trm=4:type=oap:all=no
```

```
chg-trm:trm=10:type=oap:all=no
```

**NOTE:** All terminal output group parameters must be set to **NO** for OAP terminals

After successful completion of each command, the EAGLE 5 ISS returns the following output:

```
rlghncxa03w 05-09-01 00:57:31 GMT EAGLE5 34.0.0
CHG-TRM: MASP A - COMPLTD
```

## EOAP Provisioning Procedures

- Verify the changes made in step 7 by using the **rtrv-trm** command with the port number specified in step 7. Enter these commands:

```
rtrv-trm:trm=4
```

```
rtrv-trm:trm=10
```

These are examples of the possible output:

```
rtrv-trm:trm=4
```

```
rlghncxa03w 05-09-01 00:57:31 GMT EAGLE5 34.0.0
TRM  TYPE      COMM          FC      TMOUT  MXINV  DURAL
4    OAP      19200-7-E-1 SW      30      5      00:30:00
```

```
TRM  TRAF LINK SA  SYS PU  DB  UIMRD
4    NO  NO  NO  NO  NO  NO  NO
```

```
APP  APP
```

```
TRM  SERV SS  CARD CLK  DBG  GTT  GWS  MEAS  MON  MPS  SEAS  SLAN
4    NO  NO  NO  NO  NO  NO  NO  NO  NO  NO  NO  NO
```

```
rtrv-trm:trm=10
```

```
rlghncxa03w 05-09-01 00:57:31 GMT EAGLE5 34.0.0
TRM  TYPE      COMM          FC      TMOUT  MXINV  DURAL
10   OAP      19200-7-E-1 SW      30      5      00:30:00
```

```
TRM  TRAF LINK SA  SYS PU  DB  UIMRD
10   NO  NO  NO  NO  NO  NO  NO
```

```
APP  APP
```

```
TRM  SERV SS  CARD CLK  DBG  GTT  GWS  MEAS  MON  MPS  SEAS  SLAN
10   NO  NO  NO  NO  NO  NO  NO  NO  NO  NO  NO  NO
```

- Return the terminals to service that were taken out of service in step 4 using the **rst-trm** command. For this example, enter these commands:

```
rst-trm:trm=4
```

```
rst-trm:trm=10
```

After successful completion of each command, the EAGLE 5 ISS returns the following output:

```
rlghncxa03w 05-09-01 00:57:31 GMT EAGLE5 34.0.0
Allow message sent to terminal
```

```
rlghncxa03w 05-09-01 00:57:31 GMT EAGLE5 34.0.0
Command Completed.
```

- Back up the changes using the **chg-db:action=backup:dest=fixed** command. The following messages appear; the active Maintenance and Administration Subsystem Processor (MASP) message appears first:

```
BACKUP (FIXED) : MASP A - Backup starts on active MASP.
```

```
BACKUP (FIXED) : MASP A - Backup on active MASP to fixed disk
complete.
```

## EOAP Provisioning Procedures

BACKUP (FIXED) : MASP A - Backup starts on standby MASP.  
BACKUP (FIXED) : MASP A - Backup on standby MASP to fixed disk  
complete.

---

### Configuring the OAP from the EAGLE 5 ISS Terminal

This procedure is used to configure the OAP for the SEAS feature using these commands:

- **chg-oap-config**
- **act-oap-config**

**NOTE:** These commands enable you to configure the OAP from the EAGLE 5 ISS terminal. After the initial configuration is performed, you should no longer perform OAP configuration from a terminal directly connected to the OAP.

This procedure can be used to configure the Texas Micro OAPs or the Embedded OAPs (EOAPs). This procedure cannot be used to upgrade the EOAP software. Upgrading the EOAP software is covered in the EOAP Upgrade Procedures in the *Release Documentation* manual and is beyond the scope of this procedure.

### Configuring the EAGLE 5 ISS Database

Use the **chg-oap-config** command to configure the database with the OAP configuration information. The EAGLE 5 ISS updates the OAP by sending the information to the specified OAP with the **act-oap-config** command.

The **chg-oap-config** command uses these parameters:

**:aname** – The name assigned to OAP A consisting of one alphabetic character followed by 1 to 13 alphanumeric characters. The value of the **aname** parameter must be enclosed in double quotes.

**:bname** – The name assigned to OAP B consisting of one alphabetic character followed by 1 to 13 alphanumeric characters. The value of the **bname** parameter must be enclosed in double quotes.

**:aipaddr** – The IP address of OAP-A

**:bipaddr** – The IP address of OAP-B

**:anmask** – The netmask of OAP-A

**:bnmask** – The netmask of OAP-B

**:arouter** – The IP address of the default router assigned to OAP-A

**:brouter** – The IP address of the default router assigned to OAP-B

**:cfg** – The number of OAPs being configured, either a single OAP (**sng1**) or both OAPs (**dua1**).

**:seacc11i** – The common language location identifier (CLLI) of the SEAC the OAP is connecting to.

**:x25ps** – The X.25 package size for the link to the SEAC, either **7** or **8**.

**:x25mode** – The mode of the X.25 link to the SEAC, either **DCE** or **DTE**.

**NOTE:** The **chg-oap-config** command allows you to change the parameters one at a time or several at a time (in no specific order).

Refer to the *EAGLE 5 SAS Commands Manual* for additional information on the **chg-oap-config** command.

### Updating the OAP



**CAUTION:** Before an OAP can be updated with the **act-oap-config** command, the OAP configuration data must be configured in the database as shown in Table 4-3 on page 4-15 or the specified OAP may lose SEAS connectivity.

Use the **act-oap-config** command to update the OAPs with the configuration data entered into the database.

The **act-oap-config** command uses these parameters:

**:oap** – The OAP being updated, OAP A (**a**), OAP B (**b**), or both OAPs (**all**). Because the **act-oap-config** command may take the OAP out of service, it is highly recommended that only one OAP be updated at a time (so do not use the **oap=all** parameter). A more detailed explanation of this recommendation is given below. If only a single OAP was specified with the **cfg=sngl** parameter of **chg-oap-config** command, the **oap=all** only updates OAP A.

**:force** – Force the EAGLE 5 ISS to update only one OAP in a dual configuration, **yes** or **no**.

Refer to the *EAGLE 5 SAS Commands Manual* for additional information on the **act-oap-config** command.

OAPs are named and addressed according to their MMI port number on the EAGLE 5 ISS backplane. OAP-A can use any MMI port, as long as OAP-B is assigned to a higher-numbered terminal port. The **act-oap-config** command will send the configuration information to the corresponding OAP. Depending on the differences in configuration, outages are possible.

On the EOAP hardware platform, when facing the front of the EOAP chassis, OAP-A is on the left side and OAP-B the right side. For the Texas Micro OAP, the designation of OAP A and OAP-B is solely dependent of the terminal port they are connected to.

When the OAPs are updated with the **act-oap-config** command, the configuration data for OAP A, as configured by the **chg-oap-config** command, is delivered to OAP B and the configuration data for OAP B is delivered to OAP A. Depending on how the OAPs are configured in the database, this can present problems for the OAPs including both OAPs going out of service because the configuration information for the OAPs is not correct. Update only one OAP at a time.

## EOAP Provisioning Procedures

In addition, although the **act-oap-config** command completes immediately, processing on the OAP may take over 10 minutes depending on which parameters changed and which OAP hardware is installed. Also, whenever parameters are changed, the OAP reboots to use the new data. The reboot interrupts the connection between that OAP and the SEAC. By updating only one OAP at a time, the EAGLE 5 ISS and the SEAC will not be isolated, as one OAP is always connected to the SEAC. Table 4-1 shows the action and approximate completion time that you can expect after updating a group of OAP parameters. You do not need to perform the actions manually; they are all automatic when the **act-oap-config** command is executed.

**Table 4-1.** Performance Impact of **act-oap-config** Parameters

Configured Parameter Group	OAP Action				Total Time Required (in seconds)
	Restart SEAS Links	Bring Down, Rebuild, Bring Up SEAS Links	Bring Down SEAS Links; Reboot OAP	Bring Down and Rebuild SEAS Links; Reboot OAP	
Group A <b>x25ps, x25mode</b>	X				≤ 260
Group B <b>c11i, seacc11i</b>		X			≤ 320
Group C <b>aname/bname aipaddr/bipaddr anmask, bnmask arouter/brouter</b>			X		≤ 560
Group A, and B		X			≤ 320
Group A, and C			X		≤ 560
Groups B, and C		X	X		≤ 620
Group A and B		X			≤ 320
Group A and C		X	X		≤ 620
Group A, B, and C		X	X		≤ 620
Groups B and C				X	≤ 620

Before the **oap=a**, **oap=b**, or **oap=all** parameters are specified using the **act-oap-config** command, the link from the EAGLE 5 ISS to the specified OAP must be in service. The status of the terminal ports assigned to the OAP terminal type can be verified with the **rept-stat-trm** command. The entry **IS-NR** (in-service normal) must appear in the **PST** field of the **rept-stat-trm** command output for the **act-oap-config** command to be successfully executed.

The **force=yes** parameter must be specified with the **oap=a** or **oap=b** parameters.

## OAP Checksums and Alarms

The **chg-oap-config** command allows you to enter one or several parameters at a time. If the required information for a feature has already been configured in the database, you do not have to re-enter all the parameters for that feature when you make a change. It is mandatory, however, that the configuration data in the EAGLE 5 ISS database and the OAP database match.

Table 4-2 shows the fields of the **rtrv-oap-config** command output that must be configured. Table 4-2 also shows the parameters of the **chg-oap-config** command that are used to configure the OAP configuration data.

**Table 4-2.** Fields Displayed for the **RTRV-OAP-CONFIG** Command

Fields Displayed	Required Entry before Configuration can be sent to the OAP	CHG-OAP-CONFIG Parameter
SEAC CLLI	An entry is required.	<b>seacc11i</b>
X25 Packet Size	An entry is required.	<b>x25ps</b>
X25 Mode	An entry is required.	<b>x25mode</b>
Hostname	An entry is required.	<b>aname</b> and <b>bname</b>
IP Address	An entry may be required depending on the network configuration.	<b>aipaddr</b> and <b>bipaddr</b>
IP Netmask	An entry may be required depending on the network configuration.	<b>anmask</b> and <b>bnmask</b>
Default Router	An entry may be required depending on the network configuration.	<b>arouter</b> and <b>brouter</b>
Config	An entry is required.	<b>cfg</b>

The CLLI of the EAGLE 5 ISS - configured with the **c11i** parameter of the **chg-sid** command must be configured in the database before the OAP configuration can be updated.

To keep OAP parameters in sync with the EAGLE 5 ISS, a checksum is created using all of the OAP configuration data stored on the EAGLE 5 ISS (shown in Tables 4-3 and 4-4). The OAP also calculates this checksum based on the data it has. The OAP returns this checksum with every maintenance poll. The EAGLE 5 ISS compares the checksums, and generates the following alarm (UAM 0364) within ten seconds of any mismatch:

```

r1ghncxa03w 05-09-01 11:11:28 GMT EAGLE5 34.0.0
* 1501.0364 * OAP A Configuration data checksum
mismatch

```



## EOAP Provisioning Procedures

The alarm is cleared when a maintenance poll returns a checksum that matches the EAGLE 5 ISS's checksum, indicating that the databases are back in sync. The EAGLE 5 ISS clears the alarm within five seconds. The following UAM (UAM 0365) clears the alarm:

```
rlghncxa03w 05-09-01 11:11:28 GMT EAGLE5 34.0.0
1502.0365 OAP A Configuration data checksum alarm cleared
```



**CAUTION:** If any of the data shown in Table 4-2 on page 4-14 is not properly configured when the OAP configuration data is sent to the OAP, the OAP may go out of service.

### Example OAP Initial Configuration

The examples in this procedure are used to initially configure a dual-configuration OAP with the settings shown in Table 4-3. For a single configuration OAP, configure OAP-A only.

**Table 4-3.** Example OAP Initial Configuration

Description	Parameter	OAP A	OAP B
Hostname	<b>:aname</b> <b>:bname</b>	tekelec-12	tekelec-13
IP Address	<b>:aipaddr</b> <b>:bipaddr</b>	192.106.175.025	192.106.175.026
IP Netmask	<b>:anmask</b> <b>:bnmask</b>	255.255.255.000	255.255.255.000
Default Router	<b>:arouter</b> <b>:brouter</b>	128.132.064.001	128.132.064.001
Configuration	<b>:cfg</b>	dual	dual
SEAC CLI	<b>:seacc11i</b>	RLGHNCXB14Y	RLGHNCXB14Y
X.25 Packet Size	<b>:x25ps</b>	8	8
X.25 Mode	<b>:x25mode</b>	DTE	DTE

### Procedure

---

- 1 Verify that the SEAS feature is on (**SEAS = on**) using the **rtrv-feat** command.

**NOTE:** The **rtrv-feat** command output contains other fields that are not used by this procedure. If you wish to see all the fields displayed by the **rtrv-feat** command, see the **rtrv-feat** command description in the *Commands Manual*.

---

- Turn on the SEAS feature by entering this command:

```
chg-feat : seas=on
```

**NOTE:** Once the SEAS feature is turned on with the **chg-feat** command, it cannot be turned off. The SEAS feature is optional and must be purchased before you turn on the feature with the **chg-feat** command. If you are not sure whether you have purchased the SEAS feature, contact your Tekelec Sales Representative or Account Representative.

After successful completion of this command, the EAGLE 5 ISS returns the following output:

```
rlghncxa03w 05-09-01 11:34:04 GMT EAGLE5 34.0.0
CHG-FEAT: MASP A - COMPLD
```

- For the OAPs to be configured by the **chg-oap-config** command, the OAP ports must be out of service. To find which terminal ports are the OAP ports, display the terminal configuration in the database using the **rtrv-trm** command. The OAP ports are shown by the entry **OAP** in the **TYPE** field, as shown in bold in the example **rtrv-trm** output. This is an example of the possible output:

```
rlghncxa03w 05-09-01 11:34:04 GMT EAGLE5 34.0.0
TRM  TYPE      COMM          FC  TMOUT  MXINV  DURAL
1    VT320      9600-7-E-1 SW   30    5     99:59:59
2    KSR        9600-7-E-1 HW   30    5     INDEF
3    PRINTER    4800-7-E-1 HW   30    0     00:00:00
4    OAP      19200-7-E-1 SW   30    5     00:30:00
5    VT320      9600-7-O-1 NONE 30    5     00:00:30
6    VT320      9600-7-E-2 SW   30    9     INDEF
7    PRINTER    9600-7-N-2 HW   30    5     00:30:00
8    KSR        19200-7-E-2 BOTH 30    5     00:30:00
9    VT320      9600-7-E-1 SW   30    7     00:30:00
10   OAP      19200-7-E-1 SW   30    5     00:30:00
11   VT320      4800-7-E-1 HW   30    5     00:30:00
12   PRINTER    9600-7-E-1 HW   30    4     00:30:00
13   VT320      9600-7-O-1 NONE 30    5     00:30:00
14   VT320      9600-7-E-2 SW   30    8     00:30:00
15   VT320      9600-7-N-2 HW   30    5     00:30:00
16   VT320      9600-7-E-2 BOTH 30    3     00:30:00
```

```
TRM  TRAF  LINK  SA  SYS  PU  DB  UIMRD
1    NO   YES   NO  YES  NO  YES  YES
2    NO   NO    NO  NO   NO  NO   NO
3    YES  YES   YES  NO   YES  YES  YES
4    NO   NO    NO  NO   NO  NO   NO
5    NO   YES   NO  NO   NO  NO   YES
6    NO   NO    YES  NO   NO  NO   NO
7    YES  YES   YES  YES  YES  YES  YES
8    NO   NO    NO  NO   YES  NO   YES
9    NO   YES   NO  NO   NO  YES  NO
10   NO   NO    NO  NO   NO  NO   NO
11   YES  YES   YES  YES  YES  YES  YES
12   YES  YES   YES  YES  YES  YES  YES
```

## EOAP Provisioning Procedures

13	NO	YES	NO	NO	NO	NO	YES
14	NO	NO	YES	NO	NO	NO	NO
15	YES	YES	YES	NO	YES	YES	YES
16	NO	NO	NO	NO	YES	NO	YES

	APP	APP										
TRM	SERV	SS	CARD	CLK	DBG	GTT	GWS	MEAS	MON	MPS	SEAS	SLAN
1	YES	YES	YES	YES	YES	YES	YES	YES	YES	YES	NO	NO
2	YES	YES	YES	YES	YES	YES	YES	YES	YES	YES	NO	NO
3	YES	YES	YES	YES	YES	YES	YES	YES	YES	YES	NO	NO
4	NO	NO	NO	NO	NO	NO	NO	NO	NO	NO	NO	NO
5	YES	YES	YES	YES	YES	YES	YES	YES	YES	YES	NO	NO
6	YES	YES	YES	YES	YES	YES	YES	YES	YES	YES	NO	NO
7	NO	YES	YES	YES	YES	YES	YES	YES	YES	YES	NO	NO
8	YES	YES	YES	YES	YES	YES	YES	YES	YES	YES	YES	YES
9	YES	YES	YES	YES	YES	YES	YES	YES	YES	YES	YES	YES
10	NO	NO	NO	NO	NO	NO	NO	NO	NO	NO	NO	NO
11	NO	NO	NO	NO	NO	NO	NO	NO	NO	NO	NO	NO
12	NO	NO	NO	NO	NO	NO	NO	NO	NO	NO	NO	NO
13	NO	NO	NO	NO	NO	NO	NO	NO	NO	NO	NO	NO
14	NO	NO	NO	NO	NO	NO	NO	NO	NO	NO	NO	NO
15	NO	NO	NO	NO	NO	NO	NO	NO	NO	NO	NO	NO
16	NO	NO	NO	NO	NO	NO	NO	NO	NO	NO	NO	NO
17	NO	NO	NO	NO	NO	NO	NO	NO	NO	NO	NO	NO
18	NO	NO	NO	NO	NO	NO	NO	NO	NO	NO	NO	NO
19	NO	NO	NO	NO	NO	NO	NO	NO	NO	NO	NO	NO
20	NO	NO	NO	NO	NO	NO	NO	NO	NO	NO	NO	NO
21	NO	NO	NO	NO	NO	NO	NO	NO	NO	NO	NO	NO
22	NO	NO	NO	NO	NO	NO	NO	NO	NO	NO	NO	NO
23	NO	NO	NO	NO	NO	NO	NO	NO	NO	NO	NO	NO
24	NO	NO	NO	NO	NO	NO	NO	NO	NO	NO	NO	NO

- 
- Verify the status of the OAP ports displayed in step 3. An out-of-service OAP port is shown by the entry **OOS-MT-DSBLD** in the **PST** field. This is an example of the possible output:

```
rlghncxa03w 05-09-01 11:34:04 GMT EAGLE5 34.0.0
TRM  PST           SST           AST
1    IS-NR         Active       -----
2    IS-NR         Active       -----
3    IS-NR         Active       -----
4    IS-NR        Active     -----
5    IS-NR         Active       -----
6    IS-NR         Active       -----
7    IS-NR         Active       -----
8    IS-NR         Active       -----
9    IS-NR         Active       -----
10   IS-NR        Active     -----
11   IS-NR         Active       -----
12   IS-NR         Active       -----
13   IS-NR         Active       -----
14   IS-NR         Active       -----
15   IS-NR         Active       -----
16   IS-NR         Active       -----
```

Command Completed.

If either OAP terminal is not out-of-service, go to step 5. If both OAP terminals are out-of-service, go to step 7.

- 
5. Place the OAP terminal out of service using the **rmv-trm** command and specifying the ports. Enter these commands:

```
rmv-trm:trm=4
```

```
rmv-trm:trm=10
```

After successful completion of each command, the EAGLE 5 ISS returns the following output:

```
rlghncxa03w 05-09-01 00:57:31 GMT EAGLE5 34.0.0
Inhibit message sent to terminal
```

```
rlghncxa03w 05-09-01 00:57:31 GMT EAGLE5 34.0.0
Command Completed.
```

---

6. Verify that the OAP ports that was placed out of service in step 5 is in the OOS-MT-DSBLD state by entering the **rept-stat-trm** command. This is an example of the possible output:

```
rlghncxa03w 05-09-01 00:57:31 GMT EAGLE5 34.0.0
TRM   PST           SST           AST
1     IS-NR           Active        -----
2     IS-NR           Active        -----
3     IS-NR           Active        -----
4     OOS-MT-DSBLD Manual        -----
5     IS-NR           Active        -----
6     IS-NR           Active        -----
7     IS-NR           Active        -----
8     IS-NR           Active        -----
9     IS-NR           Active        -----
10    OOS-MT-DSBLD Manual        -----
11    IS-NR           Active        -----
12    IS-NR           Active        -----
13    IS-NR           Active        -----
14    IS-NR           Active        -----
15    IS-NR           Active        -----
16    IS-NR           Active        -----
Command Completed.
```

---

7. Display the current OAP configuration by entering the **rtrv-oap-config** command. The output will show the EOAPs not configured. This is an example of the possible output:

```
rlghncxa03w 05-09-01 11:34:04 GMT EAGLE5 34.0.0
OAP CONFIGURATION REPORT
```

DATA	OAP A	OAP B
Hostname	<Not configured>	<Not configured>
IP Address	<Not configured>	<Not configured>

## EOAP Provisioning Procedures

```

IP Netmask           <Not configured>      <Not configured>
Default Router       <Not configured>      <Not configured>
Config               <Not configured>      <Not configured>
SEAC CLLI           <Not configured>      <Not configured>
X25 Packet Size     <Not configured>      <Not configured>
X25 Mode            <Not configured>      <Not configured>

```

Before the OAP configuration can be sent to the specified OAP with the **act-oap-config** command, the fields of the **rtrv-oap-config** command output shown in Table 4-2 on page 4-14 must be correctly configured. If these fields do contain incorrect entries and the OAP configuration is sent to the specified OAP, the specified OAP may go out of service.

8. Make sure that there are no alarms for either OAP. Enter the **rept-stat-seas** command.

The following is an example of the possible output:

```

rlghncxa03w 05-09-01 15:59:06 GMT EAGLE5 34.0.0
SEAS Subsystem Report      IS-NR      Active      -----
SEAS Interfaces Configured = 2  Interfaces IS-NR = 2

```

	GPL	PST	SST	AST
-----				
SEAS SYSTEM		IS-NR	Active	-----
TDM Port	4	IS-NR	Active	-----
TDM Port	10	IS-NR	Active	-----
OAP	A 026-001-000	IS-NR	Active	-----
OAP	B 026-001-000	IS-NR	Active	-----
X.25 Link	A1	IS-NR	Active	-----
X.25 Link	B1	IS-NR	Active	-----

```

SEAS SYSTEM ALARM STATUS = No Alarms.
OAP A        ALARM STATUS = No Alarms.
OAP B        ALARM STATUS = No Alarms.
X25 Link A1 ALARM STATUS = No Alarms.
X25 Link A2 ALARM STATUS = No Alarms.
X25 Link B1 ALARM STATUS = No Alarms.
X25 Link B2 ALARM STATUS = No Alarms.

```

```

X25 A1 PVCs IS-NR      = 1,2,3
X25 A1 PVCs OOS-MT    = ---
X25 B1 PVCs IS-NR      = 1,2,3
X25 B1 PVCs OOS-MT    = ---

```

```

X25 A2 PVCs IS-NR      = 1,2,3
X25 A2 PVCs OOS-MT    = ---
X25 B2 PVCs IS-NR      = 1,2,3
X25 B2 PVCs OOS-MT    = ---

```

Command Completed.

If alarms are shown for the OAPs in the **rept-stat-seas** output, contact the Customer Care Center. Refer to "Customer Care Center" on page 1-10 for the contact information.

---

**NOTE:** When steps 9 through 12 are performed, UAM 0364 will be generated indicating that the OAP configuration data on the OAP and the EAGLE 5 ISS do not match.

9. If you upgraded from a single-configuration to OAP to a dual-configuration OAP, configure the EAGLE 5 ISS database with the new number of OAPs:

**chg-oap-config:config=dual**

After successful completion of this command, the EAGLE 5 ISS returns the following output:

```
rlghncxa03w 05-09-01 11:34:04 GMT EAGLE5 34.0.0
CHG-OAP-CONFIG: MASP A - COMPLTD
```

---

10. Configure the new hostname:

**chg-oap-config:aname="tekelec-12"**

**chg-oap-config:bname="tekelec-13"**

where:

**:aname** is a 14-character (1 alphabetic character followed by 1 to 13 alphanumeric characters) hostname for OAP-A. The value must be enclosed in quotes ("").

**:bname** is a 14-character (1 alphabetic character followed by 1 to 13 alphanumeric characters) hostname for OAP-B. The value must be enclosed in quotes ("").

After successful completion of each command, the EAGLE 5 ISS returns the following output:

```
rlghncxa03w 05-09-01 11:34:04 GMT EAGLE5 34.0.0
CHG-OAP-CONFIG: MASP A - COMPLTD
```

---

11. Configure the IP network for the SEAS feature. Enter the following command and parameter required:

```
chg-oap-config:aipaddr=192.106.175.025
```

```
chg-oap-config:bipaddr=192.106.175.026
```

where:

**:aipaddr** is the OAP-A IP address (network service access point).

**:bipaddr** is the OAP-B IP address (network service access point).

**:amask** or **:bmask** is the the netmask for OAP-A or OAP-B. If you are unsure as to whether your network requires this configuration, check with your Information Services department.

**:arouter** or **:brouter** is the IP address of the default router assigned to OAP-A or OAP-B. If you are unsure as to whether your network requires this configuration, check with your Information Services department.

After successful completion of this command, the EAGLE 5 ISS returns the following output:

```
rlghncxa03w 05-09-01 11:34:04 GMT EAGLE5 34.0.0  
CHG-OAP-CONFIG: MASP A - COMPLTD
```

---

12. Configure the SEAS network. Enter the following command with these three required parameters:

```
chg-oap-config:seacc11i="rlghncxb14y":x25ps=8:x25mode=dte
```

where:

**:seacc11i** is the 11-character (1 alphabetic character followed by 1 to 10 alphanumeric characters) common language location identifier (CLLI) of the SEAC that the OAP is connecting to. The value must be enclosed in quotes ("").

**:x25ps** is the x.25 package size for the link to the SEAC. The value is either 7 or 8.

**:x25mode** is the mode of the X.25 link to the SEAC.

After successful completion of this command, the EAGLE 5 ISS returns the following output:

```
rlghncxa03w 05-09-01 11:34:04 GMT EAGLE5 34.0.0  
CHG-OAP-CONFIG: MASP A - COMPLTD
```

---

13. Verify the changes in the database using the **rtrv-oap-config** command. This is an example of the possible output. The fields that have changed in this example are shown in bold.

```
rlghncxa03w 05-09-01 11:34:04 GMT EAGLE5 34.0.0  
OAP CONFIGURATION REPORT
```

DATA	OAP A	OAP B
Hostname	<b>tekelec-12</b>	<b>tekelec-13</b>
IP Address	<b>192.106.175.025</b>	<b>192.106.175.026</b>
IP Netmask	<b>255.255.255.000</b>	<b>255.255.255.000</b>
Default Router	<b>128.132.064.001</b>	<b>128.132.064.001</b>
Config	dual	dual
SEAC CLLI	<b>RLGHNCXB14Y</b>	<b>RLGHNCXB14Y</b>
X25 Packet Size	<b>8</b>	<b>8</b>
X25 Mode	<b>DTE</b>	<b>DTE</b>

14. For the OAPs to be updated by the **act-oap-config** command, the OAP ports must be in service. Return the OAP ports to service that were inhibited in step 5. Use the **rst-trm** command. For this example, enter these commands:

```
rst-trm:trm=4
rst-trm:trm=10
```

After successful completion of this command, the EAGLE 5 ISS returns the following output:

```
rlghncxa03w 05-09-01 15:08:45 EDT EAGLE5 34.0.0
Allow message sent to terminal
```

15. Verify that the OAP ports are returned to service by entering the **rept-stat-trm** command.

This is an example of the possible output:

```
rlghncxa03w 05-09-01 11:34:04 GMT EAGLE5 34.0.0
TRM   PST           SST           AST
1     IS-NR          Active        -----
2     IS-NR          Active        -----
3     IS-NR          Active        -----
4     IS-NR          Active        -----
5     IS-NR          Active        -----
6     IS-NR          Active        -----
7     IS-NR          Active        -----
8     IS-NR          Active        -----
9     IS-NR          Active        -----
10    IS-NR          Active        -----
11    IS-NR          Active        -----
12    IS-NR          Active        -----
13    IS-NR          Active        -----
14    IS-NR          Active        -----
15    IS-NR          Active        -----
16    IS-NR          Active        -----
Command Completed.
```

If the entry **IS-NR** is not shown in the **PST** field of the **rept-stat-trm** output, the OAP port has not been returned to service. Contact the Customer Care Center. Refer to "Customer Care Center" on page 1-10 for the contact information.



**NOTE: Performing step 16 clears the alarm condition indicated by UAM 0364 and generates UAM 0365 indicating that the OAP configuration data on the OAP and the EAGLE 5 ISS match.**

16. Send the OAP configuration data to the OAP using the **act-oap-config** command. If only one OAP is being updated, the **force=yes** parameter must be specified with the **act-oap-config** command, unless the **cfg=sngl** parameter was specified with the **chg-oap-config** command. If only one OAP is being updated, perform steps a and b in Method A for the specific OAP.

If the **cfg=dual** parameter was specified with the **chg-oap-config** command, both OAPs must be updated. Use one of the following methods:

Method A updates one OAP at a time using the **force=yes** parameter. This method allows SEAS traffic to continue being sent to the EAGLE 5 ISS while the OAP configuration is being updated. It can take up to 15 minutes to update the configuration of the OAP, during which time the OAP being updated will be out of service.

Method B updates both OAPs at the same time using the **oap=all** parameter. This method will take both OAPs out of service and may interrupt all SEAS traffic to the EAGLE 5 ISS. This is NOT recommended. **Method A is the preferred method.**

**Method A:** Perform steps a through d in this method for each OAP, one OAP at a time.

- a. Update OAP A by entering this command:

**act-oap-config:oap=a:force=yes**

After successful completion of this command, the EAGLE 5 ISS returns the following output:

```
rlghncxa03w 05-09-01 11:34:04 GMT EAGLE5 34.0.0
ACT-OAP-CONFIG: MASP A - COMPLTD
```

- b. Wait 15 minutes, then enter the **rept-stat-seas** command to make sure that there are no alarms for OAP A.

These are examples of the possible output:

**rept-stat-seas**

```
rlghncxa03w 05-09-01 15:59:06 GMT EAGLE5 34.0.0
SEAS Subsystem Report      IS-NR      Active      -----
SEAS Interfaces Configured = 2  Interfaces IS-NR = 2
```

	GPL	PST	SST	AST	
SEAS SYSTEM		IS-NR	Active	----	
TDM Port	4	IS-NR	Active	----	
TDM Port	10	IS-NR	Active	----	
OAP	A	026-001-000	IS-NR	Active	----
OAP	B	026-001-000	IS-NR	Active	----

```

X.25 Link      A1      IS-NR      Active      -----
X.25 Link      B1      IS-NR      Active      -----

SEAS SYSTEM ALARM STATUS = No Alarms.
OAP A        ALARM STATUS = No Alarms.
OAP B        ALARM STATUS = No Alarms.
X.25 Link A1 ALARM STATUS = No Alarms.
X.25 Link A2 ALARM STATUS = No Alarms.
X.25 Link B1 ALARM STATUS = No Alarms.
X.25 Link B2 ALARM STATUS = No Alarms.

X25 A1 PVCs IS-NR      = 1,2,3
X25 A1 PVCs OOS-MT     = ---
X25 B1 PVCs IS-NR      = 1,2,3
X25 B1 PVCs OOS-MT     = ---

X25 A2 PVCs IS-NR      = 1,2,3
X25 A2 PVCs OOS-MT     = ---
X25 B2 PVCs IS-NR      = 1,2,3
X25 B2 PVCs OOS-MT     = ---
Command Completed.

```

- c. Update OAP B by entering this command.

**act-oap-config:oap=b:force=yes**

After successful completion of this command, the EAGLE 5 ISS returns the following output:

```

rlghncxa03w 05-09-01 11:34:04 GMT EAGLE5 34.0.0
ACT-OAP-CONFIG: MASP A - COMPLTD

```

- d. Wait 15 minutes, then enter the **rept-stat-seas** command to make sure that there are no alarms for OAP B.

These are examples of the possible output:

**rept-stat-seas**

```

rlghncxa03w 05-09-01 15:59:06 GMT EAGLE5 34.0.0
SEAS Subsystem Report      IS-NR      Active      -----
SEAS Interfaces Configured = 2  Interfaces IS-NR = 2

-----
                                GPL          PST          SST          AST
-----
SEAS SYSTEM                                IS-NR      Active      -----
TDM Port          4                                IS-NR      Active      -----
TDM Port          10                               IS-NR      Active      -----
OAP                A      026-001-000  IS-NR      Active      -----
OAP                B      026-001-000  IS-NR      Active      -----
X.25 Link          A1                                IS-NR      Active      -----
X.25 Link          B1                                IS-NR      Active      -----

SEAS SYSTEM ALARM STATUS = No Alarms.
OAP A        ALARM STATUS = No Alarms.
OAP B        ALARM STATUS = No Alarms.
X.25 Link A1 ALARM STATUS = No Alarms.
X.25 Link A2 ALARM STATUS = No Alarms.

```

## EOAP Provisioning Procedures

```
X25 Link B1 ALARM STATUS = No Alarms.
X25 Link B2 ALARM STATUS = No Alarms.

X25 A1 PVCs IS-NR      = 1,2,3
X25 A1 PVCs OOS-MT    = ---
X25 B1 PVCs IS-NR      = 1,2,3
X25 B1 PVCs OOS-MT    = ---

X25 A2 PVCs IS-NR      = 1,2,3
X25 A2 PVCs OOS-MT    = ---
X25 B2 PVCs IS-NR      = 1,2,3
X25 B2 PVCs OOS-MT    = ---
Command Completed.
```

If alarms are shown for the OAPs in the **rept-stat-seas** output, contact the Customer Care Center. Refer to "Customer Care Center" on page 1-10 for the contact information.

**Method B:** Perform steps a through d to update both OAPs at the same time. This method is NOT recommended.

- a. Enter the following command:

```
act-oap-config:oap=all
```

After successful completion of this command, the EAGLE 5 ISS returns the following output:

```
rlghncxa03w 05-09-01 11:34:04 GMT EAGLE5 34.0.0
ACT-OAP-CONFIG: MASP A - COMPLTD
```

- b. Wait 15 minutes, then enter the **rept-stat-seas** command to make sure that there are no alarms for the OAPs. This is an example of the possible output:

```
rept-stat-seas
```

```
rlghncxa03w 05-09-01 15:59:06 GMT EAGLE5 34.0.0
SEAS Subsystem Report      IS-NR      Active      -----
SEAS Interfaces Configured = 2  Interfaces IS-NR = 2
```

	GPL	PST	SST	AST	
SEAS SYSTEM		IS-NR	Active	-----	
TDM Port	4	IS-NR	Active	-----	
TDM Port	10	IS-NR	Active	-----	
OAP	A	026-001-000	IS-NR	Active	-----
OAP	B	026-001-000	IS-NR	Active	-----
X.25 Link	A1	IS-NR	Active	-----	
X.25 Link	B1	IS-NR	Active	-----	

```
SEAS SYSTEM ALARM STATUS = No Alarms.
OAP A        ALARM STATUS = No Alarms.
OAP B        ALARM STATUS = No Alarms.
X25 Link A1 ALARM STATUS = No Alarms.
X25 Link A2 ALARM STATUS = No Alarms.
X25 Link B1 ALARM STATUS = No Alarms.
```

```
X25 Link B2 ALARM STATUS = No Alarms.
```

```
X25 A1 PVCs IS-NR = 1,2,3
```

```
X25 A1 PVCs OOS-MT = ---
```

```
X25 B1 PVCs IS-NR = 1,2,3
```

```
X25 B1 PVCs OOS-MT = ---
```

```
X25 A2 PVCs IS-NR = 1,2,3
```

```
X25 A2 PVCs OOS-MT = ---
```

```
X25 B2 PVCs IS-NR = 1,2,3
```

```
X25 B2 PVCs OOS-MT = ---
```

```
Command Completed.
```

If alarms are shown for the OAPs in the **rept-stat-seas** output, contact the Customer Care Center. Refer to "Customer Care Center" on page 1-10 for the contact information.

---

17. Back up the changes using the **chg-db:action=backup:dest=fixed** command. These messages appear; the active Maintenance and Administration Subsystem Processor (MASP) message appears first:

```
BACKUP (FIXED) : MASP A - Backup starts on active MASP.
```

```
BACKUP (FIXED) : MASP A - Backup on active MASP to fixed disk  
complete.
```

```
BACKUP (FIXED) : MASP A - Backup starts on standby MASP.
```

```
BACKUP (FIXED) : MASP A - Backup on standby MASP to fixed disk  
complete.
```

---

## Reprovisioning

### Changing the OAP Configuration from the EAGLE 5 ISS Terminal

Use this procedure if you need to change OAP settings, for example, the number of OAPs after you have upgraded to a dual configuration, the host ID, or the IP address.

**NOTE:** The `chg-oap-config` command is valid only if the SEAS feature is turned on.

#### Example of OAP Configuration Changes

The examples in this procedure are used to change a dual-configuration OAP with the settings shown in Table 4-4. For a single configuration OAP, configure OAP-A only.

**Table 4-4.** Example OAP Initial Configuration

Description	Parameter	OAP A	OAP B
Hostname	<code>:aname</code> <code>:bname</code>	tekelec-22	tekelec-23
IP Address	<code>:aipaddr</code> <code>:bipaddr</code>	192.106.175.005	192.106.175.006
IP Netmask	<code>:anmask</code> <code>:bnmask</code>	255.255.255.001	255.255.255.001
Default Router	<code>:arouter</code> <code>:brouter</code>	128.132.064.005	128.132.064.005
Configuration	<code>:cfg</code>	dual	dual
SEAC CLI	<code>:seacc11i</code>	RLGHNCXB18Y	RLGHNCXB18Y
X.25 Packet Size	<code>:x25ps</code>	7	7
X.25 Mode	<code>:x25mode</code>	DCE	DCE

When configuring the OAP, the EAGLE 5 ISS generates a UAM 0364 because the OAP configuration in the database does not match the OAP configuration on the OAP:

```
rlghncxa03w 05-09-01 11:11:28 GMT EAGLE5 34.0.0
* 1501.0364 * OAP A Configuration data checksum
mismatch
```

The alarm is cleared when a maintenance poll returns a checksum that matches the EAGLE 5 ISS's checksum, indicating that the databases are synchronized. The EAGLE 5 ISS clears the alarm within five seconds. The following UAM clears the alarm:

```
rlghncxa03w 05-09-07 11:11:28 GMT EAGLE5 34.0.0
```

1502.0365 OAP A Configuration data checksum alarm cleared

## Procedure

---

- For the OAPs to be configured by the **chg-oap-config** command, the OAP ports must be out of service. To find which terminal ports are the OAP ports, display the terminal configuration in the database using the **rtrv-trm** command. The OAP ports are shown by the entry **OAP** in the **TYPE** field, as shown in bold in the example **rtrv-trm** output. This is an example of the possible output:

```
rlghncxa03w 05-09-01 11:34:04 GMT EAGLE5 34.0.0
TRM  TYPE      COMM          FC      TMOUT  MXINV  DURAL
1    VT320      9600-7-E-1 SW      30      5      99:59:59
2    KSR        9600-7-E-1 HW      30      5      INDEF
3    PRINTER    4800-7-E-1 HW      30      0      00:00:00
4    OAP      19200-7-E-1 SW      30      5      00:30:00
5    VT320      9600-7-O-1 NONE    30      5      00:00:30
6    VT320      9600-7-E-2 SW      30      9      INDEF
7    PRINTER    9600-7-N-2 HW      30      5      00:30:00
8    KSR        19200-7-E-2 BOTH   30      5      00:30:00
9    VT320      9600-7-E-1 SW      30      7      00:30:00
10   OAP      19200-7-E-1 SW      30      5      00:30:00
11   VT320      4800-7-E-1 HW      30      5      00:30:00
12   PRINTER    9600-7-E-1 HW      30      4      00:30:00
13   VT320      9600-7-O-1 NONE    30      5      00:30:00
14   VT320      9600-7-E-2 SW      30      8      00:30:00
15   VT320      9600-7-N-2 HW      30      5      00:30:00
16   VT320      9600-7-E-2 BOTH   30      3      00:30:00
```

```
TRM  TRAF LINK SA  SYS PU  DB  UIMRD
1    NO  YES  NO  YES NO  YES YES
2    NO  NO   NO  NO  NO  NO  NO
3    YES YES  YES NO  YES YES YES
4    NO  NO   NO  NO  NO  NO  NO
5    NO  YES  NO  NO  NO  NO YES
6    NO  NO   YES NO  NO  NO  NO
7    YES YES  YES YES YES YES YES
8    NO  NO   NO  NO  YES NO YES
9    NO  YES  NO  NO  NO  YES NO
10   NO  NO   NO  NO  NO  NO  NO
11   YES YES  YES YES YES YES YES
12   YES YES  YES YES YES YES YES
13   NO  YES  NO  NO  NO  NO YES
14   NO  NO   YES NO  NO  NO  NO
15   YES YES  YES NO  YES YES YES
16   NO  NO   NO  NO  YES NO YES
```

```
APP  APP
TRM  SERV SS  CARD CLK  DBG  GTT  GWS  MEAS  MON  MPS  SEAS  SLAN
1    YES YES YES  YES YES YES YES YES YES YES NO  NO
2    YES YES YES  YES YES YES YES YES YES YES NO  NO
3    YES YES YES  YES YES YES YES YES YES YES NO  NO
4    NO  NO  NO   NO  NO  NO  NO  NO  NO  NO  NO  NO
```

## EOAP Provisioning Procedures

---

5	YES	YES	YES	YES	YES	YES	YES	YES	YES	YES	NO	NO
6	YES	YES	YES	YES	YES	YES	YES	YES	YES	YES	NO	NO
7	NO	YES	YES	YES	YES	YES	YES	YES	YES	YES	NO	NO
8	YES	YES	YES	YES	YES	YES	YES	YES	YES	YES	YES	YES
9	YES	YES	YES	YES	YES	YES	YES	YES	YES	YES	YES	YES
10	NO	NO	NO	NO	NO	NO	NO	NO	NO	NO	NO	NO
11	NO	NO	NO	NO	NO	NO	NO	NO	NO	NO	NO	NO
12	NO	NO	NO	NO	NO	NO	NO	NO	NO	NO	NO	NO
13	NO	NO	NO	NO	NO	NO	NO	NO	NO	NO	NO	NO
14	NO	NO	NO	NO	NO	NO	NO	NO	NO	NO	NO	NO
15	NO	NO	NO	NO	NO	NO	NO	NO	NO	NO	NO	NO
16	NO	NO	NO	NO	NO	NO	NO	NO	NO	NO	NO	NO

---

2. Verify the status of the OAP port(s) to be inhibited. For a dual-configuration OAP, both OAP ports must be out of service. This is an example of the possible output:

```
rlghncxa03w 05-09-01 11:34:04 GMT EAGLE5 34.0.0
TRM    PST                SST                AST
1      IS-NR              Active            -----
2      IS-NR              Active            -----
3      IS-NR              Active            -----
4      IS-NR              Active            -----
5      IS-NR              Active            -----
6      IS-NR              Active            -----
7      IS-NR              Active            -----
8      IS-NR              Active            -----
9      IS-NR              Active            -----
10     IS-NR              Active            -----
11     IS-NR              Active            -----
12     IS-NR              Active            -----
13     IS-NR              Active            -----
14     IS-NR              Active            -----
15     IS-NR              Active            -----
16     IS-NR              Active            -----
Command Completed.
```

If the OAP port is not out-of-service, go to step 3. If the OAP port is out-of-service, go to step 5.

- 
3. Place the OAP port(s) out of service using the **rmv-trm** command and specifying the ports. Enter these commands:

```
rmv-trm:trm=4
rmv-trm:trm=10
```

After successful completion of each command, the EAGLE 5 ISS returns the following output:

```
rlghncxa03w 05-09-01 00:57:31 GMT EAGLE5 34.0.0
Inhibit message sent to terminal

rlghncxa03w 05-09-01 00:57:31 GMT EAGLE5 34.0.0
Command Completed.
```

---

4. Verify that the OAP port that was taken out of service in step 3 is in the OOS-MT-DSBLD state by entering the **rept-stat-trm** command. This is an example of the possible output:

```
rlghncxa03w 05-09-01 00:57:31 GMT EAGLE5 34.0.0
TRM   PST           SST           AST
1     IS-NR         Active      -----
2     IS-NR         Active      -----
3     IS-NR         Active      -----
4     OOS-MT-DSBLD Manual      -----
5     IS-NR         Active      -----
6     IS-NR         Active      -----
7     IS-NR         Active      -----
8     IS-NR         Active      -----
9     IS-NR         Active      -----
10    OOS-MT-DSBLD Manual      -----
11    IS-NR         Active      -----
12    IS-NR         Active      -----
13    IS-NR         Active      -----
14    IS-NR         Active      -----
15    IS-NR         Active      -----
16    IS-NR         Active      -----
Command Completed.
```

---

5. Display the current OAP configuration by entering the **rtrv-oap-config** command. This is an example of the possible output:

```
rlghncxa03w 05-09-01 11:34:04 GMT EAGLE5 34.0.0
OAP CONFIGURATION REPORT

DATA                               OAP A                               OAP B
rlghncxa03w 05-09-01 11:34:04 GMT EAGLE5 34.0.0
OAP CONFIGURATION REPORT

DATA                               OAP A                               OAP B
Hostname                           tekelec-12                           tekelec-13
IP Address                          192.106.175.025                       192.106.175.026
IP Netmask                          255.255.255.000                       255.255.255.000
Default Router                      128.132.064.001                       128.132.064.001
Config                              dual                                   dual
SEAC CLLI                          RLGHCXB14Y                            RLGHCXB14Y
X25 Packet Size                     8                                       8
X25 Mode                            DTE                                    DTE
```

Before the OAP configuration can be sent to the specified OAP with the **act-oap-config** command, the fields of the **rtrv-oap-config** command output must be correctly configured. If these fields do contain incorrect entries and the OAP configuration is sent to the specified OAP, the specified OAP may go out of service.

---



6. Make sure that there are no alarms for either OAP. Enter the **rept-stat-seas** command.

The following are examples of the possible output:

**rept-stat-seas**

```
rlghncxa03w 05-09-01 15:59:06 GMT EAGLE5 34.0.0
SEAS Subsystem Report      IS-NR      Active      -----
SEAS Interfaces Configured = 2  Interfaces IS-NR = 2

                                GPL          PST          SST          AST
-----
SEAS SYSTEM                  IS-NR      Active      -----
TDM Port          4                  IS-NR      Active      -----
TDM Port          10                 IS-NR      Active      -----
OAP               A    026-001-000  IS-NR      Active      -----
OAP               B    026-001-000  IS-NR      Active      -----
X.25 Link         A1                 IS-NR      Active      -----
X.25 Link         B1                 IS-NR      Active      -----

SEAS SYSTEM  ALARM STATUS = No Alarms.
OAP A        ALARM STATUS = No Alarms.
OAP B        ALARM STATUS = No Alarms.
X25 Link A1  ALARM STATUS = No Alarms.
X25 Link A2  ALARM STATUS = No Alarms.
X25 Link B1  ALARM STATUS = No Alarms.
X25 Link B2  ALARM STATUS = No Alarms.

X25 A1 PVCs IS-NR      = 1,2,3
X25 A1 PVCs OOS-MT    = ---
X25 B1 PVCs IS-NR      = 1,2,3
X25 B1 PVCs OOS-MT    = ---

X25 A2 PVCs IS-NR      = 1,2,3
X25 A2 PVCs OOS-MT    = ---
X25 B2 PVCs IS-NR      = 1,2,3
X25 B2 PVCs OOS-MT    = ---
Command Completed.
```

If alarms are shown for the OAPs in the **rept-stat-seas** output, contact the Customer Care Center. Refer to "Customer Care Center" on page 1-10 for the contact information.

---

**NOTE:** When steps 7 through 10 are performed, UAM 0364 will be generated indicating that the OAP configuration data on the OAP and the EAGLE 5 ISS do not match.

7. If you upgraded from a single-configuration OAP to a dual-configuration OAP, configure the EAGLE 5 ISS database with the new number of OAPs:

**chg-oap-config:config=dual**

After successful completion of this command, the EAGLE 5 ISS returns the following output:

```
rlghncxa03w 05-09-01 11:34:04 GMT EAGLE5 34.0.0
CHG-OAP-CONFIG: MASP A - COMPLTD
```

---

8. Configure the new hostname; for example, enter these commands:

```
chg-oap-config:aname="tekelec-22"
chg-oap-config:bname="tekelec-23"
```

where:

**:aname** is a 14-character (1 alphabetic character followed by 1 to 13 alphanumeric characters) hostname for OAP-A. The value must be enclosed in quotes ("").

**:bname** is a 14-character (1 alphabetic character followed by 1 to 13 alphanumeric characters) hostname for OAP-B. The value must be enclosed in quotes ("").

After successful completion of each command, the EAGLE 5 ISS returns the following output:

```
rlghncxa03w 05-09-01 11:34:04 GMT EAGLE5 34.0.0
CHG-OAP-CONFIG: MASP A - COMPLTD
```

---

9. Configure the IP network for the SEAS feature. For example, enter these commands:

```
chg-oap-config:aipaddr=192.106.175.005
chg-oap-config:bipaddr=192.106.175.006
```

where:

**:aipaddr** is the OAP-A IP address (network service access point).

**:bipaddr** is the OAP-B IP address (network service access point).

These parameters may also be used in this step. If you are unsure as to whether your network requires this configuration, check with your Information Services department.

**:amask** or **:bmask** is the the netmask for OAP-A or OAP-B.

**:arouter** or **:brouter** is the IP address of the default router assigned to OAP-A or OAP-B.

After successful completion of this command, the EAGLE 5 ISS returns the following output:

```
rlghncxa03w 05-09-01 11:34:04 GMT EAGLE5 34.0.0
CHG-OAP-CONFIG: MASP A - COMPLTD
```

---

10. Configure the SEAS network. For example, enter these commands:

```
chg-oap-config:seacc11i="rlghncxb18y":x25ps=7:x25mode=dce
```

where:

**:seacc11i** is the 11-character (1 alphabetic character followed by 1 to 10 alphanumeric characters) common language location identifier (CLLI) of the SEAC that the OAP is connecting to. The value must be enclosed in quotes ("").

**:x25ps** is the x.25 package size for the link to the SEAC. The value is either 7 or 8.

**:x25mode** is the mode of the X.25 link to the SEAC.

After successful completion of this command, the EAGLE 5 ISS returns the following output:

```
rlghncxa03w 05-09-01 11:34:04 GMT EAGLE5 34.0.0
CHG-OAP-CONFIG: MASP A - COMPLTD
```

---

11. Verify the changes in the database using the **rtrv-oap-config** command. Confirm the correctness of all settings before continuing to the next step. This is an example of the possible output. The fields that have changed in this example are shown in bold.

```
rlghncxa03w 05-09-01 11:34:04 GMT EAGLE5 34.0.0
OAP CONFIGURATION REPORT
```

DATA	OAP A	OAP B
Hostname	<b>tekelec-22</b>	<b>tekelec-23</b>
IP Address	<b>192.106.175.005</b>	<b>192.106.175.006</b>
IP Netmask	<b>255.255.255.001</b>	<b>255.255.255.001</b>
Default Router	<b>128.132.064.005</b>	<b>128.132.064.005</b>
Config	dual	dual
SEAC CLLI	<b>RLGHNCXB18Y</b>	<b>RLGHNCXB18Y</b>
X25 Packet Size	<b>7</b>	<b>7</b>
X25 Mode	<b>DCE</b>	<b>DCE</b>

---

12. For the OAPs to be updated by the **act-oap-config** command, the OAP ports must be in service. Return the OAP ports to service that were inhibited in step 5. Use the **rst-trm** command. For this example, enter these commands:

```
rst-trm:trm=4
```

```
rst-trm:trm=10
```

After successful completion of this command, the EAGLE 5 ISS returns the following output:

```
rlghncxa03w 05-09-01 15:08:45 EDT EAGLE5 34.0.0
Allow message sent to terminal
```

---

13. Verify that the OAP ports are returned to service by entering the **rept-stat-trm** command.

This is an example of the possible output:

```
rlghncxa03w 05-09-01 11:34:04 GMT EAGLE5 34.0.0
TRM   PST           SST           AST
1     IS-NR          Active        -----
2     IS-NR          Active        -----
3     IS-NR          Active        -----
4     IS-NR          Active        -----
5     IS-NR          Active        -----
6     IS-NR          Active        -----
7     IS-NR          Active        -----
8     IS-NR          Active        -----
9     IS-NR          Active        -----
10    IS-NR          Active        -----
11    IS-NR          Active        -----
12    IS-NR          Active        -----
13    IS-NR          Active        -----
14    IS-NR          Active        -----
15    IS-NR          Active        -----
16    IS-NR          Active        -----
Command Completed.
```

If the entry **IS-NR** is not shown in the **PST** field of the **rept-stat-trm** output, the OAP port has not been returned to service. Contact the Customer Care Center. Refer to "Customer Care Center" on page 1-10 for the contact information.

---

**NOTE:** Performing step 14 clears the alarm condition indicated by UAM 0364 and generate UAM 0365 indicating that the OAP configuration data on the OAP and the EAGLE 5 ISS match.

14. Send the OAP configuration data to the OAP using the **act-oap-config** command. If only one OAP is being updated, the **force=yes** parameter must be specified with the **act-oap-config** command, unless the **cfg=sngl** parameter was specified with the **chg-oap-config** command. If only one OAP is being updated, perform steps a and b in Method A for the specific OAP.

If the **cfg=dual** parameter was specified with the **chg-oap-config** command, both OAPs must be updated. Use one of the following methods:

Method A updates one OAP at a time using the **force=yes** parameter. This method allows SEAS traffic to continue being sent to the EAGLE 5 ISS while the OAP configuration is being updated. It can take up to 15 minutes to update the configuration of the OAP, during which time the OAP being updated will be out of service.

Method B updates both OAPs at the same time using the **oap=all** parameter. This method will take both OAPs out of service and may interrupt all SEAS traffic to the EAGLE 5 ISS. This is not recommended. **Method A is the preferred method.**

## EOAP Provisioning Procedures

**Method A:** Perform steps a through d in this method for each OAP, one OAP at a time.

- a. Update OAP A by entering this command:

```
act-oap-config:oap=a:force=yes
```

After successful completion of this command, the EAGLE 5 ISS returns the following output:

```
rlghncxa03w 05-09-01 11:34:04 GMT EAGLE5 34.0.0
ACT-OAP-CONFIG: MASP A - COMPLTD
```

- b. Wait 15 minutes, then enter the **rept-stat-seas** command to make sure that there are no alarms for OAP A.

These are examples of the possible output:

```
rept-stat-seas
```

```
rlghncxa03w 05-09-01 15:59:06 GMT EAGLE5 34.0.0
SEAS Subsystem Report      IS-NR      Active      -----
SEAS Interfaces Configured = 2  Interfaces IS-NR = 2
```

		GPL	PST	SST	AST
SEAS SYSTEM			IS-NR	Active	-----
TDM Port	4		IS-NR	Active	-----
TDM Port	10		IS-NR	Active	-----
OAP	A	026-001-000	IS-NR	Active	-----
OAP	B	026-001-000	IS-NR	Active	-----
X.25 Link	A1		IS-NR	Active	-----
X.25 Link	B1		IS-NR	Active	-----

```
SEAS SYSTEM  ALARM STATUS = No Alarms.
OAP A        ALARM STATUS = No Alarms.
OAP B        ALARM STATUS = No Alarms.
X25 Link A1  ALARM STATUS = No Alarms.
X25 Link A2  ALARM STATUS = No Alarms.
X25 Link B1  ALARM STATUS = No Alarms.
X25 Link B2  ALARM STATUS = No Alarms.
```

```
X25 A1 PVCs IS-NR    = 1,2,3
X25 A1 PVCs OOS-MT   = ---
X25 B1 PVCs IS-NR    = 1,2,3
X25 B1 PVCs OOS-MT   = ---
```

```
X25 A2 PVCs IS-NR    = 1,2,3
X25 A2 PVCs OOS-MT   = ---
X25 B2 PVCs IS-NR    = 1,2,3
X25 B2 PVCs OOS-MT   = ---
```

```
Command Completed.
```

- c. Update OAP B by entering this command.

```
act-oap-config:oap=b:force=yes
```

After successful completion of this command, the EAGLE 5 ISS returns the following output:

```
rlghncxa03w 05-09-01 11:34:04 GMT EAGLE5 34.0.0
ACT-OAP-CONFIG: MASP A - COMPLTD
```

- d. Wait 15 minutes, then enter the **rept-stat-seas** command to make sure that there are no alarms for OAP B.

These are examples of the possible output:

```
rept-stat-seas
```

```
rlghncxa03w 05-09-01 15:59:06 GMT EAGLE5 34.0.0
SEAS Subsystem Report      IS-NR      Active  -----
SEAS Interfaces Configured = 2  Interfaces IS-NR = 2
```

	GPL	PST	SST	AST
SEAS SYSTEM		IS-NR	Active	-----
TDM Port	4	IS-NR	Active	-----
TDM Port	10	IS-NR	Active	-----
OAP	A 026-001-000	IS-NR	Active	-----
OAP	B 026-001-000	IS-NR	Active	-----
X.25 Link	A1	IS-NR	Active	-----
X.25 Link	B1	IS-NR	Active	-----

```
SEAS SYSTEM ALARM STATUS = No Alarms.
OAP A        ALARM STATUS = No Alarms.
OAP B        ALARM STATUS = No Alarms.
X25 Link A1 ALARM STATUS = No Alarms.
X25 Link A2 ALARM STATUS = No Alarms.
X25 Link B1 ALARM STATUS = No Alarms.
X25 Link B2 ALARM STATUS = No Alarms.
```

```
X25 A1 PVCs IS-NR    = 1,2,3
X25 A1 PVCs OOS-MT  = ---
X25 B1 PVCs IS-NR    = 1,2,3
X25 B1 PVCs OOS-MT  = ---
```

```
X25 A2 PVCs IS-NR    = 1,2,3
X25 A2 PVCs OOS-MT  = ---
X25 B2 PVCs IS-NR    = 1,2,3
X25 B2 PVCs OOS-MT  = ---
```

```
Command Completed.
```

If alarms are shown for the OAPs in the **rept-stat-seas** output, contact the Customer Care Center. Refer to "Customer Care Center" on page 1-10 for the contact information.

**Method B:** Perform steps a through d to update both OAPs at the same time. This method is NOT recommended.

## EOAP Provisioning Procedures

- a. Enter the following command:

```
act-oap-config:oap=all
```

After successful completion of this command, the EAGLE 5 ISS returns the following output:

```
rlghncxa03w 05-09-01 11:34:04 GMT EAGLE5 34.0.0
ACT-OAP-CONFIG: MASP A - COMPLTD
```

- b. Wait 15 minutes, then enter the **rept-stat-seas** command to make sure that there are no alarms for the OAPs. This is an example of the possible output:

```
rept-stat-seas
```

```
rlghncxa03w 05-09-01 15:59:06 GMT EAGLE5 34.0.0
SEAS Subsystem Report      IS-NR      Active      -----
SEAS Interfaces Configured = 2  Interfaces IS-NR = 2
```

	GPL	PST	SST	AST	
-----					
SEAS SYSTEM		IS-NR	Active	----	
TDM Port	4	IS-NR	Active	----	
TDM Port	10	IS-NR	Active	----	
OAP	A	026-001-000	IS-NR	Active	----
OAP	B	026-001-000	IS-NR	Active	----
X.25 Link	A1		IS-NR	Active	----
X.25 Link	B1		IS-NR	Active	----

```
SEAS SYSTEM ALARM STATUS = No Alarms.
OAP A        ALARM STATUS = No Alarms.
OAP B        ALARM STATUS = No Alarms.
X25 Link A1 ALARM STATUS = No Alarms.
X25 Link A2 ALARM STATUS = No Alarms.
X25 Link B1 ALARM STATUS = No Alarms.
X25 Link B2 ALARM STATUS = No Alarms.
```

```
X25 A1 PVCs IS-NR    = 1,2,3
X25 A1 PVCs OOS-MT   = ---
X25 B1 PVCs IS-NR    = 1,2,3
X25 B1 PVCs OOS-MT   = ---
```

```
X25 A2 PVCs IS-NR    = 1,2,3
X25 A2 PVCs OOS-MT   = ---
X25 B2 PVCs IS-NR    = 1,2,3
X25 B2 PVCs OOS-MT   = ---
```

```
Command Completed.
```

If alarms are shown for the OAPs in the **rept-stat-seas** output, contact the Customer Care Center. Refer to "Customer Care Center" on page 1-10 for the contact information.

- 
15. Back up the changes using the **chg-db:action=backup:dest=fixed** command. These messages appear; the active Maintenance and Administration Subsystem Processor (MASP) message appears first:

## EOAP Provisioning Procedures

BACKUP (FIXED) : MASP A - Backup starts on active MASP.  
BACKUP (FIXED) : MASP A - Backup on active MASP to fixed disk  
complete.  
BACKUP (FIXED) : MASP A - Backup starts on standby MASP.  
BACKUP (FIXED) : MASP A - Backup on standby MASP to fixed disk  
complete.

---



## VI Editor Quick Reference

Function	Command	Description
<p><b>Invoke <i>vi</i></b> by typing <i>vi &lt;filename&gt;</i>. <i>vi</i> begins in command mode.  <b>Start input mode</b> with any of the “Entering Text” commands listed below.  <b>Return to command mode</b> by typing the command again.  <b>Commands with a #</b> before them denote to repeat the command a number of times or to move to the line of the same number.</p>		
Scrolling	CTRL-d	scroll down a half screen
	CTRL-u	scroll up a half screen
	CTRL-f	scroll forward a screen
	CTRL-b	scroll backward a screen
Cursor Positioning	<#>j	down # of lines
	<#>k	up # of lines
	<#>h	left # of spaces
	<#>l	right # of spaces
	arrow keys	replace h, j, k, and l commands
	<#>G	line # of the file
	G	last line of the file
	H	top of the screen
	M	middle of the screen
	L	last line of the screen
	0 (zero)	beginning of current line
	\$	end of current line
Entering Text	a	append text after cursor
	i	insert text before cursor
	o	open a new line below the current line
	O	open a new line above the current line
Changing Text	<#>x	delete # of characters after and including cursor
	<#>dd	delete # of lines including current line
	D	delete remainder of line to the right of cursor
	J	join next line to the current line
	r	replace character with the next typed character
Copying Changes	<#>yy or <#>Y	yank # of lines, including current line to clipboard
	p	put line from clipboard below the current line
Undoing Changes	u	undoes last command
	U	undoes all changes made to current line before leaving line

<p><b>Invoke <i>vi</i></b> by typing <i>vi &lt;filename&gt;</i>. <i>vi</i> begins in command mode.  <b>Start input mode</b> with any of the “Entering Text” commands listed below.  <b>Return to command mode</b> by typing the command again.  <b>Commands with a #</b> before them denote to repeat the command a number of times or to move to the line of the same number.</p>		
Function	Command	Description
Searching and Replacing	/pattern	search for next occurrence of pattern
	?pattern	search for preceding occurrence of pattern
	n	repeat the last search in the same direction
	n	repeat the last search in the opposite direction
Saving Text and Exiting <i>vi</i>	:w	write to disk and remain in <i>vi</i>
	:q	quit, ignoring changes since last <i>w</i>
	:q!	emphatic quit; use when <i>q</i> fails
	:wq	write to disk and quit <i>vi</i>
	ZZ	same as :wq
Miscellaneous	.	repeat last change
	u	undo last change

# 5

## Test Procedures

Overview .....	5-2
Test Setup .....	5-3
EOAP Tests .....	5-5
Verify Aurora Serial Port Devices .....	5-5
Verify EOAP OSI and X25 Processes .....	5-5
Verify Hosts IP Address .....	5-6
Verify All Processes are Running .....	5-6
Verify AURORA Serial Connections to EAGLE 5 ISS (Single) .....	5-7
Verify AURORA Serial Connections to EAGLE 5 ISS (Dual) .....	5-9
Enter the EOAP Configuration .....	5-11
LoopbackTest of the Test X.25 Interface .....	5-14
Verify LEDs Report No Errors on the EOAP .....	5-17
Test Modem (Logical) .....	5-18
Identify EOAP GPL .....	5-18
Verify EOAP-to-SEAS Connection Status .....	5-20

## Overview

These procedures test EOAP operation for a single-configuration (EOAP-A). Test a dual configuration by rerunning this procedure for EOAP-B. The test verifies the hardware associated with the EOAP and not the actual connection to the SEAC.

**NOTE 1:** The EOAP checklist must be completed and signed by the tester and the customer before these test cases can be performed.

**NOTE 2:** The test procedures in this document are intended to test EOAP Release 30.0 and later.



**WARNING:** Commands in this document are CASE SENSITIVE. Use care when typing in commands, passwords and any other alphanumeric data. This data includes anything typed into the VT520 terminal attached to the EOAP.

Command interface and input locations are:

- EAGLE 5 ISS commands should be directed to the EOAP via a VT520 terminal or PC using PROCOMM with VT320 Emulation connected to the EAGLE 5 ISS MMI terminal ports. These tests will report the status of the EOAP and the corresponding connections.
- Unix commands should be entered into the EOAP via the VT-520. These tests will report the status of the EOAP and the corresponding connections.

EOAP support tests include the following test procedures:

1. Verify each EOAP AURORA serial port device.
2. Verify the EOAP OSI and X25 processes.
3. Verify Hosts IP Address
4. Verify all processes are running.
5. Verify EOAP (single) serial connection to the EAGLE 5 ISS.
6. Verify EOAP (dual) serial connection to the EAGLE 5 ISS.
7. Enter the EOAP configuration.
8. Loopback test of the X.25 interface.
9. Verify the LEDs report no errors on the EOAP.
10. Modem Test (Logical)
11. EOAP GPL Identification
12. Verify the EAGLE 5 ISS reports the status of the (SEAS) EAGLE 5 ISS-to-EOAP connection.

## Test Setup

### EOAP Connections:

The *Eagle Installation Manual* describes how to connect the hardware pieces. Figure 5-1 details the connections required for this test.

- VT-520
- EAGLE 5 ISS
- modem

### Test Equipment:

Below is the required test hardware for the EOAP. For the complete list of EOAP hardware and current part numbers, see the BOM of the EOAP being tested.

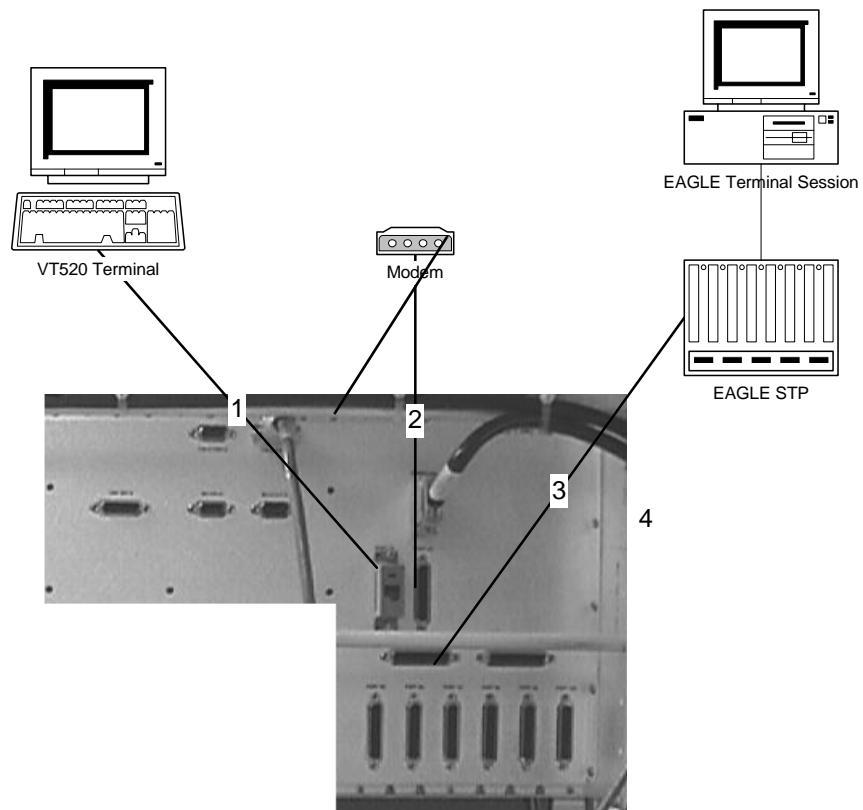
- VT-520 terminal or PC running PROCOMM PLUS.
- RS232C terminal cable(830-0709-XX ) with VT-520 connector adapter (for VT-520 terminal) for connection of the terminal to Ports 1A/1B and/or 2A /2B.
- AURORA synchronous loopback plug.
- EAGLE 5 ISS terminal cable (830-0708-XX) for connection from the EAGLE 5 ISS MMI ports to the EOAP backplane ports 3A/3B and/or 4A/4B.

### Hardware Connections:

See Figure 5-1 for locations of ports and their destinations.

Refer to the *Eagle Installation Manual* for EOAP frame connection and installation procedures.

Figure 5-1. EOAP Connection Diagram



## EOAP Tests

Connect the EOAP as shown in Figure 5-1 and power it up before executing any tests. Start the first test procedure at the first login prompt displayed by the EOAP.

**NOTE 1:** The customer is required to have a CLI.

**NOTE 2:** The EOAP is frame mounted equipment. Utilize the installation and power up procedure outline in the *Eagle Installation Manual* for the proper cabling and fuse assignments.

### Verify Aurora Serial Port Devices

This test will verify that the Aurora device drivers are correctly installed.

#### Test 1

---

- 1 Enter the command to check the Aurora device drivers:

```
% pkginfo | grep AURA*
```

Compare your output to the following output. Your output should contain the three packages shown here in **BOLD**.

```
tekelec-XXX:ccsproj:440->pkginfo | grep AURA*
```

```
system AURAase Aurora 2520/4020/4520/8520P/CP 2000P/3000P Base Driver
system AURAasea Aurora 2520/4020/4520/8520P/CP 2000P/3000P Asynchronous Driver
system AURAases Aurora 2520/4520/8520P/CP 2000P/3000P Synchronous Driver
```

---

### Verify EOAP OSI and X25 Processes

This test will confirm that the OSI and X25 processes are running.

#### Test 2

---

- 1 From the terminal, issue the following commands:

```
% ps -ef | grep osi
```

```
tekelec-XXX:ccsproj:441->ps -ef | grep osi
root 250 1 0 07:23:09 ? 0:00 /usr/sbin/osinetd
root 251 250 0 07:23:09 ? 0:00 /usr/sbin/osilogd
```

```
% ps -e | grep x25
```

```
tekelec-XXX:ccsproj:442->ps -ef | grep x25
root 223 222 0 07:23:08 ? 0:00 x25netd
root 222 1 0 07:23:08 ? 0:00 x25netd
```

---

- Verify that the process names in the output matches the screen capture in step 1. If the processes are NOT running, this may indicate the licenses are not installed correctly.

The processes shown in **BOLD** must be confirmed as present for this test to pass.

---

## Verify Hosts IP Address

**This procedure will test and verify HOSTS address were installed in to the ETC/HOSTS File**

### Test 3

---

- Enter the command to check the hosts IP address:

```
tekelec-XXX:ccsproj% more /etc/hosts
```

Compare the output to the screen shot to the right. The output should contain the two address examples shown here in **BOLD**.

```
eoapl200a:ccsproj%more /etc/hosts
127.0.x.x      localhost
129.200.x.x   tekelec-xx    loghost
```

---

## Verify All Processes are Running

### Test 4

---

- Log into the EOAP:

```
Console login: ccsproj
```

```
Password: XXXXXXXX
```

```
Last login: Wed Aug  9 07:23:48 on console
Sun Microsystems Inc.  SunOS 5.5.1    Generic May 1996
You have new mail.
```

---

- Type the following command to change to the EOAP Application Executables:

```
Console login: cd /ccsosmr
```

```
Console login: ccsproj%ls
```

```
MR.os54  STPCCSM1013  filelist  lost+found  modelSTP
```

```
Console login: ccsproj% cd STP*/bin
```



**NOTE:** STP\* is an example of the instance usually in caps

---

- 3 To verify that all processes are up and running, enter:

*% ccsmr all.status*

**NOTE:** Only applicable processes are listed.

Verify all these Processes are running. If a process is not shown on the screen, then the process is *not* running.

The following example is for a default instance with X25Config of L2P3; the X.25 PVC daemons will be different if the instance is not configured with L2P3.

```
tekelec-XXX:ccsproj% ccsmr all.status

***** System (msDI) registration report starts *****
***** date/time==> Wed Aug 9 07:34:32 2000
* Process=(msDI00), Host(tekelec-XXX)/PID=(352): IPC directory daemon
* Process=(ysT300), Host(tekelec-XXX)/PID=(390):
* Process=(ysA201), Host(tekelec-XXX)/PID=(405): UAL Timeout/PVC state cntl
daemon
* Process=(ysA301), Host(tekelec-XXX)/PID=(421): UAL Multi-Seg. Re-assembly
daemon
* Process=(ysA401), Host(tekelec-XXX)/PID=(437): UAL conf. fail/clear daemon
* Process=(ysAD001), Host(tekelec-XXX)/PID=(463): OS Contract OS to NE daemon
* Process=(ysAD01), Host(tekelec-XXX)/PID=(494): UAL test msg echo
* Process=(ysT100), Host(tekelec-XXX)/PID=(492):
* Process=(ysT200), Host(tekelec-XXX)/PID=(493):
* Process=(ysA102), Host(tekelec-XXX)/PID=(618): UAL/X.25 PVC daemon
* Process=(ysA101), Host(tekelec-XXX)/PID=(613): UAL/X.25 PVC daemon
* Process=(ysA103), Host(tekelec-XXX)/PID=(632): UAL/X.25 PVC daemon
* Process=(ysTT00), Host(tekelec-XXX)/PID=(644):
* Process=(emsAgent), Host(tekelec-XXX)/PID=(673): EMS AGENT
* Process=(emsStatusUpdate), Host(tekelec-XXX)/PID=(688): EMS Agent Status
```

---

### Verify AURORA Serial Connections to EAGLE 5 ISS (Single)

This procedure will test each of the AURORA serial ports connected to the EAGLE 5 ISS. The Aurora card's serial ports 3A and 4A will be connected to an EAGLE 5 ISS terminal connection on the backplane. Refer to Figure 5-1 for connection example.

**NOTE:** A maximum of two EOAP ports can be assigned. For the location of the serial ports, refer to Figure 5-1. EAGLE 5 ISS terminal x was used for this example. Any configurable terminal can be used.

### Test 5

---

- 1 Test serial port 3A

Connect the AURORA serial port 3A to the EAGLE 5 ISS terminal port X and wait 5 seconds for the maintenance poll. From the EAGLE 5 ISS command terminal, enter the following commands to configure the EAGLE 5 ISS for use with an EOAP:

If site is SEAS only:

*CHG-FEAT:SEAS=ON*

*CHG-FEAT:FAN=ON (If not already ON)*

*INH-TRM:TRM=X*

*CHG-TRM:TRM=X:TYPE=OAP:ALL=NO*

*ALW-TRM:TRM=X*

*RTRV-TRM:TRM=X*

*REPT-STAT-TRM:TRM=X*

**NOTE 1: "X" denotes the terminals identified as OAP.**

**NOTE 2: All terminal output group parameters must be set to NO for OAP terminals**

- 
- 2 Disconnect the AURORA Serial Port 3A cable from the EAGLE 5 ISS terminal PORT X.
- 

- 3 From the EAGLE 5 ISS terminal, enter the following commands:

*RTRV-TRM:TRM=X*

*REPT-STAT-TRM:TRM=X*

A terminal failure indication should be displayed on the EAGLE 5 ISS terminal screen after disconnection of AURORA Serial Port 3A.

---

- 4 **Test serial port 4A**

Connect the AURORA serial port 4A to the EAGLE 5 ISS terminal port X and wait 5 seconds for the maintenance poll.

**NOTE: A maximum of two EOAP ports can be assigned. For the location of the serial ports please refer to Figure 5-1 on page 5-4.**

From the EAGLE 5 ISS command terminal, enter the following commands to configure the EAGLE 5 ISS for use with an EOAP:

If site is SEAS only:

*INH-TRM:TRM=X*

*CHG-TRM:TRM=X:TYPE=OAP:ALL=NO*

## Test Procedures

*ALW-TRM:TRM=X*

*RTRV-TRM:TRM=X*

*REPT-STAT-TRM:TRM=X*

**NOTE 1:** "X" denotes the terminals identified as OAP.

**NOTE 2:** All terminal output group parameters must be set to NO for OAP terminals

- 
- 5 Disconnect the AURORA Serial Port 4A cable from the EAGLE 5 ISS terminal PORT X.
- 

- 6 From the EAGLE 5 ISS terminal, enter the following commands:

*RTRV-TRM:TRM=X*

*REPT-STAT-TRM:TRM=X*

A terminal failure indication should be displayed on the EAGLE 5 ISS terminal screen after disconnection of AURORA Serial Port 4A.

---

### Verify AURORA Serial Connections to EAGLE 5 ISS (Dual)

This procedure will test each of the AURORA serial ports connected to the EAGLE 5 ISS. The Aurora card's serial ports 3A and 3B will be connected to an EAGLE 5 ISS terminal connection on the backplane. Refer to Figure 5-1 for connection example.

**NOTE:** A maximum of two EOAP ports can be assigned. For the location of the serial ports, refer to Figure 5-1. EAGLE 5 ISS terminal x was used for this example. Any configurable terminal can be used.

### Test 6

---

#### 1 Test serial port 3A

Connect the AURORA serial port 3A to the EAGLE 5 ISS terminal port X and wait 5 seconds for the maintenance poll. From the EAGLE 5 ISS command terminal, enter the following commands to configure the EAGLE 5 ISS for use with an EOAP:

If site is SEAS only:

*CHG-FEAT:SEAS=ON*

*CHG-FEAT:FAN=ON (If not already ON)*

*INH-TRM:TRM=X*

*CHG-TRM:TRM=X:TYPE=OAP:ALL=NO*

*ALW-TRM:TRM=X*

*RTRV-TRM:TRM=X*

*REPT-STAT-TRM:TRM=X*

**NOTE 1:** "X" denotes the terminals identified as OAP.

**NOTE 2:** All terminal output group parameters must be set to NO for OAP terminals

- 
- 2 Disconnect the AURORA Serial Port 3A cable from the EAGLE 5 ISS terminal PORT X.
- 

- 3 From the EAGLE 5 ISS terminal, enter the following commands:

*RTRV-TRM:TRM=X*

*REPT-STAT-TRM:TRM=X*

A terminal failure indication should be displayed on the EAGLE 5 ISS terminal screen after disconnection of AURORA Serial Port 3A.

---

- 4 **Test serial port 3B**

Connect the AURORA serial port 3B to the EAGLE 5 ISS terminal port X and wait 5 seconds for the maintenance poll.

**NOTE 1:** A maximum of two EOAP ports can be assigned. For the location of the serial ports please refer to Figure 5-1 on page 5-4.

**NOTE 2:** EAGLE 5 ISS terminal X was used for this example. Any configurable terminal can be used

From the EAGLE 5 ISS command terminal, enter the following commands to configure the EAGLE 5 ISS for use with an EOAP:

If site is SEAS only:

*INH-TRM:TRM=X*

*CHG-TRM:TRM=X:TYPE=OAP:ALL=NO*

*ALW-TRM:TRM=X*

*RTRV-TRM:TRM=X*

## Test Procedures

*REPT-STAT-TRM:TRM=X*

**NOTE 1:** "X" denotes the terminals identified as OAP.

**NOTE 2:** All terminal output group parameters must be set to NO for OAP terminals

- 
- 5 Disconnect the AURORA Serial Port 3B cable from the EAGLE 5 ISS terminal PORT X.
- 

- 6 From the EAGLE 5 ISS terminal, enter the following commands:

*RTRV-TRM:TRM=X*

*REPT-STAT-TRM:TRM=X*

A terminal failure indication should be displayed on the EAGLE 5 ISS terminal screen after disconnection of AURORA Serial Port 3B.

---

### Enter the EOAP Configuration

This procedure will Enter and Activate the OAP configuration.

**NOTE:** HostName < tekelec-xxx > should be located on the rear of the EOAP; if they are not identified contact ITAC.

### Test 7

---

- 1 Issue the command to configure the EOAP.

For Single EOAP Configuration, enter:

*chg-oap-config:aname="tekelec-xxx":cfg=sgl*

*:x25mode= DTE :x25ps= 7*

For Dual EOAP Configuration, enter:

*chg-oap-config:aname="tekelec-xx":bname="tekelec-xx":cfg=dual*

*:x25mode= DTE :x25ps= 7*

Range: one alphabetic character followed by one to 13 alphanumeric characters. The value should be enclosed in quotes (" "), for example, aname="tekelec-10".

Output for Single Configuration:

```
> chg-oap-config:aname="tekelec-xxx":cfg=sngl:x25mode=dte:x25ps=7
```

```
Command Accepted - Processing
```

```

tekelecstp 05-03-15 14:47:09 EST EAGLE5 ????.?-46.33.1
chg-oap-config:aname="tekelec-xxx":cfg=sngl:x25mode=dte:x25ps=7
Command entered at terminal #1.
;

tekelecstp 05-03-15 14:47:09 EST EAGLE5 ????.?-46.33.1
CHG-OAP-CONFIG: MASP B - COMPLTD

```

**Output for Dual Configuration:**

```

> chg-oap-config:aname="tekelec-xxx":cfg=dual:bname="tekelec=xxx":
cfg=dual:x25mode=dte:x25ps=7

Command Accepted - Processing

tekelecstp 05-03-15 14:49:23 EST EAGLE5 ????.?-46.33.1
8604.1149 CARD 1301,A INFO SLK Level-3 T19 timer expired
Report Date:05-03-15 Time:14:49:23
;

tekelecstp 05-03-15 14:49:25 EST EAGLE5 ????.?-46.33.1
chg-oap-config:aname="tekelec-xxx":cfg=dual:bname="tekelec=xxx":
cfg=dual:x25mode=dte:x25ps=7

Command entered at terminal #1.
;

tekelecstp 05-03-15 14:49:26 EST EAGLE5 ????.?-46.33.1
CHG-OAP-CONFIG: MASP B - COMPLTD
;

```

**2 Issue the command to retrieve EOAP configuration:**

*rtrv-oap-config*

```

> rtrv-oap-config

Command Accepted - Processing

tekelecstp 05-03-15 14:41:15 EST EAGLE5 ????.?-46.33.1
rtrv-oap-config
Command entered at terminal #1.
;

tekelecstp 05-03-15 14:41:15 EST EAGLE5 ????.?-46.33.1
OAP CONFIGURATION REPORT

DATA                OAP A                OAP B
-----                -
Hostname            tekelec-260          tekelec-259
IP Address           <Not configured>    <Not configured>
IP Netmask           <Not configured>    <Not configured>
Default Router       <Not configured>    <Not configured>
Config               dual                  dual
SEAC CLLI            TEKELECSTP           TEKELECSTP
X25 Packet Size     7                     7
X25 Mode             DTE                   DTE
;

```

**3 Issue the command to Activate EOAP configuration:**

## Test Procedures

### *act-oap-config*

```
> act-oap-config
```

```
Command entered at terminal #1.
```

```
;
```

```
tekelecstp 01-10-22 09:12:54 HST Rel XX.X.X-XX.X.X  
ACT-OAP-CONFIG MASP A - COMPLTD
```

---

#### 4 Example with one EOAP or L2P3 set in the DEFAULTS FILE:

### *rept-stat-seas*

```
tekelecstp 96-01-04 15:59:06 EST Rel 24.0.0  
GPL          PST          SST          AST  
-----  
SEAS SYSTEM                                OOS-MT      Fault      ----  
TDM Port    8                                IS-NR      Active     ----  
EOAP       A    024-006-000  IS-NR      Active     ----  
X25 Link    A1                                OOS-MT      Fault      ----  
X25 Link    B1                                OOS-MT      Fault      ----  
  
SEAS SYSTEM ALARM STATUS = *C 0349 SEAS unavailable  
SEAS EOAP A ALARM STATUS = No Alarms  
X25 Link A1 ALARM STATUS = ** 0343 X.25 Link unavailable  
X25 Link B1 ALARM STATUS = ** 0343 X.25 Link unavailable  
  
X25 A1 PVCs IS-NR = ---  
X25 A1 PVCs OOS-MT = ---  
  
X25 B1 PVCs IS-NR = ---  
X25 B1 PVCs OOS-MT = ---  
Command completed.
```

---

#### 5 Example with 2 EOAP's (A & B) or DUAL MODE or L1P3 set in the DEFAULTS FILE.

**NOTE: The GPL of the EOAP may be different depending on the EAGLE 5 ISS and EOAP release. The PST may vary from IS-NR to IS-ANR depending on status of X.25 links. A SST state of restricted means the EOAP is communicating to the EAGLE 5 ISS however the X.25 is FAULT. If a second EOAP is connected rept-stat-seas will display both EOAP's if the X25 Config in the EOAP's DEFAULT file, is set to L1P3.**

### *rept-stat-seas*

```
tekelecstp 96-01-04 15:59:06 EST Rel 24.0.0  
GPL          PST          SST          AST  
-----  
SEAS SYSTEM                                OOS-MT      Fault      ----  
TDM Port    8                                IS-NR      Active     ----  
TDM Port    9                                IS-NR      Active     ----  
EOAP       A    024-006-000  IS-NR      Active     ----  
EOAP       B    024-006-000  IS-NR      Active     ----  
X25 Link    A1                                OOS-MT      Fault      ----  
X25 Link    B1                                OOS-MT      Fault      ----
```

```
SEAS SYSTEM ALARM STATUS = *C 0349 SEAS unavailable
SEAS EOAP A ALARM STATUS = No Alarms
X25 Link A1 ALARM STATUS = ** 0343 X.25 Link unavailable
X25 Link B1 ALARM STATUS = ** 0343 X.25 Link unavailable

X25 A1 PVCs IS-NR = ---
X25 A1 PVCs OOS-MT = ---

X25 B1 PVCs IS-NR = ---
X25 B1 PVCs OOS-MT = ---
Command completed.
```

---

## LoopbackTest of the Test X.25 Interface

An Aurora loopback plug is connected to each of the X.25 ports on the X.25 interface. This test confirms correct operation of each port and the cable.

### Test 8

---

- 1 From the EOAP terminal, login as root:

```
Console login:
```

```
Password: XXXXXX
```

Verify the Login was successful

```
Aug 9 07:27:42 tekelec-327 login: ROOT LOGIN /dev/console
Last login: Wed Aug 9 07:25:42 on console
Sun Microsystems Inc. SunOS 5.5.1 Generic May 1996
tekelec-XX:% root
Password:XXXXXX
tekelec-XXX:root#
```

---

- 2 Place the loopback connector on port 5A of the EOAP A backplane. Enter the following command at the prompt to take down X.25 software on the links:

```
tekelec-XXX:root#cd /etc/rc2.d
```

```
tekelec-XXX:root# ./S87x25net stop
```

---

- 3 Confirm that the network has been stopped:

```
The X.25 software is being stopped - please wait
The network programs are being killed - please wait
NOTICE: LAPB Down on link 0
NOTICE: LAPB Down on link 0
The network has been stopped
```

---

- 4 Enter the following command to execute the loopback test of synchronous port 5A:



## Test Procedures

```
tekelec-XXX:root#syncloop -t 2 ases2
```

Verify that the amount of packets sent is the amount of packets received.

```
[ Data device: /dev/ases3 | Control device: /dev/ases, ppa=3 ]
speed=9600, loopback=no, nrzi=no, txc=baud, rxc=rxr
[ checking for quiet line ]
[ Trying first packet ]
[ Trying many packets ]
100
100 packets sent, 100 received
CRC errors   Aborts   Overruns   Underruns           In <-Drops-> Out
           0         0         0         0                 0         0
estimated line speed = 9485 bps
```

---

- 5 Place the loopback connector on port 6A of the EOAP A backplane. Enter the following command at the prompt to take down X.25 software on the links:

```
tekelec-XXX:root#cd /etc/rc2.d
tekelec-XXX:root#cd ./S87x25net stop
```

---

- 6 Confirm that the network has been stopped.

```
The X.25 software is being stopped - please wait
The network programs are being killed - please wait
NOTICE: LAPB Down on link 0
NOTICE: LAPB Down on link 0
The network has been stopped
```

---

- 7 Enter the following command to execute the loopback test of synchronous port 6A :

```
tekelec-XXX:root#syncloop -t 2 ases3
```

---

- 8 Verify that the amount of packets sent is the amount of packets received.

**NOTE: Confirm that the test returns no errors.**

```
[ Data device: /dev/ases2 | Control device: /dev/ases, ppa=2 ]
speed=9600, loopback=no, nrzi=no, txc=baud, rxc=rxr
[ checking for quiet line ]
[ Trying first packet ]
[ Trying many packets ]
100
100 packets sent, 100 received
CRC errors   Aborts   Overruns   Underruns           In <-Drops-> Out
           0         0         0         0                 0         0
estimated line speed = 9485 bps
```

---

- 9 Enter the following command at the prompt to bring up the X.25 software on the links:

```
tekelec-XXX:root# /etc/rc2.d/S87x25net start
```

---

- 10 Repeat Step 1 through Step 9 for B side EOAP (5B and 6B) if applicable.
-

## Test Procedures

### Verify LEDs Report No Errors on the EOAP

This test is a confirmation of the status of the LEDs. All cables are connected to the EOAP, and the EOAP is powered up.

#### Test 9

---

- 1 After power-up, verify the upper left LED (Run LED) on the EOAP processor card is **GREEN**.

**Figure 5-2.** Verify LED on EOAP Is Green



## Test Modem (Logical)

This test will verify that the modem software has been configured correctly. The last line of the screen output, shown in **BOLD**, must be identical to the example in step 2.

### Test 10

---

- 1 From the EOAP terminal at the root directory. Change to the "su" super-user.

```
tekelec-XXX:ccsproj%cd
```

```
tekelec-XXX:ccsproj%su
```

Password: (See ITAS for passwords)

```
# Aug  9 07:34:41 tekelec-XXX 'su root' succeeded for ccsproj on /dev/console
```

---

- 2 At the command line prompt, issue the command to verify modem software:

```
# pmadm -l
```

```
PMTAG          PMTYPE          SVCTAG          FLGS ID          <PMSPECIFIC>
ttymon0        ttymon          0               ux  root           /dev/term/0 - -
/usr/bin/login - 9600 - login: - - - #/dev/term/0
ttymon0        ttymon          1               ux  root           /dev/term/1 - -
/usr/bin/login - 9600 - login: - - - #/dev/term/1
ttymon0        ttymon          2               ux  root           /dev/term/2 - -
/usr/bin/login - 9600 - login: - - - #/dev/term/2
zsmon          ttymon          ttya            u   root           /dev/term/a I -
/usr/bin/login - 9600 ldterm,ttcompat ttya login: - tvi925 y #
zsmon          ttymon          3               u   root           /dev/term/b - -
/usr/bin/login - 9600E ldterm,ttcompat login: - 3 n
#
```

**NOTE:** The output from the command should look something like this. The last line (bold) is the critical one.

---

## Identify EOAP GPL

This test is to identify the GPL of the EOAP just built and tested.

### Test 11

---

- 1 From the EOAP terminal, enter the command to view the contents of the **gpl** directory for the **modelSTP**:

```
# pkgingo | grep TKLC
```

Verify the output.

## Test Procedures

Application TKLCoap OAP Applocation 28.0.16 Tekelec build 08/20/2002  
Application TKLCop702 OAP Platform upgrade 7.2 Tekelec bulild 10/25/2001  
Application TKLCop703 OAP Platform upgrade 7.3 Tekelec bulild 11/21/2001  
Application TKLCop704 OAP Platform upgrade 7.4 Tekelec bulild 02/04/2002  
Application TKLCscoop Syscheck Enhancement for OAP 1.0.3 Tekelec.Build  
11/21/2001  
Application TKLCsysck Syscheck Core Engine & Generic Modules (compiled) 1.0.4c  
Tekelec build 10/25/20001

%

**NOTE: This output is only an example of a particular Release.**

---

## Verify EOAP-to-SEAS Connection Status

### Initial conditions:

- All cables from the EAGLE 5 ISS to the EOAP are connected.
- The SEAS feature in *Verify All Processes are Running* on page 5-6 was turned on.
- The EOAP TDM ports are allowed.
- No X.25 links are available.

### Test 12

---

- 1 Generate a summary report of the status of the SEAS subsystem on the EAGLE 5 ISS using **one** EOAP or **L2P3** set in the DEFAULT FILE.

*rept-stat-seas*

```
tekelecstp 96-01-04 15:59:06 EST Rel 30.0.0
          GPL          PST          SST          AST
-----
SEAS SYSTEM          OOS-MT          Fault          ----
TDM Port      3          IS-NR          Active          ----
EOAP      A      026-000-000  IS-NR          Active          ----
X25 Link      A1          OOS-MT          Fault          ----
X25 Link      B1          OOS-MT          Fault          ----

SEAS SYSTEM ALARM STATUS = *C 0349 SEAS unavailable
SEAS EOAP A  ALARM STATUS = No Alarms
X25 Link A1 ALARM STATUS = ** 0343 X.25 Link unavailable
X25 Link B1 ALARM STATUS = ** 0343 X.25 Link unavailable

X25 A1 PVCs IS-NR    = ---
X25 A1 PVCs OOS-MT  = ---

X25 B1 PVCs IS-NR    = ---
X25 B1 PVCs OOS-MT  = ---
Command completed.
```

**NOTE:** The GPL of the EOAP may be different depending on the EAGLE 5 ISS and EOAP release. The PST may vary from IS-NR to IS-ANR depending on status of X.25 links. An SST state of "restricted" means the EOAP is communicating to the EAGLE 5 ISS, however the X.25 is FAULT. If a second EOAP is connected, *rept-stat-seas* will display both EOAPs if the X25 Config in the EOAP's DEFAULT file is set to L1P3.

---

## Test Procedures

- 2 Generate a summary report of the status of the SEAS subsystem on EAGLE 5 ISS using **two** EOAPs (Dual Mode) or **L1P3** set in the DEFAULT FILE.

*rept-stat-seas*

```
tekelecstp 96-01-04 15:59:06 EST Rel 30.0.0
-----
                GPL                PST                SST                AST
-----
SEAS SYSTEM                                OOS-MT                Fault                ----
TDM Port      3                                IS-NR                Active                ----
TDM Port      9                                IS-NR                Active                ----
EOAP          A      026-000-000            IS-NR                Active                ----
EOAP          B      026-000-000            IS-NR                Active                ----
X25 Link      A1                                OOS-MT                Fault                ----
X25 Link      B1                                OOS-MT                Fault                ----

SEAS SYSTEM ALARM STATUS = *C 0349 SEAS unavailable
SEAS EOAP A  ALARM STATUS = No Alarms
X25 Link A1 ALARM STATUS = ** 0343 X.25 Link unavailable
X25 Link B1 ALARM STATUS = ** 0343 X.25 Link unavailable

X25 A1 PVCs IS-NR      = ---
X25 A1 PVCs OOS-MT    = ---

X25 B1 PVCs IS-NR      = ---
X25 B1 PVCs OOS-MT    = ---
Command completed.
```

**NOTE:** The GPL of the EOAP may be different depending on the EAGLE 5 ISS and EOAP release. The PST may vary from IS-NR to IS-ANR depending on status of X.25 links. An SST state of "restricted" means the EOAP is communicating to the EAGLE 5 ISS, however the X.25 is FAULT. If a second EOAP is connected, *rept-stat-seas* will display both EOAPs if the X25 Config in the EOAP's DEFAULT file is set to L1P3.

---





## EOAP Test Completion Checklist and Sign Off Matrix

Confirmation that the EOAP Operational Test has been completed. The Customer's signature is only required if not completed in conjunction with the EAGLE 5 ISS Acceptance Test. Please **place a copy in the site file book**.

**Site Name:** \_\_\_\_\_

**Site Serial Number: NT** \_\_\_\_\_

**EOAP Serial Number:** \_\_\_\_\_

**Operating Company:** \_\_\_\_\_

**Operating Company Representative (PRINT):** \_\_\_\_\_

**Operating Company Representative (SIGN):** \_\_\_\_\_

**TEKELEC Representative (PRINT):** \_\_\_\_\_

**TEKELEC Representative (SIGN):** \_\_\_\_\_

**Date started:** \_\_\_\_\_ **Date completed:** \_\_\_\_\_

Test #	Test Category/Description	Pass 1	Fail 1	Initial
1	The EOAP is frame mounted equipment. Utilize the installation and power up procedure outline in the Eagle Installation Manual for the proper cabling and fuse assignments.			
2	Verify Aurora Serial Port Devices			
3	Verify All Processes are Running			
4	Verify AURORA Serial Connections to EAGLE 5 ISS (Single)			
5	Verify AURORA Serial Connections to EAGLE 5 ISS (Dual)			
6	Verify Hosts IP Address			
7	Enter the EOAP Configuration			
8	LoopbackTest of the Test X.25 Interface			
9	Verify LEDs Report No Errors on the EOAP			
10	Test Modem (Logical)			
11	Identify EOAP GPL			
12	Verify EOAP-to-SEAS Connection Status			



# 6

## Replacement Procedures

Overview .....	6-2
Air Management Card .....	6-3
Card Cage/Shelf .....	6-8
Power Down the EOAP/Fan Assembly .....	6-10
Remove Cables .....	6-14
Remove Cards.....	6-17
Remove Card Cage .....	6-18
Reconnect Cables .....	6-24
Install Cards .....	6-22
Power Up EOAP/Fan Assembly .....	6-31
CD-ROM Drive Card .....	6-34
Fan Assembly .....	6-41
Remove Fan Assembly .....	6-42
Install Replacement Fan Assembly .....	6-44
Test Fan Operation and Fan Alarm .....	6-48
Hard Drive Card .....	6-51
Replace Hard Drive Card.....	6-52
Reprovision Hard Drive.....	6-59
Power Supply Card .....	6-66
Processor Card .....	6-73
Serial Card .....	6-85

## Overview

Use this chapter to locate replacement procedures for major hardware components required to maintain the EOAP.

These components include:

- All cards
  - Air management card (P/N 870-1524-01)
  - CD-ROM drive card (P/N 870-1515-03)
  - Hard drive card (P/N 870-1514-03)
  - Power supply card (P/N 870-1521-01)
  - Processor card (P/N 870-1523-01)
  - Serial card (P/N 870-1522-01)
- EOAP shelf:
  - Card cage, empty (P/N 870-1498-01)
  - Single configuration (P/N 890-1050-01)
  - Dual configuration (P/N 890-1050-03)
- Fan assembly (P/N 890-1038-01)

Replacement procedures are listed in alphabetical order of the hardware component. When the replacement of a component requires reprovisioning or testing to return the component to full operation, the provisioning or testing procedure immediately follows the hardware installation procedure. Refer to the chapter table of contents for a listing and page numbers.

For initial installation procedures, for example, the mounting of a preassembled EOAP shelf or detailed cabling instructions, refer to Chapter 3, *Installation Procedures*. For initial provisioning procedures, for example, the provisioning of the EOAP hard drive to implement the EOAP, refer to the applicable EAGLE 5 ISS manual.

### Air Management Card

This procedure describes how to replace an air management card (P/N 870-1524-01) in the EOAP shelf. This card does not contain any circuit boards and functions mainly as filler card. For its replacement, no halting of the EOAP is required.



**WARNING:** Prior to working on or around live equipment, follow proper ESD grounding procedures to prevent damage to the equipment; reference *ESD Protection Procedure (907-0404-01)*.

#### Tools and Equipment

- ESD-safe Phillips screwdriver
- Air management card (P/N 870-1524-01)

#### Procedure

---

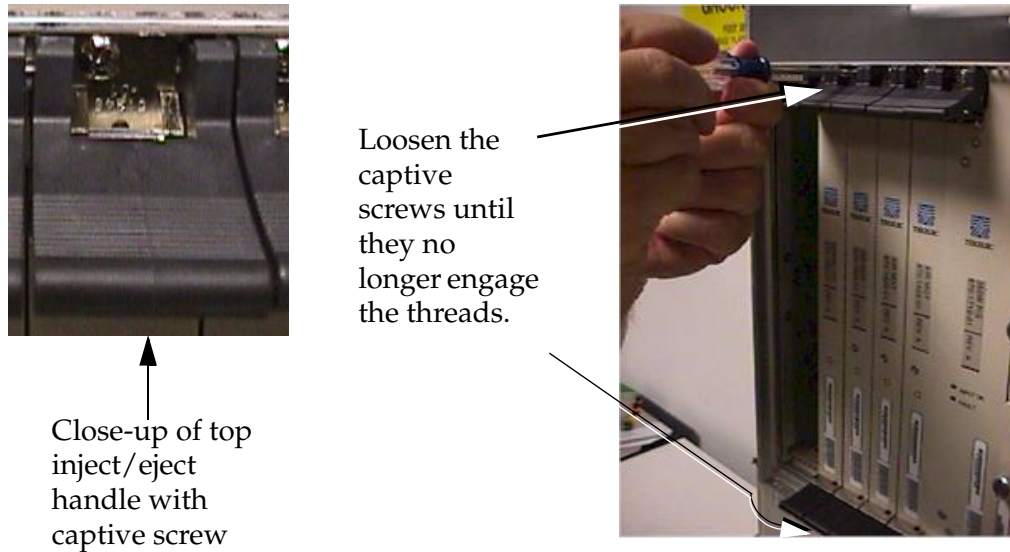
- 1 Identify the EOAP system (EOAP-A or EOAP-B) that contains the card to be replaced.

---
2. Locate the air management card to be replaced (slot 3, 4, 5, or 6).

---
3. While facing the card to be replaced, locate the two captive screws attached to the top and bottom inject/eject handle brackets on the faceplate. Figure 6-1 shows a close-up of the top handle with captive screw.

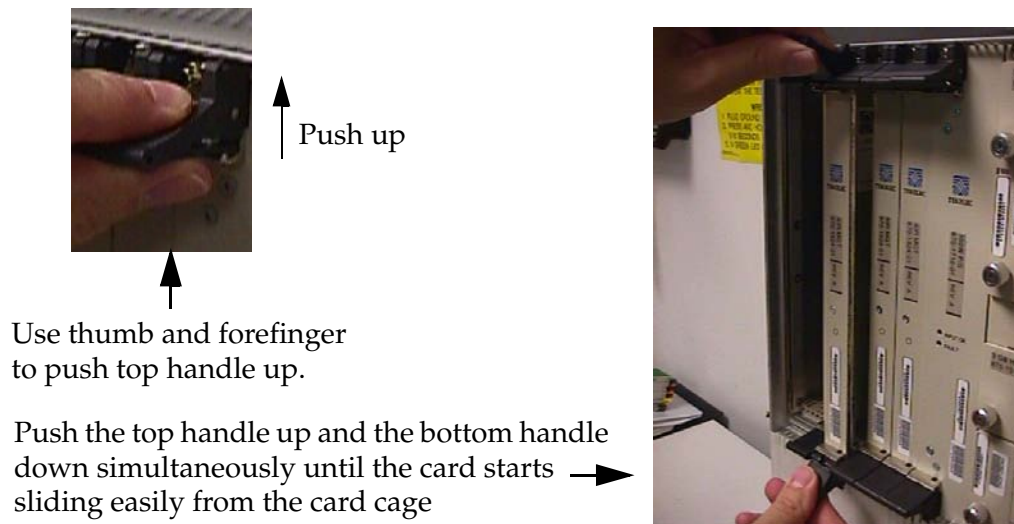
---
4. Using a small Phillips head screwdriver, loosen the captive screws until they no longer engage the threads. **Do not remove the screws** from the ejector handle brackets.

**Figure 6-1.** Top Handle and Captive Screw of Air Management Card



- Using the thumb and forefinger, push the top handle up and the bottom handle down simultaneously until the card starts sliding easily from the card cage.

**Figure 6-2.** Freeing the Card from the EOAP Card Cage



- Pull the card directly towards you until it clears the card guides and guide rails.

## Replacement Procedures

7. Remove the replacement air management card from the shipping container.

**Figure 6-3.** Air Management Card (P/N 870-1524-01)



← Replacement  
Air Management Card

- 
8. Make sure the two captive screws located in the inject/eject handle brackets are partially backed out so they do not interfere with insertion.

- 
9. Push all handles outward from the replacement card's faceplate (top handle in the "UP" position, bottom handle in the "DOWN" position.)

**Figure 6-4.** Air Management Card Handles



← Top handle in the  
"UP" position

← Bottom handle in the  
"DOWN" position

- Carefully align the replacement card's edges with the channels in the top and bottom card guides. Refer to Figure 6-5. Then push the card along the length of card guides until you feel the card's progress cease.

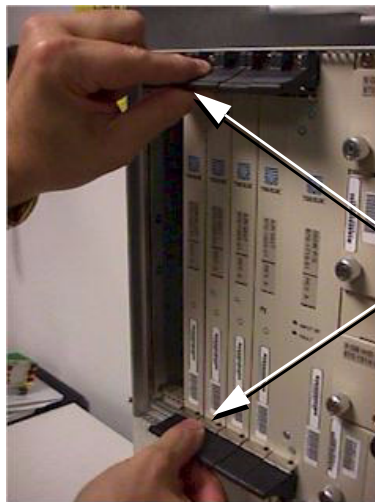
**Figure 6-5.** Inserting the Replacement Air Management Card



Push the card along the length of card guides until you feel the card's progress cease.

- Using the thumb and forefinger together, push the top inject/eject handle down and the bottom handle up until both handles are in the locked position. Figure 6-7 shows a close-up of a top inject/eject handle in the locked position.

**Figure 6-6.** Lock the Inject/Eject Handles



Handles in locked position



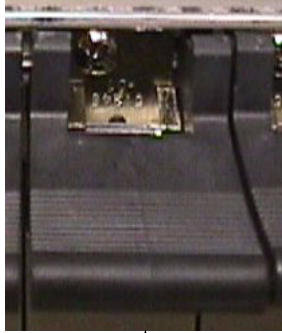
## Replacement Procedures

- Using a small Phillips head screwdriver, tighten all captive screws in the handle brackets until they seat against the handle bracket.



**WARNING:** Do not overtighten as the heads on the screws could snap off. Refer to the *Mechanical Assembly Torque Specification (906-0008-01)*.

Figure 6-7. Tighten Captive Screws



Close-up of top  
inject/eject  
handle with  
captive screw

Tighten the  
captive  
screws until  
they seat  
against the  
handle  
bracket.



## Card Cage/Shelf

This section describes how to replace an existing EOAP card cage or an EOAP shelf with cards preinstalled. Before replacing the card cage or shelf, make sure that either a substitute EOAP is set up to prevent any interruption with the STP or that the replacement is performed during a maintenance window.



**DANGER:** Exercise extreme care and strict adherence to safety precautions when working on or near electrical equipment.



**WARNING:** Perform the EOAP card cage or shelf replacement procedure in a 4-hour maintenance window. This allows for the EAGLE 5 ISS to be able to resynchronize without requiring a time-consuming bulk download.



**WARNING:** Follow proper ESD grounding procedures at all times. Reference ESD Protection Procedure (907-0404-01).

**NOTE:** Some of the following procedures require more than one person.

### Replacement Order

Replace the card cage in the stages and order listed below:

1. Power down the EOAP
2. Disconnect the cables
3. Remove the cards
4. Remove the card cage
5. Install the replacement card cage **or shelf**
6. Reconnect the cables
7. Install the cards
8. Power up the EOAP

## Replacement Procedures

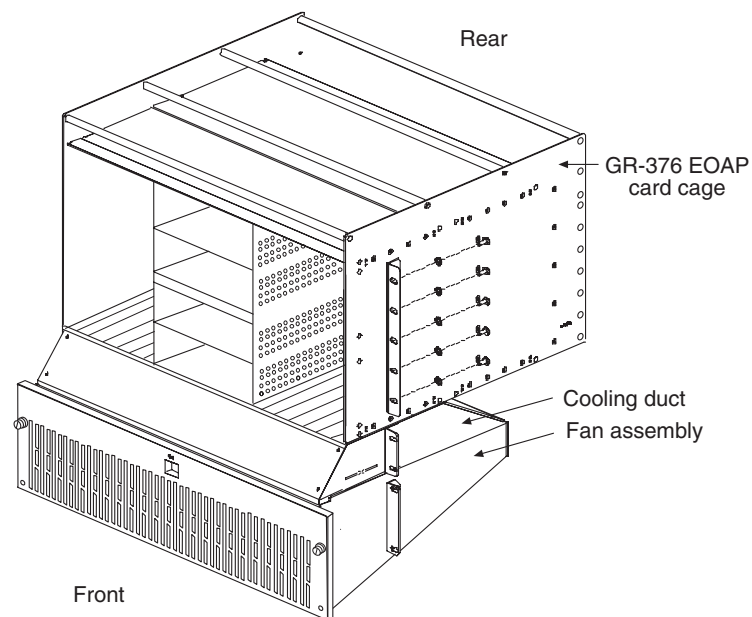
### Tools and Equipment

Use the following tools and equipment to replace the EOAP card cage or shelf:

- ESD-safe Phillips screw driver
- EOAP shelf:
  - Empty card cage (P/N 870-1498-01)
  - Single configuration (P/N 890-1050-03)
  - Dual configuration (P/N 890-1050-01)
- Screws for mounting brackets (P/N 600-0154)
- Screw/washer combinations for frame mounting (P/N 601-0010-01)

Figure 6-8 shows an empty EOAP card cage.

**Figure 6-8.** EOAP Card Cage



Use the following procedures to replace the EOAP card cage in the OAP frame.

### Power Down the EOAP/Fan Assembly

This procedure describes how to power down the EOAP shelf and the fan assembly. Powering down an EOAP shelf also stops the fan assembly because both units use the same fuses.



**WARNING:** The EOAP can operate without failure or component damage for up to one hour without the fan tray providing cooling. After powering up the EOAP, complete fan testing within this time frame.



**CAUTION:** The EOAP's open system architecture allows access to the operating system. Any undocumented changes to the files may cause the system to become corrupted and unusable. Making any undocumented changes on the EOAP, including changes to the hardware, operating system and/or the components found therein will void the warranty.

Procedure

- 1 Display the values of all terminals using the `rtrv-trm` command. This is an example of the possible output:

```
rlghncxa03w 00-06-07 11:34:04 EST Rel 26.0.0
TRM  TYPE      COMM          FC      TMOUT  MXINV  DURAL
1    VT320      9600-7-E-1 SW    30      5      99:59:59
2    KSR        9600-7-E-1 HW    30      5      INDEF
3    PRINTER    4800-7-E-1 HW    30      0      00:00:00
4    OAP        19200-7-E-1 SW    30      5      00:30:00
5    VT320      9600-7-O-1 NONE   30      5      00:00:30
6    VT320      9600-7-E-2 SW    30      9      INDEF
7    PRINTER    9600-7-N-2 HW    30      5      00:30:00
8    KSR        19200-7-E-2 BOTH  30      5      00:30:00
9    VT320      9600-7-E-1 SW    30      7      00:30:00
10   OAP        19200-7-E-1 SW    30      5      00:30:00
11   VT320      4800-7-E-1 HW    30      5      00:30:00
12   PRINTER    9600-7-E-1 HW    30      4      00:30:00
13   VT320      9600-7-O-1 NONE   30      5      00:30:00
14   VT320      9600-7-E-2 SW    30      8      00:30:00
15   VT320      9600-7-N-2 HW    30      5      00:30:00
16   VT320      9600-7-E-2 BOTH  30      3      00:30:00
```

```
TRM  TRAF  LINK  SA   SYS  PU   DB   UIMRD
1    NO   YES   NO   YES  NO   YES  YES
2    NO   NO    NO   NO   NO   NO   NO
3    YES  YES   YES  NO   YES  YES  YES
4    NO   NO    NO   NO   NO   NO   NO
5    NO   YES   NO   NO   NO   NO   YES
6    NO   NO    YES  NO   NO   NO   NO
7    YES  YES   YES  YES  YES  YES  YES
8    NO   NO    NO   NO   YES  NO   YES
9    NO   YES   NO   NO   NO   YES  NO
10   NO   NO    NO   NO   NO   NO   NO
11   YES  YES   YES  YES  YES  YES  YES
12   YES  YES   YES  YES  YES  YES  YES
13   NO   YES   NO   NO   NO   NO   YES
14   NO   NO    YES  NO   NO   NO   NO
15   YES  YES   YES  NO   YES  YES  YES
16   NO   NO    NO   NO   YES  NO   YES
```

## Replacement Procedures

The first part of the output displays the communication security attributes of the terminal port. The communication attributes of the terminal port, **BAUD**, **PRTY** (parity), **SB** (stop bits), and **DBTS** (data bits), are displayed in the **COMM** field of the **rtrv-trm** output and are displayed in this format: **BAUD-DBTS-PRTY-SB**. The second part of the **rtrv-trm** command output displays the types of unsolicited messages the terminal port may receive.

---

### 2. At the terminal connected to EOAP-A:

- a. Log into EOAP-A as root:

```
Console login: root
```

```
Password: xxxxxx
```

- b. Shut down all processes and exit back to root by entering these commands:

```
# su - ccsproj  
% cd /ccsosmr/{instance}/bin  
% ccsmr all.down  
% exit
```

- c. Halt the EOAP-A system by entering this command:

```
# /usr/sbin/init 0
```

The screen will display output similar to the following. Wait until the **ok** prompt appears before continuing with the next step:

```
Date: time apg 2 halt: halted by root  
Date: time apg 2 syslogd: going down on signal 15  
Syncing file systems ... [1] done  
Program terminated  
Type help for more information  
ok
```

---

### 3. At the terminal connected to EOAP-B:

- a. Log into EOAP-B as root:

```
Console login: root
```

```
Password: xxxxxx
```

- b. Shut down all processes and exit back to root by entering these commands:

```
# su - ccsproj  
% cd /ccsosmr/{instance}/bin  
% ccsmr all.down  
% exit
```

- c. Halt the EOAP-B system by entering this command:

```
# /usr/sbin/init 0
```

The screen will display output similar to the following. Wait until the `ok` prompt appears before continuing with the next step:

```
Date: time apg 2 halt: halted by root
Date: time apg 2 syslogd: going down on signal 15
Syncing file systems ... [1] done
Program terminated
Type help for more information
ok
```

---

4. At the EAGLE 5 ISS terminal, inhibit the EOAP-A connection by entering this command:

```
inh-trm:trm=x:force=yes
```

where *x* is the terminal number of EOAP-A.

---

5. Change the terminal port to type **none** by entering this command:

```
chg-trm:type=none:trm=x
```

where *x* is the terminal number of EOAP-A.

---

6. Inhibit the EOAP-B connection by entering this command:

```
inh-trm:trm=x:force=yes
```

where *x* is the terminal number of EOAP-B.

---

7. Change the terminal port to type **none** by entering this command:

```
chg-trm:type=none:trm=x
```

where *x* is the terminal number of EOAP-B.

---

8. Confirm that both EOAP connections are inactive. Enter the **rept-stat-seas** command. The output will display the status of the EOAPs. For this example, enter the **rept-stat-seas** command; the EOAP status is shown in bold:

```
rept-stat-seas
```

## Replacement Procedures

The system returns output similar to the following:

```
rept-stat-seas
rlghncxa03w 00-06-04 15:59:06 EST Rel 26.0.0
SEAS Subsystem Report IS-NR Active -----
SEAS Interfaces Configured = 2 Interfaces IS-NR = 2
GPL PST SST AST
-----
SEAS SYSTEM IS-NR Active -----TDM
Port 4 IS-NR Active -----TDM
Port 10 IS-NR Active -----OAP
A 250-001-000 IS-NR Active -----OAP
B 250-001-000 IS-NR Active -----X.
25 Link A1 IS-NR Active -----X.
25 Link B1 IS-NR Active -----SEAS
SYSTEM ALARM STATUS = No Alarms.
OAP A ALARM STATUS = No Alarms.
OAP B ALARM STATUS = No Alarms.
X25 Link A1 ALARM STATUS = No Alarms.
X25 Link A2 ALARM STATUS = No Alarms.
X25 Link B1 ALARM STATUS = No Alarms.
X25 Link B2 ALARM STATUS = No Alarms.
X25 A1 PVCs IS-NR = 1,2,3
X25 A1 PVCs OOS-MT = ---X25
B1 PVCs IS-NR = 1,2,3
X25 B1 PVCs OOS-MT = ---X25
A2 PVCs IS-NR = 1,2,3
X25 A2 PVCs OOS-MT = ---X25
B2 PVCs IS-NR = 1,2,3
X25 B2 PVCs OOS-MT = ---Command
Completed.
```

---

9. Remove the 10 Amp fuses (P/N 517-0012-01) from the front of the FAP for both the A and the B feeds of the EOAP/fan assembly.



**WARNING:** Ensure that you know exactly which fuse to remove. On the OAP frame, reference the fuse card on the front of the FAP.

For example, FAP 870-0243-09 uses fuse positions 1A for EOAP-A and 1B for EOAP-B. FAP 870-1606-01 offers four fuse positions on each side: 17A through 20A and 17B through 20B. Remove the same-numbered fuse location on each side.

---

You have powered down the EOAP shelf. Remove the cables next.

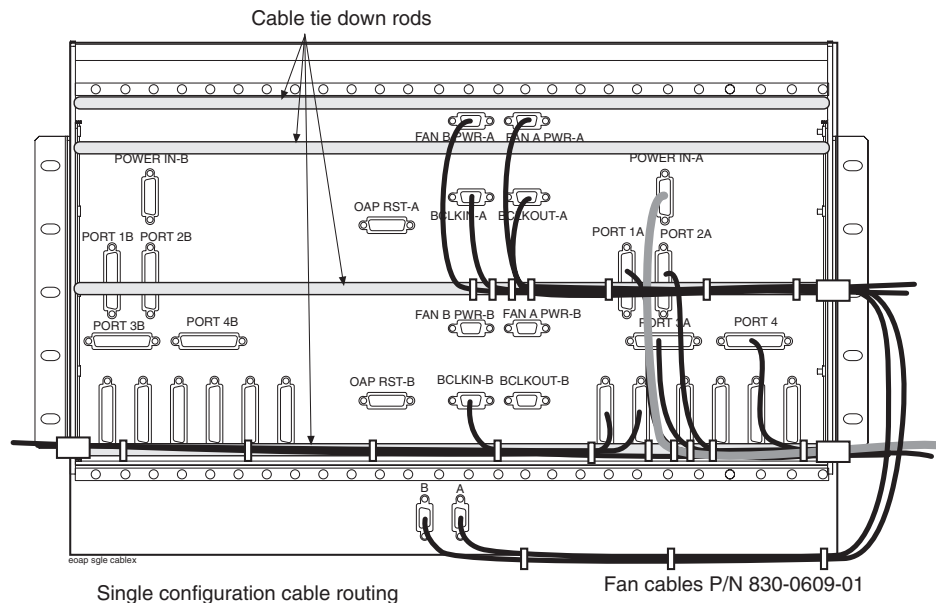
## Remove Cables

This procedure describes how to remove the cables from the front of the EOAP processor cards and the backplane of the EOAP shelf.

### Procedure

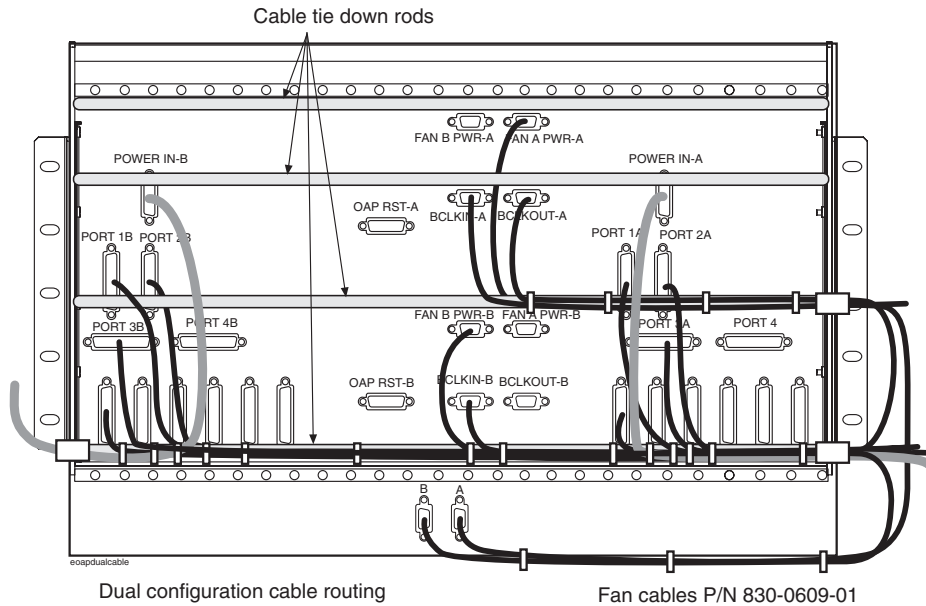
- 1 Face the front of the EOAP and locate the Ethernet cable connected to the Ethernet port of each processor card.
- 
- 2 Disconnect the cables and cut all cable ties on the shelf that can be reached from the front.
- 
- 3 Go to the back of the EOAP shelf. Cut all cable ties from the top of the shelf, the backplane, and the side of the shelf. Figure 6-9 shows the cables of a single-configuration EOAP secured to the backplane. Figure 6-10 shows the cables of a dual-configuration EOAP secured to the backplane.

**Figure 6-9.** Cables Secured on EOAP Shelf Backplane (Single Configuration)





**Figure 6-10.** Cables Secured on EOAP Shelf Backplane (Dual Configuration)



4. Pull the Ethernet cables through to the back. Temporarily tie them to the outside of the right panel support to keep them away from the shelf as it is removed and replaced.

For a single-configuration EOAP, continue with step 7..

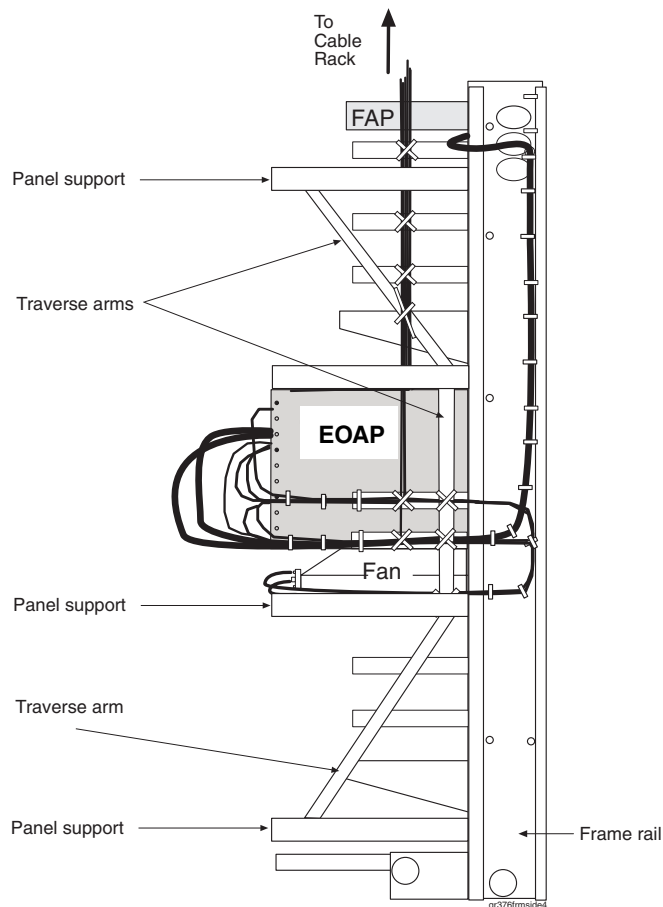
For a dual-configuration EOAP, continue with step 5..

5. Disconnect the cables from the B side of the backplane and mark them with port number and as B cable if necessary. Refer to Figure 6-10 for connector locations.
6. Use a cable tie and temporarily secure them to the left panel support or traverse arm to keep them away from the shelf as it is removed and replaced.
7. Disconnect the cables from the center and A side of the backplane and mark them with port number and as A or B cable if necessary. Refer to Figure 6-10 for connector locations.

8. Use cable ties and temporarily secure them to the outside of the right traverse arm to keep them away from the shelf as it is removed and replaced.

Figure 6-11 shows the location of side panel supports and traverse arms.

**Figure 6-11.** Location of Side Panel Supports and Traverse Arms



All cables are disconnected. Remove all cards from the shelf next.

## Replacement Procedures

### Remove Cards

This procedure describes the general steps to remove a card from the EOAP shelf. For an illustrated description of a particular card, refer to the replacement procedure of the respective card. For example, for an illustrated description of removing the power supply card, refer to *Power Supply Card* on page 6-66. Store all cards in a safe place.



**WARNING:** Store each card in an approved ESD-safe container to avoid any damage to the card.

### Procedure

---

1. Locate the two or four captive screws attached to the top and bottom inject/eject handle brackets on the faceplate.

---
2. Using a small Phillips head screwdriver, loosen the captive screws until they no longer engage the threads. **Do not remove the screws** from the ejector handle brackets.

---
3. Using the thumb and forefinger, push the top handle up and the bottom handle down simultaneously until the card is completely free from the backplane in the card cage.

---
4. Pull the card directly towards you until it clears the card guides and guide rails.

---
5. Immediately store the card properly to avoid any damage due to handling or ESD.

---

Repeat this procedure for each card until all cards are removed from the EOAP shelf. Remove the empty card cage from the frame next.

## Remove Card Cage

This procedure describes how to remove an EOAP card cage or shelf from the frame.

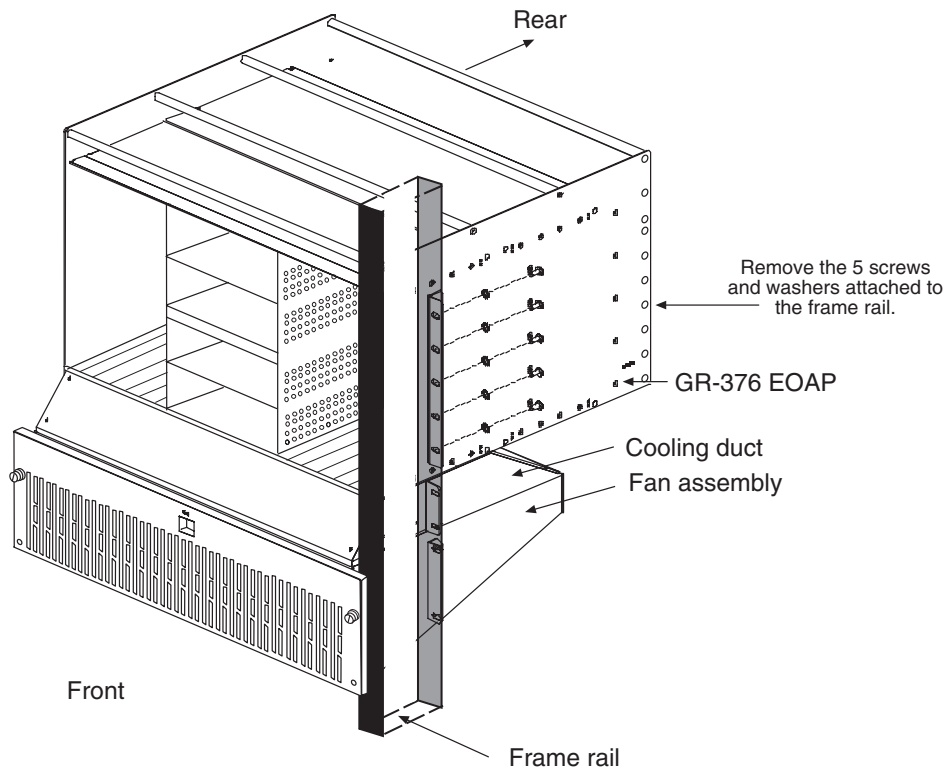
**NOTE:** This procedure requires more than one person.

### Procedure

---

- 1 On each side of the EOAP shelf, remove the five screws and washers that hold the mounting bracket to the frame rail. Store them for later use.

**Figure 6-12.** Remove Screws and Washers from Frame Rail



- 2 From the rear of the frame, pull out the card cage or shelf and store it in a secure place.
- 

You have now removed the empty card cage or the complete EOAP shelf. Install the replacement card cage or shelf in the same location next.

## Replacement Procedures

### Install Replacement Card Cage or Shelf

This procedure describes how to install a replacement EOAP card cage or shelf into the frame.



**WARNING:** Do not overtighten the screws as the heads could snap off.

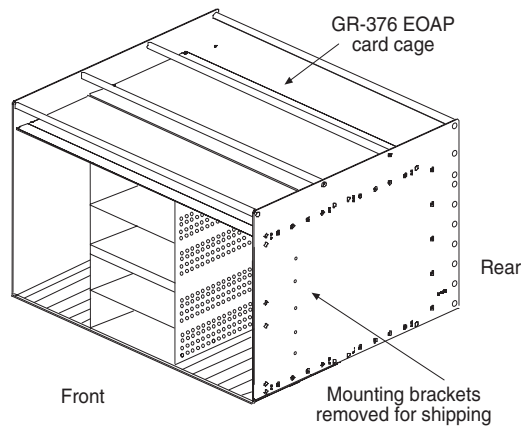
**NOTE:** This procedure requires more than one person.

### Procedure

---

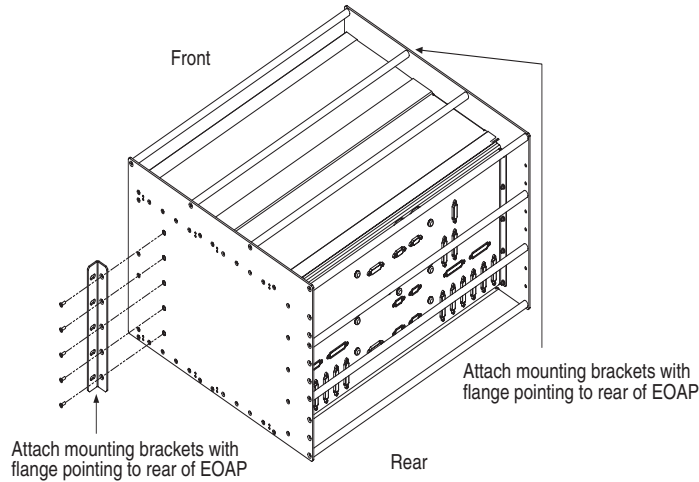
- 1 Remove the EOAP card cage or shelf from the shipping container and locate the mounting brackets.

**Figure 6-13.** Locate Mounting Brackets for EOAP Card Cage



- Using five screws (P/N 600-0154), attach the mounting brackets on each side of the EOAP so that the flange points to the rear of the EOAP.

**Figure 6-14.** Attach Mounting Bracket to EOAP Card Cage



- 
- Place fiber paper on top of the cooling duct/fan assembly to ensure that nothing drops into the equipment below.
- 
- From the rear of the frame, position the mounting brackets of the card cage or shelf against the rear of the frame rail.
-

## Replacement Procedures

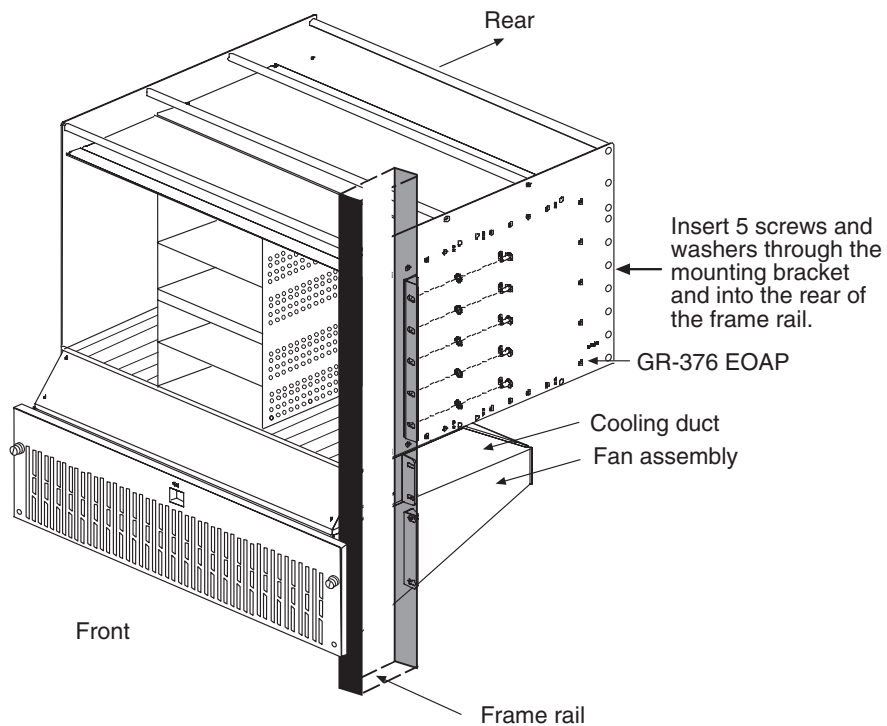
5. On each side of the card cage or shelf, insert five screws with external tooth washers (P/N 601-0010-01) through the mounting bracket and into the frame rail. Tighten the screws.



**WARNING:** When installing the EOAP card cage or shelf, avoid pinching the cables from the fan assembly and those secured from the removed shelf.

**NOTE:** Use either stored screws and washers or those provided with shipment.

**Figure 6-15.** Attach Card Cage to Rear of Frame Rail



- 
6. Remove the fiber paper from under the shelf.
- 

You have installed the replacement card cage or shelf. Install the cards (if applicable) next.

## Install Cards

This procedure describes the general steps to install a card into the EOAP shelf. For an illustrated description of a particular card, refer to the replacement procedure of the respective card. For example, for an illustrated description of installing the power supply card, refer to *Power Supply Card* on page 6-66. Store all cards in a safe place.



**WARNING:** Store each card in an approved ESD-safe container to avoid any damage to the card.

### Procedure

---

1. Locate the slot or bay for the card to be installed. The slot/bay assignments are shown in Table 6-1.

**Table 6-1.** Slot and Bay Assignment for EOAP Cards

Slot	Bay	Card Name
1 and 2	---	Processor card (EOAP-A or EOAP-B)
3	---	Serial Card (EOAP-A or EOAP-B)
4, 5, 6	---	Air management cards (EOAP-A or EOAP-B)
7 and 8	---	Power supply card (EOAP-A or EOAP-B)
---	1	Hard drive card (EOAP-A)
---	2	CD-ROM drive card (EOAP-A)
---	3	Hard drive card (EOAP-B)
---	4	CD-ROM drive card (EOAP-B)

- 
2. Prior to inserting the card, examine the EOAP backplane connector pins in the EOAP shelf for any misalignment, evidence of shorts, or other signs of damage.
- 
3. Remove the card from the storage container.
- 
4. Make sure the two or four captive screws located in the inject/eject handle brackets are partially backed out so they do not interfere with insertion.
- 
5. Push all handles outward from the replacement card's faceplate (top handle in the "UP" position, bottom handle in the "DOWN" position.)
-



## Replacement Procedures

6. Carefully align the replacement card's edges with the channels in the top and bottom card guides. Then push the card along the length of the card guides until the rear connector on the card begins engaging the mating connector on the backplane.
- 

7. Press the faceplate of the card using constant pressure until you feel the card's progress cease.



**WARNING: Do not impact the faceplate in order to mate the two connectors. Any impact to the card's faceplate can damage the faceplate, the pins in the backplane, or the backplane itself.**

---

8. Using the thumb and forefinger together, push the top inject/eject handle down and the bottom handle up until both handles are in the locked position.
- 

9. Using a small Phillips head screwdriver, tighten all captive screws in the handle brackets until they seat against the handle bracket.



**WARNING: Do not overtighten the screws as the heads could snap off.**

---

Repeat this procedure for each card until all cards are installed in the EOAP card cage. Reconnect the cables next.

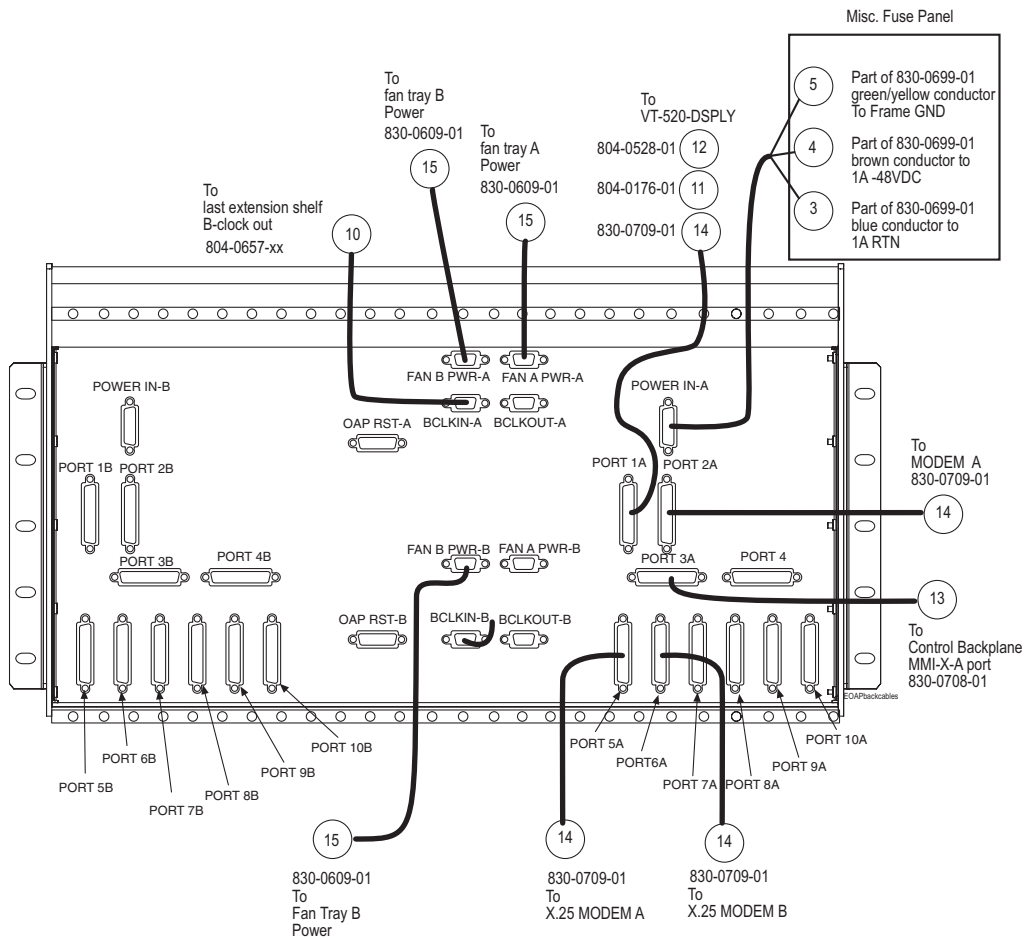
Reconnect Cables

This procedure describes how to reconnect the cables to the replacement card cage or shelf that were disconnected when the previous shelf was removed.

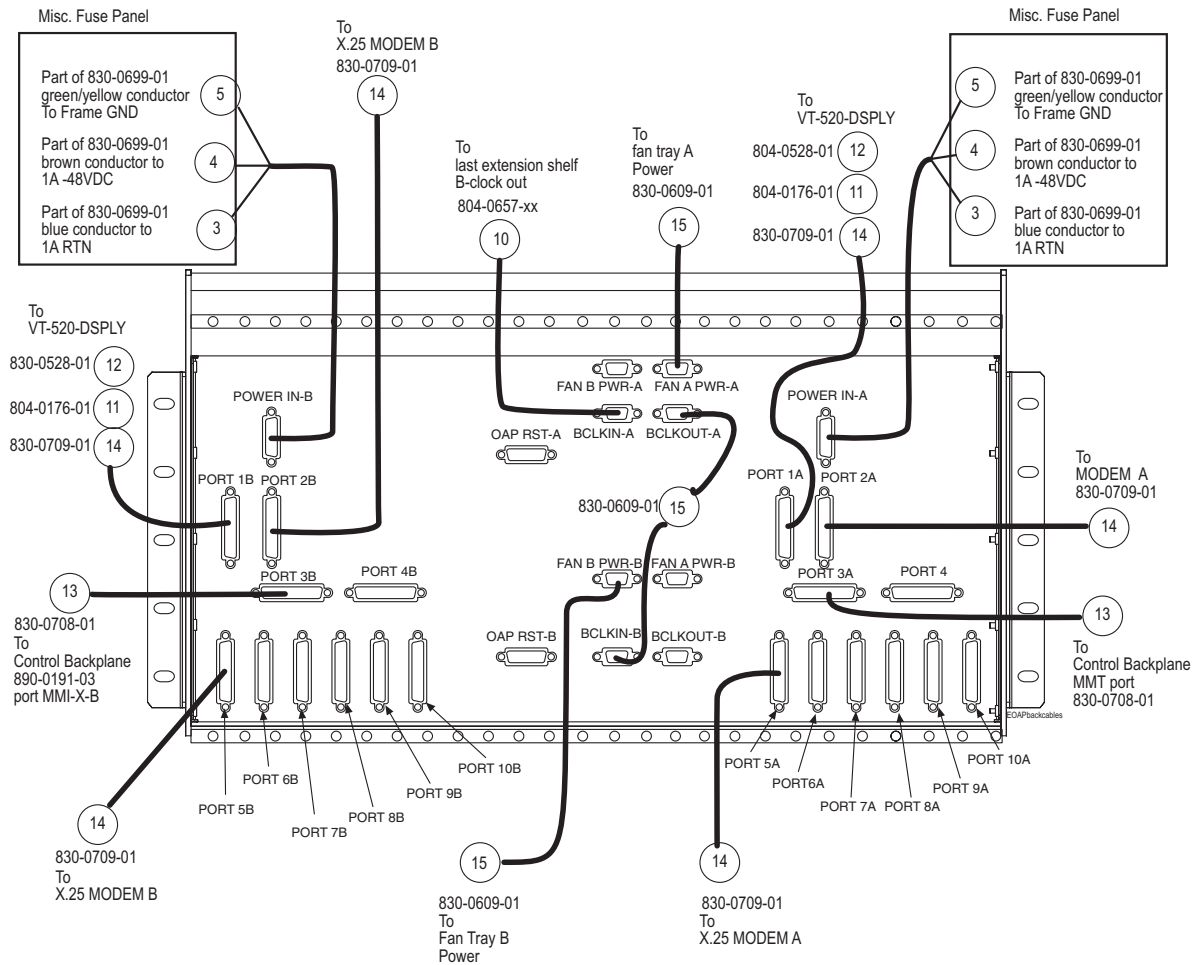
Procedure

- 1 Reconnect all cables to the EOAP backplane. Figure 6-16 shows the cables of a single-configuration EOAP secured to the backplane. Figure 6-17 shows the cables of a dual-configuration EOAP secured to the backplane.

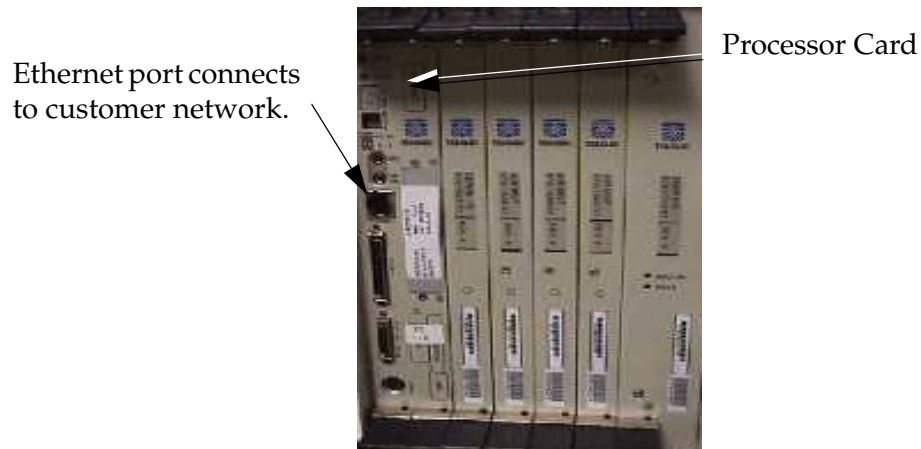
Figure 6-16. Cable Connections on EOAP Backplane (Single Configuration)



**Figure 6-17.** Cable Connections on EOAP Backplane (Dual Configuration)



2. Cut the cable tie that is holding the two Ethernet cables to the right panel support or traverse arm.
- 
3. From the back of the EOAP shelf, route the cables through to the front of the EOAP.
- 
4. Go to the front of the EOAP and locate the Ethernet port on the front panel of the EOAP-A processor card.

**Figure 6-18.** Locate Processor Card

- 
5. Take the Ethernet cable P/N 830-0710-xx labeled "EOAP-A" and insert it into the Ethernet port of EOAP-A.
- 
6. Locate the Ethernet port on the front panel of the EOAP-B processor card.
- 
7. Take the Ethernet cable P/N 830-0710-xx labeled EOAP-B and insert it into the Ethernet port of EOAP-B.

For a single-configuration EOAP, continue with step 9.. For a dual-configuration EOAP, continue with step 8..

- 
8. Secure the Ethernet cable from EOAP-B to the first and third tie-down rods on the top of the EOAP shelf. The first tie keeps the cable in place when disconnected from the port.

**NOTE: The cable may not obstruct the removal of any card in the shelf and must have enough slack to be pushed aside.**

- 
9. Secure the Ethernet cable from EOAP-A to the first and third tie-down rods on the top of the EOAP shelf. The first tie keeps the cable in place when disconnected from the port.

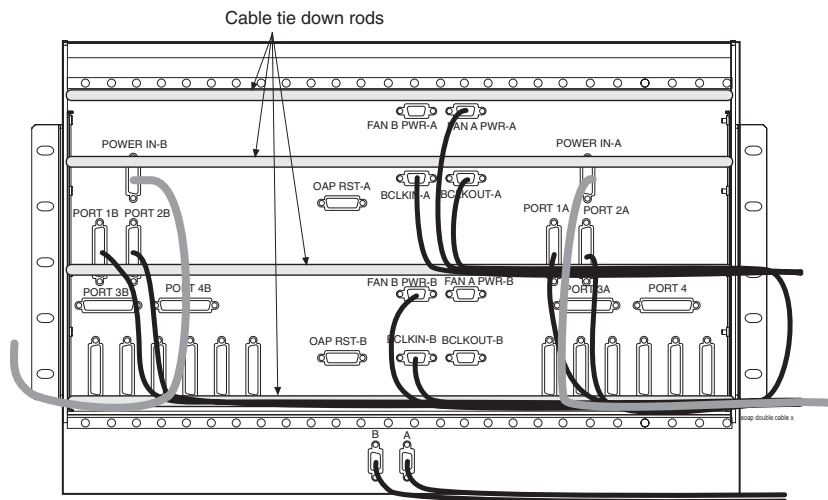
**NOTE: The cable may not obstruct the removal of any card in the shelf and must have enough slack to be pushed aside.**

- 
10. Go to the back of the EOAP shelf. On the third top tie-down rod, secure the EOAP-A cables along the rod every three or four inches, form EOAP-A cables with EOAP-B cables (if applicable), and continue securing all until you reach the frame rail.
-

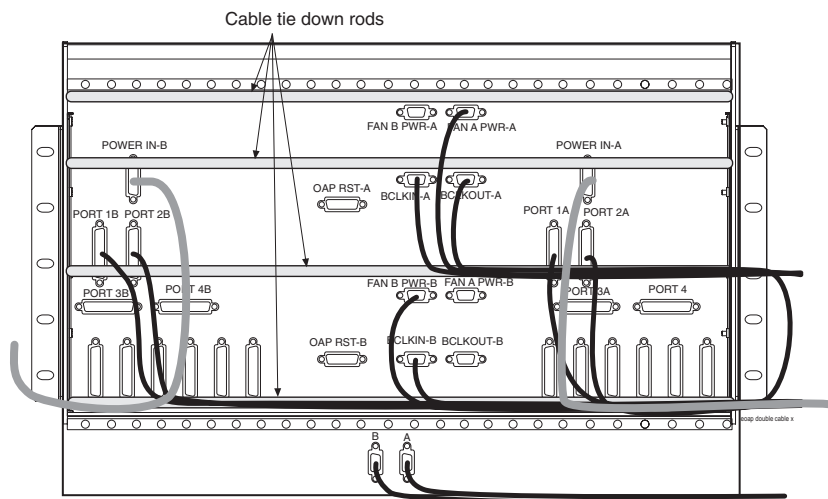
## Replacement Procedures

11. On the backplane of the EOAP shelf, finish the cables from the EOAP top center backplane.
12. Locate the Fan A power cable P/N 830-0609-xx (port FAN B PWR-A for single configuration, port FAN A PWR-A for dual configuration) and the clock connection cable P/N 830-0657-xx (port BCLKIN-A) on the top center of the EOAP shelf backplane. Refer to Figure 6-19 for a single-configuration EOAP and Figure 6-19 for a dual-configuration EOAP.

**Figure 6-19.** Locate Cables on EOAP Backplane (Single Configuration)



**Figure 6-20.** Locate Cables on EOAP Backplane (Dual Configuration)

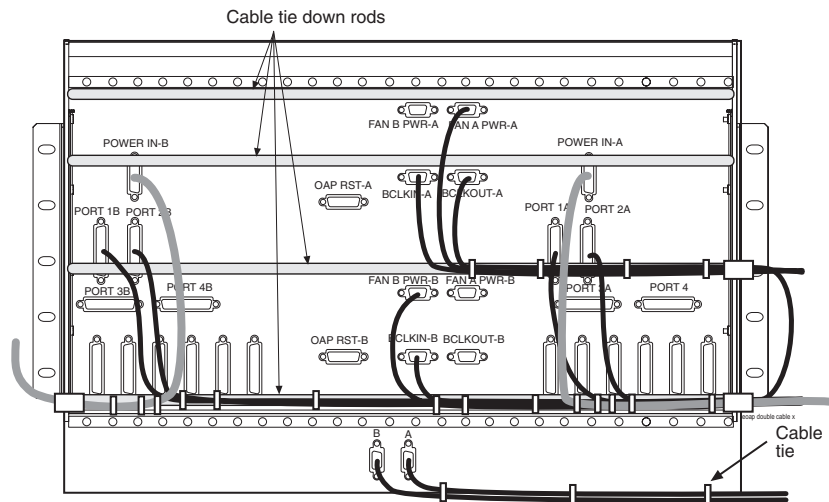


13. Use a cable tie and secure the cables to the third tie-down rod without obstructing any ports. Form these cables along the rod and secure them with cable ties every three or four inches until they reach the frame rail. Refer to Figure 6-22 for a single-configuration EOAP and to Figure 6-21 for a dual-configuration EOAP.

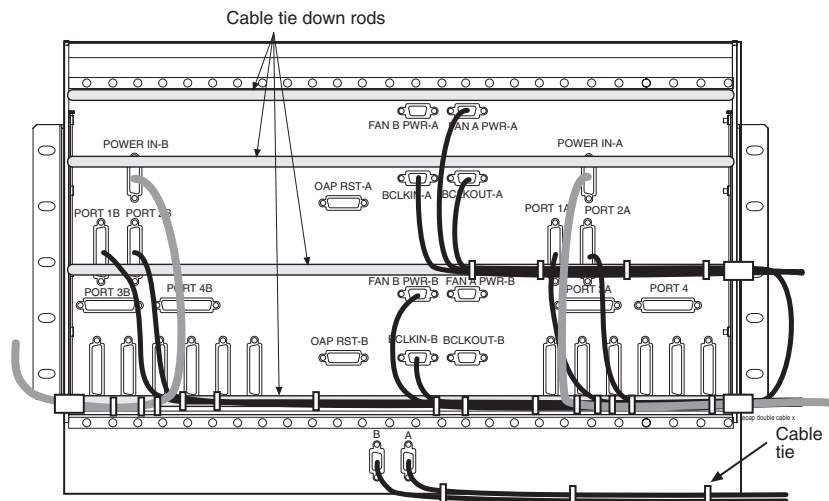
For a single-configuration EOAP, continue with step 22..

For a dual-configuration EOAP, continue with step 14..

**Figure 6-21.** Cables Secured on EOAP Shelf Backplane (Single Configuration)



**Figure 6-22.** Cables Secured on EOAP Shelf Backplane (Dual Configuration)



14. Locate terminal cable P/N 830-0709-xx (PORT 1B) on the B side of the EOAP. Refer to Figure 6-22.

## Replacement Procedures

15. Secure the cable to the bottom tie-down rod without obstructing any ports. Refer to Figure 6-22.
- 

16. Form the cable and secure it along the rod every three or four inches stopping short of the OAP RST B port.

Continue now with the EOAP-B power cable.

---

17. Locate the power cable P/N 830-0699-xx (POWER-IN B) on the B side of the EOAP. Refer to Figure 6-20.
- 

18. Secure the B power cable with cable ties to the bottom tie-down rod of the backplane without obstructing any of the ports. Continue securing the cable every three or four inches until it reaches the frame rail. Refer to Figure 6-21.
- 

19. On the bottom center of the EOAP shelf backplane, locate the Fan B power cable P/N 830-0609-xx (FAN B PWR B) and the clock in/out cable P/N 830-0609-xx (BCLKIN-B). Refer to Figure 6-20.
- 

20. Secure the cables to the bottom tie-down rod without obstructing any ports.
- 

21. Form these cables along the rod with the cables coming from the B side of the EOAP. Secure the cables with cable ties every three or four inches stopping short of the A ports on the A side of the EOAP backplane. Refer to Figure 6-21.
- 

22. Locate the A power cable P/N 830-0699-xx (POWER IN-A) and the terminal cable P/N 830-0709-xx (PORT 1A) on the A side of the EOAP. Refer to Figure 6-20.
- 

23. Use a cable tie and secure all cables to the bottom tie-down rod without obstructing any ports.
- 

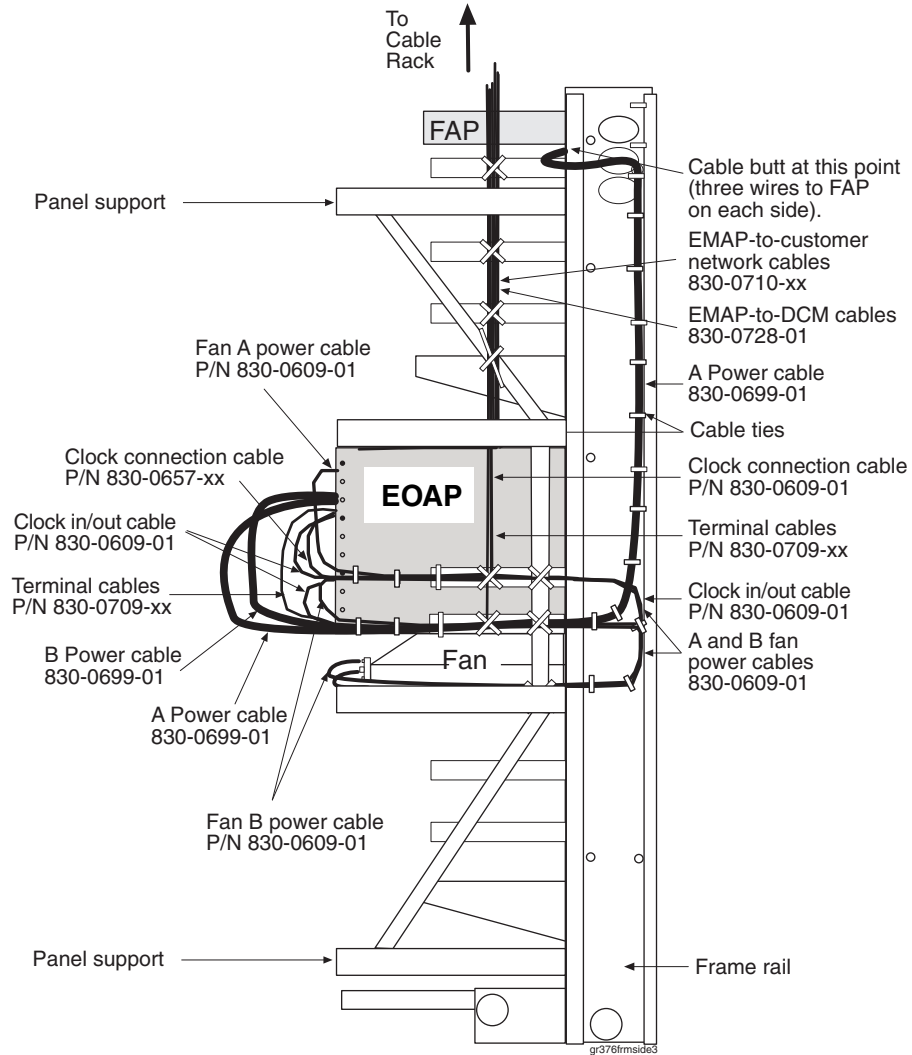
24. Form the cables along the rod. Secure the cables with cable ties every three or four inches until they reach the frame rail. Refer to Figure 6-21.

**NOTE:** Notice that the clock in/out cable (BCLKOUT-A to BCLKIN-B) is routed along the third tie-down rod and then looped back along the bottom tie-down rod to take away the slack from the cable.

---

25. At the frame rail, adjust all cables to fit them between the old and new cable ties.

**Figure 6-23.** Secure Cables from EOAP to Cable Rack



You have reconnected the cables to the EOAP card cage or shelf. Power up the EOAP/fan assembly next.



### Power Up EOAP/Fan Assembly

This procedure describes how to power up the EOAP. Powering up the EOAP also starts the fan assembly because both units use the same fuses.



**WARNING:** The EOAPs and fan assembly use the same fuses. When the EOAP is powered up, the fan assembly also receives power. Take proper care to avoid injury or equipment damage near the fan blades.



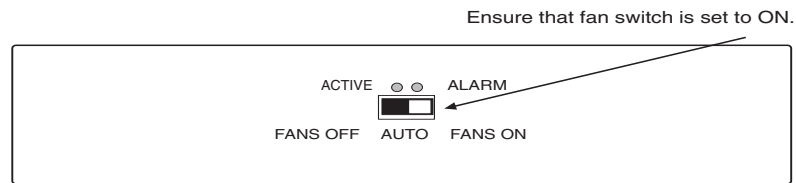
**WARNING:** The EOAP can operate without failure or component damage for up to one hour without the fan tray providing cooling. After powering up the EOAP, test the fans within this time frame to ensure proper operation.

#### Procedure

---

- 1 Make sure the switch on the front of the fan assembly is set to ON.

**Figure 6-24.** Fan Switch Set to ON



2. At the FAP, insert one EOAP/fan assembly fuse on each side.



**WARNING:** Make sure you know exactly which fuses to insert. Reference the fuse card on the front of the FAP.

For example, FAP 870-0243-09 uses fuse positions 1A for EOAP-A and 1B for EOAP-B. FAP 870-1606-01 offers four fuse positions on each side: 17A through 20A and 17B through 20B. Select the same-numbered fuse location on each side.

The EOAP requires 10 Amp fuses (P/N 517-0012-01) in the FAP for both A and B feeds of the EOAP.

3. The following message displays: `powered up` and the machine boots. The fans start running.
4. At the EAGLE 5 ISS terminal, change the terminal port of EOAP-A to type `oap` by entering this command:

```
chg-trm:type=oap:trm=x
```

where *x* is the terminal number of EOAP-A.

---

5. Allow the EOAP-A connection by entering this command:

```
alw-trm:trm=x:force=yes
```

where *x* is the terminal number of EOAP-A.

---

6. Change the terminal port of EOAP-B to type **oap** by entering this command:

```
chg-trm:type=oap:trm=x
```

where *x* is the terminal number of EOAP-B.

---

7. Allow the EOAP-B connection by entering this command:

```
alw-trm:trm=x:force=yes
```

where *x* is the terminal number of EOAP-B.

---

8. Confirm that both EOAP connections are active. Enter the **rept-stat-seas** command. The output will display the status of the EOAPs. For this example, enter the **rept-stat-seas** command; the EOAP status is shown in bold:

```
rept-stat-seas
```

The system returns output similar to the following:

```
rept-stat-seas
rlghncxa03w 00-06-04 15:59:06 EST Rel 26.0.0
SEAS Subsystem Report IS-NR Active -----
SEAS Interfaces Configured = 2 Interfaces IS-NR = 2
GPL PST SST AST
-----
SEAS SYSTEM IS-NR Active -----TDM
Port 4 IS-NR Active -----TDM
Port 10 IS-NR Active -----OAP
A 250-001-000 IS-NR Active -----OAP
B 250-001-000 IS-NR Active -----X.
25 Link A1 IS-NR Active -----X.
25 Link B1 IS-NR Active -----SEAS
SYSTEM ALARM STATUS = No Alarms.
OAP A ALARM STATUS = No Alarms.
OAP B ALARM STATUS = No Alarms.
X25 Link A1 ALARM STATUS = No Alarms.
X25 Link A2 ALARM STATUS = No Alarms.
X25 Link B1 ALARM STATUS = No Alarms.
X25 Link B2 ALARM STATUS = No Alarms.
X25 A1 PVCs IS-NR = 1,2,3
X25 A1 PVCs OOS-MT = ---X25
B1 PVCs IS-NR = 1,2,3
X25 B1 PVCs OOS-MT = ---X25
A2 PVCs IS-NR = 1,2,3
X25 A2 PVCs OOS-MT = ---X25
B2 PVCs IS-NR = 1,2,3
X25 B2 PVCs OOS-MT = ---Command
```

## Replacement Procedures

Completed.

---

The EOAP and fan assembly are now powered up. Test the fan operation next. Go to procedure *Test Fan Operation and Fan Alarm* on page 6-48.

## CD-ROM Drive Card

This procedure describes how to replace the CD-ROM drive card (P/N 870-1515-03) in the EOAP shelf. The CD-ROM drive card does not require any reprovisioning.



**WARNING:** Prior to working on or around live equipment, follow proper ESD grounding procedures to prevent damage to the equipment; reference *ESD Protection Procedure (907-0404-01)*.



**CAUTION:** The EOAP's open system architecture allows access to the operating system. Any undocumented changes to the files may cause the system to become corrupted and unusable. Making any undocumented changes on the EOAP, including changes to the hardware, operating system and/or the components found therein will void the warranty.

### Tools and Equipment

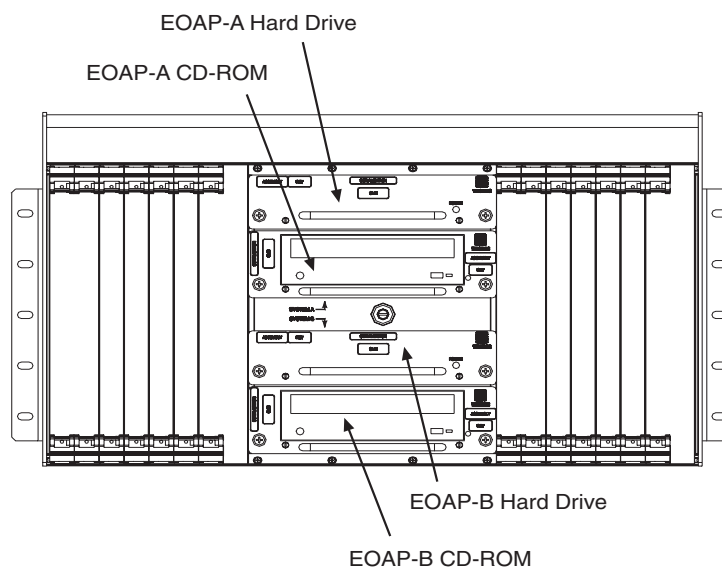
- ESD-safe Phillips screwdriver
- ESD-safe flashlight
- CD-ROM drive card (P/N 870-1515-03)

### Procedure

---

- 1 Identify the EOAP system (EOAP-A or EOAP-B) that contains the drive assembly that needs replacing.

**Figure 6-25.** EOAP-A and EOAP-B Drive Assemblies



## Replacement Procedures

2. Display the EOAP terminal numbers to identify the terminal to be inhibited; enter **rtrv-trm** command. This is an example of the possible output:

```
rlghncxa03w 00-06-07 11:34:04 EST Rel 26.0.0
TRM  TYPE      COMM          FC  TMOUT  MXINV  DURAL
1    VT320     9600-7-E-1 SW    30    5     99:59:59
2    KSR       9600-7-E-1 HW    30    5     INDEF
3    PRINTER   4800-7-E-1 HW    30    0     00:00:00
4    OAP       19200-7-E-1 SW    30    5     00:30:00
5    VT320     9600-7-O-1 NONE  30    5     00:00:30
6    VT320     9600-7-E-2 SW    30    9     INDEF
7    PRINTER   9600-7-N-2 HW    30    5     00:30:00
8    KSR       19200-7-E-2 BOTH  30    5     00:30:00
9    VT320     9600-7-E-1 SW    30    7     00:30:00
10   OAP       19200-7-E-1 SW    30    5     00:30:00
11   VT320     4800-7-E-1 HW    30    5     00:30:00
12   PRINTER   9600-7-E-1 HW    30    4     00:30:00
13   VT320     9600-7-O-1 NONE  30    5     00:30:00
14   VT320     9600-7-E-2 SW    30    8     00:30:00
15   VT320     9600-7-N-2 HW    30    5     00:30:00
16   VT320     9600-7-E-2 BOTH  30    3     00:30:00
```

```
TRM  TRAF LINK SA  SYS PU  DB  UIMRD
1    NO  YES  NO  YES NO  YES YES
2    NO  NO  NO  NO  NO  NO  NO
3    YES YES  YES NO  YES YES YES
4    NO  NO  NO  NO  NO  NO  NO
5    NO  YES  NO  NO  NO  NO  YES
6    NO  NO  YES NO  NO  NO  NO
7    YES YES  YES YES YES YES YES
8    NO  NO  NO  NO  YES NO  YES
9    NO  YES  NO  NO  NO  YES NO
10   NO  NO  NO  NO  NO  NO  NO
11   YES YES  YES YES YES YES YES
12   YES YES  YES YES YES YES YES
13   NO  YES  NO  NO  NO  NO  YES
14   NO  NO  YES NO  NO  NO  NO
15   YES YES  YES NO  YES YES YES
16   NO  NO  NO  NO  YES NO  YES
```

3. Inhibit the EOAP connection of the card to be replaced; enter this command:

```
inh-trm:trm=x
```

where *x* is the terminal number of the isolated EOAP.

The system returns this message:

```
RLGHNCXA03W 00-06-17 14:59:11 EST Release 26.0.0
Inhibit message sent to terminal
```

4. Change the terminal port to type **none** by entering this command:

```
chg-trm:type=none:trm=x
```

where *x* is the terminal number of the isolated EOAP.

The system returns this message:

```
RLGHNCXA03W 00-06-17 14:59:11 EST Release 26.0.0
CHG-TRM:  MASP A - CMPLTD
```

5. Confirm that the isolated EOAP connection is inactive. The output will display the status of the EOAPs. For this example, enter the **rept-stat-seas** command; the EOAP status is shown in bold:

```
rept-stat-seas
rlghncxa03w 00-06-04 15:59:06 EST Rel 26.0.0
SEAS Subsystem Report IS-NR Active -----
SEAS Interfaces Configured = 2 Interfaces IS-NR = 2
GPL PST SST AST
-----
SEAS SYSTEM IS-NR Active -----TDM
Port 4 IS-NR Active -----TDM
Port 10 IS-NR Active -----OAP
A 250-001-000 IS-NR Active -----OAP
B 250-001-000 IS-NR Active -----X.
25 Link A1 IS-NR Active -----X.
25 Link B1 IS-NR Active -----SEAS
SYSTEM ALARM STATUS = No Alarms.
OAP A ALARM STATUS = No Alarms.
OAP B ALARM STATUS = No Alarms.
X25 Link A1 ALARM STATUS = No Alarms.
X25 Link A2 ALARM STATUS = No Alarms.
X25 Link B1 ALARM STATUS = No Alarms.
X25 Link B2 ALARM STATUS = No Alarms.
X25 A1 PVCs IS-NR = 1,2,3
X25 A1 PVCs OOS-MT = ---X25
B1 PVCs IS-NR = 1,2,3
X25 B1 PVCs OOS-MT = ---X25
A2 PVCs IS-NR = 1,2,3
X25 A2 PVCs OOS-MT = ---X25
B2 PVCs IS-NR = 1,2,3
X25 B2 PVCs OOS-MT = ---Command
Completed.
```

---

6. If the system is running, at the terminal connected to the EOAP that needs the card replaced:

- a. Log in as root:

```
Console login: root
Password: xxxxx
```

- b. Shut down all processes and exit back to root by entering these commands:

```
# su - ccsproj
% cd /ccsosmr/{instance}/bin
% ccsmr all.down
% exit
```

- c. Halt the isolated EOAP system by entering this command:

```
# /usr/sbin/init 0
```

## Replacement Procedures

The screen will display output similar to the following. Wait until the `ok` prompt appears before continuing with the next step:

```
Date: time apg 2 halt: halted by root
Date: time apg 2 syslogd: going down on signal 15
Syncing file systems ... [1] done
Program terminated
Type help for more information
ok
```

---

7. While facing the drive card assembly to be replaced, locate the two captive screws attached to the left and right sides of the faceplate.
- 
8. Loosen the captive screws by hand until they no longer engage the threads in the floating fasteners on the drive bay faceplate.

**NOTE: The heads on the captive fasteners should spring outward when freed.**

**Figure 6-26.** CD-ROM Drive Card Captive Screws



- 
9. Grasp the drive assembly handle with one hand and carefully pull the assembly toward you. Pull until the rear connectors on the board are freed from the connectors on the backplane (see Figure 6-41 for instructions on removing a hard drive or CD-ROM drive assembly).
- 
10. Continue pulling the card directly toward you until it clears the EOAP drive bay completely. Always support the drive assembly from underneath, when possible, using the other hand.

**Figure 6-27.** Support the CD-ROM Drive Card With Both Hands





## Replacement Procedures

11. Immediately store the card properly to avoid any damage due to handling or ESD.
- 

12. Prior to inserting the replacement card, examine the pins in the EOAP backplane connector for any misalignment, evidence of shorts, or other signs of damage. The connectors look similar to those shown in Figure 6-43. If the pins show any damage, contact your Customer Care Center.
- 

13. Remove the CD-ROM drive card assembly from the shipping container.

**Figure 6-28.** CD-ROM Drive Card (P/N 870-1515-03)

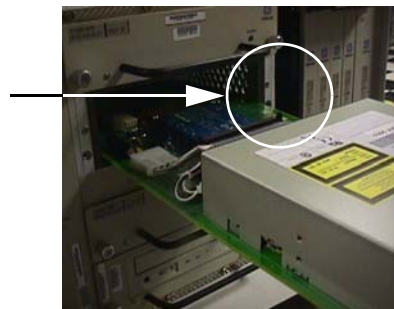


14. Use one hand to support the card assembly from underneath and the other hand to grasp the faceplate handle (see Figure 6-27).
- 

15. While facing the front of the drive bay, carefully insert the card through the proper opening. Align the edges of the card with the channels in the card guides. Then push the assembly until the rear connectors on the drive card begin engaging the mated connectors on the backplane.

**Figure 6-29.** Install the CD-ROM Drive Card

Align the edges of the card with the card guides.



16. Press the faceplate of the assembly using constant pressure until connections are fully seated.

**Figure 6-30.** Press the Faceplate



Press the faceplate near the areas where the handle is in contact with the faceplate.

17. Push in each head of the left and right captive screws on the faceplate until the threads make contact with the floating fasteners in the drive bay faceplate. Use your fingers to firmly tighten each screw.



**WARNING:** Do not overtighten the screws as the heads could snap off.

18. Boot the EOAP from the **ok** prompt.

**ok boot**

If the card does not reboot, refer to troubleshooting procedure *CD-ROM Not Responding* on page 7-8.

19. At the EAGLE 5 ISS terminal, change the terminal port of the isolated EOAP to type **oap** by entering this command:

**chg-trm:type=oap:trm=x**

where *x* is the terminal number of the isolated EOAP

20. Allow the EOAP connection by entering this command:

**alw-trm:trm=x:force=yes**

where *x* is the terminal number of the isolated EOAP.

21. After the processor card has reset the respective EOAP system, confirm that the CD-ROM drive is operational by checking the CD-ROM LED. A green LED indicates that power is supplied to the CD-ROM connector.

For troubleshooting drive cards or LEDs, refer to Chapter 7, *Basic Troubleshooting*.

You have replaced the CD-ROM drive card and confirmed that it is operational.

### Fan Assembly

This section describes how to replace an existing fan assembly. The fan assembly must be tested for proper operation after the installation. This procedure is part of the fan assembly replacement. Perform the replacement during a maintenance window and complete it within one hour.



**WARNING:** The EOAP unit can operate without failure or component damage for up to one hour without the fan tray providing cooling. Complete the replacement within this time frame to avoid having to shut down the entire EOAP unit.

#### Replacement Order

Replace the fan assembly in the stages and order listed below:

1. Remove fan assembly
2. Install replacement fan assembly
3. Test fan operation

#### Tools and Equipment

Use the following tools and equipment to replace a fan assembly:

- 1 fan assembly (P/N 890-1038-01), includes
  - mounting brackets (P/N 652-0954-01)
  - tooth washers (P/N 606-0062-01)
  - screws (P/N 600-0934-01)
  - air filters (P/N 551-0011-01)
- Safety glasses
- Tie wraps
- Wire cutter (to cut cable ties)
- Phillips screw driver

## Remove Fan Assembly

This procedure describes how to disconnect power from the fan assembly and remove the assembly from the frame.

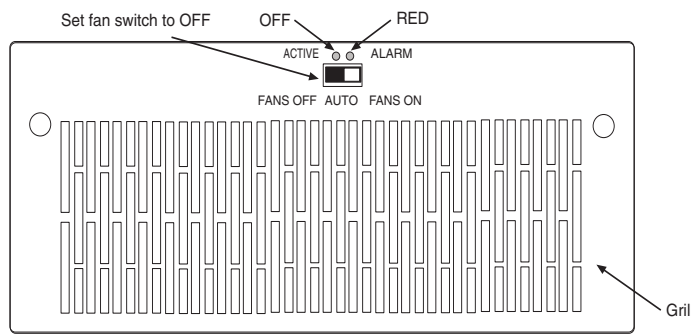
**NOTE:** Avoid removing mounting hardware from frame rail to allow for easier reinstallation of equipment.

### Procedure

---

1. Locate the fan assembly to be replaced.
- 
2. At the fan assembly, toggle the fan switch on the grill panel to the OFF position. The fan assembly stops running. The Active LED is off and the Alarm LED is red. The Minor LED at the FAP is lit. Other fan assemblies (if installed) are not affected.

**Figure 6-31.** Set Fan Switch to OFF



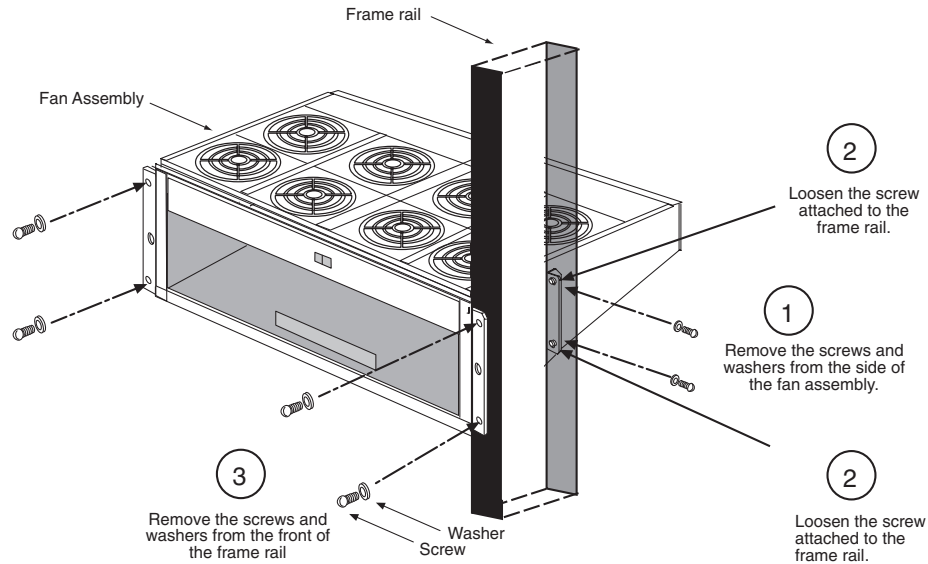
3. At the EAGLE 5 ISS terminal, confirm the fan failure by typing in this command:  
**rept-stat-trbl**  
 The EAGLE 5 ISS reports the following alarm: 302 COOLING FAN FAILURE.
- 
4. At the rear of the frame, remove the A and B power cables from fan assembly.  
**DANGER:** -48V are present at the cable. Use caution when reconnecting.
- 
5. At the fan assembly, place fiber paper on the shelf below where the fan is to be replaced. This ensures that nothing drops into the area or equipment below.
- 



## Replacement Procedures

6. From the rear of the frame and on each side of the fan assembly, locate the mounting bracket holding the fan assembly in place. Remove the two screws from the side of the fan assembly. Refer to Figure 6-32, Step 1. Temporarily store them in a safe place.

**Figure 6-32.** Remove Fan Assembly



7. On each side of the fan assembly, loosen the two screws that hold the mounting bracket to the frame rail to allow easier removal of the assembly. Refer to Figure 6-32, Step 2.
8. From the front of the frame, remove the grill and filter from the fan assembly by removing the two thumb screws from the grill faceplate. Temporarily store all in a safe place. Refer to Figure 6-33.
9. On each side of the fan assembly, remove the two screws that attach the fan assembly to the front of the frame rail. Refer to Figure 6-32, Step 3.
10. Open the doors on the lower shelf. Pull out the fan assembly from the front of the frame.

You have removed the fan assembly. Install the replacement fan assembly next.

## Install Replacement Fan Assembly

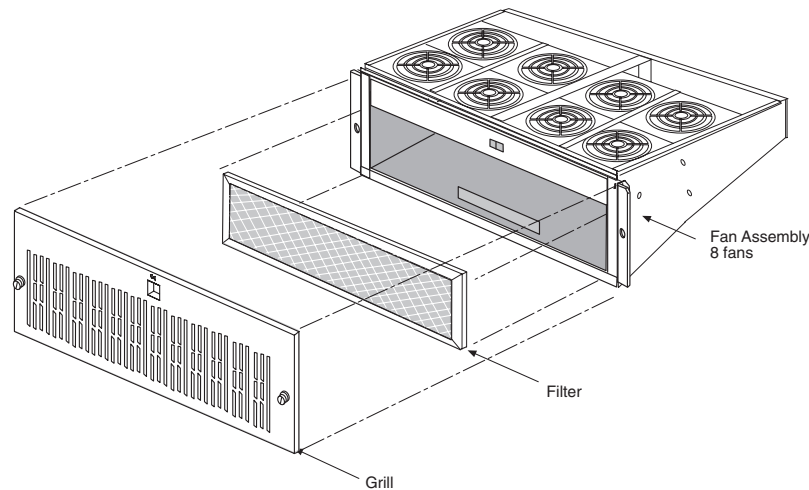
This procedure describes how to install the replacement fan assembly into the frame and reconnect the fan power cables.

### Procedure

---

- 1 Remove the replacement fan assembly from the shipping container.
- 
- 2 Remove the grill and filter from the fan assembly by removing the two thumb screws from the grill faceplate. Temporarily store all in a safe place.

**Figure 6-33.** Remove Grill and Filter from Fan Assembly



3. Open the doors on the lower shelf. From the front of the frame, slide the fan assembly into the shelf. Figure 6-34 shows a fan assembly inserted into an EAGLE 5 ISS frame. Figure 6-34 shows a fan assembly inserted into an OAP frame.

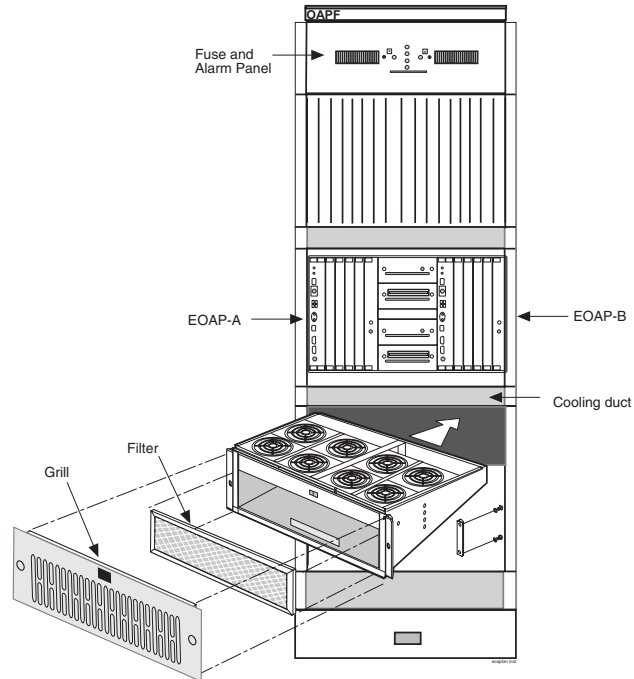
On each side of the assembly, attach it with two screws and external tooth washers (P/N 601-0010-01) to the front frame rail. Tighten the screws. Refer to Figure 6-35, Step 1.



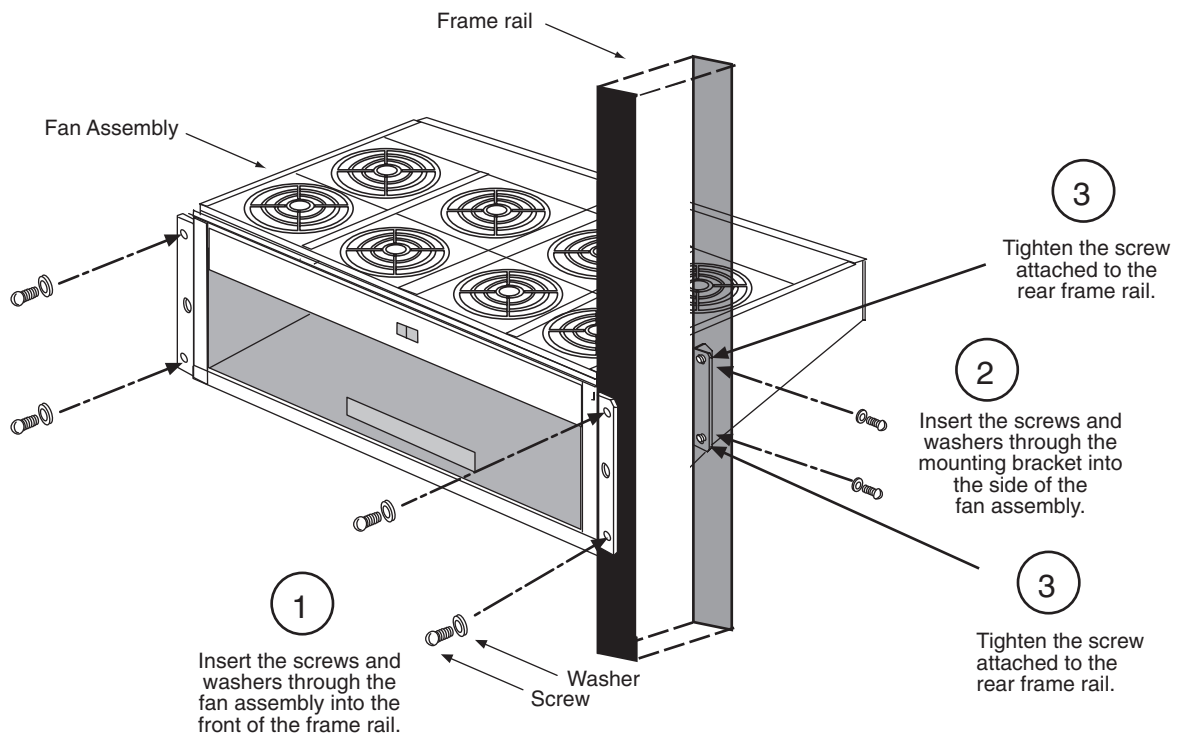
**WARNING:** Do not overtighten the screws as the heads could snap off.

## Replacement Procedures

**Figure 6-34.** Insert Fan Assembly Below EOAP Shelf



**Figure 6-35.** Attach Fan Assembly to Front of Frame Rail



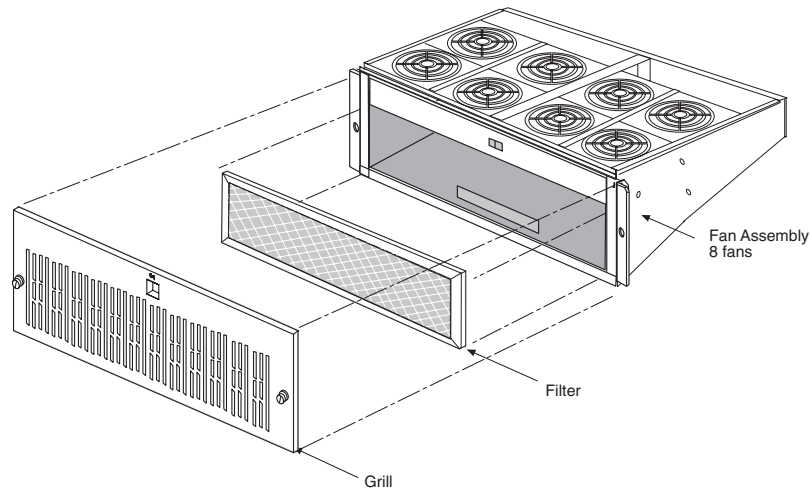
4. From the rear of the frame and on each side of the fan assembly, insert two screws into the side of the fan assembly. Refer to Figure 6-36, Step 2.

5. Align the fan assembly with the sides of the shelf and tighten the two screws that were left on the mounting bracket. Refer to Figure 6-35, Step 3.

- 
6. Replace the fan filter by setting it against the front of the fan assembly.

**NOTE:** Point the air flow arrows stamped on top and bottom of filter towards the fan assembly.

**Figure 6-36.** Replace Fan Filter and Grill



- 
7. Replace the fan grill by placing it back over the filter on the front of the assembly. Hand-tighten the thumb screws. Refer to Figure 6-36.

- 
8. At the rear of the frame, reconnect the fan power cables to the fan assembly.

**WARNING:** -48V are present at the cable. Use caution when reconnecting.





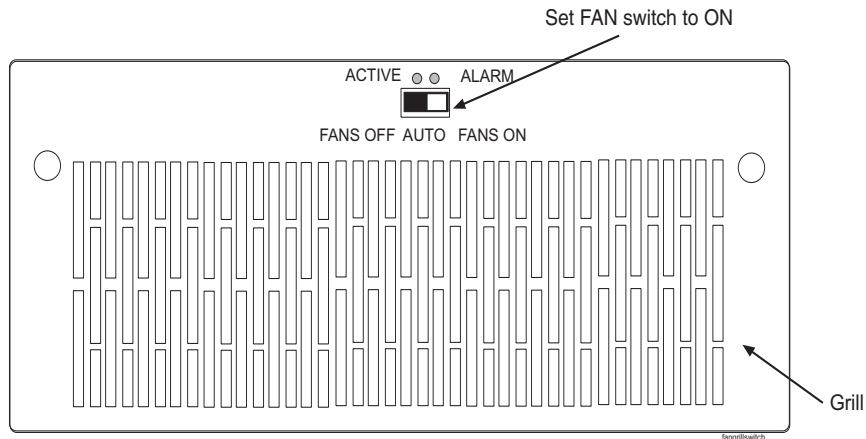
## Replacement Procedures

- At the fan assembly, set the fan switch on the grill panel to the ON position. The fans start running.



**WARNING:** Ensure that the switch is NOT set to AUTO. This setting is disabled.

Figure 6-37. Fan Switch Set to ON



You have replaced the fan assembly. Test fan operation and fan alarm next.

## Test Fan Operation and Fan Alarm

Use this procedure to test the fan operation at the EAGLE 5 ISS terminal and to ensure that the fan alarm is functioning.

**NOTE:** For more information on the commands used in this procedure, refer to the *Eagle Commands Manual*.

### Procedure

---

- 1 At the EAGLE 5 ISS terminal, retrieve the feature options to ensure that the fan feature is turned on.

**rtrv-feat**

**NOTE:** Once you have turned on the feature, you cannot turn it off. The feature applies to any and all fans installed within the system. When replacing a fan assembly, the feature should already be turned on.

The output displays a list of optional features and their status on the system:

```
rlghncxa03w 00-06-07 00:57:31 EST Rel 26.0.0
EAGLE FEATURE LIST

GTT      = on      GWS      = on      NRT      = off
X25G     = on      LAN      = on      CRMD     = off
SEAS     = on      LFS      = off     MTPRS    = off
LNP      = on      FAN     = on     DSTN4000 = off
WNP      = off     CNCF     = on      LNP12MIL = off
TLNP     = off     SCCPCNV  = off     TCAPCNV  = off
X252000  = off     PLNP     = off     NCR      = off
ITUMTPRS = off     SLSOCB  = on      EGTT     = off
```

---

2. Enable the feature if necessary by entering the following command:

**chg-feat : fan=on**

where **:fan** is the parameter for turning on the fan feature.

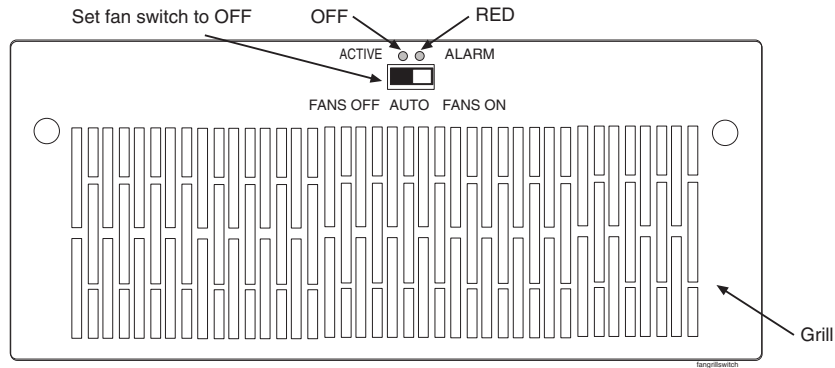
After the program updates, the system returns output similar to the following:

```
RLGHNCXA03W 00-06-11 11:34:04 EST Rel 26.0.0
CHG-FEAT: MASP A - COMPLD
```

---

3. At the fan assembly, toggle the fan switch on the grill panel to the OFF position. The fan assembly stops running. The Active LED is off and the Alarm LED is red. The Minor LED at the FAP is lit. Other fan assemblies (if installed) are not affected.

Figure 6-38. Set Fan Switch to OFF



4. At the EAGLE 5 ISS terminal, type in this command:

```
rept-stat-trbl
```

The EAGLE 5 ISS reports the following alarm: 302 COOLING FAN FAILURE.

5. At the fan assembly, turn the switch back to the ON position (refer to Figure 6-38). The Active and Alarm LEDs are green. The Minor LED at the FAP goes out. The fan assembly starts running.

6. At the EAGLE 5 ISS terminal, type in this command:

```
rept-stat-trbl
```

The EAGLE 5 ISS reports the following alarm: 303 COOLING FAN NORMAL.

7. With a flashlight, check that all fans are running. Remove the grill and filter from the fan assembly by removing the two thumb screws from the grill faceplate (see Figure 6-38). Temporarily store all in a safe place. Visually check the movement of the fans.

8. Replace the fan filter by setting it against the front of the fan assembly. Refer to Figure 6-36.

**NOTE:** Point the air flow arrows stamped on top and bottom edge of the filter towards the fan assembly.

9. Replace the fan grill by placing it back over the filter on the front of the assembly. Hand-tighten the thumb screws. Refer to Figure 6-36.

10. At the rear of the frame, remove the A power cable from the A fan assembly. Both fan LEDs are off. The Minor LED at the FAP is lit. The fans for EOAP-A stop running. Other fan assemblies (if installed) are not affected.
- 

11. At the EAGLE 5 ISS terminal, type in this command:

```
rept-stat-trbl
```

The EAGLE 5 ISS reports the following alarm: 302 COOLING FAN FAILURE.

---

12. Replace the A power cable on the rear of the fan assembly and secure the connector. The Active and Alarm LEDs are green. The Minor LED at the FAP goes out. The A fans start running.
- 

13. At the EAGLE 5 ISS terminal, type in this command:

```
rept-stat-trbl
```

The EAGLE 5 ISS reports the following alarm: 303 COOLING FAN NORMAL.

For a single-configuration EOAP, this procedure is completed.

For a dual-configuration EOAP, continue with Step 14..

---

14. At the rear of the frame, remove the B power cable from the B fan assembly. Both fan LEDs are off. The Minor LED at the FAP is lit. The fans for EOAP-B stop running. Other fan assemblies (if installed) are not affected.
- 

15. At the EAGLE 5 ISS terminal, type in this command:

```
rept-stat-trbl
```

The EAGLE 5 ISS reports the following alarm: 302 COOLING FAN FAILURE.

---

16. Replace the B power cable on the rear of the fan assembly and secure the connector. The Active and Alarm LEDs are green. The Minor LED at the FAP goes out. The B fans start running.
- 

17. At the EAGLE 5 ISS terminal, type in this command:

```
rept-stat-trbl
```

The EAGLE 5 ISS reports the following alarm: 303 COOLING FAN NORMAL.

---

You have tested the operation of the fan assembly and the fan alarm.

### Hard Drive Card

This section describes how to replace a hard drive card (P/N 870-1514-03) in the EOAP shelf. The hard drive on the replacement card is preloaded with software but must be reprovisioned after the installation. Perform the replacement during a maintenance window.



**WARNING:** Prior to working on or around live equipment, follow proper ESD grounding procedures to prevent damage to the equipment; reference *ESD Protection Procedure (907-0404-01)*.



**CAUTION:** The EOAP's open system architecture allows access to the operating system. Any undocumented changes to the files may cause the system to become corrupted and unusable. Making any undocumented changes on the EOAP, including changes to the hardware, operating system and/or the components found therein will void the warranty.

#### Replacement Order

Replace the hard drive card in the stages and order listed below:

1. Remove hard drive card
2. Install replacement hard drive card
3. Reprovision hard drive

#### Tools and Equipment

Use the following tools and equipment to replace a hard drive card:

- ESD-safe Phillips screwdriver
- ESD-safe flashlight
- Preloaded (software) hard drive card (P/N 870-1514-03)

## Replace Hard Drive Card

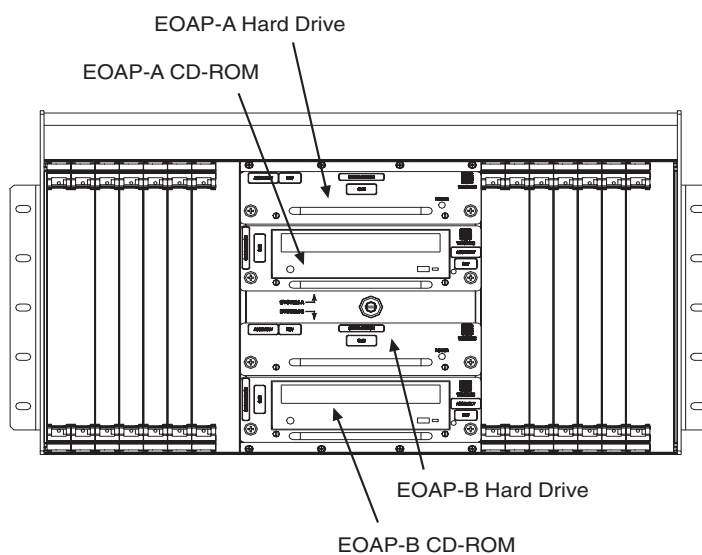
This procedure describes how to remove a hard drive card P/N 870-1514-03 from the EOAP shelf.

### Procedure

---

- 1 Identify the EOAP side (EOAP-A or EOAP-B) that contains the drive assembly that needs replacing.

**Figure 6-39.** EOAP-A and EOAP-B Drive Assemblies



2. At the EAGLE 5 ISS, make sure that the redundant EOAP is active. Enter the **rept-stat-seas** command. The output will display the status of the EOAPs. For this example, enter the **rept-stat-seas** command; the EOAP status is shown in bold:

```
rept-stat-seas
```

## Replacement Procedures

The system returns output similar to the following:

```
rept-stat-seas
rlghncxa03w 00-06-04 15:59:06 EST Rel 26.0.0
SEAS Subsystem Report IS-NR Active -----
SEAS Interfaces Configured = 2 Interfaces IS-NR = 2
GPL PST SST AST
-----
SEAS SYSTEM IS-NR Active -----TDM
Port 4 IS-NR Active -----TDM
Port 10 IS-NR Active -----OAP
A 250-001-000 IS-NR Active -----OAP
B 250-001-000 IS-NR Active -----X.
25 Link A1 IS-NR Active -----X.
25 Link B1 IS-NR Active -----SEAS
SYSTEM ALARM STATUS = No Alarms.
OAP A ALARM STATUS = No Alarms.
OAP B ALARM STATUS = No Alarms.
X25 Link A1 ALARM STATUS = No Alarms.
X25 Link A2 ALARM STATUS = No Alarms.
X25 Link B1 ALARM STATUS = No Alarms.
X25 Link B2 ALARM STATUS = No Alarms.
X25 A1 PVCs IS-NR = 1,2,3
X25 A1 PVCs OOS-MT = ---X25
B1 PVCs IS-NR = 1,2,3
X25 B1 PVCs OOS-MT = ---X25
A2 PVCs IS-NR = 1,2,3
X25 A2 PVCs OOS-MT = ---X25
B2 PVCs IS-NR = 1,2,3
X25 B2 PVCs OOS-MT = ---Command
Completed.
```

---

3. Display the EOAP terminal numbers to identify the terminal to be inhibited; enter the **rtrv-trm** command. This is an example of the possible output:

```
rlghncxa03w 00-06-07 11:34:04 EST Rel 26.0.0
TRM  TYPE  COMM  FC  TMOUT  MXINV  DURAL
1    VT320  9600-7-E-1 SW  30    5      99:59:59
2    KSR    9600-7-E-1 HW  30    5      INDEF
3    PRINTER 4800-7-E-1 HW  30    0      00:00:00
4    OAP    19200-7-E-1 SW  30    5      00:30:00
5    VT320  9600-7-O-1 NONE 30    5      00:00:30
6    VT320  9600-7-E-2 SW  30    9      INDEF
7    PRINTER 9600-7-N-2 HW  30    5      00:30:00
8    KSR    19200-7-E-2 BOTH 30    5      00:30:00
9    VT320  9600-7-E-1 SW  30    7      00:30:00
10   OAP    19200-7-E-1 SW  30    5      00:30:00
11   VT320  4800-7-E-1 HW  30    5      00:30:00
12   PRINTER 9600-7-E-1 HW  30    4      00:30:00
13   VT320  9600-7-O-1 NONE 30    5      00:30:00
14   VT320  9600-7-E-2 SW  30    8      00:30:00
15   VT320  9600-7-N-2 HW  30    5      00:30:00
16   VT320  9600-7-E-2 BOTH 30    3      00:30:00

TRM  TRAF LINK SA  SYS PU  DB  UIMRD
1    NO  YES  NO  YES NO  YES YES
2    NO  NO   NO  NO  NO  NO  NO
3    YES YES  YES NO  YES YES YES
4    NO  NO   NO  NO  NO  NO  NO
```

5	NO	YES	NO	NO	NO	NO	YES
6	NO	NO	YES	NO	NO	NO	NO
7	YES	YES	YES	YES	YES	YES	YES
8	NO	NO	NO	NO	YES	NO	YES
9	NO	YES	NO	NO	NO	YES	NO
<b>10</b>	<b>NO</b>	<b>NO</b>	<b>NO</b>	<b>NO</b>	<b>NO</b>	<b>NO</b>	<b>NO</b>
11	YES	YES	YES	YES	YES	YES	YES
12	YES	YES	YES	YES	YES	YES	YES
13	NO	YES	NO	NO	NO	NO	YES
14	NO	NO	YES	NO	NO	NO	NO
15	YES	YES	YES	NO	YES	YES	YES
16	NO	NO	NO	NO	YES	NO	YES

4. Inhibit the EOAP connection of the card to be replaced; enter this command:

**inh-trm:trm=x**

where **x** is the terminal number of the isolated EOAP.

The system returns this message:

```
RLGHNCXA03W 00-06-17 14:59:11 EST Release 26.0.0
Inhibit message sent to terminal
```

5. Change the terminal port to type **none** by entering this command:

**chg-trm:type=none:trm=x**

where **x** is the terminal number of the isolated EOAP.

The system returns this message:

```
RLGHNCXA03W 00-06-17 14:59:11 EST Release 26.0.0
CHG-TRM: MASP A - CMLPTD
```

6. Confirm that the isolated EOAP connection is inactive. Enter the **rept-stat-seas** command. The output will display the status of the EOAPs. For this example, enter the **rept-stat-seas** command; the EOAP status is shown in bold:

**rept-stat-seas**

The system returns output similar to the following:

```
rept-stat-seas
rlghncxa03w 00-06-04 15:59:06 EST Rel 26.0.0
SEAS Subsystem Report IS-NR Active -----
SEAS Interfaces Configured = 2 Interfaces IS-NR = 2
GPL PST SST AST
-----
SEAS SYSTEM IS-NR Active -----TDM
Port 4 IS-NR Active -----TDM
Port 10 IS-NR Active -----OAP
A 250-001-000 IS-NR Active -----OAP
B 250-001-000 IS-NR Active -----X.
25 Link A1 IS-NR Active -----X.
25 Link B1 IS-NR Active -----SEAS
SYSTEM ALARM STATUS = No Alarms.
OAP A ALARM STATUS = No Alarms.
```



## Replacement Procedures

### **OAP B ALARM STATUS = No Alarms.**

```
X25 Link A1 ALARM STATUS = No Alarms.  
X25 Link A2 ALARM STATUS = No Alarms.  
X25 Link B1 ALARM STATUS = No Alarms.  
X25 Link B2 ALARM STATUS = No Alarms.  
X25 A1 PVCs IS-NR = 1,2,3  
X25 A1 PVCs OOS-MT = ---X25  
B1 PVCs IS-NR = 1,2,3  
X25 B1 PVCs OOS-MT = ---X25  
A2 PVCs IS-NR = 1,2,3  
X25 A2 PVCs OOS-MT = ---X25  
B2 PVCs IS-NR = 1,2,3  
X25 B2 PVCs OOS-MT = ---Command  
Completed.
```

- 
7. If the system is running, at the terminal connected to the EOAP that needs the card replaced:

- a. Log in as root:

```
Console login: root
```

```
Password: xxxxxx
```

- b. Shut down all processes and exit back to root by entering these commands:

```
# su - ccspoj  
% cd /ccsomsr/{instance}/bin  
% ccsmr all.down  
% exit
```

- c. Halt the isolated EOAP system by entering this command:

```
# /usr/sbin/init 0
```

The screen will display output similar to the following. Wait until the `ok` prompt appears before continuing with the next step:

```
Date: time apg 2 halt: halted by root  
Date: time apg 2 syslogd: going down on signal 15  
Syncing file systems ... [1] done  
Program terminated  
Type help for more information  
ok
```

- 
8. While facing the drive card assembly to be replaced, locate the two captive screws attached to the left and right sides of the faceplate.

- 
9. Loosen the captive screws by hand until they no longer engage the threads in the floating fasteners on the drive bay faceplate.

**NOTE:** The heads on the captive fasteners should spring outward when freed.

**Figure 6-40.** Loosen Hard Drive Card Captive Screws



Loosen the captive screws by hand until they no longer engage the threads in the floating fasteners

## Replacement Procedures

10. Grasp the drive assembly handle with one hand and carefully pull the assembly toward you. Pull until the rear connectors on the board are freed from the connectors on the backplane.

**Figure 6-41.** Free Hard Drive Card from the EOAP Card Cage



- a. Grasp the handle with one hand.

- b. Pull until connectors are freed from the backplane.



- 
11. Continue pulling the card directly toward you until it clears the EOAP drive bay completely. Always support the drive assembly from underneath, when possible, using the other hand.

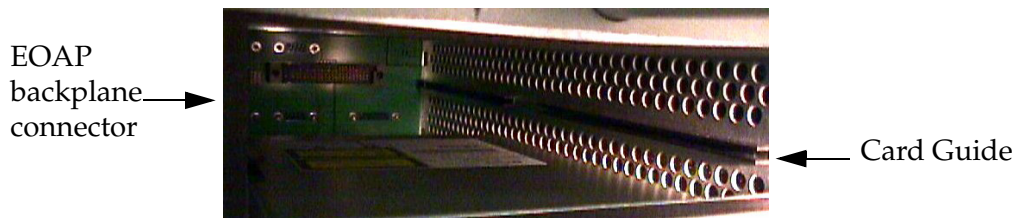
**Figure 6-42.** Support the Hard Drive Card With Both Hands



- 
12. Immediately store the card properly to avoid any damage due to handling or ESD.
-

13. Prior to inserting the replacement card, examine the pins in the EOAP backplane connector for any misalignment, evidence of shorts, or other signs of damage.

**Figure 6-43.** Examine EOAP Backplane Connector Pins



14. Remove the new drive card assembly from the shipping container.

**Figure 6-44.** Hard Drive Card (P/N 870-1514-03)

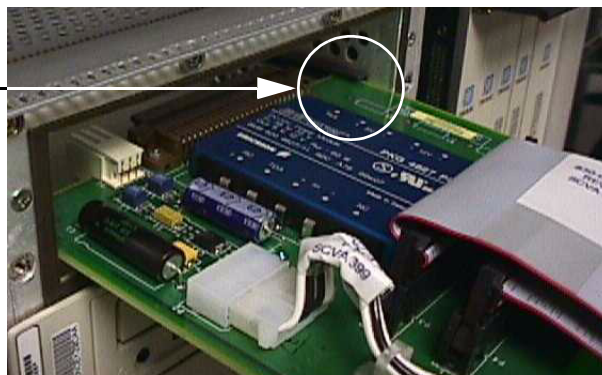


15. Use one hand to support the card assembly from underneath and the other hand to grasp the faceplate handle (see Figure 6-42).

16. While facing the front of the drive bay, carefully insert the card through the proper opening. Align the edges of the card with the channels in the card guides. Then push the assembly until the rear connectors on the drive card begin engaging the mated connectors on the backplane.

**Figure 6-45.** Installing the Hard Drive Card

Align the edges of the card with the card guides.



## Replacement Procedures

17. Press the faceplate of the assembly using constant pressure until the connections are fully seated.

**Figure 6-46.** Pressing the Faceplate



Press the faceplate near the areas where the handle is in contact with the faceplate.

18. Push in each head of the left and right captive screws on the faceplate until the threads make contact with the floating fasteners in the drive bay faceplate. Use your fingers to firmly tighten each screw.



**WARNING:** Do not overtighten the screws as the heads could snap off.

19. The system will automatically reboot to recognize the card. If the system does not automatically reboot, boot it manually from the terminal:

```
ok boot
```

20. At the EAGLE 5 ISS terminal, change the terminal port of the isolated EOAP to type **oap** by entering this command:

```
chg-trm:type=oap:trm=x
```

where *x* is the terminal number of the isolated EOAP

21. Allow the EOAP connection by entering this command:

```
alw-trm:trm=x:force=yes
```

where *x* is the terminal number of the isolated EOAP.

You have replaced the hard drive card. Reprovision the hard drive next.

### Reprovision Hard Drive

These procedures assume that the installed hard drive was preloaded with EOAP platform and UAL software.



**CAUTION:** The EOAP's open system architecture allows access to the operating system. Any undocumented changes to the files may cause the system to become corrupted and unusable. Making any undocumented changes on the EOAP, including changes to the hardware, operating system and/or the components found therein will void the warranty.

**NOTE:** In the event of a failure, repeat the section in which the failure occurred. If the failure re-occurs, contact your Customer Care Center for guidance.

## Configuring System Parameters

### Procedure

---

- 1 Log in to the EOAP as root; enter these commands:

```
Console Login: root
Password: xxxxxx
```

**NOTE:** See your Customer Care Center for the password for your equipment.

---

2. Verify that all the required processes are running by entering the following commands:

```
# su - ccsproj
% cd /ccsosmr/{instance}/bin
% ccsmr all.status
```

The system displays output similar to the following:

```
***** System (msDI) registration report starts *****
***** date/time==> Wed May 29 14:29:35 1996
* Process=(msDI00), Host(apg3)/PID=(870): IPC directory daemon
* Process=(ysT300), Host(apg3)/PID=(915):
* Process=(ysA201), Host(apg3)/PID=(920): UAL Timeout/PVC state cntl daemon
* Process=(ysA301), Host(apg3)/PID=(938): UAL Multi-Seg. Re-assembly daemon
* Process=(ysA401), Host(apg3)/PID=(954): UAL conf. fail/clear daemon
* Process=(ysA001), Host(apg3)/PID=(970): OS Contract OS to NE daemon
* Process=(ysT100), Host(apg3)/PID=(989):
* Process=(ysAD01), Host(apg3)/PID=(1012): UAL test msg echo daemon
* Process=(ysT200), Host(apg3)/PID=(1001):
! Process=(ysA101), Host(apg3)/PID=(1037): UAL/X.25 PVC daemon
! Process=(ysA102), Host(apg3)/PID=(1053): UAL/X.25 PVC daemon
! Process=(ysA103), Host(apg3)/PID=(1069): UAL/X.25 PVC daemon
* Process=(ysTT00), Host(apg3)/PID=(1130):
* Process=(emsAgent), Host(apg3)/PID=(611): EmsAgent
* Process=(emsStatusUpdate), Host(ralph)/PID=(12144): EMS Agent Status
```

**NOTE:** Only applicable processes are listed. The host and PID output will vary. The processes marked with “!” will vary depending on the X.25 configuration in the DEFAULTS file. In a single EOAP configuration, six X.25

## Replacement Procedures

processes are listed. In a dual EOAP configuration, only three X.25 processes are listed.

- 
3. Reboot the EOAP:

```
% exit
# /usr/sbin/init 6
```

---

4. Display the current EOAP configuration by entering the **rtrv-oap-config** command. This is an example of the possible output:

```
rlghncxa03w 00-06-07 11:34:04 EST Rel 26.0.0
OAP CONFIGURATION REPORT
DATA OAP A OAP B
rlghncxa03w 00-06-07 11:34:04 EST Rel 26.0.0
OAP CONFIGURATION REPORT
DATA OAP A OAP B
Hostname tekelec-12 tekelec-13
IP Address 192.106.175.025 192.106.175.026
IP Netmask 255.255.255.000 255.255.255.000
Default Router 128.132.064.001 128.132.064.001
Config dual dual
SEAC CLLI RLGHNXCXB14Y RLGHNXCXB14Y
X25 Packet Size 8 8
X25 Mode DTE DTE
```

Before the EOAP configuration can be sent to the specified EOAP with the **act-oap-config** command, certain fields of the **rtrv-oap-config** command output must be correctly configured depending on whether the SEAS feature is on or not. If these fields contain incorrect entries and the EOAP configuration is sent to the specified EOAP, the specified EOAP may go out of service. The fields that must be correctly configured before the EOAP configuration is sent to the specified EOAP. See the applicable EAGLE 5 ISS manual for more information.

If any fields of the **rtrv-oap-config** output were changed, re-verify that all settings are correct by using the **rtrv-oap-config** command.

- 
5. Make sure that there are no alarms for either EOAP. Enter the **rept-stat-seas** command.

The following are examples of the possible output:

```
rept-stat-seas
rlghncxa03w 00-06-04 15:59:06 EST Rel 26.0.0
SEAS Subsystem Report IS-NR Active -----
SEAS Interfaces Configured = 2 Interfaces IS-NR = 2
GPL PST SST AST
-----
SEAS SYSTEM IS-NR Active -----TDM
Port 4 IS-NR Active -----TDM
Port 10 IS-NR Active -----OAP
```

```

A 250-001-000 IS-NR Active -----OAP
B 250-001-000 IS-NR Active -----X.
25 Link A1 IS-NR Active -----X.
25 Link B1 IS-NR Active -----SEAS
SYSTEM ALARM STATUS = No Alarms.
OAP A ALARM STATUS = No Alarms.
OAP B ALARM STATUS = No Alarms.
X25 Link A1 ALARM STATUS = No Alarms.
X25 Link A2 ALARM STATUS = No Alarms.
X25 Link B1 ALARM STATUS = No Alarms.
X25 Link B2 ALARM STATUS = No Alarms.
X25 A1 PVCs IS-NR = 1,2,3
X25 A1 PVCs OOS-MT = ---X25
B1 PVCs IS-NR = 1,2,3
X25 B1 PVCs OOS-MT = ---X25
A2 PVCs IS-NR = 1,2,3
X25 A2 PVCs OOS-MT = ---X25
B2 PVCs IS-NR = 1,2,3
X25 B2 PVCs OOS-MT = ---Command
Completed.

```

If alarms are shown for the EOAPs in the **rept-stat-seas** output, contact your Customer Care Center (see "Customer Care Center" on page 1-10).

- 
- For the EOAP to be updated by the **act-oap-config** command, return the EOAP ports to service:

```
rst-trm:trm=4
rst-trm:trm=10
```

After successful completion of this command, the system returns the following output:

```
rlghncxa03w 00-06-17 15:08:45 EDT Rel 26.0.0
Allow message sent to terminal
```

- 
- On the EAGLE 5 ISS, allow the EOAP terminal by entering the following command, using the OAP terminal number you retrieved before you replaced the hard drive card:

```
alw-trm:trm=<OAP_terminal_number>
```

- 
- Verify that the EOAP port is returned to service by entering the **rept-stat-trm** command.

This is an example of the possible output:

```

rlghncxa03w 00-06-07 11:34:04 EST Rel 26.0.0
TRM PST   SST   AST
1   IS-NR Active -----
2   IS-NR Active -----
3   IS-NR Active -----
4   IS-NR Active -----
5   IS-NR Active -----
6   IS-NR Active -----

```



## Replacement Procedures

```
7 IS-NR Active -----
8 IS-NR Active -----
9 IS-NR Active -----
10 IS-NR Active -----
11 IS-NR Active -----
12 IS-NR Active -----
13 IS-NR Active -----
14 IS-NR Active -----
15 IS-NR Active -----
16 IS-NR Active -----
Command Completed.
```

If the entry IS-NR is not shown in the PST field of the **rept-stat-trm** output, the EOAP port has not been returned to service. Contact your Customer Care Center ( see "Customer Care Center" on page 1-10).

---

9. Send the EOAP configuration data to the EOAP using the **act-oap-config** command. The **force=yes** parameter must be specified with the **act-oap-config** command. It can take up to 15 minutes to update the configuration of the EOAP, during which time the EOAP being updated will be out of service.

Use the following commands for EOAP-A only:

- a. Update EOAP A by entering this command:

```
act-oap-config:oap=a:force=yes
```

After successful completion of this command, the system returns the following output:

```
rlghncxa03w 00-06-07 11:34:04 EST Rel 26.0.0
ACT-OAP-CONFIG: MASP A - COMPLTD
```

- b. Wait 15 minutes, then enter the **rept-stat-seas** command to make sure that there are no alarms for EOAP A.

These are examples of the possible output:

**rept-stat-seas**

```
rlghncxa03w 00-06-04 15:59:06 EST Rel 26.0.0
SEAS Subsystem Report IS-NR Active -----SEAS
Interfaces Configured = 2 Interfaces IS-NR = 2
GPL PST SST AST
```

```
-----
SEAS SYSTEM IS-NR Active -----
TDM Port 4 IS-NR Active -----
TDM Port 10 IS-NR Active -----
OAP A 250-001-000 IS-NR Active -----
OAP B 250-001-000 IS-NR Active -----
X.25 Link A1 IS-NR Active -----
X.25 Link B1 IS-NR Active -----
SEAS SYSTEM ALARM STATUS = No Alarms.
OAP A ALARM STATUS = No Alarms.
OAP B ALARM STATUS = No Alarms.
X25 Link A1 ALARM STATUS = No Alarms.
X25 Link A2 ALARM STATUS = No Alarms.
X25 Link B1 ALARM STATUS = No Alarms.
X25 Link B2 ALARM STATUS = No Alarms.
X25 A1 PVCs IS-NR = 1,2,3
X25 A1 PVCs OOS-MT = ---X25
B1 PVCs IS-NR = 1,2,3
X25 B1 PVCs OOS-MT = ---X25
A2 PVCs IS-NR = 1,2,3
X25 A2 PVCs OOS-MT = ---X25
B2 PVCs IS-NR = 1,2,3
X25 B2 PVCs OOS-MT = ---Command
Completed.
```

## Replacement Procedures

Use the following pair of commands for EOAP-B only:

- a. Update EOAP B:

```
act-oap-config:oap=b:force=yes
```

After successful completion of this command, the system returns the following output:

```
rlghncxa03w 00-06-07 11:34:04 EST Rel 26.0.0  
ACT-OAP-CONFIG: MASP A - COMPLTD
```

- b. Wait 15 minutes, then enter the **rept-stat-seas** command to make sure that there are no alarms for EOAP B.

These are examples of the possible output:

```
rept-stat-seas
```

```
rlghncxa03w 00-06-04 15:59:06 EST Rel 26.0.0  
SEAS Subsystem Report IS-NR Active -----  
SEAS Interfaces Configured = 2 Interfaces IS-NR = 2  
GPL PST SST AST
```

```
-----  
SEAS SYSTEM IS-NR Active -----  
TDM Port 4 IS-NR Active -----  
TDM Port 10 IS-NR Active -----  
OAP A 250-001-000 IS-NR Active -----  
OAP B 250-001-000 IS-NR Active -----  
X.25 Link A1 IS-NR Active -----  
X.25 Link B1 IS-NR Active -----  
SEAS SYSTEM ALARM STATUS = No Alarms.  
OAP A ALARM STATUS = No Alarms.  
OAP B ALARM STATUS = No Alarms.  
X25 Link A1 ALARM STATUS = No Alarms.  
X25 Link A2 ALARM STATUS = No Alarms.  
X25 Link B1 ALARM STATUS = No Alarms.  
X25 Link B2 ALARM STATUS = No Alarms.  
X25 A1 PVCs IS-NR = 1,2,3  
X25 A1 PVCs OOS-MT = ---X25  
B1 PVCs IS-NR = 1,2,3  
X25 B1 PVCs OOS-MT = ---X25  
A2 PVCs IS-NR = 1,2,3  
X25 A2 PVCs OOS-MT = ---X25  
B2 PVCs IS-NR = 1,2,3  
X25 B2 PVCs OOS-MT = ---Command  
Completed.
```

If alarms are shown for the EOAPs in the **rept-stat-seas** output, contact your Customer Care Center (see “Customer Care Center” on page 1-10).

---

## Power Supply Card

This procedure describes how to replace a power supply card (P/N 870-1521-01) and verify its operation after the replacement. The power supply card does not require any provisioning.



**WARNING:** Prior to working on or around live equipment, follow proper ESD grounding procedures to prevent damage to the equipment; reference *ESD Protection Procedure (907-0404-01)*.



**CAUTION:** The EOAP's open system architecture allows access to the operating system. Any undocumented changes to the files may cause the system to become corrupted and unusable. Making any undocumented changes on the EOAP, including changes to the hardware, operating system and/or the components found therein will void the warranty.

### Tools and Equipment

- Insulated Phillips screwdriver
- Insulated flashlight
- Power supply card (P/N 870-1521-01)

### Procedure

---

- 1 Identify the EOAP system (EOAP-A or EOAP-B) that contains the card to be replaced.
- 

2. At the terminal connected to the EOAP that needs the card replaced:

- a. Log in as root:

```
Console login: root
```

```
Password: xxxxxx
```

**NOTE:** See your Customer Care Center for the password for your equipment.

- b. Shut down all processes and exit back to root by entering these commands:

```
# su - ccspoj
% cd /ccsosmr/{instance}/bin
% ccsmr all.down
% exit
```

## Replacement Procedures

- c. Halt the isolated EOAP system by entering this command:

```
# /usr/sbin/init 0
```

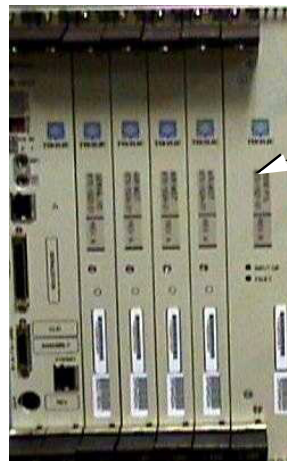
The screen will display output similar to the following. Wait until the `ok` prompt appears before continuing with the next step:

```
Date: time apg 2 halt: halted by root
Date: time apg 2 syslogd: going down on signal 15
Syncing file systems ... [1] done
Program terminated
Type help for more information
ok
```

---

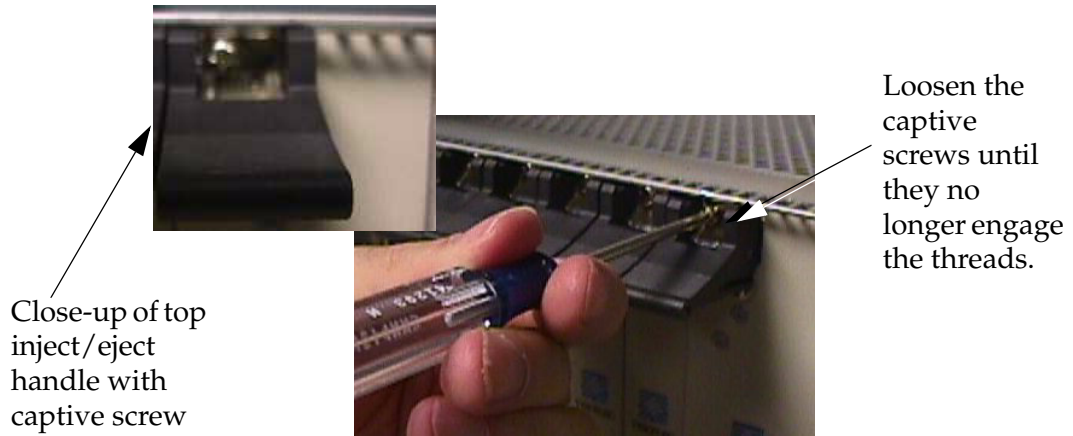
3. Locate the power supply card (slots 7 and 8).

**Figure 6-47.** Locate Power Supply Card



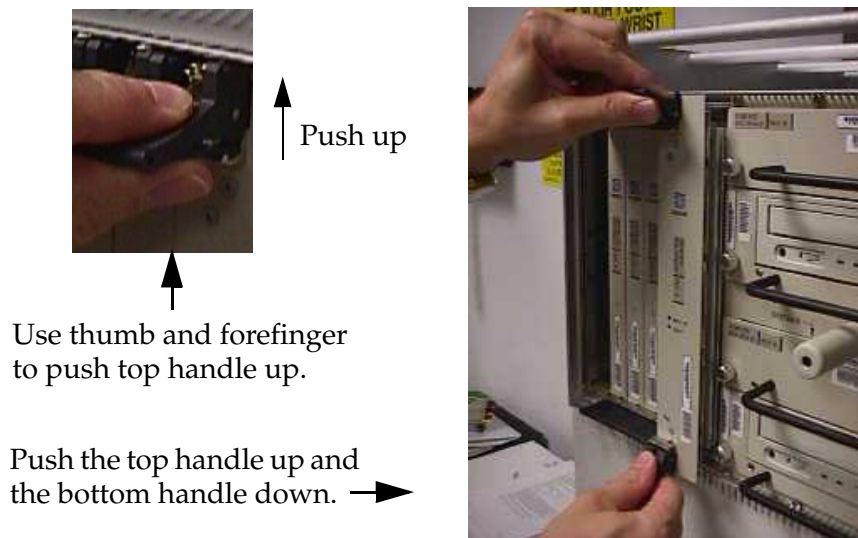
4. While facing the card to be replaced, locate the two captive screws attached to the top and bottom inject/eject handle brackets on the faceplate. Figure 6-48 shows a close-up of the top handle with captive screw.
- 
5. Using a small Phillips head screwdriver, loosen the captive screws until they no longer engage the threads. **Do not remove the screws** from the ejector handle brackets.

**Figure 6-48.** Loosening Captive Screws of Power Supply Card



6. Using the thumb and forefinger, push the top handle up and the bottom handle down simultaneously until the card is completely free from the backplane in the card cage.

**Figure 6-49.** Free the Card from the EOAP Card Cage



7. Pull the card directly towards you until it clears the card guides and guide rails.
8. Immediately store the card properly to avoid any damage due to handling or ESD.

## Replacement Procedures

9. Prior to inserting the replacement card, examine the pins in the EOAP backplane connector for any misalignment, evidence of shorts, or other signs of damage.

**Figure 6-50.** EOAP Backplane Connector Pins



← Prior to inserting the replacement card, check connectors\* for any kind of damage.

← Card guides

\*Cards removed for clarity.

- 
10. Remove the replacement power supply card from the shipping container.

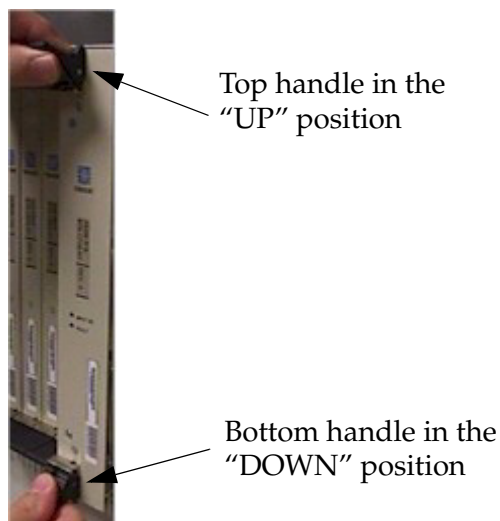
**Figure 6-51.** Power Supply Card (P/N 870-1521-01)



← Replacement Power Supply Card

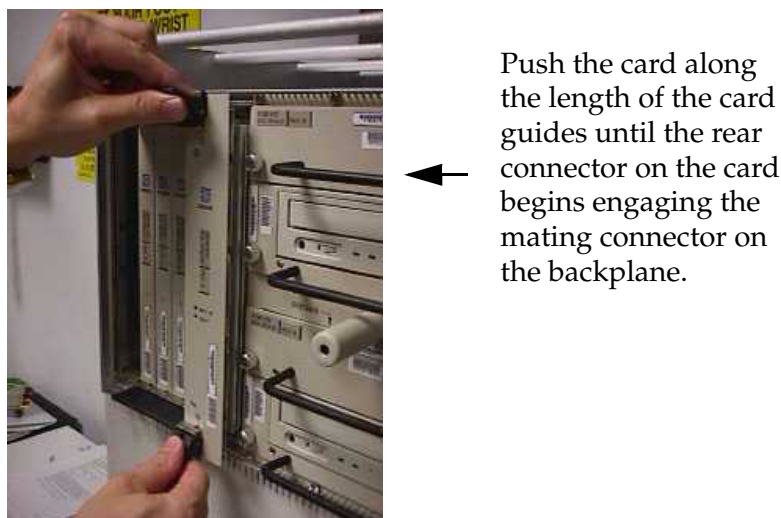
- 
11. Make sure the two captive screws located in the inject/eject handle brackets are partially backed out so they do not interfere with insertion.
- 
12. Push all handles outward from the replacement card's faceplate (top handle in the "UP" position, bottom handle in the "DOWN" position.)

**Figure 6-52.** Power Supply Card Handles



- Carefully align the replacement card's edges with the channels in the top and bottom card guides. Refer to Figure 6-53. Then push the card along the length of the card guides until the rear connector on the card begins engaging the mating connector on the backplane.

**Figure 6-53.** Inserting the Power Supply Card



- Press the faceplate of the card using constant pressure until you feel the card's progress cease.



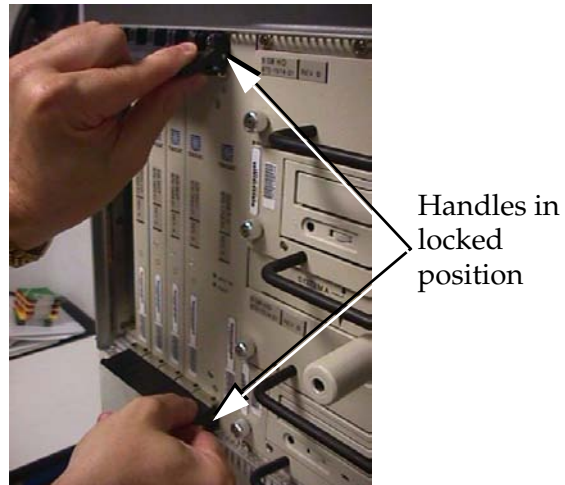
**WARNING:** Do not impact the faceplate in order to mate the two connectors. Any impact to the card's faceplate can damage the faceplate, the pins in the backplane, or the backplane itself.



## Replacement Procedures

- Using the thumb and forefinger together, push the top inject/eject handle down and the bottom handle up until both handles are in the locked position. Figure 6-55 shows a close-up of a top inject/eject handle in the locked position.

**Figure 6-54.** Handles in Locked Position

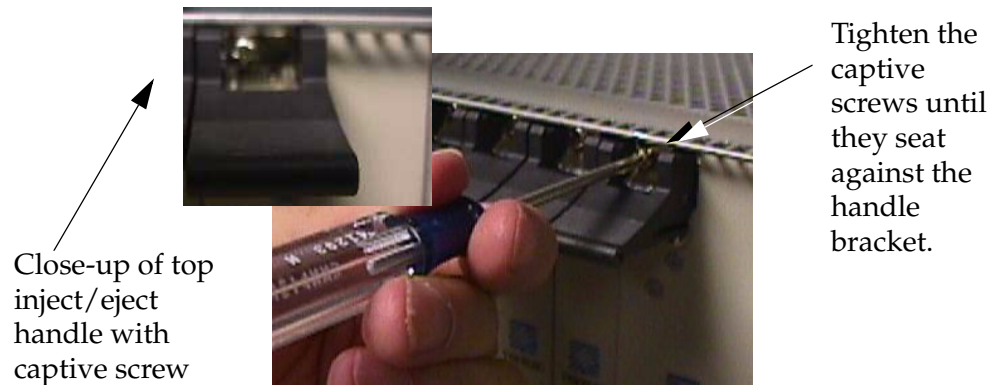


- Using a small Phillips head screwdriver, tighten all captive screws in the handle brackets until they seat against the handle bracket.



**WARNING:** Do not overtighten the screws as the heads could snap off.

**Figure 6-55.** Tighten Captive Screws



- Once the card is replaced, the system will automatically reboot. If the card does not automatically reboot, go to the terminal and type the following at the ok prompt:

ok **boot**

18. After the processor card has reset, confirm that the power supply card is operational by checking its LEDs. A green Power LED indicates that power is supplied to the power supply card.

For troubleshooting basic power problems, refer to Chapter 7, *Basic Troubleshooting*.

---

You have replaced the power supply card and confirmed that it is operational.

### Processor Card

This procedure describes how to replace the processor card (P/N 870-1523-01) in a EOAP shelf. The processor card requires reprovisioning.



**WARNING:** Prior to working on or around live equipment, follow proper ESD grounding procedures to prevent damage to the equipment.



**CAUTION:** The EOAP's open system architecture allows access to the operating system. Any undocumented changes to the files may cause the system to become corrupted and unusable. Making any undocumented changes on the EOAP, including changes to the hardware, operating system and/or the components found therein will void the warranty.

#### Replacement Order

Replace the processor card in the stages and order listed below:

1. Replace processor card
2. Reprovision processor card

#### Tools and Equipment

- Small Phillips head screwdriver
- Flashlight (to view back panel interior)
- EOAP processor card (P/N 870-1523-01)

#### Procedure

---

- 1 At the EAGLE 5 ISS, make sure that the redundant EOAP is active. Enter the **rept-stat-seas** command. The output will display the status of the EOAPs. For this example, enter the **rept-stat-seas** command; the EOAP status is shown in bold:

**rept-stat-seas**

The system returns output similar to the following:

```
rept-stat-seas
rlghncxa03w 00-06-04 15:59:06 EST Rel 26.0.0
SEAS Subsystem Report IS-NR Active -----
SEAS Interfaces Configured = 2 Interfaces IS-NR = 2
GPL PST SST AST
-----
SEAS SYSTEM IS-NR Active -----TDM
Port 4 IS-NR Active -----TDM
Port 10 IS-NR Active -----OAP
A 250-001-000 IS-NR Active -----OAP
B 250-001-000 IS-NR Active -----X.
25 Link A1 IS-NR Active -----X.
25 Link B1 IS-NR Active -----SEAS
SYSTEM ALARM STATUS = No Alarms.
OAP A ALARM STATUS = No Alarms.
OAP B ALARM STATUS = No Alarms.
X25 Link A1 ALARM STATUS = No Alarms.
X25 Link A2 ALARM STATUS = No Alarms.
X25 Link B1 ALARM STATUS = No Alarms.
X25 Link B2 ALARM STATUS = No Alarms.
X25 A1 PVCs IS-NR = 1,2,3
X25 A1 PVCs OOS-MT = ---X25
B1 PVCs IS-NR = 1,2,3
X25 B1 PVCs OOS-MT = ---X25
A2 PVCs IS-NR = 1,2,3
X25 A2 PVCs OOS-MT = ---X25
B2 PVCs IS-NR = 1,2,3
X25 B2 PVCs OOS-MT = ---Command
Completed.
```

2. Display the EOAP terminal numbers to identify the terminal to be inhibited; enter **rtrv-trm** command. This is an example of the possible output:

```
rlghncxa03w 00-06-07 11:34:04 EST Rel 26.0.0
TRM  TYPE      COMM          FC      TMOUT  MXINV  DURAL
1    VT320      9600-7-E-1 SW    30      5      99:59:59
2    KSR        9600-7-E-1 HW    30      5      INDEF
3    PRINTER    4800-7-E-1 HW    30      0      00:00:00
4    OAP        19200-7-E-1 SW  30     5     00:30:00
5    VT320      9600-7-O-1 NONE  30      5      00:00:30
6    VT320      9600-7-E-2 SW    30      9      INDEF
7    PRINTER    9600-7-N-2 HW    30      5      00:30:00
8    KSR        19200-7-E-2 BOTH  30      5      00:30:00
9    VT320      9600-7-E-1 SW    30      7      00:30:00
10   OAP        19200-7-E-1 SW  30     5     00:30:00
11   VT320      4800-7-E-1 HW    30      5      00:30:00
12   PRINTER    9600-7-E-1 HW    30      4      00:30:00
13   VT320      9600-7-O-1 NONE  30      5      00:30:00
14   VT320      9600-7-E-2 SW    30      8      00:30:00
15   VT320      9600-7-N-2 HW    30      5      00:30:00
16   VT320      9600-7-E-2 BOTH  30      3      00:30:00

TRM  TRAF LINK SA  SYS PU  DB  UIMRD
1    NO  YES  NO  YES NO  YES YES
2    NO  NO   NO  NO  NO  NO  NO
3    YES YES  YES NO  YES YES YES
4    NO  NO  NO  NO  NO  NO  NO
```

## Replacement Procedures

5	NO	YES	NO	NO	NO	NO	YES
6	NO	NO	YES	NO	NO	NO	NO
7	YES	YES	YES	YES	YES	YES	YES
8	NO	NO	NO	NO	YES	NO	YES
9	NO	YES	NO	NO	NO	YES	NO
<b>10</b>	<b>NO</b>	<b>NO</b>	<b>NO</b>	<b>NO</b>	<b>NO</b>	<b>NO</b>	<b>NO</b>
11	YES	YES	YES	YES	YES	YES	YES
12	YES	YES	YES	YES	YES	YES	YES
13	NO	YES	NO	NO	NO	NO	YES
14	NO	NO	YES	NO	NO	NO	NO
15	YES	YES	YES	NO	YES	YES	YES
16	NO	NO	NO	NO	YES	NO	YES

---

3. Inhibit the isolated EOAP connection by entering this command:

```
inh-trm:trm=x
```

where *x* is the terminal number of the isolated EOAP.

The system returns this message:

```
RLGHNCXA03W 00-06-17 14:59:11 EST Release 26.0.0  
Inhibit message sent to terminal
```

---

4. Change the terminal port to type **none** by entering this command:

```
chg-trm:type=none:trm=x
```

where *x* is the terminal number of the isolated EOAP.

The system returns this message:

```
RLGHNCXA03W 00-06-17 14:59:11 EST Release 26.0.0  
CHG-TRM: MASP A - CMPLTD
```

---

5. Confirm that the isolated EOAP connection is inactive. Enter the **rept-stat-seas** command. The output will display the status of the EOAPs. For this example, enter the **rept-stat-seas** command; the EOAP status is shown in bold:

```
rept-stat-seas
```

The system returns output similar to the following:

```
rept-stat-seas  
rlghncxa03w 00-06-04 15:59:06 EST Rel 26.0.0  
SEAS Subsystem Report IS-NR Active -----  
SEAS Interfaces Configured = 2 Interfaces IS-NR = 2  
GPL PST SST AST  
-----  
SEAS SYSTEM IS-NR Active -----TDM  
Port 4 IS-NR Active -----TDM  
Port 10 IS-NR Active -----OAP  
A 250-001-000 IS-NR Active -----OAP  
B 250-001-000 IS-NR Active -----X.  
25 Link A1 IS-NR Active -----X.  
25 Link B1 IS-NR Active -----SEAS  
SYSTEM ALARM STATUS = No Alarms.  
OAP A ALARM STATUS = No Alarms.
```

**OAP B ALARM STATUS = No Alarms.**

X25 Link A1 ALARM STATUS = No Alarms.

X25 Link A2 ALARM STATUS = No Alarms.

X25 Link B1 ALARM STATUS = No Alarms.

X25 Link B2 ALARM STATUS = No Alarms.

X25 A1 PVCs IS-NR = 1,2,3

X25 A1 PVCs OOS-MT = ---X25

B1 PVCs IS-NR = 1,2,3

X25 B1 PVCs OOS-MT = ---X25

A2 PVCs IS-NR = 1,2,3

X25 A2 PVCs OOS-MT = ---X25

B2 PVCs IS-NR = 1,2,3

X25 B2 PVCs OOS-MT = ---Command

Completed.

---

## Replacement Procedures

6. At the EOAP terminal connected to the isolated EOAP:

a. Log in as root:

```
Console login: root
```

```
Password: xxxxxx
```

b. Shut down all processes and exit back to root by entering these commands:

```
# su - ccsproj  
% cd /ccsosmr/{instance}/bin  
% ccsmr all.down  
% exit
```

c. Halt the isolated EOAP system by entering this command:

```
# /usr/sbin/init 0
```

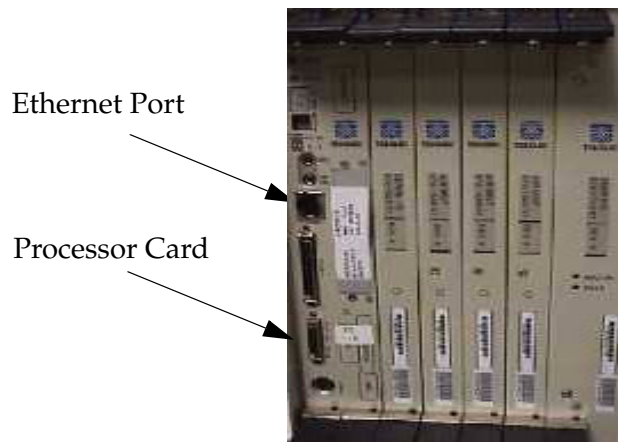
The screen will display output similar to the following. Wait until the `ok` prompt appears before continuing with the next step:

```
Date: time apg 2 halt: halted by root  
Date: time apg 2 syslogd: going down on signal 15  
Syncing file systems ... [1] done  
Program terminated  
Type help for more information  
ok
```

---

7. Locate the processor card (slots 1 and 2).

**Figure 6-56.** Locate Processor Card



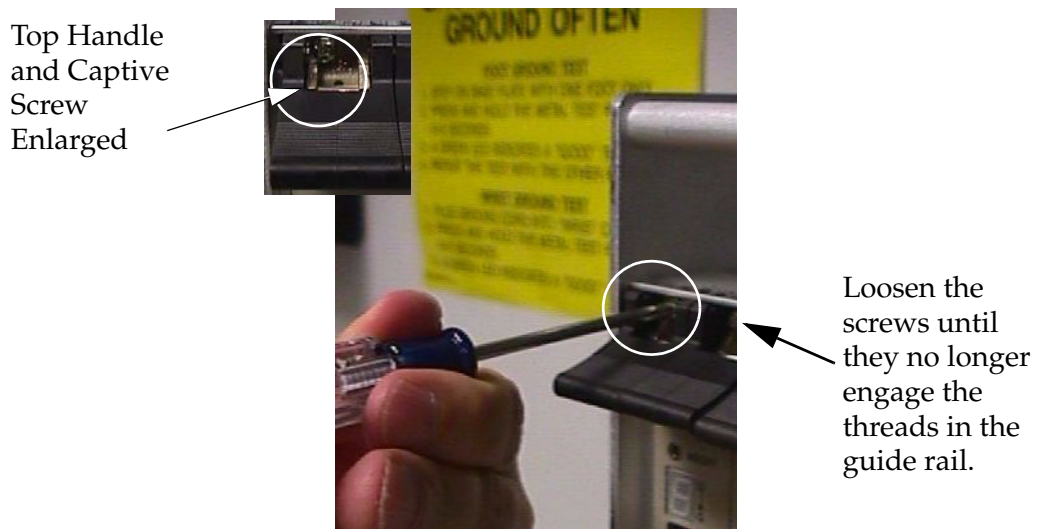
8. Locate the Ethernet port on the front of the processor card (refer to Figure 6-56). The port connects to the customer network equipment. Unplug this cable and tie it off to part of the card cage structure. You will need to plug this cable back into the replacement processor card's Ethernet port.

**NOTE: Disconnecting the Ethernet cable will result in a series of network-related error messages on the EOAP console. Ignore these messages and continue.**

9. Locate the four captive screws attached to the top and bottom inject/eject handle brackets on the faceplate. Figure 6-57 shows a close-up of the top handle with a captive screw.

10. Using a small Phillips head screwdriver, loosen the captive screws until they no longer engage the threads. **Do not remove the screws** from the ejector handle brackets.

**Figure 6-57.** Processor Card Captive Screws

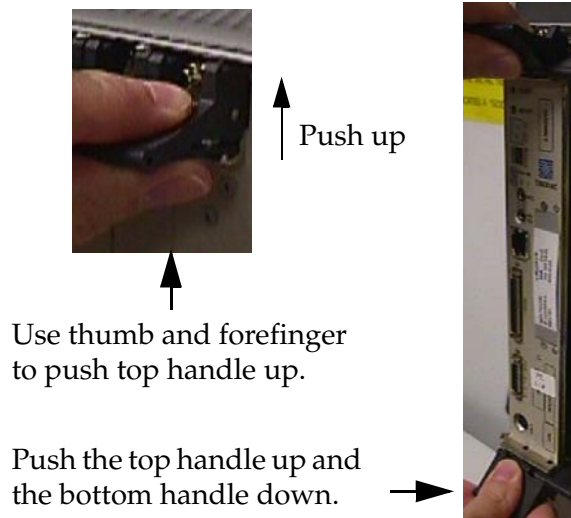




## Replacement Procedures

- Using the thumb and forefinger, push the top handle up and the bottom handle down simultaneously until the card is completely free from the backplane in the card cage.

**Figure 6-58.** Freeing the Processor Card from the EOAP Card Cage

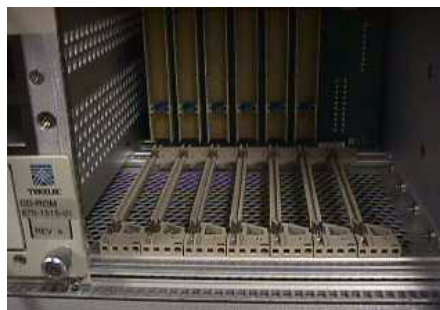


- Pull the card directly towards you until it clears the card guides and guide rails.

- Immediately store the card properly to avoid any damage due to handling or ESD.

- Prior to inserting the replacement card, examine the pins in the EOAP backplane connector for any misalignment, evidence of shorts, or other signs of damage.

**Figure 6-59.** EOAP Backplane Connector Pins



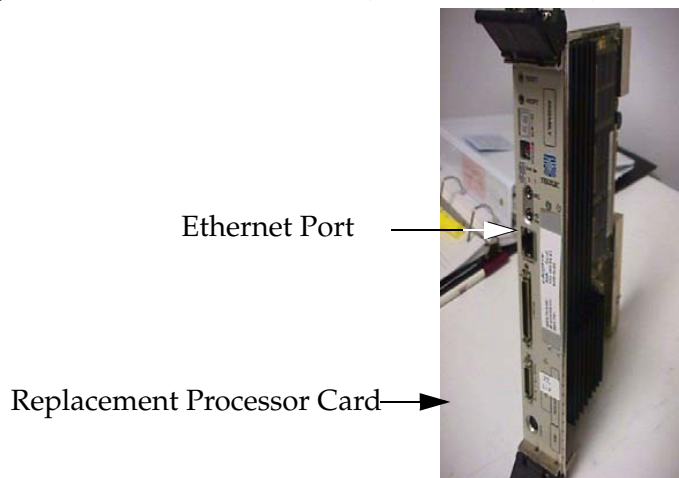
← Prior to inserting the replacement card, check connectors\* for any kind of damage.

← Card guides

\*Cards removed for clarity.

15. Remove the replacement processor card from the shipping container.

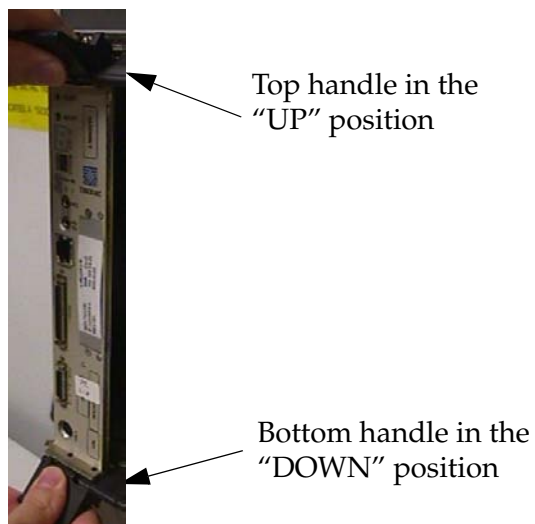
**Figure 6-60.** Processor Card (P/N 870-1523-01)



16. Make sure the four captive screws located in the inject/eject handle brackets are partially backed out so they do not interfere with insertion.

17. Push all handles outward from the replacement card's faceplate (top handle in the "UP" position, bottom handle in the "DOWN" position.)

**Figure 6-61.** Processor Card Handles



## Replacement Procedures

- Carefully align the replacement card's edges with the channels in the top and bottom card guides. Refer to Figure 6-62. Then push the card along the length of card guides until the rear connector on the card begins engaging the mating connector on the backplane.

**Figure 6-62.** Inserting the Replacement Processor Card



Push the card along the length of the card guides until the rear connector on the card begins engaging the mating connector on the backplane.

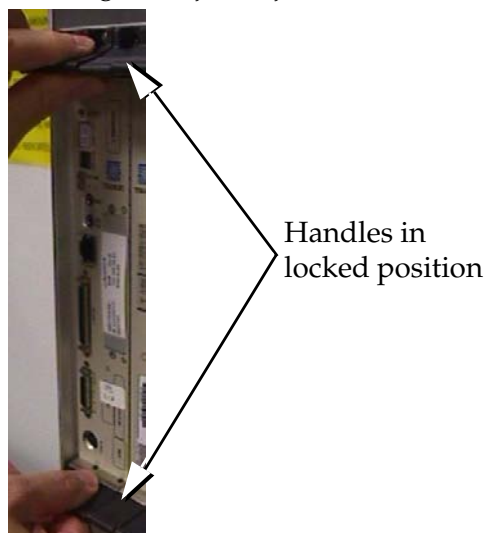
- 
- Press the faceplate of the card using constant pressure until you feel the card's progress cease.



**WARNING:** Do not impact the faceplate in order to mate the two connectors. Any impact to the card's faceplate can damage the faceplate, the pins in the backplane, or the backplane itself.

- 
- Using the thumb and forefinger together, push the top inject/eject handle down and the bottom handle up until both handles are in the locked position. Figure 6-64 shows a close-up of a top inject/eject handle in the locked position.

Figure 6-63. Locking the Inject/Eject Handles



- 
21. Using a small Phillips head screwdriver, tighten all captive screws in the handle brackets until they seat against the handle bracket.



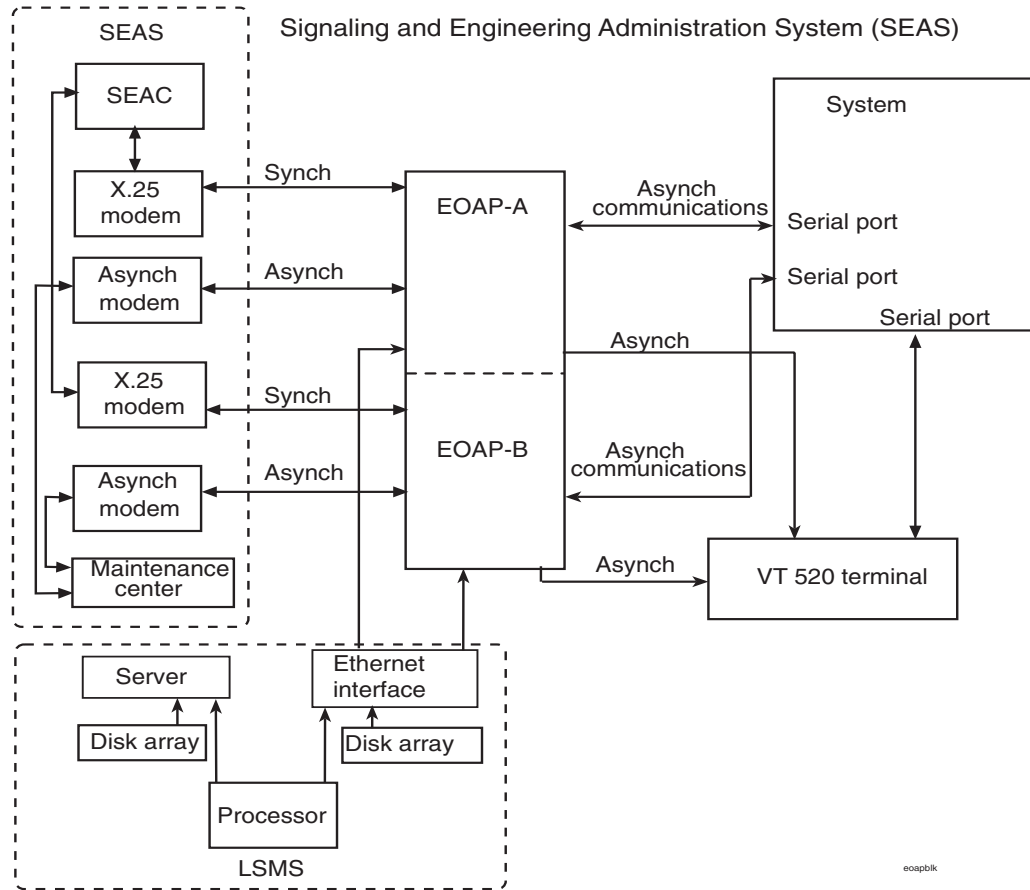
**WARNING:** Do not overtighten the screws as the heads could snap off.

Figure 6-64. Tightening Captive Screws



22. Prior to rebooting the EOAP, reconnect the Ethernet cable unplugged in step 8.. The port connects to the customer network.

**Figure 6-65.** EOAP Serial and Ethernet Connections



23. Boot the EOAP from the **ok** prompt.

**ok boot**

If the EOAP does not reboot, refer to the troubleshooting procedure *System Has Power But Will Not Boot* on page 7-6.

24. At the EAGLE 5 ISS terminal, change the terminal port of the isolated EOAP to type **oap** by entering this command:

**chg-trm:type=oap:trm=x**

where *x* is the terminal number of the isolated EOAP

25. Allow the EOAP connection by entering this command:

```
alw-trm:trm=x:force=yes
```

where *x* is the terminal number of the isolated EOAP.

---

26. Confirm the operation of the processor card by checking and resolving the LEDs. The Power LED turns green to indicate power to the processor card. If the LEDs do not resolve properly, refer to the troubleshooting procedure *Processor Card* on page 7-19.
- 

You have replaced the processor card.

## Serial Card



**CAUTION:** The EOAP's open system architecture allows access to the operating system. Any undocumented changes to the files may cause the system to become corrupted and unusable. Making any undocumented changes on the EOAP, including changes to the hardware, operating system and/or the components found therein will void the warranty.

### Tools and Equipment

- Insulated Phillips screwdriver
- Insulated flashlight
- Serial card (870-1522-01)

### Replacing a cPCI Serial Card



**WARNING:** Prior to handling any card, follow proper ESD grounding procedures to prevent damage to the card.

### Procedure

---

- 1 Identify the EOAP system (EOAP-A or EOAP-B) that contains the card to be replaced.
- 

2. If the system is running, at the terminal connected to the EOAP that needs the card replaced:

- a. Log in as root:

```
Console login: root
```

```
Password: xxxxxx
```

**NOTE:** See your Customer Care Center for the password for your equipment.

- b. Shut down all processes and exit back to root by entering these commands:

```
# su - ccsproj  
% cd /ccsosmr/{instance}/bin  
% ccsmr all.down  
% exit
```

- c. Halt the isolated EOAP system by entering this command:

```
# /usr/sbin/init 0
```

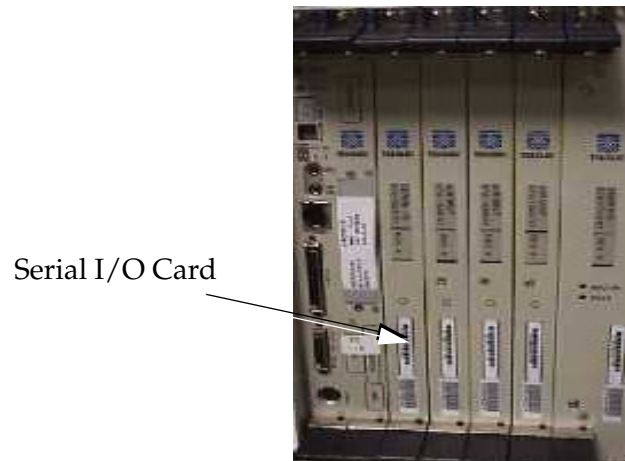
The screen will display output similar to the following. Wait until the `ok` prompt appears before continuing with the next step:

```
Date: time apg 2 halt: halted by root
Date: time apg 2 syslogd: going down on signal 15
Syncing file systems ... [1] done
Program terminated
Type help for more information
ok
```

---

3. Locate the serial card (slot 3).

**Figure 6-66.** Location of Serial Card



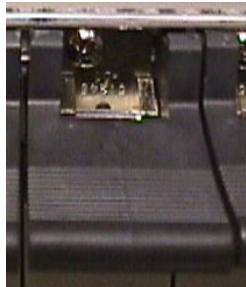
4. While facing the card to be replaced, locate the two captive screws attached to the top and bottom inject/eject handle brackets on the faceplate. Figure 6-67 shows a close-up of the top handle with captive screw.
-



## Replacement Procedures

- Using a small Phillips head screwdriver, loosen the captive screws until they no longer engage the threads. **Do not remove the screws** from the ejector handle brackets.

**Figure 6-67.** Top Handle and Captive Screw of Serial Card



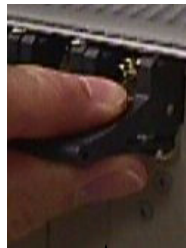
Close-up of top inject/eject handle with captive screw



Loosen the captive screws until they no longer engage the threads.

- Using the thumb and forefinger, push the top handle up and the bottom handle down simultaneously until the card is completely free from the backplane in the card cage.

**Figure 6-68.** Freeing the Card from the EOAP Card Cage



Push up

Use thumb and forefinger to push top handle up.

Push the top handle up and the bottom handle down. →



- Pull the card directly towards you until it clears the card guides and guide rails.

8. Immediately store the card properly to avoid any damage due to handling or ESD.
- 

9. Prior to inserting the replacement card, examine the pins in the EOAP backplane connector for any misalignment, evidence of shorts, or other signs of damage.

**Figure 6-69.** EOAP Backplane Connector Pins



← Prior to inserting the replacement card, check connectors\* for any kind of damage.

← Card guides

\*Cards removed for clarity.

---

10. Remove the replacement serial I/O card from the shipping container.

**Figure 6-70.** Serial Card (870-1522-01)



← Replacement Serial Card

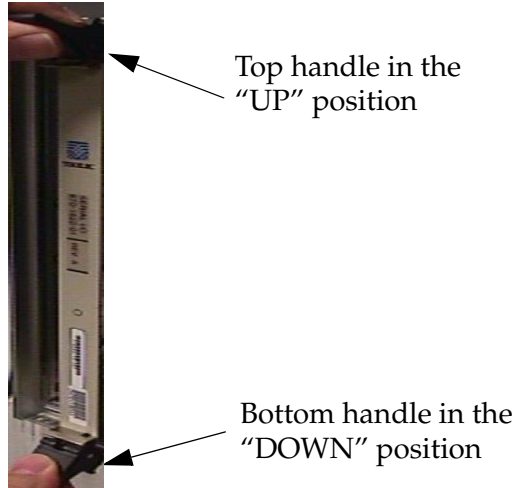
---

11. Make sure the two captive screws located in the inject/eject handle brackets are partially backed out so they do not interfere with insertion.
-

## Replacement Procedures

12. Push all handles outward from the replacement card's faceplate (top handle in the "UP" position, bottom handle in the "DOWN" position.)

**Figure 6-71.** Serial I/O Card Handles



13. Carefully align the replacement card's edges with the channels in the top and bottom card guides. Refer to Figure 6-69. Then push the card along the length of card guides until the rear connector on the card begins engaging the mating connector on the backplane.

**Figure 6-72.** Inserting the Replacement Serial Card



← Push the card along the length of the card guides until the rear connector on the card begins engaging the mating connector on the backplane.

14. Press the faceplate of the card using constant pressure until you feel the card's progress cease.

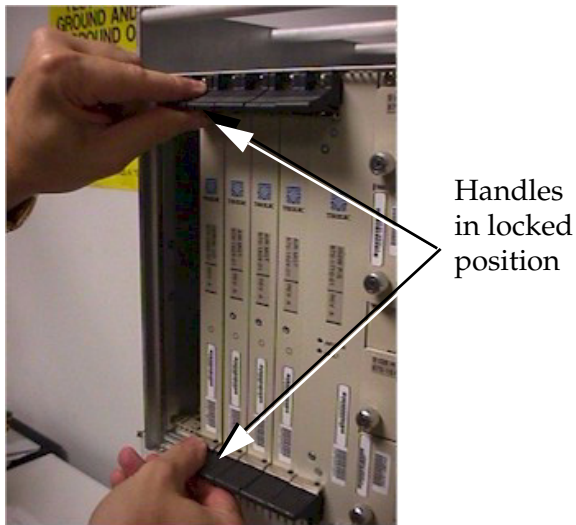


**WARNING:** Do not impact the faceplate in order to mate the two connectors. Any impact to the card's faceplate can damage the faceplate, the pins in the backplane, or the backplane itself.

---

15. Using the thumb and forefinger together, push the top inject/eject handle down and the bottom handle up until both handles are in the locked position. Figure 6-74 shows a close-up of a top inject/eject handle in the locked position.

**Figure 6-73.** Locking the Inject/Eject Handles



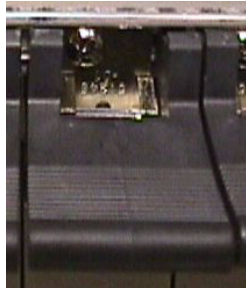
## Replacement Procedures

- Using a small Phillips head screwdriver, tighten all captive screws in the handle brackets until they seat against the handle bracket.



**WARNING:** Do not overtighten the screws as the heads could snap off.

Figure 6-74. Tighten Captive Screws



↑  
Close-up of top  
inject/eject  
handle with  
captive screw



Tighten the  
captive  
screws until  
they seat  
against the  
handle  
bracket.

- 
- At the EOAP terminal, boot the EOAP to recognize the new card.

ok **boot**

---



## Basic Troubleshooting

Power.....	7-3
No System Power.....	7-3
No Fan Power.....	7-4
No cPCI Card Power.....	7-4
No CD-ROM Drive Power.....	7-5
No Hard Drive Power.....	7-5
SCSI/Drives.....	7-6
System Has Power But Will Not Boot.....	7-6
CD-ROM Not Responding.....	7-8
Drives Detected But System Will Not Boot.....	7-10
Connect/Disconnect SCSI Devices.....	7-11
Console Devices.....	7-12
Connect/Disconnect Console Devices.....	7-12
Maintenance Modem.....	7-15
LEDs.....	7-17
Power Supply Card.....	7-17
Processor Card.....	7-19
Hard Disk.....	7-25
File System Errors.....	7-25
Full Partition Check.....	7-26

IP .....7-27

- Error: syslog: s match\_netconf: setnetconfig failed .....7-27

EOAP Internal Software .....7-28

- msDI Controlled Software .....7-28
- Trace Inter-Process Messages (Except emsAgent) .....7-34
- Required Daemons.....7-42

External Connectivity .....7-46

- No External EOAP Connectivity .....7-46

External Interfaces .....7-47

- EOAP-to-EAGLE 5 ISS Interface .....7-47
- EOAP-to-SEAS Interface .....7-51



## Basic Troubleshooting

### Power

The following troubleshooting procedures relate to power source problems that prevent certain components in the EOAP or the DCM cards from functioning properly.

#### No System Power

Use the following procedure when none of the EOAP boards have power (that is, no LEDs are lit and no power is getting to the fans).

##### Procedure

---

- 1 Verify that the fuse panel is powered (fuse panel LEDs should be "ON").

---
- 2 Verify that both power cables are correctly connected to the fuse panel and are connected to "PWR IN A" and "PWR IN B" on the EOAP.

---
- 3 Verify that the correct fuse has been installed in the correct fuse block and is at least a 10 amp fuse.  

For example, FAP 870-0243-09 uses fuse positions 1A for EOAP-A and 1B for EOAP-B. FAP 870-1606-01 offers four fuse positions on each side: 17A through 20A and 17B through 20B. Select the same-numbered fuse location on each side.

---
- 4 If the system is still without power, contact your Customer Care Center.

---

## No Fan Power

Use the following procedure when the EOAP has power, but the fans are not running.

### Procedure

---

- 1 Verify that the two fan cables are properly connected to the EOAP from the fan assembly.

---
- 2 Verify that the fan control card switch (located on the front of the fan assembly) is in the "ON" position.

---
- 3 If already connected to the EAGLE 5 ISS, verify that the fan feature bit has been turned on using the **chg-feat:fan=on** command.

---
- 4 If the fan is still without power, contact your Customer Care Center.

---

## No cPCI Card Power

Use the following procedure when the drive cards show power (LEDs are green) but the cPCI cards (processor or power supply) are not receiving power.

### Procedure

---

- 1 Reseat the power supply card:
  - a. Remove the power supply card.
  - b. Check the pins on the back of the card and the connector in the shelf backplane.

If the card shows any sign of damage, replace the card or call your Customer Care Center for a replacement card.

If the backplane is damaged, call your Customer Care Center.
  - c. If the card is not damaged, reinstall the card and wait for the reset to finish.
  - d. If the card is still not receiving power, call your Customer Care Center for assistance.

---

## Basic Troubleshooting

### No CD-ROM Drive Power

Use the following procedure when the CD-ROM drive (P/N 870-1515-01) power LED is lit but the drive is not responding.

**NOTE: The CD-ROM drive power LED only indicates that 5V power is reaching the card; it does not necessarily mean that the drive itself is receiving 5V.**

#### Procedure

---

- 1 Verify that the power cable is correctly installed on the CD-ROM drive card.

---
- 2 Inspect the power connectors on the drive card and in the backplane for damage. If any one of the connectors is damaged, contact your Customer Care Center.

---

### No Hard Drive Power

Use the following procedure, when the hard drive (P/N 870-1514-03) power LED is lit, but the drive is not responding.

**NOTE: The hard drive power LED only indicates that 5V power is reaching the card; it does not necessarily mean that the drive itself is receiving 5V.**

#### Procedure

---

- 1 Verify that the power cable is correctly installed on the drive card (3-conductor cable from the hard drive card to the back of the hard drive.)

---
- 2 Inspect the power connectors on the drive card and in the backplane for damage. If any one of the connectors is damaged, contact your Customer Care Center.

---

## SCSI/Drives

The following troubleshooting procedures relate to the SCSI components on the EOAP, in particular the hard drive and the CD-ROM drive.



**CAUTION:** The EOAP's open system architecture allows access to the operating system. Any undocumented changes to the files may cause the system to become corrupted and unusable. Making any undocumented changes on the EOAP, including changes to the hardware, operating system and/or the components found therein will void the warranty.

### System Has Power But Will Not Boot

Use the following procedure when the system is receiving power but will not boot.



**WARNING:** EOAP hardware components, including disk drives, may be removed and (re)inserted with the power on, but they are **NOT HOT SWAPPABLE** at the operating system level.

Before any hardware component is removed from the EOAP, the operating system **MUST BE HALTED**. To halt the system, log in as **root**, then at the command line, type: `/usr/sbin/init 0`. When the **ok** prompt appears, it is safe to remove the component.

After a component is (re)inserted, the system must be reset for Solaris to successfully detect the component. To reset the system, at the **ok** prompt type: `reset-all`. The system should boot up. If the system returns to the **ok** prompt after the `reset-all` command has executed, type: `setenv auto-boot? true`. Then type: `reset-all`.

### Procedure

---

- 1 Verify that the operating system is detecting the SCSI devices correctly.

```
ok  setenv auto-boot? false
```

```
ok  reset-all
```

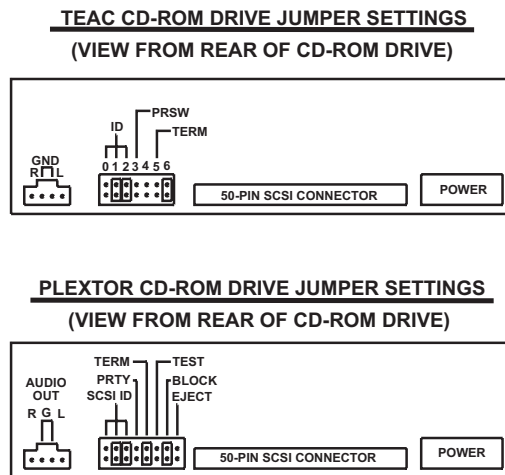
```
ok  probe-scsi
```

The `probe-scsi` command should detect the hard drive at Target 0 and the CD-ROM drive at Target 6.

---

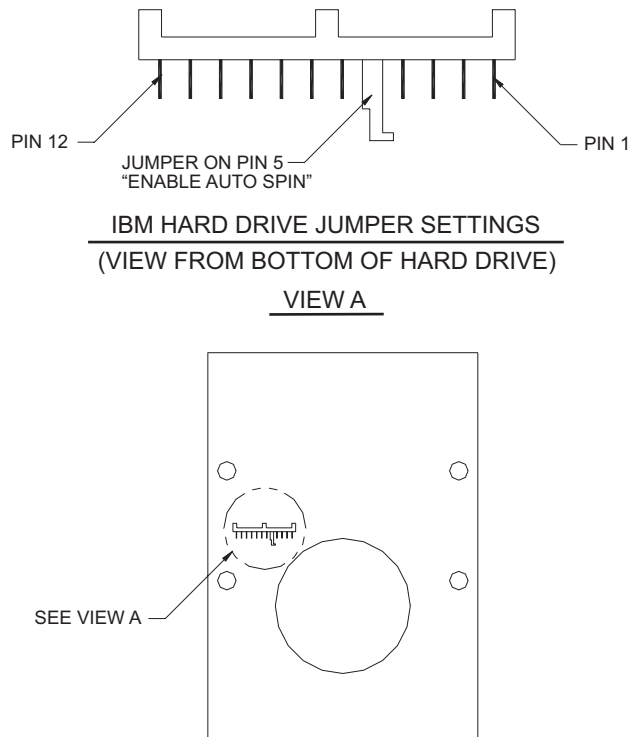
- 2 If the `probe-scsi` command fails to detect the drives or if a SCSI transport error occurs, verify that the jumpers are set correctly on the CD-ROM drive.

Figure 7-1. CD-ROM SCSI Jumper Settings



3 Next, check that the jumpers are set correctly on the hard drive.

Figure 7-2. Hard Drive SCSI Jumper Settings



4 If the CD-ROM and hard drive jumpers are OK, check that cables are correctly installed on both drive cards.

- 5 If the cables are installed correctly and the system still won't boot, contact your Customer Care Center.
- 

- 6 Once the **probe-scsi** command detects both the hard drive and the CD-ROM drive, reset the system to boot automatically; then boot the system:

```
ok setenv auto-boot? true
ok boot
```

---

### CD-ROM Not Responding

Use this procedure if you have power, the system has booted, but you cannot use the CD-ROM drive. For example, you inserted a CD into the drive but cannot see the content of the CD.

#### Procedure

---

- 1 At the terminal connected to the EOAP that needs the card replaced, halt the operating system:

- a. Log into the EOAP as root:

```
Console login: root
Password: xxxxxx
```

**NOTE: See your Customer Care Center for the password for your equipment.**

- b. Shut down all processes and exit back to root by entering these commands:

```
# su - ccspj
% cd /ccsosmr/{instance}/bin
% ccsmr all.down
% exit
```

- c. Halt the EOAP by entering this command:

```
# /usr/sbin/init 0
```

The screen will display output similar to the following. Wait until the **ok** prompt appears before continuing with the next step:

```
Date: time apg 2 halt: halted by root
Date: time apg 2 syslogd: going down on signal 15
Syncing file systems ... [1] done
Program terminated
Type help for more information
```

## Basic Troubleshooting

ok

---

- 2 Determine whether the system detects the CD-ROM drive.
    - a. Verify that the **probe-scsi** command can detect the CD-ROM drive at Target 6; enter these commands:

```
ok setenv auto-boot? false
ok reset-all
ok probe-scsi
```
    - b. If the **probe-scsi** command does not detect a Target 6 device, reboot the system using the device reconfiguration option:

```
ok boot -r
```
    - c. When the system returns to the console login prompt, repeat step 1. Then verify that the **probe-scsi** command can now detect the CD-ROM drive at Target 6 by repeating steps 2a and 2b.

If the CD-ROM drive still cannot be detected, contact your Customer Care Center for assistance.
    - d. When the CD-ROM Drive is detected, reset the system to boot automatically; then boot the system:

```
ok setenv auto-boot? true
ok boot
```
- 

### Drives Detected But System Will Not Boot

Use the following procedure when the **probe-scsi** command detects the hard drive and CD-ROM drive, but the system will not boot.

#### Procedure

---

- 1 At the OK prompt, type the following command to attempt to boot off of the hard drive:

```
# boot disk
```
  - 2 If the system does not boot up, the disk may not have been built yet or is corrupted. Contact your Customer Care Center.
-



### Connect/Disconnect SCSI Devices

#### Procedure

---

- 1 At the terminal connected to the EOAP, halt the operating system.

- a. Log in as root by entering these commands:

```
Console login: root
```

```
Password: xxxxxx
```

**NOTE: See your Customer Care Center for the password for your equipment.**

- b. Shut down all processes and exit back to root by entering these commands:

```
# su - ccspj  
% cd /ccsomsr/{instance}/bin  
% ccsmr all.down  
% exit
```

- c. Halt the EOAP by entering this command:

```
# /usr/sbin/init 0
```

The screen will display output similar to the following. Wait until the `ok` prompt appears before continuing with the next step:

```
Date: time apg 2 halt: halted by root  
Date: time apg 2 syslogd: going down on signal 15  
Syncing file systems ... [1] done  
Program terminated  
Type help for more information  
ok
```

---

- 2 To disconnect the SCSI device:

- a. Power off the SCSI device
- b. Disconnect the SCSI device

Continue with step 4.

---

- 3 To connect the SCSI device:

- c. Connect the SCSI device

- a. Power on the SCSI device

Continue with step 4.

---

- 4 Boot the system by entering this command:

ok **boot**

**NOTE:** External SCSI devices **MUST** be terminated using an external SCSI terminator. If more than one external SCSI device is connected simultaneously, the last device in the chain **MUST** be terminated using the external SCSI terminator.

---

## Console Devices



**CAUTION:** The EOAP's open system architecture allows access to the operating system. Any undocumented changes to the files may cause the system to become corrupted and unusable. Making any undocumented changes on the EOAP, including changes to the hardware, operating system and/or the components found therein will void the warranty.

### Connect/Disconnect Console Devices



**WARNING:** Solaris Console Port Break Issue

A terminal or modem connected to the EOAP serial port and acting as the system console can halt the operating system (bring it to the **ok** prompt) if you turn off or unplug the terminal, or unplug the modem or drop the connection. When the system is halted in this manner, it must be manually booted from the **ok** prompt to resume operation.

This problem affects all TMOAPs and EOAPs running Solaris 2.5.1. The problem is most often encountered when Tekelec support personnel use a modem to dial into the customer's system.

#### Solution

After the modem connection has been dropped or the terminal has been disconnected from the TMOAP/EOAP, use the EAGLE 5 ISS console to issue a reboot command to the TMOAP/EOAP.

### Procedure

---

- 1 At the terminal connected to the EOAP, halt the operating system.

- a. Log in as root by entering these commands:

```
Console login: root
```

```
Password: xxxxxx
```

**NOTE: See your Customer Care Center for the password for your equipment.**

- b. Shut down all processes and exit back to root by entering these commands:

```
# su - ccspoj
```

```
% cd /ccsosmr/{instance}/bin
```

```
% ccsmr all.down
```

```
% exit
```

- c. Halt the EOAP by entering this command:

```
# /usr/sbin/init 0
```

The screen will display output similar to the following. Wait until the `ok` prompt appears before continuing with the next step:

```
Date: time apg 2 halt: halted by root  
Date: time apg 2 syslogd: going down on signal 15  
Syncing file systems ... [1] done  
Program terminated  
Type help for more information  
ok
```

---

- 2 To disconnect the console device (terminal or modem):

- a. Power off the console device
- b. Disconnect the console device

Continue with step 4.

---

- 3 To connect the console device (terminal or modem):

- a. Connect the console device
- b. Power on the console device

Continue with step 4.

---

- 4 Boot the system by entering this command:

ok **boot**

---

## Maintenance Modem



**CAUTION:** The EOAP's open system architecture allows access to the operating system. Any undocumented changes to the files may cause the system to become corrupted and unusable. Making any undocumented changes on the EOAP, including changes to the hardware, operating system and/or the components found therein will void the warranty.

Use the following procedure if the maintenance modem is not functioning properly.



### **WARNING:** Solaris Console Port Break Issue

A terminal or modem connected to the EOAP serial port and acting as the system console can halt the operating system (bring it to the `ok` prompt) if you turn off or unplug the terminal, or unplug the modem or drop the connection. When the system is halted in this manner, it must be manually booted from the `ok` prompt to resume operation.

This problem affects all TMOAPs and EOAPs running Solaris 2.5.1. The problem is most often encountered when Tekelec support personnel use a modem to dial into the customer's system.

### Solution

After the modem connection has been dropped or the terminal has been disconnected from the TMOAP/EOAP, use the EAGLE 5 ISS console to issue a reboot command to the TMOAP/EOAP.

### Procedure

---

- 1 Verify that both the calling and receiving modems are turned on and plugged into a working telephone jack.

---
- 2 Verify that the calling modem and communication software is configured for 9600 baud, 7 data bits, even parity, and 1 stop bit (7-E-1)

---
- 3 Verify that the maintenance modem is capable of supporting the communication parameters shown in step 2.

---
- 4 Verify that the maintenance modem answers the call and the modems attempt to establish communication.

---
- 5 Verify that the maintenance modem is plugged into serial port 3.

---

- 6 Verify that the maintenance modem is set to “Auto Answer”
- 

- 7 Verify that the modem port is configured correctly:

Console login: **root**

Password: **xxxxxx**

# **pmadm -1**

The system returns output similar to the following; the last line (**bold**) indicates the port to be used with the maintenance modem:

```

ttymon0      ttymon      0          ux  root    /dev/term/0 - - /usr/bin/login
- 9600 - login: - - - #/dev/term/0
ttymon0      ttymon      1          ux  root    /dev/term/1 - - /usr/bin/login
- 9600 - login: - - - #/dev/term/1
ttymon0      ttymon      2          ux  root    /dev/term/2 - - /usr/bin/login
- 9600 - login: - - - #/dev/term/2
ttymon0      ttymon      4          ux  root    /dev/term/4 - - /usr/bin/login
- 9600 - login: - - - #/dev/term/4
zsmon       ttymon      ttya       u   root    /dev/term/a I - /usr/bin/login
- 9600 ldterm,ttcompat ttya login: - tvi925 y #
zsmon       ttymon      ttyb       u   root    /dev/term/b I - /usr/bin/login
- 9600 ldterm,ttcompat ttyb login: - tvi925 y #
zsmon       ttymon      3          u   root    /dev/term/3 - - /usr/bin/login
- 9600E ldterm,ttcompat login: - 3 n #

```

**NOTE:** The command output shows this format if the line wrap option is set. You can set the line wrap option through the Setup menu.

---

- 8 If no login prompt appears, try each of the following:
- Press return several times.
  - Switch the maintenance modem from Artecon port 3 to 2 or vice-versa.
  - Cycle power on the maintenance modem.
- 
- 9 If the login prompt appears in all CAPITAL letters, press <CTRL-D> at the prompt.
- 
- 10 If all previous steps failed, replace the maintenance modem and/or the null modem cable.
-

## LEDs

The light-emitting diodes (LEDs) on the power supply and processor cards of the EOAP allow you to perform limited troubleshooting of the cards. If an LED cannot be resolved after performing the procedures for the respective LED, call your Customer Care Center for assistance.



**CAUTION:** The EOAP's open system architecture allows access to the operating system. Any undocumented changes to the files may cause the system to become corrupted and unusable. Making any undocumented changes on the EOAP, including changes to the hardware, operating system and/or the components found therein will void the warranty.

### Power Supply Card

The EOAP power supply card has two LEDs, the Power Good LED and the Fault LED. The Power Good LED lights (green) when the input voltage is between 36VDC and 72VDC.

**Table 7-1.** Power Supply Card LEDs

Conditions	Power Supply Status	Power Good LED	Fault LED
All inputs and outputs are functioning	On	On	Off
Low AC or DC input	Off	Off	On*

\* If the input is below approx. 20V, the Fault LED will be off.

### Fault LED

The Fault LED lights (red) when the input voltage is less than 36 VDC. The Power Good LED is unlit at this time.

### Procedure

---

- 1 At the terminal connected to the EOAP, halt the operating system.

- a. Log in as root:

```
Console login: root
```

```
Password: xxxxxx
```

**NOTE:** See your Customer Care Center for the password for your equipment.

- b. Shut down all processes and exit back to root by entering these

commands:

```
# su - ccspj
% cd /ccsosmr/{instance}/bin
% ccsmr all.down
% exit
```

- c. Halt the EOAP by entering this command:

```
# /usr/sbin/init 0
```

The screen will display output similar to the following. Wait until the `ok` prompt appears before continuing with the next step:

```
Date: time apg 2 halt: halted by root
Date: time apg 2 syslogd: going down on signal 15
Syncing file systems ... [1] done
Program terminated
Type help for more information
ok
```

- 
- 2 Reseat the power supply card. If the fault LED is still lit, go to the next step.

- 
- 3 If you have a spare power supply card, install the spare power supply. If the fault LED is still lit, go to the next step.

- 
- 4 Shutdown caused by overheating. Ensure proper airflow and air temperature. Let the unit cool down and cycle the input power to restart.

**NOTE: Repeated shut down due to overheating may lead to premature failure.**

If the Fault LED is still lit, call your Customer Care Center for assistance.

- 
- 5 Boot the EOAP by entering this command:

```
ok boot
```

---



### Processor Card

#### Run LED Is Continuously Red

The EOAP processor card has a Run LED that is green to indicate normal operation.

The Run LED is continuously red when the processor card is getting power but is halted or in Reset state. The LED starts blinking to indicate that the processor did not access the PCI bus for more than one second.



**WARNING:** The following procedure has a **HIGH RISK** of corrupting the operating system and/or causing hard drive failure. Remove the hard drive card before continuing with this procedure.

#### Procedure

---

- 1 At the terminal connected to the EOAP, halt the operating system.

- a. Log in as root:

```
Console login: root
```

```
Password: xxxxxx
```

**NOTE:** See your Customer Care Center for the password for your equipment.

- b. Shut down all processes and exit back to root by entering these commands:

```
# su - ccspoj  
% cd /ccsosmr/{instance}/bin  
% ccsmr all.down  
% exit
```

- c. Halt the EOAP by entering this command:

```
# /usr/sbin/init 0
```

The screen will display output similar to the following. Wait until the `ok` prompt appears before continuing with the next step:

```
Date: time apg 2 halt: halted by root  
Date: time apg 2 syslogd: going down on signal 15  
Syncing file systems ... [1] done  
Program terminated  
Type help for more information  
ok
```

---

- 2 Reseat the processor card in the slot. If the Run LED is still red, go to the next step.
- 

- 3 Cycle the power on the system by reseating the power supply card. If the Run LED is still red, call your Customer Care Center.
- 

- 4 Boot the system by entering this command:

```
ok boot
```

---

### RUN LED Is Green But Ports Are Not Functioning

Use this troubleshooting procedure when the system boots properly but the ports are not functioning.

#### Procedure

---

- 1 Examine the BM (Backplane Monitor) LED on the front of the processor card:

- If the BM LED is flashing, communication with the serial I/O card is occurring. No further testing is necessary.
  - If the BM LED is not lit, this indicates no cPCI bus activity.
- 

- 2 At the terminal connected to the EOAP, halt the operating system:

- a. Log in as root:

```
Console login: root
```

```
Password: xxxxxx
```

- b. Shut down all processes and exit back to root by entering these commands:

```
# su - ccspj
```

```
% cd /ccsomsr/{instance}/bin
```

```
% ccsmr all.down
```

```
% exit
```

## Basic Troubleshooting

- c. Halt the EOAP by entering this command:

```
# /usr/sbin/init 0
```

The screen will display output similar to the following. Wait until the `ok` prompt appears before continuing with the next step:

```
Date: time apg 2 halt: halted by root
Date: time apg 2 syslogd: going down on signal 15
Syncing file systems ... [1] done
Program terminated
Type help for more information
ok
```

---

- 3 Reseat the serial card and processor card.

---

- 4 If the BM LED is still not lit, contact your Customer Care Center.

---

### LEDs Normal But No Ethernet Access

Use the following procedure when the LEDs are normal but there is no Ethernet access.

#### Procedure

---

- 1 Determine whether the Ethernet port is communicating with the local network. Remove and replace the Ethernet cable from the upper right front of the processor card while watching the output on the VT-520 terminal display. When the cable is removed, the system should display the following:

```
SUNW, hme0: Link Down -- cable problem?
```

When the cable is replaced, the `hme0` error message should stop being displayed.

This verifies the hardware sees the external network.

---

- 2 If, after replacing the cable, the hardware is still unable to see the network, contact your Customer Care Center.

---

## Serial Card

Use these procedures for problems with the Serial card.



**CAUTION:** The EOAP's open system architecture allows access to the operating system. Any undocumented changes to the files may cause the system to become corrupted and unusable. Making any undocumented changes on the EOAP, including changes to the hardware, operating system and/or the components found therein will void the warranty.

### Ports 3, 4, 5, or 6 Not Working

Use the following procedure when ports 3, 4, 5, or 6 on both EOAP-A and EOAP-B are not working.

**NOTE:** These ports are all connected to the Aurora Serial I/O board located in slot 3.

### Procedure

---

- 1 Check that the Aurora driver has been installed and enabled. Log in as root and reboot the operating system with device configuration display:

```
# reboot -- -r
```

The boot screen output should include a reference to the Aurora board similar to the following example:

```
Rebooting with command: boot -r
Boot device: /pci@1f,0/pci@1,1/scsi@4/disk@0,0 File and args: -r
SunOS Release 5.5.1 Version Generic_103640-12 [UNIX(R) System V
Release 4.0]
Copyright (c) 1983-1996, Sun Microsystems, Inc.
ÿconfiguring network interfaces: hme0.
Hostname: eoap1100402a
Aurora 4520CP board:0 ESCC2-10-V3.2 29.4912 MHz, rev AA, PII 0xb-H,
2.01tk1
Configuring the /devices directory
```

---

- 2 If the Aurora driver has not been installed, go to the terminal connected to the EOAP and halt the operating system:

- a. Log in as root:

```
Console login: root
```

```
Password: xxxxxx
```

## Basic Troubleshooting

- b. Shut down all processes and exit back to root by entering these commands:

```
# su - ccsproj
% cd /ccsosmr/{instance}/bin
% ccsmr all.down
% exit
```

- c. Halt the EOAP by entering this command:

```
# /usr/sbin/init 0
```

The screen will display output similar to the following. Wait until the `ok` prompt appears before continuing with the next step:

```
Date: time apg 2 halt: halted by root
Date: time apg 2 syslogd: going down on signal 15
Syncing file systems ... [1] done
Program terminated
Type help for more information
ok
```

---

- 3 Reseat the Aurora card in slot 3 to make sure that it is properly connected to the backplane.
- 
- 4 Inspect the pins on the backplane in slot 3 to verify that no pins are bent or shoring of other pins has occurred.
- 
- 5 If the card is properly seated in the slot and the system is receiving power, but the driver still does not detect the card, verify the correct Transition Card was installed in Slot 3.
- 
- 6 Use a multimeter and the relevant schematics to verify the correct pins are hooked up to the correct serial ports. The Force Transition Card and Serial I/O Transition card might have been mistakenly switched during manufacturing.
- 
- 7 Boot the system by entering this command:

```
ok boot
```

---

**Ports 7, 8, 9, or 10 Not Working**

These ports are reserved for future use and SHOULD NOT be working. No troubleshooting is necessary.

**Ports 1 or 2 Not Working**

Use the following procedure when ports 1 or 2 on both EOAP-A and EOAP-B are not working.

**Procedure**

---

- 1 Check that port 1, as the default COM port, displays a prompt when correctly connected to a VT-Terminal.  

---
- 2 If this port is not working, verify that nothing is connected to the front of the Processor card.  

---
- 3 Verify that the dial-switch on the processor card is correctly set to its Default position (arrow pointing to the letter "F").  

---

## Hard Disk



**CAUTION:** The EOAP's open system architecture allows access to the operating system. Any undocumented changes to the files may cause the system to become corrupted and unusable. Making any undocumented changes on the EOAP, including changes to the hardware, operating system and/or the components found therein will void the warranty.

### File System Errors

UNIX, like any multitasking operating system, is susceptible to disk errors resulting from failed latent writes. Problems of this nature usually result from halting the operating system improperly. When the EOAP is started again, the file systems are audited and the error will be discovered. The EOAP will not function until the errant file system is repaired. Use the following procedure to correct the problem.

#### Procedure

---

- 1 At the EOAP console terminal, a message displays that indicates which file system is corrupted and that the *fsck* utility must be run.

---
- 2 Follow the instructions on the screen to become the root user in single user mode.

---
- 3 Follow the instructions on the screen to run the *fsck* utility and answer "Y" to all questions.

---
- 4 Reboot the EOAP.  
ok **boot**

---
- 5 If the *fsck* utility indicates that a problem could not be fixed, replace the hard drive.

---

## Full Partition Check

Use this procedure to verify that all the file system partitions are present and that none are over 90% full (with the exception of the /opt partition, which may be more than 90% full if the AnswerBook files are installed. This does not affect the operation of the EOAP and can be ignored).

### Procedure

---

- 1 Log in as ccsproj:

```
Console login: ccsproj
```

```
Password: eagle1
```

```
% df -k
```

Filesystem	kbytes	used	avail	capacity	Mounted on
/dev/dsk/c0t3d0s0	<b>86327</b>	12910	64787	<b>17%</b>	/
/dev/dsk/c0t3d0s6	<b>220499</b>	177220	21239	<b>89%</b>	/usr
/proc	0	0	0	0%	/proc
fd	0	0	0	0%	/dev/fd
/dev/dsk/c0t3d0s4	<b>95891</b>	23740	62571	<b>28%</b>	/var
<b>swap</b>	<b>117992</b>	24	117968	<b>0%</b>	/tmp
/dev/dsk/c0t3d0s7	<b>106463</b>	80177	15646	<b>84%</b>	/ccsdata
/dev/dsk/c0t3d0s3	<b>239631</b>	156380	59291	<b>73%</b>	/ccsosmr
/dev/dsk/c0t3d0s5	<b>95891</b>	73621	12690	<b>85%</b>	/opt

**NOTE:** A full partition often indicates a serious problem. Simply making more room on the disk is not sufficient. The underlying problem should be fully diagnosed.

---



## IP



**CAUTION:** The EOAP's open system architecture allows access to the operating system. Any undocumented changes to the files may cause the system to become corrupted and unusable. Making any undocumented changes on the EOAP, including changes to the hardware, operating system and/or the components found therein will void the warranty.

### Error: syslog: s match\_netconf: setnetconfig failed

Use this procedure if you get the following error message: Error: syslog: s match\_netconf: setnetconfig failed.

**NOTE:** This error most often occurs when a bug in the Solaris operating system erases the contents of the `/etc/netconfig` file.

### Procedure

---

- 1 Log in as root:

```
Console login: root
```

```
Password: eagle
```

---

- 2 Verify that the netconfig file is present and that the file size is greater than zero:

```
# ls -l /etc/netconfig
```

The system returns output similar to the following:

```
-rw-r--r--  1 root    sys      1211 Jun  7 07:33 /etc/netconfig
```

If the netconfig file is missing, or if the file size is zero (or smaller than the file size shown in the example output above), replace the file from another EOAP running the same release. If the EOAP is in a dual configuration, the mate is an ideal source of the `/etc/netconfig` file.

---

## EOAP Internal Software



**CAUTION:** The EOAP's open system architecture allows access to the operating system. Any undocumented changes to the files may cause the system to become corrupted and unusable. Making any undocumented changes on the EOAP, including changes to the hardware, operating system and/or the components found therein will void the warranty.

### msDI Controlled Software

Table 7-2 lists the processes that are controlled by msDI software.

**Table 7-2.** msDI Processes

msDI0	IPC directory daemon
ysA20	UAL Timeout/PVC state cntl daemon
ysAD0	Daemon
ysT20	UIM generator
ysTT0	EAGLE 5 ISS TTY interface
emsAg	EMS Agent
msSU0	Daemon
ysA30	UAL Multi-Seg. Re-assembly daemon
ysAO0	OS Contract OS to NE daemon
ysT30	OAP Status
ysA10	UAL/X.25 PVC daemon
ysA40	UAL conf. fail/clear daemon
ysT10	Maintenance Process
ysTD0	UAL test msg echo daemon

Since msDI provides basic communication services to these processes, they share many of the same debugging tools and methods.

The debug techniques for all msDI processes (*except emsAgent*) are:

- 1 If a process is not running, check for a core file in the `/ccsosmr/{instance}/bin` directory. (See procedure *Check for a Core File* on page 7-30.)
- 2 If the `emsAgent` is not running, ensure that the Dset license file is correct. (See procedure *Verify the emsAgent Dset License (emsAgent only)* on page 7-30.)
- 3 Check the debug log file(s) for that process
- 4 Interprocess message tracing
- 5 `emsAgent` message tracing

- 6 Truss command
- 7 Top command

### Verify msDI Processes

#### Procedure

---

- 1 Log in as ccsproj:

Console login: **ccsproj**

Password: **eagle1**

---

- 2 Verify that all the required processes are running by entering the following commands:

```
% cd /ccsosmr/{instance}/bin
```

```
% ccsmr all.status
```

The system displays output similar to the following:

```
***** System (msDI) registration report starts *****
***** date/time==> Wed May 29 14:29:35 2000
* Process=(msDI00), Host (apg3)/PID=(870): IPC directory daemon
* Process=(ysT300), Host (apg3)/PID=(915):
* Process=(ysA201), Host (apg3)/PID=(920): UAL Timeout/PVC state cntl daemon
* Process=(ysA301), Host (apg3)/PID=(938): UAL Multi-Seg. Re-assembly daemon
* Process=(ysA401), Host (apg3)/PID=(954): UAL conf. fail/clear daemon
* Process=(ysA001), Host (apg3)/PID=(970): OS Contract OS to NE daemon
* Process=(ysT100), Host (apg3)/PID=(989):
* Process=(ysAD01), Host (apg3)/PID=(1012): UAL test msg echo daemon
* Process=(ysT200), Host (apg3)/PID=(1001):
! Process=(ysA101), Host (apg3)/PID=(1037): UAL/X.25 PVC daemon
! Process=(ysA102), Host (apg3)/PID=(1053): UAL/X.25 PVC daemon
! Process=(ysA103), Host (apg3)/PID=(1069): UAL/X.25 PVC daemon
* Process=(ysTT00), Host (apg3)/PID=(1130):
* Process=(emsAgent), Host (apg3)/PID=(611): EmsAgent
* Process=(emsStatusUpdate), Host (ralph)/PID=(12144): EMS Agent Status
```

**NOTE:** Only applicable processes are listed. The host and PID output will vary. The processes marked with “!” will vary depending on the X.25 configuration in the DEFAULTS file. In a single EOAP configuration, six X.25 processes are listed. In a dual EOAP configuration, only three X.25 processes are listed.

---

## Check for a Core File

### Procedure

---

- 1 Log in as ccsproj; enter the following commands:

```
Console login: ccsproj
```

```
Password: eagle1
```

---

- 2 Change to the instance binary directory; enter the following command:

```
% cd /ccsosmr/{instance}/bin
```

---

- 3 See if a core file exists; enter the following command:

```
% ls -l |grep core
```

If a core file exists, note the file creation date and time. Do not remove the file or change it in any way.

---

## Verify the emsAgent Dset License (emsAgent only)

### Procedure

---

- 1 Log in as ccsproj; enter the following commands:

```
Console login: ccsproj
```

```
Password: eagle1
```

---

- 2 Change to the Dset directory; enter the following command:

```
% cd /usr/local/Dset
```

---

- 3 Display the contents of the Dset license file; enter the following commands:

```
# cat /usr/local/Dset/license
```

```
N ffffffff wyfszmtgnlwfqzha DSGRunTime 4.1
```

```
N ffffffff oqxkrelyfdqxirza APLI 4.1
```

Note the correct spelling, capitalization, and spacing of the file contents. If the license file for this software package is incorrect, the emsAgent will not run.

---

### msDI Process Debug Log Files (Except `emsAgent`)

The msDI process has two debug log files. The log files are stored in:

`/ccsdata/log/{processname}/{processname}{instancenumber}.cur`

`/ccsdata/log/{processname}/{processname}{instancenumber}.prev`

The debug log files are flat text files. Each line of a log file contains a line of debug output produced by the process. Each line is prepended with the time, date, and name of the process.

For example, in a dual EOAP configuration, 3 UAL daemons (`ysA10` processes) are running. The log files for all three daemons are stored in `/ccsdata/log/ysA10`. The following files should be in that directory:

`ysA101.cur ysA101.prev ysA102.cur ysA102.prev ysA103.cur ysA103.prev`

The last digit in the filename indicates with which instance of the `ysA10` process the log is associated.

The `.cur` and `.prev` extensions to the log files denote “current” and “previous” log files. The current log file is the one currently being written to. When a predetermined file length for that log file has been reached, the “current” log is copied to the “previous” log. The maximum log length for most processes is 100 Kb.

`ysTT0` is the interface to the serial connection to the EAGLE 5 ISS. The log contains messages sent from the EOAP to the EAGLE 5 ISS.

`ysTT0` inserts a Maintenance Poll response into the output queue. This is an example of the possible output:

```
Fri Feb 26 15:17:00 2000: ysTT00-0 (ysTT00): InsertOAPMsgs insert ^14023213RSP
-MNT:4::000000:80,mnt::221-001-000:1:97FCA5F8:0,0,001-0-0,002-0-0,003-0-0,,,,
,,:1,2,,,,,,,,,1:000000:00:198.089.039.115,0,1;_ in MNT FD queue 6 to Port 0
```

The message is read from the queue and written to one of the serial port file descriptors. This is an example of the possible output:

```
Fri Feb 26 15:17:00 2000: ysTT00-0 (ysTT00): MNT Msg to be written to FD 6 on
Port 0: ^14023213RSP-MNT:4::000000:80,mnt::221-001-000:1:97FCA5F8:0,0,001-0-0,
002-0-0,003-0-0,,,,,1,2,,,,,,,,,1:000000:00:198.089.039.115,0,1;~
```

**emsAgent Process Debug Log Files (emsAgent only)**

The emsAgent process has two debug log files. The log files are stored in:

```
/ccsosmr/{instance}/log/emsAG/emsAgent.log
```

```
/ccsosmr/{instance}/log/emsAG/emsAgent.stdout.x
```

The emsAgent process (emsAg) is an exception to the msDI debug logging style. Debug information generated by emsAgent is directed to standard error. In order to view this information, the process must be terminated and restarted manually. A safer alternative is to use the **truss** command.

Terminating the emsAgent will cause a switchover to the emsAgent on the mate EOAP in a dual EOAP configuration. Disable the mate EOAP or emsAgent first to prevent switchover.

**Procedure**

---

- 1 Log in as ccsproj; enter the following commands:

```
Console login: ccsproj
```

```
Password: eagle1
```

---

- 2 Display the PID of the emsAgent process; enter the following commands:

```
% cd /ccsosmr/{instance}/bin
```

```
% ps -ae | grep emsAgent
```

The system returns output similar to the following:

```
759 ?          0:02  emsAgent
```

---

- 3 Terminate the running emsAgent; enter the following command:

```
% kill -9 {emsAgent PID}
```

```
%kill -9 759
```

---

- 4 Restart the emsAgent in the foreground; enter the following command:

```
% ccsmr emsAgent {instancename}
```

---

- 5 Once these steps are completed, debug information will be displayed on the console and will also be captured in the following log file:

```
/ccsosmr/{instance}/log/emsAG/emsAgent.stdout
```

---

## Basic Troubleshooting

- 6 To turn off the debug information and return the `emsAgent` to its normal run state:

- a. Substitute user to root:

```
% su - root
```

```
Password: xxxxxx
```

- b. Reboot the system

```
# /usr/sbin/init 6
```

---

- 7 The `emsAgent` has a further debug feature that allows more detailed tracing. The `SIGUSR1` and `SIGUSR2` signals toggle debug and trace modes respectively. By default, debug mode is on and trace mode is off.

To toggle the debug mode for the `emsAgent`, enter this command:

```
% kill -16 <emsAgent PID>
```

To toggle the trace mode for the `emsAgent`, enter this command:

```
% kill -17 <emsAgent PID>
```

---

## Trace Inter-Process Messages (Except `emsAgent`)

You can trace inter-process messages by activating the Inter-Process Message Tracing function, reading the trace logs, and de-activating the Inter-Process Message Tracing function.

### Procedure

---

- 1 Activate the Inter-Process Message Tracing function:

- a. Log in as `ccsproj`; enter the following commands:

```
Console login: ccsproj
```

```
Password: eagle1
```

- b. Open the system parameters file for editing; enter the following commands:

```
% cd /ccsosmr/{instance}/config
```

```
% vi sys_param
```

- c. Change the line `TRACE_DEBUG=OFF` to `TRACE_DEBUG=ON`
- d. Save the change and close the file, enter:

```
<ESC> :wq
```

- e. Restart the instance; enter the following commands:

```
% cd /ccsosmr/{instance}/bin
```

```
% ccsmr all.down
```

```
% ccsmr all.up
```

---

- 2 Read the trace logs. These logs are stored in:

```
/ccsdata/trace/{date time}/{processname}/{processname}{instancenumber}
```

The trace log files are flat text files. Each line in the file contains a line of debug output produced by the process, prepended with the time, date, and name of the process.

Retrieve the trace logs with the `ccsmr proc.trace` command and specify the following arguments:

```
<process>      bellcore name for the process, yaA103 for example
```

```
-t <hh:mm:ss>  List messages from this time
```

```
-l #           number of characters/message to display
```



## Basic Troubleshooting

The following sample output shows the basic format of a debug trace entry:

```
Incoming message from message router (SEASFTWPRD1) to OAP process ysA103
####
0323 150801 194 I X SEASFTWPRD1
2000E19076EQ7C010190TLWVLTXXA02WESEASFTWPRD1TSS          TEST-SEAS-
UPL:::EPW5IF:90,TRM::"ABCDEFGHIJKLMNPOQRSTUVWXYZ0123456789
#%&'()*+,-./:;<=>?@ABCDEFGHIJKLMNPOQRSTUVWXYZ0123456789 #%&'";
```

The 150801 is a time stamp, the I indicates Incoming (to the process), and the X indicates that the message is going to or coming from an external process, for example, EAGLE or MR.

---

### 3 De-activate the Inter-Process Message Tracing function:

- a. Log in as ccsproj; enter the following commands:

```
Console login: ccsproj
```

```
Password: eagle1
```

- b. Open the system parameters file for editing; enter the following commands:

```
% cd /ccsosmr/{instance}/config
```

```
% vi sys_param
```

- c. Change the line TRACE\_DEBUG=ON to TRACE\_DEBUG=OFF
- d. Save the change and close the file:

```
<ESC> :wq
```

- e. Restart the instance:

```
% cd /ccsosmr/{instance}/bin
```

```
% ccsmr all.down
```

```
% ccsmr all.up
```

---

*Message Tracing Example.*

**NOTE 1:** The following example shows a debugging session in which the TEST-SEAS-UPL message was not returned. The EAGLE 5 ISS's security log shows that the message was successfully received and processed. By looking at the EOAP's inter-process messages, we can find out which process is failing to forward the message.

**NOTE 2:** For releases prior to EAGLE 5 ISS release 34.0, do not send TEST-SEAS-UPL messages with a quoted string greater than 256 characters to the EOAP/OAP.

Incoming message from message router (SEASFTWPRD1) to EOAP process ysA103:

```
####
0323 150801 194 I X SEASFTWPRD1
2000E19076EQ7C010190TLWVLTXXA02WESEASFTWPRD1TSS
TEST-SEAS-UPL:::EPW5IF:90,TRM::"ABCDEFGHijklmnopqrstuvwxyz0123456789
#%&'()*+,-./:;<=>?@ABCDEFGHIJKLMNPQRSTUVWXYZ0123456789 #%&'";
```

Outgoing message from ysA103 to ysTTOO:

```
####
0323 150801 276 O T 10 1 50 0 MessageId. LWVLTXXA02WysA103
LWVLTXXA02WysTT00
2000E19076EQ7C010190TLWVLTXXA02WESEASFTWPRD1TSS
60TEST-SEAS-UPL:::EPW5IF:90,TRM::"ABCDEFGHijklmnopqrstuvwxyz012345678
9 #%&'()*+,-./:;<=>?@ABCDEFGHIJKLMNPQRSTUVWXYZ0123456789
#%&'";134
```

Incoming message from ysA103 to ysTT00:

```
####
0323 150801 276 I T 10 1 50 0 MessageId. LWVLTXXA02WysA103
LWVLTXXA02WysTT00
2000E19076EQ7C010190TLWVLTXXA02WESEASFTWPRD1TSS
60TEST-SEAS-UPL:::EPW5IF:90,TRM::"ABCDEFGHijklmnopqrstuvwxyz012345678
9 #%&'()*+,-./:;<=>?@ABCDEFGHIJKLMNPQRSTUVWXYZ0123456789
#%&'";134
```

Outgoing message from ysTT00 to the EAGLE 5 ISS:

```
####
0323 150801 144 O X ysTT00
14423981TEST-SEAS-UPL:::EPW5IF:90,TRM::"ABCDEFGHijklmnopqrstuvwxyz012
3456789 #%&'()*+,-./:;<=>?@ABCDEFGHIJKLMNPQRSTUVWXYZ0123456789
#%&'";
```

Incoming message from the EAGLE 5 ISS to ysTT00:

```
####
0323 150802 188 I X ysTT00
18826313BTRM90RSP:LWVLTXXA02W,98-03-23,15-05-51.0-CDT:TEST-SEAS-UPL:E
PW5IF:COMPLD::"ABCDEFGHijklmnopqrstuvwxyz0123456789
#%&'()*+,-./:;<=>?@ABCDEFGHIJKLMNPQRSTUVWXYZ0123456789 #%&'";
```

## Basic Troubleshooting

Outgoing message from ysTT00 to ysAO01:

```
####
0323 150802 314 O T 10 1 50 0 MessageId. LWVLTXXA02WysTT00
LWVLTXXA02WysAO01
60RSP:LWVLTXXA02W,98-03-23,15-05-51.0-CDT:TEST-SEAS-UPL:EPW5IF:COMPLD:
:"ABCDEFGHIJKLMNPOQRSTUVWXYZ0123456789
#$$%&'()*+,-./:;<=>?@ABCDEFGHIJKLMNPOQRSTUVWXYZ0123456789 #$$%&'";172
```

Incoming message from ysTT00 to ysAO01:

```
####
0323 150802 314 I T 10 1 50 0 MessageId. LWVLTXXA02WysTT00
LWVLTXXA02WysAO01
60RSP:LWVLTXXA02W,98-03-23,15-05-51.0-CDT:TEST-SEAS-UPL:EPW5IF:COMPLD:
:"ABCDEFGHIJKLMNPOQRSTUVWXYZ0123456789
#$$%&'()*+,-./:;<=>?@ABCDEFGHIJKLMNPOQRSTUVWXYZ0123456789 #$$%&'";172
```

Nothing comes out of ysAO01, and if you look at the log for this process, you will find the following error message:

```
Mon Mar 23 15:08:02 1998: (LWVLTXXA02WysAO01)-0 (ysAO01): ERROR! Send
Message failed - (Msg can't send due to no active IPC found,
PVC_key=(ESEASF'WPRD1j)) (SEASF'WPRD1)
```

### Trace **emsAgent** Inter-Process Messages (**emsAgent** only)

The **emsAgent** has a debug feature that allows more detailed tracing. The SIGUSR1 and SIGUSR2 signals toggle debug and trace modes respectively. By default, debug mode is on and trace mode is off.

To toggle the debug mode for the **emsAgent**, enter this command:

```
% kill -16 <emsAgent PID>
```

To toggle the trace mode for the **emsAgent**, enter this command:

```
% kill -17 <emsAgent PID>
```

## truss Command

The **truss** command can be executed on any running process in order to trace the system calls that process makes. This output can often be useful in debugging a process problem. The example below shows the output of the **truss** command on the **emsAgent** process. By using the **truss** command, some of the log output that is normally redirected to **/dev/null** can be viewed because of the use of the **write()** system call. For more information on using the **truss** command, read the **truss** man pages.

## Procedure

---

- 1 Log in as root:

```
Console login:  root
Password:  eagle
```

---

- 2 Get the PID of the process you want debug; enter the following command:

```
# ps -ae | grep emsAgent
```

The system returns output similar to the following:

```
759 ?          0:02  emsAgent
```

---

- 3 Enter the **truss** command:

```
# truss -p 759
```

The system returns output similar to the following:

```
tekelec-1:ccsproj%su
Password:
# truss -p 657
    Received signal #14, SIGALRM, in poll() [caught]
poll(0xEFFFD790, 5, -1)                               Err#4 EINTR
setcontext(0xEFFFD568)
sigprocmask(SIG_BLOCK, 0x001EBBA4, 0x001EBBB4) = 0
sigprocmask(SIG_BLOCK, 0x001EBBA4, 0xEFFF830) = 0
sigprocmask(SIG_SETMASK, 0xEFFF830, 0x00000000) = 0
sigprocmask(SIG_SETMASK, 0x001EBBB4, 0x00000000) = 0
write(1, " e m s _ p e r i o d i c".., 49)           = 49
sigprocmask(SIG_BLOCK, 0x001EBBA4, 0x002502E8) = 0
sigprocmask(SIG_SETMASK, 0x002502E8, 0x00000000) = 0
sigprocmask(SIG_BLOCK, 0x001EBBA4, 0x00250268) = 0
sigprocmask(SIG_BLOCK, 0x001EBBA4, 0x002501F8) = 0
setitimer(ITIMER_REAL, 0x00216F84, 0x00000000) = 0
sigprocmask(SIG_SETMASK, 0x002501F8, 0x00000000) = 0
sigprocmask(SIG_SETMASK, 0x00250268, 0x00000000) = 0
sigprocmask(SIG_BLOCK, 0x001EBBA4, 0x001EBBB4) = 0
sigprocmask(SIG_SETMASK, 0x001EBBB4, 0x00000000) = 0
poll(0xEFFFD790, 5, -1)                               (sleeping...)
poll(0xEFFFD790, 5, -1)                               = 1
```

## Basic Troubleshooting

```
getmsg(8, 0xEFFF3E8, 0xEFFF3DC, 0xEFFF2D0) = 0
sigprocmask(SIG_BLOCK, 0x001EBBA4, 0xEFFF5D0) = 0
sigprocmask(SIG_SETMASK, 0xEFFF5D0, 0x00000000) = 0
sigprocmask(SIG_BLOCK, 0x001EBBA4, 0x001EBBB4) = 0
sigprocmask(SIG_SETMASK, 0x001EBBB4, 0x00000000) = 0
sigprocmask(SIG_BLOCK, 0x001EBBA4, 0x002500E8) = 0
sigprocmask(SIG_SETMASK, 0x002500E8, 0x00000000) = 0
sigprocmask(SIG_BLOCK, 0x001EBBA4, 0x001EBBB4) = 0
sigprocmask(SIG_SETMASK, 0x001EBBB4, 0x00000000) = 0
write(1, " E M S : s u b   c r e a".., 46) = 46
write(1, " M e s s a g e   B l o c".., 31) = 31
putmsg(6, 0x0026CE34, 0x0026CD98, 0) = 0
write(1, " E M S : e m s _ s e n d".., 46) = 46
write(1, " > > U P D - L N P - 1 0".., 180) = 180
sigprocmask(SIG_BLOCK, 0x001EBBA4, 0x0026D320) = 0
setitimer(ITIMER_REAL, 0x0026D2B0, 0x0026D2B0) = 0
sigprocmask(SIG_BLOCK, 0x001EBBA4, 0x0026D2B0) = 0
setitimer(ITIMER_REAL, 0x00216F84, 0x00000000) = 0
sigprocmask(SIG_SETMASK, 0x0026D2B0, 0x00000000) = 0
sigprocmask(SIG_SETMASK, 0x0026D320, 0x00000000) = 0
write(1, " E M S : E x i t i n g :".., 46) = 46
sigprocmask(SIG_BLOCK, 0x001EBBA4, 0x001EBBB4) = 0
sigprocmask(SIG_SETMASK, 0x001EBBB4, 0x00000000) = 0
sigprocmask(SIG_BLOCK, 0x001EBBA4, 0x001EBBB4) = 0
sigprocmask(SIG_SETMASK, 0x001EBBB4, 0x00000000) = 0
poll(0xEFFFD790, 5, -1) = 1
sigprocmask(SIG_BLOCK, 0x001EBBA4, 0xEFFF650) = 0
sigprocmask(SIG_SETMASK, 0xEFFF650, 0x00000000) = 0
sigprocmask(SIG_BLOCK, 0x001EBBA4, 0x001EBBB4) = 0
sigprocmask(SIG_SETMASK, 0x001EBBB4, 0x00000000) = 0
write(1, " E M S : g a t e w a y   ".., 46) = 46
fcntl(6, F_GETFL, 0x00000000) = 2
ioctl(6, I_FIND, "sockmod") = 1
poll(0x0024D628, 1, 0) = 1
read(6, "\0\0\003\0\0\0\0\0\0 C".., 1024) = 80
write(1, " > > R S P : J H C Y T N".., 72) = 72
sigprocmask(SIG_BLOCK, 0x001EBBA4, 0x0024F710) = 0
sigprocmask(SIG_SETMASK, 0x0024F710, 0x00000000) = 0
write(1, " M e s s a g e   B l o c".., 29) = 29
putmsg(8, 0x0024FEF0, 0x0024FEE4, 0) = 0
sigprocmask(SIG_BLOCK, 0x001EBBA4, 0x001EBBB4) = 0
sigprocmask(SIG_SETMASK, 0x001EBBB4, 0x00000000) = 0
poll(0xEFFFD790, 5, -1) (sleeping...)
Received signal #14, SIGALRM, in poll() [caught]
poll(0xEFFFD790, 5, -1) Err#4 EINTR
setcontext(0xEFFFD568)
sigprocmask(SIG_BLOCK, 0x001EBBA4, 0x001EBBB4) = 0
sigprocmask(SIG_BLOCK, 0x001EBBA4, 0xEFFF830) = 0
sigprocmask(SIG_SETMASK, 0xEFFF830, 0x00000000) = 0
sigprocmask(SIG_SETMASK, 0x001EBBB4, 0x00000000) = 0
write(1, " e m s _ p e r i o d i c".., 49) = 49
sigprocmask(SIG_BLOCK, 0x001EBBA4, 0x002502E8) = 0
sigprocmask(SIG_SETMASK, 0x002502E8, 0x00000000) = 0
putmsg(8, 0x0024FEF8, 0x0024FEEC, 0) = 0
sigprocmask(SIG_BLOCK, 0x001EBBA4, 0x00250268) = 0
sigprocmask(SIG_BLOCK, 0x001EBBA4, 0x002501F8) = 0
setitimer(ITIMER_REAL, 0x00216F84, 0x00000000) = 0
sigprocmask(SIG_SETMASK, 0x002501F8, 0x00000000) = 0
sigprocmask(SIG_SETMASK, 0x00250268, 0x00000000) = 0
sigprocmask(SIG_BLOCK, 0x001EBBA4, 0x001EBBB4) = 0
```

```

sigprocmask(SIG_SETMASK, 0x001EBBB4, 0x00000000) = 0
poll(0xEFFFD790, 5, -1) = 1
getmsg(8, 0xEFFF3E8, 0xEFFF3DC, 0xEFFF2D0) = 0
sigprocmask(SIG_BLOCK, 0x001EBBA4, 0xEFFF5D8) = 0
sigprocmask(SIG_SETMASK, 0xEFFF5D8, 0x00000000) = 0
sigprocmask(SIG_BLOCK, 0x001EBBA4, 0x001EBBB4) = 0
sigprocmask(SIG_SETMASK, 0x001EBBB4, 0x00000000) = 0
sigprocmask(SIG_BLOCK, 0x001EBBA4, 0x001EBBB4) = 0
sigprocmask(SIG_SETMASK, 0x001EBBB4, 0x00000000) = 0
poll(0xEFFFD790, 5, -1) (sleeping...)

```

---

#### 4 Quit the *truss* output screen:

```

# ^C
#

```

---

### Top Command

The **top** command provides information on the performance impact of running processes. The following example was obtained by changing the terminal type to vt100 in order to allow screen re-drawing. By default, the screen is updated with new information every five seconds.

### Procedure

---

#### 1 Log in as root:

```

Console login: root
Password: eagle

```

---

#### 2 Change to the directory containing the command executable:

```

# cd /ccsosmr/MR.os54/MISC/bin

```

---

## Basic Troubleshooting

- 3 Enter the **top** command:

```
# ./top
```

The system returns output similar to the following:

```
last pid: 5171; load averages:  2.16,  2.03,  1.96
18:52:55
73 processes:  70 sleeping,  2 running,  1 on cpu
Cpu states:  0.0% idle,  7.6% user, 24.5% kernel, 67.9% wait,  0.0% swap
Memory: 27496K real, 1500K free, 27516K swap, 119404K free swap

  PID USERNAME PRI NICE  SIZE  RES STATE  TIME  WCPU   CPU COMMAND
  5099 root      27  0  1932K 1508K cpu    0:01  0.12%  1.37% top
  5170 ccsproj   3  0   828K  608K run    0:00  0.98%  0.98% sh
    1 root     33  0   412K  100K sleep  0:59  0.07%  0.78% init
  162 root      7  0  1636K  904K sleep  0:50  0.03%  0.39% nscd
  505 ccsproj  34 -10 2768K 1704K sleep  0:41  0.03%  0.39% ystTY
  5171 ccsproj  13  0   832K  284K run    0:00  0.39%  0.39% sh
   261 ccsproj  33  0  2780K 1720K sleep  0:25  0.02%  0.20% ysTlmt
   622 ccsproj  33  0   1508K  840K sleep  0:05  0.00%  0.00%
emsStatusUpdat
  225 ccsproj  33  0  1964K 1476K sleep  0:02  0.00%  0.00% ysAOsNe
  267 root      3  0  1972K  784K sleep  0:01  0.00%  0.00% vold
  596 ccsproj  33  0  3836K 2380K sleep  0:01  0.00%  0.00% emsAgent
  143 root     34  0  1400K  856K sleep  0:01  0.00%  0.00% syslogd
  287 ccsproj -25  0  1860K 1268K sleep  0:00  0.00%  0.00% ysADriver
  215 root    -25  0  1620K  344K sleep  0:00  0.00%  0.00% x25netd
  209 ccsproj -23  0  1468K  636K sleep  0:00  0.00%  0.00% ksh
  106 root    -20  0  1712K  680K sleep  0:00  0.00%  0.00% kerbd
  118 root    -17  0  1648K  668K sleep  0:00  0.00%  0.00% statd
  181 root    -17  0  1400K  668K sleep  0:00  0.00%  0.00% lpNet
```

---

- 4 Quit the *top* output screen:

```
# ^C
#
```

---

## Required Daemons

Table 7-3 lists the daemon processes that are required to be running for normal EOAP operation. This section describes how to verify the required daemons and methods for debugging.

**Table 7-3.** License, OSI, X.25 and Alarm Daemons

Process Name	Description
lic.SUNW	License Daemon
osilogd	OSI Daemon
osinetd	OSI Daemon
x25netd	X25 Daemon *
Nebs	Alarm Daemon
* There must be two x25netd processes running.	

## Verify Required Daemons

### Procedure

---

- 1 Log in as root:

Console login: **root**

Password: **eagle**

---

- 2 For each daemon listed above, execute the following command:

```
# ps -ef |grep <process_name> |grep -v grep
```

This command should return one line of output for each process, except for x25netd, which will output two lines (one line for each running process).

---



### One or More Daemon(s) Is Not Running

If any of the daemons is not running, you should reboot the system to restart the daemons before continuing debug activities:

#### Procedure

---

- 1 Log in as root:

```
Console login:  root
```

```
Password:  eagle
```

---

- 2 Reboot the system to restart the daemons

```
#  /usr/sbin/init 6
```

---

- 3 Verify the required daemons again:

```
#  ps -ef |grep <process_name> |grep -v grep
```

---

#### Examine License Key Files

If you have rebooted the system and the OSI and/or X.25 daemon is still not running, check the combined license key file and the individual license key for each product for which the daemon is not running.

**IMPORTANT:** The contents of your license files should exactly match the content of the files shown in the example output here. Note the correct spelling, capitalization, and spacing of the file contents. If the license file for the OSI and/or X25 software packages is incorrect, the daemon(s) for that package will not run.

**NOTE:** It is very unlikely that there is a license key problem. Beginning with Release 25.0, Tekelec implemented universal license keys, which are no longer host-specific and which are loaded onto the system automatically during system manufacturing process or during the upgrade from Release 24.x to Release 25.0. Because these license keys are no longer manually keyed in, the chance of an error in a license file is small.

*Examine the combined license key file:*

## Procedure

---

- 1 Log in as root:

```
Console login:  root
```

```
Password:  eagle
```

---

- 2 Examine the combined license key file; enter this command:

```
# cd /etc/opt/licenses
# cat LIC_CONFIG_FILE.combined

#cat LIC_CONFIG_FILE.combined
FEATURE_ID=solstice_x.25
VERSION_ID=9.1
FEATURE_NAME=Solstice X.25
FEATURE_VERSION=9.1 for sparc
DAEMON_NAME=lic.SUNW
LICENSE_FILE=x25_9.1
LICENSE_TYPE=0
DEMO_AVAIL=1
USE_INCREMENT=1
FEATURE_ID=solstice_x.25_x86
VERSION_ID=9.1
FEATURE_NAME=Solstice X.25
FEATURE_VERSION=9.1 for x86
DAEMON_NAME=lic.SUNW
LICENSE_FILE=x25_9.1
LICENSE_TYPE=0
DEMO_AVAIL=1
USE_INCREMENT=1
FEATURE_ID=STACK
VERSION_ID=8.0
FEATURE_NAME=SunLink OSI (Stack) 8.1.1 for Solaris 2 SPARC
FEATURE_VERSION=8.1.1
DAEMON_NAME=lic.SUNW
LICENSE_FILE=osistk8.0
LICENSE_TYPE=0
DEMO_AVAIL=1
USE_INCREMENT=1
```

---

### *Examine the X.25 license key files:*

#### **Procedure**

---

- 1 Locate the license key file; enter this command:

```
% cat x25_9.x.loc  
/opt/SUNWconn/x25
```

---

- 2 Examine the X.25 license key files

```
% cat /opt/SUNWconn/x25/x25_9.1.lic,1  
INCREMENT solstice_x.25 lic.SUNW 9.100 01-jan-0 0 AB4A7001C6C0E7F3BA24  
"Tekelec project /oap" ANY  
eoapl100402a:root#
```

---

### *Examine the OSI license key file:*

#### **Procedure**

---

- 1 Examine the OSI license key file; enter this command:

```
% cat /etc/opt/licenses/osistk8.0.lic,1  
INCREMENT STACK lic.SUNW 8.000 01-jan-0 0 BBFA00015B0268D6B85C  
"Tekelec project /oap" ANY
```

---

## External Connectivity



**CAUTION:** The EOAP's open system architecture allows access to the operating system. Any undocumented changes to the files may cause the system to become corrupted and unusable. Making any undocumented changes on the EOAP, including changes to the hardware, operating system and/or the components found therein will void the warranty.

### No External EOAP Connectivity

This problem is characterized by the `ok` prompt appearing on the EOAP console. It is caused by the stop character (zbreak) being received by the EOAP on the serial port (TTYA). This signal can sometimes be generated erroneously by connecting or disconnecting terminals or modems to and from the serial port.



**WARNING:** Solaris Console Port Break Issue

A terminal or modem connected to the EOAP serial port and acting as the system console can halt the operating system (bring it to the `ok` prompt) if you turn off or unplug the terminal, or unplug the modem or drop the connection. When the system is halted in this manner, it must be manually booted from the `ok` prompt to resume operation.

This problem affects all TMOAPs and EOAPs running Solaris 2.5.1. The problem is most often encountered when Tekelec support personnel use a modem to dial into the customer's system.

#### Solution

After the modem connection has been dropped or the terminal has been disconnected from the TMOAP/EOAP, use the EAGLE 5 ISS console to issue a reboot command to the TMOAP/EOAP.

#### Procedure

---

- 1 Log in as root:

```
Console login: root
```

```
Password: eagle
```

---

- 2 Boot the system; enter the following command:

```
ok boot
```

---

## External Interfaces



**CAUTION:** The EOAP's open system architecture allows access to the operating system. Any undocumented changes to the files may cause the system to become corrupted and unusable. Making any undocumented changes on the EOAP, including changes to the hardware, operating system and/or the components found therein will void the warranty.

### EOAP-to-EAGLE 5 ISS Interface

#### EOAP EAGLE 5 ISS Security Log

The **rtrv-secu**log command on the EAGLE 5 ISS can provide information on commands arriving from the EOAP. The command allows the specification of a terminal port. It is often useful to inhibit one EOAP port and specify the other (active) terminal port to the **rtrv-secu**log command. Maintenance responses are not logged.

#### ysTT0 Debug Log

The ysTT0 debug log file will contain all data written to this interface, including maintenance responses. It will also indicate any problems encountered while attempting to read or write to the serial ports.

#### Procedure

---

- 1 Log in as ccsproj:

```
Console login: ccsproj
```

```
Password: eagle1
```

---

- 2 Change to the process debug log directory:

```
% cd /ccsdata/log/ysTT0
```

---

- 3 Display the contents of the ysTT0) debug log file:

```
% cat ysTT0{instancenumber}.cur
```

---

#### ysTT0 Trace Log

The ysTT0 process trace logs will contain messages arriving to and sent from the ysTT0 process. Data written to or read from the EAGLE 5 ISS/EOAP interface by the EOAP can be checked here.

## Procedure

---

- 1 Log in as ccsproj:

```
Console login: ccsproj
```

```
Password: eagle1
```

---

- 2 Change to the process debug log directory:

```
% cd /ccsdata/trace/{date time}/ysTT0
```

---

- 3 Display the contents of the ysTT0) debug log file:

```
% cat ysTT0{instancenumber}
```

---

## Chameleon

A Chameleon can be placed on one of the serial connections between the EAGLE 5 ISS and an EOAP. It is often useful to inhibit one EOAP port and place the Chameleon on the other (active) link. Data written to or read from the EAGLE 5 ISS/EOAP interface by either the EAGLE 5 ISS or the EOAP can be checked here.

The following equipment is required:

- Chameleon with an RS232 interface pod
- 25-pin serial Y cable connected to the EAGLE 5 ISS, EOAP, and Chameleon

Configure the RS232 interface on the Chameleon as follows:

- Asynchronous serial
- 19200 baud
- 7 data bits
- Even parity
- 1 stop bit

## Data Checksum

## Basic Troubleshooting

The EAGLE 5 ISS and the EOAP use a data checksum to verify that they have the same values for various system and feature parameters. The following procedure allows Tekelec personnel to gather a quick list of all of the possible parameters and their current values on an EOAP.

**NOTE: This procedure is for debugging purposes only. If a problem with a particular parameter/value pair is suspected, the official method for retrieval should be used.**

### Procedure

---

- 1 Log in as ccsproj:

```
Console login: ccsproj
Password: eagle1
```

---

- 2 Verify ksh is running:

```
% echo $SHELL
/bin/ksh
```

---

- 3 Set the SeasWork environment variable

```
% export SeasWork=/ccsosmr/{instance}/work
```

---

- 4 Run the checksum:

```
% /ccsosmr/MR.os54/testq.sh
```

The output should have the following format:

```
MGR_NSAP=0x 12121212
MGR_SSEL= abc
MGR_PSEL= xyz
CLASS_TT= 000
CNAM_TT= 000
LIDB_TT= 000
ISVM_TT= 000
SEAC = SEASNJPYRRC
x25 Packet Size = 8
x25 Mode = DCE
STP CLLI = STPA
Hostname = apg3
IP address = 192.168.051.115
Netmask = 000.000.000.000
Default Router = 192.168.061.250
x25 Configuration = 1
```

---

## EAGLE 5 ISS-Initiated EOAP User Interface (ysT10)

This feature provides the EAGLE 5 ISS with a database containing various EOAP parameters. The EAGLE 5 ISS-to-EOAP process containing the EOAP configuration parameters is logged by ysT1mnt.

### Procedure

---

- 1 Log in as ccsproj:

```
Console login: ccsproj
```

```
Password: eagle1
```

---

- 2 Change to the log directory for this process:

```
% cd /ccsdata/log/ysT10
```

---

- 3 Check the process debug log for errors:

```
% cat ysT10{instance}.log
```

The following is a sample debug log entry for this process:

```
Mon Feb 9 16:59:35 1998: (ysT100)-0 (ysT100): processCfgMsg(): rec'd:  
OAP-CONFIG:TEKELECST  
P,98-11-9,17-55-07.0-EST:1:029678:AM::C6592894,PPPP,EMSS,001,004,003,  
035:SEASNJPYRRRC,8,DCE:  
TEKELECSTP,TEKELEC-23,198.089.039.056,000.000.000.000,DUAL;
```

---

- 4 Check the log of all actions performed as a result of this process for significant changes that could affect EAGLE 5 ISS-to-EOAP communication.

- a. Log in as ccsproj:

```
Console login: ccsproj
```

```
Password: eagle1
```

- b. Change to the log directory for this process:

```
% cd /ccsdata/log
```



## Basic Troubleshooting

- c. Check the process debug log for errors:

```
% cat ConfigChanges.log
```

The following is an example of an EAGLE 5 ISS-initiated change of the EOAP hostname:

```
ConfigControl.sh (pid 1658) begins on Thu Jan 29 16:59:38 EST 2000
Hostname: changing "beavis" to "tekelec-23" on Thu Jan 29 16:59:38 EST 2000
commitChanges: bringing instance down on Thu Jan 29 16:59:53 EST 2000
commitChanges: removing instance on Thu Jan 29 17:00:38 EST 2000
commitChanges: rebuilding instance on Thu Jan 29 17:00:45 EST 2000
commitChanges: rebooting OAP on Thu Jan 29 17:01:42 EST 2000
```

---

## EOAP-to-SEAS Interface

The EOAP-to-SEAS interface is built on top of X.25. The x25trace program is available for monitoring x25 packets sent and received by the EOAP.

### X.25 Trace

**NOTE:** The x25trace command takes the following parameters:

```
x25trace [-a] [-u] [-x] [-i interface] [-c count] [-l link id] [-s length] expression
```

### Procedure

---

- 1 Log in as root:

```
Console login: root
```

```
Password: eagle
```

---

- 2 Execute the **x25trace** command to verify link 0 and send the trace to a file:

```
# /opt/SUNWconn/x25/bin/x25trace -u -i /dev/lapb -l 0 >
/tmp/<trace_filename> &
```

---

- 3 Record the number response, it will be used to stop the trace process.

**NOTE:** This number is always different.

```
9229
```

---

- 4 Enter the following command to view the file containing the trace output:

```
# tail -f /tmp/<trace_filename>
```

**NOTE: The trace can be lengthy. Use Cntrl-C (^C) to stop the tail command.**

This is an example of an X.25 tracing session:

```
Parsed:
Time Protocol
0.00 HDLC Sent 1 bytes, command DISC(P),
.
.
.
185.70 HDLC Sent 1 bytes, command DISC(P),
186.40 HDLC Sent 1 bytes, command DISC(P),
187.10 HDLC Sent 1 bytes, command DISC(P),
187.80 HDLC Sent 1 bytes, command DISC(P),
188.50 HDLC Sent 1 bytes, command DISC(P),
189.20 HDLC Sent 1 bytes, command DISC(P),
189.90 HDLC Sent 1 bytes, command DISC(P),
190.55 HDLC Rcvd 1 bytes, command DISC(P),
190.55 HDLC Sent 1 bytes, response DM(F),
190.60 HDLC Sent 1 bytes, command DISC(P),
190.66 HDLC Rcvd 1 bytes, command SABM(P),
190.70 HDLC Rcvd 1 bytes, response DM(F),
196.56 HDLC Rcvd 1 bytes, command SABM(P),
196.56 HDLC Sent 1 bytes, response UA(F),
196.69 HDLC Sent 6 bytes, command I(0, 0), 5 bytes user data:
196.69 X.25 Sent 5 bytes, lcn=000, RESTART REQUEST 0700,
196.69 HDLC Rcvd 6 bytes, command I(0, 0), 5 bytes user data:
196.69 X.25 Rcvd 5 bytes, lcn=000, RESTART REQUEST 0000,
196.80 HDLC Rcvd 1 bytes, response RR(1),
198.70 HDLC Sent 1 bytes, response RR(1),
201.89 HDLC Sent 64 bytes, command I(1, 1), 63 bytes user data:
201.89 X.25 Sent 63 bytes, lcn=002, DATA (0, 0) 60 bytes user data:
201.89 X.25 Last packet
32 30 30 31 54 4d 4d 4d 4d 4d 4d 4d 4d 4d 4d 30 31 *2001TMMMMMMMMM01*
30 31 39 39 45 53 45 41 53 50 41 42 41 54 4c 54 *0199ESEASPABATLT*
54 41 52 54 4e 56 41 41 52 37 37 57 23 47 4d 20 *TARTNVAAR77W#GM *
20 20 20 20 20 20 20 20 20 20 20 20 * *

```

## Basic Troubleshooting

```
201.90 HDLC Sent 64 bytes, command I(1, 2), 63 bytes user data:
201.90 X.25 Sent 63 bytes, lcn=003, DATA (0, 0) 60 bytes user data:
201.90 X.25 Last packet
32 30 30 31 54 4d 4d 4d 4d 4d 4d 4d 30 31 *2001TMMMMMMMMM01*
30 31 39 39 45 53 45 41 53 50 41 42 41 54 4c 54 *0199ESEASPABATLT*
54 41 52 54 4e 56 41 41 52 37 37 57 23 47 4d 20 *TARTNVAAR77W#GM *
20 20 20 20 20 20 20 20 20 20 20 20 * *

201.92 HDLC Sent 64 bytes, command I(1, 3), 63 bytes user data:
201.92 X.25 Sent 63 bytes, lcn=001, DATA (0, 0) 60 bytes user data:
201.92 X.25 Last packet
32 30 30 31 54 4d 4d 4d 4d 4d 4d 4d 30 31 *2001TMMMMMMMMM01*
30 31 39 39 45 53 45 41 53 50 41 42 41 54 4c 54 *0199ESEASPABATLT*
54 41 52 54 4e 56 41 41 52 37 37 57 23 47 4d 20 *TARTNVAAR77W#GM *
20 20 20 20 20 20 20 20 20 20 20 20 * *

202.05 HDLC Rcvd 1 bytes, response RR(2),

202.06 HDLC Rcvd 4 bytes, command I(2, 1), 3 bytes user data:
202.06 X.25 Rcvd 3 bytes, lcn=002, RR(1),

202.10 HDLC Rcvd 1 bytes, response RR(3),

202.12 HDLC Rcvd 4 bytes, command I(3, 2), 3 bytes user data:
202.12 X.25 Rcvd 3 bytes, lcn=003, RR(1),

202.17 HDLC Rcvd 1 bytes, response RR(4),

202.21 HDLC Rcvd 4 bytes, command I(4, 3), 3 bytes user data:
202.21 X.25 Rcvd 3 bytes, lcn=001, RR(1),

202.21 HDLC Sent 1 bytes, response RR(4),

202.27 HDLC Rcvd 64 bytes, command I(4, 4), 63 bytes user data:
202.27 X.25 Rcvd 63 bytes, lcn=002, DATA (0, 1) 60 bytes user data:
202.27 X.25 Last packet
32 30 30 32 54 4d 4d 4d 4d 4d 4d 4d 30 31 *2002TMMMMMMMMM01*
30 31 39 38 54 41 52 54 4e 56 41 41 52 37 37 57 *0198TARTNVAAR77W*
45 53 45 41 53 50 41 42 41 54 4c 54 23 47 4d 20 *ESEASPABATLT#GM *
20 20 20 20 20 20 20 20 20 20 20 20 * *

202.28 HDLC Sent 64 bytes, command I(5, 4), 63 bytes user data:
202.28 X.25 Sent 63 bytes, lcn=002, DATA (1, 1) 60 bytes user data:
202.28 X.25 Last packet
32 30 30 33 54 4d 4d 4d 4d 4d 4d 4d 30 31 *2003TMMMMMMMMM01*
30 31 39 38 45 53 45 41 53 50 41 42 41 54 4c 54 *0198ESEASPABATLT*
54 41 52 54 4e 56 41 41 52 37 37 57 23 47 4d 20 *TARTNVAAR77W#GM *
20 20 20 20 20 20 20 20 20 20 20 20 * *

202.33 HDLC Rcvd 64 bytes, command I(4, 5), 63 bytes user data:
202.33 X.25 Rcvd 63 bytes, lcn=003, DATA (0, 1) 60 bytes user data:
202.33 X.25 Last packet
32 30 30 32 54 4d 4d 4d 4d 4d 4d 4d 30 31 *2002TMMMMMMMMM01*
30 31 39 38 54 41 52 54 4e 56 41 41 52 37 37 57 *0198TARTNVAAR77W*
45 53 45 41 53 50 41 42 41 54 4c 54 23 47 4d 20 *ESEASPABATLT#GM *
20 20 20 20 20 20 20 20 20 20 20 20 * *

202.37 HDLC Sent 64 bytes, command I(6, 5), 63 bytes user data:
202.37 X.25 Sent 63 bytes, lcn=003, DATA (1, 1) 60 bytes user data:
202.37 X.25 Last packet
32 30 30 33 54 4d 4d 4d 4d 4d 4d 4d 30 31 *2003TMMMMMMMMM01*
30 31 39 38 45 53 45 41 53 50 41 42 41 54 4c 54 *0198ESEASPABATLT*
```

## Basic Troubleshooting

```
54 41 52 54 4e 56 41 41      52 37 37 57 23 47 4d 20      *TARTNVAAR77W#GM *
20 20 20 20 20 20 20 20      20 20 20 20      *                *

202.39 HDLC Rcvd 64 bytes, command I(4, 6), 63 bytes user data:
202.39 X.25 Rcvd 63 bytes, lcn=001, DATA (0, 1) 60 bytes user data:
202.39 X.25 Last packet
32 30 30 32 54 4d 4d 4d      4d 4d 4d 4d 4d 4d 30 31      *2002TMMMMMMMMM01*
30 31 39 38 54 41 52 54      4e 56 41 41 52 37 37 57      *0198TARTNVAAR77W*
45 53 45 41 53 50 41 42      41 54 4c 54 23 47 4d 20      *ESEASPABATLT#GM *
20 20 20 20 20 20 20 20      20 20 20 20      *                *

202.41 HDLC Sen4<-:es, command I(7, 6), 63 bytes user data:
202.41 X.25 Sent 63 bytes, lcn=001, DATA (1, 1) 60 bytes user data:
202.41 X.25 Last packet
32 30 30 33 54 4d 4d 4d      4d 4d 4d 4d 4d 4d 30 31      *2003TMMMMMMMMM01*
30 31 39 38 45 53 45 41      53 50 41 42 41 54 4c 54      *0198ESEASPABATLT*
54 41 52 54 4e 56 41 41      52 37 37 57 23 47 4d 20      *TARTNVAAR77W#GM *
20 20 20 20 20 20 20 20      20 20 20 20      *                *

202.45 HDLC Rcvd 1 bytes, response RR(5),

202.45 HDLC Rcvd 4 bytes, command I(5, 7), 3 bytes user data:
202.45 X.25 Rcvd 3 bytes, lcn=002, RR(2),

202.53 HDLC Rcvd 1 bytes, response RR(6),

202.54 HDLC Rcvd 4 bytes, command I(6, 0), 3 bytes user data:
202.54 X.25 Rcvd 3 bytes, lcn=003, RR(2),

202.58 HDLC Rcvd 1 bytes, response RR(7),

202.59 HDLC Rcvd 4 bytes, command I(7, 1), 3 bytes user data:
202.59 X.25 Rcvd 3 bytes, lcn=001, RR(2),

202.59 HDLC Sent 1 bytes, response RR(2),

217.45 HDLC Sent 132 bytes, command I(2, 7), 131 bytes user data:
217.45 X.25 Sent 131 bytes, lcn=001, DATA (2, 1) M 128 bytes user data:
217.45 X.25 MORE DATA - first or middle packet
32 31 30 30 54 30 30 34      34 38 37 4b 45 57 30 31      *2100T004487KEW01*
30 31 35 30 45 53 45 41      53 50 41 42 41 54 4c 54      *0150ESEASPABATLT*
54 41 52 54 4e 56 41 41      52 37 37 57 2a 53 44 20      *TARTNVAAR77W#SD *
20 20 20 20 20 20 20 20      20 20 20 20 52 45 50 54      *                REPT*
2d 46 4c 4f 57 2d 54 48      52 55 3a 41 52 54 4e 56      *~-FLOW-THRU:ARTNV*
41 41 52 37 37 57 2c 39      38 2d 30 37 2d 31 33 2c      *AAR77W,98-07-13,*
31 34 2d 30 36 2d 33 39      2e 30 2d 45 44 54 3a 3a      *14-06-39.0-EDT.:*
3a 3a 22 20 20 20 20 61      72 74 6e 76 61 61 72 37      *.: " artnvaar7*

217.45 HDLC Sent 132 bytes, command I(2, 0), 131 bytes user data:
217.45 X.25 Sent 131 bytes, lcn=001, DATA (3, 1) M 128 bytes user data:
217.45 X.25 MORE DATA - first or middle packet
37 77 20 39 38 2d 30 37      2d 31 33 20 31 34 3a 30      *7w 98-07-13 14:0*
36 3a 33 39 20 45 44 54      20 52 65 6c 20 32 31 2e      *6:39 EDT Rel 21.*
31 2e 58 30 34 20 0d 0a      20 20 20 20 4c 49 4e 4b      *1.X04 LINK*
2d 43 4f 4d 50 20 4d 45      41 53 55 52 45 4d 45 4e      *~-COMP MEASUREMEN*
54 53 3a 20 4c 4f 43 3a      20 33 31 30 37 2c 20 50      *TS: LOC: 3107, P*
4f 52 54 3a 20 42 0a 0d      20 20 20 20 0a 0d 20 20      *ORT: B          *
20 20 4d 53 55 54 52 41      4e 20 20 20 20 3d 20 20      * MSUTRAN      = *
20 20 20 20 35 36 38 38      2c 20 4d 53 55 52 45 43      * 5688, MSUREC*

217.67 HDLC Rcvd 1 bytes, response RR(0),

217.68 HDLC Rcvd 4 bytes, command I(0, 2), 3 bytes user data:
```

## Basic Troubleshooting

```
217.68 X.25 Rcvd 3 bytes, lcn=001, RR(3),

217.68 HDLC Sent 132 bytes, command I(3, 1), 131 bytes user data:
217.68 X.25 Sent 131 bytes, lcn=001, DATA (4, 1) M 128 bytes user data:
217.68 X.25 MORE DATA - first or middle packet
56 44 20 20 20 3d 20 20 20 20 20 20 31 30 39 33 33 *VD = 10933*
2c 20 4d 53 55 52 45 54 52 4e 20 20 20 3d 20 20 *, MSURETRN = *
20 20 20 20 20 20 20 30 2c 0a 0d 20 20 20 20 4f * 0, 0*
43 54 54 52 41 4e 20 20 20 20 3d 20 20 20 20 36 *CTTRAN = 6*
34 39 39 31 38 2c 20 4f 43 54 52 45 43 56 44 20 *49918, OCTRECVD *
20 20 3d 20 20 20 20 36 32 30 32 30 36 2c 20 4d * = 620206, M*
54 43 45 55 53 47 20 20 20 20 3d 20 20 20 20 20 *TCEUSG = *
20 20 20 20 30 2c 0a 0d 20 20 20 20 44 52 4c 4b * 0, DRLK*

217.79 HDLC Rcvd 1 bytes, response RR(1),

217.90 HDLC Rcvd 1 bytes, response RR(2),

217.91 HDLC Rcvd 4 bytes, command I(2, 3), 3 bytes user data:
217.91 X.25 Rcvd 3 bytes, lcn=001, RR(4),

217.91 HDLC Sent 132 bytes, command I(4, 2), 131 bytes user data:
217.91 X.25 Sent 131 bytes, lcn=001, DATA (5, 1) M 128 bytes user data:
217.91 X.25 MORE DATA - first or middle packet
4f 54 47 20 20 20 20 3d 20 20 20 20 20 20 20 20 *OTG = *
20 30 2c 20 4d 53 55 53 52 47 54 54 20 20 20 3d * 0, MSUSRGTT =*
20 20 20 20 20 20 20 20 20 30 2c 20 4f 43 54 52 * 0, OCTR*
43 47 54 54 20 20 20 3d 20 20 20 20 20 20 20 20 *CGTT = *
20 30 2c 0a 0d 20 20 20 20 54 44 43 4e 47 4c 56 * 0, TDCNGLV*
31 20 20 20 3d 20 20 20 20 20 20 20 20 20 20 20 *1 = 0,*
20 54 44 43 4e 47 4c 56 32 20 20 20 3d 20 20 20 * TDCNGLV2 = *
20 20 20 20 20 20 30 2c 20 54 44 43 4e 47 4c 56 * 0, TDCNGLV*

218.13 HDLC Rcvd 1 bytes, response RR(3),

218.14 HDLC Rcvd 4 bytes, command I(3, 4), 3 bytes user data:
218.14 X.25 Rcvd 3 bytes, lcn=001, RR(5),

218.14 HDLC Sent 132 bytes, command I(5, 3), 131 bytes user data:
218.14 X.25 Sent 131 bytes, lcn=001, DATA (6, 1) M 128 bytes user data:
218.14 X.25 MORE DATA - first or middle packet
33 20 20 20 3d 20 20 20 20 20 20 20 20 20 30 2c *3 = 0,*
0a 0d 20 20 20 20 20 45 43 43 4e 47 4c 56 31 20 20 * ECCNGLV1 *
20 3d 20 20 20 20 20 20 20 20 20 20 30 2c 20 45 43 * = 0, EC*
43 4e 47 4c 56 32 20 20 20 3d 20 20 20 20 20 20 *CNGLV2 = *
20 20 20 30 2c 20 45 43 43 4e 47 4c 56 33 20 20 * 0, ECCNGLV3 *
20 3d 20 20 20 20 20 20 20 20 20 30 2c 0a 0d 20 * = 0, *
20 20 20 4d 53 55 44 49 53 43 30 20 20 20 3d 20 * MSUDISCO = *
20 20 20 20 20 20 20 20 30 2c 20 4d 53 55 44 49 * 0, MSUDI*

218.36 HDLC Rcvd 1 bytes, response RR(4),

218.36 HDLC Rcvd 4 bytes, command I(4, 5), 3 bytes user data:
218.36 X.25 Rcvd 3 bytes, lcn=001, RR(6),

218.36 HDLC Sent 132 bytes, command I(6, 4), 131 bytes user data:
218.36 X.25 Sent 131 bytes, lcn=001, DATA (7, 1) M 128 bytes user data:
218.36 X.25 MORE DATA - first or middle packet
53 43 31 20 20 20 3d 20 20 20 20 20 20 20 20 20 *SC1 = *
30 2c 20 4d 53 55 44 49 53 43 32 20 20 20 3d 20 *0, MSUDISC2 = *
20 20 20 20 20 20 20 20 30 2c 0a 0d 20 20 20 20 * 0, *
4d 53 55 44 49 53 43 33 20 20 20 3d 20 20 20 20 *MSUDISC3 = *
20 20 20 20 20 30 2c 20 4c 4e 4b 41 56 41 49 4c * 0, LNKAVAIL*
```

## Basic Troubleshooting

```

20 20 20 3d 20 20 20 20      20 20 31 38 30 30 2c 20      *   =      1800, *
4e 4d 47 57 53 44 53 41      42 4c 20 3d 20 20 20 20      *NMGWSDSABL =   *
20 20 20 20 20 30 0a 0d      20 20 20 20 0a 0d 3b 0a      *    0      ; *

218.58 HDLC  Rcvd 1 bytes, response RR(5),

218.59 HDLC  Rcvd 4 bytes, command I(5, 6), 3 bytes user data:
218.59 X.25  Rcvd 3 bytes, lcn=001, RR(7),

218.59 HDLC  Sent 9 bytes, command I(7, 5), 8 bytes user data:
218.59 X.25  Sent 8 bytes, lcn=001, DATA (0, 1) 5 bytes user data:
218.59 X.25  Last packet
0d 0a 0d 22 3b                                     *   ";      *

218.71 HDLC  Rcvd 1 bytes, response RR(6),

218.73 HDLC  Rcvd 4 bytes, command I(6, 7), 3 bytes user data:
218.73 X.25  Rcvd 3 bytes, lcn=001, RR(0),

218.73 HDLC  Sent 132 bytes, command I(0, 6), 131 bytes user data:
218.73 X.25  Sent 131 bytes, lcn=001, DATA (1, 1) M 128 bytes user data:
218.73 X.25  MORE DATA - first or middle packet
32 31 30 30 54 30 30 34      34 38 37 4b 45 58 30 31      *2100T004487KEX01*
30 31 35 30 45 53 45 41      53 50 41 42 41 54 4c 54      *0150ESEASPABATLT*
54 41 52 54 4e 56 41 41      52 37 37 57 2a 53 44 20      *TARTNVAAR77W*SD *
20 20 20 20 20 20 20 20      20 20 20 20 52 45 50 54      *                REPT*
2d 46 4c 4f 57 2d 54 48      52 55 3a 41 52 54 4e 56      *~-FLOW-THRU:ARTNV*
41 41 52 37 37 57 2c 39      38 2d 30 37 2d 31 33 2c      *AAR77W,98-07-13,*
31 34 2d 30 36 2d 34 30      2e 30 2d 45 44 54 3a 3a      *14-06-40.0-EDT::*
3a 3a 22 20 20 20 20 61      72 74 6e 76 61 61 72 37      *::"   artnvaar7*

218.95 HDLC  Rcvd 1 bytes, response RR(7),

218.96 HDLC  Rcvd 4 bytes, command I(7, 0), 3 bytes user data:
218.96 X.25  Rcvd 3 bytes, lcn=001, RR(1),

218.96 HDLC  Sent 132 bytes, command I(1, 7), 131 bytes user data:
218.96 X.25  Sent 131 bytes, lcn=001, DATA (2, 1) M 128 bytes user data:
218.96 X.25  MORE DATA - first or middle packet
37 77 20 39 38 2d 30 37      2d 31 33 20 31 34 3a 30      *7w 98-07-13 14:0*
36 3a 34 30 20 45 44 54      20 52 65 6c 20 32 31 2e      *6:40 EDT Rel 21.*
31 2e 58 30 34 20 0d 0a      20 20 20 20 4c 49 4e 4b      *1.X04   LINK*
2d 43 4f 4d 50 20 4d 45      41 53 55 52 45 4d 45 4e      *~-COMP MEASUREMEN*
54 53 3a 20 4c 4f 43 3a      20 33 31 30 38 2c 20 50      *TS: LOC: 3108, P*
4f 52 54 3a 20 41 0a 0d      20 20 20 20 0a 0d 20 20      *ORT: A      *
20 20 4d 53 55 54 52 41      4e 20 20 20 20 3d 20 20      *  MSUTRAN   =   *
20 20 20 20 20 32 30 31      2c 20 4d 53 55 52 45 43      *    201, MSUREC*

219.02 HDLC  Rcvd 64 bytes, command I(7, 1), 63 bytes user data:
219.02 X.25  Rcvd 63 bytes, lcn=002, DATA (1, 2) 60 bytes user data:
219.02 X.25  Last packet
32 30 30 34 54 30 30 34      34 38 37 4b 45 57 30 31      *2004T004487KEW01*
30 31 39 38 54 41 52 54      4e 56 41 41 52 37 37 57      *0198TARTNVAAR77W*
45 53 45 41 53 50 41 42      41 54 4c 54 23 53 53 20      *ESEASPABATLT#SS *
20 20 20 20 20 20 20 20      20 20 20 20                *                *

219.18 HDLC  Rcvd 1 bytes, response RR(0),

219.19 HDLC  Rcvd 4 bytes, command I(0, 2), 3 bytes user data:
219.19 X.25  Rcvd 3 bytes, lcn=001, RR(2),

219.19 HDLC  Sent 132 bytes, command I(3, 0), 131 bytes user data:
219.19 X.25  Sent 131 bytes, lcn=001, DATA (3, 1) M 128 bytes user data:

```

## Basic Troubleshooting

```
219.19 X.25 MORE DATA - first or middle packet
56 44 20 20 20 3d 20 20 20 20 20 20 38 39 34 35 *VD = 8945*
2c 20 4d 53 55 52 45 54 52 4e 20 20 20 3d 20 20 *, MSURETRN = *
20 20 20 20 20 20 20 20 30 2c 0a 0d 20 20 20 20 4f * 0, O*
43 54 54 52 41 4e 20 20 20 20 3d 20 20 20 20 20 *CTTRAN = *
20 34 38 30 30 2c 20 4f 43 54 52 45 43 56 44 20 * 4800, OCTRECVD *
20 20 3d 20 20 20 20 32 31 39 36 32 38 2c 20 4d * = 219628, M*
54 43 45 55 53 47 20 20 20 20 3d 20 20 20 20 20 *TCEUSG = *
20 20 20 20 30 2c 0a 0d 20 20 20 20 44 52 4c 4b * 0, DRLK*

219.40 HDLC Rcvd 1 bytes, response RR(1),

219.42 HDLC Rcvd 4 bytes, command I(1, 3), 3 bytes user data:
219.42 X.25 Rcvd 3 bytes, lcn=001, RR(3),

219.42 HDLC Sent 132 bytes, command I(4, 1), 131 bytes user data:
219.42 X.25 Sent 131 bytes, lcn=001, DATA (4, 1) M 128 bytes user data:
219.42 X.25 MORE DATA - first or middle packet
4f 54 47 20 20 20 3d 20 20 20 20 20 20 20 20 20 *OTG = *
20 30 2c 20 4d 53 55 53 52 47 54 54 20 20 20 3d * 0, MSUSRGTT =*
20 20 20 20 20 20 20 20 20 20 30 2c 20 4f 43 54 52 * 0, OCTR*
43 47 54 54 20 20 20 3d 20 20 20 20 20 20 20 20 *CGTT = *
20 30 2c 0a 0d 20 20 20 20 54 44 43 4e 47 4c 56 * 0, TDCNGLV*
31 20 20 20 3d 20 20 20 20 20 20 20 20 20 30 2c *1 = 0,*
20 54 44 43 4e 47 4c 56 32 20 20 20 3d 20 20 20 * TDCNGLV2 = *
20 20 20 20 20 20 30 2c 20 54 44 43 4e 47 4c 56 * 0, TDCNGLV*
```

219.52 HDLC Sent 4 bytes, command I(4, 2), 3 bytes user data:  
219.52 X.25 Sent 3 bytes, lcn=002, RR(2),

219.64 HDLC Rcvd 1 bytes, response RR(2),

219.65 HDLC Rcvd 4 bytes, command I(2, 4), 3 bytes user data:  
219.65 X.25 Rcvd 3 bytes, lcn=001, RR(4),

---

- 5 Enter the following commands to stop the x25trace process (the number used is from step 3) and to exit the process.

```
# kill 9229
# exit
```

---

### Restarting an X.25 Link

X.25 links can be restarted by either of the following:

- Rebooting the EOAP
- Restarting Processes
- Resetting a specific link or PVC
- Restarting X.25 software

**Procedure- Rebooting the EOAP**

---

- 1 Log in as root:

```
Console login:  root
```

```
Password:  eagle
```

---

- 2 Enter the following command to reboot the system.

```
#  init 6
```

---

**Procedure- Restart Processes**

---

- 1 Log in as ccspj:

```
Console login:  ccspj
```

```
Password:  eagle1
```

---

- 2 Enter the following command to stop all processes.

```
%  ccsmr all.down
```

---

- 3 Enter the following command to start all processes.

```
%  ccsmr all.up
```

---

**Procedure- Reset Specific Link or PVC**

---

- 1 Log in as ccspj:

```
Console login:  ccspj
```

```
Password:  eagle1
```

---

- 2 You can either enter the following command to take down all PVCs:

```
%  ccsmr pvc.down
```

```
Killing process (ysA101) .
```

```
Killing process (ysA102) .
```



## Basic Troubleshooting

```
Killing process(ysA103) .
```

Or you can use the command **ccsmr pvc.reset <PVC-process>** to reset an individual PVC. The **<PVC-process>** can be either **ysAM##** or **ysA1##**.

```
% ccsmr pvc.reset ysA103
```

```
Shutting down PVC process ysA103  
Killing process(ysA103) .  
Restarting          PVC process ysA103 ...  
UAL/X.25 PVC process ysA103 RESET completed!
```

---

### Procedure- Restart X.25 software

---

- 1 Login as root:

```
Console login: root
```

```
Password: eagle
```

---

- 2 Enter the following commands at the prompt to take down X.25 software on the links:

```
# cd /etc/rc2.d
```

```
# ./S87x25net stop
```

```
The X.25 software is being stopped - please wait  
The network programs are being killed - please wait  
NOTICE: LAPB Down on link 0  
NOTICE: LAPB Down on link 0  
The network has been stopped
```

---

- 3 Enter the following command at the prompt to bring up the X.25 software on the links :

```
# ./S87x25net start
```

---

### View X.25 Link and PVC Status

#### Procedure

---

- 1 Log in as ccspj:

```
Console login: ccspj
```

```
Password: eagle1
```

---

- Enter the following command to view the overall status of the X25 links and PVCs.

```
% ccsmr ual.status
```

This is an example of an X.25 overall status summary:

```
*** Abnormal UAL Node Status Summary          (TEKELECSTP) ***
***                Tue Aug 30 11:49:28 EDT 2005                ***
```

Destination Node-ID	PVC Status	Overload Status	Application Status	Update Time	Gateway Node-ID
ESEACLLI	3 of 3	Inact	No	Active	00000000000000

- Enter the following command to view the status of all the X25 links and PVCs.

```
% ccsmr ual.status -ap
```

If the x25 circuit and PVC are up you will see an A in the X25 column and a C in the UAL column. This is an example of an X.25 status summary:

```
*** UAL Channel/PVC Status Summary          (TEKELECSTP) ***
*** Tue Aug 30 09:14:31 CDT 2005          ***
```

Destination Node-ID	L PVC C Process	Status X25 UAL	X.25 Link# LCN#(hex) Host
ESEASCLLI	a ysA101	A C	0 1 tklcseasb
ESEASCLLI	b ysA102	A 0a<=(Wait-GM2)	0 2 tklcseasb
ESEASCLLI	c ysA103	A 0a<=(Wait-GM2)	0 3 tklcseasb

- Enter the following command to view the X.25 link state.

```
% ccsmr x25.vcstat
```

```
Tue Aug 30 11:49:53 2005
If Type State          SABM Recv Sent Abort  Crc Over Under
0 hdlc DOWN           0    0    0    0    0    0    0
```

# Index

600-0154-01 3-19, 3-20  
600-0193-01 3-14  
600-0934-01 3-13  
601-0010-01 3-22  
606-0062-01 3-13, 3-14  
652-0841-01 3-19, 3-20  
652-0954-01 3-13  
804-0176-01 3-8, 3-45  
830-0398-xx 3-7, 3-8, 3-11, 3-12  
830-0404-xx 3-6  
830-0528-xx 3-8, 3-34, 3-45, 3-46, 3-48, 3-68  
830-0609-xx 3-8, 3-12, 3-29, 3-35, 3-39, 3-40,  
3-50, 3-51  
830-0657-xx 3-8, 3-29, 3-33, 3-41, 3-44, 3-50,  
3-54  
830-0699-xx 3-8, 3-29, 3-32, 3-35, 3-36, 3-38,  
3-51, 3-67  
830-0708-xx 3-8, 3-29, 3-34, 3-49, 3-68  
830-0709-xx 3-8, 3-9, 3-29, 3-34, 3-46, 3-48,  
3-51, 3-68  
830-0710-xx 3-8, 3-55  
840-0016-02 3-19  
850-0488-xx 3-36  
890-1050-01 3-19  
890-1050-03 3-19

## A

acronyms  
document 1-20  
act-oap-config parameters  
performance impact 4-13  
AIPADDR parameter  
chg-oap-config 4-11  
alarms  
EOAP 4-20  
ANAME parameter  
chg-oap-config 4-11  
ANMASK parameter  
chg-oap-config 4-11  
AROUTER parameter  
chg-oap-config 4-11  
attach fan assembly to frame rail 6-45  
Aurora serial card driver 7-22

## B

backing up changes, chg-db 4-26, 4-37  
backplane monitor 7-20  
BIPADDR parameter  
chg-oap-config 4-11  
BNAME parameter  
chg-oap-config 4-11  
BNMASK parameter  
chg-oap-config 4-11  
boot disk 7-10  
BROUTER parameter  
chg-oap-config 4-11

## C

cable  
CD-ROM 7-7  
hard drive card 7-7  
cable list 3-8  
CD-ROM 7-6  
CD-ROM jumper settings 7-7  
CFG parameter  
chg-oap-config 4-11  
change features, chg-feat  
DCM 3-71, 6-48  
checksums and alarms  
EOAP 4-14  
clock connection cable  
install 3-41  
route 3-42  
clock in/out cable  
install 3-40  
command  
rtrv-oap-config 4-18, 4-30  
Common Language Location Identifier 1-12  
compliance, regulatory 1-8  
conventions  
document 1-19  
Customer Care Center 1-10, 1-12  
Customer Service Report 1-12  
Customer Service Request 1-10

## D

DCM  
change features, chg-feat 3-71, 6-48  
disconnect power

- fan assembly 6-42
- displaying
  - OAP configuration 4-18, 4-30
  - terminal configuration, rtrv-trm 4-16, 4-28
- document
  - acronyms 1-20
  - conventions 1-19
  - references 1-19

**E**

- emergency response 1-12
- EOAP 3-57
  - alarms 4-20
  - checksums and alarms 4-14
  - overview 1-2
  - serial and Ethernet cabling diagram 6-83
  - shelf 3-20
  - update configuration 4-23, 4-34
  - updating 4-13
- EOAP A
  - shutting down 6-12, 6-32, 6-35, 6-40, 6-59, 6-75, 6-84
- EOAP power cables 3-36
- EOAP provisioning
  - installing UAL software 4-4
- EOAP shelf
  - flange 6-20
  - how to remove 6-18
  - mounting brackets 6-20
  - tools and equipment 3-12, 3-19, 3-57, 3-61, 3-62
- equipment required
  - initial installation 3-20
- Ethernet 7-21
- external tooth washer 3-13

**F**

- fan power cables
  - install 3-39
- fan support 3-11
- fan switch
  - set to OFF 3-66, 3-72, 6-49
  - set to ON 6-47
- features
  - fan 3-71, 6-48
- finish cables

- backplane 3-50
- flange
  - EOAP shelf 6-20
- FORCE parameter
  - chg-oap-config 4-12
- frame for EOAP shelf 3-20
- frame rail 6-18
- fuse panel 7-3
- fuse positions
  - EOAP 7-3

**H**

- hard drive card
  - replace 6-52
  - troubleshoot 7-5
- hard drive jumper settings 7-7
- Hardware Repair and Return 1-13
- hardware return 1-13
- how to remove EOAP shelf 6-18

**I**

- initial implementation 4-4
- install
  - card into EOAP shelf 6-22
  - clock connection cable 3-41
  - clock in/out cable 3-40
  - cooling duct 3-17
  - fan power cables 3-39
  - mounting brackets 3-20
  - replacement fan assembly 6-44
  - terminal cables 3-45
- installing
  - UAL software 4-4

**L**

- LEDs 7-3
  - BM (backplane monitor) 7-20
  - drive power 7-5
  - fan assembly
    - Active 3-67, 3-72, 6-49
    - Alarm 3-67, 3-72, 6-49
    - Minor 3-67, 3-72, 6-49

**M**

- manual
  - related publications 1-2

## Index

Method A  
  update EOAP 4-23, 4-35  
Method B  
  update EOAP 4-25, 4-36  
mounting brackets  
  EOAP shelf 6-20

## N

network 7-21

## O

OAP 3-5  
OAP parameter  
  chg-oap-config 4-12  
OOS-MT-DSBLD state 4-7, 4-18, 4-30

## P

P/N 502-0040-01 3-24  
P/N 830-0657-xx 3-41  
P/N 830-0709-xx 3-29  
P/N 850-0488-xx 3-41  
parameter  
  AIPADDR  
    chg-oap-config 4-11  
  ANAME  
    chg-oap-config 4-11  
  ANMASK  
    chg-oap-config 4-11  
  AROUTER  
    chg-oap-config 4-11  
  BIPADDR  
    chg-oap-config 4-11  
  BNAME  
    chg-oap-config 4-11  
  BNMASK  
    chg-oap-config 4-11  
  BROUTER  
    chg-oap-config 4-11  
  CFG  
    chg-oap-config 4-11  
  FORCE  
    chg-oap-config 4-12  
  OAP  
    chg-oap-config 4-12  
  TRM  
    chg-trm 4-4  
  TYPE

  chg-trm 4-4  
performance impact  
  act-oap-config parameters 4-13  
port labels and functions 2-7, 3-29  
power cable  
  CD-ROM drive  
    troubleshoot 7-5  
  hard drive  
    troubleshoot 7-5  
power supply card  
  troubleshoot 7-4, 7-17  
power up  
  EOAP 6-31  
probe-scsi 7-10  
Problem-Major 1-11  
Problem-Minor 1-11  
problems  
  power source  
    no cPCI power 7-4  
    no drive power 7-5  
    no fan power 7-4  
  processor card  
    LEDs normal but no Ethernet access  
      7-21  
    RUN LED is GREEN but ports not  
      functioning 7-20  
  scsi/drive 7-6  
    drives detected but system will not  
      boot 7-10  
    system has power but will not boot  
      7-6  
  serial card 7-22  
    ports 1 or 2 not working 7-24  
    ports 3,4,5, or 6 not working 7-22  
    ports 7,8,9, or 10 not working 7-23  
procedure  
  Configuring the EOAP from the System  
    Terminal 4-11  
processor card 7-21  
  troubleshoot 7-4, 7-19

## R

reconnect cables to EOAP shelf 6-24  
references  
  document 1-19  
regulatory compliance 1-8  
remove  
  cables from EOAP shelf 6-14

- cards from EOAP shelf 6-17
- EOAP card cage 6-18
- fan assembly 6-42
- grill and filter 3-14
- Repair and Return Shipping Instructions 1-16
- replace
  - fan assembly 6-41
  - fan filter and grill 6-46
  - hard drive card 6-51, 6-52
  - power supply card 6-66
  - processor card 6-73
- replacing
  - serial I/O card (EOAP) 6-85
- rept-stat-seas 6-12, 6-32, 6-52, 6-73, 6-75
- Response 1-12
- return shipment 1-17
- Returning a Crate 1-16
- route
  - clock connection cable 3-42
  - terminal cable 3-46
- rtrv-oap-config command 4-18, 4-30

**S**

- screws 3-13
- serial card 7-21, 7-22
- serial I/O card (EOAP) 6-85
  - replacement 6-85
- site requirements 1-18
- stop bits 4-7, 6-11

**T**

- TDM 4-4
- terminal cables
  - install 3-45
  - route 3-46
- terminal configuration
  - displaying, rtrv-trm 4-16, 4-28
- test
  - fan operation 3-71, 6-48
- tools and equipment
  - EOAP shelf 3-12, 3-19, 3-57, 3-61, 3-62
- transition card 7-23
- TRM parameter
  - chg-trm 4-4
- troubelshoot
  - power cable

- hard drive 7-5
- troubleshoot
  - CD-ROM drive
    - power cable 7-5
  - hard drive card 7-5
  - power supply card 7-4, 7-17
  - processor card 7-4, 7-19
- TYPE parameter
  - chg-trm 4-4

**U**

- Update EOAP
  - Method A 4-23, 4-35
  - Method B 4-25, 4-36
- update EOAP configuration 4-23, 4-34
- updating
  - EOAP 4-13

**V**

- VT-520 7-21