

**Oracle® Communications
EAGLE**

G-Flex C7 Relay User's Guide

E54352-01 Revision A

July 2014

Oracle® Communications G-Flex C7 Relay User's Guide

Copyright © 1993, 2014,

Oracle and/or its affiliates. All rights reserved.

This software and related documentation are provided under a license agreement containing restrictions on use and disclosure and are protected by intellectual property laws. Except as expressly permitted in your license agreement or allowed by law, you may not use, copy, reproduce, translate, broadcast, modify, license, transmit, distribute, exhibit, perform, publish, or display any part, in any form, or by any means. Reverse engineering, disassembly, or decompilation of this software, unless required by law for interoperability, is prohibited.

The information contained herein is subject to change without notice and is not warranted to be error-free. If you find any errors, please report them to us in writing.

If this is software or related documentation that is delivered to the U.S. Government or anyone licensing it on behalf of the U.S. Government, the following notice is applicable:

U.S. GOVERNMENT END USERS: Oracle programs, including any operating system, integrated software, any programs installed on the hardware, and/or documentation, delivered to U.S. Government end users are "commercial computer software" pursuant to the applicable Federal Acquisition Regulation and agency-specific supplemental regulations. As such, use, duplication, disclosure, modification, and adaptation of the programs, including any operating system, integrated software, any programs installed on the hardware, and/or documentation, shall be subject to license terms and license restrictions applicable to the programs. No other rights are granted to the U.S. Government.

This software or hardware is developed for general use in a variety of information management applications. It is not developed or intended for use in any inherently dangerous applications, including applications that may create a risk of personal injury. If you use this software or hardware in dangerous applications, then you shall be responsible to take all appropriate fail-safe, backup, redundancy, and other measures to ensure its safe use. Oracle Corporation and its affiliates disclaim any liability for any damages caused by use of this software or hardware in dangerous applications.

Oracle and Java are registered trademarks of Oracle and/or its affiliates. Other names may be trademarks of their respective owners.

Intel and Intel Xeon are trademarks or registered trademarks of Intel Corporation. All SPARC trademarks are used under license and are trademarks or registered trademarks of SPARC International, Inc. AMD, Opteron, the AMD logo, and the AMD Opteron logo are trademarks or registered trademarks of Advanced Micro Devices. UNIX is a registered trademark of The Open Group.

This software or hardware and documentation may provide access to or information on content, products, and services from third parties. Oracle Corporation and its affiliates are not responsible for and expressly disclaim all warranties of any kind with respect to third-party content, products, and services. Oracle Corporation and its affiliates will not be responsible for any loss, costs, or damages incurred due to your access to or use of third-party content, products, or services.

Table of Contents

| | |
|---|-----------|
| Chapter 1: Introduction..... | 7 |
| Overview..... | 8 |
| Scope and Audience..... | 8 |
| Manual Organization..... | 8 |
| Documentation Admonishments..... | 9 |
| My Oracle Support (MOS)..... | 10 |
| Emergency Response..... | 10 |
| Related Publications..... | 10 |
| Documentation Availability, Packaging, and Updates..... | 11 |
| Locate Product Documentation on the Oracle Technology Network Site..... | 11 |
| | |
| Chapter 2: G-Flex C7 Relay (G-Flex) Feature..... | 13 |
| Introduction..... | 14 |
| G-Flex Feature Description..... | 14 |
| Number Conditioning..... | 15 |
| G-Flex Call Flows..... | 16 |
| G-Flex Relay Function Description..... | 18 |
| MTP-Routed SCCP Message Processing..... | 24 |
| G-Flex Configuration Options..... | 25 |
| DigitAction Expansion..... | 27 |
| G-Flex SCCP Service Re-Route Capability..... | 28 |
| G-Flex in an ANSI Environment..... | 31 |
| G-Flex as a "Stand-Alone" Node..... | 32 |
| Assumptions/Limitations..... | 32 |
| Hardware Requirements..... | 33 |
| MPS/EPAP Platform..... | 33 |
| | |
| Chapter 3: G-Flex MAP Layer Routing (G-Flex MLR) Feature..... | 34 |
| G-Flex MAP Layer Routing..... | 35 |
| Limitations..... | 38 |
| | |
| Chapter 4: EAGLE 5 ISS Commands..... | 39 |

| | |
|---|-----------|
| EAGLE 5 ISS Commands..... | 40 |
| Chapter 5: G-Flex Feature Configuration..... | 42 |
| Introduction..... | 43 |
| EPAP Provisioning Blacklist..... | 43 |
| EPAP Entity Provisioning..... | 44 |
| System Prerequisites..... | 44 |
| G-Flex Feature Prerequisites..... | 45 |
| G-Flex MAP Layer Routing Feature Prerequisites..... | 45 |
| G-Flex and G-Flex MLR Configuration Procedure..... | 46 |
| Configure the System for HLR Destinations..... | 48 |
| Enable and Turn on the G-Flex Feature..... | 49 |
| Provision STPOPTS Options for G-Flex..... | 50 |
| Provisioning the G-Flex Service Selector..... | 51 |
| Adding a G-Flex Service Selector..... | 51 |
| Removing a Service Selector..... | 52 |
| Changing an Existing Service Selector to a G-Flex Service Selector..... | 53 |
| Provision the STPOPTS ANSIGFLEX Option..... | 54 |
| Provisioning the GSMOPTS Options..... | 55 |
| Provision the SCCP Service State and Point Codes..... | 57 |
| Enable and Turn on the G-Flex MLR Feature..... | 57 |
| Chapter 6: Measurements..... | 60 |
| G-Flex Measurements..... | 61 |
| Chapter 7: Maintenance..... | 63 |
| G-Flex-Related Alarms..... | 64 |
| G-Flex-Related UIMs..... | 64 |
| Maintenance Commands..... | 66 |
| rept-stat-sccp..... | 68 |
| Debug Commands..... | 68 |
| Status Reporting and Problem Identification..... | 69 |
| EPAP Status and Alarm Reporting..... | 71 |
| Hourly Maintenance Report..... | 72 |
| Glossary..... | 73 |

List of Figures

| | |
|--|----|
| Figure 1: E.214 (E.212) Routing Example - Location Updating..... | 17 |
| Figure 2: Mobile Terminated Call..... | 18 |
| Figure 3: G-Flex in SCCP..... | 19 |

List of Tables

| | |
|---|----|
| Table 1: Admonishments..... | 9 |
| Table 2: G-Flex Relay Data Combinations..... | 20 |
| Table 3: National/Local Numbers to International Numbers Conversion Logic..... | 20 |
| Table 4: G-Flex Relay Forwarding Message: MTP Portion..... | 22 |
| Table 5: G-Flex Relay Forwarding Message: SCCP Portion..... | 23 |
| Table 6: GSMOPTS Configuration Options for G-Flex and G-Flex MLR..... | 25 |
| Table 7: DigitAction Applications..... | 27 |
| Table 8: G-Flex SCCP Re-Route Message Handling Summary..... | 29 |
| Table 9: G-Flex LIM Card Re-Route Message Handling Summary..... | 30 |
| Table 10: MAP Operations Processed by G-Flex MLR..... | 35 |
| Table 11: GSMOPTS Configuration Options MAPLYRRTGON and MAPLYRRTGOFF..... | 36 |
| Table 12: Commands used for the G-Flex and G-Flex MLR Features..... | 40 |
| Table 13: System Prerequisites..... | 44 |
| Table 14: G-Flex Feature Prerequisites..... | 45 |
| Table 15: G-Flex MAP Layer Routing Feature Prerequisites..... | 46 |
| Table 16: G-Flex MSU Measurements..... | 61 |
| Table 17: STP Daily and Day-to-Hour Measurements that include Counts for G-Flex MSUs..... | 62 |
| Table 18: G-Flex-Related Alarms..... | 64 |
| Table 19: G-Flex UIMs..... | 65 |
| Table 20: Maintenance Commands..... | 66 |
| Table 21: Status Reporting for EPAP-Related Features..... | 69 |

Chapter 1

Introduction

Topics:

- *Overview.....8*
- *Scope and Audience.....8*
- *Manual Organization.....8*
- *Documentation Admonishments.....9*
- *My Oracle Support (MOS).....10*
- *Emergency Response.....10*
- *Related Publications.....10*
- *Documentation Availability, Packaging, and Updates.....11*
- *Locate Product Documentation on the Oracle Technology Network Site.....11*

This chapter contains general information about the G-Flex documentation, the organization of this manual, and how to get technical assistance. This chapter provides a brief description of the G-Flex feature of the Oracle Communications EAGLE. The chapter also includes the scope, audience, and organization of the manual; how to find related publications; and how to contact Oracle for assistance.

Overview

This manual describes the configuration and operation of the G-Flex[®] C7 Relay (G-Flex) feature of the Oracle Communications EAGLE. The G-Flex feature enables efficient Home Location Register (HLR) management in ITU networks, ANSI networks, Global System for Mobile communications (GSM) networks, and IS-41 networks. G-Flex optimizes the use of subscriber numbers and number ranges by providing a logical link between any MSISDN number or IMSI and an HLR. This arrangement allows subscribers to be moved easily from one HLR to another.

The following G-Flex-related functions are described in this manual:

- The G-Flex Relay function, which provides enhancements to GTT Processing such as number conditioning, discrimination between G-Flex Relay and GTT processing, and outgoing CdPA modification. See *G-Flex Relay Function Description*.
- *DigitAction Expansion*, which provides flexible rules for formatting the SCCP CdPA GTA field.
- *G-Flex SCCP Service Re-Route Capability*, which provides the ability to re-route the traffic from one EAGLE to other G-Flex nodes within an operator's network, and inform the originating nodes to re-route the G-Flex service-related traffic to other G-Flex service nodes.
- *G-Flex in an ANSI Environment*, which increases the DSM card transaction capacity from 850 TPS to 1700 TPS for G-Flex in an ANSI system.

G-Flex is optional on EAGLE, and can be turned on, but not off, using a feature part number and a feature access key. G-Flex and North American Local Number Portability (LNP) are mutually exclusive on an EAGLE node, unless the Dual ExAP Configuration feature is enabled. The Global Title Translations (GTT) feature is required for operation of the G-Flex feature.

This manual also describes the use of the G-Flex MAP Layer Routing feature to obtain subscriber digits from either the SCCP layer or MAP layer of a message for RTDB lookup.

Scope and Audience

This manual is intended for anyone responsible for installing, maintaining, and using the G-Flex feature of Oracle Communications EAGLE. Users of this manual and the other manuals in the EAGLE family of documents must have a working knowledge of telecommunications and network installations.

Manual Organization

This document is organized into the following chapters:





- *Introduction* contains general information about the G-Flex documentation, the organization of this manual, and how to get technical assistance.
- *G-Flex C7 Relay (G-Flex) Feature* provides a functional description of G-Flex, including the G-Flex SCCP Service Re-Route Capability and use of G-Flex in an ANSI system.

- [G-Flex MAP Layer Routing \(G-Flex MLR\) Feature](#) describes the use of the G-Flex MAP Layer Routing feature.
- [EAGLE 5 ISS Commands](#) describes the EAGLE commands that can be used for G-Flex feature configuration functions.
- [G-Flex Feature Configuration](#) provides procedures for configuring the G-Flex feature, the G-Flex SCCP Service Re-Route Capability, ANSI G-Flex, and the G-Flex MAP Layer Routing feature for use in EAGLE.
- [Measurements](#) describes G-Flex-related measurements, measurements reports, and methods of collection.
- [Maintenance](#) describes G-Flex-related UAMs and UIMs; commands that can be used for maintenance functions; and status and alarm reporting for EAGLE, Oracle Communications EAGLE Application Processor Provisioning (EPAP), Service Module cards, services, and the local subsystem.

Documentation Admonishments

Admonishments are icons and text throughout this manual that alert the reader to assure personal safety, to minimize possible service interruptions, and to warn of the potential for equipment damage.

Table 1: Admonishments

| Icon | Description |
|--|--|
|  DANGER | Danger: (This icon and text indicate the possibility of <i>personal injury</i> .) |
|  WARNING | Warning: (This icon and text indicate the possibility of <i>equipment damage</i> .) |
|  CAUTION | Caution: (This icon and text indicate the possibility of <i>service interruption</i> .) |
|  TOPPLE | Topple: (This icon and text indicate the possibility of <i>personal injury and equipment damage</i> .) |

My Oracle Support (MOS)

MOS (<https://support.oracle.com>) is your initial point of contact for all product support and training needs. A representative at Customer Access Support (CAS) can assist you with MOS registration.

Call the CAS main number at **1-800-223-1711** (toll-free in the US), or call the Oracle Support hotline for your local country from the list at <http://www.oracle.com/us/support/contact/index.html>. When calling, make the selections in the sequence shown below on the Support telephone menu:

1. Select **2** for New Service Request
2. Select **3** for Hardware, Networking and Solaris Operating System Support
3. Select **2** for Non-technical issue

You will be connected to a live agent who can assist you with MOS registration and provide Support Identifiers. Simply mention you are a Tekelec Customer new to MOS.

MOS is available 24 hours a day, 7 days a week, 365 days a year.

Emergency Response

In the event of a critical service situation, emergency response is offered by the Customer Access Support (CAS) main number at **1-800-223-1711** (toll-free in the US), or by calling the Oracle Support hotline for your local country from the list at <http://www.oracle.com/us/support/contact/index.html>. The emergency response provides immediate coverage, automatic escalation, and other features to ensure that the critical situation is resolved as rapidly as possible.

A critical situation is defined as a problem with the installed equipment that severely affects service, traffic, or maintenance capabilities, and requires immediate corrective action. Critical situations affect service and/or system operation resulting in one or several of these situations:

- A total system failure that results in loss of all transaction processing capability
- Significant reduction in system capacity or traffic handling capability
- Loss of the system's ability to perform automatic system reconfiguration
- Inability to restart a processor or the system
- Corruption of system databases that requires service affecting corrective actions
- Loss of access for maintenance or recovery operations
- Loss of the system ability to provide any required critical or major trouble notification

Any other problem severely affecting service, capacity/traffic, billing, and maintenance capabilities may be defined as critical by prior discussion and agreement with Oracle.

Related Publications

For information about additional publications that are related to this document, refer to the *Related Publications Reference* document, which is published as a separate document on the Oracle Technology

Network (OTN) site. See [Locate Product Documentation on the Oracle Technology Network Site](#) for more information.

Documentation Availability, Packaging, and Updates

Tekelec provides documentation with each system and in accordance with contractual agreements. For General Availability (GA) releases, Tekelec publishes a complete EAGLE 5 ISS documentation set. For Limited Availability (LA) releases, Tekelec may publish a documentation subset tailored to specific feature content or hardware requirements. Documentation Bulletins announce a new or updated release.

The Tekelec EAGLE 5 ISS documentation set is released on an optical disc. This format allows for easy searches through all parts of the documentation set.

The electronic file of each manual is also available from the [Tekelec Customer Support](#) site. This site allows for 24-hour access to the most up-to-date documentation, including the latest versions of Feature Notices.

Printed documentation is available for GA releases on request only and with a lead time of six weeks. The printed documentation set includes pocket guides for commands and alarms. Pocket guides may also be ordered separately. Exceptions to printed documentation are:

- Hardware or Installation manuals are printed without the linked attachments found in the electronic version of the manuals.
- The Release Notice is available only on the Customer Support site.

Note: Customers may print a reasonable number of each manual for their own use.

Documentation is updated when significant changes are made that affect system operation. Updates resulting from Severity 1 and 2 Problem Reports (PRs) are made to existing manuals. Other changes are included in the documentation for the next scheduled release. Updates are made by re-issuing an electronic file to the customer support site. Customers with printed documentation should contact their Sales Representative for an addendum. Occasionally, changes are communicated first with a Documentation Bulletin to provide customers with an advanced notice of the issue until officially released in the documentation. Documentation Bulletins are posted on the Customer Support site and can be viewed per product and release.

Locate Product Documentation on the Oracle Technology Network Site

Oracle customer documentation is available on the web at the Oracle Technology Network (OTN) site, <http://docs.oracle.com>. You do not have to register to access these documents. Viewing these files requires Adobe Acrobat Reader, which can be downloaded at www.adobe.com.

1. Log into the Oracle Technology Network site at <http://docs.oracle.com>.
2. Under **Applications**, click the link for **Communications**.
The **Oracle Communications Documentation** window opens with Tekelec shown near the top.
3. Click **Oracle Communications Documentation for Tekelec Products**.
4. Navigate to your Product and then the Release Number, and click the **View** link (the **Download** link will retrieve the entire documentation set).

5. To download a file to your location, right-click the PDF link and select **Save Target As**.

Chapter 2

G-Flex C7 Relay (G-Flex) Feature

Topics:

- [Introduction.....14](#)
- [G-Flex Feature Description.....14](#)
- [Hardware Requirements.....33](#)
- [MPS/EPAP Platform.....33](#)

This chapter describes the G-Flex C7 Relay (G-Flex) feature and the following related functions:

- DigitAction Expansion
- G-Flex SCCP Service Re-Route Capability
- G-Flex in an ANSI environment (ANSI G-Flex)

The chapter includes an overview of the Oracle Communications EAGLE Application Processor Provisioning (EPAP). EPAP provides the Real Time Database (RTDB) that is used in the database lookup functions.

Introduction

This chapter describes the G-Flex C7 Relay (G-Flex) feature and the following related functions:

- The G-Flex Relay function
- DigitAction Expansion
- G-Flex SCCP Service Re-Route Capability
- G-Flex in an ANSI environment

The EPAP Provisioning Blacklist feature is described in [EPAP Provisioning Blacklist EPAP Provisioning Blacklist](#) and in [EPAP Administration Guide](#)

G-Flex Feature Description

In today's mobile networks, subscribers are assigned to Home Location Registers (HLRs) and AuCs (Authentication Centers) in blocks or ranges of subscriber numbers. These ranges are used by MSCs (Mobile Switching Centers) to route many types of signalling messages to HLRs/AuCs. In this document, the term HLR is used to include AuC, as applicable.

G-Flex allows an operator to flexibly assign individual subscribers to HLRs and route signaling messages accordingly, based on subscriber numbering.

The G-Flex C7 Relay node is located in the operator's C7/SS7 network between the MSCs and HLRs. It can also serve as the direct interface to other networks.

There are several types of numbers that identify subscribers, which are assigned by MSCs to HLR/AuCs using this range mechanism:

- MSISDN (Mobile Station International Integrated Services Digital Network) numbers, which use numbering plan E.164
- IMSI (International Mobile Subscriber Identity) numbers, which use numbering plan E.212
- MIN (Mobile Identification Number), which uses the E.164 numbering plan
- MDN (Mobile Directory Number), which uses the E.164 numbering plan

G-Flex optimizes the use of subscriber numbers and number ranges by providing a logical link between any MSISDN number or IMSI, and an HLR.

- Subscribers can be easily moved from one HLR to another.
- Each HLR can be filled to 100% of its capacity by allowing subscriber number ranges to be split over different HLRs and individual subscriber numbers to be assigned to any HLR.
- Subscriber number routing data is not required to be maintained in all MSCs in the network.

G-Flex is designed to alleviate problems in areas such as network load balancing and efficient use of HLR capacity. Today's rigid scheme for assigning subscribers to HLRs leads to several inefficiencies for network operators, as described in the following examples:

- When IMSI numbers, which identify the SIM (Subscriber Identity Module), get lost or are otherwise out of service, “holes” sometimes open in the IMSI ranges. These holes result in HLR capacity that cannot be used because switches will not be routing messages using those lost numbers anymore.
- In many cases, subscribers are “split” across multiple HLRs, as their IMSI range can point to a different HLR than their MSISDN range. Operators must take special steps to ensure that calls are not mishandled.
- With the advent of MNP (Mobile Number Portability), the MSISDN no longer indicates the subscription network. This leads to holes in the MSISDN ranges that address HLRs. As in the case with IMSIs, these MSISDN holes result in HLR capacity that cannot be used by existing MSC routing schemes.
- With the advent of MNP, operators need to handle message routing based on MSISDNs that are imported to the network from another operator and do not fit into the existing range mechanism.
- Prepaid service may result in the allocation of a large block of IMSIs to an HLR, many of which may not be put in service immediately.
- Corporate clients may reserve a large block of numbers that must be assigned to an HLR. Many of these may not be used immediately, or ever.

Number Conditioning

Incoming SCCP CdPAs (Called Party Numbers) destined for G-Flex processing are conditioned as follows to fit the RTDB lookup requirements where possible:

- If the G-Flex GTT selectors available in the incoming message match an entry in the Selector table, then the service Numbering Plan from the Selector table entry uses the CdPA Numbering Plan. Further conditioning is applied based on the CdPA Numbering Plan.
- If the G-Flex GTT selectors available in the incoming message match an entry in the Selector table, then the service Nature of Address from the Selector table entry uses the CdPA Nature of Address. Further conditioning is applied based on the CdPA Nature of Address.
- If the Nature of Address is National (Significant), the default CC (country code for E.164 or E.214) or default MCC (mobile country code for E.212) is prepended to the number for RTDB look up. The default country code to be used by the EAGLE 5 ISS must be previously provisioned in the GSMOPTS table. If not, a UIM (Unsolicited Information Message) is issued, and the message falls through to GTT.
- If the Nature of Address is Subscriber, the default CC + default NC (network code for E.164 or E.214) or default MCC + default MNC (for E.212) are prepended to the number. The default codes to be used by the EAGLE 5 ISS must be previously provisioned in the GSMOPTS table. If not, a UIM is issued, and the message falls through to GTT.
- If the Numbering Plan is E.214, the CC + NC part of the number is replaced with its corresponding MCC + MNC from the provisioned conversion data. If no matching CC + NC has been provisioned, a UIM is issued, and the message falls through to GTT.

Numbers with fewer than 5 digits after the conditioning are not processed by G-Flex. A UIM is issued, and the message falls through to GTT.

Numbers with more than 15 digits after the conditioning are not processed by G-Flex. A UIM is issued, and the message falls through to GTT.

G-Flex Call Flows

Several types of subscriber numbers can be used as a basis for routing messages to HLRs: IMSI, MSISDN, MIN, and MDN.

G-Flex handle the two types of IMSI routing:

- IMSI routing that uses the actual IMSI (an E.212 number)
- IMSI routing that uses the Mobile Global Title (MGT), which is an E.214 number derived from the IMSI

G-Flex also handles the MSISDN/MIN/MDN cases, which use the E.164 numbering plan. The call flows in this section address these three cases.

The call flows in this section show only one possible scenario for how messages are routed in the network and where various stages of GTT are performed. G-Flex C7 Relay may perform intermediate or final GTT and/or replace the SCCP (Signaling Connection Control Part) CdPA (Called Party Address) with the HLR entity address, depending on the message received and provisioned data. All call flows here assume that G-Flex C7 Relay is integrated with the EAGLE 5 ISS.

Note: In GSM networks, each network entity (for example, MSC, HLR, VLR [Visitor Location Register]) is identified by an E.164 entity address. GSM networks also route messages based on E.164 entity addresses when those addresses are known by the sender. While the routing of these messages must also be handled by G-Flex C7 Relay, this function is not considered to be a core part of G-Flex. Because these numbers are not expected to be populated in the G-Flex data, messages routed using these addresses should fall through to normal or enhance) GTT (Global Title Translation). Therefore, call flows for this type of routing are not described here.

MGT (E.214) Routing

The partial Update Location procedure shown in [Figure 1: E.214 \(E.212\) Routing Example - Location Updating](#) is an example of E.214 mobile global title routing. MGT is employed in situations where the E.164 address of the receiving node (labeled HLRB) is not yet known by the sending node (labeled VLRA).

In order to update information about the subscriber's location, VLRA sends a MAP (Mobile Application Part) Update_Location message to the G-Flex Relay (possibly through a Gateway Mobile Switching Center).

The steps in [Figure 1: E.214 \(E.212\) Routing Example - Location Updating](#) are cross-referenced in the following procedure.

1. The message is received at the G-Flex Relay. Global title information triggers G-Flex processing. Because the SCCP CdPA contains an E.214 number, G-Flex first converts the E.214 number to an international E.212 number before searching the EAGLE 5 ISS Real Time Database (RTDB) with the E.212 number (Step 1). G-Flex also handles the case where an E.212 number is received in the SCCP CdPA. In this case, the database is searched directly using the E.212 number.
2. G-Flex finds a match with HLR GT information and routes the message to the designated DPC (HLRB) (Step 2).

3. HLRB responds to VLRA with an Update_Location ack. This message has the E.164 address of VLRA in the SCCP CdPA and is routed by normal or enhanced GTT, not G-Flex (Step 3).
4. The message is relayed to VLRA (Step 4).

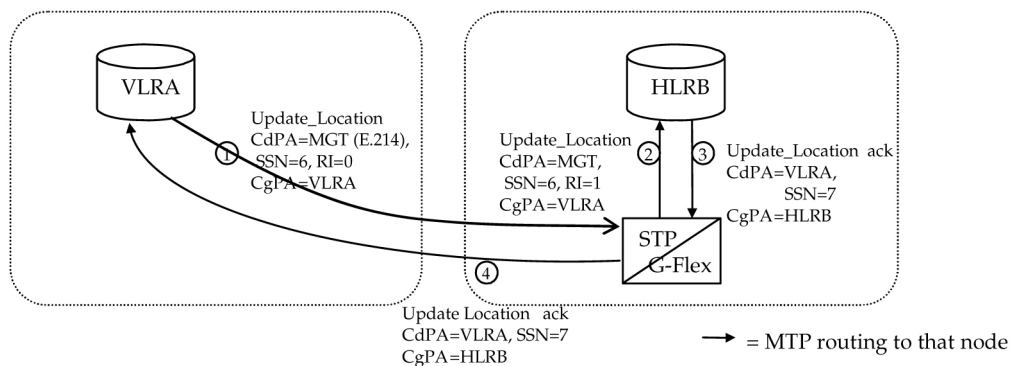

Figure 1: E.214 (E.212) Routing Example - Location Updating

There are other MAP messages from VLR to HLR that also fall into this category of requiring E.214 global title routing. All of these messages are handled the same way by G-Flex, using the process described above.

IMSI (E.212) Routing

G-Flex processing for a message routed with an E.212 number in the SCCP CdPA GTA (Global Title Address) is essentially the same as the processing for a message routed with an E.214 number. The only difference is that the number does not have to be converted to E.212 (since it is already E.212) before doing the database lookup. Therefore, those call flows are not shown here.

MSISDN/MIN/MDN (E.164) Routing

A mobile terminated call results in the GMSCB (Gateway Mobile Switching Center) querying the HLR through the use of the called number as a GTA. G-Flex is used to locate the appropriate HLR. The partial mobile terminated call procedure shown in [Figure 2: Mobile Terminated Call](#) is an example of MSISDN global title SCCP addressing. This applies to MIN and MDN routing numbers as well.

The steps in [Figure 2: Mobile Terminated Call](#) are cross-referenced in the following procedure.

1. A call is originated and an IAM (Initial Address Message) is sent from the originating network to the subscription network (Step 1).
2. Digit analysis at GMSCB detects a mobile terminated call to a mobile station and generates a MAP Send_Routing_Info (SRI) message to the G-Flex Relay (Step 2).
3. The EAGLE 5 ISS receives the message. Global title information triggers G-Flex processing. Since the SCCP CdPA contains an E.164 number, G-Flex searches the RTDB with the E.164 number, which must be converted to an international number if it is not one already. The G-Flex finds a match with HLR GT information and routes the message to the designated DPC (HLRB) (Step 3).
4. HLRB responds to GMSCB with an SRI ack. This message has the E.164 address of GMSCB in the SCCP CdPA, and is routed by normal or enhanced GTT, not G-Flex (Step 4).
5. The message is relayed to GMSCB (Step 5).

6. GMSCB sends an IAM containing the MSRN (Mobile Station Roaming Number) to the visited network (Step 6).

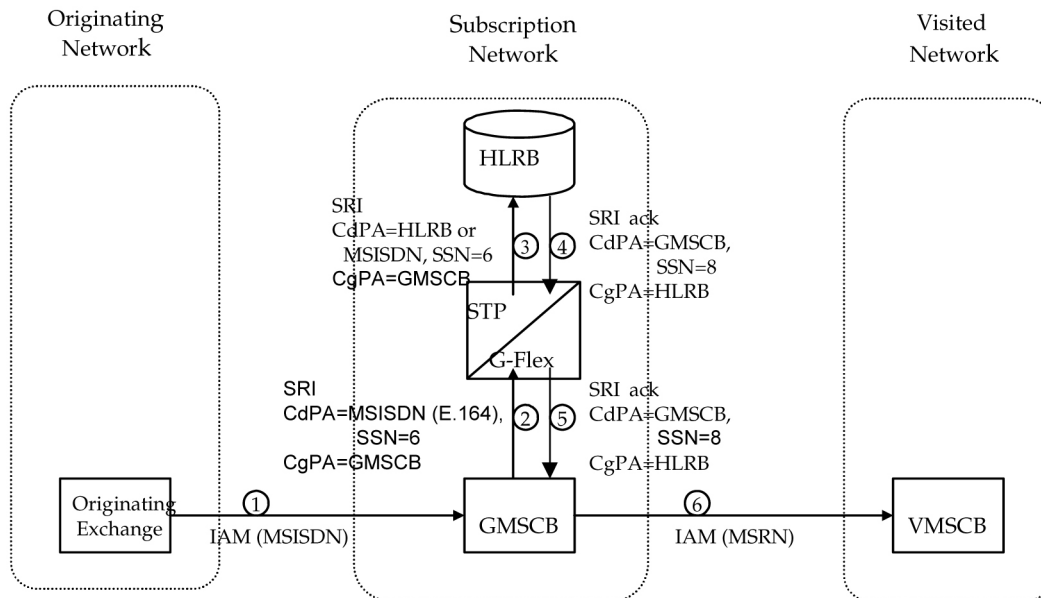

Figure 2: Mobile Terminated Call

Other MAP messages that are routed using MSISDN/MIN/MDN global title routing to an HLR are handled the same way by G-Flex. This includes mobile terminated short messages.

G-Flex Relay Function Description

The G-Flex Relay Function (G-Flex Relay) provides the following enhancements to EAGLE 5 ISS GTT:

- **Increased number of translations** – The GTT limit is 270,000 total translations. With G-Flex Relay, the number is millions. However, G-Flex Relay translations are only from international MSISDNs and IMSIs to HLRs.
- **Number conditioning** – Because the RTDB stores MSISDNs and IMSIs as international numbers and does not store MGTs, G-Flex provides the capability to condition incoming numbers to be international MSISDNs or IMSIs for the database look up.
- **Provides discrimination of messages that need its functionality** – Because G-Flex is used only for translating to HLRs, it provides a method to identify which messages are processed by G-Flex Relay and which by GTT. This is provided using a G-Flex Service Selector table that defaults back to the GTT Selector table if a match is not found, and by providing SSN-based discrimination.
- **Variable number of digits** – There is no fixed number of digits for MSISDNs or IMSIs. For example, a 12-digit MSISDN can coexist with a 15-digit one. However, the number of digits of the stored numbers must be between 5 and 15.
- **Replacement of GT with entity address** – The ability to set the outgoing CdPA GT (NP, NAI, ES, GTAI) to the HLR international entity number is provided.

Figure 3: *G-Flex in SCCP* shows the basic functioning of SCCP, with the parts for G-Flex in bold.

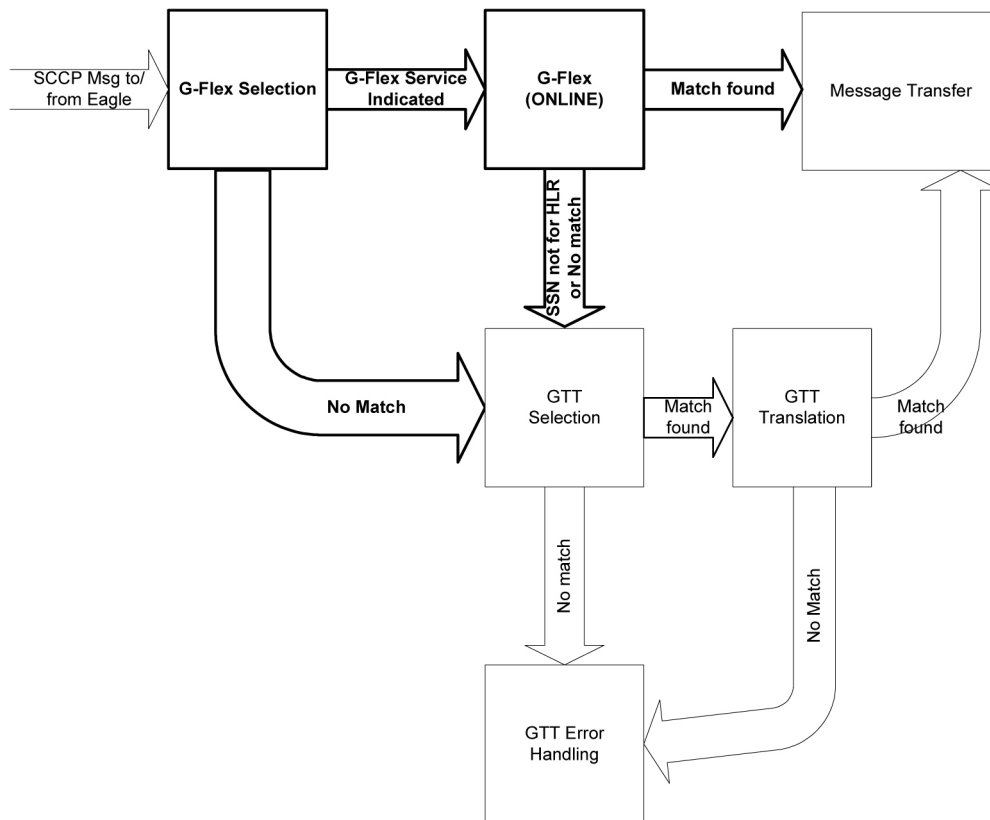

Figure 3: G-Flex in SCCP

In order to keep the diagram simple, the only error conditions shown are the no-match cases for G-Flex and G-TT selectors and translations. G-Flex has its own error handling for some cases that issues UIMs and peg measurements appropriately before letting the MSU fall through to G-TT translation. Also, there are error conditions in G-TT selection, G-TT translation, and message transfer that are handled by G-TT error handling.

G-Flex Relay is performed in the following stages.

1. The message arrives at EAGLE 5 ISS Route-on-GT. The EAGLE 5 ISS decodes the SCCP portion and uses the data to perform G-Flex selection based on the CdPA GT fields other than the ES and GTAI. The result of this selection provides two pieces of data, identification of the NP and NAI for G-Flex and a G-Flex Service Indicator. The Service Indicator is G-Flex if G-Flex Relay is required. If a G-Flex selector does not match the incoming GT fields, then G-TT selection is attempted. It is possible that G-Flex and G-TT selectors will not match the incoming GT fields. In this case, G-TT error handling is used.
2. If stage 1 indicates that G-Flex Relay is required and if the message is not a UDTS-generated by the EAGLE 5 ISS, the EAGLE 5 ISS performs SSN-based discrimination. If the G-Flex service state is ONLINE, then step 3 is performed. Otherwise, G-Flex SCCP Service Re-Route is performed.
3. The conditioned number is looked up in the RTDB.
4. If the number is found, the translation data for the number is used to alter and route the message.
5. If G-Flex Relay is not required, or the number is not found in the RTDB, the set of G-TT translations is used for translation.

Table 2: G-Flex Relay Data Combinations lists possible combinations for G-Flex selector and G-Flex data provisioning, and the resulting action of G-Flex Relay.

Table 2: G-Flex Relay Data Combinations

| G-Flex Selector Matches Incoming GT | Number in RTDB | EAGLE 5 ISS Action |
|-------------------------------------|----------------|---------------------|
| No | N/A | GTT used |
| Yes | No | Fall-through to GTT |
| Yes | Yes | G-Flex translation |

G-Flex Relay is divided into the following subtasks:

- Conversion of national/local numbers to international numbers
- Conversion of E.214 MGT to E.212 international IMSI
- RTDB lookup
- Message forwarding
- Error handling

Conversion of National/Local Numbers to International Numbers

G-Flex stores international DNs and IMSIs in the RTDB. SCCP CdPA numbers may need to be converted to international numbers in order to do an RTDB lookup. When a message needs G-Flex Relay and has either a national (significant) number or Subscriber Number as the Service NAI, then the national/local to international number conversion is triggered. G-Flex uses the SCCP CdPA GTAI number and its SNAI to convert to an international number based on the numbering plan. See [Table 3: National/Local Numbers to International Numbers Conversion Logic](#).

Table 3: National/Local Numbers to International Numbers Conversion Logic

| Service Numbering Plan | Service Nature of Address | Action |
|------------------------|-------------------------------|---|
| E.164 | National (Significant) number | Prepend GTAI digits with the default E.164 Country Code (CC). |
| E.164 | Subscriber number | Prepend GTAI digits with the default E.164 country code (CC) and network code (NC). |
| E.212 | National (Significant) number | Prepend GTAI digits with the default mobile country code (MCC). |
| E.212 | Subscriber number | Prepend GTAI digits with the default Mobile Country Code (MCC) and Mobile Network Code (MNC). |

| Service Numbering Plan | Service Nature of Address | Action |
|------------------------|-------------------------------|---|
| E.214 | National (Significant) number | Prepend GTAI digits with the default E.164 Country Code (CC). |
| E.214 | Subscriber number | Prepend GTAI digits with the default E.164 Country Code (CC) and Network Code (NC). |
| Other | N/A | Assume the default to be E.164 International number |

Notes:

- If any of the default CC, NC, MCC, or MNC are required for conversion and are not provisioned in the database, G-Flex Relay issues a UIM and falls through to GTT.
- If the converted number is fewer than five digits, G-Flex Relay falls through and performs GTT on the message. G-Flex Relay issues a UIM when a converted number is fewer than five digits.
- If the converted number is more than 15 digits, then G-Flex Relay issues a UIM when the number exceeds 15 digits and falls through to GTT.
- G-Flex Relay uses the conditioned number for database lookup purposes only and does not modify the CdPA GTAI in the message unless rcgta=yes or ccgt=yes.
- For the G-Flex selector-specified service numbering plan (IMSI, DN, or MGT), the numbering plan in the incoming message is replaced with the G-Flex Selector service numbering plan (E.164, E.212, or E.214, respectively). This is for RTDB lookup purposes only.

Conversion of E.214 MGT to E.212 IMSI

Because the RTDB does not store MGTs, the messages with E.214 MGT in the CdPA GTAI are converted to an E.212 International IMSI in order to perform the RTDB lookup. G-Flex maintains a logical MGT2IMSI conversion table to perform this conversion. The MGT2IMSI conversion table contains up to ten entries of E.164 part (CC + NC digits) and its corresponding E.212 part (MCC + MNC). If a G-Flex message has E.214 as the CdPA numbering plan, G-Flex Relay performs the following steps to derive the E.212 International IMSI:

1. G-Flex Relay uses MGT as the key and does a lookup in the MGT2IMSI conversion table to find a match on E.164 part (CC + NC digits).
2. If a match is found, G-Flex Relay replaces the matched digits of the MGT with the corresponding E.212 part (MCC + MNC digits). If a match is not found, a UIM is issued and the G-Flex Relay falls through to GTT.
3. G-Flex Relay uses this complete E.212 International IMSI number to do the RTDB lookup.

Note: If the IMSI for a particular country/network is the complete 15 digits and the E.164 CC + NC for that country is more than five digits, the MGT generated could contain a truncated MSIN. This is possible because the converted MGT is more than 15 digits and the maximum number of digits allowed in the MGT is 15 digits. (Refer to E.214 for more details on conversion.) Under these circumstances, the MGT is truncated at 15 digits. Therefore, the MGT-to-IMSI reconversion would not regenerate a complete IMSI and would lead to incorrect results and errors.

RTDB Lookup

G-Flex Relay performs the RTDB lookup using either the complete international DN or IMSI. If the DN or IMSI number is found in the RTDB and it has an HLR translation, then G-Flex Relay extracts the HLR translation data and generates a forwarding message. G-Flex Relay falls through and performs GTT for the following error cases:

- The DN number is not present in the database.
- The IMSI number is not present in the database.

The preceding error cases do not generate any UIM or UAM, but fall through to GTT processing.

If the RTDB lookup is for GTI=2 and is an even number of digits ending in 0, then G-Flex performs a less than or equal to lookup for the odd number of digits (digit length minus 1). If a match is found, G-Flex saves the record and record index.

G-Flex then tries to continue to find an exact match on the even number of digits. If the exact match is found in the RTDB, then the HLR translation data corresponding to the even number of digits record is used. Otherwise the HLR translation data corresponding to the found odd number of digits record is used. If the even and odd translation is not found, then the G-Flex Relay falls through and performs GTT.

The important issue is that the less than or equal to search re-enters the search where the comparison left off. This minimizes any impact on performance for this special case.

Message Forwarding

GFRF Forwarding Message: MTP Portion

G-Flex modifies the MTP routing label to include the HLR PC as the DPC and the EAGLE 5 ISS true PC as the OPC. G-Flex modifies the MTP Level 2 length based on the size of the forwarding message. [Table 4: G-Flex Relay Forwarding Message: MTP Portion](#) lists the fields modified by G-Flex Relay.

Table 4: G-Flex Relay Forwarding Message: MTP Portion

| Fields | Values |
|--------------------|--|
| MTP Level 2 length | Number of octets in response MSU starting from MTP3 SIO field. If number of octets is greater than 63, Level 2 length is set to 63 |
| MTP Level 3 DPC | Point code obtained from the HLR GT information in RTDB |
| MTP Level 3 OPC | EAGLE 5 ISS true PC |

G-Flex Relay Forwarding Message: SCCP Portion

The following functions are performed for the SCCP portion of the message:

Replacing the CdPA GTAI digits with the HLR entity number

When an MSISDN or IMSI number is found in the RTDB and the Replace GT flag is set for this entry, G-Flex Relay replaces the CdPA GTAI digits with the provisioned HLR entity number. G-Flex also

modifies the numbering plan (E.164), nature of address (international), and encoding scheme to match the HLR entity number.

G-Flex Relay does not replace the Global Title Indicator format (GTI) element of the GT.

Replacing of SSN in the CdPA

When the HLR translation data includes a SSN, G-Flex Relay replaces the SSN in the called party address of the message with the new SSN. If the SSN is not present in the incoming message, then G-Flex Relay updates the Subsystem Number Indicator and includes the new SSN in the Called Party Address of the message before it forwards the message to the next node.

Inclusion of OPC in the CgPA

When the routing indicator of the calling party address is set to Route-on-SSN, and no SPC is present in it, the OPC from the received message is taken and inserted into the CgPA before the message is forwarded to the next node.

Deleting the CdPA GT Digits

When G-Flex performs Final-GTT, the Routing Indicator of the Called Party Address is set to Route-on-SSN. G-Flex provides an option to delete the Global Title present in the Called Party Address. If the Delete GT option is set, G-Flex modifies the GTI to zero and deletes the GT information from the SCCP CdPA before the message is forwarded to the end node. [Table 5: G-Flex Relay Forwarding Message: SCCP Portion](#) summarizes the possible changes by G-Flex Relay to the SCCP fields.

Table 5: G-Flex Relay Forwarding Message: SCCP Portion

| Field | Value |
|--------------------------------------|--|
| SCCP CdPA Length | New CdPA length after the possible modifications |
| SCCP CdPA Routing indicator | Routing Indicator obtained from the RTDB. (GT or DPCSSN) |
| SCCP CdPA Global Title Indicator | Same as incoming message or zero |
| SCCP CdPA Subsystem Number Indicator | Same as incoming message or replaced/inserted with the subsystem number indicator based on the existence of the SSN provisioned in the HLR translation |
| SCCP CdPA SSN | Same as incoming message or replaced/inserted with the SSN provisioned in the HLR translation |
| SCCP CdPA GT | Same as incoming message or replaced or deleted with HLR entity address provisioned in the RTDB |
| SCCP CgPA Length | New CgPA length after the possible modifications |
| SCCP CgPA Point Code Indicator | Same as incoming message <i>or</i> if CgPA RI is Route-on-SSN and PCI is not 1, then set PCI to 1 |
| SCCP CgPA SPC | If the CgPA RI is Route-on-SSN and no point code is present in the CgPA SPC, then the OPC is included as the SPC (Secondary Point Code) |

| Field | Value |
|--------------------------------------|--|
| SCCP CdPA Subsystem Number Indicator | Same as incoming message or replaced/inserted with the Subsystem Number indicator based on the existence of the SSN provisioned in the HLR translation |

Error Handling

The purpose of the Error Handling is to discard or return messages that encounter routing and database failures and cannot be delivered to the HLR. When G-Flex Relay is unable to transfer a message and Return on Error is set, then G-Flex Relay follows the same error handling procedures used by GTT. The DATA field of the UDT message and the reason cause for return are included in UDTS message.

G-Flex Relay follows the same error handling procedures as GTT for the following error cases:

- Routing failures
- Network congestion

Forwarding message after replace GT and/or Insertion of OPC or SSN is greater than the CCS7 message limit (272 bytes).

An exception to GTT error handling is when the G-Flex Relay RTDB entry cannot be found. In this case, it is not considered an error and the G-Flex Relay capability will forward the message to GTT processing.

MTP-Routed SCCP Message Processing

An MTP-routed message is a "through-switched" message that is not generated by or destined to the EAGLE 5 ISS (neither the MTP OPC nor DPC is the EAGLE 5 ISS true point code or capability point code). An MTP-routed message is routed to the destination designated by the DPC of the MTP3 routing label.

Typically, MSUs that receive service on a Service Module card require the message to be GT-routed to the EAGLE 5 ISS, so that GTT service selector-based discrimination can be applied to the message to select a specific service (such as GFLEX).

When the MTP Routed Messages for SCCP Applications (MTP Msgs for SCCP Apps) feature is on, it forwards all incoming MTP-routed SCCP messages (SI=3 in the message) from LIM cards to Service Module cards for processing. The feature is available system-wide and can be enabled and turned on when the GTT feature is turned on.

If the MTP-routed message arrives with the CdPA RI=GT or RI=SSN, and the CdPA GTI=2 (ANSI) or GTI=2 or 4 (ITU), service selection is performed.

- If the GFLEX service is selected, then the message is handled by the GFLEX service and the message processing is the same as that used for GT-routed messages.
- If the service selection does not find a match, or if the service is OFFLINE, then the message is MTP-routed.

Service re-route is not performed on MTP-routed messages.

The GFLEX service is not supported for MTP-routed messages that contain SCCP CdPA GTI=0.

G-Flex Configuration Options

The GSMOPTS table contains configuration option values for the G-Flex feature and the G-Flex MAP Layer Routing (G-Flex MLR) feature. The GSMOPTS option data is loaded to the LIM cards and to Service Module cards that contain the RTDB database. The configuration option values influence number conditioning, response message formatting and generation, and G-Flex MLR processing.

The GSMOPTS options described in [Table 6: GSMOPTS Configuration Options for G-Flex and G-Flex MLR](#) can be provisioned only after the G-Flex feature and the G-Flex MLR feature are enabled and turned on.

Table 6: GSMOPTS Configuration Options for G-Flex and G-Flex MLR

| Parameter | Value | Description | Notes |
|---|------------------------------|--|--|
| CCNC - Country Code and Network Code | 2-8 digits | | Mandatory when the MCCMNC parameter is specified. |
| DEFMCC - E.212 Default Mobile Country Code | 3 hexadecimal digits, NONE | | The value NONE deletes the current parameter value. |
| DEFMNC - E.212 Default Mobile Network Code | 1-4 hexadecimal digits, NONE | | The value NONE deletes the current parameter value. |
| MCCMNC - E.212 Mobile Country Code and Mobile Network Code | 4-7 hexadecimal digits, NONE | Specifies the CgPN NAI that is used during number conditioning. | The value NONE deletes the current parameter value. |
| GFLEXMAPLAYERRTG - Type of G-Flex MLR to be performed (see G-Flex MAP Layer Routing) | NONE | G-Flex MLR is not performed. | The G-Flex MLR feature must be on to specify this parameter. |
| | IMSI | Use the IMSI parameter value for RTDB lookup. | |
| | MSISDN | Use the MSISDN parameter value for RTDB lookup. | |
| | ALL | Use the IMSI or the MSISDN parameter value for RTDB lookup, based on the message operation code. | |
| MAPLYRRTGON MAPLYRRTGOFF - Perform (ON) or do not perform (OFF) G-Flex MLR for each specified operation or all | REGSS | Perform (ON) or do not perform (OFF) G-Flex MLR processing for the registerSS operation. | The G-Flex MLR feature must be on to specify these parameters. |
| | ACTSS | Perform (ON) or do not perform (OFF) G-Flex | |

| Parameter | Value | Description | Notes |
|--|-------------|--|-------|
| operations (see G-Flex MAP Layer Routing) | | MLR processing for the activateSS operation. | |
| | DACTSS | Perform (ON) or do not perform (OFF) G-Flex MLR processing for the deactivateSS operation. | |
| | INTROSS | Perform (ON) or do not perform (OFF) G-Flex MLR processing for the interrogateSS operation. | |
| | AUTHFAILRPT | Perform (ON) or do not perform (OFF) G-Flex MLR processing for the authenticationFailureReport operation. | |
| | RSTDATA | Perform (ON) or do not perform (OFF) G-Flex MLR processing for the restoreData operation. | |
| | PROCUNSTRQT | Perform (ON) or do not perform (OFF) G-Flex MLR processing for the processUnstructuredSSRequest operation. | |
| | RDYFORSM | Perform (ON) or do not perform (OFF) G-Flex MLR processing for the readyForSM operation. | |
| | PURGMOBSS | Perform (ON) or do not perform (OFF) G-Flex MLR processing for the purgeSS operation. | |
| | SRILOC | Perform (ON) or do not perform (OFF) G-Flex MLR processing for the sendRoutingInfoForLCS operation. | |
| | ALL | Perform (ON) or do not perform (OFF) G-Flex MLR processing for all 10 of the listed operations. | |

DigitAction Expansion

DigitAction Expansion provides more flexibility to formulate the SCCP (SCCP) Called Party Address (CdPA) Global Title Address (GTA) field of the MAP messages relayed by G-Flex.

Without DigitAction Expansion, G-Flex supports four options (none, insert, prefix, and replace) to overwrite the SCCP CdPA GTA field. With DigitAction Expansion, four additional options (delcc, delccprefix, spare1, and spare2) are included to overwrite the SCCP CdPA GTA field.

DigitAction Expansion is provisioned using the PDBI Enter Network Entity or Update Network Entity commands. DigitAction Expansion can also be modified using the **Add an NE** and **Update an NE** EPAP GUI screens.

The rules for formatting the SCCP CdPA GTA field are based on the value specified in the DigitAction field. If DigitAction = none, the EAGLE 5 ISS does not overwrite the SCCP CdPA GTA. For all other values, the EAGLE 5 ISS formats the SCCP CdPA GTA according to the value assigned to DigitAction. See [Table 7: DigitAction Applications](#) for examples of DigitAction Expansion on the SCCP CdPA GTA of an outgoing message when the Entity ID = 1404 and the default country code = 886.

Table 7: DigitAction Applications

| DigitAction | Value in Incoming CdPA GTA | Value in Outgoing CdPA GTA | Meaning |
|-------------|----------------------------|----------------------------|---|
| none | 886944000213 | 886944000213 | No change to the Called Party GTA (default) |
| prefix | 886944000213 | 1404886944000213 | Prefix Called Party GTA with the entity id |
| replace | 886944000213 | 1404 | Replace Called Party GTA with the entity ID |
| insert | 886944000213 | 8861404944000213 | Insert entity ID after country code. (CC + Entity Id + NDC + SN) |
| delccprefix | 886944000213 | 1404944000213 | Delete country code and add prefix (No action is taken if country code is not present.) |
| delcc | 886944000213 | 944000213 | Delete country code |
| spare1 | 886944000213 | treated as none | No change to the Called Party GTA (default) |
| spare2 | 886944000213 | treated as none | No change to the Called Party GTA (default) |

Digit Action DELCCPREFIX

The Digit Action to delete country code if present and prefix database entity feature allows the DELCCPREFIX Digit Action to be applied to the Called Party Global Title Address (CdPA GTA) when the GTA has a National format, as well as when the GTA has an International format. The

DELCCPREFIX option in the SCCPOPTS table specifies how the DELCCPREFIX digit action is applied to a Called Party Global Title Address (CdPA GTA).

- When the SCCPOPTS:DELCCPREFIX option is set to PFXWCC, the DELCCPREFIX digit action is applied to the CdPA GTA only when the address has a International format. The Country Code is deleted and the GTA is prefixed with the Entity ID.
- When the SCCPOPTS:DELCCPREFIX option is set to PFX4ALL, the DELCCPREFIX digit action is applied to the CdPA GTA in all cases. For an International format, the Country Code is deleted and the GTA is prefixed with the Entity ID. For a National format, the GTA is prefixed with the Entity ID.

The `chg-sccpopts` command is used to specify the `delccprefix` parameter value to configure the DELCCPREFIX Digit Action functionality.

G-Flex SCCP Service Re-Route Capability

G-Flex SCCP Service Re-Route Capability provides the ability to re-route the traffic from one EAGLE 5 ISS to other G-Flex nodes within an operator's network, and inform the originating nodes to re-route the G-Flex service related traffic to other G-Flex service nodes. The following functions are used to provide G-Flex re-routing capability:

- Service Capability Point Codes
- Service State
- Service Re-routing (using alternate point codes and a configuration option)

Service State

G-Flex SCCP Service Re-Route Capability provides an option to change the state of the G-Flex service to OFFLINE or ONLINE. The service state is persistent. Booting the OAM or all of the Service Module cards would not change the service state. The service state must be manually changed .

- The G-Flex service state defaults to OFFLINE when the G-Flex feature is turned on in the system. The service must be set to ONLINE and at least one Service Module card must be IS-NR (In-Service-Normal) before G-Flex processing occurs in the system.
- The G-Flex service can be taken OFFLINE at any time, such as when the databases are incoherent or Service Module cards need to be reloaded for some reason. Taking the service OFFLINE causes processing of G-Flex traffic to stop and allows a controlled re-routing procedure to be performed. A Critical UAM is generated as a warning that the G-Flex service is disabled because it has been taken OFFLINE.

Service Re-routing

Service re-routing is optional and does not affect normal G-Flex processing.

Service re-routing can be enabled by using the `chg-sccp-serv` command to define a list of alternate PCs or to set the GTT option to YES. Re-routing is initiated by taking a service OFFLINE.

- If alternate PCs are provisioned any messages destined to that service would be re-routed to available alternate PCs defined for that service. Up to 7 alternate point codes per domain can be defined. ANSI, ITU-I, ITU-N, ITU-I spare, ITU-N spare, and ITU-N24 domains are supported. An entire set of alternate point codes is called a Re-route set. Intermediate GTT loadsharing rules apply to the Alternate PC Re-route set.
- The GTT option is used if alternate PCs are not provisioned or none of them are available. If the GTT option value is YES (the default), then messages destined to that service would fall through to GTT as part of the re-routing procedure.

Service Capability Point Codes

One or more G-Flex Capability Point Codes (CPC) can be provisioned when the G-Flex feature is on. The Capability Point Code is used to distinguish G-Flex messages from other types of messages, so that the G-Flex service OFFLINE state can be reported by sending response method TFPs to G-Flex nodes. (Response method TFX messages are not generated if CPCs are not used.)

The service CPCs aid the adjacent nodes in knowing about a service outage. When a service is taken OFFLINE and capability point codes are defined for the service, the following actions occur for all traffic destined to the service node:

- A response method TFP message is generated to the adjacent node about the service CPC.
- The TFP response to the adjacent node causes the traffic-originating nodes to stop sending service traffic to this node.
- All service traffic coming into this node is sent to the alternate service nodes.
- Adjacent nodes initiate route-set-test procedures after receipt of the TFP.

If the messages are destined to the EAGLE 5 ISS true point code, then TFP messages are not generated when a service is OFFLINE, and the originator would not be aware of the outage.

After the service is back ONLINE in the EAGLE 5 ISS, a TFA message is sent to the traffic-adjacent nodes in response to route-set-test message. The traffic-originating nodes then start sending service traffic to this node.

G-Flex Re-Route Message Handling

Table 8: G-Flex SCCP Re-Route Message Handling Summary shows the actions that the EAGLE 5 ISS takes with the G-Flex service is OFFLINE, a message requiring G-Flex service arrives at the affected node, and Service Module cards are available.

Table 8: G-Flex SCCP Re-Route Message Handling Summary

| DPC | Alternate PC Defined and Available | GTT to be Performed as Fall Through | Message Handling | Network Management |
|------------|---|-------------------------------------|---|--------------------|
| G-Flex CPC | Yes | N/A | Reroute to alternate PC based on Relative Cost (RC) | TFP concerning CPC |
| G-Flex CPC | No (Defined, and prohibited or congested) | Yes | Fall through to and perform GTT | TFP concerning CPC |
| G-Flex CPC | No (Defined, and prohibited or congested) | No | Generate UDTS (Return Cause = Network Failure) | TFP concerning CPC |
| G-Flex CPC | Not Defined | Yes | Fall through to and perform GTT | TFP concerning CPC |

| DPC | Alternate PC Defined and Available | GTT to be Performed as Fall Through | Message Handling | Network Management |
|--|---|-------------------------------------|---|--------------------|
| G-Flex CPC | Not Defined | No | Generate UDTS (Return Cause = No xlation for this addr) | TFP concerning CPC |
| True or Secondary PC or non-G-Flex CPC | Yes | N/A | Re-route to alternate PC based on Relative Cost (RC) | None |
| True or Secondary PC or non-G-Flex CPC | No (Defined, and prohibited or congested) | No | Generate UDTS (Return Cause = Network Failure) | None |
| True or Secondary PC or non-G-Flex CPC | No (Defined, and prohibited or congested) | Yes | Fall through to and perform GTT | None |
| True or Secondary PC or non-G-Flex CPC | Not Defined | Yes | Fall through to and perform GTT | None |
| True or Secondary PC or non-G-Flex CPC | Not Defined | No | Generate UDTS (Return Cause = No xlation for this addr) | None |

Table 9: G-Flex LIM Card Re-Route Message Handling Summary shows the actions of LIM re-route functions when Service Module cards are unavailable or down.

Note: G-Flex does not support Rt-on SSN.

* If some Service Module cards are available but are overloaded, this is considered a partial failure.

Table 9: G-Flex LIM Card Re-Route Message Handling Summary

| Routing Indicator in Incoming Message | DPC | Full or Partial Failure | G-Flex Service Status | Message Handling | Network Management |
|---------------------------------------|----------------|-------------------------|-----------------------|------------------|-------------------------|
| Rt-on-GT | G-Flex CPC | Full | N/A | Generate UDTS | TFP concerning CPC, UPU |
| Rt-on-GT | Non-G-Flex CPC | Full | N/A | Generate UDTS | TFP concerning CPC, UPU |
| Rt-on-GT | True PC | Full | N/A | Generate UDTS | UPU |
| Rt-on-GT | G-Flex CPC | Partial* | ONLINE | Generate UDTS | None |

| Routing Indicator in Incoming Message | DPC | Full or Partial Failure | G-Flex Service Status | Message Handling | Network Management |
|---------------------------------------|---------------------------|-------------------------|-----------------------|------------------|------------------------------------|
| Rt-on-GT | True PC or non-G-Flex CPC | Partial* | ONLINE | Generate UDTS | None |
| Rt-on-GT | G-Flex CPC | Partial* | OFFLINE | Generate UDTS | TFP concerning CPC, UPU (ITU only) |
| Rt-on-GT | True PC or non-G-Flex CPC | Partial* | OFFLINE | Generate UDTS | None |
| Rt-on-SSN | G-Flex CPC | N/A | N/A | Generate UDTS | None |

Route-Set-Test Messages

When the G-Flex service is OFFLINE,

- If a Route-Set-Test Message - Prohibited (RSP) is received for a G-Flex CPC, the EAGLE 5 ISS does not reply.
- If a Route-Set-Test Message - Restricted (RSR) is received for a G-Flex CPC, the EAGLE 5 ISS replies with a TFP concerning the CPC.

When the G-Flex service is ONLINE and at least one Service Module card is in the IS-NR state, the EAGLE 5 ISS replies with a TFA message to RSRs and RSPs for the G-Flex CPC.

Gateway Screening and GSM MAP Screening

Gateway Screening and GSM MAP Screening are not performed on messages that are re-routed to alternate PCs.

If G-Flex Re-Route processing falls through to GTT based on the SCCP-SERV GTT configuration option, Gateway Screening and GSM MAP Screening can be applied after GTT translation.

G-Flex in an ANSI Environment

The Support ANSI G-Flex at 1700 TPS per DSM function increases the transaction capacity of the G-Flex feature running on a DSM card from 850 TPS to 1700 TPS for ANSI systems. (ITU systems operate at 850 TPS per DSM.)

The STPOPTS ANSIGFLEX option (`chg-stpopts:ansigflex=yes` command) allows DSM cards to operate at 1700 TPS when the G-Flex feature is ON. The default for the ANSIGFLEX system option is NO (disabled).

The G-Flex feature must be on, no other EPAP-related features can be on, and no ITU service selectors can be provisioned, before the ANSIGFLEX system option can be set to YES.

The ANSIGFLEX system option can be set to NO after it has been set to YES. DSM card TPS granting is reduced to 850 TPS when the option setting is NO. A notification to the user concerning the reduction in SCCP capacity is generated.

Although a warning message is provided when the ANSIGFLEX option is set to NO, the user must perform system checks manually to ensure that SCCP system capacity will be sufficient after the ANSIGFLEX option is set to NO. If the user does not perform these capacity checks, the system may discard SCCP messages (TVG grant failures).

The SCCP capacity is reported in the `rept-stat-sccp:mode=perf` command output; the command lists the performance of all DSM cards, including message rates for TVG. The TVG capacities that are reported in the `rept-stat-sccp` command take into account the ANSIGFLEX system option.

G-Flex as a "Stand-Alone" Node

G-Flex can be deployed two ways (the G-Flex processing is the same for both ways, as described in this manual):

- As an integrated part of the STP (Signal Transfer Point)
- As a "stand-alone" node

Destinations, routes, and point codes can be configured so that one STP of a mated EAGLE 5 ISS pair performs only G-Flex processing, while the other STP performs all of the STP other functions.

Assumptions/Limitations

The following assumptions and limitations apply.

1. The EAGLE 5 ISS does not perform any conversion in the SCCP portion of the message to support message routing across the domain boundary (ANSI to ITU and visa versa).
2. The EAGLE 5 ISS supports message routing across network boundaries (ITU-N to ITU-I and visa versa). However, GTT and Enhanced GTT (EGTT) do not modify the National Indicator bit in the CdPA Address Indicator (AI) or convert the CdPA PC (Point Code) to match the network type.
3. For messages with E.214 numbers in the SCCP CdPA, a simple conversion can form an E.212 number. The E.212 number formed in this way is the full IMSI of the subscriber, that is, it is assumed that no truncation occurs when the E.214 number is originally formed from the E.212 number. Such truncation is allowed by the E.214 recommendation.
4. G-Flex allows for up to eight MSISDN numbers per subscriber (that is, per IMSI) to be related. It is assumed that operators do not need to support more than eight MSISDN numbers per subscriber.
5. No overload controls are required beyond the existing EAGLE 5 ISS lower level mechanisms (for example, for MTP congestion)
6. Using combinations of the GTT selectors GTI (Global Title Indicator), TT (Translation Type), NP (Number Portability), and NAI as triggers for G-Flex processing plus SSN discrimination provide the ability to limit G-Flex processing to only the messages for which it is appropriate.
7. G-Flex C7 Relay supports message routing to a single network node for a particular subscriber. For example, an individual subscriber cannot have some messages routed to his HLR and other messages routed to a separate AuC. In this example, G-Flex does not support the AuC being collocated with the HLR.
8. For performance estimates, EAGLE 5 ISS-generated UDTS messages will count as two processed messages.

Hardware Requirements

EPAP-related features that perform an RTDB lookup require Service Module cards (DSM cards, E5-SM4G cards, or E5-SM8G-B cards) running the VSCCP application. The EAGLE 5 ISS can be equipped with up to 32 (31+1) Service Module cards.

Features that do not perform an RTDB lookup require Service Module cards only for GTT processing that might be performed for the feature. These features can coexist in systems with EPAP, but do not require an EPAP connection.

MPS/EPAP Platform

Oracle provides the Multi-Purpose Server (MPS) platform as a subsystem of the Oracle Communications EAGLE. The MPS provides support for EPAP-related features that perform Real Time Database (RTDB) lookups.

The MPS is composed of hardware and software components that interact to create a secure and reliable platform. For details about the MPS hardware, refer to *Application B Card Hardware and Installation Guide*. The MPS provides the means of connecting the customer provisioning application with the EAGLE and accepts the customer number portability data, while accommodating numbers of varying lengths.

The Oracle Communications EAGLE Application Processor Provisioning (EPAP) is software that runs on the MPS hardware platform. EPAP collects and organizes customer provisioning data, and forwards the data to the EAGLE Service Module cards. For detailed information about EPAP, refer to *Administration Guide* for EPAP.

In this manual, Service Module card refers to a DSM card, an E5-SM4G card, or an E5-SM8G-B card unless a specific card is required. For more information about the supported cards, refer to *Hardware Reference*. DSM cards are not supported with Oracle Communications EAGLE Application B Card (E5-APP-B) based EPAP systems.

Chapter 3

G-Flex MAP Layer Routing (G-Flex MLR) Feature

Topics:

- [G-Flex MAP Layer Routing.....35](#)
- [Limitations.....38](#)

This chapter describes the G-Flex MAP Layer Routing (G-Flex MLR) feature. G-Flex MLR allows subscriber digits to be obtained from either the SCCP layer or the MAP layer of a message during RTDB lookup.

G-Flex MAP Layer Routing

The EAGLE 5 ISS G-Flex feature can perform RTDB subscriber number lookup based either on a subscriber's E.164 MSISDN number, or the subscriber's E.212 IMSI number. In some GSM networks, MSCs use an E.214 MGT (Mobile Global Title) number for routing between networks. G-Flex cannot perform database lookup directly with an E.214 MGT number, but it can convert the E.214 MGT into a E.212 IMSI number, and thus correctly process the message. In an ITU network, when a visited network entity (VLR, GGSN, SGSN, or GMLC) needs to contact a home network entity (AuC or HLR) given only the IMSI of a subscriber, it will convert the E.212 IMSI into an E.214 MGT. This process applies only to the first message of a dialogue. Subsequent messages of that same dialogue will be routed using E.164 numbers.

When the SCCP CdPA is truncated by the MSC in a message that is received for G-Flex service, G-Flex needs to use the subscriber number from the MAP layer for routing.

The G-Flex MLR feature supports G-Flex routing for messages based on the MAP-layer IMSI and MSISDN parameters that does not involve checking the format of the CdPA, though the messages contain SCCP Called Party Address (CdPA) parameters in ITU E.214 format. The CdPA should contain an E.214 number, but its format and content have no bearing on the G-Flex MLR function.

G-Flex MLR processes messages with the MAP operations shown in [Table 10: MAP Operations Processed by G-Flex MLR](#):

Table 10: MAP Operations Processed by G-Flex MLR

| MAP Operation Name | Processing |
|-------------------------------|---|
| updateLocation | G-Flex MLR processes messages with MAP operations that commonly encode the SCCP CdPA GTA in the E.214 format (MGT) where trailing IMSI digits may be truncated from the MGT, and that always include IMSI in the MAP layer. |
| updateGprsLocation | |
| sendParameters | |
| sendAuthenticationInfo | |
| registerSS | |
| activateSS | |
| deactivateSS | |
| interrogateSS | |
| authenticationFailureReport | |
| restoreData | |
| readyForSM | |
| purgeMS | |
| processUnstructuredSS-Request | |
| sendRoutingInfoForLCS | |

| MAP Operation Name | Processing |
|----------------------|---|
| AnyTimeInterrogation | G-Flex MLR processes messages with the AnyTimeInterrogation (ATI) operation, using the MSISDN from the MAP layer of the ATI message for conditioning and RTDB look up. The MSISDN is converted to International format for RTDB searching based on the Nature of Address Indicator in the MAP MSISDN parameter. No HomeRN deletion is required. |

For the following MAP Operations, G-Flex MLR uses the GSMOPTS GFLEXMAPLAYERRTG configuration option value to determine whether to use the IMSI or MSISDN to obtain subscriber digits from the MAP layer when performing RTDB lookup:

- updateLocation
- updateGprsLocation
- sendParameters
- sendAuthenticationInfo
- AnyTimeInterrogation

The GFLEXMAPLAYERRTG option can have the following values:

- NONE - The G-Flex MLR function is not performed for a message that contains an updateLocation, sendParameters, sendAuthenticationInfo, updateGprsLocation, or AnyTimeInterrogation operation code. Normal G-Flex processing is applied to the message. The IMSI or MSISDN is taken from the SCCP CdPA parameter for TC-BEGIN messages.
- IMSI - The G-Flex MLR function uses the IMSI for the RTDB lookup, for the updateLocation, sendParameters, sendAuthenticationInfo, and updateGprsLocation operations.
- MSISDN - The G-Flex MLR function uses the MSISDN for the RTDB lookup, for the AnyTimeInterrogation operation.
- All - The G-Flex MLR function uses the IMSI or the MSISDN for the RTDB lookup, based on the operation code of the message. If the message contains an updateLocation, sendParameters, sendAuthenticationInfo, or updateGprsLocation operation code, the G-Flex MLR function uses the IMSI parameter. If the message contains an AnyTimeInterrogation operation code, the G-Flex MLR function uses the MSISDN parameter.

For the operations shown in [Table 11: GSMOPTS Configuration Options MAPLYRRTGON and MAPLYRRTGOFF](#), G-Flex MLR uses the GSMOPTS MAPLYRRTGON configuration option to turn on processing of each specified operation or all operations, and the MAPLYRRTGOFF configuration option to turn off processing of each specified operation or all operations. The values are specified in a comma-separated list for the option in the `chg-gsmopts` command. One or both options can be specified in one command, but the same value cannot be specified in both options in the same command. When ALL is specified for one option, the other option cannot be specified in the same command.

Table 11: GSMOPTS Configuration Options MAPLYRRTGON and MAPLYRRTGOFF

| Operation Name | Configuration Option Value |
|----------------|----------------------------|
| registerSS | regss |

| Operation Name | Configuration Option Value |
|--|----------------------------|
| activateSS | actss |
| deactivateSS | dactss |
| interrogateSS | intross |
| authenticationFailureReport | authfailrpt |
| restoreData | rstdata |
| processUnstructuredSS-Request | procunstrqt |
| readyForSM | rdyformsm |
| purgeMS | purgmobss |
| sendRoutingInfoForLCS | sriloc |
| All 10 operations listed in this table | all |

"Normal" G-Flex processing is performed using the SCCP CdPA when:

- The G-Flex MLR feature is not turned on.
- The received message does not include an operation of interest.
- The operation does not contain an IMSI parameter.
- The operation does not contain an MSISDN parameter. No UIM is generated.
- The G-Flex MLR feature encounters a supported operation code that contains an invalid ACN.

The G-Flex MLR feature applies only when:

- The G-Flex MLR feature is enabled and turned on.
- An incoming MSU contains and SCCP UDT message type code or XUDT non-segmented message type code.
- The message contains a TCAP Message Type of Begin (in the MAP layer information of only the first TCAP component of the message).
- The TCAP component is Invoke.
- For the message processing controlled by the GSMOPTS GFLEXMAPLAYERRTG configuration option, the option is not NONE.
- For the message processing controlled by the MAPLYRRTGON option, the option must be set for the operation code in the incoming message, and
 - SCCP CdPA NP=E.214 if CdPA GTI=4 and NP is present.
 - SCCP CdPA GTI=2
 - The SCCP CdPA GTA length is not checked because the SCCP CdPA Encoding Scheme (ODD or EVEN) is not known in this case, and there might be filler digits ('0') that make the length determination uncertain.

The G-Flex MLR UIMs listed in [G-Flex-Related UIMs](#) are generated to indicate the following errors in the IMSI and MSISDN parameter in a message. Normal G-Flex processing is applied to the message.

- Missing IMSI (a UIM is not generated for a missing MSISDN)

- Decoding errors such as an IMSI parameter value that does not have at least 5 digits and no more than 15 digits, or an MSISDN parameter value that does not have at least 1 digit and no more than 15 digits
- MSISDN digits with the NAI set to Subscriber or National and the STPOPTS Default Country Code (DEFCC) or Default Network Destination Code (DEFNDC) configuration option is not set appropriately
- Invalid TCAP component

G-Flex MLR affects only the selection of digits for RTDB lookup. All other processing is the same as G-Flex. No changes are made to the MAP layer of the outgoing message; the SCCP layer may be changed per the provisioned Network Entity parameters in the EPAP (such as Digit Action).

Limitations

ANSI G-Flex traffic at 1700 TPS per DSM card and 5000 or 6800 TPS per E5-SM4G card are not supported by the G-Flex MLR feature. ANSI traffic operates at the standard G-Flex 850 TPS rate if the G-Flex MLR feature is turned on.

Chapter 4

EAGLE 5 ISS Commands

Topics:

- [EAGLE 5 ISS Commands.....40](#)

This chapter contains brief descriptions of the EAGLE 5 ISS commands that can be used for configuration of the G-Flex feature and related features and functions.

EAGLE 5 ISS Commands

This chapter describes the EAGLE 5 ISS commands that can be used for the configuration of the G-Flex feature and the G-Flex MAP Layer Routing (MLR) feature.

Refer to the *Commands Manual* for complete descriptions of the commands, including parameter names, valid values, and output examples for the commands.

Table 12: Commands used for the G-Flex and G-Flex MLR Features

| Type | Commands |
|----------------------|--|
| System Serial Number | ent/rtrv-serial-num |
| Card | ent/dlt/rtrv/alw/inh/init/rept-stat-card |
| STP Options | chg/rtrv-stpopts |
| Feature Control | chg/rtrv-feat, enable/chg/rtrv-ctrl-feat |
| Service Selector | chg/dlt/ent/rtrv-srvsel |
| GSM Options | chg/rtrv-gsmopts |
| SCCP Service | chg/dlt/rtrv-sccp-serv |

chg-rtrv-stpopts

The `chg/rtrv-stpopts` commands are used to change and report on the values of one or more of the STP node level processing option indicators maintained in database tables. System default values for the options are assigned initially at STP installation time.

enable/chg/rtrv-ctrl-feat

These commands are used to enable, turn on, and display the on/off status of the G-Flex feature and the G-Flex MAP Layer Routing (G-Flex MLR) feature.

ent/dlt/chg/rtrv-srvsel

The service selector (`srvsel`) commands are used to enter, delete, change, and display the service selectors required to define a service entry for a DSM service entry.

- The G-Flex service is `gflex`.
- G-Flex supports ANSI, ITU-I, ITU-N, and ITU-N24 Global Title Indicators
The Global Title Indicator (GTI) value is 1-4. The Numbering Plan and Nature of Address Indicator cannot be specified when the GTI is 2, and must be specified when the GTI is 4.
- G-Flex supports the Translation Type (TT), Nature of Address Indicator (NAI), NAI Value (NAIV), Numbering Plan (NP), NP Value (NPV), Service Nature of Address Indicator (SNAI), and Service Numbering Plan (SNP) selector values.
- The Subsystem Number (SSN) must be defined in the MAP table, and supports the asterisk (*) value.

chg/rtrv-gsmopts

The GSM Options commands are used to provision configuration options that are used for the G-Flex-related features. The options control number portability, processing for incoming messages, and formatting of response messages. See *G-Flex Configuration Options*.

Up to 10 CCNC/MCCMNC numbering plan conversion parameter combinations can be created. If NONE is specified for MCCMNC, then the CCNC combination is deleted.

chg/dlt/rtrv-sccp-serv

The SCCP Service commands are used to:

- Take SCCP services online and offline
- Shift the processing load of a service to other designated nodes
- Assign alternate point codes to PC groups used for G-Flex SCCP Service Re-Route assignment, and change the Relative Cost (RD) of existing point codes in a group

SCCP Service groups are organized by service (G-Flex or G-Port) and point code network type (ANSI, ITU-I, Spare ITU-I, ITU-N, Spare ITU-N, or ITUN-24). Up to seven PCs may be in a network type grouping for service re-route load sharing. This command allows for additions and modifications of up to 4 PCs at once.

The alternate PCs entered using the `chg-sccp-serv` command reduce the maximum number of entries that the MRN table can contain. Each Alternate PC Re-route Set uses up to 8 MRN table entries (7 for alternate PCs and one for the search key).

Chapter 5

G-Flex Feature Configuration

Topics:

- *Introduction.....43*
- *G-Flex and G-Flex MLR Configuration Procedure.....46*
- *Configure the System for HLR Destinations.....48*
- *Enable and Turn on the G-Flex Feature.....49*
- *Provision STPOPTS Options for G-Flex.....50*
- *Provisioning the G-Flex Service Selector.....51*
- *Provision the STPOPTS ANSIGFLEX Option.....54*
- *Provisioning the GSMOPTS Options.....55*
- *Provision the SCCP Service State and Point Codes.....57*
- *Enable and Turn on the G-Flex MLR Feature.....57*

This chapter provides procedures for configuring the G-Flex feature and the G-Flex MAP Layer Routing feature for use in the EAGLE 5 ISS.

The chapter also describes some EPAP provisioning considerations.

Introduction

The G-Flex feature is configured on the EAGLE 5 ISS and on the EPAP. This chapter describes prerequisites and procedures for the EAGLE 5 ISS configuration only. The EPAP configuration is explained in the *EPAP Administration Manual*. This chapter also includes procedures for configuration of the G-Flex MAP Layer Routing (G-Flex MLR) feature for use with G-Flex.

G-Flex and G-Flex MLR Configuration Procedure lists the steps for enabling and turning on the G-Flex feature and the G-Flex MLR feature, for the provisioning required for the feature, and for the provisioning of the G-Flex SCCP Service Re-Route Capability and ANSI G-Flex. Each step contains a link or reference to information and procedures to use to complete the step. Feature provisioning can be performed after the features are enabled and before the features are turned on.

The G-Flex feature and other related features are optional and must be purchased from Tekelec before they can be used in your system. If you are not sure whether you have purchased a specific feature, contact your Tekelec Sales or Account Representative.

Note: For an in-service environment, contact the *My Oracle Support (MOS)* before continuing to configure the G-Flex feature. For an environment that is not yet in-service, continue with the configuration.

EPAP Provisioning Blacklist

This feature provides blacklist functions for protected E.164 addresses of network elements, such as HLRs. All G-Flex provisioning data is checked against this blacklist to prevent inadvertent population of protected E.164 addresses into the RTDB as MSISDNs.

The G-Flex blacklist ranges are stored in the EPAP PDB database. G-Flex blacklist ranges are not sent to or stored in the RTDB.

The provisioning of blacklist ranges does not cause PDB database levels to increment.

The customer is responsible for determining the ranges of address strings that should be considered, protected, and entered into the blacklist. Reliability of this feature depends on the completeness of the blacklist.



Caution: If the G-Flex blacklist does not include all protected address strings in the customer network and one of those protected address strings is provisioned as a DN, DN Block, or IMSI, there will be unintended message routing that can cause network outages.

Provisioning of the E.164 addresses for this feature can be done only through the EPAP GUI. The EPAP GUI is used to retrieve, view, and delete entries in the blacklist. EPAP GUI menus to add and delete G-Flex blacklist ranges are accessible only to the EPAP PDBA group and the User Administration (uiadmin) user.

A maximum of 1000 blacklist ranges are supported by the EPAP. A valid G-Flex blacklist range is defined by two address strings of 5-15 hexadecimal digits, where the ending address is greater than or equal to the beginning address. Address strings must be of the same length. G-Flex blacklist ranges cannot overlap. A valid G-Flex blacklist range cannot conflict with DN, DN block, or IMSI values in the PDB. If a conflict is determined, the blacklist range will be rejected.

The EPAP Provisioning Blacklist feature provides PDBI checks against the blacklist ranges in memory when PDBI is used for the provisioning of DNSs, DN blocks, and IMSIs. The command is rejected if a conflict is found.

Refer to the *EPAP Administration Manual* for more information about using the EPAP Provisioning Blacklist.

EPAP Entity Provisioning

It is recommended that EPAP entity (SP or RN) administration not be done until after the point code and/or subsystem number has been entered into the EAGLE 5 ISS MAP table.

- EPAP-administered entity data can possibly become out-of-sync with the EAGLE 5 ISS MAP table when the creation of point codes and/or subsystem numbers in the MAP table is performed after EPAP database administration.
- If this mismatch is discovered in real-time operations, a UIM (such as SCCP did not route - DPC not in MAP tbl or SCCP did not route - SS not in MAP tbl) is sent to the EAGLE 5 ISS maintenance terminal.

System Prerequisites

Before any feature that is described in this manual can be enabled, the prerequisites listed in [Table 13: System Prerequisites](#) are required in the system.

Table 13: System Prerequisites

| Prerequisite | Verification and Provisioning |
|---|--|
| <p>The system serial number must be correct and locked.</p> <p>For new installations, the system is shipped with an unlocked serial number. The serial number can be changed if necessary and must be locked after the system is on-site.</p> <p>For systems that are being upgraded, the serial number is usually already verified and locked.</p> | <p>Note: The serial number cannot be changed after it is entered and locked in the system.</p> <p>Locate the serial number for the system on a label affixed to the control shelf (1100).</p> <p>Enter the <code>rtrv-serial-num</code> command to display the serial number and its locked status.</p> <p>Verify that the displayed serial number is correct for the system.</p> <p>If no serial number is displayed, enter the <code>ent-serial-num</code> command (without the <code>lock</code> parameter) to provision the serial number that appears on the control shelf label. Enter the <code>rtrv-serial-num</code> command and verify that the serial number was entered correctly.</p> <p>Enter the <code>ent-serial-num</code> command with the <code>lock=yes</code> parameter to lock the serial number in the system.</p> |

| Prerequisite | Verification and Provisioning |
|---|---|
| <p>A sufficient number of Service Module cards must be equipped.</p> <p>Some features require only E5-SM4G cards and cannot use DSM cards. See specific feature prerequisites, if any, in this section.</p> | <p>Enter the <code>rept-stat-card:appl=vsccp</code> command to list the Service Module cards in the system.</p> <p>If more cards or cards of a different type are needed, refer to the procedures in the <i>Database Administration Manual - GTT</i> to add Service Module cards or remove DSM cards.</p> |
| <p>The GTT feature must be on in the system.</p> <p>Some features require an additional GTT-related feature such as EGTT. See the specific feature prerequisites in this section.</p> | <p>Enter the <code>rtrv-feat</code> command to display the GTT feature status.</p> <p>If the GTT feature is on, the <code>gtt=on</code> entry appears in the output.</p> <p>If the <code>gtt=off</code> entry appears in the output, use the procedures in the <i>Database Administration Manual - GTT</i> to turn on and provision the GTT feature and any other GTT-related features and functions that will be used in the system.</p> |

G-Flex Feature Prerequisites

Before the G-Flex feature can be enabled, the following prerequisites are required in the system:

Table 14: G-Flex Feature Prerequisites

| Prerequisite | Verification and Provisioning |
|--|--|
| <p>The system must be configured for HLR destinations.</p> | <p>See Configure the System for HLR Destinations.</p> |
| <p>The ANSIGFLEX system option cannot be set to YES when G-Flex is used in an ITU system.</p> <p>If G-Flex will be used in an ANSI environment, see G-Flex in an ANSI Environment and G-Flex and G-Flex MLR Configuration Procedure.</p> | <p>Enter the <code>rtrv-stpopts</code> command.</p> <p>Verify that the ANSIGFLEX entry does not appear in the command output or that the ANSIGFLEX entry shows a value of <code>no</code>.</p> |
| <p>The LNP feature cannot be on in the system.</p> | <p>Enter the <code>rtrv-ctrl-feat</code> command.</p> <p>If the LNP feature is on, shown with a quantity greater than zero for the LNP ported TNs entry in the command output, the feature described in this manual cannot be enabled.</p> |

G-Flex MAP Layer Routing Feature Prerequisites

Before the G-Flex MAP Layer Routing (MLR) feature can be enabled, the following prerequisites are required in the system:

Table 15: G-Flex MAP Layer Routing Feature Prerequisites

| Prerequisite | Verification and Provisioning |
|--|---|
| The G-Flex feature must be enabled and on. | Enter the <code>rtrv-ctrl-feat</code> command. If the <code>G-Flex</code> entry does not appear in the output, follow the steps in the G-Flex and G-Flex MLR Configuration Procedure to enable and turn on the G-Flex feature. |
| The ANSIGFLEX system option cannot be set to Yes. | Enter the <code>rtrv-stpopts</code> command. Verify that the <code>ANSIGFLEX</code> entry does not appear in the command output or that the <code>ANSIGFLEX</code> entry shows a value of <code>no</code> . |
| The LNP feature cannot be on in the system. | Enter the <code>rtrv-ctrl-feat</code> command. If the LNP feature is on, shown with a quantity greater than zero for the <code>LNP ported TNs</code> entry in the command output, the G-Flex MLR feature cannot be enabled. |
| The E5-SM4G Throughput Capacity feature cannot be enabled in the system. | Enter the <code>rtrv-ctrl-feat</code> command. If the E5-SM4G Throughput Capacity feature entry appears in the command output, the G-Flex MLR feature cannot be enabled. |

G-Flex and G-Flex MLR Configuration Procedure

The EAGLE 5 ISS configuration of the G-Flex feature and the G-Flex MAP Layer Routing (G-Flex MLR) feature consists of the following steps. The steps contain links and references to detailed procedures and information needed to complete each step.

1. Verify, and provision if needed, the system prerequisites. See [System Prerequisites](#).
2. Verify, and provision if needed, the G-Flex feature prerequisites. See [G-Flex Feature Prerequisites](#).
3. If the G-Flex MLR feature will be used, verify and provision if needed, the G-Flex MLR feature prerequisites. See [G-Flex MAP Layer Routing Feature Prerequisites](#).
4. Enable and turn on the G-Flex feature. See [Enable and Turn on the G-Flex Feature](#).
5. Change the STPOPTS options for the Default Country Code (DEFCC) and Default Network Destination Code (DEFNDC) to values other than NONE. See [Provision STPOPTS Options for G-Flex](#).
6. Provision GSMOPTS options for G-Flex, including the following options. See [Provisioning the GSMOPTS Options](#).
 - E.214 country code and network code (CCNC)
 - Default GSM mobile country code (DEFMCC)
 - Default GSM mobile network destination code (DEFMNDC)

- E.212 mobile country code and mobile network code (MCCMNC)
7. Provision the service selector mechanism to route MSUs to the G-Flex service. See [Provisioning the G-Flex Service Selector](#).
 - G-Flex service (gflex)
 - Translation Type
Specify tt=2 when ANSI G-Flex will be used.
 - Global Title Indicators - G-Flex supports ANSI, ITU-I, and ITU-N Global Title Indicators.
ITU-N24 is not supported.
ANSI G-Flex uses only ANSI GTI=2 and GTIA=2.
ANSI G-Flex is not supported when the G-Flex MLR feature is enabled.
 - Nature of Address Indicator (NAI) and Numbering Plan (NP) - required when the GTI value is 2
 - Service Nature of Address (SNAI) and Service Numbering Plan (SNP)
 8. If G-Flex will be used in an ANSI environment, enable the ANSIGFLEX STPOPTS option. See [Provision the STPOPTS ANSIGFLEX Option](#).
 9. Set the G-Flex service state to ONLINE. See [Provision the SCCP Service State and Point Codes](#).
 10. If the [G-Flex SCCP Service Re-Route Capability](#) function will be used, provision either alternate point codes or set the GTT option to YES. See [Provision the SCCP Service State and Point Codes](#).
 11. If the G-Flex MLR feature will be used, continue with step 12.
If the G-Flex MLR feature will not be used, go to step 13.
 12. If the G-Flex MLR feature will be used,
 - a. Enable and turn on the G-Flex MLR feature. See [Enable and Turn on the G-Flex MLR Feature](#).
 - b. Provision the GSMOPTS GFLEXMAPLAYERRTG, MAPLYRRTGON, and MAPLYRRTGOFF options for the G-Flex MLR feature. See [Provisioning the GSMOPTS Options](#).
 13. Verify the operational status of the system.
 - a. Enter the `rept-stat-sccp` command to verify that all Service Module cards are loaded and in IS-NR status.
 - b. Enter the `rept-stat-mps` command to verify that all Service Module cards and the EPAP are connected and operational.
 - c. Enter the `rept-stat-db` command to verify that database levels are identical for the EPAP PDB and RTDB and the RTDB on each Service Module card.
 14. Configure the measurements collection method, scheduling, and reporting if measurements will be collected for G-Flex.

Refer to the procedures in the *Database Administration Manual - System Management* for configuring OAM-based measurements, the Measurements Platform feature, the E5-OAM Integrated Measurements feature, and the EAGLE OA&M Security feature in the EAGLE 5 ISS.
 15. Back up the changes using the `chg-db:action=backup:dest=fixed` command.

The following messages appear, the active Maintenance and Administration Subsystem Processor (MASP) appears first.

```
BACKUP (FIXED): MASP A - Backup starts on active MASP.  
BACKUP (FIXED): MASP A - Backup on active MASP to fixed disk complete.  
BACKUP (FIXED): MASP A - Backup starts on standby MASP.  
BACKUP (FIXED): MASP A - Backup on standby MASP to fixed disk complete.
```

Configure the System for HLR Destinations

This section describes the configuration of the system for HLR destinations, so that the system can communicate with the system of the HLR database. The route to this database may already be configured.

Perform the steps in the following procedure to verify that all HLR destinations for G-Flex are entered, and make configuration changes as needed. The steps contain links and references to procedures and information that is needed to complete each step.

Refer to the command descriptions in the *Commands Manual* for valid parameter values, input examples, rules for entering a command correctly, and output examples.

1. Display and note current system settings for point codes (PCs) and capability point codes (CPCs), destination point codes (DPCs), routes, and linksets.
 - Enter the `rtrv-stpopts` command to display the ITU-N point code format if the network is an ITU-N network.
 - Enter the `rtrv-sid` command to display current PCs and CPCs by network type.
 - Enter the `rtrv-dstn` command to display current DPCs.
 - Enter the `rtrv-rte` command to display current route configurations.
2. Identify PCs and CPCs; determine new PCs and CPCs to be entered.
3. Remove the system PC from the MAP table if necessary (refer to the *Database Administration Manual - Global Title Translation*, "Removing A Mated Application").
4. Change PC, CPC, DPC, route, linkset, and LIM card configurations for the HLR database.
 - Refer to the procedures in the *Database Administration Manual - SS7* to configure PCs and CPCs by network type.
 - Refer to the procedures in the *Database Administration Manual - SS7* to configure DPCs for HLR destinations.
 - Refer to the procedures in the *Database Administration Manual - System Management* to provision LIM cards in the system, if needed.
 - Refer to the procedures in the *Database Administration Manual - SS7* to assign DPCs and configure linksets, signaling links, and routes for HLR destinations.
 - Refer to the procedures in the *Database Administration Manual - Global Title Translation* to configure mated applications.
5. Allow LIM card operation in the system and verify the card operating status. Refer to the procedures in the *Database Administration Manual - System Management*.
6. Allow the operation of the signaling links in the system and verify the link operating status. Refer to the procedures in the *Database Administration Manual - SS7*.

7. Verify the service selector changes. Enter the `rtrv-srvsel` command.
8. Back up the changes using the `chg-db:action=backup:dest=fixed` command.
The following messages appear, the active Maintenance and Administration Subsystem Processor (MASP) appears first.

```
BACKUP (FIXED): MASP A - Backup starts on active MASP.
BACKUP (FIXED): MASP A - Backup on active MASP to fixed disk complete.
BACKUP (FIXED): MASP A - Backup starts on standby MASP.
BACKUP (FIXED): MASP A - Backup on standby MASP to fixed disk complete.
```

Enable and Turn on the G-Flex Feature

This procedure is used to enable and turn on the G-Flex feature in the EAGLE 5 ISS.

The feature must be enabled using its feature part number (893021901) and a feature access key.

Note: Controlled features must be purchased before you can receive the feature access key to use to enable the feature. If you are not sure if you have purchased a feature and received the feature access key, contact your Tekelec Sales Representative or Account Representative.

When the G-Flex feature is enabled, it is permanently enabled. The G-Flex feature cannot be temporarily enabled.

Provisioning of GSMOPTS options and other information can be done after the G-Flex feature is enabled and turned on.

1. Display the status of the features that are controlled with feature access keys. Enter the `rtrv-ctrl-feat` command. The output lists the enabled features in the system and shows the on/off status for each feature.

```
rlghncxa03w 10-06-29 16:40:40 EST EAGLE5 42.0.0
The following features have been permanently enabled:
Feature Name          Partnum  Status  Quantity
HC-MIM SLK Capacity   893012707  on      64
;
```

If the `rtrv-ctrl-feat` output shows an `LNP ported TNs quantity` entry, this procedure cannot be performed for the G-Flex and G-Flex MLR features.

If an entry for the G-Flex feature appears in the `rtrv-ctrl-feat` output with Status on, performing this procedure is not necessary.

2. Enable the G-Flex feature, by entering the `enable-ctrl-feat` command and specify the part number and feature access key for the feature :
`enable-ctrl-feat:partnum=893021901:fak=<feature access key>`

When a feature is enabled, the entry for the enabled feature appears in the output of the `rtrv-ctrl-feat` command. The feature Status is off.

```
rlghncxa03w 10-06-29 16:40:40 EST EAGLE5 42.0.0
The following features have been permanently enabled:
Feature Name          Partnum  Status  Quantity
HC-MIM SLK Capacity   893012707  on      64
```

```
G-Flex                893021901  off      ----
;
```

- Turn on the G-Flex feature, by entering the `chg-ctrl-feat` command with the part number 893021901. `chg-ctrl-feat:partnum=893021901:status=on`

When the feature is turned on, the feature status changes to `on` in the `rtrv-ctrl-feat` command output.

```
rlghncxa03w 10-06-29 16:40:40 EST  EAGLE5 42.0.0
The following features have been permanently enabled:
Feature Name           Partnum    Status    Quantity
HC-MIM SLK Capacity   893012707  on        64
G-Flex                 893021901  on        ----
;
```

- Back up the database changes, by entering the following command.

```
chg-db:action=backup:dest=fixed
```

The following messages appear; the active Maintenance and Administration Subsystem Processor (MASP) appears first.

```
BACKUP (FIXED) : MASP A - Backup starts on active MASP.
BACKUP (FIXED) : MASP A - Backup on active MASP to fixed disk complete.
BACKUP (FIXED) : MASP A - Backup starts on standby MASP.
BACKUP (FIXED) : MASP A - Backup on standby MASP to fixed disk complete.
```

Provision STPOPTS Options for G-Flex

Use this procedure to change the STPOPTS option values for the Default Country Code (DEFCC) and Default Network Destination Code (DEFNDC) to values other than NONE.

When the G-Flex feature has been enabled, the STP options for the default country code and the default network destination code must be changed from NONE to appropriate values for G-Flex. The `chg-stpopts` and `rtrv-stpopts` commands support the `defcc`, `defndc` and `dsmaud` parameters for the G-Flex feature.

The default country code (`defcc`) parameter and default network destination code (`defndc`) parameter can be provisioned for G-Flex after the G-Flex feature is enabled. The `defcc` and `defndc` parameter values must be changed from NONE to appropriated values before the G-Flex feature can be turned on in the system.

In the `rtrv-stpopts` command output:

- The `defcc` and `defndc` parameters are displayed with value NONE when the G-Flex feature is enabled.
- The `dsmaud` parameter is displayed with value OFF when the G-Flex feature is turned on.

After the feature is turned on:

- The `defcc` and `defndc` parameter values cannot be set to NONE.
- The DSM audit running state (`dsmaud`) parameter of the `chg-stpopts` command can be provisioned for G-Flex.

1. Verify the defcc and defndc STP option parameter values. Enter the `rtrv-stpopts` command.
2. Change the defcc and defndc STP option parameter values to the desired values that are not NONE for the G-Flex feature, using the `chg-stpopts` command.
3. Verify any changes. Enter the `rtrv-stpopts` command.
4. Back up the changes using the `chg-db:action=backup:dest=fixed` command.

The following messages appear, the active Maintenance and Administration Subsystem Processor (MASP) appears first.

```
BACKUP (FIXED): MASP A - Backup starts on active MASP.
BACKUP (FIXED): MASP A - Backup on active MASP to fixed disk complete.
BACKUP (FIXED): MASP A - Backup starts on standby MASP.
BACKUP (FIXED): MASP A - Backup on standby MASP to fixed disk complete.
```

Provisioning the G-Flex Service Selector

The procedures in this section describe how to add, change, and remove a service selector. The information is indicated that is specific to G-Flex.

Refer to the *Commands Manual* for descriptions of the commands that are used in these procedures, including parameter names, valid values, rules for using the commands correctly, and output examples.

Adding a G-Flex Service Selector

This procedure is used to add an ITU service selector for the G-Flex feature. (If G-Flex will be used in an ANSI environment, go to x.)

The G-Flex feature must be enabled and turned on before a G-Flex service selector can be added.

1. Verify that the G-Flex feature is enabled and turned on, by entering the `rtrv-ctrl-feat` command.

If the G-Flex feature is enabled and turned on, the status of the G-Flex entry is on.

```
rlghncxa03w 09-06-29 16:40:40 EST EAGLE5 41.1.0
The following features have been permanently enabled:
Feature Name          Partnum   Status   Quantity
HC-MIM SLK Capacity   893012707 on        64
G-Flex                893021901 on        ----
;
```

- If the G-Flex feature is enabled and turned on, continue with [Step 2](#).
 - If the G-Flex feature is not enabled or turned on, go to [Enable and Turn on the G-Flex Feature](#) to enable and turn on the G-Flex feature. Then continue with [Step 2](#).
2. Display any existing G-Flex service selectors in the database, by entering the `rtrv-srvsel:serv=gflex` command.
 3. Add new G-Flex service selectors, using the `ent-srvsel` command.
This command assigns applicable service selectors required to specify the service entry for Service Module services.

For an ANSI network, for example, the following commands show how to set up service selector combinations for G-Flex services:

```
ent-srvsel:gtia=2:tt=10:snp=e164:snai=intl:serv:gflex
ent-srvsel:gtia=2:tt=11:snp=e164:snai=natl:serv:gflex
ent-srvsel:gtia=2:tt=12:snp=e164:snai=sub:serv:gflex
```

For an ITU-I network, for example, enter the following command:

```
ent-srvsel:gtii=4:tt=1:snp=e164:snai=intl:serv:gflex:nai=intl
:np=e164
```

where:

:gti/gtia/gtii/gtin

Specifies the global title translation indicator (2 = ANSI, ITU; 4 = ITU). :tt - specifies the translation type.

:snp

Defines the service numbering plan (e164, e212, or e214).

:snai

Specifies the international Service Nature of Address Indicator.

:serv

Specifies the service feature.

:nai

Specifies the nature of address indicator.

:np

Specifies the numbering plan.

4. Verify the changes by entering the `rtrv-srvsel` command with the parameters and values used in [Step 3](#).
5. Enter the `chg-sccp-serv:serv=gflex:state=online` command to set the G-Flex service status to online.
6. Back up the changes using the `chg-db:action=backup:dest=fixed` command.
The following messages appear, the active Maintenance and Administration Subsystem Processor (MASP) appears first.

```
BACKUP (FIXED): MASP A - Backup starts on active MASP.
BACKUP (FIXED): MASP A - Backup on active MASP to fixed disk complete.
BACKUP (FIXED): MASP A - Backup starts on standby MASP.
BACKUP (FIXED): MASP A - Backup on standby MASP to fixed disk complete.
```

Removing a Service Selector

This procedure is used to remove a service selector from the database.

To remove a service selector, the GTI, GTII, GTIN, tt, and ssn parameter values must be entered as shown in the `rtrv-srvsel` output.

These parameters can also be used to limit the amount of information displayed with the `rtrv-srvsel` command.

1. Display the service selectors in the database, by entering the `rtrv-srvsel` command.
2. Remove the service selector from the database, using the `dlt-srvsel` command.
3. Verify the changes by entering the `rtrv-srvsel` command with the parameters and values used in [Step 2](#).
4. Back up the changes using the `chg-db:action=backup:dest=fixed` command.

The following messages appear, the active Maintenance and Administration Subsystem Processor (MASP) appears first.

```
BACKUP (FIXED): MASP A - Backup starts on active MASP.
BACKUP (FIXED): MASP A - Backup on active MASP to fixed disk complete.
BACKUP (FIXED): MASP A - Backup starts on standby MASP.
BACKUP (FIXED): MASP A - Backup on standby MASP to fixed disk complete.
```

Changing an Existing Service Selector to a G-Flex Service Selector

This procedure is used to change an existing non-G-Flex service selector to a G-Flex service selector.

The only parameter that can be changed using this procedure is the `nserv` parameter, to specify the new DSM service type (`gflex`):

The `chg-srvsel` command requires that the following parameters be specified with the values shown in the `rtrv-srvsel` output for the service selector that is being changed. If any of these parameter values need to be changed for a new G-Flex service selector, use the procedure in [Removing a Service Selector](#) to remove the existing service selector. Then use the procedure in [Adding a G-Flex Service Selector](#) to add the new G-Flex service selector with the new parameter information.

:gtii/gtin/gtin24

Global title indicator for ITU international (`gtii`) and ITU national using 14-bit point codes (`gtin`).

:tt

Translation type

:ssn

Subsystem number

:nai

Nature of address indicator

:naiv

Nature of address indicator value

:np

Numbering plan

:npv

Numbering plan value

1. Display the service selectors in the database, using the `rtrv-srvsel` command.

If the `rtrv-srvsel` output shows G-Flex service selectors, go to [Step 3](#).

- Verify that the G-Flex feature is enabled and turned on, by entering the `rtrv-ctrl-feat` command. If the feature is enabled and turned on, the status of the entry is on.

```
rlghncxa03w 09-06-29 16:40:40 EST EAGLE5 41.1.0
The following features have been permanently enabled:
Feature Name          Partnum   Status   Quantity
HC-MIM SLK Capacity   893012707 on        64
G-Flex                893021901 on        ----
;
```

- If the G-Flex feature is not enabled or turned on, go to [Enable and Turn on the G-Flex Feature](#) to enable and turn on the feature. Continue with [Step 3](#).
 - If the G-Flex feature is enabled and turned on, continue with [Step 3](#).
- Change the service selector, using the `chg-srvsel` command.

If the SNP, or SNAI parameter values are shown as dashes in the `rtrv-srvsel` output, these parameters cannot be specified with the `chg-srvsel` command.

If the `gtii/gtin/gtin24` parameter value is 2, the `np`, `nai`, `npv`, and `naiv` parameters cannot be specified with the `chg-srvsel` command.

If the `gtii/gtin/gtin24` parameter value is 4, either the `np` and `nai`, or the `npv` and `naiv` parameters must be specified with the `chg-srvsel` command. The `np` and `nai` parameters can be specified in place of the `npv` and `naiv` parameters, and the `npv` and `naiv` parameters can be specified in place of the `np` and `naiv` parameters, as long as parameter values be specified correspond to the values shown in the `rtrv-srvsel` output. Refer to the `chg-srvsel` command description in *Commands Manual*.
 - Verify the changes by entering the `rtrv-srvsel` command with the `serv=gflex` parameter and the values for the other parameters used in [Step 3](#).
 - Back up the changes using the `chg-db:action=backup:dest=fixed` command.

The following messages appear, the active Maintenance and Administration Subsystem Processor (MASP) appears first.

```
BACKUP (FIXED): MASP A - Backup starts on active MASP.
BACKUP (FIXED): MASP A - Backup on active MASP to fixed disk complete.
BACKUP (FIXED): MASP A - Backup starts on standby MASP.
BACKUP (FIXED): MASP A - Backup on standby MASP to fixed disk complete.
```

Provision the STPOPTS ANSIGFLEX Option

Use this procedure to provision the ANSIGFLEX option for allowing 1700 TPS per DSM for G-Flex in an ANSI environment.

The ANSIGFLEX system option can be set to YES only if:

- The G-Flex feature is on.
- No other EPAP-related feature or any ELAP-related feature is on.
- No ITU service selectors are provisioned.

The only service selectors that can be used when the system option is on are GTI or GTIA , SERV=GFLEX, and TT=2.

A check for ANSI service selectors is made before allowing the ANSIGFLEX system option to set to YES.

The ANSIGFLEX system option can be set to NO after it has been set to YES (chg-stpopts:ansgflex=no). DSM card TPS granting is reduced to 850 TPS when the option setting is NO. A notification to the user concerning the reduction in SCCP capacity is generated.

1. Verify that the G-Flex feature is on. Enter the `rtrv-ctrl-feat` command.
 - If the G-Flex feature is on (the G-Flex entry appears in the command output), continue with [Step 2](#).
 - If the G-Flex feature is not on, (the entry is not in the output or the Status is off in the entry), go to [G-Flex and G-Flex MLR Configuration Procedure](#) to enable, turn on, and provision the G-Flex feature. Then continue with [Step 2](#).
2. Display any provisioned service selectors. Enter the `rtrv-srvsel` command.
 - If the correct ANSI service selectors are provisioned, continue with [Step 3](#).
 - If there are no service selectors provisioned or there are ITU service selectors provisioned, go to
 - [Removing a Service Selector](#) to remove ITU service selectors (selectors that are not GTI or GTIA and tt=2)
 - [Adding a G-Flex Service Selector](#) to add ANSI service selectors
3. Enable the STPOPTS ANSIGFLEX option. Enter the `chg-stpopts:ansigflex=yes` command.
4. Back up the changes using the `chg-db:action=backup:dest=fixed` command.

The following messages appear, the active Maintenance and Administration Subsystem Processor (MASP) appears first.

```
BACKUP (FIXED): MASP A - Backup starts on active MASP.
BACKUP (FIXED): MASP A - Backup on active MASP to fixed disk complete.
BACKUP (FIXED): MASP A - Backup starts on standby MASP.
BACKUP (FIXED): MASP A - Backup on standby MASP to fixed disk complete.
```

Provisioning the GSMOPTS Options

This procedure is used to provision the configuration options for the G-Flex feature and the G-Flex MLR feature.

See [G-Flex Configuration Options](#) for information and considerations about provisioning G-Flex and G-Flex MLR configuration options.

Refer to the command descriptions in the *Commands Manual* for valid parameter values, input examples, rules for entering the commands correctly, and output examples for the commands used in this procedure.

1. Verify that the G-Flex feature is enabled and turned on, by entering the `rtrv-ctrl-feat` command.

- If the G-Flex feature is enabled and turned on (the entry appears in the output with Status on), continue with [Step 2](#).

```
rlghncxa03w 09-06-29 16:40:40 EST EAGLE5 41.1.0
The following features have been permanently enabled:
Feature Name          Partnum    Status    Quantity
HC-MIM SLK Capacity  893012707 on         64
G-Flex                893021901 on         ----
;
```

- If the G-Flex feature is not enabled (the entry does not appear in the output) or is not turned on (the entry appears with Status off, go to [Enable and Turn on the G-Flex Feature](#) to enable and turn on the feature. Then continue with [Step 2](#).
2. Display the current settings of the feature options. Enter the `rtrv-gsmopts` command.
 3. Change the GSMOPTS options for G-Flex to the required values.
 4. Verify the changes. Enter the `rtrv-gsmopts` command.
 5. Is the G-Flex MLR feature to be used with the G-Flex feature?.
 - If the G-Flex MLR feature will NOT be used, go to [Step 9](#).
 - If the G-Flex MLR feature WILL BE used, continue with [Step 6](#).
 6. If the G-Flex MLR feature will be used, verify that the G-Flex MLR feature is enabled and turned on, by entering the `rtrv-ctrl-feat` command.
 - If the G-Flex MLR feature is enabled and turned on (the entry appears in the output with Status on), continue with [Step 7](#).

```
rlghncxa03w 09-06-29 16:40:40 EST EAGLE5 41.1.0
The following features have been permanently enabled:
Feature Name          Partnum    Status    Quantity
HC-MIM SLK Capacity  893012707 on         64
G-Flex                893021901 on         ----
G-Flex MLR           893021701 on         ----
;
```

- If the G-Flex MLR feature is not enabled (the entry does not appear in the output) or is not turned on (the entry appears with Status off, go to [Enable and Turn on the G-Flex MLR Feature](#) to enable and turn on the feature. Then continue with [Step 7](#).
7. Set the GSMOPTS GFLEXMAPLAYERRTG, MAPLYRRTGON, and MAPLYRRTGOFF options to the required values for the desired G-Flex MLR processing, as described in [G-Flex MAP Layer Routing](#).
 8. Verify the changes. Enter the `rtrv-gsmopts` command.
 9. Back up the changes, using the `chg-db:action=backup:dest=fixed` command.

These messages appear, the active Maintenance and Administration Subsystem Processor (MASP) appears first.

```
BACKUP (FIXED) : MASP A - Backup starts on active MASP.
BACKUP (FIXED) : MASP A - Backup on active MASP to fixed disk complete.
BACKUP (FIXED) : MASP A - Backup starts on standby MASP.
BACKUP (FIXED) : MASP A - Backup on standby MASP to fixed disk complete.
```

Provision the SCCP Service State and Point Codes

This procedure is used to:

- Take the G-Flex service ONLINE and OFFLINE
- Indicate whether or not to use GTT as part of the re-routing procedure when the service is OFFLINE, and alternate PCs are not defined or not available
- Assign alternate point codes to PC groups used for *G-Flex SCCP Service Re-Route Capability* assignment, and change the Relative Cost (RD) of existing point codes in a group

SCCP Service groups are organized by service (G-Flex or G-Port) and point code network type (ANSI, ITU-I, Spare ITU-I, ITU-N, Spare ITU-N, or ITUN-24). Up to 7 PCs may be in a network type grouping for service re-route load sharing. This command allows for additions and modifications of up to 4 PCs at once.

Refer to the *Commands Manual* for complete descriptions of the `chg/dlt/rtrv-sccp-serv` commands, including parameter names, rules for using the commands correctly, and output examples.

1. Display the status and provisioned options for the gflex service. Enter the `rtrv-sccp-serv: serv=gflex` command.
2. Change the status and provisioned options for the gflex service as needed.
Include the `serv=gflex` parameter, and use the `status=on` parameter to set the service ONLINE.
Use other command parameters to add, change, and delete alternate point codes, relative costs, and group assignments, and change the `gtt` parameter value (the default is YES).
3. Verify the changes by entering the `rtrv-sccp-serv` command.
4. Back up the changes using the `chg-db: action=backup: dest=fixed` command.
The following messages appear, the active Maintenance and Administration Subsystem Processor (MASP) appears first.

```
BACKUP (FIXED): MASP A - Backup starts on active MASP.
BACKUP (FIXED): MASP A - Backup on active MASP to fixed disk complete.
BACKUP (FIXED): MASP A - Backup starts on standby MASP.
BACKUP (FIXED): MASP A - Backup on standby MASP to fixed disk complete.
```

Enable and Turn on the G-Flex MLR Feature

This procedure is used to enable the G-Flex MAP Layer Routing (G-Flex MLR) feature in the EAGLE 5 ISS.

The feature must be enabled using its feature part number (893021701) and a feature access key.

Note: Controlled features must be purchased before you can receive the feature access key to use to enable the feature. If you are not sure if you have purchased a feature and received the feature access key, contact your Tekelec Sales Representative or Account Representative.

When the G-Flex MLR feature is enabled, it is permanently enabled. The G-Flex MLR feature cannot be temporarily enabled.

Provisioning of the GSMOPTS options can be done after the G-Flex MLR feature is enabled and turned on.

1. Display the status of the features that are controlled with feature access keys. Enter the `rtrv-ctrl-feat` command. The output lists the enabled features in the system and shows the on/off status for each feature.

```
rlghncxa03w 10-06-29 16:40:40 EST EAGLE5 42.0.0
The following features have been permanently enabled:
Feature Name          Partnum   Status   Quantity
HC-MIM SLK Capacity   893012707 on        64
;
```

If the `rtrv-ctrl-feat` output shows a LNP ported TNs quantity entry, this procedure cannot be performed for the G-Flex MLR feature.

If an entry for the G-Flex MLR feature appears in the `rtrv-ctrl-feat` output with Status on, performing this procedure is not necessary.

2. Enable the G-Flex MAP Layer Routing feature. Enter the `enable-ctrl-feat` command and specify the part number and feature access key for the feature.

```
enable-ctrl-feat:partnum=893021701:fak=<fak>
```

When a feature is enabled, the entry for the enabled feature appears in the output of the `rtrv-ctrl-feat` command. The feature Status is off

```
rlghncxa03w 10-06-29 16:40:40 EST EAGLE5 42.0.0
The following features have been permanently enabled:
Feature Name          Partnum   Status   Quantity
HC-MIM SLK Capacity   893012707 on        64
G-Flex                893021901 on        ----
G-Flex MLR            893021701 off       ----
```

3. Turn on the G-Flex MAP Layer Routing Feature, by entering the `chg-ctrl-feat` command:

```
chg-ctrl-feat:partnum=893021701:status=on
```

When the feature is turned on, the feature status changes to on in the `rtrv-ctrl-feat` command output.

```
rlghncxa03w 10-06-29 16:40:40 EST EAGLE5 42.0.0
The following features have been permanently enabled:
Feature Name          Partnum   Status   Quantity
HC-MIM SLK Capacity   893012707 on        64
G-Flex                893021901 on        ----
G-Flex MLR            893021701 on        ----
;
```

4. Back up the database changes, by entering the following command.
`chg-db:action=backup:dest=fixed`

The following messages appear; the active Maintenance and Administration Subsystem Processor (MASP) appears first.

```
BACKUP (FIXED) : MASP A - Backup starts on active MASP.
BACKUP (FIXED) : MASP A - Backup on active MASP to fixed disk complete.
```

```
BACKUP (FIXED) : MASP A - Backup starts on standby MASP.  
BACKUP (FIXED) : MASP A - Backup on standby MASP to fixed disk complete.
```

Chapter 6

Measurements

Topics:

- [G-Flex Measurements.....61](#)

This chapter describes the measurements that can be collected and generated for the G-Flex feature, and the methods that can be used for generating reports for G-Flex measurements.

G-Flex Measurements

The EAGLE 5 ISS Measurements system supports the collection and retrieval of measurements for the G-Flex features. The G-Flex measurements can be collected and reported with the following collection methods:

- OAM-based (UI) measurements collection - G-Flex measurements are available using the File Transfer Area (FTA) and not directly to EAGLE 5 ISS UI terminals, when the E5-OAM Integrated Measurements feature is not on.
- The Measurements Platform feature enabled and the Measurements Platform collection option on
- The E5-OAM Integrated Measurements feature enabled and on and the E5-OAM Integrated Measurements collection option on

15 Minute Measurements can be used with the Measurements Platform or E5-OAM Integrated Measurements

Refer to the *Measurements* manual for descriptions of collection methods, measurements, and measurements reports

Refer to the *Commands Manual* for descriptions of the commands used to enable and turn on features, turn on measurements collection options, and schedule and generate measurements reports.

Refer to the procedures in the *Database Administration Manual - System Management* to configure the Measurements Platform feature or E5-OAM Integrated Measurements feature for use with G-Flex.

The G-Flex MSU measurements shown in [Table 16: G-Flex MSU Measurements](#) are supported for the G-Flex feature. No G-Flex measurements are counted when the G-Flex service is OFFLINE.

Table 16: G-Flex MSU Measurements

| Event Name | Description |
|------------|--|
| GFGTMATCH | G-Flex GTTs with Match – The total number of G-Flex Global Title Translation successfully completed. |
| GFGTNOMCH | G-Flex GTTs No Match – The total number of G-Flex Global Title Translations completed that did not match an entry in the RTDB. |
| GFGTNOLKUP | G-Flex GTTs No Look-up – The total number of G-Flex Global Title Translations that could not be looked up in the RTDB because of some error. Note: This counter is not available using <code>rept-meas</code> by TT. |

The measurement events shown in [Table 17: STP Daily and Day-to-Hour Measurements that include Counts for G-Flex MSUs](#) are included in the STP Daily Maintenance (MTCDD) and STP Day-to-Hour (MTCDDTH) measurement reports and include peg counts for G-FLEX MSUs. These reports are similar to those used for GTT.

The existing GTT/SCCP measurements are used for both GTT and G-Flex and appear in the same reports. This implementation does not discriminate between the MSSCCPFL, GTTUN0NS, GTTUN1NT, or GTTPERFD pegs for G-Flex or GTT applications. For example, a search failure could result from a problem in either the RTDB or GTT database. [G-Flex SCCP Service Re-Route Capability](#) will count GTT measurements if GTT is performed.

Table 17: STP Daily and Day-to-Hour Measurements that include Counts for G-Flex MSUs

| Event Name | Description |
|------------|---|
| MSSCCPFL | MSUs discarded due to SCCP routing failure. Also includes G-Flex MSUs that got a match from either the RTDB or GTT database, but cannot be routed because of PC (Point Code) or SS (Subsystem) congestion, PC or SS unavailable, SS unequipped, or an unqualified error. |
| GTTUN0NS | GTT unable to perform; no such type. Also includes G-Flex GTT MSUs that did not match on new selectors (GTI, NP, NAI) in addition to ones not matching on TT. |
| GTTUN1NT | GTT unable to perform: no translation on this address. Also includes G-Flex MSUs that fell through to GTT, obtained a selector match but still did not get a match on the GTA. |
| GTTPERFD | Number of GTTs performed. Also includes G-Flex MSUs that got a match in either the RTDB or GTT database. These measurements can also be used to determine the following: <ul style="list-style-type: none"> • Total number of G-Flex MSUs: $X = \text{GFGTMATCH} + \text{GFGTNOMCH} + \text{GFGTNOLKUP}$ • Number of non-G-Flex GTT MSUs: $\text{GTTPERFD} + \text{GTTUN1NT} + \text{GTTUN0NS} - (X)$ |

Chapter

7

Maintenance

Topics:

- *G-Flex-Related Alarms.....64*
- *G-Flex-Related UIMs.....64*
- *Maintenance Commands.....66*
- *Debug Commands.....68*
- *Status Reporting and Problem Identification.....69*

This chapter describes commands and reports that can be used for G-Flex maintenance, including status reporting and problem identification.

G-Flex-Related Alarms

Refer to the *Unsolicited Alarm and Information Messages Manual* for a complete description, formats, output examples, and the associated corrective procedure for each G-Flex-related UAM.

The alarms shown in [Table 18: G-Flex-Related Alarms](#) can be generated for the G-Flex service (including G-Flex traffic).

Table 18: G-Flex-Related Alarms

| UAM # | Severity | Message Text | Output Group (UI Output Direction) |
|-------|----------|--|---------------------------------------|
| 0328 | None | SCCP is available | GTT |
| 0329 | None | SCCP capacity normal, card(s) abnormal | GTT |
| 0330 | Major | SCCP TPS Threshold exceeded | GTT |
| 0331 | Critical | SCCP is not available | GTT |
| 0335 | None | SCCP is removed | GTT |
| 0336 | Major | LIM(s) have been denied SCCP service | GTT |
| 0526 | None | Service is available | APSS |
| 0527 | Minor | Service abnormal | APSS |
| 0528 | Critical | Service is not available | APSS |
| 0529 | Critical | Service is disabled | APSS |
| 0530 | None | Service is removed | APSS |

G-Flex-Related UIMs

The *Unsolicited Alarm and Information Messages Manual* contains a complete description of all UIM text and formats. [Table 19: G-Flex UIMs](#) describes the G-Flex and G-Flex MLR UIMs. All of the the G-Flex-related UIMs are generated to the Application Subsystem Output Group.

Table 19: G-Flex UIMs

| UIM # | Text | Description | Recovery |
|-------|--|--|---|
| 1242 | Conv to intl num - Dflt CC not found | Default CC is not defined | Define the default CC by chg-stpopts: defcc=xxxx |
| 1243 | Conv to intl num - Dflt NC not found | Conversion to international number failed because default NDC was not found | Define the default NDC by chg-stpopts: defndc=xxxx |
| 1244 | Conv to intl num - Dflt MCC not found | Default MCC is not defined | Define the default MCC by chg-gsmopts: defmcc=xxxx |
| 1245 | Conv to intl num - Dflt MNC not found | Default MNC is not defined | Define the default MNC by chg-gsmopts: defmnc=xxxx |
| 1246 | Invalid length of conditioned digits | Length of the conditioned international number is <5 or >15 | Use an international number with length within this range. |
| 1247 | Conversion of MGT to IMSI not possible | The E.212 part for the E.214 MGT digit not found in the database | Enter the E.212 part (MCC + MNC) for the E.214 MGT part (CC + NDC) in the database using chg-gsmopts: ccnc=xxxxxx:mccnc=yyyyyy |
| 1384 | G-Flex MLR: Op without IMSI erroneous | The G-Flex MLR Function encountered an updateLocation, updateGprsLocation, sendAuthenticationInfo, registerSS, activateSS, deactivateSS, interrogateSS, restoreData, readyForSM, or purgeMS operation that did not contain an IMSI parameter | No action necessary |
| 1385 | G-Flex MLR: Op without IMSI skipped | The G-Flex MLR Function encountered a sendParameters operation that did not contain an IMSI parameter | No action necessary |
| 1386 | G-Flex MLR: Op with bad TCAP skipped | The G-Flex MLR Function encountered problems decoding the TCAP and MAP layers of a message prior to attempting to identify IMSI or MSISDN parameters (for example, generic structure decoding problems such as | No action necessary |

| UIM # | Text | Description | Recovery |
|-------|--|--|---------------------|
| | | Length part errors). This UIM is not generated when a valid TCAP component other than Invoke is detected. | |
| 1387 | G-Flex MLR: Op with bad IMSI skipped | The G-Flex MLR Function encountered an IMSI parameter that contains fewer than 5 digits or more than 15 digits | No action necessary |
| 1440 | G-Flex MLR: Op with bad MSISDN skipped | The G-Flex MLR Function encountered an AnyTimeInterrogation, processUnstructuredSS-Request, or sendRoutingInfoForLCS operation that contains an invalid MSISDN parameter | No action necessary |
| 1448 | G-Flex MLR: Op w/o IMSI/MSISDN skipped | The G-Flex MLR Function encountered a processUnstructuredSS-Request operation that does not contain an IMSI or MSISDN parameter. | No action necessary |

Maintenance Commands

The following commands can be used for maintenance when an EPAP-related feature is on.

Refer to *Commands Manual* for complete descriptions of the commands, including parameters, valid parameter values, rules for using the commands, and output examples.

Table 20: Maintenance Commands

| Command | Description |
|----------------|---|
| rept-stat-sys | Reports the status of system entities, including cards. The output includes the number of Service Module cards that are in service (IS-NR) and how many are in another state (IS-ANR, OOS-MT, OOS-MT-DSBLD). |
| rept-stat-sccp | Reports operating status of services and subsystems, CPU usage, and Service Module card status. When the loc parameter is specified, the command displays detailed card traffic statistics, including cards that are denied SCCP service. See the section in this manual that describes the use of the <code>rept-stat-sccp</code> command. |

| Command | Description |
|-------------------|---|
| rept-stat-mps | Displays the overall status of the EPAP application running on the MPS (multi-purpose server). Command output for the various reports of this command include overall MPS alarm status and card status, and status for a specific Service Module card when a feature is on. |
| rept-stat-trbl | Includes a summary of any trouble notifications (UAMs) for local subsystems, cards, and linksets. The severity of each alarm is indicated in the output report. |
| rept-stat-alm | Displays the alarm counts and totals for local subsystems and Service Module card/EPAP IP links. |
| rept-stat-db | Displays the status information for the EAGLE 5 ISS databases. This includes the level information for each Service Module card, and for the active and standby EPAP RTDB. The command reports database exception status such as corrupted, incoherent, or inconsistent, as well as providing the birth dates and levels. It shows the status of each PDB and RTDB when an EPAP-related feature is enabled. |
| rtrv-tbl capacity | Retrieves table use capacity summary information. For each table listed, the number of table entry elements in use and the total allowed number of table elements is presented, along with a percent (%) full value. Information is shown for some tables only if the feature that uses the table is enabled. |
| inh-card/alw-card | <p>The <code>inh-card</code> command is used to change the operating state of the card from In-Service Normal (IS-NR) to Out-of-Service Maintenance-Disabled (OOS-MT-DSBLD). A craftsperson then can test the card or physically remove it from the shelf.</p> <p>The <code>alw-card</code> command is used to change the card from OOS-MT-DSBLD (Out-of-Service Maintenance-Disabled) to IS-NR (In-Service Normal) if card loading is successful.</p> |
| inh-alm/unhb-alm | Used to allow and inhibit reporting of alarms for a given device, including the Service Module card ports. The commands allow both Port A and Port B to be specified. Inhibited alarms will not generate UAMs or cause alarm indicators to be turned on. All <code>rept-stat-xxx</code> commands continue to display the alarms with an indication that the device has its alarms inhibited. |
| rtrv-data-rtdb | <p>Retrieves Entity data, DN data, IMEI data, IMSI data, TN data, NPANXX data, and LRN data from the RTDB on an active Service Module card.</p> <p>If the <code>loc</code> parameter is specified and the target card is an active Service Module card, the RTDB data is retrieved from that card.</p> <p>If the <code>loc</code> parameter is not specified, the RTDB data is retrieved on the active Service Module card that has the lowest IMT address.</p> <p>The RTDB status on the active Service Module card can be coherent or incoherent.</p> |

rept-stat-sccp

The `rept-stat-sccp` command provides statistics for Service Module cards and for the services that execute on the cards. The statistics can be displayed for all Service Module cards, or for a specified card.

Refer to the *Commands Manual* for a description of the `rept-stat-sccp` command, including parameter names, valid values, and output examples for the command.

The `rept-stat-sccp` command displays the following statistics for the G-Flex service when the G-Flex feature is turned on:

- State information
- Alarm information
- Number of G-Flex messages that have been re-routed for the prior 30 seconds.

The Re-route count is incremented when the G-Flex service is OFFLINE and messages are re-routed to alternate PCs or fall through to GTT.

Debug Commands

The *Commands Manual* contains descriptions of debug commands that can be used in assessing and modifying system status and operation. Most of the debug commands are used only under the direction of Tekelec support personnel.

Refer to the *Commands Manual* for a complete description of the debug commands, including the `ent-trace` command.

A G-Flex MSU trigger can be created on the Service Module card, on any one or more of the following criteria defined in the `ent-trace` command. When multiple trigger criteria are entered, the MSU is trapped when any of the criteria are satisfied.

- **E.164 MSISDN number (MSISDN)** – Use this criterion to trap messages immediately before performing a G-Flex search based on the MSISDN numbers defined in the Real Time Database (RTDB). This parameter allows a variable number of digits (from 5 to 15). The number specified must be an International E.164 number (MSISDN or Entity Number).
- **E.212 IMSI number (IMSI)** – Use this criterion to trap messages immediately before performing a G-Flex search based on the IMSI numbers defined in the RTDB. This parameter allows a variable number of digits (from 5 to 15). The number specified must be an international E.212 IMSI. This parameter cannot be used to trap on E.214 MGT.
- **Global Title digits (GT)** – Use this criterion to trap messages based on the CdPA Global Title Address (that is, either E.164, E.214 MGT, or E.212 number) present in the SCCP part of the message.
- **SSP point code (MSC or VLR PC, for example)** – After the SSN has been determined to belong to a G-Flex entity object, use this criterion to trap messages based on CgPA (Calling Party Address) SPC present in the SCCP part of the message. If no point code is present in CgPA SPC, the criteria is matched with the OPC present in the MTP part of the message.



Caution: This command can cause the OAM card to reset if too many MSUs are trapped.

CAUTION

A trace must be set on all Service Module cards (`card=sccp-all`). A repetition parameter (`rep`) can be used to control the number of MSUs that are trapped.

MSUs that satisfy any of the trigger criteria are trapped on the Service Module card are forwarded to the OAM, and are displayed.

Status Reporting and Problem Identification

EAGLE 5 commands can be used to obtain status and statistics for the EAGLE 5 system, the EPAP systems, system devices including Service Module cards, EPAP-related features, local subsystems, and SCCP services.

Refer to *Commands Manual* for complete descriptions of the commands, including parameters and valid values, rules for using the commands correctly, and output examples.

Refer to *Unsolicited Alarm and Information Messages* for descriptions and recovery procedures for UAMs and UIMs.

Refer to *EPAP Administration Manual* for descriptions of EPAP functions and operation.

Refer to *EPAP Alarms on the T1200 Platform* or *EPAP Alarms and Maintenance on the E5-APP-B Platform* for descriptions and recovery procedures for EPAP alarms.

Refer to the appropriate Feature Manual for information about the functions and operation of EPAP-related features.

Table 21: Status Reporting for EPAP-Related Features

| Reports, Status, and Statistics | Command |
|---|---|
| EAGLE 5 ISS | |
| Maintenance Status Report - indicates whether Maintenance, Routing, and SCCP Baselines have been established. | <code>rept-stat-sys</code> |
| Alarms and operating state for system devices, including Service Module ("SCCP") cards. | <code>rept-stat-sys</code> |
| Unsolicited Alarm Messages (UAMs) and Unsolicited Information Messages (UIMs) | <code>rept-stat-alm</code> <code>rept-stat-trbl</code> |
| EPAP/MPS (from the EAGLE 5 ISS) | |
| EPAP code version and operating state for each EPAP. | <code>rept-stat-mps</code> |

| Reports, Status, and Statistics | Command |
|---|---|
| MPS hexadecimal alarm strings for the active and standby EPAPs. | rept-stat-mps |
| Operating state and alarm status of equipped Service Module cards and their DSM ports and IP connections. | rept-stat-mps rept-stat-mps:loc=<Service Module card location> |
| Amount of memory used by the RTDB on the specified card, as a percent of available Service Module card memory. | rept-stat-mps:loc=<Service Module card location> |
| EPAP Provisioning Database (PDB), EPAP Real Time Database (RTDB), and Service Module card RTDB status information - Coherent, birthdate (date and time of creation), and exception (condition when a problem was detected). | rept-stat-db rept-stat-db:db=mps |
| Service Module Cards, EPAP-Related Features, Services, Local Subsystems | |
| Status of the Service Module cards, and the services executing on the cards for EPAP-related features that are turned on. Includes Service Report, Subsystem Report, and Alarm Status; Total Service Statistics. | rept-stat-sccp |
| Operating state and alarm status of equipped Service Module cards and their DSM ports and IP connections; EPAP-related feature status per card. | rept-stat-mps:loc=<Service Module card location> |
| Alarms and operating state for Service Module ("SCCP") cards. | rept-stat-sys rept-stat-mps |
| Any cards that are denied SCCP service. | rept-stat-sccp |
| Detailed view of the status of SCCP services provided by the specified Service Module card. Includes Card Alarm Status, Card Service Statistics | rept-stat-sccp:loc=<Service Module card location> |
| General SCCP traffic performance for Service Module cards. Message rates for TVG performance. | rept-stat-sccp:mode=perf |
| Statistics for EPAP-related feature local subsystems - Subsystem Report | rept-stat-sccp |
| Statistics for EPAP-related features | rept-stat-sccp |

EPAP Status and Alarm Reporting

Because EPAP has no direct means of accepting user input or displaying output messages on EAGLE 5 ISS terminals, EPAP maintenance, measurements, and status information are routed through a Service Module card. EPAP sends two types of messages to the Service Module card: *EPAP Maintenance Blocks* and *DSM Status Requests and DSM Status Messages*. Each message type is discussed in the following sections.

EPAP Maintenance Blocks

The EPAP forwards all status and error messages to the Service Module cards in maintenance blocks. Maintenance blocks are asynchronously sent whenever the EPAP has something to report. The status information that is displayed when a `rept-stat-mps` command is issued includes information that came from the maintenance blocks.

The active EPAP generates and sends maintenance blocks to the primary Service Module card. One maintenance block is sent as soon as the IP link is established between the active EPAP and the primary Service Module card. Additional maintenance blocks are sent whenever the EPAP needs to report any change in status or error conditions. The information returned in maintenance blocks is included in the output of the `rept-stat-mps` and `rept-stat-sccp` commands.

The EPAP sends maintenance blocks that contain at least the following information:

- Status of EPAP 'A' - actual states are active, standby, and down (inoperative). Maintenance blocks include a field for this information so that it can be available for the output of the `rept-stat-mps` command.
- Status of EPAP 'B' - actual states are active, standby, and down (inoperative). Maintenance blocks include a field for this information so that it can be available for the output of the `rept-stat-mps` command.
- Identification of Active EPAP - a field to identify the active EPAP.
- Congestion Indicator - an indicator showing provisioning link congestion. The link between the EPAPs and the external source of provisioning data can become congested in high-provisioning traffic situations. When this occurs and subsequently as the congestion clears, the EPAP sends maintenance blocks to the Service Module card.
- Alarm Conditions - an error code field. If the EPAP needs to report an alarm condition, it puts an appropriate UAM identifier in this field.
- Current MPS Database Size - a field indicating the current RTDB size. The Service Module card uses this information to calculate the percentage of memory used by the RTDB.

DSM Status Requests and DSM Status Messages

When the EPAP needs to know the status of a Service Module card, it sends a DSM Status Request to all Service Module cards, and each Service Module card returns its status to the EPAP.

Service Module cards send a DSM Status Message to the EPAP when any the following events occur in the Service Module card:

- The Service Module card is booted.
- The Service Module card receives a DSM Status Request message from the EPAP

- The Service Module card determines that it needs to download the entire RTDB; for example, the Service Module card determines that the RTDB needs to be downloaded because it is totally corrupted, or a craftsperson requests that the RTDB be reloaded. The Service Module card sends a Full Download Request message to the EPAP
- The Service Module card starts receiving RTDB downloads or updates. When a Service Module card starts downloading the RTDB or accepting updates, it sends a DSM Status Message informing the EPAP of the first record received. This helps the EPAP keep track of downloads in progress.

The DSM Status Message provides the following information to the EPAP:

- **DSM Memory Size.** When the Service Module card is initialized, it determines the amount of memory present. The EPAP uses the value to determine if the Service Module card has enough memory to hold the RTDB.
- **Load Mode Status.** This indicator indicates whether or not a sufficient number of the IS-NR (In-Service Normal) LIMs have access to SCCP services.

Hourly Maintenance Report

The Hourly Maintenance Report, generated automatically, includes the alarm totals of the G-Flex subsystem and Service Module card /EPAP IP links. A sample follows.

```
eagle10506 99-10-10 16:00:01 EST EAGLE 37.5.0
5072.0000 REPT COND GSM SS
"GSM SS :0440,MTCEINT-0,SA,99-10-10,16:00:01,,,,*C"
;
eagle10506 99-10-10 16:00:01 EST EAGLE 37.5.0
5073.0000 REPT COND INP SS
"INP SS :0440,MTCEINT-0,SA,99-10-10,16:20:01,,,,*C"
;
eagle10506 99-10-10 16:00:01 EST EAGLE 37.5.0
5077.0000 REPT COND EPAPDSM
"EPAPDSM :0084,MTCEINT-0,SA,99-10-10,16:00:01,,,,**"
;
eagle10506 99-10-10 16:00:01 EST EAGLE 37.5.0
5007.0000 REPT COND CARD
"CARD 1102:0422,SCMMA,SA,99-10-10,16:00:01,,,,**"
;
eagle10506 99-09-13 16:00:01 EST EAGLE 37.5.0
3561.0000 REPT COND ALARM STATUS
"ALARMS:PERM. INHIBITED,0,0,0"
"ALARMS:TEMP. INHIBITED,0,0,0"
"ALARMS:ACTIVE,10,14,3"
"ALARMS:TOTAL,10,14,3"
;
```

A

ANSI

American National Standards Institute

An organization that administers and coordinates the U.S. voluntary standardization and conformity assessment system. ANSI develops and publishes standards. ANSI is a non-commercial, non-government organization which is funded by more than 1000 corporations, professional bodies, and enterprises.

C

CC

Connection Confirmed
Country Code
Composite Clock

CdPA

Called Party Address - The field in the SCCP portion of the MSU that contains the additional addressing information of the destination of the MSU. Gateway screening uses this additional information to determine if MSUs that contain the DPC in the routing label and the subsystem number in the called party address portion of the MSU are allowed in the network where the EAGLE is located.

CPC

Capability Point Code

A capability point code used by the SS7 protocol to identify a group of functionally related STPs in the signaling network.

D

D

| | |
|-----|---|
| DN | <p>Directory number</p> <p>A DN can refer to any mobile or wireline subscriber number, and can include MSISDN, MDN, MIN, or the wireline Dialed Number.</p> |
| DPC | <p>Destination Point Code - DPC refers to the scheme in SS7 signaling to identify the receiving signaling point. In the SS7 network, the point codes are numeric addresses which uniquely identify each signaling point. This point code can be adjacent to the EAGLE, but does not have to be.</p> |
| DSM | <p>Database Service Module.</p> <p>The DSM provides large capacity SCCP/database functionality. The DSM is an application card that supports network specific functions such as EAGLE Provisioning Application Processor (EPAP), Global System for Mobile Communications (GSM), EAGLE Local Number Portability (ELAP), and interface to Local Service Management System (LSMS).</p> |

E

| | |
|-----------------------|--|
| EPAP | <p>EAGLE Provisioning Application Processor</p> |
| EPAP-related features | <p>Features that require EPAP connection and use the Real Time Database (RTDB) for lookup of subscriber information.</p> <ul style="list-style-type: none">• ANSI Number Portability Query (AINPQ) |

E

- ANSI-41 Analyzed Information Query – no EPAP/ELAP (ANSI41 AIQ)
- Anytime Interrogation Number Portability (ATI Number Portability, ATINP)
- AINPQ, INP, G-Port SRI Query for Prepaid, GSM MAP SRI Redirect, IGM, and ATINP Support for ROP
- A-Port Circular Route Prevention (A-Port CRP)
- Equipment Identity Register (EIR)
- G-Flex C7 Relay (G-Flex)
- G-Flex MAP Layer Routing (G-Flex MLR)
- G-Port SRI Query for Prepaid
- GSM MAP SRI Redirect to Serving HLR (GSM MAP SRI Redirect)
- GSM Number Portability (G-Port)
- IDP A-Party Blacklist
- IDP A-Party Routing
- IDP Relay Additional Subscriber Data (IDPR ASD)
- IDP Relay Generic Routing Number (IDPR GRN)
- IDP Service Key Routing (IDP SK Routing)
- IDP Screening for Prepaid
- INAP-based Number Portability (INP)
- Info Analyzed Relay Additional Subscriber Data (IAR ASD)
- Info Analyzed Relay Base (IAR Base)
- Info Analyzed Relay Generic Routing Number (IAR GRN)
- Info Analyzed Relay Number Portability (IAR NP)
- INP Circular Route Prevention (INP CRP)
- IS41 Mobile Number Portability (A-Port)

E

- IS41 GSM Migration (IGM)
- MNP Circular Route Prevention (MNPCR)
- MO-based GSM SMS NP
- MO-based IS41 SMS NP
- MO SMS Generic Routing Number (MO SMS GRN)
- MO- SMS B-Party Routing
- MO SMS IS41-to-GSM Migration
- MT-based GSM SMS NP
- MT-based GSM MMS NP
- MT-based IS41 SMS NP
- MTP Routed Messages for SCCP Applications (MTP Msgs for SCCP Apps)
- MTP Routed Gateway Screening Stop Action (MTPRTD GWS Stop Action)
- Portability Check for MO SMS
- Prepaid IDP Query Relay (IDP Relay, IDPR)
- Prepaid SMS Intercept Phase 1 (PPSMS)
- Service Portability (S-Port)
- S-Port Subscriber Differentiation
- Triggerless ISUP Framework Additional Subscriber Data (TIF ASD)
- Triggerless ISUP Framework Generic Routing Number (TIF GRN)
- Triggerless ISUP Number Portability (TIF NP)
- Triggerless ISUP Framework Number Substitution (TIF NS)
- Triggerless ISUP Framework SCS Forwarding (TIF SCS Forwarding)
- Triggerless ISUP Framework Simple Number Substitution (TIF SNS)
- Voice Mail Router (V-Flex)

E

| | |
|----|---|
| ES | Encoding Scheme |
| | Extension Shelf |
| | The shelves in the EAGLE hat contain cards other than control cards (E5-OAM, GPSM-II for OAM, TDM, and MDAL cards). This shelf can be added to and removed from the database. These shelves are numbered from 1200 to 6100. |

F

| | |
|-----|---|
| FTA | File Transfer Area |
| | A special area that exists on each OAM hard disk, used as a staging area to copy files to and from the EAGLE using the Kermit file-transfer protocol. |

G

| | |
|--------|---|
| G-Flex | GSM Flexible numbering |
| | A feature that allows the operator to flexibly assign individual subscribers across multiple HLRs and route signaling messages, based on subscriber numbering, accordingly. |
| GSM | Global System for Mobile Communications |
| | A second generation digital PCS mobile phone standard used in many parts of the world. |
| GTA | Global Title Address |
| GTAI | Global Title Address Information |
| GTT | Global Title Translation |

G

A feature of the signaling connection control part (SCCP) of the SS7 protocol that the EAGLE uses to determine which service database to send the query message when an MSU enters the EAGLE and more information is needed to route the MSU. These service databases also verify calling card numbers and credit card numbers. The service databases are identified in the SS7 network by a point code and a subsystem number.

GUI

Graphical User Interface

The term given to that set of items and facilities which provide the user with a graphic means for manipulating screen data rather than being limited to character based commands.

H

HLR

Home Location Register

A component within the Switching Subsystem of a GSM network. The HLR database is the central database within the GSM architecture. This is where information about the mobile communications subscribers who are assigned to a specific location area is stored. The subscriber data is used to establish connections and control services. Depending on the network size, the number of subscribers and the network organization, a number of HLRs can exist within a GSM network.

I

IAM

Initial Address Message

I

Ensures that the services offered are compatible with the reception devices, and can be used. For example, IAM prevents a phone being connected to a facsimile.

IMSI

International Mobile Subscriber Identity

A unique internal network ID identifying a mobile subscriber.

International Mobile Station Identity

IP

Intelligent Peripheral

Internet Protocol

IP specifies the format of packets, also called datagrams, and the addressing scheme. The network layer for the TCP/IP protocol suite widely used on Ethernet networks, defined in STD 5, RFC 791. IP is a connectionless, best-effort packet switching protocol. It provides packet routing, fragmentation and re-assembly through the data link layer.

ITU

International Telecommunications Union

An organization that operates worldwide to allow governments and the private telecommunications sector to coordinate the deployment and operating of telecommunications networks and services. The ITU is responsible for regulating, coordinating and developing international telecommunications, and for harmonizing national political interests.

L

L

LNP Local Number Portability
The ability of subscribers to switch local or wireless carriers and still retain the same phone number.

M

MAP Mated Application Part
Mobile Application Part
An application part in SS7 signaling for mobile communications systems.

MCC Mobile Country Code
A three-digit number that uniquely identifies a country served by wireless telephone networks. The MCC is part of the International Mobile Subscriber Identity (IMSI) number, which uniquely identifies a particular subscriber. See also MNC, IMSI.

MDN Mobile Dialed Number
Mobile Directory Number

MGT Mobile Global Title

MIN Mobile Identification Number

MNC Mobile Network Code
A number that identifies a mobile phone carrier. Used in combination with a Mobile Country Code (MCC) to uniquely identify a mobile phone operator/carrier. See also MCC.

M

| | |
|--------|---|
| MNP | <p>Mobile Number Portability</p> <p>Allows a user to keep his or her mobile phone number despite changing provider. The subscriber also keeps the network carrier code.</p> |
| MPS | <p>Multi-Purpose Server</p> <p>The Multi-Purpose Server provides database/reload functionality and a variety of high capacity/high speed offboard database functions for applications. The MPS resides in the General Purpose Frame.</p> <p>Messages Per Second</p> <p>A measure of a message processor's performance capacity. A message is any Diameter message (Request or Answer) which is received and processed by a message processor.</p> |
| MSISDN | <p>Mobile Station International Subscriber Directory Number</p> <p>The MSISDN is the network specific subscriber number of a mobile communications subscriber. This is normally the phone number that is used to reach the subscriber.</p> <p>Mobile Subscriber Integrated Services Digital Network [Number]</p> <p>Mobile Station International Subscriber Directory Number. The unique, network-specific subscriber number of a mobile communications subscriber. MSISDN follows the E.164 numbering plan; that is, normally the MSISDN is the phone number that is used to reach the subscriber.</p> |
| MSU | <p>Message Signal Unit</p> |

M

The SS7 message that is sent between signaling points in the SS7 network with the necessary information to get the message to its destination and allow the signaling points in the network to set up either a voice or data connection between themselves. The message contains the following information:

- The forward and backward sequence numbers assigned to the message which indicate the position of the message in the traffic stream in relation to the other messages.
- The length indicator which indicates the number of bytes the message contains.
- The type of message and the priority of the message in the signaling information octet of the message.
- The routing information for the message, shown in the routing label of the message, with the identification of the node that sent message (originating point code), the identification of the node receiving the message (destination point code), and the signaling link selector which the EAGLE uses to pick which link set and signaling link to use to route the message.

MTP

Message Transfer Part

The levels 1, 2, and 3 of the SS7 protocol that control all the functions necessary to route an SS7 MSU through the network

Module Test Plan

O

point. The OPC identifies the sending signaling point.

P

PDB

Provisioning Database

PDBA

Provisioning Database Application

There are two Provisioning Database Applications (PDBAs), one in EPAP A on each EAGLE. They follow an Active/Standby model. These processes are responsible for updating and maintaining the Provisioning Database (PDB).

PDBI

Provisioning Database Interface

The interface consists of the definition of provisioning messages only. The customer must write a client application that uses the PDBI request/response messages to communicate with the PDBA.

R

RN

Routing Number

The number provided by the Freephone Service Provider (FSP) to the Access Service Provider (ASP) to enable a pre-determined routing of traffic to a specific network/carrier/customer.

Route

A signaling path from an LSP to an RSP using a specified Link Set

RSP

Route Set Test - Prohibited message
Remote Signaling Point

R

Represents an SS7 network node (point code) that signaling must be sent to. An RSP has an SS7 domain (ANSI, ITUI, ITUN), a point code, and an optional Adjacent Server Group.

Remote Signaling Point

A logical element that represents a unique point code within a particular SS7 domain with which the SS7 application's Local Signaling Point interacts.

RSR

Reset Request

Route Set Test – Restricted message

RTDB

Real Time Database

S

SCCP

Signaling Connection Control Part

The signaling connection control part with additional functions for the Message Transfer Part (MTP) in SS7 signaling. Messages can be transmitted between arbitrary nodes in the signaling network using a connection-oriented or connectionless approach.

Service Nature of Address Indicator

See SNAI.

SIM

Subscriber Identity Module

An ID card the size of a credit card for GSM network subscribers, and is typically referred to as a chip card or smartcard.

SIO

Service Information Octet.

S

The network indicator code (NIC), priority (PRI), and service indicator (SI) in the SIO field in the message signaling unit (MSU). This information identifies the type of MSU (ISUP, TCAP, and so forth) that is allowed in the network where the EAGLE is located.

SP

Service Provider

Signaling Point

A set of signaling equipment represented by a unique point code within an SS7 domain.

SPC

Secondary Point Code

The SPC enables the EAGLE to assume more than one point code for SS7 routing. The EAGLE uses the SPC for routing and provisioning as if the SPC were an actual point code of the EAGLE. The EAGLE supports one ANSI true point code and up to seven secondary point codes.

Signaling Point Code

Spare Point Code

Stored Program Control

Service Provisioning over COPS
(Common Open Policy Service
protocol)

SRI

Send Routing Information

Send_Route_Information Message

SS7

Signaling System #7

A communications protocol that allows signaling points in a network to send messages to each

S

other so that voice and data connections can be set up between these signaling points. These messages are sent over its own network and not over the revenue producing voice and data paths. The EAGLE is an STP, which is a device that routes these messages through the network.

SSN

SS7 Subsystem Number

The subsystem number of a given point code. The subsystem number identifies the SCP application that should receive the message, or the subsystem number of the destination point code to be assigned to the LNP subsystem of the EAGLE.

Subsystem Number

A value of the routing indicator portion of the global title translation data commands indicating that no further global title translation is required for the specified entry.

Subsystem Number

Used to update the CdPA.

STP

Signal Transfer Point

The STP is a special high-speed switch for signaling messages in SS7 networks. The STP routes core INAP communication between the Service Switching Point (SSP) and the Service Control Point (SCP) over the network.

Spanning Tree Protocol

Subsystem Number

See SSN.

T

T

| | |
|----|---|
| TT | Translation Type Resides in the Called Party Address (CdPA) field of the MSU and determines which service database is to receive query messages. The translation type indicates which Global Title Translation table determines the routing to a particular service database. |
|----|---|

U

| | |
|------|---|
| UAM | Unsolicited Alarm Message A message sent to a user interface whenever there is a fault that is service-affecting or when a previous problem is corrected. Each message has a trouble code and text associated with the trouble condition. |
| UDTS | Unitdata Transfer Service An error response to a UDT message. |
| UIM | Unsolicited Information Message A message sent to a user interface whenever there is a fault that is not service-affecting or when a previous problem is corrected. Each message has a trouble code and text associated with the trouble condition. |
| UPU | User Part Unavailable An MTP3 management message. |