

**Oracle® Communications
EAGLE**

Maintenance Guide

Release 46.0

E54364-01 Revision A

June 2014

Oracle® Communications Maintenance Guide, Release 46.0

Copyright © 1993, 2014,

Oracle and/or its affiliates. All rights reserved.

This software and related documentation are provided under a license agreement containing restrictions on use and disclosure and are protected by intellectual property laws. Except as expressly permitted in your license agreement or allowed by law, you may not use, copy, reproduce, translate, broadcast, modify, license, transmit, distribute, exhibit, perform, publish, or display any part, in any form, or by any means. Reverse engineering, disassembly, or decompilation of this software, unless required by law for interoperability, is prohibited.

The information contained herein is subject to change without notice and is not warranted to be error-free. If you find any errors, please report them to us in writing.

If this is software or related documentation that is delivered to the U.S. Government or anyone licensing it on behalf of the U.S. Government, the following notice is applicable:

U.S. GOVERNMENT END USERS: Oracle programs, including any operating system, integrated software, any programs installed on the hardware, and/or documentation, delivered to U.S. Government end users are "commercial computer software" pursuant to the applicable Federal Acquisition Regulation and agency-specific supplemental regulations. As such, use, duplication, disclosure, modification, and adaptation of the programs, including any operating system, integrated software, any programs installed on the hardware, and/or documentation, shall be subject to license terms and license restrictions applicable to the programs. No other rights are granted to the U.S. Government.

This software or hardware is developed for general use in a variety of information management applications. It is not developed or intended for use in any inherently dangerous applications, including applications that may create a risk of personal injury. If you use this software or hardware in dangerous applications, then you shall be responsible to take all appropriate fail-safe, backup, redundancy, and other measures to ensure its safe use. Oracle Corporation and its affiliates disclaim any liability for any damages caused by use of this software or hardware in dangerous applications.

Oracle and Java are registered trademarks of Oracle and/or its affiliates. Other names may be trademarks of their respective owners.

Intel and Intel Xeon are trademarks or registered trademarks of Intel Corporation. All SPARC trademarks are used under license and are trademarks or registered trademarks of SPARC International, Inc. AMD, Opteron, the AMD logo, and the AMD Opteron logo are trademarks or registered trademarks of Advanced Micro Devices. UNIX is a registered trademark of The Open Group.

This software or hardware and documentation may provide access to or information on content, products, and services from third parties. Oracle Corporation and its affiliates are not responsible for and expressly disclaim all warranties of any kind with respect to third-party content, products, and services. Oracle Corporation and its affiliates will not be responsible for any loss, costs, or damages incurred due to your access to or use of third-party content, products, or services.

Table of Contents

Chapter 1: About This Guide.....	11
Overview.....	12
Scope and Audience.....	12
Documentation Admonishments.....	12
My Oracle Support (MOS).....	13
Emergency Response.....	13
Related Publications.....	14
Documentation Availability, Packaging, and Updates.....	14
Locate Product Documentation on the Oracle Technology Network Site.....	15
Hardware Repair and Return.....	15
Repair and Return Shipping Instructions.....	16
Maintenance Strategy.....	18
System Maintenance Log.....	19
Chapter 2: Preventive Maintenance.....	20
Introduction.....	21
Maintaining the Fuse and Alarm Panel.....	21
1U FAP P/N 870-2804-01.....	22
3U FAP.....	27
Removable Drives.....	35
Removable USB Drive.....	35
Fixed SATA Drive.....	38
Daily Procedures.....	55
Backing Up the Database Daily.....	55
System Reports Analysis.....	56
Reports Description.....	57
File Transfer for LNP and INP Measurements.....	57
Weekly Procedures.....	58
Database Archive (Weekly).....	58
Printer Inspection.....	59
Remote Access Verification.....	60
Monthly Procedures.....	60
Database Archive (Monthly).....	60
FAP Load Balance Verification (PN 870-0243-XX only).....	61

Change the Fan Tray Filter.....	66
Changing the Air Supply Filter.....	67
Cleaning Printer.....	68
Fuse Spares Inventory.....	68
Wrist Strap Test.....	68
Quarterly Procedures.....	69
Database Archive (Quarterly).....	69
Preventing Dust Buildups.....	70
Rectifier Voltage Inspection/Recording.....	70
Semi-Annual Procedures.....	71

Chapter 3: Corrective Maintenance.....72

Introduction.....	73
System Alarm Levels.....	73
Trouble Detection.....	74
Output Messages.....	80
Alarm Clearing Procedures.....	81
Retrieve Trouble Report.....	82
Hourly Status Message Reports.....	83
Maintenance System Event Logs.....	87
Obituaries.....	88
Terminal Not Responding.....	89
Printer Not Working.....	91
Modem Not Working.....	92
Link Maintenance.....	92
Link Maintenance Enhancements.....	98
Power Down of In-Service System.....	106
Power Up of the System.....	109

Appendix A: Card Removal/Replacement Procedures.....110

Introduction.....	111
EAGLE 5 ISS Replacement Parts List.....	111
E5-MASP Card Replacement.....	111
E5-MDAL Card Replacement.....	120
HIPR2 Card Replacement.....	123
HIPR Card Replacement.....	126
Determine Card Changeout Time.....	129
E5-ATM/E5-ATM-B Card Replacement.....	130
SS7 and IP7, MIM, HC-MIM and MPL Card Replacement.....	133
E5-ENET/E5-ENET-B Module.....	140

IP SIGTRAN on E5-ENET/E5-ENET-B.....	142
STPLAN/EROUTE on E5-ENET/E5-ENET-B	145
E5-TSM Card Replacement.....	149
Database Services Module (DSM).....	151
E5-SM4G/E5-SM8G-B Card Replacement.....	153
E5-IPSM Card Replacement.....	156
Database Communications Module (DCM) and EDCM/EDCM-A.....	161
Measurement Collection and Polling Module (MCPM).....	164
Replacing a Card in the EAGLE 5 ISS.....	165
Replacing Cards in the Holdover Clock.....	167
Non-Failed Clock Input (CI) Card Replacement.....	168
ST3 Card Replacement.....	169
MIS Card Replacement.....	170
TOCA Card Replacement.....	171
Fan Assembly P/N 890-0001-xx.....	173
Replace the Fan Unit.....	174
Replace Fan Controller Card.....	174
Replace Fan Assembly.....	175
Appendix B: Holdover Clock Troubleshooting Procedures.....	184
Introduction.....	185
Interpreting System Alarms, Lamps And Trouble Isolation.....	185
Appendix C: Part Numbers.....	195
Overview.....	196
Cables, Adapters.....	196
Components.....	201
Frames, Backplanes, FAPs, and Fans.....	203
Labels.....	205
Miscellaneous Parts.....	206
Power Cords for Peripherals.....	208
Glossary.....	210

List of Figures

Figure 1: FAP High-Level Block Diagram.....	22
Figure 2: Shorting Board Faceplate, Normal Mode.....	25
Figure 3: Shorting Board Faceplate, Maintenance Mode.....	25
Figure 4: Diode Board Faceplate.....	26
Figure 5: Diode Board Edge Connector J1.....	26
Figure 6: Shorting Board Faceplate, Maintenance Mode.....	27
Figure 7: Shorting Board Faceplate, Normal Mode.....	27
Figure 8: Location of FAP Components.....	28
Figure 9: FAP Component Functions.....	29
Figure 10: Removable USB Drive LOCKED.....	36
Figure 11: Removable USB Drive UNLOCKED.....	37
Figure 12: SATA Drive Locked.....	42
Figure 13: SATA Drive UNLOCKED.....	43
Figure 14: Open Diode Example.....	64
Figure 15: Steady State Example.....	64
Figure 16: Fan Assembly.....	66
Figure 17: Fan Filter Replacement.....	67
Figure 18: GMT Fuse.....	75
Figure 19: Fuse and Alarm Panel Front Layout (870-2804-01).....	76
Figure 20: Fuse and Alarm Panel Front Layout (870-0243-xx).....	77
Figure 21: Fuse and Alarm Panel Front Layout (870-1606-xx/870-2320-xx).....	77
Figure 22: Output Message Format.....	80

Figure 23: Format of Hourly Status Message Output.....	84
Figure 24: Signaling Link Network Connections.....	99
Figure 25: E5-MASP Card Inject/Eject Hardware Switch, UNLOCKED.....	114
Figure 26: E5-MASP Card Inject/Eject Hardware Switch, LOCKED.....	115
Figure 27: E5-MASP LEDs.....	120
Figure 28: E5-MDAL LEDs.....	122
Figure 29: HIPR2 LEDs.....	126
Figure 30: HIPR LEDs.....	129
Figure 31: E5-ATM/E5-ATM-B LEDs.....	133
Figure 32: E1/T1 MIM.....	137
Figure 33: MPL LEDs.....	138
Figure 34: MPLT LEDs.....	139
Figure 35: HC MIM LEDs.....	140
Figure 36: E5-ENET LEDs.....	141
Figure 37: E5-SM4G/E5-SM8G-B LEDs.....	156
Figure 38: DCM LEDs.....	163
Figure 39: EDCM-A Single-Slot LEDs.....	164
Figure 40: Push Inject/Eject Clamps Outward.....	166
Figure 41: Push in Inject/Eject Clamps.....	167
Figure 42: Holdover Clock CI Card LEDs.....	168
Figure 43: Holdover clock ST3 card LEDs.....	170
Figure 44: Holdover Clock MIS Card LEDs.....	171
Figure 45: Holdover Clock TOCA Card LEDs.....	172
Figure 46: Holdover Clock MCA Card LEDs.....	173
Figure 47: Fan Unit Mounting Screws.....	174

Figure 48: Fan card with LEDs on front of fan assembly unit.....	176
Figure 49: Fan Assembly Rear Bracket Screws.....	177
Figure 50: Fan Assembly.....	177
Figure 51: Fan tray inserted into fan tray bracket in the frame - front view.....	178
Figure 52: Tighten rear fan tray screws.....	179
Figure 53: Tighten fan side bracket screws.....	180
Figure 54: Fan card with LEDs on front of fan assembly.....	181

List of Tables

Table 1: Admonishments.....13

Table 2: Basic RMA Types.....15

Table 3: RMA Reasons for Return.....16

Table 4: System Maintenance Log.....19

Table 5: FAP Component Replacement.....22

Table 6: FAP Alarm Conditions.....23

Table 7: Additional Alarm Indicators.....24

Table 8: Power Diode Test Points.....26

Table 9: FAP Component Replacement.....29

Table 10: FAP Alarm Conditions.....31

Table 11: Additional Alarm Indicators.....32

Table 12: FAP Part Numbers and Corresponding Procedures.....32

Table 13: Tekelec Method of Procedure Test Record.....65

Table 14: Fuse and Alarm Panel Front Items (870-2804-01).....75

Table 15: Fuse and Alarm Panel Front Items (870-0243-xx).....76

Table 16: Fuse and Alarm Panel Front Items (870-1606-xx/870-2320-xx).....77

Table 17: IMT Bus Alarm Levels.....79

Table 18: Remote Link Element types.....93

Table 19: Link Fault Sectionalization Test Types.....93

Table 20: Link Fault Sectionalization Test Patterns.....94

Table 21: Hardware/Card/APPL LFS Support.....95

Table 22: Link Fault Sectionalization Data Entry Parameters.....97

Table 23: Link Fault Sectionalization Test Parameters.....	98
Table 24: Command Driven Loopback Support.....	99
Table 25: tst-slk Support.....	100
Table 26: tst-e1/tst-t1 Support.....	101
Table 27: Loopback AST Field Display.....	106
Table 28: Card Locations.....	112
Table 29: DCM Card Locations.....	161
Table 30: Input and ST3 Alarm Conditions.....	186
Table 31: Input and ST3 Corrective Actions.....	187
Table 32: Shelf and Output Alarm Conditions - Not Related to Input and ST Conditions.....	189
Table 33: Shelf and Output Corrective Actions - Not Related to Input and ST Conditions.....	192
Table 34: EAGLE 5 Cables, Connectors, and Power Cords.....	196
Table 35: EAGLE Components.....	201
Table 36: EAGLE 5 ISS Frames, Backplanes, FAPs, and Fans.....	203
Table 37: EAGLE 5 ISS Labels.....	205
Table 38: EAGLE 5 ISS Miscellaneous Part Numbers.....	206
Table 39: Power Cords for Peripherals.....	208

Chapter 1

About This Guide

Topics:

- *Overview.....12*
- *Scope and Audience.....12*
- *Documentation Admonishments.....12*
- *My Oracle Support (MOS).....13*
- *Related Publications.....14*
- *Documentation Availability, Packaging, and Updates.....14*
- *Locate Product Documentation on the Oracle Technology Network Site.....15*
- *Hardware Repair and Return.....15*
- *Maintenance Strategy.....18*
- *System Maintenance Log.....19*

This chapter describes the organization of the document and provides other information that could be useful to the reader.

Overview

Maintenance Guide provides preventive and corrective maintenance procedures used in maintaining the Oracle Communications EAGLE and the Multi-Purpose Server (MPS) systems.

Attention: Be sure to wear a wrist strap connected to the wrist strap grounding point of the EAGLE before performing any maintenance procedures on the EAGLE.

The manual is organized as follows:

- [About This Guide](#) provides general information about the organization of this manual, a description of the EAGLE maintenance strategy, and a list of acronyms and abbreviations.
- [Preventive Maintenance](#) provides recommended scheduled routines for the EAGLE.
- [Corrective Maintenance](#) provides procedures to use in response to all system alarms by the EAGLE.

In addition, these appendices of this manual provide useful reference material for maintenance, diagnostic, and troubleshooting activities.

- [Card Removal/Replacement Procedures](#)
- [Holdover Clock Troubleshooting Procedures](#)
- [Part Numbers](#)

Scope and Audience

This manual is intended for maintenance personnel who must maintain the EAGLE 5 ISS. The technician should be familiar with SS7 protocols. The manual provides preventive and corrective procedures that will aid maintenance personnel in maintaining the EAGLE 5 ISS.





Preventive maintenance procedures are routines to be carried out on a scheduled basis to help prevent system failures. These routines are industry-standard recommendations and may be adopted to fit any company maintenance plan.

The corrective maintenance procedures are those used in response to a system alarm or output message. These procedures are EAGLE 5 ISS-specific and aid in the detection, isolation, and repair of faults.

Documentation Admonishments

Admonishments are icons and text throughout this manual that alert the reader to assure personal safety, to minimize possible service interruptions, and to warn of the potential for equipment damage.

Table 1: Admonishments

Icon	Description
 DANGER	Danger: (This icon and text indicate the possibility of <i>personal injury</i> .)
 WARNING	Warning: (This icon and text indicate the possibility of <i>equipment damage</i> .)
 CAUTION	Caution: (This icon and text indicate the possibility of <i>service interruption</i> .)
 TOPPLE	Topple: (This icon and text indicate the possibility of <i>personal injury and equipment damage</i> .)

My Oracle Support (MOS)

MOS (<https://support.oracle.com>) is your initial point of contact for all product support and training needs. A representative at Customer Access Support (CAS) can assist you with MOS registration.

Call the CAS main number at **1-800-223-1711** (toll-free in the US), or call the Oracle Support hotline for your local country from the list at <http://www.oracle.com/us/support/contact/index.html>. When calling, make the selections in the sequence shown below on the Support telephone menu:

1. Select **2** for New Service Request
2. Select **3** for Hardware, Networking and Solaris Operating System Support
3. Select **2** for Non-technical issue

You will be connected to a live agent who can assist you with MOS registration and provide Support Identifiers. Simply mention you are a Tekelec Customer new to MOS.

MOS is available 24 hours a day, 7 days a week, 365 days a year.

Emergency Response

In the event of a critical service situation, emergency response is offered by the Customer Access Support (CAS) main number at **1-800-223-1711** (toll-free in the US), or by calling the Oracle Support hotline for your local country from the list at <http://www.oracle.com/us/support/contact/index.html>. The emergency response provides immediate coverage, automatic escalation, and other features to ensure that the critical situation is resolved as rapidly as possible.

A critical situation is defined as a problem with the installed equipment that severely affects service, traffic, or maintenance capabilities, and requires immediate corrective action. Critical situations affect service and/or system operation resulting in one or several of these situations:

- A total system failure that results in loss of all transaction processing capability
- Significant reduction in system capacity or traffic handling capability
- Loss of the system's ability to perform automatic system reconfiguration
- Inability to restart a processor or the system
- Corruption of system databases that requires service affecting corrective actions
- Loss of access for maintenance or recovery operations
- Loss of the system ability to provide any required critical or major trouble notification

Any other problem severely affecting service, capacity/traffic, billing, and maintenance capabilities may be defined as critical by prior discussion and agreement with Oracle.

Related Publications

For information about additional publications that are related to this document, refer to the *Related Publications Reference* document, which is published as a separate document on the Oracle Technology Network (OTN) site. See [Locate Product Documentation on the Oracle Technology Network Site](#) for more information.

Documentation Availability, Packaging, and Updates

Tekelec provides documentation with each system and in accordance with contractual agreements. For General Availability (GA) releases, Tekelec publishes a complete EAGLE 5 ISS documentation set. For Limited Availability (LA) releases, Tekelec may publish a documentation subset tailored to specific feature content or hardware requirements. Documentation Bulletins announce a new or updated release.

The Tekelec EAGLE 5 ISS documentation set is released on an optical disc. This format allows for easy searches through all parts of the documentation set.

The electronic file of each manual is also available from the [Tekelec Customer Support](#) site. This site allows for 24-hour access to the most up-to-date documentation, including the latest versions of Feature Notices.

Printed documentation is available for GA releases on request only and with a lead time of six weeks. The printed documentation set includes pocket guides for commands and alarms. Pocket guides may also be ordered separately. Exceptions to printed documentation are:

- Hardware or Installation manuals are printed without the linked attachments found in the electronic version of the manuals.
- The Release Notice is available only on the Customer Support site.

Note: Customers may print a reasonable number of each manual for their own use.

Documentation is updated when significant changes are made that affect system operation. Updates resulting from Severity 1 and 2 Problem Reports (PRs) are made to existing manuals. Other changes

are included in the documentation for the next scheduled release. Updates are made by re-issuing an electronic file to the customer support site. Customers with printed documentation should contact their Sales Representative for an addendum. Occasionally, changes are communicated first with a Documentation Bulletin to provide customers with an advanced notice of the issue until officially released in the documentation. Documentation Bulletins are posted on the Customer Support site and can be viewed per product and release.

Locate Product Documentation on the Oracle Technology Network Site

Oracle customer documentation is available on the web at the Oracle Technology Network (OTN) site, <http://docs.oracle.com>. You do not have to register to access these documents. Viewing these files requires Adobe Acrobat Reader, which can be downloaded at www.adobe.com.

1. Log into the Oracle Technology Network site at <http://docs.oracle.com>.
2. Under **Applications**, click the link for **Communications**.
The **Oracle Communications Documentation** window opens with Tekelec shown near the top.
3. Click **Oracle Communications Documentation for Tekelec Products**.
4. Navigate to your Product and then the Release Number, and click the **View** link (the **Download** link will retrieve the entire documentation set).
5. To download a file to your location, right-click the PDF link and select **Save Target As**.

Hardware Repair and Return

Any system components being returned for repair or replacement must be processed through the Tekelec Return Material Authorization (RMA) procedures. A hardware repair is defined as an item returned to Tekelec due to a failure, with the returned item being repaired and returned to the customer. It is essential that serial numbers are recorded correctly. RMAs cannot be created without a valid serial number. All repair and quality information is tracked by serial number. [Table 2: Basic RMA Types](#) lists the basic RMA types. [Table 3: RMA Reasons for Return](#) lists the RMA return reasons.

Table 2: Basic RMA Types

Replacement Type	Description	Turnaround
Priority Advance Replacement	Customer requests the URGENT replacement of a damaged product	Same Day Shipment
Advance Replacement	Customer request the replacement of a damaged product	Shipment Within 3 Business Days
Repair / Return	Customer will return a damaged product for repair	Shipment Within 5 Days After Receipt

Replacement Type	Description	Turnaround
Expendable	A damaged part, such as a cable, is replaced, but the Customer does not return the damaged product	Depends on Urgency - Shipment Within 3 Business Days

Table 3: RMA Reasons for Return

Reason for Return	Description
Damaged by Environment	Product damaged by environmental phenomena such as water damage or earthquake.
Damaged in Shipment	Damaged between shipment from Tekelec and receipt at the Customer's installation site.
DOA – Dead on Arrival	Product is not functional when it is first installed at the Customer's location.
Lab Return	Products returned from lab sites.
Product Capture	Defect to be captured by Quality or Engineering (not Product Recall).
Product Deficiency	Anything wrong with the part that doesn't fall into another category.
Product Recall	Products recalled by divisions for the repair of a defect or replacement of defective products.
Return – No Product Deficiency	Anything returned without the product being defective.

Repair and Return Shipping Instructions

All returned equipment, assemblies, or subassemblies must be shipped to the Tekelec Repair and Return Facility specified by the [My Oracle Support \(MOS\)](#). The item being returned must be shipped in the original carton or in an equivalent container assuring proper static handling procedures and with the freight charges prepaid.

The assigned RMA number must be clearly printed on the "RMA#:" line of the shipping label on the outside of the shipping package. If the RMA number is not placed on the label, the return could be delayed.

Procedure - RMA

1. Obtain and confirm the following information before contacting the [My Oracle Support \(MOS\)](#):
 - Your name:
 - Company name:

- Call-back number:
 - Email address:
 - Which product you are calling about?
 - Site location:
 - CLEI number
 - System serial number (NT, CE, LM, DS, etc.):
 - Complete software release (e.g., 28.0.1-41.53.0):
 - Upgrade forms
 - WI005153
 - WI005154
 - WI005218
 - WI005219
 - WI005220
 - Tekelec card type: (e.g., MPL, DSM, etc.):
 - Tekelec card part number (870-####-##):
 - Associated serial number (102#####):
 - Reason for return or replacement (isolated from system):
 - Full name of person the replacement card is being shipped to:
 - Shipping address:
 - Note:** If possible, include associated alarms (UAMs) and a copy of the associated output (capture file).
2. Contact the *My Oracle Support (MOS)* and request a Return of Material Authorization (RMA).
 3. If the item is a like-for-like advance replacement, the *My Oracle Support (MOS)* arranges for shipment of the replacement item to the customer.
 - a) Wait for the replacement component to arrive.
 - b) Package the defective component in the box of materials you received with your replacement. Use proper static handling procedures.
 - c) Label the outside and inside of the box with your RMA number clearly visible. Place the packing slip from the received replacements on the inside of your box.
 - d) Ship the defective component to the return address listed on the packing slip.
 4. If the item is a repair/return, the *My Oracle Support (MOS)* arranges for shipment of the replacement item to the customer.
 - a) Package the defective component in a suitable package for shipping. Use proper static handling procedures.
 - b) Label the outside and inside of the box with your RMA number clearly visible. Include a packing slip with all the information from *Step 1* along with the RMA number.
 - c) Ship the defective component to the following address:

TEKELEC
Attn: RMA Department
5200 Paramount Parkway
Morrisville, NC 27560
RMA#: <assigned by Tekelec>

- d) Wait for the repaired component to arrive.

Maintenance Strategy

The EAGLE 5 ISS is equipped with an automated surveillance system, which allows many failures to be detected and repaired autonomously. When trouble is detected, and its cause determined, the system software attempts to isolate the trouble and recover itself through reinitialization. Because of the use of distributed processing throughout the system, the reinitialization can be localized with little or no impact on the rest of the system or network.

If the system software is unable to correct the problem, an output message is generated and maintenance personnel are provided with equipment location, nature of the trouble, and alarm severity.

There are three levels of recovery in the EAGLE 5 ISS:

- Application self recovery
- System maintenance software intervention
- Maintenance personnel intervention.

Application Self Recovery

This is the most desirable method of recovery, as it is nearly transparent to the network, and does not require any system resources. Examples of applications capable of self recovery:

- Link failure
- Link set failure
- Route failure
- Interprocessor message transport (IMT) bus failure.

Failure of a link relies on SS7 maintenance to correct the trouble. This usually entails placing the link out of service (OS), re-aligning the link, then placing the link back in service.

Route failures also rely on SS7 maintenance. Transfer restricted (TFR) and transfer prohibited (TFP) are commonly used to reroute messages around a node.

System Maintenance Software Intervention

The system maintenance software operates at two levels, maintenance and administration subsystem (MAS) and application subsystem (SS7, GLS, DTA, and STPLAN). All troubles detected at the

Chapter 2

Preventive Maintenance

Topics:

- *Introduction.....21*
- *Maintaining the Fuse and Alarm Panel.....21*
- *Removable Drives.....35*
- *Daily Procedures.....55*
- *Weekly Procedures.....58*
- *Monthly Procedures.....60*
- *Quarterly Procedures.....69*
- *Semi-Annual Procedures.....71*

Introduction

The procedures on the following pages are routine maintenance procedures to be performed on a scheduled basis. These procedures are recommendations that if followed will aid in maintaining system performance and data integrity.

These routines aid in detecting trouble trends and intermittent troubles. As with any maintenance activity, personnel should be encouraged to maintain a log of all routines performed. This aids the maintenance technician as well as the Tekelec *My Oracle Support (MOS)* in determining the source of system troubles and ways to prevent certain troubles from occurring again.

Instructions for performing required maintenance routines are provided. In the event another document may be required for a specific task, that document is referenced.

Maintaining the Fuse and Alarm Panel

The Fuse and Alarm Panel (FAP) serves as a central location for identifying a variety of potential problem conditions. However, you may have to occasionally perform corrective maintenance on the FAP, itself.

The FAP consist of five major functions:

- Input connections
- Diodes
- Fuse Arrays
- Alarm circuitry
- Output connections

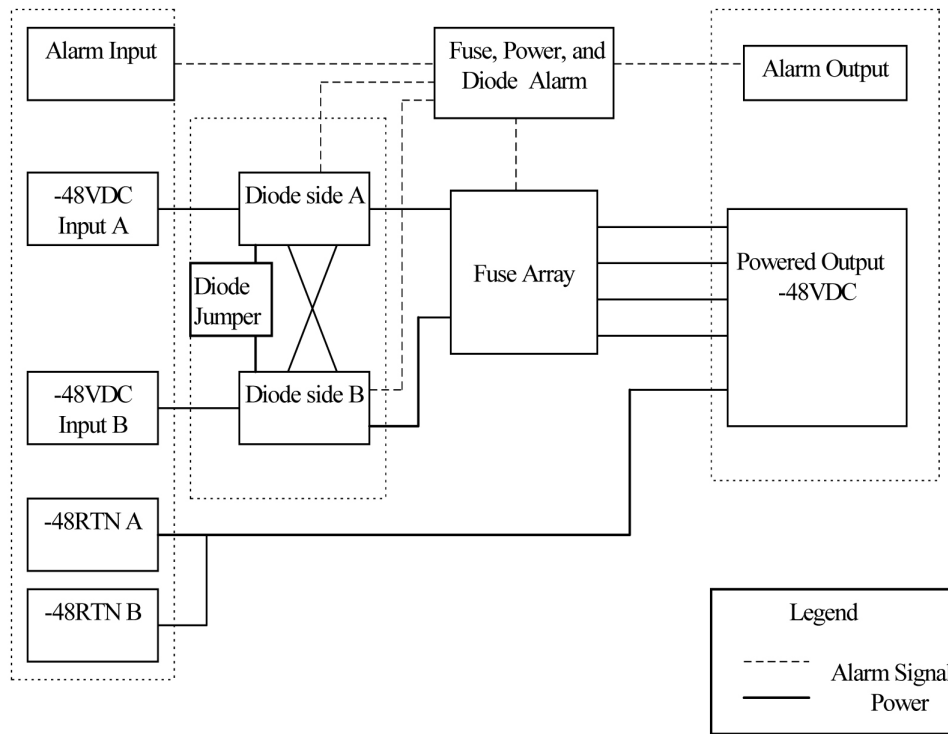

Figure 1: FAP High-Level Block Diagram

To assist your FAP maintenance efforts, this section provides information about the FAP unit:

- The FAP components
- FAP alarms
- Diode testing and the diode jumper

For more detailed information on the FAP and its components, refer to the *FAP Technical Reference (820-2888-01)*.

1U FAP P/N 870-2804-01

The 1U FAP (P/N 870-2804-01) is a low-profile unit that provides protected distribution of -48VDC power to the shelves in the frame. Allowing for the full population of a frame and for the failure of one primary supply, new installations of Control and Extension frames require two 60A feeds.

FAP Components

The FAP is composed of three field replaceable units, of which two can be hot-swapped.

Table 5: FAP Component Replacement

Component	Replacement Requirements	Part Number
Diode Board	Field replaceable	870-2806-01

Component	Replacement Requirements	Part Number
Shorting Board	Field replaceable	870-2805-01
1U FAP	Field replaceable (with service interruption)	870-2804-01 (includes Diode and Shorting Boards)

Diode Board

The diode board in the FAP contains power diodes and circuitry which allow one bus to pick up the entire load when there is a loss of input power on the other bus.

Shorting Board

The Shorting board allows the removal of the diode board without taking down the system. This permits periodic maintenance of the diodes without having to power down or remove the unit from the shelf. In the bypass position, both A and B power is connected to the fuse blocks so the diode board can be safely removed. The Shorting board has an LED which is off when the board is in normal operational mode and is green when in the bypass mode of operation.

Alarms

The FAP provides visual alarms, by means of a lit LED, for a variety of status alarms.

Table 6: FAP Alarm Conditions

Alarm	Alarm Condition	Remote Indications
Critical LED	<ul style="list-style-type: none"> • EAGLE 5 ISS command through E5-TDM • E5-MDAL not present and E5-MDAL_P jumper off 	Dependent on EAGLE 5 ISS software
Major LED	EAGLE 5 ISS command through E5-TDM	Dependent on EAGLE 5 ISS software
Minor LED	EAGLE 5 ISS command through E5-TDM	Dependent on EAGLE 5 ISS software
Fuse LED	<ul style="list-style-type: none"> • Distribution fuse blown • Alarm circuit board removed (no LED indication) • Jumper on the jumper circuit board is on • Power feed failure 	Fuse alarm to EAGLE 5 ISS through E5-TDM
PWR A LED	Power feed A is off, but power is available to B.	Fuse alarm to EAGLE 5 ISS through E5-TDM

Alarm	Alarm Condition	Remote Indications
PWR B LED	Power feed B is off, but power is available to A.	Fuse alarm to EAGLE 5 ISS through E5-TDM
Shorting Board LED	Shorting board in maintenance mode.	Fuse alarm to EAGLE 5 ISS through E5-TDM

A fuse alarm identifies the following problems or conditions within the FAP:

- blown fuse(s)
- power loss for side A or B
- alarm card removed
- maintenance mode

Use the following indicators to determine the nature of the problem:

Table 7: Additional Alarm Indicators

Indicator	Alarm Condition
Fuse alarm and fuse flag down	Blown fuse
Fuse alarm and PWR A LED	Input power loss on A
Fuse alarm and PWR B LED	Input power loss on B
Fuse alarm red and Shorting Board LED is green	Shorting Board in maintenance mode (by-passing diodes)
Fuse alarm red and Shorting Board LED is off	Shorting Board in normal mode, blown fuse

Diode Testing and the Shorting Board

The Diode Board must be tested periodically. To test the Diode Board without powering down the entire EAGLE 5 ISS, perform the following procedures.

Maintenance Mode

This section describes how to place the Shorting Board into maintenance (bypass) mode. Maintenance mode allows the removal of the Diode Board without taking down the system.

Procedure — Shorting Board Maintenance Mode

1. Check to verify the Shorting Board LED is not on, indicating the FAP is in normal mode.
2. Locate two screws securing the Shorting Board in its slot (see [Figure 2: Shorting Board Faceplate, Normal Mode](#)). Note the orientation of the Shorting Board LED. Turn the screws at each corner of the board to the left until they disengage.

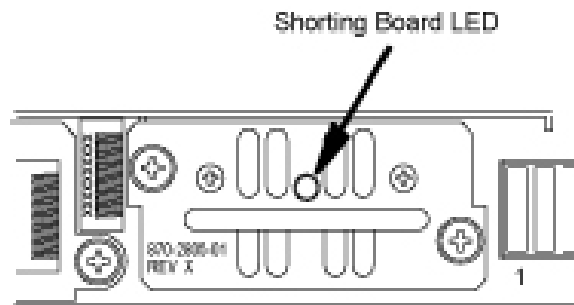

Figure 2: Shorting Board Faceplate, Normal Mode

3. Pull the board straight out of the FAP until the board is clear of the frame.
4. Turn the Shorting Board over and reinsert the board into its slot. Note the orientation of the Shorting Board LED (see [Figure 3: Shorting Board Faceplate, Maintenance Mode](#)).

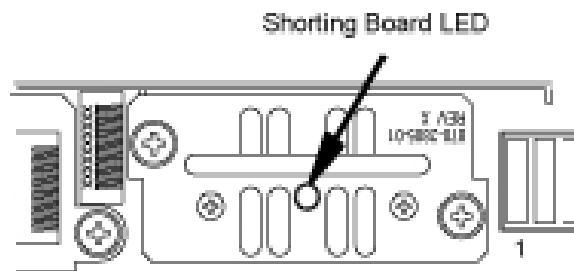

Figure 3: Shorting Board Faceplate, Maintenance Mode

The Shorting Board LED turns green and the fuse alarm LEDs turn red.

5. Ensure the board is seated properly and tighten the two screws to secure the board.
6. The Shorting Board is now in the maintenance (bypass) mode of operation.

Diode Board

This section describes how to remove and test the Diode Board.

Procedure — Remove the Diode Board

Use this procedure to remove the Diode Board for diode testing.

1. Check to verify the Shorting Board LED is on, indicating the FAP is in maintenance (bypass) mode.
2. Locate two screws securing the Diode Board in its slot. Turn the screws to the left until they disengage.

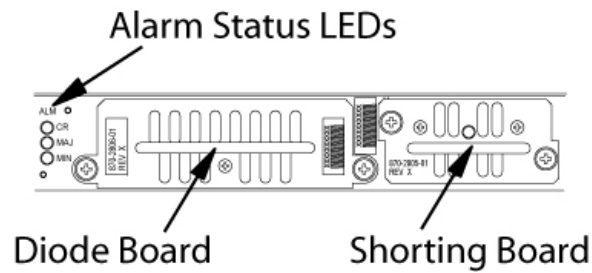

Figure 4: Diode Board Faceplate

3. Pull the board straight out of the FAP until the board is clear of the frame.

Procedure - Diode Testing

Use this procedure to test the power diodes on the Diode Board. A Digital Volt/Ohm Meter (DVM) with a Diode Setting is required. All testing is performed at the edge connector (J1) on the board.

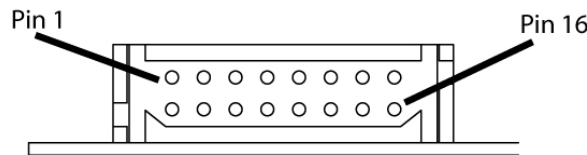

Figure 5: Diode Board Edge Connector J1

1. Set the DVM to test diodes.
2. Connect the DVM positive (+) lead and negative (-) lead to the pins indicated for each power diode.

Table 8: Power Diode Test Points

Diode	J1 Pin Positive (+) Lead	J1 Pin Negative (-) Lead
CR1 #1	3	16
CR1 #2	6	16
CR2 #1	14	1
CR2 #2	11	1
CR3 #1	4	16
CR3 #2	5	16
CR4 #1	13	1
CR4 #2	12	1

The DVM should indicate a short circuit (>0.1V, <0.2V). Record the measurement.

3. Reverse the leads.

The DVM should indicate an open circuit (OL). Record the measurement.

4. If any measurements are in error, the diode board must be replaced.
5. If the measurements are within acceptable parameters, reinstall the Diode Board.

Normal Mode

Use this procedure to place the Shorting board into normal mode. This mode of operation allows one bus to pick up the entire load when there is a loss of input power on the other bus.

Procedure — Shorting Board Normal Mode

1. Check to verify the Shorting Board LED is green, indicating the FAP is in maintenance mode.
2. Locate two screws securing the Shorting Board in its slot. Note the orientation of the Shorting Board LED (*Figure 6: Shorting Board Faceplate, Maintenance Mode*). Turn the screws at each corner of the board to the left until they disengage.

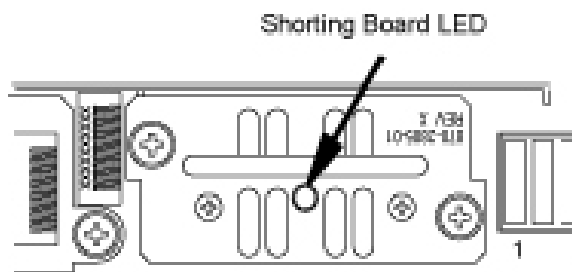

Figure 6: Shorting Board Faceplate, Maintenance Mode

3. Pull the board straight out of the FAP until the board is clear of the frame.
4. Turn the Shorting Board over and reinsert the board into its slot. Note the orientation of the Shorting Board LED (see *Figure 7: Shorting Board Faceplate, Normal Mode*).

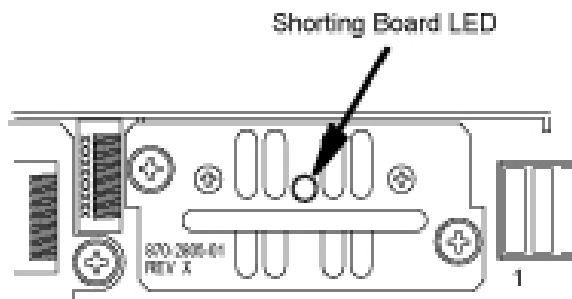

Figure 7: Shorting Board Faceplate, Normal Mode

Note: The Shorting Board LED is off and the fuse alarm LEDs turn green.

5. Ensure the board is seated properly and tighten the two screws to secure the board.
6. The Shorting Board is now in the normal mode of operation.

3U FAP

The 3U FAP is a normal-profile unit that provides protected distribution of -48VDC power to the shelves in the frame. Allowing for the full population of a frame and for the failure of one primary

supply, new installations of Control and Extension frames require two 60A feeds. The 3U FAP may be one of the following:

- 870-1606-01 (all revisions)
- 870-1616-02 with a revision G or lower
- 870-2320-01 with a revision B or lower

FAP Components

The FAP consists of nine printed circuit boards, each identified by an acronym on its label (see [Figure 8: Location of FAP Components](#)):

- Backplane (FAP_BP): Located inside the FAP unit, parallel to the back side of the FAP box.
- Alarm board (FAP_AB): Located on the center-right of the front panel, set vertically inside the FAP unit, perpendicular to the front panel.
- Diode boards (FAP_DB): Two boards located on the front panel, flanking the Alarm and Jumper boards on the left and right, and perpendicular to the front panel. Set vertically inside the FAP unit.
- Extender boards (FAB-EB): Two boards located inside the FAP unit, parallel to the bottom of the FAP box, on the far right and left of the unit.
- Fuse holder boards (FAP_FB): Two boards located inside and parallel to the front panel, on the far right and left of the FAP unit.
- Jumper board (FAP_JB): Located on the center-left of the front panel, set vertically in the unit, perpendicular to the front panel.

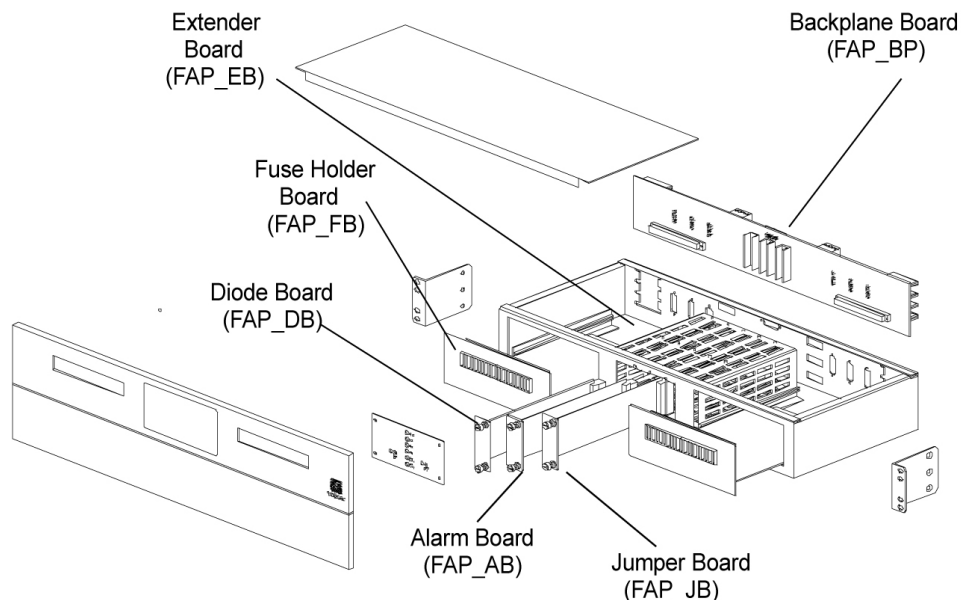

Figure 8: Location of FAP Components

Each of the FAP components has associated functions.

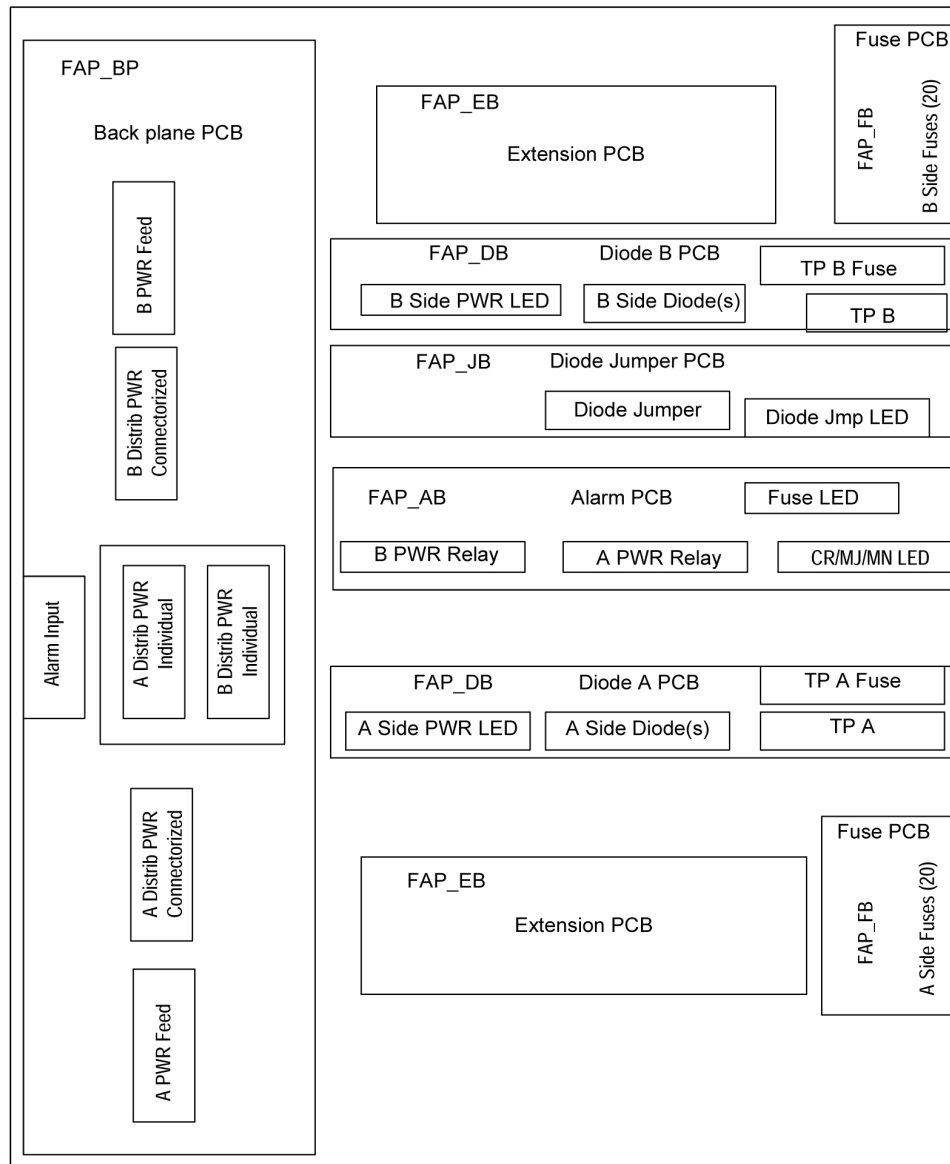

Figure 9: FAP Component Functions

The FAP is composed of nine circuit boards. Eight of these circuit boards are field replaceable, and can be hot-swapped.

Table 9: FAP Component Replacement

Component	Replacement Requirements	Part Number
FAP Backplane (FAP_BP)	Must be replaced through factory	850-0515-xx
FAP Alarm Board (FAP_AB)	Field replaceable	850-0518-xx (card) 870-1609-xx (assembly)

Component	Replacement Requirements	Part Number
FAP Diode Boards (FAP_DB_A and FAP_DB_B)	Field replaceable (one at a time)	850-0517-xx (card) 870-1608-xx (assembly)
FAP Extender Boards (FAP_EB)	Field replaceable (one at a time with service interruption)	850-0519-xx
FAP Fuse Holder Boards (FAP_FB)	Field replaceable (one at a time with service interruption)	850-0516-xx
FAP Jumper Board (FAP_JB)	Field replaceable	850-0523-xx (card) 870-1641-xx (assembly)

The following sections describe each type of circuit board:

Backplane Board (FAP_BP)

The backplane circuit board provides all of the external connections for the FAP. It consists primarily of circuit routing and connectors, but also has one pull-down resistor, which provides a default alarm signal for the Fuse Alarm in the event the alarm board is removed from the FAP.

Alarm Board (FAP_AB)

The alarm circuit board provides indicators and relays for the EAGLE status and fuse alarms. This board includes a jumper (JMP50) for future use. This jumper is installed for all existing configurations.

Diode Boards (FAP_DB)

The diode circuit boards provide power diodes and power input test points. Four diode footprints are included: two for Assembly A and two for Assembly B. Only one of the four positions is intended to be populated; the second footprint is provided for future part rating changes or additional heat-dissipation capabilities.

Extender Boards (FAP_EB)

The extender board provides connection between the backpanel board and the fuse holder boards.

Fuse Holder Boards (FAP_FB)

The fuse holder boards provide 20 fuses with a common alarm.

Jumper Board (FAP_JB)

The jumper board provides the capability to by-pass the diode boards with a fuse. Use this board only for maintenance operations.

Alarms

The FAP provides visual alarms, by means of a lit LED, for a variety of status alarms (see [Table 10: FAP Alarm Conditions](#)).

Table 10: FAP Alarm Conditions

Alarm	Alarm Condition	Remote Indications
Critical LED	<ul style="list-style-type: none"> • EAGLE 5 ISS command through E5-MCAP • E5-MDAL not present and E5-MDAL_P jumper off 	Dependent on EAGLE 5 ISS software
Major LED	EAGLE 5 ISS command through E5-MCAP	Dependent on EAGLE 5 ISS software
Minor LED	EAGLE 5 ISS command through E5-MCAP	Dependent on EAGLE 5 ISS software
Fuse LED	<ul style="list-style-type: none"> • Distribution fuse blown • Alarm circuit board removed (no LED indication) • Jumper on the jumper circuit board is on • Power feed failure 	Fuse alarm to EAGLE 5 ISS through E5-MCAP
PWR A LED	Power feed A is off, but power is available to B.	Fuse alarm to EAGLE 5 ISS through E5-MCAP
PWR B LED	Power feed B is off, but power is available to A.	Fuse alarm to EAGLE 5 ISS through E5-MCAP
OP/MAINTLED	Jumper on the jumper circuit board is on.	Fuse alarm to EAGLE 5 ISS through E5-MCAP

A fuse alarm identifies the following problems or conditions within the FAP:

- blown fuse(s)
- power loss for side A or B
- alarm card removed
- maintenance mode

Use the following indicators to determine the nature of the problem:

Table 11: Additional Alarm Indicators

Indicator	Alarm Condition
Fuse alarm and fuse flag down	Blown fuse
Fuse alarm and PWR A LED	Input power loss on A
Fuse alarm and PWR B LED	Input power loss on B
Fuse alarm and OP/MAINT LED is red	Diode jumper is installed (by-passing diodes)

Diode Testing and the Diode Jumper

The diode board must be tested periodically. To test a diode circuit board without powering down the entire EAGLE 5 ISS, perform the procedure listed in [Table 12: FAP Part Numbers and Corresponding Procedures](#) for the corresponding FAP part number.

Table 12: FAP Part Numbers and Corresponding Procedures

Part Number	FAP Procedure
870-1606-01 (all revisions)	Procedure 1
870-1616-02 revision G or lower	Procedure 1
870-1606-02 revision H or higher	Procedure 2
870-2320-01 revision B or lower	Procedure 1
870-2320-01 revision C or higher (or 870-2320-03)	Procedure 2

Procedure 1.

This procedure to test a diode circuit board without powering down the entire EAGLE 5 ISS applies to the following FAPs:

- 870-1606-01 (all revisions)
- 870-1616-02 with a revision G or lower
- 870-2320-01 with a revision B or lower

1. Check to verify the OP/MAINT LED is green, indicating the FAP is not in maintenance mode.
2. Unscrew the two thumbscrews securing the FAP jumper board and remove the board.
3. On the jumper circuit board, move the jumper (the DB-26 male connector) from P71 to P72. Tighten the thumbscrews connecting the jumper to its mate, to ensure a good connection. This repositioning overrides the diodes, establishing a direct connection between input and fuse panels.



Warning: If fuses are blown, DONOT continue with this procedure. Instead, contact [My Oracle Support \(MOS\)](#) at the appropriate number.

4. Make sure the glass fuses are installed and verify they are “good” by using the multimeter to check for continuity across each of the glass fuses.
5. Verify that two glass fuses are behind the P72 connector. If these fuses are not present, install them before continuing.
6. Slide the jumper board back into the FAP and verify both of the following alarms display:
 - the OP/MAINT LED lights red on the FAP
 - an EAGLE 5 ISS fuse alarm displays on the terminal

You may now remove either or both diode circuit boards without affecting EAGLE 5 ISS service.

Note: Using the jumper override negates the backpower protection usually provided by the diode board.

7. Locate diode board A and unscrew the two thumbscrews securing the board. Remove the board from the FAP.
8. Locate the diode to be tested. It has three pins and is attached to the large heat sink. The diode is labeled CR43.
9. Set your digital multimeter to measure resistance.
10. Measure the resistance between the center pin of the diode and either of the outside pins. Record this measurement.
11. Measure the resistance between these same pins again, but switch the multimeter leads, so the positive lead is now on the opposite pin. Record this measurement.
12. Compare the two measurements. If the diode is functioning properly, one reading should be less than 10K ohms and the other should be much greater.

If both readings are above or below 10K ohms, the diode may have failed. Replace the failed board with a spare diode board.
13. Repeat steps 9 through 11, measuring the resistance between the *other* outside pin and the center pin.

This completes the test for diode board A.
14. Repeat steps 6 through 12, using diode board B. This completes the test for diode board B.
15. Reinsert the two functional diode boards. Tighten the thumbscrews on each board to secure it to the FAP.
16. Unscrew the two thumbscrews securing the FAP jumper board and remove the board.
17. On the jumper circuit board, move the jumper (the DB-26 male connector) back from P72 to its original position on P71. Tighten the thumbscrews connecting the jumper to its mate, to ensure a good connection. This repositioning returns the diodes to their original, non-maintenance position.

18. Slide the jumper board back into the FAP. Verify the OP/MAINT LED lights green. The fuse alarm LED returns to green.

The diode board testing procedure is completed.

Procedure 2.

This procedure to test a diode circuit board without powering down the entire EAGLE 5 ISS applies to the following FAPs:

- 870-1606-02 with revision H or higher
- 870-2320-01 with revision C or higher (or 870-2320-03)

1. Check to verify the OP/MAINTLED is green, indicating the FAP is not in maintenance mode.
2. Unscrew the two thumbscrews securing the FAP jumper board and remove the board.
3. On the jumper circuit board, unclip the 12 pin connector jumper from P71 and re-attach it to P72. Insert it until the plastic retaining clips "snap". Note that the jumper has a retaining strap so it won't get dropped or lost. This repositioning overrides the diodes, establishing a direct connection between input and fuse panels.



Warning: If fuses are blown, DONOT continue with this procedure. Instead, contact [My Oracle Support \(MOS\)](#) at the appropriate number.

4. Slide the jumper board back into the FAP and verify both of the following alarms display:
 - the OP/MAINTLED lights red on the FAP
 - an EAGLE 5 ISS fuse alarm displays on the terminal

You may now remove either or both diode circuit boards without affecting EAGLE 5 ISS service.

5. Locate diode board A and unscrew the two thumbscrews securing the board. Remove the board from the FAP.
6. Locate the diode to be tested. There are two power diodes, each with three pins. They are labeled CR43 and CR44 for diode board A.
7. Set your digital multimeter to diode check mode..
8. Measure the voltage drop between the center pin of the CR43 diode and either of the outside pins with the ground probe on the center lead. Record this measurement.
9. Measure the voltage drop between these same pins again, but switch the multimeter leads, so the positive lead is now on the opposite pin. Record this measurement.
10. Compare the two measurements. If the diode is functioning properly, the first reading should be between 0.2 and 0.1 volts and the other should be read as an open circuit. Otherwise, replace² the failed board with a spare diode board.

11. Repeat [Step 9](#) through [Step 10](#), measuring the voltage between the *other* outside pin and the center pin of CR43.
12. Repeat [Step 6](#) through [Step 10](#), using diode board B.
This completes the test for diode board B.
13. Reinsert the two functional diode boards.
Tighten the thumbscrews on each board to secure it to the FAP.
14. Unscrew the two thumbscrews securing the FAP jumper board and remove the board.
15. On the jumper circuit board, unclip the 12 pin connector jumper back from P72 to its original position on P71.
Insert it until the plastic retaining clips “snap.” This repositioning returns the diodes to their original, non-maintenance position.
16. Slide the jumper board back into the FAP.
Verify the OP/MAINTLED lights green. The fuse alarm LED returns to green. The diode board testing procedure is completed.

Removable Drives

This section provides information about the removable drives associated with the EAGLE 5 ISS Maintenance Administration Subsystem Processor (MASP).

A removable drive is used for two purposes:

- To hold an off-line, backup copy of the administered data and system GPLs
- To hold a copy of the measurement tables

To use a removable drive to hold the system data, it must be formatted for system data. To use a removable drive to hold measurements data, it must be formatted for measurements data. The EAGLE 5 ISS provides the user the ability to format a removable drive for either of these purposes. A removable drive can be formatted on the EAGLE 5 ISS by using the `format-disk` command. For more information on the `format-disk` command refer to the *Commands Manual*.

Removable drives described in this section include:

- [Removable USB Drive](#)
- [Fixed SATA Drive](#)

Removable USB Drive

Purpose: This section is referenced in this manual by many procedures requiring the use of the removable USB thumb disk in the E5-MASP card. The procedures found in this section are recommended procedures for handling the removable USB drive in the E5-MASP card.

Requirements: None

Procedure - Remove USB Drive

1. Verify that the removable USB drive is locked in position and in use.

The removable drive latch (SW1) is in the LOCKED position and the Removable Media Status LED on the E5-MASP is Off. Refer to [Figure 10: Removable USB Drive LOCKED](#).

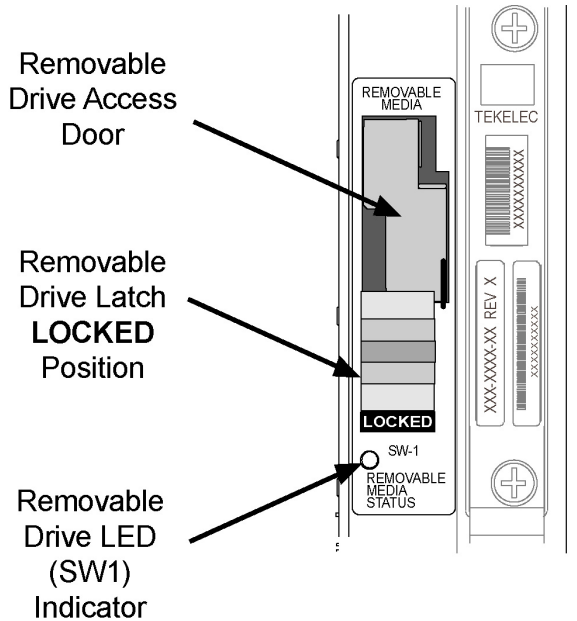

Figure 10: Removable USB Drive LOCKED

2. Move SW1 from the LOCKED to the unlocked position and wait for the LED to indicate a steady blue state. See [Figure 11: Removable USB Drive UNLOCKED](#).

When SW1 is transitioned from locked to unlocked, the LED will flash blue to indicate the drive is unlocked and in process of shutting down.



Caution: Removal of the drive prior to the LED indicating steady blue could result in drive corruption.

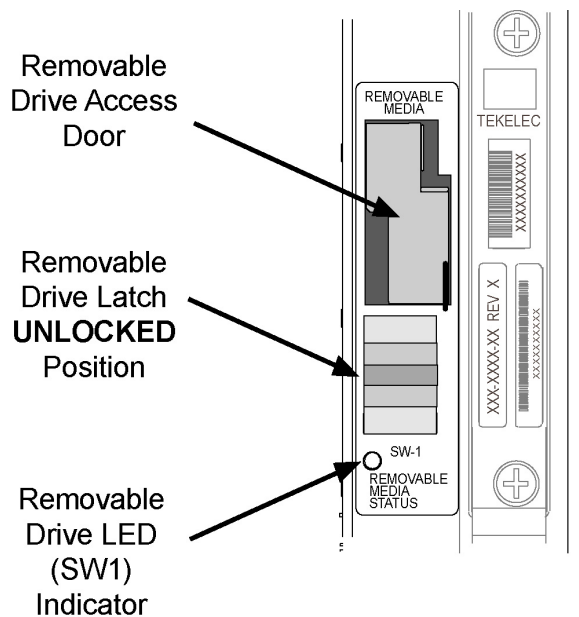

Figure 11: Removable USB Drive UNLOCKED

3. When the LED indicates a steady blue state, the removable USB drive can be safely removed. The LED is off when the USB drive is fully ejected from the drive media. The USB drive can now be removed from the drive media.
4. Lift the access door up, swing it past the detent position so that the door remains open on its own.
5. Grasp the pull tab of the slide and pull the slide out slowly until it stops (it travels about a half inch).



Caution: The full travel of the slide is less than an inch, do not try to pull the assembly to expose the full length of the thumb drive as this is beyond the slide's designed travel.

6. The USB drive is disengaged and can be taken from the inject eject assembly.
7. Insert a USB drive into the inject-eject assembly.
8. Grasp the pull tab of the slide and push the slide in slowly until you feel the USB drive is seated in its slot (it travels about a half inch).
9. Close the access door.
10. Move SW1 from the unlocked to the LOCKED position.

When SW1 is transitioned from unlocked to locked, the LED will flash blue to indicate the drive is locked and in process of coming online.

11. When the LED turns Off, the removable USB drive is ready for use.

Fixed SATA Drive

Purpose: This section is referenced in this manual by many procedures requiring the use of the fixed SATA drive in the E5-MASP card. The procedures found in this section are recommended procedures for handling the fixed drive in the E5-MASP card.

- Requirements**
- The new SATA Drives to be installed should be at the current system release.
 - Before beginning this procedure, make sure there is a copy of the current release GPLs on a removable USB drive on-hand.
 - System backups should be performed prior to the start of this procedure. Refer to [Daily Procedures](#).
 - You must be logged in to the EAGLE prior to performing this procedure.

Procedure - Remove Fixed SATA Drive

1. Enter the following command to verify that the Measurement feature bit is on.

```
rtrv-feat
```

The following is an example of a possible output. The MEASPLAT field shows whether the Measurement feature is on or off. In this example, Measurement feature is **ON**.

```
eagle3 02-01-05 00:51:32 EST EAGLE5 41.2.0-62.69.65
rtrv-feat
Command entered at terminal #7.
;

eagle3 02-01-05 00:51:32 EST EAGLE5 41.2.0-62.69.65
EAGLE FEATURE LIST

GTT      = on      GWS      = on      NRT      = off
X25G     = off     LAN      = on      CRMD     = off
SEAS     = off     LFS      = off     MTPRS    = off
FAN      = on      DSTN5000 = off     WNP      = off
CNCF     = off     TLNP     = off     SCCPCNV  = off
TCAPCNV  = off     IPISUP   = off     X252000  = off
PLNP     = off     NCR      = off     ITUMTPRS = on
SLSOCB   = off     EGT      = on      VGTT     = on
MPC      = on      ITUDUPPC = on      MEASPLAT = on
TSCSYNC  = off     E5IS     = off
```

If feature bit is turned **OFF**, go to [Step 5](#).

2. Enter the following command to retrieve the measurements setup.

```
rtrv-meas-sched
```

The following is an example of a possible output. The COLLECT field shows whether measurement collection is on or off. In this example, measurement collection is **ON**.

```
npeeagle4 02-02-04 21:13:49 EST EAGLE5 41.2.0-62.69.65
rtrv-meas-sched
Command entered at terminal #1.
;

npeeagle4 02-02-04 21:13:49 EST EAGLE5 41.2.0-62.69.65
COLLECT          = ON
GTWYLSFLTR      = (both)
-----
```

```

SYSTOT-STP      = (off)
SYSTOT-TT      = (off)
SYSTOT-STPLAN  = (off)
COMP-LNKSET    = (off)
COMP-LINK      = (off)
GTWY-STP      = (off)
GTWY-LNKSET    = (off)
MTCD-STP      = (on)
MTCD-LINK      = (on)
MTCD-STPLAN    = (on)
MTCD-LNKSET    = (on)
;

```

If measurement collection is **OFF**, go to [Step 5](#).

3. Issue the following command to turn **OFF** measurement collection.

```
chg-meas:collect=off
```

The following is an example of a possible output.

```

tekelecstp YY-MM-DD hh:mm:ss TTTT PPP  XX.x.x-YY.y.y
chg-meas:collect=off
Command entered at terminal #10.
;
tekelecstp YY-MM-DD hh:mm:ss TTTT PPP  XX.x.x-YY.y.y
CHG-MEAS: MASP A - COMPLTD
;

```

4. Enter the following command to verify measurements collection is **OFF**.

```
rtrv-meas-sched
```

The following is an example of a possible output. The **COLLECT** field shows whether measurement collection is on or off. In this example, measurement collection is **OFF**.

```

npeeagle4 02-02-04 21:13:49 EST  EAGLE5 41.2.0-62.69.65
rtrv-meas-sched
Command entered at terminal #1.
;

npeeagle4 02-02-04 21:13:49 EST  EAGLE5 41.2.0-62.69.65
COLLECT          = OFF
GTWYLSFLTR       = (both)
-----
SYSTOT-STP      = (off)
SYSTOT-TT      = (off)
SYSTOT-STPLAN  = (off)
COMP-LNKSET    = (off)
COMP-LINK      = (off)
GTWY-STP      = (off)
GTWY-LNKSET    = (off)
MTCD-STP      = (on)
MTCD-LINK      = (on)
MTCD-STPLAN    = (on)
MTCD-LNKSET    = (on)
;

```

5. Enter the following command to display the card status:

```
rept-stat-card:appl=oam
```

The following is an example of a possible output.

```
Command Accepted - Processing

tekelecstp YY-MM-DD hh:mm:ss TTTT PPP XX.x.x-YY.y.y
rept-stat-card:appl=oam
Command entered at terminal #14.
;

tekelecstp 10-04-19 16:47:51 EDT EAGLE5 41.1.0-62.64.1
CARD   VERSION      TYPE      GPL      PST      SST      AST
1113   132-064-000    E5MCAP   OAMHC   IS-NR   Standby  -----
1115   132-064-000    E5MCAP   OAMHC   IS-NR   Active   -----

Command Completed.
;
```

6. Enter the following command to display the card status:

```
this rept-stat-card
```

The following is an example of a possible output.

```
e5oam 08-12-01 15:38:32 EST EAGLE 40.1.0
CARD   VERSION      TYPE      GPL      PST      SST      AST
1108   -----      MCPM     MCP      OOS-MT-DSBLD  Manual  -----
1109   030-009-000    HIPR     HIPR     IS-NR     Active  -----
1110   030-009-000    HIPR     HIPR     IS-NR     Active  -----
1111   030-010-000    IPSM     IPS      IS-NR     Active  -----
1113   030-010-008    E5MCAP   OAMHC   IS-NR     Standby  -----
1114   -----      E5TDM     OAMHC   IS-NR     Active  -----
1115   030-010-008    E5MCAP   OAMHC   IS-NR     Active  -----
1116   -----      E5TDM     OAMHC   IS-NR     Active  -----
1117   -----      E5MDAL     OAMHC   OOS-MT     Isolated  -----

Command Completed.
```

In this sample output, 1113/1114 are standby and 1115/1116 are active.

Verify the E5-MASP card containing the fixed SATA drive to be replaced is in the **Standby** position before continuing.

- If it is **Standby**, go to [Step 10](#).
- If it is not **Standby**, go to [Step 7](#).

7. Enter the following command to force the **Active** E5-MASP card to become **Standby**

```
init-card:loc=xxxx
```

where *xxxx* is the card location (1113 or 1115).

Note: User will need to login after executing this command.

8. Enter the following command to re-login:

```
login:uid=eagle
```

9. Enter the password to complete login:

```
Enter Password : xxxxxx
```

Note: This document does not provide the passwords required in the procedures. Passwords should be acquired from the customer.

The following is an example of a possible output.

```
Command Accepted - Processing

tekelecstp YY-MM-DD hh:mm:ss TTTT PPP XX.x.x-YY.y.y
Command entered at terminal #13.
;
tekelecstp YY-MM-DD hh:mm:ss TTTT PPP XX.x.x-YY.y.y
NOTICE: This is a private computer system.
Unauthorized access or use may lead to prosecution.
0 LOGIN failures since last successful LOGIN
Last successful LOGIN was on port 13 on 09-03-04 @ 14:18:21
;
```

10. Inhibit the **Standby** card location from service by entering the following command:

```
inh-card:loc=xxxx
```

wherxxxx is the **Standby** card location.

The following is an example of a possible output.

```
Command Accepted - Processing

eagle3 02-01-18 18:00:06 EST EAGLE5 41.2.0-62.69.65
inh-card:loc=1113
Command entered at terminal #1.
;
eagle3 02-01-18 18:00:06 EST EAGLE5 41.2.0-62.69.65
Card has been inhibited.
;
eagle3 02-01-18 18:00:06 EST EAGLE5 41.2.0-62.69.65
Command Completed.
;
```

11. Verify that the SATA drive is locked in position and in use. Refer to [Figure 12: SATA Drive Locked](#).

The SATA drive latch (SW2) is in the LOCKED position and the SATA Media Status LED on the E5-MASP is Off.

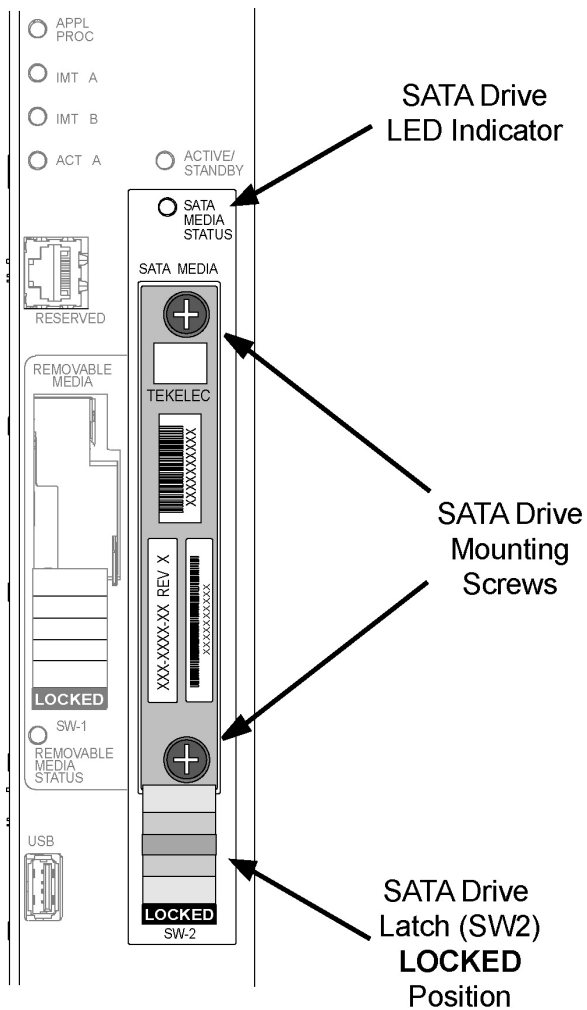

Figure 12: SATA Drive Locked

12. Move SW2 from the LOCKED to the unlocked position and wait for the LED to indicate a steady blue state. See [Figure 13: SATA Drive UNLOCKED](#).

When SW2 is transitioned from locked to unlocked, the LED will flash blue to indicate the drive is unlocked and in process of shutting down.



Caution: Removal of the drive prior to the LED indicating steady red could result in drive corruption.



Caution: If locking switch is transitioned from locked to unlocked and the E5-APP-B is in service, removal of the drive module will result in a card obit. All drive LEDs will blink red. See Figure 16.

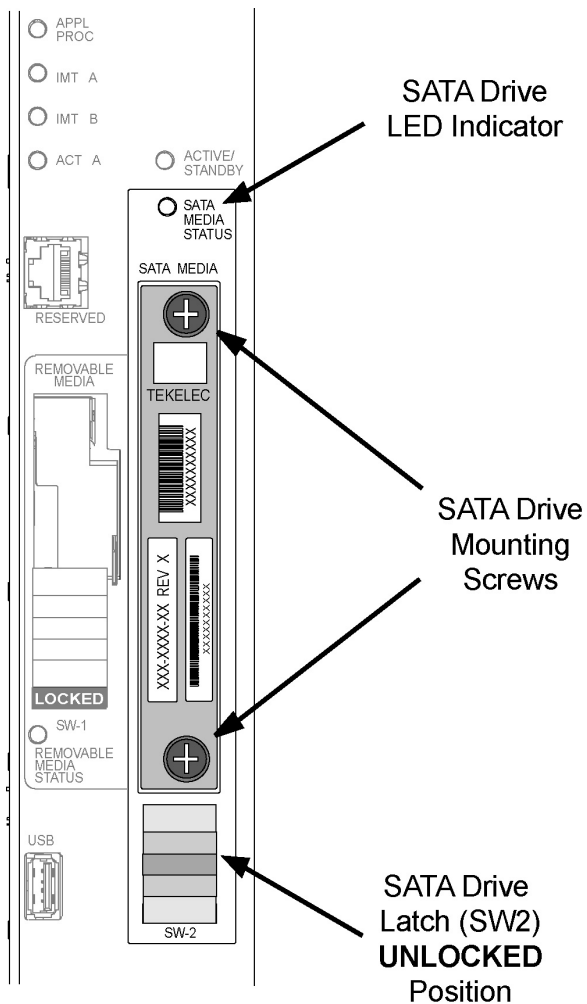

Figure 13: SATA Drive UNLOCKED

13. When the LED indicates a steady blue state, the SATA drive can be safely removed. The LED is off when the drive is fully ejected from the drive.

The drive can now be removed from the slot.

14. Loosen the SATA drive mounting screws.
15. Grasp the screws and pull the drive out slowly until it is free from the card.
16. Slide a SATA drive into the drive slot on the card.
17. Gently push the drive in slowly until it is properly seated.
18. Tighten the mounting screws.
19. Move SW2 from the unlocked to the LOCKED position.

When SW2 is transitioned from unlocked to locked, the LED will flash blue to indicate the drive is locked and in process of coming online.

20. When the LED turns Off, the SATA drive is ready for use.
21. Enter the following command to verify the card is in Standby and OOS-MT-DSBLD.

```
rept-stat-card:loc=xxxx:mode=full
```

where *xxxx* is the card location (1113 or 1115).

The following is an example of a possible output.

```
Command Accepted - Processing

eagle3 02-01-01 00:35:50 EST EAGLE5 41.2.0-62.69.65
rept-stat-card:loc=1115:mode=full
Command entered at terminal #1.
;

eagle3 02-01-01 00:35:50 EST EAGLE5 41.2.0-62.69.65
CARD  VERSION      TYPE      GPL      PST      SST      AST
1115  -----      E5MCAP   OAMHC    OOS-MT-DSBLD  Manual  -----
ALARM STATUS      = ** 0514 Standby MASP is inhibited
BLMCAP GPL version = 132-068-000
IMT BUS A         = -----
IMT BUS B         = -----
CLOCK A           = ----
CLOCK B           = ----
CLOCK I           = ----
MBD BIP STATUS    = Valid
MOTHER BOARD ID   = E5-MCAP
DBD STATUS        = Valid
DBD TYPE          = 1G ENET
DBD MEMORY SIZE   = 4096M
HW VERIFICATION CODE = ----
CURRENT TEMPERATURE = 29C ( 85F)
PEAK TEMPERATURE: = 29C ( 85F)      [02-01-01 00:23]
TROUBLE TEXT VER. = ----

Command Completed.
;
```

22. Issue the command to retrieve GPL versions.

```
rept-stat-gpl:loc=<stby E5-MASP>
```

where *<stby E5-MASP>* is the card location (1113 or 1115).

The following is an example of a possible output.

```
Command Accepted - Processing

eagle3 02-01-01 00:36:25 EST EAGLE5 41.2.0-62.69.65
rept-stat-gpl:loc=1115
Command entered at terminal #1.
;

eagle3 02-01-01 00:36:25 EST EAGLE5 41.2.0-62.69.65
GPL Auditing ON

GPL      CARD      RUNNING      APPROVED      TRIAL
OAMHC    1115      -----      132-069-061   132-069-061  *
        BLMCAP    132-068-000   132-068-000   132-068-000

Command Completed.
;
```

Verify that the OAMHC and BLMCAP GPLs match on the Running, Approved and Trial columns.

Note: If GPL are in alarm contact the [My Oracle Support \(MOS\)](#) and have system USB drives available for corrections

23. Enter the following command to put the card that was inhibited in back into service.

```
alw-card:loc=xxxx
```

where `xxxx` is the card location used in [Step 6](#).

Following is an example of a possible output.

```
Command Accepted - Processing

eagle3 02-01-18 18:02:20 EST EAGLE5 41.2.0-62.69.65
alw-card:loc=1113
Command entered at terminal #1.
;

eagle3 02-01-18 18:02:20 EST EAGLE5 41.2.0-62.69.65
Card has been allowed.
;

eagle3 02-01-18 18:02:20 EST EAGLE5 41.2.0-62.69.65
Command Completed.
;
```

Note: Allow the card to run for 5 minutes before continuing.

24. Enter the following command to verify the database is not consistent (different level as the other cards in the system).

```
rept-stat-db:display=version
```

The following is an example of a possible output.

```
Command Accepted - Processing

eagle3 02-01-10 21:52:58 EST EAGLE5 41.2.0-62.69.65
rept-stat-db:display=version
Command entered at terminal #1.
;

eagle3 02-01-10 21:52:59 EST EAGLE5 41.2.0-62.69.65
DATABASE STATUS: >> OK <<
      E5TDM 1114 ( ACTV )                E5TDM 1116 ( STDBY )
      C   LEVEL   TIME LAST BACKUP      C   LEVEL   TIME LAST BACKUP
-----
FD BKUP Y         79 02-01-05 18:06:16 EST Y         1 02-01-05 00:06:16 EST
FD CRNT Y         79
      MCAP 1113                MCAP 1115
-----
RD BKUP -         -         -         -         -         -
USB BKP -         -         -         -         -         -

CARD/APPL  LOC  C  T  LEVEL           TIME LAST UPDATE  VERSION STATUS
-----
OAMHC-RMV  1113 -  -  -           -           -           -
OAMHC-USB  1113 -  -  -           -           -           -
E5TDM-CRNT 1114 Y  N   79      02-01-04 23:46:18  132-013-000  NORMAL
E5TDM-BKUP 1114 Y  -   79      02-01-04 23:46:18  132-013-000  NORMAL
OAMHC-RMV  1115 -  -  -           -           -           -
E5TDM-CRNT 1116 Y  N   1      02-01-04 00:06:16  132-013-000  NORMAL
E5TDM-BKUP 1116 Y  -   1      02-01-04 00:06:16  132-013-000  NORMAL
```

```

EPAP A (NOACCS)
C BIRTHDATE LEVEL EXCEPTION
-----
PDB - - - -
RTDB - - - -
RTDB-EAGLE - - - -

EPAP B (NOACCS)
C BIRTHDATE LEVEL EXCEPTION
-----
PDB - - - -
RTDB - - - -
RTDB-EAGLE - - - -
;

```

Compare the VERSION STATUS of the E5-MASP cards. The DB Level in the new drive is expected to be different.

If the database VERSION on the new disk is not the same as the active disk, stop the procedure and contact the [My Oracle Support \(MOS\)](#).

25. Enter the following command to show the version numbers of the GPLs stored on each fixed disk (E5-MASP).

```
rtrv-gpl
```

The following is an example of a possible output.

```

e5oam 08-12-01 12:24:57 EST EAGLE 40.1.0
GPL Auditing ON

GPL CARD RELEASE APPROVED TRIAL REMOVE TRIAL
OAMHC 1114 030-010-000 030-010-000 030-010-000 030-010-000
OAMHC 1116 030-010-000 030-010-000 030-010-000 030-010-000
OAMHC 1115 -----
SS7ANSI 1114 030-010-000 030-010-000 030-010-000 030-010-000
SS7ANSI 1116 030-010-000 030-010-000 030-010-000 030-010-000
SS7ANSI 1115 -----
SCCP 1114 030-010-000 030-010-000 030-010-000 030-010-000
SCCP 1116 030-010-000 030-010-000 030-010-000 030-010-000
SCCP 1115 -----
GLS 1114 030-010-000 030-010-000 030-010-000 030-010-000
GLS 1116 030-010-000 030-010-000 030-010-000 030-010-000
GLS 1115 -----
...
IPSG 1114 030-010-000 030-010-000 030-010-000 030-010-000
IPSG 1116 030-010-000 030-010-000 030-010-000 030-010-000
IPSG 1115 -----
BLROM1 1114 030-010-000 030-010-000 030-010-000 030-010-000
BLROM1 1116 030-010-000 030-010-000 030-010-000 030-010-000
BLROM1 1115 -----

```

If the new SATA drive shows alarmed GPLs, contact the [My Oracle Support \(MOS\)](#).

26. Enter the following command to repair the standby's E5-MASP database:

```
chg-db:action=repair
```

The `action=repair` copies the current and backup databases from the active to the standby fixed disk.

The following is an example of a possible output.

```
RLGHNCXA03W 03-08-27 03:46:49 EST EAGLE 34.0.0
chg-db:action=repair
Command entered at terminal #10.
;
RLGHNCXA03W 03-08-27 03:46:50 EST EAGLE 34.0.0
REPAIR: MASP A - Repair starts on standby MASP.
;
```

Note: Observe that the command execution time may require approximately 20 to 45 minutes.

```
RLGHNCXA03W 03-08-27 04:15:22 EST EAGLE 34.0.0
REPAIR: MASP A - Repair from fixed disk complete.
;
```

Wait for the 'repair complete' message to display and for the E5-MASP to return to in-service status.

27. Issue the report status command for the standby E5-MASP.

```
rept-stat-card:loc=xxxx:mode=full
```

Where *xxxx* is the STBY E5-MASP slot from [Step 6](#).

The following is an example of a possible output.

```
tekelecstp YY-MM-DD hh:mm:ss TTTT PPP XX.x.x-YY.y.y
rept-stat-card:loc=xxxx
Command entered at terminal #10.
;
tekelecstp YY-MM-DD hh:mm:ss TTTT PPP XX.x.x-YY.y.y
CARD   VERSION      TYPE      GPL      PST      SST      AST
xxxx   XXX-XXX-XXX   E5MCAP   OAMHC   IS-NR   Standby  -----
ALARM STATUS      = No Alarms.
BLMCAP GPL version = XXX-XXX-XXX
IMT BUS A         = Conn
IMT BUS B         = Conn
CLOCK A           = Active
CLOCK B           = Idle
CLOCK I           = Idle
MBD BIP STATUS    = Valid
MOTHER BOARD ID   = E5-MCAP
DBD STATUS        = Valid
DBD TYPE          = 1G ENET
DBD MEMORY SIZE   = 4096M
HW VERIFICATION CODE = ----
CURRENT TEMPERATURE = 44C (112F)
PEAK TEMPERATURE: = 46C (115F)      [09-03-31 08:18]
TROUBLE TEXT VER. = ----

Command Completed.
;
```

Verify that the standby goes to IS-NR.

28. Enter the following command to verify that the database counts of both MASPs.

```
rept-stat-db:display=all
```

The following is an example of the possible output for a good database.

```
eagle3 02-01-11 16:11:25 EST EAGLE5 41.2.0-62.69.65
rept-stat-db:display=version
Command entered at terminal #1.
;

eagle3 02-01-11 16:11:26 EST EAGLE5 41.2.0-62.69.65
DATABASE STATUS: >> OK <<
      E5TDM 1114 ( ACTV )                E5TDM 1116 ( STDBY )
      C   LEVEL   TIME LAST BACKUP      C   LEVEL   TIME LAST BACKUP
-----
FD BKUP Y         79 02-01-05 18:06:16 EST Y  79 02-01-05 18:06:16 EST
FD CRNT Y         79
      MCAP 1113                          MCAP 1115
-----
RD BKUP Y         79 02-01-05 11:15:16 EST -   -   -
USB BKP -         -   -   -   -         -   -   -

CARD/APPL  LOC   C   T   LEVEL           TIME LAST UPDATE   VERSION STATUS
-----
OAMHC-RMV   1113 -   -   -                 -                 -
OAMHC-USB   1113 -   -   -                 -                 -
E5TDM-CRNT  1114 Y   N   79           02-01-04 23:46:18 132-013-000 NORMAL
E5TDM-BKUP  1114 Y   -   79           02-01-04 23:46:18 132-013-000 NORMAL
OAMHC-RMV   1115 -   -   -                 -                 -
E5TDM-CRNT  1116 Y   N   79           02-01-04 23:46:18 132-013-000 NORMAL
E5TDM-BKUP  1116 Y   -   79           02-01-04 23:46:18 132-013-000 NORMAL

      EPAP A (NOACCS)
      C   BIRTHDATE           LEVEL           EXCEPTION
-----
PDB         -   -   -                 -                 -
RTDB        -   -   -                 -                 -
RTDB-EAGLE  -   -   -                 -                 -

      EPAP B (NOACCS)
      C   BIRTHDATE           LEVEL           EXCEPTION
-----
PDB         -   -   -                 -                 -
RTDB        -   -   -                 -                 -
RTDB-EAGLE  -   -   -                 -                 -
;
```

29. Repeat [Step 5 - Step 28](#) on all remaining SATA Drives identified for replacement.
30. If [Step 3](#) was executed, issue the command to turn the measurements collection on.

```
chg-meas:collect=on
```

Execute this command only if measurement feature bit is turned on from [Step 1](#).

The following is an example of a possible output.

```
tekelecstp YY-MM-DD hh:mm:ss TTTT PPP XX.x.x-YY.y.y
chg-meas:collect=on
Command entered at terminal #10.
;

tekelecstp YY-MM-DD hh:mm:ss TTTT PPP XX.x.x-YY.y.y
CHG-MEAS: MASP A - COMPLTD
;
```

31. Enter command to copy measurements

```
copy-meas
```

To execute this command, measurement collection must be turned off. If measurement collection is on, enter the `chg-meas:collect=off` command to turn off measurement collection.

The removable drive:

- must be inserted
- must be initialized

The following is an example of a possible output.

```
eagle3 02-01-11 19:09:16 EST  EAGLE5 41.2.0-62.69.65
copy-meas
Command entered at terminal #1.
;

COPY MEASUREMENTS: MASP A - COPY STARTS ON ACTIVE MASP
COPY MEASUREMENTS: MASP A - COPY TO REMOVABLE USB DRIVE COMPLETE
;
```

32. Issue the command to retrieve measurement setup.

```
rtrv-meas-sched
```

The following is an example of a possible output. The COLLECT field shows whether measurement collection is on or off.

```
npeeagle4 02-02-04 01:13:49 EST  EAGLE5 41.2.0-62.69.65
rtrv-meas-sched
Command entered at terminal #1.
;

npeeagle4 02-02-04 01:13:49 EST  EAGLE5 41.2.0-62.69.65
COLLECT           = on
GTWYLSFLTR       = (both)
-----
SYSTOT-STP       = (off)
SYSTOT-TT        = (off)
SYSTOT-STPLAN    = (off)
COMP-LNKSET      = (off)
COMP-LINK        = (off)
GTWY-STP         = (off)
GTWY-LNKSET      = (off)
MTCD-STP         = (on)
MTCD-LINK        = (on)
MTCD-STPLAN      = (on)
MTCD-LNKSET      = (on)
;
```

If COLLECT=ON, continue to next step, otherwise repeat [Step 30](#).

Note: If [Step 30](#) is repeated and measurements do not turn on contact [My Oracle Support \(MOS\)](#).

33. Issue the report card status command.

```
rept-stat-card:appl=oam
```

The following is an example of a possible output.

```
Command Accepted - Processing

eagle3 02-01-01 00:29:24 EST EAGLE5 41.2.0-62.69.65
rept-stat-card:appl=oam
Command entered at terminal #1.
;

eagle3 02-01-01 00:29:24 EST EAGLE5 41.2.0-62.69.65
CARD VERSION TYPE GPL PST SST AST
1113 132-069-061 E5MCAP OAMHC IS-NR Active -----
1115 132-069-061 E5MCAP OAMHC IS-NR Standby -----

Command Completed.
;
```

34. Issue the command to display database status.

```
rept-stat-db:display=all
```

The following is an example of a possible output.

```
eagle3 02-01-11 16:11:25 EST EAGLE5 41.2.0-62.69.65
rept-stat-db:display=version
Command entered at terminal #1.
;

eagle3 02-01-11 16:11:26 EST EAGLE5 41.2.0-62.69.65
DATABASE STATUS: >> OK <<
      E5TDM 1114 ( ACTV )                E5TDM 1116 ( STDBY )
      C  LEVEL    TIME LAST BACKUP      C  LEVEL    TIME LAST BACKUP
-----
FD BKUP Y          79 02-01-05 18:06:16 EST Y  79 02-01-05 18:06:16 EST
FD CRNT Y          79
      MCAP 1113                MCAP 1115
-----
RD BKUP Y          79 02-01-05 11:15:16 EST -  -  -  -
USB BKP -  -  -  -  -  -  -  -

CARD/APPL LOC C T LEVEL    TIME LAST UPDATE  VERSION STATUS
-----
OAMHC-RMV 1113 - - - - - - - - - -
OAMHC-USB 1113 - - - - - - - - - -
E5TDM-CRNT 1114 Y N 79 02-01-04 23:46:18 132-013-000 NORMAL
E5TDM-BKUP 1114 Y - 79 02-01-04 23:46:18 132-013-000 NORMAL
OAMHC-RMV 1115 - - - - - - - - - -
E5TDM-CRNT 1116 Y N 79 02-01-04 23:46:18 132-013-000 NORMAL
E5TDM-BKUP 1116 Y - 79 02-01-04 23:46:18 132-013-000 NORMAL

      EPAP A (NOACCS)
      C  BIRTHDATE          LEVEL    EXCEPTION
-----
PDB - - - - - - - - - -
RTDB - - - - - - - - - -
RTDB-EAGLE - - - - - - - - - -

      EPAP B (NOACCS)
      C  BIRTHDATE          LEVEL    EXCEPTION
-----
PDB - - - - - - - - - -
RTDB - - - - - - - - - -
RTDB-EAGLE - - - - - - - - - -
```

;

Look in the columns labeled 'C' and 'LEVEL' output by this command.

- Verify entries in column 'C' show 'Y' which indicates coherence.
- Verify both 'FD CRNT' Levels are equal.

35. Report replacement drive location.

```
rept-stat-card:mode=full:loc=XXXX
```

Where XXXX location of replaced drive.

The following is an example of a possible output.

```
Command Accepted - Processing

eagle3 02-01-18 18:10:28 EST EAGLE5 41.2.0-62.69.65
rept-stat-card:mode=full:loc=1113
Command entered at terminal #1.
;

eagle3 02-01-18 18:10:28 EST EAGLE5 41.2.0-62.69.65
CARD   VERSION      TYPE      GPL      PST      SST      AST
1113   132-069-061    E5MCAP   OAMHC    IS-NR    Standby  -----
ALARM STATUS      = No Alarms.
BLMCAP GPL version = 132-068-000
IMT BUS A         = Conn
IMT BUS B         = Conn
CLOCK A           = Active
CLOCK B           = Idle
CLOCK I           = Idle
MBD BIP STATUS    = Valid
MOTHER BOARD ID   = E5-MCAP
DBD STATUS        = Valid
DBD TYPE          = 1G ENET
DBD MEMORY SIZE   = 4096M
HW VERIFICATION CODE = ----
CURRENT TEMPERATURE = 30C ( 86F)
PEAK TEMPERATURE:  = 30C ( 86F)      [02-01-18 17:58]
TROUBLE TEXT VER.  = ----

Command Completed.
;
```

36. Issue the command to OAM database.

```
rept-stat-card:appl=oam
```

The following is an example of a possible output.

```
Command Accepted - Processing

tekelecstp YY-MM-DD hh:mm:ss TTTT PPP XX.x.x-YY.y.y
rept-stat-card:appl=oam
Command entered at terminal #14.
;

tekelecstp 10-04-19 16:47:51 EDT EAGLE5 41.1.0-62.64.1
CARD   VERSION      TYPE      GPL      PST      SST      AST
1113   132-064-000    E5MCAP   OAMHC    IS-NR    Standby  -----
```

```

1115 132-064-000 E5MCAP OAMHC IS-NR Active -----
Command Completed.
;

```

37. Issue the command to display Clock status.

```
rept-stat-clk
```

The following is an example of a possible output.

```

Command Accepted - Processing

tekelecstp YY-MM-DD hh:mm:ss TTTT PPP XX.x.x-YY.y.y
rept-stat-clk
Command entered at terminal #1.
;

tekelecstp YY-MM-DD hh:mm:ss TTTT PPP XX.x.x-YY.y.y
COMPOSITE                                PST          SST          AST
SYSTEM CLOCK                             IS-NR        Idle         -----
ALARM STATUS = No Alarms.
Primary Comp Clk 1114 (CLK A) IS-NR        Active
Primary Comp Clk 1116 (CLK B) IS-NR        Active
Secondary Comp Clk 1114 (CLK A) IS-NR        Idle
Secondary Comp Clk 1116 (CLK B) IS-NR        Idle

Clock      Using      Bad
CLK A      3           0
CLK B      0           0
CLK I      0           --

HIGH SPEED                                PST          SST          AST
SYSTEM CLOCK                             IS-NR        Idle         -----
ALARM STATUS = No Alarms.
Primary HS Clk 1114 (HS CLK A) OOS-MT        Fault
Primary HS Clk 1116 (HS CLK B) OOS-MT        Fault
Secondary HS Clk 1114(HS CLK A) OOS-MT        Fault
Secondary HS Clk 1116(HS CLK B) OOS-MT        Fault

HS CLK TYPE 1114      = RS422
HS CLK LINELEN 1114  = -----
HS CLK TYPE 1116      = RS422
HS CLK LINELEN 1116  = -----

Clock      Using      Bad
HS CLK A   0           0
HS CLK B   0           0
HS CLK I   0           --

Command Completed.
;

```

Verify that there are no Clock alarms.

- If there are no clock alarms then proceed to next step.
- If clock alarms are present note the alarms and contact [My Oracle Support \(MOS\)](#).

Note: E5-MASP may require card initialization if clock errors are being reported.

Note: Card initialization is not required if customer is not using CLOCK.

38. If required, prepare E5-MASP for Clock Acceptance

Note: Both E5-MASP must be installed.

39. Issue the following command to check clock status.

```
rept-stat-clk
```

The following is an example of a possible output.

```
regnsk0613w 10-05-06 11:13:10 CST EAGLE5 41.1.2-62.69.1
rept-stat-clk
Command entered at terminal #21.
;

Command Accepted - Processing
regnsk0613w 10-05-06 11:13:10 CST EAGLE5 41.1.2-62.69.1
COMPOSITE                                PST           SST           AST
SYSTEM CLOCK                             IS-NR         Idle          -----
ALARM STATUS = No Alarms.
Primary Comp Clk 1114 (CLK A) OOS-MT        Fault
Primary Comp Clk 1116 (CLK B) OOS-MT        Fault
Secondary Comp Clk 1114 (CLK A) OOS-MT        Fault
Secondary Comp Clk 1116 (CLK B) OOS-MT        Fault

Clock      Using      Bad
CLK A      10           0
CLK B       3           0
CLK I       0           --

HIGH SPEED                                PST           SST           AST
SYSTEM CLOCK                             IS-NR         Idle          -----
ALARM STATUS = No Alarms.
Primary HS Clk 1114 (HS CLK A) IS-NR         Active
Primary HS Clk 1116 (HS CLK B) IS-NR         Active
Secondary HS Clk 1114(HS CLK A) OOS-MT        Fault
Secondary HS Clk 1116(HS CLK B) IS-NR         Idle

HS CLK TYPE 1114      = T1 FRAMED
HS CLK LINELEN 1114   = LONGHAUL
HS CLK TYPE 1116      = T1 FRAMED
HS CLK LINELEN 1116   = LONGHAUL

Clock      Using      Bad
HS CLK A    0           0
HS CLK B    0           0
HS CLK I    0           --

Command Completed.
;
```

In this example, the secondary clock is in some condition other than Idle or Active.

40. Issue the command to check clock options.

```
rtrv-clkopts
```

The following is an example of a possible output.

```
Command Accepted - Processing
regnsk0613w 10-05-06 11:13:19 CST EAGLE5 41.1.2-62.69.1
CLK OPTIONS
-----
```

```

PRIMARY
-----
HSCLKSRC      t1framed
HSCLKLL       longhaul

SECONDARY
-----
HSCLKSRC      rs422
HSCLKLL       longhaul

;
Command Executed

```

41. Issue the command to change clock options for the secondary.

```
chg-clkopts:clock=secondary:hsclksrc=t1framed:force=yes
```

Note: Issue this command only if alarms were recorded in [Step 37](#).

The following is an example of a possible output.

```

Command Accepted - Processing
  regnsk0613w 10-05-06 11:14:14 CST  EAGLE5 41.1.2-62.69.1
  CHG-CLKOPTS: MASP B - COMPLTD
;

```

42. Issue the command to change clock options primary.

```
chg-clkopts:clock=primary:hsclksrc=t1framed:force=yes
```

Note: Issue this command only if alarms were recorded in [Step 37](#).

The following is an example of a possible output.

```

Command Accepted - Processing
  regnsk0613w 10-05-06 11:14:14 CST  EAGLE5 41.1.2-62.69.1
  CHG-CLKOPTS: MASP B - COMPLTD
;

```

43. Issue the following command to check clock status.

```
rept-stat-clk
```

The following is an example of a possible output.

```

Command Executed
> rept-stat-clk

  regnsk0613w 10-05-06 11:14:27 CST  EAGLE5 41.1.2-62.69.1
  rept-stat-clk
  Command entered at terminal #21.
;

Command Accepted - Processing
  regnsk0613w 10-05-06 11:14:28 CST  EAGLE5 41.1.2-62.69.1
  COMPOSITE                PST                SST                AST
  SYSTEM CLOCK              IS-NR            Idle               -----
  ALARM STATUS = No Alarms.
  Primary Comp Clk 1114    (CLK A)  OOS-MT            Fault
  Primary Comp Clk 1116    (CLK B)  OOS-MT            Fault
  Secondary Comp Clk 1114  (CLK A)  OOS-MT            Fault

```

```

Secondary Comp Clk 1116 (CLK B) OOS-MT          Fault

Clock      Using      Bad
CLK A      10         0
CLK B      3         0
CLK I      0         --

HIGH SPEED                                PST      SST      AST
SYSTEM CLOCK                             IS-NR    Idle    -----
ALARM STATUS = No Alarms.
Primary HS Clk 1114 (HS CLK A) IS-NR    Active
Primary HS Clk 1116 (HS CLK B) IS-NR    Active
Secondary HS Clk 1114(HS CLK A) IS-NR    Idle
Secondary HS Clk 1116(HS CLK B) IS-NR    Idle

HS CLK TYPE 1114      = T1 FRAMED
HS CLK LINELEN 1114  = LONGHAUL
HS CLK TYPE 1116      = T1 FRAMED
HS CLK LINELEN 1116  = LONGHAUL

Clock      Using      Bad
HS CLK A   0         0
HS CLK B   0         0
HS CLK I   0         --

Command Completed.
;

```

44. Procedure complete.

Daily Procedures

The procedures found in this section are recommended procedures for daily routine preventive maintenance. Some procedures may refer to other chapters within this document.

Backing Up the Database Daily

Purpose: This procedure is used to make a backup of the database on the fixed disk and provide a current copy of the system data to be stored on-site. This procedure can then be used in the event a fixed disk is damaged. This procedure should not be confused with the other database archival procedures. Should the backup removable USB drive created with this procedure become unreadable, the other procedures in this chapter will ensure that a good copy of the database is still available.

Requirements:

- The databases in the current partitions of both MASPs (FDCRNT) must be coherent.
- At least one removable USB drive formatted for system data is needed for this routine. Each removable USB drive should be labeled as "Daily Backup." Each day, select the removable USB drive with this label and perform the backup procedure.

Interval: Daily

Procedure - Backing Up the Database

1. Enter the following command to check the operational status of the database:

```
rept-stat-db
```

If necessary, refer to the *Commands Manual* to interpret the output.

2. Enter the following command to create a backup of the database on the fixed disk:

```
chg-db:action=backup
```

This command should take no longer than 30 minutes to execute. It could take longer depending on other system activity that is in progress when this command is entered. During command execution, these messages appear (the active MASP is displayed first):

```
BACKUP (FIXED) : MASP A - Backup starts on active MASP.
BACKUP (FIXED) : MASP A - Backup on active MASP to fixed disk complete.
BACKUP (FIXED) : MASP B - Backup starts on standby MASP.
BACKUP (FIXED) : MASP B - Backup on standby MASP to fixed disk complete.
```

3. Insert the removable USB drive labeled “Daily Backup” into the removable USB media slot.

Reference: [Removable Drives](#)

4. Enter the following command to create a backup of the database on the removable USB drive:

```
chg-db:action=backup:dest=remove
```

During command execution, these messages should appear.

```
BACKUP (REMOVABLE) : MASP A - Backup starts on active MASP.
BACKUP (REMOVABLE) : MASP A - Backup to removable USB drive complete.
```

5. Verify that the databases on the removable USB drive (RDBKUP) and the current partition of the active MASP (FDCRNT) are coherent by entering the following command: `rept-stat-db`
If necessary, refer to the *Commands Manual* to interpret the output.
6. Remove the removable USB drive from the removable USB media slot.
Reference: [Removable Drives](#)
7. Make an entry in the site maintenance log that a backup was performed.
Place the removable USB drive in a safe place, easily accessible in the event of a catastrophic failure.

System Reports Analysis

- Purpose:** The purpose of this routine is to inspect the printer outputs for possible trouble messages and routinely check the status of the STP through traffic measurements. By inspecting printouts and measurements on a daily basis, system trends can be detected and resolved.
- Requirements:** Printer must be configured to receive traffic reports. Measurements collection must be activated before reports containing current data can be printed. Enter the following command to activate measurements collection, if necessary: `chg-meas:collect=on`

Refer to the *Commands Manual* for more information. If measurements are already allowed, an error message indicates this.

Reports Description

Purpose:	This includes a system terminal and printer output system related messages as well as network protocol messages. Any abnormal activity (this is network dependent) should be highlighted and saved for later retrieval. Refer to Corrective Maintenance for a description of system related messages and procedures for recovery.
Requirements:	None
Interval:	Daily
Variables:	hh = The end half-hour interval (0 - 2330) for requested interval

Procedure - Print Report

1. Enter the following command to print a measurements report for the STP entity
`rept-meas:type=systot:enttype=stp`
2. Enter the following command to print a measurements report for the link entity type (this command requires either the loc and port parameters or the lsn parameter):
`rept-meas:type=comp:enttype=link`
3. Review the STP report and compare with the link report.
 If excessive errors exist on any one particular link, enter the following command to print a report for the time period the errors occurred:
`rept-meas:enttype=link:period=specific:hh`
 Refer to the *Commands Manual* for more information on using the `rept-meas` command.
4. From this report, determine what events may have occurred during the 30 minute measurements collection period.

File Transfer for LNP and INP Measurements

Purpose:	The purpose of this procedure is to output LNP/INP measurements to the file transfer area (FTA) so the measurements can be collected.
Requirements:	A computer with a VT320 or KSR connection to the EAGLE 5 ISS. A communication program that both emulates VT terminals and supports Kermit file transfer. Previous LNP/INP measurement files must have been successfully transferred and deleted (<code>dlr-fta</code>) before the start of this procedure. A spreadsheet program that can import Comma Separated Value (CSV) text files. A PC running ProComm [®] for Windows and Microsoft Excel [®] can also be used.
Interval:	Daily and/or weekly.

Procedure - File Transfer

1. From the EAGLE 5 ISS VT320 or KSR terminal, enter the following command to display the contents of the FTA:
`disp-fta-dir:loc=xxxx`
 Where `xxxx` = the active E5-TDM (1114 or 1116).

2. From the EAGLE 5 ISSVT320 or KSR terminal, enter the following command to delete any existing files from the FTA:`dlt-fta:loc=xxxx:all=yes`
Where *xxxx* = the active E5-TDM (1114 or 1116)
3. In this example, from the EAGLE 5 ISSVT320 or KSR terminal, enter the following command to send LNP daily measurements to the FTA:`rept-meas:enttype=lnp:type=mtcd`
4. Enter the following command to acquire a list of the files transferred to the FTA in step 4:`disp-fta-dir:loc=xxxx`
Where *xxxx* = the active E5-TDM (1114 or 1116).
5. Enter the following command to activate the file transfer:`act-file-trns:loc=xxxx`
Where *xxxx* = the active E5-TDM (1114 or 1116).
6. Transfer the desired files (with .csv suffixes) to the PC by using the get command from within the communications program configured to run Kermit in ASCII mode.
An example of the Kermit commands to extract the previous day's records are as follows:
`> get mon_lnp.csv > get tues_ssp.csv > get thu_lrn.csv > get sat_npa.csv > finish`
7. Run a spreadsheet program and open each of the files collected to view the LNP/INP measurement data.
8. Once all the files are successfully transferred and confirmed, enter the following command to remove the files from the FTA:`dlt-fta:loc=xxxx:all=yes`
Where *xxxx* = the active E5-TDM (1114 or 1116)

Weekly Procedures

The procedures found in this section are recommended for weekly routine preventive maintenance. Some procedures may refer to other chapters within this document.

Database Archive (Weekly)

Purpose: The purpose of this procedure is to create a copy of the database on a weekly basis over a period of four weeks to be stored in an archive. The copies can then be used in the event a removable USB drive is damaged, and a new copy is required. This routine will generate four copies of the database, all taken at weekly intervals.

Each tape in this cycle should be designated as Week 1, Week 2, Week 3, or Week 4. When all four removable USB drives have been used, repeat the process starting with the Week 1 USB drive.

Requirements: Four removable USB drives formatted for system data are required for this routine. The removable USB drive should be labeled "Week 1" through "Week 4." Once each week, select the removable USB drive with the appropriate label and perform the backup procedure. Each week, select the removable USB drive with the next sequential number and perform this procedure.

Interval: Weekly

Procedure - Archive Database (Weekly)

1. Enter the following command to check the operational status of the database:

```
rept-stat-db
```

If necessary, refer to *Commands Manual* to interpret the output.

2. Insert the removable USB drive labeled "Week x" into the removable USB drive media slot.

Reference: [Removable Drives](#).

3. Enter the following command to create a backup of the database on the removable USB drive:

```
chg-db:action=backup:dest=remove
```

During command execution, these messages should appear.

```
BACKUP (REMOVABLE) : MASP A - Backup starts on active MASP.
BACKUP (REMOVABLE) : MASP A - Backup to removable USB drive complete.
```

4. Verify that the databases on the removable USB drive backup partition (RD BKUP) and the current partition of the active maintenance and administration subprocessor system (MASP) fixed disk current partition (FD CRNT) are coherent by entering the following command:

```
rept-stat-db
```

If necessary, refer to *Commands Manual* to interpret the output.

5. Remove the removable USB drive from the removable USB drive media slot.

Reference: [Removable Drives](#)

6. Make an entry in the site maintenance log that a backup was performed for the appropriate week (Week 1, Week 2, Week 3, or Week 4).

Place the removable USB drive in a safe place, easily accessible in the event of a catastrophic failure.

Printer Inspection

Purpose: This procedure verifies the printer is operational and the ribbon does not need replacement. Should the printer cease operation, system reports and trouble reports would not be printed at the system printer. Use the following procedure to verify the operation of the printer.

Requirements: A printer connected through an RS232 to a serial port on the EAGLE 5 ISS control shelf backplane. Refer to the printer user manual (provided by the printer manufacturer) for detailed specifics on maintaining the printer.

Interval: Weekly

Variables: x = TDM serial port number (1-16)

Procedure -Printer Inspection

1. Verify the carriage assembly is free of any debris.
Remove the top of the printer if necessary.
2. Check that the power indicator is illuminated (on).
If not, verify the power cord is plugged in.

3. Check the online indicator.
If off, press the select button. Verify the indicator is illuminated.
4. Verify the presence of on-line indicators using the printer *Users Manual*.
5. Enter the following command to send output to the printer: `act-echo:trm=x`.
6. Type the following command at a terminal to verify the printer is operating: `rept-stat-trm`
If the printer does not print any messages, check the printer cable and verify it is connected to a system terminal. If not, reconnect the printer cable (refer to the *Installation Manual* for cable pinouts).
7. Look at the printout.
If the ink is faded and difficult to read, replace the ribbon. Refer to the *Users Manual* provided by the manufacturer for ribbon replacement procedures.

Remote Access Verification

Purpose:	The purpose of this routine is to verify proper operation of the modem used for remote access of the EAGLE 5 ISS system.
Requirements:	Remote terminal and modem.
Interval	Weekly

Procedure - Remote Access Verification

1. From a remote PC or terminal, dial the telephone number of the modem connected to the Eagle.
2. When connected, verify you are able to log in to the EAGLE 5 ISS system and enter commands.
3. Once you have verified the operation of the modem, logoff from the EAGLE 5 ISS and terminate your connection.

Monthly Procedures

The procedures found in this section are recommended procedures for monthly routine preventive maintenance. Some procedures may refer to other chapters within this document.

Database Archive (Monthly)

Purpose:	The purpose of this procedure is to create a copy of the database on a monthly basis over a period of four months to be stored in an archive. The copies can then be used in the event a removable USB drive is damaged, and a new copy is required. This routine will generate four copies of the database, all taken at monthly intervals. Each tape in this cycle should be designated as Month 1, Month 2, Month 3, or Month 4. When all four removable USB drives have been used, repeat the process starting with the Month 1 USB drive.
Requirements:	Four removable USB drives formatted for system data are required for this routine. The removable USB drive should be labeled "Month 1" through "Month 4." Once each month, select the removable USB drive with the appropriate label and perform

the backup procedure. Each month, select the removable USB drive with the next sequential number and perform this procedure.

Interval Monthly

Procedure - Database Archive (Monthly)

1. Enter the following command to check the operational status of the database:

```
rept-stat-db
```

If necessary, refer to the *Commands Manual* to interpret the output.

2. Insert the removable USB drive labeled "Month x" into the removable USB drive media slot.

Reference: [Removable Drives](#)

3. Enter the following command to create a backup of the database on the removable USB drive:

```
chg-db:action=backup:dest=remove
```

```
BACKUP (REMOVABLE) : MASP A - Backup starts on active MASP.
BACKUP (REMOVABLE) : MASP A - Backup to removable USB drive complete.
```

4. Verify that the databases on the removable USB drive (RDBKUP) and the current partition of the active MASP (FDCRNT) are coherent by entering the following command:

```
rept-stat-db
```

If necessary, refer to the *Commands Manual* to interpret the output.

5. Remove the removable USB drive from the removable USB drive media.

Reference: [Removable Drives](#)

6. Make an entry in the site maintenance log that a backup was performed for the appropriate month (Month 1, Month 2, Month 3, or Month 4).

Place the removable USB drive in a safe place, easily accessible in the event of a catastrophic failure.

FAP Load Balance Verification (PN 870-0243-XX only)

Purpose: This procedure is used to verify the Load Balance Factor (LBF) for the A and B power supplied to each Fuse and Alarm Panel (FAP) in the EAGLE 5 ISS. This procedure applies ONLY to installed FAPs with Tekelec P/N 870-0243-XX.

The LBF is an empirically derived number that provides an indication if a Tekelec STP System Frame has an open power distribution diode. The difference in amperage between the "A" versus "B" battery leads should be within a "typical" range. Values outside of this range should be an indication of a potential problem and requires further investigation.

Requirements: Tekelec recommends that the verification be performed using a Clamping Type Multimeter (Clamp Amp Meter). If the Clamp Meter has different settings or functions than the ones described in this procedure, consult the instruction manual for this meter and determine substitute settings or functions. Results of this verification should be recorded on the form provided with this procedure and filed with the STP System maintenance records.



Caution: This procedure must be performed with the utmost Caution. All safety precautions associated with in service equipment and power must be strictly followed. Any equipment that is below the shelf that is being worked on must be protected from falling tools or debris. All jewelry, rings, watches must be removed before this procedure is started. Read this procedure completely before proceeding.

Interval: Monthly

Procedure - FAP Load Balance

1. Log in to system via a dedicated terminal or connect a PC to an EAGLE 5 ISS terminal port.
Open a capture log via ProComm Plus or other PC communications program.
2. Enter the following command to determine the status of all the cards in the system.
`rept-stat-card`
If necessary, refer to *Commands Manual* to interpret the output. Save the results to compare with the outputs at the conclusion of this procedure.
3. Enter the following command to verify the status of the signaling links.
`rept-stat-slk`
If necessary, refer to *Commands Manual* to interpret the output. Save the results to compare with the outputs at the conclusion of this procedure.
4. Enter the following command to get a report of all the device trouble notifications that are currently logged in the OAMRAM storage area.
`rept-stat-trbl`
If necessary, refer to *Commands Manual* to interpret the output. Save the results to compare with the outputs at the conclusion of this procedure.
5. Enter the following command to check the status of the IMT.
`rept-stat-imt`
If necessary, refer to *Commands Manual* to interpret the output. Save the results to compare with the outputs at the conclusion of this procedure.
6. Enter the following command to check the status of the SCCP subsystem.
`rept-stat-sccp`
If necessary, refer to *Commands Manual* to interpret the output. Save the results to compare with the outputs at the conclusion of this procedure.
7. Enter the following command to check the operational status of the database.
`rept-stat-db`
If necessary, refer to *Commands Manual* to interpret the output. Save the results to compare with the outputs at the conclusion of this procedure. Verify that FDCRNT and FDBKUP for E5-TDM 1114 and E5-TDM 1116 match. If they do not match, perform *Daily Procedures* before continuing.



Warning: Do not proceed to the next step if the backup fails.

8. Set the Clamp Amp Meter to measure DC amps.

Set the dial to the DC 400A setting and zero out/adjust the meter by turning the 0 ADJ control. The meter must read 00.0.

Note: On the inside of the Clamp Amp Meter there should be an arrow. The arrow must always be pointing towards the frame when clamped around the cable. If the meter cannot be directly observed, the DATAHOLD function can be utilized, if the meter is so equipped, and the reading will hold. The jaws of the meter must be around the cable for the DATAHOLD function to operate.

Values of less than 1.0 Amp on BOTH the "A" and "B" sides are not applicable. Ignore plus (+) or minus (-) in the meter reading.

9. Measure the current on the **A** side of the EAGLE 5 ISS Frame FAP selected for verification.

Clamp the meter around the **-48VDC A** battery cable on the FAP. Record the reading on the [Table 13: Tekelec Method of Procedure Test Record](#).

10. Depress the DATAHOLD function again, if this option was utilized in [Step 9](#) Verify the Clamp Amp Meter reading is 00.0.

The meter must read 00.0 before proceeding with [Step 11](#).

11. Measure the current on the **B** side of the EAGLE 5 ISS Frame FAP selected in [Step 9](#).

Clamp the meter around the **-48VDC B** battery cable on the FAP. Record the reading on the [Table 13: Tekelec Method of Procedure Test Record](#).

12. Calculate the Load Balance Factor (LBF) and record on the [Table 13: Tekelec Method of Procedure Test Record](#).

- a) Compute the difference between **A** and **B** sides (A-B) or (**B-A**).

- b) The difference is divided by the lower of the two (2) measured values (**A** or **B**) and expressed as a percentage.

This percentage is the LBF.

- c) Enter the LBF in the appropriate space on the Test Record form.

Refer to [Figure 14: Open Diode Example](#) and [Figure 15: Steady State Example](#) for examples of this formula. Data indicates that the acceptable range can be between 0% and 125%. The 125% point is a **Flag** that indicates further investigation is warranted. It indicates the potential for at least one open diode.

“Open Diode” Example
(Diode 3 Opens)_{aseo}

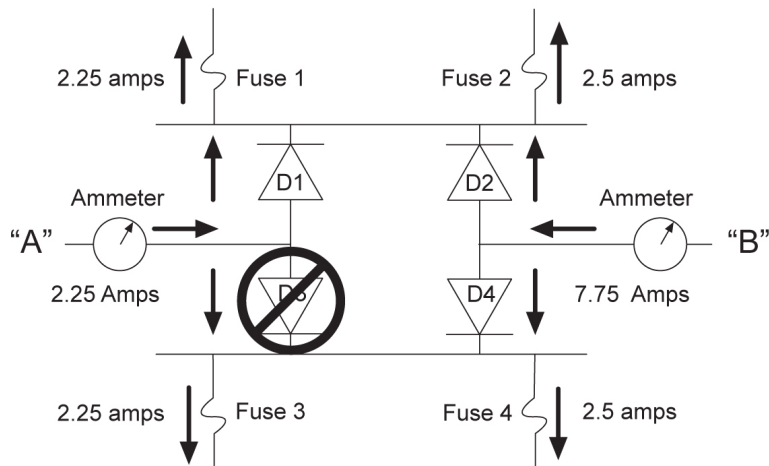

$$LBF=(A-B)/A \rightarrow LBF=(5.5/2.25)*100 \rightarrow 244\%$$

Figure 14: Open Diode Example

Steady State Example
(All diodes operational)_{ase}

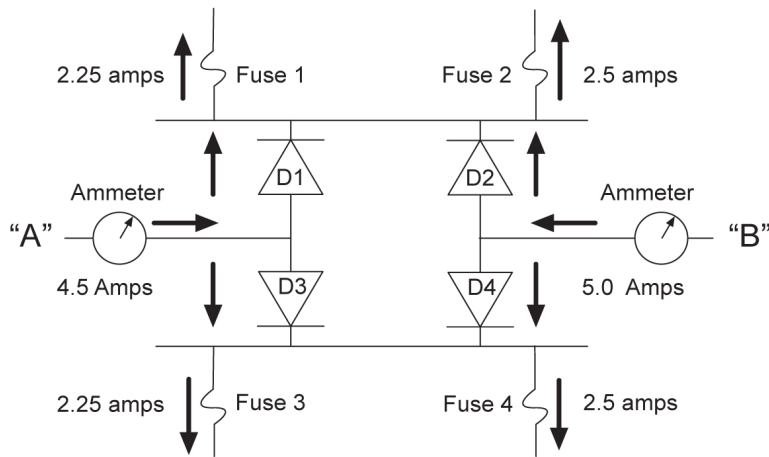

$$LBF=(A-B)/A \rightarrow LBF=(.5/4.5)*100 \rightarrow 11.1\%$$

Figure 15: Steady State Example

13. *My Oracle Support (MOS)*, for values above the 125% threshold.
14. Depress the DATAHOLD function again, if this option was utilized in [Step 9](#).
Verify the Clamp Amp Meter reading is 00.0. The meter must read 00.0 before proceeding with [Step 15](#).
15. Repeat Steps [Step 8](#) through [Step 14](#) for all EAGLE 5 ISSFAPs.

16. Enter the following command to determine the status of all the cards in the system.

```
rept-stat-card
```

Compare the output with the results from [Step 2](#). The outputs should be the same as initially recorded.
17. Enter the following command to verify the status of the signaling links.

```
rept-stat-slk
```

Compare the output with the results from [Step 3](#). The outputs should be the same as initially recorded.
18. Enter the following command to get a report of all the device trouble notifications that are currently logged in the OAMRAM storage area.

```
rept-stat-trbl
```

Compare the output with the results from [Step 4](#). The outputs should be the same as initially recorded.
19. Enter the following command to check the status of the IMT.

```
rept-stat-int
```

Compare the output with the results from [Step 5](#). The outputs should be the same as initially recorded.
20. Enter the following command to check the status of the SCCP subsystem:

```
rept-stat-sccp
```

Compare the output with the results from [Step 6](#). The outputs should be the same as initially recorded.
21. Enter the following command to check the operational status of the database.

```
rept-stat-db
```

Compare the output with the results from [Step 7](#). The outputs should be the same as initially recorded.

Table 13: Tekelec Method of Procedure Test Record

TEKELEC Method of Procedure Test Record					
Frame	A Battery	B Battery	A-B Delta (Amps)	Load Balance Factor (LBF)	Technician/Date
CF 00					
EF 00					
EF 01					
EF 02					
EF 03					
EF 04					

TEKELEC Method of Procedure Test Record					
Frame	A Battery	B Battery	A-B Delta (Amps)	Load Balance Factor (LBF)	Technician/Date
MISC					

Note: Complete this test record for all FAP tests. Retain this record in the Tekelec Eagle STP System maintenance files.

Change the Fan Tray Filter

- Purpose:** The purpose of this routine is to make sure a clean and adequate supply of air is available to cool the HC MIM cards.
- Requirements:** A replacement fan tray filter.
- Interval:** Monthly

Procedure - Change Fan Tray Filter

1. Locate the filter tab on the fan assembly.

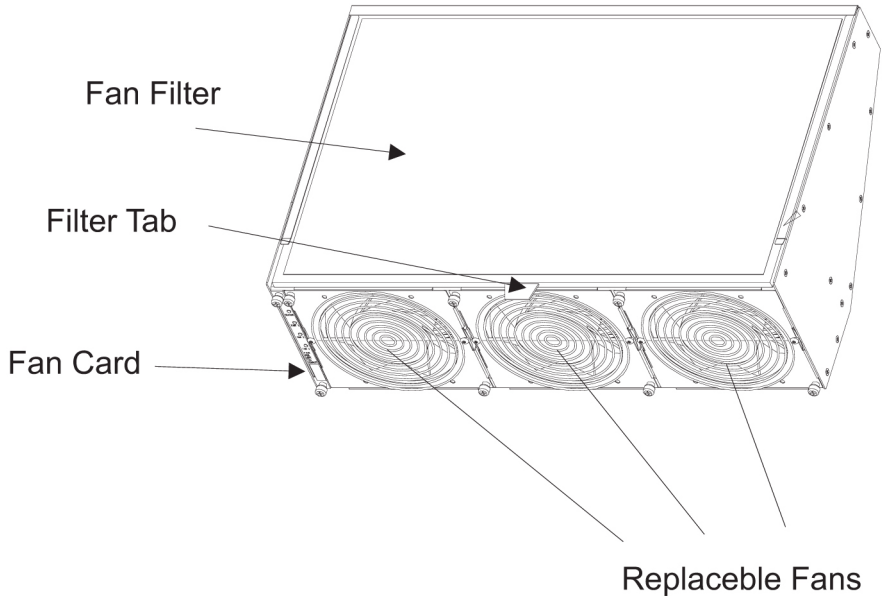

Figure 16: Fan Assembly

2. Pull the filter tab to remove the fan tray filter.
3. Insert the replacement filter into the fan filter slot.

Align the filter over the replaceable fans.

Changing the Air Supply Filter

Purpose: The purpose of this routine is to prevent dirt and dust from building up around the fan units, hindering them from cooling the shelf effectively.

Requirements: A replacement air filter (P/N 551-0011-01).

Interval Every 45 days.

Procedure - Change Air Supply Filter

1. Turn the fan power switch to the OFF position.
The *Active*LED under the fans becomes unlit and the fan Alarm LED turns red. The EAGLE 5 ISS generates a UAM indicating a fan failure.
2. Unscrew the two thumbscrews securing the grill and remove it.
The air filter is now accessible.

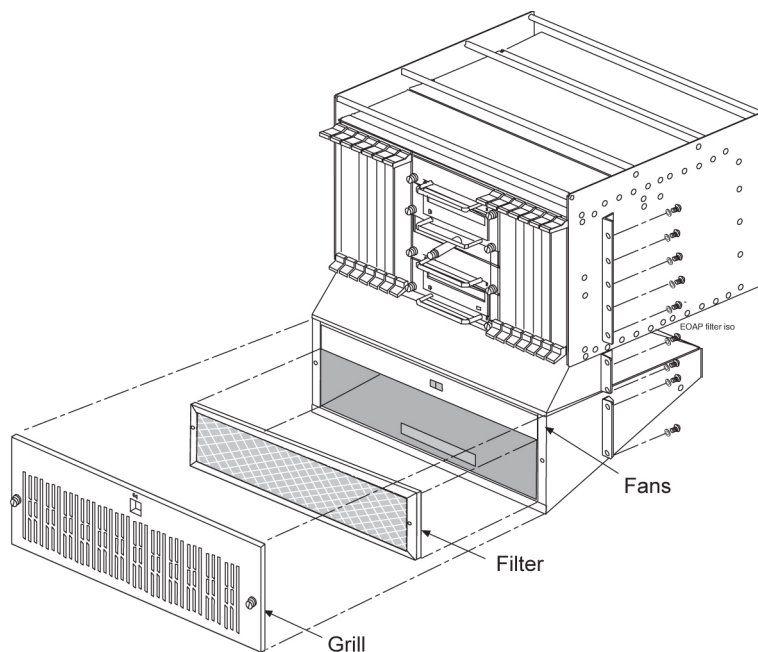

Figure 17: Fan Filter Replacement

3. Remove and discard the old air filter.
4. Position the new air filter so that it covers the opening to the fan assembly.
Check the bottom edge of the filter to make sure the airflow indicator arrows are pointing away from you and towards the fan assembly.
5. To replace the grill, position it on the fan assembly and screw in the two thumbscrews to secure the grill in place.
6. Turn the fan power switch to the ON position.

The two LEDs for the fan assembly turn green and the EAGLE 5 ISS generates a UIM to indicate the fan alarm is cleared.

Cleaning Printer

Purpose: The purpose of this routine is to prevent the system printer from building up dirt and dust around the print heads and carriage assemblies, preventing it from operating.

Requirements: Printer cleaning kit, or cleaning solvent. Cotton swabs and damp cloth.

Interval Monthly

Procedure - Clean Printer

Follow the manufacturer's procedures for cleaning the print head and carriage assembly.

Fuse Spares Inventory

Purpose: This routine verifies ample spare fuses are available. Fuses are used in the fuse and alarm panel (FAP).

Requirements None

Interval Monthly

Procedure - Fuse Inventory

Two types of fuses are used in the EAGLE 5 ISS:

1. Industry standard GMT fuse 1 amp
2. Industry standard GMT fuse 3 amp

Spare fuses are stored in a fuse tray located on the side of each frame. Check that both types of GMT fuses are in this tray. Tekelec recommends no fewer than five of each fuse type be readily accessible. If the EAGLE 5 ISS is not located at the end of a bay, check your facility's spare fuse storage. GMT fuses are industry standard fuses and are provided by Tekelec during installation of the system. Additional inventory of these fuses should be purchased through Tekelec.

Wrist Strap Test

Purpose: The purpose of this routine is to verify the integrity of the anti-static wrist strap and ground cord used when handling cards from the EAGLE 5 ISS.

Requirements: Ohmmeter, wrist strap (equipped with the EAGLE 5 ISS).

Interval: Monthly

Procedure - Wrist Strap Test

1. Detach the grounding cord from the wrist strap.



DANGER

Danger: If the resistance measured is less than 800 Kohms, you may be electrocuted if the equipment short circuits while you are wearing the wrist strap. If the resistance measured is greater than 1200 Kohms, you may damage your equipment.

2. Using an ohmmeter, measure the resistance between the two ends of the ground cord.
3. If you measure a resistance between 800 Kohms and 1200 Kohms, the ground cord is safe to continue using.
4. If you measure a resistance that is not between 800 Kohms and 1200 Kohms, discard the ground cord and wrist strap.
They are no longer safe to use.

Quarterly Procedures

The procedures found in this section are recommended procedures for quarterly routine preventive maintenance. Some procedures may refer to other chapters within this document.

Database Archive (Quarterly)

Purpose:	The purpose of this routine is to create an archive copy of the EAGLE 5 ISS database. This archive copy should be stored off-site and saved for emergency recovery when all other procedures have failed. This routine will reuse the same removable USB drive each quarter.
Requirements	This procedure requires a removable USB drive formatted for system data.
Interval	Quarterly

Procedure _Database Archive (Quarterly)

1. Enter the following command to check the operational status of the database:

```
rept-stat-db
```

If necessary, refer to the *Commands Manual* to interpret the output.

2. Insert the removable USB drive labeled "Archive" into the removable USB drive media slot.
Reference: [Removable Drives](#)
3. Enter the following command to create a backup of the database on the removable USB drive:
`chg-db:action=backup:dest=remove`

```
BACKUP (REMOVABLE) : MASP A - Backup starts on active MASP.
BACKUP (REMOVABLE) : MASP A - Backup to removable USB drive complete.
```

4. Verify that the databases on the removable USB drive (RDBKUP) and the current partition of the active MASP (FDCRNT) are coherent by entering the following command:
`rept-stat-db`

If necessary, refer to the *Commands Manual* to interpret the output.

5. Remove the removable USB drive from the removable USB drive media slot.
Reference: [Removable Drives](#)
6. Make an entry in the site maintenance log that a backup was performed on the “Archive” removable USB drive.
Place the removable USB drive in a safe place off-premise. This copy is for emergency recovery in the event all other methods of database recovery failed.

Preventing Dust Buildups

Purpose:	The purpose of this routine is to prevent dust build-up in and around the cabinet. Collection of dust within the EAGLE 5 ISS can allow electrostatic charges to build around circuit cards, possibly damaging cards installed in the system.
Requirements:	Damp cloth
Interval:	Quarterly

Procedure - Prevent Dust Buildup

1. Open the cabinet doors on the front of the cabinet(s).

Note:

Do not use compressed air. Do not remove the plexiglass panels from the rear of the frame. This procedure is to be used for removing dust from the front of the system and from around the card cages only.

Using a damp cloth, wipe the dust from the doors and from the front of the card cages.

2. Using the same cloth, wipe the dust from the air intakes and around the exterior of the system frames.

Rectifier Voltage Inspection/Recording

Purpose:	The purpose of this routine is to verify that the rectifier is providing adequate voltages and has not become a marginal supply. By identifying power supply problems early, the possibility of failure can be circumvented.
Requirements:	Volt meter capable of measuring DC voltages in the range of -20VDC to -60VDC.
Interval	Quarterly

Procedure - Rectifier Voltage Inspection

1. Locate the power source for the EAGLE 5 ISS.
2. Using a VOM, measure the -48VDC supply.
3. Verify voltages are between -46VDC and -52VDC.
(If voltages are higher or lower, refer to the manufacturers maintenance procedures for appropriate action).

Semi-Annual Procedures

The procedure found in this section is recommended for semi-annual (every 6 months) routine preventive maintenance. Some procedures may refer to other chapters within this document.

Spare Inventory Rotation

Purpose: The purpose of this routine is to verify the integrity of spare cards. By rotating spares on a regular basis, their operation can be verified before they are needed as replacements.

Requirements None

Interval Semi-annually (every 6 months)

Procedure - Semi-annual Procedures

1. Identify the spare cards in your inventory.



Warning: This procedure may interrupt service. Verify the type of card and service it provides, and only use this routine during the maintenance window.

2. Locate the card in service that matches the configuration of your spare card.
3. Verify the part numbers and revision numbers of the cards are compatible.
4. Refer to [Card Removal/Replacement Procedures](#) for the proper procedure for each card type.
5. Place the card from your spares inventory into the now empty slot.
Perform any administrative commands described in [Card Removal/Replacement Procedures](#).
6. Make an entry in the site maintenance log and place the card removed from the system into your spares inventory.

Chapter 3

Corrective Maintenance

Topics:

- *Introduction.....73*
- *System Alarm Levels.....73*
- *Trouble Detection.....74*
- *Output Messages.....80*
- *Alarm Clearing Procedures.....81*
- *Retrieve Trouble Report.....82*
- *Hourly Status Message Reports.....83*
- *Maintenance System Event Logs.....87*
- *Obituaries.....88*
- *Terminal Not Responding.....89*
- *Printer Not Working.....91*
- *Modem Not Working.....92*
- *Link Maintenance.....92*
- *Power Down of In-Service System.....106*
- *Power Up of the System.....109*

Introduction

The EAGLE 5 ISS trouble detection is distributed throughout the system. Each processor continually monitors its internal subsystems and certain external subsystems. Whenever a trouble condition changes state, the processor analyzes the change and stores the analysis for reporting to the active E5-MASP. The trouble detection software does not affect the service quality of the system.

Each E5-MASP is made up of two cards, the E5-MCAP card and the E5-TDM (terminal disk module).

The E5-MCAP card is equipped with 4 GB of physical application processor memory. The primary data interface to the E5-MCAP is RS-232 interfaces (i.e.: terminals) through the E5-TDM.

The E5-MCAP card contains one latched USB port for use with removable flash media (“thumb drive”), and one flush-mounted USB port for use with a plug-in flash drive. The removable media drive is used to install and back up customer data. The flush-mounted USB port is used for upgrade and could be used for disaster recovery. The removable flash media is used as a replacement for the legacy Magneto-Optic (MO) Drive. The E5-MCAP card is a replacement for the obsoleted legacy GPSM-II card used for the MCAP function.

Note: The E5-MCAP card can not be used for the other functions for which the GPSM-II class (e.g.: MCP, IPS, DCM) card is used.

The E5-TDM card contains four major subsystems: the Terminal Processor Subsystem, the System Clock/Control Subsystem, the SATA Subsystem, and a Power Subsystem. These subsystems provide the EAGLE 5 with 16 user-accessible terminals, distributes Composite Clocks and High Speed Master clocks throughout the EAGLE 5, distributes Shelf ID to the EAGLE 5, and disk storage for an E5-MCAP card. The E5-TDM card provides an interface to the E5-MDAL card for system alarms.

The E5-TDM card contains one fixed solid-state SATA drive that is removable and used to store primary and backup system databases, measurements, and Generic Program Loads (GPLs).

To determine which MASP is active either enter the `rept-stat-db` command, or enter the `rept-stat-card` command, or examine the LEDs on both E5-TDM cards. If the LED on the E5-TDM card is green, the associated E5-MASP is active. (If the LED on the E5-TDM card toggles between green and amber, the associated E5-MASP is standby.)

The output of the `rept-stat-db` command shows which E5-MASP is active with the indicator (ACTV) following the E5-TDM card location. The indicator (STDBY) following the E5-TDM card location shows which E5-MASP is standby.

The output of the `rept-stat-card` command shows which E5-MASP is active with the entry ACTIVE in the SST field for the E5-MCAP card. The entry STANDBY in the SST field for the E5-MCAP card shows which E5-MASP is standby.

The database commands, such as `rept-stat-db`, refer to the E5-TDM because the E5-TDM contains the fixed disk drive and the removable USB media for the E5-MASP.

System Alarm Levels

There are three levels of alarms in the EAGLE 5 ISS system. They are:

Critical	A critical alarm is an indication of a severe service affecting problem that can be related to traffic, billing, and maintenance capabilities and requires immediate maintenance attention, regardless of time of day.
Major	A major alarm is an indication of a problem that seriously affects system operation, maintenance and administration, etc. and requires immediate attention. The urgency is less than in critical situations because of a lesser immediate or impending effect on system performance, customers, and operating company operations and revenue.
Minor	A minor alarm is an indication of a problem that does not have a serious impact on service, and does not require immediate maintenance attention.

Trouble Detection

The first step in analyzing a system trouble is to know when a trouble exists. The EAGLE 5 ISS handles this task through:

- Audible alarms
- Visual alarms
- Event/error messages

Audible Alarms

The EAGLE 5 ISS has three types of audible alarms: critical, major and minor. Audible alarms are generated by the E5-maintenance disk and alarm card (E5-MDAL), and can be heard through the electronic sonalert device installed on the card. Each alarm has its own distinct cadence as described in the following:

- Critical - Two tones 0.5 seconds apart, separated by 1.5 seconds of silence.
- Major - Single tone, separated by 1.5 seconds of silence.
- Minor - Single tone of 5 seconds or continuous tone for power plant alarm.

Visual Alarms

The EAGLE 5 ISS has several types of visual alarms. They are:

- AlarmLEDs on the Fuse and Alarm Panel (FAP)
- Alarms displayed on the system terminal
- LEDs on application cards
- End cabinet alarm indicators

Maintenance personnel usually see the alarm LEDs on the fuse and alarm panel (FAP) and the alarms displayed on the system terminal screen to alert them that a system problem exists. The LEDs on a card help maintenance personnel diagnose where a problem exists.

Alarm LEDs on the Fuse and Alarm Panel (FAP)

There are six alarm LEDs on the FAP that indicate:

- Power power alarm LEDs (A and B)
- A critical alarm
- A major alarm
- A minor alarm
- A fuse alarm

The FAP provides protected distribution of power to the system. Protection is provided by the fuses placed in the GMT fuse holders used in the panel. The FAP contains a fuse fail alarm circuit that operates when one or more of the panel’s fuses fail. An LED changes from green to red when a fuse has failed. The LED remains red until the fuse has been replaced.

The fuse and alarm panel uses GMT fuses for individual circuit protection (see [Figure 18: GMT Fuse](#)). The EAGLE 5 ISS uses 3A and 1A fuses, depending on the application. When a fuse fails due to an overload condition, a small colored flag on the fuse shows the position of the fuse that has failed. The flag is gray on 1A fuses, blue on 3A fuses, black/white on 7.5A fuses, and red on 10A fuses.

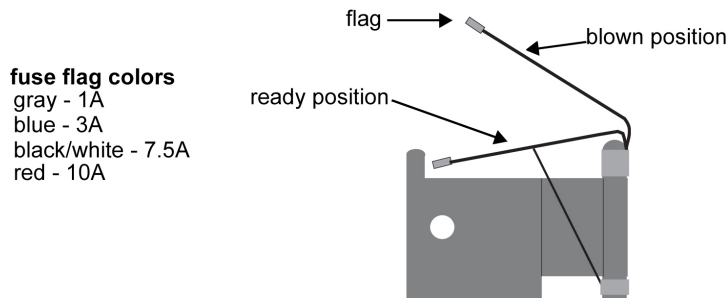

Figure 18: GMT Fuse

The panel contains two separate circuits, A and B. Current flows from the input terminals to the fuse bus. When a fuse is installed in a fuse holder, the circuit is completed to the output connector. The Fuse Fail Alarm LED on the front panel indicates the condition of the panel. Green is indicated if power is applied to the panel and there are no failed fuses. The green LED changes to red when a fuse fails. An unlit LED indicates a failed LED or no power to the fuse and alarm panel.

The fuse and alarm panel is also equipped with frame alarm LEDs that display the critical, major, and minor alarms generated by the EAGLE 5 ISS system.

The fuse and alarm panels have the A and B buses connected through diodes to allow one bus to pick up the entire load when the other bus loses power.

[Table 14: Fuse and Alarm Panel Front Items \(870-2804-01\)](#), [Table 15: Fuse and Alarm Panel Front Items \(870-0243-xx\)](#) and [Table 16: Fuse and Alarm Panel Front Items \(870-1606-xx/870-2320-xx\)](#) describe the front panel configuration of the fuse and alarm panels.

Table 14: Fuse and Alarm Panel Front Items (870-2804-01)

Fuse Panel Item	Description
Fuse Positions	2 groups of 20 GMT fuses

Fuse Panel Item	Description
PWR ALM	LED indicator for A or B diode board input power <ul style="list-style-type: none"> Green - input power applied Red - no input power to board
FUSE ALM	LED indicator for fuse fail alarm <ul style="list-style-type: none"> Green - normal Red - blown fuse
CR	LED indicator for frame critical alarm
MAJ	LED indicator for frame major alarm
MIN	LED indicator for frame minor alarm
Shorting Board	LED indicator for mode of operation <ul style="list-style-type: none"> Off - normal Green - maintenance

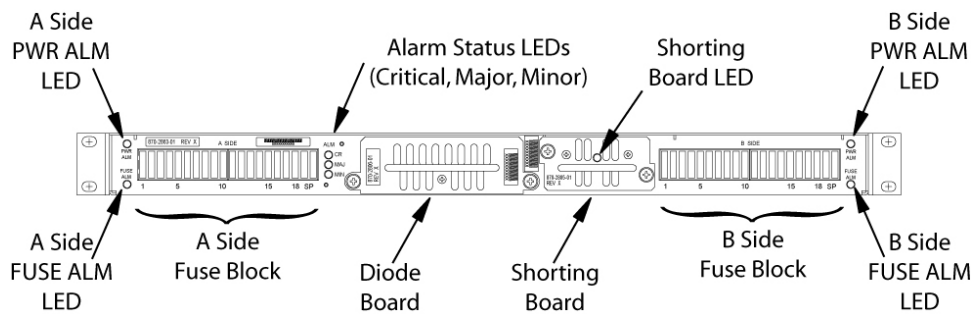

Figure 19: Fuse and Alarm Panel Front Layout (870-2804-01)

Table 15: Fuse and Alarm Panel Front Items (870-0243-xx)

Fuse Panel Item	Description
Fuse Positions	2 groups of 20 GMT fuses
Card Holder	slide-card holder with 2 designation cards for 20 fuse positions each
Fuse Alarm	LED indicator for fuse fail alarm
Critical Alarm	LED indicator for critical alarm
Major Alarm	LED indicator for major alarm
Minor Alarm	LED indicator for minor alarm
Power Alarm	LED indicator for lose of power on either A bus or B bus

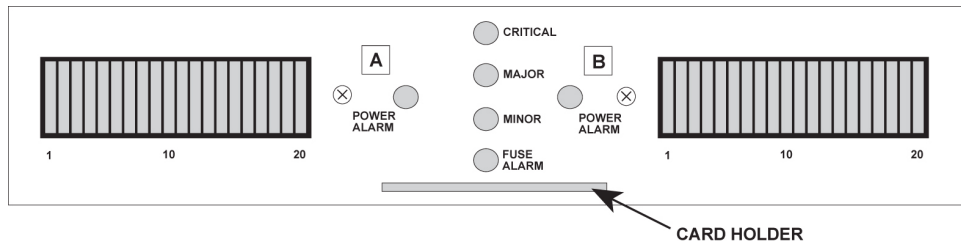

Figure 20: Fuse and Alarm Panel Front Layout (870-0243-xx)

Table 16: Fuse and Alarm Panel Front Items (870-1606-xx/870-2320-xx)

Fuse Panel Item	Description
Fuse Positions	Two groups of 20 GMT fuses
PWR ALARM	LED indicator for A or B diode board input power Green - input power applied Red - no input power to board
OP/MAINT	LED indicator for mode of operation Green - normal Red - maintenance
FUSE	LED indicator for fuse fail alarm Green - normal Red - blown fuse
CRITICAL	LED indicator for frame critical alarm
MAJOR	LED indicator for frame major alarm
MINOR	LED indicator for frame minor alarm

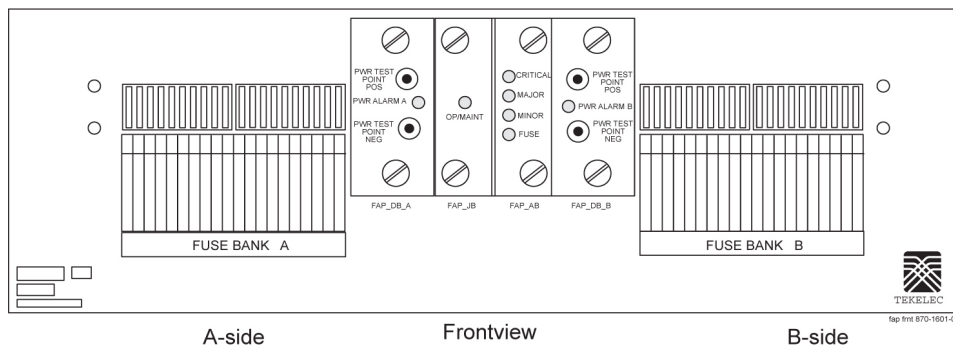

Figure 21: Fuse and Alarm Panel Front Layout (870-1606-xx/870-2320-xx)

Alarms appearing on a terminal screen

Three types of alarms may be displayed on a system terminal screen:

- CRIT - Indicates a critical alarm
- MAJR - Indicates a major alarm
- MINR - Indicates a minor alarm

These appear as three highlighted boxes in the top left corner of a terminal. If an alarm condition exists, it is displayed in one of the highlighted boxes. There is a fourth box next to the three alarm boxes that is not used. To obtain information about the alarm, use the `rept-stat-alm` command at the system terminal, followed by a carriage return.

This command provides all current alarm status. Refer to *Commands Manual* for more information about the `rept-stat-alm` command.

Alarms on Application Cards

Each application card has LEDs that indicate the condition of the card. Alarm conditions appear on the card if the card has a fault. Refer to *Installation* for the location and description of the card LEDs.

End Cabinet Alarm Indicators

There are three alarm LEDs on the end cabinet:

- A critical alarm LED
- A major alarm LED
- A minor alarm LED

When an alarm condition is present, one or more of these LEDs illuminate in the signifying the overall system alarm level. Refer to *Installation* for alarm indicators.

Event/Error Messages

Unsolicited messages are used in the EAGLE 5 ISS for trouble notification and to communicate the status of the system to Operations Services (OS). The EAGLE 5 ISS outputs two types of unsolicited messages.

- Unsolicited Alarm Messages (UAMs) are used to denote a persistent problem with device or object that needs the attention of a craftsperson. Some examples are a link failure, a subsystem being out of service, or a card not receiving a system clock.
- Unsolicited Informational Messages (UIMs) are indications of transient events that have occurred. UIM examples include messages that an MSU contains invalid data or failed a gateway screening function.

The location of a card with a fault is displayed with the event/error message. The location is displayed as a card number. Card numbers are used to locate the card in the EAGLE 5 ISS system. Refer to *Installation* for card locations.

Following is an example of an event/error message displaying the card location:

```
RLGHNCXA21W 00-02-07 12:01:43 EST EAGLE 35.0.0
** 0014.0008 ** CARD 1113 OAM Active MASP has become isolated
```

The card location always follows the word “CARD” in the message. In this example, the card number is **1113**.

IMT Bus States

The states of the IMT bus are combined from the primary state (PST) and secondary state (SST) for each IMT bus. See the *Commands Manual* for information about PST and SST states and definitions.

The `rept-stat-imt` command is used to report the status of the IMT bus. An example of the output follows:

```
RLGHNCXA03W 00-09-27 16:50:24 EST EAGLE 31.5.0
IMT  PST          SST          AST
A    IS-NR        Active      -----
ALARM STATUS      = No alarms
IMT  PST          SST          AST
B    IS-ANR       Fault       -----
ALARM STATUS      = ** 0108 Major IMT Failure Detected
Command Completed.
```

IMT System Alarm Level Determination

The state of the IMT subsystem is determined from the state of each IMT bus. If both buses are IS-NR active, the IMT subsystem is IS-NR active. If only one IMT bus is manually disabled (IS-ANR manual), the IMT subsystem is IS-ANR manual. Otherwise, the IMT subsystem state is IS-ANR fault.

The alarm level of an IMT bus in the IS-ANR fault state is determined by how many bad card connections it has. The number of bad connections required for a major alarm or a minor alarm are as follows:

- 0 failures = no alarm
- 1-2 failures = minor alarm
- 3 or more = major alarm

The alarm levels on the individual buses combine to give the overall alarm level for the IMT subsystem. [Table 17: IMT Bus Alarm Levels](#) shows the rules that are used to determine the overall alarm level of the system of IMT buses.

Table 17: IMT Bus Alarm Levels

Bus A Alarm Level	Bus B Alarm Level	Overall Alarm Level
Normal	Normal	Normal
Normal	Minor	Normal
Minor	Normal	Normal

Bus A Alarm Level	Bus B Alarm Level	Overall Alarm Level
Normal	Major	Minor
Major	Normal	Minor
Minor	Minor	Major
Minor	Major	Major
Major	Minor	Major
Major	Major	Critical

Output Messages

The EAGLE 5 ISS generates output messages in response to command input or fault conditions in the EAGLE 5 ISS or in the network. The format for these messages is generally uniform. Some messages include additional data.

Network messages provide the text description of the event, and on the lines below the text line, any additional information.

The following example shows the general format of an output message.

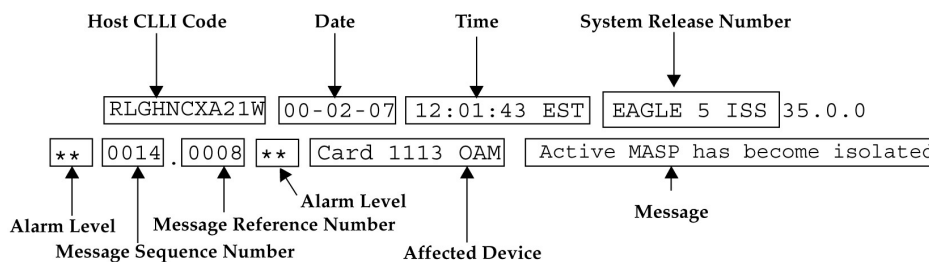

Figure 22: Output Message Format

The fields in an output message (shown in the figure above) are described next:

- Host CLI code - a maximum of one alpha character and ten alphanumeric characters. The CLI code uniquely identifies the system in terms of its physical location. The CLI code must be unique among all elements in the system.

The CLI code consists of the following:

- City = 4 characters
- State = 2 characters
- Building = 2 characters
- Equipment type = 3 characters
- **Date** - The date the message was generated, in the format *year-month-day*.

- **Time** - The time the message was generated with time zone, in the format *hour: minutes: second time zone*.
- **System Release Number** - contains a system identifier and the version ID number. The system identifier, can be `EAGLE` or `EAGLE5` depending on the product key enabled on the system. The version ID number has the software release specific GPL set that is expected to be installed on the system as approved loads. The format of the version ID number is in the form of **maj.min.maint**, defined as follows:
 - **maj** - the major release ID
 - **min** - the minor release ID
 - **maint** - the maintenance release ID
- **Alarm Level** - a one or two character indicator of the alarm level, defined as follows:
 - ***C** = Critical Alarm
 - ****** = Major Alarm
 - ***** = Minor Alarm
 - *blank* = No Alarm
- **Message Sequence Number** - This number is an index for all output messages. The number increments sequentially for every message. The output messages originating from the card in location 1113 has a range from 0001 through 4999. The range for location 1115 is 5000 through 9999.
- **Message Reference Number** - Messages that are associated with a specific action are numbered for reference. These messages are defined in this chapter, along with a corrective action.
- **Affected Device** - The device that caused the message to be generated. This generally describes the card type.

Network messages with additional data display the additional lines below the text string and message reference number (MRN). See individual messages for examples of output.

All network messages are non-alarm and are used to notify the user of network events. There may or may not be a procedure associated with these messages.

Alarm Clearing Procedures

After an audible has sounded, it can be silenced by entering the following command:

```
rls-alm:lvl=xxxx
```

where *xxxx* can be:

- `minr` - Silences a minor alarm
- `majr` - Silences a major alarm
- `crit` - Silences a critical alarm.

All alarm types can be silenced with the following command:

```
rls-alm
```

The `rls-alm` command does not clear visual alarms on the terminals or alarm indicators on the fuse and alarm panel (FAP) or frame panels.

Once an audible alarm is silenced, any new alarm conditions cause the alarm to sound again.

Silencing a specific alarm when a lower level alarm is also present results in the next highest audible alarm level being activated. For example, the system has both critical and major alarms present. When the critical alarm is silenced, the audible major alarm begins to sound.

Retrieve Trouble Report

Application maintenance software is responsible for monitoring trouble on a card. There are three types of troubles or faults:

- Abnormal situation is being reported by software.
- An SS7 message has a problem (an invalid DPC, for example)
- A hardware fault is being reported.

Trouble reports are used by Tekelec [My Oracle Support \(MOS\)](#) to help analyze problems with the EAGLE 5 ISS system. To help Tekelec [My Oracle Support \(MOS\)](#), retain any printouts of the trouble report. The output of the `rtrv-trbl` command should be reviewed with a member of Tekelec [My Oracle Support \(MOS\)](#). To display the current trouble reports, enter the following command at the system terminal:

```
rtrv-trbl:loc=1115:num=1:mode=c
```

The **mode=c** parameter provides a continuous output of the trouble reports as they occur. The **loc=** parameter specifies the active E5-MCAP. The **num** parameter indicates how many trouble reports you want to display.

A typical trouble report looks similar to this:

```
tekelecstp 00-05-15 19:04:05 EST EAGLE 35.0.0
  Card 1115 Module tc_utl.c Line 1617 Class 1103 Severity 1
  00 02 f6 00 01 23 06 22 05 00
  Report Date 00-05-15 Time19:04:05
```

The trouble reports include:

- Card number
- Module name
- Line number
- Class
- Severity

Hourly Status Message Reports

The system provides hourly reports that include a list of all alarms and any devices that are manually deactivated or inhibited. The report contains the alarms that exist at the time the report is generated. Any alarms that have occurred, and have been cleared in the last hour, are not reported. The hourly status message report is automatically generated at the beginning of each hour (08:00, 09:00, and so forth). The system sends the report to all system terminals that can receive unsolicited program update messages.

The information shown in the hourly status report can also be displayed by entering one or more of the following commands.

Note: Systems supporting an ITU network are not configured with the LNP or SEAS features.

- `rept-stat-alm`: Displays the summary of all alarm counts.
- `rept-stat-card`: When used with the **stat** parameter, displays all cards with the state specified by the **stat** parameter. Refer to the *Commands Manual* for additional information on the use of parameters with this command.
- `rept-stat-cdt`: Displays the customer defined troubles.
- `rept-stat-clk`: Displays the status of the clocks.
- `rept-stat-cluster`: Displays the summary status and statistical information for all configured cluster point codes.
- `rept-stat-db`: When used with the `display=except` parameter, displays the status of the system database by displaying the database level of the cards whose database level does not match the active fixed disk current partition. Refer to the *Commands Manual* for additional information on the use of parameters with this command.
- `rept-stat-dlk`: When used with the **:stat** parameter, displays the status of the TCP/IP data links. Refer to the *Commands Manual* for additional information on the use of parameters with this command.
- `rept-stat-dstn`: When used with the **stat** parameter, displays the destination point codes with the state specified by the **stat** parameter. Refer to the *Commands Manual* for additional information on the use of parameters with this command.
- `rept-stat-dstn`: When used with the **mode=full** parameter, displays the subsystem status. Refer to the *Commands Manual* for additional information on the use of parameters with this command.
- `rept-stat-mps`: Displays in a single report, the overall status of the EPAP (EAGLE 5 ISS Provisioning Application Processor) subsystem.
- `rept-stat-gpl`: Displays the version of the GPL currently being used by an application and which versions of the GPL are the trial and approved versions of that GPL.
- `rept-stat-imt`: Displays the primary, secondary, and associated maintenance states of the IMT buses.
- `rept-stat-lnp`: Displays the status and statistics related to LNP.

- `rept-stat-ls`: When used with the `stat` parameter, displays the linksets that have the state specified by the `stat` parameter. Refer to the *Commands Manual* for additional information on the use of parameters with this command.
- `rept-stat-sccp`: Displays the status of the TSMs running the SCCP application.
- `rept-stat-seas`: Displays the status of the SEAS subsystem.
- `rept-stat-slan`: Displays the status of the cards that make up the STPLAN subsystem.
- `rept-stat-slk`: When used with the `stat` parameter, displays the signaling links that have the state specified by the `stat` parameter. Refer to the *Commands Manual* for additional information on the use of parameters with this command.
- `rept-stat-sys`: Displays the status of these items: alarms, IMT buses, SS7 signaling links, linksets, destination point codes (DPCs), the maintenance and administration subsystem (MAS), clocks, TSMs loaded with the SCCP or GLS application, security subsystem, and the SEAS subsystem.
- `rept-stat-trbl`: Displays a report of all the device trouble notifications that are currently logged in the OAMRAM storage area. The severity of each alarm is also identified in the report.
- `rept-stat-trm`: Displays the status of the terminal serial ports.
- `rept-stat-xlist`: Displays the statistics related to the storage of exception list (x-list) entries.

If the message reference number (MRN) field has a null value (no field entry), the device has been manually removed from service (through `inh-card`, `canc-slk`, and so forth). There is no alarm for the device and the condition type is SCMMA (state change due to manual action). The date and time in the report refer to the date and time of the alarm or when the device was removed from service. The format of the output is in [Figure 23: Format of Hourly Status Message Output](#).

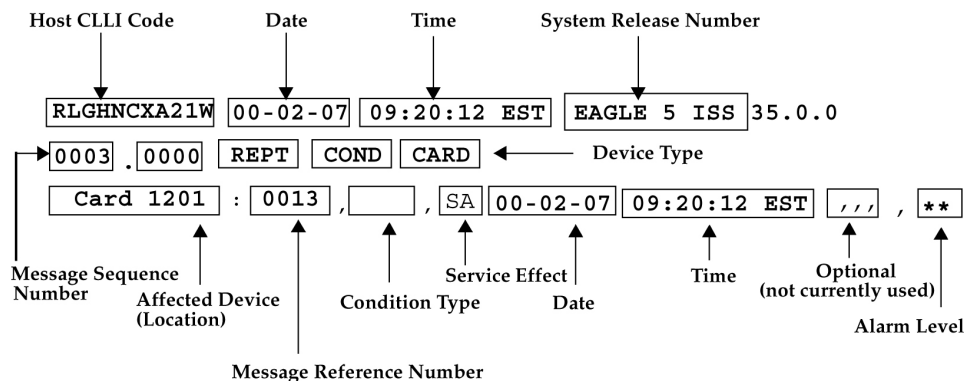

Figure 23: Format of Hourly Status Message Output

The following is a list of the device types and subsystems (with the ID of the affected device or subsystem) that the hourly status message report displays reports for. For example, if the device type being reported on is `CARD`, then card locations are displayed. Only those device types and subsystems that have disabled devices or alarm conditions are displayed in the hourly status message report. If there is more than one device type or subsystem to display, they are displayed in the following order.

1. `CARD` - the card location
2. `IMT` - the IMT bus A or IMT bus B
3. `BITS` - the BITS clock

4. TRM - the terminal port
5. SLK - the linkset name and the signaling link code (SLC)
6. DLK - the data links
7. LS - the linkset name
8. DPC - the destination point code
9. CDT - the customer defined trouble number
10. FUSEPNL - the frame ID of the system
11. SYSTEM - system
12. ALM - alarms
13. SYSCLK - system clock
14. SYSIMT - system IMT
15. SCCPSS - SCCP subsystem
16. GLSSS - GLS subsystem
17. GPL_SS - the name of the GPL
18. SLANSS - STP/LAN subsystem
19. XLISTSS - XLIST subsystem
20. SEASSS - SEAS subsystem
21. SECULOG - Security log
22. LNPSS - LNP subsystem
23. LSMS Q.3 Association - Local Services Management System Association
24. LSMSSS - Local Services Management System subsystem
25. HS System CLK - High-Speed system clock
26. EMDC Links - Element Measurement & Data Collection Application Links
27. NDCSS - Network Data Collection subsystem
28. NDC Q.3 Association - Network Data Collection Q.3 association
29. GSMSS - GSM subsystem
30. MPS (ELAP/EPAP) - Multi-Purpose Server
31. DSM Links - Database Services Module
32. INPSS - INP subsystem
33. SECURITYSS - Security subsystem

Within each device type or subsystem being reported, the subsets of the report are displayed in the following order.

1. Disabled Devices
2. Minor Alarms
3. Major Alarms
4. Critical Alarms

The *cond type* field supports five values for this release:

- SCMMA: The device has been disabled due to manual maintenance action. This condition applies regardless of a previous alarm state.
- MTCEINT-0: The reported device is off normal (ANR), but there is no alarm associated with this device. An alarmed condition for another device typically affects the state of this device. For example, out-of-service (OOS) links affect the condition of the linksets.
- MAN: The reported device is off-normal (OOS-MT), but there is no alarm associated with this device. The off-normal condition was caused by manual intervention (by entering the ent-dstn command, for example).
- NULL: No specific cond type is supported. There is sufficient information to ascertain the device condition from the report. You should use a rept-stat command for further information.
- INAUDB: The user has manually inhibited alarms for this device. The time when the device was inhibited is recorded and displayed during the hourly report.

Following is an example of the report:

```

RLGHNCXA21W 00-07-16 12:20:12 EDT EAGLE 35.0.0
1240.0000 REPT COND CARD
"CARD 1101:0013,,SA,00-07-16,10:03:29,,,,*"
"CARD 1107:,SCMMA,,00-07-16,10:03:29,,,,"
"CARD 1113:0143,,NSA,00-07-16,10:03:29,,,,*"

RLGHNCXA21W 00-07-16 12:20:12 EDT EAGLE 35.0.0
1241.0000 REPT COND SLK
"SLK ls1201-0,,NSA,00-07-16,10:03:29,,,,*"
"SLK ls1201-1,,NSA,00-07-16,10:03:30,,,,*"
"SLK ls1202-0,,NSA,00-07-16,10:03:31,,,,*"
"SLK ls1202-1,,NSA,00-07-16,10:03:32,,,,*"

RLGHNCXA21W 00-07-16 12:20:12 EDT EAGLE 35.0.0
1242.0000 REPT COND LS
"LS ls1201:,MTCEINT-0,,00-07-16,10:03:29,,,,"
"LS ls1202:0318,,NSA,00-07-16,10:03:29,,,,*"
"LS ls1203:0318,,00-07-16,10:03:29,,,,*"
"LS lsx23 :0318,,NSA,00-07-16,10:03:33,,,,*"

RLGHNCXA21W 00-07-16 12:20:12 EDT EAGLE 35.0.0
1243.0000 REPT COND DPC
"DPC 001-001-001:0313,,SA,00-07-16,10:03:29,,,,*C"
"DPC 002-002-002:0313,,SA,00-07-16,10:03:30,,,,*C"
"DPC 003-003-003:0313,,SA,00-07-16,10:03:31,,,,*C"
"DPC 001-005-* :0313,,SA,00-07-16,10:03:32,,,,*C"
"DPC 006-006-006:,MAN,,00-07-16,10:03:32,,,,"

RLGHNCXA21W 00-07-16 12:20:12 EDT EAGLE 35.0.0
1244.0000 REPT COND TRM

```

```
"TRM 2: .SCMMA,00-07-16,10:03:29,,,,,"
"TRM 3:0048,,NSA,00-07-16,10:03:29,,,,,"
```

Maintenance System Event Logs

The `rtrv-log` command is used to retrieve records from the active or standby event logs generated by the maintenance system. This command selects these records based on a span of time or a specific log file index. There are numerous ways to sort and filter the output. Refer to the *Commands Manual* for details on using the `rtrv-log` command. A sample output follows:

```
rtrv-log:sdate=030715:stime=220000:num=50:snum=106:enum=350
ncralstp00001 10-03-16 10:15:29 EST EAGLE 42.0.0
Card 1113; SYS REL= 31.3.0; STP CLLI= ncralstp00001; Timezone= EST

****03-07-16 00:23:55****
3161.0200 SLK 1103,B RCVRY-LKF: link available
****03-07-16 01:42:18****
3162.0155 * DLK 2117,A STPLAN Exceededn unavailable
****03-07-16 01:43:51****
3163.0317 LSET A123456789 RCVRY-LKSTO: linkset allowed
****03-07-16 03:00:23****
3165.0108 ** IMT BUS A Major IMT fault detected
****03-07-16 03:37:59****
3166.0292 *C GLS SYSTEM GLS is not available
****03-07-16 07:22:06****
3167.0313 *C DPC 021-005-000 DPC is prohibited
****03-07-16 09:33:17****
3168.0348 * SEAS SYSTEM SEAS is at minimum service
****03-07-16 09:34:01****
3169.0112 * IMT SYSTEM Major Failures detected on both
****03-07-16 09:35:07****
3170.0160 * CLOCK SYSTEM 1116-S clock failed
****03-07-16 09:36:34****
3171.0160 * CARD 1116 OAM 1116-S clock failed
****03-07-16 09:38:12****
3173.0308 *C SYSTEM Node isolated due to SLK failure
****03-07-16 09:39:56****
3174.0331 *C SCCP SYSTEM SCCP is not available
****03-07-16 09:41:34****
3176.0153 *C SLAN SYSTEM STPLAN not available
****03-07-16 09:45:29****
3180.0321 * XLIST X-LIST occupancy threshold Exceeded
****03-07-16 09:48:48****
3181.0175 * SECURITY 1114 LOGBUFROVL-SECULOG - upload required
;

UAM Report terminated - end of log reached.
END OF LOG REPORT.
;
```

The `rtrv-trbltx` command is used to retrieve alarm and UIM message information including MRN (message reference number), level (for Alarms), Output Group and text.

The default `rtrv-trbltx` report displays all Alarms (in numerical order), and then all UIMs. Using the optional parameters, the capability exists to display a range of Alarms or UIMs, search for Alarms,

UIMs or both message types matching a specific Output Group or sort all entries by Output Group. Refer to the *Commands Manual* for details on using the `rtrv-log` command. A sample output follows:

```
rtrv-trbltx:OUTGRP=all
ncralstp00001 03-07-16 10:15:29 EST Rel XX.X.X

Card 1113; SYS REL= XX.X.X; STP CLLI= ncralstp00001; Timezone= EST
Alarm Report
  MRN      LEVEL  OUTPUT GROUP    TEXT
-----
  Output Group - SYS
    0001  MAJR   SYS           Card has reset
    0002  MINR   SYS           Card is not running approved GPL
      :
    0912  NONE   SYS           Dynamic database is now consistent
  :
  Output Group - LINK
    0155  MINR   LINK          STPLAN connection unavailable
    0156  NONE   LINK          STPLAN connection available
      :
    0479  NONE   LINK          Link not Monitored
UIM Report
  MRN      OUTPUT GROUP    TEXT
-----
  Output Group - SYS
SCCP      1000           SYS           MTP rcvd UPU - user part is not
          1001           SYS           MTP rcvd Transfer Controlled (TFC)
          :
          1499           SYS           Invalid MRN detected
  :
  Output Group - LINK
          13nn           LINK          Example text
END OF RTRV-TRBLTX REPORT.
;
```

Obituaries

An obituary is a set of data that describes the status of the system just before a processor restarted due to a fault in hardware or software. The data includes a register and stack dump of the processor, card location, reporting module number, software code location, and class of the fault detected. In most situations, obituary reports are generated automatically when a card is reset. Obituary reports can also be retrieved manually using the `rtrv-obit` command. Refer to *Commands Manual* for information on using the `rtrv-obit` command. Obituaries should immediately be reported to the [My Oracle Support \(MOS\)](#).

To help Tekelec [My Oracle Support \(MOS\)](#), retain any printouts of the obituary. Tekelec [My Oracle Support \(MOS\)](#) can use the report to analyze the problem. A typical obituary looks like the following:

```
rtrv-obit:loc=1115:num=2
```

```
rlghncxa03w
```



```

13-04-19
12:09:15 EST EAGLE5 45.0.0-64.62.0
-----
STH: Received a BOOT APPL-Obituary reply for restart
Card 1115 Module crc_mgr.c Line 482 Class 01d3
Register Dump :
  EFL=00000246   CS =0008       EIP=0064d4d8   SS =0010
  EAX=00000000   ECX=00000000   EDX=00c8fc70   EBX=0b86570c
  ESP=030f5fa0   EBP=030f5fb0   ESI=0000000a   EDI=00000000
  DS =0010       ES =0010       FS =0010       GS =0010

Stack Dump :
[SP+1E]=eeee   [SP+16]=0b80   [SP+0E]=0b86   [SP+06]=0000
[SP+1C]=eeee   [SP+14]=42ed   [SP+0C]=570c   [SP+04]=0246
[SP+1A]=0000   [SP+12]=030f   [SP+0A]=0000   [SP+02]=0000
[SP+18]=000a   [SP+10]=5fd0   [SP+08]=0000   [SP+00]=0008

User Data Dump :
07 ff 00 00 80 ca 11 04 00 00 03 00 00 00 00 00 .....
00 00 00 00 00 00 00 00 00 00 00 00 00 00 00 .....
00 00 00 80 ca 10 04 00 .....
Report Date:13-04-12 Time:09:16:30
-----
;
rlghncxa03w 13-04-19 12:09:16 EST EAGLE5 45.0.0-64.62.0
-----
STH: Received a BOOT APPL-Obituary reply for restart
Card 1213 Module radb_mgr.c Line 652 Class 01d7
Register Dump :
  EFL=00000246   CS =0008       EIP=0061bea8   SS =0010
  EAX=06c25c83   ECX=000005e8   EDX=00000000   EBX=06c25c38
  ESP=0251fed0   EBP=0251fee0   ESI=0be2a582   EDI=00000200
  DS =0010       ES =0010       FS =0010       GS =0010

Stack Dump :
[SP+1E]=0000   [SP+16]=0b97   [SP+0E]=06c2   [SP+06]=0b97
[SP+1C]=00d4   [SP+14]=a454   [SP+0C]=5c38   [SP+04]=c429
[SP+1A]=06c2   [SP+12]=0251   [SP+0A]=0250   [SP+02]=0251
[SP+18]=5c38   [SP+10]=ff10   [SP+08]=0f14   [SP+00]=fee0

User Data Dump :
8f 82 fb ed 01 01 5a 01 5a 0b 00 86 00 00 00 99 .....Z.Z.....
54 8c 1a 87 00 00 00 f0 54 8c 1a 77 00 08 00 00 T.....T..w....
00 00 00 00 00 00 00 00 .....
Report Date:13-04-12 Time:10:40:36
-----
;

```

Terminal Not Responding

When a terminal is not responding, perform the following procedure:

1. Verify the terminal is connected to the MMI port on the back of the control shelf.
2. Verify the terminal is set up for 7-E-1.
3. From a working terminal, enter the following command to determine the port connected to the faulty terminal:

```
rtrv-trm
```

Note the port number. From the output message, verify the settings are correct. If no working terminal is available, contact the [My Oracle Support \(MOS\)](#).

4. Enter the following command to inhibit the terminal failing to respond:

```
inh-trm:trm=x
```

where *x* is the terminal that is not responding.

5. Enter the following command to re-activate the terminal failing to respond:

```
alw-trm:trm=x
```

where *x* is the terminal that is not responding. If the terminal fails to respond, go to [Step 6](#).

6. Enter the following command to ensure that the other terminal devices are functioning:

```
rept-stat-trm
```

Following is an example of the output:

```

RLGHNCXA03W 00-02-07 09:50:17 EST EAGLE 35.0.0
TRM  PST          SST          AST
 1   IS-NR        Active         -----
 2   IS-NR        Active         -----
 3   IS-NR        Active         -----
 4   OOS-MT-DSBLD  MANUAL         -----
 5   IS-NR        Active         -----
 6   IS-NR        Active         -----
 7   IS-NR        Active         -----
 8   IS-NR        Active         -----
 9   IS-NR        Active         -----
10   IS-NR        Active         -----
11   IS-NR        Active         -----
12   IS-NR        Active         -----
13   OOS-MT-DSBLD  MANUAL         -----
14   OOS-MT-DSBLD  MANUAL         -----
15   OOS-MT-DSBLD  MANUAL         -----
16   OOS-MT-DSBLD  MANUAL         -----
Command Completed.
```

7. Verify the problem is not with the terminal by swapping terminals with a known good terminal. Make sure the physical connections are firmly seated. If the terminal works, replace the original terminal.
8. If a single terminal is not functioning and you have verified that the terminal is good, the connections are good, and the settings are correct, then from another terminal inhibit the terminal port with the following command:

```
rmv-trm:trm=x
```

where *x* is the terminal port number (1 through 16).

9. Enable the terminal port with the following command:

```
rst-trm:trm=x
```

where *x* is the terminal port number (1 through 16). If this action corrects the problem, you are done with this procedure.

10. If the terminal still does not respond, contact the [My Oracle Support \(MOS\)](#).

Printer Not Working

Perform the following procedure if the printer is not working.

1. Enter the following command to determine the port connected to the faulty printer:

```
rtrv-trm
```

Note the port number. From the output message, verify the settings are correct.

2. Verify the printer is connected, and the power is on.

Run a printer test to verify the printer is operational (refer to the printer manual for printer tests). If there is no problem with the printer, continue with [Step 3](#). If there is a problem with the printer, go to [Step 4](#).

3. Enter the following command to ensure that the other terminal devices are functioning on the E5-TDM in the active E5-MASP:

```
rept-stat-trm
```

Following is an example of the output:

```

RLGHNCXA03W 00-02-07 09:50:17 EST  EAGLE 35.0.0
TRM  PST          SST          AST
1    IS-NR        Active      -----
2    IS-NR        Active      -----
3    IS-NR        Active      -----
4    OOS-MT-DSBLD  MANUAL     -----
5    IS-NR        Active      -----
6    IS-NR        Active      -----
7    IS-NR        Active      -----
8    IS-NR        Active      -----
9    IS-NR        Active      -----
10   IS-NR        Active      -----
11   IS-NR        Active      -----
12   IS-NR        Active      -----
13   OOS-MT-DSBLD  MANUAL     -----
14   OOS-MT-DSBLD  MANUAL     -----
15   OOS-MT-DSBLD  MANUAL     -----
16   OOS-MT-DSBLD  MANUAL     -----
Command Completed.

```

4. Verify the problem is not with the printer by swapping printers with a known good printer. Make sure the physical connections are firmly seated. If the printer works, replace the original.
5. If a single port is not functioning and it has been verified the printer is good, the connections are good, and the settings are correct, inhibit the printer port with the following command:

```
rmv-trm:trm=x
```

where *x* is the printer port number (1 through 16).

6. Enable the printer port with the following command:

```
rst-trm:trm=x
```

where *x* is the terminal port number (1 through 16). If this action corrects the problem, you are done with this procedure.

7. If none of the ports are active, trying resetting and then reseating the E5-TDM card.
8. If the problem persists, replace the E5-TDM card.
See [Card Removal/Replacement Procedures](#).
9. If the terminal still does not respond, contact the [My Oracle Support \(MOS\)](#).
10. If only the printer port is inactive, inhibit the printer with the following command:

```
rmv-trm:trm=x
```

where *x* is the printer number (1 through 16).
11. Enable the printer with the following command:

```
rst-trm:trm=x
```

If this action corrects the problem, you are done with this procedure. If the problem persists, reseal the E5-TDM card.
12. If reseating the E5-TDM card does not correct the problem, replace the E5-TDM card.
See [Card Removal/Replacement Procedures](#).
13. If the printer still does not respond, contact the [My Oracle Support \(MOS\)](#).

Modem Not Working

Using Procomm Plus and a modem connected to a serial port on the system, the system can be accessed the remotely. If there are problems connecting to the modem, perform the following procedure:

1. Check the physical connection.
The connector to the modem should be an RS-232 connection and firmly seated in both the serial port of the system and the modem.
2. Verify the flow control is set to hardware.
3. Start Procomm Plus and check the modem settings.
The following are possible modem settings for the recommended modem, the Motorola UDS. (Other types of modems may have different settings):
 - AT&F0 - Load factory profile and defaults
 - AT&C1 - Make DCD true
 - ATE0 - Disable command echo. If you use this command, you do not see the commands that you enter. Be careful to enter the commands correctly.
 - ATQ1 - Stop the results codes to the terminal
 - AT&W0 - Store profile in memory location 0
 - AT&Y - Select stored profile 0 on power up

Link Maintenance

Link maintenance covers the proper functionality of a signaling link, from an EAGLE 5 ISSMTP card to a remote NE.

Link Fault Sectionalization

The link fault sectionalization (LFS) feature allows maintenance personnel to perform DSOA link fault sectionalization tests, a series of far end loopback tests, from the system and identify faulty segments of an SS7 transmission path up to and including the remote network element.

The point on the signaling link at which each loopback test ends is the far end loopback point. A far end loopback point is achieved when the remote link element sends the received data back to the transmitter, allowing the transmitter to verify the received data. The remote link elements are shown in [Table 18: Remote Link Element types](#).

Table 18: Remote Link Element types

Element	Description	Valid for the Latching Link Fault Sectionalization Test?	Valid for the Non-latching Link Fault Sectionalization Test?
DSO	DSO Dataport	yes	no
OCU	OCU Dataport	yes*	yes
CSU	CSU Dataport	yes*	yes
DSU	DSU Dataport	yes*	yes
NEI	Network Element Interface	yes	no
* The OCU, CSU and DSU must be strapped or optioned to support latching link fault sectionalization loopback.			

The loopback point is moved along the signaling link path until the point is in the far end network element. Therefore, each loopback point along the link requires the initiation of one link fault sectionalization test on the SS7LIM.

The link fault sectionalization test types for loopback tests are shown in [Table 19: Link Fault Sectionalization Test Types](#).

Table 19: Link Fault Sectionalization Test Types

Link Fault Sectionalization Test Types	Description
Latching link fault sectionalization test (LLT-auto)	A loopback point is established using signaling commands and remains until it is removed by signaling commands.
Latching link fault sectionalization test (LLT-man)	A loopback point is established by manual means and remains until it is removed by manual means.
Non-latching link fault sectionalization test (NLT)	A loopback command is interleaved with the test data.

The SS7LIM must be powered up and in service with the signaling link deactivated (OOS-MT-DSBLD) before starting the link fault sectionalization tests. No signaling traffic is on the signaling link by the SS7LIM while the link is performing a link fault sectionalization test.

The system supports a maximum of 32 remote link elements for each SS7 link.

The system allows a maximum of 1024 SS7 simultaneous LFS tests.

Hardware Configuration

The link fault sectionalization feature requires a LIM hardware configured as shown in [Table 21: Hardware/Card/APPL LFS Support](#). The test data is guaranteed to be a continuous data stream, and the commands provide the ability to put any element in the link into latched loopback.

The test data is provided is shown in [Table 20: Link Fault Sectionalization Test Patterns](#). The data stream sent is verified against the data stream received and a bit error count is updated. If the bit error count is 255 or greater in one second period, the value of the bit error count remains at 255, does not overflow and the test is terminated.

Table 20: Link Fault Sectionalization Test Patterns

Test Pattern	Data	Description
B2047	N/A	2047-bit Bert pattern sent until it is terminated by software.
B2047 Non Latching	N/A	2047-bit Bert pattern sent interleaved with loopback command until it is terminated by software.
B511	N/A	511-bit Bert pattern sent until it is terminated by software.
B511 Non latching	N/A	511-bit Bert pattern sent interleaved with loopback command until it is terminated by software.
OCTET	default =h'32	A continuous series of the specified octet data is sent until it is terminated by software. (Latching only)
ALTERNATE	default = h'FF	A count of 100 octets of the specified data followed by 100 octets of 0 is sent alternating until it is terminated by software. (Latching only)

LFS tests initiated by the EAGLE 5 ISS are used to test the functionality of a signaling link (SLK) from an EAGLE 5 ISSMTP card through multiple channel banks to a remote Network Element. The number of simultaneous tests that can be run on a specific card are shown in parenthesis () in [Table 21: Hardware/Card/APPL LFS Support](#). The maximum number of simultaneous tests for a card is determined by hardware type. [Table 21: Hardware/Card/APPL LFS Support](#) shows the relationship between hardware type and LFS support. A key for the values follows:

- NV indicates APPL is not valid for the given hardware.

- **No** indicates LFS testing is not supported for this combination of hardware, provisioned type, and provisioned application.
- **Yes** indicates LFS testing is supported (max tests per card is shown in parenthesis)

Table 21: Hardware/Card/APPL LFS Support

		Provisioned Application	
MPL		Yes (1)	NV
MPL-T		Yes (8)	NV
E1/T1MIM	LIMT1	Yes (8)	Yes (8)
	LIMCH*	Yes (8)	Yes (8)
HC MIM	LIMT1	Yes (64)	Yes (64)
*If associated parent card is LIMT1			

Test Indicators

Two indicators are used by the `rept-stat-slk` and `rept-stat-ls` commands to show whether the signaling link has a far end loopback condition and if a link fault sectionalization test is in progress.

When the signaling link is in a far end loopback condition:

- The primary state (PST) is OOS-MT-DSBLD.
- The secondary state (SST) is LPBK .
- The associate state (AST) is FE .

When a link fault sectionalization test is in progress:

- The primary state (PST) is OOS-MT-DSBLD.
- The secondary state (SST) is LPBK .
- The associate state (AST) is LFS .

When both the signaling link is in a far end loopback condition and a link fault sectionalization test is in progress:

- The primary state (PST) is OOS-MT-DSBLD.
- The secondary state (SST) is LPBK .
- The associate state (AST) is FE-LFS.

Test Report

Test results are displayed to the terminal when the link fault sectionalization tests have completed. The following is an example of a link fault sectionalization test report.

```

RLGHNCXA03W 96-04-16 16:02:05 EST EAGLE 35.0.0
LOC = 1205 Port = B LSN = ----- Start time = 11:10:34
PATTERN = ALTERNATE DATA= FF MAXERR = 10 TIME = 00:02:00
TEST STATUS = ERROR, bit error exceeded threshold.
LBP CLLI          RLE REP LFST BIT_ERROR ERRORED_SEC  DURATION
2   rlgncxa05w   DSO 0  LLT  0           0           00:02:00
3   ----- OCU 0  NLT  8           2           00:02:00
5   ----- NEI 0  LLT 15          1           00:01:20

```

LFS Test Details

- EAGLE 5 ISS *Initiated LFS Loopback Test Details*

Loopback Test Type: EAGLE 5 ISS initiated Level 1 DS0LFS test

Link State: Link is down.

Equipment tested: Level 1 element(s) in a signaling path.

Purpose: Test the error rates of a signaling path.

Description: Sends loopback code to establish loopback and then performs BERT test for a specified period of time.

Typical use: To validate signaling path has acceptable error rate.

Testing Limits: 1024 concurrent link tests per system.

- *Remote Initiated LFS Loopback Test Details*

Loopback Test Type: Remote Loopback FAREND initiated DS0LFS test.

Link State: Link can be up or down.

Equipment tested: Near end H/W up to level 2 (LXVR) and far end H/W level 1 interface.

Purpose: Auto-loopback a BERT test to the far end.

Description: When receiving a loopback code, deactivate the link and go into loopback.

Typical use: Used to remotely test the far end with standard DS0BERT tests.

Testing Limits: No limit on number of cards.

Link Fault Test Commands

The link fault sectionalization feature uses the following commands:

- `ent-lbp` — add link fault sectionalization test data to the database.
- `chg-lbp` — change existing link fault sectionalization test data in the database.
- `dlt-lbp` — remove link fault sectionalization test data from the database.
- `rtrv-lbp` — display link fault sectionalization test data in the database.

- `act-lbp` — start a link fault sectionalization test.
- `dact-lbp` — stop a link fault sectionalization test.
- `rept-stat-lfs` — generates a report of all links that are under test.

The link fault sectionalization data is configured in the database using the parameters shown in [Table 22: Link Fault Sectionalization Data Entry Parameters](#).

Table 22: Link Fault Sectionalization Data Entry Parameters

Link Fault Sectionalization Data Entry Parameters	Description
Card Location	SS7LIM card location
Port Number	Port a or b, and a1, a2, a3, b1, b2, b3 on the MPL
Loopback Point Number	Identifies the remote link element for setting the loopback point. Value is from 1 to 32.
CLLI	Description of the remote link element
Remote Link Element Type	The remote element type from Table 18: Remote Link Element types .
Repetition Count	A repetition of the same element type in the link path. This is needed for configuring the link element as a latched loopback point. The value is from 0 to 31.
Link Fault Sectionalization Test Type	Link fault sectionalization test type from Table 19: Link Fault Sectionalization Test Types (LFS-man not supported for the database)

Use the `act-lbp` command to start one or a sequence of link fault sectionalization tests. The data stream sent is verified against the data stream received and the bit error counts and block error counts are displayed when the test completes.

The link fault sectionalization test parameters are described in [Table 20: Link Fault Sectionalization Test Patterns](#). If either the remote link element type, repetition count, or link fault sectionalization test type are specified with the `act-lbp` command, they must all be specified and the loopback point number parameter is ignored. Otherwise the values for remote link element type, repetition count, or link fault sectionalization test type are read from the data entered with the `ent-lbp` command using the loopback point number parameter value. The test data parameter is only valid for test patterns OCTET and ALTERNATE.

If all LBPs are selected for the loopback point number parameter, a sequential test of the LBPs, as entered in the database with the `ent-lbp` command for that signaling link, is performed until the entire signaling link has been tested. When performing a test with all LBPs, the test is aborted with the first failed test.

The test is stopped either because the amount of time for the test has expired or if the bit error threshold has been exceeded. The time duration parameter specifies the maximum time duration for one link fault sectionalization loopback point test. The default value is one second (00:00:01) and the maximum value that can be entered is 24 hours (24:00:00). The bit error threshold parameter specifies the maximum

number of bit errors allowed for one link fault sectionalization loopback point test. The default value is 56 errors and the maximum value that can be entered is 4,838,400 (24 hours x 56 errors per second).

Table 23: Link Fault Sectionalization Test Parameters

Parameters	Description
Card Location	SS7LIM card location
Port /Link Number	Signaling link id a to a31 and b to b31
Loopback Point Number	The remote link element for setting the loopback point. Value is from 1 to 32, or if this parameter is not specified, all LBPs are selected.
Remote Link Element Type	The remote element type from Table 18: Remote Link Element types .
Repetition Count	A repetition of the same element type in the link path. The value is from 0 to 31.
Link Fault Sectionalization Test Type	Link fault sectionalization test type from Table 19: Link Fault Sectionalization Test Types .
Time duration	Time for one loopback point in hours, minutes, and seconds (hh:mm:ss). The value is from 00:00:01 to 24:00:00. The default value is 1 second (00:00:01).
Error threshold	Bit error threshold. The value is from 0 to 4838400. The default value is 56.
Test pattern	The test pattern from Table 20: Link Fault Sectionalization Test Patterns . The default value is B2047.
Test data	The octet to be used for test pattern OCTET or ALTERNATE only.

The `dact -lbp` command stops the link fault sectionalization test in progress and cancels any pending link fault sectionalization tests for the SS7 link. The pending tests are the next sequential LBPs for the SS7 signaling link when an entire link test was initiated.

Link Maintenance Enhancements

The Link Maintenance Enhancements feature covers the following areas:

- Allows the operator to force a card into loopback. Without this enhancement, a card will go in and out of loopback as determined by loopback codes sent by the far end.
- `tst-slk` enhancements for ATM customers. The loopback parameters for ATM cards in the `tst-slk` command act in a similar fashion as the `act-lbp` command for standard DS0 loopbacks. Other `tst-slk` enhancements not specifically related to ATM are also provided.

Command Driven Loopback

Command Driven Loopback (CDL) is the ability to locally drive a signaling link into a manual line loopback. The data received on the signaling link is echoed (transmitted) back. Commands are used to provide this capability on an individual signaling link basis. CDL allows loopback testing of a signaling link when either far-end initiated loopbacks are prevented or when a constant loopback state is desired. This command driven setting of loopback is similar in functionality to a remote initiated loopback. *Table 24: Command Driven Loopback Support* shows a breakdown of support for Command Driven Loopback based on the MTP card type. *Figure 24: Signaling Link Network Connections* shows a conceptual view of a signaling links network connections. Local transceiver (LXVR) is a `tst-slk` initiated test in which the line transmit is looped back to the line receive internal to the card. CDL is "LXVR in reverse", the line receive is looped back to the line transmit.

Table 24: Command Driven Loopback Support

MTPCard Type	Supported	MTPCard Type	Supported
MPL (DSO)	Yes	T1-ATM	Yes
E1-ATM	Yes	T1MIM (Channel)	Yes
E1MIM (Channel)	Yes	IPLIM	No
		IPGTWY	NO

Test Indicators

If an MTP card boots, then all links on this card, by default, are not in CDL. A link in CDL is persistent across an OAM switchover. Signaling links must be inhibited (OOS-MT-DSBLD) to perform command driven loopback. Signaling links in CDL have the following conditions:

- The primary state (PST) is OOS-MT-DSBLD.
- The secondary state (SST) is LPBK .
- The associate state (AST) is CDL .

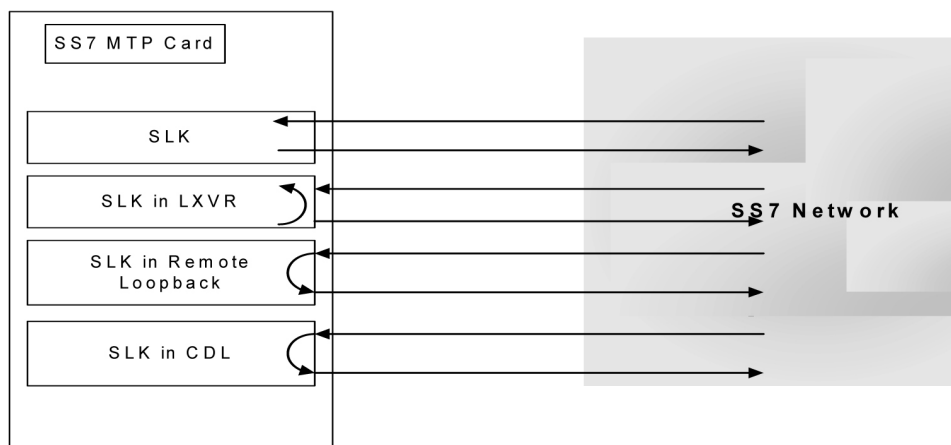

Figure 24: Signaling Link Network Connections

Test Signaling Link

The *tst-slk* command is used to flush out intermittent link problems that are not captured with the one shot testing. The *tst-slk* command allows for duration tests up to 24 hours, stopping of an in-progress test, and forcing the execution of a test. The *tst-slk* command is grouped into two categories, message based tests and hardware-based tests.

The SLTC and OAM tests are message based. These tests involve sending a message to the far end and expecting an appropriate reply. The LXVR, LINE, and PAYLOAD tests are hardware-based. These tests involve setting hardware registers and after an appropriate duration resetting hardware registers. To prevent overloading of a signaling link, message based tests are delayed 1 to 10 seconds between receipt of an appropriate reply and sending of the next test message. [Table 25: *tst-slk* Support](#) shows a breakdown of support for each *tst-slk* test based on MTP card.

Table 25: *tst-slk* Support

MTP Card Type	tst-slk Test	tst-slk Test	tst-slk Test	tst-slk Test	tst-slk Test
	SLTC	LXVR	OAM	LINE	PAYLOAD
OCU	Yes	Yes	No	No	No
MPL (DSO)	Yes	Yes	No	No	No
E1-ATM	Yes	Yes	Yes	No	No
T1-ATM	Yes	Yes	Yes	Yes	Yes
T1MIM (Channel)	Yes	No	No	No	No
E1MIM (Channel)	Yes	No	No	No	No
IPLIM	Yes	No	No	No	No
IPGTWY	No	No	No	No	No
E1 HC MIM	Yes	No	No	No	No
T1 HC MIM	Yes	No	No	No	No
T1 HC MIM	Yes	No	No	No	No

Test Signaling Links Test (*tst-slk*) Indicators

Signaling links performing *tst-slk* commands have a secondary state of LPBK, and an associated state corresponding to the type of loopback (SLTC, OAM, LXVR, PAYLOAD, LINE). The link must be OOS-MT-DSBLD for LXVR, PAYLOAD, and LINE tests.

If an OAM switchover occurs, while the *tst-slk* command is running, the test is aborted. If an MTP card with an active test boots then the test is aborted.

Test E1 and T1 Ports

The *tst-e1* and *tst-t1* commands initiate loopback testing of the specified E1 and T1 ports on the HC MIM and E5-E1T1 cards. There are 8 physical ports on the HC MIM or E5-E1T1 card. This *tst-e1/t1* command is not used for any other MTP card type. [Table 26: *tst-e1/tst-t1* Support](#) shows a breakdown of support for each *tst-e1/t1* test based on MTP card.

Table 26: *tst-e1/tst-t1* Support

MTPCard Type	tst-e1 Test	tst-t1 Test
E1 HC MIM	Yes	Yes
T1 HC MIM	Yes	Yes
E5-E1T1	Yes	Yes

Test E1/T1 Port (*tst-e1/t1*) Indicators

Signaling links performing *tst-e1/t1* commands have a secondary state of LPBK, and an associated state corresponding to the type of loopback. For *tst-e1* the loopback types are: (LXVR, LINE, and PAYLOAD). For *tst-t1*, the loopback types are: (LXVR, LINE, FELINE, PAYLOAD, and FEPAYLOAD).

If an OAM switchover occurs, while the *tst-e1/t1* command is running, the test is aborted. If an MTP card with an active test boots then the test is aborted.

tst-slk and *tst-e1/t1* Loopback Test Details

- *SLTC Loopback Test Details*

Loopback Test Type: SLTC (EAGLE 5 ISS initiated Level 3 SS7SLT).

Link State: Link is up.

Equipment tested: Near and far end up to Level 3.

Purpose: Test the entire path to the far end at Level 3.

Description: Valid only for *tst-slk* This will send an SLTM out and expects an SLTA back.

Typical use: To validate connectivity of a signaling path.

Testing Limits: 1024 concurrent link tests per system.

- *OAM Loopback Test Details*

Loopback Test Type: OAM (EAGLE 5 ISS initiated Level 1 ATM test).

Link State: Link is down.

Equipment tested: Near and far end level 1 S/W and H/W including all hardware on the cards.

Purpose: Test the entire near and far end level 1 H/W by exchanging ATM cells.

Description: Valid only for *tst-slk* Sends OAM cells out to far end for 60 seconds if no errors, 2 minutes when errors are received.

Typical use: Verifies ATM cells can be exchanged between 2 signaling points.

Testing Limits: 1024 concurrent link tests per system.

- *LINE/FELINE*> *Loopback Test Details*

Loopback Test Type: LINE/FELINE (EAGLE 5 ISS initiated Level 1-2 ATM test)

Link State: Link is down.

Equipment tested: Near end H/W up to level 2 (LXVR) and far end H/W level 1 interface.

Purpose: H/W continuity check between near and far end.

Description: This detail sequence is valid for `tst-slk:loopback=line` and `tst-t1:loopback=feline`.

`tst-t1:loopback=line` installs the local line loopback (receive to transmit) similar to an `act-cdl:loopback=line`.

The following steps occur:

1. Device under test (DUT) sends T1 bit oriented code (BOC) to remote device.
2. Remote device receives BOC and programs hardware.
3. DUT attempts level 2 alignment.
4. If link aligns (level 2), test passes, else test fails.
5. DUT sends BOC to remote device to remove loopback.
6. Remote device receives BOC and re-programs hardware.

Note: If the DUT boots in the middle of the sequence, the remote device needs to have the link activated/de-activated and it will return to the original programming.

Typical use: Used for a link in line timing to check continuity from the near end level 2 H/W to the level 1 interface at the far end.

Testing Limits: 1024 concurrent link tests per system.

- *PAYLOAD/FEPLAYLOAD* *Loopback Test Details*

Loopback Test Type: PAYLOAD/FEPLAYLOAD (EAGLE 5 ISS initiated Level 1-2 ATM test)

Link State: Link is down.

Equipment tested: Near end H/W up to level 2 (LXVR) and far end H/W level 1 interface.

Purpose: H/W continuity check between near and far end.

Description: This detail sequence is valid for `tst-slk:loopback=payload` and `tst-t1:loopback=fepayload`.

`tst-t1:loopback=payload` installs the local payload loopback (receive to transmit) similar to an `act-cdl:loopback=payload`.

The following steps occur:

1. Device under test (DUT) sends T1 bit oriented code (BOC) to remote device.
2. Remote device receives BOC and programs hardware.
3. DUT attempts level 2 alignment.

4. If link aligns (level 2), test passes, else test fails.
5. DUT sends BOC to remote device to remove loopback.
6. remote device receives BOC and re-programs hardware.

Note: If the DUT boots in the middle of sequence, the remote device needs to have the link activated/de-activated and it will return to the original programming

Typical use: Used for a link in master timing to check continuity from the near end level 2 H/W to the level 1 interface at the far end.

Testing Limits: 1024 concurrent link tests per system.

- *LXVR Loopback Test Details*

Loopback Test Type: LXVR (EAGLE 5 ISS initiated Level 1 Internal card loopback)

Link State: Link is down.

Equipment tested: Local card.

Purpose: Test the near end card only.

Description: Valid for both `tst-slk` and `tst-t1`. This tests the near end card up through level 2.

Typical use: To validate the Card on the Eagle as good.

Testing Limits: 1024 concurrent link tests per system.

Link Maintenance Enhancements Commands

The link maintenance enhancements feature utilizes the following commands:

- `act-cdl` — this command initiates a command driven loopback for testing a signaling link.
- `dact-cdl` — this command deactivates a previously initiated Command Driven Loopback if active. If not, it will attempt to clear both near-end and far-end latched loopback points.
- `rept-stat-cdl` — this command generates a report of the signaling links currently in command driven loopback (along with the amount of time the link has been in CDL). The following is an example of a possible output.

```
tekelecstp 96-04-16 16:02:05 EST EAGLE 35.0.05
SLK      CDL      CDL-TIME
1102,A1  LINE     00:04:01
1201,A   PAYLOAD  01:04:11
1203,A   LINE     00:22:21
1203,B   LINE     20:04:01
1208,A   LINE     01:05:22
1211,A   PAYLOAD  00:14:01
```

- `tst-slk` — this command provides several methods for testing SLKs.

- `rept-stat-tstslk` — this command generates a report of the status of the MTP signaling links currently under test. The report includes the type of test and the elapsed time for the test. The following is an example of a possible output.

```
tekelecstp 96-04-16 16:02:05 EST EAGLE 35.0.0
  SLK          LOOPBACK    MAX-TIME    TEST-TIME
  1102,A1     SLTC          01:00:00    00:04:01
  1201,A      OAM           02:00:00    01:04:11
  1203,A      LXVR         00:50:00    00:22:21
  1203,B      LXVR         24:00:00    20:04:01
  1208,A      PAYLOAD      01:10:00    01:05:22
  1211,A      LINE         21:30:00    00:14:01
;
```

- `tst-e1` — this command initiates the testing of E1 Ports. The loopback parameter on this command is used to select local transceiver (lxvr), line, and payload loopback tests. This command is rejected if a loopback test is not compatible with the port type. This command is only supported on HCMIM and E5-E1T1 hardware. The following is an example of a possible output.

Note: Faults are not reported with this test. Refer to the `rept-stat-e1` command and output for port status results.

```
> tst-e1:elport=1:loc=1203:loopback=lxvr

  rlgncxa03w 05-01-07 16:19:08 EST EAGLE5 33.0.0
  Command Accepted: Test Port message is sent.
;

  rlgncxa03w 05-01-07 16:19:08 EST EAGLE5 33.0.0
  Command Completed.
;
```

```
> tst-e1:elport=1:loc=1203:action=stop

  rlgncxa03w 05-01-07 16:19:08 EST EAGLE5 33.0.0
  Command Accepted: Stop Port test message is sent.
;

  rlgncxa03w 05-01-07 16:19:08 EST EAGLE5 33.0.0
  Command Completed.
;
```

- `tst-t1` — this command initiates the testing of T1 Ports. The loopback parameter on this command is used to select local transceiver (lxvr), line, far end line (feline), payload, and fare end payload (fepayload) loopback tests. This command is rejected if a loopback test is not compatible with the port type. This command is only supported on HCMIM and E5-E1T1 hardware.

The command for stopping the tests differ for feline and fepayload. In order to stop the loopback tests, for loopback=line, payload, and lxvr, the command syntax used is `tst-t1:loc=<card loc>:tlport=<tlport number>action=stop`. For the feline and fepayload loopback types, the command syntax used is `tst-t1:loc=<card loc>:tlport=<tlport number>:action=stop:loopback=<feline or fepayload>`. The following is an example of a possible output.

Note: Faults are not reported with this test. Refer to the `rept-stat-t1` command and output for port status results.

```
> tst-t1:loc=1101:t1port=2:action=start:loopback=payload
Command Accepted - Processing

e5oam 02-02-08 23:58:38 MST UNKNOWN ????.?-61.11.0
tst-t1:loc=1101:t1port=2:action=start:loopback=payload
Command entered at terminal #6.
;

e5oam 02-02-08 23:58:38 MST UNKNOWN ????.?-61.11.0
Command Accepted: Test Port message is sent.
;

e5oam 02-02-08 23:58:38 MST UNKNOWN ????.?-61.11.0
Command Completed.
;
```

```
> tst-t1:loc=1101:t1port=2:action=stop
Command Accepted - Processing

e5oam 02-02-08 23:59:01 MST UNKNOWN ????.?-61.11.0
tst-t1:loc=1101:t1port=2:action=stop
Command entered at terminal #6.
;

e5oam 02-02-08 23:59:01 MST UNKNOWN ????.?-61.11.0
Command Accepted: Stop Test Port message is sent.
;

e5oam 02-02-08 23:59:01 MST UNKNOWN ????.?-61.11.0
Command Completed.
;
```

- `rept-stat-e1`— this command generates a report of the status of the E1 port and signaling link for cards with provisioned E1 ports. The following is an example of a possible output.

```
rept-stat-e1:loc=1203:e1port=1
rlghncxa03w 05-01-04 07:01:08 EST EAGLE5 33.0.0
LOC E1PORT PST SST AST
1203 1 IS-NR Avail PARENT
ALARM STATUS = No Alarms.
UNAVAIL REASON = --
SLK TS PST SST AST
A 1 IS-NR Avail ---
A1 2 IS-NR Avail ---
Command Completed.
;
```

- `rept-stat-t1`— this command generates a report of the status of the T1 port and signaling link for cards with provisioned T1 ports. The following is an example of a possible output while `loopback=line` is in progress.

```
> rept-stat-t1:loc=1204:t1port=1
Command Accepted - Processing
```

```

tekelecstp 04-01-19 07:26:03 EST UNKNOWN ???.?-63.47.1
rept-stat-t1:loc=1204:t1port=1
Command entered at terminal #5.
;

tekelecstp 04-01-19 07:26:03 EST UNKNOWN ???.?-63.47.1
LOC  T1PORT  PST          SST          AST
1204 1          OOS-MT-DSBLD  LPBK          LINE
ALARM STATUS      = No Alarms.
UNAVAIL REASON    = No errors, allow device
SLK   TS   PST          SST          AST
A     1   OOS-MT-DSBLD  Manual      -----

Command Completed.
;

```

[Table 27: Loopback AST Field Display](#) lists how the AST field will display depending on the loopback type.

Table 27: Loopback AST Field Display

Loopback Type	AST Field Display
Local transceiver (lxvr)	LXVR
Line (line)	LINE
Far end line (feline)	FE LINE
Payload (payload)	PAYLOAD
Far end payload (fepayload)	FE PAYLD

Power Down of In-Service System



Warning:

This procedure will isolate the system and put the network in a degraded mode. [My Oracle Support \(MOS\)](#) before any part of this procedure is performed.

To minimize the impact on the rest of the network during power up, proper network planning must be performed. This requires having the MTP Restart Feature configured on the system. This power down procedure does not require any special configuration on the system. This procedure should be performed in emergency situations or with prior planning assistance from Tekelec [My Oracle Support \(MOS\)](#). Terminal access to the system is required to deactivate the links. If there is no terminal access to the system, proceed to [Step 19](#).

1. If this is an emergency power down, proceed with [Step 11](#) Otherwise continue with [Step 2](#) .
2. Enter the following command to check the operational status of the database:

```
rept-stat-db
```

If necessary, refer to *Commands Manual* to interpret the output.

3. Enter the following command to backup the database on the fixed disk:

```
chg-db:action=backup:dest=fixed
```

This command takes a minimum of 2 minutes to execute. It may take longer depending on other system activity that is in progress when this command is entered.

4. Verify that the databases of both MASP's are coherent by entering the following command:

```
rept-stat-db
```

```
The following is an example of the output from a coherent database.
> rept-stat-db
Command Accepted - Processing
  oflnmoxallw 00-10-08 15:56:40 CDT EAGLE 35.0.0
  rept-stat-db
  Command entered at terminal #4.
;
  oflnmoxallw 00-10-08 15:56:40 CDT EAGLE 35.0.0
  DATABASE STATUS: >> OK <<
          TDM 1114 ( STDBY)                TDM 1116 ( ACTV )
          C   LEVEL   TIME LAST BACKUP    C   LEVEL   TIME LAST BACKUP
          - - - - -
  FD BKUP  Y   342256 00-10-07 00:40:29 CDT  Y   342256 00-10-07 00:40:29 CDT
  FD CRNT  N   342374                Y   342375
          E5-MDAL 1117
          - - - - -
```

If necessary, refer to *Commands Manual* to interpret the output.

5. Insert a pre-formatted (for system data) removable USB drive into the removable USB drive media slot.

Refer to [Removable Drives](#). Continue with [Step 6](#).

6. Enter the following command to create a backup of the database on the removable USB drive:

```
chg-db:action=backup:dest=remove
```

7. Verify that the databases on the removable USB drive (RDBKUP) and the current partition of the active MASP (FDCRNT) are coherent by entering the following command:

```
rept-stat-db
```

The following is an example of the output from a coherent database.

```
> rept-stat-db
Command Accepted - Processing
  oflnmoxallw 00-10-08 15:56:40 CDT EAGLE 35.0.0
  rept-stat-db
  Command entered at terminal #4.
;
  oflnmoxallw 00-10-08 15:56:40 CDT EAGLE 35.0.0
  DATABASE STATUS: >> OK <<
          TDM 1114 (STDBY)                TDM 1116 ( ACTV )
          C   LEVEL   TIME LAST BACKUP    C   LEVEL   TIME LAST BACKUP
          - - - - -
  FD BKUP  Y   32256  00-10-07 00:40:29 CDT  Y   32256  00-10-07 00:40:29 CDT
  FD CRNT  N   32374                Y   32375
          E5-MDAL 1117
          - - - - -
```

If necessary, refer to the *Commands Manual* to interpret the output.

8. Remove the removable USB drive from the removable USB drive media slot.
Refer to *Removable Drives*.
9. Make an entry in the site maintenance log that a backup was performed.
10. Enter the following command to verify the status of the mate EAGLE 5 ISS:
`rept-stat-trbl`
If there is any trouble or abnormal condition, *My Oracle Support (MOS)*.
11. Enter the following command to retrieve the linksets.
`rtrv-ls`
12. Enter the following command to retrieve the links.
`rtrv-slk`
13. Enter the following command to deactivate all E-links.
Use the outputs from *Step 11* and *Step 12*.
`dact-slk:loc=xxxx:port=y`
where *xxxx* is the card location stenciled on the shelf of the system and *y* is the port number on the card specified in the *loc* parameter.
14. Enter the following command to deactivate all A-links.
Use the outputs from *Step 11* and *Step 12*..
`dact-slk:loc=xxxx:port=y`
where *xxxx* is the card location stenciled on the shelf of the system and *y* is the port number on the card specified in the *loc* parameter.
15. Enter the following command to deactivate all B-links.
Use the outputs from *Step 11* and *Step 12*.
`dact-slk:loc=xxxx:port=y`
where *xxxx* is the card location stenciled on the shelf of the system and *y* is the port number on the card specified in the *loc* parameter.
16. Enter the following command to deactivate all D-links.
Use the outputs from *Step 11* and *Step 12*.
`.dact-slk:loc=xxxx:port=y`
where *xxxx* is the card location stenciled on the shelf of the system and *y* is the port number on the card specified in the *loc* parameter.
17. Enter the following command to deactivate all C-links.
Use the outputs from *Step 11* and *Step 12*..
`dact-slk:loc=xxxx:port=y`
where *xxxx* is the card location stenciled on the shelf of the system and *y* is the port number on the card specified in the *loc* parameter.
18. Enter the following command to verify all links on the system are OOS-MT.
`rept-stat-slk`
Repeat *Step 13* through *Step 17* for any links not having the proper status.

19. Pull the fuses or open the breaker at the customer power distribution frame to turn off power to the system.

Power Up of the System



Warning: If the reason for the EAGLE 5 ISS Power Off is unknown or if damage to the EAGLE 5 ISS is suspected, do not perform this procedure. Contact the [My Oracle Support \(MOS\)](#).

1. Verify that there is no USB drive in the E5-MDAL card.
If there is a USB drive in the E5-MDAL, replace the E5-MDAL card with a spare E5-MDAL card without a USB drive. If the spare E5-MDAL card has a USB drive installed, remove the E5-MDAL card. This power up will take place without a E5-MDAL card installed.
2. At the power distribution frame, insert fuses or close the breaker to restore power to the system.
All frames with the EAGLE 5 ISS shelves must be powered up. Links that were deactivated during the power down are automatically activated during the power up.
3. Enter the following commands to monitor the system during the power-up:

```
rept-stat-card  
rept-stat-slk  
rept-stat-trbl
```

Contact [My Oracle Support \(MOS\)](#) if there is any trouble or abnormal condition during system recovery.
4. Install E5-MDAL card and remove removable USB drive, if necessary.

Card Removal/Replacement Procedures

Topics:

- *Introduction.....111*
- *EAGLE 5 ISS Replacement Parts List.....111*
- *E5-MASP Card Replacement.....111*
- *E5-MDAL Card Replacement.....120*
- *HIPR2 Card Replacement.....123*
- *HIPR Card Replacement.....126*
- *Determine Card Changeout Time.....129*
- *E5-ATM/E5-ATM-B Card Replacement.....130*
- *SS7 and IP7, MIM, HC-MIM and MPL Card Replacement.....133*
- *E5-ENET/E5-ENET-B Module.....140*
- *E5-TSM Card Replacement.....149*
- *Database Services Module (DSM).....151*
- *E5-SM4G/E5-SM8G-B Card Replacement.....153*
- *E5-IPSM Card Replacement.....156*
- *Database Communications Module (DCM) and EDCM/EDCM-A.....161*
- *Measurement Collection and Polling Module (MCPM).....164*
- *Replacing a Card in the EAGLE 5 ISS.....165*
- *Replacing Cards in the Holdover Clock.....167*
- *Fan Assembly P/N 890-0001-xx.....173*

Introduction

This appendix explains how to remove a card from the EAGLE 5 ISS. The procedures include the administrative commands required to take a card out of service and place it back into service.

In the event a numbered event message is encountered, refer to the appropriate procedure in the *Unsolicited Alarm and Information Messages* manual..

Additional information about each command can be found in the *Commands Manual*.



Caution: Always wear a wrist strap or other electrostatic protection when handling EAGLE 5 ISS cards.



Caution: Always place removed cards into an electrostatic protection bag before sending to Tekelec, or storing in inventory (unless the card is being stored in the optional spare card storage shelf).

EAGLE 5 ISS Replacement Parts List

For a listing of field replaceable parts and cables used in the EAGLE 5 ISS and their part numbers, refer to the tables in *Part Numbers*.

All parts must be replaced through the Return Material Authorization (RMA) process. Contact the *My Oracle Support (MOS)*, before replacing any parts.

E5-MASP Card Replacement

This procedure is to replace an E5-MASP card. Before the E5-MASP is replaced, it must be verified that it is the standby MASP.

The E5-MASP (made up of the E5-MCAP and E5-TDM cards) contains the removable USB drive, the fixed disk drive, the terminal processor for the 16 serial I/O ports, and an interface to the maintenance disk and alarm (E5-MDAL) card.

1. Before beginning this procedure, make sure there is a copy of the current release GPLs on a removable USB drive on-hand.
2. If the active E5-MASP card fails, the EAGLE 5 ISS automatically switches activity to the standby MASP.
3. Enter the following command to display the card status:

```
rept-stat-card
```

The following is an example of a possible output.

```
e5oam 08-12-01 15:38:32 EST EAGLE 40.1.0
CARD  VERSION      TYPE      GPL      PST      SST      AST
1108  -----      MCPM     MCP      OOS-MT-DSBLD  Manual  -----
1109  030-009-000     HIPR     HIPR     IS-NR     Active  -----
1110  030-009-000     HIPR     HIPR     IS-NR     Active  -----
1111  030-010-000     IPSM     IPS      IS-NR     Active  -----
1113  030-010-008 E5MCAP OAMHC IS-NR Standby -----
1114  -----      E5TDM     IS-NR     Active  -----
1115  030-010-008     E5MCAP   OAMHC     IS-NR     Active  -----
1116  -----      E5TDM     IS-NR     Active  -----
1117  -----      E5MDAL     OOS-MT     Isolated  -----

Command Completed.
```

In this sample output, 1113/1114 are standby and 1115/1116 are active. Perform [Step 5](#) only if the card to be replaced is not Standby.

4. From the output of the `rept-stat-card` command, executed in [Step 3](#), determine the MASP activity.

Record which E5-MCAP is Active and Standby. Record the card locations of both sets of E5-MCAPs and E5-TDMs.

Table 28: Card Locations

Card	Location
Active E5MCAP	
Active E5TDM	
Standby E5MCAP	
Standby E5TDM	

5. Verify the E5-MASP card to be replaced (failing or non-failing) is Standby before continuing.
 - a) If the E5-MASP card is failing it should already be Standby. Go to [Step 7](#)
 - b) If the card is not Standby and needs replacement, enter the following command to verify the database:

```
rept-stat-db:display=all
```

 Verify all the cards in the system have the same database count. If the counts do not match, contact the [My Oracle Support \(MOS\)](#).
 - c) Enter the following command to force the active E5-MASP card to become Standby:

```
init-card:loc=x
```

 where *x* is the card location (1113 or 1115) from [Step 3](#).
6. If [Step 5](#) was performed, execute the `rept-stat-card` command and verify if the card to be replaced is part of the Standby MASP.

7. If a failing E5-TDM card is to be replaced, perform a database backup before replacing the failed card.

Insert the removable USB drive with the current release GPLs into the Active E5-MASP removable USB port. Using [Daily Procedures](#), create a backup of the database on the Active removable USB drive. Then go to [Step 9](#).



Warning: Do not proceed to [Step 9](#) if the backup fails. Contact the [My Oracle Support \(MOS\)](#).

8. If a non-failing E5-TDM card is to be replaced, insert the removable USB drive containing the copy of the current release GPLs into the Active E5-MASP.
9. Enter the following command to verify that the security log on the standby MASP contains no entries that must be copied to the FTA area of the fixed disk:

```
rept-stat-seculog
```

The following is an example of a possible output.

```

RLGHNCXA03W 96-10-04 15:59:06 EDT EAGLE 34.0.0
-- SINCE LAST UPLOAD -- OLDEST NEWEST LAST
LOC  ROLE    ENTRIES %FULL OFLO FAIL RECORD RECORD  UPLOAD
1114 Active   8312    84   No   No   95-08-12 96-01-04 96-12-16
                                     11:23:56 15:59:06 14:02:22
1116 Standby 693      7    No   No   95-09-12 95-09-30 95-09-30
                                     11:24:12 14:00:06 14:02:13

```

- If the number shown in the ENTRIES field for the standby MASP (shown with the entry *Standby* in the ROLE field) is 0, go to [Step 12](#).
- If the number shown in the ENTRIES field for the standby MASP is greater than 0, these entries must be copied to the FTA area of the fixed disk.

To copy these entries, go to the next step.

10. Copy the security log entries on the standby MASP to the FTA area on the fixed disk using the following command:

```
copy-seculog:slog=stb:dloc=act
```

The following is a possible output of the message that should appear (the `copy-seculog:slog=stb` command was used).

```

RLGHNCXA03W 96-10-04 15:59:06 EDT EAGLE 34.0.0
Security log on E5TDM 1116 copied to file 961004s.log on E5TDM 1114

```

11. Remove the card from service by entering the following command:

```
rmv-card:loc=xxxx
```

where *xxxx* is the card location.

12. Replace the Standby E5-MASP. Refer to [Figure 27: E5-MASP LEDs](#) for description of the E5-MASP LEDs.

- a) On the standby E5-MASP card determined in [Step 6](#), slide the MASP H/S switch (SW3) up to the UNLOCKED position (see [Figure 25: E5-MASP Card Inject/Eject Hardware Switch, UNLOCKED](#)).

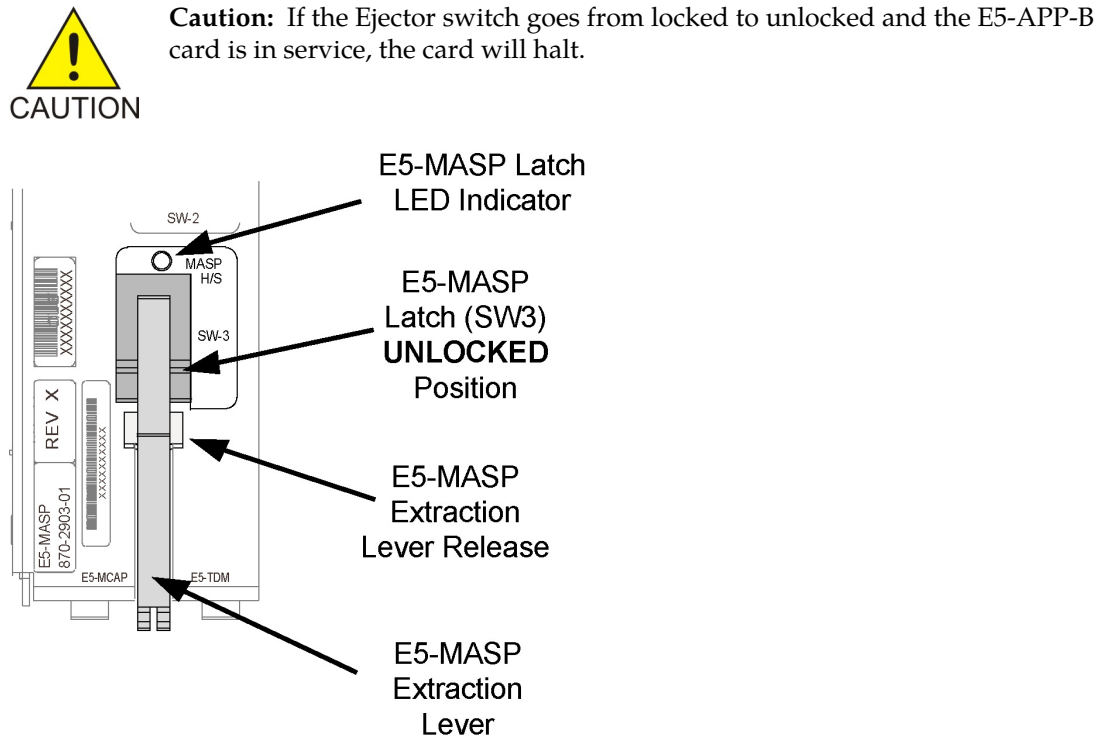

Figure 25: E5-MASP Card Inject/Eject Hardware Switch, UNLOCKED

- b) WAIT for the MASP H/S LED to go from blinking blue to a steady blue.
- c) Grasp the upper and lower card Inject/Eject (I/E) lever release interlock, located just underneath the I/E lever, and press it to meet the I/E lever. This is the mechanical interlock for the card.
- d) While holding the I/E interlock and lever, pull the levers away from the shelf until they are parallel to the floor.
- e) Remove the standby E5-MASP card. Gently pull the card towards you until the card clears the shelf.

Note: UAMs are generated during this step. An audible alarm is generated.

- f) Place the card you have removed in an electrostatic discharge (ESD) protective container, or place the card in the spare card storage shelf.
- g) Be sure that the replacement card has the same Tekelec part number and revision number as the card you have just removed.
- h) Open the ejector levers on the replacement card. Insert the spare E5-MASP card.

Carefully align the card's edges with the top and bottom card guides. Then push the card along the length of the card guides until the rear connectors on the card engage the mating connectors on the target shelf backplane.

Note: UAMs are generated during this step. An audible alarm is generated. Wait for the E5-MASP card to come up to standby mode.

- i) Push in the top and bottom inject/eject clamps.

This locks the card in place and ensures a strong connection with the pins on the target shelf backplane.

- j) Slide the MASP H/S switch (SW3) down to the LOCKED position (see [Figure 26: E5-MASP Card Inject/Eject Hardware Switch, LOCKED](#)).

Note: When the Ejector switch goes from UNLOCKED to LOCKED, the E5-APP-B Eject Status LED blinks red as the E5-APP-B card goes online.

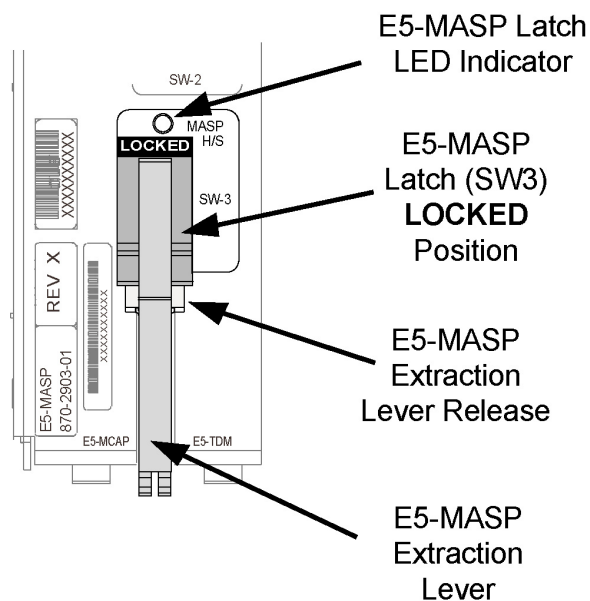

Figure 26: E5-MASP Card Inject/Eject Hardware Switch, LOCKED

- k) WAIT for the MASP H/S LED to go from blinking blue to off.
13. Insert the removable USB drive containing the appropriate GPLs from [Step 1](#) into the newly installed E5-MASP. (Refer to [Removable USB Drive](#).)
 14. Enter the following command to change the state of the appropriate card to the out of service - maintenance disabled state:
`inh-card:loc=xxxx:force=yes`
 where `xxxx` is the card location stenciled on the shelf of the EAGLE 5 ISS. Following is an example of a possible output:

```
RLGHNCXA03W 00-06-05 11:11:28 EDT EAGLE 34.0.0
Card has been inhibited.
```

15. Enter the following command to load and activate the approved GPL onto the inhibited card:
`flash-card:code=appr:loc=xxxx:force=yes`
 where `xxxx` is the card location used in the previous step. The optional `force=yes` is used to force the command to work on an IS-NR card.
16. Enter the following command to put the card that was inhibited in [Step 14](#) back into service:
`alw-card:loc=xxxx`

where *xxxx* is the card location used in [Step 14](#). Following is an example of a possible output:

```
RLGHNCXA03W 00-06-05 11:11:28 EDT EAGLE 34.0.0
Card has been allowed.
```

Note: Allow the card to run for 5 minutes before continuing.

17. Enter the following command to verify the database is consistent (same level as the other cards in the system).

```
rept-stat-db:display=version
```

The following is an example of a possible output.

```
rlghncxa03w 13-04-19 12:38:29 EST EAGLE5 45.0.0-64.62.0
DATABASE STATUS: >> OK <<
      E5TDM 1114 ( STDBY)                E5TDM 1116 ( ACTV )
      C   LEVEL   TIME LAST BACKUP      C   LEVEL   TIME LAST BACKUP
-----
FD BKUP Y       175 13-04-16 16:09:11 MST Y       175 13-04-16 16:09:11 MST
FD CRNT Y        218                        Y        218
      MCAP 1113                            MCAP 1115
-----
RD BKUP Y         1 - - -                Y         1 - - -
USB BKP - - - - - - - - -                - - - - - - - - -

CARD/APPL  LOC  C  T  LEVEL           TIME LAST UPDATE   VERSION STATUS
-----
OAMHC-RMV  1113 Y  -  1             - - -             135-000-000  NORMAL
E5TDM-CRNT 1114 Y  N  218          13-04-18 19:07:14 135-000-000  NORMAL
E5TDM-BKUP 1114 Y  -  175          13-04-16 15:51:32 135-000-000  NORMAL
OAMHC-RMV  1115 Y  -  1             - - -             135-000-000  NORMAL
OAMHC-USB  1115 -  -  -             - - -             - - -
E5TDM-CRNT 1116 Y  N  218          13-04-18 19:07:14 135-000-000  NORMAL
E5TDM-BKUP 1116 Y  -  175          13-04-16 15:51:32 135-000-000  NORMAL
;
```

18. Compare the `VERSION STATUS` of the E5-TDM cards in the output of the previous step.

- If they are identical, continue to the next step.
- If they are not the same, go to [Step 23](#)

19. Enter the following command to repair the standby's E5-MASP database:

```
chg-db:action=repair
```

Note: The system requires approximately two minutes after [Step 16](#) to acquire duplex mode. As a result, the system will reject the `chg-db:action= repair` until duplex operation fully returns.

The following is an example of a possible output.

```
RLGHNCXA03W 03-08-27 03:46:49 EST EAGLE 34.0.0
chg-db:action=repair
Command entered at terminal #10.
;
RLGHNCXA03W 03-08-27 03:46:50 EST EAGLE 34.0.0
```

```
REPAIR: MASP A - Repair starts on standby MASP.
;
```

Note: Observe that the command execution time may require approximately 20 to 45 minutes.

```
RLGHNCXA03W 03-08-27 04:15:22 EST EAGLE 34.0.0
REPAIR: MASP A - Repair from fixed disk complete.
;
```

Wait for the 'repair complete' message to display and for the to MASP return to in-service status. When the 'repair complete' message has displayed, proceed to [Step 20](#)

Note: Perform this step only if you are coming from [Step 18](#).

20. Enter the following command to show the version numbers of the GPLs stored on each fixed disk (E5-TDM).

```
rtrv-gpl
```

The following is an example of a possible output.

```
e5oam 08-12-01 12:24:57 EST EAGLE 40.1.0
GPL Auditing ON
```

GPL	CARD	RELEASE	APPROVED	TRIAL	REMOVE TRIAL
OAMHC	1114	030-010-000	030-010-000	030-010-000	030-010-000
OAMHC	1116	030-010-000	030-010-000	030-010-000	030-010-000
OAMHC	1115	-----	-----	-----	030-010-000
SS7ANSI	1114	030-010-000	030-010-000	030-010-000	030-010-000
SS7ANSI	1116	030-010-000	030-010-000	030-010-000	030-010-000
SS7ANSI	1115	-----	-----	-----	030-010-000
SCCP	1114	030-010-000	030-010-000	030-010-000	030-010-000
SCCP	1116	030-010-000	030-010-000	030-010-000	030-010-000
SCCP	1115	-----	-----	-----	030-010-000
GLS	1114	030-010-000	030-010-000	030-010-000	030-010-000
GLS	1116	030-010-000	030-010-000	030-010-000	030-010-000
GLS	1115	-----	-----	-----	030-010-000
...					
IPSG	1114	030-010-000	030-010-000	030-010-000	030-010-000
IPSG	1116	030-010-000	030-010-000	030-010-000	030-010-000
IPSG	1115	-----	-----	-----	030-010-000
BLROM1	1114	030-010-000	030-010-000	030-010-000	030-010-000
BLROM1	1116	030-010-000	030-010-000	030-010-000	030-010-000
BLROM1	1115	-----	-----	-----	030-010-000

21. Examine the output of the previous step.
- If any version is different continue with [Step 22](#).
 - If there are no differences, go to [Step 27](#).
22. Enter the following command to load the GPLs from the removable USB drive inserted in [Step 13](#):
- ```
copy-gpl:sloc=xxxx:dloc=yyyy
```
- where *xxxx* is the card location used in [Step 14](#) and *yyyy* is the mated E5-TDM location.

The following is an example of a possible output.

```
rlghncxa03w 09-01-07 00:57:31 EST EAGLE 40.1.0
COPY GPL: MASP B - COPY STARTS ON REMOVABLE DRIVE
;

rlghncxa03w 09-01-07 01:01:27 EST EAGLE 40.1.0
COPY GPL: MASP B - COPY TO STANDBY MASP COMPLETE
```

When the command has completed, go to [Step 27](#)

23. Enter the following command to verify whether measurement collection is on or off:

```
rtrv-meas-sched
```

The following is an example of a possible output. The COLLECT field shows whether measurement collection is on or off. In this example, measurement collection is on.

```
RLGHNCXA03W 95-04-03 12:22:55 EST EAGLE 34.0.0
COLLECT = on

SYSTOT-STP = off
SYSTOT-TT = off
SYSTOT-STPLAN = on
COMP-LNKSET = off
COMP-LINK = on
MTCD-STP = on
MTCD-LINK = on
MTCD-STPLAN = on
```

- If measurement collection is on, continue with [Step 24](#).
- If measurement collection is off, proceed to [Step 25](#).

24. Enter the following command to inhibit all measurements:

```
chg-meas:collect=off
```



**Caution:** Measurements must be inhibited or the `copy-disk` command cannot be executed. The `chg-meas:collect=on` command should not be executed while the `copy-disk` command is in progress. When measurements are inhibited, measurement collection is stopped. For the entire period of time when measurements are inhibited, those measurements will be lost. If possible do not inhibit measurements at midnight since doing so can result in the loss of measurements for an entire day.

The following is an example of a possible output of the message that should appear.

```
RLGHNCXA03W 94-02-07 16:12:50 EST EAGLE 34.0.0
CHG-MEAS: MASP A - COMPLTD
```

25. Enter the following `copy-disk` command along with the card location of the standby E5-TDM (shown by the indicator `STDBY` in the command output in [Step 17](#)) that the data is being copied to.

```
copy-disk:dloc=xxxx:format=yes
```

Where `xxxx` is the card location of the standby E5-TDM.

This command can take from 33 minutes to 1 hour 46 minutes to execute. It can take even longer depending on other system activity in progress when this command is entered.

The following is an example of a possible output of the message that should appear when the command has executed and completed. For this example, the `copy-disk:dloc=1116` command was entered.

```
Copy-disk (fixed): from active (1114) to standby (1116) started.
Extended processing required, please wait.
Copy-disk (fixed): from active (1114) to standby (1116) completed.
Measurements collection may be turned on now if desired.
```

The standby MASP is rebooted to load the data when the command completes successfully.

**Note:** While this command is executing, commands that affect the database configuration cannot be executed. Any attempt to execute such a command will be rejected.

26. If measurement collection was turned off in [Step 24](#), enter the following command to turn on the measurements:

```
chg-meas:collect=on
```

The following is an example of a possible output of the message that should appear.

```
RLGHNCXA03W 94-02-07 16:12:50 EST EAGLE 34.0.0
CHG-MEAS: MASP A - COMPLTD
```

27. Enter the following command to verify that the database counts of both MASPs.

```
rept-stat-db:display=all
```

The following is an example of the possible output for a good database.

```
rept-stat-db
Command Accepted - Processing
rlghncxa03w 13-04-19 12:51:29 EST EAGLE5 45.0.0-64.62.0
rept-stat-db
Command entered at terminal #4.
;
rlghncxa03w 13-04-19 12:51:29 EST EAGLE5 45.0.0-64.62.0
DATABASE STATUS: >> OK <<
 E5TDM 1114 (STDBY) E5TDM 1116 (ACTV)
 C LEVEL TIME LAST BACKUP C LEVEL TIME LAST BACKUP

FD BKUP Y 175 13-04-16 16:09:11 MST Y 175 13-04-16 16:09:11 MST
FD CRNT Y 218 Y 218
 MCAP 1113 MCAP 1115

RD BKUP Y 1 - - Y 1 - -
USB BKP - - - - - - - -
;
```

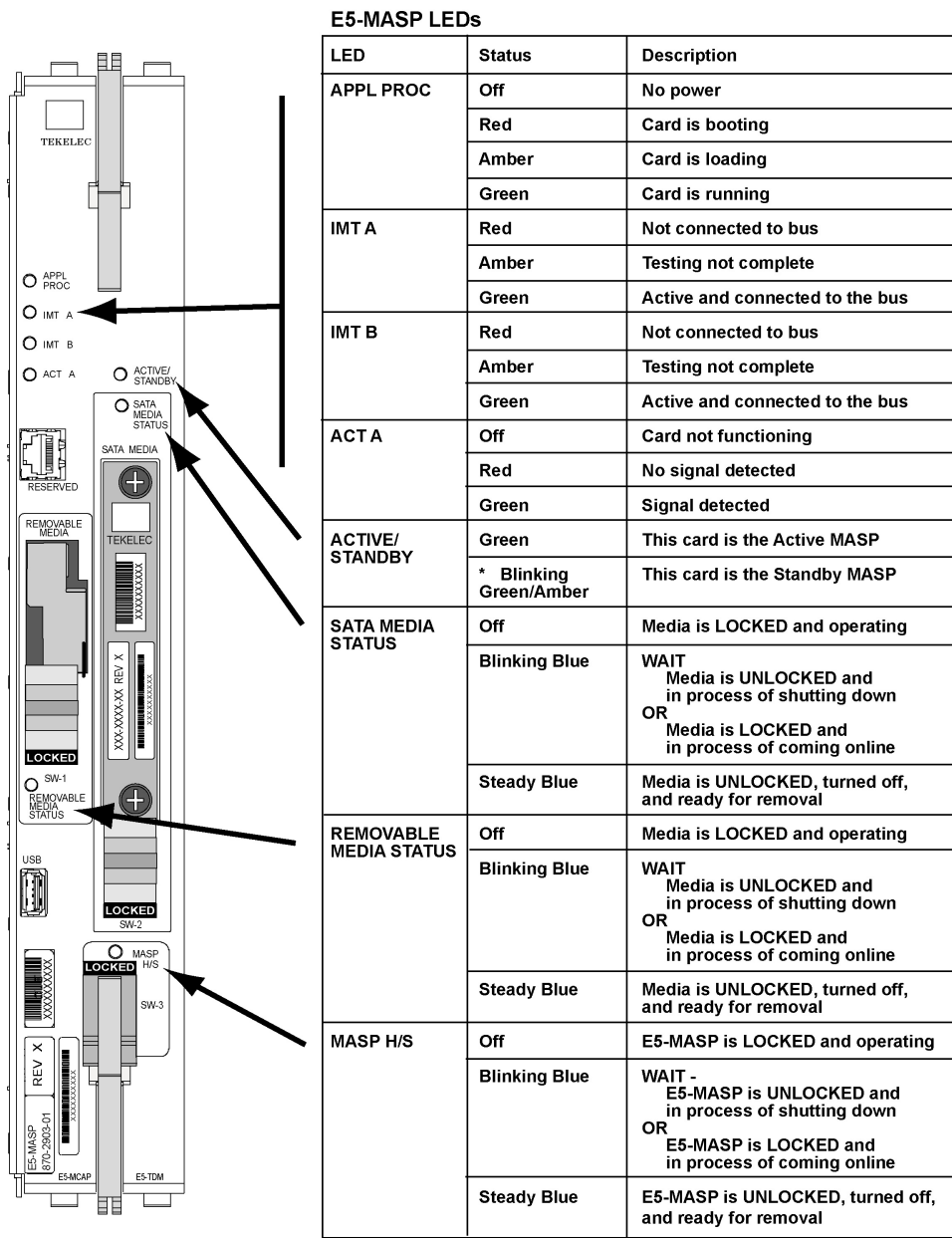

\* The LED blinks Green/Amber at a rate of 3 Green to 1 Amber.

Figure 27: E5-MASP LEDs

## E5-MDAL Card Replacement

### Description

The E5-MDAL ([Figure 28: E5-MDAL LEDs](#)) provides for external alarm indicators, such as bells, horns and lamp indicators.



Remove the card from service as described in the section titled, [Replacing a Card in the EAGLE 5 ISS](#).

**Note:** Removing the E5-MDAL creates a critical alarm at the Remote Maintenance Center (RMC) as well as the local office.

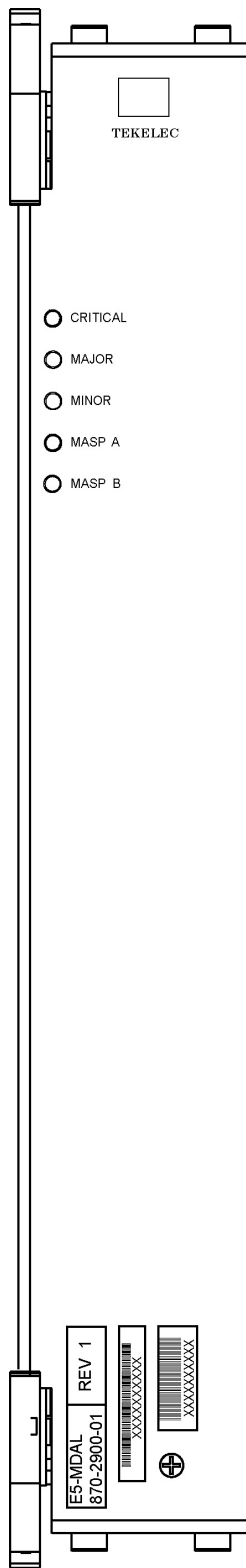

E5-MDAL LEDs

| LED      | Status | Description                               |
|----------|--------|-------------------------------------------|
| CRITICAL | Red    | A critical system alarm has been detected |
|          | Green  | No Alarm                                  |
| MAJOR    | Red    | A major system alarm has been detected    |
|          | Green  | No Alarm                                  |
| MINOR    | Amber  | A minor system alarm has been detected    |
|          | Green  | No Alarm                                  |
| MASP A   | Green  | This is the master MASP                   |
|          | Off    | This is the standby MASP                  |
| MASP B   | Green  | This is the master MASP                   |
|          | Off    | This is the standby MASP                  |

Figure 28: E5-MDAL LEDs

## HIPR2 Card Replacement

Use this procedure to remove a High-Speed Inter-processor Message Transport Packet Router 2 (HIPR2) card.

Each shelf contains two HIPR2 cards, one for each IMT bus, that provide continuity of the IMT bus signals even with failed or missing circuit modules. LEDs on the HIPR2 ([Figure 29: HIPR2 LEDs](#)) indicate connectivity to the IMT

1. Enter the following command to verify the status of the IMT buses.

```
rept-stat-imt
```



**WARNING**

**Warning:** Be sure to inhibit the correct IMT bus. If you inhibit the wrong IMT bus and then remove the HIPR2, total nodal isolation will occur. Wait until the IMT has returned to IS-NR before replacing the other HIPR2.

The following is an example of the possible output.

```
RLGHNCXA03W 98-09-27 16:50:24 EST EAGLE 34.0.0
IMT PST SST AST
 A IS-NR Active -----
ALARM STATUS = No alarms
IMT PST SST AST
 B IS-ANR Fault -----
ALARM STATUS = ** 0108 Major IMT Failure Detected
Command Completed.
```

2. Enter the following command to inhibit the IMT bus associated with the HIPR2 being removed (top HIPR2 accesses bus A, bottom HIPR2 accesses bus B).

```
rmv-imt:bus=x
```

where *x* is the IMT bus to be inhibited.

3. Remove the HIPR2, per the card replacement procedure described in the section titled [Replacing a Card in the EAGLE 5 ISS](#).

Place the new HIPR2 into its place. Be sure the revision numbers are compatible (if in doubt, contact the [My Oracle Support \(MOS\)](#)).

4. Enter the following command to restore the IMT bus.

```
alw-imt:bus=x
```

where *x* is the IMT bus inhibited.

**Note:** If UAM 0002 is output, the newly installed HIPR2 card needs to be flashed.

5. Enter the following command to determine if the newly replaced card's memory needs to be flashed:

```
rept-stat-gpl:gpl=xxxxxx
```

where *xxxxxx* is *hipr2*.

Following is an example of a HIPR2 output:

```
tekelecstp 09-07-09 16:53:23 EST EAGLE5 41.1
Output:
```

```

 GPL CARD RUNNING APPROVED TRIAL
 HIPR2 1109 128-021-000 128-021-000 128-021-000
 HIPR2 1110 128-021-000 128-021-000 128-021-000

 Command Completed.
;

```

**Note:** Mismatched GPLs should occur only during upgrades or running a trial GPL.

6. Examine the output from [Step 5](#).
  - If the GPLs match, continue with [Step 15](#).
  - If there is a GPL mismatch, continue with [Step 7](#).
7. Enter the following command to verify GPL Auditing is **ON** .  
`chg-gpl:audit=on`
8. Enter the following command to load the GPL onto the HIPR2 card.  
`init-flash:code=appr:loc=xxxx`  
 where `xxxx` is the card location newly replaced card.  
 Following is an example of a HIPR2 output using card location 1309:

```

 RLGHNCA03W 00-06-05 11:11:28 EDT EAGLE 34.0.0
 FLASH Memory Downloading for card 1309 Started.
;
 RLGHNCA03W 00-06-05 11:11:28 EDT EAGLE 34.0.0
 HIPR2 Downloading for card 1309 Complete.
;
 RLGHNCA03W 00-06-05 11:11:28 EDT EAGLE 34.0.0
 Command Completed.

```

9. Enter either of the following commands to initialize the HIPR2.



#### CAUTION

**Caution:** These commands boot the HIPR2 processor and bring down the respective IMT bus temporarily (approximately 10 seconds) until the HIPR2 card comes back into service.

Enter either

```
init-mux:bus=[a/b]
```

or

```
init-mux:loc=xxxx
```

where `xxxx` is the card location used in [Step 8](#).

**Note:** Allow the card to run for 5 minutes before continuing.

10. Enter the following command to activate the GPL loaded onto the HIPR2 card in [Step 8](#):  
`act-flash:loc=xxxx`  
 where `xxxx` is the card location used in [Step 8](#).

Following is an example of the output using card location 1309:

```

RLGHNCXA03W 00-06-05 11:11:28 EDT EAGLE 34.0.0
FLASH Memory Activation for card 1309 Completed.
;
RLGHNCXA03W 00-06-05 11:11:28 EDT EAGLE 34.0.0
Command Completed.

```

11. Enter the following command to verify the approved GPLs match the running GPLs:  
`rept-stat-gpl:gpl=hipr2`
12. If the GPLs match, continue with [Step 15](#).  
 If the GPLs do not match, continue with [Step 13](#).
13. Enter the following command determine which cards are in alarm condition (indicated by the acronym ALM in the `rept-stat-gpl` display):  
`rept-stat-gpl`
14. Note which cards are in an alarm condition and, if in doubt, [My Oracle Support \(MOS\)](#).
15. Enter the following command to verify that the HIPR2 card is in service and the IMT bus has been restored.

```
rept-stat-imt
```

```

RLGHNCXA03W 98-09-27 16:50:24 EST EAGLE 34.0.0
IMT PST SST AST
A IS-NR Active -----
ALARM STATUS = No alarms
IMT PST SST AST
B IS-NR Active -----
ALARM STATUS = No alarms
Command Completed.

```

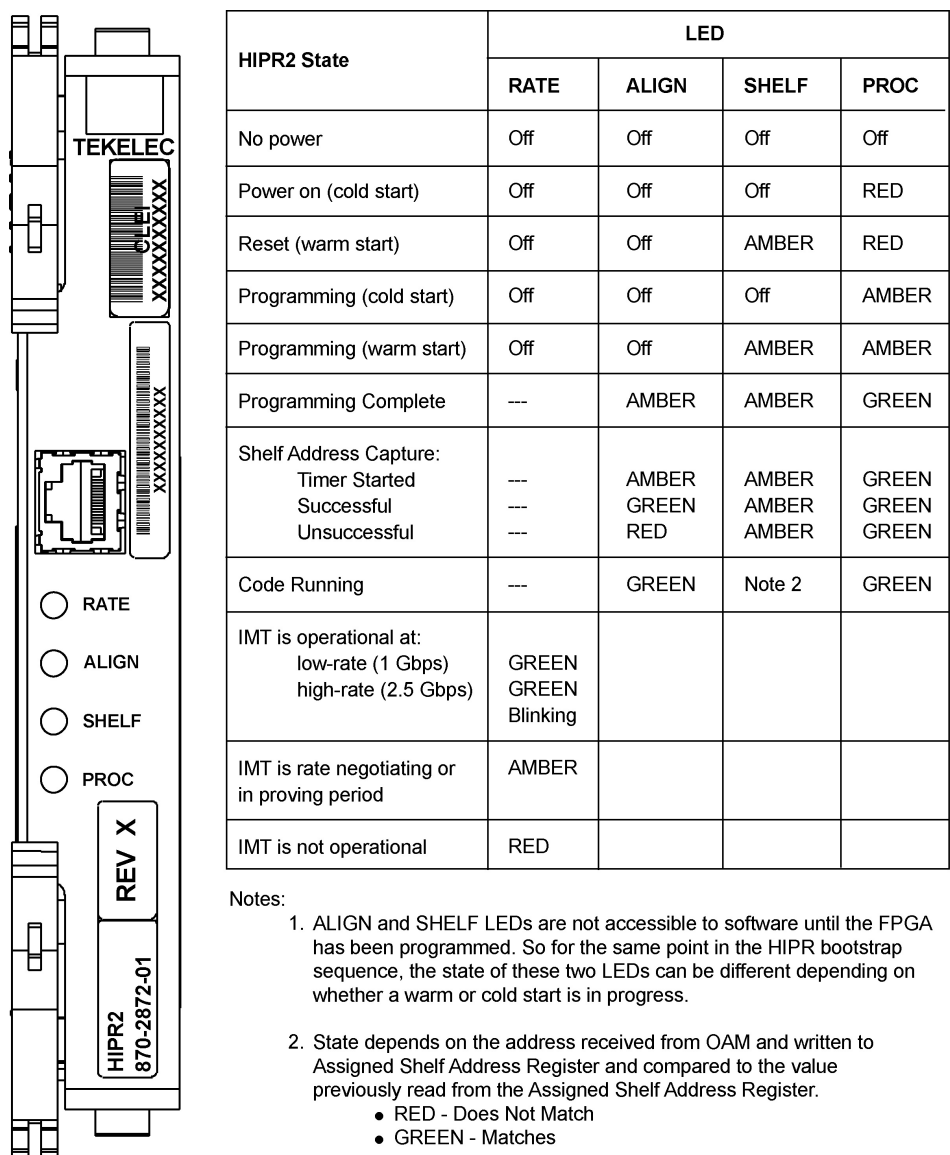

Figure 29: HIPR2 LEDs

## HIPR Card Replacement

### Description

The HIPR card provides access to the IMT bus for all cards in the shelf.

The High-Speed Inter-processor Message Transport Packet Router (HIPR) (*Figure 30: HIPR LEDs*) provides connectivity to the IMT bus by using switched 125 Mbps interfaces to each slot within a shelf. The HIPR card provides connectivity to the 1Gbps inter-shelf bus. The HIPR card transmits data between shelves only when it is necessary. Traffic between EAGLE 5 ISS cards on the same shelf are switched directly to the destination slot and do not transmit to any other cards in the shelf. Traffic

between shelves are not required to pass onto an intra-shelf IMT channel if it is not necessary. The HIPR card is required in shelves equipped with high-performance LIMs, such as the High-Capacity MIM. The HIPR card requires all other shelves within the EAGLE 5 ISS to be equipped with the HIPR card.

Each shelf contains two HIPR cards, one for each IMT bus, that provide continuity of the IMT bus signals even with failed or missing circuit modules.

1. Enter the following command to verify the status of the IMT buses.

```
rept-stat-imt
```

**Attention:** Be sure to inhibit the correct IMT bus. If you inhibit the wrong IMT bus and then remove the HIPR2, total nodal isolation will occur. Wait until the IMT has returned to IS-NR before replacing the other HIPR2.

The following is an example of the possible output.

```
RLGHNCXA03W 98-09-27 16:50:24 EST EAGLE 34.0.0
IMT PST SST AST
A IS-NR Active -----
ALARM STATUS = No alarms
IMT PST SST AST
B IS-ANR Fault -----
ALARM STATUS = ** 0108 Major IMT Failure Detected
Command Completed.
```

2. Enter the following command to inhibit the IMT bus associated with the HIPR being removed (top HIPR accesses bus A, bottom HIPR accesses bus B).

```
rmv-imt:bus=x
```

where *x* is the IMT bus to be inhibited.

3. Remove the HIPR, per the card replacement procedure described in the section titled [Replacing a Card in the EAGLE 5 ISS](#).

Place the new HIPR into its place. Be sure the revision numbers are compatible (if in doubt, contact the [My Oracle Support \(MOS\)](#)).

4. Enter the following command to restore the IMT bus.

```
alw-imt:bus=x
```

where *x* is the IMT bus inhibited.

**Note:** If UAM 0002 is output, the newly installed HIPR2 card needs to be flashed.

5. Enter the following command to determine if the newly replaced cards memory needs to be flashed:

```
rept-stat-gpl:gpl=xxxxxxx
```

where *xxxxxx* is *hipr*.

Following is an example of a *hipr* output:

**Note:** Mismatched GPLs should occur only during upgrades or running a trial GPL.

6. Examine the output from [Step 5](#).
  - If the GPLs match, continue with [Step 15](#).
  - If there is a GPL mismatch, continue with [Step 7](#).
7. Enter the following command to verify GPL Auditing is **ON**.

```
chg-gpl:audit=on
```

8. Enter the following command to load the GPL onto the HIPR card.

```
init-flash:code=appr:loc=xxxx
```

where *xxxx* is the card location newly replaced card.

Following is an example of a hipr output using card location 1309:

9. Enter either of the following commands to initialize the HIPR.



**CAUTION**

**Caution:** These commands boot the HIPR2 processor and bring down the respective IMT bus temporarily (approximately 10 seconds) until the HIPR2 card comes back into service.

Enter either:

```
init-mux:bus=[a/b]
```

or

```
init-mux:loc=xxxx
```

where *xxxx* is the card location used in [Step 8](#).

**Note:** Allow the card to run for 5 minutes before continuing.

10. Enter the following command to activate the GPL loaded onto the HIPR card in [Step 8](#):

```
act-flash:loc=xxxx
```

where *xxxx* is the card location used in [Step 7](#).

Following is an example of the output using card location 1309:

```

RLGHNCXA03W 00-06-05 11:11:28 EDT EAGLE 34.0.0
FLASH Memory Activation for card 1309 Completed.
;
RLGHNCXA03W 00-06-05 11:11:28 EDT EAGLE 34.0.0
Command Completed.
```

11. Enter the following command to verify the approved GPLs match the running GPLs:

```
rept-stat-gpl:gpl=xxxxxxx
```

where *xxxxxx* is *hipr* (the GPL SYSTEM identified in the output).

12. If the GPLs match, continue with [Step 15](#).

If the GPLs do not match, continue with [Step 13](#).

13. Enter the following command determine which cards are in alarm condition (indicated by the acronym ALM in the `rept-stat-gpl` display):

```
rept-stat-gpl
```

14. Note which cards are in an alarm condition and, if in doubt, [My Oracle Support \(MOS\)](#).

15. Enter the following command to verify that the HIPR card is in service and the IMT bus has been restored.

```
rept-stat-imt
```

```
RLGHNCXA03W 98-09-27 16:50:24 EST EAGLE 34.0.0
```



```

IMT PST SST AST
A IS-NR Active ----
ALARM STATUS = No alarms
IMT PST SST AST
B IS-NR Active ----
ALARM STATUS = No alarms
Command Completed.

```

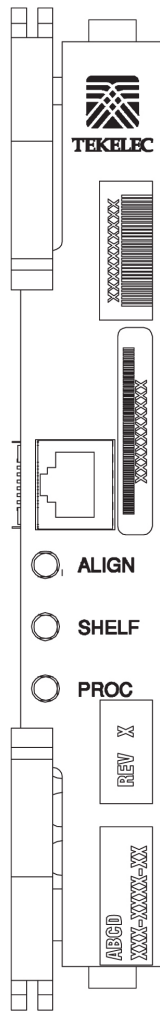

| LEDs        | Descriptions                                                                                                                                                                                                                                                                                                                                                                                                                               |
|-------------|--------------------------------------------------------------------------------------------------------------------------------------------------------------------------------------------------------------------------------------------------------------------------------------------------------------------------------------------------------------------------------------------------------------------------------------------|
| ALIGN       | <b>AMBER</b> – Programming XILINX complete<br><b>GREEN</b> – Complete code initialization (stays Amber until the first valid Shelf ID is received from MASP), Code running                                                                                                                                                                                                                                                                 |
| SHELF ID    | <b>AMBER</b> – Programming XILINX complete, Complete code initialization<br><b>RED</b> – While code running if ID address received from OAM does not match the on-board stored address read from the assigned shelf address register (see first note below)<br><b>GREEN</b> – While code running if ID address received from OAM matches the on-board stored address read from the assigned shelf address register (see second note below) |
| PROC Health | <b>RED</b> – Power on Reset<br><b>AMBER</b> – Programming XILINX<br><b>GREEN</b> – Programming XILINX complete, Complete code initialization, Code running                                                                                                                                                                                                                                                                                 |

Figure 30: HIPR LEDs

## Determine Card Changeout Time

### Description

This procedure assists the customer in deciding if the card should be changed immediately or during the Maintenance Window.

1. Replace the card immediately if *any* of the following conditions exist:

- If there is only one link on the card
  - If there is no other in-service link on this card
  - If there is no other in-service link on this card
  - If any destination is prohibited by the current failure.
2. Wait until the maintenance window to replace the card if *all* of the following conditions exist:
    - If the faulty link is not the only in-service link on the card
    - If deactivating the link will prohibit a destination
    - If no destination is prohibited by the current failure.

## E5-ATM/E5-ATM-B Card Replacement

This E5-ATM/E5-ATM-B Module provides access to remote SS7, IP and other network elements, such as a Signaling Control Point (SCP). This card is equipped with an industry-standard ATM, or DS0 interface.

1. Enter the following command to determine which links are serviced by this card:

```
rept-stat-card:loc=xxxx
```

Where *xxxx* is the card location. The following is an example of the possible output.

```

RLGHNCXA03W 98-09-27 16:43:42 EST EAGLE 34.0.0
CARD VERSION TYPE APPL PST SST AST
1201 021-002-000 LIMDS0 CCS7ITU IS-NR Active -----
ALARM STATUS = * 0022 Clock B for card failed.
IMT VERSION = 021-001-000
PROM VERSION = 021-001-000
IMT BUS A = Conn
IMT BUS B = Fault
SLK A PST = IS-NR LS=lsnssp2 CLLI=-----
SLK B PST = IS-NR LS=lsnstpi CLLI=-----
SCCP SERVICE CARD = 1212
SLAN SERVICE CARD = ----
Command Completed.

```

2. Refer to procedure to determine when to change the card.

**Note:** The `inh-slk` command will be rejected if inhibiting the link would cause a DPC to become unavailable.

3. Enter the following command to inhibit the links on both ports of this card (a and b).

```
inh-slk:loc=xxxx:port=y
```

Where *xxxx* location of the card from [Step 1](#) and *y* is the port.

4. Enter the following command to change the status of the link to out of service - maintenance disabled (`oos-mt-dsbl`).

```
dact-slk:loc=xxxx:port=y
```

Where *xxxx* location used in [Step 3](#) and *y* are the ports used in [Step 3](#).

5. Enter the following command to ensure the signaling link status is `oos-mt-dsbl` (out of service - maintenance disabled).

```
rept-stat-slk
```

The following is an example of the possible output.

```
RLGHNCXA03W 98-09-27 17:00:36 EST EAGLE 34.0.0
rept-stat-slk
SLK LSN CLLI PST SST AST
1201,A lsnsspn2 ----- OOS-MT-DSBLD Unava ----
1201,B lsnstpi ----- OOS-MT-DSBLD Unava ----
1202,A lsnstpn ----- IS-NR Avail ----
1202,B lsnstpi ----- IS-NR Avail ----
1203,A lsnstpa ----- IS-NR Avail ----
1203,B lsnscpa ----- IS-NR Avail ----
1205,A lsnscpi ----- IS-NR Avail ----
1205,B lsnsspil ----- IS-NR Avail ----
1207,A lsnstpa ----- IS-NR Avail ----
1207,B lsnsspa1 ----- IS-NR Avail ----
1211,A lsnstpn ----- IS-NR Avail ----
1211,B lsnsspnl ----- IS-NR Avail ----
Command Completed.
```

6. Enter the following command to inhibit the card and disconnect it from the IMT bus.
 

```
rmv-card:loc=xxxx
```

 Where `xxxx` location used in [Step 3](#) and [Step 4](#).
7. Remove the card, per the card replacement procedure described in the section titled [Replacing a Card in the EAGLE 5 ISS.](#).
 

Place the new card into its place. Be sure the revision numbers are compatible (if in doubt, contact the [My Oracle Support \(MOS\)](#)).
8. Enter the following command to download generic program loads and database information:
 

```
rst-card:loc=xxxx
```

 Where `xxxx` location used in [Step 6](#).
9. Enter the following command to determine which links are serviced by this card:
 

```
rept-stat-card:loc=xxxx
```

 Where `xxxx` is the location of the replaced card.
 

**Note:** The signaling link alarms will be present until the links are restored in [Step 11](#).
10. Examine the output from [Step 9](#).
 

Refer to [Corrective Maintenance](#) to clear any GPL related alarms on the newly replaced card before continuing.
11. Enter the following command to return the links to service.
 

Make sure this is done on all links:

```
act-slk:loc=xxxx:port=y
```

 Where `xxxx` location used in 3 and 4 and `y` are the ports used in [Step 3](#) and [Step 4](#).
12. Enter the following command to change the link status to IS-NR.
 

Make sure this is done on both ports, *a* and *b*.

```
unhb-slk:loc=xxxx:port=y
```

Where *xxxx* location used in [Step 3](#) and [Step 4](#) and *y* are the ports used in [Step 3](#) and [Step 4](#).

13. Enter the following command to verify the status of the card and its associated links:

```
rept-stat-card:loc=xxxx
```

Where *xxxx* is the card location. The following is an example of the possible output.

```
RLGHNCXA03W 98-09-27 16:43:42 EST EAGLE 34.0.0
CARD VERSION TYPE APPL PST SST AST
1201 024-002-000 LIMDS0
SS7ANSI
IS-NR Active -----
ALARM STATUS = No Alarms.
IMT VERSION = 024-001-000
PROM VERSION = 024-001-000
IMT BUS A = Conn
IMT BUS B = Conn
SLK A PST = IS-NR LS=lsnsspn2 CLI=-----
SLK B PST = IS-NR LS=lsnstpi CLI=-----
SCCP SERVICE CARD = 1212
SLAN SERVICE CARD = ----
Command Completed.
```

14. Enter the following command to verify the links are properly aligned and are returned to full service:

```
rept-stat-slk
```

The following is an example of the possible output.

```
RLGHNCXA03W 98-09-27 17:00:36 EST EAGLE 34.0.0
rept-stat-slk
SLK LSN CLLI PST SST AST
1201,A lsnsspn2 ----- IS-NR Avail ----
1201,B lsnstpi ----- IS-NR Avail ----
1202,A lsnstpn ----- IS-NR Avail ----
1202,B lsnstpi ----- IS-NR Avail ----
1203,A lsnstpa ----- IS-NR Avail ----
1203,B lsnscpa ----- IS-NR Avail ----
1205,A lsnscpi ----- IS-NR Avail ----
1205,B lsnsspi1 ----- IS-NR Avail ----
1207,A lsnstpa ----- IS-NR Avail ----
1207,B lsnsspal ----- IS-NR Avail ----
1211,A lsnstpn ----- IS-NR Avail ----
1211,B lsnsspn1 ----- IS-NR Avail ----
Command Completed.
```

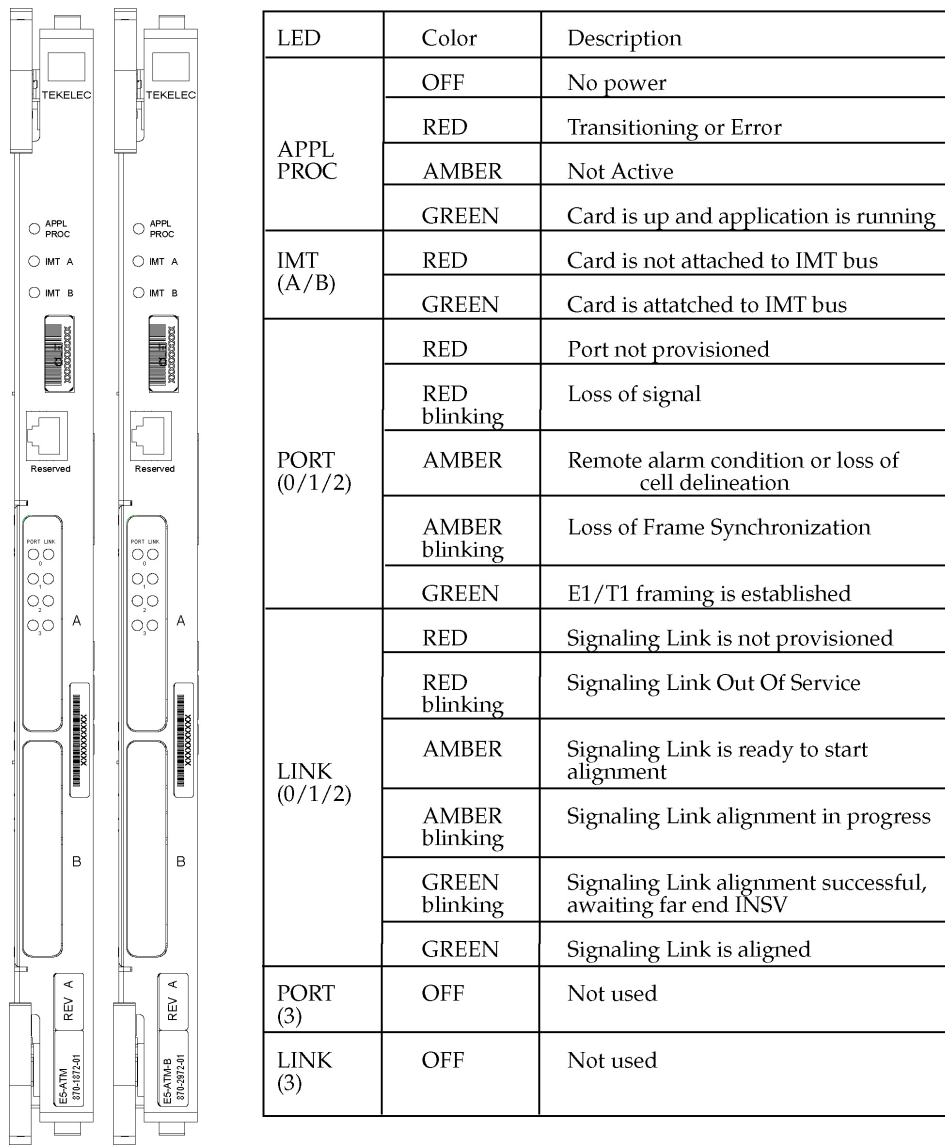

Figure 31: E5-ATM/E5-ATM-B LEDs

### SS7 and IP7, MIM, HC-MIM and MPL Card Replacement

The types of Link Interface Modules (LIM)s currently available are:

- Multi-Port LIM (MPL)
- The E1/T1 Multi-Channel Interface Module (MIM)
- High Capacity Multi-Channel Interface Module (HC-MIM)

1. Enter the following command to determine which links are serviced by this card:

```
rept-stat-card:loc=xxxx
```

Where *xxxx* is the card location. The following is an example of the possible output.

```

RLGHNCXA03W 98-09-27 16:43:42 EST EAGLE 34.0.0
CARD VERSION TYPE APPL PST SST AST
1201 021-002-000 LIMDS0 CCS7ITU IS-NR Active -----
ALARM STATUS = * 0022 Clock B for card failed.
IMT VERSION = 021-001-000
PROM VERSION = 021-001-000
IMT BUS A = Conn
IMT BUS B = Fault
SLK A PST = IS-NR LS=lsnssp2 CLLI=-----
SLK B PST = IS-NR LS=lsnstpi CLLI=-----
SCCP SERVICE CARD = 1212
SLAN SERVICE CARD = -----
Command Completed.

```

2. Refer to [Determine Card Changeout Time](#) procedure to determine when to change the card.

**Note:** The `inh-slk` command will be rejected if inhibiting the link would cause a DPC to become unavailable.

3. Enter the following command to inhibit the links on both ports of this card (a and b).

```
inh-slk:loc=xxxx:port=y
```

Where *xxxx* location of the card from [Step 1](#) and *y* is the port.

4. Enter the following command to change the status of the link to out of service - maintenance disabled (`oos-mt-dsbl`).

Enter the same location and ports from [Step 3](#)

```
dact-slk:loc=xxxx:port=y
```

Where *xxxx* location used in [Step 3](#) and *y* are the ports used in [Step 3](#).

5. Enter the following command to ensure the signaling link status is `oos-mt-dsbl` (out of service - maintenance disabled).

```
rept-stat-slk
```

The following is an example of the possible output.

```

RLGHNCXA03W 98-09-27 17:00:36 EST EAGLE 34.0.0
rept-stat-slk
SLK LSN CLLI PST SST AST
1201,A lsnssp2 ----- IS-NR Avail ----
1201,B lsnstpi ----- OOS-MT-DSBLD LPBK ----
1202,A lsnstpn ----- IS-NR Avail ----
1202,B lsnstpi ----- IS-NR Avail ----
1203,A lsnstpa ----- IS-NR Avail ----
1203,B lsnscpa ----- IS-NR Avail ----
1205,A lsnscpi ----- IS-NR Avail ----
1205,B lsnssp1l ----- IS-NR Avail ----
1207,A lsnstpa ----- IS-NR Avail ----
1207,B lsnssp1 ----- IS-NR Avail ----
1211,A lsnstpn ----- IS-NR Avail ----
1211,B lsnssp1 ----- IS-NR Avail ----
Command Completed.

```

6. Enter the following command to inhibit the card and disconnect it from the IMT bus.  
`rmv-card:loc=xxxx`  
 Where *xxxx* location used in [Step 3](#) and [Step 4](#) .
7. Remove the LIM/MIM/MPL, per the card replacement procedure described in the section titled [Replacing a Card in the EAGLE 5 ISS.](#)  
 Place the new SS7LIM into its place. Be sure the revision numbers are compatible (if in doubt, contact the [My Oracle Support \(MOS\)](#)).
8. Enter the following command to download generic program loads and database information from the E5-TDM card to the new LIM/MIM/MPL:  
`rst-card:loc=xxxx`  
 Where *xxxx* location used in [Step 6](#) .
9. Enter the following command to determine which links are serviced by this card:  
`rept-stat-card:loc=xxxx`  
 Where *xxxx* is the location of the replaced card.  
**Note:** The signaling link alarms will be present until the links are restored in [Step 11](#).
10. Examine the output from [Step 9](#).  
 Refer to [Corrective Maintenance](#) to clear any GPL related alarms on the newly replaced card before continuing.
11. Enter the following command to return the links to service.  
 Make sure this is done on all links:  
`act-slk:loc=xxxx:port=y`  
 Where *xxxx* location used in [Step 3](#) and [Step 4](#) and *y* are the ports used in [Step 3](#) and [Step 4](#).
12. Enter the following command to change the link status to IS-NR.  
 Make sure this is done on both ports, *a* and *b*.  
`unhb-slk:loc=xxxx:port=y`  
 Where *xxxx* location used in [Step 3](#) and [Step 4](#) and *y* are the ports used in [Step 3](#) and [Step 4](#).
13. Enter the following command to verify the status of the card and its associated links:  
`rept-stat-card:loc=xxxx`  
 Where *xxxx* is the card location. The following is an example of the possible output.

```

RLGHNCXA03W 98-09-27 16:43:42 EST EAGLE 34.0.0
CARD VERSION TYPE APPL PST SST AST
1201 024-002-000 LIMDS0
SS7ANSI
 IS-NR Active -----
ALARM STATUS = No Alarms.
IMT VERSION = 024-001-000
PROM VERSION = 024-001-000
IMT BUS A = Conn
IMT BUS B = Conn
SLK A PST = IS-NR LS=lsnssp2 CLLI=-----
SLK B PST = IS-NR LS=lsnstpi CLLI=-----
SCCP SERVICE CARD = 1212

```

```
SLAN SERVICE CARD = ----
Command Completed.
```

14. Enter the following command to verify the links are properly aligned and are returned to full service:

```
rept-stat-slk
```

The following is an example of the possible output.

```
RLGHNCXA03W 98-09-27 17:00:36 EST EAGLE 34.0.0
rept-stat-slk
SLK LSN CLLI PST SST AST
1201,A lsnssp2 ----- IS-NR Avail ----
1201,B lsnstpi ----- OOS-MT-DSBLD LPBK ----
1202,A lsnstpn ----- IS-NR Avail ----
1202,B lsnstpi ----- IS-NR Avail ----
1203,A lsnstpa ----- IS-NR Avail ----
1203,B lsnscpa ----- IS-NR Avail ----
1205,A lsnscpi ----- IS-NR Avail ----
1205,B lsnsspi1 ----- IS-NR Avail ----
1207,A lsnstpa ----- IS-NR Avail ----
1207,B lsnsspa1 ----- IS-NR Avail ----
1211,A lsnstpn ----- IS-NR Avail ----
1211,B lsnssp1 ----- IS-NR Avail ----
Command Completed.
```



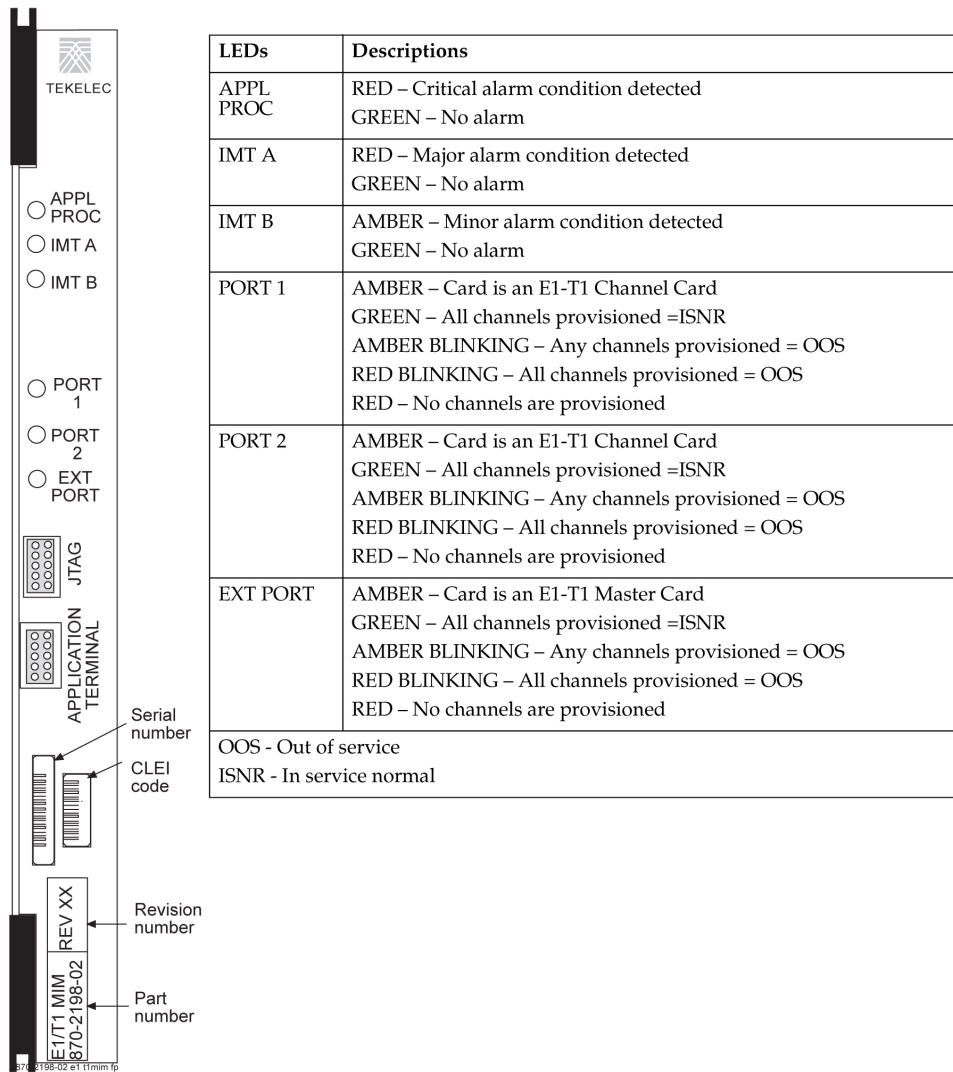

Figure 32: E1/T1 MIM

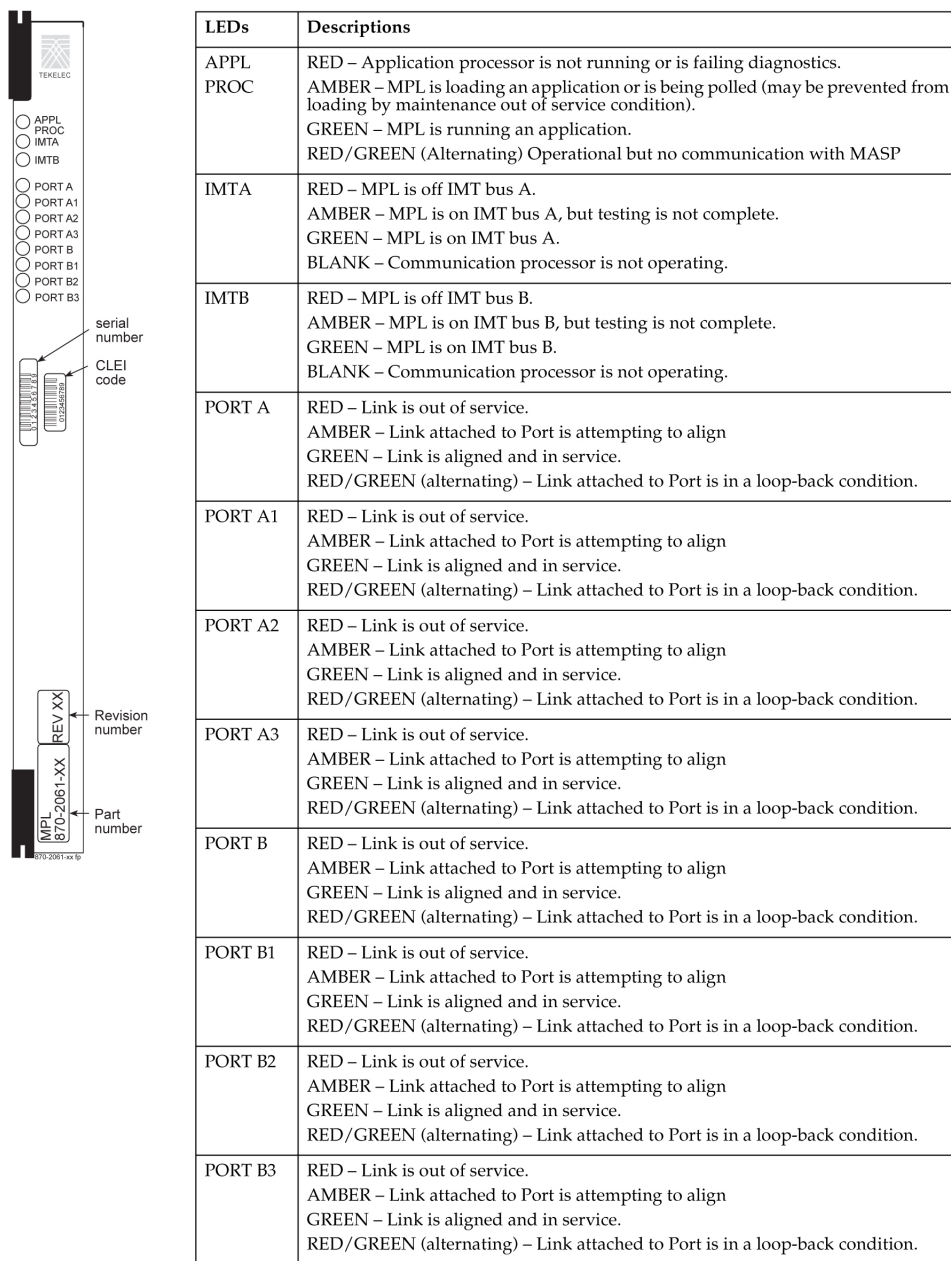

Figure 33: MPL LEDs

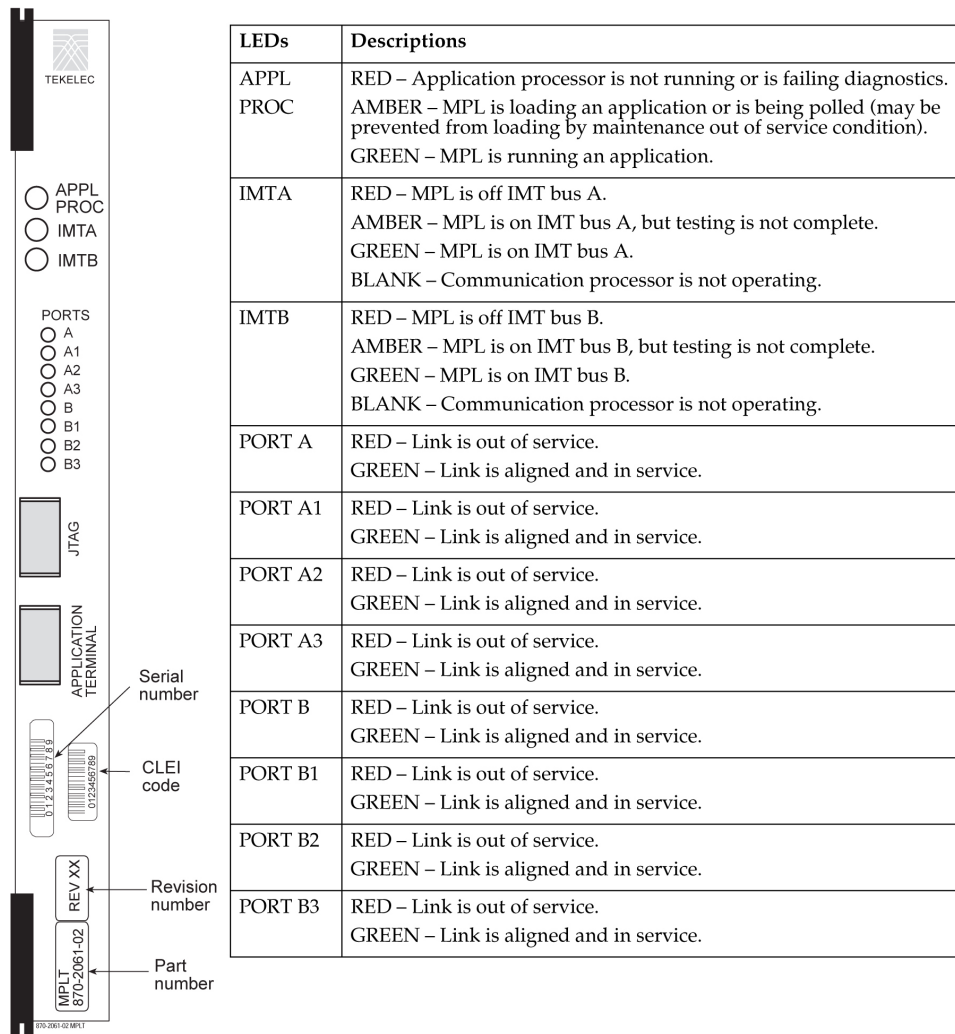
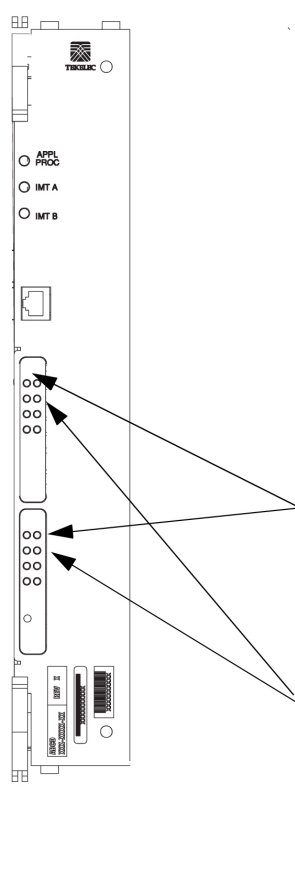

Figure 34: MPLT LEDs



| LEDs                      | Descriptions                                                                                                                                                                                                                                                                                                           |
|---------------------------|------------------------------------------------------------------------------------------------------------------------------------------------------------------------------------------------------------------------------------------------------------------------------------------------------------------------|
| APPL PROC                 | RED – Application processor is not running or is failing diagnostics.<br>AMBER – MPL is loading an application or is being polled (may be prevented from loading by maintenance out of service condition).<br>GREEN – MPL is running an application.                                                                   |
| IMTA                      | RED – MPL is off IMT bus A.<br>AMBER – MPL is on IMT bus A, but testing is not complete.<br>GREEN – MPL is on IMT bus A.<br>BLANK – Communication processor is not operating.                                                                                                                                          |
| IMTB                      | RED – MPL is off IMT bus B.<br>AMBER – MPL is on IMT bus B, but testing is not complete.<br>GREEN – MPL is on IMT bus B.<br>BLANK – Communication processor is not operating.                                                                                                                                          |
| PORT Status               | RED – Port not provisioned.<br>RED BLINKING – Loss of signal and remaining errors.<br>AMBER – Remote alarm condition<br>AMBER BLINKING – Loss of Frame Synchronization.<br>GREEN – No alarms, port has acquired timing and framing synchronization                                                                     |
| AGGREGATED CHANNEL STATUS | RED – No channels are provisioned.<br>RED BLINKING – All channels provisioned = OOS.<br>AMBER – Indicates port is the “reflected” port in Channel Bridging mode of operation.<br>Applies only to “even” numbered ports<br>AMBER BLINKING – Any channels provisioned = OOS.<br>GREEN – All channels provisioned = ISNR. |

Figure 35: HC MIM LEDs

## E5-ENET/E5-ENET-B Module

The term E5-ENET refers to either the E5-ENET (P/N 870-2212-xx) or to the E5-ENET-B (P/N 870-2971-xx).

The E5-ENET module (refer to [Figure 36: E5-ENET LEDs](#)) can run different applications. Removal and replacement procedures differ depending on the application.

**Note:** If this card is removed, the link supported by this card becomes out of service.

For removal and replacement procedures for a like-for-like card:

- If the E5-ENET card is operating with signaling interfaces such as IPLIM, IPGW, or IPSG, refer to [IP SIGTRAN on E5-ENET/E5-ENET-B](#).
- If the E5-ENET card is operating with signaling interfaces such as SLAN or EROUTE, refer to [STPLAN/EROUTE on E5-ENET/E5-ENET-B](#).

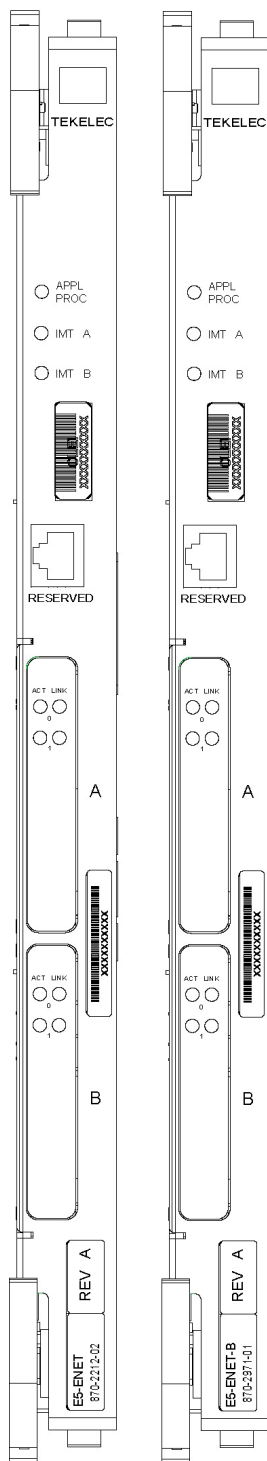

**Front Faceplate LED Indicators**

| LED       | Status | Description                           |
|-----------|--------|---------------------------------------|
| APPL PROC | Off    | No power                              |
|           | Red    | Card is booting                       |
|           | Amber  | Card is loading                       |
|           | Green  | Card is up and application is running |
| IMT A     | Red    | Not connected to bus                  |
|           | Amber  | Testing not complete                  |
|           | Green  | Active and connected to the bus       |
| IMT B     | Red    | Not connected to bus                  |
|           | Amber  | Testing not complete                  |
|           | Green  | Active and connected to the bus       |

**EROUTE/SLAN**

| LED   | ACT                                                                    | LINK                        |
|-------|------------------------------------------------------------------------|-----------------------------|
| Red   | Signaling links inactive, or 1 or more active links are out-of-service | N/A                         |
| Green | All active links are in-service                                        | Ethernet signal detected    |
| Off   | Card nonfunctional                                                     | No Ethernet signal detected |

**ACT Status LED states for IPLIMx/IPSG**

| SLK States (Port A or Port B)                                          | ACT Status LED |
|------------------------------------------------------------------------|----------------|
| No links configured                                                    | Red            |
| All provisioned links are OOS-MT-DSBLD                                 | Red            |
| No link is OOS-MT and at least one provisioned link is IS-NR or IS-ANR | Green          |
| At least one provisioned link is OOS-MT                                | Red            |

**ACT Status LED states for IPGWx**

| IPGWx SLK PST                            | ACT Status LED |       |
|------------------------------------------|----------------|-------|
|                                          | A0             | B0    |
| None configured (card must be inhibited) | Red            | Red   |
| OOS-MT-DSBLD                             | Red            | Green |
| IS-NR or IS-ANR                          | Green          | Green |

Figure 36: E5-ENET LEDs

## IP SIGTRAN on E5-ENET/E5-ENET-B

The term E5-ENET refers to either the E5-ENET (P/N 870-2212-xx) or to the E5-ENET-B (P/N 870-2971-xx).

Use this procedure to remove and replace an E5-ENET card running an application such as IPLIM, IPLIMI, IPGWI, SS7IPGW, or IPSTG.

1. Enter the following command to determine which links are serviced by this card.

```
rept-stat-card:loc=xxxx
```

Where *xxxx* is the card location.

The following is an example of the possible output.

```
rlghncxa03w 06-06-01 16:43:42 EST EAGLE 35.0.0
CARD VERSION TYPE GPL PST SST AST
1301 082-000-039 E5-ENET IPLHC IS-NR Active -----
ALARM STATUS = No Alarms.
BLIXP GPL version = 126-002-000
IMT BUS A = Conn
IMT BUS B = Disc
SIGNALING LINK STATUS
 SLK PST LS CLLI E5IS
 A IS-NR ls1m2pa ----- INACTIVE
 B OOS-MT ls1m2pa ----- INACTIVE
 A1 OOS-MT ls1m2pa ----- INACTIVE
 B1 OOS-MT ls1m2pa ----- INACTIVE
 A2 OOS-MT ls1m2pa ----- INACTIVE
 B2 OOS-MT ls1m2pa ----- INACTIVE
 A3 OOS-MT ls1m2pa ----- INACTIVE
 B3 OOS-MT ls1m2pa ----- INACTIVE

Command Completed.
;
```

2. Refer to [Determine Card Changeout Time](#) procedure to determine when to change the card.
3. Enter the following command to inhibit the links on both ports of this card (*a* and *b*).

```
inh-slk:loc=xxxx:port=y
```

Where *xxxx* location of the card from [Step 1](#) and *y* is the port.

**Note:** The `inh-slk` command will be rejected if inhibiting the link would cause a DPC to become unavailable.

The following is an example of the possible output.

```
rlghncxa03w 05-01-07 11:11:28 EST EAGLE5 33.0.0
Inhibit Link message sent to card
;
```

4. Enter the following command to change the status of the link to out of service - maintenance disabled (`oos-mt-dsbl`).

```
dact-slk:loc=xxxx:port=y
```

Where *xxxx* (card location) and *y* (port) used from [Step 3](#).

The following is an example of the possible output.

```
rlghncxa03w 04-01-07 11:11:28 EST EAGLE5 33.0.0
Deactivate Link message sent to card
;
```

5. Enter the following command to ensure the signaling link status is oos-mt-dsbl'd (out of service - maintenance disabled).

```
rept-stat-slk
```

The following is an example of the possible output.

```
RLGHNCXA03W 98-09-27 17:00:36 EST EAGLE 34.0.0
rept-stat-slk
SLK LSN CLLI PST SST AST
1201,A lsnssp2 ----- IS-NR Avail ----
1201,B lsnstpi ----- OOS-MT-DSBLD LPBK ----
1202,A lsnstpn ----- IS-NR Avail ----
1202,B lsnstpi ----- IS-NR Avail ----
1203,A lsnstpa ----- IS-NR Avail ----
1203,B lsnscpa ----- IS-NR Avail ----
1205,A lsnscpi ----- IS-NR Avail ----
1205,B lsnsspi1 ----- IS-NR Avail ----
1207,A lsnstpa ----- IS-NR Avail ----
1207,B lsnsspa1 ----- IS-NR Avail ----
1211,A lsnstpn ----- IS-NR Avail ----
1211,B lsnssp1 ----- IS-NR Avail ----
Command Completed.
```

6. Enter the following command to inhibit the card and disconnect it from the IMT bus.

```
rmv-card:loc=xxxx
```

Where *xxxx* location used in [Step 3](#) and [Step 4](#).

The following is an example of the possible output.

```
rlghncxa03w 04-01-07 11:11:28 EST EAGLE 31.3.0
Card has been inhibited.
;
```

7. Remove the E5-ENET card per the card replacement procedure described in the section titled [Replacing a Card in the EAGLE 5 ISS](#).

Place the new E5-ENET card into its place. Be sure the revision numbers are compatible (if in doubt, contact the [My Oracle Support \(MOS\)](#)).

8. Enter the following command to download generic program loads and database information from the E5-TDM card to the new E5-ENET card.

```
rst-card:loc=xxxx
```

Where *xxxx* location used in [Step 6](#).

The following is an example of the possible output.

```
rlghncxa03w 04-01-07 11:11:28 EST EAGLE 31.3.0
Card has been allowed.
;
```

9. Enter the following command to determine which links are serviced by this card.

```
rept-stat-card:loc=xxxx
```

Where *xxxx* is the location of the replaced card.

**Note:** The signaling link alarms will be present until the links are restored in [Step 11](#).

```
rlghncxa03w 06-06-01 16:43:42 EST EAGLE 35.0.0
CARD VERSION TYPE GPL PST SST AST
1301 082-000-039 E5-ENET IPLHC IS-NR Active -----
ALARM STATUS = No Alarms.
BLIXP GPL version = 126-002-000
IMT BUS A = Conn
IMT BUS B = Disc
SIGNALING LINK STATUS
SLK PST LS CLLI E5IS
A IS-NR ls1m2pa ----- INACTIVE
B OOS-MT ls1m2pa ----- INACTIVE
A1 OOS-MT ls1m2pa ----- INACTIVE
B1 OOS-MT ls1m2pa ----- INACTIVE
A2 OOS-MT ls1m2pa ----- INACTIVE
B2 OOS-MT ls1m2pa ----- INACTIVE
A3 OOS-MT ls1m2pa ----- INACTIVE
B3 OOS-MT ls1m2pa ----- INACTIVE

Command Completed.
;
```

10. Examine the output from [Step 9](#).

Refer to [Corrective Maintenance](#) to clear any GPL related alarms on the newly replaced card before continuing.

11. Enter the following command to return the links to service.

```
act-slk:loc=xxxx:port=y
```

Where *xxxx* location and *y* ports are those used in [Step 3](#) and [Step 4](#).

Make sure this is done on all links.

The following is an example of the possible output.

```
tekelecstp 05-01-21 17:00:36 EST EAGLE5 33.0.0
Activate Link message sent to card
;
```

12. Enter the following command to change the link status to IS-NR.

```
unhb-slk:loc=xxxx:port=y
```

Make sure this is done on both ports, *a* and *b*.

Where *xxxx* location used in [Step 3](#) and [Step 4](#) and *y* are the ports used in [Step 3](#) and [Step 4](#).

The following is an example of the possible output.

```
rlghncxa03w 03-03-23 13:20:59 EST EAGLE 31.3.0
Allow Link message sent to card
;
```

13. Enter the following command to verify the status of the card and its associated links.



```
rept-stat-card:loc=xxxx
```

Where *xxxx* is the card location.

The following is an example of the possible output.

```

rlghncxa03w 06-06-01 16:43:42 EST EAGLE 35.0.0
CARD VERSION TYPE GPL PST SST AST
1301 082-000-039 E5-ENET IPLHC IS-NR Active -----
ALARM STATUS = No Alarms.
BLIXP GPL version = 126-002-000
IMT BUS A = Conn
IMT BUS B = Disc
SIGNALING LINK STATUS
 SLK PST LS CLLI E5IS
 A IS-NR ls1m2pa ----- INACTIVE
 B OOS-MT ls1m2pa ----- INACTIVE
 A1 OOS-MT ls1m2pa ----- INACTIVE
 B1 OOS-MT ls1m2pa ----- INACTIVE
 A2 OOS-MT ls1m2pa ----- INACTIVE
 B2 OOS-MT ls1m2pa ----- INACTIVE
 A3 OOS-MT ls1m2pa ----- INACTIVE
 B3 OOS-MT ls1m2pa ----- INACTIVE

Command Completed.
;

```

14. Enter the following command to verify the links are properly aligned and are returned to full service.

```
rept-stat-slk
```

The following is an example of the possible output.

```

RLGHNCXA03W 98-09-27 17:00:36 EST EAGLE 34.0.0
rept-stat-slk
SLK LSN CLLI PST SST AST
1201,A lsnssp2 ----- IS-NR Avail ----
1201,B lsnstpi ----- OOS-MT-DSBLD LPBK ----
1202,A lsnstpn ----- IS-NR Avail ----
1202,B lsnstpi ----- IS-NR Avail ----
1203,A lsnstpa ----- IS-NR Avail ----
1203,B lsnscpa ----- IS-NR Avail ----
1205,A lsnscpi ----- IS-NR Avail ----
1205,B lsnsspi1 ----- IS-NR Avail ----
1207,A lsnstpa ----- IS-NR Avail ----
1207,B lsnsspa1 ----- IS-NR Avail ----
1211,A lsnstpn ----- IS-NR Avail ----
1211,B lsnsspnl ----- IS-NR Avail ----
Command Completed.

```

15. Procedure complete.

## STPLAN/EROUTE on E5-ENET/E5-ENET-B

The term E5-ENET refers to either the E5-ENET (P/N 870-2212-xx) or to the E5-ENET-B (P/N 870-2971-xx).

Use this procedure to remove and replace an E5-ENET card running an application such as STPLAN or EROUTE.

1. Enter the following command to determine what TCP/IP data links are configured.

```
rept-stat-card
```

The following is an example of a possible output.

```
rlghncxa03w 10-01-09 16:35:57 IST EAGLE 42.0.0

CARD VERSION TYPE GPL PST SST AST
1101 125-020-000 TSM GLS IS-NR Active -----
1102 128-002-000 LIMATM ATMHC IS-NR Active -----
1103 125-020-000 DSM VSCCP IS-NR Active -----
1105 125-020-000 DSM VSCCP IS-NR Active -----
1106 130-001-000 TSM GLSHC IS-NR Active -----
1107 125-020-000 STC EROUTE IS-NR Active -----
1109 125-020-000 HMUX BPHMUX IS-NR Active -----
1110 125-020-000 HMUX BPHMUX IS-NR Active -----
1111 125-020-000 IPSM IPS IS-NR Active -----
1112 125-020-000 EDSM MCP IS-NR Active -----
1113 070-019-002 E5MCAP OAMHC IS-NR Standby -----
1114 ----- E5TDM IS-NR Active -----
1115 070-019-002 E5MCAP OAMHC IS-NR Active -----
1116 ----- E5TDM IS-NR Active -----
1117 ----- E5MDAL IS-NR Active -----
1201 125-020-000 LIMDS0 SS7ANSI IS-NR Active -----
1202 ----- LIMCH SS7ANSI OOS-MT-DSBLD Manual -----
1203 125-020-000 LIMCH SS7ANSI IS-NR Active -----
1205 125-020-000 EDCM IPGWI IS-NR Active -----
1206 125-020-000 EDCM SS7IPGW IS-NR Active -----
1207 125-020-000 EDCM IPLIM IS-NR Active -----
1208 125-020-000 EDCM IPLIMI IS-NR Active -----
1209 125-020-000 HMUX BPHMUX IS-NR Active -----
1210 125-020-000 HMUX BPHMUX IS-NR Active -----
1211 125-020-000 LIMATM ATMANSI IS-NR Active -----
1213 125-020-000 LIME1ATM ATMITU IS-NR Active -----
1301 048-019-022 LIME1 SS7ANSI IS-NR Active -----
1303 125-022-000 LIME1 SS7ANSI IS-NR Active -----
1305 125-022-000 LIME1 CCS7ITU IS-NR Active -----
1309 125-017-000 HIPR HIPR IS-NR Active -----
1310 125-017-000 HIPR HIPR IS-NR Active -----
1311 125-020-000 STC EROUTE IS-NR Active -----
1313 125-020-000 DCM VXWLAN IS-NR Active -----
2101 104-002-000 LIMV35 CCS7ITU IS-NR Active -----
2103 128-018-000 DCM IPLHC IS-NR Active -----
2107 104-001-000 LIMCH CCS7ITU IS-NR Active -----
2108 128-018-000 DCM SLANHC IS-NR Active -----
2109 128-022-000 HIPR2 HIPR2 IS-NR Active -----
2110 128-022-000 HIPR2 HIPR2 IS-NR Active -----
2111 128-018-000 STC ERTHC IS-NR Active -----
1213 053-000-058 E5ENET IPSG IS-NR Active -----
Command Completed.
;
```

2. Enter the following command to determine the status of the TCP/IP data link assigned to the card to be replaced.

```
rept-stat-dlk
```

The following is an example of the possible output.

```
rlghncxa03w 10-01-27 17:00:36 EST EAGLE 42.0.0
DLK PST SST AST
1104 IS-NR Active ----
1206 IS-NR Active ALMINH
Command Completed.
;
```

3. Note the status of the TCP/IP data link.
  - If the link is out of service - maintenance disabled (OOS-MT-DSBLD), go to [Step 5](#).
  - If the link is not out of service, go to [Step 4](#).
4. Enter the following command to change the status of the TCP/IP data link to OOS-MT-DSBLD.

```
canc-dlk:loc=xxxx
```

Where *xxxx* is the card location.

The following is an example of a possible output.

```
rlghncxa03w 04-01-27 17:00:36 EST EAGLE 31.3.0
Deactivate Link message sent to card.
Command Completed.
;
```

5. Enter the following command to inhibit the card and disconnect it from the IMT bus.

```
rmv-card:loc=xxxx
```

Where *xxxx* is the card location.

**Note:** If this is the last type ENET card in the system, the `:force=yes` parameter must be used with this command.

The following is an example of a possible output.

```
rlghncxa03w 04-01-07 11:11:28 EST EAGLE 31.3.0
Card has been inhibited.
;
```

6. Remove the E5-ENET, per the card replacement procedure described in the section titled [Replacing a Card in the EAGLE 5 ISS](#).

Place the new E5-ENET into its place. Be sure the revision numbers are compatible (if in doubt, contact the [My Oracle Support \(MOS\)](#)).

7. Enter the following command to put the new E5-ENET card back into service and connect it to the IMT bus.

```
rst-card:loc=xxxx
```

where *xxxx* = card location.

The following is an example of a possible output.

```
rlghncxa03w 04-01-07 11:11:28 EST EAGLE 31.3.0
Card has been allowed.
;
```

8. Enter the following command to return the TCP/IP data link to service.

```
act-dlk:loc=xxxx
```

where *xxxx* = card location.

The following is an example of a possible output.

```
rlghncxa03w 04-01-17:00:36 EST EAGLE 31.3.0
Activate Link message sent to card.
Command Completed.
;
```

9. Enter the following command to verify the status of the card and its associated TCP/IP data link.

```
rept-stat-card
```

The following is an example of a possible output.

```
rlghncxa03w 10-01-09 16:35:57 IST EAGLE 42.0.0
```

| CARD | VERSION     | TYPE     | GPL     | PST          | SST     | AST   |
|------|-------------|----------|---------|--------------|---------|-------|
| 1101 | 125-020-000 | TSM      | GLS     | IS-NR        | Active  | ----- |
| 1102 | 128-002-000 | LIMATM   | ATMHC   | IS-NR        | Active  | ----- |
| 1103 | 125-020-000 | DSM      | VSCCP   | IS-NR        | Active  | ----- |
| 1105 | 125-020-000 | DSM      | VSCCP   | IS-NR        | Active  | ----- |
| 1106 | 130-001-000 | TSM      | GLSHC   | IS-NR        | Active  | ----- |
| 1107 | 125-020-000 | STC      | EROUTE  | IS-NR        | Active  | ----- |
| 1109 | 125-020-000 | HMUX     | BPHMUX  | IS-NR        | Active  | ----- |
| 1110 | 125-020-000 | HMUX     | BPHMUX  | IS-NR        | Active  | ----- |
| 1111 | 125-020-000 | IPSM     | IPS     | IS-NR        | Active  | ----- |
| 1112 | 125-020-000 | EDSM     | MCP     | IS-NR        | Active  | ----- |
| 1113 | 070-019-002 | E5MCAP   | OAMHC   | IS-NR        | Standby | ----- |
| 1114 | -----       | E5TDM    |         | IS-NR        | Active  | ----- |
| 1115 | 070-019-002 | E5MCAP   | OAMHC   | IS-NR        | Active  | ----- |
| 1116 | -----       | E5TDM    |         | IS-NR        | Active  | ----- |
| 1117 | -----       | E5MDAL   |         | IS-NR        | Active  | ----- |
| 1201 | 125-020-000 | LIMDS0   | SS7ANSI | IS-NR        | Active  | ----- |
| 1202 | -----       | LIMCH    | SS7ANSI | OOS-MT-DSBLD | Manual  | ----- |
| 1203 | 125-020-000 | LIMCH    | SS7ANSI | IS-NR        | Active  | ----- |
| 1205 | 125-020-000 | EDCMA    | IPGWI   | IS-NR        | Active  | ----- |
| 1206 | 125-020-000 | EDCMA    | SS7IPGW | IS-NR        | Active  | ----- |
| 1207 | 125-020-000 | EDCMA    | IPLIM   | IS-NR        | Active  | ----- |
| 1208 | 125-020-000 | EDCMA    | IPLIMI  | IS-NR        | Active  | ----- |
| 1209 | 125-020-000 | HMUX     | BPHMUX  | IS-NR        | Active  | ----- |
| 1210 | 125-020-000 | HMUX     | BPHMUX  | IS-NR        | Active  | ----- |
| 1211 | 125-020-000 | LIMATM   | ATMANSI | IS-NR        | Active  | ----- |
| 1213 | 125-020-000 | LIME1ATM | ATMITU  | IS-NR        | Active  | ----- |
| 1301 | 048-019-022 | LIME1    | SS7ANSI | IS-NR        | Active  | ----- |
| 1303 | 125-022-000 | LIME1    | SS7ANSI | IS-NR        | Active  | ----- |
| 1305 | 125-022-000 | LIME1    | CCS7ITU | IS-NR        | Active  | ----- |
| 1309 | 125-017-000 | HIPR     | HIPR    | IS-NR        | Active  | ----- |
| 1310 | 125-017-000 | HIPR     | HIPR    | IS-NR        | Active  | ----- |
| 1311 | 125-020-000 | STC      | EROUTE  | IS-NR        | Active  | ----- |
| 1313 | 125-020-000 | DCM      | VXWSLAN | IS-NR        | Active  | ----- |
| 2101 | 104-002-000 | LIMV35   | CCS7ITU | IS-NR        | Active  | ----- |

```

2103 128-018-000 DCM IPLHC IS-NR Active -----
2107 104-001-000 LIMCH CCS7ITU IS-NR Active -----
2108 128-018-000 DCM SLANHC IS-NR Active -----
2109 128-022-000 HIPR2 HIPR2 IS-NR Active -----
2110 128-022-000 HIPR2 HIPR2 IS-NR Active -----
2111 128-018-000 STC ERTHC IS-NR Active -----
1213 053-000-058 E5ENET IPSPG IS-NR Active -----
Command Completed.
;

```

10. Enter the following command to verify that the TCP/IP data link has returned to full service.

```
rept-stat-dlk
```

The following is an example of the possible output.

```

rlghncxa03w 10-01-27 17:00:36 EST EAGLE 42.0.0
DLK PST SST AST
1104 IS-NR Active ----
1206 IS-NR Active ALMINH
Command Completed.
;

```

11. Procedure is complete.

## E5-TSM Card Replacement

The E5-TSM card runs the Generic Loading Services application which is a software function that transfers a Binder generated table to the appropriate network card based on screenset to linkset assignment. The GPL is GLSHC, used for downloading gateway screening tables to link interface modules (LIMs). This is used to expedite the downloading process and bring links into service much quicker.

The absence of this card will not effect the gateway screening capability, as the screening takes place on the LIMs and SCCP cards. This only effects the ability to download screening data to the LIMs and SCCP cards.

1. Enter the following command to identify how many E5-TSM cards are presently configured for this application:

```
rept-stat-card
```

The following is an example of the possible output.

```

rlghncxa03w 08-10-04 12:57:21 EST EAGLE5 45.0.0
CARD VERSION TYPE GPL PST SST AST
1101 125-020-000 TSM GLS IS-NR Active -----
1102 128-002-000 LIMATM ATMHC IS-NR Active -----
1103 125-020-000 DSM VSCCP IS-NR Active -----
1105 125-020-000 DSM VSCCP IS-NR Active -----
1106 130-001-000 TSM GLSHC IS-NR Active -----
1107 125-020-000 STC EROUTE IS-NR Active -----
1109 125-020-000 HMUX BPHMUX IS-NR Active -----
1110 125-020-000 HMUX BPHMUX IS-NR Active -----
1111 125-020-000 IPSM IPS IS-NR Active -----

```

```

1112 125-020-000 MCPM MCP IS-NR Active -----
1113 070-019-002 E5MCAP OAMHC IS-NR Standby -----
1114 ----- E5TDM IS-NR Active -----
1115 070-019-002 E5MCAP OAMHC IS-NR Active -----
1116 ----- E5TDM IS-NR Active -----
1117 ----- E5MDAL IS-NR Active -----
1201 125-020-000 LIMDS0 SS7ANSI IS-NR Active -----
1202 ----- LIMCH SS7ANSI OOS-MT-DSBLD Manual -----
1203 125-020-000 LIMCH SS7ANSI IS-NR Active -----
1205 125-020-000 EDCMA IPGWI IS-NR Active -----
1206 125-020-000 EDCMA SS7IPGW IS-NR Active -----
1207 125-020-000 EDCMA IPLIM IS-NR Active -----
1208 125-020-000 EDCMA IPLIMI IS-NR Active -----
1209 125-020-000 HMUXA BPHMUX IS-NR Active -----
1210 125-020-000 HMUXA BPHMUX IS-NR Active -----
1211 125-020-000 LIMATM ATMANSI IS-NR Active -----
1213 125-020-000 LIMELATM ATMITU IS-NR Active -----
1301 048-019-022 LIME1 SS7ANSI IS-NR Active -----
1303 125-022-000 LIME1 SS7ANSI IS-NR Active -----
1305 125-022-000 LIME1 CCS7ITU IS-NR Active -----
1309 125-017-000 HIPR HIPR IS-NR Active -----
1310 125-017-000 HIPR HIPR IS-NR Active -----
1311 125-020-000 STC EROUTE IS-NR Active -----
1313 125-020-000 DCM STPLAN IS-NR Active -----
1401 104-002-000 LIMV35 CCS7ITU IS-NR Active -----
1403 128-018-000 DCM IPLHC IS-NR Active -----
1407 104-001-000 LIMCH CCS7ITU IS-NR Active -----
1408 128-018-000 DCM SLANHC IS-NR Active -----
1409 128-016-000 HIPR HIPR IS-NR Active -----
1410 128-016-000 HIPR HIPR IS-NR Active -----
1411 128-018-000 STC ERTHC IS-NR Active -----
1413 053-000-058 E5ENET IPSG IS-NR Active -----
Command Completed.
;

```

**Note:** In the above example, card 1101 is a TSM-256 card and card 1106 is an E5-TSM card.

2. Enter the following command to remove this card from service.

If this is the last card providing GLS in service, the `:force=yes` parameter must be specified.

```
rmv-card:loc=xxxx
```

Where `xxxx` is the card location.

The following is an example of the possible output.

```

rlghncxa03w 08-10-04 13:07:21 EST EAGLE5 40.0.0
Card has been inhibited.
;

```

3. Remove the E5-TSM card, per the card replacement procedure described in the section titled [Replacing a Card in the EAGLE 5 ISS](#).  
Place the new E5-TSM card into its place. Be sure the revision numbers are compatible (if in doubt, contact the [My Oracle Support \(MOS\)](#)).
4. Enter the following command to begin downloading gateway screening (GWS) data to the new E5-TSM card:  
`rst-card:loc=xxxx`  
Where `xxxx` is the card location.

5. Enter the following command to verify the successful download of GWS data and to verify that the new card has returned to service:

```
rept-stat-card
```

The following is an example of the possible output.

```

rlghncxa03w 08-10-04 12:57:21 EST EAGLE5 40.0.0
CARD VERSION TYPE GPL PST SST AST
1101 125-020-000 TSM GLS IS-NR Active -----
1102 128-002-000 LIMATM ATMHC IS-NR Active -----
1103 125-020-000 DSM VSCCP IS-NR Active -----
1105 125-020-000 DSM VSCCP IS-NR Active -----
1106 130-001-000 TSM GLSHC IS-NR Active -----
1107 125-020-000 STC EROUTE IS-NR Active -----
1109 125-020-000 HMUX BPHMUX IS-NR Active -----
1110 125-020-000 HMUX BPHMUX IS-NR Active -----
1111 125-020-000 IPSM IPS IS-NR Active -----
1112 125-020-000 MCPM MCP IS-NR Active -----
1113 070-019-002 E5MCAP OAMHC IS-NR Standby -----
1114 ----- E5TDM IS-NR Active -----
1115 070-019-002 E5MCAP OAMHC IS-NR Active -----
1116 ----- E5TDM IS-NR Active -----
1117 ----- E5MDAL IS-NR Active -----
1201 125-020-000 LIMDS0 SS7ANSI IS-NR Active -----
1202 ----- LIMCH SS7ANSI OOS-MT-DSBLD Manual -----
1203 125-020-000 LIMCH SS7ANSI IS-NR Active -----
1205 125-020-000 EDCMA IPGWI IS-NR Active -----
1206 125-020-000 EDCMA SS7IPGW IS-NR Active -----
1207 125-020-000 EDCMA IPLIM IS-NR Active -----
1208 125-020-000 EDCMA IPLIMI IS-NR Active -----
1209 125-020-000 HMUX BPHMUX IS-NR Active -----
1210 125-020-000 HMUX BPHMUX IS-NR Active -----
1211 125-020-000 LIMATM ATMANSI IS-NR Active -----
1213 125-020-000 LIMELATM ATMITU IS-NR Active -----
1301 048-019-022 LIME1 SS7ANSI IS-NR Active -----
1303 125-022-000 LIME1 SS7ANSI IS-NR Active -----
1305 125-022-000 LIME1 CCS7ITU IS-NR Active -----
1309 125-017-000 HIPR HIPR IS-NR Active -----
1310 125-017-000 HIPR HIPR IS-NR Active -----
1311 125-020-000 STC EROUTE IS-NR Active -----
1313 125-020-000 DCM STPLAN IS-NR Active -----
1401 104-002-000 LIMV35 CCS7ITU IS-NR Active -----
1403 128-018-000 DCM IPLHC IS-NR Active -----
1407 104-001-000 LIMCH CCS7ITU IS-NR Active -----
1408 128-018-000 DCM SLANHC IS-NR Active -----
1409 128-016-000 HIPR HIPR IS-NR Active -----
1410 128-016-000 HIPR HIPR IS-NR Active -----
1411 128-018-000 STC ERTHC IS-NR Active -----
1413 053-000-058 E5ENET IPSG IS-NR Active -----
Command Completed.
;

```

## Database Services Module (DSM)

### Description

DSM (*Figure 38: DCM LEDs*) cards are related to the TSM/DCM family, but differ by having an AMD K-6 processor and from 1 to 4 GB of memory on an applique board. The DSM card also differs from

the TSM cards by having ethernet ports. The DSMs run a version of the SCCP application that has been ported to the VxWorks OS. To differentiate the DSM-VxWorks-SCCP from the SCCP that runs on the TSM cards, the DSM version has been named VSCCP. The extra memory is required to hold a copy of the RTDB. Ethernet ports are required to connect to the EPAP to download the RTDB. Multiple DSMs are used to provide a means of load balancing in high-traffic situations. Each DSM contains an identical database. Furthermore, the DSM RTDBs need to be identical to the one maintained by the EPAPs.

**Note:** If there are provisioning scripts, such as LARG data, the DSM replacement activity should be coordinated with the DB/Admin operations to avoid extended provision otherwise RADB resets may occur.

1. Enter the following command to determine which cards are in service.

```
rept-stat-card:loc=xxxx
```

Where *xxxx* is the DSM card location.

This will indicate which link interface modules (LIMs) will be affected by removal of the DSM card.

2. Enter the following command to determine the number of DSM cards in service providing GTT.

```
rept-stat-sccp
```

The following is an example of the possible output.

```

RLGHNCXA03W 98-02-04 15:10:19 EST EAGLE 34.0.0
SCCP SUBSYSTEM REPORT IS-NR Active -----
GSM SUBSYSTEM REPORT IS-NR Active -----
INP SUBSYSTEM REPORT IS-ANR Restricted -----
 ASSUMING MATE'S LOAD
 INPQS: SSN STATUS = Allowed MATE SSN STATUS = Prohibited

SCCP Cards Configured= 4 Cards IS-NR= 2 Capacity Threshold = 100%
CARD VERSION PST SST AST MSU USAGE CPU USAGE

1212 103-001-000 IS-NR Active ALMINH 45% 30%
1301 P 103-001-000 IS-NR Active ----- 35% 40%
1305 ----- OOS-MT Isolated ----- 0% 0%
2112 ----- OOS-MT-DSBLD Manual ----- 0% 0%

SCCP Service Average MSU Capacity = 40% Average CPU Capacity = 35%
AVERAGE CPU USAGE PER SERVICE:
 GTT = 15% GFLEX = 5% GPORT = 10%
 INPMR = 2% INPQS = 3%
TOTAL SERVICE STATISTICS:
SERVICE SUCCESS ERRORS WARNINGS FORWARD TO GTT TOTAL
GTT: 1995 5 - - 2000
GFLEX: 500 1 4 10 515
GPORT: 800 0 2 3 805
INPMR: 50 5 0 15 70
INPQS: 499 1 - - 500
Command Completed.
```

**CAUTION:** Inhibiting/removing all DSM cards at one time will cause an SCCP nodal outage.

3. Enter the following command to remove the DSM card from service.

**CAUTION:** Removing/inhibiting the last IS-NR DSM card will cause an SCCP outage on the affected node. Before removing the last IS-NR DSMP card from service, ensure the mated STP DSM cards are IS-NR and capable of supporting the rerouted SCCP traffic.



```
rmv-card:loc=xxxx
```

Where *xxxx* is the DSM card location.

If this is the last DSM card in service, the **force=yes** parameter must be specified.

4. Remove the DSM card, per the card replacement procedure described in the section titled [Replacing a Card in the EAGLE 5 ISS](#).

Place the new DSM card into its place. Be sure the revision numbers are compatible (if in doubt, [My Oracle Support \(MOS\)](#)).

5. Enter the following command to return the DSM card into service.

```
rst-card:loc=xxxx
```

Where *xxxx* is the DSM card location.

This causes the MASP to begin downloading tables to the new DSM card. When the card has been successfully loaded (there will be a response on the terminal that downloading is complete). This can take up to 4 hours.

6. Enter the following command to verify the card is operational and providing SCCP services.

```
rept-stat-sccp
```

The following is an example of the possible output.

```

RLGHNCXA03W 98-02-04 15:10:19 EST EAGLE 34.0.0
SCCP SUBSYSTEM REPORT IS-NR Active -----
GSM SUBSYSTEM REPORT IS-NR Active -----
INP SUBSYSTEM REPORT IS-ANR Restricted -----
 ASSUMING MATE'S LOAD
 INPQS: SSN STATUS = Allowed MATE SSN STATUS = Prohibited

SCCP Cards Configured= 4 Cards IS-NR= 2 Capacity Threshold = 100%
CARD VERSION PST SST AST MSU USAGE CPU USAGE

1212 103-001-000 IS-NR Active ALMINH 45% 30%
1301 P 103-001-000 IS-NR Active ----- 35% 40%
1305 ----- OOS-MT Isolated ----- 0% 0%
2112 ----- OOS-MT-DSBLD Manual ----- 0% 0%

SCCP Service Average MSU Capacity = 40% Average CPU Capacity = 35%
AVERAGE CPU USAGE PER SERVICE:
 GTT = 15% GFLEX = 5% GPORT = 10%
 INPMR = 2% INPQS = 3%
TOTAL SERVICE STATISTICS:
SERVICE SUCCESS ERRORS WARNINGS FORWARD TO GTT TOTAL
GTT: 1995 5 - - 2000
GFLEX: 500 1 4 10 515
GPORT: 800 0 2 3 805
INPMR: 50 5 0 15 70
INPQS: 499 1 - - 500
Command Completed.
```

## E5-SM4G/E5-SM8G-B Card Replacement

The term E5-SM4G refers to either the E5-SM4G (P/N 870-2860-02) or the E5-SM8G-B (P/N 870-2990-01).

The E5-SM4G card is a database service module (DSM) designed to operate in the EAGLE shelf. The E5-SM4G is a replacement for the DSM card (P/N 870-1984-xx). The E5-SM4G is a double-slot EAGLE card that provides 3.1 GB of application processor memory. Ethernet ports connect to the EPAP to download the RTDB. Multiple cards are used to provide a means of load balancing in high-traffic situations. Each card contains an identical database. Furthermore, the E5-SM4G RTDBs need to be identical to the one maintained by the EPAPs.

**Note:** If there are provisioning scripts, such as LARG data, the E5-SM4G replacement activity should be coordinated with the DB/Admin operations to avoid extended provision otherwise RADB resets may occur.

1. Enter the following command to determine which cards are in service. This will indicate which link interface modules (LIMs) will be affected by removal of the E5-SM4G card.

```
rept-stat-card:loc=xxxx
```

Where xxxx is the E5-SM4G card location.

2. Enter the following command to determine the number of E5-SM4G cards in service providing GTT.

```
rept-stat-sccp
```

The following is an example of the possible output.

```

RLGHNCXA03W 98-02-04 15:10:19 EST EAGLE 34.0.0
SCCP SUBSYSTEM REPORT IS-NR Active -----
GSM SUBSYSTEM REPORT IS-NR Active -----
INP SUBSYSTEM REPORT IS-ANR Restricted -----
 ASSUMING MATE'S LOAD
 INPQS: SSN STATUS = Allowed MATE SSN STATUS = Prohibited

SCCP Cards Configured= 4 Cards IS-NR= 2 Capacity Threshold = 100%
CARD VERSION PST SST AST MSU USAGE CPU USAGE

1212 103-001-000 IS-NR Active ALMINH 45% 30%
1301 P 103-001-000 IS-NR Active ----- 35% 40%
1305 ----- OOS-MT Isolated ----- 0% 0%
2112 ----- OOS-MT-DSBLD Manual ----- 0% 0%

SCCP Service Average MSU Capacity = 40% Average CPU Capacity = 35%

AVERAGE CPU USAGE PER SERVICE:
GTT = 15% GFLEX = 5% GPORT = 10%
INPMR = 2% INPQS = 3%

TOTAL SERVICE STATISTICS:
SERVICE SUCCESS ERRORS WARNINGS FORWARD TO GTT TOTAL
GTT: 1995 5 - - 2000
GFLEX: 500 1 4 10 515
GPORT: 800 0 2 3 805
INPMR: 50 5 0 15 70
INPQS: 499 1 - - 500

Command Completed.
```



**Caution:** Inhibiting/removing all E5-SM4G cards at one time will cause an SCCP nodal outage.

- Enter the following command to remove the E5-SM4G card from service. If this is the last E5-SM4G card in service, the :force=yes parameter must be specified.



**Caution:** Removing/inhibiting the last IS-NR E5-SM4G card will cause an SCCP outage on the affected node. Before removing the last IS-NR E5-SM4G card from service, ensure the mated STP E5-SM4G cards are IS-NR and capable of supporting the rerouted SCCP traffic.

```
rmv-card:loc=xxxx
```

Where xxxx is the E5-SM4G card location.

- Remove the E5-SM4G card, per the card replacement procedure described in [Replacing a Card in the EAGLE 5 ISS](#). Place the new E5-SM4G card into its place. Be sure the revision numbers are compatible (if in doubt, contact the [My Oracle Support \(MOS\)](#)).
- Enter the following command Use the rst-card command to return the E5-SM4G card into service. This causes the MASP to begin downloading tables to the new E5-SM4G card.

```
rst-card:loc=xxxx
```

Where xxxx is the E5-SM4G card location.

This causes the MASP to begin downloading tables to the new E5-SM4G card. When the card has been successfully loaded (there will be a response on the terminal that downloading is complete). This can take up to 4 hours.

- Enter the following command to verify the card is operational and providing SCCP services.

```
rept-stat-sccp
```

The following is an example of the possible output.

```

RLGHNCXA03W 98-02-04 15:10:19 EST EAGLE 34.0.0
SCCP SUBSYSTEM REPORT IS-NR Active -----
GSM SUBSYSTEM REPORT IS-NR Active -----
INP SUBSYSTEM REPORT IS-ANR Restricted -----
 ASSUMING MATE'S LOAD
 INPQS: SSN STATUS = Allowed MATE SSN STATUS = Prohibited

SCCP Cards Configured= 4 Cards IS-NR= 2 Capacity Threshold = 100%
CARD VERSION PST SST AST MSU USAGE CPU USAGE

1212 103-001-000 IS-NR Active ALMINH 45% 30%
1301 P 103-001-000 IS-NR Active ----- 35% 40%
1305 ----- OOS-MT Isolated ----- 0% 0%
2112 ----- OOS-MT-DSBLD Manual ----- 0% 0%

SCCP Service Average MSU Capacity = 40% Average CPU Capacity = 35%

AVERAGE CPU USAGE PER SERVICE:
GTT = 15% GFLEX = 5% GPORT = 10%
INPMR = 2% INPQS = 3%

TOTAL SERVICE STATISTICS:
SERVICE SUCCESS ERRORS WARNINGS FORWARD TO GTT TOTAL
GTT: 1995 5 - - 2000
GFLEX: 500 1 4 10 515
GPORT: 800 0 2 3 805
INPMR: 50 5 0 15 70
INPQS: 499 1 - - 500

Command Completed.
```

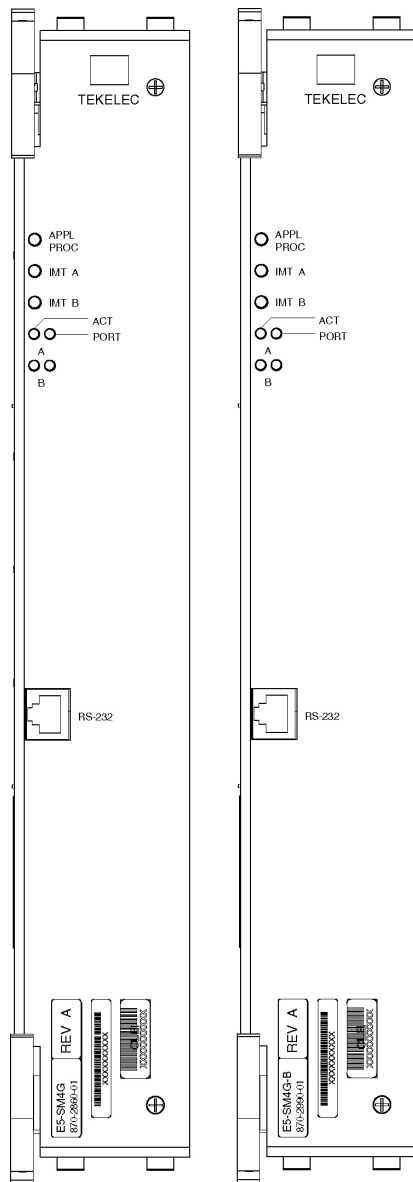

Figure 37: E5-SM4G/E5-SM8G-B LEDs

Front Faceplate LED Indicators

| LED       | Status | Description                               |
|-----------|--------|-------------------------------------------|
| APPL PROC | Off    | No power                                  |
|           | Red    | Card is booting                           |
|           | Amber  | Card is loading                           |
|           | Green  | Card is up and application is running     |
| IMT A     | Red    | Not connected to bus                      |
|           | Amber  | Testing not complete                      |
|           | Green  | Active and connected to the bus           |
| IMT B     | Red    | Not connected to bus                      |
|           | Amber  | Testing not complete                      |
|           | Green  | Active and connected to the bus           |
| ACT       | Off    | Card non-functional                       |
|           | Red    | No signal detected                        |
|           | Green  | Signal detected                           |
| PORT      | Off    | Card non-functional                       |
|           | Amber  | Data link active operating at 1 Gbps      |
|           | Green  | Data link active operating at 10/100 Mbps |

## E5-IPSM Card Replacement

The term E5-IPSM refers to either the E5-IPSM (P/N 870-2877-01) or to the E5-ENET-B (P/N 870-2971-xx) running IPS.

The E5-IPSM card is a single slot card having two Ethernet interfaces. E5-IPSM can be exchanged with IPSM cards running IPS, without any changes in provisioning information.

When command ENT-CARD is issued for IPSHC, the APPL parameter would be specified as IPS and TYPE would be specified as IPSM. The determination of actual GPL that needs to be loaded on the card is made by OAM based on the hardware board identification provided by the card itself.

1. Enter the following command to retrieve the terminal types and port numbers:

```
rtrv-trm
```

The following is an example of the possible display of the terminal settings with the IP User Interface feature enabled and three IPSM cards equipped.

```

rlghncxa03w 03-11-01 16:02:08 EST EAGLE 31.3.0
TRM TYPE COMM FC TMOUT MXINV DURAL
1 VT320 9600 -7-E-1 SW 0 5 00:01:00
2 VT320 9600 -7-E-1 SW 0 5 00:01:00
3 VT320 9600 -7-E-1 SW 0 5 00:01:00
4 KSR 9600 -7-E-1 SW 0 5 00:01:00
5 NONE 9600 -7-E-1 SW 30 5 00:01:00
6 NONE 9600 -7-E-1 SW 30 5 00:01:00
7 NONE 9600 -7-E-1 SW 30 5 00:01:00
8 NONE 9600 -7-E-1 SW 30 5 00:01:00
9 VT320 9600 -7-E-1 SW 0 5 00:01:00
10 VT320 9600 -7-E-1 SW 0 5 00:01:00
11 VT320 9600 -7-E-1 SW 0 5 00:01:00
12 KSR 9600 -7-E-1 SW 0 5 00:01:00
13 NONE 9600 -7-E-1 SW 30 5 00:01:00
14 NONE 9600 -7-E-1 SW 30 5 00:01:00
15 NONE 9600 -7-E-1 SW 30 5 00:01:00
16 NONE 9600 -7-E-1 SW 30 5 00:01:00

TRM TYPE LOC TMOUT MXINV DURAL
17 TELNET 1201 60 5 00:30:00
18 TELNET 1201 60 5 00:30:00
19 TELNET 1201 60 5 00:30:00
20 TELNET 1201 60 5 00:30:00
21 TELNET 1201 60 5 00:30:00
22 TELNET 1201 60 5 00:30:00
23 TELNET 1201 60 5 00:30:00
24 TELNET 1201 60 5 00:30:00
25 TELNET 1203 60 5 00:30:00
26 TELNET 1203 60 5 00:30:00
27 TELNET 1203 60 5 00:30:00
28 TELNET 1203 60 5 00:30:00
29 TELNET 1203 60 5 00:30:00
30 TELNET 1203 60 5 00:30:00
31 TELNET 1203 60 5 00:30:00
32 TELNET 1203 60 5 00:30:00
33 TELNET 1208 60 5 00:30:00
34 TELNET 1208 60 5 00:30:00
35 TELNET 1208 60 5 00:30:00
36 TELNET 1208 60 5 00:30:00
37 TELNET 1208 60 5 00:30:00
38 TELNET 1208 60 5 00:30:00
39 TELNET 1208 60 5 00:30:00
40 TELNET 1208 60 5 00:30:00

;

TRM TRAF LINK SA SYS PU DB DB SUB UIMRD
1 YES YES YES YES YES YES YES YES YES
2 YES YES YES YES YES YES YES YES YES
3 YES YES YES YES YES YES YES YES YES
4 YES YES YES YES NO YES YES YES YES
5 YES YES YES YES YES YES YES YES YES
6 NO YES YES YES YES YES YES YES YES

```

Maintenance

Card Removal/Replacement Procedures

|    |      |     |      |     |     |     |     |      |     |     |      |      |
|----|------|-----|------|-----|-----|-----|-----|------|-----|-----|------|------|
| 7  | NO   | YES | YES  | YES | YES | YES | YES | YES  | YES | YES | YES  | YES  |
| 8  | YES  | YES | YES  | YES | YES | YES | YES | YES  | YES | YES | YES  | YES  |
| 9  | YES  | YES | YES  | YES | YES | YES | YES | YES  | YES | YES | YES  | YES  |
| 10 | NO   | NO  | NO   | NO  | NO  | NO  | NO  | NO   | NO  | NO  | NO   | NO   |
| 11 | NO   | NO  | NO   | NO  | NO  | NO  | NO  | NO   | NO  | NO  | NO   | NO   |
| 12 | NO   | NO  | NO   | NO  | NO  | NO  | NO  | NO   | NO  | NO  | NO   | NO   |
| 13 | NO   | NO  | NO   | NO  | NO  | NO  | NO  | NO   | NO  | NO  | NO   | NO   |
| 14 | NO   | NO  | NO   | NO  | NO  | NO  | NO  | NO   | NO  | NO  | NO   | NO   |
| 15 | NO   | NO  | NO   | NO  | NO  | NO  | NO  | NO   | NO  | NO  | NO   | NO   |
| 16 | NO   | NO  | NO   | NO  | NO  | NO  | NO  | NO   | NO  | NO  | NO   | NO   |
| 17 | NO   | NO  | NO   | NO  | NO  | NO  | NO  | NO   | NO  | NO  | NO   | NO   |
| 18 | NO   | NO  | NO   | NO  | NO  | NO  | NO  | NO   | NO  | NO  | NO   | NO   |
| 19 | NO   | NO  | NO   | NO  | NO  | NO  | NO  | NO   | NO  | NO  | NO   | NO   |
| 20 | NO   | NO  | NO   | NO  | NO  | NO  | NO  | NO   | NO  | NO  | NO   | NO   |
| 21 | NO   | NO  | NO   | NO  | NO  | NO  | NO  | NO   | NO  | NO  | NO   | NO   |
| 22 | NO   | NO  | NO   | NO  | NO  | NO  | NO  | NO   | NO  | NO  | NO   | NO   |
| 23 | NO   | NO  | NO   | NO  | NO  | NO  | NO  | NO   | NO  | NO  | NO   | NO   |
| 24 | NO   | NO  | NO   | NO  | NO  | NO  | NO  | NO   | NO  | NO  | NO   | NO   |
| 25 | NO   | NO  | NO   | NO  | NO  | NO  | NO  | NO   | NO  | NO  | NO   | NO   |
| 26 | NO   | NO  | NO   | NO  | NO  | NO  | NO  | NO   | NO  | NO  | NO   | NO   |
| 27 | NO   | NO  | NO   | NO  | NO  | NO  | NO  | NO   | NO  | NO  | NO   | NO   |
| 28 | NO   | NO  | NO   | NO  | NO  | NO  | NO  | NO   | NO  | NO  | NO   | NO   |
| 29 | NO   | NO  | NO   | NO  | NO  | NO  | NO  | NO   | NO  | NO  | NO   | NO   |
| 30 | NO   | NO  | NO   | NO  | NO  | NO  | NO  | NO   | NO  | NO  | NO   | NO   |
| 31 | NO   | NO  | NO   | NO  | NO  | NO  | NO  | NO   | NO  | NO  | NO   | NO   |
| 32 | NO   | NO  | NO   | NO  | NO  | NO  | NO  | NO   | NO  | NO  | NO   | NO   |
| 33 | NO   | NO  | NO   | NO  | NO  | NO  | NO  | NO   | NO  | NO  | NO   | NO   |
| 34 | NO   | NO  | NO   | NO  | NO  | NO  | NO  | NO   | NO  | NO  | NO   | NO   |
| 35 | NO   | NO  | NO   | NO  | NO  | NO  | NO  | NO   | NO  | NO  | NO   | NO   |
| 36 | NO   | NO  | NO   | NO  | NO  | NO  | NO  | NO   | NO  | NO  | NO   | NO   |
| 37 | NO   | NO  | NO   | NO  | NO  | NO  | NO  | NO   | NO  | NO  | NO   | NO   |
| 38 | NO   | NO  | NO   | NO  | NO  | NO  | NO  | NO   | NO  | NO  | NO   | NO   |
| 39 | NO   | NO  | NO   | NO  | NO  | NO  | NO  | NO   | NO  | NO  | NO   | NO   |
| 40 | NO   | NO  | NO   | NO  | NO  | NO  | NO  | NO   | NO  | NO  | NO   | NO   |
|    | TRM  | APP | APP  |     |     |     |     |      |     |     |      |      |
|    | SERV | SS  | CARD | CLK | DBG | GTT | GWS | MEAS | MON | MPS | SEAS | SLAN |
| 1  | YES  | YES | YES  | YES | YES | YES | YES | YES  | YES | YES | NO   | NO   |
| 2  | YES  | YES | YES  | YES | YES | YES | YES | YES  | YES | YES | NO   | NO   |
| 3  | YES  | YES | YES  | YES | YES | YES | YES | YES  | YES | YES | NO   | NO   |
| 4  | YES  | YES | YES  | YES | YES | NO  | YES | YES  | YES | YES | NO   | NO   |
| 5  | YES  | YES | YES  | YES | YES | YES | YES | YES  | YES | YES | NO   | NO   |
| 6  | YES  | YES | YES  | YES | YES | YES | YES | YES  | YES | YES | NO   | NO   |
| 7  | NO   | YES | YES  | YES | YES | YES | YES | YES  | YES | YES | NO   | NO   |
| 8  | YES  | YES | YES  | YES | YES | YES | YES | YES  | YES | YES | YES  | YES  |
| 9  | YES  | YES | YES  | YES | YES | YES | YES | YES  | YES | YES | YES  | YES  |
| 10 | NO   | NO  | NO   | NO  | NO  | NO  | NO  | NO   | NO  | NO  | NO   | NO   |
| 11 | NO   | NO  | NO   | NO  | NO  | NO  | NO  | NO   | NO  | NO  | NO   | NO   |
| 12 | NO   | NO  | NO   | NO  | NO  | NO  | NO  | NO   | NO  | NO  | NO   | NO   |
| 13 | NO   | NO  | NO   | NO  | NO  | NO  | NO  | NO   | NO  | NO  | NO   | NO   |
| 14 | NO   | NO  | NO   | NO  | NO  | NO  | NO  | NO   | NO  | NO  | NO   | NO   |
| 15 | NO   | NO  | NO   | NO  | NO  | NO  | NO  | NO   | NO  | NO  | NO   | NO   |
| 16 | NO   | NO  | NO   | NO  | NO  | NO  | NO  | NO   | NO  | NO  | NO   | NO   |
| 17 | NO   | NO  | NO   | NO  | NO  | NO  | NO  | NO   | NO  | NO  | NO   | NO   |
| 18 | NO   | NO  | NO   | NO  | NO  | NO  | NO  | NO   | NO  | NO  | NO   | NO   |
| 19 | NO   | NO  | NO   | NO  | NO  | NO  | NO  | NO   | NO  | NO  | NO   | NO   |
| 20 | NO   | NO  | NO   | NO  | NO  | NO  | NO  | NO   | NO  | NO  | NO   | NO   |
| 21 | NO   | NO  | NO   | NO  | NO  | NO  | NO  | NO   | NO  | NO  | NO   | NO   |
| 22 | NO   | NO  | NO   | NO  | NO  | NO  | NO  | NO   | NO  | NO  | NO   | NO   |
| 23 | NO   | NO  | NO   | NO  | NO  | NO  | NO  | NO   | NO  | NO  | NO   | NO   |
| 24 | NO   | NO  | NO   | NO  | NO  | NO  | NO  | NO   | NO  | NO  | NO   | NO   |
| 25 | NO   | NO  | NO   | NO  | NO  | NO  | NO  | NO   | NO  | NO  | NO   | NO   |
| 26 | NO   | NO  | NO   | NO  | NO  | NO  | NO  | NO   | NO  | NO  | NO   | NO   |
| 27 | NO   | NO  | NO   | NO  | NO  | NO  | NO  | NO   | NO  | NO  | NO   | NO   |

```

28 NO NO NO NO NO NO NO NO NO NO NO NO NO
29 NO NO NO NO NO NO NO NO NO NO NO NO NO
30 NO NO NO NO NO NO NO NO NO NO NO NO NO
31 NO NO NO NO NO NO NO NO NO NO NO NO NO
32 NO NO NO NO NO NO NO NO NO NO NO NO NO
33 NO NO NO NO NO NO NO NO NO NO NO NO NO
34 NO NO NO NO NO NO NO NO NO NO NO NO NO
35 NO NO NO NO NO NO NO NO NO NO NO NO NO
36 NO NO NO NO NO NO NO NO NO NO NO NO NO
37 NO NO NO NO NO NO NO NO NO NO NO NO NO
38 NO NO NO NO NO NO NO NO NO NO NO NO NO
39 NO NO NO NO NO NO NO NO NO NO NO NO NO
40 NO NO NO NO NO NO NO NO NO NO NO NO NO
;

```

2. Enter the following command to change the state of the appropriate card to the out of service - maintenance disabled state:

```
inh-card:loc=xxxx:force=yes
```

where *xxxx* is the card location stenciled on the shelf of the EAGLE 5 ISS. Following is an example of the output:

```

RLGHNCXA03W 00-06-05 11:11:28 EDT EAGLE 34.0.0
Card has been inhibited.

```

3. Remove and replace the card as described in the section titled, [Replacing a Card in the EAGLE 5 ISS](#).
4. Enter the following command to load and activate the approved GPL onto the inhibited card:

```
flash-card:code=appr:loc=xxxx:force=yes
```

where *xxxx* is the card location used in the previous step. The optional *force=yes* is used to force the command to work on an IS-NR card. Links provisioned on the card are inhibited during command execution. The card and inhibited links are restored to their previous state when the command is completed

Following is an example of the possible output using card location 1201:

```

tekelecstp 05-04-11 01:52:11 EST EAGLE5 34.0.0
Flash Card: Downloading BLDIAG on card 1201.
;
tekelecstp 05-04-11 01:52:11 EST EAGLE5 34.0.0
Flash Card: Card 1201 download BLDIAG complete.
;
tekelecstp 05-04-11 01:52:11 EST EAGLE5 34.0.0
Flash Card: Downloading IMTPCI on card 1201.
;
tekelecstp 05-04-11 01:52:11 EST EAGLE5 34.0.0
Flash Card: Card 1201 download IMTPCI complete.
;
tekelecstp 05-04-11 01:52:11 EST EAGLE5 34.0.0
Flash Card: Downloading BLVXW on card 1201.
;
tekelecstp 05-04-11 01:52:11 EST EAGLE5 34.0.0
Flash Card: Card 1201 download BLVXW complete.
;
tekelecstp 05-04-11 01:52:11 EST EAGLE5 34.0.0
Flash Card: Activating BLDIAG on card 1201.
;

```

```

tekelecstp 05-04-11 01:52:11 EST EAGLE5 34.0.0
Flash Card: Card 1201 activation BLDIAG complete.

tekelecstp 05-04-11 01:52:11 EST EAGLE5 34.0.0
Flash Card: Activating IMTPCI on card 1201.
;
tekelecstp 05-04-11 01:52:11 EST EAGLE5 34.0.0
Flash Card: Card 1201 activation IMTPCI complete.
;
tekelecstp 05-04-11 01:52:11 EST EAGLE5 34.0.0
Flash Card: Activating BLVXW on card 1201.
;
tekelecstp 05-04-11 01:52:11 EST EAGLE5 34.0.0
Flash Card: Card 1201 activation BLVXW complete.
;
tekelecstp 05-04-11 01:52:11 EST EAGLE5 34.0.0
Flash Card: Downloading BLCPLD on card 1201.
;
tekelecstp 05-04-11 01:52:11 EST EAGLE5 34.0.0
Flash Card: Card 1201 download BLCPLD complete.
;
tekelecstp 05-04-11 01:52:11 EST EAGLE5 34.0.0
Flash Card: Activating BLCPLD on card 1201.
;
tekelecstp 05-04-11 01:52:11 EST EAGLE5 34.0.0
Flash Card: Card 12015 activation BLCPLD complete.
;
tekelecstp 05-04-11 01:52:11 EST EAGLE5 34.0.0
Command Completed.
;
tekelecstp 05-04-11 01:52:11 EST EAGLE5 34.0.0
Flash Card: Canceling links on card 1201.
;
tekelecstp 05-04-11 01:52:11 EST EAGLE5 34.0.0
Flash Card: Inhibiting card 1201.
;
tekelecstp 05-04-11 01:52:11 EST EAGLE5 Rel 34.0.0
Flash Card: Downloading BLBEPM on card 1201.
;
tekelecstp 05-04-11 01:52:11 EST EAGLE5 34.0.0
Flash Card: Card 1201 download BLBEPM complete.
;
tekelecstp 05-04-11 01:52:11 EST EAGLE5 34.0.0
Flash Card: Allowing card 1201.
;
tekelecstp 05-04-11 01:52:11 EST EAGLE5 34.0.0
Flash Card: Activating BLBEPM on card 1201.
;
tekelecstp 05-04-11 01:52:11 EST EAGLE5 34.0.0
Flash Card: Card 1201 activation BLBEPM complete.
;
tekelecstp 05-04-11 01:52:11 EST EAGLE5 34.0.0
Flash Card: Activating links on card 1201.
;
tekelecstp 05-04-11 01:52:11 EST EAGLE5 34.0.0
Command Completed.
;

```

5. After the card has been reloaded (a message appears to confirm completion of the load), enter the following command to verify the database is consistent (same level as the other cards in the system).

```
rept-stat-card
```



The following is an example of the possible output.

```
tekelecstp 07-02-25 10:02:42 EST EAGLE 37.0.0
CARD VERSION TYPE GPL PST SST AST
1201 128-013-026 IPSP IPS IS-NR Active -----
ALARM STATUS = No Alarms.
BPDCM GPL version = 128-013-012
IMT BUS A = Conn
IMT BUS B = Conn

Command Completed.
```

## Database Communications Module (DCM) and EDCM/EDCM-A

The database communication module (DCM) ([Figure 38: DCM LEDs](#)) provides access to a remote host for use by the STP LAN feature. The DCM consists of a 80486-based main assembly and an ethernet applique. Connection to a host is achieved through an ethernet LAN using the TCP/IP protocol.

If this card is removed, the TCP/IP data link supported by this card becomes out of service. Any data to be transmitted to the remote TCP/IP host connected by this TCP/IP data link is lost.

The DCM can only be inserted in the odd numbered card slots of the shelf. Slot 09 of each shelf contains the IPMX card; thus the DCM cannot be inserted in slot 09. The DCM can be inserted in the control shelf, but only in slots 01, 03, 05, 07, and 11. Slots 13, 15, and 17 refer to the extension shelf only. The DCM occupies two card slots, so the even numbered card slot adjacent to the odd numbered slot where the DCM has been inserted must be empty as shown in [Table 29: DCM Card Locations](#). The DCM is connected to the network through the odd numbered card slot connector.

**Table 29: DCM Card Locations**

| Location of the DCM | Empty Card Location | Location of the DCM | Empty Card Location |
|---------------------|---------------------|---------------------|---------------------|
| Slot 01             | Slot 02             | Slot 11             | Slot 12             |
| Slot 03             | Slot 04             | Slot 13             | Slot 14             |
| Slot 05             | Slot 06             | Slot 15             | Slot 16             |
| Slot 07             | Slot 08             | Slot 17             | Slot 18             |

The Double-Slot Enhanced Database Communications Module is a version of the DCM that includes more main memory and better processing performance. The double-slot EDCM/EDCM-A can be placed in any slot odd or even that is provisioned. Physically the next higher slot can not be provisioned for a card because of the double-slot EDCM/EDCM-A card width.

The Single-Slot EDCM-A ([Figure 39: EDCM-A Single-Slot LEDs](#)) is a version of the EDCM which requires only a single frame slot. It can be placed in any slot, odd or even, which has been provisioned for DCM. Otherwise it duplicates the performance of the Double-Slot EDCM/EDCM-A.

1. Enter the following command to determine what TCP/IP data links are configured: `rept-stat-card`

2. Enter the following command to determine the status of the TCP/IP data link assigned to the card to be replaced: `rept-stat-dlk`

The following is an example of the possible output.

```

RLGHNCXA03W 97-09-27 17:00:36 EST EAGLE 34.0.0
DLK PST SST AST
1104 IS-NR Avail ----
1206 IS-NR Avail ALMINH
Command Completed.

```

3. If the status of the TCP/IP data link is not out of service - maintenance disabled (OOS-MT-DSBLD), use the `canc-dlk` command to change the status of the TCP/IP data link to OOS-MT-DSBLD. `canc-dlk:loc=xxxx`  
Where `xxxx` is the card location.
4. Enter the following command to inhibit the card and disconnect it from the IMT bus.  
If this is the last DCM in the system, the `:force=yes` parameter must be used with this command. `rmv-card:loc=xxxx` Where `xxxx` is the card location.
5. Remove the DCM, per the card replacement procedure described in the section titled [Replacing a Card in the EAGLE 5 ISS](#).  
Place the new DCM into its place. Be sure the revision numbers are compatible (if in doubt, contact the [My Oracle Support \(MOS\)](#)).
6. Enter the following command to put the new DCM card back into service and connect it to the IMT bus: `rst-card:loc=xxxx`  
where `xxxx` = card location.
7. Enter the following command to return the TCP/IP data link to service: `act-dlk:loc=xxxx`  
where `xxxx` = card location.
8. Enter the following command to verify the status of the card and its associated TCP/IP data link: `rept-stat-card`
9. Enter the following command to verify that the TCP/IP data link has returned to full service: `rept-stat-dlk`

The following is an example of the possible output.

```

RLGHNCXA03W 97-09-27 17:00:36 EST EAGLE 34.0.0
DLK PST SST AST
1104 IS-NR Avail ----
1206 IS-NR Avail ALMINH
Command Completed.

```

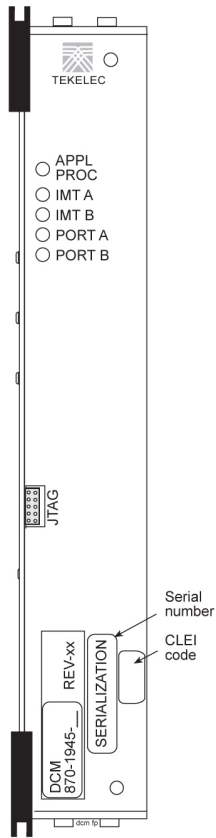

| LEDs      | Descriptions                                                    |
|-----------|-----------------------------------------------------------------|
| APPL PROC | RED – Critical alarm condition detected.<br>GREEN – No alarm    |
| IMT A     | RED – Major alarm condition detected.<br>GREEN – No alarm       |
| IMT B     | AMBER – Minor alarm condition detected.<br>GREEN – No alarm     |
| PORT A    | GREEN – PORT A is the active PORT.<br>RED – PORT A is inactive  |
| PORT B    | GREEN – PORT B is the active PORT.<br>RED – PORT B is inactive. |

Figure 38: DCM LEDs

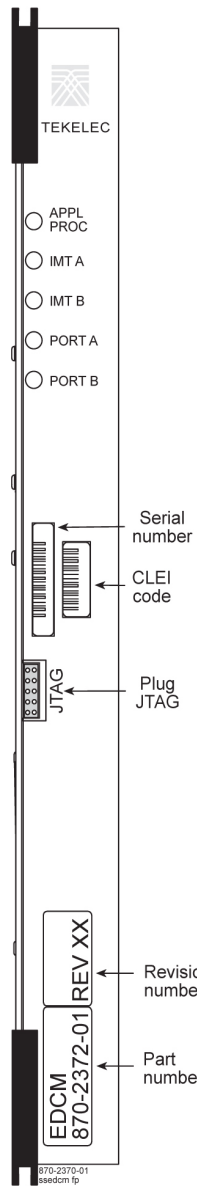

| LEDs      | Descriptions                                                    |
|-----------|-----------------------------------------------------------------|
| APPL PROC | RED – Critical alarm condition detected.<br>GREEN – No alarm    |
| IMT A     | RED – Major alarm condition detected.<br>GREEN – No alarm       |
| IMT B     | AMBER – Minor alarm condition detected.<br>GREEN – No alarm     |
| PORT A    | GREEN – PORT A is the active PORT.<br>RED – PORT A is inactive  |
| PORT B    | GREEN – PORT B is the active PORT.<br>RED – PORT B is inactive. |

Figure 39: EDCM-A Single-Slot LEDs

## Measurement Collection and Polling Module (MCPM)

**Note:** Throughout this document, the term MCPM refers to either the E5-MCPM-B (P/N 870-3089-xx) or the EDSM-2G loaded with the MCPM application (P/N 870-2372-03) cards unless specifically noted otherwise.

The primary MCPM card performs all measurements collection and reporting functions and provides on-card RAM storage for collected data and scheduled reports. The Secondary MCPM provides a redundant backup for the Primary card, and assumes collection and reporting responsibilities on the

loss of the Primary. TCP/IP connections are used to deliver measurement reports from the Primary MCPM card to the customer via an FTP client. The FTP configuration can be customized to support automatic transfer of scheduled reports from the client to the server.

1. Enter the following command to determine the status of the MCPM cards.

```
rept-stat-meas
```

2. Enter the following command to remove the faulty MCPM card from service.

If this is the last MCPM card in service, the `:force=yes` parameter must be specified:

```
rmv-card:loc=xxxx
```

where `xxxx` is the MCPM card location.

3. Remove the MCPM card, per the card replacement procedure described in the section titled [Replacing a Card in the EAGLE 5 ISS](#).

Place the new MCPM card into its place. Be sure the revision numbers are compatible (if in doubt, [My Oracle Support \(MOS\)](#)).

4. Enter the following command to return the MCPM card into service.

```
rst-card:loc=xxxx
```

Where `xxxx` is the MCPM card location.

This causes the MASP to begin downloading tables to the new MCPM card. When the card has been successfully loaded (there will be a response on the terminal that downloading is complete). This can take up to 10 minutes.

**Note:** If the card has not loaded in 30 minutes, enter the `init-card` command to re-boot the MCPM card.

5. Enter the following command to verify the card is operational: .

```
rept-stat-meas
```

## Replacing a Card in the EAGLE 5 ISS

This procedure describes the physical removal and replacement of a card in the EAGLE 5 ISS system.

**Note:** Before removing or reseating a card, the card must be taken out of service.

Card replacement procedures in this section refer to this procedure. Locate and perform the appropriate replacement procedure for the card in order to properly take the card out of service.



**Warning:** Failure to follow appropriate removal procedures may result in equipment damage.



**Warning:** Before performing any maintenance procedures on the EAGLE 5 ISS, make sure you wear a wrist strap connected to the wrist strap grounding point of the EAGLE 5 ISS.



**Warning:** This procedure may interrupt service. When possible, perform maintenance during low traffic and database provisioning periods, such as the maintenance window.

1. Locate the card to be removed.
2. Use both hands to open injector/ejector module locking tabs out from the faceplate of the card. Push the inject/eject clamps outward from the card's faceplate (top clamp in the "UP" position, bottom clamp in the "DOWN" position). Pull the levers away from the shelf until they are parallel to the floor. Gently pull the card towards you until the card clears the shelf.

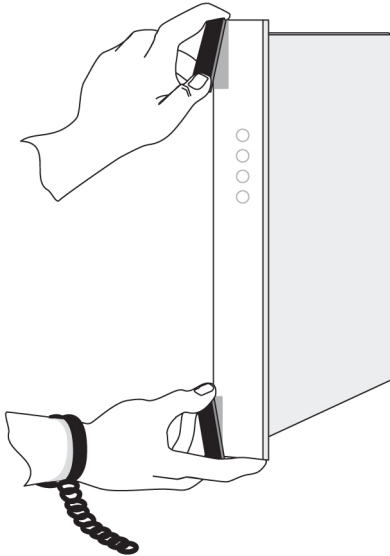

**Figure 40: Push Inject/Eject Clamps Outward**

3. Place the card you have removed in an electrostatic discharge (ESD) protective container, or place the card in the spare card storage shelf.
4. Be sure that the replacement card has the same Tekelec part number and revision number as the card you have just removed (unless this is an upgrade).
5. Open the ejector levers on the replacement card. Carefully align the card's edges with the top and bottom card guides. Then push the card along the length of the card guides until the rear connectors on the card engage the mating connectors on the target shelf backplane.
6. Press the left edge of the card's faceplate using constant pressure until you feel the card's progress cease. To ensure proper seating, the tabs must be held in the release position until the locking tabs can engage with the upper and lower flange on the shelf.



**Warning:** Do not impact the faceplate in order to mate the connectors. Any impact to the card's faceplate can damage the faceplate, the pins, or the connectors.

7. Push in the top and bottom inject/eject clamps.

This locks the card in place and ensures a strong connection with the pins on the target shelf backplane.

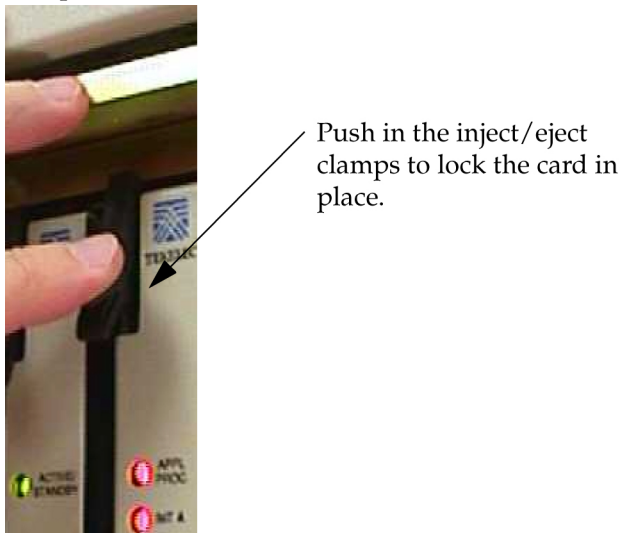

**Figure 41: Push in Inject/Eject Clamps**

8. Verify that both IMT bus LEDs are green.
9. Record the activity in the site maintenance log.
10. Return to the appropriate card removal/replacement procedure to return the card to service (such as initializing, flashing, and allowing).

**Note:** If any UAMs are generated in the system after the card comes into service, refer to the *Maintenance Manual* to find the recommended steps in diagnosing and clearing the UAM.

## Replacing Cards in the Holdover Clock

### Failed Clock Input (CI) Card Replacement

#### Description

Use this procedure to replace a failed clock input (CI) card in shelves equipped with ST3 clock cards. The input card FAIL lamp should be lit.

1. If the shelf is equipped with ST3 cards and the input card FAIL lamp is not lit, check the status of the SRCACT/SRCACTIVE lamp.  
If lit, press the transfer (XFR) button on either input card. If the input card FAIL lamp is lit, go to [Step 2](#). The SRCACT/SRCACTIVE lamp on the other input card lights and the lamp goes off.
2. Remove the failed card or the card to be removed from the shelf.
3. Set the option switches on the replacement card to the correct settings.  
(See the *Installation Manual*.) Wait for the input card to acquire the input reference signal (about 40 seconds). Then, press the XFR button to make the new input card active.

#### CI, Clock Interface Card, Holdover Clock

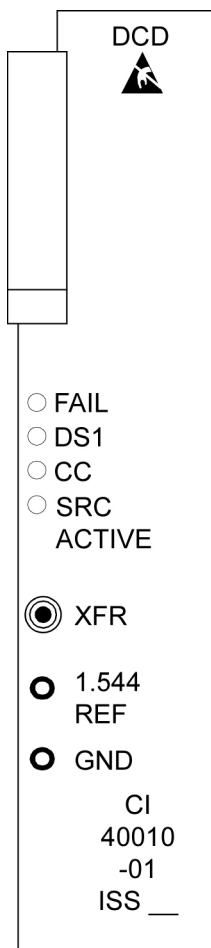

| LEDs       | Descriptions                                                                                                                                         |
|------------|------------------------------------------------------------------------------------------------------------------------------------------------------|
| FAIL       | RED - this card or its input has failed. The card's output is disabled and a minor alarm is generated.<br>BLANK - no card or input failure detected. |
| DS1        | GREEN - DS1 source is present.<br>BLANK - DS1 source is not present.                                                                                 |
| CC         | GREEN - CC (composite clock) source is present.<br>BLANK - CC source is not present.                                                                 |
| SRC ACTIVE | GREEN - the card is on-line providing a DCD reference to ST3 and output cards.<br>BLANK - card is in standby mode.                                   |

Figure 42: Holdover Clock CI Card LEDs

### Non-Failed Clock Input (CI) Card Replacement

#### Description

Use this procedure to replace non-failed clock input (CI) cards which have valid input reference signals.

1. Remove the input reference signal to the shelf associated with the clock input card to be removed.



**Caution:** Removing a non-failed clock input card with a valid input reference signal from a shelf equipped with ST3 cards, causes the DCD system outputs to run and hit all the network elements timed from the DCD system. To properly remove a non-failed clock input card, the input reference must be removed first. This squelches the CI card output. This does not apply to failed input cards.

Perform one of the following:

- a) If the reference input has a miscellaneous SYNC jack at the DSX-1, insert an open plug or the end of a patch card in the SYNC jack to squelch the input reference signal. If the input reference has an external bridging repeater, insert an open plug or the end of a patch cord in the OUT jack at the bridging repeater to squelch the input reference signal.



- b) If the input reference signal is directly cabled from the source to the DCD shelf, either lift the leads of the TB12 or TB13 wire-wrap terminals on the backplane of the DCD shelf, or short the tip (T) and ring (R) together at TB12 or TB13 on the backplane.



**Caution:** Use a clip cord that is no longer than two inches. A longer clip cord may not appear as a short to the CI card and the input reference may continue to drive it.

The DS1 lamp should be off and the FAIL lamp lit on the CI card. If this is not true, do not proceed. This indicates the input reference has not been removed.

2. Remove the CI card.  
This has no effect on the outputs.
3. Set the option switches on the replacement card to the correct settings.  
(See the *Installation Manual*.) The DS1 lamp should be off and the FAIL lamp lit on the CI card.
4. Restore the input reference by removing the open plug, clip cord, or reconnecting the leads to TB12 or TB13 wire-wrap terminals on the DCD shelf backplane.
5. Wait for the input card to acquire the input reference signal (about 40 seconds).  
If you want the new CI card to be active, press the XFR button.

## ST3 Card Replacement

### Description

Use this procedure to replace ST3 cards. The only time an ST3 card should be replaced is if the FAIL lamp is lit, or if it is in the ST A slot and the LOCK or LOCK and FAIL lamps are not lit and the network elements receiving timing from the shelf are reporting slips. (However, the second condition is more likely a timing loop rather than a bad ST3 card.)

**Note:** The ST3 card in slot B (ST B) in shelves equipped with ST3 clock cards may be removed from the shelf without any negative effect to the output, regardless if the ST3 has failed. If an ST3 is installed and not failed in slot A (ST A), it is the preferred source for the output cards. If you remove the card from the shelf, it may cause a hit to the outputs.

1. Remove the ST3 card from the shelf.  
If it is in slot A and has not failed, the ST B clock card automatically become the preferred source for the outputs. The TO cards ST and INPUT lamps should remain green.  
**Note:** There may be a one-time phase hit to the outputs. If ST A has failed, the ST B clock card is already the preferred source for the outputs. If ST B is being replaced, it is in standby and may be removed without negative effect to the outputs.
2. Insert the replacement card in the shelf.  
Lock it into place by rotating the locking lever downward. The FAIL lamp should remain lit until it has acquired the frequency and phase of the input reference signal and then go off (about one minute). If ST A is being replaced, it automatically becomes the preferred source for the output when the FAIL and LOCK lamps go off. The TO cards ST and INPUT lamps should remain lit.  
**Note:** If you are replacing both ST3 cards, allow five minutes for the first card to stabilize before replacing the other.

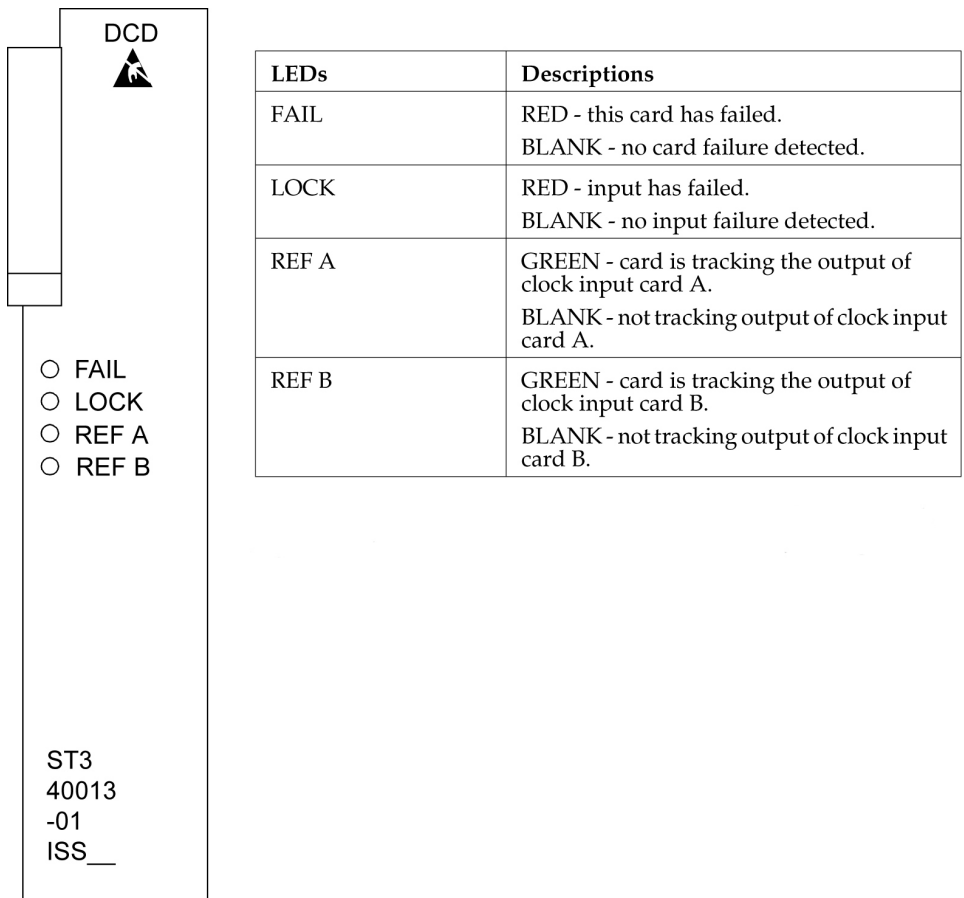

Figure 43: Holdover clock ST3 card LEDs

**Note:** If the FAIL and LOCK LEDs are both illuminated, the ST3 is in holdover mode and the card has not failed.

## MIS Card Replacement

### Description

The Maintenance Interface System (MIS) card may be removed or inserted into the shelf at any time without a negative effect to the operation of the shelf. The office alarms and shelf status (except for the battery alarm) do not function while the MIS card is removed from the shelf.

1. Remove the MIS card from the shelf.
2. Insert the replacement card.

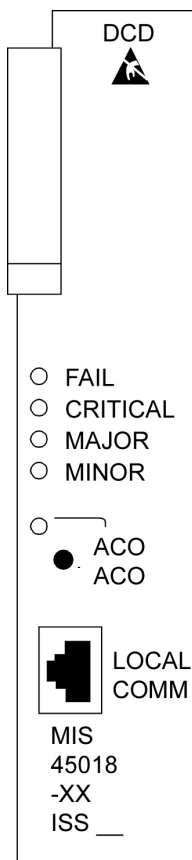

| LEDs     | Descriptions                                                                                                     |
|----------|------------------------------------------------------------------------------------------------------------------|
| FAIL     | RED - this card or its power supply has failed.<br>BLANK - no card or power supply failure detected.             |
| CRITICAL | RED - holdover clock system has failed.<br>BLANK - no holdover clock system failure detected.                    |
| MAJOR    | RED - holdover clock system or any holdover clock card has a major alarm.<br>BLANK - no major alarm detected.    |
| MINOR    | YELLOW - holdover clock system or any holdover clock card has a minor alarm.<br>BLANK - no minor alarm detected. |
| ACO      | GREEN - the ACO push button has been pressed to silence the alarm during an alarm state.                         |

Figure 44: Holdover Clock MIS Card LEDs

### TOCA Card Replacement

When an MCA-5 is installed in the MCA slot, an HS protection switch automatically activates when the TOFAIL or PORTALM lamp is lit. If the TOPORTALM lamp is lit, you must determine whether it is actually a card port failure, or a shorted or unterminated cable external to the shelf. If you determine that the PORTALM is actually a port failure on the card, replace the TO card.

1. Verify that an HS protection switch has been activated.  
If an automatic protection switch has been activated, the output protection button lamps are lit over the failed card and HSTO card. The MCA-5 AUTO lamp flashes for 6 seconds during the automatic protection switch activation, and then lights steadily.
2. If an HS protection is not activated, manually activate a switch by simultaneously pressing the output protection buttons over the TO card with FAIL or PORTALM lamp lit and a like HSTO card.

The output protection button lamps should light over the failed TO card and a like HSTO card, and the MCA-5 MAN lamp flashes until the switch is released.



**Caution:** The TO cards must not be removed without first activating an HS protection switch to minimize the loss of output signals. The possible output loss times are as follows:

- a) TO card removal: up to 6 seconds
  - b) Port or card failure: up to 3 seconds
  - c) Manual switch activation/deactivation: approximately one ms.
3. Remove the TO card from the shelf.
- Set the option switches on the replacement card to the correct settings. Insert the replacement card. The FAIL lamp on the replacement card should remain off and the INPUT lamp should light. The ST lamp should also light if the system is equipped with clock cards.
4. Wait 10 seconds after all the lamps normalize to allow the card to warm-up and generate outputs.
5. Press the lit output protection button for the HSTO card slot until the lamp goes out. The lamp over the output protection button should go off. This releases the HS protection switch and puts the replacement card online.

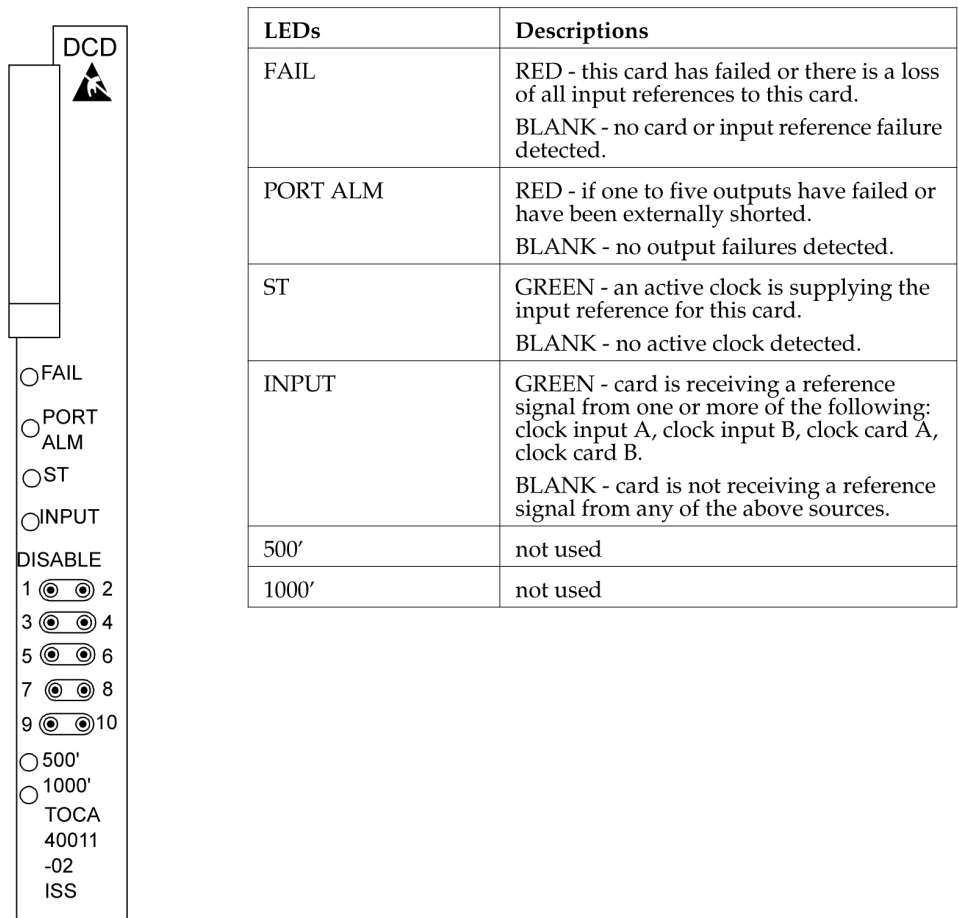
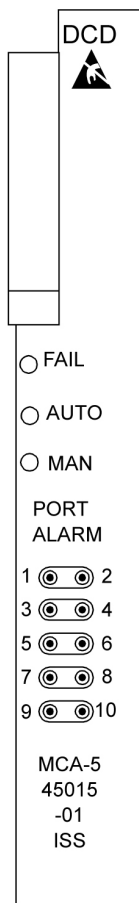

Figure 45: Holdover Clock TOCA Card LEDs



| LEDs | Descriptions                                                                                                                                |
|------|---------------------------------------------------------------------------------------------------------------------------------------------|
| FAIL | RED - this card has failed or there is a loss of all input references to this card.<br>BLANK - no card or input reference failure detected. |
| AUTO | GREEN - indicates output failure was protected automatically.<br>BLANK - no failures detected.                                              |
| MAN  | GREEN - indicates output failure was protected manually.<br>BLANK - no failures detected.                                                   |

Figure 46: Holdover Clock MCA Card LEDs

## Fan Assembly P/N 890-0001-xx

The Fan Assembly P/N 890-0001-xx is used for cooling shelves in the EAGLE frame. The assembly includes 3 fan units and a controller card.



### CAUTION

**Caution:** Do not perform procedures to [Replace Fan Assembly](#) if the Fan Assembly is used to cool shelves with HCMIM or HIPR cards. contact the [My Oracle Support \(MOS\)](#).

Refer to the following procedures to:

- [Replace the Fan Unit](#)
- [Replace Fan Controller Card](#)
- [Replace Fan Assembly](#)

## Replace the Fan Unit



**Caution:** Be careful when removing fans. Fan blades are exposed along the sides and back of the units. The fan blade speeds of remaining fans will increase after any fan is removed.

1. Loosen the two captive screws used to secure the fan to be replaced.  
Fan 1 is located next to the Fan controller card. .

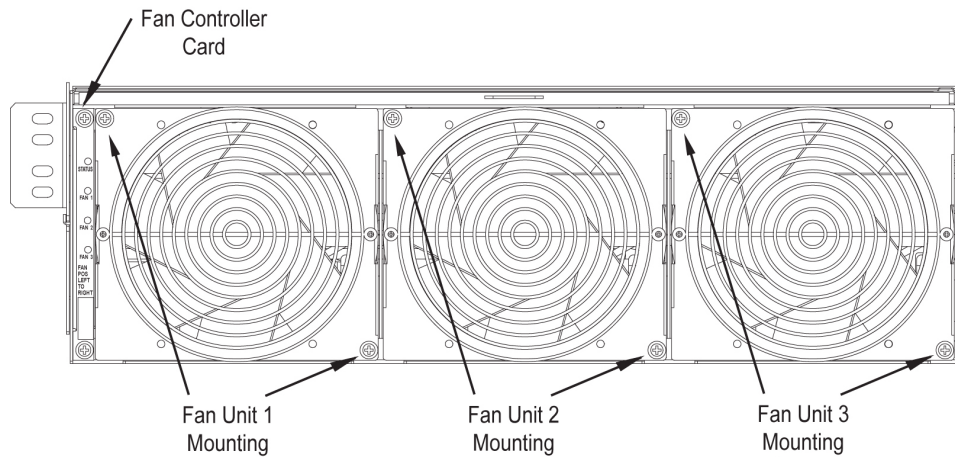

**Figure 47: Fan Unit Mounting Screws**

2. Firmly grasp the fan and pull straight out.  
The corresponding LED on the fan controller card is now red.
3. Insert the replacement fan into the appropriate slot and secure the two captive screws.  
The replaced fan should immediately come up to speed and the speeds of other fans should return to normal. The corresponding LED on the fan controller card is now green.

## Replace Fan Controller Card

1. Remove Fan 1 by removing the two captive screws used to secure Fan 1 (Refer to [Replace Fan Assembly](#)).



**Caution:** Be careful when removing fans. Fan blades are exposed along the sides and back of the units. The fan blade speeds of Fan 2 and FAN 3 will increase after FAN 1 is removed.

Fan 1 is located next to the Fan card. Firmly grasp Fan 1 and pull straight out.

2. Remove the fan controller card by removing the two captive screws used to secure the fan controller card.  
Remove Fan Controller Card by pulling straight out.
3. Insert the replacement fan controller card into the appropriate slot and secure the two captive screws.

4. Insert Fan 1 back into the space next to the fan controller card and secure (finger tighten) using the two captive screws.  
Fan 1 should immediately come up to speed and the speeds of Fans 2 and 3 should return to normal.

## Replace Fan Assembly



**Caution:** Do not perform this procedures if the Fan Assembly is used to cool shelves with HCMIM or HIPR cards. contact the Customer Care Center.

The following procedures are used to replace Fan Assembly P/N 890-0001-xx when it is used to cool shelves not populated with HCMIM or HIPR cards.

- [Procedure - Power Down the Fan Assembly](#)
- [Procedure - Remove Fan Cables and Fan Assembly](#)
- [Procedure - Install the Fan Assembly](#)
- [Procedure - Power Up the Fan Assembly](#)

### Procedure - Power Down the Fan Assembly

Use the following procedure to power down the fan assembly.

1. The fuse card located on the Fuse and Alarm Panel is marked FAN A and FAN B. Fuse positions 6, 12, and 18 are the correct locations on the FAP faceplate. The fans are fused at 3As, with blue flags per feed. Remove the appropriate fuse for the fan assembly being replaced according to the following:
  - Fuse position 6 is for the fan unit directly below the x100 shelf.
  - Fuse position 12 is for the fan directly below the x200 shelf.
  - Fuse position 18 is for the fan directly below the x300 shelf.
2. When both the A side and B side power is removed from the fan unit, all of the LEDs on the fan controller card (located on the left side of the front of the fan unit) are no longer illuminated and the all fan motors are off.

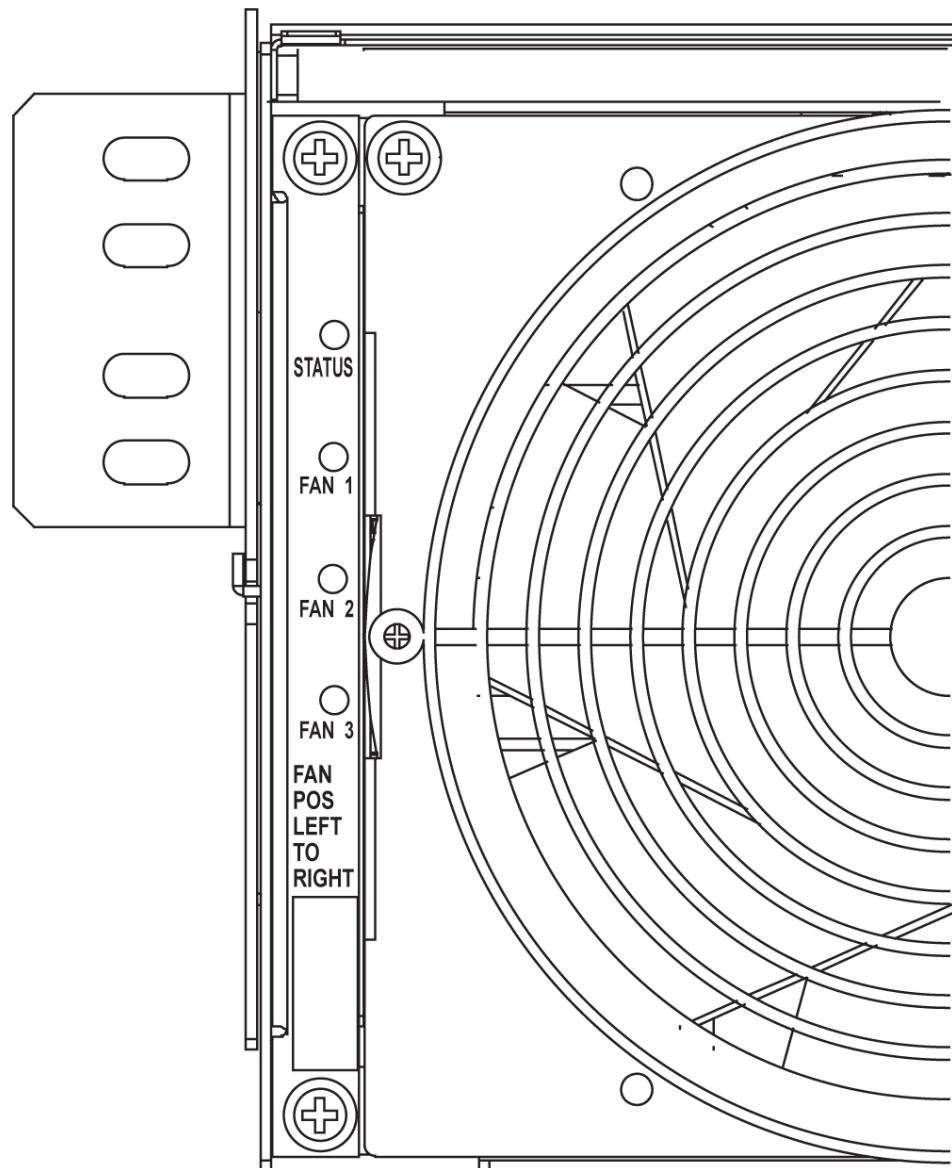

Figure 48: Fan card with LEDs on front of fan assembly unit

### Procedure - Remove Fan Cables and Fan Assembly

Use the following procedure to remove fan cables and fan assembly.

1. At the fan assembly, place fiber paper on the shelf below where the fan is to be replaced. This ensures that nothing drops into the area or equipment below.
2. From the front of the frame remove the fan filter from the fan assembly.
3. From the rear of the fan unit, loosen the screws on the fan unit connector marked FAN A POWER. Remove the connector from the fan unit.
4. From the rear of the fan unit, loosen the screws on the fan unit connector marked FAN B POWER. Remove the connector from the fan unit.



- Remove the screws from the the left and right sides of the rear of the fan tray bracket. There are two screws on each side. These screws must be removed from the rear of the frame.

Screws to be removed. Note: total of 4, 2 on each side

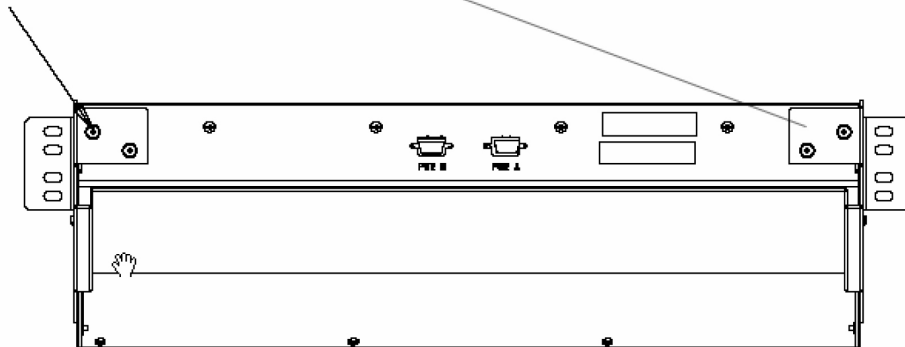

**Figure 49: Fan Assembly Rear Bracket Screws.**

- With the screws removed, carefully push on the rear of the unit until the fan assembly moves forward about an inch.
- From the front of the frame remove the fan assembly from the the fan bracket. For easier removal, tilt the unit as it is removed.

### Procedure - Install the Fan Assembly

Use the following procedure to install the fan assembly.

- Remove the new fan unit from the container. The fan unit is shipped with the three fans already installed.

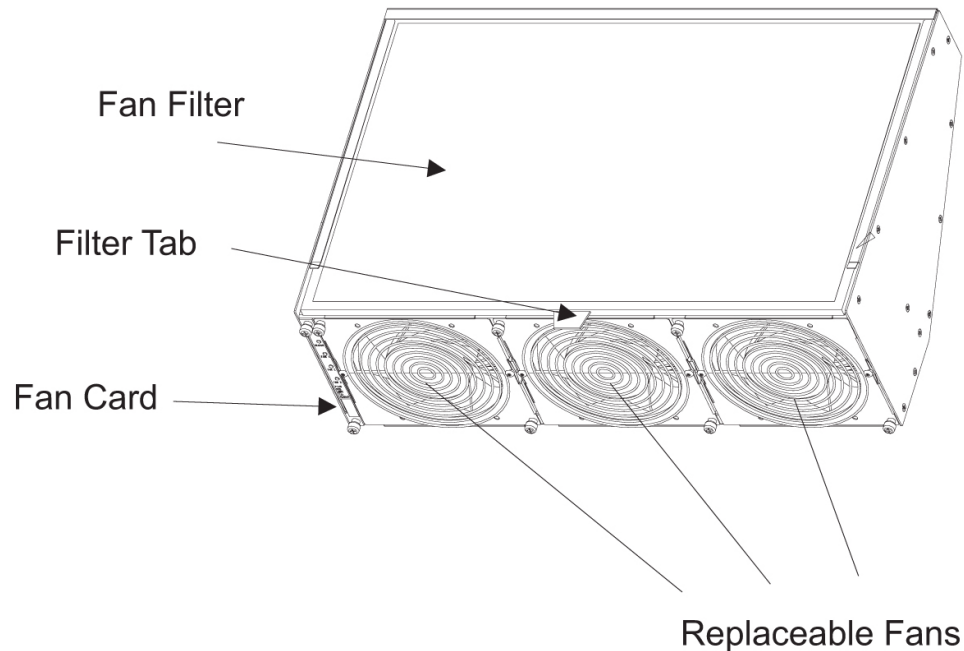

**Figure 50: Fan Assembly**

2. Insert the fan unit into the fan bracket. Tilt the unit up as it is pushed in and completely inserted into the bracket. After insertion, be sure the front of the fan unit is recessed about 1/2 inch from the front frame rails to allow the door to close.



**Figure 51: Fan tray inserted into fan tray bracket in the frame - front view**

3. When the fan unit is aligned and in place, attach the fan unit to the fan tray bracket by tightening the screws on the left and right sides of the rear of the fan tray bracket. There are two screws on each side. These screws must be tightened from the rear of the frame.



**Figure 52: Tighten rear fan tray screws**

4. From the front of the frame install the fan filter into the fan assembly.
5. At this time check and tighten all screws, including the screws holding the side brackets to the frame (if necessary). The side bracket screws should be tightened fully from the rear of the frame. Use a long hex driver or flat head screw driver.

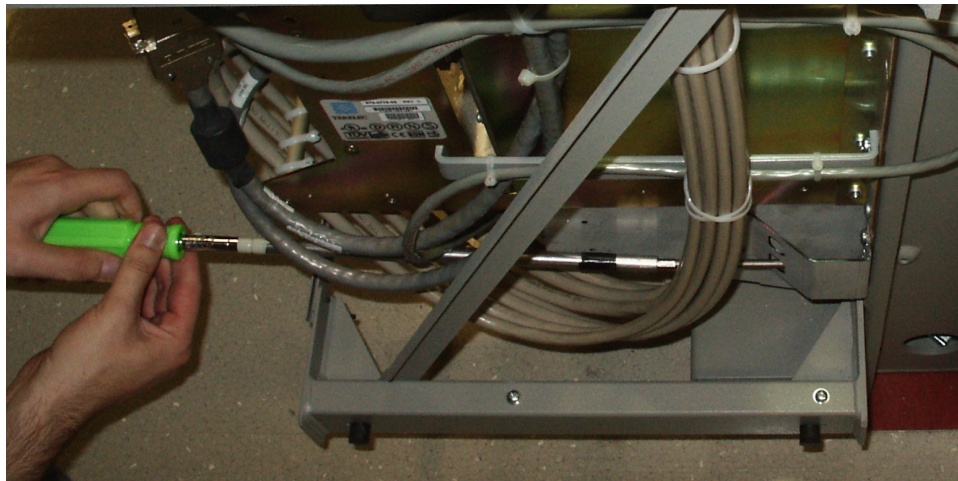

**Figure 53: Tighten fan side bracket screws**

6. Connect the fan cable at the rear of the fan assembly on the J9 connector to the FAN A POWER.
7. Connect the fan cable at the rear of the fan assembly on the J8 connector to the FAN B POWER.
8. Remove the piece of fiber paper on the top of the shelf below where the fan assembly was installed. This procedure is complete.



**Caution:** Before powering up the fans, ensure that the shelf directly above the fan does not contain any empty slots. Install an air management card in any empty slots to ensure proper air flow. These filler cards have no electrical connection to the system. See [Replacing a Card in the EAGLE 5 ISS](#) for general card installation guidelines.

### Procedure - Power Up the Fan Assembly

Use the following procedure to power up the fan assembly.

All fans are fused at 3A (blue) per feed.



**Caution:** Before powering up the fans, ensure that the shelf directly above the fan does not contain any empty slots. Install an air management card in any empty slots to ensure proper air flow. These filler cards have no electrical connection to the system. See [Replacing a Card in the EAGLE 5 ISS](#) for general card installation guidelines.

1. After the fan is installed, the powering up process depends on the shelf location.
  - a) The fuse cards located on the Fuse and Alarm Panel are marked FAN A and FAN B, fuse positions 6, 12, and 18 are marked correct locations on the FAP faceplate.
  - b) Fuse position 6 is for the fan unit directly below the x100 shelf.
  - c) Fuse position 12 is for the fan directly below the x200 shelf.
  - d) Fuse position 18 is for the fan directly below the x300 shelf.
  - e) All fans are to be fused at 3As, with blue flags, per feed.
  - f) Fill out the fuse card completely.
  - g) Ensure the FAP fuse location for the fan is properly labeled.
2. Fifteen seconds after both the A side and B side power is connected to the fan assembly all of the LEDs on the fan controller card (located on the left side of the front of the fan assembly) are green.

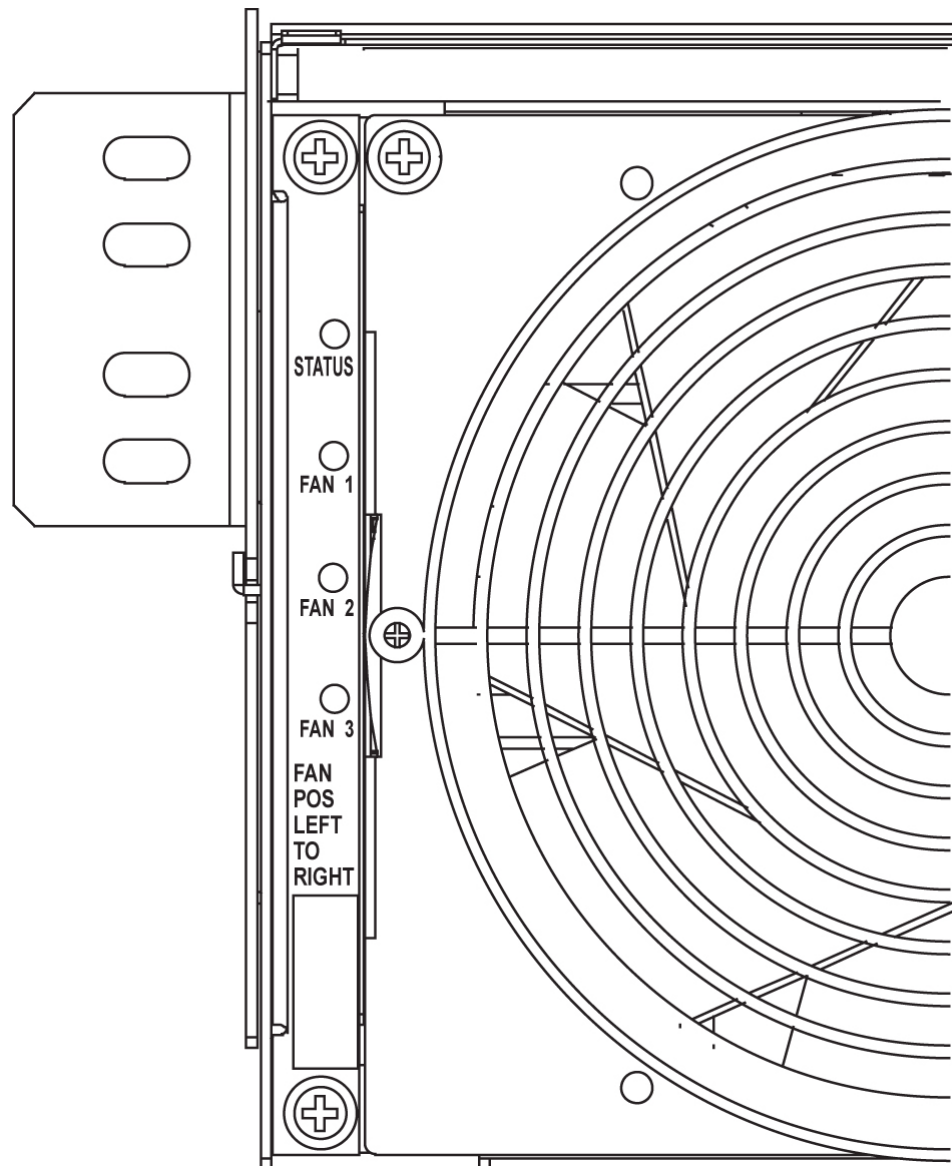

**Figure 54: Fan card with LEDs on front of fan assembly**

3. When the fans are powered up and running, a test must be conducted to ensure proper service. Go to the system terminal.
4. Check to see if the fan feature is activated.  
At the terminal, enter the command:

```
rtrv-feat
```

Example output:

```
rlghncxa03w 04-01-28 11:34:04 EST EAGLE 34.0.0.
EAGLE FEATURE LIST
GTT = on GWS = off NRT = off
```

|         |       |          |       |         |       |
|---------|-------|----------|-------|---------|-------|
| X25G    | = off | LAN      | = off | CRMD    | = off |
| SEAS    | = off | LFS      | = off | MTPRS   | = off |
| FAN     | = off | DSTN5000 | = off | WNP     | = off |
| CNCF    | = off | TLNP     | = off | SCCPCNV | = off |
| TCAPCNV | = off | IPISUP   | = off | DYNRTK  | = off |
| X252000 | = off | INP      | = off | PLNP    | = off |
| NCR     | = off | ITUMTPRS | = off | SLSOCB  | = off |
| EGTT    | = off | VGTT     | = off | MGTT    | = off |
| MPC     | = off | ITUDUPPC | = off | GFLEX   | = off |
| GPORT   | = off | MEASPLAT | = off | TSCSYNC | = off |
| E5IS    | = off |          |       |         |       |

;

If the fan feature is off (illustrated in the example), go to [Step 5](#). Otherwise, go to [Step 6](#).

- At the terminal, enter the command: `chg-feat:fan=on`  
With this command the user will perform the tests beginning with [Step 7](#).
- At the terminal, enter the command: `rept-stat-trbl`  
Check to see that there are no fan errors. Specifically, check that there are no “#302 Cooling Fan Failure” errors. Next, perform the tests beginning with [Step 7](#).
- Fan Verification (perform [Step 7](#) through [Step 12](#) for each fan assembly).  
Move to the rear of the frame and remove the A POWER cable from the FAN unit. Result: Fan 2 and Fan 3 LEDs will blink as the fans speed up to maximum speed. This may take up to 15 seconds. Once maximum speed has been reached Fan 2 and Fan 3 LEDs on the Fan Controller card will be solid green. Fan 1 LED should be red. The controller LED should be blinking green. Fan 1 should stop running and the MINORLED should be lit.
- At the system terminal enter the command: `rept-stat-trbl`  
Test each fan to ensure that the alarm and the units are working correctly. The terminal reports:

```
302 Cooling Fan Failure
```

- Replace the A POWER cable on the back of the FAN unit and secure the connector.  
Result: All fans are running and the MINORLED is not lit. The terminal reports:

```
303 Cooling Fans Normal
```

- Remove the B POWER cable from the FAN unit.  
Result: Fan 1 and Fan 2 LEDs will blink as the fans speed up to maximum speed. This may take up to 15 seconds. Once maximum speed has been reached Fan 1 and Fan 2 LEDs will be solid green. Fan 3 LED should be red. The fan controller LED should be blinking. Fan 3 should stop running and the MINORLED should be lit.
- At the system terminal enter the command: `rept-stat-trbl`  
Test each fan to ensure that the alarm and the units are working correctly. The terminal reports:

```
302 Cooling Fan Failure
```

- Replace the B POWER cable on the back of the FAN unit and secure the connector.

Result: The fans are running and the MINORLED is not lit. The terminal reports:

```
303 Cooling Fans Normal
```

13. Repeat [Step 7](#) through [Step 12](#) for each fan unit installed.  
This procedure is complete.

# Appendix B

## Holdover Clock Troubleshooting Procedures

---

### Topics:

- *Introduction.....185*
- *Interpreting System Alarms, Lamps And Trouble Isolation.....185*



## Introduction

Most alarm conditions in the holdover clock are not out-of service or service-affecting conditions. The system is designed with redundant power, reference inputs, clock input cards, stratum clock cards and output card protection switching.

The only true out-of-service condition is when all power is lost to a shelf, or all reference inputs and both stratum clock cards fail. Before taking any action on the system, such as removing cards, first consider the following troubleshooting guidelines:

- Do not touch the shelf until you have analyzed the condition and know the possible result of any planned corrective actions.
- Do not touch the shelf until you have been properly grounded.
- Both major and minor alarms in the shelf require immediate attention. But, very few alarms in the holdover clock system are service affecting. Improper corrective actions could be service affecting.
- Do not remove an ST3 clock card from the shelf, unless you are certain it is the cause of the condition. This is especially true if the ST clock card(s) is (are) in the holdover mode (the HOLD OV/HOLDOVER lamp is lit, or the HOLD OV/HOLDOVER and INP TOL lamps are lit). Removing both ST clock cards in this condition causes total loss of all outputs from the shelf and/or system.
- Write down any alarm and normal lamp conditions in the shelf. These will help you to determine where to look for the cause of the condition.

## Interpreting System Alarms, Lamps And Trouble Isolation

Alarms generated by the holdover clock are reported through the Eagle. All alarm conditions are defined in [Corrective Maintenance](#).

When troubleshooting, write down all abnormal and normal lamp conditions for the shelf with the alarm lamp lit on the SAI card. This will assist in analyzing and isolating the cause of the condition. Do not start removing or replacing cards to attempt to clear alarms, as it could lead to crashing EAGLE 5 ISS.

Tables to aid in troubleshooting are listed in the following sections. Once the basic trouble has been isolated and it has been determined that an individual card is defective, perform the appropriate card replacement procedure in [Card Removal/Replacement Procedures](#).

Table 30: Input and ST3 Alarm Conditions

| SAI/MIS LAMPS                            | ABNORMAL CARD LAMPS                                                                                                                                                          | ACTIVATED OFFICE ALARMS AND SHELF STATUS                                                                                           | ACTIVATED CLOCK STATUS A AND B | CONDITION # (NOTE) |
|------------------------------------------|------------------------------------------------------------------------------------------------------------------------------------------------------------------------------|------------------------------------------------------------------------------------------------------------------------------------|--------------------------------|--------------------|
| MAJOR and MINOR lit                      | ST3 A and B = FAIL, LOCK, and REF B lit                                                                                                                                      | Visual = MAJOR and MINOR<br>Shelf Status = MAJSI, MINSI, and CLKL.<br>(HOLDOVERALARM switch SW3 on backplane is set to MAJ or MIN) | None                           | 1                  |
| MAJOR and MINOR lit                      | Input cards A and B = FAIL lit, frequency/bit rate lamp off, SRFL lit (ACI only)<br>ST3 A and B = FAIL, LOCK, and REF B lit                                                  | Visual = MAJOR and MINOR<br>Shelf Status = MAJSI, MINSI, and CLKL.<br>(HOLDOVERALARM switch SW3 on backplane is set to MAJ or MIN) | None                           | 2                  |
| MINOR lit                                | Input card A or B = FAIL lit, frequency/bit rate lamp off or lit, SRFL lit (ACI only)<br>ST3 A and B = REF (A or B) lamp lit (associated with input card with FAIL lamp off) | Visual = MINOR<br>Shelf Status = MINSI, and CLKL (HOLDOVERALARM switch SW3 on backplane is set to MAJ or MIN)                      | None                           | 3                  |
| MINOR lit                                | ST3 A and B = LOCK lit                                                                                                                                                       | Visual = MINOR<br>Shelf Status = MINSI (HOLDOVERALARM switch SW3 on backplane is set to MAJ or MIN)                                | None                           | 4                  |
| MINOR periodically lights, then goes off | Input card A and/or B = FAIL periodically goes on and off. First occurrence only the SRCACT/SRACTIVE on FAIL card                                                            | Visual = Periodic MINOR<br>Shelf Status = Periodic MINSI and CLKL (HOLDOVERALARM switch SW3 on backplane set to MAJ or MIN)        | None                           | 5                  |

| SAI/MISLAMP                                                                                                                      | ABNORMAL CARD LAMPS                    | ACTIVATED OFFICE ALARMS AND SHELF STATUS                                                            | ACTIVATED CLOCK STATUS A AND B | CONDITIONTYPE # (NOTE) |
|----------------------------------------------------------------------------------------------------------------------------------|----------------------------------------|-----------------------------------------------------------------------------------------------------|--------------------------------|------------------------|
|                                                                                                                                  | goes off and lights on the other card. |                                                                                                     |                                |                        |
| MAJOR lit                                                                                                                        | ST3 A or B = FAIL lit                  | Visual = MAJOR<br>Shelf Status = MAJSI (HOLDOVERALARM switch SW3 on backplane is set to MAJ or MIN) | None                           | 6                      |
| For the corrective action to take for each condition type, refer to <a href="#">Table 31: Input and ST3 Corrective Actions</a> . |                                        |                                                                                                     |                                |                        |

Table 31: Input and ST3 Corrective Actions

| CONDITIONTYPE # (From <a href="#">Table 30: Input and ST3 Alarm Conditions</a> ) | CONDITION AND PROBABLE CAUSE                                                                                                                               | CORRECTIVE ACTION                                                                                                                                  |
|----------------------------------------------------------------------------------|------------------------------------------------------------------------------------------------------------------------------------------------------------|----------------------------------------------------------------------------------------------------------------------------------------------------|
| 1                                                                                | No input cards installed. Outputs are as accurate as freerunning clock cards. Timed network elements reporting high slip rate.                             | Install at least one input card.(See Appendix A).                                                                                                  |
| 2                                                                                | Input references A and B have failed (frequency/bit rate lamp off) or have exceeded BPV, OOF, or excessive zeros parameters (frequency/bit rate lamp lit). | Check input reference connections at the shelf and source ends. Reconnect if required. Isolate and repair input reference facilities, if required. |
|                                                                                  | The input reference facility framing format rearranged from D4 to ESF, or vice versa, and the input card options were not changed to match it.             | Change the option switch settings to match the current framing format. See the Installation Manual.                                                |
|                                                                                  | The input reference has been recently reassigned, and the signal amplitude is too high.                                                                    | Wire a 100 ohm, 1/4 watt resistor across T and R input terminals on the shelf backplane.                                                           |
|                                                                                  | Both input cards have failed.                                                                                                                              | Replace both input cards (See Appendix A).                                                                                                         |
| 3                                                                                | Input reference A or B has failed (frequency/bit rate lamp off) or has exceeded BPV, OOF, or excessive zeros parameters (frequency/bit rate lamp lit).     | Check input reference connections at the shelf and source ends. Reconnect if required. Isolate and repair input                                    |

| CONDITIONTYPE #<br>(From <i>Table 30: Input and ST3 Alarm Conditions</i> ) | CONDITION AND PROBABLE CAUSE                                                                                                                                                                 | CORRECTIVE ACTION                                                                                                                                                                                                                                         |
|----------------------------------------------------------------------------|----------------------------------------------------------------------------------------------------------------------------------------------------------------------------------------------|-----------------------------------------------------------------------------------------------------------------------------------------------------------------------------------------------------------------------------------------------------------|
|                                                                            |                                                                                                                                                                                              | reference A or B facility (if required).                                                                                                                                                                                                                  |
|                                                                            | Input card A or B has failed.                                                                                                                                                                | Replace the input card with the FAIL lamp lit (See Appendix A).                                                                                                                                                                                           |
|                                                                            | The input reference facility framing format rearranged from D4 to ESF, or vice versa, and the input card options were not changed to match it.                                               | Change the option switch settings to match the current framing format.                                                                                                                                                                                    |
|                                                                            | The input reference has been recently reassigned, and the signal amplitude is too high.                                                                                                      | Wire a 100 ohm, 1/4 watt resistor across T and R input terminals on the shelf backplane.                                                                                                                                                                  |
| 4                                                                          | Active input reference has exceeded pull-in range of ST3 cards. Timed network elements reporting high slip rate.                                                                             | Press transfer (XFR) pushbutton on either input card to switch SRC (source) ACTIVE lamp to the other input card. ST3 A and B LOCK lamps go off in less than 40 seconds.<br><br>Isolate source of frequency offset on input reference facility and repair. |
| 5                                                                          | Input reference facility (A and/or B) line coding rearranged from AMI to B8ZS and input card(s) option switches were not set to match the change. Input card BPV spec periodically exceeded. | Change input card(s) option switch settings from AMI to B8ZS.                                                                                                                                                                                             |
| 6                                                                          | ST3 A or B card has failed and squelched its outputs. Outputs are receiving their reference from the ST3 with its FAIL lamp off. Outputs are not affected.                                   | Replace the ST3 card (A or B) with the FAIL lamp lit (Appendix A).                                                                                                                                                                                        |

**Note:** For a description of each condition type, refer to *Table 32: Shelf and Output Alarm Conditions - Not Related to Input and ST Conditions*.

Table 32: Shelf and Output Alarm Conditions - Not Related to Input and ST Conditions

| SAI/MISLAMPS | ABNORMAL SHELF AND CARD LAMPS                                                                                                                                                                                                                                                                             | ACTIVATED OFFICE ALARMS AND SHELF STATUS                                                                        | ACTIVATED CLOCKS A AND B                               | CONDITION TYPE # (NOTE) |
|--------------|-----------------------------------------------------------------------------------------------------------------------------------------------------------------------------------------------------------------------------------------------------------------------------------------------------------|-----------------------------------------------------------------------------------------------------------------|--------------------------------------------------------|-------------------------|
| None lit     | All lamps on all cards are off                                                                                                                                                                                                                                                                            | Visual = CRITICAL (MISONLY), MAJOR, and MINOR<br><br>Shelf Status = CRTSI (MIS only), MAJSI, MINSI, and BATTALM | None                                                   | 1                       |
| MINOR lit    | MCA-5 = All 10 PORTALM lamps lit                                                                                                                                                                                                                                                                          | Visual = MINOR<br><br>Shelf Status = MINSI                                                                      | None                                                   | 2                       |
| MINOR lit    | Any TO card = PORTALM lit<br><br>Output protection pushbutton lamps = Lamp over TO card with PORTALM lit, and like HSTO card light for a short period of time (approx 3 seconds) then goes off<br><br>MCA-5 = AUTO lamp flashes for approx 6 seconds when HS protection switch is activated and released. | Visual = MINOR<br><br>Shelf Status = MINSI and PRTA (SW1 positions 3 and 5 on MCA-5 set to MAJ or MIN)          | None                                                   | 3                       |
| MINOR lit    | Shelf fuse A or B = Lamp lit                                                                                                                                                                                                                                                                              | Visual = MINOR<br><br>Shelf Status = MINSI, and BATTALM. POWERALARM switch SW2 on backplane is set to MIN)      | None                                                   | 4                       |
| MAJOR lit    | Any TO, ST, or MCA-5 = FAIL lit                                                                                                                                                                                                                                                                           | Visual = MAJOR<br><br>Shelf Status = MAJSI (MCA-5 SW1, positions 3 and 5 set to MAJ)                            | Visual = MAJOR<br><br>Shelf Status = MAJSI (MCA-5 SW1, | 5                       |

| SAI/MIS LAMPS                                                                                                                                                                                | ABNORMAL SHELF AND CARD LAMPS                                                                                                                                | ACTIVATED OFFICE ALARMS AND SHELF STATUS                                                                                                                                                                              | ACTIVATED LAMPS A AND B       | CONDITION TYPE # (NOTE) |
|----------------------------------------------------------------------------------------------------------------------------------------------------------------------------------------------|--------------------------------------------------------------------------------------------------------------------------------------------------------------|-----------------------------------------------------------------------------------------------------------------------------------------------------------------------------------------------------------------------|-------------------------------|-------------------------|
|                                                                                                                                                                                              |                                                                                                                                                              |                                                                                                                                                                                                                       | positions 3 and 5 set to MAJ) |                         |
| FAIL and MAJOR lit (MIS only)                                                                                                                                                                | MIS = FAIL lit                                                                                                                                               | Visual = MAJOR<br>Shelf Status = MAJSI                                                                                                                                                                                | None                          | 5                       |
| MAJOR and MINOR lit                                                                                                                                                                          | Shelf fuse A or B = Lamp lit                                                                                                                                 | Visual = MAJOR<br>Shelf Status = MAJSI, MINSI, and BATTALM.<br>(POWERALARM switch SW2 on backplane is set to MAJ)                                                                                                     | None                          | 4                       |
| MAJOR and MINOR lit                                                                                                                                                                          | Any TO card = FAIL lamp lit<br>Output protection pushbutton lamp = Lamps lit over TO with FAIL lamp lit and like HSTO card (HS protection switch activated). | Visual = MAJOR and MINOR<br>Shelf Status = MAJSI and MINSI (MCA-5 SW1, positions 3 and 5 set to MIN)                                                                                                                  | None                          | 5                       |
| MAJOR and MINOR lit<br>or<br>MINOR lit<br>or None lit<br>(MAJOR and MINOR lit if MCA-5 SW1, positions 3 and 5 set to MAJ; if SW1 set to MIN, then MIN lit; if set to NOALARM, then None lit) | Output protection pushbutton lamps = Lamps over TO cards and HS cards alternately light and then go off.                                                     | Visual = MAJOR and MINOR<br>or<br>MINOR<br>or None<br>Shelf Status = MAJSI and MINSI<br>or<br>MINSI<br>or None<br>(MAJOR and MINOR if MCA-5 card SW1 set to MAJ; MINOR if SW1 set to MIN; none if SW1 set to NOALARM) | None                          | 6                       |
| MINOR lit<br>or                                                                                                                                                                              | Any TO card = PORTALM lit<br>Output protection pushbutton lamps                                                                                              | Visual = MINOR<br>or                                                                                                                                                                                                  | None                          | 7                       |

| SAI/MISLAMP                                                                                                                                                                                          | ABNORMAL SHELF AND CARD LAMPS                                                                                         | ACTIVATED OFFICE ALARMS AND SHELF STATUS                                                                                                                                                                                                                                          | CORRECTIVE ACTIONS A AND B | CONDITION TYPE # (NOTE) |
|------------------------------------------------------------------------------------------------------------------------------------------------------------------------------------------------------|-----------------------------------------------------------------------------------------------------------------------|-----------------------------------------------------------------------------------------------------------------------------------------------------------------------------------------------------------------------------------------------------------------------------------|----------------------------|-------------------------|
| MAJOR and MINOR lit<br><br>(MINOR if MCA-5 SW1, positions 3 and 5, are set to MIN or NOALARM; MAJOR and MINOR lit if set to MAJ)                                                                     | = Lamps lit over TO card with PORTALM lit, and like HSTO card.                                                        | MAJOR and MINOR<br><br>Shelf Status = MINSI and PRTA<br><br>or<br><br>MAJSI, MINSI, and PRTA<br><br>(MINOR if SW1 positions 3 and 5 on MCA-5 set to MIN or NOALARM; MAJOR and MINOR if set to MAJ)                                                                                |                            |                         |
| MINOR lit<br><br>or<br><br>MAJOR lit<br><br>or<br><br>None lit<br><br>(MINOR lit if MCA-5 SW1, positions 3 and 5 set to MIN; if SW1 set to MAJ, then MAJOR is lit; if set to NOALARM, then None lit) | Output protection pushbutton lamps = Lamps lit over a TO card and like HSTO cards<br><br>MCA-5 = MAN lamp is flashing | Visual =<br><br>MINOR<br><br>or<br><br>MAJOR<br><br>or<br><br>None<br><br>Shelf Status = MINSI<br><br>or<br><br>MAJSI<br><br>or<br><br>None<br><br>(MINOR lit if MCA-5 SW1, positions 3 and 5 set to MIN; if SW1 set to MAJ, then MAJOR is lit; if set to NOALARM, then None lit) | None                       | 8                       |

**Note:** For the corrective action to take for each condition type, refer to [Table 33: Shelf and Output Corrective Actions - Not Related to Input and ST Conditions](#).

Table 33: Shelf and Output Corrective Actions - Not Related to Input and ST Conditions

| CONDITIONTYPE #<br>(FROM <i>Table 32: Shelf and Output Alarm Conditions - Not Related to Input and ST Conditions</i> ) | CONDITION AND PROBABLE CAUSE                                                                                                                                                                                                                                                                                                                                                                                                                                                                                                                                                                              | CORRECTIVE ACTIONS                                                                                                                                                                                                                                                                                                                                                                                                                                                                                                                                                                                                                |
|------------------------------------------------------------------------------------------------------------------------|-----------------------------------------------------------------------------------------------------------------------------------------------------------------------------------------------------------------------------------------------------------------------------------------------------------------------------------------------------------------------------------------------------------------------------------------------------------------------------------------------------------------------------------------------------------------------------------------------------------|-----------------------------------------------------------------------------------------------------------------------------------------------------------------------------------------------------------------------------------------------------------------------------------------------------------------------------------------------------------------------------------------------------------------------------------------------------------------------------------------------------------------------------------------------------------------------------------------------------------------------------------|
| 1                                                                                                                      | Loss of Battery A and B to shelf. All outputs are squelched. Causes could be from operating error, office battery source failure, blown fuses, or a component failure, e.g., isolation diode which shorts battery to battery return.                                                                                                                                                                                                                                                                                                                                                                      | <ol style="list-style-type: none"> <li>1. Determine cause of loss of battery and repair.</li> <li>2. Restore office battery source.</li> <li>3. Replace blown fuses in battery distribution bays, miscellaneous fuse bays, and panels, and/or on DCD shelf.</li> </ol>                                                                                                                                                                                                                                                                                                                                                            |
| 2                                                                                                                      | <p>Communication between MCA-5 and TO cards is not functioning.</p> <p>Microprocessor on the MCA-5 is failed or garbled.</p> <p>Does not affect outputs. Automatic TO protection switching function disabled. Manual TO protection switching function is still operational.</p>                                                                                                                                                                                                                                                                                                                           | <ol style="list-style-type: none"> <li>1. No TO cards in shelf. Install at least one TO card.</li> <li>2. No input references or input cards, and no clock cards installed. Install at least one clock (ST) card (See Appendix A.)</li> <li>3. MCA-5 communications bus or microprocessor garbled. Remove and reinsert the MCA-5 card to clear bus and microprocessor.</li> <li>4. MCA-5 microprocessor failed. Replace MCA-5 card (Appendix A).</li> </ol>                                                                                                                                                                       |
| 3                                                                                                                      | <p>HS protection switch activated, then released because of:</p> <ul style="list-style-type: none"> <li>• Unterminated cable on TOTA or TOTL output,</li> </ul> <p>or,</p> <ul style="list-style-type: none"> <li>• Shorted cable on TO output.</li> </ul> <p>When the condition occurred, an HS protection switch was activated, PORTALM on TO goes off, and lights on the HSTO card, output protection pushbutton lamps over the TO and HS light, MCA-5 AUTO lamp flashes, HS protection switch releases, PORTALM on HSTO goes off and lights on TO, output protection pushbutton lamps go off, and</p> | <ol style="list-style-type: none"> <li>1. Press and hold the output protection pushbutton over the TO card with PORTALM lamp lit. MCA-5 lights PORTALM lamp(s) of failed TO port. Release pushbutton.</li> <li>2. Isolate and repair cable or NE connected to that TO port.</li> <li>3. If port connection is new and not yet terminated at NE, then either insert disabling pin in that port's disabling jack on TO card faceplate, or remove cable from output wire-wrap panel, or place an appropriate resistor termination across tip (T) and ring (R) of cable at NE end, until ready to connect cable at NE end.</li> </ol> |



| CONDITIONTYPE #<br>(FROM <i>Table 32: Shelf and Output Alarm Conditions - Not Related to Input and ST Conditions</i> ) | CONDITION AND PROBABLE CAUSE                                                                                                                                                                                                                                                                                                                    | CORRECTIVE ACTIONS                                                                                                                                                                                                                                                                                                                                                                 |
|------------------------------------------------------------------------------------------------------------------------|-------------------------------------------------------------------------------------------------------------------------------------------------------------------------------------------------------------------------------------------------------------------------------------------------------------------------------------------------|------------------------------------------------------------------------------------------------------------------------------------------------------------------------------------------------------------------------------------------------------------------------------------------------------------------------------------------------------------------------------------|
|                                                                                                                        | MCA-5 AUTO lamp stops flashing (duration = 3 to 6 seconds). Non-failed ports on TO with PORTALM lit lost output for one millisecond during HS protection switch activation and release. Failed TO port is out of service.                                                                                                                       |                                                                                                                                                                                                                                                                                                                                                                                    |
| 4                                                                                                                      | Loss of Battery A or B to shelf. Does not affect outputs. Causes could be from operating error, blown fuse, or a component failure, e.g., isolation diode which shorts battery to battery return.                                                                                                                                               | <ol style="list-style-type: none"> <li>1. Determine cause of loss of battery and repair.</li> <li>2. Replace blown fuses in battery distribution bays, miscellaneous fuse bays, and panels, and/or on DCD shelf.</li> </ol>                                                                                                                                                        |
| 5                                                                                                                      | Card with FAIL lamp lit has failed, except for input card which causes a MINOR alarm when its FAIL lamp lights. Outputs are not affected if MCA-5 and HS slots are equipped.                                                                                                                                                                    | Replace the card with the FAIL lamp lit (Appendix A). Release HS protection switch, if activated, by pressing lit HS pushbutton until switch releases.                                                                                                                                                                                                                             |
| 6                                                                                                                      | A TO card's microprocessor has lost its ability to process data. The TO cards are alternately being switched to HS protection and then released. One millisecond loss of outputs each time a TO is switched to or released from HS protection.                                                                                                  | Manually switch each TO card to the HS, replace the TO card (Appendix A) and release the HS switch. Continue until the malfunctioning TO card is located and removed from the shelf.                                                                                                                                                                                               |
| 7                                                                                                                      | <p>Output port failed on TO card with PORTALM lamp lit. HS protection switch activated. Loss of output on failed port. Other output on same TO lost for one millisecond when HS protection switch activated.</p> <p>When condition occurred, an HS protection switch was activated, PORTALM lamp on TO card remained lit, output protection</p> | <ol style="list-style-type: none"> <li>1. Press and hold the output protection pushbutton over the TO card with the PORTALM lamp lit. MCA-5 lights PORTALM lamp(s) of failed TO port. Release pushbutton.</li> <li>2. Remove TO card with PORTALM lamp lit.</li> <li>3. Set option switch settings on the replacement TO card identical to settings on removed TO card.</li> </ol> |

| CONDITIONTYPE #<br>(FROM <i>Table 32: Shelf and Output Alarm Conditions - Not Related to Input and ST Conditions</i> ) | CONDITION AND PROBABLE CAUSE                                                                                        | CORRECTIVE ACTIONS                                                                                                                                                                                                                                                                                                                                             |
|------------------------------------------------------------------------------------------------------------------------|---------------------------------------------------------------------------------------------------------------------|----------------------------------------------------------------------------------------------------------------------------------------------------------------------------------------------------------------------------------------------------------------------------------------------------------------------------------------------------------------|
|                                                                                                                        | pushbutton lamps over TO and HS slots lit, and MCA-5 card's AUTO lamp flashes for 6 seconds and then lights steady. | <p>4. Insert replacement TO card in shelf slot and wait 10 seconds for TO to warm-up. Verify ST, INPUT and OPTION lamps are lit and PORTALM and/or FAIL lamps are not lit.</p> <p>5. Press output protection pushbutton over HSTO until pushbutton lamps go out (releases HS switch). MCA-5 card's AUTO lamp flashes for 6 seconds and then lights steady.</p> |
| 8                                                                                                                      | TO card manually switched to HSTO card                                                                              | Release the manual HS switch by pressing the lit pushbutton over the HSTO card for 3 seconds.                                                                                                                                                                                                                                                                  |

**Note:** For a description of each condition type, refer to *Table 32: Shelf and Output Alarm Conditions - Not Related to Input and ST Conditions*.

# Appendix C

## Part Numbers

---

### Topics:

- *Overview.....196*
- *Cables, Adapters.....196*
- *Components.....201*
- *Frames, Backplanes, FAPs, and Fans.....203*
- *Labels.....205*
- *Miscellaneous Parts.....206*
- *Power Cords for Peripherals.....208*

## Overview

This chapter lists the part numbers of Tekelec equipment, components, cables, and miscellaneous parts described in this manual.

Each table provides the item name, part number, and related notes. Items are listed by their name (as described in this manual) in alphabetical order. Shaded part numbers indicate that the item is obsolete or no longer shipped. Unless the item is indicated as obsolete, the item is still supported in the field.

**Note:** Tekelec reserves the right to ship compatible part numbers or revisions for new installations and replacements. Always check the latest Hardware Baseline for your release. The latest hardware baseline can be found in the Feature Notice of your release.

RoHS 5/6 - As of July 1, 2006, all products that comprise new installations shipped to European Union member countries will comply with the EU Directive 2002/95/EC "RoHS" (Restriction of Hazardous Substances). The exemption for lead-based solder described in the Annex will be exercised. RoHS 5/6 compliant components will have unique part numbers and are identified as the International part number in this manual.

**Note:** International part numbers will eventually replace North American part numbers to make all part numbers RoHS compliant. The items of either part number are of equivalent function or quality otherwise.



**WEEE** - All products shipped to European Union member countries comply with the EU Directive 2002/96/EC, Waste Electronic and Electrical Equipment. All components that are WEEE compliant will be appropriately marked. For more information regarding Tekelec's WEEE program, contact your sales representative.

## Cables, Adapters

Table 34: EAGLE 5 Cables, Connectors, and Power Cords

| Name                      | Part Numbers  |               | Note                                                                       |
|---------------------------|---------------|---------------|----------------------------------------------------------------------------|
|                           | North America | International |                                                                            |
| Adapter, 15-Pin to 26-Pin | 830-0425-01   | ---           |                                                                            |
| Adapter cables            | 830-0846-01   | 830-1183-01   | backplanes -03 and -04 for master timing and HS clock cable<br>830-0873-xx |
| Alarm cable               | 830-0543-01   | ---           | Holdover Clock                                                             |

| Name                                  | Part Numbers  |               | Note                                                                                                  |
|---------------------------------------|---------------|---------------|-------------------------------------------------------------------------------------------------------|
|                                       | North America | International |                                                                                                       |
| Alarm cable                           | 830-0638-xx   | 830-1163-xx   | see Filtered Rack Alarm cable                                                                         |
| AlarmNETRA Server Cable               | 830-0900-xx   | ---           |                                                                                                       |
| ATM Cable                             | 830-0987-xx   | ---           | SCSI/DB44                                                                                             |
| B Clock Cable                         | 830-0404-xx   | ---           | replaced by 830-0398-xx (NA) or 830-1150-xx (I)                                                       |
| B Clock Cable                         | 830-0398-xx   | 830-1150-xx   |                                                                                                       |
| A and B Frame Clock cable             | ---           | ---           | see B Clock Cable                                                                                     |
| BITS clock cable                      | 830-0226-xx   | 830-1146-xx   | Backplanes -03 and -04                                                                                |
| BITS clock cable                      | 830-0873-xx   | ---           | Backplane -06                                                                                         |
| BNC pen end cable                     | 830-0625-xx   | 830-1161-xx   |                                                                                                       |
| BNC to BNC cable assembly             | 830-0624-xx   | 830-1160-xx   |                                                                                                       |
| Breaker-to-Terminal Strip Power Cable | 830-0866-xx   | 830-1236-xx   |                                                                                                       |
| CD-ROM Cable                          | 830-0421-xx   | ---           |                                                                                                       |
| Frame Ground cable                    | 830-0715-xx   | 830-1171-xx   | ESP                                                                                                   |
| Composite clock cable                 | ---           | ---           | See BITS clock cable                                                                                  |
| Converter                             | 804-0176-01   | ---           |                                                                                                       |
| Crossover (CAT-5) Cable               | 830-0723-xx   | 830-1173-xx   |                                                                                                       |
| Crossover Patch Panel Cable           | 830-0789-xx   | 830-1178-xx   | DCM                                                                                                   |
| DB-26 to RJ-45                        | 830-1102-02   | 830-1102-02   | for new installations, with shielded Cat 5E cable; E5-ENET                                            |
| DB-26 to DB-26                        | 830-1103-02   | 830-1103-02   | for current installations that use DCM cable, 830-0978-xx. Does not support Gigabit Ethernet; E5-ENET |

| Name                                                | Part Numbers  |               | Note                    |
|-----------------------------------------------------|---------------|---------------|-------------------------|
|                                                     | North America | International |                         |
| DCM, 100-BASET X Interface to unterminated -xx      | 830-0711-xx   | ---           |                         |
| DCM_100 BASET X Interface_DB26 to Non-shielded RJ45 | 830-0978-xx   | ---           |                         |
| DCM 100BASE TX Interface_DB26 to RJ45 Plus to Minus | 830-0788-xx   | 830-1177-xx   |                         |
| Drive Power Cable                                   | 830-0224-xx   | ---           |                         |
| DS1 Cable                                           | 830-0849-xx   | 830-1184-xx   |                         |
| E1 cable                                            | 830-0622-xx   | 830-1233-xx   |                         |
| E1 patch cable                                      | 830-0605-02   | 830-1116-02   |                         |
| E5-ENET Fast Copy Adapter - Lower                   | 830-1343-01   |               |                         |
| E5-ENET Fast Copy Adapter - Upper                   | 830-1343-02   |               |                         |
| Ethernet cable                                      | 830-0788-xx   | 830-1177-xx   | DCM, DSM and EDCM       |
| External alarm cable                                | 830-0435-xx   | 830-1151-xx   |                         |
| Fan cable                                           | 830-0690-01   | ---           | AC power                |
| Fan power/alarm cable                               | 830-0609-01   | 830-1157-01   | incl. with fan assembly |
| Fifty Position Cable Hard Drive I/O                 | 830-0656-01   | ---           |                         |
| Filter Rack Alarm Cable                             | 830-0638-xx   | 830-1163-xx   |                         |
| Force Transition Card                               | 850-0496-01   | ---           |                         |
| Frame Ground cable                                  | 830-0715-xx   | 830-1171-xx   | ESP                     |
| Ground Breaker Panel-to-Frame cable                 | 830-0830-01   | 830-1181-01   | ESP                     |
| Ground Hub-to-Frame cable                           | 830-0822-xx   | ---           | ESP                     |
| Hazard Ground Cable                                 | 830-0257-xx   | ---           |                         |

| Name                             | Part Numbers  |               | Note                                                    |
|----------------------------------|---------------|---------------|---------------------------------------------------------|
|                                  | North America | International |                                                         |
| High Speed (BITS) Clock Cable    | 830-0873-xx   | 830-1189-xx   |                                                         |
| High Speed Master Timing Adapter | 830-0846-01   | 830-1183-01   |                                                         |
| 1/0 Green Ground Cable           | 690-0108-07   | 690-0108-R07  |                                                         |
| IMT Cable                        | 830-1134-xx   | 830-1134-xx   |                                                         |
| Interface Cable                  | 830-0366-xx   | 830-1149-xx   |                                                         |
| Local Maintenance Center Cable   | 830-0231-xx   | 830-1144-xx   |                                                         |
| Loop Back Cable Adapter          | 830-0763-01   | 830-1176-xx   |                                                         |
| MMI Port Cable                   | 830-0708-xx   | 830-1169-xx   |                                                         |
| Modem/Terminal Cable             | 830-0709-xx   | 830-1170-xx   |                                                         |
| Multi-port LIM Diagnostic Cable  | 803-0029-0    | ---           |                                                         |
| Multi-port LIM DS0 cable         | 830-0772-xx   | ---           | 26 AWG, inactive                                        |
| Multi-port LIM DS0 cable         | 830-0892-xx   | 830-1194-xx   | 24 AWG, inactive                                        |
| Multi-Port Power Cable           | 830-0814-xx   | 830-1282-xx   |                                                         |
| Network Cable                    | 830-0710-xx   | 830-1257-xx   |                                                         |
| Null Modem Cable                 | 830-0759-xx   | ---           |                                                         |
| Null-Modem for Terminal Cable    | 830-0859-xx   | 830-1186-xx   |                                                         |
| Output panel frame ground cable  | 690-0009      | ---           |                                                         |
| Pin Protector Assembly           | 830-0880-01   | ---           | use with clock cable replacement (66 min for 6 shelves) |
| Power Cable                      | 830-0315-xx   | 830-1147-xx   |                                                         |
| Power Cable, -48V                | 830-0651-xx   | ---           |                                                         |
| Power Cable, DC, BP to Hub       | 830-0868-xx   | 830-1235-xx   |                                                         |
| Power Cable, DC, Netra 1400      | 830-0814-xx   | 830-1282-xx   |                                                         |
| Power Cable, MPS                 | 830-0965-xx   |               |                                                         |
| Power Ring                       | 830-0908-xx   | ---           | AXi                                                     |

| Name                                        | Part Numbers  |               | Note                                                    |
|---------------------------------------------|---------------|---------------|---------------------------------------------------------|
|                                             | North America | International |                                                         |
| Rack Alarm Cable                            | ---           | ---           | see Filtered Rack Alarm cable                           |
| RAID Power Cable                            | 830-0872-xx   | ---           | DC                                                      |
| Remote Maintenance Center Cable             | 830-0233-xx   | 830-1146-xx   |                                                         |
| RJ45/RJ45 Cable (CAT-5) (Yellow)            | 830-0888-xx   | ---           |                                                         |
| RJ45/RJ45 Cable (CAT-5) (Blue)              | 830-0889-xx   | 830-1192-xx   |                                                         |
| RJ45 to 9 Pin Adapter                       | 830-0917-01   | ---           |                                                         |
| Row Alarm Cable                             | 830-0232-xx   | 830-1145-xx   |                                                         |
| Router Power Cable                          | 830-0869-xx   | 830-1188-xx   | DC                                                      |
| RS232 Cable                                 | 830-0527-xx   | 830-1152-xx   |                                                         |
| ATM Cable                                   | 830-0987-xx   | ---           | SCSI/DB44                                               |
| Serial I/O Transition Card                  | 850-0514-01   | ---           |                                                         |
| Serial Interface Converter Cable            | 830-0531-01   | ---           | inactive                                                |
| Serial Interface/Modem Adapter              | 830-0531-03   | 830-1153-03   | use with 830-0394-xx                                    |
| Serial Interface/Modem Adapter              | 830-0531-04   | 830-1153-04   | use with 830-0535-xx                                    |
| Serial DB44 to DB9 (X4) cable               | 830-0972-01   | 830-1231-01   | 36-inch T1x00 AS                                        |
| Serial Interface, Terminal, Printer Adapter | 830-0531-02   | 830-1153-02   | use with 830-0394-xx                                    |
| Straight Through Cable (CAT-5)              | 830-0724-xx   | ---           | RJ-45 CAT-5E                                            |
| Straight Through Cable (Patch Panel)        | ---           | ---           | see DCM 100BASE TX Interface_DB26 to RJ45 Plus to Minus |
| Switch-to-Frame Ground Cable                | 830-0884-01   | ---           |                                                         |
| Terminal/Converter Cable                    | 830-0528-01   | ---           |                                                         |
| Terminal/Printer Cable                      | 830-0535-xx   | 830-1154-xx   |                                                         |
| Terminal/Server Serial Cable                | ---           | 830-1201-xx   | DB9F/DB15M Serial w/Flow Control                        |



| Name                                     | Part Numbers  |               | Note                             |
|------------------------------------------|---------------|---------------|----------------------------------|
|                                          | North America | International |                                  |
| Terminal/Server Serial Port Adapter      | 830-0915-01   | ---           | RJ45-DB15M Adapter_NTW           |
| Terminal/Server Serial Port Adapter      | 830-0915-02   | ---           | RJ45-DB15M Adapter_MRV           |
| Terminal/Server Serial Port Adapter      | 830-0915-03   | ---           | RJ45-DB15M Adapter_EAGLE/Cydades |
| Tone and Announcement Server Alarm Cable | 830-0901-xx   | ---           |                                  |
| T1LIM-to-MPL Cable Adapter               | 830-0895-01   | ---           |                                  |
| Terminal cable adapter                   | ---           | ---           | see Terminal/Printer cable       |

## Components

Table 35: EAGLE Components

| Acronym  | Name                                  | Part Numbers  |               | Note                                                                |
|----------|---------------------------------------|---------------|---------------|---------------------------------------------------------------------|
|          |                                       | North America | International |                                                                     |
| ---      | Air Management Card                   | 870-1824-01   | 870-1824-02   | single slot, needed for empty slots when using Fan Tray 890-0001-02 |
| ---      | Breaker Panel Alarm Card              | 804-1489-01   | 804-1489-R01  |                                                                     |
| CI       | Clock Interface Card (Holdover Clock) | 804-0165-01   | ---           |                                                                     |
| E5-APP-B | EAGLE Application B Card              | 870-3096-XX   | ---           |                                                                     |
| E5-ATM   | E5-ATM Interface Module               | 870-1872-01   | ---           | Replaces EAGLE ATM card                                             |
| E5-ATM-B | E5-ATM-B Interface Module             | 870-2972-01   | 870-2972-01   | Replaces EAGLE ATM card                                             |

| Acronym   | Name                                                   | Part Numbers  |               | Note                                                  |
|-----------|--------------------------------------------------------|---------------|---------------|-------------------------------------------------------|
|           |                                                        | North America | International |                                                       |
| E5-E1T1   | E5-E1T1 Interface Module                               | 870-1873-02   | 870-1873-03   | Replaces E1/T1 MIM and MPL cards                      |
| E5-ENET   | E5-ENET Interface Module                               | 870-2212-02   | 870-2212-03   | Replaces DCM (870-1945-xx), and EDCM and EDCM-A cards |
| E5-ENET-B | E5-ENET-B Interface Module                             | 870-2971-01   | 870-2971-01   | Replaces DCM (870-1945-xx), and EDCM and EDCM-A cards |
| E5-IPSM   | IPSM Module                                            | 870-2877-01   | ---           |                                                       |
| E5-MASP   | E5 Maintenance Administration Subsystem Processor Card | 870-2903-01   |               |                                                       |
| E5-MCPM-B | E5-MCPM-B Measurements Collection and Polling Module   | 870-3089-01   | 870-3089-01   | Replaces MCPM cards                                   |
| E5-MDAL   | E5 Maintenance Disk and Alarm Card                     | 870-2900-01   |               |                                                       |
| E5-SM4G   | E5-SM4G DSM Module                                     | 870-2860-02   | ---           | Replaces DSM (870-1984-xx) cards                      |
| E5-SM8G-B | E5-SM8G-B DSM Module                                   | 870-2990-01   | 870-2990-01   | Replaces DSM (870-1984-xx) cards                      |
| E5-TSM    | E5-TSM (Translation Service Module running GLS)        | 870-2943-03   | ---           | Replaces TSM-256 as of 40.0                           |
| EDCM      | Enhanced Database Communications Module                | 870-2197-01   | ---           | double-slot Pre-IP <sup>7</sup> SG 4.0                |
| HC MIM    | High Capacity Multi-channel Interface Module           | 870-2671-01   | 870-2574-02   | Replaces IPMX                                         |
| HIPR      | High-Speed IMT Packet Router Module                    | 870-2574-01   | 870-2574-02   | Replaces IPMX and HMUX cards                          |

| Acronym | Name                                                                             | Part Numbers               |               | Note                                |
|---------|----------------------------------------------------------------------------------|----------------------------|---------------|-------------------------------------|
|         |                                                                                  | North America              | International |                                     |
| HIPR2   | High-Speed IMT Packet Router 2 Module                                            | 870-2872-01                | 870-2872-01   | Replaces IPMX, HMUX, and HIPR cards |
| MCA     | Matrix Controller Automatic (Holdover Clock)                                     | 000-0028-xx                | ---           |                                     |
| MCAP    | Maintenance Administration Subsystem (MAS) Communications Applications Processor | 870-1013-xx<br>870-1307-xx | ---           | Replaced by GPSM-II as of 30.0      |
| MIS     | Maintenance Interface System Card (Holdover Clock)                               | 804-0175-xx                | ---           |                                     |
| MPS     | Multi-purpose Server                                                             | 890-1287-xx<br>890-1374-xx | ---           | OEM Open System                     |
| TOCA    | Timing Output Composite Automatic (Holdover Clock)                               | 804-0166-xx                | ---           |                                     |

## Frames, Backplanes, FAPs, and Fans

Table 36: EAGLE 5 ISS Frames, Backplanes, FAPs, and Fans

| Acronym | Name                        | Part Numbers  |               | Note     |
|---------|-----------------------------|---------------|---------------|----------|
|         |                             | North America | International |          |
| BP      | Breaker Panel               | 804-1423-01   | 804-1423-R01  |          |
| BP      | Breaker Panel               | 870-1814-01   | ---           |          |
|         | Control Shelf Backplane -02 | 850-0330-02   | ---           | inactive |
|         | Control Shelf Backplane -03 | 850-0330-03   | ---           | inactive |
|         | Control Shelf Backplane -04 | 850-0330-04   | ---           |          |

| Acronym | Name                        | Part Numbers             |                            | Note                                  |
|---------|-----------------------------|--------------------------|----------------------------|---------------------------------------|
|         |                             | North America            | International              |                                       |
|         | Control Shelf Backplane -05 | 850-0330-05              | ---                        | not active                            |
|         | Control Shelf Backplane -06 | 850-0330-06              | 850-0330-07                | shelves 6 and 7 no longer supported   |
|         | E1 Backplane                | 850-0459-01              | 850-0459-02                |                                       |
|         | Extension Shelf Backplane   | 850-0356-01              | ---                        | inactive                              |
|         | Extension Shelf Backplane   | 850-0356-02              | ---                        | inactive                              |
|         | Extension Shelf Backplane   | 850-0356-03              | ---                        | inactive                              |
|         | Extension Shelf Backplane   | 850-0356-04              | 850-0356-06                |                                       |
|         | Fan Assembly                | 890-0001-02              | 890-0001-04                | All systems with HCMIMs<br>EAGLE 33.0 |
|         | Fan Assembly                | 890-1038-01              | 890-1038-03<br>890-1038-04 | Standard frame<br>Heavy Duty frame    |
|         | Filter, fan tray            | 551-0032-01              | ---                        |                                       |
|         | Fan filter                  | 551-0022-01              | ---                        |                                       |
| FAP     | Fuse and Alarm Panel        | 860-0434-01              | 860-0434-03<br>860-0434-04 | Heavy Duty Frame                      |
| FAP     | Fuse and Alarm Panel        | 870-1606-02 Rev C        | ---                        | Standard Frame<br>60 Amp feeds        |
| FAP     | Fuse and Alarm Panel        | 870-1606-02 Rev B        | ---                        | Standard<br>40 Amp feeds              |
| FAP     | Fuse and Alarm Panel        | 870-2320-028<br>Rev J    | 870-2320-04                | Heavy Duty Frame<br>60 Amp feeds      |
| FAP     | Fuse and Alarm Panel        | 870-2320-01<br>Rev A - I | 870-2320-03                | Heavy Duty Frame<br>40 Amp feeds      |

| Acronym | Name                 | Part Numbers      |               | Note                        |
|---------|----------------------|-------------------|---------------|-----------------------------|
|         |                      | North America     | International |                             |
| FAP     | Fuse and Alarm Panel | 870-0243-08 Rev C | ---           | Control/<br>Extension Frame |
| FAP     | Fuse and Alarm Panel | 870-0243-09 Rev C | ---           | Misc Frame                  |
|         | FAP Jumper Board     | 870-1641-01       | ---           |                             |
|         | FAP Jumper Board     | 870-1641-02       | ---           |                             |
|         | Heavy Duty Frame     | 860-0434-01       | ---           |                             |
| FAP     | Fuse and Alarm Panel | 870-2804-01       | 870-2804-01   | Control/<br>Extension Frame |
|         | FAP Shorting Board   | 870-2805-01       | 870-2805-01   |                             |
|         | FAP Jumper Board     | 870-2806-01       | 870-2806-01   |                             |

## Labels

Table 37: EAGLE 5 ISS Labels

| Name                          | Part Numbers |
|-------------------------------|--------------|
| Label, Control frame          | 658-0486-01  |
| Label, Extension frame 00     | 658-0486-02  |
| Label, Extension frame 01     | 658-0486-03  |
| Label, Extension frame 02     | 658-0486-04  |
| Label, Extension frame 03     | 658-0486-05  |
| Label, Extension frame 04     | 658-0486-06  |
| Label, Miscellaneous frame 00 | 658-0374-01  |
| Label, Miscellaneous frame 01 | 658-0374-02  |
| Label, Heavy Duty Frame       | 658-0374-01  |
| Label, CF-00, Shelf 1         | 658-0490-01  |
| Label, CF-00, Shelf 2         | 658-0490-02  |

| Name                                  | Part Numbers |
|---------------------------------------|--------------|
| Label, CF-00, Shelf 3                 | 658-0490-03  |
| Label, EF-00, Shelf 1                 | 658-0490-04  |
| Label, EF-00, Shelf 2                 | 658-0490-05  |
| Label, EF-00, Shelf 3                 | 658-0490-06  |
| Label, EF-01, Shelf 1                 | 658-0490-07  |
| Label, EF-01, Shelf 2                 | 658-0490-08  |
| Label, EF-01, Shelf 3                 | 658-0490-09  |
| Label, EF-02, Shelf 1                 | 658-0490-10  |
| Label, EF-02, Shelf 2                 | 658-0490-11  |
| Label, EF-02, Shelf 3                 | 658-0490-12  |
| Label, EF-03, Shelf 1                 | 658-0490-13  |
| Label, EF-03, Shelf 2                 | 658-0490-14  |
| Label, EF-03, Shelf 3                 | 658-0490-15  |
| Label, EF-04, Shelf 1                 | 658-0490-16  |
| Label, Field Tool Identification      | 658-0941-01  |
| Label, Field Tool Identification wrap | 658-0941-02  |

## Miscellaneous Parts

Table 38: EAGLE 5 ISS Miscellaneous Part Numbers

| Name               | Part Numbers  |               | Note                     |
|--------------------|---------------|---------------|--------------------------|
|                    | North America | International |                          |
| <b>Drives</b>      |               |               |                          |
| Dual CD-RW\DVD-ROM | 870-2746-01   | 870-2746-02   | T1x00 AS                 |
| Disk Drive, 120GB  | 804-1804-01   | 804-1804-R01  | ULTRAATA/100/133_7200RPM |
| <b>Panels</b>      |               |               |                          |
| Alarm side panel   | 870-0259-02   | ---           |                          |

| Name                                           | Part Numbers               |                              | Note                                           |
|------------------------------------------------|----------------------------|------------------------------|------------------------------------------------|
|                                                | North America              | International                |                                                |
| Alarm indicator lamps                          | 525-0067-R01               | ---                          |                                                |
| Blank side panel                               | 840-0017-02                | ---                          |                                                |
| Gray tinted plastic rear covers                | 654-0075-01                | 654-0075-R01                 |                                                |
| Brackets, unit separation                      | 652-0609-01                | 652-0609-02                  |                                                |
| Bracket                                        | 652-0954-01                | 652-0954-02                  | Fan                                            |
| <b>Kits</b>                                    |                            |                              |                                                |
| Cable Rack Mounting Kit                        | 804-1571-01                | ---                          | Heavy duty frame                               |
| Cable Rack Mounting Kit                        | 804-0219-01<br>804-0219-02 | 804-0219-R01<br>804-0219-R02 | raised floor                                   |
| External tooth washers                         | 606-0062-01                | ---                          | fan bracket                                    |
| Diode Board A                                  | 870-1608-01                | ---                          |                                                |
| Diode Board A                                  | 870-1608-03                | ---                          |                                                |
| Diode Board B                                  | 870-1608-02                | ---                          |                                                |
| Diode Board B                                  | 870-1608-04                | ---                          |                                                |
| Diode Upgrade kit                              | 840-0139-01                | ---                          | For 870-1606-02                                |
| Diode Upgrade kit                              | 840-0139-02                | ---                          | For 870-2320-01                                |
| E1 Interface Kit                               | 890-1037-01                | 890-1037-06                  |                                                |
| Mounting hardware kit                          | 840-0092-01                | 840-0092-03                  | For heavy duty frame. South America/India only |
| <b>Brackets, Screws, and other small items</b> |                            |                              |                                                |
| Brackets, unit separation                      | 652-0609-01                | 652-0609-02                  |                                                |
| Bracket                                        | 652-0954-01                | 652-0954-02                  | Fan                                            |
| Bracket, fan tray                              | 652-0012-01                | 652-0012-02                  | Fan tray                                       |
| Bracket, side, fan tray                        | 652-0015-01                | 652-0015-02                  | Fan tray                                       |
| Heat-shrink                                    | 804-0229-01                | ---                          |                                                |
| Heat-shrink                                    | 804-0228-01                | ---                          |                                                |

| Name                   | Part Numbers  |               | Note                           |
|------------------------|---------------|---------------|--------------------------------|
|                        | North America | International |                                |
| Lugs, # 6 two-hole     | 502-0085-01   | 502-0085-R01  | FAP connector                  |
| #6 AWG                 | 690-0131-01   | 690-0131-R01  |                                |
| 1/0 pink lug           | 804-0977-01   | 804-0977-R01  |                                |
| Pin Protector Assembly | 830-0880-01   |               |                                |
| Screws (12)            | 601-0010-01   | ---           |                                |
| Screws                 | 600-0193-01   | ---           | 12x24 .500 cs zinc fan bracket |
| Terminal lug           | 804-0817-02   | 804-0817-R02  |                                |
| Terminating resistor   | 104-0032-01   | ---           | E1 backplane                   |

## Power Cords for Peripherals

Table 39: Power Cords for Peripherals

| Country   | Part Number   | Country       | Part Number   |
|-----------|---------------|---------------|---------------|
| USA       | Cord provided | Latvia        | 804-1185-R01  |
| Argentina | 804-1185-R02  | Liechtenstein | 804-1185-R11  |
| Australia | 804-1185-R02  | Lithuania     | 804-1185-R01  |
| Austria   | 804-1185-R01  | Luxembourg    | 804-1185-R01  |
| Belgium   | 804-1185-R01  | Malaysia      | 804-1185-R03  |
| Brazil    | 804-1185-R01  | Malta         | 804-1185-R03  |
| Bulgaria  | 804-1185-R01  | Mexico        | Cord provided |
| Canada    | Cord provided | Monaco        | 804-1185-R01  |
| Chile     | 804-1185-R01  | Netherlands   | 804-1185-R01  |
| China     | 804-1185-R09  | New Zealand   | 804-1185-R02  |
| Columbia  | Cord provided | Norway        | 804-1185-R01  |
| Cyprus    | 804-1185-R03  | Peru          | 804-1185-R01  |



| Country        | Part Number  | Country        | Part Number   |
|----------------|--------------|----------------|---------------|
| Czech Republic | 804-1185-R01 | Philippines    | Cord provided |
| Denmark        | 804-1185-R04 | Poland         | 804-1185-R01  |
| Egypt          | 804-1185-R01 | Portugal       | 804-1185-R01  |
| Estonia        | 804-1185-R01 | Romania        | 804-1185-R01  |
| Finland        | 804-1185-R01 | Russia         | 804-1185-R01  |
| France         | 804-1185-R07 | Saudi Arabia   | Cord provided |
| Germany        | 804-1185-R01 | Singapore      | 804-1185-R03  |
| Greece         | 804-1185-R01 | Slovakia       | 804-1185-R01  |
| Hong Kong      | 804-1185-R03 | South Africa   | 804-1185-R06  |
| Hungary        | 804-1185-R01 | South Korea    | 804-1185-R01  |
| Iceland        | 804-1185-R01 | Spain          | 804-1185-R01  |
| India          | 804-1185-R06 | Sweden         | 804-1185-R01  |
| Ireland        | 804-1185-R03 | Switzerland    | 804-1185-R11  |
| Israel         | 804-1185-R12 | Taiwan         | Cord provided |
| Italy          | 804-1185-R07 | Turkey         | 804-1185-R01  |
| Ivory Coast    | 804-1185-R01 | United Kingdom | 804-1185-R03  |
| Japan          | 804-1185-R10 | United Arab    | 804-1185-R03  |

## A

|     |                                                                                                                                                                                                                                                                                                                                                                                                                                                                                                                                                                                                                                         |
|-----|-----------------------------------------------------------------------------------------------------------------------------------------------------------------------------------------------------------------------------------------------------------------------------------------------------------------------------------------------------------------------------------------------------------------------------------------------------------------------------------------------------------------------------------------------------------------------------------------------------------------------------------------|
| AC  | Alternating Current<br>Application Context<br>Authentication Center<br>Area Code                                                                                                                                                                                                                                                                                                                                                                                                                                                                                                                                                        |
| ACT | Activate                                                                                                                                                                                                                                                                                                                                                                                                                                                                                                                                                                                                                                |
| ALM | Alarm Card                                                                                                                                                                                                                                                                                                                                                                                                                                                                                                                                                                                                                              |
| AMI | Alternate Mark Inversion                                                                                                                                                                                                                                                                                                                                                                                                                                                                                                                                                                                                                |
| AND | AIN Number of Digits (in GTT address for AIN query)                                                                                                                                                                                                                                                                                                                                                                                                                                                                                                                                                                                     |
| AS  | Application Server - A logical entity serving a specific Routing Key. An example of an Application Server is a virtual switch element handling all call processing for a unique range of PSTN trunks, identified by an SS7 DPC/OPC/CIC_range. Another example is a virtual database element, handling all HLR transactions for a particular SS7 DPC/OPC/SCCP_SSN combination. The AS contains a set of one or more unique Application Server Processes, of which one or more normally is actively processing traffic.<br>Action Set<br>Authentication Server -<br>Authentication servers provide public access to certificates, and are |

## A

integrated with electronic information retrieval systems to this end. Free access to certificates is necessary to support authentication in open systems.

Application Simulator - Test tool that can simulate applications and/or SMSCs.

Application Server - A logical entity that hosts and executes services in an IMS network, interfacing through SIP or a similar protocol.

ASCII

American Standard Code for Information Interchange

Association

An association refers to an SCTP association. The association provides the transport for protocol data units and adaptation layer peer messages.

AST

Associated State

The associated state of an entity.

AT

Application-terminated

Short message traffic that terminates at an application.

authentication token

ATM

Asynchronous Transfer Mode

A packet-oriented transfer mode that uses an asynchronous time division multiplexing technique to multiplex information flow in fixed blocks, called cells.

A high-bandwidth, low-delay switching, and multiplexing

**A**

technology to support applications that include high-speed data, local area network interconnection, multimedia application and imaging, and residential applications such as video telephony and other information-based services.

**B**

BERT

Bit Error Rate Test

BITS

Building Integrated Timing System

The Building Integrated Timing System (BITS) clocks come directly from the central office BITS clock source or indirectly from an optional holdover clock installed in the system.

BP

Board Prom

**C**

CAT

Cell Attribute Table

CD

Carrier Detect  
Compact Disk  
Call Deflection

CF

Control Frame

Channel

A single Time-Division-Multiplexed (TDM) timeslot within a channelized E1/T1 port. Generically, channels can be used for transporting signaling, digitized voice, or data information. Unused channels typically are filled with defined idle

## C

codes designed to maintain sufficient ones density to ensure frame-level synchronization.

## CI

Clock Interface Card  
Critical Status Indicator  
Cell Identity

## CLLI

Common Language Location Identifier

The CLLI uniquely identifies the STP in terms of its physical location. It is usually comprised of a combination of identifiers for the STP's city (or locality), state (or province), building, and traffic unit identity. The format of the CLLI is:

The first four characters identify the city, town, or locality.

The first character of the CLLI must be an alphabetical character.

The fifth and sixth characters identify state or province.

The seventh and eighth characters identify the building.

The last three characters identify the traffic unit.

## Control Shelf

The shelf in the EAGLE that contains the Maintenance and Administration Subsystem. The Maintenance and Administration Subsystem contains 5 cards: 2 CAM cards, 2 TDMs (Terminal Disk Modules), and 1 MDAL (Maintenance Disk and Alarm) card. This shelf is designated as Shelf 1100 and cannot be added or removed from the database.

## C

|     |                                                                                                                                                                                                                                                                                  |
|-----|----------------------------------------------------------------------------------------------------------------------------------------------------------------------------------------------------------------------------------------------------------------------------------|
| CSU | Channel Service Unit                                                                                                                                                                                                                                                             |
| CSV | Comma-separated values<br>The comma-separated value file format is a delimited data format that has fields separated by the comma character and records separated by newlines (a newline is a special character or sequence of characters signifying the end of a line of text). |

## D

|          |                                                                                                                                                                                                                                                                                                    |
|----------|----------------------------------------------------------------------------------------------------------------------------------------------------------------------------------------------------------------------------------------------------------------------------------------------------|
| Database | All data that can be administered by the user, including cards, destination point codes, gateway screening tables, global title translation tables, links, LNP services, LNP service providers, location routing numbers, routes, shelves, subsystem applications, and 10 digit telephone numbers. |
| DB       | Database<br>Daughter Board<br>Documentation Bulletin<br>Data bus                                                                                                                                                                                                                                   |
| DC       | Direct Current<br>Data Collection                                                                                                                                                                                                                                                                  |
| DCM      | Database Communication Module<br>The DCM provides IP connectivity for applications. Connection to a host is achieved through an ethernet LAN using the TCP/IP protocol.                                                                                                                            |
| DLK      | Data Link                                                                                                                                                                                                                                                                                          |

## D

TCP/IP Data Link

DO

Derived Object

DPC

Destination Point Code - DPC refers to the scheme in SS7 signaling to identify the receiving signaling point. In the SS7 network, the point codes are numeric addresses which uniquely identify each signaling point. This point code can be adjacent to the EAGLE, but does not have to be.

DS0

Digital Signal Level-0 (64 Kbits/sec or 56 Kbits/sec)

A basic digital signaling rate of 64 Kbits/sec, corresponding to the capacity of one voice-frequency-equivalent channel.

DS1

Digital Signal Level-1 (1.544Mbits/sec)

A widely used standard in telecommunications in North America and Japan to transmit voice and data between devices. The data transmitted over a physical T1 line.

DSM

Database Service Module.

The DSM provides large capacity SCCP/database functionality. The DSM is an application card that supports network specific functions such as EAGLE Provisioning Application Processor (EPAP), Global System for Mobile Communications (GSM), EAGLE

## D

Local Number Portability (ELAP), and interface to Local Service Management System (LSMS).

DSO Fault sectionalization tests, a series of far-end loopback tests to identify faulty segments of an SS7 transmission path up to and including the remote network element.

DSU Data Service Unit

DTA Database Transport Access - A feature in the EAGLE that encapsulates specific MSUs into the data portion of SCCP within a new SS7 MSU and sends the new MSU to the destination using global title translation. The EAGLE uses gateway screening to determine which MSUs are used by the DTA feature.

DUT Design Under Test

DVD Digital Versatile Disk

## E

E1 The European equivalent of T1 that transmits digital data over a telephone network at 2.048 Mbps.

E5-APP-B The E5-APP-B card is a complete application server platform designed to operate within a heavy duty EAGLE shelf. An E5-APP-B card consists of the card, a microprocessor, 8 GB RAM, and two removable drive modules with



## E

an operating system and an application, such as EPAP, loaded.

E5-E1T1

EPM-based E1/T1 Multi-Channel Interface Module

An EPM-based card that provides E1 and T1 connectivity. E1T1 is an abbreviation for the ITU E1 and ANSI T1 interfaces. Thus the nomenclature defines the shelves where the card can be used and the physical interface that it provides.

E5-ENET

EPM-based Ethernet card

A high capacity single-slot IP signaling card (EPM card plus Gig Ethernet PMC cards).

EC

External Condition

Condition that is passed on the external condition interface.

EDCM

Enhanced DCM

Enhanced Database Communication Module

EF

Extension Frame

ELAP

EAGLE Local Number Portability Application Processor

The EAGLE LNP Application Processor (ELAP) platform provides capacity and performance required to support the ported number database.

**E**

|                 |                                                                                                                                                                                                                                                               |
|-----------------|---------------------------------------------------------------------------------------------------------------------------------------------------------------------------------------------------------------------------------------------------------------|
| EMDC            | <p>Element Measurement and Data Collection Application</p> <p>This application is used by the DCM card for CMIP/OSI measurement collection interface as defined by Telcordia GR-376.</p>                                                                      |
| ENET            | <p>Ethernet</p> <p>Can refer to a generic hardware type that supports one or more Ethernet interfaces.</p>                                                                                                                                                    |
| EPAP            | <p>EAGLE Provisioning Application Processor</p>                                                                                                                                                                                                               |
| ESF             | <p>Extended Super Frame</p>                                                                                                                                                                                                                                   |
| ESP             | <p>Expanded Services Platform</p> <p>The Sentinel system with the hardware and software platform that provides the interface to the Integrated EAGLE and Sentinel monitoring system. The ESP hardware and software platform runs on the model 120 server.</p> |
| Extension Shelf | <p>See ES.</p>                                                                                                                                                                                                                                                |

**F**

|     |                                                                                                                                                                                                                                                                                                            |
|-----|------------------------------------------------------------------------------------------------------------------------------------------------------------------------------------------------------------------------------------------------------------------------------------------------------------|
| FAN | <p>Cooling fan feature. The EAGLE will report on the alarm conditions of the fan assemblies. Once you have turned on the feature, you cannot turn it off. The feature applies to any and all fans installed within the system. When replacing a fan assembly, the feature should already be turned on.</p> |
|-----|------------------------------------------------------------------------------------------------------------------------------------------------------------------------------------------------------------------------------------------------------------------------------------------------------------|

**F**

|     |                                                                                                                                                                                          |
|-----|------------------------------------------------------------------------------------------------------------------------------------------------------------------------------------------|
| FAP | Fuse and Alarm Panel                                                                                                                                                                     |
| FD  | Feature Description<br>File Descriptor<br>File Duplicator<br>Fixed Disk                                                                                                                  |
| FE  | Feature Engineer<br>Front End – Used in Provisioning<br>Front End Applications<br>Front End                                                                                              |
| FTA | File Transfer Area<br><br>A special area that exists on each OAM hard disk, used as a staging area to copy files to and from the EAGLE using the Kermit file-transfer protocol.          |
| FTP | File Transfer Protocol<br><br>A client-server protocol that allows a user on one computer to transfer files to and from another computer over a TCP/IP network.<br><br>Feature Test Plan |

**G**

|     |                                                                                                                              |
|-----|------------------------------------------------------------------------------------------------------------------------------|
| GB  | Gigabyte — 1,073,741,824 bytes                                                                                               |
| GLS | Generic Loading Services<br><br>An application that is used by the TSM cards for downloading gateway screening to LIM cards. |
| GMT | Greenwich Mean Time                                                                                                          |

## G

|     |                                                                                                                                                                                                                                                                                                                                                                                                                                                                        |
|-----|------------------------------------------------------------------------------------------------------------------------------------------------------------------------------------------------------------------------------------------------------------------------------------------------------------------------------------------------------------------------------------------------------------------------------------------------------------------------|
| GPL | <p>Generic Program Load</p> <p>Software that allows the various features in the system to work. GPLs and applications are not the same software.</p>                                                                                                                                                                                                                                                                                                                   |
| GSM | <p>Global System for Mobile Communications</p> <p>A second generation digital PCS mobile phone standard used in many parts of the world.</p>                                                                                                                                                                                                                                                                                                                           |
| GTT | <p>Global Title Translation</p> <p>A feature of the signaling connection control part (SCCP) of the SS7 protocol that the EAGLE uses to determine which service database to send the query message when an MSU enters the EAGLE and more information is needed to route the MSU. These service databases also verify calling card numbers and credit card numbers. The service databases are identified in the SS7 network by a point code and a subsystem number.</p> |
| GWS | <p>Gateway Screening</p> <p>Used at gateway STPs to limit access into the network to authorized users. A gateway STP performs inter-network routing and gateway screening functions. GWS controls access to nonhome SS7 networks. Only an MSU that matches predefined criteria in the EAGLE database is allowed to enter the EAGLE.</p>                                                                                                                                |

## H

## H

## HC-MIM

## High Capacity Multi-Channel Interface Module

A card that provides access to eight E1/T1 ports residing on backplane connectors A and B. Each data stream consists of 24 T1 or 31 E1 DS0 signaling links assigned in a time-division multiplex (TDM) manner. Each channel occupies a unique timeslot in the data stream and can be selected as a local signaling link on the interface card. Each card has 8 E1 or 8 T1 port interfaces with a maximum of 64 signaling links provisioned among the 8 E1/T1 ports.

## HIPR

## High-Speed IMT Packet Router

A card that provides increased system throughput and traffic capacity. HIPR moves EAGLE from an intra-shelf ring topology to an intra-shelf switch topology. HIPR acts as a gateway between the intra-shelf IMT BUS, running at 125Mbps, and the inter-shelf operating at 1.0625Gbps. The HIPR card will seat in the same slot as an HMUX card (slots xx09 & xx10 of each shelf).

## HIPR2

## High-Speed IMT Packet Router 2

A card that provides increased system throughput and traffic capacity on the existing Fibre-Channel ring. A high rate Fibre-Channel option of 2.5 Gbps is available when an EAGLE is provisioned with all HIPR2 cards. In a mixed topology where a HIPR2 is used in an EAGLE along with HMUX and HIPR, the Fibre-Channel ring runs at the lower rate of 1.0625 Gbps.

## H

HS High Speed

## I

ID Identity, identifier

INP INAP-based Number Portability  
 Tekelec's INP can be deployed as a stand-alone or an integrated signal transfer point/number portability solution. With Tekelec's stand-alone NP server, no network reconfiguration is required to implement number portability. The NP server delivers a much greater signaling capability than the conventional SCP-based approach.  
 Intelligent Network (IN) Portability

IPLIM The application used by the SSEDCEM/E5-ENET card for IP point-to-point connectivity for ANSI point codes.

IPMX IMT Power and Multiplexer card

IS-ANR In Service - Abnormal  
 The entity is in service but only able to perform a limited subset of its normal service functions.

IS-NR In Service - Normal

ISS Integrated Signaling System

ITU International Telecommunications Union

## I

An organization that operates worldwide to allow governments and the private telecommunications sector to coordinate the deployment and operating of telecommunications networks and services. The ITU is responsible for regulating, coordinating and developing international telecommunications, and for harmonizing national political interests.

## K

KSR Keyboard Send/Receive Mode

## L

LAN Local Area Network

A private data network in which serial transmission is used for direct data communication among data stations located in the same proximate location. LAN uses coax cable, twisted pair, or multimode fiber.

See also STP LAN.

latched USB port On the E5-MCAP card, a USB port with a lockable latch. Used with removable media (flash memory "thumb" drives) to install and back up customer data.

LED Light Emitting Diode

An electrical device that glows a particular color when a specified voltage is applied to it.

LFS Link Fault Sectionalization

## L

A feature in the EAGLE that allows the maintenance personnel to perform a series of far end loopback tests, from the EAGLE and identify faulty segments of an SS7 transmission path up to and including the remote network element.

## LIM

## Link Interface Module

Provides access to remote SS7, IP and other network elements, such as a Signaling Control Point (SCP) through a variety of signaling interfaces (DS0, MPL, E1/T1 MIM, LIM-ATM, E1-ATM, IPLIMx, IPGWx). The LIMs consist of a main assembly and possibly, an interface appliqué board. These appliqués provide level one and some level two functionality on SS7 signaling links.

## Link

## Signaling Link

## Signaling Link

Carries signaling within a Link Set using a specific Association. A Link can belong to only one Link Set and one Association. There is generally one Link per Association in a Link Set.

## LLT

## Latching LFS Test

## LNP

## Local Number Portability

The ability of subscribers to switch local or wireless carriers and still retain the same phone number.

## LS

## Link Set



**L**

A group of signaling links carrying traffic to the same signaling point.

Represents a logical signaling connection from one HLR Router point code to one adjacent point code.

LSMS

Local Service Management System

An interface between the Number Portability Administration Center (NPAC) and the LNP service databases. The LSMS receives LNP data from the NPAC and downloads that data to the service databases. LNP data can be entered into the LSMS database. The data can then be downloaded to the LNP service databases and to the NPAC.

**M**

MAN

Metropolitan Area Network  
Manual

MAS

Maintenance and Administration Subsystem

A set of cards located in the Control Shelf, used to provide a central management point for the EAGLE. The MAS provides user interface, maintenance communication, peripheral services, alarm processing, system disk interface, and measurements using the following three subassemblies: GPSM-II, TDM, and MDAL.

MASP

Maintenance and Administration Subsystem Processor

The Maintenance and Administration Subsystem

## M

Processor (MASP) function is a logical pairing of the GPSM-II card and the TDM card. The GPSM-II card is connected to the TDM card by means of an Extended Bus Interface (EBI) local bus.

The MDAL card contains the removable cartridge drive and alarm logic. There is only one MDAL card in the Maintenance and Administration Subsystem (MAS) and it is shared between the two MASPs.

|          |                                                                                                                                                                                                                                         |
|----------|-----------------------------------------------------------------------------------------------------------------------------------------------------------------------------------------------------------------------------------------|
| MCA      | Matrix Controller Assembly                                                                                                                                                                                                              |
| MCAP     | Maintenance Communications & Applications Processor                                                                                                                                                                                     |
| MCPM     | Measurement Collection and Polling Module<br><br>Provides comma delimited core STP measurement data to a remote server for processing. The MCPM is either an EDSM with 2 GB of memory or an E5-MCPM-B card running the MCP application. |
| MEASPLAT | Measurements Platform                                                                                                                                                                                                                   |
| MIM      | Multi-Channel Interface Module                                                                                                                                                                                                          |
| MIN      | Mobile Identification Number                                                                                                                                                                                                            |
| MMI      | Man-Machine Interface                                                                                                                                                                                                                   |
| MPL      | Multi-port LIM                                                                                                                                                                                                                          |

## M

MPS

## Multi-Purpose Server

The Multi-Purpose Server provides database/reload functionality and a variety of high capacity/high speed offboard database functions for applications. The MPS resides in the General Purpose Frame.

## Messages Per Second

A measure of a message processor's performance capacity. A message is any Diameter message (Request or Answer) which is received and processed by a message processor.

MRN

## Message Reference Number

An unsolicited numbered message (alarm or information) that is displayed in response to an alarm condition detected by the system or in response to an event that has occurred in the system.

## Mated Relay Node

A mated relay node (MRN) group is provisioned in the database to identify the nodes that the traffic is load shared with, and the type of routing, either dominant, load sharing, or combined dominant/load sharing.

MSU

## Message Signal Unit

The SS7 message that is sent between signaling points in the SS7 network with the necessary information to get the message to its destination and allow the signaling points in the network to set up either a voice or data connection between themselves. The message contains the following information:

## M

- The forward and backward sequence numbers assigned to the message which indicate the position of the message in the traffic stream in relation to the other messages.
- The length indicator which indicates the number of bytes the message contains.
- The type of message and the priority of the message in the signaling information octet of the message.
- The routing information for the message, shown in the routing label of the message, with the identification of the node that sent message (originating point code), the identification of the node receiving the message (destination point code), and the signaling link selector which the EAGLE uses to pick which link set and signaling link to use to route the message.

MTP

Message Transfer Part

The levels 1, 2, and 3 of the SS7 protocol that control all the functions necessary to route an SS7 MSU through the network

Module Test Plan

## N

NA

North America

Not Applicable

Nature of Address

NDC

Network destination code

Network Data Collection

## N

|                 |                                                                                                                                                                                                                                                                                                                                                                                   |
|-----------------|-----------------------------------------------------------------------------------------------------------------------------------------------------------------------------------------------------------------------------------------------------------------------------------------------------------------------------------------------------------------------------------|
| NE              | <p>Network Element</p> <p>An independent and identifiable piece of equipment closely associated with at least one processor, and within a single location.</p> <p>In a 2-Tiered DSR OAM system, this includes the NOAM and all MPs underneath it. In a 3-Tiered DSR OAM system, this includes the NOAM, the SOAM, and all MPs associated with the SOAM.</p> <p>Network Entity</p> |
| NEI             | Network Element Interface                                                                                                                                                                                                                                                                                                                                                         |
| Network Element | See NE                                                                                                                                                                                                                                                                                                                                                                            |
| NLT             | Nonlatching LFS Test                                                                                                                                                                                                                                                                                                                                                              |
| NO              | <p>Network OAM&amp;P</p> <p>A server that manages a collection of SOs and their corresponding MPs. NO servers are deployed in active/standby pairs.</p>                                                                                                                                                                                                                           |
|                 | <b>O</b>                                                                                                                                                                                                                                                                                                                                                                          |
| OAM             | <p>Operations, Administration, and Maintenance</p> <p>The application that operates the Maintenance and Administration Subsystem which controls the operation of many products.</p>                                                                                                                                                                                               |
| OAM switchover  | When the Active OAM gives up control (e.g. Init, Isolated, Obit) and either the Standby OAM becomes the Active or the old Active                                                                                                                                                                                                                                                  |

## O

becomes a newly re initialized Active. This is a time when existing maintenance and status information is lost and must be relearned.

OCU

Office Channel Unit

The interface used with the LIMOCU card.

OEM

Original Equipment Manufacturer

OOS

Out of Service

OOS-MT

Out of Service - Maintenance

The entity is out of service and is not available to perform its normal service function. The maintenance system is actively working to restore the entity to service.

OP

Operation

OS

Operating System

Operations Systems

## P

PC

Point Code

The identifier of a signaling point or service control point in a network. The format of the point code can be one of the following types:

- ANSI point codes in the format network indicator-network cluster-network cluster member (**ni-nc-ncm**).

## P

- Non-ANSI domestic point codes in the format network indicator-network cluster-network cluster member (**ni-nc-ncm**).
- Cluster point codes in the format network indicator-network cluster-\* or network indicator-\*-\*.
- ITU international point codes in the format **zone-area-id**.
- ITU national point codes in the format of a 5-digit number (**nnnnn**), or 2, 3, or 4 numbers (members) separated by dashes (**m1-m2-m3-m4**) as defined by the Flexible Point Code system option. A group code is required (**m1-m2-m3-m4-gc**) when the ITUDUPPC feature is turned on.
- 24-bit ITU national point codes in the format main signaling area-subsignaling area-service point (**msa-ssa-sp**).

PST

## Primary State

A field in the `rept-stat` command outputs showing the primary state of the specified entity.

## R

RAID

## Redundant Array of Independent Disks

A group of disks presented to clients as one or more large virtual disks, with accesses coordinated among multiple disks concurrently to increase performance, reliability, or both.

**R**

|       |                                                                                                                                                                    |
|-------|--------------------------------------------------------------------------------------------------------------------------------------------------------------------|
| RAM   | Random Access Memory<br>A type of computer memory that can be accessed randomly; that is, any byte of memory can be accessed without touching the preceding bytes. |
| RD    | Receive Data<br>Removable Disk                                                                                                                                     |
| RJ    | Registered Jack                                                                                                                                                    |
| RMA   | Return Material Authorization                                                                                                                                      |
| ROM   | Read Only Memory                                                                                                                                                   |
| Route | A signaling path from an LSP to an RSP using a specified Link Set                                                                                                  |
| RS    | Requirement Specification<br>Redirect Server                                                                                                                       |
| RTDB  | Real Time Database                                                                                                                                                 |

**S**

|      |                                                                                                                                                                                                                                                                                                 |
|------|-------------------------------------------------------------------------------------------------------------------------------------------------------------------------------------------------------------------------------------------------------------------------------------------------|
| SCCP | Signaling Connection Control Part<br>The signaling connection control part with additional functions for the Message Transfer Part (MTP) in SS7 signaling. Messages can be transmitted between arbitrary nodes in the signaling network using a connection-oriented or connectionless approach. |
|------|-------------------------------------------------------------------------------------------------------------------------------------------------------------------------------------------------------------------------------------------------------------------------------------------------|



## S

|      |                                                                                                                                                                                                                                                                                                                                                                                                     |
|------|-----------------------------------------------------------------------------------------------------------------------------------------------------------------------------------------------------------------------------------------------------------------------------------------------------------------------------------------------------------------------------------------------------|
| SCSI | <p>Small Computer System Interface</p> <p>There are two independent Small Computer System Interface (SCSI) buses, one to the fixed disks on TDM cards and the other to the shared administration SCSI bus that runs on the backplane between TDMs and the MDAL card. Each SCSI bus has a block of memory that allows transfers from memory to occur without delaying the application processor.</p> |
| SEAS | <p>Signaling Engineering and Administration System</p> <p>An interface defined by Bellcore and used by the Regional Bell Operating Companies (RBOCs), as well as other Bellcore Client Companies (BCCs), to remotely administer and monitor the signaling points in their network from a central location.</p>                                                                                      |
| SLAN | <p>Signaling Transfer Point Local Area Network</p> <p>A feature in the EAGLE that copies MSUs selected through the gateway screening process and sends these MSUs over the Ethernet to an external host computer for further processing.</p>                                                                                                                                                        |
| SLC  | <p>Signaling Link Code</p>                                                                                                                                                                                                                                                                                                                                                                          |
| SLTA | <p>Signaling Link Test Acknowledgment</p>                                                                                                                                                                                                                                                                                                                                                           |
| SLTC | <p>Signaling Link Test Controller</p>                                                                                                                                                                                                                                                                                                                                                               |

## S

|      |                                                                                                                                                                                                                                                                                                                                                                                                             |
|------|-------------------------------------------------------------------------------------------------------------------------------------------------------------------------------------------------------------------------------------------------------------------------------------------------------------------------------------------------------------------------------------------------------------|
| SLTM | Signal Link Test Message                                                                                                                                                                                                                                                                                                                                                                                    |
| SR   | Screening Reference                                                                                                                                                                                                                                                                                                                                                                                         |
| SS   | Subsystem<br>Supplementary Services                                                                                                                                                                                                                                                                                                                                                                         |
| SS7  | Signaling System #7<br><br>A communications protocol that allows signaling points in a network to send messages to each other so that voice and data connections can be set up between these signaling points. These messages are sent over its own network and not over the revenue producing voice and data paths. The EAGLE is an STP, which is a device that routes these messages through the network. |
| SST  | Secondary State<br><br>The secondary state of the specified entity.<br><br>Subsystem Status Test<br><br>Subsystem Status Test network management message.<br><br>Subsystem Status Test SCCP (SCMG) management message. (CER)                                                                                                                                                                                |
| STP  | Signal Transfer Point<br><br>The STP is a special high-speed switch for signaling messages in SS7 networks. The STP routes core INAP communication between the Service Switching Point (SSP) and the Service Control Point (SCP) over the network.                                                                                                                                                          |

## S

Spanning Tree Protocol

STP LAN

Signaling Transfer Point Local Area Network.

A feature in the EAGLE that copies MSUs selected through the gateway screening process and sends these MSUs over the Ethernet to an external host computer for further processing.

STPLAN

Signaling Transfer Point Local Area Network

The application used by the SLAN card and E5-SLAN card to support the STP LAN feature. This application does not support 24-bit ITU-N point codes.

## T

T1

Transmission Level 1

A T1 interface terminates or distributes T1 facility signals for the purpose of processing the SS7 signaling links carried by the E1 carrier.

A leased-line connection capable of carrying data at 1,544,000 bits-per-second.

TCP/IP

Transmission Control Protocol/Internet Protocol

TDM

Terminal Disk Module

Time Division Multiplexing

Data transmissions within individual connections follow a pre-defined multiplex scheme

## T

where a fixed time slot is available for each channel.

|      |                                                                                                                                                                                                                                                         |
|------|---------------------------------------------------------------------------------------------------------------------------------------------------------------------------------------------------------------------------------------------------------|
| TFP  | TransFer Prohibited (Msg)<br>A procedure included in the signaling route management (functionality) used to inform a signaling point of the unavailability of a signaling route.                                                                        |
| TFR  | Transfer Restricted                                                                                                                                                                                                                                     |
| TO   | Timing Output                                                                                                                                                                                                                                           |
| TOCA | Timing Output Composite Automatic                                                                                                                                                                                                                       |
| TRM  | Termination Response Mode                                                                                                                                                                                                                               |
| TSM  | Translation Services Module<br>Provides translation capability and Global Title Translation (GTT) implementation for the Local Number Portability (LNP) function and is used for downloading gateway screening tables to link interface modules (LIMs). |
| TX   | Transmit                                                                                                                                                                                                                                                |

## U

|     |                                                                                                                                                                                                       |
|-----|-------------------------------------------------------------------------------------------------------------------------------------------------------------------------------------------------------|
| UAM | Unsolicited Alarm Message<br>A message sent to a user interface whenever there is a fault that is service-affecting or when a previous problem is corrected. Each message has a trouble code and text |
|-----|-------------------------------------------------------------------------------------------------------------------------------------------------------------------------------------------------------|

## U

associated with the trouble condition.

## UIM

## Unsolicited Information Message

A message sent to a user interface whenever there is a fault that is not service-affecting or when a previous problem is corrected. Each message has a trouble code and text associated with the trouble condition.

## V

## VOM

## Volt Ohm Meter

## VSCCP

## VxWorks Signaling Connection Control Part

The application used by the Service Module card to support EPAP-related features and LNP features. If an EPAP-related or LNP feature is not turned on, and a Service Module card is present, the VSCCP application processes normal GTT traffic.