

8

7

6

5

4

3

2



1

- NOTES: UNLESS OTHERWISE SPECIFIED
- 1) INSTALL ALL CABLE ASSEMBLIES WITH DRESSED BEND RADII IN ACCORDANCE WITH TEKELEC CABLE BEND RADIUS SPECIFICATION 906-0020-01.
  - 2) ALL INTERCONNECTION POINTS SHALL BE STRAIN RELIEVED BY POSITIVE MECHANICAL FEATURES OR FASTENERS FOR LENGTH CONFIGURATIONS.
  - 3) THIS DIAGRAM AND ALL PART NUMBERS SHOWN ARE FOR REFERENCE ONLY. REFERENCE CABLE PART NUMBERS WITH XX FOR THE DASH NUMBER ARE LENGTHS THAT ARE SITE SPECIFIC. SEE APPROPRIATE BILL OF MATERIALS FOR SPECIFIC PART NUMBERS AND QUANTITIES.
  - 4) NO ADDITIONS, DELETIONS, SUBSTITUTIONS OR MODIFICATIONS WITHOUT PRIOR WRITTEN TEKELEC APPROVAL.
  - 5) SEE TEKELEC P/N 820-2410-01 FOR CURRENT LIST HARDWARE.
  - 6) ALL POWER CABLES ARE CONNECTED WITH THE RED LEAD TO -48VDC TERMINAL AND THE BLACK LEAD TO RETURN TERMINAL.
  - 7) -48 VDC, RTN, AND GND PRIMARY CABLING EXITING THE FRAME SHALL BE 6 AWG. SEE TABLES C, D AND E FOR LENGTH CONFIGURATIONS.
  - 8) USE LABEL PN 617-0009-01 TO MAKE LABEL SET FOR FROM AND TO ON CABLES AS INDICATED ON THE CABLE TABLES AND/OR THE APPLICATION TR. EACH CABLE INDICATED WILL REQUIRE 2 LABELS AS SHOWN IN DETAIL K. PERMANENTLY PRINT LABELS WITH .09 HIGH BLACK CHARACTERS. CENTER TEXT APPROXIMATELY AS SHOWN. MAX 23 CHARACTERS PER LINE. SEE DETAIL L FOR PLACEMENT OF LABELS ON CABLES.
  - 9) USE LABEL PN 617-0009-01 TO MAKE THE FOLLOWING LABELS. PERMANENTLY PRINT LABELS WITH .09 HIGH BLACK CHARACTERS. CENTER TEXT APPROXIMATELY AS SHOWN. MAX 23 CHARACTERS PER LINE.  
 LABEL FOR SERVER A PCI 2 Serial Port 0: SERVER A PCI2 P0  
 LABEL FOR SERVER A PCI 2 Serial Port 1: CUSTOMER MMI  
 LABEL FOR SERVER A PCI 2 Serial Port 3: RESERVED  
 LABEL FOR SERVER A PCI 2 Serial Port 4: CUSTOMER TERMINAL  
 LABEL FOR SERVER A PCI 8 Serial Port 0: SERVER A PC18 P0  
 LABEL FOR SERVER B PCI 8 Serial Port 0: SERVER B PC18 P0
  - 10) SERVER F MAY BE REFERRED TO AS SERVER SPR. SEE CABLE KIT AND APPLICATION TR.
  - 11) ORIGINAL PART NUMBERS TO BE USED FOR REFERENCE ONLY. CROSS-REFERENCE PART NUMBERS, IN PARENTHESIS, SHALL BE USED FOR PRODUCTION OR REPLACEMENT SYSTEMS.

DOCUMENT CONTROL  
PRODUCTION RELEASED

REVISIONS			
REV	DESCRIPTION	DATE	APPROVED
A	RELEASED PER ECO #14993	9/13/05	ARMSTRONG
B	REVISED PER ECO #15288	10/21/05	ARMSTRONG
C	REVISED PER ECO #16098	06/26/06	ARMSTRONG

GO TO NEXT PAGE

UNLESS OTHERWISE SPECIFIED: DO NOT SCALE DRAWING. DIMENSIONS ARE IN INCHES. INTERPRET DIMENSIONS IN ACCORDANCE WITH ASME Y14.5M-1994. DRAWING TO CONFORM TO TEKELEC SPECIFICATION 907-0169-01. DEBURR AND BREAK SHARP EDGES AND CORNERS .005-.015. MACHINED SURFACE FINISH 12.5 ✓ DECIMAL TOLERANCES: .XX = ±.02 .XXX = ±.005 ANGLE TOLERANCE: ± 1°			THIS DOCUMENT AND THE DATA DISCLOSED HEREIN OR HEREMITH IS PROPRIETARY AND IS NOT TO BE REPRODUCED, USED OR DISCLOSED IN WHOLE OR PART TO ANYONE WITHOUT THE WRITTEN PERMISSION OF TEKELEC. COPYRIGHT TEKELEC 2006.	 5200 Paramount Parkway Morrisville, NC 27560		
					APPROVALS DRAWN BY J. MYERS 8/18/05 CHECKED S. LYTLE 8/19/05 APPROVED ARMSTRONG 8/19/05	INTERCONNECT DIAGRAM_ POWER_GENERIC T1000 FRAME
	NEXT ASSY USED ON APPLICATION	FINISH MATERIAL			SIZE D DIVISION NSG DRAWING NO. 892-0068-01 SCALE: NONE	REV. C SHEET 1 OF 5
	 THIRD ANGLE PROJECTION				FILE NAME: 892-0068-01_C.DWG	

8

7

6

5

4

3

2

1

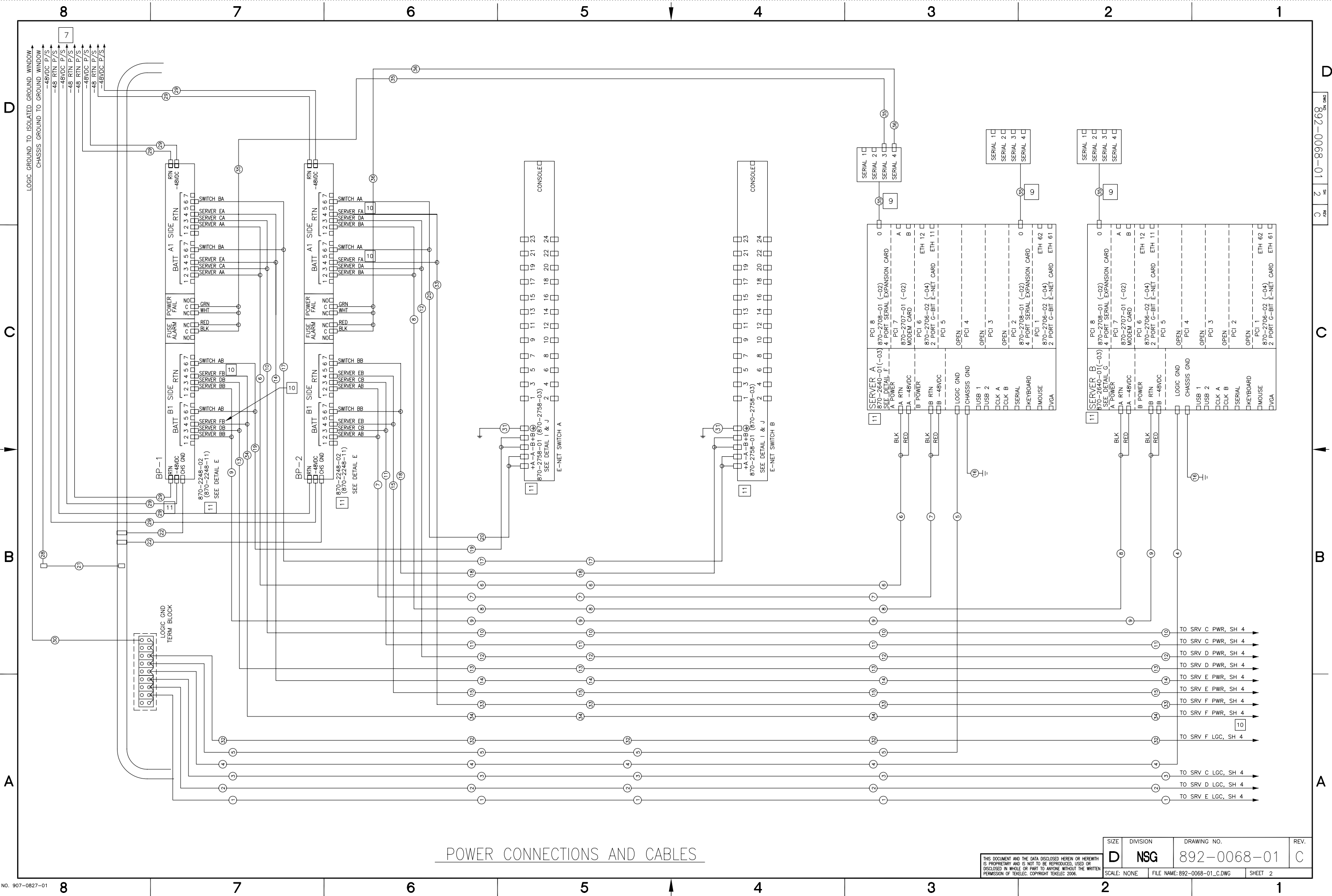

POWER CONNECTIONS AND CABLES

SIZE	DIVISION	DRAWING NO.	REV.
D	NSG	892-0068-01	C
SCALE: NONE		FILE NAME: 892-0068-01_C.DWG	SHEET 2

D

C

B

A

D

C

B

A

892-0068-01 3

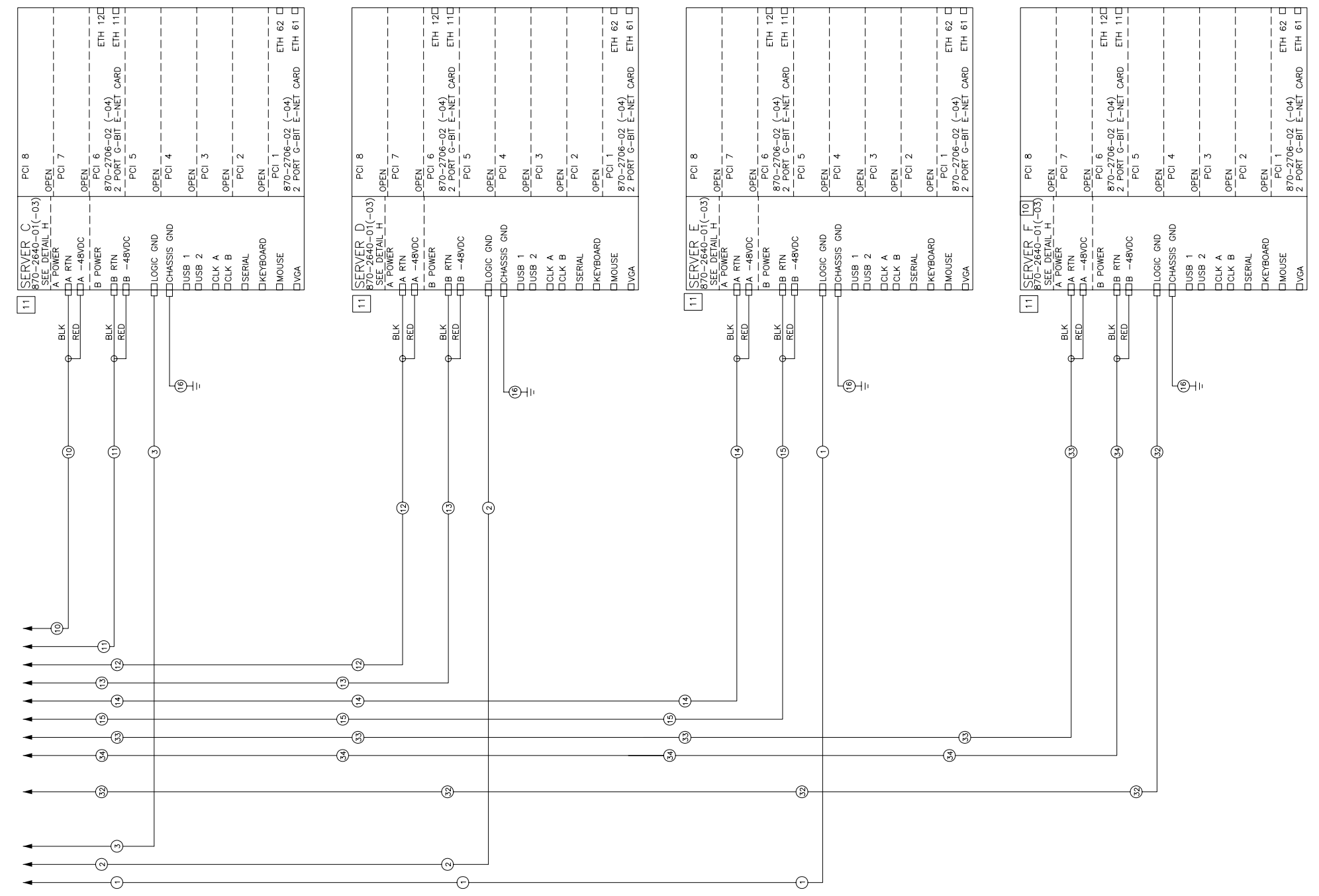

POWER CONNECTIONS AND CABLES

SIZE	DIVISION	DRAWING NO.	REV.
D	NSG	892-0068-01	C
SCALE: NONE	FILE NAME: 892-0068-01_C.DWG	SHEET 3	

11 TABLE A - POWER CABLE PART NUMBERS

ITEM NO.	TEKELEC P/N	CROSS REF. P/N	QUANTITY	LENGTH	COMMENT	LABEL
1	830-0989-05	830-1208-05	1	105.00 INCHES	FROM SERVER E TO LOGIC GROUND	SUPPLIED WITH CABLE
2	830-0989-04	830-1208-04	1	95.00 INCHES	FROM SERVER D TO LOGIC GROUND	SUPPLIED WITH CABLE
3	830-0989-03	830-1208-03	1	87.00 INCHES	FROM SERVER C TO LOGIC GROUND	SUPPLIED WITH CABLE
4	830-0989-02	830-1208-02	1	79.00 INCHES	FROM SERVER B TO LOGIC GROUND	SUPPLIED WITH CABLE
5	830-0989-01	830-1208-01	1	67.00 INCHES	FROM SERVER A TO LOGIC GROUND	SUPPLIED WITH CABLE
6	830-0988-01	830-1207-01	1	64.00 INCHES	FROM SERVER A-A PWR TO BP1-2A	SUPPLIED WITH CABLE
7	830-0988-02	830-1207-02	1	55.00 INCHES	FROM SERVER A-B PWR TO BP2-2B	SUPPLIED WITH CABLE
8	830-0988-03	830-1207-03	1	72.00 INCHES	FROM SERVER B-A PWR TO BP2-2A	SUPPLIED WITH CABLE
9	830-0988-04	830-1207-04	1	70.00 INCHES	FROM SERVER B-B PWR TO BP1-2B	SUPPLIED WITH CABLE
10	830-0988-05	830-1207-05	1	81.00 INCHES	FROM SERVER C-A PWR TO BP1-3A	SUPPLIED WITH CABLE
11	830-0988-06	830-1207-06	1	71.00 INCHES	FROM SERVER C-B PWR TO BP2-3B	SUPPLIED WITH CABLE
12	830-0988-07	830-1207-07	1	88.00 INCHES	FROM SERVER D-A PWR TO BP2-3A	SUPPLIED WITH CABLE
13	830-0988-08	830-1207-08	1	86.00 INCHES	FROM SERVER D-B PWR TO BP1-3B	SUPPLIED WITH CABLE
14	830-0988-09	830-1207-09	1	98.00 INCHES	FROM SERVER E-A PWR TO BP1-4A	SUPPLIED WITH CABLE
15	830-0988-10	830-1207-10	1	89.00 INCHES	FROM SERVER E-B PWR TO BP2-4B	SUPPLIED WITH CABLE
16	830-0927-01	830-1124-01	5	31.00 INCHES	FROM SERVER CHASSIS TO FRAME GROUND	SUPPLIED WITH CABLE
17	830-1013-09	830-1215-09	1	41.00 INCHES	FROM SWITCH BA PWR TO BP1-6A	SUPPLIED WITH CABLE
18	830-1013-10	830-1215-10	1	30.00 INCHES	FROM SWITCH BB PWR TO BP2-6B	SUPPLIED WITH CABLE
19	830-1013-11	830-1215-11	1	32.00 INCHES	FROM SWITCH AB PWR TO BP1-6B	SUPPLIED WITH CABLE
20	830-1013-12	830-1215-12	1	37.00 INCHES	FROM SWITCH AA PWR TO BP2-6A	SUPPLIED WITH CABLE
21	830-0715-03	830-1171-03	1	38.00 INCHES	CHASSIS GROUND TO GROUND WINDOW	NO
22	830-0830-01	830-1181-01	2	N/A	CIRCUIT BREAKER TO FRAME GND	NO
28	CHASSIS GND (FIELD ROUTED)	CHASSIS GND (FIELD ROUTED)	1	SITE SPECIFIC	SEE TABLE F	FIELD
29	-48VDC AND 48V RTN (FIELD ROUTED)	-48VDC AND 48V RTN (FIELD ROUTED)	8	SITE SPECIFIC	SEE TABLE E	FIELD
30	LOGIC GROUND	LOGIC GROUND	1	SITE SPECIFIC	SEE TABLE D	FIELD
31	830-1015-01	830-1216-01	2	N/A	FROM SWITCH TO FRAME GND	NO
32	830-0989-12 OR 830-0989-13	830-1208-12 OR 830-1208-13	10	120.00 INCHES	FROM SERVER F TO LOGIC GROUND FROM SERVER SPR TO LOGIC GROUND	SUPPLIED WITH CABLE
33	830-0988-15 OR 830-0988-17	830-1207-15 OR 830-1207-17	10	102.00 INCHES	FROM SERVER F-A PWR TO BP2-4A FROM SERVER SPR-A PWR TO BP2-4A	SUPPLIED WITH CABLE
34	830-0988-16 OR 830-0988-18	830-1207-16 OR 830-1207-18	10	100.00 INCHES	FROM SERVER F-B PWR TO BP1-4B FROM SERVER SPR-B PWR TO BP1-4B	SUPPLIED WITH CABLE
35	830-0961-05	830-1200-05	1	60.00 INCHES	SERIAL: FROM SERVER A PCIB P3 TO BP1 ALARMS	YES
36	830-0961-05	830-1200-05	1	60.00 INCHES	SERIAL: FROM SERVER A PCIB P4 TO BP2 ALARMS	YES

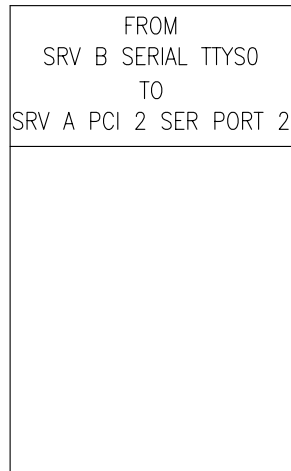
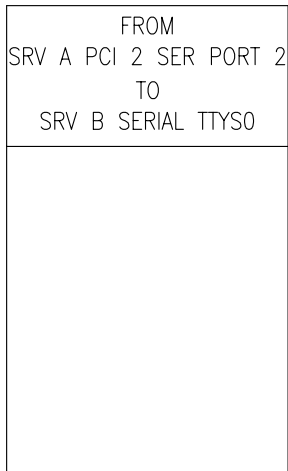

EXAMPLE OF TEXT SHOWN IN TABLES

EXAMPLE WITH TEXT REVERSED FROM FIRST LABEL

DETAIL K 8

CABLE LABEL EXAMPLE

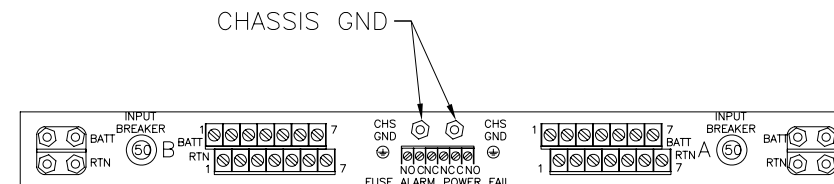
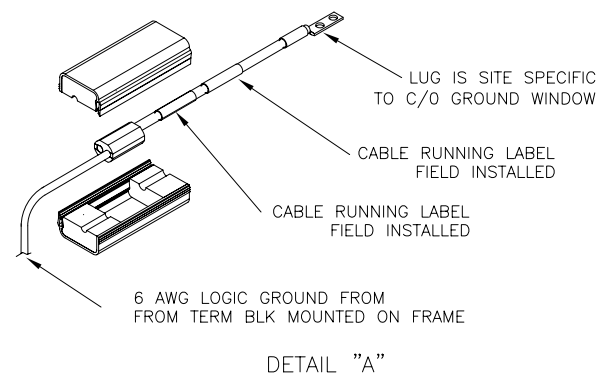

CIRCUIT BREAKER (REAR VIEW)  
870-2248-02 (870-2248-11) 11

11 TABLE B - DATA CABLE PART NUMBERS

ITEM NO.	TEKELEC P/N	CROSS-REFERENCE P/N	QUANTITY	LENGTH	COMMENT	LABEL
35	870-2708-01	870-2708-02	3	NA	4 PORT SERIAL CABLE SUPPLIED WITH PCI CARD. LABEL INFO PER NOTE 10	YES

SEE APPLICATION TR FOR ADDITIONAL DATA CABLES AND LABELING INFORMATION

9

11 TABLE C - LOGIC GROUND CABLING

DISTANCE	PRIMARY CABLE P/N (CROSS-REF. P/N)	CABLE AWG	TERMINAL P/N (CROSS-REF. P/N)	HEAT SHRINK P/N (CROSS-REF. P/N)	COMMENT	REF. DETAIL
0' - 40'	690-0131-01(-R01)	6	502-0085-01(-R01)	804-0228-01(-R01)	CABLE LENGTH IS SITE-SPECIFIC	C
40' - 160'	690-0108-07(-R01)	1/0	804-0977-01(-R01)	804-0229-01(-R01)	CABLE LENGTH IS SITE-SPECIFIC	A

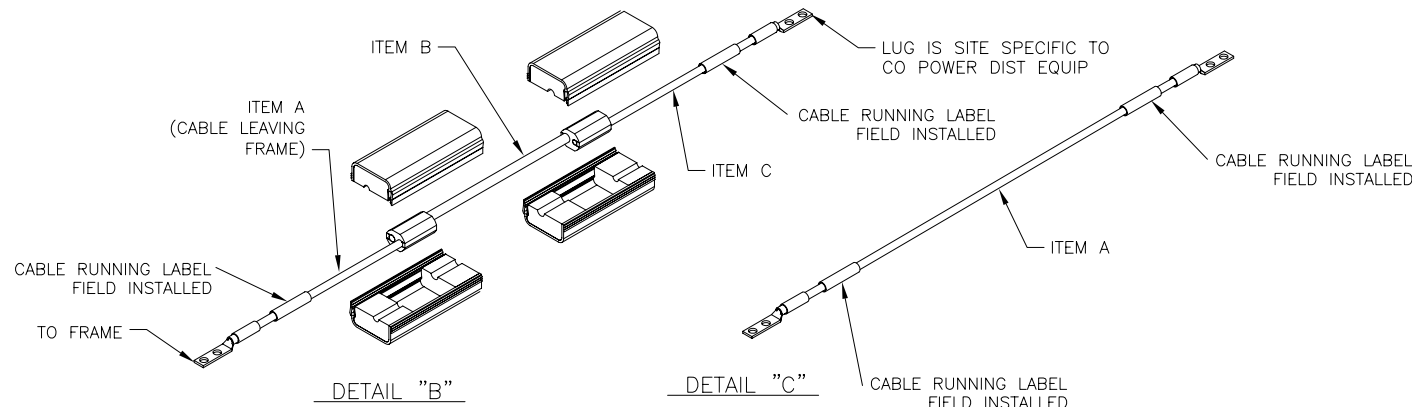
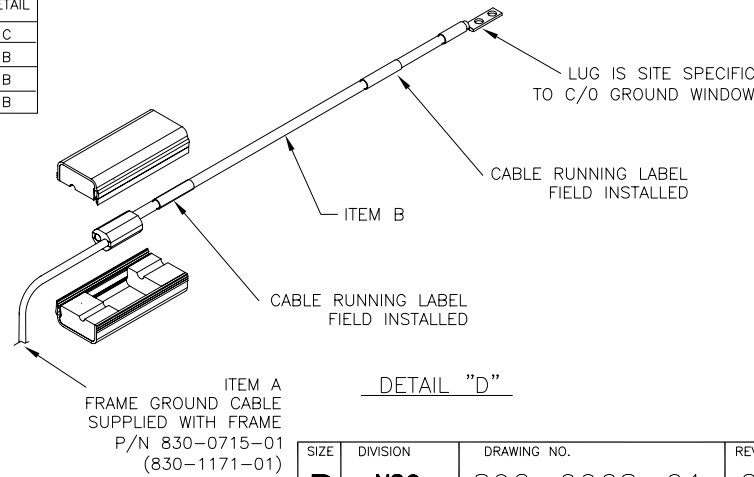

TABLE D - 48VDC & 48VRTN CABLING COMPONENTS

DISTANCE	ITEM A				ITEM B		ITEM C	HALF TAP SPLICE P/N	HTAP SOFT COVER P/N	COMMENT	REF. DETAIL
	CABLE P/N	CABLE AWG	TERMINAL LUG P/N	HEAT SHRINK P/N	CABLE P/N	CABLE AWG	CABLE CONSTRUCTION				
0' - 40'	690-0108-01(-R01)	6	502-0085-01(-R01)	804-0228-01(-R01)	N/A	--	N/A	NONE REQUIRED	NONE REQUIRED	CABLE LENGTH IS SITE-SPECIFIC	C
40' - 65'	690-0108-01(-R01)	6	502-0085-01(-R01)	804-0228-01(-R01)	690-0108-04(-R04)	4	SITE SPECIFIC	T&B 63125	T&B HTC40	CABLE LENGTH IS SITE-SPECIFIC	B
65' - 100'	690-0108-01(-R01)	6	502-0085-01(-R01)	804-0228-01(-R01)	690-0108-06(-R06)	2	SITE SPECIFIC	T&B 63125	T&B HTC40	CABLE LENGTH IS SITE-SPECIFIC, HTAPPED STUBS <= 10' EACH END	B
100' - 160'	690-0108-01(-R01)	6	502-0085-01(-R01)	804-0228-01(-R01)	690-0108-03(-R03)	1/0	SITE SPECIFIC	T&B 63125	T&B HTC40	CABLE LENGTH IS SITE-SPECIFIC, HTAPPED STUBS <= 10' EACH END	B

TABLE E - SYSTEM FRAME GROUND CABLING

DISTANCE	CABLE P/N CROSS-REF. P/N	CABLE AWG	ITEM A (830-0715-01 SUPPLIED WITH FRAME)		ITEM B		HTAP (A TO B CONNECTION) H TAP P/N	COMMENT	REF. DETAIL
			TERMINAL LUG P/N	HEAT SHRINK P/N	CABLE P/N	CABLE AWG			
0' - 40'	690-0131-01(-R01)	6	502-0085-01(-R01)	804-0228-01(-R01)	690-0131-01(-R01)	6	804-0865-01(-R01)	CABLE LENGTH IS SITE-SPECIFIC	D
40' - 160'	690-0108-01(-R01)	6	502-0085-01(-R01)	804-0228-01(-R01)	690-0108-07(-R01)	1/0	804-0865-01(-R01)	CABLE LENGTH IS SITE-SPECIFIC	D



SIZE	DIVISION	DRAWING NO.	REV.
D	NSG	892-0068-01	C

SCALE: NONE FILE NAME: 892-0068-01\_C.DWG SHEET 4

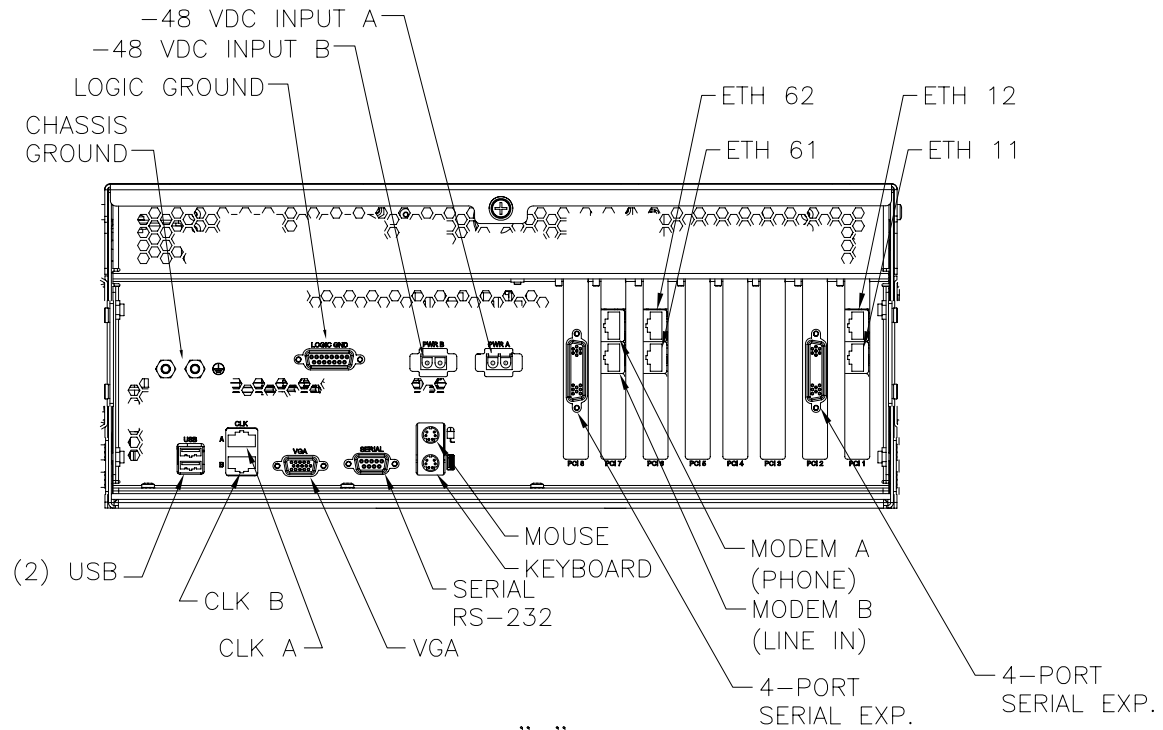

DETAIL "F"

SERVER A (REAR VIEW)

- 870-2640-01 (870-2640-03) W/ PCI CARDS:  
 SLOT 1 - 870-2706-02 (870-2706-04)  
 SLOT 2 - 870-2708-01 (870-2708-02)  
 SLOT 6 - 870-2706-02 (870-2706-04)  
 SLOT 7 - 870-2707-01 (870-2707-02)  
 SLOT 8 - 870-2708-01 (870-2708-02)

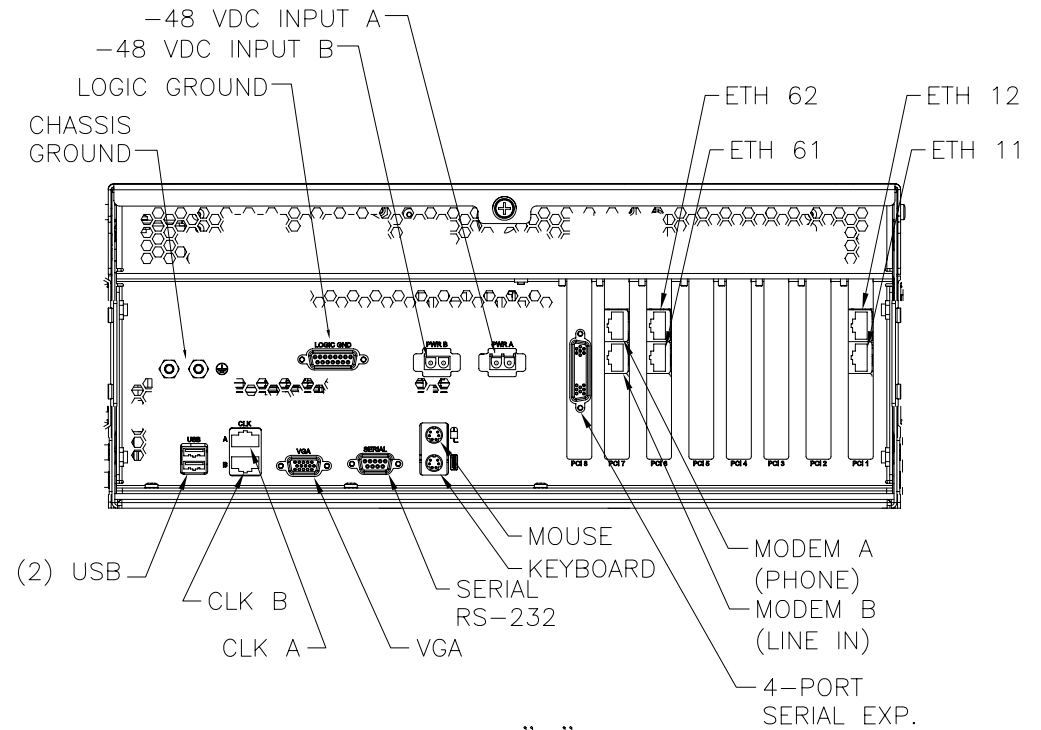

DETAIL "G"

SERVER B (REAR VIEW)

- 870-2640-01 (870-2640-02) W/ PCI CARDS:  
 SLOT 1 - 870-2706-02 (870-2706-04)  
 SLOT 6 - 870-2706-02 (870-2706-04)  
 SLOT 7 - 870-2707-01 (870-2707-02)  
 SLOT 8 - 870-2708-01 (870-2708-02)

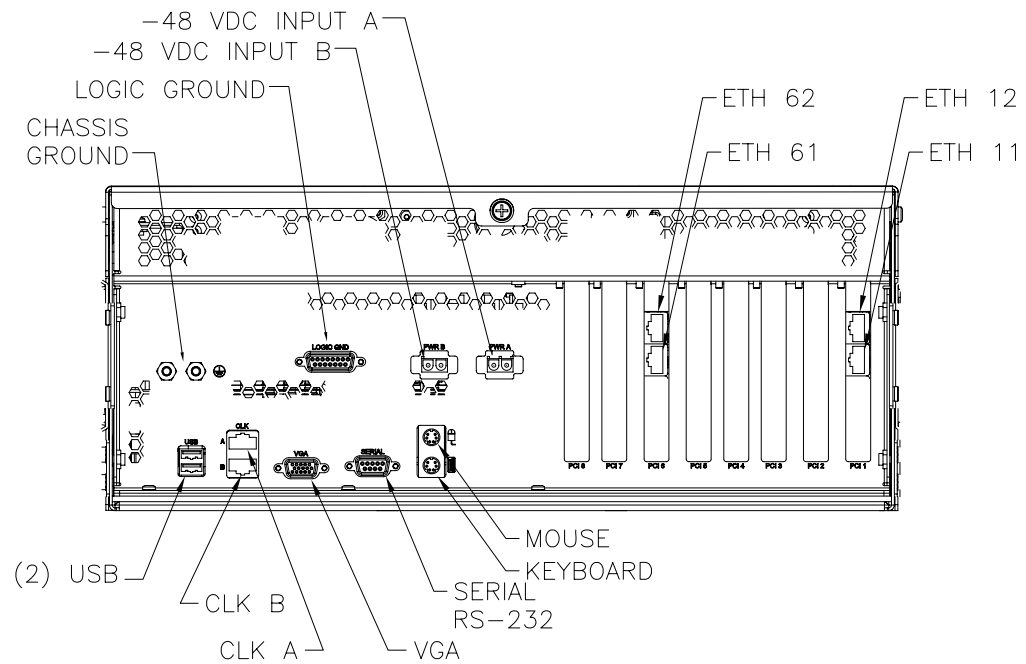

DETAIL "H"

SERVER C-F (REAR VIEW)

- 870-2640-01 (870-2640-02) W/ PCI CARDS:  
 SLOT 1 - 870-2706-02 (870-2706-04)  
 SLOT 6 - 870-2706-02 (870-2706-04)

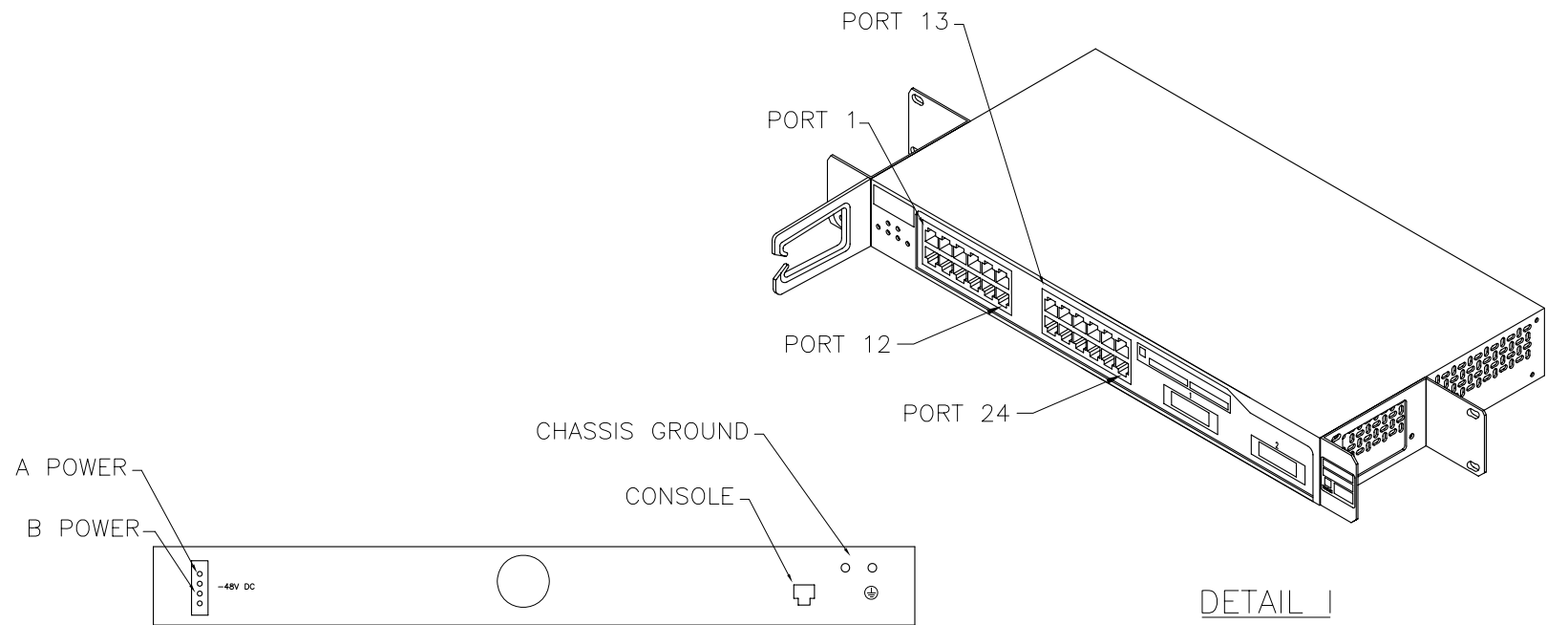

DETAIL I

ISO VIEW OF THE FRONT-SWITCH

870-2758-01 (870-2758-03)

DETAIL J

REAR VIEW-SWITCH

870-2758-01 (870-2758-03)

THIS DOCUMENT AND THE DATA DISCLOSED HEREIN OR HEREWITH IS PROPRIETARY AND IS NOT TO BE REPRODUCED, USED OR DISCLOSED IN WHOLE OR PART TO ANYONE WITHOUT THE WRITTEN PERMISSION OF TEKELEC. COPYRIGHT TEKELEC 2006.

SIZE	DIVISION	DRAWING NO.	REV.
D	NSG	892-0068-01	C
SCALE: NONE	FILE NAME: 892-0068-01_C.DWG	SHEET 5	