

Tekelec LSMS with EAGLE[®] 5 ISS

LNP Database Synchronization Manual

910-5490-001 Revision B

November 2008

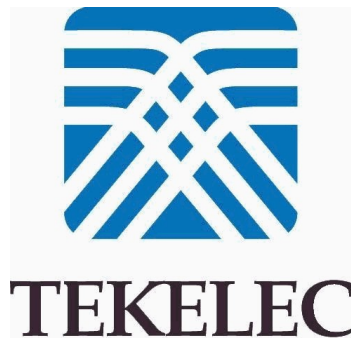

**Copyright 2008 Tekelec
All Rights Reserved
Printed in USA**

Notice

Information in this documentation is subject to change without notice. Unauthorized use, copying, or translation of this documentation can result in civil or criminal penalties.

Any export of Tekelec products is subject to the export controls of the United States and the other countries where Tekelec has operations.

No part of this documentation may be reproduced, translated, or transmitted in any form or by any means, electronic or mechanical, including photocopying or recording, for any purpose without the express written permission of an authorized representative of Tekelec.

Other product names used herein are for identification purposes only, and may be trademarks of their respective companies.

RoHS 5/6 - As of July 1, 2006, all products that comprise new installations shipped to European Union member countries will comply with the EU Directive 2002/95/EC "RoHS" (Restriction of Hazardous Substances). The exemption for lead-based solder described in the Annex will be exercised. RoHS 5/6 compliant components will have unique part numbers as reflected in the associated hardware and installation manuals.

WEEE - All products shipped to European Union member countries comply with the EU Directive 2002/96/EC, Waste Electronic and Electrical Equipment. All components that are WEEE compliant will be appropriately marked. For more information regarding Tekelec's WEEE program, contact your sales representative.

Trademarks

The Tekelec logo, EAGLE, G-Flex, G-Port, IP7, IP7 Edge, and IP7 Secure Gateway are registered trademarks of Tekelec. TekServer, A-Port, EAGLE 5 ISS, and V-Flex are trademarks of Tekelec. All other trademarks are the property of their respective owners.

Patents

This product is covered by one or more of the following U.S. and foreign patents:

U.S. Patent Numbers:

5,732,213; 5,953,404; 6,115,746; 6,167,129; 6,324,183; 6,327,350; 6,456,845; 6,606,379; 6,639,981; 6,647,113; 6,662,017; 6,735,441; 6,745,041; 6,765,990; 6,795,546; 6,819,932; 6,836,477; 6,839,423; 6,885,872; 6,901,262; 6,914,973; 6,940,866; 6,944,184; 6,954,526; 6,954,794; 6,959,076; 6,965,592; 6,967,956; 6,968,048; 6,970,542; 6,987,781; 6,987,849; 6,990,089; 6,990,347; 6,993,038; 7,002,988; 7,020,707; 7,031,340; 7,035,239; 7,035,387; 7,043,000; 7,043,001; 7,043,002; 7,046,667; 7,050,456; 7,050,562; 7,054,422; 7,068,773; 7,072,678; 7,075,331; 7,079,524; 7,088,728; 7,092,505; 7,108,468; 7,110,780; 7,113,581; 7,113,781; 7,117,411; 7,123,710; 7,127,057; 7,133,420; 7,136,477; 7,139,388; 7,145,875; 7,146,181; 7,155,206; 7,155,243; 7,155,505; 7,155,512; 7,181,194; 7,190,702; 7,190,772; 7,190,959; 7,197,036; 7,206,394; 7,215,748; 7,219,264; 7,222,192; 7,227,927; 7,231,024; 7,242,695; 7,254,391; 7,260,086; 7,260,207; 7,283,969; 7,286,516; 7,286,647; 7,286,839; 7,295,579; 7,299,050; 7,301,910; 7,304,957; 7,318,091; 7,319,857; 7,327,670

Foreign Patent Numbers:

EP1062792; EP1308054; EP1247378; EP1303994; EP1252788; EP1161819; EP1177660; EP1169829; EP1135905; EP1364520; EP1192758; EP1240772; EP1173969; CA2352246

Ordering Information

Your Tekelec Sales Representative can provide you with information about how to order additional discs.

Table of Contents

Chapter 1: Introduction.....	1
Overview.....	2
Manual Organization.....	2
Documentation Admonishments.....	3
Customer Care Center.....	4
Emergency Response.....	6
Related Publications.....	7
Documentation Availability, Packaging, and Updates.....	7
Locate Product Documentation on the Customer Support Site.....	7
Chapter 2: LNP Database Synchronization Overview.....	9
Introduction.....	10
LSMS Functions.....	11
LNP Configuration.....	13
Overview of Synchronization Methods.....	14
Maximum Number of Simultaneous Synchronization Operations.....	17
Chapter 3: Managing Resynchronization from the LSMS.....	19
Introduction.....	20
Notifications that Database Maintenance Is Required.....	20
Choosing a Synchronization Procedure.....	21
Understanding Sequence of Procedures to Be Performed.....	22
Chapter 4: Choosing a Database Maintenance Procedure.....	25
Choosing a Database Maintenance Procedure.....	26
Automatic Resynchronization Process.....	26
Chapter 5: Auditing and Reconciling Network Elements from the LSMS.....	29
Introduction.....	30
How Records Are Compared During an Audit.....	31
Displaying Audit Results.....	34

Reconciling.....	34
Audit and Reconcile Function Summary.....	35
Audit Restrictions.....	35
Audit and Reconcile Timeline.....	36
Managing Audit and Reconcile from the LSMS GUI.....	39
Audit Error Messages.....	39
Single SV/NPB Audit and Optional Reconcile from LSMS GUI.....	39
Range Audit and Optional Reconcile from LSMS GUI.....	44
Post-Audit Reconcile from the GUI.....	54
Performing an Audit Using the Command Line.....	58
Audit Logs.....	62
Chapter 6: Managing Bulk Load from the LSMS.....	67
Introduction.....	68
Bulk Load Overview.....	68
Managing Bulk Load from the LSMS.....	70
Bulk Load Procedure.....	70
Support ELAP Reload Via Database Image Function.....	76
Bulk Load Log File.....	82
Bulk Load Error Messages.....	84
Chapter 7: Copying One RTDB from Another RTDB.....	85
Copying One RTDB from Another RTDB.....	86
Verifying RTDB Status.....	86
Verifying RTDB Status at the EAGLE 5 ISS Terminal.....	86
Verifying RTDB Status at the ELAP User Interface.....	87
Restore RTDB on ELAP 8.0.....	89
Copy RTDB from Remote on ELAP 8.0.....	91
Chapter 8: Distributing the LNP Database after LSMS-Based Operation or RTDB Copy.....	93
Introduction.....	94
Distributing an RTDB LNP Database to Service Module Cards.....	94
Appendix A: LSMS GUI Messages.....	99
Introduction.....	100
GUI Messages.....	100

Appendix B: Enabling RTDB Audit on ELAP.....	115
Introduction.....	116
Enabling an RTDB Audit.....	116
Appendix C: LNP Database Synchronization Files.....	119
Introduction.....	120
Log Files.....	120
LNP Database Synchronization Log File Contents.....	121
Discrepancy Files.....	130
Discrepancy File Contents.....	131
Appendix D: Synchronization Performance Estimates.....	135
Introduction.....	136
Recommended Network Bandwidth.....	136
Performance of LSMS to NE Operations.....	136
Performance of NE to NE Operations.....	138
Glossary.....	141

List of Figures

Figure 1: Local Number Portability Network.....	10
Figure 2: LNP Configuration.....	13
Figure 3: Timeline for a Single SV/NPB Audit with Reconcile.....	36
Figure 4: Timeline for a Range Audit with Reconcile.....	37
Figure 5: Single SV/NPB Audit Window, Audit Range Tab.....	40
Figure 6: Single SV/NPB Audit Window, Audit Results Tab.....	41
Figure 7: Reconcile Complete.....	44
Figure 8: Audit Window, Audit Range Tab.....	45
Figure 9: Audit Window, Audit Results Tab.....	50
Figure 10: Abort Operation Dialog.....	52
Figure 11: Audit Complete Information Dialog.....	52
Figure 12: Audit Complete.....	52
Figure 13: Reconcile Complete.....	53
Figure 14: Reconcile Operation Complete.....	54
Figure 15: Post-Audit Reconcile Window, Input File Tab.....	56
Figure 16: Post Audit Reconcile Initialized.....	56
Figure 17: Audit Results Tab.....	56
Figure 18: Reconcile Complete.....	57
Figure 19: Reconcile Operation Complete.....	57
Figure 20: Browsing for Audit Log Files.....	63
Figure 21: Example of an Audit Log File for Two Completed Audits.....	64
Figure 22: Example of Audit Log File for Partially Completed Audit.....	64
Figure 23: Bulk Load Timeline.....	68
Figure 24: ELAP Main Menu.....	71
Figure 25: Enabling Change HS Bulk Download	71
Figure 26: Bulk Load Window.....	72
Figure 27: Abort Bulk Load Operation Dialog.....	75
Figure 28: Bulk Load Complete Information Dialog.....	75
Figure 29: Bulk Load Complete.....	75
Figure 30: ELAP Reload Via DB Image Function.....	77
Figure 31: ELAP Reload Via DB Image.....	77
Figure 32: Generate Image.....	78
Figure 33: Database Image Completed.....	78
Figure 34: Abort Bulk Download.....	79
Figure 35: Abort Confirmation.....	80
Figure 36: Transfer Database Image to ELAP.....	81
Figure 37: Image Transfer Complete.....	81

Figure 38: Open Log Files Window.....	82
Figure 39: Example Bulk Load Log File.....	83
Figure 40: ELAP Main Screen.....	87
Figure 41: ELAP RTDB Status.....	88
Figure 42: Stopping Software on the ELAP GUI.....	89
Figure 43: Stop ELAP Software - Success.....	89
Figure 44: Restore the RTDB.....	90
Figure 45: Confirm RTDB Restore.....	90
Figure 46: Successful RTDB Restoration.....	91
Figure 47: Copy RTDB from Remote.....	91
Figure 48: Copy RTDB from Remote Selection.....	92
Figure 49: ELAP Main Menu.....	116
Figure 50: Enabling Change RTDB Audit.....	116
Figure 51: Header Section Example.....	121
Figure 52: Audit Section Example.....	123
Figure 53: Reconcile Section Example.....	123
Figure 54: Bulk Load Section Example.....	124
Figure 55: Resynchronization Section Example.....	127
Figure 56: Audit Summary Section Example for NPA-NXX Range.....	129
Figure 57: Audit Summary Section Example for Time Range.....	129
Figure 58: Download Summary Section Example.....	129
Figure 59: Download Commit/Discard Section Example.....	130
Figure 60: Example of a Discrepancy File Header Section.....	131
Figure 61: Discrepancy Section Example, Audit of NPBs.....	132
Figure 62: Discrepancy Section Example, Audit of TNs.....	132
Figure 63: Discrepancy Summary Section Example.....	133

List of Tables

Table 1: Admonishments.....3

Table 2: Bulk Load Options.....16

Table 3: Maximum Number of Simultaneous Synchronization Operations for LSMS
 Release 11.0.....17

Table 4: Procedures Required for Synchronization Phases.....22

Table 5: LNP Data Type Attributes Included in Checksums.....32

Table 6: Audit Data Discrepancies.....33

Table 7: Audit Types and Functions.....35

Table 8: Audit Results Fields.....42

Table 9: Audit Range Values.....47

Table 10: Audit Results Fields.....50

Table 11: Parameters Used by Command-Line Interface.....59

Table 12: Audit Command Parameters.....60

Table 13: Fields in Bulk Load Window73

Table 14: LNP Database Synchronization Log File Directories.....120

Table 15: LNP Database Synchronization Log File Contents.....121

Table 16: LNP Data Type Key Fields.....122

Table 17: LNP Data Type Key Fields.....122

Table 18: LNP Database Synchronization Log File Directories.....130

Table 19: LNP Database Synchronization Performance Estimates.....136

Table 20: Estimating Time to Copy RTDB Across Customer Network.....138

Table 21: Estimating Time to Transfer the Entire Database.....139

Chapter 1

Introduction

Topics:

- [Overview Page 2](#)
- [Manual Organization Page 2](#)
- [Documentation Admonishments Page 3](#)
- [Customer Care Center Page 4](#)
- [Emergency Response Page 6](#)
- [Related Publications Page 7](#)
- [Documentation Availability, Packaging, and Updates Page 7](#)
- [Locate Product Documentation on the Customer Support Site Page 7](#)

This chapter contains general information about the organization of this manual and conventions used. Contact information for the Tekelec Customer Care Center is also included here.

Overview

Local Number Portability (LNP) provides a user with the ability to move the telephone service from one service provider to another without changing the telephone number. LNP is managed by Number Portability Administration Centers (NPACs), which serve different geographical regions. NPACs distribute LNP data to local service management systems (LSMSs), which, in turn, distribute the LNP data to network elements, for example, Eagle STPs. The LSMS keeps data for each NPAC region in a separate regional database. The data for any telephone number must be the same at the NPAC, the LSMS, and the network elements.

In addition, the LSMS stores locally provisioned data in a database separate from the regional databases and sends that data to all network elements. Locally provisioned data must also be the same between the LSMS and the network elements.

If the LNP databases of the LSMS and the network element get out of synchronization (for example, after an outage), the LSMS LNP database is used as the master database to synchronize the network element LNP database.

The LSMS and the network element use the following methods to synchronize their databases:

- Resynchronizing - the LSMS resends all transactions to the network element up to a maximum number of transactions or a maximum period of time .
- Reconciling - after an audit of the network element LNP data, the user can reconcile any differences discovered during the audit.
- Bulk Loading - complete replacement of the network element LNP database.

Manual Organization

The procedures described in this document are performed on ELAP version 8.0. If you are running on ELAP 7.0, please reference the *LNP Database Synchronization Manual version 38.0* on the *Customer Support Site* at <https://support.tekelec.com/index.asp>.

This manual is organized into these sections:

- [Introduction](#) on page 1 contains general information about the organization of this manual.
- [LNP Database Synchronization Overview](#) on page 9 presents an overview of the various methods available, depending on the features installed, for synchronizing the LNP database on the network element (NE) with the LNP database on the LSMS.
- [Managing Resynchronization from the LSMS](#) on page 19 describes how automatic resynchronization (which resends all transactions previously sent from the LSMS to the NE up to a maximum number of transactions) occurs and how to manage the resynchronization.
- [Choosing a Database Maintenance Procedure](#) on page 25 describes the notifications that let you know that manual intervention is required when automatic resynchronization of the LNP databases cannot be accomplished, and guides you in choosing the most appropriate and efficient synchronization procedure, depending on the features installed at the LSMS and at the NE.



- [Auditing and Reconciling Network Elements from the LSMS](#) on page 29 describes how to audit network element data. At any time, unless certain conditions exist, an audit of the subscription data contained on the network element can be initiated from the LSMS. An audit compares the subscription version data at the network element with that at the LSMS.
- [Managing Bulk Load from the LSMS](#) on page 67 describes how to initiate and manage an electronic bulk download at the LSMS. Bulk loading completely replaces an LNP database (all subscription version, NPA Split, Translation Type Service, default Global Title Translation and override Global Title Translation data) at a network element.
- [Copying One RTDB from Another RTDB](#) on page 85 describes how to copy the contents of the Real-Time Database (RTDB) that exists on the mated EAGLE LNP Application Processor (ELAP) server to an RTDB within the same network element that needs database restoration or to copy the contents of the RTDB that exists on an ELAP on the mated network element to an RTDB that needs database restoration.
- [Distributing the LNP Database after LSMS-Based Operation or RTDB Copy](#) on page 93 describes how the user distributes to all the Service Modules in the network element the NE LNP database that has been changed as a result of an LNP Database Synchronization operation. The NE LNP database may have been resynchronized as a result of a download from the LSMS as a result of a procedure in [Managing Bulk Load from the LSMS](#) on page 67.
- [LSMS GUI Messages](#) on page 99 lists in alphabetical order the messages that can appear when using the LSMS GUI functions described in this manual.
- [Enabling RTDB Audit on ELAP](#) on page 115 shows how to enable an LSMS audit when it has been disabled. By default, an ELAP allows an audit from the LSMS, but the user may have disabled this ability in order to debug a problem. An LSMS audit, as described in [Auditing and Reconciling Network Elements from the LSMS](#) on page 29 cannot be performed unless the ELAP has this setting enabled.
- [LNP Database Synchronization Files](#) on page 119 describes the files that are recorded when the various types of LNP database synchronization are performed.
- [Synchronization Performance Estimates](#) on page 135 provides estimates of the transaction rates for the various LNP database synchronization operations. Using these estimates can help decide which type of operation to use, as described in [Choosing a Database Maintenance Procedure](#) on page 25.

Documentation Admonishments

Admonishments are icons and text throughout this manual that alert the reader to assure personal safety, to minimize possible service interruptions, and to warn of the potential for equipment damage.

Table 1: Admonishments

	<p>DANGER: (This icon and text indicate the possibility of <i>personal injury</i>.)</p>
---	--

	<p>WARNING: (This icon and text indicate the possibility of <i>equipment damage</i>.)</p>
	<p>CAUTION: (This icon and text indicate the possibility of <i>service interruption</i>.)</p>

Customer Care Center

The Tekelec Customer Care Center offers a point of contact for product and service support through highly trained engineers or service personnel. When a call is received, a Customer Service Request (CSR) is issued to record the request for service. Each CSR includes an individual tracking number.

After a CSR is issued, the Customer Care Center determines the classification of the trouble. If a critical problem exists, emergency procedures are initiated. If the problem is not critical, information regarding the serial number of the system, Common Language Location Identifier (CLLI), initial problem symptoms (includes outputs and messages) is recorded. A primary Customer Care Center engineer is also assigned to work on the CSR and provide a solution to the problem. The CSR is closed when the problem is resolved.

The Tekelec Customer Care Center is available 24 hours a day, 7 days a week at the following locations:

Tekelec - Global

Email (All Regions): support.tekelec.com

- **USA and Canada**

Phone:

1-888-FOR-TKLC or 1-888-367-8552 (toll-free, within continental USA and Canada)

1-919-460-2150 (outside continental USA and Canada)

TAC Regional Support Office Hours:

8:00 a.m. through 5:00 p.m. (GMT minus 5 hours), Monday through Friday, excluding holidays

- **Central and Latin America (CALA)**

Phone:

USA access code +1-800-658-5454, then 1-888-FOR-TKLC or 1-888-367-8552 (toll-free)

TAC Regional Support Office Hours (except Brazil):

10:00 a.m. through 7:00 p.m. (GMT minus 6 hours), Monday through Friday, excluding holidays

- **Argentina**

Phone:

0-800-555-5246 (toll-free)

- **Brazil**
 - Phone:
0-800-891-4341 (toll-free)
 - TAC Regional Support Office Hours:
8:30 a.m. through 6:30 p.m. (GMT minus 3 hours), Monday through Friday, excluding holidays
- **Chile**
 - Phone:
1230-020-555-5468
- **Columbia**
 - Phone:
01-800-912-0537
- **Dominican Republic**
 - Phone:
1-888-367-8552
- **Mexico**
 - Phone:
001-888-367-8552
- **Peru**
 - Phone:
0800-53-087
- **Puerto Rico**
 - Phone:
1-888-367-8552 (1-888-FOR-TKLC)
- **Venezuela**
 - Phone:
0800-176-6497
- **Europe, Middle East, and Africa**
 - **Signaling**
 - Phone:
+44 1784 467 804 (within UK)
 - TAC Regional Support Office Hours:
8:00 a.m. through 7:00 p.m. (GMT), Monday through Friday, excluding holidays
 - **Software Solutions**
 - Phone:

+33 3 89 33 54 00

TAC Regional Support Office Hours:

8:00 a.m. through 7:00 p.m. (GMT), Monday through Friday, excluding holidays

- **Asia**

- **India**

Phone:

+91 124 436 8552 or +91 124 436 8553

TAC Regional Support Office Hours:

10:00 a.m. through 7:00 p.m. (GMT plus 5 1/2 hours), Monday through Saturday, excluding holidays

- **Singapore**

Phone:

+65 6796 2288

TAC Regional Support Office Hours:

9:00 a.m. through 6:00 p.m. (GMT plus 8 hours), Monday through Friday, excluding holidays

Emergency Response

In the event of a critical service situation, emergency response is offered by the Tekelec Customer Care Center 24 hours a day, 7 days a week. The emergency response provides immediate coverage, automatic escalation, and other features to ensure that the critical situation is resolved as rapidly as possible.

A critical situation is defined as a problem with an EAGLE 5 ISS that severely affects service, traffic, or maintenance capabilities, and requires immediate corrective action. Critical problems affect service and/or system operation resulting in:

- A total system failure that results in loss of all transaction processing capability
- Significant reduction in system capacity or traffic handling capability
- Loss of the system's ability to perform automatic system reconfiguration
- Inability to restart a processor or the system
- Corruption of system databases that requires service affecting corrective actions
- Loss of access for maintenance or recovery operations
- Loss of the system ability to provide any required critical or major trouble notification

Any other problem severely affecting service, capacity/traffic, billing, and maintenance capabilities may be defined as critical by prior discussion and agreement with the Tekelec Customer Care Center.

Related Publications

For information about additional publications that are related to this document, refer to the *Related Publications* document. The *Related Publications* document is published as a part of the *Release Documentation* and is also published as a separate document on the Tekelec Customer Support Site.

Documentation Availability, Packaging, and Updates

Tekelec provides documentation with each system and in accordance with contractual agreements. For General Availability (GA) releases, Tekelec publishes a complete EAGLE 5 ISS documentation set. For Limited Availability (LA) releases, Tekelec may publish a documentation subset tailored to specific feature content or hardware requirements. Documentation Bulletins announce a new or updated release.

The Tekelec EAGLE 5 ISS documentation set is released on an optical disc. This format allows for easy searches through all parts of the documentation set.

The electronic file of each manual is also available from the Tekelec Customer Support site. This site allows for 24-hour access to the most up-to-date documentation.

Printed documentation is available for GA releases on request only and with a lead time of six weeks. The printed documentation set includes pocket guides for commands and alarms. Pocket guides may also be ordered as a set or individually. Exceptions to printed documentation are:

- Hardware or Installation manuals are printed only without the linked attachments found in the electronic version of the manuals.
- The Release Notice is available only on the Customer Support site.

Note:

Customers may print a reasonable number of each manual for their own use.

Documentation is updated when significant changes are made that affect system operation. Updates resulting from Severity 1 and 2 PRs are made to existing manuals. Other changes are included in the documentation for the next scheduled release. Updates are made by re-issuing an electronic file to the customer support site. Customers with printed documentation should contact their Sales Representative for an addendum. Occasionally, changes are communicated first with a Documentation Bulletin to provide customers with an advanced notice of the issue until officially released in the documentation. Documentation bulletins are posted on the Customer Support site and can be viewed per product and release.

Locate Product Documentation on the Customer Support Site

Access to Tekelec's Customer Support site is restricted to current Tekelec customers only. This section describes how to log into Tekelec's Customer Support site and locate a document. Viewing the document requires Adobe Acrobat Reader, which can be downloaded at www.adobe.com.

1. Log into Tekelec's **new** Customer Support site at support.tekelec.com.
Note: If you have not registered for this new site, click the **Register Here** link. Have your customer number available. The response time for registration requests is 24 to 48 hours.
2. Click the **Product Support** tab.
3. Use the Search field to locate a document by its part number, release number, document name, or document type. The Search field accepts both full and partial entries.
4. Click a subject folder to browse through a list of related files.
5. To download a file to your location, right-click the file name and select **Save Target As**.

LNP Database Synchronization Overview

Topics:

- [Introduction Page 10](#)
- [LNP Configuration Page 13](#)
- [Overview of Synchronization Methods Page 14](#)
- [Maximum Number of Simultaneous Synchronization Operations Page 17](#)

This chapter presents an overview of the various methods available, depending on the features installed, for synchronizing the LNP database on the network element with the LNP database on the local service management system.

The procedures described in this document are performed on ELAP version 8.0. If you are running on ELAP 7.0, please reference the *LNP Database Synchronization Manual version 38.0* on the *Tekelec Customer Support Site* at: <https://support.tekelec.com/index.asp>.

Introduction

Local Number Portability (LNP) provides the ability to change (port) the telephone service from one service provider to another service provider without changing the telephone number.

LNP is managed by Number Portability Administration Centers (NPACs), which serve different geographical regions. NPACs distribute LNP data to local service management systems (LSMSs) which, in turn, distribute the LNP data to network elements, for example, Eagle STPs. The Tekelec LSMS can service up to eight NPACs and up to eight pairs of network elements, as represented in [Figure 1: Local Number Portability Network](#) on page 10.

Figure 1: Local Number Portability Network

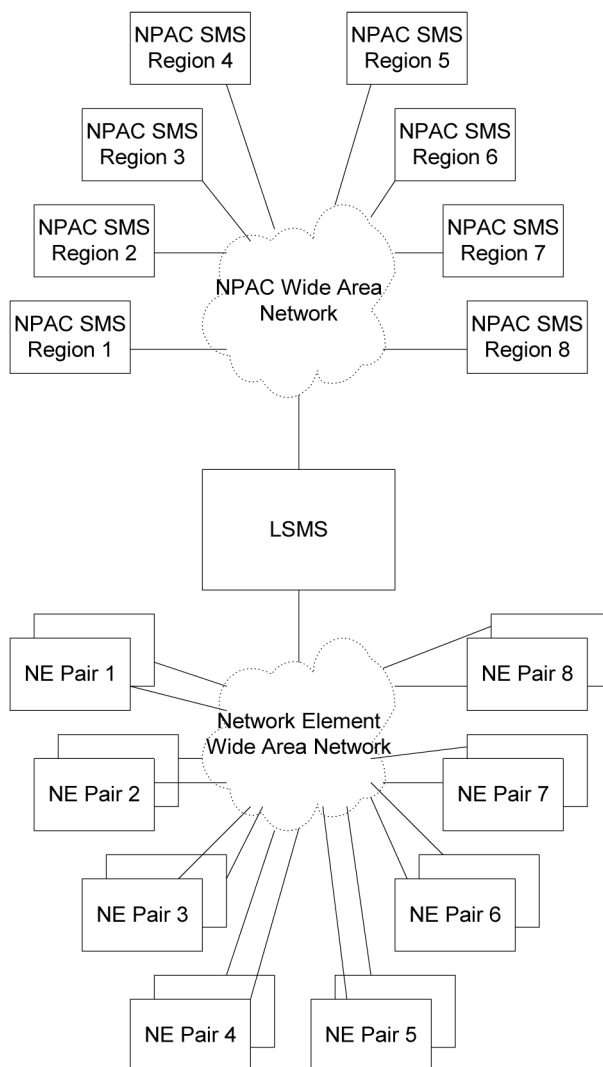

This manual describes the various methods used to keep data synchronized between the LSMS and the network element.

This manual does not describe synchronization activities between the NPAC and the LSMS. For information about how data is synchronized between the NPAC and the LSMS, refer to the *LSMS Database Administration Manual*.

LSMS Connectivity

The main function of the LSMS is to provision LNP data to the EAGLE 5 ISS. In order to perform this task, the LSMS maintains active connections with one or more NPAC region servers and one or more EAGLE 5 ISS nodes. While it is the goal of the LSMS to maintain active connections to each NPAC server and EAGLE 5 ISS node as nearly full-time as possible, the more important goal is to reliably forward the data from the NPAC to the EAGLE 5 ISS as quickly as possible. To that end, a number of protective problem detection and recovery mechanisms are built into the LSMS design. Several of these protections actually allow for the termination of application connectivity in order to gracefully restore full connectivity and guarantee total recovery of data.

In the following situations, the LSMS proactively terminates and re-establishes application connectivity with the NPAC and EAGLE 5 ISSs:

- If the LSMS detects network level connectivity failures with either the NPAC or EAGLE 5 ISS, the respective LSMS processes terminate the socket level connection and then reconnect. This disconnect and reconnect occurs in a matter of seconds. Built in resynchronization mechanisms ensure data recovery. The data transmission is delayed by the time required to disconnect and reconnect, but the execution of the recovery procedures prevents data loss.
- If the LSMS detects critical internal errors that would cause system outages, the LSMS processes are designed to terminate and allow the LSMS `sentry` process to restart them. This is only done for significant internal errors that jeopardize internal LSMS communications. Once the `sentry` process restarts the LSMS processes, resynchronization provides full data recovery. The restart time for processes by `sentry` consists of the detection time plus the restart time. Processes typically are restarted within 30 seconds.

LSMS to ELAP Connection

All normal LNP provisioning is conducted through the LSMS. Localized retrieval of data can be accomplished through the ELAP user interface.

The LSMS communicates only with the HA-Active ELAP in the MPS system using a Virtual IP (VIP) address interface. The LSMS connects to the HA-active ELAP at initialization. Although there are three ELAP states (HA-Active, HA-Standby, and Down) only the HA-Active member of the ELAP HA pair is connected to the VIP and listens for provisioning, audit and bulk download connections from the LSMS. The LSMS provisions LNP data to the HA-Active ELAP across a TCP/IP connection in the customer network.

LSMS Functions

The LSMS is responsible for the following functions:

- Sending normal updates to network elements
- Ensuring that supported network element's LNP database is synchronized with the LSMS LNP database

Sending Normal Updates

Normal updates sent by the LSMS consist of:

- *NPAC data* that is received from NPACs and forwarded to the network elements. The LSMS keeps data for each NPAC region in a separate regional database. The NPAC, LSMS, and the network elements all must have the same LNP data for a given region.
- *Locally provisioned data* that is entered by the customer in a centralized place (the LSMS) and then forwarded to one or more network elements. The LSMS stores locally provisioned data in the supplemental database, which is separate from the regional databases. The LSMS sends the locally provisioned data in the supplemental database to multiple network elements. Locally provisioned data must also be the same between the LSMS and the network elements.

Normal updates are sent from the LSMS to the active ELAP at a rate of 25 TNs per second over a connection that uses the High-Speed Operations Protocol (HSOP) over TCP/IP. The ELAP forwards the messages to all Service Module cards using an IP multicast protocol (for more information, refer to the *ELAP Administration Manual*).

Synchronizing LNP Databases

In this book, the term LNP database is used to mean a combination of regional and locally provisioned data:

- At the LSMS the LNP database is considered to be the combination of regional data and locally provisioned data that corresponds to the network element to be synchronized.
- At a network element the LNP database is considered to be one database which contains both regional data and data that was provisioned at the LSMS. The network element's LNP database usually has multiple copies at the network element; each configuration described in this manual specifies where in the network element the main LNP database is located. Synchronization methods between the main network element LNP database and its copies within a network element are described in other manuals; references are stated where appropriate.

The LSMS synchronizes with only a single copy of the network element's LNP database. Usually the synchronization occurs with the main network element LNP database; exceptions are noted as appropriate.

The LSMS is responsible for ensuring that the network element's LNP database is synchronized with the LNP database at the LSMS. If the LNP databases of the LSMS and network element get out of synchronization (for example, after an outage), the network element's LNP database must be synchronized to match the LSMS LNP database, which is considered to be the master database.

The LSMS and the network element use the following methods to synchronize their LNP databases. For information about which method to choose, see [Choosing a Database Maintenance Procedure](#) on page 25. Some methods permit synchronization from another network element LNP database that is known to be synchronized with the LSMS LNP database.

- *Resynchronizing*—the LSMS resends all transactions that were previously sent from the LSMS to the network element up to a maximum number of transactions or a maximum period of time. After any outage between the LSMS and a network element, the LSMS and the network element automatically attempt to resynchronize. If the number of transactions that needs to be retransmitted is less than the maximum number of transactions that can be stored in the LSMS resynchronization database (which can store a maximum of one million transactions), automatic resynchronization occurs without operator intervention. For more information, see [Automatic Resynchronization Process](#) on page 26
- *Reconciling*—after an audit of network element LNP data, the user can reconcile any differences discovered by the audit. Reconciling allows the user to update only the LNP database records

that are found to be different during an audit. An audit compares certain types of LNP data at the LSMS with the same types of data at the network element.

The user can choose to perform only an audit or to perform an audit and reconcile; the options are described later in this manual (see [Auditing and Reconciling Network Elements from the LSMS](#) on page 29). Although auditing without reconciling does not result in synchronized LNP databases, that option is also described in this manual.

The LSMS allows various types of audit and also allows the user to choose to reconcile any discrepancies found during the audit. Reconcile records are sent as normal updates and are available after any kind of audit. For a more detailed overview, see [Auditing and Reconciling Network Element Data](#) on page 15.

- *Bulk loading*—completely replaces a network element LNP database. Sometimes so much data needs to be corrected that neither reconciling audited data nor resynchronizing the data is sufficient. The following types of bulk loading are available (for a more detailed overview, see [Bulk Loading LNP Data](#) on page 16):
 - *Support ELAP reload via database image*—Available with the 384 Million Numbers feature and ELAP 8.0. Improves the bulk data download time by using a snapshot of the database.
 - *Electronic bulk load from the LSMS*—Available if certain optional features are installed at the LSMS and at the network element.
 - *Bulk load (reload) from RTDB on mated network element's standby ELAP*—Available if certain optional features are installed at the network element and if both network elements are treated similarly by the LSMS. This choice requires steps to be performed at the LSMS to determine whether the network elements are treated similarly by the LSMS, but actual loading of data involves only the mated network elements.

Additional information about synchronization methods is available in overview form in [Overview of Synchronization Methods](#) on page 14, and more detailed information about each synchronization method is presented in the remaining chapters of this manual.

LNP Configuration

[Figure 2: LNP Configuration](#) on page 13 shows the LNP configuration of the LSMS, MPS, and EAGLE 5 ISS.

Figure 2: LNP Configuration

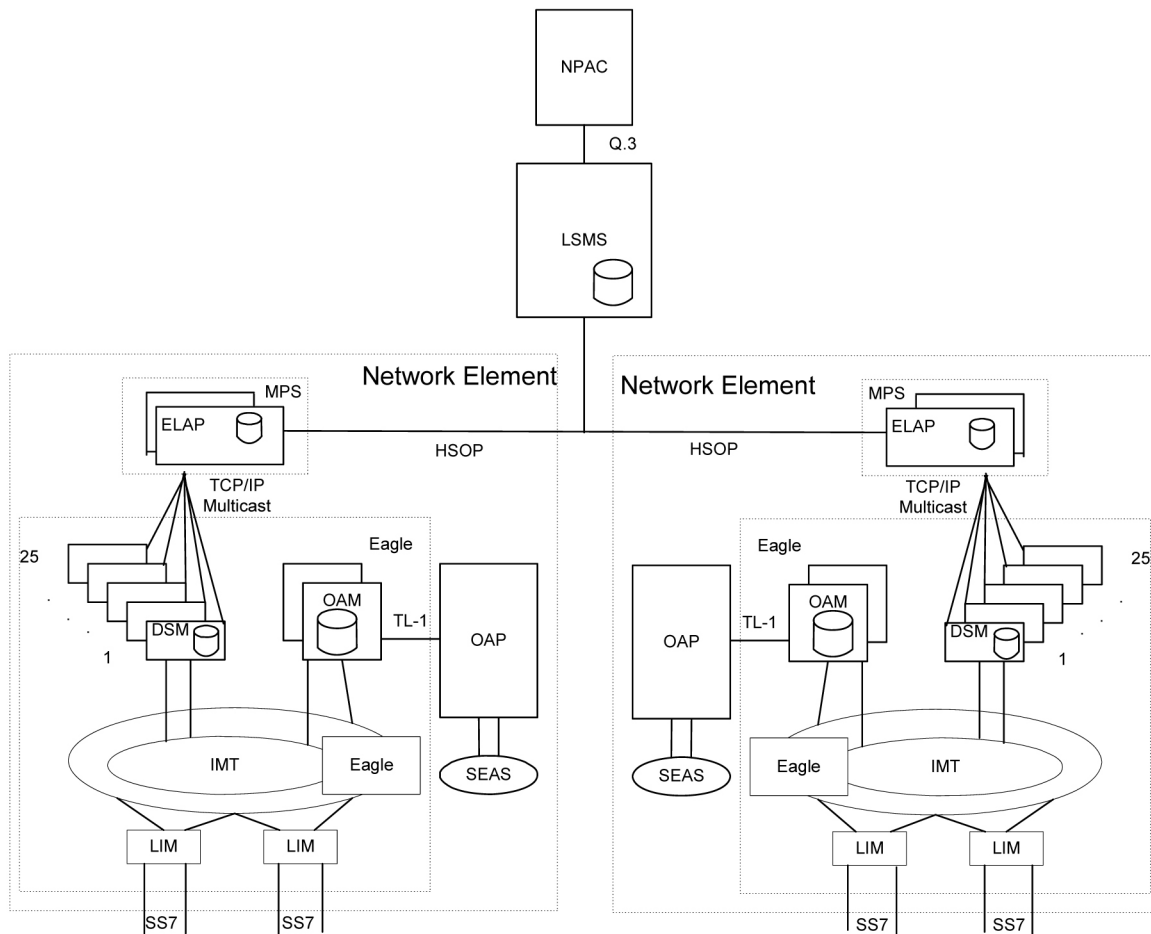

Overview of Synchronization Methods

The following sections provide an overview of the basic resynchronization methods. More detailed information is available in the remainder of this manual.

Resynchronizing LSMS and Network Element Data

The LSMS stores data that is sent to network elements in the following ways; this stored data enables the LSMS and network element to resynchronize.

A resynchronization database that stores all NPAC and locally provisioned data sent to any network element. This database holds a maximum of one million entries. This database is used for automatic resynchronization, as described in [Automatic Resynchronization](#) on page 15.

While resynchronization is occurring, any new updates received at the LSMS are stored in the pending queue. When an automatic resynchronization is complete and normal traffic between the LSMS and network element resumes, the updates in the pending queue are transmitted as normal updates.

Automatic Resynchronization

The LSMS and network element attempt to resynchronize automatically after any outage between the LSMS and a network element. When the LSMS and network element reconnect, the network element sends the LSMS the Database Time Stamp (DBTS) of the last update it received before the outage. If the LSMS finds that DBTS in the LSMS resynchronization database, it begins automatic resynchronization using the same protocol as is used for normal updates.

For information about the actions performed by the LSMS and network element during automatic resynchronization, see [Automatic Resynchronization Process](#) on page 26. If the LSMS determines that automatic resynchronization cannot be performed because the DBTS is not found in the resynchronization database, notifications are posted at both the LSMS and the network element (see [Notifications that Database Maintenance Is Required](#) on page 20). If those notifications are posted, you can choose among various options for proceeding with synchronization (see [Choosing a Synchronization Procedure](#) on page 21).

Automatic resynchronization uses the same protocol as is used for normal updates.

Auditing and Reconciling Network Element Data

The user can initiate from the LSMS an audit of various types of data at any time except as noted in [Audit and Reconcile Function Summary](#) on page 35. An audit compares the record for the specified data type at the network element with that at the LSMS. The user can also choose to reconcile any discrepancies found during an audit.

The following types of audit and reconcile are available; the first type can be performed simultaneously for a given network element with either of the other two types:

- *Audit and optional reconcile of a single SV or NPB* —This type of audit uses the normal update channel to compare a specified subscription version or number pool block record in the LSMS LNP database to the corresponding record in the LNP database. If any discrepancies are found, they can be reconciled immediately.

Note:

This type of audit is not available for LSMS releases prior to 8.X.

- *Audit and optional reconcile of SVs and/or NPBs by NPA-NXX range, or of SVs and/or NPBs by time range* —This type of audit uses the normal update channel to compare a checksum for each subscription version or number pool block record within a range of numbers or within a time range in the LSMS LNP database to the checksum of the corresponding record in the LNP database. If the checksums match, it is assumed that the records are the same.

After the audit completes, if differences were found, the LSMS user can choose to view the full records of each encountered difference. In addition, the LSMS user can specify whether any differences found should be reconciled.

- *All other audit and optional reconcile (for example of DGTT, OGTT, and NPA Splits, of all TNs and/or NPBs)* —This type of audit compares the checksum for each specified record in the LSMS LNP database to the checksum of the corresponding record in the LNP database. If the checksums match, it is assumed that the records are the same. For information about the types of data that can be audited with this type of audit, see [Types of Data to Audit and Reconcile](#) on page 30.

After the audit has completed, the LSMS user can specify whether differences found should be reconciled.

Note:

A reconcile for a Single SV/NPB audit must be performed as soon as the audit is complete, but reconciles for the other types of audits can be performed immediately or can be postponed for reconciling later. The postponement can be up to seven days.

Bulk Loading LNP Data

Bulk loading completely replaces the main LNP database at a network element. The LNP database consists of regional and locally provisioned data. Bulk loading is required if the network element is being initialized for one of the following reasons:

- Bringing the network element into the system for the first time
- Modifying the network element's area of service by reconfiguring EMS routing

The following types of bulk loading are available:

- *Support ELAP reload via database image (SERVDI)*—creates an RTDB LNP database file directly from the LSMS LNP database. This file is then transferred to the ELAP backup directory and activated using the GUI Restore from Backup menu. The amount of data transmitted over the customer WAN is significantly reduced as well as the time to reload the database. SERVDI is included with the 384 Million LNP Records feature.
- *Electronic bulk load from the LSMS to ELAP*—extracts the LNP database from the LSMS and downloads it to the RTDB of the active ELAP at the network element. The transmission from the LSMS to the ELAP requires about one hour for each million numbers in the LNP database. The distribution of the LNP database from the active ELAP to the standby ELAP and to the Database Services Module cards is part of a separate procedure (see [Distributing an RTDB LNP Database to Service Module Cards](#) on page 94).
- *Bulk load (reload) from RTDB on mated network element's standby ELAP*—copies the RTDB on standby ELAP at the mated network element to the RTDB that needs restoration. This choice requires steps to be performed at the LSMS to determine whether the network elements are treated similarly by the LSMS, but actual loading of data involves only the mated network elements.

Both network elements must be treated similarly by the LSMS.

[Table 2: Bulk Load Options](#) on page 16 compares the various bulk load options available.

Table 2: Bulk Load Options

Bulk Load Type	See Chapter:	User Action at LSMS	User Action at NE
Support ELAP reload via database image	6	Yes	Yes
Electronic bulk load from the LSMS to ELAP	6 and 8	Yes	Yes
Reload from mated ELAP RTDB	7 and 8	No	Yes
Reload from standby ELAP's RTDB on mated network element	7 and 8	Yes	Yes

Maximum Number of Simultaneous Synchronization Operations

The LSMS supports the following maximum number of simultaneous synchronization operations:

Maximum Number of Simultaneous Synchronization Operations for LSMS Release 11.0

With the 384 Million LNP Records feature, the following synchronization operations can run simultaneously, of which only one operation is allowed at a time per network element:

- Bulk loads (a maximum of two bulk loads, of different network elements, can occur simultaneously)
- Range audits (with or without reconcile) for each supported network element (the LSMS can support up to sixteen network elements)

Table 3: Maximum Number of Simultaneous Synchronization Operations for LSMS Release 11.0 on page 17 illustrates the maximum number of simultaneous operations for LSMS.

Table 3: Maximum Number of Simultaneous Synchronization Operations for LSMS Release 11.0

Synchronization Operation	Maximum Number Running Simultaneously (to different network elements)
Bulk Load	2
Range Audit (with or without reconcile)	16
Single SV/NPB Audit (with or without reconcile)	8

For example, you can perform a bulk load of STP1, a bulk load of STP2, Range Audits of STP 3, STP4, STP5, STP6, STP7, and STP8, as well as a Single SV/NPB Audit of each network element, all at the same time, for a total of 16 synchronization operations.

Chapter 3

Managing Resynchronization from the LSMS

Topics:

- [Introduction Page 20](#)
- [Notifications that Database Maintenance Is Required Page 20](#)
- [Choosing a Synchronization Procedure Page 21](#)
- [Understanding Sequence of Procedures to Be Performed Page 22](#)

This chapter describes the features required for resynchronization, the resynchronization types, and how to initiate and manage resynchronization from the Local Service Management System (LSMS).

Introduction

This chapter describes how to determine if an LNP database needs to be restored, and assists in choosing one of the methods that can be used to complete the restoration. [LNP Database Synchronization Overview](#) on page 9 provides an overview of the variety of methods available; this chapter helps you determine when you need to perform one of the methods and helps you choose which method is most appropriate.

Once you have decided which restoration method to use, see [Understanding Sequence of Procedures to Be Performed](#) on page 22 for a summary of the various procedures you must perform in the order indicated. The remainder of this manual provides the detailed instructions for the procedures to be performed.

An LNP database in a given network element needs to be restored when a condition occurs that has caused the LNP database to be corrupted or back-level. The following are examples of conditions that cause a need to restore an LNP database:

- A network outage occurs
- A hardware failure occurs at the system where the network element's LNP database resides
- Software that controls LNP databases has been stopped

When the condition has been repaired, the LSMS and network element attempt to perform automatic resynchronization, which requires no user action. For information about the actions performed by the LSMS and network element during automatic resynchronization, see [Automatic Resynchronization Process](#) on page 26.

When the LSMS and network element reconnect, the network element sends the LSMS the Database Time Stamp (DBTS) of the last update it received before the outage. If the LSMS finds that DBTS in the LSMS resynchronization database, it begins automatic resynchronization using the same protocol as is used for normal updates.

If the LSMS determines that automatic resynchronization cannot be performed because the DBTS cannot be found in the LSMS resynchronization database, notifications are posted at both the LSMS and the network element (see [Notifications that Database Maintenance Is Required](#) on page 20). If those notifications are posted, you can choose among various options for proceeding with synchronization (see [Choosing a Synchronization Procedure](#) on page 21).

Notifications that Database Maintenance Is Required

During an attempt to automatically resynchronize, if the LSMS cannot access necessary log files or cannot find the network element's DBTS in the LSMS resynchronization database, the following actions occur:

1. The LSMS sends one of the following notifications (with event number 0002 or 8043) to the LSMS graphical user interface (in addition, Surveillance notifications with the same event numbers are posted):

```
[Critical]: <Timestamp> 0002 <CLLI> NE DB maintenance required
```

2. The LSMS informs the network element that database maintenance is required.
3. The network element displays the following notification on the network element terminal (the number xxxx indicates how many other notifications have already been displayed at the terminal):

```
rlghncxa03w 01-09-07 11:50:04 GMT EAGLE 37.5
*C xxxx.0041 *C LSMS Connection A1 LNP DB Maintenance Required.
```

After any of these notifications, the LSMS administrator and the network element operator should confer and choose one of the synchronization options described in [Choosing a Synchronization Procedure](#) on page 21.

Choosing a Synchronization Procedure

When the LSMS and the network element require database maintenance (see [Notifications that Database Maintenance Is Required](#) on page 20), the LSMS and network element operators should confer to decide on the method they will use to perform the database restoration. After they have agreed which method to use, they work together to complete one or more procedures (see [Understanding Sequence of Procedures to Be Performed](#) on page 22).

Use one of the following procedures to restore an LNP database, listed by priority of least elapsed time and operator intervention (for more information about performance estimates for the various methods, see [Understanding Sequence of Procedures to Be Performed](#) on page 22):

1. *Copy the RTDB from the standby ELAP on the mated network element*—If the mated network element (NE) has both RTDBs synchronized with the LSMS (as indicated by the EMS status indicator for the mated network element displaying green on the LSMS graphical user interface), copy the standby RTDB from the mated NE to the RTDB that requires restoration.

This method requires:

- a) Determination that the mated NE's standby ELAP RTDB is current with the LSMS (indicated by the EMS status indicator displaying green for the mated network element on the LSMS graphical user interface).
If the EMS status indicator displays yellow or red, choose between method 3 and method 4 on page 22.
- b) User action at the LSMS to verify that the mated NE is configured properly as a mate.
- c) Sufficient bandwidth in the customer network, which connects the mated NEs.
- d) Stopping software both on the ELAP from which the RTDB is being copied and also on the ELAP to which the RTDB is being copied.

This method is recommended when both RTDBs at a given NE require recovery (after one RTDB has been restored, its mate can be restored by copying the newly restored RTDB).

The time required to complete this method depends on the bandwidth of the customer network, as shown in [Table 20: Estimating Time to Copy RTDB Across Customer Network](#) on page 138 (then add approximately 9 minutes to copy to the local network element's mate RTDB). For a detailed description of this method, see [Copy RTDB from Remote on ELAP 8.0](#) on page 91.

2. *Support ELAP reload via database image*—Available with the 384 Million LNP Records feature, this function replaces the Copy the RTDB from the ELAP Mate process. This method has faster reload times and provides synchronous data replication between the active and standby nodes.

This method requires:

- a) LSMS version 11.0 and ELAP version 8.0, required for the 384 Million LNP Records feature.
- b) User action at the NE to allow a user-initiated bulk load from the LSMS to occur (this action prevents an inadvertent initiation of a bulk load or resynchronization).
- c) User action at the LSMS GUI to initiate and manage the bulk download.

For detailed instructions on this method, see [SERVDI Bulk Download](#) on page 77.

3. *Perform an electronic bulk load from the LSMS*—If none of the other methods described in this section is possible, perform an electronic bulk load from the LSMS.

This method requires:

- a) User action at NE to allow an electronic bulk load from the LSMS to occur (this action prevents an inadvertent initiation of an electronic bulk load).
- b) User action at the LSMS GUI to initiate and manage the electronic bulk load.

For instructions on performing a electronic bulk load, see [Bulk Load Procedure](#) on page 70.

Understanding Sequence of Procedures to Be Performed

For most synchronization methods, the following phases must be completed:

1. Preparing for synchronization.
2. Preparing and transporting data to be used for synchronization.
3. Distributing LNP database synchronization at the network element.

Some phases are accomplished automatically by the LSMS and network element, and some phases require operator intervention. [Table 4: Procedures Required for Synchronization Phases](#) on page 22 summarizes, for the various synchronization methods described in this manual, which phases are required for each method and where those phases are described in this manual.

Table 4: Procedures Required for Synchronization Phases

	Method	Phase 1 Preparing NE	Phase 2 Initiating or Completing Data Transport	Phase 3 Distributing Data
Resynchronization Methods	Automatic resynchronization	Not required	Automatic, as described in Automatic Resynchronization Process on page 26	
Reconcile Methods	Audit and reconcile	Not required	Managing Audit and Reconcile from the LSMS GUI on page 39	Automatic

	Method	Phase 1 Preparing NE	Phase 2 Initiating or Completing Data Transport	Phase 3 Distributing Data
Bulk Load Methods	Support ELAP reload via database image	Verify that EMS Status Indicator on the LSMS is yellow	<i>SERVDI Bulk Download</i> on page 77 and <i>Restore RTDB on ELAP 8.0</i> on page 89	<i>Distributing an RTDB LNP Database to Service Module Cards</i> on page 94
	Reload from standby ELAP's RTDB on mated network element	Verify that EMS Status Indicator on the LSMS for mated network element is green or yellow	<i>Copy RTDB from Remote on ELAP 8.0</i> on page 91	<i>Distributing an RTDB LNP Database to Service Module Cards</i> on page 94
	Electronic bulk load from the LSMS to ELAP	<i>Step 3</i> on page 22	<i>Managing Bulk Load from the LSMS</i> on page 70	<i>Distributing an RTDB LNP Database to Service Module Cards</i> on page 94
	Reload from mated ELAP RTDB	Verify that EMS Status Indicator on the LSMS is yellow	<i>Restore RTDB on ELAP 8.0</i> on page 89	<i>Distributing an RTDB LNP Database to Service Module Cards</i> on page 94

Choosing a Database Maintenance Procedure

Topics:

- [Choosing a Database Maintenance Procedure Page 26](#)
- [Automatic Resynchronization Process Page 26](#)

After any network outage, the LSMS and network elements automatically attempt to resynchronize. This resynchronization occurs without operator intervention when the number of transactions that need to be retransmitted is less than or equal to the number that can be transmitted normally during a four-hour period under maximum provisioning load.

Choosing a Database Maintenance Procedure

This chapter describes the features required for resynchronization, and how to initiate and manage resynchronization from the Local Service Management System (LSMS). Resynchronization resends all transactions that were previously sent from the LSMS to the network element up to a maximum number of transactions or a maximum period of time.

Automatic Resynchronization Process

Automatic resynchronization is the process of automatically resending transactions that have occurred during an outage up to the number of transactions that could occur under the maximum provisioning load during an outage of up to four hours.

After any problem has been resolved that caused network outage between the LSMS and the network element, the LSMS and the network element's Element Management System (EMS) perform the actions described in the following sections to begin automatic resynchronization (also called "short synchronization"). The process does not require operator intervention unless it is unsuccessful, in which case notifications are posted, as described in *Notifications that Database Maintenance Is Required* on page 20.

The following actions are part of the automatic resynchronization process:

1. The Job Routing Server (JRS) of the active ELAP determines the database time stamp (DBTS) of both RTDBs (one on the active server and one on the standby server) and sends the DBTS that is the older of the two. An RTDB's DBTS represents the last time the RTDB received an update from the LSMS.
2. The LSMS determines how many transactions in the log file have a time stamp equal to or after the DBTS and does one of the following:
 - If the LSMS detects that the number of transactions requiring resynchronization exceeds the number that can be sent in four hours under maximum provisioning load, the LSMS posts at the LSMS notifications that database maintenance is required and sends a message to the network element indicating the automatic resynchronization cannot be performed. The active ELAP then sends the more recent DBTS of the two RTDBs (if the DBTS values were different), and this step is repeated. (If the more recent RTDB can be automatically resynchronized, you can copy the other RTDB from it after it has been automatically resynchronized, as described in *Copying One RTDB from Another RTDB* on page 85).
 - If the LSMS detects that the number of transactions requiring resynchronization is less than or equal to the number that can be sent in four hours under maximum provisioning load, the LSMS and EMS proceed with automatic resynchronization as described in steps #3 through #6.
3. The LSMS displays the following notification at the LSMS user interface:

```
[Major]: <Timestamp> 8054 <CLLI>: Short Synchronization Started
```

Note:

All notifications displayed during steps #3 through #6 are for information only; no user action is necessary.

4. The LSMS stores all new updates arriving at the LSMS in the pending queue.
5. In chronological order, the LSMS sends all transactions stored in the log file specific to the network element's area of service. The chronological order starts at the first record that has a time stamp equal to or before the database time stamp (DBTS). For more information about DBTS, see *Step 2*. Although the resynchronization may result in duplicate messages, duplicate messages do not result in database errors. Also, if the LSMS is able to perform automatic resynchronization based on the older DBTS, any transactions sent to update the older RTDB but not needed by the newer RTDB are ignored by the newer RTDB.
6. When resynchronization is complete, the LSMS displays the following notification at the LSMS user interface:

```
[Cleared]: <Timestamp> 8059 <CLLI>: Short Synchronization Complete
```

Automatic resynchronization is now complete; any updates stored in the LSMS pending queue are transmitted to the network element. Automatic resynchronization can occur for multiple network elements simultaneously.

Chapter 5

Auditing and Reconciling Network Elements from the LSMS

Topics:

- [Introduction Page 30](#)
- [Audit and Reconcile Timeline Page 36](#)
- [Managing Audit and Reconcile from the LSMS GUI Page 39](#)
- [Performing an Audit Using the Command Line Page 58](#)
- [Audit Logs Page 62](#)

This chapter describes how to audit network element data. In most cases, an audit of the subscription data contained on the network element can be initiated from the LSMS. An audit compares the subscription version data at the network element with that at the LSMS.

Introduction

This chapter describes auditing and optional reconciling of network element data. An audit compares the LNP data at the network element with that at the LSMS. At any time, except as noted in [Audit and Reconcile Function Summary](#) on page 35.

You can also choose to reconcile any discrepancies found during an audit. Reconciling allows you to update only the LNP database records that are found to be different during an audit.

Although auditing without reconciling does not result in synchronized LNP databases, you can perform an audit without a reconcile for information purposes.

Methods of Auditing and Reconciling

You can perform audits and optional reconciles in either of the following ways:

- Through the LSMS GUI; see [Managing Audit and Reconcile from the LSMS GUI](#) on page 39
- Through the `lsmsclaa` command line interface; see [Performing an Audit Using the Command Line](#) on page 58

Operator Action at Network Element

An audit does not require any operator action at the network element. However, it is possible for the NE operator to disable the ability to process an audit. This is sometimes necessary when the NE operator is trying to debug a problem. If the NE operator has disabled the ability to process an audit, the LSMS will receive a rejection that is posted on the GUI as the following error message:

```
Connection already in use or operation not enabled at NE '<IP address>'
```

If this message occurs, perform the procedure described in [Enabling RTDB Audit on ELAP](#) on page 115.

Types of Data to Audit and Reconcile

The LSMS offers the following types of audits that compare records in the LSMS to records in a specified network element:

- *Single SV/NPB Audit*—This type allows you to audit a single subscription version or number pool block per supported network element at any time. If the audit reveals any discrepancy, you can choose to reconcile immediately.
- *Range Audit*—You can audit the following types of ranges:
 - *Time Range Audit*—One or both of the following types of regional data found to have been created, modified, or deleted by the LSMS between the specified start and end date and time for the audit (which must be during the previous seven days).
 - Subscription version data
 - Number pool block data
 - *Object Range Audit*—One or more of the following types of data that are stored in the LSMS databases within the specified range of starting and ending values:
 - Subscription version data

- All TNs in the network element's LNP database
- All TNs within a TN range (this option is available only for LSMS releases prior to 8.0; for LSMS Release 8.X, use Single SV/NPB Audit)
- All TNs within an NPA-NXX range

- Number pool block data
 - All NPBs in the network element's LNP database
 - All NPBs within an NPA-NXX-X range (this option is available only for LSMS releases prior to 8.0; for LSMS Release 8.X, use Single SV/NPB Audit)
 - All NPBs within an NPA-NXX range

- NPA Split data
 - All TNs in the network element's LNP database with a specified Old NPA
 - All TNs within a specified Old NPA range

- Default GTT data
 - All default GTTs in the network element's LNP database with a specified NPA-NXX
 - All default GTTs within an NPA-NXX range

- Override GTT data
 - All override GTTs in the network element's LNP database with a specified LRN
 - All override GTTs within an LRN range

For more information about these types of data, refer to the *LSMS Database Administration Manual*.

How Records Are Compared During an Audit

LNP data is determined to be out of synchronization by calculating a CRC (Cyclic Redundancy Check)-32 checksum for each specified type of LNP data record at both the LSMS and at the network element, and then comparing the checksums. If the checksums do not match, it is assumed that the records do not match.

Because some network element LNP database objects may contain attributes that are not stored in the LSMS LNP database, and vice versa, the computation of a checksum may not include all attributes. In addition, some attributes, such as LNP type, that are common to both the LSMS and network element LNP databases but which have different values, are not included in the computation of the checksums. [Table 5: LNP Data Type Attributes Included in Checksums](#) on page 32 shows which attributes are included in checksums for each type of LNP data object.

Table 5: LNP Data Type Attributes Included in Checksums

LNP Data Type	Attributes Included in Checksum	Attributes Not Included in Checksum
NPA Split	<ul style="list-style-type: none"> • Old NPA (Numbering Plan Area) • New NPA • NXX 	<ul style="list-style-type: none"> • Start PDP (Permissive Dialing Period) • End PDP
Number Pool Block	<ul style="list-style-type: none"> • NPA-NXX-X • LRN (Location Routing Number) • SPID (Service Provider Identification); this attribute is included in checksum only for LSMS releases prior to 8.0 • DPC (Destination Point Code) • SSN (Subsystem Number) 	<ul style="list-style-type: none"> • LNP (Local Number Portability) type • SPID; starting with LSMS Release 8.X, this attribute is not included in checksum
Subscription Version	<ul style="list-style-type: none"> • TN (Telephone Number) • LRN • SPID; this attribute is included in checksum only for LSMS releases prior to 8.0 • DPC • SSN 	<ul style="list-style-type: none"> • LNP type • SPID; starting with LSMS Release 8.X, this attribute is not included in checksum
Default GTT	<ul style="list-style-type: none"> • NPA-NXX • AIN (Advanced Intelligent Network) • IN (Intelligent Network) • TT (Translation Type) • DPC • SSN • RI (Routing Indicator) 	<ul style="list-style-type: none"> • XLAT (Translate Indicator) • NGT (New Global Title Translation Type); the LSMS stores the NGT as part of the NPA-NXX object, while the NE stores the NGT per point code

LNP Data Type	Attributes Included in Checksum	Attributes Not Included in Checksum
Override GTT	<ul style="list-style-type: none"> • LRN • SPID • TT • DPC • SSN • RI • NGT • RGTA (Replace Global Title Address) 	<ul style="list-style-type: none"> • XLAT

Discrepancies Detected by Audit

An audit can detect the discrepancies shown in [Table 6: Audit Data Discrepancies](#) on page 33. Each discrepancy is counted, displayed on the GUI, and recorded in the audit log file (see [Audit Error Messages](#) on page 39).

Table 6: Audit Data Discrepancies

Discrepancy Type	Description
Different	Mismatching checksums indicate that the network element has the LNP data object in its database; however, on or more attributes of the object are different from the equivalent attributes on the LSMS.
Missing	The network element's LNP database does not contain this object, but the LSMS LNP database does contain it; the LSMS did not receive a checksum for this object.
Extra	The network element's LNP database contains an object that the LSMS LNP database does not contain; the LSMS received a checksum for an object not in its database.

Duplicate Data Detected by Audit

In addition to detecting these discrepancies, all types of audit except auditing by time range also detect whether duplicate data resides in the LSMS and network element LNP databases. Duplicate data is not considered to be a discrepancy and cannot be corrected by performing a reconcile

operation. Each duplicate LNP data object detected is counted and recorded in the audit log file. If duplicate LNP data is detected, contact the Tekelec [Customer Care Center](#) on page 4.

Note:

It is recommended that you correct any duplicates as soon as they are found, even before performing a reconcile. If the duplicates are not corrected, future audits may show these duplicates as different types of discrepancies at different times, and it will be more difficult to determine whether the discrepancies have been caused by originally duplicate data.

Displaying Audit Results

Results of an audit are made available in the following ways:

- Displayed as they are calculated either on:
 - The Audit Results tab of the GUI if the audit is initiated from the GUI (see [Single SV/NPB Audit and Optional Reconcile from LSMS GUI](#) on page 39 or [Range Audit and Optional Reconcile from LSMS GUI](#) on page 44)
 - On the command line interface if the audit is initiated from the command line and the `details` parameter is specified (see [Performing an Audit Using the Command Line](#) on page 58)
- Stored in a log (see [Audit Error Messages](#) on page 39).

Note:

Starting with LSMS Release 8.X, the audit log also contains information about partial audit results when an audit is aborted or otherwise interrupted. For more information about how this information can be used, see [Continuing an Interrupted Object Range Audit](#) on page 65.

- If discrepancies are found for either subscription versions or number pool blocks, discrepancy files are created with full details about how the information is different. For more information, see [Discrepancy Files](#) on page 130.

Reconciling

Any discrepancies detected during an audit can be optionally reconciled as soon as the audit completes in one of the following ways:

- The user clicks the Reconcile button at the completion of a Single SV/NPB audit initiated from the GUI (see [Single SV/NPB Audit and Optional Reconcile from LSMS GUI](#) on page 39)

Note:

The Single SV/NPB audit GUI menu item is not available for LSMS releases prior to 8.0. A single SV or NPB audit could be performed in LSMS releases prior to 8.0 by specifying the same value for the range start and end values.

- The user clicks the Reconcile Now button at the completion of a Range audit initiated from the GUI (see [Range Audit and Optional Reconcile from LSMS GUI](#) on page 44)

Note:

For LSMS releases prior to 8.0, the user clicks the Reconcile button.

- The user specifies the `reconcile` parameter when starting the audit from the command line (see [Performing an Audit Using the Command Line](#) on page 58)

Starting with LSMS 8.X, any discrepancies detected during an Object Range audit can also be reconciled up to seven days later by selecting the Save Reconcile button at the completion of the audit and then later initiating a Post-Audit Reconcile (see [Post-Audit Reconcile from the GUI](#) on page 54).

Audit and Reconcile Function Summary

[Table 7: Audit Types and Functions](#) on page 35 shows the functions performed for each type of audit.

Table 7: Audit Types and Functions

Audit Type	Rate	Generates Audit Log	Generates Full-Detail Discrepancy Log for SVs and NPBs	Records Interrupted Audit Results	Can Be Reconciled Later
Object Range	24 million records per hour	Yes	Yes	Yes	Yes
Time Range	100 records ¹ per second	Yes	Yes	No	Yes
Single SV/NPB ¹	100 records ¹ per second	Yes	Yes	No	No

¹ Single SV/NPB Audits use the normal update channel, which can process 50 records per second, but performance of Single SV/NPB is limited by how fast the GUI can process the display, which may take up to five seconds.

Audit Restrictions

Before starting any audit, consider the following restrictions:

- Only one Single SV/NPB audit of a given network element can be performed at a time. If you attempt to start a Single SV/NPB audit of a network element that is already performing a Single SV/NPB audit or reconcile, an error message will be posted and no additional audit action will occur. You can perform a Single SV/NPB audit for each supported network element simultaneously, and a Single SV/NPB audit can be performed on a given network element at the same time as a Range Audit is performed for that network element.

Note:

The Single SV/NPB audit GUI menu item is not available for LSMS releases prior to 8.0. A single SV or NPB audit could be performed in LSMS releases prior to 8.0 by specifying the same value for the range start and end values.

- Only one Range audit or bulk load of a given network element can be performed at a time. If you attempt to start a Range audit of a network element that is already performing any other database synchronization operation, an error message will be posted and no additional audit action will occur. You can perform a Range audit for each supported network element simultaneously, subject to the restrictions described in *Maximum Number of Simultaneous Synchronization Operations* on page 17.
- An audit performed at the same time that automatic resynchronization is occurring between the LSMS and the network element may result in false discrepancies because some of the LSMS data may not have been sent yet over the normal update connection to the network element. At the end of an audit, it is recommended that you determine whether an automatic resynchronization (also called short resynchronization) has occurred (look at the notifications area of the GUI). If an automatic resynchronization has occurred or is currently running, it is recommended that you perform another audit when the automatic resynchronization has completed.
- A Range audit may time out at other times, for example, when the network element is busy or when synchronization is occurring between the Number Portability Administration Center (NPAC) and the LSMS. (For more information about when NPAC-to-LSMS synchronization occurs, refer to the *LSMS Maintenance Manual*.) If the LSMS is processing a lot of other data, the audit may eventually time out, a time-out message will be posted, and no audit action will occur.

In addition, consider the following usage note about Audit by Time Range:

- Except in the case of a SV and/or NPB that has been deleted, the SV and/or NPB to audit will be retrieved from the LSMS database. For the case where an NPA Split has been created that changes the SV and/or NPB residing in the LSMS database, this feature will only audit the new, post-split SV and/or NPB. This is the case both during the NPA Splits's permissive dialing period and after the period ends. For more information about NPA Splits, refer to the *LSMS Database Administration Manual*.

Audit and Reconcile Timeline

This section provides an overview of how audit and reconcile is performed.

Single SV/NPB Audit and Reconcile Timeline

Note:

The Single SV/NPB audit is not available for LSMS releases prior to 8.0.

Figure 3: Timeline for a Single SV/NPB Audit with Reconcile on page 36 illustrates how data is sent to a network element before, during, and after a Single SV/NPB audit followed by a reconcile.

Figure 3: Timeline for a Single SV/NPB Audit with Reconcile

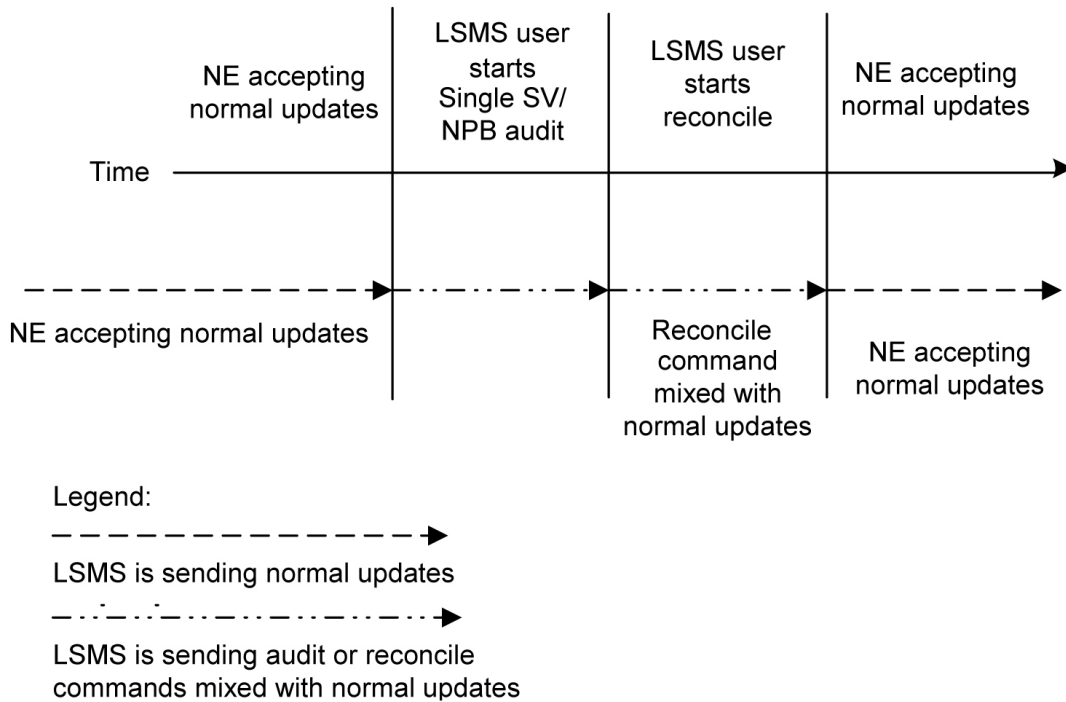

The following describes the stages in more detail:

- T1** *Single SV/NPB audit begins:* The LSMS user decides to initiate a Single SV/NPB audit. To start the audit at the LSMS, see [Managing Audit and Reconcile from the LSMS GUI](#) on page 39. No action is required at the network element.
A single SV/NPB audit completes very quickly; the LSMS user cannot abort the operation. When this stage is complete, the LSMS user can choose to reconcile immediately discrepancies that were found in the network element’s LNP database, start another audit, or terminate the audit session.
- T2** *Reconcile:* The LSMS user decides to reconcile. To choose to reconcile, see [Step 8](#) on page 52 in [Range Audit and Optional Reconcile from LSMS GUI](#) on page 44 . No action is required at the network element.
During this stage, a modify command is sent to the network element if the SV or NPB is identified as different or missing in the NE’s database, or a delete command is sent if the SV or NPB is identified as being extra in the NE’s LNP database (but not existing in the LSMS LNP database).
- T3** *Normal operations resume*

Range Audit and Reconcile Timeline

Figure 4: Timeline for a Range Audit with Reconcile on page 37 illustrates how data is sent to a network element before, during, and after a range audit followed by a reconcile.

Figure 4: Timeline for a Range Audit with Reconcile

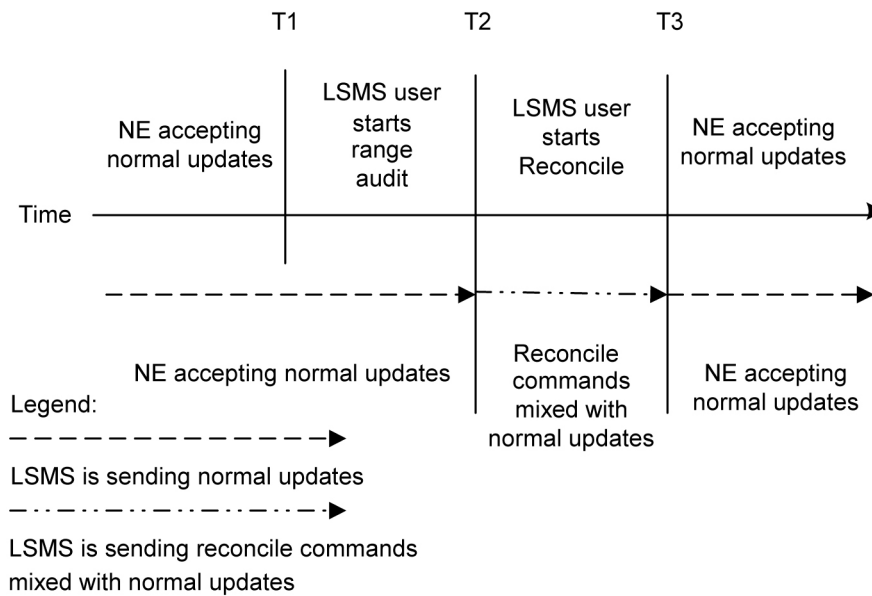

The following describes the range audit and reconcile stages in more detail:

T1 *Range audit begins:* The LSMS user decides to initiate a range audit. To start the audit at the LSMS, see [Managing Audit and Reconcile from the LSMS GUI](#) on page 39, [Step 8](#) on page 52. No action is required at the network element.

At any time during this stage, the LSMS user can choose to abort the operations. If aborted, the user can choose to terminate the operation (closing the Range Audit window), or start another range audit (either with the same ranges or different ranges).

Note:

Starting with LSMS Release 8.X, whenever an audit is interrupted, the LSMS records both completely and partially audited records in the Audit Log file. The user can examine the audit log file to determine which records have not yet been audited and perform another audit of a smaller set of records. For more information, see [Continuing an Interrupted Object Range Audit](#) on page 65.

When this stage is complete, the LSMS user can choose to reconcile immediately discrepancies that were found in the network element's LNP database, start another audit, or terminate the audit session.

Note:

Starting with LSMS Release 8.X, the user can also choose to reconcile discrepancies at a later time.

T2 *Reconcile:* The LSMS user decides to reconcile. To choose to reconcile, see [Range Audit and Optional Reconcile from LSMS GUI](#) on page 44.

During this stage, modify commands are sent to the network element for all data identified as different and missing in the NE's database, and delete commands are sent to the NE for all data identified as being extra in the NE's LNP database (but not existing in the LSMS LNP database).

Some differences between the LSMS and NE databases (such as capacity) may cause the NE to reject some of the downloaded commands. These rejections would also occur during a normal update. All commands rejected by the network element are recorded in the audit log file (see [Audit Error Messages](#) on page 39).

At any time during this stage, the LSMS user can choose to abort the operations. If aborted, this operation can be either restarted or terminated.

T3 *Normal operations resume.*

Managing Audit and Reconcile from the LSMS GUI

This section describes the following audit and reconcile procedures you can perform through the LSMS GUI.

- [Single SV/NPB Audit and Optional Reconcile from LSMS GUI](#) on page 39

Note:

The Single SV/NPB audit is not available for LSMS releases prior to 8.0.

- [Range Audit and Optional Reconcile from LSMS GUI](#) on page 44
- [Post-Audit Reconcile from the GUI](#) on page 54

You can also perform certain audit and reconcile functions of SVs or NPBs or both using the `lmsclaa` AUDIT function (see [Performing an Audit Using the Command Line](#) on page 58).

Audit Error Messages

For a listing of error messages that can appear on the GUI, along with explanation of possible cause and suggested recovery, see [LSMS GUI Messages](#) on page 99.

Single SV/NPB Audit and Optional Reconcile from LSMS GUI

Note:

The Single SV/NPB audit is not available for LSMS releases prior to 8.0.

Use the following procedure to manage from the LSMS user interface an audit and optional reconcile of a single subscription version or number pool block at a network element.

1. Ensure that none of the restricted situations described in [Audit and Reconcile Function Summary](#) on page 35 is occurring.
2. Log in as a member of the `lmsadm`, `lmsuser`, `lmsuext`, `lmsview`, or `lmsall` user group.
If you plan to perform a reconcile if one is needed, log in as a member of the `lmsuser`, `lmsuext`, or `lmsall` user group.
3. Because a Single SV/NPB Audit requires very little time, it is unlikely that an NPA Split will occur at the same time.

However, if you plan to perform a reconcile, to ensure that the reconcile and NPA Split do not interfere perform the following substeps:

Note:

Automatic split activation during a reconcile can cause the network element to be out of synchronization with the LSMS database.

- a) Generate an NPA Split Report.
Select **Pending** for Status and **All NPAC Regions** for NPAC Region. For information about creating and viewing NPA Split Data Reports, refer to the *LSMS Database Administration Manual*, (Chapter 5, "LSMS Reports").
 - b) Determine whether NPA Splits are scheduled to be activated during the time the audit and reconcile are to be performed:
 - If no Pending NPA Splits were listed in the report in *Step 3a*, or if none of the Pending NPA Splits has a PDP Start Date that occurs within the time period required to complete the audit and reconcile, go to *Step 4* on page 40.
 - If any Pending NPA Split has a PDP Start Date that occurs within the time period required to complete the audit and reconcile, continue with next substep.
 - c) If any NPA Split is scheduled to be activated within the planned resynchronization period, delay the reconcile until after the NPA Split has been activated.
4. Start the Audit window using either of the following:
- a) From the main menu on the LSMS Console window, select **LSMS-> LNP Database Synchronization-> Single SV/NPB Audit -><CLLI>**, where <CLLI> is the Common Language Location Identifier for the network element to be audited.
 - b) Right-click the LSMS Console window's EMS status icon that corresponds to the network element to be audited, and select **LNP Database Synchronization-> Single SV/NPB Audit**. The Single SV/NPB tab of the Audit window displays. If a different tab displays, click the Single SV/NPB tab. An example of this window is shown in *Figure 5: Single SV/NPB Audit Window, Audit Range Tab* on page 40.

Figure 5: Single SV/NPB Audit Window, Audit Range Tab

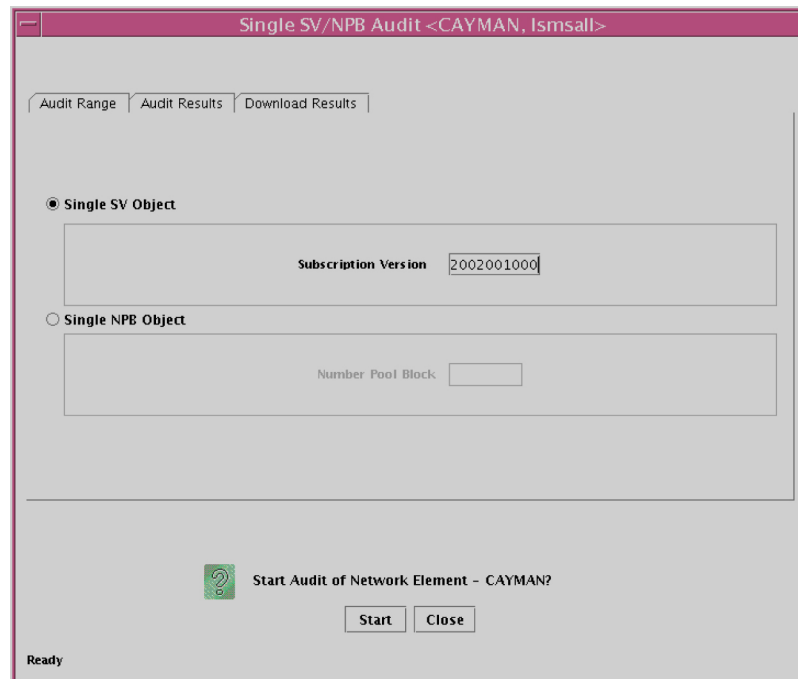

5. Do one of the following:
 - a) Click the Single SV Object radio button and type the 10-digit TN value for the object you want to audit.
 - b) Click the Single NPB Object radio button and type the 7-digit NPA-NXX-X value for the object you want to audit.
6. To initiate the audit, click the Start button.

The display automatically changes to the Audit Results tab.

Note:

It is generally not necessary to perform any action at the network element before starting an audit. However, it is possible for the NE operator to disable the ELAP's ability to be audited. If the following error message is returned, contact the NE operator to request that the procedure described in *Enabling RTDB Audit on ELAP* on page 115 be performed:
Connection already in use or operation not enabled at NE '<IP address>'

A single audit completes very quickly, and the popup message shown in *Figure 6: Single SV/NPB Audit Window, Audit Results Tab* on page 41 displays.

Figure 6: Single SV/NPB Audit Window, Audit Results Tab

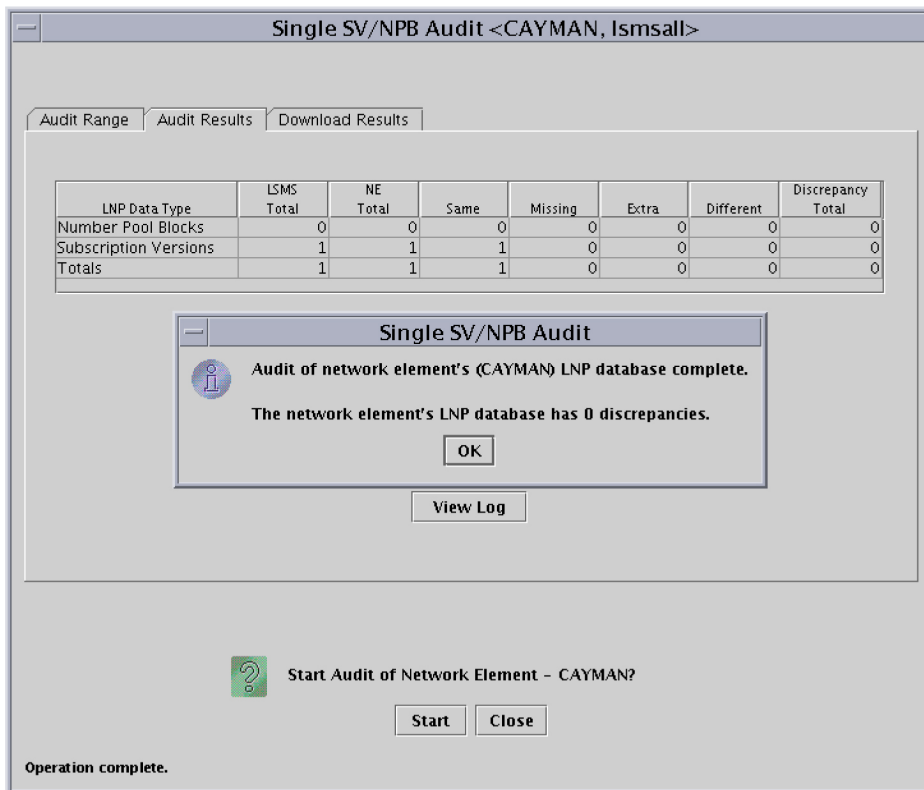

Table 8: Audit Results Fields on page 42 describes the meaning of the fields in this window.

Table 8: Audit Results Fields

Field	Description	Possible Values
LSMS Total	Number of data records that have been audited in the LSMS LNP database	00000000—99999999
NE Total	Number of data records that have been audited in the NE LNP database	00000000—99999999
Same	Number of LNP data records that are identical in both the LSMS and the NE LNP databases	00000000—99999999
Missing	Number of LNP data records that are present in the LSMS LNP database, but not in the NE LNP database	00000000—99999999

Field	Description	Possible Values
Extra	Number of LNP data records that are present in the NE LNP database, but not in the LSMS LNP database	00000000—99999999
Different	Number of LNP data records that are present in both the LSMS LNP database and the NE LNP database, but with different checksums	00000000—99999999
Discrepancy Total	Total number of LNP data record discrepancies (Missing, Extra, and Different)	00000000—99999999
Start Date/Time	Time the audit phase was started	MM/DD hh:mm:ss ¹
End Date/Time	Time the audit phase completed successfully or was abnormally terminated	MM/DD hh:mm:ss ¹
Elapsed Time	Amount of time the audit took to complete or the amount of time the audit had run before the user aborted it or a failure occurred.	hh:mm:ss ¹ [A F] ²
Full-Record Discrepancy Combobox	List of LNP database objects whose full-record discrepancy file from the previous audit is available for viewing	Number Pool Blocks or Subscription Versions
<p>¹ MM indicates month, range 01—12 DD indicates day, range 01—31 hh indicates hour, range 00—23 mm indicates minute, range 00—59 ss indicates second, range 00—59</p> <p>² A is appended at the end of the time is the operation is aborted. F is appended at the end of the time is the operation fails.</p>		

To view the audit log file, click the View Log button. For more information about the log file, see [Audit Error Messages](#) on page 39.

7. If a discrepancy is found, a discrepancy file has been created, the Full-Record Discrepancy Log area has become selectable, and the pull-down allows you to select which discrepancy file you would like to view.

For more information about the discrepancy files, see [Discrepancy Files](#) on page 130.

8. Examine the Audit Results tab to determine whether the object is listed as Missing, Extra, or Different and decide if you want to reconcile it.
 - a) If you choose not to reconcile, click the Cancel button; you have now completed this procedure.
 - b) If you choose to reconcile, click the Reconcile button.
(This button is selectable only if you have logged in as a member of the `lsmsuser`, `lsmsuext`, or `lsmsall` user group.) The reconcile update is sent over the same connection as normal updates. When the reconcile completes, a window similar to the example shown in [Figure 7: Reconcile Complete](#) on page 44 displays.

Figure 7: Reconcile Complete

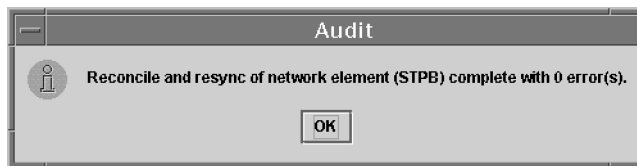

Click **OK**; you have now completed this procedure.

Range Audit and Optional Reconcile from LSMS GUI

Use the following procedure to manage from the LSMS user interface a Time Range audit or Object Range audit and optional reconcile of data at a network element.

1. Ensure that none of the restricted situations described in [Audit and Reconcile Function Summary](#) on page 35 is occurring.
2. Log in as a member of the `lsmsadm`, `lsmsuser`, `lsmsuext`, `lsmsview`, or `lsmsall` user group.
If you plan to perform a reconcile if one is needed, log in as a member of the `lsmsuser`, `lsmsuext`, or `lsmsall` user group.
3. If you plan to perform a reconcile, perform the following substeps to ensure that no NPA Split is scheduled to occur during the time required to perform the audit with reconcile.

Note:

Automatic split activation during a reconcile can cause the network element to be out of synchronization with the LSMS database. To avoid this problem, first perform the following substeps.

- a) Generate an NPA Split Report.
Select **Pending** for Status and **All NPAC Regions** for NPAC Region. For information about creating and viewing NPA Split Data Reports, refer to the *LSMS Database Administration Manual*, (Chapter 5, "LSMS Reports").

- b) Determine whether NPA Splits are scheduled to be activated during the time the audit and reconcile are to be performed (to estimate time required to perform the audit and reconcile, refer to [Synchronization Performance Estimates](#) on page 135):
 - If no Pending NPA Splits were listed in the report in *Step 3a*, or if none of the Pending NPA Splits has a PDP Start Date that occurs within the time period required to complete the reconcile, go to [Step 4](#) on page 45.
 - If any Pending NPA Split has a PDP Start Date that occurs within the time period required to complete the audit and reconcile, continue with next substep.
 - c) If any NPA Split is scheduled to be activated within the planned resynchronization period, delay the reconcile until after the NPA Split has been activated.
4. Start the Audit window using either of the following:
 - a) From the main menu on the LSMS Console window, select **LSMS-> LNP Database Synchronization->Range Audit-><CLLI>**, where <CLLI> is the Common Language Location Identifier for the network element to be audited.

Note: For LSMS releases prior to 8.0, the Range Audit menu selection appears simply as Audit for both the main menu selection and right-clicking on the EMS status icon.
 - b) Right-click the LSMS Console window's EMS status icon that corresponds to the network element to be audited, and select **LNP Database Synchronization->Range Audit**. The Audit Range tab of the Audit window displays. If a different tab displays, click the Audit Range tab. An example of this window is shown in [Figure 8: Audit Window, Audit Range Tab](#) on page 45.

Figure 8: Audit Window, Audit Range Tab

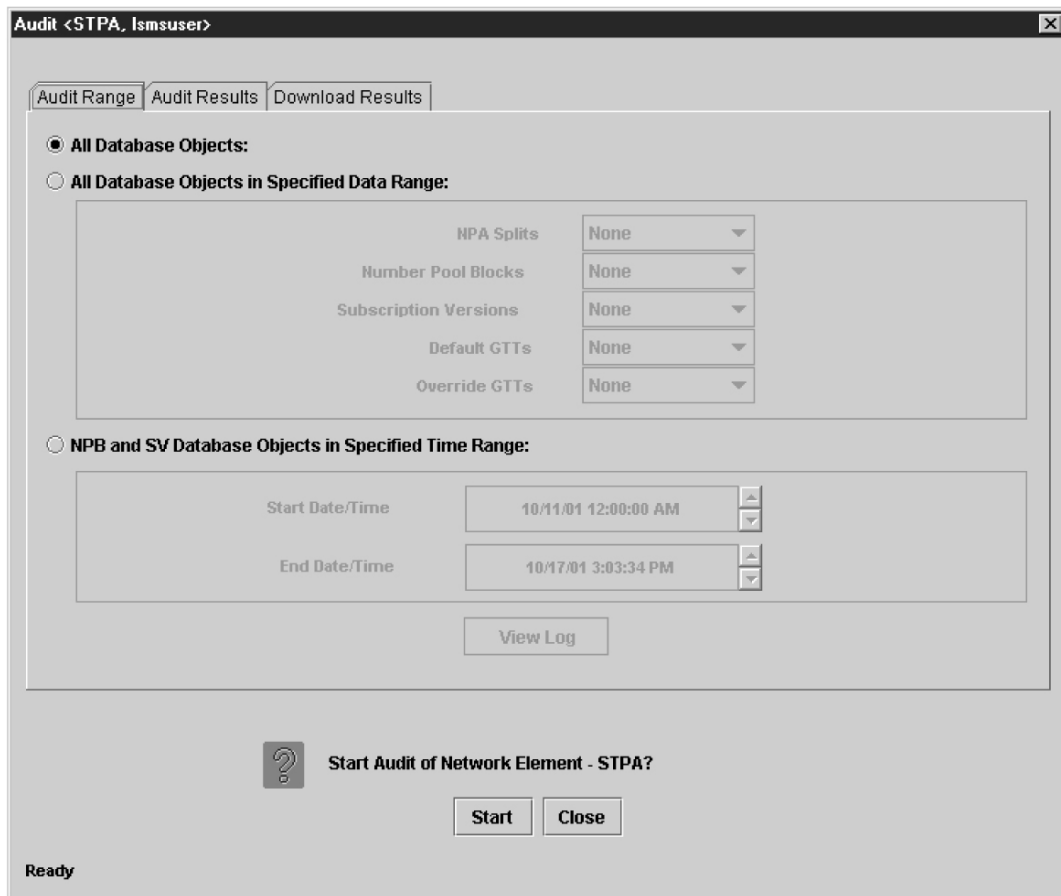

5. Select the data you want to audit by doing one of the following:
 - a) Click the All Database Objects radio button to audit all objects in the network element’s LNP database.
 - b) To audit all subscription versions and number pool blocks within a specified time range, click the NPB and SV Database Objects in Specified Time Range radio button.
 The Start Date/Time and End Date/Time fields become active and display in the form MM/DD/YY hh:mm:ss <AM | PM>, where MM represents month, DD represents day, YY represents year, hh represents hour, mm represents minute, and ss represents second. To change any of these values, double click on the value so that it is highlighted and then click the up or down arrow to increment or decrement the value by one for each click on the arrow. For example to change 10/09/01 12:00:00 AM to 10/12/01 12:00:00 PM, double click the day field (09) and click the up arrow 3 times, then double-click the AM field and click the up arrow once. These fields have the following constraints:
 - The Start Date/Time must be seven days or less than the current date and time.
 - The End Date/Time must be equal to or greater than the Start Date/Time.
 - The End Date/Time must be equal to or less than the current date and time.
 - c) To audit a subset of all objects in the network element’s LNP database, click the All Database Objects in Specified Data Range radio button, and then for each data type, click the pull-down arrow at the right of the box, and select the desired data range for that object.

Table 9: Audit Range Values on page 47 shows the possible values available in the pull-down for each data type.

Table 9: Audit Range Values

Data Type	Pull-down Values	Constraints	Results
NPA Splits	<ul style="list-style-type: none"> • None • All • Old NPA Range 	<p>If OLD NPA Range is selected, two fields appear; specify a range by entering the starting OLD NPA value in the first field and enter the ending OLD NPA value in the second field. Each value must consist of 3 numeric digits in the range 200—999.</p>	<p>Only those NPA Splits within the specified range will be audited. If no ending value is specified, the ending value defaults to the same value as the starting value.</p>
Number Pool Blocks*	<ul style="list-style-type: none"> • None • All • NPA-NXX Range • NPA-NXX-X Range (this option is available only for LSMS releases prior to 8.0) 	<p>If NPA-NXX Range or NPA-NXX-X Range is selected, two fields appear; specify a range by entering the starting NPA-NXX or NPA-NXX-X value in the first field and enter the ending NPA-NXX or NPA-NXX-X value in the second field.</p> <p>For NPA-NXX Range, each value must consist of 6 numeric digits in the range 200000—999999 (do not use hyphens or periods).</p> <p>For NPA-NXX-X Range, the NPA-NXX must be the same for the starting and ending NPA-NXX-X values and each value must consist of 7 numeric digits in</p>	<p>Only those Number Pool Blocks that have an NPA-NXX or NPA-NXX-X within the specified range will be audited. If no ending value is specified, the ending value defaults to the same value as the starting value.</p>

Data Type	Pull-down Values	Constraints	Results
		<p>the range 2000000—9999999 (do not use hyphens or periods). An audit of this type is performed only over the normal update connection.</p>	
Subscription Versions*	<ul style="list-style-type: none"> • None • All • NPA-NXX Range • TN Range (this option is available only for LSMS releases prior to 8.0) 	<p>If NPA-NXX Range or TN Range is selected, two fields appear; specify a range by entering the starting NPA-NXX or TN value in the first field and enter the ending NPA-NXX or TN value in the second field.</p> <p>For NPA-NXX Range, each value must consist of 6 numeric digits in the range 200000—999999 (do not use hyphens or periods).</p> <p>For TN Range, the NPA-NXX must be the same for the starting and ending TN values and each value must consist of 10 numeric digits in the range 2000000—9999999 (do not use hyphens or periods). An audit of this type is performed only over the normal update connection.</p>	<p>Only those Subscription Versions that have an NPA-NXX or TN within the specified range will be audited. If no ending value is specified, the ending value defaults to the same value as the starting value.</p>
Default GTTs*	<ul style="list-style-type: none"> • None • All 	<p>If NPANXX Range is selected, two fields appear; specify a</p>	<p>Only those Default GTTs that have an NPA-NXX within the</p>

Data Type	Pull-down Values	Constraints	Results
	<ul style="list-style-type: none"> NPANXX Range 	<p>range by entering the starting NPA-NXX value in the first field and enter the ending NPA-NXX value in the second field.</p> <p>Each value must consist of 6 numeric digits in the range 200000—999999 (do not use hyphens or periods).</p>	<p>specified range will be audited. If no ending value is specified, the ending value defaults to the same value as the starting value.</p>
Override GTTs	<ul style="list-style-type: none"> None All LRN Range 	<p>If LRN Range is selected, two fields appear; specify a range by entering the starting LRN value in the first field and enter the ending LRN value in the second field.</p> <p>Each value must consist of 10 numeric digits in the range 0000000000—9999999999 (do not use hyphens or periods).</p>	<p>Only those Override GTTs that have an LRN within the specified range will be audited. If no ending value is specified, the ending value defaults to the same value as the starting value.</p>
<p>* If any value other than None is selected for Subscription Versions, Number Pool Blocks, or Default GTTs, you must either select All for NPA Splits or select Old NPA and specify a range of 200—999.</p>			

6. To initiate the audit, click the Start button.

The display automatically changes to the Audit Results tab (shown in [Figure 9: Audit Window, Audit Results Tab](#) on page 50), and the Start button is replaced by the Abort button.

Note:

It is generally not necessary to perform any action at the network element before starting an audit. However, it is possible for the NE operator to disable the ELAP's ability to be audited. If the following error message is returned, contact the NE operator to request that the procedure described in [Enabling RTDB Audit on ELAP](#) on page 115 be performed: Connection already in use or operation not enabled at NE '<IP address>'

The progress is indicated by start time, elapsed time, numbers appearing in the various columns for the selected data types, and status reported in the status field at the bottom of the window.

Figure 9: Audit Window, Audit Results Tab

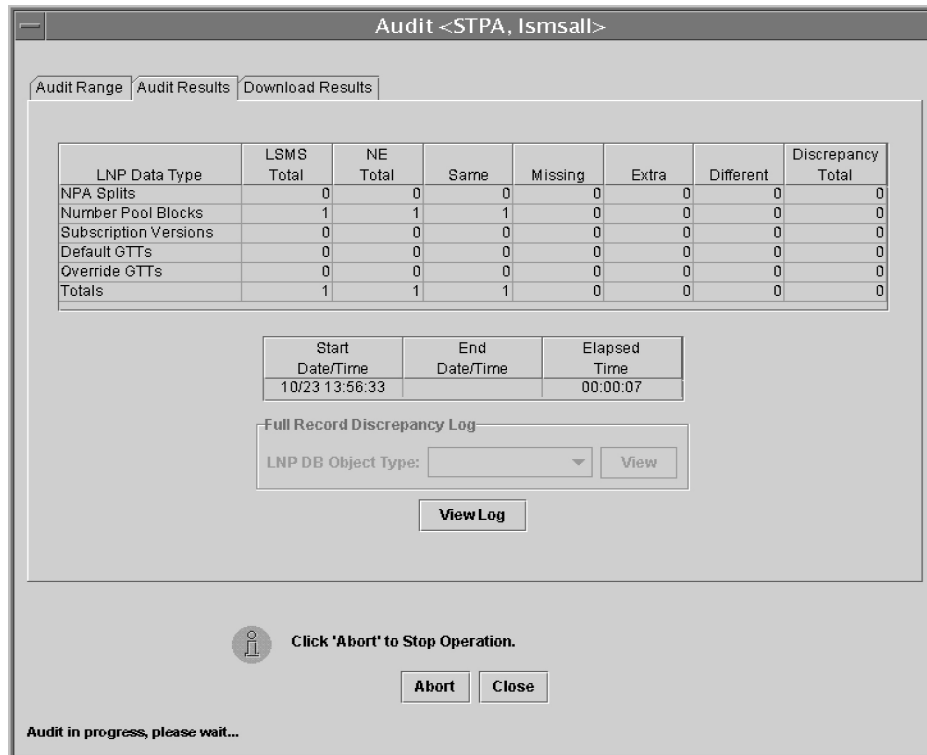

Table 10: Audit Results Fields on page 50 describes the meaning of the fields in this window.

Table 10: Audit Results Fields

Field	Description	Possible Values
LSMS Total	Number of data records that have been audited in the LSMS LNP database	00000000—99999999
NE Total	Number of data records that have been audited in the NE LNP database	00000000—99999999
Same	Number of LNP data records that are identical in both the LSMS and the NE LNP databases	00000000—99999999
Missing	Number of LNP data records that are present in the LSMS	00000000—99999999

Field	Description	Possible Values
	LNP database, but not in the NE LNP database	
Extra	Number of LNP data records that are present in the NE LNP database, but not in the LSMS LNP database	00000000—99999999
Different	Number of LNP data records that are present in both the LSMS LNP database and the NE LNP database, but with different checksums	00000000—99999999
Discrepancy Total	Total number of LNP data record discrepancies (Missing, Extra, and Different)	00000000—99999999
Start Date/Time	Time the audit phase was started	MM/DD hh:mm:ss ¹
End Date/Time	Time the audit phase completed successfully or was abnormally terminated	MM/DD hh:mm:ss ¹
Elapsed Time	Amount of time the audit took to complete or the amount of time the audit had run before the user aborted it or a failure occurred.	hh:mm:ss ¹ [A F] ²
Full-Record Discrepancy Combobox	List of LNP database objects whose full-record discrepancy file from the previous audit is available for viewing	Number Pool Blocks or Subscription Versions
<p>¹ MM indicates month, range 01—12 DD indicates day, range 01—31 hh indicates hour, range 00—23 mm indicates minute, range 00—59 ss indicates second, range 00—59</p> <p>² A is appended at the end of the time is the operation is aborted. F is appended at the end of the time is the operation fails.</p>		

To view the audit log file, click the View Log button. For more information about the log file, see [Audit Error Messages](#) on page 39.

To abort while an audit is in progress, click the Abort button. A confirmation dialog displays, as shown in [Figure 10: Abort Operation Dialog](#) on page 52.audit

Figure 10: Abort Operation Dialog

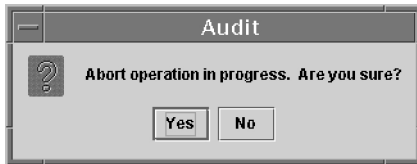

- a) Click the Yes button to immediately terminate the operation in progress.
If the LSMS has already started to create full-record discrepancy files, the operation does not stop until the full-record discrepancy files are fully created. If you want to reconcile any discrepancies found before the audit was aborted, perform the procedure described in [Post-Audit Reconcile from the GUI](#) on page 54
 - b) Click the **No** button to close the Abort confirmation dialog and return back to the main Audit window with no other effect.
7. When the audit completes, an information dialog similar to [Figure 11: Audit Complete Information Dialog](#) on page 52 displays.

Figure 11: Audit Complete Information Dialog

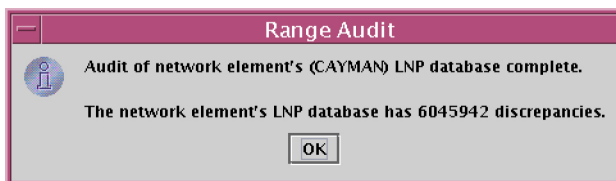

8. When the audit completes or is terminated, the Audit window displays similar to the example shown in [Figure 12: Audit Complete](#) on page 52.
- In this example, discrepancies in SVs and NPBs have been found, so a discrepancy file for each category has been created, the Full-Record Discrepancy Log area has become selectable, and the pull-down allows you to select which discrepancy file you would like to view. If you wish to view both files, first view one file, then view the other. For more information about the discrepancy files, see [Discrepancy Files](#) on page 130.

Figure 12: Audit Complete

Range Audit <CAYMAN, lsmsall>

Audit Range | Audit Results | Download Results

LNP Data Type	LSMS Total	NE Total	Same	Missing	Extra	Different	Discrepancy Total
NPA Splits	0	240	0	0	240	0	240
Number Pool Blocks	5700	10	0	5691	1	9	5701
Subscription Versions	6000000	4840001	0	1200000	40001	4800000	6040001
Default GTTs	0	0	0	0	0	0	0
Override GTTs	0	0	0	0	0	0	0
Totals	6005700	4840251	0	1205691	40242	4800009	6045942

Start Date/Time	End Date/Time	Elapsed Time
10/04 16:25:26	10/04 16:32:59	00:07:33

Full Record Discrepancy Log

LNP DB Object Type:

 Start\Save Reconcile of Network Element - CAYMAN?

Operation complete.

Examine the Audit Results tab to determine whether any objects are listed as Missing, Extra, or Different and decide if you want to reconcile them.

- If you choose not to reconcile, click the Cancel button; you have now completed this procedure.
- If you choose to reconcile later, click the Save Reconcile button.

When you are ready to perform the reconcile, follow the procedure described in [Post-Audit Reconcile from the GUI](#) on page 54.

Note: The Save Reconcile button does not exist for LSMS releases prior to 8.0, so this choice is not available.

- If you choose to reconcile immediately, ensure that you have considered any possible NPA Splits as described in [Step 3](#) on page 44; then click the Reconcile Now button.

(This button is selectable only if you have logged in as a member of the `lsmsuser`, `lsmsuext`, or `lsmsall` user group.) Reconcile updates are sent over the same connection as normal updates. When the reconcile completes, a window similar to the example shown in [Figure 13: Reconcile Complete](#) on page 53 displays.

Figure 13: Reconcile Complete

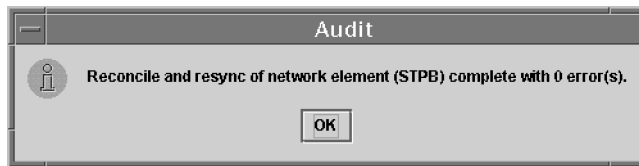

Click **OK**; a window similar to the example shown in *Figure 14: Reconcile Operation Complete* on page 54 displays.

Figure 14: Reconcile Operation Complete

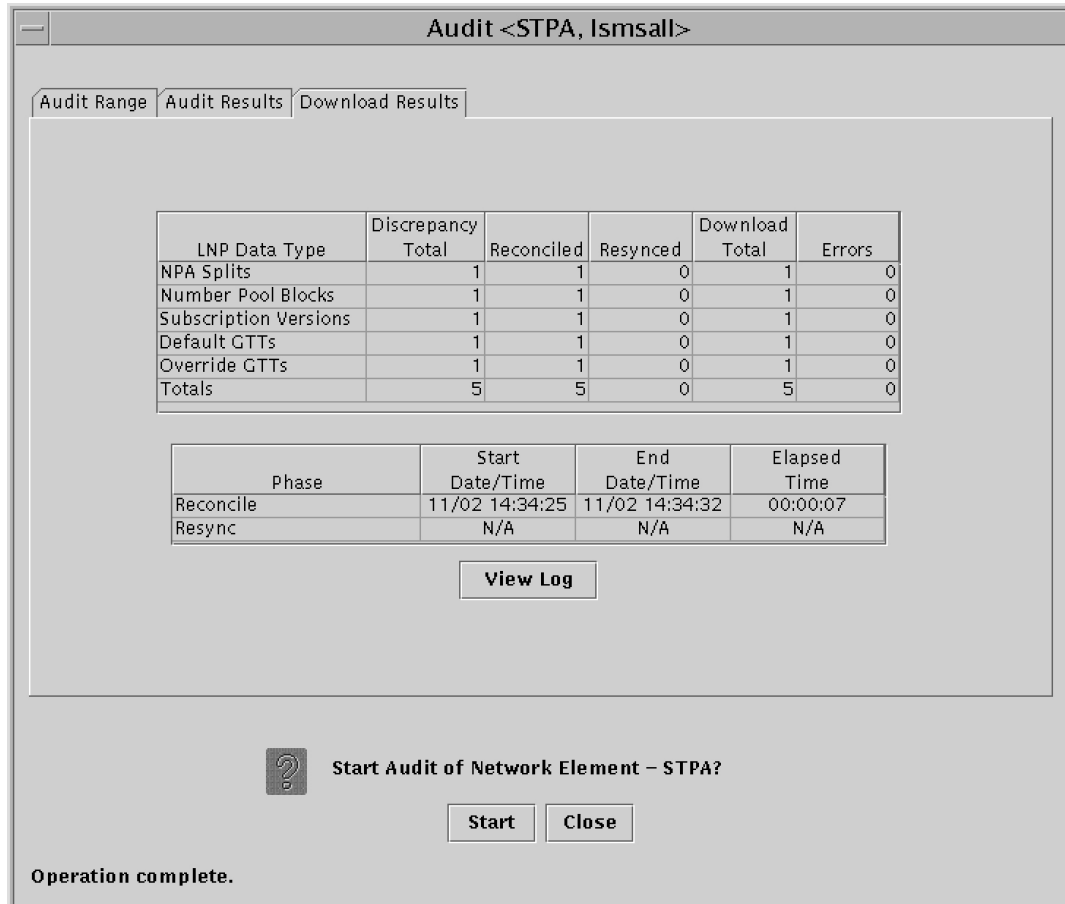

Click **OK**; you have now completed this procedure.

Post-Audit Reconcile from the GUI

Note:

The Post-Audit Reconcile is not available for LSMS releases prior to 8.0. Also, it cannot be used for Single SV/NPB Audits or for Time Range Audits.

Starting with LSMS release 8.X, a reconcile of an Object Range Audit can be performed at a time later than immediately after an audit completes. This function can be used in the following situations:

- If a large number of discrepancies is found during an audit, you might want to postpone the reconcile until a later time to avoid impacting normal traffic.
- If an Object Range Audit is aborted or interrupted, you can perform a Post-Audit Reconcile for all of the objects that were successfully audited before the interruption. You can also examine the Audit log to determine which objects were successfully audited, and perform another audit for objects that were not completely audited (for more information, see [Continuing an Interrupted Object Range Audit](#) on page 65).

The Post-Audit reconcile function is enabled by the creation of a Reconcile file that contains all the discrepant data found during the corresponding audit. Reconcile files are kept eight days, and then deleted.

Note:

Any reconcile (whether immediate or postponed) can be performed only once. When a reconcile has been performed, the reconcile file is no longer available for selection from the Post-Audit Reconcile window.

To perform a Post-Audit reconcile, perform the following procedure to choose among the available reconcile files.

1. Log in as a member of the `lsmsuser`, `lsmsuext`, or `lsmsall` user group.
2. Perform the following substeps to ensure that no NPA Split is scheduled to occur during the time required to perform the reconcile.

Note:

Automatic split activation during a reconcile can cause the network element to be out of synchronization with the LSMS database.

- a) Generate an NPA Split Report.

Select **Pending** for Status and **All NPAC Regions** for NPAC Region. For information about creating and viewing NPA Split Data Reports, refer to the *LSMS Database Administration Manual*, (Chapter 5, "LSMS Reports").

- b) Determine whether NPA Splits are scheduled to be activated during the time the reconcile is to be performed (to estimate time required to perform the reconcile, refer to [Synchronization Performance Estimates](#) on page 135 :

- If no Pending NPA Splits were listed in the report in *Step 2a*, or if none of the Pending NPA Splits has a PDP Start Date that occurs within the time period required to complete the reconcile, go to [Step 4](#) on page 56.
- If any Pending NPA Split has a PDP Start Date that occurs within the time period required to complete the reconcile, continue with next substep.

- c) If any NPA Split is scheduled to be activated within the planned resynchronization period, delay the reconcile until after the NPA Split has been activated.

3. Start the Post-Audit Reconcile window using either of the following:

- a) From the main menu on the LSMS Console window, select **LSMS-> LNP Database Synchronization->Post-Audit Reconcile-><CLLI>**, where <CLLI> is the Common Language Location Identifier for the network element to be audited.
- b) Right-click the LSMS Console window's EMS status icon that corresponds to the network element to be audited, and select **LNP Database Synchronization->Post-Audit Reconcile**.

The Input File table of the Post-Audit Reconcile window displays. If a different tab displays, click the Input File tab. An example of this window is shown in [Figure 15: Post-Audit Reconcile Window, Input File Tab](#) on page 56.

4. Click the **Browse** button and select the file that corresponds to the audit you wish to now reconcile.

The example in [Figure 15: Post-Audit Reconcile Window, Input File Tab](#) on page 56 shows a file has been selected.

Figure 15: Post-Audit Reconcile Window, Input File Tab

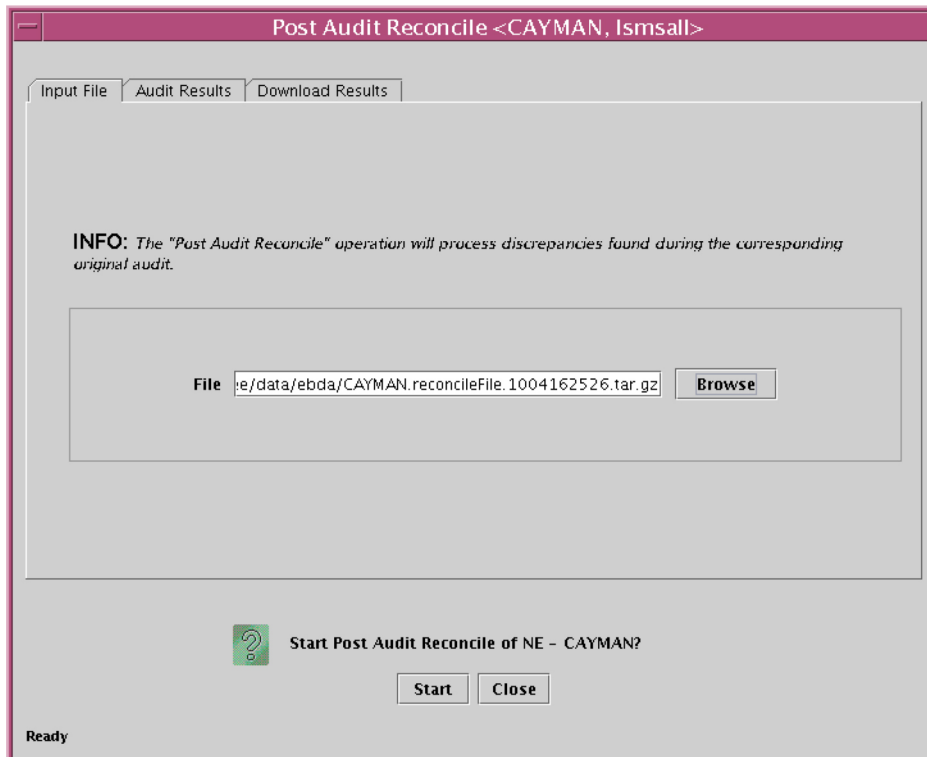

5. Click **Start**.

After the LSMS finds the file to use for reconciling, the Post Audit Reconcile pop-up window shown in [Figure 16: Post Audit Reconcile Initialized](#) on page 56 displays.

Figure 16: Post Audit Reconcile Initialized

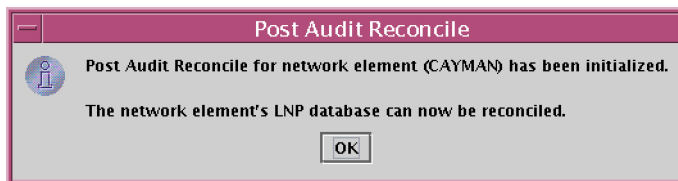

6. Click **OK**.

The Audit Results window displays, an example is shown in [Figure 17: Audit Results Tab](#) on page 56.

Figure 17: Audit Results Tab

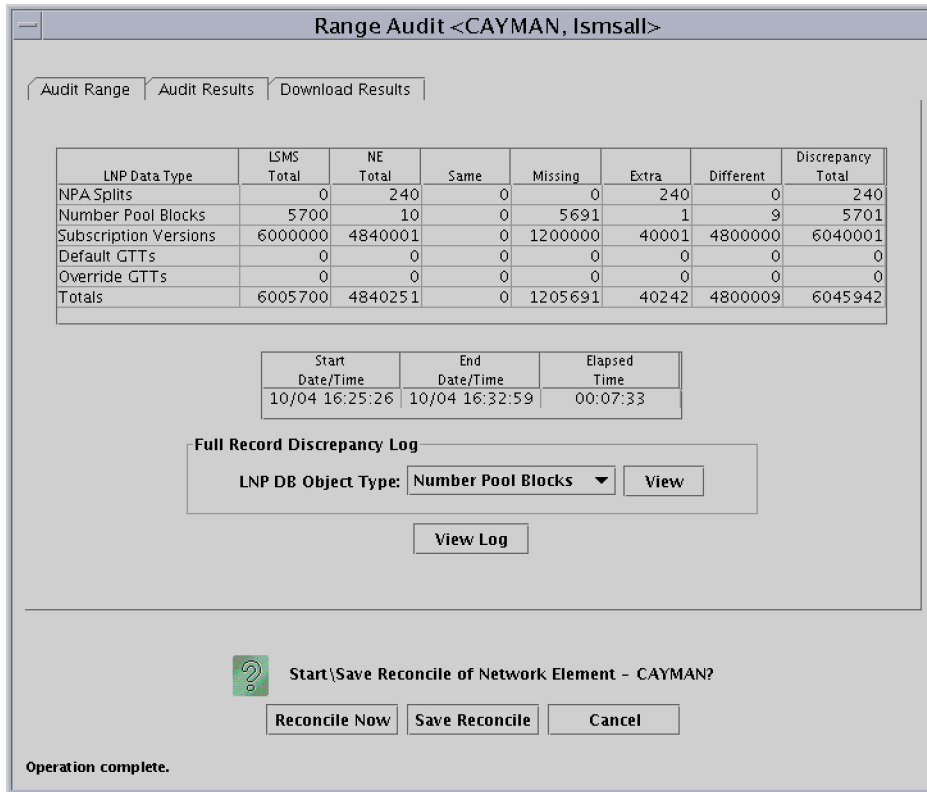

7. Ensure that you have considered any possible NPA Splits as described in [Step 2](#) on page 55; then click the Reconcile Now button.

Reconcile updates are sent over the same connection as normal updates. When the reconcile completes, a window similar to the example shown in [Figure 18: Reconcile Complete](#) on page 57 displays.

Figure 18: Reconcile Complete

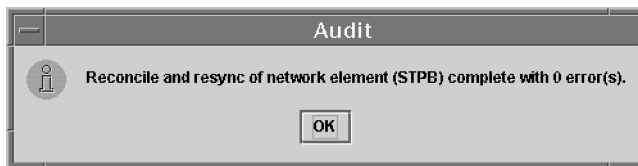

8. Click OK; a window similar to the example shown in [Figure 19: Reconcile Operation Complete](#) on page 57 displays.

Figure 19: Reconcile Operation Complete

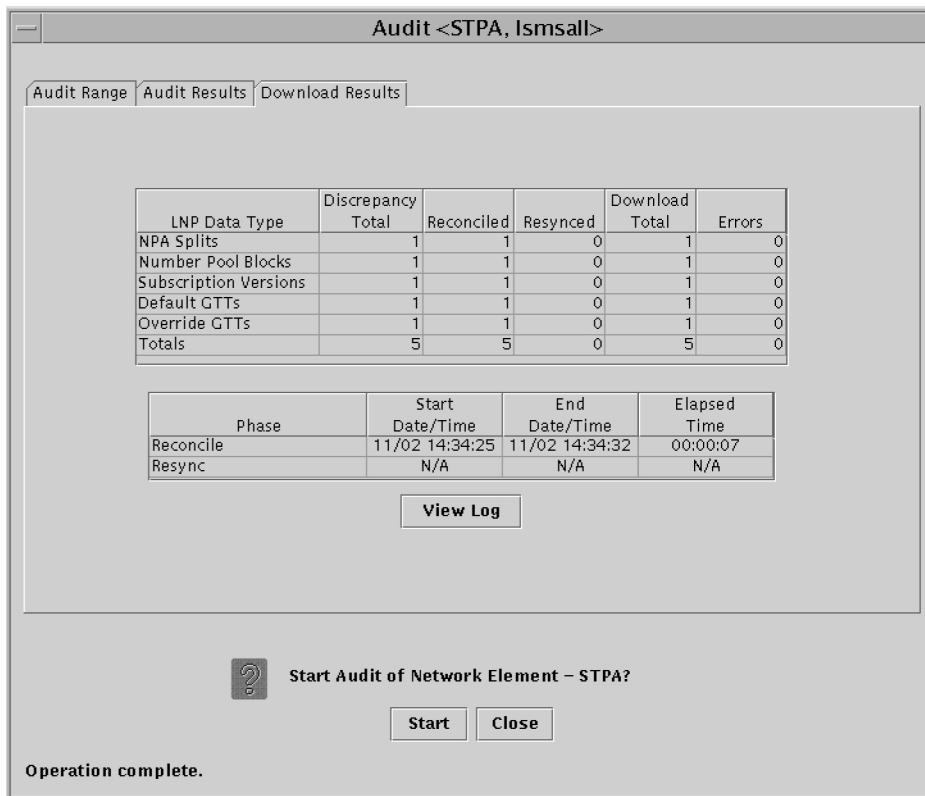

Click **OK**; you have now completed this procedure.

Performing an Audit Using the Command Line

Use the following procedure to perform a network element audit and optional reconcile of subscription versions (SVs) or Number Pool Blocks (NPBs) through the LSMS command line interface (*lsmclaa*).

Note:

Starting with LSMS Release 8.X, the *lsmclaa* AUDIT command can be used only to perform a Single SV or NPB Audit.

The *lsmclaa* command does not display a progress bar or provide a way to cancel the audit while in progress. Results of the audit performed by this command are stored in the *LsmsAudit.log* file (see [Audit Error Messages](#) on page 39) and in discrepancy files (see [Discrepancy Files](#) on page 130).

For more information about using the *lsmclaa* command, refer to the *LSMS Maintenance Manual*.

Use this procedure to perform an audit of SVs or NPBs from the command line.

1. Ensure that none of the restricted situations are described in section [Audit and Reconcile Function Summary](#) on page 35 is occurring.
2. To perform an audit only, log into the LSMS as a member of any user group.

If you need to perform a reconcile, log in as a member of the `lsmsadm`, `lsmsuser`, `lsmsuext`, or `lsmsall` user group.

3. If you plan to perform a reconcile, perform the following substeps to ensure that no NPA Split is scheduled to occur during the time required to perform the audit with reconcile.

Note:

Automatic split activation during a reconcile can cause the network element to be out of synchronization with the LSMS database. To avoid this problem, first perform the following substeps.

- a) Generate an NPA Split Report.
Select **Pending** for Status and **All NPAC Regions** for NPAC Region. For information about creating and viewing NPA Split Data Reports, refer to the *LSMS Database Administration Manual*, (Chapter 5, "LSMS Reports").
 - b) Determine whether NPA Splits are scheduled to be activated during the time the audit and reconcile are to be performed (to estimate time required to perform the audit and reconcile, refer to *Synchronization Performance Estimates* on page 135):
 - If no Pending NPA Splits were listed in the report in this section, *Step 3a*, or if none of the Pending NPA Splits has a PDP Start Date that occurs within the time period required to complete the reconcile, go to *Step 4* on page 59.
 - If any Pending NPA Split has a PDP Start Date that occurs within the time period required to complete the audit and reconcile, continue with next substep.
 - c) If any NPA Split is scheduled to be activated within the planned resynchronization period, delay the reconcile until after the NPA Split has been activated.
4. Start the command-line interface by entering the following command with parameters as defined in *Table 11: Parameters Used by Command-Line Interface* on page 59:
`$LSMS_DIR/start_cmdLine <SPID> <REGION> [<COMMANDFILE>]`

Table 11: Parameters Used by Command-Line Interface

Parameter	Description	Required?	Characters
<SPID>	Service Provider ID	Yes	4
<REGION>	Name of NPAC region	Yes (Note)	6 to 11
<COMMANDFILE>	Full name of a text file that contains a series of commands to be run by the command-line interface utility	No	1 to 256

Parameter	Description	Required?	Characters
<p>Note: To start the LSMS command line interface, you must specify one of the following values for <REGION>: Canada, Midwest, MidAtlantic, Southeast, Southwest, Northeast, Western, or WestCoast.</p>			

5. The following prompt indicates that the command-line interface has started:

```
Enter command ->
```

6. Depending on the LSMS release, enter one of the following commands at the command-line interface prompt (see [Table 12: Audit Command Parameters](#) on page 60 for a description of the command arguments):
- For LSMS releases prior to 8.0, enter the following command:

```
audit <CLLI> <StartValue> [<EndValue>] [<ObjectType>] [reconcile] [details]
```
 - Starting with LSMS Release 8.X, enter the following command:

```
audit <CLLI> <StartValue> [<ObjectType>] [reconcile] [details]
```

Table 12: Audit Command Parameters

Argument Name	Description	Required?	Values
<CLLI>	Common Language Location Identifier of the network element whose LNP database is to be audited and optionally reconciled.	Yes	1–11 alphanumeric
<StartValue>	<ul style="list-style-type: none"> For LSMS releases prior to 8.0, this argument represents the starting value for the range of objects to be audited. It must have the same NPA-NXX value as the <EndValue> parameter value Starting with LSMS Release 8.X, the argument represents the 	Yes	<ul style="list-style-type: none"> For NPB, 7 numeric characters in range 2000000 to 9999999 For SV or ALL, 10 numeric characters in range 2000000000 to 9999999999

	single SV or NPB value to be audited.		
<EndValue> (This argument can be used only for LSMS releases prior to 8.0)	<p>Ending value of the range of objects to be audited:</p> <ul style="list-style-type: none"> • Must be greater than (or equal to) the < StartValue > parameter value • Must have the same NPA-NXX value as the < StartValue > parameter value 	No	<ul style="list-style-type: none"> • For NPB, 7 numeric characters in range 2000000 to 9999999 • For SV or ALL, 10 numeric characters in range 2000000000 to 9999999999
<ObjectType>	<p>One of the following to indicate which data types in the specified range to audit:</p> <ul style="list-style-type: none"> • NPB—audit only Number Pool Blocks. • SV—audit only subscription versions. • ALL—audit both Number Pool Blocks and subscription versions. <p>Default is one of the following:</p> <ul style="list-style-type: none"> • If < StartValue > has 7 digits, the default is NPB • If < StartValue > has 10 digits, the default is ALL 	No	NPB or SV or ALL

reconcile	If this parameter is present, any discrepancies found by the audit are reconciled. (If the user is not a member of the <code>lsmsuser</code> , <code>lsmsuext</code> , or <code>lsmsall</code> groups, this parameter is ignored.)	No	N/A
details	If this parameter is present, status information is output every 5 seconds and includes audit discrepancy and reconcile download statistics.	No	N/A

- The command-line interface displays a message to indicate whether the audit or audit with reconcile was successful.

For more information about the possible messages, refer to the *LSMS Maintenance Manual*. You have now completed this procedure.

Audit Logs

Audit log files are generated for Range Audits that are initiated either from the GUI or from the command line. One log file is created for each day that a Range audit is performed. The log file is named *LsmsAudit.log.<MMDD>*, where *<MMDD>* is the timestamp that contains month and day. This log file is located in the directory */var/TKLC/lms/logs/<CLLI>*, where *<CLLI>* is the Common Language Location Identifier of the network element being audited. Log files are maintained for seven days after they are created; then they are automatically removed from the LSMS.

Note: No log file is generated for a Single SV/NPB Audit.

Viewing Audit Log Files

You can view audit log files in either of the following ways

- If you are performing a Range audit from the GUI, any time after a Range audit has begun, you can view the audit log file by clicking the View Log button. If the browser window used for displaying reports and logs is not already open, it is opened automatically and displays the log file.

- You can also use one of the following methods to open the window shown in [Figure 20: Browsing for Audit Log Files](#) on page 63 used to browse for this log:

Figure 20: Browsing for Audit Log Files



- Select **Logs ► Other...** from the main menu of the LSMS Console window.
- Click on the LSMS Console window's EMS Status Icon that corresponds to the network element being audited so that the icon is highlighted. Right-click and select **Logs ► LNP Database Synchronization ► Audit**.

Scroll down to find the folder that has the <CLLI> name for the NE that is being audited. Double-click the folder name, and then double click the file name *LsmsAudit.log.<MMDD>* that corresponds to the month and day you desire.

Audit Log File Contents

Whenever a Range audit is started, the audit log file for that day is appended (if this is the first audit of the day, the file is created). For each audit performed on that day, the audit log file contains information similar to the information displayed on the Audit Range, Audit Results, and Download Results tabs, such as start and end times for each stage, and numbers of missing, extra, and different objects in various LNP categories. The log and window also record whether database entries are present at the LSMS but missing at the NE, present at the NE but missing at the LSMS, or present at both the LSMS and NE but containing different values.

The audit log file contains the following sections:

- [Header Section](#) on page 121
- [Audit Section](#) on page 122
- [Reconcile Section](#) on page 123
- [Summary Section](#) on page 128

Note: Starting with LSMS Release 8.X, summary sections for Object Range Audits indicate whether object types were completely audited, partially audited, or not audited, and shows results for both completely and partially audited object types.

Audit Log File Example for Two Completed Audits

Figure 21: Example of an Audit Log File for Two Completed Audits on page 64 shows an example of an audit log file that contains two separate audits and reconciles performed on the same day.

Figure 21: Example of an Audit Log File for Two Completed Audits

```
Thu Nov 1 13:36:16 EST 2001

Username: lsmsuser
NE CLLI:  LARCH

-----

Thu Nov 1 13:36:15 EST 2001
Connection established with network element (192.168.61.202:1030)

Audit of Override GTTs started on Thu Nov  1 13:36:20 EST 2001

2000000000 MISSING

Audit of Override GTTs completed on Thu Nov  1 13:36:20 EST 2001

    0000000000 LRN Start
    9999999999 LRN End
        5 Total audited on LSMS
        4 Total audited on NE
        4 Same on Both
        0 Different on NE
        1 Missing on NE
        0 Extra on NE
        1 Total Discrepancies

Reconcile started on Thu Nov  1 13:37:40 EST 2001

Reconcile completed on Thu Nov  1 13:37:44 EST 2001

        NPA Splits           0 Downloaded           0 errors
    Number Pool Blocks       0 Downloaded           0 errors
    Subscription Versions     0 Downloaded           0 errors
        Default GTTs         0 Downloaded           0 errors
        Override GTTs        1 Downloaded           0 errors
        Total                 1 Downloaded           0 errors
```

Audit Log File Example for a Partially Completed Audit

Figure 22: Example of Audit Log File for Partially Completed Audit on page 64 shows an example of an audit log file for an Object Range Audit that was interrupted.

Figure 22: Example of Audit Log File for Partially Completed Audit

Mon Jun 6 14:40:20 EDT 2005

Username: lsmsall
NE CLLI: PALM

Mon Jun 6 14:40:20 EDT 2005

Connection established with network element (192.168.61.100:1030).

Audit of NPA Splits started on Mon Jun 6 14:40:20 EDT 2005

Audit of NPA Splits completed on Mon Jun 6 14:40:27 EDT 2005

```
200 Old NPA Start
999 Old NPA End
  5 Total audited on LSMS
  5 Total audited on NE
  5 Same on Both
  0 Different on NE
  0 Missing on NE
  0 Extra on NE
  0 Total Discrepancies
```

Audit of Subscription Versions started on Mon Jun 6 14:40:27 EDT 2005

```
9195551212 EXTRA
9195551213 EXTRA
9195551214 MISSING
```

Audit of Subscription Versions interrupted on Mon Jun 6 14:40:36 EDT 2005

Partial Subscription Version Summary

```
919550 NPA-NXX Start
919559 NPA-NXX End
919554 NPA-NXX Last Completed Successfully
 4999 Total audited on LSMS
 5000 Total audited on NE
 4997 Same on Both
   0 Different on NE
   1 Missing on NE
   2 Extra on NE
   3 Total Discrepancies
```

```
Objects Completely Audited: NPA Split
Objects Partially Audited:  Subscription Version
Objects Not Audited:       Default GTT, Override GTT
Partial Reconcile File:    /var/TKLC/lsms/free/ebda/<CLLI>.reconcileFile.
0606144036.tar.gz
```

Continuing an Interrupted Object Range Audit

Starting with LSMS Release 8.X, if an Object Range Audit is interrupted, you can interpret the contents of the audit log file to determine how many objects were completely audited. After the interruption has been resolved, you can complete your original audit goal by performing the

following actions in any order (the file shown in *Figure 22: Example of Audit Log File for Partially Completed Audit* on page 64 is used as an example):

- Perform a Post-Audit Reconcile (see *Post-Audit Reconcile from the GUI* on page 54), selecting the Partial Reconcile File listed in the Audit log (<CLLI>.reconcileFile.0606144036.tar.gz in the example file). This Post-Audit Reconcile will reconcile the three discrepancies found in the Subscription Version range from 919550 to 919554 (there were no discrepancies found in the NPA Splits).
- Perform another Range audit and reconcile of just SVs in the range 910555 to 910559.

Chapter 6

Managing Bulk Load from the LSMS

Topics:

- [Introduction Page 68](#)
- [Bulk Load Overview Page 68](#)
- [Managing Bulk Load from the LSMS Page 70](#)

This chapter describes how to initiate and manage an electronic bulk download at the LSMS. Bulk loading completely replaces an LNP database at a network element. Electronic bulk loading from the LSMS is available only if certain optional features are installed at the LSMS and at the network element.

Introduction

This chapter describes the features required for electronic bulk load and how to initiate and manage electronic bulk load from the Local Service Management System (LSMS). Bulk loading completely replaces an LNP database (all subscription version, number pool block, NPA Split, Translation Type Service, default Global Title Translation, and override Global Title Translation data) at a network element.

When to Perform a Bulk Load

Bulk loading is required when the network element is being initialized for one of the following reasons:

- Bringing the network element into the system for the first time
- Modifying the network element's area of service by reconfiguring EMS routing
- The network element's LNP database is corrupted and cannot be recovered using other synchronization methods

For information about procedures that may be used instead of bulk loading, see [Choosing a Synchronization Procedure](#) on page 21.

Bulk Load Restrictions

A maximum of two bulk loads (of different network elements) can be performed simultaneously. For more information about the maximum number of synchronization operations that can occur simultaneously, see [Maximum Number of Simultaneous Synchronization Operations](#) on page 17.

Bulk Load Overview

Bulk loading is the process of extracting the LNP database from the LSMS and sending the extracted data over a communications link to the network element, where it is loaded into the main LNP database. The bulk load fully replaces the network element's main LNP database.

[Figure 23: Bulk Load Timeline](#) on page 68 illustrates how data is sent to a network element before, during, and after a bulk load.

Figure 23: Bulk Load Timeline

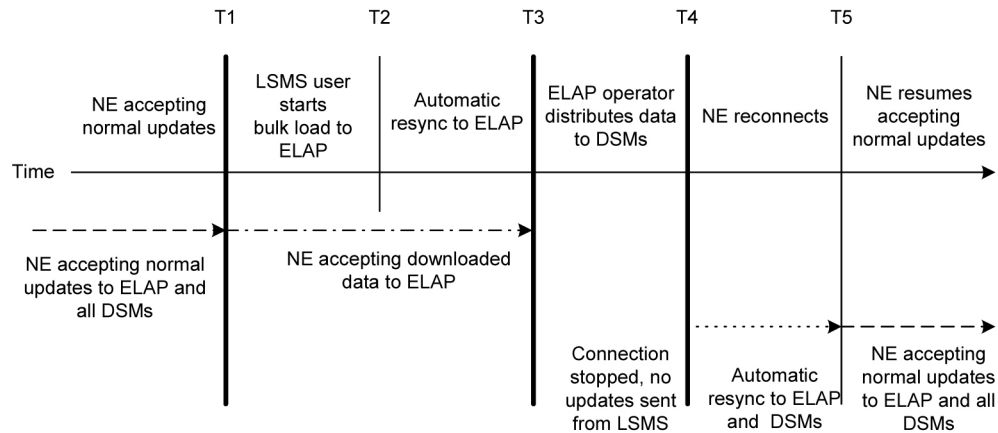

Legend:

----->
LSMS is sending normal updates

----->
LSMS is downloading updates to ELAP

.....>
LSMS is sending resynchronization commands to ELAP and all DSMs

The bulk load stages occur as follows:

T1 *Initial bulk load stage begins:* The LSMS user and network element operator decide to initiate a bulk load as a result of:

- One of the reasons listed in [Introduction](#) on page 68.
- Receiving a notification that NE database maintenance is required. For more information, see [Notifications that Database Maintenance Is Required](#) on page 20 and [Choosing a Synchronization Procedure](#) on page 21.

To start the bulk load at the LSMS, see [Managing Bulk Load from the LSMS](#) on page 67.

During the bulk load, the network element's LNP database is cleared (all LNP database entries are deleted), and the entire LSMS LNP database is downloaded to the network element.

Some differences between the LSMS and NE databases (such as capacity) may cause the NE to reject some of the downloaded commands. These rejections would also occur during a normal update. All commands rejected by the network element are recorded in the bulk load log file (see [Bulk Load Log File](#) on page 82) and can be viewed by clicking the View Log button on the Bulk Load dialog (see [Figure 26: Bulk Load Window](#) on page 72).

At any time during this stage, the LSMS user can choose to abort the bulk load. If aborted, this operation can be either restarted or terminated.

T2 *Automatic resynchronization stage begins:* As soon as the previous stage completes, the LSMS automatically begins a resynchronization to update the network element with any updates received from NPACs or any data locally provisioned since stage T1.

This stage can also result in download commands being rejected by the NE. All commands rejected by the network element are recorded in the bulk load log file (see [Bulk Load Log File](#) on page 82).

and can be viewed by clicking the View Log button on the Bulk Load dialog (see [Figure 26: Bulk Load Window](#) on page 72).

When this stage is complete, the user has the option to commit or discard the LNP data downloaded to the network element. If the user chooses to commit the changes, the DBTS is set to the time that this stage began. If the user chooses to discard the changes, the network element's LNP database is left in a Database Maintenance Required (DMR) state.

T3 *Network element database distribution stage begins:* If the LSMS user chooses in the previous stage to commit the data downloaded to the NE's database, the ELAP operator copies the newly restored ELAP RTDB to the mate ELAP, and then distributes the data to the Service Module cards as described in [Distributing the LNP Database after LSMS-Based Operation or RTDB Copy](#) on page 93.

T4 *Automatic resynchronization stage begins:* At this stage, the bulk load procedures are complete, and the LSMS and network element reconnect and begin the normal automatic resynchronization described in [Automatic Resynchronization Process](#) on page 26. During this stage, the LSMS sends all NPAC updates or locally provisioned data updates that have occurred since stage T2.

T5 *Normal operations resume.*

Managing Bulk Load from the LSMS

This section describes how to perform a bulk load, view bulk load log files, and understand bulk load error messages.

Bulk Load Procedure

Use the following procedure to manage a bulk load from the LSMS user interface.

Note: Before starting this procedure, contact the [Customer Care Center](#) on page 4 to be readily available for assistance if you encounter any problems while performing this procedure.

1. Perform the following substeps to ensure that no NPA Splits will activate during the bulk download procedure:
 - a) As `lsmsadm`, enter the following `lsmsdb` commands to output the counts for both Subscription Version and NumberPoolBlock objects:

```
% cd $LSMS_DIR/tools
% lsmsdb -c counts | grep SubscriptionVersion
1,012,345 ... CanadaDB.SubscriptionVersion
5,434,123 ... MidAtlanticDB.SubscriptionVersion
7,111,222 ... MidwestDB.SubscriptionVersion
6,333,999 ... NortheastDB.SubscriptionVersion
8,044,000 ... SoutheaststDB.SubscriptionVersion
4,999,800 ... SouthwestDB.SubscriptionVersion
6,500,000 ... WestCoastDB.SubscriptionVersion
5,250,500 ... WesternDB.SubscriptionVersion
% lsmsdb -c counts | grep NumberPoolBlock
1,205 ..... CanadaDB.NumberPoolBlock
10,400 ..... MidAtlanticDB.NumberPoolBlock
8,005 ..... MidwestDB.NumberPoolBlock
4,000 ..... NortheastDB.NumberPoolBlock
7,500 ..... SoutheaststDB.NumberPoolBlock
1,225 ..... SouthwestDB.NumberPoolBlock
```

```
7,700 ..... WestCoastDB.NumberPoolBlock
5,500 ..... WesternDB.NumberPoolBlock
```

- b) Total the counts listed in the first column of the output from both commands in substep a. Divide this total by 2 million, to determine the estimated number of hours for the bulk load.
 - c) Generate an NPA Split Report.
Select **Pending** for Status and **All NPAC Regions** for NPAC Region. For information about creating and viewing NPA Split Data Reports, refer to the *LSMS Database Administration Manual*.
 - d) Determine if NPA Splits are scheduled to be activated during the time the Bulk Load is to be performed:
 - If no Pending NPA Splits were listed in the report in substep c, or if none of the Pending NPA Splits has a PDP Start Date that occurs within the time period required to complete the Bulk Load, go to [Step 2](#) on page 71.
 - If any Pending NPA Split has a PDP Start Date that occurs within the time period required to complete the Bulk Load, continue with next substep.
 - e) Determine the date on which you want the NPA Splits to be activated.
This should be the next day after the expected completion of the Bulk Load Procedure (based on the start date/time anticipated and the estimated length of the Bulk Load procedure, from substep b). For example, if the Bulk Load is estimated to require 24 hours to complete and the Bulk Load planned to be performed starting at 12 noon on April 1st, the NPA Split should be postponed until April 3rd.
 - f) Postpone the NPA Split (refer to the *LSMS Database Administration Manual*).
2. Ensure that the network element is prepared to receive a bulk load by doing the following:
 - a) Connect your web browser to the ELAP user interface (for more information, refer to the *EAGLE 5 ISS ELAP Administration Manual*).
 - b) Log in with the user name and password for a user who is authorized to access the menu items shown in this procedure.
The ELAP GUI is displayed, as shown in [Figure 24: ELAP Main Menu](#) on page 71 .

Figure 24: ELAP Main Menu

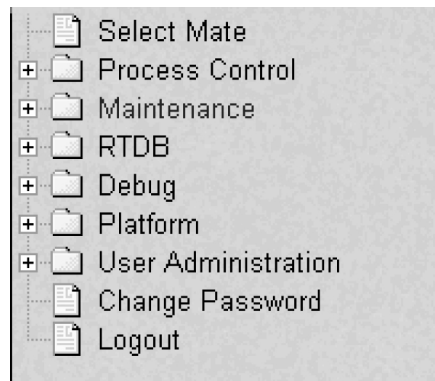

- c) Select **Maintenance > LSMS HS Bulk Download > Change Enabled**.
The window shown in [Figure 25: Enabling Change HS Bulk Download](#) on page 71 displays.

Figure 25: Enabling Change HS Bulk Download

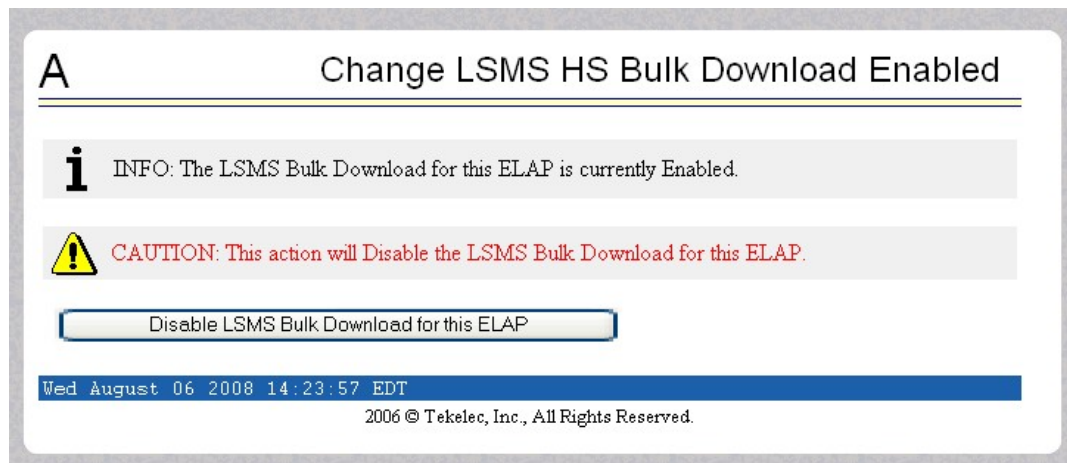

- d) If the information field indicates that the Bulkload for the ELAP is currently enabled, click the Disable Bulkload for this ELAP button and this will allow the audit.
- 3. At the LSMS, log in as a member of the `lsmsuser`, `lsmsuext`, or `lsmsall` user group.
- 4. Start the Bulk Load window using either of the following:
 - a) From the **Main Menu** on the **LSMS Console** window, select **LSMS > LNP Database Synchronization > Bulk Load > <CLLI>**, where **<CLLI>** is the Common Language Location Identifier for the network element that requires the bulk load.
 - b) Right-click the **LSMS Console** window's EMS status icon that corresponds to the network element requiring the bulk load, and select **LNP Database Synchronization ► Bulk Load**. The **Bulk Load** window displays. An example of this window is shown in *Figure 26: Bulk Load Window* on page 72.

Figure 26: Bulk Load Window

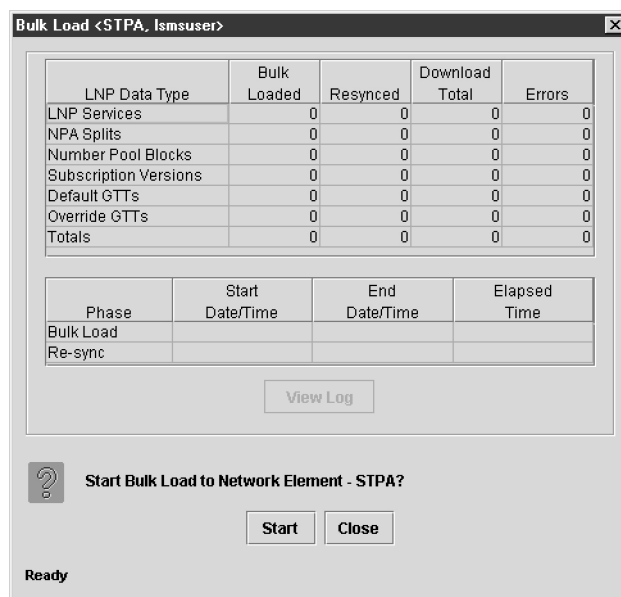

- 5. To initiate the bulk load, click the **Start** button.

The **Start** button is replaced by the **Abort** button, and the **View Log** button becomes selectable. Progress is indicated by start time, elapsed time, numbers of successful and failed update commands, and status reported in the status field at the bottom of the window. When the bulk load phase completes (as indicated in the status field and by a value appearing in the End Date/Time field for the Bulk Load phase), the Re-sync phase begins and progress continues to be indicated in the same ways. All other buttons become nonselectable. [Table 13: Fields in Bulk Load Window](#) on page 73 shows the meaning of each of the fields that appears in this window.

Table 13: Fields in Bulk Load Window

Field	Description	Possible Values
Bulk Loaded	Total number of LNP commands that were successfully transmitted and applied to the NE's LNP database during the initial download phase of the bulk load operation.	0 — 99,999,999
Resynced	Total number of LNP commands that were successfully transmitted and applied to the NE's LNP database during the resynchronization phase of the bulk load operation.	0 — 99,999,999
Download Total	Total number of LNP commands that were successfully transmitted and applied to the NE's LNP database during initial download and the resynchronization phases of the bulk load operation.	0 — 99,999,999
Errors	Total number of commands that were successfully transmitted but rejected by the NE during the initial download and the resynchronization phases of the bulk load operation.	0 — 99,999,999
Bulk Load Start Date/Time	Time at which the initial download phase of the bulk	MM/DD hh:mm:ss ¹

Field	Description	Possible Values
	load operation was started by the user.	
Bulk Load End Date/Time	Time at which the initial download phase of the bulk load operation completed successfully or terminated abnormally.	MM/DD hh:mm:ss ¹
Bulk Load Elapsed Date/Time	Amount of time the initial download phase of the bulk load operation took to complete or the amount of time it ran before the user aborted it.	MM/DD hh:mm:ss ¹ [A F] ²
Re-sync Start Date/Time	Time at which the resynchronization phase of the bulk load operation was started by the user.	MM/DD hh:mm:ss ¹
Re-sync End Date/Time	Time at which the resynchronization phase of the bulk load operation completed successfully (with or without command rejections at the NE) or terminated abnormally.	MM/DD hh:mm:ss ¹
Re-sync Elapsed Date/Time	Amount of time the resynchronization phase of the bulk load operation took to complete or the amount of time it ran before the user aborted it.	hh:mm:ss ¹ [A F] ²
Status	Appears as text at the bottom left of the window to indicate the current status of the resynchronization operation.	Varies
<p>1 MM indicates month, range 01—12 DD indicates day, range 01—31 hh indicates hour, range 00—23 mm indicates minute, range 00—59</p>		

Field	Description	Possible Values
	ss indicates second, range 00—59	
	2 A is appended at the end of the time if the operation is aborted.	
	F is appended at the end of the time if the operation fails.	

The time required to download a database from the LSMS to the network element varies depending on the number of records provisioned in the database and the quality of the transmission and connections. To view the bulk load log file, see [Bulk Load Log File](#) on page 82. To abort during either the bulk load phase or the resynchronization phase of an electronic bulk load is in progress, click the **Abort** button. A confirmation dialog displays, as shown in [Figure 27: Abort Bulk Load Operation Dialog](#) on page 75.

Figure 27: Abort Bulk Load Operation Dialog

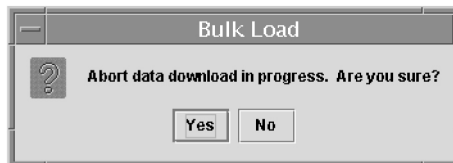

Click the **Yes** button to immediately terminate the operation in progress. Go to [Step 7](#) on page 75 as if the bulk load had completed.

Click the **No** button to close the **Abort** confirmation dialog and return back to the main **Bulk Load** window with no other effect.

- a) Click the **Yes** button to immediately terminate the operation in progress. Go to [Step 7](#) on page 75 as if the bulk load had completed.
 - b) Click the **No** button to close the **Abort** confirmation dialog and return back to the main **Bulk Load** window with no other effect.
6. When the bulk load operation completes, the information dialog shown in [Figure 28: Bulk Load Complete Information Dialog](#) on page 75 displays.

Figure 28: Bulk Load Complete Information Dialog



Click **OK**.

7. When the bulk load operation completes or is aborted, the **Abort** and **Close** buttons are replaced by **Commit** and **Discard** buttons, as shown in [Figure 29: Bulk Load Complete](#) on page 75.

Figure 29: Bulk Load Complete

Bulk Load <STPA, lsmsall>

LNP Data Type	Bulk Loaded	Resynced	Download Total	Errors
LNP Services	6	0	6	0
NPA Splits	1	0	1	0
Number Pool Blocks	1	0	1	0
Subscription Versions	1	0	1	0
Default GTTs	1	0	1	0
Override GTTs	1	0	1	0
Totals	11	0	11	0

Phase	Start Date/Time	End Date/Time	Elapsed Time
Bulk Load	10/23 14:18:46	10/23 14:20:07	00:01:21
Re-sync	10/23 14:20:08	10/23 14:20:08	00:00:00

 **Commit or Discard data downloaded to the NE?**

Please wait...

Commit before you click the **Discard** button, you can view the bulk load log file by clicking the **View Log** button (for more information about the file, including how to view it at other times, see [Bulk Load Log File](#) on page 82). To conclude the bulk load operation, you must click one of the following buttons:

Click the **Discard** button to end the bulk load application (closing the **Bulk Load** window) and to send the NE a discard command that results in changes to the ELAP's RTDB that cannot be undone. (For whatever reason you are performing this procedure, the ELAP's RTDB is now in a state of requiring database maintenance, but the bulk load application is no longer running.)

Note: On the active MPS, verify that the DB Status is Coherent and the RTDB Level is greater than zero before copying the newly downloaded database to the mated ELAP.

8. The NE operator must continue with the following steps to cause the LNP database to be distributed and return the NE to normal operation as follows:
 1. Copy the newly restored RTDB to its mate ELAP's RTDB, as described in [Copy RTDB from Remote on ELAP 8.0](#) on page 91.
 2. Distribute the data to the Service Module cards, as described in [Distributing an RTDB LNP Database to Service Module Cards](#) on page 94.

Support ELAP Reload Via Database Image Function

The Support ELAP Reload via Database Image (SERVDI) function performs bulk data downloads (BDD) that significantly reduces the time needed to reload an ELAP database. SERVDI is included with the optional 384 Million Records feature.

The SERVDI function is executed on the LSMS system and creates an RTDB LNP 384 million records database image file directly from the LSMS LNP databases. See [Figure 30: ELAP Reload Via DB Image Function](#) on page 77. The SERVDI download file must be transferred to the ELAP

system backup directory. Once transferred, the file is activated by using the restore from backup process in the ELAP GUI.

Figure 30: ELAP Reload Via DB Image Function

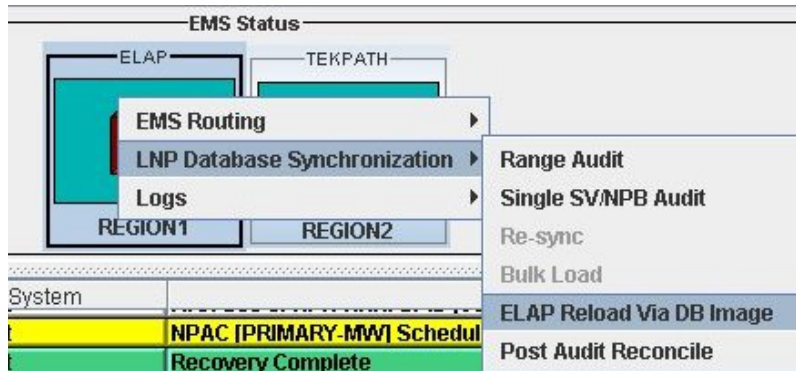

SERVDI Bulk Download

Use the following procedure to perform an ELAP bulk download from the LSMS.

Note: SERVDI is part of the additional-cost, optional 384 Million Records feature. Contact Tekelec Customer Care Center for more information.

Note: The LSMS bulk download SERVDI creates the bulkload file, but cannot send it to the active ELAP unless the Secure Shell Keys (SSKs) have been exchanged. This procedure is part of the ELAP configuration procedure, and is illustrated in the *ELAP Administration Manual - 384 Million TNs*, and the *LNP Feature Activation Guide*. Once this step is complete, the SERVDI bulk download can be sent from the LSMS to the active ELAP.

1. Log in to the LSMS GUI as a member of the permission group that is authorized to perform this operation.
2. From the LSMS Console window, select **LSMS > LNP Database Synchronization > ELAP Reload Via DB Image > <CLLI>** where <CLLI> is the ELAP network element that requires the bulk download.

Figure 31: ELAP Reload Via DB Image

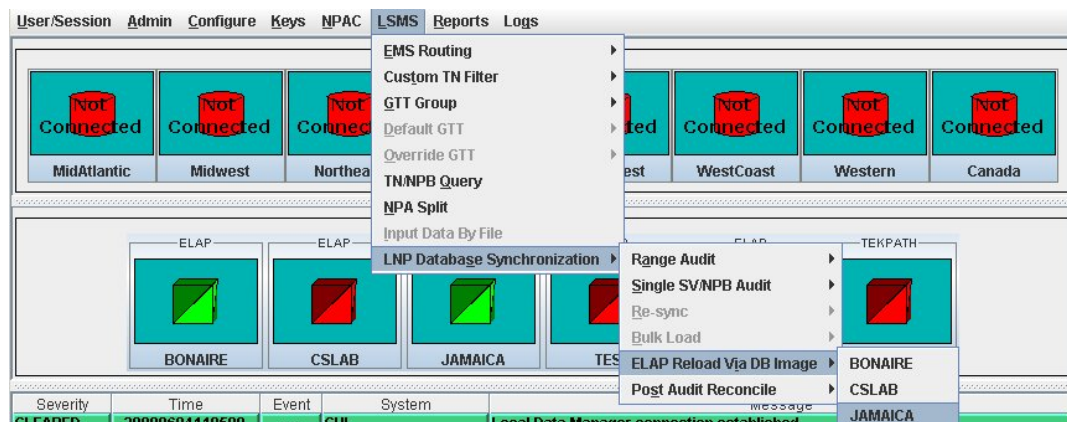

3. Click **Generate Image**.

Figure 32: Generate Image

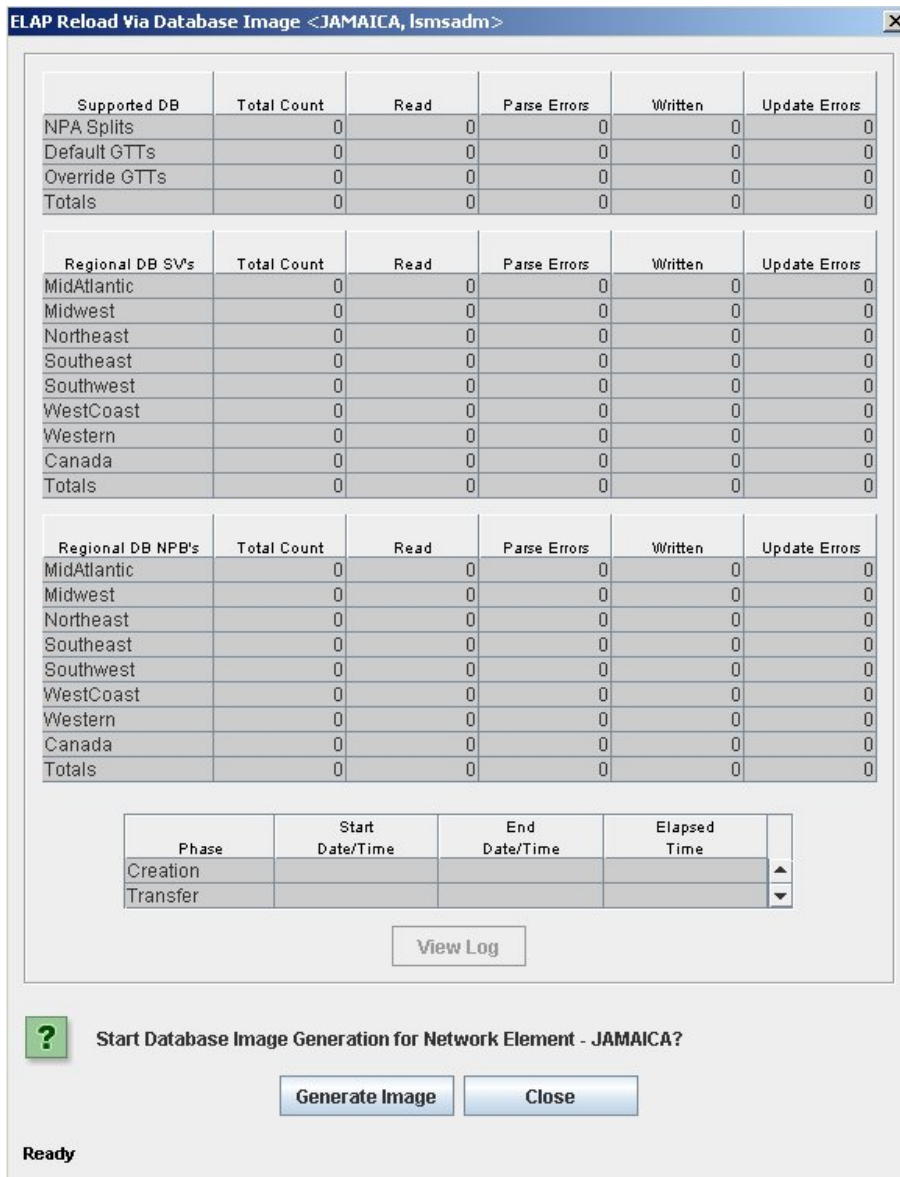

4. The LSMS creates a database file of the ELAP database image. When the process completes, a confirmation dialog appears.

Figure 33: Database Image Completed



Click **OK** to continue.

Note: If necessary, you can stop the bulk download process before the database image is complete. To stop the bulk download process, click **Abort**. A confirmation dialog appears. Click **Yes** to terminate the bulk download in progress. Click **No** to continue with the bulk download.

Figure 34: Abort Bulk Download

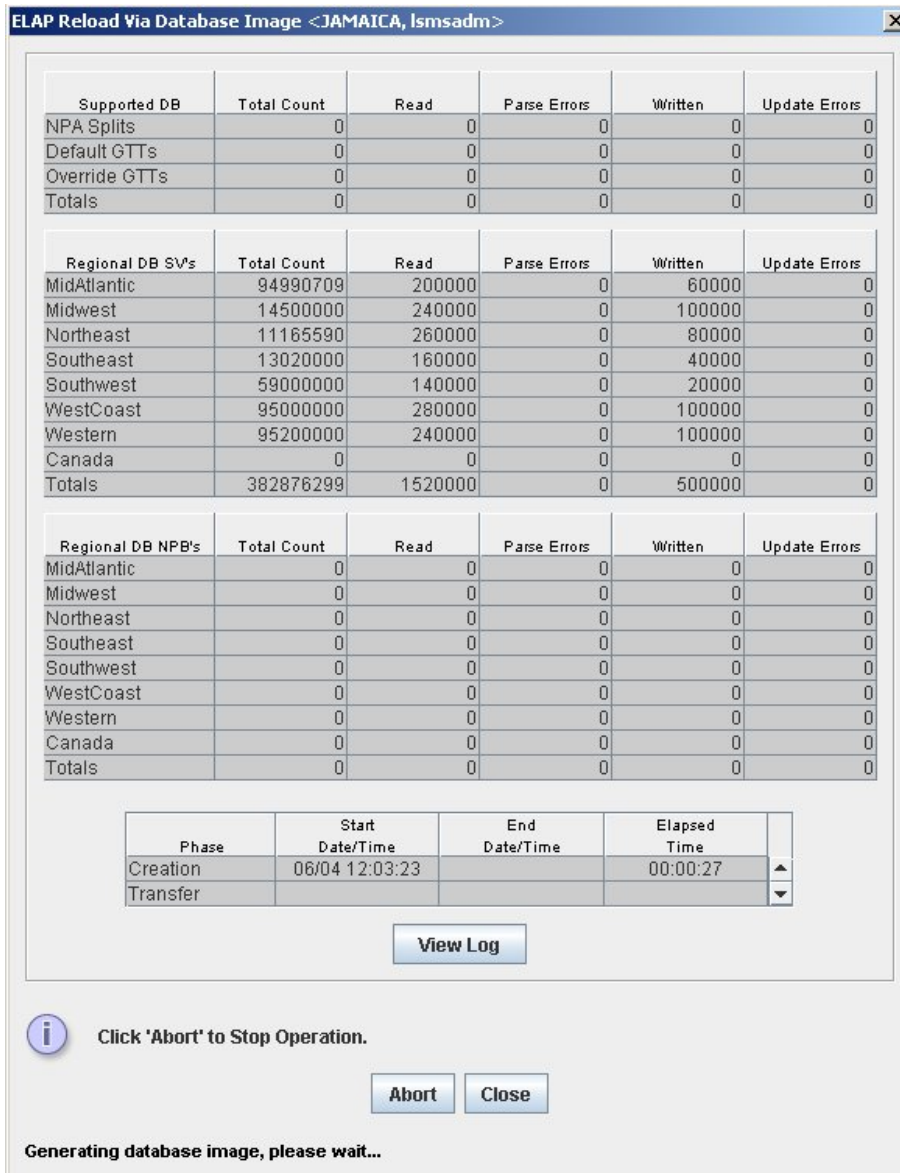
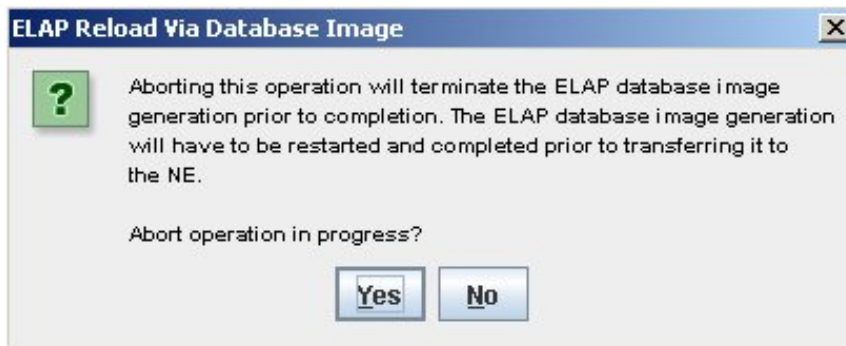
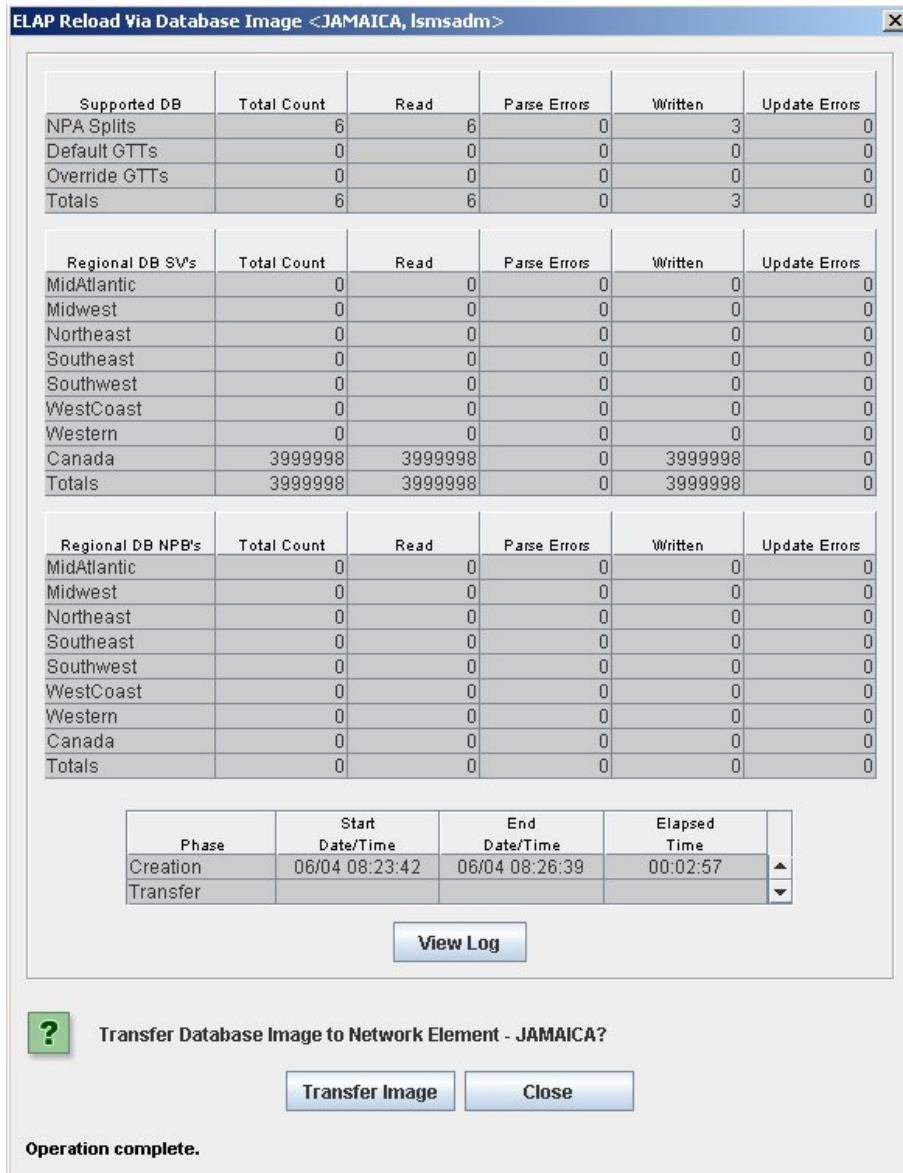

Figure 35: Abort Confirmation



- Click **Transfer Image** to transfer the bulk download to the ELAP.

Figure 36: Transfer Database Image to ELAP



When the transfer completes, a confirmation dialog appears. Click **OK** to continue.

Figure 37: Image Transfer Complete

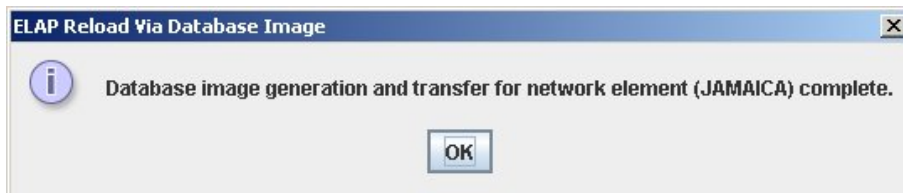

- Click **Close** to return to the main LSMS Console window.

In order to complete this process, you must reload the ELAP database using the file generated in [Step 4](#) on page 78. For more information about how to reload an ELAP database, refer to the procedure, [Restore RTDB on ELAP 8.0](#) on page 89.

Bulk Load Log File

This section describes the following topics:

- [Viewing the Bulk Load Log File](#) on page 82
- [Bulk Load Log File Contents](#) on page 83

Viewing the Bulk Load Log File

After a resynchronization has begun, you can view the electronic bulk load log file by clicking the **View Log** button. The browser window displays the log file `LsmsBulkload.log.<MMDD>`. The file is located in the directory `/usr/local/LSMS/logs/<CLLI>`. **<CLLI>** is the Common Language Location Identifier of the network element receiving the bulk load. **<MMDD>** is the timestamp that contains month and day that the file was created.

You can also use one of the following methods to open the window shown in [Figure 38: Open Log Files Window](#) on page 82 to browse for this log:

- Select **Logs > Other...** from the main menu of the **LSMS Console** window.
- Click on the **LSMS Console** window's **EMS Status** icon that corresponds to the network element receiving the bulk load so that the icon is highlighted. Right-click and select **Logs > LNP Database Synchronization > Bulk Load**.

The Open Log Files window displays.

Figure 38: Open Log Files Window



Scroll down to find the folder that has the **<CLLI>** name for the NE that was bulk loaded. Double-click the folder name, and then double-click the file name `LsmsBulkload.log.<MMDD>` that corresponds to the month and day you desire.

Note: Log files are maintained for seven days and then automatically removed from the LSMS.

Bulk Load Log File Contents

When a bulk load is started, the bulk load log file for that day is appended (if this is the first bulk load of the day, the file is created). For each bulk load performed on that day, the bulk load log file contains information similar to the information displayed on the Bulk Load main window, such as start and end times for the bulk load, and numbers of successes and failures in various LNP categories.

The bulk load log file contains the following sections:

- Header Section
- Bulk Load Section
- Resynchronization Section
- Summary Section
- Download Commit/Discard Section

See Appendix C of the *LNP Database Synchronization Manual - LSMS with EAGLE 5 ISS* for more information on these sections.

Figure 39: Example Bulk Load Log File on page 83 shows an example of a bulk load log file.

Figure 39: Example Bulk Load Log File

```
Wed Oct 31 14:02:03 GMT 2001

Username: lsmsall
NE CLLI: STPB

-----

Wed Oct 31 14:02:02 GMT 2001
Connection established with network element (192.168.61.202:1030)

Bulk download started on Wed Oct 31 14:02:13 GMT 2001

Bulk download completed on Wed Oct 31 14:02:27 GMT 2001

      LNP Services           6 Downloaded           0 errors
      NPA Splits             1 Downloaded           0 errors
      Number Pool Blocks     2 Downloaded           0 errors
      Subscription Versions 1004 Downloaded        0 errors
      Default GTTs           1 Downloaded           0 errors
      Override GTTs          1 Downloaded           0 errors
      Total                   1015 Downloaded        0 errors

Re-sync started on Wed Oct 31 14:02:29 GMT 2001

New NE LNP Database Time Stamp: Wed Oct 31 14:02:30 GMT 2001
```

Re-sync completed on Wed Oct 31 14:02:30 GMT 2001

NPA Splits	0 Downloaded	0 errors
Number Pool Blocks	0 Downloaded	0 errors
Subscription Versions	0 Downloaded	0 errors
Default GTTs	0 Downloaded	0 errors
Override GTTs	0 Downloaded	0 errors
Total	0 Downloaded	0 errors

Commit completed on Wed Oct 31 14:02:48 GMT 2001.

Username: lsmsall
 NE CLI: STPB

Bulk download started on Wed Oct 31 15:04:54 GMT 2001

Bulk download completed on Wed Oct 31 15:05:09 GMT 2001

LNP Services	6 Downloaded	0 errors
NPA Splits	1 Downloaded	0 errors
Number Pool Blocks	2 Downloaded	0 errors
Subscription Versions	1004 Downloaded	0 errors
Default GTTs	1 Downloaded	0 errors
Override GTTs	1 Downloaded	0 errors
Total	1015 Downloaded	0 errors

Re-sync started on Wed Oct 31 15:05:19 GMT 2001

New NE LNP Database Time Stamp: Wed Oct 31 15:05:20 GMT 2001

Re-sync completed on Wed Oct 31 15:05:20 GMT 2001

NPA Splits	0 Downloaded	0 errors
Number Pool Blocks	0 Downloaded	0 errors
Subscription Versions	0 Downloaded	0 errors
Default GTTs	0 Downloaded	0 errors
Override GTTs	0 Downloaded	0 errors
Total	0 Downloaded	0 errors

Discard completed on Wed Oct 31 15:10:55 GMT 2001.

Bulk Load Error Messages

For a listing of error messages that can appear on the GUI, along with explanation of possible cause and suggested recovery, see Appendix A in the *LNP Database Synchronization Manual - LSMS with EAGLE 5 ISS*.

Copying One RTDB from Another RTDB

Topics:

- [Copying One RTDB from Another RTDB Page 86](#)
- [Verifying RTDB Status Page 86](#)
- [Restore RTDB on ELAP 8.0 Page 89](#)
- [Copy RTDB from Remote on ELAP 8.0 Page 91](#)

This chapter describes how to copy the contents of the Real Time Database (RTDB) that exists on the mated EAGLE LNP Application Processor (ELAP) server to an RTDB within the same network element that needs database restoration or to copy the contents of the Real Time Database that exists on an ELAP on the mated network element to an RTDB that needs database restoration.

Copying One RTDB from Another RTDB

This section describes the procedures for copying an EAGLE LNP Application Processor (ELAP) Real Time Database (RTDB) from another ELAP RTDB to reload a corrupted or backlevel RTDB. For more information about when to perform the procedures in this section, see *The LNP Database Synchronization Manual, Choosing a Database Maintenance Procedure*.

The following procedures are covered by this section:

- [Restore RTDB on ELAP 8.0](#) on page 89
- [Copy RTDB from Remote on ELAP 8.0](#) on page 91

Restore RTDB on ELAP 8.0

In previous versions of ELAP, databases were copied from the mate. The Copy from Mated ELAP function is no longer supported with the 384 Million LNP Records feature. If you have purchased the 384 Million Records feature and are running on ELAP 8.0, follow the procedures for Restore RTDB on ELAP 8.0 in place of the previous process to copy the RTDB from the mated ELAP.

ELAP 8.0 uses a Distributed Replicated Block Device (DRBD) to replicate the database, which provides significantly faster download times. The DRBD replicates the database by using a snapshot image of the database. This new function, Support ELAP Reload Via Database Image, or SERVDI, is executed on the LSMS for the bulk download, and the process is completed with the procedure to restore the RTDB. See [Restore RTDB on ELAP 8.0](#) on page 89 for the detailed procedure.

For more information on the SERVDI function, see [SERVDI Bulk Download](#) on page 77.

Copy RTDB from Remote on ELAP 8.0

With the 384 Million LNP Records feature, it is no longer necessary to stop the software before performing this procedure. ELAP 8.0 uses a snapshot image of the database to replicate the database, making this a significantly faster process.

After completing the Copy RTDB from Remote procedure, the database must be restored to make the transferred file the active RTDB. See [Restore RTDB on ELAP 8.0](#) on page 89 for the procedure to restore the RTDB.

Verifying RTDB Status

Before or after executing the Copy One RTDB to Another RTDB procedure, verify the status of the RTDBs using either or both of the following methods:

- [Verifying RTDB Status at the EAGLE 5 ISS Terminal](#) on page 86
- [Verifying RTDB Status at the ELAP User Interface](#) on page 87

Verifying RTDB Status at the EAGLE 5 ISS Terminal

To verify the status of the ELAP RTDBs at the EAGLE 5 ISS terminal, enter the `rept-stat-db:db=mps` command.

The command output displays database timestamp (DBTS) of both ELAP RTDBs in the RTDB-EAGLE field, as shown in bold in the following example. The DBTS indicates the last time an update was received by this RTDB from the LSMS. If the two DBTS values are not the same, the RTDB with the lower DBTS may need database maintenance.

```

ELAP A (ACTV)
      C      BIRTHDATE      LEVEL      EXCEPTION
      -      -            -            -
RTDB      Y      00-05-01 10:19:18      17283      - RTDB-EAGLE
00-05-03 16:01:48 17283
      -

ELAP B (STDBY)
      C      BIRTHDATE      LEVEL      EXCEPTION
      -      -            -            -
RTDB      Y      00-05-01 10:19:18      17283      -RTDB-EAGLE
00-05-03 16:01:48 17283
      -

```

Verifying RTDB Status at the ELAP User Interface

To verify the status of ELAP RTDBs at the ELAP user interface (view the status of the databases), perform the following procedure.

1. Open a browser window and connect your web browser to the ELAP GUI (for more information about connecting to the ELAP GUI, refer to the *ELAP Administration Manual*).

Log in with the user name and password for a user who is authorized to access the menu items shown in this procedure. The ELAP GUI is displayed, [Figure 40: ELAP Main Screen](#) on page 87.

Figure 40: ELAP Main Screen

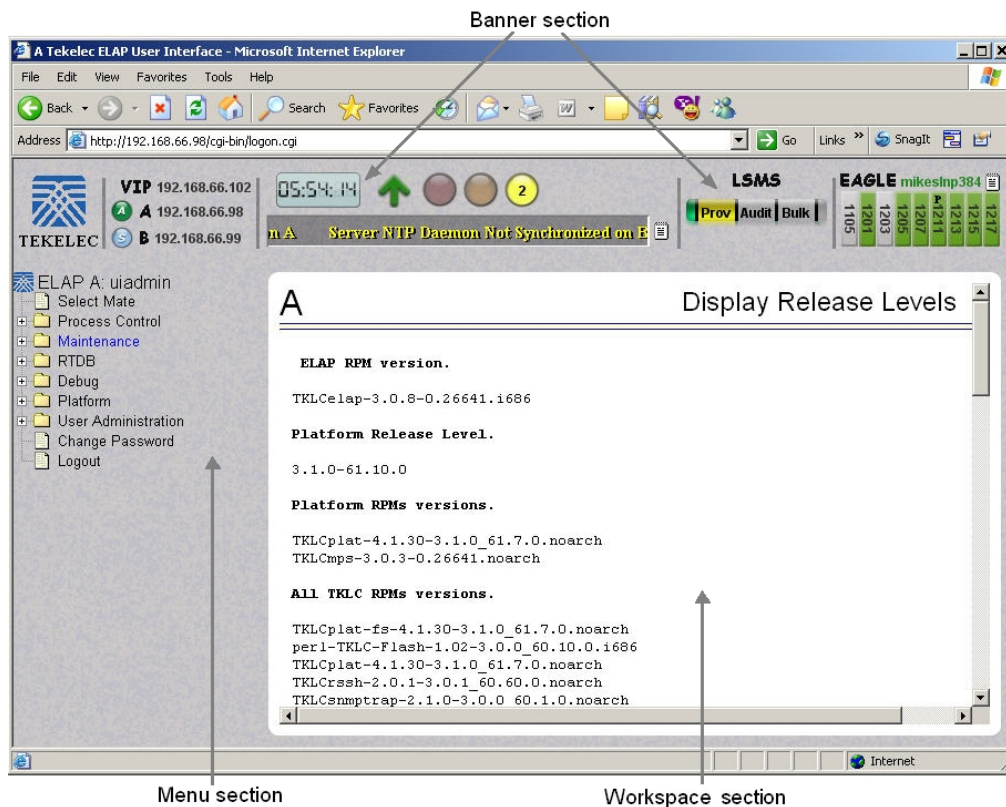

- From the Main Menu, select **RTDB > View RTDB Status**.

The ELAP GUI workspace displays the RTDB status, as shown in *Figure 41: ELAP RTDB Status* on page 88.

Figure 41: ELAP RTDB Status

Local RTDB Status	
DB Status:	Coherent
RTDB Level:	8708
Counts:	TNs=8708, NPANXXs=778, LRNs=2, SPs=2, MRs=8, MRGroups=2
Reload:	None
Audit Enabled:	Yes
RTDB Birthday:	09/26/2005 20:44:35 GMT

Mate RTDB Status	
DB Status:	Coherent
RTDB Level:	8708
Counts:	TNs=8708, NPANXXs=778, LRNs=2, SPs=2, MRs=8, MRGroups=2
Reload:	None
Audit Enabled:	Yes
RTDB Birthday:	09/26/2005 20:44:44 GMT

Note the values displayed for DB Level and DB Birthday for both the local RTDB and the mate RTDB.

- To verify that both RTDBs are ready for normal service, ensure that:
 - The status for both RTDBs displays

- b) Both RTDBs are coherent
- c) Both RTDBs have the same birthday
- d) Both RTDBs have the same level (if provisioning is occurring, the levels might be different by a very small number)

If you are not sure how to interpret the status of the RTDBs, contact the [Customer Care Center](#) on page 4.

You have now completed this procedure.

Restore RTDB on ELAP 8.0

Follow these steps to restore the RTDB from a backup file after performing a bulk download.

1. Open a browser window and connect your web browser to the ELAP GUI (for more information about connecting to the ELAP GUI, refer to the *ELAP Administration Manual*).
2. Log in with the user name and password for an authorized user.
3. From the ELAP GUI menu, select **Process Control** ► **Stop Software** to ensure that no other updates are occurring. The screen shown in [Figure 42: Stopping Software on the ELAP GUI](#) on page 89 displays. Click the **Stop ELAP Software** button.

Figure 42: Stopping Software on the ELAP GUI

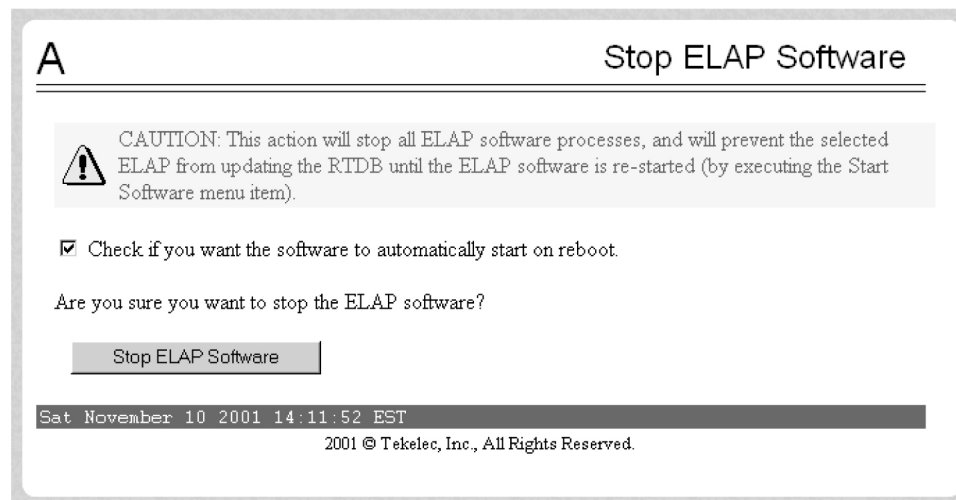

After the software on the selected ELAP has stopped, the screen shown in [Figure 43: Stop ELAP Software - Success](#) on page 89 is displayed.

Figure 43: Stop ELAP Software - Success

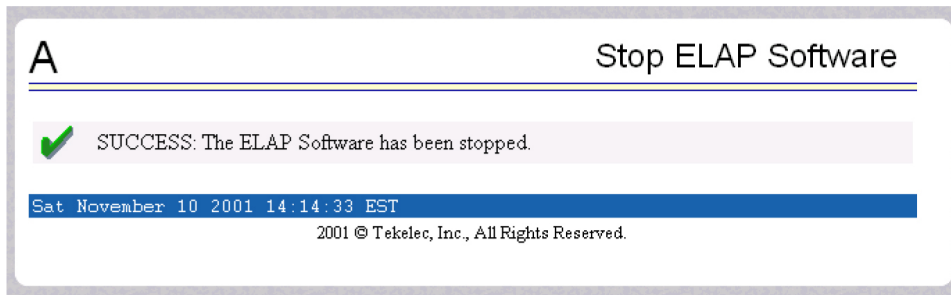

4. Select **RTDB** ► **Maintenance** ► **Restore RTDB**.

The Restore the RTDB screen displays, *Figure 44: Restore the RTDB* on page 90.

Figure 44: Restore the RTDB

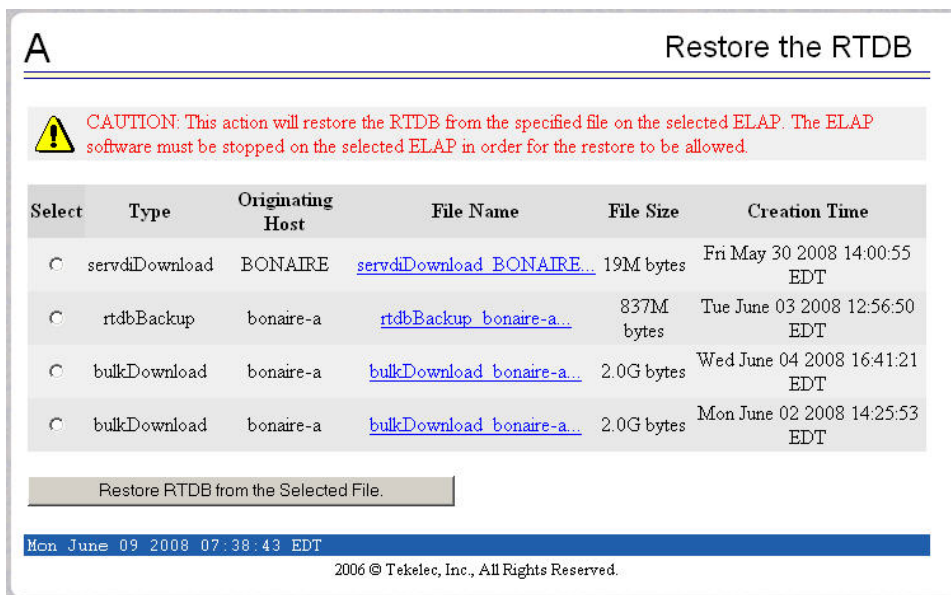

5. Select the appropriate file to restore and click the **Restore RTDB from the Selected File** button.

6. To confirm restoring the file, click the **Confirm RTDB Restore** button on the confirmation dialog, *Figure 45: Confirm RTDB Restore* on page 90.

Figure 45: Confirm RTDB Restore

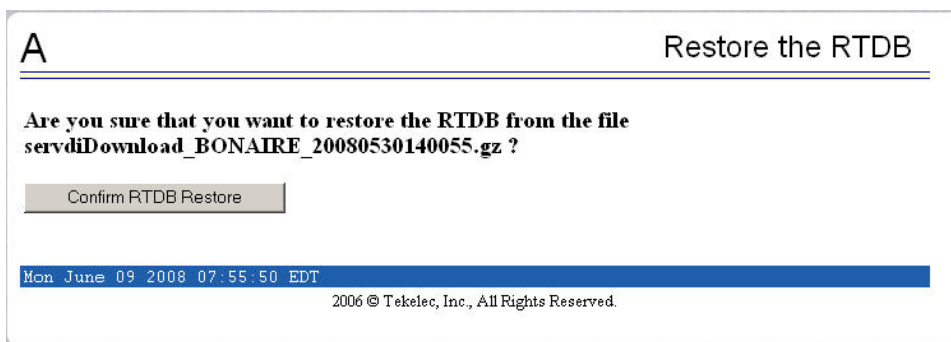

7. After the file is successfully restored, the screen shown in [Figure 46: Successful RTDB Restoration](#) on page 91 displays.

Figure 46: Successful RTDB Restoration

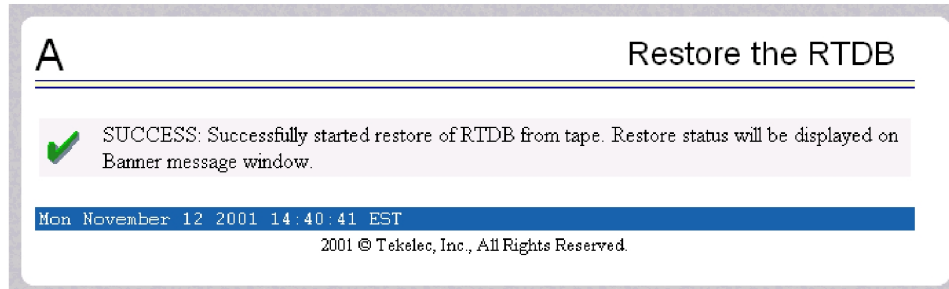

Copy RTDB from Remote on ELAP 8.0

With the 384 Million Records feature on ELAP 8.0, it is no longer necessary to stop the software before performing this procedure. You must restore the RTDB to make the transferred file the active RTDB.

Follow these steps to copy the RTDB from a remote ELAP to the local ELAP.

1. Open a browser window and connect your web browser to the ELAP GUI (for more information about connecting to the ELAP GUI, refer to the *ELAP Administration Manual*).
2. Log in with the user name and password for a user who is authorized to access the menu items shown in this procedure.
3. From the ELAP GUI menu, select **RTDB** ► **Maintenance** ► **Copy from Remote**.

The Copy RTDB from Remote screen displays, [Figure 47: Copy RTDB from Remote](#) on page 91.

Figure 47: Copy RTDB from Remote

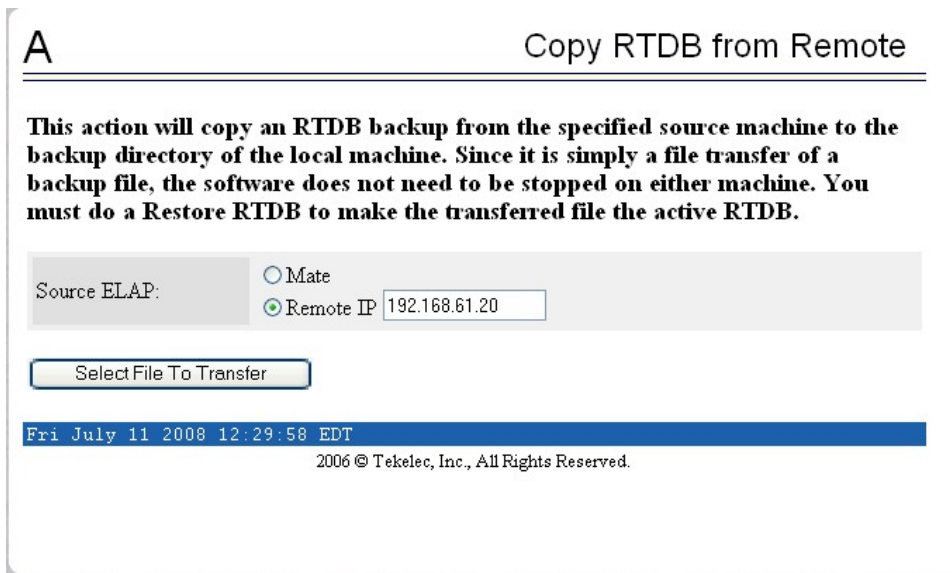

4. To copy the local RTDB, choose the source to reload. If you are selecting a Remote IP address, enter the address in the text field. Click the **Select File To Transfer** button.
5. Select the appropriate file from the screen that opens, as shown in [Figure 48: Copy RTDB from Remote Selection](#) on page 92. Click the **Copy the selected remote RTDB backup** button.

Figure 48: Copy RTDB from Remote Selection

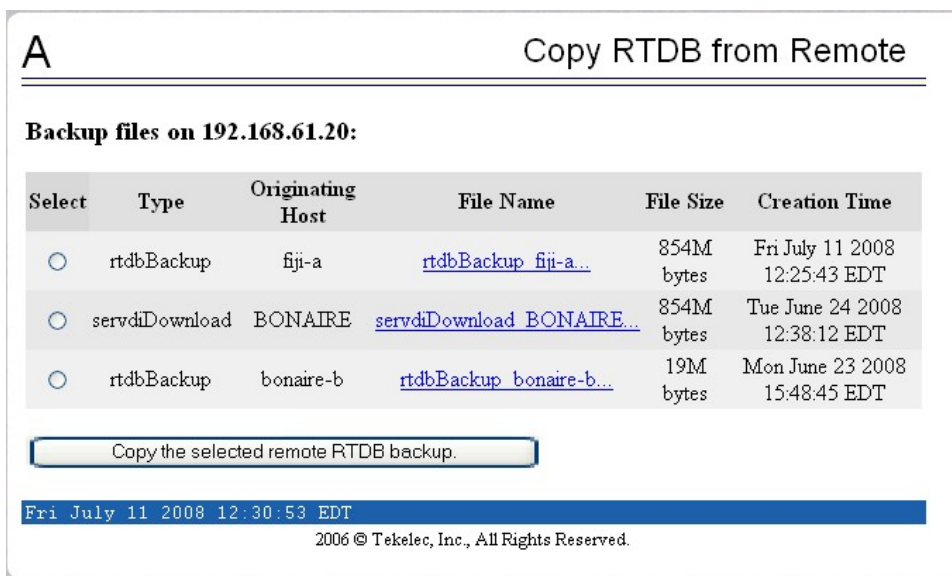

After the reload is complete, a confirmation message displays.

To reload the RTDB, follow the procedure as shown in [Restore RTDB on ELAP 8.0](#) on page 89.

Distributing the LNP Database after LSMS-Based Operation or RTDB Copy

Topics:

- [Introduction Page 94](#)
- [Distributing an RTDB LNP Database to Service Module Cards Page 94](#)

After an RTDB copy or a synchronization operation initiated from the LSMS GUI, the remaining NE LNP databases must be synchronized with the newly synchronized NE database. This chapter describes the method to distribute the LNP database to the Service Module cards in the network element.

Introduction

The network element has multiple copies of the LNP database. Synchronization operations are performed on one database. After an RTDB copy or a synchronization operation initiated from the LSMS GUI, the remaining NE LNP databases must be synchronized with the newly synchronized NE database in one of the following ways:

- Automatic Data Distribution

After the following LNP database synchronization operations, data is distributed automatically from the network element's newly synchronized LNP database to all other LNP databases at the network element:

- Automatic resynchronization (see "Automatic Resynchronization Process" in the *LNP Database Synchronization Manual - LSMS with EAGLE 5 ISS*)
- Reconcile (see "Audit and Reconcile Overview" in the *LNP Database Synchronization Manual - LSMS with EAGLE 5 ISS*)
- Network Element Database is not Required after Copying an RTDB from its mate ELAP
If network element's database synchronization is accomplished only by copying an RTDB from its mate ELAP's RTDB (but not when copying from the mate RTDB is performed after copying an RTDB from the remote mated network element or after a bulk load from the LSMS), it is not necessary to distribute the data to the Service Module cards because they are already synchronized with the RTDB that was used to restore from. Therefore, after the copy, the Service Module cards are now synchronized with both RTDBs.
- Other Network Element Database Distribution

After other LNP database synchronization operations, the network element main LNP database must be distributed by operator intervention to other LNP databases within the network element (both the mate RTDB and the service module cards). See [Customer Care Center](#) on page 4.

Distributing an RTDB LNP Database to Service Module Cards

This section describes how to distribute the LNP database to the Service Module cards after the RTDB has been updated by one of the following actions:

- Copied from an RTDB on the mated network element (see [Copying One RTDB from Another RTDB](#) on page 86)
- Updated by one of the following operations sent from the LSMS:
 - Bulk loaded from the LSMS (see [Managing Bulk Load from the LSMS](#) on page 70)
 - Support ELAP reload via database image (SERVDI) bulk download from the LSMS (see [SERVDI Bulk Download](#) on page 77)

Distributing an RTDB LNP Database to a Service Module Card

Perform the following procedure to distribute the data from the ELAP's LNP database to the Service Module cards.

1. Distribute the imported LNP database onto each Service Module card, which will also silence the LNP database alarms.

Use one of the following methods:

- a) Method A loads the imported LNP database onto one Service Module card at a time by reloading each Service Module.

This method allows the global title translation and LNP functions to continue running while the new LNP database is being loaded. When the Service Module card is reinitializing, its database goes temporarily out of service for the period of time that it takes to reload the database on the Service Module card. The time required to reload the database depends upon the size of the database and can take as long as 15 minutes for an LNP database containing 2,000,000 LNP subscriptions.

- b) Method B loads the imported LNP database onto all Service Module cards in the EAGLE 5 ISS by reinitializing all the Service Module cards at once.



CAUTION

CAUTION: This method not only loads the imported LNP database onto the Service Module cards at the same time, but takes all the Service Module cards out of service and the LNP subsystem will be offline. This method should only be used in emergency situations.

Method A: Perform steps **a** and **b** in this method for each Service Module card, one Service Module card at a time.

1. Take the Service Module card out of service with the `rmv-card` command specifying the location of the Service Module card. If there is only one Service Module card in the EAGLE 5 ISS, the `force=yes` parameter must be specified with the `rmv-card` command. For this example, enter this command:

```
rmv-card:loc=1301
```

After successful completion of this command, the EAGLE 5 ISS returns the following output:

```
rlghncxa03w 06-08-01 11:11:28 GMT EAGLE5 37.5.0
Card has been inhibited.
```

2. Return the Service Module card to service with the `rst-card` command with the location of the Service Module card and the option `data=persist` to allow a warm restart if possible. This command validates that the LNP database on the specified Service Module card is correct. If the LNP database is correct, no further loading is required. If the LNP database is not correct, it is automatically reloaded from the RTDB; loading may require up to an hour. For this example, enter this command:

```
rst-card:loc=1301:data=persist
```

After successful completion of this command, the EAGLE 5 ISS returns the following output:

```
rlghncxa03w 06-08-01 11:11:28 GMT EAGLE5 37.5.0
Card has been allowed.
```

- When the Service Module card is returned to service, the major alarm is silenced and UAM 0431, LNP database has been corrected, is generated. For this example, this message is generated:

```
rlghncxa03w 06-08-01 11:11:28 GMT EAGLE5 37.5.0
0012.0431 CARD 1301 DSM LNP database has been corrected
```

- Repeat steps a and b for the other Service Module cards in the EAGLE 5 ISS.

If any of the Service Module cards continue to boot, contact the [Customer Care Center](#) on page 4.

Method B: Enter the `dsm` command.



CAUTION

This command initializes all the Service Module cards at once and not only loads the imported LNP database onto the Service Module cards at the same time, but takes all the Service Module cards out of service and the LNP subsystem will be offline. This method should only be used in emergency situations.

Note: A more graceful way of initializing the Service Module cards is to reroute all global title translation traffic, including LNP traffic, to the mate network element using the `inh-map-ss` command. The `inh-map-ss` command takes the mated application subsystem out of service. When the mated application subsystem is out of service, all global title translation traffic, including LNP traffic, is rerouted to the mate network element.

The mated application subsystem must be inhibited with the `inh-map-ss` command before the Service Module cards are reinitialized with the `init-card:appl=vdsm` command. After the `init-card:appl=vdsm` command has finished executing and all the Service Module cards have reinitialized, return the mated application subsystem to service with the `alw-map-ss` command.

When the imported database has been loaded onto each Service Module card, UAM 0431 is displayed for each Service Module card showing that the UAM 0429 has been cleared and the database on the Service Module card matches the database on the MASPs. This is an example of UAM 0431.

```
rlghncxa03w 06-08-01 11:11:28 GMT EAGLE5 37.5.0
0012.0431 CARD 1301 DSM LNP database has been corrected
```

If any of the Service Module cards continue to boot, contact the [Customer Care Center](#) on page 4.

- Verify that the Service Module cards are in-service by entering the `rept-stat-dsm` command.

The state of the Service Module cards, shown in the PST field of the `dsm` command output, should be IS-NR (in-service normal). This is an example of the possible output:

```
rlghncxa03w 06-08-01 09:12:36 GMT EAGLE5 37.5.0
CARD   VERSION   PST           SST           AST           MSU   CPU
                USAGE   USAGE
-----
1301   123-002-001 IS-NR         Active        -----    33%   46%
1303   123-002-001 IS-NR         Active        -----    34%   50%
1305   123-002-001 IS-NR         Active        -----    21%   29%
1307   123-002-001 IS-NR         Active        -----    35%   52%
1311   123-002-001 IS-NR         Active        -----    15%   20%
-----
```

```
DSM Service Average MSU Capacity = 28% Average CPU Capacity = 40%  
Command Completed.
```

If the state of any Service Module card is not IS-NR, contact the [Customer Care Center](#) on page 4.

Note: The `rept-stat-dsm` command output contains other fields that are not used by this procedure. If you wish to see all the fields displayed by the `rept-stat-dsm` command, see the `rept-stat-dsm` command description in the *EAGLE 5 ISS Commands Manual*.

Appendix

A

LSMS GUI Messages

Topics:

- [Introduction Page 100](#)
- [GUI Messages Page 100](#)

This section lists the messages that can appear in the LSMS GUI, and provides a description and recovery for each message.

Introduction

This appendix lists in alphabetical order the messages that can appear when you are using the LSMS graphical user interface (GUI) functions described in this book. For each message, this appendix shows the probable cause for the message, which LSMS LNP Database Synchronization GUI functions the message can appear for, and suggested recovery steps if the message indicates an error situation.

For information about other messages that may occur during the procedures described in this manual, refer to one of the following:

- *LSMS Maintenance Manual* for error messages that may occur from LSMS commands
- *Eagle STP Commands Error Recovery Manual* for error messages that may occur from commands entered at the network element

Note:

If you cannot find the message in this appendix, contact the [Customer Care Center](#) on page 4.

GUI Messages

A TN filter has not been assigned to the EMS

May Occur During: Any LNP database synchronization operation

Explanation

The attempted operation cannot be performed until a TN filter is assigned to the EMS. The operation is not started.

Recovery

Assign one or more regional TN filters or a single custom TN filter to the EMS for which the operation is being performed (for information about assigning TN filters, refer to the *LSMS Database Administration Manual*) and try the operation again.

An LNP DB synchronization operation is already in progress for NE

May Occur During: Any LNP database synchronization operation

Explanation

The attempted operation cannot be performed because another LNP database synchronization operation is already in progress for that network element. Only one bulk load, audit, or resynchronization operation for a given network element can be initiated at one time.

Recovery

Wait until the LNP database synchronization operation currently in progress completes and try the operation again. If the error persists, contact your system administrator to determine whether

a user at another location may still have an LNP database synchronization operation window open for this network element.

Audit input queue failure**May Occur During: Audit****Explanation**

The auditor was attempting to read LSMS data to be audited, but that queue had a failure. The audit is not completed.

Recovery

Contact the [Customer Care Center](#) on page 4.

Audit input queue shutdown**May Occur During: Audit****Explanation**

The auditor was attempting to read LSMS data to be audited, but that queue was shut down. The audit is not completed.

Recovery

Contact the [Customer Care Center](#) on page 4.

Audit input queue timeout. Please contact Tekelec Technical Services.**May Occur During: Audit****Explanation**

The auditor was attempting to read LSMS data to be audited, but that queue has stayed empty too long. The audit is not completed.

Recovery

Contact the [Customer Care Center](#) on page 4.

Audit NE input queue failure.**May Occur During: Audit****Explanation**

The auditor was attempting to read network element data to be audited, but that queue had a failure. The audit is not completed.

Recovery

Contact the [Customer Care Center](#) on page 4.

Audit NE input queue shutdown**May Occur During: Audit****Explanation**

The auditor was attempting to read data to be audited from the network element, but that queue was shut down. The audit is not completed.

Recovery

Contact the [Customer Care Center](#) on page 4.

Audit NE input queue timeout. Please contact Tekelec Technical Services.

May Occur During: Audit**Explanation**

The auditor was attempting to read data to be audited from the network element, but no response was received in the allowed time. The audit is not completed.

Recovery

Try the operation again. If the error persists, contact the [Customer Care Center](#) on page 4.

Auditing of <objType> is not supported by the NE

May Occur During: Audit**Explanation**

An audit was attempted to be performed on a network element that does not support the object type indicated by <objType>, where <objType> is one of the following:

- NPA Split
- Number Pool Blocks
- Subscription Versions
- Default GTTs
- Override GTTs

The audit is not performed.

Recovery

Select "All Database Objects in Specified Ranges" radio button and select only the object types that are supported by the version of software running on the network element.

Bulk Load is required. NE's LNP DB timestamp (<timestamp>) is invalid

May Occur During: Reconcile**Explanation**

The network element's LNP database timestamp (DBTS) is invalid. The operation is not started.

Recovery

A bulk download is required. Contact the [Customer Care Center](#) on page 4.

Bulk Load is required. NE's LNP DB timestamp (<timestamp>) is older than 7 days

May Occur During: Reconcile

Explanation

The LSMS user attempted to reconcile or resynchronize a network element's LNP database whose DBTS is older than seven days. (The transaction logs needed to perform this operation go back only seven days.) The operation is not started.

Recovery

A bulk download is required.

Connection already in use at NE '<IP address>'

May Occur During: Any non-ELAP-based LNP database synchronization operation

Explanation

An attempt was made to start an LNP database synchronization operation to a network element for which an LNP database synchronization operation is already running. The operation is not performed.

Recovery

Do the following:

1. Examine the notifications area of the LSMS GUI to determine whether another LNP database synchronization operation is already running (look for event numbers 8066 through 8085 and read the message text to determine what has occurred). If another LNP database synchronization operation is in progress, wait until it has completed, and try your operation again.
2. If this error still occurs, contact the [Customer Care Center](#) on page 4.

Connection already in use or operation not enabled at NE '<IP address>'

May Occur During: Any LNP database synchronization operation

Explanation

An attempt was made to start an LNP database synchronization operation to a network element for which one of the following is true:

- An LNP database synchronization operation is already running
- The ELAP is not enabled to receive the operation

The operation is not performed

Recovery

Do the following:

1. Examine the notifications area of the LSMS GUI to determine whether another LNP database synchronization operation is already running (look for event numbers 8066 through 8085 and read the message text to determine what has occurred). If another LNP database synchronization operation is in progress, wait until it has completed, and try your operation again.
2. Contact the NE operator to determine whether the ELAP has been enabled for this synchronization operation.
3. If this error still occurs, contact the [Customer Care Center](#) on page 4.

Disk space in <directory> is insufficient for operation**May Occur During: Audit****Explanation**

The directory identified by <directory> is used for storing temporary files. It does not have sufficient space to perform the operation. The audit is not performed.

Recovery

Remove all unnecessary files from the specified directory (to determine the amount of disk space needed for the operation, look at the *LSMSTrace.log*). Try the operation again.

EBDA session ID already in use. Retry operation**May Occur During: Any LNP database synchronization operation****Explanation**

An attempt was made to start an LNP database synchronization operation to a network element using a session ID that was already in use by another LNP database synchronization operation. The operation did not start.

Recovery

Try the operation again.

ELAP architecture does not support LNP quantity requested**May Occur During: Feature Activation****Explanation**

The EAGLE prevents the feature quantities from being enabled and activated without the proper ELAP operating system.

Recovery

Check the version of the ELAP operating system and the Service Module cards installed. Contact the [Customer Care Center](#) on page 4 to verify the requirements.

Error in receiving NE data (errno=<nnn>)**May Occur During: Any LNP database synchronization operation****Explanation**

An error occurred while waiting to receive a message from the network element. The operation is not completed. The connection was probably dropped.

Recovery

Find out why the error occurred and try it again. If the error persists, contact the [Customer Care Center](#) on page 4.

Failed aborting operation in progress**May Occur During: Any LNP database synchronization operation****Explanation**

The operation in progress cannot be aborted.

Recovery

Look in the *LSMSTrace.log* for the reason for the failure. Correct the problem and retry the operation. If the error persists, contact the [Customer Care Center](#) on page 4.

Failed committing data downloaded to the NE

May Occur During: Any LNP database synchronization operation

Explanation

The operation was not completed. One of the following may have occurred:

- The NE operator canceled the download
- A timeout occurred while waiting for an acknowledgement
- The connection has been dropped

Changes have not been committed, so the download has had no effect.

Recovery

Try the operation again.

Failed connecting to NE '<IP address>'

May Occur During: Any LNP database synchronization operation

Explanation

An attempt was made to start an operation to a network element, but an error prevented the establishment of the connection. The operation is not performed.

Recovery

Verify that the displayed IP address is correct. Then, try the operation again. If the error persists, contact the [Customer Care Center](#) on page 4.

Failed discarding data downloaded to the network element's LNP database

May Occur During: Any LNP database synchronization operation

Explanation

The operation was not completed. One of the following may have occurred:

- A timeout occurred while waiting for an acknowledgement
- The connection has been dropped
- The network element operator has canceled the download

Recovery

Try the operation again.

Failed initializing EBDA process

May Occur During: Any LNP database synchronization operation

Explanation

An error occurred during the initialization of the EBDA process. The operation is not performed.

Recovery

Look in the *LSMSTrace.log* for the reason for the failure. Correct the problem and retry the operation. If the error persists, contact the [Customer Care Center](#) on page 4.

Failed receiving data over normal update connection with NE (errno=<nn>)**May Occur During: Audit only or audit and reconcile****Explanation**

An attempt was made to read a message from the network element, but no response was received in the allowed time. The cause may be a dropped connection with the network element. The operation is not performed.

Recovery

Try the operation again. If the error persists, contact the [Customer Care Center](#) on page 4.

Failed sending data over normal update connection with NE (errno=<nn>)**May Occur During: Audit and reconcile****Explanation**

A failure occurred while auditing or reconciling the network element's LNP database using the normal update connection with the network element. The operation is terminated.

Recovery

To determine the reason for failure, look in the *LSMSTrace.log*. Try the operation again. If the error persists, contact the [Customer Care Center](#) on page 4.

Failed starting operation**May Occur During: Any LNP database synchronization operation****Explanation**

The requested operation failed to start.

Recovery

Look in the *LSMSTrace.log* for the reason for the failure. Correct the problem and retry the operation. If the error persists, contact the [Customer Care Center](#) on page 4.

LNP ported TNs 240M and up Qty Feat Req E5SM4G**May Occur During: Enabling a new feature or feature quantities****Explanation**

E5-SM4G cards are required for LNP ported telephone numbers 240 million and above.

Recovery

Remove non-compliant Service Module cards (DSM, TSM) and replace with E5-SM4G cards.

LSMS's normal update connection with NE is not currently established

May Occur During: Audit and Reconcile

Explanation

The LSMS user attempted to perform an operation that requires the normal update, but that connection is not currently established. The normal update connection is the connection between the LSMS and one of the following at the MPS. The operation is not started.

Recovery

Establish the connection and try the operation again.

Maximum number of discrepancies has been reached - Bulk Load required

May Occur During: Audit

Explanation

The maximum number of discrepancies that can be detected in the network element's LNP database by an audit before a bulk load is required has been reached. The operation is terminated.

Recovery

Perform a Bulk Load operation to the network element (for more information, see [Choosing a Synchronization Procedure](#) on page 21).

Maximum number of simultaneous Bulk Load LNP DB synchronization operations has been reached

May Occur During: Bulk Load

Explanation

The LSMS user attempted to perform a Bulk Load LNP database synchronization operation while the maximum permitted number of Bulk Load operations are currently in progress. The operation was not started.

Recovery

Try the operation again.

Maximum number of simultaneous LNP DB synchronization operations has been reached

May Occur During: Any LNP database synchronization operation

Explanation

The LSMS user attempted to perform an LNP database synchronization operation while the maximum permitted number of LNP database synchronization operations are currently in progress. The operation was not started.

Recovery

Try the operation again.

NE dropped the connection (errno=<nn>)

May Occur During: Any LNP database synchronization operation

Explanation

A message was sent to the network element, but the network element dropped the connection without sending a response message. The operation has failed.

Recovery

Try the operation again. If the problem persists, contact the [Customer Care Center](#) on page 4.

NE has reset the connection (errno=<nn>)

May Occur During: Any LNP database synchronization operation**Explanation**

A message was sent to the network element, but the network element reset the connection without sending a response message. The operation has failed.

Recovery

Try the operation again. If the problem persists, contact the [Customer Care Center](#) on page 4.

Network element is currently being re-synced with the LSMS. Operation terminated.

May Occur During: Audit only or audit and reconcile**Explanation**

The user attempted to perform an operation that uses the normal update connection with the network element while an automatic resynchronization (also called a short synchronization) is in progress. The operation is not started.

Recovery

Do either of the following and then try the operation again:

- Look in the notifications area of the LSMS GUI console window for the following notifications, where <CLLI> is the Common Language Location Identifier for the network element for which you wish to perform the operation.

1. Verify that the following notification has been posted:

```
[Major]: <Timestamp> 8054 <CLLI>: Short Synchronization Started
```

2. Wait until the following notification is posted before trying the operation again:

```
[Cleared]: <Timestamp> 8059 <CLLI>: Short Synchronization Complete
```

- Perform the following steps to determine whether the `eagle agent` process is currently using the normal update connection:
 1. Log in to the active server as `lsmsadm`.
 2. Enter the following command:

```
$LSMS_DIR/eagle status <CLLI>
```
 3. Examine the output to determine whether the `eagle agent` is currently resynchronizing with the network element.

One or more NPAC regions in the regional TN filter are set inactive**May Occur During: Any LNP database synchronization operation****Explanation**

The regional TN filters for the EMS of this network element include at least one NPAC region that is currently set to inactive. The operation is not performed.

Recovery

Do one of the following and then try the operation again:

- Activate all NPAC regions that are selected in the EMS's regional TN filter by doing the following:
 1. On the LSMS GUI console window, right-click anywhere in the NPAC status area and ensure that all NPAC regions are clicked (this ensures that even inactive regions are displayed on the console window).
 2. From the main menu, select **LSMS>EMS Routing>View**.
 3. Determine whether any of the NPAC regions shown as highlighted in the View EMS Routing window are shown as having inactive status on the console. Activate those NPAC regions by right-clicking the NPAC status icon and selecting **Associate**.
- Deselect all inactive NPAC regions that are selected in the EMS's regional TN filter by doing the following:
 1. On the LSMS GUI console window, right-click anywhere in the NPAC status area and ensure that all NPAC regions are clicked (this ensures that even inactive regions are displayed on the console window).
 2. From the main menu, select **LSMS>EMS Routing>View**.
 3. Select only the NPAC regions that have active status on the console.
 4. Click OK.

One or more NPAC regions must be set active**May Occur During: Any LNP database synchronization operation****Explanation**

There are currently no active NPAC regions. The operation is not performed.

Recovery

Do the following and then try the operation again:

- Activate all NPAC regions that are selected in the EMS's regional TN filter by doing the following:
 1. On the LSMS GUI console window, right-click anywhere in the NPAC status area and ensure that all NPAC regions are clicked (this ensures that even inactive regions are displayed on the console window).
 2. From the main menu, select **LSMS>EMS Routing>View**.

3. Determine whether any of the NPAC regions shown as highlighted in the View EMS Routing window are shown as having inactive status on the console. Activate those NPAC regions by right-clicking the NPAC status icon and selecting **Associate**.

Operation automatically terminated - client unexpectedly disconnected

May Occur During: Any LNP database synchronization operation (only recorded in log file)

Explanation

The operation in progress is terminated. The Local Service Manager (*lsman*) server process terminated its connection with the EBDA process.

Recovery

Verify that the *lsman* process is running using the **sup status** command (for information about using this command, refer to the *LSMS Maintenance Manual*).

- If the *lsman* process is currently running, it may have been automatically restarted since the LNP database synchronization operation was attempted. Try the operation again.
- If the *lsman* process is not currently running, it should be restarted automatically within a few minutes. Wait a few minutes and repeat the **sup status** command. If it is now running, try the operation again.

If the error persists, contact the [Customer Care Center](#) on page 4.

Operation forcefully terminated by external process

May Occur During: Any LNP database synchronization operation (only recorded in log file)

Explanation

The operation in progress is terminated. The LSMS user has logged out while an LNP database operation is in progress.

Recovery

Log back in and try the operation again.

Out of memory

May Occur During: Audit

Explanation

The operation process discovered it was out of heap space when sending a message to another thread within this operation. The operation is not completed.

Recovery

Contact the [Customer Care Center](#) on page 4.

Problem with the NE connection (errno=<nn>)

May Occur During: Any LNP database synchronization operation

Explanation

An attempt to send a message to the network element failed with an unexpected error. The operation did not complete.

Recovery

Try the operation again. If the error persists, contact the [Customer Care Center](#) on page 4.

Protocol violation on connection with NE. Please contact Tekelec Technical Services.

May Occur During: Any LNP database synchronization operation

Explanation

An attempt was made to send a message to the network element, but the network element was not in the proper state to accept that kind of message. Probably the network element is in a reset state because the connection was dropped or the network element operator issued a **chg-db:action=canceled** command. The operation was not completed.

Recovery

Try the operation again. A different error message should appear. Follow the recovery procedure recommended for that error message.

Re-sync operation is not permitted while the LSMS is connected with the NE

May Occur During: User-initiated resynchronization

Explanation

The user attempted to initiate a resynchronization when the LSMS is connected to the network element.

Recovery

When the LSMS has a connection to the MPS, there is no need for a user-initiated resynchronization. If the connection to the MPS is down and this error still appears, contact the [Customer Care Center](#) on page 4.

Received unexpected response from the NE

May Occur During: Audit

Explanation

A message that is neither a normal response nor any of the expected error responses was received from the network element in response to an audit request. The audit is not completed.

Recovery

Try the operation again. If the problem persists, contact the [Customer Care Center](#) on page 4.

Received unexpected response over normal update connection - protocol violation

May Occur During: Audit only or audit and reconcile

Explanation

A message that is neither a normal response nor any of the expected error responses was received from the network element over the normal update connection in response to an audit or update request. The operation is terminated.

Recovery

Try the operation again. If the problem persists, contact the [Customer Care Center](#) on page 4.

The entire range of NPA Splits must be selected if auditing NPBs, SVs and/or Default GTTs

May Occur During: Audit**Explanation**

The user attempted to initiate an audit of one or more of the following without specifying the entire range of NPA Splits:

- Default GTTs
- NPBs by NPA-NXX range
- SVs by NPA-NXX range

The operation is not started. (An audit by time range or of NPBs by NPA-NXX-X range and/or SVs by TN range does not require or support auditing of NPA Splits.)

Recovery

Select one of the following values for the Old NPA range and try the operation again:

- ALL
- 200-999

Timeout connecting to NE. IP-address '<IP address>' (errno=<nnn>)

May Occur During: Any LNP database synchronization operation**Explanation**

An attempt was made to start an operation to a network element, but the connection was not established because of an unexpected error. The operation is not performed.

Recovery

Verify that the displayed IP address is correct, then try again. If the error persists, contact the [Customer Care Center](#) on page 4.

Timeout receiving data from the NE

May Occur During: Any LNP database synchronization operation**Explanation**

An attempt was made to read a message from the network element (NE), but no response was received in the allowed time. The operation is not completed. The connection was probably dropped.

Recovery

Try the operation again. If the error persists, contact the [Customer Care Center](#) on page 4.

Timeout sending data to NE (errno=<nn>)**May Occur During:** Any LNP database synchronization operation**Explanation**

Too much time elapsed while trying to send a message to the network element. The operation is not completed. The connection was probably dropped.

Recovery

Find out why the timeout occurred, and try the operation again. If the error persists, contact the [Customer Care Center](#) on page 4.

TN quantity cannot be enabled in mixed DSM/E5-SM4G system**Explanation**

E5-SM4G cards are required for LNP ported telephone numbers 240 million and above.

Recovery

Remove non-compliant Service Module cards (DSM, TSM) and replace with E5-SM4G cards.

Unable to access normal update connection**May Occur During:** Audit only or audit and reconcile**Explanation**

The EBDA process was not able to connect to an `eagle` agent process to perform the requested synchronization operation to an NE's LNP database. Either the `eagle` agent is not running or it is currently performing an automatic resynchronization with the LSMS. The operation is not performed.

Recovery

Do the following:

1. Use the `eagle status` command to verify that the `eagle` agent process is running (for information about using this command, refer to the *LSMS Maintenance Manual*).
2. If the `eagle` agent process is not running, contact the system administrator to determine whether the `eagle` agent process was manually stopped. If it was not manually stopped, it should be automatically restarted soon.
3. Try the operation again. If the error persists, contact the [Customer Care Center](#) on page 4.

Unable to connect to EBDA process**May Occur During:** Any LNP database synchronization operation**Explanation**

Although the EBDA process started when the LNP database synchronization operation was started through the GUI, by the time the Local Services Manager (*lsman*) needed to connect to an EBDA process to start the requested synchronization operation to an NE's LNP database, it was unable to connect. The operation is not performed.

Recovery

Do the following:

1. Log in to the active server as **root**.
2. Determine whether the EBDA process is running by entering the following command, where **<CLLI>** is the Common Language Location Identifier for the network element for which you wish to perform an LNP database synchronization operation:

```
ps -ef |grep ebda |grep -v <CLLI>
```
3. If no output appears, the EBDA process is no longer running, so try the operation again.
4. If output appears, the EBDA process is running although the *lsman* process is unable to connect to it. Enter the following command to kill the EBDA process (where **<pid>** is the process ID returned by the command in step 2), and then try the operation again.

```
kill -SIGKILL <pid>
```
5. If the error persists, contact the [Customer Care Center](#) on page 4.

Unable to start EBDA process

May Occur During: Any LNP database synchronization operation

Explanation

The Local Services Manager (*lsman*) was not able to start an EBDA process for the requested synchronization operation to an NE's LNP database. The operation is not performed.

Recovery

Try the operation again. If the error persists, contact the [Customer Care Center](#) on page 4.

Unknown EBDA session ID. Connection to EBDA process has been lost

May Occur During: Any LNP database synchronization operation

Explanation

In the course of performing the operation, the EBDA process died. The operation was not completed.

Recovery

Contact the [Customer Care Center](#) on page 4.

User is not authorized to perform operation to NE's LNP database

May Occur During: Any LNP database synchronization operation

Explanation

SPID security is enabled. The LSMS user is not authorized to perform the LNP database synchronization operation for the specified network element. The operation was not started.

Recovery

Contact your system administrator to be given authorization to access the data of the login SPID.

Appendix B

Enabling RTDB Audit on ELAP

Topics:

- [Introduction Page 116](#)
- [Enabling an RTDB Audit Page 116](#)

Appendix B describes how to enable an RTDB audit on the ELAP when it has been disabled. An RTDB audit cannot be performed unless the ELAP has this setting enabled.

Introduction

Under normal conditions, an audit does not require any operator action at the network element. However, it is possible for the NE operator to disable the ability to process an audit. This is sometimes necessary when the NE operator is trying to debug a problem. If the NE operator has disabled the ability to process an audit, the LSMS will receive a rejection that is posted on the GUI as the following error message:

```
Connection already in use or operation not enabled at NE '<IP address>'
```

If this message occurs, request that the network element perform [Enabling an RTDB Audit](#) on page 116.

Enabling an RTDB Audit

If the LSMS operator requests that the NE operator enable an RTDB audit, perform the following procedure:

1. Log in to the ELAP GUI with the name and password of any user who is authorized to use the Maintenance menu items (for more information about connecting to the ELAP GUI and user authorization, refer to the *ELAP Administration Manual*).

The ELAP Main Menu displays, as shown in [Figure 49: ELAP Main Menu](#) on page 116.

Figure 49: ELAP Main Menu

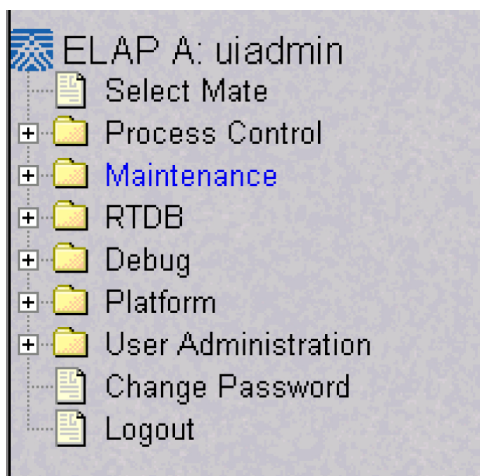

If the ELAP that you logged into is not Active, and the other ELAP is active, select **Select Mate** from the main menu. (If both ELAPs are Standby, correct the situation preventing one ELAP from taking the active role, and repeat this step.)

2. Select **Maintenance** ► **RTDB Audit** ► **Change Enabled**.

The window shown in [Figure 50: Enabling Change RTDB Audit](#) on page 116 displays.

Figure 50: Enabling Change RTDB Audit

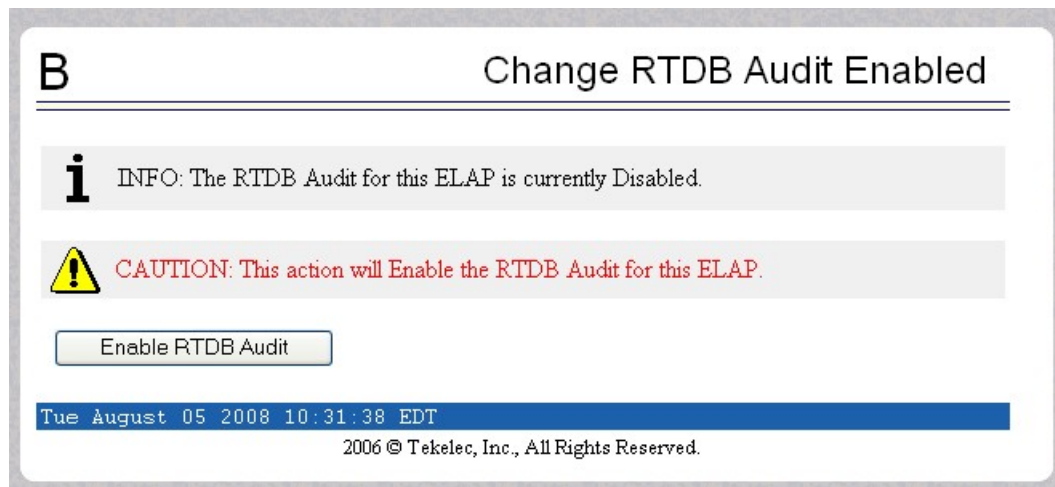

3. If the Information field indicates that the RTDB Audit for this ELAP is currently Disabled (as shown in [Figure 50: Enabling Change RTDB Audit](#) on page 116), click the **Enable RTDB Audit** button.
(If the Information field indicates that the RTDB Audit for this ELAP is Enabled, the ELAP is already prepared for the audit.)
You have now completed this procedure.

Appendix C

LNP Database Synchronization Files

Topics:

- [Introduction Page 120](#)
- [Log Files Page 120](#)
- [Discrepancy Files Page 130](#)

This appendix describes the files that are recorded when the various types of LNP database synchronization are performed.

Introduction

This appendix describes the contents of the following files that are created for LNP Database Synchronization operations.

- A log file is created to record the results of each audit or electronic bulk load (see [Log Files](#) on page 120).
- After an audit, the LSMS user has the option to view a discrepancy file that shows the full records at both the LSMS and at the network element for any discrepancies found in subscription versions or number pool blocks (see [Discrepancy Files](#) on page 130).

Log Files

When the LSMS user starts an audit, or electronic bulk load operation, the LSMS creates a log file to record the results of the operation.

Location of LNP Database Synchronization Log Files

[Table 14: LNP Database Synchronization Log File Directories](#) on page 120 shows the names of various LNP database synchronization log files and the directories where they are stored. In this table, <CLLI> indicates the Common Language Location Identifier of the network element for which the LNP database synchronization operation is performed, and <MMDD> indicates the month and day the operation was performed. Log files are maintained only for a period of seven days; after a log file has been stored seven days, it is automatically deleted.

Table 14: LNP Database Synchronization Log File Directories

LNP Database Synchronization Operation	Log File Directory and Name
Audit	/var/TKLC/lrms/logs/<CLLI>/LrmsAuditlog-<MMDD>
Electronic bulk load	/var/TKLC/lrms/logs/<CLLI>/LrmsBulkloadlog-<MMDD>

Viewing an LNP Database Synchronization Log File

An LNP database synchronization log file can be viewed in any of the following ways:

- By clicking the View Log button on the window used to start the operation any time after the operation has started
- By selecting **Logs>Other...** from the main LSMS menu; in the file chooser dialog that displays, scroll to find the directory named <CLLI>, where <CLLI> is the Common Language Location Identifier (CLLI) of the network element the operation is performed for, double-click the directory to open it, and double-click the file name that corresponds to the month and day the operation was performed

- By highlighting the EMS status icon for the network element the operation is performed for, right-clicking and selecting **Logs>LNP Database Synchronization><operation>**, where **<operation>** is the operation being performed; in the file chooser dialog that displays, double-click the file name that corresponds to the month and day the operation was performed

LNP Database Synchronization Log File Contents

An LNP database synchronization log file consists of a number of sections. [Table 15: LNP Database Synchronization Log File Contents](#) on page 121 shows which sections are present for each type of log file. The sections are described in [Header Section](#) on page 121 .

Table 15: LNP Database Synchronization Log File Contents

Log File Section	LNP Database Synchronization Operation Type A=Audit/Reconcile, B=Bulk Load, R=Resync
Header	A, B, R
Audit	A
Reconcile	A
Bulk Load	B
Re-sync	A, B, R
Summary	A, B, R
Download Commit/Discard	B, R

Header Section

The log file for every type of LNP database synchronization has a header section, which includes:

- Name of the user that started the operation
- Common Language Location Identifier (CLLI) of the network element for which the operation is performed
- Date and time a connection was established with the network element
- IP address and port number of the network element for which the operation is being performed

[Figure 51: Header Section Example](#) on page 121 shows an example of a header section.

Figure 51: Header Section Example

Fri Oct 5 12:01:33 EST 2001

Username: lsmsuser
NE CLLI: MRSVNC27560

Fri Oct 5 12:01:32 EST 2001

Connection established with network element (192.168.61.202:1030)

Audit Section

The log file for every type of audit has an audit section, which includes:

- Type of LNP data currently being audited
- Date and time the audit started and completed
- List of duplicates and discrepancies found in the network element's LNP database for the type of data being audited. The list contains:
 - LNP data type's key field, as shown in [Table 16: LNP Data Type Key Fields](#) on page 122

Table 16: LNP Data Type Key Fields

LNP Data Type	Key Field
Subscription version (SV)	TN
Number pool block (NPB)	NPA-NXX-X
NPA Split	Old NPA
Default GTT	NPA-NXX
Override GTT	LRN

- Type of discrepancy, as described in [Table 17: LNP Data Type Key Fields](#) on page 122

Table 17: LNP Data Type Key Fields

Discrepancy Type	Meaning
DUPLICATE	Receiving a checksum more than once for the same LNP object from the LSMS or the NE indicates that a duplicate LNP object exist.
MISSING	Not receiving a checksum for a LNP object that resides in the LSMS database indicates that the NE is missing that LNP object.

Discrepancy Type	Meaning
EXTRA	Receiving a checksum for a LNP object from the NE that does not reside in the LSMS database indicates that the NE has an extra LNP object which needs to be deleted.
DIFFERENT	Mismatching checksums indicate that the NE has the LNP data object in its database; however, one or more attributes of that LNP data object (for example, LRN) are different from the one on the LSMS.

- For duplicate NPBs or SVs found in the LSMS LNP database, the NPAC regions in whose databases the duplicates reside

Figure 52: Audit Section Example on page 123 shows an example of an audit section.

Figure 52: Audit Section Example

```
Audit of Subscription Versions started on Fri Oct 5 12:01:33 EST 2001

4445550002 DUPLICATE (NE)
4445550003 DUPLICATE (LSMS - Midwest and Southeast NPAC regions)
9194605513 MISSING
9194605557 MISSING
9194600001 EXTRA
9194600000 DIFFERENT

Audit of Subscription Versions completed on Fri Oct 5 13:05:13 EST 2001
```

Reconcile Section

When the user chooses to reconcile at the end of any type of audit, the log file for the audit has a reconcile section, which includes:

- Date and time the reconcile started and completed
- The following information for all commands that failed or were rejected by the network element (the maximum number of command rejections logged per operation is 100,000):
 - Date
 - Time
 - Failure reason
 - Command name
 - Attributes

Figure 53: Reconcile Section Example on page 123 shows an example of a reconcile section.

Figure 53: Reconcile Section Example

Reconcile started on Fri Oct 5 13:05:33 EST 2001

Fri Oct 5 13:05:43 EST 2001

E3197 Cmd Rej: NGT# Translation Type is not reserved for LNP

UPDATE-DEFAULT-GTT:

```
NPA-NXX:      919555
SPID:         TKLC
AIN:          LA
IN:           NLI
TT:           15
DPC:          002002002
SSN:          55
RI:           D
NGT:          20
TT:           25
DPC:          003003003
SSN:          40
RI:           D
NGT:          0
TT:           120
DPC:          004004004
SSN:          200
RI:           D
NGT:          0
TT:           245
DPC:          219040022
SSN:          0
RI:           G
NGT:          0
```

Reconcile completed on Fri Oct 5 13:06:01 EST 2001

Bulk Load Section

The log file has a bulk load section, which includes:

- Date and time the bulk load started and completed
- The following information for all commands that failed or were rejected by the network element (the maximum number of command rejections logged per operation is 100,000):
 - Date
 - Time
 - Failure reason
 - Command name
 - Attributes

Figure 54: Bulk Load Section Example on page 124 shows an example of a bulk load section.

Figure 54: Bulk Load Section Example

Bulk Load started on Fri Oct 5 12:01:33 EST 2001

Fri Oct 5 12:05:33 EST 2001

E3139 Cmd Rej: Translation Type is already in LNP database

UPDATE-LNP-SERVICE:

AIN TT: 1
IN TT: 6
CNAM TT: 6
LIDB TT: 2
CLASS TT: 3
ISVM TT: 5

Fri Oct 5 12:05:53 EST 2001

E3205 Cmd Rej: NPANXX already Split

UPDATE-NPA-SPLIT:

NEW NPA-NXX: 919555
OLD NPA-NXX: 919556

Fri Oct 5 12:09:01 EST 2001

E3130 Cmd Rej: Failed Reading LNP NPANXX table

UPDATE-SUBSCRIPTION-VERSION:

TN: 9195555555
LRN: 7878787878
SPID: TKLC
LNP-TYPE: 0
CLASS-DPC: 002002002
CLASS-SSN: 82
LIDB-DPC:
LIDB-SSN:
ISVM-DPC: 002002002
ISVM-SSN: 14
CNAM-DPC: 002002002
CNAM-SSN: 3

Fri Oct 5 12:12:11 EST 2001

E2466 Cmd Rej: Translation TYPE specified does not exist

UPDATE-DEFAULT-GTT:

NPA-NXX: 919555
SPID: TKLC
AIN: LA
IN: NLI
TT: 15
DPC: 002002002
SSN: 55
RI: D
NGT: 20
TT: 0
DPC: 001001000
SSN: 0
RI: G
NGT: 0
TT:
DPC:
SSN:
RI:
NGT:
TT:
DPC:
SSN:
RI:
NGT:

Fri Oct 5 12:28:22 EST 2001

E3261 Cmd Rej: NMRGT# Translation Type is not a reserved service for LNP

UPDATE-OVERRIDE-GTT:

LRN: 9194600000
SPID: TKLC
TT: 011
DPC: 001001001
SSN: 055
RI: G
NGT: 008
RGTA: T
TT:
DPC:
SSN:
RI:
NGT:
RGTA:
TT:
DPC:
SSN:
RI:
NGT:
RGTA:
TT:
DPC:
SSN:
RI:
NGT:
RGTA:

Bulk Load completed on Fri Oct 5 12:30:33 EST 2001

Resynchronization Section

The log files contain a resynchronization section. In addition, the LNP database synchronization operations contain a resynchronization section; these operations use the automatic resynchronization function of the LSMS to transmit all data updates that may have been received at the LSMS during the time the LNP database operation was occurring.

The resynchronization section includes:

- Date and time the resynchronization started and completed
- Network element's LNP database timestamp (DBTS)
- The following information for all commands that failed or were rejected by the network element (the maximum number of command rejections logged per operation is 100,000):
 - Date
 - Time
 - Failure reason
 - Command name
 - Attributes
- Network element's LNP DBTS after the resynchronization operation completed

Figure 55: Resynchronization Section Example on page 127 shows an example of a resynchronization section.

Figure 55: Resynchronization Section Example

```
Re-sync started on Fri Oct 5 13:06:02 EST 2001

Old NE LNP Database Time Stamp: Wed Oct 3 06:25:43 EST 2001

Fri Oct 5 13:06:42 EST 2001
E3130 Cmd Rej: Failed Reading LNP NPANXX table

UPDATE-NUMBER-POOL-BLOCK:
  TIMESTAMP: 20011003130746
  NPA-NXX-X: 9195555
  LRN:      7878787878
  SPID:     TKLC
  LNP-TYPE: 1
  CLASS-DPC: 002002002
  CLASS-SSN: 82
  LIDB-DPC:
  LIDB-SSN:
  ISVM-DPC: 002002002
  ISVM-SSN: 14
  CNAM-DPC: 002002002
  CNAM-SSN: 3

Fri Oct 5 13:07:42 EST 2001
```

E3234 Cmd Rej: TN does not exist

DELETE-SUBSCRIPTION-VERSION:
TIMESTAMP: 20011003130746
TN: 8031023801

Fri Oct 5 13:08:03 EST 2001
E3169 Cmd Rej: NPA-NXX does not exist

DELETE-NPA-SPLIT:
TIMESTAMP: 20011003130746
NPA-NXX: 803102

Fri Oct 5 13:08:31 EST 2001
E3169 Cmd Rej: NPA-NXX does not exist

DELETE-DEFAULT-GTT:
TIMESTAMP: 20011003130746
NPA-NXX: 803102

Fri Oct 5 13:10:42 EST 2001
E3270 Cmd Rej: LRN does not exist

DELETE-OVERRIDE-GTT:
TIMESTAMP: 20011003130746
LRN: 8031020000

New NE LNP Database Time Stamp: Fri Oct 5 13:06:17 EST 2001

Re-sync completed on Fri Oct 5 13:16:17 EST 2001

Summary Section

Every LNP database synchronization log file contains a summary section. The contents of the summary section depends on the type of LNP database synchronization operation, as described in the following sections:

- [Summary Section for Audit Operation](#) on page 128
- [Summary Section for Download Operations](#) on page 129

Summary Section for Audit Operation

The log file for an audit includes an audit summary section, which includes:

- Range (data or time) of the LNP data type audited
- Total number of LNP data objects audited on both the LSMS and the network element
- Total number of LNP data objects that are identical on both the LSMS and the network element
- Total number of LNP data objects found for each type of discrepancy and total number of discrepancies
- The following items, which are included only when duplicates are detected:
 - Total number of LNP data objects found to be duplicate on the LSMS
 - Total number of LNP data objects found to be duplicate on the NE
 - A note explaining that duplicate data cannot be corrected by performing a reconcile

Figure 56: Audit Summary Section Example for NPA-NXX Range on page 129 shows an example of a audit summary section for an audit performed for an NPA-NXX range.

Figure 56: Audit Summary Section Example for NPA-NXX Range

```
000000 NPA-NXX Start
      999999 NPA-NXX End
          6805 Total audited on LSMS
          6804 Total audited on NE
          6801 Same on Both
              1 Different on NE
              2 Missing on NE
              1 Extra on NE
          4 Total Discrepancies
          1 Duplicates on LSMS
          1 Duplicates on NE
```

Note: Duplicate data has been found in the LSMS and/or NE LNP database. Duplicate data cannot be corrected by performing a reconcile LNP database synchronization operation. Please contact Tekelec Technical Service.

Figure 57: Audit Summary Section Example for Time Range on page 129 shows an example of a audit summary section for an audit performed for a time range.

Figure 57: Audit Summary Section Example for Time Range

```
20011003000000 Start Time
20011005153021 End Time
      6805 Total audited on LSMS
      6804 Total audited on NE
      6801 Same on Both
          1 Different on NE
          2 Missing on NE
          1 Extra on NE
      4 Total Discrepancies
```

Summary Section for Download Operations

Electronic bulk load synchronization operations have a period during which LNP data is downloaded to the network element without being interspersed with normal data updates.

The log files for these types of operations includes a download summary section, which includes:

- Total number of objects that were successfully downloaded and applied to the network element's LNP database
- Total number of objects that were successfully downloaded to, but rejected by, the network element

Figure 58: Download Summary Section Example on page 129 shows an example of a download summary section.

Figure 58: Download Summary Section Example

NPA Splits	4	Downloaded	0 errors
Number Pool Blocks	5	Downloaded	0 errors
Subscription Versions	4	Downloaded	0 errors
Default GTTs	3	Downloaded	0 errors
Override GTTs	3	Downloaded	0 errors
Total	19	Downloaded	0 errors

Download Commit/Discard Section

The log files for the following types of LNP database synchronization operations include a download commit/discard section:

- Electronic bulk load
- User-initiated resynchronization

The download commit/discard section includes:

- Date and time the download started and completed
- Status of the commit or discard request

Figure 59: Download Commit/Discard Section Example on page 130 shows an example of a reconcile section.

Figure 59: Download Commit/Discard Section Example

```
Commit completed on Fri Oct 5 13:08:03 EST 2001
```

Discrepancy Files

After an audit has completed, the LSMS user has the option of viewing full records information about any subscription version (SV) or number pool block (NPB) data objects that were found to be missing, extra, or different.

Location of Discrepancy Files

Table 18: LNP Database Synchronization Log File Directories on page 130 shows the names of the two types of discrepancy files and the directories where they are stored. In this table, <CLLI> indicates the Common Language Location Identifier of the network element for which the audit was performed, and <MMDD> indicates the month and day the audit was performed. Log files are maintained only for a period of seven days; after a log file has been stored seven days, it is automatically deleted.

Table 18: LNP Database Synchronization Log File Directories

LNP Data Object Type	Full-Record Discrepancy File Directory and Name
Subscription version	/var/TKLC/lsms/logs/<CLLI>/LsmsAudit.sv.discrepancy.log.<MMDD>
Number pool block	/var/TKLC/lsms/logs/<CLLI>/LsmsAudit.npb.discrepancy.log.<MMDD>

Viewing a Discrepancy File

An LNP database synchronization log file can be viewed in any of the following ways:

- By clicking the View Discrepancies button on the Audit Results tab of the Audit window used to start an audit of SVs or NPBs any time after the audit has completed
- By selecting **Logs>Other...** from the main LSMS menu; in the file chooser dialog that displays, scroll to find the directory named <CLLI>, where <CLLI> is the Common Language Location Identifier (CLLI) of the network element the operation is performed for, double-click the directory to open it, and double-click the file name that corresponds to the month and day the operation was performed
- By highlighting the EMS status icon for the network element the operation is performed for, right-clicking and selecting **Logs>LNP Database Synchronization-><operation>**, where <operation> is the operation being performed; in the file chooser dialog that displays, double-click the file name that corresponds to the month and day the operation was performed

Discrepancy File Contents

A discrepancy file consists of the following sections:

- Header section (see [Header Section](#) on page 131)
- Discrepancy section (see [Discrepancy Section](#) on page 131)
- Summary section (see [Discrepancy Summary Section](#) on page 132)

Header Section

Each type of discrepancy file contains a header section, which includes:

- Date and time the discrepancy file was generated
- Name of the user that started the operation
- Common Language Location Identifier (CLLI) of the network element for which the operation is performed

Figure 60: Example of a Discrepancy File Header Section on page 131 shows an example of a header section.

Figure 60: Example of a Discrepancy File Header Section

```
Fri Oct 5 15:18:03 EST 2001
```

```
Username: lsmsuser  
NE CLLI: MRSVNC27560
```

Discrepancy Section

Each type of discrepancy file contains a discrepancy section, which includes:

- Date and time the discrepancy file was generated
- Type of LNP data discrepancy
- Side-by-side comparison of LSMS and network element LNP data records (including attributes names and values)

A full-record discrepancy file contains up to a maximum of 1000 discrepancies.

Figure 61: Discrepancy Section Example, Audit of NPBs on page 132 shows an example of a discrepancy section for an audit of Number Pool Blocks (NPBs).

Figure 61: Discrepancy Section Example, Audit of NPBs

Full-record details of Number Pool Block discrepancies

DIFFERENT	NE	LSMS

NPA-NXX-X:	9194603	9194603
LRN:	2923640000	2923640000
SPID:	TKLC	TKLC
CLASS DPC:	230101171	230101171
CLASS SSN:	30	30
IDB DPC:	100100100	100100100
LIDB SSN:	45	45
ISVM DPC:	200200200	
ISVM SSN:	25	
CNAM DPC:	031002008	031002008
CNAM SSN:	40	40
MISSING	NE	LSMS

NPA-NXX-X:		031023232
LRN:		2923640000
SPID:		TKLC
CLASS DPC:		230101171
CLASS SSN:		30
LIDB DPC:		100100100
LIDB SSN:		45
ISVM DPC:		200200200
ISVM SSN:		25
CNAM DPC:		031002008
CNAM SSN:		40

Figure 62: Discrepancy Section Example, Audit of TNs on page 132 shows an example of a discrepancy section for an audit of subscription versions (TNs).

Figure 62: Discrepancy Section Example, Audit of TNs

Full-record details of Subscription Version discrepancies

DIFFERENT	NE	LSMS

TN:	9194603232	9194603232
LRN:	2923640000	2923640000
SPID:	TKLC	TKLC
CLASS DPC:	230101171	230101171
CLASS SSN:	30	30
IDB DPC:	100100100	100100100
LIDB SSN:	45	45
ISVM DPC:	200200200	
ISVM SSN:	25	
CNAM DPC:	031002008	031002008
CNAM SSN:	40	40

Discrepancy Summary Section

Each type of discrepancy file contains a summary section, which includes:

- Total number of each type of discrepancy included in the report

- Date and time the discrepancy file was completed

Figure 63: Discrepancy Summary Section Example on page 133 shows an example of a discrepancy summary section.

Figure 63: Discrepancy Summary Section Example

```
SUMMARY
-----
      1 Different on NE
      0 Missing on NE
      1 Extra on NE
      2 Total Discrepancies

Fri Oct 5 15:18:03 EST 2001
```

Appendix D

Synchronization Performance Estimates

Topics:

- [Introduction Page 136](#)
- [Recommended Network Bandwidth Page 136](#)
- [Performance of LSMS to NE Operations Page 136](#)
- [Performance of NE to NE Operations Page 138](#)

This section provides estimates of the transaction rates for the LNP database synchronization operations. Using these estimates can help decide which type of operation to use in choosing a database maintenance procedure.

Introduction

This appendix provides estimates of the transaction rates for the various LNP database synchronization operations. Using these estimates can help you decide which type of operation to use.

Recommended Network Bandwidth

To use any LNP database synchronization operation other than manual bulk load, it is recommended that the network connection between the LSMS and each network element have a minimum bandwidth that is equal to or greater than 50% of a T1 line (a minimum bandwidth of at least 96,000 bytes per second).

The estimates shown in this appendix assume that the LNP database synchronization operation uses bandwidth of 96,000 bytes per second.

Performance of LSMS to NE Operations

Table 19: LNP Database Synchronization Performance Estimates on page 136 shows the performance estimates of various LNP database synchronization operations. These estimates are based on a single LNP database synchronization operation running on an LSMS system with minimal system activity.

Table 19: LNP Database Synchronization Performance Estimates

LNP Database Synchronization Operation	Connection (Note)	Data Objects Per Hour (LSMS Release 11.0 and ELAP Release 8.0)	Data Objects Per Hour (LSMS Release 8.X and ELAP Release 5.0)	Worst Case Performance Based On:
Audit	Dedicated	24 million	12,000,000	Amount of time it takes to look up data in the LNP databases and calculate checksums (LSMS - 600 objects per second, NE - 3400 objects per second) and on the number of discrepancies the

LNP Database Synchronization Operation	Connection (Note)	Data Objects Per Hour (LSMS Release 11.0 and ELAP Release 8.0)	Data Objects Per Hour (LSMS Release 8.X and ELAP Release 5.0)	Worst Case Performance Based On:
				LSMS finds (the LSMS can record up to 1 million discrepancies per hour).
Support ELAP Reload via Database Image (SERVDI)	Dedicated	150 million		Amount of time it takes to create an LNP database image file in the LSMS (2.5 million objects per second). Time to transfer to NE is listed in Table 21: Estimating Time to Transfer the Entire Database on page 139.
Bulk load	Dedicated	8 million	2,000,000 to 4,000,000	Amount of time it takes to look up data in the LSMS and create an update command (600 objects per second) transmit it (assuming 50% of T1, 750 Kbps) and insert data into NE database (333 objects per second).
Reconcile	Normal	180,000	180,000	Amount of time it takes to look up data in the LSMS and create an update command (600 objects per second) transmit it (25 objects per second) and insert data into NE

LNP Database Synchronization Operation	Connection (Note)	Data Objects Per Hour (LSMS Release 11.0 and ELAP Release 8.0)	Data Objects Per Hour (LSMS Release 8.X and ELAP Release 5.0)	Worst Case Performance Based On:
				database (333 objects per second).
<p>Note:</p> <p>This is the rate for the normal update channel, which includes both normal updates and reconciles. The rate for reconciles depends on how much normal traffic exists.</p>				

Performance of NE to NE Operations

Table 20: Estimating Time to Copy RTDB Across Customer Network on page 138 shows estimates of the time required to copy an RTDB across the customer network, depending on the speed of the customer network.

Table 20: Estimating Time to Copy RTDB Across Customer Network

Speed of Customer Network	Estimated Time to Copy One Million Numbers
100 Megabits/second	11.5 seconds*
10 Megabits/second	40 seconds*
1.44 Megabits/second	3.7 minutes
128 Kilobits/second	41.67 minutes
56 Kilobits/second	95.25 minutes
*At this network speed, system performance is limited by ELAP disk	

Starting with ELAP 8.0, the database size for transfer is no longer dependent on the number of database entries. *Table 21: Estimating Time to Transfer the Entire Database* on page 139 shows the estimated transfer times for the database as a whole.

Table 21: Estimating Time to Transfer the Entire Database

Speed of Customer Network	Estimated Time to Copy Database
100 Megabits/second	2 minutes
10 Megabits/second	15 minutes
1.44 Megabits/second	95 minutes
128 Kilobits/second	17 hours
56 Kilobits/second	40 hours

Glossary

C

CLLI

Common Language Location Identifier

The CLLI uniquely identifies the STP in terms of its physical location. It is usually comprised of a combination of identifiers for the STP's city (or locality), state (or province), building, and traffic unit identity. The format of the CLLI is:

The first four characters identify the city, town, or locality.

The first character of the CLLI must be an alphabetical character.

The fifth and sixth characters identify state or province.

The seventh and eighth characters identify the building.

The last three characters identify the traffic unit.

CSR

Customer Service Request

D

Database

All data that can be administered by the user, including cards, destination point codes, gateway screening tables, global title translation tables, links, LNP services, LNP service providers, location routing numbers, routes, shelves, subsystem applications, and 10 digit telephone numbers.

DB

Database

Daughter Board

Documentation Bulletin

	D	
DD		Detailed Design
	E	
ELAP		EAGLE Local Number Portability Application Processor
EMS		Element Management System The EMS feature consolidates real-time element management at a single point in the signaling network to reduce ongoing operational expenses and network downtime and provide a higher quality of customer service.
	G	
GUI		Graphical User Interface The term given to that set of items and facilities which provide the user with a graphic means for manipulating screen data rather than being limited to character based commands.
	H	
HS		High Speed
	I	
IS-NR		In Service - Normal
ISS		Integrated Signaling System
	L	
LNP		Local Number Portability
LSMS		Local Service Management System
	M	
MPS		Multi-Purpose Server

M

The Multi-Purpose Server provides database/reload functionality and a variety of high capacity/high speed offboard database functions for applications. The MPS resides in the General Purpose Frame.

N

NE

Network Element

An independent and identifiable piece of equipment closely associated with at least one processor, and within a single location.

NPA

Number Plan Area

The North American "Area Codes." (3 digits: 2- to-9, 0-or1, 0-to-9. Middle digit to expand soon).

NPAC

Number Portability Administration Center

P

PDP

Permissive Dialing Period

R

RTDB

Real Time Database

T

TCP/IP

Transmission Control Protocol/Internet Protocol

U

UAM

Unsolicited Alarm Message.

LNP Database Synchronization Manual

Index

A

- aborting 52
- audit 52
- Active/Standby
 - ELAP relation to LSMS connection 11
 - relation to LSMS connection 11
- admonishments, documentation 3
- audit 30, 35
 - restrictions 35
- automatic resynchronization 15, 26

B

- BDD 76
- bulk load
 - from LSMS 13
 - overview 16

C

- command line interface (lsmsclaa), LSMS 58
- connection
 - LSMS to ELAP 11

D

- database maintenance required 20
- database time stamp (DBTS) 27
- Distributed Replicated Block Device 86
- documentation
 - admonishments 3
- DRBD 86

E

- ELAP 11

L

- LNP
 - provisioning 11
- LNP data, overview 12
- local number portability (LNP) 10

- log file

- used for automatic resynchronization 26

- LSMS

- command line interface (lsmsclaa) 58
 - connection to ELAP for provisioning 11
 - data 12
 - ELAP connection for provisioning 11

M

- managing
 - audit 39
- messages 100

N

- network element data
 - automatic resynchronization of 26
- notification, database maintenance required 20
- notifications 26, 27
- Number Portability Administration Center (NPAC) 2, 10

O

- overview 30

P

- provisioning
 - LNP 11
 - LSMS-ELAP connection 11

R

- resynchronization 15, 26, 68
 - automatic 15

S

- SERVDI 76, 86
- short synchronization 26
- stages 38
- subscription version 36
- Support ELAP Reload Via Database Image 86

