

**Oracle Utilities Analytics for Oracle
Utilities Extractors and Schema and
Oracle Utilities Analytics Dashboards**

User's Guide

Release 2.5.0.0.2

E48997-03

May 2014

E48997-03

Copyright © 2013, 2014 Oracle and/or its affiliates. All rights reserved.

This software and related documentation are provided under a license agreement containing restrictions on use and disclosure and are protected by intellectual property laws. Except as expressly permitted in your license agreement or allowed by law, you may not use, copy, reproduce, translate, broadcast, modify, license, transmit, distribute, exhibit, perform, publish, or display any part, in any form, or by any means. Reverse engineering, disassembly, or decompilation of this software, unless required by law for interoperability, is prohibited.

The information contained herein is subject to change without notice and is not warranted to be error-free. If you find any errors, please report them to us in writing.

If this is software or related documentation that is delivered to the U.S. Government or anyone licensing it on behalf of the U.S. Government, the following notice is applicable:

U.S. GOVERNMENT END USERS: Oracle programs, including any operating system, integrated software, any programs installed on the hardware, and/or documentation, delivered to U.S. Government end users are "commercial computer software" pursuant to the applicable Federal Acquisition Regulation and agency-specific supplemental regulations. As such, use, duplication, disclosure, modification, and adaptation of the programs, including any operating system, integrated software, any programs installed on the hardware, and/or documentation, shall be subject to license terms and license restrictions applicable to the programs. No other rights are granted to the U.S. Government.

This software or hardware is developed for general use in a variety of information management applications. It is not developed or intended for use in any inherently dangerous applications, including applications that may create a risk of personal injury. If you use this software or hardware in dangerous applications, then you shall be responsible to take all appropriate fail-safe, backup, redundancy, and other measures to ensure its safe use. Oracle Corporation and its affiliates disclaim any liability for any damages caused by use of this software or hardware in dangerous applications.

Oracle and Java are registered trademarks of Oracle and/or its affiliates. Other names may be trademarks of their respective owners.

Intel and Intel Xeon are trademarks or registered trademarks of Intel Corporation. All SPARC trademarks are used under license and are trademarks or registered trademarks of SPARC International, Inc. AMD, Opteron, the AMD logo, and the AMD Opteron logo are trademarks or registered trademarks of Advanced Micro Devices. UNIX is a registered trademark of The Open Group.

This software or hardware and documentation may provide access to or information on content, products, and services from third parties. Oracle Corporation and its affiliates are not responsible for and expressly disclaim all warranties of any kind with respect to third-party content, products, and services. Oracle Corporation and its affiliates will not be responsible for any loss, costs, or damages incurred due to your access to or use of third-party content, products, or services.

Contents

Preface	i-i
Audience	i-i
Related Documents	i-i
Notational Conventions	i-ii
Chapter 1	
Overview Of Oracle Utilities Analytics	1-1
Application Requirements.....	1-1
Oracle Utilities Analytics Overview.....	1-2
Data Processing.....	1-3
Oracle Warehouse Builder Based Extract, Transform and Load (ETL).....	1-4
Extraction.....	1-4
Transfer.....	1-4
Load.....	1-4
Aggregation.....	1-5
Oracle Data Integrator Based Extract, Load and Transform (ELT).....	1-5
Chapter 2	
Getting Started	2-1
Accessing Oracle Utilities Analytics Dashboards.....	2-1
Logging In.....	2-1
Logging Out.....	2-1
Using Oracle Utilities Analytics Dashboards.....	2-2
About the Home Page.....	2-2
Using the Main Menu.....	2-2
Using the Dashboard Elements.....	2-3

Preface

This guide describes how to perform basic tasks using Oracle Utilities Extractors and Schema and Oracle Utilities Analytics Dashboards in Oracle Utilities Analytics, Release 2.5.0.0.2. The guide also identifies and describes the technical requirements to use the product, the architecture, and the user interface.

Audience

This guide is intended for all users of Oracle Utilities Analytics.

Related Documents

For more information, see the following documents:

- *Oracle Utilities Analytics for Oracle Utilities Extractors and Schema and Oracle Utilities Analytics Dashboards Installation Guide*
- *Oracle Utilities Analytics for Oracle Utilities Extractors and Schema and Oracle Utilities Analytics Dashboards Quick Install Guide*
- *Oracle Utilities Analytics for Oracle Utilities Extractors and Schema and Oracle Utilities Analytics Dashboards User's Guide*
- *Oracle Utilities Analytics for Oracle Utilities Extractors and Schema and Oracle Utilities Analytics Dashboards Administration Guide*
- *Oracle Utilities Analytics Dashboards for Customer Analytics, Revenue Analytics, and Credit & Collections Analytics Metric Reference Guide*
- *Oracle Utilities Analytics Dashboards for Exception Analytics Metric Reference Guide*
- *Oracle Utilities Analytics Dashboards for Mobile Workforce Analytics Metric Reference Guide*
- *Oracle Utilities Analytics Dashboards for Distribution Analytics and Outage Analytics Metric Reference Guide*
- *Oracle Utilities Analytics Dashboards for Work and Asset Analytics Metric Reference Guide*
- *Oracle Utilities Analytics Dashboards for Operational Device Analytics Metric Reference Guide*
- *Oracle Utilities Extractors and Schema for Oracle Utilities Customer Care and Billing Data Mapping Guide*
- *Oracle Utilities Extractors and Schema for Oracle Utilities Meter Data Management Data Mapping Guide*
- *Oracle Utilities Extractors and Schema for Oracle Utilities Mobile Workforce Management Data Mapping Guide*

-
- *Oracle Utilities Extractors and Schema for Oracle Utilities Network Management System Data Mapping Guide*
 - *Oracle Utilities Extractors and Schema for Oracle Utilities Operational Device Management Data Mapping Guide*
 - *Oracle Utilities Extractors and Schema for Oracle Utilities Work & Asset Management Data Mapping Guide*

Notational Conventions

The following notational conventions are used in this document:

Notation	Indicates
boldface	Graphical user interface elements associated with an action, terms defined in text, or terms defined in the glossary
<i>italic</i>	Book titles, emphasis, or placeholder variables for which you supply particular values
monospace	Commands within a paragraph, URLs, code in examples, text that appears on the screen, or text that you enter

Chapter 1

Overview Of Oracle Utilities Analytics

Oracle Utilities Analytics for Oracle Utilities Extractors and Schema and Oracle Utilities Analytics Dashboards provides spatial and non-spatial analytics for Oracle Utilities Customer Care and Billing, Oracle Utilities Network Management System, Oracle Utilities Meter Data Management, Oracle Utilities Work and Asset Management, Oracle Utilities Mobile Workforce Management, and Oracle Utilities Operational Device Management data.

Oracle Business Intelligence Enterprise Edition (OBIEE) built-in metaphors are utilized to display non-spatial information in tables, bar graphs, pie charts, and gauges. For spatial analytics, Oracle Map Viewer technology is integrated with Oracle Business Intelligence Enterprise Edition to display events, weather data, and other information that is geographically related.

Application Requirements

The following table lists the system requirements necessary to access Oracle Utilities Analytics..

System/Software	Requirement
Browser	IE 9.x Firefox 17+
Operating System (Client)	Windows 7 (64-bit)
Operating System (Server)	AIX 7.1 (64-bit) Oracle Enterprise Linux 6.3 (64-bit) Oracle Enterprise Linux 6.4 (64-bit) Red Hat Enterprise Linux 6.3 (64-bit) Red Hat Enterprise Linux 6.4 (64-bit) Oracle Solaris 11 (64-bit) Windows Server 2008 R2 (64-bit)
Application Server	WebLogic 10.3.6
Database	Oracle 11.2.0.3
Standard Resolution	1280 x 1024

The following table lists down the supported source applications for Oracle Utilities Analytics.

Source Application	Requirement
Oracle Utilities Customer Care & Billing	2.4.0.1 + Single fix patch 17711271

Source Application	Requirement
Oracle Utilities Network Management System	1.9.1 1.10.0.3.1 1.11.0.1 1.12
Oracle Utilities Work & Asset Management	1.9.1
Oracle Utilities Meter Data Management	2.0.1 SP8 + Single fix patches 14741869, 15983267 + Framework patch 14741833 2.0.1 SP9 2.1.0
Oracle Utilities Operational Device Management	2.0.1.1
Oracle Utilities Mobile Workforce Management	2.1.0 SP4 +Single fix patch 14791886 + Framework patch 14741833

Oracle Utilities Analytics Overview

This section describes the fundamental Oracle Utilities Analytics concepts. See *Oracle Utilities Analytics for Oracle Utilities Extractors and Schema and Oracle Utilities Analytics Dashboards Administration Guide* for a recommended approach to designing and setting up Oracle Utilities Analytics.

Oracle Utilities Analytics (OUA) comes with a rich set of pre-built analytics created using Oracle Business Intelligence Enterprise Edition (OBIEE). These analytics offer a detailed insight into vital Key Performance Indicators (KPI) for the various source applications.

These analytics are built on top of various star schemas that are delivered in the data warehouse for different source application. For better performance, these analytics have been optimized to retrieve data from specially designed materialized views in the data warehouse. These materialized views are highly optimized to summarize data efficiently and make data retrieval much faster.

The pre-built analytics are created for each source application and grouped as separate catalog files as per the application. These product based catalogs are licensed individually.

Using the Oracle Business Intelligence Enterprise Edition Admin tool, a metadata repository is first built using the star schemas available in the Oracle Business Intelligence data warehouse. This repository file consists of three distinct layers:

- **Physical Layer:** Contains information about physical data sources.
- **Business Layer:** Contains the business logic for the fields
- **Presentation Layer:** Tables grouped as subject areas for fact based reporting

Once the repository file is created and deployed on Oracle Business Intelligence (BI) server, dashboards are created based on subject areas from the presentation layer. These dashboards are saved in the various web catalog files.

Below is a high level architecture diagram for Oracle Business Intelligence Enterprise Edition components.

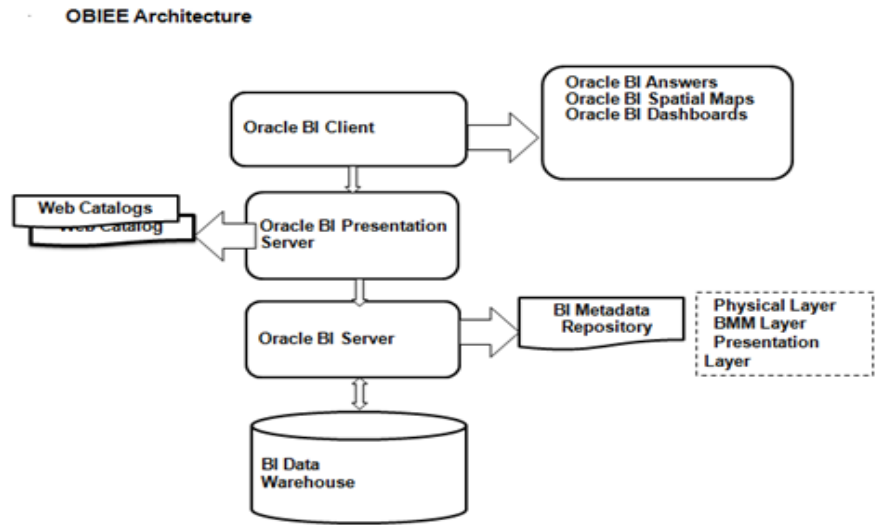

When Oracle Utilities Analytics product is shipped for the analytics portion, the metadata repository and the source application specific catalog files are also delivered.

Note: For details on Oracle Business Intelligence Enterprise Edition, refer to the *Oracle Fusion Middleware User's Guide for Oracle Business Intelligence Enterprise Edition*.

Data Processing

The architecture for Oracle Warehouse Builder based Extract, Transform, and Load (ETL) and Oracle Data Integrator based Extract, Load and Transform (ELT) is different. The diagram below illustrates the overall data processing pipeline using these two different methodologies.

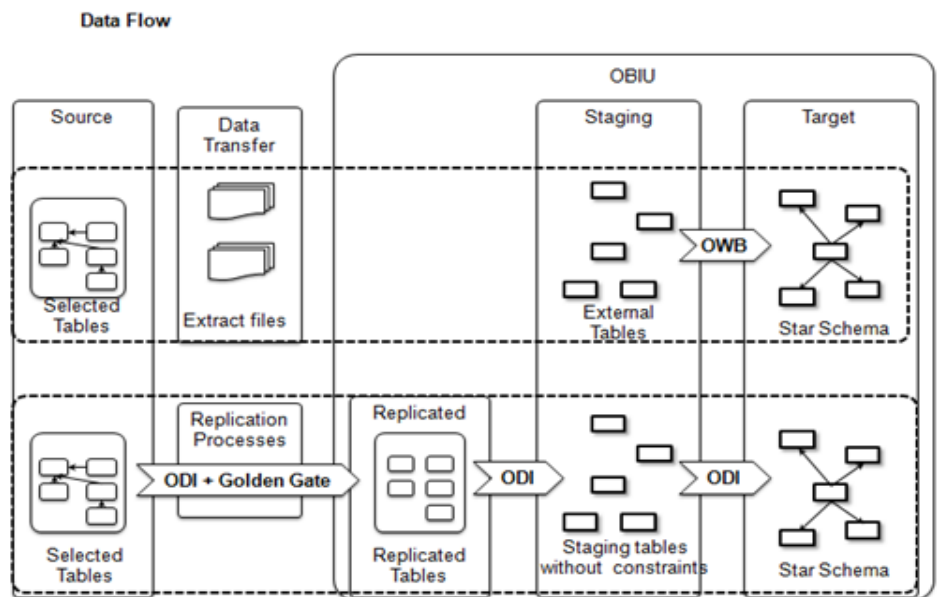

Oracle Warehouse Builder Based Extract, Transform and Load (ETL)

The Oracle Warehouse Builder based methodology uses a three phase approach where the source system extractors extract data into flat files. These files are transferred to the target system and from there, the Oracle Warehouse Builder process flows load the data into the target star schema.

Oracle Utilities Analytics uses Oracle Warehouse Builder to store the following items:

- Table designs of the star schemas.
- Data mappings used to generate batch jobs that perform the extract, transform, and load operations.
- Process flows that validate the extracted information, load the star schemas, and perform exception handling.

The following processes are involved in this methodology:

- **Extraction**
- **Transfer**
- **Load**
- **Aggregation**

Extraction

Extraction process executes on the source system and performs the transformations to convert data into a format that is accepted by the target data warehouse.

Extractors are provided for the Oracle Utilities suite of products. The extract programs execute in the operational database as they are extracting operational data. Oracle Utilities Analytics uses flat files as the source to load data into the data warehouse. The flat files are generated through an extraction process in the edge applications. Every fact and dimension in the data warehouse schema has a corresponding extract batch process. These batch processes extract data from the source system and transfer it to flat files. Along with each data flat file containing the extracted data, a single-record control file containing the batch information about the extractor program is also generated. The data and the control flat files, in turn, are loaded into Oracle Utilities Business Intelligence Data Warehouse.

Note: Extractor programs are packaged with the edge applications.

Transfer

Data files generated on the source can be copied over to the target using FTP/SFTP/SCP or utilize a shared file location.

Load

External tables in the target database point to these files and Oracle Warehouse Builder process flow loads the target data warehouse. Data validation and reference key transformations are performed by the load process.

The flat files produced by the extract programs serve as input to the load programs. The load programs use this data to populate the star schemas in the data warehouse.

Note: Refer to the **Appendix I** for complete information on Oracle Warehouse Builder based ETL and its components.

Aggregation

In this release, materialized views will continue to be used for storing aggregated data. However, the dependency on Oracle database's Query Rewrite feature has been removed, and Oracle Business Intelligence Enterprise Edition RPD is upgraded by providing a mapping between the subject areas and the different aggregations that can be utilized by fetching the data directly from the materialized views.

Oracle Data Integrator Based Extract, Load and Transform (ELT)

Oracle Data Integrator (ODI) is a comprehensive data integration platform that covers all data integration requirements ranging from high-volume, high-performance batch loads to event-driven, trickle-feed integration processes to Service-Oriented Architecture (SOA) enabled data services.

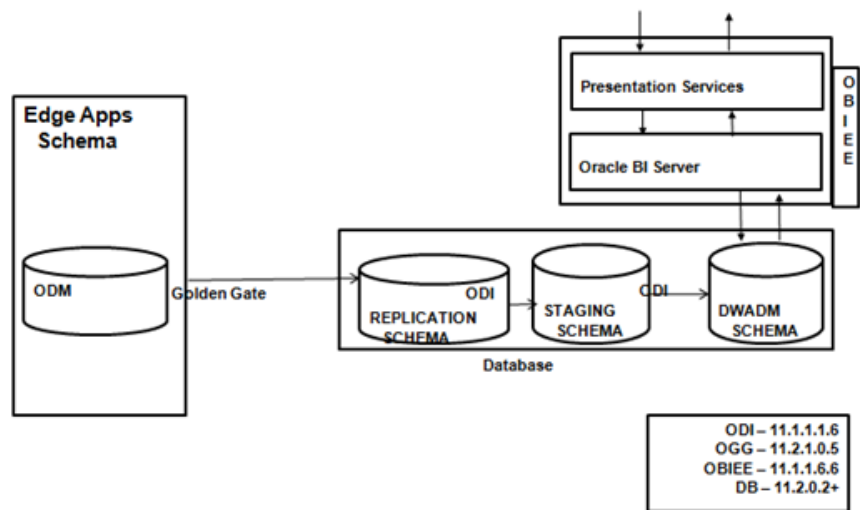

Chapter 2

Getting Started

Oracle Utilities Analytics comprises a set of answers and dashboards that are built on top of Oracle Business Intelligence Enterprise Edition.

This guide contains information that is specific to Oracle Utilities Analytics and does not cover common end user tasks for Oracle Business Intelligence Enterprise Edition. See **Related Documents** for a list of all available documents and the product library to which each document belongs.

Accessing Oracle Utilities Analytics Dashboards

This section explains how to perform the basic login and logout tasks in Oracle Utilities Analytics Dashboards.

Logging In

To access Oracle Utilities Analytics, you use a URL, a user ID, and a password provided through your implementation. To login into the application, follow this procedure:

1. Type the URL into the address field on your browser (for example, `http://hostname:port/analytics`). The Oracle Utilities Analytics **Sign In** screen appears.
2. Type your user ID and assigned password.
3. Check the language displayed in the **Select a Language** drop-down box. By default, English is selected and the text displayed in the application appears in English. Choose a different language depending on your requirement.

Note: The dashboard analyses display translated text only if a customer has purchased and installed the language pack for Oracle Utilities Analytics Dashboards.

4. Click **Sign In**. After your credentials have been verified, the dashboard to which you have access rights will appear.

Note: The login credentials are provided by the system administrator. You are not privileged to change your login details. For any modifications, please contact your system administrator.

Logging Out

To logout of the Oracle Utilities Analytics Dashboards application, click **Sign Out**. You are directed to the **Sign In** screen.

Using Oracle Utilities Analytics Dashboards

About the Home Page

Home page is the first page you see when you log in. This page displays all the items (dashboards, tasks, reports, and more) you have recently accessed and also the reports most important or popular.

Tip: Since you are likely to return to the Home page very often, the application makes it easy to navigate to this page from anywhere within the application. Click the **Home** link in the upper right corner of any screen to return to home.

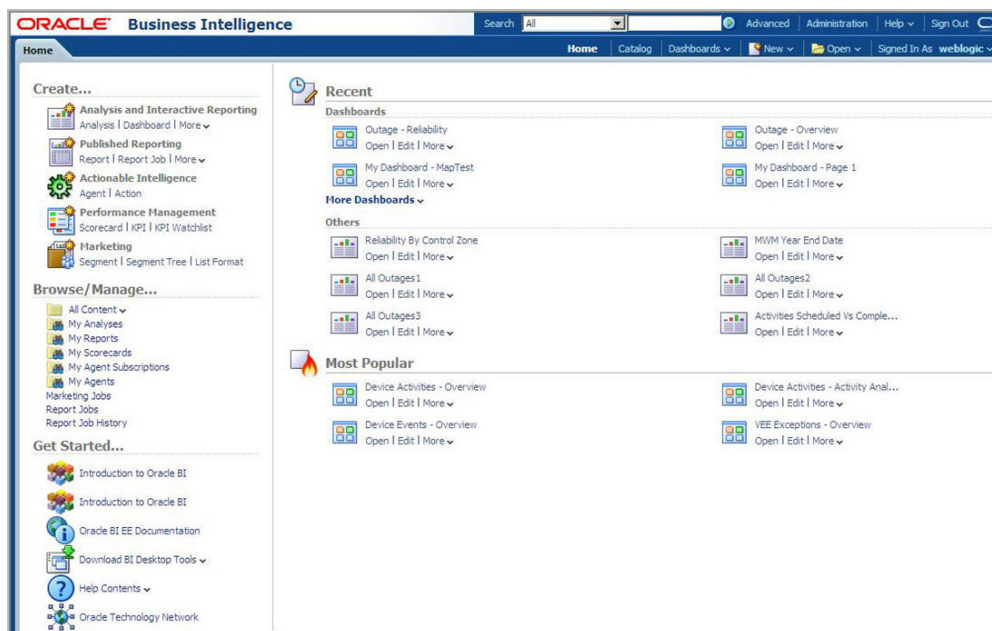

Home Screen

The administrator can set a dashboard as the default dashboard for different users. See OBIEE documentation for more details about customization.

Using the Main Menu

The Main menu appears at the top of the application window



Main Menu Toolbar

The following table briefly describes the available menu options:

Menu	Description
Search	Allows you to search for various entities in the application. You can also use advanced search for specific search results.

Menu	Description
Dashboards	Displays the Recent and Most Popular dashboards by default. From here, you can edit an existing dashboard depending on your logon privileges.
New	Allows you to create a new item, such as dashboard, filter, analysis, and more.
Administration	Allows you to display and edit application settings. Note that only authorized users will have access to this option.
Help	Opens the online help for the application.
Sign Out	Logs you out of the current session.

Using the Dashboard Elements

Oracle Utilities Analytics comprises dashboards which are grouped by analytics. Use the **Dashboards** menu option to open the required dashboard.

Note: Not all answers and dashboards are accessible to all users. Based on your assigned role, only certain analytics (or dashboards) are available for you to access.

The following figure provides a snapshot of dashboards available in the Meter Data Analytics subject area.

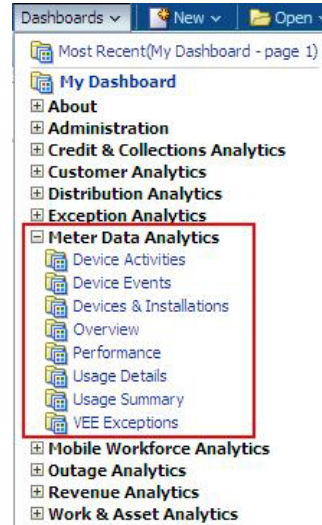

About the Dashboard Page

The dashboard page is the first page you see when you open a dashboard. You can customize a dashboard page by generating custom analyses and reports. When you are working in an application, you can return to its dashboard page at any time. To do so, click the application name on the upper left of the screen.

The figure below illustrates the key elements in each dashboard page.

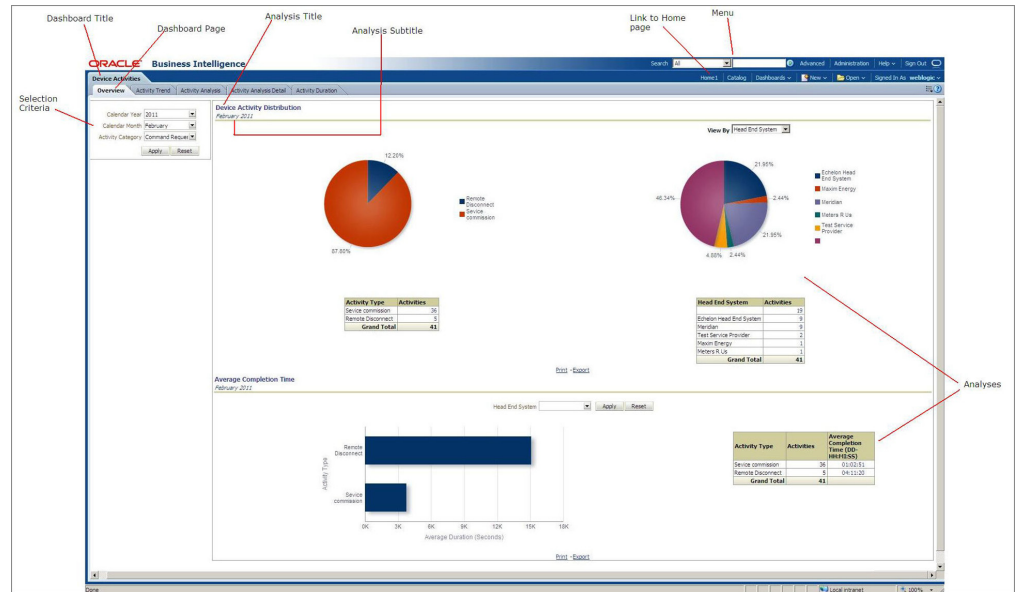

Dashboard Page Elements

Dashboard Title

The title bar contains the name of the dashboard you are viewing.

Dashboard Page

Each dashboard comprises a set of dashboard pages segregated by the analytics. Each page, in turn, consists of analyses grouped per category.

Analysis Title and Subtitle

Each analysis has a title and subtitle specifying what that analysis represents or denotes. Usually, the month (or over months) is displayed as a subtitle for an analysis, meaning the analysis displays data for that month.

Selection Criteria

For an analysis to compile data, you need to select the criteria for which you want the data. The criteria details can include calendar year, calendar month, activity type, and more.

Data Display

Based on your selection criteria, the application generates data as maps, pie charts, bar graphs, gauges, and tables.

Geographic Maps

Geographic map zones are used to show geographic coordinate-oriented points of interest.

For example, a map zone can show:

- The count of AMI meters installed
- The count of AMR meters installed
- Percentage of devices changed over the month
- ...

The following figure shows a geographic map zone that highlights device installation in a geographic area.

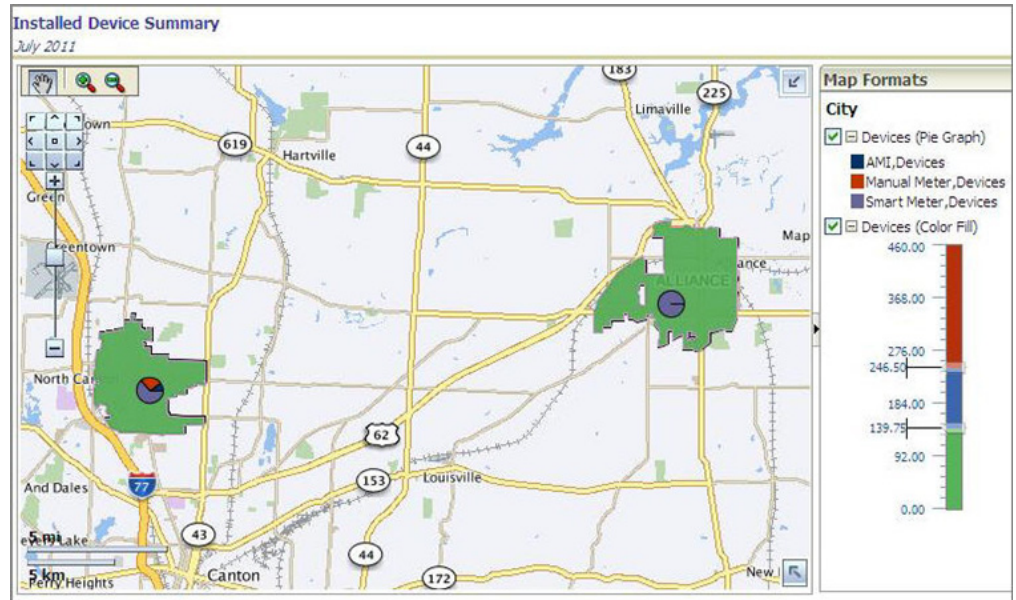

Sample Map

Navigating the Map

Spatial data is displayed in a map view. Below is a list of icons in the navigation tool bar which appears on the top left corner of the map window.



Use the Pan icon to move the map around. Click the icon on the tool bar. The mouse pointer changes to the Pan tool and shows a hand when over the map. Click and drag the map in the required direction



Use to zoom in on the area currently displayed on the map.



Use to zoom out on the area currently displayed on the map.



Displays or removes the map legend. This button works like a toggle. Click once to hide the legend; click again to display the legend.

Panning and Zooming



Pans the map. For example, click the > arrow to pan East.



Slide the zoom bar to zoom in (slide towards the +) or out (slide towards the -). You can also click a map level, such as Street or City, to zoom to that level.

Filtering Map Data

Use the check boxes in the Legend panel to filter the contents of the page. When a legend object is checked, data corresponding to that level are included in the map; when a legend object is unchecked, the data for that level are not displayed.

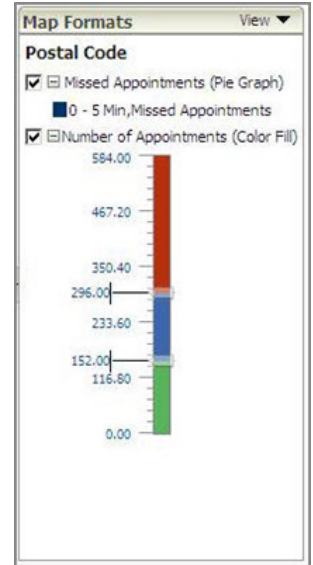

Graphs

A graph shows the value of a measure for a given dimensional attribute in a specific time-period (the x-axis shows the quantity, the y-axis shows the distinct values of the dimensional attribute). For example, you can set up a report graph that shows the average duration for each activity type.

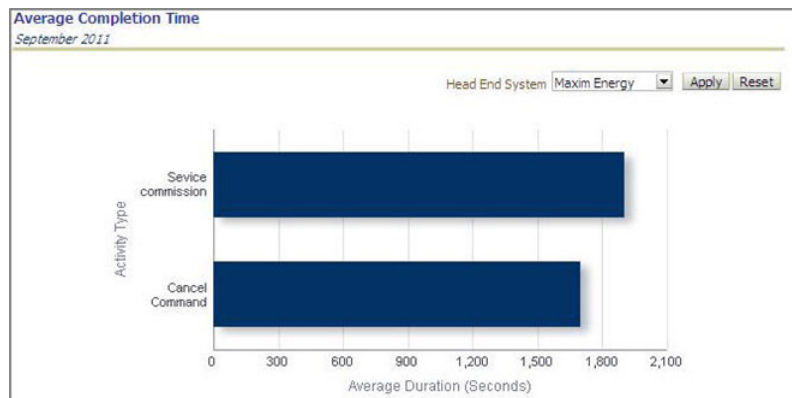

Sample Graph

The application displays data in the form of bar graphs, stacked bar graphs, pie charts, and also tables.

Gauges

Gauges highlight the state of a key performance indicator (KPI) in a given period. For example, you could use gauges to highlight:

- Revenue compared to budget revenue
- Outage duration compared to a target value
- Asset repair counts compared to the same time last year
- ...

The following figure shows a gauge that highlights the percentage of normal intervals that have been received.



Sample Gauge

Hover text

Hover text appears as a brief description of the object that the mouse is pointing to on the screen. The application can be configured to show hover text when you mouse over any element.

Drill Down/ Drill Back

Use the drill down option to navigate from one dashboard page to another dashboard page for granular level details.

You can drill back from a dashboard page in a dashboard to the respective edge application. An example to drill back would be navigating from Activity Analysis Detail dashboard page to Oracle Utilities Meter Data Management 360 Degrees View for specific device details.

Column Sorter

You can sort the rows in a table depending on your requirement. Click the up or down arrow in the header row of the table to arrange records in ascending or descending order. The related values are swapped accordingly.

Hierarchy Nodes

Hierarchical columns allow for the encapsulation of the presentation of a dimension hierarchy in an analysis report within a single column. The advantage of the hierarchical column is that it offers a better user experience in navigating within a hierarchy.

You can expand and collapse individual levels within the same report column using the plus (+) and minus (-) icons adjacent to display member values.

Print

Use the **Print** option to print the contents of the current page. Select either PDF or HTML. A browser window opens, displaying the contents in the selected format. Use the Print option available from the browser window to print the contents.

Export

Use the **Export** option to export the results of an analysis or a view in various formats such as PDF, Excel, PowerPoint, etc. Once exported, the data can be customized per requirement.

Using Page Options

Some dashboard pages support additional options available from the **Page Options** menu in the upper-right corner of the page. Examples of Page Options include:

- **Apply Saved Customization:** Allows you to select and apply a Saved Selection.
- **Save Current Customization:** Allows you to create a new Saved Selection based on your current settings.

-
- **Edit Saved Customization:** Allows you to delete or rename a Saved Selection or designate a Saved Selection as the default for the current dashboard page.
 - **Clear My Customization:** Clears any unsaved selections.
 - **Create Bookmark Link:** Creates a bookmark for this dashboard page and adds it to your browser's favorites or bookmarks list.

Ad-hoc Reporting

You can create new analysis or customize existing analyses by using existing star schema or extending the schema. See *Oracle Utilities Analytics for Oracle Utilities Extractors and Schema* and *Oracle Utilities Analytics Dashboards Administration Guide* for detailed information about OBIEE Customization.