

# Oracle FS Path Manager 4 for AIX

## Installation Guide



FLASH STORAGE  
SYSTEMS

Part Number E51080-01  
Oracle FS Path Manager release 4.0.0  
2014 September

Copyright © 2005, 2014, Oracle and/or its affiliates. All rights reserved.

This software and related documentation are provided under a license agreement containing restrictions on use and disclosure and are protected by intellectual property laws. Except as expressly permitted in your license agreement or allowed by law, you may not use, copy, reproduce, translate, broadcast, modify, license, transmit, distribute, exhibit, perform, publish or display any part, in any form, or by any means. Reverse engineering, disassembly, or decompilation of this software, unless required by law for interoperability, is prohibited.

The information contained herein is subject to change without notice and is not warranted to be error-free. If you find any errors, please report them to us in writing.

If this is software or related documentation that is delivered to the U.S. Government or anyone licensing it on behalf of the U.S. Government, the following notice is applicable:

U.S. GOVERNMENT RIGHTS Programs, software, databases, and related documentation and technical data delivered to U.S. Government customers are "commercial computer software" or "commercial technical data" pursuant to the applicable Federal Acquisition Regulation and agency-specific supplemental regulations. As such, the use, duplication, disclosure, modification, and adaptation shall be subject to the restrictions and license terms set forth in the applicable Government contract, and, to the extent applicable by the terms of the Government contract, the additional rights set forth in FAR 52.227-19, Commercial Computer Software License (December 2007). Oracle USA, Inc., 500 Oracle Parkway, Redwood City, CA 94065.

This software or hardware is developed for general use in a variety of information management applications. It is not developed or intended for use in any inherently dangerous applications, including applications that may create a risk of personal injury. If you use this software or hardware in dangerous applications, then you shall be responsible to take all appropriate fail-safe, backup, redundancy, and other measures to ensure its safe use. Oracle Corporation and its affiliates disclaim any liability for any damages caused by use of this software or hardware in dangerous applications.

Oracle and Java are registered trademarks of Oracle and/or its affiliates. Other names may be trademarks of their respective owners.

This software or hardware and documentation may provide access to or information on content, products and services from third parties. Oracle Corporation and its affiliates are not responsible for and expressly disclaim all warranties of any kind with respect to third-party content, products, and services. Oracle Corporation and its affiliates will not be responsible for any loss, costs, or damages incurred due to your access to or use of third-party content, products, or services.

Copyright © 2005, 2014, Oracle et/ou ses affiliés. Tous droits réservés.

Ce logiciel et la documentation qui l'accompagne sont protégés par les lois sur la propriété intellectuelle. Ils sont concédés sous licence et soumis à des restrictions d'utilisation et de divulgation. Sauf disposition de votre contrat de licence ou de la loi, vous ne pouvez pas copier, reproduire, traduire, diffuser, modifier, breveter, transmettre, distribuer, exposer, exécuter, publier ou afficher le logiciel, même partiellement, sous quelque forme et par quelque procédé que ce soit. Par ailleurs, il est interdit de procéder à toute ingénierie inverse du logiciel, de le désassembler ou de le décompiler, excepté à des fins d'interopérabilité avec des logiciels tiers ou tel que prescrit par la loi.

Les informations fournies dans ce document sont susceptibles de modification sans préavis. Par ailleurs, Oracle Corporation ne garantit pas qu'elles soient exemptes d'erreurs et vous invite, le cas échéant, à lui en faire part par écrit.

Si ce logiciel, ou la documentation qui l'accompagne, est concédé sous licence au Gouvernement des Etats-Unis, ou à toute entité qui délivre la licence de ce logiciel ou l'utilise pour le compte du Gouvernement des Etats-Unis, la notice suivante s'applique :

U.S. GOVERNMENT RIGHTS. Programs, software, databases, and related documentation and technical data delivered to U.S. Government customers are "commercial computer software" or "commercial technical data" pursuant to the applicable Federal Acquisition Regulation and agency-specific supplemental regulations. As such, the use, duplication, disclosure, modification, and adaptation shall be subject to the restrictions and license terms set forth in the applicable Government contract, and, to the extent applicable by the terms of the Government contract, the additional rights set forth in FAR 52.227-19, Commercial Computer Software License (December 2007). Oracle America, Inc., 500 Oracle Parkway, Redwood City, CA 94065.

Ce logiciel ou matériel a été développé pour un usage général dans le cadre d'applications de gestion des informations. Ce logiciel ou matériel n'est pas conçu ni n'est destiné à être utilisé dans des applications à risque, notamment dans des applications pouvant causer des dommages corporels. Si vous utilisez ce logiciel ou matériel dans le cadre d'applications dangereuses, il est de votre responsabilité de prendre toutes les mesures de secours, de sauvegarde, de redondance et autres mesures nécessaires à son utilisation dans des conditions optimales de sécurité. Oracle Corporation et ses affiliés déclinent toute responsabilité quant aux dommages causés par l'utilisation de ce logiciel ou matériel pour ce type d'applications.

Oracle et Java sont des marques déposées d'Oracle Corporation et/ou de ses affiliés. Tout autre nom mentionné peut correspondre à des marques appartenant à d'autres propriétaires qu'Oracle.

Ce logiciel ou matériel et la documentation qui l'accompagne peuvent fournir des informations ou des liens donnant accès à des contenus, des produits et des services émanant de tiers. Oracle Corporation et ses affiliés déclinent toute responsabilité ou garantie expresse quant aux contenus, produits ou services émanant de tiers. En aucun cas, Oracle Corporation et ses affiliés ne sauraient être tenus pour responsables des pertes subies, des coûts occasionnés ou des dommages causés par l'accès à des contenus, produits ou services tiers, ou à leur utilisation.

# Contents

- List of Tables ..... 6
- List of Figures ..... 7
- Preface ..... 8
  - Oracle Resources ..... 8
  - Typographical Conventions ..... 9
  - Command Syntax Conventions ..... 9
- Chapter 1: Introduction to Oracle FS Path Manager ..... 11**
  - FSPM Overview ..... 11
  - FSPM Requirements ..... 11
  - FSPM Architecture ..... 12
    - Control Path ..... 14
    - Data Path ..... 14
  - FSPM Features ..... 15
  - Boot from SAN ..... 17
  - FSPM and Virtual I/O Server ..... 17
  - Operating Limits ..... 18
  - Supported SAN Protocols ..... 19
    - Supported Fibre Channel Hardware ..... 19
      - Supported Fibre Channel Host Bus Adapters ..... 19
      - Fibre Channel Settings Configuration Options ..... 19
      - Supported Fibre Channel Switches ..... 19
    - FCoE Support Overview ..... 20
      - Supported FCoE Adapter Requirements ..... 20
      - Supported FCoE Switches ..... 20
    - Supported iSCSI Software and Hardware ..... 20
      - Supported iSCSI HBAs ..... 20
      - Supported iSCSI-to-FC Routers ..... 21
      - Supported iSCSI Switches ..... 21
    - Configuring iSCSI on AIX ..... 21
    - iSCSI Initiator Names ..... 23
- Chapter 2: Install FSPM ..... 24**
  - Prepare to Install the FSPM Software ..... 24
    - Delete SAN Host Before FSPM Installation ..... 25
    - Verify Management Network Requirements ..... 25
  - Configure SAN Host Connections ..... 26
    - Configure the iSCSI-to-FC Router ..... 28
  - FSPM Download and Installation Overview ..... 29
    - Download the FSPM Software ..... 29
    - Install the FSPM Software ..... 29
    - Install the FSPM Software Without Rebooting ..... 30

---

Configure SAN Host Access to the LUNs.....	31
Configure Bootable SAN-Attached Disk Overview .....	34
Perform Installation from Operating System Media .....	34
Use AIX to Clone an Existing Boot Disk.....	35
Install FSPM on a Bootable Oracle FS System LUN.....	35
AIX Bootlist Considerations .....	36
Install FSPM on Virtual I/O Servers .....	37
Load Balancing Configurations .....	37
Path Selection Overview .....	38
Stop and Start FSPM Software.....	39
Host Reconfiguration Overview .....	40
Updating FC or iSCSI Initiators Information .....	41
iSCSI HBAs or IP Addresses Change .....	42
Rename the FSPM Host.....	42
Upgrade FSPM Software .....	43
Upgrade FSPM without Rebooting the Host .....	43
Remove the FSPM Software (Optional).....	45
<b>Index.....</b>	<b>47</b>

# List of Tables

Table 1: Oracle resources.....8

Table 2: Typography to mark certain content.....9

Table 3: Typography to mark command syntax.....9

Table 4: FSPM interaction diagram key.....12

Table 5: FSPM 4 for AIX features.....15

Table 6: FSPM operating limits.....18

# List of Figures

- Figure 1: FSPM interaction with an Oracle FS System server.....13
- Figure 2: Delete SAN Host.....25
- Figure 3: Example of Host Ports grouped under Unassociated Host Name.....28
- Figure 4: After FSPM installation: Host Ports grouped under Host Name.....32
- Figure 5: LUN Host mapping detail.....33

# Preface

## Oracle Resources

Table 1: Oracle resources

For help with...	Contact...
Support	<a href="http://www.oracle.com/support">http://www.oracle.com/support</a> (www.oracle.com/support)
Training	<a href="https://education.oracle.com">https://education.oracle.com</a> (https://education.oracle.com)
Documentation	<ul style="list-style-type: none"><li>• <b>Oracle Technology Network Documentation:</b> (<a href="http://docs.oracle.com">http://docs.oracle.com</a>)</li><li>• From the Oracle FS System Manager (GUI): Help &gt; Documentation</li><li>• From Oracle FS System HTTP access: (<a href="http://system-name-ip/documentation.php">http://system-name-ip/documentation.php</a> where system-name-ip is the name or the public IP address of your system)</li></ul>
Documentation feedback	<a href="http://www.oracle.com/goto/docfeedback">http://www.oracle.com/goto/docfeedback</a> ( <a href="http://www.oracle.com/goto/docfeedback">http://www.oracle.com/goto/docfeedback</a> )
Contact Oracle	<a href="http://www.oracle.com/us/corporate/contact/index.html">http://www.oracle.com/us/corporate/contact/index.html</a> ( <a href="http://www.oracle.com/us/corporate/contact/index.html">http://www.oracle.com/us/corporate/contact/index.html</a> )



## Typographical Conventions

Table 2: Typography to mark certain content

Convention	Meaning
<i>italics</i>	<p>Within normal text, words in italics indicate one of the following items:</p> <ul style="list-style-type: none"> <li>• Hypertext, as in a URL</li> <li>• A reference to a book title</li> <li>• New terms and emphasized words</li> <li>• Command variables</li> </ul>
monospace	<p>Indicates one of the following, depending on the context:</p> <ul style="list-style-type: none"> <li>• The name of a file or the path to the file</li> <li>• <i>Output</i> displayed by the system on the command line</li> </ul>
<b>monospace</b> (bold)	<i>Input</i> provided by an administrator on the command line.
>	Indicates a menu item or a navigation path in the Oracle FS System Manager (GUI). For example, “Click SAN > Storage > LUNS > Action > Clone” means to click the Clone link on the SAN page in the GUI.
...	Indicates that one or more steps have been omitted from the path or menu structure. The ellipsis is used within an expression of a navigation path or within a cascading menu structure. For example, in the SAN > Storage > LUNS > ... > Clone menu structure, the ... implies that one or more menu items have been omitted.

## Command Syntax Conventions

Table 3: Typography to mark command syntax

Typographic symbol	Meaning
[ ]	Square brackets. Delimits an optional command parameter or a set of optional command parameters.
{ }	Braces. Delimits a set of command parameters, one of which must be selected.
	Vertical bar. Separates mutually exclusive parameters.
...	Ellipsis. Indicates that the immediately preceding parameter or group of parameters can be repeated.
monospace	Indicates the name of a command or the name of a command option (sometimes called a <i>flag</i> or <i>switch</i> ).
<i>italic</i>	Indicates a variable for which you need to supply a value.

Command parameters that are not enclosed within square brackets ( [ ] ) are required.

**Important:** The above symbols (and font styling) are based on the POSIX.1-2008 specification. These symbols are used in the command syntax only to clarify how to use the command parameters. *Do not enter these symbols on the command line.*

# Introduction to Oracle FS Path Manager

The following information provides an overview of the Oracle FS Path Manager (FSPM) and its features.

## FSPM Overview

The information in this document is for system administrators who want to use the Oracle FS Path Manager (FSPM) software on a SAN host running AIX. FSPM supports SAN multipathing to the Oracle FS System and to the Pillar Axiom system. The FSPM software replaces the Axiom Path Manager (APM) software.

FSPM automates the task of configuring information about the host in the Oracle FS System Manager. Oracle recommends that you install FSPM as part of initially connecting the host in the SAN to the Oracle FS System. This document describes the sequence of steps for doing this.

This document describes how to install and configure FSPM.

**Note:** In this document, references to an Oracle FS System, also refer to a Pillar Axiom System unless specifically noted. References to the Oracle FS System Controller, also refer to a Pillar Axiom System Slammer Control Unit unless specifically noted.

If you are updating your Pillar Axiom software or Oracle Flash Storage System software, complete that update before installing the FSPM software on the SAN host.

This release supports both Fibre Channel (FC) and iSCSI Controller and Slammer ports. You can connect your host to Fibre Channel or iSCSI ports on Controller or Slammer.

You can also connect your host through iSCSI-to-FC routers to FC ports on Controller or Slammer.

## FSPM Requirements

For updated information on which product versions are supported, review the *Oracle FS Path Manager Release Notes*.

**Note:** In this document, references to an Oracle FS System, also refer to a Pillar Axiom System unless specifically noted. References to the Oracle FS System Controller, also refer to a Pillar Axiom System Slammer Control Unit unless specifically noted.

The Pilot provides an interface for the FSPM software to communicate with the Oracle FS System through port 26012 or with a Pillar Axiom system through port 26004. These ports are enabled by default and must remain open.

### Related Links

[Verify Management Network Requirements](#)

## FSPM Architecture

The Oracle FS Path Manager (FSPM) software consists of a path control module (PCM) and a daemon. The PCM integrates with the AIX Multi-Path I/O (MPIO) subsystem. The PCM and daemon run on the host system to present multiple paths as single logical units.

FSPM prevents multiple paths from being presented as multiple disk drives. Every configured multipathed Oracle FS System LUN will be presented as a single disk drive to the operating system. The driver supports failover across redundant paths. The daemon assists with driver configuration and uses the control path to send and receive information about the hosts. It runs as a background process at the user level and looks after management tasks. The daemon sends host attributes to the Oracle FS System system. The software then takes control of the paths, hides actual paths from the operating system, and behaves like a virtual HBA with a single path to each LUN.

*Figure 1: FSPM interaction with an Oracle FS System server* illustrates how the FSPM software installed on a SAN host interacts with an Oracle FS System system. Refer to the table below to determine the significance of the lines and colors in the figure.

**Table 4: FSPM interaction diagram key**





Graphic element	Description
————	Data path
-----	Control path
	Oracle-supplied hardware and software
	Non-Oracle FS System hardware and software
	SAN host kernel space
	SAN host user space

Figure 1: FSPM interaction with an Oracle FS System server



Legend	1 User	10 FSPM Path Control Module (PCM)
	2 User application	11 iSCSI software initiator (iSCSI)
	3 SAN host	12 TCP/IP driver (iSCSI)
	4 FSPM daemon	13 HBA driver (FC or iSCSI) or NIC driver (iSCSI)
	5 Control paths (all dashed lines)	14 HBA (FC or iSCSI) or NIC (iSCSI)
	6 Oracle FS System administrator	15 SCSI over Fibre Channel (FC) or iSCSI over IP (iSCSI)
	7 Oracle FS System command line interface (CLI) or graphical user interface (GUI)	16 Data path (all solid lines)
	8 Encrypted XML messages over TCP/IP	17 Oracle FS System server
	9 Network card	18 Drive Enclosure storage enclosure pool

### Related Links

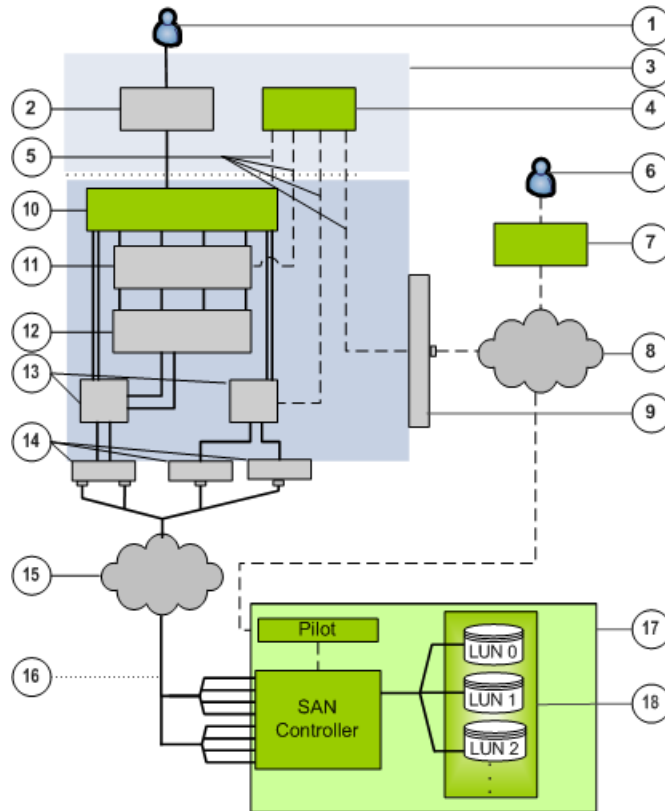
[Control Path](#)

[Data Path](#)

## Control Path

The FSPM control path to the Pilot of an Oracle FS System provides a separate path from the data path to the Controller of an Oracle FS System to manage multipathing and communication.

FSPM uses a daemon to control multipathing and communication. The FSPM daemon uses the control path to perform these actions:

- Get information from the Pilot management controller
- Get FC and iSCSI port information from the HBA and CNA drivers and iSCSI initiator
- Configure the FSPM Path Control Module
- Send information such as host attributes and statistics to the Pilot management controller and, if requested, collect logs from the host

The FSPM daemon sends a description of the host to the Pilot on each connected Oracle FS System. In the Oracle FS System Services, this description creates a definition for the host that includes FC ports in the host and, if iSCSI is configured, the iSCSI initiator name.

The Oracle FS System Manager (GUI) and Oracle FS CLI list the World Wide Names (WWNs) of the FC ports and IP addresses from the host used to make iSCSI connections to the Oracle FS System.

If you use iSCSI on the host to connect to a Controller through an iSCSI-to-FC router, these connections are described as FC connections. Within Oracle FS System Manager (GUI) and Oracle FS CLI, the iSCSI connections are displayed as originating from the FC ports on the switch assigned to the host iSCSI initiator. The port WWNs are displayed as FC HBA ports on the host. The HBA model associated with these ports is displayed in the GUI as iSCSI-FC router.

To establish the control path to an Oracle FS System host, the host must be able to connect to the Oracle FS System over the data path. As part of the connection sequence, the Controller returns the IP address of the Pilot to the FSPM host over the data path. The host uses the IP address of the Pilot to establish the control path to the Oracle FS System.

## Data Path

The FSPM driver, a Path Control Module (PCM) that works with the AIX Multipath I/O (MPIO) driver, manages I/O to storage devices over the data path.

The FSPM driver:

- Controls and manages all data paths to the Oracle FS System LUNs
- Groups multiple data paths to an Oracle FS System LUN and presents this group to the host operating system as a single LUN or drive
- Determines which data paths to use
- Identifies and uses optimized data paths when possible

- Provides load balancing across the best available paths
- Handles data path failover and failback
- Manages data path errors

A path that provides the best performance is referred to as an optimized path and is the preferred path for data transfer.

## FSPM Features

FSPM to provide the following functions:

- Routes I/O to Oracle FS System LUNs using the best available data paths
- Allocates traffic among the available paths to ensure that access to the LUNs is not interrupted if a path fails
- Automatically configures the host information in the Oracle FS System Manager (GUI) and updates the host configuration information if the host information changes

Automatic configuration of host information enables the GUI to report information about the instance of FSPM running on the host. An example is the number of working paths reported to the GUI from FSPM. In some environments, automatic configuration includes features such as load balancing.

Each FSPM release provides different features and the features provided for each platform vary. The following table describes the specific features implemented in FSPM 4.

**Table 5: FSPM 4 for AIX features**

Feature	Benefit
Automatic data path failover	Automatically switches to the most suitable paths available after a path failure or fail back.
Automatic recognition of SAN hosts by the Oracle FS System Services.	Sends a description of the host to each Pilot management controller on connected Oracle FS Systems, enabling the Oracle FS System Services to create a host definition. This definition provides information including the WWNs for each host FC port, iSCSI Initiator Names associated with the hosts, and the version of FSPM running on the host.

Table 5: FSPM 4 for AIX features (continued)

Feature	Benefit
Call-Home log collection	<p>When an Oracle FS administrator uses Oracle FS System Manager (GUI) to collect system information, the Oracle FS System can be instructed to send a request to each connected FSPM host. The FSPM host collects diagnostic information and sends the information to the Oracle FS System, where the information is bundled with any other requested information.</p> <p>The Oracle FS System can transmit this information to Oracle Customer Support. The information collected from each FSPM host includes</p> <ul style="list-style-type: none"> <li>• Log files from the FSPM components</li> <li>• Configuration and status information from the operating system</li> <li>• System and error logs from the operating system</li> </ul> <p>No customer data is transmitted.</p> <p><b>Note:</b> For more information on Call-Home, refer to the <i>Oracle Flash Storage System Administrator's Guide</i>.</p>
Support for FC connections to Controllers	<p>Makes connections to Oracle FS System storage arrays over a high-speed FC network infrastructure.</p>
Support for iSCSI connections to Controllers	<p>Makes connections to Oracle FS System storage arrays over long distances using an IP network infrastructure.</p> <p><b>Note:</b> iSCSI connections to FC ports on Controllers require iSCSI-to-FC routers.</p>
Support for Boot from SAN	<p>Supports using an Oracle FS System LUN on an FC SAN as a boot disk. Booting from an Oracle FS System LUN on an iSCSI SAN is not supported in this release.</p>
Support for AIX features (refer to the IBM AIX documentation for details)	<ul style="list-style-type: none"> <li>• Dynamic reconfiguration</li> <li>• Live Partition Mobility</li> <li>• Large LUNs (larger than 2 TB)</li> <li>• PowerHA SystemMirror</li> </ul> <p><b>Note:</b> PowerHA SystemMirror was previously known as HACMP and PowerHA.</p> <ul style="list-style-type: none"> <li>• Logical Partitioning (LPARs)</li> <li>• Virtual I/O Server</li> <li>• Dynamic Tracking of FC devices</li> <li>• Fast I/O Failure for FC devices</li> <li>• Virtual Fibre Channel Adapters (NPIV)</li> </ul>



## Related Links

[Boot from SAN](#)

## Boot from SAN

Oracle FS Path Manager (FSPM) supports booting from an Oracle FS System LUN.

There are two methods from which you can choose:

- Clean installation from the AIX CD—This method involves loading the AIX OS onto an Oracle FS System LUN, then configuring the FSPM software on that LUN. You must install FSPM *after* completing this procedure.
- Use AIX to clone an existing boot disk—This method involves cloning an existing bootable hard disk using the `alt_clone` command to copy an existing operating system disk onto an Oracle FS System LUN. You can perform this procedure before or after you install FSPM.

Either method creates a bootable disk; choose the best method for your situation.

After you create a bootable Oracle FS System LUN, you can use the facilities of the Oracle FS System to make copies or clones of that LUN.

**Important:** When you use the Oracle FS System to copy a LUN to use as a boot disk, make sure AIX is not using the disk. If an Oracle FS System LUN is the boot LUN for an AIX system, and you want to use the features of the Oracle FS System to copy or clone that LUN, you should first shut the AIX system down or boot it from a different disk. Copies of AIX boot LUNs taken while AIX is booted from them cannot be reliably used as boot LUNs.

## FSPM and Virtual I/O Server

Oracle FS Path Manager (FSPM) supports Virtual I/O Servers.

When you install FSPM on Virtual I/O Server, multi-pathed Oracle FS System LUNs that are mapped to the Virtual I/O Server can be virtualized as SCSI devices for access by client partitions in the same way as other disks. FSPM is installed on the Virtual I/O Server not the client partition.

If your system has more than one Virtual I/O Server, FSPM can be installed on each server. The Oracle FS System LUNs can be mapped to all the Virtual I/O Servers. Each server exposes a virtual view of each LUN to the client partitions. In this configuration, the client partitions can access the LUNs through multiple Virtual I/O Servers—that is, the client partitions have multiple virtual paths to each LUN. To manage these multiple paths to the virtual LUNs, AIX in the client partitions uses Multipath I/O (MPIO) with the default Path Control Module (PCM) in failover mode. FSPM cannot be used in the client partitions to manage these virtual paths.

With multiple Virtual I/O Servers, MPIO with the default PCM is used in the clients to manage the paths to the virtual disks presented by FSPM in the Virtual I/O Servers.

Since FSPM is installed on the Virtual I/O Servers, the Virtual I/O Servers show up as hosts in the Oracle FS System, the LUNs must be mapped to those Virtual I/O Server hosts. In a system with multiple Virtual I/O Servers, the LUNs should be mapped to all the Virtual I/O Servers on the system. The normal Virtual I/O Server facilities are used to make the LUNs visible from the Virtual I/O Servers to the individual client partitions.

**Note:** For information on which version of Virtual I/O Servers are supported, review the *Oracle FS Path Manager Release Notes*.

Client partitions can use the Virtual Fibre Channel adapters or the iSCSI Initiator to directly access LUNs on the Oracle FS System. In this case, FSPM is installed in the client partitions to manage direct connections to the Oracle FS System and not on the Virtual I/O Server.

**Note:** A LUN must be accessed by a client partition through only one mechanism at a time. That is, a LUN can be accessed as a:

- virtual SCSI disk through one or more Virtual I/O Servers
- Fibre Channel disk through Virtual Fibre Channel adapters
- an iSCSI disk through iSCSI initiators

**Note:** A client partition must use only one of those mechanisms for each LUN at any one time.

## Operating Limits

FSPM provides access over multiple data paths to LUNs defined on an Oracle FS System.

FSPM and the Oracle FS System operating software limits are described in this document.

**Table 6: FSPM operating limits**

FSPM capabilities	Maximum value
Target storage systems	Eight for each FSPM host in any combination of Oracle FS Systems and Pillar Axiom systems
Connect to LUNs	Up to 256 for each Pillar Axiom system and 4096 for each Oracle FS System
Handle data paths	32 to each LUN
Handle FC HBA ports	32 for each SAN host

**Important:** Not all combinations of the operating limits were tested. If you configure an operating system to operate at or near these limits, the system might not work properly when these limits are used concurrently with each other.

## Supported SAN Protocols

Provides information about FC and iSCSI protocols supported by Oracle FS Path Manager (FSPM).

FSPM supports FC and iSCSI connections to the Oracle FS System.

## Supported Fibre Channel Hardware

Before you install the Oracle FS Path Manager (FSPM) software on the host, verify that your Fibre Channel SAN components are supported.

The following sections list tested and approved hardware compatible with the Oracle FS System at the time of this release.

### *Supported Fibre Channel Host Bus Adapters*

FSPM for AIX supports Fibre Channel host bus adapters (HBAs) that are supported by the AIX operating system.

This release supports all FC HBAs that are supported by IBM for the AIX operating system used with FSPM

Installation instructions and drivers for these HBAs are available from the [IBM support download page](http://www.ibm.com/support) (<http://www.ibm.com/support>).

### *Fibre Channel Settings Configuration Options*

AIX provides two configuration options to modify the behavior of the Fibre Channel (FC) drivers when events occur in the SAN. These options are *Fast I/O Failure* and *Dynamic Tracking*. Oracle recommends that you enable both of these options for all FC ports used to connect to the Oracle FS System system, unless other software or hardware components using these ports require a different setting.

More information about these two options can be found in the [AIX documentation](http://publib.boulder.ibm.com/infocenter/pseries/v5r3/topic/com.ibm.aix.prftungd/doc/prftungd/log_vol_disk_io_perf.htm) ([http://publib.boulder.ibm.com/infocenter/pseries/v5r3/topic/com.ibm.aix.prftungd/doc/prftungd/log\\_vol\\_disk\\_io\\_perf.htm](http://publib.boulder.ibm.com/infocenter/pseries/v5r3/topic/com.ibm.aix.prftungd/doc/prftungd/log_vol_disk_io_perf.htm)).

### *Supported Fibre Channel Switches*

Supported Fibre Channel (FC) switches work with Oracle FS Path Manager (FSPM) software as described in the *Oracle Flash Storage System Support and Interoperability Guide*.

For a list of supported FC switches, review the *Oracle FS System Oracle Flash Storage System Support and Interoperability Guide*, which can be found on the [Oracle](#)

*Technology Network* (<http://www.oracle.com/technetwork/documentation/oracle-unified-ss-193371.html>).

**Note:** Refer to the vendor's website for the most recent installation instructions, patches, and firmware.

## FCoE Support Overview

The Oracle FS Path Manager (FSPM) software can be used on SAN hosts that use Fibre Channel over Ethernet (FCoE) connections from Converged Network Adapters (CNAs) through a switch to an FC SAN.

FSPM manages FCoE connections the same as FC connections.

**Note:** For additional information on FCoE support including adapters, review the *Oracle Flash Storage System Support and Interoperability Guide*.

### *Supported FCoE Adapter Requirements*

All FCoE adapters that meet the FC HBA requirements are supported.

### *Supported FCoE Switches*

The supported Fibre Channel over Ethernet (FCoE) converged network adapters (CNAs) were tested in conjunction with the Brocade 8000 switch.

For best results, the Brocade 8000 switch must be running Fabric OS version 6.4.0a or higher.

## Supported iSCSI Software and Hardware

Oracle FS Path Manager (FSPM) for AIX supports the following Internet Small Computer System Interface (iSCSI) software and hardware:

- The iSCSI software initiator included in your AIX distribution.
- The iSCSI-to-Fibre Channel routing features of the Cisco MDS 9000 family of routers and switches.
- The iSCSI host bus adapters (HBAs) and Transmission Control Protocol (TCP) Offload Engines (TOEs) listed in this document.

### *Supported iSCSI HBAs*

Oracle FS Path Manager (FSPM) supports IBM Internet Small Computer System Interface (iSCSI) host bus adapters (HBAs) and Transmission Control Protocol (TCP) Offload Engines (TOEs):

All iSCSI HBAs supported by the AIX operating system version that FSPM is installed on are supported.

---

## Supported iSCSI-to-FC Routers

iSCSI-to-FC routing features enable a host to use iSCSI to access LUNs through FC ports on Oracle FS System Controllers.

Oracle FS Path Manager supports the iSCSI-to-FC routing features of the Cisco MDS 9000 family of multilayer directors and fabric switches. The only supported iSCSI-to-FC routing solution is the solution provided by this family of switches.

The iSCSI-to-FC features were tested on Cisco MDS SAN-OS Release 3.0 (2a).

For more information on these features, go to the [Cisco](http://www.cisco.com) (www.cisco.com) website and search on the product family, Cisco MDS 9000.

## Supported iSCSI Switches

For a list of supported iSCSI switches,

- Refer to the *Oracle FS System Support and Interoperability Guide*, which can be found on the [Oracle Technology Network Documentation](http://www.oracle.com/technetwork/documentation/oracle-unified-ss-193371.html) website (http://www.oracle.com/technetwork/documentation/oracle-unified-ss-193371.html).

**Note:** Refer to the vendor's website for the most recent installation instructions, patches, and firmware.

## Configuring iSCSI on AIX

Oracle FS Path Manager (FSPM) for AIX supports Internet Small Computer System Interface (iSCSI) connections. The following information will help you configure iSCSI to work with FSPM and your Oracle FS System.

The unit of configuration for iSCSI on AIX is a logical device called an *iSCSI protocol device*. One iSCSI protocol device represents the iSCSI software initiator, which operates over the normal Transmission Control Protocol (TCP) / Internet Protocol (IP) stack and the network interface cards (NICs) that TCP/IP is configured to use. Each iSCSI TCP Offload Engine (TOE) or host bus adapter (HBA) port also has its own iSCSI protocol device.

Each iSCSI protocol device can connect to a maximum of one port on each iSCSI target. An Oracle FS System is a single iSCSI target with multiple iSCSI ports. This means that each iSCSI protocol device can connect to only one Controller port on an Oracle FS System. To make multipath connections to a Oracle FS System LUN, the host must have a minimum of two iSCSI protocol devices. For example, these protocol devices could be one of:

- The software initiator and one HBA
- Two HBAs

This enables two connections to the Oracle FS System, which would be enough to enable minimal multipathing for a dual-Controller Oracle FS System.

To enable multipathing, the target discovery policy for each iSCSI protocol device must be configured to ensure that they discover the appropriate

Controller ports. For example, with two iSCSI protocol devices, one should be configured to only discover a port on one Controller, and the other should be configured to discover a port on the other Controller.

There are several ways to configure target discovery (or explicitly configure target ports) for each iSCSI protocol device, a few of which are documented in the AIX documentation. The ability of FSPM to automatically discover the management IP addresses of attached Oracle FS System varies with how target discovery is configured.

- If an iSCSI protocol device is configured to use the file or Object Data Manager (ODM) discovery policies, FSPM will be able to discover Oracle FS System Pilots without additional configuration. As long as it is possible to make an iSCSI connection between the relevant host and Controller ports, FSPM will automatically find the Pilot IP address.
- For discovery policies other than file or ODM, the iSCSI protocol device must first bring an iSCSI LUN on the Oracle FS System online. This involves typing in the initiator name of the iSCSI protocol device at the Oracle FS System and mapping a LUN to it, or making a LUN globally visible over iSCSI from the Oracle FS System, and then running the `cfgmgr` command on the host.

FSPM will be able to discover the Oracle FS System management address, even if the LUN itself is deleted or unmapped at the Oracle FS System, as long as the following conditions are true:

- The configuration information exists on the host for an iSCSI LUN on the Oracle FS System.
- It is possible to make an iSCSI connection between the relevant host and Controller ports.

**Important:** AIX does not support the configuration of combo LUNs.

Combo LUNs are LUNs that are accessible through both Fibre Channel and iSCSI. A LUN on an Oracle FS System must not be made visible to AIX over Fibre Channel and iSCSI at the same time or the LUN configuration at the host will become confused and behave unpredictably.

If a LUN has been accessible by the host in the past over one protocol, and the same LUN is to be made accessible over the other protocol, then the LUN's existing configuration information should be deleted from AIX before making it accessible over the new protocol. The configuration information is deleted by using the `rmdev` command:

**Example:**

```
rmdev -l hdiskx -d
```

Where *hdiskx* is the name and number of an hdisk device.

## iSCSI Initiator Names

In AIX, an iSCSI initiator name must be configured for the iSCSI software initiator and for each iSCSI HBA.

The iSCSI Standard, [RFC 3720](http://tools.ietf.org/html/rfc3720) (<http://tools.ietf.org/html/rfc3720>), places requirements on the format of the iSCSI initiator names. Oracle FS Path Manager (FSPM) depends on these requirements being met for it to work properly with iSCSI on AIX. In particular, the following rules should be followed:

- 1 iSCSI initiator names must be unique to each host. iSCSI initiators within a single host can each have their own names or they can all share the same name, but an iSCSI initiator name used on one host must not be used on any other host that accesses the same Oracle FS System.
- 2 iSCSI initiator names must be different from host names. An iSCSI initiator name must not be the same as any host name visible to the Oracle FS System.
- 3 iSCSI initiator names must be configured in AIX in the “normalized” string format described in [RFC 3722](http://tools.ietf.org/html/rfc3722) (<http://tools.ietf.org/html/rfc3722>). For example, names containing only lower case characters, numbers, and the dash, dot and colon characters from the ASCII character set meet this requirement.

See [RFC 3720](http://tools.ietf.org/html/rfc3720#section-3.2.6) (<http://tools.ietf.org/html/rfc3720#section-3.2.6>) for more information on iSCSI names.

# Install FSPM

The following information describes the process to install and configure FSPM.

## Prepare to Install the FSPM Software

Oracle recommends that you install FSPM on the host or hosts as part of the process of initially connecting a host or hosts to the Oracle FS System through the SAN and assigning storage to the host. The sequence of steps in this document assumes that there are no configuration entries in the Oracle FS System Manager for a SAN host. If there are host configuration entries, these entries must be deleted as described in this document before you install FSPM.

To ensure a successful installation of FSPM, perform the following tasks:

- 1 Read the *Oracle FS Path Manager Release Notes* to verify which version of Pillar Axiom or Oracle FS System software is required for FSPM.
- 2 Ensure that the required operating system patches and updates are installed. Review the *Oracle FS Path Manager Release Notes* for further information.
- 3 If you are using Fibre Channel (FC) or FC over Ethernet (FCoE) connections, verify that your FC SAN components and HBAs are supported by FSPM and installed according to the manufacturer's instructions.
- 4 If you are using iSCSI connections, verify that your iSCSI configurations are supported by the FSPM and installed according to the manufacturer's instructions.
- 5 Follow the installation process in order as described in this section. It is important to follow the process as you cannot perform these tasks out of order. For example, before installing FSPM, it is important to verify port access and pre-configure SAN host for Oracle FS System. Installing FSPM first and then performing these other tasks out of sequence will cause installation problems.

### Related Links

[Verify Management Network Requirements](#)

[FSPM Requirements](#)

[Operating Limits](#)

[Configure SAN Host Connections](#)



## Delete SAN Host Before FSPM Installation

Before you install the FSPM software on a SAN host, you need to delete any SAN host on an Pillar Axiom system or Oracle FS System that was manually created for that SAN host.

During installation, FSPM automatically creates a host entry for the host in the Oracle FS System Services and associates the host's initiators with the entry. If you manually associated any of the host's initiators with a host entry and mapped LUNs to the host, you must delete that host entry before installing FSPM on the host. If you do not follow this process to delete the host entry, the LUN mappings are deleted and you need to recreate the LUN mappings after installing FSPM.

**Note:** In this section, all references to GUI screens refer to the layout of the Oracle FS System Manager (GUI) version 6.1. Other GUI versions are organized differently, but all versions offer equivalent functionality. Review the *Administrator's Guide* for details on how to access the features in older versions of the GUI.

- 1 From the GUI, navigate to the SAN > Storage > Hosts page.
- 2 Select the host you want to delete.
- 3 Select SAN > Storage > Hosts > Actions > Delete Host  
The Delete SAN Host dialog is displayed.
- 4 On the Delete SAN Host dialog, make sure Delete mappings and initiators? is not checked, which is the default value. If the box is checked, uncheck the box. This saves the associated LUN mappings to the host which FSPM restores as part of the FSPM installation process.

**Figure 2: Delete SAN Host**

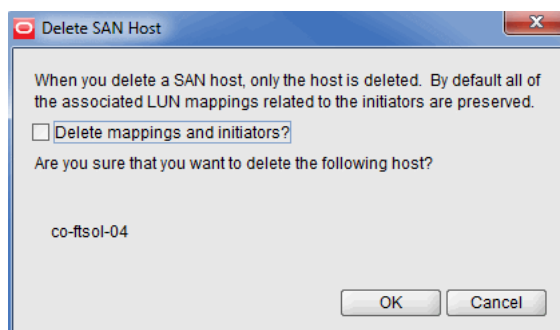

- 5 Select OK to delete the SAN host.

You can also delete the SAN Host using the Oracle FS CLI. Review the *Oracle FS CLI Reference Guide* for further information.

## Verify Management Network Requirements

FSPM communicates with the Pilot using secure encrypted messages. The SAN host where the FSPM is installed requires a TCP/IP connection for

---

communication with Oracle FS System Manager (GUI) or Pillar Axiom Storage Services Manager (GUI).

The network configuration must enable the SAN host to connect to a Pillar Axiom storage system using TCP port 26004 or an Oracle FS System using TCP port 26012. These ports are used to connect control path to the Pilot management Ethernet interfaces.

Network firewalls may be running on the host or in the network between the host and the Pilot. Firewall settings can block access to ports 26004 or 26012. Changes to the firewall settings can block a port that was previously open.

To resolve the blocked port, first determine if TCP port 26004 on a Pillar Axiom storage system or TCP port 26012 on an Oracle FS System is open and not blocked. You can test connectivity from the host to the system by using the `telnet` command to access the Pillar Axiom storage system or the Oracle FS System. No data is returned if you can successfully access the system; the port is open and not blocked. If you successfully access the Pillar Axiom storage system or the Oracle FS System with the `telnet` command, quit or escape from the `telnet` session.

To access the Pillar Axiom storage system or the Oracle FS System with `telnet`, you need the IP or DNS name of the Pillar Axiom storage system or Oracle FS System.

Here is an example of the command for the Pillar Axiom storage system port:

```
telnet axiom_ip_or_dns_name 26004
```

Here is an example of the command for the Oracle FS System port:

```
telnet oraclefs_ip_or_dns_name 26012
```

If the `telnet` command fails then unblock TCP port 26004 on a Pillar Axiom storage system or TCP port 26012 on an Oracle FS System After unblocking the TCP port, verify that the TCP port is open using the `telnet` command.

## Configure SAN Host Connections

Before you install the FSPM software, configure your SAN host connections for the Oracle FS System.

- Prerequisites:      Verify that your host and Oracle FS System meets the following requirements:
- Available FC or iSCSI ports on an Oracle FS System Controller or Pillar Axiom Slammer.
  - Supported HBA and converged network adapter (CNA) drivers.

- 
- Ethernet connections to the management ports on the Pilot.
  - A network configuration that enables an application on the SAN host to connect to an Pillar Axiom storage system TCP port 26004 or Oracle FS System TCP port 26012 on the Pilot. Make sure these TCP ports are open.

Prepare your SAN host components to connect with the Oracle FS System.

**Note:** In this section, all references to GUI screens refer to the layout of the Oracle FS System Manager (GUI) version 6.1. Other GUI versions are organized differently, but all versions offer equivalent functionality. Review the *Administrator's Guide* for details on how to access the features in older versions of the GUI.

- 1 Verify that all FC and iSCSI components and software are installed on the SAN host as described in this document.
- 2 Set up the SAN (physical connectivity and any required switch zoning) so there is at least one path through the SAN the host and a Controller port on each Oracle FS System.

This enables the FSPM Service to discover the Oracle FS System and automatically create host entries in the Oracle FS System Manager. Proper setup is necessary so that all required host ports can access the Controller ports on the Oracle FS System.

- 3 If you are using iSCSI connections, verify that your network is configured for iSCSI multipathing, and the iSCSI software initiator is configured correctly. See the instructions in this document on configuring an iSCSI SAN.

If you are using the iSCSI-to-Fibre Channel routing features of the Cisco MDS 9000, review the configuration information on iSCSI-to- FC Router in this document.

- 4 From the GUI, navigate to the SAN > Storage > Hosts page.
- 5 Verify the SAN connections.

When hosts first make SAN connections to the Oracle FS System, all initiators that are not yet associated with a host entry are listed under a false host name Unassociated. Fibre Channel initiators are listed by their Port WWNs and iSCSI initiators are listed by their Initiator Names. This is shown in the following illustration:

**Figure 3: Example of Host Ports grouped under Unassociated Host Name**

Host Name	Controller-Initiator Connect...	Number of LUNs Mapped	Oracle FS Path Manager			HBA
			Status	Version	Host IP Address	HBA Alias Name
Unassociated						
10.00.00.00:C9.76.63.F4	Connected		Connected			
10.00.00.00:C9.76.63.F5	Connected		Connected			
10.00.00.90:FA.11.B5.54	Connected		Connected			
10.00.00.90:FA.11.B5.55	Connected		Connected			
21.00.00.E0.8E.84.14.9C	Connected		Connected			

- 6 Choose one of the following depending on your SAN protocol configuration:
  - If you are using iSCSI as your SAN protocol, and you have configured iSCSI with the file or Object Data Manager (ODM) discovery policy, no further action is required.
  - If you are using Fibre Channel as your SAN protocol, or if you have configured iSCSI with a discovery policy other than file or ODM, verify that at least one LUN is visible to at least one port in the host. This LUN can be unmapped or mapped to one of the host ports. Review information on configuring iSCSI on AIX for additional information.
    - If you map the LUN to one of the ports, it maps to all ports on the host after the FSPM software is installed on the host.
    - If you decide that this LUN is temporary, delete it after you install the software.

## Configure the iSCSI-to-FC Router

FSPM supports the iSCSI-to-Fibre Channel routing features of the Cisco MDS 9000 family of multi-layer directors and fabric switches. These features require configuration to work with the Oracle FS Path Manager (FSPM).

For more information on these features, refer to the [Cisco documentation](http://www.cisco.com/en/US/products/ps10495/products_installation_and_configuration_guides_list.html) ([http://www.cisco.com/en/US/products/ps10495/products\\_installation\\_and\\_configuration\\_guides\\_list.html](http://www.cisco.com/en/US/products/ps10495/products_installation_and_configuration_guides_list.html)).

- 1 Present the Oracle FS System Controller or Pillar Axiom Slammer ports as iSCSI targets.  
Choose Dynamic Mapping or Static Mapping. However, we recommend that you use dynamic mapping because the main Cisco features for static mapping requirements are supplied by FSPM and the Oracle FS System Manager (GUI).
- 2 Present the iSCSI hosts as virtual FC hosts.  
The hosts must be presented in transparent initiator mode (not in proxy-initiator mode). When you assign World Wide Names (WWNs) for the iSCSI initiators, use the static mapping mechanism.

After you configure the switch, FSPM on the iSCSI hosts interacts with the Oracle FS System or Pillar Axiom system in exactly the same way as when both hosts and Controllers or Slammers use the same SAN protocol.

## FSPM Download and Installation Overview

After you prepare your SAN for FSPM, you can download and install the FSPM package from the Oracle Technology Network (OTN).

Once FSPM is downloaded and installed, you configure access from the SAN host to the Oracle FS System LUNs.

### Related Links

[Configure SAN Host Access to the LUNs](#)

## Download the FSPM Software

The software and documentation are distributed as a single zip archive that is available for download from the Oracle Technology Network (OTN).

Prerequisite: Join the [Oracle Technology Network](#) to gain access to software and documentation downloads:  
<http://www.oracle.com/technetwork/community/join/why-join/index.html>

Follow these steps to access and download the software:

- 1 On the Oracle Technology Network, open the [Oracle Flash Storage System Downloads](#) page (<http://www.oracle.com/technetwork/server-storage/san-storage/downloads/index.html>) in a web browser.
- 2 From Oracle FS System Downloads, select Accept License Agreement.
- 3 Locate and select the name of the software package to download for your operating system version.
- 4 Extract the contents of the software bundle archive to a local drive connected to the SAN host.

The archive contains software installation packages for all supported hardware platforms, as well as documentation, for the specified version. Extract the package on a local drive for your hardware platform and the documentation.

After you download the software, you can install it on your host system.

## Install the FSPM Software

- 1 Log in as `root`.
- 2 Change to the directory containing the FSPM software.

- 3 Run the following command to create or update the Table of Contents (.toc) file that describes the software packages in the FSPM directory.

```
# inutoc .
```

- 4 Use one of the normal AIX methods to install the software.  
Choose one of:

- `installp` – Installs the software from the command line.
- `smit` – Starts the System Management Interface Tool (SMIT).
- `smitty` – Starts the ASCII terminal version of the System Management Interface Tool (SMITTY).

**Note:** If you use `smit` or `smitty`, follow the prompts on the Install Software menu.

- 5 As the installation finishes, the installer instructs you to reboot the host. This is not always necessary based on these conditions:
  - If the system is using an Oracle FS System LUN as the boot disk, reboot the system now, and continue at Step 5 of [Install FSPM on a Bootable Oracle FS System LUN](#).
  - If the system is not using an Oracle FS System LUN as the boot disk, connect any additional paths to your LUNs and make any new LUNs visible to the host.
- 6 Choose one of:
  - Reboot the host as instructed.
  - Complete the installation without rebooting the host by following the steps to install the software without rebooting the system.

## Install the FSPM Software Without Rebooting

Follow these instructions to install Oracle FS Path Manager (FSPM) without rebooting the operating system.

- 1 Follow the steps to install the FSPM software.
- 2 Remove the configuration information and device definition from AIX for any Oracle FS System LUN or Pillar Axiom LUN disk devices.

Use the `rmdev` command to remove the configuration and definition:

Example:

```
# rmdev -l hdiskx -d
```

Where *hdiskx* is the name and number of the device to be deleted.

**Note:** The devices for Oracle FS System LUN or Pillar Axiom LUN have a description of `Other FC SCSI Disk Drive` or `Other iSCSI Disk Drive`. Confirm that the disk devices you are removing are for Oracle FS System

LUN or Pillar Axiom LUNs, because other disk devices could be using these descriptions, too.

- 3 Create the configuration entries for the new multipath devices for the LUNs, and bring the paths and LUNs online.

Use the following command to create and activate the new configuration:

```
# cfgmgr
```

It may be necessary to run `cfgmgr` more than once to bring all LUNs and paths online.

- 4 Start the FSPM daemon to complete the task

Run the following command to start the daemon

```
# startsrc -s fspmd
```

## Configure SAN Host Access to the LUNs

Follow this procedure to ensure that the Oracle FS Path Manager (FSPM) software is installed correctly and working on your system.

**Note:** In this section, all references to GUI screens refer to the layout of the Oracle FS System Manager (GUI) version 6.1. Other GUI versions are organized differently, but all versions offer equivalent functionality. Review the *Administrator's Guide* for details on how to access the features in older versions of the GUI.

Before the FSPM software is installed, a device is present for each path to a LUN. These devices are labeled `Other FC SCSI Disk Drive` or `Other iSCSI Disk Drive` on the AIX host. The installation automatically assigns one device for each LUN, labeled `MPIO Oracle FS FC SCSI Disk Drive`, `MPIO Oracle FS iSCSI Disk Drive`, `MPIO Pillar Axiom FC SCSI Disk Drive`, or `MPIO Pillar Axiom iSCSI Disk Drive` on the AIX host. Do the following after you install the software:

- 1 Use the following command to verify that one device is assigned to each LUN:

```
lsdev -c disk
```

Sample command output before FSPM installation (two paths per LUN):

```
hdisk0 Available 07-08-00-3,0 16 Bit LVD SCSI Disk Drive
hdisk1 Available 07-08-00-8,0 16 Bit LVD SCSI Disk Drive
hdisk2 Available 03-08-02 Other FC SCSI Disk Drive
hdisk3 Available 03-08-02 Other FC SCSI Disk Drive
hdisk4 Available 01-09-01 Other iSCSI Disk Drive
hdisk5 Available 01-09-01 Other iSCSI Disk Drive
```

Sample command output after FSPM installation (two paths per LUN):

```
hdisk0 Available 07-08-00-3,0 16 Bit LVD SCSI Disk Drive
hdisk1 Available 07-08-00-8,0 16 Bit LVD SCSI Disk Drive
hdisk2 Available 04-08-02
      MPIO Pillar Axiom FC SCSI Disk Drive
hdisk3 Defined 03-08-02 Other FC SCSI Disk Drive
hdisk4 Available 01-09-01
```

```
MPIO Pillar Axiom iSCSI Disk Drive
hdisk5 Defined 01-09-01 Other iSCSI Disk Drive
```

Note that the device for one path to each LUN has been converted into a device for the multipath LUN, and that devices for any other paths to each LUN are left in the `Defined` state. Any redundant `Defined` devices can be removed using the `rmdev` command.

**Tip:** These redundant devices will not be created if you ensure that there is only one path to each LUN before you install FSPM.

- 2 In the GUI, navigate to SAN > Storage > Hosts.
- 3 Verify that the individual entries for the host ports are grouped under the host name.

An example of after the FSPM installation is shown below:

**Figure 4: After FSPM installation: Host Ports grouped under Host Name**

Hosts		Oracle FS Path Manager			HBA
Host Name	Controller-Initiator C...	Number of LUNs Mapped	Status	Version	Host IP Address
co-ifs01-01		5	Communicating	4.0.1	10.79.186.179
	10:00:00:90:FA:11:B6:54		Not Connected		
	10:00:00:90:FA:11:B6:55		Not Connected		
	21:00:00:24:FF:46:ED:6A		Connected		
	21:00:00:24:FF:46:ED:6B		Connected		
	iqn.1986-03.com:sun:01:0010e0203b36.5212b476		Not Connected		

**Note:** The following Oracle FS Path Manager Status and Controller-Initiator Connectivity messages can be displayed on the Hosts page:

**FSPM Status**     **Communicating:** The host control path is logged in to the Pilot.

**Note:** Communicating status is required for the FSPM control path to report path status and use the Oracle FS System to collect FSPM diagnostic logs.

**Not Registered:** A control path from an FSPM host listed as `Unknown` has never logged in to the Pilot.

**Not Communicating:** The FSPM host control path was logged in to the Pilot but is not now logged in to the Pilot.

**Controller-Initiator**     **Connected:** The host SAN connection is logged in to a Controller on the Oracle FS System.

**Connectivity**     **Not connected:** The host SAN connection is not logged in to a Controller on the Oracle FS System.

See the Oracle FS Manager Online Help for information about the remaining fields on the Hosts page.

- 4 Create new LUNs on the Oracle FS System for this host and set up mappings of LUNs to the new host entry.



- 5 Verify the FSPM version you installed. Select the name of the new host and the select Actions > View Host > Oracle FS Path Manager to view the version information.
- 6 Review the LUN names on the Oracle FS System under the LUN Name column.

**Note:** After you map a LUN to the host, it can take two or three minutes for FSPM to make the LUN accessible at the host and report its name and other information to the GUI. You may need to refresh the GUI screen to see the information when it is reported as there can be a delay between the time the configuration change was made and when the change is displayed on the GUI.

**Figure 5: LUN Host mapping detail**

Name	Controller-Initiator Connectivity	Map via LUN Number	LUN Name on Host
co-ftun-04_nun2			
co-ftun-04			
10.00.00.05:1E:78:64:C7	Connected		5  dev/vdisk00000B08413030303035385A544A0000B0s2
10.00.00.05:1E:78:64:C8	Connected		5  dev/vdisk00000B08413030303035385A544A0000B0s2

- 7 Review the load balancing algorithm being used for each LUN to determine if you need to change the current load balancing setting.
- 8 Review the numbers of optimized and non-optimized paths currently reported by FSPM under the Optimized Paths and Non-Optimized Paths. For AIX hosts, these number of optimized and non-optimized numbers are only valid when a LUN is in use on the host, such as when it is a member of a varied-on volume group. When a LUN is not in use, the numbers are shown as 0.
- 9 Select the SAN > Storage > Host-LUN Mapping and verify that the host and LUN connections are as expected. The Host-LUN Mapping tab should display the LUNs that are mapped to the host and information about the LUN. Verify that the following information is displayed:
  - The LUN numbers used to make the LUN visible to the host.
  - An indication whether or not each SAN port on the host has a connection to at least one port on the Controller.

The LUNs on are now available for use as physical volumes on your AIX host. You can now use normal AIX administration procedures to bring them into use. For example, you could use the System Storage Management page in `smit` or `smitty` to assign the LUNs to volume groups.

**Tip:** The host information in the Oracle FS System Manager will also tell you which AIX device name has been allocated to which LUN.

---

## Configure Bootable SAN-Attached Disk Overview

There are two methods for configuring a bootable SAN-attached disk: clean installation from AIX CD or clone an existing boot disk.

Both methods are described in this document.

### Perform Installation from Operating System Media

You can configure to boot from a SAN-attached disk by installing AIX from operating system media onto a LUN. (This is sometimes referred to as performing a clean installation. A clean installation is where you install the operating system for the first time and not overwrite or upgrade an existing version.)

Perform this procedure while installing the AIX operating system from an operating system media.

- 1 In the Oracle FS System Manager, create a LUN and map it to the system.
- 2 Enter the `cfgmgr` command and verify that the LUN is visible to the system.
- 3 Use the `lspv` command to list the physical volumes and note the volume IDs.
- 4 Stop AIX.
- 5 Verify that there is only one path to the Oracle FS System by techniques including masking ports at the Oracle FS System, switch zoning, or removing the Fibre Channel connections. For information on these techniques, review the *Oracle Flash Storage System Administrator's Guide*.

**Important:** There must be exactly one path to the new boot LUN. If you boot from the LUN when there is more than one path to the boot LUN, some configuration commands might fail.

- 6 Begin the AIX installation from the operating system media. Change the installation destination to the Oracle FS System LUN, and follow the prompts to install AIX.
- 7 Reboot AIX.

**Note:** If the system boots from the internal drive, alter the bootlist to boot from the new LUN. See *AIX Bootlist Considerations* for details.

- 8 Install any necessary AIX patches. For patch information, refer to the [IBM Web site](http://www.ibm.com/support/fixcentral) (<http://www.ibm.com/support/fixcentral>).
- 9 Install Oracle FS Path Manager software.

---

## Use AIX to Clone an Existing Boot Disk

Configure to boot from a SAN-attached disk by using AIX to copy the current root volume group onto a LUN.

- If you install the Oracle FS Path Manager (FSPM) on the system before cloning the current boot LUN onto a Oracle FS System LUN, FSPM is installed and running when you boot from the LUN.
- If you clone a system that does not have FSPM installed, then install FSPM on the new boot LUN after booting from it.

- 1 In the Oracle FS System Manager (GUI), create a LUN and map it to the system.
- 2 If FSPM is not installed on the system, ensure that there is only a single path connected between the host and the new LUN.
- 3 Enter the `cfgmgr` command and verify the LUN is visible to the system.
- 4 Run the following command:

```
smit alt_clone
```

**Note:** If `smit` does not have the `alt_clone` shortcut, you must load the `bos.alt_disk_install.rte` fileset from the AIX installation CD.

- 5 In the template, enter the target disk to install.

Most of the remaining fields should stay at their default values, but you may want to change the following settings (optional):

- Verbose Output
- Reboot when Complete
- Set bootlist to boot from this disk on next reboot

Refer to the AIX documentation for more information.

- 6 Press Return to begin the copy process.

After the copy finishes, you can boot from the destination LUN. When you are ready to boot from the new LUN, use the `bootlist` command to make sure that the LUN comes first in the list, and then reboot the system. Additional information on AIX bootlist is provided in this document.

## Install FSPM on a Bootable Oracle FS System LUN

Follow these steps to install the Oracle FS Path Manager (FSPM) on a system with an Oracle FS System LUN or Pillar Axiom LUN boot disk.

- 1 Make sure that only a single path is connected between the host and the boot LUN.
- 2 Unmap any other Oracle FS System LUNs from the host.
- 3 Install the FSPM software.

- 4 Reboot the system without reconnecting any paths to Oracle FS System LUNs.  
The only Oracle FS System LUN or Pillar Axiom LUN visible to the host during this first reboot must be the single path to the boot LUN.
- 5 After the system boots, connect any additional paths to the boot LUN, and map in any other required Oracle FS System LUNs.
- 6 Bring the additional paths and LUNs online by rebooting the system again or running the `cfgmgr` command. It may be necessary to run `cfgmgr` more than once to bring all paths online.

## AIX Bootlist Considerations

When you have multiple paths to a boot LUN on a Oracle FS System, the Oracle FS Path Manager (FSPM) ensures that the system uses an alternative path to the LUN if one fails while AIX is running. However, FSPM is not involved when the system starts booting.

The system firmware uses a list of paths to boot devices known as the *bootlist*. It tries each entry in the bootlist in turn until it is able to boot the system from one of the devices. If you wish to be able to boot from a multipathed LUN when some paths have failed, you must make sure that multiple paths to the LUN appear in the bootlist.

The bootlist is set up in AIX using the `bootlist` command. For example, the following command requests AIX to set the bootlist up so that the system attempts to boot from `hdisk3`, but if it fails to do so it should try `hdisk5`.

```
bootlist -m normal -o hdisk3 hdisk5
```

There are two important points to note when setting the bootlist with multipathed devices:

- If the disk names you pass to the `bootlist` command are for multipathed disks, the command converts each disk name into a list of all paths to that disk which are in the available state at the time.

In the example above, if there are eight available paths to `hdisk3` the command attempts to create a bootlist consisting of the eight paths to `hdisk3` followed by however many paths there are to `hdisk5`. It is not possible to control the order of individual paths to a multipathed disk.

- Only a limited number of entries are allowed in the bootlist.

The number allowed depends on the hardware model of your system. Some systems allow five entries, for example. In the example above where there are eight available paths to `hdisk3` and the system allows five entries in the bootlist, the command would set up a bootlist containing five paths to `hdisk3` (chosen effectively at random out of the eight available) and no paths to `hdisk5`.

After you install FSPM on a system booted from a Oracle FS System LUN.

Oracle recommends that you use the `bootlist` command to set the bootlist appropriately for your situation. Although you cannot control the order in which individual paths to a LUN will be placed in the list, you can control how many paths get added, and which ones. The `bootlist` command only adds paths that are in the available state. You could use the `rmpath` command to temporarily make some paths unavailable while setting up the bootlist. Alternatively, you could use port masking on the Oracle FS System, or configuration utilities on your SAN switches, to temporarily remove paths from the configuration, then reboot the host to take the paths out of the available state.

## Install FSPM on Virtual I/O Servers

Install Oracle FS Path Manager (FSPM) on Virtual I/O Server as described below to enable LUN mapping to the Virtual I/O Server.

FSPM can be installed in one or more Virtual I/O servers (VIOS) with LUNs mapped from the Oracle FS System to the VIOS. The VIOS can then make these LUNs visible to client partitions as virtual SCSI disks. In this case FSPM is installed in the VIOS and not in the client partitions; the client partitions are using storage provided by the VIOS, which interfaces with the Oracle FS System. Live Partition Mobility is supported for client partitions which use this configuration option.

Client partitions can use Virtual Fibre Channel adapters or the iSCSI Initiator to directly access LUNs on the Oracle FS System. In this case, FSPM is installed in the client partitions to manage these direct connections to the Oracle FS System and not in the VIOS.

Virtual I/O Server is based on AIX, but normally gives you a restricted shell interface with a limited set of specialized commands. You cannot log in directly as root.

- 1 Log in to Virtual I/O Server as the prime administrator (`padmin`).
- 2 Run the following command:

```
oem_setup_env
```

This puts you into a normal shell logged in as root.

- 3 Follow the FSPM software installation process.

## Load Balancing Configurations

FSPM can be configured for static or round-robin load balancing. You can also configure load balancing separately for each LUN.

In static load balancing, the software selects the best available path and all commands are sent over that path until the path is no longer operational or a better path becomes available. Then, a failover to another appropriate path is initiated.

---

In round-robin load balancing, commands are sent by turn over the best available paths. This ensures that LUN commands are evenly distributed over any path that is available to access the LUNs. Round-robin load balancing is the default method to manage data paths.

**Note:** Round robin is the preferred method as round robin balances I/O across all available optimized paths.

Load balancing allows the paths to share the load in different ways:

- Balances access to a LUN across all optimized Oracle FS System Controller ports available for that LUN
- Balances access from a host across the host HBA channels

To configure round-robin or static load balancing through Oracle FS System Manager (GUI), refer to the *Oracle Flash Storage System Administrator's Guide* for additional information.

**Note:** Load balancing may be configured at the host as well as at the Oracle FS System or Pillar Axiom. The normal AIX multipath disk configuration mechanisms (such as the Web-based System Manager, SMIT, smitty, and the `chdev` command) support setting the load balancing for Oracle FS System and Pillar Axiom LUNs.

For Pillar Axiom storage system, if you change load balancing settings from the host and leave the FSPM control path connection communicating with the Pilot, the Pillar Axiom can override your changes at the host at any time. Running FSPM without a control path connection ensures that the Pillar Axiom cannot override your changes at the host, but other control path functions are not available

For Oracle FS System, you can change the load balancing settings on the Oracle FS System or on the host and regardless of where the settings are changed, the settings are updated on both the Oracle FS System and the host.

## Path Selection Overview

Oracle FS Path Manager (FSPM) selects the best paths to access Oracle FS System LUNs.

Path selection is based on three factors:

- Path optimization state
- Path performance
- Path availability

A path's optimization state depends on whether the LUN is currently homed on the Controller to which the path is connected. An *optimized path* is a path that connects through the Controller where the LUN is resident or *homed*. A *non-optimized path* is a path that connects through to a Controller where the LUN is not resident (homed) on the that Controller. Optimized paths are always

preferred, but if an optimized path is not available, the non-optimized path is used temporarily for I/O traffic.

Path performance is determined by how quickly and reliably a path transfer I/O traffic to and from a LUN.

Path availability is determined by the ability of the path to transfer I/O traffic. An available path is fully functional but if the path stops working, the path is considered unavailable.

These factors determine how the paths to each Oracle FS System LUN are divided into groups.

FSPM groups the paths in the following order of preference:

- Optimized
- Non-optimized

For each LUN, the currently configured load balancing algorithm is used to select paths from the most preferred group that has paths available. Only paths from a single group are used at any one time.

When an active path fails, I/O traffic is transferred to a different path. I/O performance is reduced for a short time while the operating system recognizes the failure and makes the path transfer. After the path transfer is complete, I/O performance improves.

If the failing path is optimized and the new path is non-optimized, I/O performance can continue to be reduced after path transfer because a lower-performance path is in use. Within a few minutes of traffic being transferred to a non-optimized path, the Oracle FS System attempts to move the LUN to the appropriate Controller for path optimization. After transfer to an optimized path succeeds, I/O performance improves.

## Stop and Start FSPM Software

Follow these instructions to stop or start the Oracle FS Path Manager (FSPM) service (also referred to as a daemon) that runs on the host where FSPM is installed.

FSPM installs a service which monitors status and manages the Control Path connections to an Oracle FS System. The service is configured to start automatically when the host is booted up and to remain running until the host is shut down. (When the host is restarted, the service is restarted.) Generally, you do not need to stop nor start the service after installation. As part of troubleshooting procedures, Oracle Customer Support can request you to stop and start the service. Do not stop the service unless requested by Oracle Customer Support as diagnostic information can be lost.

The following information describes how to determine if the FSPM service is running. This information also describes how to restart the service, stop the service, and start the service.

---

**Note:** Stopping or restarting the service can delete diagnostic information which is useful when investigating problems. You should only stop or restart the service if you are performing troubleshooting procedures or requested to do so by Oracle Customer Support. If you are trying to resolve a problem with FSPM, collect logs from the Oracle FS System before restarting the service. Make sure you include the FSPM host in the collected set of system logs. See the *Oracle Flash Storage System Administrator's Guide* or the Oracle FS System Manager (GUI) online help for information on how to collect system logs.

- 1 Verify that you have administrator privileges to restart, stop, or start services.
- 2 To verify the status (running or stopped) of the FSPM service on the host, perform the following:

- From the command line, run the following command:

```
lssrc -s fspmd
```

If the FSPM service is stopped, you need to start the service. Follow the steps in this document.

- 3 To restart the FSPM service, perform the following:

- From the command line, run the following command:

```
stopsrc -s fspmd; startsrc -s fspmd
```

After restarting the FSPM service, verify the service status is running by following the steps in this document.

- 4 To stop the FSPM service, use the following command:

- From the command line, run the following command:

```
stopsrc -s fspmd
```

After stopping the FSPM service, verify the service status is stopped by following the steps in this document.

- 5 To start the FSPM service, use the following command:

- From the command line, run the following command:

```
startsrc -s fspmd
```

After starting the FSPM service, verify the service status is running by following the steps in this document.

## Host Reconfiguration Overview

Once you have installed Oracle FS Path Manager (FSPM) and the host is using LUNs from a Oracle FS System, you may need to reconfigure the host.

Reconfiguring the host in any of the following ways affects how the Oracle FS System recognizes connections from the host.



- 
- Add, remove, or replace a Fibre Channel (FC), FCoE, or iSCSI HBA
  - Add, remove, or change an iSCSI initiator name used by the host
  - Add, remove, or change IP addresses the host uses to connect through iSCSI
  - Add, remove, or change IP addresses the host uses to connect to the Pilot management controller
  - Rename the host

If you need to make any of these changes, refer to the following sections for instructions.

## Updating FC or iSCSI Initiators Information

Follow these instructions if you add, remove, or replace a SAN initiator identifier in the host.

Changes to Fibre Channel (FC) HBAs installed in the host, and changes to iSCSI initiator names used by the host, effect how the Oracle FS System recognizes connections from the host. When the SAN initiators used by the host are changed, the Oracle FS System definition of the host must be updated to match, and any LUN mappings to the host must be adjusted. Oracle FS Path Manager (FSPM) does most of this automatically when you follow these steps.

- 1 Make the changes to the configuration.

FSPM tries to ensure that the changes are automatically passed to the Oracle FS System when the FSPM daemon is restarted.

If you replaced all the FC HBAs in the host, you must make a LUN on the Oracle FS System system visible to at least one of the new ports on the host. This LUN can be unmapped or mapped to one of the host ports. If you map the LUN to one of the ports, it maps to all ports on the host after the FSPM daemon is restarted. If you decide that this LUN is temporary, delete it after you restart the daemon.

- 2 Choose one of:

- Reboot the host as part of reconfiguring the HBAs and after setting up the mapping described earlier, if necessary.

No further action is needed.

- Do not reboot the host as part of the reconfiguration (for example, if you use a “hot plug” method to change HBAs).

Restart the FSPM software after the reconfiguration is completed and after setting up the mapping described earlier, if necessary. To restart the FSPM, review the information on starting and stopping the FSPM software as described in this document.

The FSPM daemon discovers the change when it starts up after the system reboot or after being explicitly restarted. The FSPM daemon updates the Oracle FS

---

System management software. The LUN mappings to the host are automatically adjusted to match the new SAN connections from the host.

### iSCSI HBAs or IP Addresses Change

Changes to an iSCSI HBA do not require any further actions if the iSCSI initiator name or IP addresses are not changed.

If you change an iSCSI HBA and do not change the iSCSI initiator name or IP address that the host uses to make iSCSI connections to the Oracle FS System, no changes are required.

### Rename the FSPM Host

Follow these instructions to rename a host where Oracle FS Path Manager (FSPM) is installed and to ensure the new host name change is updated in the Oracle FS System configuration information.

FSPM installs a service which monitors status and manages the Control Path connections to an Oracle FS System. When the FSPM service running on a host makes a Control Path connection to a Pilot, it sends the hostname which FSPM discovered from the host to the Oracle FS System. That hostname is used as the name of the host entry in the Oracle FS System Services. If you want to change the hostname of a SAN host that is running FSPM, use the following sequence of steps to create an FSPM host entry in the Oracle FS System Services with the new name and the same LUN mappings as the old FSPM host entry.

**Note:** If you rename a host without going through this process, the LUN mappings to the host are lost. You will not be able to access the Oracle FS System LUNs from the host until the LUN mappings are recreated. This process preserves the LUN mappings from the original host name to the renamed host name.

The following information describes how to rename a host where FSPM is installed.

- 1 From the Oracle FS System Manager (GUI), ensure that one of the host initiators is connected to the Oracle FS System. Follow these steps:
  - a) From the GUI, select SAN > Storage > Hosts.
  - b) Under the Host Name locate the host to be renamed.
  - c) Under the Controller-Initiator Connectivity verify that Connected is displayed for one of the connections.
- 2 Stop the FSPM service. Follow information provided in this document.
- 3 Review the existing LUN mappings for the host you are renaming before deleting the host. From the GUI, select SAN > Storage > Host-LUN Mapping to review the LUN mappings to the host you are deleting.
- 4 From the GUI, select SAN > Storage > Hosts to select the host you want to delete.

- 5 From the GUI select SAN > Storage > Hosts > Actions > Delete Host and delete the host entry with the old host name. The Delete SAN Host dialog is displayed.
  - a) When the Delete SAN Host dialog is displayed, make sure the Delete mappings and initiators is not checked. This preserves the associated LUN mappings to the host. Select OK to delete the SAN Host.
  - b) You can also delete a SAN Host using the Oracle FS CLI. Review the *Oracle Flash Storage System CLI Reference* for further information.
- 6 From the host operating system, rename the host.
- 7 Start the FSPM service (also referred to as the daemon) following the instructions in this document.

Once the FSPM is started, FSPM logs into the Pilots and sends a message that includes the new host name. The Oracle FS System creates an FSPM host entry with the new host name and transfers the initiators and LUN mappings associated to the host. (These values were preserved when the host was deleted.)
- 8 From the GUI, select SAN > Storage > Host-LUN Mapping to verify the LUN mappings are restored to the renamed host.

## Upgrade FSPM Software

Follow these steps to upgrade the Oracle FS Path Manager (FSPM)

The simplest procedure for upgrading requires you to reboot the system. If the system is not using an Oracle FS System or Pillar Axiom LUN as the boot disk, it is possible to upgrade without rebooting.

**Important:** To upgrade the software without rebooting the host, do not follow these instructions. Follow the instructions on how to upgrade FSPM without rebooting a host.

- 1 Download the newest version.
- 2 Follow steps 1 through 4 in [Install the FSPM Software](#).
- 3 Restart the host.

**Note:** You do not need to disconnect or connect paths during an upgrade.

### Related Links

[Install the FSPM Software](#)

[Upgrade FSPM without Rebooting the Host](#)

## Upgrade FSPM without Rebooting the Host

Follow these instructions to upgrade the Oracle FS Path Manager (FSPM) software without rebooting the host.

- 1 Download the new version of FSPM.
- 2 Log in as root.
- 3 Take all Oracle FS System or Pillar Axiom LUNs out of use on the host. Vary off any volume groups using Oracle FS System or Pillar Axiom LUNs. The Oracle FS System Manager (GUI) shows path counts of 0 when these LUNs are out of use.

- 4 Remove the configuration from AIX for all Oracle FS System or Pillar Axiom LUN disk devices.

These devices have the description `MPIO Oracle FS FC SCSI Disk Drive` or `MPIO Oracle FS iSCSI Disk Drive`.

Use the following command to remove the Oracle FS System or Pillar Axiom LUNs:

```
# rmdev -l hdiskx
```

Where *hdiskx* is the name and number of the device.

**Tip:** If the command fails, it will most likely be because the device is still in use. Take the device out of use, and then repeat the command. The LUN Name on Host column in the Oracle FS System Manager (GUI) will be empty when the device configuration has been removed from the host.

**Important:** Do not proceed further until all Oracle FS System or Pillar Axiom LUNs have been taken out of use and their device configuration has been removed from the host.

- 5 Install the FSPM software but do not reboot the host.
- 6 Recreate the configuration for the LUNs, and bring the paths and LUNs online.

Use the following command to create and activate the new configuration:

```
# cfgmgr
```

It may be necessary to run `cfgmgr` more than once to bring all LUNs and paths online.

- 7 Start the FSPM daemon to complete the task.

Run the following command to start the daemon:

```
# startsrc -s fspmd
```

**Tip:** After you start the daemon, the Host Information pages in the GUI could take a minute or two to display updates. The version of FSPM currently running on the host is shown in the Identity tab.

**Note:** You do not need to disconnect or connect paths during an upgrade.

## Remove the FSPM Software (Optional)

To completely remove the Oracle FS Path Manager (FSPM) software from your system, follow these steps:

- 1 If possible, ensure that any Oracle FS System LUNs are not in use by AIX. For example, any volume groups that include a Oracle FS System LUN should be *varied off* with the `varyoffvg` command. This is not possible if the system is booted from a Oracle FS System LUN since the boot LUN is in use.
- 2 Use facilities such as port masking on the Oracle FS System system, and switch configuration to ensure that there is only one path for each LUN between the host and the Oracle FS System system. This is particularly important for the boot LUN if the system is booted from a Oracle FS System LUN.
- 3 Use one of the normal AIX methods to remove the `fspm.rte` software package.

Choose one of:

- From the command line, enter:
 

```
installp -ug fspm.rte
```
- From smit (System Management Interface Tool) or smitty (ASCII terminal version of the System Management Interface Tool):
  - 1 Go to the Software Installation and Maintenance option.
  - 2 Select Software Maintenance and Utilities.
  - 3 Choose Remove Installed Software.
  - 4 In the Software Name field, enter:
 

```
fspm.rte
```

- 4 Reboot the system.

**Note:** If the system is currently booted from a Oracle FS System or Pillar Axiom LUN, the following message may be displayed a number of times while the software is being removed:

```
unable to identify boot disk
```

This message can safely be ignored.

If any Oracle FS System LUN is busy during the uninstall (which is often true if the system is booted from a Oracle FS System LUN) an error message will be displayed during the uninstall for each busy LUN as follows:

```
Method error (/usr/lib/methods/ucfgdevice):
0514-062 Cannot perform the requested function because
the specified device is busy.
```

---

In this case, after the reboot some configuration commands will cause error messages. For example:

```
# lsdev -c disk
lsdev: 0514-521 Cannot find information in the predefined device
        configuration database for the customized device hdisk7.
hdisk0 Available 06-08-01-3,0 16 Bit LVD SCSI Disk Drive
hdisk1 Available 06-08-01-4,0 16 Bit LVD SCSI Disk Drive
hdisk6 Available 07-08-02      Other FC SCSI Disk Drive
hdisk7 Defined   07-09-02      N/A
hdisk8 Available 07-08-02      Other FC SCSI Disk Drive
```

To correct this, simply follow the instructions below to install the FSPM software package again and immediately remove it again. You do not need to make any changes to the SAN configuration.

**Important:** Do not reboot the host during this sequence.

- 1 Follow the steps for installing the FSPM software. Do not reboot the host when instructed to do so.
- 2 Follow the steps above to remove the package again. You do not need to reboot the host at the end.

The configuration commands will no longer produce errors. For example:

```
# lsdev -c disk
hdisk0 Available 06-08-01-3,0 16 Bit LVD SCSI Disk Drive
hdisk1 Available 06-08-01-4,0 16 Bit LVD SCSI Disk Drive
hdisk6 Available 07-08-02      Other FC SCSI Disk Drive
hdisk8 Available 07-08-02      Other FC SCSI Disk Drive
```

## Related Links

[Install the FSPM Software](#)

# Index

## A

### AIX

bootlist considerations [36](#)

## B

### boot from SAN

about [17](#)

how to

clone existing boot disk [35](#)

install from operating system media [34](#)

### bootlist

considerations [36](#)

Brocade [20](#)

## C

### Cisco MDS switch

configure [28](#)

### CNA drivers

recommended settings [20](#)

### CNAs

FCoE [20](#)

### configure

SAN [26](#)

configure SAN hosts [26](#)

contact information [8](#)

contacts, Oracle [8](#)

control path [14](#)

### conventions

command syntax [9](#)

typographical [9](#)

customer support [8](#)

## D

### delete

SAN [25](#)

delete SAN hosts [25](#)

### documentation

feedback [8](#)

### download

FSPM software [29](#)

## E

education programs [8](#)

Emulex [20](#)

## F

### FC

iSCSI-to-FC routers [21](#)

protocol [19](#)

### FCoE

supported CNA settings [20](#)

supported CNAs [20](#)

supported switches [20](#)

### features

FSPM [15](#)

feedback, documentation [8](#)

### Fibre Channel

supported HBAs [19](#)

supported switches [19](#)

### FSPM

how to

confirm software installation [31](#)

download software [29](#)

install on bootable Oracle FS System LUN [35](#)

install software [29](#)

remove software [45](#)

uninstall software [45](#)

upgrade software [43](#)

how to,

install software without rebooting [30](#)

install on Virtual I/O Server [37](#)

interaction with Oracle FS System [12](#)

requirements [11](#)

Virtual I/O Server [17](#)

### FSPM software

control path [14](#)

data path [14](#)

definition [15](#)

features [15](#)

operating limits [18](#)

pre-installation requirements [24](#)

## H

### HBAs

Fibre Channel [19](#)

iSCSI [20](#)

### host name

how to

rename [42](#)

## I

### install boot from SAN

how to

clone existing boot disk [35](#)

install from operating system media [34](#)

install FSPM on bootable LUN [35](#)

install FSPM software [29](#)

install FSPM software without rebooting [30](#)

### iSCSI

- how to
  - configure Cisco MDS switch [28](#)
  - configure iSCSI-to-FC router [28](#)
- protocol [19](#)
- supported HBAs [20](#)
- supported routers [21](#)
- supported switches [21](#)
- iSCSI HBA
  - name [23](#)
- iSCSI initiator
  - name [23](#)
- iSCSI-to-FC router
  - configure [28](#)

## L

- load balancing
  - round-robin [37](#)
  - static [37](#)
- LUN access
  - multi-protocol [38](#)
  - precedence [38](#)
  - preferred paths [38](#)

## M

- management network
  - pre-installation requirements [25](#)
- multi-protocol access
  - definition [38](#)
  - precedence [38](#)
  - preferred paths [38](#)

## N

- name
  - iSCSI HBA [23](#)
  - iSCSI initiator [23](#)
- no reboot [30](#)
- non-optimized path [38](#)

## O

- online help [8](#)
- optimized path [38](#)
- Oracle Documentation [8](#)
- Oracle FS System
  - interaction with FSPM [12](#)
- Oracle Technology Network [8](#)

## P

- POSIX.1-2008 specification [9](#)
- pre-installation requirements
  - management network [25](#)
- product support [8](#)

## Q

- Qlogic [20](#)

## R

- rename
  - FSPM host name [42](#)
- requirements
  - FSPM system [11](#)
- round-robin load balancing [37](#)
- routers
  - iSCSI-to-FC [21, 28](#)

## S

- sales information [8](#)
- SAN hosts
  - configure [26](#)
  - delete before installation [25](#)
- SAN protocols [19](#)
- service (daemon)
  - how to
    - stop or stop service [39](#)
- software (FSPM)
  - confirm installation [31](#)
  - install [29](#)
  - remove [45](#)
  - upgrade [43](#)
- static load balancing [37](#)
- stop or start
  - FSPM software [39](#)
- Support portal [8](#)
- supported
  - FSPM models [11](#)
- switches
  - Cisco MDS [28](#)
  - FCoE [20](#)
  - Fibre Channel [19](#)
  - iSCSI [21](#)
- syntax conventions [9](#)

## T

- training programs [8](#)
- typographical conventions [9](#)

## U

- upgrade FSPM software [43](#)

## V

- Virtual I/O Server
  - about [17](#)
- Virtual I/O Server
  - install FSPM [37](#)