

**Oracle® Communications
Performance Intelligence Center
Hardware Installation Guidelines**
Release 10.2
E66862 Revision 3

September 2016

Hardware Installation Guidelines

Oracle Communications Performance Intelligence Center Hardware Installation Guidelines, Release 10.2

Copyright © 2003, 2016, Oracle and/or its affiliates. All rights reserved.

This software and related documentation are provided under a license agreement containing restrictions on use and disclosure and are protected by intellectual property laws. Except as expressly permitted in your license agreement or allowed by law, you may not use, copy, reproduce, translate, broadcast, modify, license, transmit, distribute, exhibit, perform, publish, or display any part, in any form, or by any means. Reverse engineering, disassembly, or decompilation of this software, unless required by law for interoperability, is prohibited.

The information contained herein is subject to change without notice and is not warranted to be error-free. If you find any errors, please report them to us in writing.

If this is software or related documentation that is delivered to the U.S. Government or anyone licensing it on behalf of the U.S. Government, the following notices are applicable:

U.S. GOVERNMENT END USERS: Oracle programs, including any operating system, integrated software, any programs installed on the hardware, and/or documentation, delivered to U.S. Government end users are "commercial computer software" pursuant to the applicable Federal Acquisition Regulation and agency-specific supplemental regulations. As such, use, duplication, disclosure, modification, and adaptation of the programs, including any operating system, integrated software, any programs installed on the hardware, and/or documentation, shall be subject to license terms and license restrictions applicable to the programs. No other rights are granted to the U.S. Government.

This software or hardware is developed for general use in a variety of information management applications. It is not developed or intended for use in any inherently dangerous applications, including applications that may create a risk of personal injury. If you use this software or hardware in dangerous applications, then you shall be responsible to take all appropriate fail-safe, backup, redundancy, and other measures to ensure its safe use. Oracle Corporation and its affiliates disclaim any liability for any damages caused by use of this software or hardware in dangerous applications.

Oracle and Java are registered trademarks of Oracle and/or its affiliates. Other names may be trademarks of their respective owners.

Intel and Intel Xeon are trademarks or registered trademarks of Intel Corporation. All SPARC trademarks are used under license and are trademarks or registered trademarks of SPARC International, Inc. AMD, Opteron, the AMD logo, and the AMD Opteron logo are trademarks or registered trademarks of Advanced Micro Devices. UNIX is a registered trademark of The Open Group.

This software or hardware and documentation may provide access to or information about content, products, and services from third parties. Oracle Corporation and its affiliates are not responsible for and expressly disclaim all warranties of any kind with respect to third-party content, products, and services unless otherwise set forth in an applicable agreement between you and Oracle. Oracle Corporation and its affiliates will not be responsible for any loss, costs, or damages incurred due to your access to or use of third-party content, products, or services, except as set forth in an applicable agreement between you and Oracle.

My Oracle Support (MOS) (<https://support.oracle.com>) is your initial point of contact for all product support and training needs. A representative at Customer Access Support (CAS) can assist you with MOS registration.

Call the CAS main number at 1-800-223-1711 (toll-free in the US), or call the Oracle Support hotline for your local country from the list at <http://www.oracle.com/us/support/contact/index.html>.

See more information on MOS in the Appendix section.

Hardware Installation Guidelines

TABLE OF CONTENTS

1	INTRODUCTION	8
1.1	Purpose.....	8
1.2	Target audience.....	8
1.3	Acronyms and Terminology.....	8
1.4	References	9
1.5	Foreword	9
2	PIC MANAGEMENT	11
2.1	Hardware options for PIC Management server	11
2.2	Networking guidelines for PIC Management server	11
3	PIC MEDIATION AND STORAGE.....	13
3.1	Hardware options for Mediation servers	14
3.2	Networking guidelines for PIC Mediation	14
3.3	Hardware options for Packet Data Unit Storage server.....	16
3.4	Networking guidelines for Packet Data Unit Storage servers	16
3.5	Hardware options for Data Record Storage server	18
3.6	Networking guidelines for Data Record Storage server.....	18
4	INTEGRATED ACQUISITION FOR EAGLE MONITORING	20
4.1	Hardware options for Eagle Integrated acquisition.....	20
4.2	Networking guidelines for EAGLE Integrated Acquisition.....	21
4.2.1	Default configuration.....	22
4.2.2	Alternate configuration	24
4.3	Networking guidelines for standard configuration.....	25
4.4	IP addressing.....	26
5	PROBED ACQUISITION	27
5.1	Hardware options for Probed acquisition servers.....	27
5.2	Networking guidelines for Probed acquisition	27
6	INTEGRATED ACQUISITION FOR DSR MONITORING	29
6.1	Hardware options for integrated acquisition servers for OCSDR monitoring.....	29
6.2	Networking guidelines for Integrated Acquisition for OCSDR monitoring.....	29
7	VIRTUAL MACHINE.....	31
8	PRE-PACKAGED OPTION FOR DSR MONITORING	32
8.1	Hardware options Pre-Packaged servers for DSR monitoring.....	32
8.2	Networking guidelines for Pre-Packaged option for OCSDR monitoring.....	33
9	HARDWARE CONFIGURATION SETS.....	35
9.1	Configuration set 1 (Oracle X6-2).....	35
9.2	Configuration set 2 (Oracle X5-2).....	36
9.3	Configuration set 3 (Oracle Netra X5-2)	37
9.4	Configuration set 4 (HP DL380 Gen9 v2)	38
9.5	Configuration set 5 (HP DL380 Gen9 v1)	39
9.6	Configuration set 6 (HP DL360 Gen8 v2 + D2700)	41
9.7	Configuration set 7 (HP DL360 Gen8 v1 + D2700)	43

Hardware Installation Guidelines

9.8	Configuration set 8 (HP DL360 G6 + D2700)	44
9.9	Configuration set 10 (Oracle X5-2)	46
9.10	Configuration set 11 (Oracle Netra X5-2)	47
9.11	Configuration set 12 (HP DL360 Gen9 v2)	48
9.12	Configuration set 13 (HP DL360 Gen9 v1)	50
9.13	Configuration set 14 (HP DL360 Gen8 v2)	51
9.14	Configuration set 15 (HP DL360 Gen8 v1)	52
9.15	Configuration set 16 (HP DL360 G6)	54
9.16	Configuration set 17 (Oracle ZFS)	55
9.17	Configuration set 18 (Oracle X6-2L)	56
9.18	Configuration set 19 (HP DL380 Gen9 v2)	57
9.19	Configuration set 20 (HP DL380 Gen9 v1)	59
9.20	Configuration set 21 (HP DL360 Gen8 v2 + D2700)	60
9.21	Configuration set 22 (HP DL360 Gen8 v1 + D2700)	62
9.22	Configuration set 23 (HP DL360 G6)	63
9.23	Configuration set 24 (Oracle Database Appliance)	65
9.24	Configuration set 25 (Oracle E5-APP-B)	65
9.25	Configuration set 27 (Oracle X5-2)	66
9.26	Configuration set 28 (Oracle Netra X5-2)	68
9.27	Configuration set 29 (HP DL360 Gen9 v2)	70
9.28	Configuration set 30 (HP DL360 Gen9 v1)	72
9.29	Configuration set 31 (HP DL360 Gen8 v2)	74
9.30	Configuration set 32 (HP DL360 Gen8 v1)	75
9.31	Configuration set 33 (HP DL360 G6)	78
9.32	Configuration set 35 (Oracle X5-2 for Pre-package)	79
9.33	Configuration set 36 (Oracle Netra X5-2 for Pre-package)	81
9.34	Configuration set 37 (optional hard disk for Pre-package storage option)	83
9.35	SFP(+) modules	83
10	ANNEXES	85
10.1	Port identification on HP server Gen8 v1 & v2:	85
10.2	Port identification on HP server DL360 Gen9	86
10.3	Port identification on HP server DL380 Gen9:	86
10.4	Port identification on D2700 Storage Array:	87
10.5	Port identification on ODA X5-2	88
10.6	Port identification on Oracle X5-2	89
10.7	Port identification on Oracle Netra X5-2	89
10.8	Port identification on X6-2	91
10.9	Port identification on X6-2L	92
10.10	Port identification on ZFS ZS3-2	94
10.11	RAID configurations	96
10.12	Cable specification for Falco (SS7 to Sigtran converter)	97
10.13	Cisco Switch	99
10.14	Cisco basic knowledge	99
10.14.1	Configure and access the serial console on TPD	100
10.14.2	Configure and access the serial console on TVOE	100
10.14.3	4948&4948EF Reset to factory defaults	101
10.14.4	Assign an IP address on a 3020	101
10.14.5	2950 & 3020 Reset to factory defaults	102
10.14.6	Configure telnet access on a 3020	103
10.14.7	Configure SSH access	105
10.14.8	Recover a switch from rommon prompt	106

Hardware Installation Guidelines

10.14.9	Upgrade IOS software	107
10.14.10	Backup the switch config on a server	108
10.14.11	Configure Cisco 4948/4948E/4948E-F switch	108
10.14.12	Configure Cisco 3020 switch	109
10.14.13	Flush ARP table	110
10.15	Mediation switch configuration template	111
10.15.1	Switch port allocation	111
10.15.2	Control Frame Switch	111
10.15.3	Extension Frame Switch	114
10.16	Blade mediation switch configuration template	119
10.16.1	Switch port allocation	120
10.16.2	Aggregation Switch	121
10.16.3	Enclosure Switch	128
10.16.4	G6 MSA cabling diagram	131
10.17	Integrated Acquisition switch configuration template	139
10.17.1	Switch port allocation	139
10.17.2	Yellow-sw1-1 Switch (Layer 3)	139
10.17.3	Blue-sw1-1 Switch (Layer 3)	145
10.17.4	Yellow-sw2-1 Switch (Layer 3)	150
10.17.5	Blue-sw2-1 Switch (Layer 3)	154
10.17.6	Yellow-sw3-1 Switch (Layer 3)	157
10.17.7	Blue-sw3-1 Switch (Layer 3)	160
10.17.8	Single Switch yellow-blue-sw1-1	162
10.17.9	RMS Layer 2 switch configurations (PIC 9.x and earlier)	166
10.17.10	IMF on E5-AppB	187
10.18	My Oracle Support (MOS)	197
10.19	Locate Product Documentation on the Oracle Help Center Site	198

List of Tables

Table 1: Acronyms and Terminology 8

Table 5: configuration set 1 with Oracle X6-2 8 SFF 35

Table 6: configuration set 2 with Oracle X5-2 8 SFF 36

Table 7: configuration set 3 with Oracle Netra X5-2 8 SFF 37

Table 8: Configuration set 4 with HP DL380 Gen9 v2 8 SFF 39

Table 9: Configuration set 5 with HP DL380 Gen9 v1 8 SFF 40

Table 10: Configuration set 6 with HP DL360 Gen8 v2 + D2700 42

Table 11: Configuration set 7 with HP DL360 Gen8 v1 + D2700 43

Table 12: Configuration set 8 with HP DL360 G6 + D2700 45

Table 14: configuration set 10 with Oracle X5-2 46

Table 15: configuration set 11 with Oracle Netra X5-2 2 SFF 47

Table 16: Configuration set 12 with HP DL360 Gen9 v2 2 SFF 49

Table 17: Configuration set 13 with HP DL360 Gen9 v1 50

Table 18: Configuration set 14 with HP DL360 Gen8 v2 51

Table 19: Configuration set 15 with HP DL360 Gen8 v1 53

Table 20: Configuration set 16 with HP DL360 G6 54

Table 21: Configuration set 17 with ZFS 55

Table 22: Configuration set 17 with Oracle X6-2L 56

Table 23: Configuration set 19 with HP DL380 Gen9 v2 24+2 SFF 58

Table 24: Configuration set 19 with HP DL380 Gen9 v1 24+2 SFF 59

Table 25: Configuration set 21 with HP DL360 Gen8 v2 + D2700 61

Table 26: Configuration set 22 with HP DL360 Gen8 v1 + D2700 62

Table 27: Configuration set 23 with HP DL360 G6 + D2700 64

Table 28: Configuration set 24 with ODA 65

Table 31: configuration set 27 with Oracle X5-2 copper RJ45 interfaces 66

Table 32: configuration set 27 with Oracle X5-2 SFP+ interfaces 67

Table 33: configuration set 28 with Oracle Netra X5-2 copper RJ45 interfaces 68

Table 34: configuration set 28 with Oracle Netra X5-2 SFP+ interfaces 69

Table 35: configuration set 29 with HP Gen9 v2 with SFP+ card 70

Table 36: configuration set 30 with HP Gen9 v1 with SFP+ card 72

Table 37: configuration set 31 with HP Gen8 v2 with SFP+ card 74

Table 38: configuration set 32 with HP Gen8 v1 with SFP+ card 76

Table 39: configuration set 32 with HP Gen8 v1 with 1G RJ45 card (NEBS) 76

Table 40: configuration set 32 with HP Gen8 v1 with 1G RJ45 card (non NEBS) 77

Table 41: Configuration set 33 with HP DL360 G6 for 1G copper links 78

Table 44: configuration set 35 with Oracle X5-2 copper RJ45 interfaces for virtual machines hosting 80

Table 45: configuration set 35 with Oracle X5-2 SFP+ interfaces for virtual machines hosting 80

Table 46: configuration set 36 with Oracle Netra X5-2 copper RJ45 interfaces 81

Table 40: configuration set 36 with Oracle Netra X5-2 SFP+ interfaces 82

Table 41: Configuration set 37 optional hard disk for Pre-package storage option 83

Table 48: SFP+ modules available on HP Intel X520 card 83

Table 49: SFP+ modules available on HP Intel X560 card 83

Table 50: Qualified SFP(+) modules on Oracle hardware Sun Dual 10GbE SFP+ card 84

Table 51: Cable for Falco: sample configuration for unprotected links 99

Table 52: Cisco 4948E-F configuration 99

Hardware Installation Guidelines

List of Figures

Figure 1 : Rear view for HP DL360 server Gen8 v1 & v2 used for Mediation.....	85
Figure 2 : Rear view for HP DL360 server Gen8 v1 & v2 used for Probed acquisition	85
Figure 3 : Rear view for HP DL360 server Gen9.....	86
Figure 4 : Front view for HP DL38 Gen9.....	86
Figure 5 : Rear view for HP DL380 Gen9	86
Figure 6 : Rear view for D2700 storage array	87
Figure 7 : Drive Bay numbering.....	87
Figure 8- Front view of Oracle Database Appliance (storage shelf connections)	88
Figure 9- Rear view of Oracle Database Appliance (power and network connections)	88
Figure 10- Rear view of Oracle X5-2 Server	89
Figure 11- Front view of Oracle Netra X5-2 Server	90
Figure 12- Rear view of Oracle Netra X5-2 Server.....	90
Figure 13- Front view of Oracle X6-2 server	91
Figure 14- Front view of Oracle X6-2 server	92
Figure 15- Front view of Oracle X6-2L server	92
Figure 16- Rear view of Oracle X6-2L server.....	93
Figure 17- Front view of Oracle ZFS ZS3-2 Controller	94
Figure 18- Rear view of Oracle ZFS ZS3-2 Controller.....	94
Figure 19- Front view of Oracle DE2-24P drive enclosure	95
Figure 20- Rear view of Oracle DE2-24P drive enclosure	95
Figure 21- SS7 line inputs to Falco.....	97
Figure 22- Cable for Falco: sample configuration for unprotected links	98

1 Introduction

1.1 Purpose

Purpose of this document is to provide detailed guidelines to Oracle CGBU consulting team as well as to value-added reseller consulting teams, relating to the installation services of servers and any further Hardware required to support the PIC 10.2 software.

Moreover, this document delivers Guidelines to support the implementation of the PIC Software.

It is divided in 5 sections:

- PIC management
- PIC Mediation and Storage
- PIC integrated acquisition
- PIC probed acquisition
- Annex

Any BOM provided in the document are Oracle recommended configurations to be used with the PIC 10.2 version. This hardware is qualified to work with PIC for the usage defined in each section. Some adaptations are still possible and are documented at the end of each section when available.

Implementation on HP blades is not covered by this document.

 CAUTION	<p>This document provides generic guidelines for PIC supported hardware as well as rules and recommendations to build a setup compatible with PIC installation. This document can't be use to replace the installation guides provided by the manufacturers of the hardware depict in this document. It is particularly true for safety rules and recommendations present in these documents.</p>
--	---

1.2 Target audience

This guide is intended for technical personnel who are responsible for installing, configuring, and maintaining the hardware. Users should be familiar with hardware from HP, Oracle, Cisco switches, and shall have networking concepts understanding.

This document present high level rules for successful implementation of PIC. Users are expected to read the manufacturer documentations for the selected hardware. PIC software installation is covered in the installation Guide.

1.3 Acronyms and Terminology

PIC	Performance Intelligence Center
ILOM	Oracle Integrated Lights Out Manager
ILO	HP Integrated Lights Out
ODA	Oracle Database Appliance software
BOM	Bill Of Materials
RMS	Rack Mount Server
O&M	Operation and Maintenance

Table 1: Acronyms and Terminology

Hardware Installation Guidelines

1.4 References

- Installation reference documentations : <http://eis.us.oracle.com/>
- PIC 10.2 documentations: http://docs.oracle.com/cd/E60682_01/index.htm
- PIC Data Warehouse Server (DWS) on Third-Party Server Installation Guide (Doc ID 2028670.1)
- PIC Packet Data Unit Storage (PDU) on Third-Party Server Installation Guide (Doc ID 2034894.1)
- Management Server (NSP) on Third-Party Server Installation Guide (Doc ID 2062544.1)
- Oracle Linux on Third-Party Server Installation Guide for Performance Intelligence Center (PIC) product (Doc ID 2061666.1)
- Oracle ASM and Database on Third-Party Server Installation Guide for Performance Intelligence Center (PIC) products (Doc ID 2062491.1)
- Oracle 12c ASM and Database on Third-Party Server Installation Guide for Performance Intelligence Center (PIC) Products (Doc ID 2151499.1)
- Tekelec Platform 7.0 documentations : http://docs.oracle.com/cd/E57832_01/index.htm
- Oracle ODA documentations: http://docs.oracle.com/cd/E22693_01/index.htm
- Oracle X5-2 documentations: http://docs.oracle.com/cd/E41059_01/
- Oracle ZFS documentations: http://docs.oracle.com/cd/E56021_01/index.html
- Oracle X6-2 documentations: http://docs.oracle.com/cd/E62159_01/
- Oracle X6-2L documentations: http://docs.oracle.com/cd/E62172_01/
- Oracle Netra X5-2 documentations: http://docs.oracle.com/cd/E53596_01
- HP Product Bulletin site: http://h18004.www1.hp.com/products/quickspecs/productBulletin.html#CD_Files
- Network Critical site: www.networkcritical.com
- Microtel Innovation site (converter): <http://microtelinnovation.com/>

1.5 Foreword

This document provides server BOMs, global guidelines to connect equipment together, and requirements for successful PIC implementation. It doesn't supersede Manufacturer's documentations for the equipment. Some References are provided but it doesn't constitute the complete list.

In addition to servers and switches, other equipment may be required like racks, power distribution units, installation kits, cable management kits, cage nuts, screw, power cables, data cables, floor mounting kit, clamps, labels They are not depicted in this document. They shall be defined by the customer according to his setup or by a 3 party vendor/installer. Oracle can offer an additional service to define with the customer the installation design and additional items. This operation is performed by Oracle Consulting. Note that this may require a site survey.

When mixing AC and DC power supplies in the same plant, electrical best practice safety rules shall be strictly applied. For instance, Oracle strongly recommends that no AC powered cabinet shall be installed within 7 Ft. of DC powered equipment due to safety reasons. This may create a shock or current loop that can be severely hazardous to personnel. Exception may be granted if Telcordia reference GR1275-CORE-i08 below are fulfilled.

R19-5 [864] All elements of the integrated ground plane (MBN) (auxiliary framing, cable rack, vent ducts, pipes, etc.) within a minimum of 6 feet of an isolated ground plane (IBN) (analog or digital) shall be bonded to the Main Ground Bus (MGB) (SPCB) in the GW (SPCW) with a minimum #6 AWG stranded copper conductor.

-
- R19-22 [880] All equipment, such as printers, terminals, stand alone units, etc., that are metalically connected to the isolated ground plane (IBN) equipment shall be:
- Insulated from contact with integrated ground plane (MBN) members.
 - Powered from sources within the isolated ground plane (IBN) or AC power that has been routed through and bonded to the MGB (SPCB).
-

Hardware Installation Guidelines

2 PIC Management

2.1 Hardware options for PIC Management server

PIC Management software can be installed on:

- Oracle Hardware
- HP RMS

PIC Management server	
Oracle Hardware	HP
X6-2 (AC only)	HP Gen9 v1 & v2
Netra X5-2	HP Gen8 v1&v2 + D2700
X5-2 (AC only)	HP G6 + D2700

PIC Management supports following hardware configurations:

- [Configuration set 1 \(X6-2\)](#)
- [Configuration set 2 \(X5-2\)](#)
- [Configuration set 3 \(Netra X5-2\)](#)
- [Configuration set 4 \(HP Gen9 v2\)](#)
- [Configuration set 5 \(HP Gen9 v1\)](#)
- [Configuration set 6 \(HP Gen8 v2\)](#)
- [Configuration set 7 \(HP Gen8 v1\)](#)
- [Configuration set 8 \(HP G6\)](#)

2.2 Networking guidelines for PIC Management server

Synthesis:

Management server requires:

- On HP and Oracle hardware: One Ethernet access for management
- Number of network ports for web access and downlink is variable (see details bellow)

Number of port is variable according to server configuration. Both Management port (for server management) and Network ports (for backbone connectivity) shall be connected to customer network.

Please refer to annex section for network ports identification

Management ports:

1 port per HP server (named ILO)
Or 1 port for Oracle hardware (named ILOM).

All servers shall have their management port (ILO for HP or ILOM for Oracle hardware) connected to the network and configured for remote access:

- Server management port is a 1000 Base-T RJ45 Ethernet compatible
- Server management port is untagged.

Hardware Installation Guidelines

- Initial Network Connection configuration shall be performed by the customer to allow remote connection to ILO(M). Please refer to Oracle documentation for ILOM initial configuration, or to HP ILO configuration and setup for HP servers.
- Static IP configuration for management port (ILO or ILOM) can be freely allocated (DHCP is not recommended).

Network ports:

All HP Ethernet network ports are RJ45 1000 Base-T compatible

Oracle Ethernet network ports are RJ45 1000 Base-T and 10G Base-T compatible.

Management server can be installed using 1 or 2 network ports:

- 1 network port: Eth01 network port used for both frontend, backend and alarms output.
- 2 network ports (recommended option): 2 ports are used to differentiate frontend and backend: :
 - Eth02: port for frontend (web access to GUI)
 - Eth01: port for backend (acquisition and mediation servers and alarms output)
- In case of 2 network ports, default route shall be on Eth02 (Web GUI access) and static routes to PIC mediation and acquisition servers shall be added on Eth01.
- IP addresses can be freely allocated (in different subnets for the 2 network case).

In case of presence of a Firewall, some TCP/UDP ports shall be opened. The list of ports to open is available in PIC Security guide on Oracle Technology Network site.

By default, all network ports are untagged (VLAN if needed are configured on customer switch)

Switch template configurations and cabling are available in the appendix section of this document.

Hardware Installation Guidelines

3 PIC Mediation and storage

PIC Mediation is a set of servers being logically grouped to create a subsystem (logical entity of servers). It is composed of

- Base server to create xDR and KPI
- Data Record storage supporting database instances
- Packet Data Unit storage servers

PIC Mediation can be installed on:

- Oracle Hardware
- HP RMS

Mediation base			Data Record Storage		Packet Data Unit Storage	
Oracle Hardware		HP	Oracle Hardware	HP	Oracle Hardware	HP
X5-2		HP Gen9 v1&v2	ODA	HP Gen9 v1&v2	ZFS	HP Gen9 v1&v2
		HP Gen8 v1&v2	X6-2L	HP Gen8 v1&v2 + D2700	X6-2L	HP Gen8 v1&v2 + D2700
Netra X5-2		HP G6		HP G6 + D2700		

More information is provided in the following sections.

Local switches are to interconnect servers together is strongly recommended.

3.1 Hardware options for Mediation servers

PIC Mediation supports following configurations:

- [Configuration set 10 \(X5-2\)](#)
- [Configuration set 11 \(Netra X5-2\)](#)
- [Configuration set 12 \(HP Gen9 v2\)](#)
- [Configuration set 13 \(HP Gen9 v1\)](#)
- [Configuration set 14 \(HP Gen8 v2\)](#)
- [Configuration set 15 \(HP Gen8 v1\)](#)
- [Configuration set 16 \(HP G6\)](#)

Mixing servers is allowed in the same subsystem.

3.2 Networking guidelines for PIC Mediation

Synthesis:

Each Mediation server requires:

- One Ethernet access for management
- One Ethernet access for uplink

Both Management port (for server management) and Network ports (for backbone connectivity) shall be connected to customer network.

Please refer to annex section for network ports identification.

For management ports:

All servers shall have their management port (ILO for HP or ILOM for Oracle hardware) connected to the network and configured for remote access:

- Server management port is a 1000 Base-T RJ45 Ethernet compatible
- Server management port is untagged.
- Initial Network Connection configuration shall be performed by the customer to allow remote connection to ILO(M). Please refer to Oracle documentation for ILOM initial configuration, or to HP ILO configuration and setup for HP servers.
- Static IP configuration for management port (ILO or ILOM) can be freely allocated (DHCP is not recommended).

For network ports:

All HP Ethernet network ports are RJ45 1000 Base-T compatible

Oracle Ethernet network ports are RJ45 1000 Base-T and 10G Base-T compatible.

All ports are native (VLAN if needed are configured on customer switch).

All IP addresses shall be routable to allow remote access (including for support). In case of presence of a Firewall, some TCP/UDP ports shall be opened. The list of ports to open is available in PIC security guide.

Hardware Installation Guidelines

Mediation server can be installed using 1 or 2 network ports:

- 1 network port: Eth01 network port used for all
- 2 network ports: Eth1 & Eth02 used in bound mode.

It is recommended to allocate IP addresses of network ports in the same subnet using static IP addresses for all servers in a subsystem. For performance reasons, it is recommended to have high throughput performance and low latency between the mediation and the storage servers. Typically a switch (or 2 switches with path redundancy) shall be used to interconnect mediation and storage servers of a subsystem.

If production and management traffic separation is requested, IP addresses shall be allocated in different subnets for production and management. Other IP addresses (for management and ILO) can be allocated in the same or different subnets using static IP addresses.

Switch template configuration and cabling are available in appendix of this document.

3.3 Hardware options for Packet Data Unit Storage server

PIC Packet Data Unit Storage server supports following configurations:

- [Configuration set 17 \(ZFS\)](#)
- [Configuration set 18 \(X6-2L\)](#)
- [Configuration set 19 \(HP Gen9 v2\)](#)
- [Configuration set 20 \(HP Gen9 v1\)](#)
- [Configuration set 21 \(HP Gen8 v2\)](#)
- [Configuration set 22 \(HP Gen8 v1\)](#)
- [Configuration set 23 \(HP G6\)](#)

Mixing servers with different storage size is not allowed in the same subsystem.

3.4 Networking guidelines for Packet Data Unit Storage servers

Synthesis:

Each packet data unit server requires:

- On HP: One Ethernet access for management
- On ZFS: One Ethernet access for management
- On Other Oracle hardware: One Ethernet access for management
- Number of network ports for storage is variable (see details below)

Number of port is variable according to server type and configuration. Both Management port (for server management) and Network port (for backbone connectivity) shall be connected to customer network.

Please refer to annex section for network ports identification.

For management ports:

All servers shall have their management port (ILO for HP or ILOM for Oracle hardware) connected to the network and configured for remote access:

- Server management port is a 1000 Base-T RJ45 Ethernet compatible
- Server management port is untagged.
- Initial Network Connection configuration shall be performed by the customer to allow remote connection to ILO(M). Please refer to Oracle documentation for ILOM initial configuration, or to HP ILO configuration and setup for HP servers.
- Static IP configuration for management port (ILO or ILOM) can be freely allocated (DHCP is not recommended).

For network ports:

ZFS and HP RMS Ethernet network ports are RJ45 1000 Base-TX compatible.

X6-2L Ethernet network ports are RJ45 1000 Base-T and 10G Base-T compatible.

Please refer to annex section for network ports identification.

All ports are native (VLAN if needed are configured on customer switch).

All IP addresses shall be routable to allow remote access (including for support). In case of presence of a Firewall, some TCP/UDP ports shall be opened. The list of ports to open is available in PIC security guide.

Hardware Installation Guidelines

It is recommended to allocate IP addresses of network ports in the same subnet using static IP addresses for all servers in a subsystem. For performance reasons, it is recommended to have high throughput performance and low latency between the mediation and the storages. Typically a switch (or 2 switches with path redundancy) shall be used to interconnect mediation and storage servers of a subsystem.

If production and management traffic separation is requested, IP addresses shall be allocated in different subnets for production and management. Other IP addresses (for management and ILO) can be allocated in the same or different subnets using static IP addresses.

Switch template configuration and cabling are available in appendix of this document.

Eth01 and Eth02 bonding is supported on all servers.

3.5 Hardware options for Data Record Storage server

PIC Data Record storage server supports following configurations:

- [Configuration set 18 \(X6-2L\)](#)
- [Configuration set 24 \(ODA\)](#)
- [Configuration set 19 \(HP Gen9 v2\)](#)
- [Configuration set 20 \(HP Gen9 v1\)](#)
- [Configuration set 21 \(HP Gen8 v2\)](#)
- [Configuration set 22 \(HP Gen8 v1\)](#)
- [Configuration set 23 \(HP G6\)](#)

Note that ODA (Configuration set 24) can be shared by Management server function and Data Record Storage, or support two Data Record Storage instance.

Mixing servers with different storage size is not allowed in the same subsystem.

Note that customer shall have Oracle Enterprise Edition 11g and partitioning option licenses, or Oracle Technology Foundation for Monitoring Applications license for each Data Record Storage instance, before starting the installation.

3.6 Networking guidelines for Data Record Storage server

Synthesis:

Each Mediation server requires:

- One Ethernet access for management
- One Ethernet access for uplink

Each storage server (for packet or data unit) requires:

- On HP: One Ethernet access for management
- On ODA: Two Ethernet access for management
- On other Oracle hardware: One Ethernet access for management
- Number of network ports for storage is variable (see details bellow)

Number of port is variable according to server type and configuration. Both Management port (for server management) and Network port (for backbone connectivity) shall be connected to customer network.

Please refer to annex section for network ports identification.

For management ports:

All servers shall have their management port (ILO for HP or ILOM for Oracle hardware) connected to the network and configured for remote access:

- Server management port is a 1000 Base-T RJ45 Ethernet compatible
- Server management port is untagged.
- Port is native (VLAN if needed are configured on customer switch).
- Initial Network Connection configuration shall be performed by the customer to allow remote connection to ILO(M). Please refer to Oracle documentation for ILOM initial configuration, or to HP ILO configuration and setup for HP servers.
- Static IP configuration for management port (ILO or ILOM) can be freely allocated (DHCP is not recommended).

Hardware Installation Guidelines

For network ports:

HP RMS Ethernet network ports are RJ45 1000 Base-TX compatible.

ODA and X6-2L Ethernet network ports are RJ45 1000 Base-T and 10G Base-T compatible

All ports are native (VLAN if needed are configured on customer switch).

Eth01 and Eth02 bonding is supported on all servers.

All IP addresses shall be routable to allow remote access (including for support). In case of presence of a Firewall, some TCP/UDP ports shall be opened. The list of ports to open is available in PIC security guide.

It is recommended to allocate IP addresses of network ports in the same subnet using static IP addresses for all servers in a subsystem. For performance reasons, it is recommended to have high throughput performance and low latency between the mediation and the storages. Typically a switch (or 2 switches with path redundancy) shall be used to interconnect mediation and storage servers of a subsystem.

If production and management traffic separation is requested, IP addresses shall be allocated in different subnets for production and management. Other IP addresses (for management and ILO) can be allocated in the same or different subnets using static IP addresses.

Switch template configuration and cabling are available in appendix of this document.

4 Integrated Acquisition for Eagle monitoring

All Eagle integrated acquisition servers, are grouped inside a logical entity called a subsystem. Inside the subsystem, they exchange management and surveillance information. Only one subsystem can be connected to an EAGLE. And an EAGLE can be monitored by only one Integrated Acquisition subsystem.

Integrated acquisition can be installed on:

- E5-APP-B cards (installed in Eagle frame)
- Oracle RMS server
- HP RMS server

Integrated Acquisition	
Oracle Hardware	HP
X5-2 (AC only)	HP Gen9 v1 & v2
Netra X5-2	HP Gen8 v1&v2
E5-APP-B	HP G6

More information is provided in the following sections.

4.1 Hardware options for Eagle Integrated acquisition

PIC Mediation supports following configurations:

- [Configuration set 10 \(X5-2\)](#)
- [Configuration set 11 \(Netra X5-2\)](#)
- [Configuration set 12 \(HP Gen9 v2\)](#)
- [Configuration set 13 \(HP Gen9 v1\)](#)
- [Configuration set 14 \(HP Gen8 v2\)](#)
- [Configuration set 15 \(HP Gen8 v1\)](#)
- [Configuration set 16 \(HP G6\)](#)
- [Configuration set 25 \(E5-APP-B\)](#)

Oracle HW can be mixed with HP RMS servers in the same subsystem. But performance of each server in the subsystem shall be aligned to the server with the lowest performance.

No mixed configuration is allowed in a subsystem with E5-APP-B (E5-APP-B cards can't be mixed with Oracle or HP RMS).

Mixing AC and DC equipment within the same cabinet is not allowed for safety rules.

Eagle power supply is DC only. Some Oracle hardware is available in AC only. Therefore, electrical best practice safety rules shall be strictly applied. For instance, Oracle strongly recommends that no AC powered cabinet shall be installed within 7 Ft. of DC powered equipment due to safety reasons. This may create a shock or current loop that can be severely hazardous to personnel. Exception may be granted if Telcordia reference GR1275-CORE-i08 below are fulfil.

Hardware Installation Guidelines

R19-5 [864] All elements of the integrated ground plane (MBN) (auxiliary framing, cable rack, vent ducts, pipes, etc.) within a minimum of 6 feet of an isolated ground plane (IBN) (analog or digital) shall be bonded to the Main Ground Bus (MGB) (SPCB) in the GW (SPCW) with a minimum #6 AWG stranded copper conductor.

R19-22 [880] All equipment, such as printers, terminals, stand alone units, etc., that are metallically connected to the isolated ground plane (IBN) equipment shall be:

- Insulated from contact with integrated ground plane (MBN) members.
- Powered from sources within the isolated ground plane (IBN) or AC power that has been routed through and bonded to the MGB (SPCB).

4.2 Networking guidelines for EAGLE Integrated Acquisition

Synthesis:

Switches are mandatory (1 or more according to equipment to connect)

Each Integrated acquisition server requires

- One Ethernet access for management
- Two Ethernet access for uplink

In addition, STC and Fast copy Eagle cards are dual attached to the switches.

Switches are connected to customer network through one or 2 ports.

At least management ports of 2 servers (for server management) shall be connected directly to customer network. Network ports (for backbone connectivity) and management ports of other servers are connected to the switch(es). Switch(es) shall be connected to customer network.

Please refer to annex section for network ports identification

For management ports:

All servers shall have their management port (ILO for HP or ILOM for Oracle hardware) connected to the network and configured for remote access:

- Server management port is a 1000 Base-T RJ45 Ethernet compatible
- Server management port is untagged.
- Initial Network Connection configuration shall be performed by the customer to allow remote connection to ILO(M). Please refer to Oracle documentation for ILOM initial configuration, or to HP ILO configuration and setup for HP servers.
- Static IP configuration for management port (ILO or ILOM) can be freely allocated (DHCP is not recommended).

For network ports:

- All Ethernet network ports are RJ45 1000 Base-TX compatible.
- Please refer to annex section for network ports identification.

For Eagle cards

All Eagle cards connected to switches (fast copy ports or STC ports) are:

- Native untagged RJ45 100 Base-T compliant.
- Tagging shall be done on the switch according to the selected configuration (see below)

When Fast copy is activated on the Eagle, switch shall support jumbo frame (minimum size 1530 bytes).

Switches are part of the integrated acquisition architecture. They are mandatory. One or more switches are required according to number of servers and Eagle cards to connect. For new systems it is recommended to use the configuration described in the following chapter and assuming the system is installed in accordance with the switch port allocation described in section 6.13.1

If requested by customer an alternate configuration can be used and is described in section 4.2.2 and in this case you have to configure the switch as for the default and then add the few lines described in this section.

The Layer 3 configuration described in section 6.13.2 to 6.13.7 for RMS Servers and 6.13.10.2 to 6.13.10.3 for E5-AppB cards are designed for the CISCO 49448EF switch but is keeping also some commands in order to remain compatible with the previous CISCO 4948.

In case of switch installed to extend existing systems it is recommended the same Layer 2 configuration used in the previous PIC releases and remembered in section:

1. 6.13.19 for HP RMS
2. 6.13.10.4 for E5-AppB

Layer 2 configurations can still be used even if you have 4948EF instead of 4948 switches, if you don't want to use Layer 3 configuration for a new system installation. The template configuration may be customized as long as you respect the constraints described in the following section.



CAUTION:

In case of switch reconfiguration, the communication to IMF server may be lost.

It is recommended, to avoid any communication lost during switch reconfiguration, to change interface status to down state on all IMF sub-system servers before starting switch reconfiguration:

- For yellow switch reconfiguration, use “ifdown eth01”
- For blue switch reconfiguration, use “ifdown eth03”

After switch reconfiguration, don't forget to restart the interface using ifdup command.

Use this procedure only if you really need to avoid any communication lost.

4.2.1 Default configuration

The interfaces to customer switch are configured in native mode. If customer uses vlans they must be configured on his switch (transparent for Oracle) :

1. Vlan 100 172.21.49.0 255.255.255.0

vlan can't be changed and is transparent to the customer

IP can't be changed and shall not be used for servers communicating with IMF (NSP&IXP&VPN)

2. Vlan 101 172.22.49.0 255.255.255.0

Vlan can't be changed and is transparent to the customer

IP can't be changed and shall not be used for servers communicating with IMF (NSP&IXP&VPN)

3. Vlan 200 192.168.0.0 255.255.255.224 internal network minimum size for largest configuration

IP must be changed according values customer provided

Hardware Installation Guidelines

Vlan can't be changed and is transparent to the customer

In the following config 192.168.0.1 is reserved and shall be used as default route for the IMF servers. 192.168.0.2 & 192.168.0.3 are reserved for switch IP

4. Vlan 300 192.168.10.0 255.255.255.224 iLO network

IP must be changed according values customer provided

5. Vlan 400 192.168.20.0 255.255.255.240 external network (demarcation)

IP must be changed according values customer provided

Note: the commands "switchport trunk encapsulation dot1q" and "media-type rj45" will fail on the 4948EF switch but it is kept this config for compatibility with the previous 4948

Note: While the configuration you may receive warnings like the one bellow, but this is expected.

%Warning: portfast should only be enabled on ports connected to a single

Warning: portfast should only be enabled on ports connected to a single

Warning: portfast should only be enabled on ports connecy bridging loops.

Warning: portfast should only be enabled on ports connecy bridging loops.t this is expected. 4948vers. 192.168.0.2 & 192.168.0.3 are reserved for switch IPwhen portfast is

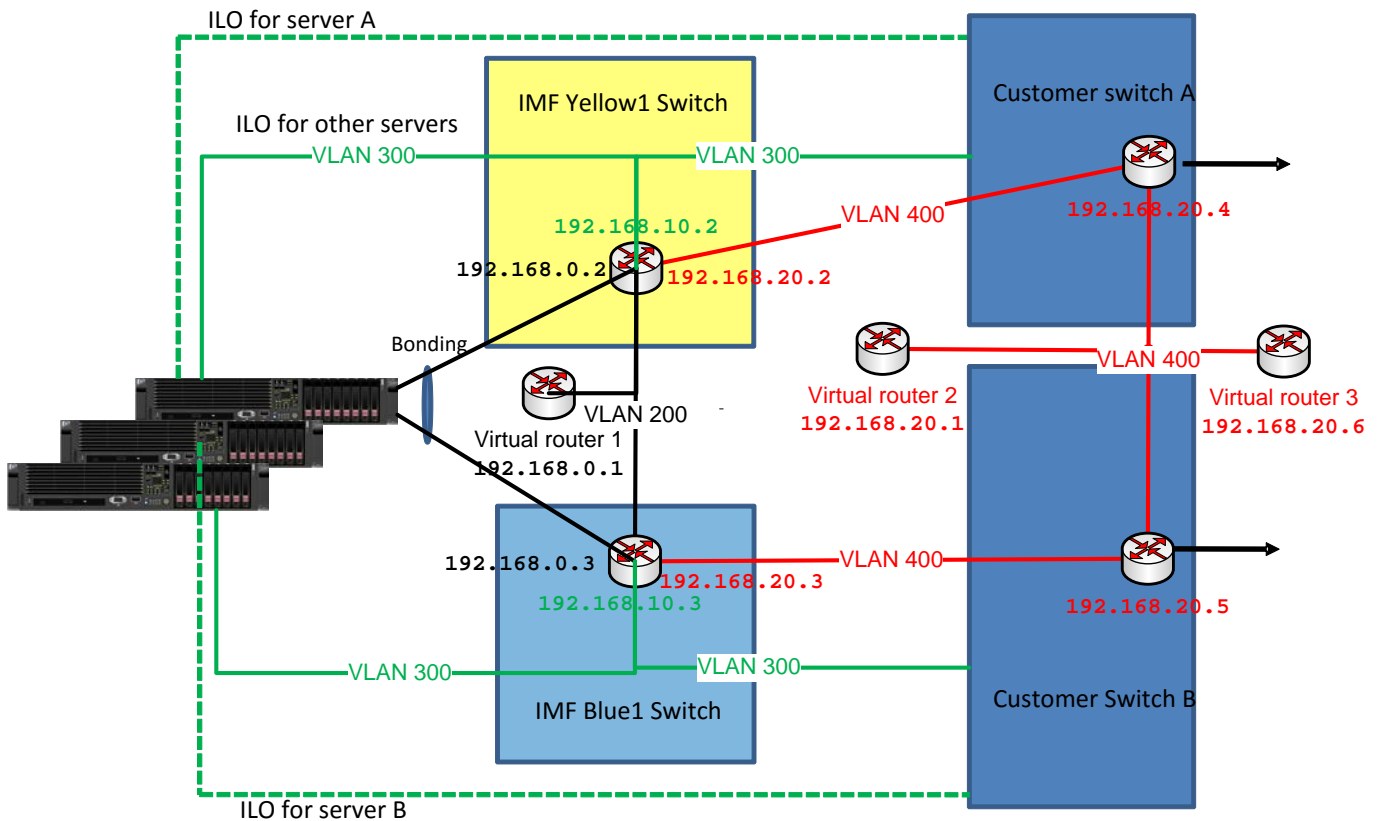

4.2.2 Alternate configuration

If the customer wants to configure on Oracle switches, we can use the alternate config below just by adding the few lines below to the default config.



This configuration can be dangerous, because customer must guarantee there is no link between the two switch access, otherwise it would make a loop and his network may crash.

```
interface Port-channel1
  switchport trunk allowed vlan 100,101,200,300,400
interface GigabitEthernet 1/1
  switchport trunk allowed vlan 100,101,200,300,400
interface GigabitEthernet 1/2
  switchport trunk allowed vlan 100,101,200,300,400
no track 1 int gigabitEthernet 1/47 line-protocol
track 1 interface port-channel 1 line-protocol
```

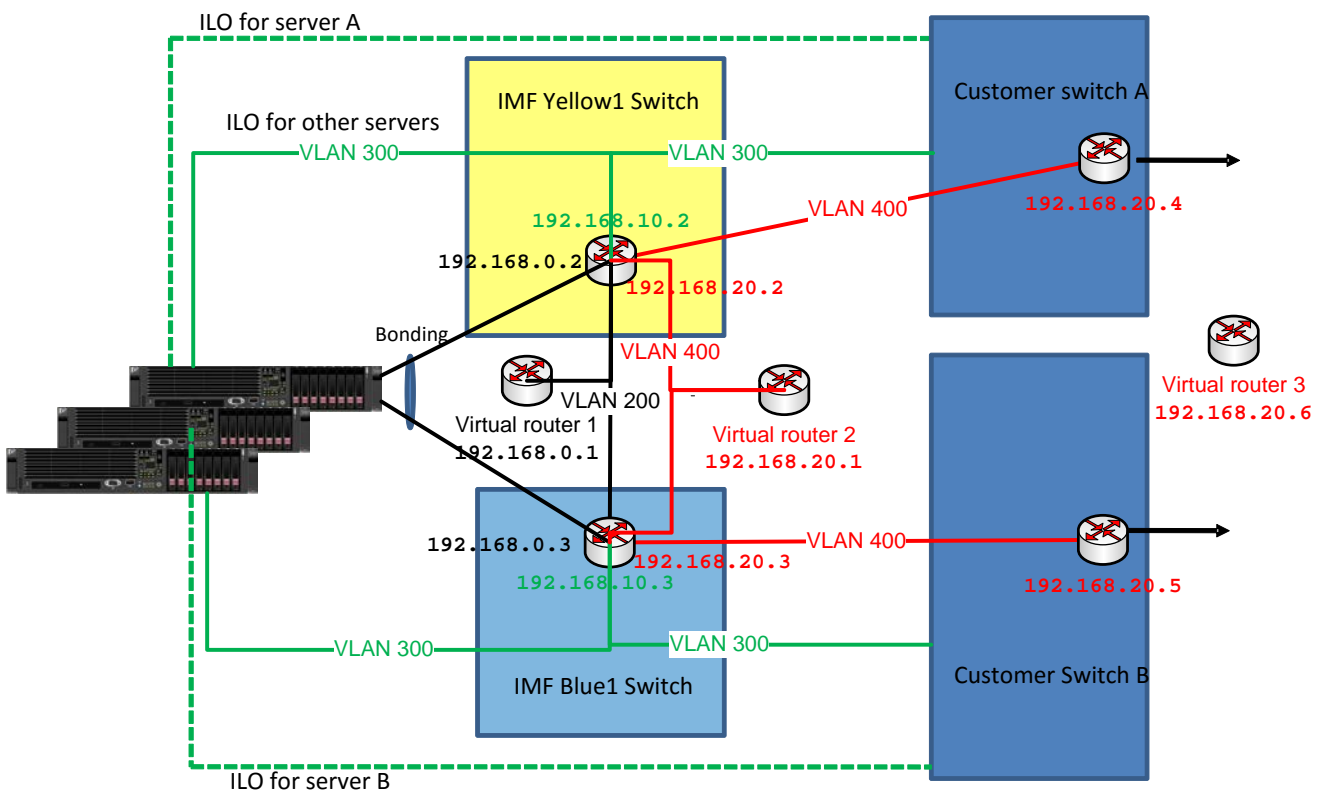

Hardware Installation Guidelines

4.3 Networking guidelines for standard configuration

According to the number of cards and servers to connect, more than one switch may be necessary. In that case, it is recommended to build a fully redundant network topology and to distribute the port from each server/card to 2 different switches connected in redundant way.

Following connection and port configuration shall be done:

- Eagle cards:
For all cards for which Fast copy is enable,
 1. Connect port C of the Fast Copy card, and port A for the STC cards to the switch.
In the switch, port shall be configured as untagged native port (mode access) and shall belong to VLAN 100.
 2. Connect port D of the Fast Copy card, and port B for the STC cards to the switch.
In the switch, port shall be configured as untagged native port (mode access) and shall belong to VLAN 101

- Integrated servers:
 1. Connect port Eth01 of IMF servers to a switch.
In the switch, port shall be configured as 802.1.Q tagged port (mode trunk). Vlan 100, 101 and 200 shall be allowed on the port.
 2. Connect port Eth03 of IMF servers to another switch (according to the redundant topology)..
In the switch, port shall be configured as 802.1.Q tagged port (mode trunk). Vlan 100, 101 and 200 shall be allowed on the port.
 3. It is recommended to
 - i. connect the ILO port of HP server, or the ILOM port for X5-2 of the first server to a customer switch to allow remote access even when PIC switch configuration is not done
 - ii. connect the serial port of the same server on the console port of the switch (for initial configuration and troubleshooting)
 4. The other ILO/ILOM port can be connected to any switch with available ports.
In the switch, port shall be configured as untagged native port (mode access) and shall belong to VLAN 300 or any other VLAN number suitable for the customer (except 100 and 101).

- Connection to customer network:
According to customer will, one, two or more ports can be reserved to connect to customer network.
These ports are freely configured by the customer.
One or more of these ports shall belong to VLAN 200 for integrated server access to the customer network.
One or more of these ports shall belong to the VLAN selected for the management (300 or any other vlan number except 100 and 101).
IP routing in the switch can be used too.

Following VLAN numbers are reserved. They can't be changed:

- VLAN 100: internal yellow network (Path 1 between Eagle and integrated servers)
- VLAN 101: internal bleu network (Path 2 between Eagle and integrated servers)
- VLAN 200: integrated servers to customer network

VLAN 100 and 101 are local and shall not be transmitted to customer backbone.

A specific VLAN number can be allocated for Management (access to ILO or ILOM).

Each VLAN shall belong to the same broadcasting domain.

4.4 IP addressing

VLAN 100 and 101 are using a specific subnets 172.21.48.00/23 and to 172.22.48.00/23 respectively. These addresses are reserved and shall not be used in PIC whole system. But as they are internal, they can be used by the customer for any servers not interconnected with PIC.

All integrated servers shall be in the same subnet on VLAN 200. Subnet can be freely set. It is recommended to use a subnet large enough to allow future extension. Static IP configuration shall be used (DHCP shall not be used).

For management ILO/ILOM ports:

Static IP configuration for management port (ILO or ILOM) can be freely allocated (DHCP is not recommended).

Hardware Installation Guidelines

5 Probed Acquisition

Probed acquisition can be installed on:

- Oracle server
- HP RMS
-

Probed Acquisition		
Oracle Hardware	HP	
X5-2 (AC only)	HP Gen9 v1 & v2	
	HP Gen8 v1&v2	
Netra X5-2	HP G6	

More information is provided in the following sections.

5.1 Hardware options for Probed acquisition servers

PIC Probed acquisition supports the following configurations:

- [Configuration set 27 \(X5-2\)](#)
- [Configuration set 28 \(Netra X5-2\)](#)
- [Configuration set 29 \(HP Gen9 v2\)](#)
- [Configuration set 30 \(HP Gen9 v1\)](#)
- [Configuration set 31 \(HP Gen8 v2\)](#)
- [Configuration set 32 \(HP Gen8 v1\)](#)
- [Configuration set 33 \(HP G6\)](#)

In addition for network acquisition cards with SFP(+) slots, they shall be populated with the SFP(+) modules according to network technology. See [SFP\(+\) module section](#) for recommended ones.

5.2 Networking guidelines for Probed acquisition

Synthesis:

Each probe server requires:

- One Ethernet access for management
- One to four Ethernet access for uplink

In addition, probe is connected to customer network links/switches for acquisition.

Both Management port (for server management) and Network ports (for backbone connectivity) shall be connected to customer network.

Please refer to annex section for network ports identification.

For management ports:

All servers shall have their management port (ILO for HP or ILOM for Oracle hardware) connected to the network and configured for remote access:

- Server management port is a 1000 Base-T RJ45 Ethernet compatible
- Server management port is untagged.

Hardware Installation Guidelines

- Initial Network Connection configuration shall be performed by the customer to allow remote connection to ILO(M). Please refer to Oracle documentation for ILOM initial configuration, or to HP ILO configuration and setup for HP servers.
- Static IP configuration for management port (ILO or ILOM) can be freely allocated (DHCP is not recommended).

For network ports:

All Ethernet network ports are RJ45 1000 Base-TX compatible.

In addition, Oracle hardware is 10G Base-T compatible for network ports

For uplink, probe implementation requires from 1 to 4 Ethernet ports according to customer option:

- One Ethernet link only:
 - Eth01: it is used for production and management traffic.
 - Other ports are unused
- Network ports aggregation for production and/or management traffic separation:
 - Eth01: it is reserved for management only when management and production traffic shall be separated. It is unused if no traffic separation.
 - Eth02: it is used for production traffic (and for management when no management/production separation).
 - Eth03 & Eth04: they are used with a bond grouping Eth02, Eth03 and Eth04 in case redundant path or aggregated (if more than 1 Gb/s output) are requested. Unused if not.
- Server needs several IP addresses:
 - One for Eth02 port only or for the eth02 to Eth04 bound
 - Optionally, one for Eth01 port when management and production traffic shall be separated

All Probe servers are independent. IP addresses can be freely allocated to probe ports.

All ports are native (VLAN if needed are configured on customer switch).

All IP addresses shall be routable to allow remote access (including for support). In case of presence of a Firewall, some TCP/UDP ports shall be opened. The list of ports to open is available in PIC security guide..

Static IP configuration shall be used (DHCP shall not be used).

On acquisition side, customer shall copy network traffic to the probe. Port mirroring and tapping are supported. It is the responsibility of the customer to provide the Taps or to configure the switch. When using optical passive taps, particular attention shall be done on power budget. Probe receiver sensitivity is SFP module selection dependent.

Hardware Installation Guidelines

6 Integrated Acquisition for DSR monitoring

Integrated acquisition for DSR monitoring can be installed on:

- Oracle server
- HP RMS

Integrated Acquisition for DSR monitoring		
Oracle Hardware	HP	
X5-2 (AC only)	HP Gen9 v1 & v2	
Netra X5-2		

More information is provided in the following sections.

6.1 Hardware options for integrated acquisition servers for OCSDR monitoring

PIC Integrated Acquisition for DSR monitoring supports the following configurations:

- [Configuration set 27 \(X5-2\)](#)
- [Configuration set 28 \(Netra X5-2\)](#)
- [Configuration set 29 \(HP Gen9 v2\)](#)
- [Configuration set 30 \(HP Gen9 v1\)](#)

In addition for network acquisition cards with SFP(+) slots, they shall be populated with the SFP(+) modules according to network technology. See [SFP\(+\) module section](#) for recommended ones.

6.2 Networking guidelines for Integrated Acquisition for OCSDR monitoring

Synthesis:

Each integrated acquisition server for DSR monitoring requires:

- One Ethernet access for management
- One to four Ethernet access for uplink

In addition, probe is connected to customer network links/switches for acquisition.

Both Management port (for server management) and Network ports (for backbone connectivity) shall be connected to customer network.

Please refer to annex section for network ports identification.

For management ports:

All servers shall have their management port (ILO for HP or ILOM for Oracle hardware) connected to the network and configured for remote access:

- Server management port is a 1000 Base-T RJ45 Ethernet compatible
- Server management port is untagged.
- Initial Network Connection configuration shall be performed by the customer to allow remote connection to ILO(M). Please refer to Oracle documentation for ILOM initial configuration, or to HP ILO configuration and setup for HP servers.

Hardware Installation Guidelines

- Static IP configuration for management port (ILO or ILOM) can be freely allocated (DHCP is not recommended).

For network ports:

All Ethernet network ports are RJ45 1000 Base-TX compatible.

In addition, Oracle hardware is 10G Base-T compatible for network ports

For uplink, probe implementation requires from 1 to 4 Ethernet ports according to customer option:

- One Ethernet link only:
 - Eth01: it is used for production and management traffic.
 - Other ports are unused
- Network ports aggregation for production and/or management traffic separation:
 - Eth01: it is reserved for management only when management and production traffic shall be separated. It is unused if no traffic separation.
 - Eth02: it is used for production traffic (and for management when no management/production separation).
 - Eth03 & Eth04: they are used with a bond grouping Eth02, Eth03 and Eth04 in case redundant path or aggregated (if more than 1 Gb/s output) are requested. Unused if not.
- Server needs several IP addresses:
 - One for Eth02 port only or for the eth02 to Eth04 bound
 - Optionally, one for Eth01 port when management and production traffic shall be separated
- One of the network port shall have connectivity to the VIP of the DSR's SOAM

All Probe servers are independent. IP addresses can be freely allocated to probe ports.

All ports are native (VLAN if needed are configured on customer switch).

All IP addresses shall be routable to allow remote access (including for support). In case of presence of a Firewall, some TCP/UDP ports shall be opened. The list of ports to open is available in PIC security guide..

Static IP configuration shall be used (DHCP shall not be used).

On acquisition side, the network traffic to and from the DSR shall be copied to the probe. According to DSR topology and available ports on the switch when available, port mirroring or tapping can be used. Document "Topology Specific Interconnections for Non-standard Port Mirroring" (CGBU_017238) can be provided to customer on request for configuration of the aggregation switch provided with the DSR, when port mirroring implementation is possible and desired. For the other cases, it is the responsibility of the customer to provide the Taps. When using optical passive taps, particular attention shall be done on power budget. Probe receiver sensitivity is SFP module selection dependent.

Hardware Installation Guidelines

7 Virtual machine

The virtualization allows to share a same server for multiple PIC components.

The supported components for the virtualization on the same server are:

- 1 MGMT server,
- Up to N Mediation servers, according to the hardware capacity
- 1 Acquisition server, if the appropriate cards for the traffic capture are settled in the host.

The server must be chosen among the recommended ones for Mediation and Probed Acquisition hardware.

Virtualization is supported and documented for probed acquisition, mediation and Management. Virtualization for storage is under control of the customer.

PIC has been tested on HP Gen9 RMS server with:

- KVM hypervisor version 1.2.8-16.0.1 or more (Oracle Linux 7.1 or more)
- VMware ESXi version 5.5

Technical description	Minimum Requirements
Architecture	i386 64 bits
Virtual CPU	minimum 4 cores
Virtual Memory	minimum 16 GB
Virtual Disk storage	1 virtual disk Minimum disk size 300GB Configured in IDE mode
Virtual CDROM	1
Ethernet Interface for acquisition	1 to 8 ports without any IP add configured Mode direct or PCI pass-through is recommended for high throughput ports (specifically for acquisition port) Virtio driver compatible
Ethernet Interface for production and management network access	1 to 4 ports* NAT is not supported IP addresses shall be accessible from network Virtio driver compatible
Virtual graphical interface	vnc interface compatibility for remote console access

Installation and virtual machine configuration are detailed in PIC 10.2 Installation guide available on Oracle Technology Network site

8 Pre-Packaged option for DSR monitoring

The Pre-Packaged option for OCSDR monitoring can include Acquisition + Mediation + Management in the same server. More information are available on PIC planning guide available on Oracle Technology Network site.

Pre-Packaged for DSR monitoring can be installed on:

- X5-2 oracle server

In addition for the xDR storage option, an additional server is required:

- X6-2L oracle server

Pre-Packaged DSR
X5-2 (AC only)
Netra X5-2
+
xDR + PDU storage option
X6-2L (AC only)

More information is provided in the following sections.

Pre-Packaged solution uses a pre-defined virtualization setup including the management, the acquisition and the mediation virtual machines.

8.1 Hardware options Pre-Packaged servers for DSR monitoring

PIC Pre-Packaged for DSR monitoring, with integrated acquisition, mediation and management, supports the following configurations:

- [Configuration set 35 \(X5-2\)](#)
- [Configuration set 36 \(Netra X5-2\)](#)

In addition for network acquisition cards with SFP(+) slots, they shall be populated with the SFP(+) modules according to network technology. See [SFP\(+\) module section](#) for recommended ones.

Optionally, xDR and PDU storage can be added. The xDR storage is done on an additional server and the PDU storage is performed on the Pre-Packaged DSR server. The additional xDR Storage server supports the following configuration:

- [Configuration set 18 \(X6-2L\)](#)

Number of disk can be adapted to customer needs with 14 disks or 26 disks.

Note that Oracle Enterprise Edition 11g and partitioning option licenses, or Oracle Technology Foundation for Monitoring Applications license for each Data Record Storage instance, is included in the Pre-Packaged.

Hardware Installation Guidelines

8.2 Networking guidelines for Pre-Packaged option for OCSDR monitoring

Synthesis:

Each Prepackage server requires:

- One IP in VLAN used for management (ILOM)
- One /28 VLAN for backend bridge
- One /29 VLAN for Storage bridge even when option is not used

In addition, server is connected to customer network links/switches for acquisition, and there are three Production VLAN which are not intended to be visible from customer network.

- On the first site one /30 VLAN for frontend bridge (web browser access) is also required

Optionally, xDR storage server requires:

- One IP in VLAN for management (ILOM)
- One IP in VLAN for Storage

IP addresses for each port shall be allocated in different subnets.

Static IP configuration shall be used (DHCP shall not be used).

Both Management port (for server management) and Network ports (for backbone connectivity) shall be connected to customer network.

Please refer to annex section for network ports identification and to the installation guide pre-package for a sample implementation.

Management ports on Prepackage server and xDR storage (option) :

1 port per server (named ILOM).

Each server shall have its ILOM port connected to the customer network and configured to allow remote access (including for support). :

- Server management port is a 1000 Base-T RJ45 Ethernet compatible
- Server management port is untagged.
- Initial Network Connection configuration shall be performed by the customer to allow remote connection .
- Please refer to Oracle documentation for ILOM initial configuration
- A fix IP address is recommended to identify uniquely the server

Network ports on Prepackage server:

Network ports are RJ45 1000 Base-T and 10G Base-T compatible.

Please refer to annex section for network ports identification.

All IP addresses shall be routable to allow remote access (including for support).

On the first Site:

Net0: is used for backend.

Net1: is used for access to the frontend GUI

Net2: is used for xDR export and access to external database(when present).

All ports are native (VLAN if needed are configured on customer switch).

On other sites:

Hardware Installation Guidelines

Net0: is used for backend.

Net1: is used for xDR export and access to external database(when present).

All ports are native (VLAN if needed are configured on customer switch).

For network ports on xDR storage (option):

X6-2L Ethernet network ports are RJ45 1000 Base-T and 10G Base-T compatible.

Port is native and for performance reasons, it is recommended to have high throughput performance and low latency between the Prepackaged server and the xDR storage server.

On acquisition side, customer shall copy network traffic to the Prepackage server. Port mirroring and tapping are supported. It is the responsibility of the customer to provide the Taps or to configure the switch. When using optical passive taps, particular attention shall be done on power budget. Receiver sensitivity is SFP module selection dependent.

Hardware Installation Guidelines

9 Hardware configuration sets

9.1 Configuration set 1 (Oracle X6-2)

Oracle X6-2 is available in AC only

Oracle SKU	Technical description	Qty (AC only)
7113252	Oracle Server X6-2: 1 RU base chassis with motherboard, internal 12 Gb SAS RAID HBA, 2 PSUs, slide rail kit, and cable management arm	1
7113237	One Intel® Xeon® E5-2690 v4 14-core 2.6 GHz processor	2
7110350	Heat sink for 1U	2
7113240	One 16 GB DDR4-2400 registered DIMM	4
7110339	Eight 2.5 inch drive slots, 1 DVD-RW drive slot and disk cage for 1U	1
7111107	One 1.2 TB 10000 rpm 2.5-inch SAS-3 HDD with marlin bracket	8
7110359	DVD filer panel	1
7102748	PCIe filler panel	3

Table 2: configuration set 1 with Oracle X6-2 8 SFF

Warning: an USB flash drive (8GB) will be required for initial installation or disaster recovery

In addition, 2 power cords shall be ordered according to installation country or Power distribution unit installed in the frame.

Customer can perform following adaptations on previous BOM:

- CPU: other CPUs are supported.
Pre-requisite: 10 cores minimum (on one or 2 processors)
Note that Ethernet ports Eth03 and Eth04 (NET2 and NET3) are non-functional in single-processor systems.
- Memory: Other memory allocation is supported.
Pre-requisite: 64 GB minimum.
- Disk type and size: other disks are supported
Pre-requisite: 8 disks minimum
all disks shall have same storage capacity
600 GB disk storage capacity (per disk) minimum.

Note that customer changes can affect server and system performances and ability to upgrade in future releases.

For server size, weight, BTU, power information... Documentations are available at http://docs.oracle.com/cd/E62159_01/

Please refer to Setup and Installation section for Oracle hardware installation. This document will drive you through the initial installation steps:

- Server installation in the rack.
- Attaching network and power Cables
- Booting Up the First Time
- Launching Oracle System Assistant to configure:
 - Server's network connection

- Install latest server firmware
- Configure Oracle ILOM and BIOS,
- Configure hardware

OS and PIC software installation on Oracle hardware server are provided in PIC 10.2 Installation guide available on Oracle Technology Network site.

9.2 Configuration set 2 (Oracle X5-2)

Oracle X5-2 is available in AC only

Oracle SKU	Technical description	Qty (AC only)
7112843	Oracle Server X5-2 for Communications: 1 RU base chassis with motherboard,	1
7110339	XATO,DISK_CAGE,2.5" X 8HDD	1
7110346	ATO,E5-2699 V3,2.3G,145W,18 CORE,C-1 (SR1XD),CPU	2
7110350	XATO,HEATSINK,CPU,1U	2
7110360	XATO,OSA 8 GB MLC USB FLASH DRIVE	1
7110359	ATO,DVD,GEN5,BLANK FILLER PANEL,1U/2U	1
7102748	ATO PCIe FILLER,VENTED,LOW PROFILE	3
7110353	XATO,DIMM,16GB,DDR4,2133	8
7111107	1.2 TB 10000 rpm 2.5-inch SAS-3 HDD with marlin bracket (for factory installation)	8

Table 3: configuration set 2 with Oracle X5-2 8 SFF

In addition, 2 power cords shall be ordered according to installation country or Power distribution unit installed in the frame.

Customer can perform following adaptations on previous BOM:

- CPU: other CPUs are supported.
Pre-requisite: 8 cores minimum (on one or 2 processors)
- Memory: Other memory allocation is supported.
Pre-requisite: 64 GB minimum.
- Disk type and size: other disks are supported
Pre-requisite: 8 disks minimum
all disks shall have same storage capacity
600 GB disk storage capacity (per disk) minimum.

Note that customer changes can affect server and system performances and ability to upgrade in future releases.

For server size, weight, BTU, power information.... Documentations are available at http://docs.oracle.com/cd/E41059_01/

Please refer to Setup and Installation section for Oracle hardware installation. This document will drive you through the initial installation steps:

- Server installation in the rack.

Hardware Installation Guidelines

- Attaching network and power Cables
- Booting Up the First Time
- Launching Oracle System Assistant to configure:
 - Server's network connection
 - Install latest server firmware
 - Configure Oracle ILOM and BIOS,
 - Configure hardware

OS and PIC software installation on Oracle hardware server are provided in PIC 10.2 Installation guide available on Oracle Technology Network site.

9.3 Configuration set 3 (Oracle Netra X5-2)

Oracle Netra X5-2 is available in AC and DC
 Oracle Netra X5-2 is NEBS compliant.

Oracle SKU	Technical description	Qty DC	Qty AC
7111082	Netra Server X5-2: 2 RU AC base chassis with motherboard and 8 HDDs	-	1
7111083	Netra Server X5-2: 2 RU DC base chassis with motherboard and 8 HDDs	1	-
7110346	Intel® Xeon® E5-2699 v3 18-core 2.3 GHz processor	2	2
7102981	Heat sink	2	2
7111036	One 16 GB DDR4-2133 DIMM	8	8
7111043	Memory filler panels	16	16
7111107	One 1.2 TB 10000 rpm 2.5-inch SAS-3 HDD with marlin bracket	8	8
7110116	Oracle Storage 12 Gb SAS PCIe RAID HBA, internal: 8 port and 1 GB memory	1	1
5394A	PCIe filler panel	5	5
7901A-4	19-inch 2-post rackmount kit	1	1
7111044	SAS cable kit	1	1
7111052	OSA 8 GB USB stick	1	1

Table 4: configuration set 3 with Oracle Netra X5-2 8 SFF

In addition, 2 power cords shall be ordered according to installation country or Power distribution unit installed in the frame.

Customer can perform following adaptations on previous BOM:

- CPU: other CPUs are supported.
Pre-requisite: 8 cores minimum (on one or 2 processors)
- Memory: Other memory allocation is supported.
Pre-requisite: 64 GB minimum.
- Disk type and size: other disks are supported
Pre-requisite: 8 disks minimum

Hardware Installation Guidelines

all disks shall have same storage capacity
600 GB disk storage capacity (per disk) minimum.

Note that customer changes can affect server and system performances and ability to upgrade in future releases.

For server size, weight, BTU, power information... Documentations are available at
http://docs.oracle.com/cd/E53596_01/

Please refer to Setup and Installation section for Oracle hardware installation. This document will drive you through the initial installation steps:

- Server installation in the rack.
- Attaching network and power Cables
- Booting Up the First Time
- Launching Oracle System Assistant to configure:
 - Server's network connection
 - Install latest server firmware
 - Configure Oracle ILOM and BIOS,
 - Configure hardware

OS and PIC software installation on Oracle hardware server are provided in PIC 10.2 Installation guide available on Oracle Technology Network site.

9.4 Configuration set 4 (HP DL380 Gen9 v2)

HP DL380 Gen9 v2 is available in AC and DC

HP P/N	Technical description	Qty AC	Qty DC
719064-B21	HP ProLiant DL380 Gen9 8SFF	1	1
817951-L21	HPE DL380 Gen9 Intel® Xeon® E5-2680v4 (2.4GHz/14-core/35MB/120W) FIO Processor Kit	1	1
817951-B21	HPE DL380 Gen9 Intel® Xeon® E5-2680v4 (2.4GHz/14-core/35MB/120W) Processor Kit	1	1
805349-B21	HP 16GB (1x16GB) Single Rank x4 DDR4-2400 CAS-17-17-17 Registered Memory Kit	4	4
749974-B21	HP Smart Array P440ar/2GB FBWC 12Gb 2-ports Int FIO SAS Controller	1	1
720479-B21	HP 800 W Flex Slot Platinum Hot Plug Power Supply Kit	2	-
720480-B21	HP 800 W Flex Slot-48VDC Hot Plug Power Supply Kit	-	2
512485-B21	HP iLO Advanced including 1yr 24x7 Technical Support and Updates Single Server License	1	1
720863-B21	HP 2U Small Form Factor Ball Bearing Rail Kit	1	1
720865-B21	HP 2U Cable Management Arm for Ball Bearing Rail Kit	1	1
768900-B21	HP DL380 Gen9 Systems Insight Display Kit	1	1
758959-B22	HP LEGACY FIO MODE SETTING	1	1
719070-B21	HP DL380 G9 Chassis NEBS Conversion Kit	1	1

Hardware Installation Guidelines

719079-B21	HP DL380 Gen9 High Performance Fan Kit	1	1
785069-B21	HP 900GB 12G SAS 10K rpm SFF (2.5-inch) SC Ent 3yr Warranty Hard Drive	8	8

Table 5: Configuration set 4 with HP DL380 Gen9 v2 8 SFF

In addition, for each HP server, 2 power cords shall be ordered according to installation country or Power distribution unit installed in the frame.

For AC, all pre-configured servers with standard AC power supply option kit, ship with one standard 6-foot IEC C-13/C-14 jumper cord per power supply (for HP Gen9: reference A0K02A). If a different power cord is required, please check HP web site

Customer can perform following adaptations on previous BOM:

- CPU: other CPUs are supported.
Pre-requisite: 8 cores minimum (on one or 2 processors)
- Memory: Other memory allocation is supported.
Pre-requisite: 64 GB minimum.
- Disk type and size: other disks are supported
Pre-requisite: 8 disks minimum
all disks shall have same storage capacity
600 GB disk storage capacity (per disk) minimum.

Note that customer changes can affect server and system performances and ability to upgrade in future releases.

Internal disks shall be connected to SAS A.

Documentation on HP servers & storage array is available on HP web site or using Product bulletin tool. It includes server size, weight, BTU, power information.... The HP Product Bulletin is a free application that only takes a few minutes to download. The download site is located at

http://h18004.www1.hp.com/products/quickspecs/productBulletin.html#CD_Files

Required HP power for a cabinet can be estimated using HP Power advisor tool available on HP web site:

<http://www8.hp.com/us/en/products/servers/solutions.html?compURI=1439951#.UxSoL7QUdtk>

OS and PIC management software installation and configuration on HP, are provided in PIC 10.2 Installation guide available on Oracle Technology Network site. Note that customer shall have Weblogic 11g and Oracle Enterprise Edition 11g and partitioning option licenses, or Oracle Technology Foundation for Monitoring Applications license for this server, before starting the installation.

OS and PIC software installation and configuration of management server on HP servers are provided in Management Server (NSP) on Third-Party Server Installation Guide for Performance Intelligence Center (PIC) products (Doc ID 2062544.1) available on My Oracle Support site.

9.5 Configuration set 5 (HP DL380 Gen9 v1)

HP DL380 Gen9 v1 is available in AC and DC

Hardware Installation Guidelines

HP P/N	Technical description	Qty AC	Qty DC
719064-B21	HP ProLiant DL380 Gen9 8SFF	1	1
762766-L21	HP DL380 Gen9 Intel® Xeon® E5-2680v3 (2.5GHz/12-core/30MB/120W) FIO Processor Kit	1	1
762766-B21	HP DL380 Gen9 Intel® Xeon® E5-2680v3 (2.5GHz/12-core/30MB/120W) FIO Processor Kit	1	1
726719-B21	HP 16GB (1x16GB) Dual Rank x4 DDR4-2133 CAS-15-15-15 Reg Memory Kit	4	4
749974-B21	HP Smart Array P440ar/2GB FBWC 12Gb 2-ports Int FIO SAS Controller	1	1
720479-B21	HP 800 W Flex Slot Platinum Hot Plug Power Supply Kit	2	-
720480-B21	HP 800 W Flex Slot-48VDC Hot Plug Power Supply Kit	-	2
512485-B21	HP iLO Advanced including 1yr 24x7 Technical Support and Updates Single Server License	1	1
720863-B21	HP 2U Small Form Factor Ball Bearing Gen8 Rail Kit with CMA	1	1
720865-B21	HP 2U Cable Management Arm for Ball Bearing Rail Kit	1	1
768900-B21	HP DL380 Gen9 Systems Insight Display Kit	1	1
758959-B22	HP LEGACY FIO MODE SETTING	1	1
719070-B21	HP DL380 G9 Chassis NEBS Conversion Kit	1	1
719079-B21	HP DL380 Gen9 High Performance Fan Kit	1	1
785069-B21	HP 900GB 12G SAS 10K rpm SFF (2.5-inch) SC Ent 3yr Warranty Hard Drive	8	8

Table 6: Configuration set 5 with HP DL380 Gen9 v1 8 SFF

In addition, for each HP server, 2 power cords shall be ordered according to installation country or Power distribution unit installed in the frame.

For AC, all pre-configured servers with standard AC power supply option kit, ship with one standard 6-foot IEC C-13/C-14 jumper cord per power supply (for HP Gen9: reference A0K02A). If a different power cord is required, please check HP web site

Customer can perform following adaptations on previous BOM:

- CPU: other CPUs are supported.
Pre-requisite: 8 cores minimum (on one or 2 processors)
- Memory: Other memory allocation is supported.
Pre-requisite: 64 GB minimum.
- Disk type and size: other disks are supported
Pre-requisite: 8 disks minimum
all disks shall have same storage capacity
600 GB disk storage capacity (per disk) minimum.

Note that customer changes can affect server and system performances and ability to upgrade in future releases.

Internal disks shall be connected to SAS A.

Hardware Installation Guidelines

Documentation on HP servers & storage array is available on HP web site or using Product bulletin tool. It includes server size, weight, BTU, power information.... The HP Product Bulletin is a free application that only takes a few minutes to download. The download site is located at

http://h18004.www1.hp.com/products/quickspecs/productBulletin.html#CD_Files

Required HP power for a cabinet can be estimated using HP Power advisor tool available on HP web site:

<http://www8.hp.com/us/en/products/servers/solutions.html?compURI=1439951#.UxSoL7QUdtk>

OS and PIC management software installation and configuration on HP, are provided in PIC 10.2 Installation guide available on Oracle Technology Network site. Note that customer shall have Weblogic 11g and Oracle Enterprise Edition 11g and partitioning option licenses, or Oracle Technology Foundation for Monitoring Applications license for this server, before starting the installation.

OS and PIC software installation and configuration of management server on HP servers are provided in Management Server (NSP) on Third-Party Server Installation Guide for Performance Intelligence Center (PIC) products (Doc ID 2062544.1) available on My Oracle Support site.

9.6 Configuration set 6 (HP DL360 Gen8 v2 + D2700)

Configuration set 6 is composed of:

- One HP DL360 Gen8 v2 server
- One D2700 storage array

HP Gen8 v2 server and storage D2700 are available in AC only

The HP server shall be connected to the storage array

HP P/N	Technical description	Qty (AC only)
654081-B21	HP ProLiant DL360p Gen8 8 SFF Configure-to-order Server	1
708641-B21	HP 16GB 2Rx4 PC3-14900R-13 Kit	4
652241-B21	HP 9.5mm SATA DVD RW JackBlack Optical Drive	1
684208-B21	HP Ethernet 1Gb 4-port 331FLR FIO Adapter	1
631679-B21	HP 1GB P-series Smart Array Flash Backed Write Cache	1
512485-B21	HP iLO Advanced including 1yr 24x7 Technical Support and Updates Single Server License	1
712506-L21	HP DL360p Gen8 Intel Xeon E5-2680v2 (2.8GHz/10-core/25MB/115W) Processor Kit	1
712506-B21	HP DL360p Gen8 Intel Xeon E5-2680v2 (2.8GHz/10-core/25MB/115W) FIO Processor Kit	1
652583-B21	HP 600GB 6G SAS 10K rpm SFF (2.5-inch) SC Enterprise 3yr Warranty Hard Drive	2
734807-B21	HP 1U Small Form Factor Easy Install Rail Kit	1
656363-B21	HP 750W Common Slot Platinum Plus Hot Plug Power Supply Kit	2
631673-B21	Smart Array P421/1GB FBWC Controller	1

Hardware Installation Guidelines

Storage Array:		
AJ941A	HP D2700 Disk Enclosure	1
507127-B21	HP 300GB 6G SAS 10K 2.5in DP ENT HDD	10

Table 7: Configuration set 6 with HP DL360 Gen8 v2 + D2700

Note : This BOM is intended for PIC 10.1.x. For older release of PIC, please use only 32GB of RAM: 2 x 708641-B21 (HP 16GB 2Rx4 PC3-14900R-13 Kit)

In addition, for each HP server, 2 power cords shall be ordered according to installation country or Power distribution unit installed in the frame.

For AC, all pre-configured servers with standard AC power supply option kit, ship with one standard 6-foot IEC C-13/C-14 jumper cord per power supply. If a different power cord is required, please check HP web site

Customer can perform following adaptations on previous BOM:

- CPU: other CPUs are supported.
Pre-requisite: 8 cores minimum (on one or 2 processors)
- Memory: Other memory allocation is supported.
Pre-requisite: 64 GB minimum.
- Storage Array Disks: customer can select other disks (as far as supported by the D2700)
Pre-requisites:
 - all disks in the storage array shall have same storage capacity
 - Disks shall be installed in position 1 to 10 in the storage array (see annex section for drive bay numbering).
- Server Disk type and size: other disks are supported
Pre-requisite: 2 disks minimum
 - both disks shall have same storage capacity
 - 600 GB disk storage capacity (per disk) minimum.

Note that customer changes can affect server and system performances and ability to upgrade in future releases.

Internal disks shall be connected to SAS A.

For D2700, Port 1E of SAS controller card in the HP server shall be connected to the port P1 of the I/O module A of the D2700 storage enclosure. Port 2E shall not be connected. Please refer to annex section for port identification.

Documentation on HP servers & storage array is available on HP web site or using Product bulletin tool. It includes server size, weight, BTU, power information.... The HP Product Bulletin is a free application that only takes a few minutes to download. The download site is located at

http://h18004.www1.hp.com/products/quickspecs/productBulletin.html#CD_Files

Required HP power for a cabinet can be estimated using HP Power advisor tool available on HP web site:

<http://www8.hp.com/us/en/products/servers/solutions.html?compURI=1439951#.UxSoL7QUdtk>

OS and PIC management software installation and configuration on HP, are provided in PIC 10.2 Installation guide available on Oracle Technology Network site. Note that customer shall have Weblogic 11g and Oracle Enterprise Edition 11g and partitioning option licenses, or Oracle Technology Foundation for Monitoring Applications license for this server, before starting the installation.

Hardware Installation Guidelines

OS and PIC software installation and configuration of management server on HP servers are provided in Management Server (NSP) on Third-Party Server Installation Guide for Performance Intelligence Center (PIC) products (Doc ID 2062544.1) available on My Oracle Support site.

9.7 Configuration set 7 (HP DL360 Gen8 v1 + D2700)

Configuration set 7 is composed of:

- One HP DL360 Gen8 v1 server
- One D2700 storage array

HP Gen8 v1 server and storage D2700 are available in AC only
The HP server shall be connected to the storage array

HP P/N	Technical description	Qty (AC only)
655651-B21	HP DL360p Gen8 4-LFF CTO Server	1
647899-B21	HP 8GB 1Rx4 PC3-12800R-11 Kit	4
652238-B21	HP 9.5mm SATA DVD ROM Jb Kit	1
684208-B21	HP Ethernet 1GbE 4P 331FLR FIO Adptr	1
661069-B21	HP 512MB FWC for P series smart array	1
512485-B21	HP iLO Advanced including 1yr 24x7 Technical Support and Updates Single Server License	1
654768-L21	HP DL360p Gen 8 E52630 FIO kit	1
654768-B21	HP DL360p Gen 8 E52630 kit	1
652620-B21	HP 600GB 6G SAS 15K 3.5in SC ENT HDD	2
663202-B21	HP 1U LFF BB Gen8 Rail Kit	1
503296-B21	HP 460W CS Gold Ht Plg Pwr Supply Kit	2
631673-B21	Smart Array P421/1GB FBWC Controller	1
Storage Array:		
AJ941A	HP D2700 Disk Enclosure	1
507127-B21	HP 300GB 6G SAS 10K 2.5in DP ENT HDD	10

Table 8: Configuration set 7 with HP DL360 Gen8 v1 + D2700

In addition, 4 power cords shall be ordered according to installation country or Power distribution unit installed in the frame (2 for the HP server and 2 for the D2700 enclosure).

All pre-configured servers with standard AC power supply option kit, ship with one standard 6-foot IEC C-13/C-14 jumper cord per power supply. If a different power cord is required, please check HP web site

Customer can perform following adaptations on previous BOM:

- CPU: other CPUs are supported.
Pre-requisite: 8 cores minimum (on one or 2 processors)
- Memory: Other memory allocation is supported.

Hardware Installation Guidelines

Pre-requisite: 32 GB minimum.

- Storage Array Disks: customer can select other disks (as far as supported by the D2700)
Pre-requisites:
 - all disks in the storage array shall have same storage capacity
 - Disks shall be installed in position 1 to 10 in the storage array (see annex section for drive bay numbering).
- Server Disk type and size: other disks are supported
Pre-requisite: 2 disks minimum
both disks shall have same storage capacity
600 GB disk storage capacity (per disk) minimum.

Note that customer changes can affect server and system performances and ability to upgrade in future releases.

Internal disks shall be connected to SAS A.

For D2700, Port 1E of SAS controller card in the HP server shall be connected to the port P1 of the I/O module A of the D2700 storage enclosure. Port 2E shall not be connected. Please refer to annex section for port identification.

Documentation on HP servers & storage array is available on HP web site or using Product bulletin tool. It includes server size, weight, BTU, power information.... The HP Product Bulletin is a free application that only takes a few minutes to download. The download site is located at

http://h18004.www1.hp.com/products/quickspecs/productBulletin.html#CD_Files

Required HP power for a cabinet can be estimated using HP Power advisor tool available on HP web site:

<http://www8.hp.com/us/en/products/servers/solutions.html?compURI=1439951#.UxSoL7QUdtk>

OS and PIC management software installation and configuration on HP, are provided in PIC 10.2 Installation guide available on Oracle Technology Network site. Note that customer shall have Weblogic 11g and Oracle Enterprise Edition 11g and partitioning option licenses, or Oracle Technology Foundation for Monitoring Applications license for this server, before starting the installation.

OS and PIC software installation and configuration of management server on HP servers are provided in Management Server (NSP) on Third-Party Server Installation Guide for Performance Intelligence Center (PIC) products (Doc ID 2062544.1) available on My Oracle Support site.

9.8 Configuration set 8 (HP DL360 G6 + D2700)

Configuration set 6 is composed of:

- One HP DL360 G6 server
- One D2700 storage array

HP G6 server and storage D2700 are available in AC only

The HP server shall be connected to the storage array

HP P/N	Technical description	Qty
484184-B21	HP ProLiant DL360 G6 Rack CTO Chassis	1
505880-L21	HP E5540 DL360 G6 FIO Kit	1
505880-B21	HP E5540 DL360 G6 Kit	1

Hardware Installation Guidelines

500658-B21	HP 4GB 2Rx4 PC3-10600R-9 Kit	6
507127-B21	HP 300GB 10K 6G 2.5 SAS DP HDD ((Installed in drive bay 1 & 2)	2
532068-B21	HP DL360G6 12.7mm SATA DVD-RW Kit	1
462968-B21 or 534108-B21	HP 256MB FIO P-Series Cache Mod	1
503296-B21	HP 460W HE 12V Hotplg AC Pwr Supply Kit	2
512485-B21	HP iLO Adv 1-Svr incl 1yr TS/U SW	1
578229-B21	HP Smart Array P411/512MB FBWC (Installed in slot 1)	1
Storage Array:		
AJ941A	HP D2700 Disk Enclosure	1
507127-B21	HP 300GB 6G SAS 10K 2.5in DP ENT HDD	10

Table 9: Configuration set 8 with HP DL360 G6 + D2700

In addition, 4 power cords shall be ordered according to installation country or Power distribution unit installed in the frame (2 for the HP server and 2 for the D2700 enclosure).

Pre-configured server with standard AC power supply option kit, ships with one standard 6-foot IEC C-13/C-14 jumper cord per power supply. If a different power cord is required, please check HP web site

Customer can perform following adaptations on previous BOM:

- CPU: other CPUs are supported.
Pre-requisite: 8 cores minimum (on one or 2 processors)
- Memory: Other memory allocation is supported.
Pre-requisite: 24 GB minimum.
- Storage Array Disks: customer can select other disks (as far as supported by the D2700)
Pre-requisites:
 - all disks in the storage array shall have same storage capacity
 - Disks shall be installed in position 1 to 10 in the storage array (see annex section for drive bay numbering).
- Server Disks: other disks are supported
Pre-requisite: 2 disks minimum
Server's disks shall have same storage capacity
600 GB disk storage capacity (per disk) minimum.

Note that customer changes can affect server and system performances and ability to upgrade in future releases.

Internal disks shall be connected to SAS A.

For D2700, Port 1E of SAS controller card in the HP server shall be connected to the port P1 of the I/O module A of the D2700 storage enclosure. Port 2E shall not be connected. Please refer to annex section for port identification.

Documentation on HP servers & storage array is available on HP web site or using Product bulletin tool. It includes server size, weight, BTU, power information.... The HP Product Bulletin is a free application that only takes a few minutes to download. The download site is located at

http://h18004.www1.hp.com/products/quickspecs/productBulletin.html#CD_Files

Required HP power for a cabinet can be estimated using HP Power advisor tool available on HP web site:

<http://www8.hp.com/us/en/products/servers/solutions.html?compURI=1439951#.UxSoL7QUdtk>

Hardware Installation Guidelines

OS and PIC management software installation and configuration on HP, are provided in PIC 10.2 Installation guide available on Oracle Technology Network site. Note that customer shall have Weblogic 11g and Oracle Enterprise Edition 11g and partitioning option licenses, or Oracle Technology Foundation for Monitoring Applications license for this server, before starting the installation.

OS and PIC software installation and configuration of management server on HP servers are provided in Management Server (NSP) on Third-Party Server Installation Guide for Performance Intelligence Center (PIC) products (Doc ID 2062544.1) available on My Oracle Support site.

9.9 Configuration set 10 (Oracle X5-2)

Oracle X5-2 is available in AC only

Oracle SKU	Technical description	Qty (AC only)
7112843	Oracle Server X5-2 for Communications: 1 RU base chassis with motherboard,	1
7110339	XATO,DISK_CAGE,2.5" X 8HDD	1
7110346	ATO,E5-2699 V3,2.3G,145W,18 CORE,C-1 (SR1XD),CPU	2
7110350	XATO,HEATSINK,CPU,1U	2
7110360	XATO,OSA 8 GB MLC USB FLASH DRIVE	1
7110359	ATO,DVD,GEN5,BLANK FILLER PANEL,1U/2U	1
7102748	ATO PCIe FILLER,VENTED,LOW PROFILE	3
7110353	XATO,DIMM,16GB,DDR4,2133	8
7111107	1.2 TB 10000 rpm 2.5-inch SAS-3 HDD with marlin bracket (for factory installation)	2

Table 10: configuration set 10 with Oracle X5-2

In addition, 2 power cords shall be ordered according to installation country or Power distribution unit installed in the frame.

Customer can perform following adaptations on previous BOM:

- CPU: other CPUs are supported.
Pre-requisite: 8 cores minimum (on one or 2 processors)
- Memory: Other memory allocation is supported.
Pre-requisite: 16GB minimum.
- Disk type and size: other disks are supported
Pre-requisite: 2 disks minimum
all disks shall have same storage capacity
600 GB disk storage capacity (per disk) minimum.

Note that customer changes can affect server and system performances and ability to upgrade in future releases.

For server size, weight, BTU, power information.... Documentations are available at http://docs.oracle.com/cd/E41059_01/

Hardware Installation Guidelines

Please refer to Setup and Installation section for Oracle hardware installation. This document will drive you through the initial installation steps:

- Server installation in the rack.
- Attaching network and power Cables
- Booting Up the First Time
- Launching Oracle System Assistant to configure:
 - Server's network connection
 - Install latest server firmware
 - Configure Oracle ILOM and BIOS,
 - Configure hardware

OS and PIC software installation on Oracle hardware server are provided in PIC 10.2 Installation guide available on Oracle Technology Network site.

9.10 Configuration set 11 (Oracle Netra X5-2)

Oracle Netra X5-2 is available in AC and DC
 Oracle Netra X5-2 is NEBS compliant.

Oracle SKU	Technical description	Qty DC	Qty AC
7111082	Netra Server X5-2: 2 RU AC base chassis with motherboard and 8 HDDs	-	1
7111083	Netra Server X5-2: 2 RU DC base chassis with motherboard and 8 HDDs	1	-
7110346	Intel® Xeon® E5-2699 v3 18-core 2.3 GHz processor	2	2
7102981	Heat sink	2	2
7111036	One 16 GB DDR4-2133 DIMM	8	8
7111043	Memory filler panels	16	16
7111107	One 1.2 TB 10000 rpm 2.5-inch SAS-3 HDD with marlin bracket	2	2
7110116	Oracle Storage 12 Gb SAS PCIe RAID HBA, internal: 8 port and 1 GB memory	1	1
5394A	PCIe filler panel	5	5
7901A-4	19-inch 2-post rackmount kit	1	1
7111044	SAS cable kit	1	1
7111052	OSA 8 GB USB stick	1	1

Table 11: configuration set 11 with Oracle Netra X5-2 2 SFF

In addition, 2 power cords shall be ordered according to installation country or Power distribution unit installed in the frame.

Customer can perform following adaptations on previous BOM:

- CPU: other CPUs are supported.
 Pre-requisite: 8 cores minimum (on one or 2 processors)

Hardware Installation Guidelines

- Memory: Other memory allocation is supported.
Pre-requisite: 16 GB minimum.
- Disk type and size: other disks are supported
Pre-requisite: 2 disks minimum
all disks shall have same storage capacity
600 GB disk storage capacity (per disk) minimum.

Note that customer changes can affect server and system performances and ability to upgrade in future releases.

For server size, weight, BTU, power information.... Documentations are available at http://docs.oracle.com/cd/E53596_01/

Please refer to Setup and Installation section for Oracle hardware installation. This document will drive you through the initial installation steps:

- Server installation in the rack.
- Attaching network and power Cables
- Booting Up the First Time
- Launching Oracle System Assistant to configure:
 - Server's network connection
 - Install latest server firmware
 - Configure Oracle ILOM and BIOS,
 - Configure hardware

OS and PIC software installation on Oracle hardware server are provided in PIC 10.2 Installation guide available on Oracle Technology Network site.

9.11 Configuration set 12 (HP DL360 Gen9 v2)

HP DL360 Gen9 v2 is available in AC and DC

HP P/N	Technical description	Qty AC	Qty DC
755258-B21	HP ProLiant DL360 Gen9 8SFF Configure-to-order Server	1	1
818184-B21	HPE DL360 Gen9 Intel® Xeon® E5-2680v4 (2.4GHz/14-core/35MB/120W) Processor Kit	1	1
818184-L21	HPE DL360 Gen9 Intel® Xeon® E5-2680v4 (2.4GHz/14-core/35MB/120W) FIO Processor Kit	1	1
805349-B21	HP 16GB (1x16GB) Single Rank x4 DDR4-2400 CAS-17-17-17 Registered Memory Kit	4	4
785069-B21	HP 900GB 12G SAS 10K rpm SFF (2.5-inch) SC Enterprise 3yr Warranty Hard Drive (Install in Drive Bays 1 and 2)	2	2
749974-B21	HP Smart Array P440ar/2GB FBWC 12Gb 2-ports Int FIO SAS Controller	1	1
720479-B21	HP 800W Flex Slot Platinum Hot Plug Power Supply Kit - AC	2	-
720480-B21	HP 800 W Flex Slot-48VDC Hot Plug Power Supply Kit	-	2

Hardware Installation Guidelines

512485-B21	HP iLO Advanced incl 1yr 24x7 Tech Support and Updates Single Server License	1	1
663201-B21	HP 1U Small Form Factor Ball Bearing Rail	1	1
764636-B21	HP DL360 Gen9 SFF Systems Insight Display Kit	1	1
758959-B22	HP LEGACY FIO MODE SETTING	1	1
764646-B21	HP DL360 Gen9 Rear Serial Port and Enablement Kit	1	1

Table 12: Configuration set 12 with HP DL360 Gen9 v2 2 SFF

Note: Optionally to access to switch console port, a serial cable shall be added.

In addition, for each HP server, 2 power cords shall be ordered according to installation country or Power distribution unit installed in the frame.

For AC, all pre-configured servers with standard AC power supply option kit, ship with one standard 6-foot IEC C-13/C-14 jumper cord per power supply (for HP Gen9: reference A0K02A). If a different power cord is required, please check HP web site

Customer can perform following adaptations on previous BOM:

- CPU: other CPUs are supported.
Pre-requisite: 8 cores minimum (on one or 2 processors)
- Memory: Other memory allocation is supported.
Pre-requisite: 16 GB minimum.
- Disk type and size: other disks are supported
Pre-requisite: 2 disks minimum
all disks shall have same storage capacity
600 GB disk storage capacity (per disk) minimum.

Note that customer changes can affect server and system performances and ability to upgrade in future releases.

Internal disks shall be connected to SAS A.

Documentation on HP servers & storage array is available on HP web site or using Product bulletin tool. It includes server size, weight, BTU, power information.... The HP Product Bulletin is a free application that only takes a few minutes to download. The download site is located at

http://h18004.www1.hp.com/products/quickspecs/productBulletin.html#CD_Files

Required HP power for a cabinet can be estimated using HP Power advisor tool available on HP web site:

<http://www8.hp.com/us/en/products/servers/solutions.html?compURI=1439951#.UxSoL7QUdtk>

OS and PIC management software installation and configuration on HP, are provided in PIC 10.2 Installation guide available on Oracle Technology Network site. Note that customer shall have Weblogic 11g and Oracle Enterprise Edition 11g and partitioning option licenses, or Oracle Technology Foundation for Monitoring Applications license for this server, before starting the installation.

OS and PIC software installation and configuration of management server on HP servers are provided in Management Server (NSP) on Third-Party Server Installation Guide for Performance Intelligence Center (PIC) products (Doc ID **2062544.1**) available on My Oracle Support site.

9.12 Configuration set 13 (HP DL360 Gen9 v1)

HP DL360 Gen9 v1 is available in AC and DC

HP P/N	Technical description	Qty AC	Qty DC
755258-B21	HP ProLiant DL360 Gen9 8SFF Configure-to-order Server	1	1
755394-L21	E5-2680v3 HP DL360 Gen9 Intel® Xeon® E5-2680v3 (2.5GHz/12-core/30MB/120W) Processor Kit	1	1
755394-B21	E5-2680v3 HP DL360 Gen9 Intel® Xeon® E5-2680v3 (2.5GHz/12-core/30MB/120W) Processor Kit	1	1
726719-B21	HP 16GB (1x16GB) Dual Rank x4 DDR4-2133 CAS-15-15-15 Registered Memory Kit	4	4
785069-B21	HP 900GB 12G SAS 10K rpm SFF (2.5-inch) SC Enterprise 3yr Warranty Hard Drive (Install in Drive Bays 1 and 2)	2	2
749974-B21	HP Smart Array P440ar/2GB FBWC 12Gb 2-ports Int FIO SAS Controller	1	1
720479-B21	HP 800W Flex Slot Platinum Hot Plug Power Supply Kit - AC	2	-
720480-B21	HP 800 W Flex Slot-48VDC Hot Plug Power Supply Kit	-	2
512485-B21	HP iLO Advanced incl 1yr 24x7 Tech Support and Updates Single Server License	1	1
663201-B21	HP 1U Small Form Factor Ball Bearing Rail	1	1
764636-B21	HP DL360 Gen9 SFF Systems Insight Display Kit	1	1
758959-B22	HP LEGACY FIO MODE SETTING	1	1
764646-B21	HP DL360 Gen9 Rear Serial Port and Enablement Kit	1	1

Table 13: Configuration set 13 with HP DL360 Gen9 v1

Note: Optionally to access to switch console port, a serial cable shall be added.

In addition, for each HP server, 2 power cords shall be ordered according to installation country or Power distribution unit installed in the frame.

For AC, all pre-configured servers with standard AC power supply option kit, ship with one standard 6-foot IEC C-13/C-14 jumper cord per power supply (for HP Gen9: reference A0K02A). If a different power cord is required, please check HP web site

Customer can perform following adaptations on previous BOM:

- CPU: other CPUs are supported.
Pre-requisite: 8 cores minimum (on one or 2 processors)
- Memory: Other memory allocation is supported.
Pre-requisite: 16 GB minimum.
- Disk type and size: other disks are supported
Pre-requisite: 2 disks minimum
all disks shall have same storage capacity
600 GB disk storage capacity (per disk) minimum.

Note that customer changes can affect server and system performances and ability to upgrade in future releases.

Internal disks shall be connected to SAS A.

Hardware Installation Guidelines

Documentation on HP servers & storage array is available on HP web site or using Product bulletin tool. It includes server size, weight, BTU, power information.... The HP Product Bulletin is a free application that only takes a few minutes to download. The download site is located at

http://h18004.www1.hp.com/products/quickspecs/productBulletin.html#CD_Files

Required HP power for a cabinet can be estimated using HP Power advisor tool available on HP web site:

<http://www8.hp.com/us/en/products/servers/solutions.html?compURI=1439951#.UxSoL7QUDtk>

OS and PIC management software installation and configuration on HP, are provided in PIC 10.2 Installation guide available on Oracle Technology Network site. Note that customer shall have Weblogic 11g and Oracle Enterprise Edition 11g and partitioning option licenses, or Oracle Technology Foundation for Monitoring Applications license for this server, before starting the installation.

OS and PIC software installation and configuration of management server on HP servers are provided in Management Server (NSP) on Third-Party Server Installation Guide for Performance Intelligence Center (PIC) products (Doc ID 2062544.1) available on My Oracle Support site.

9.13 Configuration set 14 (HP DL360 Gen8 v2)

HP DL360 Gen8 v2 is available in AC only

HP P/N	Technical description	Qty (AC only)
654081-B21	HP ProLiant DL360p Gen8 8 SFF Configure-to-order Server	1
708641-B21	HP 16GB 2Rx4 PC3-14900R-13 Kit	4
652241-B21	HP 9.5mm SATA DVD RW JackBlack Optical Drive	1
684208-B21	HP Ethernet 1Gb 4-port 331FLR FIO Adapter	1
631679-B21	HP 1GB P-series Smart Array Flash Backed Write Cache	1
512485-B21	HP iLO Advanced including 1yr 24x7 Technical Support and Updates Single Server License	1
712506-L21	HP DL360p Gen8 Intel Xeon E5-2680v2 (2.8GHz/10-core/25MB/115W) Processor Kit	1
712506-B21	HP DL360p Gen8 Intel Xeon E5-2680v2 (2.8GHz/10-core/25MB/115W) FIO Processor Kit	1
652583-B21	HP 600GB 6G SAS 10K rpm SFF (2.5-inch) SC Enterprise 3yr Warranty Hard Drive	2
734807-B21	HP 1U Small Form Factor Easy Install Rail Kit	1
656363-B21	HP 750W Common Slot Platinum Plus Hot Plug Power Supply Kit	2

Table 14: Configuration set 14 with HP DL360 Gen8 v2

Note : This BOM is intended for PIC 10.1.x. For older release of PIC, please use only 32GB of RAM: 2 x 708641-B21 (HP 16GB 2Rx4 PC3-14900R-13 Kit)

In addition, for each HP server, 2 power cords shall be ordered according to installation country or Power distribution unit installed in the frame.

Hardware Installation Guidelines

For AC, all pre-configured servers with standard AC power supply option kit, ship with one standard 6-foot IEC C-13/C-14 jumper cord per power supply (for HP Gen9: reference A0K02A). If a different power cord is required, please check HP web site

Customer can perform following adaptations on previous BOM:

- CPU: other CPUs are supported.
Pre-requisite: 8 cores minimum (on one or 2 processors)
- Memory: Other memory allocation is supported.
Pre-requisite: 16 GB minimum.
- Disk type and size: other disks are supported
Pre-requisite: 2 disks minimum
all disks shall have same storage capacity
600 GB disk storage capacity (per disk) minimum.

Note that customer changes can affect server and system performances and ability to upgrade in future releases.

Internal disks shall be connected to SAS A.

Documentation on HP servers & storage array is available on HP web site or using Product bulletin tool. It includes server size, weight, BTU, power information.... The HP Product Bulletin is a free application that only takes a few minutes to download. The download site is located at

http://h18004.www1.hp.com/products/quickspecs/productBulletin.html#CD_Files

Required HP power for a cabinet can be estimated using HP Power advisor tool available on HP web site:

<http://www8.hp.com/us/en/products/servers/solutions.html?compURI=1439951#.UxSoL7QUdtk>

OS and PIC management software installation and configuration on HP, are provided in PIC 10.2 Installation guide available on Oracle Technology Network site. Note that customer shall have Weblogic 11g and Oracle Enterprise Edition 11g and partitioning option licenses, or Oracle Technology Foundation for Monitoring Applications license for this server, before starting the installation.

OS and PIC software installation and configuration of management server on HP servers are provided in Management Server (NSP) on Third-Party Server Installation Guide for Performance Intelligence Center (PIC) products (Doc ID 2062544.1) available on My Oracle Support site.

9.14 Configuration set 15 (HP DL360 Gen8 v1)

HP DL360 Gen8 v1 is available in AC only

HP P/N	Technical description	Qty (AC only)
655651-B21	HP DL360p Gen8 4-LFF CTO Server	1
647899-B21	HP 8GB 1Rx4 PC3-12800R-11 Kit	4
652238-B21	HP 9.5mm SATA DVD ROM Jb Kit	1
684208-B21	HP Ethernet 1GbE 4P 331FLR FIO Adptr	1
661069-B21	HP 512MB FWC for P series smart array	1
512485-B21	HP iLO Advanced including 1yr 24x7 Technical Support and Updates Single Server License	1
654768-L21	HP DL360p Gen 8 E52630 FIO kit	1

Hardware Installation Guidelines

654768-B21	HP DL360p Gen 8 E52630 kit	1
652620-B21	HP 600GB 6G SAS 15K 3.5in SC ENT HDD	2
663202-B21	HP 1U LFF BB Gen8 Rail Kit	1
503296-B21	HP 460W CS Gold Ht Plg Pwr Supply Kit	2

Table 15: Configuration set 15 with HP DL360 Gen8 v1

In addition, for each HP server, 2 power cords shall be ordered according to installation country or Power distribution unit installed in the frame.

For AC, all pre-configured servers with standard AC power supply option kit, ship with one standard 6-foot IEC C-13/C-14 jumper cord per power supply (for HP Gen9: reference A0K02A). If a different power cord is required, please check HP web site

Customer can perform following adaptations on previous BOM:

- CPU: other CPUs are supported.
Pre-requisite: 8 cores minimum (on one or 2 processors)
- Memory: Other memory allocation is supported.
Pre-requisite: 16 GB minimum.
- Disk type and size: other disks are supported
Pre-requisite: 2 disks minimum
all disks shall have same storage capacity
600 GB disk storage capacity (per disk) minimum.

Note that customer changes can affect server and system performances and ability to upgrade in future releases.

Internal disks shall be connected to SAS A.

Documentation on HP servers & storage array is available on HP web site or using Product bulletin tool. It includes server size, weight, BTU, power information.... The HP Product Bulletin is a free application that only takes a few minutes to download. The download site is located at

http://h18004.www1.hp.com/products/quickspecs/productBulletin.html#CD_Files

Required HP power for a cabinet can be estimated using HP Power advisor tool available on HP web site:

<http://www8.hp.com/us/en/products/servers/solutions.html?compURI=1439951#.UxSoL7QUdtk>

OS and PIC management software installation and configuration on HP, are provided in PIC 10.2 Installation guide available on Oracle Technology Network site. Note that customer shall have Weblogic 11g and Oracle Enterprise Edition 11g and partitioning option licenses, or Oracle Technology Foundation for Monitoring Applications license for this server, before starting the installation.

OS and PIC software installation and configuration of management server on HP servers are provided in Management Server (NSP) on Third-Party Server Installation Guide for Performance Intelligence Center (PIC) products (Doc ID 2062544.1) available on My Oracle Support site.

9.15 Configuration set 16 (HP DL360 G6)

HP DL360 G6 is available in AC only

HP P/N	Technical description	Qty AC
484184-B21	HP ProLiant DL360 G6 Rack CTO Chassis	1
505880-L21	HP E5540 DL360 G6 FIO Kit	1
505880-B21	HP E5540 DL360 G6 Kit	1
500658-B21	HP 4GB 2Rx4 PC3-10600R-9 Kit	6
507127-B21	HP 300GB 10K 6G 2.5 SAS DP HDD ((Installed in drive bay 1 & 2)	2
532068-B21	HP DL360G6 12.7mm SATA DVD-RW Kit	1
462968-B21 or 534108-B21	HP 256MB FIO P-Series Cache Mod	1
503296-B21	HP 460W HE 12V Hotplg AC Pwr Supply Kit	2
512485-B21	HP iLO Adv 1-Svr incl 1yr TS/U SW	1

Table 16: Configuration set 16 with HP DL360 G6

In addition, for each HP server, 2 power cords shall be ordered according to installation country or Power distribution unit installed in the frame.

For AC, all pre-configured servers with standard AC power supply option kit, ship with one standard 6-foot IEC C-13/C-14 jumper cord per power supply (for HP Gen9: reference A0K02A). If a different power cord is required, please check HP web site

Customer can perform following adaptations on previous BOM:

- CPU: other CPUs are supported.
Pre-requisite: 8 cores minimum (on one or 2 processors)
- Memory: Other memory allocation is supported.
Pre-requisite: 16 GB minimum.
- Disk type and size: other disks are supported
Pre-requisite: 2 disks minimum
all disks shall have same storage capacity
600 GB disk storage capacity (per disk) minimum.

Note that customer changes can affect server and system performances and ability to upgrade in future releases.

Internal disks shall be connected to SAS A.

Documentation on HP servers & storage array is available on HP web site or using Product bulletin tool. It includes server size, weight, BTU, power information.... The HP Product Bulletin is a free application that only takes a few minutes to download. The download site is located at

http://h18004.www1.hp.com/products/quickspecs/productBulletin.html#CD_Files

Required HP power for a cabinet can be estimated using HP Power advisor tool available on HP web site:

<http://www8.hp.com/us/en/products/servers/solutions.html?compURI=1439951#.UxSoL7QUdtk>

OS and PIC management software installation and configuration on HP, are provided in PIC 10.2 Installation guide available on Oracle Technology Network site. Note that customer shall have Weblogic 11g and Oracle Enterprise Edition

Hardware Installation Guidelines

11g and partitioning option licenses, or Oracle Technology Foundation for Monitoring Applications license for this server, before starting the installation.

OS and PIC software installation and configuration of management server on HP servers are provided in Management Server (NSP) on Third-Party Server Installation Guide for Performance Intelligence Center (PIC) products (Doc ID 2062544.1) available on My Oracle Support site.

9.16 Configuration set 17 (Oracle ZFS)

ZFS ZS3-2 is available in AC only

Oracle SKU	Technical description	Qty (AC only)
7106195	Oracle ZFS Storage ZS3-2 appliance...	1
7103796	Oracle ZFS Storage ZS3-2: model family...	1
7103829	Oracle ZFS Storage ZS3-2: controller	1
7102984	One 16 GB DDR3-1600 registered DIMM	16
5394A	PCIe filler panel	4
6331A-N	2.5-inch HDD filler panel	4
7103898	Oracle Storage Drive Enclosure DE2-24P: model...	1
7103910	Oracle Storage Drive Enclosure DE2-24P: base chassis	1
7103912	One 900 GB 10000 rpm 2.5 inch SAS-2 HDD with evo bracket	24

Table 17: Configuration set 17 with ZFS

In addition, 2 power cords shall be ordered according to installation country or Power distribution unit installed in the frame. Example for international: Power cord International, 4 meters, IEC309-I... is 333R-40-10-309.

Two additional storage array can be added if more storage capacity is required.

Oracle SKU	Technical description	Qty (AC only)
7103910	Oracle Storage Drive Enclosure DE2-24P: base chassis (for factory installation)	1
7103912	One 900 GB 10000 rpm 2.5 inch SAS-2 HDD with evo bracket (for factory installation)	24

Two additional power cords shall be added for each additional storage array.

For server size, weight, BTU, power information... documentation is available at: http://docs.oracle.com/cd/E56021_01/index.html

The documentation will drive you through the Oracle hardware installation steps and information:

- Hardware Overview
 - Controller Overview
 - Physical Specifications

- Electrical Specifications
- Acoustic Noise Emissions
- Internal Components
- Motherboard, Memory, and PCIe Cards
- Optional Cable Management Arm
- Attached Storage
- ZS3-2 Controller Installation Tasks
- Cabling
- Powering On and Configuring the System
 - Connecting to ILOM
 - Powering On the Appliance
 - Completing Configuration

It is strongly recommended to refer to PIC 10.2 Installation guide available on Oracle Technology Network site before starting installation of ZFS. More specific details are provided for installation of ZS3-2 ZFS for PIC PDU storage.

9.17 Configuration set 18 (Oracle X6-2L)

Oracle X6-2L is available in AC only

Oracle SKU	Technical description	Qty (AC only)
7113278	Oracle Server X6-2L: 2 RU base chassis with motherboard, internal 12 Gb SAS RAID HBA, 2 PSUs, slide rail kit, and cable management arm	1
7113239	One Intel® Xeon® E5-2630 v4 10-core 2.2 GHz processor	2
7110351	Heat sink for 2U	2
7113240	One 16 GB DDR4-2400 registered DIMM	4
7113280	Twenty-four 2.5-inch drive slots disk cage and two 2.5-inch drive rear slots disk cage	1
7111107	One 1.2 TB 10000 rpm 2.5-inch SAS-3 HDD with marlin bracket	14 or 26
6331A-N	2.5-inch HDD filler panel	12 or 0
7110359	DVD filer panel	1
7102748	PCIe filler panel	5

Table 18: Configuration set 17 with Oracle X6-2L

Warning: an USB flash drive (8GB) will be required for initial installation or disaster recovery

In addition, 2 power cords shall be ordered according to installation country or Power distribution unit installed in the frame.

Customer can perform following adaptations on previous BOM:

- CPU: other CPUs are supported.
Pre-requisite: 10 cores minimum (on one or 2 processors)
Note that Ethernet ports Eth03 and Eth04 (NET2 and NET3) are non-functional in single-processor systems.

Hardware Installation Guidelines

- Memory: Other memory allocation is supported.
Pre-requisite: 24 GB minimum.
- Disk type and size: other disks are supported
Pre-requisite: 10 disks minimum
all disks shall have same storage capacity
600 GB disk storage capacity (per disk) minimum.

Note that customer changes can affect server and system performances and ability to upgrade in future releases.

For server size, weight, BTU, power information.... documentation is available at http://docs.oracle.com/cd/E62172_01/index.html

The documentation will drive you through the Oracle hardware installation steps and information:

- Hardware Overview
 - Controller Overview
 - Physical Specifications
 - Electrical Specifications
 - Acoustic Noise Emissions
 - Internal Components
 - Motherboard, Memory, and PCIe Cards
 - Optional Cable Management Arm
 - Attached Storage
- Cabling
- Powering On and Configuring the System
 - Connecting to ILOM
 - Powering On the Appliance
 - Completing Configuration

It is strongly recommended to refer to PIC 10.2 Installation guide available on Oracle Technology Network site before starting installation of X6-2L.

9.18 Configuration set 19 (HP DL380 Gen9 v2)

HP DL380 Gen9 v2 is available in AC and DC

HP P/N	Technical description	Qty AC	Qty DC
767032-B21	HP ProLiant DL380 Gen9 24SFF	1	1
817951-L21	HPE DL380 Gen9 Intel® Xeon® E5-2680v4 (2.4GHz/14-core/35MB/120W) FIO Processor Kit	1	1
817951-B21	HPE DL380 Gen9 Intel® Xeon® E5-2680v4 (2.4GHz/14-core/35MB/120W) Processor Kit	1	1
805349-B21	HP 16GB (1x16GB) Single Rank x4 DDR4-2400 CAS-17-17-17 Registered Memory Kit	4	4
749974-B21	HP Smart Array P440ar/2GB FBWC 12Gb 2-ports Int FIO SAS Controller	1	1
720479-B21	HP 800 W Flex Slot Platinum Hot Plug Power Supply Kit	2	-

Hardware Installation Guidelines

720480-B21	HP 800 W Flex Slot-48VDC Hot Plug Power Supply Kit	-	2
512485-B21	HP iLO Advanced including 1yr 24x7 Technical Support and Updates Single Server License	1	1
720863-B21	HP 2U Small Form Factor Ball Bearing Gen8 Rail Kit	1	1
720865-B21	HP 2U Cable Management Arm for Ball Bearing Rail Kit	1	1
768900-B21	HP DL380 Gen9 Systems Insight Display Kit	1	1
758959-B22	HP LEGACY FIO MODE SETTING	1	1
724864-B21	HP DL380 Gen9 2SFF Front/Rear SAS/SATA Kit	1	1
727250-B21	HP 12Gb SAS Expander Card with Cables for DL380 GEN9 (Install in Slot 2)	1	1
785069-B21	HP 900GB 12G SAS 10K rpm SFF (2.5-inch) SC Ent 3yr Warranty Hard Drive	26	26

Table 19: Configuration set 19 with HP DL380 Gen9 v2 24+2 SFF

In addition, for each HP server, 2 power cords shall be ordered according to installation country or Power distribution unit installed in the frame.

For AC, all pre-configured servers with standard AC power supply option kit, ship with one standard 6-foot IEC C-13/C-14 jumper cord per power supply (for HP Gen9: reference A0K02A). If a different power cord is required, please check HP web site

Customer can perform following adaptations on previous BOM:

- CPU: other CPUs are supported.
Pre-requisite: 8 cores minimum (on one or 2 processors)
- Memory: Other memory allocation is supported.
Pre-requisite: 24 GB minimum.
- Disk type and size: other disks are supported
Pre-requisite: 10 disks minimum
all disks shall have same storage capacity
600 GB disk storage capacity (per disk) minimum.

Note that customer changes can affect server and system performances and ability to upgrade in future releases.

Internal disks shall be connected to SAS A.

Documentation on HP servers & storage array is available on HP web site or using Product bulletin tool. It includes server size, weight, BTU, power information.... The HP Product Bulletin is a free application that only takes a few minutes to download. The download site is located at

http://h18004.www1.hp.com/products/quickspecs/productBulletin.html#CD_Files

Required HP power for a cabinet can be estimated using HP Power advisor tool available on HP web site:

<http://www8.hp.com/us/en/products/servers/solutions.html?compURI=1439951#.UxSoL7QUdtk>

OS and PIC management software installation and configuration on HP, are provided in PIC 10.2 Installation guide available on Oracle Technology Network site. Note that customer shall have Weblogic 11g and Oracle Enterprise Edition 11g and partitioning option licenses, or Oracle Technology Foundation for Monitoring Applications license for this server, before starting the installation.

OS and PIC software installation and configuration of management server on HP servers are provided in Management Server (NSP) on Third-Party Server Installation Guide for Performance Intelligence Center (PIC) products (Doc ID 2062544.1) available on My Oracle Support site.

Hardware Installation Guidelines

9.19 Configuration set 20 (HP DL380 Gen9 v1)

HP DL380 Gen9 v1 is available in AC and DC

HP P/N	Technical description	Qty AC	Qty DC
767032-B21	HP ProLiant DL380 Gen9 24SFF Configure-to-order Server	1	1
762766-L21	HP DL380 Gen9 Intel® Xeon® E5-2680v3 (2.5GHz/12-core/30MB/120W) FIO Processor Kit	1	1
762766-B21	HP DL380 Gen9 Intel® Xeon® E5-2680v3 (2.5GHz/12-core/30MB/120W) FIO Processor	1	1
726719-B21	HP 16GB (1x16GB) Dual Rank x4 DDR4-2133 CAS-15-15-15 Reg Memory Kit	4	4
749974-B21	HP Smart Array P440ar/2GB FBWC 12Gb 2-ports Int FIO SAS Controller	1	1
720479-B21	HP 800 W Flex Slot Platinum Hot Plug Power Supply Kit	2	-
720480-B21	HP 800 W Flex Slot-48VDC Hot Plug Power Supply Kit	-	2
512485-B21	HP iLO Advanced including 1yr 24x7 Technical Support and Updates Single Server License	1	1
720863-B21	HP 2U Small Form Factor Ball Bearing Gen8 Rail Kit with CMA	1	1
720865-B21	HP 2U Cable Management Arm for Ball Bearing Rail Kit	1	1
768900-B21	HP DL380 Gen9 Systems Insight Display Kit	1	1
758959-B22	HP LEGACY FIO MODE SETTING	1	1
724864-B21	HP DL380 Gen9 2SFF Front/Rear SAS/SATA Kit	1	1
727250-B21	HP 12Gb SAS Expander Card with Cables for DL380 Gen9 (Install in Slot 2)	1	1
785069-B21	HP 900GB 12G SAS 10K rpm SFF (2.5-inch) SC Ent 3yr Warranty Hard Drive	26	26

Table 20: Configuration set 19 with HP DL380 Gen9 v1 24+2 SFF

In addition, for each HP server, 2 power cords shall be ordered according to installation country or Power distribution unit installed in the frame.

For AC, all pre-configured servers with standard AC power supply option kit, ship with one standard 6-foot IEC C-13/C-14 jumper cord per power supply (for HP Gen9: reference A0K02A). If a different power cord is required, please check HP web site

Customer can perform following adaptations on previous BOM:

- CPU: other CPUs are supported.
Pre-requisite: 8 cores minimum (on one or 2 processors)
- Memory: Other memory allocation is supported.
Pre-requisite: 24 GB minimum.
- Disk type and size: other disks are support
Pre-requisite: 10 disks minimum
all disks shall have same storage capacity

- 600 GB disk storage capacity (per disk) minimum.
- Server Disk type and size: other disks are supported
 - Pre-requisite: 2 disks minimum
 - both disks shall have same storage capacity
 - 600 GB disk storage capacity (per disk) minimum.

Note that customer changes can affect server and system performances and ability to upgrade in future releases.

Internal disks shall be connected to SAS A.

Documentation on HP servers & storage array is available on HP web site or using Product bulletin tool. It includes server size, weight, BTU, power information.... The HP Product Bulletin is a free application that only takes a few minutes to download. The download site is located at

http://h18004.www1.hp.com/products/quickspecs/productBulletin.html#CD_Files

Required HP power for a cabinet can be estimated using HP Power advisor tool available on HP web site:

<http://www8.hp.com/us/en/products/servers/solutions.html?compURI=1439951#.UxSoL7QUDtk>

OS and PIC management software installation and configuration on HP, are provided in PIC 10.2 Installation guide available on Oracle Technology Network site. Note that customer shall have Weblogic 11g and Oracle Enterprise Edition 11g and partitioning option licenses, or Oracle Technology Foundation for Monitoring Applications license for this server, before starting the installation.

OS and PIC software installation and configuration of management server on HP servers are provided in Management Server (NSP) on Third-Party Server Installation Guide for Performance Intelligence Center (PIC) products (Doc ID 2062544.1) available on My Oracle Support site.

9.20 Configuration set 21 (HP DL360 Gen8 v2 + D2700)

Configuration set 21 is composed of:

- One HP DL360 Gen8 v2 server
- One D2700 storage array

HP Gen8 v2 server and storage D2700 are available in AC only

The HP server shall be connected to the storage array

HP P/N	Technical description	Qty (AC only)
654081-B21	HP ProLiant DL360p Gen8 8 SFF Configure-to-order Server	1
708641-B21	HP 16GB 2Rx4 PC3-14900R-13 Kit	4
652241-B21	HP 9.5mm SATA DVD RW JackBlack Optical Drive	1
684208-B21	HP Ethernet 1Gb 4-port 331FLR FIO Adapter	1
631679-B21	HP 1GB P-series Smart Array Flash Backed Write Cache	1
512485-B21	HP iLO Advanced including 1yr 24x7 Technical Support and Updates Single Server License	1
712506-L21	HP DL360p Gen8 Intel Xeon E5-2680v2 (2.8GHz/10-core/25MB/115W) Processor Kit	1
712506-B21	HP DL360p Gen8 Intel Xeon E5-2680v2 (2.8GHz/10-core/25MB/115W) FIO Processor Kit	1

Hardware Installation Guidelines

652583-B21	HP 600GB 6G SAS 10K rpm SFF (2.5-inch) SC Enterprise 3yr Warranty Hard Drive	2
734807-B21	HP 1U Small Form Factor Easy Install Rail Kit	1
656363-B21	HP 750W Common Slot Platinum Plus Hot Plug Power Supply Kit	2
631673-B21	Smart Array P421/1GB FBWC Controller	1
Storage Array:		
AJ941A	HP D2700 Disk Enclosure	1
507127-B21	HP 300GB 6G SAS 10K 2.5in DP ENT HDD	25
or 581286-B21	HP 600 GB 2.5 inch 10000 rpm SAS HDD dual port	25

Table 21: Configuration set 21 with HP DL360 Gen8 v2 + D2700

Note : This BOM is intended for PIC 10.1.x. For older release of PIC, please use only 32GB of RAM: 2 x 708641-B21 (HP 16GB 2Rx4 PC3-14900R-13 Kit)

In addition, 4 power cords shall be ordered according to installation country or Power distribution unit installed in the frame (2 for the HP server and 2 for the D2700 enclosure),.

All pre-configured servers with standard AC power supply option kit, ship with one standard 6-foot IEC C-13/C-14 jumper cord per power supply. If a different power cord is required, please check HP web site

Customer can perform following adaptations on all HP qualified BOMs:

- CPU: other CPU is supported.
Pre-requisite: 8 cores minimum (on one or 2 processors)
- Memory: Other memory allocation is supported.
Pre-requisite: 24 GB minimum.
- Disk size and numbers on D2700:
Customer can select other storage disks (as far as supported by the D2700) with bigger sizes or fastest access.
Pre-requisites: all disks shall have same storage capacity
all D2700 slots shall be fully populated (25 disks).
- Server Disk type and size: other disks are supported
Pre-requisite: 2 disks minimum
both disks shall have same storage capacity
600 GB disk storage capacity (per disk) minimum.

Customer changes can affect server and system performances and ability to upgrade in future releases.

Hard disk in Bay 3 shall be connected to SAS connector A.

Port 1E of SAS controller card in the HP server shall be connected to the port P1 of the I/O module A of the D2700 storage enclosure. Port 2E shall not be connected. See annex section of this document for port selection and identification.

All Ethernet connectors are RJ45 1000 Base-TX compatible.

Documentation on HP servers & storage array is available on HP web site or using Product bulletin tool. It includes server size, weight, BTU, power information.... The HP Product Bulletin is a free application that only takes a few minutes to download. The download site is located at

http://h18004.www1.hp.com/products/quickspecs/productBulletin.html#CD_Files

Required HP power for a cabinet can be estimated using HP Power advisor tool available on HP web site:

<http://www8.hp.com/us/en/products/servers/solutions.html?compURI=1439951#.UxSoL7QUdtk>

OS and PIC software installation and configuration of Packet Data Unit Storage server on HP servers are provided in PIC Packet Data Unit Storage (PDU) Server on HP DL380 Gen 9 Installation (Doc ID 2034894.1) available on My Oracle Support site.

9.21 Configuration set 22 (HP DL360 Gen8 v1 + D2700)

Configuration set 22 is composed of:

- One HP DL360 Gen8 v1 server
- One D2700 storage array

HP Gen8 v1 server and storage D2700 are available in AC only
 The HP server shall be connected to the storage array

HP P/N	Technical description	Qty (AC only)
655651-B21	HP DL360p Gen8 4-LFF CTO Server	1
647899-B21	HP 8GB 1Rx4 PC3-12800R-11 Kit	4
652238-B21	HP 9.5mm SATA DVD ROM Jb Kit	1
684208-B21	HP Ethernet 1GbE 4P 331FLR FIO Adptr	1
661069-B21	HP 512MB FWC for P series smart array	1
512485-B21	HP iLO Advanced including 1yr 24x7 Technical Support and Updates Single Server License	1
654768-L21	HP DL360p Gen 8 E52630 FIO kit	1
654768-B21	HP DL360p Gen 8 E52630 kit	1
652620-B21	HP 600GB 6G SAS 15K 3.5in SC ENT HDD	2
663202-B21	HP 1U LFF BB Gen8 Rail Kit	1
503296-B21	HP 460W CS Gold Ht Plg Pwr Supply Kit	2
631673-B21	Smart Array P421/1GB FBWC Controller	1
Storage Array:		
AJ941A	HP D2700 Disk Enclosure	1
507127-B21	HP 300GB 6G SAS 10K 2.5in DP ENT HDD	25
or 581286-B21	HP 600 GB 2.5 inch 10000 rpm SAS HDD dual port	25

Table 22: Configuration set 22 with HP DL360 Gen8 v1 + D2700

In addition, 4 power cords shall be ordered according to installation country or Power distribution unit installed in the frame (2 for the HP server and 2 for the D2700 enclosure),.

For AC, all pre-configured servers with standard AC power supply option kit, ship with one standard 6-foot IEC C-13/C-14 jumper cord per power supply (for HP Gen9: reference A0K02A). If a different power cord is required, please check HP web site

Customer can perform following adaptations on all HP qualified BOMs:

- CPU: other CPU is supported.
Pre-requisite: 8 cores minimum (on one or 2 processors)
- Memory: Other memory allocation is supported.

Hardware Installation Guidelines

Pre-requisite: 24 GB minimum.

- Disk size and numbers on D2700:
Customer can select other storage disks (as far as supported by the D2700) with bigger sizes or fastest access.
Pre-requisites: all disks shall have same storage capacity
all D2700 slots shall be fully populated (25 disks).
- Server Disk type and size: other disks are supported
Pre-requisite: 2 disks minimum
both disks shall have same storage capacity
600 GB disk storage capacity (per disk) minimum.

Customer changes can affect server and system performances and ability to upgrade in future releases.

Hard disk in Bay 3 shall be connected to SAS connector A.

Port 1E of SAS controller card in the HP server shall be connected to the port P1 of the I/O module A of the D2700 storage enclosure. Port 2E shall not be connected. See annex section of this document for port selection and identification.

All Ethernet connectors are RJ45 1000 Base-TX compatible.

Documentation on HP servers & storage array is available on HP web site or using Product bulletin tool. It includes server size, weight, BTU, power information.... The HP Product Bulletin is a free application that only takes a few minutes to download. The download site is located at

http://h18004.www1.hp.com/products/quickspecs/productBulletin.html#CD_Files

Required HP power for a cabinet can be estimated using HP Power advisor tool available on HP web site:

<http://www8.hp.com/us/en/products/servers/solutions.html?compURI=1439951#.UxSoL7QUdtk>

OS and PIC software installation and configuration of Packet Data Unit Storage server on HP servers are provided in PIC Packet Data Unit Storage (PDU) Server Installation (Doc ID 2034894.1) available on My Oracle Support site.

9.22 Configuration set 23 (HP DL360 G6)

HP DL360 G6 is available in AC only

HP P/N	Technical description	Qty (AC only)
484184-B21	HP ProLiant DL360 G6 Rack CTO Chassis	1
505880-L21	HP E5540 DL360 G6 FIO Kit	1
505880-B21	HP E5540 DL360 G6 Kit	1
500658-B21	HP 4GB 2Rx4 PC3-10600R-9 Kit	6
507127-B21	HP 300GB 10K 6G 2.5 SAS DP HDD ((Installed in drive bay 1 & 2)	2
532068-B21	HP DL360G6 12.7mm SATA DVD-RW Kit	1
462968-B21 or 534108-B21	HP 256MB FIO P-Series Cache Mod	1
503296-B21	HP 460W HE 12V Hotplg AC Pwr Supply Kit	2
512485-B21	HP iLO Adv 1-Svr incl 1yr TS/U SW	1

Hardware Installation Guidelines

578229-B21	HP Smart Array P411/512MB FBWC (Installed in slot 1)	1
Storage Array:		
AJ941A	HP D2700 Disk Enclosure	1
507127-B21	HP 300GB 6G SAS 10K 2.5in DP ENT HDD	25
or 581286-B21	HP 600 GB 2.5 inch 10000 rpm SAS HDD dual port	25

Table 23: Configuration set 23 with HP DL360 G6 + D2700

In addition, 4 power cords shall be ordered according to installation country or Power distribution unit installed in the frame (2 for the HP server and 2 for the D2700 enclosure),.

For AC, all pre-configured servers with standard AC power supply option kit, ship with one standard 6-foot IEC C-13/C-14 jumper cord per power supply (for HP Gen9: reference A0K02A). If a different power cord is required, please check HP web site

Customer can perform following adaptations on all HP qualified BOMs:

- CPU: other CPU is supported.
Pre-requisite: 8 cores minimum (on one or 2 processors)
- Memory: Other memory allocation is supported.
Pre-requisite: 24 GB minimum.
- Disk size and numbers on D2700:
Customer can select other storage disks (as far as supported by the D2700) with bigger sizes or fastest access.
Pre-requisites: all disks shall have same storage capacity
all D2700 slots shall be fully populated (25 disks).
- Server Disk type and size: other disks are supported
Pre-requisite: 2 disks minimum
both disks shall have same storage capacity
600 GB disk storage capacity (per disk) minimum.

Customer changes can affect server and system performances and ability to upgrade in future releases.

Hard disk in Bay 3 shall be connected to SAS connector A.

Port 1E of SAS controller card in the HP server shall be connected to the port P1 of the I/O module A of the D2700 storage enclosure. Port 2E shall not be connected. See annex section of this document for port selection and identification.

All Ethernet connectors are RJ45 1000 Base-TX compatible.

Documentation on HP servers & storage array is available on HP web site or using Product bulletin tool. It includes server size, weight, BTU, power information.... The HP Product Bulletin is a free application that only takes a few minutes to download. The download site is located at

http://h18004.www1.hp.com/products/quickspecs/productBulletin.html#CD_Files

Required HP power for a cabinet can be estimated using HP Power advisor tool available on HP web site:

<http://www8.hp.com/us/en/products/servers/solutions.html?compURI=1439951#.UxSoL7QUdtk>

OS and PIC software installation and configuration of Packet Data Unit Storage server on HP servers are provided in PIC Packet Data Unit Storage (PDU) Server Installation (Doc ID 2034894.1) available on My Oracle Support site.

Hardware Installation Guidelines

9.23 Configuration set 24 (Oracle Database Appliance)

ODA X5-2 is available in AC only

Oracle SKU	Technical description	Qty (AC only)
7110250	Oracle Database Appliance X5-2: model family...	1
7110252	Oracle Database Appliance X5-2	1

Table 24: Configuration set 24 with ODA

In addition, 6 power cords shall be ordered according to installation country or Power Distribution Unit installed in the frame.

An additional storage enclosure extension can be added to the ODA to obtain more disk capacity:

Oracle SKU	Technical description	Qty (AC only)
7110281	Oracle Database Appliance X5-2 Storage Expansion	1

Two additional power cords shall be ordered for the extension.

For server size, weight, BTU, power information.... documentation is available at http://docs.oracle.com/cd/E22693_01/index.htm

Please refer to documentation for initial installation of the server. This document will drive you through the initial installation steps:

- Attaching Supplied Cables
- Attaching Storage Expansion Shelf
- Attaching Peripheral Devices
- Booting Up the First Time
- Configuring Oracle Integrated Lights Out Manager.
- Configuring Initial Network Connection
- Validating Oracle Appliance Manager Software Version

It is strongly recommended to refer to PIC 10.2 Installation guide available on Oracle Technology Network site before starting installation. For Oracle Database appliance, refer to the specific section for ODA configuration.

9.24 Configuration set 25 (Oracle E5-APP-B)

E5-APP-B is an Eagle card directly installed inside a heavy duty Eagle frame.

E5-APP-B installation may include

- Provisioning of the Eagle card and installation in the Eagle frame
- Provisioning of the Terminal server (if not present) and installation in the Eagle frame
- Provisioning of the switches (one or 2 switches) and installation in the Eagle frame

- Connection of the E5-APP-B cards, to the terminal server and the switch(es)
- Connection of the Fast copy card (if option selected) to the switch(es)
- Connection of the switch console port to Terminal server
- Connection of the Terminal server to the customer network (1 port RJ45 Ethernet 1000Base-TX)
- Connection of the switch(es) in the Eagle frame to the customer network (1 port RJ45 Ethernet 1000Base-TX per switch)

E5-APP-B documentation can be found at https://docs.oracle.com/cd/E58681_01/docs.461/E58719_rev_2.pdf

9.25 Configuration set 27 (Oracle X5-2)

Oracle X5-2 is available in AC only.

There are 2 options for traffic acquisition:

- One for acquisition of 1G/10G traffic on RJ45 copper links
- One for acquisition of 1G/10G traffic on optical fiber links

No mix is allowed.

This affect only the acquisition ports, not the management and network (to mediation) ports.

With 1G/10 RJ45 copper acquisition interfaces:

Oracle SKU	Technical description	Qty (AC only)
7112843	ATO,BASE,CONFIG,1U	1
7110339	XATO,DISK_CAGE,2.5" X 8HDD	1
7110346	ATO,E5-2699 V3,2.3G,145W,18 CORE,C-1 (SR1XD),CPU	2
7110350	XATO,HEATSINK,CPU,1U	2
7110360	XATO,OSA 8 GB MLC USB FLASH DRIVE	1
7110359	ATO,DVD,GEN5,BLANK FILLER PANEL,1U/2U	1
7102748	ATO PCIe FILLER,VENTED,LOW PROFILE	1
6331A-N	ASSY,HDD,MARLIN-FILLER PANEL	6
7110353	XATO,DIMM,16GB,DDR4,2133	8
7111107	1.2 TB 10000 rpm 2.5-inch SAS-3 HDD with marlin bracket (for factory installation)	2
7100563	Sun Dual Port 10GBase-T Adapter (for factory installation)	2

Table 25: configuration set 27 with Oracle X5-2 copper RJ45 interfaces

With 1G/10 fiber SFP+ acquisition interfaces:

Oracle SKU	Technical description	Qty (AC only)
7112843	Oracle Server X5-2 for Communications: 1 RU base chassis with motherboard,	1
7110339	XATO,DISK_CAGE,2.5" X 8HDD	1
7110346	ATO,E5-2699 V3,2.3G,145W,18 CORE,C-1 (SR1XD),CPU	2
7110350	XATO,HEATSINK,CPU,1U	2
7110360	XATO,OSA 8 GB MLC USB FLASH DRIVE	1
7110359	ATO,DVD,GEN5,BLANK FILLER PANEL,1U/2U	1

Hardware Installation Guidelines

7102748	ATO PCIe FILLER, VENTED, LOW PROFILE	1
6331A-N	ASSY, HDD, MARLIN-FILLER PANEL	6
7110353	XATO, DIMM, 16GB, DDR4, 2133	8
7111107	1.2 TB 10000 rpm 2.5-inch SAS-3 HDD with marlin bracket (for factory installation)	2
1109A-Z	ASSY, 2X10GbE SFP+, X8PCIe 2.0, LP, Lead Free (Niantic)	2

Table 26: configuration set 27 with Oracle X5-2 SFP+ interfaces

In addition, SPF(+) modules according to network type shall be ordered.
Each acquisition card has 2 SPF(+) slots. 2 cards per server.
Total: 4 SFP+ acquisition ports for the server.

In addition, 2 power cords shall be ordered according to installation country or Power distribution unit installed in the frame.

Customer can perform following adaptations on previous BOMs:

- CPU: other CPUs are supported.
Pre-requisite: 8 cores minimum (on one or 2 processors)
- Memory: Other memory allocation is supported.
Pre-requisite: 16 GB minimum.
- Disk type and size: other disks are supported
Pre-requisite: 2 disks minimum
all disks shall have same storage capacity
600 GB disk storage capacity (per disk) minimum.

Note that customer changes can affect server and system performances and ability to upgrade in future releases.

For server size, weight, BTU, power information.... Documentations are available at http://docs.oracle.com/cd/E41059_01/

Please refer to Setup and Installation section for Oracle hardware installation. This document will drive you through the initial installation steps:

- Server installation in the rack.
- Attaching network and power Cables
- Booting Up the First Time
- Launching Oracle System Assistant to configure:
 - Server's network connection
 - Install latest server firmware
 - Configure Oracle ILOM and BIOS,
 - Configure hardware

OS and PIC software installation on Oracle hardware server are provided in PIC 10.2 Installation guide available on Oracle Technology Network site.

9.26 Configuration set 28 (Oracle Netra X5-2)

Oracle Netra X5-2 is available in AC and DC. It is NEBS compliant.

There are 2 options for traffic acquisition:

- One for acquisition of 1G/10G traffic on RJ45 copper links
- One for acquisition of 1G/10G traffic on optical fiber links

No mix is allowed.

This affect only the acquisition ports, not the management and network (to mediation) ports.

With 1G/10 RJ45 copper acquisition interfaces:

Oracle SKU	Technical description	Qty DC	Qty AC
7111082	Netra Server X5-2: 2 RU AC base chassis with motherboard and 8 HDDs	-	1
7111083	Netra Server X5-2: 2 RU DC base chassis with motherboard and 8 HDDs	1	-
7110346	Intel® Xeon® E5-2699 v3 18-core 2.3 GHz processor	2	2
7102981	Heat sink	2	2
7111036	One 16 GB DDR4-2133 DIMM	8	8
7111043	Memory filler panels	16	16
7111107	One 1.2 TB 10000 rpm 2.5-inch SAS-3 HDD with marlin bracket	2	2
6331A-N	2.5-inch HDD filler panel	6	6
7100563	Sun Dual Port 10GBase-T Adapter	2	2
7110116	Oracle Storage 12 Gb SAS PCIe RAID HBA, internal: 8 port and 1 GB memory	1	1
5394A	PCIe filler panel	3	3
7901A-4	19-inch 2-post rackmount kit	1	1
7111044	SAS cable kit	1	1
7111052	OSA 8 GB USB stick	1	1

Table 27: configuration set 28 with Oracle Netra X5-2 copper RJ45 interfaces

Each acquisition card has 2 RJ5 ports each. 2 cards per server.

Total: 4 acquisition ports for the server.

With 1G/10 fiber SFP+ acquisition interfaces:

Oracle SKU	Technical description	Qty DC	Qty AC
7111082	Netra Server X5-2: 2 RU AC base chassis with motherboard and 8 HDDs	-	1
7111083	Netra Server X5-2: 2 RU DC base chassis with motherboard and 8 HDDs	1	-
7111083	Netra Server X5-2: 2 RU DC base chassis with motherboard	1	1
7110346	Intel® Xeon® E5-2699 v3 18-core 2.3 GHz processor	2	2
7102981	Heat sink	2	2

Hardware Installation Guidelines

7111036	One 16 GB DDR4-2133 DIMM	8	8
7111043	Memory filler panels	16	16
7111107	One 1.2 TB 10000 rpm 2.5-inch SAS-3 HDD with marlin bracket	2	2
6331A-N	2.5-inch HDD filler panel	6	6
1109A-Z	Sun Dual 10GbE SFP+ PCIe Low Profile Adapter	2	2
7110116	Oracle Storage 12 Gb SAS PCIe RAID HBA, internal: 8 port and 1 GB memory	1	1
5394A	PCIe filler panel	3	3
7901A-4	19-inch 2-post rackmount kit	1	1
7111044	SAS cable kit	1	1
7111052	OSA 8 GB USB stick	1	1

Table 28: configuration set 28 with Oracle Netra X5-2 SFP+ interfaces

In addition, SPF(+) modules according to network type shall be ordered.
 Each acquisition card has 2 SPF(+) slots . 2 cards per server.
 Total: 4 SFP+ acquisition ports for the server.

In addition, 2 power cords shall be ordered according to installation country or Power distribution unit installed in the frame.

Customer can perform following adaptations on previous BOMs:

- CPU: other CPUs are supported.
Pre-requisite: 8 cores minimum (on one or 2 processors)
- Memory: Other memory allocation is supported.
Pre-requisite: 16 GB minimum.
- Disk type and size: other disks are supported
Pre-requisite: 2 disks minimum
all disks shall have same storage capacity
600 GB disk storage capacity (per disk) minimum.

Note that customer changes can affect server and system performances and ability to upgrade in future releases.

For server size, weight, BTU, power information... Documentations are available at http://docs.oracle.com/cd/E53596_01/

Please refer to Setup and Installation section for Oracle hardware installation. This document will drive you through the initial installation steps:

- Server installation in the rack.
- Attaching network and power Cables
- Booting Up the First Time
- Launching Oracle System Assistant to configure:
 - Server's network connection
 - Install latest server firmware
 - Configure Oracle ILOM and BIOS,
 - Configure hardware

Hardware Installation Guidelines

OS and PIC software installation on Oracle hardware server are provided in PIC 10.2 Installation guide available on Oracle Technology Network site.

9.27 Configuration set 29 (HP DL360 Gen9 v2)

HP DL360 Gen9 v2 is available in AC and DC

HP Gen9 v2 has 4 SFP+ ports which can be used for 1G/10G on

- RJ45 copper links
- and optical fiber links

Mix is allowed.

HP P/N	Technical description	Qty AC	Qty DC
755258-B21	HP ProLiant DL360 Gen9 8SFF Configure-to-order Server	1	1
818184-B21	HPE DL360 Gen9 Intel® Xeon® E5-2680v4 (2.4GHz/14-core/35MB/120W) Processor Kit	1	1
818184-L21	HPE DL360 Gen9 Intel® Xeon® E5-2680v4 (2.4GHz/14-core/35MB/120W) FIO Processor Kit	1	1
805349-B21	HP 16GB (1x16GB) Single Rank x4 DDR4-2400 CAS-17-17-17 Registered Memory Kit	4	4
785069-B21	HP 900GB 12G SAS 10K rpm SFF (2.5-inch) SC Enterprise 3yr Warranty Hard Drive (Install in Drive Bays 1 and 2)	2	2
629135-B22	HP Ethernet 1Gb 4-port 331FLR Adapter (Flex LOM)	1	1
749974-B21	HP Smart Array P440ar/2GB FBWC 12Gb 2-ports Int FIO SAS Controller	1	1
720479-B21	HP 800W Flex Slot Platinum Hot Plug Power Supply Kit - AC	2	-
720480-B21	HP 800 W Flex Slot-48VDC Hot Plug Power Supply Kit	-	2
512485-B21	HP iLO Advanced incl 1yr 24x7 Tech Support and Updates Single Server License	1	1
663201-B21	HP 1U Small Form Factor Ball Bearing Rail	1	1
764636-B21	HP DL360 Gen9 SFF Systems Insight Display Kit	1	1
758959-B22	HP LEGACY FIO MODE SETTING	1	1
665249-B21	HP Ethernet 10Gb Dual Port 560SFP+ Adapter (Install cards in Slot 1 and slot 2)	2	2

Table 29: configuration set 29 with HP Gen9 v2 with SFP+ card

Note : HP Ethernet 1Gb 4-port 331FLR Adapter (Flex LOM) P/N 629135-B22 is not used in PIC 10.2 but is planned for future use.

In addition, SPF(+) modules according to network type shall be ordered.

Each acquisition card has 2 SPF(+) slots . 2 cards per server.

Total: 4 SFP+ acquisition ports for the server.

In addition, for each HP server, 2 power cords shall be ordered according to installation country or Power distribution unit installed in the frame.

Hardware Installation Guidelines

For AC, all pre-configured servers with standard AC power supply option kit, ship with one standard 6-foot IEC C-13/C-14 jumper cord per power supply (for HP Gen9: reference A0K02A). If a different power cord is required, please check HP web site

Customer can perform following adaptations on previous BOM:

- CPU: other CPU is supported.
Pre-requisite: 8 cores minimum. (on one or 2 processors)
- Memory: Other memory allocation is supported.
Pre-requisite: 16 GB minimum.
- Disk type and size: other disks are supported
Pre-requisite: 2 disks minimum
all disks shall have same storage capacity
600 GB disk storage capacity (per disk) minimum

Customer changes can affect server and system performances and ability to upgrade in future releases.

Internal disks shall be connected to SAS A.

Documentation on HP servers & storage array is available on HP web site or using Product bulletin tool. It includes server size, weight, BTU, power information.... The HP Product Bulletin is a free application that only takes a few minutes to download. The download site is located at

http://h18004.www1.hp.com/products/quickspecs/productBulletin.html#CD_Files

Required HP power for a cabinet can be estimated using HP Power advisor tool available on HP web site:

<http://www8.hp.com/us/en/products/servers/solutions.html?compURI=1439951#.UxSoL7QUdtk>

OS and PIC management software installation and configuration on HP, are provided in PIC 10.2 Installation guide available on Oracle Technology Network site. Note that customer shall have Weblogic 11g and Oracle Enterprise Edition 11g and partitioning option licenses, or Oracle Technology Foundation for Monitoring Applications license for this server, before starting the installation.

OS and PIC software installation and configuration of management server on HP servers are provided in Management Server (NSP) on Third-Party Server Installation Guide for Performance Intelligence Center (PIC) products (Doc ID **2062544.1**) available on My Oracle Support site.

9.28 Configuration set 30 (HP DL360 Gen9 v1)

HP DL360 Gen9 v1 is available in AC and DC

HP Gen9 v1 has 4 SFP+ ports which can be used for 1G/10G on

- RJ45 copper links
- and optical fiber links

Mix is allowed.

HP P/N	Technical description	Qty DC	Qty AC
755258-B21	HP ProLiant DL360 Gen9 8SFF Configure-to-order Server	1	1
755394-L21	E5-2680v3 HP DL360 Gen9 Intel® Xeon® E5-2680v3 (2.5GHz/12-core/30MB/120W) Processor Kit	1	1
755394-B21	E5-2680v3 HP DL360 Gen9 Intel® Xeon® E5-2680v3 (2.5GHz/12-core/30MB/120W) Processor Kit	1	1
726719-B21	HP 16GB (1x16GB) Dual Rank x4 DDR4-2133 CAS-15-15-15 Registered Memory Kit	4	4
785069-B21	HP 900GB 12G SAS 10K rpm SFF (2.5-inch) SC Enterprise 3yr Warranty Hard Drive (Install in Drive Bays 1 and 2)	2	2
629135-B22	HP Ethernet 1Gb 4-port 331FLR Adapter (Flex LOM)	1	1
749974-B21	HP Smart Array P440ar/2GB FBWC 12Gb 2-ports Int FIO SAS Controller	1	1
720479-B21	HP 800W Flex Slot Platinum Hot Plug Power Supply Kit - AC	-	2
720480-B21	HP 800 W Flex Slot-48VDC Hot Plug Power Supply Kit	2	-
512485-B21	HP iLO Advanced incl 1yr 24x7 Tech Support and Updates Single Server License	1	1
663201-B21	HP 1U Small Form Factor Ball Bearing Rail Kit	1	1
764636-B21	HP DL360 Gen9 SFF Systems Insight Display Kit	1	1
758959-B22	HP LEGACY FIO MODE SETTING	1	1
665249-B21	HP Ethernet 10Gb Dual Port 560SFP+ Adapter (Install cards in Slot 1 and slot 2)	2	2

Table 30: configuration set 30 with HP Gen9 v1 with SFP+ card

Note : HP Ethernet 1Gb 4-port 331FLR Adapter (Flex LOM) P/N 629135-B22 is not used in PIC 10.2 but is planned for future use.

In addition, SPF(+) modules according to network type shall be ordered.

Each acquisition card has 2 SPF(+) slots . 2 cards per server.

Total: 4 SFP+ acquisition ports for the server.

In addition, for each HP server, 2 power cords shall be ordered according to installation country or Power distribution unit installed in the frame.

For AC, all pre-configured servers with standard AC power supply option kit, ship with one standard 6-foot IEC C-13/C-14 jumper cord per power supply (for HP Gen9: reference A0K02A). If a different power cord is required, please check HP web site

Hardware Installation Guidelines

Customer can perform following adaptations on previous BOMs:

- CPU: other CPU is supported.
Pre-requisite: 8 cores minimum. (on one or 2 processors)
- Memory: Other memory allocation is supported.
Pre-requisite: 16 GB minimum.
- Disk type and size: other disks are supported
Pre-requisite: 2 disks minimum
all disks shall have same storage capacity
600 GB disk storage capacity (per disk) minimum

Customer changes can affect server and system performances and ability to upgrade in future releases.

Internal disks shall be connected to SAS A.

Documentation on HP servers & storage array is available on HP web site or using Product bulletin tool. It includes server size, weight, BTU, power information.... The HP Product Bulletin is a free application that only takes a few minutes to download. The download site is located at

http://h18004.www1.hp.com/products/quickspecs/productBulletin.html#CD_Files

Required HP power for a cabinet can be estimated using HP Power advisor tool available on HP web site:

<http://www8.hp.com/us/en/products/servers/solutions.html?compURI=1439951#.UxSoL7QUdtk>

OS and PIC management software installation and configuration on HP, are provided in PIC 10.2 Installation guide available on Oracle Technology Network site. Note that customer shall have Weblogic 11g and Oracle Enterprise Edition 11g and partitioning option licenses, or Oracle Technology Foundation for Monitoring Applications license for this server, before starting the installation.

OS and PIC software installation and configuration of management server on HP servers are provided in Management Server (NSP) on Third-Party Server Installation Guide for Performance Intelligence Center (PIC) products (Doc ID **2062544.1**) available on My Oracle Support site.

9.29 Configuration set 31 (HP DL360 Gen8 v2)

HP DL360 Gen8 v2 is available in AC and DC

HP Gen8 v2 has 4 SFP+ ports which can be used for 1G/10G on

- RJ45 copper links
- and optical fiber links

Mix is allowed.

HP P/N	Technical description	Qty DC	Qty AC
654081-B21	HP ProLiant DL360p Gen8 8 SFF Configure-to-order Server	1	1
708641-B21	HP 16GB 2Rx4 PC3-14900R-13 Kit	4	4
652241-B21	HP 9.5mm SATA DVD RW JackBlack Optical Drive	1	1
684208-B21	HP Ethernet 1Gb 4-port 331FLR FIO Adapter	1	1
631679-B21	HP 1GB P-series Smart Array Flash Backed Write Cache	1	1
512485-B21	HP iLO Advanced including 1yr 24x7 Technical Support and Updates Single Server License	1	1
712506-L21	HP DL360p Gen8 Intel Xeon E5-2680v2 (2.8GHz/10-core/25MB/115W) Processor Kit	1	1
712506-B21	HP DL360p Gen8 Intel Xeon E5-2680v2 (2.8GHz/10-core/25MB/115W) FIO Processor Kit	1	1
652583-B21	HP 600GB 6G SAS 10K rpm SFF (2.5-inch) SC Enterprise 3yr Warranty Hard Drive	2	2
734807-B21	HP 1U Small Form Factor Easy Install Rail Kit	1	1
656363-B21	HP 750W Common Slot Platinum Plus Hot Plug Power Supply Kit	-	2
636673-B21	HP 750W Common Slot -48VDC Hot Plug Power Supply Kit	2	-
665249-B21	HP Ethernet 10Gb 2-port 560SFP+ Adapter	2	2

Table 31: configuration set 31 with HP Gen8 v2 with SFP+ card

Note : This BOM is intended for PIC 10.1.x. For older release of PIC, please use only 32GB of RAM: 2 x 708641-B21 (HP 16GB 2Rx4 PC3-14900R-13 Kit)

In addition, SPF(+) modules according to network type shall be ordered.

Each acquisition card has 2 SPF(+) slots . 2 cards per server.

Total: 4 SFP+ acquisition ports for the server.

In addition, for each HP server, 2 power cords shall be ordered according to installation country or Power distribution unit installed in the frame.

For AC, all pre-configured servers with standard AC power supply option kit, ship with one standard 6-foot IEC C-13/C-14 jumper cord per power supply (for HP Gen9: reference A0K02A). If a different power cord is required, please check HP web site

Customer can perform following adaptations on previous BOMs:

Hardware Installation Guidelines

- CPU: other CPU is supported.
Pre-requisite: 8 cores minimum. (on one or 2 processors)
- Memory: Other memory allocation is supported.
Pre-requisite: 16 GB minimum.
- Disk type and size: other disks are supported
Pre-requisite: 2 disks minimum
all disks shall have same storage capacity
600 GB disk storage capacity (per disk) minimum

Customer changes can affect server and system performances and ability to upgrade in future releases.

Internal disks shall be connected to SAS A.

Documentation on HP servers & storage array is available on HP web site or using Product bulletin tool. It includes server size, weight, BTU, power information.... The HP Product Bulletin is a free application that only takes a few minutes to download. The download site is located at

http://h18004.www1.hp.com/products/quickspecs/productBulletin.html#CD_Files

Required HP power for a cabinet can be estimated using HP Power advisor tool available on HP web site:

<http://www8.hp.com/us/en/products/servers/solutions.html?compURI=1439951#.UxSoL7QUdtk>

OS and PIC management software installation and configuration on HP, are provided in PIC 10.2 Installation guide available on Oracle Technology Network site. Note that customer shall have Weblogic 11g and Oracle Enterprise Edition 11g and partitioning option licenses, or Oracle Technology Foundation for Monitoring Applications license for this server, before starting the installation.

OS and PIC software installation and configuration of management server on HP servers are provided in Management Server (NSP) on Third-Party Server Installation Guide for Performance Intelligence Center (PIC) products (Doc ID 2062544.1) available on My Oracle Support site.

9.30 Configuration set 32 (HP DL360 Gen8 v1)

HP DL360 Gen8 v1 is available in AC and DC.

There are 3 options for traffic acquisition:

- One for acquisition of 1G/10G traffic on SFP+ interfaces (for copper and fiber links)
- One for NEBS acquisition of 1G traffic on copper links
- One for acquisition of 1G traffic on copper links

With 1G/10G copper or fiber SFP+ acquisition interfaces (NEBS version):

HP P/N	Technical description	Qty DC	Qty AC
655651-B21	HP DL360p Gen8 4-LFF CTO Server	1	1
647899-B21	HP 8GB 1Rx4 PC3-12800R-11 Kit	4	4
652238-B21	HP 9.5mm SATA DVD ROM Jb Kit	1	1
684208-B21	HP Ethernet 1GbE 4P 331FLR FIO Adptr	1	1
661069-B21	HP 512MB FWC for P series smart array	1	1
512485-B21	HP iLO Advanced including 1yr 24x7 Technical Support	1	1

Hardware Installation Guidelines

	and Updates Single Server License		
654786-L21	HP DL360p Gen8 E5-2670 FIO Kit	1	1
654786-B21	HP DL360p Gen8 E5-2670 Kit	1	1
652620-B21	HP 600GB 6G SAS 15K 3.5in SC ENT HDD	2	2
663202-B21	HP 1U LFF BB Gen8 Rail Kit	1	1
503296-B21	HP 460W CS Gold Ht Plg Pwr Supply Kit	-	2
636673-B21	HP 750W-48V DC Common Slot Power Supply	2	-
C3N52AA (Intel E10G42BTDA)	HP X520 10GbE Dual Port Adapter	2	2

Table 32: configuration set 32 with HP Gen8 v1 with SFP+ card

Note: This Configuration is NEBS compliant.

This configuration has 4 SFP+ ports which can be used for 1G/10G on

- RJ45 copper links
- and optical fiber links

Mix is allowed.

In addition, SPF(+) modules according to network type shall be ordered.

Each acquisition card has 2 SPF(+) slots . 2 cards per server.

Total: 4 SFP+ acquisition ports for the server.

With 1G copper acquisition interfaces (NEBS):

HP P/N	Technical description	Qty DC	Qty AC
654081-B21	HP DL360p Gen8 8-SFF CTO Server	1	1
647899-B21	HP 8GB 1Rx4 PC3-12800R-11 Kit	4	4
652241-B21	HP 9.5mm SATA DVD RW JackBlack Optical Drive	1	1
684208-B21	HP Ethernet 1GbE 4P 331FLR FIO Adptr	1	1
661069-B21	HP 512MB FWC for P series smart array	1	1
512485-B21	HP iLO Advanced including 1yr 24x7 Technical Support and Updates Single Server License	1	1
654786-L21	HP DL360p Gen8 E5-2670 FIO Kit	1	1
654786-B21	HP DL360p Gen8 E5-2670 Kit	1	1
652583-B21	HP 600GB 6G SAS 10K 2.5in SC ENT HDD	2	2
663201-B21	HP 1U SFF BB Gen8 Rail Kit	1	1
656363-B21	HP 750W CS Plat PL Ht Plg Pwr Supply Kit	-	2
636673-B21	HP 750W-48V DC Common Slot Power Supply	2	-
647594-B21	HP Ethernet 1Gb 4-port 331T	2	2

Table 33: configuration set 32 with HP Gen8 v1 with 1G RJ45 card (NEBS)

Note: This configuration has 8 RJ45 acquisition 1G Ethernet ports

Hardware Installation Guidelines

With 1G copper acquisition interfaces (non NEBS):

HP P/N	Technical description	Qty DC	Qty AC
655651-B21	HP DL360p Gen8 4-LFF CTO Server	1	1
647899-B21	HP 8GB 1Rx4 PC3-12800R-11 Kit	4	4
652238-B21	HP 9.5mm SATA DVD ROM Jb Kit	1	1
684208-B21	HP Ethernet 1GbE 4P 331FLR FIO Adptr	1	1
661069-B21	HP 512MB FWC for P series smart array	1	1
512485-B21	HP iLO Advanced including 1yr 24x7 Technical Support and Updates Single Server License	1	1
654786-L21	HP DL360p Gen8 E5-2670 FIO Kit	1	1
654786-B21	HP DL360p Gen8 E5-2670 Kit	1	1
652620-B21	HP 600GB 6G SAS 15K 3.5in SC ENT HDD	2	2
663202-B21	HP 1U LFF BB Gen8 Rail Kit	1	1
503296-B21	HP 460W CS Gold Ht Plg Pwr Supply Kit	-	2
636673-B21	HP 750W-48V DC Common Slot Power Supply	2	-
593722-B21	HP NC365T 4-port Ethernet Server Adapter	2	2

Table 34: configuration set 32 with HP Gen8 v1 with 1G RJ45 card (non NEBS)

Note: This configuration has 8 RJ45 acquisition 1G Ethernet ports

In addition, for each HP server, 2 power cords shall be ordered according to installation country or Power distribution unit installed in the frame.

For AC, all pre-configured servers with standard AC power supply option kit, ship with one standard 6-foot IEC C-13/C-14 jumper cord per power supply (for HP Gen9: reference A0K02A). If a different power cord is required, please check HP web site

Customer can perform following adaptations on previous BOMs:

- CPU: other CPU is supported.
Pre-requisite: 8 cores minimum. (on one or 2 processors)
- Memory: Other memory allocation is supported.
Pre-requisite: 16 GB minimum.
- Disk type and size: other disks are supported
Pre-requisite: 2 disks minimum
all disks shall have same storage capacity
600 GB disk storage capacity (per disk) minimum

Customer changes can affect server and system performances and ability to upgrade in future releases.

Internal disks shall be connected to SAS A.

Documentation on HP servers & storage array is available on HP web site or using Product bulletin tool. It includes server size, weight, BTU, power information.... The HP Product Bulletin is a free application that only takes a few minutes to download. The download site is located at

http://h18004.www1.hp.com/products/quickspecs/productBulletin.html#CD_Files

Hardware Installation Guidelines

Required HP power for a cabinet can be estimated using HP Power advisor tool available on HP web site:
<http://www8.hp.com/us/en/products/servers/solutions.html?compURI=1439951#.UxSoL7QUdtk>

OS and PIC management software installation and configuration on HP, are provided in PIC 10.2 Installation guide available on Oracle Technology Network site. Note that customer shall have Weblogic 11g and Oracle Enterprise Edition 11g and partitioning option licenses, or Oracle Technology Foundation for Monitoring Applications license for this server, before starting the installation.

OS and PIC software installation and configuration of management server on HP servers are provided in Management Server (NSP) on Third-Party Server Installation Guide for Performance Intelligence Center (PIC) products (Doc ID 2062544.1) available on My Oracle Support site.

9.31 Configuration set 33 (HP DL360 G6)

HP DL360 G6 is available in AC and DC
Configuration is available for 1G RJ45 Ethernet copper links only.

HP P/N	Technical description	Qty DC	Qty AC
494329-B21	HP DL380G6 CTO Chassis	1	1
492244-L21	HP E5540 DL380 G6 FIO Kit	1	1
492244-B21	HP E5540 DL380 G6 Kit	1	1
500658-B21	HP 4GB 2Rx4 PC3-10600R-9 Kit	6	6
534916-B21	HP 512MB Flash Backed Write Cache	1	1
507127-B21	HP 300GB 10K 6G 2.5 SAS DP HDD (Drive Bay 1 & 2)	2	2
512327-B21	HP 750W CS HE Power Supply Kit	0	2
437573-B21	HP 1200w PSU 48VDC	2	0
481043-B21	HP Slim SATA DVD RW Optical Drive	1	1
512485-B21	HP ILO Adv 1-Svr incl 1yr TS/U SW	1	1
435508-B21	HP NC364T PCIe 4Pt Gigabit Server Adptr	2	2

Table 35: Configuration set 33 with HP DL360 G6 for 1G copper links

In addition, for each HP server, 2 power cords shall be ordered according to installation country or Power distribution unit installed in the frame.

For AC, all pre-configured servers with standard AC power supply option kit, ships with one standard 6-foot IEC C-13/C-14 jumper cord per power supply (for HP Gen9: reference A0K02A). If a different power cord is required, please check HP web site

Customer can perform following adaptations on previous BOMs:

- CPU: other CPU is supported.
Pre-requisite: 8 cores minimum. (on one or 2 processors)
- Memory: Other memory allocation is supported.
Pre-requisite: 16 GB minimum.
- Disk type and size: other disks are supported
Pre-requisite: 2 disks minimum
all disks shall have same storage capacity
600 GB disk storage capacity (per disk) minimum

Hardware Installation Guidelines

Customer changes can affect server and system performances and ability to upgrade in future releases.

Internal disks shall be connected to SAS A.

Documentation on HP servers & storage array is available on HP web site or using Product bulletin tool. It includes server size, weight, BTU, power information.... The HP Product Bulletin is a free application that only takes a few minutes to download. The download site is located at

http://h18004.www1.hp.com/products/quickspecs/productBulletin.html#CD_Files

Required HP power for a cabinet can be estimated using HP Power advisor tool available on HP web site:

<http://www8.hp.com/us/en/products/servers/solutions.html?compURI=1439951#.UxSoL7QUdtk>

OS and PIC management software installation and configuration on HP, are provided in PIC 10.2 Installation guide available on Oracle Technology Network site. Note that customer shall have Weblogic 11g and Oracle Enterprise Edition 11g and partitioning option licenses, or Oracle Technology Foundation for Monitoring Applications license for this server, before starting the installation.

OS and PIC software installation and configuration of management server on HP servers are provided in Management Server (NSP) on Third-Party Server Installation Guide for Performance Intelligence Center (PIC) products (Doc ID **2062544.1**) available on My Oracle Support site.

9.32 Configuration set 35 (Oracle X5-2 for Pre-package)

Oracle X5-2 is available in AC only.

There are 2 options for traffic acquisition:

- One for acquisition of 1G/10G traffic on RJ45 copper links
- One for acquisition of 1G/10G traffic on optical fiber links

No mix is allowed.

This affect only the acquisition ports, not the management and network ports.

With 1G/10 RJ45 copper acquisition interfaces:

Oracle SKU	Technical description	Qty (AC only)
7112843	ATO,BASE,CONFIG,1U	1
7110339	XATO,DISK_CAGE,2.5" X 8HDD	1
7110346	ATO,E5-2699 V3,2.3G,145W,18 CORE,C-1 (SR1XD),CPU	2
7110350	XATO,HEATSINK,CPU,1U	2
7110360	XATO,OSA 8 GB MLC USB FLASH DRIVE	1
7110359	ATO,DVD,GEN5,BLANK FILLER PANEL,1U/2U	1
7102748	ATO PCIe FILLER,VENTED,LOW PROFILE	1
6331A-N	ASSY,HDD,MARLIN-FILLER PANEL	6
7110353	XATO,DIMM,16GB,DDR4,2133	8
7111107	1.2 TB 10000 rpm 2.5-inch SAS-3 HDD with marlin bracket (for factory installation)	2
7100563	Sun Dual Port 10GBase-T Adapter (for factory installation)	2

Table 36: configuration set 35 with Oracle X5-2 copper RJ45 interfaces for virtual machines hosting

With 1G/10 fiber SFP+ acquisition interfaces:

Oracle SKU	Technical description	Qty (AC only)
7112843	Oracle Server X5-2 for Communications: 1 RU base chassis with motherboard,	1
7110339	XATO,DISK_CAGE,2.5" X 8HDD	1
7110346	ATO,E5-2699 V3,2.3G,145W,18 CORE,C-1 (SR1XD),CPU	2
7110350	XATO,HEATSINK,CPU,1U	2
7110360	XATO,OSA 8 GB MLC USB FLASH DRIVE	1
7110359	ATO,DVD,GEN5,BLANK FILLER PANEL,1U/2U	1
7102748	ATO PCIe FILLER,VENTED,LOW PROFILE	1
6331A-N	ASSY,HDD,MARLIN-FILLER PANEL	6
7110353	XATO,DIMM,16GB,DDR4,2133	8
7111107	1.2 TB 10000 rpm 2.5-inch SAS-3 HDD with marlin bracket (for factory installation)	2
1109A-Z	ASSY,2X10GbE SFP+,X8PCIe 2.0,LP,Lead Free (Niantic)	2

Table 37: configuration set 35 with Oracle X5-2 SFP+ interfaces for virtual machines hosting

In addition, SPF(+) modules according to network type shall be ordered.
 Each acquisition card has 2 SPF(+) slots . 2 cards per server.
 Total: 4 SFP+ acquisition ports for the server.

In addition, 2 power cords shall be ordered according to installation country or Power distribution unit installed in the frame.

For server size, weight, BTU, power information.... Documentations are available at http://docs.oracle.com/cd/E41059_01/

Please refer to Setup and Installation section for Oracle hardware installation. This document will drive you through the initial installation steps:

- Server installation in the rack.
- Attaching network and power Cables
- Booting Up the First Time
- Launching Oracle System Assistant to configure:
 - Server's network connection
 - Install latest server firmware
 - Configure Oracle ILOM and BIOS,
 - Configure hardware

OS and PIC software installation on Oracle hardware server are provided in PIC 10.2 Installation guide available on Oracle Technology Network site.

Hardware Installation Guidelines

9.33 Configuration set 36 (Oracle Netra X5-2 for Pre-package)

Oracle Netra X5-2 is available in AC and DC. It is NEBS compliant.

There are 2 options for traffic acquisition:

- One for acquisition of 1G/10G traffic on RJ45 copper links
- One for acquisition of 1G/10G traffic on optical fiber links

No mix is allowed.

This affect only the acquisition ports, not the management and network (to mediation) ports.

With 1G/10 RJ45 copper acquisition interfaces:

Oracle SKU	Technical description	Qty DC	Qty AC
7111082	Netra Server X5-2: 2 RU AC base chassis with motherboard and 8 HDDs	-	1
7111083	Netra Server X5-2: 2 RU DC base chassis with motherboard and 8 HDDs	1	-
7110346	Intel® Xeon® E5-2699 v3 18-core 2.3 GHz processor	2	2
7102981	Heat sink	2	2
7111036	One 16 GB DDR4-2133 DIMM	8	8
7111043	Memory filler panels	16	16
7111107	One 1.2 TB 10000 rpm 2.5-inch SAS-3 HDD with marlin bracket	2	2
6331A-N	2.5-inch HDD filler panel	6	6
7100563	Sun Dual Port 10GBase-T Adapter	2	2
7110116	Oracle Storage 12 Gb SAS PCIe RAID HBA, internal: 8 port and 1 GB memory	1	1
5394A	PCIe filler panel	3	3
7901A-4	19-inch 2-post rackmount kit	1	1
7111044	SAS cable kit	1	1
7111052	OSA 8 GB USB stick	1	1

Table 38: configuration set 36 with Oracle Netra X5-2 copper RJ45 interfaces

Each acquisition card has 2 RJ5 ports each. 2 cards per server.

Total: 4 acquisition ports for the server.

With 1G/10 fiber SFP+ acquisition interfaces:

Oracle SKU	Technical description	Qty DC	Qty AC
7111082	Netra Server X5-2: 2 RU AC base chassis with motherboard and 8 HDDs	-	1
7111083	Netra Server X5-2: 2 RU DC base chassis with motherboard and 8 HDDs	1	-
7111083	Netra Server X5-2: 2 RU DC base chassis with motherboard	1	1
7110346	Intel® Xeon® E5-2699 v3 18-core 2.3 GHz processor	2	2
7102981	Heat sink	2	2

Hardware Installation Guidelines

7111036	One 16 GB DDR4-2133 DIMM	8	8
7111043	Memory filler panels	16	16
7111107	One 1.2 TB 10000 rpm 2.5-inch SAS-3 HDD with marlin bracket	2	2
6331A-N	2.5-inch HDD filler panel	6	6
1109A-Z	Sun Dual 10GbE SFP+ PCIe Low Profile Adapter	2	2
7110116	Oracle Storage 12 Gb SAS PCIe RAID HBA, internal: 8 port and 1 GB memory	1	1
5394A	PCIe filler panel	3	3
7901A-4	19-inch 2-post rackmount kit	1	1
7111044	SAS cable kit	1	1
7111052	OSA 8 GB USB stick	1	1

Table 39: configuration set 36 with Oracle Netra X5-2 SFP+ interfaces

In addition, SPF(+) modules according to network type shall be ordered.
 Each acquisition card has 2 SPF(+) slots . 2 cards per server.
 Total: 4 SFP+ acquisition ports for the server.

In addition, 2 power cords shall be ordered according to installation country or Power distribution unit installed in the frame.

For server size, weight, BTU, power information.... Documentations are available at http://docs.oracle.com/cd/E53596_01/

Please refer to Setup and Installation section for Oracle hardware installation. This document will drive you through the initial installation steps:

- Server installation in the rack.
- Attaching network and power Cables
- Booting Up the First Time
- Launching Oracle System Assistant to configure:
 - Server's network connection
 - Install latest server firmware
 - Configure Oracle ILOM and BIOS,
 - Configure hardware

OS and PIC software installation on Oracle hardware server are provided in PIC 10.2 Installation guide available on Oracle Technology Network site.

Hardware Installation Guidelines

9.34 Configuration set 37 (optional hard disk for Pre-package storage option)

These disks should be added in Configuration set 35 or 36.

Oracle SKU	Technical description	Qty (AC only)
7111107	One 1.2 TB 10000 rpm 2.5-inch SAS-3 HDD with marlin bracket (for PDU Storage on the X5-2)	6

Table 40: Configuration set 37 optional hard disk for Pre-package storage option

9.35 SFP(+) modules

SFP modules tested by PIC and qualified to work with the HP INTEL X520 card are:

Interface	Tested SFP+ modules
1000 Base-T adapter	FINISAR PN: FCLF8521-3
Dual 1000 Base LX / 10GE base LR adapter	SUN X2129A PN:530-4449 AVAGO PN:AFBR-709DMZ-SN1
Dual 1000 Base SX / 10GE base SR adapter	AVAGO PN:AFBR-703SDZ FINISAR PN:FTLX8571D3BCL SUN X2129A PN:530-4449* AVAGO PN:AFBR-703SDDZ-SN1*
10GE base SR adapter	SUN X2129A PN:530-4449 AVAGO PN:AFBR-703SDZ

Table 41: SFP+ modules available on HP Intel X520 card

Note *: not hot swappable (reboot required for SFP module recognition)

on HP INTEL X560 SFP+ card:

Interface	Tested SFP+ modules
1000 Base-T adapter	FINISAR PN: FCLF8521-3
Dual 1000 Base SX / 10GE base SR adapter	SUN X5562A PN:135-1205 AVAGO PN:AFCT-701SDDZ-SN1
Dual 1000 Base SX / 10GE base SR adapter	SUN X2129A PN:530-4449 AVAGO PN:AFBR-703SDDZ-SN1
10GE base SR adapter	AVAGO PN:AFBR-703SDZ FINISAR PN:FTLX8571D3BCL
Dual 1000 Base LX / 10GE base LR adapter	SUN X5562A PN:135-1205 AVAGO PN:AFCT-701SDDZ-SN1

Table 42: SFP+ modules available on HP Intel X560 card

on Sun Dual 10GbE SFP+ PCIe Low Profile card:

Oracle SKU	Technical description
5562A-Z	Sun SFP+ to Dual 1000 Base LX/10GE base LR adapter

2129A	Sun SFP+ to Dual 1000 Base SX/10GE base SR adapter
-------	--

Table 43: Qualified SFP(+) modules on Oracle hardware Sun Dual 10GbE SFP+ card.

This list is by no means exhaustive. Selected cards are compliant with the standards and shall be compatible with almost all brands of SFP/SFP+. But no commitment can be taken.

Hardware Installation Guidelines

10 ANNEXES

10.1 Port identification on HP server Gen8 v1 & v2:

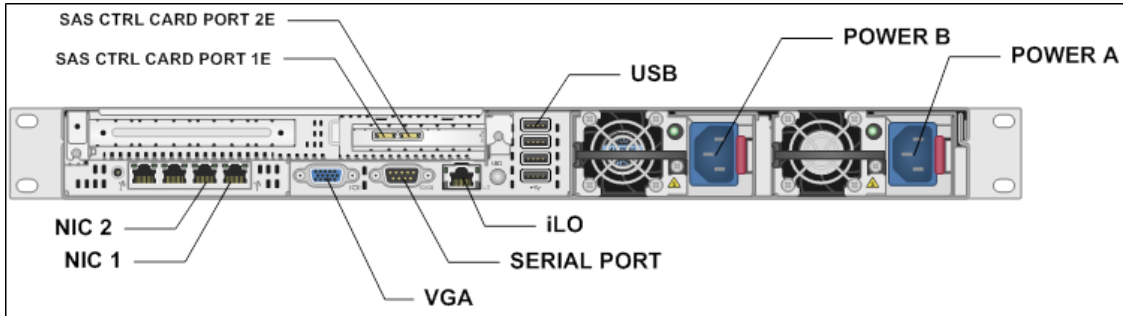

Figure 1 : Rear view for HP DL360 server Gen8 v1 & v2 used for Mediation

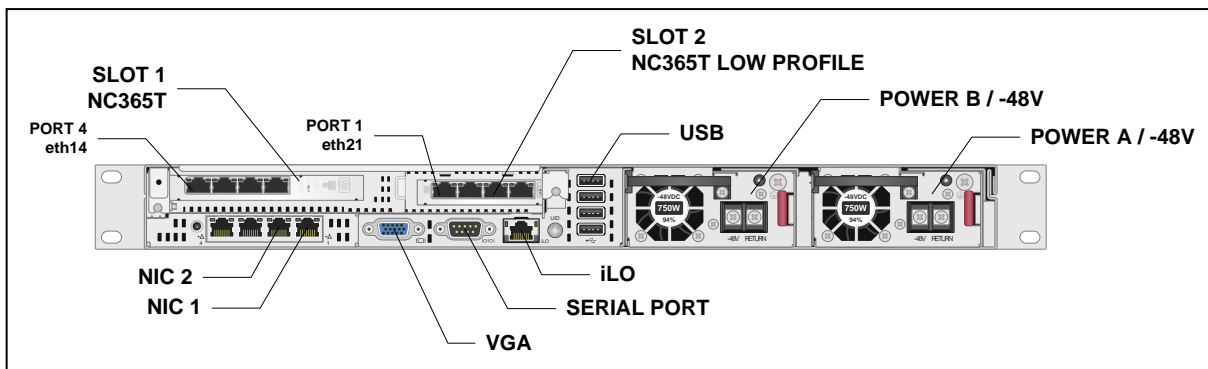

Figure 2 : Rear view for HP DL360 server Gen8 v1 & v2 used for Probed acquisition

Note: Slot and network port used for acquisition are similar for the 1Gb 4-port NC365T Adapter and 10Gb 2-port 560SFP+ Adapter, as well as for Gen9 in the following section.

10.2 Port identification on HP server DL360 Gen9

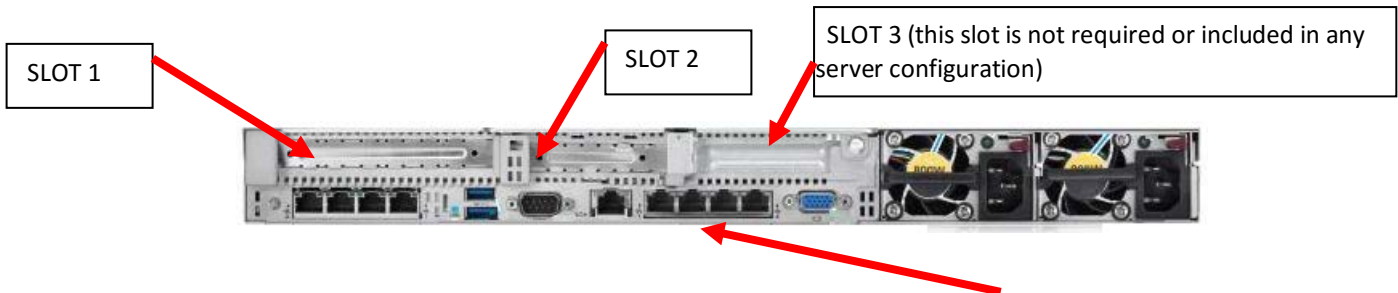

Figure 3 : Rear view for HP DL360 server Gen9

Embedded 4 x 1GbE Network Adapter
Eth01, Eth02, Eth03, Eth04

10.3 Port identification on HP server DL380 Gen9:

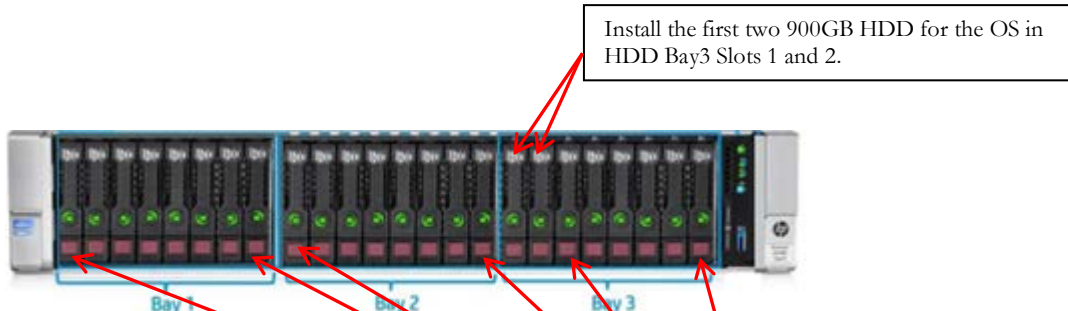

Figure 4 : Front view for HP DL38 Gen9

After installing the 900GB HDD in Bay 3 slots 1 and 2 for the OS, install the 900GB hard drives in the remaining HDD slots in Bay 3 then start filling up BAY 2 starting with slot 1 with any remaining 900GB HDD, then start filling up BAY 1 starting with slot 1 with any remaining 900GB HDD.

Install any remaining 900GB HDD in the rear
HDD slots 25 and 26



Figure 5 : Rear view for HP DL380 Gen9

Hardware Installation Guidelines

10.4 Port identification on D2700 Storage Array:

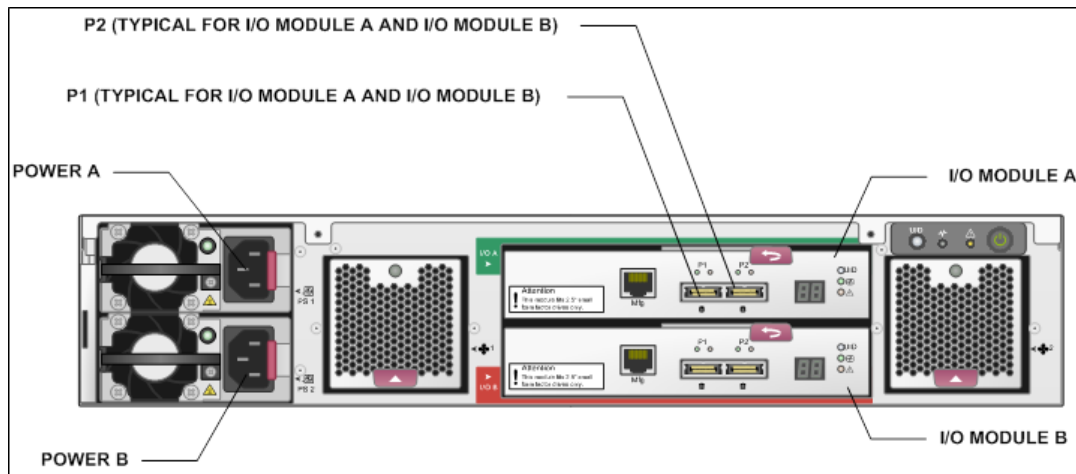
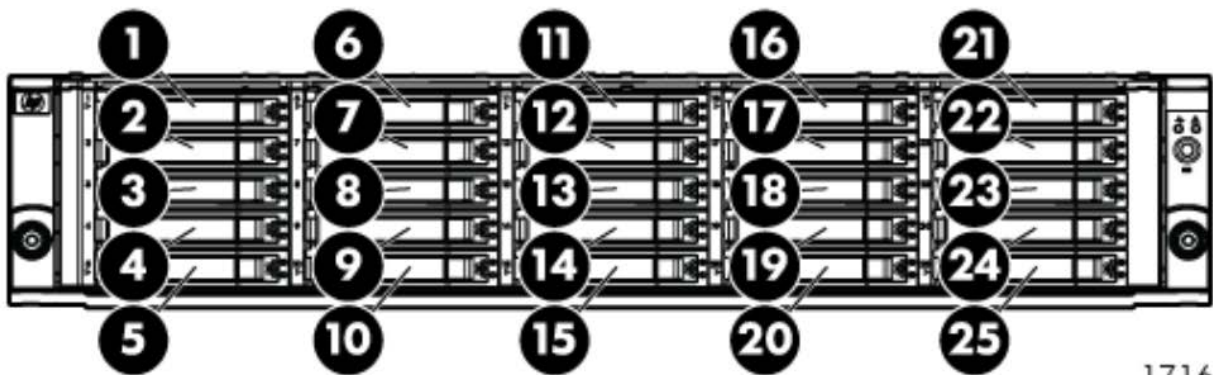

Figure 6 : Rear view for D2700 storage array



17163

Figure 7 : Drive Bay numbering

10.5 Port identification on ODA X5-2

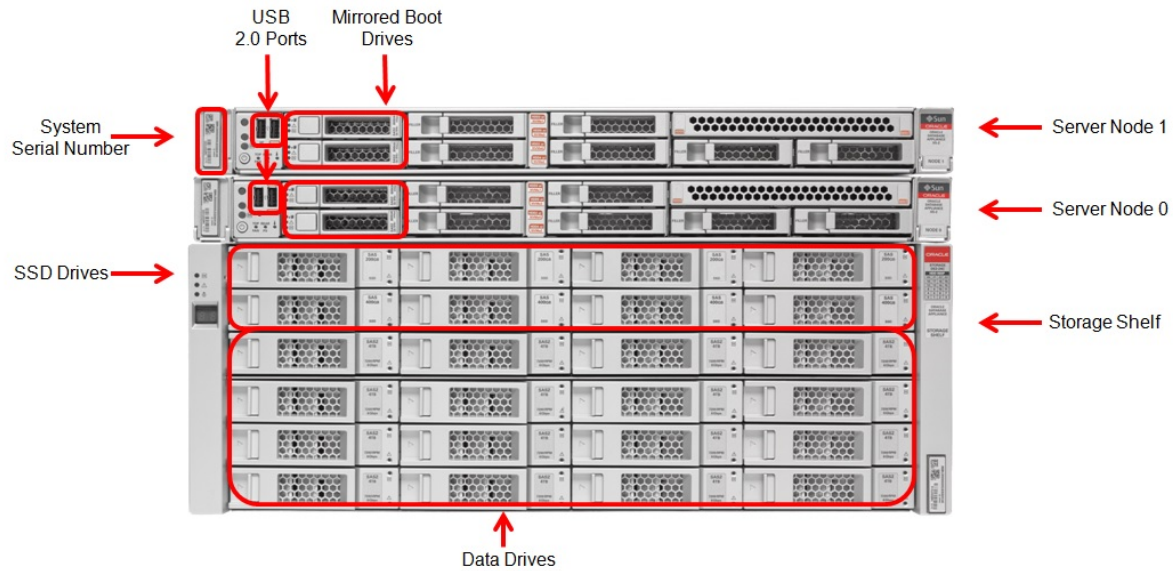

Figure 8- Front view of Oracle Database Appliance (storage shelf connections)

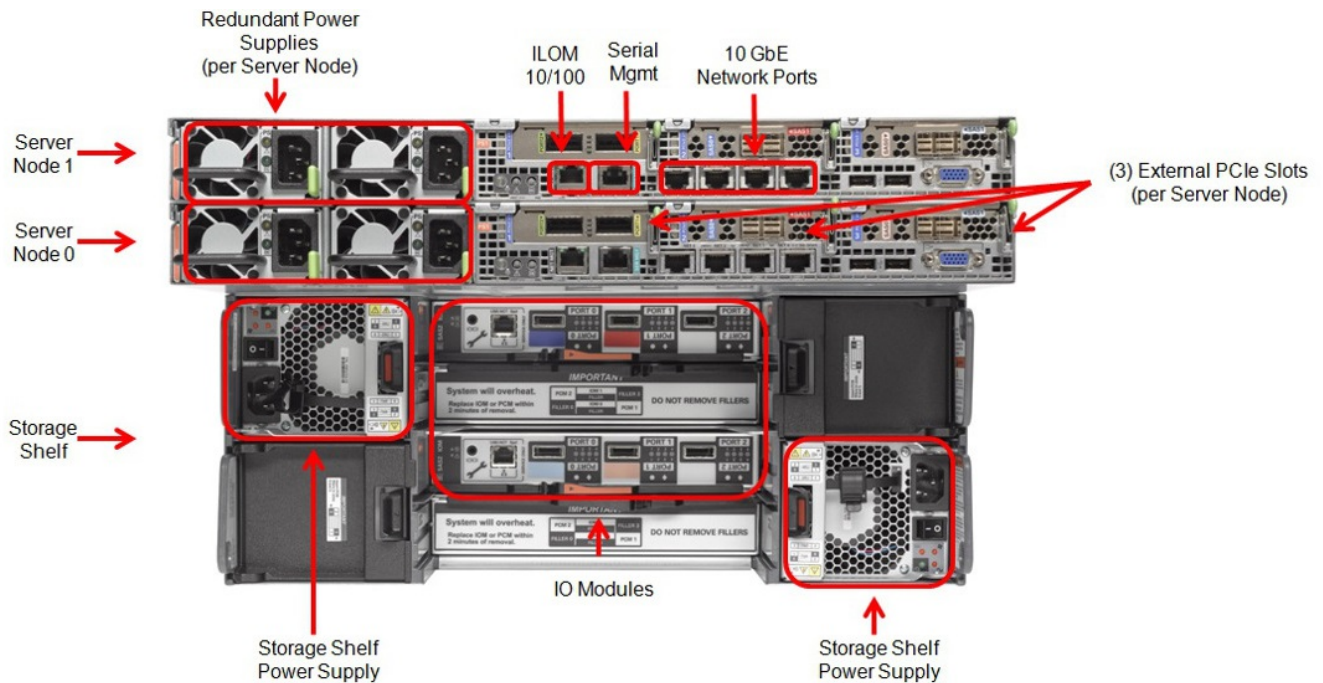

Figure 9- Rear view of Oracle Database Appliance (power and network connections)

Hardware Installation Guidelines

10.6 Port identification on Oracle X5-2

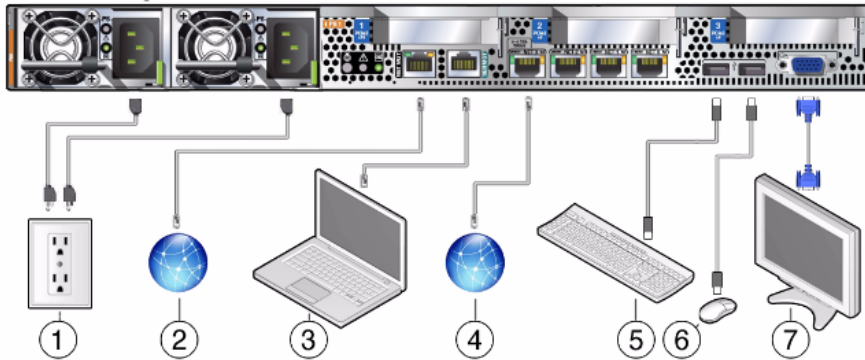
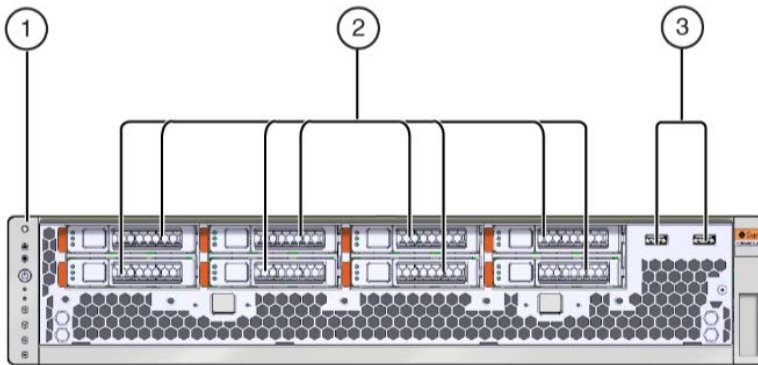

Figure Legend

- | | |
|--|--------------------|
| 1 Power supply 0 input power
Power supply 1 input power | 5 USB port (USB 0) |
| 2 Network management port (NET MGT) | 6 USB port (USB 1) |
| 3 Serial management port (SER MGT) | 7 Video port (VGA) |
| 4 Ethernet ports (NET3, NET2, NET1, NET0) | |

Figure 10- Rear view of Oracle X5-2 Server

10.7 Port identification on Oracle Netra X5-2



No.	Description
1	Indicators and switches, top to bottom:
2	Eight SAS drive slots or four SAS drive slots and four NMVe slots
3	Two USB 2.0 connectors

Figure 11- Front view of Oracle Netra X5-2 Server

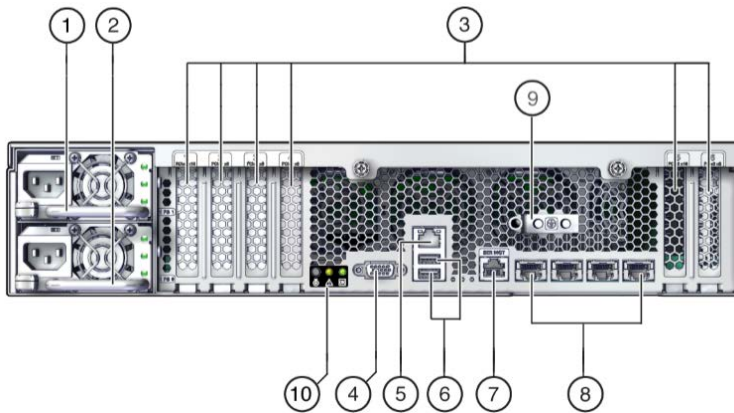

No.	Description
1	Hot-swappable power supply (AC or DC), PS1
2	Hot-swappable power supply (AC or DC), PS0
3	The number of available PCIe slots depends on the CPU configuration. <ul style="list-style-type: none"> ■ Single Processor – Two PCIe 3.0 low-profile card slots (slot 5 and slot 6) ■ Dual Processor – Six PCIe 3.0 low-profile card slots
4	SP 15-pin VGA video port
5	SP NET MGT port
6	Two USB 3.0 ports
7	SP SER MGT port
8	Four 10 Gigabit Ethernet ports (left to right: NET 3, NET 2, NET 1, NET 0)
9	Chassis ground posts
10	Chassis Status LEDs: <ul style="list-style-type: none"> ■ Locator LED and button ■ Service Required LED ■ Main Power OK LED

Figure 12- Rear view of Oracle Netra X5-2 Server

Hardware Installation Guidelines

10.8 Port identification on X6-2

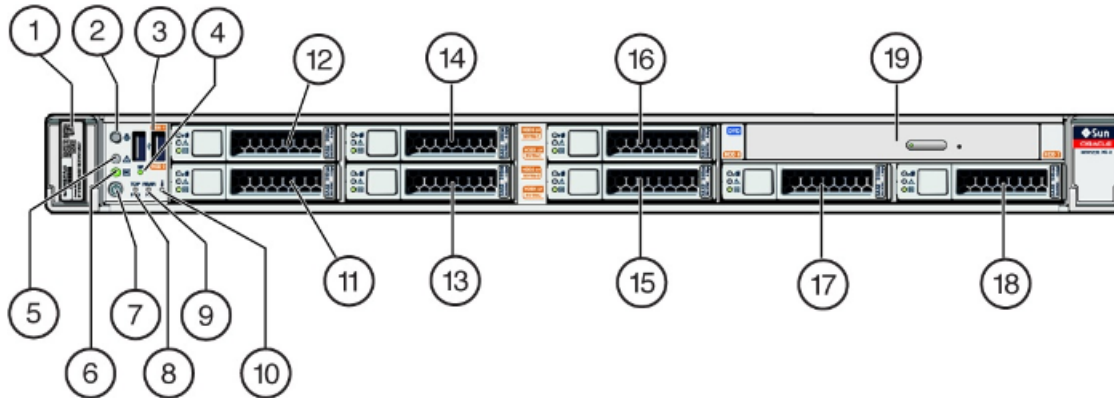

Figure 13- Front view of Oracle X6-2 server

- ① Product Serial Number (PSN) label and Radio Frequency Identification (RFID) tag
- ② Locator LED/button: white
- ③ USB 2.0 connectors (2)
- ④ SP OK LED: green
- ⑤ Service Required LED: amber
- ⑥ Power/OK LED: green
- ⑦ Power button
- ⑧ Service Required LED: Top: Fan Module (amber)
- ⑨ Service Required LED: Rear: Power Supply (amber)
- ⑩ Service Required LED: Overtemp Icon: System Over Temperature Warning (amber)
- ⑪ Storage drive 0
- ⑫ Storage drive 1
- ⑬ Storage drive 2
- ⑭ Storage drive 3
- ⑮ Storage drive 4
- ⑯ Storage drive 5
- ⑰ Storage drive 6
- ⑱ Storage drive 7
- ⑲ Optional SATA DVD Drive

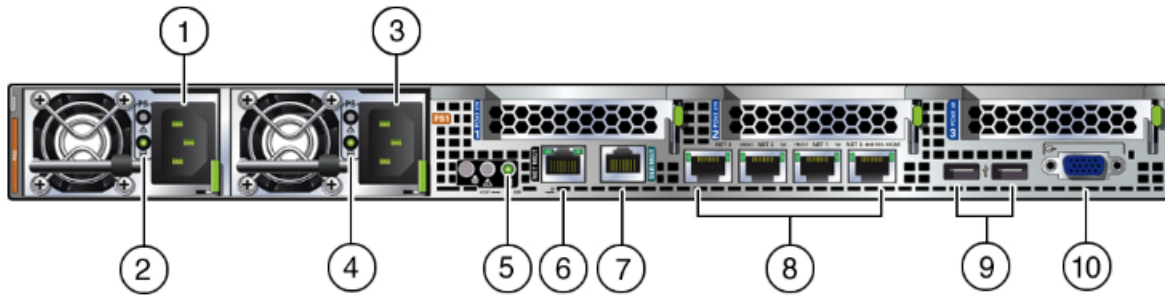

Figure 14- Front view of Oracle X6-2 server

- ① AC inlet 0
- ② AC OK Led
- ③ AC inlet 1
- ④ AC OK Led
- ⑤ Power OK Led
- ⑥ Ethernet MGT port (ILOM)
- ⑦ Serial Management port
- ⑧ Ethernet ports Net0-3 (Eth01 to Eth04)
- ⑨ USB ports
- ⑩ VGA video ports

10.9 Port identification on X6-2L

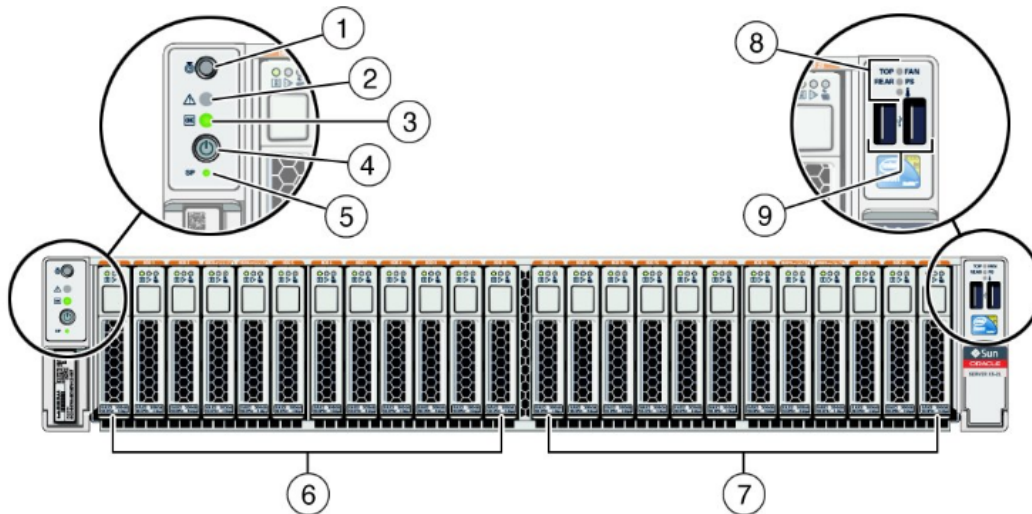

Figure 15- Front view of Oracle X6-2L server

- ① Locator LED/Locator button: white
- ② Service Required LED: amber

Hardware Installation Guidelines

- ③ Power/OK LED: green
- ④ Power button
- ⑤ SP OK LED: green
- ⑥ Storage drives 0 through 11
- ⑦ Storage drives 12 through 23
- ⑧ Service Required LEDs (3): Top: Fan Module (amber); Rear: Power Supply (amber); Overtemp Icon: System Over Temperature Warning (amber)
- ⑨ USB 2.0 connectors (2)

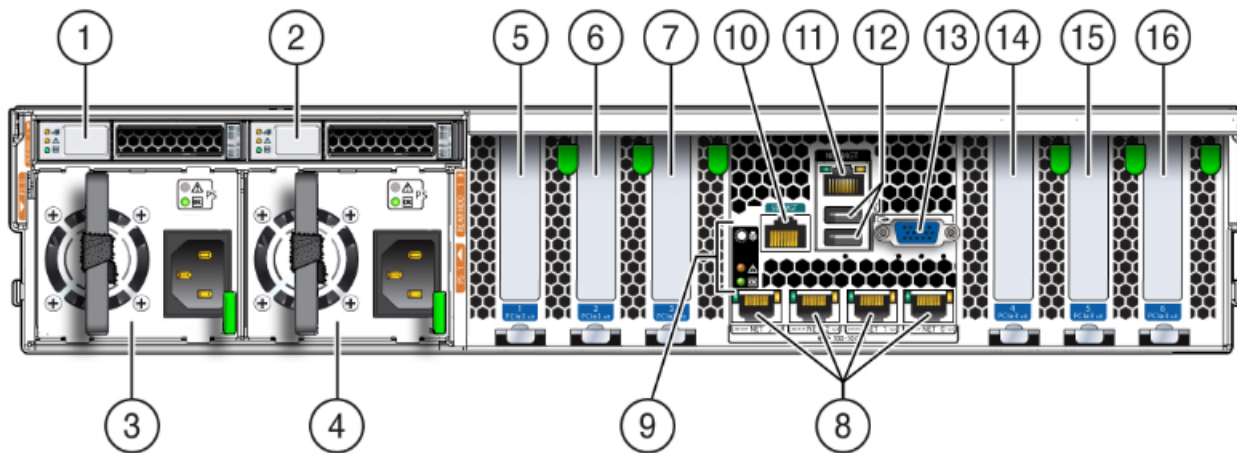

Figure 16- Rear view of Oracle X6-2L server

- ① Rear storage drive 0
- ② Rear storage drive 1
- ③ Power supply unit 0 (PSU0)
- ④ Power supply unit 0 (PSU1)
- ⑤ PCIe slot 1
- ⑥ PCIe slot 2
- ⑦ PCIe slot 3
- ⑧ Ethernet ports Net3-0 (Eth04 to Eth01)
- ⑨ System status LEDs: Locator/Button: white; Service Required: amber; Power/OK: green)
- ⑩ Serial management (SER MGT)/RJ-45 serial port
- ⑪ Oracle Integrated Lights Out Manager (ILOM) service processor (SP) network management (NET MGT) 10/100/1000BASE-T port
- ⑫ USB 2.0 ports (2)
- ⑬ DB-15 video connector
- ⑭ PCIe slot 4
- ⑮ PCIe slot 5
- ⑯ PCIe slot 6

10.10 Port identification on ZFS ZS3-2

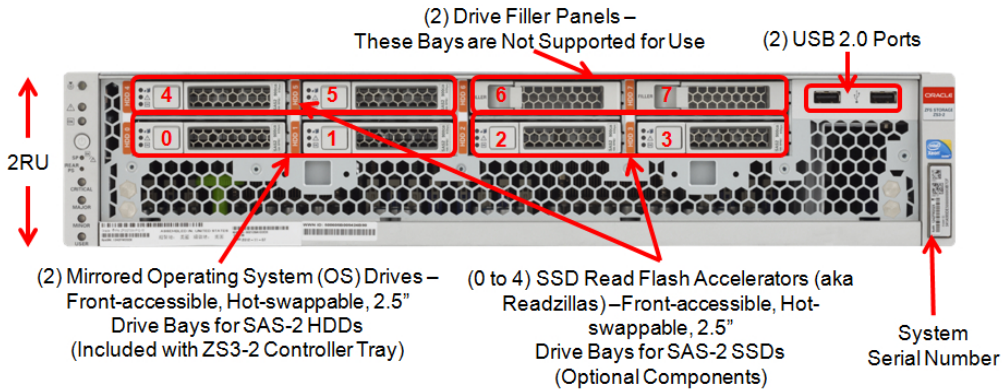

Figure 17- Front view of Oracle ZFS ZS3-2 Controller

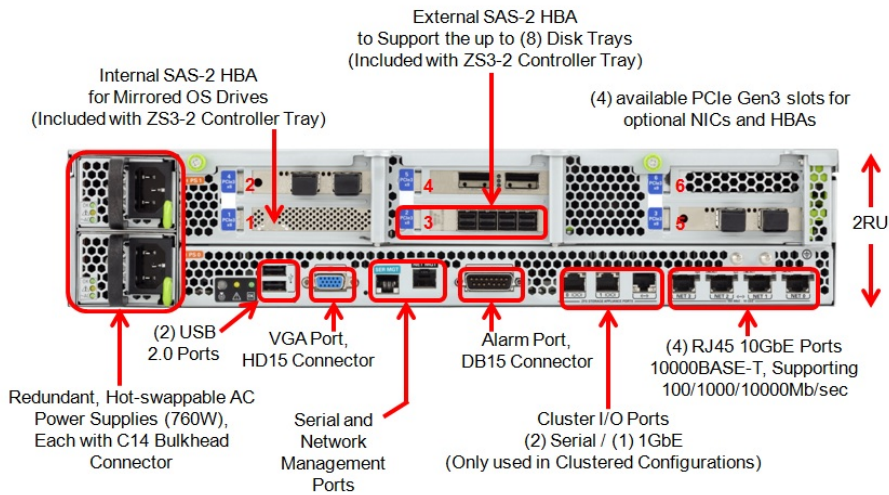

Figure 18- Rear view of Oracle ZFS ZS3-2 Controller

Hardware Installation Guidelines

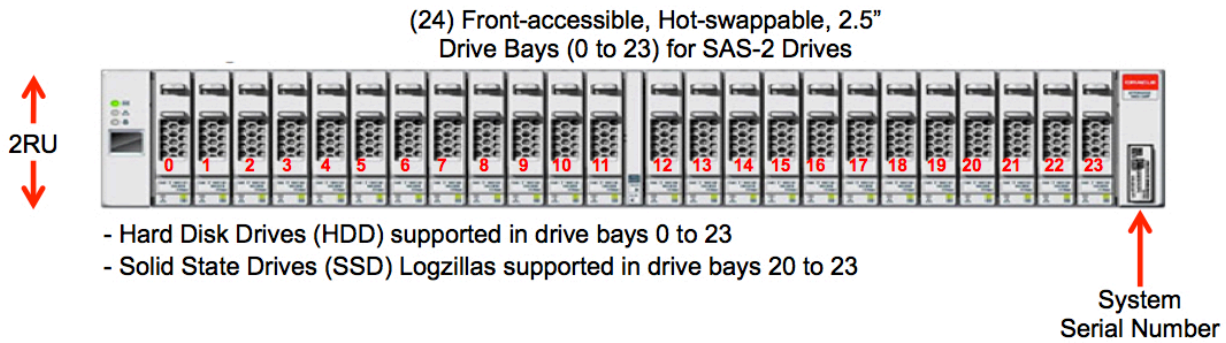

Figure 19- Front view of Oracle DE2-24P drive enclosure

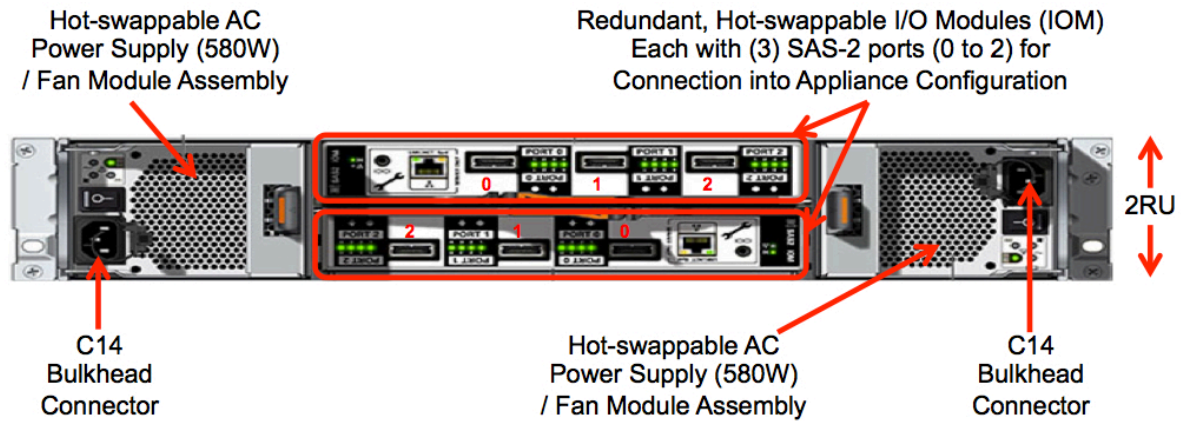

Figure 20- Rear view of Oracle DE2-24P drive enclosure

10.11 RAID configurations

Raid configuration is provided for information.

For management server on HP G6 and Gen8 servers:

Server internal disks:

- Disk 1 & 2 are configured in a RAID 1 (system)

Storage array disks:

- Disk 1 to 6 are configured in a RAID 10 (data)
- Disk 7 to 8 are configured in a RAID 1 (redo)
- Disk 9 to 10 are configured in a RAID 1 (backup)

For management server on Gen9, X5-2, and X6-2 servers:

Server internal disks:

- Disk 1 & 2 are configured in a RAID 1 (system)
- Disk 3 to 6 are configured in a RAID 10 (data)
- Disk 7 to 8 are configured in a RAID 1 (Backup)

For Data Record storage on HP on HP G6 and Gen8 servers:

Server internal disks:

- Disk 1 & 2 are configured in a RAID 1

Storage array disks:

- Disk 1 to 4 are configured in a RAID 5 (ASM disk 1)
- Disk 5 to 8 are configured in a RAID 5 (ASM disk 2)
- Disk 9 to 12 are configured in a RAID 5 (ASM disk 3)
- Disk 13 to 16 are configured in a RAID 5 (ASM disk 4)
- Disk 17 to 20 are configured in a RAID 5 (ASM disk 5)
- Disk 21 to 24 are configured in a RAID 5 (ASM disk 6)

For Data Record storage on HP on HP Gen9 and X6-2L servers:

Server internal disks:

- Disk 25 & 26 are configured in a RAID 1
- Disk 1 to 24 are configured in a RAID 10 (ASM disk 1)

For Packet Data storage on HP on HP G6 and Gen8 servers:

Server internal disks:

- Disk 1 & 2 are configured in a RAID 1

Storage array disks:

- Disk 1 to 12 are configured in a RAID 5 (pdu_1 disk)
- Disk 13 to 24 are configured in a RAID 5 (pdu_2 disk)

For Packet Data storage on HP on HP Gen9 and X6-2L servers:

Server internal disks:

- Disk 25 & 26 are configured in a RAID 1
- Disk 1 to 24 are configured in a RAID 10 (pdu_0 disk)

For mediation and acquisition on servers:

Server internal disks:

Hardware Installation Guidelines

- Disk 1 & 2 are configured in a RAID 1

10.12 Cable specification for Falco (SS7 to Sigtran converter)

Ethernet ports:

Falco shall be directly connected to the probe through a cross Ethernet male cable.

An additional RJ45 Ethernet port connected to the network is required for remote O&M.

SS7 line inputs:

For connection to DDF, customer shall provide cables from its DDF to the line inputs of the Falco.

On Falco side, a patch panel provides the RJ45 female interface to connect inputs line:

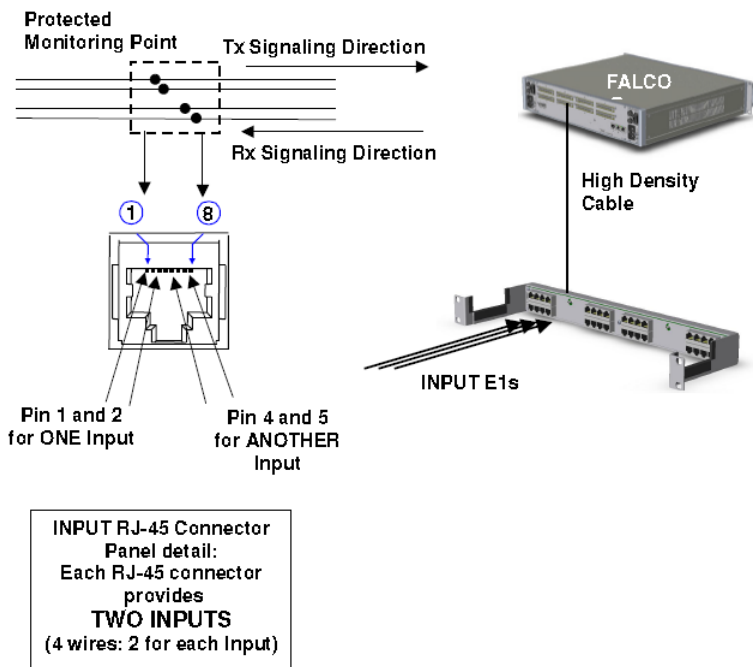

Figure 21- SS7 line inputs to Falco

Each RJ-45 Connector transports two Rx's.

On pins 1 and 2 there are the odd E1 Inputs (1, 3, 5...127)

On pins 4 and 5 there are the even E1 Inputs (2, 4, 6...128)

A Protected Monitoring Point is required, as per ITU G.772. If not, external protection by resistors on the cable to the DDF is always required.

It is strongly recommended to have shielded cables to limit electrical noise interferences from external environment.

a) Cable termination sample configuration for unprotected E1

Cable termination is wrapped. Customer shall adapt termination to its specific DDF case.

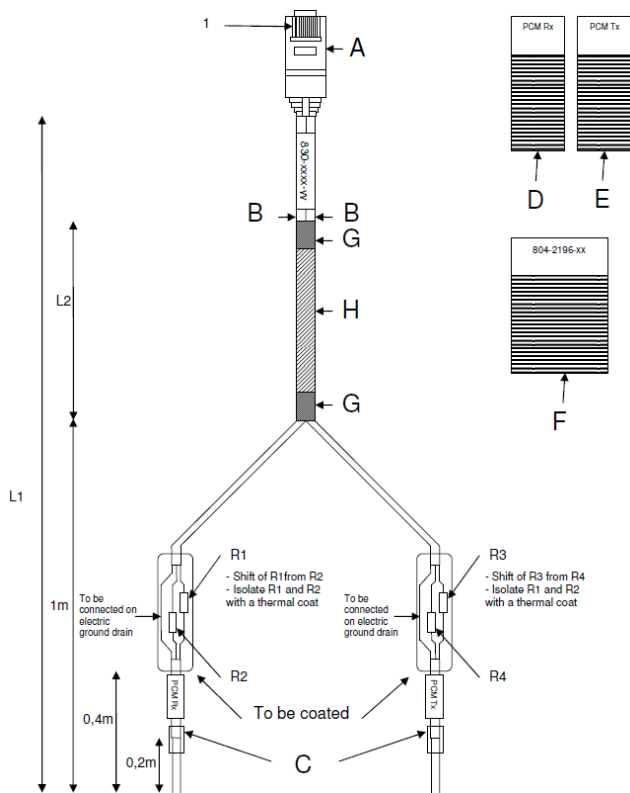

Figure 22- Cable for Falco: sample configuration for unprotected links

CABLE SPECIFICATIONS

Pair	Function	A	Remarks
Pair 1	PCM Rx-	1	
	PCM Rx+	2	
	Drain		Connected on A metallic body
Pair 2	PCM Tx-	4	
	PCM Tx+	5	
	Drain		Connected on A metallic body

Quantity	Reference	Label
1	RJ45 male 8 contacts.	A
1	Grey cover for RJ45 connector.	A
2	Shielded 1 pair cable 1 120Ω, length L1.	B
2	HELAVIA black sleeve type A2-C black L=25mm for 3,5 to 6mm wire's diameter.	C
2	Polyester label.	D-E
1	Polyester label.	F
4	560 ohms resistor 1% 1/2W.	R1, R2, R3, R4

Hardware Installation Guidelines

2	Black sleeve for 6,0 wire's diameter. Length 20mm	G
1	Gray polyamide plaited insulation, diameter 8mm, length L2	H

Table 44: Cable for Falco: sample configuration for unprotected links

b) Sample configuration for unprotected T1

Same configuration and network diagram applies for T1. Only the resistors (R1 to R4) value shall be changed to 470 ohms.

c) Configuration for protected links

Cable shall not be equipped with resistors

10.13 Cisco Switch

PIC is supporting Cisco 4948E-F switch.

Cisco 4948E-F Switches shall be mounted on the rear of the cabinet. This installation simplifies the Ethernet cables connections as most of the equipment to connect on the switches has their Ethernet ports on the rear.

Note from Cisco install guide: If you are installing the Catalyst 4948E-F switch chassis in a data center that is configured as hot isle and cold isle, you might need to install the Panduit Air Duct kit, Model CDE2. The kit extends the air intake from the rear of the chassis to the front of the equipment rack allowing the system to draw in cool air from the cool isle. To install the air duct assembly, refer to the installation note that ships with the kit.

Qualified BOMs for Cisco 4948E-F is the following:

	P/N	Description	Qty
Cisco	WS-C4948E-F	CISCO 4948E-F_48 PORT_10GBE_SWITCH_ROHS	1
Power DC	PWR-C49-300DC-F	CISCO_4948E-F_DC POWER SUPPLY	1
Software	S49EIPBK9-12254WO(=)	CISCO_4948E-F_IOS SOFTWARE_IP BASE_3DE	1
redundant power	PWR-C49-300DC-F/2	CISCO 4948E-F_DC REDUNDANT POWER SUPPLY	1
Software	WS-C4900-SW-LIC	CISCO 4948E_IP BASE UPGRADE LICENSE	1

Table 45: Cisco 4948E-F configuration

Customer can choose a Cisco 4948E instead for front mounting.

Other version of IOS can be selected by the customer. IP Base is recommended minimum version.

10.14 Cisco basic knowledge

enable to move from user mode to privileged mode

disable to move from privileged mode to user mode

show running-config to display the current configuration in RAM

show startup-config to display the saved configuration in NVRAM

configure terminal to move from privileged mode to config mode

interface gi1/1 to move from config mode to an interface config

copy running-config startup-config save the current configuration

show interfaces display the interfaces status

reload to reboot the switch

show version to display the ROM and IOS information

show tech-support to display a full switch status report. It should be captured in a file because it is long and takes a few minutes

10.14.1 Configure and access the serial console on TPD

Setup minicom access for 4948/4948E switches. This procedure is generic and can be used on any PIC server running TPD and connected to a switch console through a serial cable.

Determine whether needed minicom files are already available by issuing the following command:

```
# ls /etc/minirc.*
```

The minicom configuration name is: "minirc.<name_of_configuration>".

If the minicom configuration file is not already present, proceed with the rest of this step, otherwise skip to the next step:

Setup the serial connections for a switch by issuing the following command:

```
# remoteConsole --add --name=<name_of_configuration> --bps=9600 --parity=N --databits=8  
--handshake=none --port=<switch_serial_port>
```

Note:

- The default switch_serial_port should be /dev/ttyS1
- The name_of_configuration depends on the user's choice (ex: switch, yellow-sw1-1, blue-sw1-1...)

Connect serially to switch by issuing the following command as root on the management server:

```
# minicom <name_of_configuration>
```

Press RETURN to get started.

Press **Enter**

If the "autoinstall" line below does not appear, the switch may not be in factory default condition, continue with the step, disregarding this line:

```
Would you like to terminate autoinstall? [yes]:Enter
```

```
Switch> enable
```

```
Switch#
```

If "enable" command above prompts for a password, the switch is not in factory default configuration. This may be due to a previous configuration attempt. This procedure is for initial install.

To exit from the console, enter <ctrl-a><q> and you will be returned to the server prompt.

10.14.2 Configure and access the serial console on TVOE

From TVOE server: Setup conserver serial access a switch and open the firewall to allow for future tftp use in this procedure.

From management server, configure the conserver service to enable serial access to the switches:

```
# conserverAdm --addConsole --name=switch_console --device=/dev/ttyS4
```

Open the conserver port on the firewall of the TVOE management server:

```
# iptables -I INPUT -s <pmac_mgmtVLAN_ip_address>/255.255.255.255 -p all -j ACCEPT
```

```
# service iptables save
```

Note: The default devices should be /dev/ttyS4 and /dev/ttyS5 for PM&C

Connect serially to switch by issuing the following command from the PM&C server or any other servers you open the port on the firewall.

```
# console -M <TVOE_server_mgmtVLAN_ip_address> -l platcfg switch_console
```

Hardware Installation Guidelines

```
Enter platcfg@pmac5000101's password: <platcfg_password>
[Enter '^Ec?' for help]
Press Enter
Switch>
```

Depending on the switch config you might have to provide also the appropriate password to access the switch console after having provided the platcfg password.

To exit from the console, enter <ctrl-E><c><. > and you will be returned to the server prompt.

10.14.3 4948&4948EF Reset to factory defaults



Using this procedure you might lose the network connectivity.
It is advice to not do it with a remote connection
In privileged mode type

```
Switch#write erase
Erasing the nvram filesystem will remove all configuration files! Continue? [confirm]
[OK]
Erase of nvram: complete
*May 23 07:28:47.754: %SYS-7-NV_BLOCK_INIT: Initialized the geometry of nvram
Switch#erase cat4000_flash:
Erasing the cat4000_flash filesystem will remove all files! Continue? [confirm]
[OK]
Erase of cat4000_flash: complete
Switch#reload
System configuration has been modified. Save? [yes/no]: <- if the question is asked the
answer to this question is no
Proceed with reload? [confirm]
```

Once the switch rebooted you might receive the following question before to get the prompt

```
Press RETURN to get started!
 00:00:01: %C4K_IOSSYS-3-BLANKSTARTUPCONFIG: Blank or invalid startup-config, bo
s00:00:17: %SPANTREE-5-EXTENDED_SYSID: Extended SysId enabled for type vlan
 00:00:18: %C4K_IOSMODPORTMAN-6-MODULEONLINE: Module 1 (WS-C4948 S/N: FOX11450NC
e00:00:37: %SYS-5-RESTART: System restarted --
Cisco IOS Software, Catalyst 4500 L3 Switch Software (cat4500-IPBASEK9-M), Vers
)Technical Support: http://www.cisco.com/techsupport
Copyright (c) 1986-2008 by Cisco Systems, Inc.
Compiled Tue 29-Jul-08 12:15 by tinhuang

Would you like to terminate autoinstall? [yes]: <- if the question is asked the answer
to this question is yes
```

Configure the switch to boot properly by verifying that the bootvar is showing the correct configuration, from 0-IPBASEK9-M), V# dir bootflash:

determine from the output the latest image (check the version at cisco website if necessary)

if the width of the screen does not permit to see the complete output, use the following (the question mark Number", and if it # show file info bootflash:?

```
# show bootvar
```

if how b variablebootflash:oes not permit to /or config register is not 0x2102:

basically follow:

```
# config terminal
(config)# boot system flash bootflash:<name of image with latest version>
(config)# config-register 0x2102
(config)# end
# write memory
# show bootvar
```

10.14.4 Assign an IP address on a 3020

Refer to E53486 Oracle Communications Tekelec Platform 7.0.x Configuration Guide, section 3.5.2
Configure initial OA settings via configuration wizard step 8 OA GUI: EBIPA settings

10.14.5 2950 & 3020 Reset to factory defaults



Using this procedure you might lose the network connectivity.
It is advice to not do it with a remote connection
In privileged mode type

```
Switch#write erase
Erasing the nvram filesystem will remove all configuration files! Continue? [confirm]
[OK]
Erase of nvram: complete
*May 23 07:28:47.754: %SYS-7-NV_BLOCK_INIT: Initialized the geometry of nvram
Switch#delete flash:vlan.dat
Delete filename [vlan.dat]?
Delete flash:vlan.dat? [confirm]
Switch#reload
System configuration has been modified. Save? [yes/no]: <- if the question is asked the
answer to this question is no
Proceed with reload? [confirm]
```

Hardware Installation Guidelines

10.14.6 Configure telnet access on a 3020

Connect on the OA from the enclosure, and Navigate to the Interconnect Bays. Open the management URL. Take care if you reset the switch the password is back to the default value.

The screenshot displays the HP BladeSystem Onboard Administrator web interface. The browser address bar shows the URL <https://10.31.5.150/>. The page title is "HP BladeSystem Onboard Administrator". The user is logged in as "root" with options for "Home" and "Sign Out".

The main content area is titled "Interconnect Bay Summary". It features a table with the following columns: Bay, Status, UID, Power State, Module Type, Management URL, and Product Name. The table lists four interconnect bays:

Bay	Status	UID	Power State	Module Type	Management URL	Product Name
1	OK	Off	On	Ethernet	http://10.31.5.157	Cisco Catalyst Blade Switch 3020 for HP
2	OK	Off	On	Ethernet	http://10.31.5.158	Cisco Catalyst Blade Switch 3020 for HP
3	OK	Off	On	Fibre Channel	http://10.31.5.155	Brocade 4/24 SAN Switch for HP c-Class BladeSystem
4	OK	Off	On	Fibre Channel	http://10.31.5.156	Brocade 4/24 SAN Switch for HP c-Class BladeSystem

Below the table is a "Refresh" button. A note at the bottom of the table states: "* The URL information provided for interconnect modules may not be updated if the user modifies it via the interconnect module's management interface. In such a case, the user needs to manually type in the updated URL into the client web browser."

The interface also includes a "Systems and Devices" sidebar on the left, showing a tree view with "Interconnect Bays" selected. On the right, there are "Front View" and "Rear View" images of the enclosure.

If it is the first access the web interface will open directly on the express setup, otherway you can access it from the configure menu.

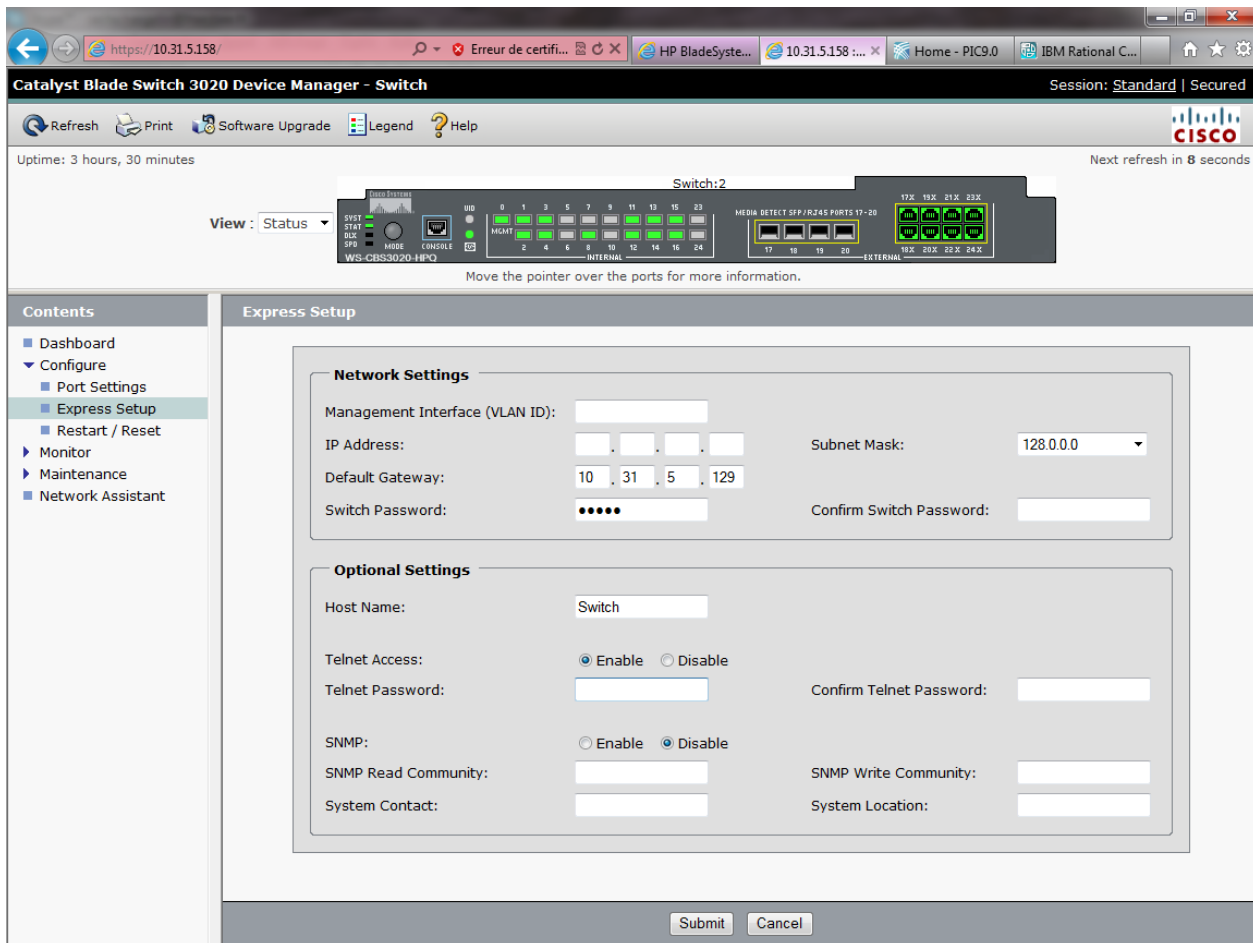

delines

From there you can enable the telnet access and define the password. You will have also to specify the VLAN ID to 1 and an IP in this VLAN, but don't configure the gateway. The IP will be removed while the switch config, and all configuration will be done using telnet on the EBIPA address.

Hardware Installation Guidelines

Network Settings

Management Interface (VLAN ID):

IP Address: . . .

Subnet Mask:

Default Gateway: . . .

Switch Password:

Confirm Switch Password:

Optional Settings

Host Name:

Telnet Access: Enable Disable

Telnet Password:

Confirm Telnet Password:

SNMP: Enable Disable

SNMP Read Community:

SNMP Write Community:

System Contact:

System Location:

10.14.7 Configure SSH access

In order to configure the SSH access you must have an IOS supporting the encryption. To check you must ensure the IOS file name contain "K9"

Move from the user mode to privileged mode.

```
Switch#enable
```

```
Switch#show version | include cat4500
```

```
Cisco IOS Software, Catalyst 4500 L3 Switch Software (cat4500e-ENTSERVICESK9-M), Version 12.2(54)WO, RELEASE SOFTWARE (fc1)
```

```
System image file is "bootflash:cat4500e-entservicesk9-mz.122-54.WO.bin"
```

If it is the case than you can proceed with the following commands once you moved to the config mode:

```
Switch# configure terminal
```

```
username root password 0 ***** ! <----- replace ***** with password  
specified in password dragon as Cisco SSH
```

```
ip domain-name tekelec.com
```

```
crypto key generate rsa
```

```
% You already have RSA keys defined named switch1B.tekelec.com.
% Do you really want to replace them? [yes/no]: yes
Choose the size of the key modulus in the range of 360 to 2048 for your
  General Purpose Keys. Choosing a key modulus greater than 512 may take
  a few minutes.
How many bits in the modulus [512]: 1024
% Generating 1024 bit RSA keys, keys will be non-exportable...[OK]
ip ssh version 2
line vty 0 15
  login local
  transport input ssh
end
```

10.14.8 Recover a switch from rommon prompt

In case the switch configuration failed and the switch would be in rommon follow this procedure to boot the switch.

Note: This is a generic procedure and the ios file name might be different depending on version running on your switch.

```
rommon 6 >dir bootflash:
  File size                Checksum                File name
  -----
  12632100 bytes (0xc0c024)  0x8136853a            cat4500-ipbasek9-mz.122-31.SGA8.bin
  456060 bytes (0x6f57c)    0x66d8b2a7            cat4500-ios-promupgrade-122_31r_SGA1
  Total space = 60817408 bytes, Available = 47728992 bytes
```

```
rommon 8 >confreg
Configuration Summary :
=> console baud: 9600
=> autoboot from: commands specified in 'BOOT' environment variable
do you wish to change the configuration? y/n [n]: y
enable "diagnostic mode"? y/n [n]: n
enable "use net in IP bcast address"? y/n [n]:
enable "load rom after netboot fails"? y/n [n]:
enable "use all zero broadcast"? y/n [n]:
enable "break/abort has effect"? y/n [n]: y
enable "ignore system config info"? y/n [n]:
change console baud rate? y/n [n]:
change the boot characteristics? y/n [n]: y
enter to boot:
0 = disable autoboot
1 = the first file from internal flash device
2 = commands specified in 'BOOT' environment variable
[2]:
Configuration Summary :
=> break/abort has effect
=> console baud: 9600
=> autoboot from: commands specified in 'BOOT' environment variable

do you wish to save this configuration? y/n [n]: y
You must reset or power cycle for new configuration to take effect
rommon 10 >boot bootflash:cat4500-ipbasek9-mz.122-31.SGA8.bin
Rommon reg: 0xE2004180
#####
k2diags version 5.2_c
Switch> enable
Switch# config t
```

Modify the configuration to boot using the new software and no more the previous one.

```
Switch#configure terminal
Enter configuration commands, one per line.  End with CNTL/Z.
Switch(config)#boot system flash bootflash:cat4500-ipbasek9-mz.122-53.SG2.bin
Switch(config)#no boot system flash bootflash:cat4500-ipbase-mz.122-46.SG.bin
Switch(config)#config-register 0x2102
Switch(config)#exit
Switch #copy running-config startup-config
Switch #reload
```

After reloading, verify that the switch is booting to the expected version:

```
Switch#show version | include bootflash
System image file is "bootflash:cat4500-ipbasek9-mz.122-53.SG2.bin"
```

10.14.10 Backup the switch config on a server

Use the following command to backup a switch configuration on a server.

```
blue-sw1-1#copy running-config scp:
Address or name of remote host []? 172.22.49.10
Destination username [root]?
Destination filename [blue-sw1-1-config]?
Writing blue-sw1-1-config
Password:
!!
9314 bytes copied in 14.292 secs (652 bytes/sec)
blue-sw1-1#
```

10.14.11 Configure Cisco 4948/4948E/4948E-F switch

This procedure describes how to configure the Cisco switches.

Configure the switches from the applicable server as follows:

Note: Not all the switches listed may be applicable for your particular configuration.

- Yellow-sw1-1 from IMF-1A server
- Blue-sw1-1 from IMF-1B server
- Yellow-sw2-1 from IMF-1C server
- Blue-sw2-1 from IMF-1D server
- Yellow-sw3-1 from IMF-1E server
- Blue-sw3-2 from IMF-1F server

In case there are more switches required than IMF servers, the console port of the additional switch will have to be moved on one of the servers or configured using a laptop.

For an estimated time for this procedure, refer to the IMF flowcharts in Installation Overview.

Mediation switch are connected to the first MEDIATION server from the cabinet.

Note: In case in the procedure would failed, refer to section 6.10.8 in order to recover the switch from rommon prompt.

Hardware Installation Guidelines

- A. Configure and access the serial console from the server (PM&C, IMF or IXP) on the switches
 - a. Refer to section 6.10.1 or 6.10.2
- B. Reset the switch to factory default
 - a. If you are reconfiguring a switch backup the current config in a file using the command
- C. Configure the switch using the appropriate template
 - a. Refer to following sections to select the appropriate configuration template and adapt it to the customer IP network.
 - i. Section 6.11 for mediation
 - ii. Section 6.12 for Blades
 - iii. Section 6.13 for Intergrated Acquisition
 - b. As there is no log file for the following steps it is recomanded to enable the log feature from your terminal in case something would not work as expected and assistance is required.
 - c. Move from the user mode to privledge mode and then to config mode

```
Switch# enable
```

```
Switch# configure terminal
```

Note : if you reset the switch to factory default no password should be requested to connect on it and move to enable mode.

- d. Adapt the template configuration to your network. The lines you need to customize are hilighted with Yellow comments. Paste the command in block and not necessary one by one but don't do it with too much commands at a time in order to take care if an error message would appear.
- e. Once the config is in place you can check it is matching your expectation using the command

```
Switch# show running-config
```

- f. If the configuration is fine then you can save it in the flash in order to have it automatically reloaded if the switch reboot

```
Switch# copy running-config startup-config
```

- g. If there is an issue in your config you can can reboot the switch without saving and then restart the config from the step a

```
Switch# reload
```

- h. Finally to configure the SSH access to the switch refer to section 6.10.7
- i. Once the config is in place you can check it is matching your expectation using the command

```
Switch# show running-config
```

- j. If the configuration is fine then you can save it in the flash in order to have it automatically reloaded if the switch reboot

```
Switch# copy running-config startup-config
```

- k. If there is an issue in your config you can can reboot the switch without saving and then restart the config from the step h

```
Switch# reload
```

10.14.12 Configure Cisco 3020 switch

- A. Assign IP addresses to the switches
 - a. Refer to E53486 Oracle Communications Tekelec Platform 7.0.x Configuration Guide, section 3.5.2 Configure initial OA settings via configuration wizard step 8 OA GUI: EBIPA settings if this was not done earlier
- B. Reset the switch to factory default
 - a. If you are reconfiguring a switch backup the current config in a file using the command

```
Switch# show running-config
```

- b. Refer to section 6.10.5 to reset the switch. Take care to only erase the vlan.dat and not the whole content of the flash.
- C. Reconfigure the telnet access
 - a. Refer to section 6.10.6.
- D. Configure the switch using the appropriate template
 - a. Refer to the following section 6.12.3.
 - b. As there is no log file for the following steps it is recommended to enable the log feature from your terminal in case something would not work as expected and assistance is required.
 - c. Open a telnet session on the switch and then move from the user mode to privilege mode and then to config mode

```
Switch# enable
```

```
Switch# configure terminal
```

Note : if you reset the switch to factory default no password should be requested to connect on it and move to enable mode.

- d. Paste all the commands from the template config you have adapted to your network. The lines you need to customize are highlighted with yellow comments. You can paste the command in block and not necessarily one by one but don't do it with too many commands at a time in order to take care if an error message would appear.
- e. Once the config is in place you can check it is matching your expectation using the command

```
Switch# show running-config
```

- f. If the configuration is fine then you can save it in the flash in order to have it automatically reloaded if the switch reboots

```
Switch# copy running-config startup-config
```

- g. If there is an issue in your config you can reboot the switch without saving and then restart the config from step a

```
Switch# reload
```

10.14.13 Flush ARP table

- A. Check VIP address mapping on the Switch (in enable mode)

```
Switch #show arp
```

Protocol	Address	Age (min)	Hardware Addr	Type	Interface
Internet	172.21.49.10	1	0010.1326.a103	ARPA	Vlan100
Internet	172.21.49.11	0	001e.6700.c9a4	ARPA	Vlan100

Use the ifconfig command on the Master IMF server to get the MAC address of its interfaces:

```
bond0.200 Link encap:Ethernet HWaddr 00:10:13:26:A1:03
          inet addr:10.31.2.101 Bcast:10.31.2.255 Mask:255.255.255.0
          inet6 addr: fe80::210:13ff:fe26:a103/64 Scope:Link
```

Compare the **Hardware Addr** with the **HWaddr** (be careful in this example 0010.1326.a103 is equal to 00:10:13:26:A1:03).

If the values are equal or if no entry matches the VIP address, then it is not necessary to flush the ARP table of the Cisco switch.

If the VIP address is associated to a wrong MAC address, then continue the procedure.

- B. Flush the ARP table on the Switch (in enable mode)

```
Switch# clear arp-cache
```

Hardware Installation Guidelines

10.15 Mediation switch configuration template

The VLAN values must be customized according customer requirement

10.15.1 Switch port allocation

The first IXP Server iLO are directly connected to customer network. Server E in the control frame and server A in the extension frames



Port	Port 3	Port 5	Port 7	Port 9	Port 11	Port 13	Port 15	Port 17	Port 19	Port 21	Port 23	Port 25	Port 27	Port 29	Port 31	Port 33	Port 35	Port 37	Port 39	Port 41	Port 43	Port 45	Port 47
Ctrl Frame RM Port 1 ServerA iLO eth2	Port 3 ServerB iLO eth2	Port 5 Free eth3	Port 7 Free eth3	Port 9 Free eth1	Port 11 ServerF iLO eth1	Port 13 ServerG iLO eth1	Port 15 ServerH iLO eth1	Port 17 ServerI iLO eth1	Port 19 ServerJ iLO eth1	Port 21 ServerK iLO eth1	Port 23 ServerL iLO eth1	Port 25 Next Frame eth1	Port 27 Next Frame eth1	Port 29 Next Frame eth1	Port 31 Next Frame eth1	Port 33 Next Frame eth1	Port 35 Next Frame eth1	Port 37 Next Frame eth1	Port 39 Next Frame eth1	Port 41 Cust Net iLO Frontend	Port 43 ServerA eth4 eth5	Port 45 ServerB eth4 eth5	Port 47 Cust Net SW A Cust Net SW B
Ext Frame RM 7.1 and higher Port 1 Free eth1	Port 3 ServerB iLO eth1	Port 5 ServerC iLO eth1	Port 7 ServerD iLO eth1	Port 9 ServerE iLO eth1	Port 11 ServerF iLO eth1	Port 13 ServerG iLO eth1	Port 15 ServerH iLO eth1	Port 17 ServerI iLO eth1	Port 19 ServerJ iLO eth1	Port 21 ServerK iLO eth1	Port 23 ServerL iLO eth1	Port 25 Free eth1	Port 27 Free eth1	Port 29 Free eth1	Port 31 Free eth1	Port 33 Free eth1	Port 35 Free eth1	Port 37 Free eth1	Port 39 Free eth1	Port 41 Free eth1	Port 43 Free eth1	Port 45 Free eth1	Port 47 iLO Ctrl Frame Eth Ctrl Frame
Ext Frame RM 7.0 and lower Port 1 Free eth1	Port 3 ServerB iLO eth1	Port 5 ServerC iLO eth1	Port 7 ServerD iLO eth1	Port 9 ServerE iLO eth1	Port 11 Free eth1	Port 13 Free eth1	Port 15 Free eth1	Port 17 Free eth1	Port 19 Free eth1	Port 21 ServerF iLO eth1	Port 23 ServerG iLO eth1	Port 25 ServerH iLO eth1	Port 27 ServerI iLO eth1	Port 29 ServerJ iLO eth1	Port 31 ServerK iLO eth1	Port 33 ServerL iLO eth1	Port 35 Free eth1	Port 37 Free eth1	Port 39 Free eth1	Port 41 Free eth1	Port 43 Free eth1	Port 45 Free eth1	Port 47 iLO Ctrl Frame Eth Ctrl Frame

10.15.2 Control Frame Switch

Note : The command “spanning-tree portfast trunk” will return the following warning, you can ignore:

```
%Warning: portfast should only be enabled on ports connected to a single host.
Connecting hubs, concentrators, switches, bridges, etc... to this interface
when portfast is enabled, can cause temporary bridging loops.
```

Use with CAUTION

Note : the commands “switchport trunk encapsulation dot1q” and “media-type rj45” will fail on the 4948EF switch but it is kept this config for compatibility with the previous 4948

```
!
no service pad
service timestamps debug uptime
service timestamps log uptime
service password-encryption
service compress-config
!
hostname Switch
!
enable secret ***** ! <----- replace ***** with password specified in password dragon as Cisco enable
!
no aaa new-model
ip subnet-zero
no ip source-route
no ip domain-lookup
```

```

!
vtp mode transparent
!
!
!
power redundancy-mode redundant
no file verify auto
!
spanning-tree mode rapid-pvst
no spanning-tree optimize bpdu transmission
spanning-tree extend system-id
!
vlan internal allocation policy ascending
!
!
vlan 100          ! <----- replace VLAN with customer value
  name iLO
!
vlan 200          ! <----- replace VLAN with customer value
  name CUST
!
vlan 300          ! <----- replace VLAN with customer value
  name NSP_Front
!
Interface range Gi1/1 ,Gi1/3 ,Gi1/5 ,Gi1/7 ,Gi1/9
  description Server iLO Access
  switchport access vlan 100  ! <----- replace VLAN with customer value
  switchport mode access
  spanning-tree portfast
!
Interface range Gi1/11 ,Gi1/13 ,Gi1/15 ,Gi1/17 ,Gi1/19
  description Server iLO Access
  switchport access vlan 100  ! <----- replace VLAN with customer value
  switchport mode access
  spanning-tree portfast
!
Interface range Gi1/21 ,Gi1/23 ,Gi1/25 ,Gi1/27 ,Gi1/29
  description Server iLO Access
  switchport access vlan 100  ! <----- replace VLAN with customer value
  switchport mode access
  spanning-tree portfast
!
Interface range Gi1/31 ,Gi1/33 ,Gi1/35 ,Gi1/37 ,Gi1/39
  description Server iLO Access
  switchport access vlan 100  ! <----- replace VLAN with customer value
  switchport mode access

```

Hardware Installation Guidelines

```
spanning-tree portfast
!
Interface range Gi1/41
description Server iLO Access
switchport access vlan 100 ! <----- replace VLAN with customer value
switchport mode access
spanning-tree portfast
!
interface range Gi1/2 ,Gi1/4 ,Gi1/6 ,Gi1/8 ,Gi1/10
description Server CUST Access
switchport access vlan 200 ! <----- replace VLAN with customer value
switchport mode access
spanning-tree portfast
!
interface range Gi1/12 ,Gi1/14 ,Gi1/16 ,Gi1/18 ,Gi1/20
description Server CUST Access
switchport access vlan 200 ! <----- replace VLAN with customer value
switchport mode access
spanning-tree portfast
!
interface range Gi1/22 ,Gi1/24 ,Gi1/26 ,Gi1/28 ,Gi1/30
description Server CUST Access
switchport access vlan 200 ! <----- replace VLAN with customer value
switchport mode access
spanning-tree portfast
!
interface range Gi1/32 ,Gi1/34 ,Gi1/36 ,Gi1/38 ,Gi1/40
description Server CUST Access
switchport access vlan 200 ! <----- replace VLAN with customer value
switchport mode access
spanning-tree portfast
!
interface range GigabitEthernet1/42 - 46
description NSP NIC2 CUST Ethernet Access
switchport access vlan 300 ! <----- replace VLAN with customer value
switchport mode access
spanning-tree portfast
!
interface GigabitEthernet1/47
description 802.1Q trunk link to backbone SWA
switchport trunk encapsulation dot1q
switchport mode trunk
media-type rj45
!
interface GigabitEthernet1/48
description 802.1Q trunk link to backbone SWB
```

```
switchport trunk encapsulation dot1q
switchport mode trunk
media-type rj45
spanning-tree cost 20
!
interface Vlan1
no ip address
shutdown
!
interface Vlan100
! <----- replace VLAN with customer value
description Optional Switch Virtual Interface (SVI) for iLO Subnet - switch management
no ip address
shutdown
!
interface Vlan200
! <----- replace VLAN with customer value
description Optional Switch Virtual Interface (SVI) for CUST Subnet - switch management
no ip address
shutdown
!
no ip http server
!
!
!
no cdp run
!
control-plane
!
!
line con 0
password ***** ! <----- replace ***** with password specified in password dragon as Cisco telnet
exec-timeout 30 0
logging synchronous
stopbits 1
!
end
```

10.15.3 Extension Frame Switch

Note : The command “spanning-tree portfast trunk” will return the following warning, you can ignore:

```
%Warning: portfast should only be enabled on ports connected to a single host.
Connecting hubs, concentrators, switches, bridges, etc... to this interface
when portfast is enabled, can cause temporary bridging loops.
Use with CAUTION
```

Hardware Installation Guidelines

Note: the commands “switchport trunk encapsulation dot1q” and “media-type rj45” will fail on the 4948EF switch but it is kept this config for compatibility with the previous 4948

```
!  
no service pad  
service timestamps debug uptime  
service timestamps log uptime  
service password-encryption  
service compress-config  
!  
hostname Switch  
!  
enable secret ***** ! <----- replace ***** with password specified in password dragon as Cisco enable  
!  
no aaa new-model  
ip subnet-zero  
no ip source-route  
no ip domain-lookup  
!  
vtp mode transparent  
!  
!  
power redundancy-mode redundant  
no file verify auto  
!  
spanning-tree mode rapid-pvst  
no spanning-tree optimize bpdu transmission  
spanning-tree extend system-id  
!  
vlan internal allocation policy ascending  
!  
!  
vlan 100 ! <----- replace VLAN with customer value  
  name iLO  
!  
vlan 200 ! <----- replace VLAN with customer value  
  name CUST  
!  
Interface range Gi1/1 ,Gi1/3 ,Gi1/5 ,Gi1/7 ,Gi1/9  
  description Server iLO Access  
  switchport access vlan 100 ! <----- replace VLAN with customer value  
  switchport mode access  
  spanning-tree portfast  
!  
Interface range Gi1/11 ,Gi1/13 ,Gi1/15 ,Gi1/17 ,Gi1/19
```

```

description Server iLO Access
switchport access vlan 100 ! <----- replace VLAN with customer value
switchport mode access
spanning-tree portfast
!
Interface range Gi1/21 ,Gi1/23 ,Gi1/25 ,Gi1/27 ,Gi1/29
description Server iLO Access
switchport access vlan 100 ! <----- replace VLAN with customer value
switchport mode access
spanning-tree portfast
!
Interface range Gi1/31 ,Gi1/33 ,Gi1/35 ,Gi1/37 ,Gi1/39
description Server iLO Access
switchport access vlan 100 ! <----- replace VLAN with customer value
switchport mode access
spanning-tree portfast
!
Interface range Gi1/41 ,Gi1/43 ,Gi1/45
description Server iLO Access
switchport access vlan 100 ! <----- replace VLAN with customer value
switchport mode access
spanning-tree portfast
!
interface range Gi1/2 ,Gi1/4 ,Gi1/6 ,Gi1/8 ,Gi1/10
description Server CUST Access
switchport access vlan 200 ! <----- replace VLAN with customer value
switchport mode access
spanning-tree portfast
!
interface range Gi1/12 ,Gi1/14 ,Gi1/16 ,Gi1/18 ,Gi1/20
description Server CUST Access
switchport access vlan 200 ! <----- replace VLAN with customer value
switchport mode access
spanning-tree portfast
!
interface range Gi1/22 ,Gi1/24 ,Gi1/26 ,Gi1/28 ,Gi1/30
description Server CUST Access
switchport access vlan 200 ! <----- replace VLAN with customer value
switchport mode access
spanning-tree portfast
!
interface range Gi1/32 ,Gi1/34 ,Gi1/36 ,Gi1/38 ,Gi1/40
description Server CUST Access
switchport access vlan 200 ! <----- replace VLAN with customer value
switchport mode access
spanning-tree portfast

```

Hardware Installation Guidelines

```
!  
interface range Gi1/42 ,Gi1/44 ,Gi1/46  
  description Server CUST Access  
  switchport access vlan 200 ! <----- replace VLAN with customer value  
  switchport mode access  
  spanning-tree portfast  
!  
interface GigabitEthernet1/47  
  description Connection to Control Frame Switch on iLO VLAN  
  switchport access vlan 100 ! <----- replace VLAN with customer value  
  switchport mode access  
  spanning-tree portfast  
!  
interface GigabitEthernet1/48  
  description Connection to Control Frame Switch on CUST VLAN  
  switchport access vlan 200 ! <----- replace VLAN with customer value  
  switchport mode access  
  spanning-tree portfast  
!  
!  
interface Vlan1  
  no ip address  
  shutdown  
!  
interface Vlan100 ! <----- replace VLAN with customer value  
  description Optional Switch Virtual Interface (SVI) for iLO Subnet - switch management  
  no ip address  
  shutdown  
!  
interface Vlan200 ! <----- replace VLAN with customer value  
  description Optional Switch Virtual Interface (SVI) for CUST Subnet - switch management  
  no ip address  
  shutdown  
!  
no ip http server  
!  
!  
!  
no cdp run  
!  
control-plane  
!  
!  
line con 0  
  password ***** ! <----- replace ***** with password specified in password dragon as Cisco telnet  
  exec-timeout 30 0
```

Hardware Installation Guidelines

```
logging synchronous  
stopbits 1  
!  
end
```

Hardware Installation Guidelines

10.16 Blade mediation switch configuration template

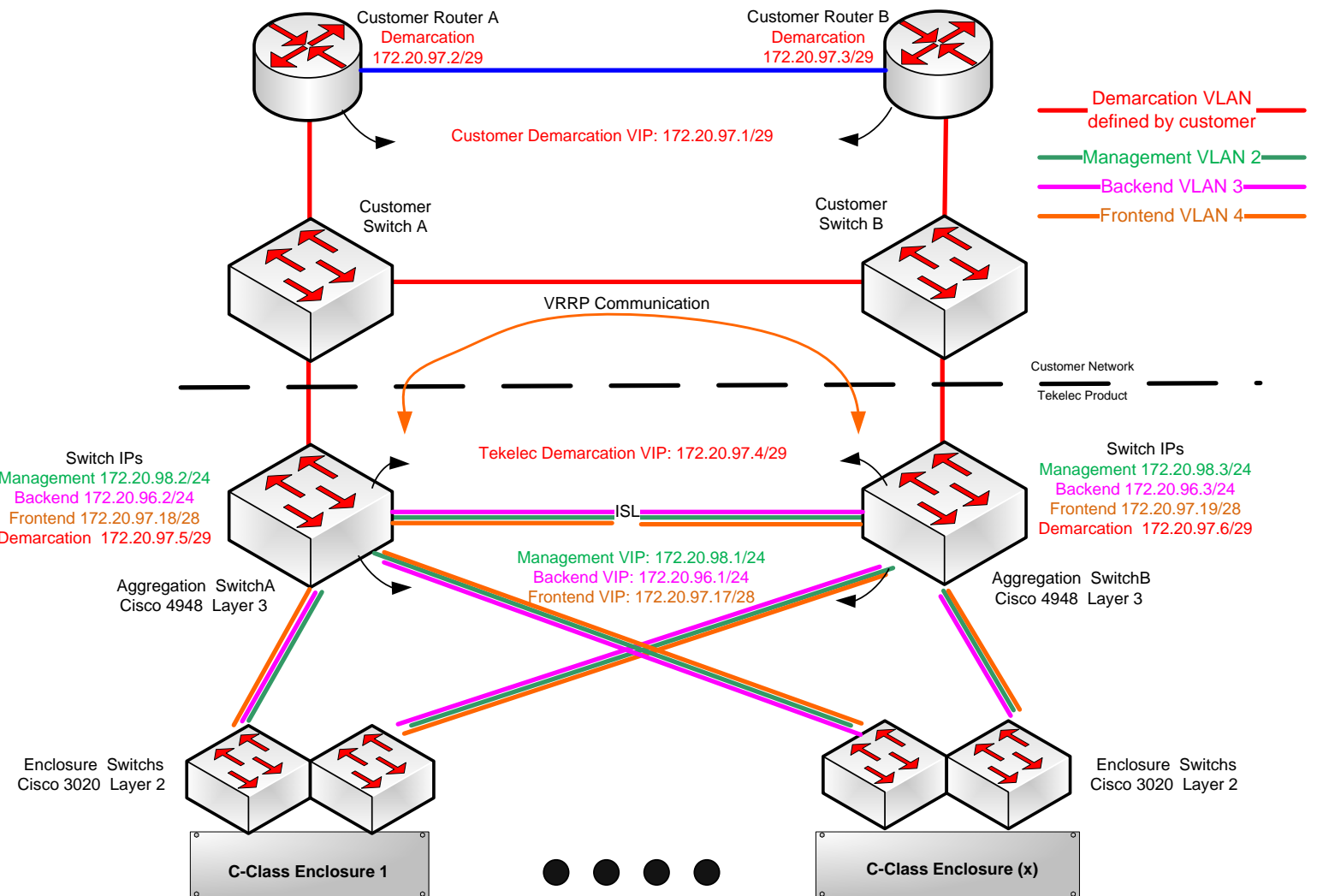

10.16.1 Switch port allocation

All the following information assume the cabling has been done according the Tekelec System Interconnect diagrams 893-0103-XX to be used for G6 & G8 servers with P2000 storage arrays

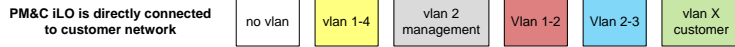

Enclosure 7 Switch1

Port 1 Server1 eth2	Port 3 Server3 eth2	Port 5 Server5 eth2	Port 7 Server7 eth2	Port 9 Server9 eth2	Port 11 Server11 eth2	Port 13 Server13 eth2	Port 15 Server15 eth2	Port 17 Agg SW A P29	Port 19 Agg SW A P31	Port 21 SAN contr1	Port 23 SAN contr3
Port 2 Server2 eth2	Port 4 Server4 eth2	Port 6 Server6 eth2	Port 8 Server8 eth2	Port 10 Server10 eth2	Port 12 Server12 eth2	Port 14 Server14 eth2	Port 16 Server16 eth2	Port 18 Agg SW A P30	Port 20 Agg SW A P32	Port 22 SAN contr2	Port 24 SAN contr4

Enclosure 1 Switch1

Port 1 Server1 eth2	Port 3 Server3 eth2	Port 5 Server5 eth2	Port 7 Server7 eth2	Port 9 Server9 eth2	Port 11 Server11 eth2	Port 13 Server13 eth2	Port 15 Server15 eth2	Port 17 Agg SW A P5	Port 19 Agg SW A P7	Port 21 SAN contr1	Port 23 SAN contr3
Port 2 Server2 eth2	Port 4 Server4 eth2	Port 6 Server6 eth2	Port 8 Server8 eth2	Port 10 Server10 eth2	Port 12 Server12 eth2	Port 14 Server14 eth2	Port 16 Server16 eth2	Port 18 Agg SW A P6	Port 20 Agg SW A P8	Port 22 SAN contr2	Port 24 SAN contr4

Aggregation SwitchA

Port 1 Agg SW B P1	Port 3 Agg SW B P3	Port 5 Enc1 SW1 P17	Port 7 Enc1 SW1 P19	Port 9 Enc2 SW1 P17	Port 11 Enc2 SW1 P19	Port 13 Enc3 SW1 P17	Port 15 Enc3 SW1 P19	Port 17 Enc4 SW1 P17	Port 19 Enc4 SW1 P19	Port 21 Enc5 SW1 P17	Port 23 Enc5 SW1 P19	Port 25 Enc6 SW1 P17	Port 27 Enc6 SW1 P19	Port 29 Enc7 SW1 P17	Port 31 Enc7 SW1 P19	Port 33 Enc1 OA1	Port 35 Enc3 OA1	Port 37 Enc5 OA1	Port 39 Enc7 OA1	Port 41 Free	Port 43 Free	Port 45 For Laptop	Port 47 Free
Port 2 Agg SW B P2	Port 4 Agg SW B P4	Port 6 Enc1 SW1 P18	Port 8 Enc1 SW1 P20	Port 10 Enc2 SW1 P18	Port 12 Enc2 SW1 P20	Port 14 Enc3 SW1 P18	Port 16 Enc3 SW1 P20	Port 18 Enc4 SW1 P18	Port 20 Enc4 SW1 P20	Port 22 Enc5 SW1 P18	Port 24 Enc5 SW1 P20	Port 26 Enc6 SW1 P18	Port 28 Enc6 SW1 P20	Port 30 Enc7 SW1 P18	Port 32 Enc7 SW1 P20	Port 34 Enc2 OA1	Port 36 Enc4 OA1	Port 38 Enc6 OA1	Port 40 PM&C Eth1	Port 42 Free	Port 44 Free	Port 46 For Laptop	Port 48 Cust Net eth
Port 1 Agg SW A P1	Port 3 Agg SW A P3	Port 5 Enc1 SW2 P17	Port 7 Enc1 SW2 P19	Port 9 Enc2 SW2 P17	Port 11 Enc2 SW2 P19	Port 13 Enc3 SW2 P17	Port 15 Enc3 SW2 P19	Port 17 Enc4 SW2 P17	Port 19 Enc4 SW2 P19	Port 21 Enc5 SW2 P17	Port 23 Enc5 SW2 P19	Port 25 Enc6 SW2 P17	Port 27 Enc6 SW2 P19	Port 29 Enc7 SW2 P17	Port 31 Enc7 SW2 P19	Port 33 Enc1 OA2	Port 35 Enc3 OA2	Port 37 Enc5 OA2	Port 39 Enc7 OA2	Port 41 Free	Port 43 Free	Port 45 For Laptop	Port 47 Free
Port 2 Agg SW A P2	Port 4 Agg SW A P4	Port 6 Enc1 SW2 P18	Port 8 Enc1 SW2 P20	Port 10 Enc2 SW2 P18	Port 12 Enc2 SW2 P20	Port 14 Enc3 SW2 P18	Port 16 Enc3 SW2 P20	Port 18 Enc4 SW2 P18	Port 20 Enc4 SW2 P20	Port 22 Enc5 SW2 P18	Port 24 Enc5 SW2 P20	Port 26 Enc6 SW2 P18	Port 28 Enc6 SW2 P20	Port 30 Enc7 SW2 P18	Port 32 Enc7 SW2 P20	Port 34 Enc2 OA2	Port 36 Enc4 OA2	Port 38 Enc6 OA2	Port 40 PM&C Eth2	Port 42 Free	Port 44 Free	Port 46 For Laptop	Port 48 Cust Net eth

Aggregation SwitchB

Enclosure 1 Switch2

Port 1 Server1 eth2	Port 3 Server3 eth2	Port 5 Server5 eth2	Port 7 Server7 eth2	Port 9 Server9 eth2	Port 11 Server11 eth2	Port 13 Server13 eth2	Port 15 Server15 eth2	Port 17 Agg SW B P5	Port 19 Agg SW B P7	Port 21 SAN contr1	Port 23 SAN contr3
Port 2 Server2 eth2	Port 4 Server4 eth2	Port 6 Server6 eth2	Port 8 Server8 eth2	Port 10 Server10 eth2	Port 12 Server12 eth2	Port 14 Server14 eth2	Port 16 Server16 eth2	Port 18 Agg SW B P6	Port 20 Agg SW B P8	Port 22 SAN contr2	Port 24 SAN contr4

Enclosure 7 Switch2

Port 1 Server1 eth2	Port 3 Server3 eth2	Port 5 Server5 eth2	Port 7 Server7 eth2	Port 9 Server9 eth2	Port 11 Server11 eth2	Port 13 Server13 eth2	Port 15 Server15 eth2	Port 17 Agg SW B P29	Port 19 Agg SW B P31	Port 21 SAN contr1	Port 23 SAN contr3
Port 2 Server2 eth2	Port 4 Server4 eth2	Port 6 Server6 eth2	Port 8 Server8 eth2	Port 10 Server10 eth2	Port 12 Server12 eth2	Port 14 Server14 eth2	Port 16 Server16 eth2	Port 18 Agg SW B P30	Port 20 Agg SW B P32	Port 22 SAN contr2	Port 24 SAN contr4

Hardware Installation Guidelines

10.16.2 Aggregation Switch

Note : The command “spanning-tree portfast trunk” will return the following warning, you can ignore:

```
%Warning: portfast should only be enabled on ports connected to a single host.
Connecting hubs, concentrators, switches, bridges, etc... to this interface
when portfast is enabled, can cause temporary bridging loops.
```

Use with CAUTION

Note : the commands “switchport trunk encapsulation dot1q” and “media-type rj45” will fail on the 4948EF switch but it is kept this config for compatibility with the previous 4948

```
!
!
! Aggregation Switch configuration
! MASTER VRRP switch
!
!
hostname switchA      ! <----- replace the hostname to identify the switch
!
!
spanning-tree mode rapid-pvst
no spanning-tree optimize bpdu transmission
spanning-tree extend system-id
!
enable secret ***** ! <----- replace ***** with password specified in password dragon as Cisco enable
service password-encryption
no service pad
service timestamps debug datetime
service timestamps log datetime
no logging console
no aaa new-model
track 1 interface GigabitEthernet1/48 line-protocol
ip subnet-zero
vtp mode transparent
!
power redundancy-mode redundant
!
!
! VLAN CONFIGURATION (internal)
!
!
vlan internal allocation policy ascending
!
vlan 2
name management
```

```
!  
vlan 3  
    name backend  
!  
vlan 4  
    name frontend  
!  
vlan 110      ! <----- Enter customer value for demarcation VLAN  
  
    name customer  
!  
!  
!   INTER switch1A to other switch ETHERCHANNEL (internal)  
!  
!  
interface Port-channel1  
    description Trunk_between_switch1A_and_Enc1SW1  
    switchport  
    switchport trunk encapsulation dot1q  
    switchport trunk allowed vlan 1-4  
    switchport mode trunk  
!  
interface Port-channel2  
    description Trunk_between_switch1A_and_Enc2SW1  
    switchport  
    switchport trunk encapsulation dot1q  
    switchport trunk allowed vlan 1-4  
    switchport mode trunk  
!  
interface Port-channel3  
    description Trunk_between_switch1A_and_Enc3SW1  
    switchport  
    switchport trunk encapsulation dot1q  
    switchport trunk allowed vlan 1-4  
    switchport mode trunk  
!  
interface Port-channel4  
    description Trunk_between_switch1A_and_Enc4SW1  
    switchport  
    switchport trunk encapsulation dot1q  
    switchport trunk allowed vlan 1-4  
    switchport mode trunk  
!  
interface Port-channel5  
    description Trunk_between_switch1A_and_Enc5SW1  
    switchport
```

Hardware Installation Guidelines

```
switchport trunk encapsulation dot1q
switchport trunk allowed vlan 1-4
switchport mode trunk
!
interface Port-channel6
description Trunk_between_switch1A_and_Enc6SW1
switchport
switchport trunk encapsulation dot1q
switchport trunk allowed vlan 1-4
switchport mode trunk
!
interface Port-channel7
description Trunk_between_switch1A_and_Enc7SW1
switchport
switchport trunk encapsulation dot1q
switchport trunk allowed vlan 1-4
switchport mode trunk
!
interface Port-channel8
description Trunk_between_switch1A_and_switch1B
switchport
switchport trunk encapsulation dot1q
switchport trunk allowed vlan 1-4
switchport mode trunk
switchport nonegotiate
!
!
! INTER switch1A to other switch PORTS (internal)
!
!
interface range GigabitEthernet1/1-4
description Trunk_between_switch1A_and_switch1B
switchport trunk encapsulation dot1q
switchport trunk allowed vlan 1-4
switchport mode trunk
switchport nonegotiate
channel-group 8 mode active
!
interface range GigabitEthernet1/5-8
description Trunk_between_cxeny(en1)-sw1
switchport trunk encapsulation dot1q
switchport trunk allowed vlan 1-4
switchport mode trunk
channel-group 1 mode active
spanning-tree portfast trunk
!
```

```
interface range GigabitEthernet1/9-12
  description ISL_to_cxeny(en2)-sw1
  switchport trunk encapsulation dot1q
  switchport trunk allowed vlan 1-4
  switchport mode trunk
  channel-group 2 mode active
  spanning-tree portfast trunk
!
interface range GigabitEthernet1/13-16
  description ISL_to_cxeny(en3)-sw1
  switchport trunk encapsulation dot1q
  switchport trunk allowed vlan 1-4
  switchport mode trunk
  channel-group 3 mode active
  spanning-tree portfast trunk
!
interface range GigabitEthernet1/17-20
  description ISL_to_cxeny(en4)-sw1
  switchport trunk encapsulation dot1q
  switchport trunk allowed vlan 1-4
  switchport mode trunk
  channel-group 4 mode active
  spanning-tree portfast trunk
!
interface range GigabitEthernet1/21-24
  description ISL_to_cxeny(en5)-sw1
  switchport trunk encapsulation dot1q
  switchport trunk allowed vlan 1-4
  switchport mode trunk
  channel-group 5 mode active
  spanning-tree portfast trunk
!
interface range GigabitEthernet1/25-28
  description ISL_to_cxeny(en6)-sw1
  switchport trunk encapsulation dot1q
  switchport trunk allowed vlan 1-4
  switchport mode trunk
  channel-group 6 mode active
  spanning-tree portfast trunk
!
interface range GigabitEthernet1/29-32
  description ISL_to_cxeny(en7)-sw1
  switchport trunk encapsulation dot1q
  switchport trunk allowed vlan 1-4
  switchport mode trunk
  channel-group 7 mode active
```

Hardware Installation Guidelines

```
spanning-tree portfast trunk
!
!
! OA PORTS
!
!
interface range GigabitEthernet1/33-39
  description cxeny(enX)-OA
  switchport access vlan 2
  switchport mode access
  spanning-tree portfast
!
!
! PM&C PORTS
!
!
interface GigabitEthernet1/40
  description clmsl-nic
  switchport trunk encapsulation dot1q
  switchport trunk allowed vlan 1-3
  switchport mode trunk
  spanning-tree portfast trunk
!
interface GigabitEthernet1/41
  description clmsl-iLO for compatibilty with G6 & G5, it is recomanded to connect directly on customer network
  switchport access vlan 2
  switchport mode access
  spanning-tree portfast
!
!
! UNUSED PORTS
!
!
interface range GigabitEthernet1/42-44
  description Unused
  shutdown
!
interface GigabitEthernet1/47
  description Unused
  shutdown
!
!
! Laptop PORTS
!
!
interface range GigabitEthernet1/45-46
```

Hardware Installation Guidelines

```
description for Laptop connection
switchport access vlan 2
switchport mode access
spanning-tree portfast
no shutdown
!
!
! Customer uplink PORTS
!
!
interface GigabitEthernet1/48
description Customer_Uplink
switchport access vlan 110
switchport mode access
media-type rj45
no shutdown
!
!
! VLAN INTERFACE CONFIGURATION
!
!
interface Vlan1
ip address dhcp
no shutdown
!
interface Vlan2
description IP address, netmask, and gateway for this switch in the management VLAN
ip address 172.20.98.2 255.255.255.0 ! <----- Enter IP and netmask FOR management VLAN
vrrp 2 ip 172.20.98.1 ! <----- replace IP with gateway for management VLAN
vrrp 2 track 1
no shutdown
!
interface Vlan3
description IP address, netmask, and gateway for this switch in the backend VLAN
ip address 172.20.96.2 255.255.255.128 ! <----- Enter IP and netmask FOR backend VLAN
vrrp 3 ip 172.20.96.1 ! <----- replace IP with gateway for backend VLAN
vrrp 3 track 1
no shutdown
!
interface Vlan4
description IP address, netmask, and gateway for this switch in the frontend VLAN
ip address 172.20.97.18 255.255.255.240 ! <----- Enter IP and netmask for frontend VLAN
vrrp 4 ip 172.20.97.17 ! <----- replace IP with gateway for frontend VLAN
vrrp 4 track 1
no shutdown
!
```

Hardware Installation Guidelines

description VLAN ID, IP address, netmask, and gateway for this switch in the demarcation VLAN

```
interface Vlan110      ! <----- Enter customer value for demarcation VLAN
 ip address 172.20.97.5 255.255.255.248      ! <----- Enter IP and netmask for demarcation VLAN
 vrrp 5 ip 172.20.97.4      ! <----- replace IP with gateway for demarcation VLAN
 vrrp 5 track 1
 no shutdown
!
ip route 0.0.0.0 0.0.0.0 172.20.97.1 ! <----- replace IP with customer default gateway
ip route 0.0.0.0 0.0.0.0 172.20.96.3 200      ! <----- replace IP with other aggregation switch IP address in
backend vlan
no ip http server
!
!
logging 172.20.96.4      ! <----- replace IP with PM&C address
no cdp run
!
snmp-server user cfguser cfguser v1
snmp-server user cfguser cfguser v2c
snmp-server community cfguser RO
snmp-server enable traps snmp authentication linkdown linkup coldstart warmstart
snmp-server enable traps tty
snmp-server enable traps fru-ctrl
snmp-server enable traps entity
snmp-server enable traps cpu threshold
snmp-server enable traps vlancreate
snmp-server enable traps vldelete
snmp-server enable traps envmon fan shutdown supply temperature status
snmp-server enable traps config
snmp-server enable traps ipmulticast
snmp-server enable traps bridge newroot topologychange
snmp-server enable traps syslog
snmp-server enable traps vlan-membership
snmp-server host 172.20.96.132 version 2c tekelec      ! <----- replace IP with WL1 address
!
control-plane
!
!
line con 0
 password ***** ! <----- replace ***** with password specified in password dragon as Cisco telnet
 login
 stopbits 1
!
ntp clock-period 17179480
ntp server 10.27.8.4      ! <----- replace IP with NTP server address
end
```

10.16.3 Enclosure Switch

```

!
!
! Enclosure Switch configuration
!
!
hostname C3020A_IOBAY
!
no service config
no service pad
service timestamps debug datetime
service timestamps log datetime
enable secret ***** ! <----- replace ***** with password specified in password dragon as Cisco enable
service password-encryption
!
link state track 1
ip subnet-zero
no ip domain-lookup
!
spanning-tree mode rapid-pvst
no spanning-tree optimize bpdu transmission
spanning-tree etherchannel guard misconfig
spanning-tree extend system-id
spanning-tree vlan 1-1024 priority 53248
!
!
! VLAN CONFIGURATION (internal)
!
!
vlan internal allocation policy ascending
!
vlan 2
 name management
!
vlan 3
 name backend
!
vlan 4
 name frontend
!
interface Port-channel1
 description ISL_between_4948_and_3020
 switchport trunk allowed vlan 1-4
 switchport mode trunk
 link state group 1 upstream

```

Hardware Installation Guidelines

```
!  
interface range GigabitEthernet0/17-20  
  description ISL_between_4948_and_3020  
  switchport trunk allowed vlan 1-4  
  switchport mode trunk  
  channel-group 1 mode active  
  spanning-tree portfast trunk  
!  
interface FastEthernet0  
  description IP address configured in the OA interface  
! ip address dhcp          ! <----- remove the comment only in case the interface would not be already  
configured in dhcp  
!  
interface range GigabitEthernet0/1-16  
  description bay.ethx  
  switchport mode trunk  
  link state group 1 downstream  
  spanning-tree portfast trunk  
!  
interface range GigabitEthernet0/21-24  
  description P2000 SAN controller  
  switchport access vlan 2  
  switchport mode access  
  spanning-tree portfast  
!  
interface Vlan1  
  no ip address  
  shutdown  
!  
ip classless  
ip http server  
ip http secure-server  
!  
logging 172.20.96.4      ! <----- replace IP with PM&C management address  
no cdp run  
snmp-server community tekelec RO  
snmp-server enable traps snmp authentication linkdown linkup coldstart warmstart  
snmp-server enable traps tty  
snmp-server enable traps entity  
snmp-server enable traps cpu threshold  
snmp-server enable traps vlancreate  
snmp-server enable traps vlandelete  
snmp-server enable traps envmon fan shutdown supply temperature status  
snmp-server enable traps config  
snmp-server enable traps bridge newroot topologychange  
snmp-server enable traps syslog
```

Hardware Installation Guidelines

```
snmp-server enable traps vlan-membership
snmp-server host 172.20.96.132 version 2c tekelec ! <----- replace IP with WL1 backend address
!
control-plane
!
!
line con 0
 password ***** ! <----- replace ***** with password specified in password dragon as Cisco telnet
 login
line vty 0 15
 password ***** ! <----- replace ***** with password specified in password dragon as Cisco telnet
 login
!
ntp clock-period 36028892
ntp server 10.31.3.132 ! <----- replace IP with NTP server address
end
```

Hardware Installation Guidelines

```
enable secret ***** ! <----- replace ***** with password specified in password dragon as Cisco enable
!
no aaa new-model
!
track 1 interface GigabitEthernet1/48 line-protocol
ip subnet-zero
!
vtp mode transparent
!
!
!
!
!
power redundancy-mode redundant
no file verify auto
!
spanning-tree mode rapid-pvst
no spanning-tree optimize bpdu transmission
spanning-tree extend system-id
spanning-tree vlan 1-1024 priority 45056
!
vlan internal allocation policy ascending
!
vlan 2
  name management
!
vlan 3
  name backend
!
vlan 4
  name frontend
!
vlan 10      ! <----- replace VLAN with customer value
  name cust
!
interface Port-channel1
  description ISL_between_clas1_and_clen1-sw1
  switchport
  switchport trunk encapsulation dot1q
  switchport trunk allowed vlan 1-4
  switchport mode trunk
  spanning-tree portfast trunk
!
interface Port-channel2
  description ISL_between_clas1_and_cxeny(en2)-sw1
  switchport
  switchport trunk encapsulation dot1q
  switchport trunk allowed vlan 1-4
  switchport mode trunk
  spanning-tree portfast trunk
!
interface Port-channel3
  description ISL_between_clas1_and_cxeny(en3)-sw1
  switchport
  switchport trunk encapsulation dot1q
  switchport trunk allowed vlan 1-4
  switchport mode trunk
  spanning-tree portfast trunk
!
interface Port-channel4
  description ISL_between_clas1_and_cxeny(en4)-sw1
  switchport
  switchport trunk encapsulation dot1q
  switchport trunk allowed vlan 1-4
  switchport mode trunk
  spanning-tree portfast trunk
```

Hardware Installation Guidelines

```
!  
interface Port-channel5  
  description ISL_between_clas1_and_cxeny(en5)-sw1  
  switchport  
  switchport trunk encapsulation dot1q  
  switchport trunk allowed vlan 1-4  
  switchport mode trunk  
  spanning-tree portfast trunk  
!  
interface Port-channel6  
  description ISL_between_clas1_and_cxeny(en6)-sw1  
  switchport  
  switchport trunk encapsulation dot1q  
  switchport trunk allowed vlan 1-4  
  switchport mode trunk  
  spanning-tree portfast trunk  
!  
interface Port-channel7  
  description ISL_between_clas1_and_cxeny(en7)-sw1  
  switchport  
  switchport trunk encapsulation dot1q  
  switchport trunk allowed vlan 1-4  
  switchport mode trunk  
  spanning-tree portfast trunk  
!  
interface Port-channel8  
  description ISL_between_clas1_and_cxeny(en8)-sw1  
  switchport  
  switchport trunk encapsulation dot1q  
  switchport trunk allowed vlan 1-4  
  switchport mode trunk  
  spanning-tree portfast trunk  
!  
interface Port-channel9  
  description ISL_between_clas1_and_cxeny(en9)-sw1  
  switchport  
  switchport trunk encapsulation dot1q  
  switchport trunk allowed vlan 1-4  
  switchport mode trunk  
  spanning-tree portfast trunk  
!  
interface Port-channel10  
  description ISL_between_clas1_and_clas2  
  switchport  
  switchport trunk encapsulation dot1q  
  switchport trunk allowed vlan 1-4  
  switchport mode trunk  
  spanning-tree portfast trunk  
!  
interface range GigabitEthernet1/1-4  
  description switch1B.gil/1-4  
  switchport trunk encapsulation dot1q  
  switchport trunk allowed vlan 1-4  
  switchport mode trunk  
  channel-group 10 mode active  
  spanning-tree portfast trunk  
!  
interface range GigabitEthernet1/5-8  
  description ISL_to_clen1(en1)-sw1  
  switchport trunk encapsulation dot1q  
  switchport trunk allowed vlan 1-4  
  switchport mode trunk  
  channel-group 1 mode active  
  spanning-tree portfast trunk  
!  
interface range GigabitEthernet1/9-12  
  description ISL_to_cxeny(en2)-sw1
```

Hardware Installation Guidelines

```
switchport trunk encapsulation dot1q
switchport trunk allowed vlan 1-4
switchport mode trunk
channel-group 2 mode active
spanning-tree portfast trunk
!
interface range GigabitEthernet1/13-16
description ISL_to_cxeny(en3)-sw1
switchport trunk encapsulation dot1q
switchport trunk allowed vlan 1-4
switchport mode trunk
channel-group 3 mode active
spanning-tree portfast trunk
!
interface range GigabitEthernet1/17-20
description ISL_to_cxeny(en4)-sw1
switchport trunk encapsulation dot1q
switchport trunk allowed vlan 1-4
switchport mode trunk
channel-group 4 mode active
spanning-tree portfast trunk
!
interface GigabitEthernet1/21-24
description ISL_to_cxeny(en5)-sw1
switchport trunk encapsulation dot1q
switchport trunk allowed vlan 1-4
switchport mode trunk
channel-group 5 mode active
spanning-tree portfast trunk
!
interface range GigabitEthernet1/25-28
description ISL_to_cxeny(en6)-sw1
switchport trunk encapsulation dot1q
switchport trunk allowed vlan 1-4
switchport mode trunk
channel-group 6 mode active
spanning-tree portfast trunk
!
interface range GigabitEthernet1/29-32
description ISL_to_cxeny(en7)-sw1
switchport trunk encapsulation dot1q
switchport trunk allowed vlan 1-4
switchport mode trunk
channel-group 7 mode active
spanning-tree portfast trunk
!
interface range GigabitEthernet1/33-36
description ISL_to_cxeny(en8)-sw1
switchport trunk encapsulation dot1q
switchport trunk allowed vlan 1-4
switchport mode trunk
channel-group 8 mode active
spanning-tree portfast trunk
!
interface range GigabitEthernet1/37-40
description ISL_to_cxeny(en9)-sw1
switchport trunk encapsulation dot1q
switchport trunk allowed vlan 1-4
switchport mode trunk
channel-group 9 mode active
spanning-tree portfast trunk
!
interface range GigabitEthernet1/41-45
description oal&iLO
switchport access vlan 2
switchport mode access
spanning-tree portfast
```

Hardware Installation Guidelines

```
!  
interface GigabitEthernet1/46  
  description clms1-nic1  
  switchport trunk encapsulation dot1q  
  switchport trunk allowed vlan 1-3  
  switchport mode trunk  
  media-type rj45  
  spanning-tree portfast trunk  
!  
interface GigabitEthernet1/47  
  description unused  
  switchport trunk encapsulation dot1q  
  switchport mode trunk  
  shutdown  
  media-type rj45  
  spanning-tree portfast trunk  
!  
interface GigabitEthernet1/48  
  description Customer_Uplink  
  switchport access vlan 10      ! <----- replace VLAN with customer value  
  switchport mode access  
  media-type rj45  
  spanning-tree portfast  
!  
interface Vlan1  
  no ip address  
!  
interface Vlan2  
  description IP address, netmask, and gateway for this switch in the management VLAN  
  ip address 10.240.8.2 255.255.255.0      ! <----- replace IP and netmask for management VLAN  
  vrrp 2 ip 10.240.8.1      ! <----- replace IP with gateway for management VLAN  
  vrrp 2 track 1  
  no shutdown  
!  
interface Vlan3  
  description IP address, netmask, and gateway for this switch in the backend VLAN  
  ip address 10.240.9.2 255.255.255.0      ! <----- Enter IP and netmask for backend VLAN  
  vrrp 3 ip 10.240.9.1      ! <----- replace IP with gateway for backend VLAN  
  vrrp 3 track 1  
  no shutdown  
!  
interface Vlan4  
  description IP address, netmask, and gateway for this switch in the frontend VLAN  
  ip address 10.240.10.2 255.255.255.0      ! <----- Enter IP and netmask for frontend VLAN  
  vrrp 4 ip 10.240.10.1      ! <----- replace IP with gateway for frontend VLAN  
  vrrp 4 track 1  
  no shutdown  
!  
interface Vlan10  
  ! <----- replace VLAN with customer value  
  description VLAN ID, IP address, netmask, and gateway for this switch in the demarcation VLAN  
  ip address 10.250.54.24 255.255.255.0      ! <----- Enter IP and netmask for demarcation VLAN  
  vrrp 10 ip 10.250.54.26      ! <----- replace IP with Oracle gateway for demarcation VLAN  
  no shutdown  
!  
  ip route 0.0.0.0 0.0.0.0 10.250.54.1      ! <----- replace IP with customer default gateway  
  no ip http server  
  no ip http secure-server  
!  
!  
logging 10.27.8.0      ! <----- replace IP with PM&C address  
no cdp run  
!
```

Hardware Installation Guidelines

```
snmp-server community cfguser RO
snmp-server enable traps snmp authentication linkdown linkup coldstart warmstart
snmp-server enable traps flash insertion removal
snmp-server enable traps cpu threshold
snmp-server enable traps envmon fan shutdown supply temperature status
snmp-server enable traps port-security
snmp-server enable traps storm-control trap-rate 5
snmp-server enable traps config
snmp-server enable traps hsrp
snmp-server enable traps mac-notification change move threshold
snmp-server enable traps bridge newroot topologychange
snmp-server enable traps vlan-membership
snmp-server host 10.31.5.211 version 2c cfguser      ! <----- replace IP with WLL address
!
control-plane
!
!
line con 0
  password ***** ! <----- replace ***** with password specified in password dragon as Cisco telnet
  login
  stopbits 1
!
ntp clock-period 17179453
ntp server 10.240.8.4 ! <----- replace IP with NTP server address
end
```

2. Enclosure Switch 3020

```
version 12.2
no service pad
service timestamps debug uptime
service timestamps log uptime
service password-encryption
!
hostname clen1p1
!
no logging console
enable secret ***** ! <----- replace ***** with password specified in password dragon as Cisco enable
!
no aaa new-model
clock timezone gmt+1 1
system mtu routing 1500
vtp mode transparent
ip subnet-zero
!
!
spanning-tree mode rapid-pvst
no spanning-tree optimize bpdu transmission
spanning-tree etherchannel guard misconfig
spanning-tree extend system-id
spanning-tree vlan 1-1024 priority 53248
!
```

Hardware Installation Guidelines

```
vlan internal allocation policy ascending
!
vlan 2
  name management
!
vlan 3
  name backend
!
vlan 4
  name frontend
!
!
!
interface Port-channel1
  description ISL_between_4948_and_3020
  switchport trunk allowed vlan 1-4
  switchport mode trunk
  spanning-tree portfast trunk
!
interface FastEthernet0
  ip address dhcp
!
interface range GigabitEthernet0/1-16
  description bay.ethx
  switchport mode trunk
  spanning-tree portfast trunk
!
interface range GigabitEthernet0/17-20
  description ISL_between_4948_and_3020
  switchport trunk allowed vlan 1-4
  switchport mode trunk
  channel-group 1 mode active
  spanning-tree portfast trunk
!
interface range GigabitEthernet0/21-24
  description cxsan-fc-port-mngt
  switchport trunk native vlan 2
  switchport trunk allowed vlan 2,3
  switchport mode trunk
  spanning-tree portfast trunk
!
interface Vlan1
  no ip address
  shutdown
!
ip classless
```

Hardware Installation Guidelines

```
ip route 0.0.0.0 0.0.0.0 10.31.5.129 254 ! <----- replace IP with customer default gateway
ip http server
ip http secure-server
!
logging 10.27.8.0 ! <----- replace IP with PM&C address
no cdp run
snmp-server community cfguser RO
snmp-server enable traps snmp authentication linkdown linkup coldstart warmstart
snmp-server enable traps cpu threshold
snmp-server enable traps flash insertion removal
snmp-server enable traps port-security
snmp-server enable traps envmon fan shutdown supply temperature status
snmp-server enable traps storm-control trap-rate 5
snmp-server enable traps config
snmp-server enable traps hsrp
snmp-server enable traps bridge newroot topologychange
snmp-server enable traps mac-notification change move threshold
snmp-server enable traps vlan-membership
snmp-server host 10.31.5.211 version 2c cfguser ! <----- replace IP with WL1 address
!
control-plane
!
!
line con 0
  exec-timeout 0 0
  password ***** ! <----- replace ***** with password specified in password dragon as Cisco telnet
  login
line vty 0 4
  password ***** ! <----- replace ***** with password specified in password dragon as Cisco telnet
  login
line vty 5 15
  password ***** ! <----- replace ***** with password specified in password dragon as Cisco telnet
  login
!
ntp clock-period 36029033
ntp server 10.31.5.132 ! <----- replace IP with NTP server address
end
```

Hardware Installation Guidelines

10.17 Integrated Acquisition switch configuration template

10.17.1 Switch port allocation

All or no vian	vian 100 yellow	vian 101 blue	vian 400 backend	vian 300 oobm or iLO
----------------	-----------------	---------------	------------------	----------------------

Yellow SW3	Port 1 Yellow1 SW P41	Port 3 Eagle Links	Port 5 Eagle Links	Port 7 Eagle Links	Port 9 Eagle Links	Port 11 Eagle Links	Port 13 Eagle Links	Port 15 Eagle Links	Port 17 Eagle Links	Port 19 Eagle Links	Port 21 Eagle Links	Port 23 Eagle Links	Port 25 Eagle Links	Port 27 Eagle Links	Port 29 Eagle Links	Port 31 Eagle Links	Port 33 Eagle Links	Port 35 Eagle Links	Port 37 Eagle Links	Port 39 Eagle Links	Port 41 Eagle Links	Port 43 Eagle Links	Port 45 Eagle Links	Port 47 Eagle Links
Yellow SW2	Port 2 Yellow1 SW P42	Port 4 Eagle Links	Port 6 Eagle Links	Port 8 Eagle Links	Port 10 Eagle Links	Port 12 Eagle Links	Port 14 Eagle Links	Port 16 Eagle Links	Port 18 Eagle Links	Port 20 Eagle Links	Port 22 Eagle Links	Port 24 Eagle Links	Port 26 Eagle Links	Port 28 Eagle Links	Port 30 Eagle Links	Port 32 Eagle Links	Port 34 Eagle Links	Port 36 Eagle Links	Port 38 Eagle Links	Port 40 Eagle Links	Port 42 Eagle Links	Port 44 Eagle Links	Port 46 Eagle Links	Port 48 Eagle Links
Yellow SW1	Port 1 ServerG eth01	Port 3 ServerH eth01	Port 5 ServerI eth01	Port 7 ServerJ eth01	Port 9 ServerK eth01	Port 11 ServerL eth01	Port 13 Eagle Links	Port 15 Eagle Links	Port 17 Eagle Links	Port 19 Eagle Links	Port 21 Eagle Links	Port 23 Eagle Links	Port 25 Eagle Links	Port 27 Eagle Links	Port 29 Eagle Links	Port 31 Eagle Links	Port 33 Eagle Links	Port 35 Eagle Links	Port 37 Eagle Links	Port 39 Eagle Links	Port 41 Yellow3 SW P1	Port 43 Yellow2 SW P1	Port 45 For Laptop	Port 47 Cust Net eth
Blue SW1	Port 2 Blue1 SW P2	Port 4 ServerB eth01	Port 6 ServerC eth01	Port 8 ServerD eth01	Port 10 ServerE eth01	Port 12 Eagle Links	Port 14 Eagle Links	Port 16 Eagle Links	Port 18 Eagle Links	Port 20 Eagle Links	Port 22 Eagle Links	Port 24 Eagle Links	Port 26 Eagle Links	Port 28 Eagle Links	Port 30 Eagle Links	Port 32 Eagle Links	Port 34 Eagle Links	Port 36 Eagle Links	Port 38 Eagle Links	Port 40 Eagle Links	Port 42 Yellow3 SW P2	Port 44 Yellow2 SW P2	Port 46 For Laptop	Port 48 Cust Net iLO
Blue SW2	Port 1 Blue1 SW P43	Port 3 ServerG eth03	Port 5 ServerH eth03	Port 7 ServerI eth03	Port 9 ServerJ eth03	Port 11 ServerK eth03	Port 13 Eagle Links	Port 15 Eagle Links	Port 17 Eagle Links	Port 19 Eagle Links	Port 21 Eagle Links	Port 23 Eagle Links	Port 25 Eagle Links	Port 27 Eagle Links	Port 29 Eagle Links	Port 31 Eagle Links	Port 33 Eagle Links	Port 35 Eagle Links	Port 37 Eagle Links	Port 39 Eagle Links	Port 41 Blue3 SW P1	Port 43 Blue2 SW P1	Port 45 For Laptop	Port 47 Cust Net eth
Blue SW3	Port 2 Blue1 SW P44	Port 4 ServerH eth03	Port 6 ServerI eth03	Port 8 ServerJ eth03	Port 10 ServerK eth03	Port 12 Eagle Links	Port 14 Eagle Links	Port 16 Eagle Links	Port 18 Eagle Links	Port 20 Eagle Links	Port 22 Eagle Links	Port 24 Eagle Links	Port 26 Eagle Links	Port 28 Eagle Links	Port 30 Eagle Links	Port 32 Eagle Links	Port 34 Eagle Links	Port 36 Eagle Links	Port 38 Eagle Links	Port 40 Eagle Links	Port 42 Blue3 SW P2	Port 44 Blue2 SW P2	Port 46 For Laptop	Port 48 Cust Net iLO

Server A and B iLO are directly connected to customer network

10.17.2 Yellow-sw1-1 Switch (Layer 3)

```

! IMF YELLOW1 SWITCH configuration
!
!
hostname yellow-sw1-1
!
no spanning-tree vlan 1-4094
no spanning-tree optimize bpdu transmission
!
enable secret ***** ! <----- replace ***** with password specified in password dragon as Cisco enable
service password-encryption
no service pad
service timestamps debug datetime
service timestamps log datetime
no logging console
no aaa new-model
track 1 interface GigabitEthernet1/47 line-protocol
ip subnet-zero
!

```

```
ip multicast-routing
!
power redundancy-mode redundant
!
!
! VLAN CONFIGURATION (internal)
!
!
vlan 100
  name internal_yellow
!
vlan 101
  name internal_blue
!
vlan 200
  name IMF2IXP_internal_(backend)
!
vlan 300
  name oobm_or_iLO
!
vlan 400
  name IMF2IXP_external_(frontend)
!
!
! INTER YELLOW SW1 TO BLUE SW1 ETHERCHANNEL (internal)
!
!
interface Port-channel1
  description Trunk_between_yellow_sw1_and_blue_sw1
  switchport
  switchport trunk encapsulation dot1q
  switchport trunk allowed vlan 100,101,200,300
  mtu 9198
  no shutdown
!
!
! INTER YELLOW SW 1 TO YELLOW SW2 ETHERCHANNEL (internal)
!
!
interface Port-channel2
  description Trunk_between_yellow_sw1_and_yellow_sw2
  switchport
  switchport trunk encapsulation dot1q
  switchport trunk allowed vlan 100,101,200,300
  switchport mode trunk
  mtu 9198
```

Hardware Installation Guidelines

```
no shutdown
!
!
! INTER YELLOW SW 1 TO YELLOW SW3 ETHERCHANNEL (internal)
!
!
interface Port-channel3
  description Trunk_between_yellow_sw1_and_yellow_sw3
  switchport
  switchport trunk encapsulation dot1q
  switchport trunk allowed vlan 100,101,200,300
  switchport mode trunk
  mtu 9198
  no shutdown
!
!
! INTER YELLOW SW1 TO BLUE SW1 PORTS (internal)
!
!
Interface range GigabitEthernet 1/1 - 2
  description ISL_between_yellow_sw1_and_blue_sw1
  switchport trunk encapsulation dot1q
  switchport trunk allowed vlan 100,101,200,300
  switchport mode trunk
  switchport nonegotiate
  mtu 9198
  channel-group 1 mode active
  no shutdown
!
!
! INTER yellow SW1 TO yellow SW2 PORTS (internal)
!
!
Interface range GigabitEthernet 1/43 - 44
  description Trunk_between_yellow_sw1_and_yellow_sw2
  switchport trunk encapsulation dot1q
  switchport trunk allowed vlan 100,101,200,300
  switchport mode trunk
  mtu 9198
  channel-group 1 mode active
  no shutdown
!
!
! INTER yellow SW1 TO yellow SW3 PORTS (internal)
!
!
```

Hardware Installation Guidelines

```
Interface range GigabitEthernet 1/41 - 42
description Trunk_between_yellow_sw1_and_yellow_sw3
switchport trunk encapsulation dot1q
switchport trunk allowed vlan 100,101,200,300
switchport mode trunk
mtu 9198
channel-group 1 mode active
no shutdown
!
!
! IMF Servers PORTS
!
!
interface range GigabitEthernet 1/3 - 5
description IMF servers ports
switchport trunk encapsulation dot1q
switchport mode trunk
mtu 9198
no shutdown
!
interface range GigabitEthernet 1/7 - 8
description IMF servers ports
switchport trunk encapsulation dot1q
switchport mode trunk
mtu 9198
no shutdown
!
interface range GigabitEthernet 1/10
description IMF servers ports
switchport trunk encapsulation dot1q
switchport mode trunk
mtu 9198
no shutdown
!
!
! iLO PORTS
!
!
interface GigabitEthernet 1/6
description IMF iLO ports
switchport access vlan 300
switchport mode access
no shutdown
!
interface GigabitEthernet 1/9
description IMF iLO ports
```

Hardware Installation Guidelines

```
switchport access vlan 300
switchport mode access
no shutdown
!
!
! EAGLE PORTS
!
!
interface range GigabitEthernet 1/11 - 40
description Eagle FC or STC ports
switchport access vlan 100
switchport mode access
mtu 9198
no shutdown
!
!
! PORT TO CUSTOMER SWITCH A
!
!
interface GigabitEthernet 1/47
description to customer switch A
switchport access vlan 400
switchport mode access
media-type rj45
no shutdown
!
interface GigabitEthernet 1/48
description reserved for optional direct access to ILO in case of disaster
switchport access vlan 300
switchport mode access
media-type rj45
no shutdown
!
!
! Laptop PORTS
!
!
interface range GigabitEthernet 1/45 - 46
description for Laptop
switchport access vlan 200
switchport mode access
media-type rj45
no shutdown
!
!
! VLAN INTERFACE CONFIGURATION
```

Hardware Installation Guidelines

```
!  
!  
interface Vlan1  
  no ip address  
!  
!  
interface VLAN 100  
  ip address 172.21.49.1 255.255.254.0  
  ip pim dense-mode  
  no shutdown  
!  
!  
track 1 int gigabitEthernet 1/47 line-protocol  
interface Vlan200  
  description internal VRRP for IMF to IXP traffic. Both IP addresses and netmask must be configured according  
customer network.  
  ip address 192.168.0.2 255.255.255.224      ! <----- replace IP with the value provided by the customer  
  vrrp 1 ip 192.168.0.1      ! <----- replace IP with default gateway  
  vrrp 1 priority 100  
  vrrp 1 track 1  
  vrrp 1 preempt  
  no shutdown  
!  
!  
interface Vlan300  
  description oobm or iLO optional IP. IP address and netmask must be configured according customer network.  
  ip address 192.168.10.2 255.255.255.240      ! <----- replace IP with the value provided by the customer  
  no shutdown  
!  
!  
interface Vlan 400  
  description external VRRP for IMF to IXP traffic to Customer switches. Both IP addresses and netmask must be  
configured according customer network.  
  ip address 192.168.20.2 255.255.255.248      ! <----- replace IP with the value provided by the customer  
  vrrp 2 ip 192.168.20.1      ! <----- replace IP with default gateway  
  vrrp 2 priority 100  
  vrrp 2 preempt  
  no shutdown  
!  
!  
no ip http server  
no ip http secure-server  
!  
ip route 0.0.0.0 0.0.0.0 192.168.20.6 1      ! <----- replace IP with customer default gateway  
!  
!
```

Hardware Installation Guidelines

```
line con 0
 password ***** ! <----- replace ***** with password specified in password dragon as Cisco telnet
 login
!
logging 172.21.49.10
!
no cdp run
!
end
```

10.17.3 Blue-sw1-1 Switch (Layer 3)

```
! IMF BLUE1 SWITCH configuration
!
!
hostname blue-sw1-1
!
no spanning-tree vlan 1-4094
no spanning-tree optimize bpdu transmission
!
enable secret ***** ! <----- replace ***** with password specified in password dragon as Cisco enable
service password-encryption
no service pad
service timestamps debug datetime
service timestamps log datetime
no logging console
no aaa new-model
track 1 interface GigabitEthernet1/47 line-protocol
ip subnet-zero
!
ip multicast-routing
!
power redundancy-mode redundant
!
!
! VLAN CONFIGURATION (internal)
!
!
vlan 100
 name internal_yellow
!
vlan 101
 name internal_blue
!
vlan 200
 name IMF2IXP_internal_(backend)
```

```
!  
vlan 300  
  name oobm_or_iLO  
!  
vlan 400  
  name IMF2IXP_external_(frontend)  
!  
!  
! INTER YELLOW SW1 TO BLUE SW1 ETHERCHANNEL (internal)  
!  
!  
interface Port-channel1  
  description Trunk_between_yellow_sw1_and_blue_sw1  
  switchport  
  switchport trunk encapsulation dot1q  
  switchport trunk allowed vlan 100,101,200,300  
  mtu 9198  
  no shutdown  
!  
!  
! INTER BLUE SW 1 TO BLUE SW2 ETHERCHANNEL (internal)  
!  
!  
interface Port-channel2  
  description Trunk_between_ blue_sw1_and_ blue_sw2  
  switchport  
  switchport trunk encapsulation dot1q  
  switchport trunk allowed vlan 100,101,200,300  
  switchport mode trunk  
  mtu 9198  
  no shutdown  
!  
!  
! INTER BLUE SW 1 TO BLUE SW3 ETHERCHANNEL (internal)  
!  
!  
interface Port-channel3  
  description Trunk_between_ blue_sw1_and_blue_sw3  
  switchport  
  switchport trunk encapsulation dot1q  
  switchport trunk allowed vlan 100,101,200,300  
  switchport mode trunk  
  mtu 9198  
  no shutdown  
!  
!
```

Hardware Installation Guidelines

```
! INTER BLUE SW1 TO yellow SW1 PORTS (internal)
!
!
Interface range GigabitEthernet 1/1 - 2
  description ISL_between_blue_sw1_and_yellow_sw1
  switchport trunk encapsulation dot1q
  switchport trunk allowed vlan 100,101,200,300
  switchport mode trunk
  switchport nonegotiate
  mtu 9198
  channel-group 1 mode active
  no shutdown
!
!
! INTER BLUE SW1 TO BLUE SW2 PORTS (internal)
!
!
Interface range GigabitEthernet 1/43 - 44
  description Trunk_between_blue_sw1_and_blue_sw2
  switchport trunk encapsulation dot1q
  switchport trunk allowed vlan 100,101,200,300
  switchport mode trunk
  mtu 9198
  channel-group 1 mode active
  no shutdown
!
!
! INTER BLUE SW1 TO BLUE SW3 PORTS (internal)
!
!
Interface range GigabitEthernet 1/41 - 42
  description Trunk_between_blue_sw1_and_blue_sw3
  switchport trunk encapsulation dot1q
  switchport trunk allowed vlan 100,101,200,300
  switchport mode trunk
  mtu 9198
  channel-group 1 mode active
  no shutdown
!
!
! IMF Servers PORTS
!
!
interface range GigabitEthernet 1/3 - 6
  description IMF servers ports
  switchport trunk encapsulation dot1q
```

Hardware Installation Guidelines

```
switchport mode trunk
mtu 9198
no shutdown
!
interface range GigabitEthernet 1/8 - 9
description IMF servers ports
switchport trunk encapsulation dot1q
switchport mode trunk
mtu 9198
no shutdown
!
!
! iLO PORTS
!
!
interface GigabitEthernet 1/7
description IMF iLO ports
switchport access vlan 300
switchport mode access
no shutdown
!
interface GigabitEthernet 1/10
description IMF iLO ports
switchport access vlan 300
switchport mode access
no shutdown
!
!
! EAGLE PORTS
!
!
interface range GigabitEthernet 1/11 - 40
description Eagle FC or STC ports
switchport access vlan 101
switchport mode access
mtu 9198
no shutdown
!
!
! PORT TO CUSTOMER SWITCH B
!
!
interface GigabitEthernet 1/47
description to customer switch B
switchport access vlan 400
switchport mode access
```

Hardware Installation Guidelines

```
media-type rj45
no shutdown
!
!
interface GigabitEthernet 1/48
description not used to avoid loop risk on iLO VLAN.
switchport access vlan 300
switchport mode access
media-type rj45
shutdown
!
!
! Laptop PORTS
!
!
interface range GigabitEthernet 1/45 - 46
description for Laptop
switchport access vlan 200
switchport mode access
media-type rj45
no shutdown
!
!
! VLAN INTERFACE CONFIGURATION
!
!
interface Vlan1
no ip address
!
!
interface VLAN 101
ip address 172.22.49.1 255.255.254.0
ip pim dense-mode
no shutdown
!
!
track 1 int gigabitEthernet 1/47 line-protocol
interface Vlan200
description internal VRRP for IMF to IXP traffic. Both IP addresses and netmask must be configured according
customer network.
ip address 192.168.0.3 255.255.255.224 ! <----- replace IP with the value provided by the customer
vrrp 1 ip 192.168.0.1 ! <----- replace IP with default gateway
vrrp 1 priority 99
vrrp 1 track 1
vrrp 1 preempt
no shutdown
```

```
!  
!  
interface Vlan 400  
  description external VRRP for IMF to IXP traffic to Customer switches. Both IP addresses and netmask must be  
  configured according customer network.  
  ip address 192.168.20.3 255.255.255.248 ! <----- replace IP with the value provided by the customer  
  vrrp 2 ip 192.168.20.1 ! <----- replace IP with default gateway  
  vrrp 2 priority 99  
  vrrp 2 preempt  
  no shutdown  
!  
!  
no ip http server  
no ip http secure-server  
!  
ip route 0.0.0.0 0.0.0.0 192.168.20.6 1 ! <----- replace IP with customer default gateway  
!  
!  
line con 0  
  password ***** ! <----- replace ***** with password specified in password dragon as Cisco telnet  
  login  
!  
logging 172.22.49.10  
!  
no cdp run  
!  
end
```

10.17.4 Yellow-sw2-1 Switch (Layer 3)

```
! IMF YELLOW2 SWITCH configuration  
!  
!  
hostname yellow-sw2-1  
!  
no spanning-tree vlan 1-4094  
no spanning-tree optimize bpdu transmission  
!  
enable secret ***** ! <----- replace ***** with password specified in password dragon as Cisco enable  
service password-encryption  
no service pad  
service timestamps debug datetime  
service timestamps log datetime  
no logging console  
no aaa new-model  
track 1 interface GigabitEthernet1/47 line-protocol  
ip subnet-zero
```

Hardware Installation Guidelines

```
!  
ip multicast-routing  
!  
power redundancy-mode redundant  
!  
!  
! VLAN CONFIGURATION (internal)  
!  
!  
vlan 100  
    name internal_yellow  
!  
vlan 101  
    name internal_blue  
!  
vlan 200  
    name IMF2IXP_internal_(backend)  
!  
vlan 300  
    name oobm_or_iLO  
!  
vlan 400  
    name IMF2IXP_external_(frontend)  
!  
!  
! INTER YELLOW SW 2 TO YELLOW SW 1 ETHERCHANNEL (internal)  
!  
!  
interface Port-channel2  
    description Trunk_between_yellow_sw2_and_yellow_sw1  
    switchport  
    switchport trunk encapsulation dot1q  
    switchport trunk allowed vlan 100,101,200,300  
    switchport mode trunk  
    mtu 9198  
    no shutdown  
!  
!  
! INTER yellow SW2 TO yellow SW1 PORTS (internal)  
!  
!  
Interface range GigabitEthernet 1/1 - 2  
    description Trunk_between_yellow_sw2_and_yellow_sw1  
    switchport trunk encapsulation dot1q  
    switchport trunk allowed vlan 100,101,200,300  
    switchport mode trunk
```

```
mtu 9198
channel-group 1 mode active
no shutdown
!
!
! IMF Servers PORTS
!
!
interface GigabitEthernet 1/3
description IMF servers ports
switchport trunk encapsulation dot1q
switchport mode trunk
mtu 9198
no shutdown
!
interface range GigabitEthernet 1/5 - 6
description IMF servers ports
switchport trunk encapsulation dot1q
switchport mode trunk
mtu 9198
no shutdown
!
interface range GigabitEthernet 1/8 - 9
description IMF servers ports
switchport trunk encapsulation dot1q
switchport mode trunk
mtu 9198
no shutdown
!
interface range GigabitEthernet 1/11
description IMF servers ports
switchport trunk encapsulation dot1q
switchport mode trunk
mtu 9198
no shutdown
!
!
! iLO PORTS
!
!
interface GigabitEthernet 1/4
description IMF iLO ports
switchport access vlan 300
switchport mode access
no shutdown
!
```

Hardware Installation Guidelines

```
interface GigabitEthernet 1/7
  description IMF iLO ports
  switchport access vlan 300
  switchport mode access
  no shutdown
!
interface GigabitEthernet 1/10
  description IMF iLO ports
  switchport access vlan 300
  switchport mode access
  no shutdown
!
!
! EAGLE PORTS
!
!
interface range GigabitEthernet 1/12 - 48
  description Eagle FC or STC ports
  switchport access vlan 100
  switchport mode access
  mtu 9198
  no shutdown
!
!
! VLAN INTERFACE CONFIGURATION
!
!
interface Vlan1
  no ip address
!
!
interface VLAN 100
  ip address 172.21.49.2 255.255.254.0
  ip pim dense-mode
  no shutdown!
!
interface Vlan200
  description for remote access though telnet
  ip address 192.168.0.4 255.255.255.224
customer
  no shutdown
!
!
no ip http server
no ip http secure-server
!
```

```

ip route 0.0.0.0 0.0.0.0 192.168.0.1 1      ! <----- replace IP with VLAN 200 vrrp IP
!
!
line con 0
  password ***** ! <----- replace ***** with password specified in password dragon as Cisco telnet
  login
!
logging 172.21.49.10
!
no cdp run
!
end

```

10.17.5 Blue-sw2-1 Switch (Layer 3)

```

! IMF BLUE2 SWITCH configuration
!
!
hostname blue-sw2-1
!
no spanning-tree vlan 1-4094
no spanning-tree optimize bpdu transmission
!
enable secret ***** ! <----- replace ***** with password specified in password dragon as Cisco enable
service password-encryption
no service pad
service timestamps debug datetime
service timestamps log datetime
no logging console
no aaa new-model
track 1 interface GigabitEthernet1/47 line-protocol
ip subnet-zero
!
ip multicast-routing
!
power redundancy-mode redundant
!
!
! VLAN CONFIGURATION (internal)
!
!
vlan 100
  name internal_yellow
!
vlan 101
  name internal_blue

```

Hardware Installation Guidelines

```
!  
vlan 200  
  name IMF2IXP_internal_(backend)  
!  
vlan 300  
  name oobm_or_iLO  
!  
vlan 400  
  name IMF2IXP_external_(frontend)  
!  
!  
! INTER BLUE SW 2 TO BLUE SW 1 ETHERCHANNEL (internal)  
!  
!  
interface Port-channel2  
  description Trunk_between_ blue_sw2_and_ blue_sw1  
  switchport  
  switchport trunk encapsulation dot1q  
  switchport trunk allowed vlan 100,101,200,300  
  switchport mode trunk  
  mtu 9198  
  no shutdown  
!  
!  
! INTER BLUE SW2 TO BLUE SW1 PORTS (internal)  
!  
!  
Interface range GigabitEthernet 1/1 - 2  
  description Trunk_between_blue_sw2_and_blue_sw1  
  switchport trunk encapsulation dot1q  
  switchport trunk allowed vlan 100,101,200,300  
  switchport mode trunk  
  mtu 9198  
  channel-group 1 mode active  
  no shutdown  
!  
!  
! IMF Servers PORTS  
!  
!  
interface range GigabitEthernet 1/3 - 4  
  description IMF servers ports  
  switchport trunk encapsulation dot1q  
  switchport mode trunk  
  mtu 9198  
  no shutdown
```

```
!  
interface range GigabitEthernet 1/6 - 7  
description IMF servers ports  
    switchport trunk encapsulation dot1q  
    switchport mode trunk  
    mtu 9198  
    no shutdown  
!  
interface range GigabitEthernet 1/9 - 10  
description IMF servers ports  
    switchport trunk encapsulation dot1q  
    switchport mode trunk  
    mtu 9198  
    no shutdown  
!  
!  
! iLO PORTS  
!  
!  
interface GigabitEthernet 1/5  
description IMF iLO ports  
    switchport access vlan 300  
    switchport mode access  
    no shutdown  
!  
interface GigabitEthernet 1/8  
description IMF iLO ports  
    switchport access vlan 300  
    switchport mode access  
    no shutdown  
!  
interface GigabitEthernet 1/11  
description IMF iLO ports  
    switchport access vlan 300  
    switchport mode access  
    no shutdown  
!  
!  
! EAGLE PORTS  
!  
!  
interface range GigabitEthernet 1/12 - 48  
description Eagle FC or STC ports  
    switchport access vlan 101  
    switchport mode access  
    mtu 9198
```

Hardware Installation Guidelines

```
no shutdown
!
!
! VLAN INTERFACE CONFIGURATION
!
!
interface Vlan1
no ip address
!
!
interface VLAN 101
ip address 172.22.49.2 255.255.254.0
ip pim dense-mode
no shutdown
!
!
interface Vlan200
description for remote access though telnet
ip address 192.168.0.5 255.255.255.224 ! <----- replace IP with the value provided by the
customer
no shutdown
!
!
no ip http server
no ip http secure-server
!
ip route 0.0.0.0 0.0.0.0 192.168.0.1 1 ! <----- replace IP with VLAN 200 vrrp IP
!
!
line con 0
password ***** ! <----- replace ***** with password specified in password dragon as Cisco telnet
login
!
logging 172.22.49.10
!
no cdp run
!
end
```

10.17.6 Yellow-sw3-1 Switch (Layer 3)

```
! IMF YELLOW3 SWITCH configuration
!
!
hostname yellow-sw3-1
!
```

Hardware Installation Guidelines

```
no spanning-tree vlan 1-4094
no spanning-tree optimize bpdu transmission
!
enable secret ***** ! <----- replace ***** with password specified in password dragon as Cisco enable
service password-encryption
no service pad
service timestamps debug datetime
service timestamps log datetime
no logging console
no aaa new-model
track 1 interface GigabitEthernet1/47 line-protocol
ip subnet-zero
!
ip multicast-routing
!
power redundancy-mode redundant
!
!
! VLAN CONFIGURATION (internal)
!
!
vlan 100
  name internal_yellow
!
vlan 101
  name internal_blue
!
vlan 200
  name IMF2IXP_internal_(backend)
!
vlan 300
  name oobm_or_iLO
!
vlan 400
  name IMF2IXP_external_(frontend)
!
!
! INTER YELLOW SW 3 TO YELLOW SW 1 ETHERCHANNEL (internal)
!
!
interface Port-channel3
  description Trunk_between_yellow_sw3_and_yellow_sw1
  switchport
  switchport trunk encapsulation dot1q
  switchport trunk allowed vlan 100,101,200,300
  switchport mode trunk
```

Hardware Installation Guidelines

```
mtu 9198
no shutdown
!
!
! INTER yellow SW3 TO yellow SW1 PORTS (internal)
!
!
Interface range GigabitEthernet 1/1 - 2
description Trunk_between_yellow_sw3_and_yellow_sw1
switchport trunk encapsulation dot1q
switchport trunk allowed vlan 100,101,200,300
switchport mode trunk
mtu 9198
channel-group 1 mode active
no shutdown
!
!
! EAGLE PORTS
!
!
interface range GigabitEthernet 1/3 - 48
description Eagle FC or STC ports
switchport access vlan 100
switchport mode access
mtu 9198
no shutdown
!
!
! VLAN INTERFACE CONFIGURATION
!
!
interface Vlan1
no ip address
!
!
interface VLAN 100
ip address 172.21.49.3 255.255.254.0
ip pim dense-mode
no shutdown
!
!
interface Vlan200
description for remote access though telnet
ip address 192.168.0.6 255.255.255.224 ! <----- replace IP with the value provided by the
customer
no shutdown
```

```
!  
!  
no ip http server  
no ip http secure-server  
!  
ip route 0.0.0.0 0.0.0.0 192.168.0.1 1      ! <----- replace IP with yellow VLAN 200 vrrp IP  
!  
!  
line con 0  
  password ***** ! <----- replace ***** with password specified in password dragon as Cisco telnet  
  login  
!  
logging 172.21.49.10  
!  
no cdp run  
!  
end
```

10.17.7 Blue-sw3-1 Switch (Layer 3)

```
! IMF BLUE3 SWITCH configuration  
!  
!  
hostname blue-sw3-1  
!  
no spanning-tree vlan 1-4094  
no spanning-tree optimize bpdu transmission  
!  
enable secret ***** ! <----- replace ***** with password specified in password dragon as Cisco enable  
service password-encryption  
no service pad  
service timestamps debug datetime  
service timestamps log datetime  
no logging console  
no aaa new-model  
track 1 interface GigabitEthernet1/47 line-protocol  
ip subnet-zero  
!  
ip multicast-routing  
!  
power redundancy-mode redundant  
!  
!  
! VLAN CONFIGURATION (internal)  
!  
!
```



Hardware Installation Guidelines

```
vlan 100
  name internal_yellow
!
vlan 101
  name internal_blue
!
vlan 200
  name IMF2IXP_internal_(backend)
!
vlan 300
  name oobm_or_iLO
!
vlan 400
  name IMF2IXP_external_(frontend)
!
!
! INTER BLUE SW 3 TO BLUE SW 1 ETHERCHANNEL (internal)
!
!
interface Port-channel3
  description Trunk_between_ blue_sw3_and_ blue_sw1
  switchport
  switchport trunk encapsulation dot1q
  switchport trunk allowed vlan 100,101,200,300
  switchport mode trunk
  mtu 9198
  no shutdown
!
!
! INTER BLUE SW3 TO BLUE SW1 PORTS (internal)
!
!
Interface range GigabitEthernet 1/1 - 2
  description Trunk_between_blue_sw3_and_blue_sw1
  switchport trunk encapsulation dot1q
  switchport trunk allowed vlan 100,101,200,300
  switchport mode trunk
  mtu 9198
  channel-group 1 mode active
  no shutdown
!
!
! EAGLE PORTS
!
!
interface range GigabitEthernet 1/3 - 48
```

```
description Eagle FC or STC ports
switchport access vlan 101
switchport mode access
mtu 9198
no shutdown
!
!
! VLAN INTERFACE CONFIGURATION
!
!
interface Vlan1
no ip address
!
!
interface VLAN 101
ip address 172.22.49.3 255.255.254.0
ip pim dense-mode
no shutdown!
!
interface Vlan200
description for remote access though telnet
ip address 192.168.0.7 255.255.255.224 ! <----- replace IP with the value provided by the
customer
no shutdown
!
!
no ip http server
no ip http secure-server
!
ip route 0.0.0.0 0.0.0.0 192.168.0.1 1 ! <----- replace IP with yellow VLAN 200 vrrp IP
!
!
line con 0
password ***** ! <----- replace ***** with password specified in password dragon as Cisco telnet
login
!
logging 172.22.49.10
!
no cdp run
!
end
```

10.17.8 Single Switch yellow-blue-sw1-1

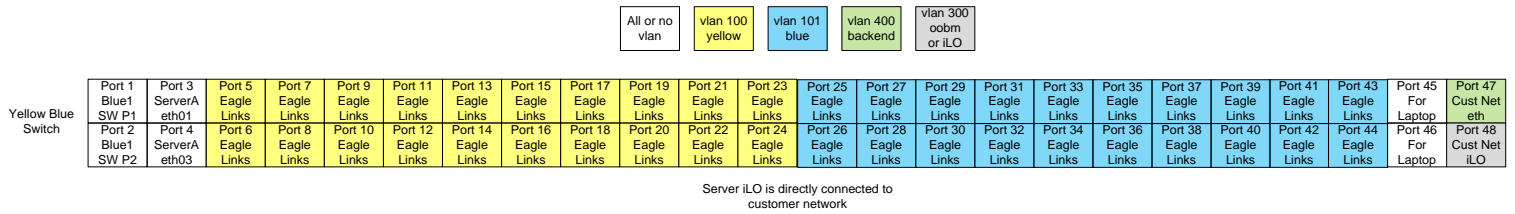
Hardware Installation Guidelines



```
enable secret ***** ! <----- replace ***** with password specified in password dragon as Cisco enable
service password-encryption
no service pad
service timestamps debug uptime
service timestamps log uptime
service compress-config
!
hostname yellow-blue-sw1-1
!
no logging console
!
no aaa new-model
ip subnet-zero
!
ip multicast-routing
vtp mode transparent
!
!
!
power redundancy-mode redundant
no file verify auto
spanning-tree mode pvst
no spanning-tree optimize bpdu transmission
spanning-tree extend system-id
!
!
! VLAN CONFIGURATION (internal)
!
!
vlan internal allocation policy ascending
!
vlan 100
  name internal_yellow
!
vlan 101
  name internal_blue
!
```

Hardware Installation Guidelines

```
vlan 200
  name IMF2IXP_internal_(backend)
!
vlan 300
  name oobm_or_iLO
!
!
! INTER YELLOW SW1 TO BLUE SW1 ETHERCHANNEL (internal)
!
!
interface Port-channel1
  description Red_Wan_Trunk_between_Yellow_and_Blue (unused here but reserved)
  switchport
  switchport trunk encapsulation dot1q
  switchport mode trunk
  mtu 9198
!
!
! INTER YELLOW SW1 TO BLUE SW1 PORTS (internal)
!
!
Interface range GigabitEthernet 1/1 - 2
  description Red_Wan_Trunk_between_Yellow_and_Blue (unused here but reserved)
  switchport trunk encapsulation dot1q
  switchport mode trunk
  mtu 9198
  channel-group 1 mode active
!
!
! IMF Servers PORTS
!
!
interface range GigabitEthernet1/3 - 4
  description for IMF 1A external + internal networks port
  switchport trunk encapsulation dot1q
  switchport trunk allowed vlan 1,100,101,200,300
  switchport mode trunk
  mtu 9198
  spanning-tree portfast trunk
!
!
! EAGLE PORTS
!
!
interface range GigabitEthernet1/5 - 24
  description yellow network port for Eagle connectivity
```

Hardware Installation Guidelines

```
switchport access vlan 100
switchport mode access
mtu 9198
spanning-tree portfast
!
!
interface range GigabitEthernet1/25-44
description blue network port for Eagle connectivity
switchport access vlan 101
switchport mode access
mtu 9198
spanning-tree portfast
!
interface range GigabitEthernet1/45-46
description unused
shutdown
!
!
! PORT TO CUSTOMER SWITCH A
!
!
interface GigabitEthernet1/47
description port where customer is connected to IMF
switchport access vlan 200
switchport mode access
media-type rj45
!
interface GigabitEthernet1/48
description port where customer is connected to ILO
switchport access vlan 300
switchport mode access
media-type rj45
!
interface Vlan1
no ip address
!
interface Vlan100
ip address 172.21.49.1 255.255.254.0
no ip route-cache cef
no ip route-cache
no shutdown
!
interface Vlan101
ip address 172.22.49.1 255.255.254.0
no ip route-cache cef
```

```
no ip route-cache
no shutdown
!
!
interface Vlan200
 ip address 10.27.56.166 255.255.255.240 ! <----- replace IP with an address from customer network
 no shutdown
!
no ip http server
no ip http secure-server
!
ip route 0.0.0.0 0.0.0.0 10.248.4.17 1 ! <----- replace IP with customer default gateway
!
!
logging 172.21.49.10
no cdp run
!
line con 0
 password ***** ! <----- replace ***** with password specified in password dragon as Cisco telnet
 login
!
!
!
End
```

10.17.9 RMS Layer 2 switch configurations (PIC 9.x and earlier)

1. Yellow-sw1-1 (Layer 2)

```
!
no service pad
service timestamps debug datetime
service timestamps log datetime
service password-encryption
no logging console
!
hostname yellow-sw1-1
enable secret ***** ! <----- replace ***** with password specified in password dragon as Cisco enable
!
ip subnet-zero
vtp mode transparent
!
!
spanning-tree mode pvst
no spanning-tree optimize bpdu transmission
spanning-tree extend system-id
spanning-tree vlan 1-1024 priority 40960
```

Hardware Installation Guidelines

```
!  
ip multicast-routing  
!  
!  
! VLAN CONFIGURATION (internal)  
!  
!  
vlan 100  
  name yellow  
!  
vlan 101  
  name blue  
!  
vlan 200  
  name cust  
!  
vlan 300  
  name oobm  
!  
!  
! INTER YELLOW SW1 TO BLUE SW1 ETHERCHANNEL (internal)  
!  
!  
interface Port-channel1  
  description Red_Wan_Trunk_between_Yellow_and_Blue  
  switchport  
  switchport trunk encapsulation dot1q  
  switchport trunk allowed vlan 1,100,101,200,300  
  switchport mode trunk  
  mtu 9198  
  spanning-tree portfast trunk  
!  
!  
! INTER YELLOW SW 1 TO YELLOW SW2 ETHERCHANNEL (internal)  
!  
!  
interface Port-channel2  
  description Trunk_between_Yellow_sw1_and_Yellow_sw2  
  switchport  
  switchport trunk encapsulation dot1q  
  switchport trunk allowed vlan 1,100,101,200,300  
  switchport mode trunk  
  mtu 9198  
  spanning-tree portfast trunk  
!  
!
```

Hardware Installation Guidelines

```
! INTER YELLOW SW 1 TO YELLOW SW3 ETHERCHANNEL (internal)
!
!
interface Port-channel3
  description Trunk_between_Yellow_sw1_and_Yellow_sw3
  switchport
  switchport trunk encapsulation dot1q
  switchport trunk allowed vlan 1,100,101,200,300
  switchport mode trunk
  mtu 9198
  spanning-tree portfast trunk
!
!
! INTER YELLOW SW1 TO BLUE SW1 PORTS (internal)
!
!
interface range gigabitEthernet 1/1 - 2
  description ISL_between_yellow_sw1_and_blue_sw1
  switchport trunk encapsulation dot1q
  switchport trunk allowed vlan 1,100,101,200,300
  switchport mode trunk
  mtu 9198
  channel-group 1 mode active
  spanning-tree portfast trunk
  no shutdown
!
!
! INTER yellow SW1 TO yellow SW3 PORTS (internal)
!
!
interface range gigabitEthernet 1/41 - 42
  description Trunk_between_yellow_sw1_and_yellow_sw3
  switchport trunk encapsulation dot1q
  switchport trunk allowed vlan 1,100,101,200,300
  switchport mode trunk
  mtu 9198
  channel-group 3 mode active
  spanning-tree portfast trunk
  no shutdown
!
!
! INTER yellow SW1 TO yellow SW2 PORTS (internal)
!
!
interface range gigabitEthernet 1/43 - 44
  description Trunk_between_yellow_sw1_and_yellow_sw2
```

Hardware Installation Guidelines

```
switchport trunk encapsulation dot1q
switchport trunk allowed vlan 1,100,101,200,300
switchport mode trunk
mtu 9198
channel-group 2 mode active
spanning-tree portfast trunk
no shutdown
!
!
! IMF Servers PORTS
!
!
interface range gigabitEthernet 1/3 - 5
description IMF servers ports
switchport trunk encapsulation dot1q
switchport mode trunk
mtu 9198
spanning-tree portfast trunk
no shutdown
!
interface range gigabitEthernet 1/7 - 8
description IMF servers ports
switchport trunk encapsulation dot1q
switchport mode trunk
mtu 9198
spanning-tree portfast trunk
no shutdown
!
interface gigabitEthernet 1/10
description IMF servers ports
switchport trunk encapsulation dot1q
switchport mode trunk
mtu 9198
spanning-tree portfast trunk
no shutdown
!
!
! iLO PORTS
!
!
interface gigabitEthernet 1/6
description IMF iLO ports
switchport mode access
switchport access vlan 300
spanning-tree portfast
no shutdown
```

Hardware Installation Guidelines

```
!  
interface gigabitEthernet 1/9  
description IMF iLO ports  
  switchport mode access  
  switchport access vlan 300  
  spanning-tree portfast  
  no shutdown  
!  
!  
! EAGLE PORTS  
!  
!  
interface range gigabitEthernet 1/11 - 40  
description Eagle FC or STC ports  
  switchport mode access  
  switchport access vlan 100  
  mtu 9198  
  spanning-tree portfast  
  no shutdown  
!  
!  
! Laptop PORTS  
!  
!  
interface range GigabitEthernet 1/45 - 46  
description for Laptop  
  switchport access vlan 200  
  switchport mode access  
  media-type rj45  
  no shutdown  
!  
!  
! PORT TO CUSTOMER SWITCH A  
!  
!  
interface gigabitEthernet 1/47  
description to customer switch A  
  switchport mode access  
  switchport access vlan 200  
  media-type rj45  
  no shutdown  
!  
interface gigabitEthernet 1/48  
description to customer switch A (iLO)  
  switchport mode access  
  switchport access vlan 300
```

Hardware Installation Guidelines

```
media-type rj45
no shutdown
!
interface VLAN 100
 ip address 172.21.49.1 255.255.254.0
 ip pim dense-mode
 no shutdown
!
no ip route-cache
!
no ip http server
!
no cdp run
!
line con 0
 password ***** ! <----- replace ***** with password specified in password dragon as Cisco telnet
 login
!
logging 172.21.49.10
!
end
```

2. Blue-sw1-1 (Layer 2)

```
!
no service pad
service timestamps debug datetime
service timestamps log datetime
service password-encryption
no logging console
!
hostname blue-sw1-1
enable secret ***** ! <----- replace ***** with password specified in password dragon as Cisco enable
!
ip subnet-zero
vtp mode transparent
!
!
spanning-tree mode pvst
no spanning-tree optimize bpdu transmission
spanning-tree extend system-id
spanning-tree vlan 1-1024 priority 40960
!
ip multicast-routing
!
```

```
!  
! VLAN CONFIGURATION (internal)  
!  
!  
vlan 100  
    name yellow  
!  
vlan 101  
    name blue  
!  
vlan 200  
    name cust  
!  
vlan 300  
    name oobm  
!  
!  
! INTER YELLOW SW1 TO BLUE SW1 ETHERCHANNEL (internal)  
!  
!  
interface Port-channel1  
    description Red_Wan_Trunk_between_Yellow_and_Blue  
    switchport  
    switchport trunk encapsulation dot1q  
    switchport trunk allowed vlan 1,100,101,200,300  
    switchport mode trunk  
    mtu 9198  
    spanning-tree portfast trunk  
!  
!  
! INTER BLUE SW 1 TO BLUE SW2 ETHERCHANNEL (internal)  
!  
!  
interface Port-channel2  
    description Trunk_between_Blue_sw1_and_Blue_sw2  
    switchport  
    switchport trunk encapsulation dot1q  
    switchport trunk allowed vlan 1,100,101,200,300  
    switchport mode trunk  
    mtu 9198  
    spanning-tree portfast trunk  
!  
!  
! INTER BLUE SW 1 TO BLUE SW3 ETHERCHANNEL (internal)  
!  
!
```

Hardware Installation Guidelines

```
interface Port-channel3
  description Trunk_between_Blue_sw1_and_Blue_sw3
  switchport
  switchport trunk encapsulation dot1q
  switchport trunk allowed vlan 1,100,101,200,300
  switchport mode trunk
  spanning-tree portfast trunk
!
!
! INTER BLUE SW1 TO yellow SW1 PORTS (internal)
!
!
interface range gigabitEthernet 1/1 - 2
  description ISL_between_blue_sw1_and_yellow_sw1
  switchport trunk encapsulation dot1q
  switchport trunk allowed vlan 1,100,101,200,300
  switchport mode trunk
  mtu 9198
  channel-group 1 mode active
  spanning-tree portfast trunk
  no shutdown
!
!
! INTER BLUE SW1 TO BLUE SW3 PORTS (internal)
!
!
interface range gigabitEthernet 1/41 - 42
  description Trunk_between_blue_sw1_and_blue_sw3
  switchport trunk encapsulation dot1q
  switchport trunk allowed vlan 1,100,101,200,300
  switchport mode trunk
  channel-group 3 mode active
  mtu 9198
  spanning-tree portfast trunk
  no shutdown
!
!
! INTER BLUE SW1 TO BLUE SW2 PORTS (internal)
!
!
interface range gigabitEthernet 1/43 - 44
  description Trunk_between_blue_sw1_and_blue_sw2
  switchport trunk encapsulation dot1q
  switchport trunk allowed vlan 1,100,101,200,300
  switchport mode trunk
  channel-group 2 mode active
```

Hardware Installation Guidelines

```
mtu 9198
spanning-tree portfast trunk
no shutdown
!
!
! IMF Servers PORTS
!
!
interface range gigabitEthernet 1/3 - 6
description IMF servers ports
switchport trunk encapsulation dot1q
switchport mode trunk
mtu 9198
spanning-tree portfast trunk
no shutdown
!
interface range gigabitEthernet 1/8 - 9
description IMF servers ports
switchport trunk encapsulation dot1q
switchport mode trunk
mtu 9198
spanning-tree portfast trunk
no shutdown
!
!
! iLO PORTS
!
!
interface gigabitEthernet 1/7
description IMF iLO ports
switchport mode access
switchport access vlan 300
spanning-tree portfast
no shutdown
!
interface gigabitEthernet 1/10
description IMF iLO ports
switchport mode access
switchport access vlan 300
spanning-tree portfast
no shutdown
!
!
! EAGLE PORTS
!
!
```

Hardware Installation Guidelines

```
interface range gigabitEthernet 1/11 - 40
description Eagle FC or STC ports
switchport mode access
switchport access vlan 101
mtu 9198
spanning-tree portfast
no shutdown
!
!
! Laptop PORTS
!
!
interface range GigabitEthernet 1/45 - 46
description for Laptop
switchport access vlan 200
switchport mode access
media-type rj45
no shutdown

!
!
! PORT TO CUSTOMER SWITCH B
!
!
interface gigabitEthernet 1/47
description to customer switch B
switchport mode access
switchport access vlan 200
media-type rj45
no shutdown
!
interface gigabitEthernet 1/48
description to customer switch B (iLO)
switchport mode access
switchport access vlan 300
media-type rj45
no shutdown
!
interface VLAN 101
ip address 172.22.49.1 255.255.254.0
ip pim dense-mode
no shutdown
!
no ip route-cache
!
no ip http server
```

```
!  
no cdp run  
!  
line con 0  
  password ***** ! <----- replace ***** with password specified in password dragon as Cisco telnet  
  login  
!  
logging 172.22.49.10  
!  
end
```

3. Yellow-sw2-1 (Layer 2)

```
!  
no service pad  
service timestamps debug datetime  
service timestamps log datetime  
service password-encryption  
no logging console  
!  
hostname yellow-sw2-1  
enable secret ***** ! <----- replace ***** with password specified in password dragon as Cisco enable  
!  
ip subnet-zero  
vtp mode transparent  
!  
boot-start-marker  
boot system flash bootflash:cat4500-ipbasek9-mz.122-53.SG2.bin  
boot-end-marker  
!  
!  
spanning-tree mode pvst  
no spanning-tree optimize bpdu transmission  
spanning-tree extend system-id  
spanning-tree vlan 1-1024 priority 53248  
!  
ip multicast-routing  
!  
!  
! VLAN CONFIGURATION (internal)  
!  
!  
vlan 100  
  name yellow  
!
```

Hardware Installation Guidelines

```
vlan 101
  name blue
!
vlan 200
  name cust
!
vlan 300
  name oobm
!
!
! INTER YELLOW SW 2 TO YELLOW SW 1 ETHERCHANNEL (internal)
!
!
interface Port-channel1
  description Trunk_between_Yellow_sw2_and_Yellow_sw1
  switchport
  switchport trunk encapsulation dot1q
  switchport trunk allowed vlan 1,100,101,200,300
  switchport mode trunk
  mtu 9198
  spanning-tree portfast trunk
!
!
! INTER yellow SW2 TO yellow SW1 PORTS (internal)
!
!
interface range gigabitEthernet 1/1 - 2
  description Trunk_between_yellow_sw2_and_yellow_sw1
  switchport trunk encapsulation dot1q
  switchport trunk allowed vlan 1,100,101,200,300
  switchport mode trunk
  mtu 9198
  channel-group 1 mode active
  spanning-tree portfast trunk
  no shutdown
!
!
! IMF Servers PORTS
!
!
interface gigabitEthernet 1/3
  description IMF servers ports
  switchport trunk encapsulation dot1q
  switchport mode trunk
  mtu 9198
  spanning-tree portfast trunk
```

```
no shutdown
!
interface range gigabitEthernet 1/5 - 6
description IMF servers ports
switchport trunk encapsulation dot1q
switchport mode trunk
mtu 9198
spanning-tree portfast trunk
no shutdown
!
interface range gigabitEthernet 1/8 - 9
description IMF servers ports
switchport trunk encapsulation dot1q
switchport mode trunk
mtu 9198
spanning-tree portfast trunk
no shutdown
!
interface gigabitEthernet 1/11
description IMF servers ports
switchport trunk encapsulation dot1q
switchport mode trunk
mtu 9198
spanning-tree portfast trunk
no shutdown
!
!
! iLO PORTS
!
!
interface gigabitEthernet 1/4
description IMF iLO ports
switchport mode access
switchport access vlan 300
spanning-tree portfast
no shutdown
!
interface gigabitEthernet 1/7
description IMF iLO ports
switchport mode access
switchport access vlan 300
spanning-tree portfast
no shutdown
!
interface gigabitEthernet 1/10
description IMF iLO ports
```

Hardware Installation Guidelines

```
switchport mode access
switchport access vlan 300
spanning-tree portfast
no shutdown
!
!
! EAGLE PORTS
!
!
interface range gigabitEthernet 1/12 - 48
description Eagle FC or STC ports
switchport mode access
switchport access vlan 100
mtu 9198
spanning-tree portfast
no shutdown
!
interface VLAN 100
ip address 172.21.49.2 255.255.254.0
ip pim dense-mode
no shutdown
!
no ip route-cache
!
no ip http server
!
no cdp run
!
line con 0
password ***** ! <----- replace ***** with password specified in password dragon as Cisco telnet
login
!
logging 172.21.49.10
!
end
```

4. Blue-sw2-1 (Layer 2)

```
!
no service pad
service timestamps debug datetime
service timestamps log datetime
service password-encryption
no logging console
!
```

Hardware Installation Guidelines

```
hostname blue-sw2-1
enable secret ***** ! <----- replace ***** with password specified in password dragon as Cisco enable
!
ip subnet-zero
vtp mode transparent
!
!
spanning-tree mode pvst
no spanning-tree optimize bpdu transmission
spanning-tree extend system-id
spanning-tree vlan 1-1024 priority 53248
!
ip multicast-routing
!
!
! VLAN CONFIGURATION (internal)
!
!
vlan 100
    name yellow
!
vlan 101
    name blue
!
vlan 200
    name cust
!
vlan 300
    name oobm
!
!
! INTER BLUE SW 2 TO BLUE SW 1 ETHERCHANNEL (internal)
!
!
interface Port-channell
    description Trunk_between_Blue_sw2_and_Blue_sw1
    switchport
    switchport trunk encapsulation dot1q
    switchport trunk allowed vlan 1,100,101,200,300
    switchport mode trunk
    mtu 9198
    spanning-tree portfast trunk
!
!
! INTER BLUE SW2 TO BLUE SW1 PORTS (internal)
!
```

Hardware Installation Guidelines

```
!  
interface range gigabitEthernet 1/1 - 2  
description Trunk_between_blue_sw2_and_blue_sw1  
switchport trunk encapsulation dot1q  
switchport trunk allowed vlan 1,100,101,200,300  
switchport mode trunk  
mtu 9198  
channel-group 1 mode active  
spanning-tree portfast trunk  
no shutdown  
!  
!  
! IMF Servers PORTS  
!  
!  
interface range gigabitEthernet 1/3 - 4  
description IMF servers ports  
switchport trunk encapsulation dot1q  
switchport mode trunk  
mtu 9198  
spanning-tree portfast trunk  
no shutdown  
!  
interface range gigabitEthernet 1/6 - 7  
description IMF servers ports  
switchport trunk encapsulation dot1q  
switchport mode trunk  
mtu 9198  
spanning-tree portfast trunk  
no shutdown  
!  
interface range gigabitEthernet 1/9 - 10  
description IMF servers ports  
switchport trunk encapsulation dot1q  
switchport mode trunk  
mtu 9198  
spanning-tree portfast trunk  
no shutdown  
!  
!  
! iLO PORTS  
!  
!  
interface gigabitEthernet 1/5  
description IMF iLO ports  
switchport mode access
```

Hardware Installation Guidelines

```
switchport access vlan 300
spanning-tree portfast
no shutdown
!
interface gigabitEthernet 1/8
description IMF iLO ports
switchport mode access
switchport access vlan 300
spanning-tree portfast
no shutdown
!
interface gigabitEthernet 1/11
description IMF iLO ports
switchport mode access
switchport access vlan 300
spanning-tree portfast
no shutdown
!
!
! EAGLE PORTS
!
!
interface range gigabitEthernet 1/12 - 48
description Eagle FC or STC ports
switchport mode access
switchport access vlan 101
mtu 9198
spanning-tree portfast
no shutdown
!
interface VLAN 101
ip address 172.22.49.2 255.255.254.0
ip pim dense-mode
no shutdown
!
no ip route-cache
!
no ip http server
!
no cdp run
!
line con 0
password ***** ! <----- replace ***** with password specified in password dragon as Cisco telnet
login
!
logging 172.22.49.10
```

Hardware Installation Guidelines

```
!  
end
```

5. Yellow-sw3-1 (Layer 2)

```
!  
no service pad  
service timestamps debug datetime  
service timestamps log datetime  
service password-encryption  
no logging console  
!  
hostname yellow-sw3-1  
enable secret ***** ! <----- replace ***** with password specified in password dragon as Cisco enable  
!  
ip subnet-zero  
vtp mode transparent  
!  
!  
spanning-tree mode pvst  
no spanning-tree optimize bpdu transmission  
spanning-tree extend system-id  
spanning-tree vlan 1-1024 priority 53248  
!  
ip multicast-routing  
!  
!  
! VLAN CONFIGURATION (internal)  
!  
!  
vlan 100  
    name yellow  
!  
vlan 101  
    name blue  
!  
vlan 200  
    name cust  
!  
vlan 300  
    name oobm  
!  
!  
! INTER YELLOW SW 3 TO YELLOW SW 1 ETHERCHANNEL (internal)  
!
```

```
!  
interface Port-channel1  
  description Trunk_between_Yellow_sw3_and_Yellow_sw1  
  switchport  
  switchport trunk encapsulation dot1q  
  switchport trunk allowed vlan 1,100,101,200,300  
  switchport mode trunk  
  mtu 9198  
  spanning-tree portfast trunk  
!  
!  
! INTER yellow SW3 TO yellow SW1 PORTS (internal)  
!  
!  
interface range gigabitEthernet 1/1 - 2  
  description Trunk_between_yellow_sw3_and_yellow_sw1  
  switchport trunk encapsulation dot1q  
  switchport trunk allowed vlan 1,100,101,200,300  
  switchport mode trunk  
  mtu 9198  
  channel-group 1 mode active  
  spanning-tree portfast trunk  
  no shutdown  
!  
!  
! EAGLE PORTS  
!  
!  
interface range gigabitEthernet 1/3 - 48  
  description Eagle FC or STC ports  
  switchport mode access  
  switchport access vlan 100  
  mtu 9198  
  spanning-tree portfast  
  no shutdown  
!  
interface VLAN 100  
  ip address 172.21.49.3 255.255.254.0  
  ip pim dense-mode  
  no shutdown  
!  
no ip route-cache  
!  
no ip http server  
!  
no cdp run
```

Hardware Installation Guidelines

```
!  
line con 0  
  password ***** ! <----- replace ***** with password specified in password dragon as Cisco telnet  
  login  
!  
logging 172.21.49.10  
!  
end
```

6. Blue-sw3-1 (Layer 2)

```
!  
no service pad  
service timestamps debug datetime  
service timestamps log datetime  
service password-encryption  
no logging console  
!  
hostname blue-sw3-1  
enable secret ***** ! <----- replace ***** with password specified in password dragon as Cisco enable  
!  
ip subnet-zero  
vtp mode transparent  
!  
!  
spanning-tree mode pvst  
no spanning-tree optimize bpdu transmission  
spanning-tree extend system-id  
spanning-tree vlan 1-1024 priority 53248  
!  
ip multicast-routing  
!  
!  
! VLAN CONFIGURATION (internal)  
!  
!  
vlan 100  
  name yellow  
!  
vlan 101  
  name blue  
!  
vlan 200  
  name cust  
!  
!
```

```
vlan 300
  name oobm
!
!
! INTER BLUE SW 3 TO BLUE SW 1 ETHERCHANNEL (internal)
!
!
interface Port-channel1
  description Trunk_between_Blue_sw3_and_Blue_sw1
  switchport
  switchport trunk encapsulation dot1q
  switchport trunk allowed vlan 1,100,101,200,300
  switchport mode trunk
  mtu 9198
  spanning-tree portfast trunk
!
!
! INTER BLUE SW3 TO BLUE SW1 PORTS (internal)
!
!
interface range gigabitEthernet 1/1 - 2
  description Trunk_between_blue_sw3_and_blue_sw1
  switchport trunk encapsulation dot1q
  switchport trunk allowed vlan 1,100,101,200,300
  switchport mode trunk
  mtu 9198
  channel-group 1 mode active
  spanning-tree portfast trunk
  no shutdown
!
!
! EAGLE PORTS
!
!
interface range gigabitEthernet 1/3 - 48
  description Eagle FC or STC ports
  switchport mode access
  switchport access vlan 101
  mtu 9198
  spanning-tree portfast
  no shutdown
!
interface VLAN 101
  ip address 172.22.49.3 255.255.254.0
  ip pim dense-mode
  no shutdown
```

Hardware Installation Guidelines

```
service timestamps debug datetime
service timestamps log datetime
no logging console
no aaa new-model
track 1 interface GigabitEthernet1/47 line-protocol
ip subnet-zero
!
ip multicast-routing
!
power redundancy-mode redundant
!
!
! VLAN CONFIGURATION (internal)
!
!
vlan 100
  name internal_yellow
!
vlan 101
  name internal_blue
!
vlan 200
  name IMF2IXP_internal_(backend)
!
vlan 400
  name IMF2IXP_external_(frontend)
!
!
! INTER YELLOW SW1 TO BLUE SW1 ETHERCHANNEL (internal)
!
!
interface Port-channel1
  description Trunk_between_yellow_sw1_and_blue_sw1
  switchport
  switchport trunk encapsulation dot1q
  switchport trunk allowed vlan 100,101,200,300
  mtu 9198
  no shutdown

!
!
! INTER YELLOW SW1 TO BLUE SW1 PORTS (internal)
!
!
Interface range GigabitEthernet 1/1 - 2
  description ISL_between_yellow_sw1_and_blue_sw1
```

Hardware Installation Guidelines

```
switchport trunk encapsulation dot1q
switchport trunk allowed vlan 100,101,200,300
switchport mode trunk
switchport nonegotiate
mtu 9198
channel-group 1 mode active
no shutdown
!
!
! IMF Servers PORTS
!
!
interface range GigabitEthernet 1/3 - 8
description IMF servers ports
switchport trunk encapsulation dot1q
switchport mode trunk
mtu 9198
no shutdown
!
!
! EAGLE PORTS
!
!
interface range GigabitEthernet 1/9 - 46
description Eagle FC or STC ports
switchport access vlan 100
switchport mode access
mtu 9198
no shutdown
!
!
! PORT TO CUSTOMER SWITCH A
!
!
interface GigabitEthernet 1/47
description to customer switch A
switchport access vlan 400
switchport mode access
media-type rj45
no shutdown
!
!
! Laptop PORTS
!
!
interface range GigabitEthernet 1/48
```

Hardware Installation Guidelines

```
description for Laptop
switchport access vlan 200
switchport mode access
media-type rj45
no shutdown
!
!
! VLAN INTERFACE CONFIGURATION
!
!
interface Vlan1
no ip address
!
!
interface VLAN 100
ip address 172.21.49.1 255.255.254.0
ip pim dense-mode
no shutdown
!
!
track 1 int gigabitEthernet 1/47 line-protocol
interface Vlan200
description internal VRRP for IMF to IXP traffic. Both IP addresses and netmask must be configured according
customer network.
ip address 192.168.0.2 255.255.255.224 ! <----- replace IP with the value provided by the customer
vrrp 1 ip 192.168.0.1 ! <----- replace IP with default gateway
vrrp 1 priority 100
vrrp 1 track 1
vrrp 1 preempt
no shutdown
!
!
interface Vlan 400
description external VRRP for IMF to IXP traffic to Customer switches. Both IP addresses and netmask must be
configured according customer network.
ip address 192.168.20.2 255.255.255.248 ! <----- replace IP with the value provided by the customer
vrrp 2 ip 192.168.20.1 ! <----- replace IP with default gateway
vrrp 2 priority 100
vrrp 2 preempt
no shutdown
!
!
no ip http server
no ip http secure-server
!
ip route 0.0.0.0 0.0.0.0 192.168.20.6 1 ! <----- replace IP with customer default gateway
```

Hardware Installation Guidelines

```
!  
!  
line con 0  
  password ***** ! <----- replace ***** with password specified in password dragon as Cisco telnet  
  login  
!  
logging 172.21.49.10  
!  
no cdp run  
!  
end
```

3. Blue-sw1-1 Switch (Layer 3)

```
! IMF BLUE SWITCH configuration  
!  
!  
hostname blue-sw1-1  
!  
no spanning-tree vlan 1-4094  
no spanning-tree optimize bpdu transmission  
!  
enable secret ***** ! <----- replace ***** with password specified in password dragon as Cisco enable  
service password-encryption  
no service pad  
service timestamps debug datetime  
service timestamps log datetime  
no logging console  
no aaa new-model  
track 1 interface GigabitEthernet1/47 line-protocol  
ip subnet-zero  
!  
ip multicast-routing  
!  
power redundancy-mode redundant  
!  
!  
! VLAN CONFIGURATION (internal)  
!  
!  
vlan 100  
  name internal_yellow  
!  
vlan 101  
  name internal_blue  
!
```

```
vlan 200
  name IMF2IXP_internal_(backend)
!
vlan 400
  name IMF2IXP_external_(frontend)
!
!
! INTER YELLOW SW TO BLUE SW ETHERCHANNEL (internal)
!
!
interface Port-channel1
  description Trunk_between_yellow_sw1_and_blue_sw1
  switchport
  switchport trunk encapsulation dot1q
  switchport trunk allowed vlan 100,101,200,300
  mtu 9198
  no shutdown
!
!
! INTER BLUE SW TO YELLOW SW PORTS (internal)
!
!
Interface range GigabitEthernet 1/1 - 2
  description ISL_between_blue_sw1_and_yellow_sw1
  switchport trunk encapsulation dot1q
  switchport trunk allowed vlan 100,101,200,300
  switchport mode trunk
  switchport nonegotiate
  mtu 9198
  channel-group 1 mode active
  no shutdown
!
!
! IMF Servers PORTS
!
!
interface range GigabitEthernet 1/3 - 8
  description IMF servers ports
  switchport trunk encapsulation dot1q
  switchport mode trunk
  mtu 9198
  no shutdown
!
!
! EAGLE PORTS
!
```

Hardware Installation Guidelines

```
!  
interface range GigabitEthernet 1/9 - 46  
description Eagle FC or STC ports  
    switchport access vlan 101  
    switchport mode access  
    mtu 9198  
    no shutdown  
!  
!  
! PORT TO CUSTOMER SWITCH B  
!  
!  
interface GigabitEthernet 1/47  
description to customer switch B  
    switchport access vlan 400  
    switchport mode access  
    media-type rj45  
    no shutdown  
!  
!  
! Laptop PORTS  
!  
!  
interface range GigabitEthernet 1/48  
description for Laptop  
    switchport access vlan 200  
    switchport mode access  
    media-type rj45  
    no shutdown  
!  
!  
! VLAN INTERFACE CONFIGURATION  
!  
!  
interface Vlan1  
    no ip address  
!  
!  
interface VLAN 101  
    ip address 172.22.49.1 255.255.254.0  
    ip pim dense-mode  
    no shutdown  
!  
!  
track 1 int gigabitEthernet 1/47 line-protocol  
interface Vlan200
```

Hardware Installation Guidelines

description internal VRRP for IMF to IXP traffic. Both IP addresses and netmask must be configured according customer network.

```
ip address 192.168.0.3 255.255.255.224 ! <----- replace IP with the value provided by the customer
vrrp 1 ip 192.168.0.1 ! <----- replace IP with default gateway
vrrp 1 priority 99
vrrp 1 track 1
vrrp 1 preempt
no shutdown
!
!
interface Vlan 400
```

description external VRRP for IMF to IXP traffic to Customer switches. Both IP addresses and netmask must be configured according customer network.

```
ip address 192.168.20.3 255.255.255.248 ! <----- replace IP with the value provided by the customer
vrrp 2 ip 192.168.20.1 ! <----- replace IP with default gateway
vrrp 2 priority 99
vrrp 2 preempt
no shutdown
!
!
no ip http server
no ip http secure-server
```

```
!
ip route 0.0.0.0 0.0.0.0 192.168.20.6 1 ! <----- replace IP with customer default gateway
!
!
line con 0
 password ***** ! <----- replace ***** with password specified in password dragon as Cisco telnet
 login
!
logging 172.22.49.10
!
no cdp run
!
end
```

4. Single Switch yellow-blue-sw1-1 (Layer 2)

```
enable secret ***** ! <----- replace ***** with password specified in password dragon as Cisco enable
service password-encryption
no service pad
service timestamps debug uptime
service timestamps log uptime
service compress-config
!
```

Hardware Installation Guidelines

```
hostname yellow-blue-sw1-1
!
no logging console
!
no aaa new-model
ip subnet-zero
!
ip multicast-routing
vtp mode transparent
!
!
!
power redundancy-mode redundant
no file verify auto
spanning-tree mode pvst
no spanning-tree optimize bpdu transmission
spanning-tree extend system-id
!
!
! VLAN CONFIGURATION (internal)
!
!
vlan internal allocation policy ascending
!
vlan 100
  name internal_yellow
!
vlan 101
  name internal_blue
!
vlan 200
  name IMF2IXP_internal_(backend)
!
!
! IMF Servers PORTS
!
!
interface range GigabitEthernet1/1 - 8
  description for IMF 1A external + internal networks port
  switchport trunk encapsulation dot1q
  switchport trunk allowed vlan 1,100,101,200
  switchport mode trunk
  mtu 9198
  spanning-tree portfast trunk
!
!
```

Hardware Installation Guidelines

```
! EAGLE PORTS
!
!
interface range GigabitEthernet1/9 - 27
description yellow network port for Eagle connectivity
switchport access vlan 100
switchport mode access
mtu 9198
spanning-tree portfast
!
!
interface range GigabitEthernet1/28 - 46
description blue network port for Eagle connectivity
switchport access vlan 101
switchport mode access
mtu 9198
spanning-tree portfast
!
!
! PORT TO CUSTOMER SWITCH A
!
!
interface GigabitEthernet1/47
description port where customer is connected to IMF
switchport access vlan 200
switchport mode access
media-type rj45
!
!
! Laptop PORTS
!
!
interface range GigabitEthernet 1/48
description for Laptop
switchport access vlan 200
switchport mode access
media-type rj45
no shutdown
!
!
! VLAN INTERFACE CONFIGURATION
!
!
interface Vlan1
no ip address
!
```

Hardware Installation Guidelines

```
interface Vlan100
  ip address 172.21.49.1 255.255.254.0
  no ip route-cache cef
  no ip route-cache
  no shutdown
!
interface Vlan101
  ip address 172.22.49.1 255.255.254.0
  no ip route-cache cef
  no ip route-cache
  no shutdown
!
!
interface Vlan200
  ip address 10.27.56.166 255.255.255.240 ! <----- replace IP with an address from customer network
  no shutdown
!
no ip http server
no ip http secure-server
!
ip route 0.0.0.0 0.0.0.0 10.248.4.17 1 ! <----- replace IP with customer default gateway
!
!
logging 172.21.49.10
no cdp run
!
line con 0
  password ***** ! <----- replace ***** with password specified in password dragon as Cisco telnet
  login
!
!
!
End
```

10.18 My Oracle Support (MOS)

MOS (<https://support.oracle.com>) is your initial point of contact for all product support and training needs. A representative at Customer Access Support (CAS) can assist you with MOS registration.

Hardware Installation Guidelines

Call the CAS main number at 1-800-223-1711 (toll-free in the US), or call the Oracle Support hotline for your local country from the list at <http://www.oracle.com/us/support/contact/index.html>. When calling, make the selections in the sequence shown below on the Support telephone menu:

1. Select 2 for New Service Request
2. Select 3 for Hardware, Networking and Solaris Operating System Support
3. Select 2 for Non-technical issue

You will be connected to a live agent who can assist you with MOS registration and provide Support Identifiers. Simply mention you are a Tekelec Customer new to MOS.

MOS is available 24 hours a day, 7 days a week, 365 days a year.

10.19 Locate Product Documentation on the Oracle Help Center Site

Oracle customer documentation is available on the web at the Oracle Help Center (OTN) site, <http://docs.oracle.com>. You do not have to register to access these documents. Viewing these files requires Adobe Acrobat Reader, which can be downloaded at www.adobe.com.

1. Access the Oracle Help Center site at <http://docs.oracle.com/>.
2. Click Industries.
3. Under the Oracle Communications subheading, click the Oracle Communications documentation link. The Communications Documentation page appears.
4. Under the heading "Network Visibility and Resource Management," click on Performance Intelligence Center and then the Release Number.
A list of the entire documentation set for the release appears.
5. To download a file to your location, right-click the PDF link, select Save target as (or similar command based on your browser), and save to a local folder.