



April 2017

Oracle[®] Communications Performance Intelligence Center

Planning Guide

Release 10.2

E72801-04

- Table of Contents -

1	INTRODUCTION TO PERFORMANCE INTELLIGENCE CENTER PLANNING GUIDE	6
1.1	INTRODUCTION TO PERFORMANCE INTELLIGENCE CENTER (OCPIC)	6
1.2	USEFUL CONCEPTS	7
2	HARDWARE CONSIDERATIONS.....	9
3	GENERAL DISCLAIMER	11
4	DATA ACQUISITION.....	12
4.1	OCPIC EAGLE INTEGRATED ACQUISITION	13
4.2	OCPIC PROBED ACQUISITION	18
4.3	OCPIC OCDSR INTEGRATED PROBED ACQUISITION	31
4.4	ACQUISITION DATA FEED OPTION	33
5	PERFORMANCE INTELLIGENCE CENTER MEDIATION	35
5.1	OCPIC MEDIATION HARDWARE SERVERS (MEDIATION AND STORAGE)	36
5.2	MIXED HARDWARE CONFIGURATION FOR OCPIC MEDIATION	40
5.3	SUPPORT OF EXISTING BLADES SYSTEM BY OCPIC MEDIATION.....	41
5.4	MEDIATION: DATA RECORD STORAGE SERVER BENCHMARK RESULTS	42
5.5	MEDIATION: PACKET DATA UNIT STORAGE SERVER BENCHMARK RESULTS	44
5.6	MEDIATION: RECORDS, PACKET DATA UNITS AND KPI STORAGE MAXIMUM CAPACITY	46
5.7	MEDIATION BASE SERVER BENCHMARK RESULTS	47
5.8	MEDIATION: KPI ENGINE PERFORMANCE (OCPIC MANAGEMENT KPI APPLICATION)	49
5.9	MEDIATION: STATIC ENRICHMENT.....	50
5.10	MEDIATION OPTION: OCPIC MEDIATION DATA FEED.....	51
6	VIRTUALIZATION	54
7	OCDSR PRE-PACKAGED ACCOUNTING AND NETWORK MONITORING CONFIGURATIONS	57
7.1	OCDSR PRE-PACKAGED MONITORING VIRTUALIZATION LAYOUT	59
8	OCPIC MANAGEMENT AND OPTIONAL APPLICATIONS	62
8.1	OCPIC MANAGEMENT HARDWARE SERVERS.....	63
8.2	OCPIC MANAGEMENT PERFORMANCE DIMENSIONING RULES.....	64
8.3	OCPIC MANAGEMENT OPTION: TROUBLESHOOTING APPLICATION	67
8.4	OCPIC MANAGEMENT OPTION: NETWORK AND SERVICE ALARM APPLICATION	68
8.5	OCPIC MANAGEMENT OPTION: DASHBOARD APPLICATION	69
8.6	OCPIC MANAGEMENT OPTION: SS7 NETWORK SURVEILLANCE APPLICATION	69
9	NETWORK REQUIREMENTS.....	71
9.1	BANDWIDTH REQUIREMENTS	71
10	APPENDIX 1 – ACRONYMS	73
11	APPENDIX 2 - E1/T1 CONVERSION TABLES	78
12	APPENDIX 3 – EAGLE TPS TO OCPIC MBPS CONVERSION.....	79
13	APPENDIX 4 – HOW TO CONFIGURE AN OCPIC FOR OCDSR MONITORING.....	80
14	APPENDIX 5 – BUILDERS CONTENT OF MEDIATION PROTOCOL LICENSES	81
15	APPENDIX 6: MY ORACLE SUPPORT.....	84
16	APPENDIX 7: LOCATE PRODUCT DOCUMENTATION.....	85

-List of Figures -

Figure 1 – Performance Intelligence Center Architecture	6
Figure 2 – What is meant by destination?	7
Figure 3 – 10.2 shipping baseline HW per OCPIC component	10
Figure 4 – Acquisition Configurations	13
Figure 5 – HSL/LSL to SIGTRAN Converters - connectivity	22
Figure 6 – HSL/LSL to SIGTRAN Converters layers	22
Figure 7 – GboE1 to GboIP Converters – layers	25
Figure 8 – 1G Ethernet TAPs	27
Figure 9 – Breakout mode.....	27
Figure 10 – Link Aggregation mode	28
Figure 11 – Backplane Aggregation mode	28
Figure 12 – Passive optical TAP	29
Figure 13 – Data feed at Acquisition overview	34
Figure 14 – Mediation Subsystem overview	35
Figure 15 – Storage onto Customer IT infrastructure	38
Figure 16 – Blade system overview reminder.....	41
Figure 17 – Data Record and KPI Latency for applications and feeds.....	43
Figure 18 – Packet Data Units compression	45
Figure 19 – OCPIC Mediation Data Feed overview	51
Figure 20 – Performance Intelligence Center Virtualization configurations	54
Figure 21 – configurations for OCDSR Pre-Package monitoring.....	58
Figure 22 – Virtualized engineered OCDSR Pre-Package	60
Figure 23 – OCPIC Management and Application overview	62

-List of Tables –

Table 1 – Hardware Lifecycle Planning.....	9
Table 2 – Acquisition supported interfaces.....	12
Table 3 – EAGLE Integrated Acquisition Hardware baseline for OCPIC 10.2.....	14
Table 4 – EAGLE Integrated Acquisition E5-APP-B configuration (linked).....	15
Table 5 – Integrated Acquisition frame configuration (linked)	16
Table 6 – Integrated Acquisition Input Bandwidth per Server Type	17
Table 7 – Probed Acquisition Hardware baseline for OCPIC 10.2	18
Table 8 – IP Probed Acquisition benchmark results for VoIP traffic (including the RTP voice bearer)	20
Table 9 – IP Probed Acquisition benchmark results for SIGTRAN traffic with content filtering.....	21
Table 10 – IP Probed Acquisition benchmark results for other IP traffic: GPRS,VoIP signaling traffic (no RTP), SIGTRAN without content filtering	21
Table 11 – HSL/LSL to SIGTRAN converter versions	23
Table 12 – Probed Acquisition SS7 converters’ patch pannels	24
Table 13 – Probed Acquisition: Gb over E1 converters’ patch panel.....	26
Table 14 – Gb over E1 converter dimensioning	26
Table 15 – 1G Ethernet TAPs chassis.....	27
Table 16 – 1G Ethernet TAPs modules	29
Table 17 – Optical TAPs	29
Table 18 – Optical TAP modules	30
Table 19 – Standards and fibers types conversion table.....	30
Table 20 – OCDSR Integrated Acquisition Hardware baseline for OCPIC 10.2.....	31
Table 21 – OCDSR Integrated Acquisition benchmark	33
Table 22 – Benchmark results	34
Table 23 – Mediation Hardware baseline for OCPIC 10.2	36
Table 24 – Data record storage server Hardware baseline for OCPIC 10.2.....	37
Table 25 – Packet Data Unit server Hardware baseline for OCPIC 10.2.....	39
Table 26 – Compact ODA Appliance.....	40
Table 27 – PM&C server Hardware baseline for OCPIC 10.2	42
Table 28 – Benchmark results for Data Record Storage Server performances.....	42
Table 29 – Packet Data Unit Server performances.....	44
Table 30 – Data Record, Packet Data Units and KPI storage retention maximum capacity	46
Table 31 – Max Mediation Base Server performances	47
Table 32 – Limits for Static Enrichment per base server (linked).....	50
Table 33 – OTO or CSV extraction Data Feed.....	53
Table 34 – OTO or CSV Streaming	53
Table 35 – VM minimal HW resources	55
Table 36– OCDSR Pre-Packaged Accounting and Network Monitoring HW baseline – Acquisition/Mediation/Management	58
Table 37– OCDSR Pre-Packaged Accounting and Network Monitoring HW baseline – Optional xDR storage..	59
Table 38– OCDSR Pre-Packaged one box performance (virtualized OCDSR Integrated Acquisition + Mediation + (Management)).....	59
Table 39– OCPIC Management server Hardware baseline for OCPIC 10.2	63
Table 40– Management Configuration Limits	64
Table 41 – CCM Configuration Limits	64
Table 42 – KPI Configuration Limits.....	65
Table 43– Historical KPI application option Limits	65
Table 44– Security application Limits.....	65
Table 45– Interactive Export Limits (linked).....	66
Table 46– Scheduled Export Limits.....	66
Table 47– System Alarms Limits.....	67
Table 48– Audit Viewer Limits.....	67

Table 49– Troubleshooting application Option Limits	67
Table 50– Troubleshooting application Option responsiveness	67
Table 51– Network and Service Alarm Limits	68
Table 52– Network and Service Alarm Forwarding Limits	68
Table 53– Typical Network and Service Alarm responsiveness	68
Table 54– Dashboard application Limits	69
Note: each dashboard panel uses one simultaneous user license	69
Table 55– Typical Dashboard application responsiveness.....	69
Table 56– SS7 Network Surveillance application for TDM Limits	70
Table 57– SS7 Network Surveillance application for SIGTRAN Limits.....	70
Table 58 – Acronyms table.....	73
Table 59 – LSL at 64000 bps equivalence.....	78
Table 60– LSL at 56000 bps equivalence.....	78
Table 61– Average MSU size	79

1 INTRODUCTION TO PERFORMANCE INTELLIGENCE CENTER PLANNING GUIDE

This document intent is to provide readers with best practices and rules to configure and design its Performance Intelligence Center (OCPIC) system.

Dimensioning rules are derived from benchmark tests results performed in lab. The assumptions in performance tables are the conditions used during benchmark, and represent a fair usage of the system. They are as close as possible to real traffic based on OCPIC usage experience. But they can't be always extrapolate to customer real traffic case.

This document covers the various aspects of each OCPIC component including:

- dimensioning rules and limits for the following functional areas
 - Acquisition for collecting signaling data from the network
 - Mediation for correlating and storing the data
 - Data feeds to export xDRs and KPIs to flat files or external DB
 - OCPIC Management and Applications for accessibility to the data
- Frames configurations
- Network requirements

1.1 INTRODUCTION TO PERFORMANCE INTELLIGENCE CENTER (OCPIC)

Oracle Communications Performance Intelligence Center (OCPIC) is a comprehensive suite of applications, which provides an in-depth understanding of the network and equips wire line and wireless operators with the tools required to make informed business investment and cost reduction decisions.

OCPIC provides a set of tools needed to capture network traffic data and convert it into useful business intelligence for troubleshooting, managing traffic, services and QoS metrics in a flexible manner.

The OCPIC architecture has 3 building blocks:

- Data Collection
- Mediation
- Applications.

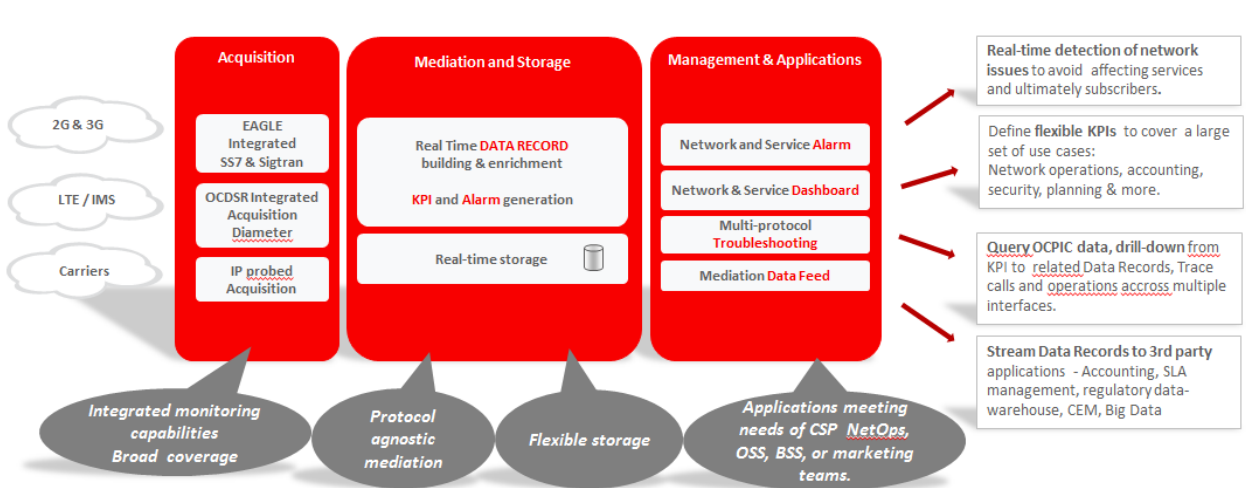

Figure 1 – Performance Intelligence Center Architecture

1.2 USEFUL CONCEPTS

1.2.1 Dataflows and destinations

The schema hereafter explains the concept of destination that is used throughout the planning guide. This is specifically the case in the assumptions used to measure the performances of the acquisition.

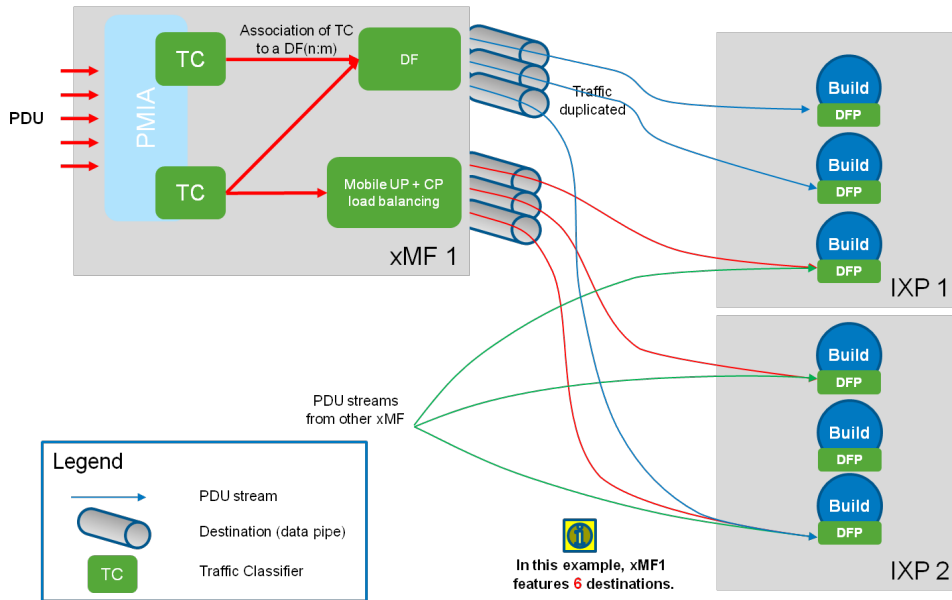

Figure 2 – What is meant by destination?

In the example from figure above, the probe xMF1 has 6 destinations. A destination is a unique relationship between a PDU stream and a Build DFP (Data Flow Processing).

Following rules apply:

- 1 Traffic Classifier (defined by a set of filter) can send to multiple Data Flows (DF)
- 1 DF can receive traffic from multiple TC
- 1 DF (no load balancing) can duplicate traffic to many destinations on many Mediation servers

1.2.2 PMIA active filters

The filtering for IP protocols in the Probed Acquisition is based on a Pattern Matching core function called the PMIA (Pattern Matching IP Algorithm). The PMIA is internally protocol agnostic but it automatically manages the specific case like fragmentation, reassembly... The PMIA executes pattern match check and functions call according to the program loaded into its engine. It can be seen as protocol agnostic algorithm running protocol aware filtering program.

The program is generated according to the customer configuration. It is composed of the unitary instructions used to check the customer configured unitary filtering rules, and the specific commands required by a protocol to drill into the packet through the different layers of this protocol. Therefore, the complexity of the program depends on the complexity of the filtering rules defined by the customer and the complexity of the filtered protocol.

Execution of each instruction of the filtering program is taking resources. So, the performance of the filtering depends on the complexity of the filtering rules defined by the customer, and the complexity of the filtered protocol, but not only. The analysis of a packet usually doesn't require going through all the check of the

program. As in any algorithm, packet analysis may go through different path. Therefore some packets may require execution of lot of instruction to be correctly classified, where others will require only a few, for the same filtering program. It is why the notion of “active filter” indicator is specified in the dimensioning rules provided in this document. It is the average number of unitary PMIA Engine instruction performed per packet for complete filtering.

2 HARDWARE CONSIDERATIONS

OCPIC 10.2 has introduced among others:

- Possibility to virtualize Acquisition, Mediation and Management servers
- Simple and compact OCDSR Pre-Packaged Accounting and Network Monitoring configurations
- Possibility to use Customer IT Storage Infrastructure to store xDR, PDU and KPIs in lieu of OCPIC internal storage
- Oracle X6-2 and X6-2L servers support

The following table shows the HW Lifecycle Planning accordingly:

Table 1 – Hardware Lifecycle Planning

OCPIC release↓	HP G6	HP Gen8 v1 & v2	E5-APP-B EAGLE Integrated Acquisition	Oracle X5-2 Management, Mediation & Acquisition	Oracle Netra X5-2 AC/DC Acquisition	Oracle X6-2 Management, Mediation, Acquisition	HP Gen9 V1 & V2 Management, Mediation & Acquisition	Virtual Management Mediation & Probed Acquisition	ODA/ZFS Storage Appliances, XDR&PDU storage.	X6-2L xDR/PDU storage.	xDR/PDU Storage on Customer Infrastructure
HW type →	HP		ORACLE				HP	VIRTUALIZED	ORACLE	ORACLE	CUSTOMER
9.0.4	✓	✓									
10.1	✓	✓	✓								
10.1.5	✓	✓	✓	✓			✓		✓		
10.2	✓	✓	✓	✓	✓	✓	✓	✓	✓	✓	✓
10.2 OCDSR Pre-Packages					✓ One Netra X5-2 AC/ DC box virtualized.			✓ One X6-2 box virtualized.		✓	✓

Shipping baseline and supported HW will be detailed in the subsequent sections per OCPIC component. Figure 3 gives an overview of shipping baseline per component.

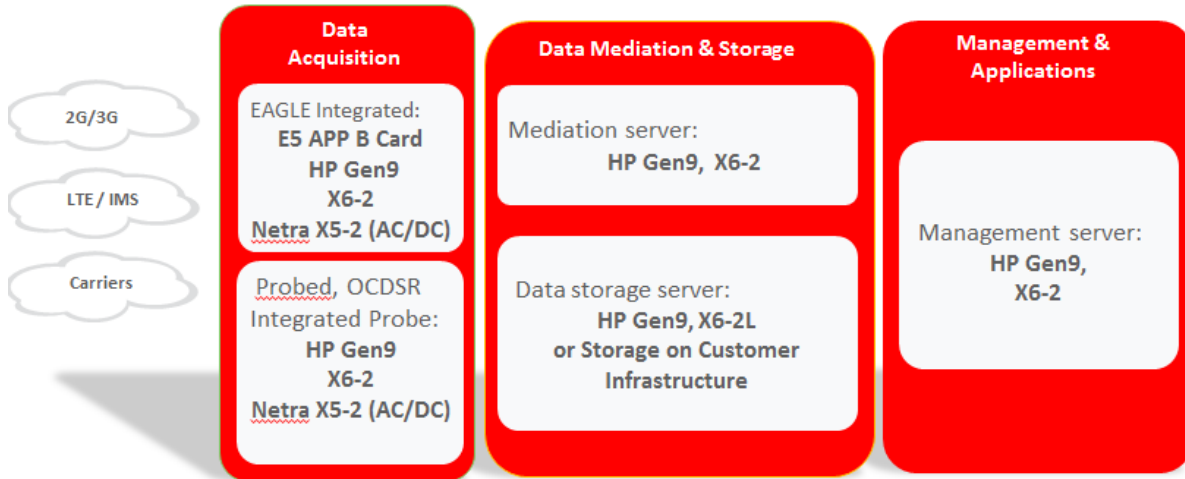

Figure 3 – 10.2 shipping baseline HW per OCPIC component

The document “OCPIC 10.2 Hardware Installation Guide” provides the complete description (BOM among others) of shipping baseline and supported baseline HW *qualified* by Oracle. This document can be found on OHC (Oracle Help Center); see reference in annex 7.

As an alternative of using qualified shipping baseline HW, Customer can choose specific Hardware on his own responsibility.

3 GENERAL DISCLAIMER

All dimensioning information, performance figures (Mbps, nb of Users...) and rules provided in this document are derived from benchmark tests results performed in lab on *qualified* HW shipping baseline. Actual results may differ according to Customer case.

Important notes on all performance figures presented in this document:

- they are given for current shipping baseline HW***
- they are not applicable for virtualized HW except for OCDSR Pre-Packaged Monitoring configurations***
- they are not applicable for xDR and PDU storage on Customer IT Storage Infrastructure (Cloud)***

4 DATA ACQUISITION

This section provides the information to configure the Oracle Performance Intelligence Center solution available for acquisition.

Table 2 – Acquisition supported interfaces

Acquisition equipment	IP over Ethernet	Diameter	SIGTRAN	SS7 LSL/HSL over E1 / T1	Gb over IP	Gb over HSL	GPRS
Oracle Communications Performance Intelligence Center, Integrated Acquisition			☑ Using integrated monitoring interface	☑ Using integrated monitoring interface			
Oracle Communications Performance Intelligence Center, Probed Acquisition	☑		☑	☑*	☑	☑**	☑
Oracle Communications Performance Intelligence Center, OCDSR Integrated Acquisition	☑	☑					

Note*: with SS7 to SIGTRAN converter

Note **: with Gb over E1 to Gb over IP converter

This section also covers TAP and PORT MIRRORING solution.

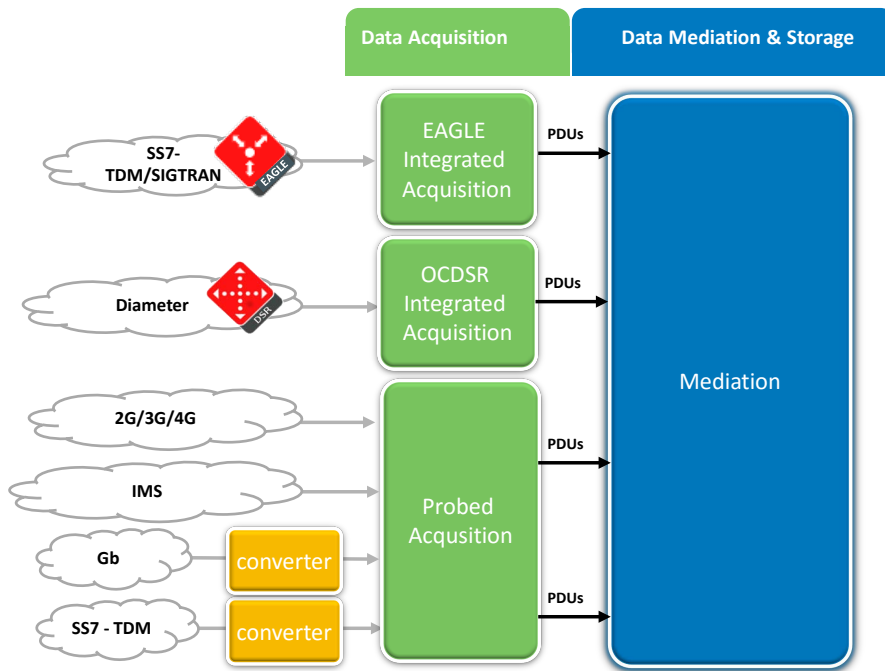

Figure 4 – Acquisition Configurations

4.1 OCPIE EAGLE INTEGRATED ACQUISITION

Integrated Acquisition is provided within a subsystem: Integrated Acquisition servers are exchanging management and surveillance information. Only one subsystem can be connected to an EAGLE. And an EAGLE can be monitored by only one Integrated Acquisition subsystem.

The Integrated Acquisition subsystem can be installed:

- On E5-APP-B EAGLE cards directly installed inside the EAGLE frame.
Implementation on E5-APP-B cards is designed for small/medium EAGLE configurations (see limitation in the following sections). It requires free space into the EAGLE frame for E5-APP-B cards, a terminal server and switches.
- On RMS servers positioned close to the EAGLE frame.
Implementation on RMS is performed inside a frame dedicated to Integrated Acquisition, positioned close to the EAGLE frame. It is designed for all configurations (small, medium and large).

Integrated Acquisition subsystem supported with following Hardware:

- Integrated Acquisition Rack mount servers or EAGLE E5-APP-B cards
- Switches
- Power breaker panel for DC (N/A for E5-APP-B cards)
- Cabinet (N/A to E5-APP-B)

4.1.1 EAGLE Integrated Acquisition - Servers Hardware

Table 3 – EAGLE Integrated Acquisition Hardware baseline for OCPIC 10.2

	Server		
	Form Factor	Series	PWR
Shipping base line	EAGLE Card	E5-APP-B v2	DC (power provided by EAGLE)
Shipping base line	RMS	HP DL360 Gen9	AC or DC
Shipping base line	RMS	Oracle X6-2	AC
Shipping base line	RMS	Netra X5-2	AC or DC
Supported base line	RMS	Oracle X5-2	AC
Supported base line	RMS	HP DL360 Gen8	AC or DC
Supported base line	RMS	HP DL380 G6	AC or DC

4.1.2 EAGLE Integrated Acquisition System upgrade and HW mix

It is not possible to mix AC and DC in the same cabinet. In case of AC implementation, electrical best practice safety rules shall be strictly applied. For instance, Oracle requests that no AC powered cabinet shall be installed within 7 Ft. of DC powered equipment due to safety reasons. This may create a shock or current loop that can be severely hazardous to personnel.

HP G6, HP Gen8, HP Gen9, Oracle X5-2 (resp. Netra X5-2) and X6-2 can be mixed in the same subsystem and in the same frame provided they have the same power supply.

In case of mix, performance of the subsystem is aligned to the performance of the oldest server generation.

No mix is supported with E5-APP-B implementation.

Shipping base line for switches is Cisco 4948E-F. Cisco switches 4948 are still supported. Mix hardware configuration is not recommended.

In case of swap of the Integrated Acquisition architecture from RMS to E5-APP-B card, the Cisco switches in the RMS frame can be reused for 4948 and 4948E-F only with above switches limitations.

4.1.3 EAGLE Integrated Acquisition with E5-APP-B

Warning: EAGLE install base and limitations in the EAGLE shall be checked before quoting E5-APP-B solution (see EAGLE workbook and planning guide too). In case of blocking point, INTEGRATED APPLICATION solution on RMS shall be proposed instead.

OCPIC workbook configuration output shall be checked into EAGLE planning guide and EAGLE workbook to finish the configuration: all hardware (E5-APP-B cards, switches, Terminal server and EAGLE extension) are managed by the EAGLE workbook / planning guide. Only the OCPIC software and dimensioning information are managed by the OCPIC workbook / planning guide.

E5-APP-B cards are directly installed in the EAGLE frame. E5-APP-B cards can be installed exclusively in **EAGLE heavy duty frame**. The Free slots shall be available in the EAGLE to install the E5-APP-B cards. In addition to E5-APP-B cards, a terminal server and 1 or 2 Cisco switches shall be inside the EAGLE frame. Both shall be installed inside an available shelve.

Note that the terminal server is shared with other EAGLE application (like EPAP). If one is already installed for other EAGLE applications, it will be shared with OCPIC.

Verification of the install base for free slot and potential future evolution shall be studied with the customer.

Maximum of 6 E5-APP-B cards are supported (or 4 if no switch redundancy). The number of cards depends on monitored traffic volume (see below).

1 to maximum of 2 switches are supported. The number of Cisco switches depends on the number of EAGLE cards (STC and IPGW or IPSG in Fast copy mode) and E5-APP-B cards to connect.

Shall be use in the computational of the number of EAGLE cards to connect, the sum of:

- The number of STC cards
- The number of all IPSG cards in the EAGLE if fast copy is activated on IPSG, or zero otherwise
- Number of all IPGW cards in the EAGLE if fast copy is activated on IPGW, or zero otherwise

Two configurations are supported on E5-APP-B cards:

Table 4 – EAGLE Integrated Acquisition E5-APP-B configuration (linked)

	#EAGLE cards to connect	#Integrated servers	#Switches
Configuration 1 wo switch redundancy.	<=19 max	<=4 max	1
Configuration 2 with switch redundancy.	<=38 max Recommended 30	<=6 max Recommended 4	2

Recommendations are provided to allow future extension (safety margin shall be adapted according to customer case). If the configuration of the EAGLE is larger than the provided max limitations, E5-APP-B cards can't be used for integrated monitoring. Solution based on RMS shall be used instead (configuration with one switch can be extended using 2 switches configuration).

4.1.4 EAGLE Integrated Acquisition with RMS

All links between the Integrated Acquisition servers / switches / EAGLE cards are direct links (no possibility to introduce customer links, like WAN, routers, remote links...). The maximum distance between the EAGLE and the Integrated Acquisition frame is 100 meters (according to the Ethernet standard). But to avoid complex and costly cabling between the EAGLE and the Integrated Acquisition frames, the best approach is to have both equipment collocated. With Fast copy, this recommendation is even more recommended as the number of Ethernet links between the EAGLE and the Integrated Acquisition servers is usually significantly increased.

All Integrated Acquisition probes, switches and Power distribution Unit are installed inside a single frame close to EAGLE frame.

Maximum of 12 servers (HP G6, HP Gen8, HP Gen 9, Oracle X5-2, X6-2, Netra X5-2, or mixed HP G6/HP Gen8/HP Gen9/Oracle X5-2/X6-2) and 6 Cisco switches are supported in the frame.

The number of servers depends on monitored traffic (see below).

The number of Cisco switches depends on the number of EAGLE cards (STC and IPGW or IPSG in Fast copy mode) and Integrated Acquisition servers to connect.

Shall be use in the computational of the number of EAGLE cards to connect, the sum of :

- The number of STC cards
- The number of all IPSG cards on the EAGLE if fast copy is activated on IPSG, or zero otherwise
- Number of all IPGW cards on the EAGLE if fast copy is activated on IPGW, or zero otherwise

The number of switches to provision is provided in tables bellow:

Table 5 – Integrated Acquisition frame configuration (linked)

Both conditions shall be fulfilled		#Switch needed
#EAGLE cards to connect	#Integrated servers	
20 max	<=2	1*
30 max	<=6	2
67 max	<=12	4
113 max	<=12	6

Note *: One switch configuration doesn't provide switch redundancy solution. A minimum of 2 switches are required for redundancy.

Shipping base line for switches is Cisco 4948E-F. Cisco switches 4948 are still supported. Mix configuration is not recommended.

4.1.5 NEBS compliancy

Oracle X5-2 and X6-2 servers are not NEBS compliant.

E5-APP-B cards and Oracle Netra X5-2 servers are NEBS compliant.

4.1.6 EAGLE Integrated Acquisition Supported Features

All supported hardware is supporting the following features:

- STC copy
- Fast copy
- IP raw
- 6h buffering
- Wan redundancy
- Failover
- Traffic filtering and load balancing:

Monitoring is performed per linkset. Inside a linkset, filters are available on:

- SSN
- Global Title

- Point Code
- Combination between filters is possible

4.1.7 EAGLE Integrated Acquisition performance dimensioning

Integrated Acquisition dimensioning shall respect simultaneously 2 rules:

- Input bandwidth rule for the traffic entering in each Integrated Acquisition server
AND
- the number of entries rule

Rule 1: INPUT BANDWIDTH RULE

Bandwidth dimensioning rules are derived from benchmark tests results performed in lab. Results may differ to customer case.

Table 6 – Integrated Acquisition Input Bandwidth per Server Type

	Max input bandwidth per server (FC+STC)
E5-APP-B	50 Mb/s
HP DL360 Gen8 HP DL360 Gen9 Oracle X5-2/X6-2 Netra X5-2	100 Mb/s
Test conditions	- 140 bytes average MSU, ISUP and SCCP traffic - ISUP filtering conditions: PC - SCCP filtering conditions: 10GT and up to 34 SSN

Up to 40 destinations can be configured

Rule 2: NUMBER OF ENTRIES RULE

Each server is supporting a max of 1024 entries.

An entry is defined as follows:

- 1 for each LSL
- 1 for each ATM or SE HSL
- 1 for each SIGTRAN link monitored through STC
- 2 for each M2PA association monitored through Fast Copy
- 1 for each M3UA association monitored through Fast Copy
- 1 for each M3UA link (inside the M3UA association) monitored through Fast Copy/CPIC probed acquisition

4.2 OCPIC PROBES ACQUISITION

Probed Acquisition server is available in standalone mode only. Each Probed Acquisition server is independent from the others. They shall not be configured in subsystem mode even if they are on the same physical site.

Probes Acquisition is used for capturing network traffic from TAP or port mirroring.

It is also used by the new OCPIC 10.2 OCSDR Integrated Acquisition. Only differences are it communicates with OCSDR for retrieving OCSDR configuration and it captures Diameter traffic only.

Servers are provided in rack mount form. They can be installed in any cabinet with following limitation: Oracle does not recommend to mix AC and DC equipment in the same cabinet (specifically, AC and DC equipment shall not use a common ground and AC equipment shall not be closer than 7 feet to any DC equipment for safety reason).

If required, Probed Acquisition DC on HP or Oracle Netra X5-2 can be installed into an Integrated Acquisition DC frame (G6, Gen8, Gen9 or Netra X5-2). Total Server number (Integrated and Probed Acquisition) can't exceed max number of Integrated Acquisition servers for the frame (see Integrated Acquisition section).

The Probed Acquisition server is IP Ethernet only as shipping baseline.

Previous Probed Acquisition SS7 and Probed Acquisition Gb versions are no more in OCPIC 10.2 shipping baseline. They are replaced by an IP Probed Acquisition + a converter (see converter section below) . However they are still interoperable with OCPIC 10.2 (HP G6).

4.2.1 Probed Acquisition Servers Hardware

Table 7 – Probed Acquisition Hardware baseline for OCPIC 10.2

	Server		
	Form Factor	Series	PWR
Shipping base line	RMS	DL360 Gen9	AC or DC
Shipping base line	RMS	Oracle X6-2	AC
Shipping base line	RMS	Oracle Netra X5-2	AC or DC
Supported base line	RMS	Oracle X5-2	AC
Supported base line	RMS	DL360 Gen8	AC or DC
Supported base line	RMS	DL380 G6	AC or DC

Probed Acquisition on Tek servers and HP G4/G5 are no more supported by OCPIC 10.x.

4.2.2 IP Probed Acquisition supported interfaces

Probed Acquisition server interfaces are divided in 3 categories:

- Acquisition interfaces
- Northbound interfaces to customer management network (for management and traffic upload to the mediation)

- Optional northbound interfaces for production (PDU traffic flows)
-

Acquisition interfaces:

X6-2, Netra X5-2:

- 1G/10G copper: 4 port 10G Base T compatible 1G 1000 Base T RJ45
- 1G/10G optical: 4 port SFP+ (SFP+ modules shall be ordered in addition to the server):
 - 1G/10G optical: Dual 1000BASE-SX/10G base SR (MM Fibers)
 - 1G/10G optical: Dual 1000BASE-LX/10G base LR (SM Fibers)

HP Gen9:

- 1G/10G copper/optical: 4 port SFP+ (SFP+ module shall be ordered in addition to the server):
 - 1G/10G Electrical: 1G 1000 Base T
 - 1G/10G optical: Dual 1000BASE-SX/10G base SR (MM Fibers)
 - 1G/10G optical: Dual 1000BASE-LX/10G base LR (SM Fibers)

Northbound interfaces to customer management network:

For northbound interfaces to customer management network, the IP Probed Acquisition requires

- one 1G Ethernet port and IP address to the customer monitoring network
- one 1G Ethernet port and IP address to the management network (ILO port)

Only native mode is supported for northbound interfaces (no VLAN tagging).

4.2.3 Probed Acquisition Supported Features

All supported Probed Acquisition hardware is supporting the following features:

- Packet truncation dataflow (each dataflow can be configured with a different value).
- 6h buffering:

For performance reason, buffering is by default deactivated for IP Probed Acquisition. It is not recommended to activate 6h buffering on Probed Acquisition to avoid severe performance degradation.

In case of communication loss with the Mediation (for duration longer than few seconds), there may be traffic loss.

- Traffic filtering and load balancing:

Probed Acquisition IP supports filtering function on IPv4 packet on the following fields:

- IP source/destination host address or subnet
- IP TCP or UDP destination port
- IP TCP or UDP source port
- IP TCP or UDP port ranges with odd/even option
- IP protocol number for SCTP, TCP, ICMP, UDP or all IP.

- VLAN number or multiple numbers
- Probe physical interface

For GPRS, filters are available for encapsulation and encapsulated packets inside GTP tunnels

For SIGTRAN traffic, extended filters are available for:

- Point Code filtering (including OPC/DPC)
- SSN
- SIO
- Global Title

For IPv6, filters on IPv6 addresses, protocol, ports... are not applicable. All IPv6 packets are identified by a unique filter: IP v6 traffic type. It means that all IPv6 traffic can be sent to a unique destination.

Filters may be combined using parenthesized group of filters and operators.

Negation (Not), Concatenation (and), and Alternation (or) are also supported.

4.2.4 IP Probed Acquisition - 1G/10G performance dimensioning rules

IP Probed Acquisition server performances are variable according to filtered protocol and hardware type.

Benchmark results are applicable for Probed Acquisition 1G and 10G.

Table 8 – IP Probed Acquisition benchmark results for VoIP traffic (including the RTP voice bearer)

VoIP	
Max input bandwidth per port (8 ports)	170 Mb/s
Max input bandwidth per port (4 ports)	250 Mb/s
Max bandwidth per server	900 Mb/s
Max output bandwidth per server	300 Mb/s
Max destinations for this output	40 dest.
Assumptions	- buffering function deactivated, - 80 Byte PDU (average) - no IP fragmentation - up to 20 matching filter patterns per PDU in average

Note: If RTP bearer is not present on the monitored links, Probed Acquisition performances shall be used according to monitored traffic.

Note: if 6h buffering function activated, decrease output performance to 100Mb/s

Table 9 – IP Probed Acquisition benchmark results for SIGTRAN traffic with content filtering

SIGTRAN	
Max input bandwidth per server	300 Mb/s
Max output bandwidth per server	300 Mb/s
Maximum destinations	40 dest.
Assumptions	<ul style="list-style-type: none"> - buffering function deactivated - PDU average size has minimal impact because filtering applies on chunks - no IP fragmentation - up to 100 matching filter patterns per PDU in average

Note: Complex TC filtering lines along with many destinations will impact overall performance

Note: if 6h buffering function activated, decrease output performance to 100Mb/s

Table 10 – IP Probed Acquisition benchmark results for other IP traffic: GPRS, VoIP signaling traffic (no RTP), SIGTRAN without content filtering

IP and GPRS	
Max input bandwidth per server IP filtering	4000 Mb/s
Max output bandwidth per server	1500 Mb/s
Maximum destinations	40 dest.
Control Plane output / total input ratio	0,5%
Assumptions	<ul style="list-style-type: none"> - buffering function deactivated, - up to 40 matching filter patterns per PDU in average

Note: if 6h buffering function activated, decrease output performance to 100Mb/s

4.2.5 Probed Acquisition: HSL/LSL to SIGTRAN Converters

To acquire SS7 traffic on legacy HSL and LSL links, Oracle is proposing a solution using a SS7 LSL to SIGTRAN converter. This converter is usable for monitoring purpose only.

The Probed Acquisition server and the converter are directly connected through cross cable Ethernet links. Customer's SS7 LSL and HSL links are connected through a patch panel (provided with the converter) to the converter:

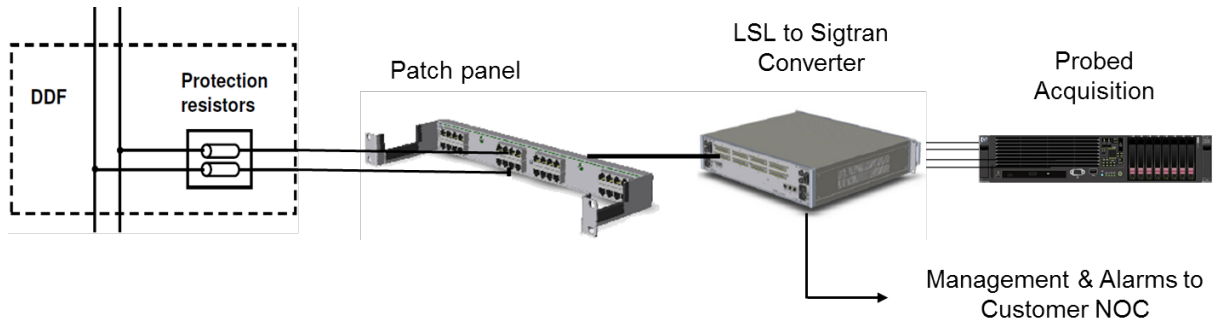

Figure 5 – HSL/LSL to SIGTRAN Converters - connectivity

The patch panel is the demarcation line between Oracle and customer domains of responsibilities and supplies.

The converter extracts the MSU above the MTP2 preserving the MTP3 and above layers.

Note that the conversion doesn't allow low layer visibility. Information like Q.752, SLOR... are no more available.

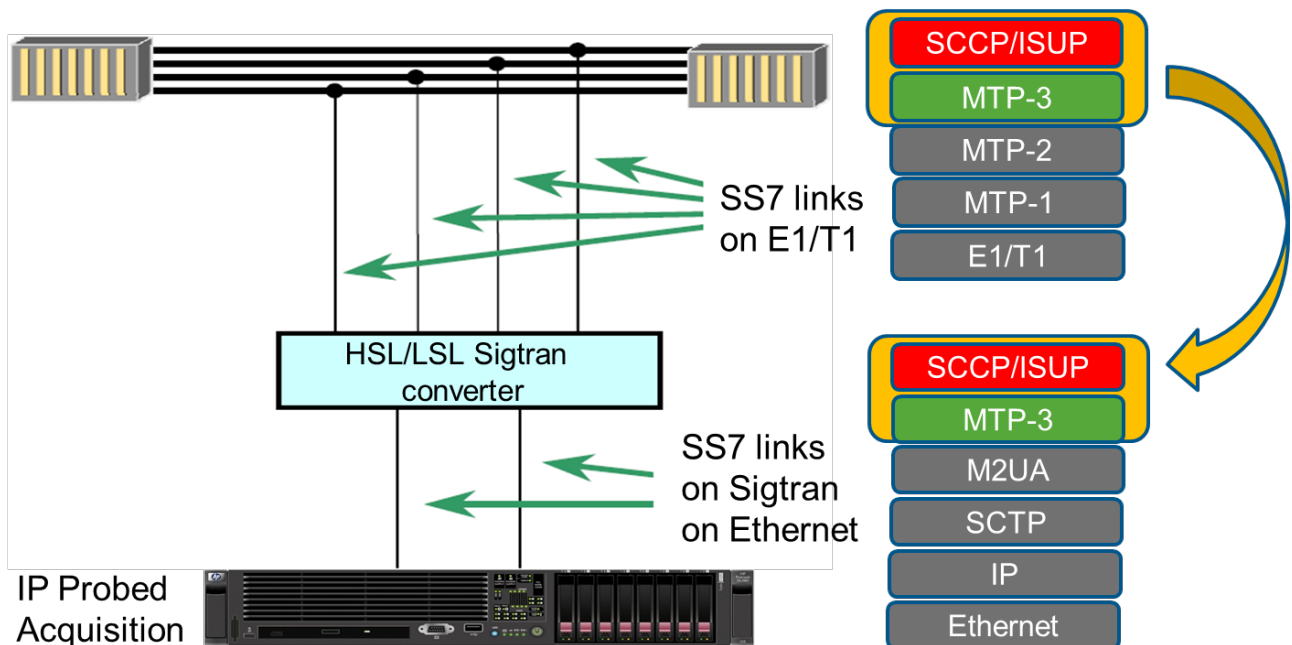

Figure 6 – HSL/LSL to SIGTRAN Converters layers

SIGTRAN transposed MSU are then processed by a standard Probed Acquisition server.

SS7 Converter is available for:

Table 11 – HSL/LSL to SIGTRAN converter versions

	E1 converter (AC or DC)	T1 converter (AC or DC)	Mix E1/T1
E1	<input checked="" type="checkbox"/> 2 versions: - 64 E1 200 LSL max at 0,4 Erlg 160 LSL ax at 0,8 Erlg - 128 E1 2x 200 LSL max at 0,4 Erlg 2 x160 LSL ax at 0,8 Erlg	<input type="checkbox"/>	<input type="checkbox"/>
T1	<input type="checkbox"/>	<input checked="" type="checkbox"/> 2 versions: - 64 T1 200 LSL max at 0,4 Erlg 160 LSL ax at 0,8 Erlg - 128 T1 2x 200 LSL max at 0,4 Erlg 2x 160 LSL ax at 0,8 Erlg	<input type="checkbox"/>

The Converter is compliant with following standards:

- ITU-T G.703 Physical/Electrical characteristics of hierarchical digital interfaces
- ITU-T G.704 Synchronous frame structures used at 1544, 6312, 2048, 8448 and 44736 kbit/s hierarchical levels
- ITU-T G.736 Characteristics of a synchronous digital multiplex equipment operating at 2048 kbps
- ITU-T G.772 Protected monitoring points provided on digital transmission systems
- ITU-T G.823 The control of jitter and wander within digital networks which are based on the 2048 kbps hierarchy
- ITU-T I.421 Primary rate User-network interface



“56K LSL link on E1” is not supported.

4.2.5.1 CABLES AND PATCH PANEL FOR HSL/LSL TO SIGTRAN CONVERTERS

The cables to the patch panel shall be provided by the customer. External protection by resistors is always required, as per ITUG.772 recommendations to create a protected monitoring point (PMP).

Patch panel interfaces are available for:

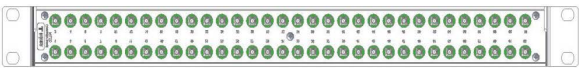
Table 12 – Probed Acquisition SS7 converters’ patch panels

	E1	T1	Mix (E1+T1)
75 Ω (unbalanced) 	<input checked="" type="checkbox"/> 64 inputs per patch panel (for 32 bidirectional E1 links): unbalanced Circuits (1.0/2.3) connectors	<input checked="" type="checkbox"/>	<input checked="" type="checkbox"/>
100 Ω 	<input checked="" type="checkbox"/>	<input checked="" type="checkbox"/> 64 inputs per patch panel (for 32 bidirectional T1 links):RJ45 connectors	<input checked="" type="checkbox"/>
120 Ω (balanced) 	<input checked="" type="checkbox"/> 64 inputs per patch panel (for 32 bidirectional E1 links):RJ45 connectors	<input checked="" type="checkbox"/>	<input checked="" type="checkbox"/>

4.2.6 Probed Acquisition: Gb over E1 To Gb over IP Converter

As for SS7, the Gb Probed Acquisition is replaced by an IP Probed Acquisition server and a front head Gb over E1 to Gb over IP converter.

The Probed Acquisition server and the converter are directly connected through cross cable Ethernet links. Customer’s Gb links are connected through a patch panel (provided with the converter) to the converter.

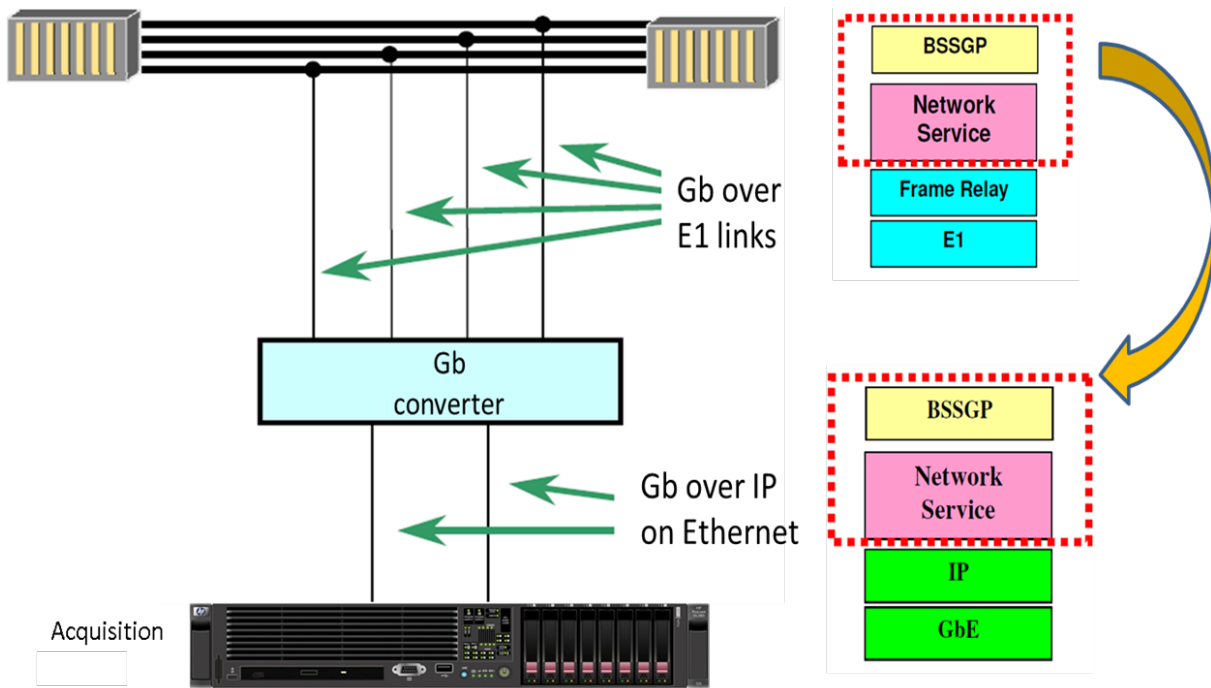

Figure 7 – GboE1 to GboIP Converters – layers

The converter extracts the messages above the frame relay layer, preserving the NS/BSSGP layers and above. The patch panel is the demarcation line between Oracle and customer domains of responsibilities and supplies.

The cables to the patch panel shall be provided by the customer. External protection by resistors is always required, as per ITUG.772 recommendations to create a protected monitoring point (PMP).

Patch panel interfaces are available for:

Table 13 – Probed Acquisition: Gb over E1 converters’ patch panel

	E1 Gb links
120 Ω (balanced)	<input checked="" type="checkbox"/> 64 inputs per patch panel (for 32 bidirectional E1 Gb links):RJ45 connectors
	

Table 14 – Gb over E1 converter dimensioning

	Gb over E1 converter (AC or DC)
64 E1 Gb links	200 frame relay PVC

The Converter is compliant with following standards:

- ITU-T G.703 Physical/Electrical characteristics of hierarchical digital interfaces
- ITU-T G.704 Synchronous frame structures used at 1544, 6312, 2048, 8448 and 44736 kbit/s hierarchical levels
- ITU-T G.736 Characteristics of a synchronous digital multiplex equipment operating at 2048 kbps
- ITU-T G.772 Protected monitoring points provided on digital transmission systems
- ITU-T G.823 The control of jitter and wander within digital networks which are based on the 2048 kbps hierarchy
- ITU-T I.421 Primary rate User-network interface

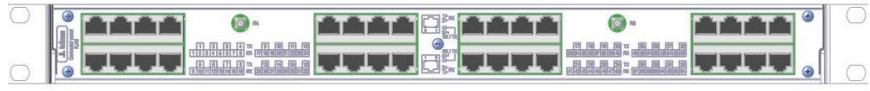
4.2.7 TAP and PORT MIRRORING

To connect the Probed Acquisition server acquisition ports on the customer network, two possibilities exist:

- Using port Mirroring

Customer is responsible to configure the port mirror on his switch to forward a copy of the relevant network traffic to the probe. The link between the switch and the probe is independent of network mirrored links types (1G, 10G, copper/optical...) and number. The type of the link between the switch and the probe, shall be chosen according to the port type used on the customer switch for port mirror, and the link capacity shall be large enough to support the mirrored traffic.

For instance, It is possible to mirror a 10G link on a 1G connection if mirrored traffic is filtered to fall under 1Gb/s capacity. On the reverse, mirroring of a 1G network link can be not possible on a 1G link to the probe if total inbound and outbound bandwidth on the network link is above 1Gb/s.

Port mirror is available on any supported interface on the probe.

Several port mirrors are supported by the probe up to the supported capacity of the probe.

- Using TAPs

Oracle’s TAP portfolio is composed of TAP for 1G and TAP for 10G links.

Taps are installed inserted on customer links. They are passive and provide network link protection in case of TAP failure.

4.2.7.1 ETHERNET 1G TAP

TAP 1G Oracle portfolio is composed of a rack mount chassis which can handle up to four TAP modules of any type. In addition to TAP modules, each chassis shall have a management module for configuration. Dual AC or DC power supplies are available on the chassis.

Table 15 – 1G Ethernet TAPs chassis

Description	Legacy PTO	GF PTO
chassis AC (4 modules + 1 management)	804-2952-G01PT	7109456
chassis DC (4 modules + 1 management)	804-2952-G02PT	7109455
management module (1 per chassis mandatory)	804-2954-G04PT	7110429

According to customer network link, one TAP module for each link shall be selected. They are all independent.

TAP module can be hot-plugged for installation or removal without affecting the other installed modules.



Figure 8 – 1G Ethernet TAPs

Four TAP modules are available for 1G Ethernet links. Different modules exist according to network link type (100/1000 Ethernet RJ45 copper, 1000BASE-SX multimode fiber , 1000BASE-LX single mode fiber) and supported modes. All Taps are by default configured in breakout mode and support link aggregation mode :

Breakout mode: always applicable

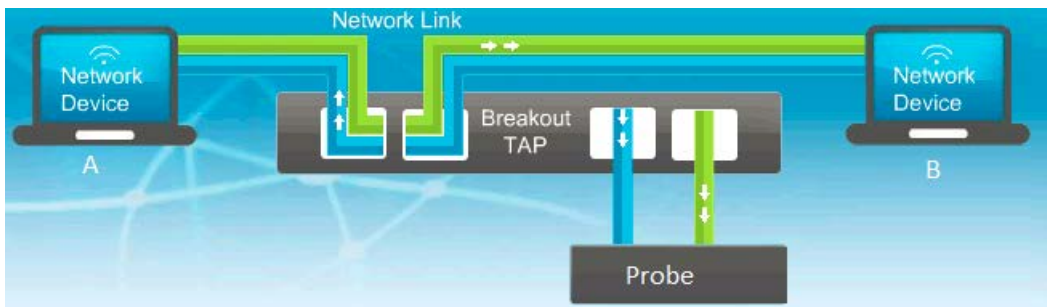

Figure 9 – Breakout mode

Traffic from A to B is sent on one output port.

Traffic from B to A is sent on another output port.
2 ports are needed on the probe for each tapped link

Link Aggregation mode: for low speed link

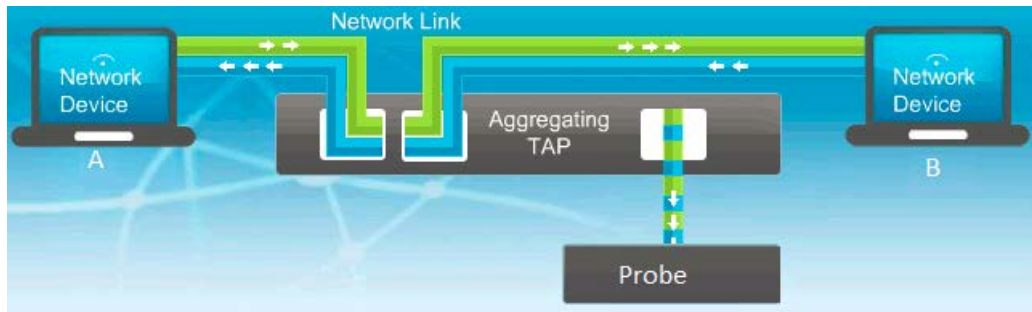

Figure 10 – Link Aggregation mode

Traffic from A to B and B to A is sent on only one output port to the probe.
Only one port is needed on the probe for each tapped link.

Link Aggregation mode is only available when total bandwidth (A to B and B to A) is less than the link capacity to the probe and it is recommended to keep a safety margin to allow small burst on the link. Therefore, Link Aggregation is applicable if total bandwidth on the link (Rx + Tx) is typically less than 600Mb/s.

It is possible to mix link aggregation and breakout mode on different modules in the same chassis.

Backplane aggregation mode: for multiple low speed links

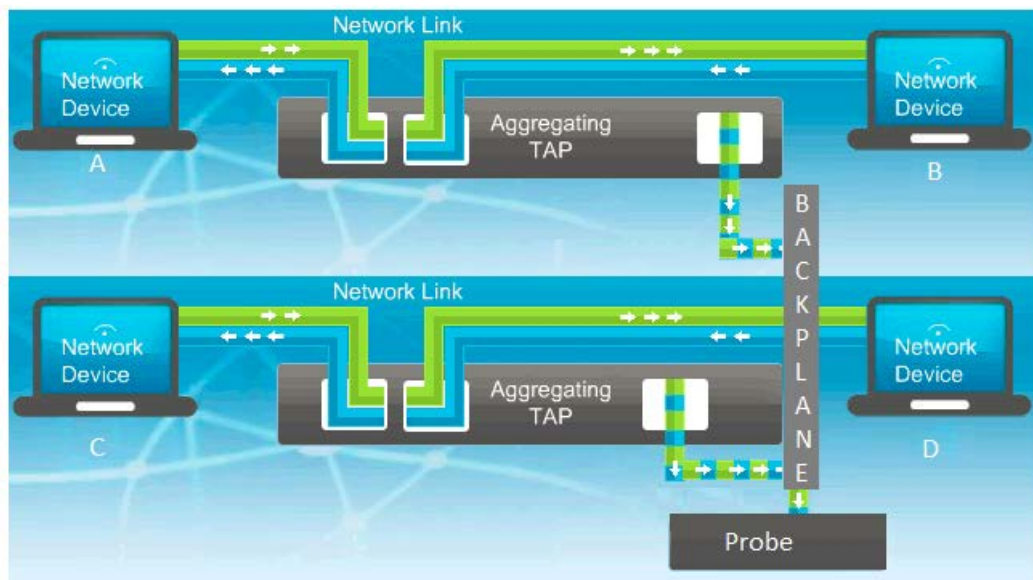

Figure 11 – Backplane Aggregation mode

Traffic from both directions from different modules in the same chassis are aggregated on the chassis backplane and sent to only one output port to the probe.

Only one port is needed on the probe for all backplane aggregated tapped links on the chassis.

Backplane aggregation mode is per chassis only.

It is possible to mix backplane aggregation and breakout or link aggregation mode in the same chassis.

Backplane Aggregation mode is only available for small bandwidth links. The total bandwidth (Rx and Tx for all modules configured in Backplane Aggregation mode) shall be less than 600Mb/s.

Note that all modules are connected to the probe through 1000BASE-T Gigabit Ethernet links.

Table 16 – 1G Ethernet TAPs modules

Description	Legacy PTO	GF PTO
Network link: fiber 1000BASE-SX Multimode fiber (1 link) ratio 50/50 Link to probe: 1000BASE-T RJ45 copper	804-2953-G01PT	7110447
Network link: 100Base-TX or 1000BASE-T RJ45 copper (1 link) Link to probe: 1000BASE-T RJ45 copper	804-2953-G02PT	7110444
Network link: fiber 1000BASE-LX Single mode fiber (1 link) ratio 50/50 Link to probe: 1000BASE-T RJ45 copper Backplane aggregation option supported	804-2954-G02PT	7110446
Network link: 100Base-TX or 1000BASE-T RJ45 copper (1 link) Link to probe: 1000BASE-T RJ45 copper Backplane aggregation option supported	804-2954-G03PT	7110443

4.2.7.2 OPTICAL PASSIVE TAP

In addition to the 1G TAP, OCPIC proposes pure passive optical TAP which can be used on 10G optical links.

The optical TAP portfolio is composed of a rack mount chassis which can handle up to 8 TAP modules of any type. Each TAP module can be hot-plugged for installation or removal without affecting the other installed modules. Each TAP module supports the tapping of 2 links (of the same type). No power supply is required.

Table 17 – Optical TAPs

Description	Legacy PTO	GF PTO
rack for 8 modules	805-0612-G01PT	7108094
Blanking Plate	805-0612-G02PT	7108096

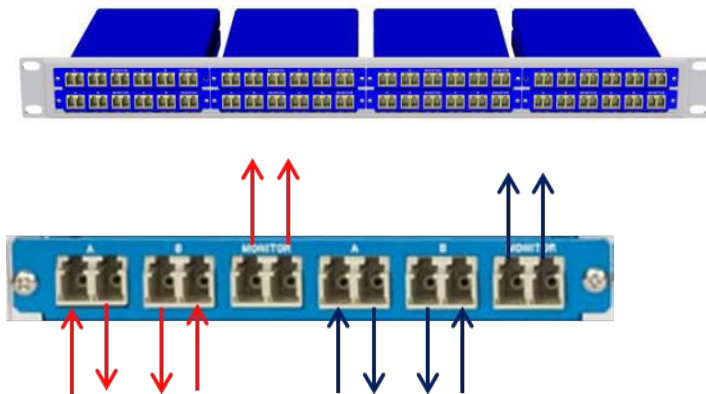

Figure 12 – Passive optical TAP

Modules are available for:

- Multi-mode fiber, 850/1310 dual wavelengths, 50 micron OM3
- Multi-mode fiber, 850/1310 dual wavelengths, 62.5 micron
- Single mode fiber, 1310/1550 dual wavelengths, 9 micron

By default, the splitter ratio is set to 50/50.

Each module is dual: it allows connection of 2 links (4 fibers).

They are not configurable. Breakout is the only supported option.

Table 18 – Optical TAP modules

Short Description	Legacy PTO	GF PTO
Network link: Multi-mode fiber, 850/1300 dual wavelengths, 62.5 micron (2 links) ratio 50/50 Link to TAP: same as Network link	805-0598-G03PT	7108050
Network link: Multi-mode fiber, 850/1300 dual wavelengths, 50 micron OM3(2 links) ratio 50/50 Link to TAP: same as Network link	805-0598-G01PT	7108048
Network link: 0:50 Single mode fiber, 1310/1550 dual wavelengths, 9 micron, ratio 50/50 Link to TAP: same as Network link	805-0598-G05PT	7108053

As a reminder, the correspondence table between fibers type and Ethernet standards is the following:

Table 19 – Standards and fibers types conversion table

Cable Type	1G			10G		
	Copper	Single-mode	Multi-mode	Single-mode	Multi-mode	Super Single-mode
TAP TYPE	T	LX	SX	LR	SR	ER
Laser	N/A	1270–1355 nm	770-860 nm	1310nm	850nm	1550nm
CORE Ø	N/A	9/125µm	50/125 µm 62.5/125 µm	9/125µm	50/125 µm 62.5/125 µm	9/125 µm

Passive optical TAP modules are not powered. It means there is no signal regeneration. Therefore, max distance between equipment shall be checked with the customer and power budget shall be verified for the different equipment connected on the passive optical TAP modules.

4.2.8 PCAP Capture on Probed Acquisition

The Probed Acquisition server allows Ethereal like capture and storing directly on the probe. Filters can be defined to extract only the relevant data for the capture.

Capture has been tested up to 250Mb/s of filtered traffic to store in the capture file.

Capture file is limited to 2GB (captured traffic overlapping in case of bigger capture size).

The monitoring, main objective of the probe, is protected against probe capture overloading. If captured traffic exceeds probe performance limits, capture may be incomplete. If this happens, a message is logged in the probe.

4.3 OCPIC OCDSR INTEGRATED PROBES ACQUISITION

In the OCDSR monitoring case, OCPIC can take benefit of a management link to OCDSR enabling to acquire the configuration tables from OCDSR. This allows OCPIC LTE Diameter xDRs (generic) to be populated with the explicit names of the OCDSR peers equipment which is very convenient for trace and troubleshooting.

This configuration is fully dedicated to OCDSR monitoring and only OCDSR Diameter traffic can be monitored here.

HW configuration is based on Probed Acquisition HW (see §4.2)

PCAP capture (§4.2.8) and Acquisition Data Feed (§4.4) functions are still valid for OCDSR Integrated Acquisition (Diameter traffic).

4.3.1 OCDSR Integrated Acquisition Servers Hardware

Table 20 – OCDSR Integrated Acquisition Hardware baseline for OCPIC 10.2

	Server		
	Form Factor	Series	PWR
Shipping base line	RMS	DL360 Gen9	AC or DC
Shipping base line	RMS	Oracle X6-2	AC
Shipping base line	RMS	Oracle Netra X5-2	AC or DC
Supported base line	RMS	Oracle X5-2	AC

Note: OCDSR Integrated Acquisition is also supported on OCDSR Pre-Packaged Accounting and Network Monitoring virtualized HW configurations. See section §7 for more details.

4.3.2 OCDSR Integrated Acquisition supported interfaces

Probed Acquisition server interfaces are divided in 3 categories:

- Acquisition interfaces
- Northbound interfaces to customer management network (for management and traffic upload to the mediation)
- Optional northbound interfaces specifically assigned to production (PDU traffic flows)

Acquisition interfaces:

X6-2, Netra X5-2:

- 1G/10G copper: 4 port 10G Base T compatible 1G 1000 Base T RJ45
- 1G/10G optical: 4 port SFP+ (SFP+ modules shall be ordered in addition to the server):
 - 1G/10G optical: Dual 1000BASE-SX/10G base SR (MM Fibers)
 - 1G/10G optical: Dual 1000BASE-LX/10G base LR (SM Fibers)

HP Gen9:

- 1G/10G copper/optical: 4 port SFP+ (SFP+ module shall be ordered in addition to the server):
 - 1G/10G Electrical: 1000 Base T
 - 1G/10G optical: Dual 1000BASE-SX/10G base SR (MM Fibers)
 - 1G/10G optical: Dual 1000BASE-LX/10G base LR (SM Fibers)

Northbound interfaces to customer management network:

For northbound interfaces to customer management network, the IP Probed Acquisition requires

- one 1G Ethernet port and IP address to the customer monitoring network
- one 1G Ethernet port and IP address to the management network (ILO port)

Only native mode is supported for northbound interfaces (no VLAN tagging).

4.3.3 OCDSR Integrated Acquisition Supported Features

All supported Probed Acquisition hardware is supporting the following features:

- Packet truncation dataflow (each dataflow can be configured with a different value).
- 6h buffering:

For performance reason, buffering is by default deactivated for OCDSR Integrated Acquisition. It is not recommended to activate 6h buffering on OCDSR Integrated Acquisition to avoid severe performance degradation.

In case of communication loss with the Mediation (for duration longer than few seconds), there may be traffic loss.

- Traffic filtering and load balancing are automatic, there is no need of manual configuration (except Mediation destinations).

Diameter traffic loadsharing to Mediation servers/DFPs is based on automatic roundrobin rule on Session Id.

For IPv6, filters on IPv6 addresses, protocol, ports... are not applicable. All IPv6 packets are identified by a unique filter: IP v6 traffic type. It means that all IPv6 traffic can be sent to a unique destination.

4.3.4 OCDSR Integrated Acquisition - 1G/10G performance dimensioning rules

Benchmark results are applicable for OCDSR Integrated Acquisition 1G and 10G.

Table 21 – OCDSR Integrated Acquisition benchmark

IP and GPRS	
Max input bandwidth per server	4000 Mb/s
Max output bandwidth per server	1500 Mb/s
Maximum destinations	40 dest.
Assumptions	- buffering function deactivated, - up to 40 matching filter patterns per PDU in average

Note: if 6h buffering function activated, decrease output performance to 100Mb/s

4.4 ACQUISITION DATA FEED OPTION

Feed from the acquisition server allows direct PDU feed from the acquisition (integrated or probed) to the customer server. Feature is available for any protocols carried on:

- LSL*
- HSL*
- SIGTRAN
- IP
- EAGLE*

Note *: INTEGRATED APPLICATION only

It is compatible with the Filterable MSU capabilities of the OCPIC probes (see integrated and probed acquisition sections).

With the acquisition data feed feature, Oracle provides a software which establishes a Linux process that, after loading on the customer provided server, allows for the establishment of a LAN/WAN connection from all probes to the customer server. The customer server can be located remotely. The PDU are stored in a file (full PDU content + a header). The file is rotated at configurable interval (from 15 sec to 1 hour).

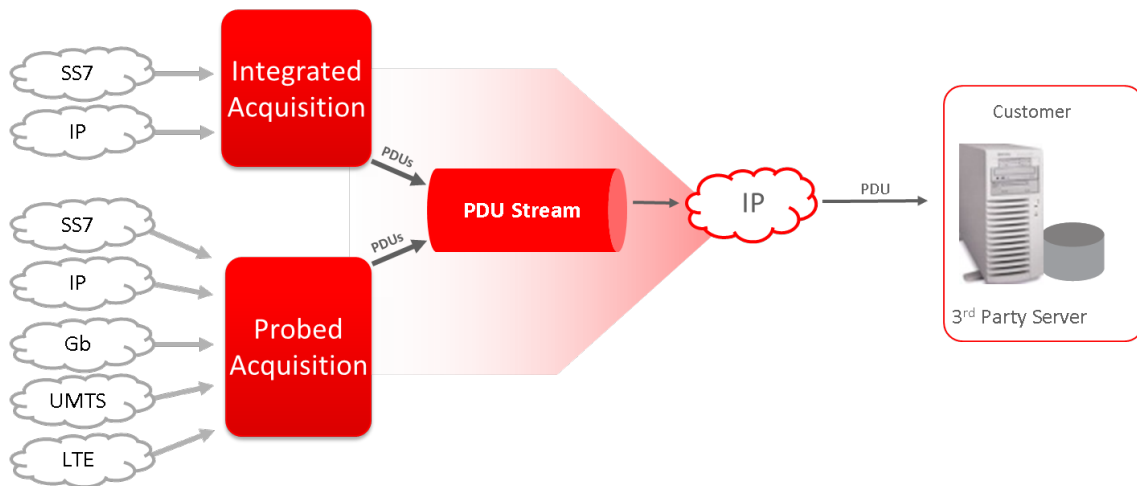

Figure 13 – Data feed at Acquisition overview

Table 22 – Benchmark results

Per instance on customer server	Limits	Comments
Number of EAGLE Integrated Acquisition servers feeding customer machine	12	Only 8 max when mixed with Probed Acquisition servers
Number of Probed Acquisition or OCDSR Integrated Acquisition servers feeding customer machine	2	
Maximum BW	50 Mb/s	

5 PERFORMANCE INTELLIGENCE CENTER MEDIATION

OCPIC Mediation is composed of several servers assembled into subsystems. Inside a subsystem, Mediation servers are exchanging management, surveillance information and data.

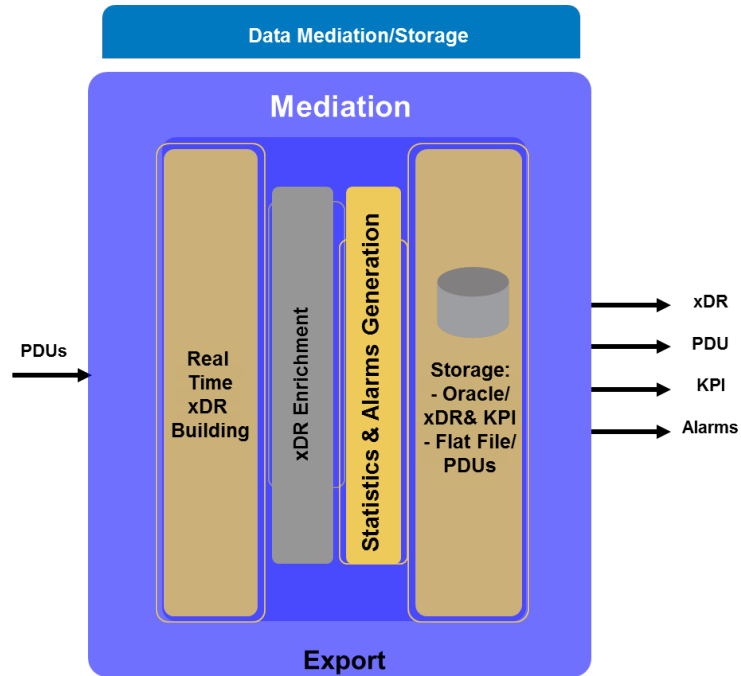

Figure 14 – Mediation Subsystem overview

There are 3 components:

- Mediation server (to analyze captured data and generate xDR),
- Data record storage server (to store xDR)
- Packet Data Unit server (to store captured data used for xDR generation)

Smallest possible subsystem is defined as being one of each.

5.1 OCPIC MEDIATION HARDWARE SERVERS (MEDIATION AND STORAGE)

Table 23 – Mediation Hardware baseline for OCPIC 10.2

		Server		
		Form Factor	Series	PWR
Mediation server	Shipping base line	RMS	HP DL360 Gen9	AC and DC
	Shipping base line	RMS	Oracle X6-2	AC
	Supported base line	RMS	Oracle X5-2	AC
	Supported base line	RMS	HP DL360 Gen8	AC
	Supported base line	RMS	HP DL360 G6	AC

Table 24 – Data record storage server Hardware baseline for OCPIC 10.2

		Server		
		Form Factor	Series	PWR
Data record storage server	Shipping base line	RMS	HP DL380 Gen9	AC and DC
		Disk	26 x 900 GB HDD	
	Shipping base line	RMS	Oracle X6-2L	AC
		Disk	26 x 1.2TB HDD	
	Supported base line	RMS	ODA X5-2	AC
		Disk	2x8 HDD (4 TB/HDD) + possible 1 rack extension 16 DD	
	<i>Use of Customer IT infrastructure (*)</i>	Use of Customer IT infrastructure for Data Record storage (Oracle DB) in lieu of OCPIC storage servers. This option can be selected on a per Mediation site basis.		
	Supported base line	RMS	HP DL360 Gen8	AC
		Storage Array	+ 1 D2700	
		Disk	+ 25 HDD (300 or 600GB)	
	Supported base line	RMS	HP DL360 Gen6	AC
		Storage Array	+ 1 D2700	
		Disk	+ 25 HDD (300 or 600GB)	

Oracle ODA X5-2 Appliance includes 2 Data Record storage servers.

No disk capacity mix is allowed in the same subsystem.

DL360 G5 and MSA 30 Storage array are not supported in OCPIC 10.x

OCPIC configuration with no xDR storage is possible on a per mediation site basis

(*) specifications for xDR storage onto Customer IT storage infrastructure.

Workbook provides specifications of the xDR storage for the customer or the partner to be able to provision and dimension his database:

- xDR Storage DB Type and version Oracle 11g Enterprise with partitioning
- Number of Mediation subsystems (*)
- Number of users (OCPIC simultaneous users)
- xDR insertion rate into Storage (Mbps) – peak value
- xDR Storage - Total nb xDR/sec
- xDR Storage (and KPIs) - Nb days
- xDR Storage Estimated Payload (in GB)
- xDR Storage HDD RAID Recommended Config: RAID 10

(*) customer can configure from 1 to 4 database instances per Mediation subsystem. xDR storage is evenly distributed over the instances (roundrobin rule). Provided database instances are properly dimensioned, this can assure a N+1 redundancy in insertion. E.g. if 4 instances are configured and one goes down, then the 3 remaining ones take over the xDR flow assuring no loss of xDR in insertion. Conversely, xDRs stored in the failed disk are no more accessible for reading.

Note :

- *Technology Foundation for Monitoring Applications License cannot be used here. Customer needs to have his own Oracle DB license.*
- *Oracle RAC Cluster is not supported*

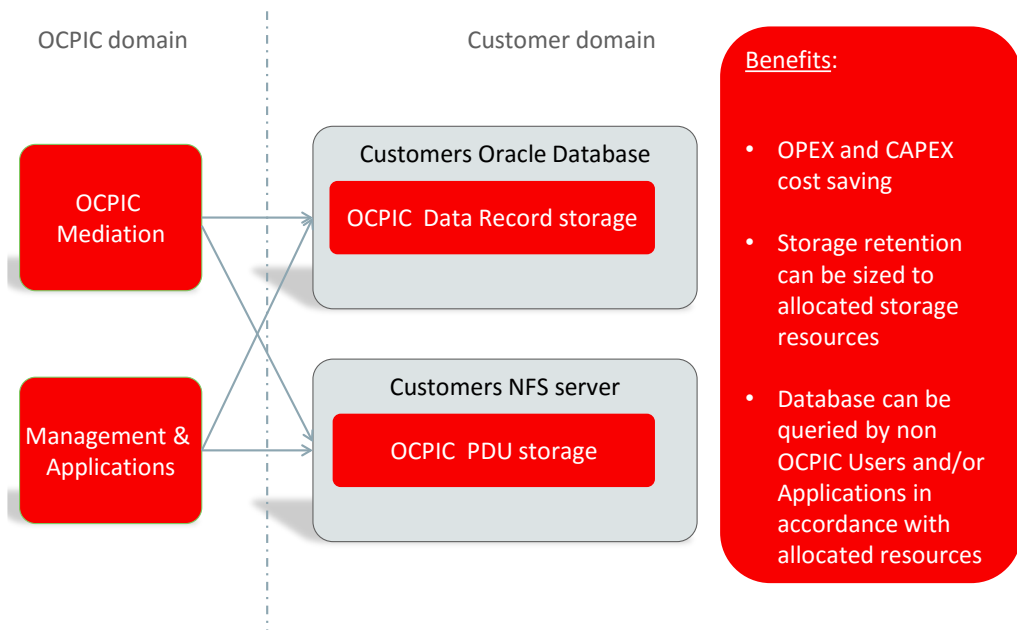

Figure 15 – Storage onto Customer IT infrastructure

Table 25 – Packet Data Unit server Hardware baseline for OCPIC 10.2

		Server		
		Form Factor	Series	PWR
Packet Data Unit storage server	Shipping base line	RMS	HP DL380 Gen9	AC and DC
		Disk	26 x 900 GB HDD	
	Shipping base line	RMS	Oracle X6-2L	AC
		Disk	26 x 1.2TB HDD	
	Supported base line	RMS	ZS3-2 (ZFS Appliance)	AC
		Disk	24 HDD (900 GB/HDD) + possible 1 or 2 rack extension 24 HDD each	
	<i>Use of Customer IT infrastructure (*)</i>	Use of Customer IT infrastructure for Packet Data Units storage (NFS) in lieu of OCPIC storage servers. This option can be selected on a per Mediation site basis.		
	Supported base line	RMS	HP DL360 Gen8	AC
		Storage Array	+ 1 D2700	
		Disk	+ 25 HDD (300 or 600GB)	
	Supported base line	RMS	HP DL360 Gen6	AC
		Storage Array	+ 1 D2700	
		Disk	+ 25 HDD (300 or 600GB)	

No disk capacity mix is allowed in the same subsystem.

DL360 G5 and MSA 30 Storage array are not supported in OCPIC 10.x

OCPIC configuration with no PDU storage is possible on a per mediation site basis

(*) specifications for PDU storage onto Customer IT storage infrastructure.

Workbook provides specifications of the PDU storage for the customer or the partner to be able to provision and dimension his Packet Data Unit repository:

- NFS v4
- Number of Mediation subsystems (**)
- Number of users (OCPIC simultaneous users)
- PDU insertion rate into Storage (Mb/s)
- PDU Storage - Nb Days
- PDU Storage Estimated Payload (in GB)

(**) customer can configure from 1 to 4 NFS instances per Mediation subsystem. PDU storage is evenly distributed over the instances (roundrobin rule). Provided NFS instances are properly dimensioned, this can assure a N+1 redundancy in insertion. E.g. if 4 instances are configured and one goes down, then

the 3 remaining ones take over the PDU flow assuring no loss of PDU in insertion. Conversely, PDUs stored in the failed disk are no more accessible for reading.

Note :

- A given NFS mount can be used by only one mediation subsystem

Compact ODA Appliance (supported baseline only, no more shipping base line):

A compact solution, including Data Record and Packet Data Unit storage in a single ODA Appliance has been introduced in OCPIC 10.1.5 to address the need of a reduced footprint solution for small sites and/or for small OCPIC configurations.

Table 26 – Compact ODA Appliance

		Server		
		Form Factor	Series	PWR
Compact ODA Appliance (xDR/PDU and Storage)	Shipping base line	RMS	ODA X5-2	AC

Half of ODA Appliance is used for Data Record storage (Oracle DB), the other one is used for Packet Data Unit storage (NFS server).

No rack extension is possible for this compact configuration.

5.2 MIXED HARDWARE CONFIGURATION FOR OCPIC MEDIATION

For mixing server generations in a Mediation rack mount subsystem, the following rules apply:

- G6, Gen8, Gen9 , X5-2 and X6-2 servers can be fully mixed in the same subsystem as Mediation servers
- Mixed G6/Gen8 Data Record servers must have 24+1 disk drives and the same Data Record retention disk space (4.2 or 8.4 TB)
- Mixed G6/Gen8 PDU servers must have 24+1 disk drives and the same Packet Data Unit retention disk space (4.7 or 9.4 TB)
- Generally speaking mixing different types of HW in xDR or PDU server in the same subsystem is only possible if they have the same disk capacity and the same disk RAID redundancy schema (e.g. RAID10), meaning the same payload storage capacity

Only non-mixed subsystems deliver maximal performance without bottlenecks. So it is recommended to avoid as much as possible mix of configurations of different generations inside a Mediation subsystem. Preferred solution is to create a new subsystem in order to deliver full processing and storage capacity.

5.3 SUPPORT OF EXISTING BLADES SYSTEM BY OCPIC MEDIATION

WARNING: HP G6 and Gen8 blade systems are still supported in OCPIC 10.2 but this equipment is no more in the shipping baseline. Customer is still allowed to extend his existing system with new blades and storage, but not with new enclosure. Mix of HP G6 and HP Gen8 blade is allowed with P2000/D2700 only. As for RMS, HDD are 300GB or 600GB capacity and no disk capacity mix is allowed in the same subsystem.

Extension of existing OCPIC system on blades can be performed with new subsystem based on RMS hardware.

As a reminder, blade architecture inside a C7000 enclosure is the following

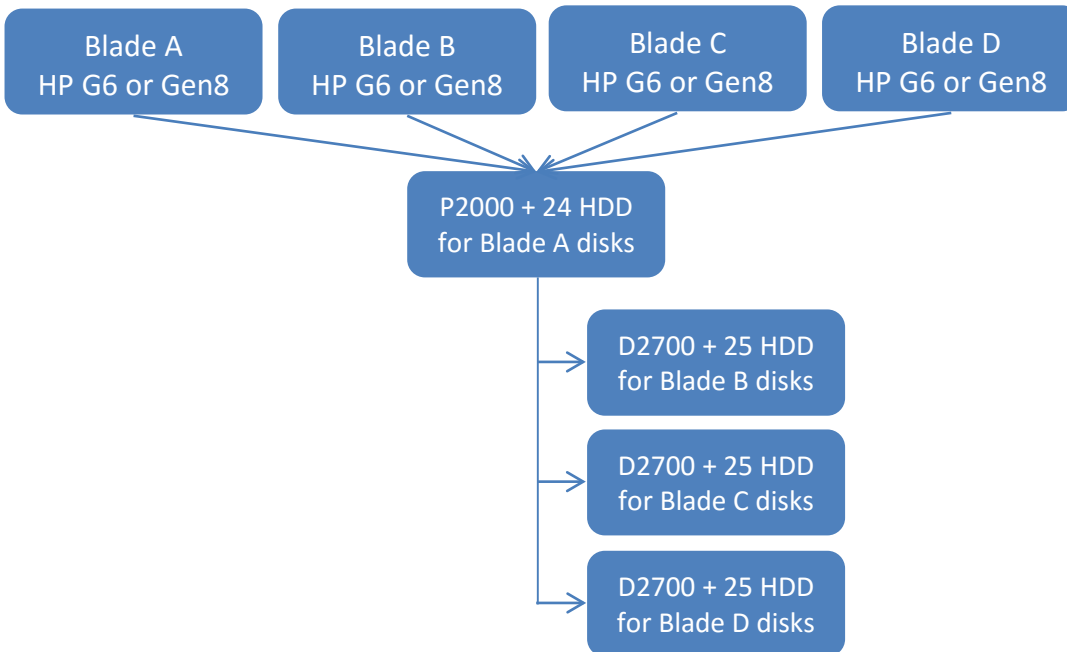

Figure 16 – Blade system overview reminder

IMPORTANT NOTE: the maximum number of Data Record storage servers per P2000 is 2. Remaining slots can be used for Packet Data Unit Storage (for instance one P2000 used for Data Record storage for blade 1 + one D2700 attached to the P2000 for Data Record storage for blade 2 can only be extended with additional one or two D2700 for Packet Data unit storage for blade 3 and 4).

OCPIC 10.2 supports PM&C server (installed in each base storage and Network Extension blade cabinet) on HP G6 and HP Gen8. But as for blades, PM&C is no more in the shipping base line of OCPIC 10.2.

Table 27 – PM&C server Hardware baseline for OCPIC 10.2

		Server		
		Form Factor	Series	PWR
PM&C	Supported base line	RMS	DL360 Gen8	AC
	Supported base line	RMS	DL360 G6	AC

5.4 MEDIATION: DATA RECORD STORAGE SERVER BENCHMARK RESULTS

Table 28 – Benchmark results for Data Record Storage Server performances

Performances (shipping baseline)	Unit	HP Gen9	Oracle ODA X5-2	Oracle X6-2L	Notes
Number of DWS / pool	DB instances	4			
Max. xDR insertion rate per server no data feed	Mb/s	100 *			
Max xDR insertion rate per server with data feed	Mb/s	60 *			Oracle DB streaming and CSV streaming do not impact this performance
Max xDRsessions for above insertion rate	xDR sessions per subsystem	25			With more sessions max insertion rate might not be reached
Max indexes per session	Index per table	6			
Max. OQDE rate per xDR server	Mb/s	30 *			
Payload capacity for Data Records and index without extension	TB	9,7	12,1	12,9	Half ODA Appliance
Payload capacity for Data Records and index with HDD extension	TB	N/A	24,2	N/A	Half (ODA + extension DD rack)
Raw HDD storage without extension	TB	21,6	32	28,8	Half ODA Appliance.
Assumptions	(*) In case of multiple outputs, this capability is shared between internal storage, OTO streaming and CSV streaming (since OCPIC9) Oracle ODA X5-2 column actually corresponds to half of ODA X5-2 to allow sizing granularity (sharing Management or DR or PDU storage). However only whole ODA appliances can be ordered and installed (2 servers, all standard HDDs).				

OQDE = Oracle Query Extraction Rate. OQDE rate includes all query sources: CSV + OTO extraction rate

5.4.1 Data Record, KPI Storage and Mediation Data Feed Latency Time

The following figures provide the latency time between the last message in a transaction and the availability for query of a Data Record in the Data Record Storage database.

Latency time to store Data Record in the Data Record Storage database

- min. 35s, max. 1min from receiving the last message in a transaction to data availability in the database, ready to be queried.
- This time may vary based on system congestion or downtime.

Latency time to store a KPI

- Max is 1mn from the end of KPI period

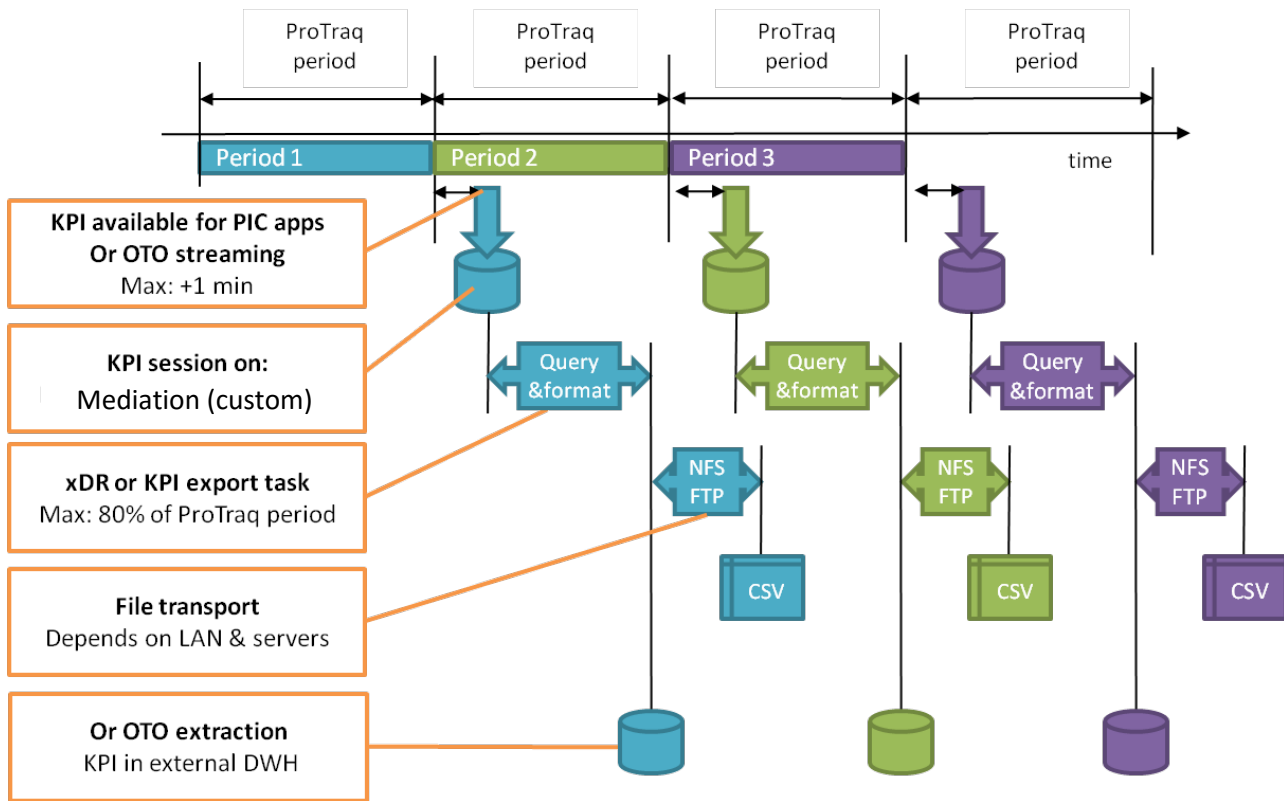

Figure 17 – Data Record and KPI Latency for applications and feeds

Latency to export a KPI starting at the end of the KPI period to export is

- OTO Streaming: max 1 min.
- OTO Extraction: max 1 min + 80% of KPI period
- NFS feeds (NFS or FTP): OTO extraction latency + file transport.

For instance if the aggregation period is 15 min, the latency starting at the end of KPI period is:

- Latency to have it available for application and OTO streaming is: 1 min
- Latency to have the data available in external DWH is: 1 min + 80% of 15 min = 13 min

5.5 MEDIATION: PACKET DATA UNIT STORAGE SERVER BENCHMARK RESULTS

In OCPI 10.2, Packet Data Unit Server cannot simultaneously act as Mediation server anymore.

Table 29 – Packet Data Unit Server performances

Performances (shipping baseline)	Unit	HP Gen9	Oracle X6-2L	Oracle ZS3-2	Compact ODA Appliance (*)
Average compression ratio for PDU storage		5/1 or 2/1 according to protocols	5/1 or 2/1	5/1 or 2/1 according to protocols	5/1 or 2/1 according to protocols
Number of PDU servers (2 mounts each) per mediation subsystem	Servers	4	4	4	N/A
Max. PDU storage insertion rate	Mb/s	150	150	300	100
Raw storage capacity without DD extension	TB	21,6	28,8	21,6	32
Payload capacity for PDU without DD extension	TB	9,7	12,9	13,6	12,1
Payload capacity for PDU with 1 DD rack extension	TB	N/A	N/A	27,2	N/A
Payload capacity for PDU with 2 DD racks extension	TB	N/A	N/A	40,8	N/A
Assumptions	(*) For Compact ODA Appliance, half of ODA is used for PDU storage (NFS server), the other half for Data Record storage (Oracle DB)				

PDU compression:

From OCPIC 10.2, compression is applied on PDU flow at the output of mediation (flow Y' in figure 18) towards the Packet Data Unit Storage server. It enables to increase storage capacity of PDU storage. Compression rate differs from protocol categories as shown in the figure.

PROTOCOL CATEGORY	COMPRESSION RATE	PROTOCOLS
IP signaling category	5/1	Diameter, Radius, SCTP, ...
GnGpGi category	2/1	FTP, HTTP, POP, SMTP, ... (with PMF only)
VoIP category	2/1	SIP, H.248, ...
SS7 category	2/1	ISUP, MAP, INAP, ...
CN-AN category	2/1	BSSAP, UMTS, S1AP
Gb category	2/1	Unciphered GPRS Gb CONTROL PLANE only

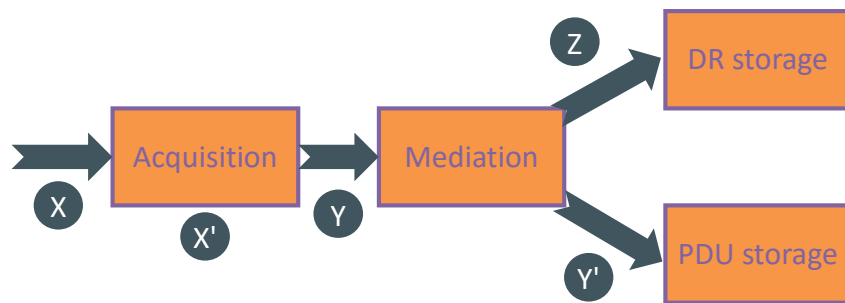

Order of magnitude	SS7 Mbps	IP Mbps
X (PDU in)	100	4000
X' (filtered)	100 (100%)	1000 (25%)
Y (X'+wrapper)	120 (1.20)	1050 (1.05)
Y' (PDU insertion compressed)	60 (2/1)	200 (5/1)
Z (DR insertion)	50 (0.45)	200 (0.2)

Figure 18 – Packet Data Units compression

5.6 MEDIATION: RECORDS, PACKET DATA UNITS AND KPI STORAGE MAXIMUM CAPACITY

Table 30 – Data Record, Packet Data Units and KPI storage retention maximum capacity

Storage	Unit	Maximum storage retention
Data Record	Days	365
Packet Data Unit	Days	100
KPIs	Year	2

IMPORTANT NOTE FOR KPI STORAGE DIMENSIONNING:

Dimensioning tool does not take into account the disk volume necessary for KPIs as generally it is neglectible vs. volume necessary for Data Records.

HOWEVER, some use cases (eg. accounting, small KPI period such as 30s...) may lead to non neglectible volume. In that case, necessary volume shall be calculated and added manually to the configuration.

Hence, the recommendation is to check the volume systematically in accounting projects and as soon as configuration may include a great number of KPI configurations with period lower than 1 hour.

5.7 MEDIATION BASE SERVER BENCHMARK RESULTS

Table 31 – Max Mediation Base Server performances

Performances (shipping baseline)	Max Performance	Compression Ratio	Comments
Number of such servers per mediation subsystem	12		
Max. PDU input per category (Mb/s per server) (***)			Only one out of ... or weighted average (by %)
- IP signaling category	up to 600 (6x100)	(5/1)	Diameter, Radius, SCTP, ...
- GnGpGi category	up to 400 (5x80)	(2/1)	FTP, HTTP, POP, SMTP, ... (with PMF only)
- VoIP category	up to 160 (4x40)	(2/1)	SIP, H.248, ...
- SS7 category	up to 240 (4x60)	(2/1)	ISUP, MAP, INAP, ...
- CN-AN category	up to 75 (3x25)	(2/1)	BSSAP, UMTS, S1AP
- Gb category (****)	up to 30 (3x10)	(2/1)	Unciphered GPRS Gb CONTROL PLANE only
Max. xDR builders number (**)	10		Final builders (that generate xDR for a session).
Max. KPI operations per second with builder(s) OPS (*)	1 000 000		
Max. KPI operations per second without builder OPS (*)	30 000 000		Means 0 Mb/s PDU input supported on this server
Max. KPI operations per second for whole subsystem OPS (*)	64 000 000		This is an overall limit for multiple servers in the same subsystem
Max. xDR output per Mediation server Mb/s	up to 100		In case of multiple outputs this capability is shared between internal storage, OTO streaming and CSV streaming. CSV streaming could be a bottleneck when exporting lots of very small columns, best performance is obtained with 10-20 significant fields.
Assumption		Compression ratio divides the PDU output rate going to the PDU storage server. It impacts the use of TB on PDU storage servers in the same proportion. PDUs are only compressed after xDR building. E.g. 100 Mb/s DIAMETER PDU in produce 20 Mb/s PDU storage output.	Listed performance is only reached with native acquisition mode. In case of external probes (e.g. Neptune) manual sizing is needed, ensuring that there is no mix of Gb and other categories on the same base server and that total input does not exceed Release 9 values: 225 Mb/s for GnGp, 30 Mb/s for CN_AN, 27 Mb/s for Gb unciphered.

(*) OPS = Operation Per Second. See §5.8.

(**) Total number of final builders whatever the number of DFPs. Final builders corresponds to builders listed in the dimensioning tool.

(***) Differences per protocol are caused by differences in size of PDU, differences in PDU correlated as one xDR and complexity of protocol coding. Examples:

- 10 Mbps of ISUP = 30 000 frames
- 10 Mbps of SIP = 2 000 frames
- BSSAP : up to 20 frames for 1 xDR
- Diameter: 2 frames for 1 xDR

(****) Sizing assumes that all Gb User Plane is filtered out at Probed Acquisition level.

IMPORTANT NOTE : performances in general and especially max. PDU input (Mbps) Mediation server are given for nominal usage of the system. In particular, low correlation rate due to network topology (eg. asymmetrical traffic routing - eg. if 2 IPX carriers are involved - preventing the system to capture all messages of a given call or transaction and thus leading to a low correlation rate which hits the memory limit of the server and increase disk space for storage) may severely degrade the announced performance.

5.8 MEDIATION: KPI ENGINE PERFORMANCE (OCPIC MANAGEMENT KPI APPLICATION)

This section details the maximum KPI performance of a Mediation base server and the calculation to estimate the performance required by customer and consequently, to determine the number of necessary mediation base servers.

KPIs performance is calculated as number of OPS/s (Operation Per Second), which is dependent on three factors row operations, column operations and xDR/s.

The next sections explain the calculation of OP/s.

It is worth noting static enrichment consumes also OP/s. Calculation of the contribution of static enrichment to OP/s is explained in section §5.9 (static enrichment).

IMPORTANT NOTE ON ACCOUNTING BASED PROJECTS:

Accounting (eg. SS7 accounting) generally requires extensive number of dimension combinations and as a result a huge number of OCPIC Management KPI rows with extensive use of TOP OCPIC Management KPI application function.

As TOP function is favorable in term of MOPS performance, generally in this case, MOPs result is misleading because the number of Mbps xDR forwarded to the KPI server reach its limit before the max MOPs is hit. But the limit in term of Mbps xDR for feeding a KPI server is not known and not modeled in the dimensioning tool.

So recommendation is to systematically work with PLM for dimensioning any configuration dealing with accounting.

5.8.1 Row operations are calculated as below

Row operations = number of rows X average number of conditions X Top criteria

Average number of conditions gives the average number of filter conditions over OCPIC Management KPI cells. Eg. "OPC = x" is one condition; "OPC=x OR OPC=y" are 2 conditions.

TOP criteria for TOP N OCPIC Management KPI configuration provides an equivalent number of OCPIC Management KPI rows as $\log_2(N)$ (e.g. for TOP 1000, the number of equivalent rows is $\log_2(1000) = 10$)

TOP criteria for standard OCPIC Management KPI will be 1.

5.8.2 Column operations are calculated as below

column operations = number of columns X average number of conditions

xDR per second is the number of records selected by the "corner filter"

5.8.3 Number Operations per second (OPS) is calculated as below

OPS/s rate = (rows operations + column operations) X (xDR/sec)

NOTE: OCPIC KPI Management OPS/s is monitored in Capacity Management statistics which is very helpful to check a posteriori the actual performance supported by each Mediation base module.

The following spreadsheet gives some examples of OCPIC KPI Management configurations with the maximum number of such configurations according to the Mediation subsystem hardware configuration:



KPI OPS
calculation.xlsx

This spreadsheet may be used to estimate the number of Operations Per Seconds (OPS) necessary for a given customer. OPS is the measure used to dimension base servers.

5.9 MEDIATION: STATIC ENRICHMENT

5.9.1 Limits For Static Enrichment

xDR enrichment is a feature of OCPIC management to enrich Data Record with customer configured information.

Table 32 – Limits for Static Enrichment per base server (linked)

Performances (shipping baseline)	System Limit	Comments
Maximum number of input fields	10	When size of enrichment fields exceed 5% of previous xDR size, set proportionally higher peak bandwidth to account for the increase in processing and storing.
Maximum enrichment table size	200 000 rows per table	Each table uses 1 ProTraq configuration slot and Ops like a TOP KPI at same row count

5.9.2 Number of Operations per second (OPS) is calculated as below

For calculating the contribution of one static enrichment in terms of OP/s, the procedure is as follows:

- the number of fields in static enrichment is considered as the number of columns
- average number of conditions equals 1
- the number of rows of static enrichment is (N) is considered as the number of TOP rows, thus TOP N.

5.10 MEDIATION OPTION: OCPIC MEDIATION DATA FEED

OCPIC Mediation Data Feed is a capability to export signaling data to external 3rd party applications and databases. Support exists for

- xDRs formats including CDRs, TDRs, IPDRs, etc.
 - Document (dictionary) exists for each protocol supported by the OCPIC
- KPIs

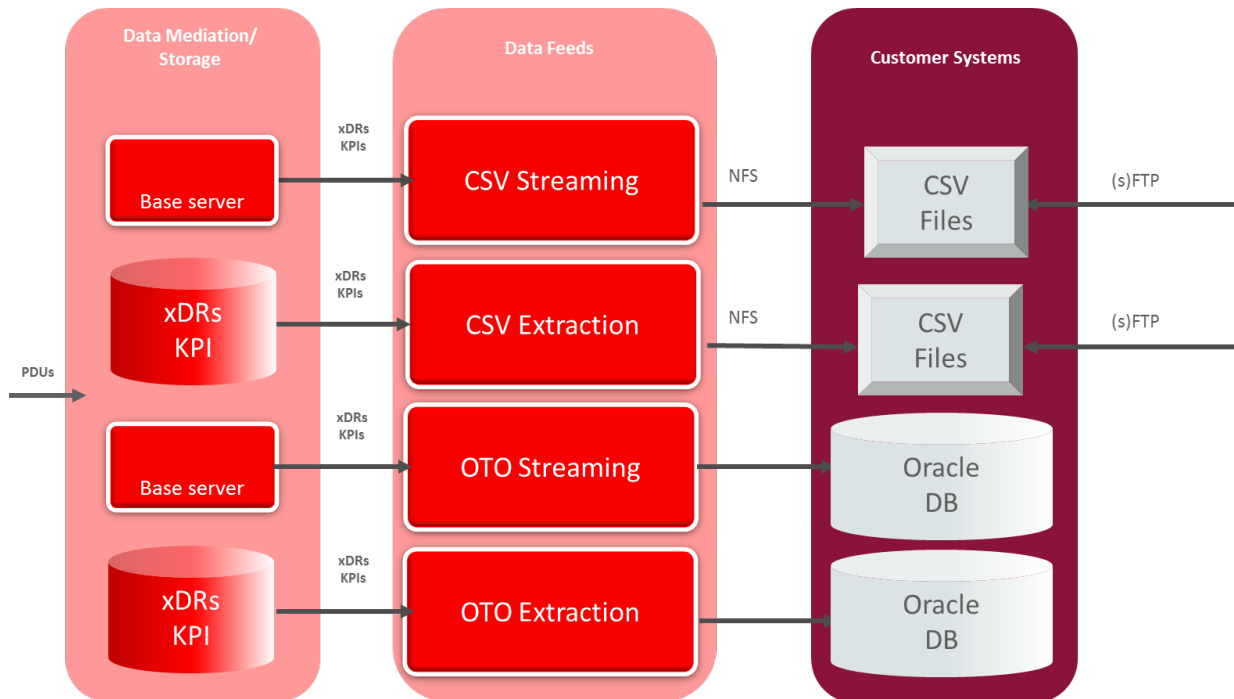

Figure 19 – OCPIC Mediation Data Feed overview

In the process of making data available for third applications it is necessary to distinguish:

- How the data are sourced:
 - Extractions mode refers to queries on the Oracle DB. Data are first stored in the Oracle DB. A query will extract the data corresponding to the data feed.
 - Streaming mode refers to filtering on data streams before the storage in the Oracle DB.
 - It is recommended to use the streaming mode for performances.
- What is the target of the data:
 - Oracle and in that case a filter will apply on the feed but all the fields are sent initially to the Oracle DB.
 - Non Oracle using csv format and in that case the fields can be selected.
- How the data are provided
 - Directly to an external server through NFS

- Stored still using NFS to an Export Server that can be configured to be a FTP server. The third party application will read the data either using NFS or FTP.

The following policy and guidelines apply to all the OCPIC Mediation Data Feeds:

- The maximum data that can be extracted from the system cannot exceed the maximum input capacity and rate.
- The PDU Server(s) can be used to setup and execute the data feed, however the output rate and performance will be low.
- Max Oracle Query Data Extraction rate (OQDE rate) represents: PPS query rate + NFS Feed query rate + FTP Feed query rate + OTO extraction query rate

Specific policy and guidelines for Oracle streaming target:

- Oracle recommends a Linux / Unix based external data warehouse
- Customer to provide Oracle DB license, server and Oracle DBA for initial setup.
- The target Oracle database must be 11g compatible, enterprise edition with partitioning option
- The external data warehouse must support a sufficient amount of storage capacity.
- Purging the data on the external data warehouse is the responsibility of the customer.
- 6 hour buffering for xDR and KPIs at the Mediation

Specific policy and guidelines for Oracle extraction target:

- Oracle recommends a Linux / Unix based external data warehouse
- Customer to provide Oracle DB license, server and Oracle DBA for initial setup.
- The target Oracle database must be 11g compatible, enterprise edition with partitioning option
- The external data warehouse must support a sufficient amount of storage capacity.
- The data older than the lifetime will be automatically removed during the nightly automatic purge
- Buffering of the xDRs / KPI is up to session lifetime (configurable)

Specific policy and guidelines when exporting CSV directly to an external server using NFS:

- Oracle recommends a Linux / Unix based target server (3rd party server)
- The target server must support NFS (Network File System) protocol. The necessary configuration, setup and the security administration of the server is the responsibility of the customer.
- The target server must support a sufficient amount of storage capacity.
- The maximum file size on the target server depends upon the architecture of the server. The data feed has no restriction or limitation on the size of the file.
- Purging the data on the target server is the responsibility of the customer.

- Buffering of the xDRs / KPI is up to session lifetime (configurable)

Export server is not supported in OCPIC 10.x

The following tables are giving parameters to be used for OCPIC internal system engineering when having the need of data feeds.

Table 33 – OTO or CSV extraction Data Feed

Performances (shipping baseline)	Max performance	Comments
Max. extraction rate per xDR Server	30 Mb/s	10% derating for a pool of 2, 3 or 4
Max number of feeds per subsystem	12	
Max number of feeds per mediation server	4	base servers resources are used to convert to CSV/GZ
Max Extraction rate per mediation server	8 Mb/s	

Table 34 – OTO or CSV Streaming

Performances (shipping baseline)	Max performance	Comments
Max feed rate per Mediation server	up to 100 Mb/s (*)	In case of multiple outputs this capability is shared between internal storage, OTO streaming and CSV streaming (since OCPIC9)
Assumptions	<ul style="list-style-type: none"> - target database is Oracle 10g or more, Enterprise edition with partitioning - no more than 6 indexes are activated on each target table - 40 GB REDO space minimum on an dedicated volume or part of an ASM group - 2.4 GB minimum SGA size, and other DBA best practices for huge DWH - Extraction depends on input capacity provided by the external DWH tuning 	
<p>(*) this throughput of 100 Mbps corresponds to the max output from a Mediation server meaning 100 Mbps of xDRs. It does not correspond to PDU input to base server. Generally speaking, xDR Mbps output rate from Mediation server is lower than PDU rate at the input of Mediation (the ratio depends on protocols and protocol distribution). This maximal 100 Mbps rate must be shared between storage and streaming output for export; for example: 60 Mbps for storage (internal or external) and 40 Mbps for streaming. In the example, not all xDRs generated by the mediation (60 Mbps) are exported as streaming but only a part of, through filtering (40 Mbps out of 60 Mbps).</p>		

6 VIRTUALIZATION

OCPIC components can be virtualized on Customer Cloud environments.

Important notes:

- **Probed Acquisition, Diameter Signaling Router Integrated Acquisition, Mediation and Management can be virtualized**
- **xDR and PDU storage virtualization is done through IT Customer Storage Cloud Infrastructure. See detail in chapter 6.1**
- **EAGLE Integrated Acquisition cannot be virtualized**
- **No performance can be guaranteed and predicted in such virtualized configurations. It depends on the context and VMs configuration**

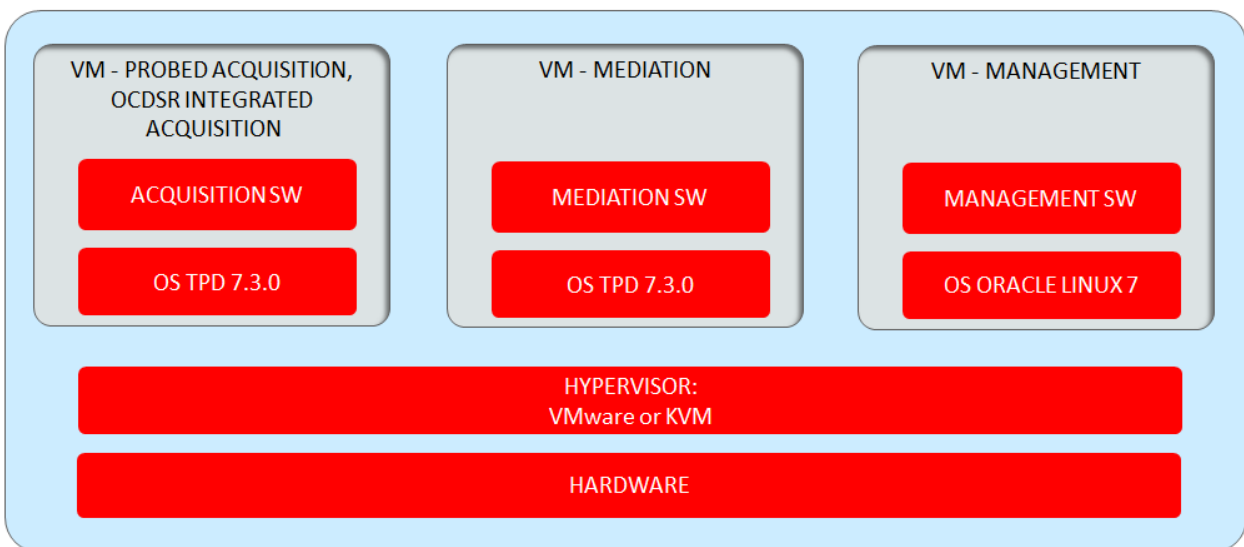

Figure 20 – Performance Intelligence Center Virtualization configurations

The following table provides minimal HW resources required for VMs. As said, capacity figures are purely indicative, not committed and depend on the context.

Table 35 – VM minimal HW resources

Function	Maximum Capacity	Minimum vCPUs	Minimum RAM	Minimum HDD	vNIC	Comments
Management	5 users	2	64 GB	550 GB	1 Ethernet interface for backend 1 Ethernet interface for frontend (optional)	Alarms and Logs retention must be configured to 5 days, at most
	20 users	8	64 GB	2 TB	1 Ethernet interface for backend 1 Ethernet interface for frontend (optional)	
Acquisition VoIP and Sigtran SS7	240 Mbps	8	16 GB	64 GB	1 Ethernet interface for backend 1 Ethernet interface for frontend (optional) 1 or more Ethernet interface in pass through for frame capture depending on the number of interface to capture	SIP (no RTP), H.248, Sigtran SS7
Acquisition IP Signalling and GnGp	1 Gbps	8	16 GB	64 GB	1 Ethernet interface for backend 1 Ethernet interface for frontend (optional) 1 or more Ethernet interface in pass through for frame capture depending on the number of interface to capture	Diameter, Gn, Gp
Mediation Build IP Signalling	100 Mbps	4	16 GB	64 GB	1 Ethernet interface for backend 1 Ethernet interface for frontend (optional)	Diameter...
	200 Mbps	8	16 GB	64 GB		
Mediation Build GnGp	80 Mbps	4	16 GB	64 GB		Gn, Gp...
	160 Mbps	8	16 GB	64 GB		
Mediation Build VoIP	40 Mbps	4	16 GB	64 GB		SIP, H.248...
	80 Mbps	8	16 GB	64 GB		

Mediation Build SS7	60 Mbps	4	16 GB	64 GB		ISUP, MAP, INAP...
	120 Mbps	8	16 GB	64 GB		
Mediation Store	For 8 vCPUs Build Mediation	4	8 GB	64 GB	1 Ethernet interface for backend 1 Ethernet interface for frontend (optional)	DFP Store process necessary for xDR export and storage
	For 2 x 4 vCPUs Build Mediation	4	8 GB	64 GB	1 Ethernet interface for backend 1 Ethernet interface for frontend (optional)	DFP Store process necessary for xDR export and storage

Note: KPIs process not included

7 OCDSR PRE-PACKAGED ACCOUNTING AND NETWORK MONITORING CONFIGURATIONS

OCDSR Pre-Packaged Accounting and Network Monitoring configurations have been created in OCPIC 10.2 to address the following needs in OCDSR monitoring:

- Addressing 3 diameter monitoring use cases:
 - Diameter Feed to Accounting
 - Diameter Network Monitoring
 - Diameter Feed to Accounting + Network Monitoring
- Minimal footprint and cost
- Easy to dimension and price through specific and simplified workbook

It is a *qualified* engineered solution.

Main characteristics:

- 1 or 2 OCDSR nodes (in failover mode) – one OCPIC box for each node
- Up to 50 KMPS network traffic
- Average Diameter message size = 655B to 1 250B (configurable)
- Egress + Ingress traffic captured and processed
- Virtualized Acquisition + Mediation (+ Management) in a box (X6-2 AC or Netra X5-2 AC/DC) performance up to 1 Gbps Diameter traffic. Use of KVM (open source) or VMware hypervisor (license fee, to be provided by customer)
- Possibility to process N% of traffic in mediation (for reducing mediation protocol license cost)
- No OCPIC KPI
- Single builder: LTE Diameter xDR builder (generic, multi-interface)
- Optional xDR and PDU storage for Network Monitoring
- Exported TDR CSV files compatible with NAA – Network Assurance Analytics application
- **For business critical accounting application (e.g. for actual billing, not for checking) it is absolutely mandatory to double the system (doubling acquisition/mediation/management) boxes. In this case, accounting xDRs are exported by the 2 separated chains. It is up to the 3rd party accounting application to arbitrate between these 2 set of files.**

Note: configuration not matching this shall be sized with extended OCPIC sizing tool.

Four configurations has been defined according to different use cases:

Configuration type	Max Network KMPS – failover mode	Network Monitoring Traffic volume i+e	Accounting Traffic volume i+e	Storage xDR	TDR accounting /export	SW Mngmt licenses
Accounting	50	-	Up to 100%	-	CSV export for Accounting	1 user. No Apps
Accounting with 10% Network Monitoring	50	Up to 10%	Up to 100%	X6-2L	CSV export for Accounting	Max 5 users. xDR browser
Network Monitoring	50	Up to 100%	-	X6-2L	-	Max 5 users. XDR browser
Accounting and Network Monitoring	50	Up to 100%	Up to 100%	Customer Cloud	(*) From Customer Cloud (Oracle DB)	Max 5 users. xDR browser

(*) xDR Oracle database in Customer Cloud dimensionning, provisionning and administration is fully under the customer’s responsibility . Workbook provides some inputs for helping customer dimension database (e.g. Mbps and xDR/s insertion rate). For dimensioning, Customer shall also take into account the database OCPIC and non OCPIC usages (nb of users, nb of non OCPIC applications accessing the database, xDR retention.....).

Figure 211 – configurations for OCDSR Pre-Package monitoring

Table 36– OCDSR Pre-Packaged Accounting and Network Monitoring HW baseline – Acquisition/Mediation/Management

		Server		
		Form Factor	Series	PWR
OCDSR Pre-Packaged Accounting and Network Monitoring	Shipping base line	RMS	X6-2 8 x 1.2TB HDD	AC
	Shipping base line	RMS	Netra X5-2 8 x 1.2TB HDD	AC and DC

Table 37– OCDSR Pre-Packaged Accounting and Network Monitoring HW baseline – Optional xDR storage

		Server		
		Form Factor	Series	PWR
OCDSR Pre-Packaged Accounting and Network Monitoring	Shipping base line	RMS	X6-2L 14 x 1.2TB HDD	AC

See performance and capacity of XDR storage on X6-2L in table 28. Note that in pre-packaged solution, there are 14 HDD instead of 26 but they can be extended to 26.

Table 38– OCDSR Pre-Packaged one box performance (virtualized OCDSR Integrated Acquisition + Mediation + (Management))

Metric	Values	Comments
Configuration		For each DSR site, one box X6-2 with virtual Acquisition, Mediation. + Optional Management on one site.
Maximum input rate (Mb/s)	1000	
Mediation Throughput capacity (Mbps)	110	export + xDR storage cumulated
Z ratio XDR/PDU (%)	20	xDR storage
Y' ratio PDU compression (N/1)	5	PDU storage
Integrated PDU storage payload (GB)	3,2 TB	6x1.2TB RAID10 for storage (+2 HDD for system)

7.1 OCDSR PRE-PACKAGED MONITORING VIRTUALIZATION LAYOUT

This section describes the virtualized layout, for information.

There is one Acquisition/Mediation server per OCDSR site. One of them is also hosting Management server and a small DRS for the Capacity Management feature..

Both servers are receiving the double of the Network traffic in case of OCDSR failover. In other words, most of the time, each server is running at half capacity.

Two Mediation Virtual Machines (VM) are used for the Builder processing versus too many DataFlow processing in one VM.

A Mediation VM is also dedicated for the Storage processing. KPI processing is not proposed in this configuration for performance reason.

In case of Accounting without Troubleshooting, there is no need of External Data record Storage and no need of PDU Storage.

Two servers must be installed for OCDSR Integrated Acquisition , one on each DSR site.

Two vSwitch bridges are created for Acquisition to the Mediation Builder; another vSwitch bridge is created for the two Mediation Builder to the Mediation Storage.

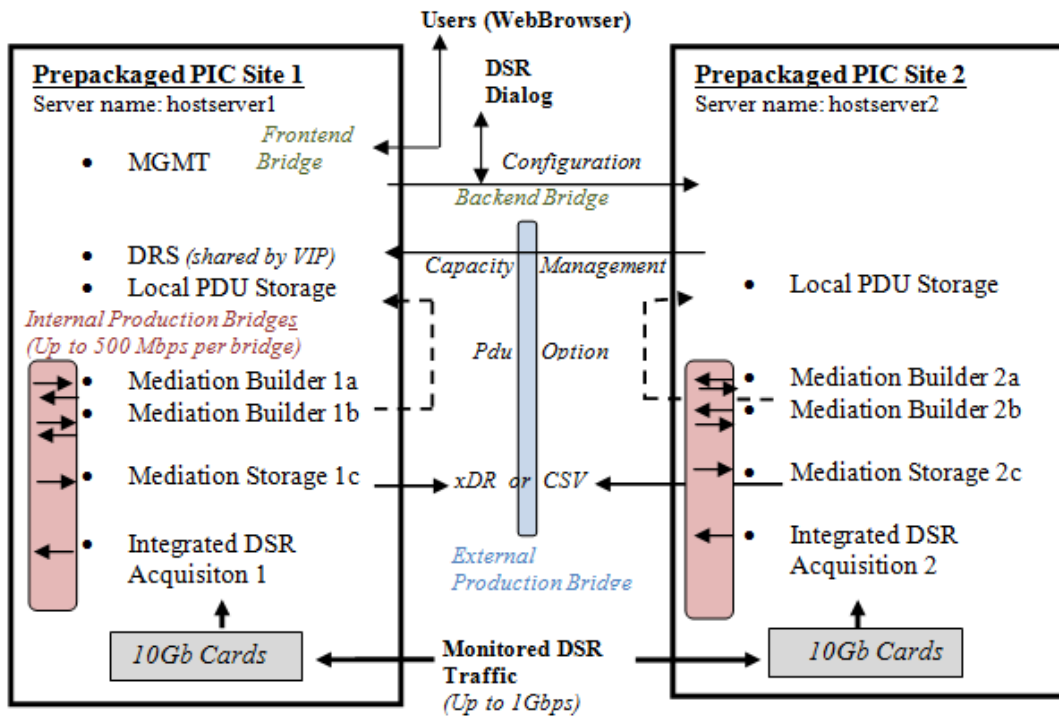

Figure 222 – Virtualized engineered OCDSR Pre-Package

Virtual machines layout:

Function	vCPU	Minimum RAM	Minimum HDD	Configuration
Hypervisor	2		200 GB (*)	(*) This disk volume is what remains on the host
Management, DRS, PDU Storage	2	64 GB	550 GB (150 GB MGMT, 400 GB oracle). 3.6 TB for PDU storage	No. users = 1 to 5 (subject to licensing condition) Capacity Management Session, Alarms and Logs retention must be configured to 5 days, at most Option: PDU Storage for the “Troubleshooting Use Case”
Acquisition	8	16 GB	64 GB	Load Balancing for 12 DFPs.
Mediation-1a	8	16 GB	64 GB	6 DFPs Builder
Mediation-1b	8	16 GB	64 GB	6 DFPs Builder
Mediation-1c	8	16 GB	64 GB	Accounting Use Case: 12 DFPs CSV Store Troubleshooting Use Case: 12 DFPs xDR Store

8 OCPIC MANAGEMENT AND OPTIONAL APPLICATIONS

The OCPIC Management server is hosting graphical user interface to access OCPIC O&M functionalities and optional applications.

Functionalities are grouped in three different categories:

- Configuration
- Business
- Self-Surveillance

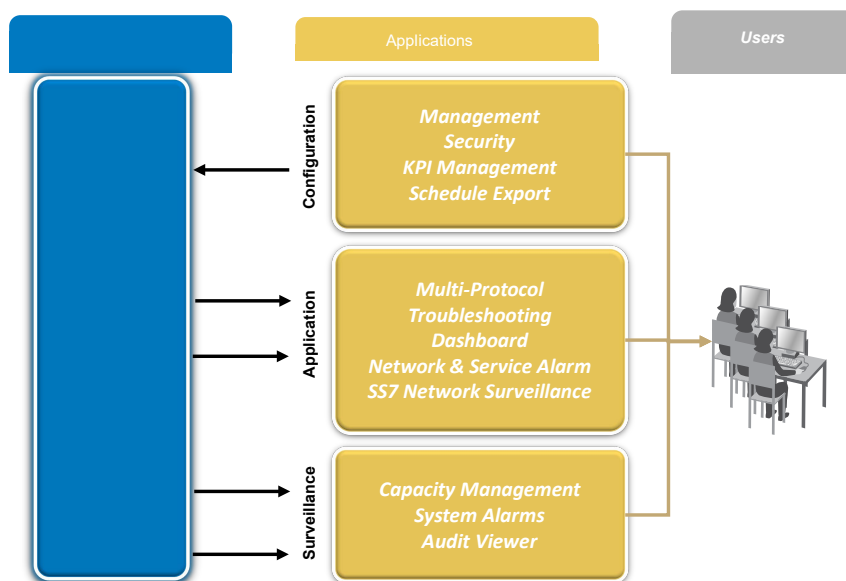

Figure 23 – OCPIC Management and Application overview

8.1 OCPIC MANAGEMENT HARDWARE SERVERS

Table 39– OCPIC Management server Hardware baseline for OCPIC 10.2

		Server		
		Form Factor	Series	PWR
OCPIC Management server	RMS shipping base line (1 box only)	RMS Disks included (8 x 900 GB)	DL380 Gen9	AC and DC
	RMS shipping base line (1 box only)	RMS Disks included (8 x 1.2 TB)	X6-2	
	RMS supported base line (1 box only)	RMS Disks included (8 x 1.2 TB)	X5-2	AC
	RMS Supported base line (1 box only)	RMS	DL360 Gen8	
		Storage Array	+ 1x D2700	
		Disk	+ 10x HDD (*)	
	RMS supported base line (1 box only)	RMS	1x DL360 G6	
		Storage Array	+ 1x D2700	
		Disk	+ 10x HDD (*)	
	Blade supported base line (1 box only)	Blade	1x BL360 G6	
		Storage Array	+ 1x P200	
		Disk	+ 10x HDD (*)	
	Blade supported base line (1 box only)	Blade	1x BL360 Gen8	
Storage Array		+ 1x P200		
Disk		+ 10x HDD (*)		

(*) HDD are 300GB capacity.

Note:

- RMS and Blade 4 box OCPIC Management are no more supported in OCPIC 10.2
- Upgrade of existing 4 box hardware, needs replacement of the existing OCPIC Management server(s) by a one box version on HP Gen8, HP Gen9, X5-2 or X6-2
- For HP Gen9, X5-2 and X6-2, Management server runs on Oracle Linux 7.

8.2 OCPIC MANAGEMENT PERFORMANCE DIMENSIONING RULES

There are no dimensioning parameters of the OCPIC Management server associated with the number of managed Mediation Servers. However, in terms of query performance, there are some recommended limits about the maximum number of mediation servers and the number of sessions that can be queried using a Network View (see OCPIC Troubleshooting application section).

8.2.1 OCPIC Management: Management configuration limits

Table 40– Management Configuration Limits

Parameter	System Limit	Recommended Value
Events / seconds received from OCPIC servers and applications		25 events/s
Alarms retention period (except if Max Event stored applies first)	30 days	
Max Event Stored	39 Million	
Simultaneous users	50	
DWS managed		60

8.2.2 OCPIC Management: Centralized Configuration Manager

Table 41 – CCM Configuration Limits

Parameter	System Limit	Recommended
xMF subsystem per site	1	
Links / acquisition server	256	
Max number of sessions in a Network View	Not enforced in GUI	20
Max number of DFP Store per mediation subsystem	Not enforced in GUI	25
Max number of DFP Operate per mediation subsystem	Not enforced in GUI	25
Max number of DFP Build per mediation subsystem	Not enforced in GUI	25
Max number of streams from integrated acquisition to mediation	40	max routed from Integrated Acquisition
Max number of streams from probed acquisition to mediation	40	max routed from Probed Acquisition
Maximum number of streams per mediation Subsystem	500	
Maximum number of streams per mediation server	127	Warning: some streams are required for internal connections
Max Session lifetime	365 days	

8.2.3 OCPIC Management : OCPIC Management KPI application

Table 42 – KPI Configuration Limits

Parameter	System Limit	Recommended Value
Max. rows per configuration	1 000	
Max. number of cells per configuration	10 000	
Max. configurations applied to 1 server	100	
Max. configurations attached to 1 session	20	
Max. dynamic rows for TOP session	100 000	20 000
Max. number of fields per top filter	10	
Feeds to a centralized KPI application (OCPIC Management KPI))	50	

Note: When KPI configuration limits are exceeded, this may impact Mediation performance and stability

Table 43– Historical KPI application option Limits

Parameter	System Limit	Recommended Value
xDRs history	30 days back	
xDRs post-processed	1000 Million	
Process priority	10% of CPU usage	
Sessions	Single sessions only, no network view	
Simultaneous processes	1 per mediation sub-system	

8.2.4 OCPIC Management : Security

Table 44– Security application Limits

Parameter	System Limit	Recommended Value
Max number of tokens for OCPIC Management on HP G6 1 box	30	
Max number of tokens for OCPIC Management on HP Gen8, Gen9, ODA X5-2 (1 box)	50	
Max number of users	n/a	1 000
Max number of profiles	n/a	100
Max number of privacies	n/a	100

8.2.5 OCPIC Management : Q.752

Q.752 are a set of statistical counts defined by the ITU standard for SS7 data which are

- Applicable to ITU networks and signaling links
- Applicable to ANSI networks and signaling links

Following are the policy and guidelines:

- Supported for integrated acquisition only
- Supported on Low Speed Links (LSL) only
- Q.752 builder shall be available at mediation

There is a limitation of 1 DFP of Q752 traffic per subsystem.

8.2.6 OCPIC Management: xDR Export

xDR export is available on demand (interactive) or can be scheduled on regular bases.

Table 45– Interactive Export Limits (linked)

Format	Limits	Units
ZIP *	100 000	xDR/export
TXT **	10 000	xDR/export
XML	1 000	xDR/export
HTML	1 000	xDR/export
CSV	650 000	xDR/export
XLS	65 535	xDR/export
PCAP (SIGTRAN + Diameter)	10 000	PDU/export

* for ZIP export, if PDU are exported, the max depends on the protocol

** for TXT exports, if PDU are exported, the performance should be downgraded to 1 000 xDR/export

Table 46– Scheduled Export Limits

Criteria/Format	Limits	Units
# of export tasks per system	5	scheduled tasks
Minimum export period	3 600	seconds
ZIP	1 000 000	xDR/period
TXT	100 000	xDR/period
XML	10 000	xDR/period
HTML	10 000	xDR/period
CSV	1 000 000	xDR/period
XLS	65 535	xDR/period

Note: Although xDRs as well as KPIs can be exported using the scheduled export, it is not recommended to use it for millions of records a day. Use the Data Feed feature instead.

8.2.7 OCPIC Management: System Alarm application

Table 47– System Alarms Limits

Parameter	System Limit	Recommended Value
Alarms retention period (except if Max Event stored applies first)	30 days	n/a
Max Event Stored	39 Million	n/a

8.2.8 OCPIC Management: Audit Viewer application

Table 48– Audit Viewer Limits

Parameter	System Limit	Recommended Value
User’s actions retention period	120 days	n/a

8.3 OCPIC MANAGEMENT OPTION: TROUBLESHOOTING APPLICATION

Table 49– Troubleshooting application Option Limits

Parameter	System Limit	Recommended Value
Maximum traces per user	5	
Minimum latency for trace display after network event	15 sec	
Minimum latency for historical traces	30 sec per last 24hrs	
Maximum xDRs cells per page for Display	100 000	
Number of records exported directly to Excel	65 000	NA

Table 50– Troubleshooting application Option responsiveness

Troubleshooting application first page response time for multi-users query on ...	Average query response time
High cardinality* query 2 indexed fields multi-session (1-5, 1 subsystem) 20 fields(max)	< 20 seconds
Multi-session (8-10, 1 subsystem), at least 1 indexed field, 20 fields(max)	< 50 seconds
Multi-session (40, 2 subsystems), at least 1 indexed field, 20 fields(max)	< 120 seconds

Note *: high cardinality means that the table contains many different values for the same field, for instance: IMSI, MSISDN.

8.4 OCPIC MANAGEMENT OPTION: NETWORK AND SERVICE ALARM APPLICATION

Network and Service Alarm application option is a monitoring tool which displays a list of alarms (surveillance, SS7 network, QoS) and can animate objects on maps, according to the associated severity of the alarms.

Network and Service Alarm application can also be configured to forward alarms to 3rd party application

Table 51– Network and Service Alarm Limits

Parameter	System Limit	Recommended Value
Alarms retention period (except if Max Event stored applies first)	30 days	

Table 52– Network and Service Alarm Forwarding Limits

Parameter	System Limit	Recommended Value
Max. Managed Objects in SNMP agent	100 000	10000
Max. number of forwarded opened alarms referenced in the MIB database	10 000	n/a
Max events / sec handled (average / peak)	25/sec	n/a
Simultaneous users requesting MIB	3	n/a

Table 53– Typical Network and Service Alarm responsiveness

Action	Average for typical deployment
initial map open	< one (1) minute
refresh	< ten (10) seconds
Maximum delay of detection of alarms and generation of SNMP event (alarm forwarding)	20 sec

8.5 OCPIC MANAGEMENT OPTION: DASHBOARD APPLICATION

Table 54– Dashboard application Limits

Parameter	System Limit	Recommended Limit
Max. panels / dashboard	6	n/a
Max. KPI / panel	None. Impact on performance	Readability
Max points per chart	None. Impact on performance	200 points / chart
Min. refresh interval	30 sec to hours. Defined in OCPIC Management KPI Configuration	n/a
Max simultaneous KPIs	None. Impact on performance	50 KPIs (1 OCPIC Management KPI cell) / mediation subsystem every 5 min. For instance, for a system with 3 Mediation subsystem and 10 users, the recommendation is that each user will be able to display up to 15 simultaneous charts refreshed every 5 minutes.
Max. rows in a table	1000	100
Max. visible results of a top	10	n/a

Note: each dashboard panel uses one simultaneous user license

Table 55– Typical Dashboard application responsiveness

Action	Average for typical deployment
Dashboard Application Initial dashboard open	< one (1) minute
Dashboard Application dashboard refresh	< ten (10) seconds

8.6 OCPIC MANAGEMENT OPTION: SS7 NETWORK SURVEILLANCE APPLICATION

SS7 Network Surveillance application is available for TDM and SIGTRAN links in 2 different displays.

8.6.1 SS7 Network Surveillance application for TDM

Following are the policy and guidelines:

- Supported on integrated acquisition only
- Supported on Low Speed Links (LSL) and High Speed Links (HSL – T1/E1)
 - MTP2 and MTP3
- Not supported on SIGTRAN or ATM
- Display of the data depends upon the browser and the amount of displayed rows

Table 56– SS7 Network Surveillance application for TDM Limits

Parameter	System Limit	Recommended Value
Link Status window refresh interval	1 / 3 / 5 secs	Default 5
NetMgmt window refresh interval	5 / 10 / 15 secs	Default 15
Number of LSL links	No limit	See number of rows
Number of rows	No limit	1000
Simultaneous windows	No limit	10

8.6.2 SS7 Network Surveillance application for SIGTRAN

Following are the policy and guidelines:

- Supported on Acquisition (Probed and Integrated)
- Supported on SCTP, M2PA, M3UA and SCTP layers
- Display of the data depends upon the browser and the amount of displayed rows

Table 57– SS7 Network Surveillance application for SIGTRAN Limits

Parameter	System Limit	Recommended Value
Status window refresh interval	1 / 3 / 5 secs	Default 1
Stat window refresh interval	5 / 10 / 15 secs	Default 5
Top 'N' window refresh interval	5 / 10 / 15 secs	Default 5
Number of SCTP, M2PA, M3UA, SUA	No limit	See number of rows
Number of rows	No limit	1000
Simultaneous windows	No limit	10
Top N Associations	100	10

9 NETWORK REQUIREMENTS

This chapter contains information to help answer IT requests. It contains information on:

- Bandwidth requirements
- IP addresses requirements

9.1 BANDWIDTH REQUIREMENTS

9.1.1 OCPIC Management server to Workstation

The MINIMUM requirements for a network are:

1 Mb/s per simultaneous user between the OCPIC Management server and the user workstation

Less than 250ms round trip delay (50 ms recommended). From workstation to Server and server to Mediation.

Note: 250 ms round trip delay can impact some applications that require a query/response mechanism that normally occurs on a LAN network, however some response time can be higher than on a normal LAN.

9.1.2 OCPIC Mediation server to OCPIC management server

1 Mb/s per simultaneous user between the OCPIC Management server (NSP) and the Mediation subsystem

9.1.3 Acquisition (Integrated or Probed) server to Mediation

The bandwidth between Acquisition and Mediation depends on the traffic. It is calculated based on customer's assumptions. Please note that there is a traffic overhead from Acquisition server to Mediation server due to transport protocol headers. In some case it can be up to the double. Detailed values of bandwidth can be found as an output of the sizer.

When Q752 is activated, the MSUs have to be sent twice, thus doubling the traffic.

Warning: Network connections are relying on TCP protocol to provide high reliability. Even if TCP implementation on probes is optimized for high speed and potentially high latency network, embedded TCP congestion avoidance mechanisms (present in all TCP code), may limit the bandwidth. Whatever is the network capacity, the achieved bandwidth performance on a TCP session can be much lower than expected, specifically with high packet loss probability. So to achieve high transmission performance between the probe and the mediation, it is mandatory to control network QoS to optimize the TCP max bandwidth. A fair assumption of the theoretical TCP bandwidth capacity can be defined using following formula:

$$\text{Max TCP bandwidth} = \text{MSS} / (\text{RTT} \times \text{SQRT}(\text{PLP}))$$

- MSS: Max Segment Size (of TCP)
- RTT: Round Trip Time
- PLP: Packet Loss Probability

Formula shall be used during to get an indication of the network QoS requirements to customer to insure a safe implementation of the OCPIC components.

For instance, to achieve 300 Mbps probe output bandwidth on Probed Acquisition, application of the formula gives the following customer network QoS requirement (MSS is typically 1460 bytes on Ethernet):

- RTT shall be less than 100 msec
- PLP shall be less than 10^{-7}

Important note: long distance (eg. intercontinental) between Acquisition and Mediation is prohibited. In that case, it is imperative Acquisition and Mediation servers be colocated at the same location.

10 APPENDIX 1 – ACRONYMS

This section defines the specific terms, acronyms, and abbreviations used in this document.

Table 58 – Acronyms table

Acronym	Definition
A Interface	the GSM interface between a BSS and an MSC
AIN	advanced intelligent network
AMA	automatic message accounting
ANSI	American National Standards Institute
API	application programming interface
ARPU	Average Revenue Per User
ASCII	American standard code for information interchange
ASR	answer seizure ratio
ATM	asynchronous transfer mode
BOM	Bill of Material
BCD	binary coded decimal
B-G Interfaces	all GSM interfaces that use the MAP protocol
BHC	base hardware configuration
BIB	backward indicator bit
BNS	billing number services
BSC	base station controller
BSN	backward sequence number
BSS	GSM base station subsystem
BSSMAP	GSM base station subsystem mobile application part
CDMA	code division multiple access
CDR	call detail record
CIC	ISUP circuit identification code
CIMD2	Computer Interface to Message Distribution 2, Nokia
CLLI	common language location identifier
CMISE	common management information service element
CORBA	common object request broker architecture
CPN	called party number
CR	an SCCP connection request message
CRC	cyclic redundancy check
DCM	data communication module cards
DIR	direction, transmit or receive
DSR	Diameter Signalling Router
DTAP	GSM direct transfer application part
ECM	enhanced communications module
EECM	Ethernet enhanced communications module

Acronym	Definition
EMI/UCP	External Machine Interface/Universal Computer Protocol,
EMR	event message report
ESP	extended services platform
FIB	forward indicator bit
FIFO	First-in/First-Out
Filter	A set criteria for matching against all buffered messages which to display in a protocol analysis form
FISU	fill in signal unit
FSN	forward sequence number
FTP	file transfer protocol
GDMO	guidelines for the definition of managed objects
GMM	GPRS mobility management
GMSC	gateway mobile switching center
GPL	generic program load
GPRS	General Purpose Radio System
GSM	global system for mobile communications
GSM A	global system for mobile communications, A-interface
GSM MAP	global system for mobile communications, mobile application
GTP-C	GPRS tunneling protocol-control
GTT	global title translation
GUI	graphical user interface
HLR	GSM home location register
ICTM	inter-carrier TCAP monitoring
IMF	Integrated acquisition server (Integrated Message Feeder)
IMSI	international mobile subscriber identity
IN	intelligent network
INAP	intelligent network application part
IP	Internet protocol
IPDR	IP Detail Record
IS41	interim standard 41, a signaling protocol used in the North American standard cellular system
IS634	interim standard 634, the interface between cellular base stations and mobile traffic switching offices
ISDN	integrated services digital network
ISP	Internet service provider
ISUP	ISDN user part
ITU	International Telecommunications Union
KMPS	Kilo Message Per Second
KPI	Key Performance Indicator
KQI	Key Quality Indicator
LAN	local area network
LATA	local access transport area

Acronym	Definition
LAP-B	link access procedure-balanced
LEC	local exchange carrier
LIC	link interface card – The LIC is a processor card of the i2000 hardware shelf. Every appliqué in the i2000 resides on an LIC. The term LIC may refer to any of the following PCBAs: the 8Mhz LIC, the 16Mhz LIC, or the 32Mhz 486 LIC or “ALICE”.
LIDB	Line information database
LIM	link interface modules
LNP	local number portability
LTE	Long Term Evolution
LUP	location update
M2PA	MTP2 user peer-to-peer adaptation layer
M3PA	MTP3 user peer-to-peer adaptation layer
M2UA	MTP2 User Adaptation Layer
M3UA	MTP3 User Adaptation Layer
MAP	GSM mobile application part
MBS	message buffer server
MGCP	media gateway control protocol
MIB	managed information base
MIT	managed information tree
MMC	mobile-to-mobile call
MO	managed object
MOC	mobile-originated call
MS	mobile station
MSC	mobile switching center
MSISDN	mobile-station ISDN number
MSU	message signal unit
MSW	Message Switch
MT	message type
MTC	mobile-terminated call
MTP	message transfer part – message transaction part that provides functions for basic routing of signaling messages between signaling points
NEBS	network equipment building standards
NFS	network file system
NMS	network management system
NNM	HP OpenView Network Node Manager
NOC	network operations center
NOCC	network operation control center
NPLT	network performance load test
NTP	network time protocol
NUP	network user part
OAM&P	operations administration maintenance and provisioning
OCDSR	Oracle Communications Diameter Signalling Router

Acronym	Definition
ODS	operational data store
OHC	Oracle help center
OPC	origination point code
OSI	open system interconnection
PA	Protocol Analysis
PCI	peripheral component interconnect
PCM	Pulse Coded Modulation
PCS	personal communications service
PDF	Protocol Definition File
PDU	protocol data unit
PDR	Peg Count Data Record
PLMN	Public Land Mobile Network
PSTN	public switched telephone network
PTO	Pick to Order
QoS	Quality of Service
RAC	Real Application Cluster
RAM	random access memory
ROI	return on investment
SAS	signaling application system
SCCP	signaling connection control part
SCP	service control point
SCP/AP	service control point/application part
SCSI	small computer system interface
SCTP	simple control transmission protocol
SDP	session description protocol
SDR	Session Detail Record
SI	MTP service indicator
SIP	session initiation protocol
SLA	Service Level Agreement
SLR	SCCP source local reference
SLTM/SLTA	signaling link test message/signaling link test acknowledge
SMPP	Short Message Peer to Peer
SMS	Short Message Service
SMS-C	Short Message Service Center
SNAP	signaling node application platform
SNMP	simple network management protocol
SP	signaling point
SQL	structured query language
SS7	Signaling system number 7 provides two key abilities: fast-call setup via high-speed circuit-switched connections and transactions capabilities that deal with remote data base interactions
SSN	SCCP subsystem number

Acronym	Definition
SSP	service switching point
STC	Sentinel Data Transport card (DTC)
STP	signal transfer point
SU	signaling unit
SUA	SCCP user adaptation layer
TAC	technical assistance center
TCAP	transaction capabilities application part
TCP	transmission control protocol
TCP/IP	transmission control protocol/Internet protocol
TDR	Transaction Detail Record
TID	TCAP transaction ID
TMN	telecommunications management network
TMSI	temporary mobile subscriber identity
TGN	trunk group number
TUP	telephone user part
UDM	user defined message
VoIP	Voice over IP
VLR	Visitor Location Register
VPN	Virtual Private Network
WAN	wide area network
WWW	World Wide Web
xDR	x Detail Record

11 APPENDIX 2 - E1/T1 CONVERSION TABLES

These tables are helpers in order to convert a number of LSL (lines) with some known occupancy rate, Erlang (columns). Each cell indicates the equivalent Mbits/s.

Table 59 – LSL at 64000 bps equivalence

Links\ Erlang	0.1	0.2	0.3	0.4	0.5	0.6	0.7	0.8
32	0.4	0.8	1.2	1.6	2.0	2.3	2.7	3.1
64	0.8	1.6	2.3	3.1	3.9	4.7	5.5	6.3
128	1.6	3.1	4.7	6.3	7.8	9.4	10.9	12.5
192	2.3	4.7	7.0	9.4	11.7	14.1	16.4	18.8
256	3.1	6.3	9.4	12.5	15.6	18.8	21.9	25.0
320	3.9	7.8	11.7	15.6	19.5	23.4	27.3	31.3
384	4.7	9.4	14.1	18.8	23.4	28.1	32.8	37.5
448	5.5	10.9	16.4	21.9	27.3	32.8	38.3	43.8
512	6.3	12.5	18.8	25.0	31.3	37.5	43.8	50.0
1024	12.5	25.0	37.5	50.0	62.5	75.0	87.5	100.0
1536	18.8	37.5	56.3	75.0	93.8	112.5	131.3	150.0
2048	25.0	50.0	75.0	100.0	125.0	150.0	175.0	200.0

Table 60– LSL at 56000 bps equivalence

Links\ Erlang	0.1	0.2	0.3	0.4	0.5	0.6	0.7	0.8
32	0.3	0.7	1.0	1.4	1.7	2.1	2.4	2.7
64	0.7	1.4	2.1	2.7	3.4	4.1	4.8	5.5
128	1.4	2.7	4.1	5.5	6.8	8.2	9.6	10.9
192	2.1	4.1	6.2	8.2	10.3	12.3	14.4	16.4
256	2.7	5.5	8.2	10.9	13.7	16.4	19.1	21.9
320	3.4	6.8	10.3	13.7	17.1	20.5	23.9	27.3
384	4.1	8.2	12.3	16.4	20.5	24.6	28.7	32.8
448	4.8	9.6	14.4	19.1	23.9	28.7	33.5	38.3
512	5.5	10.9	16.4	21.9	27.3	32.8	38.3	43.8
1024	10.9	21.9	32.8	43.8	54.7	65.6	76.6	87.5
1536	16.4	32.8	49.2	65.6	82.0	98.4	114.8	131.3
2048	21.9	43.8	65.6	87.5	109.4	131.3	153.1	175.0

12 APPENDIX 3 – EAGLE TPS TO OCPIC MBPS CONVERSION

The formula used to convert TPS into Mbps is the following:

$$\text{Mbps} = ((2 \times \text{TPS} \times \text{Av. MSU size}) \times 8) / 1024 / 1024$$

Where:

- **Mbps** = the expected result in Megabits per second
- **TPS** = number of TPS to be monitored. Note that it is usually 40% of the maximum capacity of an EAGLE node.
- **Av. MSU Size** = the Average 'Message Signaling Unit' (MSU) size in Bytes

As you can see, the TPS to Mbps conversion is dependent on the average MSU size selected (or used). Therefore it is mandatory that you pay special attention to this parameter. Also, before comparing the EAGLE and OCPIC dimensioning, make sure that you are using the same TPS and same average MSU Size.

Information about MSU size:

Table 61– Average MSU size

	TDM Links	SIGTRAN
All ISUP, NUP and similar	40	140
AIN, LIBD, CLASS, AIN, BSSAP, INAP, CAMEL, CAP, BICC Short, etc...	80	180
MAP, IS41, WIN, BICC Long, etc...	120	230

So, bottom line is that the average MSU size used in the EAGLE dimensioning needs to match what you used in the OCPIC one.

13 APPENDIX 4 – HOW TO CONFIGURE AN OCPIC FOR OCDSR MONITORING

For a OCDSR monitoring opportunity it is possible to use OCPIC, find here how to translate the OCDSR **MPS** traffic information into **Mbps** required to size the OCPIC solution. Follow the following instructions:

1. Get the **MPS** Max capacity used to size the OCDSR.
2. Use the following formula to convert the **MPS** capacity to convert it into **Mbps**

$$\text{Mbps} = ((2 \times \text{MPS} \times \text{Av. MSU size} \times 40\%) \times 8) / 1024 / 1024$$

Where:

- **Mbps** = the expected result in Megabits per second
- **MPS** = the maximum MPS capacity of the DSR node. Note that it is usually assumed that the node will run at 40% of this maximum capacity of the DSR node.
- **Av. MSU Size** = the Average 'Message Signaling Unit' (MSU) size in Bytes (usually between 750 to 3,000 Bytes)
- **Why a 2x factor:** this factor is used because all messages that are getting into the DSR will also get out of the DSR (as it is a Diameter Signaling Router) -> therefore the acquisition (-ie: probe) will see the same message twice: one time on its' way in and one time on its' way out.
- **Why 40% load factor:** like on Eagle STP, the OCDSR is sized for a max **MPS** capacity (let's say 10,000 MPS) but most of the time it is running in pair, so the traffic (the 10,000 MPS) is splitted across each node (so 5,000 MPS per node) and finally we usually account for a 20% extract traffic buffer (for peak traffic and other) -> Typically we end up having 4,000 MPS per node, which represent 40% of the max MPS capacity of the OCDSR pair.

14 APPENDIX 5 – BUILDERS CONTENT OF MEDIATION PROTOCOL LICENSES

Oracle Communications Performance Intelligence Center, Mediation Protocol License :

- SGs
- Diameter S6 / S13
- Diameter Gx / S7
- Diameter Rx
- DIAMETER (Generic)
- Diameter Cc / Gy / Ro / Rf
- Diameter Cx / Dx
- Diameter Sh / Dh
- Diameter Gq
- RTCP Stat
- IP DNS ENUM TDR
- SMPP TDR
- UCP TDR
- H323 - H225 / RAS
- H323 - H245
- H248
- MEGACO
- MGCP CDR
- MGCP TDR
- H323 / ISDN Q931
- SIP
- SIP T ITU, SIP-I
- SIP-T ANSI
- Not Processed Messages SUDR RTU
- M2PA Non call related SUDR
- M2UA Non call related SUDR
- M3UA Non call related SUDR
- SUA Non call related SUDR
- SCTP SUDR
- AIN
- BICC ANSI
- ISUP ANSI
- IS41 C
- WIN (IS771 and IS 826)
- CLASS TDR
- LIDB
- ISUP ETSI
- SS7 ISUP ETSI SUPER CORRELATION
- BICC ETSI
- TUP
- BT NUP
- IUP
- ISDN over Sigtran (Q931)
- INAP and CAMEL
- INAP and CAMEL Compact

- MAP
- MAP Compact
- MAP SM TDR
- MAP Virtual HLR
- MAP MULTILEG TDR
- Usage Measurement SUDR
- IS41 Data Export TDR
- Diameter SUDR Accounting
- INAP SUDR ProAccount
- ISUP ETSI SUDR ProAccount
- MAP SUDR ProAccount
- SS7 MAP DATA BROKER TDR
- SS7 CAMEL DATA BROKER TDR
- SS7 IS41 DATA BROKER TDR
- Generic ProTrace SuDR
- BSSAP TDR
- RAN MM
- RAN SMS TDR
- RAN USSD TDR
- Iu-CS Control Plan
- RAN MM
- RAN SMS TDR
- RAN USSD TDR
- Iu-PS Control Plan
- UMTS Iu-PS GMM xDR
- UMTS Iu-PS SM xDR
- Gn/Gp GTP v1 TDR
- Gn/Gp SDR
- IP SESSION SUMMARY
- Gn/Gp/Gi FTP IPDR
- Gn/Gp/Gi HTTP IPDR
- Gn/Gp/Gi IMAP4 IPDR
- Gn/Gp/Gi MMS over WAPv1 TDR
- Gn/Gp/Gi MMS over WAPv2 TDR
- Gn/Gp/Gi pop3 IPDR
- Gn/Gp/Gi SMTP IPDR
- Gn/Gp/Gi TCP IPDR
- Gn/Gp/Gi Video Streaming IPDR
- Gn/Gp/Gi WAP IPDR
- Gn/Gp/Gi WAP V2 IPDR
- Gn/Gp/Gi DNS IPDR
- Gi DHCP IPDR
- Gi Radius IPDR
- Gi DNS IPDR
- Gs (BSSAP+)
- Gb TDRGTP V2 Ctrl Plane P Tun. Mgnt
- GTP User Plane
- S1-AP

Oracle Communications Performance Intelligence Center, Mediation Protocol II License :

- Diameter Gy
- Diameter S9
- E-ISUP
- PIC_XB SS7 SIGTRAN TRANSPORT SUDR_RTU_INVOICE_ONLY
- RAN CC2
- RAN EMM
- RAN ESM
- GTP V2 Mobility Management

Oracle Communications Performance Intelligence Center, Mediation Protocol III License :

- LTE Diameter (Generic)
- Diameter AAA
- Diameter LCS
- GTPv2 Sv

15 APPENDIX 6: MY ORACLE SUPPORT

MOS (<https://support.oracle.com>) is your initial point of contact for all product support and training needs. A representative at Customer Access Support (CAS) can assist you with MOS registration.

Call the CAS main number at 1-800-223-1711 (toll-free in the US), or call the Oracle Support hotline for your local country from the list at <http://www.oracle.com/us/support/contact/index.html>. When calling, make the selections in the sequence shown below on the Support telephone menu:

1. Select 2 for New Service Request
2. Select 3 for Hardware, Networking and Solaris Operating System Support
3. Select 2 for Non-technical issue

You will be connected to a live agent who can assist you with MOS registration and provide Support Identifiers. Simply mention you are a Tekelec Customer new to MOS.

MOS is available 24 hours a day, 7 days a week.

16 APPENDIX 7: LOCATE PRODUCT DOCUMENTATION

Oracle Communications customer documentation is available on the web at the Oracle Help Center (OHC) site, <http://docs.oracle.com>. You do not have to register to access these documents. Viewing these files requires Adobe Acrobat Reader, which can be downloaded at www.adobe.com.

4. Access the **Oracle Help Center** site at <http://docs.oracle.com>.
5. Click **Industries** icon.
6. Under the **Oracle Communications** heading, click **Oracle Communications documentation**.
7. The Communications Documentation page appears. Go to the **Analytics** section.
8. Click on **Performance Intelligence Center** and then the release number.

A list of the entire documentation set for the selected release appears.

To download a file to your location, right-click the **PDF** link and select Save Target As (or similar command based on your browser), and save to a local folder.

Note: As long as the documentation site has not been significantly refactored, you may use this link as a shortcut to step 5:

<http://docs.oracle.com/en/industries/communications/performance-intelligence-center/index.html>



April 2017

Oracle Corporation
World Headquarters
500 Oracle Parkway
Redwood Shores, CA 94065
U.S.A.

Worldwide Inquiries:
Phone: +1.650.506.7000
Fax: +1.650.506.7200

oracle.com

Copyright © 2017, Oracle and/or its affiliates. All rights reserved.

This document is provided for information purposes only, and the contents hereof are subject to change without notice. This document is not warranted to be error-free, nor subject to any other warranties or conditions, whether expressed orally or implied in law, including implied warranties and conditions of merchantability or fitness for a particular purpose. We specifically disclaim any liability with respect to this document, and no contractual obligations are formed either directly or indirectly by this document. This document may not be reproduced or transmitted in any form or by any means, electronic or mechanical, for any purpose, without our prior written permission.

Oracle and Java are registered trademarks of Oracle and/or its affiliates. Other names may be trademarks of their respective owners.

Intel and Intel Xeon are trademarks or registered trademarks of Intel Corporation. All SPARC trademarks are used under license and are trademarks or registered trademarks of SPARC International, Inc. AMD, Opteron, the AMD logo, and the AMD Opteron logo are trademarks or registered trademarks of Advanced Micro Devices. UNIX is a registered trademark of The Open Group. 0113

Hardware and Software, Engineered to Work Together