

Oracle Utilities Smart Grid Gateway Integration for Outage Operations

Implementation Guide

Oracle Utilities Network Management System
V1.12.0.2
Oracle Utilities Smart Grid Gateway v2.1.0.3

Release 2.1.0.3 Media Pack
E40671-03

April 2015

Oracle Utilities Smart Grid Gateway Integration for Outage Operations, Release 2.1.0.3 Media Pack

E40671-03

Copyright © 2015, Oracle and/or its affiliates. All rights reserved.

Primary Author: Oracle Corporation

This software and related documentation are provided under a license agreement containing restrictions on use and disclosure and are protected by intellectual property laws. Except as expressly permitted in your license agreement or allowed by law, you may not use, copy, reproduce, translate, broadcast, modify, license, transmit, distribute, exhibit, perform, publish, or display any part, in any form, or by any means. Reverse engineering, disassembly, or decompilation of this software, unless required by law for interoperability, is prohibited.

The information contained herein is subject to change without notice and is not warranted to be error-free. If you find any errors, please report them to us in writing.

If this is software or related documentation that is delivered to the U.S. Government or anyone licensing it on behalf of the U.S. Government, the following notice is applicable:

U.S. GOVERNMENT END USERS: Oracle programs, including any operating system, integrated software, any programs installed on the hardware, and/or documentation, delivered to U.S. Government end users are “commercial computer software” pursuant to the applicable Federal Acquisition Regulation and agency-specific supplemental regulations. As such, use, duplication, disclosure, modification, and adaptation of the programs, including any operating system, integrated software, any programs installed on the hardware, and/or documentation, shall be subject to license terms and license restrictions applicable to the programs. No other rights are granted to the U.S. Government.

This software or hardware is developed for general use in a variety of information management applications. It is not developed or intended for use in any inherently dangerous applications, including applications that may create a risk of personal injury. If you use this software or hardware in dangerous applications, then you shall be responsible to take all appropriate fail-safe, backup, redundancy, and other measures to ensure its safe use. Oracle Corporation and its affiliates disclaim any liability for any damages caused by use of this software or hardware in dangerous applications.

Oracle and Java are registered trademarks of Oracle and/or its affiliates. Other names may be trademarks of their respective owners.

Intel and Intel Xeon are trademarks or registered trademarks of Intel Corporation. All SPARC trademarks are used under license and are trademarks or registered trademarks of SPARC International, Inc. AMD, Opteron, the AMD logo, and the AMD Opteron logo are trademarks or registered trademarks of Advanced Micro Devices. UNIX is a registered trademark of The Open Group.

This software or hardware and documentation may provide access to or information on content, products, and services from third parties. Oracle Corporation and its affiliates are not responsible for and expressly disclaim all warranties of any kind with respect to third-party content, products, and services. Oracle Corporation and its affiliates will not be responsible for any loss, costs, or damages incurred due to your access to or use of third-party content, products, or services.

Contents

Chapter 1 Overview

1.1	Additional Resources	1-1
1.2	Prerequisites	1-1
1.3	About the Integration Product	1-2
1.3.1	About the Products	1-2
1.3.1.1	Oracle Utilities Network Management System	1-2
1.3.1.2	Oracle Utilities Smart Grid Gateway	1-2
1.4	Supported Business Processes	1-2

Chapter 2 Understanding the Integration Process

2.1	Technical Overview	2-1
2.2	Integration Points	2-4
2.2.1	Oracle Utilities Network Management System Batch Ping Request	2-4
2.2.1.1	Business Processing	2-5
2.2.1.2	Technical Details	2-6
2.2.2	Oracle Utilities Smart Grid Gateway Batch Ping Response	2-7
2.2.2.1	Business Process	2-7
2.2.2.2	Technical Details	2-8
2.2.3	Oracle Utilities Network Management System Batch Enable / Disable Request	2-9
2.2.3.1	Business Processing	2-9
2.2.3.2	Technical Details	2-10
2.2.4	Oracle Utilities Smart Grid Gateway Batch Unsuppress / Suppress Request	2-11
2.2.4.1	Business Processing	2-11
2.2.4.2	Technical Details	2-12
2.2.5	Oracle Utilities Smart Grid Gateway Device Power Status Update	2-13
2.2.5.1	Business Processing	2-13
2.2.5.2	Technical Details	2-14

Chapter 3 Configuring the Integration

3.1	Integration Configuration Checklist	3-1
3.1.1	Oracle Utilities Network Management System Configuration Checklist	3-1
3.1.2	Oracle Utilities Smart Grid Gateway Configuration Checklist	3-2
3.1.3	Integration Product Configuration Checklist	3-2
3.2	Data Synchronization	3-2
3.3	Setting Up Oracle Utilities Network Management System	3-2
3.3.1	Enable the AMR Component of the MultiSpeak Adapter	3-2

3.3.2	Configure Integration SOA Composite URLs	3-3
3.3.3	Configure Credentials for Accessing Integration SOA Composites	3-3
3.3.4	Configure Additional Communication Parameters	3-3
3.4	Setting Up Oracle Utilities Smart Grid Gateway	3-4
3.4.1	Admin Data Setup	3-4
3.4.1.1	Oracle Utilities Smart Grid Gateway Master Configuration	3-5
3.4.1.2	Configure Activity Types	3-5
3.4.1.3	Create XAI Senders	3-6
3.4.1.4	Create Outbound Message Types	3-9
3.4.1.5	Create External System	3-9
3.4.1.6	Create Service Provider	3-10
3.4.1.7	Configure Extendable Lookups	3-12
3.5	Setting Up the Process Integration	3-12
3.5.1	Configure Configuration Properties	3-12
3.5.1.1	Module Configuration	3-13
3.5.1.2	Service Configuration	3-13
3.5.2	Configure Domain Value Maps	3-16
3.5.3	Error Handling	3-18
3.5.3.1	Error Notification Setup	3-18

Chapter 4 Monitoring and Troubleshooting

4.1	Monitoring from Oracle Utilities Network Management System	4-1
4.2	Monitoring from Oracle Utilities Smart Grid Gateway	4-1
4.2.1	Oracle Utilities Smart Grid Gateway Error Logs	4-1
4.2.2	Notifications	4-2
4.2.3	Connection Errors	4-2
4.3	Monitoring from the Integration	4-2
4.3.1	Monitoring Using WebLogic SOA Enterprise Manager	4-2
4.3.2	Monitoring Using the WebLogic Logs	4-3
4.3.3	Data Purge	4-3
4.4	Troubleshooting	4-3

Chapter 5 Customization Options

5.1	Extension Methods	5-1
5.1.1	Pre-Transformation Extension Scope	5-1
5.1.2	Pre-Invoke Extension Scope	5-1
5.1.3	Post-Invoke Extension Scope	5-2
5.1.4	Post-Transformation Extension Scope	5-2
5.1.5	Custom Transformations	5-2
5.1.6	Override Transformations	5-2

Appendix A Data Mapping

Part 1

Understanding the Integration

This section provides an overview of the participating applications and information regarding the business processes addressed by this integration.

This section contains the following chapters:

- [Overview](#)
- [Understanding the Integration Process](#)

Chapter 1

Overview

This document provides configuration and administration information for the integration between Oracle Utilities Network Management System and Oracle Utilities Smart Grid Gateway.

- [Additional Resources](#)
- [Prerequisites](#)
- [Supported Business Processes](#)

1.1 Additional Resources

The following additional resources are available:

Resource	Location
<i>Oracle Utilities Smart Grid Gateway Integration for Outage Operations Release 2.1.0.3 Media Pack Installation Guide</i>	Same folder as this document, with the distribution for this product.
<i>Oracle Utilities Network Management System Documentation for Release v1.12.0.2</i>	Same folder as this document, with the distribution for this product.
<i>Oracle Utilities Smart Grid Gateway Documentation for Release v2.1.0.3</i>	Refer to Oracle Utilities Smart Grid Gateway documentation located on the Oracle Technology Network. http://www.oracle.com/technetwork/documentation

Note: Please refer to the Oracle Technology Network (OTN) site for the most recent version of this documentation.

1.2 Prerequisites

All participating applications namely, Oracle Utilities Network Management System, (NMS), Oracle Utilities Smart Grid Gateway (SGG), Oracle Service-Oriented Architecture (SOA) Suite and Oracle Utilities Smart Grid Gateway Integration for Outage Operations Media Pack must be installed, set up, and working properly.

1.3 About the Integration Product

This section provides general information about the functionality and processing of Oracle Utilities Smart Grid Gateway Integration for Outage Operations release 2.1.0.3 Media Pack. This is a direct integration of Oracle Utilities Network Management System and Oracle Utilities Smart Grid Gateway using Service-Oriented Architecture (SOA) Suite, and does not require the AIA Foundation Pack to be installed.

1.3.1 About the Products

The following products are involved in the integration:

- [Oracle Utilities Network Management System](#)
- [Oracle Utilities Smart Grid Gateway](#)

1.3.1.1 Oracle Utilities Network Management System

Oracle Utilities Network Management System (NMS) processes trouble calls from the customers and analyzes those to determine the probable outage locations. It can generate the Estimated Restoration Times (ERTs) that can then be provided back to the customers. Also, it keeps a history of all of the customer calls that were entered in the system, as well as a history of all events that were known to affect a customer even if the customer did not call in. In addition to responding to unplanned outages and non-outage problems, Oracle Utilities Network Management System helps a utility plan maintenance work or new construction that may impact existing customers. When the detailed switching plans are generated in Oracle Utilities Network Management System, information is provided to the customers about planned outages that impact them.

The following application versions are supported by this integration. Install the applicable version on an Oracle database with the latest supported media pack:

- v1.12.0.2
- v1.12.0.1
- v1.11.0.4

1.3.1.2 Oracle Utilities Smart Grid Gateway

Oracle Utilities Smart Grid Gateway (SGG) standardizes communications and orchestrates long-running business processes that commission, connect, and monitor the state of smart meters. Oracle Utilities Smart Grid Gateway also standardizes measurement data and meter events for devices associated with different head-end systems / metering systems.

The following application versions are supported by this integration. Install the applicable version on an Oracle database with the latest supported media pack:

- v2.1.0.3
- v2.1.0.2

1.4 Supported Business Processes

The integration between Oracle Utilities Network Management System (NMS) and Oracle Utilities Smart Grid Gateway (SGG) provides power outage and restoration information along with some filtering in support of the Outage Management System

(OMS) capability of Oracle Utilities Network Management System. It assists in outage detection, outage verification, and restoration verification.

The integration provides meter status information to Oracle Utilities Network Management System. It supports “meter pings” (sending a request to the AMI head-end to request a power-on status from the meter). It also supports “turning off” the message flows from Oracle Utilities Smart Grid Gateway to Oracle Utilities Network Management System and vice versa for a list of one or more meters, which handles cases of ignoring bad meters that provide false statuses, or meters that are being put into a test mode.

The integration uses SOAP web services as the underlying technology.

On Oracle Utilities Network Management System side, the integration is developed by extending functionality of the existing AMR/AMI component of the Oracle Utilities Network Management System MultiSpeak adapter. It uses version 4.1 of the MultiSpeak specification.

The following list summarizes the functionality included in the integration:

- **Meter Ping Requests:** The integration provides ability to send a list of meter IDs from Oracle Utilities Network Management System to Oracle Utilities Smart Grid Gateway to have the meters in the “pinged” state to determine current power status (on/off).
- **Batch Ping Response:** The integration supports the ability to send the current meter power status for the list of the meter IDs sent by Oracle Utilities Network Management System. The system sends a bulk response once everything is back, or sends what is available at a certain point in time, and sends subsequent bulk responses when more responses become available.

Note: The **Meter Ping Requests** and **Batch Ping Response** functionality of the integration are supported for only those Smart Grid Gateway Adapters that support the Device Status Check/Ping command.

- **Batch Enable / Disable Request:** The integration provides the ability for the Oracle Utilities Network Management System users to select a list of one or more meter IDs to start or stop ignoring meter statuses due to problems with false statuses, meter “chattering”, needing to conduct tests on meter, etc. The list is sent to Oracle Utilities Smart Grid Gateway, and results in Oracle Utilities Smart Grid Gateway either with no longer sending statuses for those meters (disabled), or with resuming sending of statuses (enabled).
- **Batch Unsuppress / Suppress Request:** The integration provides ability to Oracle Utilities Network Management System to receive a list of meter IDs that have been disabled or enabled from Oracle Utilities Smart Grid Gateway via the Oracle Utilities Smart Grid Gateway user interface. Oracle Utilities Network Management System takes this list into account for outage verification and restoration verification.

Note: The terminologies used in Oracle Utilities Network Management System and Oracle Utilities Smart Grid Gateway descriptions are different. On Oracle Utilities Network Management System, **Enable / Disable Meter** activities are used. On Oracle Utilities Smart Grid Gateway, it is referred as **Unsuppress /Suppress Device**.

- **Processing of Meter Statuses:** The integration supports processing of meter power statuses (“last gasp” power off messages and “restoration” power-up messages) in Oracle Utilities Smart Grid Gateway for outage detection, outage verification, and restoration verification.

Note: The Device Power Status Update is also referred as the Device Event Transmission / Notification.

The following diagram provides a visual representation of this processing:

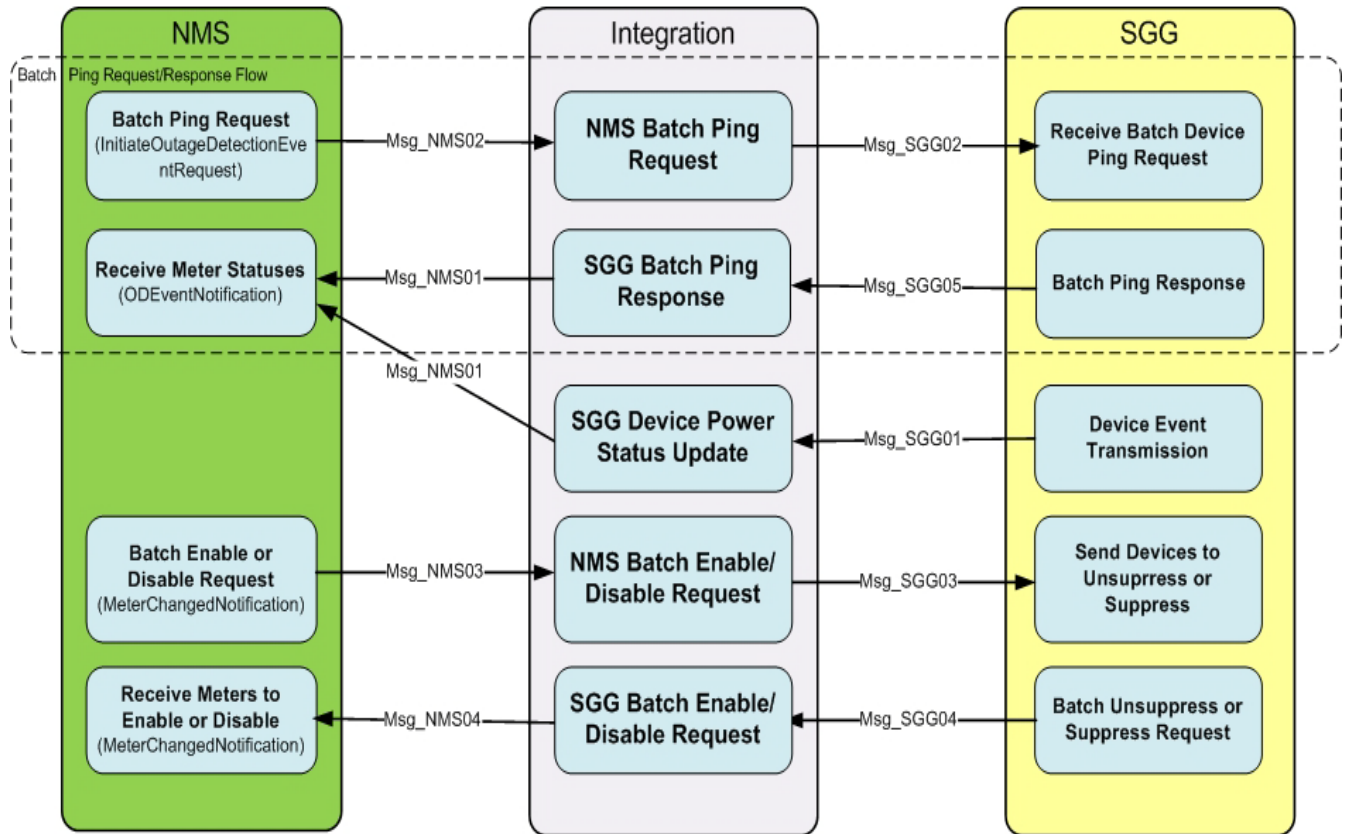

Oracle Utilities Network Management System -Oracle Smart Grid Gateway
Integration Points

Note: The meter in Oracle Utilities Network Management system is referred as “device” in Oracle Utilities Smart Grid Gateway.

Chapter 2

Understanding the Integration Process

This section outlines the overall technical overview, business processes, and specific integration points handled by the integration.

- [Technical Overview](#)
- [Integration Points](#)

2.1 Technical Overview

This direct integration between Oracle Utilities Network Management System and Oracle Utilities Smart Grid Gateway uses web services to facilitate communication between the two applications. The technical processes include the following:

- All end-to-end integration points are synchronous.
- Both Oracle Utilities Network Management System and Oracle Utilities Smart Grid Gateway interact with the integration layer using web services.
- The integration layer is made up of Service-Oriented Architecture (SOA) composites deployed on the SOA Suite. These composites use Business Process Execution Language (BPEL) components.
- Oracle Utilities Network Management System *Batch Ping Request* and Oracle Utilities Network Management System *Batch Enable/Disable Request* integration points are initiated from Oracle Utilities Network Management System.
- Oracle Utilities Smart Grid Gateway *Batch Ping Response*, Oracle Utilities Smart Grid Gateway *batch Unsuppress/Suppress Request* and Oracle Utilities Smart Grid Gateway *Device Power Status Update* integration points are initiated from Oracle Utilities Smart Grid Gateway.
- The integration BPEL processes convert the message from one edge application format to another edge application format. The Domain Value Map (DVMs) are used for the transformation.

Oracle Utilities Network Management System Initiated Integration Processes

Oracle Utilities Network Management System initiated integration processes invoke integration BPEL process:

- Oracle Utilities Network Management System invokes integration processes using a web service, then invokes Oracle Utilities Smart Grid Gateway using an XAI Inbound service.
- The Request Transformation converts messages from Oracle Utilities Network Management System format to Oracle Utilities Smart Grid Gateway format, then converts the message from Oracle Utilities Smart Grid Gateway format back to Oracle Utilities Network Management System format.
- All error responses are sent back to Oracle Utilities Network Management System.

Oracle Utilities Smart Grid Gateway Initiated Integration Processes

Oracle Utilities Smart Grid Gateway initiated integration processes invoke integration BPEL process:

- Oracle Utilities Smart Grid Gateway invokes integration processes using real-time sender configuration.
- The integration process invokes the Oracle Utilities Network Management System web service.
- The Request Transformation converts message from Oracle Utilities Smart Grid Gateway format to Oracle Utilities Network Management System format. The Response Transformation converts message from Oracle Utilities Network Management System format to Oracle Utilities Smart Grid Gateway format.
- All error responses are sent back to Oracle Utilities Smart Grid Gateway.

Extensibility Options

The integration process offers the following extension scopes:

- Pre-transformation Extension scope
- Pre-invoke Extension scope
- Post-invoke Extension scope
- Post-transformation Extension scope
- Custom Transformations
 - Request custom transformation
 - Response custom transformation
- Override transformations
 - Request override transformation
 - Response override transformation

The following diagram provides a graphical representation of this processing:

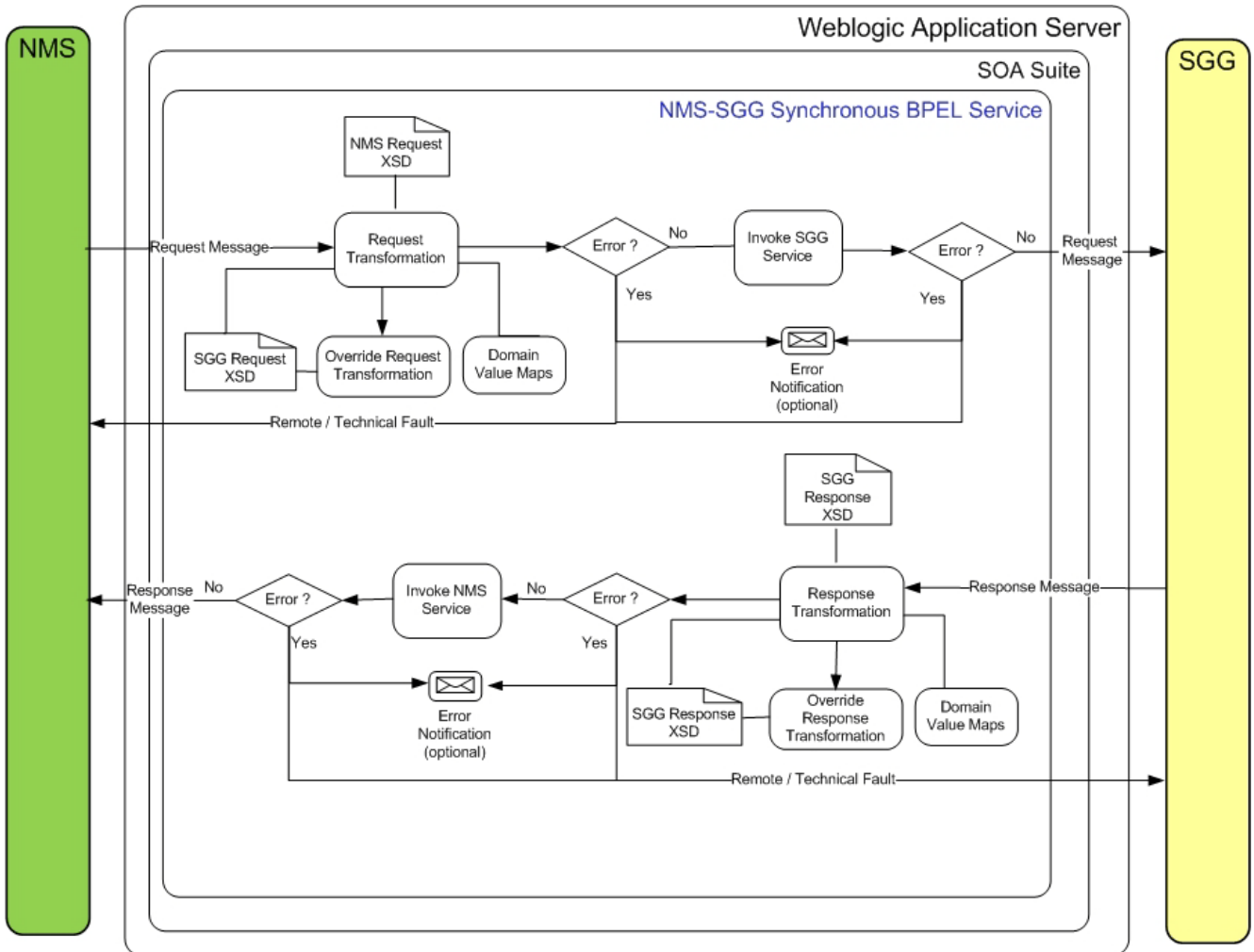

Synchronous Request

The diagram above illustrates synchronous request - reply communication pattern, and supports the message exchange between Oracle Utilities Network Management System and Oracle Utilities Smart Grid Gateway. The integration transforms the request message from the sender and the response message from the receiver, and applying custom/override transformation and domain value maps. The success or failure response is delivered to the sender.

2.2 Integration Points

The integration points include:

- [Oracle Utilities Network Management System Batch Ping Request](#)
- [Oracle Utilities Smart Grid Gateway Batch Ping Response](#)
- [Oracle Utilities Network Management System Batch Enable / Disable Request](#)
- [Oracle Utilities Smart Grid Gateway Batch Unsuppress / Suppress Request](#)
- [Oracle Utilities Smart Grid Gateway Device Power Status Update](#)

2.2.1 Oracle Utilities Network Management System Batch Ping Request

This integration point sends meter ping request from Oracle Utilities Network Management System to Oracle Utilities Smart Grid Gateway to determine the current power status of the meter. Oracle Utilities Network Management System receives the acknowledgement from Oracle Utilities Smart Grid Gateway informing that the request has reached Oracle Utilities Smart Grid Gateway.

The following diagram provides a graphical representation of this processing:

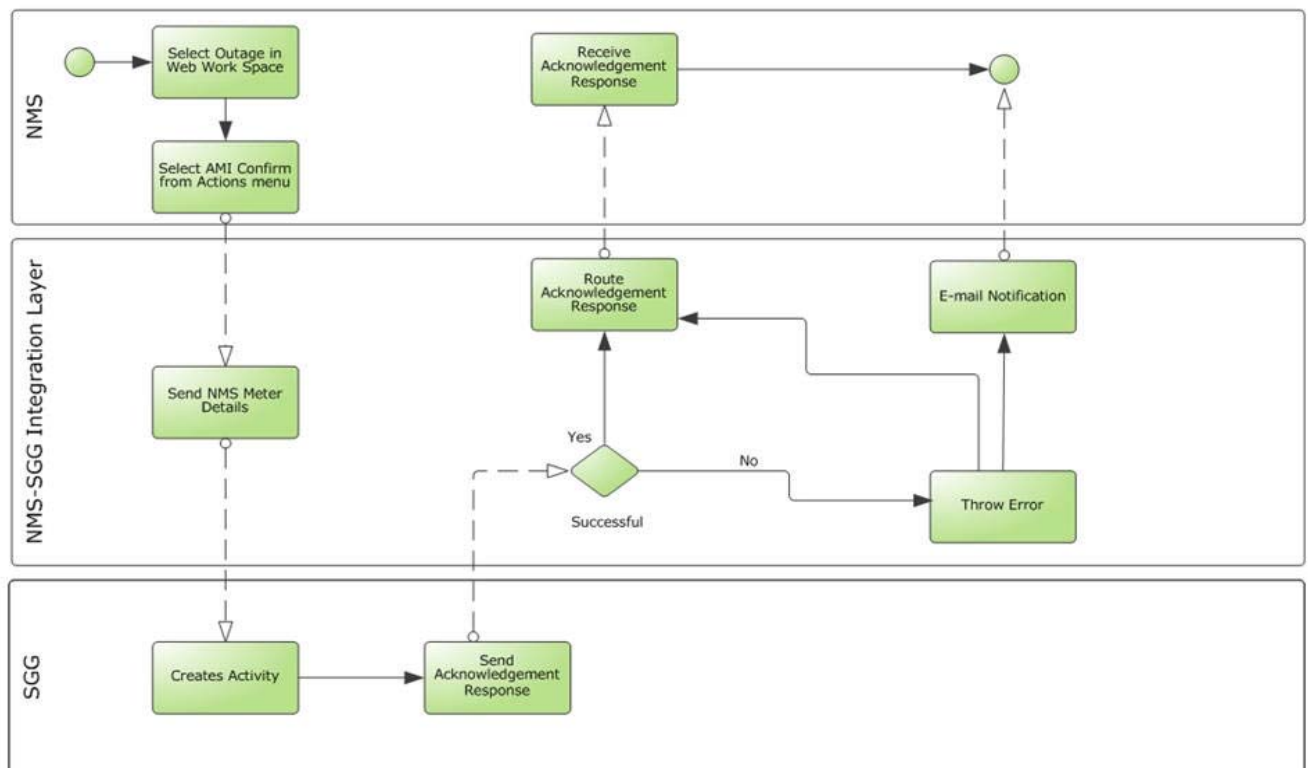

Batch Ping Request

2.2.1.1 Business Processing

The following steps are performed:

- Oracle Utilities Network Management System sends a meter ping request (Msg_NMS02) to the integration layer by invoking a web service in the integration layer.
- Oracle Utilities Network Management System sends a list of one or more meter IDs in the form of an XML message.
- The integration reads the following values from the configuration properties and assigns them to the respective fields of the Oracle Utilities Smart Grid Gateway request (Msg_SGG02):
 - `externalRequesterId`
Must be the same as Oracle Utilities Smart Grid Gateway's external system ID.
 - `expirationDateTimeDuration`
Used in case Oracle Utilities Network Management System `expTime` and `units` fields are not populated based on which timed response is sent by Oracle Utilities Smart Grid Gateway.
 - `responseCreationMethod`
Used to parameterize batch ping requests sent to Oracle Utilities Smart Grid Gateway. This property can be set to `ONE` or `WAIT`
 - **ONE** - Oracle Utilities Smart Grid Gateway sends separate responses for each device.
 - **WAIT** - Oracle Utilities Smart Grid Gateway sends a single response with all devices.
- The message is transformed by integration layer and sent to the Oracle Utilities Smart Grid Gateway **BulkRequest BPEL** service.
- Oracle Utilities Smart Grid Gateway **BulkRequest BPEL** process sends an acknowledgement to the integration that is sent back to Oracle Utilities Network Management System.
- The **bulkRequestResponse** sent by **BulkRequest BPEL** process does not contain actual meter ping response. It is an acknowledgement to communicate that the message was received by Oracle Utilities Smart Grid Gateway.
- If there is any error in Oracle Utilities Smart Grid Gateway in processing the request sent by Oracle Utilities Network Management System, Oracle Utilities Smart Grid Gateway throws a fault and the same is assigned to the *errorObject* element of response and sent back to Oracle Utilities Network Management System. In case of success, the *errorObject* list will be **empty** in the response.
- In case of meters that do not exist in Oracle Utilities Smart Grid Gateway, Oracle Utilities Smart Grid Gateway sends bulk notification to the service URL that is provided in the ping request message **CallbackURL** element. This URL is configured to the **SGGBatchPingCallBackRespBPEL** component of the **SGGNMSBatchPingRespEBF** composite that receives the error message and logs the same for error notification purposes.
- The e-mail notification can be sent to the users based on the error notification flag configuration value.

- The actual meter ping response is sent by Oracle Utilities Smart Grid Gateway through the “Batch Ping Response” integration point.

2.2.1.2 Technical Details

This section provides details of the composites and Oracle Utilities Smart Grid Gateway services used for the Batch Ping Request integration point.

Composites

Composite Name	Description
NMSSGGBatchPingReqEBF	Composite that processes the batch ping request from Oracle Utilities Network Management System and sends the acknowledgment back to Oracle Utilities Network Management System.

Oracle Utilities Smart Grid Gateway Services

Service Name	Operation Name	Description
BulkRequest Service	bulkRequest	Bulk request service is Oracle Utilities Smart Grid Gateway BPEL service. It is used to check the device status for the meter(s) pinged.

2.2.2 Oracle Utilities Smart Grid Gateway Batch Ping Response

This integration point sends meter power status from Oracle Utilities Smart Grid Gateway to Oracle Utilities Network Management System.

The following diagram provides a graphical representation of this processing:

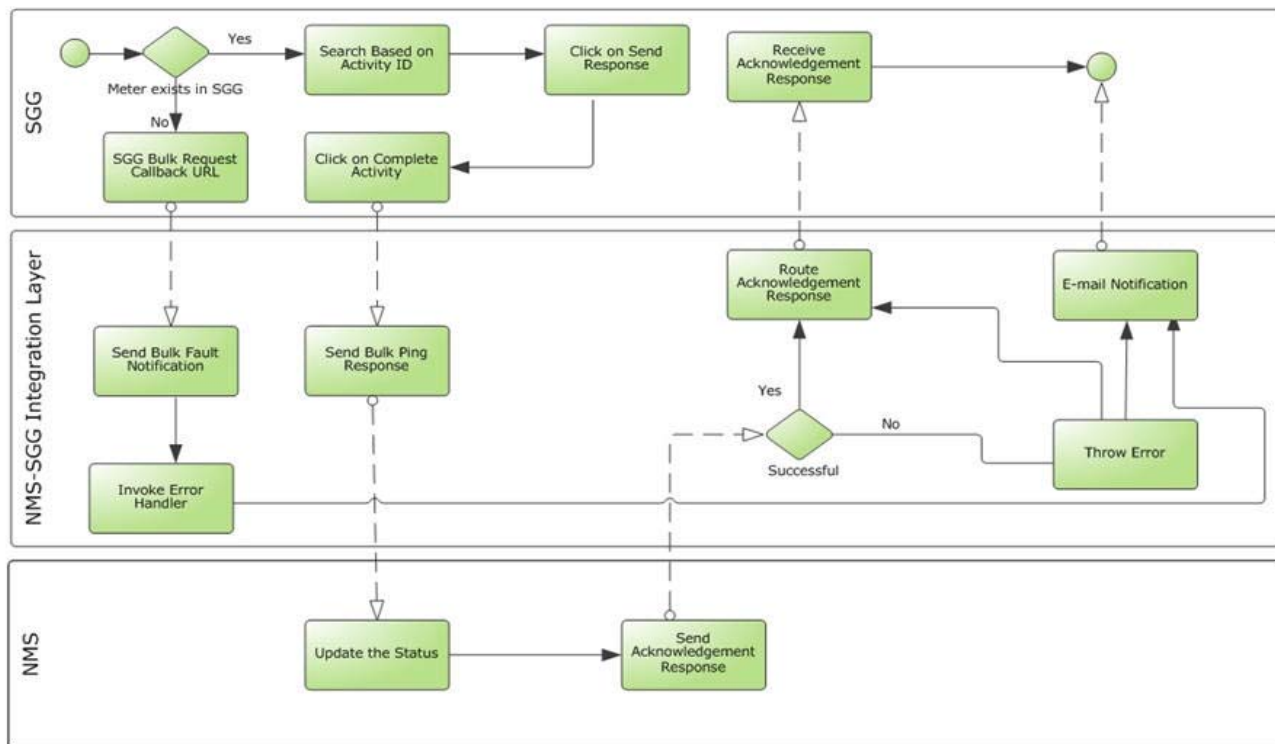

Batch Ping Response

2.2.2.1 Business Process

The following steps are performed:

- Oracle Utilities Smart Grid Gateway sends the meter power status information (Msg_SGG05) with a list of meters and meter statuses for the meter ping request (Msg_NMS02) sent from Oracle Utilities Network Management System.
- The **D1-BulkResp** message sent from Oracle Utilities Smart Grid Gateway can contain single or multiple meters statuses based on the *responseCreationMethod*, which was set in the Batch Ping Request configuration.

The *responseCreationMethod* property can be set to ONE, or WAIT.

- **ONE** - Oracle Utilities Smart Grid Gateway sends separate responses for each device
- **WAIT** - Oracle Utilities Smart Grid Gateway sends a single response with all devices.
- The message is transformed by integration layer and passed as **ODEventNotification** (Msg_NMS01) to Oracle Utilities Network Management System **OA_Server** > **ODEventNotification** web service operation.

- Once Oracle Utilities Network Management System receives the meter ping response from Oracle Utilities Smart Grid Gateway, it sends success or failure **ODEventNotificationResponse** to the integration indicating if the device ping response was successfully processed in Oracle Utilities Network Management System. This response is transformed and sent to Oracle Utilities Smart Grid Gateway.
- The Oracle Utilities Network Management System response contains empty **ODEventNotificationResponseResult** in case of success and an *errorObject* in case of failure.
- Each returned *errorObject* indicates a failed meter in Oracle Utilities Network Management System. The attribute *objectID* in the *errorObject* element contains meter identifier associated with the error. If the *objectID* is not populated for the *errorObject* element, it means that the processing for all the meters has failed in Oracle Utilities Network Management System.
- The e-mail notification is sent to the users based on the error notification flag configuration value.
- In case of meters that do not exist in Oracle Utilities Smart Grid Gateway, Oracle Utilities Smart Grid Gateway sends bulk notification to the service URL that is provided in the ping request message **CallbackURL** element.
- This URL is configured to the **SGGBatchPingCallBackRespBPPEL** component of the **SGGNMSBatchPingRespEBF** composite that receives the error message and logs the same for error notification purposes.
- If required, the batch ping response from Oracle Utilities Smart Grid Gateway can be automated by configuring the **D1-CRWT** batch job.

2.2.2.2 Technical Details

This section provides details of the composites and Oracle Utilities Network Management System services used for the Batch Ping Response integration point.

Composites

Composite Name	Description
SGGNMSBatchPingRespEBF	Composite that processes the batch ping response from Oracle Utilities Smart Grid Gateway and sends the acknowledgment back to Oracle Utilities Smart Grid Gateway.

Oracle Utilities Network Management System Services

Service Name	Operation Name	Description
OA_Server service	ODEventNotification	Used to notify Oracle Utilities Network Management System about the change in outage detection events by sending an array of changed OutageDetectionEvent objects. It returns information about failed transactions using an array of errorObjects.

2.2.3 Oracle Utilities Network Management System Batch Enable / Disable Request

This integration point sends a list of meters from Oracle Utilities Network Management System to Oracle Utilities Smart Grid Gateway to be enabled/disabled.

The following diagram provides a graphical representation of this processing:

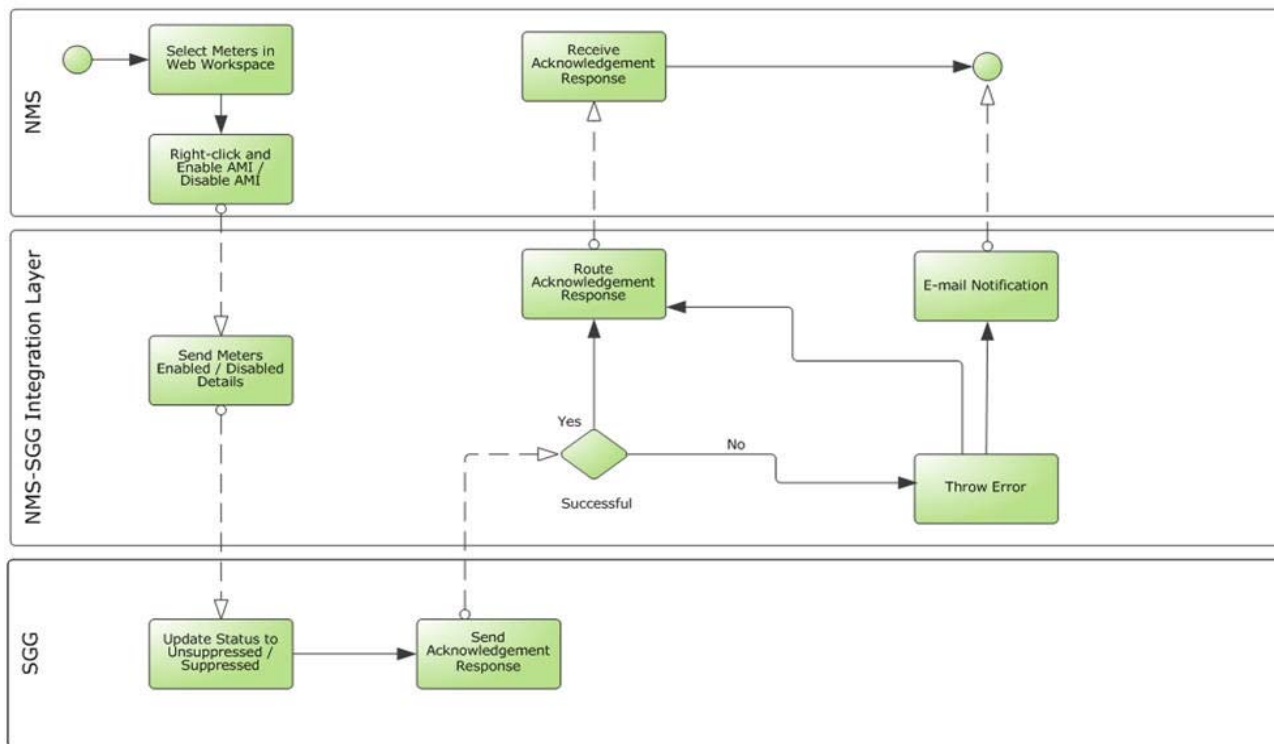

Batch Enable / Disable Request

2.2.3.1 Business Processing

This integration point sends a list of meter IDs that have been selected to be enabled or disabled from Oracle Utilities Network Management System to Oracle Utilities Smart Grid Gateway. Oracle Utilities Network Management System receives a response from Oracle Utilities Smart Grid Gateway once the meters are unsuppressed or suppressed in Oracle Utilities Smart Grid Gateway.

The following steps are performed:

- Oracle Utilities Network Management System sends a meter enable /disable request (Msg_NMS03) to the integration layer by invoking a web service in the integration layer. Oracle Utilities Network Management System sends a list of one or more meter IDs.
- The integration process reads *externalRequesterId* value from configuration, which is assigned to *suppressedServiceProviderExternalReferenceId* of the Oracle Utilities Smart Grid Gateway request.
- The **MeterChangedNotification** message is transformed by integration layer and the transformed message (Msg_SGG03) is sent to the Oracle Utilities Smart Grid Gateway D1-MaintainSuppression XAI Inbound Service.

- Oracle Utilities Network Management System sends the D1-MaintainSuppression success / failure response to Oracle Utilities Network Management System through the integration layer.
- In case of success, empty **MeterChangedNotificationResult** is sent to Oracle Utilities Network Management System.
- In case of failure, *errorObject* is sent to Oracle Utilities Network Management System in **MeterChangedNotificationResult**.
- Each meter failure is mapped to one *errorObject* and the failed meter ID is mapped to *objectID* attribute.
- If this *objectID* attribute value is empty in the *errorObject*, Oracle Utilities Network Management System assumes that all of the device enable/disable requests have failed in Oracle Utilities Network Management System.
- The error message is returned in the *errorString* attribute.
- The e-mail notification can be sent to the users based on the error notification flag configuration value.

2.2.3.2 Technical Details

This section provides details of the composites and Oracle Utilities Smart Grid Gateway services used for the Oracle Utilities Network Management System enable /disable request integration point.

Composites

Composite Name	Description
NMSSGGBatchEnableReqEBF	Composite that processes the enable /disable messages from Oracle Utilities Network Management System to Oracle Utilities Smart Grid Gateway and sends a response back to Oracle Utilities Network Management System once the meter is unsuppressed /suppressed in Oracle Utilities Smart Grid Gateway.

Oracle Utilities Smart Grid Gateway Services

Service Name	Operation Name	Description
D1-MaintainSuppression XAI Inbound service	D1-MaintainSuppression	Receives the enable /disable request from Oracle Utilities Network Management System and un suppress/suppress the same meter in Oracle Utilities Smart Grid Gateway.

2.2.4 Oracle Utilities Smart Grid Gateway Batch Unsuppress / Suppress Request

This integration point enables Oracle Utilities Smart Grid Gateway to send a list of meters to enable /disable via the Oracle Utilities Smart Grid Gateway user interface.

The following diagram provides a graphical representation of this processing:

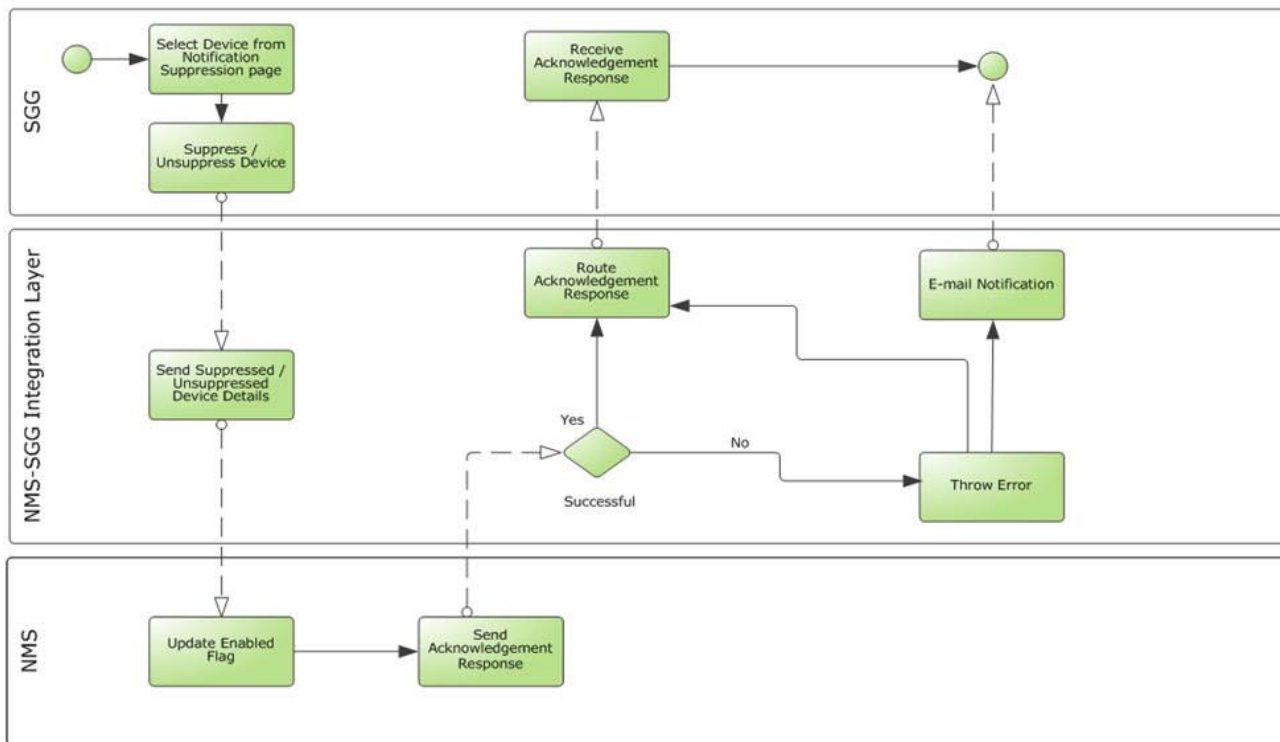

Batch Unsuppress / Suppress Request

2.2.4.1 Business Processing

The following steps are performed:

- Oracle Utilities Smart Grid Gateway sends a meter unsuppress/suppress request to the integration layer by invoking a web service in the integration layer.
- Oracle Utilities Smart Grid Gateway sends a list of one or more meter IDs along with the meter status in the form of an XML message.
- The D1-OutboundMessageNotifSupp message (Msg_SGG04) sent by Oracle Utilities Smart Grid Gateway is transformed by integration layer and passed as **MeterChangedNotification** (Msg_NMS04) to Oracle Utilities Network Management System **OA_Server** > **MeterChangedNotification** web service operation.
- Oracle Utilities Network Management System sends success or failure **MeterChangedNotificationResponse** to the integration that is transformed and sent to Oracle Utilities Smart Grid Gateway.
- Each meter failure is mapped to one *errorObject* and the failed meter ID needs to be mapped to *objectID* attribute.

- The Oracle Utilities Network Management System response contains empty **MeterChangedNotificationResult** in case of success and an *errorObject* in case of failure.
- If there is no *objectID* is populated for the *errorObject* element, it indicates all of the meters processing has failed in Oracle Utilities Smart Grid Gateway.
- The e-mail notification is sent to the users based on the error notification flag configuration value.

2.2.4.2 Technical Details

This section provides details of the composites and Oracle Utilities Network Management System services used for the Batch Ping Response integration point.

Composites

Composite Name	Description
SGGNMSBatchEnableReqEBF	Composite that processes the unsuppress/suppress messages from Oracle Utilities Smart Grid Gateway to Oracle Utilities Network Management System and sends a response back to Oracle Utilities Smart Grid Gateway once the meter is enabled/disabled in Oracle Utilities Network Management System.

Oracle Utilities Network Management System Services

Service Name	Operation Name	Description
OA_Server service	MeterChangedNotification	Used to notify Oracle Utilities Network Management System about the change in the meter object by sending the changed meter object(s). It returns information about failed transactions using an array of errorObjects.

2.2.5 Oracle Utilities Smart Grid Gateway Device Power Status Update

This integration point sends meter power status update from Oracle Utilities Smart Grid Gateway to Oracle Utilities Network Management System.

The following diagram provides a graphical representation of this processing:

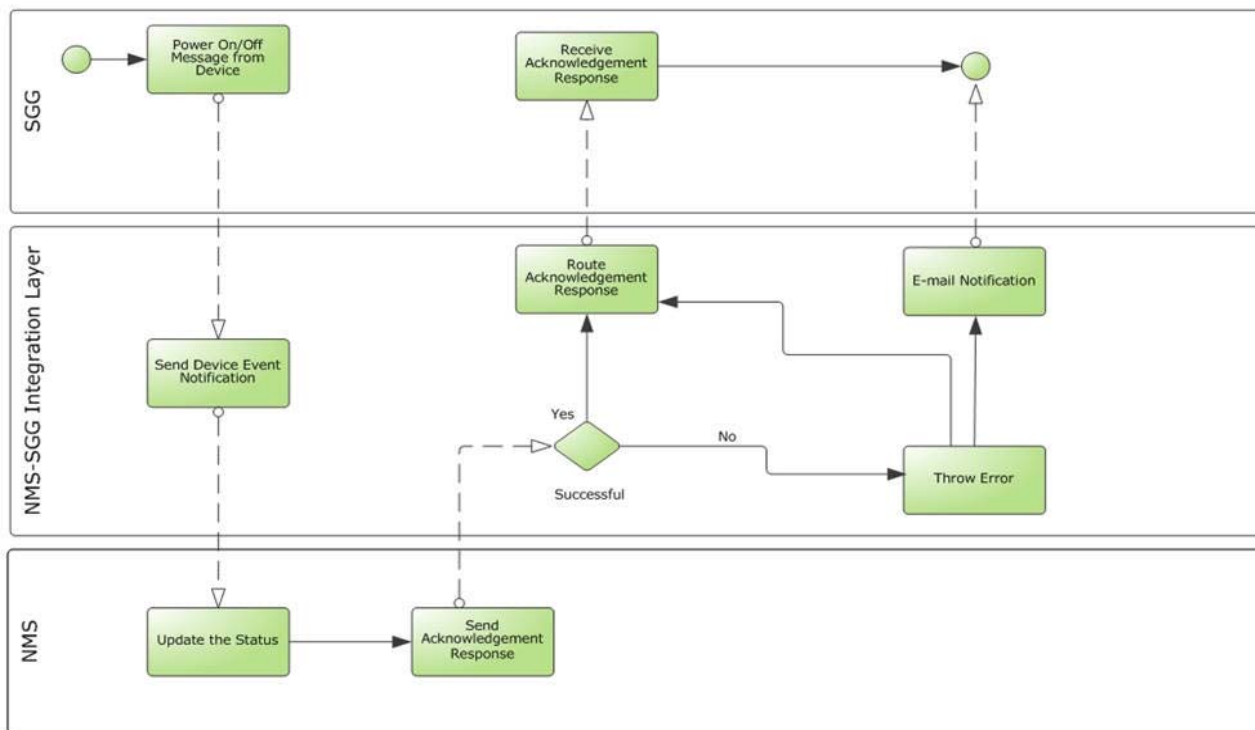

Device Power Status Update

2.2.5.1 Business Processing

The following steps are performed:

- When a meter loses power as a result of an outage or power is restored to the meter, the meter generates a “power-off” or “power-on” message that is sent from the head-end system to Oracle Utilities Smart Grid Gateway.
- Oracle Utilities Smart Grid Gateway sends the device event information with the list of devices and event names, in form of an XML message to the integration layer.
- The **D1-DeviceEventNotification** schema in Oracle Utilities Smart Grid Gateway supports multiple events, but by default Oracle Utilities Smart Grid Gateway sends only one event information per message.
- The **D1-DeviceEventNotification** message (Msg_SGG01) is transformed by integration layer and passed as **ODEventNotification** (Msg_NMS01) to Oracle Utilities Network Management System **OA_Server > ODEventNotification** web service operation.
- Oracle Utilities Network Management System sends success or failure **ODEventNotificationResponse** to the integration that is transformed and sent to Oracle Utilities Smart Grid Gateway.

- The Oracle Utilities Network Management System response contains empty **ODEventNotificationResult** in case of success and an *errorObject* in case of failure.
- Each returned *errorObject* indicates an error. Attribute *objectID* in the *errorObject* element contains meter identifier associated with the error.
- If there is no *objectID* is populated for the *errorObject* element then it means all of the meters processing has been failed in Oracle Utilities Smart Grid Gateway.
- The e-mail notification is sent to the users based on the error notification flag configuration value.
- If required, the device event notification from Oracle Utilities Smart Grid Gateway can be automated by configuring the D1-DEVPR batch job.

2.2.5.2 Technical Details

This section provides details of the composites and Oracle Utilities Network Management System services used for the Batch Ping Response integration point.

Composites

Composite Name	Description
SGGNMSPowerStatusUpdateReqEBF	Device power status update process composite

Oracle Utilities Network Management System Services

Service Name	Operation Name	Description
OA_Server service	ODEventNotification	Used to notify Oracle Utilities Network Management System about the change in outage detection events by sending an array of changed OutageDetectionEvent objects. It returns information about failed transactions using an array of errorObjects.

Part 2

Implementing the Integration Product

This section provides details about how to configure the participating applications and the middle layer for the integration. Information on error handling, monitoring, customization options and data mapping is also included.

It provides details about the configuration settings required for the integration, and discusses details related to:

- [Configuring the Integration](#)
- [Monitoring and Troubleshooting](#)
- [Customization Options](#)

Chapter 3

Configuring the Integration

This section provides details regarding the configuration settings required for the integration, and also discusses the following in detail:

- [Integration Configuration Checklist](#)
- [Data Synchronization](#)
- [Setting Up Oracle Utilities Network Management System](#)
- [Setting Up Oracle Utilities Smart Grid Gateway](#)
- [Setting Up the Process Integration](#)

3.1 Integration Configuration Checklist

The configuration is required to implement the integration between Oracle Utilities Network Management System and Oracle Utilities Smart Grid Gateway. For the complete details, see the following sections:

- [Oracle Utilities Network Management System Configuration Checklist](#)
- [Oracle Utilities Smart Grid Gateway Configuration Checklist](#)
- [Integration Product Configuration Checklist](#)

Note: Please refer to the product documentation for Oracle Utilities Network Management System, or for Oracle Utilities Smart Grid Gateway for complete configuration information.

3.1.1 Oracle Utilities Network Management System Configuration Checklist

Oracle Utilities Network Management System MultiSpeak Adapter Configuration:

- [Enable the AMR Component of the MultiSpeak Adapter](#)
- [Configure Integration SOA Composite URLs](#)
- [Configure Credentials for Accessing Integration SOA Composites](#)
- [Configure Additional Communication Parameters](#)

3.1.2 Oracle Utilities Smart Grid Gateway Configuration Checklist

Complete administrative data setup as needed to implement the integration.

3.1.3 Integration Product Configuration Checklist

In the integration layer, you must configure the system properties in configuration properties file, and domain value maps.

- [Configure Configuration Properties](#): Set Module Configurations properties that are shared by multiple integration points and Service Configurations properties that are used by a specific BPEL process.
- [Configure Domain Value Maps](#): Set Domain Value Maps (DVMs) to map codes and other static values across applications.

3.2 Data Synchronization

Meter synchronization between Oracle Utilities Network Management System and Oracle Utilities Smart Grid Gateway is not supported by this integration. Before using this integration, it is assumed that the meters have been mapped between Oracle Utilities Network Management System and Oracle Utilities Smart Grid Gateway.

Oracle Utilities Network Management System has its own internal meter identifiers, which do not necessarily match meter identifiers used by Oracle Utilities Smart Grid Gateway. Mapping between Oracle Utilities Network Management System and Oracle Utilities Smart Grid Gateway meter identifiers is configured in the AMR_CU_METERS database table. Column METER_ID contains Oracle Utilities Network Management System meter identifier and column METER_NO contains external (in this case Utilities Smart Grid Gateway) meter identifier.

3.3 Setting Up Oracle Utilities Network Management System

This section describes how to configure the Oracle Utilities Network Management System to meet the requirements for the integration.

MultiSpeak Adapter Configuration

Configuration for the AMR component of the Oracle Utilities Network Management System MultiSpeak Adapter is normally stored in the <project name>_amr.sql file (for example: OPAL_amr.sql).

During Oracle Utilities Network Management System setup, SQL commands in this file are executed to insert configuration information into CES_PARAMETERS database table.

3.3.1 Enable the AMR Component of the MultiSpeak Adapter

```

/*
 * Enable/disable AMR interface.
 *
 * Default: true (enabled)
 */
INSERT INTO ces_parameters (app, attrib, value)
VALUES ('AMRInterface', 'config.enabled', 'true');
```

3.3.2 Configure Integration SOA Composite URLs

For Oracle Utilities Network Management System Batch Ping Request

```
INSERT INTO ces_parameters (app, attrib, value)
VALUES ('AMRInterface',
'multispeak.od_oa.url.InitiateOutageDetectionEventRequest',
'http://SOA_HOST:SOA_PORT/soa-infra/services/NMS-SGG/
NMSSGGBatchPingReqEBF/NMSSGGBatchPingReqBPPEL_Client_ep');
```

For Oracle Utilities Network Management System Batch Enable/Disable Request

```
INSERT INTO ces_parameters (app, attrib, value)
VALUES ('AMRInterface',
'multispeak.od_oa.url.MeterChangedNotification',
'http://SOA_HOST:SOA_PORT/soa-infra/services/NMS-SGG/
NMSSGGBatchEnableReqEBF/NMSSGGBatchEnableReqBPPEL_Client_ep');
```

3.3.3 Configure Credentials for Accessing Integration SOA Composites

```
INSERT INTO ces_parameters (app, attrib, value)
VALUES ('AMRInterface', 'multispeak.od_oa.username',
SOA_managerServer_username);
INSERT INTO ces_parameters (app, attrib, value)
VALUES ('AMRInterface', 'multispeak.od_oa.password',
'SOA_managedServer_password');
```

The password should be encrypted using WebLogic Encrypt utility.

3.3.4 Configure Additional Communication Parameters

Configure additional communication parameters, such as number of retries, request timeout, etc.

These parameters affect behavior of Oracle Utilities Network Management System MultiSpeak Adapter in case of communication errors.

```
/*
 * Timeout (in seconds) for web service requests.
 * Request would fail if response is not received before
 * the timeout expires.
 *
 * Default: 30 seconds
 */
INSERT INTO ces_parameters (app, attrib, value)
VALUES ('AMRInterface', 'config.ws_request_timeout', '30');
/*
 * If difference between current time and ping request time is greater
 * than
 * value of this property then the request is too old to be sent to
 * Oracle Utilities Smart Grid Gateway.
 * Such requests are marked as completed in Oracle Utilities Network
 * Management System.
 *
 * Default: 3600 seconds
 */
INSERT INTO ces_parameters (app, attrib, value)
VALUES ('AMRInterface', 'config.max_ping_request_age', '3600');
```

```

/*
 * Maximum number of ping attempts for a request.
 *
 * Default: 3
 */
INSERT INTO ces_parameters (app, attrib, value)
VALUES ('AMRInterface', 'multispeak.max_ping_attempts', '3');
/*
 * Amount of time in seconds to wait for reply from SGG
 * before resending ping request.
 *
 * Default: 60 seconds
 */
INSERT INTO ces_parameters (app, attrib, value)
VALUES ('AMRInterface', 'multispeak.ping_attempt_interval', '60');
/*
 * Maximum number of retries for a request to enable/disable meters.
 *
 * Default: 3
 */
INSERT INTO ces_parameters (app, attrib, value)
VALUES ('AMRInterface', 'multispeak.max_update_attempts', '3');
/*
 * Amount of time in seconds to wait after failure before retrying
 * request to enable/disable meters.
 *
 * Default: 60 seconds
 */
INSERT INTO ces_parameters (app, attrib, value)
VALUES ('AMRInterface', 'multispeak.update_attempt_interval', '60');

```

For more information on configuring and working with Oracle Utilities Network Management System, see the *Oracle Utilities Network Management System Adapters Guide* and *Configuration Guide*.

3.4 Setting Up Oracle Utilities Smart Grid Gateway

The following sections provide details of the [Admin Data Setup](#) in the Oracle Utilities Smart Grid Gateway needed to facilitate the integration.

For more information on configuring and working with Oracle Utilities Smart Grid Gateway, see the *Oracle Utilities Smart Grid Gateway Installation* and *Configuration Guides*.

3.4.1 Admin Data Setup

This section describes the setup for configuring your system for the integration:

- [Oracle Utilities Smart Grid Gateway Master Configuration](#)
- [Configure Activity Types](#)
- [Create Service Provider](#)
- [Create Outbound Message Types](#)
- [Create External System](#)
- [Create Service Provider](#)
- [Configure Extendable Lookups](#)

3.4.1.1 Oracle Utilities Smart Grid Gateway Master Configuration

Configure whether meter suppression should be enabled.

To Set Up Master Configuration

1. On the **Admin** menu, navigate to **M > Master Configuration**.
2. Click the **Add** or **Edit** icon next to **Smart Grid Gateway Master Configuration**.
3. Select **Yes** from the **Enable Suppression** drop-down list.
4. Click **Save**.

3.4.1.2 Configure Activity Types

An activity type defines the properties common to a specific type of activity. The activity types include types of communications between an application and a head-end system, such as a connection requests, meter ping requests, or on-demand meter readings, as well as device event types. Configure the following activity types.

To Configure Suppression Activity Type

1. On the **Admin** menu, navigate to **A > Activity Type**.
2. Click the **Add** or **Edit** icon next to the **Device Event Notification Suppression** activity.
3. Enter the following details:
 - **Activity Type:** Enter a unique name - OUTAGEEVENTSUPPRESSION
 - **Description:** Device Event Notification Suppression
 - **Activity Type Status:** Active
 - **Related Transaction BO:** Device Event Notification Suppression (this value comes by default)
 - **Failed Outbound Message To Do Type:** Select **Suppressions Exist** from the drop-down list
 - **Failed Outbound Message To Do Role:** Select **System Default Role** from the drop-down list

To Configure Bulk Request Header Activity Type

1. On the **Admin** menu, navigate to **A > Activity Type**.
2. Click the **Add** or **Edit** icon next to the **Bulk Request Header** activity.
3. Enter the following details:
 - **Activity Type:** Enter a unique name - BULKREQUESTHEADER
 - **Description:** Bulk Request Header
 - **Activity Type Status:** Active
 - **To Do Type:** Select To Do Type (this is an optional field)
 - **To Do Role:** Select To Do Role (this is an optional field)
 - **Retry Frequency:** Configure this value as 00:00:30 (30seconds)
 - **Maximum Retries:** Activity retry count, configure accordingly

To Configure Bulk Response Activity Type

1. On the **Admin** menu, navigate to **A > Activity Type**.
2. Click the **Add** or **Edit** icon next to the **Bulk Response** activity.
3. Enter the following details:
 - **Activity Type:** Enter a unique name - BULKRESPONSE
 - **Description:** Bulk Response
 - **Activity Type Status:** Active
 - **To Do Type:** Select To Do Type (this is an optional field)
 - **To Do Role:** Select To Do Role (this is an optional field)
 - **Retry Frequency:** Configure this value as 00:00:30 (30seconds)
 - **Maximum Retries:** Activity retry count, configure accordingly

To Configure Device Status Check Activity Type

1. On the **Admin** menu, navigate to **A > Activity Type**.
2. Click the **Add** or **Edit** icon next to the **Device Status Check** activity.
3. Enter the following details:
 - **Activity Type:** Enter a unique name - DEVICESTATUSCHECK
 - **Description:** Device Status Check
 - **Related Transaction BO:** Device Status Check (this comes by default)
 - **Activity Type Status:** Active
 - **Activity Type:** CategoryCommand Request(this comes by default)
 - **Activity Expiration Days:** The number of days in which the activity which is non-final state, gets discarded
 - **To Do Type:** Select To Do Type (this is an optional field)
 - **To Do Role:** Select To Do Role (this is an optional field)
 - **Retry Frequency:** Configure this value as 00:00:30 (30seconds)
 - **Maximum Retries:** Activity retry count, configure accordingly

3.4.1.3 Create XAI Senders

The XAI senders need to be configured for each integration service in order to send and receive messages to/from external services.

To Create XAI Senders

1. On the **Admin** menu, navigate to **X > XAI Sender +**.
2. Enter a unique XAI sender and its description.
3. Populate the following values based on the tables given below:
 - **Invocation Type:** Real-time
 - **XAI Class:** *RTHTTPSNDR (Realtime HTTP Sender)*
 - **Active:** Select the checkbox
 - **MSG Encoding:** UTF-8 message encoding

4. Click the **Context** tab and set values for the following context types based on the tables given below:
 - **HTTP Header:** SOAP Action: Integration SOA composite service operation
 - **HTTP Login Password:** Integration SOA managed server password
 - **HTTP Login User:** Integration SOA managed server user name
 - **HTTP Method(POST/GET):** POST
 - **HTTP URL 1:** Integration SOA composite service URL

As part of the XAI Sender configuration, the following sets of fields need to be filled appropriately based on the integration service.

Device Event Notification

Field	Description
XAI Sender	DMNMSDVCEVT
Description	Device Event Notification for Oracle Utilities Network Management System and Oracle Utilities Smart Grid Gateway Integration
Invocation Type	Real-time
XAI Class	RTHTTPSNDR
Msg Encoding	UTF-8
Http Header	SOAPAction:DeviceEventNotification
Http Login Password	As Appropriate
Http Login User	As appropriate
Http Method	POST
Http URL	http://SOA_HOST:SOA_PORT/soa-infra/services/ PARTITION_NAME / SGGNMSPowerStatusUpdateReqEBF/ SGGNMSPowerStatusUpdateReqBPEL_Client_ep

Suppression Notification

Field	Description
XAI Sender	DMNMSSPRNTF
Description	Suppression Notification for Oracle Utilities Network Management System and Oracle Utilities Smart Grid Gateway
Invocation Type	Real-time
XAI Class	RTHTTPSNDNR
Msg Encoding	UTF-8
Http Header	SOAPAction:processSuppressionNotification
Http Login Password	As Appropriate
Http Login User	As appropriate
Http Method	POST
Http URL	http://SOA_HOST:SOA_PORT/soa-infra/services/ PARTITION_NAME / SGGNMSBatchEnableReqEBF/ SGGNMSBatchEnableReqBPEL_Client_ep

Bulk Response

Field	Description
XAI Sender	DMNMSBLKRSP
Description	Bulk Response for Oracle Utilities Network Management System and Oracle Utilities Smart Grid Gateway Integration
Invocation Type	Real-time
XAI Class	RTHTTPSNDNR
Msg Encoding	UTF-8
Http Header	SOAPAction:http://xmlns.oracle.com/ouaf/ssn/BulkResponse
Http Login Password	As Appropriate
Http Login User	As appropriate
Http Method	POST
Http URL	http://SOA_HOST:SOA_PORT/soa-infra/services/ PARTITION_NAME / SGGNMSPowerStatusUpdateReqEBF/ SGGNMSBatchPingRespEBF

3.4.1.4 Create Outbound Message Types

Create a new Outbound Message Type for each Oracle Utilities Smart Grid Gateway outbound integration service by performing the steps given below:

To Create Outbound Message Types

1. On the **Admin** menu, navigate to **O > Outbound Message Type +**.
2. Enter an outbound message type, its description, and then the detailed description.
3. Select the **Outbound Message** business object based on the table below.
4. These message types will then be associated with the respective external systems.

Outbound Message Type Name	Outbound Message Type Description	Business Object
DM-BULKRESP	Outbound Message Type for Bulk Device Status Check for Oracle Utilities Network Management System	D1-OutboundMessageBulk
DM-DVCEVTNTF	Outbound Message Type for Device Event Notification	D1-DeviceEventNotification
DM-SUPPRNOTF	Outbound Message Type for Suppression Notification for Oracle Utilities Network Management System and Oracle Utilities Smart Grid Gateway	D1-OutboundMessageNotifSupp

3.4.1.5 Create External System

Create external system for Oracle Utilities Network Management System by performing the steps given below:

To Create the External System

1. On the **Admin** menu, navigate to **E > External System +**.
2. Enter a unique name for the external system and its description.
3. Associate the outbound message types created to the external system. For each outbound message type, set the following:

External system name: OUNMS

Description: External System for Oracle Utilities Network Management System

Outbound Message Type	Field	Values
DM-BULKRESP	Processing Method	Real-time
	XAI Sender	DMNMSBLKRSP
	Date/Time Format	XSD
	Message XSL	D1-BulkResp.xml
	Response XSL	

Outbound Message Type	Field	Values
DM-SUPPRNOTF	Processing Method	Real-time
	XAI Sender	DMNMSSPRNTF
	Date/Time Format	XSD
	Message XSL	D1-OutboundMessageNotifSuppRequest.xml
	Response XSL	
DM-DVCEVTNTF	Processing Method	Real-time
	XAI Sender	DMNMSDVCEVT
	Date/Time Format	XSD
	Message XSL	D1-DeviceEventNotificationRequest.xml
	Response XSL	

3.4.1.6 Create Service Provider

The service providers are external entities that serve various roles related to the application. The service providers can include head-end systems, outage management systems that receive meter event data from the application, or from other parties that require or provide information to the system. Configure the following properties for the service provider for the external system.

To Create the Service Provider

1. On the **Admin** menu, navigate to **S > Service Provider +**.
2. Select the **External Application** business object.
3. Enter the following details:
 - **Service Provider Name:** OUNMS
 - **Description:** Oracle Utilities Network Management System
 - **External Reference ID:** Enter the unique ID for the service provider. For example, NMS
 - **External System:** Select the external system as **OUNMS** from the drop-down menu
 - **Utility Device ID Type:** Select the **Serial Number** from the drop-down menu
 - **Utility Service Point ID Type:** Select the **External ID** from the drop-down menu
 - **Default Suppression Type:** Select the **Device Event Notification Suppression** from the drop-down menu
4. Click **Save**.

5. Associate the processing roles to the service provider. For each processing role, set the following:

Processing Role	Field	Values
Bulk Response	Description	Bulk Command Response
	BO	How to Send Activity Response
	Status	Active
	Default Outbound Message Type	DM-BULKRESP
Response - Success	Description	Successful Command Response
	BO	How to Send Activity Response
	Status	Active
	Default Outbound Message Type	DM-BULKRESP
Suppression Notification	Description	Suppression Notification
	BO	How to Send Activity Response
	Status	Active
	Default Outbound Message Type	DM-SUPPRNOTF
Send Device Event	Description	Send Device Event
	BO	How to Send Device Event Related Info
	Status	Active
	Processing Method/Device Event Category	A category created in D1-DvcEventCategoryLookup Extendable lookup (For example, "Device Events Related to Power Conditions")
	Processing Method/Default Outbound Message Type	DM-DVCEVTNTF

3.4.1.7 Configure Extendable Lookups

These are the global values configured in Oracle Utilities Smart Grid Gateway, and can be used within the system for this integration.

To Configure Extendable Lookups

1. On the **Admin** menu, navigate to **E > Extendable Lookup**.
2. Search for the specific BO.
3. Add a new extendable lookup value for the above BO.
4. Configure the values based on the BO.
5. Configure the following extendable lookups in Oracle Utilities Smart Grid Gateway:

D1-DvcEventCategoryLookup

Used to collect a set of events to send to subscribing systems:

Device Event Category	Description
PowerEvents	Device Events related to Power conditions

D1-StdEventNameLookup

Normalized name of events across multiple head-end systems and referenced on Device Event Types:

Standard Event Name	Description
Power On	Restoration Event
Power Off	Outage Event

D1-DeviceEventMappingLookup

Global event names:

Global Event Names	Description
Power On	Restoration Event
Power Off	Outage Event

3.5 Setting Up the Process Integration

To configure Oracle Integration Pack for Oracle Utilities Network Management System - Oracle Utilities Smart Grid Gateway Direct Integration, you must complete the following configurations:

- [Configure Configuration Properties](#)
- [Configure Domain Value Maps](#)
- [Error Handling](#)

3.5.1 Configure Configuration Properties

The ConfigurationProperties.xml file contains properties, which can be defaulted in the integration. It also contains flags to enable e-mail notifications in the integration.

ConfigurationProperties.xml is located in MDS under the directory:
apps/NMS-SGG/AIAMetaData/config.

Note: Whenever the ConfigurationProperties.xml file is updated, it must be reloaded to the MDS repository so that the update is reflected in applications or services, which use these updated properties. Reload the ConfigurationProperties.xml by rebooting.

Two sets of configuration properties are described in this section:

- **Module Configuration:** The properties, which are shared by multiple integration points within this integration.
- **Service Configuration:** The properties, which are used by a specific composite process.

3.5.1.1 Module Configuration

Module configuration has application level properties, which are used by all SOA composites.

Property Name	Default/ Shipped value	Description
SGG.externalRequesterId	OUNMS	External Requester ID is Oracle Utilities Smart Grid Gateway's external System ID. Example: Oracle Utilities Network Management System This will be implementer's choice.

3.5.1.2 Service Configuration

The service configuration properties are specific to the SOA composites. These are used to make changes in a specific composite behavior.

Service Name	Property Name	Default Value	Description
NMSSGGBatchPingReqEBF	BusinessError.NotificationFlag	false	If set to true, business error notification is sent via e-mail.
	TechnicalError.NotificationFlag	false	If set to true, technical error notification is sent via e-mail.

Service Name	Property Name	Default Value	Description
	SGG.expirationDateTimeDuration	P0Y0M0DT0H0M0S	<p>If Oracle Utilities Network Management System expiration time is not being passed, this property will be mapped to Oracle Utilities Smart Grid Gateway expirationDateTime.</p> <p>For example: P0Y0M0DT0H0M0S</p> <p>This is as per ISO 8601 standards.</p>
	SGG.callbackURL	http:// SOA_HOST:SOA_PORT/soa-infra/services/ NMS-SGG/ SGGNMSBatchPingRespEBF/ SGGBatchPingCallBack RespBPEL_Client_ep	Call back URL to be passed to Oracle Utilities Smart Grid Gateway, so that any error response sent by Oracle Utilities Smart Grid Gateway would be passed to this URL.
	SGG.responseCreationMethod	WAIT	<p>Based on this value, the response will be sent to Oracle Utilities Network Management System.</p> <p>For example: ONE,WAIT</p>
	SGG.BatchPingReqService.EndPoint	<Administrator adds this>	Endpoint for the Oracle Utilities Smart Grid Gateway BulkRequest BPEL service.
	SGG.BatchPingReqService.PortType	<Administrator adds this>	Port type for the Oracle Utilities Smart Grid Gateway BulkRequest BPEL service.
	SGG.BatchPingReqService.ServiceName	<p><Administrator adds this></p> <p>{http:// xmlns.oracle.com/ MDF_D1_SOA_jws/ BulkRequest/ BulkRequest}BulkRequestService</p>	The service name for the Oracle Utilities Smart Grid Gateway BulkRequest BPEL service.
	SGGNMSBatchPingRespEBF		
	BusinessError.NotificationFlag	false	If set to true, business error notification is sent via e-mail.
	TechnicalError.NotificationFlag	false	If set to true, technical error notification is sent via e-mail.

Service Name	Property Name	Default Value	Description
	NMS.BulkRespService.EndPoint	<Administrator adds this>	Endpoint for the Oracle Utilities Network Management System OA_Server webservice.
	NMS.BulkRespService.ServiceName	<Administrator adds this> {http://www.multispeak.org/Version_4.1_Release}OA_Server	The service name for the Oracle Utilities Network Management System OA_Server webservice.
	NMS.BulkRespService.PortType	<Administrator adds this>	Port type for the OA_Server webservice.
NMSSGGBatchEnableReqEBF			
	BusinessError.NotificationFlag	false	If set to true, business error notification is sent via e-mail.
	TechnicalError.NotificationFlag	false	If set to true, technical error notification is sent via e-mail.
	SGG.EnableReqService.EndPoint	<Administrator adds this>	Endpoint for the Oracle Utilities Smart Grid Gateway D1-MaintainSuppressionService XAI inbound service.
	SGG.EnableReqService.ServiceName	<Administrator adds this> {http://ouaf.oracle.com/spl/XAIXapp/xaiserver/D1-MaintainSuppression}D1-MaintainSuppressionService	The service name for the Oracle Utilities Smart Grid Gateway D1-MaintainSuppressionService XAI inbound service.
	SGG.EnableReqService.PortType	<Administrator adds this>	Port type for the Oracle Utilities Smart Grid Gateway D1-MaintainSuppressionService XAI inbound service.
SGGNMSBatchEnableReqEBF			
	BusinessError.NotificationFlag	false	If set to true, business error notification is sent via e-mail.
	TechnicalError.NotificationFlag	false	If set to true, technical error notification is sent via e-mail.

Service Name	Property Name	Default Value	Description
	NMS.EnableReqService.EndPoint	<Administrator adds this>	Endpoint for the Oracle Utilities Network Management System OA_Server webservice.
	NMS.EnableReqService.ServiceName	<Administrator adds this> {http://www.multispeak.org/Version_4.1_Release}OA_Server	The service name for the Oracle Utilities Network Management System OA_Server webservice.
	NMS.EnableReqService.PortType	<Administrator adds this>	Port type for the Oracle Utilities Network Management System OA_Server webservice.
SGGNMSPowerStatusUpdateReqEBF			
	BusinessError.NotificationFlag	false	If set to true, business error notification is sent via e-mail.
	TechnicalError.NotificationFlag	false	If set to true, technical error notification is sent via e-mail.
	NMS.DevEventNotifService.EndPoint	<Administrator adds this>	Endpoint for the Oracle Utilities Network Management System OA_Server webservice.
	NMS.DevEventNotifService.ServiceName	<Administrator adds this> {http://www.multispeak.org/Version_4.1_Release}OA_Server	The service name for the Oracle Utilities Network Management System OA_Server webservice.
	NMS.DevEventNotifService.PortType	<Administrator adds this>	Port type for the Oracle Utilities Network Management System OA_Server webservice.

3.5.2 Configure Domain Value Maps

The Domain Value Maps (DVMs) are the standard features of the Oracle SOA Suite. They map codes and other static values across applications.

For example: Different types of country codes configured in each of the applications can be mapped using a DVM. The country code for USA can be "US" in one application and map to "USA" in the other application.

The DVMs are static in nature, though administrators can add additional values as needed.

Transactional business processes never update the Domain Value Maps (DVMs). Instead they only read from DVMs. DVMs are stored in the XML files and cached in memory at run-time.

To Maintain Information within Domain Value Maps

1. Open a browser and access the SOA Composer application (<http://host:port/soa/composer/>).
2. On the SOA Composer, select **Open** from the drop-down list and select **Open DVM**.

The list of all DVM files in the MDS repository is displayed.

3. Select the relevant DVM you wish to maintain.
4. Edit the selected DVM by clicking the **Edit** button in the top navigation bar for editing DVM.
5. Once the DVM is edited, click **Save** in the navigation bar.

This saves the DVM data for that session.

6. Click **Commit** after updating each DVM.

This saves the DVM data in the MDS repository.

The DVMs for the integration are described below:

DVMs	Integration Points	Description
NMSSGG_DevicePingStatus	Oracle Utilities Smart Grid Gateway Batch Ping Response	Maps Oracle Utilities Smart Grid Gateway device functional state to Oracle Utilities Network Management System outage event type
NMSSGG_MeterSuppressionStatus	Oracle Utilities Network Management System Batch Enable/Disable Request and Oracle Utilities Smart Grid Gateway Batch unsuppress/suppress request	Maps Oracle Utilities Network Management System meter status to Oracle Utilities Smart Grid Gateway suppression/unsuppression request and vice versa
NMSSGG_DeviceEventType	Oracle Utilities Smart Grid Gateway Device Power Status Update	Maps Oracle Utilities Smart Grid Gateway device event type to Oracle Utilities Network Management System outage event type

NMSSGG_DevicePingStatus

This DVM is used to transform an Oracle Utilities Smart Grid Gateway device functional state to Oracle Utilities Network Management System outage event type.

NMS_OutageEventType	SGG_DeviceFunctionalState
Outage event type in Oracle Utilities Network Management System.	Device functional state in Oracle Utilities Smart Grid Gateway.
Example: PowerOn /PowerOff	Example: Operational /Malfunctioned

NMSSGG_MeterSuppressionStatus

This DVM is used to transform Oracle Utilities Network Management System disable/enabled meter status to Oracle Utilities Smart Grid Gateway suppression/unsuppression request and vice versa.

NMS_OutageEventType	SGG_DeviceFunctionalState
Meter status in Oracle Utilities Network Management System.	Suppression action in Oracle Utilities Smart Grid Gateway.
Example: Active/Inactive	Example: Suppress/Unsuppress

NMSSGG_DeviceEventType

This DVM is used to transform Oracle Utilities Smart Grid Gateway device event type to Oracle Utilities Network Management System outage event type.

NMS_MeterStatus	SGG_SuppressionRequest
Outage event type in Oracle Utilities Network Management System.	Standard event name in Oracle Utilities Smart Grid Gateway's D1-StdEventNameLookup extendable Llookup.
Example: PowerOn /PowerOff /Outage/Restoration	Example: PowerOn /PowerOff /Outage/Restoration

For more information, refer to the chapters *Working with Domain Value Maps* and *Using SOA Composer with Domain Value Maps* in the Oracle® *Fusion Middleware Developer's Guide for Oracle SOA Suite*.

3.5.3 Error Handling

The integration includes two types of errors:

- **Business Errors:** Triggered when the called services return an error.
- **Technical Errors:** Triggered when there are connectivity issues in invoking / accessing the services.

NMS_EventType	SGG_DeviceFunctionalState
Outage event type in Oracle Utilities Network Management System.	Standard event name in Oracle Utilities Smart Grid Gateway's D1-StdEventNameLookup extendable lookup.
Example: PowerOn /PowerOff /Outage/Restoration	Example: PowerOn /PowerOff /Outage/Restoration

3.5.3.1 Error Notification Setup

Enable e-mail notification for the Error Handling module.

To Set Up Error Notification

1. Login to the **Enterprise Manager** console.

2. Expand **SOA**, and then right-click **SOA Infra**. From the menu, click **SOA Administration**, and then click **Workflow Notification Properties**.
3. From the drop-down list, select **EMAIL**.
4. Enter the **Email IDs** in the **From Address** field.

INTEGRATION_ERR_STORE

The INTEGRATION_ERR_STORE table is used to store all the error details for each message failure. The table is populated for each integration point based on the BusinessError.NotificationFlag and TechnicalError.NotificationFlag properties for each service in the ConfigurationProperties.xml file.

INTEGRATION_ERR_LOOKUP

The error handling module configuration is governed by the Integration_err_lookup table. This table contains processing instructions for each composite. The Error_Processing_Parent composite picks data for one composite and calls error_Processing_Detail for processing. The configuration in this table is used to process the error records stored in the INTEGRATION_ERR_STORE table.

S. No.	Column Name	Default	Default/ Suggested values
1	LookUp_ID	The sequence ID of entry in this table. This is auto-generated.	Auto generated
2	IP_Name	The name of the composite processed. Example, NMSSGGBatchPingReqEBF	This column is pre-populated with the individual enterprise business process name. Do not modify. Modifying this value will break the code.
3	Processing_Status	The current status of processing it has to be one of the following: <ul style="list-style-type: none"> • HALTED (waiting for manual intervention) • NOT REQUIRED • ALIVE 	NOT REQUIRED
4	Run_Flag	The processing flag status, Y or N. Unread value = N, read value =Y.	N
5	Next_Runtime	The next runtime when the error record should be processed for this composite.	SYSDATE+200
6	Halt_For_Error	Allowed values Y or N. When set to Y, manual intervention is required after one successful error record processing. When set to N, processing continues without halting.	N

S. No.	Column Name	Default	Default/ Suggested values
7	RunTime_Interval	<p>The runtime in minutes after which the next error processing should be done.</p> <p>Example: P10Y0M0DT0H0M0S</p> <p>The next processing is done after 10 years 0 months 0 days 0 hours 0 minutes and 0 seconds.</p> <p>This value must be updated based on the business requirement. Setting fewer intervals may have impact on performance.</p>	Default : P10Y0M0DT0H0M0S
8	Email_ID	<p>The e-mail IDs to which error notifications are sent.</p> <p>These values can be different or the same for all the composites.</p>	Default: email@domain.com
9	Email_Content_Type	<p>GENERIC - One e-mail is sent for all errors. No detailed information is included.</p> <p>SINGLE - One e-mail is sent for all errors with details included in the attachment.</p> <p>MULTIPLE - Multiple e-mails are sent and each email has information equal to the value specified in Error_Count_Per_Notification column.</p> <p>These values are case-sensitive and must always be given in upper case.</p>	Default: GENERIC
10	Email_XSL	<p>XSL to be applied for creating e-mail.</p> <p>The content, which includes subject/body and attachment. Look and feel can be modified here.</p>	<p>Default file is provided for all the composites and present under the XSL folder of composite.</p> <p>Example: xsl/Transformation_Create_Email.xsl</p> <p>Copy this to the MDS folder and enter the MDS path in this column for additional configuration.</p>
11	Error_Count_Per_Proc essing	<p>A notification is sent after the number of records set here, is processed.</p> <p>For example: If this is set to 50, then an e-mail notification containing 50 records is sent after 50 records are created in the error store.</p>	Default: 100

S. No.	Column Name	Default	Default/ Suggested values
12	Email_Attachment_Location	<p>The location where the e-mail attachment is created on the server.</p> <p>This value should point to the location/ folder where the attachment should be stored.</p> <p>This is used to create the attachment file in the following format.</p> <p>INTEGRATION_ERR_LOOKUP.Email_Attachment_Location + IP_Name + Date (in YYYYMMDDHH24MMSS)</p>	
13	Email_Attachment_Flag	<p>Y - Send e-mail with attachment. In this case, it is not mandatory to have Email_Attachment_Location specified.</p> <p>N - Send e-mail without attachment, but send the attachment location. In this case, Email_Attachment_Location has to be specified.</p> <p>ServerName</p> <p>+INTEGRATION_ERR_LOOKUP.Email_Attachment_Location + IntegrationPoint_Name + Date in YYYYMMDDHH24MMSS</p>	N
14	Publish_Human_Task_Flag	<p>Y - Publish human task</p> <p>N - Do not publish human task</p> <p>If Halt_For_Error value is set to Y and Publish_Human_Task_Flag is also Y, then human task is published and the user can take action from worklist application.</p>	N
15	ID_Human_Task	<p>User/ Group ID to which human task should be published in case Halt_For_Error is set to Y.</p> <p>This ID must be present in the WebLogic realm pointed by fusion middleware.</p>	Weblogic
16	Last_Updated_Date	Last updated date and time.	SYSDATE

S. No.	Column Name	Default	Default/ Suggested values
17	Purge_Error_Store_Flag	<p>Y - Purge data</p> <p>N - No purge require</p> <p>The process PurgeIntegrationErrorStore is deployed when the flag, <code>purge.process.deploy=true</code> (in the <code>deploy.properties</code> file) is set to true during installation.</p> <p>If <code>flag.purge.process = false</code>, then value of this column Purge_Error_Store_Flag will always be N.</p>	Default: N
18	Purge_Processing_Status_Flag	<p>Y - Purge Processing in process</p> <p>N - Purge processing not happening</p> <p>The process PurgeIntegrationErrorStore is only deployed when the flag, <code>purge.process.deploy=true</code> (in the <code>deploy.properties</code> file) is set to true during installation.</p> <p>If <code>flag.purge.process = false</code>, then value of this column Purge_Error_Store_Flag will always be N.</p>	Default: N
19	Purge_Frequency	<p>Number of days after which data should be purged. This will be in the picture format.</p> <p>Example: P10Y0M0DT0H0M0S</p> <p>The next processing will be done after 10 years 0 months 0 days 0 hours 0 minutes and 0 seconds.</p> <p>This value has to be updated based on the business requirement. Setting fewer intervals may have impact on performance.</p> <p>Set this value as appropriate.</p> <p>Applicable only when <code>flag.purge.process = true</code> in <code>deploy.properties</code> file during installation and the process PurgeIntegrationErrorStore ID deployed.</p>	Default: P10Y0M0DT0H0M0S

S. No.	Column Name	Default	Default/ Suggested values
20	Next_Purge_Date	The next purge date. Format: Next_Purge_date + Purge_Frequency Applicable only when flag.purge.process = true in deploy.properties file during installation and the process PurgeIntegrationErrorStore ID deployed.	SYSDATE+100
21	Purge_File_Name	The directory name where the purge file should be stored. Applicable only when flag.purge.process = true in deploy.properties file during installation and the process PurgeIntegrationErrorStore ID deployed.	'Location on server where purge record should be persisted'

To Customize Error Email Notifications for Individual Integration Points

1. Use the composite: UpdateIntegrationErrorLookupTable.
2. Open the following URL in a browser to get the screen that provides options to update the contents of table. [http://<SOA_HOST>:<SOA_PORT>/soa-infra/services/<partition>/ UpdateIntegrationErrorLookupTable/ updateintegrationerrorlookuptablebpel_client_ep](http://<SOA_HOST>:<SOA_PORT>/soa-infra/services/<partition>/UpdateIntegrationErrorLookupTable/updateintegrationerrorlookuptablebpel_client_ep).
3. Expand **WS-Security** and provide authentication information. This username and password will be the same as that used to login to the WebLogic Enterprise Manager console.
4. Expand the **Payload** section. This displays several editable text fields. Only the ipName field is mandatory and should be entered as one of the values from INTEGRATION_ERR_LOOKUP.IP_NAME field. By default, all the checkboxes appearing next to the text fields are checked.
5. Provide values in the text field. If you do not want to have a particular value updated, then uncheck the box.

Chapter 4

Monitoring and Troubleshooting

This section discusses in details the following:

- [Monitoring from Oracle Utilities Network Management System](#)
- [Monitoring from Oracle Utilities Smart Grid Gateway](#)
- [Monitoring from the Integration](#)
- [Troubleshooting](#)

4.1 Monitoring from Oracle Utilities Network Management System

The information about errors and warnings can be found in the log files of the WebLogic server where Oracle Utilities Network Management System MultiSpeak Adapter is deployed.

1. Login to the machine where the Oracle Utilities Network Management System MultiSpeak Adapter is installed.
2. The logs are stored in: <Weblogic installation folder>/user_projects/domains/<NMS Domain name>/servers/<Server name>/logs

For example: /slot/ems1234/oracle/Middleware/user_projects/domains/nms/servers/nms_1/logs

For more information about troubleshooting Oracle Utilities Network Management System, see the chapter “*Troubleshooting and Support*” in the *Oracle Utilities Network Management System Configuration Guide*.

4.2 Monitoring from Oracle Utilities Smart Grid Gateway

This section describes in detail the following:

- [Oracle Utilities Smart Grid Gateway Error Logs](#)
- [Notifications](#)
- [Connection Errors](#)

4.2.1 Oracle Utilities Smart Grid Gateway Error Logs

Many times a **Log** tab appears on errored object, such as Activities and Communications. It contains the significant events that have occurred since the object was created. These events could include related objects, such as outbound messages, or error messages such

as, explanations of missing configuration. More serious errors are very easy to detect when manually advancing BO lifecycle states by pressing the appropriate button on an errored activity. It should fail again in a similar way, but adding information to the user log. This log is accessible when "?utilities=true&debug=true&tools=true" is included in the URL and by clicking the **Show User Log** button at the top of the page.

Sometimes it is necessary to use the Oracle Enterprise Manager to check the status of a SOA service (for instance when an activity does not complete in a reasonable time). More details can be seen by navigating to the appropriate composite and viewing the trace of the problematic instance.

For more information about errors and notifications, see the *Oracle Utilities Smart Grid Gateway documentation*.

4.2.2 Notifications

The exceptions typically show up as To-Do items.

- Device Event propagation errors can be seen under the D1-DETD To Do Type
- Device Enable/Disable errors can be seen under the D1-SUPEX To Type
- Other errors can be seen under the F1-OUTMS and D1-ATVTD To Do Types

4.2.3 Connection Errors

Information about errors can be found in the log files.

For information about error logs and their respective folders, see the section Oracle Utilities Smart Grid Gateway Error Logs.

4.3 Monitoring from the Integration

The section describes the utilities used to monitor the integration, use any of the following:

- [Monitoring Using WebLogic SOA Enterprise Manager](#)
- [Monitoring Using the WebLogic Logs](#)
- [Data Purge](#)

4.3.1 Monitoring Using WebLogic SOA Enterprise Manager

1. Login to the **WebLogic SOA Server Enterprise Manager**, and then navigate to **SOA > SOA-Infra > NMS-SGG**.

All composite processes deployed for the integration are available under the partition NMS-SGG.

2. Select the appropriate process to list all the instances for the processes sorted by time of execution.

The instances also have the number of meters processed as part of the display name.

3. Click the appropriate process instance and it will display the flow for the process.

The composite flow lists all activities in the process instance.

4.3.2 Monitoring Using the WebLogic Logs

1. Login to the machine where the SOA Server is installed.
2. The SOA logs are stored in: <Weblogic installation folder>/user_projects/domains/<SOA Domain name>/servers/<SOA Server name>/logs.

For example: /slot/ems1234/oracle/Middleware/user_projects/domains/soa_domain/servers/soa_server1/logs

4.3.3 Data Purge

To maintain maximum system performance, the Oracle Fusion Middleware database should be purged periodically.

For information about how to complete this task, refer to the note in Doc ID 815896.1, “SOA11g Purge Scripts,” on <https://support.oracle.com>.

4.4 Troubleshooting

At times, the integration might experience errors or issues with connection, processing, or sending or receiving messages. The following are the common scenarios, which help you to troubleshoot error, if any, and find possible solutions:

Possible Error Scenario	Resolution
Oracle Utilities Network Management System is unable to connect to the integration layer	<p>Verify whether the integration composite endpoint URLs are configured in Oracle Utilities Network Management System.</p> <p>Verify whether the integration layer is running, the SOA composite is deployed and it is accepting the requests.</p>
Oracle Utilities Smart Grid Gateway is unable to connect to the integration layer	<p>Verify whether the integration composite endpoint URLs are configured in Oracle Utilities Smart Grid Gateway.</p> <p>Verify whether the integration layer is running, the SOA composite is deployed and it is accepting the requests.</p>

Possible Error Scenario	Resolution
The integration is unable to connect to Oracle Utilities Network Management System	<p data-bbox="951 218 1273 247">Perform the following steps:</p> <ol data-bbox="951 268 1507 1066" style="list-style-type: none"><li data-bbox="951 268 1507 331">1. Check the SOA composite process to find out where the failure occurred.<li data-bbox="951 352 1507 562">2. Verify whether or not the Oracle Utilities Network Management System credentials are properly configured in the integration layer by logging into the enterprise manager console and navigating to Weblogic domain > <Domain Name>.<li data-bbox="951 583 1507 646">3. Right-click the <Domain Name> and select Security > Credentials.<li data-bbox="951 667 1507 835">4. Under the credential map oracle.wsm.security, select the key NMS-SGG_NMS. Verify whether or not the user and password for Oracle Utilities Network Management System are correct.<li data-bbox="951 856 1507 961">5. Verify whether the Oracle Utilities Network Management System environment is up and running.<li data-bbox="951 982 1507 1066">6. Verify whether the Oracle Utilities Network Management System service policies are attached in the integration composite.

Possible Error Scenario	Resolution
The integration is unable to connect to Oracle Utilities Smart Grid Gateway	<p>Perform the following steps:</p> <ol style="list-style-type: none"> 1. Check the SOA composite process to find out where the failure occurred. 2. Verify whether or not the Oracle Utilities Smart Grid Gateway credentials are properly configured in the integration layer by logging into the enterprise manager console and navigating to Weblogic domain > <Domain Name>. 3. Right-click the <Domain Name> and select Security > Credentials. 4. Under the credential map oracle.wsm.security, select the key NMS-SGG_SGG_XAI. Verify whether or not the SGG XAI user password is correct. 5. If the error is while accessing the Oracle Utilities Smart Grid Gateway BPEL composite, then select the key NMS-SGG_SGG_BPEL. Verify whether or not the Oracle Utilities Smart Grid Gateway XAI user password is correct. 6. Verify whether the Oracle Utilities Smart Grid Gateway environment is up and running. 7. Verify whether the Oracle Utilities Smart Grid Gateway SOA environment is up and running. 8. Verify whether the Oracle Utilities Smart Grid Gateway service policies are attached in the integration composite. 9. Verify whether the security policies and the CSF-keys are attached to the Oracle Utilities Smart Grid Gateway SOA composites. 10. Verify whether the Bulk Notification reference in the BulkRequest Oracle Utilities Smart Grid Gateway SOA composite has the security policy and the CSF-key attached to it.

Chapter 5

Customization Options

This chapter provides information on the various methods that can be used to extend or customize the integration.

5.1 Extension Methods

The Integration Process allows extensibility of transaction messages using the following methods:

- [Pre-Transformation Extension Scope](#)
- [Pre-Invoke Extension Scope](#)
- [Post-Invoke Extension Scope](#)
- [Post-Transformation Extension Scope](#)
- [Custom Transformations](#)
 - Request custom transformation
 - Response custom transformation
- [Override Transformations](#)
 - Request override transformation
 - Response override transformation

Implementers can add/implement their logic in these custom scopes of a specific composite once they login to Jdeveloper with the **Customization Developer Role**.

5.1.1 Pre-Transformation Extension Scope

The pre-transformation extension scope is invoked before the main transformation is executed. This transformation aids in converting the source XML that comes in as an input to the integration process and helps the implementation to invoke external web services and/or transform the input XML.

5.1.2 Pre-Invoke Extension Scope

The pre-transformation extension scope is invoked before the main transformation is executed. This transformation aids in converting the source XML that comes in as an input to the integration process and helps the implementation to invoke external web services and/or transform the input XML.

5.1.3 Post-Invoke Extension Scope

The pre-transformation extension scope is invoked before the main transformation is executed. This transformation aids in converting the source XML that comes in as an input to the integration process and helps the implementation to invoke external web services and/or transform the input XML.

5.1.4 Post-Transformation Extension Scope

The post-transformation extension scope is invoked after the main transformation is executed. This transformation aids in converting the target XML that comes in as an input to the target queue and helps the implementation to invoke external web services and/or transform the output XML.

5.1.5 Custom Transformations

The custom transformations are used to add data to the message in the incoming and outgoing messages.

Custom transformations named “XX_Custom.xml” are shipped with the product, which will add the new data mappings to the main transformations.

Using custom transformations enables the implementation to define and pass additional data from source system to the target system.

5.1.6 Override Transformations

The override transformations are used to override the message in the incoming and outgoing messages.

Override transformations named "XX_Override.xml" is shipped with the product, which sends the output derived from the main transformations.

Using override transformations enables the implementation to pass any data from source system to the target system.

For more details on customization, refer to http://docs.tpu.ru/docs/oracle/en/fmw/11.1.1.6.0/dev.1111/e10224/bp_customize.htm.

Appendix A

Data Mapping

This section provides the mapping details for each of the integration point:

- [Oracle Utilities Network Management System Batch Ping Request](#)
- [Oracle Utilities Smart Grid Gateway Batch Ping Response](#)
- [Oracle Utilities Network Management System Batch Enable/Disable Request](#)
- [Oracle Utilities Smart Grid Gateway Batch Unsuppress/Suppress Request](#)
- [Oracle Utilities Smart Grid Gateway Device Power Status Update](#)

Oracle Utilities Network Management System Batch Ping Request

This section provides data mapping details for the following:

- [Oracle Utilities Network Management System Batch Ping Request](#)
- [Oracle Utilities Network Management System Batch Ping Request's Response](#)

Oracle Utilities Network Management System Batch Ping Request

Oracle Utilities Network Management System Batch Ping Request Mapping details for each integration point are as shown in the table below:

Oracle Utilities Network Management System Batch Ping Request Mapping			Oracle Utilities Smart Grid Gateway Batch Ping Request Mapping			DVM Mapping		
Element Name	Parent Element	Type	Element Name	Parent Element	Type	DVM	Oracle Utilities Network Management System Column	Oracle Utilities Smart Grid Gateway Column
InitiateOutageDetectionEventRequest		OutermostTag	bulkReqeust		OutermostTag			
meterIDs	InitiateOutageDetectionEventRequest	List	utilityDeviceIds	bulkReqeust	List			
meterID	meterIDs	Field	utilityDeviceIdentifierNumber	utilityDeviceIds	Field			
transactionID	InitiateOutageDetectionEventRequest	Field	externalBulkRequestId	bulkReqeust	Field			
			ExternalRequesterId	bulkReqeust	Field			
expTime	InitiateOutageDetectionEventRequest	Field	ExpirationDateTime	bulkReqeust	Field			
Units	InitiateOutageDetectionEventRequest	Attribute						
			CommandIdentifier	bulkReqeust	Field			
			timedResponseBeforeAllReceived	bulkReqeust	Field			
			responseCreationMethod	bulkReqeust	Field			
			callbackURL	bulkReqeust	Field			

Oracle Utilities Network Management System Batch Ping Request's Response

Oracle Utilities Network Management System Batch Ping Request Mapping details for each integration point are as shown in the table below:

Oracle Utilities Smart Grid Gateway Batch Ping Request Response Mapping			Oracle Utilities Network Management System Batch Ping Request Response Mapping			DVM Mapping		
Element Name	Parent Element	Type	Element Name	Parent Element	Type	DVM	Oracle Utilities Network Management System Column	Oracle Utilities Smart Grid Gateway Column
bulkRequestResponse		Outermost Tag	InitiateOutageDetectionEventRequestResponse		Outermost Tag			
			InitiateOutageDetectionEventRequestResult	InitiateOutageDetectionEventRequestResponse	List			
Fault	bulkRequestResponse	Group	errorObject	InitiateOutageDetectionEventRequestResult	Group			
faultString	fault	Field	errorString	InitiateOutageDetectionEventRequestResult	Attribute			
faultCode	fault	Field	eventTime	InitiateOutageDetectionEventRequestResult	Attribute			

Oracle Utilities Smart Grid Gateway Batch Ping Response

This section provides data mapping details for the following:

- [Oracle Utilities Smart Grid Gateway Batch Ping Response](#)
- [Oracle Utilities Smart Grid Gateway Batch Ping Response's Result](#)

Oracle Utilities Smart Grid Gateway Batch Ping Response

Oracle Utilities Smart Grid Gateway Batch Ping Response Request Mapping			Oracle Utilities Network Management System Batch Ping Response Request Mapping			DVM Mapping		
Element Name	Parent Element	Type	Element Name	Parent Element	Type	DVM	Oracle Utilities Network Management System Column	Oracle Utilities Smart Grid Gateway Column
D1-BulkResp		OutermostTag	ODEventNotification		OutermostTag			
transaction	D1-BulkResp	Group						
transactionId	transaction	Field	transactionID	ODEventNotification	Field			
			ODEvents	ODEventNotification	List			
			outageDetectionEvent	ODEvents	Group			
utilityDeviceIdentifierNumber	transaction	Field	objectID	outageDetectionEvent	Attribute			
deviceFunctionalState	transaction	Field	outageEventType	outageEventType	Field	NMSSGG_DevicePingStatus	NMS_OutageEventType	SGG_DeviceFunctionalState
			eventTime	outageDetectionEvent	Field			
commands	D1-BulkResp	List						
command	commands	Group						
transaction	command	Group						
			ODEvents	ODEventNotification	List			
			outageDetectionEvent	ODEvents	Group			
utilityDeviceIdentifierNumber	transaction	Field	objectID	outageDetectionEvent	Attribute			
deviceFunctionalState	transaction	Field	outageEventType	outageDetectionEvent	Field			
			eventTime	outageDetectionEvent	Field			

Oracle Utilities Smart Grid Gateway Batch Ping Response's Result

Oracle Utilities Network Management System Batch Ping Response Result Mapping			Oracle Utilities Smart Grid Gateway Batch Ping Response Result Mapping			DVM Mapping		
Element Name	Parent Element	Type	Element Name	Parent Element	Type	DVM	Oracle Utilities Network Management System Column	Oracle Utilities Smart Grid Gateway Column
ODEventNotificationResposne		OutermostTag	D1-Response					
ODEventNotificationResult	ODEventNotificationResposne	List	Response	D1-Response	List			
errorObject	ODEventNotificationResult	Group	errorObject	Response	Group			
objectID	ODEventNotificationResult	Attribute	objectID	Response	Attribute			
errorString	ODEventNotificationResult	Attribute	errorString	Response	Attribute			
nounType	ODEventNotificationResult	Attribute	nounType	Response	Attribute			
eventTime	ODEventNotificationResult	Attribute	eventTime	Response	Attribute			

Oracle Utilities Network Management System Batch Enable/Disable Request

This section provides data mapping details for the following:

- [Oracle Utilities Network Management System Batch Enable/Disable Request](#)
- [Oracle Utilities Network Management System Batch Enable/Disable Response](#)

Oracle Utilities Network Management System Batch Enable/Disable Request

Oracle Utilities Network Management System Batch Enable/Disable Request Mapping			Oracle Utilities Smart Grid Gateway Devices Enable/Disable Request Mapping			DVM Mapping		
Element Name	Parent Element	Type	Element Name	Parent Element	Type	DVM	Oracle Utilities Network Management System Column	Oracle Utilities Smart Grid Gateway Column
MeterChangedNotification		Outermost Tag	D1-MaintainSuppression		Outermost Tag			
			dateTimeTagFormat					
			suppressedServiceProviderExternalReferenceId	D1-MaintainSuppression				
			suppressionType	D1-MaintainSuppression				
changedMeters	MeterChangedNotification	List						
electricMeters	changedMeters	List	suppressionRequests	D1-MaintainSuppression	List			
electricMeter	electricMeters	Group	suppressionRequest	suppressionRequest	Group			
meterNo	electricMeter	Field	utilityDeviceIdentifierNumber	suppressionRequest	Field			
meterStatusList	electricMeter	List						
meterStatus	meterStatusList	Field	suppressionAction	suppressionRequests	Field	NMSSGG_MeterSuppressionStatus	NMS_MeterStatus	SGG_SuppressionRequest

Oracle Utilities Network Management System Batch Enable/Disable Response

Oracle Utilities Smart Grid Gateway Devices Enable/Disable Response Mapping			Oracle Utilities Network Management System Devices Enable/Disable Response Mapping			DVM Mapping	Oracle Utilities Network Management System Column	Oracle Utilities Smart Grid Gateway Column
Element Name	Parent Element	Type	Element Name	Parent Element	Type	DVM		
D1-MaintainSuppression		OutermostTag	MeterChangedNotificationResponse		OutermostTag			
dateTimeTagFormat		Attribute						
suppressionRequestErrors	D1-MaintainSuppression	List	MeterChangedNotificationResult	MeterChangedNotificationResponse	List			
suppressionRequestError	suppressionRequestErrors	Group	errorObject	MeterChangedNotificationResult	Group			
errorMessage	suppressionRequestError	Field	errorString	MeterChangedNotificationResult	Attribute			
utilityDeviceIdentifierNumber	suppressionRequestError	Field	objectID	MeterChangedNotificationResult	Attribute			
			eventTime	MeterChangedNotificationResult	Attribute			

Oracle Utilities Smart Grid Gateway Batch Unsuppress/Suppress Request

This section provides data mapping details for the following:

- [Oracle Utilities Smart Grid Gateway Batch Unsuppress/Suppress Request](#)
- [Oracle Utilities Smart Grid Gateway Batch Unsuppress/Suppress Response](#)

Oracle Utilities Smart Grid Gateway Batch Unsuppress/Suppress Request

Oracle Utilities Smart Grid Gateway Batch Unsuppress/ Suppress Request Mapping			Oracle Utilities Network Management System Batch Unsuppress/ Suppress Request Mapping			DVM Mapping		
Element Name	Parent Element	Type	Element Name	Parent Element	Type	DVM	Oracle Utilities Network Management System Column	Oracle Utilities Smart Grid Gateway Column
D1-OutboundMessageNotifSupp		OutermostTag	MeterChangedNotification					
transactions	D1-OutboundMessageNotifSupp	List	changedMeters	MeterChangedNotification				
			electricMeters	changedMeters				
transaction	transactions	Group	electricMeter	electricMeters				
utilityDeviceIdentifierNumber	transaction	Field	meterNo	electricMeter	Field			
			meterStatusList	electricMeter				
suppressionAction	transaction	Field	meterStatus	meterStatusList	Field	NMSSGG_MeterSuppressionStatus	NMS_MeterStatus	SGG_SuppressionRequest

Oracle Utilities Smart Grid Gateway Batch Unsuppress/Suppress Response

Oracle Utilities Network Management System Batch Unsuppress/Suppress Response Mapping			Oracle Utilities Smart Grid Gateway Batch Unsuppress/Suppress Response Message Mapping			DVM Mapping		
Element Name	Parent Element	Type	Element Name	Parent Element	Type	DVM	Oracle Utilities Network Management System Column	Oracle Utilities Smart Grid Gateway Column
MeterChangedNotificationResponse		Outermost Tag	D1-Response		Outermost Tag			
MeterChangedNotificationResult	MeterChangedNotificationResponse	List	Response	D1-Response	List			
errorObject	MeterChangedNotificationResult	Group	errorObject	Response	Group			
errorString	MeterChangedNotificationResult	Attribute	errorString	Response	Attribute			
objectID	MeterChangedNotificationResult	Attribute	objectID	Response	Attribute			
eventTime	MeterChangedNotificationResult	Attribute	eventTime	Response	Attribute			
nounType	MeterChangedNotificationResult	Attribute	nounType	Response	Attribute			

Oracle Utilities Smart Grid Gateway Device Power Status Update

This section provides data mapping details for the following:

- [Oracle Utilities Smart Grid Gateway Device Power Status Update Request](#)
- [Oracle Utilities Smart Grid Gateway Device Power Status Update Response](#)

Oracle Utilities Smart Grid Gateway Device Power Status Update Request

Oracle Utilities Smart Grid Gateway Device Power Status Update Request Mapping			Oracle Utilities Network Management System Device Power Status Update Request Mapping			DVM Mapping		
Element Name	Parent Element	Type	Element Name	Parent Element	Type	DVM	Oracle Utilities Network Management System Column	Oracle Utilities Smart Grid Gateway Column
D1-DeviceEventNotification		Outermost Tag	ODEventNotification		Outermost Tag			
			ODEvents	ODEventNotification	List			
			outageDetectionEvent	ODEvents	Group			
utilityDeviceIdentifierNumber	D1-DeviceEventNotification	Field	objectID	outageDetectionEvent	Attribute			
eventDateTime	D1-DeviceEventNotification	Field	eventTime	outageDetectionEvent	Field			
standardEventName	D1-DeviceEventNotification	Field	outageEventType	outageDetectionEvent	Field	NMSSGG_DeviceEventType	NMS_EventType	SGG_EventType

Oracle Utilities Smart Grid Gateway Device Power Status Update Response

Oracle Utilities Network Management System Device Power Status Update Response Mapping			Oracle Utilities Smart Grid Gateway Device Power Status Update Response Mapping			DVM Mapping		
Element Name	Parent Element	Type	Element Name	Parent Element	Type	DVM	Oracle Utilities Network Management System Column	Oracle Utilities Smart Grid Gateway Column
ODEventNotificationResposne		OutermostTag	D1-Response		OutermostTag			
ODEventNotificationResult	ODEventNotificationResposne	List	Response	D1-Response	List			
errorObject	ODEventNotificationResult	Group	errorObject	Response	Group			
errorString	ODEventNotificationResult	Attribute	errorString	Response	Attribute			
objectID	ODEventNotificationResult	Attribute	objectID	Response	Attribute			
eventTime	ODEventNotificationResult	Attribute	eventTime	Response	Attribute			
nounType	ODEventNotificationResult	Attribute	nounType	Response	Attribute			

