

**Oracle® Communications
Performance Intelligence Center
Hardware Installation Guidelines**
Release 10.1.5
E64544 Revision 3

January 2016

Oracle® Communications Hardware Installation Guidelines

Copyright © 2003, 2016 Oracle and/or its affiliates. All rights reserved.

This software and related documentation are provided under a license agreement containing restrictions on use and disclosure and are protected by intellectual property laws. Except as expressly permitted in your license agreement or allowed by law, you may not use, copy, reproduce, translate, broadcast, modify, license, transmit, distribute, exhibit, perform, publish, or display any part, in any form, or by any means. Reverse engineering, disassembly, or decompilation of this software, unless required by law for interoperability, is prohibited.

The information contained herein is subject to change without notice and is not warranted to be error-free. If you find any errors, please report them to us in writing.

If this is software or related documentation that is delivered to the U.S. Government or anyone licensing it on behalf of the U.S. Government, the following notice is applicable:

U.S. GOVERNMENT END USERS: Oracle programs, including any operating system, integrated software, any programs installed on the hardware, and/or documentation, delivered to U.S. Government end users are "commercial computer software" pursuant to the applicable Federal Acquisition Regulation and agency-specific supplemental regulations. As such, use, duplication, disclosure, modification, and adaptation of the programs, including any operating system, integrated software, any programs installed on the hardware, and/or documentation, shall be subject to license terms and license restrictions applicable to the programs. No other rights are granted to the U.S. Government.

This software or hardware is developed for general use in a variety of information management applications. It is not developed or intended for use in any inherently dangerous applications, including applications that may create a risk of personal injury. If you use this software or hardware in dangerous applications, then you shall be responsible to take all appropriate fail-safe, backup, redundancy, and other measures to ensure its safe use. Oracle Corporation and its affiliates disclaim any liability for any damages caused by use of this software or hardware in dangerous applications.

Oracle and Java are registered trademarks of Oracle and/or its affiliates. Other names may be trademarks of their respective owners.

Intel and Intel Xeon are trademarks or registered trademarks of Intel Corporation. All SPARC trademarks are used under license and are trademarks or registered trademarks of SPARC International, Inc. AMD, Opteron, the AMD logo, and the AMD Opteron logo are trademarks or registered trademarks of Advanced Micro Devices. UNIX is a registered trademark of The Open Group.

This software or hardware and documentation may provide access to or information on content, products, and services from third parties. Oracle Corporation and its affiliates are not responsible for and expressly disclaim all warranties of any kind with respect to third-party content, products, and services. Oracle Corporation and its affiliates will not be responsible for any loss, costs, or damages incurred due to your access to or use of third-party content, products, or services.

Hardware Installation Guidelines

TABLE OF CONTENTS

1	INTRODUCTION	8
1.1	Purpose.....	8
1.2	Target audience.....	8
1.3	Acronyms and Terminology.....	8
1.4	References.....	9
1.5	Foreword.....	9
2	PIC MANAGEMENT	10
2.1	Hardware options for PIC Management server.....	10
2.1.1	Qualified BOM for PIC Management on X5-2 RMS server.....	10
2.1.2	Documentation for PIC Management on X5-2 Oracle hardware.....	10
2.1.3	Qualified HP RMS BOM for PIC Management.....	11
2.1.4	Documentation for Management server on HP RMS.....	13
2.2	Networking guidelines for PIC Management server.....	14
3	PIC MEDIATION AND STORAGE	16
3.1	Hardware options for Mediation server.....	16
3.1.1	Qualified BOM for Mediation on Oracle X5-2.....	16
3.1.2	Documentation for Mediation on Oracle X5-2.....	17
3.1.3	Qualified BOM for Mediation on HP RMS.....	17
3.1.4	Documentation for Mediation server on HP RMS.....	20
3.2	Hardware options for Packet Data Unit Storage.....	21
3.2.1	Qualified BOM for Packet Data Unit Storage server on Oracle ZFS Appliance.....	21
3.2.2	Documentation for Packet Data Unit Storage server on Oracle ZFS Appliance.....	21
3.2.3	Qualified BOM for Packet Data Unit Storage server on HP RMS.....	22
3.2.4	Documentation for Packet Data Unit Storage server on HP RMS.....	24
3.3	Hardware options for Data Record storage.....	26
3.3.1	Qualified BOM for Data Record storage on Oracle Data Base Appliance.....	26
3.3.2	Documentation for Data Record storage on Oracle Data Base Appliance.....	26
3.3.3	Qualified BOM for Data Record storage on HP RMS.....	27
3.3.4	Documentation for Data Record Storage server on HP RMS.....	29
3.4	Networking guidelines for PIC Mediation.....	30
4	INTEGRATED ACQUISITION	32
4.1	Hardware options for Integrated acquisition.....	32
4.1.1	Documentation for Integrated Acquisition on E5-APP-B.....	32
4.1.2	Qualified BOM for Integrated acquisition on Oracle X5-2.....	32
4.1.3	Documentation for Integrated acquisition on Oracle X5-2.....	33
4.1.4	Qualified BOM for Integrated acquisition on HP RMS.....	34
4.1.5	Documentation for Integrated Acquisition on HP RMS.....	37
4.2	Networking guidelines for Integrated Acquisition.....	37
4.2.1	Default configuration.....	39
4.2.2	Alternate configuration.....	40
4.2.3	Networking guidelines for standard configuration.....	41
4.2.4	IP addressing.....	42
5	PROBED ACQUISITION	43

- 5.1 Hardware options for Probed acquisition43
 - 5.1.1 Qualified BOM for Probed acquisition on Oracle X5-243
 - 5.1.2 Documentation for Probed acquisition on Oracle X5-244
 - 5.1.3 Qualified BOM for Probed acquisition on HP RMS.....44
 - 5.1.4 Documentation for Probed acquisition on HP RMS.....48
- 5.2 Networking guidelines for Probed Acquisition49
- 6 ANNEXES 51**
 - 6.1 Port identification on HP server Gen8 v1 & v2:51
 - 6.2 Port identification on HP server DL360 Gen9.....52
 - 6.3 Port identification on HP server DL380 Gen9:.....52
 - 6.4 Port identification on D2700 Storage Array:53
 - 6.5 Port identification on ODA X5-2.....54
 - 6.6 Port identification on Oracle X5-255
 - 6.7 Port identification on ZFS ZS3-2.....55
 - 6.8 RAID configurations57
 - 6.9 Cable specification for Falco (SS7 to Sigtran converter)58
 - 6.10 Cisco Switch.....61
 - 6.11 Cisco basic knowledge61
 - 6.11.1 Configure and access the serial console on TPD.....62
 - 6.11.2 Configure and access the serial console on TVOE62
 - 6.11.3 4948&4948EF Reset to factory defaults63
 - 6.11.4 Assign an IP address on a 3020.....64
 - 6.11.5 2950 & 3020 Reset to factory defaults.....64
 - 6.11.6 Configure telnet access on a 302065
 - 6.11.7 Configure SSH access.....67
 - 6.11.8 Recover a switch from rommon prompt.....68
 - 6.11.9 Upgrade IOS software69
 - 6.11.10 Backup the switch config on a server70
 - 6.11.11 Configure Cisco 4948/4948E/4948E-F switch70
 - 6.11.12 Configure Cisco 3020 switch71
 - 6.11.13 Flush ARP table72
 - 6.12 Mediation switch configuration template74
 - 6.12.1 Switch port allocation74
 - 6.12.2 Control Frame Switch74
 - 6.12.3 Extension Frame Switch77
 - 6.13 Blade mediation switch configuration template.....82
 - 6.13.1 Switch port allocation83
 - 6.13.2 Aggregation Switch84
 - 6.13.3 Enclosure Switch91
 - 6.13.4 G6 MSA cabling diagram94
 - 6.13.4.1 Aggregation Switch 494894
 - 6.13.4.2 Enclosure Switch 3020.....99
 - 6.14 Integrated Acquisition switch configuration template.....102
 - 6.14.1 Switch port allocation102
 - 6.14.2 Yellow-sw1-1 Switch (Layer 3).....102
 - 6.14.3 Blue-sw1-1 Switch (Layer 3).....108
 - 6.14.4 Yellow-sw2-1 Switch (Layer 3).....113
 - 6.14.5 Blue-sw2-1 Switch (Layer 3).....117
 - 6.14.6 Yellow-sw3-1 Switch (Layer 3).....121
 - 6.14.7 Blue-sw3-1 Switch (Layer 3).....123
 - 6.14.8 Single Switch yellow-blue-sw1-1126

Hardware Installation Guidelines

6.14.9	RMS Layer 2 switch configurations (PIC 9.x and earlier)	129
6.14.9.1	Yellow-sw1-1 (Layer 2).....	129
6.14.9.2	Blue-sw1-1 (Layer 2)	134
6.14.9.3	Yellow-sw2-1 (Layer 2).....	139
6.14.9.4	Blue-sw2-1 (Layer 2)	142
6.14.9.5	Yellow-sw3-1 (Layer 2).....	146
6.14.9.6	Blue-sw3-1 (Layer 2)	148
6.14.10	IMF on E5-AppB	150
6.14.10.1	Switch port allocation.....	150
6.14.10.2	Yellow-sw1-1 Switch (Layer 3).....	150
6.14.10.3	Blue-sw1-1 Switch (Layer 3)	154
6.14.10.4	Single Switch yellow-blue-sw1-1 (Layer 2)	157
6.15	Configurations summary	161
6.16	MY ORACLE SUPPORT (MOS)	162
6.17	LOCATE PRODUCT DOCUMENTATION ON THE ORACLE HELP CENTER SITE	163

List of Tables

Table 1: Acronyms and Terminology.....	8
Table 2: Oracle X5-2 BOM for PIC Management RMS Server.....	10
Table 3: HP Gen9 qualified BOM for PIC Management RMS server.....	12
Table 4: HP Gen8 v2 qualified BOM for PIC Management RMS server.....	12
Table 5: HP Gen8 v1 qualified BOM for PIC Management RMS server.....	13
Table 6: HP G6 qualified BOM for PIC Management RMS Server.....	13
Table 7: Oracle X5-2 BOM for PIC Mediation RMS Server.....	17
Table 8: HP Gen9 qualified BOM for PIC Mediation RMS server.....	18
Table 9: HP Gen8v2 qualified BOM for PIC Mediation RMS Server.....	19
Table 10: HP Gen8v1 qualified BOM for PIC Mediation RMS Server.....	19
Table 11: HP G6 qualified BOM for PIC Mediation RMS Server.....	19
Table 12: Oracle ZFS BOM for PIC Packet Data Unit RMS Server.....	21
Table 13: HP Gen9 qualified BOM for PIC Data Record storage RMS server.....	23
Table 14: HP Gen8 v2 qualified BOM for PIC Packet Data Unit Storage server.....	23
Table 15: HP Gen8 v1 qualified BOM for PIC Packet Data Unit Storage server.....	24
Table 16: HP G6 qualified BOM for PIC Packet Data Unit Storage Server.....	24
Table 17: Oracle Database appliance X5-2 for PIC Data Record storage RMS server.....	26
Table 18: Oracle Database appliance X5-2 additional storage for PIC Data Record storage RMS server.....	26
Table 19: HP Gen9 qualified BOM for PIC Data Record storage RMS server.....	27
Table 20: HP Gen8 v2 qualified BOM for PIC Data Record storage RMS server.....	28
Table 21: HP Gen8 v1 qualified BOM for PIC Data Record storage RMS server.....	29
Table 22: HP G6 qualified BOM for PIC Data Record storage RMS Server.....	29
Table 23: Oracle X5-2 BOM for PIC Integrated acquisition RMS Server.....	33
Table 24: HP Gen9 qualified BOM for PIC Integrated Acquisition (NEBS compliant).....	35
Table 25: HP Gen8 v2 qualified BOM for PIC Integrated Acquisition (NEBS version).....	35
Table 26: HP G8 v1 qualified BOM for PIC Integrated Acquisition (non NEBS version).....	36
Table 27: HP Gen8 v1 qualified BOM for PIC Integrated Acquisition (NEBS version).....	36
Table 28: HP G6 qualified BOM for PIC Integrated Acquisition.....	37
Table 29: Oracle X5-2 BOM for PIC Probed acquisition RMS Server on copper links.....	43
Table 30: Oracle X5-2 BOM for PIC Probed acquisition RMS Server on optical links.....	44
Table 31: Qualified SFP(+) modules on Oracle X5-2.....	44
Table 32: HP Gen9 qualified BOM for PIC Probed 1G/10G Acquisition.....	45
Table 33: HP Gen8 v2 qualified BOM for PIC Probed 1G/10G Acquisition.....	46
Table 34: HP Gen8 v1 qualified BOM for PIC Probed 1G/10G Acquisition (NEBS version).....	46
Table 35: HP G8 v1 qualified BOM for PIC Probed 1G Acquisition (non NEBS version).....	47
Table 36: HP Gen8 v1 qualified BOM for PIC Probed 1G Acquisition (NEBS version).....	47
Table 37: HP G6 qualified BOM for PIC Probed 1G Acquisition.....	48
Table 38: SFP+ modules available on HP Intel X520 card.....	49
Table 39: SFP+ modules available on HP Intel X560 card.....	49
Table 40: Cable for Falco: sample configuration for unprotected links.....	61
Table 41: Cisco 4948E-F configuration.....	61

Hardware Installation Guidelines

List of Figures

Figure 2 : Rear view for HP DL360 server Gen8 v1 & v2 used for Mediation	51
Figure 3 : Rear view for HP DL360 server Gen8 v1 & v2 used for Probed acquisition	51
Figure 4 : Rear view for HP DL360 server Gen9	52
Figure 5 : Front view for HP DL38 Gen9	52
Figure 6 : Rear view for HP DL380 Gen9	52
Figure 7 : Rear view for D2700 storage array	53
Figure 8 : Drive Bay numbering	53
Figure 9- Front view of Oracle Database Appliance (storage shelf connections)	54
Figure 10- Rear view of Oracle Database Appliance (power and network connections)	54
Figure 11- Rear view of Oracle X5-2 Server	55
Figure 12- Front view of Oracle ZFS ZS3-2 Controller	55
Figure 13- Rear view of Oracle ZFS ZS3-2 Controller	56
Figure 14- Front view of Oracle DE2-24P drive enclosure	56
Figure 15- Rear view of Oracle DE2-24P drive enclosure	57
Figure 16- SS7 line inputs to Falco	59
Figure 17- Cable for Falco: sample configuration for unprotected links	60

1 Introduction

1.1 Purpose

Purpose of this document is to provide detailed guidelines to Oracle CGBU consulting team as well as to value-added reseller consulting teams, relating to the installation services of servers and any further Hardware required to support the PIC 10.1.5 software.

Moreover, this document delivers Guidelines to support the implementation of the PIC Software.

It is divided in 5 sections:

- PIC management
- PIC Mediation and Storage
- PIC integrated acquisition
- PIC probed acquisition
- Annex

Any BOM provided in the document are Oracle recommended configurations to be used with the PIC 10.1.5 version. This hardware is qualified to work with PIC for the usage defined in each section. Some adaptations are still possible and are documented at the end of each section when available.

Implementation on HP blades is not covered by this document.

 CAUTION	<p>This document provides generic guidelines for PIC supported hardware as well as rules and recommendations to build a setup compatible with PIC installation. This document can't be use to replace the installation guides provided by the manufacturers of the hardware depict in this document. It is particularly true for safety rules and recommendations present in these documents.</p>
--	---

1.2 Target audience

This guide is intended for technical personnel who are responsible for installing, configuring, and maintaining the hardware. Users should be familiar with hardware from HP, Oracle, Cisco switches, and shall have networking concepts understanding.

This document present high level rules for successful implementation of PIC. Users are expected to read the manufacturer documentations for the selected hardware. PIC software installation is covered in the installation Guide.

1.3 Acronyms and Terminology

PIC	Performance Intelligence Center
ILOM	Oracle Integrated Lights Out Manager
ILO	HP Integrated Lights Out
ODA	Oracle Database Appliance software
BOM	Bill Of Materials
RMS	Rack Mount Server
O&M	Operation and Maintenance

Table 1: Acronyms and Terminology

Hardware Installation Guidelines

1.4 References

- Installation reference documentations : <http://eis.us.oracle.com/>
- PIC 10.1.5 documentations: http://docs.oracle.com/cd/E64826_01/index.htm
- PIC Data Warehouse Server (DWS) on Third-Party Server Installation Guide (Doc ID 2028670.1)
- PIC Packet Data Unit Storage (PDU) on Third-Party Server Installation Guide (Doc ID 2034894.1)
- Management Server (NSP) on Third-Party Server Installation Guide (Doc ID 2062544.1)
- Oracle linux on Third-Party Server Installation Guide for Performance Intelligence Center (PIC) product (Doc ID 2061666.1)
- Oracle ASM and Database on Third-Party Server Installation Guide for Performance Intelligence Center (PIC) products (Doc ID 2062491.1)
- Tekelec Platform 7.0 documentations : http://docs.oracle.com/cd/E57832_01/index.htm
- Oracle ODA documentations: http://docs.oracle.com/cd/E22693_01/index.htm
- Oracle X5-2 Documentations: http://docs.oracle.com/cd/E41059_01/
- Oracle ZFS Documentations: http://docs.oracle.com/cd/E56021_01/index.html
- HP Product Bulletin site: http://h18004.www1.hp.com/products/quickspecs/productBulletin.html#CD_Files
- Network Critical site: www.networkcritical.com

1.5 Foreword

This document provides server BOMs, global guidelines to connect equipment together, and requirements for successful PIC implementation. It doesn't supersede Manufacturer's documentations for the equipment. Some References are provided but it doesn't constitute the complete list.

In addition to servers and switches, other equipment may be required like racks, power distribution units, installation kits, cable management kits, cage nuts, screw, power cables, data cables, floor mounting kit, clamps, labels They are not depicted in this document. They shall be defined by the customer according to his setup or by a 3 party vendor/installer. Oracle can offer an additional service to define with the customer the installation design and additional items. This operation is performed by Oracle Consulting. Note that this may require a site survey.

When mixing AC and DC power supplies in the same plant, electrical best practice safety rules shall be strictly applied. For instance, Oracle strongly recommends that no AC powered cabinet shall be installed within 7 Ft. of DC powered equipment due to safety reasons. This may create a shock or current loop that can be severely hazardous to personnel. Exception may be granted if Telcordia reference GR1275-CORE-i08 below are fulfilled.

R19-5 [864] All elements of the integrated ground plane (MBN) (auxiliary framing, cable rack, vent ducts, pipes, etc.) within a minimum of 6 feet of an isolated ground plane (IBN) (analog or digital) shall be bonded to the Main Ground Bus (MGB) (SPCB) in the GW (SPCW) with a minimum #6 AWG stranded copper conductor.

R19-22 [880] All equipment, such as printers, terminals, stand alone units, etc., that are metallicly connected to the isolated ground plane (IBN) equipment shall be:

- Insulated from contact with integrated ground plane (MBN) members.
- Powered from sources within the isolated ground plane (IBN) or AC power that has been routed through and bonded to the MGB (SPCB).

2 PIC Management

2.1 Hardware options for PIC Management server

PIC Management software can be installed on:

- Oracle Hardware
- HP RMS

PIC Management servers	
Oracle Hardware	HP
X5-2	HP Gen9
	HP Gen8 v1&v2 + D2700
	HP G6 + D2700

More information is provided in the following sections.

2.1.1 Qualified BOM for PIC Management on X5-2 RMS server

PIC management software has been qualified on following hardware BOM:

Oracle SKU	Technical description	Qty
7112843	Oracle Server X5-2 for Communications: 1 RU base chassis with motherboard,	1
7110339	XATO,DISK_CAGE,2.5" X 8HDD	1
7110346	ATO,E5-2699 V3,2.3G,145W,18 CORE,C-1 (SR1XD),CPU	2
7110350	XATO,HEATSINK,CPU,1U	2
7110360	XATO,OSA 8 GB MLC USB FLASH DRIVE	1
7110359	ATO,DVD,GEN5,BLANK FILLER PANEL,1U/2U	1
7102748	ATO PCIe FILLER,VENTED,LOW PROFILE	3
7110353	XATO,DIMM,16GB,DDR4,2133	8
7111107	1.2 TB 10000 rpm 2.5-inch SAS-3 HDD with marlin bracket (for factory installation)	8

Table 2: Oracle X5-2 BOM for PIC Management RMS Server

In addition, 2 power cords shall be ordered according to installation country or Power distribution unit installed in the frame. Example for international: Power cord International, 4 meters, IEC309-I... SKU is 333R-40-10-309.

2.1.2 Documentation for PIC Management on X5-2 Oracle hardware

Customer can perform following adaptations on X5-2 qualified BOM:

- CPU: other CPUs are supported.
Pre-requisite: 8 cores minimum (on one or 2 processors)
- Memory: Other memory allocation is supported.
Pre-requisite: 24GB minimum.

Customer changes can affect server and system performances and ability to upgrade in future releases.

Hardware Installation Guidelines

For server size, weight, BTU, power information... documentation on Oracle X5-2 is available at http://docs.oracle.com/cd/E41059_01/

Please refer to Setup and Installation section for X5-2 installation. This document will drive you through the initial X5-2 installation steps:

- Server installation in the rack.
- Attaching network and power Cables
- Booting Up the First Time
- Launching Oracle System Assistant to configure:
 - Server's network connection
 - Install latest server firmware
 - Configure Oracle ILOM and BIOS,
 - Configure hardware

OS and PIC software installation on X5-2 server are provided in PIC 10.2 Installation guide available on Oracle Technology Network site.

2.1.3 Qualified HP RMS BOM for PIC Management

Management on HP RMS is composed of:

- One HP server
- One storage array (except for DL380 HP Gen9)

The HP server shall be connected to the storage array (when needed).

Linked to HP lifecycle, different generations of servers are supported by PIC:

- HP Gen9/HP Gen8v2
- HP Gen8 v1

HP G6 Detailed BOM are provided for each generation.

PIC management software has been qualified to run on following hardware BOMs:

a) HP Gen9 server for PIC Management server :

HP P/N	Technical description	Qty AC	Qty DC
719064-B21	HP ProLiant DL380 Gen9 8SFF	1	1
762766-L21	HP DL380 Gen9 Intel® Xeon® E5-2680v3 (2.5GHz/12-core/30MB/120W) FIO Processor Kit	1	1
762766-B21	HP DL380 Gen9 Intel® Xeon® E5-2680v3 (2.5GHz/12-core/30MB/120W) FIO Processor Kit	1	1
726719-B21	HP 16GB (1x16GB) Dual Rank x4 DDR4-2133 CAS-15-15-15 Reg Memory Kit	4	4
749974-B21	HP Smart Array P440ar/2GB FBWC 12Gb 2-ports Int FIO SAS Controller	1	1
720479-B21	HP 800 W Flex Slot Platinum Hot Plug Power Supply Kit	2	-
720480-B21	HP 800 W Flex Slot-48VDC Hot Plug Power Supply Kit	-	2
512485-B21	HP iLO Advanced including 1yr 24x7 Technical Support and Updates Single Server License	1	1

Hardware Installation Guidelines

720863-B21	HP 2U Small Form Factor Ball Bearing Gen8 Rail Kit with CMA	1	1
768900-B21	HP DL380 Gen9 Systems Insight Display Kit	1	1
758959-B22	HP LEGACY FIO MODE SETTING	1	1
719070-B21	HP DL380 G9 Chassis NEBS Conversion Kit	1	1
719079-B21	HP DL380 Gen9 High Performance Fan Kit	1	1
785069-B21	HP 900GB 12G SAS 10K rpm SFF (2.5-inch) SC Ent 3yr Warranty Hard Drive	8	8

Table 3: HP Gen9 qualified BOM for PIC Management RMS server

b) HP Gen8 server v2 for PIC Management server :

HP P/N	Technical description	Qty
654081-B21	HP ProLiant DL360p Gen8 8 SFF Configure-to-order Server	1
708641-B21	HP 16GB 2Rx4 PC3-14900R-13 Kit	4
652241-B21	HP 9.5mm SATA DVD RW JackBlack Optical Drive	1
684208-B21	HP Ethernet 1Gb 4-port 331FLR FIO Adapter	1
631679-B21	HP 1GB P-series Smart Array Flash Backed Write Cache	1
512485-B21	HP iLO Advanced including 1yr 24x7 Technical Support and Updates Single Server License	1
712506-L21	HP DL360p Gen8 Intel Xeon E5-2680v2 (2.8GHz/10-core/25MB/115W) Processor Kit	1
712506-B21	HP DL360p Gen8 Intel Xeon E5-2680v2 (2.8GHz/10-core/25MB/115W) FIO Processor Kit	1
652583-B21	HP 600GB 6G SAS 10K rpm SFF (2.5-inch) SC Enterprise 3yr Warranty Hard Drive	2
734807-B21	HP 1U Small Form Factor Easy Install Rail Kit	1
656363-B21	HP 750W Common Slot Platinum Plus Hot Plug Power Supply Kit	2
631673-B21	Smart Array P421/1GB FBWC Controller	1
Storage Array:		
AJ941A	HP D2700 Disk Enclosure	1
507127-B21	HP 300GB 6G SAS 10K 2.5in DP ENT HDD	10

Table 4: HP Gen8 v2 qualified BOM for PIC Management RMS server

Note : This BOM is intended for PIC 10.1.x. For older release of PIC, please use only 32GB of RAM: 2 x 708641-B21 (HP 16GB 2Rx4 PC3-14900R-13 Kit)

c) HP Gen8 server v1 for PIC Management server :

HP P/N	Technical description	Qty
655651-B21	HP DL360p Gen8 4-LFF CTO Server	1
647899-B21	HP 8GB 1Rx4 PC3-12800R-11 Kit	4
652238-B21	HP 9.5mm SATA DVD ROM Jb Kit	1
684208-B21	HP Ethernet 1GbE 4P 331FLR FIO Adptr	1
661069-B21	HP 512MB FWC for P series smart array	1
512485-B21	HP iLO Advanced including 1yr 24x7 Technical Support and	1

Hardware Installation Guidelines

	Updates Single Server License	
654768-L21	HP DL360p Gen 8 E52630 FIO kit	1
654768-B21	HP DL360p Gen 8 E52630 kit	1
652620-B21	HP 600GB 6G SAS 15K 3.5in SC ENT HDD	2
663202-B21	HP 1U LFF BB Gen8 Rail Kit	1
503296-B21	HP 460W CS Gold Ht Plg Pwr Supply Kit	2
631673-B21	Smart Array P421/1GB FBWC Controller	1
Storage Array:		
AJ941A	HP D2700 Disk Enclosure	1
507127-B21	HP 300GB 6G SAS 10K 2.5in DP ENT HDD	10

Table 5: HP Gen8 v1 qualified BOM for PIC Management RMS server

d) HP G6 server for PIC Management server :

HP P/N	Technical description	Qty
484184-B21	HP ProLiant DL360 G6 Rack CTO Chassis	1
505880-L21	HP E5540 DL360 G6 FIO Kit	1
505880-B21	HP E5540 DL360 G6 Kit	1
500658-B21	HP 4GB 2Rx4 PC3-10600R-9 Kit	6
507127-B21	HP 300GB 10K 6G 2.5 SAS DP HDD ((Installed in drive bay 1 & 2)	2
532068-B21	HP DL360G6 12.7mm SATA DVD-RW Kit	1
462968-B21 or 534108-B21	HP 256MB FIO P-Series Cache Mod	1
503296-B21	HP 460W HE 12V Hotplg AC Pwr Supply Kit	2
512485-B21	HP iLO Adv 1-Svr incl 1yr TS/U SW	1
578229-B21	HP Smart Array P411/512MB FBWC (Installed in slot 1)	1
Storage Array:		
AJ941A	HP D2700 Disk Enclosure	1
507127-B21	HP 300GB 6G SAS 10K 2.5in DP ENT HDD	10

Table 6: HP G6 qualified BOM for PIC Management RMS Server

In addition, for each HP server as well as for each D2700 enclosure, 2 power cords shall be ordered according to installation country or Power distribution unit installed in the frame. Example for DC power cable on HP Gen9 (one termination to be adapted to PDU): J6X43A HP No Plug 12AWG 48V DC 3.0m Power Cord. For AC, all pre-configured servers with standard AC power supply option kit, ship with one standard 6-foot IEC C-13/C-14 jumper cord per power supply (for HP Gen9: reference A0K02A). If a different power cord is required, please check the HP web site

2.1.4 Documentation for Management server on HP RMS

Customer can perform following adaptations on all HP qualified BOM:

- CPU: other CPUs are supported.
Pre-requisite: 8 cores minimum per server (on one or 2 processors)
- Memory: Other memory allocation is supported.
Pre-requisite: 24GB minimum.

Hardware Installation Guidelines

- Storage Array Disks: customer can select other disks (as far as supported by the D2700) with fastest access.
Pre-requisites:
 - all disks in the storage array shall have same storage capacity
 - Disks shall be installed in position 1 to 10 in the storage array (see annex section for drive bay numbering).
- On HP Gen9: Customer can select other storage disks (as far as supported by the HP gen9) with bigger sizes or fastest access.

Internal disks shall be connected to SAS A.

For D2700, Port 1E of SAS controller card in the HP server shall be connected to the port P1 of the I/O module A of the D2700 storage enclosure. Port 2E shall not be connected. Please refer to annex section for port identification.

Documentation on HP servers & storage array is available on HP web site or using Product bulletin tool. It includes server size, weight, BTU, power information.... The HP Product Bulletin is a free application that only takes a few minutes to download. The download site is located at

http://h18004.www1.hp.com/products/quickspecs/productBulletin.html#CD_Files

Required HP power for a cabinet can be estimated using HP Power advisor tool available on HP web site:

<http://www8.hp.com/us/en/products/servers/solutions.html?compURI=1439951#.UxSoL7QUDtk>

OS and PIC management software installation and configuration on HP, are provided in PIC 10.1.5 Installation guide available on Oracle Technology Network site. Note that customer shall have Weblogic 11g and Oracle Enterprise Edition 11g and partitioning option licenses, or Oracle Technology Foundation for Monitoring Applications license for this server, before starting the installation.

OS and PIC software installation and configuration of management server on HP servers are provided in Management Server (NSP) on Third-Party Server Installation Guide for Performance Intelligence Center (PIC) products (Doc ID 2062544.1) available on My Oracle Support site.

2.2 Networking guidelines for PIC Management server

Synthesis:

Management server requires:

- On HP and X5-2: One Ethernet access for management
- Number of network ports for web access and downlink is variable (see details bellow)

Servers shall be connected to the customer network. Number of port is variable according to server type. Both Management port (for server management) and Network port (for backbone connectivity) shall be connected to customer network.

Management ports:

1 port per HP server (named ILO)

1 port for X5-2 (named ILOM).

All servers shall have their ILO for HP or ILOM for X5-2 port connected to the network and configured for remote access:

- Server management port is a 1000 Base-T RJ45 Ethernet compatible
- Server management port is untagged.

Hardware Installation Guidelines

- Initial Network Connection configuration shall be performed by the customer to allow remote connection to ILO(M).
- Please refer to Oracle X5-2 documentation for ILOM initial configuration, or to HP ILO configuration and setup for HP servers.
- A fix IP address is recommended to identify uniquely the server

Network ports:

All Ethernet network ports are RJ45 1000 Base-T compatible.

Please refer to annex section for network ports identification.

All IP addresses shall be routable to allow remote access (including for support).

In case of presence of a Firewall, some TCP/UDP ports shall be opened. The list of ports to open is available in PIC Security guide on Oracle Technology Network site.

By default, all network ports are untagged (VLAN if needed are configured on customer switch)

Management server can be installed using 1 or 2 network ports:

- 1 network port: Eth01 network port used for both frontend, backend and alarms output.
- 2 network ports (recommended option): 2 ports are used to differentiate frontend and backend: :
 - Eth02: port for frontend (web access to GUI)
 - Eth01: port for backend (acquisition and mediation servers and alarms output)
- In case of 2 network ports, default route shall be on Eth02 (Web GUI access) and static routes to PIC mediation and acquisition servers shall be added on Eth01.
- IP addresses can be freely allocated (in different subnets for the 2 network case).

Switch template configurations and cabling are available in appendix of this document.

3 PIC Mediation and storage

PIC Mediation is a set of servers being logically grouped to create a subsystem (logical entity of servers). It is composed of

- Base server to create xDR and KPI
- Data Record storage database instances
- Packet Data Unit storage servers

PIC Mediation can be installed on:

- Oracle Hardware
- HP RMS

Mediation base		Data Record Storage		Packet Data Unit Storage	
Oracle Hardware	HP	Oracle Hardware	HP	Oracle Hardware	HP
X5/2	HP Gen9	ODA	HP Gen9	ZFS	HP Gen9
	HP Gen8 v1&v2		HP Gen8 v1&v2 + D2700		HP Gen8 v1&v2 + D2700
	HP G6		HP G6 + D2700		HP G6 + D2700

More information is provided in the following sections.

3.1 Hardware options for Mediation server

PIC Mediation can be installed on:

- Oracle X5-2 server
- HP RMS

3.1.1 Qualified BOM for Mediation on Oracle X5-2

PIC mediation software has been qualified on following hardware BOM:

Oracle SKU	Technical description	Qty
7112843	Oracle Server X5-2 for Communications: 1 RU base chassis with motherboard,	1
7110339	XATO,DISK_CAGE,2.5" X 8HDD	1
7110346	ATO,E5-2699 V3,2.3G,145W,18 CORE,C-1 (SR1XD),CPU	2
7110350	XATO,HEATSINK,CPU,1U	2
7110360	XATO,OSA 8 GB MLC USB FLASH DRIVE	1
7110359	ATO,DVD,GEN5,BLANK FILLER PANEL,1U/2U	1
7102748	ATO PCIe FILLER,VENTED,LOW PROFILE	3
6331A-N	ASSY,HDD,MARLIN-FILLER PANEL	6
7110353	XATO,DIMM,16GB,DDR4,2133	8
7111107	1.2 TB 10000 rpm 2.5-inch SAS-3 HDD with marlin bracket (for factory installation)	2

Hardware Installation Guidelines

Table 7: Oracle X5-2 BOM for PIC Mediation RMS Server

In addition, 2 power cords shall be ordered (per server) according to installation country or Power distribution unit installed in the frame.

3.1.2 Documentation for Mediation on Oracle X5-2

Customer can perform following adaptations on X5-2 qualified BOM:

- CPU: other CPUs are supported.
Pre-requisite: 8 cores minimum (on one or 2 processors)
- Memory: Other memory allocation is supported.
Pre-requisite: 24GB minimum.
- Hard drives: the 2 HDD can be replaced by SDD disks ATO,ASSY,SSD,400GB ME,2.5”,SAS3,MARLIN (For Factory Installation), SKU 7110932

Customer changes can affect server and system performances and ability to upgrade in future releases.

For server size, weight, BTU, power information.... documentation on Oracle X5-2 is available at http://docs.oracle.com/cd/E41059_01/

Please refer to Setup and Installation section for X5-2 installation. This document will drive you through the initial X5-2 installation steps:

- Server installation in the rack.
- Attaching network and power Cables
- Booting Up the First Time
- Launching Oracle System Assistant to configure:
 - Server's network connection
 - Install latest server firmware
 - Configure Oracle ILOM and BIOS,
 - Configure hardware

OS and PIC software installation on X5-2 server are provided in PIC 10.1.5 Installation guide available on Oracle Technology Network site.

3.1.3 Qualified BOM for Mediation on HP RMS

Linked to HP lifecycle, different generations of servers are supported by PIC:

- HP Gen9
- HP Gen8v2
- HP Gen8 v1

HP G6 Detailed BOM are provided for each generation.

PIC mediation software has been qualified on following hardware BOMs:

- a) **HP Gen9 for PIC Mediation server :**

Hardware Installation Guidelines

HP P/N	Technical description	Qty AC	Qty DC
755258-B21	HP ProLiant DL360 Gen9 8SFF Configure-to-order Server	1	1
755394-L21	E5-2680v3 HP DL360 Gen9 Intel® Xeon® E5-2680v3 (2.5GHz/12-core/30MB/120W) Processor Kit	1	1
755394-B21	E5-2680v3 HP DL360 Gen9 Intel® Xeon® E5-2680v3 (2.5GHz/12-core/30MB/120W) Processor Kit	1	1
726719-B21	HP 16GB (1x16GB) Dual Rank x4 DDR4-2133 CAS-15-15-15 Registered Memory Kit	4	4
785069-B21	HP 900GB 12G SAS 10K rpm SFF (2.5-inch) SC Enterprise 3yr Warranty Hard Drive (Install in Drive Bays 1 and 2)	2	2
749974-B21	HP Smart Array P440ar/2GB FBWC 12Gb 2-ports Int FIO SAS Controller	1	1
720479-B21	HP 800W Flex Slot Platinum Hot Plug Power Supply Kit - AC	2	-
720480-B21	HP 800 W Flex Slot-48VDC Hot Plug Power Supply Kit	-	2
512485-B21	HP iLO Advanced incl 1yr 24x7 Tech Support and Updates Single Server License	1	1
663201-B21	HP 1U Small Form Factor Ball Bearing Rail	1	1
764636-B21	HP DL360 Gen9 SFF Systems Insight Display Kit	1	1
758959-B22	HP LEGACY FIO MODE SETTING	1	1
764646-B21	HP DL360 Gen9 Rear Serial Port and Enablement Kit	1	1

Table 8: HP Gen9 qualified BOM for PIC Mediation RMS server

Note: Optionally to access to switch console port, a serial cable shall be added.

b) HP Gen8 server v2 for Mediation server:

HP P/N	Technical description	Qty AC
654081-B21	HP ProLiant DL360p Gen8 8 SFF Configure-to-order Server	1
708641-B21	HP 16GB 2Rx4 PC3-14900R-13 Kit	4
652241-B21	HP 9.5mm SATA DVD RW JackBlack Optical Drive	1
684208-B21	HP Ethernet 1Gb 4-port 331FLR FIO Adapter	1
631679-B21	HP 1GB P-series Smart Array Flash Backed Write Cache	1
512485-B21	HP iLO Advanced including 1yr 24x7 Technical Support and Updates Single Server License	1
712506-L21	HP DL360p Gen8 Intel Xeon E5-2680v2 (2.8GHz/10-core/25MB/115W) Processor Kit	1
712506-B21	HP DL360p Gen8 Intel Xeon E5-2680v2 (2.8GHz/10-core/25MB/115W) FIO Processor Kit	1
652583-B21	HP 600GB 6G SAS 10K rpm SFF (2.5-inch) SC Enterprise 3yr Warranty Hard Drive	2
734807-B21	HP 1U Small Form Factor Easy Install Rail Kit	1
656363-B21	HP 750W Common Slot Platinum Plus Hot Plug Power Supply Kit	2

Hardware Installation Guidelines

Table 9: HP Gen8v2 qualified BOM for PIC Mediation RMS Server

Note : This BOM is intended for PIC 10.1.x. For older release of PIC, please use only 32GB of RAM: 2 x 708641-B21 (HP 16GB 2Rx4 PC3-14900R-13 Kit)

c) HP Gen8 server v1 for PIC Mediation :

HP P/N	Technical description	Qty AC
655651-B21	HP DL360p Gen8 4-LFF CTO Server	1
647899-B21	HP 8GB 1Rx4 PC3-12800R-11 Kit	4
652238-B21	HP 9.5mm SATA DVD ROM Jb Kit	1
684208-B21	HP Ethernet 1GbE 4P 331FLR FIO Adptr	1
661069-B21	HP 512MB FWC for P series smart array	1
512485-B21	HP iLO Advanced including 1yr 24x7 Technical Support and Updates Single Server License	1
654768-L21	HP DL360p Gen 8 E52630 FIO kit	1
654768-B21	HP DL360p Gen 8 E52630 kit	1
652620-B21	HP 600GB 6G SAS 15K 3.5in SC ENT HDD	2
663202-B21	HP 1U LFF BB Gen8 Rail Kit	1
503296-B21	HP 460W CS Gold Ht Plg Pwr Supply Kit	2

Table 10: HP Gen8v1 qualified BOM for PIC Mediation RMS Server

d) HP G6 server for PIC Mediation :

HP P/N	Technical description	Qty AC
484184-B21	HP ProLiant DL360 G6 Rack CTO Chassis	1
505880-L21	HP E5540 DL360 G6 FIO Kit	1
505880-B21	HP E5540 DL360 G6 Kit	1
500658-B21	HP 4GB 2Rx4 PC3-10600R-9 Kit	6
507127-B21	HP 300GB 10K 6G 2.5 SAS DP HDD ((Installed in drive bay 1 & 2)	2
532068-B21	HP DL360G6 12.7mm SATA DVD-RW Kit	1
462968-B21 or 534108-B21	HP 256MB FIO P-Series Cache Mod	1
503296-B21	HP 460W HE 12V Hotplg AC Pwr Supply Kit	2
512485-B21	HP iLO Adv 1-Svr incl 1yr TS/U SW	1

Table 11: HP G6 qualified BOM for PIC Mediation RMS Server

In addition, for each HP server as well as for each D2700 enclosure, 2 power cords shall be ordered according to installation country or Power distribution unit installed in the frame.

Example for DC power cable on HP Gen9 (one termination to be adapted to PDU): J6X43A HP No Plug 12AWG 48V DC 3.0m Power Cord.

All pre-configured servers with standard AC power supply option kit, ship with one standard 6-foot IEC C-13/C-14 jumper cord per power supply (for HP Gen9 A0K02A). If a different power cord is required, please check the HP web site.

3.1.4 Documentation for Mediation server on HP RMS

Customer can perform following adaptations on all HP qualified BOMs:

- CPU: other CPU is supported.
Pre-requisite: 8 cores minimum (on one or 2 processors)
- Memory: Other memory allocation is supported.
Pre-requisite: 24GB minimum.

Customer changes can affect server and system performances and ability to upgrade in future releases.

Hard disk backplane shall be connected to SAS connector A.

Documentation on HP servers is available on HP web site or using Product bulletin tool. It includes server size, weight, BTU, power information.... The HP Product Bulletin is a free application that only takes a few minutes to download. The download site is located at

http://h18004.www1.hp.com/products/quickspecs/productBulletin.html#CD_Files

Required HP power for a cabinet can be estimated using HP Power advisor tool available on HP web site:

<http://www8.hp.com/us/en/products/servers/solutions.html?compURI=1439951#.UxSoL7QUdtk>

OS and PIC Mediation software installation and configuration on HP servers are provided in PIC 10.1.5 Installation guide available on Oracle Technology Network site.

Hardware Installation Guidelines

3.2 Hardware options for Packet Data Unit Storage

PIC PDU storage can be installed on:

- Oracle ZFS Appliance Hardware
- HP servers RMS

3.2.1 Qualified BOM for Packet Data Unit Storage server on Oracle ZFS Appliance

PIC Packet Data Unit storage has been qualified on following hardware BOM:

Oracle SKU	Technical description	Qty
7106195	Oracle ZFS Storage ZS3-2 appliance...	1
7103796	Oracle ZFS Storage ZS3-2: model family...	1
7103829	Oracle ZFS Storage ZS3-2: controller	1
7102984	One 16 GB DDR3-1600 registered DIMM	16
5394A	PCIe filler panel	4
6331A-N	2.5-inch HDD filler panel	4
7103898	Oracle Storage Drive Enclosure DE2-24P: model...	1
7103910	Oracle Storage Drive Enclosure DE2-24P: base chassis	1
7103912	One 900 GB 10000 rpm 2.5 inch SAS-2 HDD with evo bracket	24

Table 12: Oracle ZFS BOM for PIC Packet Data Unit RMS Server

In addition, 2 power cords shall be ordered according to installation country or Power distribution unit installed in the frame. Example for international: Power cord International, 4 meters, IEC309-I... is 333R-40-10-309.

An additional storage array can be added if more storage capacity is required.

Oracle SKU	Technical description	Qty
7103910	Oracle Storage Drive Enclosure DE2-24P: base chassis (for factory installation)	1
7103912	One 900 GB 10000 rpm 2.5 inch SAS-2 HDD with evo bracket (for factory installation)	24

Two additional power cords shall be added.

3.2.2 Documentation for Packet Data Unit Storage server on Oracle ZFS Appliance

For server size, weight, BTU, power information.... documentation on Oracle ZFS is available at http://docs.oracle.com/cd/E56021_01/index.html

Please refer to Oracle ZFS Storage ZS3-2 Quick Setup for ZS3-2 ZFS installation. This document will drive you through the ZS3-2 ZFS hardware installation steps and information:

- ZS3-2 Hardware Overview
 - Controller Overview
 - Physical Specifications
 - Electrical Specifications

Hardware Installation Guidelines

- Acoustic Noise Emissions
- Internal Components
- Motherboard, Memory, and PCIe Cards
- Optional Cable Management Arm
- Attached Storage
- ZS3-2 Controller Installation Tasks
- Cabling
- Powering On and Configuring the System
 - Connecting to ILOM
 - Powering On the Appliance
 - Completing Configuration

It is strongly recommended to refer to PIC 10.1.5 Installation guide available on Oracle Technology Network site before starting installation of ZFS. More specific details are provided for installation of ZS3-2 ZFS for PIC PDU storage.

3.2.3 Qualified BOM for Packet Data Unit Storage server on HP RMS

PDU storage server is composed of:

- One HP server
- One storage array (except for DL380 HP Gen9)

The selected HP server shall be connected to the storage array (when needed).

HP Storage Array has been qualified for 300GB disks for 7.2 TB of PIC Packet Data Unit Storage, and 600GB disks for 14.4 TB respectively.

Linked to HP lifecycle, different generations of servers are supported by PIC:

- HP Gen9
- HP Gen8v2
- HP Gen8 v1
- HP G6

Detailed BOM are provided for each generation.

PIC Packet Data Unit Storage has been qualified on following hardware BOMs:

a) HP Gen9 for PIC Packet Data Unit Storage server:

HP P/N	Technical description	Qty AC	Qty DC
767032-B21	HP ProLiant DL380 Gen9 24SFF Configure-to-order Server	1	1
762766-L21	HP DL380 Gen9 Intel® Xeon® E5-2680v3 (2.5GHz/12-core/30MB/120W) FIO Processor Kit	1	1
762766-B21	HP DL380 Gen9 Intel® Xeon® E5-2680v3 (2.5GHz/12-core/30MB/120W) FIO Processor	1	1
726719-B21	HP 16GB (1x16GB) Dual Rank x4 DDR4-2133 CAS-15-15-15 Reg Memory Kit	4	4
749974-B21	HP Smart Array P440ar/2GB FBWC 12Gb 2-ports Int FIO SAS Controller	1	1
720479-B21	HP 800 W Flex Slot Platinum Hot Plug Power Supply Kit	2	-

Hardware Installation Guidelines

720480-B21	HP 800 W Flex Slot-48VDC Hot Plug Power Supply Kit	-	2
512485-B21	HP iLO Advanced including 1yr 24x7 Technical Support and Updates Single Server License	1	1
720863-B21	HP 2U Small Form Factor Ball Bearing Gen8 Rail Kit with CMA	1	1
768900-B21	HP DL380 Gen9 Systems Insight Display Kit	1	1
758959-B22	HP LEGACY FIO MODE SETTING	1	1
724864-B21	HP DL380 Gen9 2SFF Front/Rear SAS/SATA Kit	1	1
727250-B21	HP 12Gb SAS Expander Card with Cables for DL380 Gen9 (Install in Slot 2)	1	1
785069-B21	HP 900GB 12G SAS 10K rpm SFF (2.5-inch) SC Ent 3yr Warranty Hard Drive	26	26

Table 13: HP Gen9 qualified BOM for PIC Data Record storage RMS server

b) HP Gen8 server v2 for PIC Packet Data Unit Storage server:

HP P/N	Technical description	Qty
654081-B21	HP ProLiant DL360p Gen8 8 SFF Configure-to-order Server	1
708641-B21	HP 16GB 2Rx4 PC3-14900R-13 Kit	4
652241-B21	HP 9.5mm SATA DVD RW JackBlack Optical Drive	1
684208-B21	HP Ethernet 1Gb 4-port 331FLR FIO Adapter	1
631679-B21	HP 1GB P-series Smart Array Flash Backed Write Cache	1
512485-B21	HP iLO Advanced including 1yr 24x7 Technical Support and Updates Single Server License	1
712506-L21	HP DL360p Gen8 Intel Xeon E5-2680v2 (2.8GHz/10-core/25MB/115W) Processor Kit	1
712506-B21	HP DL360p Gen8 Intel Xeon E5-2680v2 (2.8GHz/10-core/25MB/115W) FIO Processor Kit	1
652583-B21	HP 600GB 6G SAS 10K rpm SFF (2.5-inch) SC Enterprise 3yr Warranty Hard Drive	2
734807-B21	HP 1U Small Form Factor Easy Install Rail Kit	1
656363-B21	HP 750W Common Slot Platinum Plus Hot Plug Power Supply Kit	2
631673-B21	Smart Array P421/1GB FBWC Controller	1
Storage Array:		
AJ941A	HP D2700 Disk Enclosure	1
507127-B21	HP 300GB 6G SAS 10K 2.5in DP ENT HDD	25
or 581286-B21	HP 600 GB 2.5 inch 10000 rpm SAS HDD dual port	25

Table 14: HP Gen8 v2 qualified BOM for PIC Packet Data Unit Storage server

Note : This BOM is intended for PIC 10.1.x. For older release of PIC, please use only 32GB of RAM: 2 x 708641-B21 (HP 16GB 2Rx4 PC3-14900R-13 Kit)

c) HP Gen8 server v1 for PIC Packet Data Unit Storage server:

HP P/N	Technical description	Qty
655651-B21	HP DL360p Gen8 4-LFF CTO Server	1
647899-B21	HP 8GB 1Rx4 PC3-12800R-11 Kit	4

Hardware Installation Guidelines

652238-B21	HP 9.5mm SATA DVD ROM Jb Kit	1
684208-B21	HP Ethernet 1GbE 4P 331FLR FIO Adptr	1
661069-B21	HP 512MB FWC for P series smart array	1
512485-B21	HP iLO Advanced including 1yr 24x7 Technical Support and Updates Single Server License	1
654768-L21	HP DL360p Gen 8 E52630 FIO kit	1
654768-B21	HP DL360p Gen 8 E52630 kit	1
652620-B21	HP 600GB 6G SAS 15K 3.5in SC ENT HDD	2
663202-B21	HP 1U LFF BB Gen8 Rail Kit	1
503296-B21	HP 460W CS Gold Ht Plg Pwr Supply Kit	2
631673-B21	Smart Array P421/1GB FBWC Controller	1
Storage Array:		
AJ941A	HP D2700 Disk Enclosure	1
507127-B21	HP 300GB 6G SAS 10K 2.5in DP ENT HDD	25
or 581286-B21	HP 600 GB 2.5 inch 10000 rpm SAS HDD dual port	25

Table 15: HP Gen8 v1 qualified BOM for PIC Packet Data Unit Storage server

d) HP G6 server for PIC Packet Data Unit Storage server:

HP P/N	Technical description	Qty
484184-B21	HP ProLiant DL360 G6 Rack CTO Chassis	1
505880-L21	HP E5540 DL360 G6 FIO Kit	1
505880-B21	HP E5540 DL360 G6 Kit	1
500658-B21	HP 4GB 2Rx4 PC3-10600R-9 Kit	6
507127-B21	HP 300GB 10K 6G 2.5 SAS DP HDD ((Installed in drive bay 1 & 2)	2
532068-B21	HP DL360G6 12.7mm SATA DVD-RW Kit	1
462968-B21 or 534108-B21	HP 256MB FIO P-Series Cache Mod	1
503296-B21	HP 460W HE 12V Hotplg AC Pwr Supply Kit	2
512485-B21	HP iLO Adv 1-Svr incl 1yr TS/U SW	1
578229-B21	HP Smart Array P411/512MB FBWC (Installed in slot 1)	1
Storage Array:		
AJ941A	HP D2700 Disk Enclosure	1
507127-B21	HP 300GB 6G SAS 10K 2.5in DP ENT HDD	25
or 581286-B21	HP 600 GB 2.5 inch 10000 rpm SAS HDD dual port	25

Table 16: HP G6 qualified BOM for PIC Packet Data Unit Storage Server

In addition, for each HP server as well as for each D2700 enclosure, 2 power cords shall be ordered according to installation country or Power distribution unit installed in the frame. Example for DC power cable on HP Gen9 (one termination to be adapted to PDU): J6X43A HP No Plug 12AWG 48V DC 3.0m Power Cord.

3.2.4 Documentation for Packet Data Unit Storage server on HP RMS

Hardware Installation Guidelines

Customer can perform following adaptations on all HP qualified BOMs:

- CPU: other CPU is supported.
Pre-requisite: 8 cores minimum (on one or 2 processors)
- Memory: Other memory allocation is supported.
Pre-requisite: 24GB minimum.
- Disk size and numbers:
 - on D2700:
Customer can select other storage disks (as far as supported by the D2700) with bigger sizes or fastest access.
Pre-requisites:
 - all disks shall have same storage capacity
 - all D2700 slots shall be fully populated (25 disks).
 - On HP Gen9:
Customer can select other storage disks (as far as supported by the HP gen9) with bigger sizes or fastest access.
For smaller storage, fewer disks can be used.
Pre-requisites:
 - all disks shall have same storage capacity
 - minimum disk size is 600GB
 - From 10 to 26 disks can be installed.

Customer changes can affect server and system performances and ability to upgrade in future releases.

Hard disk in Bay 3 shall be connected to SAS connector A.

Port 1E of SAS controller card in the HP server shall be connected to the port P1 of the I/O module A of the D2700 storage enclosure. Port 2E shall not be connected. See annex section of this document for port selection and identification.

All Ethernet connectors are RJ45 1000 Base-TX compatible.

Documentation on HP servers & storage array is available on HP web site or using Product bulletin tool. It includes server size, weight, BTU, power information.... The HP Product Bulletin is a free application that only takes a few minutes to download. The download site is located at

http://h18004.www1.hp.com/products/quickspecs/productBulletin.html#CD_Files

Required HP power for a cabinet can be estimated using HP Power advisor tool available on HP web site:

<http://www8.hp.com/us/en/products/servers/solutions.html?compURI=1439951#.UxSoL7QUdtk>

OS and PIC software installation and configuration of Packet Data Unit Storage server on HP servers are provided in PIC Packet Data Unit Storage (PDU) Server on HP DL380 Gen 9 Installation (Doc ID **2034894.1**) available on My Oracle Support site.

3.3 Hardware options for Data Record storage

PIC Data Record storage can be installed on:

- Oracle Data Base Appliance Hardware
- HP servers RMS

3.3.1 Qualified BOM for Data Record storage on Oracle Data Base Appliance

PIC Data Record storage has been qualified on Oracle X4-2, replaced by following hardware BOM with Oracle 11g :

Oracle SKU	Technical description	Qty
7110250	Oracle Database Appliance X5-2: model family...	1
7110252	Oracle Database Appliance X5-2	1

Table 17: Oracle Database appliance X5-2 for PIC Data Record storage RMS server

In addition, 6 power cords shall be ordered according to installation country or Power Distribution Unit installed in the frame. Example for international: 6x Power cord International, 4 meters, IEC309-I... (333R-40-10-309)

An additional storage enclosure extension can be added to the ODA to obtain more disk capacity:

Oracle SKU	Technical description	Qty
7110281	Oracle Database Appliance X5-2 Storage Expansion	1

Table 18: Oracle Database appliance X5-2 additional storage for PIC Data Record storage RMS server

2 additional power cords shall be ordered for each extension.

3.3.2 Documentation for Data Record storage on Oracle Data Base Appliance

For server size, weight, BTU, power information.... documentations on ODA is available at http://docs.oracle.com/cd/E22693_01/index.htm

Please refer to Oracle® Database Appliance Getting Started Guide for initial installation of the server. This document will drive you through the initial ODA installation steps:

- Attaching Supplied Cables
- Attaching Storage Expansion Shelf
- Attaching Peripheral Devices
- Booting Up the First Time
- Configuring Oracle Integrated Lights Out Manager.
- Configuring Initial Network Connection
- Validating Oracle Appliance Manager Software Version

It is strongly recommended to refer to PIC 10.1.5 Installation guide available on Oracle Technology Network site before starting installation of ODA. This document provides details on PIC default option to select for ODA configuration.

Note that customer shall have Oracle Enterprise Edition 11g and partitioning option licenses, or Oracle Technology Foundation for Monitoring Applications license for this server, before starting the installation.

Hardware Installation Guidelines

ODA can be shared by Management server function and Data Record Storage, or have two Data Record Storage instance in case you want to share the capacity between different Mediation sub-systems

All Ethernet connectors are RJ45 10G Base-TX

3.3.3 Qualified BOM for Data Record storage on HP RMS

Data Record storage is composed of:

- One HP server
- One storage array (except for DL380 HP Gen9)

Linked to HP lifecycle, different generations of Data Record HP servers are supported by PIC:

- HP Gen9
- HP Gen8v2
- HP Gen8 v1
- HP G6

Detailed BOM are provided for each generation.

PIC Data Record Storage has been qualified on following hardware BOMs:

a) HP Gen9 for PIC Data Record storage server:

HP P/N	Technical description	Qty AC	Qty DC
767032-B21	HP ProLiant DL380 Gen9 24SFF Configure-to-order Server	1	1
762766-L21	HP DL380 Gen9 Intel® Xeon® E5-2680v3 (2.5GHz/12-core/30MB/120W) FIO Processor Kit	1	1
762766-B21	HP DL380 Gen9 Intel® Xeon® E5-2680v3 (2.5GHz/12-core/30MB/120W) FIO Processor	1	1
726719-B21	HP 16GB (1x16GB) Dual Rank x4 DDR4-2133 CAS-15-15-15 Reg Memory Kit	4	4
749974-B21	HP Smart Array P440ar/2GB FBWC 12Gb 2-ports Int FIO SAS Controller	1	1
720479-B21	HP 800 W Flex Slot Platinum Hot Plug Power Supply Kit	2	-
720480-B21	HP 800 W Flex Slot-48VDC Hot Plug Power Supply Kit	-	2
512485-B21	HP iLO Advanced including 1yr 24x7 Technical Support and Updates Single Server License	1	1
720863-B21	HP 2U Small Form Factor Ball Bearing Gen8 Rail Kit with CMA	1	1
768900-B21	HP DL380 Gen9 Systems Insight Display Kit	1	1
758959-B22	HP LEGACY FIO MODE SETTING	1	1
724864-B21	HP DL380 Gen9 2SFF Front/Rear SAS/SATA Kit	1	1
727250-B21	HP 12Gb SAS Expander Card with Cables for DL380 Gen9 (Install in Slot 2)	1	1
785069-B21	HP 900GB 12G SAS 10K rpm SFF (2.5-inch) SC Ent 3yr Warranty Hard Drive	26	26

Table 19: HP Gen9 qualified BOM for PIC Data Record storage RMS server

b) HP Gen8 server v2 for PIC Data Record storage server:

HP P/N	Technical description	Qty
654081-B21	HP ProLiant DL360p Gen8 8 SFF Configure-to-order Server	1
708641-B21	HP 16GB 2Rx4 PC3-14900R-13 Kit	4
652241-B21	HP 9.5mm SATA DVD RW JackBlack Optical Drive	1
684208-B21	HP Ethernet 1Gb 4-port 331FLR FIO Adapter	1
631679-B21	HP 1GB P-series Smart Array Flash Backed Write Cache	1
512485-B21	HP iLO Advanced including 1yr 24x7 Technical Support and Updates Single Server License	1
712506-L21	HP DL360p Gen8 Intel Xeon E5-2680v2 (2.8GHz/10-core/25MB/115W) Processor Kit	1
712506-B21	HP DL360p Gen8 Intel Xeon E5-2680v2 (2.8GHz/10-core/25MB/115W) FIO Processor Kit	1
652583-B21	HP 600GB 6G SAS 10K rpm SFF (2.5-inch) SC Enterprise 3yr Warranty Hard Drive	2
734807-B21	HP 1U Small Form Factor Easy Install Rail Kit	1
656363-B21	HP 750W Common Slot Platinum Plus Hot Plug Power Supply Kit	2
631673-B21	Smart Array P421/1GB FBWC Controller	1
Storage Array:		
AJ941A	HP D2700 Disk Enclosure	1
507127-B21	HP 300GB 6G SAS 10K 2.5in DP ENT HDD	25
or 581286-B21	HP 600 GB 2.5 inch 10000 rpm SAS HDD dual port	25

Table 20: HP Gen8 v2 qualified BOM for PIC Data Record storage RMS server

Note : This BOM is intended for PIC 10.1.x. For older release of PIC, please use only 32GB of RAM: 2 x 708641-B21 (HP 16GB 2Rx4 PC3-14900R-13 Kit)

c) HP Gen8 server v1 for PIC Data Record storage server:

HP P/N	Technical description	Qty
655651-B21	HP DL360p Gen8 4-LFF CTO Server	1
647899-B21	HP 8GB 1Rx4 PC3-12800R-11 Kit	4
652238-B21	HP 9.5mm SATA DVD ROM Jb Kit	1
684208-B21	HP Ethernet 1GbE 4P 331FLR FIO Adptr	1
661069-B21	HP 512MB FWC for P series smart array	1
512485-B21	HP iLO Advanced including 1yr 24x7 Technical Support and Updates Single Server License	1
654768-L21	HP DL360p Gen 8 E52630 FIO kit	1
654768-B21	HP DL360p Gen 8 E52630 kit	1
652620-B21	HP 600GB 6G SAS 15K 3.5in SC ENT HDD	2
663202-B21	HP 1U LFF BB Gen8 Rail Kit	1
503296-B21	HP 460W CS Gold Ht Plg Pwr Supply Kit	2
631673-B21	Smart Array P421/1GB FBWC Controller	1
Storage Array:		

Hardware Installation Guidelines

AJ941A	HP D2700 Disk Enclosure	1
507127-B21	HP 300GB 6G SAS 10K 2.5in DP ENT HDD	25
or 581286-B21	HP 600 GB 2.5 inch 10000 rpm SAS HDD dual port	25

Table 21: HP Gen8 v1 qualified BOM for PIC Data Record storage RMS server

d) HP G6 server for PIC Data Record storage server :

HP P/N	Technical description	Qty
484184-B21	HP ProLiant DL360 G6 Rack CTO Chassis	1
505880-L21	HP E5540 DL360 G6 FIO Kit	1
505880-B21	HP E5540 DL360 G6 Kit	1
500658-B21	HP 4GB 2Rx4 PC3-10600R-9 Kit	6
507127-B21	HP 300GB 10K 6G 2.5 SAS DP HDD ((Installed in drive bay 1 & 2)	2
532068-B21	HP DL360G6 12.7mm SATA DVD-RW Kit	1
462968-B21 or 534108-B21	HP 256MB FIO P-Series Cache Mod	1
503296-B21	HP 460W HE 12V Hotplg AC Pwr Supply Kit	2
512485-B21	HP iLO Adv 1-Svr incl 1yr TS/U SW	1
578229-B21	HP Smart Array P411/512MB FBWC (Installed in slot 1)	1
Storage Array:		
AJ941A	HP D2700 Disk Enclosure	1
507127-B21	HP 300GB 6G SAS 10K 2.5in DP ENT HDD	25
or 581286-B21	HP 600 GB 2.5 inch 10000 rpm SAS HDD dual port	25

Table 22: HP G6 qualified BOM for PIC Data Record storage RMS Server

In addition, for each HP server as well as for each D2700 enclosure, 2 power cords shall be ordered according to installation country or Power distribution unit installed in the frame. Example for DC power cable on HP Gen9 (one termination to be adapted to PDU): J6X43A HP No Plug 12AWG 48V DC 3.0m Power Cord.

3.3.4 Documentation for Data Record Storage server on HP RMS

Customer can perform following adaptations on all HP qualified BOMs:

- CPU: other CPU is supported.
Pre-requisite: 8 cores minimum (on one or 2 processors)
- Memory: Other memory allocation is supported.
Pre-requisite: 24GB minimum.
- Disk size and numbers:
 - on D2700:
Customer can select other storage disks (as far as supported by the D2700) with bigger sizes or fastest access.
Pre-requisites:
 - all disks shall have same storage capacity
 - all D2700 slots shall be fully populated (25 disks).
 - On HP Gen9:

Hardware Installation Guidelines

Customer can select other storage disks (as far as supported by the HP gen9) with bigger sizes or fastest access.

For smaller storage, fewer disks can be used.

Pre-requisites:

- all disks shall have same storage capacity
- minimum disk size is 600GB
- from 10 to 26 disks can be installed.

Port 1E of SAS controller card in the HP server shall be connected to the port P1 of the I/O module A of the D2700 storage enclosure. Port 2E shall not be connected. See annex section of this document for port selection and identification.

All Ethernet connectors are RJ45 1000 Base-TX compatible.

Documentation on HP servers & storage array is available on HP web site or using Product bulletin tool. It includes server size, weight, BTU, power information.... The HP Product Bulletin is a free application that only takes a few minutes to download. The download site is located at

http://h18004.www1.hp.com/products/quickspecs/productBulletin.html#CD_Files

Required HP power for a cabinet can be estimated using HP Power advisor tool available on HP web site:

<http://www8.hp.com/us/en/products/servers/solutions.html?compURI=1439951#.UxSoL7QUdtk>

OS and PIC software installation and configuration of Data Record Storage server on HP servers are provided in PIC Data Warehouse Server (DWS) on HP DL380 Gen 9 Installation (**Doc ID 2028670.1**) available on My Oracle Support site.

Note that customer shall have Oracle Enterprise Edition 11g and partitioning option licenses, or Oracle Technology Foundation for Monitoring Applications license for this server, before starting the installation.

3.4 Networking guidelines for PIC Mediation

Synthesis:

Each Mediation server requires:

- One Ethernet access for management
- One Ethernet access for uplink

Each storage server (for packet or data unit) requires:

- On HP: One Ethernet access for management
- On ODA: Two Ethernet access for management
- On ZFS: One Ethernet access for management
- Number of network ports for storage is variable (see details bellow)

Servers shall be connected to the customer network. Number of port is variable according to server type. Both Management port (for server management) and Network port (for backbone connectivity) shall be connected to customer network.

For management ports:

All servers shall have their ILO for HP or ILOM for ODA ports connected to the network and configured for remote access to server management functionalities:

- Server management port is a 1G Ethernet untagged port.

Hardware Installation Guidelines

- Initial Network Connection configuration shall be performed by the customer to allow remote connection to ILO(M).
- Please refer to Oracle® Database Appliance Getting Started Guide for ILOM initial configuration, or to HP ILO configuration and setup for HP servers.
- Static IP configuration for management port (ILO or ILOM) can be freely allocated (DHCP is not recommended).

For network ports:

All ODA, ZFS, X5/2 and HP RMS Ethernet network ports are RJ45 1000 Base-TX compatible.

Please refer to annex section for network ports identification.

All ports are native (VLAN if needed are configured on customer switch).

All IP addresses shall be routable to allow remote access (including for support). In case of presence of a Firewall, some TCP/UDP ports shall be opened. The list of ports to open is available in PIC security guide.

It is recommended to allocate all IP addresses for servers in the same subnet using static IP addresses. For performance reasons, it is recommended to have high throughput performance and low latency between the mediation and the storages. Typically a switch (or 2 switches with path redundancy) shall be used to interconnect all servers of a subsystem.

If production and management traffic separation is requested, IP addresses shall be allocated in different subnets for production and management. Other IP addresses (for management and ILO) can be allocated in the same or different subnets using static IP addresses.

Switch template configuration and cabling are available in appendix of this document.

4 Integrated Acquisition

4.1 Hardware options for Integrated acquisition

All integrated acquisition servers monitoring an Eagle, are grouped inside a logical entity called a subsystem. Inside the subsystem, they exchange management and surveillance information. Only one subsystem can be connected to an EAGLE. And an EAGLE can be monitored by only one Integrated Acquisition subsystem.

Integrated acquisition can be installed on:

- E5-APP-B cards (installed in Eagle frame)
- X5-2 oracle server
- HP RMS server

Integrated Acquisition	
Oracle Hardware	HP
X5-2	HP Gen9
E5-APP-B	HP Gen8 v1&v2
	HP G6

More information is provided in the following sections.

4.1.1 Documentation for Integrated Acquisition on E5-APP-B

E5-APP-B installation may include

- Provisioning of the Eagle card and installation in the Eagle frame
- Provisioning of the Terminal server (if not present) and installation in the Eagle frame
- Provisioning of the switches (one or 2 switches) and installation in the Eagle frame
- Connection of the E5-APP-B cards, to the terminal server and the switch(es)
- Connection of the Fast copy card (if option selected) to the switch(es)
- Connection of the switch console port to Terminal server
- Connection of the Terminal server to the customer network (1 port RJ45 Ethernet 1000Base-TX)
- Connection of the switch(es) in the Eagle frame to the customer network (1 port RJ45 Ethernet 1000Base-TX per switch)

No mixed configuration is allowed in a subsystem with E5-APP-B (E5-APP-B cards can't be mixed with Oracle or HP RMS).

E5-APP-B documentation can be found at https://docs.oracle.com/cd/E58681_01/docs.461/E58719_rev_2.pdf

4.1.2 Qualified BOM for Integrated acquisition on Oracle X5-2

PIC Integrated acquisition has been qualified on following hardware BOM:

Hardware Installation Guidelines

Oracle SKU	Technical description	Qty
7112843	Oracle Server X5-2 for Communications: 1 RU base chassis with motherboard,	1
7110339	XATO,DISK_CAGE,2.5" X 8HDD	1
7110346	ATO,E5-2699 V3,2.3G,145W,18 CORE,C-1 (SR1XD),CPU	2
7110350	XATO,HEATSINK,CPU,1U	2
7110360	XATO,OSA 8 GB MLC USB FLASH DRIVE	1
7110359	ATO,DVD,GEN5,BLANK FILLER PANEL,1U/2U	1
7102748	ATO PCIe FILLER,VENTED,LOW PROFILE	3
6331A-N	ASSY,HDD,MARLIN-FILLER PANEL	6
7110353	XATO,DIMM,16GB,DDR4,2133	8
7111107	1.2 TB 10000 rpm 2.5-inch SAS-3 HDD with marlin bracket (for factory installation)	2

Table 23: Oracle X5-2 BOM for PIC Integrated acquisition RMS Server

Note: Oracle X5-2 is available in AC only (no DC version) and it is not NEBS compliant.

In addition, for each server, 2 power cords shall be ordered according to installation country or Power Distribution Unit installed in the frame. Example for international: 6x Power cord International, 4 meters, IEC309-I... (333R-40-10-309)

4.1.3 Documentation for Integrated acquisition on Oracle X5-2

Customer can perform following adaptations on X5-2 qualified BOM:

- CPU: other CPUs are supported.
Pre-requisite: 8 cores minimum (on one or 2 processors)
- Memory: Other memory allocation is supported.
Pre-requisite: 24GB minimum.
- Hard drives: the two HDD disks can be replaced by SDD disks ATO,ASSY,SSD,400GB ME,2.5",SAS3,MARLIN (For Factory Installation), SKU 7110932

Customer changes can affect server and system performances and ability to upgrade in future releases.

Documentation on Oracle X5-2 is available at http://docs.oracle.com/cd/E41059_01/

Please refer to Setup and Installation section for X5-2 installation. This document will drive you through the initial X5-2 installation steps:

- server installation in the rack.
- Attaching network and power Cables
- Booting Up the First Time
- Launching Oracle System Assistant to configure:
 - Server's network connection
 - Install latest server firmware
 - Configure Oracle ILOM and BIOS,
 - Configure hardware

Details on OS and PIC software installation on X5-2 servers are provided in PIC 10.1.5 Installation guide available on Oracle Technology Network site.

Hardware Installation Guidelines

Oracle HW can be mixed with HP RMS servers in the same subsystem. But performance of each server in the subsystem shall be aligned to the server with the lowest performance.

Eagle power supply is DC only. X5-2 is available in AC only. Therefore, electrical best practice safety rules shall be strictly applied. For instance, Oracle strongly recommends that no AC powered cabinet shall be installed within 7 Ft. of DC powered equipment due to safety reasons. This may create a shock or current loop that can be severely hazardous to personnel. Exception may be granted if Telcordia reference GR1275-CORE-i08 below are fulfilled.



Details on OS and PIC software installation and configuration of integrated acquisition on Oracle servers are provided in PIC 10.1.5 Installation guide available on Oracle Technology Network site.

4.1.4 Qualified BOM for Integrated acquisition on HP RMS

Linked to HP lifecycle, different generations of servers are supported by PIC:

- HP Gen9
- HP Gen8v2
- HP Gen8 v1
- HP G6

PIC Integrated acquisition has been qualified on following hardware BOMs:

a) HP Gen9 server for PIC Integrated Acquisition (NEBS compliant) :

HP P/N	Technical description	Qty DC	Qty AC
755258-B21	HP ProLiant DL360 Gen9 8SFF Configure-to-order Server	1	1
755394-L21	E5-2680v3 HP DL360 Gen9 Intel® Xeon® E5-2680v3 (2.5GHz/12-core/30MB/120W) Processor Kit	1	1
755394-B21	E5-2680v3 HP DL360 Gen9 Intel® Xeon® E5-2680v3 (2.5GHz/12-core/30MB/120W) Processor Kit	1	1
726719-B21	HP 16GB (1x16GB) Dual Rank x4 DDR4-2133 CAS-15-15-15 Registered Memory Kit	4	4
785069-B21	HP 900GB 12G SAS 10K rpm SFF (2.5-inch) SC Enterprise 3yr Warranty Hard Drive (Install in Drive Bays 1 and 2)	2	2
749974-B21	HP Smart Array P440ar/2GB FBWC 12Gb 2-ports Int FIO SAS Controller	1	1
720479-B21	HP 800W Flex Slot Platinum Hot Plug Power Supply Kit -	2	-

Hardware Installation Guidelines

	AC		
720480-B21	HP 800 W Flex Slot-48VDC Hot Plug Power Supply Kit	-	2
512485-B21	HP iLO Advanced incl 1yr 24x7 Tech Support and Updates Single Server License	1	1
663201-B21	HP 1U Small Form Factor Ball Bearing Rail	1	1
764636-B21	HP DL360 Gen9 SFF Systems Insight Display Kit	1	1
758959-B22	HP LEGACY FIO MODE SETTING	1	1
764646-B21	HP DL360 Gen9 Rear Serial Port and Enablement Kit	1	1

Table 24: HP Gen9 qualified BOM for PIC Integrated Acquisition (NEBS compliant)

b) HP Gen8 v2 server for PIC Integrated Acquisition NEBS version:

HP P/N	Technical description	Qty DC	Qty AC
654081-B21	HP ProLiant DL360p Gen8 8 SFF Configure-to-order Server	1	1
708641-B21	HP 16GB 2Rx4 PC3-14900R-13 Kit	4	4
652241-B21	HP 9.5mm SATA DVD RW JackBlack Optical Drive	1	1
684208-B21	HP Ethernet 1Gb 4-port 331FLR FIO Adapter	1	1
631679-B21	HP 1GB P-series Smart Array Flash Backed Write Cache	1	1
512485-B21	HP iLO Advanced including 1yr 24x7 Technical Support and Updates Single Server License	1	1
712506-L21	HP DL360p Gen8 Intel Xeon E5-2680v2 (2.8GHz/10-core/25MB/115W) Processor Kit	1	1
712506-B21	HP DL360p Gen8 Intel Xeon E5-2680v2 (2.8GHz/10-core/25MB/115W) FIO Processor Kit	1	1
652583-B21	HP 600GB 6G SAS 10K rpm SFF (2.5-inch) SC Enterprise 3yr Warranty Hard Drive	2	2
734807-B21	HP 1U Small Form Factor Easy Install Rail Kit	1	1
656363-B21	HP 750W Common Slot Platinum Plus Hot Plug Power Supply Kit	-	2
636673-B21	HP 750W Common Slot -48VDC Hot Plug Power Supply Kit	2	-

Table 25: HP Gen8 v2 qualified BOM for PIC Integrated Acquisition (NEBS version)

Note : This BOM is intended for PIC 10.1.x. For older release of PIC, please use only 32GB of RAM: 2 x 708641-B21 (HP 16GB 2Rx4 PC3-14900R-13 Kit)

c) HP Gen8 v1 server for PIC Integrated Acquisition non NEBS version:

HP P/N	Technical description	Qty DC	Qty AC
655651-B21	HP DL360p Gen8 4-LFF CTO Server	1	1
647899-B21	HP 8GB 1Rx4 PC3-12800R-11 Kit	4	4
652238-B21	HP 9.5mm SATA DVD ROM Jb Kit	1	1
684208-B21	HP Ethernet 1GbE 4P 331FLR FIO Adptr	1	1

Hardware Installation Guidelines

661069-B21	HP 512MB FWC for P series smart array	1	1
512485-B21	HP iLO Advanced including 1yr 24x7 Technical Support and Updates Single Server License	1	1
654786-L21	HP DL360p Gen8 E5-2670 FIO Kit	1	1
654786-B21	HP DL360p Gen8 E5-2670 Kit	1	1
652620-B21	HP 600GB 6G SAS 15K 3.5in SC ENT HDD	2	2
663202-B21	HP 1U LFF BB Gen8 Rail Kit	1	1
503296-B21	HP 460W CS Gold Ht Plg Pwr Supply Kit	-	2
636673-B21	HP 750W-48V DC Common Slot Power Supply	2	-

Table 26: HP G8 v1 qualified BOM for PIC Integrated Acquisition (non NEBS version)

d) HP Gen8 v1 server for PIC Integrated Acquisition NEBS version:

HP P/N	Technical description	Qty DC	Qty AC
654081-B21	HP DL360p Gen8 8-SFF CTO Server	1	1
647899-B21	HP 8GB 1Rx4 PC3-12800R-11 Kit	4	4
652241-B21	HP 9.5mm SATA DVD RW JackBlack Optical Drive	1	1
684208-B21	HP Ethernet 1GbE 4P 331FLR FIO Adptr	1	1
661069-B21	HP 512MB FWC for P series smart array	1	1
512485-B21	HP iLO Advanced including 1yr 24x7 Technical Support and Updates Single Server License	1	1
654786-L21	HP DL360p Gen8 E5-2670 FIO Kit	1	1
654786-B21	HP DL360p Gen8 E5-2670 Kit	1	1
652583-B21	HP 600GB 6G SAS 10K 2.5in SC ENT HDD	2	2
663201-B21	HP 1U SFF BB Gen8 Rail Kit	1	1
656363-B21	HP 750W CS Plat PL Ht Plg Pwr Supply Kit	-	2
636673-B21	HP 750W-48V DC Common Slot Power Supply	2	-

Table 27: HP Gen8 v1 qualified BOM for PIC Integrated Acquisition (NEBS version)

e) HP G6 server for PIC Integrated Acquisition :

HP P/N	Technical description	Qty
494329-B21	HP ProLiant DL380 G6 CTO Chassis	1
492244-L21	HP E5540 DL360 G6 FIO Kit	1
492244-B21	HP E5540 DL360 G6 Kit	1
500658-B21	HP 4GB 2Rx4 PC3-10600R-9 Kit	6
507127-B21	HP 300GB 10K 6G 2.5 SAS DP HDD ((Installed in drive bay 1 & 2)	2
481043-B21	HP Slim SATA DVD-RW Kit	1
462967-B21	HP 512MB P-Series BBWC Upgrade	1
437573-B21	HP 1200W PSU 48VDC	2
512485-B21	HP iLO Adv 1-Svr incl 1yr TS/U SW	1

Hardware Installation Guidelines

Table 28: HP G6 qualified BOM for PIC Integrated Acquisition

In addition, for each HP server, 2 power cords shall be ordered according to installation country or Power distribution unit installed in the frame. Example for DC power cable on HP Gen9 (one termination to be adapted to PDU): J6X43A HP No Plug 12AWG 48V DC 3.0m Power Cord. For AC, all pre-configured servers with standard AC power supply option kit, ship with one standard 6-foot IEC C-13/C-14 jumper cord per power supply (for HP Gen9: reference A0K02A). If a different power cord is required, please check the HP web site.

4.1.5 Documentation for Integrated Acquisition on HP RMS

Customer can perform following adaptations on HP qualified BOMs:

- CPU: other CPUs are supported.
Pre-requisite: 8 cores minimum. (on one or two processors)
- Memory: Other memory allocation is supported.
Pre-requisite: 24GB minimum.

Customer changes can affect server and system performances and ability to upgrade in future releases.

Different generation of HP RMS server can be mixed, and HP RMS servers can be mixed with Oracle HW in the same subsystem. But performance of each server in the subsystem shall be aligned to the server with the lowest performance.

All Ethernet used connectors are RJ45 1000 Base-TX compatible.

Documentation on HP servers is available on HP web site or using Product bulletin tool. It includes server size, weight, BTU, power information... . The HP Product Bulletin is a free application that only takes a few minutes to download.

The download site is located at

http://h18004.www1.hp.com/products/quickspecs/productBulletin.html#CD_Files

Required HP power for a cabinet can be estimated using HP Power advisor tool available on HP web site:

<http://www8.hp.com/us/en/products/servers/solutions.html?compURI=1439951#.UxSoL7QUdtk>

OS and PIC acquisition software installation and configuration on HP servers are provided in PIC 10.1.5 Installation guide available on Oracle Technology Network site.

4.2 Networking guidelines for Integrated Acquisition

Synthesis:

Switches are mandatory (1 or more according to equipment to connect)

Each Integrated acquisition server requires

- One Ethernet access for management
- Two Ethernet access for uplink

In addition, STC and Fast copy Eagle cards are dual attached to the switches.

Switches are connected to customer network through one or 2 ports.

All servers shall have their ILO for HP or ILOM for ODA ports connected to the network and configured for remote access to server management functionalities:

- Server management port is a 1G Ethernet untagged port.
- Initial Network Connection configuration shall be performed by the customer to allow remote connection to ILO(M).

Hardware Installation Guidelines

- Please refer to Oracle® Database Appliance Getting Started Guide for ILOM initial configuration, or to HP ILO configuration and setup for HP servers.
- Static IP configuration for management port (ILO or ILOM) can be freely allocated (DHCP is not recommended).

For network ports:

- All Ethernet network ports are RJ45 1000 Base-TX compatible.
- Please refer to annex section for network ports identification.

All Eagle cards connected to switches (fast copy ports or STC ports) are:

- Native untagged RJ45 100 Base-T compliant.
- Tagging shall be done on the switch according to the selected configuration (see below)

When Fast copy is activated on the Eagle, switch shall support jumbo frame (minimum size 1530 bytes).

Switches are part of the integrated acquisition architecture. They are mandatory. One or more switches are required according to number of servers and Eagle cards to connect. For new systems it is recommended to use the configuration described in the following chapter and assuming the system is installed in accordance with the switch port allocation described in section 6.13.1

If requested by customer an alternate config can be used and is described in section 4.2.2 and in this case you have to configure the switch as for the default and then add the few lines described in this section.

The Layer 3 configuration described in section 6.13.2 to 6.13.7 for RMS Servers and 6.13.10.2 to 6.13.10.3 for E5-AppB cards are designed for the CISCO 49448EF switch but is keeping also some commands in order to remain compatible with the previous CISCO 4948.

In case of switch installed to extend existing systems it is recommended the same Layer 2 config used in the previous PIC releases and remembered in section:

1. 6.13.19 for HP RMS
2. 6.13.10.4 for E5-AppB

Layer 2 configurations can still be used even if you have 4948EF instead of 4948 switches, if you don't want to use Layer 3 configuration for a new system installation. The template configuration may be customized as long as you respect the constraints described in the following section.



CAUTION:

In case of switch reconfiguration, the communication to IMF server may be lost.

It is recommended, to avoid any communication lost during switch reconfiguration, to change interface status to down state on all IMF sub-system servers before starting switch reconfiguration:

- For yellow switch reconfiguration, use “ifdown eth01”
- For blue switch reconfiguration, use “ifdown eth03”

After switch reconfiguration, don't forget to restart the interface using ifdup command.

Use this procedure only if you really need to avoid any communication lost.

Hardware Installation Guidelines

4.2.1 Default configuration

The interfaces to customer switch are configured in native mode. If customer use vlans they must be configured on his switch (transparent for Oracle) :

1. Vlan 100 172.21.49.0 255.255.255.0

vlan can't be changed and is transparent to the customer

IP can't be changed and shall not be used for servers communicating with IMF (NSP&IXP&VPN)

2. Vlan 101 172.22.49.0 255.255.255.0

Vlan can't be changed and is transparent to the customer

IP can't be changed and shall not be used for servers communicating with IMF (NSP&IXP&VPN)

3. Vlan 200 192.168.0.0 255.255.255.224 internal network minimum size for largest config

IP must be changed according values customer provided

Vlan can't be changed and is transparent to the customer

In the following config 192.168.0.1 is reserved and shall be used as default route for the IMF servers. 192.168.0.2 & 192.168.0.3 are reserved for switch IP

4. Vlan 300 192.168.10.0 255.255.255.224 iLO network

IP must be changed according values customer provided

5. Vlan 400 192.168.20.0 255.255.255.240 external network (demarcation)

IP must be changed according values customer provided

Note : the commands "switchport trunk encapsulation dot1q" and "media-type rj45" will fail on the 4948EF switch but it is kept this config for compatibility with the previous 4948

Note : While the configuration you may receive warnings like the one bellow, but this is expected.

%Warning: portfast should only be enabled on ports connected to a single

Warning: portfast should only be enabled on ports connected to a single

Warning: portfast should only be enabled on ports connecy bridging loops.

Warning: portfast should only be enabled on ports connecy bridging loops.t this is

expected. 4948vers. 192.168.0.2 & 192.168.0.3 are reserved for switch IPwhen portfast is

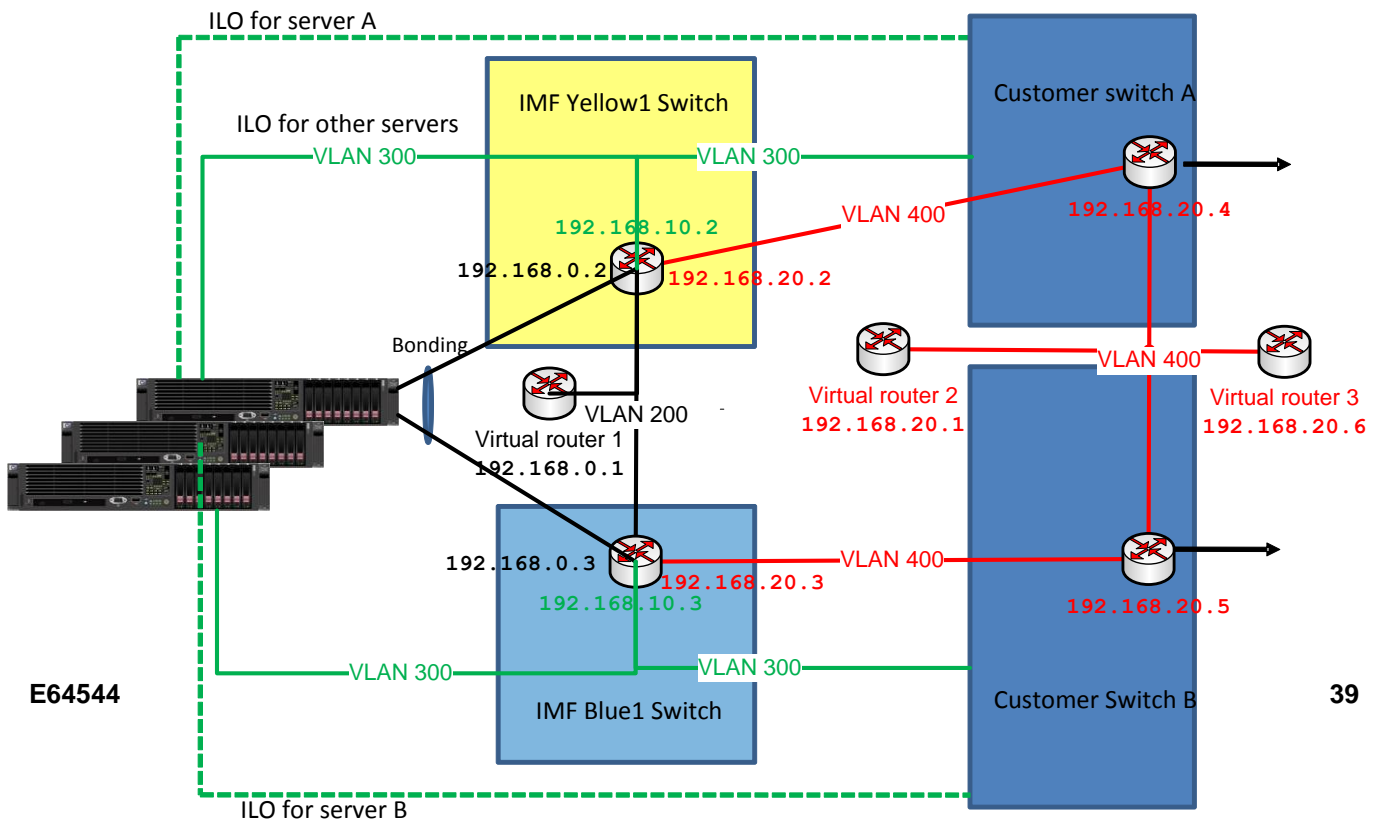

4.2.2 Alternate configuration

If the customer wants to configure on Oracle switches, we can use the alternate config below just by adding the few lines below to the default config.



This configuration can be dangerous, because customer must guarantee there is no link between the two switch access, otherwise it would make a loop and his network may crash.

```
interface Port-channel1
  switchport trunk allowed vlan 100,101,200,300,400
interface GigabitEthernet 1/1
  switchport trunk allowed vlan 100,101,200,300,400
interface GigabitEthernet 1/2
  switchport trunk allowed vlan 100,101,200,300,400
no track 1 int gigabitEthernet 1/47 line-protocol
track 1 interface port-channel 1 line-protocol
```

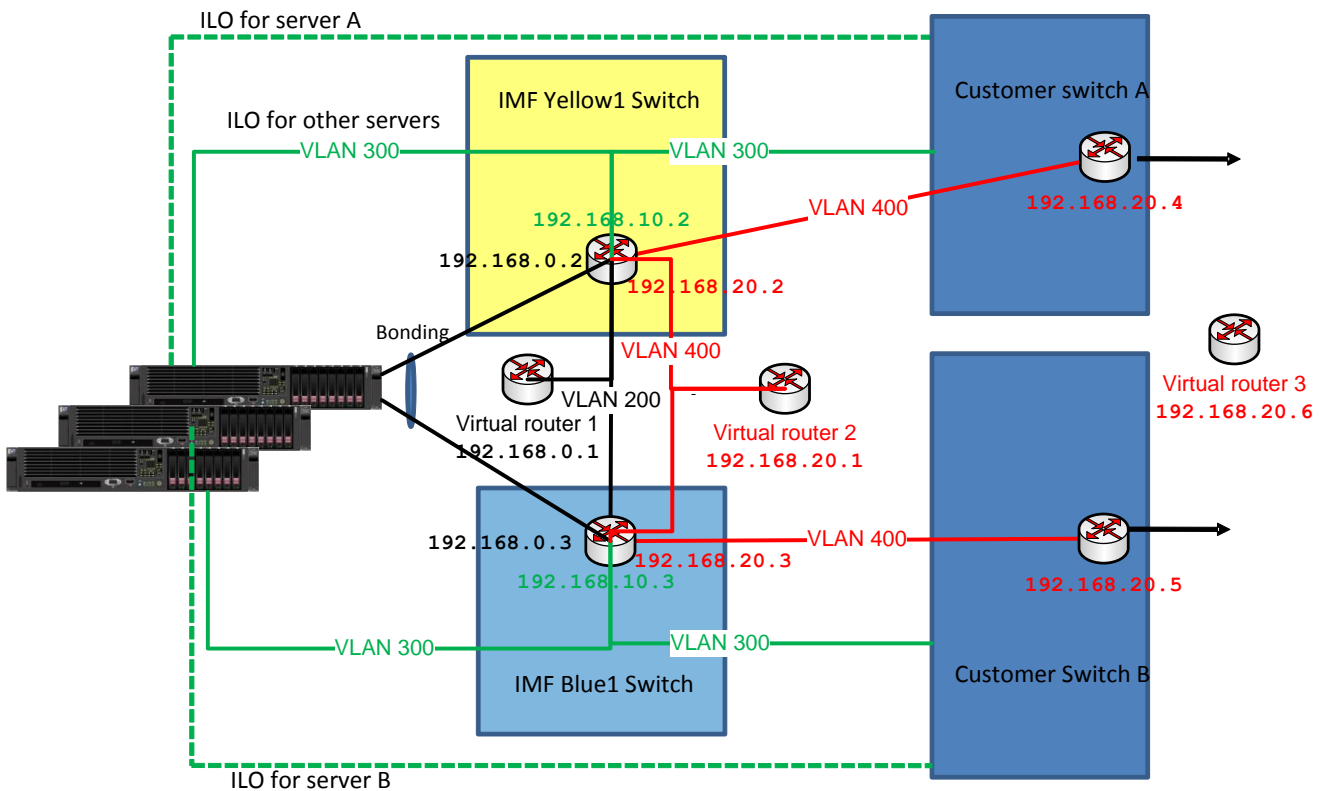

Hardware Installation Guidelines

4.2.3 Networking guidelines for standard configuration

According to the number of cards and servers to connect, more than one switch may be necessary. In that case, it is recommended to build a fully redundant network topology and to distribute the port from each server/card to 2 different switches connected in redundant way.

Following connection and port configuration shall be done:

- Eagle cards:
For all cards for which Fast copy is enable,
 1. Connect port C of the Fast Copy card, and port A for the STC cards to the switch.
In the switch, port shall be configured as untagged native port (mode access) and shall belong to VLAN 100.
 2. Connect port D of the Fast Copy card, and port B for the STC cards to the switch.
In the switch, port shall be configured as untagged native port (mode access) and shall belong to VLAN 101

- Integrated servers:
 1. Connect port Eth01 of IMF servers to a switch.
In the switch, port shall be configured as 802.1.Q tagged port (mode trunk). Vlan 100, 101 and 200 shall be allowed on the port.
 2. Connect port Eth03 of IMF servers to another switch (according to the redundant topology)..
In the switch, port shall be configured as 802.1.Q tagged port (mode trunk). Vlan 100, 101 and 200 shall be allowed on the port.
 3. It is recommended to
 - i. connect the ILO port of HP server, or the ILOM port for X5-2 of the first server to a customer switch to allow remote access even when PIC switch configuration is not done
 - ii. connect the serial port of the same server on the console port of the switch (for initial configuration and troubleshooting)
 4. The other ILO/ILOM port can be connected to any switch with available ports.
In the switch, port shall be configured as untagged native port (mode access) and shall belong to VLAN 300 or any other VLAN number suitable for the customer (except 100 and 101).

- Connection to customer network:
According to customer will, one, two or more ports can be reserved to connect to customer network. These ports are freely configured by the customer.
One or more of these ports shall belong to VLAN 200 for integrated server access to the customer network.
One or more of these ports shall belong to the VLAN selected for the management (300 or any other vlan number except 100 and 101).
IP routing in the switch can be used too.

Following VLAN numbers are reserved. They can't be changed:

- VLAN 100: internal yellow network (Path 1 between Eagle and integrated servers)
- VLAN 101: internal bleu network (Path 2 between Eagle and integrated servers)
- VLAN 200: integrated servers to customer network

VLAN 100 and 101 are local and shall not be transmitted to customer backbone.

A specific VLAN number can be allocated for Management (access to ILO or ILOM).

Each VLAN shall belong to the same broadcasting domain.

4.2.4 IP addressing

VLAN 100 and 101 are using a specific subnets 172.21.48.00/23 and to 172.22.48.00/23 respectively. These addresses are reserved and shall not be used in PIC whole system. But as they are internal, they can be used by the customer for any servers not interconnected with PIC.

All integrated servers shall be in the same subnet on VLAN 200. Subnet can be freely set. It is recommended to use a subnet large enough to allow future extension. Static IP configuration shall be used (DHCP shall not be used).

For management ILO/ILOM ports:

Static IP configuration for management port (ILO or ILOM) can be freely allocated (DHCP is not recommended).

Hardware Installation Guidelines

5 Probed Acquisition

5.1 Hardware options for Probed acquisition

Integrated acquisition can be installed on:

- X5-2 oracle server
- HP RMS

Integrated Acquisition	
Oracle Hardware	HP
X5-2	HP Gen9
	HP Gen8 v1&v2
	HP G6

More information is provided in the following sections.

5.1.1 Qualified BOM for Probed acquisition on Oracle X5-2

PIC Probed acquisition has been qualified on following hardware BOM for copper 1G/10G network :

Oracle SKU	Technical description	Qty
7112843	ATO,BASE,CONFIG,1U	1
7110339	XATO,DISK_CAGE,2.5" X 8HDD	1
7110346	ATO,E5-2699 V3,2.3G,145W,18 CORE,C-1 (SR1XD),CPU	2
7110350	XATO,HEATSINK,CPU,1U	2
7110360	XATO,OSA 8 GB MLC USB FLASH DRIVE	1
7110359	ATO,DVD,GEN5,BLANK FILLER PANEL,1U/2U	1
7102748	ATO PCIe FILLER,VENTED,LOW PROFILE	1
6331A-N	ASSY,HDD,MARLIN-FILLER PANEL	6
7110353	XATO,DIMM,16GB,DDR4,2133	8
7111107	1.2 TB 10000 rpm 2.5-inch SAS-3 HDD with marlin bracket (for factory installation)	2
7100563	Sun Dual Port 10GBase-T Adapter (for factory installation)	2

Table 29: Oracle X5-2 BOM for PIC Probed acquisition RMS Server on copper links

Note: Oracle X5-2 is available in AC only (no DC version) and it is not NEBS compliant.

PIC Probed acquisition has been qualified on following hardware BOM for optical 1G/10G network :

Oracle SKU	Technical description	Qty
7112843	Oracle Server X5-2 for Communications: 1 RU base chassis with motherboard,	1
7110339	XATO,DISK_CAGE,2.5" X 8HDD	1
7110346	ATO,E5-2699 V3,2.3G,145W,18 CORE,C-1 (SR1XD),CPU	2
7110350	XATO,HEATSINK,CPU,1U	2
7110360	XATO,OSA 8 GB MLC USB FLASH DRIVE	1
7110359	ATO,DVD,GEN5,BLANK FILLER PANEL,1U/2U	1

Hardware Installation Guidelines

7102748	ATO PCIe FILLER, VENTED, LOW PROFILE	1
6331A-N	ASSY, HDD, MARLIN-FILLER PANEL	6
7110353	XATO, DIMM, 16GB, DDR4, 2133	8
7111107	1.2 TB 10000 rpm 2.5-inch SAS-3 HDD with marlin bracket (for factory installation)	2
1109A-Z	ASSY, 2X10GbE SFP+, X8PCIe 2.0, LP, Lead Free (Niantic)	2

Table 30: Oracle X5-2 BOM for PIC Probed acquisition RMS Server on optical links

Note: Oracle X5-2 is available in AC only (no DC version) and it is not NEBS compliant.

In addition, shall be ordered

- 2 power cords according to installation country or Power Distribution Unit installed in the frame. Example for international: 6x Power cord International, 4 meters, IEC309-I... (333R-40-10-309)
- SPF(+) modules according to network type (each acquisition card has 2 SPF(+) slot each. Total: 4 ports)

SFP modules tested by PIC and qualified with the Sun Dual 10GbE SFP+ PCIe Low Profile card are:

Oracle SKU	Technical description
5562A-Z	Sun SFP+ to Dual 1000 Base LX/10GE base LR adapter
2129A-Z	Sun SFP+ to Dual 1000 Base SX/10GE base SR adapter

Table 31: Qualified SFP(+) modules on Oracle X5-2

This list is by no means exhaustive. Selected card is compliant with the standards and shall be compatible with almost all brands of SFP/SFP+. But no commitment can be taken.

SFP(+) slots of the network acquisition card shall be populated with the SFP(+) module according to network technology.

5.1.2 Documentation for Probed acquisition on Oracle X5-2

Customer can perform following adaptations on X5-2 qualified BOM:

- CPU: other CPUs are supported.
Pre-requisite: 8 cores minimum. (on one or 2 processors)
- Memory: Other memory allocation is supported.
Pre-requisite: 24GB minimum.
- Hard drives: the 2 HDD disks can be replaced by SSD disks ATO, ASSY, SSD, 400GB ME, 2.5", SAS3, MARLIN (For Factory Installation), SKU 7110932

Customer changes can affect server and system performances and ability to upgrade in future releases.

OS and PIC acquisition software installation and configuration on Oracle servers, are provided in PIC 10.1.5 Installation guide available on Oracle Technology Network site.

5.1.3 Qualified BOM for Probed acquisition on HP RMS

Linked to HP lifecycle, different generations of servers are supported by PIC:

- HP Gen9

Hardware Installation Guidelines

- HP Gen8v2
- HP Gen8 v1
- HP G6

a) HP Gen9 server for PIC Probed Acquisition 1G/10G version:

HP P/N	Technical description	Qty DC	Qty AC
755258-B21	HP ProLiant DL360 Gen9 8SFF Configure-to-order Server	1	1
755394-L21	E5-2680v3 HP DL360 Gen9 Intel® Xeon® E5-2680v3 (2.5GHz/12-core/30MB/120W) Processor Kit	1	1
755394-B21	E5-2680v3 HP DL360 Gen9 Intel® Xeon® E5-2680v3 (2.5GHz/12-core/30MB/120W) Processor Kit	1	1
726719-B21	HP 16GB (1x16GB) Dual Rank x4 DDR4-2133 CAS-15-15-15 Registered Memory Kit	4	4
785069-B21	HP 900GB 12G SAS 10K rpm SFF (2.5-inch) SC Enterprise 3yr Warranty Hard Drive (Install in Drive Bays 1 and 2)	2	2
629135-B22	HP Ethernet 1Gb 4-port 331FLR Adapter (Flex LOM)	1	1
749974-B21	HP Smart Array P440ar/2GB FBWC 12Gb 2-ports Int FIO SAS Controller	1	1
720479-B21	HP 800W Flex Slot Platinum Hot Plug Power Supply Kit - AC	2	-
720480-B21	HP 800 W Flex Slot-48VDC Hot Plug Power Supply Kit	-	2
512485-B21	HP iLO Advanced incl 1yr 24x7 Tech Support and Updates Single Server License	1	1
663201-B21	HP 1U Small Form Factor Ball Bearing Rail Kit (Required for Zone 4 installations)	1	1
764636-B21	HP DL360 Gen9 SFF Systems Insight Display Kit	1	1
758959-B22	HP LEGACY FIO MODE SETTING	1	1
665249-B21	HP Ethernet 10Gb Dual Port 560SFP+ Adapter (Install cards in Slot 1 and slot 2)	2	2

Table 32: HP Gen9 qualified BOM for PIC Probed 1G/10G Acquisition

Note: Optionally to add serial port on HP Gen9 for access to switch console port, add one HP P/N 764646-B21 (HP DL360 Gen9 Rear Serial Port and Enablement Kit). The serial cable shall be added.

Note : HP Ethernet 1Gb 4-port 331FLR Adapter (Flex LOM) P/N 629135-B22 is not used in PIC 10.1.5 but is planned for future use.

b) HP Gen8 v2 server for PIC Probed Acquisition1G/10G:

HP P/N	Technical description	Qty DC	Qty AC
654081-B21	HP ProLiant DL360p Gen8 8 SFF Configure-to-order Server	1	1
708641-B21	HP 16GB 2Rx4 PC3-14900R-13 Kit	4	4

Hardware Installation Guidelines

652241-B21	HP 9.5mm SATA DVD RW JackBlack Optical Drive	1	1
684208-B21	HP Ethernet 1Gb 4-port 331FLR FIO Adapter	1	1
631679-B21	HP 1GB P-series Smart Array Flash Backed Write Cache	1	1
512485-B21	HP iLO Advanced including 1yr 24x7 Technical Support and Updates Single Server License	1	1
712506-L21	HP DL360p Gen8 Intel Xeon E5-2680v2 (2.8GHz/10-core/25MB/115W) Processor Kit	1	1
712506-B21	HP DL360p Gen8 Intel Xeon E5-2680v2 (2.8GHz/10-core/25MB/115W) FIO Processor Kit	1	1
652583-B21	HP 600GB 6G SAS 10K rpm SFF (2.5-inch) SC Enterprise 3yr Warranty Hard Drive	2	2
734807-B21	HP 1U Small Form Factor Easy Install Rail Kit	1	1
656363-B21	HP 750W Common Slot Platinum Plus Hot Plug Power Supply Kit	-	2
636673-B21	HP 750W Common Slot -48VDC Hot Plug Power Supply Kit	2	-
665249-B21	HP Ethernet 10Gb 2-port 560SFP+ Adapter	2	2

Table 33: HP Gen8 v2 qualified BOM for PIC Probed 1G/10G Acquisition

Note : This BOM is intended for PIC 10.1.x. For older release of PIC, please use only 32GB of RAM: 2 x 708641-B21 (HP 16GB 2Rx4 PC3-14900R-13 Kit)

c) HP Gen8 v1 server for PIC Probed Acquisition 1G/10G NEBS version:

HP P/N	Technical description	Qty DC	Qty AC
655651-B21	HP DL360p Gen8 4-LFF CTO Server	1	1
647899-B21	HP 8GB 1Rx4 PC3-12800R-11 Kit	4	4
652238-B21	HP 9.5mm SATA DVD ROM Jb Kit	1	1
684208-B21	HP Ethernet 1GbE 4P 331FLR FIO Adptr	1	1
661069-B21	HP 512MB FWC for P series smart array	1	1
512485-B21	HP iLO Advanced including 1yr 24x7 Technical Support and Updates Single Server License	1	1
654786-L21	HP DL360p Gen8 E5-2670 FIO Kit	1	1
654786-B21	HP DL360p Gen8 E5-2670 Kit	1	1
652620-B21	HP 600GB 6G SAS 15K 3.5in SC ENT HDD	2	2
663202-B21	HP 1U LFF BB Gen8 Rail Kit	1	1
503296-B21	HP 460W CS Gold Ht Plg Pwr Supply Kit	-	2
636673-B21	HP 750W-48V DC Common Slot Power Supply	2	-
C3N52AA (Intel E10G42BTDA)	HP X520 10GbE Dual Port Adapter	2	2

Table 34: HP Gen8 v1 qualified BOM for PIC Probed 1G/10G Acquisition (NEBS version)

d) HP Gen8 v1 server for PIC Probed Acquisition 1G non NEBS version:

Hardware Installation Guidelines

HP P/N	Technical description	Qty DC	Qty AC
655651-B21	HP DL360p Gen8 4-LFF CTO Server	1	1
647899-B21	HP 8GB 1Rx4 PC3-12800R-11 Kit	4	4
652238-B21	HP 9.5mm SATA DVD ROM Jb Kit	1	1
684208-B21	HP Ethernet 1GbE 4P 331FLR FIO Adptr	1	1
661069-B21	HP 512MB FWC for P series smart array	1	1
512485-B21	HP iLO Advanced including 1yr 24x7 Technical Support and Updates Single Server License	1	1
654786-L21	HP DL360p Gen8 E5-2670 FIO Kit	1	1
654786-B21	HP DL360p Gen8 E5-2670 Kit	1	1
652620-B21	HP 600GB 6G SAS 15K 3.5in SC ENT HDD	2	2
663202-B21	HP 1U LFF BB Gen8 Rail Kit	1	1
503296-B21	HP 460W CS Gold Ht Plg Pwr Supply Kit	-	2
636673-B21	HP 750W-48V DC Common Slot Power Supply	2	-
593722-B21	HP NC365T 4-port Ethernet Server Adapter	2	2

Table 35: HP G8 v1 qualified BOM for PIC Probed 1G Acquisition (non NEBS version)

e) HP Gen8 v1 server for PIC Probed Acquisition 1G NEBS version:

HP P/N	Technical description	Qty DC	Qty AC
654081-B21	HP DL360p Gen8 8-SFF CTO Server	1	1
647899-B21	HP 8GB 1Rx4 PC3-12800R-11 Kit	4	4
652241-B21	HP 9.5mm SATA DVD RW JackBlack Optical Drive	1	1
684208-B21	HP Ethernet 1GbE 4P 331FLR FIO Adptr	1	1
661069-B21	HP 512MB FWC for P series smart array	1	1
512485-B21	HP iLO Advanced including 1yr 24x7 Technical Support and Updates Single Server License	1	1
654786-L21	HP DL360p Gen8 E5-2670 FIO Kit	1	1
654786-B21	HP DL360p Gen8 E5-2670 Kit	1	1
652583-B21	HP 600GB 6G SAS 10K 2.5in SC ENT HDD	2	2
663201-B21	HP 1U SFF BB Gen8 Rail Kit	1	1
656363-B21	HP 750W CS Plat PL Ht Plg Pwr Supply Kit	-	2
636673-B21	HP 750W-48V DC Common Slot Power Supply	2	-
647594-B21	HP Ethernet 1Gb 4-port 331T	2	2

Table 36: HP Gen8 v1 qualified BOM for PIC Probed 1G Acquisition (NEBS version)

f) HP G6 server for PIC Probed Acquisition :

HP P/N	Technical description	Qty DC	Qty AC
494329-B21	HP DL380G6 CTO Chassis	1	1
492244-L21	HP E5540 DL380 G6 FIO Kit	1	1
492244-B21	HP E5540 DL380 G6 Kit	1	1
500658-B21	HP 4GB 2Rx4 PC3-10600R-9 Kit	6	6
534916-B21	HP 512MB Flash Backed Write Cache	1	1
507127-B21	HP 300GB 10K 6G 2.5 SAS DP HDD (Drive Bay 1 & 2)	2	2
512327-B21	HP 750W CS HE Power Supply Kit	0	2
437573-B21	HP 1200w PSU 48VDC	2	0
481043-B21	HP Slim SATA DVD RW Optical Drive	1	1
512485-B21	HP ILO Adv 1-Svr incl 1yr TS/U SW	1	1
435508-B21	HP NC364T PCIe 4Pt Gigabit Server Adptr (ETH CARDS INSTALLED IN SLOTS 2 AND 3)	2	2

Table 37: HP G6 qualified BOM for PIC Probed 1G Acquisition

In addition, for each HP server, shall be ordered

- 2 power cords according to installation country or Power distribution unit installed in the frame.
- SPF(+) modules according to network type for servers with SFP cards (2 SPF(+) slots on each card)

Example for DC power cable on HP Gen9 (one termination to be adapted to PDU): J6X43A HP No Plug 12AWG 48V DC 3.0m Power Cord.

All pre-configured servers with standard AC power supply option kit, ship with one standard 6-foot IEC C-13/C-14 jumper cord per power supply (for HP Gen9: A0K02A). If a different power cord is required, please check the HP web site.

5.1.4 Documentation for Probed acquisition on HP RMS

Customer can perform following adaptations on all HP qualified BOMs:

- CPU: other CPU is supported.
Pre-requisite: 8 cores minimum. (on one or 2 processors)
- Memory: Other memory allocation is supported.
Pre-requisite: 24GB minimum.

Customer changes can affect server and system performances and ability to upgrade in future releases.

Each network acquisition card has 2 SPF(+) slots each. SFP(+) slots of the network acquisition card shall be populated with the SFP(+) module according to network technology.

SFP modules tested by PIC and qualified to work with the HP INTEL X520 card are:

Interface	Tested SFP+ modules
1000 Base-T adapter	FINISAR PN: FCLF8521-3
Dual 1000 Base LX / 10GE base LR adapter	SUN X2129A PN:530-4449 AVAGO PN:AFBR-709DMZ-SN1
Dual 1000 Base SX / 10GE base SR adapter	AVAGO PN:AFBR-703SDZ FINISAR PN:F7LX8571D3BCL SUN X2129A PN:530-4449*

Hardware Installation Guidelines

	AVAGO PN:AFBR-703SDDZ-SN1*
10GE base SR adapter	SUN X2129A PN:530-4449 AVAGO PN:AFBR-703SDZ

Table 38: SFP+ modules available on HP Intel X520 card

Note *: not hot swappable (reboot required for SFP module recognition)

And on HP INTEL X560 SFP+ card:

Interface	Tested SFP+ modules
1000 Base-T adapter	FINISAR PN: FCLF8521-3
Dual 1000 Base SX / 10GE base SR adapter	SUN X5562A PN:135-1205 AVAGO PN:AFCT-701SDDZ-SN1
Dual 1000 Base SX / 10GE base SR adapter	SUN X2129A PN:530-4449 AVAGO PN:AFBR-703SDDZ-SN1
10GE base SR adapter	AVAGO PN:AFBR-703SDZ FINISAR PN:FTLX8571D3BCL
Dual 1000 Base LX / 10GE base LR adapter	SUN X5562A PN:135-1205 AVAGO PN:AFCT-701SDDZ-SN1

Table 39: SFP+ modules available on HP Intel X560 card

This list is by no means exhaustive. Selected card is compliant with the standards and shall be compatible with almost all brands of SFP/SFP+. But no commitment can be taken.

OS and PIC acquisition software installation and configuration on HP servers are provided in PIC 10.1.5 Installation guide available on Oracle Technology network site.

5.2 Networking guidelines for Probed Acquisition

Synthesis:

Each probe server requires:

- One Ethernet access for management
- One Ethernet access for uplink

In addition, probe is connected to customer network links/switches for acquisition.

Probes implementation requires a minimum of 2 Ethernet ports:

- Eth01 for traffic uplink.
- ILO or ILOM for server management

Server needs 2 IP addresses:

- One for ILO or ILOM
- One for Eth01 port

All Probe servers are independent. IP addresses can be freely allocated to probe ports.

All Ethernet ports are RJ45 1000 Base-TX compatible.

Hardware Installation Guidelines

Please refer to annex section for ports identification.

All ports are native (VLAN if needed are configured on customer switch).

All IP addresses shall be routable to allow remote access (including for support). In case of presence of a Firewall, some TCP/UDP ports shall be opened. The list of ports to open is available in PIC security guide..

Static IP configuration shall be used (DHCP shall not be used).

On acquisition side, customer shall copy network traffic to the probe. Port mirroring and tapping are supported. It is the responsibility of the customer to provide the Taps or to configure the switch. When using optical passive taps, particular attention shall be done on power budget. Probe receiver sensitivity is SFP module selection dependent.

Hardware Installation Guidelines

6 ANNEXES

6.1 Port identification on HP server Gen8 v1 & v2:

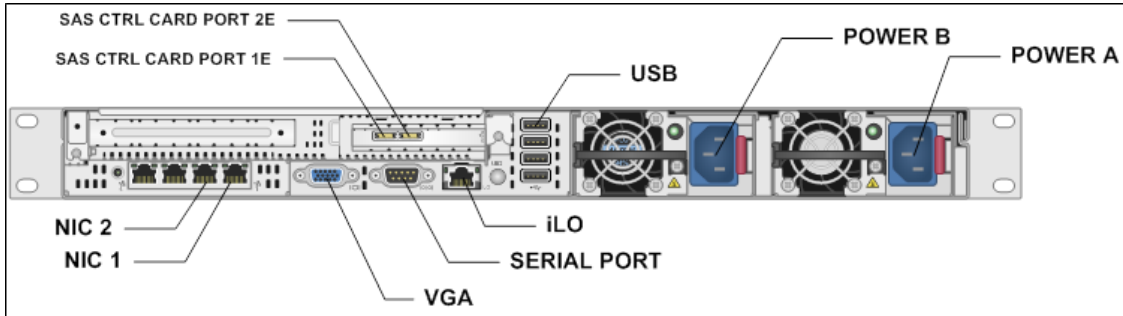

Figure 1 : Rear view for HP DL360 server Gen8 v1 & v2 used for Mediation

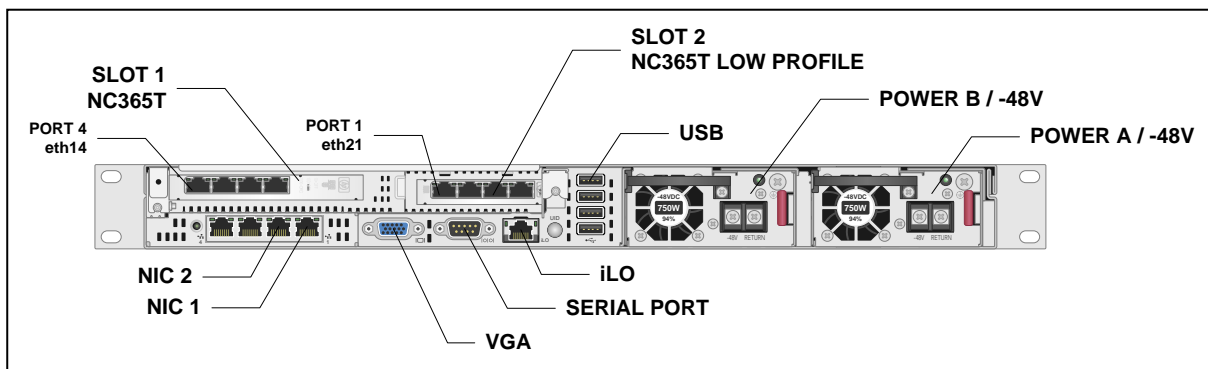

Figure 2 : Rear view for HP DL360 server Gen8 v1 & v2 used for Probed acquisition

Note: Slot and network port used for acquisition are similar for the 1Gb 4-port NC365T Adapter and 10Gb 2-port 560SFP+ Adapter, as well as for Gen9 in the following section.

6.2 Port identification on HP server DL360 Gen9

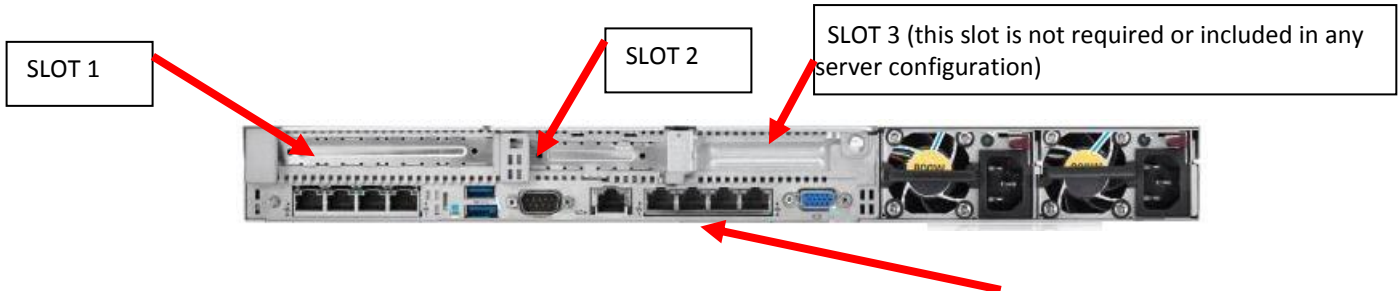
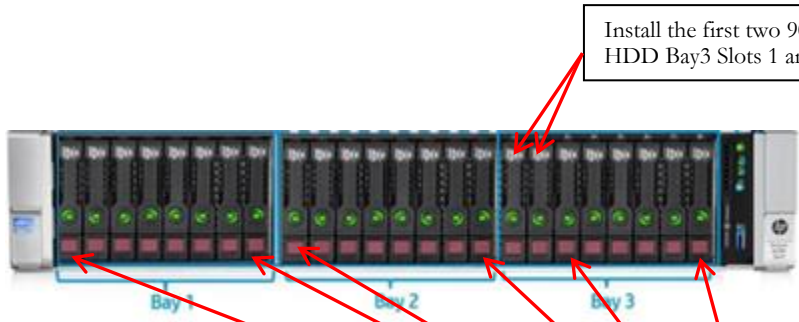

Figure 3 : Rear view for HP DL360 server Gen9

Embedded 4 x 1GbE Network Adapter
Eth01, Eth02, Eth03, Eth04

6.3 Port identification on HP server DL380 Gen9:



Install the first two 900GB HDD for the OS in
HDD Bay3 Slots 1 and 2.

Figure 4 : Front view for HP DL38 Gen9

After installing the 900GB HDD in Bay 3 slots 1 and 2 for the OS, install the 900GB hard drives in the remaining HDD slots in Bay 3 then start filling up BAY 2 starting with slot 1 with any remaining 900GB HDD, then start filling up BAY 1 starting with slot 1 with any remaining 900GB HDD.

Install any remaining 900GB HDD in the rear
HDD slots 25 and 26



Figure 5 : Rear view for HP DL380 Gen9

Hardware Installation Guidelines

6.4 Port identification on D2700 Storage Array:

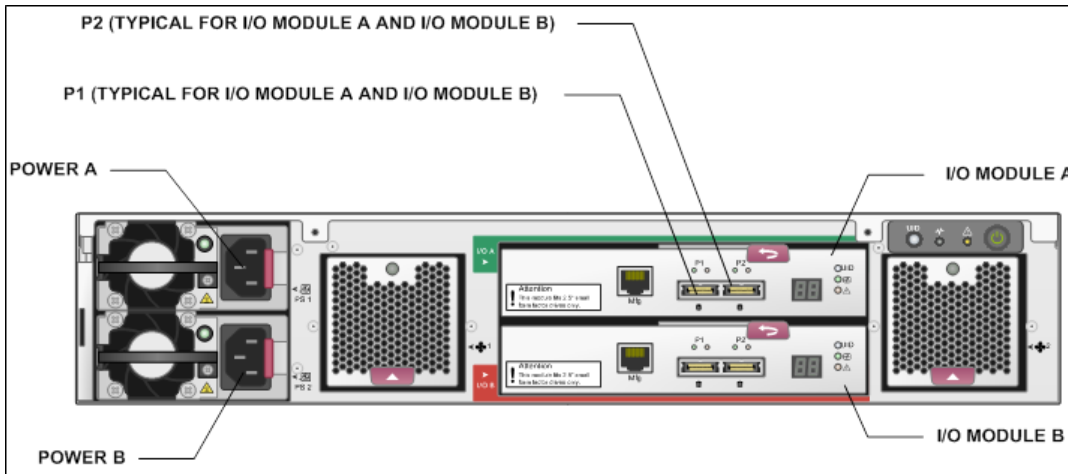
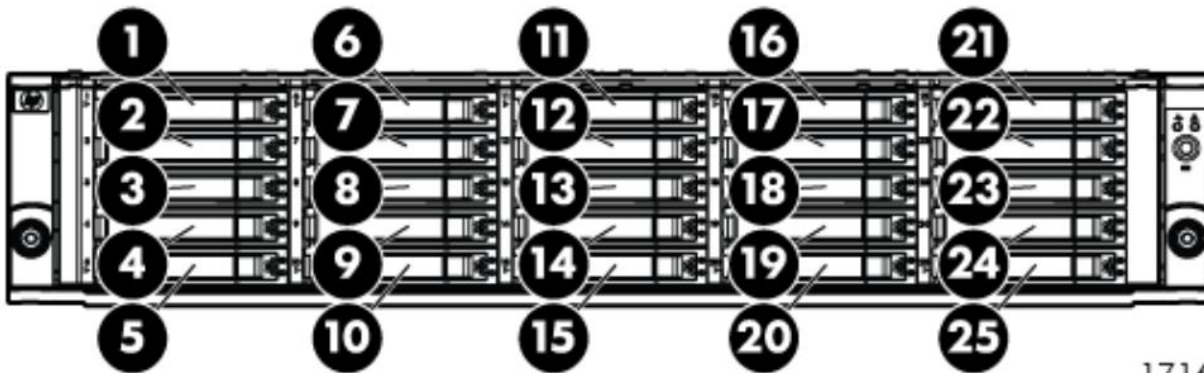

Figure 6 : Rear view for D2700 storage array



17163

Figure 7 : Drive Bay numbering

6.5 Port identification on ODA X5-2

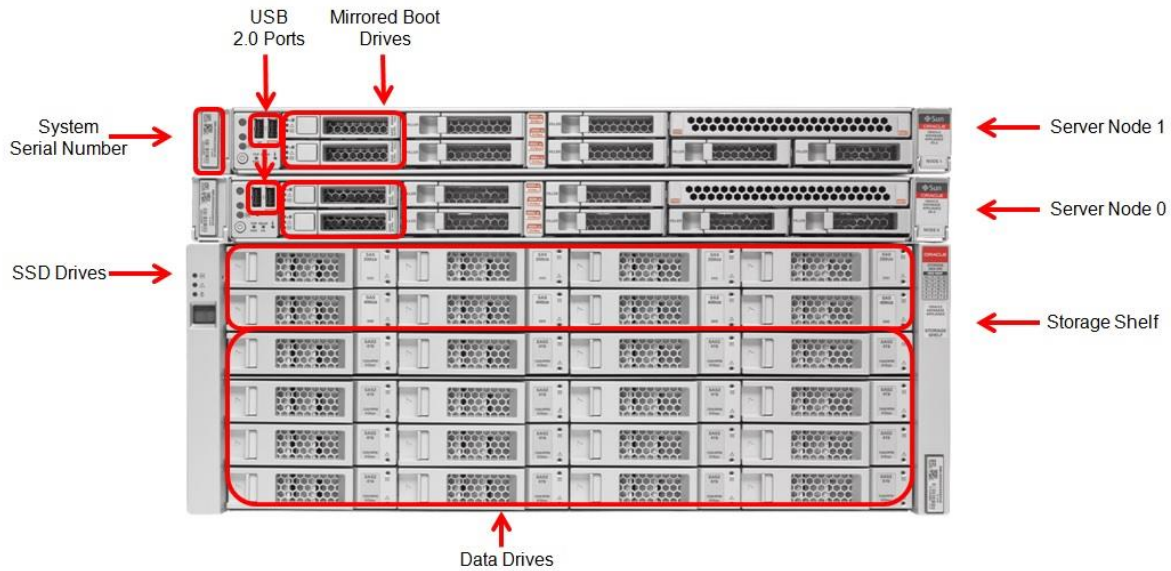

Figure 8- Front view of Oracle Database Appliance (storage shelf connections)

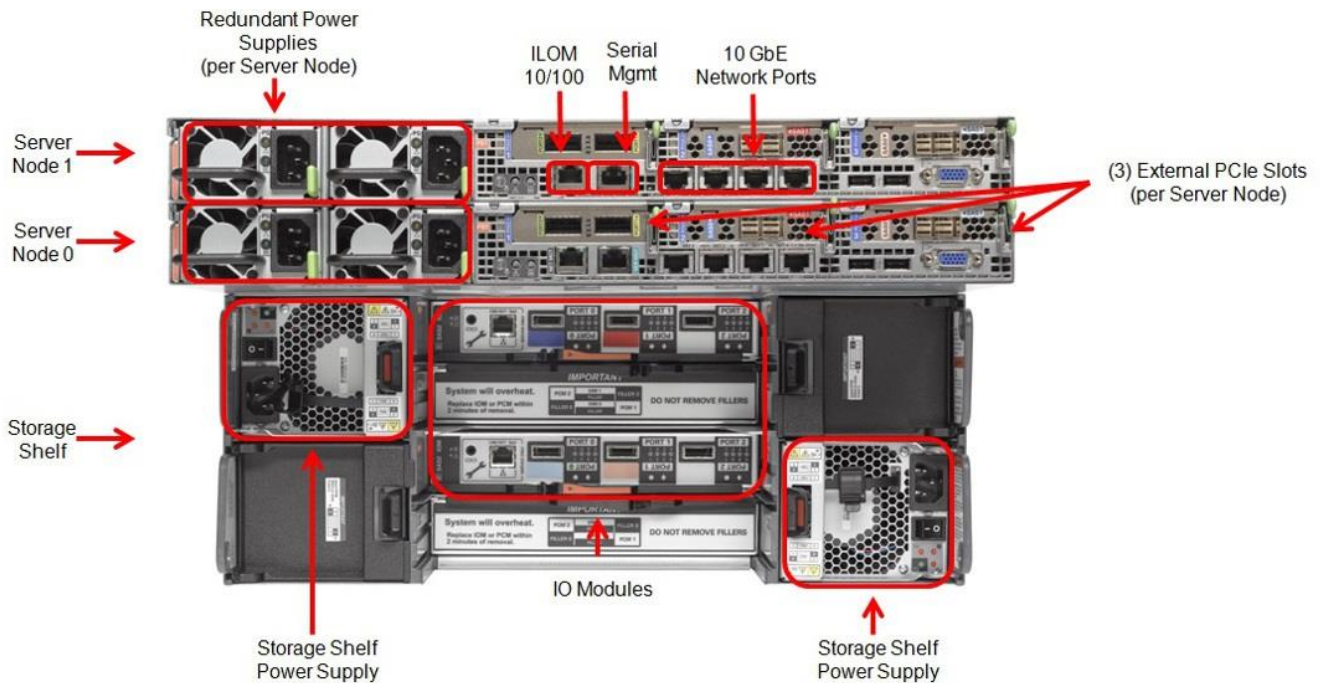

Figure 9- Rear view of Oracle Database Appliance (power and network connections)

Hardware Installation Guidelines

6.6 Port identification on Oracle X5-2

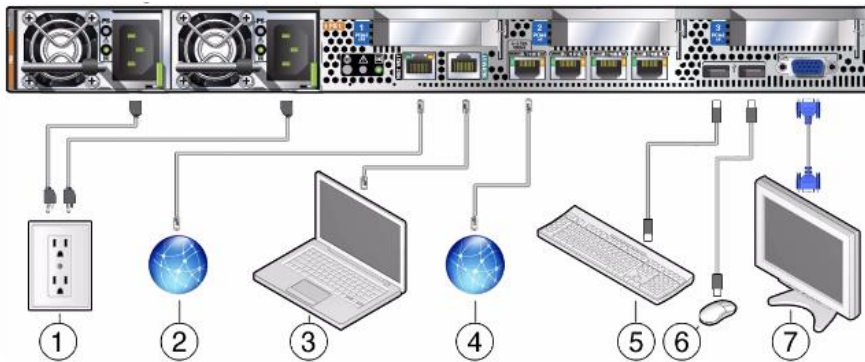

Figure Legend

- | | |
|--|--------------------|
| 1 Power supply 0 input power
Power supply 1 input power | 5 USB port (USB 0) |
| 2 Network management port (NET MGT) | 6 USB port (USB 1) |
| 3 Serial management port (SER MGT) | 7 Video port (VGA) |
| 4 Ethernet ports (NET3, NET2, NET1, NET0) | |

Figure 10- Rear view of Oracle X5-2 Server

6.7 Port identification on ZFS ZS3-2

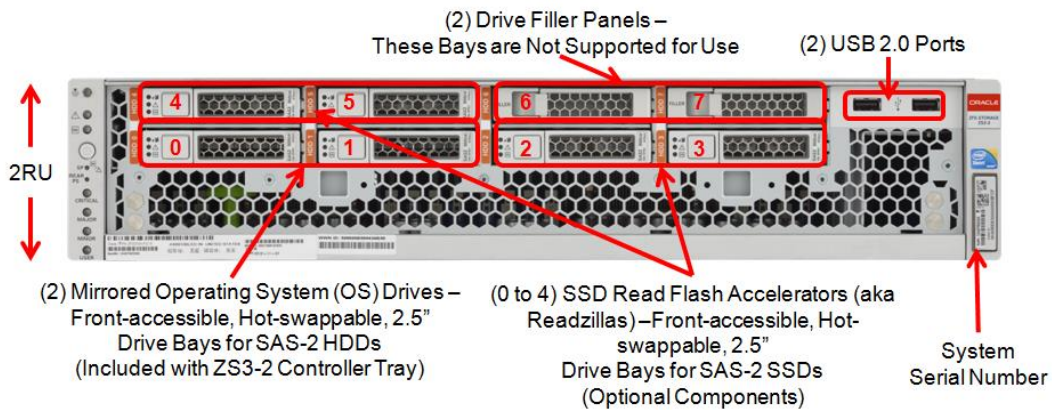

Figure 11- Front view of Oracle ZFS ZS3-2 Controller

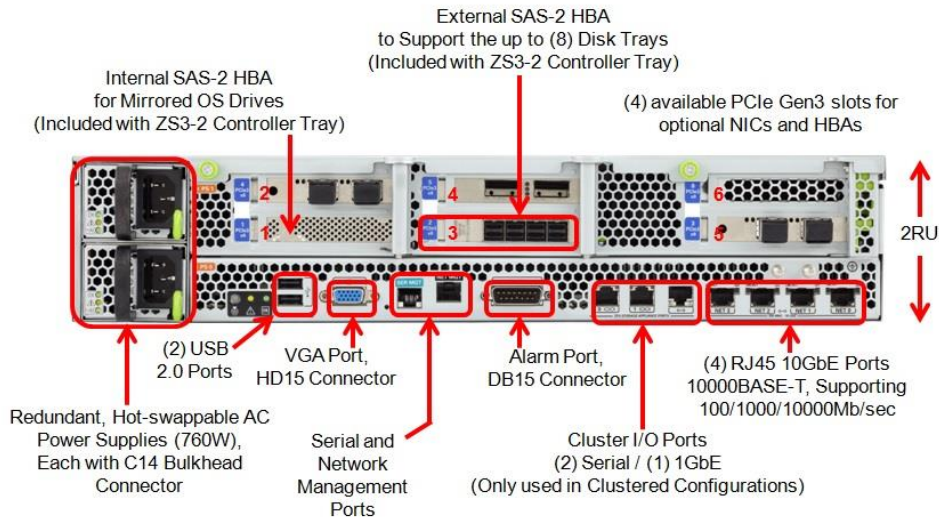

Figure 12- Rear view of Oracle ZFS ZS3-2 Controller

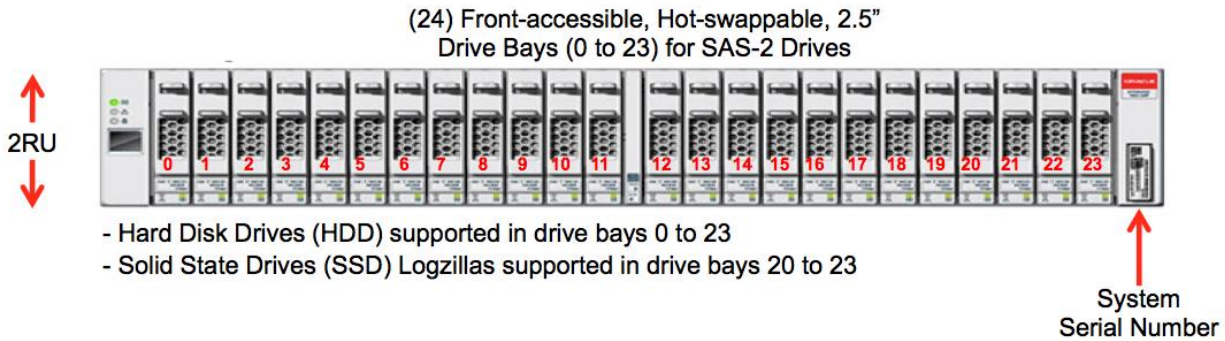

Figure 13- Front view of Oracle DE2-24P drive enclosure

Hardware Installation Guidelines

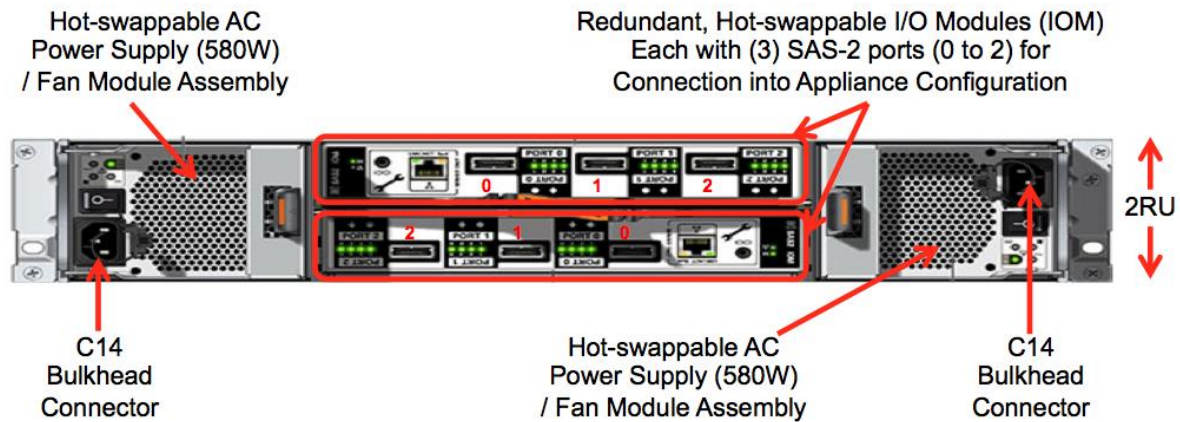

Figure 14- Rear view of Oracle DE2-24P drive enclosure

6.8 RAID configurations

Raid configuration is provided for information.

For management server on HP G6 and Gen8 servers:

Server internal disks:

- Disk 1 & 2 are configured in a RAID 1 (system)

Storage array disks:

- Disk 1 to 6 are configured in a RAID 10 (data)
- Disk 7 to 8 are configured in a RAID 1 (redo)
- Disk 9 to 10 are configured in a RAID 1 (backup)

For management server on Gen9 and X5-2 servers:

Server internal disks:

- Disk 1 & 2 are configured in a RAID 1 (system)
- Disk 3 to 6 are configured in a RAID 10 (data)
- Disk 7 to 8 are configured in a RAID 1 (Backup)

For Data Record storage on HP on HP G6 and Gen8 servers:

Server internal disks:

- Disk 1 & 2 are configured in a RAID 1

Storage array disks:

- Disk 1 to 4 are configured in a RAID 5 (ASM disk 1)
- Disk 5 to 8 are configured in a RAID 5 (ASM disk 2)
- Disk 9 to 12 are configured in a RAID 5 (ASM disk 3)
- Disk 13 to 16 are configured in a RAID 5 (ASM disk 4)

- Disk 17 to 20 are configured in a RAID 5 (ASM disk 5)
- Disk 21 to 24 are configured in a RAID 5 (ASM disk 6)

For Data Record storage on HP on HP Gen9 servers:

Server internal disks:

- Disk 25 & 26 are configured in a RAID 1
- Disk 1 to 24 are configured in a RAID 10 (ASM disk 1)

For Packet Data storage on HP on HP G6 and Gen8 servers:

Server internal disks:

- Disk 1 & 2 are configured in a RAID 1

Storage array disks:

- Disk 1 to 12 are configured in a RAID 5 (pdu_1 disk)
- Disk 13 to 24 are configured in a RAID 5 (pdu_2 disk)

For Packet Data storage on HP on HP Gen9 servers:

Server internal disks:

- Disk 25 & 26 are configured in a RAID 1
- Disk 1 to 24 are configured in a RAID 10 (pdu_0 disk)

For mediation and acquisition on servers:

Server internal disks:

- Disk 1 & 2 are configured in a RAID 1

6.9 Cable specification for Falco (SS7 to Sigtran converter)

Ethernet ports:

Falco shall be directly connected to the probe through a cross Ethernet male cable.

An additional RJ45 Ethernet port connected to the network is required for remote O&M.

SS7 line inputs:

For connection to DDF, customer shall provide cables from its DDF to the line inputs of the Falco.

On Falco side, a patch panel provides the RJ45 female interface to connect inputs line:

Hardware Installation Guidelines

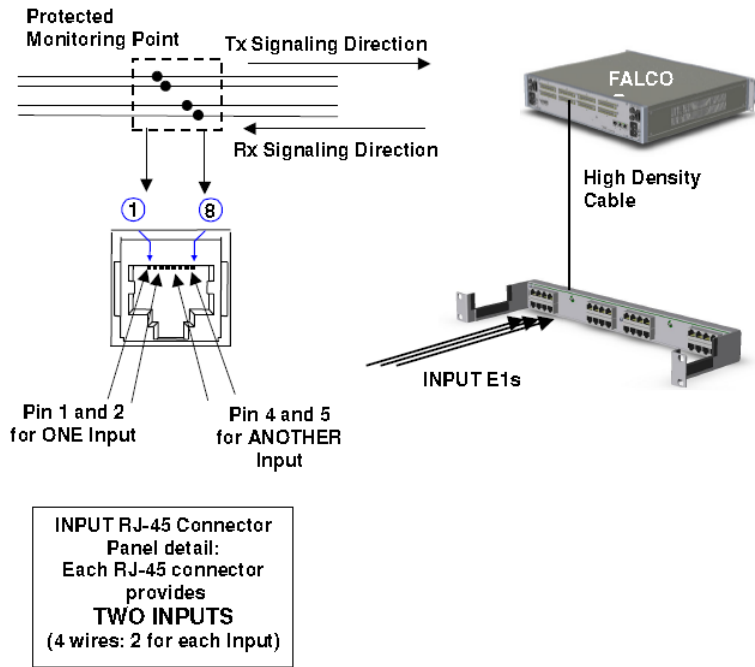

Figure 15- SS7 line inputs to Falco

Each RJ-45 Connector transports two Rx's.
 On pins 1 and 2 there are the odd E1 Inputs (1, 3, 5...127)
 On pins 4 and 5 there are the even E1 Inputs (2, 4, 6...128)

A Protected Monitoring Point is required, as per ITU G.772. If not, external protection by resistors on the cable to the DDF is always required.

- a) Cable termination sample configuration for unprotected E1
 Cable termination is wrapped. Customer shall adapt termination to its specific DDF case.

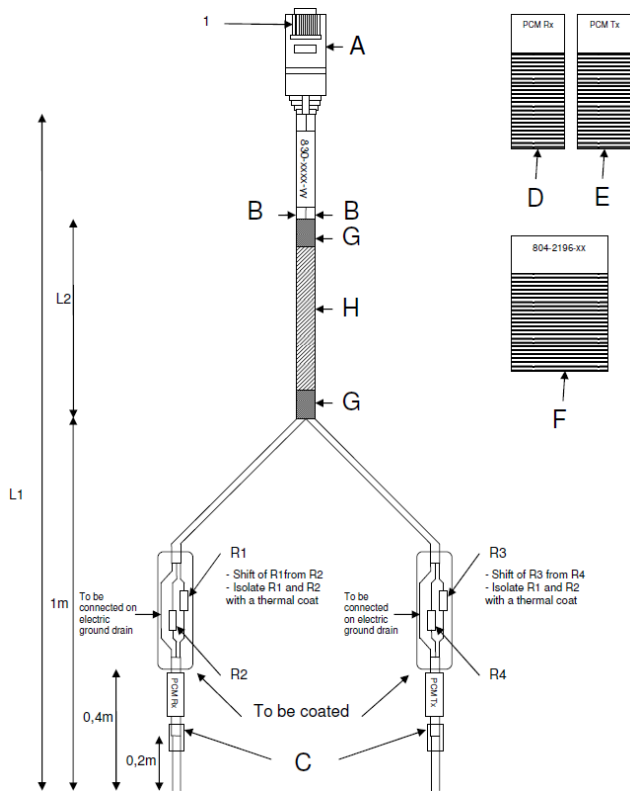

Figure 16- Cable for Falco: sample configuration for unprotected links

CABLE SPECIFICATIONS

Pair	Function	A	Remarks
Pair 1	PCM Rx-	1	
	PCM Rx+	2	
	Drain		Connected on A metallic body
Pair 2	PCM Tx-	4	
	PCM Tx+	5	
	Drain		Connected on A metallic body

Quantity	Reference	Label
1	RJ45 male 8 contacts.	A
1	Grey cover for RJ45 connector.	A
2	Shielded 1 pair cable 1 120Ω, length L1.	B
2	HELAVIA black sleeve type A2-C black L=25mm for 3,5 to 6mm wire's diameter.	C
2	Polyester label.	D-E
1	Polyester label.	F
4	560 ohms resistor 1% 1/2W.	R1, R2, R3, R4

Hardware Installation Guidelines

2	Black sleeve for 6,0 wire's diameter. Length 20mm	G
1	Gray polyamide plaited insulation, diameter 8mm, length L2	H

Table 40: Cable for Falco: sample configuration for unprotected links

b) Sample configuration for unprotected T1

Same configuration and network diagram applies for T1. Only the resistors (R1 to R4) value shall be changed to 470 ohms.

c) Configuration for protected links

Cable shall not be equipped with resistors

6.10 Cisco Switch

PIC is supporting Cisco 4948E-F switch.

Cisco 4948E-F Switches shall be mounted on the rear of the cabinet. This installation simplifies the Ethernet cables connections as most of the equipment to connect on the switches has their Ethernet ports on the rear.

Note from Cisco install guide: If you are installing the Catalyst 4948E-F switch chassis in a data center that is configured as hot isle and cold isle, you might need to install the Panduit Air Duct kit, Model CDE2. The kit extends the air intake from the rear of the chassis to the front of the equipment rack allowing the system to draw in cool air from the cool isle. To install the air duct assembly, refer to the installation note that ships with the kit.

Qualified BOMs for Cisco 4948E-F is the following:

	P/N	Description	Qty
Cisco	WS-C4948E-F	CISCO 4948E-F_48 PORT_10GBE_SWITCH_ROHS	1
Power DC	PWR-C49-300DC-F	CISCO_4948E-F_DC POWER SUPPLY	1
Software	S49EIPBK9-12254WO(=)	CISCO_4948E-F_IOS SOFTWARE_IP BASE_3DE	1
redundant power	PWR-C49-300DC-F/2	CISCO 4948E-F_DC REDUNDANT POWER SUPPLY	1
Software	WS-C4900-SW-LIC	CISCO 4948E_IP BASE UPGRADE LICENSE	1

Table 41: Cisco 4948E-F configuration

Customer can choose a Cisco 4948E instead for front mounting.

Other version of IOS can be selected by the customer. IP Base is recommended minimum version.

6.11 Cisco basic knowledge

enable to move from user mode to privileged mode

disable to move from privileged mode to user mode

show running-config to display the current configuration in RAM

show startup-config to display the saved configuration in NVRAM

configure terminal to move from privileged mode to config mode

interface gil/1 to move from config mode to an interface config

copy running-config startup-config save the current configuration

show interfaces display the interfaces status

reload to reboot the switch

show version to display the ROM and IOS information

show tech-support to display a full switch status report. It should be captured in a file because it is long and takes a few minutes

6.11.1 Configure and access the serial console on TPD

Setup minicom access for 4948/4948E switches. This procedure is generic and can be used on any PIC server running TPD and connected to a switch console through a serial cable.

Determine whether needed minicom files are already available by issuing the following command:

```
# ls /etc/minirc.*
```

The minicom configuration name is: "minirc.<name_of_configuration>".

If the minicom configuration file is not already present, proceed with the rest of this step, otherwise skip to the next step:

Setup the serial connections for a switch by issuing the following command:

```
# remoteConsole --add --name=<name_of_configuration> --bps=9600 --parity=N --databits=8
--handshake=none --port=<switch_serial_port>
```

Note:

- The default switch_serial_port should be /dev/ttyS1
- The name_of_configuration depends on the user's choice (ex: switch, yellow-sw1-1, blue-sw1-1...)

Connect serially to switch by issuing the following command as root on the management server:

```
# minicom <name_of_configuration>
```

Press RETURN to get started.

Press **Enter**

If the "autoinstall" line below does not appear, the switch may not be in factory default condition, continue with the step, disregarding this line:

```
Would you like to terminate autoinstall? [yes]:Enter
```

```
Switch> enable
```

```
Switch#
```

If "enable" command above prompts for a password, the switch is not in factory default configuration. This may be due to a previous configuration attempt. This procedure is for initial install.

To exit from the console, enter **<ctrl-a><q>** and you will be returned to the server prompt.

6.11.2 Configure and access the serial console on TVOE

From TVOE server: Setup conserver serial access a switch and open the firewall to allow for future tftp use in this procedure.

From management server, configure the conserver service to enable serial access to the switches:

```
# conserverAdm --addConsole --name=switch_console --device=/dev/ttyS4
```

Open the conserver port on the firewall of the TVOE management server:

```
# iptables -I INPUT -s <pmac_mgmtVLAN_ip_address>/255.255.255.255 -p all -j ACCEPT
```

```
# service iptables save
```

Note: The default devices should be /dev/ttyS4 and /dev/ttyS5 for PM&C

Connect serially to switch by issuing the following command from the PM&C server or any other servers you open the port on the firewall.

Hardware Installation Guidelines

```
# console -M <TVOE_server_mgmtVLAN_ip_address> -l platcfg switch_console
Enter platcfg@pmac5000101's password: <platcfg_password>
[Enter '^Ec?' for help]
Press Enter
Switch>
```

Depending on the switch config you might have to provide also the appropriate password to access the switch console after having provided the platcfg password.

To exit from the console, enter <ctrl-E><c><. > and you will be returned to the server prompt.

6.11.3 4948&4948EF Reset to factory defaults



Using this procedure you might lose the network connectivity.
It is advice to not do it with a remote connection
In privileged mode type

```
Switch#write erase
Erasing the nvram filesystem will remove all configuration files! Continue? [confirm]
[OK]
Erase of nvram: complete
*May 23 07:28:47.754: %SYS-7-NV_BLOCK_INIT: Initialized the geometry of nvram
Switch#erase cat4000_flash:
Erasing the cat4000_flash filesystem will remove all files! Continue? [confirm]
[OK]
Erase of cat4000_flash: complete
Switch#reload
System configuration has been modified. Save? [yes/no]: <- if the question is asked the
answer to this question is no
Proceed with reload? [confirm]
```

Once the switch rebooted you might receive the following question before to get the prompt

```
Press RETURN to get started!
 00:00:01: %C4K_IOSSYS-3-BLANKSTARTUPCONFIG: Blank or invalid startup-config, bo
s00:00:17: %SPANTREE-5-EXTENDED_SYSID: Extended SysId enabled for type vlan
 00:00:18: %C4K_IOSMODPORTMAN-6-MODULEONLINE: Module 1 (WS-C4948 S/N: FOX11450NC
e00:00:37: %SYS-5-RESTART: System restarted --
Cisco IOS Software, Catalyst 4500 L3 Switch Software (cat4500-IPBASEK9-M), Vers
)Technical Support: http://www.cisco.com/techsupport
Copyright (c) 1986-2008 by Cisco Systems, Inc.
Compiled Tue 29-Jul-08 12:15 by tinhuang
```

Would you like to terminate autoinstall? [yes]: <- if the question is asked the answer to this question is yes

Configure the switch to boot properly by verifying that the bootvar is showing the correct configuration, from 0-IPBASEK9-M), V# dir bootflash:

determine from the output the latest image (check the version at cisco website if necessary)

if the width of the screen does not permit to see the complete output, use the following (the question mark Number", and if it # show file info bootflash:?

```
# show bootvar
```

if how b variable bootflash: does not permit to /or config register is not 0x2102:

basically follow:

```
# config terminal
(config)# boot system flash bootflash:<name of image with latest version>
(config)# config-register 0x2102
(config)# end
# write memory
# show bootvar
```

6.11.4 Assign an IP address on a 3020

Refer to E53486 Oracle Communications Tekelec Platform 7.0.x Configuration Guide, section 3.5.2 Configure initial OA settings via configuration wizard step 8 OA GUI: EBIPA settings

6.11.5 2950 & 3020 Reset to factory defaults



Using this procedure you might lose the network connectivity.
It is advice to not do it with a remote connection
In privileged mode type

```
Switch#write erase
Erasing the nvram filesystem will remove all configuration files! Continue? [confirm]
[OK]
Erase of nvram: complete
*May 23 07:28:47.754: %SYS-7-NV_BLOCK_INIT: Initialized the geometry of nvram
Switch#delete flash:vlan.dat
Delete filename [vlan.dat]?
Delete flash:vlan.dat? [confirm]
Switch#reload
System configuration has been modified. Save? [yes/no]: <- if the question is asked the
answer to this question is no
Proceed with reload? [confirm]
```

Hardware Installation Guidelines

6.11.6 Configure telnet access on a 3020

Connect on the OA from the enclosure, and Navigate to the Interconnect Bays. Open the management URL. Take care if you reset the switch the password is back to the default value.

The screenshot displays the HP BladeSystem Onboard Administrator web interface. The browser address bar shows <https://10.31.5.150/>. The page title is "Interconnect Bay Summary". On the left, a navigation tree shows "Primary: Lab_01_01" with sub-items like "Enclosure Information", "Enclosure Settings", "Active Onboard Administrator", "Device Bays", "Interconnect Bays", "Power and Thermal", and "Users/Authentication". The "Interconnect Bays" section is expanded, showing a list of four bays:

Bay	Status	UID	Power State	Module Type	Management URL *	Product Name
1	OK	Off	On	Ethernet	http://10.31.5.157	Cisco Catalyst Blade Switch 3020 for HP
2	OK	Off	On	Ethernet	http://10.31.5.158	Cisco Catalyst Blade Switch 3020 for HP
3	OK	Off	On	Fibre Channel	http://10.31.5.155	Brocade 4/24 SAN Switch for HP c-Class BladeSystem
4	OK	Off	On	Fibre Channel	http://10.31.5.156	Brocade 4/24 SAN Switch for HP c-Class BladeSystem

Below the table is a "Refresh" button and a note: "* The URL information provided for interconnect modules may not be updated if the user modifies it via the interconnect module's management interface. In such a case, the user needs to manually type in the updated URL into the client web browser." On the right side, there are two panels: "Lab_01_01" showing a "Front View" and "Rear View" of the server rack.

If it is the first access the web interface will open directly on the express setup, otherway you can access it from the configure menu.

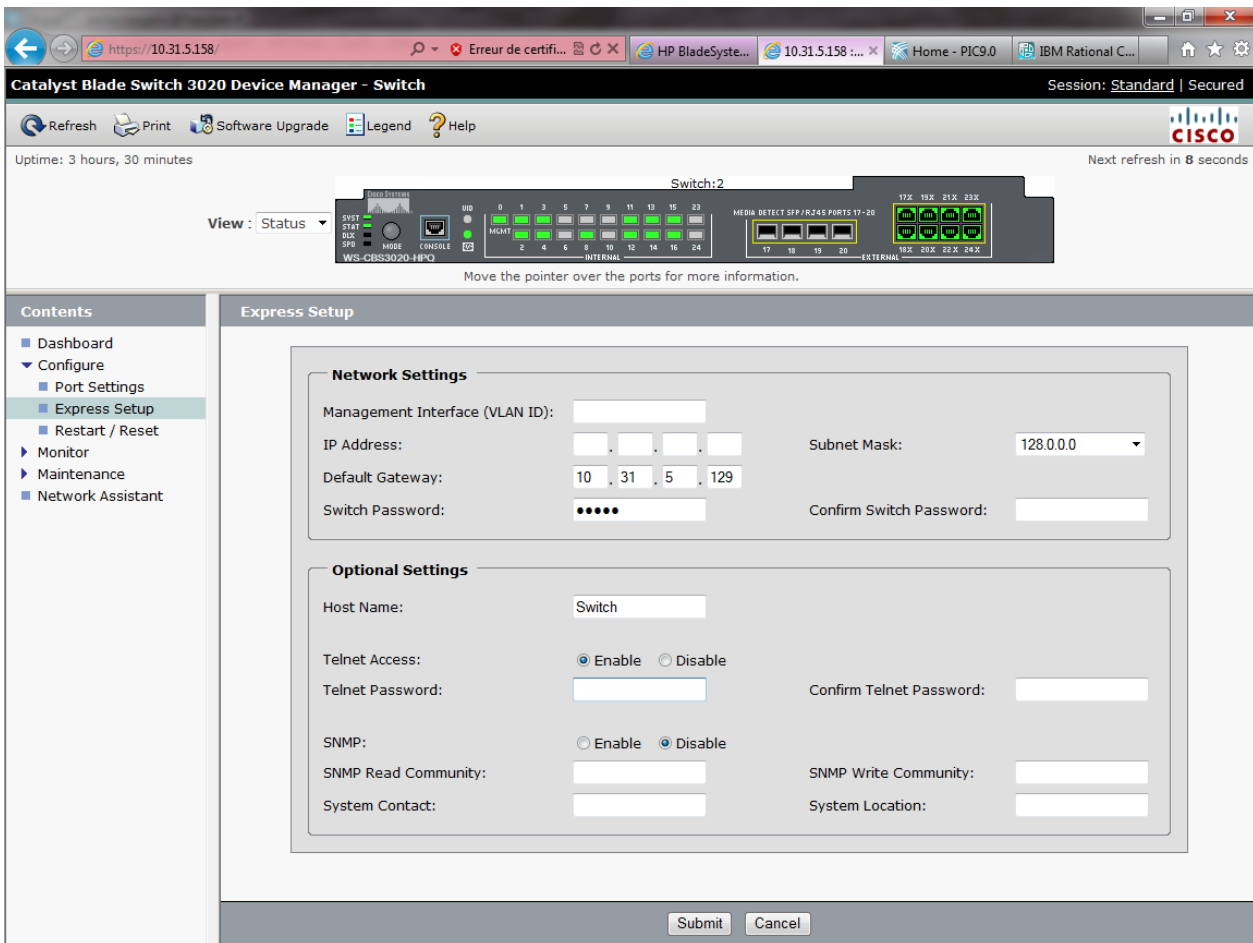

delines

From there you can enable the telnet access and define the password. You will have also to specify the VLAN ID to 1 and an IP in this VLAN, but don't configure the gateway. The IP will be removed while the switch config, and all configuration will be done using telnet on the EBIPA address.

Hardware Installation Guidelines

The screenshot shows the 'Catalyst Blade Switch 3020 Express Setup' web interface. The browser address bar shows 'http://10.31.5.158/'. The interface has a header with 'Refresh', 'Print', and 'Help' icons, and the Cisco logo. The main content area is divided into two sections: 'Network Settings' and 'Optional Settings'. The 'Network Settings' section contains fields for 'Management Interface (VLAN ID)', 'IP Address', 'Subnet Mask' (set to 128.0.0.0), 'Default Gateway', 'Switch Password', and 'Confirm Switch Password'. The 'Optional Settings' section contains fields for 'Host Name' (set to Switch), 'Telnet Access' (radio buttons for 'Enable' and 'Disable', with 'Disable' selected), 'Telnet Password', 'Confirm Telnet Password', 'SNMP' (radio buttons for 'Enable' and 'Disable', with 'Disable' selected), 'SNMP Read Community', 'SNMP Write Community', 'System Contact', and 'System Location'. At the bottom of the form, there are 'Submit' and 'Cancel' buttons.

6.11.7 Configure SSH access

In order to configure the SSH access you must have an IOS supporting the encryption. To check you must ensure the IOS file name contain "K9"

Move from the user mode to privileged mode.

```
Switch#enable
Switch#show version | include cat4500
Cisco IOS Software, Catalyst 4500 L3 Switch Software (cat4500e-ENTSERVICESK9-M), Version 12.2(54)WO, RELEASE SOFTWARE (fc1)
System image file is "bootflash:cat4500e-entservicesk9-mz.122-54.WO.bin"
```

If it is the case than you can proceed with the following commands once you moved to the config mode:

```
Switch# configure terminal
username root password 0 ***** ! <----- replace ***** with password
specified in password dragon as Cisco SSH
ip domain-name tekelec.com
```

```

crypto key generate rsa
% You already have RSA keys defined named switch1B.tekelec.com.
% Do you really want to replace them? [yes/no]: yes
Choose the size of the key modulus in the range of 360 to 2048 for your
  General Purpose Keys. Choosing a key modulus greater than 512 may take
  a few minutes.
How many bits in the modulus [512]: 1024
% Generating 1024 bit RSA keys, keys will be non-exportable...[OK]
ip ssh version 2
line vty 0 15
  login local
  transport input ssh
end

```

6.11.8 Recover a switch from rommon prompt

In case the switch configuration failed and the switch would be in rommon follow this procedure to boot the switch.

Note: This is a generic procedure and the ios file name might be different depending on version running on your switch.

```

rommon 6 >dir bootflash:
  File size           Checksum           File name
  -----
12632100 bytes (0xc0c024)  0x8136853a      cat4500-ipbasek9-mz.122-31.SGA8.bin
 456060 bytes (0x6f57c)   0x66d8b2a7      cat4500-ios-promupgrade-122_31r_SGA1
Total space = 60817408 bytes, Available = 47728992 bytes

rommon 8 >confreg
Configuration Summary :
=> console baud: 9600
=> autoboot from: commands specified in 'BOOT' environment variable
do you wish to change the configuration? y/n [n]: y
enable "diagnostic mode"? y/n [n]: n
enable "use net in IP bcast address"? y/n [n]:
enable "load rom after netboot fails"? y/n [n]:
enable "use all zero broadcast"? y/n [n]:
enable "break/abort has effect"? y/n [n]: y
enable "ignore system config info"? y/n [n]:
change console baud rate? y/n [n]:
change the boot characteristics? y/n [n]: y
enter to boot:
0 = disable autoboot
1 = the first file from internal flash device
2 = commands specified in 'BOOT' environment variable
[2]:
Configuration Summary :
=> break/abort has effect
=> console baud: 9600
=> autoboot from: commands specified in 'BOOT' environment variable

do you wish to save this configuration? y/n [n]: y
You must reset or power cycle for new configuration to take effect
rommon 10 >boot bootflash:cat4500-ipbasek9-mz.122-31.SGA8.bin
Rommon reg: 0xE2004180
#####
k2diags version 5.2_c

```

Hardware Installation Guidelines

```
Switch> enable
Switch# config t
Switch(config)# config-reg 0x2102
Switch(config)# boot system flash bootflash:cat4500-ipbasek9-mz.122-31.SGA8.bin
Switch(config)# end
Switch# copy running-config startup-config
Switch# reload
Configuration has been modified, save? No
<reboots>
```

The following links provide additional info if needed.

http://www.cisco.com/en/US/products/hw/switches/ps663/products_configuration_example09186a0080094ecf.shtml

6.11.9 Upgrade IOS software

Copy the new IOS file on the server you will use as tftp server in the directory /tftpboot.

In the following example 10.10.10.10 is the IXP used as tftp server and 10.10.10.11 is the switch to load the new software. The tftp server must have an IP connectivity to the switch.

```
[root@ixp0000-1a tftpboot]# ping 10.10.10.11
PING 10.10.10.11 (10.10.10.11) 56(84) bytes of data.
64 bytes from 10.10.10.11: icmp_seq=1 ttl=255 time=0.659 ms
64 bytes from 10.10.10.11: icmp_seq=2 ttl=255 time=1.47 ms
64 bytes from 10.10.10.11: icmp_seq=3 ttl=255 time=1.38 ms
```

If the switch have no IP configured, from the privileged mode

```
Switch#configure terminal
Switch(config)#interface vlan 1
Switch(config-if)#ip address 10.10.10.11 255.255.255.0
```

Start the tftp service on the server

```
[root@ixp0000-1a tftpboot]# service xinetd start
Starting xinetd:
[root@ixp0000-1a tftpboot]# /usr/TKLC/plat/sbin/tftpctl --start
RCS_VERSION=1.3
Stopping xinetd: [ OK ]
Starting xinetd: [ OK ]
```

Copy the new software to the switch

```
Switch#copy tftp: bootflash:
Address or name of remote host []? 10.10.10.10
Source filename []? cat4500-ipbasek9-mz.122-53.SG2.bin
Destination filename [cat4500-ipbasek9-mz.122-53.SG2.bin]?
Accessing tftp://10.10.10.10/cat4500-ipbasek9-mz.122-53.SG2.bin...
Loading cat4500-ipbasek9-mz.122-53.SG2.bin from 10.10.10.10 (via Vlan1):
!!!!!!!!!!!!!!!!!!!!!!!!!!!!!!!!!!!!!!!!!!!!!!!!!!!!!!!!!!!!!!!!!!!!!!!!!!!!
[OK - 16332568 bytes]
CCCCCCCCCCCCCCCCCCCCCCCCCCCCCCCCCCCCCCCCCCCCCCCCCCCCCCCCCCCCCCCCCCCCCCCC
CCCCCCCCCCCCCCCCCCCCCCCCCCCCCCCCCCCCCCCCCCCCCCCCCCCCCCCCCCCCCCCCCCCCCCCC
16332568 bytes copied in 73.440 secs (222393 bytes/sec)
Switch#dir bootflash:
Directory of bootflash:/
 1  -rwx      14569696  May 23 2009 11:53:09 +00:00  cat4500-ipbase-mz.122-46.SG.bin
```

```
2 -rwx 16332568 Aug 14 2013 05:29:21 +00:00 cat4500-ipbasek9-mz.122-53.SG2.bin
60817408 bytes total (775240 bytes free)
```

Modify the configuration to boot using the new software and no more the previous one.

```
Switch#configure terminal
```

```
Enter configuration commands, one per line. End with CNTL/Z.
```

```
Switch(config)#boot system flash bootflash:cat4500-ipbasek9-mz.122-53.SG2.bin
```

```
Switch(config)#no boot system flash bootflash:cat4500-ipbase-mz.122-46.SG.bin
```

```
Switch(config)#config-register 0x2102
```

```
Switch(config)#exit
```

```
Switch #copy running-config startup-config
```

```
Switch #reload
```

After reloading, verify that the switch is booting to the expected version:

```
Switch# #show version | include bootflash
```

```
System image file is "bootflash:cat4500-ipbasek9-mz.122-53.SG2.bin"
```

6.11.10 Backup the switch config on a server

Use the following command to backup a switch configuration on a server.

```
blue-sw1-1#copy running-config scp:
```

```
Address or name of remote host []? 172.22.49.10
```

```
Destination username [root]?
```

```
Destination filename [blue-sw1-1-config]?
```

```
Writing blue-sw1-1-config
```

```
Password:
```

```
!!
```

```
9314 bytes copied in 14.292 secs (652 bytes/sec)
```

```
blue-sw1-1#
```

6.11.11 Configure Cisco 4948/4948E/4948E-F switch

This procedure describes how to configure the Cisco switches.

Configure the switches from the applicable server as follows:

Note: Not all the switches listed may be applicable for your particular configuration.

- Yellow-sw1-1 from IMF-1A server
- Blue-sw1-1 from IMF-1B server
- Yellow-sw2-1 from IMF-1C server
- Blue-sw2-1 from IMF-1D server
- Yellow-sw3-1 from IMF-1E server
- Blue-sw3-2 from IMF-1F server

In case there are more switches required than IMF servers, the console port of the additional switch will have to be moved on one of the servers or configured using a laptop.

For an estimated time for this procedure, refer to the IMF flowcharts in Installation Overview.

Mediation switch are connected to the first MEDIATION server from the cabinet.

Hardware Installation Guidelines

Note: In case in the procedure would failed, refer to section 6.10.8 in order to recover the switch from rommon prompt.

- A. Configure and access the serial console from the server (PM&C, IMF or IXP) on the switches
 - a. Refer to section 6.10.1 or 6.10.2
- B. Reset the switch to factory default
 - a. If you are reconfiguring a switch backup the current config in a file using the command
 - b. Refer to section 6.10.3 to reset the switch
- C. Configure the switch using the appropriate template
 - a. Refer to following sections to select the appropriate configuration template and adapt it to the customer IP network.
 - i. Section 6.11 for mediation
 - ii. Section 6.12 for Blades
 - iii. Section 6.13 for Intergrated Acquisition
 - b. As there is no log file for the following steps it is recomanded to enable the log feature from your terminal in case something would not work as expected and assistance is required.
 - c. Move from the user mode to priviledge mode and then to config mode

```
Switch# enable
```

```
Switch# configure terminal
```

Note : if you reset the switch to factory default no password should be requested to connect on it and move to enable mode.

- d. Adapt the template configuration to your network. The lines you need to customize are higlied with Yellow comments. Paste the command in block and not necessary one by one but don't do it with too much commands at a time in order to take care if an error message would appear.
- e. Once the config is in place you can check it is matching your expectation using the command

```
Switch# show running-config
```

- f. If the configuration is fine then you can save it in the flash in order to have it automatically reloaded if the switch reboot

```
Switch# copy running-config startup-config
```

- g. If there is an issue in your config you can can reboot the switch without saving and then restart the config from the step a

```
Switch# reload
```

- h. Finally to configure the SSH access to the switch refer to section 6.10.7
- i. Once the config is in place you can check it is matching your expectation using the command

```
Switch# show running-config
```

- j. If the configuration is fine then you can save it in the flash in order to have it automatically reloaded if the switch reboot

```
Switch# copy running-config startup-config
```

- k. If there is an issue in your config you can can reboot the switch without saving and then restart the config from the step h

```
Switch# reload
```

6.11.12 Configure Cisco 3020 switch

- A. Assign IP addresses to the switches

Hardware Installation Guidelines

- a. Refer to E53486 Oracle Communications Tekelec Platform 7.0.x Configuration Guide, section 3.5.2 Configure initial OA settings via configuration wizard step 8 OA GUI: EBIPA settings if this was not done earlier
- B. Reset the switch to factory default
 - a. If you are reconfiguring a switch backup the current config in a file using the command
 - b. Refer to section 6.10.5 to reset the switch. Take care to only erase the vlan.dat and not the whole content of the flash.
- C. Reconfigure the telnet access
 - a. Refer to section 6.10.6.
- D. Configure the switch using the appropriate template
 - a. Refer to the following section 6.12.3.
 - b. As there is no log file for the following steps it is recommended to enable the log feature from your terminal in case something would not work as expected and assistance is required.
 - c. Open a telnet session on the switch and then move from the user mode to privilege mode and then to config mode

```
Switch# show running-config  
Switch# enable  
Switch# configure terminal
```

Note : if you reset the switch to factory default no password should be requested to connect on it and move to enable mode.

- d. Paste all the commands from the template config you have adapted to your network. The lines you need to customize are highlighted with yellow comments. You can paste the command in block and not necessarily one by one but don't do it with too many commands at a time in order to take care if an error message would appear.
 - e. Once the config is in place you can check it is matching your expectation using the command
- ```
Switch# show running-config
```
- f. If the configuration is fine then you can save it in the flash in order to have it automatically reloaded if the switch reboots
- ```
Switch# copy running-config startup-config
```
- g. If there is an issue in your config you can reboot the switch without saving and then restart the config from step a
- ```
Switch# reload
```

### 6.11.13 Flush ARP table

- A. Check VIP address mapping on the Switch (in enable mode)

```
Switch #show arp
Protocol Address Age (min) Hardware Addr Type Interface
Internet 172.21.49.10 1 0010.1326.a103 ARPA Vlan100
Internet 172.21.49.11 0 001e.6700.c9a4 ARPA Vlan100
```

Use the `ifconfig` command on the Master IMF server to get the MAC address of its interfaces:

```
bond0.200 Link encap:Ethernet HWaddr 00:10:13:26:A1:03
 inet addr:10.31.2.101 Bcast:10.31.2.255 Mask:255.255.255.0
 inet6 addr: fe80::210:13ff:fe26:a103/64 Scope:Link
```

Compare the **Hardware Addr** with the **HWaddr** (be careful in this example 0010.1326.a103 is equal to 00:10:13:26:A1:03).

If the values are equal or if no entry matches the VIP address, then it is not necessary to flush the ARP table of the Cisco switch.

If the VIP address is associated to a wrong MAC address, then continue the procedure.



## Hardware Installation Guidelines

B. Flush the ARP table on the Switch (in enable mode)

```
Switch# clear arp-cache
```

## 6.12 Mediation switch configuration template

The VLAN values must be customized according customer requirement

### 6.12.1 Switch port allocation

The first IXP Server iLO are directly connected to customer network. Server E in the control frame and server A in the extension frames

|                |              |               |                   |
|----------------|--------------|---------------|-------------------|
| All or no vlan | vlan 100 iLO | vlan 200 CUST | vlan 300 Frontend |
|----------------|--------------|---------------|-------------------|

|                             |                     |                     |                     |                     |                      |                      |                      |                      |                      |                      |                      |                      |                      |                      |                      |                      |                      |                    |                    |                    |                           |                      |                      |                        |
|-----------------------------|---------------------|---------------------|---------------------|---------------------|----------------------|----------------------|----------------------|----------------------|----------------------|----------------------|----------------------|----------------------|----------------------|----------------------|----------------------|----------------------|----------------------|--------------------|--------------------|--------------------|---------------------------|----------------------|----------------------|------------------------|
| Ctrl Frame RM               | Port 1 ServerA iLOM | Port 3 ServerB iLOM | Port 5 Free         | Port 7 Free         | Port 9 Free          | Port 11 ServerF iLO  | Port 13 ServerG iLO  | Port 15 ServerH iLO  | Port 17 ServerI iLO  | Port 19 ServerJ iLO  | Port 21 ServerK iLO  | Port 23 ServerL iLO  | Port 25 Next Frame   | Port 27 Next Frame   | Port 29 Next Frame   | Port 31 Next Frame   | Port 33 Next Frame   | Port 35 Next Frame | Port 37 Next Frame | Port 39 Next Frame | Port 41 Cust Net iLO      | Port 43 ServerA eth4 | Port 45 ServerB eth4 | Port 47 Cust Net SW A  |
|                             | Port 2 ServerA eth2 | Port 4 ServerB eth2 | Port 6 ServerA eth3 | Port 8 ServerB eth3 | Port 10 ServerE eth1 | Port 12 ServerF eth1 | Port 14 ServerG eth1 | Port 16 ServerH eth1 | Port 18 ServerI eth1 | Port 20 ServerJ eth1 | Port 22 ServerK eth1 | Port 24 ServerL eth1 | Port 26 Next Frame   | Port 28 Next Frame   | Port 30 Next Frame   | Port 32 Next Frame   | Port 34 Next Frame   | Port 36 Next Frame | Port 38 Next Frame | Port 40 Next Frame | Port 42 Cust Net Frontend | Port 44 ServerA eth5 | Port 46 ServerB eth5 | Port 48 Cust Net SW B  |
| Ext Frame RM 7.1 and higher | Port 1 Free         | Port 3 ServerB iLO  | Port 5 ServerC iLO  | Port 7 ServerD iLO  | Port 9 ServerE iLO   | Port 11 ServerF iLO  | Port 13 ServerG iLO  | Port 15 ServerH iLO  | Port 17 ServerI iLO  | Port 19 ServerJ iLO  | Port 21 ServerK iLO  | Port 23 ServerL iLO  | Port 25 Free         | Port 27 Free         | Port 29 Free         | Port 31 Free         | Port 33 Free         | Port 35 Free       | Port 37 Free       | Port 39 Free       | Port 41 Free              | Port 43 Free         | Port 45 Free         | Port 47 iLO Ctrl Frame |
|                             | Port 2 ServerA eth1 | Port 4 ServerB eth1 | Port 6 ServerC eth1 | Port 8 ServerD eth1 | Port 10 ServerE eth1 | Port 12 ServerF eth1 | Port 14 ServerG eth1 | Port 16 ServerH eth1 | Port 18 ServerI eth1 | Port 20 ServerJ eth1 | Port 22 ServerK eth1 | Port 24 ServerL eth1 | Port 26 Free         | Port 28 Free         | Port 30 Free         | Port 32 Free         | Port 34 Free         | Port 36 Free       | Port 38 Free       | Port 40 Free       | Port 42 Free              | Port 44 Free         | Port 46 Free         | Port 48 Eth Ctrl Frame |
| Ext Frame RM 7.0 and lower  | Port 1 Free         | Port 3 ServerB iLO  | Port 5 ServerC iLO  | Port 7 ServerD iLO  | Port 9 ServerE iLO   | Port 11 Free         | Port 13 Free         | Port 15 Free         | Port 17 Free         | Port 19 Free         | Port 21 ServerF iLO  | Port 23 ServerG iLO  | Port 25 ServerH iLO  | Port 27 ServerI iLO  | Port 29 ServerJ iLO  | Port 31 ServerK iLO  | Port 33 ServerL iLO  | Port 35 Free       | Port 37 Free       | Port 39 Free       | Port 41 Free              | Port 43 Free         | Port 45 Free         | Port 47 iLO Ctrl Frame |
|                             | Port 2 ServerA eth1 | Port 4 ServerB eth1 | Port 6 ServerC eth1 | Port 8 ServerD eth1 | Port 10 ServerE eth1 | Port 12 Free         | Port 14 Free         | Port 16 Free         | Port 18 Free         | Port 20 Free         | Port 22 ServerF eth1 | Port 24 ServerG eth1 | Port 26 ServerH eth1 | Port 28 ServerI eth1 | Port 30 ServerJ eth1 | Port 32 ServerK eth1 | Port 34 ServerL eth1 | Port 36 Free       | Port 38 Free       | Port 40 Free       | Port 42 Free              | Port 44 Free         | Port 46 Free         | Port 48 Eth Ctrl Frame |

### 6.12.2 Control Frame Switch

**Note :** The command “spanning-tree portfast trunk” will return the following warning, you can ignore:

```
%Warning: portfast should only be enabled on ports connected to a single host.
Connecting hubs, concentrators, switches, bridges, etc... to this interface
when portfast is enabled, can cause temporary bridging loops.
Use with CAUTION
```

**Note :** the commands “switchport trunk encapsulation dot1q” and “media-type rj45” will fail on the 4948EF switch but it is kept this config for compatibility with the previous 4948

```
!
no service pad
service timestamps debug uptime
service timestamps log uptime
service password-encryption
service compress-config
!
hostname Switch
!
enable secret ***** ! <----- replace ***** with password specified in password dragon as Cisco enable
!
no aaa new-model
ip subnet-zero
no ip source-route
```

## Hardware Installation Guidelines

```
no ip domain-lookup
!
vtp mode transparent
!
!
!
power redundancy-mode redundant
no file verify auto
!
spanning-tree mode rapid-pvst
no spanning-tree optimize bpdu transmission
spanning-tree extend system-id
!
vlan internal allocation policy ascending
!
!
vlan 100 ! <----- replace VLAN with customer value
 name iLO
!
vlan 200 ! <----- replace VLAN with customer value
 name CUST
!
vlan 300 ! <----- replace VLAN with customer value
 name NSP_Front
!
Interface range Gi1/1 ,Gi1/3 ,Gi1/5 ,Gi1/7 ,Gi1/9
 description Server iLO Access
 switchport access vlan 100 ! <----- replace VLAN with customer value
 switchport mode access
 spanning-tree portfast
!
Interface range Gi1/11 ,Gi1/13 ,Gi1/15 ,Gi1/17 ,Gi1/19
 description Server iLO Access
 switchport access vlan 100 ! <----- replace VLAN with customer value
 switchport mode access
 spanning-tree portfast
!
Interface range Gi1/21 ,Gi1/23 ,Gi1/25 ,Gi1/27 ,Gi1/29
 description Server iLO Access
 switchport access vlan 100 ! <----- replace VLAN with customer value
 switchport mode access
 spanning-tree portfast
!
Interface range Gi1/31 ,Gi1/33 ,Gi1/35 ,Gi1/37 ,Gi1/39
 description Server iLO Access
 switchport access vlan 100 ! <----- replace VLAN with customer value
```

```
switchport mode access
spanning-tree portfast
!
Interface range Gi1/41
description Server iLO Access
switchport access vlan 100 ! <----- replace VLAN with customer value
switchport mode access
spanning-tree portfast
!
interface range Gi1/2 ,Gi1/4 ,Gi1/6 ,Gi1/8 ,Gi1/10
description Server CUST Access
switchport access vlan 200 ! <----- replace VLAN with customer value
switchport mode access
spanning-tree portfast
!
interface range Gi1/12 ,Gi1/14 ,Gi1/16 ,Gi1/18 ,Gi1/20
description Server CUST Access
switchport access vlan 200 ! <----- replace VLAN with customer value
switchport mode access
spanning-tree portfast
!
interface range Gi1/22 ,Gi1/24 ,Gi1/26 ,Gi1/28 ,Gi1/30
description Server CUST Access
switchport access vlan 200 ! <----- replace VLAN with customer value
switchport mode access
spanning-tree portfast
!
interface range Gi1/32 ,Gi1/34 ,Gi1/36 ,Gi1/38 ,Gi1/40
description Server CUST Access
switchport access vlan 200 ! <----- replace VLAN with customer value
switchport mode access
spanning-tree portfast
!
interface range GigabitEthernet1/42 - 46
description NSP NIC2 CUST Ethernet Access
switchport access vlan 300 ! <----- replace VLAN with customer value
switchport mode access
spanning-tree portfast
!
interface GigabitEthernet1/47
description 802.1Q trunk link to backbone SWA
switchport trunk encapsulation dot1q
switchport mode trunk
media-type rj45
!
interface GigabitEthernet1/48
```

## Hardware Installation Guidelines

```
description 802.1Q trunk link to backbone SWB
switchport trunk encapsulation dot1q
switchport mode trunk
media-type rj45
spanning-tree cost 20
!
interface Vlan1
no ip address
shutdown
!
interface Vlan100 ! <----- replace VLAN with customer value
description Optional Switch Virtual Interface (SVI) for iLO Subnet - switch management
no ip address
shutdown
!
interface Vlan200 ! <----- replace VLAN with customer value
description Optional Switch Virtual Interface (SVI) for CUST Subnet - switch management
no ip address
shutdown
!
no ip http server
!
!
!
no cdp run
!
control-plane
!
!
line con 0
password ***** ! <----- replace ***** with password specified in password dragon as Cisco telnet
exec-timeout 30 0
logging synchronous
stopbits 1
!
end
```

### 6.12.3 Extension Frame Switch

**Note:** The command “spanning-tree portfast trunk” will return the following warning, you can ignore:

```
%Warning: portfast should only be enabled on ports connected to a single host.
Connecting hubs, concentrators, switches, bridges, etc... to this interface
when portfast is enabled, can cause temporary bridging loops.
```

Use with CAUTION

## Hardware Installation Guidelines

**Note:** the commands “switchport trunk encapsulation dot1q” and “media-type rj45” will fail on the 4948EF switch but it is kept this config for compatibility with the previous 4948

```
!
no service pad
service timestamps debug uptime
service timestamps log uptime
service password-encryption
service compress-config
!
hostname Switch
!
enable secret ***** ! <----- replace ***** with password specified in password dragon as Cisco enable
!
no aaa new-model
ip subnet-zero
no ip source-route
no ip domain-lookup
!
vtp mode transparent
!
!
power redundancy-mode redundant
no file verify auto
!
spanning-tree mode rapid-pvst
no spanning-tree optimize bpdu transmission
spanning-tree extend system-id
!
vlan internal allocation policy ascending
!
!
vlan 100 ! <----- replace VLAN with customer value
 name iLO
!
vlan 200 ! <----- replace VLAN with customer value
 name CUST
!
Interface range Gi1/1 ,Gi1/3 ,Gi1/5 ,Gi1/7 ,Gi1/9
 description Server iLO Access
 switchport access vlan 100 ! <----- replace VLAN with customer value
 switchport mode access
 spanning-tree portfast
!
Interface range Gi1/11 ,Gi1/13 ,Gi1/15 ,Gi1/17 ,Gi1/19
```

## Hardware Installation Guidelines

```
description Server iLO Access
switchport access vlan 100 ! <----- replace VLAN with customer value
switchport mode access
spanning-tree portfast
!
Interface range Gi1/21 ,Gi1/23 ,Gi1/25 ,Gi1/27 ,Gi1/29
description Server iLO Access
switchport access vlan 100 ! <----- replace VLAN with customer value
switchport mode access
spanning-tree portfast
!
Interface range Gi1/31 ,Gi1/33 ,Gi1/35 ,Gi1/37 ,Gi1/39
description Server iLO Access
switchport access vlan 100 ! <----- replace VLAN with customer value
switchport mode access
spanning-tree portfast
!
Interface range Gi1/41 ,Gi1/43 ,Gi1/45
description Server iLO Access
switchport access vlan 100 ! <----- replace VLAN with customer value
switchport mode access
spanning-tree portfast
!
interface range Gi1/2 ,Gi1/4 ,Gi1/6 ,Gi1/8 ,Gi1/10
description Server CUST Access
switchport access vlan 200 ! <----- replace VLAN with customer value
switchport mode access
spanning-tree portfast
!
interface range Gi1/12 ,Gi1/14 ,Gi1/16 ,Gi1/18 ,Gi1/20
description Server CUST Access
switchport access vlan 200 ! <----- replace VLAN with customer value
switchport mode access
spanning-tree portfast
!
interface range Gi1/22 ,Gi1/24 ,Gi1/26 ,Gi1/28 ,Gi1/30
description Server CUST Access
switchport access vlan 200 ! <----- replace VLAN with customer value
switchport mode access
spanning-tree portfast
!
interface range Gi1/32 ,Gi1/34 ,Gi1/36 ,Gi1/38 ,Gi1/40
description Server CUST Access
switchport access vlan 200 ! <----- replace VLAN with customer value
switchport mode access
spanning-tree portfast
```

## Hardware Installation Guidelines

```
!
interface range Gi1/42 ,Gi1/44 ,Gi1/46
 description Server CUST Access
 switchport access vlan 200 ! <----- replace VLAN with customer value
 switchport mode access
 spanning-tree portfast
!
interface GigabitEthernet1/47
 description Connection to Control Frame Switch on iLO VLAN
 switchport access vlan 100 ! <----- replace VLAN with customer value
 switchport mode access
 spanning-tree portfast
!
interface GigabitEthernet1/48
 description Connection to Control Frame Switch on CUST VLAN
 switchport access vlan 200 ! <----- replace VLAN with customer value
 switchport mode access
 spanning-tree portfast
!
!
interface Vlan1
 no ip address
 shutdown
!
interface Vlan100 ! <----- replace VLAN with customer value
 description Optional Switch Virtual Interface (SVI) for iLO Subnet - switch management
 no ip address
 shutdown
!
interface Vlan200 ! <----- replace VLAN with customer value
 description Optional Switch Virtual Interface (SVI) for CUST Subnet - switch management
 no ip address
 shutdown
!
no ip http server
!
!
!
no cdp run
!
control-plane
!
!
line con 0
 password ***** ! <----- replace ***** with password specified in password dragon as Cisco telnet
 exec-timeout 30 0
```



## Hardware Installation Guidelines

```
logging synchronous
stopbits 1
!
end
```

6.13 Blade mediation switch configuration template

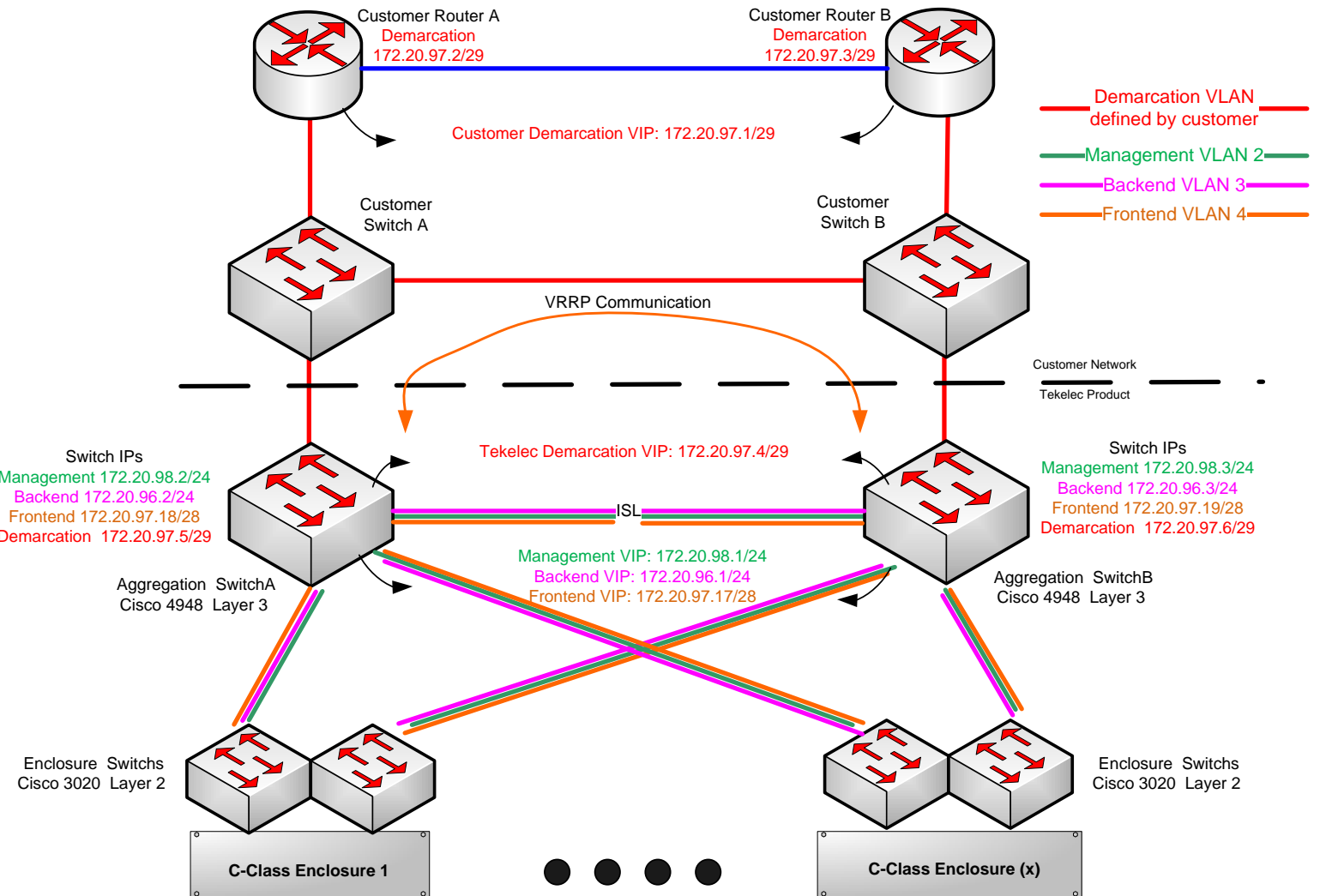

# Hardware Installation Guidelines

## 6.13.1 Switch port allocation

All the following information assume the cabling has been done according the Tekelec System Interconnect diagrams 893-0103-XX to be used for G6 & G8 servers with P2000 storage arrays

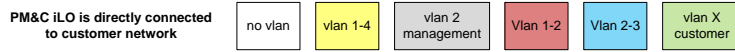

**Enclosure 7 Switch1**

|                        |                        |                        |                        |                          |                          |                          |                          |                         |                         |                       |                       |
|------------------------|------------------------|------------------------|------------------------|--------------------------|--------------------------|--------------------------|--------------------------|-------------------------|-------------------------|-----------------------|-----------------------|
| Port 1<br>Server1 eth2 | Port 3<br>Server3 eth2 | Port 5<br>Server5 eth2 | Port 7<br>Server7 eth2 | Port 9<br>Server9 eth2   | Port 11<br>Server11 eth2 | Port 13<br>Server13 eth2 | Port 15<br>Server15 eth2 | Port 17<br>Agg SW A P29 | Port 19<br>Agg SW A P31 | Port 21<br>SAN contr1 | Port 23<br>SAN contr3 |
| Port 2<br>Server2 eth2 | Port 4<br>Server4 eth2 | Port 6<br>Server6 eth2 | Port 8<br>Server8 eth2 | Port 10<br>Server10 eth2 | Port 12<br>Server12 eth2 | Port 14<br>Server14 eth2 | Port 16<br>Server16 eth2 | Port 18<br>Agg SW A P30 | Port 20<br>Agg SW A P32 | Port 22<br>SAN contr2 | Port 24<br>SAN contr4 |

**Enclosure 1 Switch1**

|                        |                        |                        |                        |                          |                          |                          |                          |                        |                        |                       |                       |
|------------------------|------------------------|------------------------|------------------------|--------------------------|--------------------------|--------------------------|--------------------------|------------------------|------------------------|-----------------------|-----------------------|
| Port 1<br>Server1 eth2 | Port 3<br>Server3 eth2 | Port 5<br>Server5 eth2 | Port 7<br>Server7 eth2 | Port 9<br>Server9 eth2   | Port 11<br>Server11 eth2 | Port 13<br>Server13 eth2 | Port 15<br>Server15 eth2 | Port 17<br>Agg SW A P5 | Port 19<br>Agg SW A P7 | Port 21<br>SAN contr1 | Port 23<br>SAN contr3 |
| Port 2<br>Server2 eth2 | Port 4<br>Server4 eth2 | Port 6<br>Server6 eth2 | Port 8<br>Server8 eth2 | Port 10<br>Server10 eth2 | Port 12<br>Server12 eth2 | Port 14<br>Server14 eth2 | Port 16<br>Server16 eth2 | Port 18<br>Agg SW A P6 | Port 20<br>Agg SW A P8 | Port 22<br>SAN contr2 | Port 24<br>SAN contr4 |

**Aggregation SwitchA**

|                       |                       |                        |                        |                         |                         |                         |                         |                         |                         |                         |                         |                         |                         |                         |                         |                     |                     |                     |                      |                 |                 |                       |                         |
|-----------------------|-----------------------|------------------------|------------------------|-------------------------|-------------------------|-------------------------|-------------------------|-------------------------|-------------------------|-------------------------|-------------------------|-------------------------|-------------------------|-------------------------|-------------------------|---------------------|---------------------|---------------------|----------------------|-----------------|-----------------|-----------------------|-------------------------|
| Port 1<br>Agg SW B P1 | Port 3<br>Agg SW B P3 | Port 5<br>Enc1 SW1 P17 | Port 7<br>Enc1 SW1 P19 | Port 9<br>Enc2 SW1 P17  | Port 11<br>Enc2 SW1 P19 | Port 13<br>Enc3 SW1 P17 | Port 15<br>Enc3 SW1 P19 | Port 17<br>Enc4 SW1 P17 | Port 19<br>Enc4 SW1 P19 | Port 21<br>Enc5 SW1 P17 | Port 23<br>Enc5 SW1 P19 | Port 25<br>Enc6 SW1 P17 | Port 27<br>Enc6 SW1 P19 | Port 29<br>Enc7 SW1 P17 | Port 31<br>Enc7 SW1 P19 | Port 33<br>Enc1 OA1 | Port 35<br>Enc3 OA1 | Port 37<br>Enc5 OA1 | Port 39<br>Enc7 OA1  | Port 41<br>Free | Port 43<br>Free | Port 45<br>For Laptop | Port 47<br>Free         |
| Port 2<br>Agg SW B P2 | Port 4<br>Agg SW B P4 | Port 6<br>Enc1 SW1 P18 | Port 8<br>Enc1 SW1 P20 | Port 10<br>Enc2 SW1 P18 | Port 12<br>Enc2 SW1 P20 | Port 14<br>Enc3 SW1 P18 | Port 16<br>Enc3 SW1 P20 | Port 18<br>Enc4 SW1 P18 | Port 20<br>Enc4 SW1 P20 | Port 22<br>Enc5 SW1 P18 | Port 24<br>Enc5 SW1 P20 | Port 26<br>Enc6 SW1 P18 | Port 28<br>Enc6 SW1 P20 | Port 30<br>Enc7 SW1 P18 | Port 32<br>Enc7 SW1 P20 | Port 34<br>Enc2 OA1 | Port 36<br>Enc4 OA1 | Port 38<br>Enc6 OA1 | Port 40<br>PM&C Eth1 | Port 42<br>Free | Port 44<br>Free | Port 46<br>For Laptop | Port 48<br>Cust Net eth |
| Port 1<br>Agg SW A P1 | Port 3<br>Agg SW A P3 | Port 5<br>Enc1 SW2 P17 | Port 7<br>Enc1 SW2 P19 | Port 9<br>Enc2 SW2 P17  | Port 11<br>Enc2 SW2 P19 | Port 13<br>Enc3 SW2 P17 | Port 15<br>Enc3 SW2 P19 | Port 17<br>Enc4 SW2 P17 | Port 19<br>Enc4 SW2 P19 | Port 21<br>Enc5 SW2 P17 | Port 23<br>Enc5 SW2 P19 | Port 25<br>Enc6 SW2 P17 | Port 27<br>Enc6 SW2 P19 | Port 29<br>Enc7 SW2 P17 | Port 31<br>Enc7 SW2 P19 | Port 33<br>Enc1 OA2 | Port 35<br>Enc3 OA2 | Port 37<br>Enc5 OA2 | Port 39<br>Enc7 OA2  | Port 41<br>Free | Port 43<br>Free | Port 45<br>For Laptop | Port 47<br>Free         |
| Port 2<br>Agg SW A P2 | Port 4<br>Agg SW A P4 | Port 6<br>Enc1 SW2 P18 | Port 8<br>Enc1 SW2 P20 | Port 10<br>Enc2 SW2 P18 | Port 12<br>Enc2 SW2 P20 | Port 14<br>Enc3 SW2 P18 | Port 16<br>Enc3 SW2 P20 | Port 18<br>Enc4 SW2 P18 | Port 20<br>Enc4 SW2 P20 | Port 22<br>Enc5 SW2 P18 | Port 24<br>Enc5 SW2 P20 | Port 26<br>Enc6 SW2 P18 | Port 28<br>Enc6 SW2 P20 | Port 30<br>Enc7 SW2 P18 | Port 32<br>Enc7 SW2 P20 | Port 34<br>Enc2 OA2 | Port 36<br>Enc4 OA2 | Port 38<br>Enc6 OA2 | Port 40<br>PM&C Eth2 | Port 42<br>Free | Port 44<br>Free | Port 46<br>For Laptop | Port 48<br>Cust Net eth |

**Aggregation SwitchB**

**Enclosure 1 Switch2**

|                        |                        |                        |                        |                          |                          |                          |                          |                        |                        |                       |                       |
|------------------------|------------------------|------------------------|------------------------|--------------------------|--------------------------|--------------------------|--------------------------|------------------------|------------------------|-----------------------|-----------------------|
| Port 1<br>Server1 eth2 | Port 3<br>Server3 eth2 | Port 5<br>Server5 eth2 | Port 7<br>Server7 eth2 | Port 9<br>Server9 eth2   | Port 11<br>Server11 eth2 | Port 13<br>Server13 eth2 | Port 15<br>Server15 eth2 | Port 17<br>Agg SW B P5 | Port 19<br>Agg SW B P7 | Port 21<br>SAN contr1 | Port 23<br>SAN contr3 |
| Port 2<br>Server2 eth2 | Port 4<br>Server4 eth2 | Port 6<br>Server6 eth2 | Port 8<br>Server8 eth2 | Port 10<br>Server10 eth2 | Port 12<br>Server12 eth2 | Port 14<br>Server14 eth2 | Port 16<br>Server16 eth2 | Port 18<br>Agg SW B P6 | Port 20<br>Agg SW B P8 | Port 22<br>SAN contr2 | Port 24<br>SAN contr4 |

**Enclosure 7 Switch2**

|                        |                        |                        |                        |                          |                          |                          |                          |                         |                         |                       |                       |
|------------------------|------------------------|------------------------|------------------------|--------------------------|--------------------------|--------------------------|--------------------------|-------------------------|-------------------------|-----------------------|-----------------------|
| Port 1<br>Server1 eth2 | Port 3<br>Server3 eth2 | Port 5<br>Server5 eth2 | Port 7<br>Server7 eth2 | Port 9<br>Server9 eth2   | Port 11<br>Server11 eth2 | Port 13<br>Server13 eth2 | Port 15<br>Server15 eth2 | Port 17<br>Agg SW B P29 | Port 19<br>Agg SW B P31 | Port 21<br>SAN contr1 | Port 23<br>SAN contr3 |
| Port 2<br>Server2 eth2 | Port 4<br>Server4 eth2 | Port 6<br>Server6 eth2 | Port 8<br>Server8 eth2 | Port 10<br>Server10 eth2 | Port 12<br>Server12 eth2 | Port 14<br>Server14 eth2 | Port 16<br>Server16 eth2 | Port 18<br>Agg SW B P30 | Port 20<br>Agg SW B P32 | Port 22<br>SAN contr2 | Port 24<br>SAN contr4 |

### 6.13.2 Aggregation Switch

**Note:** The command “spanning-tree portfast trunk” will return the following warning, you can ignore:

```
%Warning: portfast should only be enabled on ports connected to a single host.
Connecting hubs, concentrators, switches, bridges, etc... to this interface
when portfast is enabled, can cause temporary bridging loops.
```

Use with CAUTION

**Note:** the commands “switchport trunk encapsulation dot1q” and “media-type rj45” will fail on the 4948EF switch but it is kept this config for compatibility with the previous 4948

```
!
!
! Aggregation Switch configuration
! MASTER VRRP switch
!
!
hostname switchA ! <----- replace the hostname to identify the switch
!
!
spanning-tree mode rapid-pvst
no spanning-tree optimize bpdu transmission
spanning-tree extend system-id
!
enable secret ***** ! <----- replace ***** with password specified in password dragon as Cisco enable
service password-encryption
no service pad
service timestamps debug datetime
service timestamps log datetime
no logging console
no aaa new-model
track 1 interface GigabitEthernet1/48 line-protocol
ip subnet-zero
vtp mode transparent
!
power redundancy-mode redundant
!
!
! VLAN CONFIGURATION (internal)
!
!
vlan internal allocation policy ascending
!
vlan 2
 name management
```

## Hardware Installation Guidelines

```
!
vlan 3
 name backend
!
vlan 4
 name frontend
!
vlan 110 ! <----- Enter customer value for demarcation VLAN

 name customer
!
!
! INTER switch1A to other switch ETHERCHANNEL (internal)
!
!
interface Port-channel1
 description Trunk_between_switch1A_and_Enc1SW1
 switchport
 switchport trunk encapsulation dot1q
 switchport trunk allowed vlan 1-4
 switchport mode trunk
!
interface Port-channel2
 description Trunk_between_switch1A_and_Enc2SW1
 switchport
 switchport trunk encapsulation dot1q
 switchport trunk allowed vlan 1-4
 switchport mode trunk
!
interface Port-channel3
 description Trunk_between_switch1A_and_Enc3SW1
 switchport
 switchport trunk encapsulation dot1q
 switchport trunk allowed vlan 1-4
 switchport mode trunk
!
interface Port-channel4
 description Trunk_between_switch1A_and_Enc4SW1
 switchport
 switchport trunk encapsulation dot1q
 switchport trunk allowed vlan 1-4
 switchport mode trunk
!
interface Port-channel5
 description Trunk_between_switch1A_and_Enc5SW1
 switchport
```

## Hardware Installation Guidelines

```
switchport trunk encapsulation dot1q
switchport trunk allowed vlan 1-4
switchport mode trunk
!
interface Port-channel6
description Trunk_between_switch1A_and_Enc6SW1
switchport
switchport trunk encapsulation dot1q
switchport trunk allowed vlan 1-4
switchport mode trunk
!
interface Port-channel7
description Trunk_between_switch1A_and_Enc7SW1
switchport
switchport trunk encapsulation dot1q
switchport trunk allowed vlan 1-4
switchport mode trunk
!
interface Port-channel8
description Trunk_between_switch1A_and_switch1B
switchport
switchport trunk encapsulation dot1q
switchport trunk allowed vlan 1-4
switchport mode trunk
switchport nonegotiate
!
!
! INTER switch1A to other switch PORTS (internal)
!
!
interface range GigabitEthernet1/1-4
description Trunk_between_switch1A_and_switch1B
switchport trunk encapsulation dot1q
switchport trunk allowed vlan 1-4
switchport mode trunk
switchport nonegotiate
channel-group 8 mode active
!
interface range GigabitEthernet1/5-8
description Trunk_between_cxeny(en1)-sw1
switchport trunk encapsulation dot1q
switchport trunk allowed vlan 1-4
switchport mode trunk
channel-group 1 mode active
spanning-tree portfast trunk
!
```

## Hardware Installation Guidelines

```
interface range GigabitEthernet1/9-12
 description ISL_to_cxeny(en2)-sw1
 switchport trunk encapsulation dot1q
 switchport trunk allowed vlan 1-4
 switchport mode trunk
 channel-group 2 mode active
 spanning-tree portfast trunk
!
interface range GigabitEthernet1/13-16
 description ISL_to_cxeny(en3)-sw1
 switchport trunk encapsulation dot1q
 switchport trunk allowed vlan 1-4
 switchport mode trunk
 channel-group 3 mode active
 spanning-tree portfast trunk
!
interface range GigabitEthernet1/17-20
 description ISL_to_cxeny(en4)-sw1
 switchport trunk encapsulation dot1q
 switchport trunk allowed vlan 1-4
 switchport mode trunk
 channel-group 4 mode active
 spanning-tree portfast trunk
!
interface range GigabitEthernet1/21-24
 description ISL_to_cxeny(en5)-sw1
 switchport trunk encapsulation dot1q
 switchport trunk allowed vlan 1-4
 switchport mode trunk
 channel-group 5 mode active
 spanning-tree portfast trunk
!
interface range GigabitEthernet1/25-28
 description ISL_to_cxeny(en6)-sw1
 switchport trunk encapsulation dot1q
 switchport trunk allowed vlan 1-4
 switchport mode trunk
 channel-group 6 mode active
 spanning-tree portfast trunk
!
interface range GigabitEthernet1/29-32
 description ISL_to_cxeny(en7)-sw1
 switchport trunk encapsulation dot1q
 switchport trunk allowed vlan 1-4
 switchport mode trunk
 channel-group 7 mode active
```

## Hardware Installation Guidelines

```
spanning-tree portfast trunk
!
!
! OA PORTS
!
!
interface range GigabitEthernet1/33-39
 description cxeny(enX)-OA
 switchport access vlan 2
 switchport mode access
 spanning-tree portfast
!
!
! PM&C PORTS
!
!
interface GigabitEthernet1/40
 description clmsl-nic
 switchport trunk encapsulation dot1q
 switchport trunk allowed vlan 1-3
 switchport mode trunk
 spanning-tree portfast trunk
!
interface GigabitEthernet1/41
 description clmsl-iLO for compatibilty with G6 & G5, it is recomanded to connect directly on customer network
 switchport access vlan 2
 switchport mode access
 spanning-tree portfast
!
!
! UNUSED PORTS
!
!
interface range GigabitEthernet1/42-44
 description Unused
 shutdown
!
interface GigabitEthernet1/47
 description Unused
 shutdown
!
!
! Laptop PORTS
!
!
interface range GigabitEthernet1/45-46
```



## Hardware Installation Guidelines

```
description for Laptop connection
switchport access vlan 2
switchport mode access
spanning-tree portfast
no shutdown
!
!
! Customer uplink PORTS
!
!
interface GigabitEthernet1/48
description Customer_Uplink
switchport access vlan 110
switchport mode access
media-type rj45
no shutdown
!
!
! VLAN INTERFACE CONFIGURATION
!
!
interface Vlan1
ip address dhcp
no shutdown
!
interface Vlan2
description IP address, netmask, and gateway for this switch in the management VLAN
ip address 172.20.98.2 255.255.255.0 ! <----- Enter IP and netmask FOR management VLAN
vrrp 2 ip 172.20.98.1 ! <----- replace IP with gateway for management VLAN
vrrp 2 track 1
no shutdown
!
interface Vlan3
description IP address, netmask, and gateway for this switch in the backend VLAN
ip address 172.20.96.2 255.255.255.128 ! <----- Enter IP and netmask FOR backend VLAN
vrrp 3 ip 172.20.96.1 ! <----- replace IP with gateway for backend VLAN
vrrp 3 track 1
no shutdown
!
interface Vlan4
description IP address, netmask, and gateway for this switch in the frontend VLAN
ip address 172.20.97.18 255.255.255.240 ! <----- Enter IP and netmask for frontend VLAN
vrrp 4 ip 172.20.97.17 ! <----- replace IP with gateway for frontend VLAN
vrrp 4 track 1
no shutdown
!
```

## Hardware Installation Guidelines

```
description VLAN ID, IP address, netmask, and gateway for this switch in the demarcation VLAN
interface Vlan110 ! <----- Enter customer value for demarcation VLAN
 ip address 172.20.97.5 255.255.255.248 ! <----- Enter IP and netmask for demarcation VLAN
 vrrp 5 ip 172.20.97.4 ! <----- replace IP with gateway for demarcation VLAN
 vrrp 5 track 1
 no shutdown
!
ip route 0.0.0.0 0.0.0.0 172.20.97.1 ! <----- replace IP with customer default gateway
ip route 0.0.0.0 0.0.0.0 172.20.96.3 200 ! <----- replace IP with other aggregation switch IP address in
backend vlan
no ip http server
!
!
logging 172.20.96.4 ! <----- replace IP with PM&C address
no cdp run
!
snmp-server user cfguser cfguser v1
snmp-server user cfguser cfguser v2c
snmp-server community cfguser RO
snmp-server enable traps snmp authentication linkdown linkup coldstart warmstart
snmp-server enable traps tty
snmp-server enable traps fru-ctrl
snmp-server enable traps entity
snmp-server enable traps cpu threshold
snmp-server enable traps vlancreate
snmp-server enable traps vldelete
snmp-server enable traps envmon fan shutdown supply temperature status
snmp-server enable traps config
snmp-server enable traps ipmulticast
snmp-server enable traps bridge newroot topologychange
snmp-server enable traps syslog
snmp-server enable traps vlan-membership
snmp-server host 172.20.96.132 version 2c tekelec ! <----- replace IP with WL1 address
!
control-plane
!
!
line con 0
 password ***** ! <----- replace ***** with password specified in password dragon as Cisco telnet
 login
 stopbits 1
!
ntp clock-period 17179480
ntp server 10.27.8.4 ! <----- replace IP with NTP server address
end
```

## Hardware Installation Guidelines

### 6.13.3 Enclosure Switch

```
!
!
! Enclosure Switch configuration
!
!
hostname C3020A_IOBAY
!
no service config
no service pad
service timestamps debug datetime
service timestamps log datetime
enable secret ***** ! <----- replace ***** with password specified in password dragon as Cisco enable
service password-encryption
!
link state track 1
ip subnet-zero
no ip domain-lookup
!
spanning-tree mode rapid-pvst
no spanning-tree optimize bpdu transmission
spanning-tree etherchannel guard misconfig
spanning-tree extend system-id
spanning-tree vlan 1-1024 priority 53248
!
!
! VLAN CONFIGURATION (internal)
!
!
vlan internal allocation policy ascending
!
vlan 2
 name management
!
vlan 3
 name backend
!
vlan 4
 name frontend
!
interface Port-channel1
 description ISL_between_4948_and_3020
 switchport trunk allowed vlan 1-4
 switchport mode trunk
 link state group 1 upstream
```

## Hardware Installation Guidelines

```
!
interface range GigabitEthernet0/17-20
 description ISL_between_4948_and_3020
 switchport trunk allowed vlan 1-4
 switchport mode trunk
 channel-group 1 mode active
 spanning-tree portfast trunk
!
interface FastEthernet0
 description IP address configured in the OA interface
! ip address dhcp ! <----- remove the comment only in case the interface would not be already
configured in dhcp
!
interface range GigabitEthernet0/1-16
 description bay.ethx
 switchport mode trunk
 link state group 1 downstream
 spanning-tree portfast trunk
!
interface range GigabitEthernet0/21-24
 description P2000 SAN controller
 switchport access vlan 2
 switchport mode access
 spanning-tree portfast
!
interface Vlan1
 no ip address
 shutdown
!
ip classless
ip http server
ip http secure-server
!
logging 172.20.96.4 ! <----- replace IP with PM&C management address
no cdp run
snmp-server community tekelec RO
snmp-server enable traps snmp authentication linkdown linkup coldstart warmstart
snmp-server enable traps tty
snmp-server enable traps entity
snmp-server enable traps cpu threshold
snmp-server enable traps vlancreate
snmp-server enable traps vlandelete
snmp-server enable traps envmon fan shutdown supply temperature status
snmp-server enable traps config
snmp-server enable traps bridge newroot topologychange
snmp-server enable traps syslog
```

## Hardware Installation Guidelines

```
snmp-server enable traps vlan-membership
snmp-server host 172.20.96.132 version 2c tekelec ! <----- replace IP with WL1 backend address
!
control-plane
!
!
line con 0
 password ***** ! <----- replace ***** with password specified in password dragon as Cisco telnet
 login
line vty 0 15
 password ***** ! <----- replace ***** with password specified in password dragon as Cisco telnet
 login
!
ntp clock-period 36028892
ntp server 10.31.3.132 ! <----- replace IP with NTP server address
end
```

### 6.13.4 G6 MSA cabling diagram

All the following information assume the cabling has been done according the Tekelec System Interconnect diagrams 892-0093-01, 892-0094-01, 892-0095-01, and 892-0094-02 to be used for G6 servers with MSA storage arrays

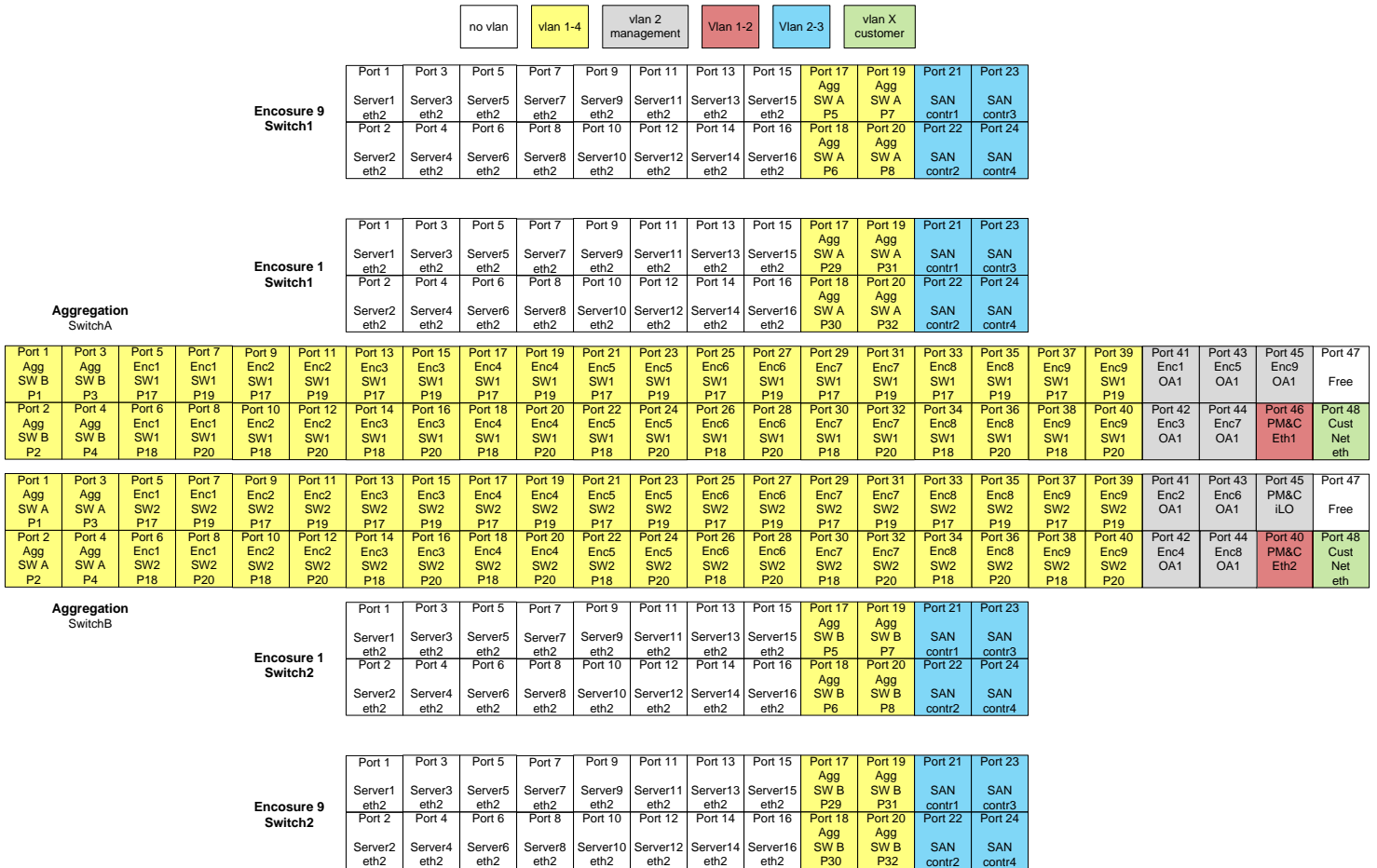

#### 6.13.4.1 Aggregation Switch 4948

```

!
! No configuration change since last restart
! NVRAM config last updated at 15:38:22 gmt-5 Thu Apr 16 2009
!
version 12.2
no service pad
service timestamps debug datetime
service timestamps log datetime
service password-encryption
service compress-config
!
hostname switch1A
!
no logging console

```

## Hardware Installation Guidelines

```
enable secret ***** ! <----- replace ***** with password specified in password dragon as Cisco enable
!
no aaa new-model
!
track 1 interface GigabitEthernet1/48 line-protocol
ip subnet-zero
!
vtp mode transparent
!
!
!
!
!
power redundancy-mode redundant
no file verify auto
!
spanning-tree mode rapid-pvst
no spanning-tree optimize bpdu transmission
spanning-tree extend system-id
spanning-tree vlan 1-1024 priority 45056
!
vlan internal allocation policy ascending
!
vlan 2
 name management
!
vlan 3
 name backend
!
vlan 4
 name frontend
!
vlan 10 ! <----- replace VLAN with customer value
 name cust
!
interface Port-channel1
 description ISL_between_clas1_and_clen1-sw1
 switchport
 switchport trunk encapsulation dot1q
 switchport trunk allowed vlan 1-4
 switchport mode trunk
 spanning-tree portfast trunk
!
interface Port-channel2
 description ISL_between_clas1_and_cxeny(en2)-sw1
 switchport
 switchport trunk encapsulation dot1q
 switchport trunk allowed vlan 1-4
 switchport mode trunk
 spanning-tree portfast trunk
!
interface Port-channel3
 description ISL_between_clas1_and_cxeny(en3)-sw1
 switchport
 switchport trunk encapsulation dot1q
 switchport trunk allowed vlan 1-4
 switchport mode trunk
 spanning-tree portfast trunk
!
interface Port-channel4
 description ISL_between_clas1_and_cxeny(en4)-sw1
 switchport
 switchport trunk encapsulation dot1q
 switchport trunk allowed vlan 1-4
 switchport mode trunk
 spanning-tree portfast trunk
```

```
!
interface Port-channel5
 description ISL_between_clas1_and_cxeny(en5)-sw1
 switchport
 switchport trunk encapsulation dot1q
 switchport trunk allowed vlan 1-4
 switchport mode trunk
 spanning-tree portfast trunk
!
interface Port-channel6
 description ISL_between_clas1_and_cxeny(en6)-sw1
 switchport
 switchport trunk encapsulation dot1q
 switchport trunk allowed vlan 1-4
 switchport mode trunk
 spanning-tree portfast trunk
!
interface Port-channel7
 description ISL_between_clas1_and_cxeny(en7)-sw1
 switchport
 switchport trunk encapsulation dot1q
 switchport trunk allowed vlan 1-4
 switchport mode trunk
 spanning-tree portfast trunk
!
interface Port-channel8
 description ISL_between_clas1_and_cxeny(en8)-sw1
 switchport
 switchport trunk encapsulation dot1q
 switchport trunk allowed vlan 1-4
 switchport mode trunk
 spanning-tree portfast trunk
!
interface Port-channel9
 description ISL_between_clas1_and_cxeny(en9)-sw1
 switchport
 switchport trunk encapsulation dot1q
 switchport trunk allowed vlan 1-4
 switchport mode trunk
 spanning-tree portfast trunk
!
interface Port-channel10
 description ISL_between_clas1_and_clas2
 switchport
 switchport trunk encapsulation dot1q
 switchport trunk allowed vlan 1-4
 switchport mode trunk
 spanning-tree portfast trunk
!
interface range GigabitEthernet1/1-4
 description switch1B.gil/1-4
 switchport trunk encapsulation dot1q
 switchport trunk allowed vlan 1-4
 switchport mode trunk
 channel-group 10 mode active
 spanning-tree portfast trunk
!
interface range GigabitEthernet1/5-8
 description ISL_to_clen1(en1)-sw1
 switchport trunk encapsulation dot1q
 switchport trunk allowed vlan 1-4
 switchport mode trunk
 channel-group 1 mode active
 spanning-tree portfast trunk
!
interface range GigabitEthernet1/9-12
 description ISL_to_cxeny(en2)-sw1
```



## Hardware Installation Guidelines

```
switchport trunk encapsulation dot1q
switchport trunk allowed vlan 1-4
switchport mode trunk
channel-group 2 mode active
spanning-tree portfast trunk
!
interface range GigabitEthernet1/13-16
description ISL_to_cxeny(en3)-sw1
switchport trunk encapsulation dot1q
switchport trunk allowed vlan 1-4
switchport mode trunk
channel-group 3 mode active
spanning-tree portfast trunk
!
interface range GigabitEthernet1/17-20
description ISL_to_cxeny(en4)-sw1
switchport trunk encapsulation dot1q
switchport trunk allowed vlan 1-4
switchport mode trunk
channel-group 4 mode active
spanning-tree portfast trunk
!
interface GigabitEthernet1/21-24
description ISL_to_cxeny(en5)-sw1
switchport trunk encapsulation dot1q
switchport trunk allowed vlan 1-4
switchport mode trunk
channel-group 5 mode active
spanning-tree portfast trunk
!
interface range GigabitEthernet1/25-28
description ISL_to_cxeny(en6)-sw1
switchport trunk encapsulation dot1q
switchport trunk allowed vlan 1-4
switchport mode trunk
channel-group 6 mode active
spanning-tree portfast trunk
!
interface range GigabitEthernet1/29-32
description ISL_to_cxeny(en7)-sw1
switchport trunk encapsulation dot1q
switchport trunk allowed vlan 1-4
switchport mode trunk
channel-group 7 mode active
spanning-tree portfast trunk
!
interface range GigabitEthernet1/33-36
description ISL_to_cxeny(en8)-sw1
switchport trunk encapsulation dot1q
switchport trunk allowed vlan 1-4
switchport mode trunk
channel-group 8 mode active
spanning-tree portfast trunk
!
interface range GigabitEthernet1/37-40
description ISL_to_cxeny(en9)-sw1
switchport trunk encapsulation dot1q
switchport trunk allowed vlan 1-4
switchport mode trunk
channel-group 9 mode active
spanning-tree portfast trunk
!
interface range GigabitEthernet1/41-45
description oal&iLO
switchport access vlan 2
switchport mode access
spanning-tree portfast
```

## Hardware Installation Guidelines

```
!
interface GigabitEthernet1/46
 description clms1-nic1
 switchport trunk encapsulation dot1q
 switchport trunk allowed vlan 1-3
 switchport mode trunk
 media-type rj45
 spanning-tree portfast trunk
!
interface GigabitEthernet1/47
 description unused
 switchport trunk encapsulation dot1q
 switchport mode trunk
 shutdown
 media-type rj45
 spanning-tree portfast trunk
!
interface GigabitEthernet1/48
description Customer_Uplink
switchport access vlan 10 ! <----- replace VLAN with customer value
switchport mode access
media-type rj45
spanning-tree portfast
!
interface Vlan1
no ip address
!
interface Vlan2
description IP address, netmask, and gateway for this switch in the management VLAN
ip address 10.240.8.2 255.255.255.0 ! <----- replace IP and netmask for management VLAN
 vrrp 2 ip 10.240.8.1 ! <----- replace IP with gateway for management VLAN
 vrrp 2 track 1
no shutdown
!
interface Vlan3
description IP address, netmask, and gateway for this switch in the backend VLAN
ip address 10.240.9.2 255.255.255.0 ! <----- Enter IP and netmask for backend VLAN
 vrrp 3 ip 10.240.9.1 ! <----- replace IP with gateway for backend VLAN
 vrrp 3 track 1
no shutdown
!
interface Vlan4
description IP address, netmask, and gateway for this switch in the frontend VLAN
ip address 10.240.10.2 255.255.255.0 ! <----- Enter IP and netmask for frontend VLAN
 vrrp 4 ip 10.240.10.1 ! <----- replace IP with gateway for frontend VLAN
 vrrp 4 track 1
no shutdown
!
interface Vlan10
 ! <----- replace VLAN with customer value
description VLAN ID, IP address, netmask, and gateway for this switch in the demarcation VLAN
ip address 10.250.54.24 255.255.255.0 ! <----- Enter IP and netmask for demarcation VLAN
 vrrp 10 ip 10.250.54.26 ! <----- replace IP with Oracle gateway for demarcation VLAN
no shutdown
!
ip route 0.0.0.0 0.0.0.0 10.250.54.1 ! <----- replace IP with customer default gateway
no ip http server
no ip http secure-server
!
!
logging 10.27.8.0 ! <----- replace IP with PM&C address
no cdp run
!
```

## Hardware Installation Guidelines

```
snmp-server community cfguser RO
snmp-server enable traps snmp authentication linkdown linkup coldstart warmstart
snmp-server enable traps flash insertion removal
snmp-server enable traps cpu threshold
snmp-server enable traps envmon fan shutdown supply temperature status
snmp-server enable traps port-security
snmp-server enable traps storm-control trap-rate 5
snmp-server enable traps config
snmp-server enable traps hsrp
snmp-server enable traps mac-notification change move threshold
snmp-server enable traps bridge newroot topologychange
snmp-server enable traps vlan-membership
snmp-server host 10.31.5.211 version 2c cfguser ! <----- replace IP with WLL address
!
control-plane
!
!
line con 0
 password ***** ! <----- replace ***** with password specified in password dragon as Cisco telnet
 login
 stopbits 1
!
ntp clock-period 17179453
ntp server 10.240.8.4 ! <----- replace IP with NTP server address
end
```

### 6.13.4.2 Enclosure Switch 3020

```
version 12.2
no service pad
service timestamps debug uptime
service timestamps log uptime
service password-encryption
!
hostname clenlp1
!
no logging console
enable secret ***** ! <----- replace ***** with password specified in password dragon as Cisco enable
!
no aaa new-model
clock timezone gmt+1 1
system mtu routing 1500
vtp mode transparent
ip subnet-zero
!
!
spanning-tree mode rapid-pvst
no spanning-tree optimize bpdu transmission
spanning-tree etherchannel guard misconfig
spanning-tree extend system-id
spanning-tree vlan 1-1024 priority 53248
!
```

## Hardware Installation Guidelines

```
vlan internal allocation policy ascending
!
vlan 2
 name management
!
vlan 3
 name backend
!
vlan 4
 name frontend
!
!
!
interface Port-channel1
 description ISL_between_4948_and_3020
 switchport trunk allowed vlan 1-4
 switchport mode trunk
 spanning-tree portfast trunk
!
interface FastEthernet0
 ip address dhcp
!
interface range GigabitEthernet0/1-16
 description bay.ethx
 switchport mode trunk
 spanning-tree portfast trunk
!
interface range GigabitEthernet0/17-20
 description ISL_between_4948_and_3020
 switchport trunk allowed vlan 1-4
 switchport mode trunk
 channel-group 1 mode active
 spanning-tree portfast trunk
!
interface range GigabitEthernet0/21-24
 description cxsan-fc-port-mngt
 switchport trunk native vlan 2
 switchport trunk allowed vlan 2,3
 switchport mode trunk
 spanning-tree portfast trunk
!
interface Vlan1
 no ip address
 shutdown
!
ip classless
```

## Hardware Installation Guidelines

```
ip route 0.0.0.0 0.0.0.0 10.31.5.129 254 ! <----- replace IP with customer default gateway
ip http server
ip http secure-server
!
logging 10.27.8.0 ! <----- replace IP with PM&C address
no cdp run
snmp-server community cfguser RO
snmp-server enable traps snmp authentication linkdown linkup coldstart warmstart
snmp-server enable traps cpu threshold
snmp-server enable traps flash insertion removal
snmp-server enable traps port-security
snmp-server enable traps envmon fan shutdown supply temperature status
snmp-server enable traps storm-control trap-rate 5
snmp-server enable traps config
snmp-server enable traps hsrp
snmp-server enable traps bridge newroot topologychange
snmp-server enable traps mac-notification change move threshold
snmp-server enable traps vlan-membership
snmp-server host 10.31.5.211 version 2c cfguser ! <----- replace IP with WL1 address
!
control-plane
!
!
line con 0
 exec-timeout 0 0
 password ***** ! <----- replace ***** with password specified in password dragon as Cisco telnet
 login
line vty 0 4
 password ***** ! <----- replace ***** with password specified in password dragon as Cisco telnet
 login
line vty 5 15
 password ***** ! <----- replace ***** with password specified in password dragon as Cisco telnet
 login
!
ntp clock-period 36029033
ntp server 10.31.5.132 ! <----- replace IP with NTP server address
end
```

## 6.14 Integrated Acquisition switch configuration template

### 6.14.1 Switch port allocation



|            |                             |                            |                            |                            |                             |                             |                           |                           |                           |                           |                           |                           |                           |                           |                           |                           |                           |                           |                           |                           |                             |                             |                           |                            |
|------------|-----------------------------|----------------------------|----------------------------|----------------------------|-----------------------------|-----------------------------|---------------------------|---------------------------|---------------------------|---------------------------|---------------------------|---------------------------|---------------------------|---------------------------|---------------------------|---------------------------|---------------------------|---------------------------|---------------------------|---------------------------|-----------------------------|-----------------------------|---------------------------|----------------------------|
| Yellow SW3 | Port 1<br>Yellow1<br>SW P41 | Port 3<br>Eagle<br>Links   | Port 5<br>Eagle<br>Links   | Port 7<br>Eagle<br>Links   | Port 9<br>Eagle<br>Links    | Port 11<br>Eagle<br>Links   | Port 13<br>Eagle<br>Links | Port 15<br>Eagle<br>Links | Port 17<br>Eagle<br>Links | Port 19<br>Eagle<br>Links | Port 21<br>Eagle<br>Links | Port 23<br>Eagle<br>Links | Port 25<br>Eagle<br>Links | Port 27<br>Eagle<br>Links | Port 29<br>Eagle<br>Links | Port 31<br>Eagle<br>Links | Port 33<br>Eagle<br>Links | Port 35<br>Eagle<br>Links | Port 37<br>Eagle<br>Links | Port 39<br>Eagle<br>Links | Port 41<br>Eagle<br>Links   | Port 43<br>Eagle<br>Links   | Port 45<br>Eagle<br>Links | Port 47<br>Eagle<br>Links  |
| Yellow SW2 | Port 2<br>Yellow1<br>SW P42 | Port 4<br>Eagle<br>Links   | Port 6<br>Eagle<br>Links   | Port 8<br>Eagle<br>Links   | Port 10<br>Eagle<br>Links   | Port 12<br>Eagle<br>Links   | Port 14<br>Eagle<br>Links | Port 16<br>Eagle<br>Links | Port 18<br>Eagle<br>Links | Port 20<br>Eagle<br>Links | Port 22<br>Eagle<br>Links | Port 24<br>Eagle<br>Links | Port 26<br>Eagle<br>Links | Port 28<br>Eagle<br>Links | Port 30<br>Eagle<br>Links | Port 32<br>Eagle<br>Links | Port 34<br>Eagle<br>Links | Port 36<br>Eagle<br>Links | Port 38<br>Eagle<br>Links | Port 40<br>Eagle<br>Links | Port 42<br>Eagle<br>Links   | Port 44<br>Eagle<br>Links   | Port 46<br>Eagle<br>Links | Port 48<br>Eagle<br>Links  |
| Yellow SW1 | Port 1<br>Yellow1<br>SW P43 | Port 3<br>ServerG<br>eth01 | Port 5<br>ServerH<br>eth01 | Port 7<br>ServerI<br>eth01 | Port 9<br>ServerK<br>eth01  | Port 11<br>ServerL<br>eth01 | Port 13<br>Eagle<br>Links | Port 15<br>Eagle<br>Links | Port 17<br>Eagle<br>Links | Port 19<br>Eagle<br>Links | Port 21<br>Eagle<br>Links | Port 23<br>Eagle<br>Links | Port 25<br>Eagle<br>Links | Port 27<br>Eagle<br>Links | Port 29<br>Eagle<br>Links | Port 31<br>Eagle<br>Links | Port 33<br>Eagle<br>Links | Port 35<br>Eagle<br>Links | Port 37<br>Eagle<br>Links | Port 39<br>Eagle<br>Links | Port 41<br>Eagle<br>Links   | Port 43<br>Eagle<br>Links   | Port 45<br>Eagle<br>Links | Port 47<br>Eagle<br>Links  |
| Blue SW1   | Port 2<br>Yellow1<br>SW P44 | Port 4<br>ServerG<br>iLO   | Port 6<br>ServerI<br>eth01 | Port 8<br>ServerJ<br>eth01 | Port 10<br>ServerK<br>iLO   | Port 12<br>Eagle<br>Links   | Port 14<br>Eagle<br>Links | Port 16<br>Eagle<br>Links | Port 18<br>Eagle<br>Links | Port 20<br>Eagle<br>Links | Port 22<br>Eagle<br>Links | Port 24<br>Eagle<br>Links | Port 26<br>Eagle<br>Links | Port 28<br>Eagle<br>Links | Port 30<br>Eagle<br>Links | Port 32<br>Eagle<br>Links | Port 34<br>Eagle<br>Links | Port 36<br>Eagle<br>Links | Port 38<br>Eagle<br>Links | Port 40<br>Eagle<br>Links | Port 42<br>Eagle<br>Links   | Port 44<br>Eagle<br>Links   | Port 46<br>Eagle<br>Links | Port 48<br>Eagle<br>Links  |
| Blue SW2   | Port 1<br>Blue1<br>SW P1    | Port 3<br>ServerA<br>eth01 | Port 5<br>ServerC<br>eth01 | Port 7<br>ServerD<br>eth01 | Port 9<br>ServerE<br>iLO    | Port 11<br>Eagle<br>Links   | Port 13<br>Eagle<br>Links | Port 15<br>Eagle<br>Links | Port 17<br>Eagle<br>Links | Port 19<br>Eagle<br>Links | Port 21<br>Eagle<br>Links | Port 23<br>Eagle<br>Links | Port 25<br>Eagle<br>Links | Port 27<br>Eagle<br>Links | Port 29<br>Eagle<br>Links | Port 31<br>Eagle<br>Links | Port 33<br>Eagle<br>Links | Port 35<br>Eagle<br>Links | Port 37<br>Eagle<br>Links | Port 39<br>Eagle<br>Links | Port 41<br>Yellow3<br>SW P1 | Port 43<br>Yellow2<br>SW P1 | Port 45<br>For<br>Laptop  | Port 47<br>Cust Net<br>eth |
| Blue SW3   | Port 2<br>Blue1<br>SW P2    | Port 4<br>ServerB<br>eth01 | Port 6<br>ServerC<br>iLO   | Port 8<br>ServerE<br>eth01 | Port 10<br>ServerF<br>iLO   | Port 12<br>Eagle<br>Links   | Port 14<br>Eagle<br>Links | Port 16<br>Eagle<br>Links | Port 18<br>Eagle<br>Links | Port 20<br>Eagle<br>Links | Port 22<br>Eagle<br>Links | Port 24<br>Eagle<br>Links | Port 26<br>Eagle<br>Links | Port 28<br>Eagle<br>Links | Port 30<br>Eagle<br>Links | Port 32<br>Eagle<br>Links | Port 34<br>Eagle<br>Links | Port 36<br>Eagle<br>Links | Port 38<br>Eagle<br>Links | Port 40<br>Eagle<br>Links | Port 42<br>Yellow3<br>SW P2 | Port 44<br>Yellow2<br>SW P2 | Port 46<br>For<br>Laptop  | Port 48<br>Cust Net<br>iLO |
| Blue SW2   | Port 1<br>Blue1<br>SW P43   | Port 3<br>ServerG<br>eth03 | Port 5<br>ServerH<br>iLO   | Port 7<br>ServerJ<br>eth03 | Port 9<br>ServerK<br>eth03  | Port 11<br>ServerL<br>iLO   | Port 13<br>Eagle<br>Links | Port 15<br>Eagle<br>Links | Port 17<br>Eagle<br>Links | Port 19<br>Eagle<br>Links | Port 21<br>Eagle<br>Links | Port 23<br>Eagle<br>Links | Port 25<br>Eagle<br>Links | Port 27<br>Eagle<br>Links | Port 29<br>Eagle<br>Links | Port 31<br>Eagle<br>Links | Port 33<br>Eagle<br>Links | Port 35<br>Eagle<br>Links | Port 37<br>Eagle<br>Links | Port 39<br>Eagle<br>Links | Port 41<br>Eagle<br>Links   | Port 43<br>Eagle<br>Links   | Port 45<br>Eagle<br>Links | Port 47<br>Eagle<br>Links  |
| Blue SW3   | Port 2<br>Blue1<br>SW P44   | Port 4<br>ServerH<br>eth03 | Port 6<br>ServerI<br>eth03 | Port 8<br>ServerJ<br>iLO   | Port 10<br>ServerL<br>eth03 | Port 12<br>Eagle<br>Links   | Port 14<br>Eagle<br>Links | Port 16<br>Eagle<br>Links | Port 18<br>Eagle<br>Links | Port 20<br>Eagle<br>Links | Port 22<br>Eagle<br>Links | Port 24<br>Eagle<br>Links | Port 26<br>Eagle<br>Links | Port 28<br>Eagle<br>Links | Port 30<br>Eagle<br>Links | Port 32<br>Eagle<br>Links | Port 34<br>Eagle<br>Links | Port 36<br>Eagle<br>Links | Port 38<br>Eagle<br>Links | Port 40<br>Eagle<br>Links | Port 42<br>Eagle<br>Links   | Port 44<br>Eagle<br>Links   | Port 46<br>Eagle<br>Links | Port 48<br>Eagle<br>Links  |
| Blue SW1   | Port 1<br>Yellow1<br>SW P1  | Port 3<br>ServerA<br>eth03 | Port 5<br>ServerC<br>eth03 | Port 7<br>ServerD<br>eth03 | Port 9<br>ServerE<br>iLO    | Port 11<br>Eagle<br>Links   | Port 13<br>Eagle<br>Links | Port 15<br>Eagle<br>Links | Port 17<br>Eagle<br>Links | Port 19<br>Eagle<br>Links | Port 21<br>Eagle<br>Links | Port 23<br>Eagle<br>Links | Port 25<br>Eagle<br>Links | Port 27<br>Eagle<br>Links | Port 29<br>Eagle<br>Links | Port 31<br>Eagle<br>Links | Port 33<br>Eagle<br>Links | Port 35<br>Eagle<br>Links | Port 37<br>Eagle<br>Links | Port 39<br>Eagle<br>Links | Port 41<br>Blue3<br>SW P1   | Port 43<br>Blue2<br>SW P1   | Port 45<br>For<br>Laptop  | Port 47<br>Cust Net<br>eth |
| Blue SW2   | Port 2<br>Yellow1<br>SW P2  | Port 4<br>ServerB<br>eth03 | Port 6<br>ServerD<br>eth03 | Port 8<br>ServerE<br>eth03 | Port 10<br>ServerF<br>iLO   | Port 12<br>Eagle<br>Links   | Port 14<br>Eagle<br>Links | Port 16<br>Eagle<br>Links | Port 18<br>Eagle<br>Links | Port 20<br>Eagle<br>Links | Port 22<br>Eagle<br>Links | Port 24<br>Eagle<br>Links | Port 26<br>Eagle<br>Links | Port 28<br>Eagle<br>Links | Port 30<br>Eagle<br>Links | Port 32<br>Eagle<br>Links | Port 34<br>Eagle<br>Links | Port 36<br>Eagle<br>Links | Port 38<br>Eagle<br>Links | Port 40<br>Eagle<br>Links | Port 42<br>Blue3<br>SW P2   | Port 44<br>Blue2<br>SW P2   | Port 46<br>For<br>Laptop  | Port 48<br>Cust Net<br>iLO |
| Blue SW3   | Port 1<br>Blue1<br>SW P41   | Port 3<br>Eagle<br>Links   | Port 5<br>Eagle<br>Links   | Port 7<br>Eagle<br>Links   | Port 9<br>Eagle<br>Links    | Port 11<br>Eagle<br>Links   | Port 13<br>Eagle<br>Links | Port 15<br>Eagle<br>Links | Port 17<br>Eagle<br>Links | Port 19<br>Eagle<br>Links | Port 21<br>Eagle<br>Links | Port 23<br>Eagle<br>Links | Port 25<br>Eagle<br>Links | Port 27<br>Eagle<br>Links | Port 29<br>Eagle<br>Links | Port 31<br>Eagle<br>Links | Port 33<br>Eagle<br>Links | Port 35<br>Eagle<br>Links | Port 37<br>Eagle<br>Links | Port 39<br>Eagle<br>Links | Port 41<br>Eagle<br>Links   | Port 43<br>Eagle<br>Links   | Port 45<br>Eagle<br>Links | Port 47<br>Eagle<br>Links  |
| Blue SW2   | Port 2<br>Blue1<br>SW P42   | Port 4<br>Eagle<br>Links   | Port 6<br>Eagle<br>Links   | Port 8<br>Eagle<br>Links   | Port 10<br>Eagle<br>Links   | Port 12<br>Eagle<br>Links   | Port 14<br>Eagle<br>Links | Port 16<br>Eagle<br>Links | Port 18<br>Eagle<br>Links | Port 20<br>Eagle<br>Links | Port 22<br>Eagle<br>Links | Port 24<br>Eagle<br>Links | Port 26<br>Eagle<br>Links | Port 28<br>Eagle<br>Links | Port 30<br>Eagle<br>Links | Port 32<br>Eagle<br>Links | Port 34<br>Eagle<br>Links | Port 36<br>Eagle<br>Links | Port 38<br>Eagle<br>Links | Port 40<br>Eagle<br>Links | Port 42<br>Eagle<br>Links   | Port 44<br>Eagle<br>Links   | Port 46<br>Eagle<br>Links | Port 48<br>Eagle<br>Links  |

Server A and B iLO are directly connected to customer network

### 6.14.2 Yellow-sw1-1 Switch (Layer 3)

```

! IMF YELLOW1 SWITCH configuration
!
!
hostname yellow-sw1-1
!
no spanning-tree vlan 1-4094
no spanning-tree optimize bpdu transmission
!
enable secret ***** ! <----- replace ***** with password specified in password dragon as Cisco enable
service password-encryption
no service pad
service timestamps debug datetime
service timestamps log datetime
no logging console
no aaa new-model
track 1 interface GigabitEthernet1/47 line-protocol

```

## Hardware Installation Guidelines

```
ip subnet-zero
!
ip multicast-routing
!
power redundancy-mode redundant
!
!
! VLAN CONFIGURATION (internal)
!
!
vlan 100
 name internal_yellow
!
vlan 101
 name internal_blue
!
vlan 200
 name IMF2IXP_internal_(backend)
!
vlan 300
 name oobm_or_iLO
!
vlan 400
 name IMF2IXP_external_(frontend)
!
!
! INTER YELLOW SW1 TO BLUE SW1 ETHERCHANNEL (internal)
!
!
interface Port-channel1
 description Trunk_between_yellow_sw1_and_blue_sw1
 switchport
 switchport trunk encapsulation dot1q
 switchport trunk allowed vlan 100,101,200,300
 mtu 9198
 no shutdown
!
!
! INTER YELLOW SW 1 TO YELLOW SW2 ETHERCHANNEL (internal)
!
!
interface Port-channel2
 description Trunk_between_yellow_sw1_and_yellow_sw2
 switchport
 switchport trunk encapsulation dot1q
 switchport trunk allowed vlan 100,101,200,300
```

## Hardware Installation Guidelines

```
switchport mode trunk
mtu 9198
no shutdown
!
!
! INTER YELLOW SW 1 TO YELLOW SW3 ETHERCHANNEL (internal)
!
!
interface Port-channel3
description Trunk_between_yellow_sw1_and_yellow_sw3
switchport
switchport trunk encapsulation dot1q
switchport trunk allowed vlan 100,101,200,300
switchport mode trunk
mtu 9198
no shutdown
!
!
! INTER YELLOW SW1 TO BLUE SW1 PORTS (internal)
!
!
Interface range GigabitEthernet 1/1 - 2
description ISL_between_yellow_sw1_and_blue_sw1
switchport trunk encapsulation dot1q
switchport trunk allowed vlan 100,101,200,300
switchport mode trunk
switchport nonegotiate
mtu 9198
channel-group 1 mode active
no shutdown
!
!
! INTER yellow SW1 TO yellow SW2 PORTS (internal)
!
!
Interface range GigabitEthernet 1/43 - 44
description Trunk_between_yellow_sw1_and_yellow_sw2
switchport trunk encapsulation dot1q
switchport trunk allowed vlan 100,101,200,300
switchport mode trunk
mtu 9198
channel-group 1 mode active
no shutdown
!
!
! INTER yellow SW1 TO yellow SW3 PORTS (internal)
```



## Hardware Installation Guidelines

```
!
!
Interface range GigabitEthernet 1/41 - 42
description Trunk_between_yellow_sw1_and_yellow_sw3
switchport trunk encapsulation dot1q
switchport trunk allowed vlan 100,101,200,300
switchport mode trunk
mtu 9198
channel-group 1 mode active
no shutdown
!
!
! IMF Servers PORTS
!
!
interface range GigabitEthernet 1/3 - 5
description IMF servers ports
switchport trunk encapsulation dot1q
switchport mode trunk
mtu 9198
no shutdown
!
interface range GigabitEthernet 1/7 - 8
description IMF servers ports
switchport trunk encapsulation dot1q
switchport mode trunk
mtu 9198
no shutdown
!
interface range GigabitEthernet 1/10
description IMF servers ports
switchport trunk encapsulation dot1q
switchport mode trunk
mtu 9198
no shutdown
!
!
! iLO PORTS
!
!
interface GigabitEthernet 1/6
description IMF iLO ports
switchport access vlan 300
switchport mode access
no shutdown
!
```

## Hardware Installation Guidelines

```
interface GigabitEthernet 1/9
 description IMF iLO ports
 switchport access vlan 300
 switchport mode access
 no shutdown
!
!
! EAGLE PORTS
!
!
interface range GigabitEthernet 1/11 - 40
 description Eagle FC or STC ports
 switchport access vlan 100
 switchport mode access
 mtu 9198
 no shutdown
!
!
! PORT TO CUSTOMER SWITCH A
!
!
interface GigabitEthernet 1/47
 description to customer switch A
 switchport access vlan 400
 switchport mode access
 media-type rj45
 no shutdown
!
interface GigabitEthernet 1/48
 description reserved for optional direct access to ILO in case of disaster
 switchport access vlan 300
 switchport mode access
 media-type rj45
 no shutdown
!
!
! Laptop PORTS
!
!
interface range GigabitEthernet 1/45 - 46
 description for Laptop
 switchport access vlan 200
 switchport mode access
 media-type rj45
 no shutdown
!
```

## Hardware Installation Guidelines

```
!
! VLAN INTERFACE CONFIGURATION
!
!
interface Vlan1
 no ip address
!
!
interface VLAN 100
 ip address 172.21.49.1 255.255.254.0
 ip pim dense-mode
 no shutdown
!
!
track 1 int gigabitEthernet 1/47 line-protocol
interface Vlan200
 description internal VRRP for IMF to IXP traffic. Both IP addresses and netmask must be configured according
customer network.
 ip address 192.168.0.2 255.255.255.224 ! <----- replace IP with the value provided by the customer
 vrrp 1 ip 192.168.0.1 ! <----- replace IP with default gateway
 vrrp 1 priority 100
 vrrp 1 track 1
 vrrp 1 preempt
 no shutdown
!
!
interface Vlan300
 description oobm or iLO optional IP. IP address and netmask must be configured according customer network.
 ip address 192.168.10.2 255.255.255.240 ! <----- replace IP with the value provided by the customer
 no shutdown
!
!
interface Vlan 400
 description external VRRP for IMF to IXP traffic to Customer switches. Both IP addresses and netmask must be
configured according customer network.
 ip address 192.168.20.2 255.255.255.248 ! <----- replace IP with the value provided by the customer
 vrrp 2 ip 192.168.20.1 ! <----- replace IP with default gateway
 vrrp 2 priority 100
 vrrp 2 preempt
 no shutdown
!
!
no ip http server
no ip http secure-server
!
ip route 0.0.0.0 0.0.0.0 192.168.20.6 1 ! <----- replace IP with customer default gateway
```

```
!
!
line con 0
 password ***** ! <----- replace ***** with password specified in password dragon as Cisco telnet
 login
!
logging 172.21.49.10
!
no cdp run
!
end
```

### 6.14.3 Blue-sw1-1 Switch (Layer 3)

```
! IMF BLUE1 SWITCH configuration
!
!
hostname blue-sw1-1
!
no spanning-tree vlan 1-4094
no spanning-tree optimize bpdu transmission
!
enable secret ***** ! <----- replace ***** with password specified in password dragon as Cisco enable
service password-encryption
no service pad
service timestamps debug datetime
service timestamps log datetime
no logging console
no aaa new-model
track 1 interface GigabitEthernet1/47 line-protocol
ip subnet-zero
!
ip multicast-routing
!
power redundancy-mode redundant
!
!
! VLAN CONFIGURATION (internal)
!
!
vlan 100
 name internal_yellow
!
vlan 101
 name internal_blue
```

## Hardware Installation Guidelines

```
!
vlan 200
 name IMF2IXP_internal_(backend)
!
vlan 300
 name oobm_or_iLO
!
vlan 400
 name IMF2IXP_external_(frontend)
!
!
! INTER YELLOW SW1 TO BLUE SW1 ETHERCHANNEL (internal)
!
!
interface Port-channel1
 description Trunk_between_yellow_sw1_and_blue_sw1
 switchport
 switchport trunk encapsulation dot1q
 switchport trunk allowed vlan 100,101,200,300
 mtu 9198
 no shutdown
!
!
! INTER BLUE SW 1 TO BLUE SW2 ETHERCHANNEL (internal)
!
!
interface Port-channel2
 description Trunk_between_blue_sw1_and_blue_sw2
 switchport
 switchport trunk encapsulation dot1q
 switchport trunk allowed vlan 100,101,200,300
 switchport mode trunk
 mtu 9198
 no shutdown
!
!
! INTER BLUE SW 1 TO BLUE SW3 ETHERCHANNEL (internal)
!
!
interface Port-channel3
 description Trunk_between_blue_sw1_and_blue_sw3
 switchport
 switchport trunk encapsulation dot1q
 switchport trunk allowed vlan 100,101,200,300
 switchport mode trunk
 mtu 9198
```

## Hardware Installation Guidelines

```
no shutdown
!
!
! INTER BLUE SW1 TO yellow SW1 PORTS (internal)
!
!
Interface range GigabitEthernet 1/1 - 2
 description ISL_between_blue_sw1_and_yellow_sw1
 switchport trunk encapsulation dot1q
 switchport trunk allowed vlan 100,101,200,300
 switchport mode trunk
 switchport nonegotiate
 mtu 9198
 channel-group 1 mode active
 no shutdown
!
!
! INTER BLUE SW1 TO BLUE SW2 PORTS (internal)
!
!
Interface range GigabitEthernet 1/43 - 44
 description Trunk_between_blue_sw1_and_blue_sw2
 switchport trunk encapsulation dot1q
 switchport trunk allowed vlan 100,101,200,300
 switchport mode trunk
 mtu 9198
 channel-group 1 mode active
 no shutdown
!
!
! INTER BLUE SW1 TO BLUE SW3 PORTS (internal)
!
!
Interface range GigabitEthernet 1/41 - 42
 description Trunk_between_blue_sw1_and_blue_sw3
 switchport trunk encapsulation dot1q
 switchport trunk allowed vlan 100,101,200,300
 switchport mode trunk
 mtu 9198
 channel-group 1 mode active
 no shutdown
!
!
! IMF Servers PORTS
!
!
```

## Hardware Installation Guidelines

```
interface range GigabitEthernet 1/3 - 6
description IMF servers ports
 switchport trunk encapsulation dot1q
 switchport mode trunk
 mtu 9198
 no shutdown
!
interface range GigabitEthernet 1/8 - 9
description IMF servers ports
 switchport trunk encapsulation dot1q
 switchport mode trunk
 mtu 9198
 no shutdown
!
!
! iLO PORTS
!
!
interface GigabitEthernet 1/7
description IMF iLO ports
 switchport access vlan 300
 switchport mode access
 no shutdown
!
interface GigabitEthernet 1/10
description IMF iLO ports
 switchport access vlan 300
 switchport mode access
 no shutdown
!
!
! EAGLE PORTS
!
!
interface range GigabitEthernet 1/11 - 40
description Eagle FC or STC ports
 switchport access vlan 101
 switchport mode access
 mtu 9198
 no shutdown
!
!
! PORT TO CUSTOMER SWITCH B
!
!
interface GigabitEthernet 1/47
```

## Hardware Installation Guidelines

```
description to customer switch B
switchport access vlan 400
switchport mode access
media-type rj45
no shutdown
!
!
interface GigabitEthernet 1/48
description not used to avoid loop risk on iLO VLAN.
switchport access vlan 300
switchport mode access
media-type rj45
shutdown
!
!
! Laptop PORTS
!
!
interface range GigabitEthernet 1/45 - 46
description for Laptop
switchport access vlan 200
switchport mode access
media-type rj45
no shutdown
!
!
! VLAN INTERFACE CONFIGURATION
!
!
interface Vlan1
no ip address
!
!
interface VLAN 101
ip address 172.22.49.1 255.255.254.0
ip pim dense-mode
no shutdown
!
!
track 1 int gigabitEthernet 1/47 line-protocol
interface Vlan200
description internal VRRP for IMF to IXP traffic. Both IP addresses and netmask must be configured according
customer network.
ip address 192.168.0.3 255.255.255.224 ! <----- replace IP with the value provided by the customer
vrrp 1 ip 192.168.0.1 ! <----- replace IP with default gateway
vrrp 1 priority 99
```



## Hardware Installation Guidelines

```
vrrp 1 track 1
vrrp 1 preempt
no shutdown
!
!
interface Vlan 400
 description external VRRP for IMF to IXP traffic to Customer switches. Both IP addresses and netmask must be
 configured according customer network.
 ip address 192.168.20.3 255.255.255.248 ! <----- replace IP with the value provided by the customer
 vrrp 2 ip 192.168.20.1 ! <----- replace IP with default gateway
 vrrp 2 priority 99
 vrrp 2 preempt
 no shutdown
!
!
no ip http server
no ip http secure-server
!
ip route 0.0.0.0 0.0.0.0 192.168.20.6 1 ! <----- replace IP with customer default gateway
!
!
line con 0
 password ***** ! <----- replace ***** with password specified in password dragon as Cisco telnet
 login
!
logging 172.22.49.10
!
no cdp run
!
end
```

### 6.14.4 Yellow-sw2-1 Switch (Layer 3)

```
! IMF YELLOW2 SWITCH configuration
!
!
hostname yellow-sw2-1
!
no spanning-tree vlan 1-4094
no spanning-tree optimize bpdu transmission
!
enable secret ***** ! <----- replace ***** with password specified in password dragon as Cisco enable
service password-encryption
no service pad
service timestamps debug datetime
service timestamps log datetime
```

## Hardware Installation Guidelines

```
no logging console
no aaa new-model
track 1 interface GigabitEthernet1/47 line-protocol
ip subnet-zero
!
ip multicast-routing
!
power redundancy-mode redundant
!
!
! VLAN CONFIGURATION (internal)
!
!
vlan 100
 name internal_yellow
!
vlan 101
 name internal_blue
!
vlan 200
 name IMF2IXP_internal_(backend)
!
vlan 300
 name oobm_or_iLO
!
vlan 400
 name IMF2IXP_external_(frontend)
!
!
! INTER YELLOW SW 2 TO YELLOW SW 1 ETHERCHANNEL (internal)
!
!
interface Port-channel2
 description Trunk_between_yellow_sw2_and_yellow_sw1
 switchport
 switchport trunk encapsulation dot1q
 switchport trunk allowed vlan 100,101,200,300
 switchport mode trunk
 mtu 9198
 no shutdown
!
!
! INTER yellow SW2 TO yellow SW1 PORTS (internal)
!
!
Interface range GigabitEthernet 1/1 - 2
```

## Hardware Installation Guidelines

```
description Trunk_between_yellow_sw2_and_yellow_sw1
switchport trunk encapsulation dot1q
switchport trunk allowed vlan 100,101,200,300
switchport mode trunk
mtu 9198
channel-group 1 mode active
no shutdown
!
!
! IMF Servers PORTS
!
!
interface GigabitEthernet 1/3
description IMF servers ports
switchport trunk encapsulation dot1q
switchport mode trunk
mtu 9198
no shutdown
!
interface range GigabitEthernet 1/5 - 6
description IMF servers ports
switchport trunk encapsulation dot1q
switchport mode trunk
mtu 9198
no shutdown
!
interface range GigabitEthernet 1/8 - 9
description IMF servers ports
switchport trunk encapsulation dot1q
switchport mode trunk
mtu 9198
no shutdown
!
interface range GigabitEthernet 1/11
description IMF servers ports
switchport trunk encapsulation dot1q
switchport mode trunk
mtu 9198
no shutdown
!
!
! iLO PORTS
!
!
interface GigabitEthernet 1/4
description IMF iLO ports
```

## Hardware Installation Guidelines

```
switchport access vlan 300
switchport mode access
no shutdown
!
interface GigabitEthernet 1/7
description IMF iLO ports
switchport access vlan 300
switchport mode access
no shutdown
!
interface GigabitEthernet 1/10
description IMF iLO ports
switchport access vlan 300
switchport mode access
no shutdown
!
!
! EAGLE PORTS
!
!
interface range GigabitEthernet 1/12 - 48
description Eagle FC or STC ports
switchport access vlan 100
switchport mode access
mtu 9198
no shutdown
!
!
! VLAN INTERFACE CONFIGURATION
!
!
interface Vlan1
no ip address
!
!
interface VLAN 100
ip address 172.21.49.2 255.255.254.0
ip pim dense-mode
no shutdown!
!
interface Vlan200
description for remote access though telnet
ip address 192.168.0.4 255.255.255.224
customer
no shutdown
!
```

! <----- replace IP with the value provided by the

## Hardware Installation Guidelines

```
!
no ip http server
no ip http secure-server
!
ip route 0.0.0.0 0.0.0.0 192.168.0.1 1 ! <----- replace IP with VLAN 200 vrrp IP
!
!
line con 0
 password ***** ! <----- replace ***** with password specified in password dragon as Cisco telnet
 login
!
logging 172.21.49.10
!
no cdp run
!
end
```

### 6.14.5 Blue-sw2-1 Switch (Layer 3)

```
! IMF BLUE2 SWITCH configuration
!
!
hostname blue-sw2-1
!
no spanning-tree vlan 1-4094
no spanning-tree optimize bpdu transmission
!
enable secret ***** ! <----- replace ***** with password specified in password dragon as Cisco enable
service password-encryption
no service pad
service timestamps debug datetime
service timestamps log datetime
no logging console
no aaa new-model
track 1 interface GigabitEthernet1/47 line-protocol
ip subnet-zero
!
ip multicast-routing
!
power redundancy-mode redundant
!
!
! VLAN CONFIGURATION (internal)
!
!
```

## Hardware Installation Guidelines

```
vlan 100
 name internal_yellow
!
vlan 101
 name internal_blue
!
vlan 200
 name IMF2IXP_internal_(backend)
!
vlan 300
 name oobm_or_iLO
!
vlan 400
 name IMF2IXP_external_(frontend)
!
!
! INTER BLUE SW 2 TO BLUE SW 1 ETHERCHANNEL (internal)
!
!
interface Port-channel2
 description Trunk_between_blue_sw2_and_blue_sw1
 switchport
 switchport trunk encapsulation dot1q
 switchport trunk allowed vlan 100,101,200,300
 switchport mode trunk
 mtu 9198
 no shutdown
!
!
! INTER BLUE SW2 TO BLUE SW1 PORTS (internal)
!
!
Interface range GigabitEthernet 1/1 - 2
 description Trunk_between_blue_sw2_and_blue_sw1
 switchport trunk encapsulation dot1q
 switchport trunk allowed vlan 100,101,200,300
 switchport mode trunk
 mtu 9198
 channel-group 1 mode active
 no shutdown
!
!
! IMF Servers PORTS
!
!
interface range GigabitEthernet 1/3 - 4
```

## Hardware Installation Guidelines

```
description IMF servers ports
switchport trunk encapsulation dot1q
switchport mode trunk
mtu 9198
no shutdown
!
interface range GigabitEthernet 1/6 - 7
description IMF servers ports
switchport trunk encapsulation dot1q
switchport mode trunk
mtu 9198
no shutdown
!
interface range GigabitEthernet 1/9 - 10
description IMF servers ports
switchport trunk encapsulation dot1q
switchport mode trunk
mtu 9198
no shutdown
!
!
! iLO PORTS
!
!
interface GigabitEthernet 1/5
description IMF iLO ports
switchport access vlan 300
switchport mode access
no shutdown
!
interface GigabitEthernet 1/8
description IMF iLO ports
switchport access vlan 300
switchport mode access
no shutdown
!
interface GigabitEthernet 1/11
description IMF iLO ports
switchport access vlan 300
switchport mode access
no shutdown
!
!
! EAGLE PORTS
!
!
```

## Hardware Installation Guidelines

```
interface range GigabitEthernet 1/12 - 48
description Eagle FC or STC ports
 switchport access vlan 101
 switchport mode access
 mtu 9198
 no shutdown
!
!
! VLAN INTERFACE CONFIGURATION
!
!
interface Vlan1
 no ip address
!
!
interface VLAN 101
 ip address 172.22.49.2 255.255.254.0
 ip pim dense-mode
 no shutdown
!
!
interface Vlan200
 description for remote access though telnet
 ip address 192.168.0.5 255.255.255.224 ! <----- replace IP with the value provided by the
customer
 no shutdown
!
!
no ip http server
no ip http secure-server
!
ip route 0.0.0.0 0.0.0.0 192.168.0.1 1 ! <----- replace IP with VLAN 200 vrrp IP
!
!
line con 0
 password ***** ! <----- replace ***** with password specified in password dragon as Cisco telnet
 login
!
logging 172.22.49.10
!
no cdp run
!
end
```



## Hardware Installation Guidelines

### 6.14.6 Yellow-sw3-1 Switch (Layer 3)

```
! IMF YELLOW3 SWITCH configuration
!
!
hostname yellow-sw3-1
!
no spanning-tree vlan 1-4094
no spanning-tree optimize bpdu transmission
!
enable secret ***** ! <----- replace ***** with password specified in password dragon as Cisco enable
service password-encryption
no service pad
service timestamps debug datetime
service timestamps log datetime
no logging console
no aaa new-model
track 1 interface GigabitEthernet1/47 line-protocol
ip subnet-zero
!
ip multicast-routing
!
power redundancy-mode redundant
!
!
! VLAN CONFIGURATION (internal)
!
!
vlan 100
 name internal_yellow
!
vlan 101
 name internal_blue
!
vlan 200
 name IMF2IXP_internal_(backend)
!
vlan 300
 name oobm_or_iLO
!
vlan 400
 name IMF2IXP_external_(frontend)
!
!
! INTER YELLOW SW 3 TO YELLOW SW 1 ETHERCHANNEL (internal)
!
```

## Hardware Installation Guidelines

```
!
interface Port-channel3
 description Trunk_between_yellow_sw3_and_yellow_sw1
 switchport
 switchport trunk encapsulation dot1q
 switchport trunk allowed vlan 100,101,200,300
 switchport mode trunk
 mtu 9198
 no shutdown
!
!
! INTER yellow SW3 TO yellow SW1 PORTS (internal)
!
!
Interface range GigabitEthernet 1/1 - 2
 description Trunk_between_yellow_sw3_and_yellow_sw1
 switchport trunk encapsulation dot1q
 switchport trunk allowed vlan 100,101,200,300
 switchport mode trunk
 mtu 9198
 channel-group 1 mode active
 no shutdown
!
!
! EAGLE PORTS
!
!
interface range GigabitEthernet 1/3 - 48
 description Eagle FC or STC ports
 switchport access vlan 100
 switchport mode access
 mtu 9198
 no shutdown
!
!
! VLAN INTERFACE CONFIGURATION
!
!
interface Vlan1
 no ip address
!
!
interface VLAN 100
 ip address 172.21.49.3 255.255.254.0
 ip pim dense-mode
 no shutdown
```

## Hardware Installation Guidelines

```
!
!
interface Vlan200
 description for remote access though telnet
 ip address 192.168.0.6 255.255.255.224 ! <----- replace IP with the value provided by the
customer
 no shutdown
!
!
no ip http server
no ip http secure-server
!
ip route 0.0.0.0 0.0.0.0 192.168.0.1 1 ! <----- replace IP with yellow VLAN 200 vrrp IP
!
!
line con 0
 password ***** ! <----- replace ***** with password specified in password dragon as Cisco telnet
 login
!
logging 172.21.49.10
!
no cdp run
!
end
```

### 6.14.7 Blue-sw3-1 Switch (Layer 3)

```
! IMF BLUE3 SWITCH configuration
!
!
hostname blue-sw3-1
!
no spanning-tree vlan 1-4094
no spanning-tree optimize bpdu transmission
!
enable secret ***** ! <----- replace ***** with password specified in password dragon as Cisco enable
service password-encryption
no service pad
service timestamps debug datetime
service timestamps log datetime
no logging console
no aaa new-model
track 1 interface GigabitEthernet1/47 line-protocol
ip subnet-zero
!
```

```
ip multicast-routing
!
power redundancy-mode redundant
!
!
! VLAN CONFIGURATION (internal)
!
!
vlan 100
 name internal_yellow
!
vlan 101
 name internal_blue
!
vlan 200
 name IMF2IXP_internal_(backend)
!
vlan 300
 name oobm_or_iLO
!
vlan 400
 name IMF2IXP_external_(frontend)
!
!
! INTER BLUE SW 3 TO BLUE SW 1 ETHERCHANNEL (internal)
!
!
interface Port-channel3
 description Trunk_between_blue_sw3_and_blue_sw1
 switchport
 switchport trunk encapsulation dot1q
 switchport trunk allowed vlan 100,101,200,300
 switchport mode trunk
 mtu 9198
 no shutdown
!
!
! INTER BLUE SW3 TO BLUE SW1 PORTS (internal)
!
!
Interface range GigabitEthernet 1/1 - 2
 description Trunk_between_blue_sw3_and_blue_sw1
 switchport trunk encapsulation dot1q
 switchport trunk allowed vlan 100,101,200,300
 switchport mode trunk
 mtu 9198
```

## Hardware Installation Guidelines

```
channel-group 1 mode active
no shutdown
!
!
! EAGLE PORTS
!
!
interface range GigabitEthernet 1/3 - 48
description Eagle FC or STC ports
switchport access vlan 101
switchport mode access
mtu 9198
no shutdown
!
!
! VLAN INTERFACE CONFIGURATION
!
!
interface Vlan1
no ip address
!
!
interface VLAN 101
ip address 172.22.49.3 255.255.254.0
ip pim dense-mode
no shutdown!
!
interface Vlan200
description for remote access though telnet
ip address 192.168.0.7 255.255.255.224 ! <----- replace IP with the value provided by the
customer
no shutdown
!
!
no ip http server
no ip http secure-server
!
ip route 0.0.0.0 0.0.0.0 192.168.0.1 1 ! <----- replace IP with yellow VLAN 200 vrrp IP
!
!
line con 0
password ***** ! <----- replace ***** with password specified in password dragon as Cisco telnet
login
!
logging 172.22.49.10
!
```

## Hardware Installation Guidelines

```
no cdp run
!
end
```

### 6.14.8 Single Switch yellow-blue-sw1-1

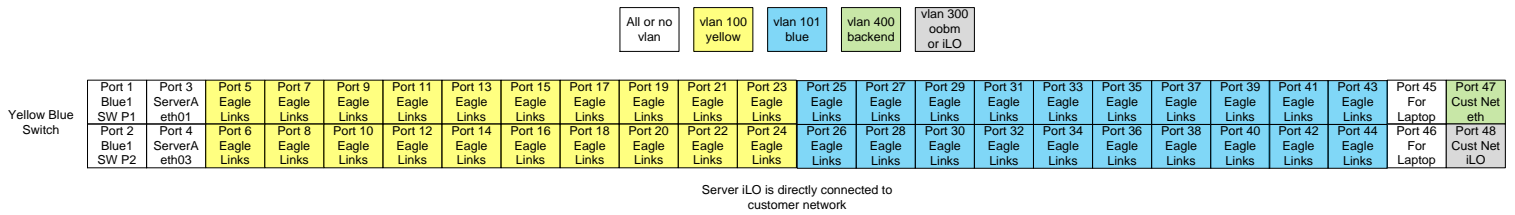

```
enable secret ***** ! <----- replace ***** with password specified in password dragon as Cisco enable
service password-encryption
no service pad
service timestamps debug uptime
service timestamps log uptime
service compress-config
!
hostname yellow-blue-sw1-1
!
no logging console
!
no aaa new-model
ip subnet-zero
!
ip multicast-routing
vtp mode transparent
!
!
!
power redundancy-mode redundant
no file verify auto
spanning-tree mode pvst
no spanning-tree optimize bpdu transmission
spanning-tree extend system-id
!
!
! VLAN CONFIGURATION (internal)
!
!
vlan internal allocation policy ascending
!
```

## Hardware Installation Guidelines

```
vlan 100
 name internal_yellow
!
vlan 101
 name internal_blue
!
vlan 200
 name IMF2IXP_internal_(backend)
!
vlan 300
 name oobm_or_iLO
!
!
! INTER YELLOW SW1 TO BLUE SW1 ETHERCHANNEL (internal)
!
!
interface Port-channel1
 description Red_Wan_Trunk_between_Yellow_and_Blue (unused here but reserved)
 switchport
 switchport trunk encapsulation dot1q
 switchport mode trunk
 mtu 9198
!
!
! INTER YELLOW SW1 TO BLUE SW1 PORTS (internal)
!
!
Interface range GigabitEthernet 1/1 - 2
 description Red_Wan_Trunk_between_Yellow_and_Blue (unused here but reserved)
 switchport trunk encapsulation dot1q
 switchport mode trunk
 mtu 9198
 channel-group 1 mode active
!
!
! IMF Servers PORTS
!
!
interface range GigabitEthernet1/3 - 4
 description for IMF 1A external + internal networks port
 switchport trunk encapsulation dot1q
 switchport trunk allowed vlan 1,100,101,200,300
 switchport mode trunk
 mtu 9198
 spanning-tree portfast trunk
!
```

## Hardware Installation Guidelines

```
!
! EAGLE PORTS
!
!
interface range GigabitEthernet1/5 - 24
description yellow network port for Eagle connectivity
switchport access vlan 100
switchport mode access
mtu 9198
spanning-tree portfast
!
!
interface range GigabitEthernet1/25-44
description blue network port for Eagle connectivity
switchport access vlan 101
switchport mode access
mtu 9198
spanning-tree portfast
!
interface range GigabitEthernet1/45-46
description unused
shutdown
!
!
! PORT TO CUSTOMER SWITCH A
!
!
interface GigabitEthernet1/47
description port where customer is connected to IMF
switchport access vlan 200
switchport mode access
media-type rj45
!
interface GigabitEthernet1/48
description port where customer is connected to ILO
switchport access vlan 300
switchport mode access
media-type rj45
!
interface Vlan1
no ip address
!
interface Vlan100
ip address 172.21.49.1 255.255.254.0
no ip route-cache cef
no ip route-cache
```



## Hardware Installation Guidelines

```
no shutdown
!
interface Vlan101
 ip address 172.22.49.1 255.255.254.0
 no ip route-cache cef
 no ip route-cache
 no shutdown
!
!
interface Vlan200
 ip address 10.27.56.166 255.255.255.240 ! <----- replace IP with an address from customer network
 no shutdown
!
no ip http server
no ip http secure-server
!
ip route 0.0.0.0 0.0.0.0 10.248.4.17 1 ! <----- replace IP with customer default gateway
!
!
logging 172.21.49.10
no cdp run
!
line con 0
 password ***** ! <----- replace ***** with password specified in password dragon as Cisco telnet
 login
!
!
!
End
```

### 6.14.9 RMS Layer 2 switch configurations (PIC 9.x and earlier)

#### 6.14.9.1 Yellow-sw1-1 (Layer 2)

```
!
no service pad
service timestamps debug datetime
service timestamps log datetime
service password-encryption
no logging console
!
hostname yellow-sw1-1
enable secret ***** ! <----- replace ***** with password specified in password dragon as Cisco enable
!
ip subnet-zero
vtp mode transparent
```

## Hardware Installation Guidelines

```
!
!
spanning-tree mode pvst
no spanning-tree optimize bpdu transmission
spanning-tree extend system-id
spanning-tree vlan 1-1024 priority 40960
!
ip multicast-routing
!
!
! VLAN CONFIGURATION (internal)
!
!
vlan 100
 name yellow
!
vlan 101
 name blue
!
vlan 200
 name cust
!
vlan 300
 name oobm
!
!
! INTER YELLOW SW1 TO BLUE SW1 ETHERCHANNEL (internal)
!
!
interface Port-channel1
 description Red_Wan_Trunk_between_Yellow_and_Blue
 switchport
 switchport trunk encapsulation dot1q
 switchport trunk allowed vlan 1,100,101,200,300
 switchport mode trunk
 mtu 9198
 spanning-tree portfast trunk
!
!
! INTER YELLOW SW 1 TO YELLOW SW2 ETHERCHANNEL (internal)
!
!
interface Port-channel2
 description Trunk_between_Yellow_sw1_and_Yellow_sw2
 switchport
 switchport trunk encapsulation dot1q
```

## Hardware Installation Guidelines

```
switchport trunk allowed vlan 1,100,101,200,300
switchport mode trunk
mtu 9198
spanning-tree portfast trunk
!
!
! INTER YELLOW SW 1 TO YELLOW SW3 ETHERCHANNEL (internal)
!
!
interface Port-channel3
 description Trunk_between_Yellow_sw1_and_Yellow_sw3
 switchport
 switchport trunk encapsulation dot1q
 switchport trunk allowed vlan 1,100,101,200,300
 switchport mode trunk
 mtu 9198
 spanning-tree portfast trunk
!
!
! INTER YELLOW SW1 TO BLUE SW1 PORTS (internal)
!
!
interface range gigabitEthernet 1/1 - 2
 description ISL_between_yellow_sw1_and_blue_sw1
 switchport trunk encapsulation dot1q
 switchport trunk allowed vlan 1,100,101,200,300
 switchport mode trunk
 mtu 9198
 channel-group 1 mode active
 spanning-tree portfast trunk
 no shutdown
!
!
! INTER yellow SW1 TO yellow SW3 PORTS (internal)
!
!
interface range gigabitEthernet 1/41 - 42
 description Trunk_between_yellow_sw1_and_yellow_sw3
 switchport trunk encapsulation dot1q
 switchport trunk allowed vlan 1,100,101,200,300
 switchport mode trunk
 mtu 9198
 channel-group 3 mode active
 spanning-tree portfast trunk
 no shutdown
!
```

## Hardware Installation Guidelines

```
!
! INTER yellow SW1 TO yellow SW2 PORTS (internal)
!
!
interface range gigabitEthernet 1/43 - 44
description Trunk_between_yellow_sw1_and_yellow_sw2
 switchport trunk encapsulation dot1q
 switchport trunk allowed vlan 1,100,101,200,300
 switchport mode trunk
 mtu 9198
 channel-group 2 mode active
 spanning-tree portfast trunk
 no shutdown
!
!
! IMF Servers PORTS
!
!
interface range gigabitEthernet 1/3 - 5
description IMF servers ports
 switchport trunk encapsulation dot1q
 switchport mode trunk
 mtu 9198
 spanning-tree portfast trunk
 no shutdown
!
interface range gigabitEthernet 1/7 - 8
description IMF servers ports
 switchport trunk encapsulation dot1q
 switchport mode trunk
 mtu 9198
 spanning-tree portfast trunk
 no shutdown
!
interface gigabitEthernet 1/10
description IMF servers ports
 switchport trunk encapsulation dot1q
 switchport mode trunk
 mtu 9198
 spanning-tree portfast trunk
 no shutdown
!
!
! iLO PORTS
!
!
```

## Hardware Installation Guidelines

```
interface gigabitEthernet 1/6
description IMF iLO ports
switchport mode access
switchport access vlan 300
spanning-tree portfast
no shutdown
!
interface gigabitEthernet 1/9
description IMF iLO ports
switchport mode access
switchport access vlan 300
spanning-tree portfast
no shutdown
!
!
! EAGLE PORTS
!
!
interface range gigabitEthernet 1/11 - 40
description Eagle FC or STC ports
switchport mode access
switchport access vlan 100
mtu 9198
spanning-tree portfast
no shutdown
!
!
! Laptop PORTS
!
!
interface range GigabitEthernet 1/45 - 46
description for Laptop
switchport access vlan 200
switchport mode access
media-type rj45
no shutdown
!
!
! PORT TO CUSTOMER SWITCH A
!
!
interface gigabitEthernet 1/47
description to customer switch A
switchport mode access
switchport access vlan 200
media-type rj45
```

```
no shutdown
!
interface gigabitEthernet 1/48
description to customer switch A (iLO)
switchport mode access
switchport access vlan 300
media-type rj45
no shutdown
!
interface VLAN 100
ip address 172.21.49.1 255.255.254.0
ip pim dense-mode
no shutdown
!
no ip route-cache
!
no ip http server
!
no cdp run
!
line con 0
password ***** ! <----- replace ***** with password specified in password dragon as Cisco telnet
login
!
logging 172.21.49.10
!
end
```

### 6.14.9.2 Blue-sw1-1 (Layer 2)

```
!
no service pad
service timestamps debug datetime
service timestamps log datetime
service password-encryption
no logging console
!
hostname blue-sw1-1
enable secret ***** ! <----- replace ***** with password specified in password dragon as Cisco enable
!
ip subnet-zero
vtp mode transparent
!
!
spanning-tree mode pvst
```

## Hardware Installation Guidelines

```
no spanning-tree optimize bpdu transmission
spanning-tree extend system-id
spanning-tree vlan 1-1024 priority 40960
!
ip multicast-routing
!
!
! VLAN CONFIGURATION (internal)
!
!
vlan 100
 name yellow
!
vlan 101
 name blue
!
vlan 200
 name cust
!
vlan 300
 name oobm
!
!
! INTER YELLOW SW1 TO BLUE SW1 ETHERCHANNEL (internal)
!
!
interface Port-channel1
 description Red_Wan_Trunk_between_Yellow_and_Blue
 switchport
 switchport trunk encapsulation dot1q
 switchport trunk allowed vlan 1,100,101,200,300
 switchport mode trunk
 mtu 9198
 spanning-tree portfast trunk
!
!
! INTER BLUE SW 1 TO BLUE SW2 ETHERCHANNEL (internal)
!
!
interface Port-channel2
 description Trunk_between_Blue_sw1_and_Blue_sw2
 switchport
 switchport trunk encapsulation dot1q
 switchport trunk allowed vlan 1,100,101,200,300
 switchport mode trunk
 mtu 9198
```

## Hardware Installation Guidelines

```
spanning-tree portfast trunk
!
!
! INTER BLUE SW 1 TO BLUE SW3 ETHERCHANNEL (internal)
!
!
interface Port-channel3
 description Trunk_between_Blue_sw1_and_Blue_sw3
 switchport
 switchport trunk encapsulation dot1q
 switchport trunk allowed vlan 1,100,101,200,300
 switchport mode trunk
 spanning-tree portfast trunk
!
!
! INTER BLUE SW1 TO yellow SW1 PORTS (internal)
!
!
interface range gigabitEthernet 1/1 - 2
 description ISL_between_blue_sw1_and_yellow_sw1
 switchport trunk encapsulation dot1q
 switchport trunk allowed vlan 1,100,101,200,300
 switchport mode trunk
 mtu 9198
 channel-group 1 mode active
 spanning-tree portfast trunk
 no shutdown
!
!
! INTER BLUE SW1 TO BLUE SW3 PORTS (internal)
!
!
interface range gigabitEthernet 1/41 - 42
 description Trunk_between_blue_sw1_and_blue_sw3
 switchport trunk encapsulation dot1q
 switchport trunk allowed vlan 1,100,101,200,300
 switchport mode trunk
 channel-group 3 mode active
 mtu 9198
 spanning-tree portfast trunk
 no shutdown
!
!
! INTER BLUE SW1 TO BLUE SW2 PORTS (internal)
!
!
```



## Hardware Installation Guidelines

```
interface range gigabitEthernet 1/43 - 44
description Trunk_between_blue_sw1_and_blue_sw2
 switchport trunk encapsulation dot1q
 switchport trunk allowed vlan 1,100,101,200,300
 switchport mode trunk
 channel-group 2 mode active
 mtu 9198
 spanning-tree portfast trunk
 no shutdown
!
!
! IMF Servers PORTS
!
!
interface range gigabitEthernet 1/3 - 6
description IMF servers ports
 switchport trunk encapsulation dot1q
 switchport mode trunk
 mtu 9198
 spanning-tree portfast trunk
 no shutdown
!
interface range gigabitEthernet 1/8 - 9
description IMF servers ports
 switchport trunk encapsulation dot1q
 switchport mode trunk
 mtu 9198
 spanning-tree portfast trunk
 no shutdown
!
!
! iLO PORTS
!
!
interface gigabitEthernet 1/7
description IMF iLO ports
 switchport mode access
 switchport access vlan 300
 spanning-tree portfast
 no shutdown
!
interface gigabitEthernet 1/10
description IMF iLO ports
 switchport mode access
 switchport access vlan 300
 spanning-tree portfast
```

## Hardware Installation Guidelines

```
no shutdown
!
!
! EAGLE PORTS
!
!
interface range gigabitEthernet 1/11 - 40
description Eagle FC or STC ports
switchport mode access
switchport access vlan 101
mtu 9198
spanning-tree portfast
no shutdown
!
!
! Laptop PORTS
!
!
interface range GigabitEthernet 1/45 - 46
description for Laptop
switchport access vlan 200
switchport mode access
media-type rj45
no shutdown
!
!
! PORT TO CUSTOMER SWITCH B
!
!
interface gigabitEthernet 1/47
description to customer switch B
switchport mode access
switchport access vlan 200
media-type rj45
no shutdown
!
interface gigabitEthernet 1/48
description to customer switch B (iLO)
switchport mode access
switchport access vlan 300
media-type rj45
no shutdown
!
interface VLAN 101
ip address 172.22.49.1 255.255.254.0
```

## Hardware Installation Guidelines

```
ip pim dense-mode
no shutdown
!
no ip route-cache
!
no ip http server
!
no cdp run
!
line con 0
password ***** ! <----- replace ***** with password specified in password dragon as Cisco telnet
login
!
logging 172.22.49.10
!
end
```

### 6.14.9.3 Yellow-sw2-1 (Layer 2)

```
!
no service pad
service timestamps debug datetime
service timestamps log datetime
service password-encryption
no logging console
!
hostname yellow-sw2-1
enable secret ***** ! <----- replace ***** with password specified in password dragon as Cisco enable
!
ip subnet-zero
vtp mode transparent
!
boot-start-marker
boot system flash bootflash:cat4500-ipbasek9-mz.122-53.SG2.bin
boot-end-marker
!
!
spanning-tree mode pvst
no spanning-tree optimize bpdu transmission
spanning-tree extend system-id
spanning-tree vlan 1-1024 priority 53248
!
ip multicast-routing
!
!
```

## Hardware Installation Guidelines

```
! VLAN CONFIGURATION (internal)
!
!
vlan 100
 name yellow
!
vlan 101
 name blue
!
vlan 200
 name cust
!
vlan 300
 name oobm
!
!
! INTER YELLOW SW 2 TO YELLOW SW 1 ETHERCHANNEL (internal)
!
!
interface Port-channel1
 description Trunk_between_Yellow_sw2_and_Yellow_sw1
 switchport
 switchport trunk encapsulation dot1q
 switchport trunk allowed vlan 1,100,101,200,300
 switchport mode trunk
 mtu 9198
 spanning-tree portfast trunk
!
!
! INTER yellow SW2 TO yellow SW1 PORTS (internal)
!
!
interface range gigabitEthernet 1/1 - 2
 description Trunk_between_yellow_sw2_and_yellow_sw1
 switchport trunk encapsulation dot1q
 switchport trunk allowed vlan 1,100,101,200,300
 switchport mode trunk
 mtu 9198
 channel-group 1 mode active
 spanning-tree portfast trunk
 no shutdown
!
!
! IMF Servers PORTS
!
!
```

## Hardware Installation Guidelines

```
interface gigabitEthernet 1/3
description IMF servers ports
 switchport trunk encapsulation dot1q
 switchport mode trunk
 mtu 9198
 spanning-tree portfast trunk
 no shutdown
!
interface range gigabitEthernet 1/5 - 6
description IMF servers ports
 switchport trunk encapsulation dot1q
 switchport mode trunk
 mtu 9198
 spanning-tree portfast trunk
 no shutdown
!
interface range gigabitEthernet 1/8 - 9
description IMF servers ports
 switchport trunk encapsulation dot1q
 switchport mode trunk
 mtu 9198
 spanning-tree portfast trunk
 no shutdown
!
interface gigabitEthernet 1/11
description IMF servers ports
 switchport trunk encapsulation dot1q
 switchport mode trunk
 mtu 9198
 spanning-tree portfast trunk
 no shutdown
!
!
! iLO PORTS
!
interface gigabitEthernet 1/4
description IMF iLO ports
 switchport mode access
 switchport access vlan 300
 spanning-tree portfast
 no shutdown
!
interface gigabitEthernet 1/7
description IMF iLO ports
 switchport mode access
```

```
switchport access vlan 300
spanning-tree portfast
no shutdown
!
interface gigabitEthernet 1/10
description IMF iLO ports
switchport mode access
switchport access vlan 300
spanning-tree portfast
no shutdown
!
!
! EAGLE PORTS
!
!
interface range gigabitEthernet 1/12 - 48
description Eagle FC or STC ports
switchport mode access
switchport access vlan 100
mtu 9198
spanning-tree portfast
no shutdown
!
interface VLAN 100
ip address 172.21.49.2 255.255.254.0
ip pim dense-mode
no shutdown
!
no ip route-cache
!
no ip http server
!
no cdp run
!
line con 0
password ***** ! <----- replace ***** with password specified in password dragon as Cisco telnet
login
!
logging 172.21.49.10
!
end
```

### 6.14.9.4 Blue-sw2-1 (Layer 2)

!

## Hardware Installation Guidelines

```
no service pad
service timestamps debug datetime
service timestamps log datetime
service password-encryption
no logging console
!
hostname blue-sw2-1
enable secret ***** ! <----- replace ***** with password specified in password dragon as Cisco enable
!
ip subnet-zero
vtp mode transparent
!
!
spanning-tree mode pvst
no spanning-tree optimize bpdu transmission
spanning-tree extend system-id
spanning-tree vlan 1-1024 priority 53248
!
ip multicast-routing
!
!
! VLAN CONFIGURATION (internal)
!
!
vlan 100
 name yellow
!
vlan 101
 name blue
!
vlan 200
 name cust
!
vlan 300
 name oobm
!
!
! INTER BLUE SW 2 TO BLUE SW 1 ETHERCHANNEL (internal)
!
!
interface Port-channel1
 description Trunk_between_Blue_sw2_and_Blue_sw1
 switchport
 switchport trunk encapsulation dot1q
 switchport trunk allowed vlan 1,100,101,200,300
 switchport mode trunk
```

## Hardware Installation Guidelines

```
mtu 9198
spanning-tree portfast trunk
!
!
! INTER BLUE SW2 TO BLUE SW1 PORTS (internal)
!
!
interface range gigabitEthernet 1/1 - 2
description Trunk_between_blue_sw2_and_blue_sw1
switchport trunk encapsulation dot1q
switchport trunk allowed vlan 1,100,101,200,300
switchport mode trunk
mtu 9198
channel-group 1 mode active
spanning-tree portfast trunk
no shutdown
!
!
! IMF Servers PORTS
!
!
interface range gigabitEthernet 1/3 - 4
description IMF servers ports
switchport trunk encapsulation dot1q
switchport mode trunk
mtu 9198
spanning-tree portfast trunk
no shutdown
!
interface range gigabitEthernet 1/6 - 7
description IMF servers ports
switchport trunk encapsulation dot1q
switchport mode trunk
mtu 9198
spanning-tree portfast trunk
no shutdown
!
interface range gigabitEthernet 1/9 - 10
description IMF servers ports
switchport trunk encapsulation dot1q
switchport mode trunk
mtu 9198
spanning-tree portfast trunk
no shutdown
!
!
```



## Hardware Installation Guidelines

```
! iLO PORTS
!
!
interface gigabitEthernet 1/5
description IMF iLO ports
switchport mode access
switchport access vlan 300
spanning-tree portfast
no shutdown
!
interface gigabitEthernet 1/8
description IMF iLO ports
switchport mode access
switchport access vlan 300
spanning-tree portfast
no shutdown
!
interface gigabitEthernet 1/11
description IMF iLO ports
switchport mode access
switchport access vlan 300
spanning-tree portfast
no shutdown
!
!
! EAGLE PORTS
!
!
interface range gigabitEthernet 1/12 - 48
description Eagle FC or STC ports
switchport mode access
switchport access vlan 101
mtu 9198
spanning-tree portfast
no shutdown
!
interface VLAN 101
ip address 172.22.49.2 255.255.254.0
ip pim dense-mode
no shutdown
!
no ip route-cache
!
no ip http server
!
no cdp run
```

```
!
line con 0
 password ***** ! <----- replace ***** with password specified in password dragon as Cisco telnet
 login
!
logging 172.22.49.10
!
end
```

### 6.14.9.5 Yellow-sw3-1 (Layer 2)

```
!
no service pad
service timestamps debug datetime
service timestamps log datetime
service password-encryption
no logging console
!
hostname yellow-sw3-1
enable secret ***** ! <----- replace ***** with password specified in password dragon as Cisco enable
!
ip subnet-zero
vtp mode transparent
!
!
spanning-tree mode pvst
no spanning-tree optimize bpdu transmission
spanning-tree extend system-id
spanning-tree vlan 1-1024 priority 53248
!
ip multicast-routing
!
!
! VLAN CONFIGURATION (internal)
!
!
vlan 100
 name yellow
!
vlan 101
 name blue
!
vlan 200
 name cust
!
!
```

## Hardware Installation Guidelines

```
vlan 300
 name oobm
!
!
! INTER YELLOW SW 3 TO YELLOW SW 1 ETHERCHANNEL (internal)
!
!
interface Port-channel1
 description Trunk_between_Yellow_sw3_and_Yellow_sw1
 switchport
 switchport trunk encapsulation dot1q
 switchport trunk allowed vlan 1,100,101,200,300
 switchport mode trunk
 mtu 9198
 spanning-tree portfast trunk
!
!
! INTER yellow SW3 TO yellow SW1 PORTS (internal)
!
!
interface range gigabitEthernet 1/1 - 2
 description Trunk_between_yellow_sw3_and_yellow_sw1
 switchport trunk encapsulation dot1q
 switchport trunk allowed vlan 1,100,101,200,300
 switchport mode trunk
 mtu 9198
 channel-group 1 mode active
 spanning-tree portfast trunk
 no shutdown
!
!
! EAGLE PORTS
!
!
interface range gigabitEthernet 1/3 - 48
 description Eagle FC or STC ports
 switchport mode access
 switchport access vlan 100
 mtu 9198
 spanning-tree portfast
 no shutdown
!
interface VLAN 100
 ip address 172.21.49.3 255.255.254.0
 ip pim dense-mode
 no shutdown
```

```
!
no ip route-cache
!
no ip http server
!
no cdp run
!
line con 0
 password ***** ! <----- replace ***** with password specified in password dragon as Cisco telnet
 login
!
logging 172.21.49.10
!
end
```

### 6.14.9.6 Blue-sw3-1 (Layer 2)

```
!
no service pad
service timestamps debug datetime
service timestamps log datetime
service password-encryption
no logging console
!
hostname blue-sw3-1
enable secret ***** ! <----- replace ***** with password specified in password dragon as Cisco enable
!
ip subnet-zero
vtp mode transparent
!
!
spanning-tree mode pvst
no spanning-tree optimize bpdu transmission
spanning-tree extend system-id
spanning-tree vlan 1-1024 priority 53248
!
ip multicast-routing
!
!
! VLAN CONFIGURATION (internal)
!
!
vlan 100
 name yellow
!
!
```

## Hardware Installation Guidelines

```
vlan 101
 name blue
!
vlan 200
 name cust
!
vlan 300
 name oobm
!
!
! INTER BLUE SW 3 TO BLUE SW 1 ETHERCHANNEL (internal)
!
!
interface Port-channel1
 description Trunk_between_Blue_sw3_and_Blue_sw1
 switchport
 switchport trunk encapsulation dot1q
 switchport trunk allowed vlan 1,100,101,200,300
 switchport mode trunk
 mtu 9198
 spanning-tree portfast trunk
!
!
! INTER BLUE SW3 TO BLUE SW1 PORTS (internal)
!
!
interface range gigabitEthernet 1/1 - 2
 description Trunk_between_blue_sw3_and_blue_sw1
 switchport trunk encapsulation dot1q
 switchport trunk allowed vlan 1,100,101,200,300
 switchport mode trunk
 mtu 9198
 channel-group 1 mode active
 spanning-tree portfast trunk
 no shutdown
!
!
! EAGLE PORTS
!
!
interface range gigabitEthernet 1/3 - 48
 description Eagle FC or STC ports
 switchport mode access
 switchport access vlan 101
 mtu 9198
 spanning-tree portfast
```



## Hardware Installation Guidelines

```
no spanning-tree vlan 1-4094
no spanning-tree optimize bpdu transmission
!
enable secret ***** ! <----- replace ***** with password specified in password dragon as Cisco enable
service password-encryption
no service pad
service timestamps debug datetime
service timestamps log datetime
no logging console
no aaa new-model
track 1 interface GigabitEthernet1/47 line-protocol
ip subnet-zero
!
ip multicast-routing
!
power redundancy-mode redundant
!
!
! VLAN CONFIGURATION (internal)
!
!
vlan 100
 name internal_yellow
!
vlan 101
 name internal_blue
!
vlan 200
 name IMF2IXP_internal_(backend)
!
vlan 400
 name IMF2IXP_external_(frontend)
!
!
! INTER YELLOW SW1 TO BLUE SW1 ETHERCHANNEL (internal)
!
!
interface Port-channel1
 description Trunk_between_yellow_sw1_and_blue_sw1
 switchport
 switchport trunk encapsulation dot1q
 switchport trunk allowed vlan 100,101,200,300
 mtu 9198
 no shutdown
!
```

## Hardware Installation Guidelines

```
!
! INTER YELLOW SW1 TO BLUE SW1 PORTS (internal)
!
!
Interface range GigabitEthernet 1/1 - 2
 description ISL_between_yellow_sw1_and_blue_sw1
 switchport trunk encapsulation dot1q
 switchport trunk allowed vlan 100,101,200,300
 switchport mode trunk
 switchport nonegotiate
 mtu 9198
 channel-group 1 mode active
 no shutdown
!
!
! IMF Servers PORTS
!
!
interface range GigabitEthernet 1/3 - 8
 description IMF servers ports
 switchport trunk encapsulation dot1q
 switchport mode trunk
 mtu 9198
 no shutdown
!
!
! EAGLE PORTS
!
!
interface range GigabitEthernet 1/9 - 46
 description Eagle FC or STC ports
 switchport access vlan 100
 switchport mode access
 mtu 9198
 no shutdown
!
!
! PORT TO CUSTOMER SWITCH A
!
!
interface GigabitEthernet 1/47
 description to customer switch A
 switchport access vlan 400
 switchport mode access
 media-type rj45
 no shutdown
```



## Hardware Installation Guidelines

```
!
!
! Laptop PORTS
!
!
interface range GigabitEthernet 1/48
 description for Laptop
 switchport access vlan 200
 switchport mode access
 media-type rj45
 no shutdown
!
!
! VLAN INTERFACE CONFIGURATION
!
!
interface Vlan1
 no ip address
!
!
interface VLAN 100
 ip address 172.21.49.1 255.255.254.0
 ip pim dense-mode
 no shutdown
!
!
track 1 int gigabitEthernet 1/47 line-protocol
interface Vlan200
 description internal VRRP for IMF to IXP traffic. Both IP addresses and netmask must be configured according
 customer network.
 ip address 192.168.0.2 255.255.255.224 ! <----- replace IP with the value provided by the customer
 vrrp 1 ip 192.168.0.1 ! <----- replace IP with default gateway
 vrrp 1 priority 100
 vrrp 1 track 1
 vrrp 1 preempt
 no shutdown
!
!
interface Vlan 400
 description external VRRP for IMF to IXP traffic to Customer switches. Both IP addresses and netmask must be
 configured according customer network.
 ip address 192.168.20.2 255.255.255.248 ! <----- replace IP with the value provided by the customer
 vrrp 2 ip 192.168.20.1 ! <----- replace IP with default gateway
 vrrp 2 priority 100
 vrrp 2 preempt
 no shutdown
```

```
!
!
no ip http server
no ip http secure-server
!
ip route 0.0.0.0 0.0.0.0 192.168.20.6 1 ! <----- replace IP with customer default gateway
!
!
line con 0
 password ***** ! <----- replace ***** with password specified in password dragon as Cisco telnet
 login
!
logging 172.21.49.10
!
no cdp run
!
end
```

### 6.14.10.3 Blue-sw1-1 Switch (Layer 3)

```
! IMF BLUE SWITCH configuration
!
!
hostname blue-sw1-1
!
no spanning-tree vlan 1-4094
no spanning-tree optimize bpdu transmission
!
enable secret ***** ! <----- replace ***** with password specified in password dragon as Cisco enable
service password-encryption
no service pad
service timestamps debug datetime
service timestamps log datetime
no logging console
no aaa new-model
track 1 interface GigabitEthernet1/47 line-protocol
ip subnet-zero
!
ip multicast-routing
!
power redundancy-mode redundant
!
!
! VLAN CONFIGURATION (internal)
!
!
```

## Hardware Installation Guidelines

```
vlan 100
 name internal_yellow
!
vlan 101
 name internal_blue
!
vlan 200
 name IMF2IXP_internal_(backend)
!
vlan 400
 name IMF2IXP_external_(frontend)
!
!
! INTER YELLOW SW TO BLUE SW ETHERCHANNEL (internal)
!
!
interface Port-channel1
 description Trunk_between_yellow_sw1_and_blue_sw1
 switchport
 switchport trunk encapsulation dot1q
 switchport trunk allowed vlan 100,101,200,300
 mtu 9198
 no shutdown
!
!
! INTER BLUE SW TO YELLOW SW PORTS (internal)
!
!
Interface range GigabitEthernet 1/1 - 2
 description ISL_between_blue_sw1_and_yellow_sw1
 switchport trunk encapsulation dot1q
 switchport trunk allowed vlan 100,101,200,300
 switchport mode trunk
 switchport nonegotiate
 mtu 9198
 channel-group 1 mode active
 no shutdown
!
!
! IMF Servers PORTS
!
!
interface range GigabitEthernet 1/3 - 8
 description IMF servers ports
 switchport trunk encapsulation dot1q
 switchport mode trunk
```

## Hardware Installation Guidelines

```
mtu 9198
no shutdown
!
!
! EAGLE PORTS
!
!
interface range GigabitEthernet 1/9 - 46
description Eagle FC or STC ports
switchport access vlan 101
switchport mode access
mtu 9198
no shutdown
!
!
! PORT TO CUSTOMER SWITCH B
!
!
interface GigabitEthernet 1/47
description to customer switch B
switchport access vlan 400
switchport mode access
media-type rj45
no shutdown
!
!
! Laptop PORTS
!
!
interface range GigabitEthernet 1/48
description for Laptop
switchport access vlan 200
switchport mode access
media-type rj45
no shutdown
!
!
! VLAN INTERFACE CONFIGURATION
!
!
interface Vlan1
no ip address
!
!
interface VLAN 101
ip address 172.22.49.1 255.255.254.0
```

## Hardware Installation Guidelines

```
ip pim dense-mode
no shutdown
!
!
track 1 int gigabitEthernet 1/47 line-protocol
interface Vlan200
 description internal VRRP for IMF to IXP traffic. Both IP addresses and netmask must be configured according
 customer network.
 ip address 192.168.0.3 255.255.255.224 ! <----- replace IP with the value provided by the customer
 vrrp 1 ip 192.168.0.1 ! <----- replace IP with default gateway
 vrrp 1 priority 99
 vrrp 1 track 1
 vrrp 1 preempt
 no shutdown
!
!
interface Vlan 400
 description external VRRP for IMF to IXP traffic to Customer switches. Both IP addresses and netmask must be
 configured according customer network.
 ip address 192.168.20.3 255.255.255.248 ! <----- replace IP with the value provided by the customer
 vrrp 2 ip 192.168.20.1 ! <----- replace IP with default gateway
 vrrp 2 priority 99
 vrrp 2 preempt
 no shutdown
!
!
no ip http server
no ip http secure-server
!
ip route 0.0.0.0 0.0.0.0 192.168.20.6 1 ! <----- replace IP with customer default gateway
!
!
line con 0
 password ***** ! <----- replace ***** with password specified in password dragon as Cisco telnet
 login
!
logging 172.22.49.10
!
no cdp run
!
end
```

### 6.14.10.4 Single Switch yellow-blue-sw1-1 (Layer 2)

```
enable secret ***** ! <----- replace ***** with password specified in password dragon as Cisco enable
```

## Hardware Installation Guidelines

```
service password-encryption
no service pad
service timestamps debug uptime
service timestamps log uptime
service compress-config
!
hostname yellow-blue-sw1-1
!
no logging console
!
no aaa new-model
ip subnet-zero
!
ip multicast-routing
vtp mode transparent
!
!
!
power redundancy-mode redundant
no file verify auto
spanning-tree mode pvst
no spanning-tree optimize bpdu transmission
spanning-tree extend system-id
!
!
! VLAN CONFIGURATION (internal)
!
!
vlan internal allocation policy ascending
!
vlan 100
 name internal_yellow
!
vlan 101
 name internal_blue
!
vlan 200
 name IMF2IXP_internal_(backend)
!
!
! IMF Servers PORTS
!
!
interface range GigabitEthernet1/1 - 8
 description for IMF 1A external + internal networks port
 switchport trunk encapsulation dot1q
```

## Hardware Installation Guidelines

```
switchport trunk allowed vlan 1,100,101,200
switchport mode trunk
mtu 9198
spanning-tree portfast trunk
!
!
! EAGLE PORTS
!
!
interface range GigabitEthernet1/9 - 27
description yellow network port for Eagle connectivity
switchport access vlan 100
switchport mode access
mtu 9198
spanning-tree portfast
!
!
interface range GigabitEthernet1/28 - 46
description blue network port for Eagle connectivity
switchport access vlan 101
switchport mode access
mtu 9198
spanning-tree portfast
!
!
! PORT TO CUSTOMER SWITCH A
!
!
interface GigabitEthernet1/47
description port where customer is connected to IMF
switchport access vlan 200
switchport mode access
media-type rj45
!
!
! Laptop PORTS
!
!
interface range GigabitEthernet 1/48
description for Laptop
switchport access vlan 200
switchport mode access
media-type rj45
no shutdown
!
!
```

## Hardware Installation Guidelines

```
! VLAN INTERFACE CONFIGURATION
!
!
interface Vlan1
 no ip address
!
interface Vlan100
 ip address 172.21.49.1 255.255.254.0
 no ip route-cache cef
 no ip route-cache
 no shutdown
!
interface Vlan101
 ip address 172.22.49.1 255.255.254.0
 no ip route-cache cef
 no ip route-cache
 no shutdown
!
!
interface Vlan200
 ip address 10.27.56.166 255.255.255.240 ! <----- replace IP with an address from customer network
 no shutdown
!
no ip http server
no ip http secure-server
!
ip route 0.0.0.0 0.0.0.0 10.248.4.17 1 ! <----- replace IP with customer default gateway
!
!
logging 172.21.49.10
no cdp run
!
line con 0
 password ***** ! <----- replace ***** with password specified in password dragon as Cisco telnet
 login
!
!
!
End
```



## Hardware Installation Guidelines

### 6.15 Configurations summary

For latest configurations:

| Configurations | Management<br>Data Record storage<br>On ODA | Packet unit<br>storage<br>on ZFS | Management<br>on HP G9 | Mediation<br>on X5-2 |
|----------------|---------------------------------------------|----------------------------------|------------------------|----------------------|
| Server         | 2x X5 wo extension                          | ZS3                              | DL380                  | X5-2                 |
| CPU            | 2x 2x 18c                                   | 4x8c                             | 2x 12c                 | 2x 18c               |
| RAM            | 2x8x32GB                                    | 512GB                            | 4x16GB                 | 8x16GB               |
| System HDD     | 2x2x600 sff                                 | See data HDD                     | 2x 900 sff             | 2x1200 sff           |
| NIC            | 2x 4x 1GE + 2x 10GE                         | 4x 10GE                          | 4x 1GE                 | 4x 10GE              |
| RU             | 6U                                          | 6U                               | 2U                     | 1U                   |
| POWER          | AC                                          | AC                               | AC or DC               | AC                   |
| Data HDD       | 16x4000 lff                                 | 24x900 sff                       | 6x 900 sff             | -                    |

| Configurations | Mediation<br>On HP G9 | Acquisition<br>On X5-2 | Acquisition<br>On HP G9 | Packet Unit storage<br>Data Record storage<br>On HP G9 |
|----------------|-----------------------|------------------------|-------------------------|--------------------------------------------------------|
| server         | DL360                 | X5-2                   | DL360                   | DL380                                                  |
| CPU            | 2x12c                 | 2x18c                  | 2x12c                   | 2x12c                                                  |
| RAM            | 4x16GB                | 8x16GB                 | 4x16GB                  | 4x16GB                                                 |
| System HDD     | 2x900 sff             | 2x1200 sff             | 2x900 sff               | 2x 900 sff                                             |
| NIC            | 4x1GE                 | 4x1GE + 4x10GE         | 4x1GE + 4x10GE          | 4x1GE                                                  |
| RU             | 1U                    | 1U                     | 1U                      | 2U                                                     |
| POWER          | AC or DC              | AC                     | AC or DC                | AC or DC                                               |
| Data HDD       | -                     | -                      | -                       | 24x 900 sff                                            |

### 6.16 My Oracle Support (MOS)

MOS (<https://support.oracle.com>) is your initial point of contact for all product support and training needs. A representative at Customer Access Support (CAS) can assist you with MOS registration.

Call the CAS main number at 1-800-223-1711 (toll-free in the US), or call the Oracle Support hotline for your local country from the list at <http://www.oracle.com/us/support/contact/index.html>. When calling, make the selections in the sequence shown below on the Support telephone menu:

1. Select 2 for New Service Request
2. Select 3 for Hardware, Networking and Solaris Operating System Support
3. Select 2 for Non-technical issue

You will be connected to a live agent who can assist you with MOS registration and provide Support Identifiers. Simply mention you are a Tekelec Customer new to MOS.

MOS is available 24 hours a day, 7 days a week, 365 days a year.

## Hardware Installation Guidelines

### 6.17 Locate Product Documentation on the Oracle Help Center Site

Oracle customer documentation is available on the web at the Oracle Help Center (OTN) site, <http://docs.oracle.com>. You do not have to register to access these documents. Viewing these files requires Adobe Acrobat Reader, which can be downloaded at [www.adobe.com](http://www.adobe.com).

1. Access the Oracle Help Center site at <http://docs.oracle.com/>.
2. Click Industries.
3. Under the Oracle Communications subheading, click the Oracle Communications documentation link. The Communications Documentation page appears.
4. Under the heading “Network Visibility and Resource Management,” click on Performance Intelligence Center and then the Release Number.  
A list of the entire documentation set for the release appears.
5. To download a file to your location, right-click the PDF link, select Save target as (or similar command based on your browser), and save to a local folder.