

Oracle® Communications  
User Data Repository

Network Interconnect Reference

Release 12.1

**E72704-01**

March 2016

**ORACLE®**

Oracle Communications User Data Repository Network Interconnect Reference, Release 12.1

E72704-01

Copyright © 2014, 2016, Oracle and/or its affiliates. All rights reserved.

This software and related documentation are provided under a license agreement containing restrictions on use and disclosure and are protected by intellectual property laws. Except as expressly permitted in your license agreement or allowed by law, you may not use, copy, reproduce, translate, broadcast, modify, license, transmit, distribute, exhibit, perform, publish, or display any part, in any form, or by any means. Reverse engineering, disassembly, or decompilation of this software, unless required by law for interoperability, is prohibited.

The information contained herein is subject to change without notice and is not warranted to be error-free. If you find any errors, please report them to us in writing.

If this is software or related documentation that is delivered to the U.S. Government or anyone licensing it on behalf of the U.S. Government, then the following notice is applicable:

U.S. GOVERNMENT END USERS: Oracle programs, including any operating system, integrated software, any programs installed on the hardware, and/or documentation, delivered to U.S. Government end users are "commercial computer software" pursuant to the applicable Federal Acquisition Regulation and agency-specific supplemental regulations. As such, use, duplication, disclosure, modification, and adaptation of the programs, including any operating system, integrated software, any programs installed on the hardware, and/or documentation, shall be subject to license terms and license restrictions applicable to the programs. No other rights are granted to the U.S. Government.

This software or hardware is developed for general use in a variety of information management applications. It is not developed or intended for use in any inherently dangerous applications, including applications that may create a risk of personal injury. If you use this software or hardware in dangerous applications, then you shall be responsible to take all appropriate fail-safe, backup, redundancy, and other measures to ensure its safe use. Oracle Corporation and its affiliates disclaim any liability for any damages caused by use of this software or hardware in dangerous applications.

Oracle and Java are registered trademarks of Oracle and/or its affiliates. Other names may be trademarks of their respective owners.

Intel and Intel Xeon are trademarks or registered trademarks of Intel Corporation. All SPARC trademarks are used under license and are trademarks or registered trademarks of SPARC International, Inc. AMD, Opteron, the AMD logo, and the AMD Opteron logo are trademarks or registered trademarks of Advanced Micro Devices. UNIX is a registered trademark of The Open Group.

This software or hardware and documentation may provide access to or information about content, products, and services from third parties. Oracle Corporation and its affiliates are not responsible for and expressly disclaim all warranties of any kind with respect to third-party content, products, and services unless otherwise set forth in an applicable agreement between you and Oracle. Oracle Corporation and its affiliates will not be responsible for any loss, costs, or damages incurred due to your access to or use of third-party content, products, or services, except as set forth in an applicable agreement between you and Oracle.



**CAUTION:** Use only the Installation procedure included in the Install Kit. Before installing any system, please access My Oracle Support (MOS) (<https://support.oracle.com>) and review any Technical Service Bulletins (TSBs) that relate to this procedure.

My Oracle Support (MOS) (<https://support.oracle.com>) is your initial point of contact for all product support and training needs. A representative at Customer Access Support (CAS) can assist you with MOS registration.

Call the CAS main number at 1-800-223-1711 (toll-free in the US), or call the Oracle Support hotline for your local country from the list at <http://www.oracle.com/us/support/contact/index.html>.

See more information on MOS in the Appendix section.

**TABLE OF CONTENTS**

<b>INTRODUCTION .....</b>	<b>5</b>
1.1 Purpose.....	5
1.2 References.....	5
1.3 Acronyms.....	5
<b>2.0 INTERCONNECTION NAMING CONVENTIONS.....</b>	<b>6</b>
<b>3.0 BASE TOPOLOGY NETWORK DIAGRAM .....</b>	<b>9</b>
OA internal Connections .....	9
<b>4.0 TOPOLOGY SPECIFIC NETWORK DIAGRAM: TOPOLOGY 1 .....</b>	<b>10</b>
Aggregation Switches with L3 Demarcation .....	10
4.1 Interconnections Topology 1 .....	11
<b>5.0 TOPOLOGY SPECIFIC NETWORK DIAGRAM: TOPOLOGY 1A.....</b>	<b>14</b>
Aggregation Switches with L3 Demarcation and backup network .....	14
5.1 Interconnections Topology 1A .....	15
<b>6.0 TOPOLOGY SPECIFIC NETWORK DIAGRAM: TOPOLOGY 3 WITH RMS .....</b>	<b>18</b>
One Physical Network No Aggregation Switches .....	18
<b>7.0 INTERCONNECTIONS TOPOLOGY 3.....</b>	<b>19</b>
<b>8.0 TOPOLOGY SPECIFIC NETWORK DIAGRAM: TOPOLOGY 3A.....</b>	<b>21</b>
One Physical Network No Aggregation Switches, Backup Network .....	21
<b>9.0 INTERCONNECTIONS TOPOLOGY 3A .....</b>	<b>22</b>
<b>10.0 TOPOLOGY SPECIFIC NETWORK DIAGRAM: TOPOLOGY 4 .....</b>	<b>25</b>
separate OAM and Signaling Without Aggregation Switches .....	25
10.1 Interconnections Topology 4.....	26
<b>11.0 TOPOLOGY SPECIFIC NETWORK DIAGRAM: TOPOLOGY 4A.....</b>	<b>29</b>
Two Physical Networks, No Aggregation Switches, backup network .....	29
11.1 Interconnections Topology 4A .....	30
<b>12.0 TOPOLOGY SPECIFIC NETWORK DIAGRAM: TOPOLOGY 7 .....</b>	<b>34</b>
Two Physical networks, No Aggregation Switches .....	34
12.1 iNTERCONNECTIONS .....	35
12.1.1 Standard Eight Port Configuration.....	35
12.1.2 Six Port Configuration .....	35
12.1.3 Four Port Configuration .....	36
<b>13.0 TOPOLOGY SPECIFIC NETWORK DIAGRAM: TOPOLOGY 7E.....</b>	<b>37</b>
Three Physical networks, No Aggregation Switches, Second signaling network.....	37
13.1 iNTERCONNECTIONS .....	38
13.1.1 Standard Eight Port Configuration.....	38
13.1.2 Six Port Configuration .....	38
13.1.3 Four Port Configuration .....	39
<b>APPENDIX A. SWITCH CONFIGURATIONS .....</b>	<b>40</b>
<b>APPENDIX B. RECOMMENDED INTERCONNECTS FOR RMS WITHOUT INTERFACE BONDING .....</b>	<b>42</b>

**LIST OF FIGURES**

Figure 1: OA Internal Connections.....	9
Figure 2: Logical Diagram Topology 1 .....	10
Figure 3: Logical Diagram Topology 1A .....	14
Figure 4: Logical Diagram Topology 3 Including RMS.....	18
Figure 5: Logical Diagram Topology 3A .....	21
Figure 6: Logical Diagram Topology 4 .....	25
Figure 7: Logical Diagram Topology 4A .....	29
Figure 8: Logical Diagram Topology 7.....	34
Figure 9: Logical Diagram Topology 7E .....	37
Figure 10: Supported C7000 Enclosure Switch Configurations for Topology 1/1A.....	40
Figure 11: Supported C7000 Enclosure Switch Configurations for Topology 4/4A.....	41

**LIST OF TABLES**

Table 1: Uplink/Switch Type Cross Reference .....	7
Table 2: Uplink/Switch Type Cross Reference (Base Hardware Notation).....	7
Table 3: Uplink/Switch Type Cross Reference (TPD Device Assignment Notation) .....	7
Table 4: Interconnection Table: Topology 1 .....	11
Table 5: Interconnection Table: Topology 1A.....	15
Table 6: Interconnection Table: Topology 3.....	19
Table 7: Interconnection Table: Topology 3A.....	22
Table 8: Interconnection Table Topology 4.....	26
Table 9: Interconnection Table Topology 4A.....	30
Table 10 Topology 7 Interconnection Table.....	35
Table 11 Topology 7 Interconnection Table with Six Ports .....	35
Table 12 Topology 7 Interconnection Table with Four Ports .....	36
Table 13 Topology 7E Standard Configuration.....	38
Table 14 Topology 7E Six Port Configuration .....	38
Table 15 Topology 7E Four Port Configuration.....	39
Table 16: Interconnection Table Lab.....	42

## INTRODUCTION

---

### 1.1 PURPOSE

The purpose of this document is to specify point to point interconnection of network elements for blade and rack mount server systems for supported topologies and their variants. Point to point connections within this document are networking specific only, application specific connections are not documented.

---

### 1.2 REFERENCES

- [1] Platform Networking Standard Topologies WP006587, Tekelec, Current Revision.
  - [2] Oracle Communications User Data Repository Network Interconnect ReferenceHW Specification, TR007055, Tekelec, Current Revision.
  - [3] HP G6 Application Cabinet, FE005927, Tekelec, Revision 9.0.
  - [4] Network Interconnect: Topology 1, TR007111, Tekelec, Revision 1.5
  - [5] Network Interconnect: Topology 4, TR007114. Tekelec, Revision 1.4
  - [6] Network Interconnect: Topology 7, TR007117. Oracle, Revision 2.0
- 

### 1.3 ACRONYMS

Item	DESCRIPTION
NIC	Network Interface Card
10G	10 Gigabits per second
1G	1 Gigabit per second
Gbps	Gigabit per second
Mbps	Megabit per second
OA	OnBoard Administrator
iLO	Integrated Lights-Out
ILOM	Integrated Lights Out Manager
OOBM	Out of Band Management - references access via iLO, ILOM, or other out of band access method

## 2.0 INTERCONNECTION NAMING CONVENTIONS

The following is the naming convention:

ag(x)

where ag(x) = aggregate\_switch(number) ie, ag1 (aka switch1A)

en(x) – sw(y)

where en(x) = the C7000 enclosure(number) ie, en2

where sw(y) = the IO Bay number, ie IO bay 2 = sw2

rms(x)

where rms(x)=rackmount server(number) ie, rms1, rms2

rms(x)-ms(y)

where rms(x)=rack mount server(number) ie, rms1, rms2

where ms(y) = management\_server(number) ie, ms1, ms2

rmsx-xih refers to the xIH RMS used for port monitoring.

Port next refers to the next available port within the established pattern.

The term 33+n refers to the ports starting with 33 incrementing by 1 until all ports are filled.

NIC(number) refers to the (number) physical port, ie. NIC1 is the first physical port, NIC2 is the second physical port, etc

NICx(number)

where x= the slot number corresponding to the server adapter card location

**where (number)=the port number**

Table 1: Uplink/Switch Type Cross Reference

Uplink Number	Cisco 3020	HP 6120	HP 6125G	HP6125XLG
Uplink 1	Port 17	Port 17	Port 5	Port 5
Uplink 2	Port 18	Port 18	Port 6	Port 6
Uplink 3	Port 19	Port 19	Port 7	Port 7
Uplink 4	Port 20	Port 20	Port 8	Port 8
Uplink 5	Port 21	Port 21	Port 3	Port 9
Uplink 6	Port 22	Port 22	Port 4	Port 10
Uplink 7	Port 23	Port 23	Port 1	Port 11
Uplink 8	Port 24	Port 24	Port 2	Port 12

Table 2: Uplink/Switch Type Cross Reference (Base Hardware Notation)

NIC ID	All HP and Sun X3-2	Sun X5-2 Config 0 (LOM only)	Sun X5-2 Config 1 (LOM and qty 1 dual port PCI)	Sun X5-2 Config 2 (LOM and qty 2 dual port PCI)
NIC1	NIC1	NET0	NET0	NET0
NIC2	NIC2	NET2	NET2	NET2
NIC3	NIC3	N/A	NETx1	NETx1
NIC4	NIC4	N/A	N/A	NETy0
NIC5	NICx1	NET1	NET1	NET1
NIC6	NICx2	NET3	NET3	NET3
NIC7	NICx3	N/A	NETx0	NETx0
NIC8	NICx4	N/A	N/A	NETy1

Table 3: Uplink/Switch Type Cross Reference (TPD Device Assignment Notation)

NIC ID	HP RMS and Sun X3-2 (Qty 1 quad port expansion card)	HP RMS and Sun X3-2 (Qty 2 dual port expansion card)	Sun X5-2 Config 0 (LOM only) <b>(4 Port)</b>	Sun X5-2 Config 1 (LOM and qty 1 dual port PCI) <b>(6 Port)</b>	Sun X5-2 Config 2 (LOM and qty 2 dual port PCI) <b>(8 Port)</b>
NIC1	eth1	eth1	eth1	eth1	eth1
NIC2	eth2	eth2	eth3	eth3	eth3
NIC3	eth3	eth3	N/A	eth22	eth22
NIC4	eth4	eth4	N/A	N/A	eth31
NIC5	eth11	eth11	eth2	eth2	eth2
NIC6	eth12	eth12	eth4	eth4	eth4

NIC7	eth13	eth21	N/A	eth21	eth21
NIC8	eth14	eth22	N/A	N/A	eth32

Note: Sun X5-2 Config 2 is a fully redundant configuration and should therefore be considered the most robust platform for all topology variants within this document.



### 3.0 BASE TOPOLOGY NETWORK DIAGRAM

#### OA INTERNAL CONNECTIONS

Figure 1: OA Internal Connections

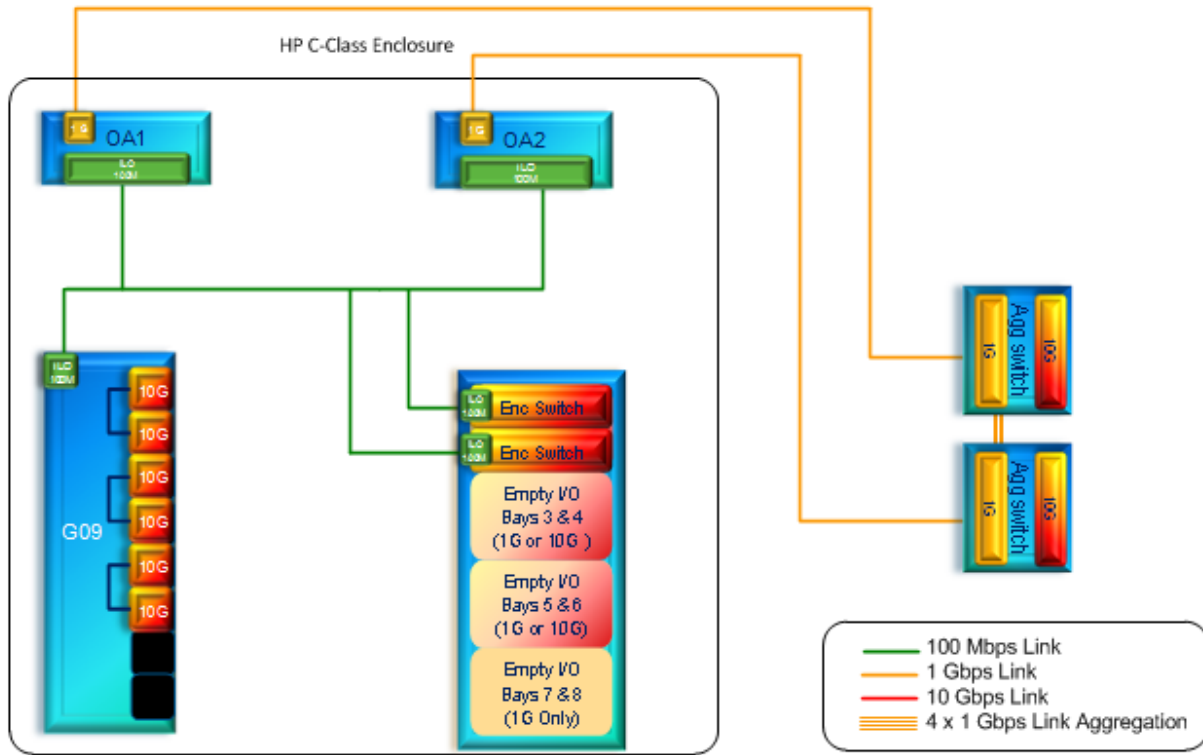

Note: The information in this figure is common to all topologies within this Technical Reference.

## 4.0 TOPOLOGY SPECIFIC NETWORK DIAGRAM: TOPOLOGY 1

### AGGREGATION SWITCHES WITH L3 DEMARCATON

Figure 2: Logical Diagram Topology 1

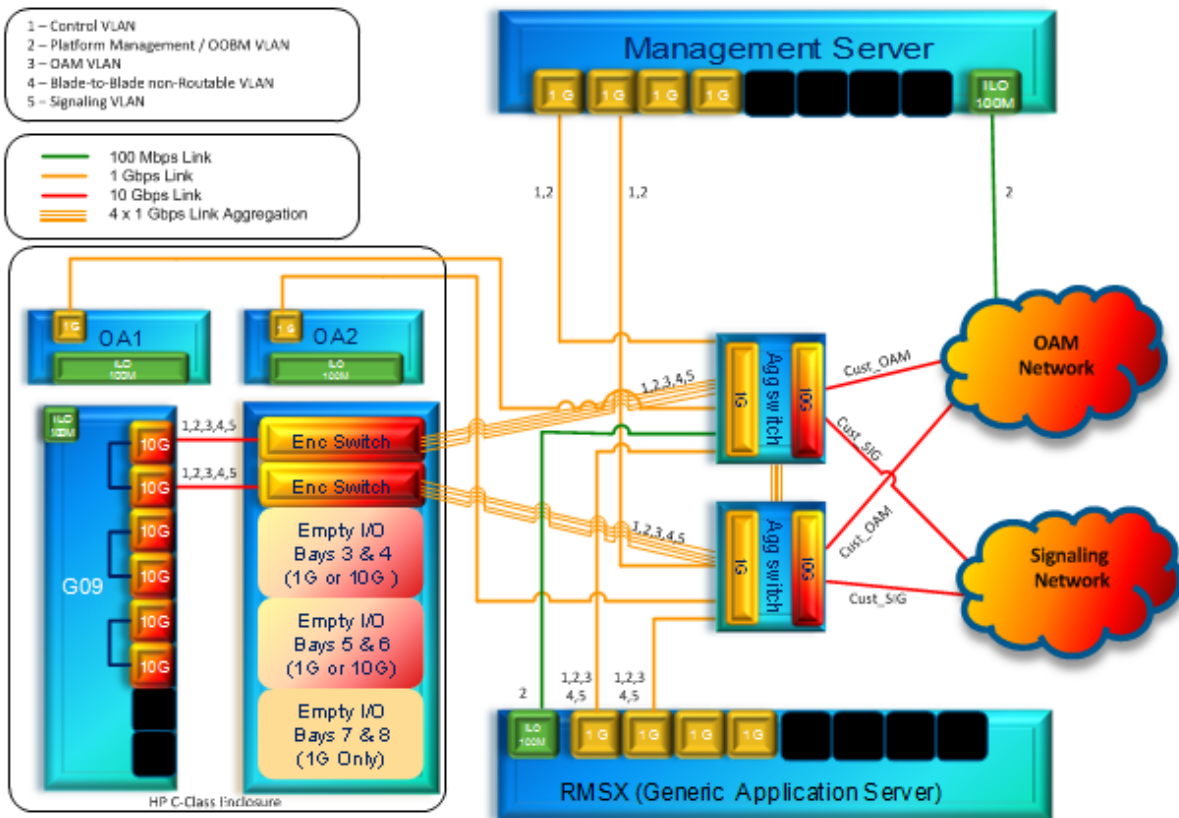

#### Characteristics:

- Aggregate all traffic from enclosure switches into a smaller number of uplinks.
  - Reduce number of interconnects into Customer network.
  - Support separation of traffic (such as OAM and Signaling traffic) at the aggregation switch level by providing separate uplinks into Customer networks.
  - Prevent any inter-enclosure traffic from impacting Customer network.
  - Hide the Layer-2 topology and provide Layer-3 interfaces to customer networks.
  - Prevent any VLAN ID conflicts with Customer L2 domain.
  - For inter-blade traffic, prevent any private IP address conflicts with Customer network.
- Note: Most OOBM connections are 100 Mbps, but some servers/switches are capable of 1 Gbps

#### 4.1 INTERCONNECTIONS TOPOLOGY 1

Table 4: Interconnection Table: Topology 1

Item #	Port (to)	Port (from)
1	ag1 port 1	ag2 port 1
2	ag1 port 2	ag2 port 2
3	ag1 port 3	ag2 port 3
4	ag1 port 4	ag2 port 4
5	ag1 port 45-48, 51-52 (if present)	Uplink to Customer Network (Optional)
6	ag1 port 49	Uplink to Customer OAM Network
7	ag1 port 50	Uplink to Customer Signaling Network
8	ag2 port 49	Uplink to Customer OAM Network
9	ag2 port 50	Uplink to Customer Signaling Network
10	ag2 port 45-48, 51-52 (if present)	Uplink to Customer Network (Optional)
Enclosures 1 through x		
11	en1-sw1 uplink 1	ag1 port 5
12	en1-sw1 uplink 2	ag1 port 6
13	en1-sw1 uplink 3	ag1 port 7
14	en1-sw1 uplink 4	ag1 port 8
15	en1-sw2 uplink 1	ag2 port 5
16	en1-sw2 uplink 2	ag2 port 6
17	en1-sw2 uplink 3	ag2 port 7
18	en1-sw2 uplink 4	ag2 port 8
19	en1-OA1 iLO	ag1 port 33
20	en1-OA2 iLO	ag2 port 33
Management Server 1		
21	rms1-ms1 NIC1	ag1 port 40
22	rms1-ms1 NIC2	ag2 port 40
23	rms1-ms1 OOBM	OAM Network / Optional ag1port41
24	rms1-ms1 Serial 1 (fan-out cable)	ag1 console
25	rms1-ms1 Serial 2 (fan-out cable)	ag2 console
Management Server 2 (If applicable)		
26	rms2-ms2 NIC1	ag1 port 42
27	rms2-ms2 NIC2	ag2 port 42
28	rms2-ms2 OOBM	OAM Network / Optional ag2port41
Rack Mount Server 3 and 4 – no enclosure 7 allowed		
29	rms3 NIC1	ag1 port 32
30	rms3 NIC2	ag2 port 32
31	rms3 OOBM	ag1 port 39
32	rms4 NIC1	ag1 port 31
33	rms4 NIC2	ag2 port 31
34	rms4 OOBM	ag2 port 39
Rack Mount Server 5 and 6 – no enclosure 6-7 allowed		
35	rms5 NIC1	ag1 port 30
36	rms5 NIC2	ag2 port 30
37	rms5 OOBM	ag1 port 38
38	rms6 NIC1	ag1 port 29
39	rms6 NIC2	ag2 port 29
40	rms6 OOBM	ag2 port 38

Item #	Port (to)	Port (from)
Rack Mount Server 7 and 8 – no enclosure 5-7 allowed		
41	rms7 NIC1	ag1 port 28
42	rms7 NIC2	ag2 port 28
43	rms7 OOBM	ag1 port 37
44	rms8 NIC1	ag1 port 27
45	rms8 NIC2	ag2 port 27
46	rms8 OOBM	ag2 port 37
Rack Mount Server 9 and 10 – no enclosure 4-7 allowed		
47	rms9 NIC1	ag1 port 26
48	rms9 NIC2	ag2 port 26
49	rms9 OOBM	ag1 port 36
50	rms10 NIC1	ag1 port 25
51	rms10 NIC2	ag2 port 25
52	rms10 OOBM	ag2 port 36
Rack Mount Server 11 and 12 – no enclosure 3-7 allowed		
53	rms11 NIC1	ag1 port 24
54	rms11 NIC2	ag2 port 24
55	rms11 OOBM	ag1 port 35
56	rms12 NIC1	ag1 port 23
57	rms12 NIC2	ag2 port 23
58	rms12 OOBM	ag2 port 35
Rack Mount Server 13 and 14 – no enclosure 2-7 allowed		
59	rms13 NIC1	ag1 port 22
60	rms13 NIC2	ag2 port 22
61	rms13 OOBM	ag1 port 34
62	rms14 NIC1	ag1 port 21
63	rms14 NIC2	ag2 port 21
64	rms14 OOBM	ag2 port 34
RMS only – no enclosures allowed		
65	rms15 NIC1	ag1 port 20
66	rms15 NIC2	ag2 port 20
67	rms15 OOBM	ag1 port 33

<b>Item #</b>	<b>Port (to)</b>	<b>Port (from)</b>
68	rms16 NIC1	ag1 port 19
69	rms16 NIC2	ag2 port 19
70	rms16 OOBM	ag2 port 33
71	rms17 NIC1	ag1 port 18
72	rms17 NIC2	ag2 port 18
73	rms17 OOBM	ag1 port 10
74	rms18 NIC1	ag1 port 17
75	rms18 NIC2	ag2 port 17
76	rms18 OOBM	ag2 port 10
77	rms19 NIC1	ag1 port 16
78	rms19 NIC2	ag2 port 16
79	rms19 OOBM	ag1 port 9
80	rms20 NIC1	ag1 port 15
81	rms20 NIC2	ag2 port 15
82	rms20 OOBM	ag2 port 9
83	rms21 NIC1	ag1 port 14
84	rms21 NIC2	ag2 port 14
85	rms21 OOBM	ag1 port 8
86	rms22 NIC1	ag1 port 13
87	rms22 NIC2	ag2 port 13
88	rms22 OOBM	ag2 port 8
89	rms23 NIC1	ag1 port 12
90	rms23 NIC2	ag2 port 12
91	rms23 OOBM	ag1 port 7
92	rms24 NIC1	ag1 port 11
93	rms24 NIC2	ag2 port 11
94	rms24 OOBM	ag2 port 7

## 5.0 TOPOLOGY SPECIFIC NETWORK DIAGRAM: TOPOLOGY 1A

### AGGREGATION SWITCHES WITH L3 DEMARCATION AND BACKUP NETWORK

Figure 3: Logical Diagram Topology 1A

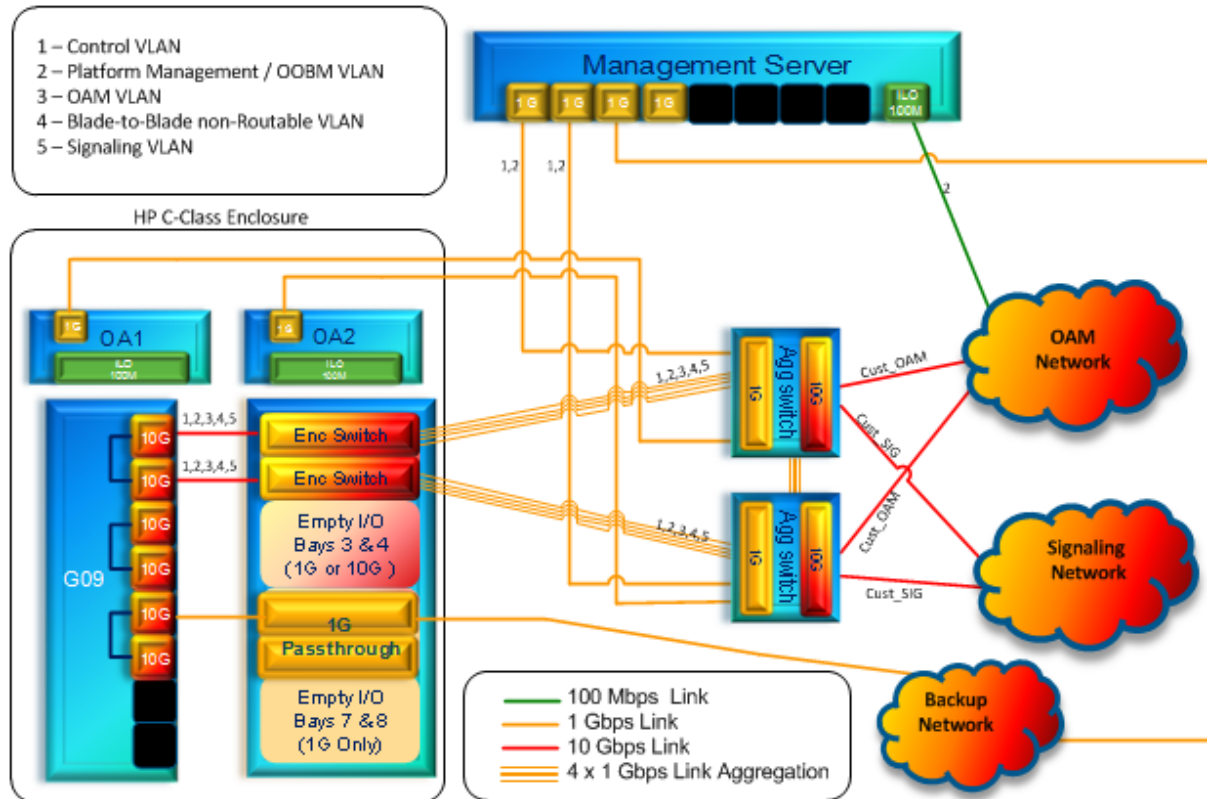

**Characteristics:**

Supports a physically separate backup network within Topology 1.

Note: Most OOBM connections are 100 Mbps, but some servers/switches are capable of 1 Gbps

Note: Though no RMS is shown in this Topology 1A diagram, backup networks are supported by RMS per the interconnect table which follows.

## 5.1 INTERCONNECTIONS TOPOLOGY 1A

Table 5: Interconnection Table: Topology 1A

Item #	Port (to)	Port (from)
1	ag1 port 1	ag2 port 1
2	ag1 port 2	ag2 port 2
3	ag1 port 3	ag2 port 3
4	ag1 port 4	ag2 port 4
5	ag1 port 49	Uplink to Customer OAM Network
6	ag1 port 50	Uplink to Customer Signaling Network
7	ag2 port 49	Uplink to Customer OAM Network
8	ag2 port 50	Uplink to Customer Signaling Network
Enclosures 1 through x		
9	en1-sw1 uplink 1	ag1 port 5
10	en1-sw1 uplink 2	ag1 port 6
11	en1-sw1 uplink 3	ag1 port 7
12	en1-sw1 uplink 4	ag1 port 8
13	en1-sw2 uplink 1	ag2 port 5
14	en1-sw2 uplink 2	ag2 port 6
15	en1-sw2 uplink 3	ag2 port 7
16	en1-sw2 uplink 4	ag2 port 8
17	en1-sw5 port-x (pass-thru note 1)	Backup Network
18	en1-sw6 port-x (pass-thru note 1)	Backup Network (optional)
19	en1-OA1 iLO	ag1 port 33
20	en1-OA2 iLO	ag2 port 33
Management Server 1		
21	rms1-ms1 NIC1	ag1 port 40
22	rms1-ms1 NIC2	ag2 port 40
23	rms1-ms1 OOBM	OAM Network / Optional ag1port41
24	rms1-ms1 Serial 1 (fan-out cable)	ag1 console
25	rms1-ms1 Serial 1 (fan-out cable)	ag2 console
26	rms1-ms1 NICx4	Backup Network (optional)
Management Server 2 (If applicable)		
27	rms2-ms2 NIC1	ag1 port 42
28	rms2-ms2 NIC2	ag2 port 42
29	rms2-ms2 OOBM	OAM Network / Optional ag2port41
30	rms2-ms2 NICx4	Backup Network (optional)
Rack Mount Server 3 and 4 – no enclosure 7 allowed		
31	rms3 NIC1	ag1 port 32
32	rms3 NIC2	ag2 port 32
33	rms3 OOBM	ag1 port 39
34	rms3 NICx4	Backup Network (optional)
35	rms4 NIC1	ag1 port 31
36	rms4 NIC2	ag2 port 31
37	rms4 OOBM	ag2 port 39
38	rms4 NICx4	Backup Network (optional)
Rack Mount Server 5 and 6 – no enclosure 6-7 allowed		
39	rms5 NIC1	ag1 port 30
40	rms5 NIC2	ag2 port 30
41	rms5 OOBM	ag1 port 38
42	rms5 NICx4	Backup Network (optional)
43	rms6 NIC1	ag1 port 29

Item #	Port (to)	Port (from)
44	rms6 NIC2	ag2 port 29
45	rms6 OOBM	ag2 port 38
46	rms6 NICx4	Backup Network (optional)
Rack Mount Server 7 and 8 – no enclosure 5-7 allowed		
47	rms7 NIC1	ag1 port 28
48	rms7 NIC2	ag2 port 28
49	rms7 OOBM	ag1 port 37
50	rms7NICx4	Backup Network (optional)
51	rms8 NIC1	ag1 port 27
52	rms8 NIC2	ag2 port 27
53	rms8 OOBM	ag2 port 37
54	rms8 NICx4	Backup Network (optional)
Rack Mount Server 9 and 10 – no enclosure 4-7 allowed		
55	rms9 NIC1	ag1 port 26
56	rms9 NIC2	ag2 port 26
57	rms9 OOBM	ag1 port 36
58	rms9 NICx4	Backup Network (optional)
59	rms10 NIC1	ag1 port 25
60	rms10 NIC2	ag2 port 25
61	rms10 OOBM	ag2 port 36
62	rms10 NICx4	Backup Network (optional)
Rack Mount Server 11 and 12 – no enclosure 3-7 allowed		
63	rms11 NIC1	ag1 port 24
64	rms11 NIC2	ag2 port 24
65	rms11 OOBM	ag1 port 35
66	rms11 NICx4	Backup Network (optional)
67	rms12 NIC1	ag1 port 23
68	rms12 NIC2	ag2 port 23
69	rms12 OOBM	ag2 port 35
70	rms12 NICx4	Backup Network (optional)
Rack Mount Server 13 and 14 – no enclosure 2-7 allowed		
71	rms13 NIC1	ag1 port 22
72	rms13 NIC2	ag2 port 22
73	rms13 OOBM	ag1 port 34
74	rms13 NICx4	Backup Network (optional)
75	rms14 NIC1	ag1 port 21
76	rms14 NIC2	ag2 port 21
77	rms14 OOBM	ag2 port 34
78	rms14 NICx4	Backup Network (optional)
RMS only – no enclosures allowed		
79	rms15 NIC1	ag1 port 20
80	rms15 NIC2	ag2 port 20
81	rms15 OOBM	ag1 port 33
82	rms15 NICx4	Backup Network (optional)
83	rms16 NIC1	ag1 port 19
84	rms16 NIC2	ag2 port 19
85	rms16 OOBM	ag2 port 33
86	rms16 NICx4	Backup Network (optional)
87	rms17 NIC1	ag1 port 18
88	rms17 NIC2	ag2 port 18
89	rms17 OOBM	ag1 port 10
90	rms17 NICx4	Backup Network (optional)



Item #	Port (to)	Port (from)
91	rms18 NIC1	ag1 port 17
92	rms18 NIC2	ag2 port 17
93	rms18 OOBM	ag2 port 10
94	rms18 NICx4	Backup Network (optional)
95	rms19 NIC1	ag1 port 16
96	rms19 NIC2	ag2 port 16
97	rms19 OOBM	ag1 port 9
98	rms19 NICx4	Backup Network (optional)
99	rms20 NIC1	ag1 port 15
100	rms20 NIC2	ag2 port 15
101	rms20 OOBM	ag2 port 9
102	rms20 NICx4	Backup Network (optional)
103	rms21 NIC1	ag1 port 14
104	rms21 NIC2	ag2 port 14
105	rms21 OOBM	ag1 port 8
106	rms21 NICx4	Backup Network (optional)
107	rms22 NIC1	ag1 port 13
108	rms22 NIC2	ag2 port 13
109	rms22 OOBM	ag2 port 8
110	rms22 NICx4	Backup Network (optional)
111	rms23 NIC1	ag1 port 12
112	rms23 NIC2	ag2 port 12
113	rms23 OOBM	ag1 port 7
114	rms23 NICx4	Backup Network (optional)
115	rms24 NIC1	ag1 port 11
116	rms24 NIC2	ag2 port 11
117	rms24 OOBM	ag2 port 7
118	rms24 NICx4	Backup Network (optional)

Note1: Nomenclature en1-sw5 port-x  
where x denotes the port that coincides with the front-side card slot, ie card in slot 15, en1-sw5 port-15

## 6.0 TOPOLOGY SPECIFIC NETWORK DIAGRAM: TOPOLOGY 3 WITH RMS

### ONE PHYSICAL NETWORK NO AGGREGATION SWITCHES

Figure 4: Logical Diagram Topology 3 Including RMS

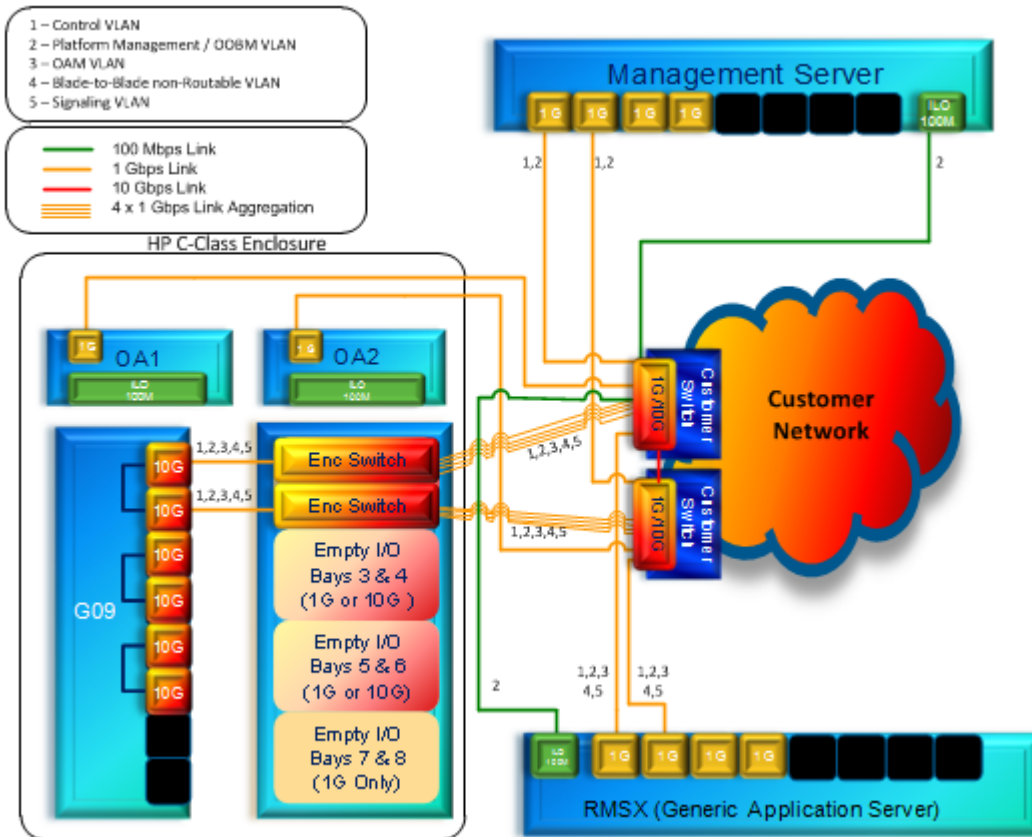

Substantially similar to **Topology 4** without the second pair of Enclosure Switches.

Note: Figure above is a logical diagram only, see tables below for point connections.

Note: Most OOBM connections are 100 Mbps, but some servers/switches are capable of 1 Gbps

**7.0 INTERCONNECTIONS TOPOLOGY 3****Table 6: Interconnection Table: Topology 3**

Item #	Port (to)	Port (from)
Enclosures 1 through x		
95	en1-sw1 uplink 1	Customer Switch 1
96	en1-sw1 uplink 2-4 (optional)	Customer Switch 1
97	en1-sw2 uplink 1	Customer Switch 2
98	en1-sw2 uplink 2-4 (optional)	Customer Switch 2
99	enx-sw1 uplink 1	Customer Switch 1
100	enx-sw1 uplink 2-4 (optional)	Customer Switch 1
101	enx-sw2 uplink 1	Customer Switch 2
102	enx-sw2 uplink 2-4 (optional)	Customer Switch 2
103	en1-OA1 iLO	Customer Switch 1
104	en1-OA2 iLO	Customer Switch 2
105	enx-OA1 iLO	Customer Switch 1
106	enx-OA2 iLO	Customer Switch 2
Management Server 1		
107	rms1-ms1 NIC1	Customer Switch 1
108	rms1-ms1 NIC2	Customer Switch 2
109	rms1-ms1 OOBM	Customer Switch 1
Management Server 2 (If applicable)		
110	rms2-ms2 NIC1	Customer Switch 1
111	rms2-ms2 NIC2	Customer Switch 2
112	rms2-ms2 OOBM	Customer Switch 2
Rack Mount Server 3 and 4 – no enclosure 7 allowed		
113	rms3 NIC1	Customer Switch 1
114	rms3 NIC2	Customer Switch 2
115	rms3 OOBM	Customer Switch 1
116	rms4 NIC1	Customer Switch 1
117	rms4 NIC2	Customer Switch 2
118	rms4 OOBM	Customer Switch 2
Rack Mount Server 5 and 6 – no enclosure 6-7 allowed		
119	rms5 NIC1	Customer Switch 1
120	rms5 NIC2	Customer Switch 2
121	rms5 OOBM	Customer Switch 1
122	rms6 NIC1	Customer Switch 1
123	rms6 NIC2	Customer Switch 2
124	rms6 OOBM	Customer Switch 2
Rack Mount Server 7 and 8 – no enclosure 5-7 allowed		
125	rms7 NIC1	Customer Switch 1
126	rms7 NIC2	Customer Switch 2
127	rms7 OOBM	Customer Switch 1
128	rms8 NIC1	Customer Switch 1
129	rms8 NIC2	Customer Switch 2
130	rms8 OOBM	Customer Switch 2
Rack Mount Server 9 and 10 – no enclosure 4-7 allowed		
131	rms9 NIC1	Customer Switch 1
132	rms9 NIC2	Customer Switch 2
133	rms9 OOBM	Customer Switch 1
134	rms10 NIC1	Customer Switch 1
135	rms10 NIC2	Customer Switch 2

Item #	Port (to)	Port (from)
136	rms10 OOBM	Customer Switch 2
Rack Mount Server 11 and 12 – no enclosure 3-7 allowed		
137	rms11 NIC1	Customer Switch 1
138	rms11 NIC2	Customer Switch 2
139	rms11 OOBM	Customer Switch 1
140	rms12 NIC1	Customer Switch 1
141	rms12 NIC2	Customer Switch 2
142	rms12 OOBM	Customer Switch 2
Rack Mount Server 13 and 14 – no enclosure 2-7 allowed		
143	rms13 NIC1	Customer Switch 1
144	rms13 NIC2	Customer Switch 2
145	rms13 OOBM	Customer Switch 1
146	rms14 NIC1	Customer Switch 1
147	rms14 NIC2	Customer Switch 2
148	rms14 OOBM	Customer Switch 2
RMS only – no enclosures allowed		
149	rms15 NIC1	Customer Switch 1
150	rms15 NIC2	Customer Switch 2
151	rms15 OOBM	Customer Switch 1
152	rms16 NIC1	Customer Switch 1
153	rms16 NIC2	Customer Switch 2
154	rms16 OOBM	Customer Switch 2
155	rms17 NIC1	Customer Switch 1
156	rms17 NIC2	Customer Switch 2
157	rms17 OOBM	Customer Switch 1
158	rms18 NIC1	Customer Switch 1
159	rms18 NIC2	Customer Switch 2
160	rms18 OOBM	Customer Switch 2
161	rms19 NIC1	Customer Switch 1
162	rms19 NIC2	Customer Switch 2
163	rms19 OOBM	Customer Switch 1
164	rms20 NIC1	Customer Switch 1
165	rms20 NIC2	Customer Switch 2
166	rms20 OOBM	Customer Switch 2
167	rms21 NIC1	Customer Switch 1
168	rms21 NIC2	Customer Switch 2
169	rms21 OOBM	Customer Switch 1
170	rms22 NIC1	Customer Switch 1
171	rms22 NIC2	Customer Switch 2
172	rms22 OOBM	Customer Switch 2
173	rms23 NIC1	Customer Switch 1
174	rms23 NIC2	Customer Switch 2
175	rms23 OOBM	Customer Switch 1
176	rms24 NIC1	Customer Switch 1
177	rms24 NIC2	Customer Switch 2
178	rms24 OOBM	Customer Switch 2

Note1: Point to point RMS connections are identical between the zero enclosure condition and the no enclosure 3-7 condition listed above.

## 8.0 TOPOLOGY SPECIFIC NETWORK DIAGRAM: TOPOLOGY 3A

### ONE PHYSICAL NETWORK NO AGGREGATION SWITCHES, BACKUP NETWORK

Figure 5: Logical Diagram Topology 3A

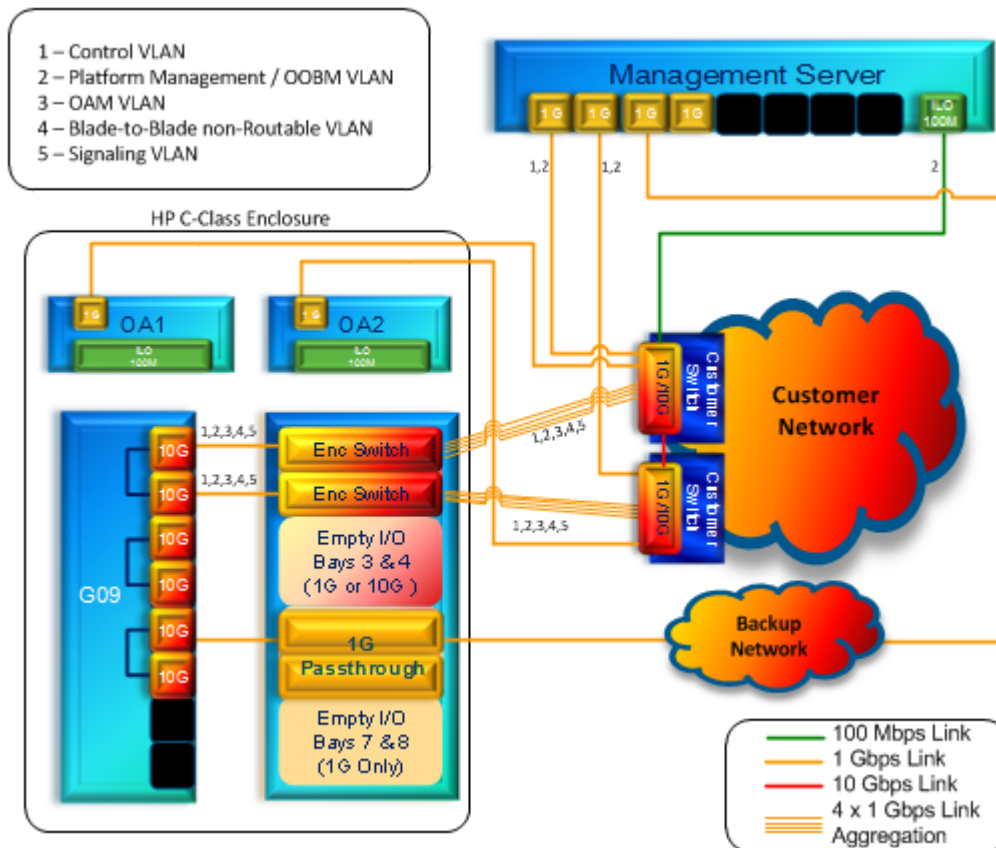

#### Characteristics:

Substantially similar to **Topology 4A** without the second pair of Enclosure Switches.

Note: Figure above is a logical diagram only, see tables below for point connections.

Supports a physically separate backup network within Topology 3.

## 9.0 INTERCONNECTIONS TOPOLOGY 3A

**Table 7: Interconnection Table: Topology 3A**

Item #	Port (to)	Port (from)
Enclosures 1 through x		
119	en1-sw1 uplink 1	Customer Switch 1
120	en1-sw1 uplink 2-4 (optional)	Customer Switch 1
121	en1-sw2 uplink 1	Customer Switch 2
122	en1-sw2 uplink 2-4 (optional)	Customer Switch 2
123	enx-sw1 uplink 1	Customer Switch 1
124	enx-sw1 uplink 2-4 (optional)	Customer Switch 1
125	enx-sw2 uplink 1	Customer Switch 2
126	enx-sw2 uplink 2-4 (optional)	Customer Switch 2
127	en1-sw5 port-x (note1)	Backup Network
128	enx-sw5 port-x (note1)	Backup Network (optional)
129	en1-OA1 iLO	Customer Switch 1
130	en1-OA2 iLO	Customer Switch 2
131	enx-OA1 iLO	Customer Switch 1
132	enx-OA2 iLO	Customer Switch 2
Management Server 1		
133	rms1-ms1 NIC1	Customer Switch 1
134	rms1-ms1 NIC2	Customer Switch 2
135	rms1-ms1 OOBM	Customer Switch 1
136	rms1-ms1 NIC8	Backup Network (optional)
Management Server 2 (If applicable)		
137	rms2-ms2 NIC1	Customer Switch 1
138	rms2-ms2 NIC2	Customer Switch 2
139	rms2-ms2 OOBM	Customer Switch 2
140	rms2-ms2 NIC8	Backup Network (optional)
Rack Mount Server 3 and 4 – no enclosure 7 allowed		
141	rms3 NIC1	Customer Switch 1
142	rms3 NIC2	Customer Switch 2
143	rms3 OOBM	Customer Switch 1
144	rms3 NIC8	Backup Network (optional)
145	rms4 NIC1	Customer Switch 1
146	rms4 NIC2	Customer Switch 2
147	rms4 OOBM	Customer Switch 2
148	rms4 NIC8	Backup Network (optional)
Rack Mount Server 5 and 6 – no enclosure 6-7 allowed		
149	rms5 NIC1	Customer Switch 1
150	rms5 NIC2	Customer Switch 2
151	rms5 OOBM	Customer Switch 1
152	rms5 NIC8	Backup Network (optional)
153	rms6 NIC1	Customer Switch 1
154	rms6 NIC2	Customer Switch 2
155	rms6 OOBM	Customer Switch 2
156	rms6 NIC8	Backup Network (optional)
Rack Mount Server 7 and 8 – no enclosure 5-7 allowed		
157	rms7 NIC1	Customer Switch 1
158	rms7 NIC2	Customer Switch 2
159	rms7 OOBM	Customer Switch 1
160	rms7NIC8	Backup Network (optional)

Item #	Port (to)	Port (from)
161	rms8 NIC1	Customer Switch 1
162	rms8 NIC2	Customer Switch 2
163	rms8 OOBM	Customer Switch 2
164	rms8 NIC8	Backup Network (optional)
Rack Mount Server 9 and 10 – no enclosure 4-7 allowed		
165	rms9 NIC1	Customer Switch 1
166	rms9 NIC2	Customer Switch 2
167	rms9 OOBM	Customer Switch 1
168	rms9 NIC8	Backup Network (optional)
169	rms10 NIC1	Customer Switch 1
170	rms10 NIC2	Customer Switch 2
171	rms10 OOBM	Customer Switch 2
172	rms10 NIC8	Backup Network (optional)
Rack Mount Server 11 and 12 – no enclosure 3-7 allowed		
173	rms11 NIC1	Customer Switch 1
174	rms11 NIC2	Customer Switch 2
175	rms11 OOBM	Customer Switch 1
176	rms11 NIC8	Backup Network (optional)
177	rms12 NIC1	Customer Switch 1
178	rms12 NIC2	Customer Switch 2
179	rms12 OOBM	Customer Switch 2
180	rms12 NIC8	Backup Network (optional)
Rack Mount Server 13 and 14 – no enclosure 2-7 allowed		
181	rms13 NIC1	Customer Switch 1
182	rms13 NIC2	Customer Switch 2
183	rms13 OOBM	Customer Switch 1
184	rms13 NIC8	Backup Network (optional)
185	rms14 NIC1	Customer Switch 1
186	rms14 NIC2	Customer Switch 2
187	rms14 OOBM	Customer Switch 2
188	rms14 NIC8	Backup Network (optional)
RMS only – no enclosures allowed		
189	rms15 NIC1	Customer Switch 1
190	rms15 NIC2	Customer Switch 2
191	rms15 OOBM	Customer Switch 1
192	rms15 NIC8	Backup Network (optional)
193	rms16 NIC1	Customer Switch 1
194	rms16 NIC2	Customer Switch 2
195	rms16 OOBM	Customer Switch 2
196	rms16 NIC8	Backup Network (optional)
197	rms17 NIC1	Customer Switch 1
198	rms17 NIC2	Customer Switch 2
199	rms17 OOBM	Customer Switch 1
200	rms17 NIC8	Backup Network (optional)
201	rms18 NIC1	Customer Switch 1
202	rms18 NIC2	Customer Switch 2
203	rms18 OOBM	Customer Switch 2
204	rms18 NIC8	Backup Network (optional)
205	rms19 NIC1	Customer Switch 1
206	rms19 NIC2	Customer Switch 2
207	rms19 OOBM	Customer Switch 1

Item #	Port (to)	Port (from)
208	rms19 NIC8	Backup Network (optional)
209	rms20 NIC1	Customer Switch 1
210	rms20 NIC2	Customer Switch 2
211	rms20 OOBM	Customer Switch 2
212	rms20 NIC8	Backup Network (optional)
213	rms21 NIC1	Customer Switch 1
214	rms21 NIC2	Customer Switch 2
215	rms21 OOBM	Customer Switch 1
216	rms21 NIC8	Backup Network (optional)
217	rms22 NIC1	Customer Switch 1
218	rms22 NIC2	Customer Switch 2
219	rms22 OOBM	Customer Switch 2
220	rms22 NIC8	Backup Network (optional)
221	rms23 NIC1	Customer Switch 1
222	rms23 NIC2	Customer Switch 2
223	rms23 OOBM	Customer Switch 1
224	rms23 NIC8	Backup Network (optional)
225	rms24 NIC1	Customer Switch 1
226	rms24 NIC2	Customer Switch 2
227	rms24 OOBM	Customer Switch 2
228	rms24 NIC8	Backup Network (optional)

Note1: Nomenclature en1-sw5 port-x  
where x denotes the port that coincides with the front-side card slot, ie card in slot 15, en1-sw5 port-15



## 10.0 TOPOLOGY SPECIFIC NETWORK DIAGRAM: TOPOLOGY 4

### SEPARATE OAM AND SIGNALING WITHOUT AGGREGATION SWITCHES

Figure 6: Logical Diagram Topology 4

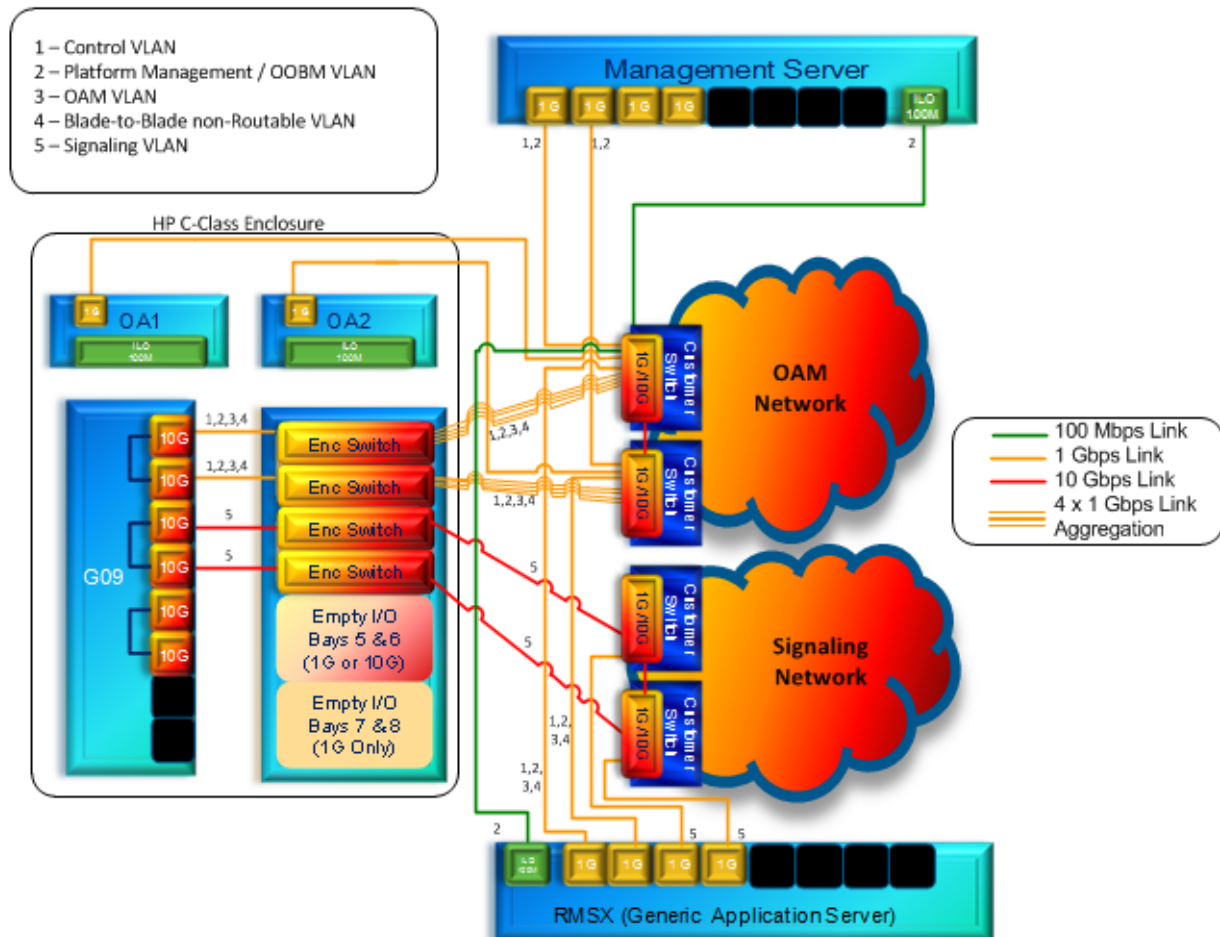

#### Characteristics:

Support Customer deployments where aggregation switches are not feasible (for network policy reasons etc.)

Share one physical network for OAM, Control, internal and iLO networks.

Provide logical separation of OAM, Control, Internal and iLO traffic via VLANs

Support a separate physical network for signaling traffic.

Allow integration with Customer L2 domain.

Allow Customer routers/firewalls to define the L2 boundaries.

Note: 6120XG switches can support 4x1G or 1x10G uplink.

Note: Most OOBM connections are 100 Mbps, but some servers/switches are capable of 1 Gbps

**10.1 INTERCONNECTIONS TOPOLOGY 4****Table 8: Interconnection Table Topology 4**

Item #	Port (to)	Port (from)
<b>Enclosures 1 through x</b>		
1	en1-sw1 uplink 1	Customer Switch 1/OAM Network
2	en1-sw1 uplink 2-4 (optional)	Customer Switch 1/OAM Network
3	en1-sw2 uplink 1	Customer Switch 2/OAM Network
4	en1-sw2 uplink 2-4 (optional)	Customer Switch 2/OAM Network
5	en1-sw3 uplink 1	Customer Switch 1/Signaling Network
6	en1-sw4 uplink 1	Customer Switch 2/Signaling Network
7	en1-sw3 uplink 2-4 (optional)	Customer Switch 1/Signaling Network
8	en1-sw4 uplink 2-4 (optional)	Customer Switch 2/Signaling Network
9	en1-OA1 iLO	Customer Switch 1/OAM Network
10	en1-OA2 iLO	Customer Switch 2/OAM Network
<b>Management Server 1</b>		
11	rms1-ms1 NIC1	Customer Switch 1/OAM Network
12	rms1-ms1 NIC2	Customer Switch 2/OAM Network
13	rms1-ms1 NICx1	Customer Switch 1/Signaling Network (optional)
14	rms1-ms1 NICx2	Customer Switch 2/Signaling Network (optional)
15	rms1-ms1 OOBM	Customer Switch 1/OAM Network
<b>Management Server 2 (If applicable)</b>		
16	rms2-ms2 NIC1	Customer Switch 1/OAM Network
17	rms2-ms2 NIC2	Customer Switch 2/OAM Network
18	rms2-ms2 NICx1	Customer Switch 1/Signaling Network (optional)
19	rms2-ms2 NICx2	Customer Switch 2/Signaling Network (optional)
20	rms2-ms2 OOBM	Customer Switch 2/OAM Network
<b>Rack Mount Server 3 and 4 – no enclosure 7 allowed</b>		
21	rms3 NIC1	Customer Switch 1/OAM Network
22	rms3 NIC2	Customer Switch 2/OAM Network
23	rms3 NICx1	Customer Switch 1/Signaling Network
24	rms3 NICx2	Customer Switch 2/Signaling Network
25	rms3 OOBM	Customer Switch 1/OAM Network
26	rms4 NIC1	Customer Switch 1/OAM Network
27	rms4 NIC2	Customer Switch 2/OAM Network
28	rms4 NICx1	Customer Switch 1/Signaling Network
29	rms4 NICx2	Customer Switch 2/Signaling Network
30	rms4 OOBM	Customer Switch 2/OAM Network
<b>Rack Mount Server 5 and 6 – no enclosure 6-7 allowed</b>		
31	rms5 NIC1	Customer Switch 1/OAM Network
32	rms5 NIC2	Customer Switch 2/OAM Network
33	rms5 NICx1	Customer Switch 1/Signaling Network
34	rms5 NICx2	Customer Switch 2/Signaling Network
35	rms5 OOBM	Customer Switch 1/OAM Network
36	rms6 NIC1	Customer Switch 1/OAM Network
37	rms6 NIC2	Customer Switch 2/OAM Network
38	rms6 NICx1	Customer Switch 1/Signaling Network
39	rms6 NICx2	Customer Switch 2/Signaling Network
40	rms6 OOBM	Customer Switch 2/OAM Network
<b>Rack Mount Server 7 and 8 – no enclosure 5-7 allowed</b>		
41	rms7 NIC1	Customer Switch 1/OAM Network
42	rms7 NIC2	Customer Switch 2/OAM Network

Item #	Port (to)	Port (from)
43	rms7 NICx1	Customer Switch 1/Signaling Network
44	rms7 NICx2	Customer Switch 2/Signaling Network
45	rms7 OOBM	Customer Switch 1/OAM Network
46	rms8 NIC1	Customer Switch 1/OAM Network
47	rms8 NIC2	Customer Switch 2/OAM Network
48	rms8 NICx1	Customer Switch 1/Signaling Network
49	rms8 NICx2	Customer Switch 2/Signaling Network
50	rms8 OOBM	Customer Switch 2/OAM Network
Rack Mount Server 9 and 10 – no enclosure 4-7 allowed		
51	rms9 NIC1	Customer Switch 1/OAM Network
52	rms9 NIC2	Customer Switch 2/OAM Network
53	rms9 NICx1	Customer Switch 1/Signaling Network
54	rms9 NICx2	Customer Switch 2/Signaling Network
55	rms9 OOBM	Customer Switch 1/OAM Network
56	rms10 NIC1	Customer Switch 1/OAM Network
57	rms10 NIC2	Customer Switch 2/OAM Network
58	rms10 NICx1	Customer Switch 1/Signaling Network
59	rms10 NICx2	Customer Switch 2/Signaling Network
60	rms10 OOBM	Customer Switch 2/OAM Network
Rack Mount Server 11 and 12 – no enclosure 3-7 allowed		
61	rms11 NIC1	Customer Switch 1/OAM Network
62	rms11 NIC2	Customer Switch 2/OAM Network
63	rms11 NICx1	Customer Switch 1/Signaling Network
64	rms11 NICx2	Customer Switch 2/Signaling Network
65	rms11 OOBM	Customer Switch 1/OAM Network
66	rms12 NIC1	Customer Switch 1/OAM Network
67	rms12 NIC2	Customer Switch 2/OAM Network
68	rms12 NICx1	Customer Switch 1/Signaling Network
69	rms12 NICx2	Customer Switch 2/Signaling Network
70	rms12 OOBM	Customer Switch 2/OAM Network
Rack Mount Server 13 and 14 – no enclosure 2-7 allowed		
71	rms13 NIC1	Customer Switch 1/OAM Network
72	rms13 NIC2	Customer Switch 2/OAM Network
73	rms13 NICx1	Customer Switch 1/Signaling Network
74	rms13 NICx2	Customer Switch 2/Signaling Network
75	rms13 OOBM	Customer Switch 1/OAM Network
76	rms14 NIC1	Customer Switch 1/OAM Network
77	rms14 NIC2	Customer Switch 2/OAM Network
78	rms14 NICx1	Customer Switch 1/Signaling Network
79	rms14 NICx2	Customer Switch 2/Signaling Network
80	rms14 OOBM	Customer Switch 2/OAM Network
RMS only – no enclosures allowed		
81	rms15 NIC1	Customer Switch 1/OAM Network
82	rms15 NIC2	Customer Switch 2/OAM Network
83	rms15 NICx1	Customer Switch 1/Signaling Network
84	rms15 NICx2	Customer Switch 2/Signaling Network
85	rms15 OOBM	Customer Switch 1/OAM Network
86	rms16 NIC1	Customer Switch 1/OAM Network
87	rms16 NIC2	Customer Switch 2/OAM Network
88	rms16 NICx1	Customer Switch 1/Signaling Network
89	rms16 NICx2	Customer Switch 2/Signaling Network

Item #	Port (to)	Port (from)
90	rms16 OOBM	Customer Switch 2/OAM Network
91	rms17 NIC1	Customer Switch 1/OAM Network
92	rms17 NIC2	Customer Switch 2/OAM Network
93	rms17 NICx1	Customer Switch 1/Signaling Network
94	rms17 NICx2	Customer Switch 2/Signaling Network
95	rms17 OOBM	Customer Switch 1/OAM Network
96	rms18 NIC1	Customer Switch 1/OAM Network
97	rms18 NIC2	Customer Switch 2/OAM Network
98	rms18 NICx1	Customer Switch 1/Signaling Network
99	rms18 NICx2	Customer Switch 2/Signaling Network
100	rms18 OOBM	Customer Switch 2/OAM Network
101	rms19 NIC1	Customer Switch 1/OAM Network
102	rms19 NIC2	Customer Switch 2/OAM Network
103	rms19 NICx1	Customer Switch 1/Signaling Network
104	rms19 NICx2	Customer Switch 2/Signaling Network
105	rms19 OOBM	Customer Switch 1/OAM Network
106	rms20 NIC1	Customer Switch 1/OAM Network
107	rms20 NIC2	Customer Switch 2/OAM Network
108	rms20 NICx1	Customer Switch 1/Signaling Network
109	rms20 NICx2	Customer Switch 2/Signaling Network
110	rms20 OOBM	Customer Switch 2/OAM Network
111	rms21 NIC1	Customer Switch 1/OAM Network
112	rms21 NIC2	Customer Switch 2/OAM Network
113	rms21 NICx1	Customer Switch 1/Signaling Network
114	rms21 NICx2	Customer Switch 2/Signaling Network
115	rms21 OOBM	Customer Switch 1/OAM Network
116	rms22 NIC1	Customer Switch 1/OAM Network
117	rms22 NIC2	Customer Switch 2/OAM Network
118	rms22 NICx1	Customer Switch 1/Signaling Network
119	rms22 NICx2	Customer Switch 2/Signaling Network
120	rms22 OOBM	Customer Switch 2/OAM Network
121	rms23 NIC1	Customer Switch 1/OAM Network
122	rms23 NIC2	Customer Switch 2/OAM Network
123	rms23 NICx1	Customer Switch 1/Signaling Network
124	rms23 NICx2	Customer Switch 2/Signaling Network
125	rms23 OOBM	Customer Switch 1/OAM Network
126	rms24NIC1	Customer Switch 1/OAM Network
127	rms24 NIC2	Customer Switch 2/OAM Network
128	rms24 NICx1	Customer Switch 1/Signaling Network
129	rms24 NICx2	Customer Switch 2/Signaling Network
130	rms24 OOBM	Customer Switch 2/OAM Network

## 11.0 TOPOLOGY SPECIFIC NETWORK DIAGRAM: TOPOLOGY 4A

### *TWO PHYSICAL NETWORKS, NO AGGREGATION SWITCHES, BACKUP NETWORK*

Figure 7: Logical Diagram Topology 4A

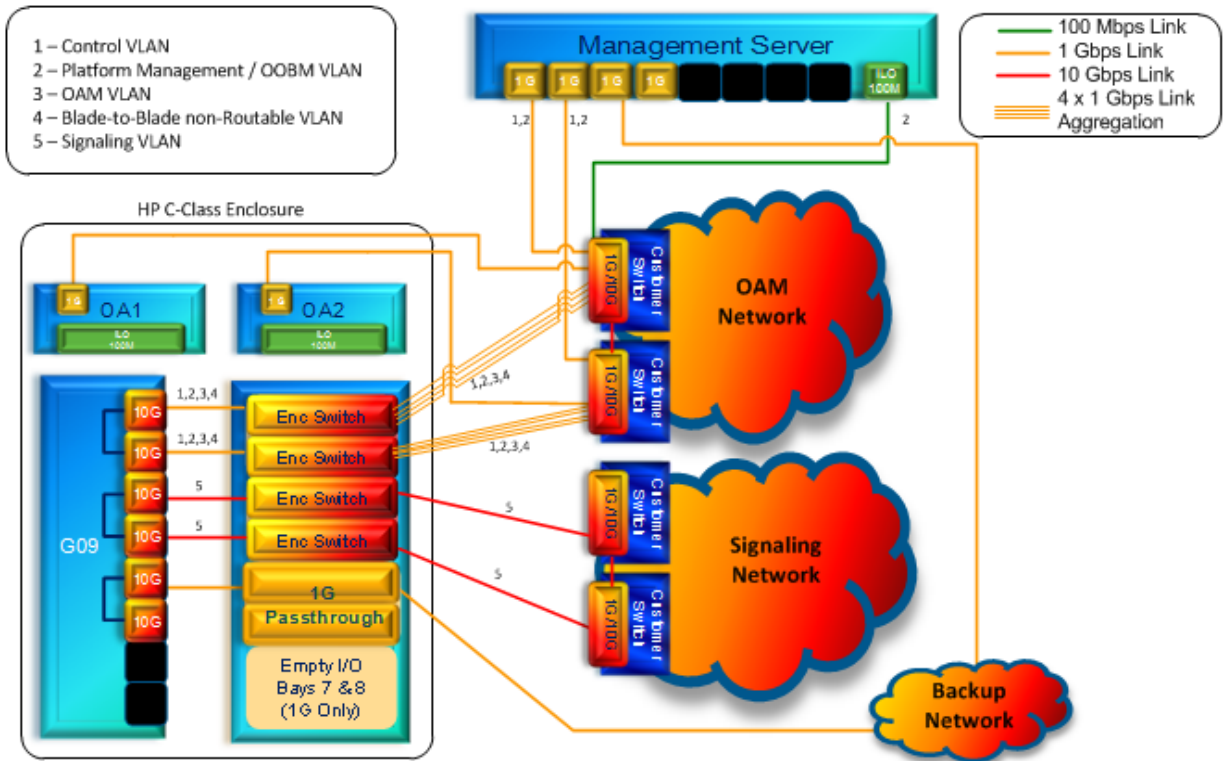

#### Characteristics:

Supports a physically separate backup network within Topology 4.

Note: 6120XG switches can support 4x1G or 1x10G uplink.

Note: Most OOBM connections are 100 Mbps, but some servers/switches are capable of 1 Gbps

Note: Though no RMS is shown in this Topology 4A diagram, backup networks are supported by RMS per the interconnect table which follows.

**11.1 INTERCONNECTIONS TOPOLOGY 4A****Table 9: Interconnection Table Topology 4A**

Item #	Port (to)	Port (from)
Enclosures 1 through x		
1	en1-sw1 uplink 1	Customer Switch 1/OAM Network
2	en1-sw1 uplink 2-4 (optional)	Customer Switch 1/OAM Network
3	en1-sw2 uplink 1	Customer Switch 2/OAM Network
4	en1-sw2 uplink 2-4 (optional)	Customer Switch 2/OAM Network
5	en1-sw3 uplink 1	Customer Switch 1/Signaling Network
6	en1-sw4 uplink 1	Customer Switch 2/Signaling Network
7	en1-sw3 uplink 2-4 (optional)	Customer Switch 1/Signaling Network
8	en1-sw4 uplink 2-4 (optional)	Customer Switch 2/Signaling Network
9	en1-sw5 port -x (note 1)	Backup Network
10	en1-sw6 port -x (note 1)	Backup Network (optional)
11	en1-OA1 iLO	Customer Switch 1/OAM Network
12	en1-OA2 iLO	Customer Switch 2/OAM Network
Management Server 1		
13	rms1-ms1 NIC1	Customer Switch 1/OAM Network
14	rms1-ms1 NIC2	Customer Switch 2/OAM Network
15	rms1-ms1 NICx1	Customer Switch 1/Signaling Network
16	rms1-ms1 NICx2	Customer Switch 2/Signaling Network (optional)
17	rms1-ms1 OOBM	Customer Switch 1/OAM Network
18	rms1-ms1 NICx4	Backup Network (optional)
Management Server 2 (If applicable)		
19	rms2-ms2 NIC1	Customer Switch 1/OAM Network
20	rms2-ms2 NIC2	Customer Switch 2/OAM Network
21	rms2-ms2 NICx1	Customer Switch 1/Signaling Network (optional)
22	rms2-ms2 NICx2	Customer Switch 2/Signaling Network (optional)
23	rms2-ms2 OOBM	Customer Switch 2/OAM Network
24	rms2-ms2 NICx4	Backup Network (optional)
Rack Mount Server 3 and 4 – no enclosure 7 allowed		
36	rms3 NIC1	Customer Switch 1/OAM Network
37	rms3 NIC2	Customer Switch 2/OAM Network
38	rms3 NICx1	Customer Switch 1/Signaling Network
39	rms3 NICx2	Customer Switch 2/Signaling Network
40	rms3 OOBM	Customer Switch 1/OAM Network
41	ms3 NICx4	Backup Network (optional)
42	rms4 NIC1	Customer Switch 1/OAM Network
43	rms4 NIC2	Customer Switch 2/OAM Network
44	rms4 NICx1	Customer Switch 1/Signaling Network
45	rms4 NICx2	Customer Switch 2/Signaling Network
46	rms4 OOBM	Customer Switch 2/OAM Network
47	ms4 NICx4	Backup Network (optional)
Rack Mount Server 5 and 6 – no enclosure 6-7 allowed		
48	rms5 NIC1	Customer Switch 1/OAM Network
49	rms5 NIC2	Customer Switch 2/OAM Network
50	rms5 NICx1	Customer Switch 1/Signaling Network
51	rms5 NICx2	Customer Switch 2/Signaling Network
52	rms5 OOBM	Customer Switch 1/OAM Network
53	ms5 NICx4	Backup Network (optional)
54	rms6 NIC1	Customer Switch 1/OAM Network

Item #	Port (to)	Port (from)
55	rms6 NIC2	Customer Switch 2/OAM Network
56	rms6 NICx1	Customer Switch 1/Signaling Network
57	rms6 NICx2	Customer Switch 2/Signaling Network
58	rms6 OOBM	Customer Switch 2/OAM Network
59	ms6 NICx4	Backup Network (optional)
Rack Mount Server 7 and 8 – no enclosure 5-7 allowed		
60	rms7 NIC1	Customer Switch 1/OAM Network
61	rms7 NIC2	Customer Switch 2/OAM Network
62	rms7 NICx1	Customer Switch 1/Signaling Network
63	rms7 NICx2	Customer Switch 2/Signaling Network
64	rms7 OOBM	Customer Switch 1/OAM Network
65	ms7 NICx4	Backup Network (optional)
66	rms8 NIC1	Customer Switch 1/OAM Network
67	rms8 NIC2	Customer Switch 2/OAM Network
68	rms8 NICx1	Customer Switch 1/Signaling Network
69	rms8 NICx2	Customer Switch 2/Signaling Network
70	rms8 OOBM	Customer Switch 2/OAM Network
71	ms8 NICx4	Backup Network (optional)
Rack Mount Server 9 and 10 – no enclosure 4-7 allowed		
72	rms9 NIC1	Customer Switch 1/OAM Network
73	rms9 NIC2	Customer Switch 2/OAM Network
74	rms9 NICx1	Customer Switch 1/Signaling Network
75	rms9 NICx2	Customer Switch 2/Signaling Network
76	rms9 OOBM	Customer Switch 1/OAM Network
77	ms9 NICx4	Backup Network (optional)
78	rms10 NIC1	Customer Switch 1/OAM Network
79	rms10 NIC2	Customer Switch 2/OAM Network
80	rms10 NICx1	Customer Switch 1/Signaling Network
81	rms10 NICx2	Customer Switch 2/Signaling Network
82	rms10 OOBM	Customer Switch 2/OAM Network
83	ms10 NICx4	Backup Network (optional)
Rack Mount Server 11 and 12 – no enclosure 3-7 allowed		
84	rms11 NIC1	Customer Switch 1/OAM Network
85	rms11 NIC2	Customer Switch 2/OAM Network
86	rms11 NICx1	Customer Switch 1/Signaling Network
87	rms11 NICx2	Customer Switch 2/Signaling Network
88	rms11 OOBM	Customer Switch 1/OAM Network
89	ms11 NICx4	Backup Network (optional)
90	rms12 NIC1	Customer Switch 1/OAM Network
91	rms12 NIC2	Customer Switch 2/OAM Network
92	rms12 NICx1	Customer Switch 1/Signaling Network
93	rms12 NICx2	Customer Switch 2/Signaling Network
94	rms12 OOBM	Customer Switch 2/OAM Network
95	ms12 NICx4	Backup Network (optional)
Rack Mount Server 13 and 14 – no enclosure 2-7 allowed		
96	rms13 NIC1	Customer Switch 1/OAM Network
97	rms13 NIC2	Customer Switch 2/OAM Network
98	rms13 NICx1	Customer Switch 1/Signaling Network
99	rms13 NICx2	Customer Switch 2/Signaling Network
100	rms13 OOBM	Customer Switch 1/OAM Network
101	ms13 NICx4	Backup Network (optional)

Item #	Port (to)	Port (from)
102	rms14 NIC1	Customer Switch 1/OAM Network
103	rms14 NIC2	Customer Switch 2/OAM Network
104	rms14 NICx1	Customer Switch 1/Signaling Network
105	rms14 NICx2	Customer Switch 2/Signaling Network
106	rms14 OOBM	Customer Switch 2/OAM Network
107	ms14 NICx4	Backup Network (optional)
RMS only – no enclosures allowed		
108	rms15 NIC1	Customer Switch 1/OAM Network
109	rms15 NIC2	Customer Switch 2/OAM Network
110	rms15 NICx1	Customer Switch 1/Signaling Network
111	rms15 NICx2	Customer Switch 2/Signaling Network
112	rms15 OOBM	Customer Switch 1/OAM Network
113	ms15 NICx4	Backup Network (optional)
114	rms16 NIC1	Customer Switch 1/OAM Network
115	rms16 NIC2	Customer Switch 2/OAM Network
116	rms16 NICx1	Customer Switch 1/Signaling Network
117	rms16 NICx2	Customer Switch 2/Signaling Network
118	rms16 OOBM	Customer Switch 2/OAM Network
119	ms16 NICx4	Backup Network (optional)
120	rms17 NIC1	Customer Switch 1/OAM Network
121	rms17 NIC2	Customer Switch 2/OAM Network
122	rms17 NICx1	Customer Switch 1/Signaling Network
123	rms17 NICx2	Customer Switch 2/Signaling Network
124	rms17 OOBM	Customer Switch 1/OAM Network
125	ms17 NICx4	Backup Network (optional)
126	rms18 NIC1	Customer Switch 1/OAM Network
127	rms18 NIC2	Customer Switch 2/OAM Network
128	rms18 NICx1	Customer Switch 1/Signaling Network
129	rms18 NICx2	Customer Switch 2/Signaling Network
130	rms18 OOBM	Customer Switch 2/OAM Network
131	ms18 NICx4	Backup Network (optional)
132	rms19 NIC1	Customer Switch 1/OAM Network
133	rms19 NIC2	Customer Switch 2/OAM Network
134	rms19 NICx1	Customer Switch 1/Signaling Network
135	rms19 NICx2	Customer Switch 2/Signaling Network
136	rms19 OOBM	Customer Switch 1/OAM Network
137	ms19 NICx4	Backup Network (optional)
138	rms20 NIC1	Customer Switch 1/OAM Network
139	rms20 NIC2	Customer Switch 2/OAM Network
140	rms20 NICx1	Customer Switch 1/Signaling Network
141	rms20 NICx2	Customer Switch 2/Signaling Network
142	rms20 OOBM	Customer Switch 2/OAM Network
143	ms20 NICx4	Backup Network (optional)
144	rms21 NIC1	Customer Switch 1/OAM Network
145	rms21 NIC2	Customer Switch 2/OAM Network
146	rms21 NICx1	Customer Switch 1/Signaling Network
147	rms21 NICx2	Customer Switch 2/Signaling Network
148	rms21 OOBM	Customer Switch 1/OAM Network
149	ms21 NICx4	Backup Network (optional)
150	rms22 NIC1	Customer Switch 1/OAM Network
151	rms22 NIC2	Customer Switch 2/OAM Network
152	rms22 NICx1	Customer Switch 1/Signaling Network



Item #	Port (to)	Port (from)
153	rms22 NICx2	Customer Switch 2/Signaling Network
154	rms22 OOBM	Customer Switch 2/OAM Network
155	ms22 NICx4	Backup Network (optional)
156	rms23 NIC1	Customer Switch 1/OAM Network
157	rms23 NIC2	Customer Switch 2/OAM Network
158	rms23 NICx1	Customer Switch 1/Signaling Network
159	rms23 NICx2	Customer Switch 2/Signaling Network
160	rms23 OOBM	Customer Switch 1/OAM Network
161	ms23 NICx4	Backup Network (optional)
162	rms24NIC1	Customer Switch 1/OAM Network
163	rms23 NIC2	Customer Switch 2/OAM Network
164	rms24 NICx1	Customer Switch 1/Signaling Network
165	rms24 NICx2	Customer Switch 2/Signaling Network
166	rms24 OOBM	Customer Switch 2/OAM Network
167	ms24 NICx4	Backup Network (optional)

Note1: Nomenclature en1-sw5 port-x  
where x denotes the port that coincides with the front-side card slot, ie card in slot 15, en1-sw5 port-15

## 12.0 TOPOLOGY SPECIFIC NETWORK DIAGRAM: TOPOLOGY 7

### TWO PHYSICAL NETWORKS, NO AGGREGATION SWITCHES

**Figure 8: Logical Diagram Topology 7**

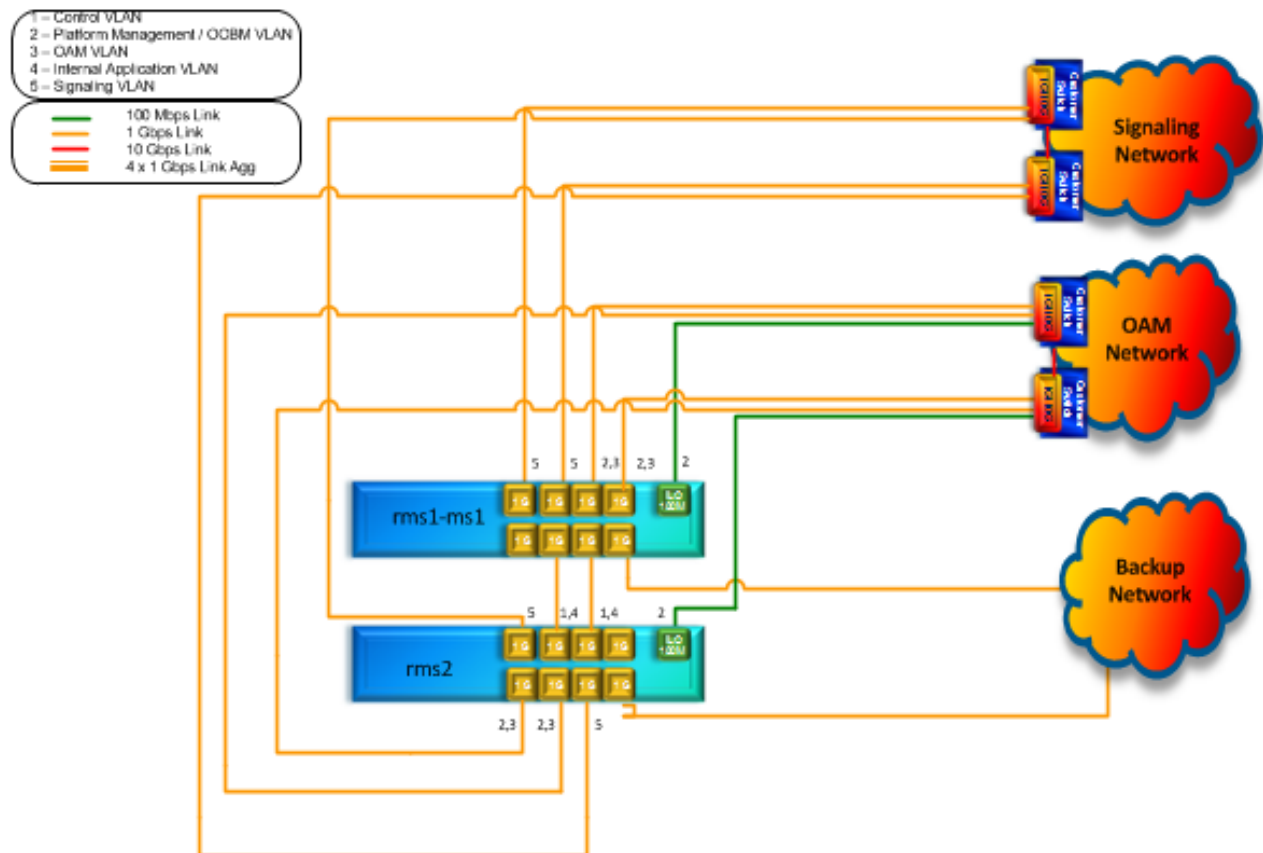

**NOTE:** This topology is supported only in UDR 10.2 and higher.

**NOTE:** This figure is a logical representation to show the network design, and not meant in any way to define actual physical port locations on the servers. For information regarding how the physical ports are connected, please refer to the interconnect tables below.

#### Characteristics:

- Support Customer deployments where aggregation switches are not feasible (for network policy reasons etc.).
- Share one physical network for OAM, Control, internal and Platform Management networks.
- Provide logical separation of OAM, Control, internal and OOBM traffic via VLANs.
- Control and internal traffic uses a direct connection between the 2 servers, without the use of the customer switches.
- Supports an optional, physically separate backup network within Topology 7.
- Limited to two servers maximum.

## 12.1 INTERCONNECTIONS

### 12.1.1 Standard Eight Port Configuration

This configuration is considered standard for Topology 7 across all hardware platforms. In Table 3, the hardware configuration represented here applies to all HP and Sun X3-2 servers, and to Sun X5-2 with Qty 2 dual PCI.

*Table 10 Topology 7 Interconnection Table*

Item #	Port (to)	Port (from)
Rack Mount Server 1		
1	rms1-ms1 NIC1	rms2-NIC1
2	rms1-ms1 NIC2	rms2-NIC2
3	rms1-ms1 NIC3	Customer Switch 2/OAM Network
4	rms1-ms1 NIC4	Customer Switch 2/Signaling Network
5	rms1-ms1 NIC5	Customer Switch 1/OAM Network
6	rms1-ms1 NIC6	<i>unused</i>
7	rms1-ms1 NIC7	Customer Switch 1/Signaling Network
8	rms1-ms1 NIC8	Backup Network (optional)
9	rms1-ms1 OOBM	Customer Switch 1/OAM Network
Rack Mount Server 2		
10	rms2-NIC1	rms1-ms1 NIC1
11	rms2-NIC2	rms1-ms1 NIC2
12	rms2-NIC3	Customer Switch 2/OAM Network
13	rms2-NIC4	Customer Switch 2/Signaling Network
14	rms2-NIC5	Customer Switch 1/OAM Network
15	rms2-NIC6	<i>unused</i>
16	rms2-NIC7	Customer Switch 1/Signaling Network
17	rms2-NIC8	Backup Network (optional)
18	rms2 OOBM	Customer Switch 2/OAM Network

### 12.1.2 Six Port Configuration

In Table 3, the hardware configuration represented here applies to only Sun X5-2 with Qty 1 dual PCI.

*Table 11 Topology 7 Interconnection Table with Six Ports*

Item #	Port (to)	Port (from)
Rack Mount Server 1		
1	rms1-ms1 NIC1	rms2-NIC1
2	rms1-ms1 NIC2	rms2-NIC2
3	rms1-ms1 NIC3	Customer Switch 2/OAM Network
4	rms1-ms1 NIC5	Customer Switch 1/OAM Network
5	rms1-ms1 NIC6	Customer Switch 1/Signaling Network
6	rms1-ms1 NIC7	Customer Switch 2/Signaling Network
7	rms1-ms1 OOBM	Customer Switch 1/OAM Network
Rack Mount Server 2		
8	rms2-NIC1	rms1-ms1 NIC1
9	rms2-NIC2	rms1-ms1 NIC2
10	rms2-NIC3	Customer Switch 2/OAM Network
11	rms2-NIC5	Customer Switch 1/OAM Network

Item #	Port (to)	Port (from)
12	rms2-NIC6	Customer Switch 1/Signaling Network
13	rms2-NIC7	Customer Switch 2/Signaling Network
14	rms2 OOBM	Customer Switch 2/OAM Network

### 12.1.3 Four Port Configuration

In Table 3, the hardware configuration represented here applies to only Sun X5-2 without any PCI expansion card (with LOM only).

*Table 12 Topology 7 Interconnection Table with Four Ports*

Item #	Port (to)	Port (from)
Rack Mount Server 1		
1	rms1-ms1 NIC1	Customer Switch 1/OAM Network
2	rms1-ms1 NIC2	Customer Switch 2/OAM Network
3	rms1-ms1 NIC5	Customer Switch 1/Signaling Network
4	rms1-ms1 NIC6	Customer Switch 2/Signaling Network
5	rms1-ms1 OOBM	Customer Switch 1/OAM Network
Rack Mount Server 2		
6	rms2-NIC1	Customer Switch 1/OAM Network
7	rms2-NIC2	Customer Switch 2/OAM Network
8	rms2-NIC3	Customer Switch 1/Signaling Network
9	rms2-NIC5	Customer Switch 2/Signaling Network
10	rms2 OOBM	Customer Switch 2/OAM Network

### 13.0 TOPOLOGY SPECIFIC NETWORK DIAGRAM: TOPOLOGY 7E

#### THREE PHYSICAL NETWORKS, NO AGGREGATION SWITCHES, SECOND SIGNALING NETWORK

Figure 9: Logical Diagram Topology 7E

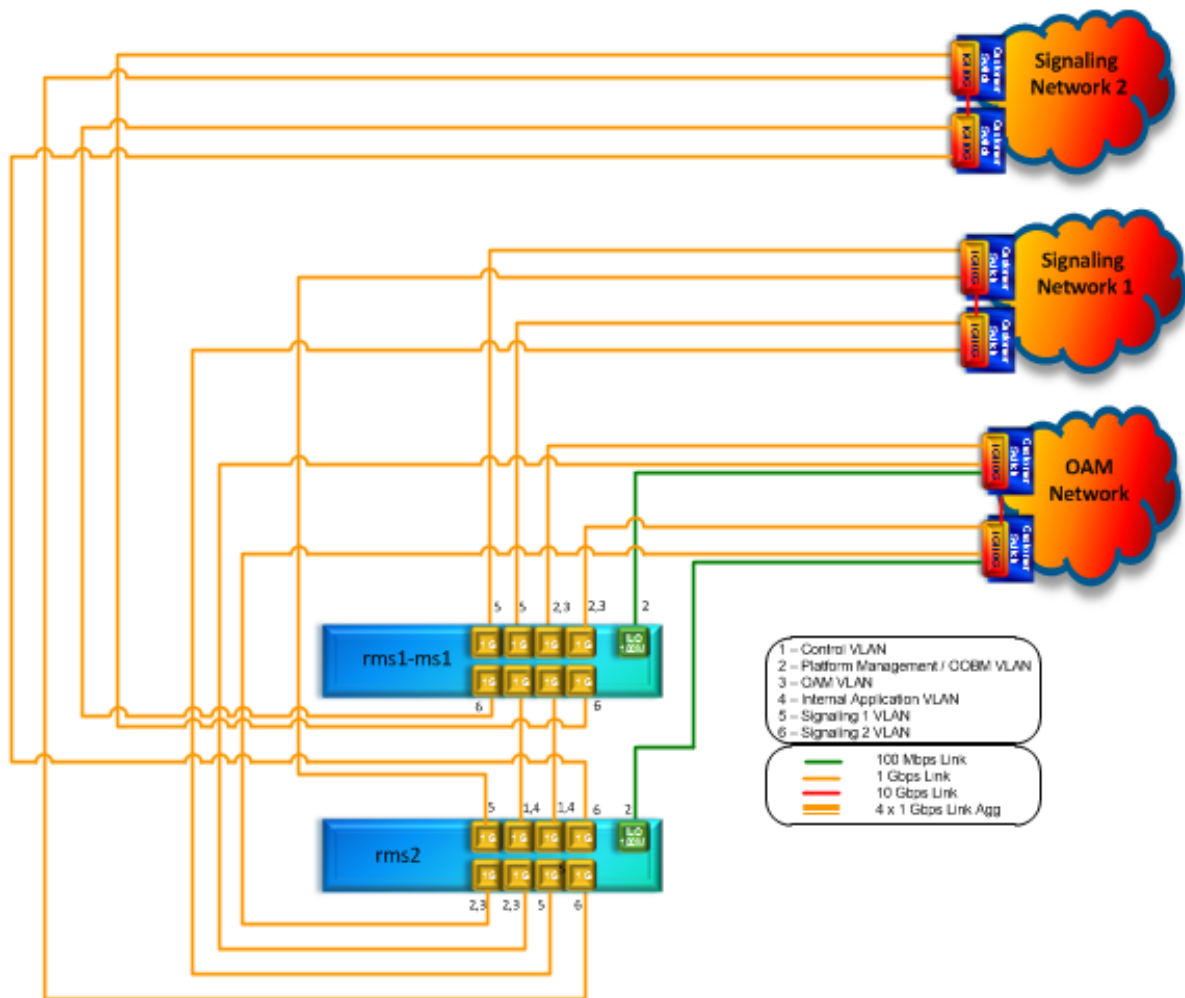

**NOTE:** This topology is supported only in UDR 10.2 and higher.

**NOTE:** This figure is a logical representation to show the network design, and not meant in any way to define actual physical port locations on the servers. For information regarding how the physical ports are connected, please refer to the interconnect tables below.

**Characteristics:**

- Support s a physically separate second signaling network within Topology 7.

## 13.1 INTERCONNECTIONS

### 13.1.1 Standard Eight Port Configuration

This configuration is considered standard for Topology 7 across all hardware platforms. In Table 3, the hardware configuration represented here applies to all HP and Sun X3-2 servers, and to Sun X5-2 with Qty 2 dual PCI.

*Table 13 Topology 7E Standard Configuration*

Item #	Port (to)	Port (from)
Rack Mount Server 1		
1	rms1-ms1 NIC1	rms2-NIC1
2	rms1-ms1 NIC2	rms2-NIC2
3	rms1-ms1 NIC3	Customer Switch 2/OAM Network
4	rms1-ms1 NIC4	Customer Switch 2/Signaling Network 1
5	rms1-ms1 NIC5	Customer Switch 1/OAM Network
6	rms1-ms1 NIC6	Customer Switch 1/Signaling Network 2
7	rms1-ms1 NIC7	Customer Switch 1/Signaling Network 1
8	rms1-ms1 NIC8	Customer Switch 2/Signaling Network 2
9	rms1-ms1 OOBM	Customer Switch 1/OAM Network
Rack Mount Server 2		
10	rms2-NIC1	rms1-ms1 NIC1
11	rms2-NIC2	rms1-ms1 NIC2
12	rms2-NIC3	Customer Switch 2/OAM Network
13	rms2-NIC4	Customer Switch 2/Signaling Network 1
14	rms2-NIC5	Customer Switch 1/OAM Network
15	rms2-NIC6	Customer Switch 1/Signaling Network 2
16	rms2-NIC7	Customer Switch 1/Signaling Network 1
17	rms2-NIC8	Customer Switch 2/Signaling Network 2
18	rms2 OOBM	Customer Switch 2/OAM Network

### 13.1.2 Six Port Configuration

In Table 3, the hardware configuration represented here applies to only Sun X5-2 with Qty 1 dual PCI.

*Table 14 Topology 7E Six Port Configuration*

Item #	Port (to)	Port (from)
Rack Mount Server 1		
1	rms1-ms1 NIC1	Customer Switch 1/OAM Network
2	rms1-ms1 NIC2	Customer Switch 2/OAM Network
3	rms1-ms1 NIC3	Customer Switch 2/Signaling Network 1
4	rms1-ms1 NIC5	Customer Switch 1/Signaling Network 1
5	rms1-ms1 NIC6	Customer Switch 1/Signaling Network 2
6	rms1-ms1 NIC7	Customer Switch 2/Signaling Network 2
7	rms1-ms1 OOBM	Customer Switch 1/OAM Network
Rack Mount Server 2		
8	rms2-NIC1	Customer Switch 1/OAM Network
9	rms2-NIC2	Customer Switch 2/OAM Network
10	rms2-NIC3	Customer Switch 2/Signaling Network 1

Item #	Port (to)	Port (from)
11	rms2-NIC5	Customer Switch 1/Signaling Network 1
12	rms2-NIC6	Customer Switch 1/Signaling Network 2
13	rms2-NIC7	Customer Switch 2/Signaling Network 2
14	rms2 OOBM	Customer Switch 2/OAM Network

### 13.1.3 Four Port Configuration

In Table 3, the hardware configuration represented here applies to only Sun X5-2 without any PCI expansion card (with LOM only).

*Table 15 Topology 7E Four Port Configuration*

Item #	Port (to)	Port (from)
Rack Mount Server 1		
1	rms1-ms1 NIC1	Customer Switch 1/OAM Network
2	rms1-ms1 NIC2	Customer Switch 2/OAM Network
3	rms1-ms1 NIC5	Customer Switch 1/Signaling Network 1 & 2
4	rms1-ms1 NIC6	Customer Switch 2/Signaling Network 1 & 2
5	rms1-ms1 OOBM	Customer Switch 1/OAM Network
Rack Mount Server 2		
6	rms2-NIC1	Customer Switch 1/OAM Network
7	rms2-NIC2	Customer Switch 2/OAM Network
8	rms2-NIC5	Customer Switch 1/Signaling Network 1 & 2
9	rms2-NIC6	Customer Switch 2/Signaling Network 1 & 2
10	rms2 OOBM	Customer Switch 2/OAM Network

**APPENDIX A. SWITCH CONFIGURATIONS**

*Figure 10: Supported C7000 Enclosure Switch Configurations for Topology 1/1A*

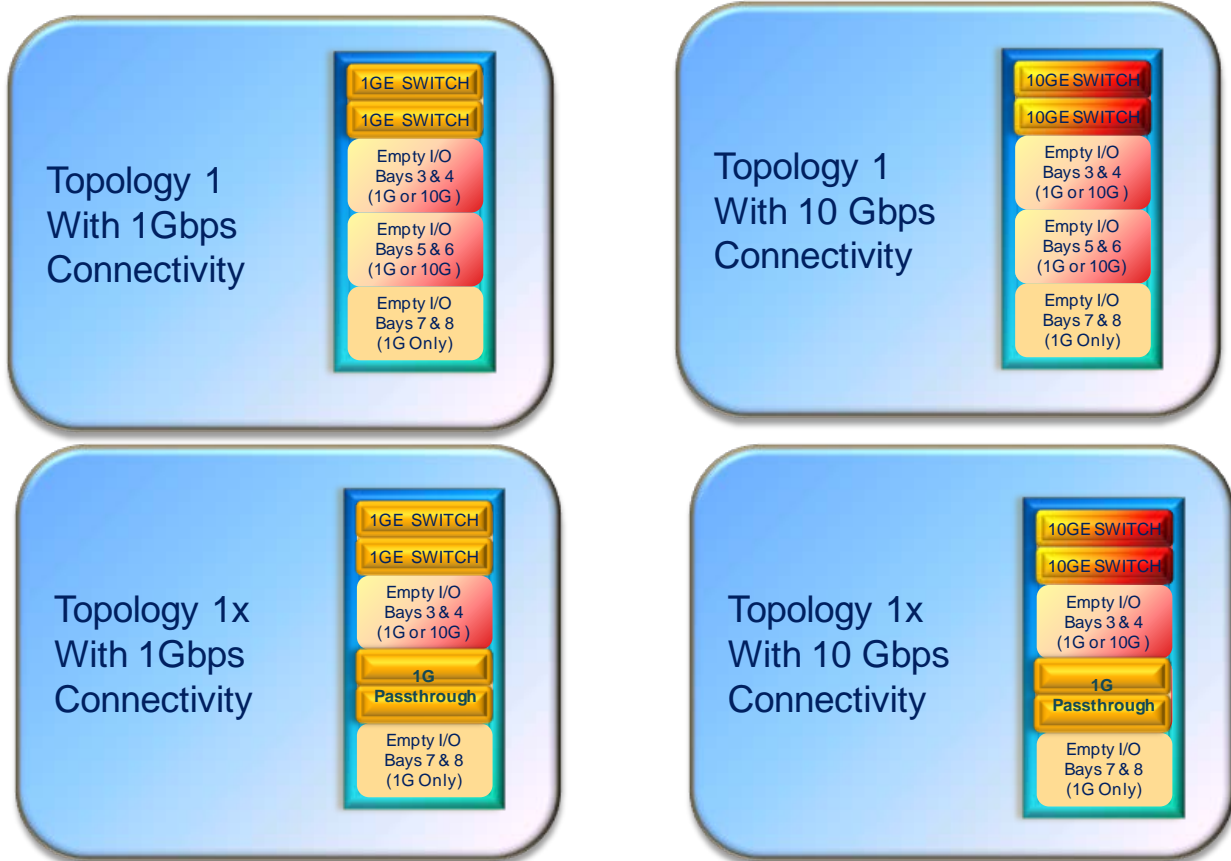

Approved 1 Gbps Switches are: Cisco 3020 and HP 6125G.

Approved 10 Gbps Switches are: HP 6120 and HP6125XLG.



Figure 11: Supported C7000 Enclosure Switch Configurations for Topology 4/4A

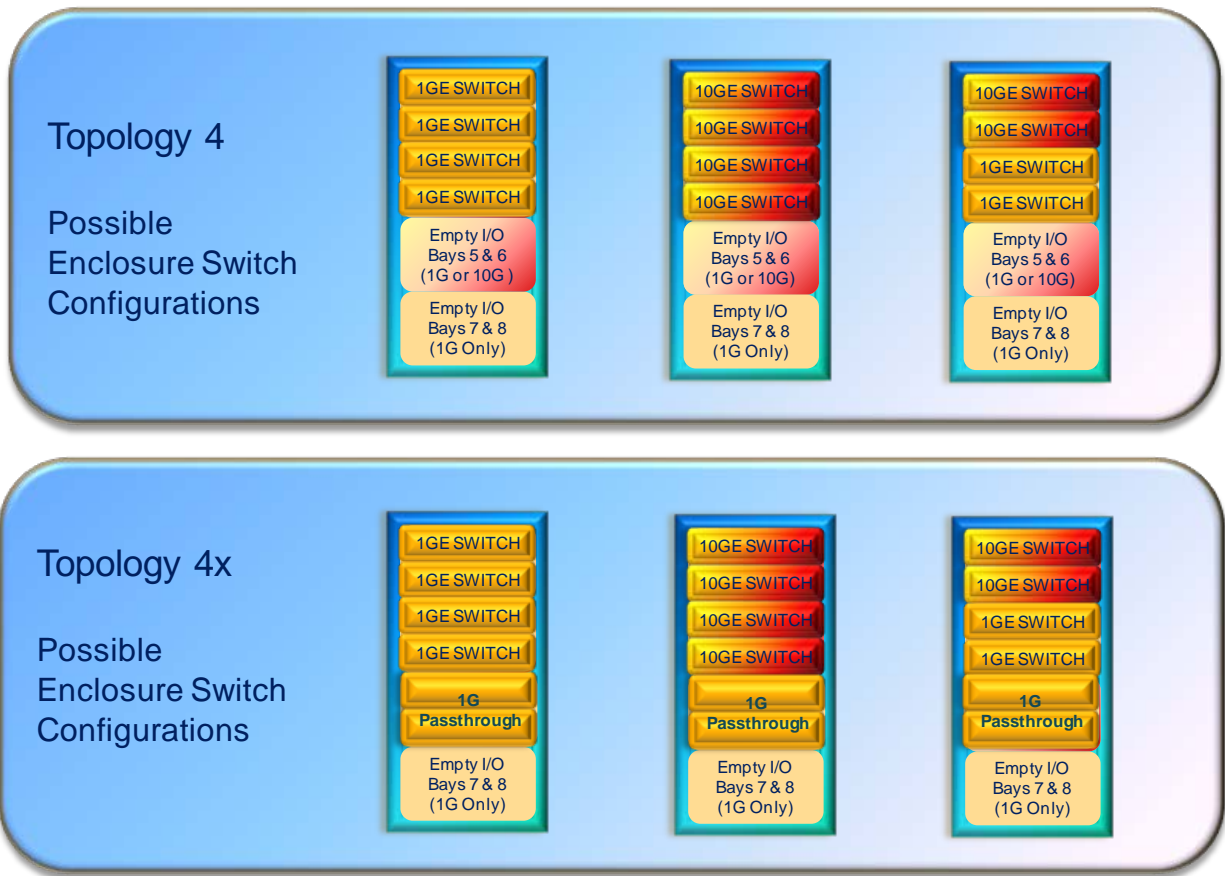

Approved 1 Gbps Switches are: Cisco 3020 and HP 6125G.

Approved 10 Gbps Switches are: HP 6120 and HP6125XLG.

## APPENDIX B. RECOMMENDED INTERCONNECTS FOR RMS WITHOUT INTERFACE BONDING

**Note:** This section presents a recommendation to accommodate lab environments that, due to equipment constraint, do not have the support of switches capable of providing bonded interfaces. **This configuration is not meant or implied to be an officially supported topology for UDR deployments.**

Table 16: Interconnection Table Lab

Item #	Port (to)	Port (from)
Management Server 1 (If applicable)		
1	rms1-ms1 NIC1	Customer Switch 1/OAM Network
2	rms1-ms1 NIC2	Customer Switch 2/OAM Network
3	rms1-ms1 NICx1	Customer Switch 1/Signaling Network (optional)
4	rms1-ms1 NICx2	Customer Switch 2/Signaling Network (optional)
5	rms1-ms1 OOBM	Customer Switch 1/OAM Network
6	rms1-ms1 NICx4	Backup Network (optional)
Management Server 2 (If applicable)		
7	rms2-ms2 NIC1	Customer Switch 1/OAM Network
8	rms2-ms2 NIC2	Customer Switch 2/OAM Network
9	rms2-ms2 NICx1	Customer Switch 1/Signaling Network (optional)
10	rms2-ms2 NICx2	Customer Switch 2/Signaling Network (optional)
11	rms2-ms2 OOBM	Customer Switch 2/OAM Network
12	rms2-ms2 NICx4	Backup Network (optional)
Rack Mount Server 3 and 4 – no enclosure 7 allowed		
13	rms3 NIC1	Routed OAM Network (XMI)
14	rms3 NIC2	Internal OAM Network (IMI)
15	rms3 NIC3	First Signaling Network (XSI-1)
16	rms3 NIC4	Second Signaling Network (XSI-2) (optional)
17	rms3 OOBM	Routed OAM Network
18	ms3 NICx4	Backup Network (optional)
19	rms4 NIC1	Routed OAM Network (XMI)
20	rms4 NIC2	Internal OAM Network (IMI)
21	rms4 NIC3	First Signaling Network (XSI-1)
22	rms4 NIC4	Second Signaling Network (XSI-2) (optional)
23	rms4 OOBM	Routed OAM Network
24	ms4 NICx4	Backup Network (optional)
Rack Mount Server 5 and 6 – no enclosure 6-7 allowed		
25	rms5 NIC1	Routed OAM Network (XMI)
26	rms5 NIC2	Internal OAM Network (IMI)
27	rms5 NIC3	First Signaling Network (XSI-1)
28	rms5 NIC4	Second Signaling Network (XSI-2) (optional)
29	rms5 OOBM	Routed OAM Network
30	ms5 NICx4	Backup Network (optional)
31	rms6 NIC1	Routed OAM Network (XMI)
32	rms6 NIC2	Internal OAM Network (IMI)
33	rms6 NIC3	First Signaling Network (XSI-1)
34	rms6 NIC4	Second Signaling Network (XSI-2) (optional)
35	rms6 OOBM	Routed OAM Network

Item #	Port (to)	Port (from)
36 37	ms6 NICx4	Backup Network (optional)
Rack Mount Server 7 and 8 – no enclosure 5-7 allowed		
38	rms7 NIC1	Routed OAM Network (XMI)
39	rms7 NIC2	Internal OAM Network (IMI)
40	rms7 NIC3	First Signaling Network (XSI-1)
41	rms7 NIC4	Second Signaling Network (XSI-2) (optional)
42	rms7 OOBM	Routed OAM Network
43	ms7 NICx4	Backup Network (optional)
44	rms8 NIC1	Routed OAM Network (XMI)
45	rms8 NIC2	Internal OAM Network (IMI)
46	rms8 NIC3	First Signaling Network (XSI-1)
47	rms8 NIC4	Second Signaling Network (XSI-2) (optional)
48	rms8 OOBM	Routed OAM Network
49	ms8 NICx4	Backup Network (optional)
Rack Mount Server 9 and 10 – no enclosure 4-7 allowed		
50	rms9 NIC1	Routed OAM Network (XMI)
51	rms9 NIC2	Internal OAM Network (IMI)
52	rms9 NIC3	First Signaling Network (XSI-1)
53	rms9 NIC4	Second Signaling Network (XSI-2) (optional)
54	rms9 OOBM	Routed OAM Network
55	ms9 NICx4	Backup Network (optional)
56	rms10 NIC1	Routed OAM Network (XMI)
57	rms10 NIC2	Internal OAM Network (IMI)
58	rms10 NIC3	First Signaling Network (XSI-1)
59	rms10 NIC4	Second Signaling Network (XSI-2) (optional)
60	rms10 OOBM	Routed OAM Network
61	ms10 NICx4	Backup Network (optional)
Rack Mount Server 11 and 12 – no enclosure 3-7 allowed		
85	rms11 NIC1	Routed OAM Network (XMI)
86	rms11 NIC2	Internal OAM Network (IMI)
108	rms11 NIC3	First Signaling Network (XSI-1)
109	rms11 NIC4	Second Signaling Network (XSI-2) (optional)
110	rms11 OOBM	Routed OAM Network
111	ms11 NICx4	Backup Network (optional)
112	rms12 NIC1	Routed OAM Network (XMI)
113	rms12 NIC2	Internal OAM Network (IMI)
114	rms12 NIC3	First Signaling Network (XSI-1)
115	rms12 NIC4	Second Signaling Network (XSI-2) (optional)
116	rms12 OOBM	Routed OAM Network
117	ms12 NICx4	Backup Network (optional)
Rack Mount Server 13 and 14 – no enclosure 2-7 allowed		
118	rms13 NIC1	Routed OAM Network (XMI)
119	rms13 NIC2	Internal OAM Network (IMI)
120	rms13 NIC3	First Signaling Network (XSI-1)
121	rms13 NIC4	Second Signaling Network (XSI-2) (optional)
122	rms13 OOBM	Routed OAM Network
123	ms13 NICx4	Backup Network (optional)
124	rms14 NIC1	Routed OAM Network (XMI)
125	rms14 NIC2	Internal OAM Network (IMI)
126	rms14 NIC3	First Signaling Network (XSI-1)

<b>Item #</b>	<b>Port (to)</b>	<b>Port (from)</b>
127	rms14 NIC4	Second Signaling Network (XSI-2) (optional)
128	rms14 OOBM	Routed OAM Network
129	ms14 NICx4	Backup Network (optional)