

StorageTek Enterprise Library Software

Configuring HSC and VTCS

Version 7.3

ORACLE

Part Number: E65941-01
February 2016

Submit comments about this document to STP_FEEDBACK_US@ORACLE.COM.

Configuring HSC and VTCS

E65941-01

Copyright © 2016 Oracle and/or its affiliates. All rights reserved.

This software and related documentation are provided under a license agreement containing restrictions on use and disclosure and are protected by intellectual property laws. Except as expressly permitted in your license agreement or allowed by law, you may not use, copy, reproduce, translate, broadcast, modify, license, transmit, distribute, exhibit, perform, publish, or display any part, in any form, or by any means. Reverse engineering, disassembly, or decompilation of this software, unless required by law for interoperability, is prohibited.

The information contained herein is subject to change without notice and is not warranted to be error-free. If you find any errors, please report them to us in writing.

If this is software or related software documentation that is delivered to the U.S. Government or anyone licensing it on behalf of the U.S. Government, the following notice is applicable:

U.S. GOVERNMENT RIGHTS Programs, software, databases, and related documentation and technical data delivered to U.S. Government customers are "commercial computer software" or "commercial technical data" pursuant to the applicable Federal Acquisition Regulation and agency-specific supplemental regulations. As such, the use, duplication, disclosure, modification, and adaptation shall be subject to the restrictions and license terms set forth in the applicable Government contract, and, to the extent applicable by the terms of the Government contract, the additional rights set forth in FAR 52.227-19, Commercial Computer Software License (December 2007). Oracle USA, Inc., 500 Oracle Parkway, Redwood City, CA 94065.

This software or hardware is developed for general use in a variety of information management applications. It is not developed or intended for use in any inherently dangerous applications, including applications which may create a risk of personal injury. If you use this software or hardware in dangerous applications, then you shall be responsible to take all appropriate fail-safe, backup, redundancy, and other measures to ensure the safe use. Oracle Corporation and its affiliates disclaim any liability for any damages caused by use of this software or hardware in dangerous applications.

Oracle is a registered trademark of Oracle Corporation and/or its affiliates. Oracle and Java are registered trademarks of Oracle and/or its affiliates. Other names may be trademarks of their respective owners.

AMD, Opteron, the AMD logo, and the AMD Opteron logo are trademarks or registered trademarks of Advanced Micro Devices. Intel and Intel Xeon are trademarks or registered trademarks of Intel Corporation. All SPARC trademarks are used under license and are trademarks or registered trademarks of SPARC International, Inc. UNIX is a registered trademark licensed through X/Open Company, Ltd.

This software or hardware and documentation may provide access to or information on content, products, and services from third parties. Oracle Corporation and its affiliates are not responsible for and expressly disclaim all warranties of any kind with respect to third-party content, products, and services. Oracle Corporation and its affiliates will not be responsible for any loss, costs, or damages incurred due to your access to or use of third-party content, products, or services.

Contents

Contents iii

Preface xv

Audience xv

Prerequisites xv

Documentation Accessibility xvi

Access to Oracle Support xvi

What's New? xvii

Chapter 1.Planning for HSC/VTCS Configuration 1

How VSM Measures Sizes and Capacities 4

Determining HSC/VTCS Configuration Values 5

Control Data Sets 5

Control Data Set Placement 6

Control Data Set Sharing 6

Sharing Requirements 6

Sharing Recommendations 7

Additional Recommendations when HSC runs on an MSP guest under VM 8

Additional Recommendations when the CDS is shared between MSP and VM 8

Limiting CDS Access Privileges 9

Serializing CDSs 10

Set Utility Serialization 10

GRS Serialization 11

Multiple HSC TapePlex Considerations 11

HSC CDS Performance and Sharing Tips	12
Unicenter CA-MIM/MII Considerations	13
When HSC RESERVEs Must Remain as RESERVEs (All Environments)	13
When You May Want to Leave HSC RESERVEs as RESERVEs	14
When HSC RESERVEs Must be Converted to Global Enqueues	14
How to Leave HSC RESERVEs as RESERVEs in an MIM/MII Environment	14
How to Convert HSC RESERVEs to Global Enqueues in a GRS Environment	16
How to Convert HSC RESERVEs to Global Enqueues in an MIM/MII Environment	17
CDS DASD Space Requirements	18
Calculating minimum DASD space for HSC using SLICREAT	18
Calculating DASD Space Requirements for POOLPARM/VOLPARM	18
Calculating DASD Space Requirements for VTCS	19
Calculating DASD Space Requirements for VAULTVOL	19
Calculating DASD Space Requirements for CDKLOCK	19
CDS VTCS Level Requirements	20
Specifying Valid CDS Levels for VTCS 7.2	21
Backing Out from an I Level CDS	22
Planning for LSMs	24
Placement of ACS network connections on your network	24
LSM Unit address requirements	24
LSM Pass-Thru Port (PTP) relationships	24
Host-to-Host Communication options	24
Calculating Cartridge Capacity - SL8500 and SL3000	25
Planning for the SL8500	26
Planning for Library-Attached Transports	27
Planning for library-attached transports as RTDs	28
Planning for Library Volumes	29
Guidelines for MVCs	29
VTCS Considerations to Correctly Specify MVC Media	30
Using the STORclas MEDIA Parameter for MVC Media Preferencing	34
Planning for VTSSs	37

Planning for VTDs	38
Planning for VTVs	39
Data Chaining a VTD Read Forward or Write Command	40

Chapter 2.Planning VTCS Operating Policies 41

Making CDS Logging Required	42
Usage Notes	42
Running IMPORT/EXPORT When Logging Required is Enabled	42
Locked Resource Policy	43
VTSS Policies	44
AMT Settings	45
Deleting Scratched VTVs	47
Usage Notes	47
VTV Page Size	48
Usage Notes	48
Maximum VTV Size	49
Usage Notes	49
Maximum RTDs per VTSS	51
Usage Notes	51
RTD/CLINK Addresses - Maximum 32 RTDs	52
General VTV Policies	55
Maximum VTVs per MVC	55
Usage Notes	55
Hosts Disabled from Migration, Consolidation and Export by VTV or Management Class	56
Usage Notes	56
Recall VTVs with Read Data Checks	57
Usage Notes	57
Early Time to First Byte (ETTFB)	58
Usage Notes	58
VTV Migration Policies	59
Streamed/Stacked Migrates	60
Usage Notes	60
Minimum Residency Time before Automatic Migration Candidacy	61

Usage Notes	61
Maximum Residency Interval before Deletion	62
Usage Notes	62
Immediate Migration Delay Interval	63
Usage Notes	63
Maximum and Minimum Concurrent Migration Tasks	64
Usage Notes	64
Prioritizing Automatic and Immediate Migration Workloads	65
Usage Notes	65
Controlling Migration Workloads	66
Usage Notes	66
Conditionally Change Migration Preferencing/Depreferencing	67
Usage Notes	67
Putting It All Together: VTV Migration Control Example for an Enterprise	68
Enabling the Remote and Local ACS Migrations	69
Migration Policies for a Vault Solution	71
Enabling the “Other Data” Migrations	72
VTV Replication Policies	73
VTCS Replication - Always or Changed VTV Only	74
Usage Notes	74
VTCS Replication - Synchronous or Asynchronous	75
Usage Notes	75
MVC Policies	76
Standard Reclaim Threshold - Determines MVC Eligibility for Reclamation (Requires Recall/Remigration)	78
Usage Notes	78
Dynamic Reclaim Threshold - No MVC Mount or VTV Recall/Remigration Occurs	79
What is Dynamic Reclaim?	79
Usage Notes	80
VLE Reclaim Threshold - Determines VMVC Eligibility for Reclamation	82
Usage Notes	82
Free MVCs Threshold - Starts Automatic Space Reclamation	83
Usage Notes	83

Eligible/Total MVCs Threshold - Starts Automatic Space Reclamation	84
Usage Notes	84
Maximum MVCs Processed Per Reclaim	85
Usage Notes	85
Maximum MVCs Concurrently Processed for Reclamation and Drain	86
Hosts Disabled from Reclamation	86
Usage Notes	86
MVC Retain Interval	87
Usage Notes	87
MVC Mount Timeout Interval	87
Non-Library Resident MVC Policies	88
MVC Initialization on First Mount	89

Chapter 3.Preparing for Configuration 91

Defining A Security System User ID for HSC and VTCS	92
Configuring MSP Device Numbers and Esoterics	93
Assigning MSP Device Numbers to VTDs and Library Drives	93
Assigning MSP Device Numbers to RTDs	93
Setting the MSP Missing Interrupt Handler (MIH) Value	93

Chapter 4.Configuring HSC 95

Creating the HSC CDS	96
Coding the LIBGEN Macros	97
Running the SLICREAT Utility To Format the New CDS	103
Running the CDSCREAT Utility to Create the CDS (Tapeless VSM Only)	105
Defining and Creating CDS Log Files	107
Running Multiple HSC Tapeplexes on One LPAR (MULT Mode)	108
Defining Volumes to ELS	109
Why Should I Use POOLPARAM/VOLPARAM?	109
Some Caveats with POOLPARAM/VOLPARAM	111
Defining Library Volumes	111
Defining Cleaning Cartridges	112
Defining MVCs	112
Defining VTVs	113

Validating and Applying the Volume Definitions	113
Defining the SYS1.PARMLIB Member SMFPRMxx	114
Creating the HSC PARMLIB Member	115
EXECPARM Statement	117
Syntax	117
Parameters	117
Defining Command Authority	118
Creating and Cataloging the HSC Startup Procedure	119
Running Multiple HSC Tapeplexes on One LPAR (MULT Mode)	120
EXEC Statement	121
Syntax	121
Parameters	121
Sample HSC Startup Procedure	124
DD Statements for the HSC Startup Procedure	124
Performance Considerations	125
Define Dispatching Priority for ELS Software	125
Reduce Pass-Thrus	125
Unavoidable Pass-Thrus	125
Unnecessary Pass-Thrus	125
Scheduled Pass-Thrus	126
Methods to Reduce Pass-Thru Activity	126
Reduce Operator Intervention	127
Reduce Scheduling Contention	129

Chapter 5.Reconfiguring a TapePlex 131

When Do You Need to Reconfigure Your TapePlex?	132
The MERGEcdfs Utility	133
Basic MERGEcdfs Procedure	133
▼ Create a New, Empty CDS	134
▼ Prepare to Run MERGEcdfs	138
▼ Run the MERGEcdfs utility	140
Ensure the Merge was Successful	140
▼ Consolidating Two Data Centers	141

- ▼ Combining Two Separate ACSs into One ACS 142
- ▼ Combining Two Separate Streamline Libraries 143
 - Configurations for ACSs Numbered Right to Left 143
 - Configurations for ACSs Numbered Left to Right 144
- ▼ Removing PTPs and Splitting an ACS Using MERGEcds 147
- ▼ Renaming a VTSS 148
- ▼ Removing Vaulted Volume Information 149

Reconfiguring a Tapeplex Without MERGEcds 150

Using Dynamic Reconfiguration 150

- ▼ Adding LSMs 151
- ▼ Dynamically Reconfiguring Streamline Library Transports 151
 - Adding Transports 152
 - Removing Transports 153
 - Replacing Transports 153
 - Changing Transport Unit Addresses 154
 - ▼ Adding SL8500 or SL3000 ACSs 155
 - ▼ Deleting an SL8500 or SL3000 ACS 155
 - ▼ Adding and Removing SL8500 or SL3000 Expansion Modules 156
 - ▼ Changing SL8500 CAP Types - HSC Down 157
 - ▼ Changing SL8500 CAP Types - HSC Up 158
- ▼ Using Audit Instead of MERGEcds for Streamline Libraries 159

Adding a New VTSS 160

HSC SET VAULTVOL and SET VAULT Utilities 161

HSC SET CDKLOCK Utility 161

Partitioning Streamline Libraries 162

Overview 162

Partitioning Requirements and Prerequisites 162

Restrictions 163

CAP Considerations 163

Definitions 164

Host Group 164

SL8500 Enhanced Partition 164

SL3000 Partition 165

Partitioning Procedures	168
Start from Scratch – LIBGEN, SLICREAT	168
Convert a Non-partitioned Library to a Partitioned Library	170
Convert a Partitioned Library to a Non-partitioned Library	173
Add a Library to the HSC Complex	177
Remove a Library from the HSC Complex	180
Adding a Partition to the Library	183
Removing a Partition from the Library	187
Moving a Partition from One Host Group to another Host Group	190
Adding Resources to a Library	194
Removing Resources from a Library	198
Changing the CAP State for Bulk CAP - HSC Down	201
Changing the CAP State for Bulk CAP - HSC Up	201
Varying the ACS Online After a Configuration Change	202

Chapter 6. Configuring VTCS 203

Building a Simple CONFIG Deck	205
▼ To build a simple CONFIG deck:	206
Updating the Tape Management System for VSM	209
Defining MVC Pool Volser Authority	210

Chapter 7. Starting and Stopping HSC 213

Starting HSC	214
HSC Startup Scenarios	215
IPLing the System	215
Preinitializing HSC as an MSP Subsystem	216
Initializing HSC Under the Master Subsystem	216
Starting HSC As a Subsystem	217
Specifying the HSC Service Level at Startup	217
Starting the HSC Behavior Change	218
Configuration Mismatches	219
Stopping HSC	220

Appendix A. ELS Configuration Record 221

Appendix B.HSC LIBGEN Macros 225

Syntax	226
Parameters	226
Syntax	229
Parameters	229
Syntax	230
Parameters	230
Syntax	231
Parameters	231
Syntax	235
Parameters	235
Syntax	236
Parameters	236
Syntax	243
Parameters	244
Syntax	249
Parameters	249
Syntax	251
Parameters	252

Appendix C.LIBGEN Macro Samples 253

One Host, Two ACSs, One 9310 LSM, One SL8500 Library Configuration	254
Four Host, Two ACSs, Two SL8500 Libraries Configuration	258
Three Host, Three ACSs, Two SL8500 Libraries, One SL3000 Library Configuration	263
Three Host, Two ACSs, Two SL3000 Libraries Configuration	267
One Host, One ACS, One 9310 LSM, Dual LMU Configuration	269
Two Host, One ACS, Two 9310 LSM Configuration	272

Appendix D.Special Cases: A Gallery of Advanced Uses of CONFIG 277

CONFIG Example: All Hosts Access VTDs in One VTSS, Only Selected Hosts Access VTDs in Second VTSS	278
CONFIG Example: Update Configuration to Add RTDs	279
CONFIG Example: Update Configuration to Add MVCs and VTVs and Change AMTs	280

CONFIG Example: Denying Host Access to a Physically Removed VTSS 281

CONFIG Examples: Using the Maximum 32 RTDs Feature 282

▼ Implementing Support for Maximum of 32 RTDs 282

Appendix E. Configuring SL8500 Library Communications 283

TCP/IP Communications - Important Considerations 284

SL8500 TCP/IP Connections 284

Shared Networks 285

Dual IP Connections 286

Two SL8500 Network Connections - Two Mainframe IP Addresses 286

Sample Configuration - Two Dedicated Routes 291

Setup Statements and Displays 292

Two SL8500 Network Connections - One Mainframe IP Address 297

Sample Configuration - One Host IP, Two SL8500 Network Connections 301

Setup Statements and Displays 302

Multiple SL8500 Library Connections 305

Connecting to Multiple SL8500 Libraries in an ACS 305

Sample Configuration - Four SL8500 Network Connections, Four Mainframe IP Addresses 306

Powering Down the SL8500 - HSC Requirements 307

Multiple TCP/IP Redundant Electronics 308

Sample Configuration #1 - One SL8500 Network Single Redundant Pair Connections, Four Mainframe IP Addresses 309

Sample Configuration #2 - One SL8500 Network Dual Redundant Pair Connections, Four Mainframe IP Addresses 311

Sample Configuration #3 - One SL8500 Network Dual Redundant Pair and 2 Dual TCP/IP Connections, Four Mainframe IP Addresses 313

Troubleshooting Library Connectivity Problems 315

Basic Tracing 315

Packet Tracing 317

Appendix F. Configuring SL3000 Library Communications 319

TCP/IP Communications - Important Considerations 320

Shared Networks 320

SL3000 Dual IP Connections 321

Two SL3000 Network Connections - Two Mainframe IP Addresses 321

Sample Configuration - Two Dedicated Routes	326
Setup Statements and Displays	328
Two SL3000 Network Connections - One Mainframe IP Address	333
Sample Configuration - One Host IP, Two SL3000 Network Connections	337
Setup Statements and Displays	338
Troubleshooting Library Connectivity Problems	342

Appendix G. VSM4 ESCON Configuration 343

VSM4 with 32 Ports	345
VSM4 Configuration Examples - 32 Ports	349
VSM4 Configuration Example: 16 Host Ports, 16 RTD Ports	350
VSM 4 Configuration Example: 20 Host Ports, 12 RTD Ports	352
VSM4 with 16 Ports	354
VSM4 Configuration Examples - 16 Ports	356
VSM4 Configuration Example: 8 Host Ports, 8 RTD Ports	357
VSM 4 Configuration Example: 10 Host Ports, 6 RTD Ports	359
CONFIG Example for VSM4 with 10 Host Ports, 6 RTD Ports	360
IOSRF Example for Single MSP Host Connected to a VSM4 Via ESCON Directors	361
Logical Paths for VSM 4 with 32 Ports	362

Appendix H. VSM4 FICON Front-End and Back-End Configuration 365

VSM4 FICON VCF Card Options	366
VSM4 FICON Front-End and Back-End Configuration Examples	372
VSM4 Configuration Example: 8 VCF Cards, FICON Directors, 16 RTDs	373
CONFIG Example for VSM4 FICON with 8 VCF Cards, FICON Directors, 16 RTDs	374
VSM4 Configuration Example: 8 VCF Cards, 4 CLINKs, FICON Directors for 8 RTDs	375
CONFIG Example for Bi-Directional Clustered VSM4 FICON Back-End	376
IOSRF Example for Single MSP Host Connected to a VSM5 Via FICON Directors	378

Appendix I. VSM5 FICON Configuration 383

VSM5 FICON VCF Card Options - Maximum 16 RTDs	384
VSM5 FICON VCF Card Options - Maximum 32 RTDs	387

FICON Port Processing	388
FICON Port Operations Best Practices	389
VSM5 FICON Front-End and Back-End Configuration Examples	390
▼ Implementing Support for Maximum of 32 RTDs	391
VSM5 Configuration Example: 8 VCF Cards, FICON Directors, 32 RTDs	392
CONFIG Example for VSM5 FICON with 8 VCF Cards, FICON Directors, 32 RTDs	393
VSM5 DOP Panels for Maximum 32 RTDs	394
IOSRF Example for Single MSP Host Connected to a VSM5 Via FICON Directors	397

Appendix J.VSM5 ESCON/FICON Configurations 401

VSM5 ICE/VCF Card Options	402
VSM5 Configuration Example: 8 ICE Cards, 16 Host Ports, 16 RTD Ports	407
IOSRF Example for Single MSP Host Connected to a VSM5 Via ESCON Directors	409

Appendix K.VSM5 New Models 411

Appendix L.VSM 6 Configuration 413

Reconfiguring VTCS	414
--------------------	-----

Appendix M.Tapeless VSM 423

How Does Tapeless VSM Work?	424
Tapeless VSM Example	425
▼ Configuring the System	426
▼ Defining Policies	427
Using CTR in "Tapeless" and "With Tape" Environments	428
LIBGEN Example for Tapeless ACS	429

Preface

Oracle's StorageTek Enterprise Library Software (ELS) is a solution consisting of the following base software:

- StorageTek Storage Management Component (SMC)
- StorageTek Host Software Component (HSC)
- StorageTek Virtual Tape Control Software (VTCS)
- StorageTek Concurrent Disaster Recovery Test (CDRT)

Audience

This guide is for StorageTek or customer personnel who are responsible for configuring HSC and VTCS. See *Introducing ELS* for an overview of the ELS solution. See *ELS Command, Control Statement, and Utility Reference* for information about VTCS, SMC, and HSC commands, control statements, and utilities. See *Configuring and Managing SMC* for information about configuring SMC. See *Installing ELS* for information about installing ELS.

Prerequisites

To perform the tasks described in this guide, you should understand the following:

- MSP operating system
- JES
- Enterprise Library Software (ELS)

Documentation Accessibility

For information about Oracle's commitment to accessibility, visit the Oracle Accessibility Program website at

<http://www.oracle.com/pls/topic/lookup?ctx=acc&id=docacc>.

Access to Oracle Support

Oracle customers that have purchased support have access to electronic support through My Oracle Support. For information, visit

<http://www.oracle.com/pls/topic/lookup?ctx=acc&id=info> or visit

<http://www.oracle.com/pls/topic/lookup?ctx=acc&id=trs> if you are hearing impaired.

What's New?

This revision includes the following updates:

- Added a section about controlling CDS accesses.
See [“Limiting CDS Access Privileges”](#) on page 9 and [“Creating the HSC CDS”](#) on page 96.
- Added calculations for sizing VTCS DASD space based on I level CDSs, which are introduced in ELS 7.3.
See [“Calculating DASD Space Requirements for VTCS”](#) on page 19.
- Added a procedure for downgrading from an I level CDS.
See [“Backing Out from an I Level CDS”](#) on page 22.
- Added 32 Gb to the maximum VTV size table.
See [“Maximum VTV Size”](#) on page 49.
- Added support for the SL8500 Bulk CAP feature.
See [“Changing SL8500 CAP Types - HSC Down”](#) on page 157, [“Changing SL8500 CAP Types - HSC Up”](#) on page 158, [“Changing the CAP State for Bulk CAP - HSC Down”](#) on page 201, and [“Changing the CAP State for Bulk CAP - HSC Up”](#) on page 201.

Planning for HSC/VTCS Configuration

TABLE 1-1 is designed to help plan and verify completion of your system's configuration tasks, and if you look at the notes, you'll see that, depending on your situation (new or upgrade install, adding hardware or not, etc.), you may not have to do anything for a specific task except check it off...

TABLE 1-1 HSC/VTCS Configuration Checklist

Task	Required or Optional?	Notes	✓ to Verify Completion
"Determining HSC/VTCS Configuration Values" on page 5	Required	Plan configuration values...a must do, because you can't just take defaults here.	
"Planning VTCS Operating Policies" on page 41	Optional	You have a choice...that is, you can take the defaults and worry about changing them later. If you take that route, it's not a bad idea to take a high level pass through this chapter with an eye toward reading it thoroughly when you have the time...	

TABLE 1-1 HSC/VTCS Configuration Checklist

Task	Required or Optional?	Notes	✓ to Verify Completion
Chapter 3, "Preparing for Configuration"			
"Defining A Security System User ID for HSC and VTCS" on page 92	Required	None of these tasks is difficult, but they are all critical. For example, Depending on the default settings of your security system, VSM may not be able to mount and write to MVCs until you have defined a security system user ID for HSC and tape volume security profiles for the MVCs!	
"Configuring MSP Device Numbers and Esoterics" on page 93			
"Setting the MSP Missing Interrupt Handler (MIH) Value" on page 93			
Chapter 4, "Configuring HSC" Note: This chapter is for first time customers. If you are an existing customer, do the tasks in Chapter 5, "Reconfiguring a TapePlex"			
"Creating the HSC CDS" on page 96	Required	Here, you define the ACSs, LSMs, and drives so ELS can use them.	
"Defining Volumes to ELS" on page 109		The new and improved ELS 7.2 lets you define all volumes--Library Volumes, MVCs, VTVs, and cleaning cartridge--one time only with the POOLPARAM/VOLPARAM statements and SET VOLPARAM utility.	
"Defining the SYS1.PARMLIB Member SMFPRMxx" on page 114		Technically speaking, this is optional...but highly recommended , because you need the SMF information to know how your system is performing.	
"Creating the HSC PARMLIB Member" on page 115		The HSC PARMLIB is where critical items such as the COMMPATH and FEATURES statements reside.	
"Defining Command Authority" on page 118		This is required to ensure that the correct personnel and applications have access to the ELS resources required.	
"Creating and Cataloging the HSC Startup Procedure" on page 119		As you probably already know, an HSC startup proc is required...	

TABLE 1-1 HSC/VTCS Configuration Checklist

Task	Required or Optional?	Notes	✓ to Verify Completion
<i>Chapter 5, "Reconfiguring a TapePlex"</i>			
	Optional	How much of reconfiguring a TapePlex you actually have to do depends on whether you're adding any hardware or changing values in the PARMLIB data sets.	
<i>Chapter 6, "Configuring VTCS"</i> Note: This chapter is for customers who license VTCS. If you do not, skip on down to Chapter 7, "Starting and Stopping HSC" .			
"Building a Simple CONFIG Deck" on page 205	Required if you license VTCS	A step procedure to create a basic CONFIG deck.	
"Updating the Tape Management System for VSM" on page 209		Required to give your TMS access to VTVs and keep the TMS from stepping on MVCs.	
"Defining MVC Pool Volser Authority" on page 210		Updating your security package to give the HSC user update authority to MVCs.	
<i>Chapter 7, "Starting and Stopping HSC"</i>			
Starting and stopping HSC (required)			

How VSM Measures Sizes and Capacities

VTCS uses the binary standard rather than the decimal standard in displaying and calculating sizes and capacities for VTVs and MVCs. Thus:

- 1 kilobyte(KB)=1024 bytes
- 1 megabyte(MB)=1000 kilobytes or 1000×1024 byte
- 1 gigabyte(GB)=1000 megabytes or $1000 \times 1000 \times 1024$ bytes

Note, however, that VTCS uses the decimal standard in displaying and calculating sizes and capacities for VTSSs. Thus:

- 1 kilobyte(KB)=1000 bytes
- 1 megabyte(MB)=1000 kilobytes or 1000×1000 bytes
- 1 gigabyte(GB)=1000 megabytes or $1000 \times 1000 \times 1000$ bytes

Determining HSC /VTCS Configuration Values

The following sections tell how to determine configuration values for the HSC/VTCS system. Many of the following sections provide configuration planning information for HSC followed by planning information for VTCS. For example, to define RTDs, you must first define them as library-attached transports, then as RTDs. If you want transports to function as “native Nearline only” you define them as library-attached transports only, not as RTDs. The following sections are ordered as “both HSC and VTCS” followed by “VTCS only.”

Note that if you are configuring devices for VTCS, unless otherwise noted, in each of the following sections, the values you determine must match wherever you use them. For example, the unit addresses described in [“Planning for Library-Attached Transports” on page 27](#) must match the following:

- The device addresses on the HSC SLIDRIVS macro.
- The MSP device addresses you assign via the IOGRP facility (if you will share these transports with MSP).

Control Data Sets

The control data sets (CDSs) contain:

- inventory information on all volumes (real, virtual, and vaulted)
- configuration information, including how many ACSs, LSMs, tape transports, etc.
- information about library hardware resource ownership across multiple processors.

The control data sets are:

Primary CDS (required)

The primary CDS resides on a DASD. The primary CDS must be accessible by all CPUs configured with the library. All configuration information about the TapePlex is stored in this data set, and it is continuously updated to reflect changes in the library.

Secondary CDS (optional, but strongly recommended)

This data set is an exact duplicate of the primary CDS and is also continuously updated to reflect changes in the library. In general, if the primary CDS becomes corrupted, the HSC continues to operate by automatically switching to the secondary CDS. The secondary CDS then becomes the new primary CDS, but the data set name remains unchanged.

Standby CDS (optional, but strongly recommended)

This data set is a formatted CDS containing only the first CDS record and cannot be used as is to continue normal operations. In general, if the primary CDS becomes corrupted, and a switch to the secondary occurs, the contents of the secondary CDS are copied to the standby. The standby CDS then becomes the new secondary data set, but the data set name remains unchanged.

Control Data Set Placement

For performance and recovery considerations, each copy of the CDS should reside on a separate disk volume. Separate control units and channel paths are also recommended to provide adequate recovery conditions.

If possible, place each control data set on its own dedicated volume. Do not place HSC control data sets on any volumes containing HSC journal data sets.

The following restrictions also apply:

1. VSM **does not** support copies of the CDS at multiple sites (for example, Primary CDS at one site and Secondary at another). A link failure would allow the two sites to run independently, and VSM cannot enforce separation of all resources. This prevents reconciliation of the two divergent CDSs as can be accomplished in a pure non-VSM environment.
2. Similarly, copies of the **entire** CDS at two sites where a link failure may occur is not recommended. For more information, see *ELS Legacy Interfaces Reference*.
3. Copies of the **entire** CDS at two sites that are **not** linked is not allowed.
4. The client-server approach of using HSC on only one host and SMC on all other hosts is recommended for TapePlexes spanning multiple geographic locations.

Control Data Set Sharing

Sharing Requirements

Sharing CDS devices between multiple host systems and processors requires that the CDS devices be defined with the SHARED attribute in SYS1.IPLLIB(KHSDEVxx).

If the control data sets are required by more than one system, then the primary, secondary, and standby control data sets must be capable of being shared in read/write mode by all host systems that share the devices.

Sharing Recommendations

Several HSC functions use the MSP RESERVE/RELEASE service to serialize CDS access between multiple hosts. If your MSP system is configured to issue device reserves in support of the RESERVE/RELEASE service, I/O contention to the device can be noticed from other systems. This is because the device will appear busy to any system not holding the reserve, and cause those I/O operations to be queued. If queued long enough, IOS start pending messages will begin to appear on those systems.

The dynamic nature of the MSP operating environment makes it impossible to predict a maximum length of time that the HSC, or any other authorized program, will hold a RESERVE. The vast majority of HSC functions hold a RESERVE for a short interval, generally only a few I/O operations to the CDS. However, some functions require a longer interval to perform the work. For example, the BACKUP utility can take several minutes to finish; the RESERVE must be held for the duration to guarantee the integrity of the backup.

Given the above, consider these recommendations:

1. Do **not** place copies of the HSC control data set on the same volume(s) as other data sets that generate high I/O activity to that volume during normal processing. This applies to all control data set copies including the secondary (shadow) and the standby. If possible, place each control data set on its own dedicated volume (no other data sets on the volume)
2. Do **not** place other datasets that require RESERVE/RELEASE functions on the same volume as the HSC control data sets. You must ensure programs that interact with each other do not access multiple CDS volumes concurrently, or a *deadly embrace* scenario can occur.

For example, TMS catalog and audit data sets, JES Checkpoint, and RACF databases are known to cause contention and lockout problems when on the same volume as HSC CDSs. Backup copy of a data set that is used only occasionally for restore purposes normally does not cause a significant problem. However, if response problems or lockouts do occur, an examination should be made of all ENQ and I/O activity related to that volume.

3. The default or recommended missing interrupt handler time interval for most disk devices should be high enough to avoid problems with the HSC reserves. However, if I/O contention due to HSC reserves begins to cause significant problems, consider increasing the missing interrupt handler time interval. Specific recommendations are detailed in the following sections.
4. Do **not** use the I/O Timing facility (the MIH((time1),(time2)) parameter in the KHSDEVxx member of the system IPLLIB on MSP systems) for devices containing the HSC control data sets.

Additional Recommendations when HSC runs on an MSP guest under VM

In order to prevent errors caused by contention lockout situations with other hosts when an MSP system is running as a guest under VM, it is strongly recommended that the VM missing interrupt interval for each disk device containing the primary, secondary, and standby control data sets be set to a value **greater** (at least 1 minute) than the value of the MSP missing interrupt interval.

Note – If using SLUADMIN utility to backup and restore the CDS, set the MSP missing interrupt interval value higher than the time it usually takes to complete the backup or restore.

The VM missing interrupt interval is specified on the SET MITIME command or on the INIT_MITIME statement. The MSP missing interrupt interval is specified on the TIME parameter of the MIH statement. Refer to the appropriate Fujitsu publications for more information about setting these values.

Additional Recommendations when the CDS is shared between MSP and VM

When there are no MSP guest systems running under VM, but only “native” MSP systems that share the CDS with VM systems, the MSP and VM missing interrupt intervals act independently of each other, however, for long-term ease of management, you may want to follow the same recommendations for when HSC runs on an MSP guest under VM in case you ever change a native MSP system to run as an MSP guest under VM:

1. It is strongly recommended that the VM missing interrupt interval for each disk device containing the primary, secondary, and standby control data sets be set to a value **greater** (at least 1 minute) than the value of the MSP missing interrupt interval.
2. If using SLUADMIN utility to backup and restore the CDS, set the MSP missing interrupt interval value higher than the time it usually takes to complete the backup or restore.

The VM missing interrupt interval is specified on the SET MITIME command or on the INIT_MITIME statement. The MSP missing interrupt interval is specified on the TIME parameter of the MIH statement. Refer to the appropriate Fujitsu publications for more information about setting these values.

Other considerations that apply to sharing a CDS between MSP and VM systems include, but are not limited to, the following:

- ARCS DEFRAG running on MSP can cause lockout conditions on VM. Also, because DEFRAG can move data sets, control data set integrity can be compromised. Avoid running a DEFRAG on CDS volumes while the HSC is in operation on any shared system
- ARCS processing of CDS volumes has also been known to cause lockout conditions.

Make sure the HSC command prefix does not conflict with any of the VM facilities, such as the CP line editing symbol.

Limiting CDS Access Privileges

Use your system security software (such as RACF, ACF-2, or TopSecret) to give WRITE access to the CDS primary, secondary and standby data sets for the user ID associated with the HSC started task. You must also submit SLUADMIN utility jobs with this user ID because some SLUADMIN utility functions update the CDS.

Caution – DO NOT ASSIGN CDS WRITE ACCESS TO ANY OTHER USER.

ELS utilities such as SLUCONDB and ExPR require READ access to the CDS data sets. Assign CDS READ access only to user IDs that require this access.

Serializing CDSs

Resource serialization in the Fujitsu MSP operating system is generally accomplished using either the Fujitsu Global Resource Serialization (GRS) facility or a third-party software product such as Unicenter CA-MIM/MII.

A resource is identified by two names:

- An 8-character QNAME
- A 1-255 character RNAME

The relationship between the two names is hierarchical; different RNAMEs can be used to describe specific different resources that are generically related to a single QNAME.

The HSC and HSC utilities use two principal QNAMES:

1. The default QNAME of STKALSQN can be changed and is used by the HSC to serialize access to the HSC CDS to serialize LSM-related processing.

Note – If you have changed STKALSQN to a different QNAME, just substitute your name for the STKALSQN references in this documentation.

2. The StorageTek-defined QNAME of STKENQNM cannot be changed and is used to serialize HSC utilities, such as the SET utility.

Set Utility Serialization

One of the facilities provided by the SET utility is to change the QNAME that was defined during LIBGEN (the STKALSQN default or customer-defined QNAME) and stored in the CDS. The SET utility and HSC also use the STKENQNM QNAME to maintain serialization while the customer-defined QNAME is being changed.

The SET utility issues two RESERVEs against the CDS prior to an update:

1. a RESERVE with the StorageTek-defined QNAME "STKENQNM"
2. a RESERVE using the existing customer-defined QNAME (or the default value of "STKALSQN")

When the HSC is started on any host, it initially serializes on the CDS using the StorageTek-defined QNAME. This prevents the HSC from being started while the customer-defined QNAME is potentially in the process of being changed. If the serialization is successful (no SET utility in progress), the customer-defined QNAME is read from the CDS and is used for future serialization requests.

GRS Serialization

In GRS environments only, resources can be serialized across multiple systems by global (SCOPE=SYSTEMS) requests or serialized on individual systems only by local (SCOPE=SYSTEM) requests. GRS provides three ways (Resource Name Lists) to change how a request is to be processed:

- The Systems Exclusion Resource Name List (referred to as the Systems Exclusion List) allows global requests to be converted to local requests
- The Systems Inclusion Resource Name List allows local requests to be converted to global requests
- The Resource Conversion Resource Name List (referred to as the Reserve Conversion List) allows RESERVE requests to be suppressed.

These three lists are built from statements specified in the KANGQT00 member of SYSx.IPLLIB in GRS environments.

Note when a RESERVE is issued, there is also an enqueue associated with the RESERVE. If a matching entry is found in the Systems Exclusion List, the RESERVE is issued, and the enqueue associated with a RESERVE is issued as a local enqueue request. If a matching entry is not found in the Systems Exclusion List, the RESERVE is issued and the enqueue associated with a RESERVE is issued as global enqueue request.

Caution – If no matching entry is found in the Systems Exclusion List and the Reserve Conversion List, double serialization occurs. Avoid this at all costs. The Fujitsu *Task Management General Description* publication shows a diagram of this process.

Multiple HSC TapePlex Considerations

If you have multiple HSC TapePlexes (each TapePlex must use a different set of primary, secondary, and standby CDSs) within the same GRS or MIM/MII serialization complex, make sure you change the default HSC QNAME STKALSQN to a different value for each HSC TapePlex. This ensures the serialization resources for one TapePlex does not delay the serialization of resources for the other TapePlexes. The default name can be changed either through the MAJNAME parameter on the SLILIBRY macro in LIBGEN or through the SET MAJNAME command of the SLUADMIN utility.

Note – With multiple TapePlexes, remember to replicate the STKALSQN examples shown in this documentation as many times as necessary and change STKALSQN to the different values you chose for each TapePlex.

Example

For two HSC TapePlexes, you could change the default HSC QNAME of STKALSQN to HSCPLEX1 for one TapePlex and HSCPLEX2 for the other. This allows the two TapePlexes to operate simultaneously without interfering with each other.

As a specific case, LCM management runs issue global enqueues for the HSC QNAME and an RNAME of PROCESSLSM $aa:ll$, where aa is the ACSid and ll is the LSMid. In a configuration of two HSC TapePlexes, there is an LSM 00 in an ACS 00 for each TapePlex, which results in the same RNAME of PROCESSLSM00:00. Two simultaneous LCM management runs for LSM 00 in ACS 00. Two simultaneous LCM management runs for LSM 00 in ACS 00 will conflict unless the HSC QNAMEs are different for the two TapePlexes.

HSC CDS Performance and Sharing Tips

Follow these tips for optimal CDS performance and sharing:

1. Place each copy of the HSC CDS (primary, secondary, and standby) on its own dedicated volume with no other data sets on those volumes. This is especially important when you do not convert HSC RESERVEs. A RESERVE issued by one system locks out access to all data on the volume for all other systems, so if you put a catalog or the TMC on the same volume as an HSC CDS, you will create a performance problem. Isolating the HSC CDSs to dedicated volumes can also simplify recovery after an outage.
2. Make sure all HSC CDS devices are gened as SHARED in your I/O device definitions. To do this, assign a value of YES to the SHARED feature for the device in SYS1.IPLLIB(KHSDEV xx).
3. Make sure you use the LMU communication method for all HSC host-to-host communication. This is specified by the METHOD parameter on the COMMPATH command and control statement.
4. If you use both HSC and VTCS software, and all hosts are running on release 6.1 or later, consider converting the CDS to the "F" level format (or later), which reduces CDS I/O during HSC/VTCS initialization and periodically thereafter when VTCS refreshes its cache.

Unicenter CA-MIM/MII Considerations

Start the HSC only after the CA-MII address space has fully initialized.

Follow Computer Associates' recommendations to start the CA-MII address space using their MIMASC utility, make sure the CA-MII address space is in the WLM SYSTEM service class so that it runs with a dispatching priority of FF, and add a PPT entry in the SYS1.PARMLIB(PPTPRMxx) member on all systems in the MIM/MII serialization complex for the MIMDRBGN program. Refer to the CA documentation for other tuning recommendations.

Whenever you need to add a QNAME statement for the HSC, you must specify SCOPE=SYSTEMS and not SCOPE=RESERVES on the QNAME statement, since other NCS products (LCM and LibraryStation) issue global enqueues that must be propagated to all systems. Specifying SCOPE=RESERVES prevents these enqueues from being propagated and will cause problems.

When HSC RESERVEs Must Remain as RESERVEs (All Environments)

Caution – Do not convert HSC RESERVEs to global enqueues in the following configurations and environments, or CDS data integrity will be compromised and CDS damage will occur.

- No serialization facility or product (e.g., GRS or CA-MIM/MII) is used, and the HSC CDSs are on devices that are shared by multiple systems.
 - Even unconverted RESERVEs are insufficient to guarantee data integrity in this case. You should consider why you are trying to share data without a serialization product.
- A serialization facility or product is used, but the HSC CDSs are on devices shared by multiple serialization complexes (GRS or MIM/MII).
 - Even unconverted RESERVEs are insufficient to guarantee data integrity in this case. The Fujitsu *MSP Planning: Global Resource Serialization* publication indicates that multiple serialization complexes cannot share resources.
 - Computer Associates cites this restriction in their paper *Unicenter CA-MII Data Sharing for z/OS*.
- The environment consists of a GRS star configuration that attempts to share the HSC CDSs between a sysplex and a system that is not part of the sysplex.
 - Fujitsu cites this restriction in *MSP Task Management General Description*.
- The HSC CDSs reside on devices shared by MSP and AVM systems.
 - Fujitsu cites this restriction in *MSP Task Management General Description*.
 - Computer Associates cites this restriction in their paper *Unicenter CA-MII Data Sharing for z/OS*.

When You May Want to Leave HSC RESERVEs as RESERVEs

You may not want to convert HSC RESERVEs to global enqueues in the following configurations and environments.

- You use GRS in a ring configuration and converting HSC RESERVEs affects ring performance.
 - Fujitsu cites this consideration in *MSP task Management General Description*.
 - Performance can suffer due to propagation delays in GRS ring configurations. Deciding whether or not to convert RESERVEs is best determined by actual experience, but as an arbitrary rule, do not convert RESERVEs if there are more than three or four systems in your GRS ring.
- You use GRS in a ring configuration and converting HSC RESERVEs affects HSC/VTCS performance.
 - Because of ring propagation delays for global enqueues, HSC and VTCS throughput may significantly degrade during periods of high HSC and/or VTCS activity.
- You have a large virtual tape configuration. For example, if you have several million Virtual Tape Volumes (VTVs) defined and have not yet migrated the CDS to the “F” level format, you may experience slow HSC/VTCS initialization times and higher CDS I/O activity due to the need for VTCS to initialize and periodically refresh its cache of VTV information.

When HSC RESERVEs Must be Converted to Global Enqueues

Convert HSC RESERVEs to global enqueues if the HSC CDSs are on devices that are defined to GDPS.

How to Leave HSC RESERVEs as RESERVEs in an MIM/MII Environment

For PROCESS=SELECT and PROCESS=ALLSYSTEMS environments:

- Whenever you need to add a QNAME statement for the HSC, specify SCOPE=SYSTEMS and not SCOPE=RESERVEs on the QNAME statement, since other NCS products (LCM and LibraryStation) issue global enqueues that must be propagated to all systems. Specifying SCOPE=RESERVEs prevents enqueues from being propagated and causes problems.

For PROCESS=SELECT and PROCESS=ALLSYSTEMS environments with LCM and/or LibraryStation:

- To not convert the CDS RESERVEs but propagate the other STKALSQN global enqueue requests, use an Exempt List and specify the QNAME statements as follows:

```
STKALSQN EXEMPT=YES,GDIF=YES,RESERVEs=KEEP,SCOPE=SYSTEMS
STKENQNM EXEMPT=NO,GDIF=NO,RESERVEs=KEEP,SCOPE=SYSTEMS
```

- Make sure an Exempt List can be used. If the GDIINIT statement specifies EXEMPT=NONE, either change it to specify EXEMPT=*membername*, or remove the EXEMPT parameter to cause the default member name of GDIEXEMPT to be used.

- In the GDIEXEMPT member (or whatever you named it) of the MIM parameter data set, specify:

```
LOCAL QNAME=STKALSQN RNAME=hsc.primarycds.datasetname  
LOCAL QNAME=STKALSQN RNAME=hsc.secondarycds.datasetname  
LOCAL QNAME=STKALSQN RNAME=hsc.standbycds.datasetname  
GLOBAL QNAME=STKALSQN
```

- Enter the following in the MIM commands member for **every** system in the MIM/MII serialization complex.

```
SET GDIF EXEMPTRESERVES=YES
```

Caution – The same value of EXEMPTRESERVES=YES must be specified and in effect on all systems in the MIM/MII serialization complex at the same time, otherwise, a data integrity exposure will exist for all shared data. If you have any questions about changing to EXEMPTRESERVES=YES, contact Computer Associates before making the change.

For PROCESS=SELECT environments without LCM and LibraryStation:

- You have a choice. PROCESS=SELECT implies that only those resources that are explicitly defined with QNAME statements will be processed by CA-MIM/MII, so you can do **one** of the following:
 - Make sure there are **no** QNAME statements or Exempt List entries for the HSC, and CA-MIM/MII will leave all HSC RESERVEs alone.
 - Explicitly add and enable new QNAME statements for the HSC, and make sure that Exempt List entries do not exist for the HSC. If you choose this option, you must specify GDIF=NO, RESERVES=KEEP, and SCOPE=SYSTEMS on the QNAME statements for the HSC. As a precaution, also specify EXEMPT=NO on the QNAME statements to prevent the Exempt List from overriding any QNAME statement values. For example:

```
STKALSQN EXEMPT=NO,GDIF=NO,RESERVES=KEEP,SCOPE=SYSTEMS
STKENQNM EXEMPT=NO,GDIF=NO,RESERVES=KEEP,SCOPE=SYSTEMS
```

For PROCESS=ALLSYSTEMS environments without LCM and LibraryStation:

- Add and enable new QNAME statements for the HSC and make sure Exempt List entries do not exist for the HSC.

Specify GDIF=NO, RESERVES=KEEP and SCOPE=SYSTEMS on the QNAME statements for the HSC. As a precaution, also specify EXEMPT=NO on the QNAME statements to prevent the Exempt List from overriding any QNAME statement values. You must code your HSC QNAME statements as shown below, since the dynamic addition of HSC resources by PROCESS=ALLSYSTEMS inappropriately defaults to assign the EXEMPT=YES and GDIF=YES attributes. For example:

```
STKALSQN EXEMPT=NO,GDIF=NO,RESERVES=KEEP,SCOPE=SYSTEMS
STKENQNM EXEMPT=NO,GDIF=NO,RESERVES=KEEP,SCOPE=SYSTEMS
```

How to Convert HSC RESERVEs to Global Enqueues in a GRS Environment

For both GRS ring and star configurations:

- Include one RNL(CON) statement for the STKALSQN resource and one RNL(CON) statement for the STKENQNM resource:

```
RNLDEF RNL(CON) TYPE(GENERIC) QNAME(STKALSQN)
RNLDEF RNL(CON) TYPE(GENERIC) QNAME(STKENQNM)
```

- Remove all RNLDEF RNL(EXCL) statements for the HSC from the GRNRNLxx member on all systems, otherwise, the HSC RESERVEs will not be converted to global enqueues. The Reserve Conversion List is not searched if an entry is found for the HSC RESERVE in the Systems Exclusion List.

How to Convert HSC RESERVEs to Global Enqueues in an MIM/MII Environment

For both PROCESS=SELECT and PROCESS=ALLSYSTEMS environments:

- Whenever you need to add a QNAME statement for the HSC, specify SCOPE=SYSTEMS and not SCOPE=RESERVES on the QNAME statement since other NCS products (LCM and LibraryStation) issue global enqueues that must be propagated to all systems. Specifying SCOPE=RESERVES prevents these enqueues from being propagated and causes problems.

For PROCESS=SELECT environments:

- Specify GDIF=YES, RESERVES=CONVERT, and SCOPE=SYSTEMS on the QNAME statements for the HSC. Make sure Exempt List entries do not exist for the HSC, and as a precaution, also specify EXEMPT=NO to prevent the Exempt List from overriding any QNAME statement values. For example:

```
STKALSQN EXEMPT=NO,GDIF=YES,RESERVES=CONVERT,SCOPE=SYSTEMS
STKENQNM EXEMPT=NO,GDIF=YES,RESERVES=CONVERT,SCOPE=SYSTEMS
```

For PROCESS=ALLSYSTEMS environments:

- If the GDIINIT statement specifies RESERVES=KEEP, you must specify the same QNAME statements as required for PROCESS=SELECT environments since the dynamic addition of HSC resources by PROCESS=ALLSYSTEMS will not (by default) assign the RESERVES=CONVERT attribute needed to convert the RESERVE:

```
STKALSQN EXEMPT=NO,GDIF=YES,RESERVES=CONVERT,SCOPE=SYSTEMS
STKENQNM EXEMPT=NO,GDIF=YES,RESERVES=CONVERT,SCOPE=SYSTEMS
```

If the GDIINIT statement specifies or is defaulted to RESERVES=CONVERT, you do not need to specify any QNAME statements unless you have special requirements that conflict with the defaults assigned to dynamically added QNAMEs. See “Selecting the GDIF Processing Mode” in the *Unicenter CA-MII Systems Programming Guide* for the defaults assigned to dynamically added QNAMEs.

CDS DASD Space Requirements

This section tells how to calculate the CDS DASD space required for ELS. The space in the CDS supports the following areas:

- HSC - Library hardware configuration and library volumes
- VTCS - VSM hardware configuration and VSM volumes (VTV/MVC)
- HSC SET VOLPARM - VOLPARM input card images
- HSC SET VAULTVOL - Vault volumes
- HSC SET CDKLOCK - Locking service for Open Systems ACSAPI

SLICREAT creates the HSC area from the HSC LIBGEN process. The other areas are created dynamically. The space for the dynamic areas must be initially allocated by SLICREAT; however, if insufficient space is allocated by SLICREAT, you can use CDS EXPAND procedure to dynamically expand the CDS. See *Managing HSC and VTCS* for more information.

Calculating minimum DASD space for HSC using SLICREAT

You can determine the minimum DASD space required for the CDSs by executing SLICREAT without specifying the SLSCNTL and SLSJRNN DD statements. The HSC generates a message that indicates the minimum space requirements in 4096-byte blocks. When you execute SLICREAT to create the CDS, you must specify the number of blocks for each of the CDS data sets that is **at least** as large as the minimum. Space requirements for the other CDS areas will affect the size of the CDS.

NOTE - If you are specifying multiple CDSs (SLSCNTL2, SLSSTBY), StorageTek recommends that you allocate the same amount of space (in blocks) for all your data sets when you define them.

Note – If the data sets are defined with different space allocations, the HSC uses the size of the smallest data set to determine the number of 4K blocks that it will use for the CDS. The additional space in the other CDS data sets, if any, will not be used by the HSC.

The difference in the space between the minimum space required (returned by SLICREAT) and the size of the smallest CDS data set is formatted as CDS free blocks. These free blocks are available to create the dynamic areas (VTCS, and so forth).

Calculating DASD Space Requirements for POOLPARM/VOLPARM

The HSC SET VOLPARM utility uses CDS space to store the input card images. The number of blocks required for this function can be calculated by the following formula:
(input / 50)

where *input* is the number of input records in the SET VOLPARM utility.

Note - When the SET VOLPARM utility is used to specify VTV and MVC volumes, the VTCS areas for these are built when the SET VOLPARM data is applied. See the following section for information on calculating space for VTVs and MVCs.

Calculating DASD Space Requirements for VTCS

This section tells how to calculate the additional CDS DASD space required for VTCS. The additional number of 4K blocks required in the CDS for VTCS is expressed as:

- For F and G format CDSs:

$$(\# \text{ VTV ranges}) + (\# \text{ VTV ranges})/862 + (\# \text{ VTVs defined})/23 + (\# \text{ VTVs defined})/19826 + (\# \text{ MVC ranges}) + (\# \text{ MVCs defined})/37 + 18 * (\# \text{ of VTSSs}) + 14$$

- For H format CDSs:

$$(\# \text{ VTV ranges}) + (\# \text{ VTV ranges})/862 + (\# \text{ VTVs defined})/23 + (\# \text{ VTVs defined})/19826 + (\# \text{ MVC ranges}) + (\# \text{ MVCs defined})/37 + 18 * (\# \text{ of VTSSs}) + 14 + (\# \text{ MVC volumes to be used for Dynamic Reclaim})/7$$

- For I format CDSs:

- If dynamic reclaim is not being used, use the H format calculation.
- If dynamic reclaim is being used, use the H format calculation plus the following:

$$(\# \text{ VTV ranges}) + (\# \text{ VTV ranges})/862 + (\# \text{ VTVs defined})/23 + (\# \text{ VTVs defined})/19826 + (\# \text{ MVC ranges}) + (\# \text{ MVCs defined})/37 + 18 * (\# \text{ of VTSSs}) + 14 + (\# \text{ MVC volumes to be used for Dynamic Reclaim})/7$$

Your StorageTek representative will run the VSM pre-sales planning tool to identify VSM candidate data sets. This will assist you in estimating the number of VTVs and MVCs required.

Calculating DASD Space Requirements for VAULTVOL

The HSC VAULT facility uses the CDS to store information on Vaulted Volumes. The number of blocks required for this function can be calculated by the following formula:

$$(nnnn * 1.2 / 99)$$

where *nnnn* is the number of Vaulted Volumes specified in the SET VAULTVOL utility.

To increase/decrease the number of Vaulted Volumes, the CDS MERGE procedure must be run.

Calculating DASD Space Requirements for CDKLOCK

The HSC Open Systems locking service uses a CDS subfile to store resource lock information. This subfile is only required if the open system platforms use the XAPI enhancement to the ACSAPI to provide resource (drive or volume) serialization. The number of blocks required for this subfile can be calculated by the following formula:

$$(xxx/10) + (xxx/15) + (xxx/20)$$

where *xxx* is the maximum number of HSC drives that are used by the Open System platforms.

For example, if 200 HSC drives can be used by Open Systems, allocate 44 blocks for the CDKLOCK subfile. To increase or decrease the size of the CDKLOCK subfile follow the MERGEcds procedure.

CDS VTCS Level Requirements

You can determine what level CDS you currently have with the HSC D CDS command as shown in the example in [FIGURE 1-1](#). In this example:

- The HSC CDS level is 6.1

Note – The HSC CDS level is the same for HSC 6.1 and above, so D CDS shows **CDS LEVEL = 060100** for all three releases.

- The VTCS CDS level is **H**

```
.SLS2716l Database Information 029 029

SYS00001 = VTCS.HARDWARE.CFG16Y.CDS
  PRIVOL = ENG001  FLAGS(40) ACTIVE

JOURNALING NOT ACTIVE FOR THIS SUB-SYSTEM

LOG DATA SET STATUS:
SYS00013 = VTCS.HARDWARE.CFG16Y.HSCLOG1
  ACTIVE
SYS00014 = VTCS.HARDWARE.CFG16Y.HSCLOG2
  ACTIVE
UTILIZATION = .76%

CDS LEVEL = 060100      DATE = 20090313
CREATE   = I813156     TIME = 14:53:37
VSM CDS LEVEL = H

LAST CDS BACKUP = NONE
LAST CDS RESTORE = NONE
LAST NCO ON

ENQNAME = STKALSQN    - SMFTYPE = 255
CLEAN PREFIX = CLN    - LABTYPE = (00) SL
RECOVERY = (00) NO RECOVERY
THIS HOST IS = ECCL   - CDS BLOCK COUNT = 12,060
```

FIGURE 1-1 Example Output from the HSC D CDS Command

As described in TABLE 1-2, each supported VTCS version supports **only** a subset of these VTCS Levels. If you are, therefore, running with multiple versions of VTCS against a CDS, it is important to ensure that the CDS is set at a level that is supported by **all** the versions being run. **Also note that** VTCS functions are **only** by running the CDS at a certain level.

TABLE 1-2 CDS Levels for Supported VTCS Versions

This VTCS CDS Level...	...is valid for these VTCS/NCS versions...	...and provides these enhancements
E	6.0, 6.1, 6.2, 7.0	<ul style="list-style-type: none"> ■ 4 MVC copies ■ 800 Mb VTVs
F	6.1, 6.2, 7.0.7.1, 7.2	<ul style="list-style-type: none"> ■ Near Continuous Operations (NCO) ■ Bi-directional clustering ■ Improved CDS I/O performances - reduces the I/O required to manage virtual scratch sub-pools
G	6.2, 7.0.7.1, 7.2	<ul style="list-style-type: none"> ■ 400Mb/800Mb/2Gb/4Gb VTVs ■ Standard/Large VTV Pages ■ 65000 VTVs per MVC
H	7.1, 7.2	<ul style="list-style-type: none"> ■ Dynamic Reclaim ■ Autonomous Device Support
I	7.3	<ul style="list-style-type: none"> ■ VSM 6 32 GB VTV support

Specifying Valid CDS Levels for VTCS 7.2

TABLE 1-3 describes the valid CDS levels for VTCS 7.2 and the corresponding CONFIG CDSLEVEL values.

TABLE 1-3 Valid CONFIG CDSLEVEL Values for VTCS 7.2

CDS VTCS Level	CDSLEVEL Value
F	V61ABOVE
G	V62ABOVE
H	V71ABOVE
I	V73ABOVE

Note –

- VTCS 7.3 will tolerate sharing the CDS with down-level VTCS versions. However, to run mixed 7.3 and down-level you need to run at a CDS level valid for all versions. For example, VTCS 7.3 and VTCS 7.2 can share the same CDS, but the VTCS level must be H.
 - Conversely, if you want specific features, you must be at the required CDS level, which may require you to upgrade down-level hosts. For example, VSM 6 32 GB VTVs requires CDS Level I, which is only valid at VTCS 7.3 and above.
-

Backing Out from an I Level CDS

To downgrade from an I level CDS:

1. Run the SLUADMIN BACKUp command against the current CDS.
2. Enter the VTVRpt command and identify all 32GB VTVs.
3. Copy the 32GB VTVs to non-32GB VTVs.
4. Using the VTVMAINT command, change the management class for all 32GB VTVs to a management class that contains only DELSCR(YES).
5. Run the SLUADMIN SCRAtch utility to scratch the 32GB VTVs. At this point the 32GB VTVs are no longer recoverable.
6. Stop all active HSCs. See “Stopping HSC” on page 220.
7. Update the VTCS configuration.
 - a. Enter CONFIg CDSLEVEL.
 - b. Enter CONFIg GLOBAL MAXVTVSZ.
 - c. Code CONFIg VTVVOL and CONFIg MVCVOL statements. Run a VTCS DECOMP utility to show the current VTVVOL and MVCVOL statements.
8. Run the SLUADMIN CONFIG utility.
9. Update any MGMTCLAS that references MAXVTVSZ(32000).
10. Start HSC. See “Starting HSC” on page 214.

Using CDS Logging to Help Recover the CDS

The HSC Transaction Logging Service is an internal HSC service that records information into one or, optionally, two Log Files. If all copies of the CDS fail (that is, you lose the Primary, Seconary, and Standby copies), recovery from a backup can be time consuming. When recovering from a backup, CDS logging can aid in resynchronizing the CDS with the data content of the VSM subsystem.

Planning for CDS logging includes the following:

- Do you want one or two copies of the log file? Two copies gives more redundancy but takes up additional DASD space.
- How much DASD space do you need for logging? It is dependent on the activity on your system and the frequency with which you do backups. Log file space requirements depend on the number of VTVs mounted between log file off loads. Use TABLE 1-4 to size your log file space allocation.

TABLE 1-4 Log file Sizing

Log file size (Mb)	VTV Mounts
1	10,000
2	20,000
4	40,000
8	80,000

TABLE 1-4 Log file Sizing

Log file size (Mb)	VTV Mounts
16	160,000
32	320,000
64	640,000

- Where do I place the log files? Basically, each log file should reside on different volumes and not on the same volume as any of the CDS copies.

Planning for LSMs

Planning for LSMs is an important phase of the installation process. Effective planning for StorageTek automated tape libraries is part of a smooth ACS installation process. Ensure that planning considerations are reviewed for:

- Placement of ACS network connections on your network
- LSM Unit address requirements
- LSM/Pass-thru Port (PTP) relationships
- Host-to-Host communication options
- SL8500 libraries
- SL3000 libraries

Placement of ACS network connections on your network

TCP/IP Network attached libraries should be attached to a separate subnet or a controlled network to protect it from floods of ARP broadcasts. All Streamline libraries are TCP/IP network attached. In addition, some legacy LSM hardware can also be attached via TCP/IP network.

LSM Unit address requirements

Some legacy hardware LSMs may use a LMU Station that emulates a 3278-2 terminal attached to a local controller. This LMU station must be assigned an MSP unit address. The LMU must be defined as a 3x74 local controller. The IOGRP facility is used to assign MSP unit addresses as a 3278-2 terminal to the LMU station.

LSM Pass-Thru Port (PTP) relationships

If your ACS contains two or more connected LSMs, you must define the LSM/PTP relationships. The Master LSM controls the PTP; the Slave LSM does not. You define the Master/Slave LSM relationships in the SLILSM Macro. Legacy LSMs (e.g. 9310 Powderhorn) can be a master of a maximum of two PTPs. Even though a Legacy LSM may have more than two PTPs, it can control only two PTPs; it is possible for one LSM to be both a master and a slave. Streamline libraries are different. The SL8500 can control 8 PTPs. The SL3000 has no PTPs

Host-to-Host Communication options

To optimize performance, StorageTek recommends that you set the HSC COMMPATH METHod parameter to LMU when multiple HSC systems share the same CDS. LMU COMMPATH is strongly recommended for all VSM environments where multiple VTCS systems share the same CDS. For an example, see [“Creating the HSC PARMLIB Member” on page 115](#),

Calculating Cartridge Capacity - SL8500 and SL3000

Message SLS0557I displays the total cartridge capacity for the library. **For the SL8500 and SL3000 libraries**, you must first vary the library online (Vary ACS command) to see the actual capacity of the library rather than the maximum capacity of the library. Before you vary the library, the maximum capacity is based on the highest possible number of panels that the HSC allows to be defined, not the number you defined in LIBGEN.

After you vary the library online, enter the Display Acs or Display Lsm command to show the actual library capacity. Refer to *ELS Command, Control Statement, and Utility Reference* for information about the Vary and Display commands.

Planning for the SL8500

Configuring and managing an SL8500 Library is **significantly different** than the other supported LSMs. Therefore, the SL8500 warrants some separate planning considerations, which are shown in the example SL8500 configuration in [Step 8 on page 101](#) through [Step 10 on page 102](#):

- The SL8500 library contains four rails on which four handbots travel, and HSC sees each rail in an SL8500 as an entire LSM. When you configure an SL8500, the SLIACS macro LSM parameter specifies the assembler labels of the 4 SLILSM macros for each SL8500 rail, where the first label corresponds to the first rail, the second label to the second rail, and so forth.

When you are defining the adjacent LSMs in an SL8500 with only internal passthru ports (elevators), the adjacent LSMs are the other rails, as shown in [Step 9 on page 101](#).

- Each SL8500 has 3 “internal PTPs” (elevators) and can also have actual PTPs that connect two SL8500s. On the SLILSM PASSTHRU parameter, 0 denotes an internal PTP, 1 an external PTP. The first LSM (rail) in an SL8500 is **always** the PTP master.
- For an SL8500 with no external PTPs, the adjacent LSMs are the other rails, as specified on the SLILSM ADJACNT parameter.
- HSC sees SL8500 panels as follows:
 - Panel 0 = CAP panel
 - Panel 1 = drive panel (**Note**: this is the **only** drive panel)
 - Panels 2 through n = cell storage panels. The total number of panels depends on the configuration of the library.
 - base library — 2-10
 - With one expansion module — 2-18 (expansion module is 8-15)
 - With two expansion modules — 2-26 (expansion modules are 8-23)
 - With three expansion modules — 2-34 (expansion modules are 8-31).

When you are configuring SL8500 panels, this translates into the following:

- Specify SLILSM DRIVE=(1) for the single drive panel.
- Specify DOOR=SL8500-1 for a single SL8500 CAP, specify DOOR=SL8500-2 for two SL8500 CAPs
- To HSC, as viewed from inside the library, SL8500 column numbers are positive starting with +1 to the right of the center line of the drive bays. They are negative starting with -1 to the left of the drive bays. HSC reports two columns for each cell storage panel (columns 0 and 1).
- To HSC, the SL8500 outer wall = 1 and the inner wall = 2.
- SL8500 row numbers: within each LSM (rail), rows are numbered consecutively from the top down. Row numbers start with 1 for the SL8500 and 0 for HSC.

Note – The SL8500 library uses TCP/IP protocol over an Ethernet physical interface to communicate with the host and HSC. **Note the following:**

- When SL8500s are connected via passthru ports, all hosts must communicate with only one SL8500; preferably the first or rightmost one.
- The SL8500 library should be attached to a separate subnet or a controlled network to protect it from floods of ARP broadcasts.

Planning for Library-Attached Transports

Determine 4-digit hexadecimal MSP unit addresses for your system's library-attached transports. You will use these addresses to:

- Add a SLIDRIVS macro (ADDRESS parameter) to define RTD device addresses during the HSC LIBGEN process as described in [“Coding the LIBGEN Macros” on page 97](#).
- Use the IOGRP facility to assign MSP device numbers to these transports as described in [“Configuring MSP Device Numbers and Esoterics” on page 93](#).

Note –

- **LTO and SDLT transports are not supported as direct-attach devices in an MSP environment.** These transports are recognized by HSC but are accessible only to open systems clients using LibraryStation.
- Nonexistent devices can be defined in LIBGEN SLIDRIVS macro only if the LIBGEN and LSM panel types match. Changing an LSM panel type can only be done by a qualified service provider. Nonexistent drives are treated by HSC as incompatible with any media type.

When the new devices are actually installed, be sure to reconfigure your MSP unit address and esoteric definitions to accurately reflect the changes.

- StorageTek recommends specifying unit addresses for devices not defined on a host **if that host may be used as a server for another host where device addresses have been configured.**
- **After** you define library-attached transports to HSC, you can define them as RTDs as described in [“Planning for library-attached transports as RTDs” on page 28](#).
- See *Configuring and Managing SMC* for defining different unit addresses for client server.

Planning for library-attached transports as RTDs

After you define library-attached transports to HSC as described in [“Planning for Library-Attached Transports”](#) on page 27, you can define them as RTDs as follows:

- Specify the MSP device numbers on the CONFIG VTSS RTD DEVNO parameter.

You also specify the RTD identifier on the CONFIG VTSS RTD NAME parameter. To help identify the RTDs connected to each VTSS, StorageTek recommends that you choose RTD identifiers that reflect the VTSS name (specified on the VTSS NAME parameter) and the RTD’s MSP device number (specified on the RTD DEVNO parameter).

In configurations where multiple VTSSs are connected to and dynamically share the same RTD, in each VTSS definition you can either assign unique RTD identifiers or use the same RTD identifier.

- StorageTek **strongly recommends** that you define your RTDs to MSP via IORGP (as normal F6473K tape drives), even if you do not intend to vary them online to MSP. This prevents the RTD addresses used in CONFIG and LIBGEN from accidentally being used for other devices. If you do not do this, and subsequently use the addresses for other MSP devices, you will cause problems with LOGREC processing, because VTCS will write records using the RTD addresses, and MSP will write records for other devices with those same addresses.
- You can specify that library-attached transports can only be used as RTDs. For more information, see [“Creating the HSC CDS”](#) on page 96.
- Ensure that you use the drive operator’s panel or T10000 Virtual Operator Panel (VOP) to enable the SL PROT (Standard Label Protect) function on the RTDs (ESCON or FICON).

Planning for Library Volumes

Determine the volume serial ranges and media types for VTVs and for all cartridges that will reside in the ACS. You will use these VOLSER ranges to create POOLPARAM/VOLPARAM statements to define real, virtual, scratch, MVC, and cleaning tape pools.

Guidelines for MVCs

- Create separate volser range for MVCs to prevent HSC from writing to MVCs and to prevent VSM from writing to conventional Library Volumes. If you use POOLPARAM/VOLPARAM, VOLSER range validation is automatic.
- VTCS, not MSP, controls access to MVCs. The tape management system does not control VSM access to an MVC volume and does not record its usage. If you choose to define MVCs to the tape management system, to ensure that the tape management system does not accidentally access MVCs, follow the guidelines in [“Updating the Tape Management System for VSM” on page 209](#).
- Use your security system to restrict access to MVCs as described in [“Defining MVC Pool Volser Authority” on page 210](#).
- HSC automatically marks newly entered MVC volumes as non-scratch. If you define existing Library Volumes as MVCs, ensure that these volumes do not contain data you need, then run the HSC UNSCratch Utility to unscratch them. For more information, see *ELS Command, Control Statement, and Utility Reference*.
- You define MVC media and recording technique as described in [“VTCS Considerations to Correctly Specify MVC Media” on page 30](#). **Note that** VTCS requires a **unique value** for the MEDIA parameter on the STORCLAS statement!

VTCS Considerations to Correctly Specify MVC Media

TABLE 1-5 describes the values required to specify the desired media and recording technique on the HSC VOLPARM/POOLARM statements and HSC STORCLAS statement to correctly specify the desired MVC media.

TABLE 1-5 RTD Model/MVC Media Values

Transport Model	TAPEREQ/ VOLPARM MEDIA	RECTECH	STORCLAS MEDIA	Cartridge Type - Specified by STORCLAS MEDIA	Density	Encrypted?
4490	STANDARD	STANDARD	STANDARD	standard length 3480 cartridge	single	N/A
9490, 9490EE	ECART	ECART	ECART	3490E cartridge	single	N/A
9490EE	ZCART	ZCART	ZCART	3490EE cartridge	single	N/A
9840	STK1R	STK1RA	STK1RAB	T9840A or T9840B cartridge	single	N/A
T9840B		STK1RB	STK1RAB	T9840A or T9840B cartridge	single	N/A
T9840C		STK1RC	STK1RC	T9840C cartridge	double	N/A
T9840D - T9840D Non- Encryptin g Transport		STK1RD	STK1RD	T9840D cartridge	triple	no
T9840DE - T9840D Encryptin g Transport		STK1RDE	STK1RDE	T9840D cartridge for encryption	triple	yes
T9940A	STK2P	STK2PA	STK2PA	T9940A cartridge	single	N/A
T9940B		STK2PB	STK2PB	T9940B cartridge	double	N/A

TABLE 1-5 RTD Model/MVC Media Values

Transport Model	TAPEREQ/ VOLPARM MEDIA	RECTECH	STORCLAS MEDIA	Cartridge Type - Specified by STORCLAS MEDIA	Density	Encrypted?
T1A34 - T10000A Non- Encryptin g Transport	T10000T1	T1A34	T1A000T1	T10000 full capacity cartridge	single	no
T1AE34 - T10000A Encryptin g Transport		T1AE34	T1A000E1	T10000 full capacity cartridge for encryption	single	yes
T1A34 - T10000A Non- Encryptin g Transport	T10000TS	T1A34	T1A000TS	T10000 sport cartridge	single	no
T1AE34 - T10000A Encryptin g Transport		T1AE34	T1A000ES	T10000 sport cartridge for encryption	single	yes
T1B34 - T10000B Non- Encryptin g Transport	T10000T1	T1B34	T1B000T1	T10000 full capacity cartridge	double	no
T1BE34 - T10000B Encryptin g Transport		T1BE34	T1B000E1	T10000 full capacity cartridge for encryption	double	yes
T1B34 - T10000B Non- Encryptin g Transport	T10000TS	T1B34	T1B000TS	T10000 sport cartridge	double	no
T1BE34 - T10000B Encryptin g Transport		T1BE34	T1B000ES	T10000 sport cartridge for encryption	double	yes

TABLE 1-5 RTD Model/MVC Media Values

Transport Model	TAPEREQ/ VOLPARM MEDIA	RECTECH	STORCLAS MEDIA	Cartridge Type - Specified by STORCLAS MEDIA	Density	Encrypted?
T1C34 - T1000C Non- Encryptin g Transport	T1000T2	T1C34	T1C000T2	T1000C full capacity cartridge	triple	no
T1CE34 - T1000C Encryptin g Transport		T1CE34	T1C000E2	T1000C full capacity cartridge for encryption	triple	yes
T1C34 - T1000C Non- Encryptin g Transport	T1000TT	T1C34	T1C000TT	T1000C sport cartridge	triple	no
T1CE34 - T1000C Encryptin g Transport		T1CE34	T1C000ET	T1000C sport cartridge for encryption	triple	yes

Use [TABLE 1-5](#) as a guideline to:

- Create VOLPARM/POOLARM statements that segregate single/double density media or encrypted/non-encrypted media.
- Specify the correct STORCLAS MEDIA values to assign the desired cartridge type and recording technique to MVCs.
- Determine which transport models can write to/read from which media. A higher capability transport (double density vs. single, or encryption vs. non-encryption) can read from media written by a lower capability transport but can only write to that media from the beginning of the tape. A lower capability transport, however, cannot read from media written by a higher capability transport but can write to that media from the beginning of the tape.

Examples

- If you are adding T10000C encrypting transports and new media to encrypt, create new POOLPARAM/VOLPARAM statements for the new media and STORCLAS statements to allow VTCS to select this media. For example:

```
POOLPARAM NAME(SYS1MVC10C)TYPE(MVC)MVCFREE(40) MAXMVC(4)
THRESH(60)INPTHRSH(10) START(70)
VOLPARAM VOLSER(MVC900-MVC999) MEDIA(T10000T2) RECTECH(T1CE34)
STORCLAS NAME(10CENCRYPT) INPLACE(YES) MEDIA(T1C000E2)
```

Note – In the preceding example:

- The T10000 MVCs have been *partitioned*, which allows them to be *dynamically reclaimed*.
 - Dynamic reclaim is *enabled* by specifying INPLACE(YES) for Storage Class 10CENCRYPT.
 - For MVC pool SYS1MVC10C, as required, *both* a standard reclaim threshold (THRESH(60)) and a dynamic reclaim threshold (INPTHRSH(10)) are specified.
-
- If you are adding T10000C encrypting transports and want to convert existing media to encryption media, change existing VOLPARAMs to specify encryption and change existing STORCLAS statements to request encryption. For example:

```
POOLPARAM NAME(SYS1MVC10C)TYPE(MVC)MVCFREE(40) MAXMVC(4)
THRESH(60)INPTHRSH(10) START(70)
VOLPARAM VOLSER(MVC900-MVC999) MEDIA(T10000T2) RECTECH(T1CE34)
STORCLAS NAME(T10K) INPLACE(YES) MEDIA(T1C000E2)
```

Here's how it works: If you have MVCs that already contain data, you cannot add "encrypted" VTVs to these MVCs. You can, however, encrypt data on initialized MVCs that do not contain data. To make this strategy work, therefore, ensure that you have sufficient free T10000 MVCs and also consider doing demand drains on MVCs that contain data to free them up.

Using the STORclas MEDIA Parameter for MVC Media Preferencing

By default, in mixed-media VSM systems, VTV automatic and demand migrations (and consolidations) attempt to go to MVCs by media type in this order:

1. Standard length 3480 cartridge
2. 3490E cartridge
3. 3490EE cartridge
4. T9840A/B cartridge
5. T9840C cartridge
6. T9840D cartridge
7. T9940A cartridge
8. T9940B cartridge
9. T10000A sport cartridge
10. T10000B sport cartridge
11. T10000C sport cartridge
12. T10000D sport cartridge
13. T10000A full capacity cartridge
14. T10000B full capacity cartridge
15. T10000C full capacity cartridge
16. T10000D full capacity cartridge

By default, for automatic and demand space reclamations, VSM attempts to write VTVs to output MVCs by media type in this order:

1. T10000D full capacity cartridge
2. T10000C full capacity cartridge
3. T10000B full capacity cartridge
4. T10000A full capacity cartridge
5. T10000D sport cartridge
6. T10000C sport cartridge
7. T10000B sport cartridge
8. T10000A sport cartridge
9. T9940B cartridge
10. T9940A cartridge
11. T9840D cartridge
12. T9840C cartridge
13. T9840A/B cartridge

14. 3490EE cartridge
15. 3490E cartridge
16. Standard length 3480 cartridge

The MEDIA parameter of the STORclas statement specifies a preference list of MVC media types. This list supersedes the default media selection list. **Note that** for reclamation, VTCS attempts to write VTVs back to MVCs in the **reverse** of the order specified on the MEDIA parameter. for more information about STORCLAS MEDIA values, see [“VTCS Considerations to Correctly Specify MVC Media”](#) on page 30.

For example, if you specify the following on the MEDIA parameter of the STORclas statement...

MEDIA(STK1RAB,STK1RC,STK2PB)

- ...to select an MVC for migration to this Storage Class, VTCS searches for a usable MVC in the order STK1RAB, STK1RC, STK2PB.
- ...to select an MVC for the output of reclaim to this Storage Class, VTCS searches for a usable MVC in the order STK2PB, STK1RC, STK1RAB.

You can specify the media and ACS preferencing via the Storage Class(es) specified on the MIGpol parameter of the MGMTclas control statement.

To optimize recall processing in mixed-media systems, ensure that your MVC pool has at least one media type compatible with each RTD type.

Planning for VTSSs

Determine your system's 1 to 8 character VTSS IDs, which you specify when you run VTCS CONFIG to install and configure your VSM system as described in [Chapter 6, "Configuring VTCS"](#).

Caution – Note the following:

- The VTSS ID can consist of the characters "A-Z", "0-9", "@", "\$", and "#".
 - You specify the VTSS ID *only* via the NAME parameter, which sets the VTSS ID in both the VTSS microcode (as displayed in the Subsystem Name field in the LOP or VOP) and in the configuration area of the HSC CDS. After VSM is put into operation, the VTSS ID is also stored in each VTV record in the CDS. Each VTV record contains either:
 - The VTSS ID on which that VTV is resident.
 - The VTSS ID from which the VTV was migrated.
 - Once you set the VTSS ID via the NAME parameter, you *cannot* change this identifier in the HSC CDS. That is, the CONFIG utility *will not* let you change the NAME parameter after an initial setting. Moreover, changing the VTSS ID using the Subsystem Name field of the LOP, VOP, or DOP *cannot* change the VTSS ID in the HSC CDS.
 - It is especially critical that you *do not* attempt to rename a VTSS that contains data on VTVs, which includes VTSS-resident VTVs and migrated VTVs!
 - For an initial setting *only* (not a change), you can set the VTSS ID in the NAME parameter only if the VTSS ID value in the VTSS microcode is:
 - The factory setting (all blanks).
 - A value of 99999999 (eight 9s).
 - Therefore, for an initial setting *only*, if the name in the VTSS microcode *is not* all blanks or 99999999, your StorageTek hardware representative must use the VTSS LOP, VOP, or DOP to set the VTSS ID to 99999999. This will enable you to set the VTSS ID to the value you want via the NAME parameter.
-

Planning for VTDs

Determine MSP unit addresses for your system's VTDs as follows:

- For each VTSS in your VSM configuration, determine a unique unit address range for the VTDs in that VTSS. Do not use duplicate addresses or overlapping address ranges, either within the VTDs in a VTSS or across VTSSs.
- For each VTSS in your VSM configuration, define its VTD unit addresses to VTCS via CONFIG.

In a multi-host, multi-VTSS configuration, you can configure your VTD unit addresses to restrict host access to VTSSs. Note that the VTDs created and MVCs initially written to from a VTSS are considered that VTSS's resources, so only hosts with access to a VTSS also have access to its VTDs and MVCs. For more information, see [Chapter 6, "Configuring VTCS"](#). **Also note**, however, that restricting access by host restricts your ability to use the client/server feature. Also, if you are using client/server, you will need to define host access to VTDs that do not have data path access to some drives (as these drives will be used by client hosts). In that case, you need to use the NOVERIFY parameter when the VTDs are defined to server hosts.

- For each SMC host, use the IOGRP facility to define to MSP the VTDs that host can access as described in ["Configuring MSP Device Numbers and Esoterics" on page 93](#). The unit addresses you specify via the IOGRP facility *must* match the unit address range you specified for that host via CONFIG, or use the SMC unit address mapping facility to use different addresses. See *Configuring and Managing SMC* for more details.
- If you use CA-MIA or MSP shared tape feature, add VTDs to the list of managed devices.

Planning for VTVs

Use these guidelines to plan for VTVs:

- Depending on the VTV size you choose and the media your volumes were previously written on, you may need to update the JCL volume count. You can do this without changing the JCL. For more information, see the *Configuring and Managing SMC* document.
- HSC/VTCS **does not allow** allocation of unlabeled tapes to VTVs. Unlabeled VTVs can cause the following for scratch VTV allocation requests:
 - If your JCL specifies a virtual esoteric, SMC fails the allocation.
 - If you have a default esoteric such as CART and specify allocation to virtual (via SMC policy), the allocation will go to a non-virtual device.
- You must define VTV volsers to your tape management system; for more information, see [“Updating the Tape Management System for VSM” on page 209](#).
- Ensure that VTV volser ranges do not duplicate or overlap existing TMS ranges or volsers of real tape volumes, including Library Volumes, *including* MVCs and Library Volumes that are regularly entered and ejected from the ACS!
- If VTDs are being used across multiple MSP images and VTV volsers are unique, add a generic entry for SYSZVOLS to the SYSTEM inclusion RNL to insure that a VTV is used by only one job at a time. If you are using automatic tape switching, also add a generic entry for SYSZVOLS to the SYSTEM inclusion RNL to prevent a system from holding a tape device while it waits for a mount of a volume that is being used by another system.

For more information, see the Fujitsu publication *MSP Planning: Global Resource Serialization*.

- HSC support lets you mix VTV and real volume types in the same scratch pool. In this case, ensure that the mount request specifies a VTD as transport type (for example, via POLICY MEDIA (VIRTUAL)). In addition, if you are routing data to a specific VTSS (for example, by using esoteric substitution) and the request specifies a subpool, ensure that the subpool contains scratch VTVs.

See *Managing HSC and VTCS* for information about displaying and managing scratch subpools.

- By default, VTCS assigns a Management Class to VTVs only on scratch mounts. You can, however, specify that VTCS assigns a Management Class whenever VTCS mounts a VTV (for read or write).

Caution – If you specify that VTCS assigns a Management Class whenever VTCS mounts a VTV, these attributes can change, which can cause undesirable or unpredictable results.

For example, if an application writes data set PROD.DATA to VTV100 with a Management Class of PROD, then writes data set TEST.DATA to VTV100 with a Management Class of TEST, then the VTV (and both data sets) has a Management Class of TEST. Similarly, it is possible to write SMC POLICY statements that assign different management classes to the same data set (for example, based on jobname), which can also cause a VTV's Management Class to change.

- To accommodate your VSM system's VTVs, you may need to increase the DASD space for your tape management system. After you determine the number and range of VTVs your VSM system requires, see your tape management system documentation for specific information on calculating the DASD space requirements.

Data Chaining a VTD Read Forward or Write Command

Note that when data chaining a Read Forward or Write command, the VTSS requires the minimum data chained update count.

Planning VTCS Operating Policies

This chapter describes the VTCS operating policies. You must set your VTSS AMTs, as described in “[AMT Settings](#)” on page 45. Otherwise, you can just take the defaults, let the system run for a while, and see what’s working/not working and adjust accordingly.

The following sections describe VTCS operating policies:

- “[Making CDS Logging Required](#)” on page 42
- “[Locked Resource Policy](#)” on page 43
- “[VTSS Policies](#)” on page 44
- “[General VTV Policies](#)” on page 55
- “[VTV Migration Policies](#)” on page 59
- “[VTV Replication Policies](#)” on page 73
- “[MVC Policies](#)” on page 76

Note that these are **rough** groupings only. All the pieces and parts of VSM interact with each other constantly, so it’s impossible to talk VTVs without thinking about MVCs, and vice versa. These policies are set globally on the CONFIG statement¹, some of which you can override on a per job basis.

1. There is one exception, and that’s VTV size (MAXVtvsz on MGMTclas).

Making CDS Logging Required

TABLE 2-1 Enable CDS Logging

This policy does the following...	Valid values are...	The default is...	To set the policy, use...
Makes CDS logging required.	<ul style="list-style-type: none">■ LOGPOL=REQuired■ LOGPOL=OPTional	LOGPOL=OPTional	CONFIG GLOBAL LOGPOL parameter

Usage Notes

- If all copies of the CDS fail, recovery can be time consuming. CDS logging can aid in re-synchronizing the CDS with the data content of the VSM subsystem. **Note that** recovery using logs will recreate a usable CDS but it **may not** fully restore VTV and MVC metadata.
- Note that the CONFIG GLOBAL LOGPOL setting merely specifies whether logging is required or optional. For information on setting up logging, see [“Defining and Creating CDS Log Files” on page 107](#). For information on *Managing HSC and VTCS*. For your initial configuration, you may want to go with the default (LOGPOL=OPT) and change this value, if desired, when you actually decide to implement logging.
- Logging works as follows:
 - If you specify LOGPOL=REQ and **all** hosts sharing the CDS are at 7.0 or above, logging is enabled for all systems, which aids recreation of a CDS.
 - If you specify LOGPOL=REQ and **some** hosts sharing the CDS are at below 7.0, logging is enabled for **only** 7.0 and above systems, so recovery is from logs for **only** those hosts. On hosts below 7.0, VTCS does not initialize.
 - If you specify LOGPOL=OPT and **some** hosts sharing the CDS are at below 7.0, logging is enabled for **only** 7.0 and above systems, so recovery is from logs for **only** those hosts. Hosts below 7.0 initialize but do **not** do logging.

Running IMPORT/EXPORT When Logging Required is Enabled

To run IMPORT/EXPORT when Logging Required is enabled:

1. Back up the CDS
2. Run CONFIG to turn off logging required.
3. Run the utility.
4. Run CONFIG to re-enable logging required.
5. Back up the CDS.
6. Resume normal activity.

Locked Resource Policy

TABLE 2-2 Locked Resource Policy

This policy does the following...	Valid values are...	The default is...	To set the policy, use...
specifies the minimum number of minutes that a resource is locked before message SLS6946E is issued.	Valid values are 0, or any value between 5 and 240. If 0 is specified, message SLS6946E will not be issued when a required resource is locked.	If this parameter is not specified, the current default of 10 minutes is retained.	CONFIG LOCKTOUT= <i>mmm</i>

Note – LOCKTOUT is only supported at 'F' level CDS (V61ABOVE) and above.

VTSS Policies

The following sections describe these VTSS policies:

- [“AMT Settings” on page 45](#). AMT settings are critical because they start and stop automatic migration and all its attendant functions. On this one, you have CONFIG settings that you can override with the SET MIGOPT command.
- [“Deleting Scratched VTVs” on page 47](#). Deleting scratched VTVs can free buffer space but has some associated potential risks, so read the usage notes before enabling this feature.
- [“VTV Page Size” on page 48](#) and [“Maximum VTV Size” on page 49](#). These two are linked, and even though they are VTV policies, they are more about optimizing VTSS usage, so they’re discussed here. Large VTV page sizes, when matched with the appropriate VTSS model, can optimize performance within the VTSS. VTV page sizes are about the page data size within the VTSS, not the actual VTV size. VTV page sizes, however, are actively linked to VTV sizes, which can improve performance in high-capacity VTSSs. In fact, selecting VTV sizes of 2 or 4 GB **enforces** a Large VTV Page.
- [“Maximum RTDs per VTSS” on page 51](#). Your choices are 16 or 32 maximum, and it’s a CONFIG GLOBAL setting.

AMT Settings

TABLE 2-3 AMT Settings

This policy does the following...	Valid values are...	The default is...	To set the policy, use...
Controls the automatic space management/migration cycle. This cycle begins when DBU (Disk Buffer Utilization) exceeds the high AMT (HAMT) or as dexcribed in TABLE 2-4 . AMTs are a percentage of DBU.	<ul style="list-style-type: none"> ■ LAMT - 5 - 95, must be one less than HAMT. ■ HAMT - 5 - 95, must be one greater than LAMT. 	<ul style="list-style-type: none"> ■ LAMT - 70 ■ HAMT - 80 	<ul style="list-style-type: none"> ■ CONFIG VTSS LOW and HIGH parameters ■ SET MIGOPT HIGHthld and LOWthld parameters.

TABLE 2-4 VTSS Models Maximum VTVs and Automigration Thresholds

VSM Model	Maximum VTVs	Autmigration Starts Above...
VSM2/VSM3	100,000	97,000
VSM4/VSM5	300,000	291,000
VSMc Models: <ul style="list-style-type: none"> ■ VSM5-45TB-IFF3 ■ VSM5-68TB-IFF3 ■ VSM5-90TB-IFF3 	500,000	485,000

Usage Notes

- With CONFIG, AMT settings take effect when you start HSC and apply to the specified VTSS.
- With SET MIGOPT:
 - AMT settings take effect immediately and apply to the specified VTSS or if no VTSS is specified, to all VTSSs. If you try to set *global values* (no VTSS specified) and the values are not valid for one VTSS (for example, MAXMIG(5) and one VTSS only has 4 RTDs connected), VTCS will not set values for any VTSSs
 - You can set the LAMT, the HAMT, or both.
- The following are general guidelines for changing the defaults:
 - The *difference* between the high and low AMTs affects the duration of the space management/migration cycle.
 - *Lowering* the HAMT tends to trigger *more frequent* space management/migration cycles.
 - *Raising* the HAMT tends to trigger *less frequent* space management/migration cycles.
 - *Lowering* the LAMT tends to free more VTSS space *and* migrate *more* VTVs.
 - *Raising* the LAMT tends to keep more VTVs resident in VTSS space *and* migrate *fewer* VTVs.

Tip – You can use Display VTSS to display the DBU, HAMT, and LAMT for each VTSS in your system. You can also use Display MIGrate to display migration status.

Deleting Scratched VTVs

TABLE 2-5 Delete Scratched VTVs Settings

This policy does the following...	Valid values are...	The default is...	To set the policy, use...
Specifies whether VSM deletes scratched VTVs.	NO, YES, FORCE	NO	MGMTCLAS DELSCR

Usage Notes

- Specifying DELSCR(YES) deletes scratch VTVs unless this would cause a processing delay due to unavailable resources.
- Specifying DELSCR(FORCE) waits for access to any resources that are required and deletes scratch VTVs, which may cause a processing delay.
- Specifying DELSCR(YES) or DELSCR(FORCE) causes VSM to delete scratched VTVs, which frees VTSS buffer space and (logically) deletes any VTV copies from MVCs so that MVC space can be reclaimed.

Note – As an alternative, you can take the default DELSCR(NO) and, as needed, run the DELETSR NOTREF command to delete scratch VTVs (from the VTSS and MVCs) *n* days after the VTV was last referenced. For more information, see *ELS Command, Control Statement, and Utility Reference*.

Caution –

- When you scratch a VTV with DELSCR YES or FORCE attribute, VSM erases the VTV data at scratch synchronization time, which eliminates the ability to “unscratch” a VTV to recover data!
- When using SLUCONDB to synchronize scratches, it is important to avoid the following to avoid inadvertently scratching a VTV resulting in data loss at scratch synchronization time:
 - Running the HSC SLUADMIN Scratch Update Utility at the same time that SLUCONDB is running.
 - Not specifying the current TMS database and/or the current HSC CDS when using SLUCONDB.

For more information about HSC scratch synchronization with the Scratch Conversion Utility (SLUCONDB), see *ELS Command, Control Statement, and Utility Reference*.

Also note that for HSC, the DELDISP parameter has two values that affect how HSC manages the scratch status of VTVs and real volumes that were mounted scratch and the delete disposition on the dismount message is delete ('D').

VTV Page Size

TABLE 2-6 VTV Page Size

This policy does the following...	Valid values are...	The default is...	To set the policy, use...
Specifies the default page size used to store VTV data in the VTSS and on the MVCs for 400 and 800 MB VTVs only. For 2 and 4 GB VTVs (MAXVtvsz 2000 or 4000) a VTVPAGE setting of LARGE is always used.	STANDARD or LARGE	STANDARD	CONFIG GLOBAL VTVPAGE MGMTclas VTVPAGE

Usage Notes

- Large page size (which requires that the CDS is at a G level or above) can provide improved performance within the VTSS and for migrates and recalls. For more information about CDS levels, see [“CDS VTCS Level Requirements”](#) on page 20.

Caution –

- The page size of a VTV can **only** be changed by a VTV scratch mount. Additional restrictions may also apply for scratch VTVs that were previously resident in a VTSS.
 - VTVPAGE **does not** apply to VSM2s. The VTSS microcode requirements are as follows:
 - For VSM3s: microcode level N01.00.77.00 or higher.
 - For VSM4s/VSM5s: microcode level D02.02.00.00 or higher.
 - If you specify LARGE and the CDS level and/or VTSS microcode **do not** support LARGE, VTCS issues warning messages and VTVPAGE defaults to STANDARD.
 - Creating VTVs with large pages makes these VTVs **unreadable** in configurations that do not support large VTV pages.
-

Maximum VTV Size

TABLE 2-7 Maximum VTV Size

This policy does the following..	Valid values are...	The default is...	To set the policy, use...
Specifies the maximum size of a VTV.	400 - 400 Mb. 800 - 800 Mb. The CDS must be at a D level or above. 2000 - 2 Gb. The CDS must be at a G level or above. 4000 - 4 Gb. The CDS must be at a G level or above. 32000 - 32Gb. The CDS must be at an I level or above and this only applies to VSM 6.	400	CONFIG GLOBAL MAXVTVSZ, MGMTCLAS MAXVTVSZ

Usage Notes

- The size of a VTV changes *only* after it goes through a scratch cycle. Therefore, if you change the Management Class and DISP=MOD, then it will still retain the original size.
- If you specify a VTV size that is not supported by the configuration, VTCS issues warning messages and MAXVtvsz defaults to the largest VTV size supported by the configuration.
- MAXVtvsz **does not** apply to VSM2s.

Caution – Specifying 2GB, 4GB, or 32GB VTVs:

- Increases MVC usage.
 - May degrade space management of smaller-capacity VTSSs, which have relatively small cache and buffer sizes.
 - Increases delays to jobs waiting recalls. Although the actual data transfer time from an MVC is the same and there may be fewer interruptions, each interruption lasts longer, which can cause job time-outs.
-

- The CONFIG GLOBAL and MGMTCLAS MAXVTVSZ parameters interact as follows:
 - If MAXVTVSZ is specified on MGMTCLAS, this value overrides the CONFIG GLOBAL MAXVTVSZ value.
 - If MAXVTVSZ is **not** specified on MGMTCLAS, the CONFIG GLOBAL MAXVTVSZ value, if specified, is used. Otherwise, MAXVTVSZ defaults to 400MB.

- If MAXVTVSZ is **not** specified on MGMTCLAS or on CONFIG GLOBAL, MAXVTVSZ defaults to 400MB.

Maximum RTDs per VTSS

You can connect up to 32 RTDs per VTSS.

TABLE 2-8 Maximum RTDS per VTSS - 16 or 32

This policy does the following...	Valid values are...	The default is...	To set the policy, use...
Specifies the maximum RTDs per VTSS.	16, 32	16	CONFIG GLOBAL MAXRTDs

Usage Notes

- For maximum 32 RTDs support, you must fulfill the requirements described in [TABLE I-3 on page 391](#).
- The VTCS addressing scheme for maximum 32 RTDs is different than that for maximum 16 RTDs. For more information, see [“RTD/CLINK Addresses - Maximum 32 RTDs” on page 52](#).

RTD/CLINK Addresses - Maximum 32 RTDs

VSM5 is available **only** with 8 VCF (FICON) cards in the configuration for a maximum of 32 RTDs shown in [FIGURE 2-1](#).

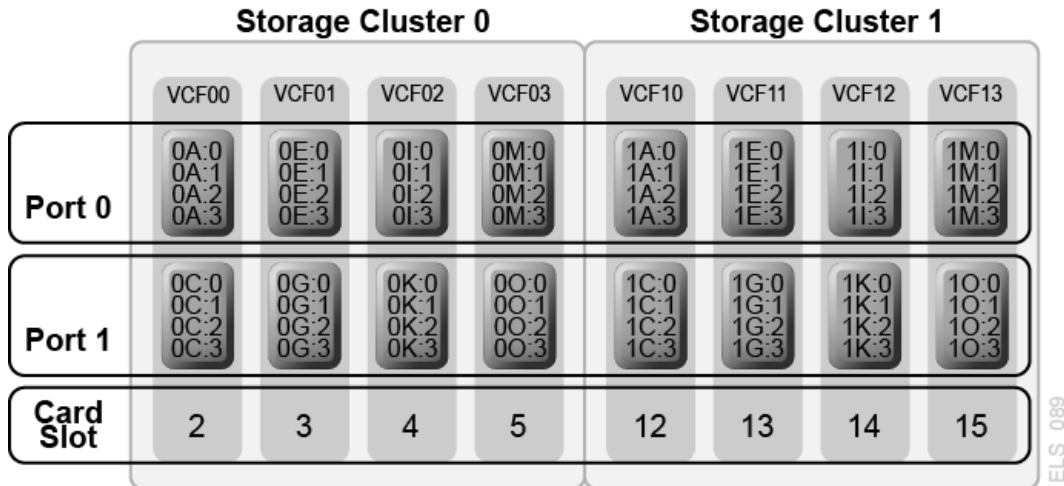

FIGURE 2-1 VSM5 with 8 VCF cards - Max 32 RTDs

As [FIGURE 2-1](#) shows, each FICON interface supports 4 devices attached via FICON directors. **Note that** the addressing scheme used by VTCS is **different** from that used for support of 2 devices per interface. The device addresses are now in the format *CI:R*, where:

- *C* is the cluster number (0 or 1)
- *I* is the interface number (A, C, E, G, I, K, M, or O)
- *R* is the device number on the interface (0, 1, 2, or 3).

[TABLE 2-9](#) on page 53 shows the “old” address (maximum 16 RTDs) and its corresponding “new” address (maximum 32 RTDs).

Note – If you upgrade an existing configuration from maximum 16 to maximum 32 RTDs, you have to change the addresses in your CONFIG deck on your RTD statements, your CLINK statements, or both.

TABLE 2-9 RTD/CLINK Addresses - Maximum 32 RTDs

Cluster Number	Interface	RTD/CLINK	Old Address (Maximum 16 RTDs)	New Address (Maximum 32 RTDs)
0	A	0	0A	0A:0
0	A	1	0B	0A:1
0	A	2	-	0A:2
0	A	3	-	0A:3
0	C	0	0C	0C:0
0	C	1	0D	0C:1
0	C	2	-	0C:2
0	C	3	-	0C:3
0	E	0	0E	0E:0
0	E	1	0F	0E:1
0	E	2	-	0E:2
0	E	3	-	0E:3
0	G	0	0G	0G:0
0	G	1	0H	0G:1
0	G	2	-	0G:2
0	G	3	-	0G:3
0	I	0	0I	0I:0
0	I	1	0J	0I:1
0	I	2	-	0I:2
0	I	3	-	0I:3
0	K	0	0K	0K:0
0	K	1	0L	0K:1
0	K	2	-	0K:2
0	K	3	-	0K:3
0	M	0	0M	0M:0
0	M	1	0N	0M:1
0	M	2	-	0M:2
0	M	3	-	0M:3
0	O	0	0O	0O:0
0	O	1	0P	0O:1
0	O	2	-	0O:2
0	O	3	-	0O:3
1	A	0	1A	1A:0

TABLE 2-9 RTD/CLINK Addresses - Maximum 32 RTDs

1	A	1	1B	1A:1
1	A	2	-	1A:2
1	A	3	-	1A:3
1	C	0	1C	1C:0
1	C	1	1D	1C:1
1	C	2	-	1C:2
1	C	3	-	1C:3
1	E	0	1E	1E:0
1	E	1	1F	1E:1
1	E	2	-	1E:2
1	E	3	-	1E:3
1	G	0	1G	1G:0
1	G	1	1H	1G:1
1	G	2	-	1G:2
1	G	3	-	1G:3
1	I	0	1I	1I:0
1	I	1	1J	1I:1
1	I	2	-	1I:2
1	I	3	-	1I:3
1	K	0	1K	1K:0
1	K	1	1L	1K:1
1	K	2	-	1K:2
1	K	3	-	1K:3
1	M	0	1M	1M:0
1	M	1	1N	1M:1
1	M	2	-	1M:2
1	M	3	-	1M:3
1	O	0	1O	1O:0
1	O	1	1P	1O:1
1	O	2	-	1O:2
1	O	3	-	1O:3

General VTV Policies

The following sections describe these VTV policies, roughly in order of importance:

- [Maximum VTVs per MVC](#). Take the default, unless...well, see the discussion about high-capacity media.
- [“Hosts Disabled from Migration, Consolidation and Export by VTV or Management Class” on page 56](#). I don’t really have a “for instance” for this one. If, for whatever reason, you don’t want a host to do these things you can explicitly turn them off. The default is not to disable any hosts, so if this isn’t an issue, don’t worry about it.
- [“Recall VTVs with Read Data Checks” on page 57](#). The default is to recall VTVs with Read Data Checks...might as well try, right? If this doesn’t suit you, you can turn it off either globally or per specific operation.
- [“Early Time to First Byte \(ETTFB\)” on page 58](#). ETTFB (also known as the concurrent tape recall/mount feature) allows host applications to read data while VTVs are being recalled from RTDs.

Maximum VTVs per MVC

TABLE 2-10 Maximum VTVs per MVC

This policy does the following...	Valid values are...	The default is...	To set the policy, use...
Specifies the maximum number of VTVs that can be migrated to a single MVC.	<ul style="list-style-type: none"> ■ 4 to 32000 for a D, E or F level CDS. ■ 4 to 65000 for a G level CDS. 	<ul style="list-style-type: none"> ■ 32000 for a D, E or F level CDS. ■ 65000 for a G level CDS. 	CONFIG GLOBAL MAXVTV parameter

Usage Notes

- This policy applies to all MVCs and, at the time you set the policy, applies only to future migrations. That is, it will not lower the number of VTVs already migrated to an MVC. If the policy is not specified, the default is as shown in [TABLE 2-10](#) unless the available MVC space is less than any remaining current VTSS resident VTV.
- Generally, use the default to allow VSM to automatically manage VTV stacking. However, with high-capacity media (for example, in a VSM system where all MVCs are type STK2P), specifying a value lower than the maximum may improve recall performance in some situations. Note, however, that a very low value can reduce that percentage of usable MVC space. If the maximum VTVs per MVC is exceeded, then usable space is reported as 0%.
- For more information about CDS levels, see [“CDS VTCS Level Requirements” on page 20](#).

Hosts Disabled from Migration, Consolidation and Export by VTV or Management Class

TABLE 2-11 Hosts Disabled from Migration, Consolidation, or Export by VTV or MGMTclas

This policy does the following...	Valid values are...	The default is...	To set the policy, use...
Specifies that a host cannot initiate automatic and demand migration and consolidation processing, or export by VTV or Management Class.	NOMIGRAT, if not specified, migration, etc., is not disabled	do not disable	CONFIG HOST

Usage Notes

- Specifying NOMIGRAT also causes NORECLAM to be set; for more information, see [“Hosts Disabled from Reclamation”](#) on page 86.
- MGMTclas IMMEdmig KEEP and IMMEdmig DELETE are mutually exclusive with CONFIG HOST NOMIGRAT. If you specify both, the IMMEdmig value overrides NOMIGRAT (for only those VTVs with the IMMEdmig value), and VTCS does not issue a message about this override.

Recall VTVs with Read Data Checks

TABLE 2-12 Recall VTVs with Read Data Checks

This policy does the following...	Valid values are...	The default is...	To set the policy, use...
Specifies whether VTCS recalls VTVs with read data checks.	YES - Recall VTVs with Read Data Checks. NO - Do not recall VTVs with Read Data Checks.	NO	CONSOLID RECALWER EEXPORT RECALWER MVC DRAIN RECALWER RECALL RECALWER

Usage Notes

- The global default is RECALWER=NO, and cannot be overridden at the global level. It can be overridden by specifying RECALWER=YES at the command level as described in TABLE 2-12.
- During MVC reclaims, VTCS will never recall VTVs with read data checks, regardless of the RECALWER setting.
- If a recall fails with a data check, and RECALWER=YES, VTCS attempts to recover the data, which includes both swapping to alternative MVC volumes (if more than one copy of the VTV was migrated) and swapping to other RTDs. If all attempts to recover the data has failed, VTCS has two options::
 1. Recall the VTV with the data check. This means that when the application attempts to read the data, a data check is presented to the application and the application can take what ever recovery steps are required (for example, try to operate just like a real tape).
 2. Fail the recall, in which case the VTV will not mount and the application will time out.

Early Time to First Byte (ETTFB)

TABLE 2-13 ETTFB Policy

This policy does the following...	Valid values are...	The default is...	To set this policy, use...
Reduces time to first byte for recalled VTVs	YES, NO	NO	CONFIG GLOBAL FASTRECL

Usage Notes

ETTFB (also known as the concurrent tape recall/mount feature) allows host applications to read data while VTVs are being recalled from RTDs. ETTFB is done by overlapping the VTV recall and mount phases, which allows the application to read the VTV data sooner. If the application attempts to read part of the VTV that has not been recalled, the application's I/O request is blocked until the required VTV data is been recalled.

ETTFB is a good choice for applications that serially access the VTV data. ETTFB is generally **not** a benefit for those applications that stack multiple files on a single VTV, including HSM and image management applications. In these types of applications, the desired data is usually not at the beginning of the VTV, but rather at some random location in the VTV

CONFIG GLOBAL FASTRECL=YES is the global setting to enable ETTFB, which you can override on a per VTSS basis via the CONFIG VTSS NOERLYMT parameter.

VTVs that have incurred an ETTFB recall error have an error flag set in their VTV record in the CDS. These VTVS are subsequently not selected for ETTFB. If you want to reset the error flag, do the following:

1. Enter a **VTVMMAINT SCRATCH (ON)** command for the VTV.
2. Migrate the VTV to a new MVC copy.
3. Import the VTV.
4. Create a new version of the VTV.
5. Scratch the VTV.

VTV Migration Policies

The following sections describe VTV Migration policies, and end with a comprehensive example in [“Putting It All Together: VTV Migration Control Example for an Enterprise”](#) on page 68:

- [“Streamed/Stacked Migrates”](#) on page 60. Enabling streamed/stacked migrates can improve migration performance, and it’s a CONFIG GLOBAL setting.
- [“Minimum Residency Time before Automatic Migration Candidacy”](#) on page 61. A method to influence VTV availability. You can also influence how quickly VTVs are automigrated after the interval expires per [“Maximum Residency Interval before Deletion”](#) on page 62
- [“Maximum Residency Interval before Deletion”](#) on page 62. The opposite of the above bullet, a method to quickly safeguard your data and conserve VTSS space.
- [“Immediate Migration Delay Interval”](#) on page 63 This specifies the amount of time in minutes to wait until immediate migrate selects VTVs for migration.
- [“Maximum and Minimum Concurrent Migration Tasks”](#) on page 64. Something to pay attention to because a thoughtful setting can help optimize your VSM resources. Again, you have a global setting that you can override with the SET MIGOPT command.
- [“Prioritizing Automatic and Immediate Migration Workloads”](#) on page 65. A carefully planned setting can help optimize your VSM resources. Higher values may speed up migration, lower values optimize cartridge use for volumes being sent offsite.
- [“Controlling Migration Workloads”](#) on page 66, which is the inverse of the above bullet, and applies to the full range of migration types.
- [“Conditionally Change Migration Preferencing/Depreferencing”](#) on page 67.

Tip – You can use Display MIGrate to display migration status.

Streamed/Stacked Migrates

This policy enables streamed/stacked migrates.

TABLE 2-14 Stacked Migrates Policy

This policy does the following...	Valid values are...	The default is...	To set the policy, use...
Specifies whether streamed/stacked migrates is enabled	STREAM, STACKED NO	NO	CONFIG GLOBAL FASTMIGR

Usage Notes

Enabling the stacked migrates feature can improve migration performance as follows:

STREAM

The streaming method is used for migrations. VTCS monitors the responses from the RTD and uses them to decide as to when a VTV has become migrated. Full advantage is made of the buffer within the RTD to improve the throughput when performing migration.

This option also implies the use of the STACKED feature as well.

STACKED

The stacked method is used for migrations. VTCS maintains a small queue of requests to the VTSS. Advantage will be taken of the various buffers in the VTSS and RTD to improve the throughput when performing a migration. For backward compatibility, the value YES is also taken to mean STACKED.

No

Disable stacked migrates (the default).

Note – FASTMIGR=STREAM | STACKED has the following prerequisites:

- FASTMIGR=STACKED. VSM4/VSM5 microcode D02.05.00.00 or higher. If this level of microcode is not installed on all VTSSs in the configuration, Stacked Migration will be limited to the VTSSs that have it installed.
- FASTMIGR=STREAM. VSM4/VSM5 microcode D02.15.xx.00 or higher. If this level of microcode is not installed on all VTSSs in the configuration, Streamed Migration will be limited to the VTSSs that have it installed.
- ELS 7.0 or higher with PTFs.
- CDS level G or higher.
- FICON ports for FICON RTDs and CLINKs.

For the Stacked Migration feature to be enabled, all hosts must be running the prerequisites, otherwise:

- If a host is active that does not support or tolerate stacked migrates, this will cause the CONFIG utility to return an error.
 - If a host is started and does not tolerate or support this feature, the host will shut down.
-

Minimum Residency Time before Automatic Migration Candidacy

TABLE 2-15 Minimum VTV Residency Interval

This policy does the following...	Valid values are...	The default is...	To set the policy, use...
By default, VSM selects VTVs for automatic migration based on size and usage. You can, however, specify a VTV's minimum residency time before automatic migration candidacy.	1 - 9999	none	MGMTCLAS RESTIME

Usage Notes

- The RESTIME value in a VTV's Management Class sets the recommended interval that the VTV remains VTSS-resident from the time that instance of the VTV is created, which is a **method to influence VTV availability**. A new instance of the VTV is created whenever the VTV is updated. At automigration time, the creation date and time of the VTV instance plus the RESTIME value is compared to the TOD clock to determine if the VTV is an automatic migration candidate.
- Note the following:
 - A VTV's Management Class (and attributes, such as RESTIME) is set after a scratch mount or optionally after a specific mount if VTVattr = ALLmount.
 - The RESTIME value is only a recommendation. VTCS can migrate a VTV before its residency interval expires if the DBU has not reached the LAMT or the specified migrate-to-threshold value and no VTVs have expired their residency intervals.
 - You can do a demand migrate of a VTV and delete it from the VTSS even if its residency interval has not expired.

The following scenario shows how the RESTIME parameter works:

1. You create Management Class with a RESTIME of 10 hours.
2. A job requests a scratch mount for the Management Class you created in [Step 1](#). VTCS selects and mounts a scratch VTV. The VTV is updated, so at dismount time, its RESTIME value is set to 10 hours (which began when VTCS mounted the VTV).
3. VTCS migrates the VTV after 3 hours, then recalls the VTV 2 hours later for a read. The RESTIME value is not reset, and there are now 5 hours of residency remaining.
4. 2 hours later, a job updates the VTV, which was 7 hours old. The update creates a new instance of the VTV and the residency interval will restart from the time the VTV was mounted for update.
5. 24 hours later, VTCS migrates the VTV, then recalls it 2 days later for a read. VTCS does not create a new instance of the VTV because it is not updated. The residency interval has expired and the VTV is therefore an automatic migration candidate based only on least-recently-used/size criteria.

6. A week later, the VTV is scratched. VTCS eventually selects and mounts the VTV to satisfy a scratch mount request. If the VTV is updated, its residency interval is set to the RESTIME value of the Management Class being used.

Maximum Residency Interval before Deletion

TABLE 2-16 Maximum Residency Interval before Deletion

This policy does the following...	Valid values are...	The default is...	To set the policy, use...
Specifies the maximum residency interval for migrated VTVs before deletion from the VTSS.	0 - 9999 hours	9999	MGMTCLAS DISCARD

Usage Notes

DISCARD lets you improve VTSS buffer management by requesting that VTVs that will not be used after a known time interval are preferenced for auto migration. DISCARD applies to automatic and immediate migration requests as follows:

- At the start of auto migration, VTVs are preferenced for deletion from the VTSS if the DISCARD value is expired and all required migrated copies exist on MVCs. If the DISCARD value is **not** expired, the VTV is treated the same as a VTV that does not have a DISCARD value assigned.
- For immediate migrate requests, whether a VTV is deleted is based on comparisons of the IMMDELAY and DISCARD times when the VTV is initially placed on the immediate or delayed migration queues. For example, if a class of data is created and referenced immediately and you set both IMMDELAY and DISCARD to 2 hours, the VTVs are immediate migrated and deleted from the VTSS after 2 hours.
- At the start of auto migration, DISCARD is ignored if RESTIME has not expired. If RESTIME has expired, then DISCARD is honored.

Immediate Migration Delay Interval

TABLE 2-17 Immediate Migration Delay Interval

This policy does the following...	Valid values are...	The default is...	To set the policy, use...
Specifies the immediate migration delay time in minutes.	0 to 9999	9999	MGMTCLAS IMMDELAY, MIGRVTV IMMDELAY

Usage Notes

- IMMDELAY lets you control the interval when immediate migration is done. For example, you may want some copies of a VTV migrated immediately while other copies are migrated at a later time, such as when the VTV meets the criteria for auto migration. The IMMDELAY parameter specifies the immediate migration delay time, which is the time in minutes to wait until immediate migrate selects VTVs for migration. Higher values preference VTV residency, which allows VTVs used in multi-step jobs to remain resident so that the jobs can complete before the VTVs are processed for migration. A value of zero equals migrate immediate.

A default strategy is to consider IMMDELAY as a switch:

- A value of 0 means migrate this VTV copy as quickly as possible.
- A value of 9999 indicates no immediate migrate (the default) and indicates that this VTV copy is migrated only when selected for auto migration.

StorageTek recommends that you do **not** use any other values until you evaluate using IMMDELAY as a switch. Then you *might* want to specify some other values to “spread out” your migration activity.

- If the VTV requires replication, a value of 0 (immediate migrate) will be assigned. This can be overridden by MGMTCLAS or MIGRVTV IMMDELAY settings.

Maximum and Minimum Concurrent Migration Tasks

TABLE 2-18 Maximum and Minimum Concurrent Migration Tasks

This policy does the following...	Valid values are...	The default is...	To set the policy, use...
Specifies the maximum and minimum number of concurrent automatic migration, immediate migration, and migrate-to-threshold tasks for each VTSS.	MAXMIG - 1 to the number of RTDs connected to the VTSS. See “Maximum RTDs per VTSS” on page 51 for more information.	Half the number of VTDs connected to the VTSS.	CONFIG VTSS MAXMIG or SET MIGOPT
	MINMIG - 1 to the MAXMIG setting.	1	CONFIG VTSS MINMIG or SET MIGOPT

Usage Notes

- Use these parameters to balance migration tasks with other tasks (such as recall and reclaim) for the RTDs you have defined for each VTSS.
- In some situations, VTCS may not be able to activate *all* the migration tasks specified by the MAXMIG parameter. For example:
 - The VSM-wide RTD configuration consists of four 9840 and four 9490 transports.
 - No Storage Classes with STK1R as the primary media have been defined.
 - There is sufficient MVC media for the 9490 transports.

In this configuration, because only the 9490 media is used, only a maximum of four migration tasks are activated using the 9490 RTDs.

- Similarly, there are circumstances when VTCS will start *less* than the number of migration tasks specified by the MINMIG parameter. For example:
 - The configuration consists of a single VTSS with 4 RTDs in ACS 0 and 4 RTDs in ACS 1. All RTD device types are identical.
 - MINMIG and MAXMIG are both set to 8.
 - Two Storage Classes are defined, which point, respectively, to ACS 0 and ACS 1.

In this configuration, if there are migrates queued for both Storage Classes, then VTCS will start 8 requests. If however, there are only migrations queued for one Storage Class, then VTCS *will not* start 8 requests because the workload can only be serviced by one Storage Class and this class can only run on 4 RTDs.

- Finally, also note that when you reset the MINMIG and/or MAXMIG values, the actual number of migration tasks may not be immediately affected because of the way that VTCS manages migration tasks.

Tip – You can use Display MIGrate to display migration status.

Prioritizing Automatic and Immediate Migration Workloads

TABLE 2-19 Prioritizing Automatic and Immediate Migration Workloads

This policy does the following...	Valid values are...	The default is...	To set the policy, use...
Prioritizes Automatic and Immediate Migration Workloads	0-9	0	MIGRSEL SCHPREF

Usage Notes

In general, MIGRSEL SCHPREF provides finer control over how Storage Classes are treated for migration. Via the MIGPOL parameter, a Management Class can request that multiple VTV copies are migrated to multiple Storage Class destinations. By default, all migrated copies are treated equally. With MIGRSEL SCHPREF, however, you can request that VTCS preferences one or more Storage Classes and the accompanying migrations.

For example, a Management Class requests two MVC copies, where one copy is business critical (perhaps for DR purposes) and the other is not. In this case, you can assign a higher preference to your business critical copy. This preferencing requests that more resources (RTDs/MVCs) are used to service the business critical copy.

MIGRSEL SCHPREF is the tool to preference Storage Classes and their accompanying migrations and MIGRSEL SCHPREF also provides the ability to set a scheduling preference for a narrow and specific set of conditions. For example, if I am migrating on a specific host from a specific VTSS and my immediate wait time has reached a specified threshold, I can then apply the specified preference value.

With that framework in mind, use MIGRSEL SCHPREF as follows:

- Use MIGRSEL SCHPREF to preference automatic and immediate migration per Storage Class. Higher values can produce quicker migration times but may not optimize MVC usage. Lower values may produce slower migration times but may optimize MVC usage.
- MIGRSEL SCHPREF allows you to specify the VTSS and host to which the preferencing applies.
- You can also specify MIGRSEL IMMWAIT, which specifies the age of the queued migrate request in minutes that the MIGRSEL rule applies to. Valid values are 0-999, the default is 999. The search criteria is considered true if the IMMWAIT value is greater than or equal to the search value.
- The MIGRSEL SCHPREF setting may be affected by the number of RTDs available, the SCHLIMIT setting, and the GLOBAL MAXMIG parameter for the VTSS.

You can also specify MIGRSEL IMMWAIT, which specifies the age of the queued migrate request in minutes that the MIGRSEL rule applies to. Valid values are 0-999, the default is 999. The search criteria is considered true if the IMMWAIT value is greater than or equal to the search value. An IMMWAIT value of zero will only match to a search value of zero.

Controlling Migration Workloads

TABLE 2-20 Controlling Migration Workloads

This policy does the following...	Valid values are...	The default is...	To set the policy, use...
Controls migration workloads.	0-99	99 (no limit up to the VTSS MAXMIG value)	MIGRSEL SCHLIMIT

Usage Notes

MIGRSEL SCHLIMIT, like MIGRSEL SCHPREF, provides finer control over how Storage Classes are treated for migration but in the opposite direction. That is, MIGRSEL SCHLIMIT, applies limits on migration resources (RTDs/MVCs) per Storage Class, and you can do so on a VTSS and/or host basis. Use MIGRSEL SCHLIMIT as follows:

- Use MIGRSEL SCHLIMIT to deprefer migration per Storage Class. Lower values deprefer migration, and you can specify automatic, immediate, demand, and reclaim migrates. Lower values can do the following:
 - Optimize MVC usage. You can use this strategy where you want to limit the number of MVCs used. Example: a workload migrated to a Storage Class that is subsequently used for offsite vaulting.
 - Preference migration to other Storage Classes.
 - Restricts migration concurrency to better use MVCs.
 - Limits migration to keep RTDs available for auto recalls.
 - Reduce MVC swapping when workloads change.
- MIGRSEL SCHLIMIT allows you to specify the VTSS and host to which the preferencing applies.
- For auto and immediate migration processing, MIGRSEL SCHLIMIT depreferences migration for the VTSS to Storage Class relationship. This comparison is not global and only effects requests driven by the individual VTCS host
- For demand migration requests, MIGRSEL SCHLIMIT it will cause the request to be held if the scheduling of it would cause the number of globally active migration requests on the VTSS that satisfy the same FUNCTION and STORCLAS selection criteria to be exceeded. The migration requests will be released and a MVC picked once the constraint subsides.

Conditionally Change Migration Preferencing/Depreferencing

TABLE 2-21 Conditionally Change Migration Preferencing/Depreferencing

This policy does the following...	Valid values are...	The default is...	To set the policy, use...
Conditionally changes migration preferencing/depreferencing	0-999 minutes	999	MIGRSEL IMMWAIT

Usage Notes

In the world of VTV migration, *things change*. VTCS puts VTV migration candidates on migration wait queues, where they wait until resources are available. Some days, VTVs are on a wait queue longer than others, so VTVs aren't migrated in a timely fashion. You can use MIGRSEL IMMWAIT to conditionally manage variations in wait queue times. MIGRSEL IMMWAIT essentially sets a wait time limit, and if the wait time is less than or equal to this limit, VTCS starts the condition specified on the MIGRSEL statement to which the IMMWAIT value applies.

For example, I have a "local" Storage Class that I want where I want to limit/deprefer the immediate migration resources:

```
MIGRSEL STOR(LOCAL)FUNCTION(IMMED)SCHLIMIT(1)
```

I know from consulting the VTV dashboard that the normal immediate queue wait time for this Storage Class is 15 minutes. I can live with 15 minutes, any more and my immediate migrations are no longer immediate. So to ratchet down some of the limiting, I do the following:

```
MIGRSEL STOR(LOCAL)FUNCTION(IMMED)IMMWAIT(15) SCHLIMIT(2)
```

Again, more granularity of control: set a basic preferencing/depreferencing, and automatically adjust it based on changes in queue wait times.

Putting It All Together: VTV Migration Control Example for an Enterprise

With VTV migration control, we have gained finer control over:

- VTSS space management.
- Speedy migration of critical data (for example, to MVCs destined for a remote ACS).
- MVC usage (for example, to ensure maximum space usage for MVCs destined for offsite vaulting).

The good part is that you can do all of the above concurrently. For example, if you want two VTV copies, one local and one remote, you can preference migration for the “remote” Storage Class **and** specify that VTVs are deleted from the VTSS ASAP after migration completes. Similarly, you can depreference migration for the “local” Storage Class **and** specify relatively long VTSS residency so that VTV availability is enhanced.

Let’s demonstrate Enhanced Migration Control for an enterprise that has four typical classes of data, and name their corresponding Storage Classes accordingly:

- The REMOTE Storage Class is for MVCs going to a remote ACS. They are the primary backup for critical data so they require **high migration preferencing** to ensure speedy migration as described in [“Enabling the Remote and Local ACS Migrations” on page 69](#).
- The LOCAL Storage Class is for the local VTV copy of critical data. As described above, I will **depreference migration to these MVCs** (but optimize data availability) as shown in [“Enabling the Remote and Local ACS Migrations” on page 69](#).
- The LTRVLT1 Storage Class is for MVCs destined for long term retention in an offsite vaulting. You can also do vaulting for DR, and you can do both of these (and manage “floor” volumes) with the ELS Vault Solution. For more information on this scenario, see *Managing HSC and VTCS*. In [“Migration Policies for a Vault Solution” on page 71](#), we’re just going to show the code to achieve the above business objectives for vaulting volumes.
- The OTHER Storage Class is for temporary data sets and other things I need to safeguard...but as cheaply as possible. I want this data out of the VTSS buffer as quickly as possible, which I do via DISCARD and DELSCR as described in [“Enabling the “Other Data” Migrations” on page 72](#).

Enabling the Remote and Local ACS Migrations

In this scenario, we have the overall business goals of optimizing VTSS buffer use, ensuring speedy migration of critical data, while maintaining data availability. We want two MVC copies of each VTV, which are represented by these two Storage Classes:

- The REMOTE Storage Class is for MVCs going to a remote ACS. They are the primary backup for critical data so they require **high migration preferencing** to ensure speedy migration. We've chosen T10K media for the REMOTE Storage Class, so we want to optimize media use.
- The LOCAL Storage Class is for the local VTV copy of critical data. The goal here is to **deprefer migration to these MVCs...but optimize data availability**, which includes specifying T98490D media.

And, of course, we want to use VTSS space as efficiently as possible.

To (efficiently) enable both remote and local ACS migrations:

1. **Create the LOCAL and REMOTE Storage Classes with the appropriate media and ACS values:**

```
STOR NAME(LOCAL) ACS(00)MEDIA(STK1R)
STOR NAME(REMOTE) ACS(01) MEDIA(T1B000E1)
```

2. **Create MIGRSEL statements corresponding to the LOCAL and REMOTE Storage Classes:**

```
MIGRSEL STOR(LOCAL)FUNCTION(IMMED)SCHLIMIT(1)
MIGRSEL STOR(REMOTE) FUNCTION(IMMED)SCHPREF(9)
```

In this example:

- The LOCAL Storage Class throttles down immediate migration tasks severely, because I figure that auto migration will get the data migrated soon enough.
- The REMOTE Storage Class gives immediate migration tasks the highest priority possible, because I want these VTVs on MVC space ASAP.

This step sets the priorities for the immediate migrate speed. Data availability/VTSS buffer management is addressed in the next step.

3. Create MIGRVTV statements corresponding to the LOCAL and REMOTE Storage Classes:

```
MIGRVTV STOR(LOCAL)IMMDELAY(9999)
MIGRVTV STOR(REMOTE)IMMDELAY(0)
```

These statements used the “switch” philosophy for IMMDELAY:

- REMOTE is set to 0, so migrate VTV copies to it ASAP.
- LOCAL is set to 9999, so migrate VTV copies to it only when you select the VTV for auto-migration.

As you can see, you’ve gained more and more granularity, finer and finer control, which will continue in the next step.

4. ...create a MGMTCLAS statement that points to the LOCAL and REMOTE Storage Classes:

```
MGMT NAME(COMPLY) MIGPOL(LOCAL,REMOTE)DISCARD(0)DELSR(YES)
```

The above example provides this additional fine tuning for both Storage Classes:

- After the VTVs are successfully immediately migrated, they’re not likely to be re-referenced again, so delete them from the VTSS to optimize VTSS buffer space.
- If the VTV is scratched, and you run LCM (best practices) scratch synchronization, delete the VTV from the VTSS, which is more good VTSS buffer management.

5. Create and activate an SMC POLICY statement to point to the COMPLY Management Class and specify virtual media:

```
POLICY NAME(CPLY) MEDIA(VIRTUAL) MGMT(COMPLY)
```

6. Create a TAPEREQ statement that points to the CPLY Policy:

```
TAPEREQ DSN(LOVEDONES.***) POLICY(CPLY)
```

7. Activate the new TAPEREQ set by issuing the SMC TREQDEF command.

Migration Policies for a Vault Solution

As we said in “[Putting It All Together: VTV Migration Control Example for an Enterprise](#)” on page 68, you can do vaulting for a variety of reasons and using a range of different methods. For more information on the ELS Vault Solution, see *Managing HSC and VTCS*. Here’s we’re just going to show the code for the migration policies that control the data management, using a Long Term Vault (LTR) vault as an example.

To implement migration policies for vaulting:

1. **Create the LTRVLT Storage Class.**

For example:

```
STOR NAME (LTRVLT1) ACS(00) MEDIA(STK2PB)
```

2. **Create a MIGRSEL statement corresponding to the DRLOC and DRVLT Storage Classes:**

```
MIGRSEL STOR(LTRVLT1) FUNCTION(IMMED)SCHPREF(9)
```

So for the LTRVLT1 Storage Class, I’m going to give immediate migration tasks the highest priority possible, because I want this data protected on an MVC ASAP.

3. **Create a MIGRVTV statement corresponding to the LTRVLT1 Storage Class:**

```
MIGRVTV STOR(LTRVLT1)IMMDELAY(0)
```

LTRVLT1 IMMDELAY is set to 0, so migrate VTV copies to it ASAP.

4. **Create a Management Class that points to the Storage Class in [Step 1](#).**

For example:

```
MGMT NAME(LTRV) DISCARD(0) DELSCR(YES) MIGPOL(LTRVLT1)
```

This Management Class says:

- After the VTVs are successfully immediately migrated, they’re not likely to be re referenced again, so delete ‘em from the VTSS to optimize VTSS buffer space.
- If the VTV is scratched, and you run LCM (best practices) scratch synchronization, delete the VTV from the VTSS...more good VTSS buffer management.

5. **Use the SMC POLICY command to point to the Management Class in [Step 4](#).**

For example:

```
POLICY NAME(VLTRV1) MGMT(LTRV1)
```

6. **Create a TAPEREQ statement to route the LTR data to VSM and assign the corresponding Policy/Management Class to the data.**

For example:

```
TAPEREQ DSN(COMPLY*) POLICY(VLTRV1)
```

7. **Activate the new TAPEREQ set by issuing the SMC TREQDEF command.**

Enabling the “Other Data” Migrations

As we said, the OTHER Storage Class is for temporary data sets and other things I need to safeguard...but as cheaply as possible. I want this data out of the VTSS buffer as quickly as possible, which I do via DISCARD and DELSCR.

To enable the “other data” migrations:

1. Create the OTHER Storage Class:

```
STOR NAME(OTHER) ACS(00)MEDIA(STK1R)
```

So OTHER goes to the local ACS only, 9840D media in case I need it back quickly. For “Other Data” I’m pretty much going to let automigration run as is, and not worry about using MIGRSEL/MIGRVTV to fine tune things.

2. Create a MGMTCLAS statement that points to the OTHER Storage Class:

```
MGMT NAME(TEMPS) MIGPOL(OTHER)DISCARD(0)DELSR(YES)
```

This statement specifies the following:

- After the VTVs are successfully immediately migrated, delete them from the VTSS to optimize VTSS buffer space.
- If the VTV is scratched, and you run LCM (best practices) scratch synchronization, delete the VTV from the VTSS...more good VTSS buffer management.

3. Create and activate an SMC POLICY statement to point to the TEMPS Management Class and specify virtual media:

```
POLICY NAME(TDATA) MEDIA(VIRTUAL) MGMT(TEMPS)
```

4. ...create a TAPEREQ statement that points to the CPLY Policy:

```
TAPEREQ DSN(TEMP*.**) POLICY(TDATA)
```

5. Activate the new TAPEREQ set by issuing the SMC TREQDEF command.

VTV Replication Policies

VTSS CLINKs are capable of replication, which is copying VTVs from one VTSS to another. The following sections describe VTSS replication policies...

- [“VTCS Replication - Always or Changed VTV Only” on page 74](#). Here, the concept is simple but read the section so that you understand how “changed VTVs” are defined.
- [“VTCS Replication - Synchronous or Asynchronous” on page 75](#). You have another choice with replication (assuming that you have satisfied all the requirements), which is synchronous or asynchronous processing.

VTCS Replication - Always or Changed VTV Only

TABLE 2-22 VTV Replication - Always or Changed VTV Only

This policy does the following...	Valid values are...	The default is...	To set the policy, use...
Specifies whether a VTV is always replicated or only when changed.	ALWAYS, CHANGED	ALWAYS	CONFIG GLOBAL REPLicat

Usage Notes

- ALWAYS means the replicate request is added to the VTCS replication queue every time the VTV is dismounted, regardless of whether the VTV was changed while it was mounted (the default).
- CHANGED means the replicate request is added to the VTCS replication queue if the VTV:

Was changed while it was mounted **or**

Was only read while mounted but less than the expected number of MVC copies of the VTV exist.

Note – Regardless of the CONFIG GLOBAL REPLicat setting, replication **also** requires that:

- The VTV must be dismounted in a VTSS that supports replication **and** there cannot be an identical copy of the VTV in the other VTSS in the Cluster.
 - In addition to the CONFIG GLOBAL REPLicat value, you **must** specify REPLicat(YES) on a VTV's Management Class for replication to occur.
-

VTCS Replication - Synchronous or Asynchronous

TABLE 2-23 VTV Replication - Synchronous or Asynchronous

This policy does the following...	Valid values are...	The default is...	To set the policy, use...
Specifies whether synchronous replication is enabled.	YES, NO	NO	CONFIG GLOBAL SYNCHREP

Usage Notes

YES means that synchronous replication is enabled...but make sure you have all the requirements lined up as described in *Creating ELS Disaster Recovery Solutions*.

Note –

- **Regardless** of the CONFIG GLOBAL SYNCHREP setting, replication **also** requires that you **must** specify REPlicat(YES) on a VTV's Management Class for replication to occur.
- Synchronous replication **does incur** a performance penalty. That is, when synchronous replication is specified, the replication of the new or modified VTV to the other VTSS is made prior to the completion of the rewind/unload of the original VTV. When the virtual volume completes close processing, VTSS has completed performing the replication of the volume. Synchronous replication ensures that, under normal conditions, two identical copies of a virtual volume exist, as soon as the rewind/unload command has completed. You should consider using synchronous replication if it is mandatory for your operation to have the highest level of protection for your tape data. With synchronous replication in an unconstrained environment, the time required to replicate a virtual volume **can significantly** delay the completion of the rewind/unload command. This time will increase in a constrained environment and for larger VTV sizes.

If a synchronous replication cannot be completed immediately (likely caused by the failure of the connections between the VTSSs), the synchronous replications will operate as asynchronous replications until the failure has been corrected. If a synchronous replication is changed to an asynchronous replication, the system is notified with a warning message.

MVC Policies

The following sections describe these MVC policies...and some of these take some thought, so take your time, and remember, it's usually a good idea to supplement automatic reclamation with demand reclamation as described in *Managing HSC and VTCS*.

- [“Standard Reclaim Threshold - Determines MVC Eligibility for Reclamation \(Requires Recall/Remigration\)” on page 78](#). It makes sense that you want to maximize results when you do a standard reclaim, because it costs you resources that you could be otherwise using for migrates and recalls. This is the threshold value you can use to specify how fragmented an MVC must be to make it a reclaim candidate.
- [“Dynamic Reclaim Threshold - No MVC Mount or VTV Recall/Remigration Occurs” on page 79](#). For T10000B and above media, dynamic reclaim, which requires no recalls or migrates, optimizes reclamation for capacity-centric media.

Note that the reclaim thresholds **only** dictate when an MVC becomes a reclaim candidate. They do not **start** automatic reclamation; see the next two bullets.

Note – Reclamation turns fragmented MVC space (space that contains non-current VTVs) into usable space (writable MVC space). MVC reports and Display MVCpool show the percentages of MVC space that is fragmented, used (space that contains current VTVs), available, and usable. **Note that** usable space may be zero even if there is still space physically available. For example, if the maximum VTVs per MVC is exceeded, then usable space is reported as 0%. You set maximum VTVs per MVC. Similarly, if a data check error has been reported against an MVC, VTCS will not use this MVC for output and usable space is reported as 0%.

- [“VLE Reclaim Threshold - Determines VMVC Eligibility for Reclamation” on page 82](#). There is a reclaim policy for VMVCs.
- [“Free MVCs Threshold - Starts Automatic Space Reclamation” on page 83](#) and [“Eligible/Total MVCs Threshold - Starts Automatic Space Reclamation” on page 84](#).

There are **two** different triggers that start automatic reclamation. More fine tuning, more granularity. You'll see that these triggers supplement rather than compete with each other. If either you run low on Free MVCs or your ratio of eligible to total MVCs gets too low, automatic reclamation starts.

- [“Maximum MVCs Processed Per Reclaim” on page 85](#). VTCS reclaims MVCs one at a time. You can, however, specify the maximum number you want to reclaim in one run, either automatic or demand. More fine tuning...you can say that when reclamation starts, run it to reclaim this number of MVCs, because that's the value that will allow me to have sufficient free MVCs.
- [“Maximum MVCs Concurrently Processed for Reclamation and Drain” on page 86](#). A reasonable question is, what's the difference between this and maximum MVCs processed per reclaim, especially since you can only reclaim one MVC at a time? It turns out that reclaim and drain are separate but related processes that can be processing multiple MVCs, and you get to say how many.
- [“Hosts Disabled from Reclamation” on page 86](#). If you don't want a host to initiate reclamation, you can explicitly turn it off. The default is not to disable any hosts, so if this isn't an issue, don't worry about it.

- [“MVC Retain Interval” on page 87](#). The idea is pretty simple: if you think you’re going to write more data to an MVC once it’s mounted and initially written to, you can specify a value that will keep it available. A similar control is the MVC mount timeout interval, see [“MVC Mount Timeout Interval” on page 87](#).
- [“Non-Library Resident MVC Policies” on page 88](#). The non-library resident MVC policies specify how VTCS processes MVCs that are not in the ACS.
- [“MVC Initialization on First Mount” on page 89](#). Initializing MVCs before they’re used is no longer required, thanks to this global and MVC Pool parameter: you can now specify that the MVC is initialized at first mount.

Standard Reclaim Threshold - Determines MVC Eligibility for Reclamation (Requires Recall/Remigration)

TABLE 2-24 Standard Reclaim Threshold

This policy does the following...	Valid values are...	The default is...	To set the policy, use...
Specifies the standard reclaim threshold (as a percentage) that determines when an MVC is eligible for demand or automatic reclamation.	4 - 98	40	CONFIG RECLAIM THRESHLD RECLAIM THRESHLD MVCPOOL THRESH

Usage Notes

- Inevitably, MVCs become “Swiss Cheesed” with holes where non-current VTVs reside, which is sub-optimal space use. Customers can use the CONFIG utility to set MVC space reclamation parameters, and they also can use the RECLAIM command or utility to adjust these parameters. When MVCs reach specified thresholds, VTCS automatically starts standard space reclamation, reclaiming space one MVC at a time. VSM reclaims space by copying only valid VTVs from the selected MVC to the VTSS, then copying these VTVs back to another MVC with sufficient space. VSM copies only those VTVs placed after the first open space on the MVC, which saves I/O cycles. The space reclamation thus reduces MVC fragmentation and allows the migration to succeed.

If fragmented space on an MVC exceeds the value specified on THRESHLD, VTCS makes the MVC eligible for reclamation. Regardless of the percentage of fragmented space on an MVC versus this value, however, VTCS also considers where fragmented space occurs. For example, if the first fragmented space is near the end of the MVC, VTCS may process the MVC before an MVC with more total fragmented space.

- You can use Display MVCpool to display the MVCs eligible for reclamation in your MVC pool, as well as information about MVC status and space.
- To optimize recall processing in mixed-media systems, ensure that your MVC pool has at least one media type compatible with each RTD type.
- The MEDIA parameter of the STORclas statement (which defines Storage Classes) specifies a preference list of MVC media types. This list supersedes the default media selection list.
- If the system’s MVCs are highly fragmented, a demand standard MVC space reclamation can be scheduled (using RECLAIM) as an off-hours batch job.

Dynamic Reclaim Threshold - No MVC Mount or VTV Recall/Remigration Occurs

TABLE 2-25 Dynamic Reclaim Threshold

This policy does the following...	Valid values are...	The default is...	To set the policy, use...
Specifies if dynamic reclaim is enabled.	YES,NO	no default	CONFIG RECLAIM INPLACE STORCLAS INPLACE
Specifies the dynamic reclaim threshold (as a percentage) that determines when an MVC is eligible for demand or automatic reclamation.	less than CONFIG RECLAIM THRESHLD and between 3 and 97	half the CONFIG RECLAIM THRESHLD value (rounded up).	CONFIG RECLAIM INPTHRSH MVCPool INPTHRSH POOLPARAM TYPE(MVC) INPTHRSH

What is Dynamic Reclaim?

As shown in [FIGURE 2-2](#), with a standard MVC whose fragmentation exceeds the standard reclaim threshold, standard reclaim must recall/remigrate VTVs (V3, V4, and V5, in this example) in order to reclaim MVC space.



FIGURE 2-2 Standard Reclaim Example

[FIGURE 2-3](#) shows a blank partitioned MVC with all partitions free.



FIGURE 2-3 Blank Partitioned MVC

[FIGURE 2-4](#) shows a partitioned MVC with all partitions full. The VTVs are in light blue, on top, and the partitions are in dark blue, on the bottom.



FIGURE 2-4 Full Partitioned MVC

FIGURE 2-5 shows a fragmented partitioned MVC, where VTVs 6 and 14 have expired, which frees partitions 6, 7, 15, and 16. These partitions are “dynamically reclaimed”, which means they are now available for migration of new VTVs. For dynamic reclaim, VTCS just updates the CDS to mark the freed partitions as writeable; the MVC is not mounted and no data movement occurs.



FIGURE 2-5 Dynamically Reclaimed Partitioned MC

FIGURE 2-6 shows the dynamically reclaimed MVC shown in FIGURE 2-5. VTVs 21 and 22 were subsequently migrated to partitions 6 and 7 and 15 and 16 respectively. **Note that** VTV 21 spans partitions 6 and 7 and VTV 22 spans partitions 15 and 16 because each partition on the MVC is automatically linked to the next partition.



FIGURE 2-6 Dynamically Reclaimed Partitioned MVC - - New Migrations

Usage Notes

- Dynamic reclaim **only** applies to T10000B and above media (full and full encrypted only) that have been formatted by T10000 drives capable of creating partitions. Dynamic reclaim requires an H level CDS, VSM5 microcode D02.11.16.00 or later, T10KB firmware 1.41a.209 or later.
- You can specify Dynamic Reclaim policies at the global, system wide level or on a Storage Class and MVC pool level. The global policies are set by the VTCS CONFIG RECLAIM statement:
 - The INPLACE(YES/NO) parameter controls the usage of dynamic reclaim. Its setting can either be explicitly specified upon the STORCLAS statement or inherited from the RECLAIM statement in the VTCS configuration. The default is INPLACE=NO. The setting that is derived for a Storage Class does not force usage of media formatted in either mode. So it is quite acceptable to use with drives or media that do not support partitioning. Also, any media written in a different mode will continue to be a migration target. This will avoid the need to actively manage the transition when dynamic reclaim is activated. Its effect is to cause new media allocated to the Storage Class to be formatted and written in either standard (INPLACE=NO) or partitioned (INPLACE=YES) mode. The switch can only occur when media is empty.

If a hard switch-over is required between standard and dynamic reclaim, then a lengthy process is required. Parameters setting (for example, MEDIA on the STORCLAS statement) will need to be used. MVCs will need to be either taken out of the MVC pool or set into a read-only state by using MVCMAINT. Finally, MVCs formatted in the wrong mode would need to be drained.

- The INPTHRSH parameter specifies the fragmentation level that makes partitioned MVCs eligible for Dynamic reclaim. When a partitioned MVC's fragmentation falls between the INPTHRSH value and the THRESH value, it first becomes eligible for Dynamic Reclaim. If no space is freed on the initial reclaim attempt, the reclaim will be retried when the fragmentation level has risen significantly. Should the fragmentation level reach the standard THRESHOLD be reached, then a fall-back method of moving VTVs will be performed. This will still be less than for standard format media.
- The VTCS CONFIG RECLAIM statements provide the global defaults for the system. These can be overridden at the Storage Class and MVCPool level:
 - The STORCLAS INPLACE parameter specifies whether or not Dynamic Reclaim is enabled for this Storage Class. Note that initially, you may want to specify INPLACE(NO) in the VTCS CONFIG RECLAIM statement and INPLACE(YES) for selected Storage Classes so you can evaluate the effects of Dynamic Reclaim. Subsequently, if you decide you want Dynamic Reclaim to apply to all eligible media, you can specify INPLACE(YES) on the VTCS CONFIG RECLAIM statement.
 - The INPTHRSH parameter on the POOLPARM statement can be used to set a Dynamic Reclaim threshold specifically for this set of MVC media. This can be used if you wish to treat some MVCs differently from the VTCS CONFIG RECLAIM defaults.
- Dynamic Reclaim can be disabled either globally at a system wide level or at the Storage Class level:
 - To disable Dynamic reclaim globally specify INPLACE(NO) in the VTCS CONFIG RECLAIM statement and ensure that any Storage Class definition does not override this to YES.
 - To disable Dynamic for one or more Storage Classes change INPLACE to NO in the Storage Class policy statements.

Note – Any MVCs that are currently in use for migration will continue in partitioned format. If you wish to stop active MVCs from further migrates then use the MVCMAINT utility to mark them as read-only. Once the partitioned volumes are empty they will be automatically re-used in non-partitioned mode. An MVC will become empty either when all VTVs have expired or the MVC has been DRAINEd.

VLE Reclaim Threshold - Determines VMVC Eligibility for Reclamation

TABLE 2-26 VLE Reclaim Threshold

This policy does the following...	Valid values are...	The default is...	To set the policy, use...
Specifies the reclaim threshold (as a percentage) that determines when an VMVC is eligible for demand or automatic reclamation.	4 - 98	30	CONFIG RECLAIM VLTHRES

Usage Notes

- CONFIG RECLAIM **VLTHRES** applies **only** to VMVCs.
- VLE MVC media (VMVCs) is subject to fragmentation and must be reclaimed just like real MVCs. The VMVC reclaim process, however, uses far fewer resources than a standard reclaim. The reclaim threshold for a VMVC is specified via the CONFIG RECLAIM VLTHRES parameter. The lower that you set VLTHRES, the more frequent VTCS will run reclaim on the VMVCs and the greater the effective capacity of the VMVCs (less fragmentation).

Free MVCs Threshold - Starts Automatic Space Reclamation

TABLE 2-27 Free MVCs Threshold

This policy does the following...	Valid values are...	The default is...	To set the policy, use...
Specifies the minimum number of free MVCs. If the actual number drops below this value, automatic reclamation starts.	0 - 255	40	CONFIG GLOBAL MVCFREE

Usage Notes

- A free MVC has 100% usable space and does not contain any migrated VTVs.
- VTCS checks the MVCFREE value for each ACS. VTCS issues message SLS6616I and starts an automatic space reclamation if *both* of the following occurs:
 - Free MVCs is equal to or less than the value specified on CONFIG MVCFREE.
 - There is at least one eligible MVC as defined by the CONFIG RECLAIM THRESHLD parameter; for more information, see [“Eligible/Total MVCs Threshold - Starts Automatic Space Reclamation”](#) on page 84.
- If you set MVCFREE=0, VTCS actually uses the default value (40).
- StorageTek **strongly recommends** that you ensure that your MVC pool always has *at least* one eligible MVC for each MVC media type.

Otherwise, you may need to change the CONFIG GLOBAL MVCFREE value, add more MVCs to the pool, or both. You can use Display to display the number of free MVCs in your MVC pool.

Eligible/Total MVCs Threshold - Starts Automatic Space Reclamation

TABLE 2-28 Eligible/Total MVCs Threshold

This policy does the following...	Valid values are...	The default is...	To set the policy, use...
Specifies a percentage value that represents the ratio of reclaim candidates to total MVCs, which triggers automatic space reclamation as described in “Usage Notes” on page 84	1 - 98	35	CONFIG RECLAIM START

Usage Notes

- CONFIG RECLAIM START specifies a percentage value, which is equal to:

$$(Reclaim\ Candidates / Reclaim\ Candidates + Free\ MVCs) * 100$$

Where:

Reclaim Candidates

is the number of Reclaim Candidates determined by the CONFIG RECLAIM THRESHLD parameter. For more information, see [“Eligible/Total MVCs Threshold - Starts Automatic Space Reclamation” on page 84](#).

Reclaim Candidates + Free MVCs

equals the number of Reclaim Candidates *plus* the number of free MVCs. A free MVC:

- Has 100% usable space and does not contain any migrated VTVs.
 - Is defined as described in [“Defining MVCs” on page 112](#).
 - Is writeable.
 - Is resident in the ACS.
- For each ACS (not globally for all ACSs), VTCS issues message SLS6616I and starts an automatic space reclamation if *both* of the following occurs:
 - The actual value of $(Reclaim\ Candidates / Reclaim\ Candidates + Free\ MVCs) * 100$ exceeds the value specified on CONFIG RECLAIM START parameter.
 - The number of eligible MVCs exceeds the value specified on the MAXMVC parameter; for more information, see [“Maximum MVCs Processed Per Reclaim” on page 85](#).

Note – The only exception to the above two conditions occurs if an SLS6699 message indicates a critical shortage of free MVCs, in which case automatic reclamation will start anyway.

- The following are general guidelines for specifying values for the START parameter:

- A *low* value (for example, 5%), starts automatic space reclamation when there are *few* eligible MVCs compared to free MVCs *unless* you set the MAXMVC value high compared to the number of eligible MVCs.
- A *high* value (for example, 95%), starts automatic space reclamation when there are *many* eligible MVCs compared to free MVCs unless you set the MAXMVC value *very* high and your MVC pool is *very* small.
- You can use Display MVCPOOL to display eligible and free MVCs.

Maximum MVCs Processed Per Reclaim

TABLE 2-29 Maximum MVCs Processed Per Reclaim

This policy does the following...	Valid values are...	The default is...	To set the policy, use...
Specifies the maximum number of MVCs that will be processed in a single space reclamation run.	1 - 98	40	CONFIG RECLAIM MAXMVC RECLAIM MAXMVC

Usage Notes

- Automatic and demand space reclamation processes one MVC at a time. You can, however, use MAXMVC to control the **maximum** number of MVCs that will be processed in a single space reclamation run (automatic or demand).
- For automatic space reclamation to start via the CONFIG RECLAIM START parameter setting, the number of eligible MVCs (determined by the CONFIG RECLAIM THRESHLD parameter) must also exceed the MAXMVC value. For more information, see [“Eligible/Total MVCs Threshold - Starts Automatic Space Reclamation” on page 84](#).
- The following are general guidelines for specifying values for the MAXMVC parameter:
 - A *low* value reclaims *fewer* MVCs in a single run but may have *negligible* effect on migrations and recalls and may start automatic space reclamation *more* frequently; for more information, see [“Eligible/Total MVCs Threshold - Starts Automatic Space Reclamation” on page 84](#).
 - A *high* value reclaims *more* MVCs in a single run but may have *considerable* effect on migrations and recalls and may start automatic space reclamation *less* frequently; for more information, see [“Eligible/Total MVCs Threshold - Starts Automatic Space Reclamation” on page 84](#).
- You can use Display MVCpool to display eligible and free MVCs.

Maximum MVCs Concurrently Processed for Reclamation and Drain

TABLE 2-30 Maximum MVCs Concurrently Processed for Reclamation and Drain

This policy does the following...	Valid values are...	The default is...	To set the policy, use...
Specifies the maximum number of MVCs concurrently processed for reclamation and drain.	1 - 99	1	<ul style="list-style-type: none"> ■ CONFIG RECLAIM CONMVC ■ MVCDRAIN CONMVC ■ RECLAIM CONMVC

Hosts Disabled from Reclamation

TABLE 2-31 Hosts Disabled from Reclamation

This policy does the following...	Valid values are...	The default is...	To set the policy, use...
Specifies that a host cannot initiate automatic and demand reclamation.	NORECLAM, if not specified, reclamation is not disabled	do not disable	CONFIG HOST NORECLAM

Usage Notes

- Specifying NOMIGRAT also causes NORECLAM to be set.
- Disabled hosts can still do demand MVC drains via MVCDRAIN.

MVC Retain Interval

TABLE 2-32 MVC Retain Interval

This policy does the following...	Valid values are...	The default is...	To set the policy, use...
Specifies how long VTCS will retain an MVC on an RTD in idle mode after a migration.	1 - 60 minutes	10	CONFIG VTSS RETAIN parameter

Usage Notes

- Retaining the MVC can reduce MVC mounts.
- When VTCS shuts down, VTCS dismounts all MVCs regardless of the MVC retain interval.

MVC Mount Timeout Interval

TABLE 2-33 MVC Mount Timeout Interval

This policy does the following...	Valid values are...	The default is...	To set the policy, use...
Specifies the interval before MVC mount timeout.	5 - 30 minutes	15	CONFIG GLOBAL MVCMTTO= <i>mm</i> parameter

Non-Library Resident MVC Policies

The non-library resident MVC policies specify how VTCS processes MVCs that are not in the ACS.

This policy does the following...	Valid values are...	The default is...	To set the policy, use...
Specifies whether non-library resident MVCs are selected for drain/reclaim processing.	YES, NO	YES (select non-library resident MVCs for drain/reclaim)	CONFIG GLOBAL NLIBDRNR

This policy does the following...	Valid values are...	The default is...	To set the policy, use...
Specifies whether non-library resident MVCs are selected for migration processing.	YES, NO	YES (select non-library resident MVCs for migration)	CONFIG GLOBAL NLIBMIGR

This policy does the following...	Valid values are...	The default is...	To set the policy, use...
Specifies whether non-library resident MVCs are selected for reclamation processing.	YES, NO	YES (select non-library resident MVCs for reclamation)	CONFIG GLOBAL NLIBRECL

MVC Initialization on First Mount

TABLE 2-34 MVC Initialization on First Mount

This policy does the following...	Valid values are...	The default is...	To set the policy, use...
Specifies whether uninitialized MVCs are initialized when first mounted.	NO, YES	NO for CONFIG GLOBAL, none for MVCPOOL	CONFIG GLOBAL INITMVC parameter, MVCPOOL NAME INITMVC parameter

Note –

- MVCPOOL INITMVC overrides GLOBAL INITMVC. There is no default for MVCPOOL INITMVC; if not specified for a named MVC Pool the CONFIG GLOBAL value (or default) is used.
 - Initialization of MVCs in the DEFAULTPOOL is controlled by the GLOBAL INITMVC specification (or default).
 - MVC Initialization applies only to VSM4/5 and requires microcode level D02.05.00.00 or higher. If this level of microcode is not installed on all VTSSs in the configuration, MVC initialization will be limited to the VTSSs that have it installed.
-

Preparing for Configuration

In the next chapter, we start configuring the ELS software. But first, there are several items you need to get done in MSP to ensure a successful configuration. So **before** configuring HSC/VTCS, complete the preparation tasks described in the following sections:

- “Defining A Security System User ID for HSC and VTCS” on page 92
- “Configuring MSP Device Numbers and Esoterics” on page 93
- “Setting the MSP Missing Interrupt Handler (MIH) Value” on page 93

Note – See *Installing ELS* for information on installing the ELS software.

Defining A Security System User ID for HSC and VTCS

ELS software (HSC and VTCS) uses the MSP System Authorization Facility (SAF) to control the usage of MVCs. Before mounting an MVC and before issuing writes to an MVC, VSM issues a SAF query to verify that the HSC user has UPDATE authority for the MVC.

You must define a security system user ID to be used by the SAF queries. All VSM SAF queries are issued by HSC, so the security system user ID must be associated with the HSC started task. Refer to your security system documentation for details on how to associate a security system user ID with the HSC started task.

You must also set up tape volume security profiles to ensure that VSM is authorized to mount MVCs, to ensure that VSM is authorized to update MVCs, and to guard against accidental overwrites of MVCs; for more information, see [“Defining MVC Pool Volser Authority” on page 210](#).

Caution – Depending on the default settings of your security system, VSM may not be able to mount and to write to MVCs until you have defined a security system user ID for HSC and tape volume security profiles for the MVCs.

Configuring MSP Device Numbers and Esoterics

The following sections tell how to use the IOGRP facility to do the following:

- Assign MSP device numbers to VTDs, library drives, and RTDs.
- Associate these MSP device numbers and esoterics.

You determined these values in [“Determining HSC/VTCS Configuration Values”](#) on page 5. See your Fujitsu documentation for more information on the IOGRP facility.

Assigning MSP Device Numbers to VTDs and Library Drives

Use the IOGRP facility to assign MSP device numbers to these devices (VTDs are seen as F6473K devices)

Note – You do not need to define any specific esoterics (except in JES) but you *may* want to define any number of esoterics to be referenced by SMC policies. For considerations for defining esoterics for ELS, see *Configuring and Managing SMC*.

Assigning MSP Device Numbers to RTDs

Use the IOGRP facility to assign MSP device numbers to these RTDs.

Tip – You must use the same unit addresses you determined for these transports for LIBGEN updates as described in [“Planning for Library-Attached Transports”](#) on page 27.

Setting the MSP Missing Interrupt Handler (MIH) Value

The VTSS’s internal error recovery procedures requires the MSP missing-interrupt handler (MIH) value to be 20 minutes. You set this value by modifying the MIH parameter in SYS1.IPLLIB KHSDEVxx.

Note – When you are using VSM synchronous replication, set the MIH value to 45 minutes.

Configuring HSC

Before you configure VTCS, you must configure HSC if you are a **new customer**. If you are an **existing customer**, go to [Chapter 5, “Reconfiguring a TapePlex”](#).

Your task list for configuring HSC is as follows:

- “Creating the HSC CDS” on page 96
- “Defining Volumes to ELS” on page 109
- “Defining the SYS1.PARMLIB Member SMFPRMxx” on page 114
- “Creating the HSC PARMLIB Member” on page 115
- “Defining Command Authority” on page 118
- “Creating and Cataloging the HSC Startup Procedure” on page 119
- “Performance Considerations” on page 125

Note – For information on routing data sets to VSM, see *Configuring and Managing SMC*.

Creating the HSC CDS

Creating the CDS consists of the following:

- “Coding the LIBGEN Macros” on page 97
- “Running the SLICREAT Utility To Format the New CDS” on page 103

For more information on the LIBGEN macros, see [Appendix B, “HSC LIBGEN Macros”](#).

For **only** Tapeless VSM configurations (no RTDs attached, can have VLEs attached), see [“Running the CDSCREAT Utility to Create the CDS \(Tapeless VSM Only\)”](#) on page 105.

Caution – It is critical that you control user access privileges to the CDS. See [“Limiting CDS Access Privileges”](#) on page 9 for more information.

Coding the LIBGEN Macros

The LIBGEN macros specify the library configuration. You code the LIBGEN macros in a data set pointed to by the assembler JCL SYSIN DD statement. TABLE 4-1 describes the LIBGEN macros and shows their required order in the input data set. “LIBGEN Macro Samples” on page 253 shows examples of LIBGEN input data sets. For more information on the LIBGEN utility, see *ELS Command, Control Statement, and Utility Reference*. For more information on the LIBGEN macros, see Appendix B, “HSC LIBGEN Macros”.

StorageTek **strongly recommends** that you **do not** “pre-define” hardware via the LIBGEN process (for example, by defining transports that are not physically installed but will be in the future). Only use the LIBGEN process to define hardware that is actually installed. If you need to add hardware after performing an initial LIBGEN, use the techniques described in “Reconfiguring a TapePlex” on page 131.

TABLE 4-1 LIBGEN Macros

Macro	Description
SLIRCVRY	Specifies HSC recovery values.
SLILIBRY	Specifies global settings. You can also define future ACSs with SLILIBRY.
SLIALIST	Specifies the list of ACSs.
SLIACS	To define the ACSs, create one SLIACS macro for each ACS listed in the SLIALIST macro.
SLISTATN	Specifies the list of the stations (LMU interfaces) that connect a host to an ACS. Specify one SLISTATN macro for each station entry listed in the SLIACS macro.
SLILSM	To define each LSM, create one SLILSM macro for each LSM listed in the SLIACS macro LSM, LSM2, LSM3, and LSM4 parameters.
SLIDLIST	To define the transport list for each LSM, create one SLIDLIST macro for each DRVELST parameter entry in the SLILSM macro. This SLIDLIST macro lists the SLIDRIVS macros for each host.
SLIDRIVS	Specifies the transport device addresses used by each host attached to an LSM.
SLIENDGN	Specifies the end of the LIBGEN macros.

To make this LIBGEN procedure real-world, let's create an input file step by step that ends up looking like the example file shown in [“One Host, Two ACSs, One 9310 LSM, One SL8500 Library Configuration”](#) on page 254.

To create an example LIBGEN input file:

1. Create the SLIRCVRY macro:

```
LIBGEN01 SLIRCVRY TCHNIQE=ALL
```

In this macro, we specified the label for the generated CSECT, and specified all 3 copies of the CDS plus journaling.

The TCHNIQE parameter on the SLIRCVRY LIBGEN macro determines how many CDS copies will be initialized by the SLICREAT program and whether or not journals will be initialized by SLICREAT. If journaling is specified by the TCHNIQE parameter, journals must be defined before HSC will successfully initialize.

2. Create the SLILIBRY macro:

```
SLILIBRY HOSTID=HSC1,           X
      SMF=255,                   X
      COMPRFX=#,                 X
      ACSLIST=NAMEACS,          X
      MAJNAME=STKALSQN,         X
      SCRLABL=SL,               X
      EJCTPAS=GOODAY,          X
      CLNPRFX=CLN,              X
```

In this macro, we specified the following:

- Only host HSC1 accesses the configuration.
- The SMF record type, here 255, which must match the type specified in [“Defining the SYS1.PARMLIB Member SMFPRMxx”](#) on page 114.
- # is the operator command prefix character.
- NAMEACS is the assembler label of the SLIALIST macro.
- STKALSQN is the ENQ/DEQ/QNAME used by host software for serialization.
- Put Standard Labels on scratch volumes.
- GOODAY is the eject password.
- CLN is the cleaning cartridge prefix.

3. Create the SLIALIST macro:

```
NAMEACS SLIALIST ACS00,ACS01
```

In this macro, we specified the following:

- The assembler label is indeed NAMEACS, as specified in the SLILIBRY macro.
- ACS00 and ACS01 are the two ACSs.

4. Create the SLIACS macro for ACS00:

```
ACS00 SLIACS STATION=(ST000), X  
LSM=(LSM0000)
```

In this macro, we specified the following:

- The assembler label is indeed ACS00, as specified in the SLIALIST macro.
- The STATION parameter specifies ST000 as the assembler label of the SLISTATN macro.
- The LSM parameter specifies LSM0000 as the assembler label of the (single) SLILSM macro for the 9310 LSM.

5. Create the succeeding macros referenced by the ACS00 SLIACS macro, starting with SLISTATN:

```
ST000 SLISTATN ADDRESS=(0A0,0A1)
```

In this macro, we specified the following:

- The assembler label is indeed ST000, as specified in the SLIACS macro.
- The ADDRESS parameter specifies 0A0 and 0A1 as the device addresses of the two LMUs that control the 9310 LSM.

6. Create the SLILSM macro for the 9310 LSM:

```
LSM0000 SLILSM DRIVE=(1,2,9,10), X  
DRVELST=(P000001,P000002,P000009,P000010), X  
TYPE=9310, X  
DOOR=ECAP
```

In this macro, we specified the following:

- The assembler label is indeed LSM0000, as specified in the SLIACS macro.
- The DRVELST parameter specifies P0000001, P0000002, P0000009, and P0000010 as the assembler labels of the SLIDLIST macros that define the transports in each transport panel.
- The LSM type is 9310.
- The access door has an Extended CAP.

7. Create the SLIDLIST and SLIDRVS macros for the 9310 LSM:

```
P000001 SLIDLIST HOSTDRV=D0000010
*
D0000010 SLIDRVS ADDRESS=(410,411,412,413)
*
P000002 SLIDLIST HOSTDRV=D0000020
*
D0000020 SLIDRVS ADDRESS=(414,415,416,417)
*
P000009 SLIDLIST HOSTDRV=D0000090
*
D0000090 SLIDRVS ADDRESS=(510,511,512,513)
*
P000010 SLIDLIST HOSTDRV=D000100
*
D000100 SLIDRVS ADDRESS=(,,,)

```

In these macros, we specified the following:

- The assembler labels of the SLIDLIST macros that define the drive panels are indeed P0000001, P0000002, P0000009, and P0000010 as specified on the SLILSM macro.
- Each SLIDLIST HOSTDRV parameter specifies the assembler label of the corresponding SLIDRVS macro.
- The assembler labels on the SLIDRVS macros match, and the ADDRESS parameters specify the unit addresses of each drive on each panel.

Note –

- These are the device addresses you determined in [“Planning for Library-Attached Transports” on page 27](#).
 - We did **not** specify drive addresses for panel P000010, so we can add drives there later if necessary.
-

Tip – This example shows a single host. For additional information on defining device addresses in a client/server environment, see *Configuring and Managing SMC* .

8. Create the SLIACS macro for ACS01:

ACS01	SLIACS FUTRLSM=(8500,16), LSM=(LSM0100,LSM0101,LSM0102,LSM0103)	X
-------	--	---

Note – Before you configure HSC for the SL8500, verify that all components of the SL8500 are operational. HSC builds its library configuration from the information reported by the library. If SL8500 components are not operational, the library information may not be reported to HSC, and the HSC configuration of the SL8500 is incomplete.

To verify that all the components of the SL8500 are operational, use the SLConsole (either the panel on the SL8500 or a remote SLConsole). Select Tools, then select System Detail.

- All SL8500 components should be green. If the components are not green, and you have already configured the SL8500 to HSC, the missing components probably have not been configured.
- If the drives are red, the drive configuration can be updated dynamically using the SET SLIDRIVS utility (refer to *ELS Command, Control Statement, and Utility Reference*) and the MODify CONFIG command. If only the drives are red, you can proceed with the HSC configuration.
- The elevators (Elevator Folder) must be green. If the elevators are not green, **do not** configure the SL8500 to HSC. The elevators are the logical PTPs. Without PTPs, HSC will not know that the SL8500 rails are connected.

In this macro, we specified the following:

- The assembler label is indeed ACS01, as specified in the SLIALIST macro.
- The FUTRLSM parameter defines four SL8500s that will later be physically added to the configuration. HSC sees each rail in an SL8500 as an entire LSM. An SL8500 library contains four rails (LSMs), thus the *lsmnum* value must be in multiples of four, so in this example 16 LSMs equals 4 future SL8500s.
- The LSM parameter specifies the assembler labels of the 4 SLILSM macros for each SL8500 rail (starting with the first).

9. Create the SLILSM macro for the first SL8500 rail/LSM:

LSM0100	SLILSM PASTHRU=((0,M),(0,M),(0,M)), ADJACNT=(LSM0101,LSM0102,LSM0103), DRIVE=(1), DRVELST=(P010001), TYPE=8500, DOOR=8500-1	X X X X
---------	--	------------------

In this macro, we specified the following:

- The assembler label is indeed LSM0100, as specified in the SLIACS macro.
- The PASTHRU parameter specifies:
 - 0, which is the value for SL8500 internal PTPs (elevators), repeated three times because the SL8500 has 4 LSMs and each LSM needs to pass thru to the other 3 LSMs.

- M designates this LSM as the master. In an SL8500, the lowest numbered LSM is always the master.
- The ADJACNT parameter specifies the assembler labels of the other 3 rails (LSMs) in the SL8500.
- The DRIVE parameter specifies only one transport panel, which is always the case for SL8500 rails/LSMs, and the DRVELST parameter specifies P010001 as the assembler label of the SLID LIST macro that defines the transports in the single drive panel.
- The LSM type is 8500.
- DOOR=SL8500-1 means that there is a single SL8500 CAP.

10. Create the SLIDLIST and SLIDRVS macros for the first SL8500 rail/LSM:

```
P010001 SLIDLIST HOSTDRV=(D0100010,D0100011)
*
D0100010 SLIDRVS ADDRESS=(,,9400,,,9401,,,,,)
D0100011 SLIDRVS ADDRESS=(,,9400,,,9401,,,,,)
```

In these macros, we specified the following:

- The assembler labels of the SLIDLIST macro that defines the single SL8500 drive panel is indeed P010001 as specified on the SLILSM macro.
- Each SLIDLIST HOSTDRV parameter specifies the assembler label of the corresponding SLIDRVS macro.
- The assembler labels on the SLIDRVS macros match, and the ADDRESS parameters specify the unit addresses of each drive on each panel.

Note –

- These are the device addresses you determined in [“Planning for Library-Attached Transports”](#) on page 27.
 - This example shows a drive panel for each of the two hosts. For more information on defining device addresses in a client/server environment, see *Configuring and Managing SMC* .
-

11. Repeat Step 8 on page 101 through Step 10 on page 102 for the other 3 SL8500 rails/LSMs.

The numbers will change but the basic coding does not except that these LSMs, in terms of PTP control, are Slave LSMs, which is always the case with SL8500s.

12. Finally, create the SLIENDGN macro...

...and you're done!

Running the SLICREAT Utility To Format the New CDS

After you code the LIBGEN macros as described in “Coding the LIBGEN Macros” on page 97, assemble and link-edit the LIBGEN macros and run the SLICREAT utility to format the new CDS:

1. Assemble and link-edit the LIBGEN macros.

FIGURE 4-1 shows example LIBGEN assembler and linkage editor JCL. Update this example with your LIBGEN macros and run the job.

```
/*
//ASM EXEC PGM=JLAX00,PARM=(LANGLVL(1))
//SYSPRINT DD SYSOUT=*
//SYSTEM DD SYSOUT=* (optional)
//SYSLIB DD DSN=SYS1.MACLIB,DISP=SHR
// DD DSN=SLS.SLSMAC,DISP=SHR
//SYSUT1 DD UNIT=SYSDA,SPACE=(CYL,(3,1))
//SYSLIN DD DSN=&&OBJ,UNIT=SYSDA,
// SPACE=(CYL,(1,1)),DISP=(,PASS)
//SYSIN DD *

LIBGEN deck goes here

/*
//LKED EXEC PGM=IEWL,PARM='LIST,XREF,RENT,REUS,REFR,RMODE=24',
// COND=(0,NE)
//SYSPRINT DD SYSOUT=*
//SYSLMOD DD DSN=SLS.your.hsc.linklib(lgename),DISP=SHR
//SYSUT1 DD UNIT=SYSDA,SPACE=(CYL,(3,1))
//SYSLIN DD DSN=&&OBJ,DISP=(OLD,DELETE)
/*
```

FIGURE 4-1 Assembler and Linkage Editor LIBGEN Example JCL

2. Run SLICREAT to format the New CDS.

FIGURE 4-1 shows example JCL for the SLICREAT program. This sample is also included in the HSC SAMPLIB as member JCLCRT.

```
//SLICREAT JOB (account),'programmer',CLASS=A
//CREATE EXEC PGM=SLICREAT, CDS CREATE MODULE
// PARM='libgen-load-module-name',
// REGION=0M
//*
//STEPLIB DD DSN=your.hsc.linklib,DISP=SHR
//SYSPRINT DD SYSOUT=* MESSAGES
//*
//*****
//* LIBRARY PRIMARY CONTROL DATASET (CDS)
//*****
//SLSCNTL DD DSN=SLS.SLSCNTL, PRIMARY CDS
// SPACE=(4096,s,,CONTIG,ROUND), REPLACE 's' WITH YOUR
// DISP=(NEW,CATLG,DELETE), SPACE CALCULATIONS
// UNIT=SYSDA
//*****
//* LIBRARY SECONDARY CONTROL DATASET (CDS)
//*****
//SLSCNTL2 DD DSN=SLS.SLSCNTL2, SECONDARY CDS
// SPACE=(4096,s,,CONTIG,ROUND), REPLACE 's' WITH YOUR
// DISP=(NEW,CATLG,DELETE), SPACE CALCULATIONS
// UNIT=SYSDA
//*****
//* LIBRARY STANDBY CONTROL DATASET (CDS)
//*****
//SLSSTBY DD DSN=SLS.SLSSTBY, STANDBY CDS
// SPACE=(4096,s,,CONTIG,ROUND), REPLACE 's' WITH YOUR
// DISP=(NEW,CATLG,DELETE), SPACE CALCULATIONS
// UNIT=SYSDA
//*****
```

FIGURE 4-2 SLICREAT Example JCL

In “CDS DASD Space Requirements” on page 18, you determined the size of the CDS to support your ELS system.

Note –

- For an example of using SLICREAT to format journals, see *ELS Legacy Interfaces Reference*.
 - Run SLICREAT with the highest level of the software that you are running on any LPAR.
-

Running the CDSCREAT Utility to Create the CDS (Tapeless VSM Only)

For **only** Tapeless VSM configurations (no RTDs attached, can have VLEs attached), Run CDSCREAT to create the CDS. [FIGURE 4-1](#) shows example JCL for the CDSREAT program.

```
//CDSCREAT JOB (account),'programmer',CLASS=A
//CREATE EXEC PGM=CDSCREAT, CDS CREATE MODULE
// PARM='libgen-load-module-name',
// REGION=0M
/*
//STEPLIB DD DSN=your.hsc.linklib,DISP=SHR
//SYSPRINT DD SYSOUT=* MESSAGES
/*
//*****
/* LIBRARY PRIMARY CONTROL DATASET (CDS)
//*****
//SLSCNTL DD DSN=SLS.SLSCNTL, PRIMARY CDS
// SPACE=(4096,s,,CONTIG,ROUND), REPLACE 's' WITH YOUR
// DISP=(NEW,CATLG,DELETE), SPACE CALCULATIONS
// UNIT=SYSDA
//*****
/* LIBRARY SECONDARY CONTROL DATASET (CDS)
//*****
//SLSCNTL2 DD DSN=SLS.SLSCNTL2, SECONDARY CDS
// SPACE=(4096,s,,CONTIG,ROUND), REPLACE 's' WITH YOUR
// DISP=(NEW,CATLG,DELETE), SPACE CALCULATIONS
// UNIT=SYSDA
//*****
/* LIBRARY STANDBY CONTROL DATASET (CDS)
//*****
//SLSSTBY DD DSN=SLS.SLSSTBY, STANDBY CDS
// SPACE=(4096,s,,CONTIG,ROUND), REPLACE 's' WITH YOUR
// DISP=(NEW,CATLG,DELETE), SPACE CALCULATIONS
// UNIT=SYSDA
//*****
//SLSPRINT DD SYSOUT=*
//SLSIN DD *
CDSCREAT X
HOSTID=(EC20,EC21), X
COMPRFX=4B, X
TCHNIQE=STANDBY
/*
```

CODE EXAMPLE 4-1 CDSCREAT Example JCL

Note – In “[CDS DASD Space Requirements](#)” on page 18, you determined the size of the CDS to support your ELS system.

In [CODE EXAMPLE 4-1](#) on page 105:

- Hosts EC20 and EC21 are the SMF IDs of the hosts where the subsystem will execute.
- 4B is the hexadecimal representation of the command prefix character ('.')
- STANDBY indicates that three HSC CDS data sets are to be formatted and used by the system.

For details of all CDSCREAT parameters, see *ELS Commands, Control Statements, and Utilities*.

Note – In a tapeless configuration, you cannot issue commands or use parameters that reference library components.

Defining and Creating CDS Log Files

To define and create CDS log files:

1. Use the FMTLOG utility to pre-format the log files.

The size of the allocated log files depends on the number of transactions your system generates, as well as the frequency of performing the offload. StorageTek suggests you allocate and activate some test log files and determine the rate at which they fill before determining the size of the production log files.

Sample JCL:

```
//FMTLOG JOB (account),REGION=1024K
//S1 EXEC PGM=SLUADMIN,PARM=MIXED
//STEPLIB DD DSN=hlq.SEALINK,DISP=SHR
//SLSLOG1 DD DSN=hlq.CDSLOG1,DISP=(,CATLG,DELETE),
// UNIT=SYSDA,SPACE=(CYL,100)
//SLSLOG2 DD DSN=hlq.CDSLOG2,DISP=(,CATLG,DELETE),
// UNIT=SYSDA,SPACE=(CYL,100)
//SLSPRINT DD SYSOUT=*
//SLSIN DD *
FMTLOG
/*
```

Note – Data sets must be cataloged, so that they can be located by dynamic allocation. You can assign either one or two log files. If you assign two log files, the second is a copy of the first. There is no “automatic switching” between log files. If an error occurs on a file, it is disabled and logging continues on the other file.

2. Use the SET LOGFILE utility to activate the log files.

Sample JCL:

```
//SETLOG JOB (account),REGION=1024K
//S1 EXEC PGM=SLUADMIN,PARM=MIXED
//STEPLIB DD DSN=hlq.SEALINK,DISP=SHR
//SLSPRINT DD SYSOUT=*
//SLSIN DD *
SET LOGFILE(hlq.CDSLOG1,hlq.CDSLOG2)
/*
```

Running Multiple HSC Tapeplexes on One LPAR (MULT Mode)

ELS now supports the ability to run multiple instances of HSC on the same LPAR. The following restrictions apply when HSC is started in MULT mode:

- If any HSC on the LPAR specifies the MULT parameter, then **all** HSC subsystems on that LPAR must specify the MULT parameter.
- Two HSC subsystems on the same LPAR must represent separate tapeplexes, that is, each HSC must point to a different set of CDSs.
- ExPR started task is not supported on any LPAR where HSC is running in MULT mode.
- A new parameter, **SSYS**, is required on any SLUADMIN step running on an LPAR where HSC is in MULT mode.
- The SLIEXERS installation utility cannot be run on an LPAR where HSC is in MULT mode.
- Any application using the HSC Significant Event Notification (SEN) facility on an LPAR where HSC is running in MULT mode must be modified to pass a subsystem name parameter. See *ELS Programming Reference* for more detail on the SEN facility.

The following are recommendations for running multiple HSCs on one LPAR:

- Each HSC subsystem should specify a unique command prefix.
- Each HSC subsystem should specify MSGPRFX(YES) in its EXECPARM parameter. Using this parameter, along with a unique command prefix, identifies the HSC subsystem source for HSC console EXEC JCL parameters. Using this parameter, along with a unique command prefix, identifies the HSC subsystem source for HSC console messages.
- Each HSC subsystem should use a unique SMF record ID. This allows statistics to be collected for individual HSC subsystems.
- Each HSC subsystem should use a unique ENQUEUE name. This can be done by using the SLUADMIN SET MAJNAME utility. Specifying the same enqueue name for multiple CDSs can lead to performance issues.

Defining Volumes to ELS

With ELS 7.2, you now use the HSC POOLPARM and VOLPARM statements to define **all** volumes and their pools...native Library Volumes, cleaning cartridges, MVCs, and VTVs...and the HSC SET VOLPARM utility to load them. For more information, see *ELS Command, Control Statement, and Utility Reference*.

Tip – Do you want to switch to POOLPARM/VOLPARM way but don't know how to do the conversion? The VOLPCONV utility helps to convert existing VOLDEF, SCRDEF, MVCDEF, CONFIG VTVVOL, and CONFIG MVCVOL statements to SET VOLPARM statements. For more information, see *ELS Command, Control Statement, and Utility Reference*.

So in the following sections, you'll use the same basic procedure, with variations for the type of volume and its pool. But first, a discussion of the benefits of converting to POOLPARM/VOLPARM and some *caveats* about their use.

Why Should I Use POOLPARM/VOLPARM?

POOLPARM/VOLPARM provides the following advantages over the legacy method of defining volumes:

- **Reduce system outages.**

Using POOLPARM/VOLPARM allows you to dynamically delete VTV or MVC ranges from the CDS, without requiring a CDS MERGE process. Deleting VTV or MVC ranges dynamically requires CDS level G or above (CDSLEVEL=V62ABOVE) and also requires that none of the volumes in the deleted range be currently in use.

- **Simplify maintenance of volume parameters.**

- All POOLPARM/VOLPARM parameters are maintained in the CDS.
- Edits ensure that all volsers in your environment are defined only once and belong to only one pool.
- Current contents of POOLPARM/VOLPARM is available by running the LIBGEN utility (see CU Ref for details)
- When the SET VOLPARM utility is run with APPLY=YES, all updates occur immediately on all hosts.

- **Improved management of scratch subpool allocation.**

- POOLPARM/VOLPARM allows only non-subpool scratch volumes to be selected when no scratch subpool is specified. Non-subpool scratch volumes are those volumes defined before any pool definition.
- Using POOLPARM/VOLPARM rejects mount requests for undefined subpool names from SMC.
- POOLPARM/VOLPARM provides the ability to limit access to scratch subpools based on client host ID in a client/server environment.

- **Improved reporting.**
 - Your VOLRPT will automatically pick up subpool definitions, flag MVCs, and show volumes in DR test scratch subpools, as well as flagging undefined volumes.
 - HSC D VOLUME DETAIL shows pool residency.
- **Pre-validation.**
 - You can use the SLUADMIN utility to pre-validate your POOLPARAM/VOLPARAM statements before activating them.
 - You can use the SMC POLICY VALIDATE in the SMC subsystem or SMCUSIM utility to ensure that all SMC POLICY statements specify valid subpools.
- **POOLPARAM/VOLPARAM supports volume segregation in the Concurrent Disaster Recovery Test utility.**
 - Using POOLPARAM/VOLPARAM automatically segregates DR test scratch subpools and MVC pools from production. When POOLPARAM/VOLPARAM is in effect, DR test systems can use only volumes defined in DRTEST pools.
 - In a DR test environment, you can scratch volumes defined as part of DRTEST scratch subpools.
- **Using POOLPARAM/VOLPARAM supports volume segregation in a Cross TapePlex Replication environment.**
 - Defining POOLPARAM with TYPE=EXTERNAL and OWNRPLEX name ensures that the receiving TapePlex cannot use a VTV as scratch and can receive a VTV only from the specified OWNRPLEX
 - Changing a POOLPARAM from TYPE=EXTERNAL to TYPE=SCRATCH allows the receiving TapePlex to scratch VTVs received from another TapePlex in case of an actual disaster.
- **A utility is provided to assist in converting existing volume definitions to POOLPARAM** (for more information, see *ELS Command, Control Statement, and Utility Reference*).
 - Input includes existing VOLDEF, SCRDEF, MVCPOOL, and VTCS CONFIG definitions
 - Note that the conversion utility cannot convert “wildcard” characters in VOLATTR statements. You must manually convert wildcard specifications to volume ranges.

Some Caveats with POOLPARAM/VOLPARAM

A few things to remember when using POOLPARAM/VOLPARAM:

- VTCS CONFIG MVCVOL and VTVVOL definitions are no longer honored.
- HSC control commands SCRPFDEF, VOLDEF and MVCDEF are no longer honored.
- Your pool definitions are the same on all hosts. You can, however, use the HOSTID parameter to limit access to scratch subpools.
- Mounts for invalid subpools will be rejected.
- Mounts with no specified subpool can be satisfied only by non-subpool volumes.
- You can disable POOLPARAM/VOLPARAM by running the SET VOLPARAM utility with an empty SLSPARM input file. Once POOLPARAM/VOLPARAM is disabled, the previous version of POOLPARAM/VOLPARAM remains in effect for MVC and VTV definitions until you run VTCS CONFIG, and the previous POOLPARAM/VOLPARAM POOL definitions remain in effect until you run the VOLDEF, SCRPFDEF and MVCDEF commands on the HSC host(s).
- If you run CDRT with POOLPARAM/VOLPARAM in effect you must have DRTEST pools defined or scratch mounts will not be satisfied, and no MVCs can be used.

Defining Library Volumes

To define Library Volumes:

1. **Create a POOLPARAM statement to define volume scratch pools.**

For example, to define a scratch pool for use by hosts MSP1 and MSP2:

```
POOLPARAM NAME(SYS19840P1)TYPE(SCRATCH)HOSTID(MSP1,MSP2)LABEL(SL)
```

2. **Create a VOLPARAM statement to define the volumes.**

For example, to define a range of 9840C volumes:

```
VOLPARAM VOLSER(C1000-C1999)MEDIA(STK1R)RECTECH(STK1RC)
```

3. **Ensure that you define sufficient cleaning cartridges.**

Go to [“Defining Cleaning Cartridges”](#) on page 112.

Note – Once you install higher density (or encryption-capable) drives for existing media, note that if you eject and re-enter an existing cartridge, HSC sets the density to “unknown” whenever the ACS contains drives other than the lowest density for the media, and sets the encryption status to “unknown” whenever the ACS contains encrypting drives for the media. This means that in the allocation process, SMC attempts to allocate the specific volume to the highest density drives and to encrypting drives, whenever the volume is flagged as “unknown.”

To manage this situation, you can use VOLPARAMs for the volume to indicate its actual density (encryption status), and then, once it is scratched, reset the VOLPARAM to the desired recording technique.

Defining Cleaning Cartridges

To define cleaning cartridges:

1. **Create a POOLPARAM statement to define the cleaning cartridge pool.**

For example, to define the 9840 cleaning cartridge Pool with cleaning parameters:

```
POOLPARAM TYPE(CLEAN)MAXCLEAN(25)
```

2. **Create a VOLPARAM statement to define the cleaning cartridges.**

For example, to define a range of 9840 cleaning cartridges:

```
VOLPARAM VOLSER(CLN300-CLN310)MEDIA(STK1U)
```

3. **Do you need to define MVCs?**

If so, go to [“Defining MVCs” on page 112](#). Otherwise, go to [“Validating and Applying the Volume Definitions” on page 113](#).

Defining MVCs

Note – POOLPARAM/VOLPARAM is the preferred method for defining MVCs for ELS 7.0 but you can still use CONFIG to define MVCs. For more information, see *ELS Legacy Interfaces Reference*. Also note that if you have existing volsers defined via CONFIG, you must run DECOM against your CONFIG deck, remove the CONFIG definitions, and rerun CONFIG before you create POOLPARAM/VOLPARAM definitions.

To define MVCs:

1. **Create a POOLPARAM statement to define the MVC pool.**

For example, to define the T10000 MVC Pool with reclaim parameters:

```
POOLPARAM NAME(SYS1MVCT1)TYPE(MVC)MVCFREE(40) MAXMVC(4) THRESH(60)  
START(70)
```

2. **Create a VOLPARAM statement to define the MVCs.**

For example, to define a range of T10000 Full volumes to be encrypted:

```
VOLPARAM VOLSER(T2000-T2999)MEDIA(T10000T1)RECTECH(T1AE)
```

3. **Define VTVs.**

Go to [“Defining VTVs” on page 113](#).

Defining VTVs

Note – POOLPARAM/VOLPARAM is the preferred method for defining VTVs for ELS 7.0 but you can still use CONFIG to define MVCs. For more information, see *ELS Legacy Interfaces Reference*. Also note that if you have existing volsers defined via CONFIG, you must run DECOM against your CONFIG deck, remove the CONFIG definitions, and rerun CONFIG before you create POOLPARAM/VOLPARAM definitions.

To define VTVs:

1. **Create a POOLPARAM statement to define the volume scratch pool.**

For example, to define a VTV scratch pool for use by hosts MSP1 and MSP2:

```
POOLPARAM NAME(SYS1VTV1)TYPE(SCRATCH)HOSTID(MSP1,MSP2)LABEL(SL)
```

2. **Create a VOLPARAM statement to define the VTVs.**

For example, to define a range of VTVs initialized as scratch:

```
VOLPARAM VOLSER(V5000-V5999)MEDIA(VIRTUAL)INITSCR
```

Validating and Applying the Volume Definitions

1. **Run SET VOLPARAM to validate the POOLPARAM/VOLPARAM statements.**

```
SET VOLPARAM APPLY(NO)
```

APPLY(NO) validates the statements without loading them. If you like the results, go to [Step 2](#). Otherwise, rework your volume definitions, then go to [Step 2](#).

2. **Run SET VOLPARAM to load the POOLPARAM/VOLPARAM statements.**

```
SET VOLPARAM APPLY(YES)
```

3. **Physically enter the cartridges into the ACS.**

For more information, see *Managing HSC and VTCS*.

Defining the SYS1.PARMLIB Member SMFPRMxx

HSC can produce SMF record subtypes for HSC and VTCS events. To produce these record subtypes, you must add two statements to your SMF parameters in SYS1.PARMLIB member SMFPRMxx to specify the following:

- HSC subsystem for which records are produced
- Recording interval in seconds
- SMF record subtypes. The record subtypes must be specified as a list (*subtype1, subtype2,...subtypen*), as a range (*subtype1-subtypen*), or as a combination (*subtype1, subtype2-subtypen*). A range must be specified using a dash; a colon is invalid for a range.

Note – The TYPE parameter in the SMFPRMxx member must match the SLILIBRY SMF= parameter specified in [“Coding the LIBGEN Macros” on page 97](#).

Tip – StorageTek recommends that you specify that your system produces the HSC SMF record subtypes 1 through 8 and 10, 11, 13, 14, 15, 16, 17, 18, 19, 20, 21, 25, 26, 27, 28, 29, 30, and 31 as shown in [FIGURE 4-3](#). For more information on SMF record layouts, see *ELS Programming Reference*.

[FIGURE 4-3](#) shows example statements that produce record subtypes 1 through 8 and 10, 11, 13, 14, 15, 16, 17, 18, 19, 20, 21, 25, 26, 27, 28, 29, 30, and 31 at 15 minute intervals for HSC subsystem SLS0.

```
SUBSYS(SLS0,INTERVAL(001500),TYPE(255))
OPTION SUBTYPE(1-8, 10, 11, 13, 14, 15, 16, 17, 18, 19, 20, 21, 25, 26, 27, 28, 29, 30, 31)
```

FIGURE 4-3 SYS1.PARMLIB member SMFPRMxx example for VTCS SMF records

Creating the HSC PARMLIB Member

The HSC PARMLIB member is where you specify any commands that you want executed at HSC startup as shown in the example in [FIGURE 4-4](#).

```
CDSDEF DSN1(HSC1.PRIM),DSN2(HSC1.BKUP),DSN3(HSC1.STDBY)
MGMTDEF DSN(HSC.PARMS)
COMMP METH LMU
CAPP 9,01:00:00,AUTO
MNTD AUTOCLN(ON) EJCTAUTO(ON)
```

FIGURE 4-4 Example: Updating the HSC PARMLIB Member

In [FIGURE 4-4](#):

CDSDEF

The CDSDEF control statement in the HSC PARMLIB determines how many CDS copies are allocated by the HSC. These definitions are invoked at HSC initialization and remain set until HSC termination. The definitions cannot be altered without HSC shutdown and restart.

Caution – The number of CDS copies implied by the TCHNIQE parameter must be the same as the number of CDS copies implied by the CDSDEF control statement otherwise the HSC will not initialize.

- If the number of CDS copies defined on the CDSDEF control statement is more than are specified by the TCHNIQE parameter, do the following:
 - Stop the HSC on all hosts
 - Run a SLUADMIN SET TCHNIQE to increase the number of copies to match the number implied by the CDSDEF control statement
 - Restart HSC
 - If the number of CDS copies defined on the CDSDEF control statement is less than are specified by the TCHNIQE parameter, do the following:
 - Stop the HSC on all hosts
 - Run a SLUADMIN SET TCHNIQE to decrease the number of copies to match the number implied by the CDSDEF control statement
 - Restart HSC
-

The control data set names are recorded in the Database Heartbeat (DHB) record. During HSC initialization, the data set names in the DHB are compared with the data set names specified on the CDSDEF control statement in the HSC PARMLIB.

If a data set name specified on the CDSDEF statement does not match any of the control data set names recorded in the DHB, that control data set is disabled. If all the specified control data sets are disabled, the HSC will not initialize. The specific assignment of enabled control data sets to the primary, secondary, and standby control data set(s) is made based on the control data set assignments recorded in the Database Heartbeat record.

HSC.PARMS

is the data set that contains your system's MGMTclas and STORclas statements.

COMMP METH LMU

specifies that LMU is the communications method. StorageTek recommends that you specify the HSC COMMPath METHod parameter to LMU when multiple HSC systems share the same CDS.

CAPP 9,01:00:00,AUTO

specifies CAP preferences.

MNTD AUTOCLN(ON) EJCTAUTO(ON)

specifies automatic drive cleaning and automatic ejection of spent cleaning cartridges.

EXECPARM Statement

The EXECPARM statement provides an alternative method of specifying GTF Eid and Fid parameters.

Syntax

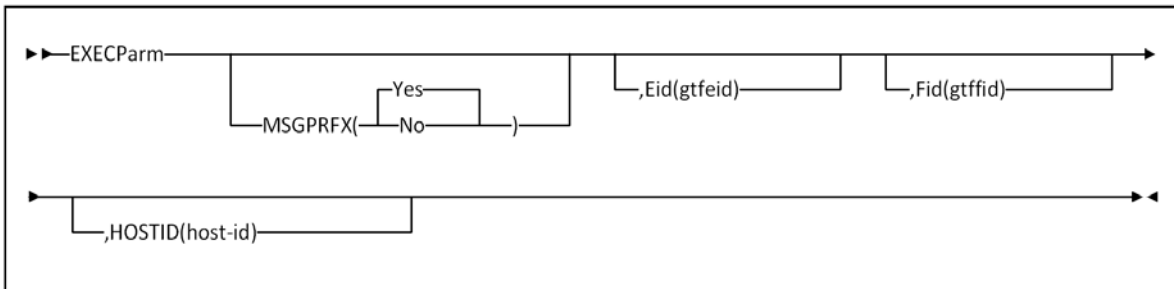

FIGURE 4-5 EXECPARM Syntax

Parameters

MSGPRFX

optionally, specifies control of whether the command prefix is to precede WTO or WTOR messages to the operator.

Yes

indicates that the command prefix is to display preceding WTO or WTOR messages to the operator.

No

indicates that the command prefix is not to display preceding WTO or WTOR messages to the operator.

Eid

optionally, *gtfeid* specifies a GTF event ID.

PARAM='Eid(*user-specified-event-id*)' parameter is valid for use in the HSC initialization procedure as an alternative method of specifying the GTF event ID.

Fid

optionally, *gtffid* specifies a GTF format ID.

PARAM='Fid(*user-specified-format-id*)' parameter is valid for use in the HSC initialization procedure as an alternative method of specifying the GTF format ID.

HOSTID

optionally, *host-id* specifies the system ID associated with the request to process the EXECPARM control statement.

Note – If the *hostid* specified does not match the host executing the command, the command is ignored and no message is issued.

Defining Command Authority

If HSC user exit SLSUX15 sets a return code of UX15CHKA, the exit issues a command authorization request to the system security product. FIGURE 4-6 shows an example of RACF profile and permissions commands to give user SAM15 update access to all HSC/VTCS commands and user JOE13 query access to all HSC/VTCS commands.

Note that you can no longer specify the .VT prefix for VTCS commands, which is no longer passed to SLSUX15. See *ELS Programming Reference* for a sample of how to define command security based on the originating host ID of the command.

```
*****
* Define a profile in the OPERCMDS class for all HSC and VTCS commands *
*****
RDEFINE OPERCMDS subsystem.* UACC (NONE)
*****
***** Allow user JOE13 access to all query HSC/VTCS commands
*****
*****PERMIT subsystem.command CLASS(OPERCMDS) ID(JOE13) ACCESS (QUERY)
*****
***** Allow user SAM15 update access to all HSC/VTCS commands
*****
*****PERMIT subsystem.command CLASS(OPERCMDS) ID(SAM15) ACCESS (UPDATE)
*****
```

FIGURE 4-6 Example RACF ELS command authorization file

Creating and Cataloging the HSC Startup Procedure

You start HSC by entering the MSP START command that invokes the HSC startup procedure, which resides in the cataloged procedure library of the host system. For more information, see:

- [“Running Multiple HSC Tapeplexes on One LPAR \(MULT Mode\)” on page 120](#)
- [“EXEC Statement” on page 121.](#)
- [“Sample HSC Startup Procedure” on page 124](#)
- [“EXEC Parm Statement” on page 117](#) for an alternative method of specifying GTF Eid and Fid parameters.

Note – If you previously controlled which hosts started VTCS by referencing or not referencing the VTCS software in your JCL concatenation, this capability is provided in ELS 7.0 by using the NOVTCS parameter on the HSC startup PARM. For more information, see [“EXEC Statement” on page 121.](#)

Running Multiple HSC Tapeplexes on One LPAR (MULT Mode)

ELS now supports the ability to run multiple instances of HSC on the same LPAR. The following restrictions apply when HSC is started in MULT mode:

- If any HSC on the LPAR specifies the MULT parameter, then **all** HSC subsystems on that LPAR must specify the MULT parameter.
- Two HSC subsystems on the same LPAR must represent separate tapeplexes, that is, each HSC must point to a different set of CDSs.
- The ExPR started task is not supported on any LPAR where HSC is running in MULT mode.
- A new parameter, **SSYS**, is required on any SLUADMIN step running on an LPAR where HSC is in MULT mode.
- The SLIEXERS installation utility cannot be run on an LPAR where HSC is in MULT mode.
- Any application using the HSC Significant Event Notification (SEN) facility on an LPAR where HSC is running in MULT mode must be modified to pass a subsystem name parameter. See *ELS Programming Reference* for more detail on the SEN facility.

The following are recommendations for running multiple HSCs on one LPAR:

- Each HSC subsystem should specify a unique command prefix.
- Each HSC subsystem should specify MSGPRFX(YES) in its EXEC Parm or EXEC JCL parameters. Using this parameter, along with a unique command prefix, identifies the HSC subsystem source for HSC console EXEC JCL parameters. Using this parameter, along with a unique command prefix, identifies the HSC subsystem source for HSC console messages.
- .Each HSC subsystem should use a unique SMF record ID. This allows statistics to be collected for individual HSC subsystems.
- .Each HSC subsystem should use a unique ENQUEUE name. This can be done by using the SLUADMIN SET MAJNAME utility. Specifying the same enqueue name for multiple CDSs can lead to performance issues.

EXEC Statement

The EXEC statement specifies HSC startup options.

Syntax

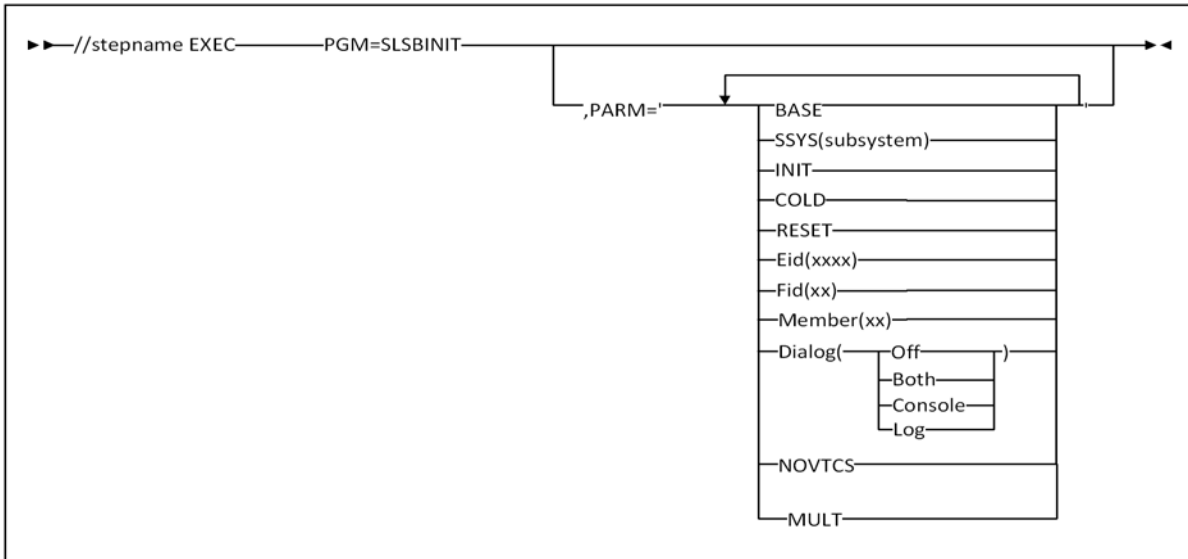

FIGURE 4-7 EXEC Statement Syntax

Parameters

PARM=

defines the list of parameters passed to the HSC initialization routine.

Note – If you enter more than one of the following parameters, you must separate them with a blank space (e.g., `BASE SSYS(subsystem) RESET`).

BASE

specifies that the HSC initialize and execute at the base service level.

SSYS

specifies that HSC initialization search for the *subsystem* name specified. If the name is not found or is not a valid name, the subsystem terminates. *subsystem* must be a 1- to 4-character name or problems can occur when initializing the HSC.

This parameter permits you to symbolically specify the subsystem and retain the same startup procedure whether starting the HSC before or after JES.

COLD

specifies that any permanent in-memory data structures previously allocated by HSC are reallocated and reinitialized.

This parameter should be used only when absolutely necessary. (The installation instructions for some HSC maintenance may direct you to perform a COLD start.)

Note – You do **not** need to include the COLD parameter when you are initializing a HSC that is at a different release level than the HSC that was previously running on a host. When an initializing HSC detects a release level difference, it performs an automatic internal cold start.

RESET

specifies that all subsystem status flags in the MSP Subsystem Communications Vector Table (SSCVT) for the HSC are unconditionally reset. Use of this option may correct a situation in which the HSC was terminated abnormally without resetting the status flags; for example, if the HSC was terminated with the MSP FORCE command.

These messages are possible symptoms of this situation:

... ACS subsystem CCCC is ACTIVE

or

... ACS subsystem CCCC is TERMINATING

or

... ACS subsystem CCCC is INITIALIZING

at HSC startup, when a display of active jobs indicates that the subsystem is not, in fact, active.

This parameter should only be used in extreme situations and may not correct all error conditions. Contact StorageTek Software Support before using this parameter.

Eid

xxxx is 1 to 4 hex characters specifying the GTF event ID used for the duration of this subsystem. "E" is the abbreviation for this parameter. The default Eid value is **E086**.

Fid

xx is 1 to 2 hex characters specifying the GTF format ID used for the duration of this subsystem. "F" is the abbreviation for this parameter. The default Fid value is **17**.

Note – See "EXEC Parm Statement" on page 117 for an alternate method of specifying GTF, EID, and FID parameters.

Member

For MSP, xx is the suffix of the SLSSYSxx member in SYS1.PARMLIB, or an SLSSYSxx DD statement in the startup procedure used as the automatic commands (PARMLIB control statements) data set. "M" is the abbreviation for this parameter.

Dialog

specifies that messages can be displayed on the operator console and/or written to the system log. This option can be used to further restrict where messages are displayed based on the ROUTCDE. These messages indicate that the HSC is waiting for an active task to complete before the HSC terminates.

For more information on Dialog, see "OPTION Command and Control Statement" in the *ELS Command, Control Statement, and Utility Reference*.

If Dialog is specified, one of the options **must** be selected. There is no default. The options for Dialog include:

Off

specifies that you do not want active task termination messages displayed on the operator console or written to the system log.

Both

specifies that messages are displayed on the operator console and written to the system log.

Console

specifies that messages are displayed on the operator console only.

Log

specifies that messages are written to the system log only.

NOVTCS

specifies that VTCS should not initialize on a host even though VTCS data is present in the CDS.

Sample HSC Startup Procedure

FIGURE 4-8 shows HSC SAMPLIB member JCLPROC, which is a sample HSC startup procedure.

```
//SLS0  PROC PROG=SLSBINIT,PRM=' '  
//*  
//IEFPROC EXEC PGM=&PROG,TIME=1440,  
// PARM='&PRM E(E086) F(23) M(00) SSYS(SLS0)',REGION=6M  
//*  
//STEPLIB DD DSN=SEA700.SEALINK,DISP=SHR  
//*  
//SLSSYS00 DD DSN=SLS.PARMS,DISP=SHR
```

FIGURE 4-8 Sample HSC Startup Procedure

In FIGURE 4-8:

- In the example PROC shown above, SLS0 is used as both the name of the startup procedure (line 1) and as the subsystem name defined in the SSYS parameter “SSYS(SLS0)” in line 4. This is just an example, you can code any values that work for your site but **note the following**:
 - HSC subsystem names must be 4 characters in length and must be defined in your IEFSSNxx member.
 - If the startup procedure name and the subsystem name are identical, the SSYS parameter is not required in the startup procedure. If the startup procedure name is **not** identical to the subsystem name, then the SSYS parameter must point the startup procedure to the required HSC subsystem.
 - TIME=1440 or TIME=NOLIMIT must be specified to ensure that HSC does not time out and terminate.
 - StorageTek recommends that you run HSC/VTCS with a region size of **at least 6 MB** except if you are running utilities or commands that manipulate manifest files, in which case you need the maximum region size your system will allow.

DD Statements for the HSC Startup Procedure

SLSSYSxx

statement that defines the data set containing the HSC PARMLIB. In the example procedure above, xx is replaced by the suffix “00”. The SLSSYS00 DD statement matches the M(00) declaration and points to the PARMLIB member “00” that contains your start-up parameters.

SLSUEXIT

statement that defines the data set containing HSC user exits.

Performance Considerations

Define Dispatching Priority for ELS Software

Depending on your requirements, set these software components so the amount of resources available to them is as follows:

- HSC/VTCS — greater than batch and any started task or application requiring quick access to tape but less than an online system
- SMC/HTTP server— greater than the HSC, or if the HSC is inactive, greater than batch and any started task or application requiring quick access to tape but less than an online system

Your requirements may dictate that these products be given access to greater or lesser resources than we recommend here but you must determine this for your environment. The information above is meant only to serve as a guideline.

During initialization, the HSC uses SYSEVENT TRANSWAP to make its address space non-swappable. The HSC address space cannot be swapped out once this has been accomplished.

Reduce Pass-Thrus

The number of pass-thrus required to mount, dismount, and replace cartridges in LSMs can impact library performance. In a large or busy ACS, this impact may be significant especially during periods of heavy mount activity. There are three types of pass-thrus:

- unavoidable
- unnecessary
- scheduled.

Unavoidable Pass-Thrus

The HSC attempts to minimize the number of pass-thrus required; however, depending upon available tape transports and locations of cartridges, pass-thrus often cannot be avoided. By running Activities Reports on a regular basis and examining the results, you can see that mounts for different LSMs take longer than mounts for the same LSM.

Unnecessary Pass-Thrus

Scratch mounts, dismounts, enters, and ejects that require pass-thrus are unnecessary and should be avoided. These types of activities divert the robotics from productive work especially during periods of peak activity.

If scratch subpools are properly defined and managed, scratch cartridges normally are not involved in pass-thrus. Scratch mounts are the same as specific mounts as far as pass-thrus that cannot be avoided.

The effect of unnecessary pass-thrus is not obvious in the Activities Report. You must compare their number with average mount times to see the effect on performance.

Scheduled Pass-Thrus

Using the Scratch Redistribution utility to balance scratch cartridges involves moving cartridges to various LSMs to achieve scratch balancing. This type of activity involves heavy pass-thru usage. If you must balance scratch volumes across your library, schedule such activity during off peak hours. This approach will make sure that the pass-thru activity involved does not directly interfere with mounts and dismounts for high-priority production.

Methods to Reduce Pass-Thru Activity

There are various methods to reduce pass-thru activity:

Set MNTD Float to ON

The Float option of the MNTD command specifies whether the HSC is to select a new home cell location when it dismounts a volume that requires a pass-thru when it is dismounted.

When MNTD Float is set to ON, cartridges are not passed back to their original LSM. The cartridges are assigned new cells in the LSM where they are dismounted. This action eliminates most unnecessary pass-thrus.

Set MNTD SCRDISM to CURRENT

When MNTD SCRDISM is set to CURRENT, scratch cartridges mounted in a 9360 (WolfCreek) LSM are dismounted in the same device rather than being archived in the next largest storage device.

Provide adequate free cells

Setting MNTD Float to ON can be overridden if there are no free cells in the dismounting LSM. Dismounted cartridges are passed to other LSMs to find a new home cell.

Use the Display Lsm command to determine the number of free cells in each LSM. Use MOVE or Eject to create free cells if they are needed.

Eject through the CAP closest to the cartridge

If you eject a cartridge through the CAP of the LSM where it resides, no pass-thrus are required.

If you eject a cartridge without specifying a CAPid, the cartridge is ejected through the highest priority CAP that is not busy. This type of activity may cause one or more unnecessary, nonproductive pass-thrus.

The recommended way to accomplish ejects without affecting performance with pass-thrus, is to use multiple CAP option on the EJECT utility. By specifying multiple CAPs (i.e., CAP(00:00:00,00:00:01,00:00:02)), the desired effect (i.e., no pass-thrus) is achieved.

Redistribute cartridges during off-peak times

You can use the MOVE command and utility to move cartridges within an LSM or between LSMs. The Scratch Redistribution utility can be used to move scratch cartridges between LSMs until an equilibrium is reached. Each inter-LSM movement of cartridges causes pass-thrus which delay robot movement in mounting a cartridge.

Depending on the number of cartridges to be redistributed, you may prefer to schedule moves and scratch redistribution during periods of low data center activity. The redistribution runs faster and performance is not affected during off peak times.

Reduce Operator Intervention

Although the ACS runs mostly unattended, situations occur where operator intervention is required. Excessive and unnecessary operator intervention impacts library performance. There are specific ways in which operator intervention can be reduced. These include:

Set SMC ALLOCDef DEFer(ON)

If a keep is issued for a cartridge while it is being mounted, the HSC issues a message indicating that the robot cannot dismount the volume. An operator must unload the tape transport and then reply "R" to the message.

This situation is caused by programs allocating cartridges through JCL, not opening the data set on the cartridge, and terminating before the mount completes. It causes unnecessary mounts, extends dismount time, and delays the availability of cartridges and transports.

If a message requiring operator intervention occurs frequently, you may want to set ALLOCDef DEFer(ON) so ACS mounts are deferred until the data set is opened. Alternatively, you can code User Exit 09 for JES or User Exit 11 for JES with SETUP processing to selectively defer a subset of ACS mounts.

Set CAP Preference

In a multiple-LSM ACS, the CAPPref command establishes an ordered list of CAPs to use should the operator or HSC start an activity that requires a CAP without specifying a CAPid.

To enter or eject cartridges faster, set CAPPref such that the CAP closest to the cartridge racks is preferred. This minimizes operator travel distance.

In large ACS configurations, of five or more LSMs, consider setting CAPPref such that a CAP in the middle of the ACS has the highest priority. This may make the operators walk further but it reduces the number of pass-thrus should the default (highest priority) CAPid be used for ejecting cartridges.

Prefetch Enters

Nonlibrary cartridges that are mounted on library transports are delayed while the operator fetches and enters them. This is a common occurrence for HSC sites with all transports attached to the library.

If you or your scheduling system can predict which nonlibrary cartridges will be mounted in the library before a mount message appears, your operator can improve performance by entering those cartridges in advance.

Avoid Crashing Test Systems

Library attached hosts own library resources, including CAPs, tape drives, and cartridges. If a host fails, another host must clean up the resources held by the failing host. This delays mounts and dismounts on the recovering host while recovery takes place.

You should attempt to shut down the HSC properly before IPLing a system. This is especially important for test systems that may be restarted several times a day.

Use Unit Affinity Separation

Unit affinity separation can improve library performance by eliminating the need for operators to enter or eject tape cartridges when volumes are requested with unit affinity. Without unit affinity separation, a tape transport is selected based on the location of the first volume.

Refer to the *SMC Configuration and Administration Guide* for information about the ALLOCDef command SEPLvl parameter, which specifies the exclusion level at which affinity chains are separated.

Reduce Tape Transport Contention

Balanced use of library tape transports results in better robotic and system performance. In a multiple LSM library, you want the workload to be spread evenly among the robots rather than overloading one robot while the others are idle. Within each LSM, you want mounts to be evenly distributed among transports rather than having the robot wait for a cartridge to be rewound so it can mount the next cartridge on the same tape transport.

Tape transport contention can be reduced by:

- ensuring scratch cartridge balance
- managing multi-host tape transports
- avoiding dedicating tape transports
- using two tape transports for multi-volume files.

Reduce Scheduling Contention

Effective scheduling can increase library performance. Controlling the following scheduling related areas can help significantly in further increasing library performance:

- strive for a balanced workload
- schedule nonproductive library activities during low-demand times.

Balancing the Workload

If you experience higher than expected average mount times but at the same time experience an improvement in production throughput, it could be an indication that your system is periodically flooded with work rather than having a balanced workload.

For example, all of your production jobs may be getting submitted at the beginning of a shift so that the library robots are overworked for the first few hours of the shift. Then, the robots may remain idle for the remainder of the shift. If you are using a scheduling software package and it releases jobs every hour on the hour, there may be tremendous tape transport contention for the first few minutes of each hour while the transports are unused for the remainder of each hour.

These situations tend to elevate average mount times; however, as long as the work is performed on time, there is probably no need to change conditions. However, if the work is not getting performed on schedule, you can improve performance by balancing your production workload.

Scheduling Nonproductive Activities During Low-Demand Times

There are several library utilities, which, though very essential, severely impact the library's ability to mount and dismount cartridges. The following utilities should not be run when high-priority production jobs are pending:

- AUDIt
- EJECT
- Initialize Cartridge
- MOVE
- Scratch Redistribution
- Scratch Update.

These utilities should be scheduled during quiet periods so they do not contend with mounts and dismounts. Running these activities during quiet periods also makes sure that the tasks complete faster. In the case of mass enters or ejects, operator's time can also be optimized.

Reconfiguring a TapePlex

“Configuring HSC” on page 95 explained how to configure HSC, which includes performing a LIBGEN, which is how you initially define hardware to HSC.

“Reconfiguring a TapePlex” is for existing customers who want to add hardware to their systems either on release boundaries or between release boundaries. The idea being that adding hardware to an existing system is usually easier, because you don’t have to redefine each and every piece of hardware, and also because adding hardware is an easier path...for example, to add transports, you don’t have to stop HSC, recreate your entire LIBGEN, and so forth...you can just use SET SLIDRVS and dynamic reconfiguration (via MODIFY CONFIG) to make it happen.

When Do You Need to Reconfigure Your TapePlex?

Whenever the hardware components that make up your tapeplex change, you need to perform a reconfiguration task to synchronize the HSC CDS with the physical tape hardware. Some reasons for reconfiguring a tapeplex include:

- Consolidating two data centers
- Splitting a single data center into two tapeplexes
- Adding, changing or removing physical tape hardware, including drives, LSMs, and ACSs.
- Adding, changing or removing VTSSs.
- Adding, changing or removing VAULT information.

Depending on the existing configuration and the type of change being done, you will need to use one of the following tools/procedures:

- HSC MERGEcds utility
- HSC dynamic reconfiguration process
- VTCS CONFIG utility
- HSC SET VOLPARM utility
- HSC SET VAULT and/or SET VAULTVOL utility
- HSC AUDIT utility
- HSC SET CDKLOCK utility

The MERGEcds Utility

The MERGEcds utility is used to migrate information from an existing CDS into a new, formatted CDS. The MERGEcds utility is normally used for the following types of changes:

- Consolidating or splitting data centers
- Adding LSMs or ACSs to a configuration when FUTRLSM or FUTRACS was not specified or was insufficient for the new configuration.
- Deleting LSMs or ACSs from a configuration
- Changing panel types in a non-Streamline library
- Deleting or renaming VTSSs
- Changing the number of vaulted volumes in a CDS where the reserved number of vaulted volumes is too small (or, when the number of vaulted volumes is larger than needed and you want to decrease the size of the CDS)
- Changing the size of the CDKLOCK subfile. The MERGEcds utility does not copy the content of the old CDKLOCK subfile to the new CDS.

Basic MERGEcds Procedure

The following sections describe how to use the MERGEcds utility to add an ACS to an existing HSC. This procedure is the basis for using MERGEcds for the examples in the other section, such as merging data centers.

Create a New, Empty CDS

Note – This procedure can be run at any time before the actual MERGEcDS operation.

To create a new, empty CDS:

1. Run the HSC LIBGEN utility to create LIBGEN macros that reflect your current real hardware configuration (and, optionally, your VOLPARM and vaulted volume data).

For example:

```
//SLSLIBGN JOB (ACCT),'LIBGEN',NOTIFY=&SYSUID
//SLSLIBGN EXEC PGM=SLUADMIN,PARM='MIXED'
//STEPLIB DD DSN=hlq.SEALINK,DISP=SHR
/* NOTE: CDS DD STATEMENTS NOT NEEDED IF HSC ACTIVE
//SLSPRINT DD SYSOUT=*
/* NOTE: SET VOLPARM, SET VAULTVOL, SET VAULT ARE
/* OUTPUT IN THE DATASET BELOW
//SLSSET DD DSN=hlq.SLSSET,DISP=(NEW,CATLG,DELETE),
// SPACE=(CYL,1)
/* NOTE: SET VOLPARM POOLPARM/VOLPARM CONTROL STATEMENTS
/* ARE IN THE DATA SET BELOW.
//SLSPARM DD DSN=hlq.SLSPARM,DISP=(NEW,CATLG,DELETE),
// SPACE=(CYL,1)
/* NOTE: LIBGEN MACROS ARE OUTPUT IN THE DATA SET
/* BELOW
//SLSLIBGN DD DSN=hlq.SLSLIBGN,DISP=(NEW,CATLG,DELETE),
// SPACE=(CYL,1)
//SLSIN DD *
LIBGEN
//
```

2. Update the SLSLIBGN output file to add the new ACS to your configuration.
See [Chapter 4, “Configuring HSC”](#) and samples in [Appendix C, “LIBGEN Macro Samples”](#) for more information on updating LIBGEN macros.
3. If necessary, update your VOLPARM and POOLPARM statements to reflect new volume ranges.
4. If necessary, update the SET VAULTVOL, SET VAULT, and SET CDKLOCK statements to reflect your desired new configuration.

5. Assemble the updated LIBGEN module.

For example:

```
//SLSASSML JOB (ACCT),'ASSM LIBGEN',NOTIFY=&SYSUID
//ASM EXEC PGM=ASMA90,
// PARM='XREF(SHORT),TERM,TEST,RENT'
//SYSLIB DD DSN=hlq.SEAMAC,DISP=SHR
// DD DSN=SYS1.MACLIB,DISP=SHR
//SYSPRINT DD SYSOUT=*
//SYSTEM DD SYSOUT=*
/* NOTE: UPDATED LIBGEN MACROS ARE IN THE DATA SET
/* BELOW
//SYSIN DD DSN=hlq.LIBGEN,DISP=SHR
//SYSLIN DD DSN=&&TMPOBJ,DISP=(,PASS,DELETE),
// UNIT=SYSDA,SPACE=(CYL,(1,1)),
// DCB=(LRECL=80,BLKSIZE=3040,RECFM=FB)
//SYSUT1 DD DSN=&SYSUT1,UNIT=VIO,SPACE=(CYL,(1,1))
/*
//LKED EXEC PGM=IEWL,COND=(0,LT,ASM),REGION=512K,
// PARM='LIST,LET,XREF,TEST,RENT'
//SYSLIN DD DSN=&&TMPOBJ,DISP=(OLD,DELETE)
//SYSPRINT DD SYSOUT=*
//SYSLMOD DD DSN=hlq.LIBGNLIB(LGYMMDD),DISP=SHR
//SYSUT1 DD UNIT=VIO,SPACE=(CYL,(1,1))
//
```

6. If your configuration includes VSM data, run the VTCS DECOM utility to create the current source for your VSM configuration.

For example:

```
//SLSDECOM JOB (ACCT),'VTCS DECOMP',NOTIFY=&SYSUID
//SLSDECOM EXEC PGM=SLUADMIN,PARM='MIXED'
//STEPLIB DD DSN=hlq.SEALINK,DISP=SHR
/* NOTE: CDS DD STATEMENTS NOT NEEDED IF HSC ACTIVE
//SLSPRINT DD SYSOUT=*
/* NOTE: CONFIG CONTROL CARDS ARE OUTPUT IN THE DATA SET
/* BELOW
//CONFIG DD DSN=hlq.CONFIG,DISP=(NEW,CATLG,DELETE),
// SPACE=(CYL,1)
//SLSIN DD *
DECOMP FLATDD(CONFIG)
//
```

7. Run the SLICREAT utility to determine the number of blocks needed for real tape processing, using the output of the LIBGEN assembly.

For example:

```
//SLICREA1 JOB (ACCT),'SLICREAT SIZE',NOTIFY=&SYSUID
//SLICREA1 EXEC PGM=SLICREAT,PARM=LGYMMDD,REGION=1M
//STEPLIB DD DSN=hlq.SEALINK,DISP=SHR
//      DD DSN=hlq.LIBGNLIB,DISP=SHR
//SYSPRINT DD SYSOUT=*
//
```

8. If your configuration includes VSM data, vaulted volume data, and/or VOLPARM control statements, see [“CDS DASD Space Requirements”](#) on page 18 to calculate the additional space needed.
9. Run the SLICREAT utility to create the new CDS, using the your block calculation for the new CDS size.

For example:

```
//SLICREA2 JOB (ACCT),'SLICREAT CDS',NOTIFY=&SYSUID
//SLICREA1 EXEC PGM=SLICREAT,PARM=LGYMMDD,REGION=1M
//STEPLIB DD DSN=hlq.SEALINK,DISP=SHR
//      DD DSN=hlq.LIBGNLIB,DISP=SHR
//SLSCNTL DD DSN=hlq.DBASEPRM.NEW,DISP=(NEW,CATLG,DELETE),
//      UNIT=SYSDA,SPACE=(4096,xxx,CONTIG)
//SLSCNTL2 DD DSN=hlq.DBASESEC.NEW,DISP=(NEW,CATLG,DELETE),
//      UNIT=SYSDA,SPACE=(4096,xxx,CONTIG)
//SLSSTBY DD DSN=hlq.DBASESBY.NEW,DISP=(NEW,CATLG,DELETE),
//      UNIT=SYSDA,SPACE=(4096,xxx,CONTIG)
//SYSPRINT DD SYSOUT=*
//
```

10. Run the SLUADMIN SET utility to add the VOLPARM definitions, vaulted volume count, and vault information and and CDKLOCK to the new CDS.

For example:

```
//SLSSETCD JOB (ACCT),'SET CDS',NOTIFY=&SYSUID
//SLSLIBGN EXEC PGM=SLUADMIN,PARM='MIXED'
//STEPLIB DD DSN=hlq.SEALINK,DISP=SHR
//SLSCNTL DD DSN=hlq.DBASEPRM.NEW,DISP=SHR
//SLSCNTL2 DD DSN=hlq.DBASESEC.NEW,DISP=SHR
//SLSSTBY DD DSN=hlq.DBASESBY.NEW,DISP=SHR
//SLSPRINT DD SYSOUT=*
/* NOTE: ORIGINAL OR MODIFIED POOLPARM/VOLPARM CONTROL
/* STATEMENTS ARE IN THE DATA SET BELOW
//SLSPARM DD DSN=hlq.SLSPARM,DISP=SHR
/* NOTE: ORIGINAL OR MODIFIED SET COMMANDS FOR
/* VOLPARM, VAULTVOL, AND VAULT ARE IN THE DATA SET
/* BELOW
//SLSIN DD DSN=hlq.SLSSET,DISP=SHR
//
```

11. Run the VTCS CONFIG utility to create the CDS VSM data areas.

For example:

```
//SLSCONFIG JOB (ACCT),'VTCS CONFIG',NOTIFY=&SYSUID
//SLSCONFIG EXEC PGM=SLUADMIN,PARM='MIXED'
//STEPLIB DD DSN=hlq.SEALINK,DISP=SHR
//SLSCNTL DD DSN=hlq.DBASEPRM.NEW,DISP=SHR
//SLSCNTL2 DD DSN=hlq.DBASESEC.NEW,DISP=SHR
//SLSSTBY DD DSN=hlq.DBASESBY.NEW,DISP=SHR
//SLSPRINT DD SYSOUT=*
/* NOTE: ORIGINAL OR MODIFIED VTCS CONFIG CONTROL
/* STATEMENTS ARE IN THE DATA SET BELOW
//SLSIN DD DSN=hlq.CONFIG,DISP=SHR
//
```

Prepare to Run MERGEcds

To prepare to run MERGEcds:

1. Issue the Display CDS command to determine the primary CDS.
2. Quiesce tape activity on all HSC and client hosts.
3. Stop HSC on all active hosts.
4. Run the SLUADMIN BACKUP utility to back up your current production CDS.

For example:

```
//SLSBKUP JOB (ACCT),'CDS BKUP',NOTIFY=&SYSUID
//SLSBKUP EXEC PGM=SLUADMIN,PARM='MIXED'
//STEPLIB DD DSN=hlq.SEALINK,DISP=SHR
//SLSCNTL DD DSN=hlq.DBASEPRM,DISP=SHR
//SLSCNTL2 DD DSN=hlq.DBASESEC,DISP=SHR
//SLSSTBY DD DSN=hlq.DBASESBY,DISP=SHR
//SLSBKUP DD DSN=hlq.CDSBKUP,
//    DISP=(NEW,CATLG,DELETE),
//    UNIT=SYSDA,SPACE=(CYL,xxx),
//    DCB=(LRECL=4096,BLKSIZE=4096,RECFM=F)
//SLSPRINT DD SYSOUT=*
//SLSIN DD *
BACKUP
//
```

5. Run the SLUADMIN RESTORE utility to restore your production CDS to a new name.

For example:

```
//SLSRESTR JOB (ACCT),'CDS RESTORE',NOTIFY=&SYSUID
//SLSRESTR EXEC PGM=SLUADMIN,PARM='MIXED'
//STEPLIB DD DSN=hlq.SEALINK,DISP=SHR
//SLSCNTL DD DSN=hlq.DBASEPRM.OLD,DISP=SHR
//SLSCNTL2 DD DSN=hlq.DBASESEC.OLD,DISP=SHR
//SLSSTBY DD DSN=hlq.DBASESBY.OLD,DISP=SHR
//SLSBKUP DD DSN=hlq.CDSBKUP,DISP=SHR
//SLSPRINT DD SYSOUT=*
//SLSIN DD *
RESTORE
//
```

Note – Instead of backing up and restoring the production CDS, you can rename the primary CDS (from your Display CDS command) to a new name, and use that CDS as input to the MERGEcds.

6. Rename your new CDS(s) to the production names.

Using the names in the above JCL samples, rename hlq.DBASEPRM.NEW to hlq.DBASEPRM, rename hlq.DBASESEC.NEW to hlq.DBASESEC, and rename hlq.DBASESBY.NEW to hlq.DBASESBY.

7. Modify your HSC PARMLIB CAPPREF statement to reflect CAPs in the new ACS.

For example, to set priority to 9 (highest), mode to automatic to CAP 00, LSM 00 in new ACS 01:

```
CAPP 9,01:00:00,AUTO
```

Run the MERGEcds utility

To run the MERGEcds utility:

1. Start HSC at BASE level, specifying the new CDS(s) in the CDSDEF statement.
2. Run the SLUADMIN MERGECDS utility.

For example, MERGEcds VALIDATE:

```
//SLSMERGV JOB (ACCT),'CDS MERGE VALIDATE',NOTIFY=&SYSUID
//SLSMERGV EXEC PGM=SLUADMIN,PARM='MIXED'
//STEPLIB DD DSN=hlq.SEALINK,DISP=SHR
//SLSFCNTL DD DSN=hlq.DBASEPRM.OLD,DISP=SHR
//SLSPRINT DD SYSOUT=*
//SLSIN DD *
MERGECDS ALL VALIDATE
//
```

For example, actual merge:

```
//SLSMERGE JOB (ACCT),'CDS MERGE',NOTIFY=&SYSUID
//SLSMERGE EXEC PGM=SLUADMIN,PARM='MIXED'
//STEPLIB DD DSN=hlq.SEALINK,DISP=SHR
//SLSFCNTL DD DSN=hlq.DBASEPRM.OLD,DISP=SHR
//SLSPRINT DD SYSOUT=*
//SLSIN DD *
MERGECDS ALL
//
```

Ensure the Merge was Successful

To ensure that the merge was successful:

1. Review the merge output to ensure that all the CDS pieces were successfully merged.
2. Run the SLUADMIN BACKUP utility to back up the new CDS.
3. Bring HSC to FULL service level, issuing the command:
SRVLEV FULL
4. Connect the new ACS to the HSC, issuing the command:
Vary ACS *acs-id* Online
5. Modify the new LSMs online, issuing the command:
F LSM *acs-id:lsm-id* Online
6. Resume normal tape activity
7. If the merge output showed duplicate volumes or errant or in-transit volumes, use the SLUADMIN AUDIT utility to audit the home cells of these cartridges.

In the following examples, the basic steps for executing the MERGEcds procedure are identical to the process described above. These examples illustrate additional steps and MERGE control cards that are needed for other scenarios.

Consolidating Two Data Centers

In consolidating two data centers, we assume that each data center has its own CDS.

To merge the two CDSs:

1. **Create a new CDS that reflects the library, virtual, and vaulted volume sections of both input CDSs...**

...as described in [“Create a New, Empty CDS”](#) on page 134.

2. **Next, put data from the first CDS into the new CDS...**

...as described in [“Prepare to Run MERGEcds”](#) on page 138 and [“Run the MERGEcds utility”](#) on page 140.

3. **To merge data from the second CDS, you need to run an additional MERGEcds step. For example, actual merge:**

```
//SLSMERG2 JOB (ACCT),'CDS MERGE 2',NOTIFY=&SYSUID
//SLSMERG2 EXEC PGM=SLUADMIN,PARM='MIXED'
//STEPLIB DD DSN=hlq.SEALINK,DISP=SHR
//SLSFCNTL DD DSN=hlq.DBASEPRM.CDS2,DISP=SHR
//SLSFCTL2 DD DSN=hlq.DBASESEC.CDS2,DISP=SHR
//SLSFSDBY DD DSN=hlq.DBASESBY.CDS2,DISP=SHR
//SLSPRINT DD SYSOUT=*
//SLSIN DD *
MERGECDS
/* NOTE: In THE FOLLOWING EXAMPLE, DATA CENTER 1
/* HAD 4 ACSS AND DATA CENTER 2 HAD 2 ACSS
/* DATA CENTER 1 HAD A VAULT NAMED VAULT1, AND
/* DATA CENTER 2 ALSO HAD A VAULT NAMED VAULT1.
//SLSMERGE DD *
MERGE FACS(00) TACS(04)
MERGE FACS(01) TACS(05)
ALLVIRT /* NO VTSS NAME CONFLICT */
MERGE FVALT(VAULT1) TVALT(VAULT5)
//
```

4. **Ensure that the merge was successful...**

...as described in [“Ensure the Merge was Successful”](#) on page 140.

Combining Two Separate ACSs into One ACS

The process of combining two ACSs into a single ACS requires a MERGEcds to change the definition of LSMs in the ACS being merged.

To combine two separate ACSs into one:

- 1. Create a new CDS that reflects the existing library hardware plus the new combined ACS, and the virtual and vaulted volume data...**

...as described in [“Create a New, Empty CDS”](#) on page 134.

- 2. Next, put data into the new CDS...**

...as described in [“Prepare to Run MERGEcds”](#) on page 138 and [“Run the MERGEcds utility”](#) on page 140, using the following sample JCL:

```
Merging two ACSs:
//SLSMERG3 JOB (ACCT),'CDS MERGE 3',NOTIFY=&SYSUID
//SLSMERG3 EXEC PGM=SLUADMIN,PARM='MIXED'
//STEPLIB DD DSN=hlq.SEALINK,DISP=SHR
//SLSFCNTL DD DSN=hlq.DBASEPRM.OLD,DISP=SHR
//SLSPRINT DD SYSOUT=*
//SLSIN DD *
MERGECDS
/* NOTE: In THE FOLLOWING EXAMPLE, ACSS 02 (4 LSMS)
/* AND 03 (4 LSMS) ARE COMBINED INTO A SINGLE ACS.
//SLSMERGE DD *
MERGE FLSM(03:00) TLSM(02:04)
MERGE FSLM(03:01) TLSM(02:05)
MERGE FLSM(03:02) TLSM(02:06)
MERGE FLSM(03:03) TLSM(02:07)
ALLVIRT
ALLVALT
//
```

- 3. Check for warning messages if panel types in either ACS have changed.**

If any panel types are changed, run the SLUADMIN AUDIT utility to audit the contents of the changed panels.

- 4. Ensure that the merge was successful...**

...as described in [“Ensure the Merge was Successful”](#) on page 140.

Combining Two Separate Streamline Libraries

SL8500 PTP support allows multiple, separate SL8500s to be combined into a single ACS by running the MERGEcds utility. To minimize losing information about cartridges and to reduce operational downtime, follow the procedures described in this section.

Two configurations are shown below. In the first configuration (see [FIGURE 5-1](#) and [FIGURE 5-2](#)), the ACSs to be merged are numbered from right to left (as you face them from the CAP side). In the second, they are numbered from left to right. It is assumed that the resulting ACS uses the lower or lowest ACSid, which is ACS0. The placement and numbering of the pre-merge ACSs determines how volume data is mapped from the original ACSs' LSMs into the merged ACS' LSMs. In an ACS with multiple SL8500s, the LSMs are always numbered from right to left, so volumes in the left most SL8500 must be in the four highest numbered LSMs. Conversely volumes in the right most LSM must be in the four lowest numbered LSMs. Once the individual ACSs are physically merged into a single ACS, the MERGEcds utility is used to map each LSM of the pre-merge ACSs into an LSM in the merged, single ACS. The physical location of the volumes within the merged ACS is identical to what it was prior to the merge but their location designator, their LSMid, has probably changed.

Configurations for ACSs Numbered Right to Left

[FIGURE 5-1](#) and [FIGURE 5-2](#) illustrate merging three ACSs numbered right to left, as you face them from the CAP side.

ACS 2	ACS 1	ACS 0
LSM 02:00	LSM 01:00	LSM 00:00
LSM 02:01	LSM 01:01	LSM 00:01
LSM 02:02	LSM 01:02	LSM 00:02
LSM 02:03	LSM 01:03	LSM 00:03

ELS_095

FIGURE 5-1 Existing Right to Left Configuration - Three Separate ACSs

ACS 0				
LSM 00:08	PTP	LSM 00:04	PTP	LSM 00:00
LSM 00:09		LSM 00:05		LSM 00:01
LSM 00:0A		LSM 00:06		LSM 00:02
LSM 00:0B		LSM 00:07		LSM 00:03

ELS_096

FIGURE 5-2 Desired Configuration - Single ACS

Configurations for ACSs Numbered Left to Right

FIGURE 5-3 and FIGURE 5-4 illustrate merging three ACSs numbered left to right, as you face them from the CAP side.

ACS 0	ACS 1	ACS 2
LSM 00:00	LSM 01:00	LSM 02:00
LSM 00:01	LSM 01:01	LSM 02:01
LSM 00:02	LSM 01:02	LSM 02:02
LSM 00:03	LSM 01:03	LSM 02:03

ELS_097

FIGURE 5-3 Existing Left to Right Configuration - Three Separate ACSs

ACS 0				
LSM 00:08	P T P	LSM 00:04	P T P	LSM 00:00
LSM 00:09		LSM 00:05		LSM 00:01
LSM 00:0A		LSM 00:06		LSM 00:02
LSM 00:0B		LSM 00:07		LSM 00:03

ELS_096

FIGURE 5-4 Desired Configuration - Single ACS

To combine two Separate Streamline libraries:

1. Create a new CDS for the two libraries...
...as described in "Create a New, Empty CDS" on page 134.

2. Next, put data into the new CDS...

...as described in “Prepare to Run MERGEcds” on page 138 and “Run the MERGEcds utility” on page 140. The following JCL examples show control cards for this example, using right to left numbering of ACSs and next left to right numbering.

SLSMERGE Statements - ACSs Numbered Right to Left

When you merge LSMs numbered right to left, the LSM numbers of the “from” LSM and the “to” LSM in the MERGE statements both increase regularly as you move from right to left merging individual LSMs. See the set of MERGE statements below.

```
MERGE FLSM( 01: 00)  TLSM( 00: 04)
MERGE FLSM( 01: 01)  TLSM( 00: 05)
MERGE FLSM( 01: 02)  TLSM( 00: 06)
MERGE FLSM( 01: 03)  TLSM( 00: 07)
MERGE FLSM( 02: 00)  TLSM( 00: 08)
MERGE FLSM( 02: 01)  TLSM( 00: 09)
MERGE FLSM( 02: 02)  TLSM( 00: 0A)
MERGE FLSM( 02: 03)  TLSM( 00: 0B)
MERGE FLSM( 00: 00)  TLSM( 00: 00)
MERGE FLSM( 00: 01)  TLSM( 00: 01)
MERGE FLSM( 00: 02)  TLSM( 00: 02)
MERGE FLSM( 00: 03)  TLSM( 00: 03)
```

SLSMERGE Statements - ACSs Numbered Left to Right

When you merge LSMs numbered left to right, the LSM numbers of the original ACSs are increasing in the opposite direction from those in the merged ACS, where LSMs are number right to left. Therefore, as you merge LSMs moving right to left, the LSM numbers of the “to” LSMs increase regularly but the LSM numbers of the “from” LSMs decrease (in blocks of four increasing numbers). See the set of MERGE statements below.

```
MERGE FLSM (00:00)  TLSM (00:08)
MERGE FLSM (00:01)  TLSM (00:09)
MERGE FLSM (00:02)  TLSM (00:0A)
MERGE FLSM (00:03)  TLSM (00:0B)
MERGE FLSM (01:00)  TLSM (00:04)
MERGE FLSM (01:01)  TLSM (00:05)
MERGE FLSM (01:02)  TLSM (00:06)
MERGE FLSM (01:03)  TLSM (00:07)
MERGE FLSM (02:00)  TLSM (00:00)
MERGE FLSM (02:01)  TLSM (00:01)
MERGE FLSM (02:02)  TLSM (00:02)
MERGE FLSM (02:03)  TLSM (00:03)
```

These updates must occur first

These updates must occur last

ELS_098

Note – When you merge LSMs numbered from left to right, the order the SLSMERGE statements are processed is important. In the example below, the “to” LSMs for the pre-existing ACS 2 (02:00-02:03) become the “from” LSMs 00:00-00:03. You must first update ACS 0, LSMs 00:00-00:03 to be “from” LSMs 00:08-00:0B. Otherwise, the volumes from both “from” LSMs 00:00-00:03 and 02:00-02:03 will be assigned to 00:08-00:0B.

3. Ensure that the merge was successful...

...as described in [“Ensure the Merge was Successful”](#) on page 140.

Removing PTPs and Splitting an ACS Using MERGEcds

StorageTek recommends you locate the new ACS to the left side of the split, which ensures that HSC assigns higher-numbered LSMs to the new ACS and avoids renumbering the LSMs that remain in the existing LSM.

If you create a new ACS to the right side of the split, all volume addresses must be remapped using MERGEcds. The procedures below do not discuss creating the new ACS to the right of the split.

To remove PTPs and split an ACS using MERGEcds:

1. Create a new CDS...

...as described in [“Create a New, Empty CDS”](#) on page 134.

2. Next, put data into the new CDS...

...as described in [“Prepare to Run MERGEcds”](#) on page 138 and [“Run the MERGEcds utility”](#) on page 140. using the following sample JCL.

```
//SLSMERG7 JOB (ACCT),'CDS MERGE 7',NOTIFY=&SYSUID
//SLSMERG7 EXEC PGM=SLUADMIN,PARM='MIXED'
//STEPLIB DD DSN=hlq.SEALINK,DISP=SHR
//SLSFCNTL DD DSN=hlq.DBASEPRM.OLD,DISP=SHR
//SLSPRINT DD SYSOUT=*
//SLSIN DD *
MERGECDS
/* NOTE: SLSMERGE STATEMENTS, ACS NUMBERED RIGHT
/* TO LEFT
//SLSMERGE DD *
MERGE FLSM(00:08) TLSM(01:00)
MERGE FLSM(00:09) TLSM(01:01)
MERGE FLSM(00:0A) TLSM(01:02)
MERGE FLSM(00:0B) TLSM(01:03)
MERGE FLSM(00:0C) TLSM(01:04)
MERGE FLSM(00:0D) TLSM(01:05)
MERGE FLSM(00:0E) TLSM(01:06)
MERGE FLSM(00:0F) TLSM(01:07)
//
```

3. Ensure that the merge was successful...

...as described in [“Ensure the Merge was Successful”](#) on page 140.

Renaming a VTSS

A VTSS rename can be done only by using the MERGEcds utility, which allows VTV and MVC data in the CDS to reflect the new VTSS name.

To rename a VTSS using MERGEcds:

1. Create a new CDS...

...as described in [“Create a New, Empty CDS”](#) on page 134.

2. Next, put data into the new CDS...

...as described in [“Prepare to Run MERGEcds”](#) on page 138 and [“Run the MERGEcds utility”](#) on page 140, using the following sample JCL:

```
//SLSMERG4 JOB (ACCT),'CDS MERGE 4',NOTIFY=&SYSUID
//SLSMERG4 EXEC PGM=SLUADMIN,PARM='MIXED'
//STEPLIB DD DSN=hlq.SEALINK,DISP=SHR
//SLSFCNTL DD DSN=hlq.DBASEPRM.OLD,DISP=SHR
//SLSPRINT DD SYSOUT=*
//SLSIN DD *
MERGECDS
//SLSMERGE DD *
ALLREAL
MERGE FVTSS(VTSS1) TVTSS(VTSSA)
ALLVALT
//
```

3. Ensure that the merge was successful...

...as described in [“Ensure the Merge was Successful”](#) on page 140.

Removing Vaulted Volume Information

To remove vaulted volume information from the CDS, you must run the Merge process.

To remove vaulted volume information:

1. **Create a new CDS**, removing the SET VAULTVOL and SET VAULT control cards from the LIBGEN SLSSET output file...
...as described in [“Create a New, Empty CDS”](#) on page 134.
2. **Next, put data into the new CDS...**
...as described in [“Prepare to Run MERGEcds”](#) on page 138 and [“Run the MERGEcds utility”](#) on page 140, using the following sample JCL:

```
//SLSMERG5 JOB (ACCT),'CDS MERGE 5',NOTIFY=&SYSUID
//SLSMERG5 EXEC PGM=SLUADMIN,PARM='MIXED'
//STEPLIB DD DSN=hlq.SEALINK,DISP=SHR
//SLSFCNTL DD DSN=hlq.DBASEPRM.OLD,DISP=SHR
//SLSPRINT DD SYSOUT=*
//SLSIN DD *
MERGECDS
//SLSMERGE DD *
ALLREAL
ALLVIRT
NOVALT
//
```

3. **Ensure that the merge was successful...**
...as described in [“Ensure the Merge was Successful”](#) on page 140.

Reconfiguring a Tapeplex Without MERGEcds

Using Dynamic Reconfiguration

Dynamic reconfiguration, which you do via `MODIFY CONFIG`, is a key tool for NCO, the idea being that `MODIFY CONFIG` lets you change your hardware configuration without having to recycle HSC. Specifically, `MODIFY CONFIG` does the following:

- Modifies a CAP or an LSM online or offline to all hosts, independent of the issuing host.
- Starts dynamic hardware reconfiguration for a SL3000 or a SL8500 library.
- Adds, deletes, or updates an SL3000 or SL8500 ACS definition in the CDS that was preallocated using the `SLLIBRY FUTRACS` parameter.

There are some guidelines for dynamic reconfiguration, however, see below.

Caution –

- **Do not** run any CDS-related commands or utilities while making NCO changes.
 - Back up the CDS before and after you perform a hardware reconfiguration.
 - For any active HSC that accesses the CDS being modified by dynamic reconfiguration, **all ACSs and LSMs must be varied online** to maintain configuration integrity across hosts. An inactive HSC can be started after dynamic reconfiguration has completed on another host but once an HSC becomes active, it must be at the full service level, and all ACSs and LSMs must be varied online.
 - In a multi-host environment, StorageTek recommends that **all active hosts run HSC 6.2-level or above software**. Any hosts not at 6.2 level or above **must** be brought down before initiating dynamic hardware reconfiguration and brought back up after the hardware reconfiguration is complete. The non-6.2 hosts recognize the hardware changes at this time.
-

Adding LSMs

Adding LSMs without FUTRLSM defined requires running the MERGEcds utility as described in [“Basic MERGEcds Procedure” on page 133](#). If you have defined FUTRLSM, you can use Dynamic Reconfiguration to add a new LSM as follows:

1. Use dynamic reconfiguration to bring the new LSM online:

MODIFY CONFIG

2. If necessary, add transports and volumes.

For more information, see:

- [“Defining Volumes to ELS” on page 109](#)
- [“Adding Transports” on page 152](#)

3. If necessary, populate LSM by any of the following:

- Entering volumes through CAPs.
- Opening the access door, manually populating storage cells, then doing an audit of all cells.
- Let PTPs move volumes from attached LSMs.

Dynamically Reconfiguring Streamline Library Transports

This section tells how to do the following:

- [“Adding Transports” on page 152](#)
- [“Removing Transports” on page 153](#)
- [“Replacing Transports” on page 153](#)

Adding Transports

Note –

- If you enter new cartridges into the library, update your SET VOLPARM definitions to include the new volumes. Then review SMC POLICY statements to determine if you want to add or modify policies if you are adding a new type of transport to your environment.
 - If your new transports will be RTDs, then update your VTCS CONFIG.
 - If you are adding a new RTD device type, update the STORCLAS definitions for the storage classes that will be directed to the new device type.
-

This section provides a procedure to add drives to an Streamline Library and HSC configuration. In this case, the Streamline Library panel already contains operational transports, and the HSC remains active during this time, so NCO is used to add the transports.

To dynamically add transports to a Streamline Library:

1. Install the new transports and power them on.
2. Use the SET SLIDRIVS utility to add the MSP drive address and drive location to the CDS.

For example:

```
//DRVADD EXEC PGM=SLUADMIN
/*
//STEPLIB DD DSN=SYS1.SEALINK
/*
//SLSCNTL DD DISP=SHR,DSN=SYS1.DBASEPRM
//SLSCNTL2 DD DISP=SHR,DSN=SYS1.DBASESEC
//SLSPRINT DD SYSOUT=*
//SLSIN DD *
  SET SLIDRIVS(A00,A01,A02,A03,A04,A05,A06,A07,A08,A09,+
  A10,A11,A12,A13,A14,A15),FORLSMID(00:00),FORPANEL(01)
/*
```

In this example, we are adding two transports to fill the 16-drive panel for LSM 00 (rail 01). A14 and A15 represent the new drives being added; A00-A13 are the existing operational drives.

3. Use dynamic reconfiguration to bring the new transports online:

```
MODIFY CONFIG
```

4. Back up the CDS.

Removing Transports

This section provides a procedure to remove transports from a Streamline Library and HSC configuration. In this case, the Streamline Library panel already contains operational transports, and the HSC remains active during this time, so NCO is used to remove the transports.

To dynamically remove transports from a Streamline Library:

1. **Power off the transports and deinstall them.**
2. **Use the SET SLIDRIVS utility to remove the MSP drive address and drive location to the CDS.**

For example:

```
//DRVREM EXEC PGM=SLUADMIN
/*
//STEPLIB DD DSN=SYS1.SEALINK
/*
//SLSCNTL DD DISP=SHR,DSN=SYS1.DBASEPRM
//SLSCNTL2 DD DISP=SHR,DSN=SYS1.DBASESEC
//SLSPRINT DD SYSOUT=*
//SLSIN DD *
    SET SLIDRIVS(B00,B01,B02,B03,B04,B05,B06,B07,B08,B09,+
        B10,B11,B12,B13,,),FORLSMID(00:01),FORPANEL(01)
/*
```

In this example, we are removing two drives and specifying a primary and secondary CDS. B14 and B15 represent the drives being removed; B00-B13 represent the remaining operational drives.

3. **Use dynamic reconfiguration to remove the transports:**

```
MODIFY CONFIG
```

4. **Back up the CDS.**

Replacing Transports

The following procedure tells how to replace transports on a Streamline Library panel, while retaining the same unit addresses. The HSC remains active during this time, so NCO is used to replace the transports. See also the note [on page 152](#).

To dynamically replace transports in a Streamline Library:

1. **Power off the old transports and deinstall them.**
2. **Install and power on the new transports.**
3. **Enter MODify CONFIG to replace the transports.**
...if you are changing transport types. Otherwise, continue with [Step 4](#).
4. **Back up the CDS.**

Changing Transport Unit Addresses

The following procedure tells how to change the unit addresses for transports on a Streamline Library panel that contains operational drives. The HSC remains active during this time, so NCO is used to change the transport unit addresses.

To dynamically change transport addresses in a Streamline Library:

1. Use the SET SLIDRIVS utility to change the MSP unit address and drive location in the CDS.

For example:

```
//UNITADDR EXEC PGM=SLUADMIN
/*
//STEPLIB DD DSN=SYS1.SEALINK
/*
//SLSCNTL DD DISP=SHR,DSN=SYS1.DBASEPRM
//SLSCNTL2 DD DISP=SHR,DSN=SYS1.DBASESEC
//SLSPRINT DD SYSOUT=*
//SYSOUT DD SYSOUT=*
//SYSUDUMP DD SYSOUT=*
//SLSIN DD *
    SET SLIDRIVS(F00,F01,F02,F03,F04,F05,F06,F07,F08,F09,+
        F10,F11,F12,F13,F14,F15),FORLSMID(00:02),FORPANEL(01)
/*
```

In this example, we are changing unit addresses on all transports on a 16-drive panel and specifying a primary and secondary CDS.

2. Use dynamic reconfiguration to activate the new transport unit addresses:

MODIFY CONFIG

3. Back up the CDS.

Adding SL8500 or SL3000 ACSs

Dynamic hardware reconfiguration for the SL3000 and SL8500 libraries also allows you to dynamically add up to 9 ACSs.

To dynamically add SL8500 or SL3000 ACSs:

1. Run a backup of the CDS.
2. Issue the HSC MODify CONFIG ADD ACSType command.
MODIFY CONFIG ADD ACSTYPE(SL3000)
or
MODIFY CONFIG ADD ACSTYPE(SL8500)
3. Add a new LMUPATH statement for the ACS.
LMUPATH ACS(*acs_id*) LMUADDR(*ip_address*)
4. Issue the LMUPDEF command on all hosts to activate the new LMUPATH statement.
LMUPDEF DATASET(*dataset_name*)
5. Run the SET SLIDRIVS utility or issue the SET SLIDRIVS command to add drives to the new ACS.
SET SLIDRIVS(*drv1,drv2,drv3,...*) FORLSMID (*lsm_id*), +
FORPANEL(*panel_id*)
6. Vary the new ACS online to all hosts:
VARY ACS *aa* ONLINE
7. Vary the LSMs online.
MODIFY LSM *lsm_id* ONLINE

Deleting an SL8500 or SL3000 ACS

Dynamic hardware reconfiguration for the SL3000 and SL8500 libraries also allows you to dynamically delete an entire ACS.

To dynamically delete an SL8500 or SL3000 ACS:

1. Run a backup of the CDS.
2. Vary the LSMs offline.
MODIFY LSM *lsm_id* OFFLINE
3. Vary the ACS offline to all hosts.
4. Issue the HSC MODify CONFIG DELEte ACSid(*acs-id*) command.
5. Remove the LMUPATH statement defined for the deleted ACS.
6. Issue the LMUPDEF command on all hosts to remove the LMUPATH statement.

Adding and Removing SL8500 or SL3000 Expansion Modules

Adding and removing expansion modules is a hardware-disruptive process. However, HSC can dynamically recognize changes and continue to support other libraries without the need to recycle the HSC.

The following procedure describes how to add or remove expansion modules. The HSC remains active during this time, so NCO is used to make the changes.

To dynamically add or remove SL8500 or SL3000 expansion modules:

1. **Enter the MODify LSM OFFline command to modify all Streamline Libraries offline to all HSC hosts in the affected library.**

All drives and cartridges in the Streamline Libraries are now unavailable.

2. **Physically add or remove the expansion modules.**
3. **Enter the MODify LSM ONline command to modify the Streamline Libraries online to the HSC.**

During the modify online process, HSC automatically discovers the panel configuration changes. A WTOR is issued to the operator describing the change and requesting confirmation to make the changes permanent to the CDS.

- Replying “NO” aborts the configuration change. The CDS is not updated and the old configuration is preserved. This means you could attempt to access a cell that's been removed and any new cell will not be recognized by the HSC.
- Replying “YES” causes the CDS to be updated with the new configuration and also propagates the changes to all other active hosts in the complex. The HSC updates its in-memory control blocks.

4. **Back up the CDS.**
5. **Use dynamic reconfiguration to add the expansion modules:**

MODIFY CONFIG

For SL8500s, continue with [Step 6](#). There are no special issues with the SL3000. Run the normal HSC audit, then back up the CDS.

6. **Determine the highest panel number in the expanded SL8500.**

In an SL8500 library without expansion modules, the highest panel number is 10. Each additional expansion module adds eight panels, so for an SL8500 with one expansion module, the highest panel number is 18; for two expansion modules the highest panel number is 26; and so forth. The three highest panel numbers are in the CEM, so in an SL8500 containing one expansion module, panels 16, 17, and 18 are located in the CEM.

7. **Audit the three panels containing the highest panel numbers in each LSM (rail) in the expanded SL8500.**
8. **Audit any panel that includes cartridges that may have been moved during installation of the Storage Expansion Module.**
9. **Audit each LSM in the expanded SL8500.**
10. **Back up the CDS again.**

Changing SL8500 CAP Types - HSC Down

The following procedure describes how to change CAP types from SL8500 standard rotational CAPs to a Bulk CAP while the HSC is down.

1. **Replace the CAPs in the library and verify they are operational.**
2. **Start HSC and wait for initialization to complete.** See [Chapter 7, “Starting and Stopping HSC”](#).
During startup, reconfiguration starts. Wait for reconfiguration to complete.
3. **If the LSMs affected are offline:**
 - a. **Enter MODify LSM (*lsm-range*) ONline**
where *lsm-range* is a range of LSMs where the CAP changes are being made.
 - b. **Enter Display Cap to verify the CAP changes to the library.**
4. **If the LSMs affected are online, enter Display Cap to verify the CAP changes to the library.**
5. **Start HSC activity.**

Changing SL8500 CAP Types - HSC Up

The following procedure describes how to change CAP types from SL8500 standard rotational CAPs to a Bulk CAP while the HSC is up.

1. **Enter MODify LSM (*lsm-range*) OFFline**
where *lsm-range* is the range of LSMs where the CAP changes are being made.
2. **Enter Vary ACS(*acs-id*) OFFline**
where *acs-id* is the ACS where the CAP changes are to be made.
3. **Replace the CAPs in the library and verify they are operational.**
4. **Stop all HSC activity.**
5. **Enter Vary ACS(*acs-id*) ONline**
where *acs-id* is the ACS where the CAP changes are to be made.
During the vary ACS process, reconfiguration starts. Wait for reconfiguration to complete.
6. **Enter MODify LSM (*lsm-range*) ONline**
where *lsm-range* is the range of LSMs where the CAP changes are being made.
7. **Enter Display Cap to verify the CAP changes to the library.**
8. **Start HSC activity.**

Using Audit Instead of MERGEcds for Streamline Libraries

If your environment contains only Streamline Libraries and no virtual or vaulted volume data, you can elect to use the SLUADMIN AUDIT utility to populate the CDS when combining or splitting ACSs instead of using the MERGEcds utility.

The following procedure explains how to use the AUDIt utility to add volumes to a new CDS:

1. Create a new CDS...

...as described in [“Create a New, Empty CDS”](#) on page 134. Place all LSMs in a single ACS.

2. Next, put data into the new CDS...

...as described in [“Prepare to Run MERGEcds”](#) on page 138 and [“Run the MERGEcds utility”](#) on page 140.

3. Ensure that the merge was successful...

...as described in [“Ensure the Merge was Successful”](#) on page 140.

4. Start HSC with the new CDS on only one host.

Keep the drives offline to MSP, since there is no reason to support automated mounts until AUDIt has added the volumes to the new CDS.

5. Run the AUDIt utility to audit the newly configured LSMs. The order in which the LSMs are audited does not matter, and the entire ACS or all LSMs can be audited at the same time. AUDIt adds the volumes to the new CDS.

6. Run the BACKup utility to back up the CDS after the audits.

7. Restart HSC on all hosts. Vary the drives online to MSP.

8. Run the Database Decompilation (LIBGEN) utility to generate LIBGEN macro statements from a modified CDS.

9. You should then perform a scratch synchronization using the SLUCONDB utility.

Note – If your environment includes virtual or vaulted volume data, you must use the MERGEcds utility to put this data into the new CDS. You can, however, elect to bypass merging the real volumes by using the NOREAL control statement in the SLSMERGE input, and use the SLUADMIN AUDIT utility to populate the real volume data. Using this procedure will result in loss of volume metadata.

Adding a New VTSS

To add VTSSs:

- 1. Install the new VTSS.**
- 2. Run the DECOM utility to decompile your CONFIG deck.**
For more information, see *ELS Command, Control Statement, and Utility Reference*.
- 3. Update the CONFIG deck with the appropriate VTSS and VTD statements.**
For more information, see *ELS Command, Control Statement, and Utility Reference* and [“Configuring VTCS” on page 203](#).
- 4. Run the CONFIG utility.**
- 5. If necessary, add volumes.**

VTVs and MVCs can be dynamically added or deleted from your configuration by using the SET VOLPARM utility.

HSC SET VAULTVOL and SET VAULT Utilities

The HSC SET VAULTVOL utility can be used to reserve a section of an existing HSC CDS for vaulted volumes. You must ensure that your existing CDS is large enough to hold the projected vault data, using the following formula: The HSC SET VAULT utility can be used to dynamically add, rename, or delete vaults.

If your CDS contains VAULT information, you must specify whether or not this data is to be merged into the new CDS during a CDS merge process.

HSC SET CDKLOCK Utility

The HSC SET CDKLOCK utility can be used to reserve a section of an existing HSC CDS for Open Systems resource lock information. This command can also be used to manage the status of the subfile and change the default expiration of active locks.

Note – The CDS merge process does not copy CDKLOCK information from the old CDS to the new CDS. Resource lock information is transient and may not be valid during the merge process.

Partitioning Streamline Libraries

Overview

There are many businesses uses for partitioning your Streamline libraries, for example:

- Enabling service centers to keep a client from accessing another client's tapes,
- Keeping various departments within the same company separate, and
- Dividing a library between production and test environments.

The SL3000 and SL8500 Libraries can be configured with one to eight partitions as ACSs with cell, drive, and CAP assignments. Both Libraries use the StreamLine Library Console (SLC) to perform partition and resource assignment functions.

The following procedures describe how to configure HSC partitioning on the SL3000 or SL8500 library.

- starting from scratch – LIBGEN, SLICREAT
- converting a non-partitioned ACS to a partitioned ACS
- converting a partitioned ACS to a non-partitioned ACS
- adding a library to the HSC Complex
- removing a library from the HSC Complex
- adding a partition to the library
- removing a partition from the library
- moving a partition from one host group to another host group
- adding resources to the library
- removing resources from the library

Partitioning Requirements and Prerequisites

- Read the *SL8500 Best Practices Guide* or *SL3000 User's Guide*.
- Call StorageTek Software Support to schedule a CSE to configure the Streamline Library. **This is required.**
- **For SL3000s:** Make sure you have installed firmware Version 2.00 or higher **and** SLConsole version FRS 4.00 or higher
- **For SL8500 enhanced partitioning support** (dynamically adding and removing library resources of partitions and so forth), ensure that you have the following prerequisites:
 - SL8500 firmware Compatibility 23 level –Release 7.0x.
 - SLC release level 5.55 or higher

Note – Customers **MUST** be current on maintenance.

- HSC 6.2 (MSP) – LF620EY and subsequent PTFs
- ELS 7.1 (MSP) – ELS 7.1 base level

Restrictions

- Hosts prior to HSC 6.1, or hosts without the partitioning PTF, cannot bring the partitioned ACS online.
- If the Library being partitioned is not part of the CDS (either as a real or future library), it cannot be dynamically added to the CDS. A LIBGEN/SLICREAT/MergeCDS process must be performed. For more information, see “Creating the HSC CDS” on page 96.
- Volumes remaining in a partition being removed from one host group will be deleted from that CDS when the ACS is deleted using the HSC command Modify Config Delete acs-id.
- Volumes located in a partition that is added to a host group will be available to that CDS after an AUDIt or MERGEcds.
- Volume history will only be preserved if MERGEcds is run.
- When converting a partitioned library to non-partitioned library, a MERGEcds is possible to retain volume history from previously defined partitions.
- If a volume is mounted on a drive in a partition that is removed before the drive goes OFFLINE, the volume will be deleted from the CDS, and any future MOUNT activity to that drive will end in an error.
- When moving volumes from one partition to another, neither the HSC CDS nor the library support duplicate volumes.
- Prior to backing up the CDS described in the procedures below, NCS and VTCS systems must be in an idle state. This means draining all batch tape initiators, varying all automated MSP tape devices offline (real and virtual) and varying all RTDs defined in the VTCS configuration offline to VTCS.
- When a VTCS CONFIG RESET is required, all host systems must be down.
- If an HSC group owns multiple partitions within a Streamline library, anything done to that partition is considered disruptive and will affect all partitions connected to an HSC group. For any changes that involve adding or removing partitions or adding or removing partition resources, all activity (i.e., drive(s), cap(s), etc.) must be stopped for all ACSs connected to the library. All ACSs connected to the library must be varied offline. Perform the specific activity and then vary the ACSs online. Activity can now be started for all ACSs.

CAP Considerations

Partitioning affects CAP usage. Consider two situations that can be a common occurrence:

- AUTO CAP – In partitioning mode, AUTO CAP is disabled. If you are using AUTO CAP prior to partitioning the library, change it to manual. If it is not changed, HSC changes it.
- Release CAP – A CAP can only be released from the owning host.
- Overriding a CAP Reservation – See the *SL8500 Best Practices Guide* or *SL3000 User's Guide*.

Definitions

Host Group

A set of hosts connected to an ACS and sharing one CDS. For HSC, there can be up to 16 hosts in a host group.

SL8500 Enhanced Partition

For an SL8500 library, a partition is a segment of one SL8500 unit consisting of cells with a minimum of 1 to n magazines (13 or 14 cells to a magazine), maximum of 2 shared CAPs, and 1 to n drives for a maximum of 8 partitions. A partition is an ACS. A partition has exclusive control of cells and drives. Installed CAPs are shared amongst all defined partitions. [FIGURE 5-5](#) shows an SL8500 divided into 2 partitions.

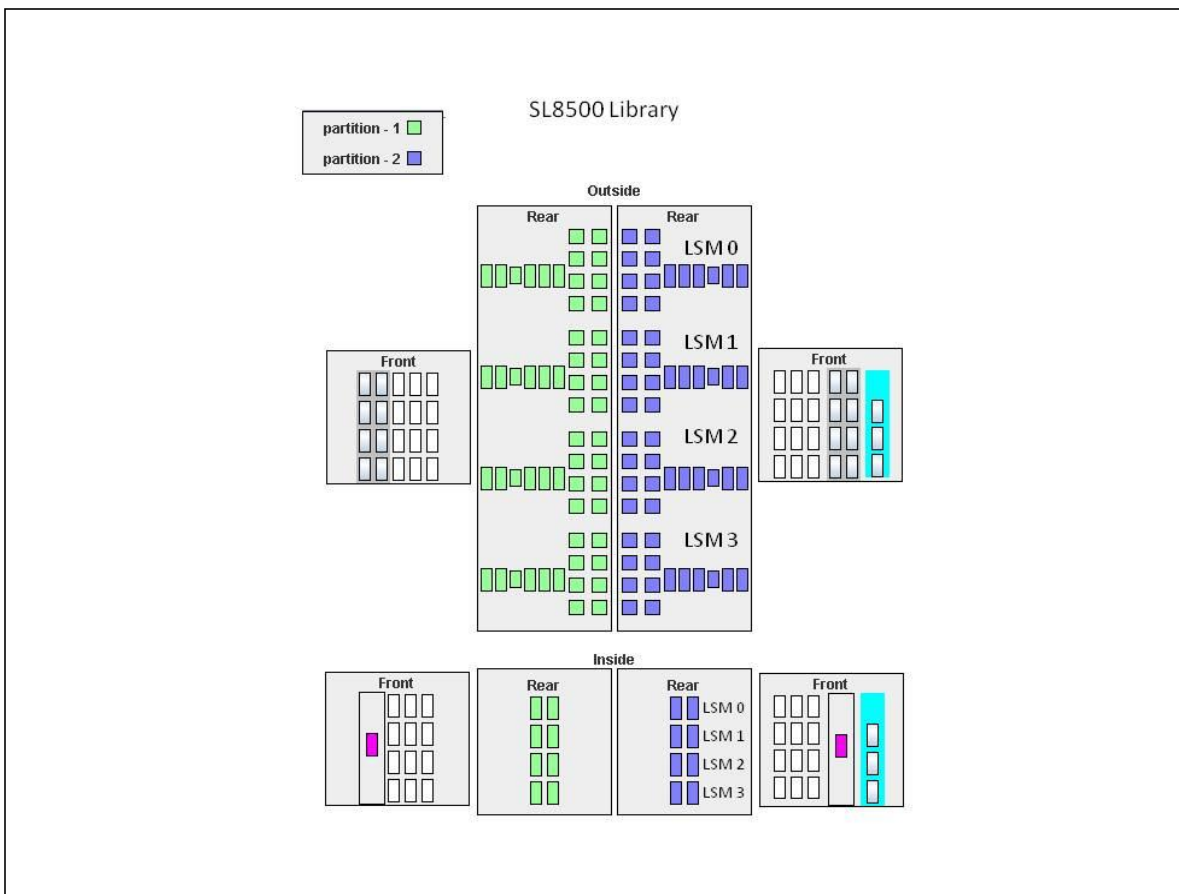

FIGURE 5-5 SL8500 Partitioning Example

SL3000 Partition

For an SL3000 library, a partition is a segment of one SL3000 unit consisting of cells with a minimum of 1 to n in increments of 100, CAPs, and drives for a maximum of 8 partitions. A partition is an ACS. A partition has exclusive control of cells and drives. Installed CAPs may be assigned to one partition (exclusive), assigned to multiple partitions (shared), or unassigned.

FIGURE 5-6 on page 166 and FIGURE 5-7 on page 167 illustrate an SL3000 divided into 4 partitions:

- Partition 1 assigned to ACSLS:
 - 200 cells
 - 1st and 2nd CAPs shared
 - 24 drives
- Partitions 2 and 3 assigned to HSC Host Group A:
 - 200 cells each
 - 1st and 2nd CAPs shared for each
 - 6 drives each
- Partition 4 assigned to HSC Host Group B:
 - 200 cells
 - 1st and 2nd CAPs shared, 3rd and 4th CAPs exclusively assigned
 - 12 drives

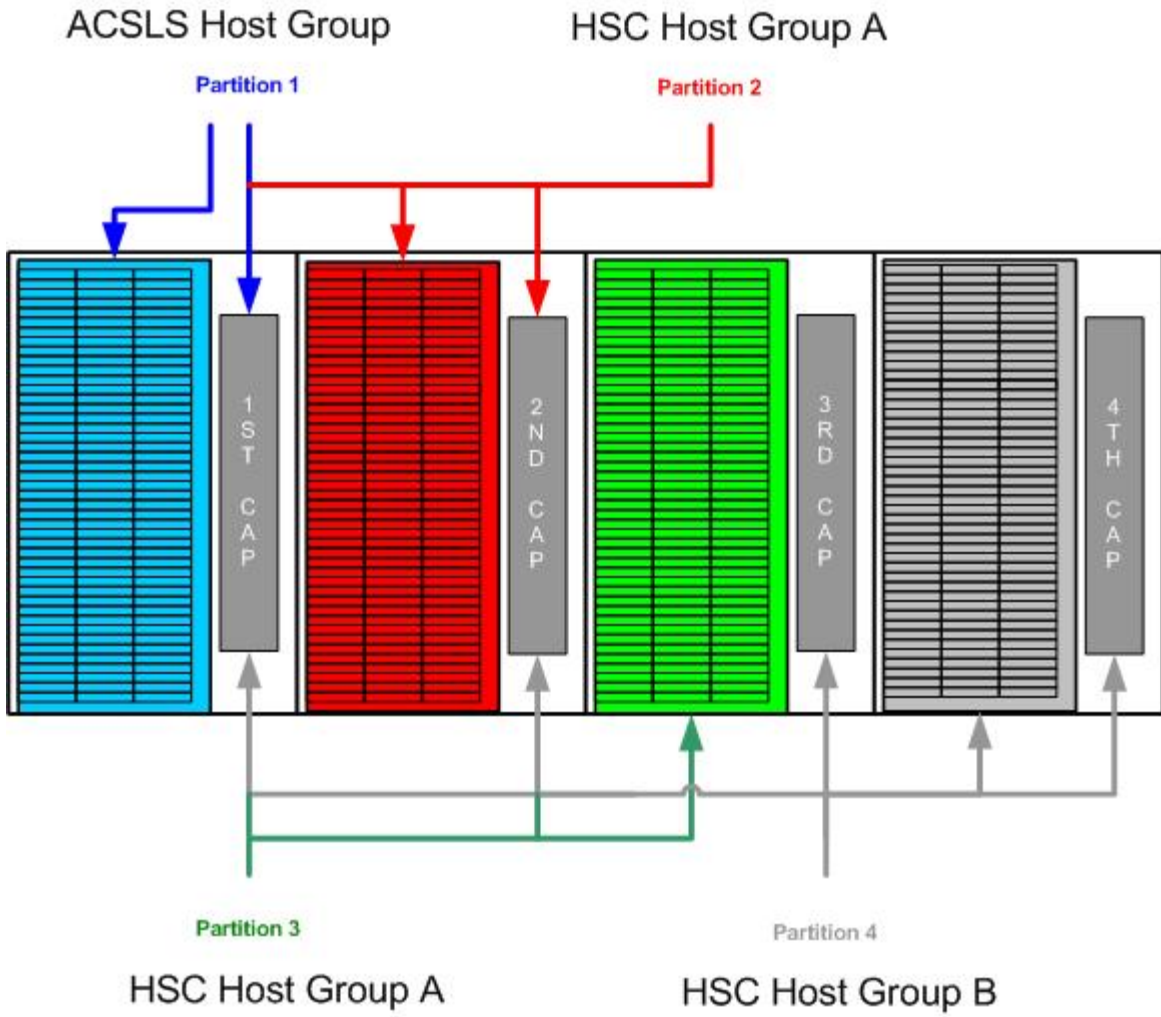

FIGURE 5-6 SL3000 Partition and Host Group Example for Cells and CAPs

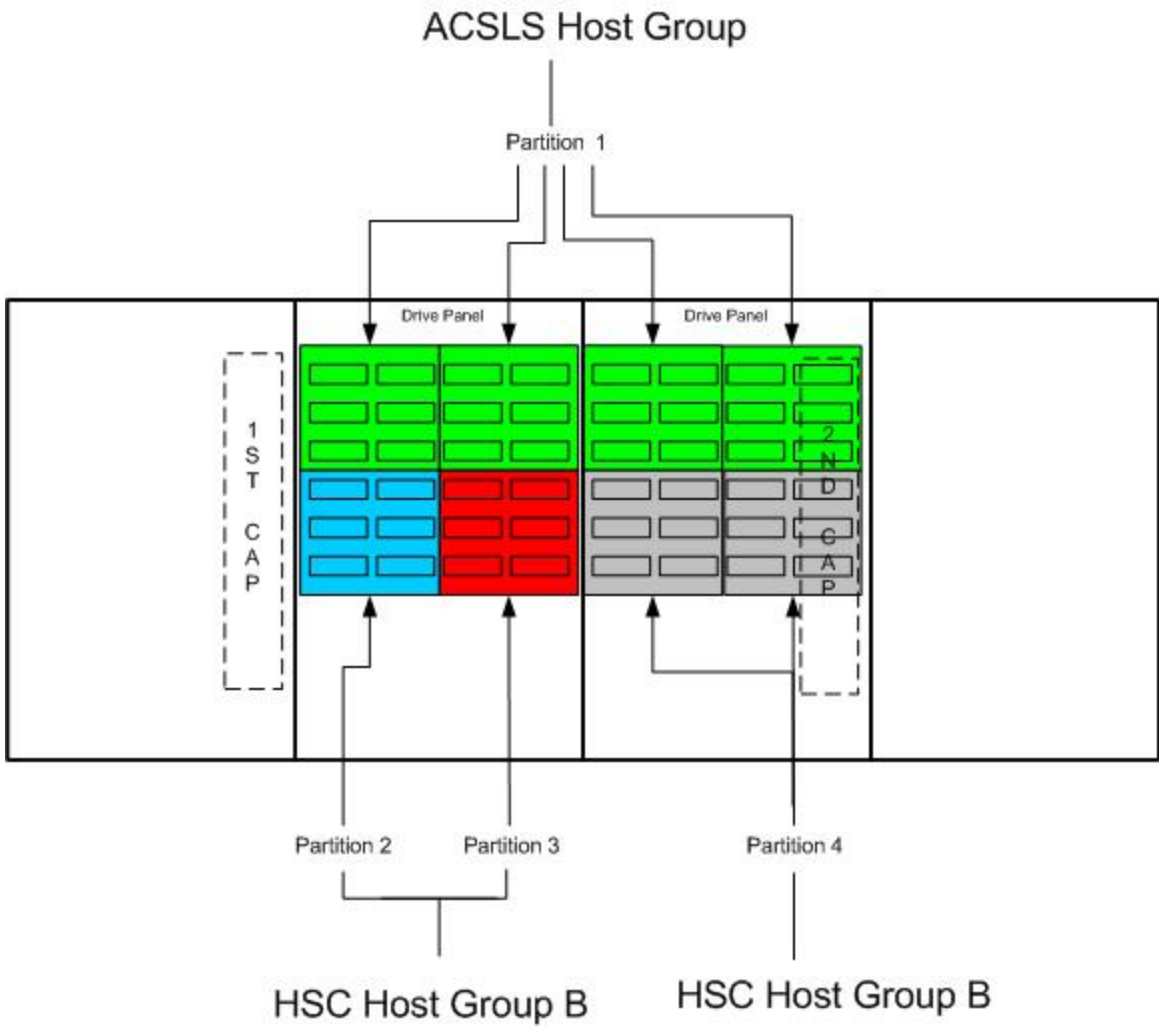

FIGURE 5-7 SL3000 Partition and Host Group Example for Drives

Partitioning Procedures

Start from Scratch – LIBGEN, SLICREAT

This procedure creates a partitioned Streamline library from scratch. No LIBGEN changes are required.

Note – It is important that all SL8500 LSMs are online even if they are not defined/allocated to the partition. If the LSMs are not online, CAPs may not be operational.

1. Run an HSC 7.0 or later LIBGEN assemble and the SLICREAT program.

Create a new CDS using the procedures in “[Creating the HSC CDS](#)” on page 96. HSC must use HSC 7.0 or later SMP/E libraries. After running the SLICREAT program, a standard CDS is created.

Note –

- If there are plans to add SL3000 or SL8500 ACSes (partitions) in the HSC Complex in the future, it is important to add FUTRACS to the SLILIBRY LIBGEN macro. [FIGURE 5-8](#) shows a LIBGEN example for an SL3000 library and [FIGURE 5-9](#) shows a LIBGEN example for an SL8500 library.

```
*
LIBGEN SLIRCVRY TCHNIQE=SHADOW
*
      SLILIBRY SMF=245,                X
      ACSLIST=ACSLIST,                X
      HOSTID=(HST1,HST2),             X
      DELDISP=SCRTCH,                 X
      MAJNAME=STKASBADD,              X
      CLNPRFX=CLN,                    X
      COMPRFX=/,                      X
      FUTRACS=(2),                    X
      SCRLABL=SL                       X
*
ACSLIST SLIALIST ACS00
*
ACS00  SLIACS ACSDRV=(TACS0,TACS0),   X
      LSM=(LSM0000)
*
LSM0000 SLILSM TYPE=3000
*
*
      SLIENDGN ,
```

FIGURE 5-8 FUTRACS Example for SL3000 Library

```

*
LIBGEN SLIRCVRY TCHNIQE=SHADOW
*
    SLILIBRY SMF=245,                X
    ACSLIST=ACSLIST,                X
    HOSTID=(HST1,HST2),             X
    DELDISP=SCRATCH,                X
    MAJNAME=STKASBADD,              X
    CLNPRFX=CLN,                    X
    COMPRFX=/,                      X
    FUTRACS=(2),                    X
    SCRLABL=SL                       X
*
ACSLIST SLIALIST ACS00
*
ACS00  SLIACS ACSDRV=(TACS0,TACS0), X
       LSM=(LSM0000,LSM0001,LSM0002,LSM0003, X
       LSM0004,LSM0005,LSM0006,LSM0007)
*
LSM0000 SLILSM TYPE=8500
LSM0001 SLILSM TYPE=8500
LSM0002 SLILSM TYPE=8500
LSM0003 SLILSM TYPE=8500
LSM0004 SLILSM TYPE=8500
LSM0005 SLILSM TYPE=8500
LSM0006 SLILSM TYPE=8500
LSM0007 SLILSM TYPE=8500
*
    SLIENDGN ,

```

FIGURE 5-9 FUTRACS Example for SL8500 Library

- If virtual tape is being implemented, VTCS CONFIG must be run to define the configuration to VTCS.
2. Run the [“Convert a Non-partitioned Library to a Partitioned Library”](#) on page 170 to partition the library.

Note – After the HSC starts for the first time for a newly added SL8500 library, modify all LSMs online even though a partition may not have all the LSMs allocated/defined. For example:

```
MODIFY LSM lsm-id ONLINE
```

The Streamline library is now partitioned and is available for use. Start HSC as usual.

Convert a Non-partitioned Library to a Partitioned Library

This procedure converts an existing non-partitioned Library to a partitioned Library. For SL8500s, the ACS must contain only one SL8500.

After completing the following steps, you will create a partitioned Streamline library.

1. Stop activity for the ACS connected to the library.

In preparation for reconfiguring the partition, stop all CAP and tape activity (both real and virtual) from all active hosts in that library, including RTD tape processing. **Failure to do this will result in lost cartridges and errors on dismount.**

Vary drives offline to ALL MSP hosts that will no longer have access to the drives. From the MSP console, issue the following command to see if the drives in the affected LSM are offline to MSP:

```
D U,,,xxx-yyy
```

where *xxx-yyy* is the drive ID or UCB range. If the drives are not offline to MSP, vary the drives offline with the MSP command:

```
VARY xxx-yyy OFFLINE
```

Additionally, any RTDs that reside on the affected LSM will need to be varied offline. To do this, issue the VTCS command:

```
V RTD(rtd_id) OFF
```

2. Issue the Display Cap command.

Issue the Display Cap command to verify the CAP is in manual status since this procedure does not go through the NCO process. If the CAP status is AUTOMATIC, issue the CAP Preference command to change the CAP to MANUAL:

```
CAPP prefval cap-id MANUAL
```

3. Vary the affected ACS offline to all hosts.

The ACS to be partitioned must be offline to **all** hosts. Issue the HSC command:

```
VARY ACS acs-id OFFLINE
```

4. Back up the CDS.

Before making changes to the CDS, it is best practice to create a backup copy for recovery purposes. This backup copy can be restored, if problems are encountered, to recover to a known CDS state using documented HSC recovery procedures.

Use the HSC BACKup utility to create the backup CDS copy.

Note – If VTCS is involved, **all tape activity (real and virtual) must be stopped**. All VTDs must be varied offline to MSP. All RTDs defined in the VTCS configuration must be varied offline to VTCS. It is highly recommended that all initiators be drained that feed both real and VTD processing. NCS and VTCS must be in an idle state prior to creating the backup copy of the CDS to avoid possibility of data loss.

5. Change the Streamline library configuration file to partition the ACS.

The internal configuration file in the Streamline library must be changed must be changed to partition the LSM, assign cell, drive, and CAP resources to that partition. This change is made through the SLConsole.

6. Run the SET SLIDRIVS utility on the host group (optional).

If not all the drives need to be configured to the partitioned ACS, modify drives to the LSM of the ACS by running the SLUADMIN utility for SET SLIDRIVS.

```
SET SLIDRIVS(drv1,drv2,drv3,,,,,,,,,,,,,) + FORLSMID(lsm-id),FORPANEL(12)
```

7. Modify the HSC LMUPATH parameter in PARMLIB.

Add the PARTID(00*n*) keyword to the LMUPATH HSC parameter in PARMLIB. The ID(*n*) is obtained from the SLConsole.

Example:

```
LMUPATH ACS(acs-id) LMUADDR(ip-address) PARTID(00n)
```

8. Issue the HSC LMUPDEF command on all hosts.

To activate the modified LMUPATH statement, issue the HSC command:

```
LMUPDEF DATASET(dataset.name)
```

9. Vary the affected ACS online to all Hosts.

Issue the HSC command:

```
Vary ACS acs-id Online.
```

HSC retains the online/offline status of each pre-existing LSM. If the LSMs do not modify online when the ACS is varied online, issue the HSC command:

```
MODIFY LSM lsm-id ONLINE
```

No additional mounts occur to the ACS until the ACS is varied online.

Note – Virtual tape environments are required to vary any RTDs online to VTCS. Additionally, any VTDs varied offline need to be varied online to MSP.

10. Vary drives ONLINE to MSP (if necessary).

From the MSP console, issue

```
D U,,,xxx-yyy
```

where *xxx-yyy* is the drive ID range (both real and virtual), to see if the new drives are online to MSP. If they are not, bring the real drives online with the MSP command:

```
VARY xxx-yyy ONLINE
```

11. Vary RTDs ONLINE to VTCS (if necessary).

From the MSP console, issue

```
V RTD(rtd_id) ON
```

for the RTDs that reside on the LSMs being allocated.

12. Re-establish connections to all defined libraries (if necessary).

Re-establish connections to all defined libraries to acquire drive configuration information from these libraries. To re-drive any outstanding mounts that may have been lost due to hardware or communication errors, issue the SMC RESYNCHRONIZE command.

The ACS is now partitioned and available for use with all four LSMs in a single partition. If you are running multiple HSC hosts, the new configuration is propagated automatically to all hosts.

Convert a Partitioned Library to a Non-partitioned Library

This procedure converts an existing partitioned Library to a non-partitioned Library. For SL8500s, the ACS must contain only one SL8500.

1. Stop activity for the ACS connected to the library.

In preparation for reconfiguring the partition, stop all CAP and tape activity (both real and virtual) from all active hosts in that library, including RTD tape processing. **Failure to do this will result in lost cartridges and errors on dismount.**

Vary drives offline to ALL MSP hosts that will no longer have access to the drives. From the MSP console, issue the following command to see if the drives in the affected LSM are offline to MSP:

```
D U,,,xxx-yyy
```

where *xxx-yyy* is the drive ID or UCB range. If the drives are not offline to MSP, vary the drives offline with the MSP command:

```
VARY xxx-yyy OFFLINE
```

Additionally, any RTDs that reside on the affected LSM will need to be varied offline. To do this, issue the VTCS command:

```
V RTD(rtid_id) OFF
```

Caution – Failure to perform this step may result in the devices being removed becoming allocated. This may cause severe operational consequences including loss of access for any cartridge mounted at the time of the non-partitioning.

Note – If VTCS is involved, any RTDs moving out of the CDS of the host groups affected will require a VTCS CONFIG RESET to be run to remove the specific RTDs from the VTCS configuration.

2. Run the Volume Report utility.

Run a volume report on the affected ACS(s) and keep the output. This data can be used later to verify where volumes were in the ACS(s) before it was removed.

Note – Systems with VTCS should run an MVC report for cross reference purposes.

3. Back up the CDS.

Before making changes to the CDS, it is best practice to create a backup copy for recovery purposes. This backup copy can be restored, if problems are encountered, to recover to a known CDS state using documented HSC recovery procedures.

Use the HSC BACKUP utility to create the backup CDS copy.

Note – If VTCS is involved, **all tape activity (real and virtual) must be stopped.** All VTDs must be varied offline to MSP. All RTDs defined in the VTCS configuration must be varied offline to VTCS. It is highly recommended that all initiators be drained that feed both real and VTD processing. NCS and VTCS must be in an idle state prior to creating the backup copy of the CDS to avoid the possibility of data loss.

4. Vary all ACSs connected to the library OFFLINE to all host groups.

The ACS(s) to be un-partitioned must be offline to all hosts. Issue the HSC command:
VARY ACS *acs-id* OFFLINE

5. Change the Streamline library configuration file to unpartition the ACS.

The internal configuration file in must be changed to delete all partitions. This change is made through the SLConsole.

6. Issue the HSC F CONFIG DELEte ACS command.

To delete an ACS from an HSC host group, issue the HSC command as in the examples below:

```
F CONFIG DELETE ACS(03)
F CONFIG DELETE ACS(04)
F CONFIG DELETE ACS(05)
```

Note –

- If running multiple HSC hosts, the new configuration will be propagated automatically to all hosts.
 - Deleting an ACS deletes its volumes from the CDS.
 - If this is the last ACS in the HSC host group, the following steps may apply. At this time, the HSC can be stopped.
 - Run a volume report on the affected ACS and keep the output. This data can be used later to verify where volumes were in the ACS before it was removed.
 - Eject all cartridges from the affected ACS.
-

7. Run the SET SLIDRIVS utility on the remaining host group.

Add drives to the new LSM of the ACS by running the SLUADMIN utility or command for SET SLIDRIVS.

```
SET SLIDRIVS(drv1,drv2,drv3,,,,,,,,,,,,,) +
FORLSMID(lsm-id),FORPANEL(12)
```

8. Modify LMUPDEF in PARMLIB for all host groups.

Remove all the LMUPATH statements referencing the ACSs previously defined to all LMUPDEF HSC parameter files of all affected host groups. If a particular host group will have ownership of the library after it becomes un-partitioned, add or change the LMUPATH statement using the following example:

```
LMUPATH ACS(03) LMUADDR(ip-address)
```

9. Issue the HSC LMUPDEF command on all host groups.

To activate the modified HSC LMUPATH statement, issue the HSC command:

```
LMUPDEF DATASET(dataset.name)
```

10. Vary the ACS ONLINE to the remaining host group.

Issue the HSC command for the host group taking ownership of library:

```
Vary ACS acs-id Online
```

The HSC retains the online/offline status of each pre-existing LSM. If the LSM does not modify online when the ACS is varied online, issue the HSC command:

```
MODIFY LSM lsm-id ONLINE
```

No additional mounts will occur to the ACS until the ACS is varied online. All other hosts will complete their configuration process when the ACS is varied online.

Note – When an ACS is varied online, the panels are discovered to complete the configuration process. During this time, if any cartridges are discovered, an SLS4416E message will be displayed. It is important to follow the user response section of this message before proceeding to the next step. This section will instruct the user to perform the following step in the order listed:

- Run the HSC SLUADMIN Audit utility with APPLY(NO) for the panels indicated to discover and resolve issues.
- Run the HSC SLUADMIN Volume Report utility if necessary to gather volume information.
- Run the HSC SLUADMIN Audit utility with APPLY(YES) to apply updates to the CDS.
- Run the HSC SLUADMIN SET Utility specifying FREEZE OFF for any panels in the frozen state.

Refer to [“Varying the ACS Online After a Configuration Change”](#) on page 202 for further details of this process.

Note – Virtual tape environments will be required to vary any RTDs online to VTCS.

11. Vary drives ONLINE to MSP (if necessary).

From the MSP console, issue the following command to see if the new drives are online to MSP:

```
D U,,,xxx-yyy
```

where *xxx-yyy* is the drive ID range (both real and virtual). If they are not, bring the real drives online with the MSP command:

```
VARY xxx-yyy ONLINE
```

12. Vary RTDs ONLINE to VTCS (if necessary).

From the MSP console, issue

```
V RTD(rtd_id) ON
```

for the RTDs that reside on the LSMs being allocated.

13. Run the HSC Scratch Update utility (if necessary).

Run the HSC Scratch Update utility.

This step may be bypassed if no volumes have been added, deleted, or moved. It must be run if new LSMs have been added to the configuration.

14. Re-establish connections to all defined libraries (if necessary).

Re-establish connections to all defined libraries to acquire drive configuration information from these libraries. To re-drive any outstanding mounts that may have been lost due to hardware or communication errors, issue the SMC RESYNCHRONIZE command.

The ACS is now unpartitioned and available for use. If you are running multiple HSC hosts, the new configuration is propagated automatically to all hosts.

Add a Library to the HSC Complex

This procedure adds a SL3000 or SL8500 Library for either an existing or new configuration.

After completion of the following steps, a SL3000 or SL8500 library is ready for use.

If adding more libraries to the complex than what currently exist, the FUTRACS parameter in SLILIBRY must be coded in the LIBGEN with enough ACSs to accommodate the total number of libraries planned for access.

To add a library to the HSC Complex:

1. Back up the CDS (if necessary).

Before making changes to the CDS, it is best practice to create a backup copy for recovery purposes. This backup copy can be restored if problems are encountered to recover to a known CDS state using documented HSC recovery procedures.

Use the HSC BACKUP utility to create the backup CDS copy.

Note –

- This step is necessary if you are adding partitions other than the first time.
 - If VTCS is involved, ALL tape activity (real and virtual) must be stopped. All virtual tape drives must be varied offline to MSP. All RTDs defined in the VTCS configuration must be varied offline to VTCS. It is highly recommended that all initiators be drained that feed both real and virtual drive processing. NCS and VTCS must be in an idle state prior to creating the backup copy of the CDS to avoid possibility of data loss.
-

2. Issue the HSC F CONFIG ADD ACSType command (Optional).

If adding more Libraries to HSC than what currently exist, issue the HSC command as in the examples below:

```
F CONFIG ADD ACST(SL3000)
F CONFIG ADD ACST(SL8500)
```

3. Add the HSC LMUPATH statement in PARMLIB.

For a new ACS, add an HSC LMUPATH statement in LMUPDEF in PARMLIB.

Example:LMUPATH ACS(acs-id) LMUADDR(ip-address)

Note – Refer to the LMUPATH Control Statement in *ELS Command, Control Statement, and Utility Reference*.

4. Issue the HSC LMUPDEF command on all hosts.

To activate the modified HSC LMUPATH statement, issue the HSC command:

```
LMUPDEF DATASET(dataset.name)
```

5. Run the SET SLIDRIVS utility (match CDS drive configuration to the library).

Add drives to an LSM of an added ACS by running the SLUADMIN utility or command for SET SLIDRIVS.

```
SET SLIDRIVS(drv1,drv2,drv3,,,,,,,,,,,,) +  
FORLSMID(lsm_id),FORPANEL(12)
```

Note – If VTCS is involved any RTDs moving into the CDS will require a VTCS CONFIG RESET to be run to add the specific RTDs to the VTCS configuration.

6. Vary the new Library (ACS) ONLINE to all hosts.

Issue the HSC command:

```
Vary ACS acs-id Online
```

Issue the following command to modify the LSM online:

```
MODIFY LSM lsm-id ONLINE
```

All other hosts will complete their configuration process when the ACS is varied online.

7. Audit LSM of ACS (Optional).

From [Step 6](#), when an SLS4416E message is displayed, some panels are populated with cartridges that are not cataloged to HSC. These panels must be audited for HSC to be aware of these cartridges. To audit the panel, run the HSC SLUADMIN AUDIT utility as follows:

```
AUDIT ACS(xx) LSM(yy) PANEL(zz)
```

8. Unfreeze panels/LSM (Optional).

If the panels were audited in [Step 7](#), the panels can now be unfrozen. To unfreeze the panels/LSM, run the HSC SLUADMIN utility for SET FREEZE as follows:

```
SET FREEZE (OFF) FORLSMID(lsm-id) FORPANEL(panel-id)
```

9. Run the HSC SCRATCH Update utility (if necessary).

Run an HSC SCRATCH Update utility.

This step may be bypassed if no volumes have been added, deleted, or moved. It must be run if new LSMs have been added to the configuration.

10. Vary drives ONLINE to MSP (if necessary).

From the MSP console, issue

```
D U,,,xxx-yyy
```

where *xxx-yyy* is the drive id range (both real and virtual), to see if the new drives are online to MSP. If they are not, bring the real drives online with the MSP command:

```
VARY xxx-yyy ONLINE
```

11. Vary RTDs ONLINE to VTCS (if necessary).

From the MSP console, issue

```
V RTD(rtd_id) ON
```

for the RTDs that reside on the LSMs being allocated.

Note –

- Virtual tape environments will be required to vary any RTDs online to VTCS. Additionally, any virtual tape drives varied offline will need to be varied online to MSP.
 - Prior to performing this step, ensure that SET SLIDRIVS ([Step 5](#)) is performed so that the CDS drive configuration matches EXACTLY to the new drive configuration on the SL3000 Library.
-

12. Re-synchronize SMC.

To add drives for SMC, issue the SMC RESYNCHRONIZE command.

The Library is now added to the HSC complex and is available for use to all HSC hosts. If running multiple HSC hosts, the new configuration will be propagated automatically to all hosts.

Remove a Library from the HSC Complex

This procedure removes a Library from the HSC Complex.

Note – If this is the last ACS in the HSC host group, only steps 1 through 6 may apply. At this time, HSC can be stopped.

To remove a library from the HSC Complex:

1. Stop activity for affected ACS connected to HSC.

In preparation for removing a Library from HSC, stop all affected ACS CAP and tape activity (both real and virtual) from all active hosts, including RTD tape processing, in that ACS. Failure to do so will result in lost cartridges and errors on dismount.

Vary drives (both real and virtual) offline to all MSP hosts that will no longer have access to the drives. From the MSP console, issue

```
D U,,,xxx-yyy
```

where xxx-yyy is the drive ID or UCB range, to see if the drives in the affected ACS are offline to MSP. If not, vary the drives offline with the MSP command:

```
VARY xxx-yyy OFFLINE
```

Additionally, any RTDs that reside on the affected ACS will need to be varied offline. To do this, issue the VTCS command:

```
V RTD(rtd_id) OFF
```

Caution – Failure to perform this step may result in the devices being removed becoming allocated. This may cause severe operational consequences including loss of access for any cartridge mounted at the time of the partitioning.

Note – If VTCS is involved any RTDs moving out of the CDS will require a VTCS CONFIG RESET to be run to remove the specific RTDs from the VTCS configuration.

2. Run the SET Freeze utility to freeze affected LSM.

To stop cartridges from migrating to the LSM of the partition being removed, run the HSC SLUADMIN SET FREEZE utility:

```
SET FREEZE(ON) FORLSMID(lsm-id)
```

Note –

- When an LSM is frozen, no new cell allocations will occur, however, any cartridge from the LSM that is currently mounted on a drive will return to its home cell.
- Since there is one LSM to an SL3000 Library, freezing the LSM is freezing the ACS.

3. Run the Volume Report utility.

Run a volume report on the affected ACS and keep the output. This data can be used later to verify where volumes were in the ACS before it was removed.

Note – Systems with VTCS should run an MVC report for cross reference purposes.

4. Eject cartridges out of the affected ACS (Optional).

Eject all cartridges from the affected ACS.

5. Vary affected ACS connected to HSC OFFLINE to all hosts.

The affected ACS connected to HSC must be offline to all hosts. Issue the HSC command:

```
VARY ACS acs-id OFFLINE
```

6. Back up the CDS.

Before making changes to the CDS, it is best practice to create a backup copy for recovery purposes. This backup copy can be restored if problems are encountered to recover to a known CDS state using documented HSC recovery procedures.

Use the HSC BACKUP utility to create the backup CDS copy.

Note – If VTCS is involved, ALL tape activity (real and virtual) must be stopped. All virtual tape drives must be varied offline to MSP. All RTDs defined in the VTCS configuration must be varied offline to VTCS. It is highly recommended that all initiators be drained that feed both real and virtual tape drive processing. NCS and VTCS must be in an idle state prior to creating the backup copy of the CDS to avoid possibility of data loss.

7. Issue the HSC F CONFIG DELEte ACS command.

To delete a partition(s) in an HSC Host Group, issue the HSC command as the examples below show:

```
F CONFIG DELETE ACS(03)
```

```
F CONFIG DELETE ACS(04)
```

```
F CONFIG DELETE ACS(05)
```

Note –

- If running multiple HSC hosts, the new configuration will be propagated automatically to all hosts.
 - Deleting an ACS deletes its volumes from the CDS. Remove the HSC LMUPATH parameter in PARMLIB.
-

8. Remove the LMUPATH statements referencing the ACS previously defined to the LMUPDEF HSC parameter file of the affected host group.

9. Issue the HSC LMUPDEF command on all hosts.

To refresh the modified HSC LMUPDEF HSC parameter file within a host group, issue the HSC command to all hosts:

```
LMUPDEF DATASET(dataset.name)
```

10. Re-synchronize SMC.

Issue the SMC RESYNCHRONIZE command.

The Library is removed from the HSC Complex.

Adding a Partition to the Library

This procedure adds a partition to the library for either an existing or new configuration.

After completing the following steps, a partitioned SL3000 or SL8500 with up to eight partitions may be created. At a later time, remove any partitions from this library using [“Removing a Partition from the Library”](#) on page 187.

If you are adding more partitions to an ACS than what currently exist, the FUTRACS parameter in the SLILIBRY macro must be coded in the LIBGEN with enough ACSs to accommodate the total number of partitions being accessed within a SL3000 or SL8500 library.

1. Stop activity for all ACSs connected to the library.

In preparation for adding a partition to the library, stop all CAP and tape activity (both real and virtual) from all active hosts, including RTD tape processing, in that ACS.

Failure to do so will result in lost cartridges and errors on dismount.

Vary drives (both real and virtual) offline to all MSP hosts that will no longer have access to the drives. From the MSP console, issue

```
D U,,,xxx-yyy
```

where *xxx-yyy* is the drive ID or UCB range, to see if the drives in the affected ACS are offline to MSP. If not, vary the drives offline with the MSP command:

```
VARY xxx-yyy OFFLINE
```

Additionally, any RTDs that reside on the affected ACS will need to be varied offline. To do this, issue the VTCS command:

```
V RTD(rtd_id) OFF
```

Note –

- This step is necessary if you are adding partitions other than the first time.
 - If VTCS is involved, any RTDs moving out of the CDS will require a VTCS CONFIG RESET to be run to remove the specific RTDs from the VTCS configuration.
-

2. Vary all ACSs connected to the library OFFLINE to all hosts.

ALL ACSs connected to the library must be offline to all hosts. Issue the HSC command:

```
VARY ACS acs-id OFFLINE
```

3. Back up the CDS (if necessary).

Before making changes to the CDS, it is best practice to create a backup copy for recovery purposes. This backup copy can be restored if problems are encountered to recover to a known CDS state using documented HSC recovery procedures.

Use the HSC BACKUP utility to create the backup CDS copy.

Note –

- This step is necessary if you are adding partitions other than the first time.
 - If VTCS is involved, **ALL tape activity (real and virtual) must be stopped**. All virtual tape drives must be varied offline to MSP. All RTDs defined in the VTCS configuration must be varied offline to VTCS. It is highly recommended that all initiators be drained that feed both real and virtual tape drive processing. NCS and VTCS must be in an idle state prior to creating the backup copy of the CDS to avoid possibility of data loss.
-

4. Change the SL3000 or SL8500 configuration to add the partition and assign resources to the partition.

The internal configuration file in the SL3000 or SL8500 must be changed to show the newly added partition(s) to a library. This change is made through the SLConsole.

Note – If scratch volumes exist, update and reload SCRPFDEF, VOLDEF, and TAPEREQ PARMLIB members accordingly. This must be done prior to executing step 5.

5. Issue the HSC F CONFIG ADD ACSType command (optional).

If you are adding more partitions to an ACS than currently exist, issue the HSC command as in the examples below:

```
F CONFIG ADD ACST(SL3000)
F CONFIG ADD ACST(SL8500)
```

6. Change or add the HSC LMUPATH statement in PARMLIB.

If an LMUPATH statement was defined for an SL3000 or SL8500 using “[Start from Scratch – LIBGEN, SLICREAT](#)” on page 168, change the HSC LMUPATH statement to add the PARTID keyword in LMUPDEF in PARMLIB. Verify the partition ID defined from the SLConsole is the same as the PARTID in the HSC LMUPDEF. For a new partition, add an HSC LMUPATH statement in LMUPDEF in PARMLIB.

Example:LMUPATH ACS(acs-id) LMUADDR(ip-address) PARTID(nnn)

7. Issue the HSC LMUPDEF command on all hosts.

To activate the modified HSC LMUPATH statement, issue the HSC command:

```
LMUPDEF DATASET(dataset.name)
```

8. Run the SET SLIDRIVS utility (match CDS drive configuration to the library).

Add drives to an LSM of an added ACS by running the SLUADMIN utility or command for SET SLIDRIVS.

```
SET SLIDRIVS(drv1,drv2,drv3,,,,,,,,,,,,,) +  
FORLSMID(lsm-id),FORPANEL(12)
```

Note – If VTCS is involved, any RTDs moving into the CDS will require a VTCS CONFIG RESET to be run to add the specific RTDs to the VTCS configuration.

9. Vary all ACSs connected to the library ONLINE to all hosts.

Issue the HSC command:

```
Vary ACS acs-id Online
```

The HSC retains the online/offline status of each pre-existing LSM. If the LSM is not modified online when the ACS is varied online, issue the HSC command:

```
MODIFY LSM lsm-id ONLINE
```

No additional mounts will occur to the ACS until the ACS is varied online. All other hosts will complete their configuration process when the ACS is varied online.

10. Audit LSM of ACS (optional).

From step 9, when an SLS4416E message is displayed, some panels are populated with cartridges that are not cataloged to HSC. These panels must be audited for the HSC to be aware of these cartridges. To audit the panel, run the HSC AUDIt utility as follows:

```
AUDIT ACS(xx) LSM(yy) PANEL(zz)
```

11. Unfreeze panels/LSM (optional).

If the panels were audited in step 10, the panels can now be unfrozen. To unfreeze the panels/LSM, run the HSC SLUADMIN SET FREEZE utility as follows:

```
SET FREEZE (OFF) FORLSMID(lsm-id) FORPANEL(panel-id)
```

12. Run the HSC Scratch Update utility (if necessary).

Run an HSC Scratch Update utility.

This step may be bypassed if no volumes have been added, deleted, or moved. It must be run if new LSMs have been added to the configuration.

13. Vary drives ONLINE to MSP (if necessary).

From the MSP console, issue the following command to see if the new drives are online to MSP:

```
D U,,,xxx-yyy
```

where *xxx-yyy* is the drive ID range (both real and virtual). If they are not, bring the real drives online with the MSP command:

```
VARY xxx-yyy ONLINE
```

14. Vary RTDs ONLINE to VTCS (if necessary).

From the MSP console, issue

```
V RTD(rtd_id) ON
```

for the RTDs that reside on the LSMs being allocated.

Note –

- Virtual tape environments will be required to vary any RTDs online to VTCS. Additionally, any virtual tape drives varied offline will need to be varied online to MSP.
- Prior to performing this step, ensure that SET SLIDRIVS (step 8) is performed so that the CDS drive configuration matches EXACTLY to the new drive configuration on the SL3000 library.

15. Re-synchronize the SMC.

To add drives for the SMC, issue the SMC RESYNCHRONIZE command.

The partition is now added to the library and is available for use. If running multiple HSC hosts, the new configuration will be propagated automatically to all hosts.

Removing a Partition from the Library

Note – If this is the last ACS in the HSC host group, only steps 1 through 6 may apply. At this time, the HSC can be stopped.

This procedure removes a partition from an existing library.

1. Stop activity for affected ACSs being deleted.

In preparation for removing a partition from the library, stop all CAP and tape activity (both real and virtual) from all active hosts, including RTD tape processing, in that ACS. **Failure to do so will result in lost cartridges and errors on dismount.**

Vary drives (both real and virtual) offline to all MSP hosts that will no longer have access to the drives. From the MSP console, issue the following command to see if the drives in the affected ACS are offline to MSP:

```
D U,,,xxx-yyy
```

where *xxx-yyy* is the drive ID or UCB range. If not, vary the drives offline with the MSP command:

```
VARY xxx-yyy OFFLINE
```

Additionally, any RTDs that reside on the affected ACS will need to be varied offline. To do this, issue the VTCS command:

```
V RTD(rtd_id) OFF
```

Caution – Failure to perform this step may result in the devices being removed becoming allocated. This may cause severe operational consequences including loss of access for any cartridge mounted at the time of the partitioning.

Note – If VTCS is involved, any RTDs moving out of the CDS will require a VTCS CONFIG RESET to be run to remove the specific RTDs from the VTCS configuration.

2. Run the SET Freeze utility to freeze affected LSM.

To stop cartridges from migrating to the LSM of the partition being removed, run the HSC SLUADMIN SET FREEZE utility:

```
SET FREEZE(ON) FORLSMID(lsm-id)
```

Note –

- When an LSM is frozen, no new cell allocations will occur, however, any cartridge from the LSM that is currently mounted on a drive will return to its home cell.
 - Since there is one LSM in an SL3000 library, freezing the LSM is freezing the ACS.
-

3. Run the Volume Report utility.

Run a volume report on the affected ACS and keep the output. This data can be used later to verify where volumes were in the ACS before it was removed.

Note – Systems with VTCS should run an MVC report for cross reference purposes.

4. Eject cartridges out of the affected ACS (optional).

Eject all cartridges from the affected ACS.

5. Vary the affected ACS OFFLINE to all hosts.

ACSs being deleted must be offline to all hosts. Issue the HSC command:

```
VARY ACS acs-id OFFLINE
```

6. Back up the CDS.

Before making changes to the CDS, it is best practice to create a backup copy for recovery purposes. This backup copy can be restored if problems are encountered to recover to a known CDS state using documented HSC recovery procedures.

Use the HSC BACKUP utility to create the backup CDS copy.

Note – If VTCS is involved, ALL tape activity (real and virtual) must be stopped. All virtual tape drives must be varied offline to MSP. All RTDs defined in the VTCS configuration must be varied offline to VTCS. It is highly recommended that all initiators be drained that feed both real and virtual tape drive processing. HSC and VTCS must be in an idle state prior to creating the backup copy of the CDS to avoid possibility of data loss.

7. Issue the HSC F CONFIG DELETE ACS command.

To delete a partition(s) in an HSC Host Group, issue the HSC command as the examples below show:

```
F CONFIG DELETE ACS(03)
F CONFIG DELETE ACS(04)
F CONFIG DELETE ACS(05)
```

Note –

- If running multiple HSC hosts, the new configuration will be propagated automatically to all hosts.
 - Deleting an ACS deletes its volumes from the CDS.
 - If the last allocated ACS is deleted, the HSC no longer has connections to any library and can be stopped. Steps 8 through 10 can be ignored.
-

8. Remove the HSC LMUPATH parameter in PARMLIB.

Remove the LMUPATH statements referencing the ACS previously defined to the LMUPDEF HSC parameter file of the affected host group.

9. Issue the HSC LMUPDEF command on all hosts.

To refresh the modified HSC LMUPDEF HSC parameter file within a host group, issue the HSC command to all hosts:

```
LMUPDEF DATASET(dataset.name)
```

10. Change the SL3000 configuration to remove the affected partition from the library (optional).

The internal configuration file in the SL3000 may be changed to remove the partition. This change happens through the SLConsole.

11. Vary all ACSs connected to the library ONLINE to all hosts.

Issue the HSC command:

Vary ACS *acs-id* Online

The HSC retains the online/offline status of each pre-existing LSM. If the LSM is not modified online when the ACS is varied online, issue the HSC command:

MODIFY LSM *lsm-id* ONLINE

No additional mounts will occur to the ACS until the ACS is varied online. All other hosts will complete their configuration process when the ACS is varied online.

12. Vary drives ONLINE to MSP (if necessary).

From the MSP console, issue the following command to see if the new drives are online to MSP:

D U,,,*xxx-yyy*

where *xxx-yyy* is the drive ID range (both real and virtual). If they are not, bring the real drives online with the MSP command:

VARY *xxx-yyy* ONLINE

13. Vary RTDs ONLINE to VTCS (if necessary).

From the MSP console, issue

V RTD(*rtd_id*) ON

for the RTDs that reside on the LSMs being allocated.

Note – Virtual tape environments will be required to vary any RTDs online to VTCS. Additionally, any virtual tape drives varied offline will need to be varied online to MSP

14. Re-synchronize the SMC.

Issue the SMC RESYNCHRONIZE command.

The partition is removed from the library, and the remaining library resources are available for use.

Moving a Partition from One Host Group to another Host Group

This procedure moves a partition from one host group to another and preserves the history of the partition volumes being allocated.

Note – If this is the last ACS in the “from” HSC host group, only steps 1 through 4 may apply. At this time, the “from” HSC can be stopped. Proceed with steps 9 through 20.

“From” Host Group:

1. Stop activity for all ACSs connected to the library.

In preparation for moving the partition, you must stop all CAP and tape activity (both real and virtual), from all active hosts, including virtual tape processing, in that ACS of the host group of where the partition is moving from. **Failure to do this will result in lost cartridges and errors on dismount.**

Vary drives offline to all MSP hosts that will no longer have access to the drives. From the MSP console, issue the following command to see if the drives in the affected LSM are offline to MSP.

```
D U,,,xxx-yyy
```

where *xxx-yyy* is the drive ID or UCB range. If they are not, bring them offline with the MSP command:

```
VARY xxx-yyy OFFLINE
```

Additionally, any RTDs that reside on the affected LSM will need to be varied offline. To do this issue the VTCS command:

```
V RTD(rtd_id) OFF
```

Caution – Failure to perform this step to vary these drives offline from MSP will result in these devices becoming allocated while removing the LSM from the partition. This may cause severe operational consequences including loss of access for any cartridge that was mounted at the time of the partitioning.

Note – If VTCS is involved, any RTDs moving out of the CDS of the “from host group” will require a VTCS CONFIG RESET to be run to remove the specific RTDs from the VTCS configuration.

2. Run the Volume Report utility.

Run a volume report on the affected ACS and keep the output. This data can be used later to verify where volumes were in the ACS before it was relocated.

Note – Systems with VTCS should run an MVC report for cross reference purposes.

3. Vary the ACS being removed OFFLINE to all hosts.

The ACS must be offline to all hosts. Issue the HSC command:

```
VARY ACS acs-id OFFLINE
```

4. Back up the CDS (CDS01).

Use the HSC BACKUP utility to create the backup CDS copy as CDS01.

5. Remove the HSC LMUPATH parameter in PARMLIB.

Remove the LMUPATH statements referencing the partition previously defined to the LMUPDEF HSC parameter file.

6. Issue the HSC LMUPDEF command on all hosts.

To refresh the modified HSC LMUPDEF HSC parameter file within a host group, issue the HSC command to all hosts:

```
LMUPDEF DATASET(dataset.name)
```

7. Issue the HSC F CONFIG DELEte ACS command.

To delete a partition from a HSC Host Group, issue the HSC command as in the examples below:

```
F CONFIG DELETE ACS(03)
F CONFIG DELETE ACS(04)
F CONFIG DELETE ACS(05)
```

Note –

- If running multiple HSC hosts, the new configuration will be propagated automatically to all hosts.
 - Deleting an ACS deletes its volumes from the CDS.
-

8. Re-synchronize the SMC.

To add drives for the SMC, issue the SMC RESYNCHRONIZE command.

“To” Host Group:

9. Back up the CDS (CDS02).

Use the HSC BACKUP utility to create the backup CDS copy as CDS02.

10. Issue the HSC F CONFIG ADD ACSType command.

To add a partition to an HSC Host Group, issue the HSC command as in the examples below:

```
F CONFIG ADD ACST(SL3000)
F CONFIG ADD ACST(SL8500)
```

Note – If running multiple HSC hosts, the new configuration will be propagated automatically to all hosts.

11. Add the HSC LMUPATH statement in PARMLIB.

Add an HSC LMUPATH statement in LMUPDEF in PARMLIB.

Example: LMUPATH ACS(acs-id) LMUADDR(ip-address) PARTID(nnn)

12. Issue the HSC LMUPDEF command on all hosts.

To activate the modified HSC LMUPATH statement, issue the HSC command:

```
LMUPDEF DATASET(dataset.name)
```

13. Set the Service Level to BASE for all hosts.

Set the service level to BASE for the host group to allow a MERGEcdfs to be started.

Issue the HSC command:

```
SRVLEV BASE
```

14. Run the MERGEcdfs utility.

Input will be CDS01. Output will be an updated CDS02. This example will move the ACS volume history from ACS 00 (CDS01) to ACS 04.

Note –

- If merging a non-VTCS ACS into a VTCS ACS, the REALonly parameter is necessary on the MERGEcdfs.
- After MERGEcdfs, if scratch volumes exist, update and reload the SCRPFDEF, VOLDEF, and TAPEREQ PARMLIB members accordingly.

```
//jobcard
//STEP1 EXEC PGM=SLUADMIN,PARM='MIXED'
//STEPLIB DD DISP=SHR,DSN=dataset.name
/*
//SLSPRINT DD SYSOUT=*
/*
//SLSFCNTL DD DSN=CDS01.primary,DISP=SHR
/*
//SLSIN DD *
MERGECDS
//SLSMERGE DD *
MERGE FACS(00) TACS(04)
/*
//
```

15. Run the SET SLIDRIVS utility.

Add drives to the new ACS of the “to host group” by running the SLUADMIN utility or command for SET SLIDRIVS.

```
SET SLIDRIVS(drv1,drv2,drv3,,,,,,,,,,,,,) + FORLSMID(lsm-id),FORPANEL(12)
```

Note – If VTCS is involved, any RTDs moving into the CDS will require a VTCS CONFIG RESET to be run to add the specific RTDs to the VTCS configuration.

16. Set the Service Level to FULL for all hosts.

Set the service level to FULL for the host group after the MERGEcdfs has completed.

Issue the HSC command:

```
SRVLEV FULL
```

17. Run the HSC Scratch Update utility (if necessary).

Run an HSC Scratch Update utility.

This step may be bypassed if no volumes have been added, deleted, or moved. It must be run if new LSMs have been added to the configuration.

Adding Resources to a Library

This procedure allows resources to be added to an existing library Library or partition within the Library defined as an ACS. Resource additions can consist of cells, drives, drive bays, CAPs, expansion module and the SL3000 dual Tallbot.

Caution –

- If you are changing the library configuration, for example, changing UPC labels, the cartridges in the cells being removed must be ejected or moved, and the cells being removed must be unassigned to all partitions using the SLConsole prior to physically adding the library resources.
- When you are using the SLConsole to add ACS resources, make all necessary changes at the same time and issue one APPLY. The HSC performs a reconfiguration every time an SLConsole partition APPLY occurs.

1. Stop activity for all ACSs connected to the library.

In preparation for adding resources to the library, stop all CAP and tape activity (both real and virtual) from all active hosts in that library, including RTD tape processing.

Failure to do this will result in lost cartridges and errors on dismount.

Vary drives offline to ALL MSP hosts that will no longer have access to the drives.

From the MSP console, issue the following command to see if the drives in the affected LSM are offline to MSP.

```
D U,,,xxx-yyy
```

where *xxx-yyy* is the drive ID or UCB range. If not, vary the drives offline with the MSP command:

```
VARY xxx-yyy OFFLINE
```

Additionally, any RTDs that reside on the affected LSM will need to be varied offline.

To do this, issue the VTCS command:

```
V RTD(rtd_id) OFF
```

Caution – Failure to perform this step may result in the devices being removed becoming allocated. This may cause severe operational consequences including loss of access for any cartridge mounted at the time of the non-partitioning.

Note – If VTCS is involved, any RTDs moving out of the CDS of the host groups affected will require a VTCS CONFIG RESET to be run to remove the specific RTDs from the VTCS configuration.

2. Back up the CDS containing the ACS to be changed.

Use the HSC BACKUP utility to create the backup CDS copy.

Note – If VTCS is involved, all CAP and tape activity (real and virtual) must be stopped. All virtual tape drives must be varied offline to MSP. All RTDs defined in the VTCS configuration must be varied offline to VTCS.

It is highly recommended that all initiators be drained that feed both real and virtual tape drive processing. NCS and VTCS must be in an idle state prior to creating the backup copy of the CDS to avoid possibility of data loss.

3. Vary all ACSs connected to the library OFFLINE to all hosts.

ALL ACSs connected to the library must be offline to all hosts. Issue the HSC command:

```
VARY ACS acs-id OFFLINE
```

4. Change the Library configuration to the affected ACS.

The internal configuration file in the Library is changed to reconfigure the ACS, i.e., adding or deleting cell allocations or changing the exclusivity status of a CAP. This change is accomplished through the SLConsole.

Note –

- CAPs:
 - If assigning a CAP, use the SLConsole to assign the CAP to only one partition (dedicated) or a set of partitions (shared).
 - Only dedicated SL3000 CAPs can be set to auto. All SL8500 CAPs in a partitioned library are shared.
 - Prior to reassigning a CAP, it must be set to manual.
 - If installing a CAP, verify the cells that occupied the CAP space are unassigned to any partition. Assign the CAP as described in the previous bullet.
 - Drives – If installing or assigning a drive, use the SLConsole to assign the drive to a partition.
 - Drive Bays – If installing a drive bay, after verifying the cells are unassigned to any partition, use the SLConsole to assign the drive slots to a partition.
 - Cells – If assigning cells, use the SLConsole to assign cells to a partition.
-

SL3000 Note –

- Dual Tallbots – If installing a second robot, verify the outermost three columns (front and back) of each outermost Cartridge Expansion Module (CEM) are unassigned to any partition .
 - Outermost CEMs must be transformed into Parking Expansion Modules (PEMs) when installing the second robot.
 - Expansion Modules
 - If installing a Drive Expansion Module (DEM) no additional setup is needed.
 - If installing a CEM to either end, no additional setup is needed
 - Prior to installing a CEM to a location other than to either end of the library (i.e., between a PEM and either a CEM, DEM, or Base Drive Module) the volumes in the PEM must be either moved to available space within the partition or ejected if no space is available. After the volumes are removed from the PEM, the partitions need to unassign the cell locations.
-

5. Run the SET SLIDRIVS utility if adding drives (optional).

Add drives to the changed ACS by running the SLUADMIN utility or command for SET SLIDRIVS

```
SET SLIDRIVS(drv1,drv2,drv3,,,,,,,,,,,,,) +  
FORLSMID(lsm-id),FORPANEL(12)
```

Note – If VTCS is involved, any RTDs moving into the CDS will require a VTCS CONFIG RESET to be run to add the specific RTDs to the VTCS configuration.

6. Vary all ACSs connected to the library ONLINE to all hosts.

Issue the HSC command:

Vary ACS *acs-id* Online

The HSC retains the online/offline status of each pre-existing LSM. If the LSMs do not modify online when the ACS is varied online, issue the HSC command:

```
MODIFY LSM lsm-id ONLINE
```

No additional mounts will occur to the ACS until the ACS is varied online.

All other hosts will complete their configuration process when the ACS is varied online.

Note – When an ACS is varied online, the panels are discovered to complete the configuration process. During this time, if any cartridges are discovered, an SLS4416E message will be displayed. It is important to follow the user response section of this message before proceeding to the next step. This section will instruct the user to perform the following step in the order listed:

- Run the HSC SLUADMIN Audit utility with APPLY(NO) for the panels indicated to discover and resolve issues.
 - Run the HSC SLUADMIN Volume Report utility if necessary to gather volume information.
 - Run the HSC SLUADMIN Audit utility with APPLY(YES) to apply updates to the CDS.
 - Run the HSC SLUADMIN SET Utility specifying FREEZE OFF for any panels in the frozen state. See [“Varying the ACS Online After a Configuration Change” on page 202](#) for further details of this process.
-

Note – Virtual tape environments will be required to vary any RTDs online to VTCS. Additionally, any virtual tape drives varied offline will need to be varied online to MSP.

7. Modify CAPs ONLINE (optional).

Issue the following HSC command to use CAPs that are added to the partition.

```
MODIFY CAP cap-id ONLINE
```

8. Update the ACS Configuration for drives (optional).

From the MSP console, issue the following command to add drives for the affected ACS to HSC.

```
F CONFIG UPDATE ACS(acs-id)
```

where *acs-id* is the ID of the affected ACS.

9. Vary drives ONLINE to MSP if adding drives (optional).

From the MSP console, issue the following command to see if the new drives are online to MSP.

```
D U,,,xxx-yyy
```

where *xxx-yyy* is the drive ID range (both real and virtual). If they are not, bring the real drives online with the MSP command:

```
VARY xxx-yyy ONLINE
```

10. Vary drives ONLINE to VTCS if adding RTDs (optional).

From the MSP console, issue

```
V RTD(rtd_id) ON
```

for the RTDs that reside on the LSMs being allocated.

11. Re-synchronize the SMC.

Issue the SMC RESYNCHRONIZE command.

If you are running multiple HSC hosts, the new configuration will be propagated automatically to all hosts in the affected host group.

Removing Resources from a Library

This procedure allows resources to be removed from an existing Library or partition of a Library defined as an ACS. Resource removal can consist of cells, drives, drive bays, CAPs, expansion modules and SL3000 dual Tallbot.

Note – When you are using the SLConsole to remove ACS resources, make all necessary changes at the same time and issue one APPLY. The HSC performs a reconfiguration every time an SLConsole partition APPLY occurs.

1. Back up the CDS containing the ACS to be changed.

Use the HSC BACKUP utility to create the backup CDS copy.

Note – If VTCS is involved, ALL CAP and tape activity (real and virtual) must be stopped. All virtual tape drives must be varied offline to MSP. All RTDs defined in the VTCS configuration must be varied offline to VTCS. It is highly recommended that all initiators be drained that feed both real and virtual tape drive processing. HSC and VTCS must be in an idle state prior to creating the backup copy of the CDS to avoid possibility of data loss.

2. Stop activity for all ACSs connected to the library.

In preparation for removing resources from the library, stop all CAP and tape activity (both real and virtual) from all active hosts in that ACS, including RTD tape processing. **Failure to do this will result in lost cartridges and errors on dismount.**

Vary drives offline to ALL MSP hosts that will no longer have access to the drives. From the MSP console, issue the following command to see if the drives in the affected LSM are offline to MSP.

```
D U,,,xxx-yyy
```

where *xxx-yyy* is the drive ID or UCB range. If not, vary the drives offline with the MSP command:

```
VARY xxx-yyy OFFLINE
```

Additionally, any RTDs that reside on the affected LSM will need to be varied offline. To do this, issue the VTCS command:

```
V RTD(rtd_id) OFF
```

Caution – Failure to perform this step may result in the devices being removed becoming allocated. This may cause severe operational consequences including loss of access for any cartridge mounted at the time of the partitioning.

Note – If VTCS is involved, any RTDs moving out of the CDS will require a VTCS CONFIG RESET to be run to add the specific RTDs from the VTCS configuration.

3. Eject cartridges out of the affected cells to be removed (optional).

If cells to be removed contain cartridges, optionally eject all cartridges from the affected ACS.

4. Vary drives OFFLINE to MSP if removing drives (optional).

From the MSP console, issue the following command to see if the new drives are offline to MSP.

```
D U,,,xxx-yyy
```

where *xxx-yyy* is the drive ID range (both real and virtual). If they are not, vary the real drives offline with the MSP command:

```
VARY xxx-yyy OFFLINE
```

5. Vary drives OFFLINE to VTCS if removing RTDs (optional).

From the MSP console, issue

```
V RTD(rtd_id) OFF
```

for the RTDs that reside in the LSMs being unallocated.

6. Modify affected CAPs OFFLINE (optional).

Issue the following HSC command to no longer use CAPs that are removed from the partition.

```
MODIFY CAP cap-id OFFLINE
```

7. Vary all ACSs connected to the library OFFLINE to all hosts.

All ACSs must be offline to all hosts. Issue the HSC command:

```
VARY ACS acs-id OFFLINE
```

8. Run the SET SLIDRIVS utility if deleting drives (optional).

Delete drives to the changed partition (ACS) by running the SLUADMIN utility or command for SET SLIDRIVS

```
SET SLIDRIVS(,,,,,,,) +  
FORLSMID(lsm-id),FORPANEL(12)
```

Note – If VTCS is involved, any RTDs moving out of the CDS will require a VTCS CONFIG RESET to be run to remove the specific RTDs from the VTCS configuration.

9. Change the Library configuration.

The internal configuration file in the SL3000 must be changed to reconfigure the ACS. This change is made through the SLConsole.

Note –

- CAPs
 - If removing a CAP, use the SLConsole to unassign the CAP from all partitions.
 - If unassigning a CAP, verify the CAP is in manual mode. Use the SLConsole to unassign the CAP from one or more partitions.
 - Drives – If removing or unassigning a drive, use the SLConsole to unassign the drive from the partition.
 - Drive Bays – If removing a drive bay, use the SLConsole to unassign the drive slots from their partition.
 - Cells – If unassigning cells, use the SLConsole to unassign cells from the partition.
 - Cartridges left in unassigned cells will become orphaned.
-

SL3000 Note –

- Dual Tallbots:
 - If removing a second robot, no additional setup is needed.
 - Outermost PEMs must be transformed into CEMs when removing the second robot.
 - Outermost PEMs must be transformed into CEMs when removing the second robot.
 - Expansion Modules:
 - **ATTENTION:** Prior to removing a DEM, cartridges must be either moved to available space or ejected if space is not available. After the volumes are removed from the DEM, the partitions need to unassign the cell locations.
 - **ATTENTION:** Prior to removing a CEM from the library, cartridges must be either moved to available space or ejected if space is not available. After the volumes are removed from the CEM, the partitions need to unassign the cell locations.
 - **ATTENTION:** Prior to removing a CEM from a location other than from either end of the library (i.e., between a PEM and either a CEM, DEM or Base Drive Module) the volumes in the PEM must be either moved to available space within the partition or ejected if no space is available. After the volumes are removed from the PEM, the partitions need to unassign the cell locations.
-

10. Vary all ACSs connected to the library ONLINE to all hosts.

Issue the HSC command:

Vary ACS *acs-id* Online

The HSC retains the online/offline status of each pre-existing LSM. If the LSMs do not modify online when the ACS is varied online, issue the HSC command:

MODIFY LSM *lsm-id* ONLINE

No additional mounts will occur to the ACS until the ACS is varied online.

All other hosts will complete their configuration process when the ACS is varied online.

Note –

- Virtual tape environments will be required to vary any RTDs online to VTCS. Additionally, any virtual tape drives varied offline will need to be varied online to MSP.
 - Refer to [“Varying the ACS Online After a Configuration Change”](#) on page 202 for further details of this process.
-

11. Re-synchronize the SMC.

Issue the SMC RESYNCHRONIZE command.

If you are running multiple HSC hosts, the new configuration will be propagated automatically to all hosts.

Changing the CAP State for Bulk CAP - HSC Down

This procedure details how you can add a Bulk CAP to a partition or remove a Bulk CAP from a partition while the HSC is down.

1. **Using the SLC, add the CAP(s) to the partition(s) or remove the CAP(s) from the partition(s) and then apply the changes. See the *SL8500 User's Guide* for information.**
2. **Start HSC and wait for initialization to complete. See [Chapter 7, "Starting and Stopping HSC"](#).**

During startup, reconfiguration starts. Wait for reconfiguration to complete.

3. **If the LSMs affected are offline:**
 - a. **Enter MODify LSM (*lsm-range*) ONline**
where *lsm-range* is a range of LSMs where the CAP changes are being made.
 - b. **Enter Display Cap to verify the CAP changes to the library.**
 - c. **Start HSC activity.**
4. **If the LSMs affected are online:**
 - a. **Enter Display Cap to verify the CAP changes to the library.**
 - b. **Start HSC activity.**

Changing the CAP State for Bulk CAP - HSC Up

This procedure details how you can add a Bulk CAP to a partition or remove a Bulk CAP from a partition while the HSC is up.

1. **Enter MODify LSM (*lsm-range*) OFFline**
where *lsm-range* is the range of LSMs where the CAP changes are being made.
2. **Stop all HSC activity.**
3. **Using the SLC, add the CAP(s) to the partition(s) or remove the CAP(s) from the partition(s) and then apply the changes. See the *SL8500 User's Guide* for information.**
Reconfiguration starts. Wait for reconfiguration to complete.
4. **Enter MODify LSM (*lsm-range*) ONline**
where *lsm-range* is the range of LSMs where the CAP changes are being made.
5. **Enter Display Cap to verify the CAP changes to the library.**
6. **Start HSC activity.**

Varying the ACS Online After a Configuration Change

In several partitioning procedures, there is a “vary ACS online” step that needs to be performed when a hardware configuration change is completed for an SL3000 library. When this step is executed, the HSC will run a reconfiguration for the ACS that is affected. During Reconfiguration of an ACS, the following occurs:

- The ACS configuration containing details of the LSM is read from the library.
- CAP and drive configuration information are read from the library.
- Library configuration information (LSM, CAP, and drive) is then synchronized with the equivalent information in the HSC database.
- LSM cell geography is discovered and updated in the HSC database.

Below is an HSC log example of an SL3000 ACS that change from a library with a Basic Expansion Module (BEM) to a library with a BEM, a DEM, and 2 CEMs:

```
/SLS0000I V ACS 00 ONLINE
/SLS4459I Library configuration changes started
/SLS4400I HSC dynamic reconfiguration initiated
/SLS0668I LSM 00:00 READY; TEMP OUTAGE QUEUE WILL BE RE-DRIVEN.
/SLS0054I ACS 00 now ONLINE
/SLS4415I Configuration change for LSM 00:00, total cells increased by
      1,148, free cells increased by 748
/SLS4419I CAP 00:00:04 status changed from UNALLOCATED to OFFLINE
/SLS4419I CAP 00:00:05 status changed from UNALLOCATED to OFFLINE
/SLS4419I CAP 00:00:07 status changed from UNALLOCATED to OFFLINE
/SLS1969I User exit 06 module SLSUX06 INACTIVE
/SLS4407I HSC dynamic reconfiguration processing has ended.
/SLS4460I Library configuration changes complete on ECCL
```

Configuring VTCS

If you license VTCS, it's now time to configure VTCS, which you do with the VTCS CONFIG utility...so now would be a good time to open up your *ELS Command, Control Statement, and Utility Reference*.

Much of the CONFIG deck is devoted to what you would expect...defining to VTCS the essential virtual/hardware parts of the VSM solution...VTSSs, VTVs, VTDs, and RTDs. What you **also** have the option of doing is setting non-default operating values, which we discussed in [Chapter 2, "Planning VTCS Operating Policies"](#).

Tip – One of the big pluses of ELS 7.2 is that you no longer have to define VTVs and MVCs via CONFIG...now, it's all done via the POOLPARM/VOLPARM statements, which you created in ["Defining MVCs"](#) on page 112 and ["Defining VTVs"](#) on page 113.

This chapter has two major CONFIG sections:

- “Building a Simple CONFIG Deck” on page 205 is basically a procedure where we build an example basic CONFIG deck step by step. To lead you through this, we’ll do it in ordered fashion, building the CONFIG deck as we go, as described in TABLE 6-1.
- “Special Cases: A Gallery of Advanced Uses of CONFIG” on page 277 shows variations of the CONFIG deck beyond the basic model, such as the deck where you disable a host from initiating migrations.

TABLE 6-1 VTCS Configuration Tasks

Step	Notes	Planning Information
Step 1 on page 206	Are you doing an upgrade install? Then you want to run DECOM to get a true picture of your current configuration. You can then update the DECOM listing and resubmit it to CONFIG to update your configuration. Typically, you run DECOM with the highest level of the VTCS (6.0 or 6.1) that supports the CDS ‘from’ level. First time install? Skip on down to Step 2 on page 206.	
Step 2 on page 206	The actual CDS level specification is pretty easy but deciding which level takes some Deep Thought, so please study carefully the planning section before you begin coding...	“CDS VTCS Level Requirements” on page 20
Step 3 on page 207	This is where you specify global operating policies, such as the number of free MVCs...if you want to. Remember, you can always take the defaults, and tune things up later...	“Planning VTCS Operating Policies” on page 41
Step 4 on page 207	Moving right along to the MVC reclamation policies...	“MVC Policies” on page 76
Step 5 on page 208	...and, to complete the hardware definitions, CONFIG statements for the system’s VTSSs, the RTDs attached to the VTSSs, and the VTDs in each VTSS.	<ul style="list-style-type: none"> ■ “Planning for VTSSs” on page 37 ■ “Planning for Library-Attached Transports” on page 27 ■ “Planning for VTDs” on page 38

Building a Simple CONFIG Deck

The following procedure shows how to build a simple CONFIG deck. For more complex examples, see [“Special Cases: A Gallery of Advanced Uses of CONFIG”](#) on page 277.

Caution – StorageTek **strongly recommends** that you **do not** “pre-define” hardware via the CONFIG deck (for example, by defining VTSSs that are not physically installed but will be in the future). **Only** use CONFIG to define hardware that is actually installed.

To build a simple CONFIG deck:

1. Run the VTCS DECOM Utility...

...if you're doing an upgrade install. Otherwise, skip to [Step 2](#).

[FIGURE 6-1](#) shows example JCL to run the DECOM utility with output to flat file CFG22202.

```
//DECOM EXEC PGM=SLUADMIN,PARM='MIXED'  
//STEPLIB DD DSN=hlq.SEALINK,DISP=SHR  
//SLSCNTL DD DSN=hlq.DBASEPRM,DISP=SHR  
//SLSCNTL2 DD DSN=hlq.DBASESEC,DISP=SHR  
//SLSSTBY DD DSN=hlq.DBASEBY,DISP=SHR  
//CFG22202 DD DSN=hlq.CFG22202,DISP=SHR  
//SLSPRINT DD SYSOUT=*  
//SLSIN DD *  
DECOM FLATDD(CFG22202)
```

FIGURE 6-1 Example JCL for the DECOM utility

2. Start the CONFIG deck by specifying the CDS Level.

[FIGURE 6-2](#) shows CONFIG JCL example to specify CDS level G.

```
//CREATECF EXEC PGM=SLUADMIN,PARM='MIXED'  
//STEPLIB DD DSN=hlq.SEALINK,DISP=SHR  
//SLSCNTL DD DSN=hlq.DBASEPRM,DISP=SHR  
//SLSCNTL2 DD DSN=hlq.DBASESEC,DISP=SHR  
//SLSSTBY DD DSN=hlq.DBASEBY,DISP=SHR  
//SLSPRINT DD SYSOUT=*  
//SLSIN DD *  
CONFIG CDSLEVEL(V62ABOVE)
```

FIGURE 6-2 CONFIG Example: CDSLEVEL(V62ABOVE) to Specify Level G

Note – In [FIGURE 6-2](#), per VTCS NCO support, we do not have to specify RESET. RESET is **not** required when going from F to G level but all hosts accessing the CDS must be at VTCS/NCS 7.0 during the CDS level change. See *ELS Command, Control Statement, and Utility Reference* for details about when RESET is required.

3. Specify global values.

FIGURE 6-3 shows our example CONFIG deck all spruced up with global values. .

```
//CREATECF EXEC PGM=SLUADMIN,PARM='MIXED'  
//STEPLIB DD DSN=hlq.SEALINK,DISP=SHR  
//SLSCNTL DD DSN=hlq.DBASEPRM,DISP=SHR  
//SLSCNTL2 DD DSN=hlq.DBASESEC,DISP=SHR  
//SLSSTBY DD DSN=hlq.DBASETBY,DISP=SHR  
//SLSPRINT DD SYSOUT=*  
//SLSIN DD *  
CONFIG RESET CDSLEVEL(V62ABOVE)  
GLOBAL MAXVTV=65000 MVCFREE=60 VTVATTR=SCRATCH RECALWER=YES  
VTVPAGE=LARGE MAXRTDS=32 FASTMIGR=YES
```

FIGURE 6-3 CONFIG example: Specifying Global Values

Tip – If a Lock Structure is already defined to VTCS, you can use DECOM, Display CONFIG, and Display LOCKS to display information about the Lock Structure.

4. Specify reclamation policy values.

FIGURE 6-4 shows our example CONFIG deck, now sporting reclamation policy values.

```
//CREATECF EXEC PGM=SLUADMIN,PARM='MIXED'  
//STEPLIB DD DSN=hlq.SEALINK,DISP=SHR  
//SLSCNTL DD DSN=hlq.DBASEPRM,DISP=SHR  
//SLSCNTL2 DD DSN=hlq.DBASESEC,DISP=SHR  
//SLSSTBY DD DSN=hlq.DBASETBY,DISP=SHR  
//SLSPRINT DD SYSOUT=*  
//SLSIN DD *  
CONFIG RESET CDSLEVEL(V62ABOVE)  
GLOBAL MAXVTV=65000 MVCFREE=60 VTVATTR=SCRATCH RECALWER=YES  
LOCKSTR=STK_VTCS_LOCKS VTVPAGE=LARGE MAXRTDS=32 FASTMIGR=  
YES  
RECLAIM THRESHLD=70 MAXMVC=30 START=40 CONMVC=5
```

FIGURE 6-4 CONFIG example: Specifying Reclamation Values

5. Define VTSSs, RTDs, and VTDs.

FIGURE 6-5 shows our example CONFIG deck that next defines our VTSSs, the RTDs attached to each VTSS (both VSM4s), and the VTDs in each VTSS. **Note that** the RTD and VTD definitions immediately follow the VTSS statement.

```
//CREATECF EXEC PGM=SLUADMIN,PARM='MIXED'
//STEPLIB DD DSN=hlq.SEALINK,DISP=SHR
//SLSCNTL DD DSN=hlq.DBASEPRM,DISP=SHR
//SLSCNTL2 DD DSN=hlq.DBASESEC,DISP=SHR
//SLSSTBY DD DSN=hlq.DBASESTBY,DISP=SHR
//SLSPRINT DD SYSOUT=*
//SLSIN DD *
CONFIG RESET CDSLEVEL(V62ABOVE)
GLOBAL MAXVTV=65000 MCVFREE=60 VTVATTR=SCRATCH RECALWER=YES
LOCKSTR=STK_VTCS_LOCKS VTVPAGE=LARGE MAXRTDS=32 FASTMIGR=
YES
RECLAIM THRESHLD=70 MAXMVC=30 START=40 CONMVC=5
VTSS NAME=VSM41 LOW=70 HIGH=80 MAXMIG=8 MINMIG=4 RETAIN=5
RTD NAME=PR11A00 DEVNO=1A00 CHANIF=0C
RTD NAME=PR11A01 DEVNO=1A01 CHANIF=0D
RTD NAME=PR11A02 DEVNO=1A02 CHANIF=0K
RTD NAME=PR11A03 DEVNO=1A03 CHANIF=0L
RTD NAME=PR12A08 DEVNO=2A08 CHANIF=1C
RTD NAME=PR12A09 DEVNO=2A09 CHANIF=1D
RTD NAME=PR12A0A DEVNO=2A0A CHANIF=1K
RTD NAME=PR12A0B DEVNO=2A0B CHANIF=1L
VTD LOW=9900 HIGH=99FF
VTSS NAME=VSM42 LOW=70 HIGH=80 MAXMIG=8 MINMIG=4 RETAIN=5
RTD NAME=PR23A00 DEVNO=3A00 CHANIF=0C
RTD NAME=PR23A01 DEVNO=3A01 CHANIF=0D
RTD NAME=PR23A02 DEVNO=3A02 CHANIF=0K
RTD NAME=PR23A03 DEVNO=3A03 CHANIF=0L
RTD NAME=PR24A08 DEVNO=4A08 CHANIF=1C
RTD NAME=PR24A09 DEVNO=4A09 CHANIF=1D
RTD NAME=PR24A0A DEVNO=4A0A CHANIF=1K
RTD NAME=PR24A0B DEVNO=4A0B CHANIF=1L
VTD LOW=9900 HIGH=99FF
```

FIGURE 6-5 CONFIG example: Defining VTSSs

Updating the Tape Management System for VSM

To update your tape management system (such as CA-1 and CA-Dynam/TLMS), do the following:

- Add volser ranges for VTVs to your tape management system. Ensure that you do *not* assign vault codes to VTVs.
- Access to the MVCs via an RTD bypasses the MSP intercepts put in place by the tape management system so that it does *not* record within its database any access to the MVCs by VSM and does *not* automatically provide protection against inadvertent overwrites of non-expired data on MVCs. Therefore, if you choose to define MVCs to the tape management system, StorageTek **strongly recommends** that you define them as non-scratch, non-expiring volumes.
- The tape management system requires an entry in the MSP Subsystem Name Table; this entry must precede the entry for SMC.

Note – If you are using AutoMedia for MSP, ensure that VTVs are defined as virtual volumes to direct AutoMedia to bypass DSN checking, which allows AutoMedia to recall, mount, and reuse non-resident scratch VTVs.

Caution – Note the following:

- VTCS has an automatic interface to notify RMM when a VTV becomes scratch but RMM does not notify VTCS when you unscratch a VTV by changing the CV status to non-scratch. If this is done, you must also run the HSC SLUADMIN utility to unscratch the VTV for VTCS. Otherwise, you may encounter a mount failure when VTCS attempts to select the VTV to service a scratch mount request.
 - RMM has additional integrity checks at mount time to ensure that the correct volume has been mounted. Because VTCS has features and optimizations that sometimes present a new initialized version of a VTV rather than the current copy of a VTV, it is necessary for VTCS to override these RMM integrity checks. VTCS does these overrides via the LISTVOLUME and CHANGEVOLUME API calls to update the RMM database. You must therefore ensure that HSC has been given the appropriate security access to the RMM API. For more information, see your RMM documentation.
-

Defining MVC Pool Volser Authority

When VSM needs to mount an MVC and to write to an MVC, a SAF query is issued to verify that the HSC user (see “Defining A Security System User ID for HSC and VTCS” on page 92) has UPDATE authority for the MVC. The SAF query is issued on behalf of HSC and passed to the system security product (such as RACF, CA-ACF2, or CA-Top Secret).

VSM requires UPDATE authority for the volsers in the MVC pool. All other users should have an access of NONE for these volsers. Similarly, VSM should not have UPDATE authority for any volsers that are not in the MVC pool. See the documentation for your security product for procedures to add the appropriate tape volume security for VSM. TABLE 6-2 summarizes these definitions.

TABLE 6-2 Security Class, Resource Class, and Access Values for MVC Pool Volser Authority

Class	Resource Name	Recommended User Access Levels
tape volume security	MVC Pool Volume Serials	UPDATE - allows VSM to write on MVC

FIGURE 6-6 shows an example of a RACF profile and permissions commands to give the user ID VSM8HSC update access to MVC volser CVC024.

```

*****
* Define a profile in the TAPEVOL security class for MVC CVC024 *
*****
RDEFINE TAPEVOL security CVC024 UACC(NONE)
***** Allow user ID
VSM8HSC update access to MVC CVC024 *
*****PERMIT CVC024
CLASS(TAPEVOL) ACCESS(UPDATE) ID(VSM8HSC)
*****

```

FIGURE 6-6 Example RACF MVC volser access file

Caution – Note the following:

- To ensure that MVCs are not accidentally overwritten, for each MVC volser, you must update your TAPEVOL security as described above and your tape management system. For more information, see [“Updating the Tape Management System for VSM” on page 209](#).
- You must also run the HSC UNSCratch Utility to unscratch any current scratch cartridges in the MVC range. For more information, see *Managing HSC and VTCS*.
- Depending on the default settings of your security system, VSM may not be able to mount and to write to MVCs until you have defined a security system user ID for HSC and TAPEVOL profiles for the MVCs.
- If you add new ranges of MVCs to your VSM system, remember to update the TAPEVOL profiles to include the new ranges.

Starting and Stopping HSC

If you're a new customer, you have to start HSC. If you're an existing customer doing an upgrade *and* all of your configuration changes are non-disruptive, you will not have to restart HSC.

Starting HSC

To start HSC:

1. **Ensure that you have completed ELS installation and configuration...**

...as described in *Installing ELS* and *Configuring HSC and VTCS* (this book).

2. **Modify your HSC start-up JCL procedure as required.**

For more information, see [“Creating and Cataloging the HSC Startup Procedure” on page 119](#).

3. **Enter the MSP START command to run HSC startup procedure:**

For example:

```
S SLSO
```

If your CDS configuration contains VTCS configuration data, VTCS starts automatically unless you specify the startup parameter NOVTC (for more information, see [“Creating and Cataloging the HSC Startup Procedure” on page 119](#)). For more information on startup scenarios, see [“HSC Startup Scenarios” on page 215](#).

Note –

- If your SMF options for HSC did not specify the SUBTYPE parameter, HSC issues a message that SMF record subtypes 1 through 6 are being recorded.
 - If you did not specify GTF EID and FID parameters on the PARM operand in HSC start procedure, HSC issues a message indicating that default EID and FID values are being used.
 - HSC can be started prior to hardware arrival to make sure that it has been installed properly. HSC subsystem comes up with the LMU stations offline. HSC operator commands may be entered but any functions requiring interaction with the ACS hardware result in error messages.
 - Alternately, a JCL substitution symbol may be specified in HSC cataloged procedure, and additional parameters passed via the START command using the substitution symbol.
 - HSC can be initialized to a full or base service level by issuing the MSP START command. HSC can also be preinitialized or initialized under the MSP Master subsystem (MSTR) through the START command.
 - In a multiple-host configuration, start one host at a time. **Do not bring up multiple hosts simultaneously.**
-

4. **Start SMC.**

For more information, see *Configuring and Managing SMC* .

5. **If necessary, do post-startup tasks.**

These are required *only* when the CDS is first initialized:

- All LSMs are offline, so vary them online with HSC MODify ONLINE. For subsequent executions of HSC, the last recorded status of the LSMs is obtained from the CDS.
- All CAP preferences are zero (never selected), so use the CAPPREF command to set CAP preferences.

HSC Startup Scenarios

TABLE 7-1 shows examples of the START command options, which are further described in the following sections.

TABLE 7-1 HSC Initialization

HSC Start Command	Proc Name Same as IEFSSNxx Entry	SLSBPREI in IEFSSNxx or Previous HSC Start With PARM='INIT'
HSC Started Under MSTR and PROC in SYS1.PROCLIB		
S SLS0	Yes	No
S SLS0,SUB=MSTR	Yes	Ignored
S SLS0,PARM='SSYS(SLS0)',SUB=MSTR	No	Ignored
HSC Started Under JES and PROC in Any PROCLIB		
S SLS0	Yes	Yes
S SLS0,PARM='SSYS(SLS0)'	No	Yes
S SLS0,PARM='INIT,SSYS(SLS0)' S SLS0,PARM='SSYS(SLS0)'	No	No

IPLing the System

A system IPL is required after defining HSC as a subsystem via the Subsystem Name Table entry SUBSYSxx for the first time. Once HSC has been defined, you do not need to re-IPL to stop and start HSC. If you are migrating from a previous HSC release and HSC is defined in the IEFSSNxx member, then a system IPL is not required. You must perform a COLD start at the first HSC startup. Subsequent HSC startups should not require a COLD start unless a problem is encountered.

If you are using SLSBPREI to initialize HSC under JES, see [“Preinitializing HSC as an MSP Subsystem”](#) on page 216 for additional information about starting HSC.

If you are **not** using SLSBPREI, refer to [“Initializing HSC Under the Master Subsystem”](#) on page 216 for additional information about starting HSC without SLSBPREI.

Preinitializing HSC as an MSP Subsystem

HSC must be initialized as an MSP Subsystem. There are two ways to preinitialize HSC:

- specifying SLSBPRES as HSC subsystem initialization routine in the IEFSSNxx member of the system PARMLIB and IPLing MSP as follows:

```
SUBSYS SUBNAME(SLS0) INITRTN(SLSBPRES) /* keyword format */
```

Note – SLSBPRES must reside in SYS1.LINKLIB or its link list. After installation, copy the SLSBPRES module from HSC SEALINK to a library in the MSP link list.

Initializing HSC Under the Master Subsystem

If you want to initialize HSC under the Master subsystem (MSTR), consider the following:

- If SLSBPRES is **not** part of the subsystem definition in IEFSSNxx or a previous initialization of the subsystem occurred using the INIT parameter, then enter the following to start HSC under Master subsystem control:

```
S SLS0,SUB=MSTR
```

- If SLSBPRES is **not** part of the subsystem definition in IEFSSNxx and the subsystem name is the same as the startup procedure name, then no preinitialization or SUB=MSTR is necessary:

```
S SLS0
```

- If you want to initialize HSC under JES later, you can use the INIT parameter to preinitialize HSC.
- When running HSC under the Master subsystem, JES services are not used. It is also possible to receive duplicate messages in the system log.

Starting HSC As a Subsystem

If the EXEC statement PARM parameter specifies a subsystem, you can start HSC as a subsystem. For more information, see [“EXEC Statement” on page 121](#). For example:

```
S SLS0,PARM='SSYS(SLS0)'
```

Specifying the HSC Service Level at Startup

To start HSC at Full Service Level:

```
S SLS0
```

To start HSC at Base Service Level:

```
S SLS0,PARM='BASE'
```

The BASE parameter should be used with other parameters in the START command since these parameters override whatever is specified in HSC START Procedure. A sample START command with parameters is:

```
S SLS0,PARM='BASE E(086) F(23) M(00) SSYS(SLS0)'
```

Starting the HSC Behavior Change

For a partitioned SL8500 and SL3000 libraries, NCO will automatically be invoked at HSC startup. This must be done for HSC to update these libraries' configuration for HSC to operate properly. Below is an example of new messages seen during HSC startup:

```
SLS0054I ACS 00 now ONLINE
SLS0668I LSM 00:00 IS OFFLINE; TEMP OUTAGE QUEUE HAS BEEN PURGED.
SLS0054I ACS 01 now ONLINE
SLS0668I LSM 01:00 IS OFFLINE; TEMP OUTAGE QUEUE HAS BEEN PURGED.
SLS2256I Automatic CAP Service AVAILABLE
SLS1505I HSC service level FULL initialization complete
SLS4459I Library configuration changes started
SLS0668I LSM 01:01 IS OFFLINE; TEMP OUTAGE QUEUE HAS BEEN PURGED.
SLS0668I LSM 01:02 IS OFFLINE; TEMP OUTAGE QUEUE HAS BEEN PURGED.
SLS0668I LSM 01:03 IS OFFLINE; TEMP OUTAGE QUEUE HAS BEEN PURGED.
SLS4400I HSC dynamic reconfiguration initiated
SLS4402I CDS drive record not found for existing transport; id = 00:00:10:00
SLS4402I CDS drive record not found for existing transport; id = 00:00:10:02
SLS4405D CDS / LMU conflicts exist; allow dynamic reconfig to proceed; Reply 'Y' or 'N'
SLS4419I CAP 00:00:01 status changed from UNALLOCATED to OFFLINE
SLS4419I CAP 00:00:03 status changed from UNALLOCATED to OFFLINE
SLS4419I CAP 00:00:04 status changed from UNALLOCATED to OFFLINE
SLS4414I Initial configuration for LSM 00:00, total cells 2,710, free cells 2,710
SLS4407I HSC dynamic reconfiguration processing has ended.
SLS4460I Library configuration changes complete on ECCL
SLS4459I Library configuration changes started
SLS4400I HSC dynamic reconfiguration initiated
SLS4402I CDS drive record not found for existing transport; id = 01:00:01:00
SLS4402I CDS drive record not found for existing transport; id = 01:00:01:01
SLS4402I CDS drive record not found for existing transport; id = 01:00:01:02
SLS4402I CDS drive record not found for existing transport; id = 01:00:01:03
SLS4405D CDS / LMU conflicts exist; allow dynamic reconfig to proceed; Reply 'Y' or 'N'
SLS4401I LSM/Rail 01:02 successfully unallocated from current HSC configuration
SLS4401I LSM/Rail 01:03 successfully unallocated from current HSC configuration
SLS4407I HSC dynamic reconfiguration processing has ended.
SLS4460I Library configuration changes complete on ECCL
```

Configuration Mismatches

During HSC initialization, HSC remains active if LSM or panel type configuration mismatches occur between the CDS and LMU. Specifically, these mismatches include different:

- Numbers of LSMs
- Or unknown types of LSMs
- Or unknown panel types in an LSM.

In these cases, the affected ACS(s) are forced offline. HSC continues to support the unaffected ACS(s), and you can correct the configuration problems and bring the affected ACSs back online.

Stopping HSC

You can stop HSC in either of two ways:

- By first quiescing HSC, which you do with the MSP STOP command, where:
 1. HSC waits for pending work to complete. This includes actions against the LMU such as current mounts and dismounts, utilities, active CAPs, operator commands, and station termination(s).
 2. HSC updates the CDS and journals as pending work completes.
 3. HSC cleans up resources, terminates, and displays a termination message on the system console.
- By forcing HSC termination with the MSP Cancel command.

If this doesn't stop HSC, enter another Cancel command. If *this* doesn't work, use the MSP FORCE command.

Caution – StorageTek **does not** recommend forced termination of HSC because unpredictable results may occur on startups following forced terminations.

A forced termination of HSC causes all HSC processes to abort immediately and termination occurs. Any of the following can occur:

- Volumes can be left in-transit, however, mounted volumes are not affected by forced HSC termination.
 - Outstanding utilities can abend.
 - The CDS and journals can lose synchronization.
-

If you **do** choose to force HSC termination:

1. Before forcing termination, verify that alternative library paths exist for the active SMC to continue performing allocation influencing and mount automation.
2. Errant volume records are created for volumes left in the playground, CAPs, or passthru ports. Operator intervention may be required to resolve the status of errant volumes when HSC execution is resumed. Transports may require operator intervention to satisfy mount requests.

ELS Configuration Record

TABLE A-1 lists the configuration values you determined. It also provides a record of your site's ELS configuration, which can help you and Sun StorageTek service troubleshoot problems with your ELS system.

TABLE A-1 ELS Configuration Record

Configuration Value	Planning Information	Your Site's Selection
HSC/VTCS Configuration Values		
CDS DASD space	"CDS DASD Space Requirements" on page 18	
CDS VTCS Level	"CDS VTCS Level Requirements" on page 20	
Host-to-Host Communication options	"Host-to-Host Communication options" on page 24	
SL8500 and SL3000 cartridge capacity	"Calculating Cartridge Capacity - SL8500 and SL3000" on page 25	
SL8500 configuration parameters	"Planning for the SL8500" on page 26	
Library transports, unit addresses	"Planning for Library-Attached Transports" on page 27	
Library volumes, volsers, media types, pools	"Planning for Library Volumes" on page 29	
LSM IP Addresses	"LIBGEN Macro Samples" on page 253	
LSM PTP Relationships	"LSM Pass-Thru Port (PTP) relationships" on page 24	
Library Transport Address	"Planning for Library-Attached Transports" on page 27	
HSC Security System ID	"Defining Command Authority" on page 118	
HSC Start parameters	"Creating and Cataloging the HSC Startup Procedure" on page 119	
HSC Start procedure	"Starting HSC" on page 214	

TABLE A-1 ELS Configuration Record

VTSS names	"Planning for VTSSs" on page 37	
VTD unit addresses	"Planning for VTDs" on page 38	
VTV volsers (all)	"Planning for VTVs" on page 39	
VTV volsers (scratch pool ranges)		
RTD unit addresses	"Planning for library-attached transports as RTDs" on page 28	
MVC VOLSERS - POOLPARM/VOLPARM statements	"Guidelines for MVCs" on page 29	

TABLE A-1 ELS Configuration Record

	VTSS Policies	
AMT settings	“AMT Settings” on page 45	
VTV Page Size	“VTV Page Size” on page 48	
Maximum and minimum concurrent automatic migration, immediate migration, and migrate-to-threshold tasks (CONFIG MAXMIG/MINMIG)	“Prioritizing Automatic and Immediate Migration Workloads” on page 65	
	VTV Policies	
Maximum VTVs per MVC (CONFIG MAXMVC)	“Maximum VTVs per MVC” on page 55	
Hosts disabled from migration, consolidation, and export by VTV or Management Class (CONFIG NOMIGRAT)	“Hosts Disabled from Reclamation” on page 86	
Recall VTVs with Read Data Checks	“Recall VTVs with Read Data Checks” on page 57	
	MVC Space Reclamation Policies	
MVC fragmented space thresholds	<ul style="list-style-type: none"> ■ “Standard Reclaim Threshold - Determines MVC Eligibility for Reclamation (Requires Recall/Remigration)” on page 78 ■ “Dynamic Reclaim Threshold - No MVC Mount or VTV Recall/Remigration Occurs” on page 79 	
Free MVCs threshold (CONFIG MVCFREE)	“Free MVCs Threshold - Starts Automatic Space Reclamation” on page 83	
Eligible/Total MVCs threshold (CONFIG START)	“Eligible/Total MVCs Threshold - Starts Automatic Space Reclamation” on page 84	
Maximum MVCs processed per reclaim (CONFIG MAXMVC)	“Maximum MVCs Processed Per Reclaim” on page 85	
Maximum MVCs Concurrently Processed for Reclamation and Drain	“Maximum MVCs Processed Per Reclaim” on page 85	
Hosts disabled from reclamation (CONFIG NORECLAM)	“Hosts Disabled from Reclamation” on page 86	
MVC retain interval	“MVC Retain Interval” on page 87	
HSC Configuration Values		

TABLE A-1 ELS Configuration Record

HSC CDS DASD space	"CDS DASD Space Requirements" on page 18	
LSM IP Addresses	"LIBGEN Macro Samples" on page 253	
LSM PTP Relationships	"LSM Pass-Thru Port (PTP) relationships" on page 24	
Library Transport Address	"Planning for Library-Attached Transports" on page 27	
HSC Security System ID	"Defining Command Authority" on page 118	
HSC Start parameters	"Creating and Cataloging the HSC Startup Procedure" on page 119	
HSC Start procedure	"Starting HSC" on page 214	
HSC Configuration Settings		

HSC LIBGEN Macros

This appendix describes the HSC LIBGEN macros.

SLIACS

The SLIACS macro defines the following items:

- the communication paths between a host (or hosts) and an ACS
- the LSMs attached to an ACS
- preallocating space in the CDS for additional SL8500 LSMs.

There must be one and only one SLIACS macro for each ACS.

The SLIACS macro for the first ACS must appear immediately after the SLIALIST macro. The SLIACS macro for each subsequent ACS must appear immediately after the last SLIDRIVS macro for the prior ACS definition.

Syntax

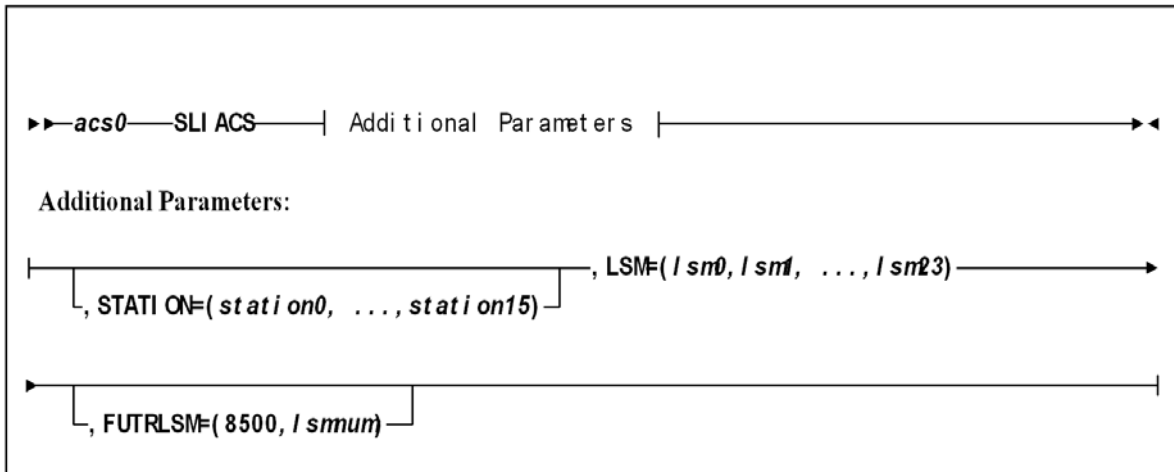

FIGURE 7-1 SLIACS Syntax

Parameters

acs0

assembler label referred to by the SLIALIST macro ACS positional parameter.

SLIACS

name of this macro.

STATION=

station0, ..., station15 are the assembler labels of the SLISTATN macro. They define the station numbers used to communicate between a host and an ACS. Multiple hosts (maximum of 16) may refer to the same SLISTATN macro.

Note – To establish communication with an ACS if the LIBGEN SLISTATN macro has been omitted, use the SET SLISTATN utility to add station addresses for the ACS. See *ELS Command, Control Statement, and Utility Reference* for a description of this utility.

This parameter is optional.

If STATION is specified, parameters can be omitted for hosts that are not attached to the ACS by using the comma delimiter as follows:

STATION=(,STN1)

where Host0 does not have a defined connection and STN1 is a defined connection to Host1.

Note – Users running TCP/IP LMU network attachment are not required to supply either SLIACS station number or SLISTATN station address statements. However, if you intend to transition between TCP/IP and 3270 station connections, you should specify both the SLIACS STATION labels and SLISTATN ADDRESS settings.

If STATION is omitted, the ACS has no defined 3270 connections to any host. Leaving out this parameter is desirable if the user wants to define a future ACS and automatically bypass the “ACS *acs-id* is disconnected” message.

Examples:

If the SLILIBRY macro has been entered as:

SLILIBRY HOSTID(MSP0,MSP1)

and, if the STATION parameter is specified as:

STATION=(STN0),

STN0 corresponds to MSP0.

If STATION is specified as:

STATION=(STN0,STN1),

STN0 corresponds to MSP0, and STN1 corresponds to MSP1.

LSM, LSM2, LSM3, LSM4=

lsm0,lsm1 ... are the assembler labels of the SLILSM macros that define each LSM configured within the ACS.

The number of assembler labels that can be specified on an **LSM**, **LSM2**, **LSM3**, or **LSM4** parameter is variable and depends on the length of each label, the number of imbedded commas, and the opening and closing parentheses.

The total number of characters specified cannot exceed the Fujitsu limitation of 255 characters. The **LSM2**, **LSM3**, and **LSM4** are optional parameters not required if the number of LSMs in the ACS and your naming convention results in a string length less than 255 characters.

For example, if each assembler label is four characters long, a maximum of 50 assembler labels can be specified on the **LSM** parameter:

200 label characters + 49 imbedded commas + 2 parentheses =
251 characters

Adding another assembler label results in a LIBGEN assembly error. To resolve this problem, add an **LSM2** parameter on the SLIACS macro and specify the fifty-first assembler label on that parameter.

In general, if the ACS contains more LSMs (assembler labels) than can be supported by the **LSM** parameter, you must code **LSM2**, **LSM3**, or **LSM4** parameters, as necessary, for the other LSMs. It is recommended that you code additional **LSMx** parameters in ascending order for easier maintainability. Also, note that there is an architectural limit of 256 LSMs for each ACS.

Examples:

```
LSM=(L000)  
LSM=(L000,L001,L002)
```

```
FUTRLSM=
```

8500 indicates to preallocate space in the CDS for SL8500 LSMs. This space is used when new LSMs are to be added to the ACS through PTP connections.

lsmnum defines the number of future preformatted LSM records written to the CDS. The number specified must be between 4 and 124.

This parameter is optional.

Note –

- An SL8500 library contains four rails (LSMs), thus the *lsmnum* value must be in multiples of four (4, 8, 12, 16, and so on).
 - If the number specified in *lsmnum* is too small, another LIBGEN will be required to add additional LSMs. If the number entered for *lsmnum* is too large, the result is unused CDS space reserved for future expansion.
-

SLIALIST

The SLIALIST macro contains the assembler labels of the SLIACS macro(s). The first ACS listed has an ACSid of 00, the second 01, etc.

Syntax

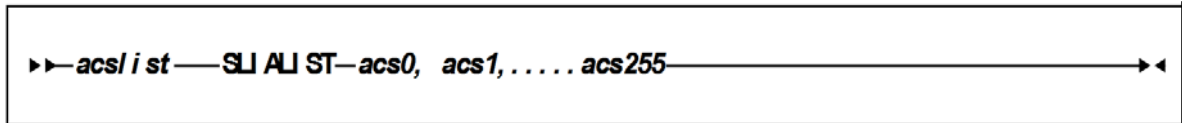

FIGURE 7-2 SLIALIST Syntax

Parameters

`acslist`

assembler label referred to by the SLILIBRY macro ACSLIST parameter.

`SLIALIST`

name of this macro.

`acs0,acs1,...,acs255`

label name used by the SLIACS macro(s). One label name is specified for each ACS, and at least one label name is required.

The order of the SLIACS label names is important. The ACSs are defined in sequence order. For example, label `acs0` assigns that SLIACS macro to ACS 00, label `acs1` assigns that SLIACS macro to ACS 01 and so forth.

If the FUTRACS parameter is specified on the SLILIBRY macro, an unallocated ACS can be created by omitting a label name. For example, to create three ACSs where one ACS is unallocated:

`ACSLIST SLIALIST ACS0,,ACS2`

An unallocated ACS can be added as a functioning ACS to the HSC configuration by using the MODify CONFIG ADD ACSTYPE command as described in [“Adding SL8500 or SL3000 ACSs” on page 155](#).

SLIDLIST

Each SLIDLIST macro specifies an assembler label corresponding to a SLIDRIVS macro which identifies the unique host addresses associated with the transports residing on a cartridge drive panel.

The first SLIDLIST macro for an LSM must appear immediately after the SLILSM macro which refers to it. Subsequent SLIDLIST macros for the LSM must appear immediately after the last SLIDRIVS macro for the preceding SLIDLIST macro.

Syntax



FIGURE 7-3 SLIDLIST Syntax

Parameters

drvelst0

specifies the assembler label that is referred to by the SLILSM macro DRVELST parameter.

SLIDLIST

name of this macro.

HOSTDRV=

(*drives0*,...,*drives15*) specifies the assembler label name of each SLIDRIVS macro which defines transport addresses.

Note – The HOSTDRV operands are positional. The SLILIBRY macro HOSTID parameter determines the positional ordering of the operands specified in the HOSTDRV parameter. The first operand specified in the HOSTDRV parameter corresponds to the first host specified in the SLILIBRY macro HOSTID parameter, etc.

Examples:

HOSTDRV=(DRV0)

where DRV0 is for Host0

HOSTDRV=(DRV0,DRV1)

where DRV0 is for Host0 and DRV1 is for Host1

HOSTDRV=(DRV0,DRV0)

where DRV0 is for Host0 and DRV0 is for Host1

SLIDRIVS

The SLIDRIVS macro lists the transport device addresses used by a host, which correspond to a specific cartridge drive panel. A SLIDRIVS macro must be specified for each unique operand coded in the SLIDLIST macro HOSTDRV parameter. The SLIDRIVS macro(s) must appear immediately following the SLIDLIST macro which references it.

Syntax

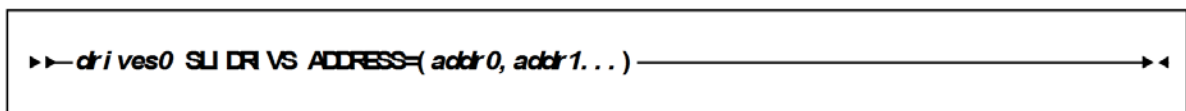

```
>> drives0 SLIDRIVS ADDRESS=( addr0, addr1... )
```

FIGURE 7-4 SLIDRIVS Syntax

Parameters

drives0

specifies the assembler label that is referenced by the SLIDLIST macro HOSTDRV parameter.

SLIDRIVS

name of this macro.

ADDRESS=

addr0,addr1,... specifies the host-unique device addresses associated with transports residing in a cartridge drive panel. Nonexistent transports are indicated by position-holding commas. Duplicate unit addresses are not allowed for a given host.

Note – If addresses exceed more than one line, place a comma after the last address and a nonblank character in column 72 (e.g., an X). Continue on the next line starting in column 16. Unlike control statements, no plus (+) or minus (-) continuation characters are required after the last parameter value.

Drives on a panel are defined from top to bottom. When multiple drive columns are present on a 9310 panel, the drive column on the left is defined first, followed by the drive column on the right (as viewed from outside the LSM). The HSC considers these addresses to be attached to an LSM. Verify the addresses you use with your Customer Service Engineer (CSE).

Examples:

ADDRESS=(410,411,412,413)	for a 4480 M24, 4490 M34, 9490 M34, 9490EE M34, or SD-3 H34 device
ADDRESS=(410,412,)	for a 4480 M22 or 4490 M32 device
ADDRESS=(,B75,,B76)	for a 9490 or 9490EE M32 or SD-3 H32 device
ADDRESS=(,B75,,)	for an SD-3 H31 device
ADDRESS=(,B75,B76,B77)	for an SD-3 H33 device
ADDRESS=(C10,C11,C12,C13,C14, X C15,C16,C17,C18,C19)	for a 9840, T9840B, T9840C, T9940A, or T9940B device (10-drive panel)
ADDRESS=(C10,C11,C12,C13,C14, X C15,C16,C17,C18,C19,C1A,C1B, X C1C,C1D,C1E,C1F,C20,C21,C22, X C23)	for a 9840, T9840B, T9840C, T9940A, or T9940B device (20-drive panel)
ADDRESS=(,,,9A01,,,9A02,,,9A03,,,9A04)	for an SL8500 device (16-drive panel)
ADDRESS=(,,,,00CA,,,,00CB,,,,00CC,,,, X 00CD,,,,00CE,,,,)	for an SL3000 device (24-drive panel)

Note –

- If you are executing the HSC as a remote server for the SMC, and drive addresses are defined differently on different HSC server hosts, you may need to specify either or both the HSC SET DRVHOST utility or the SMC DRIVEMAP command to define client/server drive mapping. Refer to the SMC DRIVEMAP command in the *Configuring and Managing SMC* and the SET DRVHOST utility in the *ELS Command, Control Statement, and Utility Reference*.
- You must specify at least one drive address for each ACS. For example, you cannot specify

ADDRESS=(,,)

for **all** drive addresses in an ACS.

Caution – If you fail to enter at least one drive address, the Database Decompile utility will fail against this CDS.

- The total number of drive positions, including position-holding commas, must be 4, 10, 16, or 20 depending on the LSM type:
 - 4410 or 9360 LSM, 4-drive panels are supported.
 - 9740 LSM, 4-drive or 10-drive panels are supported.
 - 9310 LSM, 4-drive, 10-drive, and 20-drive panels are supported.

- SL3000: 32 drives per panel are supported for panel 10; 24 drives per panel are supported for panel 12

Outside and back of the SL3000 library, drive panel numbering proceeds from top to bottom, right to left. [FIGURE B-1](#) shows an example of drive numbering for drive addresses on panels 12 and 10.

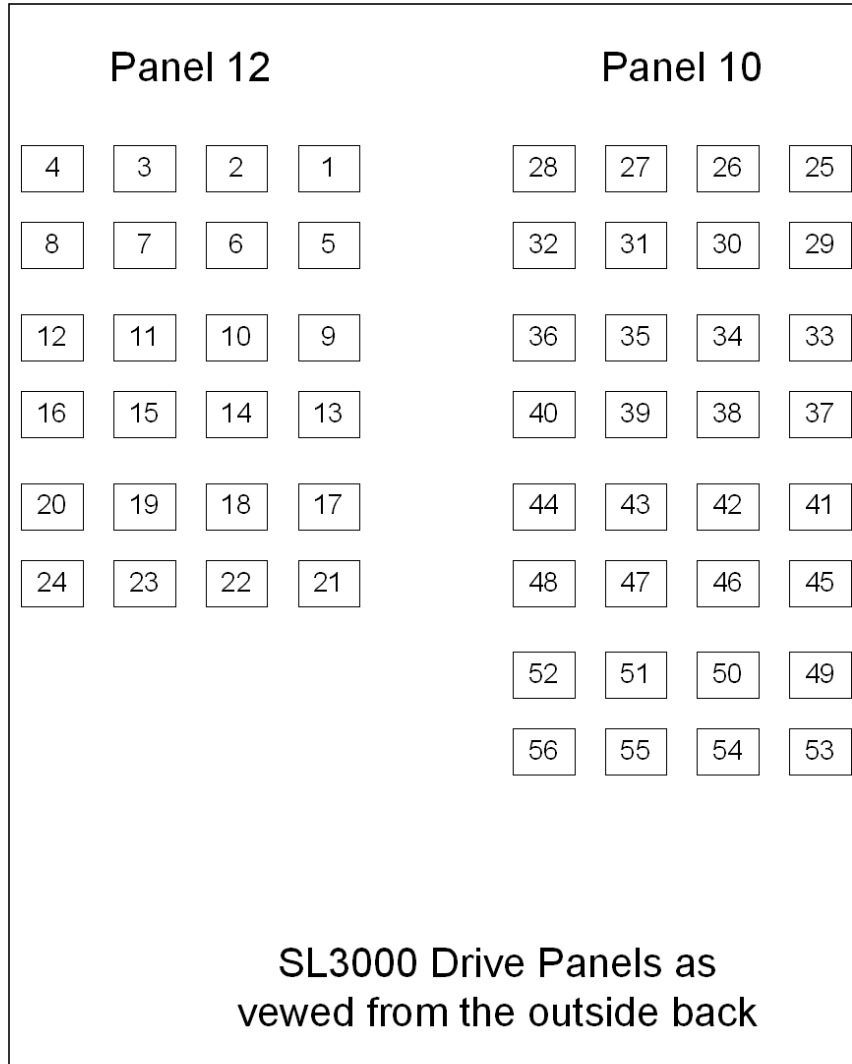

FIGURE B-1 SL3000 Drive Panel Layout

- SL8500, 16-drive panels are supported.
- Outside the SL8500 library, drive panel numbering proceeds from top to bottom, right to left, as viewed outside the structure from the drive end. TABLE 7-2 shows an example of drive numbering for drives on one LSM (LSM0) and drive addresses on drives 3 and 15.

TABLE 7-2 SL8500 Drive Panel Layout Example - Outside Library

LSM	Drive Panel				Row
	+2	+1	-1	-2	
LSM0 (Rail 1)	12	8	4	0	1
	13	9	5	1	2
	14	10	6	2	3
	15 (1624)	11	7	3 (1621)	4

Inside the library, drive panel numbering is top to bottom, left to right, as viewed inside the library from the CAP end. TABLE 7-3 shows the same drive configuration as TABLE 7-2.

TABLE 7-3 SL8500 Drive Panel Layout Example - Inside Library

LSM	Drive Panel				Row
	-2	-1	+1	+2	
LSM0 (Rail 1)	0	4	8	12	1
	1	5	9	13	2
	2	6	10	14	3
	3 (1621)	7	11	15 (1624)	4

To specify the drives above, the SLIDRIVs statement is:

SLIDRIVS ADDRESS=(,,1621,,,,,,,,,1624)

Refer to *Configuring HSC and VTCS* for more information.

- The total number of drive positions specified by all SLIDRIVS statements for a single panel must be the same.
- For an ExtendedStore library, panel 10 must be defined using commas to indicate nonexistent transports. Example:

ADDRESS=(,,)

- On all LSMs except the 9740, drives are defined to the HSC from top to bottom, with *addr0* representing the topmost drive and *addrn* the bottommost drive.

On a 9740 10-drive panel LSM, the drives are populated and configured in the 9740 LSM from bottom to top. (9740 4-drive panels are configured to the 9740 LSM from top to bottom, as are all other LSM drive panels.)

An example showing how to define a 9740 10-drive panel containing five 9840 drives is:

ADDRESS=(,,,,BD4,BD3,BD2,BD1,BD0)

SLIENDGN

The SLIENDGN macro specifies the end of the LIBGEN macros. It must appear as the last statement of the LIBGEN. No comments or other statements can follow this macro because they generate assembler warning messages.

Syntax

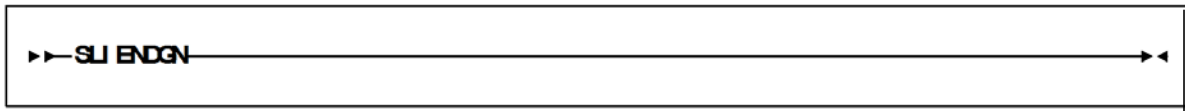

FIGURE 7-5 SLIENDGN Syntax

Parameters

SLIENDGN

name of this macro. The SLIENDGN macro has no parameters.

SLILIBRY

The SLILIBRY macro defines the global characteristics of the library. Only one SLILIBRY macro is specified and immediately follows the SLIRCVRY macro.

Syntax

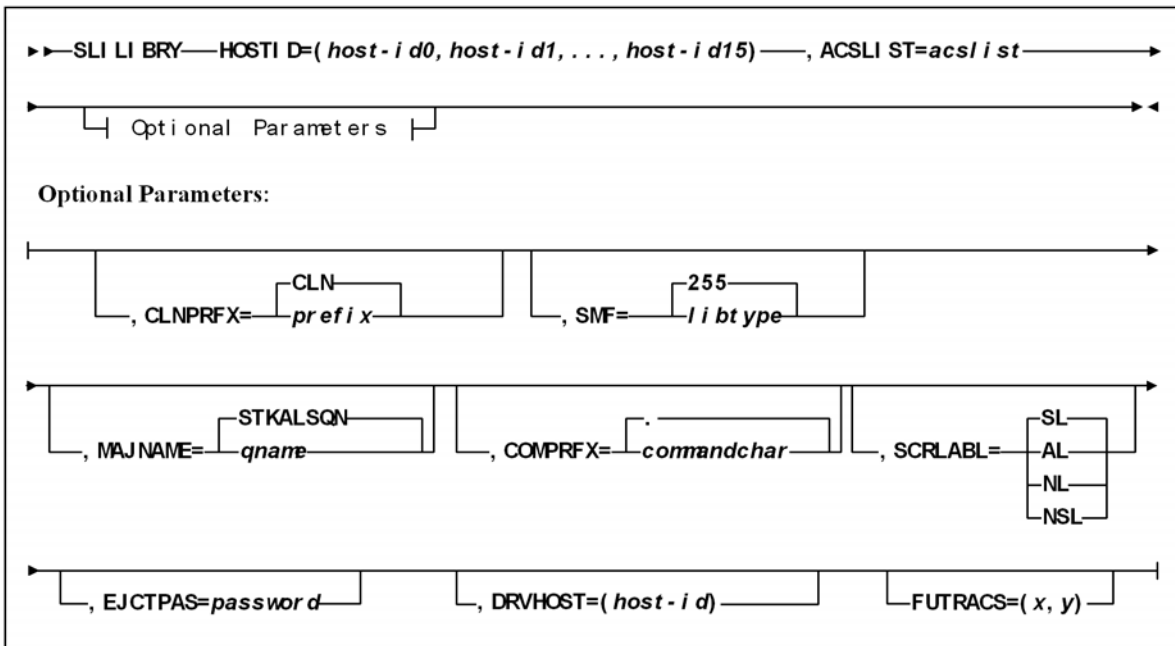

FIGURE 7-6 SLILIBRY Syntax

Parameters

SLILIBRY

name of this macro.

HOSTID=

host-id0, host-id1, ..., host-id15 identifies each host that accesses the library. This represents the SMF system ID for JES. Valid characters for a HOSTID are A-Z, 0-9, #, \$, and @.

Example:

HOSTID=(MSPA,MSPB)

where MSPA is Host0 and MSPB is Host1.

Note – The order of the hosts specified is positional. This information is used by other LIBGEN macros. Any changes in host order here may affect other areas of your LIBGEN configuration.

ACSLIST=

acslst is the assembler label of the SLIALIST macro that defines ACSs in the configuration.

Example:

ACSLIST=LACSLIST

CLNPRFX=

prefix is the three-character prefix that applies to all types of cleaning cartridges. Valid characters are A-Z, 0-9, \$, #, and @. All cartridges having this prefix followed by numerics on their external labels are treated as cleaning cartridges. CLN is the default.

Examples:

CLNPRFX=CLN

CLNPRFX=KCR

Note – Cleaning cartridges defined by VOLATTR control statements must still use the cleaning prefix established in the LIBGEN.

SMF=

libtype is the System Management Facility (SMF) record type used by the HSC to record cartridge movement and library performance. The value specified must match the SUBSYS type specified for the HSC in SMFPRMxx. The default is 255.

Example:

SMF=235

MAJNAME=

qname specifies the ENQ/DEQ/QNAME used by host software for serialization. It must conform to the requirements for an ENQ/RESERVE/DEQ QNAME as defined by the Fujitsu publication *MSP Supervisor Services and Macros*. The default is **STKALSQN**.

Example:

MAJNAME=STKALSQN

COMPREFX=

commandchar specifies the command prefix character used to direct operator commands to the HSC. It is a single character. The default command prefix character is a **period** (.).

Example command prefixes are: *¢*, #, !

Note – Make sure that the prefix character used does not conflict with any of the following:

- another subsystem's command prefix character (such as "\$" for JES, "*" for JES, or ";" the delimiter for TSO)

- the command delimiter for MSP — specified as the value for the CMDDELIM keyword in SYS1.PARMLIB (CONSOLxx) and described in the Fujitsu publication *Installation and Tuning Guide for MSP*
- a JES line editing character as specified in the JES initialization statements or default. For JES, the initialization statement is CONDEF.
For JES the initialization statement is CONSTD. Descriptions of these statements and default values can be found in the Fujitsu MSP publication *Initialization and Tuning Guide*.
- If you are running the HSC on a VM host that shares the CDS with an HSC running on MSP, make sure that your command prefix does not conflict with any of the VM facilities, such as the CP line editing symbol.

A null character can be specified as the command prefix character. During library operation, to specify an HSC command when the command prefix is a null character, you **must** use the MSP MODIFY command to issue commands to the HSC.

Even if you have specified a command prefix, you may use either method for issuing commands to the HSC:

- Specify an HSC command with the command prefix preceding the command.
- Specify an HSC command using the MSP MODIFY command. The following formats for the MSP MODIFY command may be used:

Example:

MODIFY *HSC-subsystem-name*,*HSC-command*

or

F *HSC-subsystem-name*,*HSC-command*

where *HSC-subsystem-name* is the HSC subsystem name specified in the HSC startup proc.

Examples of how a specific HSC command can be issued are:

MODIFY *HSC-subsystem-name*,DISPLAY CDS

or

F *HSC-subsystem-name*,DISPLAY CDS

TABLE 7-4 Mapping of Command Prefix Codes to Characters

Hex	Character	Description
40	null	blank
4A	¢	cent
4B	.	period
4C	<	less than
4D	(left parenthesis
4E	+	plus
4F		vertical bar
50	&	ampersand
5A	!	exclamation point

TABLE 7-4 Mapping of Command Prefix Codes to Characters (Continued)

Hex	Character	Description
5B	\$	dollar sign
5C	*	asterisk
5D)	right parenthesis
5E	;	semicolon
5F	¬	not symbol
60	-	minus
61	/	slash
6B	,	comma
6C	%	percent
6D	_	underscore
6E	>	greater than
6F	?	question mark
7A	:	colon
7B	#	crosshatch
7C	@	at sign
7E	=	equals sign
7F	“	double quote

Note – If you specify a null command prefix (hex 40), you must use the MSP MODIFY command to perform any HSC operator command.

Example:

F SLS0, MOUNT EDU050, B30

where

F

an abbreviation for the MSP MODIFY command

SLS0

an HSC subsystem

MOUNT

an HSC operator command

EDU050

a VOLSER

B30

a designated tape drive

Because of Fujitsu assembler restrictions, a single ampersand (&) cannot be specified as a command prefix. However, if you want to use an ampersand (&) as the command prefix, specify two ampersands (&&). When the LIBGEN file is assembled, the assembler strips off the first ampersand and leaves the second one. The result is that the valid command prefix is a single ampersand.

Example:

```
COMPRFX=&&
```

If specifying a left parenthesis (4D) or right parenthesis (5D), the prefix character must be enclosed in single quotes. For example:

```
COMPRFX='('
```

```
COMPRFX=')'
```

Another example of specifying a valid command prefix is:

```
COMPRFX=@
```

```
SCRLABL=
```

specifies the magnetic label type of a library controlled scratch volume. The HSC assumes nonspecific requests with other than the SCRLABL label type are outside the library. If a nonspecific volume is requested with the label type specified, it is considered a scratch volume. Parameter options are:

SL

standard label. The default is **SL**.

AL

ANSI label

NL

nonlabeled

NSL

nonstandard label.

Automated mounts of scratch volumes other than the SCRLABL label type can be performed by using user exits.

Example:

```
SCRLABL=NSL
```

```
EJCTPAS=
```

password specifies that a password is required for the Eject operator command. The password is one to eight alphanumeric characters. Acceptable characters include A-Z (must be capitalized) and numbers 0-9.

Note – Existing passwords do not need to be changed to conform to these restrictions but any new passwords must follow the guidelines described above. If EJCTPAS is not specified, no password is used. An encrypted form of the password is maintained in the control data set.

Example:

```
EJCTPAS=GOODDAY
```

```
DRVHOST
```

hostid specifies a host ID to be used as the “master” host for drive address definitions in a client/server environment. This parameter provides a consistent server environment when a single SMC can communicate with multiple servers that have different defined drive addresses. DRVHOST is used in conjunction with the SMC DRIVEMAP command (refer to *Configuring and Managing SMC*).

If DRVHOST is not specified, each HSC host reports its defined drive configuration to the SMC.

Example: DRVHOST=MSPA

FUTRACS=(*x,y*)

This parameter is used when new ACSs are to be added to the library complex. *x* specifies the number of ACSs, and *y* optionally specifies the number of LSMs to add for each added ACS.

Caution – The additional CDS records you create can cause your system to generate an 878-10 ABEND error if there is not enough space to hold the internal records for some operations. If you run out of space during the HSC INIT, you need to re-create your LIBGEN and lower these numbers.

Note –

- The number of ACSs specified can be between 1 and 255 but the total number of real ACSs and FUTRACS must not exceed 255.
 - The number of LSMs for each FUTRACS must be a multiple of 4 and range between 4 and 40.
 - If you do not specify LSMs (*y*), it defaults to 12.
 - The FUTRACSs are generic, meaning you can use them to dynamically add an SL3000 or a string of SL8500s, not to exceed the number of LSMs generated.
 - You **must** specify REGION=0M on your HSC start JCL.
-

SLILSM

This macro defines the panel numbers and relative position of cartridge drive panels around an LSM, the assembler labels for the SLIDLIST macro, the panel number for each pass-thru port in an LSM, and the assembler labels of SLILSM macros.

The first SLILSM macro for an ACS must appear immediately after the last SLISTATN macro for an ACS. Subsequent SLILSM macros for the ACS must appear immediately after the last SLIDRIVS macro referred to by the preceding SLILSM macro. The SLILSM macros are coded in the same order as specified in the SLIACS macro **LSM**, **LSM2**, **LSM3**, and **LSM4** parameters.

Note –

- For the SL3000 library, the only required parameter is **TYPE=3000**, although the other parameters are still valid. If you specify only **TYPE=3000** and decompile the CDS, the other relevant parameters are shown in the decompile output.
 - For the SL8500 library with the enhanced partitioning feature, the only required parameter is **TYPE=8500**, although the other parameters are still valid. If you specify only **TYPE=8500** and decompile the CDS, the other relevant parameters are shown in the decompile output.
 - It important to follow the Start from Scratch procedure even if you do not partition the library after completing the LIBGEN. For more information, see [“Start from Scratch – LIBGEN, SLICREAT” on page 168.](#)
-

Syntax

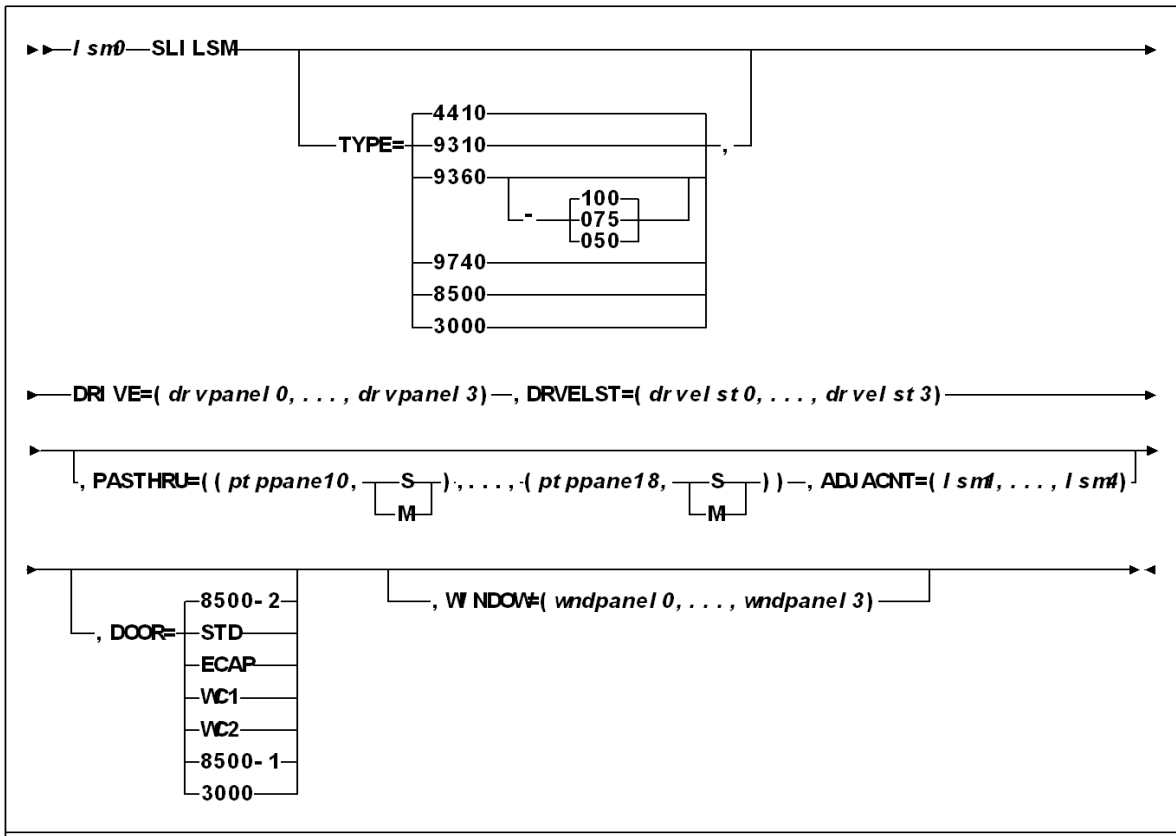

FIGURE 7-7 SLILSM Syntax

Parameters

lsm0

assembler label referred to by the SLIACS macro **LSM**, **LSM2**, **LSM3**, and **LSM4** parameters.

SLILSM

specifies the name of this macro.

TYPE=

specifies the LSM type.

Caution – The value specified must match both the physical hardware configuration and the value coded by the StorageTek CSE or panel mismatch errors appear at startup. Confirm the value you are specifying on the **TYPE** parameter with your CSE.

Options include:

4410

standard LSM. **4410** is the default.

9310

specifies a PowderHorn™ LSM.

9360-xxx

specifies a WolfCreek™ LSM with a distinct cartridge capacity.
Allowable values for *xxx* are:

050

500 cartridge capacity WolfCreek. This is a WolfCreek LSM without cell arrays on panels 3 and 4.

075

750 cartridge capacity WolfCreek. This is a WolfCreek LSM without cell arrays on panel 4.

100

1000 cartridge capacity WolfCreek. This is the default value.

9740

specifies a TimberWolf LSM.

8500

specifies an SL8500 library.

3000

specifies an SL3000 library.

Note – For the SL3000 library, the **DRIVE** and **DRVELST** parameters are optional. If you do not specify them, you must run the SET SLIDRIVS utility to add the MSP drive unit addresses.

DRIVE=

dropanel0,...,*dropanel3* specifies the range of panel numbers. *dropanel0* specifies the panel number of the first cartridge drive panel moving clockwise from the door; *dropanel1* specifies the second cartridge drive panel, etc. The following are LSM-specific panel requirements:

- For the 4410 standard LSM and the 9310 PowderHorn LSM, *dropanel* must be in the range from 1 through 10, with a maximum of four panels specified. For the ExtendedStore™ LSM, panel 10 **must** be defined as a drive panel because the SLIDRIVS macro requires a definition for panel 10 (see “SLIDRIVS” on page 231 for additional information).
- 9360 (WolfCreek) LSMs must have one drive defined in panel 1, with the optional drive/viewing window available in panel 3.
- In 9740 (TimberWolf) LSMs, panel 1 is the drive panel (up to 10 drives can be specified), and panel 3 includes a viewing window if optional cells are not requested.
- For SL8500 libraries, panel 1 is the only drive panel.
- For SL3000 libraries, panels 10 and 12 are the only drive panels.

Examples:

DRIVE=(9,10)

DRIVE=(1,2,9,10)

DRIVE=(7,8,9,10)

DRIVE=(1) (WolfCreek or TimberWolf DRIVE example)

DRVELST=

drvelst0,...,*drvelst3* defines the assembler labels for the SLIDLIST macros. The positional ordering of the DRVELST parameter is determined by the DRIVE parameter.

Example:

DRVELST=(PANEL1,PANEL2,PANEL9,PANEL10)

PASTHRU=

ptppanel0 specifies the panel number for each pass-thru port in the LSM.

- For 4410 Standard, and 9310 PowderHorn LSMs, *ptppanel0* is a decimal number in the range from 1 through 9 and identifies the panel number of a pass-thru port (PTP).
- For the 9360 WolfCreek and 9740 TimberWolf LSMs, the only valid values for *ptppanel0* are 0 and 2.
- For SL8500, valid values for *ptppanel0* are 0 (internal elevator) and 1 (external PTPs).

Note – The SL8500 contains 3 internal PTPs (elevator) that move cartridges between LSMs (rails).

- For SL3000, this parameter is invalid.

The S or M specification defines LSM/PTP relationship.

S

indicates this LSM does not control the PTP (slave).

M

indicates this LSM controls the PTP (master).

There can be a total of four pass-thru port panels per 4410 and 9310 LSMs and a total of two pass-thru ports for the 9360, 9740, and SL8500 LSMs.

A maximum of two master (M) pass-thru ports are allowed per LSM as shown in FIGURE 7-8 on page 246.

For 9360 WolfCreek LSMs, panel zero (0) is always a master PTP. When a 9360 WolfCreek LSM is connected to a 4410 or 9310 LSM, the panel of the 9360 (panel 0 and or 2) connected to the 4410 or 9310 LSM is always a master. When 9360s are connected in a series with other 9360s, panel 0 is always a master and panel 2 is always a slave.

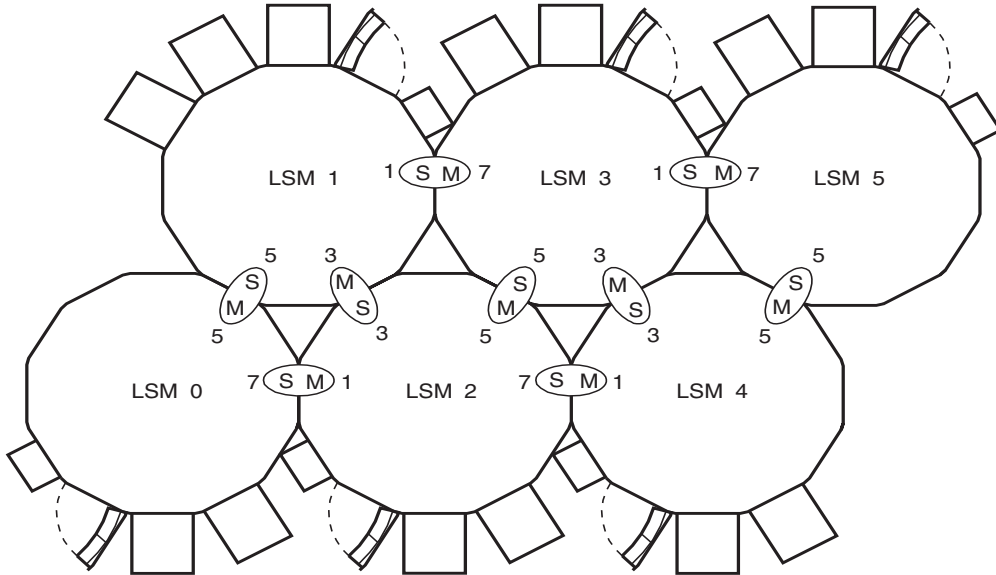

C29360

FIGURE 7-8 Example of Pass-thru Port Relationships

For 9740 TimberWolf LSMs, panel 2 is the master PTP and panel 0 is the slave. 9740 LSMs can attach only to other 9740s.

For SL8500 libraries, the lowest numbered LSM is always the master PTP.

If the PASTHRU parameter is specified, the ADJACNT parameter must also be specified. The order of PTPs listed must correspond to that specified in the ADJACNT parameter.

Examples:

- PASTHRU=((5,M))
- PASTHRU=((5,M),(7,S))
- PASTHRU=((1,M),(3,M),(5,S))
- PASTHRU=((0,M),(2,S)) (WolfCreek Example)
- PASTHRU=((2,M),(0,S)) (9740 Example)
- PASTHRU=((0,M),(0,M),(0,M)) (SL8500 Example)

Note – All of parentheses delimiters must be included in the macro statement even if only one PTP is specified. For example, if only one PTP is specified, the double parentheses must be indicated as shown in the following example.

Example:

PASTHRU=((6,M))

ADJACNT=

lsm0,lsm1,lsm2,lsm3 specifies the assembler labels of SLILSM macros, as coded in the SLILSM macro, which are connected via PTPs to this LSM. If the ADJACNT parameter is specified, the PASTHRU parameter must also be specified. The order listed must correspond to that specified in the PASTHRU parameter.

Examples:

ADJACNT=(LSM1)

where LSM1 is *ptppanel0*

ADJACNT=(LSM2,LSM0)

where LSM2 is *ptppanel0* and LSM0 is *ptppanel2*

Note – For the SL3000 library, this parameter is invalid.

DOOR=

optionally specifies the CAP configuration in the LSM access door.

Note – The 9740 TimberWolf LSM contains either a 10-cell removable magazine or a 14-cell permanent rack. The HSC receives CAP configuration information directly from the LMU, so it is not necessary to specify this parameter for the 9740.

STD

indicates the LSM access door contains a standard CAP (capacity of twenty-one cartridges). Default is **STD**.

ECAP

indicates the LSM access door contains an enhanced CAP. The enhanced CAP door features two large CAPs (capacity of forty cartridges each), and one small CAP, referred to as the priority CAP or PCAP (capacity of one cartridge).

WC1

indicates the LSM access door contains a WolfCreek CAP having a 20-cell capacity and a PCAP.

WC2

indicates the LSM access door contains an optional WolfCreek CAP having a 30-cell capacity. This is in addition to the capacity provided by the WC1 CAP door. Thus a WolfCreek with an optional WC2 CAP has the following configuration: WC1 with 20-cell capacity and a PCAP plus a WC2 with 30-cell capacity.

8500-1

indicates an SL8500 configured with one CAP (capacity of 39 cartridges).

8500-2

indicates an SL8500 configured with two CAPs (capacity of 39 cartridges each).

3000

indicates an SL3000.

WINDOW=

wndpanel0,...,*wndpanel3* specifies one or more panel numbers containing a viewing window. *wndpanel0* specifies the panel number of the first window panel moving clockwise from the access door; *wndpanel1* specifies the second window panel, etc. The panel number(s) designated for the viewing window(s) must be enclosed in parentheses. Viewing windows are an available option on the following LSM types:

- PowderHorn (9310)
- WolfCreek (9360)
- TimberWolf (9740).
- SL3000 - available only on panel 13. If not specified, the HSC self-discovers the window at HSC INIT.

Note – The standard LSM (TYPE=4410) does not allow the replacement of a panel with a viewing window. TYPE=4410 is the default LSM type. You must enter an LSM type of TYPE=9310 (PowderHorn), TYPE=9360-xxx (WolfCreek), or TYPE=9740 (TimberWolf) in order to specify a viewing window.

Only one viewing window can be specified for a WolfCreek or a TimberWolf LSM, and it must be defined in panel number three (3). Selecting any panel number other than three causes an error message to be displayed. If the viewing window is defined for the WolfCreek LSM, panel three may not be designated as a DRIVE panel.

The following example shows the WolfCreek and TimberWolf LSM viewing window selection:

Example:

WINDOW=(3)

The PowderHorn LSM supports from one to four viewing windows. Panel numbers one (1) through nine (9) are eligible for designations as viewing windows. Panel numbers zero (0), ten (10), and eleven (11), are not eligible as viewing windows. If panels zero, ten, or eleven are designated as viewing windows, an error message is issued describing their ineligibility.

The following examples show PowderHorn LSM viewing window selections:

Examples:

WINDOW=(2)

WINDOW=(2,5,7,9)

If more than one panel is designated as a viewing window, the panel numbers must be separated by commas and the entire list must be enclosed in parentheses. Panel numbers selected for viewing windows may not be designated as DRIVE panels or as PASTHRU panels.

SLIRCVRY

The SLIRCVRY macro defines criteria to determine when a control data set has become inoperable and requires recovery processing. Only one SLIRCVRY macro is specified, and it is the first macro in the LIBGEN.

Syntax

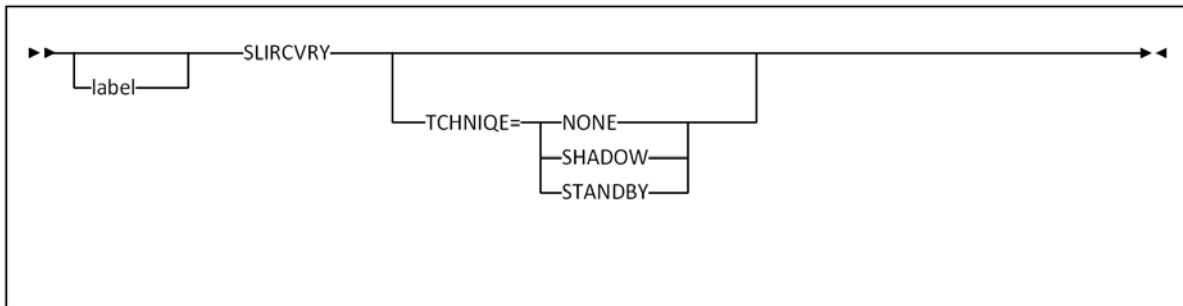

FIGURE 7-9 SLICVRY Syntax

Parameters

label

name of the CSECT generated by LIBGEN. If not specified, an unnamed CSECT is generated.

SLIRCVRY

name of this macro.

TCHNIQE

parameter that selects the form of recovery from a CDS failure.

BOTH

specifies that two distinct copies of the control data set (primary and secondary) and journals are specified for recovery purposes. The default is **BOTH**.

NONE

specifies no form of recovery is used for the control data set. Thus, the primary control data set must be rebuilt, if inaccessible.

SHADOW

specifies that there is to be two distinct copies of the control data set (primary and secondary) for recovery purposes. It is recommended that these data sets reside on separate HDAs and separate strings. A journal is not recorded.

JOURNAL

specifies that there is to be only one primary control data set and that journals are kept. These data sets are to be used for recovery purposes.

The journals contain a record of all transactions that update the control data set. There are two journals per host. It is recommended that they are placed on separate HDAs from the primary control data set DASD volume.

STANDBY

specifies that primary, secondary, and standby control data sets are to be recorded for recovery purposes. No journals are recorded during HSC operation.

ALL

specifies that all control data sets (primary, secondary, and standby) and journals are to be kept and available for recovery purposes.

Note –

- The SLIRCVRY LIBGEN macro TCHNIQE parameter determines how many CDS copies will be initialized by the SLICREAT program and whether or not journals will be initialized by SLICREAT.
 - The number of CDS copies used by the HSC is dependent on the number of CDS copies defined in the CDSDEF PARMLIB control statement. It is **not** determined by the TCHNIQE parameter.
 - The HSC uses all of the CDS copies defined in the CDSDEF control statement (whether this includes more or less CDS copies than are specified by the TCHNIQE parameter). However, if journaling is specified by the TCHNIQE parameter, journals must be defined for successful HSC initialization.
 - If you are adding a new CDS copy to an existing configuration, you must do the following:
 1. Backup and restore existing CDS copies.
 2. Use SET TCHNIQE to set the recovery technique.
-

SLISTATN

The SLISTATN macro contains LMU station addresses that connect a host system to an ACS. One SLISTATN macro is used for each station label coded in the SLIACS macro STATION parameter. The SLISTATN macro must appear immediately following the SLIACS macro which references them and in the order specified on the SLIACS macro STATION parameter.

Normally, the HSC waits for offline stations when it attempts to initiate communication. This means message IEF238D is issued when the HSC allocates the station.

However, if the HSC has already established communication with at least one station, the HSC does not wait for other stations to come on during initialization. Therefore, list the stations that are designated for backup usage last. These backup stations are normally offline.

Note – If you are using only TCP/IP LMU connections, you can omit this macro statement but if you are using 3270 or a combination of 3270 with TCP/IP, then you need to include the SLISTATN macro.

Syntax

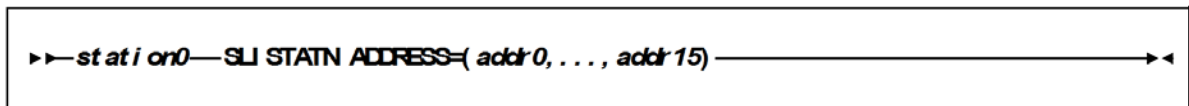

FIGURE 7-10 SLISTATN Syntax

Parameters

station0

assembler label referred to by the SLIACS macro STATION parameter.

SLISTATN

name of this macro.

ADDRESS=

addr0,...,addr15 specifies the LMU addresses that connect the ACS to the host system.

A minimum of one and a maximum of 16 station addresses may be used by a single host to communicate with an ACS. A maximum of 16 connections per ACS is allowed. In a dual LMU configuration the maximum is 32 connections per ACS; 16 to each LMU in the dual LMU configuration.

Examples:

ADDRESS=(0A0)

ADDRESS=(0A0,0A1)

LIBGEN Macro Samples

This appendix contains the following examples of library configurations and the corresponding LIBGEN files:

- “One Host, Two ACSs, One 9310 LSM, One SL8500 Library Configuration” on page 254
- “Four Host, Two ACSs, Two SL8500 Libraries Configuration” on page 258
- “Three Host, Three ACSs, Two SL8500 Libraries, One SL3000 Library Configuration” on page 263
- “Three Host, Two ACSs, Two SL3000 Libraries Configuration” on page 267
- “One Host, One ACS, One 9310 LSM, Dual LMU Configuration” on page 269
- “Two Host, One ACS, Two 9310 LSM Configuration” on page 272

Note –

- For two host configurations, it is **required** that host IDs be included in the LIBGEN for each host having access to the library CDS. An example is:

SLLIBRY ...

HOSTID=(HSC1,HSC2)

- HSC **does not distinguish** the type of host; that is, production or test machine.
 - The source code for the sample LIBGENs shown in this appendix is included in the SAMPLIB as members LIBGEN nn , where nn is the corresponding LIBGEN example number.
-

One Host, Two ACSs, One 9310 LSM, One SL8500 Library Configuration

The configuration shown in [FIGURE C-1 on page 255](#), which is defined by the LIBGEN01 sample shown in [FIGURE C-2 on page 256](#) and [FIGURE C-3 on page 257](#), consists of the following:

- One host (HSC1)
- Two ACSs (ACS00 and ACS01)
- One 9310 LSM with:
 - 4 transport panels (P000001, P000002, P000009, P000010) and an enhanced CAP
 - Two LMU station addresses (0A0,0A1)
 - 16 transports (410-417 and 510-517)
- One SL8500 standalone library containing 4 LSMs (LSM0100, LSM0101, LSM0102, LSM0103) with:
 - 4 transport panels (P010001, P010101, P010201, P010301)
 - 8 transports (9400-9407).

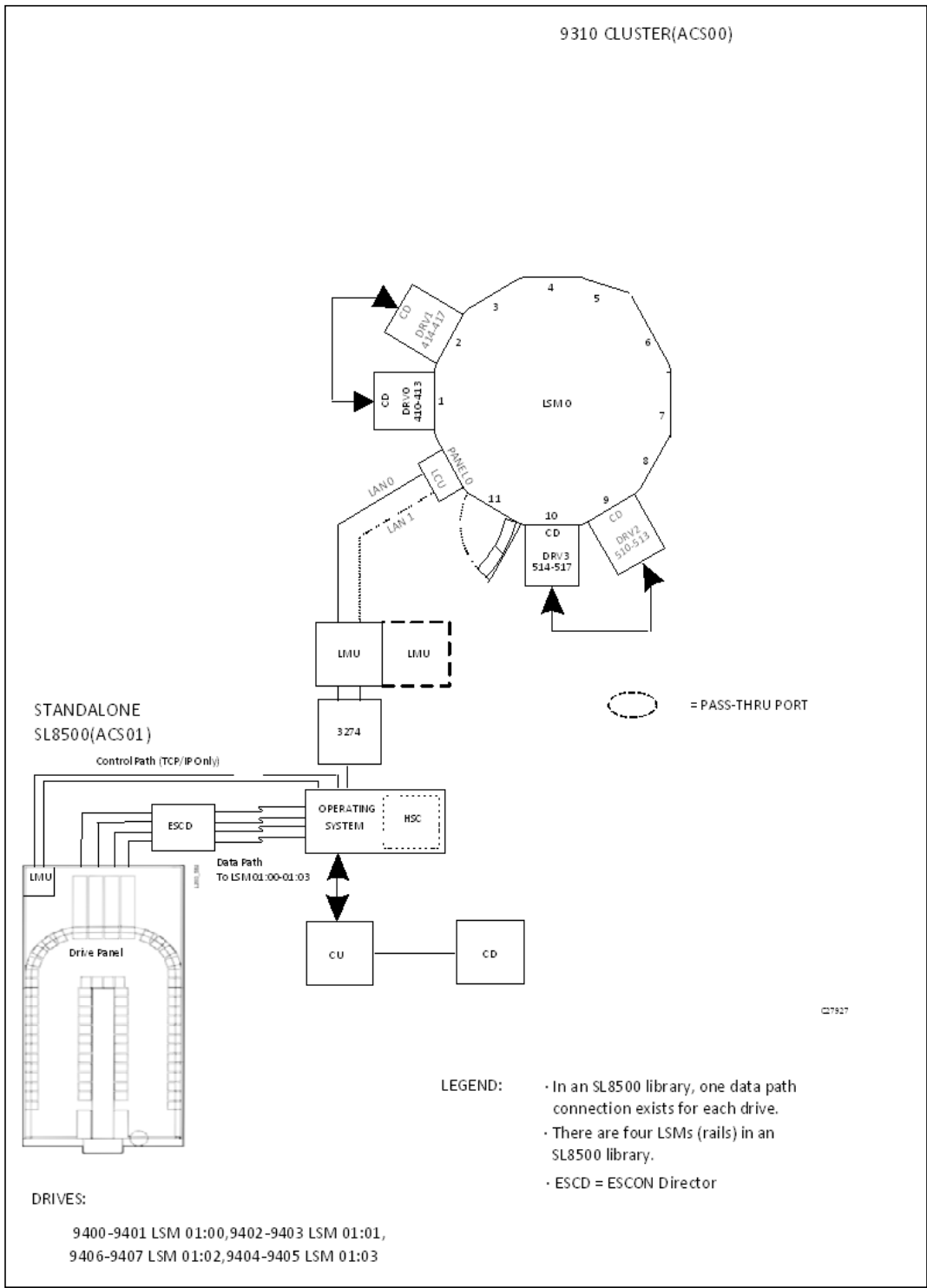

FIGURE C-1 One Host, Two ACSs, One 9310 LSM, One SL8500 Library Configuration

```

*      Label definitions:
*
*      ACS- 'ACSxx'where 'xx' is the ACS number in printable hex.
*      LSM- 'LSMxxyy'where 'xx' is the ACS number in printable hex, and 'yy'
*           is the LSM number within the ACS in printable hex.
*      STATION- 'STxxh'where 'xx' is the ACS number in printable hex, and 'h'
*           is the host index in printable hex.
*      PANEL- 'Pxyypp'where 'xx' is the ACS number in printable hex,'yy' is
*           the LSM number in printable hex, and 'pp' is the panel
*           number in decimal.
*      DRIVE- 'Dxyypph'where 'xx' is the ACS number in printable hex, 'yy' is
*           the LSM number in printable hex, 'pp' is the panel
*           number in printable hex, and 'h' is the host index in
*           printable hex.

```

```
*****
```

```
LIBGEN01 SLIRCVRY TCHNIQE=BOTH
```

```

*
*      SLILIBRY HOSTID=HSC1,                X
*      SMF=235,                            X
*      COMPRFX=#,                          X
*      ACSLIST=NAMEACS,                    X
*      MAJNAME=STKALSQN,                   X
*      SCRLABL=SL,                         X
*      EJCTPAS=GOODAY,                    X
*      CLNPRFX=CLN,                        X
*
NAMEACS SLIALIST ACS00,ACS01
*
ACS00  SLIACS STATION=ST000,                X
      LSM=(LSM0000)
*
ST000  SLISTATN ADDRESS=(0A0,0A1)
*
LSM0000 SLILSM  DRIVE=(1,2,9,10),          X
      DRVELST=(P000001,P000002,P000009,P000010), X
      TYPE=9310,                            X
      DOOR=ECAP
*
P000001 SLIDLIST HOSTDRV=D0000010
*
D0000010 SLIDRIVS ADDRESS=(410,411,412,413)
*
P000002 SLIDLIST HOSTDRV=D0000020
*
D0000020 SLIDRIVS ADDRESS=(414,415,416,417)
*
P000009 SLIDLIST HOSTDRV=D0000090
*
D0000090 SLIDRIVS ADDRESS=(510,511,512,513)

```

FIGURE C-2 LIBGEN01 for One Host, Two ACSs, One 9310 LSM, One SL8500 Library (Part 1)

```

P000010 SLIDLIST HOSTDRV=D0000100
*
D0000100 SLIDRIVS ADDRESS=(514,515,516,517)
*
ACS01  SLIACS FUTRLSM=(8500,16),          X
        LSM=(LSM0100,LSM0101,LSM0102,LSM0103)
*
LSM0100 SLILSM PASTHRU=((0,M),(0,M),(0,M)),      X
        ADJACNT=(LSM0101,LSM0102,LSM0103),      X
        DRIVE=(1),                                X
        DRVELST=(P010001),                        X
        TYPE=8500,                                X
        DOOR=8500-1
*
P010001 SLIDLIST HOSTDRV=(D0100010,D0100011)
*
D0100010 SLIDRIVS ADDRESS=(,,,9400,,,,,9401,,,,,)
D0100011 SLIDRIVS ADDRESS=(,,,9400,,,,,9401,,,,,)
*
LSM0101 SLILSM PASTHRU=((0,S),(0,S),(0,S)),      X
        ADJACNT=(LSM0100,LSM0102,LSM0103),      X
        DRIVE=(1),                                X
        DRVELST=(P010101),                        X
        TYPE=8500,                                X
        DOOR=8500-1
*
P010101 SLIDLIST HOSTDRV=(D0101010,D0101011)
*
D0101010 SLIDRIVS ADDRESS=(,,,,,,,,,9402,,,,,9403)
D0101011 SLIDRIVS ADDRESS=(,,,,,,,,,9402,,,,,9403)
*
LSM0102 SLILSM PASTHRU=((0,S),(0,S),(0,S)),      X
        ADJACNT=(LSM0100,LSM0101,LSM0103),      X
        DRIVE=(1),                                X
        DRVELST=(P010201),                        X
        TYPE=8500,                                X
        DOOR=8500-1
*
P010201 SLIDLIST HOSTDRV=(D0102010,D0102011)
*
D0102010 SLIDRIVS ADDRESS=(,,,,,,,,,9406,,,,,9407)
D0102011 SLIDRIVS ADDRESS=(,,,,,,,,,9406,,,,,9407)
*
LSM0103 SLILSM PASTHRU=((0,S),(0,S),(0,S)),      X
        ADJACNT=(LSM0100,LSM0101,LSM0102),      X
        DRIVE=(1),                                X
        DRVELST=(P010301),                        X
        TYPE=8500,                                X
        DOOR=8500-1
*
P010301 SLIDLIST HOSTDRV=(D0103010,D0103011)
*
D0103010 SLIDRIVS ADDRESS=(,,,9404,,,,,9405,,,,,)
D0103011 SLIDRIVS ADDRESS=(,,,9404,,,,,9405,,,,,)
*
        SLIENDGN

```

FIGURE C-3 LIBGEN01 for One Host, Two ACSs, One 9310 LSM, One SL8500 Library (Part 2)

Four Host, Two ACSs, Two SL8500 Libraries Configuration

The configuration which is defined by the LIBGEN851 sample shown in [FIGURE C-4 on page 259](#) through [FIGURE C-7 on page 262](#), consists of the following:

- Four hosts (EC20, EC21, EC22, ECCY)
- Two ACSs (ACS00 and ACS01)
- Two SL8500 libraries connected by PTPs, each containing 4 LSMs with 4 transport panels and transports per panel.

```

*      Label definitions:
*
*      ACS- 'ACSxx'where 'xx' is the ACS number in printable hex.
*      LSM- 'LSMxxyy'where 'xx' is the ACS number in printable hex, and 'yy'
*           is the LSM number within the ACS in printable hex.
*      STATION- 'STxxh'where 'xx' is the ACS number in printable hex, and 'h'
*           is the host index in printable hex.
*      PANEL- 'Pxyypp'where 'xx' is the ACS number in printable hex,'yy' is
*           the LSM number in printable hex, and 'pp' is the panel
*           number in decimal.
*      DRIVE- 'Dxyypph'where 'xx' is the ACS number in printable hex, 'yy' is
*           the LSM number in printable hex, 'pp' is the panel
*           number in printable hex, and 'h' is the host index in
*           printable hex.
***** THIS SAMPLE IS A 2-ACS
CONFIGURATION, EACH WITH A SINGLE 8500.
*
LIBGEN851 SLIRCVRY TCHNIQE=SHADOW
*
      SLILIBRY SMF=245,                X
      ACSLIST=ACSLIST,                X
      HOSTID=(EC20,EC21,EC22,ECCY),    X
      DELDISP=SCRATCH,                X
      MAJNAME=ARVID,                  X
      CLNPRFX=CLN,                    X
      COMPRFX=-,                      X
      SCRLABL=SL
*
ACSLIST SLIALIST ACS00,ACS01
*
* NEXT ACS
*
ACS00 SLIACS LSM=(LSM0000,LSM0001,LSM0002,LSM0003)
*
LSM0000 SLILSM PASTHRU=((0,M),(0,M),(0,M)),          X
      ADJACNT=(LSM0001,LSM0002,LSM0003),          X
      DRIVE=(1),                                  X
      DRVELST=(P00001),                          X
      TYPE=8500,                                  X
      DOOR=8500-1
*
P00001 SLIDLIST HOSTDRV=(D000010,D000010,D000010,D000010)
*
D000010 SLIDRIVS ADDRESS=(9000,9001,9002,9003)
*
LSM0001 SLILSM PASTHRU=((0,S),(0,M),(0,M)),          X
      ADJACNT=(LSM0000,LSM0002,LSM0003),          X
      DRIVE=(1),                                  X
      DRVELST=(P00101),                          X
      TYPE=8500,                                  X
      DOOR=8500-1

```

FIGURE C-4 LIBGEN851 for Four Hosts, Two ACSs, Two SL8500 Libraries (Part 1)

```

*
P00101 SLIDLIST HOSTDRV=(D001010,D001010,D001010,D001010)
*
D001010 SLIDRIVS ADDRESS=(9010,9011,9012,9013)
*
LSM0002 SLILSM PASTHRU=((0,S),(0,S),(0,M)),           X
          ADJACNT=(LSM0000,LSM0001,LSM0003),         X
          DRIVE=(1),                                  X
          DRVELST=(P00201),                           X
          TYPE=8500,                                  X
          DOOR=8500-1
*
P00201 SLIDLIST HOSTDRV=(D002010,D002010,D002010,D002010)
*
D002010 SLIDRIVS ADDRESS=(9020,9021,9022,9023)
*
LSM0003 SLILSM PASTHRU=((0,S),(0,S),(0,S)),           X
          ADJACNT=(LSM0000,LSM0001,LSM0002),         X
          DRIVE=(1),                                  X
          DRVELST=(P00301),                           X
          TYPE=8500,                                  X
          DOOR=8500-1
*
P00301 SLIDLIST HOSTDRV=(D003010,D003010,D003010,D003010)
*
D003010 SLIDRIVS ADDRESS=(9030,9031,9032,9033)
*
* NEXT ACS
*
ACS01 SLIACS LSM=(LSM0100,LSM0101,LSM0102,LSM0103)
*
LSM0100 SLILSM PASTHRU=((0,M),(0,M),(0,M)),           X
          ADJACNT=(LSM0101,LSM0102,LSM0103),         X
          DRIVE=(1),                                  X
          DRVELST=(P01001),                           X
          TYPE=8500,                                  X
          DOOR=8500-1
*
P01001 SLIDLIST HOSTDRV=(D010010,D010010,D010010,D010010)
*
D010010 SLIDRIVS ADDRESS=(9100,9101,9102,9103)
*
LSM0101 SLILSM PASTHRU=((0,S),(0,M),(0,M)),           X
          ADJACNT=(LSM0100,LSM0102,LSM0103),         X
          DRIVE=(1),                                  X
          DRVELST=(P01101),                           X
          TYPE=8500,                                  X
          DOOR=8500-1

```

FIGURE C-5 LIBGEN851 for Four Hosts, Two ACSs, Two SL8500 Libraries (Part 2)

```

*
P00101 SLIDLIST HOSTDRV=(D001010,D001010,D001010,D001010)
*
D001010 SLIDRIVS ADDRESS=(9010,9011,9012,9013)
*
LSM0002 SLILSM PASTHRU=((0,S),(0,S),(0,M)), X
ADJACNT=(LSM0000,LSM0001,LSM0003), X
DRIVE=(1), X
DRVELST=(P00201), X
TYPE=8500, X
DOOR=8500-1
*
P00201 SLIDLIST HOSTDRV=(D002010,D002010,D002010,D002010)
*
D002010 SLIDRIVS ADDRESS=(9020,9021,9022,9023)
*
LSM0003 SLILSM PASTHRU=((0,S),(0,S),(0,S)), X
ADJACNT=(LSM0000,LSM0001,LSM0002), X
DRIVE=(1), X
DRVELST=(P00301), X
TYPE=8500, X
DOOR=8500-1
*
P00301 SLIDLIST HOSTDRV=(D003010,D003010,D003010,D003010)
*
D003010 SLIDRIVS ADDRESS=(9030,9031,9032,9033)
*
* NEXT ACS
*
ACS01 SLIACS LSM=(LSM0100,LSM0101,LSM0102,LSM0103)
*
LSM0100 SLILSM PASTHRU=((0,M),(0,M),(0,M)), X
ADJACNT=(LSM0101,LSM0102,LSM0103), X
DRIVE=(1), X
DRVELST=(P01001), X
TYPE=8500, X
DOOR=8500-1
*
P01001 SLIDLIST HOSTDRV=(D010010,D010010,D010010,D010010)
*
D010010 SLIDRIVS ADDRESS=(9100,9101,9102,9103)
*
LSM0101 SLILSM PASTHRU=((0,S),(0,M),(0,M)), X
ADJACNT=(LSM0100,LSM0102,LSM0103), X
DRIVE=(1), X
DRVELST=(P01101), X
TYPE=8500, X
DOOR=8500-1

```

FIGURE C-6 LIBGEN851 for Four Hosts, Two ACSs, Two SL8500 Libraries (Part 3)

```

*
P01101 SLIDLIST HOSTDRV=(D011010,D011010,D011010,D011010)
*
D011010 SLIDRIVS ADDRESS=(9110,9111,9112,9113)
*
LSM0102 SLILSM PASTHRU=((0,S),(0,S),(0,M)),           X
          ADJACNT=(LSM0100,LSM0101,LSM0103),         X
          DRIVE=(1),                                  X
          DRVELST=(P01201),                            X
          TYPE=8500,                                   X
          DOOR=8500-1
*
P01201 SLIDLIST HOSTDRV=(D012010,D012010,D012010,D012010)
*
D012010 SLIDRIVS ADDRESS=(9120,9121,9122,9123)
*
LSM0103 SLILSM PASTHRU=((0,S),(0,S),(0,S)),           X
          ADJACNT=(LSM0100,LSM0101,LSM0102),         X
          DRIVE=(1),                                  X
          DRVELST=(P01301),                            X
          TYPE=8500,                                   X
          DOOR=8500-1
*
P01301 SLIDLIST HOSTDRV=(D013010,D013010,D013010,D013010)
*
D013010 SLIDRIVS ADDRESS=(9130,9131,9132,9133)
*
      SLIENDGN ,

```

FIGURE C-7 LIBGEN851 for Four Hosts, Two ACSs, Two SL8500 Libraries (Part 4)

Three Host, Three ACSs, Two SL8500 Libraries, One SL3000 Library Configuration

The configuration which is defined by the LIBGEN853 sample shown in [FIGURE C-8 on page 264](#) through [FIGURE C-10 on page 266](#), consists of the following:

- Three hosts (EC20 , EC21 , EC22)
- Three ACSs (ACS00, ACS01, and ACS02)
- Two SL8500 libraries connected by PTPs, each containing 4 LSMs with 4 transport panels and transports per panel.
- One SL3000 library whose drives must be defined via SLIDRIVS.

```

*      Label definitions:
*
*      ACS - 'ACSxx'where 'xx' is the ACS number in printable hex.
*      LSM - 'LSMxxyy'where 'xx' is the ACS number in printable hex, and 'yy'
*            is the LSM number within the ACS in printable hex.
*      STATION- 'STxxh'where 'xx' is the ACS number in printable hex, and 'h'
*            is the host index in printable hex.
*      PANEL- 'Pxyypp'where 'xx' is the ACS number in printable hex,'yy' is
*            the LSM number in printable hex, and 'pp' is the panel
*            number in decimal.
*      DRIVE- 'Dxyypph'where 'xx' is the ACS number in printable hex, 'yy' is
*            the LSM number in printable hex, 'pp' is the panel
*            number in printable hex, and 'h' is the host index in
*            printable hex.
*****
* THIS SAMPLE IS A 3-ACS CONFIGURATION WITH TWO SL8500S AND A
* SINGLE SL3000.
*
* NOTE: FOR THE SL3000, YOU MUST RUN SLIDRIVS TO ADD THE
*       MSP UNIT ADDRESSES FOR THE TAPE DRIVES.
*
LIBGEN853 SLIRCVRY TCHNIQE=SHADOW
*
      SLILIBRY SMF=245,                X
      ACSLIST=ACSLIST,                X
      HOSTID=(EC20,EC21,EC22),        X
      DELDISP=SCRATCH,                X
      MAJNAME=ARVID,                  X
      CLNPRFX=CLN,                    X
      COMPRFX=-,                       X
      SCRLABL=SL
*
ACSLIST SLIALIST ACS00,ACS01,ACS02
*
* FIRST ACS
*
ACS00 SLIACS LSM=(LSM0000,LSM0001,LSM0002,LSM0003)
*
LSM0000 SLILSM PASTHRU=((0,M),(0,M),(0,M)),      X
      ADJACNT=(LSM0001,LSM0002,LSM0003),      X
      DRIVE=(1),                                X
      DRVELST=(P00001),                          X
      TYPE=8500,                                  X
      DOOR=8500-2
*
P00001 SLIDLIST HOSTDRV=(D000010,D000010,D000010)
*
D000010 SLIDRIVS ADDRESS=(9000,9001,9002,9003)
*
LSM0001 SLILSM PASTHRU=((0,S),(0,M),(0,M)),      X
      ADJACNT=(LSM0000,LSM0002,LSM0003),      X
      DRIVE=(1),                                X
      DRVELST=(P00101),                          X
      TYPE=8500,                                  X
      DOOR=8500-2
*
P00101 SLIDLIST HOSTDRV=(D001010,D001010,D001010)
*
D001010 SLIDRIVS ADDRESS=(9010,9011,9012,9013)

```

FIGURE C-8 LIBGEN853 for Three Hosts, Three ACSs, Two SL8500s, One SL3000 (Part 1)

```

*
LSM0002 SLILSM PASTHRU=((0,S),(0,S),(0,M)),           X
        ADJACNT=(LSM0000,LSM0001,LSM0003),           X
        DRIVE=(1),                                   X
        DRVELST=(P00201),                             X
        TYPE=8500,                                   X
        DOOR=8500-2
*
P00201 SLIDLIST HOSTDRV=(D002010,D002010,D002010)
*
D002010 SLIDRIVS ADDRESS=(9020,9021,9022,9023)
*
LSM0003 SLILSM PASTHRU=((0,S),(0,S),(0,S)),           X
        ADJACNT=(LSM0000,LSM0001,LSM0002),           X
        DRIVE=(1),                                   X
        DRVELST=(P00301),                             X
        TYPE=8500,                                   X
        DOOR=8500-2
*
P00301 SLIDLIST HOSTDRV=(D003010,D003010,D003010)
*
D003010 SLIDRIVS ADDRESS=(9030,9031,9032,9033)
*
* NEXT ACS
*
ACS01 SLIACS LSM=(LSM010)
*
LSM010 SLILSM TYPE=3000
*
** NEXT ACS
*
ACS02 SLIACS LSM=(LSM0200,LSM0201,LSM0202,LSM0203)
*
LSM0200 SLILSM PASTHRU=((0,M),(0,M),(0,M)),           X
        ADJACNT=(LSM0201,LSM0202,LSM0203),           X
        DRIVE=(1),                                   X
        DRVELST=(P02001),                             X
        TYPE=8500,                                   X
        DOOR=8500-2
*
P02001 SLIDLIST HOSTDRV=(D020010,D020010,D020010)
*
D020010 SLIDRIVS ADDRESS=(9200,9201,9202,9203)

```

FIGURE C-9 LIBGEN853 for Three Hosts, Three ACSs, Two SL8500s, One SL3000 (Part 2)

```

LSM0201 SLILSM PASTHRU=((0,S),(0,M),(0,M)),           X
        ADJACNT=(LSM0200,LSM0202,LSM0203),           X
        DRIVE=(1),                                   X
        DRVELST=(P02101),                             X
        TYPE=8500,                                   X
        DOOR=8500-2
*
P02101  SLIDLIST HOSTDRV=(D021010,D021010,D021010)
*
D021010 SLIDRIVS ADDRESS=(9210,9211,9212,9213)
*
LSM0202 SLILSM PASTHRU=((0,S),(0,S),(0,M)),           X
        ADJACNT=(LSM0200,LSM0201,LSM0203),           X
        DRIVE=(1),                                   X
        DRVELST=(P02201),                             X
        TYPE=8500,                                   X
        DOOR=8500-2
*
P02201  SLIDLIST HOSTDRV=(D022010,D022010,D022010)
*
D022010 SLIDRIVS ADDRESS=(9220,9221,9222,9223)
*
LSM0203 SLILSM PASTHRU=((0,S),(0,S),(0,S)),           X
        ADJACNT=(LSM0200,LSM0201,LSM0202),           X
        DRIVE=(1),                                   X
        DRVELST=(P02301),                             X
        TYPE=8500,                                   X
        DOOR=8500-2
*
P02301  SLIDLIST HOSTDRV=(D023010,D023010,D023010)
*
D023010 SLIDRIVS ADDRESS=(9230,9231,9232,9233)
*
*
        SLIENDGN ,

```

FIGURE C-10 LIBGEN853 for Three Hosts, Three ACSs, Two SL8500s, One SL3000 (Part 3)

Three Host, Two ACSs, Two SL3000 Libraries Configuration

The configuration which is defined by the LIBGEN33 sample shown in [FIGURE C-8 on page 264](#), consists of the following:

- Three hosts (EC20, EC21, 9999)
- Two ACSs (ACS00, ACS01)
- Two SL3000 libraries whose drives must be defined via SLIDRIVS.
- The FUTRACS parameter allows you to add two SL8500s or two SL3000s in the future.

```

*      Label definitions:
*
*      ACS - 'ACSxx'where 'xx' is the ACS number in printable hex.
*      LSM - 'LSMxxyy'where 'xx' is the ACS number in printable hex, and 'yy'
*            is the LSM number within the ACS in printable hex.
*      STATION- 'STxxh'where 'xx' is the ACS number in printable hex, and 'h'
*            is the host index in printable hex.
*      PANEL- 'Pxyypp'where 'xx' is the ACS number in printable hex,'yy' is
*            the LSM number in printable hex, and 'pp' is the panel
*            number in decimal.
*      DRIVE- 'Dxyypph'where 'xx' is the ACS number in printable hex, 'yy' is
*            the LSM number in printable hex, 'pp' is the panel
*            number in printable hex, and 'h' is the host index in
*            printable hex.
*****
*
* This sample is a 2-ACS configuration, each with a single SL3000.
* It also allows for 2 more SL3000's or 2 SL8500's to be added
* in the future.
*
* NOTE: For the second SL3000, you must run SLIDRIVS to add the
*       MSP unit addresses for the tape drives.
*
LIBGEN33 SLIRCVRY TCHNIQE=SHADOW
*
      SLILIBRY SMF=245,                X
      FUTRACS=(2,4),                  X
      ACSLIST=ACSLIST,                X
      HOSTID=(EC20,EC21,9999),        X
      MAJNAME=SUNENQ,                 X
      CLNPRFX=CLN,                    X
      COMPRFX=-,                      X
      SCRLABL=SL
*
ACSLIST SLIALIST ACS00,ACS01
*
* First ACS (SL3000)
*
ACS00 SLIACS LSM=(LSM000)
*
LSM000 SLILSM TYPE=3000,              X
      DRIVE=(12),                      X
      DRVELST=(P000012)
*
P000012 SLIDLIST HOSTDRV=(D0000120,D0000120,D0000120)
*
D0000120 SLIDRIVS ADDRESS=(3001,3002,3003,3004,3005,3006,3007,3008, X
      3009,3010,3011,3012,3013,3014,3015,3016, X
      3017,3018,3019,3020,3021,3022,3023,3024, X
      3025,3026,3027,3028,3029,3030,3031,3032)
*
*
* Second ACS (SL3000)
*
ACS01 SLIACS LSM=(LSM001)
*
LSM001 SLILSM TYPE=3000
*
      SLIENDGN ,

```

FIGURE C-11 LIBGEN33 for Three Hosts, Two ACSs, Two SL3000s

One Host, One ACS, One 9310 LSM, Dual LMU Configuration

The configuration shown in [FIGURE C-12 on page 270](#), which is defined by the LIBGEN04 sample shown in [FIGURE C-13 on page 271](#), consists of the following:

- One host (HSC1)
- One 9310 LSM (LSM0000)
- 4 LMU station addresses (0A0,0A1,0C0,0C1)
- 4 transport panels (1,2,9,10)
- 16 transports (410-417 and 510-517).

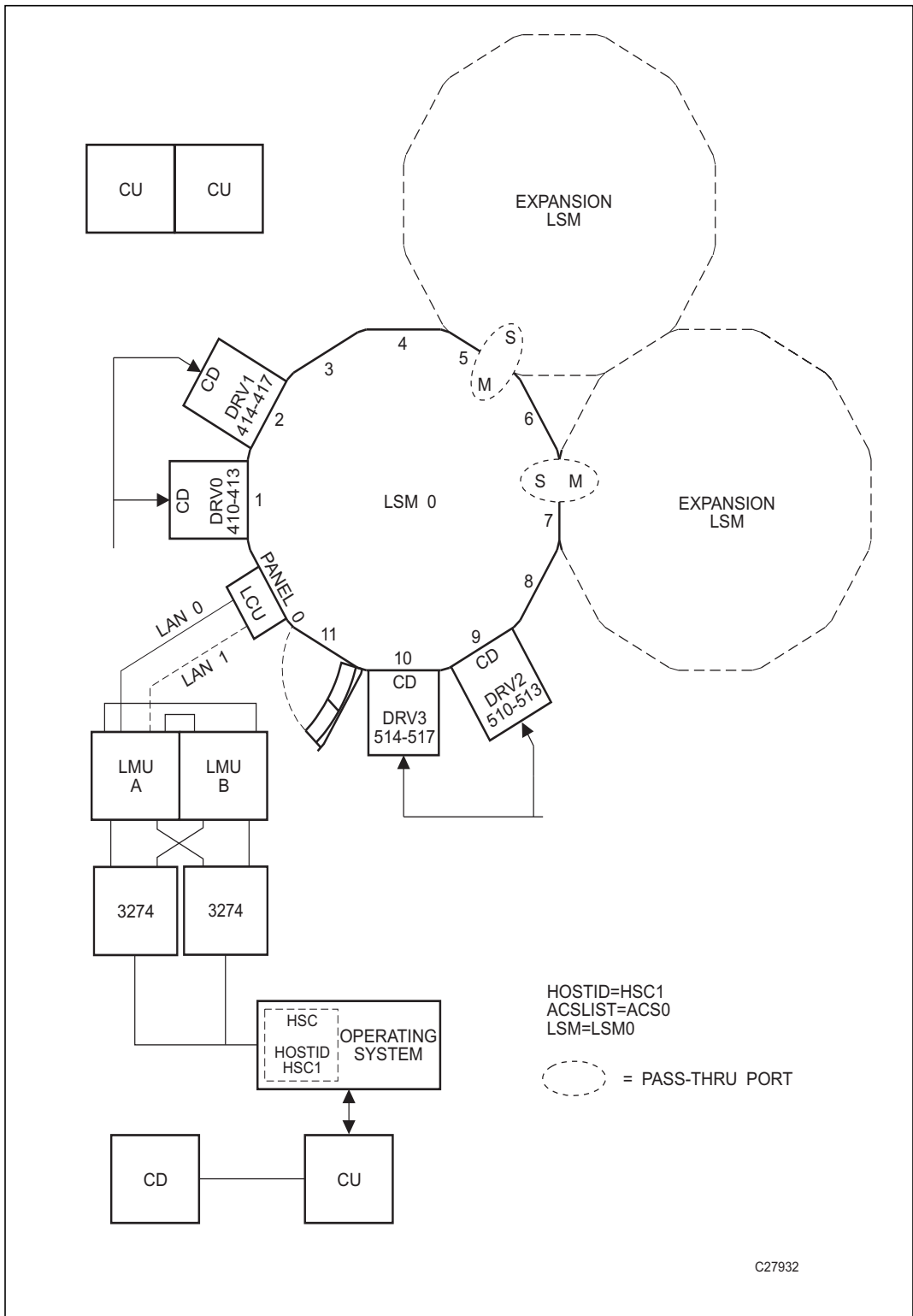

FIGURE C-12 One Host, One ACS, One 9310 LSM, Dual LMU Configuration

```

*      Label definitions:
*
*      ACS- 'ACSxx'where 'xx' is the ACS number in printable hex.
*      LSM- 'LSMxxyy'where 'xx' is the ACS number in printable hex, and 'yy'
*           is the LSM number within the ACS in printable hex.
*      STATION- 'STxxh'where 'xx' is the ACS number in printable hex, and 'h'
*           is the host index in printable hex.
*      PANEL- 'Pxyypp'where 'xx' is the ACS number in printable hex,'yy' is
*           the LSM number in printable hex, and 'pp' is the panel
*           number in decimal.
*      DRIVE- 'Dxyypph'where 'xx' is the ACS number in printable hex, 'yy' is
*           the LSM number in printable hex, 'pp' is the panel
*           number in printable hex, and 'h' is the host index in
*           printable hex.
*****

```

```

LIBGEN04 SLIRCVRY TCHNIQE=BOTH

```

```

*
*      SLILIBRY HOSTID=HSC1,           X
*      SMF=235,                       X
*      COMPRFX=#,                     X
*      ACSLIST=NAMEACS,               X
*      MAJNAME=STKALSQN,              X
*      SCRLABL=SL,                   X
*      EJCTPAS=GOODDAY,              X
*      CLNPRFX=CLN,                  X
*
NAMEACS SLIALIST ACS00
*
ST000 SLISTATN ADDRESS=(0A0,0A1,0C0,0C1)
*
LSM0000 SLILSM DRIVE=(1,2,9,10),           X
        DRVELST=(P000001,P000002,P000009,P000010), X
        TYPE=9310,                       X
        DOOR=STD
*
P000001 SLIDLIST HOSTDRV=D0000000
D0000000 SLIDRIVS ADDRESS=(410,411,412,413)
P000002 SLIDLIST HOSTDRV=D0000010
D0000010 SLIDRIVS ADDRESS=(414,415,416,417)
P000009 SLIDLIST HOSTDRV=D0000020
D0000020 SLIDRIVS ADDRESS=(510,511,512,513)
P000010 SLIDLIST HOSTDRV=D0000030
D0000030 SLIDRIVS ADDRESS=(514,515,516,517)
*
        SLIENDGN

```

FIGURE C-13 LIBGEN04 for One Host, One ACS, One 9310 LSM, Dual LMU Configuration

Two Host, One ACS, Two 9310 LSM Configuration

The configuration shown in [FIGURE C-14 on page 273](#), which is defined by the LIBGEN05 sample shown in [FIGURE C-15 on page 274](#) and [FIGURE C-16 on page 275](#), consists of the following:

- Two hosts (HSC1,HSC2)
- One Automated Cartridge System (ACS00)
- One 9310 LSM designated as LSM0000 with four transport panels (1,2,9,10) and a standard CAP.
- One 9310 LSM designated as LSM0001 with four transport panels (7,8,9,10) and an enhanced CAP.
- 4 LMU station addresses (0A0,0A1,0A2,0A3)
- 32 transports (410-41F and 510-51F).

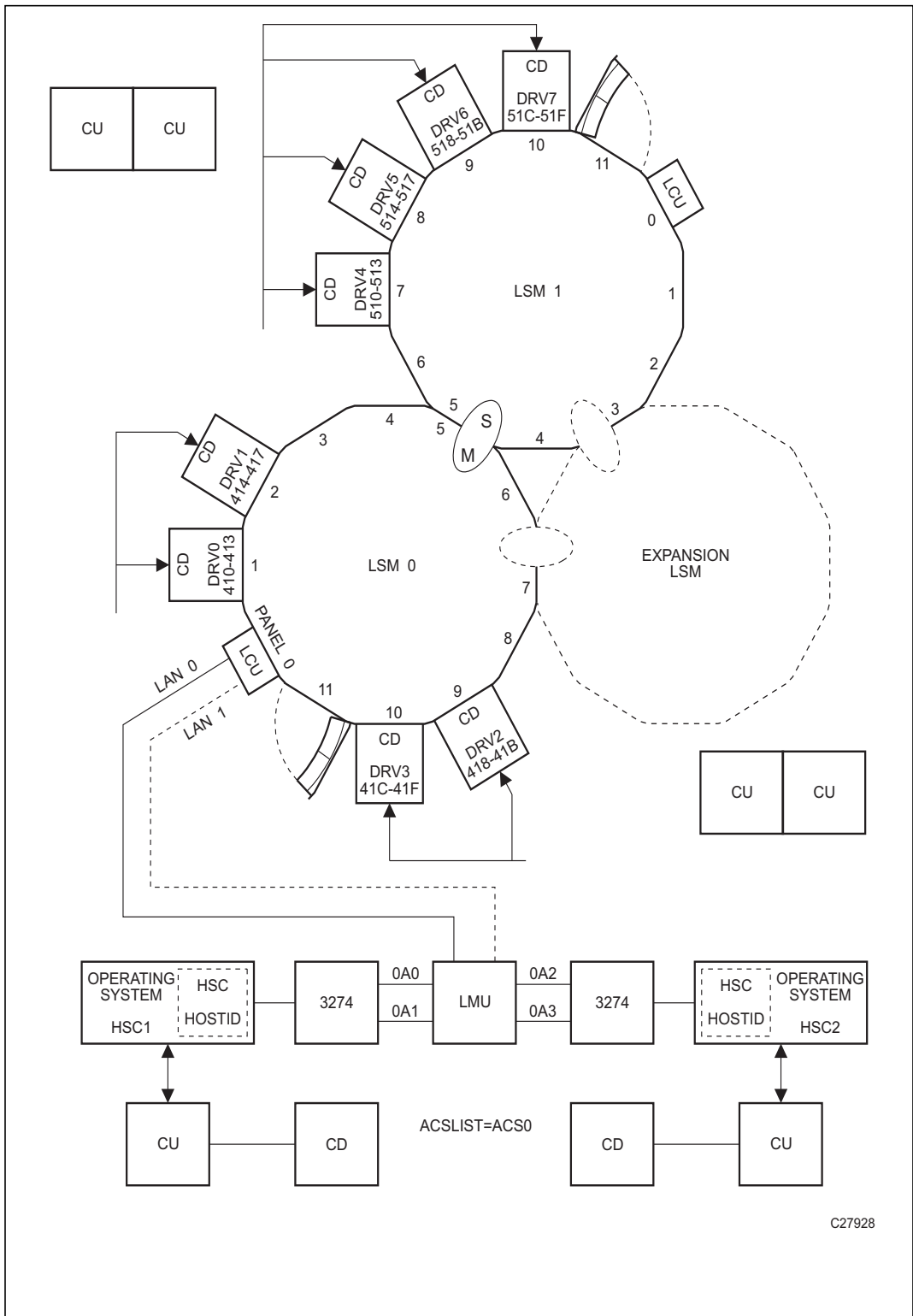

FIGURE C-14 Two Host, One ACS, Two 9310 LSM Configuration

```

*      Label definitions:
*
*      ACS - 'ACSxx'where 'xx' is the ACS number in printable hex.
*      LSM - 'LSMxxyy'where 'xx' is the ACS number in printable hex, and 'yy'
*            is the LSM number within the ACS in printable hex.
*      STATION- 'STxxh'where 'xx' is the ACS number in printable hex, and 'h'
*            is the host index in printable hex.
*      PANEL- 'Pxxyypp'where 'xx' is the ACS number in printable hex,'yy' is
*            the LSM number in printable hex, and 'pp' is the panel
*            number in decimal.
*      DRIVE- 'Dxxyypph'where 'xx' is the ACS number in printable hex, 'yy' is
*            the LSM number in printable hex, 'pp' is the panel
*            number in printable hex, and 'h' is the host index in
*            printable hex.

```

```
*****
```

```
LIBGEN05 SLIRCVRY TCHNIQ=SHADOW
```

```

*
*      SLILIBRY SMF=235,                X
*      HOSTID=(HSC1,HSC2),            X
*      ACSLIST=NAMEACS,                X
*      MAJNAME=STKALSQN,                X
*      COMPRFX=#,                      X
*      SCRLABL=SL,                      X
*      EJCTPAS=GOODDAY,                 X
*      CLNPRFX=CLN,                     X

```

```

*
NAMEACS SLIALIST ACS00
*

```

```

ST000 SLISTATN ADDRESS=(0A0,0A1)
ST001 SLISTATN ADDRESS=(0A2,0A3)
*

```

```

LSM0000 SLILSM DRIVE=(1,2,9,10),      X
*      DRVELST=(P000001,P000002,P000009,P000010),  X
*      PASTHRU=((5,M)),                    X
*      ADJACNT=(LSM0001),                  X
*      TYPE=9310,                          X
*      DOOR=STD

```

```

*
P000001 SLIDLIST HOSTDRV=(D0000000,D0000000)
D0000000 SLIDRIVS ADDRESS=(410,411,412,413)
P000002 SLIDLIST HOSTDRV=(D0000010,D0000010)
D0000010 SLIDRIVS ADDRESS=(414,415,416,417)
P000009 SLIDLIST HOSTDRV=(D0000020,D0000020)
D0000020 SLIDRIVS ADDRESS=(418,419,41A,41B)
P000010 SLIDLIST HOSTDRV=(D0000030,D0000030)
D0000030 SLIDRIVS ADDRESS=(41C,41D,41E,41F)
*

```

```

LSM0001 SLILSM DRIVE=(7,8,9,10),      X
*      DRVELST=(P000107,P000108,P000109,P000110),  X
*      PASTHRU=((5,S)),                    X
*      ADJACNT=(LSM0000),                  X
*      TYPE=9310,                          X
*      DOOR=ECAP

```

FIGURE C-15 LIBGEN05 for Two Host, One ACS, Two 9310 LSM Configuration (Part 1)

```
*
P000107 SLIDLIST HOSTDRV=(D0000040,D0000040)
D0000040 SLIDRIVS ADDRESS=(510,511,512,513)
P000108 SLIDLIST HOSTDRV=(D0000050,D0000050)
D0000050 SLIDRIVS ADDRESS=(514,515,516,517)
P000109 SLIDLIST HOSTDRV=(D0000060,D0000060)
D0000060 SLIDRIVS ADDRESS=(518,519,51A,51B)
P000110 SLIDLIST HOSTDRV=(D0000070,D0000070)
D0000070 SLIDRIVS ADDRESS=(51C,51D,51E,51F)
*
```

SLIENDGN

FIGURE C-16 LIBGEN05 for Two Host, One ACS, Two 9310 LSM Configuration (Part 2)

Special Cases: A Gallery of Advanced Uses of CONFIG

In this section, you're going to learn everything you ever wanted to know about wringing every last bit of functionality out of the CONFIG utility. Note that in many of these examples, you're changing the configuration, which is something you typically do when you're doing an upgrade install: upgrade the hardware configuration, run DECOM, then update the CONFIG deck to match the hardware changes at a release boundary.

Note that when you're doing something like adding RTDs, there's more to it than just plugging in the hardware and updating the CONFIG deck...you need to do all the tasks discussed in ["Planning for Library-Attached Transports"](#) on page 27.

CONFIG Example: All Hosts Access VTDs in One VTSS, Only Selected Hosts Access VTDs in Second VTSS

FIGURE D-1 shows example CONFIG JCL to define a VSM configuration as follows:

- The VTD statement specifies default VTD addresses 8900 - 893F for VTSS1. All hosts have access to these VTDs by their default addresses.
- No default VTD addresses are specified for VTSS2. The VTD statements that immediately follow the HOST statements for MSP1 and MSP2 specify that only these hosts can access the VTDs in VTSS2 by the addresses 9900 - 993F. HOST statement MSP3 is a placeholder; this host cannot access the VTDs in VTSS2, and is disabled from initiating migrates and reclaims.

```
//UPDATECFG EXEC PGM=SLUADMIN,PARM='MIXED'  
//STEPLIB DD DSN=hlq.SEALINK,DISP=SHR  
//SLSCNTL DD DSN=hlq.DBASEPRM,DISP=SHR  
//SLSCNTL2 DD DSN=hlq.DBASESEC,DISP=SHR  
//SLSSTBY DD DSN=hlq.DBASETBY,DISP=SHR  
//CFG22202 DD DSN=hlq.CFG22202,DISP=SHR  
//SLSPRINT DD SYSOUT=*  
//SLSIN DD *  
CONFIG CDSLEVEL(V62ABOVE)  
GLOBAL MAXVTV=65000 MCVFREE=60 VTVATTR=SCRATCH RECALWER=YES  
LOCKSTR=STK_VTCS_LOCKS VTVPAGE=LARGE MAXRTDS=32 FASTMIGR=  
YES  
RECLAIM THRESHLD=70 MAXMVC=30 START=40 CONMVC=5  
VTSS NAME=VTSS1 LOW=70 HIGH=80 MAXMIG=3 RETAIN=5  
RTDNAME=VT128800 DEVNO=8800 CHANIF=0A  
RTDNAME=VTS18801 DEVNO=8801 CHANIF=0I  
RTDNAME=VTS18802 DEVNO=8802 CHANIF=1A  
RTDNAME=VTS18803 DEVNO=8803 CHANIF=1I  
VTDLOW=8900 HIGH=893F  
VTSS NAME=VTSS2 LOW=70 HIGH=80 MAXMIG=3 RETAIN=5  
RTDNAME=VTS28804 DEVNO=8804 CHANIF=0A  
RTDNAME=VTS28805 DEVNO=8805 CHANIF=0I  
RTDNAME=VTS28806 DEVNO=8806 CHANIF=1A  
RTDNAME=VTS28807 DEVNO=8807 CHANIF=1I  
HOST NAME=MSP1  
VTD LOW=9900 HIGH=993F  
HOST NAME=MSP2  
VTD LOW=9900 HIGH=993F  
HOST NAME=MSP3 NOMIGRAT NORECLAM
```

FIGURE D-1 CONFIG example: All hosts access VTDs in one VTSS, selected hosts access VTDs in second VTSS

CONFIG Example: Update Configuration to Add RTDs

FIGURE D-2 shows example JCL to run CONFIG to add RTDs VTS18811 and VTS18813 (connected to VTSS1) to the configuration shown in Figure 19 on page 98. Because of NCO, you can add the RTDs dynamically (no RESET required), by simply adding new definitions for RTDs VTS18811 and VTS18813.

```
//UPDATECFG EXEC PGM=SLUADMIN,PARM='MIXED'  
//STEPLIB DD DSN=hlq.SEALINK,DISP=SHR  
//SLSCNTL DD DSN=hlq.DBASEPRM,DISP=SHR  
//SLSCNTL2 DD DSN=hlq.DBASESEC,DISP=SHR  
//SLSSTBY DD DSN=hlq.DBASETBY,DISP=SHR  
//CFG22202 DD DSN=hlq.CFG22202,DISP=SHR  
//SLSPRINT DD SYSOUT=*  
//SLSIN DD *  
CONFIG CDSLEVEL(V62ABOVE)  
GLOBAL MAXVTV=65000 MCVFREE=60 VTVATTR=SCRATCH RECALWER=YES  
LOCKSTR=STK_VTCS_LOCKS VTVPAGE=LARGE MAXRTDS=32 FASTMIGR=  
YES  
RECLAIM THRESHLD=70 MAXMVC=30 START=40 CONMVC=5  
VTSS NAME=VTSS1 LOW=70 HIGH=80 MAXMIG=3 RETAIN=5  
RTDNAME=VTS18800 DEVNO=8800 CHANIF=0A  
RTDNAME=VTS18801 DEVNO=8801 CHANIF=0I  
RTDNAME=VTS18802 DEVNO=8802 CHANIF=1A  
RTDNAME=VTS18803 DEVNO=8803 CHANIF=1I  
RTDNAME=VTS18811 DEVNO=8811 CHANIF=0E  
RTDNAME=VTS18813 DEVNO=8813 CHANIF=1E  
VTDLOW=8900 HIGH=893F  
VTSS NAME=VTSS2 LOW=70 HIGH=80 MAXMIG=3 RETAIN=5  
RTDNAME=VTS28804 DEVNO=8804 CHANIF=0A  
RTDNAME=VTS28805 DEVNO=8805 CHANIF=0I  
RTDNAME=VTS28806 DEVNO=8806 CHANIF=1A  
RTDNAME=VTS28807 DEVNO=8807 CHANIF=1I  
HOST NAME=MSP1  
VTD LOW=9900 HIGH=993F  
HOST NAME=MSP2  
VTD LOW=9900 HIGH=993F  
HOST NAME=MSP3
```

FIGURE D-2 CONFIG example: updating configuration to add RTDs

CONFIG Example: Update Configuration to Add MVCs and VTVs and Change AMTs

FIGURE D-3 shows example JCL to run CONFIG to modify the configuration shown in FIGURE D-2 on page 279 by:

- Adding VTVs C25001 to C50000 as scratch.
- Adding MVCs N45000 to N45999.
- Changing the LAMT to 50 and the HAMT to 85 on both VTSS1 and VTSS2.

```
//UPDATECFG EXEC PGM=SLUADMIN,PARM='MIXED'  
//STEPLIB DD DSN=hlq.SEALINK,DISP=SHR  
//SLSCNTL DD DSN=hlq.DBASEPRM,DISP=SHR  
//SLSCNTL2 DD DSN=hlq.DBASESEC,DISP=SHR  
//SLSSTBY DD DSN=hlq.DBASETBY,DISP=SHR  
//CFG22202 DD DSN=hlq.CFG22202,DISP=SHR  
//SLSPRINT DD SYSOUT=*  
//SLSIN DD *  
CONFIG CDSLEVEL(V62ABOVE)  
GLOBAL MAXVTV=65000 MVCFREE=60 VTVATTR=SCRATCH RECALWER=YES  
LOCKSTR=STK_VTCS_LOCKS VTVPAGE=LARGE MAXRTDS=32 FASTMIGR=  
YES  
RECLAIM THRESHLD=70 MAXMVC=30 START=40 CONMVC=5  
VTVVOL LOW=C25001 HIGH=C50000 SCRATCH  
MVCVOL LOW=N45000 HIGH=N45999  
VTSS NAME=VTSS1 LOW=50 HIGH=85 MAXMIG=3 RETAIN=5  
RTDNAME=VTS18800 DEVNO=8800 CHANIF=0A  
RTDNAME=VTS18801 DEVNO=8801 CHANIF=0I  
RTDNAME=VTS18802 DEVNO=8802 CHANIF=1A  
RTDNAME=VTS18803 DEVNO=8803 CHANIF=1I  
RTDNAME=VTS18811 DEVNO=8811 CHANIF=0E  
RTDNAME=VTS18813 DEVNO=8813 CHANIF=1E  
VTDLOW=8900 HIGH=893F  
VTSS NAME=VTSS2 LOW=50 HIGH=85 MAXMIG=3 RETAIN=5  
RTDNAME=VTS28804 DEVNO=8804 CHANIF=0A  
RTDNAME=VTS28805 DEVNO=8805 CHANIF=0I  
RTDNAME=VTS28806 DEVNO=8806 CHANIF=1A  
RTDNAME=VTS28807 DEVNO=8807 CHANIF=1I  
HOST NAME=MSP1  
VTD LOW=9900 HIGH=993F  
HOST NAME=MSP2  
VTD LOW=9900 HIGH=993F  
HOST NAME=MSP3
```

FIGURE D-3 CONFIG example: updating configuration to add MVCs and VTVs and change AMTs

CONFIG Example: Denying Host Access to a Physically Removed VTSS

If you remove a VTSS, you need a way to let the hosts know the VTSS is no longer in the configuration. [FIGURE D-4](#) shows JCL to run CONFIG to deny host access to VTSS2 that you physically removed from your configuration. In this example, you simply respecify the VTSS statement for VTSS2 with no parameters to deny host access to this VTSS.

```
//UPDATECFG EXEC PGM=SLUADMIN,PARM='MIXED'  
//STEPLIB DD DSN=hlq.SEALINK,DISP=SHR  
//SLSCNTL DD DSN=hlq.DBASEPRM,DISP=SHR  
//SLSCNTL2 DD DSN=hlq.DBASESEC,DISP=SHR  
//SLSSTBY DD DSN=hlq.DBASETBY,DISP=SHR  
//CFG22202 DD DSN=hlq.CFG22202,DISP=SHR  
//SLSPRINT DD SYSOUT=*  
//SLSIN DD *  
CONFIG CDSLEVEL(V62ABOVE)  
GLOBAL MAXVTV=65000 MVCFREE=60 VTVATTR=SCRATCH RECALWER=YES  
LOCKSTR=STK_VTCS_LOCKS VTVPAGE=LARGE MAXRTDS=32 FASTMIGR=  
YES  
RECLAIM THRESHLD=70 MAXMVC=30 START=40 CONMVC=5  
VTSS NAME=VTSS1 LOW=70 HIGH=80 MAXMIG=3 RETAIN=5  
RTDNAME=VTS18800 DEVNO=8800 CHANIF=0A  
RTDNAME=VTS18801 DEVNO=8801 CHANIF=0I  
RTDNAME=VTS18802 DEVNO=8802 CHANIF=1A  
RTDNAME=VTS18803 DEVNO=8803 CHANIF=1I  
RTDNAME=VTS18811 DEVNO=8811 CHANIF=0E  
RTDNAME=VTS18813 DEVNO=8813 CHANIF=1E  
VTDLOW=8900 HIGH=893F  
VTSS NAME=VTSS2
```

FIGURE D-4 CONFIG example: updating configuration to deny host access to a physically removed VTSS

CONFIG Examples: Using the Maximum 32 RTDs Feature

As described in “Maximum RTDs per VTSS” on page 51, you can specify up to 32 RTDs attached to a VTSS. With this feature enabled, it turns out you can also attach greater than 16 RTDs and have some ports left for CLINK originators and terminators. What follows is a general procedure for implementing Maximum 32 RTDs with links to two examples with CONFIG decks.

Implementing Support for Maximum of 32 RTDs

1. Ensure that your system has the Synchronous Replication requirements described in [TABLE I-3 on page 391](#).
2. Use CONFIG GLOBAL to enable support for maximum of 32 RTDs
CONFIG GLOBAL MAXRTDS=32

Note – Enabling support for a maximum of 32 RTDs **does not** require CONFIG RESET. However, regressing from 32 RTDs supported to 16 RTDs supported **does** require CONFIG RESET.

3. Update your CONFIG RTD and CONFIG CLINK statements as required.

Configuring SL8500 Library Communications

The SL8500 is different from other LSMs, and the way it communicates with HSC is also different...as explained in this appendix.

TCP/IP Communications - Important Considerations

SL8500 TCP/IP Connections

When you create an SL8500 library complex by connecting libraries together with passthru ports, all hosts must connect to only **one** library in the complex— preferably to the first or rightmost library.

For the complex, there are three types of TCP/IP connections for SL8500 discussed in the following sections:

- [“Dual IP Connections” on page 286](#) - A redundancy feature to allow up to two connections to the first library of a complex.
- [“Multiple SL8500 Library Connections” on page 305](#) - Starting with the SL8500 3.9x firmware release, an SL8500 complex is capable of network connecting up to 4 libraries to HSC. This enhances connecting redundancy to the complex compared to dual TCP/IP.
- [“Multiple TCP/IP Redundant Electronics” on page 308](#) - Starting with the SL8500 6.x firmware release, an SL8500 complex is capable of redundant electronics of the library controller with network connecting up to 16 libraries in pairs (one active and one standby) to HSC. This enhances hardware reliability to the complex compared to the other 2 types.

Note – It is crucial that you **read completely** these sections to understand these procedures.

Shared Networks

The following are some examples of issues that can arise when you connect an SL8500 to a shared network.

- A TCP/IP-connected library can handle standard host traffic but it cannot resolve floods of *Address Resolution Protocol* (ARP) broadcasts. **For this reason, it is best to attach the library on a controlled network, such as behind a switch or router.**

Later generation networks, such as 1000Base-T and Gig-E, support earlier communication modes; however, devices that are communicating with the library may transmit data at bandwidths that could overwhelm the library.

It is best to attach the library on a controlled network, such as with a switch that can isolate the library from network broadcasts.

- When you connect the library on shared networks and broadcasts are sent to all network nodes, they may also be directed to the library (even though it does not need them).

During the time the library is receiving these irrelevant broadcasts, it cannot receive from or respond to other requests in a timely fashion. This heavy broadcast traffic on the network can saturate the library to the point that, to the host, it may appear that the TCP/IP connection has been lost. It may also result in Overdue Response Handler (ORH) messages on the host system.

- Heavy network traffic can also overwhelm the Ethernet controller causing the processor to continuously reset and re-initialize the controller, then recover the host-to-library communications.

Dual IP Connections

The LMUPATH control statement allows users to define network LMU attachments (see *ELS Command, Control Statement, and Utility Reference*). In a dual IP connection environment for an SL8500, specify a second LMUADDR parameter to define dual IP. HSC automatically determines whether or not the connection is dual IP or dual LMU.

Note – Vary the ACS offline and back online to pick up the revised LMUPATH statement that includes the second connection.

FIGURE E-1 on page 287 and FIGURE E-2 show examples of a dual IP connection for the HSC.

Two SL8500 Network Connections - Two Mainframe IP Addresses

To establish two dedicated routes on different subnetworks from the HSC to two dedicated routes to the SL8500, use the process described in this section. **To configure the SL8500 dual TCP/IP feature, refer to *StreamLine SL8500 Modular Library System Dual TCP/IP Feature* or *StreamLine SL3000 Modular Library System Installation Guide*.**

FIGURE E-1 on page 287 shows dual IP connections with two SL8500 network connections.

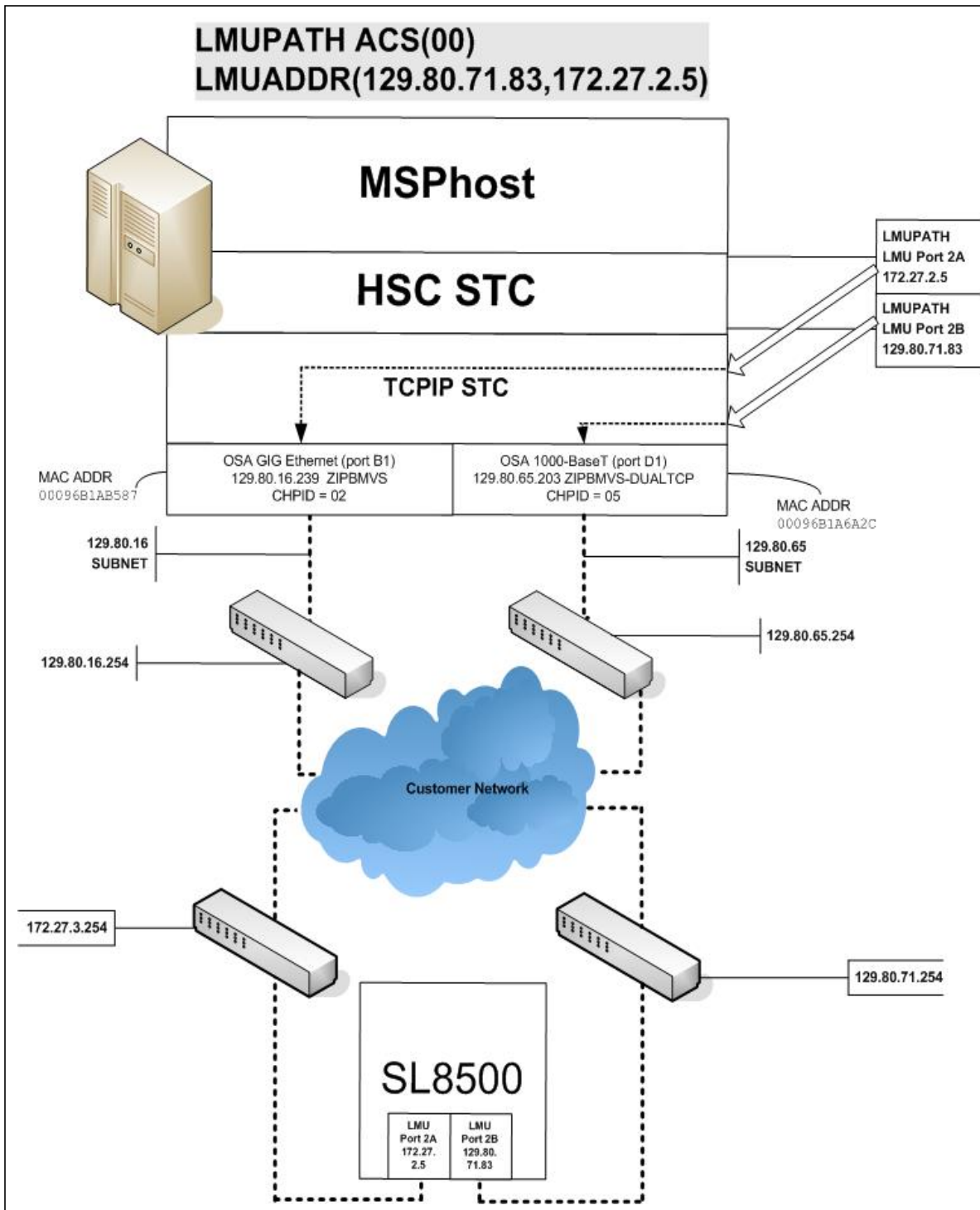

FIGURE E-1 Dual IP Connection with two SL8500 Connections

Note – In the following examples, the entries *in italics* represent the second connection.

1. Complete the Network Entries Worksheet (see TABLE E-1 for a sample) for each set of two dedicated routes to the SL8500. The worksheet can be found in the *StreamLine SL8500 Modular Library System Dual TCP/IP Feature* document.

TABLE E-1 Network Entries Worksheet

Description		IP Address
Port 2A	HBC Card Port 2A	172.27.2.5
	Gateway Port 2A	172.27.3.254
	Netmask	/23
	Host to Port 2A	129.80.16.239
Port 2B	HBC Car Port 2B	129.80.71.83
	Gateway Port 2B	129.80.71.254
	Netmask	/23
	Host to Port 2B	129.80.65.203

2. Define a second DEVICE and LINK statement in your TCP/IP profile data set for a second mainframe network connection:

Example:

```
; OSA CARD #1
DEVICE ECCQD01 MPCIPA NONROUTER AUTORESTART
LINK ZIPBMSP IPAQENET ECCQD01

; OSA CARD #2
DEVICE ECCQA01 MPCIPA NONROUTER AUTORESTART
LINK ZIPB2MSP IPAQENET ECCQA01
```

3. Define a second home address in your TCP/IP profile data set.

Example:

```
HOME
129.80.16.239 ZIPBMSP
129.80.65.203 ZIPB2MSP
```

4. Define a second router on the second subnetwork in the routing paragraph of your TCP/IP profile data set. Remember that you must also configure the SL8500 routing tables according to the instructions described in the *StreamLine SL8500 Modular Library System Dual TCP/IP Feature* document.

Example:

```
BEGINROUTES
; NETWORK MASK          FIRSTHOP  LINKNAME  PACKETSIZE

ROUTE 129.80.16.0/24    =          ZIPBMSP  MTU 1492
ROUTE 129.80.65.0/24    =          ZIPB2MSP  MTU 1492
ROUTE 172.27.2.5 HOST    129.80.16.254 ZIPBMSP  MTU 1492
ROUTE 129.80.71.83 HOST    129.80.65.254 ZIPB2MSP  MTU 1492
ROUTE DEFAULT 129.80.16.254          ZIPBMSP  MTU 1492
ROUTE DEFAULT 129.80.65.254          ZIPB2MSP  MTU 1492
ENDROUTES
```

5. Define two dedicated static routes to the SL8500 destination port (2A and 2B) IP addresses over two different routers.

Example:

```
; NETWORK MASK  ROUTER  LINKNAME  PACKETSIZE
ROUTE Sl8500-port-2A-IP-Address HOST    129.80.16.254 MSPHOST1  MTU 1492
ROUTE Sl8500-port-2B-IP-Address HOST    129.80.64.254 MSPHOST2  MTU 1492

BEGINROUTES
; NETWORK MASK  FIRSTHOP  LINKNAME  PACKETSIZE
ROUTE 129.80.16.0/24    =          ZIPBMSP  MTU 1492
ROUTE 129.80.65.0/24    =          ZIPB2MSP  MTU 1492
ROUTE 172.27.2.5      HOST    129.80.16.254 ZIPBMSP  MTU 1492
ROUTE 129.80.71.83    HOST    129.80.65.254 ZIPB2MSP  MTU 1492
ROUTE DEFAULT 129.80.16.254          ZIPBMSP  MTU 1492
ROUTE DEFAULT 129.80.65.254          ZIPB2MSP  MTU 1492
ENDROUTES
```

6. Start the second mainframe network connection device.

```
V TCP/IP,tcp-stc-name,START,device_name
```

7. Define a second LMUADDR parameter for the port 2A IP address on the SL8500.

Example:

```
LMUPATH ACS(00) LMUADDR(129.80.71.83,172.27.2.5)
```

8. Enter the LMUPDEF command containing the LMUPATH statements that define the host name or IP address for each ACS.

```
LMUPDEF DSN('xxx.xxx.xxx.xxx')
```

In the following example, LMUPDEF loads LMUPATH parameters from YOUR.DSN(MEMBER).

```
LMUPDEF DSN('YOUR.DSN(MEMBER)')
```

9. Allow the trained SL8500 service representative to enter the network connections to the SL8500 library for either port 2A and 2B, whichever is applicable.
10. Vary the ACS offline and back online to pick up the revised LMUPATH statement that includes the second connection. This can be done one host at a time to minimize down time.

Sample Configuration - Two Dedicated Routes

FIGURE E-2 shows a sample configuration with two dedicated routes, followed by the statements that apply to it.

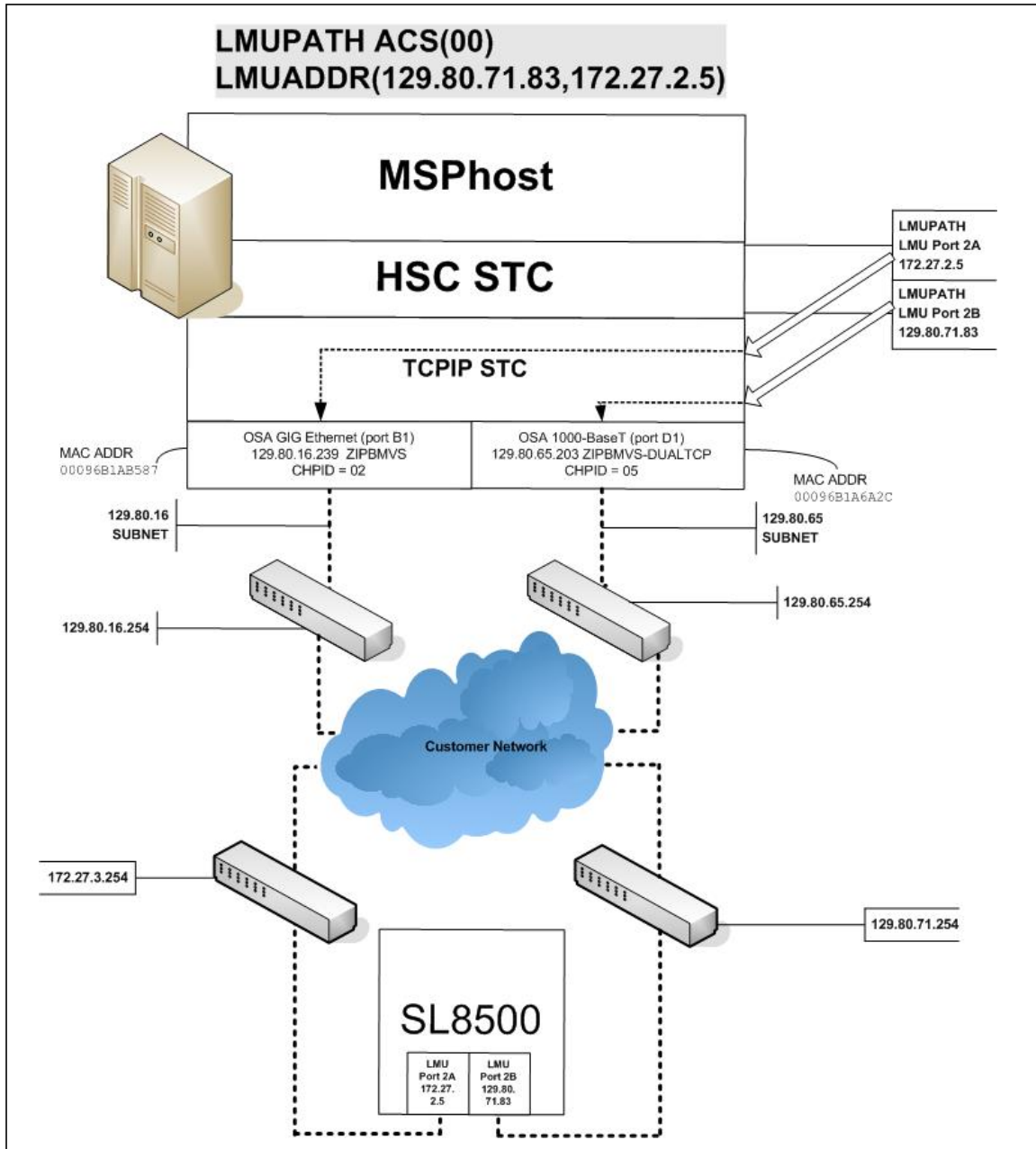

FIGURE E-2 Dual IP Configuration Sample - Different Subnetworks

Setup Statements and Displays

The following information shows the statements and displays used in [FIGURE E-2](#) on page 291.

HSC LMUPDEF PARMLIB Member

```
OPTION TITLE('DUAL TCPIP CONNECTING TO SL8500')
LMUPATH ACS(00) LMUADDR(129.80.71.83,172.27.2.5)
```

TCP/IP Profile Data Set

```
; OSA CARD #1
DEVICE ECCQD01 MPCIPA NONROUTER AUTORESTART
LINK ZIPBMSP IPAQENET ECCQD01

; OSA CARD #2
DEVICE ECCQA01 MPCIPA NONROUTER AUTORESTART
LINK ZIPB2MSP IPAQENET ECCQA01

HOME
  129.80.16.239 ZIPBMSP
  129.80.65.203 ZIPB2MSP

BEGINROUTES
;      NETWORK MASK  FIRSTHOP  LINKNAME  PACKETSIZE
ROUTE 129.80.16.0/24    =      ZIPBMSP  MTU 1492
ROUTE 129.80.65.0/24    =      ZIPB2MSP  MTU 1492
ROUTE 172.27.2.5  HOST      129.80.16.254 ZIPBMSP  MTU 1492
ROUTE 129.80.71.83 HOST      129.80.65.254 ZIPB2MSP  MTU 1492
ROUTE DEFAULT 129.80.16.254          ZIPBMSP  MTU 1492
ROUTE DEFAULT 129.80.65.254          ZIPB2MSP  MTU 1492

ENDROUTES

INCLUDE ZIP.TCPIP.PROFILES(COMMON)

START ECCQD01
START ECCQA01
```

TCP/IP Console Displays

```

D TCPIP,TCPIP,NETSTAT,DEV
EZZ2500I NETSTAT CS V1R4 TCPIP 229
DEVNAME: LOOPBACK      DEVTYPE: LOOPBACK
DEVSTATUS: READY
LNKNAME: LOOPBACK      LNKTYPE: LOOPBACK  LNKSTATUS: READY
NETNUM: 0  QUESIZE: 0
BYTESIN: 1781074      BYTESOUT: 1781074
ACTMTU: 65535
BSD ROUTING PARAMETERS:
MTU SIZE: 00000      METRIC: 00
DESTADDR: 0.0.0.0    SUBNETMASK: 0.0.0.0
MULTICAST SPECIFIC:
MULTICAST CAPABILITY: NO

```

```

DEVNAME: ECCQD01      DEVTYPE: MPCIPA
DEVSTATUS: READY      CFGROUTER: NON ACTROUTER: NON
LNKNAME: ZIPBMSP      LNKTYPE: IPAQENET  LNKSTATUS: READY
NETNUM: 0  QUESIZE: 0  SPEED: 0000001000
BYTESIN: 34704496     BYTESOUT: 11207410
IPBROADCASTCAPABILITY: NO
ARPOFFLOAD: YES ARPOFFLOADINFO: YES
ACTMTU: 8992
INBPERF: BALANCED
BSD ROUTING PARAMETERS:
MTU SIZE: 00000      METRIC: 00
DESTADDR: 0.0.0.0    SUBNETMASK: 255.255.255.0
MULTICAST SPECIFIC:
MULTICAST CAPABILITY: YES
GROUP      REFCNT
-----
224.0.0.1      0000000001

```

```

DEVNAME: ECCQA01      DEVTYPE: MPCIPA
DEVSTATUS: READY      CFGROUTER: NON ACTROUTER: NON
LNKNAME: ZIPB2MSP     LNKTYPE: IPAQENET  LNKSTATUS: READY
NETNUM: 0  QUESIZE: 0  SPEED: 0000000100
BYTESIN: 147508801    BYTESOUT: 2188246
IPBROADCASTCAPABILITY: NO
ARPOFFLOAD: YES ARPOFFLOADINFO: YES
ACTMTU: 1492
INBPERF: BALANCED
BSD ROUTING PARAMETERS:
MTU SIZE: 00000      METRIC: 00
DESTADDR: 0.0.0.0    SUBNETMASK: 255.255.255.0
MULTICAST SPECIFIC:
MULTICAST CAPABILITY: YES
GROUP      REFCNT
-----
224.0.0.1      0000000001

```

3 OF 3 RECORDS DISPLAYED

```

D TCPIP,TCPIP,NETSTAT,ROUTE
EZZ2500I NETSTAT CS V1R4 TCPIP 250
DESTINATION  GATEWAY  FLAGS  REFCNT  INTERFACE
DEFAULT      129.80.16.254  UGS    000003  ZIPBMSP
DEFAULT      129.80.65.254  UGS    000002  ZIPB2MSP
127.0.0.1    0.0.0.0    UH     000003  LOOPBACK
129.80.16.0  0.0.0.0    US     000002  ZIPBMSP
129.80.16.239 0.0.0.0    UH     000000  ZIPBMSP
129.80.65.0  0.0.0.0    US     000000  ZIPB2MSP
129.80.65.203 0.0.0.0    UH     000000  ZIPB2MSP
129.80.71.83 129.80.65.254 UGHS   000001  ZIPB2MSP
172.27.2.5   129.80.16.254 UGHS   000001  ZIPBMSP
9 OF 9 RECORDS DISPLAYED

```

HSC Display Showing SL8500 Connection

```
D ACS
SLS0000I D ACS
SLS1000I ACS 00 STATUS: CONNECTED 334
ACTIVE QUEUE ELEMENTS          2
COMPATIBILITY LEVELS: HSC=13, LMU=13
DUAL LMU NOT CONFIGURED
IP ADDR 129.80.71.83 ONLINE
IP ADDR 172.27.2.5 ONLINE
SCRATCH VOLUMES AVAILABLE..... 210
FREE CELLS AVAILABLE.....      2008
D TCPIP,TCPIP,NETSTAT,HOME
EZZ2500I NETSTAT CS V1R4 TCPIP 252
HOME ADDRESS LIST:
ADDRESS    LINK      FLG
129.80.16.239  ZIPBMSP   P
129.80.65.203  ZIPB2MSP
127.0.0.1     LOOPBACK
3 OF 3 RECORDS DISPLAYED
```

SLConsole Display of SL8500 Ports 2A/2B IP Addresses

The screenshot shows the 'Streamline Library Console' interface. On the left, a tree view lists the following components with green checkmarks: Library:2,0,0,0,0; CAP Folder:2,0,0,0,0; Drive Folder:2,0,0,0,0; Elevator Folder:2,0,0,0,0; Ptp Folder:2,0,0,0,0; and Robot Folder:2,0,0,0,0. The main area is titled 'Library' and has tabs for 'Status' and 'Properties'. Under 'Properties', there are sub-tabs for 'General', 'Complex', 'Library Controller', and 'Drive Controller'. The 'Physical' section contains the following data:

Vendor	STK
Frame Serial Number	516000000454
Expansion Module Count	0
Total Slot Count	1448
Empty Slot Count	954
Physical PTP Count	4
Drive Count	25
Robot Count	4
Cap Count	1
Elevator Count	2

The 'Host Interface TCP/IP 2B' section contains the following data:

DNS Domain Name	sl85001
IP Address	129.80.71.83
NetMask	255.255.254.0
MAC Address	00:10:4F:06:F8:32

The 'Host Interface TCP/IP 2A' section contains the following data:

IP Address	172.27.2.5
NetMask	255.255.254.0
MAC Address	00:10:4F:06:F8:33

At the bottom of the console, there is a status bar with the Storagetek logo, a green checkmark for 'Comm Status', 'UserID: test', and a green checkmark for 'Library:SL85001'.

Two SL8500 Network Connections - One Mainframe IP Address

To establish one host IP route from the HSC to two routes to the SL8500, use the process described in this section. **To configure the SL8500 dual TCP/IP feature, refer to the *StreamLine SL8500 Modular Library System Dual TCP/IP Feature* document.**

[FIGURE E-3 on page 298](#) shows dual IP (one host IP) with two SL8500 network connections.

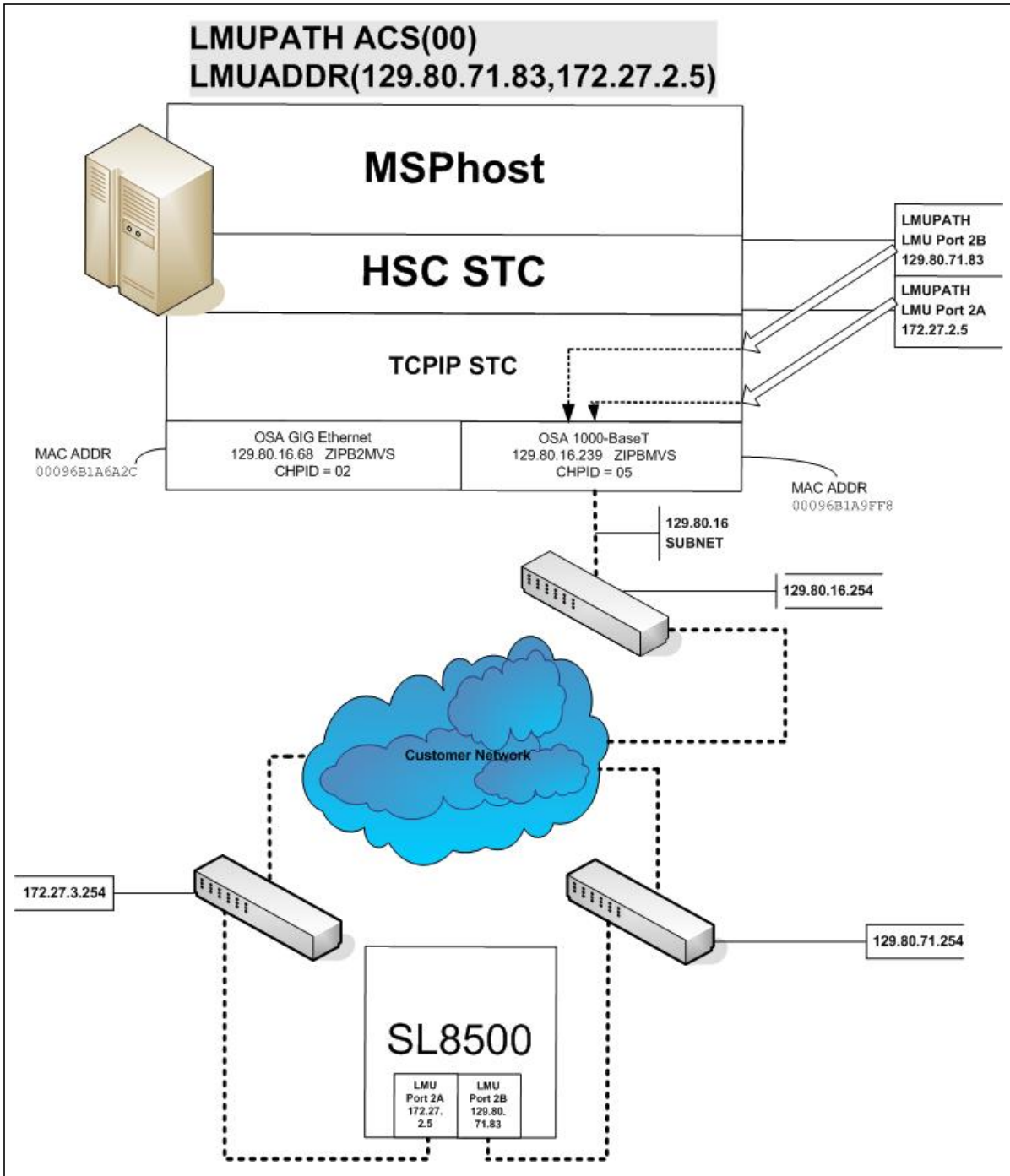

FIGURE E-3 Dual IP (one host IP) with Two SL8500 Network Connections

In the following examples, the entries *in italics* represent the second connection.

1. Complete the Network Entries Worksheet (see TABLE E-2 for a sample) for each set of routes to the SL8500. The worksheet can be found in the *StreamLine SL8500 Modular Library System Dual TCP/IP Feature* document.

TABLE E-2 Network Entries Worksheet

Description		IP Address
Port 2A	HBC Card Port 2A	172.27.2.5
	Gateway Port 2A	172.27.3.254
	Netmask	/23
	Host to Port 2A	129.80.16.239
Port 2B	HBC Car Port 2B	129.80.71.83
	Gateway Port 2B	129.80.71.254
	Netmask	/23
	Host to Port 2B	129.80.16.239

2. Define two dedicated static routes to the SL8500 destination port (2A and 2B) IP addresses over one router.

Example:

```
BEGINROUTES
; DESTINATION      FIRSTHOP  LINKNAME  PACKETSIZE
ROUTE 129.80.16.0/24 = &SYSNAME.MSP MTU 1492
ROUTE 172.27.2.5 HOST 129.80.16.254 &SYSNAME.MSP MTU 1492
ROUTE 129.80.71.83 HOST 129.80.16.254 &SYSNAME.MSP MTU 1492
ROUTE DEFAULT      129.80.16.254 &SYSNAME.MSP MTU 1492

ENDROUTES
```

3. Define a second LMUADDR parameter for the port 2A IP address on the SL8500.

Example:

```
LMUPATH ACS(00) LMUADDR(129.80.71.83,172.27.2.5)
```

4. Enter the LMUPDEF command containing the LMUPATH statements that define the host name or IP address for each ACS.

```
LMUPDEF DSN('xxx.xxx.xxx(xxx)')
```

In the following example, LMUPDEF loads LMUPATH parameters from YOUR.DSN(MEMBER).

```
LMUPDEF DSN('YOUR.DSN(MEMBER)')
```

5. Allow the trained SL8500 service representative to enter the network connections to the SL8500 library for either port 2A and 2B, whichever is applicable.
6. Vary the ACS offline and back online to pick up the revised LMUPATH statement that includes the second connection. This can be done one host at a time to minimize down time.

Sample Configuration - One Host IP, Two SL8500 Network Connections

FIGURE E-4 shows a sample dual IP (one host IP) configuration with two SL8500 network connections, followed by the statements that apply to it.

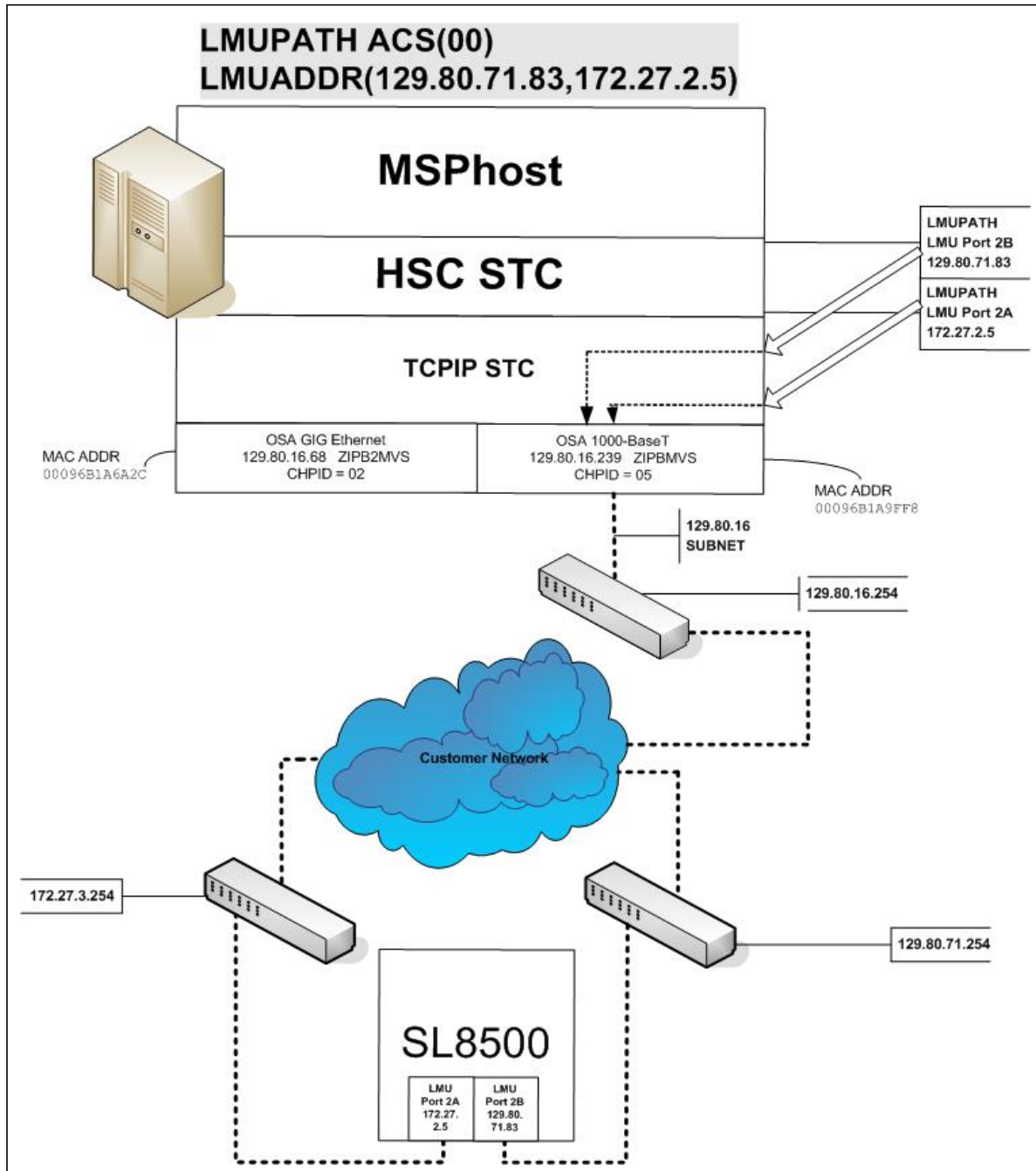

FIGURE E-4 Dual IP (one host IP) with Two SL8500 Network Connections

Setup Statements and Displays

The following information shows the statements and displays used in [FIGURE E-4](#).

HSC LMUPDEF PARMLIB Member

```
OPTION TITLE('DUAL TCPIP CONNECTING TO SL85001')
LMUPATH ACS(00) LMUADDR(129.80.71.83,172.27.2.5)
```

TCP/IP Profile Data Set

```
: OSA CARD #1
DEVICE ECCQD01 MPCIPA NONROUTER AUTORESTART
LINK ZIPBMSP IPAQENET ECCQD01

HOME
  129.80.&IPADDR1 &SYSNAME.MSP

BEGINROUTES
;      NETWORK MASK  FIRSTHOP  LINKNAME  PACKETSIZE
ROUTE 129.80.16.0/24  =        &SYSNAME.MSP  MTU 1492
ROUTE 172.27.2.5 HOST    129.80.16.254 &SYSNAME.MSP  MTU 1492
ROUTE 129.80.71.83 HOST    129.80.16.254 &SYSNAME.MSP  MTU 1492
ROUTE DEFAULT

ENDROUTES

INCLUDE ZIP.TCPIP.PROFILES(COMMON)

START ECCQD01
```

TCP/IP Console Displays

```
D TCPIP,,N,DEV
EZZ2500I NETSTAT CS V1R4 TCPIP 931
DEVNAME: LOOPBACK      DEVTYPE: LOOPBACK
DEVSTATUS: READY
LNKNAME: LOOPBACK      LNKTYPE: LOOPBACK  LNKSTATUS: READY
NETNUM: 0  QUESIZE: 0
BYTESIN: 2136824      BYTESOUT: 2136824
ACTMTU: 65535
BSD ROUTING PARAMETERS:
MTU SIZE: 00000      METRIC: 00
DESTADDR: 0.0.0.0    SUBNETMASK: 0.0.0.0
MULTICAST SPECIFIC:
MULTICAST CAPABILITY: NO
DEVNAME: ECCQD01      DEVTYPE: MPCIPA
DEVSTATUS: READY      CFGROUTER: NON  ACTROUTER: NON
LNKNAME: ZIPBMSP      LNKTYPE: IPAQENET  LNKSTATUS: READY
NETNUM: 0  QUESIZE: 0  SPEED: 0000001000
BYTESIN: 48605838     BYTESOUT: 9790950
IPBROADCASTCAPABILITY: NO
ARPOFFLOAD: YES  ARPOFFLOADINFO: YES
ACTMTU: 8992
INBPERF: BALANCED
BSD ROUTING PARAMETERS:
MTU SIZE: 00000      METRIC: 00
DESTADDR: 0.0.0.0    SUBNETMASK: 255.255.255.0
MULTICAST SPECIFIC:
MULTICAST CAPABILITY: YES
GROUP      REFCNT
-----
224.0.0.1      0000000001
2 OF 2 RECORDS DISPLAYED

D TCPIP,,N,ROUTE
EZZ2500I NETSTAT CS V1R4 TCPIP 933
DESTINATION  GATEWAY  FLAGS  REFCNT  INTERFACE
DEFAULT      129.80.16.254  UGS    000001  ZIPBMSP
127.0.0.1    0.0.0.0      UH     000004  LOOPBACK
129.80.16.0  0.0.0.0      US     000000  ZIPBMSP
129.80.16.239 0.0.0.0      UH     000000  ZIPBMSP
129.80.71.83 129.80.16.254 UGHS   000001  ZIPBMSP
172.27.2.5   129.80.16.254 UGHS   000001  ZIPBMSP
6 OF 6 RECORDS DISPLAYED

D TCPIP,,N,HOME
EZZ2500I NETSTAT CS V1R4 TCPIP 935
HOME ADDRESS LIST:
ADDRESS  LINK      FLG
129.80.16.239  ZIPBMSP  P
127.0.0.1    LOOPBACK
2 OF 2 RECORDS DISPLAYED
```

HSC Display Showing SL8500 Connection

```
D ACS
SLS0000I D ACS
SLS1000I ACS 00 STATUS: CONNECTED 942
ACTIVE QUEUE ELEMENTS          1
COMPATIBILITY LEVELS: HSC=13, LMU=13
DUAL LMU NOT CONFIGURED
IP ADDR 129.80.71.83 ONLINE
IP ADDR 172.27.2.5 ONLINE
SCRATCH VOLUMES AVAILABLE..... 210
FREE CELLS AVAILABLE.....      2007
```

SLConsole Display of SL8500 Ports 2A/2B IP Addresses

The screenshot shows the 'Streamline Library Console' interface. On the left, a tree view shows the library structure: Library:2,0,0,0,0, with sub-items CAP Folder, Drive Folder, Elevator Folder, Ptp Folder, and Robot Folder, all marked with green checkmarks. The main pane displays the 'Properties' tab for the selected library, with sub-tabs for General, Complex, Library Controller, and Drive Controller. The 'Physical' section lists hardware details: Vendor (STK), Frame Serial Number (516000000454), Expansion Module Count (0), Total Slot Count (1448), Empty Slot Count (954), Physical PTP Count (4), Drive Count (25), Robot Count (4), Cap Count (1), and Elevator Count (2). The 'Host Interface TCP/IP 2B' section shows DNS Domain Name (sl85001), IP Address (129.80.71.83), NetMask (255.255.254.0), and MAC Address (00:10:4F:06:F8:32). The 'Host Interface TCP/IP 2A' section shows IP Address (172.27.2.5), NetMask (255.255.254.0), and MAC Address (00:10:4F:06:F8:33). The bottom status bar includes the StoragTek logo, a green checkmark for 'Comm Status', 'UserID: test', and a green checkmark for 'Library:SL85001'.

Multiple SL8500 Library Connections

Connecting to Multiple SL8500 Libraries in an ACS

When SL8500 3.9x or higher firmware is installed, the HSC can connect to more than one SL8500 in an ACS (library complex).

The HSC supports up to four connections to an ACS. Some *possible* connections are:

- four connections to four SL8500s
- two connections to each of two SL8500s
- two connections to one SL8500 and two connections to two other SL8500s.

When the HSC establishes two connections to one SL8500, the HSC provides dual TCP/IP or multiple TCP/IP connectivity. Refer to the [“TCP/IP Communications - Important Considerations” on page 284](#) discussion for more information.

Note –

- To optimize library performance and minimize inter-library communication among SL8500s, connect to the libraries with the most activity. The HSC distributes communications to the libraries evenly.
- LMUPATH control statements are used to define network LMU attachments.

The following example shows multiple LMUADDR parameters consisting of four IP addresses. In this case, the first, second, third, and fourth IP addresses indicate a TCP/IP connection to each of four separate SL8500 libraries connected in ACS 00:

```
LMUPATH ACS(00)+ LMUADDR(123.456.789.012,123.456.789.013,123.456.789.014,123.456.789.015)
```

Sample Configuration - Four SL8500 Network Connections, Four Mainframe IP Addresses

FIGURE E-5 on page 306 shows a sample of a four IP (four host IPs) configuration with four SL8500 network connections. This configuration applies to SL8500 3.x or higher firmware.

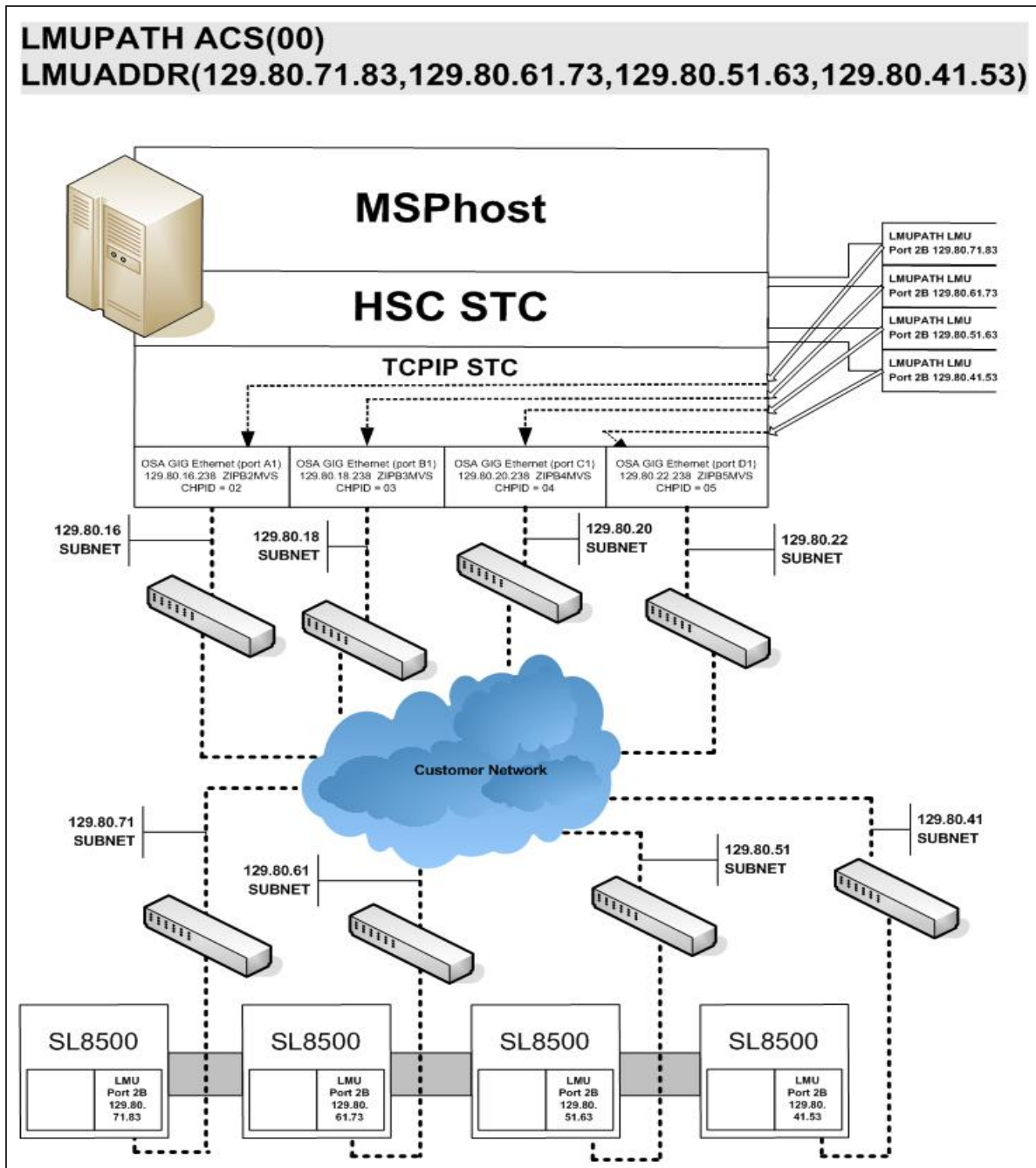

FIGURE E-5 Four IP Addresses (four host IPs) with Four SL8500 Network Connections

Powering Down the SL8500 - HSC Requirements

Prior to powering down the SL8500, the HSC requires that the following procedure must be followed:

1. Vary the drives offline at the MSP host level.
2. Modify the LSM(s) offline (see the MODify Command in the *ELS Command, Control Statement, and Utility Reference*).

For specific information about powering off the SL8500, refer to the *SL8500 User's Guide*.

Multiple TCP/IP Redundant Electronics

The LMUPATH control statement allows users to define network Library Controller attachments. In a Multiple TCP/IP redundant electronics environment for an SL8500 complex, specify up to 32 network connections using the LMUADDR parameter. When specified, HSC automatically adjusts when Redundant Electronics is installed.

Note – Vary the ACS offline, updating the LMUPDEF file to accommodate redundant electronics, read the new LMUPDEF file, and vary the ACS back online to pick up the revised LMUPATH statement that includes the added connections.

Sample Configuration #1 - One SL8500 Network Single Redundant Pair Connections, Four Mainframe IP Addresses

FIGURE E-6 on page 310 shows a sample four IP (four host IPs) configuration with one single redundant pair SL8500 network connections. This configuration applies to SL8500 6.0 or higher firmware.

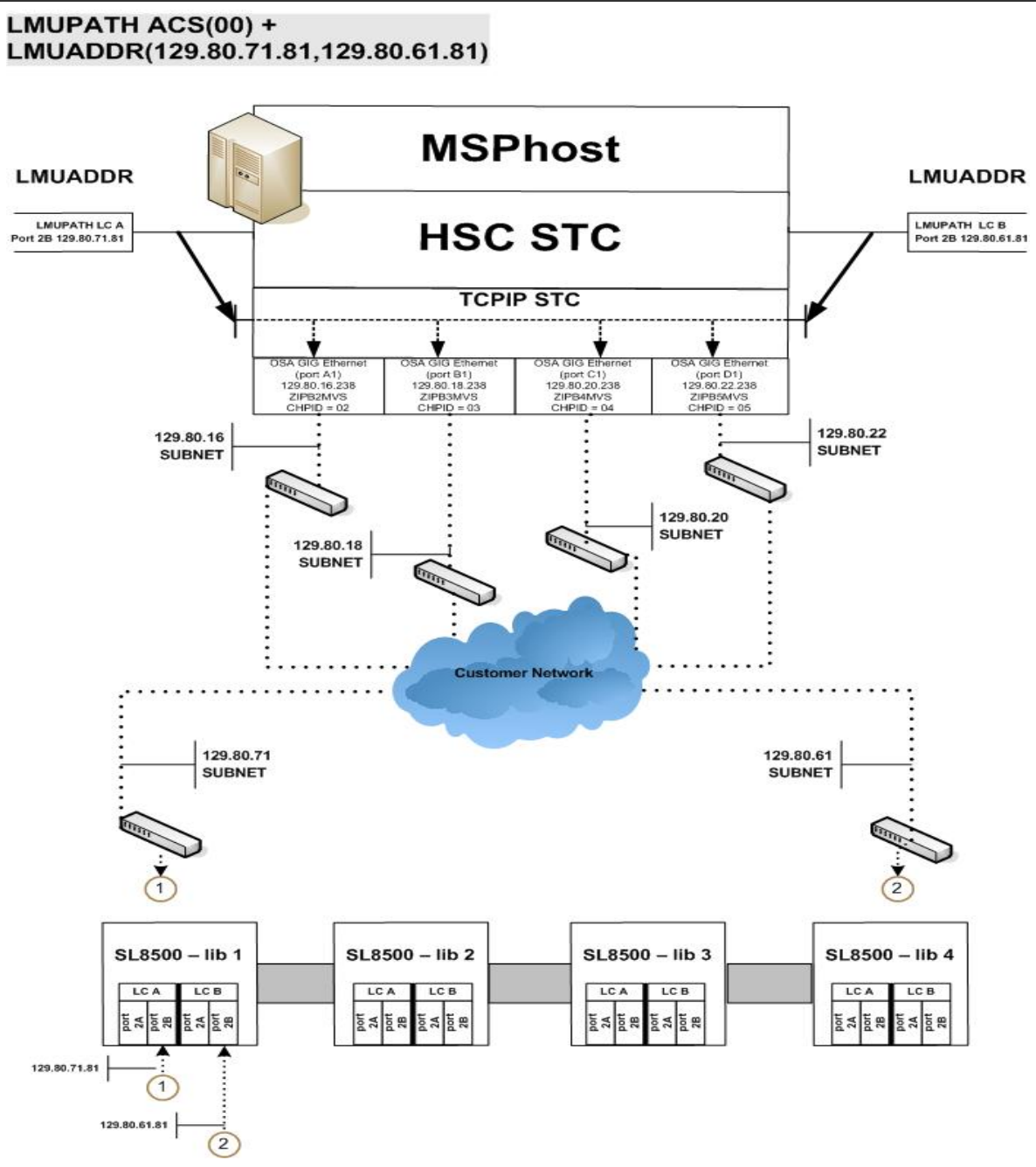

FIGURE E-6 Four IP (four host IPs) with One Single Redundant Pair SL8500 Network Connections

Sample Configuration #2 - One SL8500 Network Dual Redundant Pair Connections, Four Mainframe IP Addresses

FIGURE E-7 on page 312 shows a sample four IP (four host IPs) configuration with one dual redundant pair SL8500 network connections. This configuration applies to SL8500 6.0 or higher firmware.

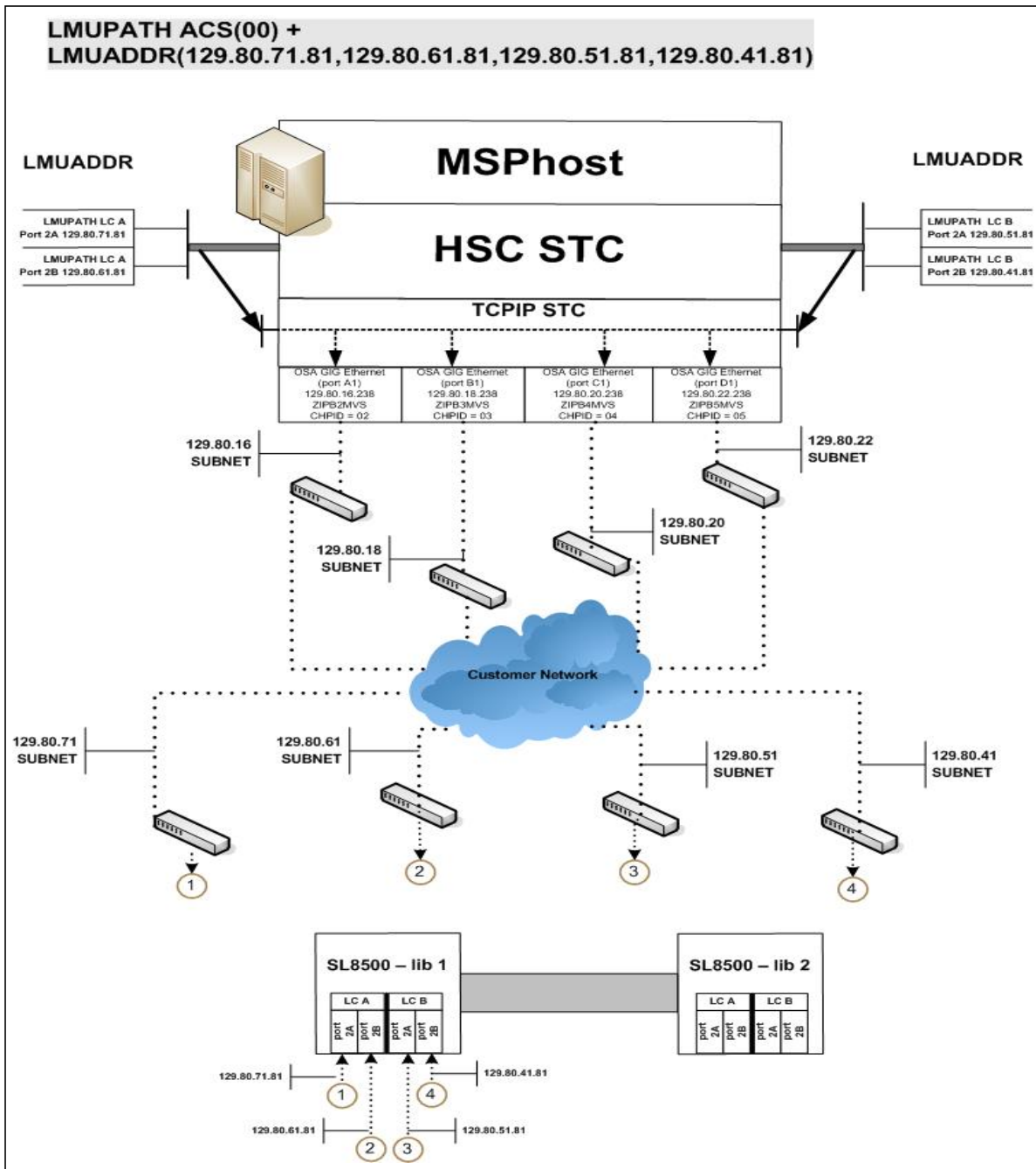

FIGURE E-7 Four IP (four host IPs) with One Dual Redundant Pair SL8500 Network Connections

Sample Configuration #3 - One SL8500 Network Dual Redundant Pair and 2 Dual TCP/IP Connections, Four Mainframe IP Addresses

FIGURE E-8 on page 314 shows a sample four IP (four host IPs) configuration with one dual redundant pair SL8500 and two dual TCP/IP network connections. This configuration applies to SL8500 6.0 or higher firmware.

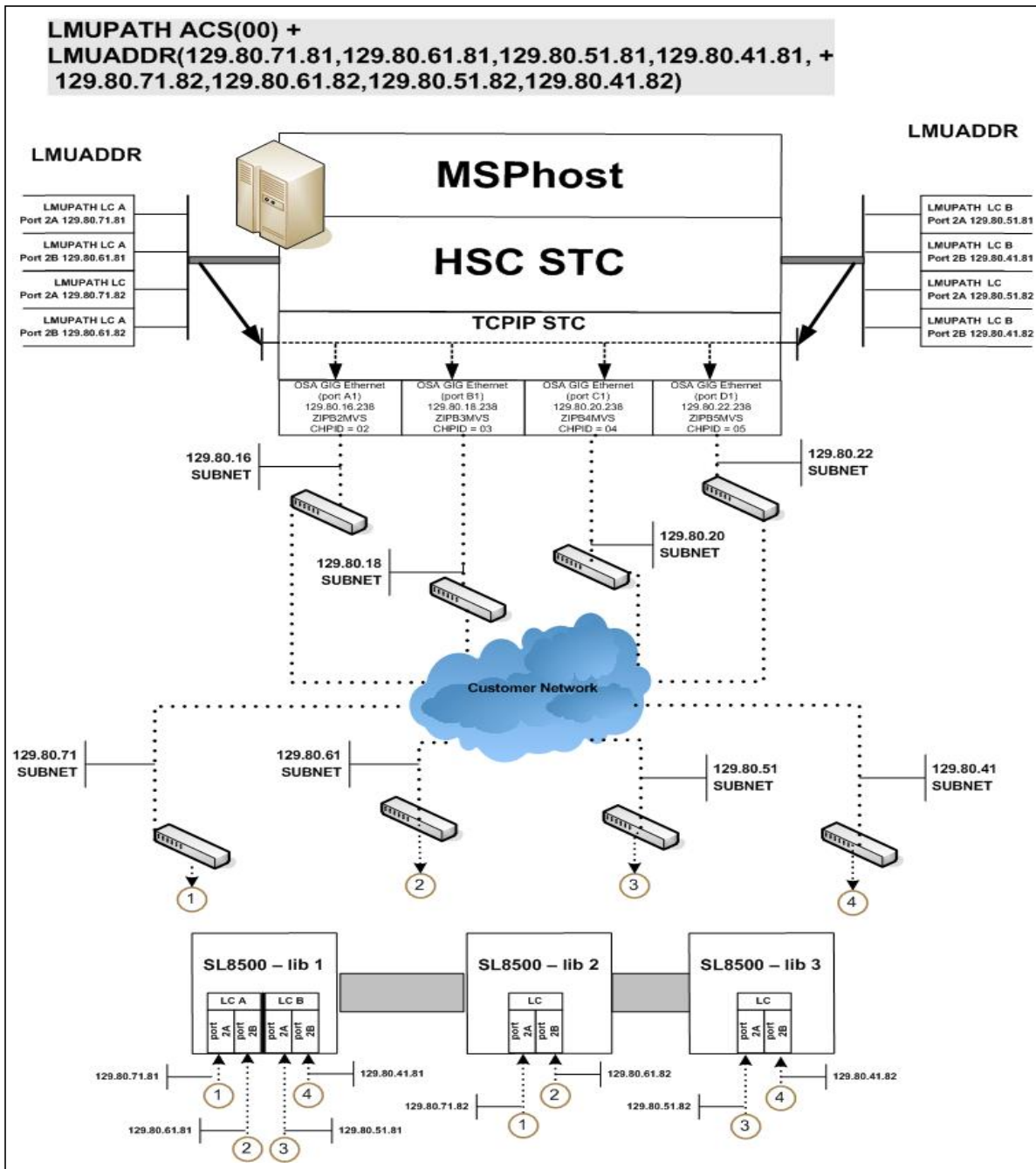

FIGURE E-8 Four IP (four host IPs) with One Dual Redundant Pair SL8500 and 2 Dual TCP/IP Network Connections

Troubleshooting Library Connectivity Problems

This section covers procedures on helping you to provide important data to StorageTek/Oracle support when Library connectivity problems occur.

Basic Tracing

The following procedure tells how to produce diagnostic data for basic SL3000/SL8500 host connectivity problems.

1. Using the SLConsole, start a monitor trace (select All) and start spooling to an output file as shown in the example in [FIGURE E-9](#).

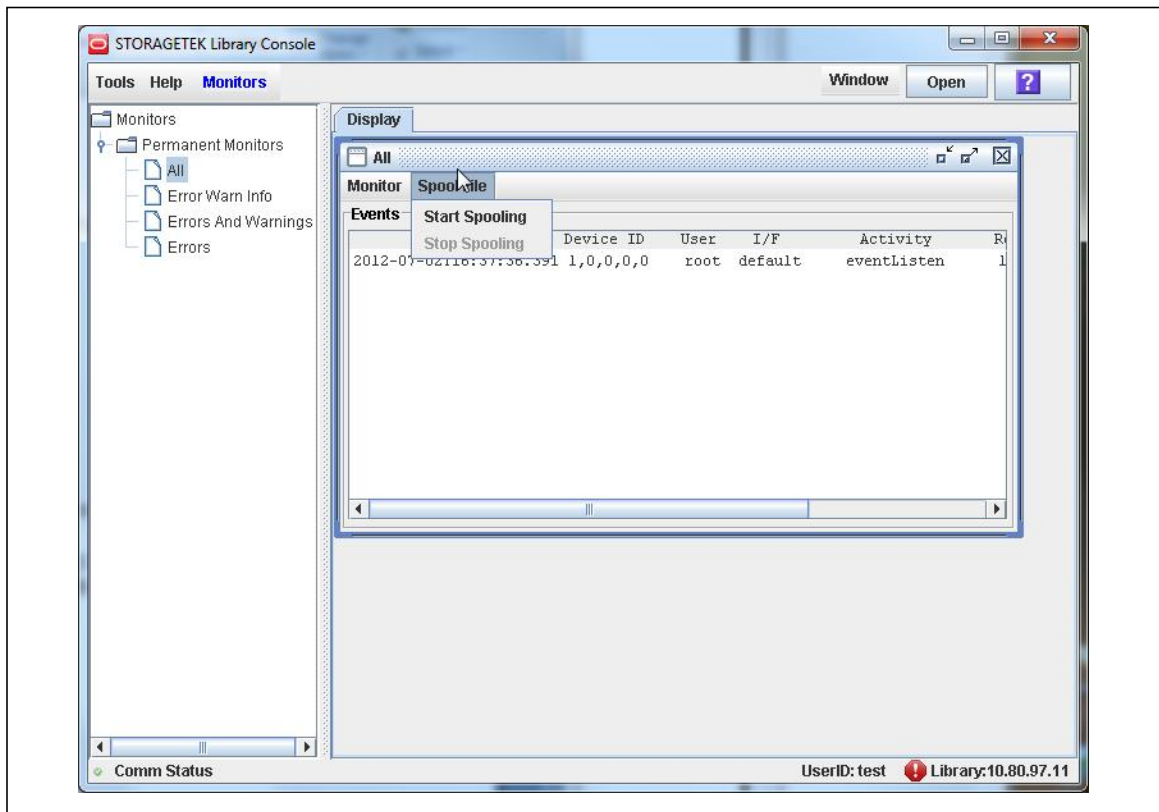

FIGURE E-9 Example SLC Console (Monitor Trace)

2. Update the HSC PARMLIB member (in bold) to add LMU tracing on as shown in the example.

```
CDSDEF DSN1(HSC1.PRIM),DSN2(HSC1.BKUP),DSN3(HSC1.STDBY)
MGMTDEF DSN(HSC.PARMS)COMMP METH LMUFEAT VSM(ADVMGMT)
CAPP 9,01:00:00,AUTO
MNTD AUTOCLN(ON) EJCTAUTO(ON)
/* turn LMU trace on */
TR LMU
```

3. Start GTF to trace the HSC job as shown in the JCL example below.

```
//GTFTEST PROC MEMBER=GTFTST
//IEFPROC EXEC PGM=AHLGTF,PARM='MODE=EXT,DEBUG=NO,TIME=YES',
//      REGION=2880K,ACCT=505341SPKC
//IEFRDER DD  DSNAME=GTF.OUTPUT,DISP=SHR /* output trace file */
//SYSLIB DD  DSNAME=TEST.PARMLIB(&MEMBER),DISP=SHR
```

OR, via a GTF SYSLIB member shown in the following example.

```
TRACE=USR,JOBNAMEP
JOBNAME=(HSCT*) /* HSCT* = HSC jobname prefix (jobname example:
HSCT1234) */
END
```

4. After problem occurs:
 - a. Stop GTF.
 - b. Stop the spooling in the monitor trace.
 - c. Stop HSC.
5. Send to the monitor trace, GTF output files, and HSC log to StorageTek/Oracle support.

Packet Tracing

A packet trace, which traces the actual data packets that are being transferred across the line, can be helpful when trying to determine if data is actually being sent across properly. The following procedure tells how to run a packet trace.

1. **Create an external writer proc in SYS1.PROCLIB(CTTCP) as shown in the following example.**

```
//CTTCP PROC
//CTTCP EXEC PGM=ITTTTCWR
//TRCOUT01 DD DSN=Your_data_set,UNIT=SYSDA,
//          SPACE=(CYL,(100),,CONTIG),DISP=(NEW,CATLG)
```

2. **Enter the following MSP commands:**

```
TRACE CT,WTRSTART=CTTCP
TRACE CT,ON,COMP=SYSTCPDA,SUB=(your TCP/IP started task name)
R n,WTR=CTTCP,END
D TRACE,COMP=SYSTCPDA,SUB=(your TCP/IP started task name)
```

Note – This will verify that trace was started successfully.

```
V TCPIP,your TCP/IP started task name,PKT,ON,IP=xx.xx.xx.xx
```

Where *xx.xx.xx.xx* is the IP address you want to trace.

3. **Run the trace until the error occurs.**

4. **Enter the following MSP commands:**

```
V TCPIP,your TCP/IP started task name,PKT,OFF
TRACE CT,ON,COMP=SYSTCPDA,SUB=(your TCP/IP started task name)
R n,WTR=DISCONNECT,END
TRACE CT,OFF,COMP=SYSTCPDA,SUB=(your TCP/IP started task name)
TRACE CT,WTRSTOP=CTTCP,FLUSH
```

5. **To format the trace, use IPCS and the following command:**

```
CTRACE COMP(SYSTCPDA) FULL
```

OR use IPCS menu option 2, Option 7, Option 1, Option D and then enter component name SYSTCPDA and report type FULL.

Configuring SL3000 Library Communications

The SL3000 is different from other LSMs, and the way it communicates with HSC is also different...as explained in this appendix.

TCP/IP Communications - Important Considerations

There are two types of TCP/IP connections for SL3000 discussed in this appendix:

- [“SL3000 Dual IP Connections” on page 321](#) - A connecting redundancy feature to allow up to two connections to the library.

Note – It is crucial that you **read completely** this section to understand these procedures.

Shared Networks

The following are some examples of issues that can arise when you connect a Streamline library to a shared network.

- A TCP/IP-connected library can handle standard host traffic but it cannot resolve floods of *Address Resolution Protocol* (ARP) broadcasts. **For this reason, it is best to attach the library on a controlled network, such as behind a switch or router.**

Later generation networks, such as 1000Base-T and Gig-E, support earlier communication modes; however, devices that are communicating with the library may transmit data at bandwidths that could overwhelm the library.

It is best to attach the library on a controlled network, such as with a switch that can isolate the library from network broadcasts.

- When you connect the library on shared networks and broadcasts are sent to all network nodes, they may also be directed to the library (even though it does not need them).

During the time the library is receiving these irrelevant broadcasts, it cannot receive from or respond to other requests in a timely fashion. This heavy broadcast traffic on the network can saturate the library to the point that, to the host, it may appear that the TCP/IP connection has been lost. It may also result in Overdue Response Handler (ORH) messages on the host system.

- Heavy network traffic can also overwhelm the Ethernet controller causing the processor to continuously reset and re-initialize the controller, then recover the host-to-library communications.

SL3000 Dual IP Connections

The LMUPATH control statement allows users to define network LMU attachments. In a dual IP connection environment for an SL3000, specify a second LMUADDR parameter to define dual IP. The HSC automatically determines whether or not the connection is dual IP or dual LMU.

Note – Vary the ACS offline and back online to pick up the revised LMUPATH statement that includes the second connection.

FIGURE F-1 on page 322 and FIGURE F-2 on page 327 show examples of a dual IP connection for HSC.

Two SL3000 Network Connections - Two Mainframe IP Addresses

To establish two dedicated routes on different subnetworks from the HSC to two dedicated routes to the SL3000, use the process described in this section. **To configure the SL3000 dual TCP/IP feature, refer to chapter 4 of the *StreamLine SL3000 Modular Library System Installation Guide*.**

FIGURE F-1 on page 322 shows dual IP connections with two SL3000 network connections.

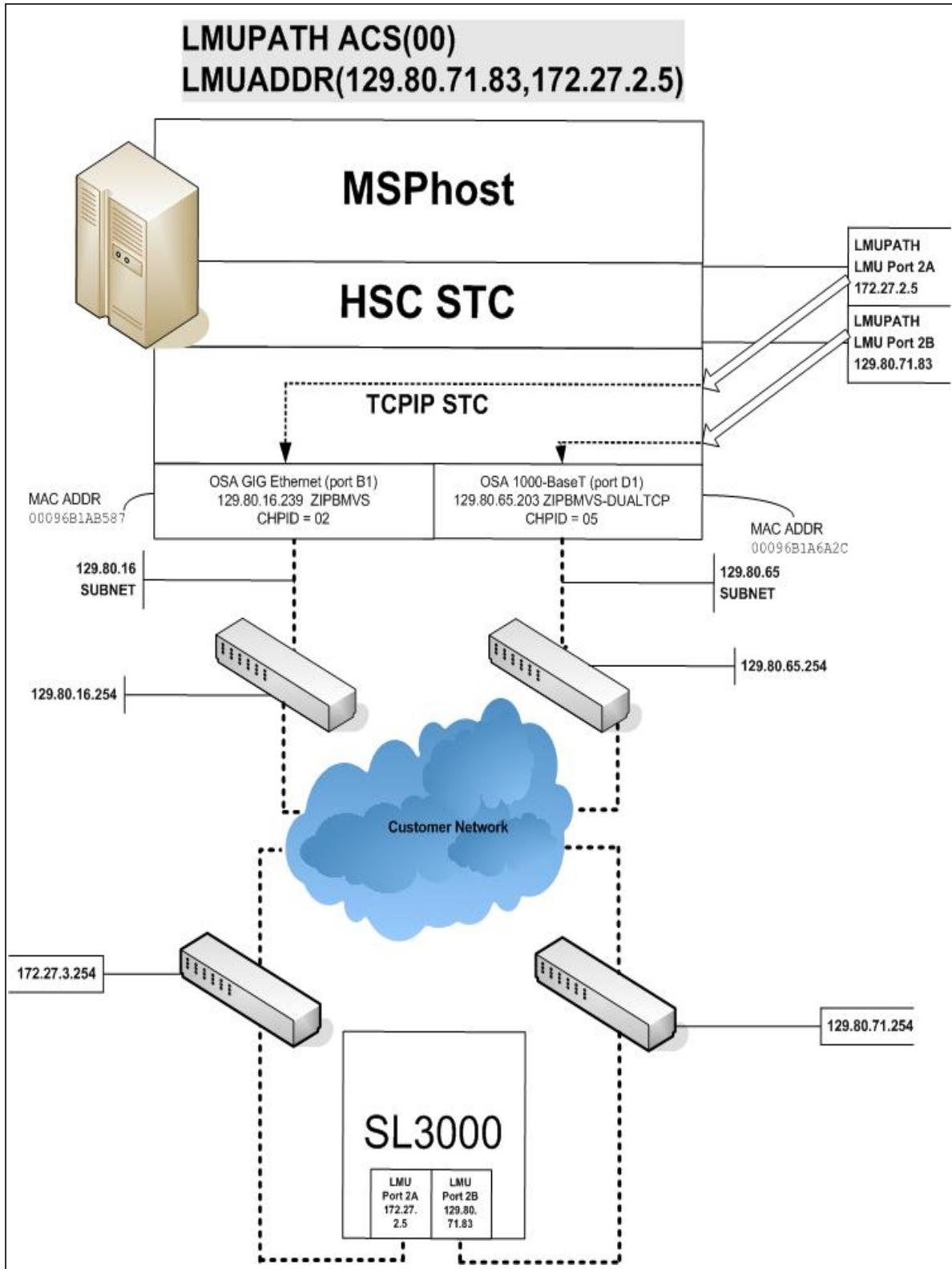

FIGURE F-1 Dual IP with Two SL3000 Network Connections - Different Subnetworks

In the following examples, the entries *in italics* represent the second connection.

1. Create and complete the Network Entries Worksheet (see TABLE F-1 for a sample) for each set of two dedicated routes to the SL3000. The worksheet can be found in chapter 4 of the *SL3000 Modular Library System Installation Guide*.

TABLE F-1 Network Entries Worksheet

Description		IP Address
Port 2A	HBC Card Port 2A	172.27.2.5
	Gateway Port 2A	172.27.3.254
	Netmask	/23
	Host to Port 2A	129.80.16.239
Port 2B	HBC Car Port 2B	129.80.71.83
	Gateway Port 2B	129.80.71.254
	Netmask	/23
	Host to Port 2B	129.80.65.203

2. Define a second DEVICE and LINK statement in your TCP/IP profile data set for a second mainframe network connection.

For example:

```

; OSA CARD #1
DEVICE ECCQD01 MPCIPA NONROUTER AUTORESTART
LINK ZIPBMSP IPAQENET ECCQD01

; OSA CARD #2
DEVICE ECCQA01 MPCIPA NONROUTER AUTORESTART
LINK ZIPB2MSP IPAQENET ECCQA01

```

3. Define a second home address in your TCP/IP profile data set.

For example:

```

HOME
129.80.16.239 ZIPBMSP
129.80.65.203 ZIPB2MSP

```

- Define a second router on the second subnetwork in the routing paragraph of your TCP/IP profile data set.

Remember that you must also configure the SL3000 routing tables according to the instructions described in chapter 4 of the *SL3000 Modular Library System Installation Guide*.

For example:

```
BEGINROUTES
; NETWORK MASK          FIRSTHOP  LINKNAME PACKETSIZE

ROUTE 129.80.16.0/24    =          ZIPBMSP  MTU 1492
ROUTE 129.80.65.0/24    =          ZIPB2MSP  MTU 1492
ROUTE 172.27.2.5 HOST   129.80.16.254 ZIPBMSP  MTU 1492
ROUTE 129.80.71.83 HOST 129.80.65.254 ZIPB2MSP  MTU 1492
ROUTE DEFAULT 129.80.16.254          ZIPBMSP  MTU 1492
ROUTE DEFAULT 129.80.65.254          ZIPB2MSP  MTU 1492
ENDROUTES
```

- Optionally, define two dedicated static routes to the SL3000 destination port (2A and 2B) IP addresses over two different routers.

For example:

```
; NETWORK MASK ROUTER  LINKNAME PACKETSIZE
ROUTE S/3000-port-2A-IP-Address HOST 129.80.16.254 MSPHOST1 MTU 1492
ROUTE S/3000-port-2B-IP-Address HOST 129.80.64.254 MSPHOST2 MTU 1492

BEGINROUTES
; NETWORK MASK  FIRSTHOP  LINKNAME PACKETSIZE
ROUTE 129.80.16.0/24    =          ZIPBMSP  MTU 1492
ROUTE 129.80.65.0/24    =          ZIPB2MSP  MTU 1492
ROUTE 172.27.2.5  HOST   129.80.16.254 ZIPBMSP  MTU 1492
ROUTE 129.80.71.83  HOST  129.80.65.254 ZIPB2MSP  MTU 1492
ROUTE DEFAULT 129.80.16.254          ZIPBMSP  MTU 1492
ROUTE DEFAULT 129.80.65.254          ZIPB2MSP  MTU 1492
ENDROUTES
```

6. Start the second mainframe network connection device.

```
V TCPIP,tcp-stc-name,START,device_name
```

7. Define a second LMUADDR parameter for the port 2A IP address on the SL3000.
For example:

```
V TCPIP,tcp-stc-name,START,device_name
```

8. Enter the LMUPDEF command containing the LMUPATH statements that define the host name or IP address for each ACS.

```
LMUPDEF DSN('xxx.xxx.xxx(xxx)')
```

In the following example, LMUPDEF loads LMUPATH parameters from YOUR.DSN(MEMBER).

```
LMUPDEF DSN('YOUR.DSN(MEMBER)')
```

9. Allow the trained SL3000 service representative to enter the network connections to the SL3000 library for either port 2A and 2B, whichever is applicable.
10. Vary the ACS offline and back online to pick up the revised LMUPATH statement that includes the second connection. This can be done one host at a time to minimize down time.

Sample Configuration - Two Dedicated Routes

FIGURE F-2 on page 327 shows a sample configuration with two dedicated routes, followed by the statements that apply to it.

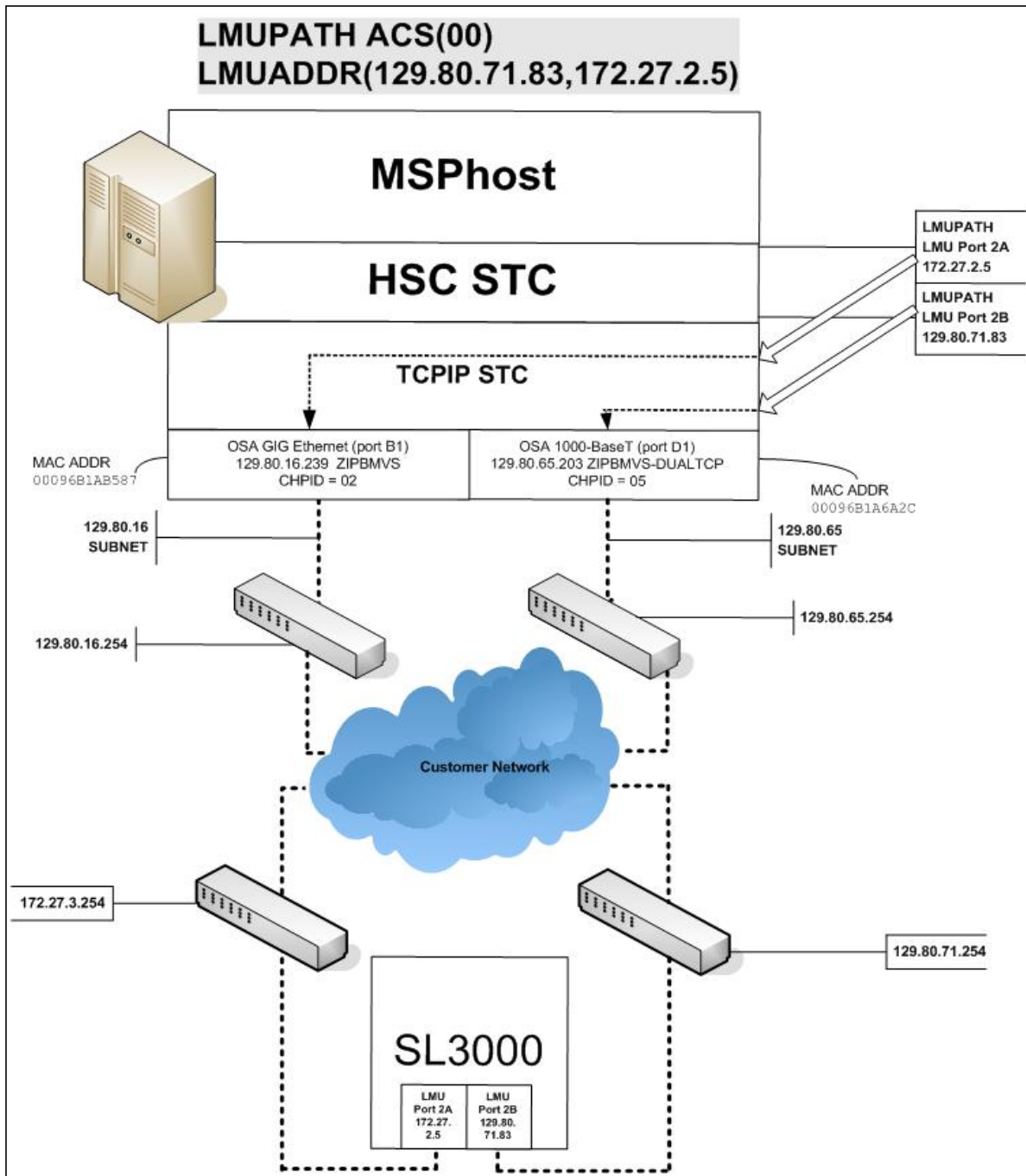

FIGURE F-2 Dual IP Configuration Sample - Different Subnetworks

Setup Statements and Displays

The following information shows the statements and displays used in [FIGURE F-2](#) on page 327.

HSC LMUPDEF PARMLIB Member

```
OPTION TITLE('DUAL TCPIP CONNECTING TO SL3000')
LMUPATH ACS(00) LMUADDR(129.80.71.83,172.27.2.5)
```

TCP/IP Profile Data Set

```
; OSA CARD #1
DEVICE ECCQD01 MPCIPA NONROUTER AUTORESTART
LINK ZIPBMSP IPAQENET ECCQD01

; OSA CARD #2
DEVICE ECCQA01 MPCIPA NONROUTER AUTORESTART
LINK ZIPB2MSP IPAQENET ECCQA01

HOME
  129.80.16.239 ZIPBMSP
  129.80.65.203 ZIPB2MSP

BEGINROUTES
;      NETWORK MASK  FIRSTHOP  LINKNAME  PACKETSIZE
ROUTE 129.80.16.0/24    =      ZIPBMSP  MTU 1492
ROUTE 129.80.65.0/24    =      ZIPB2MSP  MTU 1492
ROUTE 172.27.2.5  HOST    129.80.16.254 ZIPBMSP  MTU 1492
ROUTE 129.80.71.83 HOST    129.80.65.254 ZIPB2MSP  MTU 1492
ROUTE DEFAULT 129.80.16.254          ZIPBMSP  MTU 1492
ROUTE DEFAULT 129.80.65.254          ZIPB2MSP  MTU 1492

ENDROUTES

INCLUDE ZIP.TCPIP.PROFILES(COMMON)

START ECCQD01
START ECCQA01
```

TCP/IP Console Displays

```

D TCPIP,TCPIP,NETSTAT,DEV
EZZ2500I NETSTAT CS V1R4 TCPIP 229
DEVNAME: LOOPBACK      DEVTYPE: LOOPBACK
DEVSTATUS: READY
LNKNAME: LOOPBACK      LNKTYPE: LOOPBACK  LNKSTATUS: READY
NETNUM: 0  QUESIZE: 0
BYTESIN: 1781074      BYTESOUT: 1781074
ACTMTU: 65535
BSD ROUTING PARAMETERS:
MTU SIZE: 00000      METRIC: 00
DESTADDR: 0.0.0.0    SUBNETMASK: 0.0.0.0
MULTICAST SPECIFIC:
MULTICAST CAPABILITY: NO

DEVNAME: ECCQD01      DEVTYPE: MPCIPA
DEVSTATUS: READY      CFGROUTER: NON  ACTROUTER: NON
LNKNAME: ZIPBMSP      LNKTYPE: IPAQENET  LNKSTATUS: READY
NETNUM: 0  QUESIZE: 0  SPEED: 0000001000
BYTESIN: 34704496     BYTESOUT: 11207410
IPBROADCASTCAPABILITY: NO
ARPOFFLOAD: YES  ARPOFFLOADINFO: YES
ACTMTU: 8992
INBPERF: BALANCED
BSD ROUTING PARAMETERS:
MTU SIZE: 00000      METRIC: 00
DESTADDR: 0.0.0.0    SUBNETMASK: 255.255.255.0
MULTICAST SPECIFIC:
MULTICAST CAPABILITY: YES
GROUP      REFCNT
-----
224.0.0.1      0000000001

DEVNAME: ECCQA01      DEVTYPE: MPCIPA
DEVSTATUS: READY      CFGROUTER: NON  ACTROUTER: NON
LNKNAME: ZIPB2MSP     LNKTYPE: IPAQENET  LNKSTATUS: READY
NETNUM: 0  QUESIZE: 0  SPEED: 0000000100
BYTESIN: 147508801    BYTESOUT: 2188246
IPBROADCASTCAPABILITY: NO
ARPOFFLOAD: YES  ARPOFFLOADINFO: YES
ACTMTU: 1492
INBPERF: BALANCED
BSD ROUTING PARAMETERS:
MTU SIZE: 00000      METRIC: 00
DESTADDR: 0.0.0.0    SUBNETMASK: 255.255.255.0
MULTICAST SPECIFIC:
MULTICAST CAPABILITY: YES
GROUP      REFCNT
-----
224.0.0.1      0000000001
3 OF 3 RECORDS DISPLAYED
D TCPIP,TCPIP,NETSTAT,ROUTE
EZZ2500I NETSTAT CS V1R4 TCPIP 250
DESTINATION  GATEWAY  FLAGS  REFCNT  INTERFACE
DEFAULT     129.80.16.254  UGS    000003  ZIPBMSP
DEFAULT     129.80.65.254  UGS    000002  ZIPB2MSP
127.0.0.1   0.0.0.0        UH     000003  LOOPBACK
129.80.16.0 0.0.0.0        US     000002  ZIPBMSP
129.80.16.239 0.0.0.0      UH     000000  ZIPBMSP
129.80.65.0  0.0.0.0        US     000000  ZIPB2MSP
129.80.65.203 0.0.0.0      UH     000000  ZIPB2MSP
129.80.71.83 129.80.65.254 UGHS   000001  ZIPB2MSP
172.27.2.5   129.80.16.254 UGHS   000001  ZIPBMSP
9 OF 9 RECORDS DISPLAYED

```

HSC Display Showing SL3000 Connection

```
D ACS
SLS0000I D ACS
SLS1000I ACS 00 STATUS: CONNECTED 334
ACTIVE QUEUE ELEMENTS          2
COMPATIBILITY LEVELS: HSC=13, LMU=13
DUAL LMU NOT CONFIGURED
IP ADDR 129.80.71.83 ONLINE
IP ADDR 172.27.2.5 ONLINE
SCRATCH VOLUMES AVAILABLE..... 210
FREE CELLS AVAILABLE.....      2008
D TCPIP,TCPIP,NETSTAT,HOME
EZZ2500I NETSTAT CS V1R4 TCPIP 252
HOME ADDRESS LIST:
ADDRESS    LINK      FLG
129.80.16.239  ZIPBMSP   P
129.80.65.203  ZIPB2MSP
127.0.0.1     LOOPBACK
3 OF 3 RECORDS DISPLAYED
```

SLConsole Display of SL3000 Ports 2A/2B IP Addresses

The screenshot displays the StorageTek Library Console interface. The main window is titled "StorageTek Library Console" and has a menu bar with "Tools", "Help", and "System Detail". On the right side of the menu bar are "Apply", "Refresh", and a help icon. The left sidebar shows a tree view of the library structure:

- Library:1,0,0,0,0 (Warning icon)
- CAP Folder:1,0,0,0,0 (Success icon)
- Drive Folder:1,0,0,0,0 (Warning icon)
- Power Supply Folder:1,0,0,0,0 (Success icon)
- Robot Folder:1,0,0,0,0 (Success icon)

The main content area is titled "Library" and has tabs for "Status", "Properties", and "Auto Clean". The "Properties" tab is active, with sub-tabs for "General", "Library Controller", and "Drive Controller". The "General" sub-tab is selected, showing the following information:

Physical

Vendor	STK
Frame Serial Number	57100000016
Expansion Module Count	4
Total Slot Count	2192
Empty Slot Count	211
Drive Count	8
Robot Count	2
Cap Count	4
Drive Power Supply Count	8
Hardware Power Supply Count	6

Host Interface TCP/IP 2B

DNS Domain Name	andre3k
IP Address	10.80.41.200
NetMask	255.255.254.0
MAC Address	00:10:4F:00:B9:AE

Host Interface TCP/IP 2A

IP Address	10.80.40.200
NetMask	255.255.254.0
MAC Address	00:10:4F:00:B9:AF

The status bar at the bottom shows "SL3000" on the left, "Comm Status" and "UserID: mfg" in the center, and a warning icon followed by "Library:010.080.040.200" on the right.

Two SL3000 Network Connections - One Mainframe IP Address

To establish one host IP route from the HSC to two routes to the SL3000, use the process described in this section. **To configure the SL3000 dual TCP/IP feature, refer to chapter 4 of the *SL3000 Modular Library System Installation Guide*.**

[FIGURE F-3 on page 334](#) shows dual IP (one host IP) with two SL3000 network connections.

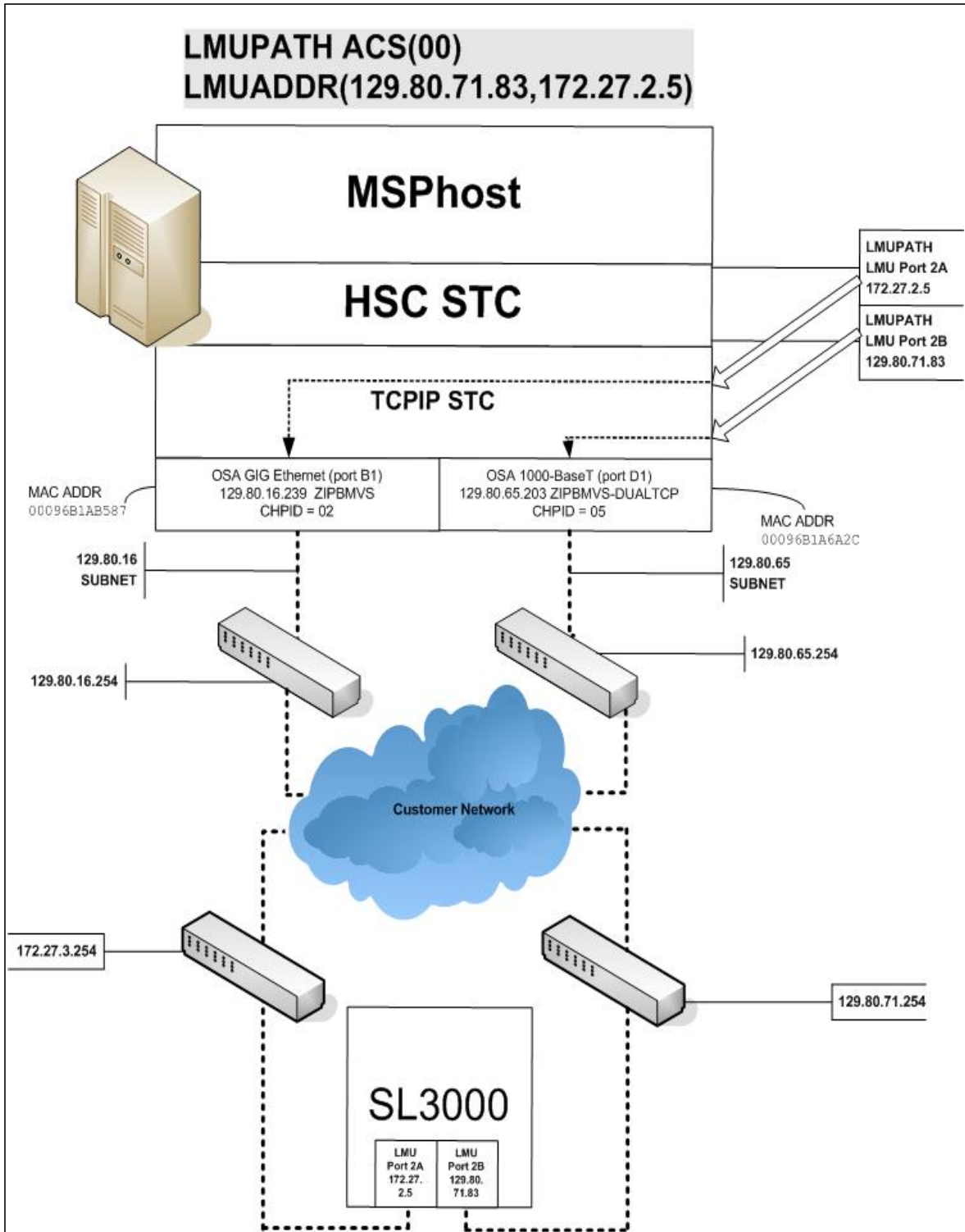

FIGURE F-3 Dual IP (one host IP) with Two SL3000 Network Connections

In the following examples, the entries *in italics* represent the second connection.

1. Complete the Network Entries Worksheet (see TABLE F-2 for a sample) for each set of routes to the SL3000. The worksheet can be found in chapter 4 of the *SL3000 Modular Library System Installation Guide*.

TABLE F-2 Network Entries Worksheet

Description		IP Address
Port 2A	HBC Card Port 2A	172.27.2.5
	Gateway Port 2A	172.27.3.254
	Netmask	/23
	Host to Port 2A	129.80.16.239
Port 2B	HBC Car Port 2B	129.80.71.83
	Gateway Port 2B	129.80.71.254
	Netmask	/23
	Host to Port 2B	129.80.16.239

2. Optionally, define two dedicated static routes to the SL3000 destination port (2A and 2B) IP addresses over one router.

For example:

```

BEGINROUTES
; DESTINATION      FIRSTHOP  LINKNAME  PACKETSIZE
ROUTE 129.80.16.0/24 = &SYSNAME.MSP MTU 1492
ROUTE 172.27.2.5 HOST    129.80.16.254 &SYSNAME.MSP MTU 1492
ROUTE 129.80.71.83 HOST  129.80.16.254 &SYSNAME.MSP MTU 1492
ROUTE DEFAULT        129.80.16.254 &SYSNAME.MSP MTU 1492

ENDROUTES

```

3. Define a second LMUADDR parameter for the port 2A IP address on the SL3000.

For example:

```
LMUPATH ACS(00) LMUADDR(129.80.71.83,172.27.2.5)
```

4. Enter the LMUPDEF command containing the LMUPATH statements that define the host name or IP address for each ACS.

```
LMUPDEF DSN('xxx.xxx.xxx(xxx)')
```

In the following example, LMUPDEF loads LMUPATH parameters from YOUR.DSN(MEMBER).

```
LMUPDEF DSN('YOUR.DSN(MEMBER)')
```

5. Allow the trained SL3000 service representative to enter the network connections to the SL3000 library for either port 2A and 2B, whichever is applicable.

6. Vary the ACS offline and back online to pick up the revised LMUPATH statement that includes the second connection. This can be done one host at a time to minimize down time.

Sample Configuration - One Host IP, Two SL3000 Network Connections

FIGURE F-4 shows a sample dual IP (one host IP) configuration with two SL3000 network connections, followed by the statements that apply to it.

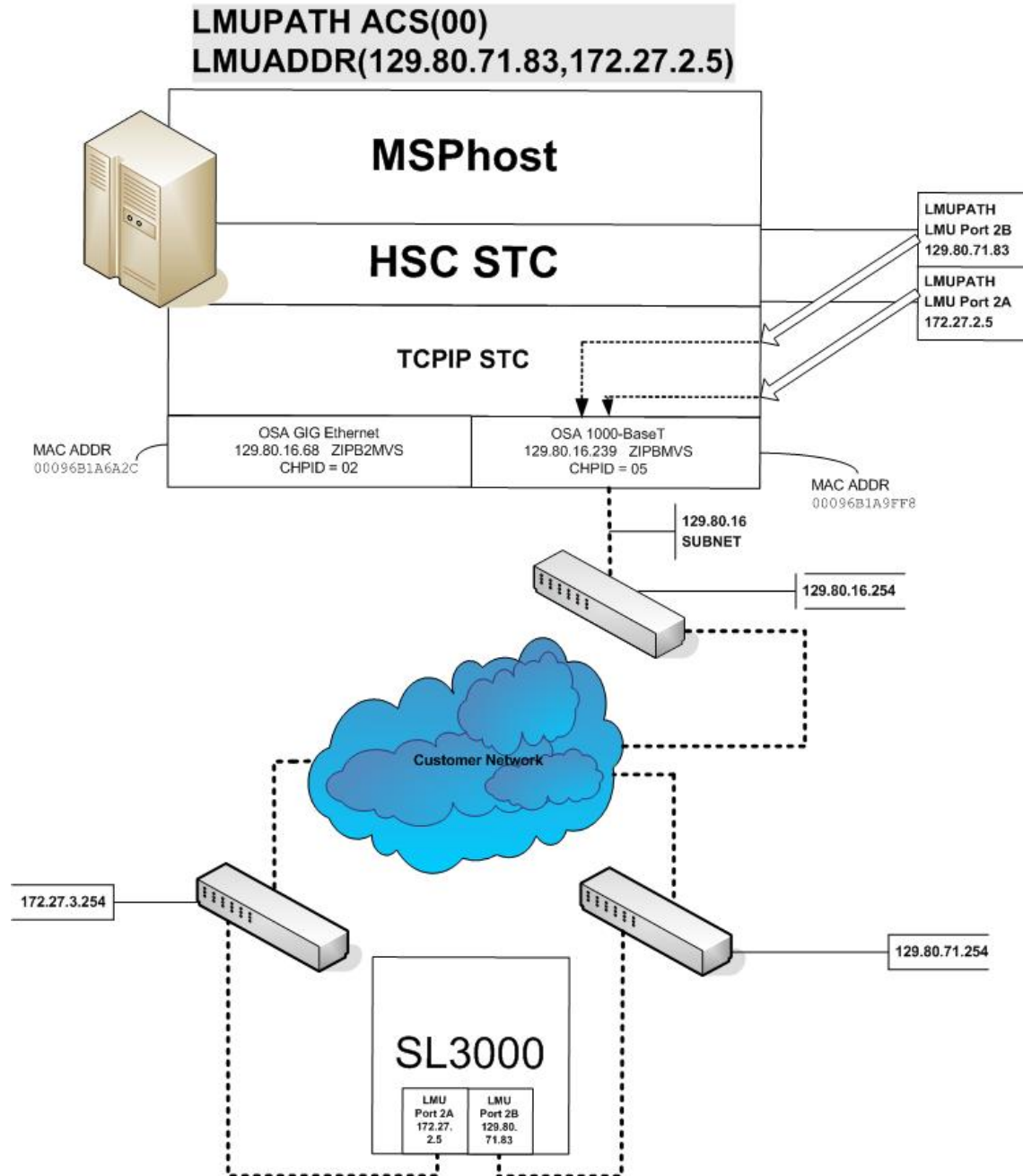

FIGURE F-4 Dual IP (one host IP) with Two SL3000 Network Connections

Setup Statements and Displays

The following information shows the statements and displays used in [FIGURE F-4](#) on page [337](#).

HSC LMUPDEF PARMLIB Member

```
OPTION TITLE('DUAL TCPIP CONNECTING TO SL30001')
LMUPATH ACS(00) LMUADDR(129.80.71.83,172.27.2.5)
```

TCP/IP Profile Data Set

```
; OSA CARD #1
DEVICE ECCQD01 MPCIPA NONROUTER AUTORESTART
LINK ZIPBMSP IPAQENET ECCQD01

HOME
  129.80.&IPADDR1 &SYSNAME.MSP

BEGINROUTES
;      NETWORK MASK  FIRSTHOP  LINKNAME  PACKETSIZE
ROUTE 129.80.16.0/24    =      &SYSNAME.MSP  MTU 1492
ROUTE 172.27.2.5 HOST   129.80.16.254 &SYSNAME.MSP  MTU 1492
ROUTE 129.80.71.83 HOST   129.80.16.254 &SYSNAME.MSP  MTU 1492
ROUTE DEFAULT

ENDROUTES

INCLUDE ZIP.TCPIP.PROFILES(COMMON)

START ECCQD01
```

TCP/IP Console Displays

```
D TCPIP,,N,DEV
EZZ2500I NETSTAT CS V1R4 TCPIP 931
DEVNAME: LOOPBACK      DEVTYPE: LOOPBACK
DEVSTATUS: READY
LNKNAME: LOOPBACK      LNKTYPE: LOOPBACK  LNKSTATUS: READY
NETNUM: 0  QUESIZE: 0
BYTESIN: 2136824      BYTESOUT: 2136824
ACTMTU: 65535
BSD ROUTING PARAMETERS:
MTU SIZE: 00000      METRIC: 00
DESTADDR: 0.0.0.0    SUBNETMASK: 0.0.0.0
MULTICAST SPECIFIC:
MULTICAST CAPABILITY: NO
DEVNAME: ECCQD01      DEVTYPE: MPCIPA
DEVSTATUS: READY      CFGROUTER: NON  ACTROUTER: NON
LNKNAME: ZIPBMSP      LNKTYPE: IPAQENET  LNKSTATUS: READY
NETNUM: 0  QUESIZE: 0  SPEED: 0000001000
BYTESIN: 48605838     BYTESOUT: 9790950
IPBROADCASTCAPABILITY: NO
ARPOFFLOAD: YES  ARPOFFLOADINFO: YES
ACTMTU: 8992
INBPERF: BALANCED
BSD ROUTING PARAMETERS:
MTU SIZE: 00000      METRIC: 00
DESTADDR: 0.0.0.0    SUBNETMASK: 255.255.255.0
MULTICAST SPECIFIC:
MULTICAST CAPABILITY: YES
GROUP      REFCNT
-----
224.0.0.1      0000000001
2 OF 2 RECORDS DISPLAYED
```

```
D TCPIP,,N,ROUTE
EZZ2500I NETSTAT CS V1R4 TCPIP 933
DESTINATION  GATEWAY  FLAGS  REFCNT  INTERFACE
DEFAULT      129.80.16.254  UGS    000001  ZIPBMSP
127.0.0.1    0.0.0.0    UH     000004  LOOPBACK
129.80.16.0  0.0.0.0    US     000000  ZIPBMSP
129.80.16.239 0.0.0.0    UH     000000  ZIPBMSP
129.80.71.83 129.80.16.254 UGHS   000001  ZIPBMSP
172.27.2.5   129.80.16.254 UGHS   000001  ZIPBMSP
6 OF 6 RECORDS DISPLAYED
```

```
D TCPIP,,N,HOME
EZZ2500I NETSTAT CS V1R4 TCPIP 935
HOME ADDRESS LIST:
ADDRESS  LINK  FLG
129.80.16.239  ZIPBMSP  P
127.0.0.1    LOOPBACK
2 OF 2 RECORDS DISPLAYED
```

HSC Display Showing SL3000 Connection

```
D ACS
SLS0000I D ACS
SLS1000I ACS 00 STATUS: CONNECTED 942
ACTIVE QUEUE ELEMENTS          1
COMPATIBILITY LEVELS: HSC=13, LMU=13
DUAL LMU NOT CONFIGURED
IP ADDR 129.80.71.83 ONLINE
IP ADDR 172.27.2.5 ONLINE
SCRATCH VOLUMES AVAILABLE..... 210
FREE CELLS AVAILABLE.....      2007
```

SLConsole Display of SL3000 Ports 2A/2B IP Addresses

The screenshot shows the StorageTek Library Console interface. The left sidebar lists system components: Library:1,0,0,0,0 (warning), CAP Folder:1,0,0,0,0 (success), Drive Folder:1,0,0,0,0 (warning), Power Supply Folder:1,0,0,0,0 (success), and Robot Folder:1,0,0,0,0 (success). The main window displays the 'Library' properties under the 'General' tab. It includes sections for Physical, Host Interface TCP/IP 2B, and Host Interface TCP/IP 2A.

Physical	
Vendor	STK
Frame Serial Number	57100000016
Expansion Module Count	4
Total Slot Count	2192
Empty Slot Count	211
Drive Count	8
Robot Count	2
Cap Count	4
Drive Power Supply Count	8
Hardware Power Supply Count	6

Host Interface TCP/IP 2B	
DNS Domain Name	andre3k
IP Address	10.80.41.200
NetMask	255.255.254.0
MAC Address	00:10:4F:00:B9:AE

Host Interface TCP/IP 2A	
IP Address	10.80.40.200
NetMask	255.255.254.0
MAC Address	00:10:4F:00:B9:AF

At the bottom of the console, the status bar shows 'SL3000', 'Comm Status', 'UserID: mfg', and a warning icon next to 'Library:010.080.040.200'.

Troubleshooting Library Connectivity Problems

For more information, see [“Troubleshooting Library Connectivity Problems”](#) on page 315.

VSM4 ESCON Configuration

The newest generation VTSS is the VSM4, which provides the following advantages over its predecessors:

- Enhanced connectivity options
- Greater throughput
- Greater VTSS capacity
- 4x the number of VTDs and 3x the maximum number of VTVs per VTSS
- Improved reliability and serviceability

TABLE G-1 summarizes the VSM3 to VSM4 ESCON enhancements that you see from a software and system configuration perspective.

TABLE G-1 VSM3 to VSM4 Comparison: Software and System Configuration ESCON Enhancements

Product Feature	VSM3	VSM4
ESCON Interfaces	<p>16 total where:</p> <ul style="list-style-type: none"> ■ 2 to 14 can be host channels ■ 2 to 8 can be Nearlink/CLINK connections 	<p>32 total where:</p> <ul style="list-style-type: none"> ■ 2 to 28 can be host channels ■ 2 to 16 can be Nearlink/CLINK connections <p>Note: VSM4s are shipped with 16 ports enabled. With the 16 ports enabled option, only the top port on each CIP is enabled (Port 0 or Port 2). 32 ports enabled is an optional, separately priced feature that is activated via microcode diskette.</p> <p>On a VSM4 with 32 ports enabled, each ICE3 ESCON interface card contains two pairs of ESCON ports.</p>
Maximum Logical Paths	128	<p>16 per port for the 16 port standard configuration = 256 logical paths</p> <p>16 per port for the 32 port optional configuration= 512 logical paths</p> <p>Note: VSM4 provides a theoretical maximum of 512 logical paths per VTSS but you cannot allocate all 512 logical paths for host-to-VTSS connections.</p>
VTDS per VTSS	64	256
Maximum resident VTVs per VTSS	100,000	300,000

VSM4 with 32 Ports

For the 32 port option, the 8 ICE3 cards have four ESCON ports per card as shown in FIGURE G-1.

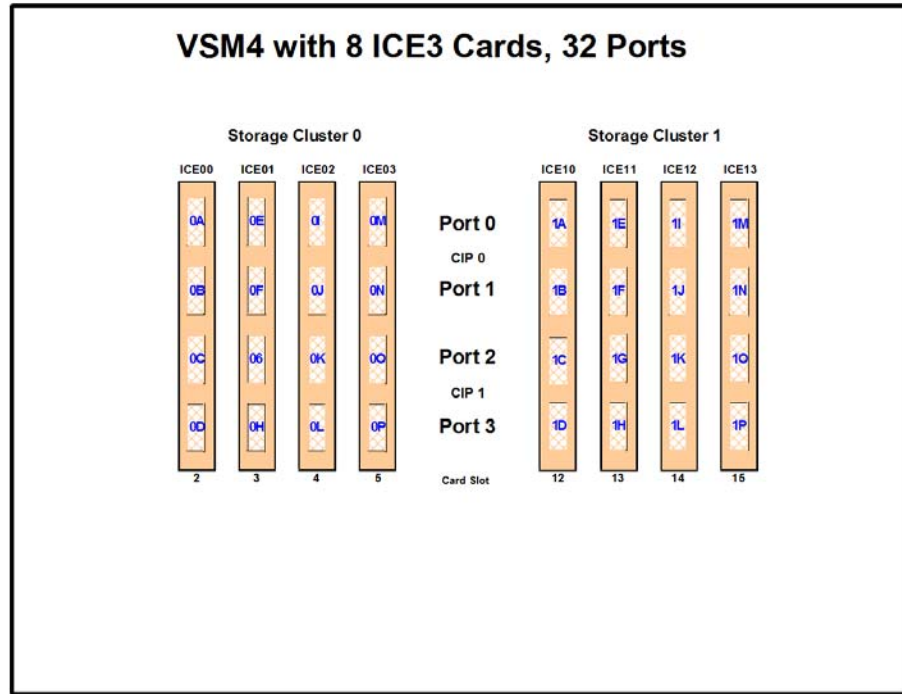

FIGURE G-1 VSM4 with 32 Ports

Note – In FIGURE G-1 and all the other figures in this appendix, the ports are shown with their channel interface identifiers for **enabled** ports (32 in FIGURE G-1). These channel interface identifiers are the values that are required for the CHANIF values that you code for the CONFIG utility. Each value is two characters in length and has a value from 0A to 1P. The first digit is the VTSS cluster ID (valid values are 0 or 1). The second digit is the group or adapter ID (valid values are A to P).

In FIGURE G-1, note the following:

- Each ICE3 card contains two pairs of ESCON ports. Each pair is controlled by its own Channel Interface Processor (CIP).

Note – With microcode level D02.06.00.00 or higher, multiple Nearlink device connections via a ESCON switch or Director on the same port now allow:

- **Up to a total of 16 simultaneous NearLink I/O transfers**, which can be spread across multiple targets on as many as 14 NearLink ports.
- **Up to a total of 2 simultaneous NearLink I/O transfers** are allowed per port.

Note –

- For a VSM4, each CIP can operate with only *one* of two modes, which is set at the VTSS LOP:
 - *Host Mode*. In Host Mode, either or both ESCON ports can connect to host CPU channels, including via ESCON Director(s) or channel extenders. Ports of a CIP in Host mode **cannot** connect to RTDs or to Secondary VTSSs via CLINKS. Note, however, that Secondary VTSSs must have an ESCON port in Host Mode to connect via a CLINK *from* an ESCON port in Nearlink Mode in a Primary VTSS.
Also note that you can have two physical paths from the same LPAR to the same CIP, as long as the two physical paths address different (not overlapping) logical control units. For example, a single host LPAR can address logical control units 0-7 on one CIP port, and 8-F on the other CIP port of the same CIP.
 - *Nearlink Mode*. In Nearlink Mode, either or both ESCON ports can connect to an RTD or via a CLINK to a Secondary VTSS. Ports of a CIP in Nearlink mode **cannot** connect to host CPU channels. You can set a **maximum** of 8 CIPs to Nearlink Mode, and here's the important discussion: only **one** Nearlink port per CIP is active at one time. What are Best Practices for optimizing port operations?

See TABLE G-2...

TABLE G-2 Optimizing VSM4 Port Operations

Configuration - Two Ports on a CIP	Best Practices
Two CLINKs	Attach a maximum of 2because each port allows two active operations. Note, however, that these operations share the bandwidth of the port.
CLINK and RTD	An advantage if you attach one CLINK originator/one RTD per director, because both can be active.
Two RTDs	<p>An advantage for the following:</p> <p>Optimize use of local and remote RTDs. During busy shifts, use only local RTDs on the FIP. During quiet periods, switch to remote RTDs for deep archive and DR work. Because you can have two active devices, you can also simultaneously run one local and one remote RTD. Note, however, that these operations share the bandwidth of the port.</p> <p>Optimize use of different drive technologies. As described in the previous bullet, use a T9840 as a local RTD, then switch to a T9940 for deep archive. You can also use this feature to migrate from older drive technology (such as 9490) to newer technology (such as 9840). Use Management and Storage Classes to read in data from older media, then switch to the newer technology drive to place data on new media. This technique effectively gives you greater physical connectivity to different drive technologies without incurring the overhead of full time, real time FICON connections to each drive type. Also as above, because you can have two active devices, you can also simultaneously run two RTDs with different drive technologies. Note, however, that these operations share the bandwidth of the port.</p>

- On a VSM4 with 32 ports enabled, you have a theoretical maximum of 512 logical paths on the VSM4. However, you must have some RTD connections so you cannot allocate all 512 logical paths for host-to-VTSS connections. What's the minimum number of RTDs? Well, it's like this: (1) CONFIG will not allow fewer than 2 RTDS per VTSS. (2) CONFIG cannot check device type but StorageTek strongly recommends at least two RTDS of each device type in each ACS to which the VTSS is attached....otherwise, you can seriously compromise error recovery, and also impact the efficiency of space reclamation. If you had only two RTDs, Best Practices would suggest that you connect them to different ICE3 cards...and once you've done that, you've effectively used up 4 Nearlink ports due to the CIP mode nature of the ICE3 card. Therefore, in an 8 ICE card configuration, this leaves 28 available ports for host-to-VTSS ESCON channel connections, which equals a maximum of 16 x 28 or 448 logical paths. For more information, see "Logical Paths for VSM 4 with 32 Ports" on page 362.

- A host logical path is the communication path between a host and all of the 256 VTDs within the VSM4. [TABLE G-3](#) summarizes the configuration options and maximum host logical paths for a VSM4 with 32 enabled ports.

TABLE G-3 VSM4 Configuration Options - 32 Ports

Host CIPs	Maximum Host Connections	Nearlink CIPs	Max Nearlink Connections	Maximum Host Logical Paths
8	16	8	16	256
9	18	7	14	288
10	20	6	12	320
11	22	5	10	352
12	24	4	8	384
14	28	2	4	448

- In IOGRP:
 - From a single MSP host, you can only define 8 channels (CHPIDs) running to a single control unit (single VSM4). **Also note that ICE3 cards cannot** have 2 paths from the same LPAR connected to two ports with a common CIP.
 - You use the CNTLUNIT statement to define each VSM4 as 16 3490 images.
 - You use the IODEVICE statement to define the 16 VTDs that are associated with each 3490 image.

VSM4 Configuration Examples - 32 Ports

For VSM4s with 32 ports, let's look at two examples of port configurations:

- [“VSM4 Configuration Example: 16 Host Ports, 16 RTD Ports”](#) on page 350
- [“VSM 4 Configuration Example: 20 Host Ports, 12 RTD Ports”](#) on page 352

For a VSM4 host gen example, see [“IOSRF Example for Single MSP Host Connected to a VSM4 Via ESCON Directors”](#) on page 361.

VSM4 Configuration Example: 16 Host Ports, 16 RTD Ports

FIGURE G-2 shows CONFIG channel interface identifiers of 16 for hosts, 16 for RTDs for a VSM4.

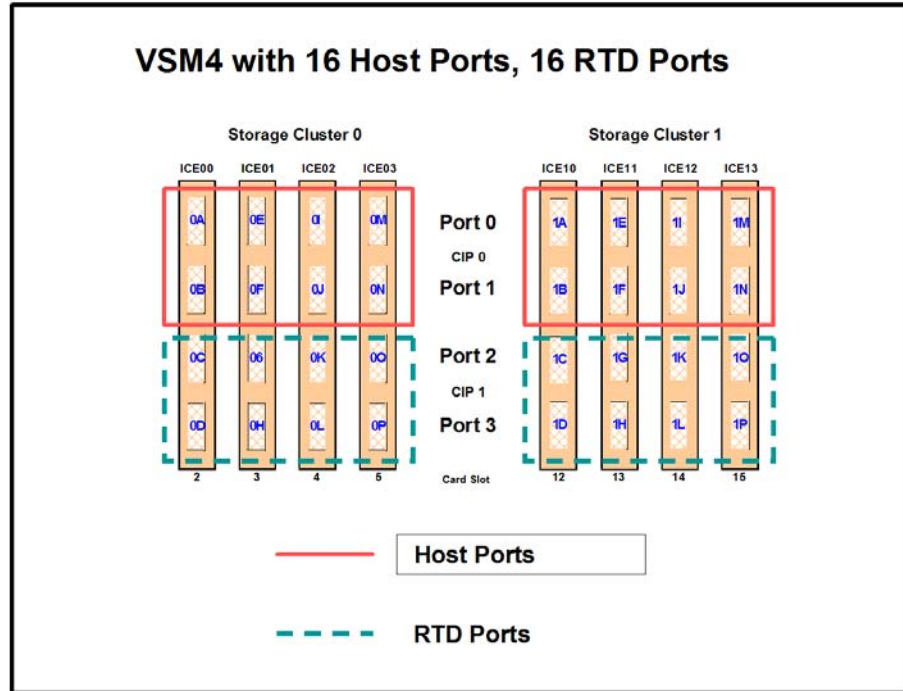

FIGURE G-2 VSM4 with 16 Host Ports, 16 RTD Ports

CONFIG Example for VSM4 with 16 Host Ports, 16 RTD Ports

FIGURE G-3 shows example CONFIG JCL to define the VSM4 configuration shown in FIGURE G-2 on page 350.

```
//CREATECF EXEC PGM=SLUADMIN,PARM='MIXED'  
//STEPLIB DD DSN=hlq.SEALINK,DISP=SHR  
//SLSCNTL DD DSN=hlq.DBASEPRM,DISP=SHR  
//SLSCNTL2 DD DSN=hlq.DBASESEC,DISP=SHR  
//SLSSTBY DD DSN=hlq.DBASETBY,DISP=SHR  
//SLSPRINT DD SYSOUT=*  
//SLSIN DD *  
CONFIG  
GLOBAL MAXVTV=32000MVCFREE=40  
RECLAIM THRESHLD=70MAXMVC=40 START=35  
VTSS NAME=VSM401 LOW=70 HIGH=80 MAXMIG=8 RETAIN=5  
RTD NAME=VSM42A00 DEVNO=2A00 CHANIF=0C  
RTD NAME=VSM42A01 DEVNO=2A01 CHANIF=0D  
RTD NAME=VSM42A02 DEVNO=2A02 CHANIF=0G  
RTD NAME=VSM42A03 DEVNO=2A03 CHANIF=0H  
RTD NAME=VSM42A04 DEVNO=2A04 CHANIF=0K  
RTD NAME=VSM42A05 DEVNO=2A05 CHANIF=0L  
RTD NAME=VSM42A06 DEVNO=2A06 CHANIF=0O  
RTD NAME=VSM42A07 DEVNO=2A07 CHANIF=0P  
RTD NAME=VSM42A08 DEVNO=2A08 CHANIF=1C  
RTD NAME=VSM42A09 DEVNO=2A09 CHANIF=1D  
RTD NAME=VSM42A0A DEVNO=2A0A CHANIF=1G  
RTD NAME=VSM42A0B DEVNO=2A0B CHANIF=1H  
RTD NAME=VSM42A0C DEVNO=2A0C CHANIF=1K  
RTD NAME=VSM42A0D DEVNO=2A0D CHANIF=1L  
RTD NAME=VSM42A0E DEVNO=2A0E CHANIF=1O  
RTD NAME=VSM42A0F DEVNO=2A0F CHANIF=1P  
VTD LOW=9900 HIGH=99FF
```

FIGURE G-3 CONFIG example: VSM4 with 16 Host Ports, 16 RTD Ports

VSM 4 Configuration Example: 20 Host Ports, 12 RTD Ports

FIGURE G-4 shows port assignments of 20 for hosts, 12 for RTDs for a VSM4.

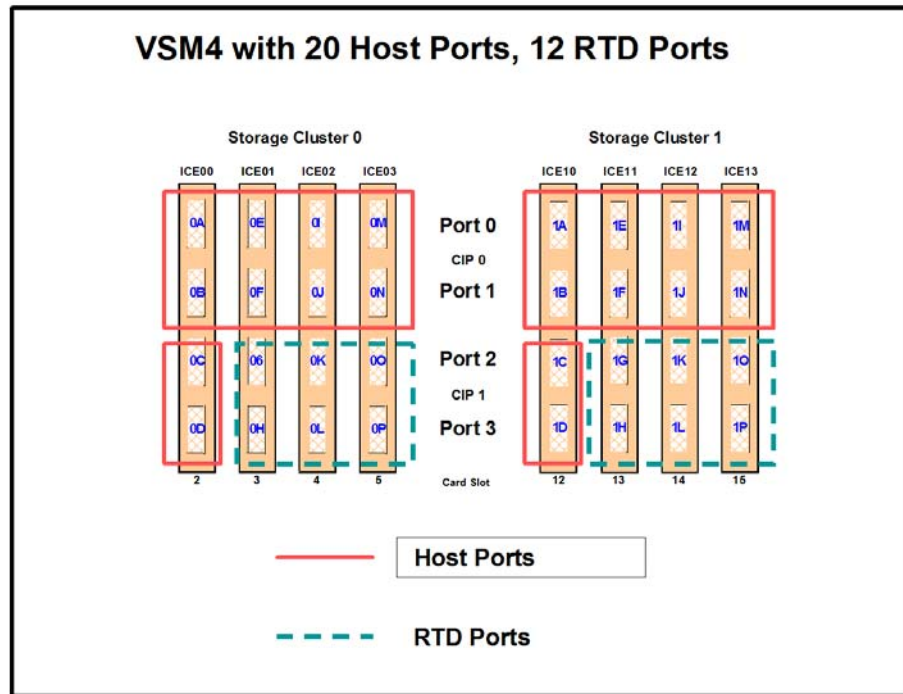

FIGURE G-4 VSM4 with 20 Host Ports, 12 RTD Ports

CONFIG Example for VSM4 with 20 Host Ports, 12 RTD Ports

FIGURE G-5 shows example CONFIG JCL to define the VSM4 configuration shown in FIGURE G-4 on page 352.

```
//CREATECF EXEC PGM=SLUADMIN,PARM='MIXED'  
//STEPLIB DD DSN=hlq.SEALINK,DISP=SHR  
//SLSCNTL DD DSN=hlq.DBASEPRM,DISP=SHR  
//SLSCNTL2 DD DSN=hlq.DBASESEC,DISP=SHR  
//SLSSTBY DD DSN=hlq.DBASEBY,DISP=SHR  
//SLSPRINT DD SYSOUT=*  
//SLSIN DD *  
CONFIG  
GLOBAL MAXVTV=32000 MVCFREE=40  
RECLAIM THRESHLD=70 MAXMVC=40 START=35  
VTSS NAME=VSM401 LOW=70 HIGH=80 MAXMIG=6 RETAIN=5  
RTD NAME=VSM42A00 DEVNO=2A00 CHANIF=0G  
RTD NAME=VSM42A01 DEVNO=2A01 CHANIF=0H  
RTD NAME=VSM42A02 DEVNO=2A02 CHANIF=0K  
RTD NAME=VSM42A03 DEVNO=2A03 CHANIF=0L  
RTD NAME=VSM42A04 DEVNO=2A04 CHANIF=0O  
RTD NAME=VSM42A05 DEVNO=2A05 CHANIF=0P  
RTD NAME=VSM42A06 DEVNO=2A06 CHANIF=1G  
RTD NAME=VSM42A07 DEVNO=2A07 CHANIF=1H  
RTD NAME=VSM42A08 DEVNO=2A08 CHANIF=1K  
RTD NAME=VSM42A09 DEVNO=2A09 CHANIF=1L  
RTD NAME=VSM42A0A DEVNO=2A0A CHANIF=1O  
RTD NAME=VSM42A0B DEVNO=2A0B CHANIF=1P  
VTD LOW=9900 HIGH=99FF
```

FIGURE G-5 CONFIG example: VSM4 with 20 Host Ports, 12 RTD Ports

VSM4 with 16 Ports

For the 16 port option, the 8 ICE3 cards have two ESCON ports per card as shown in FIGURE G-6.

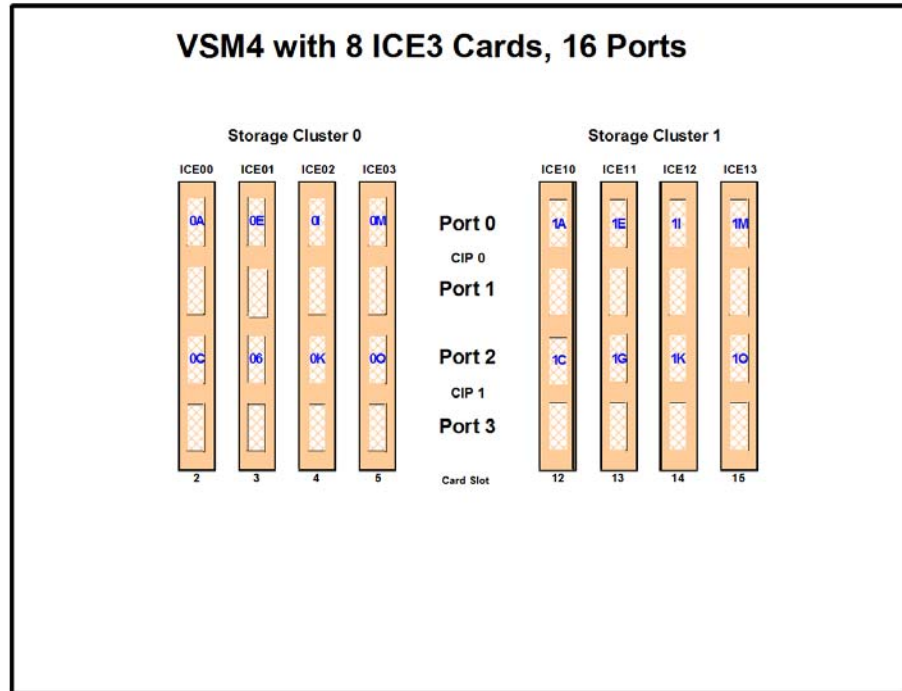

FIGURE G-6 VSM4 with 16 Ports

Note – In FIGURE G-6 and all the other figures in this appendix, the ports are shown with their channel interface identifiers for **enabled** ports (16 in FIGURE G-6). These channel interface identifiers are the values that are required for the CHANIF values that you code for the CONFIG utility. Each value is two characters in length and has a value from 0A to 1P. The first digit is the VTSS cluster ID (valid values are 0 or 1). The second digit is the group or adapter ID (valid values are A to P).

In FIGURE G-6, note the following:

- Each ICE3 card has two CIPs with a **single port enabled** on each CIP. As with the 32 port option, each CIP can operate with only *one* of two modes, which is set at the VTSS LOP:
 - *Host Mode*. In Host Mode, the single ESCON port can connect to host CPU channels, including via ESCON Director(s) or channel extenders. Ports of a CIP in Host mode **cannot** connect to RTDs or to Secondary VTSSs via CLINKS. Note, however, that Secondary VTSSs must have an ESCON port in Host Mode to connect via a CLINK *from* an ESCON port in Nearlink Mode in a Primary VTSS.

- *Nearlink Mode.* In Nearlink Mode, the single ESCON port can connect to an RTD or via a CLINK to a Secondary VTSS. Ports of a CIP in Nearlink mode **cannot** connect to host CPU channels.

You can set a **maximum** of 8 CIPs to Nearlink Mode. Therefore, in a 16 port configuration, the single port on a CIP can be either a CLINK or an RTD connection.

- On a VSM4 with 16 ports enabled, you have a **theoretical** maximum of 256 logical paths on the VSM4. However, you must have *some* RTD connections so you cannot allocate *all* 256 logical paths for host-to-VTSS connections. What's the **minimum** number of RTDs? Well, it's like this: (1) CONFIG will not allow fewer than 2 RTDs per VTSS. (2) CONFIG cannot check device type but StorageTek **strongly recommends** at least two RTDs of each device type in each ACS to which the VTSS is attached....otherwise, you can seriously compromise error recovery and also impact the efficiency of space reclamation. If you had only two RTDs, Best Practices would suggest that you connect them to different ICE3 cards...and once you've done that, you've effectively used up 4 Nearlink ports. Therefore, in an 8 ICE card 16 port configuration, this leaves 12 available ports for host-to-VTSS ESCON channel connections, which equals a **maximum** of 16 x 12 or 192 logical paths. For more information, see "Logical Paths for VSM 4 with 32 Ports" on page 362.
- A host logical path is the communication path between a host and all of the 256 VTDs within the VSM4. TABLE G-4 summarizes the configuration options and maximum host logical paths for a VSM4 with 16 enabled ports.

TABLE G-4 VSM4 Configuration Options - 16 Ports

Host CIPs	Maximum Host Connections	Nearlink CIPs	Max Nearlink Connections	Maximum Host Logical Paths
8	8	8	8	128
9	9	7	7	144
10	10	6	6	160
11	11	5	5	176
12	12	4	4	192
14	14	2	2	224

- In IOGRP:
 - From a single MSP host, you can only define 8 channels (CHPIDs) running to a single control unit (single VSM4). **Also note that** ICE3 cards **cannot** have 2 paths from the same LPAR connected to two ports with a common CIP.
 - You use the CNTLUNIT statement to define each VSM4 as 16 3490 images.
 - You use the IODEVICE statement to define the 16 VTDs that are associated with each 3490 image.

VSM4 Configuration Examples - 16 Ports

For VSM4s with 16 ports, let's look at two examples of port configurations:

- [“VSM4 Configuration Example: 8 Host Ports, 8 RTD Ports”](#) on page 357
- [“VSM 4 Configuration Example: 10 Host Ports, 6 RTD Ports”](#) on page 359

For a VSM4 host gen example, see [“IOSRF Example for Single MSP Host Connected to a VSM4 Via ESCON Directors”](#) on page 361.

VSM4 Configuration Example: 8 Host Ports, 8 RTD Ports

FIGURE G-7 shows CONFIG channel interface identifiers of 8 for hosts, 8 for RTDs for an 8 ICE3 card VSM4 with 16 ports.

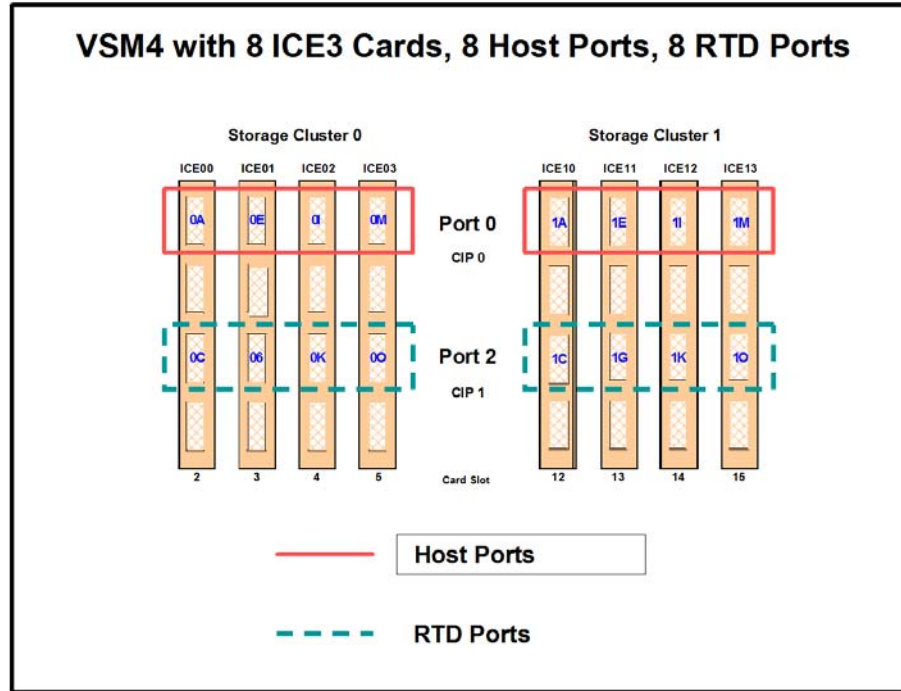

FIGURE G-7 VSM4 with 8 Host Ports, 8 RTD Ports

CONFIG Example for VSM4 with 8 Host Ports, 8 RTD Ports

FIGURE G-8 shows CONFIG JCL to define the VSM4 configuration shown in FIGURE G-7 on page 357.

```
//CREATECF EXEC PGM=SLUADMIN,PARM='MIXED'  
//STEPLIB DD DSN=hlq.SEALINK,DISP=SHR  
//SLSCNTL DD DSN=hlq.DBASEPRM,DISP=SHR  
//SLSCNTL2 DD DSN=hlq.DBASESEC,DISP=SHR  
//SLSSTBY DD DSN=hlq.DBASESTBY,DISP=SHR  
//SLSPRINT DD SYSOUT=*  
//SLSIN DD *  
CONFIG  
GLOBAL MAXVTV=32000MVCFREE=40  
RECLAIM THRESHLD=70MAXMVC=40 START=35  
VTSS NAME=VSM401 LOW=70 HIGH=80 MAXMIG=8 RETAIN=5  
RTD NAME=VSM42A00 DEVNO=2A00 CHANIF=0C  
RTD NAME=VSM42A02 DEVNO=2A02 CHANIF=0G  
RTD NAME=VSM42A04 DEVNO=2A04 CHANIF=0K  
RTD NAME=VSM42A06 DEVNO=2A06 CHANIF=0O  
RTD NAME=VSM42A08 DEVNO=2A08 CHANIF=1C  
RTD NAME=VSM42A0A DEVNO=2A0A CHANIF=1G  
RTD NAME=VSM42A0C DEVNO=2A0C CHANIF=1K  
RTD NAME=VSM42A0E DEVNO=2A0E CHANIF=1O  
VTD LOW=9900 HIGH=99FF
```

FIGURE G-8 CONFIG example: VSM4 with 8 Host Ports, 8 RTD Ports

VSM 4 Configuration Example: 10 Host Ports, 6 RTD Ports

FIGURE G-9 shows port assignments of 10 for hosts, 6 for RTDs for a VSM4 with 16 ports.

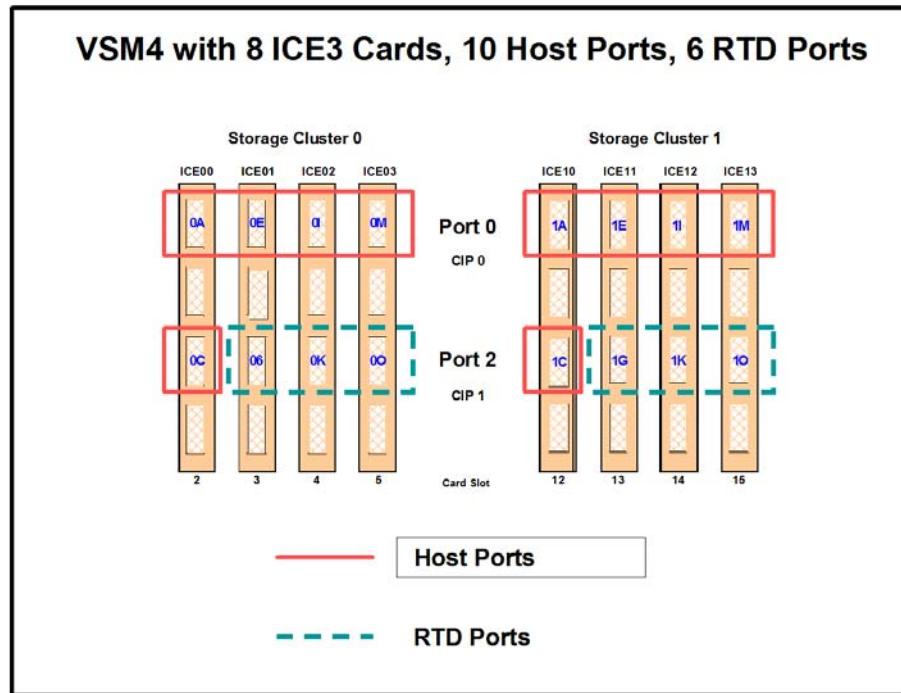

FIGURE G-9 VSM4 with 10 Host Ports, 6 RTD Ports

CONFIG Example for VSM4 with 10 Host Ports, 6 RTD Ports

FIGURE G-10 shows example CONFIG JCL to define the VSM4 configuration shown in FIGURE G-9 on page 359.

```
//CREATECF EXEC PGM=SLUADMIN,PARM='MIXED'  
//STEPLIB DD DSN=hlq.SEALINK,DISP=SHR  
//SLSCNTL DD DSN=hlq.DBASEPRM,DISP=SHR  
//SLSCNTL2 DD DSN=hlq.DBASESEC,DISP=SHR  
//SLSSTBY DD DSN=hlq.DBASETBY,DISP=SHR  
//SLSPRINT DD SYSOUT=*  
//SLSIN DD *  
CONFIG  
GLOBAL MAXVTV=32000MVCFREE=40  
RECLAIM THRESHLD=70MAXMVC=40 START=35  
VTSS NAME=VSM401 LOW=70 HIGH=80 MAXMIG=8 RETAIN=5  
RTD NAME=VSM42A02 DEVNO=2A02 CHANIF=0G  
RTD NAME=VSM42A04 DEVNO=2A04 CHANIF=0K  
RTD NAME=VSM42A06 DEVNO=2A06 CHANIF=0O  
RTD NAME=VSM42A0A DEVNO=2A0A CHANIF=1G  
RTD NAME=VSM42A0C DEVNO=2A0C CHANIF=1K  
RTD NAME=VSM42A0E DEVNO=2A0E CHANIF=1O  
VTD LOW=9900 HIGH=99FF
```

FIGURE G-10 CONFIG example: VSM4 with 10 Host Ports, 6 RTD Ports

IOSRF Example for Single MSP Host Connected to a VSM4 Via ESCON Directors

FIGURE G-11 shows a configuration diagram for a single MSP host connected to a VSM4 via ESCON Directors, and FIGURE G-12 on page 362 shows example IOSRF statements for this configuration. **Note that:**

- From MSPA, you define 8 CHPIDs, with each path switched in the ESCON Director, for a total of 8 channels running to the VSM4.
- You code CTRLR statements to define the VSM4 as 16 F6473K images.
- You code DEVICE statement to define the 16 VTDs that are associated with each F6473K image.

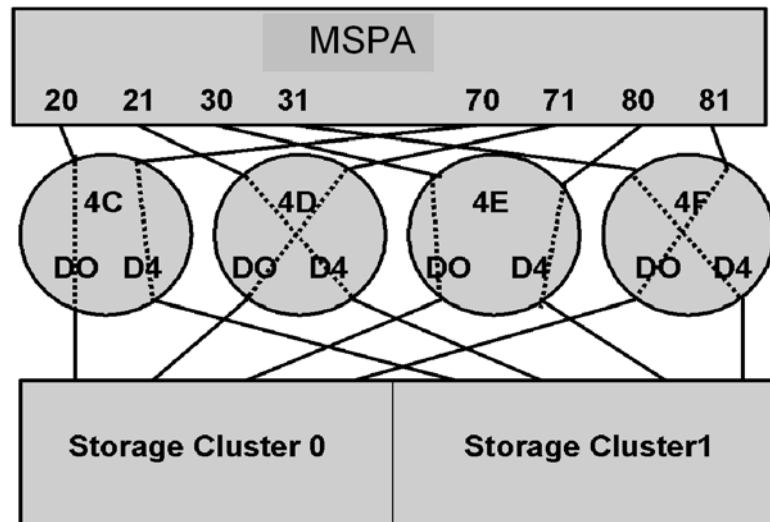

FIGURE G-11 Configuration Diagram: Single MSP Host Connected to a VSM4 via ESCON Directors

```

CHANNEL CHPID(0A-0D),TYPE(BMC),INTF(OCLINK),OCLS(01)
CHANNEL CHPID(24-27),TYPE(BMC),INTF(OCLINK),OCLS(02)
.
.
CTRLR  CTRLNUM(D00),NAME(F1751),CHPID(0A),UNITADDR(00-0F),
        FEATURE(DSF,SUP),LINKADDR(B0),CULOGADR(0)
CTRLR  CTRLNUM(D01),NAME(F1751),CHPID(0B),UNITADDR(00-0F),
        FEATURE(DSF,SUP),LINKADDR(B1),CULOGADR(0)
.
.
CTRLR  CTRLNUM(D10),NAME(F1751),CHPID(0A),UNITADDR(00-0F),
        FEATURE(DSF,SUP),LINKADDR(B0),CULOGADR(1)
CTRLR  CTRLNUM(D11),NAME(F1751),CHPID(0B),UNITADDR(00-0F),
        FEATURE(DSF,SUP),LINKADDR(B1),CULOGADR(1)
.
CTRLR  CTRLNUM(D20),NAME(F1751),CHPID(0A),UNITADDR(00-0F),
        FEATURE(DSF,SUP),LINKADDR(B0),CULOGADR(2)
CTRLR  CTRLNUM(D21),NAME(F1751),CHPID(0B),UNITADDR(00-0F),
        FEATURE(DSF,SUP),LINKADDR(B1),CULOGADR(2)
.
.
CTRLR  CTRLNUM(D30),NAME(F1751),CHPID(0A),UNITADDR(00-0F),
        FEATURE(DSF,SUP),LINKADDR(B0),CULOGADR(3)
CTRLR  CTRLNUM(D31),NAME(F1751),CHPID(0B),UNITADDR(00-0F),
        FEATURE(DSF,SUP),LINKADDR(B1),CULOGADR(3)
.
.
DEVICE DEVNUM(D00-D0F),NAME(F6473K),FEATURE(DPR,STCHK),
        CTRLNUM(D00,D01,D02,D03,D04,D05,D06,D07),UNITADDR(00)
DEVICE DEVNUM(D10-D1F),NAME(F6473K),FEATURE(DPR,STCHK),
        CTRLNUM(D10,D11,D12,D13,D14,D15,D16,D17),UNITADDR(00)
DEVICE DEVNUM(D20-D2F),NAME(F6473K),FEATURE(DPR,STCHK),
        CTRLNUM(D20,D21,D22,D23,D24,D25,D26,D27),UNITADDR(00)
DEVICE DEVNUM(D30-D3F),NAME(F6473K),FEATURE(DPR,STCHK),
        CTRLNUM(D30,D31,D32,D33,D34,D35,D36,D37),UNITADDR(00)

```

FIGURE G-12 IOSRF Example: Single MSP Host Connected to a VSM4 via ESCON Directors

Logical Paths for VSM 4 with 32 Ports

A VSM4 with 32 ports has 4x the number of logical paths available to VSM2s and VSM3s. Does this mean that a VSM4 has enough logical paths for connectivity, redundancy, and throughput for *all* attached hosts? Even with 16 RTDs and 31 hosts

attached, the answer is “yes” as shown in [FIGURE G-13](#).

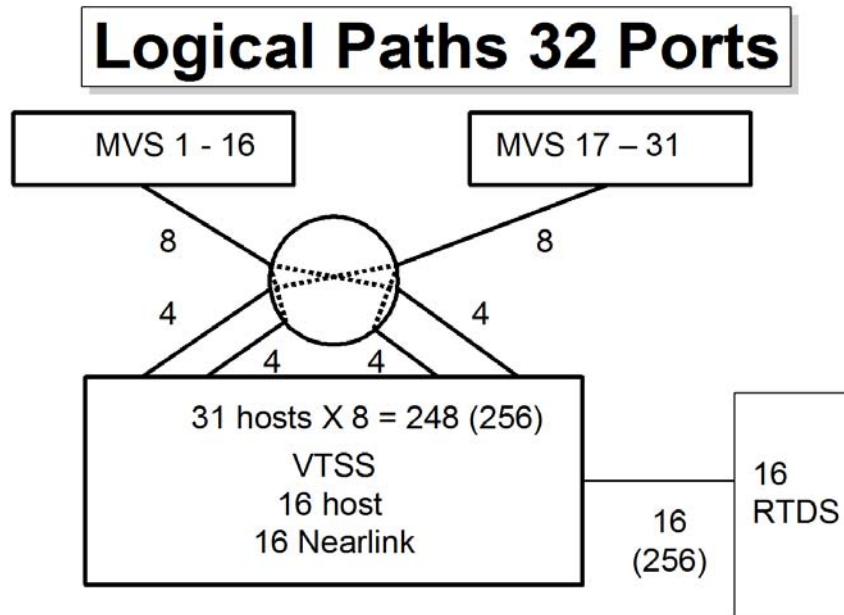

FIGURE G-13 Logical Paths for VSM 4 with 32 Ports, 31 Hosts, 16 RTDs

In [FIGURE G-13](#):

- The 16 RTDs consume 16 x 16 or 256 logical paths.
- The **maximum** logical paths we allocated for a VSM2/3 was 4 to a host requiring maximum throughput (which also satisfied the redundancy/connectivity requirements). Therefore, if we allocated **double** that number, or 8 logical paths, for each of the 31 hosts in this configuration, we only consume 248, or 8 less than the logical paths remaining for host connections.

Therefore, logical path allocation isn't an issue, as it was with VSM2s and VSM3s.

VSM4 FICON Front-End and Back-End Configuration

The VSM4 FICON Back-End connectivity feature adds value to the previously available FICON front-end connectivity. [TABLE H-1](#) summarizes the supported card configurations for VSM4 FICON Front-End plus Back-End connectivity.

TABLE H-1 Supported Card Configurations for VSM4 FICON Front-End plus Back-End Connectivity

VCF Cards	FICON Ports	ICE Cards	ESCON Ports	Total Ports	Total Logical Paths (16 per ICE Port, 64 per VCF Port)
2	4	6	24	28	640
4	8	4	16	24	768
6	12	2	8	20	896
8	16	0	0	16	1024

VSM4 FICON VCF Card Options

VSM4 supports the following FICON VCF card options:

- [FIGURE H-1](#) shows a VSM4 with 6 ICE cards, 2 VCF cards.
- [FIGURE H-2 on page 367](#) shows a VSM4 with 4 ICE cards, 4 VCF cards.
- [FIGURE H-3 on page 368](#) shows a VSM4 with 2 ICE cards, 6 VCF cards.
- [FIGURE H-4 on page 369](#) shows a VSM4 with 8 VCF cards.

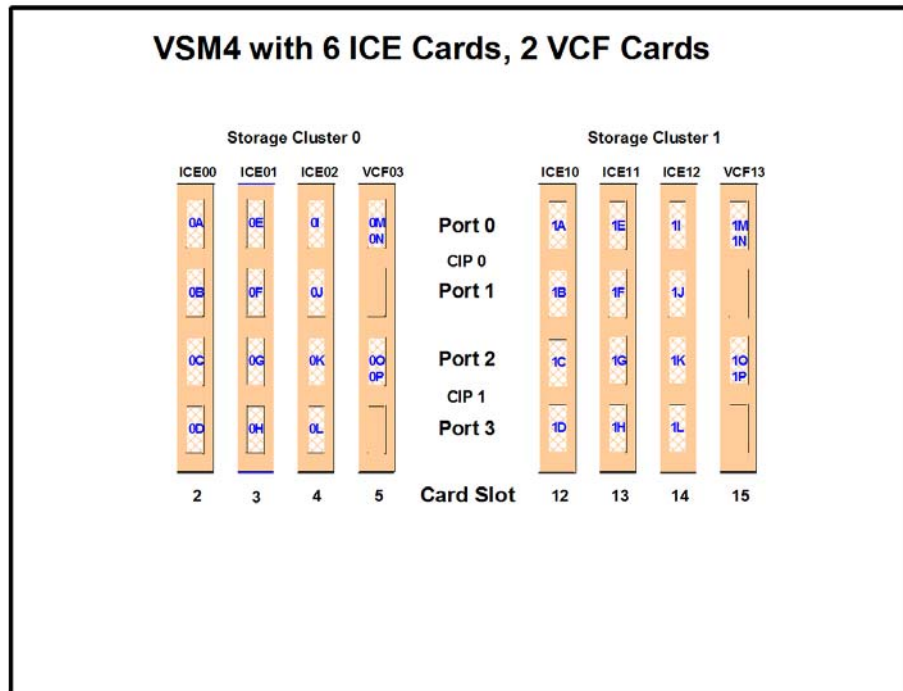

FIGURE H-1 VSM4 with 6 ICE cards, 2 VCF cards

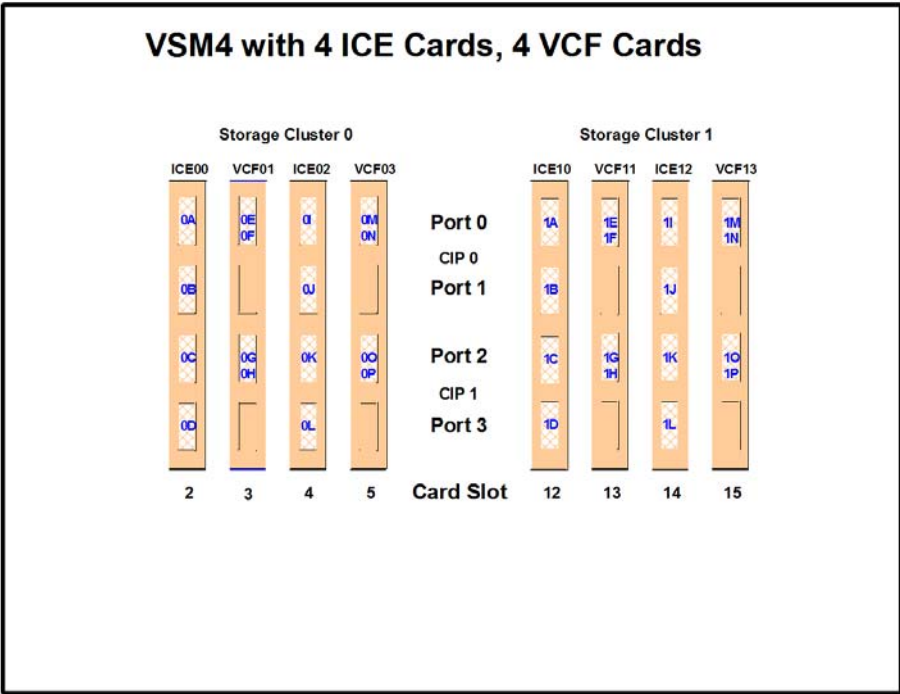

FIGURE H-2 VSM4 with 4 ICE cards, 4 VCF cards

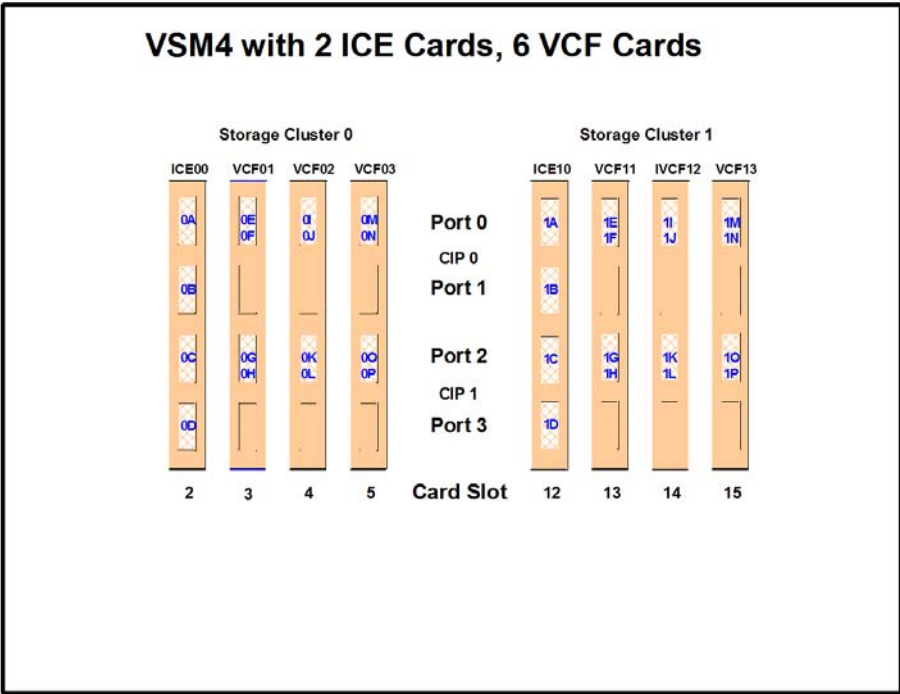

FIGURE H-3 VSM4 with 2 ICE cards, 6 VCF cards

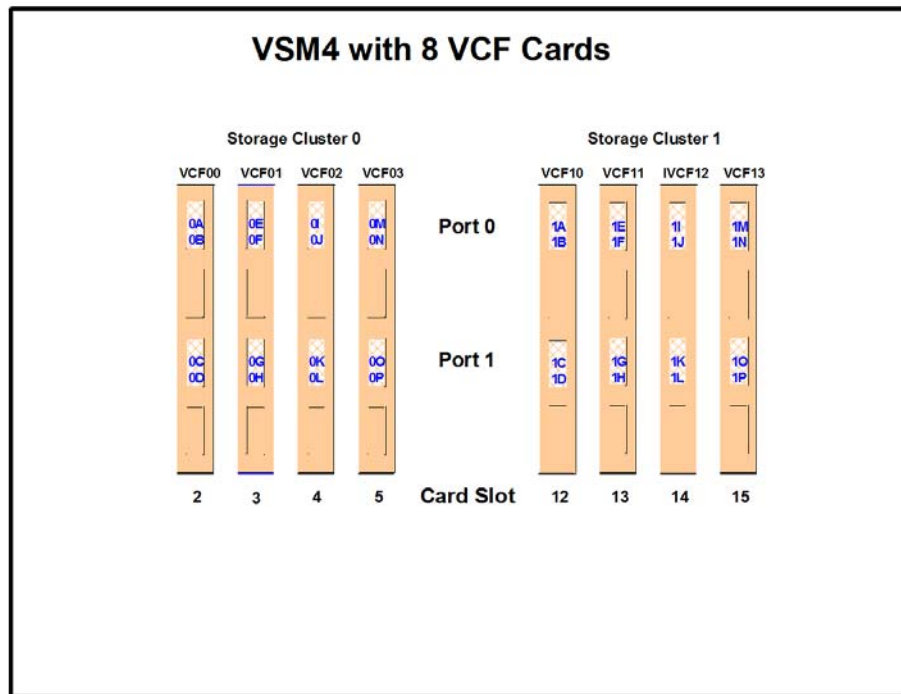

FIGURE H-4 VSM4 with 8 VCF cards

Note –

- In FIGURE H-1 on page 366 through FIGURE H-4 on page 369, the VCF cards must go in:
 - Slots 5 and 15 in a two-VCF card configuration
 - Slots 3, 5, 13, and 15 in a four-VCF card configuration.
 - Slots 3, 4, 5, 13, 14, and 15 in a six-VCF card configuration.
 - All slots in an eight-VCF card configuration.
- FICON ports are controlled by a FICON Interface processor (FIP), ESCON ports are controlled by a CIP. Regardless of the card configuration, there can be only a total of 14 Nearlink FIPs and/or CIPs.

Note – With microcode level D02.06.00.00 or higher, multiple Nearlink device connections via a FICON or ESCON switch or Director on the same port now allow:

- **Up to a total of 16 simultaneous NearLink I/O transfers**, which can be spread across multiple targets on as many as 14 NearLink ports.
 - **Up to a total of 2 simultaneous NearLink I/O transfers** are allowed per port.
-
- All FICON ports can be configured as either a Host port or Nearlink (RTD/CLINK origination) port. All ESCON ports continue to be configurable as host or Nearlink ports in pairs on a per CIP basis.
 - As shown in FIGURE H-1 on page 366 through FIGURE H-4 on page 369, the ports are shown with their channel interface identifiers where **all ports are enabled**. These channel interface identifiers are the values that are required for the CHANIF values

that you code for the CONFIG utility. Each value is two characters in length and has a value from 0A to 10. The first digit is the VTSS cluster ID (valid values are 0 or 1). The second digit is the group or adapter ID (valid values are A to P).

Each FICON port can attach to two RTDs, or two CLINKs, or an RTD/CLINK combination via a FICON director or supported switch (in FICON mode). **Note that**, as shown in these figures, **for RTDs only**, each FICON port has two CHANID values **only if** the port is connected to a FICON director which is then connected to two RTDs. Nearlink RTD connections that are paired via a FICON switch or director on the same port dynamically alternate between both RTDs for atomic operations such as mount, migrate VTV, recall VTV, etc.

- **Each ICE card** contains two pairs of ESCON ports. Each pair is controlled by its own Channel Interface Processor (CIP). Each CIP switches between the two ports, so that **only one port** can transfer data at a time, which emulates a FICON port attached to a director attached to RTDs.
- Each host FICON channel supports 64 logical paths (times 16 logical units). However, in IOGRP:
 - From a single MSP host, you can only define 8 channels (CHPIDs) running to a single control unit (single VSM4).
 - You use the CNTLUNIT statement to define each VSM4 as 16 3490 control unit images.
 - You use the IODEVICE statement to define the 16 VTDs that are associated with each 3490 control unit image.
- For a VSM4, each ESCON CIP or FICON FIP can operate with only *one* of two modes, which is set at the VTSS LOP:
 - *Host Mode*. In Host Mode, ports can connect to the host CPU channels, including via Director(s) or channel extenders. A port in Host Mode can also serve as a CLINK terminator.

Also note that for ESCON ports, you can have two physical paths from the same LPAR to the same CIP, as long as the two physical paths address different (not overlapping) logical control units. For example, a single host LPAR can address logical control units 0-7 on one CIP port, and 8-F on the other CIP port of the same CIP.
 - *Nearlink Mode*. In Nearlink Mode, ports can connect to an RTD. A port in Nearlink Mode can also serve as a CLINK originator.
 - **For clustering**, you need an originator port in Nearlink mode on one VTSS connected via a CLINK to a terminator port in Host mode on the other VTSS.

Caution – In bi-directional clustering, each CLINK must be attached to the same Storage Cluster on each VTSS, which is a requirement. Failure to configure in this manner can produce Replicate, Channel, and Communication errors! For more information and examples, see *ELS Disaster Recovery and Offsite Data Management Guide*.

In both FICON and ESCON, what are Best Practices for optimizing port operations? See [TABLE H-2...](#)

TABLE H-2 Optimizing VSM4 FICON/ESCON Port Operations

Configuration - Two ESCON Ports on a CIP (ICE) or FICON port attached to a FICON Director (VCF)	Best Practices
Two CLINKs	Attach a maximum of 2because each port allows two active operations. Note, however, that these operations share the bandwidth of the port.
CLINK and RTD	An advantage if you attach one CLINK originator/one RTD per director, because both can be active.
Two RTDs	<p>An advantage for the following:</p> <p>Optimize use of local and remote RTDs. During busy shifts, use only local RTDs on the FIP. During quiet periods, switch to remote RTDs for deep archive and DR work. Because you can have two active devices, you can also simultaneously run one local and one remote RTD. Note, however, that these operations share the bandwidth of the port.</p> <p>Optimize use of different drive technologies. As described in the previous bullet, use a T9840 as a local RTD, then switch to a T9940 for deep archive. You can also use this feature to migrate from older drive technology (such as 9490) to newer technology (such as 9840). Use Management and Storage Classes to read in data from older media, then switch to the newer technology drive to place data on new media. This technique effectively gives you greater physical connectivity to different drive technologies without incurring the overhead of full time, real time FICON connections to each drive type. Also as above, because you can have two active devices, you can also simultaneously run two RTDs with different drive technologies. Note, however, that these operations share the bandwidth of the port.</p>

VSM4 FICON Front-End and Back-End Configuration Examples

For VSM4s with both FICON Front-End and Back-End connectivity, let's look at two examples of VCF card configurations and implementation:

- “VSM4 Configuration Example: 8 VCF Cards, FICON Directors, 16 RTDs” on page 373
- “VSM4 Configuration Example: 8 VCF Cards, 4 CLINKs, FICON Directors for 8 RTDs” on page 375

For a VSM4 host gen example, see “IOSRF Example for Single MSP Host Connected to a VSM5 Via FICON Directors” on page 378.

VSM4 Configuration Example: 8 VCF Cards, FICON Directors, 16 RTDs

FIGURE H-5 shows CONFIG channel interface identifiers for a VSM4 with 8 VCF cards. In this configuration, we've allocated 8 ports to RTDs and 8 ports to host connections. The RTD ports are all connected to FICON directors, each of which is attached to RTDs, so the CHANID identifiers for both RTDs are shown on each port. This allows Back-End connection to 16 RTDs, although, as with ESCON, only one RTD per port/Director can be active at a time.

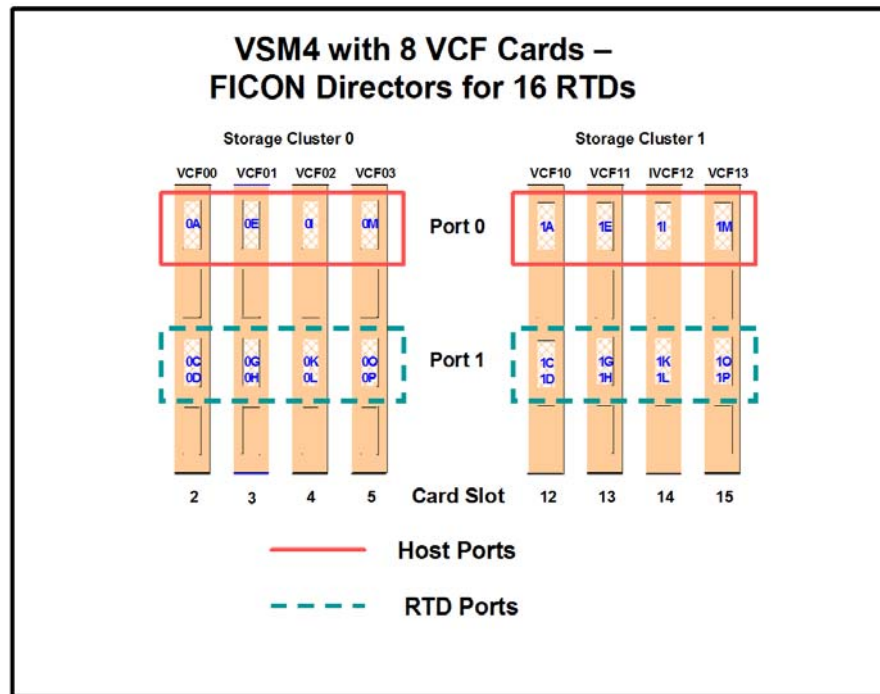

FIGURE H-5 VSM4 with 8 VCF Cards, FICON Directors for 16 RTDs

CONFIG Example for VSM4 FICON with 8 VCF Cards, FICON Directors, 16 RTDs

FIGURE H-6 shows example CONFIG JCL to define the VSM4 configuration shown in FIGURE H-5 on page 373.

```
//CREATECF EXEC PGM=SLUADMIN,PARM='MIXED'  
//STEPLIB DD DSN=hlq.SEALINK,DISP=SHR  
//SLSCNTL DD DSN=hlq.DBASEPRM,DISP=SHR  
//SLSCNTL2 DD DSN=hlq.DBASESEC,DISP=SHR  
//SLSSTBY DD DSN=hlq.DBASETBY,DISP=SHR  
//SLSPRINT DD SYSOUT=*  
//SLSIN DD *  
CONFIG  
GLOBAL MAXVTV=32000 MVCFREE=40  
RECLAIM THRESHLD=70 MAXMVC=40 START=35  
VTSS NAME=VSM401 LOW=70 HIGH=80 MAXMIG=8 RETAIN=5  
RTD NAME=VSM42A00 DEVNO=2A00 CHANIF=0C  
RTD NAME=VSM42A01 DEVNO=2A01 CHANIF=0D  
RTD NAME=VSM42A02 DEVNO=2A02 CHANIF=0G  
RTD NAME=VSM42A03 DEVNO=2A03 CHANIF=0H  
RTD NAME=VSM42A04 DEVNO=2A04 CHANIF=0K  
RTD NAME=VSM42A05 DEVNO=2A05 CHANIF=0L  
RTD NAME=VSM42A06 DEVNO=2A06 CHANIF=0O  
RTD NAME=VSM42A07 DEVNO=2A07 CHANIF=0P  
RTD NAME=VSM42A08 DEVNO=2A08 CHANIF=1C  
RTD NAME=VSM42A09 DEVNO=2A09 CHANIF=1D  
RTD NAME=VSM42A0A DEVNO=2A0A CHANIF=1G  
RTD NAME=VSM42A0B DEVNO=2A0B CHANIF=1H  
RTD NAME=VSM42A0C DEVNO=2A0C CHANIF=1K  
RTD NAME=VSM42A0D DEVNO=2A0D CHANIF=1L  
RTD NAME=VSM42A0E DEVNO=2A0E CHANIF=1O  
RTD NAME=VSM42A0F DEVNO=2A0F CHANIF=1P  
VTD LOW=9900 HIGH=99FF
```

FIGURE H-6 CONFIG example: VSM4 with 8 VCF cards, FICON Directors, 16 RTDs

VSM4 Configuration Example: 8 VCF Cards, 4 CLINKs, FICON Directors for 8 RTDs

FIGURE H-7 shows CONFIG channel interface identifiers for a VSM4 with 8 VCF cards. In this configuration, we've allocated:

- 8 Host ports.
- 4 ports for RTDs. The RTD ports are all connected to FICON directors, each of which is attached to RTDs, so the CHANID identifiers for both RTDs are shown on each port. This allows Back-End connection to 8 RTDs. As with ESCON, only one RTD per port/Director can be active at a time.
- 4 ports for CLINK connections to form a Bi-Directional VTSS Cluster, and 8 ports to host connections. To form the clustered VTSS, we'll have two VSM4s (VSM4PR1 and VSM4PR2) configured identically as shown in FIGURE H-7. As shown in Figure 46 on page 150, Bi-Directional Clustering requires pairs of Uni-Directional CLINKs with the FIPs configured so that the data flows in **opposite directions** on the CLINKs. To make that happen, let's make 0G and 1G the sending (Nearlink Mode) ports on both VTSSs and 0O and 1O the receiving (Host Mode) on both VTSSs.

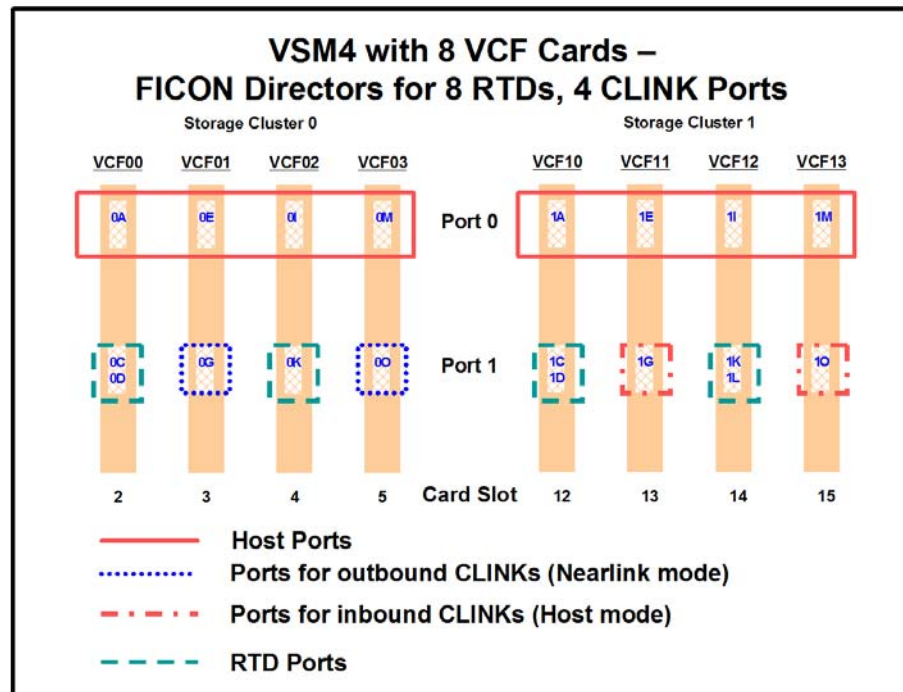

FIGURE H-7 VSM4 with 8 VCF Cards, 8 Host Ports, FICON Directors for 8 RTDs, 4 CLINK Ports

CONFIG Example for Bi-Directional Clustered VSM4 FICON Back-End

FIGURE H-8 shows example CONFIG JCL to define a Bi-Directional Cluster of two VSM4s (VSMPR1 and VSMPR2) with identical VCF card configurations shown in FIGURE H-7 on page 375.

Caution – Bi-Directional Clustering **requires** VTCS 6.1! You **cannot** configure a Bi-Directional Cluster at releases lower than VTCS 6.1!

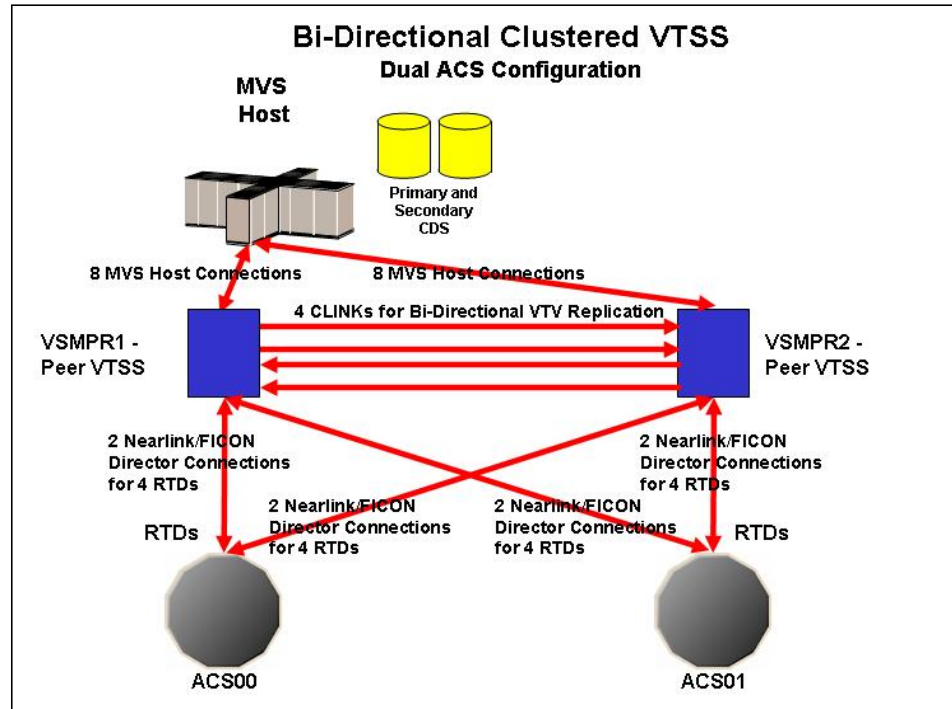

FIGURE H-8 Dual ACS Bi-Directional Clustered VTSS Configuration

FIGURE H-9 shows example CONFIG JCL to define a Bi-Directional Cluster of two VSM4s (VSMPR1 and VSMPR2) as shown in FIGURE H-8 on page 376. **Note that:**

- The CLUSTER statement defines the Cluster as consisting of VSMPR1 and VSMPR2.
- There are CLINK statements using the sending (Nearlink Mode) ports of **both VTSSs** to enable the Cluster as Bi-Directional. As described on page 156, the Nearlink ports are 0G and 1G on both VTSSs.

```
//CREATECF EXEC PGM=SLUADMIN,PARM='MIXED'
//STEPLIB DD DSN=hlq.SEALINK,DISP=SHR
//SLSCNTL DD DSN=hlq.DBASEPRM,DISP=SHR
//SLSCNTL2 DD DSN=hlq.DBASESEC,DISP=SHR
//SLSSTBY DD DSN=hlq.DBASETBY,DISP=SHR
//SLSPRINT DD SYSOUT=*
//SLSIN DD *
CONFIG RESET CDSLEVEL(V61ABOVE)
GLOBAL MAXVTV=32000MVCFREE=40
RECLAIM THRESHLD=70MAXMVC=40 START=35
VTSS NAME=VSMPR1 LOW=70 HIGH=80 MAXMIG=8 MINMIG=4 RETAIN=5
RTD NAME=PR11A00 DEVNO=1A00 CHANIF=0C
RTD NAME=PR11A01 DEVNO=1A01 CHANIF=0D
RTD NAME=PR11A02 DEVNO=1A02 CHANIF=0K
RTD NAME=PR11A03 DEVNO=1A03 CHANIF=0L
RTD NAME=PR12A08 DEVNO=2A08 CHANIF=1C
RTD NAME=PR12A09 DEVNO=2A09 CHANIF=1D
RTD NAME=PR12A0A DEVNO=2A0A CHANIF=1K
RTD NAME=PR12A0B DEVNO=2A0B CHANIF=1L
VTD LOW=9900 HIGH=99FF
VTSS NAME=VSMPR2 LOW=70 HIGH=80 MAXMIG=8 MINMIG=4 RETAIN=5
RTD NAME=PR23A00 DEVNO=3A00 CHANIF=0C
RTD NAME=PR23A01 DEVNO=3A01 CHANIF=0D
RTD NAME=PR23A02 DEVNO=3A02 CHANIF=0K
RTD NAME=PR23A03 DEVNO=3A03 CHANIF=0L
RTD NAME=PR24A08 DEVNO=4A08 CHANIF=1C
RTD NAME=PR24A09 DEVNO=4A09 CHANIF=1D
RTD NAME=PR24A0A DEVNO=4A0A CHANIF=1K
RTD NAME=PR24A0B DEVNO=4A0B CHANIF=1L
VTD LOW=9900 HIGH=99FF
CLUSTER NAME=CLUSTER1 VTSSs(VSMPR1,VSMPR2)
CLINK VTSS=VSMPR1 CHANIF=0G
CLINK VTSS=VSMPR1 CHANIF=1G
CLINK VTSS=VSMPR2 CHANIF=0G
CLINK VTSS=VSMPR2 CHANIF=1G
```

FIGURE H-9 CONFIG example: Dual ACS Bi-Directional Clustered VTSS System, VSM4 FICON Back-End

IOSRF Example for Single MSP Host Connected to a VSM5 Via FICON Directors

FIGURE H-10 shows a configuration diagram for a single MSP host connected to a VSM5 via FICON Directors, and FIGURE H-11 on page 379 shows example IOSRF statements for this configuration. **Note that:**

- From MSPA, you define 8 CHPIDs, with each path switched in the FICON Director, for a total of 8 channels running to the VSM5.
- You code 16 CTRLR statements to define the VSM5 as 16 F6473K images.
- You code DEVICE statement to define the 16 VTDs that are associated with each F6473K image.
- If ESCON and FICON channels are configured to the same logical control unit, MSP issues message CBDG489I, which indicates that mixing ESCON and FICON channel paths on a logical control unit should be used only for the migration from ESCON to native FICON, but should not be used permanently. This is a warning message only, and does not indicate an error.

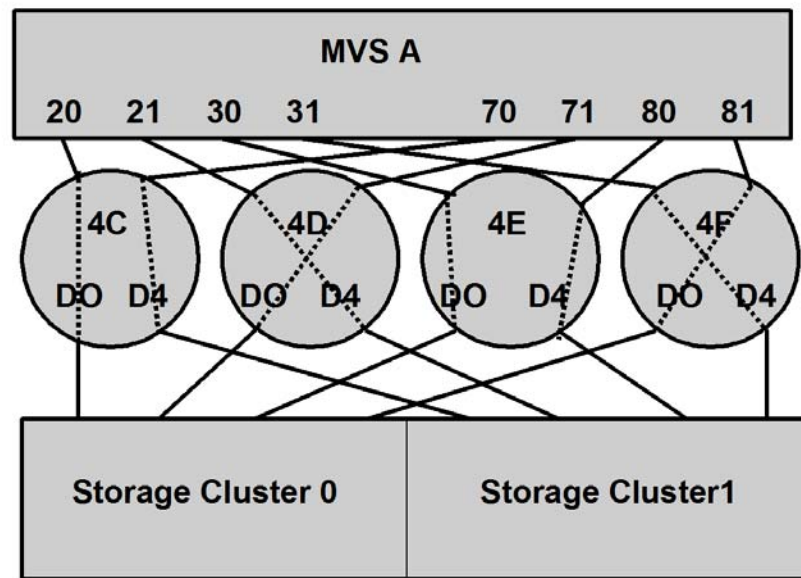

FIGURE H-10 Configuration Diagram: Single MSP Host Connected to a VSM5 via FICON Directors

```

CHANNEL CHPID(0A-0D),TYPE(BMC),INTF(OCLINK),OCLS(01)
CHANNEL CHPID(24-27),TYPE(BMC),INTF(OCLINK),OCLS(02)
.
.
CTRLR  CTRLNUM(D00),NAME(F1751),CHPID(0A),UNITADDR(00-0F),
        FEATURE(DSF,SUP),LINKADDR(B0),CULOGADR(0)
CTRLR  CTRLNUM(D01),NAME(F1751),CHPID(0B),UNITADDR(00-0F),
        FEATURE(DSF,SUP),LINKADDR(B1),CULOGADR(0)
.
.
CTRLR  CTRLNUM(D10),NAME(F1751),CHPID(0A),UNITADDR(00-0F),
        FEATURE(DSF,SUP),LINKADDR(B0),CULOGADR(1)
CTRLR  CTRLNUM(D11),NAME(F1751),CHPID(0B),UNITADDR(00-0F),
        FEATURE(DSF,SUP),LINKADDR(B1),CULOGADR(1)
.
CTRLR  CTRLNUM(D20),NAME(F1751),CHPID(0A),UNITADDR(00-0F),
        FEATURE(DSF,SUP),LINKADDR(B0),CULOGADR(2)
CTRLR  CTRLNUM(D21),NAME(F1751),CHPID(0B),UNITADDR(00-0F),
        FEATURE(DSF,SUP),LINKADDR(B1),CULOGADR(2)
.
.
CTRLR  CTRLNUM(D30),NAME(F1751),CHPID(0A),UNITADDR(00-0F),
        FEATURE(DSF,SUP),LINKADDR(B0),CULOGADR(3)
CTRLR  CTRLNUM(D31),NAME(F1751),CHPID(0B),UNITADDR(00-0F),
        FEATURE(DSF,SUP),LINKADDR(B1),CULOGADR(3)
.
.
DEVICE DEVNUM(D00-D0F),NAME(F6473K),FEATURE(DPR,STCHK),
        CTRLNUM(D00,D01,D02,D03,D04,D05,D06,D07),UNITADDR(00)
DEVICE DEVNUM(D10-D1F),NAME(F6473K),FEATURE(DPR,STCHK),
        CTRLNUM(D10,D11,D12,D13,D14,D15,D16,D17),UNITADDR(00)
DEVICE DEVNUM(D20-D2F),NAME(F6473K),FEATURE(DPR,STCHK),
        CTRLNUM(D20,D21,D22,D23,D24,D25,D26,D27),UNITADDR(00)
DEVICE DEVNUM(D30-D3F),NAME(F6473K),FEATURE(DPR,STCHK),

```

FIGURE H-11 IOSRF Example: Single MSP Host Connected to a VSM5 via FICON Directors

Tip – Unlike ESCON, FICON supports multiple active I/Os per channel. If the number of active VTDs is less than the number of channels configured to the VTSS, the I/Os to those VTDs may not be evenly spread across all the channels. As the number of active VTDs increases to be greater than the number of channels configured to the VTSS, the channel subsystem will spread the I/Os across all the channels. If it is desired to spread the I/Os across all of the channels even when only a few VTDs are active, it is necessary to use the preferred path feature to force the channel subsystem to spread the I/Os across the channels. The preferred path feature is specified via the PATH= parameter on the DEVICE statement. When you specify preferred path on the DEVICE statement, the channel subsystem always tries the preferred path first. If it is busy or unavailable, the channel subsystem next tries the channel path following the preferred path in the rotation order, and so on.

FIGURE H-11 on page 379 (repeated in FIGURE H-12) shows DEVICE statements for STRING1 **without** using preferred pathing.

```
STRING1  DEVICE ADDRESS=(0500,16),  
          CUNUMBER=(001),  
          UNIT=F6473K,  
          UNITADD=00,STADET=Y
```

FIGURE H-12 DEVICE Statements for STRING 1 without Preferred Pathing

Figure H-13 shows DEVICE statements for STRING1 using preferred pathing. If you're using preferred pathing, you need to use these kind of DEVICE statements for all paths, such as STRING2 through STRING16 in Figure H-11 on page 379.

```
STRING10 DEVICE ADDRESS=(0500,2),
CUNUMBER=(001),
UNIT=F6473K,
UNITADD=00,STADET=Y,
PATH=20

STRING12 DEVICE ADDRESS=(0502,2),
CUNUMBER=(001),
UNIT=F6473K,
UNITADD=00,STADET=Y,
PATH=21

STRING14 DEVICE ADDRESS=(0504,2),
CUNUMBER=(001),
UNIT=F6473K,
UNITADD=00,STADET=Y,
PATH=30

STRING16 DEVICE ADDRESS=(0506,2),
CUNUMBER=(001),
UNIT=F6473K,
UNITADD=00,STADET=Y,
PATH=31

STRING18 DEVICE ADDRESS=(0508,2),
CUNUMBER=(001),
UNIT=F6473K,
UNITADD=00,STADET=Y,
PATH=70

STRING1A DEVICE ADDRESS=(050A,2),
CUNUMBER=(001),
UNIT=F6473K,
UNITADD=00,STADET=Y,
PATH=71

STRING1C DEVICE ADDRESS=(050C,2),
CUNUMBER=(001),
UNIT=F6473K,
UNITADD=00,STADET=Y,
PATH=80

STRING1E DEVICE ADDRESS=(050E,2),
CUNUMBER=(001),
UNIT=F6473K,
UNITADD=00,STADET=Y,
PATH=81
```

FIGURE H-13 DEVICE Statements for STRING 1 Using Preferred Pathing

VSM5 FICON Configuration

The VSM5, provides greater capacity and throughput than the VSM4, while retaining its advantages over the VSM3. [TABLE I-1](#) summarizes the VSM5 features.

TABLE I-1 VSM5 Features

Feature	Description
Host/Nearlink Interfaces	Up to 16 (FICON only)
RTDs supported	Up to 32 via FICON directors (in 3490-emulation mode only), can be a mixture of the following: 9840B, 9840C, 9940B, T10000.
LSMs supported	9740, 9360, 4410, 9310, SL8500 , SL3000
Maximum VTDs per VTSS	256
Maximum VTVs per VTSS	300,000

VSM5 FICON VCF Card Options - Maximum 16 RTDs

VSM5 is available **only** with VCF (FICON) cards in the following configurations for a maximum of 16 RTDs:

- [FIGURE I-1](#) shows a VSM5 with 8 VCF cards.
- [FIGURE I-2 on page 385](#) shows a VSM5 with 6 VCF cards, 2 empty card slots.
- [FIGURE I-3 on page 386](#) shows a VSM5 with 4 VCF cards, 4 empty card slots.

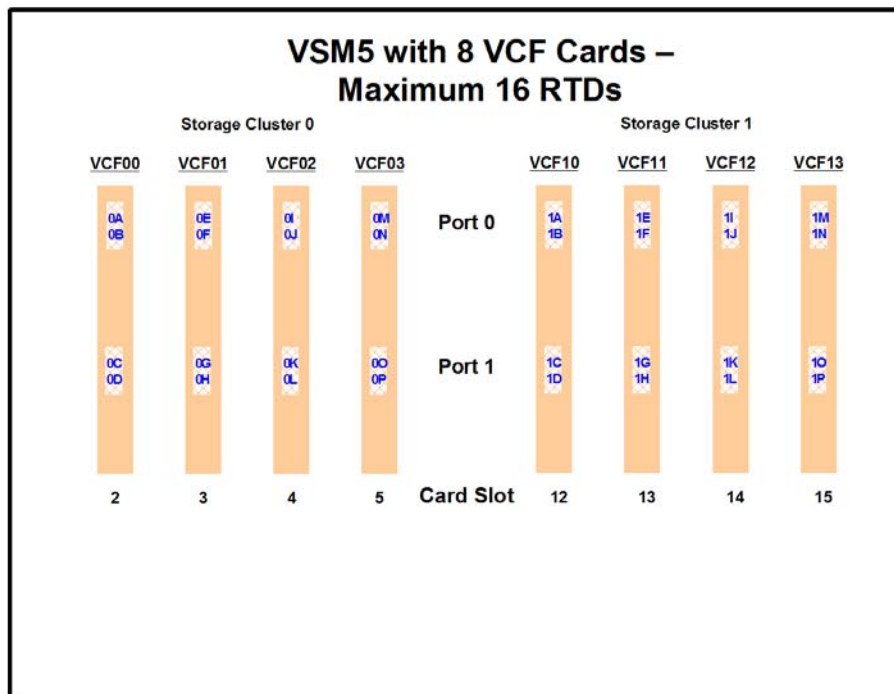

FIGURE I-1 VSM5 with 8 VCF cards - Max 16 RTDs

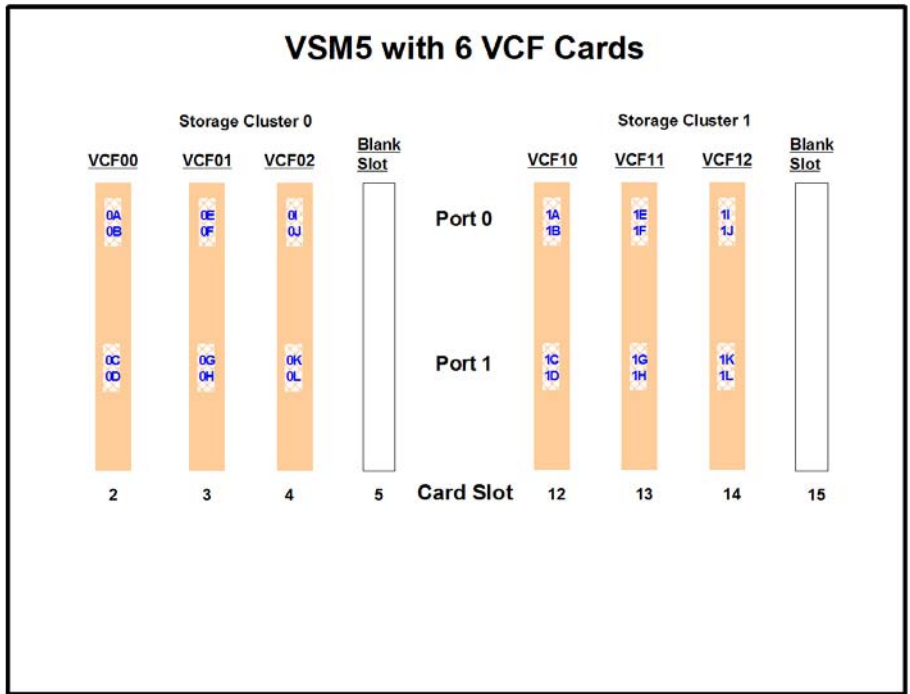

FIGURE I-2 VSM5 with 6 VCF cards, 2 empty card slots

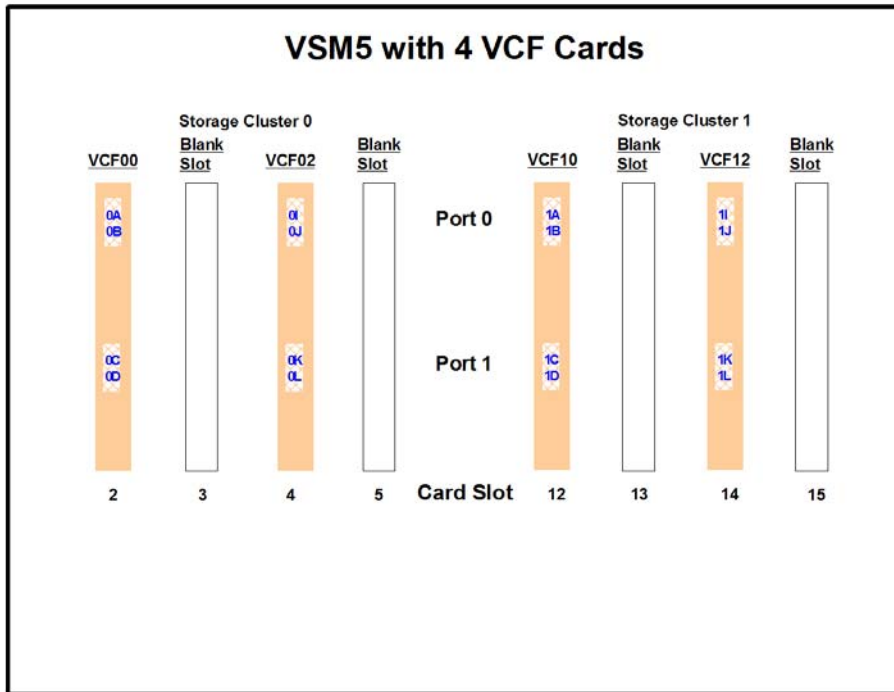

FIGURE I-3 VSM5 with 4 VCF cards, 4 empty card slots

Note –

- In [FIGURE I-1](#) on page 384 through [FIGURE I-3](#) on page 386, the VCF cards must go in:
 - All slots in an eight-VCF card configuration.
 - Slots 2, 3, 4, 13, 14, and 15 in a six-VCF card configuration.
 - Slots 2, 4, 14, and 15 in a four-VCF card configuration.

VSM5 FICON VCF Card Options - Maximum 32 RTDs

VSM5 is available **only** with 8 VCF (FICON) cards in the configuration for a maximum of 32 RTDs shown in [FIGURE I-4](#). For more information on device addressing, see “RTD/CLINK Addresses - Maximum 32 RTDs” on page 52.

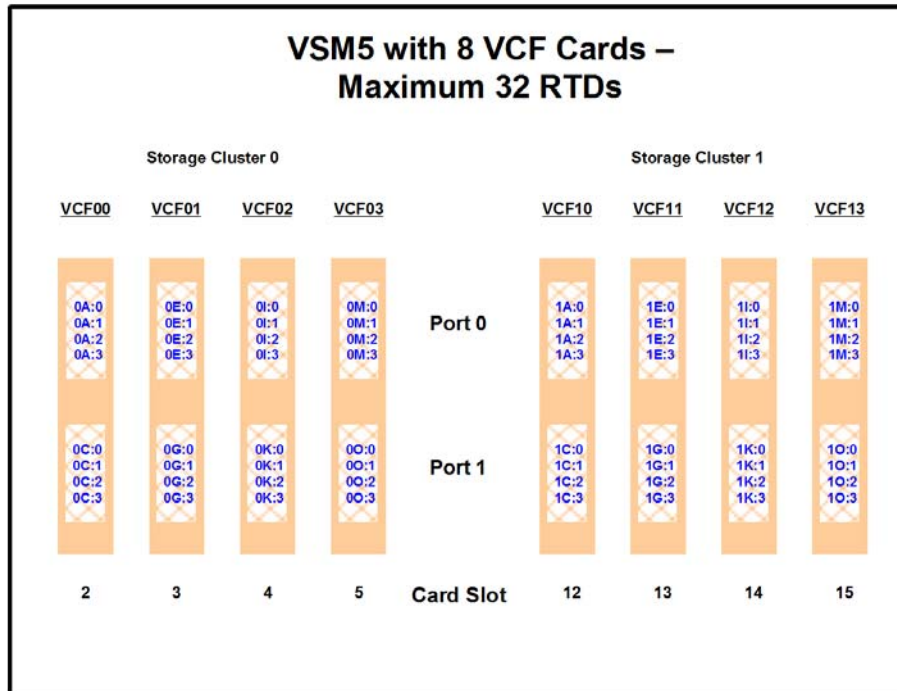

FIGURE I-4 VSM5 with 8 VCF cards - Max 32 RTDs

FICON Port Processing

FICON ports processing is as follows:

- FICON ports are controlled by a FICON Interface processor (FIP) and there can be only a total of 14 Nearlink FIPs (for maximum of 16 RTDs supported) or 28 Nearlink FIPs (for maximum of 32 RTDs supported).
- For a VSM5, each FIP can operate with only *one* of two modes, which is set at the VTSS DOP:
 - *Host Mode*. In Host Mode, ports can connect to the host CPU channels, including via Director(s) or channel extenders. A port in Host Mode can also serve as a CLINK terminator.
 - *Nearlink Mode*. In Nearlink Mode, ports can connect to an RTD. A port in Nearlink Mode can also serve as a CLINK originator.
 - **For clustering**, you need an originator port in Nearlink mode on one VTSS connected via a CLINK to a terminator port in Host mode on the other VTSS.
- In [FIGURE I-1 on page 384](#) through [FIGURE I-4 on page 387](#), the ports are shown with their channel interface identifiers where **all ports are enabled**. For more information on device addressing, see [“RTD/CLINK Addresses - Maximum 32 RTDs” on page 52](#).

Each FICON port can attach to up to 4 RTDs, or up to 4 CLINKs, or up to 4 RTD/CLINK combinations via a FICON director or supported switch (in FICON mode). **Note that**, as shown in these figures, each FICON port has multiple device addresses **only if** the port is connected to a FICON director which is then connected to multiple devices.

Note – With microcode level D02.06.00.00 or higher, multiple Nearlink device connections via a FICON switch or Director on the same port now allow:

- **Up to a total of 16 simultaneous NearLink I/O transfers**, which can be spread across multiple targets on as many as 14 NearLink ports.
- **Up to a total of 2 simultaneous NearLink I/O transfers** are allowed per port.

-
- Each host FICON channel supports 64 logical paths (times 16 logical units). However, in IOGRP:
 - From a single MSP host, you can only define 8 channels (CHPIDs) running to a single control unit (single VSM5).
 - You use the CNTLUNIT statement to define each VSM5 as 16 3490 control unit images.
 - You use the IODEVICE statement to define the 16 VTDs that are associated with each 3490 control unit image.

Caution – In bi-directional clustering, each CLINK **must be** attached to **the same Storage Cluster** on each VTSS, **which is a requirement**. Failure to configure in this manner can produce Replicate, Channel, and Communication errors! For more information and examples, see [ELS Disaster Recovery and Offsite Data Management Guide](#).

FICON Port Operations Best Practices

For FICON, what are Best Practices for optimizing port operations? See [TABLE I-2...](#)

TABLE I-2 Optimizing VSM5 FICON Port Operations

Configuration - FICON port attached to a FICON Director	Best Practices
Multiple CLINKs (up to 4)	Attach a maximum of 2because each port allows two active operations. Note, however, that these operations share the bandwidth of the port.
CLINK and RTD combinations	An advantage if you attach one CLINK originator/one RTD per director, because both can be active.
Up to 4 RTDs	<p>An advantage for the following:</p> <p>Optimize use of local and remote RTDs. During busy shifts, use only local RTDs on the FIP. During quiet periods, switch to remote RTDs for deep archive and DR work. Because you can have two active devices, you can also simultaneously run one local and one remote RTD. Note, however, that these operations share the bandwidth of the port.</p> <p>Optimize use of different drive technologies. As described in the previous bullet, use a T9840 as a local RTD, then switch to a T9940 for deep archive. You can also use this feature to migrate from older drive technology (such as 9490) to newer technology (such as 9840). Use Management and Storage Classes to read in data from older media, then switch to the newer technology drive to place data on new media. This technique effectively gives you greater physical connectivity to different drive technologies without incurring the overhead of full time, real time FICON connections to each drive type. Also as above, because you can have two active devices, you can also simultaneously run two RTDs with different drive technologies. Note, however, that these operations share the bandwidth of the port.</p>

VSM5 FICON Front-End and Back-End Configuration Examples

For VSM5s, let's look at an examples of VCF card configurations and implementation in ["VSM5 Configuration Example: 8 VCF Cards, FICON Directors, 32 RTDs"](#) on page 392.

For a VSM5 host gen example, see ["IOSRF Example for Single MSP Host Connected to a VSM5 Via FICON Directors"](#) on page 397.

Implementing Support for Maximum of 32 RTDs

1. Ensure that your system has the Maximum 32 RTDs requirements described in [TABLE I-3](#).

TABLE I-3 32 RTDs/Stacked Migrates Support Requirements for VTCS/NCS 7.0

32 RTDs/Stacked Migrates Support requires...	..the following VSM4/VSM5 microcode...	...and CDS level...
FICON RTDs and FICON ports for the CLINKs	D02.05.00.00 or higher	“F” or higher

2. Use **CONFIG GLOBAL** to enable support for maximum of 32 RTDs.
CONFIG GLOBAL MAXRTDS=32

Note – Enabling support for a maximum of 32 RTDs **does not** require CONFIG RESET. However, regressing from 32 RTDs supported to 16 RTDs supported **does** require CONFIG RESET.

3. Update your CONFIG RTD and CONFIG CLINK statements as required.

For more information, see:

- “Maximum RTDs per VTSS” on page 51
- “VSM5 Configuration Example: 8 VCF Cards, FICON Directors, 32 RTDs” on page 392

Note – The CONFIG utility RTD statement defines the RTDs connected to the VTSS. Specifically, the CONFIG RTD CHANIF parameter specifies the channel interface on the VTSS that communicates with the RTD.

Similarly, the The CONFIG utility CLINK statement defines the channel interface for a CLINK originator via the CONFIG CLINK CHANIF parameter.

Code values for the CHANIF parameter as follows:

- Regardless of whether the Maximum 32 RTDs feature is enabled, if you do not have a total of greater than 16 (RTDs, CLINK originators, or a combination of RTDs and CLINK originators) on that VTSS, you can use the “old” addressing scheme on the CHANIF parameters.
- If, however, the Maximum 32 RTDs feature is enabled and you have total of greater than 16 (RTDs, CLINK originators, or a combination of RTDs and CLINK originators) on that VTSS, you must use the “new” addressing scheme on the corresponding CHANIF parameters.

For more information, see “Maximum RTDs per VTSS” on page 51.

4. Use the **VSM5 DOP** to reenter your RTD device addresses.
See “VSM5 DOP Panels for Maximum 32 RTDs” on page 394.

VSM5 Configuration Example: 8 VCF Cards, FICON Directors, 32 RTDs

FIGURE I-5 shows CONFIG channel interface identifiers for a VSM5 with 8 VCF cards and the Maximum 32 RTDs feature enabled. In this configuration, we've allocated 8 ports to RTDs and 8 ports to host connections. The RTD ports are all connected to FICON directors, each of which is attached to 4 RTDs, so the CHANID identifiers for all 4 RTDs are shown on each port. This allows Back-End connection to 32 RTDs, although only one RTD per port/Director can be active at a time.

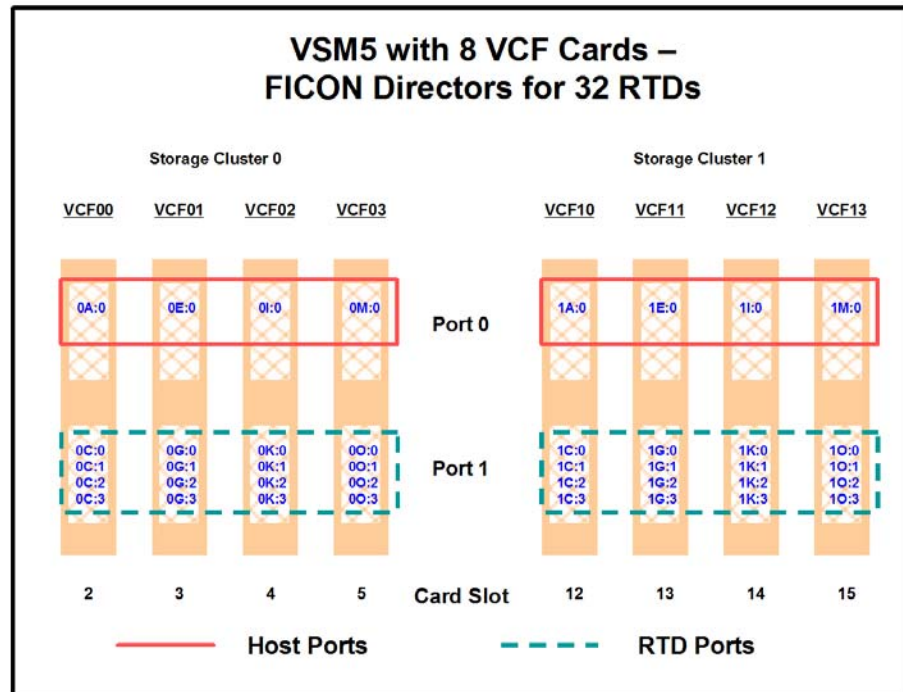

FIGURE I-5 VSM5 with 8 VCF Cards, FICON Directors for 32 RTDs

CONFIG Example for VSM5 FICON with 8 VCF Cards, FICON Directors, 32 RTDs

FIGURE I-6 shows example CONFIG JCL to define the VSM5 configuration shown in FIGURE I-5 on page 392.

```
//CREATECF EXEC PGM=SLUADMIN,PARM='MIXED'  
//STEPLIB DD DSN=hlq.SEALINK,DISP=SHR  
//SLSCNTL DD DSN=hlq.DBASEPRM,DISP=SHR  
//SLSCNTL2 DD DSN=hlq.DBASESEC,DISP=SHR  
//SLSSTBY DD DSN=hlq.DBASETBY,DISP=SHR  
//SLSPRINT DD SYSOUT=*  
//SLSIN DD *  
CONFIG  
GLOBAL MAXVTV=32000 MVCFREE=40 VTVATTR=SCRATCH RECALWER=YES  
LOCKSTR=VTCS_LOCKS  
REPLICAT=ALWAYS VTVPAGE=LARGE SYNCHREP=YES MAXRTDS=32  
RECLAIM THRESHLD=70 MAXMVC=40 START=35  
VTSS NAME=VSM501 LOW=70 HIGH=80 MAXMIG=8 RETAIN=5  
RTD NAME=VSM52A00 DEVNO=2A00 CHANIF=0C:0  
RTD NAME=VSM52A01 DEVNO=2A01 CHANIF=0C:1  
RTD NAME=VSM52A02 DEVNO=2A02 CHANIF=0C:2  
RTD NAME=VSM52A03 DEVNO=2A03 CHANIF=0C:3  
RTD NAME=VSM52A04 DEVNO=2A04 CHANIF=0G:0  
RTD NAME=VSM52A05 DEVNO=2A05 CHANIF=0G:1  
RTD NAME=VSM52A06 DEVNO=2A06 CHANIF=0G:2  
RTD NAME=VSM52A07 DEVNO=2A07 CHANIF=0G:3  
RTD NAME=VSM52A08 DEVNO=2A08 CHANIF=0K:0  
RTD NAME=VSM52A09 DEVNO=2A09 CHANIF=0K:1  
RTD NAME=VSM52A0A DEVNO=2A0A CHANIF=0K:2  
RTD NAME=VSM52A0B DEVNO=2A0B CHANIF=0K:3  
RTD NAME=VSM52A0C DEVNO=2A0C CHANIF=0O:0  
RTD NAME=VSM52A0D DEVNO=2A0D CHANIF=0O:1  
RTD NAME=VSM52A0E DEVNO=2A0E CHANIF=0O:2  
RTD NAME=VSM52A0F DEVNO=2A0F CHANIF=0O:3  
RTD NAME=VSM53A00 DEVNO=3A00 CHANIF=1C:0  
RTD NAME=VSM53A01 DEVNO=3A01 CHANIF=1C:1  
RTD NAME=VSM53A02 DEVNO=3A02 CHANIF=1C:2  
RTD NAME=VSM53A03 DEVNO=3A03 CHANIF=1C:3  
RTD NAME=VSM53A04 DEVNO=3A04 CHANIF=1G:0  
RTD NAME=VSM53A05 DEVNO=3A05 CHANIF=1G:1  
RTD NAME=VSM53A06 DEVNO=3A06 CHANIF=1G:2  
RTD NAME=VSM53A07 DEVNO=3A07 CHANIF=1G:3  
RTD NAME=VSM53A08 DEVNO=3A08 CHANIF=1K:0  
RTD NAME=VSM53A09 DEVNO=3A09 CHANIF=1K:1  
RTD NAME=VSM53A0A DEVNO=3A0A CHANIF=1K:2  
RTD NAME=VSM53A0B DEVNO=3A0B CHANIF=1K:3  
RTD NAME=VSM53A0C DEVNO=3A0C CHANIF=1O:0  
RTD NAME=VSM53A0D DEVNO=3A0D CHANIF=1O:1  
RTD NAME=VSM53A0E DEVNO=3A0E CHANIF=1O:2  
RTD NAME=VSM53A0F DEVNO=3A0F CHANIF=1O:3  
VTD LOW=9900 HIGH=99FF
```

FIGURE I-6 CONFIG example: VSM5 with 8 VCF cards, FICON Directors, 32 RTDs

VSM5 DOP Panels for Maximum 32 RTDs

Channel Configuration Status Screen

To access the *Channel Configuration Status* screen, click the active *Channel Status* text field on the *Configuration / Status Menu* screen.

Card	Name	Cl	Lk	Gr	En	Type	RTD Port	ID
VCF00		0	0	A	Y	HOST		
		0	0	B	N			
		0	1	C	Y	HOST		
		0	1	D	N			
VCF01		0	0	E	Y	NEARLINK	00	22
							FF	FF
							FF	FF
							FF	FF
VCF02		0	0	F	N	HOST		
		0	1	G	Y			
		0	1	H	N			
		0	0	I	Y	HOST		
VCF03		0	0	J	N			
		0	1	K	Y	HOST		
		0	1	L	N			
		0	0	M	Y	HOST		
VCF10		0	0	N	N			
		0	1	O	Y	HOST		
		0	1	P	N			
		1	0	A	Y	HOST		
VCF11		1	0	B	N			
		1	1	C	Y	HOST		
		1	1	D	N			
		1	0	E	Y	NEARLINK	61	20
VCF12							FF	FF
							FF	FF
							FF	FF
		1	0	F	N			
VCF13		1	1	G	Y	HOST		
		1	1	H	N			
		1	0	I	Y	HOST		
		1	0	J	N			
VCF13		1	1	K	Y	HOST		
		1	1	L	N			
		1	0	M	Y	NEARLINK	00	00
							FF	FF
						FF	FF	
						FF	FF	
	1	0	N	N				
	1	1	O	Y	HOST			
	1	1	P	N				

FIGURE I-7 Channel Configuration Status Screen

Channel Configuration and RTD Path Validation Screen

To access the *Channel Configuration and RTD Path Validation* screen, click on a VCF card shown on the *Channel Configuration Status* screen.

To set the configuration of a VCF card channel for host or Nearlink use, select the channel (0 or 1) and type from the pull-down lists, then click Continue to display a subscreen with the message **Success**, indicating the configuration change completed successfully. Click Cancel to undo changed settings and return to the *Channel Configuration Status* screen.

To validate a RTD path, select a validation path (0 or 1) from the pull-down list, then click Validate RTD Path to display a subscreen with the message **Channel path n was successfully validated**, indicating the selected RTD path is operational.

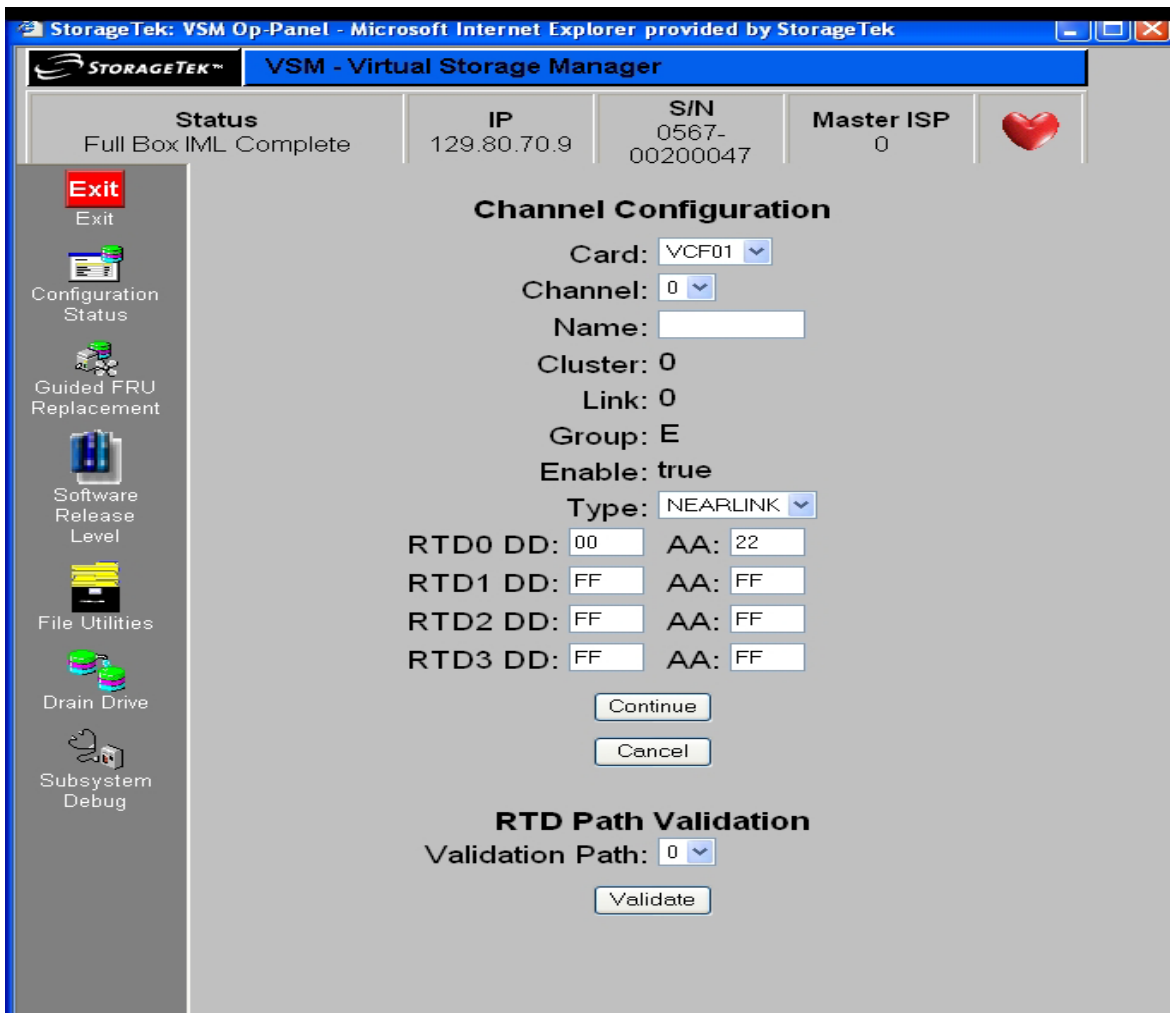

FIGURE I-8 Channel Configuration and RTD Path Validation Screen

Real Tape Drive Status Screen

To access the *Real Tape Drive Status* screen, click the active *Real Tape Drive Status* text field on the *Configuration / Status Menu* screen, [FIGURE I-9](#). To validate a real tape drive (RTD), click the active button in the *Valid* column for the RTD. The VTSS support facility validates the RTD, then displays a subscreen with the message **RTD *n* was successfully validated**. See `hic_stat` for details.

Note – RTD configuration is preserved/restored across cold IML (EPO or CPD) but the links are reset and RTDs are offline until you vary them online with the VTCS VARY RTD ONLINE command.

ID	Valid	Uncfg	Name	Cl	Card	Link	Grp	Status	Type
0	<input type="checkbox"/>	NA	RTD0	0	VCF00	0	A	ONLINE	9840
1	<input type="checkbox"/>	NA	RTD1	0	VCF02	0	I	ONLINE	9840
2	<input type="checkbox"/>	NA	RTD2	1	VCF10	0	A	ONLINE	9840
3	<input type="checkbox"/>	NA	RTD3	1	VCF12	0	I	ONLINE	9840
4	<input type="checkbox"/>	NA	RTD4	0	VCF01	0	E	ONLINE	TITANIUM
6	<input type="checkbox"/>	NA	RTD6	1	VCF11	0	E	ONLINE	TITANIUM

FIGURE I-9 Real Tape Drive Status Screen

IOSRF Example for Single MSP Host Connected to a VSM5 Via FICON Directors

FIGURE I-10 shows a configuration diagram for a single MSP host connected to a VSM5 via FICON Directors, and FIGURE I-11 on page 398 shows example IOSRF statements for this configuration. **Note that:**

- From MSPA, you define 8 CHPIDs, with each path switched in the FICON Director, for a total of 8 channels running to the VSM5.
- You code 16 CTRLR statements to define the VSM5 as 16 F6473K images.
- You code DEVICE statement to define the 16 VTDs that are associated with each F6473K image.
- If ESCON and FICON channels are configured to the same logical control unit, MSP issues message CBDG489I, which indicates that mixing ESCON and FICON channel paths on a logical control unit should be used only for the migration from ESCON to native FICON, but should not be used permanently. This is a warning message only, and does not indicate an error.

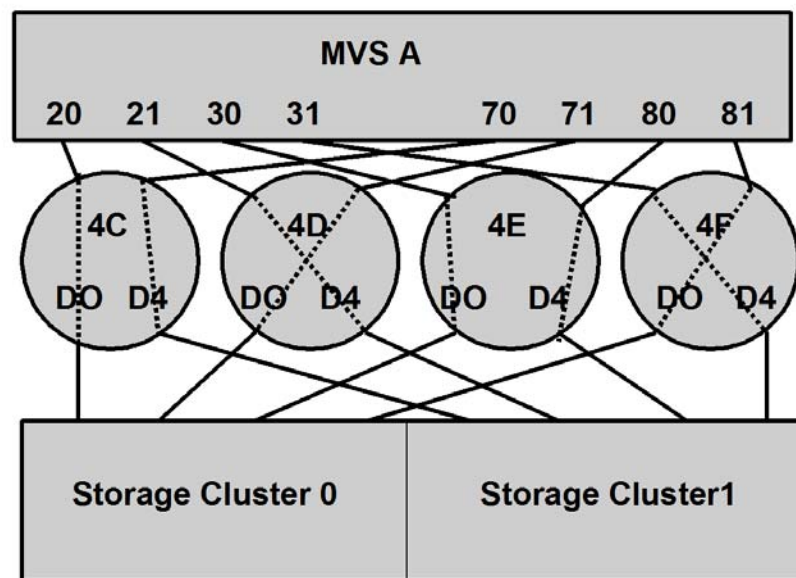

FIGURE I-10 Configuration Diagram: Single MSP Host Connected to a VSM5 via FICON Directors

```

CHANNEL CHPID(0A-0D),TYPE(BMC),INTF(OCLINK),OCLS(01)
CHANNEL CHPID(24-27),TYPE(BMC),INTF(OCLINK),OCLS(02)
.
.
CTRLR  CTRLNUM(D00),NAME(F1751),CHPID(0A),UNITADDR(00-0F),
        FEATURE(DSF,SUP),LINKADDR(B0),CULOGADR(0)
CTRLR  CTRLNUM(D01),NAME(F1751),CHPID(0B),UNITADDR(00-0F),
        FEATURE(DSF,SUP),LINKADDR(B1),CULOGADR(0)
.
.
CTRLR  CTRLNUM(D10),NAME(F1751),CHPID(0A),UNITADDR(00-0F),
        FEATURE(DSF,SUP),LINKADDR(B0),CULOGADR(1)
CTRLR  CTRLNUM(D11),NAME(F1751),CHPID(0B),UNITADDR(00-0F),
        FEATURE(DSF,SUP),LINKADDR(B1),CULOGADR(1)
.
.
CTRLR  CTRLNUM(D20),NAME(F1751),CHPID(0A),UNITADDR(00-0F),
        FEATURE(DSF,SUP),LINKADDR(B0),CULOGADR(2)
CTRLR  CTRLNUM(D21),NAME(F1751),CHPID(0B),UNITADDR(00-0F),
        FEATURE(DSF,SUP),LINKADDR(B1),CULOGADR(2)
.
.
CTRLR  CTRLNUM(D30),NAME(F1751),CHPID(0A),UNITADDR(00-0F),
        FEATURE(DSF,SUP),LINKADDR(B0),CULOGADR(3)
CTRLR  CTRLNUM(D31),NAME(F1751),CHPID(0B),UNITADDR(00-0F),
        FEATURE(DSF,SUP),LINKADDR(B1),CULOGADR(3)
.
.
DEVICE DEVNUM(D00-D0F),NAME(F6473K),FEATURE(DPR,STCHK),
        CTRLNUM(D00,D01,D02,D03,D04,D05,D06,D07),UNITADDR(00)
DEVICE DEVNUM(D10-D1F),NAME(F6473K),FEATURE(DPR,STCHK),
        CTRLNUM(D10,D11,D12,D13,D14,D15,D16,D17),UNITADDR(00)
DEVICE DEVNUM(D20-D2F),NAME(F6473K),FEATURE(DPR,STCHK),
        CTRLNUM(D20,D21,D22,D23,D24,D25,D26,D27),UNITADDR(00)
DEVICE DEVNUM(D30-D3F),NAME(F6473K),FEATURE(DPR,STCHK),

```

FIGURE I-11 IOSRF Example: Single MSP Host Connected to a VSM5 via FICON Directors

Tip – Unlike ESCON, FICON supports multiple active I/Os per channel. If the number of active VTDS is less than the number of channels configured to the VTSS, the I/Os to those VTDS may not be evenly spread across all the channels. As the number of active VTDS increases to be greater than the number of channels configured to the VTSS, the channel subsystem will spread the I/Os across all the channels. If it is desired to spread the I/Os across all of the channels even when only a few VTDS are active, it is necessary to use the preferred path feature to force the channel subsystem to spread the I/Os across the channels. The preferred path feature is specified via the PATH= parameter on the DEVICE statement. When you specify preferred path on the DEVICE statement, the channel subsystem always tries the preferred path first. If it is busy or unavailable, the channel subsystem next tries the channel path following the preferred path in the rotation order, and so on.

FIGURE I-11 on page 398 (repeated in FIGURE I-12) shows DEVICE statements for STRING1 **without** using preferred pathing.

```
STRING1  DEVICE ADDRESS=(0500,16),  
          CUNUMBER=(001),  
          UNIT=F6473K,  
          UNITADD=00,STADET=Y
```

FIGURE I-12 DEVICE Statements for STRING 1 without Preferred Pathing

Figure I-13 shows DEVICE statements for STRING1 using preferred pathing. If you're using preferred pathing, you need to use these kind of DEVICE statements for all paths, such as STRING2 through STRING16 in Figure I-11 on page 398.

```
STRING10 DEVICE ADDRESS=(0500,2),
CUNUMBER=(001),
UNIT=F6473K,
UNITADD=00,STADET=Y,
PATH=20

STRING12 DEVICE ADDRESS=(0502,2),
CUNUMBER=(001),
UNIT=F6473K,
UNITADD=00,STADET=Y,
PATH=21

STRING14 DEVICE ADDRESS=(0504,2),
CUNUMBER=(001),
UNIT=F6473K,
UNITADD=00,STADET=Y,
PATH=30

STRING16 DEVICE ADDRESS=(0506,2),
CUNUMBER=(001),
UNIT=F6473K,
UNITADD=00,STADET=Y,
PATH=31

STRING18 DEVICE ADDRESS=(0508,2),
CUNUMBER=(001),
UNIT=F6473K,
UNITADD=00,STADET=Y,
PATH=70

STRING1A DEVICE ADDRESS=(050A,2),
CUNUMBER=(001),
UNIT=F6473K,
UNITADD=00,STADET=Y,
PATH=71

STRING1C DEVICE ADDRESS=(050C,2),
CUNUMBER=(001),
UNIT=F6473K,
UNITADD=00,STADET=Y,
PATH=80

STRING1E DEVICE ADDRESS=(050E,2),
CUNUMBER=(001),
UNIT=F6473K,
UNITADD=00,STADET=Y,
PATH=81
```

FIGURE I-13 DEVICE Statements for STRING 1 Using Preferred Pathing

VSM5 ESCON/FICON Configurations

TABLE J-1 summarizes the supported VCF (FICON) and ICE (ESCON) card configurations for VSM5. VSM5 ESCON support requires microcode level D02.07.00.00 or H01.07.00.00.

TABLE J-1 Supported Card Configurations for VSM5 ESCON/FICON

VCF Cards	FICON Ports	ICE Cards	ESCON Ports	Total Ports	Total Logical Paths (16 per ICE Port, 64 per VCF Port)
0	0	8	32	32	512
4	8	4	16	24	768

VSM5 ICE/VCF Card Options

VSM5 supports the following ICE/VCF card options:

- [FIGURE J-1](#) shows a VSM5 with 8 ICE cards.
- [FIGURE J-2 on page 403](#) shows a VSM5 with 4 ICE cards, 4 VCF cards.

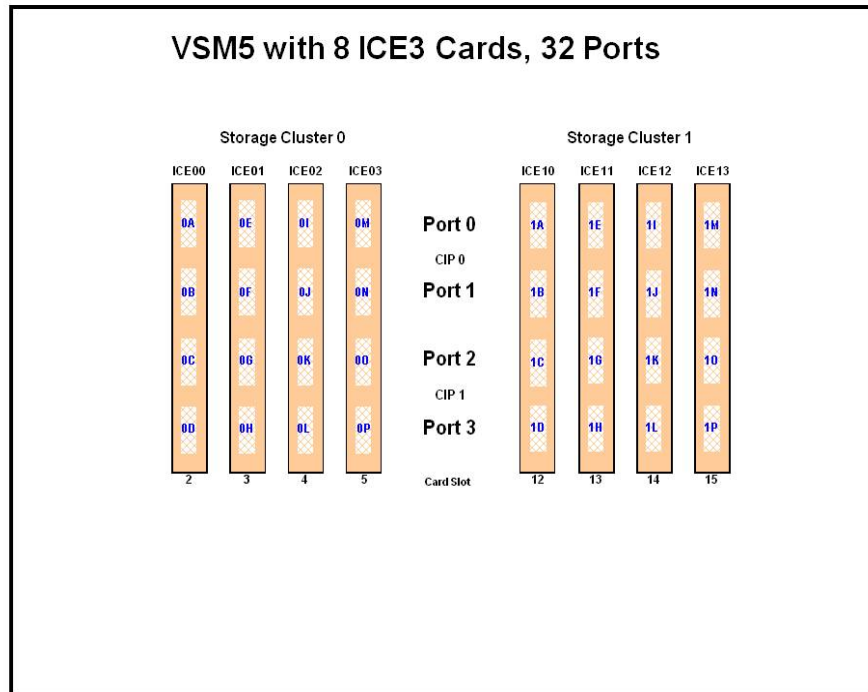

FIGURE J-1 VSM5 with 8 ICE cards

Note –

- In [FIGURE J-2 on page 403](#), the VCF cards must go in: Slots 3, 4, 13, and 14 in a four-VCF card configuration.
- FICON ports are controlled by a FICON Interface processor (FIP), ESCON ports are controlled by a CIP. Regardless of the card configuration, there can be only a total of 14 Nearlink FIPs and/or CIPs.

Note – With microcode level D02.06.00.00 or higher, multiple Nearlink device connections via a FICON or ESCON switch or Director on the same port now allow:

- **Up to a total of 16 simultaneous NearLink I/O transfers**, which can be spread across multiple targets on as many as 14 NearLink ports.
- **Up to a total of 2 simultaneous NearLink I/O transfers** are allowed per port.

-
- All FICON ports can be configured as either a Host port or Nearlink (RTD/CLINK origination) port. All ESCON ports continue to be configurable as host or Nearlink ports in pairs on a per CIP basis.
 - As shown in [FIGURE J-1 on page 402](#) and [FIGURE J-2 on page 403](#), the ports are shown with their channel interface identifiers. These channel interface identifiers are the values that are required for the CHANIF values that you code for the CONFIG utility. Each value is two characters in length and has a value from 0A to 1O. The first digit is the VTSS cluster ID (valid values are 0 or 1). The second digit is the group or adapter ID (valid values are A to P).

Each FICON port can attach to four RTDs, or two CLINKs, or an RTD/CLINK combination via a FICON director or supported switch (in FICON mode). **Note that**, as shown in these figures, **for RTDs only**, each FICON port has two CHANIF values **only if** the port is connected to a FICON director which is then connected to two RTDs. Nearlink RTD connections that are paired via a FICON switch or director on the same port dynamically alternate between both RTDs for atomic operations such as mount, migrate VTV, recall VTV, etc.

- **Each ICE card** contains two pairs of ESCON ports. Each pair is controlled by its own Channel Interface Processor (CIP). Each CIP switches between the two ports, so that **only one port** can transfer data at a time, which emulates a FICON port attached to a director attached to RTDs.
- Each host FICON channel supports 64 logical paths (times 16 logical units). However, in IOGRP:
 - From a single MSP host, you can only define 8 channels (CHPIDs) running to a single control unit (single VSM5).
 - You use the CNTLUNIT statement to define each VSM5 as 16 3490 control unit images.
 - You use the IODEVICE statement to define the 16 VTDs that are associated with each 3490 control unit image.
- For a VSM5, each ESCON CIP or FICON FIP can operate with only *one* of two modes, which is set at the VTSS DOP:
 - *Host Mode*. In Host Mode, ports can connect to the host CPU channels, including via Director(s) or channel extenders. A port in Host Mode can also serve as a CLINK terminator.

Also note that for ESCON ports, you can have two physical paths from the same LPAR to the same CIP, as long as the two physical paths address different (not overlapping) logical control units. For example, a single host LPAR can address logical control units 0-7 on one CIP port, and 8-F on the other CIP port of the same CIP.

- *Nearlink Mode*. In Nearlink Mode, ports can connect to an RTD. A port in Nearlink Mode can also serve as a CLINK originator.

Caution – In bi-directional clustering, each CLINK must be attached to the same Storage Cluster on each VTSS, which is a requirement. Failure to configure in this manner can produce Replicate, Channel, and Communication errors!

In both FICON and ESCON, what are Best Practices for optimizing port operations? See TABLE J-2...

TABLE J-2 Optimizing VSM5 FICON/ESCON Port Operations

Configuration - Two ESCON Ports on a CIP (ICE) or FICON port attached to a FICON Director (VCF)	Best Practices
Multiple CLINKs (up to 4)	Attach a maximum of 2.... because each port allows two active operations. Note, however, that these operations share the bandwidth of the port.
CLINK and RTD combinations	An advantage if you attach one CLINK originator/one RTD per director, because both can be active.
Up to 4 RTDs	<p>An advantage for the following:</p> <p>Optimize use of local and remote RTDs. During busy shifts, use only local RTDs on the FIP. During quiet periods, switch to remote RTDs for deep archive and DR work. Because you can have two active devices, you can also simultaneously run one local and one remote RTD. Note, however, that these operations share the bandwidth of the port.</p> <p>Optimize use of different drive technologies. As described in the previous bullet, use a T9840 as a local RTD, then switch to a T9940 for deep archive. You can also use this feature to migrate from older drive technology (such as 9490) to newer technology (such as 9840). Use Management and Storage Classes to read in data from older media, then switch to the newer technology drive to place data on new media. This technique effectively gives you greater physical connectivity to different drive technologies without incurring the overhead of full time, real time FICON connections to each drive type. Also as above, because you can have two active devices, you can also simultaneously run two RTDs with different drive technologies. Note, however, that these operations share the bandwidth of the port.</p>

VSM5 Configuration Example: 8 ICE Cards, 16 Host Ports, 16 RTD Ports

FIGURE J-3 shows CONFIG channel interface identifiers of 16 for hosts, 16 for RTDs for a VSM5.

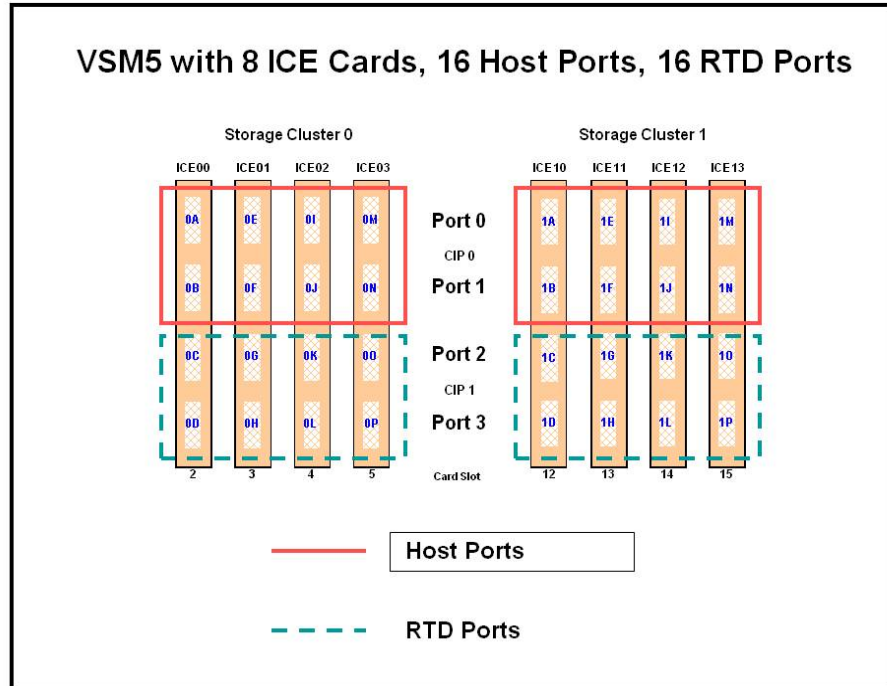

FIGURE J-3 VSM5 with 16 Host Ports, 16 RTD Ports

CONFIG Example for VSM5 with 16 Host Ports, 16 RTD Ports

FIGURE J-4 shows example CONFIG JCL to define the VSM5 configuration shown in FIGURE J-3 on page 407.

```
//CREATECF EXEC PGM=SLUADMIN,PARM='MIXED'  
//STEPLIB DD DSN=hlq.SEALINK,DISP=SHR  
//SLSCNTL DD DSN=hlq.DBASEPRM,DISP=SHR  
//SLSCNTL2 DD DSN=hlq.DBASESEC,DISP=SHR  
//SLSSTBY DD DSN=hlq.DBASETBY,DISP=SHR  
//SLSPRINT DD SYSOUT=*  
//SLSIN DD *  
CONFIG  
GLOBAL MAXVTV=32000MVCFREE=40  
RECLAIM THRESHLD=70MAXMVC=40 START=35  
VTSS NAME=VSM501 LOW=70 HIGH=80 MAXMIG=8 RETAIN=5  
RTD NAME=VSM52A00 DEVNO=2A00 CHANIF=0C  
RTD NAME=VSM52A01 DEVNO=2A01 CHANIF=0D  
RTD NAME=VSM52A02 DEVNO=2A02 CHANIF=0G  
RTD NAME=VSM52A03 DEVNO=2A03 CHANIF=0H  
RTD NAME=VSM52A04 DEVNO=2A04 CHANIF=0K  
RTD NAME=VSM52A05 DEVNO=2A05 CHANIF=0L  
RTD NAME=VSM52A06 DEVNO=2A06 CHANIF=0O  
RTD NAME=VSM52A07 DEVNO=2A07 CHANIF=0P  
RTD NAME=VSM52A08 DEVNO=2A08 CHANIF=1C  
RTD NAME=VSM52A09 DEVNO=2A09 CHANIF=1D  
RTD NAME=VSM52A0A DEVNO=2A0A CHANIF=1G  
RTD NAME=VSM52A0B DEVNO=2A0B CHANIF=1H  
RTD NAME=VSM52A0C DEVNO=2A0C CHANIF=1K  
RTD NAME=VSM52A0D DEVNO=2A0D CHANIF=1L  
RTD NAME=VSM52A0E DEVNO=2A0E CHANIF=1O  
RTD NAME=VSM52A0F DEVNO=2A0F CHANIF=1P  
VTD LOW=9900 HIGH=99FF
```

FIGURE J-4 CONFIG example: VSM5 with 16 Host Ports, 16 RTD Ports

IOSRF Example for Single MSP Host Connected to a VSM5 Via ESCON Directors

FIGURE J-5 shows a configuration diagram for a single MSP host connected to a VSM5 via ESCON Directors, and FIGURE J-6 on page 410 shows example IOSRF statements for this configuration. **Note that:**

- From MSPA, you define 8 CHPIDs, with each path switched in the ESCON Director, for a total of 8 channels running to the VSM5.
- You code 16 CTRLR statements to define the VSM5 as 16 F6473K images.
- You code DEVICE statement to define the 16 VTDs that are associated with each F6473K image.

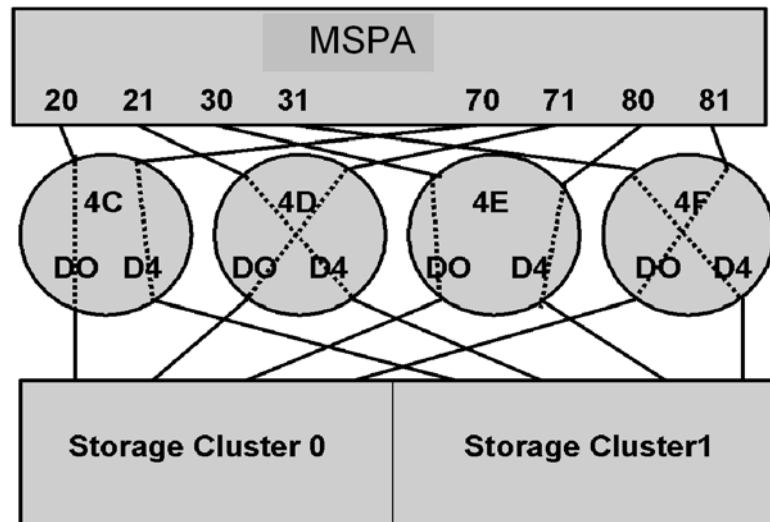

FIGURE J-5 Configuration Diagram: Single MSP Host Connected to a VSM5 via ESCON Directors

```

CHANNEL CHPID(0A-0D),TYPE(BMC),INTF(OCLINK),OCLS(01)
CHANNEL CHPID(24-27),TYPE(BMC),INTF(OCLINK),OCLS(02)
.
.
CTRLR  CTRLNUM(D00),NAME(F1751),CHPID(0A),UNITADDR(00-0F),
        FEATURE(DSF,SUP),LINKADDR(B0),CULOGADR(0)
CTRLR  CTRLNUM(D01),NAME(F1751),CHPID(0B),UNITADDR(00-0F),
        FEATURE(DSF,SUP),LINKADDR(B1),CULOGADR(0)
.
.
CTRLR  CTRLNUM(D10),NAME(F1751),CHPID(0A),UNITADDR(00-0F),
        FEATURE(DSF,SUP),LINKADDR(B0),CULOGADR(1)
CTRLR  CTRLNUM(D11),NAME(F1751),CHPID(0B),UNITADDR(00-0F),
        FEATURE(DSF,SUP),LINKADDR(B1),CULOGADR(1)
.
CTRLR  CTRLNUM(D20),NAME(F1751),CHPID(0A),UNITADDR(00-0F),
        FEATURE(DSF,SUP),LINKADDR(B0),CULOGADR(2)
CTRLR  CTRLNUM(D21),NAME(F1751),CHPID(0B),UNITADDR(00-0F),
        FEATURE(DSF,SUP),LINKADDR(B1),CULOGADR(2)
.
.
CTRLR  CTRLNUM(D30),NAME(F1751),CHPID(0A),UNITADDR(00-0F),
        FEATURE(DSF,SUP),LINKADDR(B0),CULOGADR(3)
CTRLR  CTRLNUM(D31),NAME(F1751),CHPID(0B),UNITADDR(00-0F),
        FEATURE(DSF,SUP),LINKADDR(B1),CULOGADR(3)
.
.
DEVICE DEVNUM(D00-D0F),NAME(F6473K),FEATURE(DPR,STCHK),
        CTRLNUM(D00,D01,D02,D03,D04,D05,D06,D07),UNITADDR(00)
DEVICE DEVNUM(D10-D1F),NAME(F6473K),FEATURE(DPR,STCHK),
        CTRLNUM(D10,D11,D12,D13,D14,D15,D16,D17),UNITADDR(00)
DEVICE DEVNUM(D20-D2F),NAME(F6473K),FEATURE(DPR,STCHK),
        CTRLNUM(D20,D21,D22,D23,D24,D25,D26,D27),UNITADDR(00)
DEVICE DEVNUM(D30-D3F),NAME(F6473K),FEATURE(DPR,STCHK),
        CTRLNUM(D30,D31,D32,D33,D34,D35,D36,D37),UNITADDR(00)

```

FIGURE J-6 IOSRF Example: Single MSP Host Connected to a VSM5 via ESCON Directors

VSM5 New Models

The VSM5 provides new models that offer the capacities shown in [TABLE K-1](#).

TABLE K-1 VSM5 New Model Capacities

Drive Capacity	1-Array TBE	2-Arrays TBE	3-Arrays TBE	4-Arrays TBE	VSM Model	Product Family ID
450GB		45			VSM5-45TB-IFF3	580
450GB			68		VSM5-68TB-IFF3	580
450GB				90	VSM5-90TB-IFF3	580
146GB		7.5/11/14			VSM5-1.25TB- IFF3	567
146GB			16/18/21		VSM5-16TB-IFF3	567
146GB				23/25/28	VSM5-23TB-IFF3	567
146GB	.8/1.25				VSM5E -.8TB	567

Note –

- TBE =The approximate maximum effective capacity in Terabytes (TB).
- Models VSM5-45TB-IFF3, VSM5-68TB-IFF3, and VSM5-90TB-IFF3 can contain a maximum of 500,000 VTVs
- VSM5 new models require the following VTSS microcode:
 - **For Models VSM5-45TB-IFF3, VSM5-68TB-IFF3, and VSM5-90TB-IFF3 only,** VTSS microcode level H02.07.
 - **For all other Models,** VTSS microcode level D02.07.
- Models VSM5-1.25TB-IFF3, VSM5-16TB-IFF3, and VSM5-23TB-IFF3 support ESCON channel cards. For more information, see [“VSM5 ESCON/FICON Configurations” on page 401](#).

TABLE K-2 shows the supported channel card configurations for:

- VSM5 - All models **including** VSM5c but **not including** VSM5e and VSM5econ. For information on VSM5econ, see [“VSM5 ESCON/FICON Configurations”](#) on page 401.
- VSM5e.

TABLE K-2 VSM5 New Model Supported Channel Card Configurations

VSM Model	Storage Cluster 0				Storage Cluster 1			
	2	3	4	5	12	13	14	15
5	VCF		VCF		VCF		VCF	
	VCF	VCF	VCF		VCF	VCF	VCF	
	VCF	VCF	VCF	VCF	VCF	VCF	VCF	VCF
5e	VCF		VCF		VCF		VCF	
	ICE		ICE		ICE		ICE	

VSM 6 Configuration

VSM 6, which supported by ELS 7.0 and above, provides greater connectivity, capacity, and throughput than the VSM5. [TABLE L-1](#) summarizes the ELS features.

TABLE L-1 ELS Features

Feature	Description
Host Interfaces	FICON
RTD support	RTD connections must be FICON channel.
VLE support	VLE TCP/IP connections are supported.
VTSS clustering support	TCP/IP CLINKs only are supported for the following connections: <ul style="list-style-type: none">• VSM5 to VSM6• VSM 6 to VSM 6
Maximum VTDs per VTSS	256
Maximum VTVs per VTSS	1,000,000

Reconfiguring VTCS

Note – You can now use the CDSCREATE utility to create a new CDS for Tapeless VSM; for more information, see [“Running the CDSCREATE Utility to Create the CDS \(Tapeless VSM Only\)”](#) on page 105.

To add ELSs to your configuration, you need to update the VTCS CONFIG file as follows:

1. **Run the DECOM utility to produce a CONFIG deck of your current configuration.**
You update the CONFIG deck to add the VSM 6s, then submit the updated file to the CONFIG utility.
2. **Update the CONFIG deck to add CONFIG VTSS statements for the VSM 6s you are adding as shown in the example in [CODE EXAMPLE L-1](#).**

```
VTSS NAME=VSM6A LOW=70 HIGH=80 MAXMIG=8 MINMIG=4 RETAIN=5
VTD LOW=8900 HIGH=89FF
VTSS NAME=VSM6B LOW=70 HIGH=80 MAXMIG=8 MINMIG=4 RETAIN=5
VTD LOW=9900 HIGH=99FF
```

CODE EXAMPLE L-1 Adding a VSM 6 to the CONFIG Deck.

3. **If necessary, add definitions for VTSS clustering.**

You can only cluster VSM 6s with other VSM 6s or with VSM5s, and you must use TCP/IP connections for clustering (via the CONFIG CLINK IPIF parameter) as shown in the example of a cluster of two VSM 6s in [CODE EXAMPLE L-2](#). Additionally, VSM 6s can be part of a Cross-TapePlex Replication (CTR) configuration.

```
TAPEPLEX THISPLEX=TMSPA
VTSS NAME=VSM6A LOW=70 HIGH=80 MAXMIG=8 MINMIG=4 RETAIN=5
.
.
VTSS NAME=VSM6B LOW=70 HIGH=80 MAXMIG=8 MINMIG=4 RETAIN=5
.
.
CLUSTER NAME=CLUSTER6 VTSSs (VSM6A, VSM6B)
  CLINK VTSS=VSM6A IPIF=0I:0
  CLINK VTSS=VSM6A IPIF=1I:0
CLINK VTSS=VSM6B IPIF=0I:0
  CLINK VTSS=VSM6B IPIF=1I:1
CLINK VTSS=VSM6A IPIF=0A:0
  CLINK VTSS=VSM6A IPIF=1A:0
CLINK VTSS=VSM6B IPIF=0A:0
  CLINK VTSS=VSM6B IPIF=1A:0
```

CODE EXAMPLE L-2 Adding Definitions for VSM 6 Clustering

Note – Valid values for CONFIG CLINK IPIF in the *ci:p* format are *c=0* or *1*, *i=A* or *I*, *p=0* through *3* for VSM5s and VSM 6s. For VSM5s, this value must match the value specified on the VSM5 IFF Configuration Status Screen. For VSM 6s, this must be unique for each VTSS; and **does not** correspond to an actual value on the VSM 6 TCP/IP ports!

For more information on VTSS clustering, see *ELS Disaster Recovery and Offsite Data Management Guide*.

If your VSM 6s **do not** have RTDs attached, go to [Step 5](#). Otherwise, continue with [Step 4](#).

4. If necessary, add definitions for VSM 6-to-RTD connections.

VSM 6-to-RTD connections use FICON interfaces, and these connections are **initially defined** at the VSM 6. For more information, see *VSM 6 Installation, Configuration, and Service Guide*.

Next, you define the paths to the RTDs via the CONFIG RTDPATH statement, as shown in [CODE EXAMPLE L-3](#).

```
TAPEPLEX THISPLEX=TMSPA STORMNGR=VL1
VTSS NAME=VSM6A LOW=70 HIGH=80 MAXMIG=8 MINMIG=4 RETAIN=5
.
.
.
RTDPATH NAME=VSM6ARTD1 CHANIF=0A:0
RTDPATH NAME=VSM6ARTD2 CHANIF=0C:0
RTDPATH NAME=VSM6ARTD3 CHANIF=0E:0
RTDPATH NAME=VSM6ARTD4 CHANIF=0G:0
```

CODE EXAMPLE L-3 Adding Definitions for VSM 6-to-RTD Connections

In [CODE EXAMPLE L-3](#), VSM6A has four FICON connections to RTDs.

Note – Valid values for CONFIG RTDPATH CHANIF in the *ci:p* format are *c=0* or *1*, *i=A, C, E, G, I, K, M, or O*, *p=0* through *3* for VSM5s and VSM 6s. For VSM5s, this value must match the actual FICON interface values. For VSM 6s, this must be unique for each VTSS; and **does not** correspond to an actual value on the VSM 6 FICON ports!

If your VSM 6s **do not** have VLEs attached, go to [Step 7](#). Otherwise, continue with [Step 5](#).

5. If necessary, add definitions for VSM 6-to-VLE connections:.

For ELS 7.2, VLE support is included in the base level. For ELS 7.0 and 7.1, get the latest **SMP/E** receive **HOLDDATA** and PTFs described in [TABLE L-2](#) and **SMP/E APPLY** with **GROUPEXTEND**.

TABLE L-2 ELS Supporting PTFs for VLE

ELS 7.0	ELS 7.1
L1H16C1	L1H16J6
L1H1672	L1H1674

For VTCS 7.0 and above, the **CONFIG TAPEPLEX** statement defines the TapePlex that VTCS is running under and provides the list of defined VLEs on the **CONFIG TAPEPLEX STORMNGR** parameter as shown in [CODE EXAMPLE L-4](#).

```

TAPEPLEX THISPLEX=TMSPA STORMNGR=VLE1
VTSS NAME=VTSS1 LOW=70 HIGH=80 MAXMIG=8 MINMIG=4 RETAIN=5
RTDPATH NAME=VL1RTD1 STORMNGR=VLE1 IPIF=0A:0
RTDPATH NAME=VL1RTD2 STORMNGR=VLE1 IPIF=0A:1
RTDPATH NAME=VL1RTD3 STORMNGR=VLE1 IPIF=0I:0
RTDPATH NAME=VL1RTD4 STORMNGR=VLE1 IPIF=0I:1
RTDPATH NAME=VL1RTD5 STORMNGR=VLE1 IPIF=1A:0
RTDPATH NAME=VL1RTD6 STORMNGR=VLE1 IPIF=1A:1
RTDPATH NAME=VL1RTD7 STORMNGR=VLE1 IPIF=1I:0
RTDPATH NAME=VL1RTD8 STORMNGR=VLE1 IPIF=1I:1
VTD LOW=6900 HIGH=69FF
    
```

CODE EXAMPLE L-4 VTCS 7.0 CONFIG VLE Example

In [CODE EXAMPLE L-4](#), note:

- The **CONFIG TAPEPLEX** statement, which defines **TMSPA** as the TapePlex that VTCS is running under and the names of all connected VLEs (which in this example is a single VLE called **VLE1**).
- The **CONFIG RTDPATH** statements, which define a single VLE RTD for each path from the VTSS to the VLE. In this example, the **CONFIG RTDPATH** statements for **VTSS1** specify:
 - The name of the **RTDPATH**.
 - The connections to the defined VLEs (**VLE1**).
 - The **IPIF** value for each VTSS to VLE port connection in *ci:p* format where *c* is 0 or 1, *i* is A or I, and *p* is 0 through 3.

Note – For VSM5s, this value must match the values specified on the VSM5 IFF Configuration Status Screen. For VSM 6s, this must be unique for each VTSS but does **not** correspond to an actual value on the VSM 6 TCP/IP ports.

6. If desired, define VLE virtual devices.

VTCS 7.1 and above systems can, of course, drive VLE as VTCS 7.0 does as described on page 416. In this mode, however, the number of VLE RTD targets is limited by the number of paths from a VTSS. Additionally, the VLE RTDs are assigned to fixed VTSS paths. The path from a VTSS to the VLE is always reserved by VTCS regardless of whether any VTSS to VLE data transfer is occurring.

However, with VTCS 7.1 and above (with the PTFs described in TABLE L-2 on page 416), you can define a VLE with more VLE RTD targets than there are paths from the VTSS to the VLE, which means:

- The path from the VTSS to the VLE is **not** reserved unless a VTSS to VLE data transfer is required.
- More VLE RTD operations can occur simultaneously. For example, an audit of a VMVC does not require data transfer between the VTSS and the VLE.

As shown in CODE EXAMPLE L-5, the VLEs are defined via a **CONFIG STORMNGR** statement, **not** the **CONFIG TAPEPLEX STORMNGR** parameter. The **CONFIG STORMNGR** statement specifies the VLEs that VTCS connects to. Additionally, for each VLE, the **CONFIG STORMNGR VLEDEV** parameter defines the number and the names of the RTD devices that the VLE emulates. The more devices defined (up to the maximum of 96 devices per VLE), the greater the level of concurrent activities VTCS can schedule on the VLEs.

```
TAPEPLEX THISPLEX=TMSPC
STORMNGR NAME=VLE1 VLEDEV(S000-S05F)
STORMNGR NAME=VLE2 VLEDEV(S000-S05F)
VTSS NAME=VTSS1 LOW=70 HIGH=80 MAXMIG=8 MINMIG=4 RETAIN=5
RTDPATH NAME=VL1RTD1 STORMNGR=VLE1 IPIF=0A:0
RTDPATH NAME=VL1RTD2 STORMNGR=VLE1 IPIF=0A:1
RTDPATH NAME=VL1RTD3 STORMNGR=VLE1 IPIF=0I:0
RTDPATH NAME=VL1RTD4 STORMNGR=VLE1 IPIF=0I:1
RTDPATH NAME=VL1RTD5 STORMNGR=VLE2 IPIF=1A:0
RTDPATH NAME=VL1RTD6 STORMNGR=VLE2 IPIF=1A:1
RTDPATH NAME=VL1RTD7 STORMNGR=VLE2 IPIF=1I:0
RTDPATH NAME=VL1RTD8 STORMNGR=VLE2 IPIF=1I:1
VTD LOW=6900 HIGH=69FF
```

CODE EXAMPLE L-5 VTCS 7.1 CONFIG VLE Example

In [CODE EXAMPLE L-5 on page 417](#), note:

- The **CONFIG TAPEPLEX** statement now simply defines **TMSPC** as the TapePlex that VTCS is running under. It does **not** define the connected VLEs.
- The **CONFIG STORMNGR** statements, which define the VLEs configured in this system - **VLE1** and **VLE2** in this example. These statements also specify the number of VLE devices via the **VLEDEV** parameter. In this example, each VLE has the maximum of 96 emulated devices, which allows VTCS to schedule up to 96 processes on each VLE. The VLE device addresses are in the form of *Sxxx* (where *xxx* is a hexadecimal value. For example, S000-S05F represents 96 emulated devices.
- The **CONFIG RTDPATH** statements for VTSS1, which specify:
 - The name of the **RTDPATH**.
 - The connections to the two ELSs.
 - The **IPIF** value for each VTSS to ELS port connection in *ci:p* format where:
 - *c* is 0 or 1.
 - *i* is A or I.
 - *p* is 0 through 3.

Note – For VSM5s, this value must match the values specified on the VSM5 IFF Configuration Status Screen. For VSM 6s, this must be unique for each VTSS but does **not** correspond to an actual value on the VSM 6 TCP/IP ports.

7. If desired, you can use a VSM 6 in a Cross-TapePlex Replication (CTR) configuration.

For more information, see *ELS Disaster Recovery and Offsite Data Management Guide*.

8. Finally, adjust your policies as needed.

For more information, see *Configuring HSC and VTCS*.

9.

IOCP Example for Single MSP Host Connected to a VSM 6 Via FICON Directors

FIGURE L-1 shows a configuration diagram for a single MSP host connected to a VSM 6 via FICON Directors, and FIGURE L-2 on page 420 shows example IOCP statements for this configuration. **Note that:**

- From MSPA, you define 8 CHPIDs, with each path switched in the FICON Director, for a total of 8 channels running to the VSM 6.
- You code 16 CNTLUNIT statements to define the VSM 6 as 16 3490 images.
- You code IODEVICE statement to define the 16 VTDs that are associated with each 3490 image.
- If ESCON and FICON channels are configured to the same logical control unit, MSP issues message CBDG489I, which indicates that mixing ESCON and FICON channel paths on a logical control unit should be used only for the migration from ESCON to native FICON but should not be used permanently. This is a warning message only, and does not indicate an error.

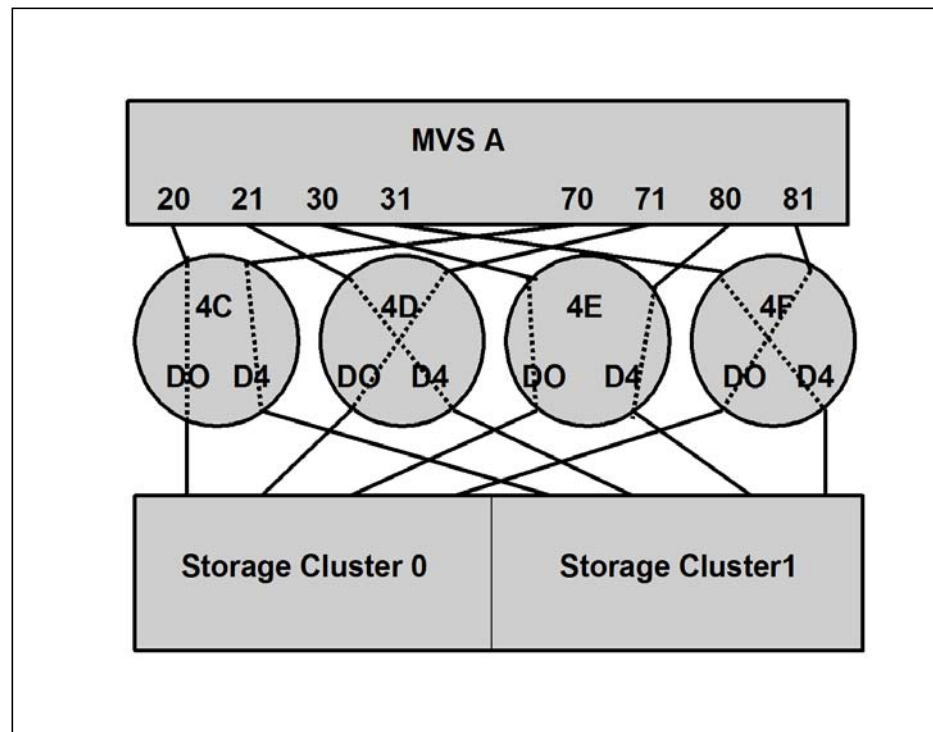

FIGURE L-1 Configuration Diagram: Single MSP Host Connected to a VSM 6 via FICON Directors

```

ESCD4CCHPID PATH=(20,70),TYPE=FC,SWITCH=4C
ESCD4DCHPID PATH=(21,71),TYPE=FC,SWITCH=4D
ESCD4ECHPID PATH=(30,80),TYPE=FC,SWITCH=4E
ESCD4F CHPID PATH=(31,81),TYPE=FC,SWITCH=4F

CU1CNTLUNIT CUNUMBR=001,
              PATH=(20,21,30,31,70,71,80,81),
              LINK=(D0,D4,D0,D4,D4,D0,D4,D0),
              UNIT=3490,CUADD=0,
              UNITADD=((00,16))

STRING1 IODEVICE ADDRESS=(0500,16),
         CUNUMBER=(001),
         UNIT=3490,
         UNITADD=00,STADET=Y

CU2CNTLUNIT CUNUMBR=002,
              PATH=(20,21,30,31,70,71,80,81),
              LINK=(D0,D4,D0,D4,D4,D0,D4,D0),
              UNIT=3490,CUADD=1,
              UNITADD=((00,16))

STRING2 IODEVICE ADDRESS=(0510,16),
         CUNUMBER=(002),
         UNIT=3490,
         UNITADD=00,STADET=Y
.
.
.
CU15CNTLUNIT CUNUMBR=015,
              PATH=(20,21,30,31,70,71,80,81),
              LINK=(D0,D4,D0,D4,D4,D0,D4,D0),
              UNIT=3490,CUADD=E,
              UNITADD=((00,16))

STRING15 IODEVICE ADDRESS=(05E0,16),
         CUNUMBER=(015),
         UNIT=3490,
         UNITADD=00,STADET=Y

CU16CNTLUNIT CUNUMBR=016,
              PATH=(20,21,30,31,70,71,80,81),
              LINK=(D0,D4,D0,D4,D4,D0,D4,D0),
              UNIT=3490,CUADD=F,
              UNITADD=((00,16))

STRING16 IODEVICE ADDRESS=(05F0,16),
         CUNUMBER=(016),
         UNIT=3490,
         UNITADD=00,STADET=Y

```

FIGURE L-2 IOCP Example: Single MSP Host Connected to a VSM 6 via FICON Directors

Note – Unlike ESCON, FICON supports multiple active I/Os per channel. If the number of active VTDs is less than the number of channels configured to the VTSS, the I/Os to those VTDs may not be evenly spread across all the channels. As the number of active VTDs increases to be greater than the number of channels configured to the VTSS, the channel subsystem will spread the I/Os across all the channels. If it is desired to spread the I/Os across all of the channels even when only a few VTDs are active, it is necessary to use the preferred path feature to force the channel subsystem to spread the I/Os across the channels. The preferred path feature is specified via the PATH= parameter on the IODEVICE statement. When you specify preferred path on the IODEVICE statement, the channel subsystem always tries the preferred path first. If it is busy or unavailable, the channel subsystem next tries the channel path following the preferred path in the rotation order, and so on.

FIGURE L-2 on page 420 (repeated in FIGURE L-3) shows IODEVICE statements for STRING1 **without** using preferred pathing.

```
STRING1 IODEVICE ADDRESS=(0500,16),  
        CUNUMBER=(001),  
        UNIT=3490,  
        UNITADD=00,STADET=Y
```

FIGURE L-3 IODEVICE Statements for STRING 1 without Preferred Pathing

FIGURE L-4 on page 422 shows IODEVICE statements for STRING1 **using** preferred pathing. If you're using preferred pathing, you need to use these kind of IODEVICE statements for **all** paths.

```

STRING10 IODEVICE ADDRESS=(0500,2),
        CUNUMBER=(001),
        UNIT=3490,
        UNITADD=00,STADET=Y,
        PATH=20

STRING12 IODEVICE ADDRESS=(0502,2),
        CUNUMBER=(001),
        UNIT=3490,
        UNITADD=00,STADET=Y,
        PATH=21

STRING14 IODEVICE ADDRESS=(0504,2),
        CUNUMBER=(001),
        UNIT=3490,
        UNITADD=00,STADET=Y,
        PATH=30

STRING16 IODEVICE ADDRESS=(0506,2),
        CUNUMBER=(001),
        UNIT=3490,
        UNITADD=00,STADET=Y,
        PATH=31

STRING18 IODEVICE ADDRESS=(0508,2),
        CUNUMBER=(001),
        UNIT=3490,
        UNITADD=00,STADET=Y,
        PATH=70

STRING1A IODEVICE ADDRESS=(050A,2),
        CUNUMBER=(001),
        UNIT=3490,
        UNITADD=00,STADET=Y,
        PATH=71

STRING1C IODEVICE ADDRESS=(050C,2),
        CUNUMBER=(001),
        UNIT=3490,
        UNITADD=00,STADET=Y,
        PATH=80

STRING1E IODEVICE ADDRESS=(050E,2),
        CUNUMBER=(001),
        UNIT=3490,
        UNITADD=00,STADET=Y,
        PATH=81

```

FIGURE L-4 IODEVICE Statements for STRING 1 Using Preferred Pathing

Tapeless VSM

“Tapeless VSM” basically means that you can have a VTSS without any RTDs directly attached to the VTSS; in the CONFIG deck, there are no RTD statements for the tapeless VTSS. Tapeless VSM applies to VSM4s and VSM5s.

How Does Tapeless VSM Work?

Configuring and managing a Tapeless VSM works as follows:

1. In the CONFIG deck, there are no RTD statements for the Tapeless VTSS.

Note – For clustered VTSS configurations, **all** VTSSs in the cluster must be Tapeless or **all** VTSSs in the cluster must have RTDs attached. You **cannot** mix Tapeless VTSSs and VTSSs with RTDs attached within a cluster.

2. The new MGMTCLAS NOMIGRAT parameter specifies that VTVs in the Management Class **are not** candidates for migration, consolidation or export, but **are** candidates to reside on a tapeless VTSS.

VTSS selection is changed to prefer Tapeless VTSSs for VTVs in Management Classes with NOMIGRAT, and to disallow VTVs without NOMIGRAT from VTSSs with no RTDs.

NOMIGRAT parameter is mutually exclusive with the ACSLIST, IMMEDMIG, DUPLEX, MIGPOL, ARCHAGE, ARCHPOL, RESTIME, CONSRC and CONTGT parameters.

3. A Management Class can specify DELSCR(YES), which is a proactive method to cause VSM to delete scratched VTVs, which frees VTSS buffer space and (logically) deletes any VTV copies from MVCs so that MVC space can be reclaimed. As an alternative, you can specify DELSCR(NO) and use the DELETSCR utility (which now provides a VTSS parameter to scratch VTVs on a per VTSS basis) to do demand deletes of scratched VTVs.

For a sample configuration, see [“Tapeless VSM Example” on page 425](#).

Note – If you have an environment that is completely Tapeless (no RTDs attached to any VTSS system), then in your LIBGEN you need to code a dummy ACS as shown in the example in [“LIBGEN Example for Tapeless ACS” on page 429](#).

Tapeless VSM Example

FIGURE M-1 shows a simple Tapeless VSM configuration where VTSSA has no RTDs attached.

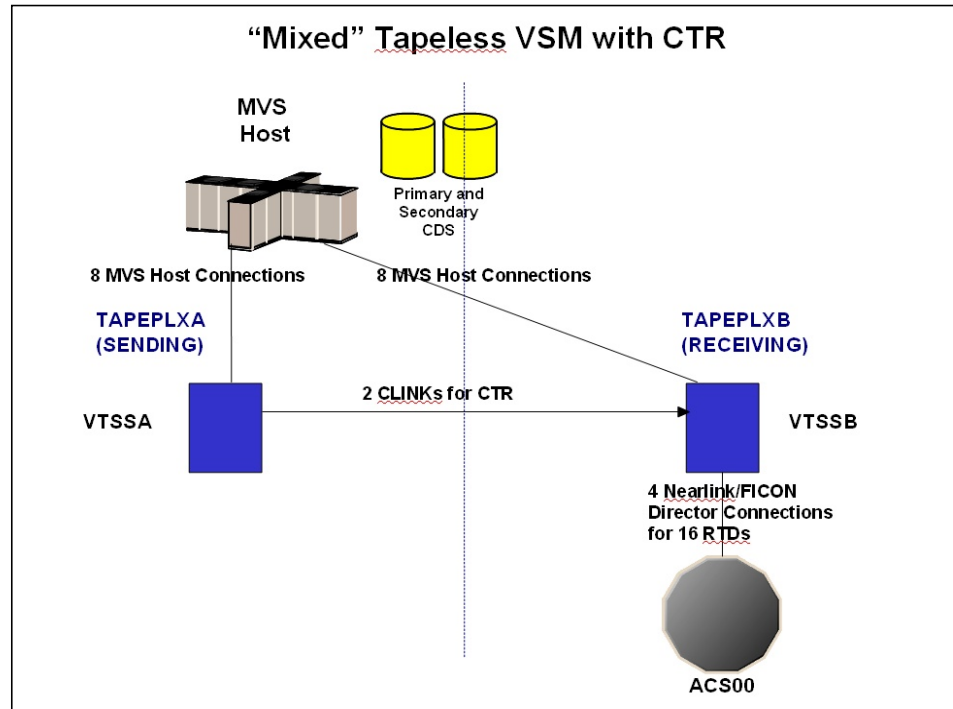

FIGURE M-1 Tapeless VSM

Configuring the System

To configure the example system shown in [FIGURE M-1](#) on page 425, code a CONFIG deck as shown in [FIGURE M-2](#).

In this figure, **note that** there are no RTD statements for VTSSA because it is Tapeless.

```
//CREATECF EXEC PGM=SWSADMIN,PARM='MIXED'  
//STEPLIB DD DSN=hlq.SLSLINK,DISP=SHR  
//SLS_CNTL DD DSN=FEDB.VSMLMULT.DBASEPRM,DISP=SHR  
//SLS_CNTL2 DD DSN=FEDB.VSMLMULT.DBASESEC,DISP=SHR  
//SLSSTBY DD DSN=FEDB.VSMLMULT.DBASETBY,DISP=SHR  
//SLSPRINT DD SYSOUT=*  
//SLSIN DD *  
  CONFIG RESET CDSLEVEL(V62ABOVE)  
  GLOBAL MAXVTV=32000 MVCFREE=40 VTVATTR=SCRATCH RECALWER=YES LOCKSTR=  
  VTCS_LOCKS  
  REPLICAT=CHANGED VTVPAGE=LARGE MAXRTDS=32  
  RECLAIM THRESHLD=70 MAXMVC=40 START=35  
  VTVVOL LOW=905000 HIGH=999999 SCRATCH  
  VTVVOL LOW=C00000 HIGH=C25000 SCRATCH  
  VTVVOL LOW=RMM000 HIGH=RMM020 SCRATCH  
  MVCVOL LOW=N25980 HIGH=N25989  
  MVCVOL LOW=N35000 HIGH=N35999  
  VTSS NAME=VTSSA  
  VTD LOW=8900 HIGH=89FF
```

FIGURE M-2 CONFIG example: Tapeless VSM

Defining Policies

To define policies for the example system shown in [FIGURE M-7 on page 428](#), do the following:

1. Enable the Advanced Management Feature.
2. Create a Storage Class for VTSSA.

```
STOR NAME(TAPEL)
```

FIGURE M-3 “Tapeless” Storage Class

3. Create the Management Classes that point to the Storage Classes in [Step 2](#).

```
MGMT NAME(TAPEL) NOMIGRAT DELSCR(YES)
```

FIGURE M-4 “Tapeless” Management Class

In [FIGURE M-4](#) we created a Management Class that points to the corresponding Storage Class created in [Step 2](#).

Note – In addition to NOMIGRAT, the Management Class in [FIGURE M-4](#) specifies DELSCR(YES), which is a proactive method to cause VSM to delete scratched VTVs, which frees VTSS buffer space and (logically) deletes any VTV copies from MVCs so that MVC space can be reclaimed. As an alternative, you can specify DELSCR(NO) and use the DELETSCR utility (which now provides a VTSS parameter to scratch VTVs on a per VTSS basis) to do demand deletes of scratched VTVs.

4. Create an SMC Policy that specifies virtual media and assigns the Management Class created in [Step 3](#).

```
POLICY NAME(PTAPEL) MEDIA(VIRTUAL) MGMT(TAPEL)
```

FIGURE M-5 “Tapeless” Policy

5. Create a TAPEREQ statement to route data to VSM and assign the “Tapeless” Policy to the data.

```
TAPEREQ DSN(*.HR.***) POLICY(PTAPEL)
```

FIGURE M-6 TAPEREQ Statement to Route Data, Assign Policy

In [FIGURE M-6](#), the TAPEREQ statement specifies to route data sets with HLQ mask *.HR.** to VSM and assign Policy PTAPEL.

Note – Although you can use SMC policies to direct your migrations to a specific esoteric, StorageTek recommends using **only** MGMTCLAS so that the SMC/VTCS allocation influencing can use any VTSS that supports the MGMTCLAS requirements.

Using CTR in “Tapeless” and “With Tape” Environments

FIGURE M-7 shows two *non-clustered* VTSSs (VTSSA and VTSSB in separate TapePlexes) where VTSSA has no RTDs attached. VTSSA sends VTVs to VTSSB via CTR so that VTSSB can migrate the VTVs to tape in ACS00.

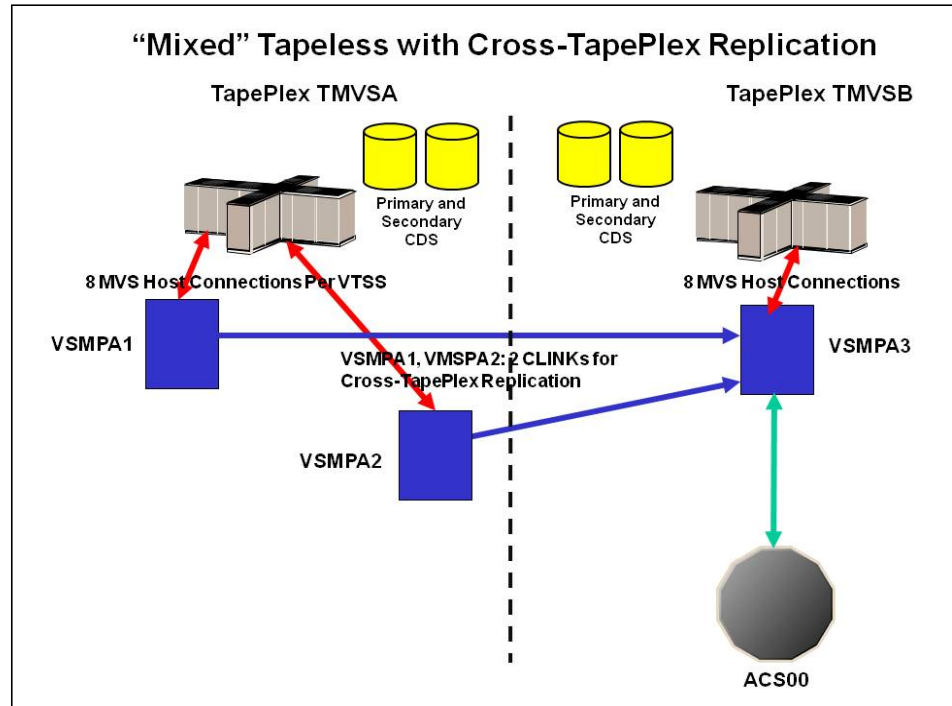

FIGURE M-7 Mixed Tapeless VSM

As shown in FIGURE M-7, therefore, you can construct a “Tapeless” TapePlex, use CTR to connect this TapePlex to another TapePlex that has RTDs attached. With this configuration, you can make a “TapeLess” copy in the first TapePlex and replicate it to the second TapePlex where it can be migrated to tape. For more information on DTR, see *ELS Disaster Recovery and Offsite Data Management Guide*.

LIBGEN Example for Tapeless ACS

FIGURE M-8 and FIGURE M-9 on page 430 show a LIBGEN example for a Tapeless ACS, where the SLISTATN ADDRESS=(0032) statement denotes a dummy ACS. **Note** that for new Tapeless VSM configurations, you can alternatively use the CDSCREAT utility as described in “Running the CDSCREAT Utility to Create the CDS (Tapeless VSM Only)” on page 105.

```

*
* LABELS WILL BE GENERATED IN THE OUTPUT LIBGEN AS FOLLOWS:
* ACS  - "ACSXX"  WHERE "XX" IS THE HEX ACS NUMBER 00-FF
*       STARTING WITH ZERO
* LSM  - "LSMXXYY" WHERE "XX" IS THE HEX ACS NUMBER OF THIS LSM
*       AND "YY" IS THE HEX LSM NUMBER (00-FF) IN THAT
*       ACS, STARTING AT ZERO FOR EACH NEW ACS
* STATION - "STXXH"  WHERE "XX" IS THE HEX ACS NUMBER AND H IS THE
*       HOST INDEX IN HEX (0-F)
* PANEL  - "PXXYYPP" WHERE "XX" IS THE HEX ACS NUMBER, YY IS THE HEX
*       LSM NUMBER, AND PP IS THE DECIMAL PANEL NUMBER
*       OF THE DRIVE PANEL
* DRIVE  - "DXXYYPPH" WHERE "XX" IS THE HEX ACS NUMBER, YY IS THE HEX
*       LSM NUMBER, PP IS THE DRIVE PANEL NUMBER IN DEC
*       IMAL, AND H IS THE HOST INDEX IN HEX
*
LIBGEN SLIRCVRY TCHNIQE=NONE
*
      SLILIBRY SMF=231,           X
      ACSLIST=ACSLIST,         X
      HOSTID=(EC20,EC21),      X
      MAJNAME=STKALSQN,        X
      CLNPRFX=CLN,             X
      COMPRFX=!,               X
      DRVHOST=,                 X
      SCRLABL=SL
*
ACSLIST SLIALIST ACS00
*
ACS00  SLIACS LSM=(LSM0000,LSM0001,LSM0002,LSM0003),      X
      STATION=(ST000,ST001)
*
ST000  SLISTATN ADDRESS=(0032)
ST001  SLISTATN ADDRESS=(0032)
*
LSM0000 SLILSM PASTHRU=((0,M),(0,M),(0,M)),                X
      ADJACNT=(LSM0001,LSM0002,LSM0003),                  X
      DRIVE=(1),                                           X
      DRVELST=(P000001),                                   X
      TYPE=8500,                                           X
      DOOR=8500-2
*

```

FIGURE M-8 LIBGEN Example for Tapeless ACS (Part 1)

```

P000001 SLIDLIST HOSTDRV=(D0000010,D0000010)
*
D0000010 SLIDRIVS ADDRESS=(,,,,,,,,,,,,,)
*
LSM0001 SLILSM PASTHRU=((0,S),(0,M),(0,M)),           X
          ADJACNT=(LSM0000,LSM0002,LSM0003),         X
          DRIVE=(1),                                  X
          DRVELST=(P000101),                          X
          TYPE=8500,                                  X
          DOOR=8500-2
*
P000101 SLIDLIST HOSTDRV=(D0001010,D0001010)
*
D0001010 SLIDRIVS ADDRESS=(,,,,,,,,,,,,,)
*
LSM0002 SLILSM PASTHRU=((0,S),(0,S),(0,M)),           X
          ADJACNT=(LSM0000,LSM0001,LSM0003),         X
          DRIVE=(1),                                  X
          DRVELST=(P000201),                          X
          TYPE=8500,                                  X
          DOOR=8500-2
*
P000201 SLIDLIST HOSTDRV=(D0002010,D0002010)
*
D0002010 SLIDRIVS ADDRESS=(,,,,,,,,,,,,,)
*
LSM0003 SLILSM PASTHRU=((0,S),(0,S),(0,S)),           X
          ADJACNT=(LSM0001,LSM0002,LSM0000),         X
          DRIVE=(1),                                  X
          DRVELST=(P000301),                          X
          TYPE=8500,                                  X
          DOOR=8500-2
*
P000301 SLIDLIST HOSTDRV=(D0003010,D0003010)
*
D0003010 SLIDRIVS ADDRESS=(,,,,,,,,,,,,,)
*
          SLIENDGN ,

```

FIGURE M-9 LIBGEN Example for Tapeless ACS (Part 2)

Index

A

- ACSLIST 237
- adding tape drives, dynamic hardware
 - reconfiguration 152
- ADDRESS 231
- ADJACNT 247
- AL 240
- ALL 250
- ALLOCDef SMC command, setting to ON,
 - performance consideration 127
- AMTs
 - policies 45
- archiving, stopping 126

B

- balancing
 - library workload 129
- Bulk CAP
 - adding to or removing from a partition with the HSC down 201
 - adding to or removing from a partition with the HSC up 201

C

- calculating SL3000 library cartridge capacity 25
- calculating SL8500 library cartridge capacity 25
- CAP *See* Cartridge Access Port
- cartridge
 - capacity, calculating for SL3000 library 25
 - capacity, calculating for SL8500 library 25
- Cartridge Access Port (CAP)
 - ejecting cartridges through closest 126
 - setting CAP preference 127
- cartridges
 - ejecting through closest CAP 126
 - entering
 - in advance of mount message 127
 - redistributing during off-peak times 126
- changing unit addresses for tape drives, dynamic hardware reconfiguration 154

- client/server drive mapping, defining 232
- CLNPRFX 237
- COMPRFX 237
- CONFIG utility 28, 37
- configurations, library 253
- Configuring VSM
 - starting VTCS 213
- control data set
 - definition of types 5
 - formatting 104, 105
 - HSC performance and sharing in multiple library complex 12
 - limiting CDS access privileges 9
 - primary 5
 - secondary 5
 - standby CDS 6
- crashing test systems, avoiding 128

D

- DD statements, descriptions for START PROC 124
- defining
 - drives on a panel 231
- DOOR 247
- DRIVE 245
- DRVELST 245
- drvelst 230
- DRVHOST 240
- dual IP connection 286
- dual IP connections 321
- duplicate copy, control data set 5
- dynamic hardware reconfiguration
 - adding tape drives 152
 - changing unit addresses for tape drives 154
 - removing tape drives 153
 - replacing tape drives 153

E

- EJCTPAS 240
- ejecting cartridges
 - through closest CAP, performance consideration

126

esoterics
 configuring 93

examples
 HOSTID parameter in SLILBRY 236
 library
 configurations 253

EXECParm control statement
 parameters
 Eid 117
 Fid 117
 HOSTID 117
 MSGPRFX 117

F
 FUTRACS 241
 FUTRLSM 228

G
 GRS serialization 10

H
 HCD facility 38
 high AMT
 policies 45
 Host Software Component (HSC)
 CDS performance and sharing in a multiple library
 complex 12
 defining client/server drive mapping 232
 forced termination, SMC consideration 220
 initializing under the master subsystem 216
 multiple library considerations 11
 preinitializing as an MSP subsystem 216
 RESERVEs, converting to global enqueues in a
 GRS environment 16
 RESERVEs, leaving in an MIM/MII environment
 14
 RESERVEs, maintaining 13, 14
 start task procedure 119
 starting
 using the SSYS parameter 217
 terminating the HSC 220

HOSTID 236
 host-id 236
 hosts
 enabled for migration 56

HSC
 defining a security system user ID 92
 reconfiguration
 formatting the new CDS 104, 105
 LIBGEN definitions for RTDs 27
 overview 95
 updating the LIBGEN 97
 SLUADMIN utility 211
 user exits

SLSUX15 118

I
 I/O Device Reserve Considerations 10
 IEFSSNxx member 216
 installation
 IPLing the system 119
 parameters for START command 121
 proc for START command 121

IP connection, dual 286
 IP connections
 dual 321
 multiple 305

IPL requirements 119
 IPLing the System 119

J
 JOURNAL 250

L
 label 249
 LIBGEN
 updating 97
 library
 balancing workload 129
 modifications 131
 multiple HSC library complexes, serializing 11
 reducing scheduling contention 128
 library configurations 253
 library scheduling contention, reducing 129
 Library Storage Module (LSM)
 preallocating CDS space for SL8500 LSMs 228
 SLIACS parameter 227
 SLILSM parameter 244

libtype 237
 low AMT
 policies 45
 lsm0 244

M
 MAJNAME 237
 migration
 policies 64
 MIH, setting 93
 MIM/MII serialization, considerations 13
 MNTD
 Float, setting to ON, performance consideration
 126
 modifying library 131
 multiple IP connections 305
 MVCs
 defining and selecting 39
 maximum retain interval 87, 89

- policies
 - space reclamation 83
- RTV access 211
- space reclamation
 - policies 84, 85, 86
- unscratching current scratch cartridges 211

N

- NCO *See* Near Continuous Operation
- Near Continuous Operation (NCO)
 - adding tape drives 152
 - changing unit addresses for tape drives 154
 - preallocating CDS space for SL8500 LSMs 228
 - removing tape drives 153
 - replacing tape drives 153
- NL 240
- NONE 249
- nonlibrary cartridges, entering before a mount
 - message is issued 127
- nonproductive activities, scheduling 129
- NSL 240

P

- parameters
 - 050 244
 - 075 244
 - 100 244
 - 4410 244
 - 9310 244
 - 9360 244
 - 9740 244
 - ACSLIST 229, 237
 - ADDRESS 231, 252
 - ADJACNT 247
 - AL 240
 - ALL 250
 - BASE 121
 - BOTH 249
 - CLN 237
 - CLNPRFX 237
 - COLD 121
 - COMPRFX 237
 - Dialog 122
 - DOOR 247
 - DRIVE 245
 - DRVELST 245
 - drvelst 230
 - DRVHOST 240
 - Eid 117, 122
 - EJCTPAS 240
 - Fid 117, 122
 - FUTRACS 241
 - FUTRLSM 228
 - gtfeid 117
 - gtffid 117
 - HOSTDRV 230

- HOSTID 117, 236
- JOURNAL 250
- label 249
- LSM 227, 244
- MAJNAME 237
- Member 122
- MSGPRFX 117
- NL 240
- NONE 249
- NSL 240
- PARM= 121
- PASTHRU 245
- RESET 122
- SCRLABL 240
- SHADOW 249
- SL 240
- SL3000 244
- SL8500 244
- SMF 237
- SSYS 121
- STANDBY 250
- STATION 226
- station 252
- TCHNIQE 249
- TYPE 244
- WINDOW 248
- PARMLIB control statements
 - IEFSSNxx member 216
- partitioning
 - adding or removing a Bulk CAP to or from a partition
 - HSC down 201
 - HSC up 201
 - SL3000
 - adding a partition to the library procedure 183
 - adding resources to a library procedure 194
 - moving a partition from one host group to another host group 190
 - partition description 165
 - removing a partition from the library procedure 187
 - removing resources from a library procedure 198
 - varying the ACS online after a configuration change 202
- pass-thrus
 - reducing 125
 - scheduled 126
 - unavoidable 125
 - unnecessary 125
- PASTHRU 245
- performance considerations
 - balancing library workload 129
- prefix 237
- preinitializing the HSC as an MSP subsystem 216
- primary control data set 5

- procedures, dynamic hardware reconfiguration
 - adding tape drives 152
 - adding/removing expansion modules 155, 156
 - changing CAP types, HSC down 157
 - changing CAP types, HSC up 158
 - changing unit addresses for tape drives 154
 - removing tape drives 153
 - replacing tape drives 153
- ptppanel0 245

R

- reconfiguring the library 131
- recovery utility
 - MVC access 211
 - VTV access 211
- redistributing cartridges during off-peak times, performance consideration 126
- reducing
 - operator intervention 127
 - pass-thru activity 126
 - pass-thrus 125
 - scheduling contention 128
- removing tape drives, dynamic hardware reconfiguration 153
- replacing tape drives, dynamic hardware reconfiguration 153
- resource serialization 10
- RTDs
 - defining for sharing with MSP 27
 - LIBGEN definitions 27
 - planning for 27
 - policies 87, 89
 - UNITATTR control statement 27
- RTV utility
 - MVC access 211
 - VTV access 211

S

- scheduled pass-thrus 126
- SCRLABL 240
- secondary control data set 5
- security
 - defining for VSM 211
- serialization
 - CA-MIM/MII considerations 13
 - HSC CDS performance and sharing tips 12
 - HSC RESERVEs, converting to global enqueues in a GRS environment 16
 - HSC RESERVEs, leaving in an MIM/MII environment 14
 - HSC RESERVEs, maintaining 14
 - HSC RESERVEs, maintaining 13
 - multiple HSC library complex 11
 - resource 10

- setting CAP preference, performance consideration 127
- setting MNTD SCRDISM to CURRENT, performance consideration 126
- SL 240
- SL3000 library
 - calculating cartridge capacity 25
 - drive panel numbering 233
 - dual IP connections 321
 - partitioning
 - adding a partition to a library procedure 183
 - adding resources to a library procedure 194
 - definition 165
 - moving a partition from one host group to another host group procedure 190
 - removing a partition from a library procedure 187
 - removing resources from a library procedure 198
 - varying the ACS online after a configuration change 202
- SL8500 library
 - before configuring the HSC for the SL8500 101
 - calculating cartridge capacity 25
 - changing CAP types
 - HSC down 157
 - HSC up 158
 - connecting to multiple SL8500s in an ACS 305
 - drive panel numbering 234
 - dual IP connection 286
 - merging ACSs
 - configuring ACSs numbered left to right 144
 - configuring ACSs numbered right to left 143
 - multiple IP connections 305
 - Near Continuous Operation (NCO)
 - adding tape drives 152
 - adding/removing expansion modules 155, 156
 - changing unit addresses for tape drives 154
 - removing tape drives 153
 - swapping tape drives 153
 - Near Continuous Operation (NCO), SLIACS FUTURLSM parameter 228
 - partitioning
 - CAP considerations 163
 - converting a non-partitioned ACS to a partitioned ACS 170
 - converting a partitioned ACS to a non-partitioned ACS 173
 - definitions 164
 - overview 162
 - requirements and prerequisites 162
 - restrictions 163
 - start from scratch procedure 168
 - powering down the SL8500 307
 - row numbering 26
 - sample configuration - one host IP, two network

- connections 301
- sample configuration - two dedicated routes 291
- side numbering 26
- TCP/IP communications
 - connections 284, 320
 - shared networks 284, 320
- two network connections - one mainframe IP address 297
- two network connections - two mainframe IP addresses 286
- SL8500 partitioning
 - adding or removing a Bulk CAP to or from a partition
 - HSC down 201
 - HSC up 201
- SLIACS
 - parameters
 - FUTRLSM 228
 - LSM 227
 - STATION 226
 - purpose 226
- SLIALIST
 - parameters 229
 - acslis 229
 - purpose 229
 - syntax 229
- SLIDLIST
 - parameters
 - drvelst0 230
 - HOSTDRV 230
 - purpose 230
- SLIDRIVS
 - parameters
 - ADDRESS 231
 - purpose 231
 - SL3000 library drive panel numbering 233
 - SL8500 library drive panel numbering 234
- SLIENDGN
 - purpose 235
- SLILIBRY
 - parameters 237
 - ACSLIST 237
 - CLNPRFX 237
 - COMPRFX 237
 - DRVHOST 240
 - EJECTPAS 240
 - FUTRACS 241
 - HOSTID 236
 - MAJNAME 237
 - SCRLABL 240
 - purpose 236
- SLILSM
 - parameters
 - 050 244
 - 075 244
 - 100 244
 - 3000 244
 - 4410 244
 - 8500 244
 - 9310 244
 - 9360 244
 - 9740 244
 - ADJACNT 247
 - DOOR 247
 - DRIVE 245
 - DRVELST 245
 - LSM 244
 - PASTHRU 245
 - TYPE 244
 - WINDOW 248
 - purpose 242
- SLIRCVRY
 - parameters
 - ALL 250
 - BOTH 249
 - JOURNAL 250
 - label 249
 - NONE 249
 - SHADOW 249
 - STANDBY 250
 - TCHNIQE 249
 - purpose 249
- SLISTATN
 - parameters
 - ADDRESS 252
 - station 252
 - purpose 251
- SLSBPREI subsystem initialization routine 216
- SLSSYS DD statement for START PROC 124
- SLSUEXIT DD statement for START PROC 124
- SLSUX15 user exit
 - issuing command authorization request to security product 118
- SLUADMIN utility
 - unscratching current scratch cartridges 211
- SMF 237
- SMF record formats 114
- SMFPRMxx, producing SMF records 114
- space reclamation
 - MVCs 83, 84, 85, 86
- specifying
 - GTF event ID 117
 - GTF format ID 117
- SSYS parameter, starting the HSC using 217
- STANDBY 250
- standby control data set 6
- START procedure
 - DD statement descriptions 124
 - parameters 121
 - SLSSYS DD statement 124
 - SLSUEXIT DD statement 124

- syntax 121
- start task procedure
 - HSC
 - coding and cataloging 119
- STATION 226
- stopping the HSC 220
- syntax
 - HSC START procedure 214

T

- tape management system
 - planning for 39, 40
 - updating 209
- tape transport
 - contention, reducing 129
- TAPEVOL security class 210
- TCHNIQE 249
- terminating, the HSC 220
- TYPE 244

U

- unavoidable pass-thrus 125
- Unicenter CA-MIM/MII serialization 10
- UNITATTR control statement 27, 37
- unnecessary pass-thrus 125

V

- VSM
 - configuration
 - defining VSM security 211
 - record 221
 - updating the tape management system 209
 - values 5
 - policies
 - AMTs 45
 - hosts enabled for migration 56
 - maximum concurrent migration tasks 64
 - maximum VTVs per MVC 55
 - migration 56
 - MVC space reclamation 85
 - RTDs 87, 89
 - space reclamation 83
 - security 211
- VTCS
 - configuration values 5
 - pre-installation
 - configuring MSP unit addresses/esoterics 93
 - defining a security system user ID 92
 - setting the MIH value 93
 - SMF record formats 114
- VTDs
 - configuring
 - esoterics 93
 - MSP device numbers 93

- data chaining a read forward or write command 40
- MSP device numbers 38
- planning for 38
- UNITATTR control statement 37

- VTSSs
 - planning for 37
- VTVs
 - defining to tape management system 39
 - migration
 - policies 56, 64
 - RTV access 211

W

- WINDOW 248

